

DOCUMENT RESUME

ED 246.290

CE 039 352

AUTHOR McColman, Don
 TITLE Heavy Duty Tireman. Open Pit Mining Job Training Series.
 INSTITUTION British Columbia Dept. of Education, Victoria.
 REPORT NO ISBN-0-7718-8361-7
 PUB DATE 83
 NOTE 82p.; Joint project of the Ministry of Education and the member companies of the Mining Association of British Columbia. For related documents, see CE 039 353-359.
 AVAILABLE FROM Publication Services Branch, Ministry of Education, 878 Viewfield Road, Victoria, BC V9A 4V1 (\$6.00).
 PUB TYPE Guides - Classroom Use - Guides (For Teachers) (052)
 EDRS PRICE MF01 Plus Postage. PC Not Available from EDRS.
 DESCRIPTORS Adult Education; Behavioral Objectives; Coal; Communication (Thought Transfer); Communication Skills; Competency Based Education; Course Content; Course Descriptions; Curriculum Guides; *Equipment Maintenance; *Equipment Utilization; Foreign Countries; Interpersonal Communication; Job Skills; Learning Modules; *Machinists; Metals; *Mining; On the Job Training; Organizational Communication; Postsecondary Education; Repair; Safety; *Trade and Industrial Education
 IDENTIFIERS British Columbia; *Heavy Equipment Operators; *Tires

ABSTRACT

This training outline for heavy duty tiremen, one in a series of eight outlines, is designed primarily for company training foremen or supervisors and for trainers to use as an industry-wide guideline for heavy equipment operator training in open pit mining in British Columbia. Intended as a guide for preparation of lesson plans both for classroom and on-the-job training activities, this outline is divided into eight modules. Each module is based on 3 to 13 objectives. For each objective, key points and procedures are outlined. Module topics are basic safety and operating rules, communications, preparation of the equipment for tire changes, remove the tire from the equipment front and rear, replace the tires on the equipment front and rear, tire removal from the rim assembly, install tire on rim assembly, and special assignments. A skill profile chart is attached. (YLB)

 * Reproductions supplied by EDRS are the best that can be made *
 * from the original document. *

OPEN PIT MINING JOB TRAINING SERIES

HEAVY DUTY TIREMAN

U.S. DEPARTMENT OF EDUCATION
NATIONAL INSTITUTE OF EDUCATION
EDUCATIONAL RESOURCES INFORMATION
CENTER (ERIC)

This document has been reproduced as
received from the person or organization
originating it.
Minor changes have been made to improve
reproduction quality.

- Points of view or opinions stated in this docu-
ment do not necessarily represent official NIE
position or policy.

"PERMISSION TO REPRODUCE THIS
MATERIAL IN MICROFICHE ONLY
HAS BEEN GRANTED BY

J. A. Ralbridge

TO THE EDUCATIONAL RESOURCES
INFORMATION CENTER (ERIC)."

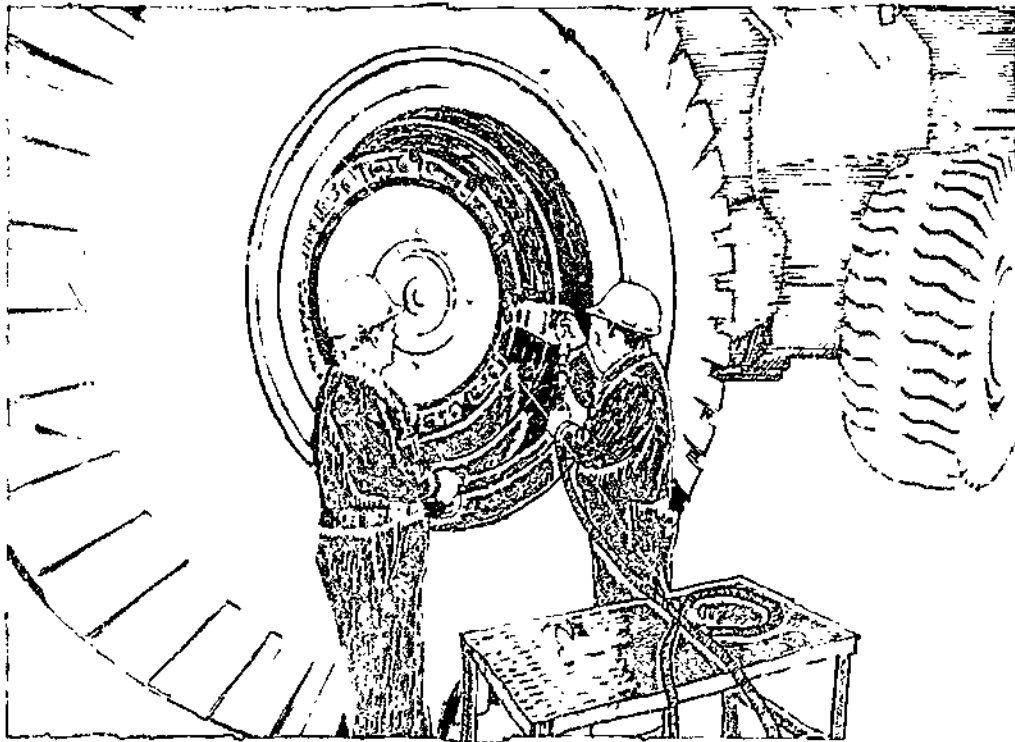

ED246290

Titles in the Open Pit Mining Job Training Series

- Haulage Truck Operator
- Rubber Tire Dozer Operator
- Track Dozer Operator
- Front End Loader Operator
- Grader Operator
- Rotary Drill Operator
- Shovel Operator
- Heavy Duty Fireman

**OPEN PIT MINING
JOB TRAINING SERIES
HEAVY DUTY TIREMAN**

**A joint project
of the
Ministry of Education
and
member companies of the
Mining Association of British Columbia**



**Province of
British Columbia
Ministry of Education
POST-SECONDARY DEPARTMENT
1983**

**Canadian Cataloguing in Publication Data
McColman, Don.**

Heavy duty tireman

(Open pit mining job training series, ISSN
0715-0709)

Written by Don McColman. Cf. p.

"A joint project of the Ministry of Education and
member companies of the Mining Association of
British Columbia."

ISBN 0-7718-8361-7

1. Tires, Rubber — Maintenance and repair - Study
and teaching - British Columbia. I. British Columbia.
Ministry of Education. Post-secondary Dept. II. Mining
Association of British Columbia. III. Title. IV. Series.

TL270.M32 629.2'482'0288 C83-092139-7

For further information contact:

Co-ordinator, Natural Resource Programs
Post-Secondary Department
Ministry of Education
St. Ann's Academy
835 Humboldt Street
Victoria, B.C.
V8V 2M4
Telephone: (604) 387-5541

Copies of this publication can be ordered from:

Publication Services Branch
Ministry of Education
878 Viewfield Road
Victoria, B.C.
V9A 4V1
Telephone: (604) 387-5331

© Ministry of Education, Province of British Columbia, Canada
No part of this publication may be reproduced in any
form without permission in writing from the publisher.

CONTENTS

INTRODUCTION

THE DEVELOPMENT PROCESS

USE OF TRAINING OUTLINES

MODULE 1. BASIC SAFETY AND OPERATING RULES

- OBJECTIVE 1-1** Explain the importance of safety and operating rules. 3
- 1-2** Explain the various types of tires and their specific applications. 5
- 1-3** Describe the basic construction of an off-the-road tire. 6
- 1-4** Explain the different types of problems that can arise and their causes. 9
- 1-5** Describe the wheel assembly parts. 12
- 1-6** Describe the various problems that can arise with the wheel assembly parts. 14
- 1-7** Explain the importance of having proper procedures for tire removal laid out before starting. 16
- 1-8** Explain the importance of checking all of the equipment before starting. 17
- 1-9** Describe the proper jacking and blocking procedures. 18
- 1-10** Explain the importance of bleeding the air from the tire(s) before removal. 19
- 1-11** Describe the proper method of nut and clamp removal. 20
- 1-12** Describe the proper method of inflating an earthmover tire. 21
- 1-13** Explain the importance of maintaining proper air pressures. 22

MODULE 2. COMMUNICATIONS

- OBJECTIVE 2-1** Relay the status of projects underway. 25
- 2-2** Fill out report forms. 26
- 2-3** Operate the mobile radio. 27

MODULE 3. PREPARATION OF THE EQUIPMENT FOR TIRE CHANGES

- OBJECTIVE 3-1** Park the unit on the jacking pad. 31
- 3-2** Jack and block the unit. 32
- 3-3** Determine the problem with the tire or wheel assembly. 33
- 3-4** Bleed air from the tires. 34

MODULE 4. REMOVE THE TIRE FROM THE EQUIPMENT FRONT AND REAR

- OBJECTIVE**
- 4-1 Ensure that the air has been bled. 37
 - 4-2 Remove the valve hardware holding devices. 38
 - 4-3 Grasp the tire with the manipulator. 39
 - 4-4 Loosen all of the wheel nuts and clamps. 40
 - 4-5 Remove the nuts and clamps. 41
 - 4-6 Remove the outside tire. 42
 - 4-7 Remove the spacer-band. 43
 - 4-8 Remove the inside tire. 44

MODULE 5. REPLACE THE TIRES ON THE EQUIPMENT FRONT AND REAR

- OBJECTIVE**
- 5-1 Check and clean the wheel motor assembly. 47
 - 5-2 Install the proper valve hardware on replacement tires. 48
 - 5-3 Pick up and install the inside tire. 49
 - 5-4 Install the spacer band. 50
 - 5-5 Pick up and install the outside tire. 51
 - 5-6 Install all of the wheel nuts and clamps. 52
 - 5-7 Tighten and torque the nuts. 53
 - 5-8 Inflate the tires to proper specifications. 54
 - 5-9 Prepare for re-torque procedures. 55

MODULE 6. TIRE REMOVAL FROM THE RIM ASSEMBLY

- OBJECTIVE**
- 6-1 Determine the problem with the tire or rim. 59
 - 6-2 Remove the tire from the wheel assembly. 60
 - 6-3 Mark with a paint stick or spray paint. 61
 - 6-4 Stack in the appropriate pile. 62

MODULE 7. INSTALL TIRE ON RIM ASSEMBLY

- OBJECTIVE**
- 7-1 Prepare the rim parts. 65
 - 7-2 Prepare the tire. 66
 - 7-3 Perform installation procedures. 67

MODULE 8. SPECIAL ASSIGNMENTS

- OBJECTIVE**
- B-1 Perform air and heat checks. 71
 - B-2 Service tires with ballast. 72
 - B-3 Perform fleet surveys. 73
 - B-4 Recognize special problems. 74
 - B-5 Service back-up equipment. 75

INTRODUCTION

The *Open Pit Mining Job Training Series* was developed through the co-operation of member companies of the Mining Association of British Columbia and the Post-Secondary Department of the Ministry of Education. The series was initiated by the education and training committee of the Mining Association. The committee chairman, Les Redford, has given invaluable support throughout the project.

The training outlines in the series are primarily written for company training foremen or supervisors and for trainers to serve as an industry-wide guideline for heavy equipment operator training in open pit mining in British Columbia.

THE DEVELOPMENT PROCESS

DACUM

Each of the training outlines in the series was developed using the DACUM process, a systematic model for developing modular training programs. A series of four booklets describing the DACUM process is available from:

Publication Services Branch.
Ministry of Education.
878 Viewfield Road,
Esquimalt, B.C.
V9A 4V1
Telephone: (604) 387-5331

Project Initiation

The Mining Association's education and training committee gave early direction to the project. Committee members actively working with chairman Les Fedford were:

Bill Scribner, Brenda Mines Limited
Bill Dement, Craigmont Mines Limited
Tom Nicholson, Mining Association of British Columbia
Glen Martin, Similkameen Division, Newmont Mines Limited

Vic Dawson of the Ministry of Energy, Mines and Petroleum Resources also participated with the committee in setting directions.

The first workshop with representatives from the mining industry, the Mining Association, and the Ministry of Education was held in April, 1979. Project goals and priorities were set and an activity plan was established.

DACUM Workshop and Skill Profile Charts

A three day DACUM workshop was held in June 1979. This workshop was conducted by Diane Morrison, a program developer from the Ministry of Education. The following representatives participated in the workshop:

Fred Mason, Afton Mines Limited
Ivan Moser, Afton Mines Limited
Bill Savilow, B.C. Coal Ltd.
Vern Bouck, Bethlehem Copper Corporation
Ray Chenier, Bethlehem Copper Corporation
Bill Scribner, Brenda Mines Limited
Ron Owens, Cyprus Anvil Mining Corporation
Dennis LeDuc, Endako Mines Division, Placer Development Limited
Terry Perrier, Fording Coal Limited
Barry Tripp, Granisle Mine, Noranda Mines Limited
Tom Nicholson, Mining Association of British Columbia
Fred Savage, Ministry of Education

Jack Murray, Noranda Mines Limited
Ed Rudolph, Noranda Mines Limited
Don Rankin, Similkameen Division, Newmont Mines Limited
Don Barker, Zapata Granby Limited

The DACUM workshop produced heavy equipment operator skill profile charts. Each chart listed the essential skills needed by the operator on the job. During the following months, the skill profile charts were circulated to representatives throughout the mining industry for validation.

Training Outlines

Once the skill profile charts were approved, the next step was to write training outlines. For each skill on the charts, one or more objectives were written that state what the trainee must be able to perform at the end of the training program to demonstrate mastering the skill. A trainee who can do all the objectives in the outlines is considered to have the skills required to perform on the job. A training outline developed using this approach is often referred to as a performance or competency-based outline.

Bill Savilow from B.C. Coal Ltd. (formerly Kaiser Resources) was selected to write six training outlines from the skill profile charts. He worked part-time on the outlines while continuing his responsibilities in the training department at B.C. Coal. Bill wrote the *Haulage Truck Operator*, *Rubber Tire Dozer Operator*, *Track Dozer Operator*, *Front-End Loader Operator*, *Grader Operator* and *Rotary Drill Operator* outlines during 1980 and 1981.

Don McColman of Newmont Mines wrote *Heavy Duty Tireman*, and Larry Hartley of Utah Mines wrote *Shovel Operator*.

Bruce Kurschenska of B.C. Coal Ltd. supplied the photographs upon which the cover illustrations are based.

Reviewing the Training Outlines

Throughout 1980 and 1981 a series of workshops were held to review the outlines. The workshops were conducted by Diane Morrison and attended by participants from various mining companies. The participants who played an extremely important role in examining and revising the training outlines to reflect training standards required across the industry were:

Hans Geertsema, Afton Mines Limited
Fred Mason, Afton Mines Limited
Bill Savilow, B.C. Coal Ltd.
Vern Bouck, Bethlehem Copper Corporation
Jerry LeBlanc, Bethlehem Copper Corporation
Don Miller, Brenda Mines Limited
Gerry Cooper, Brinco Mining Limited
Richard Schwengler, Equity Silver Mines Limited
Don Fraser, Cyprus Anvil Mining Corporation
Terry Wozniak, Fording Coal Limited
Norm Myhre, Gibraltar Mines Limited
George Sutherland, Highmont Operating Corporation

Fred Savage, Ministry of Education
Don McColman, Newmont Mines Limited
John Graham, Noranda Mines Limited
Charles Heikkila, Noranda Mines Limited
Les Redord, Noranda Mines Limited
Dennis LeDuc, Placer Development Limited
Larry Hartley, Utah Mines Limited

In addition, the following individuals participated in the review workshop for the *Heavy Duty Tireman* outline:

Claude Bourgeois, Placer Development Limited
John Cochrane, Noranda Mines Limited

Field-testing the Haulage Truck Operator Outline

In June 1980 three companies (B.C. Coal Ltd; Noranda Mines Limited, Granisle Mine; Brinco Mining Limited) offered to field-test the new *Haulage Truck Operator* outline for a six month period and report back to the group. During the fall, it was further agreed that the other participating mines in the project would also field-test the outline and would complete a questionnaire. In the winter of 1981 all mines reported that the outline had been used successfully to improve the truck operator training at their mine and some reported making major revisions of their training programs as a result of the outline.

USE OF TRAINING OUTLINES

Additions and Modifications

References are made in the outlines to areas where policies will vary from company to company and it is up to trainers to insert their company policies in these places.

For Lesson Plans

The outlines do not contain lesson plans. Rather the trainer should use the outlines as a guide when preparing lesson plans both for classroom and on-the-job training activities. Trainers are encouraged to expand upon the outlines to suit their own situation.

For Testing

The outline should also be used as a guideline for written, oral, and practical testing. Trainers should ensure that upon completion of training, each trainee can perform every objective listed in the outline. It will take time and experience on-the-job before a trainee becomes a proficient operator. Regular on-the-job monitoring by supervisors and trainers can greatly assist the trainee in developing and maintaining the skills needed to be a heavy equipment operator.

Sample tests for the outlines have been written and are available to trainers from:

Research & Curriculum Development Branch,
Ministry of Education,
7451 Elmbridge Way,
Richmond, B.C.
V6X 1B8
Telephone: (604) 278-3433

For Trainees

The outlines provide valuable information on operating heavy equipment and give clear statements on what trainees must be able to do by the end of their training. Therefore, it is recommended that trainees be given a copy of both the skill profile chart and the outline.

BASIC SAFETY AND OPERATING RULES

module 1

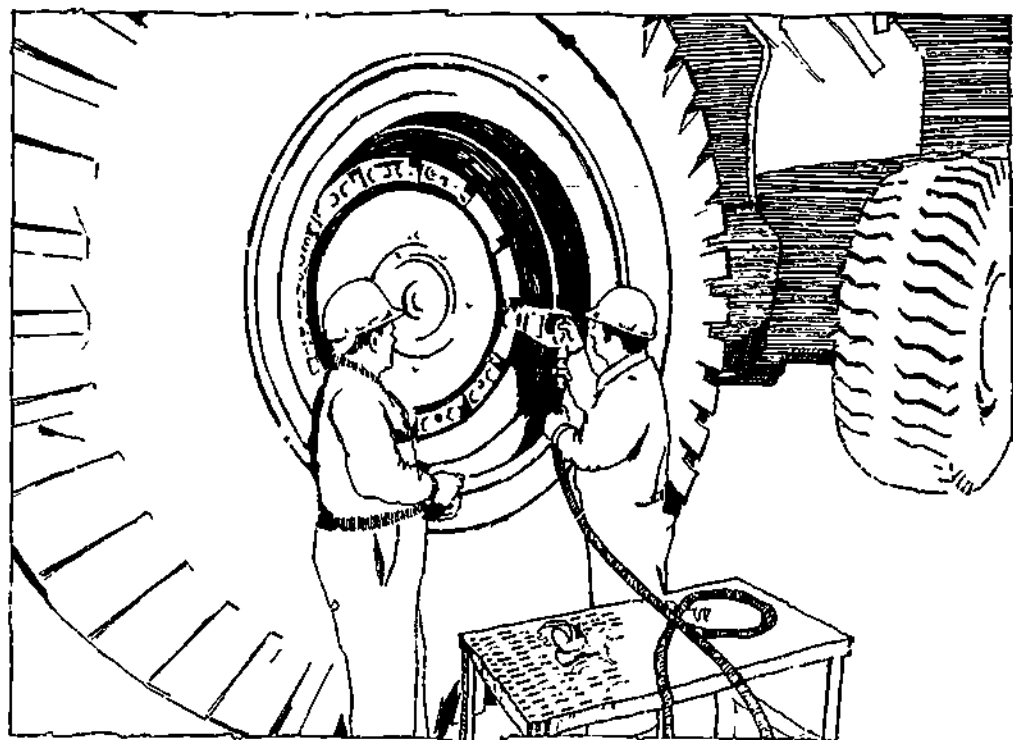

OBJECTIVE 1-1

The tireman will explain how safety and operating rules set by the company and the *Mines Regulation Act* protect the tireman and fellow workers on the mine site.

KEYPOINTS/PROCEDURES

1. The inexperienced tireman should not be left alone at any time while working on heavy duty tires. No person (e.g., mechanics or mechanic's helpers) other than a fully qualified tireman should perform work on heavy duty tires.

2. **Personal wear**

The safety rules concerning personal wear are set for the protection of the worker and include proper:

- Hard hats
- Eye protection
- Gloves
- Footwear
- Hearing protection

3. **Personal conduct**

Rules concerning personal conduct are enforced for the safety of all personnel on the mine site and cover:

- Horseplay.
- Reading on-the-job.
- Alcohol and drugs.

4. **Pre-start check**

Safety rules ensure personal protection while conducting pre-start checks and also ensure that the tire manipulator and associated equipment is in a safe operating condition before it is put to work changing tires. Special caution is required when:

- Working around moving components on the manipulator such as fans and belts.
- Removing radiator caps.
- Climbing on or off the manipulator.

It is essential to report immediately any operational problems with the brakes or steering. The tire manipulator must always be equipped with a fire extinguisher.

Rules 263 (d) and 263 (e) of the *Mines Regulation Act* and rules 195 (d) and 195 (e) of the *Coal Mines Regulation Act* state:

(d) The driver or operator of any vehicle or mobile equipment shall examine and test his equipment at the beginning of each shift before putting it into use; and if any unsafe condition is noted, such equipment shall not be used and the immediate supervisor shall be notified.

(e) For each vehicle or piece of mobile equipment, a logbook or other suitable record shall be maintained, in which shall be entered a record of all unsafe conditions and the repairs made, and all notations shall be signed by the person making the entry, and the logbook or records shall be available for inspection at all times.

It is the tire manipulator operator's responsibility to comply with these rules.

5. Operating

Operating rules ensure the safety of the manipulator operator and of all other persons on the mine site.

Only persons authorized by the company are allowed to operate the tire manipulator.

There is a blind area immediately surrounding the tire manipulator, especially when a tire is being held in the vertical position in preparation for mounting on a truck. The manipulator operator must conduct a check of this area before moving the unit. Rule 264 (a) (iii) of the *Mines Regulation Act* and rule 196 (a) (iii) of the *Coal Mines Regulation Act* state:

No person shall operate or put in motion any vehicle or mobile equipment unless he has just previously inspected on foot the area over which the equipment is to be moved.

The manipulator operator must immediately follow all warning signals given by others on the mine site including horns, lights and hand signals.

6. Traffic control scheme

It is the tire manipulator operator's responsibility to obey the traffic control scheme as set out by the company. Rule 264 (b) of the *Mines Regulation Act* and 196 (b) of the *Coal Mines Regulation Act* both state:

The owner, agent, or manager of every mine shall prepare a traffic control scheme for his operation and shall have it accepted by the inspector, and the scheme shall show the maximum allowable speeds for the vehicles in use, rules for passing, "stop" and "yield" locations, priority rules for various vehicles, rules for night operation, maximum operating grades, emergency run-off protection, and such other information as may be required by the inspector.

Since the majority of all large earthmover tire work is performed in the shop area, any further information regarding the movement of the tire manipulator to and from the pit area can be dealt with as the situation arises.

OBJECTIVE 1-2

The tireman will determine what specific tire is best for a job.

KEYPOINTS/PROCEDURES

1. All tires are classified by the "Tire and Rim Association" (TRA).
2. **Dump trucks (TRA Codes E-1, E-2, E-3, E-4, E-5 and E-7)**
Dump truck tires have high heat and wear resistance due to the heavy loads they must carry at high speeds. High cut resistance can also be incorporated during their construction.
3. **Scrapers (TRA Codes E-2, E-3, E-4 and E-7)**
The most common type of scraper tire in use has a wide base, and should have the same properties as those for a haulage truck. Superior flotation and traction are also required.
4. **Front-end loaders (TRA Codes L-2, L-3, L-4, L-5, L-4S and L-5S)**
Cut and wear resistance are vital, and the tire must provide stability for the loader. Certain working conditions require flotation and traction properties. Resistance to heat build-up is available for the loaders that are used in load-and-carry situations. For underground mining, because of the wet and rough conditions, use the L-4S and L-5S because of their high wear and cut resistance.
5. **Rubber tire dozers (TRA Codes L-2, L-3, L-4 and L-5)**
Since the rubber tire dozer is used not only for dozing and levelling but sometimes for pushing scrapers, tires with better traction than loader tires are necessary. Other requirements vary widely depending on the job conditions.
6. **Graders (TRA Codes G-1, G-2 and G-3)**
Graders are used basically for road levelling, clearing and snow-removal. This unit requires tires that provide high traction and directional stability.

OBJECTIVE 1-3

The tireman will describe the various components of an off-the-road tire, and describe their function.

KEYPOINTS/PROCEDURES

CROSS-SECTIONAL DIAGRAM OF OFF-THE-ROAD TIRE

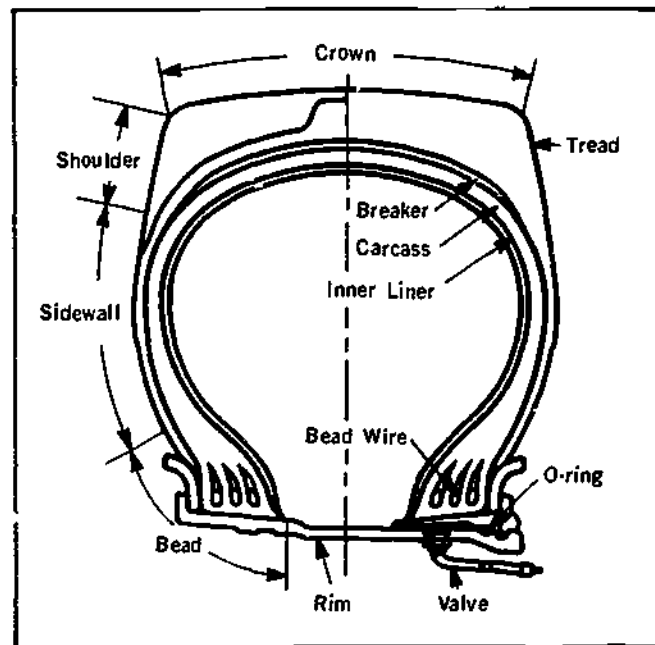

1. Though the construction of off-the-road tires depends largely on the intended use of the tire, all tires have a tread, carcass, beads, breakers, sidewalls, and in a tubeless tire, an inner liner.
2. **Tread**
The tread is the outermost covering of the tire and is the only part which normally comes in contact with the ground. It must therefore be designed to protect the body of the tire from cuts and wear. Depending on the intended use of the tire, the rubber compound used in the tread can be changed to alter cut, heat, and oil resistance. The tread pattern also has a large effect on the performance of the tire.
3. **Carcass**
The compressed air in a tire supports the load placed on the tire. The carcass forms a semi-rigid frame for the compressed air, but it is flexible enough to absorb some shocks and jolts. The carcass consists of a number of rubber-coated layers of fabric called plies.
4. **Beads**
The beads fix the tire to the rim to support the load. The end of all cord plies are wound around strong bead wires.

5. Breakers

The breakers are rubber-coated layers of cord between the tread and carcass, binding the two together. They prevent cuts in the tread from reaching the carcass and also absorb shocks.

6. Sidewalls

The sidewalls are composed of a flexible, crack-resistant rubber and protect the carcass from damage. High cut-resistant sidewalls can be used where large rocks and chuck holes are a problem.

7. Inner liner

The inner walls of tubeless tires are lined. The liner is made of an air-impermeable rubber compound and is comparable to tubes used in tube-type tires. Tubeless tires generally weigh less than comparable tube-type tires and are simpler to maintain because the tube and flap are eliminated.

STRUCTURAL DIAGRAM OF OFF-THE-ROAD TIRE

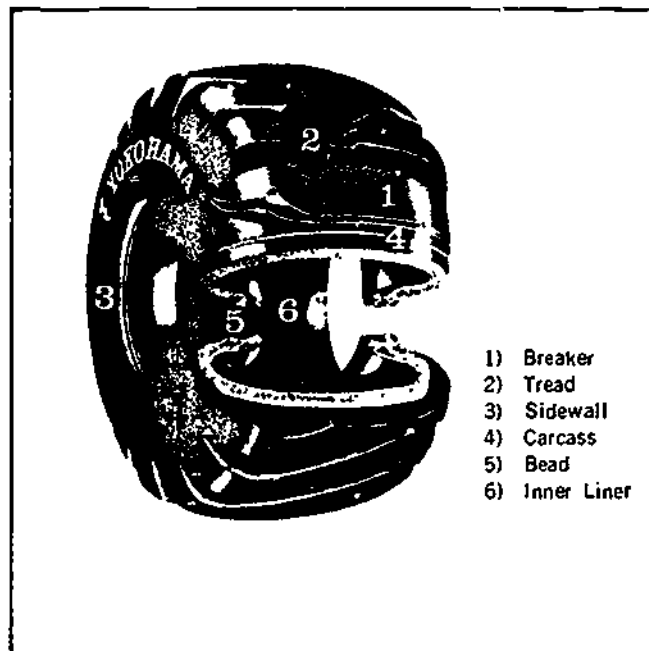

8. Steel breakers

The steel-breaker tire has steel-cord breakers which give very high cut resistance. It is especially useful where sharp rocks are a problem. The adhesiveness between the steel cord and rubber is, however, more susceptible to heat damage than that between nylon cord and rubber, so steel-breaker tires should not be subjected to conditions where heat generation is great. Because of the difficulty involved in recapping steel-breaker tires, they should not be used for jobs where more-easily recapped tires can be used. Steel-breaker tires whose steel breaker extends to the sidewall are also available for jobs where the sidewalls require high cut resistance.

The exception to the steel-breaker bias ply tire is the radial tire. The radial earth-mover tire has steel and is designed for high speed situations where heat is a problem.

STEEL BREAKER

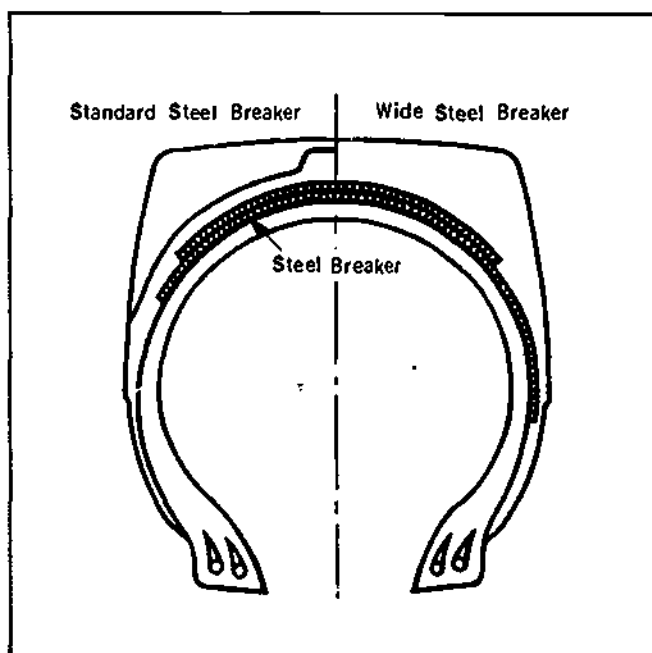

9. Shredded wire undertread

Shredded wire undertread tires employ a layer of rubber containing shredded wire between the tread and breaker to prevent cuts and retard their growth.

SHREDDED WIRE UNDERTREAD

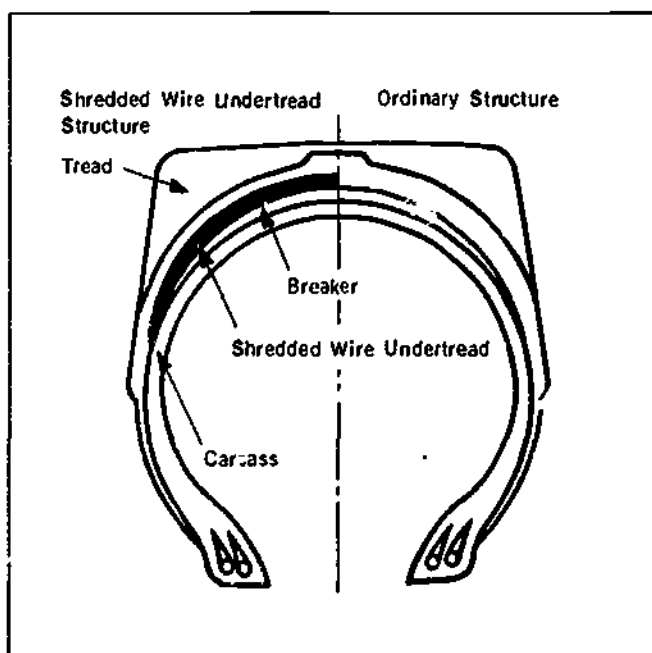

OBJECTIVE 1-4

The tireman will recognize the various problems that can arise, describe how they were caused and know how to handle them.

KEYPOINTS/PROCEDURES

1. Separations

A separation is a heat problem that is generally caused by a rock cut or the breakdown of the internal construction of the tire. The two areas rubbing together through the normal rotation of the tire lead to the build-up of heat by friction. The various types are:

- **Cut separation** — This is caused by the tire rolling over a rock. The cut generally is on an angle in the direction the tire was rolling.
- **Ply separation** — Heat build-up in the tread area can cause a separation between the plies of the carcass and the tread. This type is less common than shoulder separation.
- **Tread and shoulder separations** — This is more common than ply separation because of the heavier construction, more heat, and more flexing. A large pocket can form on the shoulder. It contains the materials from which the tire was constructed.
- **Bead separation** — An underinflated tire can cause the chafing of the bead area which in turn causes a separation of the cord body ends. The result is a bulge against the side flange.

Some separations should be removed and held for inspection. Cut separations that are vented can sometimes be run out, enabling the mine or contractor to achieve a lower end tire cost. Heat and ply separations, most of the time, should be removed as soon as possible.

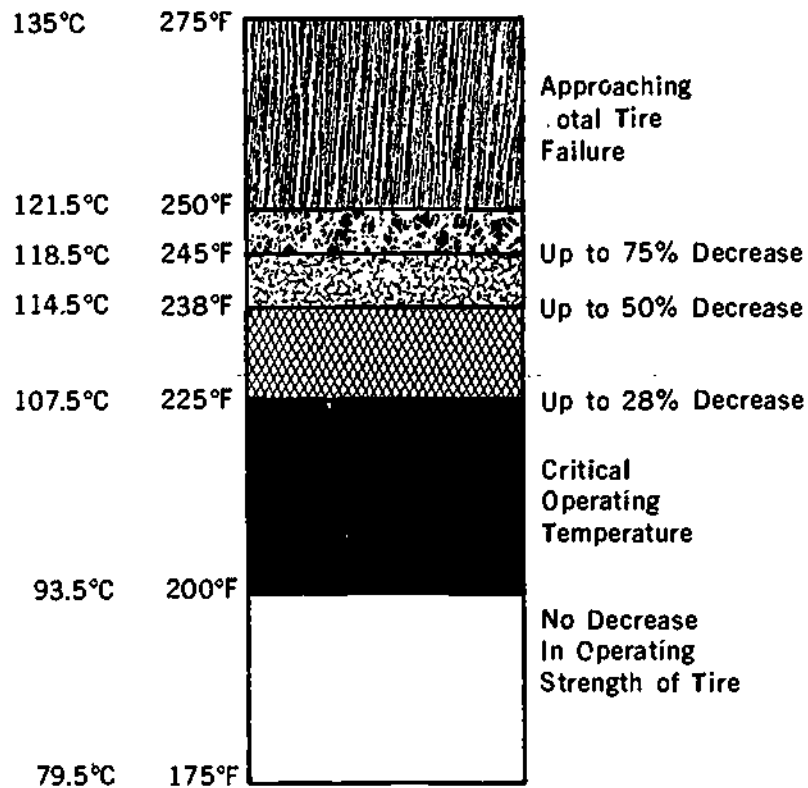

2. Bulges resulting from separations are not to be punctured under any circumstances. The chart gives the temperatures of the tire and the various percentages of deterioration of strength. Correct air pressures are important in the control of excessive heat build-up. Tires which squirm and deflect in severe turns lead to heat build-up as they distort. Methods to control the generation of internal heat are to:

- Use higher inflation pressures.
- Reduce the distortion and squirming in turns.
- Reduce the load or speed.
- Control the road and pit bottom conditions to eliminate bouncing.
- Reduce skidding.
- Reduce the length of the haul.

3. Rock cuts and impact breaks

The various types of rock cuts and impact breaks are:

- Small rock cuts — These can be of a minor nature or require spot repairs, spot and reinforcement, or full section repairs. They are caused by the tire rolling over rocks on the road, or at the loading and dump areas. Tread compounds, air pressures, loads, speed, and road and pit bottom conditions also must be considered when rock cutting occurs. The decision to repair or not is based on injury size and location, tread depth and costs.

- **Impact breaks** — This injury is the result of the tire rolling over a large rock on the road or in the loading and dump areas. It occurs when the tensile strength of the cord body is exceeded, resulting in the breakage of one or more plies. This tire may not blowout right away, but days later under ideal conditions, usually in the afternoon when the tire has warmed up from working. Poor road, pit, and dump areas are the major cause, although over-inflation can be a contributing factor.
- **Sidewall injuries** — These injuries most often result in the loss of the tire. Driving too close to the edges of the roads and clipping spilled rock result in these injuries. Shovel loading areas and dumps are areas where sidewall damage can occur. Air pressures and loading must be considered. Equipment damage can also be a cause.

OBJECTIVE 1-5

The tireman will know all of the wheel assembly parts and describe how they fit together.

KEYPOINTS/PROCEDURES

RIM STRUCTURE

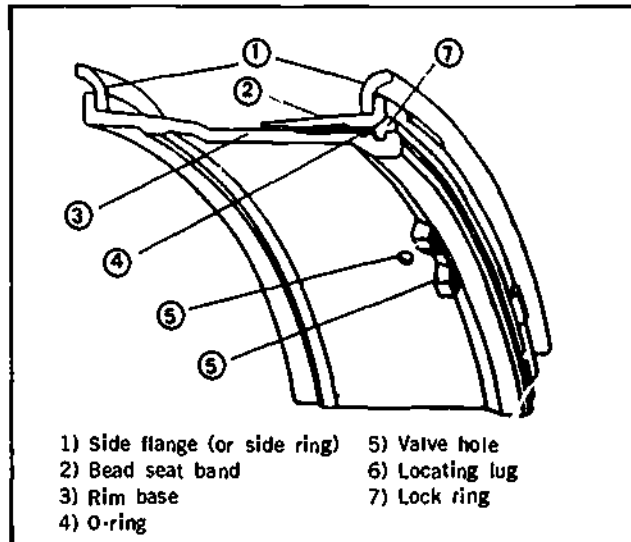

1. Side flange

Each wheel assembly has two side flanges (or side rings). Side flange height is matched to tire size.

2. Bead seat band

The full tapered bead seat rim has a 5° taper in the bead seat which strengthens the connection between the rim and the tire. Fine grooves called knurling are formed on the surface completely around the band, further preventing slippage.

3. Rim base

All sections of the rim base are double welded for maximum strength. Gutter sections are designed to meet the speed, inflation and load requirements of the earth-moving industry.

4. O-ring

The O-ring (also called the seal ring or gasket) forms an air-tight seal between the separate parts of the rim. Each tire and rim size requires a specific O-ring. They are not used on tube type tires. O-rings are identified as in the following example:

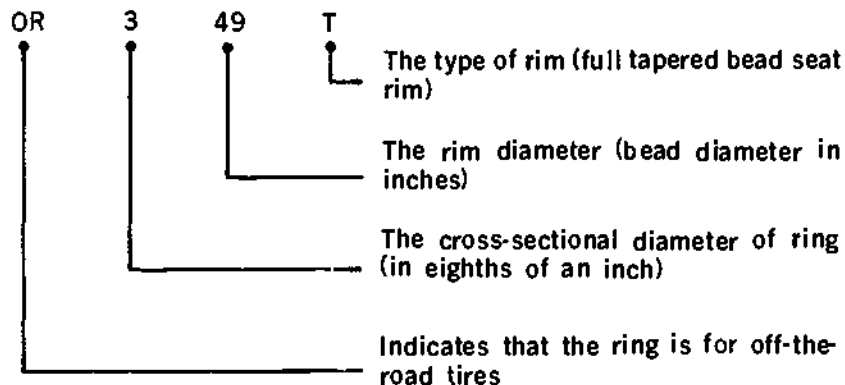

5. Valve hole

The valve hole is generally located in the center of the base rim and accommodates the large bore spud.

6. Locating lug

The locating lug is welded on the back side of the gutter section, in line with the valve hole. Its purpose is to slide down a slot in the wheel motor, protecting the valve stem from being destroyed in the tire installation process. The locating lug is the only item which can be welded. None of the other rim parts are to be reworked, welded, heated or brazed under any circumstances.

7. Lock ring

This lock ring is the most important piece of the whole wheel assembly. It locks the tire and all fitted parts to the base rim. Exercise special care to not use bent lock rings or rings of a different series.

8. Spud (not shown)

The spud is made of brass, with a rubber grommet. The valve stem screws into this item.

9. Valve stems (not shown)

The short stem is approximately 4 1/2 inches in length, and is rigid. It is used on the front and outside rear positions. The long stem is approximately 29 1/2 inches in length, and can be either rigid or flexible. It is used on the inside rear position. Other stem lengths are available.

10. Part numbers (not shown)

Following is a sample part number for a rim base:

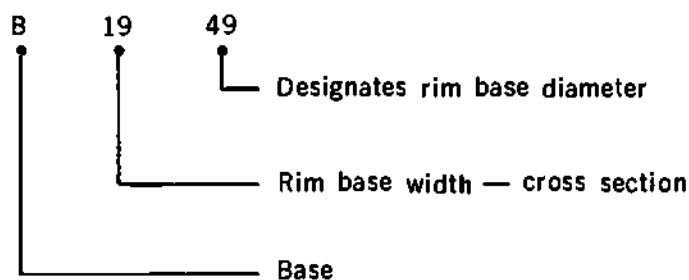

All wheel parts are stamped and identified accordingly.

OBJECTIVE 1-6

The tireman will recognize the various problems that can arise with the rim parts, explain why they occur, and determine their disposition.

KEYPOINTS/PROCEDURES

1. Side flange

Side flanges are prone to breaking in the butt weld, generally from fatigue. Equipment damage results in bends. They are to be removed from service and scrapped.

2. Bead seat band

This item is also prone to cracking in the butt weld area, generally from fatigue. Dropping on cement floors can result in the bending of the tapered edge of the bead seat band. They are to be removed from service and scrapped.

3. Rim base

Cracks can develop in the O-ring gutter, the lock ring gutter and along the butt welds.

Cracks in the O-ring gutter are generally caused by fatigue and cannot be determined while the tire and wheel assembly are mounted on the truck. They periodically lead to the loss of air. The rim base is not repairable and must be scrapped.

Cracks in the lock ring gutter are generally caused by fatigue. They can sometimes be determined while the tire and wheel assembly are mounted on the truck. Nuts and clamps are all that hold the broken rim base in place. The rim base is not repairable and must be scrapped.

Cracks in the butt welds are generally caused by fatigue. Equipment damage also leads to cracked butt welds. They generally lead to the loss of air while mounted on the truck. Broken butt welds must be treated with extreme caution. The rim base is not repairable and must be scrapped.

4. O-ring

The O-ring is to be used one time only. If the bead of a mounted tire is broken for any reason, the O-ring gutter must be cleaned and a new O-ring installed. It is a good habit to cut all old O-rings so that they cannot be used again.

5. Valve holes

The valve hole is generally trouble-free. It must be inspected and cleaned thoroughly before a new valve spud assembly is installed.

6. Locating lug

Any time a wheel comes loose and spins on the wheel motor assembly, the locating lug is torn off the rim base. This item can be purchased separately. The old weld can be carefully ground down and a new locating lug welded in place. Of all the items that comprise a complete wheel assembly, this is the only area in which welding is permissible. This job can be done on-site, but is not to be done while the tire is mounted on the rim base.

7. Lock ring

The lock ring is generally damaged during the installation or removal procedure. Equipment damage is also a contributing factor. Bent or flattened lock rings are not repairable and must be scrapped. Lock rings vary by make and series. Extreme caution must be used to not mix them up.

OBJECTIVE 1-7

The tireman will be able to explain the importance of having proper procedures for all events of tire removal before starting the job.

KEYPOINTS/PROCEDURES

1. Proper procedures ensure that:
 - Vehicle jacking and blocking is done in the right sequence.
 - The bleeding of air is performed correctly.
 - All paper work, i.e., tire change reports are filled out correctly.
 - The tire manipulator is positioned properly before nut and clamp removal takes place.
 - Nut and clamp removal is performed correctly.
 - Tires are removed, repaired and re-installed in the correct sequence.
 - All nuts and clamps are torqued to their correct specifications.
 - The tires are re-inflated to their correct pressures.
 - The proper tags are installed in the cab to ensure that the truck returns for re-torquing.
 - All parties involved are informed of the status of the job underway, e.g., should the tireman who starts the job not finish it because of a shift change, etc.

OBJECTIVE 1-8

The tire man will explain the importance of checking all equipment before starting a job to ensure safe operation during tire changing procedures.

KEYPOINTS/PROCEDURES

1. Proper equipment checks ensure that:
 - Broken tire hammer handles are replaced.
 - Bent or broken tire irons are repaired or replaced.
 - All jacking equipment with leaking or broken hoses and connections are repaired or replaced. Also that all fluid levels are topped up.
 - The tire manipulator has no problems with the pads, or any other part of the unit.
 - Proper wheel chocks are available for blocking.

OBJECTIVE 1-9

The tireman will demonstrate the proper jacking and blocking procedures to prepare a unit for tire changing.

KEYPOINTS/PROCEDURES

1. Follow these jacking and blocking procedures:
 - a. Slide the jack stand under the reinforcing plate of the suspension support at the base of the axle box. (The jack stand should be designed to the proper height so as to not require any steel shims after the jack has been put in place.)
 - b. Slide the jack into place on top of the jack stand, aligning the head of the jack under the suspension support.

Caution:
Never jack on the flat material of the axle box itself. This area will not support the weight of the truck. In normal jacking, always install a thin piece of hardwood or rubber between the stand and jack, and the jack and the bottom of the unit to prevent slippage.
 - c. Jack the unit only high enough to allow easy removal and re-installation of the tires.
 - d. Slide a support stand under the same area as was used to jack the truck. Lay a thin piece of hardwood or rubber between the top of the stand and the unit.
 - e. Gently release the pressure off of the jack, allowing part of the weight of the truck to be taken up by the stand.
2. Front wheel jacking procedures use almost the identical technique. Some jack stands and blocking stands are custom made to use for these purposes only.

OBJECTIVE 1-10

The tireman must describe the importance of bleeding the air from the tires before nut and clamp removal.

KEYPOINTS/PROCEDURES

1. The following problems can occur if the air is not bled from the tires:
 - The rim base assembly can crack in the lock ring gutter, the O-ring gutter, the butt welds and circumferential welds, due to fatigue, equipment damage, etc.
 - In the lock ring gutter and the O-ring gutter only the clamps and nuts are holding the assembly together. Releasing the clamps before the total bleeding of air could result in a devastating explosion of the rim.
 - Broken butt welds can show up as a slight crack with minor air loss. A sudden jar of the assembly during removal could result in the expansion of this crack, resulting in an explosion of the rim.
 - Side flanges that crack or are bent because of equipment damage could fail completely.
 - Lock rings that are bent, or are not seated properly could be released from the lock ring gutter.

Note:

The bleeding of air from all tires before the removal procedure starts is of critical importance. Tires must be bled down to zero pounds per square inch. One specific instance where the air pressure in an inside rear dual cannot be bled due to the turning of the inside tire is dealt with in OBJECTIVES 4-1 to 4-8.

OBJECTIVE 1-11

The tireman will describe the proper procedures for nut and clamp removal.

KEYPOINTS/PROCEDURES

1. After the unit has been jacked up and all air pressures bled, the tireman should follow these procedures for nut and clamp removal:
 - a. Place the tire manipulator in its proper location, grasp the outside tire firmly and apply slight inward pressure.
 - b. Use the impact gun to loosen all of the wheel nuts, backing them off no more than $\frac{1}{4}$ of an inch.
 - c. Use a hooked tire iron (e.g., Ken tool No. T-41 or T-42) to release each clamp.
 - d. Using the impact gun, remove all of the nuts. Have a small pail close by to hold the nuts and lugs.
 - e. Remove all of the clamps.

OBJECTIVE 1-12

The tireman will describe the proper method and tools to use to inflate earthmover tires safely.

KEYPOINTS/PROCEDURES

1. Before air inflation starts, the tireman must note the following:
 - Rim components are not to be hammered on while inflation is taking place.
 - Make sure the area is clear of all personnel.
 - Never stand in front of or sit on any assembly that is in the inflation stage.
 - Always use an extended air hose with a clip-on air chuck which allows the tireman to stand well clear of the assembly. A hand operated valve can be used, or an automatic valve that shuts off when the desired air pressure is reached.
2. Follow these procedures to inflate the tire:
 - a. Double check to ensure that all of the components are properly seated prior to inflation.
 - b. Replace the valve stem and core if required.
 - c. Clip the air chuck onto the valve stem and back away from the wheel assembly. Do not stand in front or in back of the tire assembly. The lock ring should only be tapped lightly with a hammer, to make sure that it is seated.
 - d. Check the assembly at 5 psi to ensure that the components have seated properly. If not, deflate the tire, remedy the problem, and start the inflation procedure again. If it is necessary to tap the lock ring or other components, use only a rubber, plastic, lead or brass faced mallet. Do not use a steel hammer.
 - e. Inflate the tire to 10 psi.

OBJECTIVE 1-13

The tireman will describe the importance of proper air pressure maintenance.

KEYPOINTS/PROCEDURES

1. Optimum traction, flotation and load endurance can only be obtained if the proper inflation pressures are maintained. Proper inflation, therefore, is essential to get the best performance from tires.
2. The following problems result from under-inflation:
 - Heat is generated due to excessive deflection, which leads to early tread and ply separation.
 - Cord fatigue is accelerated, resulting in broken cords.
 - Sidewalls become much more susceptible to rock penetration.
 - Cracks develop in the inner liner.
 - Tread wear is uneven and radial cracks develop.
 - The rim becomes displaced, leading to air leaks in tubeless tires.
3. The following problems result from over-inflation:
 - Increased ground contact pressure at the center of the tread results in excessive wear in this area.
 - Vulnerability to rupture from rock cuts or shock results from reduced protection of the cord.
 - Riding comfort decreases and the tendency to slip increases.
 - The potential for bead failure increases due to excessive pressure being exerted on this area of the tire.
 - The percentage of rim cracks and rim damage increases greatly with over-inflation.
 - Tread shear on tires increases, causing more separations.
4. The air pressure in a tire rises as the tire heats up during operation. This rise varies among tires and makes, so it should be noted for tires in continuous operation. If a pressure rise of more than 25% takes place from heat generation, the cold pressure inflation should be checked. Do not bleed tires to compensate for pressure increases resulting from operating. Reducing inflation pressure can cause the internal temperature to rise, leading to tire failure or tire explosions.

COMMUNICATIONS

module 2

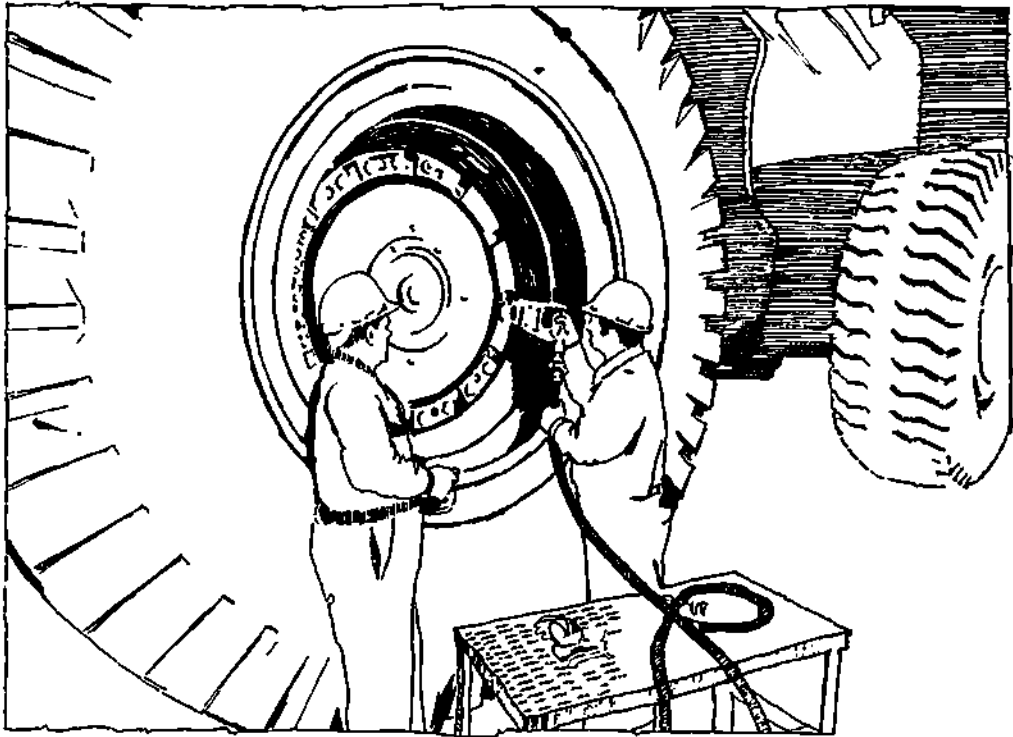

OBJECTIVE 2-1

The tireman will explain the importance of relaying the status of any projects underway to co-workers and the supervisors.

KEYPOINTS/PROCEDURES

1. Relaying the status of projects underway:
 - Ensures that all procedural steps are followed properly. If one is missed, serious problems could arise.
 - Eliminates unnecessary down time on equipment that can result, e.g., from the installation of the wrong tires on the unit.
 - Keeps production people informed on when to expect the unit back in the ready line.

OBJECTIVE 2-2

Given a sample of the reporting forms used by the company, the tireman will complete tire change reports, timecards and the daily logbook.

KEYPOINTS/PROCEDURES

1. Tire change reports

The tire change report forms should be filled out to include the:

- Unit number.
- Date.
- Shift (day shift, afternoon or graveyard).
- Hourmeter reading.
- Tireman's name.
- Supervisor's name.
- Wheel position.
- Tread depth.
- Disposition of the tire, e.g., mismatch, spare pile, runout, separation, rock cut or rotation.
- Make, serial and brand numbers of the tire.

These reports are used to track the location and history of the tires. It is imperative that they be accurate.

2. Timecards

Timecards should include the:

- Unit code of the type equipment that the tireman was working on.
- Hour slot of how much time the tireman worked on that unit.

3. Daily logbooks

The daily logbooks should be filled out regularly. They cover the following information:

- General repairs to the manipulator.
- Any general information on the manipulator which can help the oncoming tireman in the areas of steering, brakes, etc.

Rule 263 (e) of the *Mines Regulation Act* and Rule 195 (e) of the *Coal Mines Regulation Act* state:

(e) For each vehicle or piece of mobile equipment, a logbook or other suitable record shall be maintained, in which shall be entered a record of all unsafe conditions and the repairs made, and all notations shall be signed by the person making the entry, and the logbook or records shall be available for inspection at all times.

It is important that the tireman on the following shift know the prior shift's history of the manipulator. It is important to report unsafe or hazardous equipment conditions first of all to the supervisor and then to the oncoming tireman.

OBJECTIVE 2-3

The tireman will operate the mobile radio on the mine site and explain the proper procedures for its use.

KEYPOINTS/PROCEDURES

1. Radios are not common in tire manipulators, but the tireman should know their proper use, to call for equipment or in the event of an emergency.
2. Proper and effective use of the radio is important. Follow these procedures:
 - a. Identify the sender by radio location.
 - b. Identify the receiver by unit or vehicle number.
 - c. Wait until the receiver acknowledges.
 - d. Relay the message in a clear and precise manner.
3. Radio use is restricted to required transmissions. Use no profane language over the radio at any time.
4. In the event of an unsafe situation or an emergency, contact the tire supervisor immediately. If radio silence is necessary, either the supervisor or another party can call for it. This depends on procedures established at the mine.

PREPARATION OF THE EQUIPMENT FOR TIRE CHANGES

module 3

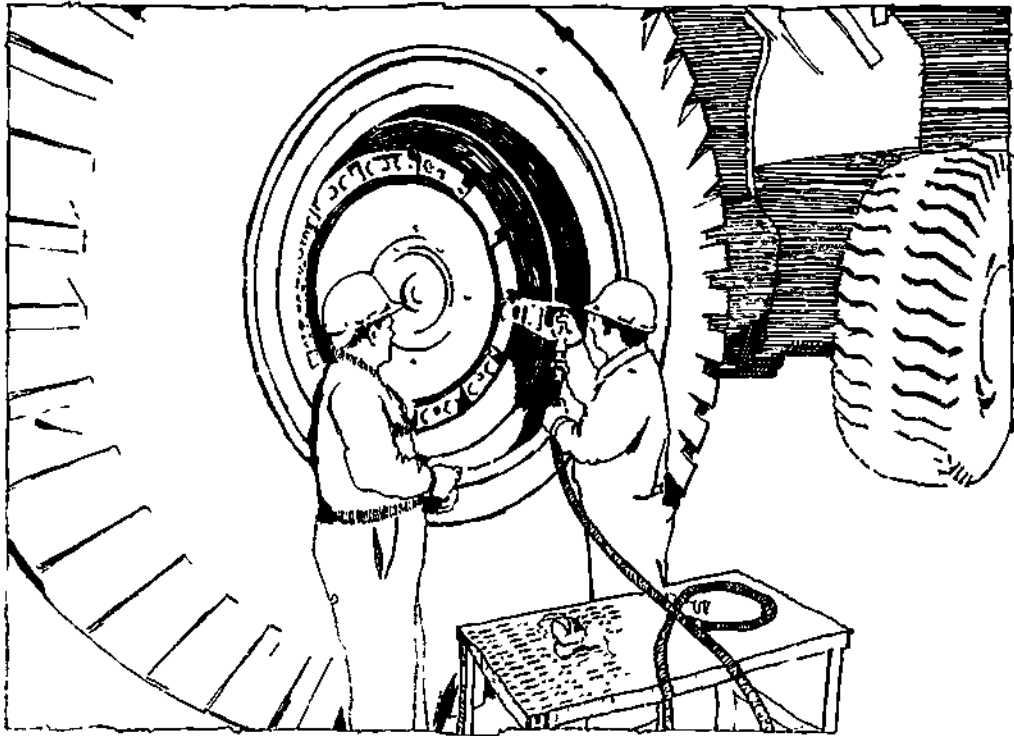

OBJECTIVE 3-1

The tireman will park the unit on the tire pad or the shop floor.

KEYPOINTS/PROCEDURES

1. The tire pad should be made of reinforced concrete of sufficient strength to support the weight of the unit.
2. Follow these procedures to park the unit:
 - a. Drive or back the unit onto the pad, leaving enough room to move the tire manipulator. It is a good practice to have a second person on the floor to act as a guide, especially when moving in and out of the shop.
 - b. Make sure the maxi-brake is applied before the operator of the unit leaves the cab. By also applying the hand brake, the front wheel brakes are applied, stopping the hub from turning if it is a front tire that is to be changed.
 - c. Place a wheel chock in front of the rear duals and another at the rear to prevent the truck from accidentally rolling away, should the brakes be released during the tire changing process.

OBJECTIVE 3-2

The tireman will jack and block the unit as described.

KEYPOINTS/PROCEDURES

1. Follow the procedures given in OBJECTIVE 1-9 for jacking and blocking.

OBJECTIVE 3-3

The tireman will determine the problem with the tire or wheel assembly before the actual tire removal starts.

KEYPOINTS/PROCEDURES

1. Follow these procedures to determine the problem with the tire or wheel assembly:
 - a. Do a visual check of the tire for obvious injuries, such as face rock cuts, impact breaks, shoulder injuries, torn or blown sidewalls, and separations.
 - b. Do a visual check of the rim components to locate any cracks in the back side of the gutter sections, broken butt welds. Also determine if the tire has turned on the wheel motor. A turned inside tire either pulls the valve stem inside the space between the wheel motor and the rim base, or it completely shears it off. If there is an outside flat, check the valve stem and spud. A sheared valve stem does not always guarantee a total loss of air from the tire. Check the lock ring. If it is even partially out of the lock ring gutter, no further diagnosis can be done until the tire assembly is removed from the unit.
 - c. If it has been determined that there is no visual problem with the flat tire or the rim components, have a pressurized spray gun (of the D100 type) handy, filled with a soapy solution that bubbles when sprayed on escaping air. Remove the valve cap and hang the clip on valve on the valve stem to start the air inflation procedure. Use the spray gun to check all rock cuts in the tire, however minor. Check all welded areas of the rim assembly, where accessible. If a leak is found in either the tire or rim assembly, remove the air chuck, mark the problem with chalk or spray paint, and bleed the air down to zero psi.
 - d. If these procedures do not succeed, the tire has to be bled to zero psi, removed from the unit, and further checked. The procedures are given in OBJECTIVE 6-1.
 - e. If it is determined that the inside tire has turned on the wheel motor and the tire has not gone flat, special care must be exercised. The procedures are given in OBJECTIVES 4-1 to 4-8.

OBJECTIVE 3-4

The tireman will demonstrate the correct procedures for the bleeding of air from the tires before the removal procedures start.

KEYPOINTS/PROCEDURES

1. Always wear proper eye protection, preferably goggles. Gloves are also recommended. The release of high pressure air sprays contaminants from inside the tire out through the valve stem. These contaminants (particles of dirt, etc.) can become deeply imbedded in the skin of the hands, wrists, and arms. Proper hearing protection must also be worn.
2. Stand to the side of the valve stem and follow these procedures:
 - a. Remove the valve cap.
 - b. Carefully remove the valve core.
 - c. If the air stops flowing, use a piece of wire to try and remove the obstruction from the valve stem.
 - d. Should the valve stem be damaged and the air cannot be released by the removal of the valve core, use a wrench to loosen the valve stem nut from the spud. Carefully unscrew the nut, using caution to keep the hand and arm clear of the spud. The release of air is much more dramatic than through the valve stem itself. Allow the tire to bleed down to zero psi.
 - e. On super large bore valve hardware, the removal of the valve core results in a much faster release of the air. Use extra caution.
 - f. Fill out the tire change reports, using one for each tire removed.
3. When working on dual tires, both tires must be deflated.

REMOVE THE TIRE FROM THE EQUIPMENT FRONT AND REAR

module 4

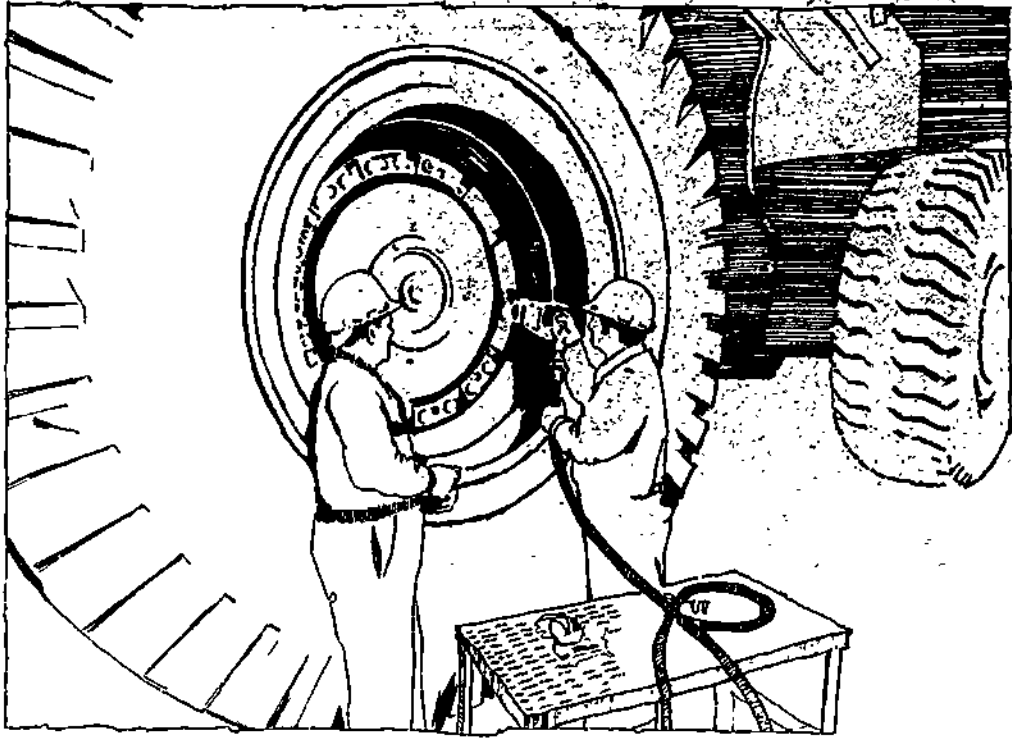

OBJECTIVE 4-1

The tireman will check to ensure that the tires have been bled down to zero psi.

KEYPOINTS/PROCEDURE

1. Follow these procedures to ensure that the air has been bled from the tires:
 - a. Use a tire gauge to check the air pressure.
 - b. Use a hammer to hit the tire on the shoulder or face area. The tire should have a soft, dull, dead feel.
 - c. On the front and outside tires the valve stem can be unscrewed from the spud.
 - d. On the rear inside tires, if it is thought or known that the tire is still inflated due to a squashed stem or turned wheel, the tires can be removed using the procedures in OBJECTIVES 4-2 to 4-8.
2. Front tires can always be bled down.

OBJECTIVE 4-2

The tireman will remove the valve hardware holding devices.

KEYPOINTS/PROCEDURES

1. These brackets are generally used on the rear wheels only, and consist of a bracket that is bolted on one end to the housing of the wheel motor. The other end ties on to the inside valve stem and keeps the stem free of vibration which leads to breakage of the stem. Place the bracket and the bolts in an area where they will not be damaged or lost.

OBJECTIVE 4-3

The tireman will locate the tire manipulator in preparation for the removal.

KEYPOINTS/PROCEDURES

1. Before the manipulator is moved to the tire, use a proper stand or hooking device to secure the rock knocker up and out of the way. This need not be done if the inside tire is not going to be removed. Doing this just before tire removal reduces the risk of it being accidentally dropped on somebody.
2. Follow these procedures to locate the tire manipulator:
 - a. Approach the tire slowly, keeping the front of the manipulator parallel to the tire being removed.
 - b. Use extreme caution when moving in to the tire so as to not hit the fuel tank or the dry break fueling attachment.
 - c. Locate the pads of the manipulator in the center of the tire and apply pressure on the pads, firmly gripping the tire.
 - d. Apply slight forward pressure on the tire. This makes sure that the tire and wheel assembly do not move during the removal of the nuts and clamps.
 - e. Set the park brake.

OBJECTIVE 4-4

The tireman will loosen all of the wheel nuts and clamps in a **safe** order.

KEYPOINTS/PROCEDURES

1. Follow these procedures to loosen all of the wheel nuts and clamps:
 - a. Using the impact gun, start at one point and back off all nuts approximately $\frac{1}{4}$ of an inch. Do not back them off any further.
 - b. Use a Ken tool No. T-41 or T-42 to pry loose each clamp. Check that every clamp is loose.

These procedures help ensure the safety of the tireman, working on an inside tire which has turned and from which the air cannot be bled down completely. Objective 1-11 gives the procedures for nut and clamp removal.

OBJECTIVE 4-5

The tireman will remove all of the nuts and clamps.

KEYPOINTS/PROCEDURES

1. Follow these procedures to remove all of the nuts and clamps:
 - a. Use the impact gun to remove the nuts. Start at the top, leaving the top clamp to last. Remove all of the clamps and place them and the nuts in a large pail. This keeps them clean and from getting lost.
 - b. On front wheel removal the clamps come loose as soon as the nut is removed. It is advisable to situate the valve stem and locating lug at the top (12 o'clock position) before applying the park brakes. This ensures easier removal of the tire and minimizes the chances of valve stem and spud damage.

OBJECTIVE 4-6

The tireman will remove the outside tire.

KEYPOINTS/PROCEDURES

1. Follow these procedures to remove the outside tire:
 - a. Apply pressure to ensure that the tire is still firmly grasped.
 - b. Slowly back away from the unit, gently tilting the tire back towards the manipulator. This tilting of the tire allows the rim assembly to slide over the wheel studs without damaging the threads. Back off in a straight line. Backing off crooked can also damage wheel studs.
 - c. Lay the tire down gently, in an area that does not hinder easy movement around the unit undergoing tire changes. Always lay the tire down with the lock ring side of the rim assembly up.
2. With front tire removal, the same procedures apply. It may be necessary to have an assistant turn the wheel hub on the truck slightly, enough to align the locating lug slot with the locating lug on the rim assembly. Keep fingers and hands out of this area. Always use a tire iron. Front tire removal does not require Objectives 4-7 and 4-8.

OBJECTIVE 4-7

The tireman will remove the spacer band.

KEYPOINTS/PROCEDURES

1. If the spacer band is bolted to the wheel motor housing, remove the bolts and place them in an area where they will not be lost.
2. The spacer band can be removed in either of the following ways:
 - Using tire irons, pry it away from the inside tire. It can then be slid to the end of the wheel motor housing and lifted to the pad with the aid of an assistant.
 - The manipulator can be used to grasp the inside tire, gently backing away from the unit. This process slides the spacer bank off the wheel motor.
3. Use care to not drop the spacer band. They bend and distort, making re-installation difficult.

OBJECTIVE 4-8

The tireman will remove the inside tire.

KEYPOINTS/PROCEDURES

1. Follow these procedures to remove the inside tire:
 - a. Approach the tire slowly, keeping the front of the manipulator parallel to the tire.
 - b. Use extreme caution when moving in to the tire so as not to hit the fuel tank or the dry break fueling attachment. Watch the other side to make sure that the tire pad does not hook the rock knocker or its support device.
 - c. Locate the pads of the manipulator slightly below the center line of the tire, and apply pressure on the pads, firmly gripping the tire.
 - d. Apply slight upward lift to the controls, then rotate the pads gently in the direction that moves the top of the tire towards the manipulator. This tips the top of the tire outwards, making it less likely for the rim base to hang up on the wheel motor housing. It is also less likely to bind.
 - e. Back the manipulator slowly away from the unit, using the rotation lever to rotate the tire as much as is required to keep the locating lug in line with the locating lug slot in the wheel motor.
 - f. When clearing the end of the wheel motor, make sure that the tire and rim assembly are high enough to clear the wheel studs. Backing off crooked may also damage the wheel studs.
 - g. Lay the tire down gently, in an area that does not hinder easy movement around the unit undergoing tire changes. Always lay the tire down with the lock ring side of the rim assembly up.

REPLACE THE TIRES ON THE EQUIPMENT FRONT AND REAR

module 5

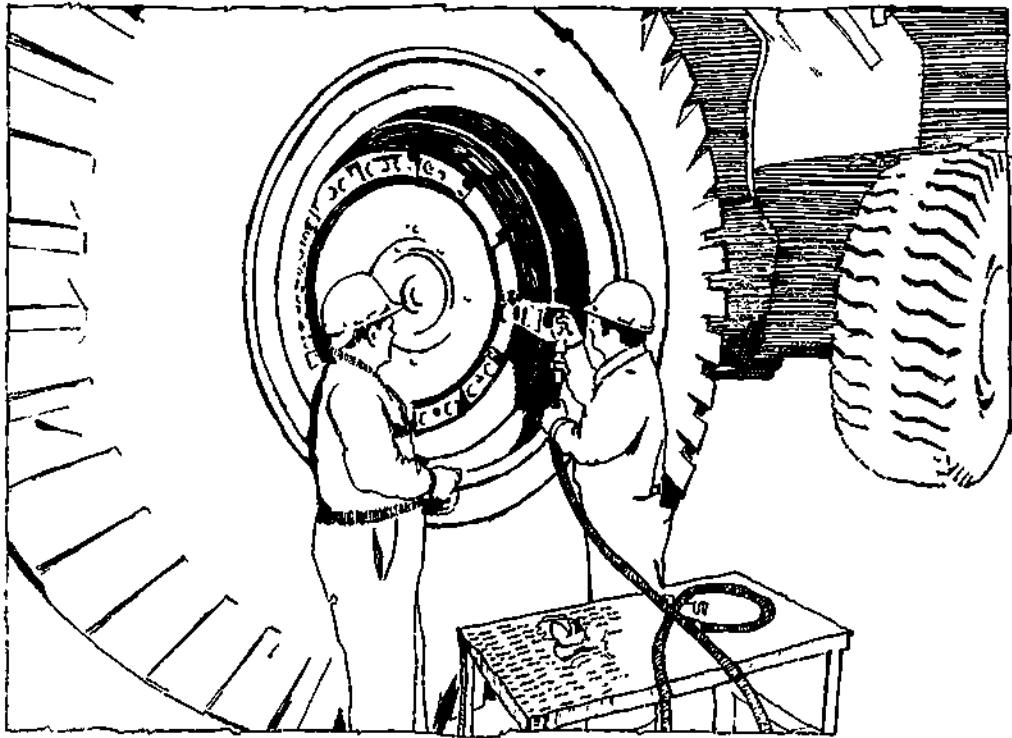

OBJECTIVE 5-1

The tireman will check and clean the wheel motor assembly before the installation of the tires.

KEYPOINTS/PROCEDURES

1. Follow these procedures to check and clean the wheel motor assembly:
 - a. Use a tire iron or scraper to remove any pockets of built-up grease and dirt from the wheel motor frame. Remove any rocks from the same areas.
 - b. Use a brush and a cleaning agent to further clean these areas.
 - c. Use rags to dry off all beveled surfaces to which the inside rim assembly is directly fitted. If compressed air is used for cleaning, always wear protective glasses, and proper face, eye, and hearing protection.
 - d. Check the wheel motor assembly for loose or broken grease lines and attachments, severely leaking seals, and loose or leaking brake components. Report them to the supervisor.
 - e. Replace all wheel studs that are bent or have damaged threads. All studs must be of sufficient length to allow full engagement of nuts.

OBJECTIVE 5-2

The tireman will bend the long inside valve stem slightly to conform to the design of the rim base, and then install it in the spud of the inside rim.

KEYPOINTS/PROCEDURES

1. On rear duals, if only one tire is being changed, the replacement tire must not vary more than $\frac{1}{2}$ inch by tread depth from the tire that remains on the unit. The larger tire goes on the outside; the smaller one on the inside. Use an earthmover tread depth gauge to measure the tread depth. Most earthmover haulage tires today have a special mark to indicate where to measure the depth, located in the bottom of the grooves (voids).

A mismatched pair of dual tires can result in the higher treaded tire carrying the weight of the load. This results in excessive heat build-up, which leads to separation and total tire failure.

2. Follow these procedures to install the valve hardware:
 - a. Use the manipulator to move the tire that is to be put on the unit to the tire pad. The valve replacement procedure can be performed with the tire held in the vertical position or laid down on the tire pad.
 - b. Bend the inside stem to conform to the beveled lock and O-ring gutter section of the rim base.
 - c. Carefully unscrew the short valve stem, then screw the long stem into place. Tighten the nut securely, using caution to not cross the threads or strip the threads of the brass spud.

OBJECTIVE 5-3

The tireman will pick up the tire and install the inside tire on the unit.

KEYPOINTS/PROCEDURES

1. Follow these procedures to pick up and install the inside tire:
 - a. While the tire is laying flat on the ground, use one arm manipulator to rotate it so that when it is lifted to the vertical position, the valve stem and locating lug are in line with the locating lug slot on the wheel motor.
 - b. Grasp the tire in the center and lift it to the vertical position. Approach the unit.
 - c. Use the lift, rotate and side-shift mechanisms as required, to center the tire with the wheel motor before attempting to slide it into place.
 - d. Move forward slowly, sliding the tire into place. Use caution to not damage the valve stem.
 - e. When the tire is in place, gently release the manipulator's grasp. Use caution so as not to snag one pad on the tire. This can result in the tire turning, and tearing off the valve stem.
 - f. Back gently away from the unit.
 - g. Remove the valve cap and depress the core. Easy release of air ensures that the stem is not damaged during installation of the tire.

OBJECTIVE 5-4

The tireman will install the spacer band on the wheel motor.

KEYPOINTS/PROCEDURES

1. Follow these procedures to install the spacer band on the wheel motor:
 - a. Check and clean the spacer band. If it is bent or out of round, replace it. Severe rim spinning can result in both edges becoming badly worn.
 - b. Lift up the spacer band and hang it on the end of the wheel motor. Slide it into place beside the inside tire.
 - c. If of the bolted design, align the holes and install the bolts. Alignment of the bolt holes may require the use of a tire manipulator to push the inside tire and rim into place.

OBJECTIVE 5-5

The tireman will pick up and install the outside tire.

KEYPOINTS/PROCEDURES

1. Follow these procedures to pick up and install the outside tire:
 - a. Pick the tire up with the manipulator and gently turn it over, laying it down with the lock ring and fitted parts facing down.
 - b. Use a piece of chalk to mark the location of the valve stem.
 - c. While the tire is laying flat on the ground, use one arm of the manipulator to rotate it so that when it is lifted to the vertical position, the valve stem and locating lug are in line with the locating lug slot on the wheel motor.
 - d. Grasp the tire in the center and lift it to the vertical position. Approach the unit.
 - e. Use the lift, rotate and side-shift mechanisms as required to center the tire with the wheel motor before attempting to slide it into place.
 - f. Move forward slowly, sliding the tire into place. Use caution to not damage the inside valve stem with the locating lug on the outside rim assembly.
 - g. Slide the tire into place and apply slight pressure with the manipulator to hold it in place while the clamps and nuts are being installed.
2. Front tire installation uses the same procedures except it does not require that it be turned lock ring side down before standing vertical. It is fitted on the front hub with the lock ring facing outwards.

OBJECTIVE 5-6

The tireman will clean, replace, and install all of the nuts and clamps.

KEYPOINTS/PROCEDURES

1. Follow these procedures to install the nuts and clamps:
 - a. Start at the valve stem and install all of the clamps, working in one direction.
 - b. Clean and inspect every nut. Any with damaged threads must be replaced. Use care when installing, as they have fine threads which makes cross-threading quite easy.
 - c. It is advisable to apply a light coat of oil to all of the studs before nut installation starts. Each nut, that is being applied to the stud should be turned two or three times to ensure it has started properly. Any that do not screw on easily with the fingers should be removed, checked or replaced. Do not force it on with the impact gun.

OBJECTIVE 5-7

The tireman will tighten and torque nuts.

KEYPOINTS/PROCEDURES

1. Follow these procedures to tighten and torque nuts:
 - a. Using the impact gun, start in the top position (12 o'clock) and gently tighten up both nuts. Do not tighten completely. Move to the bottom (6 o'clock), then to the left, then right. This procedure pulls the tire in evenly. If one lug is tightened too much, the tire can wobble.
 - b. Go over these four positions again, in the same order, this time applying full power with the impact gun. Tighten up the rest of the nuts, starting in one spot.
 - c. The tire manipulator can now be moved away from the unit.
 - d. Make one more complete round of the nuts with the impact gun, applying equal pressure to each nut.
 - e. The large one inch torque wrenches are easiest handled by two persons. Start in one spot and work around the nuts, applying 450 foot pounds to each nut. It may be necessary to go past the starting point to ensure equal tightness all around.
 - f. Finish the tire change reports.
 - g. Hang a re-torque ticket on the steering wheel to remind the operator to return to the tire pad after two or three loads to have the recently changed tires checked and re-torqued.

OBJECTIVE 5-8

The tireman will demonstrate the safe procedures of tire inflation.

KEYPOINTS/PROCEDURES

1. Follow all of the steps in order in OBJECTIVE 1-12.
2. On rear duals if the unit is hot from running, and both tires were changed, then the replacement tires, if cold, need only be inflated to their cold air specifications. If only one tire is changed, the hot one being left on must be re-inflated to the pressure it had when it came in, e.g., 85 psi, and the replacement tire, if cold, is to be inflated to its cold air specifications, e.g., 75 psi.

OBJECTIVE 5-9

The tireman will have the torque wrench and helper ready to perform the re-torque as soon as the unit arrives.

KEYPOINTS/PROCEDURES

1. Follow these re-torque procedures:
 - a. Have the operator back the unit onto the tire pad.
 - b. Check the air pressures
 - c. Check to make sure that neither the inside or the outside rims have spun on the wheel motor.
 - d. Use the torque wrench to apply 450 foot pounds to each nut as described in OBJECTIVE 5-7.
 - e. Doing these procedures with no delays ensures that the unit is returned to the production department with a minimum loss of time.

TIRE REMOVAL FROM THE RIM ASSEMBLY

module 6

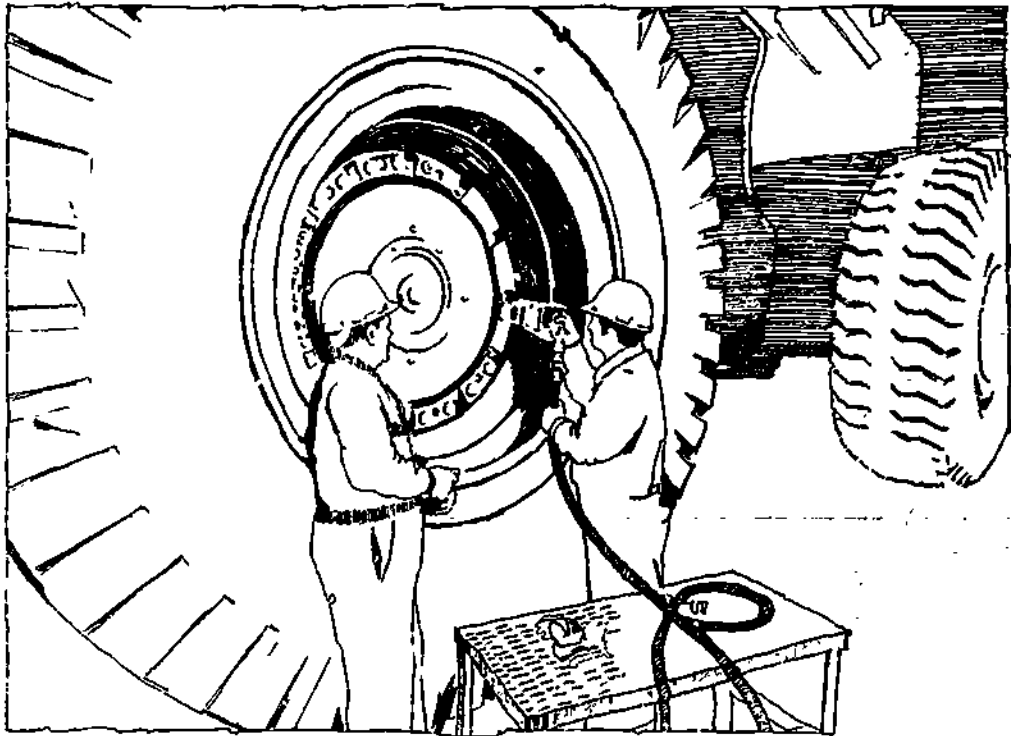

OBJECTIVE 6-1

The tireman will inspect the tire and rim assembly to determine why it went flat or had to be removed.

KEYPOINTS/PROCEDURES

1. Follow these procedures to inspect the tire and rim assembly:
 - a. Do a visual check of the tire for obvious injuries as given in Objective 3-3.
 - b. Refer to Objective 3-3, on rim component checking, paying special attention to the beveled edge behind the lock ring and the O-ring gutter section for cracks that may have not been visible because of the wheel lugs.
 - c. If no obvious rock cuts, separations, or cracked rim components turn up then check to ensure that the lock ring is properly seated. Fill the top of the rim assembly with water, up to the top of the rim base itself.
 - d. Apply the air. Air bubbles escaping from beneath the bead seat band generally indicate a broken butt weld on the bead seat band. Air bubbles that appear from the area of the lock ring generally indicate O-ring problems. The spray gun can be used to detect cracks in the rim base butt welds, etc. Spray the valve stem and spud, watching for indications of a faulty valve stem O-ring or rubber grommet on the spud. Check for leaking vent holes along the bead above the side flange.
 - e. If no leaks can be found, check the complete assembly once more. Inflate the tire to 30 psi, and let it sit overnight. Check the air pressure the next day. This process can be repeated again if there is still no indication of an air loss.
 - f. If the reason for air loss is found, mark it with a paint stick or spray paint. Then deflate it to zero psi in preparation for de-mounting.

OBJECTIVE 6-2

The tireman will dismount the tire from the rim assembly.

KEYPOINTS/PROCEDURES

1. Follow these procedures to dismount the tire from the rim assembly:
 - a. Check to ensure that the tire is completely drained of air by removing the valve core or the complete valve stem.
 - b. Lay the complete assembly on the floor, with the lock ring facing up.
 - c. Use two pry bars to remove the lock ring. Use care to not bend this component.
 - d. Remove the O-ring from its gutter. This item should be cut and scrapped immediately. They are not to be used over again.
 - e. If the lock ring proves difficult to remove, this step can be performed after separating the side flange from the bead seat band. This makes lock ring removal easier.
 - f. Place the hook of the TO-1600 hydraulic demounting tool into one of the pry bar pockets in the bead seat band. Adjust the ram adjusting screw to enable the tool to remain on a 10 percent slant beyond vertical when under pressure. In some cases, the pressure foot has to be removed to ensure a good hold. Activate the hydraulic pump and apply pressure. If necessary, release the pressure and readjust the ram adjusting screw. Depress the flange about $\frac{1}{2}$ to $\frac{3}{4}$ inch, and place a nut or similar object between the side flange and the bead seat band. Hold the tool with one hand and always stand to the side. This allows control should the tool not seat properly and fly off.
 - g. Release the pressure and move about two feet around the rim for the second bite. Continue the procedure until about $\frac{3}{4}$ of the way around the rim. Then apply pressure until the tire bead is unseated. The TO-1600 is not to be used in the immediate vicinity of the butt weld on the flange. The pressures applied by the tool can result in the breaking of the weld.
 - h. Remove the bead seat band using a hoist. A special lifting device consisting of three chains attached to a ring, with a special hook on the end of each chain makes this task much easier. Locate the hooks evenly around the bead seat band before lifting. Pry bars can be used if no hoist is available. Stand the bead seat band up against a wall.
 - i. Lift the side flange off of the rim and stand it up against a wall.
 - j. Turn the tire and rim base over and repeat procedures f. and g.
 - k. Lift the rim base out of the tire with the hoist and chains. Carefully stand it up on edge and roll it off to one side.
 - l. Lift the side flange off of the tire and stand it up against a wall.
2. The mine may have one of the new tire bead breaking devices that are available on the market. These devices utilize hydraulic rams of 100 tons or more, and break both of the beads in one or two easy moves. They ease the work load on the tire department greatly increasing efficiency.

OBJECTIVE 6-3

The tireman will mark the problem with the tire or rim for future reference.

KEYPOINTS/PROCEDURES

1. Follow these procedures to determine the disposition of the tire:
 - a. Noting the location of the injury, use the manipulator to stand the tire in a vertical position where it can be visually checked with ease.
 - b. Using a paint stick or spray paint, mark both sidewalls, both beads, and the injury on the inside of the tire. Since outside markings deteriorate, always mark the inside of the tire. A very small injury can become impossible to locate after a period of time, and can result in the added time and labour of remounting the tire just to find the leak.
2. Determine if the tire is repairable by the:
 - Amount of tread remaining.
 - Size of the injury. On a 2700 + 49, the tire is considered NWR if the injury represents more than 25 percent of the tire's cross section after it is skived out. That is about seven inches on this tire.
 - Location of the injury. This is possibly the most important in determining repairability. Face injuries are repairable. Shoulder injuries are borderline, with the size of the injury and the remaining tread generally being the deciding factors. Any injuries that start in the low shoulder area, and go through the sidewall to the bead are considered not worth repairing (NWR). High flexing of the tire causes early repair failures.

Radial tires are the exception to the shoulder-sidewall repair routine. Their design and special repair techniques allow for this type of repair.

Separations are generally classified as non-repairable. Mark these well and set them aside for inspection by the rubber manufacturer.

3. Follow these procedures to determine the disposition of the rim spare parts:
 - Clean and inspect the side flanges. Have a predetermined area which contains only rim components that have been inspected and are ready to return to service. Stand the good side flanges there.
 - Check the lock ring for bends etc. Stand the good lock rings in a vertical position.
 - Check the bead seat band for bends, etc. Stand the good bands in a vertical position.
 - Use a scraper and wire brush to thoroughly clean and check the lock and O-ring gutters. Roll the good rim base into the storage area.

All rim components are warrantable items. They have a stamp giving the date of manufacture. Check this date with the tire shop foreman who will decide if the part is to be kept for warranty.

OBJECTIVE 6-4

The tireman will keep all of the tires and rim parts stacked in appropriate piles for future inspection and use.

KEYPOINTS/PROCEDURES

1. Have separate piles for the following tires:
 - Scrap hold, for future inspection by the various rubber companies. Do not mix the brands.
 - Tires for repair that are ready for shipping.
 - Final scrap pile, for tires not requiring inspection by the rubber companies.
 - Tires ready-to-go piles.
2. Have separate piles for the following rim parts:
 - Scrap hold, for future inspection and possibly warranty by the distributor. Do not mix the brands.
 - Ready-to-go piles. The rim parts are already inspected and cleaned. Do not mix the brands or series.
 - Final scrap pile, for rim parts that are non-repairable and that don't require inspection.

INSTALL TIRE ON RIM ASSEMBLY

module 7

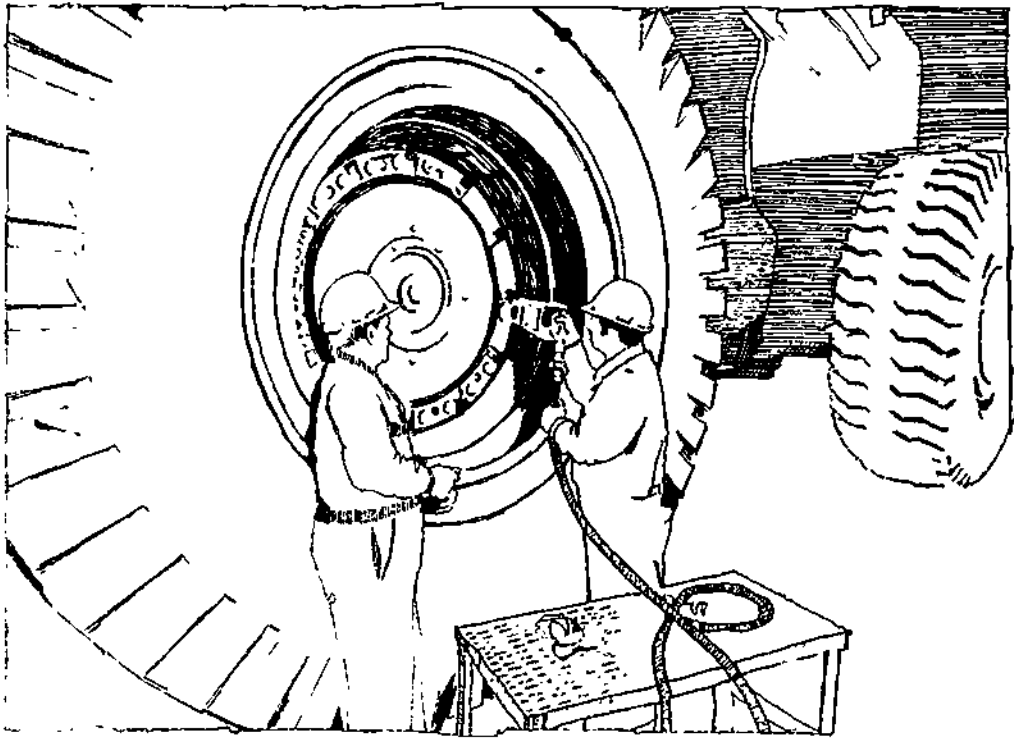

OBJECTIVE 7-1

The tireman will get all of the rim parts ready for mounting.

KEYPOINTS/PROCEDURES

1. Follow these procedures to prepare the rim parts for mounting:
 - a. Do a final check on the rim base. Look for cracks in the lock ring gutter, O-ring gutter, and butt welds. Make sure that the rim has no bent areas. Check the locating lug and have the welding department replace it if necessary. Check the brass spud and replace it as required. When tightening in a new spud, use care to not use too much torque. It is easily stripped. After inspection, paint or apply a rust inhibitor to the complete rim base.

Further inspecting can be done with the use of sand blasting and non-destructive testing (NDT) procedures such as magnaflux particles. All welds and rim parts can be checked with this procedure.

Note:

Pay special attention to the cleaning of the lock ring and O-ring gutters.

- b. Lay the rim base down on the floor, on top of a metal four-way blocking device that keeps the base properly supported during installation of the tire. This cross should be made of heavy steel, four to six inches in height. The rim base is rested on the cross, gutter side up.
- c. Place the back flange on the rim base.
- d. Inspect the remaining rim parts prior to installation, i.e., the top side flange, bead seat band and lock ring. Have a new O-ring ready.

Caution:

Double check the rim components. Make sure that the lock ring is compatible with the rim base. Never mix components of a different series. The results could be devastating. If unsure, check with the tire supervisor or the rim manufacturer.

OBJECTIVE 7-2

The tireman will select the tire and prepare it for mounting on the rim assembly.

KEYPOINTS/PROCEDURES

1. Follow these procedures to prepare the tire for mounting:
 - a. Use the manipulator to stand the tire in a vertical position. If the tire is to be branded, try to locate the brand name or serial number at a height which can be easily reached with the branding iron.
 - b. Record the data from the tire. Ply rating, make, serial number and all other data is required for proper tire record control.
 - c. Brand the tire with the allotted number. Some companies brand by the brand name, others by the serial number, always on both sides. Do not brand the numbers too deeply. Lay the branding iron well out of the way when finished.
 - d. Clean the inside of the tire of ice, sand, or any other dirt and water. Use caution to not damage the tubeless liner. The tire must be cleaned of all contaminants before mounting. Inspect the tubeless liner for damage.
 - e. Clean and dry both beads. Inspect for any damage that may have occurred during handling and transportation. Tires with damaged beads must not be mounted.
 - f. Apply a liberal coating of bead lubricant of a vegetable base. Never use oils or grease.

OBJECTIVE 7-3

The tireman will mount the tire on the rim assembly.

KEYPOINTS/PROCEDURES

1. Follow these procedures to mount the tire on the rim assembly:
 - a. Turn the tire to the horizontal position. Move it forward and gently place the tire on the rim base. Release the tire manipulator's grip and back away.
 - b. For ease of assembly, rest the arms of the tire manipulator on the sidewalls of the tire. This depresses the tire in the bead area, making assembly much easier.
 - c. Place the front flange on the rim base.
 - d. Place the bead seat band on the rim base. Use care to not cock the bead seat band. The limited clearance between the rim base and the bead seat band causes it to bind. Use the bars to get the band to drop into place properly, about $\frac{1}{2}$ inch below the O-ring gutter. The arms of the manipulator can be used to press the bead seat band into place. Do not hammer the bead seat band into place.
 - e. Lubricate the O-ring with a vegetable-based lubricant. Slip it into the O-ring groove. Then run a gloved hand around the rim to make sure that it has seated properly.
 - f. Start the lock ring into the lock ring groove and tap it into place.
 - g. Lift the tire manipulator arms off of the tire and back it away, parking it out of the immediate area.
 - h. Before inflating, double check to see that all of the components of the rim assembly are properly seated. Upon inflation, the loose components should slide out against the O-ring and lock ring. Hook the air chuck on the valve stem to start inflation. At 5 psi, check the lock ring to ensure that it has seated properly. Inflate to 10 psi. For air inflation procedures see OBJECTIVE 1-12.
 - i. The spare tires can be stacked laying flat, generally four or five high.

SPECIAL ASSIGNMENTS

module 8

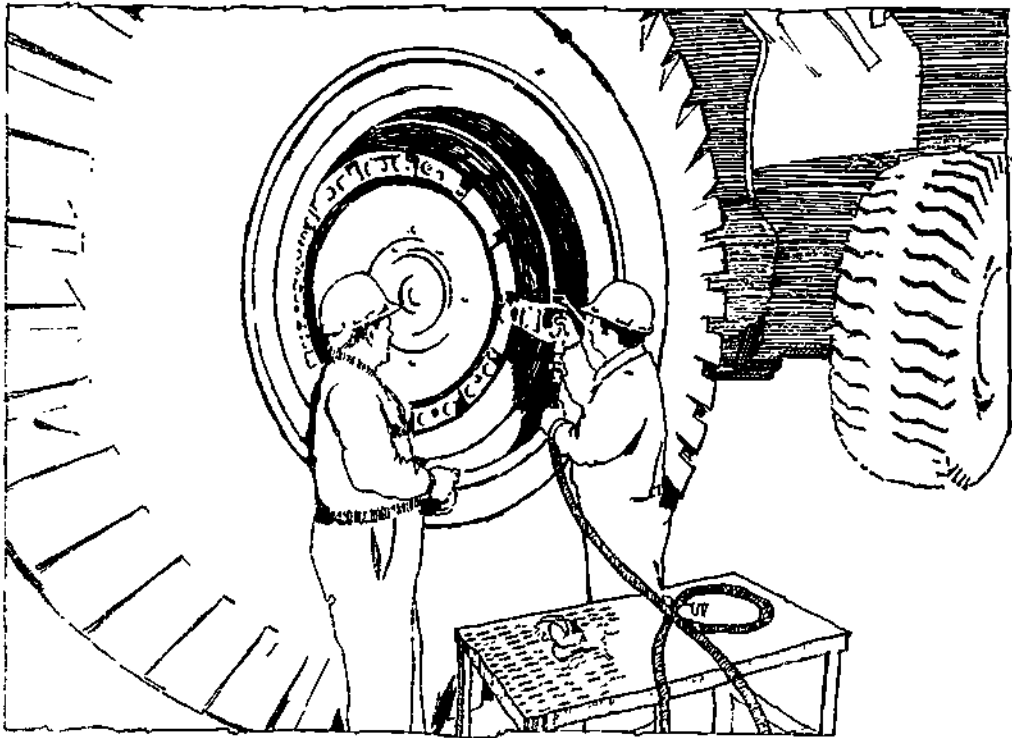

OBJECTIVE 8-1

The tireman will perform air and heat checks, recording all of the data.

KEYPOINTS/PROCEDURES

1. Air checks

Regular air checking is part of a well run tire program. Use an air check report form and record:

- The unit number, date and tireman's name.
- The tire position.
- The air pressure.
- Whether hot or cold.
- The details of the work performed or the problems found.

Use a master gauge to regularly check the tire gauges.

2. Heat checks

The checking of the heat is usually done by a technical representative of the rubber company. The internal heat is checked by:

- Pre-drilling a hole or series of holes in specific locations to specific depths.
- The use of special probes and pyrometers to check the internal temperatures in these holes.
- Recording all of the data from the tire and heat checks.

OBJECTIVE 8-2

The tireman will perform the installation and removal of ballast from graders rubber tire dozers and loaders.

KEYPOINTS/PROCEDURES

1. Of the two types of ballast, dry or liquid, liquid ballast is considered the best. Dry ballast requires specialized equipment to handle the pumping, etc. Liquid ballast is a solution of water and calcium chloride, and is easily mixed and pumped with a calcium chloride pump.
2. Ballast adds weight to the grader, rubber tire dozer, or loader, increasing the traction and stability. It does not add any weight to the load on the axles. It does, however, corrode the rim.
3. Follow these procedures to fill the tire with ballast:
 - a. Mix the required amounts of water and calcium chloride together in a large tank. Use a liquid inflation chart to determine how much to mix by volume.

Caution:

Always wear rubber boots, rubber gloves and goggles. Calcium chloride is very hard on leather boots and stings the hands, etc.

- b. Jack the unit as given in OBJECTIVES 3-1 and 3-2.
 - c. Bleed the air down to zero as given in OBJECTIVE 3-4.
 - d. Rotate the valve stem to the top. Install the valve stem adapter. Hook on the inlet hose.
 - e. Start the pump and fill the tire to valve level. It may be necessary to bleed built up air periodically as the tire fills.
 - f. Remove the valve stem adapter. Install the valve core and hook on the air chuck.
 - g. Tap the lock ring lightly to ensure a proper fit, and fill with air to the normal operating pressure. Replace the valve cap. (Use only a liquid tire gauge as calcium chloride will ruin a conventional tire gauge.)
 - h. Wash the equipment with fresh water and store it away.
4. Follow these procedures to drain the tire:
 - a. Jack the unit as given in OBJECTIVES 3-1 and 3-2.
 - b. Rotate the valve stem to the top.
 - c. Remove the valve cap. Install the valve stem adapter. Screw the valve core out with the valve core remover. This remover is part of the valve stem adapter. Allow the air to bleed off to zero psi. Stand clear of the exhausting air and liquid.
 - d. Install the outlet hose.
 - e. Rotate the tire, putting the valve stem to the bottom. Start the calcium pump and pump the contents of the tire down to valve level.
 - f. Remove the valve stem adapter, wash all equipment with fresh water, and store it away.
 - g. After the tire is removed from the wheel assembly, the remaining calcium chloride can be removed from the tire with a bucket.

OBJECTIVE 8-3

The tireman will describe the purpose of performing fleet surveys.

KEYPOINTS/PROCEDURES

1. Fleet surveys may require the:

- Unit number.
- Unit description.
- Wheel position.
- Make of the tire.
- Size of the tire.
- Brand and serial numbers.
- Tread depths.
- General condition (e.g., rock cuts, separations, shoulder lug condition, and sidewall injuries).
- Air pressures.
- Matching by the tread depth of the dual tires.
- Front wheel alignment indications.
- Wheel component conditions (spun wheels, loose nuts and lugs, broken or damaged side flanges or rim base and loose, bent or missing valve stems).
- Front tires due for rotation.
- Performance and record of any repairs done at time of the survey.

OBJECTIVE 8-4

The tireman should develop, with experience, the ability to recognize special problems that develop periodically.

KEYPOINTS/PROCEDURES

1. The following are special problems that can develop:
 - The tires can develop a chunking effect, in which small fingerprint sized chunks of the tread flake off. These are often related to factory compounding changes and can result in rapid wear, resulting in shorter tire life. This characteristic may show up in only one or two tires in a group.
 - Black marks at the base of the lugs indicate a squirming action. This can be related to low air pressures, overloading, high speed, or even a change in the design of the tire by the manufacturer. With the possibility of heat build-up, the tire must be watched closely.
 - Wheel alignment problems show up as unusual wear characteristics, generally on one shoulder of the tire. If the maintenance department confirms the wheel alignment to be okay, look immediately for an area of the operation where the unit may be doing hard turning at excessive speeds. Check the rest of the units for similar problems.
 - Recently installed tires, when checked for tread depth, can show indications of rapid wear. Though sometimes related to manufacturing compounds and carcass changes, it can also be traced to overloading, steep downhill loaded hauls or long steep uphill pulls. The end results are low hours and high cost per hour figures.

OBJECTIVE 8-5

The tireman will demonstrate the proper techniques of servicing back-up equipment such as scrapers, rubber tire dozers and front end loaders.

KEYPOINTS/PROCEDURES

1. The majority of these units have a non-removable rim base assembly. It is part of the planetary final drive system. The lock ring, bead seat band, and side flanges are of the same design as the haulage truck. They are demountable.

The only additional difference in design of the rim parts is the addition of a "driver". The rim base and bead seat band each have a pocket which must be perfectly aligned to accommodate the driver. The driver locks the bead seat band to the base and eliminates the chances of the tire turning on the rim base.

2. Follow these procedures to dismount this type of tire from the unit:
 - a. Jack and block the unit properly.
 - b. The problem with the tire must be located and marked before removal starts.
 - c. Perform the bleeding of air techniques. These units generally have a short brass valve stem.
 - d. Remove the driver. This can require the use of a tire iron.
 - e. Use the TO-1600 bead breaking tool to break the outside side flange from the bead seat band. Refer to OBJECTIVE 6-2 for the proper procedures.
 - f. Remove the lock ring and O-ring.
 - g. Remove the bead seat band.
 - h. Remove the side flange.
 - i. Use the TO-1600 to break the back bead. A short ram placed between the frame of the unit and the side flange can be used in place of the TO-1600 if there is not enough room.
 - j. Remove the tire.
3. Follow these procedures to mount this type of tire on the unit:
 - a. Clean the rim base, paying special attention to the inspection of the lock ring and O-ring gutters. Prepare all other rim parts for installation. Coat the rim base with a rust inhibitor.
 - b. Install the back side flange.
 - c. Prepare the tire, lubricate the beads, and slide it into place with the tire manipulator.
 - d. Install the outside flange.
 - e. Install the bead seat band, making sure that the pocket lines up with the pocket of the base rim.
 - f. Use the tire irons to pry the bead seat band back enough to install the O-ring.
 - g. Use a vegetable-based lubricant to prepare the O-ring. Slip it into place, making sure that it is seated properly.
 - h. Work the lock ring into place in the lock ring groove. Make sure that the ends of the lock ring are not located behind the driver. Slide the lock ring around in the groove to either side of the driver pocket.

- i. Install the driver in the driver pockets.
 - j. Inflate the assembly, standing to one side. At 5 psi tap each component to make sure it is seated properly. Replace the valve core, inflate the tire to its operating specifications, and replace the valve cap.
4. Front end loaders of the Letourneau electric drive design, and others, use a two piece demountable wheel. One set of bolts hold the wheel assembly together, and another larger set bolts the tire and wheel assembly to the unit.

Always bleed the air down to zero before removal and torque it back onto the unit before inflating back to operating specifications.



Province of
British Columbia

OPEN PIT MINING JOB HEAVY DUTY SKILL PROFI.

BASIC SAFETY AND OPERATING RULES	EXPLAIN THE IMPORTANCE OF SAFETY AND OPERATING RULES	EXPLAIN THE VARIOUS TYPES OF TIRES AND THEIR SPECIFIC APPLICATIONS	DESCRIBE THE BASIC CONSTRUCTION OF AN OFF-THE-ROAD TIRE	EXPLAIN THE DIFFERENT TYPES OF PROBLEMS THAT CAN ARISE AND THEIR CAUSES	DESCRIBE THE WHEEL ASSEMBLY PARTS	TO PROBL AM ASS
	EXPLAIN THE IMPORTANCE OF MAINTAINING PROPER AIR PRESSURES					
COMMUNICATIONS	RELAY THE STATUS OF PROJECTS UNDERWAY	FILL OUT REPORT FORMS	OPERATE THE MOBILE RADIO			
PREPARATION OF THE EQUIPMENT FOR TIRE CHANGES	PARK THE UNIT ON THE JACKING PAD	JACK AND BLOCK THE UNIT	DETERMINE THE PROBLEM WITH THE TIRE OR WHEEL ASSEMBLY	BLEED AIR FROM THE TIRES		
REMOVE THE TIRE FROM THE EQUIPMENT FRONT AND REAR	ENSURE THAT THE AIR HAS BEEN BLED	REMOVE THE VALVE HARDWARE HOLDING DEVICES	GRASP THE TIRE WITH THE MANIPULATOR	LOOSEN ALL OF THE WHEEL NUTS AND CLAMPS	REMOVE THE NUTS AND CLAMPS	T
REPLACE THE TIRES ON THE EQUIPMENT FRONT AND REAR	CHECK AND CLEAN THE WHEEL MOTOR ASSEMBLY	INSTALL THE PROPER VALVE HARDWARE ON REPLACEMENT TIRES	PICK UP AND INSTALL THE INSIDE TIRE	INSTALL THE SPACER BAND	PICK UP AND INSTALL THE OUTSIDE TIRE	V
TIRE REMOVAL FROM THE RIM ASSEMBLY	DETERMINE THE PROBLEM WITH THE TIRE OR RIM	REMOVE THE TIRE FROM THE WHEEL ASSEMBLY	MARK WITH A PAINT STICK OR SPRAY PAINT	STACK IN THE APPROPRIATE PILE		
INSTALL TIRE ON RIM ASSEMBLY	PREPARE THE RIM PARTS	PREPARE THE TIRE	PERFORM INSTALLATION PROCEDURES			
SPECIAL ASSIGNMENTS	PERFORM AIR AND HEAT CHECKS	SERVICE TIRES WITH BALLAST	PERFORM FLEET SURVEYS	RECOGNIZE SPECIAL PROBLEMS	SERVICE BACK UP EQUIPMENT	

JOB TRAINING SERIES
JTY TIREMAN
OFFICE CHART

Developed by:
Research and Curriculum Development Branch
Post-Secondary Department
Ministry of Education
1983

DESCRIBE THE VARIOUS PROBLEMS THAT CAN ARISE WITH THE WHEEL ASSEMBLY PARTS	EXPLAIN THE IMPORTANCE OF HAVING PROPER PROCEDURES FOR TIRE REMOVAL LAID OUT BEFORE STARTING	EXPLAIN THE IMPORTANCE OF CHECKING ALL OF THE EQUIPMENT BEFORE STARTING	DESCRIBE THE PROPER JACKING AND BLOCKING PROCEDURES	EXPLAIN THE IMPORTANCE OF BLEEDING THE AIR FROM THE TIRES) BEFORE REMOVAL	DESCRIBE THE PROPER METHOD OF HUT AND CLAMP REMOVAL	DESCRIBE THE PROPER METHOD OF INFLATING #4 EARTHMOVER TIRE
REMOVE THE OUTSIDE TIRE	REMOVE THE SPACER BAND	REMOVE THE INSIDE TIRE				
INSTALL ALL OF THE WHEEL NUTS AND CLAMPS	TIGHTEN AND TORQUE THE NUTS	INFLATE THE TIRES TO PROPER SPECIFICATIONS	PREPARE FOR RE-TORQUE PROCEDURES			

THE DACUM APPROACH

DACUM is a systematic model of program development used in designing career, technical and vocational training programs. The first step in the process is to establish the skills expected of a graduate entering employment. These skills are generally specified by a representative employer group in a workshop conducted by program development specialists. The product of this activity is a skill profile chart. This chart is then circulated both to the participants and to a number of other employers for review prior to further development.

The next step is to specify learner-centred performance objectives. These include not only the skills a learner must demonstrate but also the conditions under which the skill is to be performed and the criteria used to determine the acceptable standard of performance.

Once the performance objectives have been set, there are three important steps to complete the development process. These are generally undertaken by an instructor or group of instructors, in the following order:

- 1) Appropriate evaluation instruments are chosen or created to assess student capability in relation to the specific objectives of the program.
- 2) A variety of suitable instructional techniques and learning experiences are chosen to facilitate learning of the skills and knowledge required to meet the objectives.
- 3) Instructional resources (texts, films, models, and other learning aids) are selected or created.

READING THE SKILL PROFILE CHART

A skill profile chart (often referred to as a DACUM Chart), is a graphic representation of the essential skills expected of a student graduating from a specific career, vocational or technical program.

Broad areas of employee responsibility are shown in the boxes on the left of the chart. These are called "general areas of competence". The tasks or skills related to each are sequenced along the horizontal track to the right of the general area of competence.

FOR FURTHER INFORMATION

Please contact: Research and Curriculum Development Branch
Post-Secondary Department
Ministry of Education
7451 Elmbridge Way
Richmond, B.C.
V6X 1B8
Telephone: (604) 278-3433

ADDITIONAL COPIES

Additional copies of this chart and performance objectives
may be ordered from:

Publication Services
878 Viewfield Road
Esquimalt, British Columbia
V9A 4V1
Telephone: (604) 387-5331