

DOCUMENT RESUME

ED 246 264

CE 039 311

AUTHOR Henderson, Wm. Edward, Jr., Ed.
TITLE Articulated, Performance-Based Instruction Objectives Guide for Electricity/Industrial Electricity. Development Period, July, 1983--June, 1984. Edition 1.

INSTITUTION Greenville County School District, Greenville, S.C.; Greenville Technical Coll., S.C.

PUB DATE Jun 84

NOTE 674p.; For related documents, see ED 220 579-585 and CE 039 312-313.

PUB TYPE Guides - Classroom Use - Guides (For Teachers) (052)

EDRS PRICE MF04/PC27 plus Postage.

DESCRIPTORS *Articulation (Education); Behavioral Objectives; Blueprints; Communication Skills; Competency Based Education; Cost Estimates; Criterion Referenced Tests; Electrical Systems; *Electric Circuits; *Electricity; Electric Motors; Electronic Control; Electronic Equipment; Electronics; Equipment Utilization; Guidelines; *Industry; Instructional Materials; Job Performance; Job Skills; Job Training; Leadership; Learning Modules; *Lighting; Mathematics Skills; Measurement; Postsecondary Education; Safety; School Shops; Secondary Education; *Trade and Industrial Education; Work Attitudes

IDENTIFIERS *Electrical Wiring; *Industrial Wiring; South Carolina

ABSTRACT

This curriculum guide is designed to assist vocational educators in presenting an articulated, performance-based course in electricity and industrial electricity. Addressed in the individual units of the course (included in 11 modules) are the following topics: safety, leadership, communication skills, career preparation, good work habits and attitudes, basic math skills, basic measurement, blueprint reading, fundamentals of electricity, electrical tools and equipment, electrical measurement instruments, electrical wire connections, benchwork in electrical work, residential wiring and electrical maintenance, lighting, commercial wiring, industrial electrical wiring, electrical motors, industrial electrical controls and devices, industrial electronics, cost estimates of electrical work, and electricity shop and field projects. Each unit contains suggested instructional times and task listings. Also included in the guide are an outline of the South Carolina State Board of Education recommended program in electricity and industrial electricity, a discussion of the similarities between secondary and postsecondary programs, a sample proficiency report, and a bibliography. Sample outcome-referenced tests are provided along with sample articulation agreements, a discussion of the philosophy and purposes of the articulation guide, definitions, directions for the tests, and an analysis of secondary instructional times. (MN)

ED246264

ARTICULATED, PERFORMANCE-BASED INSTRUCTION OBJECTIVES GUIDE
FOR
ELECTRICITY/INDUSTRIAL ELECTRICITY

DEVELOPMENT PERIOD
JULY, 1983 - JUNE, 1984

PREPARED BY
OCCUPATIONAL EDUCATION ARTICULATION PROGRAM
TASK FORCE COMMITTEE
FOR
ELECTRICITY/INDUSTRIAL ELECTRICITY
REPRESENTING
THE SCHOOL DISTRICT OF GREENVILLE COUNTY
AND
GREENVILLE TECHNICAL COLLEGE
GREENVILLE, SOUTH CAROLINA

PUBLICATION OF
OCCUPATIONAL EDUCATION ARTICULATION PROGRAM
OF THE SCHOOL DISTRICT OF GREENVILLE COUNTY
AND GREENVILLE TECHNICAL COLLEGE

U.S. DEPARTMENT OF EDUCATION
NATIONAL INSTITUTE OF EDUCATION
EDUCATIONAL RESOURCES INFORMATION
CENTER (ERIC)

✓ This document has been reproduced as
received from the person or organization
originating it.
Minor changes have been made to improve
production quality.

- Points of view or opinions stated in this docu-
ment do not necessarily represent official NIE
position or policy.

Ca: C39311

JUNE, 1984
EDITION I

"PERMISSION TO REPRODUCE THIS
MATERIAL HAS BEEN GRANTED BY

W E Henke

TO THE EDUCATIONAL RESOURCES
INFORMATION CENTER (ERIC)"

ARTICULATED, PERFORMANCE-BASED CURRICULUM GUIDE

THE SCHOOL DISTRICT OF GREENVILLE COUNTY

DR. J. FLOYD HALL
SUPERINTENDENT

DR. NORMAN MULLINS
ASSOCIATE SUPERINTENDENT FOR EDUCATIONAL DEVELOPMENT

MRS. DORIS CLANTON
DIRECTOR, INSTRUCTIONAL SERVICES

MR. O. RICHARD COTHRAN, JR.
CONSULTANT, VOCATIONAL EDUCATION

ARTICULATION GUIDE

THE SCHOOL DISTRICT
OF GREENVILLE COUNTY

AND

GREENVILLE
TECHNICAL COLLEGE

THE SCHOOL DISTRICT OF GREENVILLE COUNTY
GREENVILLE, SOUTH CAROLINA

1984

Henderson, Wm. Edward, Jr., Ed. Articulated, Performance-based Instruction Objectives Guide for Electricity, Greenville, SC: Occupational Education Articulation Program of the School District of Greenville County and Greenville Technical College, 1984.

ACKNOWLEDGEMENT

The Articulated, Performance-based Instruction Objectives Guide for Electricity is the product of the work of the following instructor Task Force Committee participants representing the secondary programs of the School District of Greenville County and the post-secondary similar program at Greenville Technical College.

Donaldson Career Center	Marvin R. Weathers
Enoree Career Center	John H. Keenan
Foothills Career Center	Larry Harper
Golden Strip Career Center	Donald R. Boozer
Greenville Technical College	Edward Turner

The cooperation of the instructor participants and others representing the School District of Greenville County, Greenville Technical College, the South Carolina State Department of Education, and the South Carolina State Board for Technical and Comprehensive Education is appreciated.

Typist Theresa Eubanks,
Program Secretary

ABSTRACT

Title of Program: Occupational Education Articulation Program

Program Coordinator: Wm. Edward Henderson, Jr.

Sponsoring Agencies: The School District of Greenville County
and Greenville Technical College
c/o P.O. Box 2848 - 301 Camperdown Way
Greenville, SC 29602

Program Development
Period: July 1, 1983 through June 30, 1984

PURPOSE: To develop a continuous line of vocational training in similar Electricity (Residential/Industrial) programs so that students may continue their career/vocational education at the secondary and post-secondary levels without loss of time or waste of effort in repeating tasks that have been mastered previously.

To provide a system where teachers can cooperate effectively in providing a continuous occupational development program where the level and type of training that leads to entry-level employment skills will be clear to students, teachers, other educators, and potential employers.

METHOD: Electricity (Residential/Industrial) instructor representatives from the four secondary level career centers of the School District of Greenville County and the post-secondary level Electricity Department Head from Greenville Technical College were brought together in task force committee meetings and workshops to survey very similar areas of vocational training to identify possible overlaps or gaps as students continue electricity training from the secondary level to post-secondary level. In addition, lateral articulation of electricity programs at the secondary level was promoted.

This Articulated, Performance-based Instruction Objectives Guide for Electricity, was developed by The Task Force Committee on Electricity to facilitate articulation. The Task Force Committee, by the task analysis process, identified the minimum essential competencies for the secondary electricity graduate to continue training at the higher level of labor market in the trade. Major objectives for competency were

stated, performance to obtain the objectives were clarified, enabling actions were identified and placed in sequential order, instruction time was estimated, and performance standards were stated. Finally, outcome-referenced (criterion-referenced) measures of performance were developed as a guide in articulating (articulation).

RESULTS: As a result of the project development phase, the Articulated, Performance-based Instruction Objectives Guide for Electricity was developed. This articulation guide, however, is not a final product since it must be field trial tested and revised. Modifications and improvements to the guide are expected since the process of education must be reviewed continually to ensure that objectives are valid and are being met as best they can be met under given conditions.

Prior to development of this articulation guide, and Articulation Policies and Procedures Guide was developed to aid articulation activities and was used to direct program and product (guide) development activities.

Workshop guides, developed and refined during an earlier phase of the program were used to assist task force committee participants in obtaining task analysis data, writing performance-based objectives, identifying performance actions to reach the objectives, stating performance standards, and developing outcome-referenced tests. These how-to-do-it guides are usable at the instructional level as well as at the supervisory level.

CONTENTS

Electricity I	1
Electricity II	4
Employment Opportunities	7
Employment Projection	8
IBEC Electrical Apparatus Service Program	9
Sources of Information About Work of Electricians	10
State Department of Education Recommended Program	11
Greenville Technical College Electricity Program	12
Previous Articulation	19
Comparison of Articulated Programs/Subjects	20
Standards	21
Module 1.0 - Introduction	22
Suggested Instruction Times	23
Task Listings	26
Unit 1.0 A Introduction	32
Review/Follow Career Center Policies/Procedures	33
Orientation to Classroom/Shop/Lab	34
Review Course Objective and Standards	35
Unit 1.0 B - Introduction to Safety	36
General Orientation	37
Identify Desirable Safety Habits	38
Observe Classroom Safety	39
Apply Fire Safety Rules and Procedures	41
Personal Safety	43
Student's Safety Pledge/Parent's Permission	43-B
Unit 1.0 C - Introduction to Leadership/Communications	44
Work Cooperatively with Fellow Students	45
Characteristics of Leadership	46
Leadership Rating Scale	47
Participate in VICA Club Activities	48
Demonstrate Proper Use of Parliamentary Procedure	49
Communicate a Message by the Medium of a Speech	50
Unit 1.0 D - Preparing for Work	51
Describe the Free Enterprise System and the Difference Between the Labor and Management	52
Interpret Labor Laws and Regulations	53

Interpret Payroll Deductions for Taxes, etc.	54
Identify Typical Job Opportunities	55
Locate Job Opportunities	56
Prepare Resume	57
Compose Letter of Application	58
Complete a Typical Employment Application Form	59
Interview for a Job	60
Compose a Follow-up Letter	61
Identify Post-Secondary Career Development Opportunities	62
Unit 1.0 E - Introduction to Desirable Job Learning	63
Describe Good Work Habits Important to Job Success	64
Exhibit Successful Job Performance Characteristics	65
Exhibit Desirable Work Attitudes	67
Demonstrate Respect/Care for School Property	68
Unit 1.0 F - Basic Math Skills	69
Basic Math - Fractions	70
Basic Math - Decimals	71
Basic Math - Volumes	72
Basic Math - Areas	73
The Metric System	74
Unit 1.0 G - Basic Measuring	75
Measuring	76
Unit 1.0 H - Introduction to Blueprint Reading	78
Identify Working Drawings/Blueprints/Specifications	79
Interpret Common Blueprint Symbols	80
Interpret Dimensions from Blueprints	81
Read Blueprint/Specifications and Estimate/Job	82
Module 2.0 - Fundamentals of Electricity	84
Suggested Terminology	85
Suggested Instruction Times	87
Task Listings	89
Produce Voltage by Magnetism	93
Produce Voltage by Thermal Means	94
Produce Voltage by Photoelectric Means	95
Produce Voltage by Chemical Means	96
Construct an Electromagnet	98
Measure Voltage in Simple Circuit	99
Measure Amperage in a Simple Circuit	102
Measure Resistance in Simple Circuit	104
Test for Continuity	106
Determine Wattage	107
Read Microfrad Rating of Capacitors	108
Test Capacitors	110

Draw a Series Resistive Circuit/Calculate Values	112
Construct a Resistive Circuit	114
Construct Circuit with Batteries Wired in Series	115
Draw Parallel Resistive Circuit/Calculate Values	116
Construct a Parallel Resistive Circuit	117
Construct a Circuit with Batteries Wired in Parallel	118
Draw a Series-Parallel Resistive Circuit/Calculate Values.	119
Construct a Series-Parallel Resistance Circuit	120
Measure Resistance of a Single-Phase Motor	121
Connect a Single-Phase Step-Down Transformer	123
Connect a Single-Phase Step-Up Transformer	124
Connect an Auto Transformer to Provide Output Voltages	128
 Module 3.0 - Electrical Tools and Equipment	 129
Suggested Instruction Times	130
Task Listings	131
Select/Use Typical Pouch Tools	132
Select/Use Typical Speciality Tools	135
 Module 4.0 - Electrical Measuring Instruments	 144
Suggested Instruction Times	144
Task Listings	145
Electrical Measuring Instruments	146
Use the Clamp-On Ammeter	148
Use the VOM (Multimeter)	150
 Module 5.0 - Electrical Wire Connections	 152
Suggested Instruction Times	153
Task Listings	154
Crimp Wire to Terminal Using Crimping Tool	155
Slice Wire Using Solderless Connectors (Wire Nuts)	157
Solder Electrical Conductors and Connections	158
 Module 6.0 - Benchwork in Electrical Work	 160
Suggested Instruction Times	161
Task Listings	162
Inspect Workbench Area for Safe Working Environment	164
Care for Hand Tools	166
Identify and Properly Use a Bench Vise	167

Using Hand Hacksaw, Cut Material in Required Time	168
Identify Types of Fasteners	170
Assemble and Fit Parts	171
Proerply Use Hand Tools for Assembly/Disassembly	172
Bench File Workpiece	173
Drill Holes with Portable Drill	175
Inspect/Clean/Lubricate Drill Press	177
Set Up a Drill Press	179
Drill Holes to Size	181
Inspect/Clean Pedestal Grinder	183
Set Up Pedestal Grinder for Job	184
 Module 7.0 - Residential Wiring and Electrical Maintenance	 186
Standards Applicable to this Module	187
Unit 7.0 A - Compute Service Loads	188
Suggested Instruction Times	189
Task Listings	190
Calculate Individual Circuit Load	191
Balance Total Load Per Leg	193
Compute Size of Service Entrance Conductors	195
Unit 7.0 B - Install Service Entrance	197
Tool Kit and Pouch Standards	198
Suggested Instruction Times	199
Task Listings	200
Install Main Service Panel	202
Ground Service Entarance Equipment	204
Install Circuit Breakers in Panel	205
Install Main Service Disconnect	206
Install Service Entrance	207
Install Temporary Service Entrance	209
Install Underground Service Entrance	211
Unit 7.0 C - Installing Switch and Outlet Boxes (Residential)	212
Suggested Instruction Times	213
Task Listings	214
Install Bar-Hanger Mounted Box	216
Install Flush Mount Junction Box	217
Install Flush Mount Switch/Outlet Boxes in Dry/Paneled Wall	218
Install Gangable Boxes	220



Install Octagon Outlet Boxes	221
Install Recessed Fixture Housing in Ceiling	222
Unit 7.0 D - Rough in Electrical Circuits (Residential)	223
Suggested Instruction Times	224
Task Listings	225
Rough in 120/240 Circuits to Distributuion Panel Using Nonmetallic Sheathed Cable	228
Rough in Armored Cable to Outlet Box	229
Rough in Cable between Exisitng/Newly Installed Box	230
Rough in Cable for Branch Circuits	231
Rough in Circuit for Outlet Controlled by Two Each Three Way Switches with Feed to Switch Box	232
Rough in Circuit for Outlet Controlled by Two Each Three Way Switches with Feed to Outlet Box	233
Rough in Circuit for Outlet Controlled by Three-Way Switches and One Four-Way Switch with Feed to a Three-Way Switch	235
Rough in Circuit for Door Chime	237
Rough in Circuit for Intercom	238
Rough in Low-Voltage Wiring	239
Install Non-Metallic Cable in Outlet Boxes	240
Rough in Circuit for Split Circuit Duplex Receptacle	241
Orientation to Installing Conduit Underground	242
Orientation to Installing Direct Buried Cable	242
Unit 7.0 E - Rough in Telephone Wire and Accessories	243
Suggested Instruction Times	244
Task Listings	245
Plan Wiring Job	246
Install Telephone Outlets	248
Install Telephone Wire	250
Connect Wires to Junction Boxes and Jacks	252
Unit 7.0 F - Trim Out Electrical Devices (Residential)	254
Suggested Instruction Times	255
Task Listings	256
Connect Door Chime System	259
Connect/Install Duplex Receptacle Outlets	260
Connect/Install 240 Volt Four-Wire Receptacle for Range or Dryer	262
Install Ground Fault Interrupting Device (GFCI)	264
Connect Hot Water Heater	266
Connect Low-Voltage Lighting Control	267
Connect Moisture Resistance Receptacle	268

Connect Single Pole Switch	269
Connect Split Circuit Duplex Receptacle	271
Connect Three-Wire 240 Volt Receptacle	273
Connect Wires form Junction Box to Appliance/Electrical Device	275
Connect 120/240 Circuits to Circuit Breaker Panel Using Non-Metallic Cable	277
Install/Connect Three-Way Switches	279
Make Wire and Fixture Splices	281
 Unit 7.0 G - Maintain Lighting/Wiring System (Residential) . .	283
Suggested Instruction Times	284
Task Listings	285
Diagnose/Repair Flourescent Fixture Malfunction	287
Diagnose/Repair Incadescent Lighting	288
Repair Water Heater	289
Repair/Replace Frayed/Damaged Service Cord	291
Replace Fuse	292
Replace Pilot Light (lamp) Bulb	293
Test for Correct Voltage	294
Troubleshoot a Branch Circuit	295
Service Electrical Motor/Appliance	296
Install/Maintain Emergency Lighting	297
 SECOND YEAR (Seondary Level) ELECTRICITY	298
Module 8.0 - Commercial Wiring	299
Suggested Instruction Times	300
Task Listings	302
Identify/Read Electrical Wiring Information on a Commercial Floor Plan	306
Interpret Commercial Electrical Wiring Installation Specifications	308
Construct an Electrical Floor Plan for a Commercial Structure	310
Calculate Commercial Service Entrance Requirements	312
Install and Secure Rigid Conduit	314
Install and Secure Thin Wall (EMT) Conduit	316
Install and Secure Flexible Conduit	318
Install and Secure PVC Plastic Conduit	320
Pull Wire Through Conduit and Terminate it	322
Install and Secure a Surface Raceway	324
Install Conductors in Conduit	326
Install Telephone Raceway	327
Install a Commercial Single-Phase Receptacle Outlet	329
Install a Commercial Three-Phase Circuit Receptacle	331
Install/Wire a Commercial Lighting Circuit	333
Install/Wire a Commercial Standby Emergency Lighting Circuit	335

Install/Wire a Commercial Low-Voltage Signal Communi- cations or Control Circuit	337
Calculate Total Commercial Job Installation Costs	339
Module 9.0 - Industrial Electrical Wiring and Maintenance	340
Unit 9.0 A - Industrial Electrical Wiring	342
Suggested Instruction Times	343
Task Listings	344
Plan/Perform Sitework for Small Industrial Facility	346
Calculate Branch Circuit Conductors/Overcurrent Protection	347
Install Outlet, Junctions and Conduitlets	348
Wire Transformers as Required	349
Install/Wire a Commercial Emergency Alarm Circuit to Protect Workers Against Hidden Dangers	353
Unit 9.0 B - Wiring Diagrams and Schematics	354
Schematic Symbols	354-B
Suggested Instruction Times	355
Task Listings	356
Draw Basic Schematic Wiring Diagram	358
Draw Current Relay Wiring Schematics	359
Draw a Potential Relay Wiring Diagram	360
Draw Hot-Wire Relay in a Circuit	361
Draw Schematic Wiring Diagram of Low-Voltage Control Circuit	362
Draw Control Panel Diagrams	363
Update Schematic Print Files for Machinery or Control Panel	365
Unit 9.0 C - Electrical Motors	366
Suggested Instruction Times	367
Task Listings	369
Collect Motor Data Information	373
Connect Shaded-Pole Motor	375
Connect a Dual-Voltage Motor in a Circuit	376
Disassemble and Assemble a Single-Phase Motor	377
Measure Resistance of Windings in a Split-Phase Motor Identify Start/Run Windings	379
Connect a Split-Phase Motor in a Circuit	381
Reverse the Direction of Rotation of Split-Phase Motor	383
Connect a Capacitor-Start Motor	384
Install a Permanant-Split Capacitor Motor	386

Determine Condition of Starting Components of a CSR Motor	388
Disassemble/Assemble a Three-Phase Motor	389
Measure Resistance of Windings in Single-Voltage, Single Speed, Three-Phase Motor	391
Install a Single-Voltage, Three-Phase, Squirrel-Cage Insuction Motor	392
Connect a Dual-Voltage, Three-Phase Induction Motor for Low-Voltage	394
Adjust V-Belt Tension	395
Identify Motor Bearing and Bushing Problems	397
Replace Drive Sheave (Pulley)	399
Install Gear Motor Station	401
Install Direct Drive Station	402
Service and Electrical Motor	403
Install Motor Bearings and Bushings	406
Troubleshoot a Given Motor	407
 Unit 9.0 D - Industrial Electrical Controls/Devices	 409
Suggested Instruction Times	410
Task Listings	412
Install Manual Motor Control Station	415
Install Magnetic Push-Button Motor Control Station	416
Install a Three-Phase Control Magnetic Starter	418
Install Two-Station, Push-Button Control Station	419
Install Control Push-Button to Change Direction of Rotation of Motor	420
Install Hand Sequence Control Station	421
Install Timed Sequence Control Station	422
Install Automatic Sequence Control Station	423
Program a Programmable Controller	424
Install Direct Current (DC) Motor Controllers	426
Connect Capacitor Timing Starter	428
Install Jogging Control Circuit	429
Install Plugging Control Circuit	430
Install a Limit Switch	431
Install Drum Switch Control Station	432
Replace Flow Switch	434
Replace Rheostat Control	435
Troubleshoot Controls	437
 Unit 9.0 E - Introduction to Industrial Electronics	 438
Suggested Instruction Times	439
Task Listings	440
Identify Basic Symbols/Components used in Simple Industrial Electronic Circuits	442
Identify Considerations in using Simple Electronic Components	443

Draw Diagrams of Industrial Electronic Control	
Circuits using Solid State Relays	445
Install Solid State Relay in Circuit	446
Connect Diodes in Circuit	447
Connect/Replace Solid State Lamps (SSLs) (LEDs)	449
Construct a Basic SCR Speed Control Circuit	451
Construct a Triac Speed Control Circuit	453
Install Electronic Photoelectric Sensing Device	455
Construct a Photoelectric Relay Circuit	456
Install Electronic Proximity Sensing Device	458
Industrial Electricity Task Omitted	459
Module 10.0 - Estimating and Planning Electrical Work	460
Suggested Instruction Times	461
Task Listings	462
Estimate the Cost of a Specific Installation	464
Estimate Cost of Materials for a Specific Wiring Job	465
Estimate Costs of Labor to do a Specific Wiring Job	466
Inventory Equipment, Materials, and Supplies	467
Complete a Trouble Report on Tools/Equipment/Materials	
Not Servicable	468
Plan a Sequence of Work Operations	469
Module 11.0 - Electricity Shop/Field Projects	470
Practical Electrical Shop Projects	471
Tool Room Workers	473
Proficiency Report	475
Bibliography	486
Task Omitted from Secondary Guide	493

PREFACE

This Articulated, Performance-based Instruction Objectives Guide is based on the following ASSUMPTIONS:

1. The grouping of tasks is more conducive to skill development in vocational education.
2. Potential employers probably would prefer an employee well educated in the basics with more detailed on-the-job training provided by the employer.
3. Among topics that should be included in vocational education are; safety, career opportunities, how to get and keep a job, and the job attitudes that often are the key to employee success and job retention.
4. A premise of the articulated, performance-based instruction guide is that it is absolutely essential that career/vocational education/training be based on the knowledges, skills, abilities, and personal characteristics that are important to success on the job, if the vocational program is going to validly serve the needs of students and potential employers of the community.
5. Another premise in the articulated instruction guide is that vocational education can no longer be developed according to program titles, be time-based, lack flexibility, or overlook basic fundamentals if the program is to meet the needs of a constantly changing work force, meet the needs of students and employers, and be of the highest quality.
6. Substantial research clearly indicates that instructional technology and accountability demands are increasing the movement toward the use of instructional systems.

The systems approach, a method of organizing the instructional situation, methods, media, materials, and equipment so that the maximum knowledge and skill development may be achieved, is promoted because it directs its attention toward teaching the observable behaviors that the vocational student should possess at the termination of instruction.

The instructional program described in this articulated, performance-based instructional objectives guide has been assembled by participating instructor task force committee representatives

representing the School District of Greenville County and Greenville Technical College and it is based on the concept that the minimum tasks described should be those identified for successful entry level employment according to local task analysis information, state-of-the-art literature, similar/related research/publications, and the expertise of the instructor participants.

7. The articulated instruction guide illustrates one way the (secondary) curriculum may be organized. The example is not intended to imply that there are not other ways to structure the curriculum.

The articulated instruction guide should be perceived as a vehicle to facilitate the development of alternate, detailed instructional plans for the individual learner.

8. While the objectives in this guide typically have been arranged in a sequence from less to more difficult in performance or as they might occur on the job, the sequence of tasks is not meant to indicate a required pattern.
9. The "suggested minimum instruction times" are included for planning purposes and may be extended as required for the completion of task objectives. An underlying premise of the articulated instruction guide is that it is more desirable for the student to complete some objectives and gain some employable skills rather than to be introduced to a large number of tasks and not acquire any employable skills.

The actual amount of time required for each task objective may vary according to the local program objectives and depending upon the individual needs of the learner, the instructor, and the facilities/materials available.

10. While it may become necessary to modify the vocational program from the articulated guide description, a lowering of the minimum standards (competency level) recommended (typically by industry) should be avoided to ensure that the program graduate can demonstrate a minimum performance essential to employment success.
11. This articulation guide was drafted in a period of less than twelve months so that a product production deadline of twelve months might be met.

If the vocational program was too complex to describe in one-year because of the number of major tasks, emphasis was placed on successfully describing the first year of the two-year, secondary level, vocational program so that there would be a foundation for further development. Completion of the second year program tasks were described as the remaining time allowed.

Because of a restricted development time frame, emphasis was placed on developing a sound and valid articulation guide which might be refined at a later date.

Greenville, SC

W.E.H.

ELECTRICITY

LEVEL: Secondary

TITLE: Electricity I

DESIGNATION: Electricity I COMPUTER NUMBER: 755

DESCRIPTION: Electricity I and II are designed to provide the knowledges and skills necessary for the graduate to successfully enter the electrical and apprentice: (1) CONSTRUCTION ELECTRICIAN with primarily work in new construction or building projects or (2) INDUSTRIAL ELECTRICIAN whose work might involve the assembly, installation, and wiring of heating, lighting, power, air-conditioning, and refrigeration components as well as the installation of electrical machinery, electronic equipment and controls, and signal and communications systems. Another type of work in industry is as a MAINTENANCE ELECTRICIAN who specializes in keeping existing electrical systems and equipment in working order, spending most of the time on preventive maintenance and being prepared to quickly diagnose problems and make repairs to keep production activities in operation.

Electricity I concentrates on introducing the student to the fundamentals of residential, commercial, and industrial wiring, and transformers. Career opportunities in the electrical field, trade safety, the proper use and care of hand and power tools, blueprint reading, electrical math formulas, as well as basic residential wiring and electrical instruments are learned during the first year of training.

The student will learn to read and interpret the National Electrical Code to calculate voltage drop, the proper selection of various sizes and types of wires, the application of theory design, and the various laws of electricity governing current flow.

The skills and knowledges learned from Electricity I are those typically expected of the ELECTRICIAN HELPER.

OBJECTIVE: Upon completing the first year of secondary level electricity training, the student should be able to assist an electrician in the installation and repair of electrical wiring, fixtures, and equipment by performing any combination of such tasks as making linear measurements to the fraction of an inch, cutting and bending conduit, cutting and stripping wires, and making electrical connections under the supervision of the electrician.

The student should be able to properly use and care for the electrician's hand tools; power tools such as drills and sabre saws; as well as ladders and conduit benders. The student should be able to drill or cut holes for wiring and pull/push wires through openings and be able to provide mounting holes for electrical fixtures or apparatus.

The student should be able to assist the electrician in lifting, positioning, and fastening objects such as wiring, conduit, and electrical devices like motors. After the first year of training, the electricity student should be able to perform minor repairs such as replacing fuses, light bulbs, sockets and switches, or electrical parts in machines. The student should be able to correctly use and maintain hand and power tools and keep supplies and parts in order. The student should be able to disassemble defective equipment, such as motors, or assemble electrical devices, using hand tools under the supervision of the electrician.

The primary objective of the first year of training is to qualify the student for a second year of advanced study in residential, commercial, and industrial electricity; however, upon successfully completing the first year of electricity, the student should be able to demonstrate the minimum skills and knowledges expected of an ELECTRICIAN'S HELPER.

PERFORMANCE
EVALUATION:

Evaluation will be by written outcome-referenced tests emphasizing transfer and performance type tests and by simulated/actual performance tests where the student may demonstrate the performance process and product.

The student should be able to read/interpret the National Electrical Code, electrical equipment service and parts manuals, electrical blueprints and schematics as well as electrical symbols and color codes.

The student should be able to correctly identify, use and care for electrical hand tools, power tools, and electrical measuring devices such as basic voltmeters, multi-meters, and ammeter..

The student should be able to identify standard types of residential electrical wire, switches and receptacles.

The student should be able to correctly locate and install panels and boxes, meeting code requirements.

The student should be able to correctly cut and strip wire and make electrical connections to panels, switches and receptacles and electrical equipment.

PREREQUISITES: None

Suggested Grade Level: 11 (Juniors)

Recommended high school courses which may contribute to the success of the electricity student include: Physics, Trigonometry, Algebra I and II. Other helpful courses are General Mathematics, Physical Science, Industrial Arts, and Prevocation.

The electricity student should be prepared to learn, to read graphs and diagrams; translate and work with algebra and trigonometry formulas; read linear measurements to the fractions of an inch; and accurately interpret electrical test instrument dials or meters.

The successful electricity student must be able to read and interpret the National Electrical Code as well as a variety of technical manuals and instruction publications. The electricity student should be able to quickly adapt to concepts of terms such as voltage, amperage, and wattage; should be able to interpret electrical symbols, a variety of equations, and color codes; and should be willing to apply theoretical principals and problem solving techniques to resolving practical situations.

The electricity student should have average physical strength and ability, numerical and spatial aptitude, color discrimination, manual dexterity, and good eye-hand coordination,

Readiness skills for electricity training should include the ability to adapt to the use of tools such as the screwdriver, pliers, electrician's knife, hammer, hacksaw, chisel, and hand or power drill.

REQUIRED INSTRUCTION HOURS:

System	Year
Division	Class/Lab
Credits	3
Hours	540

LEVEL: Secondary
TITLE: Electricity II
DESIGNATION: ELECTRICITY II . COMPUTER NUMBER: 756

DESCRIPTION: Electricity II is designed to further prepare the graduate for entry apprenticeship as a CONSTRUCTION ELECTRICIAN or as an INDUSTRIAL or MAINTENANCE ELECTRICIAN.

The second year electricity student studies Residential, Commercial, and Industrial Wiring, applying and expanding the fundamentals learned during the first year, and applying the National Electrical Code.

Residential wiring topics include: Low voltage control systems; installing 240 volt grounded outlets; wiring a hot water heater, range, or wall heater; connecting and disconnecting a 240 volt central heating and cooling circuit; calculating loads, wire sizes, and voltage drop.

Commercial wiring topics may include calculating service loads for a small commercial building; locating service entrance equipment and writing specifications. Other commercial wiring topics may include: Calculations for electric motors, heaters, and welders; calculating 120/277 volt lighting loads and 120/208 loads for receptacles; selecting and installing a 3-phase, 4-wire, 480 volt panel; installing a 480/208-120 volt, 3-phase, 4-wire service; selecting and installing panels and distribution equipment; selecting and installing 277 volt fluorescent lighting, and operating a 3-phase synchronous motor. Additional topics may include; DC motors, single and three phase alternators, induction regulators, and other motor topics.

OBJECTIVE: Graduates of the two-year secondary program in electricity should be able to plan and layout an electrical installation, install or repair wiring, electrical fixtures, apparatuses, and control equipment. The graduate should be able to plan new electrical installations or modifications to minimize waste or materials, provide access for future maintenance, and avoid unsightly, hazardous, or unreliable wiring; consistent with specifications, blueprint and applicable electrical codes.

The graduate should be able to prepare or interpret sketches showing location of wiring and equipment, or follow blueprints, insuring that concealed wiring is installed before completion of future walls, ceilings, and flooring in construction work. The electricity graduate should be able to measure, cut, bend, thread, assemble and install electrical conduit, using such tools

as the hacksaw, pipe threader, and conduit bender. The graduate should be able to pull/push wires through conduit.

The graduate should be able to splice wires by correctly stripping insulation from terminal leads by the electrician's knife, pliers, or wire stripper and fasten wires by twisting, soldering, or using crimping devices and protecting the connection with such devices as terminal caps or electrical tape. The graduate should be able to connect wires to lighting fixtures, outlets, and power equipment; install control and distribution apparatus, such as switches, relays, and circuit-breaker panels; and fasten them in place using screws and bolts.

The electrician connects power cables to equipment such as household appliances or industrial devices, like motors, and installs grounding leads. The graduate tests the continuity of circuits to ensure electrical compatibility and safety of components and users, using testing instruments such as the ohmmeter, voltmeter, clamp-on ammeter or amprobe, multimeter or other test equipment.

The graduate should be able to observe the functioning of installed equipment of systems to detect hazards or the need for adjustments, relocation, or replacement. The graduate should be able to apply theoretical knowledge and practical skills to analyze electrical installations and repair faulty equipment of systems.

The objective of the two-year electricity program is to qualify the student as an APPRENTICE ELECTRICIAN qualified for construction or maintenance electrical work.

PERFORMANCE
EVALUATION:

Evaluation will be by written outcome-referenced tests emphasizing transfer and performance type tests and by simulated/actual performance tests where the student may demonstrate the performance process or product.

The graduate of the two-year program in electricity must be able to interpret and apply the National Electrical Code.

Performance and products must be within Code or other specified safety, fire, and shop rules/regulations.

Electrical mathematical problems must be accurately calculated, electrical symbols and blueprints or diagrams and sketches must be correctly read and electrical measuring instruments must be used and read.

Electrical tools and equipment must be correctly used and cared for and correct electrical parts/components must be selected/used.

All electrical connections must be mechanically and electrically secure. Connections must be made by the proper/recommended procedure, properly insulated, and meet Code requirements.

The graduate should be able to accurately read service manuals, use a parts catalog, and complete an equipment/material order.

Motors and machinery connected to electrical circuits must operate to specifications.

Performance must be to the minimum industrial standards outlined in this Articulated, Performance-based Instruction Objectives Guide for Electricity (secondary).

PREREQUISITES: Electricity I

Suggested Grade Level: 12

Recommended math and reading levels applicable to Electricity I represented by the ability to read and interpret the National Electrical Code and correctly perform mathematical calculations using electrical formulas.

REQUIRED INSTRUCTION HOURS:

System	Year
Division	Class/Lab
Credits	3
Hours	540

TOTAL REQUIRED INSTRUCTION HOURS FOR
SECONDARY ELECTRICITY PROGRAM:

System	2-Years
Division	Class/Lab
Credits	6
Hours	1,080

WORKING
CONDITIONS:

The electrician should like working in activities; with tangible results, involving physical and mental tasks, sometimes, requiring problem solving using tests and experiments, and working with plans and diagrams as well as energy producing and controlling devices. The electrician should be able to work satisfactorily with people.

The electrician should be prepared to follow local step-by-step procedures, emphasize safety practices, work patiently alone or as a member of a team, read and follow the National Electrical Code or other applicable codes or manuals, pay attention to detail and take pride in an accurately completed job.

Physically, the electrician must be able to operate a variety of hand and power tools, to work in a variety of postures, sometimes cramped, and should be able to climb and maintain body balance at moderate heights. The electrician's vision should be good, with correction if necessary; and work typically will require distinguishing color differences to identify components and circuits. The electrician should be capable of gripping, stretching, pulling, and lifting heavy weights of at least 50 pounds.

Electricians may be required to work on ladders or on scaffolds in awkward or cramped positions. Minor hand cuts and scratches from working with wire and metal is not uncommon. Electricians must exercise caution and accuracy in their work which often involves potentially hazardous, high-voltages: Errors in wiring installations could easily endanger both the electrician and others. For safety, electricians should follow the National Electrical Code specifications as well as local applicable codes.

Electricians may be required to furnish their own tools, including screwdrivers, pliers, knives, and hacksaws. Employers typically furnish heavier tools, such as conduit benders, pipe threaders, and most test equipment and power tools.

Within a single working day, the electrician may work in a clean, air conditioned environment; on a floor surrounded by the noise, oil, and grease of machinery; or in a crawl space, in a hot attic, or on a ladder.

EMPLOYMENT OPPORTUNITIES: Job opportunities for the qualified electrician may be found in construction, industrial, and maintenance work.

Primary work typically will be as an:

Electrician's Helper, D.O.T. 829.684-022
Electrician, D.O.T. 824.261-010

Related work might be found as an appliance repairman, installer or service man, or with public service industries.

Because of increasing use of electronic equipment such as control circuits, switches, timers, etc., in the electrical field, the electricity graduate should consider seriously additional study at the post-secondary level either during an year of schooling or in evenings while on-the-job. Job growth and opportunities probably will be linked closely with educational preparation in the future.

The requirement for electricians to be licensed is growing and graduates should consider becoming licensed to work both in the local and other geographical locations since job sites may vary.

To become a licensed electrician in the City of Greenville, the graduate must be eighteen years of age and enter into a two year apprenticeship under a Master Electrician prior to standing the Journeyman's Exam. After becoming a Journeyman's Electrician, two additional years of apprenticeship must be served under a Master Electrician prior to standing the exam for the Master's Card.

Technological trends indicate that the electrician will increasingly encounter a greater use of electronic devices, such as timers and controls, in residential and industrial settings.

EMPLOYMENT
PROJECTION:

Employment projections by the South Carolina Employment Security Commission indicate that between 1978 and 1985 there will be a 8.2 percent increase in the number of electricians working in the Greenville-Spartanburg area with about 30 new positions created between 1983-1985 when the total electricians employed is projected to be 1,580. This projection, however, does not necessarily reflect the number of electricians that may be employed on a temporary basis in construction work, that may be self-employed contractors, or that may be working in related industries.¹

¹South Carolina Occupational Projections, 1978-1985, Columbia, SC: South Carolina Employment Security Commission (Research & Analysis Department), p. 157, 1982.

Electricity

ELECTRICAL APPARATUS SERVICE PROGRAM

"The Electric Apparatus Service Program is designed as a basic four (4) year, eight (8) unit course for apprentices that, as journeyman, will be servicing electrical apparatus. The course is intended to provide the apprentice with AC and DC theory and application; motor and transformer, construction, installation, maintenance and repair; industrial electronics and motor control, as well as trade related subjects such as safety, mathematics, first aid, electrical code and job orientation."

Some of the subjects featured in this program are:

- DC Fundamentals
- Electric Circuits and Machines
- Advanced First Aid and Emergency Care
- Knot Tying and Rigging
- National Electrical Code
- AC Fundamentals
- Transformers*
- Preventive Maintenance of Electrical Equipment
- Electric Motor Repairs
- Electric Machines
- Industrial Electronics
- Electric Motors
- Understanding & Measuring Horsepower
- Electric Motor Control Fundamentals
- Electric Motor Controls & Circuits
- Automatic Control Basics

* A unit such as Transformers may be broken down as follows:

Lesson 1	Transformer Construction
Lesson 2	Transformer Principles
Lesson 3	Transformer Classification
Lesson 4	Transformer Circuitry and Cooling
Lesson 5	Transformer's Oil and Accessories
Lesson 6	Tap Changers
Lesson 7	Transformer Connections-Voltage Transformation Information
Lesson 8	Transformer Connections-Phase Transformation
Lesson 9	Practical Transformer Consideration
Lesson 10	Transformer Maintenance, Testing and Protection

Source: International Brotherhood of Electrical Workers (IBEW), 1125 Fifteenth Street, N.W., Washington, DC 20005, 1983.

SOURCES OF ADDITIONAL INFORMATION ABOUT THE WORK OF ELECTRICIANS:

Associated Independent Electrical Contractors of America
1201 North Watson Road, Suite 201
Arlington, TX 70511

International Brotherhood of Electrical Workers
1125 15th Street, NW
Washington, DC 20005

National Association of Lighting Maintenance Contractors
1750 Old Meadow Road, Suite 3-A
McLean, VA 22102

National Electrical Contractors Association
7315 Wisconsin Avenue, NW
Washington, DC 20014

National Joint Apprenticeship and Training Committee for the Electrical
Industry
9700 E. George Palmer Highway
Lanham, MD 20802

SECONDARY LEVEL
STATE DEPARTMENT OF EDUCATION
RECOMMENDED PROGRAM

ELECTRICITY

"The student completing this course will be qualified to enter electrical trades to assist with planning, layout, installation, checkout, and maintenance of electrical systems. The student learns National Electrical Code regulations related to wiring installation, electrical circuits and the measurements of voltage, current, and power of single and polyphase alternating circuits. In addition, the student learns the basic elements of motor, motor control systems, industrial electronic systems, business procedures, organization, and management principles. Upon completion of this course, the student is capable of progressing from an apprentice program to a qualified licensed electrician [sic]."*

* Typically, the secondary graduate will be required to serve an apprenticeship prior to standing the journeyman's exam and as a journeyman's typically must apprentice under a master electrician for a two year period prior to standing the master's exam.

The recommended course content included:

1. Safety
2. Magnetism
3. Basic electricity - A.C. and D.C.
4. Test equipment
5. Direct current dynamos
6. Blueprints
7. Special purpose and signal wire work
8. Lighting
9. Grounding
10. Cable work
11. Conduits
12. Motors and appliances
13. Mathematics
14. Low voltage switching (remote control)
15. Outlets
16. Repairing and installing motor controllers

Outline of High School Credit Courses, Columbia, S.C.: S.C. State Department of Education, pp. 132-133. (EDITOR'S NOTE: "This narrative description may not satisfactorily describe the secondary Electricity programs and it should be updated based on industry needs, practices, and standards.")

Defined Minimum Program for South Carolina School Districts, Columbia, S.C.: S.C. Department of Education, 1980.

POST-SECONDARY DESCRIPTION
GREENVILLE TECHNICAL COLLEGE

INDUSTRIAL ELECTRICITY/ELECTRONICS

Greenville Technical College's Industrial Electricity/Electronics curriculum is designed to give the student practical/theoretical knowledge in construction, installation, and maintenance (repair) within the electrical/electronics field. The student may elect to graduate on the completion of four quarters with an Industrial Electricity diploma or continue his studies for the additional nine months and receive an Associate Degree in Industrial Electronics.

The suggested sequence of required courses is:

FIRST QUARTER

<u>COURSE NUMBER</u>	<u>COURSE TITLE</u>	<u>CLASS</u>	<u>LAB</u>	<u>CREDIT</u>
MAT 115	Electrical Math I	5	0	5
EEM 113	Electricity D.C.	7	3	8
EEM 345	Residential Wiring A	2	3	3
EEM 346	Residential Wiring B	1	3	2
		<u>15</u>	<u>9</u>	<u>18</u>

SECOND QUARTER

MAT 126	Electrical Math II	5	0	5
EEM 123	Electricity A.C.	6	3	7
EEM 133	Electrical Instruments and Measurements	6	0	6
EEM 117	Electrical Codes and Ordinances	4	3	5
		<u>21</u>	<u>6</u>	<u>23</u>

THIRD QUARTER

EEM 137	Electrical Power Systems	2	6	4
EEM 213	Vacuum Tubes and Solid State Devices		3	4
ECO 100	Consumer Economics	3	0	3
EEM 127	A.C. Machines and Devices	3	3	4
ENG 150	Introduction to Composition	4.5	0	4.5
		<u>15.5</u>	<u>12</u>	<u>19.5</u>

FOURTH QUARTER

EEM 136	Electrical Control Circuits	3	6	5
EEM 131	Electronics and Applied Circuits	7	3	8
PSY 112	Industrial Human Relations	3	0	3
		<u>13</u>	<u>9</u>	<u>16</u>

FIFTH QUARTER

<u>COURSE NUMBER</u>	<u>COURSE TITLE</u>	<u>CLASS</u>	<u>LAB</u>	<u>CREDIT</u>
EEM 214	Industrial Electronic Applications	6	0	6
EEM 260	Applied Pneumatics & Controls	3	3	4
EEM 143	Electrical Installation & Planning	6	0	6
EEM 226	Electrical Cost Estimating	0	6	2
ENG 236	Advanced Technical Composition & Communications	4.5	0	4.5
		<u>19.5</u>	<u>9</u>	<u>22.5</u>

SIXTH QUARTER

EEM 104	Blueprint Reading - Industrial	0	9	3
EEM 118	D.C. Machines & Controls	4	0	4
EEM 238	Industrial Logic Circuits	3	9	6
		<u>7</u>	<u>18</u>	<u>13</u>

SEVENTH QUARTER

EEM 215	Microprocessor Systems I	2	3	3
EEM 216	Microprocessor Systems II	2	3	3
EEM 265	Electrical Problem Solving	3	0	3
EEM 217	Microprocessor Systems III	2	3	3
		<u>9</u>	<u>9</u>	<u>12</u>

Source: Catalog, Industrial Division, Greenville Technical College,
1982-1984, Greenville, SC: Greenville Technical College,
pp. 14-15.

Industrial Electricity Department, GTC, 1982-1984.

FIRST QUARTER

MAT 115 ELECTRICAL MATH I:

Arithmetic and algebra through linear equations in one unknown. Scientific notation, J-operator, vectors (phasors) in rectangular and polar forms. Use of calculator. Prerequisite: Satisfactory score on math placement test. (5-0-5)

EEM 113 ELECTRICITY D.C.:

The students learn Atomic Theory and Electron Flow, electrical units, Ohm's Law, resistance combinations, meter connections, magnetism and magnetic circuits, electrical power, characteristics of electrical conductors, inductance and capacitance, direct current generators and motors, and use of common DC measuring and metering equipment. (7-3-8)

EEM 345 RESIDENTIAL WIRING A:

Is designed to teach the code and local ordinance requirements for electrical installations in residential and commercial buildings. The student will learn general codes, wiring methods and fittings, and circuit requirements for the various ordinances. (2-3-3)

EEM 346 RESIDENTIAL WIRING B:

Is designed to teach the code and local ordinance requirements for electrical installations in residential and commercial buildings. The student will learn general codes, wiring methods, and fittings, and circuit requirements for the various ordinances. (1-3-2)

SECOND QUARTER

MAT 126 ELECTRICAL MATH II:

Application of arithmetic, elementary algebra, vectors, J-operators, and calculator to mathematical analysis of D.C. and A.C. circuits (series, parallel, and combination) involving current, voltage, impedance, and electrical power. Prerequisite: MAT 115. (5-0-5)

EEM 123 ELECTRICITY A.C.:

A study of the characteristics of alternating current and voltage waves, behavior of alternating current in resistors, capacitors and inductors, and three-phase systems. Also included are applications of vector algebra in the analysis of series and parallel combinations of impedance, A.C. single phase and three-phase motors and generators. (6-3-7)

EEM 133 ELECTRICAL INSTRUMENTS & MEASUREMENT:

Operating principles, movements, range extending devices, rectifiers, bridges and transformers are studied. Students learn the operation and use of electronic measuring equipment. (6-0-6)

EEM 117 ELECTRICAL CODES & ORDINANCES:

A course of study in and application of the National Electrical Code, city and county electrical ordinances. (4-3-5)

THIRD QUARTER

EEM 137 ELECTRICAL POWER SYSTEMS:

A study of the design, operation and technical details of modern power distribution systems, including auxiliary generating equipment, plant distribution and protection devices are offered in this course. System load analysis and rate and power economics are studied. (2-6-4)

EEM 213 VACUUM TUBES & SOLID STATE DEVICES:

The student learns basic electronic vacuum tube theory, including the use of tube manuals and characteristics. The student also learns the theory behind diodes, transistors, SCR's, unijunctions, all types of FET's as well as the new solid state indicating devices. (3-3-4)

ECO 100 CONSUMER ECONOMICS:

Emphasizes the role of the consumer in our society. It includes consumer decision making, money and marital happiness, money management, consumer credit, intelligent shopping, financing a home, transportation, health services, estate planning, and consumer protection. (3-0-3)

EEM 127 A.C. MACHINES & DEVICES:

A study of fundamentals involving the operation, control, and application of A.C. generators, motors, transformers, and transmission systems. Application and control are considered as they apply to industrial use. (3-3-4)

ENG 150 INTRODUCTION TO COMPOSITION:

A study and application of the principles of grammar, mechanics, and rhetoric as preparation for business and technical writing. The course will include writing correct and effective paragraphs and essays of various types, including expository, narrative, and descriptive. (4.5-0-4.5)

FOURTH QUARTER

EEM 136 ELECTRICAL & CONTROL CIRCUITS:

The principles and applications of electrical controllers are covered in this course, which serves as an introduction to automatic controls, contactors, starters, speed controllers, time delays, limit switches and pilot devices. Students learn the application in control of industrial equipment motors servounits and motor driven actuators. (3-6-5)

EEM 131 ELECTRICAL & APPLIED CIRCUITS:

An introduction to the technical concepts of electronic circuits. This course covers the principles of vacuum tubes and transistors, tuned circuits and basic circuits for power supplied detectors, amplifiers, and oscillators. (7-3-8)

PSY 112 INDUSTRIAL HUMAN RELATIONS:

Provides supervised experience and instruction designed to help the student recognize and develop the traits necessary for good relations with fellow workers, supervisors, subordinates, customers, and others. Through exercises involving awareness, self-concept and self-evaluation, role-playing, and group and individual problem solving the course helps to develop improved interpersonal relationships. (3-0-3)

FIFTH QUARTER

EEM 214 INDUSTRIAL ELECTRONIC APPLICATIONS:

A survey of electronics applications in industry to include gauges, photo electric cells, recorders, electronic timing circuits, welder and motor control and other applicable areas. (6-0-6)

EEM 260 APPLIED PNEUMATICS & CONTROLS:

A study of basic principles of air-operated control system, theory of equipment used in pneumatic controls, to include practical calibration through lab projects based on logic principles. (3-3-4)

EEM 143 ELECTRICAL INSTALLATION & PLANNING:

A course of instruction and application in the fundamentals of planning, estimating and installation of electrical system, such as service, lighting branch circuits, conduit and modifications of original plans. (6-0-6)

EEM 226 ELECTRICAL COST ESTIMATING:

The importance of understanding working plans and specifications as applied to estimating will be studied. Also, students will learn the duties and responsibilities of the estimator, preparation of the material lists, survey of material and labor and the preparation of the cost estimate. (0-6-2)

ENG 236 ADVANCED TECHNICAL COMPOSITION & COMMUNICATIONS:

Instruction in the theory and practice of planning and writing effective business and technical compositions. A research project reflecting acceptable writing styles and basic knowledge of the student's major area of study is required. Techniques of oral communication and presentations will be covered. Prerequisite: ENG 150. (4.5-0-4.5)

SIXTH QUARTER

EEM 104 BLUEPRINT READING - INDUSTRIAL:

A study of layout, planning and installation of wiring systems in commercial and industrial complexes. Blueprint reading and symbols, the related National Electrical Code, and the application of the fundamentals to practical experience in wiring conduit preparation, and installation are covered. (0-9-3)

EEM 118 D.C. MACHINES & CONTROLS:

A study of fundamentals involving the operation and control of direct current motors and generators, the speed, direction of rotation, reversing and application of D.C. motors as well as the speed, regulation parallel operation and application of D.C. generators are learned. Prerequisite: EEM 113. (4-0-4)

EEM 238 INDUSTRIAL LOGIC CIRCUITS:

This course covers the operation of the following logic circuits: AND, OR, NAND, NOR, inverters, relays and the following binary element: JK, RS, T, and D. All logic elements will be covered by the black box concept, and students will learn interpretation of data sheets, reading of logic schematics and signal training in logic circuits. Prerequisite: EEM 213. (3-9-6)

SEVENTH QUARTER

EEM 215 MICROPROCESSOR SYSTEMS I:

Using Heath Kit or equivalent microprocessor, the student will go from a beginning to a complete knowledge of microprocessor systems. The course is technical in nature and blends software and hardware so that each graduate will be capable of starting up new systems and changing and troubleshooting existing ones. Prerequisite: EEM 238. (2-3-3)

EEM 216 MICROPROCESSOR SYSTEMS II:

Same as EEM 215. (2-3-3)

EEM 265 ELECTRICAL PROBLEM SOLVING:

Advanced electrical case studies as assigned by instructor. This course may be repeated as needed for elective credit upon approval of advisor. (3-0-3)

EEM 217 MICROPROCESSOR SYSTEMS III:

Same as EEM 215. (2-3-3)

ENG 231 TECHNICAL REPORT WRITING:

Instructions in the theory and practice of planning and writing effective business and technical compositions. Basic business communication is covered, but technical writing in the field of Engineering Technology is stressed. Assignments are specifically designed to prepare for writing responsibilities from basic technical notes to a specialized research paper, which is equivalent to the Senior Project, practice, i.e., letter, resume, interview, etc. (3-0-3)

PREVIOUS ARTICULATION
(Revised)

A previous program of articulation between Greenville Technical College and the School District of Greenville County during 1975-1976 articulated the post-secondary program of Industrial Electricity with similar Electricity programs at the secondary level.

Development activities of the 1983-1984 Electricity/Industrial Electricity articulation program will revise and build upon the previously established 1976 agreement. (See Appendix A)

As a part of the 1976 articulation agreement, Greenville Technical College established a "tuition scholarship" in the Industrial Electricity program to be awarded to the most outstanding or worthy student from each of the four secondary Electricity programs of the School District of Greenville County. Initially, the tuition scholarship will be for one quarter of tuition free study. Upon completing the first quarter, the student may receive an extension for an additional quarter based upon review and approval by the Industrial Electricity instructor and Department Head.

According to 1976 agreements, a graduate of a secondary Electricity vocational program of the School District of Greenville County may be granted exemption of an Industrial Electricity course at Greenville Technical College according to the recommendation of the former secondary instructor, the student's secondary level performance as represented by grade achievement and "Proficiency Report," and by the individual's performance on "Placement Tests" administered by the Industrial Electricity Department, GTC. These procedures, established in 1976 and slightly modified, will be revised and continued in current articulation.

Every effort will be made to incorporate all previous efforts in articulation between the secondary Electricity programs and GTC's Industrial Electricity program and to ensure that provisions are established and documents to encourage the fulfillment and continuation of 1983-1984 articulation agreements.

¹"Industrial Electricity Articulation" (Appendix C), Occupational Education Program Articulation Between Secondary Vocational Education Centers and Greenville Technical College, Greenville, SC: Greenville Technical College, 1976. (Included as Appendix A in this Articulated Performance-based Instruction Guide for Electricity/Industrial Electricity.)

COMPARISON
PREVIOUSLY AND CURRENTLY ARTICULATED COURSES
GTC'S INDUSTRIAL ELECTRICITY PROGRAM

1976 ARTICULATION AGREEMENT

1983-1984 ARTICULATION

					Qtr.
a.	EEM 100 Applied Electricity	EEM 101	"Discontinued Course"		
b.	EEM 345 Residential Electricity Codes and Ordinances A	EEM 345	Residential Wiring A	*	1st
c.	EEM 346 Residential Electricity Codes and Ordinances B	EEM 346	Residential Wiring B	*	1st.
d.	EEM 113 DC Electricity	EEM 113	Electricity DC	*	1st.
e.	EEM 123 AC Electricity	EEM 123	Electricity AC		2nd.
f.	EEM 127 AC Machines and Devices	EEM 127	AC Machines and Devices		3rd.
g.	EEM 136 Electrical Control Circuits	EEM 136	Electrical Control Circuits		4th.
h.	MAT 115 Electrical Math I	MAT 115	Electrical Math I	*	1st
i.	MAT 126 Electrical Math II	MAT 126	Electrical Math II		2nd.

*Represents 1st Quarter of
Industrial Electricity

¹"Industrial Electricity Articulation" (Appendix C), Occupational Education Program Articulation Between Secondary Vocational Education Centers and Greenville Technical College, Greenville, SC: Greenville Technical College, 1976. (See Appendix A of this Articulated, Performance-based Instruction Guide for Electricity/Industrial Electricity.)

STANDARDS APPLICABLE TO ELECTRICITY

- The voltages that are to be used for computation purposes (AR 220-1) are:

120V
120/240V
208/120V
240V
480/277V
480V
600V

- Up position of switch handles will be for the "on" position where the handles/knobs are operated vertically. (AR: 240-81)
- AR 240-83d requires 277 volt circuit breakers to be marked "SWD" where they are used as switches for florescent lighting circuits.

MODULE 1.0

Module 1.0, Introduction/Orientation, has been designed to represent introductory requirements of the vocational program such as course policies, procedures, and safety regulations; leadership training, desirable work attitudes and habits that potential employers recommend be incorporated in secondary instruction, career information, and basic math and related skills necessary for success in the vocation.

Some task objectives that are described in this first module naturally will be learned early in the instructional program while competencies in other tasks may result during the first year or second year. For example, students must understand the policies of the program very early in the first year but may not develop competencies in job attitudes or career information until the second year. Job habits and attitudes typically will be taught during the entire two year training program.

Units in this module:

- UNIT 1.0 A INTRODUCTION/ORIENTATION
- UNIT 1.0 B INTRODUCTION TO SAFETY
- UNIT 1.0 C INTRODUCTION TO LEADERSHIP/
JOB COMMUNICATIONS
- UNIT 1.0 D PREPARING FOR WORK
- UNIT 1.0 E INTRODUCTION TO DESIRABLE JOB/LEARNING
CHARACTERISTICS/HABITS/ATTITUDES
- UNIT 1.0 F BASIC MATH SKILLS
- UNIT 1.0 G BASIC MEASURING
- UNIT 1.0 H INTRODUCTION TO BLUEPRINT READING

ELECTRICITY
INTRODUCTION/ORIENTATION
SUGGESTED INSTRUCTION TIMES

<u>ELECTRICITY</u> <u>UNIT/TASK</u>	SUGGESTED HOURS
UNIT 1.0 A INTRODUCTION/ORIENTATION	
1.01 Review/Follow Career Center Policies and Procedures	*
1.02 Orientation to Vocational Program Classroom/Shop/Lab	*
1.03 Review Course Objectives and Standards	7
UNIT 1.0 B INTRODUCTION TO SAFETY	
1.01 General Orientation	**
1.02 Identify Desirable Vocational Training Safety Habits	**
1.03 Observe Classroom Safety Practices	**
1.04 Apply Fire Safety Rules and Procedures	**
1.05 Apply Electrical Safety Rules and Procedures	**
1.06 Personal Safety	5
UNIT 1.0 C INTRODUCTION TO LEADERSHIP/ JOB COMMUNICATIONS	
1.01 Work Cooperatively With Fellow Students	N/A
1.02 Demonstrate Desirable Characteristics of Leadership	N/A
1.03 Participate in VICA Club Activities	N/A
1.03 Demonstrate Proper Use of Parliamentary Procedure	N/A
1.03 Communicate a Message by the Medium of a Speech	N/A

* = See 1.03

** = See 1.06

ELECTRICITY
UNIT/TASK

SUGGESTED
HOURS

UNIT 1.0 D	PREPARING FOR WORK	
1.01	Describe the Free Enterprise System and the Difference Between Labor and Management	N/A
1.02	Interpret Labor Laws and Regulations	N/A
1.03	Interpret Payroll Deductions for Taxes, etc.	N/A
1.04	Identify Typical Career Opportunities	*
1.05	Locate Job Opportunities	*
1.06	Prepare Resume	*
1.07	Compose Application Letter	*
1.08	Complete a Typical Employment Application Form	*
1.09	Interview for a Job	*
1.10	Compose Follow-up Letter	*
1.11	Identify Post-secondary Career Development Opportunities	15
UNIT 1.0 E	INTRODUCTION TO DESIRABLE JOB/LEARNING CHARACTERISTICS/HABITS/ATTITUDES	
1.01	Describe Good Work Habits Important to Job Success	N/A
1.02	Exhibit Successful Job Performance Characteristics	N/A
1.03	Exhibit Desirable Work Attitudes	N/A
1.04	Demonstrate Respect for and Care of School Property	N/A
UNIT 1.0 F	MATH SKILLS	
1.01	Basic Math - Fractions	**

* = See 1.11

** = See 1.05

<u>ELECTRICITY</u>		SUGGESTED
UNIT/TASK		HOURS
1.02	Basic Math - Decimals	**
1.03	Basic Math - Volumes	**
1.04	Basic Math - Areas	**
1.05	The Metric System	12
UNIT 1.0 G	MEASURING	
1.01	Measuring	6
UNIT 1.0 H	INTRODUCTION TO BLUEPRINT READING	
1.01	Identify Working Drawings and Blueprint and Read Specifications	3
1.02	Interpret Common Blueprint Symbols	3
1.03	Interpret Dimensions from Blueprints	3
1.04	Read Blueprint and Specifications and Estimate Materials for Job	6

** = See 1.05

TASK LISTINGS
ELECTRICITY

MODULE/TASK	DESCRIPTION
Unit 1.0 A	INTRODUCTION/ORIENTATION
1.01	(Review/Follow Career Center Policies and Procedures) Given information on career center policies and procedures, apply these policies and procedures on a day-to-day basis.
1.02	(Orientation to Vocational Program Classroom/Shop/Lab) Given information on classroom/shop or instructor's policies and procedures, apply these policies and procedures on a daily basis, meeting the standards of the instructor 100 percent.
1.03	(Review Course Objectives and Standards) Given an introduction to the vocational program, a review of the course objectives and minimum standards of performance; describe the course objectives, and the minimum performance expected to demonstrate competency in given objectives.
Unit 1.0 B	INTRODUCTION TO SAFETY
1.01	(General Orientation) Given an orientation to building, shop, and fire safety; discuss, identify, or demonstrate general shop safety behavior and fire procedures.
1.02	(Identify Desirable Vocational Training Safety Habits) Given an introduction/orientation to general safety as well as to safety in the vocational education program or on the job; identify general occupational safety habits to the satisfaction of the instructor and meet all applicable safety rules and regulations.
1.03	(Observe Classroom Safety Practices) Given a typical vocational classroom/shop/lab or job situation, exhibit an awareness of safety practices, safe work habits, and a positive attitude concerning job safety and accident prevention and meet standards established by the instructor.
1.04	(Apply Fire Safety Rules and Procedures) Given examples of types of fires, fire extinguishers, and possible shop situations, apply fire safety rules and procedures. Meet National and local fire safety procedures.

- 1.05 (Apply Electrical Safety Rules and Procedures) Given orientation to identifying electrical hazards, apply electrical safety rules and procedures. Electrical equipment with exposed wire, frayed cables, and deteriorated insulation must be reported and corrected. Proper grounding must be employed and maintained. Junction boxes, outlets, switches, breakers switches, and panels should be identified as to their use. Meet all applicable National and local standards and the standards of the instructor.
- 1.06 (Personal Safety) Given instruction, identify personal safety clothing, equipment, or procedures to ensure safety in the vocational field/training, with 100 percent accuracy, demonstrate proper use of safety behavior.
- Unit 1.0 C INTRODUCTION TO LEADERSHIP/JOB COMMUNICATIONS
- 1.01 (Work Cooperatively With Fellow Students) Given instruction and an opportunity to meet fellow students in the vocational program environment, work cooperatively with fellow students as well as with other students in related vocational learning activities. Meet the instructor's standards and cooperate to the satisfaction of fellow students as a group.
- 1.02 (Demonstrate Desirable Characteristics of Leadership) Given an introduction/orientation to desirable qualities of a good leader, describe characteristics typical of a good leader, discuss desirable leadership qualities, and demonstrate an ability to follow as well as take a leadership position. Performance should be satisfactory to the instructor and fellow students.
- 1.03 (Participate in VICA Club Activities) Given an introduction/orientation to the Vocational Industrial Club of American (VICA), describe the general purposes of VICA, describe a typical VICA program at a vocational center, recall from memory the VICA motto, state the VICA pledge from memory, identify the symbols/symbolism in the VICA emblem, identify what the colors of the VICA organization represent. Performance should be acceptable to the VICA Club sponsor, instructor, and VICA club members.
- 1.03 (Demonstrate Proper Use of Parliamentary Procedure) Given instruction, apply the principles of parliamentary procedure and describe the characteristics of good chairman.

1.03 (Communicate a Message by the Medium of a Speech) Given instruction, list purposes of a speech, characteristics of a speech, and write and orally deliver a speech. The delivered speech should contain accurate information, be technically correct in organization and delivery, and the intended message should be communicated.

Unit 1.0 D PREPARING FOR WORK

- 1.01 (Describe the Free Enterprise System and the Difference Between Labor and Management) Given an introduction/orientation to the free enterprise system of economics, describe to the satisfaction of the instructor the free enterprise system of economics as found in the United States and describe the relationship between labor and management.
- 1.02 (Interpret Labor Laws and Regulations) Given instruction, necessary references concerning labor laws and regulations, interpret typical labor laws and regulations. Performance must meet the instructor's standards.
- 1.03 (Interpret Payroll Deductions for Taxes, etc.) Given instruction and sample forms concerning income tax and other withholdings, interpret the typical forms used in income tax and other withholdings to the satisfaction of the instructor and itemize typical payroll deductions that worker encounters. Performance must be to the instructor's standards.
- 1.04 (Identify Typical Career Opportunities) Given instruction, data on the local business and industry, opportunities to study entry-level job opportunities; identify the major categories of potential employers in the local community (and the key characteristics of each).
- 1.05 (Locate Job Opportunities) Given job placement information such as newspaper ads and personal contacts, list a minimum of ten specific jobs in the community. One week will be allowed to complete the task.
- 1.06 (Prepare Resume) Given examples of suitable resume/personal data sheets, prepare and type (or print at a minimum) a personal resume on paper acceptable to the instructor with all errors acceptable corrected.
- 1.07 (Compose Application Letter) Given a newspaper ad for a job, compose a letter of application. The letter must be mailable and must include all necessary personal information.

- 1.08 (Complete a Typical Employment Application Form) Given an employment application form typical of the job, complete the form with all information accurate, neatly typed or printed in, and aligned in the form blanks.
- 1.09 (Interview for a Job) Given instruction on how to interview for a job, a job interview checklist, and a mock job interview; complete a job interview to the satisfaction of the instructor.
- 1.10 (Compose Follow-up Letter) Given a case situation by the instructor or from the textbook, compose and write a follow-up letter appropriate to the job application or interview situation and in mailable form. The finished letter must meet the instructor's standards.
- 1.11 (Identify Post-Secondary Career Development Opportunities) Given an orientation to similar post-secondary career development programs, such as offered at Greenville Technical College, a report of skill competencies developed during secondary training, and other information as needed; identify post-secondary career development opportunities.

Unit 1.0 E INTRODUCTION TO DESIRABLE JOB/LEARNING CHARACTERISTICS/HABITS/ATTITUDES

- 1.01 (Describe Good Work Habits Important to Job Success) Given introduction/orientation to desirable work habits, as described by potential employers or tradesmen, demonstrate desirable (good) work habits (based on information provided by the instructor) represent typical standards expected by business/industry (potential employers) for entry employment success.
- 1.02 (Exhibit Successful Job Performance Characteristics) Given instruction, demonstrate job performance characteristics that are considered important to entry-level career success in the vocational field. A "Job Performance Rating Sheet" will be used to evaluate performance and all items must be rated "frequently" or above.
- 1.03 (Exhibit Desirable Work Attitudes) Given instruction, demonstrate work attitudes that the majority of potential employers prefer in an entry level worker. Performance will be evaluated on a "Work Attitudes Score Card" and a minimum of 90 percent should be attained. Performance will be rated throughout training and should improve to 100 percent by the end of the training period.

1.04 (Demonstrate Respect for and Care of School Property)
Given a classroom, shop, or other instruction setting with access to furniture, equipment, tools and materials and given proper instruction; demonstrate a respect for and care of public property (training facilities) and instructional materials to the standards established by The School District of Greenville County, career center, and instructor.

Unit 1.0 F BASIC MATH SKILLS

1.01 (Basic Math - Fractions) Given a pretest or examples by the instructor, conduct the following operations with fractions:

1. Change any fraction to a decimal number, and any terminating decimal number to a fraction.
2. Arrange in order...unit and simple nonunit fractions.
3. Write equivalent fractions in higher, lower, and lowest terms.
4. Write improper fractions as whole or mixed numbers, and mixed numbers as improper fractions.
5. Multiply fractions and mixed numbers, expressing answers in simplest form.
6. Divide fractions and mixed numbers, expressing answers in simplest form.
7. Add and subtract unlike fractions, expressing answers in simplest form.
8. Add and subtract mixed numbers with unlike fractions, expressing answers in simplest form.
9. Use rational numbers to solve simple work problems.

1.02 (Basic Math - Decimals) Given a pretest or examples by the instructor, conduct the following decimal math operations:

1. Name the place value of digits in decimal numbers of up to nine digits before the decimal and six digits after the decimal.
2. Compare decimal numbers and arrange them in proper order.
3. Write the numeral for any decimal number of up to four decimal places.
4. Round decimal numbers to any designated place value up to thousandths.
5. Add and subtract decimal numbers of up to six digits.
6. Multiply decimal numbers by whole numbers or decimal numbers.
7. Divide a number by a three-digit decimal number.
8. Multiply and divide decimal numbers by powers of ten, by inspection.

- 1.03 (Basic Math - Volumes) Given a pretest or examples by the instructor, find the volume of any rectangular prism or cube.
- 1.04 (Basic Math - Areas) Given a pretest or examples by the instructor, find the area of the following types of figures:
- a. Rectangle and square
 - b. Circle
- 1.05 (The Metric System) Given basic instruction in the metric system and conversion from United States Customary units to metric; read and convert specifications and dimensions from one system into the other system on teacher or text assigned problems with 100 percent accuracy.
- Unit 1.0 G BASIC MEASURING
- 1.01 (Measuring) Given proper instructions, read a rule and use other measuring tools with the precision necessary to take measurements or set them up.

UNIT 1.0 A

INTRODUCTION/ORIENTATION

UNIT	1.0 A	INTRODUCTION/ORIENTATION
TASK	1.01	REVIEW/FOLLOW CAREER CENTER POLICIES AND PROCEDURES

PERFORMANCE OBJECTIVE:

Given information on career center policies and procedures, apply these policies and procedures on a day-to-day basis.

PERFORMANCE ACTIONS:

- 1.0101 Review center policies and procedures.
- 1.0102 Review relevant philosophy of center and, The School District of Greenville County, and the South Carolina State Department of Education.
- 1.0103 Review relevant safety policies and procedures under unit concerning safety, and practice desired safety behavior as outlined in relevant safety policies and procedures.

PERFORMANCE STANDARDS:

- Using information and materials supplied, review and apply career center policies and procedures daily.

SUGGESTED INSTRUCTION TIME: See 1.03

RELATED TECHNICAL INFORMATION:

- Center Student Handbook.
- High School Student Handbook.
- Written Policies and Procedures of The School District of Greenville County.
- Policies and Procedures of the South Carolina State Department of Education.
- "Authorization" and "release" forms (such as safety releases).

UNIT	1.0 A	INTRODUCTION/ORIENTATION
TASK	1.02	ORIENTATION TO VOCATIONAL PROGRAM CLASSROOM/SHOP/LAB

PERFORMANCE OBJECTIVE:

Given information on classroom/shop or instructor's policies and procedures, apply these policies and procedures on a daily basis, meeting the standards of the instructor 100 percent.

PERFORMANCE ACTIONS:

- 1.0201 Review with instructor the shop policies and procedures.
- 1.0202 Apply, with 100 percent accuracy, the policies and procedures for the vocational program, shop, or of the instructor.

PERFORMANCE STANDARDS:

- Apply information/instruction given during orientation and throughout training period to comply with all policies and procedures of the shop (instructor) on a day-to-day basis.
- Standards of the State, School District, Career Center, and high school, and instructor apply.

SUGGESTED INSTRUCTION TIME: See 1.03

RECOMMENDED:

- Vocational education (shop) policies and procedures should be written and posted or distributed to students.

UNIT	1.0 A	INTRODUCTION/ORIENTATION
TASK	1.03	REVIEW COURSE OBJECTIVES AND STANDARDS

PERFORMANCE OBJECTIVES:

Given an introduction to the vocational program, a review of the course objectives and minimum standards of performance; describe the course objectives, and the minimum performance expected to demonstrate competency in given objectives.

(NOTE: This task may be accomplished in general at the beginning of the first year and in detail over the two year training period.)

PERFORMANCE ACTIONS:

- 1.0301 Review each major objective of the vocational program as outlined in this articulated, performance-based instruction objectives guide.
- 1.0302 Review the minimum performance standards of the objectives.

Possible Alternate Actions:

Instructor may require students to identify objectives and standards at the initiation of each new unit of instruction.

PERFORMANCE STANDARDS:

- Using information provided, explain the objectives of the course and describe the minimum performance for each objective.

SUGGESTED INSTRUCTION TIME: 1.01 - 1.03 = 7 Hours

RECOMMENDATION:

- Course objectives, such as the Task Listing objectives, should be written and posted or distributed to students.

UNIT 1.0 B

INTRODUCTION TO SAFETY

UNIT	1.0 B	INTRODUCTION TO SAFETY
TASK	1.01	GENERAL ORIENTATION

PERFORMANCE OBJECTIVE:

Given an orientation to building, shop, and fire safety; discuss, identify, or demonstrate general shop safety behavior and fire procedures.

PERFORMANCE ACTIONS:

- 1.0101 As applicable, discuss basic safety rules applicable to the training facility.
- 1.0102 Identify general shop safety rules.
- 1.0103
 - a. Review fire safety rules with the instructor.
 - b. Identify fire safety equipment, exits, and procedures in the shop and building area during a fire.

PERFORMANCE STANDARDS:

- Follow basic safety rules and established shop safety practices.
- Follows established fire safety practices and procedures.

SUGGESTED INSTRUCTION: See 1.06

UNIT	1.0 B	INTRODUCTION TO SAFETY
TASK	1.02	IDENTIFY DESIRABLE VOCATIONAL TRAINING SAFETY HABITS

PERFORMANCE OBJECTIVE:

Given an introduction/orientation to general safety as well as to safety in the vocational education program or on the job, identify general occupational safety habits to the satisfaction of the instructor and meet all applicable safety rules and regulations.

PERFORMANCE ACTIONS:

- 1.0201 Listen to all information provided by the instructor or others concerning safety in the career center, vocational program and in live learning activities.
- 1.0202 Observe safety posters.
- 1.0203 Observe safety warning devices for hazardous materials or work areas.
- 1.0204 Demonstrate correct safety practices going to and from the classroom/shop as well as in the classroom situation.
- 1.0205 Describe the effect of safety on the production dollar, due to possible time loss.
- 1.0206 Observe learning situations or other situations for the observation of safe situations as well as violation of proper safety rules and regulations.

PERFORMANCE STANDARDS:

- To the standards of the instructor and standards applicable to the classroom or school or in the vocational field, demonstrate desirable occupational safety habits.
- "Zero" accidents.
- "Zero" safety violations.

SUGGESTED INSTRUCTION TIME: See 1.06

UNIT	1.0 B	INTRODUCTION TO SAFETY
TASK	1.03	OBSERVE CLASSROOM SAFETY PRACTICES

PERFORMANCE OBJECTIVE:

Given a typical vocational classroom/shop/lab or job situation, exhibit an awareness of safety practices, safe work habits, and a positive attitude concerning job safety and accident prevention and meet standards established by the instructor.

PERFORMANCE ACTIONS:

- 1.0301 Develop an awareness of vocational training/job hazards and become more safety conscious.
- 1.0302 Develop a serious attitude toward the daily use of safety procedures.
- 1.0303 Prepare for safety before entering the training work area.
- 1.0304 Prepare for safety at the work situation.
- 1.0305 Prepare for safety on exiting the training work area.
- 1.0306 Demonstrate knowledge of general safety color coding in the training/job facility and on equipment and tools.
- 1.0307 Practice safe procedures/habits daily.

PERFORMANCE STANDARDS:

- "Zero-level" accident record in vocational program.
- Instructor's standards based on recommended resources.
- Applicable OSHA Standards.

SUGGESTED INSTRUCTION TIME: See 1.06

POSSIBLE RESOURCES:

Current vocational program safety guide publication of The School District of Greenville County.

UNIT	1.0 B	INTRODUCTION TO SAFETY
TASK	1.03	OBSERVE CLASSROOM SAFETY PRACTICES (Con't.)

Jacobs, Clinton O., and Howard J. Turner, Developing Shop Safety Skills, Athens, GA: American Association for Vocational Instructional Materials. (Approximately 80 pages of brief, visually clear suggestions concerning a variety of shop safety situations. Good student or resource manual.)

Safety Handbook, A Guide for Trade and Industrial Programs, Clemson University, SC: Vocational Education Media Center, 1968. (No. 13/2/70, \$2.25; Accompanying 31 Transparencies, No. 9/8/68, \$5.75.) Available from Trades and Industries Division Supervisor, Office of Vocational Education, South Carolina State Department of Education or from the Vocational Education Media Center, Clemson University, SC.

Planning for Emergencies, Occupational Safety and Health Short Course Number Seven, Columbia, SC: SC State Board for Technical and Comprehensive Education.

Notgrass, Troy, Safety Handbook for ICT, The University of Texas at Austin: Center for Occupational Curriculum Development, Division of Continuing Education, 1978.

Hoerner, Thomas A., and Mervin D. Bettis, Power Tool Safety and Operation, St. Paul, MI: Hobar Publications, 1977.

RELATED TECHNICAL INFORMATION:

- Regulations of individual center or vocational program.
- Regulations of The School District of Greenville County.
- Codes, laws, and ordinances.
- Materials and equipment handbooks and manuals.
- OSHA Regulations.
- E.P.A. Regulations.

UNIT	1.0 B	INTRODUCTION TO SAFETY
TASK	1.04	APPLY FIRE SAFETY RULES AND PROCEDURES

PERFORMANCE OBJECTIVE:

Given examples of types of fires, fire extinguishers, and possible shop situations, apply fire safety rules and procedures. Meet National and local fire safety procedures.

PERFORMANCE ACTIONS:

- 1.0401 Identify and explain application for fire extinguishers of the following types:
 - a. Form
 - b. Carbon Dioxide
 - c. Soda Acid
 - d. Pump Tank
 - e. Gas Cartridge
 - f. Dry Chemical
 - g. Multi-purpose Dry Chemical
- 1.0402 Describe procedures for operating selected fire extinguishers.
- 1.0403 Identify potential causes of fire in the vocational field/shop and common methods for avoiding or preventing fires.
- 1.0404 Inspect shop/laboratory for conformity with fire safety rules and procedures.
- 1.0405 Identify/explain relevant safety precautions applicable to vocational training activities.

PERFORMANCE STANDARDS:

- Apply applicable fire safety rules and procedures to the vocational program/training meeting all applicable standards, National and local, and meeting instructor's standards.

SUGGESTED INSTRUCTION TIME: See 1.06

UNIT	1.0 B	INTRODUCTION TO SAFETY
TASK	1.05	APPLY ELECTRICAL SAFETY RULES AND PROCEDURES

PERFORMANCE OBJECTIVE:

Given orientation to identifying electrical hazards, apply electrical safety rules and procedures. Electrical equipment with exposed wire, frayed cables, and deteriorated insulation must be reported and corrected. Proper grounding must be employed and maintained. Junction boxes, outlets, switches, breakers switches, and panels should be identified as to their use. Meet all applicable National and local standards and the standards of the instructor.

PERFORMANCE ACTIONS:

- 1.0501 Explain importance of labeling circuit breakers.
- 1.0502 Explain importance of proper grounding of machines or equipment of electrically operated hand tools.
- 1.0503 Demonstrate/explain methods for using flexible extension cords, long cables, or drop lights.
- 1.0504 Identify electrical hazards and explain safety rules pertaining to the vocational field of training.
- 1.0505 Identify approved locations for all electrical equipment and power sources in the shop or at the training field location.
- 1.0506 Interpret safety precautions for electricity in the vocational shop.

PERFORMANCE STANDARDS:

- Apply electrical safety rules and procedures for the vocational shop/laboratory, including field training locations, on a day-to-day basis meeting all applicable National and local safety rules and regulations as well as the standards of the instructor.

SUGGESTED INSTRUCTION TIME: See 1.06

(NOTE: Specific safety procedures and recommendations pertaining to a tool and equipment item may be included as a part of the task description concerning the tool/equipment.)

UNIT	1.0 B	INTRODUCTION TO SAFETY
TASK	1.06	PERSONAL SAFETY

PERFORMANCE OBJECTIVE:

Given instruction, identify personal safety clothing, equipment, or procedures to ensure safety in the vocational field/training, with 100 percent accuracy, demonstrate proper use or safety behavior.

PERFORMANCE ACTIONS:

- 1.0601 List and explain personal safety/rules procedures.
- 1.0602 Identify appropriate protective clothing/equipment/etc., used in the vocational field/training, possibly from a given list, sketch, or mock-up.

PERFORMANCE STANDARDS:

- Given a list, sketch, or mock-up, identify with 100 percent accuracy personal safety clothing, equipment, etc., used in the vocational field.

SUGGESTED INSTRUCTION TIME: 1.01 - 1.06 = 5 Hours

RELATED TECHNICAL INFORMATION:

- Additional personal safety training will be integrated into occupational task training.

STUDENT'S SAFETY PLEDGE
AND
PARENT'S/GUARDIAN'S PERMISSION FOR OCCUPATIONAL TRAINING

_____, as part of vocational education training, will use/operate potentially hazardous occupational tools, machinery, equipment, and materials typical of the vocational field; provided that the student pledges to follow all safety rules and regulations of the instructor/career center/The School District of Greenville County and provided that the student's parent or guardian grants permission for occupational training by signing the release below.

TO THE STUDENT:

The vocational student will be given proper instruction, both in the use of and correct safety procedures concerning occupational tools, machinery, equipment, and materials typical to the vocational field before being allowed to use/operate them.

The student must assume responsibility for following safe practices and rules, and therefore the student is asked to subscribe to the following safety pledge.

STUDENT'S SAFETY PLEDGE

1. "I (student) promise to follow all safety rules of the instructor/of the shop.
2. "I promise never to use a tool, machine, piece of equipment, or material of the vocational program without first having permission from the instructor.
3. "I will not ask permission to use a particular tool, machine, or piece of equipment unless I have been instructed in its use, and have made 100 percent on the safety test for that tool, machine or equipment.
4. "I will report any accident or injury to the vocational instructor immediately.
5. "I will report any potentially hazardous situation to the vocational instructor immediately."

Date _____ Student's Signature _____

PARENT'S/GUARDIAN'S PERMISSION

"I hereby give my consent to allow my son/daughter to use/operate all occupational tools, machines, equipment, and materials necessary in carrying out the requirements of the vocational program of training."

Date _____ Parent's/Guardian's Signature _____

(Parents are cordially invited to visit the shop to inspect the occupational tools, machines, and equipment and to see them in operation.)

UNIT	1.0 C	INTRODUCTION TO LEADERSHIP
TASK	1.01	WORK COOPERATIVELY WITH FELLOW STUDENTS

PERFORMANCE OBJECTIVE:

Given instruction and an opportunity to meet fellow students in the vocational program environment, work cooperatively with fellow students as well as with other students in related vocational learning activities. Meet the instructor's standards and cooperate to the satisfaction of fellow students as a group.

PERFORMANCE ACTIONS:

- 1.0101 Participate in class and group learning activities.
- 1.0102 Encourage team work.
- 1.0103 Help plan student activities that promote cooperation.

PERFORMANCE STANDARDS:

- Work cooperatively with fellow students to the standards of the instructor and to the standards expected by fellow students as a group.

SUGGESTED INSTRUCTION TIME: N/A

UNIT	1.0 C	INTRODUCTION TO LEADERSHIP
TASK	1.01	WORK COOPERATIVELY WITH FELLOW STUDENTS

PERFORMANCE OBJECTIVE:

Given instruction and an opportunity to meet fellow students in the vocational program environment, work cooperatively with fellow students as well as with other students in related vocational learning activities. Meet the instructor's standards and cooperate to the satisfaction of fellow students as a group.

PERFORMANCE ACTIONS:

- 1.0101 Participate in class and group learning activities.
- 1.0102 Encourage team work.
- 1.0103 Help plan student activities that promote cooperation.

PERFORMANCE STANDARDS:

- Work cooperatively with fellow students to the standards of the instructor and to the standards expected by fellow students as a group.

SUGGESTED INSTRUCTION TIME: N/A

UNIT	1.0 C	INTRODUCTION TO LEADERSHIP
TASK	1.02	DEMONSTRATE DESIRABLE CHARACTERISTICS OF LEADERSHIP

PERFORMANCE OBJECTIVE:

Given an introduction/orientation to desirable qualities of a good leader, describe characteristics typical of a good leader, discuss desirable leadership qualities, and demonstrate an ability to follow as well as take a leadership position. Performance should be satisfactory to the instructor and fellow students.

PERFORMANCE ACTION:

- 1.0201 Define (process of) leadership and why it is desirable in a job situation.
- 1.0202 Describe (minimum of five)* positive characteristics desirable in a good leader (based on instruction).
- 1.0203 Identify (three) basic steps to becoming a good leader.
- 1.0204 Identify (five) benefits from developing good leadership qualities.
- 1.0205 Demonstrate leadership qualities by participating as a fellow or member of a group and, if required, participating as a group leader.

*Standards of instructor apply.

PERFORMANCE STANDARDS:

- Participate as a contributing member of a group, such as the vocational class or VICA, and demonstrate desirable leadership qualities as outlined by the vocational program instructor.

SUGGESTED INSTRUCTION TIME: N/A

RELATED TECHNICAL INFORMATION:

- VICA Objectives.
- State Department of Education, District, and instructor supplied materials.

(NOTE: A student self-rating checklist may be used in evaluation and evaluation may include ratings by other students as well as by the/instructor.)

LEADERSHIP RATING SCALE

DIRECTIONS: Check the appropriate parenthesis to indicate your impression of the leadership characteristics being rated.

	Not () Observed	Needs () Improvement	Observed ()
1. Exerts positive leadership.	()	()	()
2. Thoughtful of feelings of others.	()	()	()
3. Enthusiasm is sincere and contagious.	()	()	()
4. Preserves until job is completed.	()	()	()
5. Cheerful disposition.	()	()	()
6. Gets along well with team members.	()	()	()
7. Gets along well with instructor/supervisor.	()	()	()
8. Reacts constructively to criticism.	()	()	()
9. Punctual and gets job assignment done on time.	()	()	()
10. Free from prejudice.	()	()	()
11. Enjoys being a part of a group.	()	()	()
12. Reliable.	()	()	()
13. Adaptive to most situations.	()	()	()
14. Not easily discouraged.	()	()	()
15. Applies self to problems of job assignment.	()	()	()
16. Admits mistakes when made.	()	()	()
17. Tries to understand the other fellow's point of view.	()	()	()
18. Makes decisions quickly and accurately.	()	()	()
19. Seeks advise of others when appropriate.	()	()	()
20. Looks for opportunities to make improvements in job or work assignments.	()	()	()

UNIT	1.0 C	INTRODUCTION TO LEADERSHIP
TASK	1.03 (Optional)	PARTICIPATE IN VICA CLUB ACTIVITIES*

PERFORMANCE OBJECTIVE:

Given an introduction/orientation to the Vocational Industrial Club of America (VICA)*, describe the general purposes of VICA, describe a typical VICA program at a vocational center, recall from memory the VICA motto, state the VICA pledge from memory, identify the symbols/symbolism in the VICA emblem, identify what the colors of the VICA organization represent. Performance should be acceptable to the VICA Club sponsor, instructor, and VICA Club members.

*Or an alternate, approved student organization.

PERFORMANCE ACTIONS:

- 1.0301 Join the VICA Club sponsored by the Career Center and vocational program.
- 1.0302 Participate actively as a member or an officer in the local VICA Club.
- 1.0303 Describe the purpose of VICA.
- 1.0304 Recall from memory the VICA motto.
- 1.0305 State the VICA pledge from memory.
- 1.0306 Name a minimum of five beliefs the VICA creed emphasizes.

PERFORMANCE STANDARDS:

- Demonstrate orally or in writing, from memory, accurate recall of the VICA motto, pledge, and at least five of the six beliefs of the VICA creed, and described the purpose of VICA to the satisfaction of the VICA sponsor or VICA Club officers and members as well as to the satisfaction of the vocational program instructor.

SUGGESTED INSTRUCTION TIME: N/A

RELATED TECHNICAL INFORMATION:

- VICA publication(s).
- VICA emblem.
- VICA motto, pledge, and creed.
- Local VICA Club in Career Center.

UNIT	1.0 C		JOB COMMUNICATIONS
TASK	1.03	(Con't.) (Optional)	DEMONSTRATE PROPER USE OF PARLIAMENTARY PROCEDURE

PERFORMANCE OBJECTIVE:

Given instruction, apply the principles of parliamentary procedure and describe the characteristics of a good chairman.

PERFORMANCE ACTIONS:

1. Identify two basic principles upon which parliamentary procedure is based.
2. List two important characteristics of a "good" chairman.
3. Define or identify types of motions.
4. Describe/identify the order of business for a meeting conducted by parliamentary procedure.
5. Describe/identify the characteristics of the kinds of motions used in conducting a typical meeting by parliamentary procedure.
6. Demonstrate ability to use parliamentary procedure correctly.

PERFORMANCE STANDARDS:

- Define parliamentary procedure and how it is used to contribute to a meeting, identify the characteristics of a good chairman, and used parliamentary procedures correctly meeting the standards of the instructor.

SUGGESTED INSTRUCTION TIME: N/A

(NOTE. "This activity should be integrated into VICA activities and objectives.")

RELATED TECHNICAL INFORMATION:

- Robert's Rules of Order.
- VICA Club.
- Public Speaking.

UNIT	1.0 C		JOB COMMUNICATIONS
TASK	1.03	(Con't.) (Optional)	COMMUNICATE A MESSAGE BY THE MEDIUM OF A SPEECH

PERFORMANCE OBJECTIVE:

Given instruction, list purposes of a speech, characteristics of a speech, and write and orally deliver a speech. The delivered speech should contain accurate information, be technically correct in organization and delivery, and the intended message should be communicated.

PERFORMANCE ACTIONS:

1. Identify three purposes for making a speech.
2. Write an outline for a proposed speech.
3. List at least five methods/ways to make a speech effective/interesting.
4. Deliver a three to five minute speech that successfully communicates the intended message.

PERFORMANCE STANDARDS:

- Successfully communicate intended message by a speech using proper techniques and meeting instructor's (or VICA sponsor's) standards.

ALTERNATE STANDARDS:

- Student is to describe verbally, task being performed, techniques used, etc., to the instructor's standards.

SUGGESTED INSTRUCTION TIME: N/A

(NOTE: "This activity may be integrated into VICA activities and objectives.")

SUGGESTED TECHNICAL INFORMATION:

- VICA Club.
- Communications.

UNIT 1.0 D

PREPARING FOR WORK

UNIT	1.0 D	PREPARING FOR WORK
TASK	1.01	DESCRIBE THE FREE ENTERPRISE SYSTEM AND THE DIFFERENCE BETWEEN LABOR AND MANAGEMENT

PERFORMANCE OBJECTIVE:

Given an introduction/orientation to the free enterprise system of economics, describe to the satisfaction of the instructor the free enterprise system of economics as found in the United States and describe the relationship between labor and management.

PERFORMANCE ACTIONS:

- 1.0101 Read assignments in trade magazines or periodicals.
- 1.0102 Listen to talks by representatives of labor and management.
- 1.0103 Discuss the Free Enterprise System as represented by business/industry in the United States.
- 1.0104 Discuss problems concerning employ-
ee-management-trade union transactions.

PERFORMANCE STANDARDS:

- To the satisfaction of the instructor describe the Free Enterprise System of economics as represented by business/industry in the United States.

SUGGESTED INSTRUCTION TIME: N/A

RELATED TECHNICAL INFORMATION:

- Free Enterprise System of Economics.
- Management and Labor Relationships.

UNIT 1.0 D

PREPARING FOR WORK

TASK 1.02

INTERPRET LABOR LAWS AND REGULATIONS

PERFORMANCE OBJECTIVE:

Given instruction, necessary references concerning labor laws and regulations, interpret typical labor laws and regulations. Performance must meet the instructor's standards.

PERFORMANCE ACTIONS:

- 1.0201 Identify and interpret the "Fair Labor Standards Act."
- 1.0202 State the minimum wage for a worker.
- 1.0203 State the typical minimum age for a worker.
- 1.0204 Identify how to report earned income.
- 1.0205 Define overtime.
- 1.0206 Identify local or State laws that affect the worker.

PERFORMANCE STANDARDS:

- Interpret typical labor laws and regulations of the Federal, State, and local level that affect the worker.
- The instructor's standards must be met.

SUGGESTED INSTRUCTION TIME: N/A

UNIT	1.0 D	PREPARING FOR WORK
TASK	1.03	INTERPRET PAYROLL DEDUCTIONS FOR TAXES, ETC.

PERFORMANCE OBJECTIVE:

Given instruction and sample forms concerning income tax and other withholdings, interpret the typical forms used in income tax and other withholdings to the satisfaction of the instructor and itemize typical payroll deductions that worker encounters. Performance must be to the instructor's standards.

PERFORMANCE ACTIONS:

- 1.0301 Obtain a social security card (if not acquired already). [Recommended]
- 1.0302 Identify the purposes of social security withholdings from pay.
- 1.0303 Describe who is qualified for unemployment compensation.
- 1.0304 Describe who qualifies for workmen's compensation.
- 1.0305 Complete typical forms used for Federal Income Tax Withholdings.
- 1.0306 Interpret a typical Federal Income Tax Wage and Tax Statement form.
- 1.0307 Identify typical payroll deductions.

PERFORMANCE STANDARDS:

- Given typical forms used for payroll deduction and reporting of income and other taxes, interpret payroll deductions and other statements on the forms.
- Performance must be to the instructor's standards.

SUGGESTED INSTRUCTION TIME: N/A

UNIT 1.0 D

PREPARING FOR WORK

TASK 1.04

IDENTIFY TYPICAL CAREER OPPORTUNITIES

PERFORMANCE OBJECTIVE:

Given instruction, data on the local business and industry, opportunities to study entry-level job opportunities; identify the major categories of potential employers in the local community (and the key characteristics of each).

PERFORMANCE ACTIONS:

"Performance actions may vary from career center to career center due to the potential employers served and based on the emphasis of the individual vocational program."

PERFORMANCE STANDARDS:

- Identify typical types of entry-level jobs, in the local community, and the major characteristics that distinguish them based on given instruction, local market data, and student observation.
- Meet instructor's standards.

SUGGESTED INSTRUCTION TIME: See 1.11

UNIT 1.0 D

PREPARING FOR WORK

TASK 1.05

LOCATE JOB OPPORTUNITIES

PERFORMANCE OBJECTIVE:

Given job placement information such as newspaper ads and personal contacts, list a minimum of ten specific jobs in the community. One week will be allowed to complete the task.

PERFORMANCE ACTIONS:

- 1.0501 Identify job opportunity areas as related to training, skills, and interests.
- 1.0502 Contact (or list) various employment opportunity sources:
 - a. Job placement office.
 - b. Want ads:
 - c. Employment Security.
 - d. Other sources such as family, friends, school officials, etc.
- 1.0503 Estimate competition for job opportunities (number of other persons wanting same job) and target enough job opportunities to statistically qualify for one opportunity.

PERFORMANCE STANDARDS:

- Student must list a minimum of ten specific jobs in the community as advertised in the newspaper or media or through personal contacts.
- The jobs must be available currently.

SUGGESTED INSTRUCTION TIME: See 1.11

(Skill development and performance to be demonstrated over one week.)

UNIT	1.0 D		PREPARING FOR WORK
TASK	1.06	(Optional)	PREPARE RESUME

PERFORMANCE OBJECTIVE:

Given examples of suitable resume/personal data sheets, prepare and type (or print at a minimum) a personal resume on paper acceptable to the instructor with all errors acceptable corrected.

PERFORMANCE ACTIONS:

- 1.0601 Define the basic purpose of the resume.
- 1.0602 Outline the essential information a resume of personal data sheet should contain:
 - a. Personal data such as name, address, telephone, age, physical descriptions, marital status, etc.
 - b. Job objective or skills offered.
 - c. Training.
 - d. Experience.
 - e. Accomplishments, interests, etc.
 - f. References.
- 1.0603 Prepare a resume that is acceptable to the instructor.

PERFORMANCE STANDARDS:

- Prepare resume/personal data sheets on paper and in a form acceptable to the instructor with all errors acceptable corrected.

SUGGESTED INSTRUCTION TIME: See 1.11

RELATED TECHNICAL INFORMATION:

- Job Seeking - How and Where, Columbia, SC: South Carolina State Department of Education, 1981.

UNIT	1.0 D	PREPARING FOR WORK
TASK	1.07	COMPOSE LETTER OF APPLICATION

PERFORMANCE OBJECTIVE:

Given a newspaper ad for a job, compose a letter of application. The letter must be mailable and must include all necessary personal information.

PERFORMANCE ACTIONS:

- 1.0701 Assemble necessary information, supplies, and equipment.
- 1.0702 Compose a letter of application for a given business position. Include the necessary information.
- 1.0703 Proofread the letter, correcting all errors.

PERFORMANCE STANDARDS:

- Compose a letter of application for a position advertised in the local newspaper and suitable for the skills and experience of the student or for the hypothetical position described by the instructor.
- Include necessary personal information and prepare the letter in mailable form.

SUGGESTED INSTRUCTION TIME: See 1.11

RELATED TECHNICAL INFORMATION:

- Job Seeking - How and Where, Columbia, SC: South Carolina State Department of Education, 1981.

UNIT	1.0 D	PREPARING FOR WORK
TASK	1.08	COMPLETE A TYPICAL EMPLOYMENT APPLICATION FORM

PERFORMANCE OBJECTIVE:

Given an employment application form typical of the job, complete the form with all information accurate, neatly typed or printed in, and aligned in the form blanks.

PERFORMANCE ACTIONS:

- 1.0801 Assemble minimum necessary information:
 - a. Personal information such as name, address, and date of birth.
 - b. Data related to applicant such as social security number, etc.
 - c. Schooling or training information..
 - d. Past employment record.
 - e. References.
- 1.0802 Complete the application form following directions carefully with neat, aligned entries.
- 1.0803 Proofread the completed form for errors or incomplete blanks.

PERFORMANCE STANDARDS:

- Complete an employment application form typical of the job with all information accurate, neatly printed or typed in and aligned in the form blanks to the instructor's standards.

SUGGESTED INSTRUCTION TIME: See 1.11

RELATED TECHNICAL INFORMATION:

- Job Seeking - How and Where, Columbia, SC: South Carolina State Department of Education, 1981.

UNIT	1.0 D	PREPARING FOR WORK
TASK	1.09	INTERVIEW FOR A JOB

PERFORMANCE OBJECTIVE:

Given instruction on how to interview for a job, a job interview checklist, and a mock job interview; complete a job interview to the satisfaction of the instructor.

PERFORMANCE ACTIONS:

- 1.0901 Prepare for the interview:
 - a. Prepare personal appearance.
 - b. Prepare necessary information, references, or other material for the interview.
- 1.0902 Arrive at the appropriate time and identify yourself and your purpose or appointment.
- 1.0903 Give a good impression in meeting the interviewer.
- 1.0904 Exchange essential information with the interviewer to reflect your job skills, training, and experience as well as your personality. In addition, learn about the job opportunity and employer.

PERFORMANCE STANDARDS:

- Complete a mock job interview to the satisfaction of the instructor following suggested procedures.

SUGGESTED INSTRUCTION TIME: See 1.11

UNIT	1.0 D		PREPARING FOR WORK
TASK	1.10	(Optional)	COMPOSE FOLLOW-UP LETTER

PERFORMANCE OBJECTIVE:

Given a case situation by the instructor or from the textbook, compose and write a follow-up letter appropriate to the job application or interview situation and in mailable form. The finished letter must meet the instructor's standards.

PERFORMANCE ACTIONS:

- 1.1001 Assemble necessary information, supplies, and equipment.
- 1.1002 Compose a follow-up letter, in mailable form, to a given job application or interview situation.
- 1.003 Proofread the letter, correcting all errors.

PERFORMANCE STANDARDS:

- Compose and write a follow-up letter appropriate in the judgement of the instructor to a given job application or interview situation and in mailable form.

SUGGESTED INSTRUCTION TIME: See 1.11

RELATED TECHNICAL INFORMATION:

- Job Seeking - How and Where, Columbia, SC: South Carolina State Department of Education, 1981.

UNIT 1.0 E

INTRODUCTION TO DESIRABLE JOB/LEARNING
CHARACTERISTICS/HABITS/ATTITUDES

UNIT 1.0 E

INTRODUCTION TO DESIRABLE JOB/LEARNING
CHARACTERISTICS/HABITS/ATTITUDES

UNIT	1.0 E	INTRODUCTION TO DESIRABLE JOB/LEARNING CHARACTERISTICS/ HABITS/ATTITUDES
TASK	1.01	DESCRIBE GOOD WORK HABITS IMPORTANT TO JOB SUCCESS

PERFORMANCE OBJECTIVE:

Given introduction/orientation to desirable work habits, as described by potential employers or tradesmen, demonstrate desirable (good) work habits (based on information provided by the instructor) that represent typical standards expected by business/industry (potential employers) for entry employment success.

PERFORMANCE ACTIONS:

- 1.0101 Identify specific criteria for success in typical entry level job categories.
- 1.0102 Participate in planning student's learning activities.
- 1.0103 Maintain a clean, well-organized learning situation (desk, locker, work area, shop, etc.) which is conducive to effective learning.
- 1.0104 Objectively receive instructor or other critique (correction, criticism, suggestions, etc.) of learning job or job performance (behavior) or product or activity.
- 1.0105 Describe good work habits and how they are related to job success, stability, and advancement.

PERFORMANCE STANDARDS:

- Describe to the instructor's standards good work habits that are important to job success, stability, and advancement.

SUGGESTED INSTRUCTION TIME: N/A

UNIT	1.0 E	INTRODUCTION TO DESIRABLE JOB/LEARNING CHARACTERISTICS/ HABITS/ATTITUDES
TASK	1.02	EXHIBIT SUCCESSFUL JOB PERFORMANCE CHARACTERISTICS

PERFORMANCE OBJECTIVE:

Given instruction, demonstrate job performance characteristics that are considered important to entry-level career success in the vocational field. A "Job Performance Rating Sheet" will be used to evaluate performance and all items must be rated "frequently" or above.

(NOTE: It is recommended in research findings that employer-recommended "job performance characteristics" and "work attitudes" be included as part of the vocational student's overall training and that demonstrated performance in these areas be included in the total evaluation of the student.)

PERFORMANCE ACTIONS:

- 1.0201 Review important work characteristics for the vocational field.
- 1.0202 Review the "Job Performance Rating Sheet" with the instructor.
- 1.0203 Demonstrate those work characteristics that are considered important to success in the vocational field.

PERFORMANCE STANDARDS:

- Demonstrate by personal performance the work characteristics that are considered important.
- A "Rating Sheet" will be used to evaluate performance and all items must be rated "frequently" (observed) or above.

SUGGESTED INSTRUCTION TIME: N/A Integrated during two-year training period.

Accompanied by addendum page (Rating Sheet)

Rating sheet includes the following categories:

- Accuracy of work
- Care of working space
- Care of equipment

UNIT	1.0 E	INTRODUCTION TO DESIRABLE JOB/LEARNING CHARACTERISTICS/ HABITS/ATTITUDES
TASK	1.02	EXHIBIT SUCCESSFUL JOB PERFORMANCE CHARACTERISTICS

Rating sheet (Con't.):

- Speed
- Use of working time
- Initiative
- Attendance
- Attitude toward fellow workers
- Attitude toward teacher
- Observance of safety rules
- Use of materials
- Responsibility
- Accident report
- Personal appearance, cleanliness

JOB PERFORMANCE RATING SHEET

Student _____ Job Performed _____

Dates from _____ to _____

Place of work _____ Supervisor _____

DIRECTIONS: Circle the number that best fits your opinion of the student's performance using the following factors:

	<u>Never</u>	<u>Seldom</u>	<u>Frequently</u>	<u>Usually</u>	<u>Always</u>
1. Gets to work on time	1	2	3	4	5
2. Uses time properly	1	2	3	4	5
3. Shows interest in work	1	2	3	4	5
4. Shows dependability	1	2	3	4	5
5. Is ambitious	1	2	3	4	5
6. Is neat (work and self)	1	2	3	4	5
7. Works well with others	1	2	3	4	5
8. Follows directions	1	2	3	4	5
9. Works without supervision	1	2	3	4	5
10. Shows good manners	1	2	3	4	5
11. Meets people well	1	2	3	4	5
12. Uses knowledge on the job	1	2	3	4	5
13. Seeks assistance, when necessary	1	2	3	4	5

Does the worker have the skills for doing satisfactory work?
 Yes ___ No ___

List the skills or characteristics that need to be developed or improved upon:

Additional comments:

Date _____ Supervisor _____

UNIT	1.0 E	INTRODUCTION TO DESIRABLE JOB/LEARNING CHARACTERISTICS/ HABITS/ATTITUDES
TASK	1.03	EXHIBIT DESIRABLE WORK ATTITUDES

PERFORMANCE OBJECTIVE:

Given instruction, demonstrate work attitudes that the majority of potential employers prefer in an entry level worker. Performance will be evaluated on a "Work Attitudes Score Card" and a minimum of 90 percent should be attained. Performance will be rated throughout training and should improve to 100 percent by the end of the training period.*

PERFORMANCE ACTIONS:

- 1.0301 Review work attitudes considered important to success in the vocational field.
- 1.0302 Review the "Work Attitudes Score Card."
- 1.0303 Demonstrate the type of work attitudes that potential employers in the local industry report as important to job success.

PERFORMANCE STANDARDS:

- Demonstrate to 90 percent acceptable rating on a "Work Attitudes Score Card," to be completed by the instructor, those work attitudes considered important by local potential employers for entry-level job success.

SUGGESTED INSTRUCTION TIME: N/A Integrated during two-year training period.

Accompanied by addendum page (Work Attitudes Score Card)

(*NOTE: It is recommended in research study findings that employer-recommended "job performance characteristics" and "work attitudes" be included as part of the vocational student's overall training and that demonstrated performance in these areas be included in the total evaluation of the student.)

WORK ATTITUDES SCORE CARD

DIRECTIONS: Score the student on the following attitudes and work behavior by circling the appropriate description either "yes" (+) or "no" (-). Indicate any comments to support the rating or recommendations.

	Circle		Comments/ Recommendations
	(No)	(Yes)	
Cooperative	-	+	
Courteous	-	+	
Loyal to program study and job team members	-	+	
Tackful	-	+	
Self Disciplined	-	+	
Respectful	-	+	
Alert	-	+	
Motivated	-	+	
Responsible	-	+	
Trustworthy	-	+	
Dependable	-	+	
Cheerful	-	+	
Polite	-	+	
Interest	-	+	
Friendly	-	+	
Sympathetic (sensitive) to fellow students	-	+	
Accepts changes	-	+	
Follows rules and regulations	-	+	
Does share of work	-	+	
Helps others, if needed	-	+	
Works regularly	-	+	
On time	-	+	
Shows pride in work	-	+	
Keeps promises	-	+	
Does not waste time	-	+	
Controls anger	-	+	
Accepts criticism	-	+	
Follows superior's directions	-	+	

28 Items total TOTAL (+'s) _____

INTERPRETATION

28 = 100% = Level 4
 25 = 90% = Level 3
 22 = 80% = Level 2
 20 = 70% = Level 1
 17 = 60% = Level 0

Student: _____

UNIT	1.0 E	INTRODUCTION TO DESIRABLE JOB/LEARNING CHARACTERISTICS/ HABITS/ATTITUDES
TASK	1.04	DEMONSTRATE RESPECT FOR AND CARE OF SCHOOL PROPERTY

PERFORMANCE OBJECTIVE:

Given a classroom, shop, or other instructional setting with access to furniture, equipment, tools and materials, and given proper instruction; demonstrate a respect for and care of public property (training facilities) and instructional materials to the standards established by The School District of Greenville County, the career center, and the instructor.

PERFORMANCE ACTIONS:

- 1.0401 Listen to information provided by the instructor and read given or posted materials concerning student behavior and care of property.
- 1.0402 Demonstrate respect for and care of public school property including:
 - a. Facilities (building, classroom).
 - b. Furnishing (furniture).
 - c. Equipment and tools.
 - d. Instructional materials.

PERFORMANCE STANDARDS:

- Demonstrate respect for and care of school property as represented by the classroom, shop, equipment, tools and materials used in instruction.
- Performance must be to the standards of policies of the School District, the career center, and the instructor.

(NOTE: A willful disregard or disrespect (intentional damage or destruction) of instructional facilities, equipment, or materials should be considered a most serious situation since an employer typically would require payment for intended damages and might fire the employee or bring legal charges against the employee for intentional damage to facilities, equipment, or materials.)

SUGGESTED INSTRUCTION TIME: N/A Integrated during two-year training period.

UNIT 1.0 F

BASIC MATH SKILLS

UNIT	1.0 F	BASIC MATH SKILLS
TASK	1.01	BASIC MATH - FRACTIONS

PERFORMANCE OBJECTIVE:

Given a pretest or examples by the instructor, conduct the following operations with fractions:

1. Change any fraction to a decimal number, and any terminating decimal number to a fraction.
2. Arrange in order...unit and simple nonunit fractions.
3. Write equivalent fractions in higher, lower, and lowest terms.
4. Write improper fractions as whole or mixed numbers, and mixed numbers as improper fractions.
5. Multiply fractions and mixed numbers, expressing answers in simplest form.
6. Divide fractions and mixed numbers, expressing answers in simplest form.
7. Add and subtract unlike fractions, expressing answers in simplest form.
8. Add and subtract mixed numbers with unlike fractions, expressing answers in simplest form.
9. Use rational numbers to solve simple work problems.

PERFORMANCE ACTIONS:

Consult: Curriculum Guide for High School General Mathematics, Greenville, SC: The School District of Greenville County, 1979.

PERFORMANCE STANDARDS:

- Student should be able to complete pretest in Math Curriculum Guide with 90 percent accuracy.
- Consult the Math Curriculum Guide for pretests, suggested exercises, and references.

(NOTE: The level of this math skill is eighth grade, General Math I.)

SUGGESTED INSTRUCTION TIME: See 1.05

UNIT	1.0 F	BASIC MATH SKILLS
TASK	1.02	BASIC MATH - DECIMALS

PERFORMANCE OBJECTIVE:

Given a pretest or examples by the instructor, conduct the following decimal math operations:

1. Name the place value of digits in decimal numbers of up to nine digits before the decimal and six digits after the decimal.
2. Compare decimal numbers and arrange them in order.
3. Write the numeral for any decimal number of up to four decimal places.
4. Round decimal numbers to any designated place value up to thousandths.
5. Add and subtract decimal numbers of up to six digits.
6. Multiply decimal numbers by whole numbers or decimal numbers.
7. Divide a number by a three-digit decimal number.
8. Multiply and divide decimal numbers by powers of ten, by inspection.

PERFORMANCE ACTIONS:

Consult: Curriculum Guide for High School General Mathematics, Greenville, SC: The School District of Greenville County, 1979.

PERFORMANCE STANDARDS:

- Student should be able to complete pretest in Math Curriculum Guide with 90 percent accuracy.
- Consult: Curriculum Guide for High School General Mathematics, 1979, for pretests, suggested exercises, and references.

SUGGESTED INSTRUCTION TIME: See 1.05

(NOTE: The level of this math skill is eighth grade, General Math I.)

UNIT	1.0 F		BASIC MATH SKILLS
TASK	1.03	(Optional)	BASIC MATH - VOLUMES

PERFORMANCE OBJECTIVE:

Given a pretest or examples by the instructor, find the volume of any rectangular prism or cube.

PERFORMANCE ACTIONS:

Consult: Curriculum Guide for High School General Mathematics, Greenville, SC: The School District of Greenville County, 1979.

PERFORMANCE STANDARDS:

- Student should be able to complete pretest in Math Curriculum Guide with 90 percent accuracy.
- Consult: Math Curriculum Guide for pretest, suggested exercises, and references.

SUGGESTED INSTRUCTION TIME: See 1.05

(NOTE: The level of this math skill is eighth grade, General Math I.)

UNIT	1.0 F		BASIC MATH SKILLS
TASK	1.04	(Optional)	BASIC MATH - AREAS

PERFORMANCE OBJECTIVE:

Given a pretest or examples by the instructor, find the area of the following types of figures:

- a. Rectangle and square
- b. Circle

PERFORMANCE ACTIONS:

Consult: Curriculum Guide for High School General Mathematics, Greenville, SC: The School District of Greenville County, 1979.

PERFORMANCE STANDARDS:

- Student should be able to complete pretest in Math Curriculum Guide with 90 percent accuracy.
- Consult the Math Curriculum Guide for pretests, suggested exercises, and references.

SUGGESTED INSTRUCTION TIME: See 1.05

(NOTE: The level of this math skill is eighth grade, General Math I.)

UNIT	1.0 F		BASIC MATH SKILLS
TASK	1.05	(Optional)	THE METRIC SYSTEM

PERFORMANCE OBJECTIVE:

Given basic instruction in the metric system and conversion from United States Customary units to metric; read and convert specifications and dimensions from one system into the other system on teacher or text assigned problems with 100 percent accuracy.

PERFORMANCE ACTIONS:

1.0501 Demonstrate ability to read and use U.S Customary length measurements.

1.0502 Identify basic SI units and symbols.

<u>Unit</u>	<u>Name</u>	<u>Symbol</u>
Length	Meter	m

1.0503 Identify basic metric prefixes:

<u>Prefix</u>	<u>Amount</u>	<u>Fraction</u>	<u>Decimal</u>
Milli	One-thousandth	1/1000	0.001
Centi	One-hundredth	1/100	0.01
Deci	One-tenth	1/10	0.1

1.0504 Inches x 25.4 = Millimeters.

1.0505 Millimeters x 0.0394 = Inches.

PERFORMANCE STANDARDS:

- Accuracy of 100 percent using metric measurements.

SUGGESTED INSTRUCTION TIME: 1.01 - 1.05 = 12 Hours

RELATED TECHNICAL INFORMATION:

- ANSI Standards.
- System International d'United (SI) (Metric System).
- U.S. Customary Measurements System.

UNIT 1.0 G

BASIC MEASURING

UNIT	1.0 G	BASIC MEASURING
TASK	1.01	MEASURING

PERFORMANCE OBJECTIVE:

Given proper instructions, read a rule and use other measuring tools with the precision necessary to take measurements or set them up.

PERFORMANCE ACTIONS:

- 1.0101 Define measuring terms with 80 percent accuracy.
- 1.0102 Accurately identify basic tools used in measuring.
- 1.0103 Read a rule to the nearest feet, inches, and fractions of inches down to 1/16 inch.
- 1.0104 Demonstrate ability to perform following measuring skills:
 - a. Measure objects to nearest sixteenth of an inch when given pictures of objects and a measuring instrument.
 - b. Draw lines and objects to specified dimensions.

PERFORMANCE STANDARDS:

- Demonstrate ability to measure to 1/16 inch and draw lines or objects to specified dimensions (1/16 inch accuracy).

SUGGESTED INSTRUCTION TIME: 6 Hours

RELATED TECHNICAL INFORMATION:

- Graduations on rule: Halves, quarter, eighths, sixteenths.
- Rules: Tapes (steel or other), folding rule, straight rule, steel square.
- Metric measurement.

EXPANSION OF TASK:

- a. Estimate a measurement to 1/32 inch.
- b. Measure using the metric system.

UNIT	1.0 G	BASIC MEASURING
TASK	1.01	MEASURING (Con't.)

DEFINITIONS

MEASURING	Setting of limits or bounds according to a pre-determined standard.
INCH	Smallest whole unit of lineal measure typically used.
FOOT	Unit of measure consisting of twelve equal parts called inches.
FRACTION	One or more equal parts of a whole. (i.e., 1/2 inch, 1/4 inch, 3/8 inch, and 5/16 inch)
RULE	Instrument graduated in whole units and fractions of units and used in measuring.
DIMENSION	Number of full units and fraction of units between two points.

UNIT 1.0 H

INTRODUCTION TO BLUEPRINT READING

UNIT	1.0 H	INTRODUCTION TO BLUEPRINT READING
TASK	1.01	IDENTIFY WORKING DRAWINGS AND BLUEPRINT AND READ SPECIFICATIONS

PERFORMANCE OBJECTIVE:

Given an orientation to working drawings, blueprints, and specifications; differentiate between working drawings, blueprints, and specifications.

PERFORMANCE ACTIONS:

- 1.0101 Identify working drawings.
- 1.0102 Identify blueprints. Explain the relationship between blueprints and working drawings.
- 1.0103 Identify specifications.
- 1.0104 Read specifications (orientation training). (As an integrated task during training, "extract specific information from a prepared set of specifications.")

PERFORMANCE STANDARDS:

- On a written knowledge test, identify with 70 percent accuracy a working drawing, blueprint, and specifications and the relationship between working drawings and blueprints.
- (Integrated task: Extract specific information with specifications, meeting instructor's standards.)

SUGGESTED INSTRUCTION TIME: 3 Hours

RELATED TECHNICAL INFORMATION:

- Introductory related training (orientation) to zoning, building/trade permits, codes, and inspections
- Working drawings: Orthographic, Pictorials, Sections
- Interpret Alphabet of Lines

UNIT	1.0 H	INTRODUCTION TO BLUEPRINT READING
TASK	1.02	INTERPRET COMMON BLUEPRINT SYMBOLS

PERFORMANCE OBJECTIVE:

Given instruction concerning common blueprint symbols, a set of simple blueprints using the symbols, and an assignment to identify common symbols typically used in the occupational field; recognize different blueprint symbols with 100 percent accuracy and meeting the instructor's standards.

PERFORMANCE ACTIONS:

- 1.0201 Identify common blueprint symbols used in the occupational field.
- 1.0202 Interpret symbols used in blueprints typical to the occupational field and that the entry-level worker typically would encounter.
- 1.0203 Identify commonly used abbreviations used in drawings and blueprints. (Familiarization)

PERFORMANCE STANDARDS:

- Interpret common building symbols used on blueprints and drawings in the occupational field with an accuracy of 100 percent and meeting the standards of the instructor. Identify commonly used abbreviations used in drawings, blueprints, and specifications.

SUGGESTED INSTRUCTION TIME: 3 Hours

RELATED TECHNICAL INFORMATION:

- American Institute for Architects (AIA) symbols
- American standards plumbing symbols

UNIT	1.0 H	INTRODUCTION TO BLUEPRINT READING
TASK	1.03	INTERPRET DIMENSIONS FROM BLUEPRINTS

PERFORMANCE OBJECTIVE:

Given instruction, Architect's/Engineer's Scale or drawing, blueprint representations, and an assignment to interpret the blueprint with 1/16 inch accuracy.

PERFORMANCE ACTIONS:

- 1.0301 Identify Architect's/Engineer's Scale and its use.
- 1.0302 Identify methods of dimensioning on blueprints.
- 1.0303 Interpret dimension on blueprints and sketches.

PERFORMANCE STANDARDS:

- Interpret dimensions on blueprints and sketches with 1/16 inch.
- Meet instructor's standards.

SUGGESTED INSTRUCTION TIME: 3 Hours

RELATED TECHNICAL INFORMATION:

- Scales used on blueprints.
- Scaling drawings in occupational field.
- Measuring scaled lines.

(NOTE: Performance action 1.0303 may be interpret as reading and interpreting details.)

UNIT	1.0 H	INTRODUCTION TO BLUEPRINT READING
TASK	1.04	READ BLUEPRINT AND SPECIFICATIONS AND ESTIMATE MATERIALS FOR JOB

PERFORMANCE OBJECTIVE:

Given blueprints for a job, a requirement to layout/plan a job from the blueprints and specify job materials needed to complete the work, accurately read the blueprints and specifications and estimate the materials for the job with 95 percent accuracy. An accuracy of 1/16 to 1/64, depending on the instructor's requirements, in measuring is expected and final work must meet the instructor's standards.

PERFORMANCE ACTIONS:

- 1.0401 From given blueprints, layout assigned job with layout meeting the dimensions measured by the instructor within 1/16 or 1/64 inch.
- 1.0402 From blueprints and specifications, specify the materials required to complete the work.
- 1.0403 From blueprints, specifications, and assignment information, determine the proper tools and equipment needed to complete the job.

(NOTE: This action may be integrated with estimating. Estimating may be treated as a separate task or integrated with occupational math.)

- 1.0404 "As an extenuation of this task," take the job specifications and determine materials needed and how the materials should be purchased, and obtain purchase cost estimates (from local suppliers, catalogs, or information given by the instructor.)

PERFORMANCE STANDARDS:

- Given blueprint and specifications and a job assignment, determine the material requirements and estimate the cost of the material.

SUGGESTED INSTRUCTION TIME: 6 Hours

UNIT 1.0 H

INTRODUCTION TO BLUEPRINT READING

TASK 1.04

READ BLUEPRINT AND SPECIFICATIONS AND
ESTIMATE MATERIALS FOR JOB (Con't.)

RELATED TECHNICAL INFORMATION:

- Reading blueprints
- Reading specifications
- Measuring
- Layout
- Material suppliers
- Reading and interpreting "notations" on drawings

MODULE 2.0

FUNDAMENTALS OF ELECTRICITY

This unit has been organized as a general introduction to electricity. This unit description may exceed or may not fully represent the degree of which the instructor elects to cover electricity fundamentals. This unit, however, should represent a minimum approach to the fundamentals of electricity.

Typically, instructional time, in both the classroom and shop, will emphasize the application of fundamentals to practical situations.

FUNDAMENTALS OF ELECTRICITY

MINIMUM SUGGESTED TERMINOLOGY

AMPERAGE	Measurement unit for quantity of electrons, electricity, electrical current, current flow. (See below)
AMPERE (A)	Unit of intensity of electrical current (I); rate of flow of electric charge. (See below)
CAPACITOR	Device giving capacitance, usually consisting of conducting plates of foils separated by dielectric with the plates on opposite sides of the dielectric layers oppositely charged by the source voltage.
CIRCUIT	Complete path of an electrical current including the source voltage.
CONDUCTIVITY	Specific conductance of materials; mathematical inverse of resistivity.
CONDUCTANCE	Mathematical inverse of resistance.
CONDUCTOR	Material which allows the free flow or passage of an electric current through its structure, such as a wire, cable, or bus suitable for carrying electrical current.
CONTINUITY	A Continuous function or uninterrupted function.
CURRENT	Movement of electrons through a conductor.
DC	Electrical current that moves consistently in only one direction.
INSULATOR	A device that is a poor conductor of electricity and that may be used separate or support conductors to prevent an undesired flow of electricity.
MIL	One-thousandth.
OHM	Measurement unit for resistance to electrical current offered by a circuit or device.
PARALLEL CIRCUIT	Circuit where electrical devices are arranged with all positive poles, electrodes, and terminals jointed to one conductor and all negative ones to another conductor so each unit is in effect on a parallel branch.
RESISTIVITY	Specific resistance of materials expressed as ohms per circular mil foot.
RESISTOR	Device used to impede electrical current flow or to divide voltages within circuits.

FUNDAMENTALS OF ELECTRICITY

MINIMUM SUGGESTED TERMINOLOGY (Con't.)

SERIES	Circuit in which electric current has only one path throughout.
VOLTAGE	Measurement unit for electrical potential or electrical force; electromotive force (emf.)
WATTAGE	Amount of power expressed in watts.

ELECTRICITY
 FUNDAMENTALS OF ELECTRICITY
 SUGGESTED INSTRUCTION TIMES

<u>ELECTRICITY</u> <u>MODULE/TASK</u>	SUGGESTED HOURS
Module 2.0 FUNDAMENTALS OF ELECTRICITY	
2.01 Produce Voltage by Magnetism	*
2.02 Produce Voltage by Thermal Means	*
2.03 Produce Voltage by Photoelectric Means	*
2.04 Produce Voltage by Chemical Means	*
2.05 Construct an Electromagnet	6
2.06 Measure Voltage in Simple Circuit	**
2.07 Measure Amperage in a Simple Circuit	**
2.08 Measure Resistance in Simple Circuit	**
2.09 Test for Continuity	12
2.10 Determine Wattage	3
2.11 Read Microfarad Rating of Capacitors	***
2.12 Test Capacitors	3
2.13 Draw a Series Resistive Circuit and Calculate Circuit Values	****
2.14 Construct a Resistive Series Circuit	****
2.15 Construct Circuit with Batteries Wired in Series	****
2.16 Draw Parallel Resistive Circuit and Calculate Circuit Values	****
2.17 Construct a Parallel Resistive Circuit	****
2.18 Construct a Circuit with Batteries Wired in Parallel	****
2.19 Draw a Series-parallel Resistance Circuit and Calculate Circuit Values	****
2.20 Construct a Series-parallel Resistance Circuit	30

ELECTRICITY
MODULE/TASK

SUGGESTED
HOURS

2.21	Measure Resistance of a Single-Phase Motor	3
2.22	Connect a Single-phase Step-down Transformer	*****
2.23	Connect a Single-phase Step-up Transformer	*****
2.24	Connect an Auto Transformer to Provide a Variety of Output Voltages	12

* = See 2.05
** = See 2.09
*** = See 2.12
**** = See 2.20
***** = See 2.24

TASK LISTINGS
ELECTRICITY

MODULE/TASK	DESCRIPTION
MODULE	FUNDAMENTALS OF ELECTRICITY
2.01	(Produce Voltage by Magnetism) Provided with a permanent magnet, a coil wire, VOM, and adequate wire for circuit connections; produce a voltage by magnetism. The movement of the coil around the magnet or movement of the magnet through the coil must produce a voltage (deflect VOM).
2.02	(Produce Voltage by Thermal Means) Given a thermo-couple or thermopile, source of heat, VOM, and the necessary wire for connections; produce a voltage by thermal means. When the connections are made and heat is applied to the thermocouple or thermopile, a voltage must be indicated on the VOM (register a deflection).
2.03	(Produce Voltage by Photoelectric Means) Provided a photo cell, solar cells, or photoelectric cell, VOM, light source, and necessary wire for connections; produce a voltage by photoelectric means. The cell(s) must generate an electrical voltage (deflect VOM) with the proper light source activated.
2.04	(Produce Voltage by Chemical Means) Provided with a container, zinc, carbon, water, chemicals with which to make an electrolyte, a voltmeter, and the required wire for connections; produce a voltage by chemical means. When mixing process is complete and electrodes are connected to a voltmeter, a DC low voltage pre-determined by the instructor should be read on the meter (e.g., 1.5 volts).
2.05	(Construct an Electromagnet) Given specifications, iron core, magnetic wire, DC power source, and the necessary tools and materials; construct an electro-magnetic. The magnet, when completed will show a force by attracting a metal object and holding it while the voltage is maintained.
2.06	(Measure Voltage in Simple Circuit) Provided with a functional circuit, a drawing or schematic of the circuit, a VOM, and the necessary tools or materials; measure voltage in a simple circuit. The voltage reading observed should be equivalent to those stated on the schematic (or predetermined).

- 2.07 (Measure Amperage in a Simple Circuit) Provided with a functional DC circuit, a drawing or schematic of the circuit, VOM, and the necessary materials; measure the current in the simple circuit. The current reading (s) must agree with values on the schematic or predetermined by the instructor.
- 2.08 (Measure Resistance in Simple Circuit) Provided with a functional circuit, a drawing or schematic of the circuit, an ohmmeter or VOM, and required materials; measure the resistance (s) in the circuit. Resistance measurements should equal the ohm values indicated between the test points on the schematic or should equal predetermined values measured by the instructor.
- 2.09 (Test for Continuity) Provided with a VOM and accessories, an assortment of components such as fuses, wire, or other devices (or given a simple circuit to test); make continuity measurements. Identify component or circuit as a conductor or non-conductor.
- 2.10 (Determine Wattage) Given an electrical appliance and a wattmeter (or voltage and current measurements with appliances in operation), determine wattage. Measurement/estimate must be in agreement with predetermined or measured finding of the instructor.
- 2.11 (Read Microfarad Rating of Capacitors) Given an assortment of capacitors typically used in motor based systems, a capacitor analyzer if available, and information from the instructor; determine the microfarad ratings (within 5 percent using the analyzer) of the capacitors.
- 2.12 (Test Capacitors) Given an ohmmeter and assorted capacitors; test the capacitors to determine if each is open, shorted, deteriorated, or servicable.
- 2.13 (Draw a Series Resistive Circuit and Calculate Circuit Values) Given a source voltage, values for three resistors, and necessary materials; without aid of references, draw a series resistive circuit and calculate circuit values. Calculate and note on the drawing, the voltage drop across R1, R2, and R3, and the total current. Calculations must be 100 percent correct. The drawing must be correct using the proper symbols, etc.
- 2.14 (Construct a Resistive Series Circuit) Given a drawing of a series resistive circuit, power source, required components, wire conductor, VOM, and necessary tools and materials; construct the series circuit. Connections must be mechanically and electrically secure, the circuit must agree with the diagram schematic, the circuit must be operational, an measurements of resistance, voltage, and current must agree with calculated values of the circuit.

- 2.15 (Construct Circuit with Batteries Wired in Series) Given a diagram or schematic, several batteries, a VOM, wire circuit with the four batteries in series. All connections must be mechanically and electrically secure to the instructor's satisfaction and the circuit should produce a combined voltage of the batteries.
- 2.16 (Draw Parallel Resistive Circuit and Calculate Circuit Values) Given a source voltage and total current for a circuit; information that the current through R1 will be 1/2 of the current through R2 will be 1/2 of the current through R3; and provided the required tools and materials; draw a parallel resistive circuit and calculate circuit values. Calculate and note on the drawing, the values for R1, R2, and R3. The drawing must include the proper symbols, be neatly organized according to instructions given, and be acceptable to the instructor.
- 2.17 (Construct a Parallel Resistive Circuit) Provided with a drawing/schematic of a parallel resistive circuit, required components, wire conductors, power source, VOM, and necessary tools and materials; construct the required parallel resistive circuit. Connections should be mechanically and electrically secure, the circuit should operate as intended, and measurements of voltage, current, and resistance should be equivalent to the calculated values of the circuit. The product must be acceptable to the instructor.
- 2.18 (Construct a Circuit with Batteries Wired in Parallel) Given a diagram/schematic, batteries of the same voltage, wire conductors, a VOM, and necessary tools and materials; construct a circuit with the batteries wired in parallel. Connections should be mechanically and electrically secure and the circuit should product the desired voltage.
- 2.19 (Draw a Series-parallel Resistance Circuit and Calculate Circuit Values) Provided with a source voltage, the individual values of three resistors in the circuit, and the required materials; draw a series-parallel circuit and calculate the circuit values. Calculate and note on the drawing the values for the parallel and series branch circuits. Calculations for circuit values must be 100 percent accurate according to given voltage and resistance values. The series-parallel circuit drawing must be accurate, use the proper symbols, and be acceptable to the instructor.

- 2.20 (Construct a Series-parallel Resistance Circuit) Given a drawing/schematic of a series-parallel resistance components, wire conductors, VOM, and other required materials and tools; construct a series-parallel resistance circuit. All connections will be mechanically and electrically secure, the circuit must operate as intended, and the voltage and current measurements must be equivalent to the calculated values of the circuit.
- 2.21 (Measure Resistance of a Single-phase Step-down Motor) Provided with an ohmmeter (VOM) and a functional single-phase motor; measure the resistance of the windings of the motor. The resistance should be within a predetermined value (given by the instructor, indicated on manufacturer's data plate.)
- 2.22 (Connect a Single-phase Step-down Transformer) Provided with a wiring diagram, a single-phase transformer, a power source, a VOM, the necessary wire conductors, connectors, and tools; connect a single-phase step-down transformer in a circuit. The transformer must be wired properly to the power source and to the remaining circuit with mechanically and electrically secure circuits.
- The transformer provided should be suitable for the circuit demands.
- 2.23 (Connect a Single-phase Step-up Transformer) Provided with a wiring diagram (or schematic), a single-phase step-up transformer, power source, wire conductors, VOM, and necessary materials and tools; connect a single-phase step-up transformer. The transformer must be properly wired to the power source, connections should be mechanically and electrically secure, and the transformer output must provide the desired voltage and current according to the transformer rating.
- 2.24 (Connect an Auto Transformer to Provide a Variety of Output Voltages) Given a wiring diagram/schematic, an auto transformer or equivalent, instructions concerning the auto transformer or equivalent method of varying an output voltage, a power source, wire conductors, VOM, and required materials and tools; connect the auto transformer to provide one or more voltage less than the line voltage. The auto transformer or substitute must be properly wired to power the power source, connections must be mechanically and electrically secure, and required voltages must be obtained and measured.

MODULE 2.0

FUNDAMENTALS OF ELECTRICITY

TASK 2.01

PRODUCE VOLTAGE BY MAGNETISM

PERFORMANCE OBJECTIVE:

Provided with a permanent magnet, a coil wire, a VOM, and adequate wire for circuit connections; produce a voltage by magnetism. The movement of the coil around the magnet or movement of the magnet through the coil must produce a voltage (deflect VOM).

PERFORMANCE ACTIONS:

- 2.0101 Connect a generator to a VOM or equivalent (galvanometer).
- 2.0102 Rotate the armature.
- 2.0103 Observe the presence of voltage (current flow).

PERFORMANCE STANDARDS:

- Produce a voltage by a wire moving through a magnetic field, observing that voltage on a suitable device such as a galvanometer or VOM, etc.

SUGGESTED INSTRUCTION TIME: See 2.05

RELATED TECHNICAL INFORMATION:

- Explain principles of magnetism.
- Explain characteristics of lines of force (flux).
- Discuss methods of producing voltage by means of magnetism.
- Define Alternating Current (AC).
- Explain wire rule.
- Explain coil rule.
- Explain magnetic generator principles.
- Explain safety considerations.

MODULE 2.0

FUNDAMENTALS OF ELECTRICITY

TASK 2.02

PRODUCE VOLTAGE BY THERMAL* MEANS

PERFORMANCE OBJECTIVE:

Given a thermocouple or thermopile, source of heat is applied to the means. When the connections are made and heat is applied to the thermocouple or thermopile, a voltage must be indicated on the VOM (register a deflection).

PERFORMANCE ACTIONS: (A typical approach to the task)

- 2.0201 Connect a thermocouple (or thermopile) to a galvanometer (or VOM) and heat the thermopile with a heat source designated by the instructor.
- 2.0202 Heat the thermopile with a heat source designated by the instructor.
- 2.0203 Read the current flow indicated by the meter instrument.

PERFORMANCE STANDARDS:

- Produce a voltage by thermal means, observing the voltage on the VOM or a suitable device for indicating the presence of voltage.

SUGGESTED INSTRUCTION TIME: See 2.05

RELATED TECHNICAL INFORMATION:

- Explain operation of thermocouple.
- Explain operation of thermopile.
- Describe uses of thermocouples and thermopiles.
- Identify safety considerations.

*Heat energy

MODULE 2.0

FUNDAMENTALS OF ELECTRICITY

TASK 2.03

PRODUCE VOLTAGE BY PHOTOELECTRIC*
MEANS

PERFORMANCE OBJECTIVE:

Provided a photo cell, solar cells, or photoelectric cells, VOM, light source, and necessary wire for connections; produce a voltage by photoelectric means. The cell(s) must generate an electrical voltage (deflect VOM) with the proper light source activated.

PERFORMANCE ACTIONS:

- 2.0301 Connect a photoelectric, photo, or solar cell to the VOM (or galvanometer).
- 2.0302 Vary the light to the cell.
- 2.0303 Note the current flow or voltage output, as applicable.

PERFORMANCE STANDARDS:

- Produce a voltage by photoelectric means observing the voltage on a VOM or suitable device.

SUGGESTED INSTRUCTION TIME: See 2.05

RELATED TECHNICAL INFORMATION:

- Explain operation of photo cell.
- Explain operation of solar cell.
- Explain operation of photoelectric cell.
- Describe some of the uses of photo, photoelectric, and solar cells.
- Describe procedure for constructing basic photoelectric circuits.
- Identify safety considerations.

*Light energy

MODULE 2.0

FUNDAMENTALS OF ELECTRICITY

TASK 2.04

PRODUCE VOLTAGE BY CHEMICAL MEANS

PERFORMANCE OBJECTIVE:

Provided with a container, zinc, carbon, water, chemicals with which to make an electrolyte, a voltmeter, and the required wire for connections; produce a voltage by chemical means. When mixing process is complete and electrodes are connected to a voltmeter, a D.C. low voltage pre-determine by the instructor should be read on the meter (e.g., 1.5 volts).

PERFORMANCE ACTIONS:

- 2.0401 Construct a chemical cell following instructor's directions.
- 2.0402 Connect cell to VOM or other device to indicate the presence of voltage.
- 2.0403 Observe the production of voltage.

PERFORMANCE STANDARDS:

- Produce an observable voltage by a chemical energy cell according to the directions of the instructor (worksheet, etc.), observing the voltage on the VOM or a suitable device that indicates the presence of voltage.

NOTE: This task may be as simple as generating electricity by electrodes inserted in a lemon and connected to a VOM. EMPHASIS is on the student understanding how electricity may be produced.

SUGGESTED INSTRUCTION TIME: See 2.05

RELATED TECHNICAL INFORMATION:

- Identify structure of an atom.
- Explain function of electrolytes and electrodes.
- Describe a storage cell.
- Differentiate (describe difference) between a dry cell and a wet cell (lead-acid cell).
- Describe procedures for construction a wet cell.
- Define voltage.
- Define amperate.
- Define a Direct Current (DC).

MODULE 2.0

FUNDAMENTALS OF ELECTRICITY

TASK 2.04

PRODUCE VOLTAGE BY CHEMICAL MEANS

RELATED TECHNICAL INFORMATION (Con't):

- Explain how to read voltmeter scales and set up a VOM for testing.
- Identify safety considerations.

MODULE 2.0

FUNDAMENTALS OF ELECTRICITY

TASK 2.05

CONSTRUCT AN ELECTROMAGNET

PERFORMANCE OBJECTIVE:

Given specifications, iron core, magnetic wire, DC power source, and the necessary tools and materials; construct an electromagnetic. The magnet, when completed will show a force by attracting a metal object and holding it while the voltage is maintained.

PERFORMANCE ACTIONS:

- 2.0501 Assemble materials.
- 2.0502 Wind magnetic wire around an iron core according to directions given by the instructor.
(ALTERNATE: Select a relay coil, test it for continuity with the VOM, and wire it in the required electromechanical circuit [i.e., as a relay].)
- 2.0503 Assemble the required demonstration unit according to given directions.
- 2.0504 Apply required electricity.
- 2.0505 Observe electromagnetic force that attracts and holds a metal object in while voltage is applied.

PERFORMANCE STANDARDS:

- Construct an electromagnet that will attract and hold a metal object while voltage is applied.
- Recommend: Use of relay parts to demonstrate the electromagnet.

SUGGESTED INSTRUCTION TIME: 2.01 - 2.05 = 6 Hours

RELATED TECHNICAL INFORMATION:

- Explain conductor flux.
- Explain flux direction (wire rule).
- Explain flux density.
- Explain coil rule.
- Explain magnetic strength.
- Identify safety considerations.

MODULE 2.0

FUNDAMENTALS OF ELECTRICITY

TASK 2.06

CONSTRUCT AN ELECTROMAGNET

EXPANSION OF INSTRUCTION:

- Design of relays.
- Adjustment of relays.
- Electrically diagnosing faulty relays.
- Types of relays found in low-voltage control systems.

MODULE 2.0

FUNDAMENTALS OF ELECTRICITY

TASK 2.06

MEASURE VOLTAGE IN SIMPLE CIRCUIT

PERFORMANCE OBJECTIVE:

Provided with a functional circuit, a drawing or schematic of the circuit, a VOM*, and the necessary tools or materials; measure voltage in a simple circuit. The voltage reading observed should be equivalent to those stated on the schematic (or predetermined).

*VOM consists of a working, calibrated VOM with proper scale(s) for measurements and accompanying test probes/leads.

PERFORMANCE ACTIONS: (This task may be accomplished as part of practical shop work)

(NOTE: This task may follow or may be jointly conducted with the task concerning the use of the VOM. See unit on Measuring Instruments.)

- 2.0601 Assemble schematic/diagram/drawing of circuit, VOM and other materials necessary.
- 2.0602 Following given directions, measure voltage at required points in the circuit.
- 2.0603 Note voltage readings.
- 2.0604 Compare readings with voltages referenced on the schematic, etc., or predetermined readings taken by the instructor, etc.

PERFORMANCE STANDARDS:

- Measure voltage in a simple circuit noting any differences in voltage measured from voltages indicated in given information or predetermined by the instructor.
- Determine why any major differences were read.

SUGGESTED INSTRUCTION TIME: See 2.09

RELATED TECHNICAL INFORMATION:

- Define volt.
- Explain what voltmeter measures.

MODULE 2.0

FUNDAMENTALS OF ELECTRICITY

TASK 2.06

MEASURE VOLTAGE IN SIMPLE CIRCUIT

RELATED TECHNICAL INFORMATION (Con't.):

- Describe/demonstrate use of VOM: function switch, scale reading.
- Explain different units of measurement:
 - microvolt
 - millivolt
 - volt
 - kilovolt
- Explain/demonstrate procedure/techniques of measuring voltages.
- Identify safety considerations.

MODULE 2.0

FUNDAMENTALS OF ELECTRICITY

TASK 2.07

MEASURE AMPERAGE IN A SIMPLE CIRCUIT

PERFORMANCE OBJECTIVE:

Provided with a functional DC circuit, a drawing or schematic of the circuit, VOM*, and the necessary materials; measure the current in the simple circuit. The current reading(s) must agree with values of the schematic or predetermined by the instructor.

*An AC circuit may be substituted and an amprobe as the instrument.

PERFORMANCE ACTIONS: (This task may be accomplished as part of practical shop work)

(NOTE: See unit of Measuring Instruments.)

- 2.0701 Assemble schematic/diagram/drawing of circuit, test instrument, and other required materials.
- 2.0702 Following given directions, measure current at required points in the circuit.
- 2.0703 Note current readings.
- 2.0704 Compare current readings with data from given information including component (compressor, motor, etc.) data plates, if applicable.
- 2.0705 Note any significant differences in actual readings compared to predetermined readings or given information concerning currents in the circuit.

PERFORMANCE STANDARDS:

- Measure amperage in a given circuit. as required, using given information and measuring instrument.

SUGGESTED INSTRUCTION TIME: See 2.09

RELATED TECHNICAL INFORMATION:

- Define ampere, milliampere.
- Identify and read proper scales of VOM.
- Describe/demonstrate function switch selection on VOM.
- Explain use of shunt on VOM/ammeter.

MODULE 2.0

FUNDAMENTALS OF ELECTRICITY

TASK 2.07

MEASURE AMPERAGE IN A SIMPLE CIRCUIT

RELATED TECHNICAL INFORMATION (Con't):

- Describe/demonstrate proper procedures/techniques for measuring current.
- Identify safety considerations.

MODULE 2.0

FUNDAMENTALS OF ELECTRICITY

TASK 2.08

MEASURE RESISTANCE IN SIMPLE CIRCUIT

PERFORMANCE OBJECTIVE:

Provided with a functional circuit, a drawing or schematic of the circuit, an ohmmeter or VOM, and required materials; measure the resistance(s) in the circuit. Resistance measurements should equal the ohm values indicated between the test points on the schematic or should equal predetermined values measured by the instructor.

PERFORMANCE ACTIONS: (This task may be accomplished as part of practical shop work)

(NOTE: See unit on Measuring Instructions.)

- 2.0801 Assemble given information, circuit, and test instrument.
- 2.0802 Set up circuit and instrument for measuring resistances. (i.e., remove power from circuit, etc.)
- 2.0803 Make a resistance measurements as directed.
- 2.0804 Compare resistance measurements with data from given information. (i.e., resistance values given on schematic or diagram, values indicated by resistor color codes, etc.)
- 2.0805 Note any significant differences between measured resistances and resistance measures given or predetermined.

PERFORMANCE STANDARDS:

- Make resistance measurements in a given circuit, using proper procedures, and noting any significant differences in measures taken and given information.
- If significant differences are noted, identify the cause.

SUGGESTED INSTRUCTION TIME: See 2.09

RELATED TECHNICAL INFORMATION:

- Define ohm, resistance.
- Explain characteristics of a material that is:
 - conductive
 - non-conductive (insulator)
 - resistive (a resistor)

MODULE 2.0

FUNDAMENTALS OF ELECTRICITY

TASK 2.08

MEASURE RESISTANCE IN SIMPLE CIRCUIT.

RELATED TECHNICAL INFORMATION (Con't):

- Identify symbol for fixed and variable resistors.
- Describe composition of several different kinds/types of resistors.
- Identify/use the resistor color code.
- Explain why components being measured must be isolated.
- Explain why readings should be taken from center scale of meter.
- Describe how to set up VOM for resistance measurements (use of multiplier ranges, ohms scale, zero adjustment of ohms scale).
- Describe/demonstrate proper procedures/techniques for making resistance measurements.
- Identify safety consideration.

MODULE 2.0

FUNDAMENTALS OF ELECTRICITY

TASK 2.09

TEST FOR CONTINUITY

PERFORMANCE OBJECTIVE:

Provided with VOM* and accessories, an assortment of components such as fuses, wire, or other devices (or given a simple circuit to test); make continuity measurements. Identify component or circuit as a conductor or non-conductor.

*Commercial or shop made continuity tester may be substituted.

PERFORMANCE ACTIONS: (This task may be accomplished as part of practical shop work.)

(NOTE: See unit on Measuring Instruments.)

- 2.0901 Assemble test instrument, given data, and circuit.
- 2.0902 Make continuity measurements according as required.
- 2.0903 Note any open, closed or grounded circuits or components where continuity conflicts with given data (schematics, diagrams, etc.).
- 2.0904 Identify cause of any continuity readings that are not normal.

PERFORMANCE STANDARDS:

- Test a given circuit for continuity according to given schematics, diagrams, etc., and note situations where readings are different from what is normal.

SUGGESTED INSTRUCTION TIME: 2.06 - 2.09 = 12 Hours

RELATED TECHNICAL INFORMATION:

- Identify component symbols.
- Describe how to set VOM up for continuity testing.
- Explain/demonstrate procedures/techniques of continuity testing.
- Identify components/circuits which may be readily tested by continuity scale.
- Identify safety considerations.

MODULE 2.0

FUNDAMENTALS OF ELECTRICITY

TASK 2.10

DETERMINE WATTAGE

PERFORMANCE OBJECTIVE:

Given an electrical appliance and a wattmeter (or voltage and current measurements with appliance in operation), determine wattage. Measurement/estimate must be in agreement with predetermined or measured finding of the instructor.

PERFORMANCE ACTIONS: (This task may be accomplished as part of practical shop work)

(NOTE: See unit on Measuring Instruments.)

- 2.1001 Assemble unit to be measured, measuring instrument(s), and necessary materials.
- 2.1002 Take required measurements: Wattage directly or voltage and amperage.
- 2.1003
 - a. Read watts consumed by unit.
 - b. If using voltage and current, calculate watt consumed by unit.
- 2.1004 Compare measured wattage with information given on manufacturer's data plate or references available.
- 2.1005 Note if unit is operating normally.

PERFORMANCE STANDARDS:

- Determine the wattage of a given electrical appliance.
- A wattmeter may be used or wattage may be calculated from measured voltage and amperage.
- Measurements must agree with predetermined measurements or data plate.

SUGGESTED INSTRUCTION TIME: 3 Hours

RELATED TECHNICAL INFORMATION:

- Define watt.
- Explain different units of measurement.
- Explain power formula.
- Describe the proper use of a wattmeter.
- Identify safety considerations.

MODULE 2.0

FUNDAMENTALS OF ELECTRICITY

TASK 2.11

READ MICROFARAD RATING OF CAPACITORS

PERFORMANCE OBJECTIVE:

Given an assortment of capacitors typically used in motor based systems, a capacitor analyzer if available, and information from the instructor; determine the microfarad ratings (within 5 percent using the analyzer) of the capacitors.

PERFORMANCE ACTIONS: (This task may be accomplished as part of shop work.)

(NOTE: See unit on Measuring Instruments also [Use of VOM].)

2.1101 Identify different types of capacitors:

- a. List three things which may identify a starting capacitor. (See expansion task on next page*.)
- b. List three things which may identify a run capacitor. (See expansion task on next page*.)

2.1102 Determine capacitor microfarad rating to the standards of the instructor.

PERFORMANCE STANDARDS:

- Determine microfarad rating of capacitors to the standards of the instructor using the recommended methods.

SUGGESTED INSTRUCTION TIME: See 2.12

RELATED TECHNICAL INFORMATION:

- Draw/identify symbol for a capacitor.
- Explain proper use of capacitor analyzer.
- Identify different types of capacitors and where each type typically is used.
- State units of measurement for capacitors.
- Describe how to compute total capacitance in:
 - a. series: 2 capacitors; more than 2 capacitors
 - b. parallel: 2 capacitors or more
- Identify safety considerations.

MODULE 2.0

FUNDAMENTALS OF ELECTRICITY

TASK 2.11

READ MICROFARAD RATING OF
CAPACITORS (Con't.)

*EXPANSION OF TASK: "Determine replacement capacitor"

- Start capacitors are rated above 50 MFD.
- Run capacitors are rated below 50 MFD.
- Start capacitors have a tolerance of +/- 20 percent.
- Run capacitors have a +/- 10 percent tolerance (a 20 MFD capacitor may be replaced with an 18-22 MFD capacitor).
- Replacement capacitors must have the same or a higher voltage rating than the capacitor replaced.
- Starting capacitors are of electrolyte type.
- The starting capacitors is in the motor circuit only during starting conditions.
- The run capacitor is in the circuit all the time the compressor is operating.

MODULE 2.0

FUNDAMENTALS OF ELECTRICITY

TASK 2.12

TEST CAPACITORS

PERFORMANCE OBJECTIVE:

Given an VOM and assorted capacitors; test the capacitors to determine if each is open, shorted, deteriorated, or serviceable.

PERFORMANCE ACTIONS:

- 2.1201 Review directions for use of VOM to test capacitors.
- 2.1202 Identify that capacitors are either:
- Good
 - Deteriorated
 - Open
 - Short
- 2.1203 Check status of capacitors by properly using the VOM, adjusted to the recommended Ohm's Scale.
- 2.1204 Using the VOM (voltmeter) and amprobe (ammeter), determine if a capacitor is deteriorated: (Determine the microfarads of the capacitor.)
- Read voltage rating of capacitor.
 - Set up for determining MFD from voltage and amperage measurements, using a power source of equal to or less than the rating of the capacitor.
 - Take voltmeter measurement.
 - Take ammeter measurement.
 - Apply formular:
$$\text{MFD's} = \frac{2650 \times \text{Amperes}}{\text{Volts}}$$
 - Check MFD determined by measurements with MFD indicated on capacitor to estimate deterioration.

PERFORMANCE STANDARDS:

- Determine if a given capacitor is open, short, deteriorated, or serviceable using a VOM and Amprobe.
- Findings must agree with predetermined findings or be acceptable to the instructor.

SUGGESTED INSTRUCTION TIME: 2.11 - 2.12 = 3 Hours

MODULE 2.0

FUNDAMENTALS OF ELECTRICITY

TASK 2.12

TEST CAPACITORS (Con't.)

RELATED TECHNICAL INFORMATION: .

- Describe procedure for checking capacitors with the ohmmeter or VOM (using R x 1 scale).
- Describe how to safely handle capacitors (e.g., discharging prior to testing).
- Explain:
 - MFD = $2650 \times I/E$
 - Capacitance = $\frac{\text{amps} \times 2650}{\text{voltage}} = \text{MFD (uF)}$
- Describe how capacitor reactance can cause out of phase condition (where voltage lags behind current).
- Identify 3 things that can go wrong with a capacitor: open, short, or deteriorated.
- Identify safety considerations in determining capacitor deterioration by voltage and current measurements.
- Identify typical causes of capacitor failure:
 - Stuck or fused switch or relay contacts.
 - Worn or frozen motor bearings.
 - Excessive load or motor bearings.
 - Incorrect capacitor ratings.
 - Low line voltage.
 - Shorted capacitor case.
- Electrolytics are designed for about 50,000 starts.
 - Electrolytics failure typically has no external sign and 80 percent of failure are open capacitors.
- Paper oil running capacitors are good for about 15 years.
 - Paper oil running capacitors typically fail by opening and often show a bulge indicating failure.

MODULE 2.0

FUNDAMENTALS OF ELECTRICITY

TASK 2.13

DRAW A SERIES RESISTIVE CIRCUIT
AND CALCULATE CIRCUIT VALUES

PERFORMANCE OBJECTIVE:

Given a source voltage, values for three resistors, and necessary materials; without aid of references, draw a series resistive circuit and calculate circuit values. Calculate and note on the drawing, the voltage drop across R1, R2, and R3, and the total current. Calculations must be 100 percent correct. The drawing must be correct using the proper symbols, etc.

PERFORMANCE ACTIONS: (Resistors may be replaced with other resistive devices.)

2.1301 Identify given resistors (R1, R2, and R3) values and a given source voltage value.

(Sample: 20 ohms each, 120 volt source = 60 ohms total with a current of 2 amps per resistance.)

2.1302 Draw series circuit with the three resistors across the power source.

2.1303 Apply rule that resistors add in series. Apply Ohm's Law.

2.1304 Calculate circuit values including total resistance, voltage drop across each resistor, and current flow through each resistor.

2.1305 Check calculations with measuring instruments, if required by instructor: Otherwise, check if calculations with instructor's findings.

PERFORMANCE STANDARDS:

- Draw a series resistive circuit and calculate circuit values showing the voltage drop across R1, R2, and R3, and the total current.
- Calculations must be 100 percent accurate and the drawing must be correct with the proper symbols used.

SUGGESTED INSTRUCTION TIME: See 2.20

MODULE 2.0

FUNDAMENTALS OF ELECTRICITY

TASK 2.13

DRAW A SERIES RESISTIVE CIRCUIT AND
CALCULATE CIRCUIT VALUES (Con't.)

RELATED TECHNICAL INFORMATION:

- Explain Ohm's Law (Ohm's Law formula).
- Kirchoff's Law for service circuits.
- Describe characteristics of series resistive circuit.
- Explain voltage drop.
- Practice electrical circuit drawing skills.
- See sample drawing below:

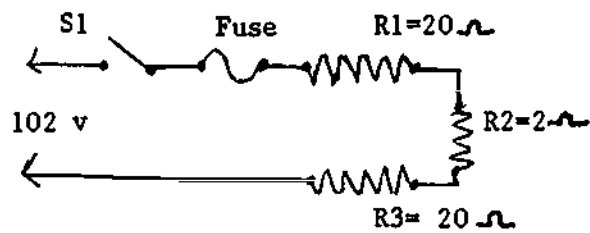

$$I = \frac{E}{R} = \frac{120v}{60\Omega} = 2 \text{ Amps.}$$

$$\begin{aligned} 20 \times 2A &= 40v \\ 20 \times 2 &= 40 \\ 20 \times 2 &= 40 \\ \hline 60\Omega \times 2 &= 120v \end{aligned}$$

$$\begin{aligned} R_{tot} &= R1 + R2 + R3 \\ R_t &= 20 + 20 + 20 \\ R \text{ total} &= 60\Omega \end{aligned}$$

MODULE 2.0

FUNDAMENTALS OF ELECTRICITY

TASK 2.14

CONSTRUCT A RESISTIVE SERIES CIRCUIT

PERFORMANCE OBJECTIVE:

Given a drawing of a series resistive circuit, power source, required components, wire conductor, VOM, and necessary tools and materials; construct the series circuit. Connections must be mechanically and electrically secure, the circuit must agree with the diagram/schematic, the circuit must be operational, and measurements of resistance, voltage, and current must agree with calculated values of the circuit.

PERFORMANCE ACTIONS:

- 2.1401 After drawing and calculating series resistive circuits, obtain from the instructor a drawing or schematic of a series resistive circuit to construct.
- 2.1402 Construct one or more series circuits, as required, following recommended techniques.
- 2.1403 Use ohmmeter to determine circuit resistances.
- 2.1404 Compare measured resistances with calculations.
- 2.1405 Measure voltage drop across resistors.
- 2.1406 As required by the instructor, use Ohm's Law and Power Law to calculate resistance, resistor wattage, and voltage drop for given practical problems.

PERFORMANCE STANDARDS:

- Following a given diagram/schematic construct an operational series circuit using three resistors.
- Mechanical and electrical connections must be secure.
- Measurements of resistance, voltage, and current must agree with calculated values of the circuit.

SUGGESTED INSTRUCTION TIME: See 2.20

RELATED TECHNICAL INFORMATION:

- Identify components indicated on drawing/schematic.
- Describe proper VOM connections to circuit for desired measurements (voltage, resistance, current).
- Explain methods of making mechanically and electrically secure connections.

MODULE 2.0

FUNDAMENTALS OF ELECTRICITY

TASK 2.15

CONSTRUCT CIRCUIT WITH BATTERIES
WIRED IN SERIES

PERFORMANCE OBJECTIVE:

Given a diagram or schematic, several batteries, a VOM, wire conductors, and the necessary tools and materials; construct a circuit with the four batteries in series. All connections must be mechanically and electrically secure to the instructor's satisfaction and the circuit should produce a combined voltage of the batteries.

PERFORMANCE ACTIONS:

- 2.1501 Wire the required number of batteries in series following recommended procedures.
- 2.1502 Calculate the voltage anticipated.
- 2.1503 Set up the VOM and measure the total voltage produced by the battery circuit.

PERFORMANCE STANDARDS:

- Construct a circuit with batteries wired in series so that a total voltage equals the combined voltage of the batteries.
- The circuit must be constructed to represent the given diagram/schematic and must be to the the instructor's standards.

SUGGESTED INSTRUCTION TIME: See 2.20

RELATED TECHNICAL INFORMATION:

- Identify symbol for a dry cell/battery.
- Review basic information concerning batteries.
- Identify safety considerations.

MODULE 2.0

FUNDAMENTALS OF ELECTRICITY

TASK 2.16

DRAW PARALLEL RESISTIVE CIRCUIT AND
CALCULATE CIRCUIT VALUES

PERFORMANCE OBJECTIVE:

Given a source voltage and total current for a circuit; information that the current through R1 will be 1/2 of the current through R2 which is 1/2 of the current through R3; and provided the required tools and materials; draw a parallel resistive circuit and calculate circuit values. Calculate and note on the drawing, the values for R1, R2, and R3. The drawing must include the proper symbols, be neatly organized according to instructions given, and be acceptable to the instructor.

PERFORMANCE ACTIONS.

- 2.1601 a. State that resistors do not add in a series.
b. State rule for parallel resistors that are:
(1) equal
(2) not equal
- 2.1602 Draw several parallel circuits from information given by the instructor.
- 2.1603 Use Ohm's Law and Kirchoff's Law to determine circuit values.
- 2.1604 Check circuit values with VOM and ammeter.

PERFORMANCE STANDARDS:

- Draw a parallel resistance circuit and calculate the circuit values based on a given voltage and current for the circuit; information that the current through R1 is 1/2 of current through R2 which is 1/2 of current through R3.
- The drawing must represent a parallel circuit, include proper symbols, and be acceptable to the instructor.

SUGGESTED INSTRUCTION TIME: See 2.20

RELATED TECHNICAL INFORMATION:

- Kirchoff's Law for parallel circuits.
- Describe characteristics of a parallel circuit.
- Explain how to solve for R-total in parallel.
- Describe/demonstrate how to draw/wire parallel circuits. Refer to sample circuits that follow.

PARALLEL-RESISTIVE CIRCUITS

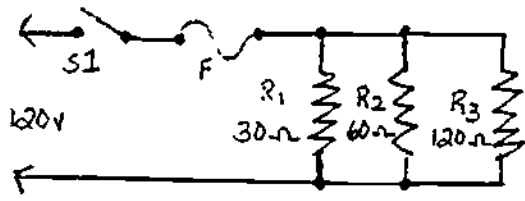

$$\frac{1}{R_T} = \frac{1}{30} + \frac{1}{60} + \frac{1}{120} = \frac{4 + 2 + 1}{120} = \frac{7}{120}$$

$$R_T = \frac{120}{7} = 17.14 \Omega$$

$$I = \frac{E}{R} = \frac{120}{17.14} = 7 \text{ amps}$$

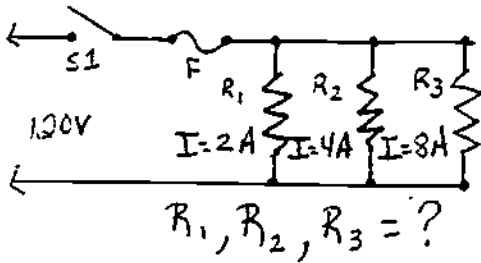

Voltage across $R_3 =$ _____

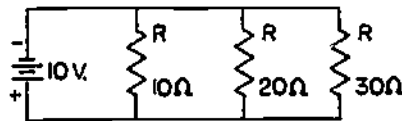

Amps thru $R_1 =$ _____

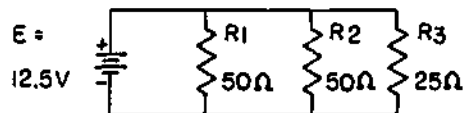

MODULE 2.0

FUNDAMENTALS OF ELECTRICITY

TASK 2.18

CONSTRUCT A CIRCUIT WITH BATTERIES
WIRED IN PARALLEL

PERFORMANCE OBJECTIVE:

Given a diagram/schematic, batteries of the same voltage, wire conductors, a VOM, and necessary tools and materials; construct a circuit with the batteries wired in parallel. Connections should be mechanically and electrically secure and the circuit should produce the desired voltage.

PERFORMANCE ACTIONS:

- 2.1801 Wire batteries in parallel as required by the instructor.
- 2.1802 Explain resulting circuit.
- 2.1803 Make required circuit measurements.

PERFORMANCE STANDARDS:

- Construct a circuit with batteries of the same voltage wired in parallel so the end result is the desired predetermined voltage.
- The circuit must be in agreement with the schematic, etc., provided and must be acceptable to the instructor.

SUGGESTED INSTRUCTION TIME: See 2.20

RELATED TECHNICAL INFORMATION:

- Describe the characteristics of a parallel circuit.
- State factors that determine current in a battery.
- Describe how to use the VOM.

MODULE 2.0

FUNDAMENTALS OF ELECTRICITY

TASK 2.17

CONSTRUCT A PARALLEL
RESISTIVE CIRCUIT

PERFORMANCE OBJECTIVE:

Provided with a drawing/schematic of a parallel resistive circuit, required components, wire conductors, power source, VOM, and necessary tools and materials; construct the required parallel resistive circuit. Connections should be mechanically and electrically secure, the circuit should operate as intended, and measurements of voltage, current, and resistance should be equivalent to the calculated values of the circuit. The product must be acceptable to the instructor.

PERFORMANCE ACTION:

- 2.1701 Assemble materials required for parallel resistive circuit.
- 2.1702 Interpret given drawing or schematic.
- 2.1703 Construct the required parallel resistive circuit.
- 2.1704 Calculate values for the circuit.
- 2.1705 Using VOM and other available instruments, make measurements to check circuit calculations and operation.

PERFORMANCE STANDARDS:

- Following a given diagram/schematic construct a parallel resistive circuit from components and materials provided so that the circuit functions as intended with voltage, current, and resistance measurements being the equivalent of calculated values.
- The wired circuit must be acceptable to the instructor.

SUGGESTED INSTRUCTION TIME: See 2.20

RELATED TECHNICAL INFORMATION:

- Identify components.
- Read pictorial/drawing, schematic.
- Describe use of VOM to measure voltage, current, and resistance.
- Describe/demonstrate how to wire a parallel circuit.

MODULE 2.0

FUNDAMENTALS OF ELECTRICITY

TASK 2.19

DRAW A SERIES-PARALLEL RESISTANCE
CIRCUIT AND CALCULATE CIRCUIT
VALUES

PERFORMANCE OBJECTIVE:

Provided with a source voltage, the individual values of three resistors in the circuit, and the required materials; draw a series-parallel circuit and calculate the circuit values. Calculate and note on the drawing the values for the parallel and series branch circuits. Calculations for circuit values must be 100 percent accurate according to given voltage and resistance values. The series-parallel circuit drawing must be accurate, use the proper symbols, and be acceptable to the instructor.

PERFORMANCE ACTIONS:

- 2.1901 Apply applicable rules (Laws).
- 2.1902 Draw a series-parallel resistive circuit using information provided by the instructor.
- 2.1903 Calculate values of the circuit not given.
- 2.1904 Check calculations and findings with those of the instructor.

PERFORMANCE STANDARDS:

- Using given circuit voltage and resistance values, draw a series-parallel circuit and calculate circuit values with 100 percent accuracy.
- The drawing and calculations must be acceptable to the instructor.

SUGGESTED INSTRUCTION TIME: See 2.20

RELATED TECHNICAL INFORMATION:

- Describe a series-parallel circuit.
- Identify/draw series branch.
- Identify/draw parallel branch.
- Explain/demonstrate calculations required to determine circuit values.

SERIES-PARALLEL RESISTANCE CIRCUIT

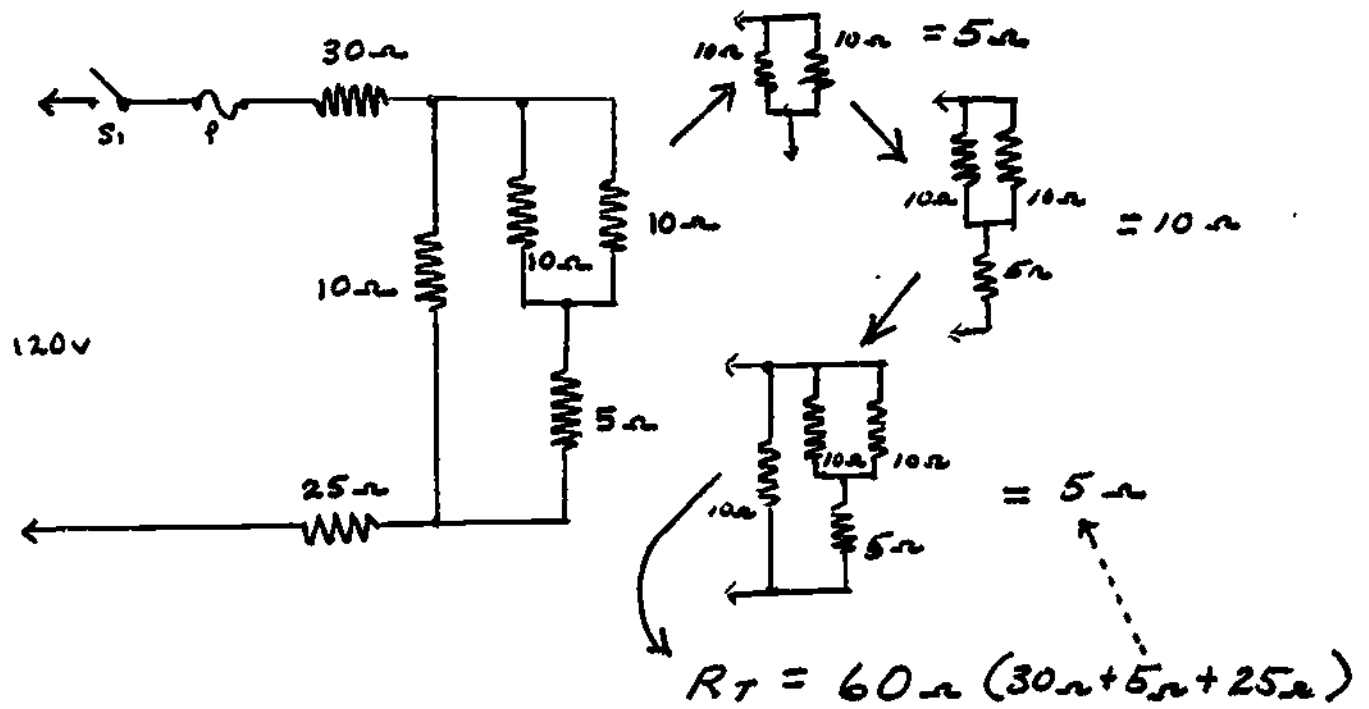

MODULE 2.0

FUNDAMENTALS OF ELECTRICITY

TASK 2.20

CONSTRUCT A SERIES-PARALLEL
RESISTANCE CIRCUIT

PERFORMANCE OBJECTIVE:

Given a drawing/schematic of a series-parallel resistance circuit, values for circuit resistances, the circuit voltage, components, wire conductors, VOM, and other required materials and tools; construct a series-parallel resistance circuit. All connections will be mechanically and electrically secure, the circuit must operate as intended, and the voltage and current measurements must be equivalent to the calculated values of the circuit.

PERFORMANCE ACTIONS:

- 2.2001 Assemble materials required for series-parallel circuit.
- 2.2002 Wire circuit according to diagram/schematic.
- 2.2003 Check circuit with schematic/diagram.
- 2.2004 Measure circuit values.
- 2.2005 Check circuit measurements against calculated values.

PERFORMANCE STANDARDS:

- Construct a series-parallel circuit resistance from given information, components, and tools and, using a VOM, check to ensure that circuit measurements of voltage and current are equivalent to calculated values.
- The circuit should operate as intended and the product must be acceptable to the instructor.

SUGGESTED INSTRUCTION TIME: 2.13 - 2.20 = 30 Hours

RELATED TECHNICAL INFORMATION:

- Identify circuit symbols.
- Identify electrical components.
- Explain method for solving R-total.
- Describe series-parallel circuit.
- Demonstrate use of VOM.

MODULE 2.0

FUNDAMENTALS OF ELECTRICITY

TASK 2.21

MEASURE RESISTANCE OF A
SINGLE-PHASE MOTOR

PERFORMANCE OBJECTIVE:

Provided with an VOM and a functional single-phase motor; measure the resistance of the windings of the motor. The resistance should be within a predetermine value (given by the instructor, indicated on manufacturer's data plate).

PERFORMANCE ACTIONS:

- 2.2101 Assemble motor, VOM, and other required materials.
- 2.2102 Set up VOM for resistance measurement.
- 2.2103 Identify motor windings:
 - a. Main wiring has fewer turns of heavy wire resulting.
 - b. Start winding has up to 6 times the resistance of main winding.
- 2.2104 Make measurements.
- 2.2105 Check measurements against predetermined value given by the instructor.

PERFORMANCE STANDARDS:

- Measure the resistance of a single-phase motor using the VOM.
- Measurement should agree with a predetermined value.
- Performance process and measurement finding must be acceptable to the instructor.

SUGGESTED INSTRUCTION TIME: 3 Hours

RELATED TECHNICAL INFORMATION:

- Identify winding markings of different types of motors.
- Identify the starting winding from the run winding by resistance check (starting winding having more resistance).
- Explain single-phase.
- Explain three-phase.
- Describe/demonstrate use of VOM for resistance measurements.

MODULE 2.20

FUNDAMENTALS OF ELECTRICITY

TASK 2.21

MEASURE RESISTANCE OF A
SINGLE-PHASE MOTOR (Con't.)

EXPANDED TECHNICAL INFORMATION:

- Describe self-starting motors.
- Identify wiring block of a typical motor (Identify the abbreviation: C, S, R).

MODULE 2.0

FUNDAMENTALS OF ELECTRICITY

TASK 2.22

CONNECT A SINGLE-PHASE
STEP-DOWN TRANSFORMER

PERFORMANCE OBJECTIVE:

Provided with a wiring diagram, a single-phase transformer, a power source, a VOM, the necessary wire conductors, connectors, and tools; connect a single-phase step-down transformer in a circuit. The transformer must be wired properly to the power source and to the remaining circuit with mechanically and electrically secure circuits.

The transformer provided should be suitable for the circuit demands.

PERFORMANCE ACTIONS:

- 2.2201 Assemble necessary materials including the step-down transformer.
- 2.2202
 - a. Check output of transformer to ensure that circuit components are not damaged by excess voltage. Then, connect transformer into circuit.
 - b. Wire the step-down transformer in the given circuit so that the circuit operates properly. (Suggested circuit is a low-voltage control system, possibly with thermostat, etc.)
- 2.2203 Check connections and circuit.

PERFORMANCE STANDARDS:

- Connect a given single-phase step-down transformer in a circuit according to diagram/schematic provided with mechanically and electrically secure connectors and meeting the instructor's standards.

SUGGESTED INSTRUCTION TIME: See 2.24

RELATED TECHNICAL INFORMATION:

- Identify symbols: transformer, conductor junction, etc.
- Differentiate between AC and DC (advantages, etc.) low-voltage control circuits.
- Explain induction.
- Describe basic transformers and how they are used.
- Explain how transformers are constructed to step-down/up voltage.
- Describe current reaction when voltage is stepped-down.

MODULE 2.0

FUNDAMENTALS OF ELECTRICITY

TASK 2.23

CONNECT A SINGLE-PHASE
STEP-UP TRANSFORMER

PERFORMANCE OBJECTIVE:

Provided with a wiring diagram (or schematic), a single-phase step-up transformer, power source, wire conductors, VOM, and necessary materials and tools; connect a single-phase step-up transformer. The transformer must be properly wired to the power source, connections should be mechanically and electrically secure, and the transformer output must provide the desired voltage and current according to the transformer rating.

PERFORMANCE ACTIONS: (This is an optional task.)

- 2.2301 a. If a step-up transformer is available for a single task, follow procedures outlined by the instructor to demonstrate proper method of wiring a step-up transformer into a circuit.
- b. As an advanced task, if transformers are available, wire a Buck/Boost circuit suitable for shop use.
- 2.2302 Low voltage bell transformers might be used for demonstration.

PERFORMANCE STANDARDS:

- Connect a single-phase step-up transformer in a circuit according to a given diagram/schematic to provide the voltage and current for which the circuit and transformer have been designed.

SUGGESTED INSTRUCTION TIME: See 2.24

RELATED TECHNICAL INFORMATION:

- Identify the symbols for a step-up transformer.
- Describe the uses of a step-up transformer.
- Explain how current reacts when voltage is stepped-up.
- Explain inductive reactance.
- Explain the out-of-phase condition (where current lags behind voltage) caused by inductive reactance.

MODULE 2.0

FUNDAMENTALS OF ELECTRICITY

TASK 2.23

CONNECT A SINGLE-PHASE
STEP-UP TRANSFORMER (Con't.)

EXPANSION OF TASK FOR ADVANCED STUDENTS OR DEMONSTRATION:

- If materials such as transformers are available, wire BUCK/BOOST TRANSFORMERS to raise or lower a source voltage. (See addendum page.)

BUCK/BOOST TRANSFORMER ORIENTATION (Optional)

PURPOSE: The industrial electrician might encounter service or installation situations where the source voltage may vary as much as 20 percent from electrical equipment data plate requirement while the electrical equipment may require a supply voltage within 5 percent of requirements.

Buck/boost transformers are the solution to most cases of over or under voltage.

BUCK/BOOST TRANSFORMER:

A low voltage signal transformer is similar to a buck/boost transformer. The buck/boost transformer typically is wound with 120/240 volt primaries and 12/24 or 16/32 volt secondaries. They are wired into a circuit so that all of the load current flows through the secondary winding before going to the load.

The resulting actions is similar to that of an auto transformer.

Look at the following diagram:

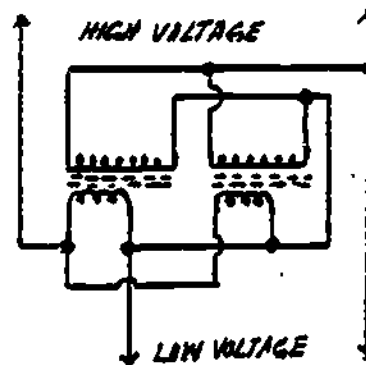
BUCK - BOOST TRANSFORMER

The load current always goes through the secondary windings but never through the primary windings. The load is connected to the low voltage for buck and to the high voltage for boost.

BOOST: Low voltage is wired in parallel to both the secondary and primary windings. The voltage of the load current flowing through the secondary windings is increased by the "in phase" induction of voltage to the secondary windings from the primary windings. The amount of voltage increase is related to the ratio of turns in the primary/secondary windings and the arrangement of windings in either series or parallel.

BUCK: High voltage is wired in series, first to the secondary windings and then to the primary windings. Load current, flowing through the secondary windings first, results in the induction current from the primary windings being slightly "out of phase". This bucking action produces a reduction in voltage.

SIMPLE BUCK-BOOST CIRCUIT FOR THE SHOP (OPTIONAL)

Circuit components may be substituted with suitable components available in the shop. The circuit shown should buck or boost line voltage by about 10 percent or from about 108 to about 132 volts for a 120 volt line.

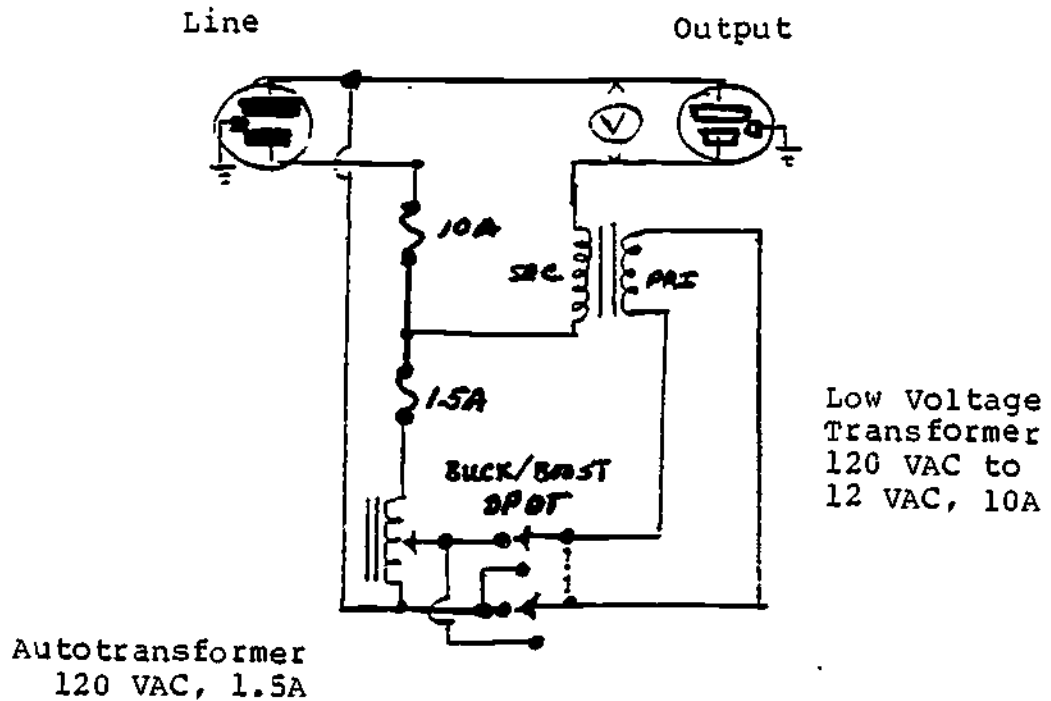

Secondary of low-voltage transformer is wired in series with high side of AC line. Current to load flows through the low voltage secondary and it must be rated to carry the expected load current. The DPDT switch phases the secondary of the low-voltage transformer to add or subtract from the source voltage (buck or boost). The autotransformer provides a means of smoothly controlling the buck/boost. The voltmeter may be omitted.

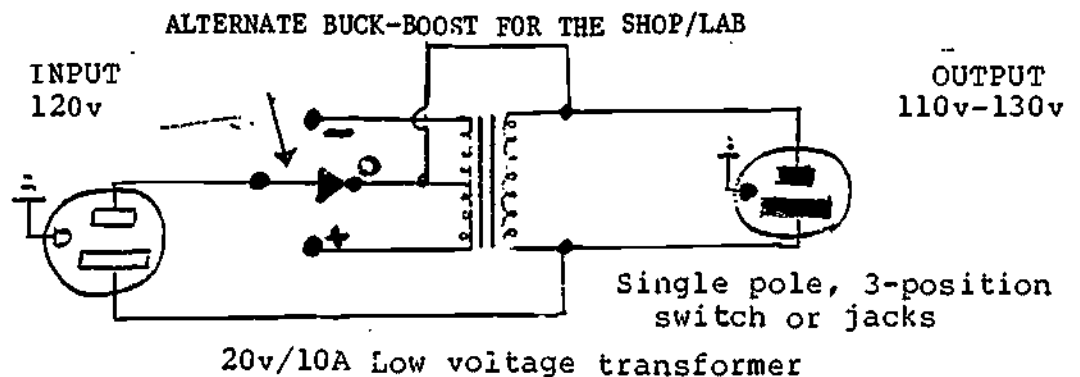

MODULE 2.0

FUNDAMENTALS OF ELECTRICITY

TASK 2.24

CONNECT AN AUTO TRANSFORMER TO
PROVIDE A VARIETY OF OUTPUT VOLTAGES

PERFORMANCE OBJECTIVES:

Given a wiring diagram/schematic, an auto transformer or equivalent, instructions concerning the auto transformer or equivalent method of varying an output voltage, a power source, wire conductors, VOM, and required materials and tools; connect the auto transformer to provide one or more voltage less than the line voltage. The autotransformer or substitute must be properly wired to power the power source, connections must be mechanically and electrically secure, and required voltages must be obtained and measured.

PERFORMANCE ACTIONS: (Orientation)

- 2.2401 If the shop has an auto transformer or the equivalent circuit, demonstrate how the auto transformer may provide a variety of output voltages.

PERFORMANCE ACTIONS:

- Connect an auto transformer or equivalent to provide a means varying the output voltage from the line voltage.
- Connections must be properly made and the circuit operation must be to the instructor's standards.

SUGGESTED INSTRUCTION TIME: 2.22 - 2.24 = 12 Hours

RELATED TECHNICAL INFORMATION:

- Describe principle of auto transformer operation.
- Identify use of auto transformer (or equivalent).
- Describe how auto transformer can be used to step-up or step-down voltages.
- Identify wire size required to handle load(s).
- Identify safety considerations.

MODULE 3.0

ELECTRICAL TOOLS AND EQUIPMENT

Upon completing this unit, the student will be able to identify by name and use commonly used "pouch" tools, bench or general tools, as well as specialized tools and equipment of the electrician. In addition, the student will be able to demonstrate proper selection, use and care of tools and equipment.

ELECTRICITY
ELECTRICAL TOOLS AND EQUIPMENT
SUGGESTED INSTRUCTION TIMES

<u>ELECTRICITY</u> <u>MODULE/TASK</u>			<u>SUGGESTED</u> <u>HOURS</u>
Module	3.0	ELECTRICAL TOOLS AND EQUIPMENT	
	3.01	Select and Use Typical Pouch Tools	15
	3.02	Select and Use Typical Speciality Tools	15

TASK LISTINGS
ELECTRICITY

MODULE/TASK	DESCRIPTION
Module 3.0	ELECTRICAL TOOLS AND EQUIPMENT
3.01	(Select and Use Typical Pouch Tools) Given electrical pouch tools, identify the tools by proper name and demonstrate the proper use and care of the tools.
3.02	(Select and Use Typical Speciality Tools) Given an electrical tools room or bench, identify speciality tools by proper name and demonstrate proper use and care of the tools.

MODULE	3.0	ELECTRICAL TOOLS AND EQUIPMENT
TASK	3.01	SELECT AND USE TYPICAL POUCH TOOLS

PERFORMANCE OBJECTIVE:

Given electrical pouch tools, identify the tools by proper name and demonstrate the proper use and care of the tools.

Suggested Pouch Tools:

- Tool pouch
- Folding rule
- Adjustable wrench
- Long nose pliers
- Side cutters (9" high leverage w/cushion grips)
- Diagonal pliers
- Groove joint pliers/utility pliers/pump pliers/tongue and groove pliers.
- Nut driver
- Adjustable wire strippers
- Six in one tool/crimping all-purpose
- Pocket knife/electrician's
- Flat blade screwdriver (6" x 3/16" round shank w/insulated grip)
- Phillips head screwdriver
- Ball peen hammer
- Neon test light

(NOTE: As a standard, see Klein Tools, General Catalog 125, 7200 McCormick Blvd., Chicago, IL 60645, for detailed pictures and descriptions of typical electrical tools.)

PERFORMANCE ACTIONS:

- 3.0101 Identify given tools.
- 3.0102 Demonstrate proper use of tools.
- 3.0103 Explain special techniques in use of certain tools such as adjustable wrench, and wire and cable cutters.

PERFORMANCE STANDARDS:

- Proper use and care of electrician's pouch (hand) tools should be according to a standard such as Klein Tool's publication, Hand Tools, Pliers, Screwdrivers, Wrenches, Striking and Struck

MODULE	3.0	ELECTRICAL TOOLS AND EQUIPMENT
TASK	3.01	SELECT AND USE TYPICAL POUCH TOOLS

PERFORMANCE STANDARDS (Con't)

- Tools, 7200 McCormick Blvd., Chicago, IL 60645. (\$1 publication available free to vocational programs.)
- Identification by proper name should be within 95 percent accuracy (pliers, screwdrivers, and hammers.)

SUGGESTED INSTRUCTION TIME: 15 Hours

RELATED TECHNICAL INFORMATION:

- For additional reference concerning proper identification, use and care of pouch (hand) tools, see:
 1. Taylor, Mark, Residential Wiring, Stillwater, OK: America Vocational Curriculum Consortium, Inc., 1983
 2. Siebert, Leo, N., ed, Introduction to Industrial Electricity - Electronics, Stillwater, OK: Oklahoma State Board of Vocational and Technical Education, 1981.
 3. Use of safety glasses in cutting.

DEMONSTRATE USE OF POUCH TOOLS

1. Cut wire with diagonal cutter pliers.
2. Use long nose pliers to loop wires for screw terminals (make wire eyes).
3. Use adjustable wrench to tighten hex-head screws, etc.
4. Use the folding rule, check depth gage markings on side of outlet box and align box for wall covering (wallboard).
5.
 - a. Remove pryouts on boxes by twisting them out with a screwdriver.
 - b. Use screwdriver to tighten screw on each side of outlet box to locate (position) box.
6. Tighten cable clamp "locknut" by using pouch or (screwdriver) and hammer.
7. Remove insulation from number 10-14 wire with electrician's knife so 1 inch of bare non-insulated wire is exposed.
8. Remove insulation with wire stripper, matching stripper notch to wire size, exposing 1 inch of conductor, and not damaging conductor.

MODULE 3.0

ELECTRICAL TOOLS AND EQUIPMENT

TASK 3.02

SELECT AND USE TYPICAL
SPECIALITY TOOLS

PERFORMANCE OBJECTIVE:

Given an electrical tools room or bench, identify speciality tools by proper name and demonstrate proper use and care of the tools.

(NOTE: Electricity program facilities and equipment and speciality tools will determine actual tasks. Measuring instruments treated separately.)

Suggested Speciality Tools:

- Soldering gun
- Hacksaw
- Pipe cutter
- EMT bender or hickey bender
- Pipe reamer
- Files: flat, half round
- Torpedo level
- Brace
- Auger bit
- Knockout punches
- Fish tape and reel
- Plump bob
- Electrician's chisel
- Keyhole saw*
- Reciprocal saw*
- Electric drill
- Power wise
- Power bender
- Hammer drill
- Screw gun (machine)

*Some equipment may be introduced by joint training other vocational programs (e.g., Carpentry, Air Conditioning, Industrial Maintenance) or by using borrowed tools and equipment.

PERFORMANCE ACTIONS:

- 3.0201 Properly identify given tools and equipment with 100 percent accuracy.
- 3.0202 Demonstrate proper use of tools.
- 3.0203 Explain special techniques in using certain tools.

MODULE	3.0	ELECTRICAL TOOLS AND EQUIPMENT
TASK	3.02	SELECT AND USE TYPICAL SPECIALITY TOOLS (Con't)

PERFORMANCE ACTIONS: (Con't):

3.0204 Demonstrate proper care of tools, including return of tools to tool rooms/box.

PERFORMANCE STANDARDS:

- Minimum standards industry expects of entry level employees.
- Performance must meet the instructor's standards.

SUGGESTED INSTRUCTION TIME: 15 Hours

RELATED TECHNICAL INFORMATION:

- See: Residential Wiring (1983) or Introduction to Industrial Electricity - Electronics (1981) for reference/standards concerning use and care of speciality tools/equipment.

DEMONSTRATE USE OF SPECIALITY TOOLS

As a minimum performance competency, demonstrate the proper selection, use and care of the following tools:

1. Use wire strippers.
2. Use cutting-crimping tool.
3. Set up and use a hacksaw, including selecting a correct blade for the task and properly installing the blade.
4. Cut and thread rigid conduit, use power vise (if cutter available).
5. Ream rigid conduit (if rigid conduit used in instruction).
6. Bend EMT conduit.
7. Use a knockout punch.
8. Use a reciprocal saw (if available), (may be combination training with carpentry or orientation training by audiovisual media) (portable electric sabre-saw may be substituted).
9. Use electric drill: Recommended that student be oriented to drilling in wood cement, and steel.
10. Correctly pull or push electrical wiring with fish tape.
11. Use brace and bit to bore hole in wood studs.
12. Use chisel to cut out notch in stud for cable run or for mounting of receptacle box.
13. Properly splice wires together select correct solder, and solder wire splice for electrically and mechanically strong joint, with no insulation melted, and with no excess solder visible.
14. Use the plumb bob and diagonal lines from each corner of a room to determine the center of the room for locating a lighting outlet.
15. Use the torpedo level to plumb, vertically and horizontally, a box or conduit.
16. File or ream ends of cut conduit to remove sharp or rough edges that might cut wiring.
17. Use EMT conduit bender to make a bend and offset.

SAFETY PRACTICES
FOR
ELECTRICAL HAND TOOLS

1. Wear eye protection.
2. Faces of hammers should be flat and not too smooth which might cause hammers to slip from nails or cause nails to fly.
3. Screwdriver tip should be properly ground and fit slot in screw head.
4. Avoid using screwdriver on objects held in hand.
5. Check wood handles on tools for splinters or rough edges: Use fine sandpaper and wipe lightly with linseed oil to keep handles smooth.
6. Never use a file unless it has a handle fastened on it.
7. Do not strike a file against anything to knock off filings. Use a card file for cleaning.
8. When using a screwdriver, do not place your hand where it might be gouged if the tool slips.
9. When caring sharp tool, hold them with the points down and pointing away from you. Walk slowly and carefully and never run!

ELECTRIC DRILL SAFETY

1. Select the correct drill or bit for your work and mount it securely to the full depth of the chuck.
2. Stock to be drilled must be held in a stationary position so it cannot be moved during operation.
3. Connect drill to properly grounded outlet.
4. Turn on the switch for a moment to see if the bit is properly centered and running true.
5. With switch off, place the point of the bit in the punched layout hole.
6. Hold drill firmly in one or both hands at the correct drilling angle.
7. Turn on the switch, feed the drill into the work. The pressure required will vary with the size of the drill and the kind of wood.
8. During the operation, keep the drill aligned with the direction of the hole.
9. When drilling deep holes, especially with a twist drill, withdraw several times to clear the cuttings.
10. Follow the same precautions and procedures as when drilling holes with a hand drill or the drill press.
11. Always remove the bit from the drill as soon as you have completed your work.
12. Do not use the electric power drill when working on wet ground unless provisions are made to prevent possible shock hazards.
13. Take care in the placement of electrical power cords.
14. Place the electric drill in a place and position where it will not be damaged when you have completed drilling.
15. When finished with the drill, clean it and return it to proper storage.
16. Use only recommended accessories. Consult manufacturer's instruction manual concerning accessories, installation, etc.

17. Do not stand on tools, place tools where they may be damaged by other tools or items, or allow tools to become wet.
18. Check each tool for damaged parts. If a part is damaged, before further use of the tool, check to ensure that it operates as intended, check for alignment and check for safety. Broken or damaged tools should be reported to the instructor immediately.

SABRE SAW SAFETY

1. Lay the saw down or hold it in a safe, secure position when plugging it in.
2. Always unplug the saw before making any adjustments on it.
3. Hold the saw shoe firmly and flat against the work. This will eliminate jumping or chattering while sawing.
4. Do not cut too small a radius with the sabre saw. The minimum radius must always be not less than three times the width of the blade.
5. Avoid allowing the electric cord to come in front of the saw where you might saw through the cord.
6. Clean up when you have completed sawing.
7. Always check with the instructor when making any adjustments on the sabre saw.
8. Do not hold the stock being cut with the fingers underneath since this might lead to cut fingers.
9. Never talk to the operator of a sabre saw.

DRILL PRESS SAFETY

1. Wear eyeshields while operating the drill press.
2. Clamp shall work in the vise or fasten it to the table.
3. Remove chips and shavings with a brush not with the hands. Stop the drill press before cleaning the table.
4. Keep fingers away from moving parts.
5. Keep hair, gloves, and loose clothing away from all moving parts.
6. Be sure that keys, drifts, and wrenches are all removed before starting the drill press.
7. Make certain bits are firmly clamped to prevent the chuck from becoming disengaged.
8. Holes to be drilled must be clearly marked.
9. Use a "V-block" for round or irregular shaped stock.
10. The only adjustment that can be made on the drill press while it is running is the speed adjustment.
11. Remove any ties, rings, and wrist watches before using the drill press.
12. Keep the floor around the machine clear of scraps and material.
13. Be sure there is no oil on the floor around the drill press.
14. Be sure the power is off before you leave the machine.
15. Set up the work so you will not damage the vise or table by drilling into them.
16. Use only sharp bits or the proper accessories with the drill press.
17. Clean the table and the floor around the machine when you are through using it.
18. Never talk to the operator of a drill press in use.

SAFETY IN ELECTRICAL SOLDERING

1. Use correct type of solder for job.
2. Protect eyes for possible spattering solder.
3. Avoid getting flux in eyes.
4. Tin soldering gun/iron for proper action.
5. Check tightness of lug nuts on soldering gun tip if gun does not heat properly...first unplugging gun from outlet.
6. Do not check heat of soldering gun/iron with wet fingers.
7. Do not touch joints that have just been soldered.
8. Avoid breathing fumes from soldering job.
9. Wear protective goggles when cleaning solder job.
10. Wash hands thoroughly after using soft solder.

MODULE 4.0
ELECTRICAL MEASURING INSTRUMENTS

ELECTRICITY
ELECTRICAL MEASURING INSTRUMENTS
SUGGESTED INSTRUCTION TIMES

<u>ELECTRICITY</u> <u>MODULE/TASK</u>			<u>SUGGESTED</u> <u>HOURS</u>
MODULE 4.0	ELECTRICAL MEASURING INSTRUMENTS		
4.01	Electrical Measuring Instruments		*
4.02	Use the Clamp-on Ammeter		*
4.03	Use the VOM (Multimeter)		30

* = See 4.03

TASK LISTINGS
ELECTRICITY

MODULE/TASK	DESCRIPTION
MODULE 4.0	ELECTRICAL MEASURING INSTRUMENTS
4.01	(Electrical Measuring Instruments) Given standard electrical measuring instruments such as the multi-meter, clamp-on ampmeter, or other instruments, demonstrate ability to identify and state how meter measuring instrument is used, demonstrate proper use and care of meter/measuring instrument.
4.02	(Use the Clamp-on Ammeter) Given AC circuits to measure, a clamp-on ammeter or clamp-on ammeter attachment for a VOM, scale expander/multiplier at instructor's discretion, instruction on operating the clamp-on ammeter; measure given AC circuits to the standards of the instructor.
4.03	(Use the VOM (Multimeter)) Given a typical VOM (Multimeter), with AC, S+DC, and Ohms Scales and test leads, and instructions concerning its operation and various circuits requiring measuring; use the VOM to measure AC, DC, and Ohms, and Continuity.

MODULE 4.0

ELECTRICAL MEASURING INSTRUMENTS

TASK 4.01

ELECTRICAL MEASURING INSTRUMENTS

PERFORMANCE OBJECTIVE:

Given standard electrical measuring instruments such as the volt-ohm-multi-meter, clamp-on ammeter, or other instruments, demonstrate ability to identify and state how meter measuring instrument is used, demonstrate proper use and care of meter/measuring instrument.

Suggested Measuring Instruments:

Amprobe or Ampmeter

Multimeter or VOM

PERFORMANCE ACTIONS:

- 4.0101 A. Amprobe, Clamp-on Ampmeter, or Current Transducer:
1. Identify scales, levers, and switches on an Amprobe, clamp-on ammeter
 2. Demonstrate ability to take amperage reading with clamp-on ammeter. Suggestion: Student read clamp-on ammeter on a number of pieces of electrical equipment such as trainers, refrigerators, air conditioners, etc. (Contract Air Conditioning Department for joint training or training aids).
 3. Check an electrical motor with an clamp-on ammeter
- 4.0102 B. Multi-meter (Volt-Ohm Meter)
1. Identify scales, switches, and meter leads of:
 - a. Voltmeter
 - b. Ohmmeter
 2. Take reading with voltmeter. Suggestion: Readings should be taken at various electrical power connections: Outlets, starters, terminal connectors, etc.
 3. Take readings with ohmmeter.
 - a. Use ohmmeter to check an electrical motor

MODULE	4.0	ELECTRICAL MEASURING INSTRUMENTS
TASK	4.01	ELECTRICAL MEASURING INSTRUMENTS (Con't.)

PERFORMANCE STANDARDS:

- Identify scales, levers, and switches and use of electrical measuring instruments, specifically the clamp-on ammeter and volt-ohm meter, with 100 percent accuracy in all functions instructed.
- Accurately demonstrate proper use and care of measuring instruments. Make reading with 100 percent accuracy.

SUGGESTED INSTRUCTION TIME: See 4.03

RELATED TECHNICAL INFORMATION:

- Learning to use the Volt-Ohm Meter typically may involve several types of learning. For example,

TASK/ACTION	TYPE OF LEARNING*
Define VOM	Concept
Use VOM to check resistance	Rule-learning
Use VOM to check continuity	Rule-learning
Identify electrical components	Concept
Test switches with VOM	Discrimination
Test motor windings	Discrimination
Diagnose electrical problem based on VOM readings	Problem Solving
Troubleshoot motor with VOM	Discrimination

*See Workshop Guide II, Part IV, page 12-14.

MODULE 4.0

ELECTRICAL MEASURING INSTRUMENTS

TASK 4.02

USE THE CLAMP-ON AMMETER

PERFORMANCE OBJECTIVE:

Given AC circuits to measure, a clamp-on ammeter or clamp-on ammeter attachment for a VOM, scale expander/multiplier at instructor's discretion, instruction on operating the clamp on ammeter; measure given AC circuits to the standards of the instructor.

PERFORMANCE ACTIONS:

- 3.0301 Assemble ammeter instruments and accessories needed.
- 3.0302 Identify scales, levers, and switches on a clamp-on ammeter.

(NOTE: For purposes of description, the Amprobe instrument will be used as a standard.)
- 3.0303 Release pointer lock. Zero meter, if appropriate.
- 3.0304 Select proper scale (usually starting at highest range).
- 3.0305 Open jaws, encircle one conductor, close jaws.
- 3.0306 Read amperage. Select appropriate scale for accurate reading.
- 3.0307 If scale cannot be read due to obstruction, lock needle, remove instrument from conductor and take reading. Release lock after reading.
- 3.0308 On completing measurement, lock pointer, store instrument in case, and return to proper storage.

PERFORMANCE STANDARDS:

- Properly set up, use, and care for clamp-on ammeter making AC amperage measurements to the standards of the instructor.

SUGGESTED INSTRUCTION TIME: See 4.03

MODULE 4.0

ELECTRICAL MEASURING INSTRUMENTS

TASK 4.02

USE THE CLAMP-ON AMMETER
(Con't.)

RELATED TECHNICAL INFORMATION:

- Operation of ammeter.
- Use of multi-function clamp-on instrument: Voltage, resistance, and current measurements.
- Use of multiplier attachments (1x, 5x, and 10x readings).
- Use of field expedient multiplier loop (10 turns = 10x).
- Zero calibration of meter.
- Zero setting ohms scale.
- Safety.

MODULE 4.0 ELECTRICAL MEASURING INSTRUMENTS
TASK 4.03 USE THE VOM (MULTIMETER)

PERFORMANCE OBJECTIVE:

Given a typical VOM (Multimeter), with AC, DC, and Ohms Scales, test leads, instructions concerning its operation and various circuits requiring measuring; use the VOM to measure AC, DC, and Ohms, and Continuity.

PERFORMANCE ACTIONS:

- 3.0401 Review school policies and procedures.
- 3.0402 Identify scales, switches, and leads.
- 3.0404 Set the VOM on the proper scale for the reading to be taken.
- 3.0405 Check to be sure the Function Switch is on the correct scale/function.
- 3.0406 Measure (read);
 - a. AC
 - b. DC
 - c. Resistance ohms
 - d. Continuity

PERFORMANCE STANDARDS:

- Demonstrate the proper set up, use, and care of an analog scale VOM to measure AC, DC, resistance, and continuity.

SUGGESTED INSTRUCTION TIME: 4.01 - 4.03 = 30 Hours

RELATED TECHNICAL INFORMATION:

- VOM theory and operation: Voltmeter, ohmmeter, etc.
- Techniques for using Vom (measuring from highest scale, down, etc.)
- Use of VOM to measure voltage, resistance.
- Use of VOM to continuity measurement.
- Use of Vom with solid state circuits such as thermostats, controls, etc., to avoid damage to circuits being measured.
- Safety.
- Comparison to DVM (Digital Volt Meter).

SKILL EXPANSION:

- Use of DVM, if digital meter available.

USE AND CARE OF THE VOM
(Volt-Ohm-Milliameter)

Primary use of the VOM will be to measure volts, amps, and ohms.

VOLTS MEASUREMENTS:

The voltmeter probes should be connected to the circuit (power source) to be measured as if it were a load such as a light bulb. You might describe the voltmeter as being connected in as a parallel circuit.

AC AMPS MEASUREMENTS:

AC current/amps typically will be measured by a clamp-on ammeter or clamp-on/snap-around current transducer (attachment/extender/adaptor*) used with VOM. The transformer jaws of the AC ammeter or VOM extender* may be closed around either leg of a circuit and the meter dial will indicate the amps of current flow through the circuit. Typically, the ammeter allows measurement of current in several scales and, in practice, the first test generally is made on a higher scale and then moved to an appropriate lower scale for accuracy.

OHMS MEASUREMENT:

To measure ohms, first be sure all power is off or discharged before connecting the ohmmeter in the circuit. The ohmmeter is powered by a battery and current in the circuit being measured will severely damage the meter components.

If the resistance of the device or circuit being tested is not known, start on the highest scale on the meter and move to the lower scale for accuracy if possible.

If the ohmmeter is being used to test resistance in a solid state circuit such as a control device or in instrumentation use only the correct scale for such measurements since the ohmmeter can cause damage to a solid state circuit.

A primary use of the ohmmeter is to test continuity. With the meter probes connected to either end of a length of wire, the meter should read the resistance of the wire in ohms. With the meter probes shorted, the meter should read "0". With the probes not connected to a circuit or if the wire being measured is open or cut, the meter should read infinite () resistance, indicating that there is no continuity or no circuit. The ohmmeter may be used for checking a circuit, a relay coil, a switch, an electric motor, or a capacitor.

MODULE 5.0

ELECTRICAL WIRE CONNECTIONS

ELECTRICITY
ELECTRICAL WIRE CONNECTIONS
SUGGESTED INSTRUCTION TIMES

<u>ELECTRICITY</u> <u>MODULE/TASK</u>			<u>SUGGESTED</u> <u>HOURS</u>
MODULE	5.0	ELECTRICAL WIRE CONNECTIONS	
	5.01	Crimp Wire to Terminal Using Crimping Tool	*
	5.02	Splice Wires Using Solderless Connectors (Wire Nuts)	*
	5.03	Solder Electrical Conductors and Connections	30

* = See 5.C3

TASK LISTINGS
ELECTRICITY

MODULE/TASK	DESCRIPTION
MODULE 5.0	ELECTRICAL WIRE CONNECTIONS
5.01	(Crimp Wire to Terminal Using Crimping Tool) Given stranded electrical wire of the size typically encountered in HVAC residential systems, crimping tool, terminal connectors, and necessary tools or materials; strip insulation from the wire to an appropriate length and crimp the required terminal on the bare wire.
5.02	(Splice Wires Using Solderless Connectors /Wire Nuts/) Given electrical wire of the type typically encountered in residential HVAC systems, wire nuts, wire stripper, knife, or crimper with stripping capability; strip insulation from two or more wires and splice them so that a proper mechanical and electrical connection is made. Install wire nut on splice.
5.03	(Solder Electrical Conductors and Connections) Given tools, equipment, and materials including a soldering gun/iron and electrical solder and wiring or electrical connections to solder; solder the electrical wires or terminals so that a tight mechanical and electrical bond is formed.

MODULE 5.0

ELECTRICAL WIRE CONNECTIONS

TASK 5.01

CRIMP WIRE TO TERMINAL USING
CRIMPING TOOL

PERFORMANCE OBJECTIVE:

Given stranded electrical wire of the size typically encountered in HVAC residential systems, crimping tool, terminal connectors, and necessary tools or materials; strip insulation from the wire to an appropriate length and crimp the required terminal on the bare wire.

PERFORMANCE ACTIONS:

5.0101 Remove insulation from about 1/4 inch (or length recommended by instructor) of wire:

a. Crimp Tool Method:

- (1) Insert wire into proper skinning hole.
- (2) Squeeze handles of crimping tool closed.
- (3) Rotate crimping tool around wire to insure clean cut.
- (4) Hold wire firmly while pulling crimping tool away from wire to remove insulation.

b. Using knife:

- (1) Carefully cut insulation at slight angle to just touch wire (avoid nicking wire).
- (2) Carefully pull insulation from wire so wire is not cut or nicked with knife.

5.0102 Insert bare wire into end of terminal of proper type and size (Wire may be twisted first).

5.0103 Place jaws of crimping tool around end of terminal of proper type and size (Wire may be twisted first).

5.0104 Close crimping tool around terminal end.

5.0105 Squeeze terminal onto wire.

5.0106 Check connection by pulling terminal: If terminal begins to slide on wire, crimp again.

PERFORMANCE STANDARDS:

- Crimp terminal connector onto wire so that a secure mechanical and electrical connection is made.

MODULE 5.0

ELECTRICAL WIRE CONNECTIONS

TASK 5.01

CRIMP WIRE TO TERMINAL USING
CRIMPING TOOL

SUGGESTED INSTRUCTION TIME: See 5.03

RELATED TECHNICAL INFORMATION:

- How to strip insulation from wire.
- Different types of terminal connectors.
- Crimping tool.
- Safety considerations.
- Potential for damaging wire by nicks or cuts.

MODULE	5.0	ELECTRICAL WIRE CONNECTIONS
TASK	5.02	SPlice WIRES USING SOLDERLESS CONNECTORS (WIRE NUTS)

PERFORMANCE OBJECTIVE:

Given electrical wire of the type typically encountered in residential HVAC systems, wire nuts, wire stripper, knife, or crimper with stripping capability; strip insulation from two or more wires and splice them so that a proper mechanical and electrical connection is made. Install wire nut on splice.

PERFORMANCE ACTIONS:

- 5.0201 Remove proper length of insulation from wires to be spliced (considering wire size and wire nut).
- 5.0202 Twist standard wire together (each wire) as instructed.
- 5.0203 Make proper type of wire splice for job:
 - Pigtail
 - Tap or end splice
- 5.0204 Check to see if splice connection is mechanical and electrical secure.
- 5.0205 Install proper size wire nut tightly on splice so that no exposed wire extends outside of wire nut. (ALTERNATE: Install in a crimp connector on wire splice.)

PERFORMANCE STANDARDS:

- Splice wires using solderless connector so that the connection is mechanically and electrically secure.

SUGGESTED INSTRUCTION TIME: See 5.03

RELATED TECHNICAL INFORMATION:

- Removing insulation from wire.
- Making secure splice of two or more wires.
- Different types of solderless connectors approved by local codes.

MODULE 5.0

ELECTRICAL WIRE CONNECTIONS

TASK 5.03

SOLDER ELECTRICAL CONDUCTORS AND CONNECTIONS

PERFORMANCE OBJECTIVE:

Given tools, equipment, and materials including a soldering gun/iron and electrical wiring or electrical connections to solder; solder the electrical wires or terminals so that a tight mechanical and electrical bond is formed.

PERFORMANCE ACTIONS:

- 5.0301 Assemble tools, equipment, and materials.
- 5.0302 Identify wires, terminals, etc., to be soldered.
- 5.0303 Remove about 1/4 inch (or appropriate length) insulation from wires and clean wires being careful not to cut them.
- 5.0304 Twist wires together to form a united conductor (Wire may be thinned to promote soldering to connectors, etc.).
- 5.0305
 - a. Splice two wires together.
 - b. Connect wire to terminal.
 - c. Connect component to terminal.
- 5.0306 Solder mechanical/electrical connection allowing solder to flow on heated joint.
- 5.0307 Allow solder to cool.
- 5.0308 Check connection.
- 5.0309 Clean and tape joint tightly with two or more layers of recognized electrical tape to ensure that no electrical hazard is exposed. (Use heat shrink tubing or tape, if required/recommended.)

PERFORMANCE STANDARDS:

- Solder given electrical conductors and connections using proper solder and soldering methods/techniques so that the soldered connections are mechanically electrically bonded together.

MODULE	5.0	ELECTRICAL WIRE CONNECTIONS
TASK	5.03	SOLDER ELECTRICAL CONDUCTORS AND CONNECTIONS (Con't.)

SUGGESTED INSTRUCTION TIME: 5.01 - 5.03 = 30 Hours

RELATED TECHNICAL INFORMATION:

- Preparing wire for splicing, connecting to terminals, etc.
- Tinning wires, terminals.
- Use of soldering iron/gun, including tinning.
- Selection of electrical solder (50/50 Rosin-core).
- Making good mechanical connections.
- Safety.

MODULE 6.0

BENCHWORK IN ELECTRICAL WORK

"For the purpose of this description, benchwork represents work placed on a bench or in a bench vise for operations usually involving hand tool.

Benchwork may be interpreted as including floor work using the same tools. The drill press and bench or pedestal grinder have been included since benchwork operations required of the electrician might involve those machines which are found in most training situations."

Benchwork operations typically are represented by the use of measuring instruments to layout work that is assembled/disassembled, sawed, drilled, filed, etc., as required.

ELECTRICITY
BENCHWORK
SUGGESTED INSTRUCTION TIMES

<u>ELECTRICITY</u> <u>MODULE/TASK</u>	SUGGESTED HOURS
Module 6.0 BENCHWORK	
6.01 Inspect Workbench Area for Safe Working Environment	*
6.02 Care for Hand Tools	*
6.03 Identify and Properly use a Bench Vise	*
6.04 Using Hand Hacksaw, Cut Given Material in Required Time	*
6.05 Identify Types of Fasteners	*
6.06 Assemble and Fit Parts	*
6.07 Properly use Hand Tools for Assembly/Disassembly	*
6.08 Bench File Workpiece	*
6.09 Drill Holes with Portable Drill	*
6.10 Inspect, Clean, and Lubricate Drill Press	*
6.11 Set up a Drill Press	*
6.12 Drill Holes to Size	*
6.13 Inspect and Clean a Pedestal Grinder	*
6.14 Set-up Pedestal Grinder for Job	*

30

* = 30 Total Hours

TASK LISTINGS
ELECTRICITY

MODULE/TASK	DESCRIPTION
Module 6.0	BENCHWORK
6.01	(Inspect Workbench Area for Safe Working Environment) Using "performance actions" as a checklist, inspect the bench work area for safe working environment. All unsafe conditions must be reported immediately. All items must be marked safe or corrected to a safe condition.
6.02	(Care for Hand Tools) Given a tool box or set of typical hand tools used in electrical work, manufacturer's standards concerning proper use and care of hand tools; care for hand tools to manufacturer's or instructor's specifications.
6.03	(Identify and Properly use a Bench Vise) Given a standard bench vise demonstrate how to fasten the vise to the bench and use it properly.
6.04	(Using Hand Hacksaw, Cut Given Material in Required Time) Furnished with workpiece and blueprint/drawing/ specifications, hacksaw; hacksaw the workpiece in a given time to within 1/16 inch outside of marked* line. (*scribed, etc.)
6.05	(Identify Types of Fasteners) Given a random selection of typical fasteners the electrician may encounter, identify each fastener and its typical application.
6.06	(Assemble and Fit Parts) Given necessary tools and materials, necessary instruction, and parts to assemble and fit; assemble and fit the parts as required to accomplish the assigned task.
6.07	(Properly use Hand Tools for Assembly/Disassembly) Given electrician's hand tools or tool box, a job requiring use of hand tools, properly select and use basic hand tools including hammers, screwdrivers, wrenches, and pliers.
6.08	(Bench File Workpiece) Given a workpiece, blueprint or drawing/specifications, and necessary equipment; hand file the workpiece within a tolerance of +/- 1/16 inch on fractional dimensions or within blueprint specifications (+/- 1 degree on angular dimensions).

- 6.09 (Drill Holes with Portable Drill) Given a workpiece, drawing/specifications, or job requirement, portable drill, and the necessary tools and materials; drill the workpiece as required.
- 6.10 (Inspect, Clean, and Lubricate Drill Press) Given a drill press, operator's manual or instructions, cleaning materials, lubricants, and the necessary hand tools and materials; inspect, clean, and lubricate the drill press according to manufacturer's recommendations or instructor's standards. The drill press and surrounding area must be free of metal chips, excess lubricant, and foreign material.
- 6.11 (Set Up a Drill Press) Given a drill press requiring set up for a drilling operation, an assortment of accessories and attachments, vise, V-block yoke and clamps, an assortment of drill bits and collets, and the necessary tools, equipment and materials; set up the drill press for a drilling operation. All components must be mechanically secure with the drill bit fastened securely in the collet and the table set up for operation.
- 6.12 (Drill Holes to Size) Given a drill press, workpiece, detail drawing, drilling specifications, an assortment of drill bits and tools, measuring instruments, and necessary materials; drill holes in specification with a tolerance of $\pm 1/32$ inches.
- 6.13 (Inspect and Clean a Pedestal Grinder) Given an operator's manual or equivalent, cleaning materials, and the necessary hand tools; inspect and clean a pedestal grinder according to the manufacturer's recommended procedures. The grinder and surrounding area must be free of metal chips, excess lubricant, and foreign material.
- 6.14 (Set-Up Pedestal Grinder for Job) Given a pedestal grinder requiring set-up for a grinding operation, a grinding wheel requiring mounting, truing, and dressing, an operator's manual or equivalent, and the necessary tool, equipment, and materials; set-up the pedestal grinder and mount, true, and dress the grinding wheel for a grinding job. The grinding wheel must run true, and the grinding surface must not be loaded or glazed. The pedestal grinder must operate according to manufacturer's specifications.

MODULE	6.0	BENCHWORK IN ELECTRICAL WORK
TASK	6.01	INSPECT WORKBENCH AREA FOR SAFE WORKING ENVIRONMENT

PERFORMANCE OBJECTIVE:

Using "performance actions" as a checklist, inspect the bench work area for safe working environment. All unsafe conditions must be reported immediately. All items must be marked safe or corrected to a safe condition.

(OMIT ITEMS NOT APPLICABLE BY INDICATING "N/A".)

PERFORMANCE ACTIONS:

- 6.0101 Inspect machine tools in bench area:
 - a. Guards/safety devices in place.
 - b. Control location clear, safe.
 - c. Power transmission or drive mechanism safe.
 - d. Overload devices in place, proper value.
 - e. Ventilation, where applicable, provided.
 - f. Metal scraps cleaned up.
 - g. Attachments/accessories available.
- 6.0102 Hand tools:
 - a. Stored properly.
 - b. Not damaged.
 - c. Clean.
 - d. Safety devices, where applicable, provided/attached.
- 6.0103 Personal protection equipment: (Where applicable)
 - a. Foot wear (no canvas shoes, etc.)
 - b. Eye protection, when appropriate.
 - c. Head protection, where applicable.
 - d. First-aid station provided.
 - e. Fire extinguisher provided.
- 6.0104 Safety signs and markings displayed in proper locations and proper color coded markings used for safety.
- 6.0105 Floors, passageways, aisles, spaces around machines:
 - a. Clean.
 - b. Free of oil grease, or other liquids.

MODULE 6.0 BENCHWORK IN ELECTRICAL WORK
TASK 6.01 INSPECT WORKBENCH AREA FOR
SAFE WORKING ENVIRONMENT

PERFORMANCE ACTIONS (Con't.):

- c. Materials not blocking work or passage area.
- d. Non-skid mats or safety mats used where appropriate.

6.0106 Disposal cans:

- a. Located in designated, convenient area.
- b. Marked.
- c. Covered, if applicable (for greasy, oily rags, etc.).

PERFORMANCE STANDARDS:

- Work bench area inspected for safety, using checklist provided.

SUGGESTED INSTRUCTION TIME: Hours

MODULE 6.0

BENCHWORK IN ELECTRICAL WORK

TASK 6.02

CARE FOR HAND TOOLS

PERFORMANCE OBJECTIVE:

Given a tool box or set of typical hand tools used in electrical work, manufacturer's standards concerning proper use and care of hand tools; care for hand tools to manufacturer's or instructor's specifications.

PERFORMANCE ACTIONS:

6.0201 Inspect hand tools and determine damage, if any:

- a. Cutting tools must be sharp with no broken teeth.
- b. Clamping tools must have clean jaws and screws.
- c. Soft jaws must be available for vises.
- d. Screwdrivers must have correctly shaped blades.
- e. Punches and chisels must not have mushroomed heads.

6.0202 Obtain any needed parts:

- a. Dismantle and replace damaged parts.
- b. Make required adjustments.

6.0203 Sharpen dull tools:

- a. Check for mushroomed heads.
- b. Check angle of cutting edge.
- c. Regrind shape as required.

PERFORMANCE STANDARDS:

- For given hand tools, demonstrate proper use and care of hand tools such as pliers, screwdrivers, wrenches, striking and struck tools to the manufacturer's or instructor's standards.

(NOTE: Most electrical hand tools are covered in the following publication which may be referred to for standards:

Proper Use and Care of Hand Tools, Pliers, Screwdrivers, Wrenches, Striking & Struck Tools, Chicago, IL: Klein Tools, Inc., 1977. (Available free in quantities to vocational programs.)

SUGGESTED INSTRUCTION TIME: Hours

RELATED TECHNICAL INFORMATION:

- Manufacturer's standards concerning care for hand tools.
- Instructor's standards for care of shop tools.
- Safety.

MODULE 6.0

BENCHWORK IN ELECTRICAL

TASK 6.03

IDENTIFY AND PROPERLY USE
A BENCH VISE

PERFORMANCE OBJECTIVE:

Given a standard bench vise demonstrate how to fasten the vise to the bench and use it properly.

PERFORMANCE ACTIONS:

- 6.0301 Explain the purpose of the bench vise.
- 6.0302 Demonstrate proper techniques of using the bench vise.

PERFORMANCE STANDARDS:

- Properly identify and demonstrate how to use a standard bench vise to the instructor's standards.

SUGGESTED INSTRUCTION TIME: Hours

RELATED TECHNICAL INFORMATION:

- Safety.

MODULE	6.0	BENCHWORK IN ELECTRICAL WORK
TASK	6.04	USING HAND HACKSAW, CUT GIVEN MATERIAL IN REQUIRED TIME

PERFORMANCE OBJECTIVE:

Furnished with workpiece and blueprint/drawing/specifications, hacksaw; hacksaw the workpiece in a given time to within 1/16 inch outside of marked* line. (*scribed, etc.)

PERFORMANCE ACTIONS:

- 6.0401 Review job blueprint/drawing/specifications.
- 6.0402 Select hacksaw and blade.
- 6.0403 Properly mount blade in hacksaw frame.
- 6.0404 Mount workpiece (conduit, angle iron, etc.) in holding device such as vise.
- 6.0405 Using correct technique*, saw workpiece to specifications:
 - a. Mark workpiece for cut.
 - b. Notch workpiece with file for start of cut.
 - c. Protect workpiece from jaws of holding device.
 - d. Saw 1/16 inch outside of scribed line.

*Cutting techniques: For heavy metal stock, hold handle with one hand, firmly grip front of saw frame with other hand. For thinner metals, the cut is usually made with one hand cut on forward stroke, lift blade slightly on return stroke.

- 6.0406 Deburr when finished.

PERFORMANCE STANDARDS:

- Using hand hacksaw, cut given material in the required time, within 1/16 inch outside of scribed line, meeting the instructor's standards for use and care of hacksaw.

SUGGESTED INSTRUCTION TIME: 3-6 Hours

MODULE 6.0

BENCHWORK IN ELECTRICAL WORK

TASK 6.04

USING HAND HACKSAW, CUT GIVEN
MATERIAL IN REQUIRED TIME (Con't.)

RELATED TECHNICAL INFORMATION:

- Identify hand hacksaw parts, design.
- Identify types of materials which may be cut by hand hacksaw.
- Identify types of blades which may be used with hacksaw (14, 18, 24, 32 teeth) and typical uses.
- Identify when and how to mount more than one blade on hacksaw.
- Describe/demonstrate proper technique in using hacksaw.
- Safety with hacksaw.

MODULE 6.0

BENCHWORK IN ELECTRICAL WORK

TASK 6.05

IDENTIFY TYPES OF FASTENERS

PERFORMANCE OBJECTIVE:

Given a random selection of typical fasteners the electrician may encounter, identify each fastener and its typical application.

PERFORMANCE ACTIONS:

6.0501 Identify fasteners:

- a. Bolts
- b. Screws
- c. Nuts
- d. Studs
- e. Washers
- f. Internal threaded inserts
- g. Rivets
- h. Pins: Cotter, Dowel, Taper, Split dowel
- i. Retaining fasteners: Rings
- j. Keys: Square, Woodruff, Rocket, Taper

6.0502 Identify some typical uses of fasteners.

PERFORMANCE STANDARDS:

- Identify types of fasteners common to electrical work and their typical uses to the standards of the instructor.

SUGGESTED INSTRUCTION TIME: Hours

RELATED TECHNICAL INFORMATION:

- Commercial Supply Catalogs

MODULE 6.0

BENCHWORK IN ELECTRICAL WORK

TASK 6.06

ASSEMBLE AND FIT PARTS

PERFORMANCE OBJECTIVE:

Given necessary tools and materials, necessary instructions, and parts to assemble and fit; assemble and fit the parts as required to accomplish the assigned task.

PERFORMANCE ACTIONS:

6.0601 Assemble and fit parts as required.

PERFORMANCE STANDARDS:

- Assemble and fit parts to the instructor's standards.

(NOTE: Orientation training: Competency will be developed through practice and experience.)

SUGGESTED INSTRUCTION TIME: 6-9 Hours

RELATED TECHNICAL INFORMATION:

- Tolerances.
- Types of fits:
 - a. Loose
 - b. Free
 - c. Medium
 - d. Snug
 - e. Wringing
 - f. Tight
 - g. Heavy force and shrink

MODULE 6.0

BENCHWORK IN ELECTRICAL WORK

TASK 6.07

PROPERLY USE HAND TOOLS FOR
ASSEMBLY/DISASSEMBLY

PERFORMANCE OBJECTIVE:

Given electrician's hand tools or tool box, a job requiring use of hand tools; properly select and use basic hand tools including hammers, screwdrivers, wrenches, and pliers.

PERFORMANCE ACTION:

- 6.0701 Properly select and demonstrate use and care of ball peen or electrician's hammer or other striking tools as required:
- a. Identify main parts of typical hammers used by electricians.
 - b. Hammer safety.
- 6.0702 Properly select and demonstrate use and care of screwdrivers:
- a. Identify basic types of screwdrivers.
 - b. Choosing a screwdriver for a given job.
- 6.0703 Properly select a wrench for a given job:
- a. Identify types:
 - open end
 - box end
 - adjustable
 - spanner
 - b. Demonstrate proper method of using wrenches:
 - safety
 - leverage
 - checking nut tightness
- 6.0704 Properly select and use pliers for benchwork:
- a. Identify major types of pliers.
 - b. Demonstrate proper use and care of pliers.

PERFORMANCE STANDARDS:

- Properly use and care for hand tools for assembly/disassembly.

SUGGESTED INSTRUCTION TIME: Hours

RELATED TECHNICAL INFORMATION:

- Care of hand tools.
- Safety.

MODULE	6.0	BENCHWORK IN ELECTRICAL WORK
TASK	6.08	BENCH FILE WORKPIECE

PERFORMANCE OBJECTIVE:

Given a workpiece, blueprint or drawing/specifications, and necessary equipment; hand file the workpiece within a tolerance of $\pm 1/16$ inch on fractional dimensions or within blueprint specifications (± 1 degree on angular dimensions).

PERFORMANCE ACTIONS:

- 6.0801 Review specifications.
- 6.0802 Select proper file.
- 6.0803 Check file handle or install handle on file.
- 6.0804 Clean file, if necessary (file should have been cleaned prior to storage in tool room/box).
- 6.0805 Mount workpiece.
- 6.0806 Test flatness or angle of work.
- 6.0807 Check for pinning (condition of file) and chalk file.
- 6.0808 File to final tolerance:
 - a. Avoid allowing file to rock or see-saw, which might produce a crowned surface.
 - b. Use flat filing or drawfiling techniques as appropriate.
- 6.0809 Upon completion of job task, clean file and return it to tool room/box.

PERFORMANCE STANDARDS:

- Hand file workpiece within a tolerance of $\pm 1/16$ inch on fractional dimensions (± 1 degree on angular dimensions) or within blueprint specifications.
- File should be held in a safe manner, flat so it does not rock or see-saw, and used in a procedure recommended by the instructor.
- Performance process and product must be to instructor's standards.

MODULE 6.0

BENCHWORK IN ELECTRICAL WORK

TASK 6.08

BENCH FILE WORKPIECE (Con't.)

SUGGESTED INSTRUCTION TIME: . Hours

RELATED TECHNICAL INFORMATION:

- File patterns, cuts or files: Single, double, rasp, and curved.
- Straightforward, flat, draw, and round-corner filing.
- Use of the file card and care of files.
- Safety with files.
- Techniques of hand filing: Instructor's standards.
- Measuring instruments.
- Use of bench vise.

MODULE 6.0

BENCHWORK IN ELECTRICAL WORK

TASK 6.09

DRILL HOLES WITH PORTABLE DRILL

PERFORMANCE OBJECTIVE:

Given a workpiece, drawing/specifications, or job requirement, portable drill, and the necessary tools and materials; drill the workpiece as required.

PERFORMANCE ACTIONS:

- 6.0901 Review specifications.
- 6.0902 Locate and center punch in workpiece.
- 6.0903 Mount workpiece in holding device.
- 6.0904 Select drill:
 - a. Check size (with drill gage, etc.).
 - b. Check sharpness.
- 6.0905 Mount drill bit in portable drill and properly tighten bit in chuck.
- 6.0906 Drill hole in workpiece:
 - a. Observe safety procedures.
 - b. Hold drill perpendicular to workpiece.
 - c. Run drill at proper speed, if adjustable.
 - d. Reduce feed pressure as drill penetrates workpiece.
 - e. Deburr hole.
- 6.0907 Verify drilled hole.
- 6.0908 Clean/care for tools and return them to proper storage.

PERFORMANCE STANDARDS:

- Drill holes with portable drill as required meeting instructor's standards for performance process and product.

SUGGESTED INSTRUCTION TIME: Hours

MODULE 6.0

BENCHWORK IN ELECTRICAL WORK

TASK 6.09

DRILL HOLES WITH PORTABLE DRILL
(Con't.)

RELATED TECHNICAL INFORMATION:

- Safety.
- Selection of drill bits.
- Use of portable drill.
- Alignment of drill/bit with workpiece.
- Electrical safety (portable power drill).

MODULE 6.0

BENCHWORK IN ELECTRICAL WORK

TASK 6.10

INSPECT, CLEAN, AND LUBRICATE
DRILL PRESS

PERFORMANCE OBJECTIVE:

Given a drill press, operator's manual or instructions, cleaning materials, lubricants, and the necessary hand tools and materials; inspect, clean, and lubricate the drill press according to manufacturer's recommendations or instructor's standards. The drill press and surrounding area must be free of metal chips, excess lubricant, and foreign material.

PERFORMANCE ACTIONS:

6.1001 Shut off power.

6.1002 Clean drill press:

- a. Brush off all chips.
- b. Wash grease and oil of machine surfaces.

6.1003 Lubricate drill press according to service manual or given instructions:

- a. Coat column and table lightly with oil.
- b. Apply grease to fittings.
- c. Apply oil to oil cups.
- d. Apply oil to sliding parts.

PERFORMANCE STANDARDS:

- Inspect, clean, and lubricate a drill press to given standards.
- The machine and surrounding area must be clean of chips, lubricant, and foreign material.
- The machine must operate properly.

SUGGESTED INSTRUCTION TIME: Hours

RELATED TECHNICAL INFORMATION:

- Describe procedures for inspecting and cleaning a drill press.
- Explain the necessary safety precautions.
- Identify materials used to clean a drill press.
- Explain reasons for performing routine inspection and cleaning of a drill press.

MODULE 6.0

BENCHWORK IN ELECTRICAL WORK

TASK 6.10

INSPECT, CLEAN, AND LUBRICATE
DRILL PRESS (Con't.)

RELATED TECHNICAL INFORMATION: (Con't.)

- Work holding devices:
 - Vise
 - C- Clamps
 - T-bolts, T-nuts
- Safety.
- V-blocks
- Clamps, Straps

MODULE 6.0

BENCHWORK IN ELECTRICAL WORK

TASK 6.11

SET UP A DRILL PRESS

PERFORMANCE OBJECTIVE:

Given a drill press requiring set up for a drilling operation, an assortment of accessories and attachments, vise, V-block yoke and clamps, an assortment of drill bits and collets, and the necessary tools, equipment and materials; set up the drill press for a drilling operation. All components must be mechanically secure with the drill bit fastened securely in the collet and the table set up for operation.

PERFORMANCE ACTIONS:

- 6.1101 Clean drill press.
- 6.1102 Select proper drill or accessories.
- 6.1103 Adjust: table, head, and depth adjustments.
- 6.1104 If straight-shank drill is used, mount drill in drill chuck. (If taper-shank drill is used, insert it directly in spindle, or in a drill sleeve and then in spindle.)
- 6.1105 Turn on power to see if drill is running straight.
- 6.1106 Mount workpiece in holding device.
- 6.1107 Follow procedures to drill workpiece (see following task objectives).

PERFORMANCE STANDARDS:

- Set up a drill press for operation using given accessories and materials so that the drill press and components are mechanically secure and prepared for the required operation.

SUGGESTED INSTRUCTION TIME: Hours

RELATED TECHNICAL INFORMATION:

- Identify: Variable speed control, head, motor, power feed, spindle, table, column, base and quill.
- Explain how to calculate speeds and feeds on a drill press.
- Identify attachments and accessories for the drill press.
- Identify sizes and capacities or various drill presses.
- Identify procedures for setting up a drill press.

MODULE 6.0

BENCHWORK IN ELECTRICAL WORK

TASK 6.11

SET UP A DRILL PRESS

RELATED TECHNICAL INFORMATION (Con't.):

- Explain how to mount a drill bit and collet in a drill press.
- Explain how to mount a vise and align a workpiece.
- Identify work hold devices available in the electricity shop or used in electrical work.
- Describe work holding procedures.
- Describe drill chucks and tool holding procedures.
- Identify safety considerations.

MODULE 6.0

BENCHWORK IN ELECTRICAL WORK

TASK 6.12

DRILL HOLES TO SIZE

PERFORMANCE OBJECTIVE:

Given a drill press, workpiece, detail drawing, drilling specifications, an assortment of drill bits and tools, measuring instruments, and necessary materials; drill holes in specification with a tolerance of $\pm 1/32$ inches.

PERFORMANCE ACTIONS:

- 6.1201 Assemble materials.
- 6.1202 Set up drill press.
- 6.1203 Select holding device and accessories.
- 6.1204 Secure work-holding device.
- 6.1205 Determine hole size.
- 6.1206 Align workpiece with center drill in chuck.
- 6.1207 Calculate speed.
- 6.1208 Set drill press speed.
- 6.1209 Center drill workpiece.
- 6.1210 Select and mount drill bit.
- 6.1211 Reset speed.
- 6.1212 Drill to specifications:
 - a. Use required lubricant.
 - b. Slow feed as drill penetrates workpiece.
 - c. Deburr hole.
- 6.1213 Measure drilled hole(s).

PERFORMANCE STANDARDS:

- Drill hole or holes to size in given workpiece with a tolerance of $\pm 1/32$ inch* or to specifications. (*or ± 1 cm.)

MODULE 6.0

BENCHWORK IN ELECTRICAL WORK

TASK 6.12

DRILL HOLES TO SIZE (Con't.)

SUGGESTED INSTRUCTION TIME: . Hours

RELATED TECHNICAL INFORMATION:

- Technique of easing up pressure as drill point breaks through work.
- Drilling techniques with thin metal.

*Tolerance standards will be determined by available measuring devices:

- a. $\pm 1/32$ inch may be located between markings on $1/16$ inch accuracy rule.
- b. 1 cm. may be located on a typical metric rule, readily available.

MODULE 6.0

BENCHWORK IN ELECTRICAL WORK

TASK 6.13

INSPECT AND CLEAN A PEDESTAL GRINDER

PERFORMANCE OBJECTIVE:

Given an operator's manual or equivalent, cleaning materials, and the necessary hand tools; inspect and clean a pedestal grinder according to the manufacturer's recommended procedures. The grinder and surrounding area must be free of metal chips, excess lubricant, and foreign material.

PERFORMANCE ACTIONS:

- 6.1301 Review instructions.
- 6.1302 Assemble cleaning materials.
- 6.1303 Inspect and clean the pedestal grinder following outlined procedures.
- 6.1304 Inspect the pedestal grinder for cleanliness and safety.
- 6.1305 Clean around the pedestal grinder as appropriate.

PERFORMANCE STANDARDS:

- Inspect and clean a pedestal grinder according to manufacturer's recommended procedures and clean surrounding area as appropriate.
- Process performance must be to instructor's standards.

SUGGESTED INSTRUCTION TIME: Hours

RELATED TECHNICAL INFORMATION:

- Safety.
- Identify proper materials used to clean a pedestal grinder.

MODULE 6.0

BENCHWORK IN ELECTRICAL WORK

TASK 6.14

SET-UP PEDESTAL GRINDER FOR JOB

PERFORMANCE OBJECTIVE:

Given a pedestal grinder requiring set-up for a grinding operation, a grinding wheel requiring mounting, truing, and dressing, an operator's manual or equivalent, and the necessary tools, equipment, and materials; set-up the pedestal grinder and mount, true, and dress the grinding wheel for a grinding job. The grinding wheel must run true, and the grinding surface must not be loaded or glazed. The pedestal grinder must operate according to manufacturer's specifications.

PERFORMANCE ACTIONS:

- 6.1401 Review manufacturer's instruction manual or equivalent.
- 6.1402 Assemble required materials, tools, and equipment.
- 6.1403 Select proper grinding wheel for job.
- 6.1404 Inspect and ring-test grinding wheel prior to mounting.
- 6.1405 Mount, true, and dress grinding wheel.
- 6.1406 Set-up pedestal grinder for required operation.
- 6.1407 Operate pedestal grinder in a safe and proper manner.
- 6.1408 Perform grinding operation to specifications.

PERFORMANCE STANDARDS:

- Set-up pedestal grinder according to instruction given; mount, true, and dress wheel; and demonstrate proper use of pedestal grinder.
- The grinding wheel must run true, and the grinding surface must not be loaded or glazed.
- The pedestal grinder must operate according to manufacturer's specifications.
- Process performance must be instructor's standards.

SUGGESTED INSTRUCTION TIME: Hours

MODULE 6.0

BENCHWORK FOR ELECTRICAL WORK

TASK 6.14

SET-UP PEDESTAL GRINDER (Con't.)

RELATED TECHNICAL INFORMATION:

- Identify:
 - a. Pedestal
 - b. Motor
 - c. Grinding wheel
 - d. Safety shield
 - e. Tool rest
 - f. Wheel guard
 - g. Coolant reservoir
 - h. Power switch
- Identify grinding wheel defects.
- Selection of proper grinding wheel for job.
- Procedures for setting up pedestal grinder demonstrated by instructor.
- Basic uses of pedestal grinder.
- Selection of coolant used for wet grinding.
- Proper use of tool rest and wheel guard.
- Safety with the pedestal grinder.
 - "Don't stand in front of grinding wheel: Stand to one side for about a minute as wheel is turned on in case wheel disintegrates."

MODULE 7.0

RESIDENTIAL WIRING AND ELECTRICAL MAINTENANCE

DESIGN OF THIS MODULE

This module on residential wiring and electrical maintenance consists of units based on a possible sequence of tasks which might occur during the wiring of a residential structure. After a temporary service is established for construction, the service is roughed in, cables pulled, boxes installed, and, finally, the wiring is trimmed out and checked for operation.

The suggested sequence in this performance/competency-based description should not restrict the learning situation since the sequence may be modified easily at the local level. The description outlines minimum tasks which may be used to determine the competency of a graduate of the secondary electricity program in residential wiring.

UNITS OF THIS MODULE:

UNIT	TITLE
7.0 A	Compute Service Loads
7.0 B	Install Service Entrance
7.0 C	Installing Switch and Outlet Boxes
7.0 D	Rough in Electrical Circuits
7.0 E	Rough in Telephone Wire and Accessories
7.0 F	Trim Out (Finish) Electrical Devices
7.0 G	Maintain Lighting/Wiring System (Residential)

STANDARDS APPLICABLE TO THIS MODULE

Standards applicable to units in this module may be found in the following publication which are believed to represent good practices.

Electrical Wiring, Athens, GA: American Association for Vocational Instructional Materials, 1981.

Maintaining the Lighting and Wiring System, Athens, GA: American Association for Vocational Instructional Materials, 1980.

Mullin, Ray C., Electrical Wiring: Residential, Albany, NY: Delmar Publishers Inc., 1981.

National Electrical Code, 1981, Quincy, MA: National Fire Protection Association, 1980.

UNIT 7.0 A

COMPUTE SERVICE LOADS

ELECTRICITY
COMPUTE SERVICE LOADS
SUGGESTED INSTRUCTION TIMES

<u>ELECTRICITY</u> <u>MODULE/TASK</u>		SUGGESTED HOURS
UNIT 7.0 A	COMPUTE SERVICE LOADS	
7.01	Calculate Individual Circuit Load	*
7.02	Balance Total Load Per Leg	*
7.03	Compute Size of Service Entrance Conductors	30

* = See 7.03

TASK LISTINGS
ELECTRICITY

MODULE/TASK	DESCRIPTION
UNIT 7.0 A	COMPUTE SERVICE LOADS
7.01	(Calculate Individual Circuit Load) Given a floor plan showing the basic wiring of a residential structure, a copy of the <u>National Electrical Code</u> , a copy of the requirements from the authority having jurisdiction (City Codes), unit data plate showing ratings of electrical appliance/equipment or given information concerning ratings; calculate individual circuit load.
7.02	(Balance Total Load Per Leg) Given instruction, a residential house floor plan showing the basic wiring system, a copy of the <u>National Electrical Code</u> , a copy of the requirements from the local codes authority; balance the total load per leg. Each phase must supply approximately half of the total load requirement for the 120 volt circuits.
7.03	(Compute Size of Service Entrance Conductors) Given a floor plan showing the basic wiring system of a residential structure, a copy of the <u>National Electrical Code</u> , a copy of the requirements of the authority having jurisdiction, and the unit data plate ratings of electrical appliances; compute the size of the service entrance conductors. The total calculated load must include all circuits to be installed. The calculation of the size of the service entrance conductors must meet the requirements as outlined by the <u>National Electrical Code</u> (Ar. 220, Ch. 9).

UNIT	7.0 A	COMPUTE SERVICE LOADS
TASK	7.01	CALCULATE INDIVIDUAL CIRCUIT LOAD

PERFORMANCE OBJECTIVE:

Given a floor plan showing the basic wiring of a residential structure, a copy of the National Electrical Code, a copy of the requirements from the authority having jurisdiction (City Codes), unit data plate showing ratings of electrical appliance/equipment or given information concerning ratings; calculate individual circuit load.

The circuit load must not total more than the allowed overcurrent device rating (circuit breaker) or the current carrying capacity of the conductors. The calculations of the individual circuit load must meet the requirements as outlined by the National Electrical Code (Chapter 9, Example 1) and the local code authority.

PERFORMANCE ACTIONS:

- 7.0101 List all possible equipment that is used at one time on an individual circuit.
- 7.0102 Determine the wattage of all appliances being used on the circuit. (Alternate: Determine amperage drawn by each appliance on circuit.)
- 7.0103 Total wattage. (Alternate: Total amperage.)
- 7.0104 Divide total wattage by applied voltage to calculate total amperage. (Omit this step if calculations were made directly in amps.)
- 7.0105 For light and convenience outlets...allow 1.5 amps per outlet or load figure given by instructor.*

PERFORMANCE STANDARDS:

- Calculate individual circuit load based on possible appliances or equipment on circuit.
- Calculations must meet instructor's standards.

SUGGESTED INSTRUCTION TIME: See 7.03

RELATED TECHNICAL INFORMATION:

- Formula for calculating amperage or wattage from given voltage and either amperage or wattage.

UNIT	7.0 A	COMPUTE SERVICE LOADS
TASK	7.01	CALCULATE INDIVIDUAL CIRCUIT LOAD

RELATED TECHNICAL INFORMATION (Con't.):

- Decimals.
- Calculating load on a circuit.

*If no ratings are given, student may use the following for 120 volt line.

Lighting:	60 watts	.5 amps	(approximates)
	100 watts	.8 amps	
	200 watts	1.7 amps	
	150 watts	2.7 amps	
Appliance:	500 watts	4.2 amps	
	1000 watts	8.3 amps	
	1500 watts	12.5 amps	(such as portable electrical space heaters)
	1700 watts	14.2 amps	
Motors:	1/2 Hp	1058 watts	
	3/4 Hp	1610 watts	
	1 Hp	1955 watts	

UNIT 7.0 A

COMPUTE SERVICE LOADS

TASK 7.02

BALANCE TOTAL LOAD PER LEG

PERFORMANCE OBJECTIVE:

Given instruction, a residential house floor plan showing the basic wiring system, a copy of the National Electrical Code, a copy of the requirements from the local codes authority; balance the total load per leg. Each phase must supply approximately half of the total load requirements for the 120 volt circuits.

(NOTE: For the purpose of this training task, OMIT ALL 240 VOLT CIRCUITS FROM CALCULATIONS, INCLUDING RANGE, HEATER, AIR CONDITIONING, ETC.)

PERFORMANCE ACTIONS:

- 7.0201 List all 120 volt circuits.
- 7.0202 Determine wattage of all appliances being used or to be installed. (Use manufacturer's data plate or other information available.)
- 7.0203 Calculate wattage total per circuit. (Calculations could be in terms of amps.)
- 7.0204 Divide total wattage per circuit by voltage to determine amps per circuit.
- 7.0205 Load each phase with an equal number of 120 volt circuits based on amperage. (Alternate: Determine the actual load on each phase based on the circuits and appliances.)
- 7.0206 Total each leg.
- 7.0207 Compare totals to determine degree of balance.
- 7.0208 As necessary, redistribute 120 volt loads on phases until approximate balance is reached.

PERFORMANCE STANDARDS:

- Calculate and balance total load per leg for 120 volt circuits so that each leg supplies approximately half of the total load requirements for the 120 volt circuits.
- Computations must be accurate and to the instructor's standards.

UNIT	7.0 A	COMPUTE SERVICE LOADS
TASK	7.02	BALANCE TOTAL LOAD PER PHASE (Con't)

SUGGESTED INSTRUCTION TIME: See 7.03

RELATED TECHNICAL INFORMATION:

- Single phase residential service.
- Formulas for determining amperage or wattage given the voltage and either amperage or wattage.
- Procedure for balancing load.

UNIT	7.0 A	COMPUTE SERVICE LOADS
TASK	7.03	COMPUTE SIZE OF SERVICE ENTRANCE CONDUCTORS

PERFORMANCE OBJECTIVE:

Given a floor plan showing the basic wiring system of a residential structure, a copy of the National Electrical Code, a copy of the requirements of the authority having jurisdiction, and the unit data plate ratings of electrical appliances; compute the size of the service entrance conductors. The total calculated load must include all circuits to be installed. The calculation of the size of the service entrance conductors must meet the requirements as outlined by the National Electrical Code (Ar. 220, Ch. 9).

PERFORMANCE ACTIONS:

- 7.0301 Calculate the general lighting load.
- 7.0302 Calculate the number of branch circuits required and their loads.
- 7.0303 Calculate the small appliance load.
- 7.0304 Calculate the washer/dryer load.
- 7.0305 Calculate the total load of the 120 volt circuits.
- 7.0306 Calculate the circuit loads of the 240 (220) volt appliances such as the range, heater, air conditioner, water heater, etc.
- 7.0307 Total the 120 and 240 volt loads.
- 7.0308 Calculate the amperes required at the service according to the National Electrical Code (Ch.9).

PERFORMANCE STANDARDS:

- Compute size of service entrance conductors according to the total electrical load and using the requirements of the National Electrical Code.

SUGGESTED INSTRUCTION TIME: 7.01 - 7.03 = 30 Hours

UNIT	7.0 A	COMPUTE SERVICE LOADS
TASK	7.03	COMPUTE SIZE OR SERVICE ENTRANCE CONDUCTORS (Con't)

RELATED TECHNICAL INFORMATION:

- National Electrical Code.
- Formula for computing the amperage or wattage from given voltage and amperage or wattage.
- Determining the rating of appliances.

NOTE:

- Greenville, SC City Codes require:
- a. Separate service to motor driven appliances.
 - b. 2 each 20 amp service in kitchen.
 - c. 1 each 20 amp service for washer.
 - d. #6-3 on range.

UNIT 7.0 B
INSTALL SERVICE ENTRANCE

TOOL KIT AND POUCH STANDARDS

References to the tool kit are based on the following tools:

- Allen wrench set
- Awl
- Bolt cutter
- Chisel, wood
- Crimper, terminal or all-purpose-tool, 6-in-1 tool
- Drill, 1/2 inch
- Drill, 3/4 inch
- File, rattail
- Hack saw
- Hammer, ball peen
- Hole saw set
- Knife, electricians
- Level - torpedo 8 inch
- Multimeter: VOM or Amp prove (Volt-ohms-amp)
- Nut driver
- Pliers, slip joint 10 inch
- Pliers, diagonal
- Pliers, lineman
- Pliers, needle-nose
- Puller, fuse
- Rule, folding
- Screwdriver, flat 4 inch, 6 inch, 8 inch, and 12 inch (plastic handles)
Suggested option: Electrician's insulated screwdriver and Speed screwdriver
- Screwdriver, Phillips 4 inch and 6 inch
- Tap tool
- Wire strippers
- Wrench, adjustable 8 inch
- Electrical tape
- Tool pouch belt
- Hard hat

Reference to the tool pouch are based on the following tools:

- Screwdrivers for job
- Lineman's pliers
- Long nose pliers
- Cutter pliers
- Nut driver for job
- Adjustable or Crescent wrench
- Groove, joint, utility, pump, pliers, etc.
- Adjustable wire strippers
- All-purpose tool/crimper
- Electrician's knife
- Electrician's hammer and ball peen hammer
- Folding rule
- Tap tool
- Electrical tape

ELECTRICITY
 INSTALL SERVICE ENTRANCE
 SUGGESTED INSTRUCTION TIMES

<u>ELECTRICITY</u> <u>MODULE/TASK</u>	SUGGESTED HOURS
UNIT 7.0 B INSTALL SERVICE ENTRANCE	
7.01 Install Main Service Panel	*
7.02 Ground Service Entrance Equipment	*
7.03 Install Circuit Breakers in Panel	*
7.04 Install Main Service Disconnect	*
7.05 Install Service Entrance	27
7.06 Install Temporary Service Entrance	2
7.07 Install Underground Service Entrance	1
	Total - <u>30</u>

* = See 7.05

TASK LISTINGS
ELECTRICITY

MODULE/TASK	DESCRIPTION
UNIT 7.0 B	INSTALL SERVICE ENTRANCE
7.01	(Install Main Service Panel) Given the main service panel, with main breaker installed in the panel, the basic electrician's tools, and necessary installation/electrical materials; install the main service panel meeting instructor's standards. The installation must meet the requirements outlined in the <u>National Electrical Code</u> (Ar. 110, 230, 384).
7.02	(Ground Service Entrance Equipment) Given instruction, basic tool kit and necessary installation/electrical materials; ground entrance equipment. Connections must be made at designated points and must be screwed tight. The grounding service entrance equipment must meet requirements of <u>National Electrical Code</u> (Ar. 250: Parts G, H, J, and K).
7.03	(Install Circuit Breakers in Panel) Given instruction, circuit breakers, the basic tool kit, and installation/electrical materials; install circuit breakers in panel. Breaker must be proper type for panel and must be installed so that it fully engages the busses and so that the load is distributed equally. The current (amps) rating of the circuit breakers must meet the requirements as outlined by the <u>National Electrical Code</u> (Ar. 240 and 384).
7.04	(Install Main Service Disconnect) Given main service disconnect, the basic tool kit, and installation/electrical materials; install a main service disconnect. The main service disconnect must be installed so that it simultaneously disconnects all ungrounded service entrance conductors. The main service disconnect must be qualified for use in the service entrance and must be of proper current (amperage) rating. The main service disconnect must meet requirements of the <u>National Electrical Code</u> (Ar. 230-H, 110, 250).
7.05	(Install Service Entrance) Given necessary equipment and the basic tool kit, 2-inch conduit, one roof flange sized for 2-inch conduit, weatherproof weather-head, and fittings; install mast-type service entrance through the roof. Service mast must be able to support service drop. Roof clearance, size, and type of conduit must meet requirements of <u>National Electrical Code</u> (Ar. 230-C and 310).

- 7.06 (Install Temporary Service Entrance) Given basic tool kit and installation/electrical materials; install temporary service entrance. Installation must provide voltage and ampacity required. Branch circuits of 15 and 20 ampere ratings must have ground fault protection. Service must be installed in weatherproof enclosure if located outside. The installation of a temporary service entrance must meet requirements of the National Electrical Code (Ar. 305, 230, 250, and 210-88).
- 7.07 (Install Underground Service Entrance) Given basic electrician's tools and equipment, installation and electrical materials; install underground service entrance to meet requirements of National Electrical Code (Ar. 230-D, 250-9, 300-5) and standards of instructor.

UNIT	7.0 B	INSTALL SERVICE ENTRANCE
TASK	7.01	INSTALL MAIN SERVICE PANEL

PERFORMANCE OBJECTIVE:

Given the main service panel with main breaker installed in the panel, the basic electrician's tools, and necessary installation/electrical materials; install the main service panel meeting instructor's standards. The installation must meet the requirements outlined in the National Electrical Code (Ar. 110, 230, 384).

Suggested Service Panel: 200 amp or typical for average residential house.

PERFORMANCE ACTIONS:

- 7.0101 Locate main service panel as near to point of service as possible.
- 7.0102 Locate height of main disconnect from floor level as required by NEC.
- 7.0103 Remove knockout from main service panel (omit if already accomplished).
- 7.0104 Mark hole for raceway.
- 7.0105 Cut hole through storm sheathing 1/2 inch larger than circle drawn for knockout.
- 7.0106 Install raceway from point of entrance to main service panel.
- 7.0107 Attach service to structure.

PERFORMANCE STANDARDS:

- Install main service panel provided by instructor as required by NEC and meeting instructor's standards.

SUGGESTED INSTRUCTION TIME: See 7.05

RELATED TECHNICAL INFORMATION:

- NEC Ar. 110, 230, 384.
- NEC # 230-48 and 300-7: Sealing Service Entrance

UNIT 7.0 B

INSTALL SERVICE ENTRANCE

TASK 7.01

INSTALL MAIN SERVICE PANEL

RELATED TECHNICAL INFORMATION (Con't)

- Safety.
- How to cut raceway hole in sheathing.
- Fasteners.
- Measuring.

UNIT	7.0 B	INSTALL SERVICE ENTRANCE
TASK	7.02	GROUND SERVICE ENTRANCE EQUIPMENT

PERFORMANCE OBJECTIVE:

Given instruction, basic tool kit and necessary installation/electrical materials; ground entrance equipment. Connections must be made at designated points and must be screwed tight. The grounding service entrance equipment must meet requirements of National Electrical Code (Ar. 250: Parts G, H, J, and K).

PERFORMANCE ACTIONS:

- 7.0201 Remove meter base cover.
- 7.0202 Locate all installation points.
- 7.0203 Apply corrosive inhibitor if required.
- 7.0204 Terminate grounding conductor at designated or proper point.
- 7.0205 Drive ground rod or bury grounding electrode.
- 7.0206 Fasten ground wire to ground electrode with approved clamp (for direct burial).
- 7.0207 Attach wire to surface of structure.
- 7.0208 If a metal water system is installed, extend grounding conductor to water pipe.

PERFORMANCE STANDARDS:

- Ground service entrance equipment (system) to meet NEC (Ar. 250-G, H, J, and K) and instructor's standards.

SUGGESTED INSTRUCTION TIME: See 7.05

RELATED TECHNICAL INFORMATION:

- Ground resistance and system grounding.
- Local city code requirements concerning bonding of grounds.
- Identification of supply service or service disconnect.
- Neutral conductor identification.
- Acceptable grounding conductors and electrodes.
- Typical potential current (amps) available at service head

UNIT	7.0 B	INSTALL SERVICE ENTRANCE
TASK	7.03	INSTALL CIRCUIT BREAKERS IN PANEL

PERFORMANCE OBJECTIVE:

Given instruction, circuit breakers, the basic tool kit, and installation/electrical materials; install circuit breakers in panel. Breakers must be proper type for panel and must be installed so that it fully engages the busses and so that the load is distributed equally. The current (amps) rating of the circuit breaker must not exceed that of the circuit conductors. The installation of the circuit breakers must meet the requirements as outlined by the National Electrical Code (Ar. 240 and 384).

PERFORMANCE ACTIONS:

- 7.0301 Check breaker size and type for suitability for use in panel.
- 7.0302 Insert breaker in box following proper procedures and techniques.
- 7.0303 Check continuity by established procedures.

PERFORMANCE STANDARDS:

- Install circuit breakers of proper size and type for panel, not to exceed current rating of circuit conductors, and to meet requirements of NEC.

SUGGESTED INSTRUCTION TIME: See 7.05

RELATED TECHNICAL INFORMATION:

- Calculating line load.
- Determining conductor current rating.
- Identifying different types of fuses such as: Edison-base, Type S, SC, etc.
- Identify circuit breakers.
- Identify proper over-current protection to use.
- Use of circuit breaker switches (e.g., for fluorescent light loads).

UNIT	7.0 B	INSTALL SERVICE ENTRANCE
TASK	7.04	INSTALL MAIN SERVICE DISCONNECT

PERFORMANCE OBJECTIVE:

Given main service disconnect, the basic tool kit, and installation/electrical materials; install a main service disconnect. The main service disconnect must be installed so that it simultaneously disconnects all ungrounded service entrance conductors. The main service disconnect must be of the proper current (amperage) rating. The main service disconnect must meet requirements of the National Electrical Code (Ar. 230-H, 110, 250).

PERFORMANCE ACTIONS:

- 7.0401 Locate installation point for main service disconnect.
- 7.0402 Attach the main service disconnect to building.
- 7.0403 Attach feed cables to main service disconnect.
- 7.0404 Connect service conductors to line lugs of disconnect.
- 7.0405 Connect load conductors to load lugs of disconnect.
- 7.0406 Terminate load conductors at load being served.

PERFORMANCE STANDARDS:

- Install main service disconnect so that it simultaneously disconnects all ungrounded service entrance conductors and according to requirements of NEC.

SUGGESTED INSTRUCTION TIME: See 7.05

UNIT	7.0 B	INSTALL SERVICE ENTRANCE
TASK	7.05	INSTALL SERVICE ENTRANCE

PERFORMANCE OBJECTIVE:

Given necessary equipment and the basic tool kit, 2-inch conduit, one roof flange sized for 2 inch conduit, weatherproof weather-head, and fittings; install mast-type service entrance through the roof. Service mast must be able to support service drop. Roof clearances, size, and type of conduit must meet requirements of National Electrical Code (Ar. 230-C and 310).

Suggested: 2 inch conduit
Use of triplex cable for service drop 18 inches between drop at mast insulator and roof.

(NOTE: Some steps may be omitted in skill training preserve training materials, but should be a part of the student's repertories.)

PERFORMANCE ACTIONS:

- 7.0501 Spot meter base. (Simulate power supplier).
- 7.0502 From meter base, construct a vertical line to roof overhand.
- 7.0503 Locate center of hole on soffit board.
- 7.0504 Bore hole slightly larger than conduit. (May be simulated to conserve training materials).
- 7.0505 Install conduit through roof down to meter base.
- 7.0506 Tighten conduit into hub of meter base.
- 7.0507 Fasten conduit to wall with appropriate conduit straps (or training materials).
- 7.0508 Install roof flange around conduit, secure to roof. (As appropriate for training orientation).
- 7.0509 Run service entrance conductors down to meter base and leave enough of free conductor from top of conduit to meet local requirements (to allow drop loops at triplex connections).
- 7.0510 Connect service entrance conductors to line lugs of meter base and tighten securely.

UNIT	7.0 B	INSTALL SERVICE ENTRANCE
TASK	7.05	INSTALL SERVICE ENTRANCE

PERFORMANCE ACTIONS (Con't):

- 7.0511 Run conductors from load lugs of meter base to disconnect in main service panel.
- 7.0512 Install weather-head correctly.
- 7.0513 Where conduit enters soffit board, seal with waterproof sealant. (Orientation training only)
- 7.0514 Test service entrance conductors for shorts or grounds.

PERFORMANCE STANDARDS:

- Install mast-type (through roof) service entrance for residential structure meeting NEC requirements, able to support service drop, and to instructor's standards.

(NOTE: This training task may be for orientation.)

SUGGESTED INSTRUCTION TIME: 7.01 - 7.05 = 27 Hours

RELATED TECHNICAL INFORMATION:

- Typical service drop clearance requirements.
- Locating service drop.
- Installation of main service panel.
- Service drop insulator rack (for other than triplex situations).
- Service entrance cables.

UNIT	7.0 B	INSTALL SERVICE ENTRANCE
TASK	7.06	INSTALL TEMPORARY SERVICE ENTRANCE*

PERFORMANCE OBJECTIVE:

Given basic tool kit and installation/electrical materials, install temporary service entrance. Installation must provide voltage and ampacity required. Branch circuits of 15 and 20 ampere ratings must have ground fault protection. Service must be installed in weather proof enclosure if located outside. The installation of a temporary service entrance must meet requirements of the National Electrical Code (Ar. 305, 230, 250, and 210-88).

*Orientation task training.

PERFORMANCE ACTIONS:

- 7.0601 Obtain approval for proposed location from power supplier.
- 7.0602 Lay pole on ground.
- 7.0603 Mark off depth pole goes into ground.
- 7.0604 Attach meter base 5 to 6 feet above ground level.
- 7.0605 Install service cable from meter base to top of service pole.
- 7.0606 Attach raceway to service pole.
- 7.0607 Install weatherhead.
- 7.0608 Install cable between meter base and main service panel.
- 7.0609 Attach service panel to pole.
- 7.0610 Install conduit from service panel to waterproof service box(es).
- 7.0611 Attach receptacle box to pole.
- 7.0612 Run all wiring and make wiring connections.
- 7.0613 Install ground fault protection.
- 7.0614 Run ground wire and fasten to pole down to ground level.

UNIT	7.0 B	INSTALL SERVICE ENTRANCE
TASK	7.06	INSTALL TEMPORARY SERVICE ENTRANCE*

PERFORMANCE ACTIONS (Con't):

- 7.0615 Dig hole for service pole. (May omit in skill training.)
- 7.0616 Install service pole. Pack earth tightly around pole.
- 7.0617 Drive ground rod or bury grounding electrode.
- 7.0618 Fasten ground wire to ground rod or electrode with approved fastener.
- 7.0619 Install pole reinforcement as required.
- 7.0620 Have installation inspected.

PERFORMANCE STANDARDS:

- Install temporary service entrance to meet instructor's standards and according to requirements of NEC.

SUGGESTED INSTRUCTION TIME: 2 Hours

UNIT	7.0 B	INSTALL SERVICE ENTRANCE
TASK	7.07	INSTALL UNDERGROUND SERVICE ENTRANCE

PERFORMANCE OBJECTIVE:

Given basic electrician's tools and equipment, installation and electrical materials; install underground service entrance to meet requirements of National Electrical Code (Ar. 230-D, 250-9, 300-5) and standards of instructor.

PERFORMANCE ACTIONS:

- 7.0701 Spot meter base location.
- 7.0702 Attach meter base to structure. Provide driving ground at meter base.
- 7.0703 Notify power supplier for service hook up.
- 7.0704 Obtain inspection.

PERFORMANCE STANDARDS:

- Install underground service entrance demonstrating proper methods, by NEC, to bring service to meter.

SUGGESTED INSTRUCTION TIME: 1 Hour

UNIT 7.0 C

INSTALLING SWITCH AND OUTLET BOXES
(Residential)

**ELECTRICITY
 INSTALLING SWITCH AND OUTLET BOXES (RESIDENTIAL)
 SUGGESTED INSTRUCTION TIMES**

<u>ELECTRICITY</u> <u>MODULE/TASK</u>	<u>SUGGESTED</u> <u>HOURS</u>
UNIT 7.0 C INSTALLING SWITCH AND OUTLET BOXES (RESIDENTIAL)	
7.01 Install Bar-hanger Mounted Box	*
7.02 Install Flush Mount Junction Box	*
7.03 Install Flush Mount Switch and Outlet Boxes in Dry Wall or Paneled Wall.	*
7.04 Install Gangable Boxes	*
7.05 Install Octagon Outlet Boxes	27
7.06 Install Recessed Fixture Housing in Ceiling	3
	<u> 3</u>
	Total - 30

* = See 7.05

TASK LISTINGS
ELECTRICITY

MODULE/TASK	DESCRIPTION
UNIT 7.0 C	INSTALLING SWITCH AND OUTLET BOXES (RESIDENTIAL)
7.01	(Install Bar-hanger Mounted Box) Given a bar-hanger box, set of floor plans showing the basic wiring system, the basic tool kit, and installation/electrical materials; install the bar-hanger mounted box at center of ceiling. The box must be securely mounted to be flush with the finished ceiling and be located according to plans. The installation of the box must meet the <u>National Electrical Code</u> (Ar. 370) and the instructor's standards.
7.02	(Install Flush Mount Junction Box) Given flush mount junction box, set of floor plans or drawing, basic tool kit, and installation/electrical materials; install flush mount junction box. Box must be flush with finished surface and the location must be according to plans. Junction box must be accessible after installation. Installation must meet requirement of <u>National Electrical Code</u> (Ar. 370-B), be mounted securely and flush with finished surface, and located according to plans.
7.03	(Install Flush Mount Switch and Outlet Boxes in Dry Wall) Given switch and outlet boxes, electrical plans, basic tool kit, and installation/electrical materials, install the box in a dry or paneled wall (plywood, etc.). Boxes must comply with <u>National Electrical Code</u> (Ar. 370-B), be mounted securely and flush with finished surface, and located according to plans.
7.04	(Install Gangable Boxes) Given gangable boxes, a set of electrical plans, the basic tool kit. and installation/electrical materials; install gangable boxes. Gangable boxes must be of required size and type, fastened securely to structure and level across top. Installation must meet requirements of <u>National Electrical Code</u> (Ar. 370-B).
7.05	(Install Octagon Outlet Boxes) Given octagon outlet box(es), set of electrical plans, basic tool kit, and installation/electrical materials; install octagon outlet box(es) securely to structure, located according to plan, installed according to the <u>National Electrical Code</u> (Ar. 370-B).

7.06

(Install Recessed Fixture Housing in Ceiling) Given recessed fixture box, electrical plan, basic tool kit, installation/electrical materials, and manufacturer's specifications for fixture; install recessed fixture box in ceiling. Box must be mounted in correct location, securely fastened to support fixture, meet manufacturer's recommended clearances, and installed according to National Electrical Code (Ar. 410-B and 410-8). Fixture must be wired so it is controlled by a wall switch.

UNIT	7.0 C	INSTALLING SWITCH AND OUTLET BOXES
TASK	7.01	INSTALL BAR-HANGER MOUNTED BOX

PERFORMANCE OBJECTIVE:

Given a bar-hanger box, set of floor plans showing the basic wiring system, the basic tool kit, and installation/electrical materials; install the bar-hanger mounted box at center of ceiling. The box must be securely mounted to be flush with the finished ceiling and be located according to plans. The installation of the box must meet the National Electrical Code (Ar. 370) and the instructor's standards.

PERFORMANCE ACTIONS:

- 7.0101 Locate proper installation point.
- 7.0102 Attach bar to joist so box will be flush with finished ceiling.

PERFORMANCE STANDARDS:

- Install bar-hanger mounted box to ceiling location, at center of ceiling unless otherwise specified.
- Meet NEC and instructor's standards.

SUGGESTED INSTRUCTION TIME: See 7.05

RELATED TECHNICAL INFORMATION:

- Identification of boxes by terminology.
- Technique to locate center of ceiling.

UNIT	7.0 C	INSTALLING SWITCH AND OUTLET BOXES
TASK	7.02	INSTALL FLUSH MOUNT JUNCTION BOX

PERFORMANCE OBJECTIVE:

Given flush mount junction box, set of floor plans or drawing, basic tool kit, and installation/electrical materials; install flush mount junction box. Box must be flush with finished surface and the location must be according to plans. Junction box must be accessible after installation. Installation must meet requirements of National Electrical Code (Ar. 370-B).

PERFORMANCE ACTIONS:

- 7.0201 Review plans and locate installation point.
- 7.0202 Locate junction box so it is accessible.
- 7.0203 Attach junction box to structure so it will be flush with finished surface.

PERFORMANCE STANDARDS:

- Install flush mount junction box so that it is flush with finished surface and the location is according to plan and the box is accessible after installation.
- Performance process and product must be to instructor's standards.

SUGGESTED INSTRUCTION TIME: See 7.05

RELATED TECHNICAL INFORMATION:

- Read plan, electrical drawing.
- Identify electrical device boxes.
- Locating box flush to surface.
- Safety.

UNIT	7.0 C	INSTALLING SWITCH AND OUTLET BOXES
TASK	7.03	INSTALL FLUSH MOUNT SWITCH AND OUTLET BOXES IN DRY WALL OR PANELED WALL

PERFORMANCE OBJECTIVE:

Given switch and outlet boxes, electrical plans, basic tool kit, and installation/electrical materials; install the box in a dry or paneled wall (plywood, etc.). Boxes must comply with National Electrical Code (Ar. 370-B), be mounted securely and flush with finished surface, and located according to plans.

PERFORMANCE ACTIONS:

- 7.0301 Locate installation points.
- 7.0302 Determine finished surface locations.
- 7.0303 Position boxes.
- 7.0304 Attach boxes to structure, flush with finished surface.

PERFORMANCE STANDARDS:

- Install flush mount switch and outlet boxes in dry wall or paneled wall so boxes are flush with finished wall and located to plan and installed according to NEC.

SUGGESTED INSTRUCTION TIME: See 7.05

RELATED TECHNICAL INFORMATION:

- Reading electrical drawing.
- Identification of electrical device boxes.
- Location of surface of finish wall.
- Installing boxes.
- Safety.

UNIT	7.0 C	INSTALLING SWITCH AND OUTLET BOXES
TASK	7.03	INSTALL FLUSH MOUNT SWITCH AND OUTLET BOXES IN DRY WALL OR PANELED WALL (Con't)

EXTENDED TRAINING:

- Attach boxes to Masonary Wall: (Optional) Install boxes in masonry wall so they are not recessed more than 1/8 inch from finished surface, are anchored permanently, and according to NEC (ar. 370-B).

UNIT	7.0 C	INSTALLING SWITCH AND OUTLET BOXES
TASK	7.04	INSTALL GANGABLE BOXES

PERFORMANCE OBJECTIVES:

Given gangable boxes, a set of electrical plans, the basic tool kit, and installation/electrical materials; install gangable boxes.

Gangable boxes must be of required size and type, fastened securely to structure and level across top. Installation must meet requirements of National Electrical Code (Ar. 370-B).

PERFORMANCE ACTIONS:

- 7.0401 Review electrical drawing.
- 7.0402 Locate installation points.
- 7.0403 Determine boxes needed.
- 7.0404 Fasten boxes together in approved manner.
- 7.0405 Attach boxes to structure so they are flush with finished surface and level across top.

PERFORMANCE STANDARDS:

- Install gangable boxes in approved manner, meeting requirements of NEC, flush with finished surface and level on top.
- Performance process and product must meet instructor's standard.

SUGGESTED INSTRUCTION TIME: See 7.05

RELATED TECHNICAL INFORMATION:

- Reading electrical plan.
- Installing boxes flush with finished surface.
- NOTE: Grounding pigtail recommended over grounding clip for appliance installation, especially solid state or computer based items.

UNIT	7.0 C	INSTALLING SWITCH AND OUTLET BOXES
TASK	7.05	INSTALL OCTAGON OUTLET BOXES

PERFORMANCE OBJECTIVE:

Given octagon outlet box(es) set of electrical plans, basic tool kit, and installation/electrical materials; install octagon outlet box(es). Outlet box(es) must be mounted securely to structure, located according to plan, installed according to the National Electrical Code (Ar. 370-B).

PERFORMANCE ACTIONS:

- 7.0501 Review plan.
- 7.0502 Determine boxes needed. Obtain boxes and materials.
- 7.0503 Locate installation points.
- 7.0504 Attach octagon outlet box(es) to structure.

PERFORMANCE STANDARDS:

- Install octagon outlet boxes as required by plan and according to requirements of NEC and meeting instructor's standards for process and product.

SUGGESTED INSTRUCTION TIME: 7.01 - 7.05 = 27 Hours

RELATED TECHNICAL INFORMATION:

- Reading electrical plan.
- Identification of electrical device boxes.
- Process of locating boxes.
- Process of installation of boxes.

UNIT	7.0 C	INSTALLING SWITCH AND OUTLET BOXES
TASK	7.06	INSTALL RECESSED FIXTURE HOUSING IN CEILING

PERFORMANCE OBJECTIVE:

Given recessed fixture box, electrical plan, basic tool kit, installation/electrical materials, and manufacturer's specifications for fixture; install recessed fixture box in ceiling. Box must be mounted in correct location, securely fastened to support fixture, meet manufacturer's recommended clearances, and installed according to National Electrical Code (Ar. 410-B and 410-8). Fixture must be wired so it is controlled by a wall switch.

PERFORMANCE ACTIONS:

- 7.0601 Review plan.
- 7.0602 Assemble materials.
- 7.0603 Locate fixture point.
- 7.0604 Make measurements and install fixture housing.
- 7.0605 Finish installation, connecting line to switch.

PERFORMANCE STANDARDS:

- Install recessed fixture housing in ceiling according to manufacturer's specifications and meeting requirements of NEC.
- Finish installation, connecting line to switch.

SUGGESTED INSTRUCTION TIME: 3 Hours

RELATED TECHNICAL INFORMATION:

- Reading electrical plans.
- Reading manufacturer's specifications.
- Measuring.
- Techniques of installation of boxes.

UNIT 7.0 D

ROUGH IN ELECTRICAL CIRCUITS
(RESIDENTIAL)

ELECTRICITY
ROUGH IN ELECTRICAL CIRCUITS (RESIDENTIAL)
SUGGESTED INSTRUCTION TIMES

<u>ELECTRICITY</u> <u>MODULE/TASK</u>		SUGGESTED HOURS
UNIT	7.0 D	ROUGH IN ELECTRICAL CIRCUITS (RESIDENTIAL)
	7.01	Rough in 120/240 Circuits to Distribution Panel Using Nonmetallic Sheathed Cable (N.M.C.)
	7.02	Rough in Armored cable to Outlet Box
	7.03	Rough in Cable Between Existing Box and Newly Installed Box
	7.04	Rough in Cable for Branch Circuits
	7.05	Rough in Circuit for Outlet Controlled by two Each Three-way Switches with Feed to Outlet Box
	7.06	Rough in Circuit for Outlet Controlled by two Each Three-way Switches with Feed to Outlet Box
	7.07	Rough in Circuit for Outlet Controlled by two Three-way Switches and one Four-way Switch with Feed to a Three-way Switch
	7.08	Rough in Circuit for Door Chime
	7.09	Rough in Circuit for Intercom
	7.10	Rough in Low-voltage Wiring (orientation)
	7.11	Install Non-metallic Cable in Outlet Boxes
	7.12	Rough in Circuit for Split Circuit Duplex Receptacle
	7.13	Orientation to Installing Conduit Underground
	7.14	Orientation to Installing Direct Buried Cable
		Total - <u>60</u>

* = See 7.07

TASK LISTINGS
ELECTRICITY

MODULE/TASK	DESCRIPTION
UNIT 7.0 D	ROUGH IN ELECTRICAL CIRCUITS (RESIDENTIAL)
7.01	(Rough in 120/240 Circuits to Distribution Panel Using Nonmetallic Sheathed Cable [N.M.C.]) Given electrical drawing, basic tool kit, installation/electrical materials; rough in 120/240 volt circuits to distribution panel (SEP box) using nonmetallic sheathed cable (N.M.C.). Installation must be to NEC (AR. 336-5, 336-10).
7.02	(Rough in Armored cable to Outlet Box) Given electrical plan, basic tool kit, installation/electrical materials, armored cable, and installed outlet box (or box to install); rough in armored cable to box. Exposed cable must be supported at intervals not exceeding 4.5 feet and must be supported with 12 inches of box or fitting Insulating bushing must be visible after installation. Cable installation must meet requirements as outlined by NEC (Ar. 333).
7.03	(Rough in Cable Between Existing Box and Newly Installed Box) Given previously roughed in wiring, 120 volt source, basic tool kit, installation/electrical materials; rough in cable between an existing box and a newly installed box. Cable must be of sufficient ampacity to serve connecting load and must be suitable for location. Interior wall finish must not be damaged. Installation must be to NEC (Ar. 300-A).
7.04	(Rough in Cable for Branch Circuits) Given electrical drawing, basic tool kit, installation/electrical materials; rough in cable (or conduit, if required by instructor) for branch circuits. Installation must be completed without damage to interior finish. wire sizes must be appropriate for load to be served and cable must extend from power source to outlet box of load served and must be terminated in approved fittings. Installation must meet NEC.
7.05	(Rough in Circuit for Outlet Controlled by Two Each Three-Way Switches with Feed to Switch Box) Given instruction, electrical drawings, basic tool kit, installation/electrical materials required; rough in circuit for outlet controlled by two each three-way switches with the feed to the switch.

The cable must be installed in the most direct path. Power source must terminate at one of the switch outlets. There must be sufficient conductors in each box for the circuit to function properly. Installation must meet NEC (Ar. 300).

- 7.06 (Rough in Circuit for Outlet Controlled by two Each Three-way Switches with Feed to Outlet Box) Given electrical drawing, basic tool kit, and installation/ electrical materials; rough in circuit for outlet controlled by two each three-way switches with feed to the device outlet box. Cable must be installed in the most direct path. Power source must terminate at outlet box. Number of conductors must be sufficient for circuit to properly operate. Circuit installation must be according to NEC (AR. 300-A).
- 7.07 (Rough in Circuit for Outlet Controlled by two Three-way Switches and one Four-way Switch with Feed to a Three-way Switch) Given instruction, electrical drawing, basic tool kit, and installation/ electrical materials; rough in circuit for outlet controlled by two each three-way switches and one four-way switch. Cable must be installed in most direct path. Power source must be terminated at one three-way switch. The number of conductors must be sufficient and properly installed for circuit design to work properly. Installation must be to NEC (Ar. 300-A).
- 7.08 (Rough in Circuit for Door Chime) Given door chime wire, boxes as necessary, basic tool kit, and other required materials; rough in circuit for a door chime. Wire of correct size must be run from each door and from transformer to point where chime is to be located. Sufficient length of wire must be left for future connection of chime system. Approved transformer of proper rating must be used.
- 7.09 (Rough in Circuit for Intercom) Given layout of intercom system, basic tool kit, and installation/ electrical materials; rough in circuit for intercom system. Cables and rough-in boxes (kits) must be installed at each location according to manufacturer's specification. Appropriate NEC sections apply.
- 7.10 (Rough in Low-voltage Thermostat Wiring) Given layout for low-voltage thermostat system, thermostat wire, location of thermostats, basic tool kit, and installation/electrical materials; rough in low-voltage thermostat wiring. The wiring must have sufficient number of conductors per cable to control

devices being served. thermostat locations must be at height specified. Rough in circuits must meet NEC (Ar. 725-C) and plan specifications.

- 7.11 (Install Nonmetallic Cable in Outlet Boxes) Given basic tool kit, installation/electrical materials, cable, and pre-installed boxes; install nonmetallic cable in outlet boxes. Cable must be secured without damage to insulation. Cable should have about 6 inches of free wire for connections in box. NEC (Ar. 336-5-10 and Ar. 300-14) applies.
- 7.12 (Rough in Circuit for Split Circuit Duplex Receptacle) Given previously installed receptacle box, basic tool kit, and installation/electrical materials; rough in circuit for a split circuit duplex receptacle. The rough in circuit must meet NEC requirements (Ar. 210-4, 210-6, subs. C. 1, 2). Performance must be to instructor's standards.
- 7.13 (Orientation to Installing Conduit Underground) Given instruction, conduit, basic tool kit, installation/electrical materials; install conduit underground. Conduit must be resistant to moisture and corrosive agents. Conduit must be identified as applicable for underground installation. Installation must be according to NEC (Ar. 300-5, Table 300-5). Trench must be properly located according to plan, etc., and to a depth no less than minimum requirements to code. Bushings must be properly installed.
- 7.14 (Orientation to Installing Direct Buried Cable) Given direct buried cable, basic tool kit, and installation/electrical materials; rough in direct buried cable according to plan. Cable must meet specification, be manufactured for direct burial, and be of correct size and type for load served. Installation must be to requirements of NEC (Ar. 300-5) and meet instructor's standards. Trench must be located according to plan, etc., be of depth no less than minimum requirements of NEC, and proper bushing must be installed where cable enters and leaves trench. Proper hook up lengths must be allowed at each end.

UNIT	7.0 D	ROUGH IN ELECTRICAL CIRCUITS
TASK	7.0i	ROUGH IN 120/240 CIRCUITS TO DISTRIBUTION PANEL USING NONMETALLIC SHEATHED CABLE (N.M.C.)

PERFORMANCE OBJECTIVE:

Given electrical drawing, basic tool kit, installation/electrical materials, rough in 120/240 volt circuits to distribution panel (SEP box) using nonmetallic sheathed cable (N.M.C.). Installation must be to NEC (Ar. 336-5, 336-10).

PERFORMANCE ACTIONS:

- 7.0101 Review electrical drawing.
- 7.0102 Assemble materials.
- 7.0103 Locate installation point.
- 7.0104 Remove proper size knockout from distribution panel. (For training this may be simulated and student instructed in proper methods to remove knockouts.)
- 7.0105 Attach nonmetallic connector to distribution panel.
- 7.0106 Pull cable from outside of distribution panel through cable connector to opposite side of panel.
- 7.0107 Tighten clamp on cable without damaging insulation.
- 7.0108 Identify circuits as to load served.

PERFORMANCE STANDARDS:

- Rough in 120/240 volt circuits to distribution panel using nonmetallic sheathed cable.
- The installation must be to NEC and to instructor's standards.

SUGGESTED INSTRUCTION TIME: 9 Hours

RELATED TECHNICAL INFORMATION:

- Reading electrical plan.
- Installation of 120/240 service.
- Installation of distribution panel.

TASK NO LONGER VALID: 6/84

UNIT	7.0 D	ROUGH IN ELECTRICAL CIRCUITS
TASK	7.02	ROUGH IN ARMORED CABLE TO OUTLET BOX

PERFORMANCE OBJECTIVE:

Given electrical plan, basic tool kit, installation/electrical materials, armored cable, and installed outlet box (or box to install); rough in armored cable to box. Exposed cable must be supported at intervals not exceeding 4.5 feet and must be supported with 12 inches of box or fitting. Insulating bushing must be visible after installation. Cable installation must meet requirements as outlined by NEC (Ar. 333).

PERFORMANCE ACTIONS:

- 7.0201 Review electrical drawing.
- 7.0202 Assemble materials.
- 7.0203 Locate electrical run and prepare studs as necessary.
- 7.0204 Remove proper size knockout from outlet box.
- 7.0205 Remove 6 inches of armor from cable (AC Flexible Armored or equivalent).
- 7.0206 Install insulation bushing.
- 7.0207 Feed wire through cable connector until cable bottoms out in connector.
- 7.0208 Tighten connector on armored cable.

PERFORMANCE STANDARDS:

- Rough in armored (AC Flexible Armored) cable to outlet box supporting cable at recommended intervals, with insulating bushing visible after installation, and meeting NEC.

SUGGESTED INSTRUCTION TIME:

UNIT	7.0 D	ROUGH IN ELECTRICAL CIRCUITS
TASK	7.03	ROUGH IN CABLE BETWEEN EXISTING BOX AND NEWLY INSTALLED BOX

PERFORMANCE OBJECTIVE:

Given previously roughed in wiring, 120 volt source, basic tool kit, installation/electrical materials; rough in cable between an existing box and a newly installed box. Cable must be of sufficient ampacity to serve connecting load and must be suitable for location.* Interior wall finish must not be damaged. Installation must be to NEC (Ar. 300-A).

*Suggested new outlet; Microwave oven outlet (1600 watts).

PERFORMANCE ACTIONS:

- 7.0301 Disconnect power to circuit.
- 7.0302 Verify that power is disconnected.
- 7.0303 Determine route for cable to travel.
- 7.0304 Prepare structure for cable travel and outlet.
- 7.0305 Remove knockouts from both boxes.
- 7.0306 Run cable following approved techniques of installation.
- 7.0307 Make required connection to extend circuit to new box.
- 7.0308 Turn power on.
- 7.0309 Check new circuit for proper operation.

PERFORMANCE STANDARDS:

- Rough in cable between existing box and newly installed box, 120 volt line, selecting proper size cable and installing it according NEC and recommended techniques without damage to existing finish of structure.

SUGGESTED INSTRUCTION TIME: 4 Hours

UNIT	7.0 D	ROUGH IN ELECTRICAL CIRCUITS
TASK	7.04	ROUGH IN CABLE FOR BRANCH CIRCUITS

PERFORMANCE OBJECTIVE:

Given electrical drawing, basic tool kit, installation/electrical materials; rough in cable (or conduit, if required by instructor) for branch circuits. Installation must be completed without damage to interior finish. Wire size must be appropriate for load to be served and cable must extend from power source to outlet box of load served and must be terminated in approved fittings. Installation must meet NEC.

PERFORMANCE ACTIONS:

- 7.0401 Review drawing.
- 7.0402 Assemble materials.
- 7.0403 Determine location for installation of cable (or conduit).
- 7.0404 Remove knockout or provide opening for boxes.
- 7.0405 Install cable connector (or conduit connector).
- 7.0406 Pull cable for circuit (or run conduit and pull cable).
- 7.0407 Fasten cable, etc., as required to meet code.

PERFORMANCE STANDARDS:

- Rough in cable for branch circuits so that installation does not damage interior finish and cable is appropriate for load to be served and installation must meet NEC.

SUGGESTED INSTRUCTION TIME: See 7.03

RELATED TECHNICAL INFORMATION:

- Reading electrical drawing.
- Installation of cable/conduit.

UNIT	7.0 D	ROUGH IN ELECTRICAL CIRCUITS
TASK	7.05	ROUGH IN CIRCUIT FOR OUTLET CONTROLLED BY TWO EACH THREE-WAY SWITCHES WITH FEED TO SWITCH BOX

PERFORMANCE OBJECTIVES:

Given instruction, electrical drawing, basic tool kit, installation/electrical materials required; rough in circuit for outlet controlled by two each three-way switches with the feed to the switch.

The cable must be installed in the most direct path. Power source must terminate at one of the switch outlets. There must be sufficient conductors in each box for the circuit to function properly. Installation must meet NEC (Ar. 300).

PERFORMANCE ACTION:

- 7.0501 Review drawing.
- 7.0502 Assemble materials.
- 7.0503 Locate previously installed boxes.
- 7.0504 Run two-wire cable of proper size to outlet box being controlled by remaining switch boxes.
- 7.0505 Strip about 6 inches from outer jacket of cable.
- 7.0506 Attach cable in outlet boxes using approved connectors.
- 7.0507 Anchor cable to building structure at required intervals.
- 7.0508 Fold conductors back into box.

PERFORMANCE STANDARDS:

- Rough in circuit for outlet controlled by two each three-way switches with feed to switch box.
- Cable installation must follow most direct path with power source terminated at one of the switch outlets.
- Must be sufficient conductors in each box for circuit to function properly and installation must be to NEC.

SUGGESTED INSTRUCTION TIME: See 7.07

UNIT	7.0 D	ROUGH IN ELECTRICAL CIRCUITS
TASK	7.06	ROUGH IN CIRCUIT FOR OUTLET CONTROLLED BY TWO EACH THREE-WAY SWITCHES WITH FEED TO OUTLET BOX

PERFORMANCE OBJECTIVE:

Given electrical drawing, basic tool kit, and installation/electrical materials; rough in circuit for outlet controlled by two each three-way switches with feed to the device outlet box. Cable must be installed in the most direct path. Power source must terminate at outlet box. Number of conductors must be sufficient for circuit to properly operate. Circuit installation must be according to NEC (Ar. 300-A).

PERFORMANCE ACTIONS:

- 7.0601 Review electrical drawing.
- 7.0602 Assemble supplies.
- 7.0603 Locate Previously installed boxes.
- 7.0604 Run cable to boxes as required:
 - a. Feeder cable to outlet box.
 - b. Three-wire cable from one switch box to outlet box.
 - c. Three-wire cable from other switch box to outlet box.
- 7.0605 Strip about 6 inches of outer jacket from each cable.
- 7.0606 Attach cable to building structure at required intervals.
- 7.0608 Fold conductors back into boxes.

PERFORMANCE STANDARDS:

- Rough in circuit for outlet controlled by two each three-way switches with feed to the outlet box.
- The circuit must be properly installed and operational, meeting NEC.

UNIT 7.0 D

ROUGH IN ELECTRICAL CIRCUITS

TASK 7.06

ROUGH IN CIRCUIT FOR OUTLET
CONTROLLED BY TWO EACH THREE-WAY
SWITCHES WITH FEED TO OUTLET BOX
(Con't)

SUGGESTED INSTRUCTION TIME: See 7.07

RELATED TECHNICAL INFORMATION:

- Three-way switch circuit.
- Working with three-way cable.
- Rules for wiring a three-way switch.

UNIT	7.0 D	ROUGH IN ELECTRICAL CIRCUITS
TASK	7.07	ROUGH IN CIRCUIT FOR OUTLET CONTROLLED BY THREE-WAY SWITCHES AND ONE FOUR-WAY SWITCH WITH FEED TO A THREE-WAY SWITCH

PERFORMANCE OBJECTIVE:

Given instruction, electrical drawing, basic tool kit, and installation/ electrical materials; rough in circuit for outlet controlled by two each three-way switches and one four-way switch with feed to a three-way switch. Cable must be installed in most direct path. Power source must be terminated at one three-way switch. The number of conductors must be sufficient and properly installed for circuit design to work properly. Installation must be to NEC (Ar. 300-A).

PERFORMANCE ACTIONS:

- 7.0701 Review electrical drawing.
- 7.0702 Assemble materials.
- 7.0703 Locate previously installed boxes.
- 7.0704 Run feed cable of proper size to one of three-way switch box.
- 7.0705 Run three-way cable from feed switch box to four-way switch box.
- 7.0706 Run three-wire cable from four-way switch box to remaining three-way switch box.
- 7.0707 Run a two-wire cable from the last three-way switch box to the outlet box being controlled.
- 7.0708 Strip at least 6 inches of outer jacket from each cable.
- 7.0709 Attach cables in outlet boxes using approved connectors.
- 7.0710 Attach cable to building structure as required/good practice.
- 7.0711 Fold conductors back into boxes.

UNIT	7.0 D	ROUGH IN ELECTRICAL CIRCUITS
TASK	7.07	ROUGH IN CIRCUIT FOR OUTLET CONTROLLED BY TWO THREE-WAY SWITCHES AND ONE FOUR-WAY SWITCH WITH FEED TO A THREE-WAY SWITCH (Con't)

PERFORMANCE STANDARDS:

- Rough in circuit for outlet controlled by two three-way switches and one four-way switch with feed to a three-way switch.

SUGGESTED INSTRUCTION TIME: 7.05 - 7.07 = 40 Hours

RELATED TECHNICAL INFORMATION:

- Reading electrical wiring diagrams.
- Three-way circuit design.
- Wiring three and four way switches.

TASK EXPANSION:

- Rough in circuit for an outlet controlled by two each three-way switches and one four-way switch with feed to the outlet. (Actions above with slight modification apply.)

UNIT	7.0 D	ROUGH IN ELECTRICAL CIRCUITS
TASK	7.08	ROUGH IN CIRCUIT FOR DOOR CHIME

PERFORMANCE OBJECTIVE:

Given door chime wire, boxes as necessary, basic tool kit, and other required materials; rough in circuit for a door chime. Wire of correct size must be run from each door and from transformer to point where chime is to be located. Sufficient length of wire must be left for future connection of chime system. Approved transformer of proper rating must be used.

PERFORMANCE ACTIONS:

- 7.0801 Review electrical print.
- 7.0802 Assemble materials.
- 7.0803 Locate installation point.
- 7.0804 Install a junction box and mount transformer.
- 7.0805 Run feeder cable from power source to function box.
- 7.0806 Run door bell wire from transformer to chime box.
- 7.0807 Run wire from each push button location of chime box.
- 7.0808 Fold wires into boxes or out of way.

PERFORMANCE STANDARDS:

- Rough circuit for door chime according to electrical drawing, using approved wire and transformer, to instructor's specifications.
- Appropriate NEC sections apply.

SUGGESTED INSTRUCTION TIME: 6 Hours

UNIT	7.0 D	ROUGH IN ELECTRICAL CIRCUITS
TASK	7.09	ROUGH IN CIRCUIT FOR INTERCOM

PERFORMANCE OBJECTIVE:

Given layout of intercom system, basic tool kit, and installation/ electrical materials; rough in circuit for intercom system. Cables and rough in boxes (kits) must be installed at each location according to manufacturer's specifications. Appropriate NEC sections apply.

PERFORMANCE ACTIONS:

- 7.0901 Review layout.
- 7.0902 Read manufacturer's installation instruction.
- 7.0903 Run power cable to master station.
- 7.0904 Attach rough-in kits to structure.
- 7.0905 Run required (appropriate size) cables from master to each remote.
- 7.0906 Tag cables are required.

PERFORMANCE STANDARDS:

- Rough in circuit for intercom according to plan and manufacturer's specifications.

SUGGESTED INSTRUCTION TIME: N/A See 7.03

UNIT	7.0 D	ROUGH IN ELECTRICAL CIRCUITS
TASK	7.10	ROUGH IN LOW-VOLTAGE WIRING

PERFORMANCE OBJECTIVE:

Given layout for low-voltage thermostat system, thermostat wire, location of thermostats, basic tool kit, and installation/electrical materials; rough in low-voltage thermostat wiring. The wiring must have sufficient number of conductors per cable to control devices being served. Thermostat locations must be at height specified. Rough in circuits must meet NEC (Ar. 725-C) and plan specifications.

PERFORMANCE ACTIONS:

- 7.1001 Review layout.
- 7.1002 Review specifications.
- 7.1003 Review manufacturer's installation instructions.
- 7.1004 Location installation points of thermostats and specified height of controls.
- 7.1005 Run low-voltage wire from equipment to thermostat locations.

PERFORMANCE STANDARDS:

- Rough in low-voltage wiring according to plan, specifications, manufacturer's instructions, and NEC.
- Meet instructor's standards.

SUGGESTED INSTRUCTION TIME: N/A

UNIT	7.0 D	ROUGH IN ELECTRICAL CIRCUITS
TASK	7.11	INSTALL NON-METALLIC CABLE IN OUTLET BOXES

PERFORMANCE OBJECTIVE:

Given basic tool kit, installation/electrical materials, cable, and pre-installed boxes; install non-metallic cable in outlet boxes. Cable must be secured without damage to insulation. Cable should have about 6 inches of free wire for connections in box. NEC (Ar. 336-5-10 and Ar. 300-14) applies.

PERFORMANCE ACTIONS:

- 7.1101 Remove one knockout from outlet box for each cable entering box.
- 7.1102 Extend cable into outlet box 6 inches.
- 7.1103 Anchor cable to box by:
 - a. Tighten clamp on cable in metal box.
 - b. Attach cable to structure within 8 inches if plastic box.

PERFORMANCE STANDARDS:

- Install non-metallic cable in outlet boxes using proper method to secure cable without damage, allowing 6 inches for later connections, and meeting NEC.

SUGGESTED INSTRUCTION TIME: See 7.03

TASK (TRAINING) EXPANSION:

- Rough in cable in switch and junction boxes not covered in the above task. (Instructor will clarify where actions differ.)

UNIT	7.0 D	ROUGH IN ELECTRICAL CIRCUITS
TASK	7.12	ROUGH IN CIRCUIT FOR SPLIT CIRCUIT DUPLEX RECEPTACLE

PERFORMANCE OBJECTIVE:

Given previously installed receptacle box, basic tool kit, and installation/electrical materials; rough in circuit for a split circuit duplex receptacle. The rough in circuit must meet NEC requirements (Ar. 210-4, 210-6, subs. C, 1, 2). Performance must be to instructor's standards.

PERFORMANCE ACTIONS:

- 7.1201 Locate previously installed wall box.
- 7.1202 Run three-wire cable from power source to wall box
(NOTE: Split 240 volt circuit must have disconnect such as a two-pole circuit breaker to disconnect both hot wires at the same time.)
- 7.1203 Strip at least 6 inches of outer jacket from each cable.
- 7.1204 Attach cable in outlet boxes using approved connectors.
- 7.1205 Attach cable to building structure as required.
- 7.1206 Fold conductors back into box.

PERFORMANCE STANDARDS:

- Rough in circuit for split circuit duplex receptacle according to NEC and instructor's standards for performance and product.
- Means to disconnect both hot wires at same time must be provided.

SUGGESTED INSTRUCTION TIME: 1 Hour

RELATED TECHNICAL INFORMATION:

- NEC requirements for split-wires 240 volt circuit.
- SEP and balancing considerations.
- Cable run should be made by recommended procedure: Orientation to wiring with 2 each 12-2 w/grd. (6 wires). Preferred method of wiring with 12-3 w/grd. (4 wires).

UNIT	7.0 D	ROUGH IN ELECTRICAL CIRCUITS
TASK	7.13	ORIENTATION TO INSTALLING CONDUIT UNDERGROUND

PERFORMANCE STANDARDS:

Given instruction, conduit, basic tool kit, installation/electrical materials; install conduit underground. Conduit must be resistant to moisture and corrosive agents. Conduit must be identified as applicable for underground installation. Installation must be according to NEC (Ar. 300-5, Table 300-5). Trench must be properly located according to plan, etc., and to a depth no less than minimum requirements of code. Bushings must be properly installed.

SUGGESTED INSTRUCTION TIME: N/A

UNIT	7.0	ROUGH IN ELECTRICAL CIRCUITS
TASK	7.14	ORIENTATION TO INSTALLING DIRECT BURIED CABLE

PERFORMANCE STANDARDS:

Given direct buried cable, basic tool kit, and installation/electrical materials; rough in direct buried cable according to plan. Cable must meet specifications, be manufactured for direct burial, and be of correct size and type for load served. Installation must be to requirements of NEC (Ar. 300-5) and meet instructor's standards. Trench must be located according to plan, etc., be of depth no less than minimum requirements of NEC, and proper bushing must be installed where cable enters and leaves trench. Proper hook up lengths must be allowed at each end.

SUGGESTED INSTRUCTION TIME: N/A

UNIT 7.0 E

ROUGH IN TELEPHONE WIRE AND ACCESSORIES

This unit concerning roughing in telephone wire and accessories, is included at the recommendation of Electricity Task Force Committee based on current practices in residential electrical wiring. It is projected by the Electricity Task Force Committee that the installation of telephone wiring and accessories will be a continuing task performed by the residential electrician.

All objectives (tasks) in this unit are based on the modular system of American Telephone & Telegraph Company. Tasks concerning installation of line cords and telephone units are omitted.

The tasks and actions and materials described in this unit are based on the following references/standards:

National Electrical Code, Quincy, MA: National Fire Protection Association, 1981 (Articles 725-5 800).

"Do-It-Yourself and Save," free brochure from American Telephone & Telegraph Company, 1981.

"How to Install Telephone Wiring," provided by Southern Bell, 20 pages, 1981.

"Technical Standards and Installation Guidelines," provided by Southern Bell, 12 pages, 1981.

ELECTRICITY
ROUGH IN TELEPHONE WIRE AND ACCESSORIES
SUGGESTED INSTRUCTION TIMES

<u>ELECTRICITY</u> <u>MODULE/TASK</u>			<u>SUGGESTED</u> <u>HOURS</u>
UNIT	7.0 E	ROUGH IN TELEPHONE WIRE AND ACCESSORIES	
	7.01	Plan Wiring Job	*
	7.02	Install Telephone Outlets	*
	7.03	Install Telephone Wire	*
	7.04	Connect Wires to Junction Boxes and Jacks	15

* = See 7.04

TASK LISTINGS
ELECTRICITY

MODULE/TASK	DESCRIPTION
UNIT 7.0 E	ROUGH IN TELEPHONE WIRE AND ACCESSORIES
7.01	(Plan Wiring Job) Given instruction, residential structure floor plan or telephone wiring plans, and specifications concerning telephone locations; plan telephone wiring installation to include (a) wiring plan including use of Network Interface or Wire Junction, as appropriate, and (b) accessory jacks for various types of telephone installations.
7.02	(Install Telephone Outlets) Given an approved plan of installation, all necessary telephone outlet accessories and related equipment, tools and fasteners; install telephone outlets according to specifications and the <u>National Electrical Code</u> (Ar. 725-5, 800). Locations must be to instructor's standards and installation must follow instruction included with each product.
7.03	(Install Telephone Wire) Given instruction, roughed in junction boxes and jacks, and Network Interface location, necessary 4-conductor wire, tools, and fasteners, and installation plan or sketch; measure and cut the required telephone wire to reach between outlets and junctions and to the Network Interface. Wire must be cut to proper length to avoid splicing, connections should be made only at junction boxes or jacks, or at the Network Interface, installation of wire should meet recommendations of <u>National Electrical Code</u> (Ar. 725-5, 800), and performance process and product must be to instructor's standards.
7.04	(Connect Wires to Junction Boxes and Jacks) Given instructions, roughed-in color coded 4-conductor telephone/communications wire, installed junction boxes and jacks and Network Interface, necessary tools and materials; connect wires to junction boxes and jacks according to junction and jack product instructions and color coding procedures of American Telephone & Telegraph Company (standard). Wires must be properly stripped and fastened to junctions and jacks to meet instructor's standards.

UNIT 7.0 E

ROUGH IN TELEPHONE WIRE AND
ACCESSORIES

TASK 7.01

PLAN WIRING JOB

PERFORMANCE OBJECTIVE:

Given instruction, residential structure floor plan or telephone wiring plan, and specifications concerning telephone locations; plan telephone wiring installation to include (a) wiring plan including use of Network Interface or Wire Junction, as appropriate, and (b) accessory jacks for various types of telephone installations.

PERFORMANCE ACTIONS:

- 7.0101 Review house plans/blueprints and specifications or customer's specifications concerning telephone locations.
- 7.0102 If telephone wiring and jack locations are not visually represented in a plan or blueprint, draw or sketch the planned system. Verify proposed telephone locations with customer.
- 7.0103 Following the telephone wiring and accessory jack location plan and customer's specifications; determine which products you will require to complete the job.
- a. If several outlets are planned, consider use of a Wire Junction "to simplify planning, save time and money, and achieve a neater installation."
 - b. Decide on the type of telephone outlet for each location:
 - (1) "Outlets with protective covers in areas where protection from dust, dirt, paint, and moisture is necessary."
 - (2) "Flush type jacks where a protruding jack is inconvenient."
 - (3) "Wall Phone Modular Jack for wall telephones."
- 7.0104 Estimate wire runs and determine length of wire for total job.
- 7.0105 Determine required junction boxes, etc.

UNIT	7.0 E	ROUGH IN TELEPHONE WIRE AND ACCESSORIES
TASK	7.01	PLAN WIRING JOB (Con't)

PERFORMANCE STANDARDS:

- Plan a given wiring job based on customer's specifications and other information provided so that all materials required for the job are determined.
- Locations should be verified with the customer and a sketch or drawing of the installation should be produced for reference.

SUGGESTED INSTRUCTION TIME: See 7.04

RELATED TECHNICAL INFORMATION:

- Suggested wire and accessories for telephone installations ("Do-It-Yourself and Save" brochure [free] from American Telephone & Telegraph Co. [Southern Bell]).
- Measuring.
- Reading of blueprints, drawings, and specifications.

UNIT 7.0 E

ROUGH IN TELEPHONE WIRE AND
ACCESSORIES

TASK 7.02

INSTALL TELEPHONE OUTLETS

PERFORMANCE OBJECTIVE:

Given an approved plan of installation, all necessary telephone outlet accessories and related equipment, tools and fasteners; install telephone outlets according to specifications and the National Electrical Code (Ar. 725-5, 800). Locations must be to instructor's standards and installation must follow instructions included with each product.

PERFORMANCE ACTIONS:

7.0201 Assemble products for telephone outlet and accessories installation/installations.

7.0202 Determine Network Interface location.

7.0203 Install outlets according to specified instructions included with each product at specified locations:

(NOTE: Install products located furthest from Network Interface or existing modular jack).

- a. Rough in wire boxes (prewired outlets, no terminating screw). (Following sub-steps may be left as trim out work.)
 - (1) Connect Flush Mounted Modular Jack with protective cover or wall phone modular jack.
 - (2) Extend modular system as required.
- b. Install prewired outlets with prewire junction box (conductor wires attached to four terminal screws).
 - (1) Install a prewired Flush Mounted Modular Jack with protective cover or a Prewired Wall Phone Modular Jack.
- c. Install Modular Jacks at baseboard locations.
- d. Install Wire Junctions as central connecting points to simplify wiring, save time and money, and produce a neater installation.

PERFORMANCE STANDARDS:

- Select proper telephone outlets and accessories such as junction boxes or outlet boxes and install them at specified locations.

UNIT	7.0 E	ROUGH IN TELEPHONE WIRE AND ACCESSORIES
TASK	7.02	INSTALL TELEPHONE OUTLETS (Con't)

SUGGESTED INSTRUCTION TIME: See 7.04

RELATED TECHNICAL INFORMATION:

- Installation of junction boxes (electrical boxes).
- Installation of telephone junction boxes and jacks.
- Wall telephone mounted at recommended height of 5 feet above floor.

RECOMMENDED:

- (Orientation by instructor.) Locations of Modular jacks, etc., on baseboards, etc.

UNIT	7.0 E	ROUGH IN TELEPHONE WIRE AND ACCESSORIES
TASK	7.03	INSTALL TELEPHONE WIRE

PERFORMANCE OBJECTIVE:

Given instruction, roughed in junction boxes and jacks, and Network Interface location, necessary 4-conductor wire, tools, and fasteners, and installation plan or sketch; measure and cut the required telephone wire to reach between outlets and junctions and to the Network Interface. Wire must be cut to proper length to avoid splicing, connections should be made only at junction boxes or jacks, or at the Network Interface, installation of wire should meet recommendations of National Electrical Code (Ar. 725-5, 800), and performance process and product must be to instructor's standards.

PERFORMANCE ACTIONS:

- 7.0301 Review plan of installation.
- 7.0302 Review location of roughed in junctions and jacks.
- 7.0303 Measure and cut telephone wire sufficient to reach between outlets and wire junctions and between wire junctions and Network Interface.
- 7.0304 Run wire along baseboards, around door jams and under window sills, as required.
- 7.0305 Drill holes for service runs through walls and floors, etc.
- 7.0306 Run wires as required, fastening them with approved method (such as staple gun, staples, etc.).

PERFORMANCE STANDARDS:

- Install 4-conductor telephone wire according to plan to connect jacks to junction boxes and to Network Interface.
- Wires should be installed according to National Electrical Code (Ar. 725-5, 800), neatly and concealed where possible.
- The telephone conductors should not be spliced.
- Connections should be appropriately fastened to the structure.
- Performance process and product must be to instructor's standards.

SUGGESTED INSTRUCTION TIME: See 7.04

UNIT	7.0 E	ROUGH IN TELEPHONE WIRE AND ACCESSORIES
TASK	7.03	INSTALL TELEPHONE WIRE (Con't)

RELATED TECHNICAL INFORMATION:

- System planning.
- Measuring wire runs.
- Cutting and stripping wires.
- Fastening wires at junction boxes and outlets.
- Fastening wire runs to structure.

SUGGESTIONS FOR INSTALLING TELEPHONE WIRING:

- "Avoid placing telephone wires in pipes, conduits, or compartments containing other electrical wiring."
- Do not place telephone wires "near bare power wires or lightning rods, antennas, hot water pipes, or heating ducts."
- "Use electrical tape to protect wires from abrasion when they are run next to grating, grillwork, or similar surfaces."
- "Do not support objects with telephone wiring,"
- Do not install wiring where it may be exposed to lighting.
- Avoid damp locations or locations that might come into contact with water.
- Avoid locations where wire might be subject to stress or pinching.
- Never splice telephone wire. Always use junction boxes or jacks for wire connections.
- Keep wire runs as short as possible.
- Avoid connecting more than 5 telephones to any one service line.
- When drilling holes through walls or floors, be careful not to hit concealed electrical wiring, pipes, etc.

UNIT	7.0 E	ROUGH IN TELEPHONE WIRE AND ACCESSORIES
TASK	7.04	CONNECT WIRES TO JUNCTION BOXES AND JACKS

PERFORMANCE OBJECTIVE:

Given instructions, roughed-in color coded 4-conductor telephone/communications wire, installed junction boxes and jacks and Network Interface, necessary tools and materials; connect wires to junction boxes and jacks according to junction and jack product instructions and color coding procedures of American Telephone & Telegraph Company (standard). Wires must be properly stripped and fastened to junctions and jacks to meet instructor's standards.

PERFORMANCE ACTIONS:

- 7.0401 Identify locations where jacks and junctions will be wired. Omit junction boxes where wires not terminated will be left.
- 7.0402 Remove junction or jack cover.
- 7.0403 Strip about 3/4 inch of insulation from wires taking care not to cut wire.
- 7.0404 Loop wire around terminal screw.
- 7.0405 Tighten screw so that wire will not loosen with vibration.
- 7.0406 Place cover on junction box or jack.

PERFORMANCE STANDARDS:

- Connect roughed in telephone conductors to pre-installed telephone junction boxes and modular jacks so that a proper mechanical electrical connection is made.
- Telephone conductors must be properly connected according to color code standards of American Telephone & Telegraph Company.
- Performance process and product must meet instructor's standards.

SUGGESTED INSTRUCTION TIME: 7.01 - 7.04 = 15 Hours

UNIT	7.0 E	ROUGH IN TELEPHONE WIRE AND ACCESSORIES
TASK	7.04	CONNECT WIRES TO JUNCTION BOXES AND JACKS (Con't.)

RELATED TECHNICAL INFORMATION:

- Identification of color coding of (a) telephone wire and (b) modular jacks, wire junction boxes, and Network Interface.
- Stripping and screw connecting wire to terminals.
- Identification of color abbreviations used by telephone company: (G), (R), (B), (Y).

UNIT 7.0 F

TRIM OUT (FINISH) ELECTRICAL DEVICES
(Residential)

ELECTRICITY
 TRIM OUT (FINISH) ELECTRICAL DEVICES (RESIDENTIAL)
 SUGGESTED INSTRUCTION TIMES

<u>ELECTRICITY MODULE/TASK</u>	<u>SUGGESTED HOURS</u>
UNIT 7.0 F TRIM OUT (FINISH) ELECTRICAL DEVICES (RESIDENTIAL)	
7.01 Connect Door Chime System	(See 7.06)
7.02 Connect/Install Duplex Receptacle Outlets.	1
7.03 Connect/Install 240 Volt Four-Wire Receptacle for Range or Dryer	not valid
7.04 Install Ground Fault Interrupting Device (GFCI)	2
7.05 Connect Hot Water Heater	3
7.06 Connect Low-Voltage Lighting Control	3
7.07 Connect Moisture Resistance Receptacle	3
7.08 Connect Single Pole Switch	3
7.09 Connect Split Circuit Duplex Receptacle	3
7.10 Connect Three-wire 240 Volt Receptacle	3
7.11 Connection Wires from Junction Box to Appliance/Electrical Device	6
7.12 Connect 120/240 Circuits to Circuit Breaker Panel Using Non-metallic Cable	15
7.13 Install/Connect Three-way Switches	1
7.14 Make Wire and Fixture Splices	2
	Total - <u>45</u>

TASK LISTINGS
ELECTRICITY

MODULE/TASK	DESCRIPTION
UNIT 7.0 F	TRIM OUT (FINISH) ELECTRICAL DEVICES (RESIDENTIAL)
7.01	(Connect Door Chime System) Given components of basic door chime system, low voltage power source, previously roughed in wiring, basic tool kit, and necessary materials; connect the door chimes system. Button at each location must meet according to NEC (Ar. 725).
7.02	(Connect/Install Duplex Receptacle Outlets) Given duplex receptacle outlets, power source, previously roughed in wiring; basic tool kit, and installation/electrical materials; connect/install duplex receptacle outlets. Connections must be by appropriate methods and with connectors suitable for purpose. Finished outlets must have correct polarity. Cover plate must be installed straight, must cover opening, and fit flush to wall. Receptacles must be mounted in a manner to present a uniform appearance. Duplex receptacle outlet installation must meet NEC (Ar. 200-10, 200-11) and be to instructor's (contractor's) standards.
7.03	(Connect/Install 240 Volt Four-wire Receptacle for Range or Dryer) Given plans and specifications, manufacturer's data, power source, previously roughed in wiring, receptacle, basic tool kit, installation/electrical materials; locate and connect 240 volt receptacles. Connections must be made using materials and conductors suitable for loads and conditions encountered. Installation must be to NEC requirements. Outlets must supply required voltages with correct polarity.
7.04	(Install Ground Fault Interrupting Device [GFCI]) Given a ground fault interrupting device for installation in a bathroom, garage location, or shop, power source, previously roughed wiring, basic tool kit, and installation/electrical materials; install the type GFCI receptacle(s). The GFCI must function to open the circuit when tested as per manufacturer's instructions. Installation must meet requirements outlined by the NEC (Ar. 210-8, and 680).
7.05	(Connect Hot Water Heater) Given hot water heater with plumbing connections made, power source, previously roughed in wiring, basic tool kit, and electrical installation materials; connect water

heater to required voltage. Heater must be grounded and connections must be tight and insulated properly. Installation must be to NEC (Ar. 422-14) and according to manufacturer's specifications.

- 7.06 (Connect Low-Voltage Lighting Control) Given low-voltage lighting control, power source, previously installed wiring, basic tool kit, and installation/electrical materials; connect low-voltage lighting control. Connections must be made using methods and connectors required by the manufacturer and the NEC.
- 7.07 (Connect Moisture Resistance Receptacle) Given moisture resistance cover plate and receptacle, power source, previously roughed in wiring, basic tool kit, and installation/electrical materials; connect moisture resistance receptacle. Receptacle must be connected using methods and connectors required by manufacturer and NEC. The receptacle must be wired for correct polarity and the connections must be tight.
- 7.08 (Connect Single Pole Switch) Given single pole switch, previously roughed in wiring and box, basic tool kit, and installation/electrical materials; connect the single pole switch as required. Connections must be made using methods and connectors required by NEC and the manufacturer. Connections must be tight. Installation must be to NEC (Ar. 380). (NEC 250, 300, 310, 336, 344, 370, 380, 402, and 410 apply.)
- 7.09 (Connect Split Circuit Duplex Receptacle) Given duplex receptacle that can be split wired, power source, previously roughed in cables and box, basic tool kit, and installation/electrical materials; connect split circuit duplex receptacle. Finished wiring must be supplied from two sources (120 volt legs, balanced). The finished installation must be to NEC, the polarity must be correct, and the receptacle and cover must be flush with wall, level across top, and cover wall opening.
- 7.10 (Connect Three-wire 240 Volt Receptacle) Given three-wire 240 (220, 230, 240) volt receptacles, power source, previously roughed in wiring, box, basic tool kit, and installation/electrical materials; connect three-wire 240 volt wall receptacle. Connections must be made using materials and conductors required by specifications and the NEC with the wired receptacle supplied with the correct voltage and polarity.

- 7.11 (Connection Wires from Junction Box to Appliance/Electrical Device) Given junction box, previously roughed in wiring, power source, basic tool kit, and installation/ electrical materials; connect wires from junction box to appliance. Wiring must be connected properly for appliance or electrical device, according to the NEC, with proper voltage supplies, correct polarity, and proper grounding. Appliance/electrical device must operate correctly when power is supplied.
- 7.12 (Connect 120/240 Circuits to Circuit Breaker Panel Using Nonmetallic Cable) Given previously roughed in non-metallic cables to circuit breaker panel for 120/240 volt circuits, breaker panel with circuit breakers, basic tool kit, and installation/ electrical materials; connect 120 and 240 volt circuits to circuit breaker panel. Cables must enter panel approved-type connectors. Circuit conductors must be attached to correct size breaker.
- 7.13 (Install/Connect Three-way Switches) Given a pair of three-way switches, power source, previously roughed in wiring and boxes, basic tool kit, and installation/ electrical materials; connect/install three-way switch. The light device must be controlled on or off from either switch location. The cover plate must be straight, cover the opening, and fit flush to the wall.
- 7.14 (Make Wire and Fixture Splices) Given power source, installed cable, and roughed-in electrical devices, etc., basic tool kit, installation/electrical materials including various types of solderless connectors (wire nuts); make required splices. Splice must be made in outlet box using connectors or other means suitable for fixtures being installed. Splice must be mechanically strong and insulated electrical to withstand applied voltage. Splice must meet the requirement of NEC (Ar. 410-11, 410-23, and 410-32).

UNIT	7.0 F	TRIM OUT (FINISH) ELECTRICAL DEVICES
TASK	7.01	CONNECT DOOR CHIME SYSTEM

PERFORMANCE OBJECTIVE:

Given components of basic door chime system, low voltage power source, previously roughed in wiring, basic tool kit, and necessary materials; connect the door chime system. Buttons at each location must operate the chime. Connection of door chime system must meet according to NEC (Ar. 725).

PERFORMANCE ACTIONS:

- 7.0101 Review specifications.
- 7.0102 Locate installation point.
- 7.0103 Turn power off.
- 7.0104 Verify that power is off with electrical instrument.
- 7.0105 Read manufacturer's installation instructions.
- 7.0106 Attach chime unit and buttons, etc., to structure.
- 7.0107 Make low-voltage wiring connections.
- 7.0108 Connect power and test system operation.

PERFORMANCE STANDARDS:

- Connect door chime system according to specifications, plan, and NEC so that system operates correctly.

SUGGESTED INSTRUCTION TIME: See 7.06

UNIT	7.0 F	TRIM OUT (FINISH) ELECTRICAL DEVICES
TASK	7.02	CONNECT/INSTALL DUPLEX, RECEPTACLE OUTLETS

PERFORMANCE OBJECTIVE:

Given duplex receptacle outlets, power source, previously roughed in wiring, basic tool kit, and installation/electrical materials; connect/install duplex receptacle outlets. Connections must be by appropriate methods and with connectors suitable for purpose. Finished outlets must have correct polarity. Cover plate must be installed straight, must cover opening, and fit flush to wall. Receptacles must be mounted in a manner to present a uniform appearance. Duplex receptacle outlet installation must meet NEC (Ar. 200-10-, 200-11) and be to instructor's (contractor's) standards.

PERFORMANCE ACTIONS:

- 7.0201 Locate installation point.
- 7.0202 Turn power off.
- 7.0203 Using electrical test instrument, verify that power is off.
- 7.0204 Cut conductor at wall box to leave 6 inches of free conductor.
- 7.0205 Remove about 3/4 inch of insulation from each wire.
- 7.0206 Connect white conductors to silver or white terminals of device.
- 7.0207 Connect black conductor to brass or gold colored terminals.
- 7.0208
 - a. Grounding conductors must be securely connected together using approved means and fastened to receptacle and to box as required.
 - b. For metal box, connect green grounding conductor and other grounding conductors to wall box.
 - c. **RECOMMENDED:** For solid state device outlets, such as those which may serve computers, etc., use ground screw rather than grounding chip.

UNIT	7.0 F	TRIM OUT (FINISH) ELECTRICAL DEVICES
TASK	7.02	CONNECT/INSTALL DUPLEX RECEPTACLE OUTLETS

PERFORMANCE ACTIONS (Con't.):

- 7.0209 Fasten outlet to wall box.
- 7.0210 Install cover plate.
- 7.0211 Turn power off.
- 7.0212 Test for correct polarity.

PERFORMANCE STANDARDS:

- Connect or install duplex receptacle outlets on 120 circuit, according to NEC, so that polarity is observed and finished installation (plate) is flush with wall, aligned, uniformed in appearance, and to instructor's standards.

SUGGESTED INSTRUCTION TIME: 1 Hour

RELATED TECHNICAL INFORMATION:

- Safety.
- Polarity testing.

UNIT	7.0 F	TRIM OUT (FINISH) ELECTRICAL DEVICES
TASK	7.03	CONNECT/INSTALL 240 VOLT FOUR-WIRE RECEPTACLE FOR RANGE OR DRYER

PERFORMANCE OBJECTIVES:

Given plans and specifications, manufacturer's data, power source, previously roughed in wiring, receptacle, basic tool kit, installation/ electrical materials; locate and connect 240 volt* receptacles. Connections must be made using materials and conductors suitable for loads and conditions encountered. Installation must be to NEC requirements. Outlets must supply required voltages with correct polarity.

*240 = 220, 230 v

PERFORMANCE ACTIONS:

- 7.0301 Review plans, specifications, and, if available, manufacturer's data plate.
- 7.0302 Location installation point.
- 7.0303 Turn power off.
- 7.0304 With electrical instrument, verify the power is off.
- 7.0305 Read manufacturer's installation instructions if available.
- 7.0306 Cut conductors at wall box to leave 6 inches of free conductor.
- 7.0307 Remove approximately 3/4 inch insulation from each conductor.
- 7.0308 Connect grounding conductor (free or bare) to ground terminal.
- 7.0309 Connect one line conductor to one main terminal (brass or gold).
- 7.0310 Connect remaining line conductor.
- 7.0311 Connect neutral conductor.
- 7.0312 Attach receptacle to wall box.

UNIT	7.0 F	TRIM OUT (FINISH) ELECTRICAL DEVICES
TASK	7.03	CONNECT/INSTALL 240 VOLT FOUR-WIRE RECEPTACLE FOR RANGE OR DRYER

PERFORMANCE ACTIONS (Con't.):

- 7.0313 Install cover plate.
- 7.0314 Turn power off.
- 7.0315 Check:
 - a. Polarity.
 - b. Voltage.

PERFORMANCE STANDARDS:

- Install/connect 240 volt four-wire receptacle for range or other device ensuring that installation is to NEC, that polarity and voltage are correct, and that job is to instructor's standards.

SUGGESTED INSTRUCTION TIME:

RELATED TECHNICAL INFORMATION:

- Instruction in working with 240 volt circuits.
- NOTE: 4 wire cable may be replace with 3-wire cable for training
- NOTE: (Exception) 1981 NEC allows white neutral wire in 3-wire cable to be used a ground wire.
- Connection of hot wires is made to receptacle terminals "X" and "Y" with white (neutral, ground) wire connected to "W" terminal.
- Range cable connects directly to SEP.
- Clothes dryer cable will be determined by the type (load) of dryer and may be from a 30 amp circuit with No. 10-2 w/ground to a heavier cable and receptacle (such as 50 amp).

TASK EXTENSION:

- Task must be extended to include: Water heater, clothes washers, electrical heater, etc.

UNIT	7.0 F	TRIM OUT (FINISH) ELECTRICAL DEVICES
TASK	7.04	INSTALL GROUND FAULT INTERRUPTING DEVICE (GFCI)

PERFORMANCE OBJECTIVE:

Given a ground fault interrupting device for installation in a bath room, garage location, or shop, power source, previously roughed in wiring, basic tool kit, and installation/electrical materials; install the type GFCI receptacle (s). The GFCI must function to open the circuit when tested as per manufacturer's instructions. Installation must meet requirements outlined by the NEC (Ar. 210-8, and 680).

PERFORMANCE ACTIONS:

- 7.0401 Read NEC requirements concerning GFCI.
- 7.0402 Locate installation points.
- 7.0403 Turn power off.
- 7.0404 With electrical instrument, verify that power is off.
- 7.0405 Read manufacturer's installation instructions.
- 7.0406 Locate circuit conductors to be protected.
- 7.0407 Remove approximately 3/4 inch of insulation from each conductor.
- 7.0408 Connect GFCI device per manufacturer's instructions.
- 7.0409 Install GFCI in box and attach plate.
- 7.0410 Turn power on.
- 7.0411 Test unit for:
 - a. Voltage.
 - b. Polarity.
 - c. Proper operation of GFCI by manufacturer's instruction.

PERFORMANCE STANDARDS:

- Install GFCI receptacle per manufacturer's instruction according to NEC and test for proper operation.

UNIT 7.0 F

TRIM OUT (FINISH)
ELECTRICAL DEVICES

TASK 7.04

INSTALL GROUND FAULT
INTERRUPTING DEVICE (GFCI)
(Con't.)

SUGGESTED INSTRUCTION TIME: 2 Hours

RELATED TECHNICAL INFORMATION:

- Training should include both:
 - a. Circuit breaker-GFCI.
 - b. Receptacle GFCI (Objective & actions described this type.).
- Orientation to how GFCI receptacle installed as first receptacle in a circuit provides protection on all other receptacles beyond it on circuit.
- Orientation to Plug-in type GFCI and portable GFCI for use in construction safety.

UNIT	7.0 F	TRIM OUT (FINISH) ELECTRICAL DEVICES
TASK	7.05	CONNECT HOT WATER HEATER

PERFORMANCE OBJECTIVE:

Given hot water heater with plumbing connections made, power source, previously roughed in wiring, basic tool kit, and electrical installation materials; connect water heater to required voltage. Heater must be grounded and connections must be to NEC (Ar. 422-14) and according to manufacturer's specifications.

PERFORMANCE ACTIONS:

- 7.0501 Review specifications, manufacturer's data plate.
- 7.0502 Locate installation point.
- 7.0503 Turn power off.
- 7.0504 Using electrical instrument, verify that power is off.
- 7.0505 Install cable connector (or conduit) in junction box on water heater.
- 7.0506 Connect cable to water heater and anchor as appropriate.
- 7.0507 Remove approximately 3/4 inch of insulation from conductors.
- 7.0508 Make connections according to code.
- 7.0509 Verify that the water heater tank has water in it (full).
- 7.0510 Turn power on.
- 7.0511 Check power consumption using clamp on ampmeter.
- 7.0512 Install box cover plate heater cover.

PERFORMANCE STANDARDS:

- Connect hot water heater according to specifications, manufacturer's data plate, NEC, so that heater is grounded and proper voltage is furnished. Heater should have water in it prior to turning on power. Check installation with clamp on ampmeter.

SUGGESTED INSTRUCTION TIME: 3 Hours

UNIT	7.0 F	TRIM OUT (FINISH) ELECTRICAL DEVICES
TASK	7.06	CONNECT LOW-VOLTAGE LIGHTING CONTROL

PERFORMANCE OBJECTIVE:

Given low-voltage lighting control, power source, previously installed wiring, basic tool kit, and installation/electrical materials; connect low-voltage lighting control. Connections must be made using methods and connectors required by the manufacturer and the NEC.

PERFORMANCE ACTIONS:

- 7.0601 Review NEC and manufacturer's instructions.
- 7.0602 Locate installation point.
- 7.0603 Turn power off.
- 7.0604 With electrical instrument, verify that power is off.
- 7.0605 Connect power leads of low-voltage control devices to light fixture using suitable connectors.
- 7.0606 Connect low-voltage control lead to relays and control switches as required to complete the wiring of the low-voltage lighting control using suitable connectors.
- 7.0607 Turn power on.
- 7.0608 Check for proper operation of low-voltage control system.

PERFORMANCE STANDARDS:

- Connect low-voltage lighting control circuits using the proper connectors and according to manufacturer's specifications and NEC requirements.

SUGGESTED INSTRUCTION TIME: 3 Hours

UNIT	7.0 F	TRIM OUT (FINISH) ELECTRICAL DEVICES
TASK	7.07	CONNECT MOISTURE RESISTANCE RECEPTACLE

PERFORMANCE OBJECTIVE:

Given moisture resistance cover plate and receptacle, power source, previously roughed in wiring, basic tool kit, and installation/ electrical materials; connect moisture resistance receptacle. Receptacle must be connected using methods and connectors required by manufacturer and NEC. The receptacle must be wired for correct polarity and the connections must be tight.

PERFORMANCE ACTIONS:

- 7.0701 Review plans, specifications.
- 7.0702 Locate installation point.
- 7.0703 Turn power off.
- 7.0704 With electrical instrument, verify that power is off.
- 7.0705 Review manufacturer's installation instructions.
- 7.0706 Remove insulation from each conductor to length recommended.
- 7.0707 Connect conductor wires to proper terminals and ground conductor as appropriate.
- 7.0708 Attach receptacle to housing. Verify that gaskets or waterproofing materials are properly placed.
- 7.0709 Install protective covers/plates.
- 7.0710 Turn power on.
- 7.0711 Check for proper polarity and voltage.

PERFORMANCE STANDARDS:

- Connect moisture resistance receptacle as required, ensuring that proper methods and connectors are used and that polarity is correct and installation and connections are tight.

SUGGESTED INSTRUCTION TIME: 3 Hours

UNIT 7.0 F

TRIM OUT (FINISH)
ELECTRICAL DEVICES

TASK 7.08

CONNECT SINGLE POLE SWITCH

PERFORMANCE OBJECTIVE:

Given single pole switch, previously roughed in wiring and box, basic tool kit, and installation/electrical materials; connect the single pole switch as required. Connections must be made using methods and connectors required by NEC and the manufacturer. Connections must be tight. Installation must be to the NEC (Ar. 380). (NEC 250, 300, 310, 336, 344, 370, 380, 402, and 410 apply.)

PERFORMANCE ACTIONS:

- 7.0801 Review plans and specifications.
- 7.0802 Locate installation point.
- 7.0803 Turn power off.
- 7.0804 With electrical instrument, verify that power is off.
- 7.0805 Remove about 3/4 inch of insulation from each conductor.
- 7.0806 Make wiring connections to switch using terminals.
- 7.0807 Check that all connections are tight.
- 7.0808 Attach switch to box.
- 7.0809 Install cover plate.
- 7.0810 Turn power on.
- 7.0811 Check for proper operation.

PERFORMANCE STANDARDS:

- Connect single pole switch in lighting circuit, ensuring that connections are secure, and that installation is to code.
- Performance process and product must be to instructor's standards.

SUGGESTED INSTRUCTION TIME: 3 Hours

UNIT	7.0F	TRIM OUT (FINISH) ELECTRICAL DEVICES
TASK	7.08	CONNECT SINGLE POLE SWITCH (Con't.)

RELATED TECHNICAL INFORMATION:

- NEC: 90, 100, 220-11, 240 and above NEC articles.
- Safety.
- Proper use of tools.
- Stripping insulation from conductors.

UNIT	7.0 F	TRIM OUT (FINISH) ELECTRICAL DEVICES
TASK	7.09	CONNECT SPLIT CIRCUIT DUPLEX RECEPTACLE

PERFORMANCE OBJECTIVE:

Given duplex receptacle that can be split wired, power source, previously roughed in cables and box, basic tool kit, and installation/ electrical materials; connect split circuit duplex receptacle. Finished wiring must be supplied from two sources (120 volt legs, balanced). The finished installation must be to NEC, the polarity must be correct, and the receptacle and cover must be flush with wall, level across top, and cover wall opening.

PERFORMANCE ACTIONS:

(NOTE: Review instruction for connecting split 240 circuit.)

- 7.0901 Review plans, specifications.
- 7.0902 Locate installation point.
- 7.0903 Turn power off.
- 7.0904 With electrical instrument, verify that power is off.
- 7.0905 Cut conductor at wall box so 6 inches of free conductor remain.
- 7.0906 Remove about 3/4 inch of insulation from each conductor.
- 7.0907 Remove break-off tabs from line side of receptacle so it can be split wired.
- 7.0908 Connect white or neutral conductor to silver or white terminal.
- 7.0909 Connect one of the other supply conductors to one of the brass (gold) terminals.
- 7.0910 Connect remaining supply conductor to remaining brass (gold) terminal.

UNIT	7.0 F	TRIM OUT (FINISH) ELECTRICAL DEVICES
TASK	7.09	CONNECT SPLIT CIRCUIT DUPLEX RECEPTACLE

PERFORMANCE ACTIONS (Con't.):

- 7.0911 Connect bare or green grounding conductor to green terminal and to wall box if metal.
- 7.0912 Attach duplex receptacles to wall box.
- 7.0913 Install cover plate.
- 7.0914 Turn power on.
- 7.0915 Check to ensure that receptacle is supplied from two sources.
- 7.0916 Check polarity.

PERFORMANCE STANDARDS:

- Connect split circuit duplex receptacle according to NEC so receptacle is mounted securely, all connections are mechanically and electrically secure, and circuit is free of electrical hazards.
- Polarity must be correct and the two circuits must be supplied from two sources.*

*Recommended that split 240 volt circuits have disconnect such as two-pole circuit breaker to disconnect both hot wires at same time.

SUGGESTED INSTRUCTION TIME: 3 Hours

RELATED TECHNICAL INFORMATION:

- NEC 210.

UNIT	7.0 F	TRIM OUT (FINISH) ELECTRICAL DEVICES
TASK	7.10	CONNECT THREE-WIRE 240 VOLT RECEPTACLE

PERFORMANCE OBJECTIVE:

Given three-wire 240 (220, 230, 240) volt receptacle, power source, previously roughed in wiring, box, basic tool kit, and installation/electrical materials; connect three-wire 240 volt wall receptacle. Connections must be made using materials and conductors required by specifications and the NEC with the wired receptacle supplied with the correct voltage and polarity.

PERFORMANCE ACTION:

- 7.1001 Review plans, specifications.
- 7.1002 Locate installation point.
- 7.1003 Assemble materials.
- 7.1004 Turn power off.
- 7.1005 Using electrical instrument, verify that power is off.
- 7.1006 Cut conductor at wall box to leave 6 inches of free conductor.
- 7.1007 Remove approximately 3/4 inch insulation from each conductor.
- 7.1008 Connect grounding conductor (green or bare) to proper grounding terminal.
- 7.1009 Connect one of the line conductors to the brass (gold) terminal.
- 7.1010 Connect remaining line conductor to other brass (gold) terminal.
- 7.1011 Attach receptacle to wall box.
- 7.1012 Install cover plate.
- 7.1013 Turn power on.
- 7.1014 Check for proper voltage and polarity.

UNIT	7.0 F	TRIM OUT (FINISH) ELECTRICAL DEVICES
TASK	7.10	CONNECT THREE-WIRE 240 VOLT RECEPTACLE (Con't.)

PERFORMANCE STANDARDS:

- Connect three-wire 240 volt wall receptacle according to specifications and NEC supplied with the proper voltage and polarity.

SUGGESTED INSTRUCTION TIME: 3 Hours

UNIT	7.0	TRIM OUT (FINISH) ELECTRICAL DEVICES
TASK	7.11	CONNECTION WIRES FROM JUNCTION BOX TO APPLIANCE/ELECTRICAL DEVICE

PERFORMANCE OBJECTIVE:

Given junction box, previously roughed in wiring, power source, basic tool kit, and installation/electrical materials; connect wires from junction box to appliance. Wiring must be connected properly for appliance or electrical device, according to the NEC, with proper voltage supplies, correct polarity, and proper grounding. Appliance/electrical device must operate correctly when power is supplied.

PERFORMANCE ACTIONS:

- 7.1101 Review plan/specifications.
- 7.1102 Review manufacturer's instructions, data plate, or specifications, if applicable.
- 7.1103 Locate installation point.
- 7.1104 Turn power off.
- 7.1105 With electrical instrument, verify that power is at work point.
- 7.1106 Cut conductors at junction box to leave 6 inches of free conductor.
- 7.1107 Run power cord from appliance/electrical device to junction box, through approved cord connector.
- 7.1108 Remove approximately 3/4 inch of insulation from each conductor.
- 7.1109 Make connections in junction box using correct connector and methods of observing correct polarity.
- 7.1110 Install cover on junction box.
- 7.1111 Turn power on for appliance circuit.
- 7.1112 Check for proper voltage and polarity.
- 7.1113 Check appliance/electrical device for proper operation.

UNIT	7.0 F	TRIM OUT (FINISH) ELECTRICAL DEVICES
TASK	7.11	CONNECTION WIRES FROM JUNCTION BOX TO APPLIANCE/ELECTRICAL DEVICE

PERFORMANCE ACTIONS (Con't.):

- 7.1114 Turn appliance/electrical device off, if appropriate.

PERFORMANCE STANDARDS:

- Connect electrical wires from junction box to appliance/electrical device according to manufacturer's specifications and NEC with proper voltage supplied, correct polarity, and proper grounding.
- Appliance or electrical device must operate correctly and be left in correct operating mode (on/off, etc.).

SUGGESTED INSTRUCTION TIME: 6 Hours

UNIT	7.0 F	TRIM OUT (FINISH) ELECTRICAL DEVICES
TASK	7.12	CONNECT 120/240 CIRCUITS TO CIRCUIT BREAKER PANEL USING NON-METALLIC CABLE

PERFORMANCE OBJECTIVE:

Given previously roughed in non-metallic cable to circuit breaker panel for 120/240 volt circuits, breaker panel with circuit breakers, basic tool kit, and installation/electrical materials; connect 120 and 240 volt circuits to circuit breaker panel. Cables must enter panel through approved-type connectors. Circuit conductors must be attached to correct size breaker.

PERFORMANCE ACTIONS:

- 7.1201 Review plans and specifications.
 - 7.1202 Locate SEP.
 - 7.1203 Turn power off.
 - 7.1204 With electrical instrument, verify that power is off.
 - 7.1205 Enter cables in SEP through approved connectors.
 - 7.1206 Remove outer jacket from each cable to where the cable enters the SEP.
 - 7.1207 Identify each cable as to circuit it serves.
 - 7.1208 Identify conductors in each cable.
- (NOTE: If two-wire cables are to serve 240 volt circuits, the white wire should be taped with black electrical tape to indicate it is a hot line conductor (or it may be marked red).
- 7.1209 Connect all bare of green grounding conductors to the grounding terminal bar.
 - 7.1210 Connect 120 volt circuit white conductors to neutral bar.
 - 7.1211 Connect all 120 volt circuit black conductors to single pole breakers of correct ampacity.

UNIT	7.0 F	TRIM OUT (FINISH) ELECTRICAL DEVICES
TASK	7.12	CONNECT 120/240 CIRCUITS TO CIRCUIT BREAKER PANEL USING NON-METALLIC CABLE

PERFORMANCE ACTIONS (Con't.):

- 7.1212 Connect 240 volt circuits to double pole breakers of correct ampacity.
- (NOTE: Any split receptacle 240 volt lines should be on double pole breakers for safety.)
- 7.1213 Check installation for shorts/grounds (Using VOM or other electrical instrument).
- 7.1214 After all circuits have checked satisfactory, attach SEP cover.
- 7.1215 Turn power on.
- 7.1216 Check each circuit for proper voltage/polarity.

PERFORMANCE STANDARDS:

- Connect 120/240 volt circuits to circuit breaker panel (SEP) using non-metallic cable roughed in through approved connectors.
- Circuits must be protected by proper ampacity breakers and installation must provide proper voltage/polarity as required and meet NEC.

SUGGESTED INSTRUCTION TIME: 15 Hours

UNIT	7.0 F	TRIM OUT (FINISH) ELECTRICAL DEVICES
TASK	7.13	INSTALL/CONNECT THREE-WAY SWITCHES

PERFORMANCE OBJECTIVE:

Given a pair of three-way switches, power source, previously roughed in wiring and boxes, basic tool kit, and installation/electrical materials; connect/install three-way switch. The light device must be controlled on or off from either switch location. The cover plate must be straight, cover the opening, and fit flush to the wall.

PERFORMANCE ACTIONS:

- 7.1301 Review specifications and plans.
- 7.1302 Locate installation point.
- 7.1303 Turn power off.
- 7.1304 Using electrical instrument, verify that power is off.
- 7.1305 Cut conductor at wall box(es) to leave 6 inches of free conductor.
- 7.1306 Remove approximately 3/4 inch of insulation from each conductor.
- 7.1307 Identify conductors.
- 7.1308 Connect source or hot lead to identified switch terminal at one switch location.
- 7.1309 Connect travelers to either of other two switch terminals.
- 7.1310 Connect switched leg to identified switch terminals at second switch location.
- 7.1311 Connect traveler to either of other two terminals at second switch location.
- 7.1312 Attach switches to wall boxes.
- 7.1313 Install cover plates.
- 7.1314 Turn power on.
- 7.1315 Test circuit for proper operation at both switch locations.

UNIT	7.0 F	TRIM OUT (FINISH) ELECTRICAL DEVICES
TASK	7.13	INSTALL/CONNECT THREE-WAY SWITCHES (Con't.)

PERFORMANCE STANDARDS:

- Install/connect three-way switches to control light device previously roughed in.
- The device must be controlled on or off from either switch location.
- Cover plates must be installed straight, cover opening, and fit flush to wall.

SUGGESTED INSTRUCTION TIME: 1 Hour

UNIT 7.0 F

TRIM OUT (FINISH)
ELECTRICAL DEVICES

TASK 7.14

MAKE WIRE AND FIXTURE SPLICES

PERFORMANCE OBJECTIVE:

Given power source, installed cable, and roughed-in electrical devices, etc., basic tool kit, installation/electrical materials including various types of solderless connectors (wire nuts); make required splices. Splice must be made in outlet box using connectors or other means suitable for fixtures being installed. Splice must be mechanically strong and insulated electrical to withstand applied voltage. Splice must meet the requirement of NEC (Ar. 410-11, 410-23, and 410-32).

PERFORMANCE ACTIONS:

- 7.1401 Locate splice point.
- 7.1402 Turn power off.
- 7.1403 With electrical instrument, verify that power is off.
- 7.1404 Determine wiring connection to be made preserving proper polarity.
- 7.1405 Remove about 3/4 inch insulation from each conductor.
- 7.1406 Connect conductors being spliced using wire nuts or other approved connectors or methods.*

*NOTE: RECOMMENDED MINIMUM PERFORMANCE FOR COMPETENCY:

- a. Simple splice
- b. Simple tap
- c. Pigtail
- d. Fixture splice (solid and stranded wire)
- e. Simple splice (stranded wire)
- f. Simple tap (stranded wire)
- g. Simple splice (solid wire to solid wire component)
- h. Wire to terminal lug
- i. Wire to terminal post
- j. Component to terminal post
- k. Hook splice for soldering

- 7.1407 Check mechanically strength of connection.

UNIT	7.0 F	TRIM OUT (FINISH) ELECTRICAL DEVICES
TASK	7.14	MAKE WIRE AND FIXTURE SPLICES

PERFORMANCE ACTIONS (Con't.):

- 7.1408 Tape or insulate connection to withstand applied voltage.
- 7.1409 Check work, close junction box.
- 7.1410 Test circuit.

PERFORMANCE STANDARDS:

- Make wire and fixture splices as required so that installation is mechanically strong, electrically insulated, meets NEC, and operates correctly.
- Performance must be to instructor's process and product standards.

SUGGESTED INSTRUCTION TIME: 2 Hours

RELATED TECHNICAL INFORMATION:

- Identification and use of solderless connectors.
- Soldering.
- Use of split-bolt splice connectors for heavy wire.
- Proper techniques for crimping.
- Proper splicing techniques (See 6 a-k Performance Actions).

UNIT 7.0 G

MAINTAIN LIGHTING/WIRING SYSTEM
(RESIDENTIAL)

Applicable in part to Commercial/Industrial Electricity

NOTE: Some tasks are omitted from this unit because they are covered satisfactorily within other units of this module. For example, if the student has demonstrated competency in installing a SEP, cable, and circuit breakers; it is assumed that recently demonstrated competency is transferrable to servicing and maintaining similar electrical systems.

Other tasks are omitted from this section because the secondary electrical shops do not have training equipment or appliances such as hot water heaters or furnaces needed for proper instruction.

Consideration should be given to some instruction on maintenance of such appliances as; water heaters, electric ranges, electric heating systems, garbage disposals, and similar large electrical appliances typical to residences.

ELECTRICITY
MAINTAIN LIGHTING/WIRING SYSTEM (RESIDENTIAL)
SUGGESTED INSTRUCTION TIMES

<u>ELECTRICITY MODULE/TASK</u>		<u>SUGGESTED HOURS</u>
UNIT 7.0 G	MAINTAIN LIGHTING/WIRING SYSTEM (RESIDENTIAL)	
7.01	Diagnose/Repair Florescent Fixture Malfunction	*
7.02	Diagnose and Repair/Replace Incandescent Lighting	*
7.03	Repair Water Heater	*
7.04	Repair/Replace Frayed/Damaged Service Cord	*
7.05	Replace Fuse	*
7.06	Replace Pilot Light (Lamp) Bulb	*
7.07	Test for Correct Voltage	*
7.08	Troubleshoot a Branch Circuit	*
7.09	Service Electrical Motor/ Appliance	*
7.10	Install/Maintain Emergency Lighting	*
	Total	<u>60</u>

* = See 7.10

TASK LISTINGS
ELECTRICITY

MODULE/TASK	DESCRIPTION
UNIT 7.0 G	MAINTAIN LIGHTING/WIRING SYSTEM (RESIDENTIAL)
7.01	(Diagnose/Repair Florescent Fixture Malfunction) Given basic tool kit and required parts, diagnose/ repair faulty florescent fixture. Defective parts must be replaced with equivalent parts and light must operate properly when repair is made.
7.02	(Diagnose and Repair/Replace Incandescent Lighting) Given basic tool kit, diagnose and repair faulty incandescent lighting. Parts must be replaced with approved equivalent parts and lights must burn properly upon completed repair.
7.03	(Repair Water Heater) Given a water heater that is not supplying hot water, the basic tool kit, and necessary repair parts; check out the water heater and repair it if possible. All replacement parts must be equivalent to the manufacturer's and the water heater must be equipped with a pressure relief valve. When repairs are completed, the water heater must heat at rated capacity and to the temperature of the thermostat setting.
7.04	(Repair/Replace Frayed/Damaged Service Cord) Given service cord which is frayed or damaged replacement cord, basic tool kit, and installation/electrical materials; repair or replace frayed service cords. Insulating materials and cord must be required size and type of conditions encountered. Defective parts must be replaced with equivalent parts. Repair or service cord must be according to NEC (Ar. 400-7-8-9).
7.05	(Replace Fuse) Given assortment of fuses and basic tool kit; replace fuses that have blown. The replaced fuse must meet requirements of NEC (Ar. 240-F).
7.06	(Replace Pilot Light [Lamp] Bulb) Given appliance with defective pilot light bulb, replacement pilot lamp, basic tool kit, replace the bulb. The replacement bulb must light correctly, be of proper size and voltage, and indicate when appliance is working. All connections must be tight and proper connectors, etc., must be used.

- 7.07 (Test for Correct Voltage) Given power source and basic test instrument, test for correct voltage. Voltage must equal the data plate requirements of the same as supplied by the power distributor for a given circuit.
- 7.08 (Troubleshoot a Branch Circuit) Given a defective branch circuit and the basic tool kit, troubleshoot a branch circuit that is defective. The circuit must be checked for an open circuit, short circuit, correct voltage, correct polarity, and proper ampacity for circuit load. All connections must be tight, and the voltage must be as required and the circuit must function properly.
- 7.09 (Service Electrical Motor/Appliance) Given an electrical motor or similar appliance, such as a furnace, basic tool kit, and installation electrical materials; service the electric motor. The motor must be cleaned of dust and other foreign materials. Connections must be checked. All bearings must be oiled and greased.
- 7.10 (Install/Maintain Emergency Lighting) Given wiring diagram for emergency lighting system, basic tool kit, and installation/electrical materials; install and maintain emergency lighting system. Emergency lighting wiring must be kept entirely independent of all other wiring and equipment. Emergency lights must operate automatically when electrical power goes off. The installation of emergency lighting must be according to NEC (Ar. 700).

UNIT	7.0 G	MAINTAIN LIGHTING AND WIRING SYSTEM (RESIDENTIAL)
TASK	7.01	DIAGNOSE/REPAIR FLORESCENT FIXTURE MALFUNCTION

PERFORMANCE OBJECTIVE:

Given basic tool kit and required parts, diagnose/repair faulty florescent fixture. Defective parts must be replaced with equivalent parts and light must operate properly when repair is made.

PERFORMANCE ACTIONS:

- 7.0101 Make preliminary analysis/diagnosis.
- 7.0102 Check voltage with electrical instrument.
- 7.0103 If bulbs are defective (burned out, flashing on/off, or burning red [or dark] at ends) replace them.
- 7.0104 If bulbs are not defective, determine if unit is self-starting or used separate starters. Replace starters as appropriate.
- 7.0105 If bulbs and starters are operative, turn power off.
- 7.0106 Remove cover from fixture and check inside wiring.
- 7.0107 Check/replace ballast.
- 7.0108 Re-install cover.
- 7.0109 Turn power on, test lighting.

PERFORMANCE STANDARDS:

- Diagnose/repair florescent fixture malfunction, repairing, and replacing defective parts as necessary so that light operates properly when job is complete.

SUGGESTED INSTRUCTION TIME: See 7.10

UNIT	7.0 G	MAINTAIN LIGHTING AND WIRING SYSTEM (RESIDENTIAL)
TASK	7.02	DIAGNOSE AND REPAIR/REPLACE INCADESCENT LIGHTING

PERFORMANCE OBJECTIVE:

Given basic tool kit, and VOM, diagnose and repair faulty incandescent lighting. Parts must be replaced with approved equivalent parts and lights must burn properly upon completed repair.

PERFORMANCE ACTIONS:

- 7.0201 Remove and test bulb with ohmmeter, continuity tester, in socket known to operate properly, etc.
- 7.0202 If bulb is good, using VOM, check voltage at fixture.
- 7.0203 If voltage at fixture is correct:
 - a. Turn power off.
 - b. Remove fixture.
 - c. Repair or replace fixture.
 - d. Re-install fixture.
- 7.0204 If voltage is incorrect, check for problem at source (SEP) such as faulty breaker.
- 7.0205 If fault is not at SEP or fixture, check cable run.
- 7.0206 Check light function.

PERFORMANCE STANDARDS:

- Diagnose and repair/replace faulty incandescent lighting fixture.
- Lighting must operate properly upon repair.

SUGGESTED INSTRUCTION TIME: See 7.10

UNIT	7.0 G	MAINTAIN LIGHTING AND WIRING SYSTEM (RESIDENTIAL)
TASK	7.03	REPAIR WATER HEATER

PERFORMANCE OBJECTIVE:

Given a water heater that is not supplying hot water, the basic tool kit, and necessary repair parts; check out the water heater and repair it if possible. All replacement parts must be equivalent to the manufacturer's and the water heater must be equipped with a pressure relief valve. When repairs are completed, the water heater must heat at rate capacity and to the temperature of the thermostat setting.

PERFORMANCE ACTIONS:

- 7.0301 Turn power off.
- 7.0302 Remove access panel from water heater. Check that power is off.
- 7.0303 Inspect wiring and terminal connections.
- 7.0304 If wiring is secure, turn power on.
- 7.0305 Check for correct voltage at line terminals on high limit control.
- 7.0306 If voltage is not correct, check power source.
- 7.0307 Check voltage at load terminals on high limit control.
- 7.0308 If there is no voltage at load terminals, press reset button on high limit control.
- 7.0309 If power is not restored, replace high limit control.
- 7.0310 Check voltage at load terminals on thermostat.
- 7.0311 If correct voltage is not present, replace thermostat.
- 7.0312 Turn power off.
- 7.0313 Check heating element(s) using ohmmeter (shorts and grounds).
- 7.0314 If element(s) is/are bad, replace following correct procedures or outlined by manufacturer.

UNIT	7.0 G	MAINTAIN LIGHTING AND WIRING SYSTEM (RESIDENTIAL)
TASK	7.03	REPAIR WATER HEATER

PERFORMANCE ACTIONS (Con't.):

- 7.0315 Determine if pressure relief valve is in place.
- 7.0316 With servicable element(s) and operable components, test unit for operation. (Check load with ammeter).
- 7.0317 Replace access panel.

PERFORMANCE STANDARDS:

- Service water heater that is not supplying hot water making the necessary repairs or replacing unit as required.
- Replacement parts must be equivalent to the manufacturer's and the unit include proper safety devices and operate to specifications.

SUGGESTED INSTRUCTION TIME: See 7.10

UNIT	7.0 G	MAINTAIN LIGHTING AND WIRING SYSTEM (RESIDENTIAL)
TASK	7.04	REPAIR/REPLACE FRAYED/DAMAGED SERVICE CORD

PERFORMANCE OBJECTIVE:

Given service cord which is frayed or damaged replacement cord, basic tool kit, and installation/electrical materials; repair or replace frayed service cords. Insulating materials and cord must be required size and type of conditions encountered. Defective parts must be replaced with equivalent parts. Repair or service cord must be according to NEC (Ar. 400-7-8-9).

PERFORMANCE ACTIONS:

- 7.0401 Turn power off. (Or, unplug line form outlet, if applicable.)
- 7.0402 Determine that power is off, using electrical instrument.
- 7.0403 If cord is to be replaced, check size for current load.
- 7.0404 Remove old cord from appliance and points of attachment.
- 7.0405 Attach new cord to appliance and secure ends of cord in box, etc., leaving free ends for connections.
- 7.0406 Remove sufficient insulation from conductor ends for connections.
- 7.0407 Connect ends of cable to existing wires or terminals paying attention to proper polarity.
- 7.0408 Turn power on.
- 7.0409 Check circuit being served for required voltage and polarity.
- 7.0410 Assure required operation of appliance.

PERFORMANCE STANDARDS:

- Repair/replace frayed, damaged, service cord so new/required cord is servicable for load and application. Performance process and product must meet instructor's standards.

SUGGESTED INSTRUCTION TIME: See 7.10

UNIT	7.0 G	MAINTAIN LIGHTING AND WIRING SYSTEM (RESIDENTIAL)
TASK	7.05	REPLACE FUSE

PERFORMANCE OBJECTIVE:

Given assortment of fuses and basic tools; replace fuses that have blown. The replaced fuse must meet requirements of NEC (Ar. 240-E).

PERFORMANCE ACTIONS:

- 7.0501 Ask customer what caused fuse to blow. Determine if fuse blew due to overload.
- 7.0502 Check fuse size. Determine that proper size fuse was being used.
- 7.0503 Turn power off serving fuse panel.
- 7.0504 Using fuse puller, remove fuse or unscrew fuse from panel.
- 7.0505 Insert correct size and type of fuse for service and circuit.
- 7.0506 Turn power on.
- 7.0507 Check circuit for proper operation.
- 7.0508 If fuse repeatedly blows, calculate load on circuits and balance as necessary to meet NEC or for safety.

PERFORMANCE STANDARDS:

- Replace blown fuse with proper type and size, checking circuit to ensure that a proper load and balance is present and that no unsafe conditions exist.

SUGGESTED INSTRUCTION TIME: See 7.10

UNIT	7.0 G	MAINTAIN LIGHTING AND WIRING SYSTEM (RESIDENTIAL)
TASK	7.06	REPLACE PILOT LIGHT (LAMP) BULB

PERFORMANCE OBJECTIVE:

Given appliance with defective pilot light bulb, replacement pilot lamp, basic tool kit, replace the bulb. The replacement bulb must light correctly, be of proper size and voltage, and indicate when appliance is working. All connections must be tight and proper connectors, etc., must be used.

PERFORMANCE ACTIONS:

- 7.0601 Assemble materials.
- 7.0602 Turn power off. Verify with electrical instrument.
- 7.0603 Remove required plates to locate bulb.
- 7.0604 Replace bulb with new one.
- 7.0605 Check work.
- 7.0606 Replace cover plates.
- 7.0607 Turn power on.
- 7.0608 Test operation of new pilot lamp.

PERFORMANCE STANDARDS:

- Replace defective pilot light bulb in given appliance using proper size and voltage bulb.

SUGGESTED INSTRUCTION TIME: See 7.10

UNIT	7.0 G	MAINTAIN LIGHTING AND WIRING SYSTEM (RESIDENTIAL)
TASK	7.07	TEST FOR CORRECT VOLTAGE

PERFORMANCE OBJECTIVE:

Given power source and basic test instrument, test for correct voltage. Voltage must equal the data plate requirements of the same as supplied by the power distributor for a given circuit.

PERFORMANCE ACTIONS:

- 7.0701 Locate circuit (line, receptacle, switch, etc.) to be tested.
- 7.0702 Determine proper voltage.
- 7.0703 Turn circuit on at distribution box (SEP).
- 7.0704 Check voltage.

PERFORMANCE STANDARDS:

- Measure voltage at given point and determine if it is correct for power supplied or for load.
- Performance process and findings must be to instructor's standards and voltage must be read correctly using proper scale and application of voltmeter.

SUGGESTED INSTRUCTION TIME: See 7.10

UNIT	7.0 G	MAINTAIN LIGHTING AND WIRING SYSTEM (RESIDENTIAL)
TASK	7.08	TROUBLESHOOT A BRANCH CIRCUIT

PERFORMANCE OBJECTIVE:

Given a defective branch circuit and the basic tool kit, troubleshoot a branch circuit that is defective. The circuit must be checked for an open circuit, short circuit, correct voltage, correct polarity, and proper ampacity for circuit load. All connections must be tight, and the voltage must be as required and the circuit must function properly.

PERFORMANCE ACTIONS:

- 7.0801 Turn power off, as required.
- 7.0802 Locate power source and the route of the circuit to be checked.
- 7.0803 Remove all cover plates.
- 7.0804 Check all connections.
- 7.0805 Check voltage with voltmeter at each outlet beginning as SEP.
- 7.0806 Check each outlet for correct polarity.
- 7.0807 If short, open, or faulty circuit has been identified; cut power off; check with ohmmeter, repair as necessary.
- 7.0808 Replace all protective covers.
- 7.0809 Return power to circuit.
- 7.0810 Check operation.

PERFORMANCE STANDARDS:

- Troubleshoot a branch circuit for proper voltage and operation and ampacity for circuit load.

SUGGESTED INSTRUCTION TIME: See 7.10

UNIT	7.0 G	MAINTAIN LIGHTING AND WIRING SYSTEM (RESIDENTIAL)
TASK	7.09	SERVICE ELECTRICAL MOTOR/APPLIANCE

PERFORMANCE OBJECTIVE:

Given an electrical motor or similar appliance, such as a furnace, basic tool kit, and installation/electrical materials; service the electric motor. The motor must be cleaned of dust and other foreign materials. Connections must be checked. All bearings must be oiled or greased.

PERFORMANCE ACTIONS:

- 7.0901 Locate motor to be served.
- 7.0902 Read manufacturer's instruction/service manual (or service/data plate).
- 7.0903 Determine that power is off by checking conductor(s) at point of connection (junction box) using voltage tester.

(NOTE: If checking motor controlled by thermostat or other device, ensure that voltage has been disconnected.) RECOMMENDED: Use "POWER OFF" tag to ensure that power will not be connected while unit is being serviced.
- 7.0904 Remove protective covers as required.
- 7.0905 Clean motor of foreign matter.
- 7.0906 Check wiring connections.
- 7.0907 Oil or lubricate as required.
- 7.0908 Replace all protective covers.
- 7.0909 Turn power on.
- 7.0910 Assure required operation of motor.

PERFORMANCE STANDARDS:

- Service electrical motor/appliance according to manufacturer's requirements or proper maintenance practices, meeting instructor's standards for procedures followed.

SUGGESTED INSTRUCTION TIME: See 7.10

UNIT	7.0 G	MAINTAIN LIGHTING AND WIRING SYSTEM (RESIDENTIAL)
TASK	7.10 (Optional)	INSTALL/MAINTAIN EMERGENCY LIGHTING (COMMERCIAL/INDUSTRIAL)

PERFORMANCE OBJECTIVE:

Given wiring diagram for emergency lighting system, basic tool kit, and installation/electrical materials; install and maintain emergency lighting system. Emergency lighting wiring must be kept entirely independent of all other wiring and equipment. Emergency lights must operate automatically when electrical power goes off. The installation of emergency lighting must be according to NEC (Ar. 700).

PERFORMANCE ACTIONS:

- 7.1001 Review wiring plan.
- 7.1002 Make wiring connections according to manufacturer's instructions.
- 7.1003 Connect power to unit and assure required operation.
- 7.1004 Locate lighting so designated escape routes are clearly visible.
- 7.1005 Test periodically and service as necessary.

PERFORMANCE STANDARDS:

- Install and maintain emergency lighting system according to NEC and manufacturer's specifications.

SUGGESTED INSTRUCTION TIME: 7.01 - 7.10 = 60 Hours

ELECTRICITY

2ND YEAR

(Secondary Level)

This second year descriptions of the secondary level Electricity Program consists of modules concerning Commercial Electrical Wiring and Industrial Electrical Maintenance which is made up of units concerning industrial wiring, controls, motors, and industrial electronics.

Some tasks in the second year description may overlap with first year tasks. Installing conduit is a good example. Conduit is installed in the Residential Wiring module during the first year. During the second year, conduit is included in the Commercial Wiring module; however, the emphasis during the second year will be on the commercial-industrial setting with different conductors being pulled and with different considerations in the selection and installation of conduit runs.

MODULE 8.0

COMMERCIAL ELECTRICAL WIRING

The general goals of this commercial wiring module are to provide the secondary electricity program graduate with skill competencies in the following areas:

- a. To be able to identify and follow engineered electrical plans.
- b. To make electrical system changes either during or after installation.
- c. To understand the operation of typical electrical fixtures and equipment associated with commercial electrical wiring and to be able to troubleshoot and repair basic problems associated with the equipment.

ELECTRICITY
COMMERCIAL ELECTRICAL WIRING
SUGGESTED INSTRUCTION TIMES

<u>ELECTRICITY</u> <u>MODULE/TASK</u>	SUGGESTED HOURS
Module 8.0 COMMERCIAL ELECTRICAL WIRING	
8.01 Identify and Read Electrical Wiring Information on a Commercial Floor Plan	*
8.02 Interpret Commercial Electrical Wiring Installation Specifications	*
8.03 Construct an Electrical Floor Plan for a Given Commercial Structure	*
8.04 Calculate Commercial Service Entrance Requirements	30
8.05 Install and Secure Rigid Conduit	6
8.06 Install and Secure Thin-wall (EMT) Conduit	12
8.07 Install and Secure Flexible Conduit	3
8.08 Install and Secure PVC Plastic Conduit	12
8.09 Pull wire through conduit and Terminate it	3
8.10 Install and Secure a Surface Raceway	3
8.11 Install Conductors in Conduit	6
8.12 Install Telephone Raceway	3
8.13 Install a Commercial Single- Phase Receptacle Outlet	3
8.14 Install Commercial Three-Phase Circuit Receptacle	3
8.15 Install and Wire a Commercial Lighting Circuit	15

* = See 8.04

ELECTRICITY
MODULE/TASK

SUGGESTED
HOURS

8.16	Install and Wire a Commercial Standby Emergency Lighting Circuit	3
8.17	Install and Wire a Commercial Low-voltage Signal Communications or Control Circuit	(See 8.12)
8.18	Calculate Total Commercial Job Installation Costs	N/A

TASK LISTINGS
ELECTRICITY

MODULE/TASK	DESCRIPTIONS
Module 8.0	COMMERCIAL ELECTRICAL WIRING
8.01	(Identify and Read Electrical Wiring Information on a Commercial Floor Plan) Provided with a set of plans and drawings for a commercial structure, identify the electrical wiring installation information and interpret it to (a) identify types of outlets and fixtures and locations, (b) identify types and locations of special purpose outlets, (c) identify run locations, (d) identify size and wattage of lighting outlets, and (e) identify load center location. Performance must be to the instructor's standards.
8.02	(Interpret Commercial Electrical Wiring Installation Specifications) Provided with a set of electric wiring specifications for a commercial structure, determine the following information; (a) outlets per circuit, (b) size of wire, (c) size of boxes for telephone outlets, (d) wattage, voltage, and wire size for heating circuits, (e) allowances for specified outlets/installations, (f) specifications for mounting switches, receptacles, and face plates, and (g) types of breakers/fuses and wire size for service entrance. Interpretation of specifications must be to the standards of the instructor.
8.03	(Construct an Electrical Floor Plan for a Given Commercial Structure) Given introductory level drafting training, a dimensioned rough sketch for a commercial structure, electrical wiring and component specifications, and agreement for you to provide the electrical service (or rewire a commercial structure such as a garage); draw a commercial floor plan that is acceptable to the instructor and that could be followed if the situation was real. The drawing must include correct proportioning and dimensioning with the required components in proper locations as represented by standard symbols and notations.
8.04	(Calculate Commercial Service Entrance Requirements) Given building dimensions, a summary of branch circuits, and total load requirements; calculate commercial service entrance requirements. Determine requirements for the type of service, the size of overcurrent protection, the required feeder and branch circuit protection and the cable size.

- 8.05 (Install and Secure Rigid Conduit) Provided with installation requirements, rigid conduit, fasteners, connectors, and the necessary tools and materials; install and secure rigid conduit. The conduit and fasteners must be mounted securely in the proper locations, connections must be mechanically secure, and bends must allow for specified conductor fill. The installation must conform to NEC 246,247.
- 8.06 (Install and Secure Thin-Wall [EMT] Conduit) Given installation requirements, EMT conduit, fasteners, connectors, and the required tools and materials; install and secure EMT conduit. Conduit and fasteners must be mechanically secure, and bends must allow for required conduit fill. Installation must conform to NEC 345-6, 346-5, 347-10, 348-5.
- 8.07 (Install and Secure Flexible Conduit) Following installation requirements provided and using given conduit, fasteners, connectors, and the required tools and materials; install and secure flexible conduit. Flexible conduit and fasteners must be mounted securely in proper locations, connections must be mechanically secure, and bends must allow conductors to be used. (NEC 350-2, 350-3, 350-4)
- 8.08 (Install and Secure PVC Plastic Conduit) Provided with instruction on handling PVC pipe, installation requirements, PVC conduit, fittings, glue, fasteners, connectors, and the necessary materials and tools; install and secure PVC plastic conduit. The conduit and fasteners must be mounted securely in the proper locations, connections must be mechanically secure and bends must allow for the specified conductor fill. Installation must conform to NEC 347 and local codes.
- 8.09 (Pull Wire Through Conduit and Terminate It) Given a run of conduit needing wire inserted, all necessary hand tools, materials, and equipment, pull wire through the conduit and terminate the wire. Wire pulled through conduit must be intact, with no breaks, and must be long enough to allow for termination in appropriate boxes. The installation must conform to all applicable articles of the NEC.
- 8.10 (Install and Secure a Surface Raceway) Given a raceway system plan and specifications, raceway, and conduit required, junction boxes, outlet boxes, fasteners, and other required materials and tools; install and secure a raceway system. The raceway must be properly fastened and, if appropriate, leveled, connections must be with approved connectors, and the raceway must be grounded by inherent design of mechanical joints or by applied bonding means. (NEC 352)

- 8.11 (Install Conductors in Conduit) Given specifications for conductors, conductor wire, roughed in conduit, and all necessary tools, equipment and materials to properly install the conduit; install the required conductors in the conduit. The installation must be according to specifications, the insulation of the conductors must not be damaged or skinned during installation, and the installation must exceed the specified percent of conduit fill. The installation must meet the instructor's standards.
- 8.12 (Install Telephone Raceway) Given a commercial structure to be built, electrical/communications plan showing planned telephone system, and specifications as well as the required conduit, raceway, boxes, fasteners, and other materials and tools; rough-in the installation. The installation must be to the standards outlined by the instructor (plans/specifications) and expected by the telephone service.
- 8.13 (Install a Commercial Single-phase Receptacle Outlet) Provided with plans and specifications, receptacle, and the required wire, connectors, tools, and materials; install and wire a commercial single-phase receptacle outlet. The receptacle outlet must be mounted securely in its correct locations, connections must be mechanically and electrically secure, and the outlet must be free of electrical hazards. Conductor size and color must conform to wiring specifications.
- 8.14 (Install Commercial Three-phase Circuit Receptacle) Provided with plans and specifications, proper receptacle, and the necessary electrical wire, connectors, materials, and tools; install and wire a commercial three-phase receptacle outlet. The receptacle outlet must be mounted securely in the proper location, connections must be mechanically and electrically secure and the circuit must be free of electrical hazards. The outlet and circuit must provide the specified ampacity, proper circuit overcurrent protection must be used, and the circuit must be adequately grounded. (NEC 210-7, 50, 52; 410-56)
- 8.15 (Install and Wire a Commercial Lighting Circuit) Provided with plans and wiring specifications, fixtures, controls, and the necessary wire, connectors, tools, and materials; install and wire a commercial lighting circuit. Fixtures and controls must be securely mounted in the proper location, connections must be mechanically and electrically hazards. Fixtures must be the type specified in the lighting system plans.

- 8.16 (Install and Wire a Commercial Standby Emergency Lighting Circuit) Provided with plans and wiring specifications, receptacles, controls, and necessary wire, connectors, materials, and tools; install and wire commercial standby emergency lighting circuit. Receptacles and controls must be mounted securely in their correct locations, connections must be mechanically and electrically secure, and the circuit must be free of electrical hazards. The circuit must have an adequate capacity and rating for the emergency operation equipment connected to it and meet specifications and plans.
- 8.17 (Install and Wire a Commercial Low-voltage Signal Communications or Control Circuit) Given plans and wiring specifications, switches, receptacles, junction boxes, relays and other components, and the necessary wire, connectors, and tools; install a commercial low-voltage signal communications or control circuit. The receptacles, switches, and components must be mounted securely in their correct locations, connections must be mechanically and electrically secure, and the circuit must be free of electrical hazards, and the conductors must be the specified size and be installed without damage to the insulation. The circuit must operate without interference from power wiring circuits.
- 8.18 (Calculate Total Commercial Job Installation Costs) Given plans, drawings, and wiring specifications for a small commercial building; calculate the total commercial job installation costs. Determine the cost of labor (using instructor provided information); fixtures, receptacles, controls, and related components wire, connectors, and related hardware, and materials.

MODULE	8.0	COMMERCIAL ELECTRICAL WIRING
TASK	8.01	IDENTIFY AND READ ELECTRICAL WIRING INFORMATION ON A COMMERCIAL FLOOR PLAN

PERFORMANCE OBJECTIVE:

Provided with a set of plans and drawings for a commercial structure, identify the electrical wiring installation information and interpret it to (a) identify types of outlets and fixtures and locations, (b) identify types and locations of special purpose outlets, (c) identify run locations, (d) identify size and wattage of lighting outlets, and (e) identify load center location. Performance must be to the instructor's standards.

PERFORMANCE ACTIONS:

- 8.0101 Review electrical symbols, especially those that are found in commercial wiring system.
- 8.0102 Assemble a multi-page electrical wiring floor plan and accompanying specifications.
- 8.0103 Interpret the electrical plan to determine:
 - a. Outlets, fixtures, and their locations.
 - b. Special purpose outlets and their locations.
 - c. Run locations.
 - d. Size and wattage of lighting outlets.
 - e. Identify load center location.
- 8.0104 If required, identify type of service entrance such as pad-mounted transformers, high-voltage, pad-mounted enclosure supplying underground service entrance, or underground vault.

PERFORMANCE STANDARDS:

- Identify and interpret electrical wiring installation information and interpret it to determine the following:
 - a. Types of outlets and fixtures and locations.
 - b. Types and locations of special purpose outlets.
 - c. Run locations.
 - d. Size and wattage of lighting outlets.
 - e. Load center location.
- Apply National Electrical Code as necessary.
- Performance must be to the instructor's standards.

SUGGESTED INSTRUCTION TIME: See 8.04

MODULE 8.0

COMMERCIAL ELECTRICAL WIRING

TASK 8.01

IDENTIFY AND READ ELECTRICAL WIRING
INFORMATION ON A COMMERCIAL FLOOR
PLAN (Con't.)

RELATED TECHNICAL INFORMATION:

- Identify component parts of a commercial floor plan.
- Identify commercial electrical components and their symbols and print notations.
- Explain commercial wall, ceiling, and floor construction as they typically effect commercial wiring practices.
- Interpret dimensioning on plans.
- Apply applicable NEC sections.

MODULE	8.0	COMMERCIAL ELECTRICAL WIRING
TASK	8.02	INTERPRET COMMERCIAL ELECTRICAL WIRING INSTALLATION SPECIFICATIONS

PERFORMANCE OBJECTIVE:

Provided with a set of electrical wiring specifications for a commercial structure, determine the following information; (a) outlets per circuit, (b) size of wire, (c) size of boxes for telephone outlets, (d) wattage, voltage, and wire size for heating circuits, (e) allowances for specified outlets/installations, (f) specifications for mounting switches, receptacles, and face plates, and (g) types of breakers/fuses and wire size for service entrance. Interpretation of specifications must be to the standards of the instructor.

PERFORMANCE ACTIONS:

- 8.0201 Review given set of electrical plans and specifications for a commercial structure.

Determine:

- a. Outlets per circuit.
- b. Size of wire for runs.
- c. Size of boxes for telephone outlets, etc.
- d. Wattage, voltage, and wire size for heating circuits.
- e. Special outlet or installation requirements.
- f. Specifications for mounting switches, receptacles, and face plates.
- g. Overcurrent devices.

- 8.0202 Make a list of required materials for installation.

- 8.0203 Note any plan/specifications errors that must be changed to conform to NEC: Make change recommendation(s).

PERFORMANCE STANDARDS:

- Using a given set of electrical wiring specifications for a commercial structure, determine:
 - a. Outlets per circuit.
 - b. Size of wire.
 - c. Size of boxes for telephone outlets.
 - d. Wattage, voltage, and wire size for heating circuits.
 - e. Allowances for specified outlets/installations.
 - f. Specifications for mounting switches, receptacles, and face plates.
 - g. Circuit breaker or fuse equipments.
 - h. Size of service entrance wire.

MODULE	8.0	COMMERCIAL ELECTRICAL WIRING
TASK	8.02	INTERPRET COMMERCIAL ELECTRICAL WIRING INSTALLATION SPECIFICATIONS (Con't.)

SUGGESTED INSTRUCTION TIME: See 8.04

RELATED TECHNICAL INFORMATION:

- Identify component parts of a set of commercial wiring diagrams.
- Describe what information is included in notices sent to contractors inviting a bid.
- Describe a bid, proposal, and an agreement.
- Identify and interpret specialized wiring information and component information in a given set of commercial specifications.
- Explain allowance for future growth in determining conductor ampacity (NEC 310-16).

MODULE	8.0	COMMERCIAL ELECTRICAL WIRING
TASK	8.03	CONSTRUCT AN ELECTRICAL FLOOR PLAN FOR A GIVEN COMMERCIAL STRUCTURE

PERFORMANCE OBJECTIVE:

Given introductory level drafting training, a dimensioned rough sketch for a commercial structure, electrical wiring and component specifications, and agreement for you to provide the electrical service (or rewire a commercial structure such as a garage); draw a commercial floor plan that is acceptable to the instructor and that could be followed if the situation was real. The drawing must include correct proportioning and dimensioning with the required components in proper locations as represented by standard symbols and notations.

PERFORMANCE ACTIONS:

- 8.0301 Assemble basic drafting tools provided by the instructor.
- 8.0302 Review information given concerning electrical requirement in commercial structure.
- 8.0303
 - a. Rough drawing on extra paper.
 - b. Complete finished drawing.
- 8.0304 Enter dimensions and notations.
- 8.0305 Check lines, symbols, dimensions, and notations.

PERFORMANCE STANDARDS:

- Construct an electrical floor plan for a given commercial structure (situation) and electrical wiring and component specifications. (For example, a typical small office or rewire a small auto garage.)
- The electrical plan must include correct proportioning and dimensioning with the required components in proper locations as represented by standard symbols and notations. While the commercial electrician is not expected to be a draftsman, the plan should communicate the work required, etc., to another electrician.
- The standards of the instructor must be met.

SUGGESTED INSTRUCTION TIME: See 8.04

MODULE	8.0	COMMERCIAL ELECTRICAL WIRING
TASK	8.03	CONSTRUCT AN ELECTRICAL FLOOR PLAN FOR A GIVEN COMMERCIAL STRUCTURE (Con't.)

RELATED TECHNICAL INFORMATION:

- Orientation to drafting (possibly in conjunction with secondary drafting programs).
- Demonstrate proper introductory drafting techniques, use of drafting tools, etc.
- Demonstrate proper use of lettering.
- Identify and use "Alphabet of Lines" in the electrical plan.
- Identify and draw common commercial electrical component symbols.
- Explain how to select positions for electrical installations, outlets, etc., and how the symbols are located on the electrical plan.

MODULE	8.0	COMMERCIAL ELECTRICAL WIRING
TASK	8.04	CALCULATE COMMERCIAL SERVICE ENTRANCE REQUIREMENTS

PERFORMANCE OBJECTIVE:

Given building dimensions, a summary of branch circuits, and total load requirements; calculate commercial service entrance requirements. Determine requirements for the type of service, the size of overcurrent protection, the required feeder and branch circuit protection and the cable size.

Suggest: 120/240 volt, 3-phase, 4-wire Delta

PERFORMANCE ACTIONS:

- 8.0401 Review given information.
- 8.0402 Assemble required materials such as NEC.
- 8.0403 Make load calculations:
 - a. Include general lighting loads.
 - b. Include special lighting loads such as decorative, show window, night lights, emergency lights, exit lights.
 - c. Include general purpose outlets.
 - d. Include specific purpose outlets.
 - e. Include motor loads.
- 8.0404 Total load requirements.
- 8.0405 Calculate commercial service entrance requirements.

PERFORMANCE STANDARDS:

- Calculate commercial service entrance requirements for given information and identify the type of service, the size of overcurrent protection, the required feeder and branch circuit protection, and the cable size.
- Calculations should be within 5 percent of predetermined answer.

SUGGESTED INSTRUCTION TIME: 8.01 - 8.04 = 30 Hours

MODULE	8.0	COMMERCIAL ELECTRICAL WIRING
TASK	8.04	CALCULATE COMMERCIAL SERVICE ENTRANCE REQUIREMENTS

RELATED TECHNICAL INFORMATION:

- Identify and state function of service entrance components.
- Explain how to perform calculations required for determining the type of service, feeder size, overcurrent protection, and the cable size. (Copper and aluminum cable.)
- Describe operation of branch circuitry.
- Determine proper size of grounding conductor and select a grounding method.
- Determine type of service entrance typically used with types of small commercial installations: Pad-mounted transformer, pad-mounted enclosure, underground vault, etc.
- Calculate required sizes of conductors for branch circuit, feeder, and service entrance conductors allowing the standard future growth factor (NEC 310-16).
- Define standard grounding method (NEC 250) and explain system grounding (250-81).
- Explain the value of and when GFP (ground-fault protection) should be installed (NEC 230-95).
- Explain difference between GFP and personnel ground-fault protection (G.F.C.I. or G.F.I.) used in residential wiring.

MODULE	8.0	COMMERCIAL ELECTRICAL WIRING
TASK	8.05	INSTALL AND SECURE RIGID CONDUIT

PERFORMANCE OBJECTIVE:

Provided with installation requirements, rigid conduit, fasteners, connectors, and the necessary tools and materials; install and secure rigid conduit. The conduit and fasteners must be mounted securely in the proper locations, connections must be mechanically secure, and bends must allow for specified conductor fill. The installation must conform to NEC 246,247.

(NOTE: This task may be orientation/demonstration or may be a competency task depending on the electricity program equipment, materials, and the time allocated for instruction.)

PERFORMANCE ACTIONS:

- 8.0501 Review installation requirements, make measurements.
- 8.0502 Determine rigid conduit, fasteners, and materials.
- 8.0503 Assemble materials, equipment, and tools.
- 8.0504 Select conduit and proper fittings and accessories according to NEC 348. Select proper size conduit for service. Select boxes for angle for U pulls (NEC 370-18).
- 8.0505 Make required conduit bends:
 - a. Heat conduit (NEC 347-6).
 - b. Form bends (NEC 347-13).
 - c. Cool conduit (NEC 347-5).
- 8.0506 Install conduit according to NEC 345, 346, and 348 and prints and specifications.

PERFORMANCE STANDARDS:

- Install and secure rigid conduit according to given requirements using materials, equipment, and tools provided.
- The installation must demonstrate proper use of fasteners, mounting, and installation according to NEC 247.

SUGGESTED INSTRUCTION TIME: 6 Hours

MODULE	8.0	COMMERCIAL ELECTRICAL WIRING
TASK	8.05	INSTALL AND SECURE RIGID CONDUIT (Con't.)

RELATED TECHNICAL INFORMATION:

- Identify typical uses of rigid conduit (Permitted: NEC 347-2; Not Permitted: 347-3).
- Determine conduit size for specified conduit fills.
- Determine conduit, connectors, and fasteners for specified run.
- Explain/demonstrate how to measure, cut, bend, and connect rigid conduit (NEC 347).
- Determine number of bends allow for specified runs.
- Identify safety considerations.

MODULE	8.0	COMMERCIAL ELECTRICAL WIRING
TASK	8.06	INSTALL AND SECURE THIN-WALL (EMT) CONDUIT

PERFORMANCE OBJECTIVE:

Given installation requirements, EMT conduit, fasteners, connectors, and the required tools and materials; install and secure EMT conduit. Conduit and fasteners must be mechanically secure, and bends must allow for required conduit fill. Installation must conform to NEC 345-6, 346-5, 347-10, 348-5.

PERFORMANCE ACTIONS:

- 8.0601 Assemble EMT conduit and accessories required for installation to meet prints/specifications.
- 8.0602 Make required bends according to recommended procedures.
- 8.0603 Install EMT conduit according to print/specifications and NEC. Demonstrate use of typical raceway support devices such as steel conduit clamps, two-hole clamps, etc.

PERFORMANCE STANDARDS:

- Install and secure EMT conduit in a given situation so that the conduit and fasteners are mechanically secure, bends are allow for fill, and the installation meets all applicable NEC articles.
- Installation procedures and product must be to the instructor's standards.

SUGGESTED INSTRUCTION TIME: 12 Hours

RELATED TECHNICAL INFORMATION:

- Identify characteristics of EMT.
- Identify typical applications of EMT.
- Determine conduit size for specified conduit fills (NEC 345-6, 346-5, 347-10, 348-5).
- Estimate EMT conduit and materials for specified installations.
- Describe how to measure, cut, bend, and connect EMT (Bends: NEC 347-13, 348-9, 346-10; Reaming: 345-8, 346-7, 347-5, 346-11; Bends: 345-10, 346-10).

MODULE	8.0	COMMERCIAL ELECTRICAL WIRING
TASK	8.06	INSTALL AND SECURE THIN-WALL (EMT) CONDUIT

RELATED TECHNICAL INFORMATION (Con't.):

- Determine bends allowed for specified runs (NEC 345-11, 246-11, 347-14, 348-10, 350-6).
- Describe how to mount/fasten EMT to supporting surface (NEC 345-12, 346-12, 348-12, 347-8) (345-3B; 346-1, 348-1).

MODULE	8.0	COMMERCIAL ELECTRICAL WIRING
TASK	8.07	INSTALL AND SECURE FLEXIBLE CONDUIT

PERFORMANCE OBJECTIVE:

Following installation requirements provided and using given conduit, fasteners, connectors, and the required tools and materials; install and secure flexible conduit. Flexible conduit and fasteners must be mounted securely in proper locations, connections must be mechanically secure, and bends must allow conductors to be used. (NEC 350-2, 350-3, 350-4)

PERFORMANCE ACTIONS:

- 8.0701 Review requirements for the installations.
- 8.0702 Identify locations where flexible metal conduit and liquid tight flexible conduit are required.
- 8.0703 Determine type of installation.
(Suggestion: For training, use flexible metal conduit between a motor and junction box and to switch. For training, use a liquid tight flexible connector to a heat pump with location on simulated outside pad.)
- 8.0704 Install flexible conduit according to procedures taught, NEC, and manufacturer's recommendations.

PERFORMANCE STANDARDS:

- Install and secure flexible conduit according to given requirements so that the conduit and fasteners are mounted securely in proper locations, with mechanically secure connections, and with bends which allow for the conductor to be used.
- The installation must conform to the NEC and meet the instructor's standards.

SUGGESTED INSTRUCTION TIME: 3 Hours

RELATED TECHNICAL INFORMATION:

- Describe typical applications for flexible conduit.
- Identify applicable NEC sections.
- Estimate the conduit, connectors, and fasteners required for specified runs.

MODULE 8.0

COMMERCIAL ELECTRICAL WIRING

TASK 8.07

INSTALL AND SECURE FLEXIBLE CONDUIT

RELATED TECHNICAL INFORMATION (Con't.):

- Describe how to cut, bend, and connect flexible conduit.
- Determine the number of bends allowed for specified runs.
- Explain/demonstrate methods of supporting flexible conduit (within 12 inch box, + every 4.5 feet).
- Describe/demonstrate how to ground flexible conduit.
- Identify safety considerations.
- For Liquid Tight Flexible Metal Conduit: See NEC 351-4, 351-5, 351-9, and 501-4b, 504, and 503-3.

MODULE	8.0	COMMERCIAL ELECTRICAL WIRING
TASK	8.08	INSTALL AND SECURE PVC PLASTIC CONDUIT

PERFORMANCE OBJECTIVE:

Provided with instruction on handling PVC conduit, installation requirements, PVC conduit, fittings, glue, fasteners, connectors, and the necessary materials and tools; install and secure PVC plastic conduit. The conduit and fasteners must be mounted securely in the proper locations, connections must be mechanically secure and bends must allow for the specified conductor fill. Installation must conform to NEC 347 and local codes.

PERFORMANCE ACTIONS:

- 8.0801 Identify when polyvinyl chloride (PVC) rigid non-metallic conduit should be installed.
- 8.0802 Determine the best method of installing fittings: Threaded or slip-on.
- 8.0803 Demonstrate proper method of making PVC fittings (Task may be orientation if materials and budget do not permit actual experience.)
- 8.0804 Demonstrate the proper method of installing a grounding conductor to metal junction boxes.
- 8.0805 Install PVC rigid nonmetallic conduit according to instructions given and NEC 347.

PERFORMANCE STANDARDS:

- Install and secure PVC plastic conduit using approved methods and conforming to applicable NEC or other codes.
- The installation must meet the instructor's standards.

SUGGESTED INSTRUCTION TIME: 12 Hours

RELATED TECHNICAL INFORMATION:

- Identify typical uses of PVC plastic conduit.
- Determine conduit size for specified conduit fills (NEC 347-10).
- Determine amount of conduit, connectors, and fasteners required for the specified run.

MODULE 8.0

COMMERCIAL ELECTRICAL WIRING

TASK 8.08

INSTALL AND SECURE PVC
PLASTIC CONDUIT

RELATED TECHNICAL INFORMATION (Con't.):

- Tell how or demonstrate the proper procedures for measuring, cutting, bending, and connecting PVC plastic conduit (NEC 347-17).
- Determine number of bends allows for the specified run(s).
- Tell how PVC plastic conduit is supported.
- Describe the grounding of PVC plastic conduit.
- Identify safety considerations.

MODULE 8.0
TASK 8.09

COMMERCIAL ELECTRICAL WIRING
PULL WIRE THROUGH CONDUIT
AND TERMINATE IT

PERFORMANCE OBJECTIVE:

Given a run of conduit needing wire inserted, all necessary hand tools, materials, and equipment; pull wire through the conduit and terminate the wire. Wire pulled through conduit must be intact, with no breaks, and must be long enough to allow for termination in appropriate boxes. The installation must conform to all applicable articles of the NEC.

PERFORMANCE ACTIONS:

8.0901 A LESS THAN 100 FOOT RUN:

- (1) Push fish tape from box at one end of run out through box at other end.
- (2) Attach wire to fish tape and pull through conduit leaving 6 inches of free wire in boxes at ends.
- (3) Proceed to step 4.
- (4) Terminate circuit wiring boxes at each end run of conduit.
- (5) Inspect installation for conformity to NEC.

8.0902 B LONGER THAN 100 FOOT RUN:

- (1) Insert pull wire in conduit.
- (2) Insert jet-line nylon rope in conduit.
- (3) Attach conductors to pull wire or rope and pull conductors through conduit.
- (4) Terminate circuit wiring in boxes at each end run of conduit.
- (5) Inspect installation for conformity to NEC.

PERFORMANCE STANDARDS:

- Pull wire through conduit and terminate it.
- Wire must not be damaged and must be continuing lengths and must conform to the NEC.
- Performance must meet instructor's standards.

SUGGESTED INSTRUCTION TIME: 3 Hours

MODULE 8.0

COMMERCIAL ELECTRICAL WIRING

TASK 8.09

PULL WIRE THROUGH CONDUIT AND
TERMINATE IT (Con't.)

RELATED TECHNICAL INFORMATION:

- Lubricating conductors for long or tight pulls.
- Number of conductors allowed in conduit according to NEC.
- Techniques of pulling wire through conductors (instructor provided).

MODULE	8.0	COMMERCIAL ELECTRICAL WIRING
TASK	8.10	INSTALL AND SECURE A SURFACE RACEWAY

PERFORMANCE OBJECTIVE:

Given a raceway system plan and specifications, raceway, and conduit required, junction boxes, outlet boxes, fasteners, and other required materials and tools; install and secure a raceway system. The raceway must be properly fastened and, if appropriate, leveled, connections must be with approved connectors, and the raceway must be grounded by inherent design of mechanical joints or by applied bonding means. (NEC 352)

(NOTE: This task may be for orientation purposes only if there is a lack of training equipment, materials, budget or allocated time.)

PERFORMANCE ACTIONS:

- 8.1001 Identify situations where a surface raceway might be employed.
- 8.1002 Identify raceway components for part of a given system.
- 8.1003 Demonstrate proper techniques of installing surface raceway components.

(NOTE: Task may be orientation if program materials and budget restrict hands-on activities.)

PERFORMANCE STANDARDS:

- Install and secure a surface raceway with proper use of junction boxes, fasteners, and leveling, with cable supports inside raceway, if required.
- Installation must be to NEC 354-1 to 354-15, 352-1, 352-6.
- Installation must be to the instructor's standards.

SUGGESTED INSTRUCTION TIME: 3 Hours

RELATED TECHNICAL INFORMATION:

- Identify typical uses of raceway system.
- Identify and explain functions of typical components that might be used in raceway installations.
- Describe raceway system requirements.

MODULE 8.0

COMMERCIAL ELECTRICAL WIRING

TASK 8.10

INSTALL AND SECURE A SURFACE RACEWAY

RELATED TECHNICAL INFORMATION (Con't.):

- Identify applicable NEC standards.
- Determine amount of raceway material and supplies.
- Describe/demonstrate methods of grounding by mechanical joints and by applied bonding.
- Describe or demonstrate procedures for installing a surface raceway, including mounting, connecting, and securing the system.
- Review NEC 100 concerning multioutlet assemblies for power and communications systems (commercial applications).

MODULE 8.0

COMMERCIAL ELECTRICAL WIRING

TASK 8.11

INSTALL CONDUCTORS IN CONDUIT

PERFORMANCE OBJECTIVE:

Given specifications for conductors, conductor wire, roughed in conduit, and all necessary tools, equipment and materials to properly install the conduit; install the required conductors in the conduit. The installation must be according to specifications, the insulation of the conductors must not be damaged or skinned during installation, and the installation must exceed the specified percent of conduit fill. The installation must meet the instructor's standards.

PERFORMANCE ACTIONS:

- 8.1101 Determine conductors required for run.
- 8.1102 Measure conductor lengths.
- 8.1103 Pull conductors following procedures taught including correct use of the fish tape.
- 8.1104 Strip insulation, prepare wire, and make required connections using the best choice of wire connectors from alternatives given by the instructor.
- 8.1105 Check installation of conductors to be sure they meet the standards of the instructor and NEC.

PERFORMANCE STANDARDS:

- Install specified conductors in a given conduit, not exceeding the specified percent of conduit fill, and not damaging or skinning the insulation of the conductors.

SUGGESTED INSTRUCTION TIME: 6 Hours

RELATED TECHNICAL INFORMATION:

- Identify and determine conductor size for different applications (Tables 310-16, 310-17, 310-18, 310-19).
- Explain conduit fill (346-6, 347-11, 352-4, 348-6, etc.).
- Describe procedures to protect insulation from damage during installation.
- Determine ampacity of conductors.
- Describe/demonstrate procedures for installing conductors in conduit.
- Identify safety considerations.

MODULE	8.0	COMMERCIAL ELECTRICAL WIRING
TASK	8.12	INSTALL TELEPHONE RACEWAY

PERFORMANCE OBJECTIVE:

Given a commercial structure to be built, electrical/communications plan showing planned telephone system, and specifications as well as the required conduit, raceway, boxes, fasteners, and other materials and tools; rough-in the installation. The installation must be to the standards outlined by the instructor (plans/specifications) and expected by the telephone service.

PERFORMANCE ACTIONS:

- 8.1201 Review plans and specifications.
- 8.1202 Determine drops, boxes and junctions, and conduit (3/4 inches or larger depending on cable).
- 8.1203 Determine bends and offsets using greater minimum radii or sweeps.
- 8.1204
 - a. Install fish tape in each conduit for communications contractor to pull.
 - b. Or, pull designated wire according to recommended procedures (if the electrical installation includes that service).
- 8.1205 Terminate conduit according to recommended procedures and specifications.
- 8.1206 Ground according to specifications and NEC 250-80, and 800-11c4.

PERFORMANCE STANDARDS:

- Install telephone raceway (and wiring if contracted) according to plans and specifications following recommended procedures that will satisfy the telephone company.
- The electrical contractor should check with Southern Bell (AT&T, etc.) "Building Industry Consulting Service" for specific engineering information and specifications.

SUGGESTED INSTRUCTION TIME: 3 Hours

MODULE 8.0

COMMERCIAL ELECTRICAL WIRING

TASK 8.12

INSTALL TELEPHONE RACEWAY (Con't.)

RELATED TECHNICAL INFORMATION:

- Installation of conduit.
- Grounding requirements (NEC 250-80, 800-11c4).
- Bending conduit for communications systems.
- Sizing conduit for communications systems.
- Terminating conduit runs.
- Considerations for 1 level and multi-level.
- Terminating system for connection to telephone service entrance.

MODULE	8.0	COMMERCIAL ELECTRICAL WIRING
TASK	8.13	INSTALL A COMMERCIAL SINGLE-PHASE RECEPTACLE OUTLET

PERFORMANCE OBJECTIVE:

Provided with plans and specifications, receptacle, and the required wire, connectors, tools, and materials; install and wire a commercial single-phase receptacle outlet. The receptacle outlet must be mounted securely in its correct locations, connections must be mechanically and electrically secure, and the outlet must be free of electrical hazards. Conductor size and color must conform to wiring specifications.

PERFORMANCE ACTIONS: (Specified actions will be recommended by instructor.)

- 8.1301 Identify receptacle outlets that are required for permanently connected, cord-and-plug connected, fastened in place, and located on a specific circuit situation.
- 8.1302 Determine outlet current requirements, over current protection, and wire size.
- 8.1303 Install the required receptacle outlet.

PERFORMANCE STANDARDS:

- Install a commercial single-phase receptacle outlet according to plans and specifications, securely mounting the outlet in the proper location, with the conductors mechanically and electrically secure so that the outlet is free of electrical hazards.
- The conductor size and color must conform to wiring specifications.

SUGGESTED INSTRUCTION TIME: 3 Hours

RELATED TECHNICAL INFORMATION:

- Identify the symbol for a single-phase receptacle outlet.
- Identify types of receptacle outlet installations.
- Explain operation of single-phase receptacle outlets.
- Determine type, size, and location of receptacle outlets from plans and specifications.
- Explain/identify color coding for commercial wiring.

MODULE 8.0

COMMERCIAL ELECTRICAL WIRING

TASK 8.13

INSTALL A COMMERCIAL SINGLE-PHASE
RECEPTACLE OUTLET

RELATED TECHNICAL INFORMATION (Con't.):

- Determine size and color of conductors required for the installation.
- Explain purpose/operation of G.F.C.I.
- Describe wiring methods of single-phase receptacle outlets.
- Describe installation procedures for single-phase receptacle outlets.
- Describe methods of grounding single-phase receptacle outlets.
- Explain/demonstrate how to strip, prepare, and fasten stranded wire.
- Identify safety considerations.

MODULE	8.0	COMMERCIAL ELECTRICAL WIRING
TASK	8.14	INSTALL COMMERCIAL THREE-PHASE CIRCUIT RECEPTACLE

PERFORMANCE OBJECTIVE:

Provided with plans and specifications, proper receptacle, and the necessary electrical wire, connectors, materials, and tools; install and wire a commercial three-phase receptacle outlet. The receptacle outlet must be mounted securely in the proper location, connections must be mechanically and electrically secure and the circuit must be free of electrical hazards. The outlet and circuit must provide the specified ampacity, proper circuit overcurrent protection must be used, and the circuit must be adequately grounded. (NEC 210-7, 50, 52; 410-56)

PERFORMANCE ACTIONS: (Specified actions will be recommended by instructor.)

- 8.1401 Determine receptacle requirements: Type receptacle or box, wire size, disconnect switch, overcurrent protection, starters, etc.
- 8.1402 Assemble materials.
- 8.1403 Install conduits and controls.
- 8.1404 Install branch circuit and control wiring.
- 8.1405 Complete connections.
- 8.1406 Check circuit.
- 8.1407 Connect to power source.
- 8.1408 Test circuit operation.

PERFORMANCE STANDARDS:

- Install a commercial three-phase receptacle circuit and outlet that is free of electrical hazards, provides specified ampacity, includes proper circuit overcurrent protection, and is adequately grounded.
- The outlet must be properly located and the installation must comply with the NEC.

SUGGESTED INSTRUCTION TIME: 3 Hours

MODULE	8.0	COMMERCIAL ELECTRICAL WIRING
TASK	8.14	INSTALL COMMERCIAL THREE-PHASE CIRCUIT RECEPTACLE (Con't.)

RELATED TECHNICAL INFORMATION:

- Identify symbol for three-phase receptacle.
- Match three-phase receptacle symbol with actual product.
- Explain operation of three-phase receptacle outlets.
- Determine type, size, and location of three-phase receptacle outlets from plans and specifications.
- Explain current carrying capacity (conductors, etc.) (210-21).
- Explain why a balance load is important.
- Describe how to balance a load in a three-phase system.
- Describe/demonstrate wiring methods for three-phase receptacle outlet circuits.
- Describe installation procedures for three-phase receptacle outlet circuits.
- Describe overcurrent protection for three-phase receptacle outlet circuits.
- Identify safety considerations.
- Calculate (for 3 ϕ motor): circuit conductor size and type, motor running overload protection, and branch circuit over-current protection.

MODULE	8.0	COMMERCIAL ELECTRICAL WIRING
TASK	8.15	INSTALL AND WIRE A COMMERCIAL LIGHTING CIRCUIT

PERFORMANCE OBJECTIVE:

Provided with plans and wiring specifications, fixtures, controls, and the necessary wire, connectors, tools, and materials; install and wire a commercial lighting circuit. Fixtures and controls must be securely mounted in the proper location, connections must be mechanically and electrically secure, and the lighting system must be free of electrical hazards. Fixtures must be the type specified in the lighting system plans.

PERFORMANCE ACTIONS:

- 8.1501 Review plan/specification requirements.
- 8.1502 Group lighting into branch circuits.
- 8.1503 Complete materials list.
- 8.1504 Assemble materials required for task demonstration.
- 8.1505 Install and operate a circuit demonstrating general illumination, exit lights, night lights, show window lighting, and emergency lighting (A separate task concerning emergency lighting may be combined with this task training).
- 8.1506 The interpretation of the plan and specifications, installation planning and calculations, circuit installation and operation must be to the instructor's standards representing what a contractor or owner would expect.

PERFORMANCE STANDARDS:

- Install and wire and commercial lighting circuit according to given plans and wiring specifications.
- The fixtures and controls must be securely mounted in the proper location, connections must be mechanically and electrically secure, and the lighting system must be free of electrical hazards.

SUGGESTED INSTRUCTION TIME: 15 Hours

MODULE	8.0	COMMERCIAL ELECTRICAL WIRING
TASK	8.15	INSTALL AND WIRE A COMMERCIAL LIGHTING CIRCUIT (Con't.)

RELATED TECHNICAL INFORMATION:

- Identify commercial lighting fixture symbols and match them with pictures or samples of the lighting fixtures and controls.
- Determine type, size, number, and location of fixtures and controls from plans and specifications.
- Explain operation of three-place and remote controls and low voltage control systems.
- Draw a commercial lighting circuit described by the instructor.
- Describe wiring methods for commercial lighting systems.
- Identify safety considerations.
- Identify illumination (lumens) considerations for commercial situations.
- Calculate lighting branch circuit requirements for florescent, exit, night, emergency, show window, and other lighting requirements.

MODULE 8.0

COMMERCIAL ELECTRICAL WIRING

TASK 8.16

INSTALL AND WIRE A COMMERCIAL
STANDBY EMERGENCY LIGHTING CIRCUIT

PERFORMANCE OBJECTIVE:

Provided with plans and wiring specifications, receptacles, controls, and necessary wire, connectors, materials, and tools; install and wire a commercial standby emergency lighting circuit. Receptacles and controls must be mounted securely in their correct locations, connections must be mechanically and electrically secure, and the circuit must be free of electrical hazards. The circuit must have an adequate capacity and rating for the emergency operation equipment connected to it and meet specifications and plans.

PERFORMANCE ACTIONS: (Instructor will identify minimum actions.)

- 8.1601 Identify requirements for battery powered lighting.
- 8.1602 Identify/describe the basic circuit of a battery powered lighting device that is charged from the AC line and operates on loss of AC power.
- 8.1603 Describe/demonstrate proper installation procedures for emergency lighting devices.

PERFORMANCE STANDARDS:

- Install and wire a commercial standby emergency lighting circuit according to plans and specifications.
- The components must be mounted securely in their correct locations, connections must be mechanically and electrically secure, the circuit must be free of electrical hazards and the circuit must have an adequate capacity and rating for the emergency operation equipment connected to it.

SUGGESTED INSTRUCTION TIME: 3 Hours

RELATED TECHNICAL INFORMATION:

- Identify symbols for emergency lighting and related circuits.
- Explain operation of standby emergency lighting systems.
- Identify sources of power used with typical emergency lighting systems.

MODULE 8.0

COMMERCIAL ELECTRICAL WIRING

TASK 8.16

INSTALL AND WIRE A COMMERCIAL STANDBY
EMERGENCY LIGHTING CIRCUIT

RELATED TECHNICAL INFORMATION (Con't.):

- Explain operation and use of battery power lighting, automatic transfer controls, and central battery power.

SEE BELOW FOR SAMPLE CIRCUITS FOR EXPANDED TRAINING

EXPANSION OF TRAINING SUGGESTIONS:

- Emergency power systems for community services, etc.

CHARGER-EMERGENCY LIGHTING CIRCUIT

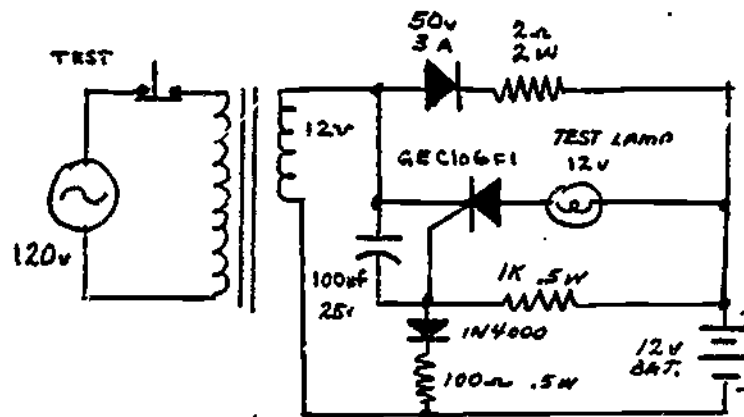

MODULE 8.0

COMMERCIAL ELECTRICAL WIRING

TASK 8.17

INSTALL AND WIRE A COMMERCIAL
LOW-VOLTAGE SIGNAL COMMUNICATIONS OR
CONTROL CIRCUIT

PERFORMANCE OBJECTIVE:

Given plans and wiring specifications, switches, receptacles, junction boxes, relays and other components, and the necessary wire, connectors, and tools; install a commercial low-voltage signal communications or control circuit. The receptacles, switches, and components must be mounted securely in their correct locations, connections must be mechanically and electrically secure, the circuit must be free of electrical hazards, and the conductors must be the specified size and be installed without damage to the insulation. The circuit must operate without interference from power wiring circuits.

PERFORMANCE ACTIONS:

- 8.1701 Review plans and specification requirements.
- 8.1702 List components of the low-voltage control/signaling system.
- 8.1703 Note NEC requirements governing the installation of low-voltage systems.
- 8.1704 Demonstrate correct methods of component location and installation (NEC 725):
 - a. Identify and relay leads.
 - b. Identify low voltage source primary/secondary.
 - c. Identify rectifier (if used) + and - terminals.
 - d. Identify the following color codes that may be used in low-voltage circuits:

Red wire	Relay on, Switch on
Black wire	Relay off, Switch off
Blue wire	Relay common
White wire	Switch common

PERFORMANCE STANDARDS:

- Install and wire a commercial low voltage circuit designated by the instructor so that receptacles, switches, and components are mounted securely in their correct locations, are mechanically and electrically secure, are free of electrical hazards, are of the specified size for the installation, are installed without damage to wire insulation or components, and so the system operates without interference from power wiring circuits.

MODULE 8.0

COMMERCIAL ELECTRICAL WIRING

TASK 8.17



INSTALL AND WIRE A COMMERCIAL
LOW-VOLTAGE SIGNAL COMMUNICATIONS OR
CONTROL CIRCUIT (Con't.)

SUGGESTED INSTRUCTION TIME: (See 8.12)

RELATED TECHNICAL INFORMATION:

- Review NEC articles, concerning low voltage systems: (Class 1, 2, & 3 - NEC 725; Communications - NEC 800; Fire - 760; Less than 50 volts - 720; Grounding - 250-5a).
- Identify low voltage component and circuit symbols.
- Explain operation of low voltage circuits.
- Determine type, size, and location of low voltage components from plans and specifications.
- Describe/demonstrate installation methods for low voltage systems.
- Identify safety considerations.

SEE ADDENDUM BELOW

LOW-VOLTAGE SYMBOLS	
	Remote Control Low Voltage Wire
T	Low-Voltage Transformer
	Rectifier for Remote Control
B_R	Box for Relays and Motor Master Controls
R	Remote Control Relay
R_P	Remote Control Pilot Light Relay
P₁₁	Separate Pilot Light R C Plate
P₁₀	Separate Pilot Light Inter Plate
MS	Master Selector Switch
MM_R	Motor Master Control for ON
MM_B	Motor Master Control for Off
S_M	Switch for Motor Master
S_{F6}	R C flush Switch
S_{F7}	R C Locator-Light Switch
S_{F8}	R C Pilot Light Switch
S_{K6}	R C Key Switch
S_{K7}	R C Locator Light Key Switch
S_{K8}	R C Pilot Light Key Switch
S_{T6}	R C Trigger Switch
S_{T7}	R C Locator Light Trigger Switch
S_{T8}	R C Pilot Light Trigger Switch
S_{T4}	Interchangeable Trigger Switch Brown
S_{T5}	Interchangeable Trigger Switch Ivory
	Remote Control Receptacle for Extension Switch

MODULE	8.0	COMMERCIAL ELECTRICAL WIRING
TASK	8.18	CALCULATE TOTAL COMMERCIAL JOB INSTALLATION COSTS

PERFORMANCE OBJECTIVE:

Given plans, drawings, and wiring specifications for a small commercial building; calculate the total commercial job installation costs. Determine the cost of labor (using instructor provided information); fixtures, receptacles, controls, and related components wire, connectors, and related hardware, and materials.

PERFORMANCE ACTIONS:

- 8.1801 Assemble information provided (specifications, plans, drawings, and formulas which will be required) as well as catalog or pricing data.
- 8.1802 Following recommended procedures for calculating the installation costs of a commercial job.

PERFORMANCE STANDARDS:

- Calculate total commercial job installation costs including wire, connectors, receptacles, fixtures, controls, and related components/hardware.
- Include labor calculations based on information given by the instructor.
- Total calculations must be acceptable to the instructor.

SUGGESTED INSTRUCTION TIME: N/A Hours

RELATED TECHNICAL INFORMATION:

- Describe how to compile a list of materials.
- Describe how to estimate labor costs based on information given by the instructor.
- Demonstrate proper use of parts catalogs.

MODULE 9.0

INDUSTRIAL ELECTRICAL WIRING AND MAINTENANCE

This module is designed to introduce the secondary electricity student to industrial wiring and maintenance fundamentals as well as to practical industrial electrical installation procedures and troubleshooting. Upon successfully completing the units of this module, the secondary graduate should be better prepared to continue training at the post-secondary level in Industrial Electricity/Electronics at Greenville Technical College or successfully enter electrical maintenance work and a training program in industry.

This module is organized around tasks that are reported to be similar to those that might be experience in typical industrial settings.

Tasks that are included in other units in this Electricity Guide and that would represent a duplication of training have been omitted from this module since a competency in those previously described tasks should have been demonstrated.

This module, Industrial Electrical Wiring and Maintenance, consists of the following units:

- Unit 9.0 A Industrial Electrical Wiring
- Unit 9.0 B Wiring Diagrams and Schematics
- Unit 9.0 C Electric Motors
- Unit 9.0 D Electric Controls and Devices
- Unit 9.0 E Introduction to Industrial Electronics

The unit, Benchwork With Hand and Power Tools, should be considered as a prerequisite to or as an integral part of this Industrial Electrical Wiring and Maintenance module.

NOTE: Some task objectives and schematics in this Industrial Electrical Wiring and Maintenance module have been designed to make use of readily available components and materials that may be recovered from industrial salvage, discarded refrigerators or air conditioners, etc., and which can be used to help students gain knowledge and skills in working with basic electrical circuits such as the installation and troubleshooting of controls and motors.

Standards in this module are based on the following publications as well as on surveys of local industrial practices.

Alerich, Walter N., Electricity 3 DC Motors & Generators Controls Transformers, 3rd Ed., Albany, NY: Delmar Publisher Inc., 1981.

Alerich, Walter N., Electricity 4 AC Motors Controls Alternators, 3rd Ed., Albany, NY: Delmar Publishers Inc., 1981.*

Electric Motors, 5th Ed., Athens, GA: American Association for Vocational Instructional Materials Engineering Center, 1982.

National Electrical Code, 1984, Quincy, MA: National Fire Protection Association, 1983.

Rockis, Gary, and Glen Mazur, Electrical Motor Controls, Alsip, IL: American Technical Publishers, Inc., 1982.*

Smith, Robert L., Electrical Wiring-Industrial, Albany, NY: Delmar Publishers Inc., 1982.

Summers, Wilford I. "Bill", ed., Analysis of the 1984 NEC, Quincy, MA: National Fire Protection Association, 1983.

Summers, Wilford I. "Bill", ed., Soares' Grounding Electrical Distribution Systems for Safety, Park Ridge, IL: International Association of Electrical Inspectors, 1981.

Wildi, Theodore, and Michael J. DeVito, Control of Industrial Motors, Montreal, Quebec: Buck Engineering Co., Inc. (Lab-Volt), 1976.*

*Publications followed by an asterisk are recommended as instructional references and were used as guides in developing objectives, identifying enabling actions, or as resources for schematics of diagrams.

UNIT 9.0 A

INDUSTRIAL ELECTRICAL WIRING

The purpose of this unit is to introduce the secondary electricity student to elementary principles of industrial electrical wiring such as the unit substation, transformers, feeder bus systems, panelboards, trolley busways, etc.

Because the secondary programs are limited in industrial type equipment and materials, training generally will be of an orientation type in this unit. Task objectives will emphasize "hands on" training that is possible in existing programs.

Resources used to develop this guide include:

Smith, Robert L., Electrical Wiring-Industrial, Albany, NY: Delmar Publishers, Inc., 1982.

Mullin, Ray C., and Robert L. Smith, Electrical Wiring-Commercial, Albany, NY: Delmar Publishers, Inc., 1981.

Commercial Electricity - Unit 5, Natchitoches, LA: Louisiana Vocational Curriculum Development and Research Center, 1981.

Miller, Rex, Industrial Electricity, Peoria, IL: Charles A. Bennett Co., Inc., 1978.

ELECTRICITY
INDUSTRIAL ELECTRICAL WIRING
SUGGESTED INSTRUCTION TIMES

<u>ELECTRICITY</u> <u>MODULE/TASK</u>		<u>SUGGESTED</u> <u>HOURS</u>
Unit 9.0 A	INDUSTRIAL ELECTRICAL WIRING	
9.01	Plan and Perform Sitework for Small Industrial Facility	6
9.02	Calculate Branch Circuit Conductors and Overcurrent Protection	9
9.03	Install Outlet, Junctions, and Conduitlets	9
9.04	Wire Transformers as Required	9
9.05	Install and Wire a Commercial Emergency Alarm Circuit to Protect Workers Against Hidden Dangers	6
	Total	<u>39</u>

TASK LISTINGS
ELECTRICITY

MODULE/TASK	DESCRIPTION
Unit 9.0 A	INDUSTRIAL ELECTRICAL WIRING
9.01	(Plan and Perform Sitework for Small Industrial Facility) Given prints and electrical specifications for small industrial facility, plan and perform sitework to include the following: a. Service locations b. Service overhead/underground c. Location of transformer(s) d. Proper bank of transformer(s) e. Correct service voltage f. Determine conflicts with other utilities
9.02	(Calculate Branch Circuit Conductors and Overcurrent Protection) Given a floor plan of a commercial facility (Building or service area), instruction and necessary materials; calculate the size and type of branch circuit conductors to be installed and the branch overcurrent protection for these circuits and show all work and list material selection. All calculations must meet or exceed local and national code standards. Performance must meet instructor's standards.
9.03	(Install Outlet, Junctions, and Conduitlets) Given a set of prints showing panel and outlet locations, etc., conduit, bender, and required tools, equipment, and materials; accurately select the proper materials, mount the required boxes and conduitlets, make the necessary bends and install the conduit runs. All boxes, outlets and fittings must be within 1/4 inch of specifications. If required, install the branch circuit conductors and make the required wiring connections for complete installation of branch circuits, and operate and test all wiring. All work must meet to local and national code standards and the standards of the instructor.
9.04	(Wire Transformers as Required) Given instruction, schematics of transformers that are to be used, schematic of load requirement, and required materials; draw the correct wiring arrangement for various transformers configurations and wire any or all of the various configurations (or simulations) at the option of the instructor.

9.05

(Install and Wire a Commercial Emergency Alarm Circuit to Protect Workers Against Hidden Dangers) Provided with plans and wiring specifications, receptacles, and the necessary wire connectors, materials and tools; install a commercial emergency alarm circuit. Components must be mounted securely in their correct location, connections must be mechanically and electrically secure, the circuit must be free of electrical hazards, and the annunciator* must be audible above the normal noise level as specified by OSHA.

UNIT	9.0 A	INDUSTRIAL ELECTRICAL WIRING
TASK	9.01 (Optional)	PLAN AND PERFORM SITEWORK FOR SMALL INDUSTRIAL FACILITY

PERFORMANCE OBJECTIVE:

Given prints and electrical specifications for a small industrial facility, plan and perform sitework to include the following:

- a. Service locations
- b. Service overhead/underground
- c. Location of transformer(s)
- d. Proper bank of transformer(s)
- e. Correct service voltage
- f. Determine conflicts with other utilities

PERFORMANCE ACTIONS:

- 9.0101 Plan sitework.
- 9.0102 Plan location and installation of service equipment according to specifications and NEC.
- 9.0103 Determine transformer hook-up and installation.

PERFORMANCE STANDARDS:

- From given prints and specifications and directions from the instructor, plan and perform required sitework for a small industrial facility to include:
 - a. Service locations
 - b. Service overhead/underground
 - c. Location of transformer(s)
 - d. Proper bank of transformers
 - e. Correct service voltage
 - f. Determine conflicts with other utilities

SUGGESTED INSTRUCTION TIME: 6 Hours

RELATED TECHNICAL INFORMATION:

- Describe how to locate utilities on a building site.
- Identify: Property lines, location of building on plot plan.
- Explain how to locate electrical service.
- Describe how to determine the voltage and transformer bank for an industrial service (Voltage and KVA rating of transformers, (transformers hook-up).
- Describe how to locate overhead and underground services.

UNIT 9.0 A INDUSTRIAL ELECTRICAL WIRING
TASK 9.02 CALCULATE BRANCH CIRCUIT CONDUCTORS
AND OVERCURRENT PROTECTION

PERFORMANCE OBJECTIVE AND STANDARDS:

Given a floor plan of a commercial facility (building or service area), instruction and necessary materials; calculate the size and type of branch circuit conductors to be installed and the branch overcurrent protection for these circuits and show all work and list material selection. All calculations must meet or exceed local and national code standards. Performance must meet instructor's standards.

SUGGESTED INSTRUCTION TIME: 9 Hours

RELATED TECHNICAL INFORMATION:

- Calculate load on branch circuits.
- Determine conductors per branch circuit.
- Determine overcurrent protection.
- Select correct wire size.
- Select proper type of conductors.
- Make branch circuit installation and connections as required.

UNIT 9.0 A

INDUSTRIAL ELECTRICAL WIRING

TASK 9.03

INSTALL OUTLET, JUNCTIONS, AND
CONDUIT FITTINGS

PERFORMANCE OBJECTIVE:

Given a set of prints showing panel and outlet locations, etc., conduit, bender, and required tools, equipment, and materials; accurately select the proper materials, mount the required boxes and conduitlets, make the necessary conduit bends and install the conduit runs. All boxes, outlets and fittings must be within 1/4 inch of specifications. If required, install the branch circuit conductors and make the required wiring connections for complete installation of branch circuits, and operate and test all wiring. All work must meet to local and national code standards and the standards of the instructor.

PERFORMANCE ACTIONS: (To be clarified by given information.)

PERFORMANCE STANDARDS:

- Install the necessary conduitlets and boxes for conduit runs to specifications +/- 1/4 inch and that meets NEC and instructor standards.

SUGGESTED INSTRUCTION TIME: 9 Hours

RELATED TECHNICAL INFORMATION:

- Select boxes and conduitlets.
- Decide on the number of conductors per each.
- Decide on the number of conduits per each.
- Decide on the outlet and junction locations.
- Bend conduit.
- Fasten or support conduit.
- Demonstrate use of: prints, electrical tools, conduit bender, fish tape, etc.

UNIT 9.0 A

INDUSTRIAL ELECTRICAL WIRING

TASK 9.04

WIRE TRANSFORMERS AS REQUIRED

PERFORMANCE OBJECTIVE:

Given instruction, schematics of transformers that are to be used, schematic of load requirement, and required materials; draw the correct wiring arrangement for various transformer configurations and wire any or all of the various configurations (or simulations) at the option of the instructor.

PERFORMANCE ACTIONS: (Draw transformer circuits, wire circuits as required.)

SUGGESTED SUB-TASKS: (Draw diagrams or wire if required.)

1. Connect two single phase transformers of the same phase and potential in parallel so the transformers will deliver twice the current at the rated voltage.
2. Given two single phase transformers of the same phase and potential, wire the transformers in series to yield a total potential equal to the sum of the two secondaries. The secondary load current should not exceed the rating of either of the secondary windings (or the winding of the least rating).
3. Given two single phase transformers of the same phase and potential, wire the transformers for a three wire output. One of the three wire outputs must equal the total of two separate secondary outputs must represent the voltage of the individual transformer (winding) output.
4. Illustrate how three single phase transformers are connected to a WYE. The voltage across the ends should be $1.73 \times$ volts input.
5. Illustrate how three single phase transformers are connected in DELTA. The voltage across the two open ends should be 'zero.' If the voltage is zero across the two open ends, they may be connected together. The output at the three points (ends) should be 240 volts, three phase, if the three transformer output voltages are 240 volts.

(NOTE: If the secondary winding of one of the transformers is accidentally reversed, the voltage across the open ends will be $240 + 240$ volts = 480 volts. DANGER!)

UNIT	9.0 A	INDUSTRIAL ELECTRICAL WIRING
TASK	9.04	WIRE TRANSFORMERS AS REQUIRED (Con't.)

PERFORMANCE STANDARDS:

- Orientation task.
- Draw transformer configurations as required.
- Wiring of transformers should be under the supervision of the instructor, especially if 120VAC or higher is used.
- "Hands on" wiring may be accomplished using low voltage transformers.
- The student should be able to identify a WYE and DELTA configuration from schematic diagrams.
- The student should be able to identify if a service is WYE or DELTA using the voltmeter.

SUGGESTED INSTRUCTION TIME: 9 Hours

RELATED TECHNICAL INFORMATION:

- Discuss how transformer winding and conductor size determine voltage and current ratings in transformer primaries and secondaries.
- Safety.
- Transformer theory.
- Blueprint reading: Service entrance requirements.
- WYE and DELTA transformer configurations.
- Single phase and three phase circuits.

STANDARDS

SINGLE AND THREE PHASE TERMINOLOGY

For standardization in this articulated, performance-based instruction guide, the following terminology/definitions concerning single and three phase apply.

SINGLE PHASE: (1 \emptyset)

Any voltage less than 208 volts can be considered as single phase (1 \emptyset). A voltmeter connected across the hot leg of the service and neutral or ground should read 120 volts.

A 240 (220/230/240) volt single phase (1 \emptyset) service generally is supplied by a 3 wire service. In a 3 wire service, between 2 or the 3 wires, the voltmeter should read 240 volts. From each of these hot leg wires to the third wire, the meter should read 120 volts.

CAUTION: There may be a service with two wires run in a conduit with the conduit serving as the neutral or ground leg. In such an installation, a voltmeter connected between each individual wire in the conduit will read 240 volts and when connected between the individual wires and the conduit will read 120 volts.

THREE PHASE: (3 \emptyset)

208-249 volts supplied by a three wire service is three phase (3 \emptyset). A voltmeter used to measure voltage between any two of the three wire service will read 208-240 volts.

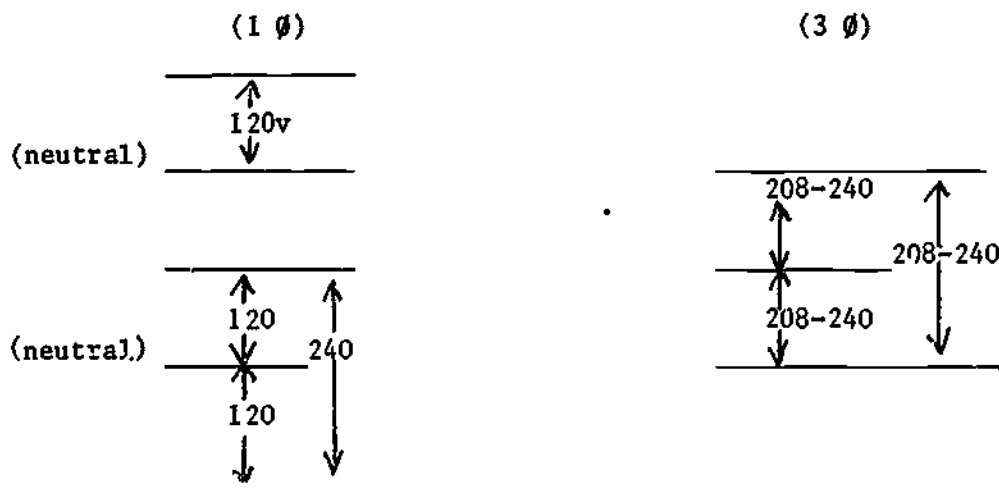

3Ø TRANSFORMER CIRCUITS

WYE:

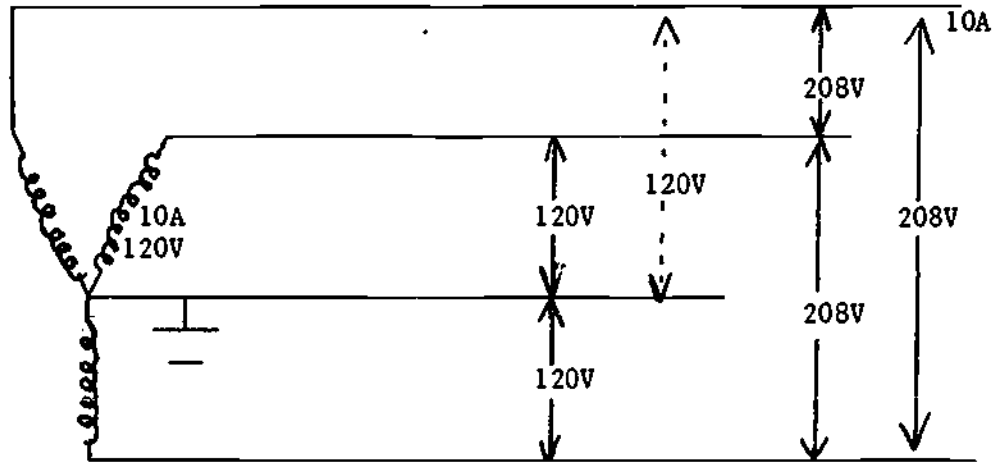

- a. Line voltage is 1.73 x winding voltage.
- b. Line current is same as winding current.

DELTA:

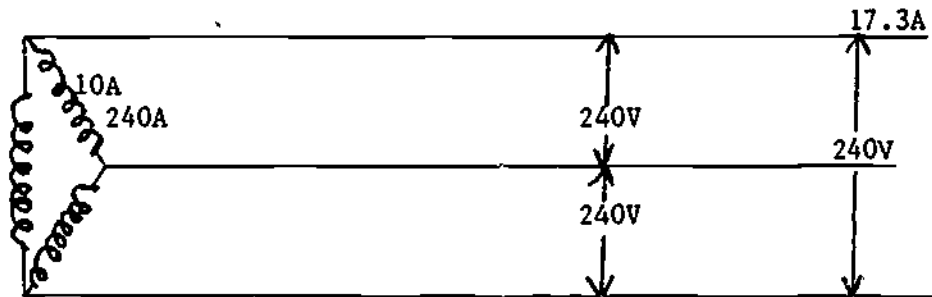

- a. Winding and line voltages are same.
- b. Line current is 1.73 x winding current.

UNIT	9.0 A	INDUSTRIAL ELECTRICAL WIRING
TASK	9.05	INSTALL AND WIRE A COMMERCIAL EMERGENCY ALARM CIRCUIT TO PROTECT WORKERS AGAINST HIDDEN DANGERS

PERFORMANCE OBJECTIVE:

Provided with plans and wiring specifications, receptacles, and the necessary wire connectors, materials and tools; install a commercial emergency alarm circuit. Components must be mounted securely in their correct location, connections must be mechanically and electrically secure, the circuit must be free of electrical hazards, and the annunciator must be audible above the normal noise level as specified by OSHA.

Suggest: 12 VDC or low voltage AC/DC sounder that might be sounded as the shop overhead door travels from 2 or 3 feet from floor to about 7-10 feet above floor to simulate how an alarm could warn of danger.

PERFORMANCE ACTIONS:

- 9.0501 Identify alarm requirements: How loud, sound and visual, operates only when vehicle is backing, etc., operates only when garage door is raised/lowered, etc?
- 9.0502 Review product catalogs and select appropriate alarm device.
- 9.0503 Install alarm according to manufacturer's recommendations and specific application requirements.
- 9.0504 Check operation of alarm device.

PERFORMANCE STANDARDS:

- Install and wire a commercial emergency alarm circuit to protect workers against hidden dangers such as lift trucks, moving doors, etc.
- Components must be securely mounted in proper locations, connections must be mechanically and electrically secure, the circuit must be free of electrical hazards, and the annunciator must be audible above the normal noise level as specified by OSHA.

SUGGESTED INSTRUCTION TIME: 6 Hours

UNIT 9.0 B

WIRING DIAGRAMS AND SCHEMATICS

Besides introducing the secondary student to common industrial wiring diagrams and schematics, this unit is designed to promote a high degree of transfer of knowledges and skills in interpreting wiring diagrams from the classroom to practical field situations.

Typical tasks may include drawing schematics of circuits such as control panels according to given information, to represent given systems/units, or to transfer pictorial information to schematics.

Learning experiences may encompass projects that integrate tasks described in this unit with other tasks or units. Emphasis will be on helping the student develop competence in interpreting diagrams/schematics of basis electrical circuits encountered in industrial electricity.

SCHEMATIC SYMBOLS

CAPACITOR

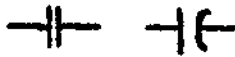

COIL (e.g., relay)



CONTACTS (relay)

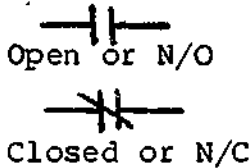

CONDUCTORS

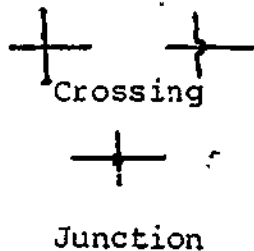

FUSE



FUSABLE LINK



GROUND



LIGHT



RESISTOR



MULTIPLE CONDUCTOR
CABLE

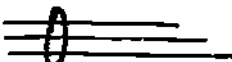

THERMOCOUPLE



TRANSFORMER



(step down shown) (secondary)

THERMAL OVERLOAD



BIMETAL SWITCH



THERMISTOR



CONNECTORS

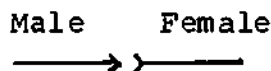

SWITCHES

SPST



SPDT



DPDT



PUSH BUTTON N/O



PUSH BUTTON N/C



PRESSURE N/O



PRESSURE N/C



TEMPERATURE N/O



TEMPERATURE N/C



MOTORS

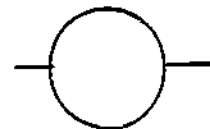

2-Lead Motor



Single-Phase



Permenant Split
Capacitor



3Ø

LINE VOLTAGE

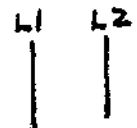

LOW-VOLTAGE SUPPLY

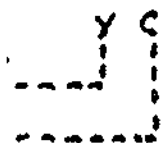

ELECTRICITY
WIRING DIAGRAMS AND SCHEMATICS
SUGGESTED INSTRUCTION TIMES

<u>ELECTRICITY</u> <u>MODULE/TASK</u>		<u>SUGGESTED</u> <u>HOURS</u>
Unit 9.0 B	WIRING DIAGRAMS AND SCHEMATICS	
9.01	Draw Basic Schematic Wiring Diagrams	3
9.02	Draw Current Relay Wiring Schematics	3
9.03	Draw a Potential Relay Wiring Diagram	3
9.04	Draw Hot-Wire Relay in a Circuit	3
9.05	Draw Schematic Wiring Diagram of Low Voltage Control Circuit	15
9.06	Draw Control Panel Diagrams	3
9.07	Update Schematic Print Files for Given Machinery or Control Panel	3
	Total	<u>33</u>

TASK LISTINGS
ELECTRICITY

MODULE/TASK	DESCRIPTION
Unit 9.0 B	WIRING DIAGRAMS AND SCHEMATICS
9.01	(Draw Basic Schematic Wiring Diagram) Provided with a simple pictorial drawing of an industrial control system, references, pencil and paper, and other required information or materials; draw a basic wiring diagram according to the information given. The schematic must match the pictorial (or actual circuit) given.
9.02	(Draw Current Relay Wiring Schematics) Given a simple industrial electricity circuit with a motor controlled by a current relay switched by a manual control device and operated off of a 120 VAC source, draw a schematic wiring diagram showing the current relay. Include an overload control in the common side of the motor power source and indicate a start capacitor in the proper lead of the motor.
9.03	(Draw a Potential Relay Wiring Diagram) Draw a schematic of a potential relay used in a circuit to control a motor. Show the start capacitor with a shunt resistor across the capacitor. The relay is to be of the NC type. The schematic must conform to standard circuits found in industrial control systems and must be acceptable to the instructor.
9.04	(Draw Hot-Wire Relay in a Circuit) Draw a schematic of a hot-wire relay controlling a motor operated from a 120 volt AC line. Show a control between the relay and line. The diagram must agree with the given information and must operate if constructed.
9.05	(draw Schematic Wiring Diagram of Low Voltage Control Circuit) Provided with an actual, simulated, or description of a low voltage control system; draw a schematic diagram that accurately represents the low voltage control system.
9.06	(Draw Control Panel Diagrams) For a given control panel with wiring and various components/controls installed; draw a diagram of the control panel. The drawing must include the following: a. Component symbols and circuit lines located and labeled according to panel wiring circuit. b. Circuit lines drawn vertically or horizontally.

- c. Circuit lines running at 90 degrees to one another or at 45 degrees for no more than 1/4 inch on the drawing.
- d. The diagram should represent the sequence of operation of the control panel.
- e. Lettering; symbols, and lines should comply with the scale used for the diagram.

9.07

(Update Schematic Print Files for Given Machinery or Control Panel) Given a schematic print file for a specific machine or control panel; update the schematic print file based on information given by the instructor or changes made in the machinery or control panel electrical circuits. All the schematic prints must be updated and filed based on the established print file system.

UNIT 9.0 B

WIRING DIAGRAMS AND SCHEMATICS

TASK 9.01

DRAW BASIC SCHEMATIC WIRING DIAGRAM

PERFORMANCE OBJECTIVE:

Provided with a simple pictorial drawing of an industrial control system, references, pencil and paper, and other required information or materials; draw a basic wiring diagram according to the information given. The schematic must match the pictorial (or actual circuit) given.

PERFORMANCE ACTIONS: Draw the required schematic.

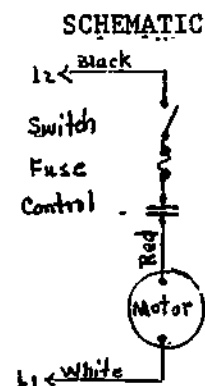
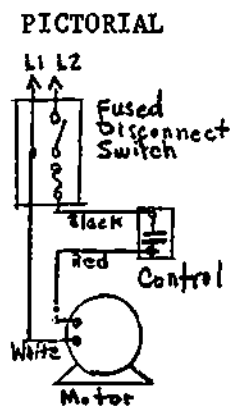

PERFORMANCE STANDARDS:

- Draw a basic schematic wiring diagram for a given industrial control system (given by pictorial or actual circuit) and based on information provided by the instructor.
- The schematic wiring diagram must match the pictorial or actual circuit and must use symbols acceptable to the instructor.

SUGGESTED INSTRUCTION TIME: 3 Hours

RELATED TECHNICAL INFORMATION:

- Identify basic industrial electricity wiring symbols used in pictorial and schematic wiring diagrams.
- Identify and draw basic symbols such as resistors, relays, switches, and motors from memory.
- Identify reference sources and locate schematic or pictorial symbols representing components of a simple industrial control circuit.

UNIT 9.0 B

WIRING DIAGRAMS AND SCHEMATICS

TASK 9.02

DRAW CURRENT RELAY WIRING SCHEMATICS

PERFORMANCE OBJECTIVE:

Given a simple industrial electricity circuit with a motor controlled by a current relay switched by a manual control device and operated off of a 120 VAC source, draw a schematic wiring diagram showing the current relay. Include an overload control in the common side of the motor power source and indicate a start capacitor in the proper lead of the motor.

PERFORMANCE ACTIONS:

- 9.0201 Draw schematic of a current relay controlling a motor. (See sample wiring schematic.)

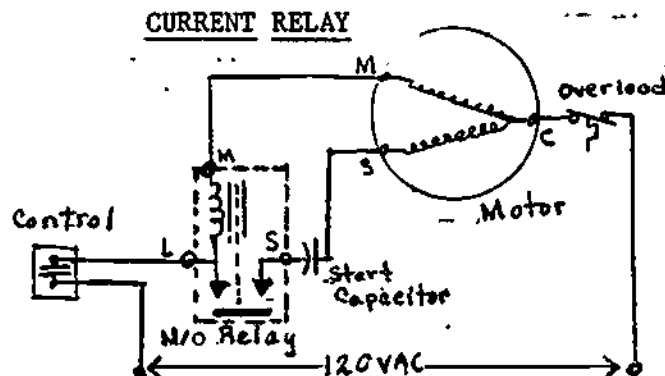

PERFORMANCE STANDARDS:

- Draw a current relay wiring schematic based on a circuit description provided by the instructor (or as stated in the objective above). The circuit drawn must conform to accepted practices of the trade and must operate if constructed.

SUGGESTED INSTRUCTION TIME: 3 Hours

RELATED TECHNICAL INFORMATION:

- Identify pictorial symbols of electrical components typically used in industrial control circuits.
- Identify schematic wiring symbols of the components typically found in industrial control circuits.
- Describe the operation of a current relay.
- Describe typical applications of the current relay.
- Describe the purpose of a start capacitor.
- Describe the function of an overload control.

UNIT 9.0 B

WIRING DIAGRAMS AND SCHEMATICS

TASK 9.03

DRAW A POTENTIAL RELAY WIRING DIAGRAM

PERFORMANCE OBJECTIVE:

Draw a schematic of a potential relay used in a circuit to control a motor. Show the start capacitor with a shunt resistor across the capacitor. The relay is to be of the NC type. The schematic must conform to standard circuits found in industrial control systems and must be acceptable to the instructor.

PERFORMANCE ACTIONS:

- 9.0301 Draw a schematic of a potential relay controlling a motor. (See sample schematic.)

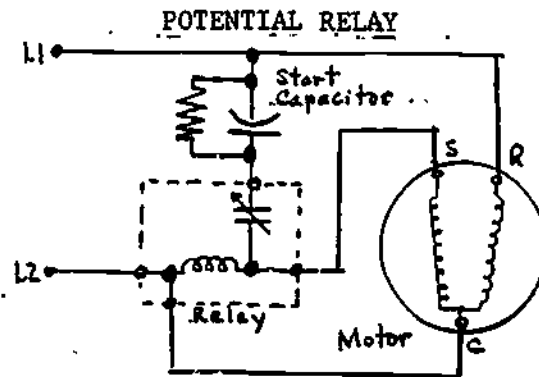

PERFORMANCE STANDARDS:

- Draw a potential relay wiring schematic where a motor is controlled by a NC relay.
- Show the start capacitor with a shunt resistor across it.
- The circuit drawn must be acceptable to the instructor and must operate if constructed.

SUGGESTED INSTRUCTION TIME: 3 Hours

RELATED TECHNICAL INFORMATION:

- Describe the operation of a potential relay.
- Identify/draw the symbol for a potential relay.
- Sketch/describe the internal layout of a potential relay.
- Describe the typical applications of the potential relay.

UNIT 9.0 B

WIRING DIAGRAMS AND SCHEMATICS

TASK 9.04

DRAW HOT-WIRE RELAY IN A CIRCUIT

PERFORMANCE OBJECTIVE:

Draw a schematic of a hot-wire relay controlling a motor operated from a 120 volt AC line. Show a control between the relay and line. The diagram must agree with the given information and must operate if constructed.

PERFORMANCE ACTIONS:

- 9.0401 Draw a schematic of a hot-wire relay controlling a motor. (See sample schematic.)

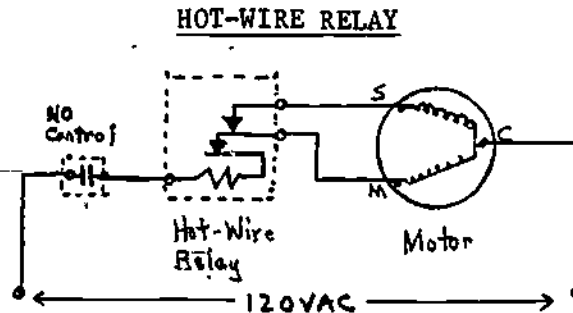

PERFORMANCE STANDARDS:

- Draw a schematic of a hot-wire relay controlling a motor operated from a 120 VAC line.
- The circuit must operate if constructed and the schematic must be acceptable to the instructor.

SUGGESTED INSTRUCTION TIME: 3 Hours

RELATED TECHNICAL INFORMATION:

- Identify schematic symbol for hot-wire relay, control device and motor.
- Describe purpose of hot-wire relay.
- Identify typical location of hot-wire relays.

UNIT	9.0 B	WIRING DIAGRAMS AND SCHEMATICS
TASK	9.05	DRAW SCHEMATIC WIRING DIAGRAM OF LOW VOLTAGE CONTROL CIRCUIT

PERFORMANCE OBJECTIVE:

Provided with an actual, simulated, or description of a low voltage control system; draw a schematic diagram that accurately represents the low voltage control system.

PERFORMANCE ACTIONS:

- 9.0501 Draw a schematic wiring diagram of a low voltage control system provided by the instructor (actual, simulated, or description) and meet the instructor's standards.

PERFORMANCE STANDARDS:

- Draw an accurate schematic wiring diagram of a given low voltage control system.
- Describe operating sequence of a typical low voltage control circuit.
- Identify typical components used in low voltage control systems.

SUGGESTED INSTRUCTION TIME: 15 Hours

UNIT	9.0 B	WIRING DIAGRAMS AND SCHEMATICS
TASK	9.06	DRAW CONTROL PANEL DIAGRAMS

PERFORMANCE OBJECTIVE:

For a given control panel with wiring and various components/controls installed; draw a diagram of the control panel. The drawing must include the following:

- a. Component symbols and circuit lines located and labeled according to panel wiring circuit.
- b. Circuit lines drawn vertically or horizontally.
- c. Circuit lines running at 90 degrees to one another or at 45 degrees for no more than 1/4 inch on the drawing.
- d. The diagram should represent the sequence of operation of the control panel.
- e. Lettering, symbols, and lines should comply with the scale used for the diagram.

PERFORMANCE ACTIONS:

- 9.0601 Examine control panel to be drawn.
- 9.0602 Review circuit carefully.
- 9.0603 Sketch control panel circuitry.
- 9.0604 Draw finished diagram of circuitry.
- 9.0605 Review diagram and compare it to the panel and panel functions.
- 9.0606 Make necessary corrections.

PERFORMANCE STANDARDS:

(NOTE: The purpose of this task is not to develop an electrical draftsman but is to help the industrial electricity student develop the necessary knowledge and skills to interpret common electrical control panel circuits found in industry and to be able to draw given circuit diagrams that can be used by others in industrial electrical maintenance.)

- Draw a control panel diagram based on given information/panel which accurately represent the functioning of the panel and which includes the following:
 - a. Symbols and circuit lines located and labeled.
 - b. Circuit lines drawn vertically or horizontally.

UNIT 9.0 B

WIRING DIAGRAMS AND SCHEMATICS

TASK 9.06

DRAW CONTROL PANEL DIAGRAMS

PERFORMANCE STANDARDS (Con't.):

- c. Circuit lines running at 90 degrees for no more than 1/4 inch.
- d. The diagram should represent the sequence of operation of the control panel.
- e. Lettering, symbols, and lines should comply with the scale used for the diagram.

SUGGESTED INSTRUCTION TIME: 3 Hours

RELATED TECHNICAL INFORMATION:

- Read electrical blueprints, schematics, and drawings.
- Interpret electrical symbols, especially wiring and controls.
- Given electrical circuits, interpret the components and accurately draw a diagram of the circuits.

UNIT	9.0 B	WIRING DIAGRAMS AND SCHEMATICS
TASK	9.07	UPDATE SCHEMATIC PRINT FILES FOR GIVEN MACHINERY OR CONTROL PANEL

PERFORMANCE OBJECTIVE:

Given a schematic print file for a specific machine or control panel; update the schematic print file based on information given by the instructor or changes made in the machinery or control panel electrical circuits. All the schematic prints must be updated and filed based on the established print file system.

PERFORMANCE ACTIONS:

- 9.0701 Identify method of filing schematic prints of electrical equipment.
- 9.0702 Locate misfiled prints and return them to their proper file location.
- 9.0703 Check print files for notes concerning print changes and attach them to their respective prints.
- 9.0704 Determine location of electrical equipment for which prints are to be updated.
- 9.0705 Compare each schematic print to the electrical equipment it represents.
- 9.0706 Update each print by drawing the changes in the circuits.
- 9.0707 Draw a new print or portion of a print where necessary.
- 9.0708 Check each updated print to be sure that it correctly represents the circuitry.
- 9.0709 Return the updated schematic print(s) to the proper file.

PERFORMANCE STANDARDS:

- Update schematic print files for given electrical equipment such as control panels based on instructor requirements and procedures.

SUGGESTED INSTRUCTION TIME: 3 Hours

UNIT 9.0 C

ELECTRICAL MOTORS

The purpose of this unit is to provide the secondary electricity student with an introduction to the fundamentals of typical electric motors that may be encountered in industrial electrical installation, maintenance or service work.

Electrical motor fundamentals includes the principles of electric motors, motor protection, and motor drives. Emphasis will be on installing, servicing, and troubleshooting motors.

Learning activities may involve more or more tasks combined for instructional efficiency and organized on a project basis.

ELECTRICITY
ELECTRICAL MOTORS
SUGGESTED INSTRUCTION TIMES

<u>ELECTRICITY</u> <u>MODULE/TASK</u>	<u>SUGGESTED</u> <u>HOURS</u>
Unit 9.0 C ELECTRICAL MOTORS	
9.01 Collect Motor Data Information	12
9.02 Connect Shaded-Pole Motor	3
9.03 Connect a Dual-Voltage Motor in a Given Circuit	6
9.04 Disassemble and Assemble a Single-Phase Motor	9
9.05 Measure Resistance of Windings in a Split-Phase Motor and Identify Start/Run Windings	12
9.06 Connect a Split-Phase Motor in a Given Circuit	3
9.07 Reverse the Direction of Rotation of a Split-Phase Motor	3
9.08 Connect a Capacitor-Start Motor	3
9.09 Install a Permanent-Split Capacitor Motor	3
9.10 Determine Condition of Starting Components of a CSR Motor	6
9.11 Disassemble/Assemble a Three-Phase Motor	9
9.12 Measure Resistance of Windings in a Single-Voltage, Single- Speed, Three-Phase Motor	12
9.13 Install a Single-Voltage, Three-Phase, Squirrel-Cage Induction Motor	3
9.14 Connect a Dual-Voltage, Three-Phase Induction Motor for Low and High Voltage	3

ELECTRICITY
MODULE/TASK

SUGGESTED
HOURS

9.15	Adjust V-Belt Tension	3
9.16	Identify Motor Bearing and Bushing Problems	3
9.17	Replace Drive Sheave (Pulley)	*
9.18	Install Gear Motor Station	*
9.19	Install Direct Drive Station	6
9.20	Service an Electrical Motor	(See 7.16)
9.21	Install Motor Bearings and Bushings	3
9.22	Troubleshoot a Given Motor	36
		Total - <u>138</u>

* = See 9.19

TASK LISTINGS
ELECTRICITY

MODULE/TASK	DESCRIPTION
Unit 9.0 C	ELECTRICAL MOTORS
9.01	(Collect Motor Data Information) Given two electric motors of different types and a blank data sheet to be completed, enter the correct information. The information must be obtained and recorded with 100 percent accuracy including the nameplate data, number of poles, operating voltage, horsepower, duty rating, number of power leads to the motor, winding insulation temperature, motor frame size, type housing, amperage, if AC or DC. Indicate if the motor is a forward only or forward-reverse type. Performance must be to the instructor's standards.
9.02	(Connect Shaded-Pole Motor) Provided with functioning shaded-pole motor, AC power source, VOM (volt-ohms-amps meter), test probe leads, electrical connection leads, electrical connectors, and the necessary tools and materials; connect a shaded-pole motor in a given circuit. The motor must be correctly connected to the supply source, connections must be mechanically and electrically secure with no exposed wiring, and the motor must run at the rated speed.
9.03	(Connect A Dual-Voltage Motor in a Given Circuit) Given a single phase, dual-voltage motor with data plate, VOM, electrical tools and materials and a circuit requiring a dual-voltage motor; connect the motor in the circuit so that it operates as intended.
9.04	(Disassemble and Assemble a Single-Phase Motor) Provided with a functioning single-phase motor*, AC power source, VOM, and the necessary tools and materials; disassemble and assemble the motor.

*Non-function motor may be substituted for functioning motor and the task may emphasize troubleshooting.

Identify any problems that may be found in motor, If the motor needs repair and the repair can be made practically in the field, repair and reassemble the motor. The reassembled motor should function properly when connected to he power source.

- 9.05 (Measure Resistance of Windings in a Split-Phase Motor and Identify Start/Run Windings) Provided with a functioning split-phase motor, a VOM, and the necessary tools and materials; measure the resistance of windings in a split-phase motor and correctly identify the start winding and run winding. Tag or mark the start and run windings if a terminal strip is not used to identify the windings.
- 9.06 (Connect a Split-Phase Motor in a Given Circuit) Provided with a given circuit requiring a split-phase motor, an AC power source, a VOM and amprobe, connection leads and electrical connectors, and the necessary tools and materials; install the motor in the circuit so that it is mechanically and electrically secure, correctly connect to the power source, and so it operates at the proper speed.
- 9.07 (Reverse the Direction of Rotation of a Split-Phase Motor) Using the given split-phase motor, AC power source, connecting leads and electrical connectors, and the necessary tools and materials; reverse the direction of rotation of a split-phase motor will rotate in the desired direction and the electrical wiring must be mechanically and electrically secure and safe.
- 9.08 (Connect a Capacitor-Start Motor) Provided with a capacitor-start motor, AC power source, VOM, connection leads, electrical connectors, and the necessary tools and materials; connect the capacitor-start motor in a given circuit. The motor must be wired correctly to the power source with mechanically and electrically secure connections so that the motor runs at the rated speed.
- 9.09 (Install a Permanent-Split Capacitor Motor) Given a permanent-split capacitor (PSC) motor, AC power source, VOM, connections leads, electrical connectors, necessary tools and materials, and a circuit in which to connect the motor; install the permanent-split capacitor motor. The PSC motor must be installed according to the wiring diagram/schematic. The motor must be wired with mechanically and electrically secure connectors to the supply source. The motor must operate at the rated speed.
- 9.10 (Determine Condition of Starting Components of a CSR Motor) Provided with a capacitor run-capacitor start (CSR) motor, VOM, and the necessary tools and materials; determine the condition of the starting components of a CSR motor. All components will be identified as either open, shorted, grounded, or good.

- 9.11 (Disassemble/Assemble a Three-Phase Motor) Provided with a three-phase motor, three-phase power source, hand tachometer, VOM, and the necessary tools and materials; disassemble and assemble the motor. Upon assembly, when connected to the rated voltage source, the motor will operate according to the current and speed indicated on the manufacturer's identification plate or by given information.
- 9.12 (Measure Resistance of Windings in a Single-Voltage, Single-Speed, Three-Phase Motor) Provided with a three-phase motor, VOM, and the necessary tools and materials; check the resistance of the windings. The resistance must read the same on all windings if the motor is good.
- 9.13 (Install a Single-Voltage, Three-Phase, Squirrel-Cage Induction Motor) Provided with a single-voltage, three-phase, squirrel-cage motor, a three-phase power source, a VOM, hand tachometer if available, connection leads, electrical connectors, and the necessary tools and materials; connect the single-voltage, three-phase motor to the given circuit according to diagrams provided. The motor must be connected correctly to the supply source; connections will be mechanically and electrically secure with no exposed wiring, and the motor must run at the rated speed.
- 9.14 (Connect a Dual-Voltage, Three-Phase Induction Motor for Low and High Voltage) Provided with a functional dual-voltage, three-phase induction motor, three-phase power source, VOM, hand tachometer if available, connection leads, electrical connectors, and the necessary hand tools and materials; connect a dual-voltage, three-phase induction motor for low voltage and high voltage. The motor must be wired for low and high voltage to the correct voltage source. Connections must be mechanically and electrically secure with not exposed wiring, and the motor must run at the rated speed.
- 9.15 (Adjust V-Belt Tension) Given a belt drive device such as a blower, driven by electrical motor and pulley, information concerning the proper tension for the belt; adjust the V-belt tension. With pressure applied at proper/recommended tension.
- 9.16 (Identify Motor Bearing and Bushing Problems) Given end bells, bearings, bushings, and tools, identify common motor bearing and bushing problems based on instruction. Bearings and bushings will be installed so the inside of the bearings are flush with the inside of the end bells. Performance must be to the instructors standards.

- 9.17 (Replace Drive Sheave (Pulley)) Given a motor with a sheave (pulley), tools and equipment, replacement pulley, and other necessary materials; remove and replace the drive pulley. The replaced drive pulley must be in proper position, mechanically secure, and aligned.
- 9.18 (Install Gear Motor Station) Given a gear motor, a load, the necessary tools, equipment, and materials; install a gear motor station that will operate at the rated voltage and speed.
- 9.19 (Install Direct Drive Station) Given a motor with a direct drive capability and a load, the necessary tools, equipment, and materials and a direct drive coupling; install a direct drive station. The driving machine must be coupled to the driven machine (load) so that there is no vibration transmitted to the load.
- 9.20 (Service an Electrical Motor) Given an electrical motor, instruction, and necessary cleaning materials and tools; provide service to the motor.
- 9.21 (Install Motor Bearings and Bushings) Given end bells, bearings, bushings, and a bearing tool, install motor bearings and bushings. Bearings and bushings will be installed so the inside of the bearings are flush with the inside of the end bells.
- 9.22 (Troubleshoot a Given Motor) Given a possibly defective motor (single-phase or three-phase) and the necessary reference information for troubleshooting the motor, VOM, clamp-on ammeter such as Amprobe, required tools and materials; troubleshoot the motor and identify repair(s) needed or if the motor should be replaced. If the motor is repaired as an extension of this task, the motor when connected to its rated voltage, will operate under load at its rated speed and current (as given on the nameplates).

UNIT	9.0 C	ELECTRICAL MOTORS
TASK	9.01	COLLECT MOTOR DATA INFORMATION

PERFORMANCE OBJECTIVE:

Given two electric motors of different types and a blank data sheet to be completed, enter the correct information. The information must be obtained and recorded with 100 percent accuracy including the nameplate data, number of poles, operating voltage, horsepower, duty rating, number of power leads to the motor, winding insulation temperature, motor frame size, type housing, amperage, if AC or DC. Indicated if the motor is a forward only or forward-reverse type. Performance must be to the instructor's standards.

PERFORMANCE ACTIONS:

- 9.0101 Obtain motor data worksheet.
- 9.0102 Inspect, etc., motor #1.
- 9.0103 Complete information for motor #1.
- 9.0104 Inspect, etc., motor #2.
- 9.0105 Complete information for motor #2.
- 9.0106 Turn worksheet in to instructor.

PERFORMANCE STANDARDS:

- Collect required data from two displaced motors with 100 percent accuracy.
- Complete worksheets to instructor's standards.

SUGGESTED INSTRUCTION TIME: 12 Hours

RELATED TECHNICAL INFORMATION:

- Explain nameplate data.
- State method for determining number of poles.
- Explain coil span.
- Explain importance of coils.
- Explain how to use wire cage.
- Explain methods of coil connections.
- Explain relationships of windings.
- Explain hand, skeen, and form windings.
- State method used to determine slot insulation.
- Explain how length of coils is found.
- Explain the necessary safety precautions.

SUGGESTED WORKSHEET

STUDENTS _____ DATE _____

MOTOR #1	
Operating voltage	_____
Phase	_____
Horsepower	_____
Duty	_____
No. of Power Leads	_____
Winding Insulation Temperature	_____
Motor Frame Size	_____
Type Housing	_____
Amperage	_____
The motor is () AC () DC	_____

MOTOR #2	
Operating voltage .	_____
Phase	_____
Horsepower	_____
Duty	_____
No. of Power Leads	_____
Winding Insulation Temperature	_____
Motor Frame Size	_____
Type Housing	_____
Amperage	_____
The motor is () AC () DC	_____

UNIT 9.0 C

ELECTRICAL MOTORS

TASK 9.02

CONNECT SHADED-POLE MOTOR

PERFORMANCE OBJECTIVE:

Provided with a functioning shaded-pole motor, AC power source, VOM (volt-ohms-amps meter), test probe leads, electrical connections leads, electrical connectors, and the necessary tools and materials; connect a shaded-pole motor in a given circuit. The motor must be correctly connected to the supply source, connections must be mechanically and electrically secure with no exposed wiring, and the motor must run at the rated speed.

PERFORMANCE ACTIONS:

- 9.0201 Assemble motor.
- 9.0202 Disconnect power.
- 9.0203 Mount motor.
- 9.0204 Wire motor in electrical circuit.
- 9.0205 Check wiring.
- 9.0206 Connect power.
- 9.0207 Test motor for proper operation.

PERFORMANCE STANDARDS:

- Connect a shaded-pole motor in a given circuit so that the motor is wired properly with mechanically and electrically secure connections to the proper supply source and so that the motor runs at the rated speed.

SUGGESTED INSTRUCTION TIME: 3 Hours

RELATED TECHNICAL INFORMATION:

- Describe operating characteristics of a shaded-pole induction motor.
- Identify advantages/disadvantages of shaded-pole motor.
- Identify typical applications of shaded-pole motors in industrial settings.
- Explain different ways for reversing shaded-pole motors.
- Explain formula for computing RPM's for a single-phase motor.
- Identify safety considerations.

UNIT 9.0 C

ELECTRICAL MOTORS

TASK 9.03

CONNECT A DUAL-VOLTAGE MOTOR IN A
GIVEN CIRCUIT

PERFORMANCE OBJECTIVE:

Given a single-phase, dual-voltage motor with data plate, VOM, electrical tools and materials and a circuit requiring a dual-voltage motor; connect the motor in the circuit so that it operates as intended.

PERFORMANCE ACTIONS: (To be determined by the instructor.)

PERFORMANCE STANDARDS:

- Install a single-phase, dual-voltage motor in a given circuit so that it operates as intended.
- Performance must be to the instructor's standards.

SUGGESTED INSTRUCTION TIME: 6 Hours

RELATED TECHNICAL INFORMATION:

- Explain the design and construction of the dual-voltage motor.
- Describe some typical/probable uses of a dual-voltage motor.

UNIT	9.0 C	ELECTRICAL MOTORS
TASK	9.04	DISASSEMBLE AND ASSEMBLE A SINGLE-PHASE MOTOR

PERFORMANCE OBJECTIVE:

Provided with a functioning single-phase motor*, AC power source, VOM, and the necessary tools and materials; disassemble and assemble the motor.

*Non-function motor may be substituted for functioning motor and the task may emphasize troubleshooting.

Identify any problems that may be found in the motor. If the motor needs repair and the repair can be made practically in the field, repair and reassemble the motor. The reassembled motor should function properly when connected to the power source.

PERFORMANCE ACTIONS:

- 9.0401 Disconnect power.
- 9.0402 Remove motor.
- 9.0403 Disassemble motor following instructor's standards for motor disassembly:
 - a. Mark motor frame and bell locations.
 - b. Remove assembly bolts.
 - c. Remove end bells.
 - d. Remove frame and stator windings from rotor and fans and shaft.
 - e. Remove windings from frame.
- 9.0404 Assemble by reversing stems.

PERFORMANCE STANDARDS:

- Disassemble and assemble a single-phase motor, identifying any problems found, and if any repairs can be accomplished practically, make repairs and reassemble the motor and connect it to the power source so that it operates at the proper speed or properly in a given circuit.

SUGGESTED INSTRUCTION TIME: 9 Hours

UNIT	9.0 C	ELECTRICAL MOTORS
TASK	9.04	DISASSEMBLE AND ASSEMBLE A SINGLE-PHASE MOTOR (Con't)

RELATED TECHNICAL INFORMATION:

- Identify components of a single-phase motor.
- Identify motor leads.
- Explain different methods used for starting single-phase motors.
- Explain starter windings.
- Explain multispeed windings.
- Explain dual-voltage windings.
- Identify wiring diagram.
- Describe how to use the tachometer or to determine the RPM's of a motor.
- Explain procedure for measuring voltage and amperage.
- Identify safety considerations.

EXPANSION OF TASK: (Clean Motor)

- With motor disassembled, clean motor with compressed air.
- Clean bearings.
- Check alignment of rotor and stator.
- Oil bearings as motor is assembled.

UNIT	9.0 C	ELECTRICAL MOTORS
TASK	9.05	MEASURE RESISTANCE OF WINDINGS IN A SPLIT-PHASE MOTOR AND IDENTIFY START/RUN WINDINGS

PERFORMANCE OBJECTIVE:

Provided with a functioning split-phase motor, a VOM, and the necessary tools and materials; measure the resistance of windings in a split-phase motor and correctly identify the start winding and run winding. Tag or mark the start and run windings if a terminal strip is not used to identify the windings.

(Note: This task may be accomplished in conjunction with one or more tasks concerning use of the VOM, measuring resistance, etc. [See related units and tasks.])

PERFORMANCE ACTIONS:

- 9.0501 Disconnect power.
- 9.0502 Set up ohmmeter.
- 9.0503 Prepare terminals or leads for measurements.
- 9.0504 Determine highest reading, second highest reading, and least reading. Start will be the second highest reading. Run will be the least reading. The highest will be between the S and R leads.

PERFORMANCE STANDARDS:

- Measure the resistance of start and run windings of a given split-phase motor and identify the windings as start and run.

SUGGESTED INSTRUCTION TIME: 12 Hours

RELATED TECHNICAL INFORMATION:

- Describe how a split-phase motor is wound.
- Describe how to use a VOM (ohmmeter) to check motor windings.
- Explain the purpose and operating characteristics of start and run windings.
- Describe/identify how to properly identify start and run windings (Identify terminal strip numbering and color identification of windings.)
- Identify safety consideration.

UNIT 9.0 C

ELECTRICAL MOTORS

TASK 9.05

MEASURE RESISTANCE OF WINDINGS IN A
SPLIT-PHASE MOTOR AND IDENTIFY
START/RUN WINDINGS (Con't)

ADDENDUM:

- Highest resistance is between Run and Start.
- Second highest resistance is between Start and Common.
- Least resistance is between Common and Run.
- The larger the motor, the less resistance.
- Be sure the Start, Run, and Common terminals are clean (brushed) before measuring resistance so that a good electrical connection is made between the ohmmeter and the motor windings.

UNIT	9.0 C	ELECTRICAL MOTORS
TASK	9.06	CONNECT A SPLIT-PHASE MOTOR IN A GIVEN CIRCUIT

PERFORMANCE OBJECTIVE:

Provided with a given circuit requiring a split-phase motor, an AC power source, a VOM and amprobe. connection leads and electrical connectors, and the necessary tools and materials; install the motor in the circuit so that it is mechanically and electrically secure, correctly connected to the power source, and so it operates at the proper speed.

PERFORMANCE ACTIONS:

- 9.0601 Disconnect power source.
- 9.0602 Assemble parts and materials.
- 9.0603 Connect electrical wiring.
- 9.0604 Check circuit.
- 9.0605 Connect power source.
- 9.0606 Check operation of motor (proper rotation and amperage draw).

PERFORMANCE STANDARDS:

- Connect a split-phase motor in a given circuit so that it is mechanically and electrically secure, correctly connected to the power source, and so it operates as intended.

SUGGESTED INSTRUCTION TIME: 3 Hours

RELATED TECHNICAL INFORMATION:

- Describe how a split-phase motor operates.
- Identify the advantages and disadvantages of the split-phase motor.
- Identify motor leads and determine if they are open, shorted, or grounded.
- Describe how motor windings are identified by color coding or by terminal markings.
- Explain the operation of the centrifugal switch.
- Describe how to properly measure the starting and running current of a motor.

UNIT	9.0	ELECTRICAL MOTORS
TASK	9.06	CONNECT A SPLIT-PHASE MOTOR IN A GIVEN CIRCUIT (Con't)

RELATED TECHNICAL INFORMATION (Con't):

- Explain how to change the direction or rotation of a motor.
- Explain why the motor selected for a given circuit must be of correct electrical specification.
- Identify safety consideration.

UNIT	9.0 C	ELECTRICAL MOTORS
TASK	9.07 (OPTIONAL)	REVERSE THE DIRECTION OF ROTATION OF A SPLIT-PHASE MOTOR

PERFORMANCE OBJECTIVE:

Using a given split-phase motor, AC power source, connecting leads and electrical connectors, and the necessary tools and materials; reverse the direction of rotation of a split-phase motor. The motor must be wired so that the motor will rotate in the desired direction and the electrical wiring must be mechanically and electrically secure and safe.

PERFORMANCE ACTIONS:

- 9.0701 Gain access to the motor starting leads at the terminal, etc.
- 9.0702 Reverse the two starting windings leads so that the old "S" connection (lead) is on the "R" terminal and the "R" lead is on the "S" terminal.

(NOTE: Reversing the two main leads will not reverse the direction of rotation.)
- 9.0703 Properly connect the wiring so no hazard exists.
- 9.0704 Connect the AC source and test the motor rotation.

PERFORMANCE STANDARDS:

- Reverse the direction of rotation of a split-phase motor so the direction is in the opposite direction from the previous direction.

SUGGESTED INSTRUCTION TIME: 3 Hours

RELATED TECHNICAL INFORMATION:

- Explain standard rotation of a split-phase motor.
- Describe the procedure/method of changing the direction of rotation of a motor.
- Explain the purpose of the start winding.
- Describe how the centrifugal mechanism works.
- Explain terminal numbers and color identification of start windings.
- Identify motor leads.
- Identify safety considerations.

UNIT	9.0 C	ELECTRICAL MOTORS
TASK	9.08	CONNECT A CAPACITOR-START MOTOR

PERFORMANCE OBJECTIVE:

Provided with a capacitor-start motor, AC power source, VOM, connection leads, electrical connectors, and the necessary tools and materials; connect the capacitor-start motor in a given circuit. The motor must be wired correctly to the power source with mechanically and electrically secure connections so that the motor runs at the rated speed.

PERFORMANCE ACTIONS:

- 9.0801 Switch power source off.
- 9.0802 Assemble parts and materials.
- 9.0803 Wire the motor correctly to the supply source.
- 9.0804 Check capacitor wiring if capacitor isolated externally.

(NOTE: Low potential terminal of capacitor [with red dot typically] is connected to the run terminal so that a shorted or grounded run capacitor will result in a direct short to ground: This will cause the line fuse or circuit breaker to drop and protect the motor. The capacitor could be connected differently [red to start] and the motor would operate; however, in case of a capacitor short, there would be no protection to ensure that the motor would not overheat and fail.)

- 9.0805 Switch power source on.
- 9.0806 Check operation of motor.

PERFORMANCE STANDARDS:

- Connect a capacitor-start motor in a given circuit so that electrical connections are mechanically and electrically secure and so the motor operates at the correct speed.

SUGGESTED INSTRUCTION TIME: 3 Hours

UNIT	9.0 C	ELECTRICAL MOTORS
TASK	9.08	CONNECT A CAPACITOR -START MOTOR (Con't)

RELATED TECHNICAL INFORMATION:

- Describe the operating characteristics of a capacitor-start motor.
- Identify advantages/disadvantages of a capacitor-start motor.
- Check motor leads for opens, shorts, and grounds.
- Describe the centrifugal mechanism.
- Describe the location and type capacitor for starting.
- Describe how to test a capacitor.
- Describe procedure for changing the direction of rotation.
- Identify safety considerations.

UNIT	9.0 C	ELECTRICAL MOTORS
TASK	9.09	INSTALL A PERMANENT-SPLIT CAPACITOR MOTOR

PERFORMANCE OBJECTIVE:

Given a permanent-split capacitor (PSC) motor, AC power source, VOM, connection leads, electrical connectors, necessary tools and materials; and a circuit in which to connect the motor; install the permanent-split capacitor motor. The PSC motor must be installed according to the wiring diagram/schematic. The motor must be wired with mechanically and electrically secure connectors to the supply source. The motor must operate at the rated speed.

PERFORMANCE ACTIONS:

- 9.0901 Assemble parts and materials.
- 9.0902 Switch power source off.
- 9.0903 Mount PSC motor.
- 9.0904 Wire motor properly so both start and run windings remain in motor circuit at all times and so running capacitor is in series with start winding and is used both for starting the motor and as a run capacitor to reduce current and increase the power factor.
- 9.0905 Switch power source on.
- 9.0906 Check operation of motor. If motor does not start properly, check voltage.

(NOTE: A starting capacitor and starting relay may be added to the electrical circuit when low voltage or heavy loads exists and cause the loss of torque or prevent the motor from starting.)

PERFORMANCE STANDARDS:

- Install a permanent-split capacitor motor in a given circuit according to the wiring diagram provided so that the motor operates at the rated speed and is mechanically and electrically connected securely to the supply source.

SUGGESTED INSTRUCTION TIME: 3 Hours

UNIT	9.0 C	ELECTRICAL MOTORS
TASK	9.09	INSTALL A PERMANENT-SPLIT CAPACITOR MOTOR (Con't)

RELATED TECHNICAL INFORMATION:

- Describe the CSR motor operating characteristics.
- Identify advantages/disadvantages of PSC motor.
- Explain: Location, type, and purpose of both capacitors.
- Compute total capacitance with capacitors in parallel and capacitors in series.
- Identify motor leads and determine if open, shorted, or grounded.
- Explain: Centrifugal switch.
- Identify typical uses of PSC motors.
- Identify safety considerations.

UNIT	9.0 C	ELECTRICAL MOTORS
TASK	9.10	DETERMINE CONDITION OF STARTING COMPONENTS OF A CSR MOTOR

PERFORMANCE OBJECTIVE:

Provided with a capacitor run-capacitor start (CSR) motor, VOM, and the necessary tools and materials; determine the condition of the starting components of a CSR motor. All components will be identified as either open, shorted, grounded, or good.

PERFORMANCE ACTIONS:

- 9.1001 Disconnect power.
- 9.1002 Remove wiring as necessary.
- 9.1003 Determine windings of motor.
- 9.1004 Check for: Opens, Shorts, Grounds.
- 9.1005 Check resistance and continuity of starting winding.
- 9.1006 As necessary, check capacitor, relay, or wiring.
- 9.1007 Determine if CSR motor is operational or needs replacement.

PERFORMANCE STANDARDS:

- Determine the condition of the starting components of a CSR motor as either open, shorted, grounded, or good.

SUGGESTED INSTRUCTION TIME: 6 Hours

RELATED TECHNICAL INFORMATION:

- Describe starting components.
- Explain characteristics of CSR motor.
- Describe correct procedure for using the ohmmeter (VOM) for testing shorts, opens, and grounds.
- Identify safety considerations.

UNIT	9.0 C	ELECTRICAL MOTORS
TASK	9.11	DISASSEMBLE/ASSEMBLE A THREE-PHASE MOTOR

PERFORMANCE OBJECTIVE:

Provided with a three-phase motor, three-phase power source, hand tachometer, VOM, and the necessary tools and materials; disassemble and assemble the motor. Upon assembly, when connected to the rated voltage source, the motor will operate according to the current and speed indicated on the manufacturer's identification plate or by given information.

PERFORMANCE ACTIONS:

9.1101 Disconnect electrical connections and remove motor from mounting as applicable.

9.1102 Remove assembly screws and nuts.

9.1103 Remove end bell(s).

9.1104 Remove stator windings, rotor and fans, etc., from frame.

(NOTE: Disassembly should be according to techniques and procedures outlined by the instructor, manufacturer's data, or other guides. Care must be observed not to damage motor components, especially wiring.)

9.1105 Inspect, clean, and lubricate motor components as appropriate.

9.1106 Assemble motor by reversing above steps.

9.1107 Check resistance of assembled motor for shorts, opens, and grounds.

9.1108 If applicable, test motor for proper operation.

PERFORMANCE STANDARDS:

- Disassemble/assemble a three-phase motor so that the assembled motor, when connected to the proper supply source, will operate at the proper speed using the rated current as given on the manufacturer's identification plate or given by the instructor.

UNIT	9.0 C	ELECTRICAL MOTORS
TASK	9.11	DISASSEMBLE/ASSEMBLE A THREE-PHASE MOTOR (Con't)

SUGGESTED INSTRUCTION TIME: 9 Hours

RELATED TECHNICAL INFORMATION:

- Explain characteristics of a three-phase motor.
- Explain rotating magnetic field.
- Draw and explain a Delta connection.
- Draw and explain a Wye connection.
- Explain multi-speed windings.
- Describe how to reverse motor direction.
- Identify motor leads.
- Identify relevant safety considerations.

UNIT	9.0 C	ELECTRICAL MOTORS
TASK	9.12	MEASURE RESISTANCE OF WINDINGS IN A SINGLE-VOLTAGE, SINGLE-SPEED, THREE-PHASE MOTOR

PERFORMANCE OBJECTIVE:

Provided with a three-phase motor, VOM, and the necessary tools and materials; check the resistance of the windings. The resistance must read the same on all windings if the motor is good.

PERFORMANCE ACTIONS:

- 9.1201 Disconnect power from circuit.
- 9.1202 Expose leads or terminals to windings.
- 9.1203 Disconnect wiring as necessary.
- 9.1204 Using ohmmeter, measure resistance of windings.

(NOTE: The resistance must read the same on all windings if the motor is good.)

PERFORMANCE STANDARDS:

- Measure the resistance of the windings in a single-voltage, single-speed, three-phase motor.
- Resistance readings must be the same on all windings if the motor is good.

SUGGESTED INSTRUCTION TIME: 12 Hours

RELATED TECHNICAL INFORMATION:

- Describe the construction of a single-voltage, single-speed, three-phase motor.
- Describe procedures for using the ohmmeter to check the conditions of motor windings.
- Describe the difference in the number of leads in single-voltage, dual voltage, single-speed, and multi-speed windings.
- Identify safety considerations.

UNIT	9.0 C	ELECTRICAL MOTORS
TASK	9.13	INSTALL A SINGLE-VOLTAGE, THREE-PHASE, SQUIRREL-CAGE INDUCTION MOTOR

PERFORMANCE OBJECTIVE:

Provided with a single-voltage, three-phase, squirrel-cage motor, a three-phase power source, a VOM, hand tachometer if available, connection leads, electrical connectors, and the necessary tools and materials; connect the single-voltage, three-phase motor to a given circuit according to diagrams provided. The motor must be connected correctly to the supply source; connections will be mechanically and electrically secure with no exposed wiring, and the motor must run at the rated speed.

PERFORMANCE ACTIONS:

- 9.1301 Disconnect electrical power.
- 9.1302 Remove existing motor, if applicable.
- 9.1303 Adjust/install/etc. motor mounting components.
- 9.1304 Mount motor:
 - a. Connect leads according to wiring diagram/schematic.
 - b. Check electrical connections.
- 9.1305 Start motor:
 - a. Observe motor operation.
 - b. Test supply voltage and amperage and compare it with the manufacturer's data plate/specifications.
- 9.1306 Stop motor.

PERFORMANCE STANDARDS:

- Install a single-voltage, three-phase, squirrel-cage induction motor in a given circuit according to the diagram provided so that the motor is connected correctly to the supply source; has mechanically and electrically secure connections with not hazardous wiring, and operates at the rated speed.

SUGGESTED INSTRUCTION TIME: 3 Hours

UNIT	9.0 C	ELECTRICAL MOTORS
TASK	9.13	INSTALL A SINGLE-VOLTAGE, THREE-PHASE, SQUIRREL-CAGE INDUCTION MOTOR (Con't)

RELATED TECHNICAL INFORMATION:

- Describe operating characteristics of a single-voltage, three-phase, squirrel-cage induction motor.
- Identify advantages/disadvantages of the three-phase motor verses the single-phase motor.
- Identify some typical uses of single-voltage, three-phase, induction motors.

UNIT	9.0 C	ELECTRICAL MOTOR;
TASK	9.14	CONNECT A DUAL-VOLTAGE, THREE-PHASE INDUCTION MOTOR FOR LOW AND HIGH VOLTAGE.

PERFORMANCE OBJECTIVE:

Provided with a functional dual-voltage, three-phase induction motor, three-phase power source, VOM, hand tachometer if available, connection leads, electrical connectors, and the necessary hand tools and materials; connect a dual-voltage, three-phase induction motor for low voltage and high voltage. The motor must be wired for low and high voltage to the correct voltage source. Connections must be mechanically and electrically secure with no exposed wiring, and the motor must run at the rated speed.

PERFORMANCE ACTIONS:

- 9.1401 Identify voltage requirements of dual voltage motor.
- 9.1402 Connect windings in parallel low voltage.
- 9.1403 Test motor operation.
- 9.1404 Connect windings in series for high voltage operation.
- 9.1405 Test motor operation.

PERFORMANCE STANDARDS:

- Connect a dual-voltage, three-phase induction motor for low and high voltage.
- Connections must be wired for the proper voltages, connections must be mechanically and electrically secure with no hazards, and the motor must run at the rated speed.

SUGGESTED INSTRUCTION TIME: 3 Hours

RELATED TECHNICAL INFORMATION:

- Describe operating characteristics of a dual-voltage, three-phase induction motor.
- Identify advantages/disadvantages of the dual-voltage, three-phase induction motor.
- Identify typical application of the dual-voltage, three-phase induction motor.
- Describe how to test motor windings.
- Identify safety considerations.

UNIT	9.0 C	ELECTRICAL MOTORS
TASK	9.15	ADJUST V-BELT TENSION

PERFORMANCE OBJECTIVE:

Given a belt drive device such as a blower, driven by electrical motor and pulley, information concerning the proper tension for the belt; adjust the V-belt tension. With pressure applied at proper/recommended tension.

PERFORMANCE ACTIONS:

- 9.1501 Ensure that both shafts are parallel so belt will ride properly on the pulleys.
- 9.1502 Check belt for damage.
- 9.1503 Check (adjust) tension for approximately 1/2 inch given with about 10 pounds of force. (Approximately 1 inch movement at center is sometimes recommended.) Snug but not tight.

PERFORMANCE STANDARDS:

- Adjust V-belt tension so that with pressure applied at the center of the belt, the belt displays the recommended tension.

SUGGESTED INSTRUCTION TIME: 3 Hours

RELATED TECHNICAL INFORMATION:

- Identify different types of belts.
- Demonstrate how to measure belt length.
- Identify safety considerations.

EXPANSION TO TASK:

- Identify various types of pulleys found in belt driven devices.
- Demonstrate adjustment of pulleys.
- Demonstrate use of V-belt-measuring guage.

UNIT 9.0 C

ELECTRICAL MOTORS

TASK 9.15

ADJUST V-BELT TENSION (Con't)

EXPANSION OF TASK:

- Given the RPM speed of a motor, the diameter of the drive pulley and the diameter of the driven pulley, determine the speed of a belt driven fan in RPMs.

SPEED OF MOTOR TO SPEED OF BELT DRIVEN FAN

Speed of Motor x Diameter of Driver Pulley - Diameter of Driven Pulley
= Speed of Driven Pulley.

Sample: Motor 1725 RPM

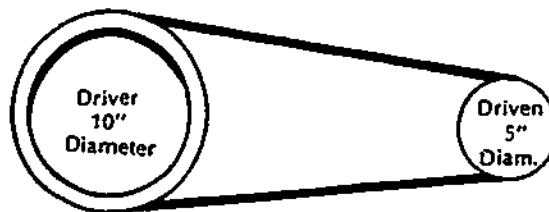

$$1725 \times 10 = 17250 \div 5 = 3450 \text{ RPM}$$

UNIT	9.0 C	ELECTRICAL MOTORS
TASK	9.16	IDENTIFY MOTOR BEARING AND BUSHING PROBLEMS

PERFORMANCE OBJECTIVE:

Given end bells, bearings, bushings, and tools, identify common motor bearing and bushing problems based on instruction. Bearings and bushings will be installed so the inside of the bearings are flush with the inside of the end bells. Performance must be to the instructor's standards.

PERFORMANCE ACTIONS:

- 9.1601 Identify precautions in cleaning bearings and in handling new bearings.
- 9.1602 Describe how typical motor bearings are removed.
- 9.1603 Describe or identify common types of bearing damage and failure in motors.
- 9.1604 Identify bearing lubrication considerations, steps, and precautions.

PERFORMANCE STANDARDS:

- Identify motor bearing and bushing problems in instructor provided motors or parts to the standards of the instructor.

SUGGESTED INSTRUCTION TIME: 3 HOURS

RELATED TECHNICAL INFORMATION:

- Explain purpose of bearings and bushings.
- Describe the operation of a bearing tool.
- List typical causes of bearing and bushing failure:
 - a. Installation damage:
 - (1) Brinelling
 - (2) Scoring
 - b. Operating condition damage:
 - (1) Loose housing fit or loose shaft
 - (2) Splitting
 - (3) Cracking
 - (4) Misalignment
 - (5) Vibration brinell

UNIT 9.0 c

ELECTRICAL MOTORS

TASK 9.16

IDENTIFY MOTOR BEARING AND BUSHING
PROBLEMS (Con't)

RELATED TECHNICAL INFORMATION (Con't):

- (6) Inadequate lubrication
 - (7) Abrasive wear
 - c. Normal fatigue:
 - (1) Pitting
- Appendix section concerning bearing problems is available for this task objective page.

UNIT	9.0 C	ELECTRICAL MOTORS
TASK	9.17	REPLACE DRIVE SHEAVE (PULLEY)

PERFORMANCE OBJECTIVE:

Given a motor with a sheave (pulley), tools and equipment, replacement pulley, and other necessary materials; remove and replace the drive pulley. The replaced drive pulley must be in proper position, mechanically secure, and aligned.

PERFORMANCE ACTIONS:

- 9.1701 Disconnect power.
- 9.1702 Remove belts or fans as applicable.
- 9.1703 Loosen pulley set screws.
- 9.1704 Attach 3 1/2 pulley puller, if required.
- 9.1705 Clean and oil shaft.
- 9.1706 Remove flywheel.
- 9.1707 Clean and oil shaft.
- 9.1708 Install replacement sheave (pulley) and alignment key if used.
- 9.1709 Position pulley correctly on shaft.
- 9.1710 Tighten set screw.
- 9.1711 Replace belts, etc.
- 9.1712 Connect power, start unit, check mechanical operation.

PERFORMANCE STANDARDS:

- Replace drive sheave pulley so that new (replaced) sheave (pulley) is in the proper position, mechanically secure, and aligned.

SUGGESTED INSTRUCTION TIME: See 9.19

UNIT	9.0 C	ELECTRICAL MOTORS .
TASK	9.17	REPLACE DRIVE SHEAVE (PULLEY) (Con't)

RELATED TECHNICAL INFORMATION (Con't):

- Identify various types of pulleys: Standard, V-step, closed and open adjustable V-pulley.
- Demonstrate use of pulley puller, allen wrenches, etc., to remove pulleys.
- Determine bore size of shaft.
- Demonstrate adjustment of pulleys.
- Describe how to match V-belts to pulley.
- Describe/demonstrate how to determine belt length.
- Describe how to prolong belt life: Align Pulleys, adjust proper belt tension, clean belts of oil and grease, use proper belts, etc.

UNIT	9.0 C	ELECTRICAL MOTORS
TASK	9.18 (Optional)	INSTALL GEAR MOTOR STATION

PERFORMANCE OBJECTIVE:

Given a gear motor, a load, the necessary tools, equipment, and materials; install a gear motor station that will operate at the rated voltage and speed.

PERFORMANCE ACTIONS: (Actions will be determined by instructor and training materials.)

PERFORMANCE STANDARDS:

- Install a gear motor station that will operate as intended.

SUGGESTED INSTRUCTION TIME: See 9.19

RELATED TECHNICAL INFORMATION:

- Explain basic operation of gear motor drives.
- Explain where gear motors might be used.
- Explain gear selection for different operations.
- Identify safety considerations.

EXPANSION OF TASK: (OPTIONAL)

- Given a chain-and-sprocket drive, install the drive so it operates as intended. (Determine sprocket socket size, teeth per inch, and chain size.)

UNIT	9.0 C		ELECTRICAL MOTORS
TASK	9.19	(Optional)	INSTALL DIRECT DRIVE STATION

PERFORMANCE OBJECTIVE:

Given a motor with a direct drive capability and a load, the necessary tools, equipment, and materials and a direct drive coupling; install a direct drive station. The driving machine must be coupled to the driven machine (load) so that there is no vibration transmitted to the load.

PERFORMANCE ACTIONS: (Actions will be determined by instructor and training materials.)

PERFORMANCE STANDARDS:

- Install a direct drive station so that there is no vibration transmitted from the driving machine to the driven machine (load).

SUGGESTED INSTRUCTION TIME: 9.17 - 9.19 = 6 Hours

RELATED TECHNICAL INFORMATION:

- Explain advantages of direct and pulley drives.
- Identify several types of direct drives (Flexible-hose, flange, flexible shaft).
- Explain alignment procedures for direct coupling both angular and axis.
- Identify safety considerations.

UNIT	9.0 C	ELECTRICAL MOTORS
TASK	9.20	SERVICE AN ELECTRICAL MOTOR

PERFORMANCE OBJECTIVE:

Given an electrical motor, instruction, and necessary cleaning materials and tools; provide service to the motor.

PERFORMANCE ACTIONS:

- 9.2001 Disconnect power from motor.
- 9.2002 Clean the motor of dust and dirt accumulation that might cause overheating by preventing air flow, etc.,. Clean dust and dirt from fans, etc., that might cause an unbalance on the motor.
- 9.2003 Check bearings for excessive end play or wear.
- 9.2004 Check shaft for freedom of rotation.
- 9.2005 Lubricate the motor according to manufacturer's recommendations being careful not to over lubricate.
- 9.2006 Check for loose, frayed, or exposed wiring.
- 9.2007 Clean starting switch contacts where applicable using correct procedures. (Emery cloth tends to insulate points where fine sandpaper does not.)
- 9.2008 Check brushes on wound rotor motors.
- 9.2009 Clean brushes and commutator where applicable. (Fine sandpaper recommended.)
- 9.2010 Check drive mechanism: Belt for tension and condition and pulleys for alignment.

PERFORMANCE STANDARDS:

- Service an electrical motor according to manufacturer's recommendations and standard shop procedures.

SUGGESTED INSTRUCTION TIME: 3 Hours

UNIT	9.0 C	ELECTRICAL MOTORS
TASK	9.20	SERVICE AN ELECTRICAL MOTOR (Con't)

RELATED TECHNICAL INFORMATION: .

- Identify the importance of selecting the proper type of oil for motor lubrication and the dangers of mixing oils that are not compatible.
- Describe grease lubrication: Know that auto chassis lubricating grease may ruin ball bearings. Know that ball bearings grease is not appropriate in a water pump that requires lithium based grease. Remember, most bearings are ruined from over lubrication rather than under lubrication.
- Describe how to check belts for tension and conditions.
- Describe how to check pulley alignment.

RECOMMENDED MAINTENANCE SCHEDULE FOR MOTORS
(AC and DC Motors)
(Based on an average environment)

"EVERY WEEK"

1. Examine commutator and brushes.
2. Check oil level in bearings.
3. See that oil rings turn with shaft.
4. See the exposed shaft is free of oil and grease from bearings.
5. Examine the starter switch, fuses, and other controls.
6. See that the motor is brought up to speed in normal time.

EVERY SIX MONTHS

1. Clean motor thoroughly, blowing out dirt from windings, and wipe commutator and brushes.
2. Inspect commutator clamping ring.
3. Check brushes and replace any that are more than half worn.
4. Examine brush holders, and clean them if dirty. Make certain that brushes ride free in the holders.
5. Check brush pressure.
6. Check brush position.
7. Drain, wash out, and replace oil in sleeve bearings.
8. Check grease in ball or roller bearings.
9. Check operating speed or speeds.
10. See that end play of shaft is normal.
11. Inspect and tighten connections on motor and control.
12. Check current input and compare it with normal.
13. Examine drive, critically, for smooth running, absence of vibration, and worn gears, chains, or belts.
14. Check motor foot bolts, end-shield bolts, pulley, coupling, gear and journal set-screws, and keys.
15. See that all covers, and belt and gear guards are in place, in good order, and securely fastened.

ONCE A YEAR

1. Clean out and renew grease in ball or roller bearing housings.
2. Test insulation by megohmmeter.
3. Check air gap.
4. Clean out magnetic dirt that may be clinging to poles.
5. Check clearance between shaft and journal boxes of sleeve bearing motors to prevent operation with worn bearings.
6. Clean out under cut slots in commutator. Check the commutator for smoothness.
7. Examine connections of commutator and armature coils.
8. Inspect armature bands.

Alerich, Walter N. Electricity 4: AC Motors, Controls, and Alternators, Albany, NY: Delmar Publishers Inc., pp. 161-162, 1981. (See Chapter 14, Motor Maintenance for additional information.)

UNIT	9.0 C		ELECTRICAL MOTORS
TASK	9.21	(Optional)	INSTALL MOTOR BEARINGS AND BUSHINGS

PERFORMANCE OBJECTIVE:

Given end bells, bearings, bushings, and a bearing tool, install motor bearings and bushings. Bearings and bushings will be installed so the inside of the bearings are flush with the inside of the end bells.

PERFORMANCE ACTIONS: (See Reference Appendixes to this task for actions.)

PERFORMANCE STANDARDS:

- Performance must be acceptable to the instructor.

SUGGESTED INSTRUCTION TIME: See 9.16

RELATED TECHNICAL INFORMATION:

- Explain purpose of bearings and bushings.
- Describe the operation of a bearing tool.
- List causes of bearing and bushing failure.
- Identify damaged/worn bearings and bushings.
- Identify safety considerations.

See Reference Appendixes for additional information.

UNIT 9.0 C

ELECTRICAL MOTORS

TASK 9.22

TROUBLESHOOT A GIVEN MOTOR

PERFORMANCE OBJECTIVE:

Given a possibly defective motor (single-phase or three-phase) and the necessary reference information for troubleshooting the motor, VOM, clamp-on ammeter such as Amprobe, required tools and materials; troubleshoot the motor and identify repair(s) needed or if the motor should be replaced. If the motor is repaired as an extension of this task, the motor when connected to its rated voltage, will operate under load at its rated speed and current (as given on the nameplate).

PERFORMANCE ACTIONS: (See pictorial suggestions. Courtesy of Amprobe Co.)

PERFORMANCE STANDARDS:

- See objective. Standards of the instructor apply.

SUGGESTED INSTRUCTION TIME: 36 Hours

RELATED TECHNICAL INFORMATION:

- A. TROUBLESHOOT A SINGLE-PHASE MOTOR
 - Explain procedure used to determine grounds in the run and start windings.
 - Explain procedure used to determine openings in the run and start windings.
 - Explain procedure for detecting shorts in the run and start windings.
 - Explain reverses.
 - Explain probable causes for a motor failing to start.
 - Explain probable causes for a motor running slower than normal speed.
 - Explain probable causes for a motor running hot.
 - Explain probable causes for motor noise.

UNIT 9.0 C

ELECTRICAL MOTORS

TASK 9.22

TROUBLESHOOT A GIVEN MOTOR

RELATED TECHNICAL INFORMATION (Con't.):

- B. TROUBLESHOOT A THREE-PHASE MOTOR

- Explain procedure used for determining grounds in each phase winding.
- Explain procedure used for determining openings in each phase winding.
- Explain procedures used for determining shorts in each winding.
- Explain reverse coil.
- Explain reverse coil groups.
- Explain reverse phases.
- Identify the probable causes for a motor failing to start.
- Identify the probable causes for a motor not running properly.

- C. TROUBLESHOOTING A DC MOTOR (OPTIONAL)

- Explain procedures for finding grounds in the fields, armature, and brush holders.
- Explain procedures for finding openings in the field circuit, and in the armature circuit.
- Explain the test procedures for identifying the six leads of a compound motor, if applicable.
- Describe procedure for determining a cumulative or differential connection.
- Describe test procedures for determining interpole polarity.
- Describe positioning of brush holders.

- D. Identify safety considerations.

MOTOR TROUBLESHOOTING GUIDE APPENDIX ACCOMPANIES THIS TASK

TROUBLESHOOTING A MOTOR WITH AN AMPROBE

Figure 1 - Locating Open Winding
Winding is open if there is no voltage indication across the winding.

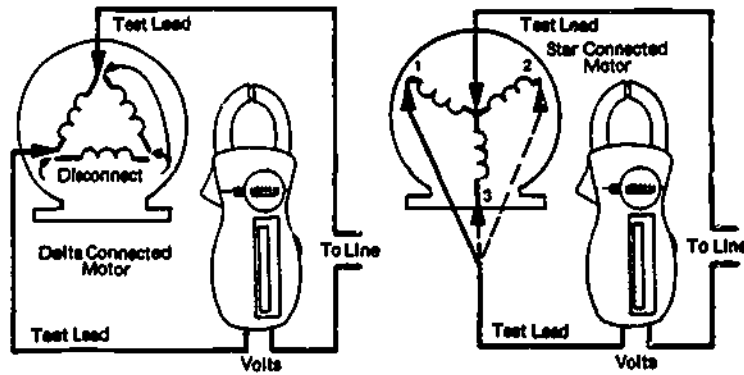

Figure 3 - Testing Centrifugal Switch
Current indication after motor is up to speed means centrifugal switch did not open.

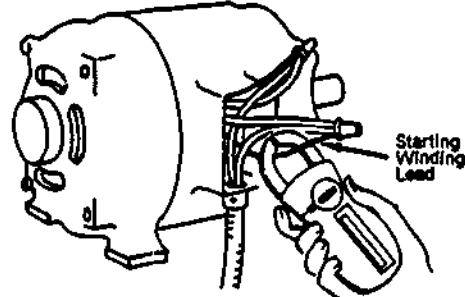

Figure 2 - Finding Location of Grounded Phase
Grounded phase is indicated by a full line voltage reading.

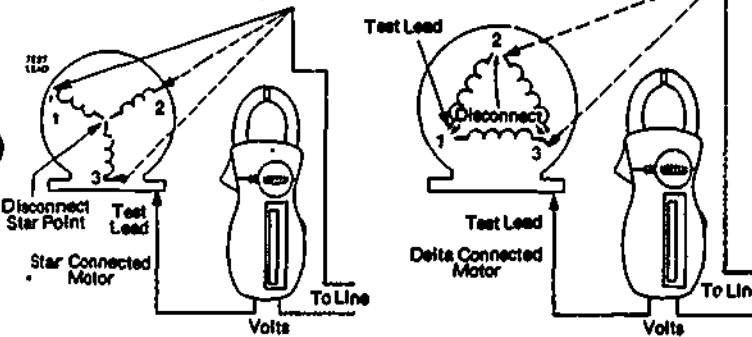

Figure 4 - Test for Winding Short Circuit
With running and starting windings and instrument connected as shown, full line voltage reading means two windings are shorted.

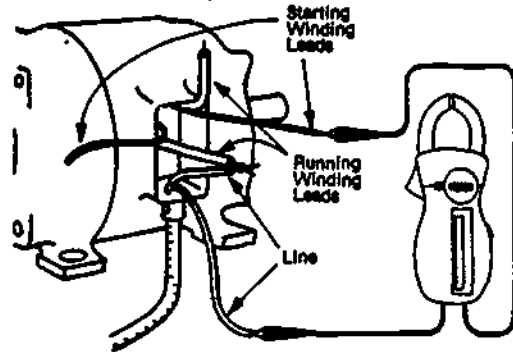

Figure 5 - Isolating Open Phase
Winding is open if there is no voltage indication across the winding.

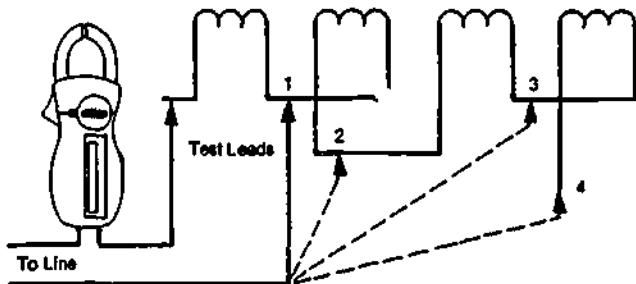
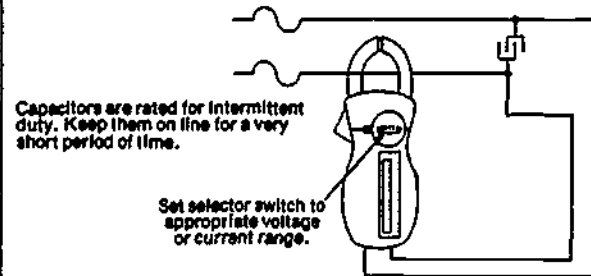

Figure 6 - Checking AC Electrolytic Capacitors
If there is no current indication, capacitor is open. Shorted capacitor will blow fuse when line voltage is applied.



TRUBLE-SHOOTING GUIDE FOR ALL MOTORS

SYMPTOMS								PROBABLE CAUSE	RECOMMENDED ACTIONS
Motor fails to start	Motors hums but will not start	Motor must be shifted to start	Motor runs-- then stops	Slow acceleration	Overheating	Excessive vibration	Low speed		
x		x						Open circuit	Check wiring--Check voltage
x								Defective motor windings	Inspect and repair
	x							Starter switch doesn't close	Clean and lubricate, or replace
	x			x	x			Bad capacitor	Check and replace
	x	x						Open rotor or starter	Locate and replace
	x		x	x	x		x	Overloaded	Lighter load
	x			x			x	Low voltage	Lighter line load--Increase size of lead wire
	x				x	x		Worn bearings	Replace
	x				x			Lack of Lubrication	Lubricate
			x					Defective over-load protection	Locate and replace
						x		Grounds or short circuits	Locate and repair
					x		x	Wrong connections	Check wiring diagrams
					x			Belt too tight	Slacken belt
					x			Dirt, dust, trash	Clean
						x		Unbalanced	Balance
						x		Misalignment	Align
						x		Loosen mounting	Tighten
x	x							Poor connection	Inspect and connect

TRUBLE-SHOOTING GUIDE FOR MOTORS WITH BRUSHES

SYMPTOMS

Motor fails to start	Slow acceleration	Low speed	Excessive sparking--starting	Excessive sparking--running	Rapid brush wear	Excessive speed	PROBABLE CAUSE	RECOMMENDED ACTION
x		x	x	x			Worn brushes	Replace brushes
x	x	x	x				Brushes stuck	Adjust brushes
x	x	x					Brushes not set	Check with marks on frame
	x	x	x				Dirty commutator	Clean and sandpaper
	x	x			x		Rough commutator	Clean and sandpaper
			x		x		High commutator bars	Turn in lathe
			x		x		High mica	Undercut mica
			x		x		Overloaded	Lighten load
			x				High voltage	Check voltage
			x		x		Low voltage	Check voltage
						x	Governor stuck	Adjust governor
						x	Governor out of adjustment	Adjust governor
					x		Poor connections	Test and tighten
					x		Commutator out of round	Turn in lathe
				x		x	Dirty short circuiting device	Clean with solvent
x							Shorted rotor winding	Inspect and repair

UNIT 9.0 D

INDUSTRIAL ELECTRICAL CONTROLS/DEVICES

The purpose of this industrial electrical controls/devices unit is to provide the secondary electricity student with a practical introduction to various industrial control components and their applications in modern manufacturing and service industries. If the secondary program has a simple microcomputer device, instruction will include an introduction to programmable controllers for timing and sequential operations.

NOTE: Installation and maintenance task have been omitted from this unit. This unit is not designed to provide the student with a total introduction to industrial electrical controls and devices because of limitations in secondary training time, equipment, and funds.

Graduates who successfully complete the tasks described in this unit should be prepared to continued their training in electrical controls at the post-secondary level or in an on-the-job training program in industry.

Recommended references for this unit are:

Rockis, Gary, and Glen Mazur. Electrical Motor Controls, Alsip, IL: American Technical Publishers, Inc., 1982.

Alerich, Walter N. Electricity 4: AC Motors, Controls, Alternators, Albany, NY: Delmar Publishers, Inc., 1981.

Alerich, Walter N. Electricity 3: DC Motors & Generators, Controls, Transformers, Albany, NY: Delmar Publishers, Inc., 1981.

ELECTRICITY
INDUSTRIAL ELECTRICAL CONTROLS/DEVICES
SUGGESTED INSTRUCTION TIMES

<u>ELECTRICITY</u> <u>MODULE/TASK</u>	SUGGESTED HOURS
Unit 9.0-D	INDUSTRIAL ELECTRICAL CONTROLS/DEVICES
9.01	Install Manual Motor Control Station 6
9.02	Install Magnetic Push-Button Motor Control Station 12
9.03	Install a Three-Phase Control Magnetic Starter 15
9.04	Install Two-Station, Push- Button Control Station 6
9.05	Install Control Push-Button to Change Direction of Rotation of Motor 6
9.06	Install Hand Sequence Control Station 3
9.07	Install Timed Sequence Control Station 15
9.08	Install Automatic Sequence Control Station (Or Computer Based Controller) 15
9.09	Program a Programmable Controller 15
9.10	Install Direct Current (DC) Motor Controllers 6
9.11	Connect Capacitor Timing Starter 3
9.12	Install Jogging Control Circuit 6
9.13	Install Plugging Control 3
9.14	Install a Limit Switch 3
9.15	Install Drum Switch Control Station 3

ELECTRICITY
MODULE/TASK

SUGGESTED
HOURS

9.16 Replace Flow Switch
9.17 Replace Rheostat Control
9.18 Troubleshoot Controls

3
3
30
Total - 153

TASK LISTINGS
ELECTRICITY

MODULE/TASK	DESCRIPTION
Unit 9.0 D	INDUSTRIAL ELECTRICAL CONTROLS/DEVICES
9.01	(Install Manual Motor Control Station) Given a manual motor controller, a functional motor, the necessary tools, equipment, and materials; install a manual motor control station. The controller must cause the motor to accelerate through all positions until the motor runs at the rated speed and current.
9.02	(Install Magnetic Push-Button Motor Control Station) Given a push-button station, an across the line magnetic starter, a functional motor, the necessary tools, equipment, and materials; install an automatic push-button motor control station. When the start button is pressed, the motor will accelerate to its rated speed and current. With the stop button depressed the motor will not start when the start button is pressed.
9.03	(Install a Three-Phase Control Magnetic Starter) Given a three-phase magnetic starter, a functional motor, push-button station, the necessary tools, wire, connectors, equipment, and materials; install a three-phase control magnetic starter. When installation is complete, the motor will accelerate to its rated speed when the start button is pressed. When the stop button is pressed and held down, the motor will not run and the magnetic starter will not energize.
9.04	(Install Two-Station, Push-Button Control Station) Given two push-button stations, a magnetic starter, a functional motor, the necessary wire, connectors, tools, equipment, and materials; install a two-station push-button, control station. Upon completion, the motor will accelerate to its rated speed and the motor can be started from either station and stopped from either station. The motor will not run if either stop button is depressed when a start button is pushed.
9.05	(Install Control Push-Button to Change Direction of Rotation of Motor) Given a reversing push-button station, a functioning motor with reversing capability, the necessary conductors, connectors, tools, equipment and materials; install a control push-button station to change direction of rotation of motor. Upon completion of the installation, the motor will accelerate to its rated speed in either direction.

- 9.06 (Install Hand Sequence Control Station) Given a hand "manual" sequence control station, a functional electrical device such as a motor, the required conductors, connectors, tools, equipment, and materials; install a hand sequence control station. Upon completion of the installation, the electrical device will operate through the desired sequence as intended.
- 9.07 (Install Timed Sequence Control Station) Given a motor controller with a timed control, a function motor, and the necessary conductors, connectors, tools, equipment, and materials; install a timed sequence control station. Upon completion of the installation, the motor will step through each sequence until the rated speed is reached.
- 9.08 (Install Automatic Sequence Control Station or Computer Based Controller) Given an automatic sequence control station, a series of electrical devices such as functioning motors (3 suggested as minimum), the necessary conductors, connectors, tools, equipment, and materials; install an automatic sequence control station. Upon completion, the electrical services will function in the proper sequence and operate as intended (i.e., proper speed if motors). The control circuit must be constructed and wired so that, if one of the electrical devices should drop out due to overload, the sequences will be interrupted and the sequence must be started over at the beginning.
- 9.09 (Program a Programmable Controller) Given a programmable controller, a predetermined program, and the necessary materials, and test equipment; program a programmable controller so that it executes all the required commands when manually or operated automatically.
- 9.10 (Install Direct Current (DC) Motor Controllers) Given a DC motor controller, a functional DC motor, the necessary tools, equipment, materials, conductors and controllers; install a DC motor controller. The controller will operate when energized and the motor will accelerate to its rated speed and current when running at full voltage.
- 9.11 (Connect Capacitor Timing Starter) Given a capacitor timing starter, line contactor, the necessary tools, materials, connectors and conductors; connect a capacitor timing starter. The capacitor timing starter will hold the line contactor closed for a period of time after the top button (switch) has been pushed.

- 9.12 (Install Jogging Control Circuit) Given a motor control with jogging capability, functional motor, the necessary tools, equipment, and materials; install a jogging control circuit. The completed circuit will function in the run position; but, when the job button is pressed, the control circuit will be energized only for that period of time. The circuit must not be energized when the stop button is pressed and held down.
- 9.13 (Install Plugging Control Circuit) Given a motor controller with plugging capability, a functional motor, the necessary tools, equipment, conductors, connectors, and materials; install a plugging control circuit. The motor will run in one direction. When plugging takes place, the motor will come to an abrupt stop and will not reverse. The plugging switch must open the instant the motor stops to prevent reversing.
- 9.14 (Install a Limit Switch) Given a machine needing a limit switch, the necessary equipment and materials, and standard electrical tools; install the limit switch. The machine must operate according to predetermined limits and performance and product must meet instructor's standards.
- 9.15 (Install Drum Switch Control Station) Given a drum switch control station, a functional motor with reversing capability, the necessary conductors, connectors, tools, equipment, and materials; install a drum switch control station. The completed station will allow the motor to accelerate to its rated speed through all positions of the controller in both directions.
- 9.16 (Replace Flow Switch) Given a fluid circuit with a defective flow switch, a replacement flow switch, and the required tools, equipment, and materials; replace the flow switch. The flow switch must detect movement of fluid within the fluid circuit.
- 9.17 (Replace Rheostat Control) Given a control circuit with a defective rheostat control, replacement control, necessary tools, equipment, and materials including VOM; replace the rheostat control so that the circuit provides resistance through the required range and operates according to the manufacturer's specifications.
- 9.18 (Troubleshoot Controls) Given possibly defective controls, necessary references, VOM, clamp-on amprobe, required tools and equipment; troubleshoot the control circuit and control devices to identify repair(s) needed or if controls should be replaced. Repaired circuits should operate as intended. Performance must be within given time and meet instructor's standards.

UNIT	9.0 D	INDUSTRIAL ELECTRICAL CONTROLS/DEVICES
TASK	9.01	INSTALL MANUAL MOTOR CONTROL STATION

PERFORMANCE OBJECTIVE:

Given a manual motor controller, a functional motor, the necessary tools, equipment, and materials; install a manual motor control station. The controller must cause the motor to accelerate through all positions until the motor runs at the rated speed and current.

PERFORMANCE ACTIONS:

- 9.0101 Review circuit diagram for installation requirements.
- 9.0102 Disconnect power as applicable.
- 9.0103 Check location where push-button station is to be installed.
- 9.0104 Install push-button station:
 - a. Make mechanical connections.
 - b. Make electrical connections.
- 9.0105 Check installation for mechanical tightness and electrical continuity.
- 9.0106 Connect power, apply test voltage to machine, check for correct operation.

PERFORMANCE STANDARDS:

- Install manual motor control station that causes the motor to accelerate through all positions until the motor runs at the rated speed and current.

SUGGESTED INSTRUCTION TIME: 6 Hours

RELATED TECHNICAL INFORMATION:

- Explain operation of manual speed controller.
- Explain advantages/disadvantages of manual speed control.
- Identify three types of manual speed controllers.
- Identify safety considerations.

UNIT	9.0 D	INDUSTRIAL ELECTRICAL CONTROLS/DEVICES
TASK	9.02	INSTALL MAGNETIC PUSH-BUTTON MOTOR CONTROL STATION

PERFORMANCE OBJECTIVE:

Given a push-button station, an across the line magnetic starter, a functional motor, the necessary tools, equipment, and materials; install an automatic push-button motor control accelerate to its rated speed and current. With the stop button depressed the motor will not start when the start button is pressed.

PERFORMANCE ACTIONS:

- 9.0201 Review circuit diagram.
- 9.0202 Disconnect power from circuit, if applicable.
- 9.0203 Locate position of control station.
- 9.0204 Make mechanical preparations as necessary.
- 9.0205 Mechanically mount control station.
- 9.0206 Make electrical conductor connections according to circuit schematic/diagram and manufacturer's instruction information.
- 9.0207 Check electrical connections.
- 9.0208 Energize circuit.
- 9.0209 Test operation of magnetic push-button control station.

PERFORMANCE STANDARDS:

- Install a magnetic push-button motor control station with a start button that, when pressed, allows the motor to accelerate to rated speed and current and with the stop button that, when pressed, will not allow motor to start when the start button is pressed.

SUGGESTED INSTRUCTION TIME: 12 Hours

UNIT 9.0 D

INDUSTRIAL ELECTRICAL
CONTROLS/DEVICES

TASK 9.02

INSTALL MAGNETIC PUSH-BUTTON MOTOR
CONTROL STATION (Con't)

RELATED TECHNICAL INFORMATION:

- Describe a magnetic control.
- Explain the operation of push-buttons.
- Explain the connections for the control circuit.
- Explain the connections for the power circuit.
- Identify safety considerations.

UNIT	9.0 D	INDUSTRIAL ELECTRICAL CONTROLS/DEVICES
TASK	9.03	INSTALL A THREE-PHASE CONTROL MAGNETIC STARTER

PERFORMANCE OBJECTIVE:

Given a three-phase magnetic starter, a functional motor, push-button station, the necessary tools, wire, connectors, equipment, and materials; install a three-phase control magnetic starter. When installation is complete, the motor will accelerate to its rated speed when the start button is pressed. When the stop button is pressed and held down, the motor will not run and the magnetic starter will not energize.

PERFORMANCE ACTIONS:

9.0301 Install a three-phase control magnetic starter.

PERFORMANCE STANDARDS:

- Install a three-phase control magnetic starter that allows the motor to accelerate to its rated speed when the start button is pressed and when the stop button is held down, the motor will not run and the magnetic starter will energize.

SUGGESTED INSTRUCTION TIME: 15 Hours

RELATED TECHNICAL INFORMATION:

- Identify motor leads.
- Identify magnetic overloads.
- Explain NEC requirements for three-phase operation.
- Identify safety considerations.

UNIT	9.0 D	INDUSTRIAL ELECTRICAL CONTROLS/DEVICES
TASK	9.04	INSTALL TWO-STATION, PUSH-BUTTON CONTROL STATION

PERFORMANCE OBJECTIVE

Given two push-button stations, a magnetic starter, a functional motor, the necessary wire, connectors, tools, equipment, and materials; install a two-station push-button, control station. Upon completion, the motor will accelerate to its rated speed and the motor can be started from either station and stopped from either station. The motor will not run if either stop button is depressed when a start button is pushed.

PERFORMANCE ACTIONS:

9.0401 Install two-station, push-button control station.

PERFORMANCE STANDARDS:

- Install two-station, push-button control station which can start and stop the motor from either station and which will not allow the motor to start if either start button is pushed while either stop button is depressed.

SUGGESTED INSTRUCTION TIME: 6 Hours

RELATED TECHNICAL INFORMATION:

- Interpret/draw schematic diagrams using multiple push-button stations.
- Explain why a stop button is connected in series.
- Explain why a start button is connected in parallel.
- Identify safety considerations.

EXPANSION OF TASK:

(Install multiple push-button station) Given two or more push-button stations, a functional motor or other electrical device, the necessary tools, equipment, and materials; install the multiple push-button station. Upon completion the electrical device operated by the station will function on or off by the controls and, when the stop button is depressed and held down, the electrical device will not operate.

- Draw a diagram (schematic) of a multiple push-button station.
- Identify wiring connections.
- Identify safety considerations.

UNIT	9.0 D	INDUSTRIAL ELECTRICAL CONTROLS/DEVICES
TASK	9.05	INSTALL CONTROL PUSH-BUTTON TO CHANGE DIRECTION OF ROTATION OF MOTOR

PERFORMANCE OBJECTIVE:

Given a reversing push-button station, a functioning motor with reversing capability, the necessary conductors, connectors, tools, equipment and materials; install a control push-button station to change direction of rotation of motor. Upon completion of the installation, the motor will accelerate to its rated speed in either direction.

PERFORMANCE ACTIONS:

9.0501 Install control push-button to change direction of rotation of motor.

PERFORMANCE STANDARDS:

- Install control push-button to change direction of rotation of a motor so it will accelerate to its rated speed in either direction.

SUGGESTED INSTRUCTION TIME: 6 Hours

RELATED TECHNICAL INFORMATION:

- Interpret wiring diagram.
- Explain how to reverse a motor (operation of reversing motor, etc.)
- Explain operation of circuit.
- Explain why an addition N.O. contact is required with a reversing push-button station.
- Identify safety considerations.

UNIT	9.0 D		INDUSTRIAL ELECTRICAL CONTROLS/DEVICES
TASK	9.06	(OPTIONAL)	INSTALL HAND SEQUENCE CONTROL STATION

PERFORMANCE OBJECTIVE:

Given a hand "manual" sequence control station, a functional electrical device such as a motor, the required conductors, connectors, tools, equipment, and materials; install a hand sequence control station. Upon completion of the installation, the electrical device will operate through the desired sequence as intended.

PERFORMANCE ACTIONS:

9.0601 Install hand sequence control station.

PERFORMANCE STANDARDS:

- Install hand sequence control station that will operate through the desired sequence as intended.

SUGGESTED INSTRUCTION TIME: 3 Hours

RELATED TECHNICAL INFORMATION:

- Define manual starter.
- Describe what is sequence control.
- Explain how "hand sequence control" is accomplished.
- Identify safety considerations.

UNIT	9.0 D	INDUSTRIAL ELECTRICAL CONTROLS/DEVICES
TASK	9.07	INSTALL TIMED SEQUENCE CONTROL STATION

PERFORMANCE OBJECTIVE:

Given a motor controller with a timed control, a function motor, and the necessary conductors, connectors, tools, equipment, and materials; install a timed sequence control station. Upon completion of the installation, the motor will step through each sequence until the rated speed is reached.

(NOTE: Following task objective page includes recommendation for secondary electricity programs to acquire home microcomputers such as the Commodore Vic 20.)

PERFORMANCE ACTIONS:

9.0701 Install timed sequence control station.

PERFORMANCE STANDARDS:

- Install a timed sequence control station that will step a motor (or other device) through each sequence until the rated speed (or desired function) is obtained.

SUGGESTED INSTRUCTION TIME: 15 Hours

RELATED TECHNICAL INFORMATION:

- Explain timed sequence.
- Explain methods used for time sequence.
- Explain time delay.
- Describe a situation where the sequence control would be desirable.
- Identify safety considerations.

UNIT	9.0 D	INDUSTRIAL ELECTRICAL CONTROLS/DEVICES
TASK	9.08	INSTALL AUTOMATIC SEQUENCE CONTROL STATION (OR COMPUTER BASED CONTROLLER)

PERFORMANCE OBJECTIVE:

Given an automatic sequence control station*, a series of electrical devices such as functioning motors (3 suggested as minimum), the necessary conductors, connectors, tools, equipment, and materials; install an automatic sequence control station. Upon completion, the electrical device will function in the proper sequence and operate as intended (i.e., proper speed if motors). The control circuit must be constructed and wired so that, if one of the electrical devices should drop out due to overload, the sequence will be interrupted and the sequence must be started over at the beginning.

*A recommended option to using a manual cam-operated sequence control device is to substitute a home microcomputer such as the Commodore Vic 20 (around \$79.) which probably would be comparable in price to a good cam-operated sequence controller. The Vic 20 already is being used satisfactorily in teaching industrial electricity by the secondary level Industrial Maintenance Mechanics program at Donaldson Career Center (Mr. Doyle Black, Instructor).

PERFORMANCE ACTIONS:

(Actions to be determined by instructor.)

PERFORMANCE STANDARDS:

- Install an automatic sequence control station (or a computer based controller) that will operate a series of electrical devices, such as motors (3 suggested minimum), in the proper sequence and function and that will interrupt the sequence if one of the devices should drop out due to overload so that the sequence will have to be started over at the beginning.

SUGGESTED INSTRUCTION TIME: 15 Hours

RELATED TECHNICAL INFORMATION:

- Explain automatic sequence control.
- Explain use of times and pilot devices in automatic control.
- Explain main motor drive.
- Explain feed motor drive.
- Determine sequence of operation from a schematic or elementary pictorial or ladder diagram.
- Identify safety considerations.

UNIT	9.0 D	INDUSTRIAL ELECTRICAL CONTROLS/DEVICES
TASK	9.09	PROGRAM A PROGRAMMABLE CONTROLLER

PERFORMANCE OBJECTIVE:

Given a programmable controller, a predetermined program and the necessary materials and test equipment, program a programmable controller so that it executes all the required commands when manually or operated automatically.

(NOTE: The Commodore Vic 20 home microcomputer (about \$79.) is recommended as a reasonably priced programmable controller than can be used to teach the principles of modern control techniques found in industrial electricity. The Vic 20 currently is being used successfully in the Industrial Maintenance Mechanics program at Donaldson Career Center to teach industrial applications of programmable controllers.

PERFORMANCE ACTIONS:

- 9.0901 Read/discuss applications of programmable controllers in manufacturing and industrial settings.
- 9.0902 Read over program to be entered into the controller. (Interpret program functions into operations.)
- 9.0903 Turn on programmer and set the address made for entering the program.
- 9.0904 Enter the program into the controller.
- 9.0905 Set the controller in the mode for checking the program entered and make any needed corrections.
- 9.0906 Energize the controller and the controlled equipment and step the controller through the complete program.
- 9.0907 Observe each step to be sure all commands are executed correctly and at the right time.
- 9.0908 Make any needed changes in the program.

PERFORMANCE STANDARDS:

- Program a programmable controller, such as a small home microcomputer (e.g., Vic 20) so that it executes all the required commands when stepped through the program manually or operated automatically.

UNIT	9.0 D	INDUSTRIAL ELECTRICAL CONTROLS DEVICES
TASK	9.09	PROGRAM A PROGRAMMABLE CONTROLLER (Con')

SUGGESTED INSTRUCTION TIME: 15 Hours

RELATED INSTRUCTION TIME:

- Describe basic function of programmable controller.
- Describe basic timing and switching functions of a home microcomputer.
- Identify key steps in operating programmable controller.
- Identify program commands.
- Describe the use of optical couplers and solid state relays to connect the programmable controller (microcomputer) to electrical circuits.
- Identify electrical considerations, especially concerning connections to the microcomputer.
- Identify safety considerations.

SEE APPENDIX SECTION FOR:

- Hook up connections and use of Commodore Vic-20 (or C-64) computer as programmable controller.

UNIT	9.0 D	INDUSTRIAL ELECTRICAL CONTROLS/DEVICES
TASK	9.10 (OPTIONAL)	INSTALL DIRECT CURRENT (DC) MOTOR CONTROLLERS

PERFORMANCE OBJECTIVE:

Given a DC motor controller, a functional DC motor, the necessary tools, equipment, materials, conductors and connectors; install a DC motor controller. The controller will operate when energized and the motor will accelerate to its rated speed and current when running at full voltage.

PERFORMANCE ACTIONS:

9.1001 Install direct current (DC) motor controllers.

PERFORMANCE STANDARDS:

- Install DC motor controller(s) that will operate when energized and will allow the motor to accelerate to its rated speed and current when running at full voltage.

SUGGESTED INSTRUCTION TIME: 6 Hours

RELATED TECHNICAL INFORMATION:

- Explain operation of mechanical latch relay.
- Explain operation of thermostat relay used with a three-wire control device.
- Explain across-the-line starting for a small DC motor.
- Explain why current limiting resistors may be used for starting DC motors.
- Identify terminal markings for DC shunt motors and manual faceplate starters.
- Explain the operation of three-terminal DC manual faceplate starter.
- Explain the difference between three-terminal and four-terminal DC manual starter.
- Explain the operation of a counter EMF controller.
- Explain operation of a voltage drop acceleration controller.
- Explain sequence of operation of a magnetic time limit controller.
- Explain sequence of operation of a series lockout relay acceleration controller.
- Describe how a dashpot is used to provide time limit acceleration.

UNIT	9.0 D		INDUSTRIAL ELECTRICAL CONTROLS/DEVICES
TASK	9.10	(OPTIONAL)	INSTALL DIRECT CURRENT (DC) MOTOR CONTROLLERS

RELATED TECHNICAL INFORMATION:

- Describe the use and operating sequence of a field acceleration relay.
- Describe the use and operating sequence of a field failure relay.
- Identify safety considerations.

UNIT	9.0 D		INDUSTRIAL ELECTRICAL CONTROLS/DEVICES
TASK	9.11	(OPTIONAL)	CONNECT CAPACITOR TIMING STARTER

PERFORMANCE OBJECTIVE:

Given a timing starter, line contactor, the necessary tools, materials, connectors and conductors; connect a capacitor timing starter. The capacitor timing starter will hold the line contactor closed for a period of time after the top button (switch) has been pushed.

PERFORMANCE ACTIONS:

9.1101 Connec. capacitor timing starter.

PERFORMANCE STANDARDS:

- Connect capacitor timing starter that will hold the line contactor closed for a period of time after the top button (switch) has been pushed.

SUGGESTED INSTRUCTION TIME: 3 Hours

RELATED TECHNICAL INFORMATION:

- Explain what determines the time period for a contractor to remain closed.
- Describe principle of capacitor timing.
- Explain how the capacitor timing principle is applied to an electromagnetic starter.
- Identify safety considerations.

UNIT 9.0 D

INDUSTRIAL ELECTRICAL
CONTROLS/DEVICES

TASK 9.12

INSTALL JOGGING CONTROL CIRCUIT

PERFORMANCE OBJECTIVE:

Given a motor control with jogging capability, functional motor, the necessary tools, equipment, and materials; install a jogging control circuit. The completed circuit will function in the run position; but, when the jog button is pressed, the control circuit will be energized only for that period of time. The circuit must not be energized when the stop button is pressed and held down.

PERFORMANCE ACTIONS:

- 9.1201 Install start-stop-jog control that must have the stop button actuated prior to jogging.

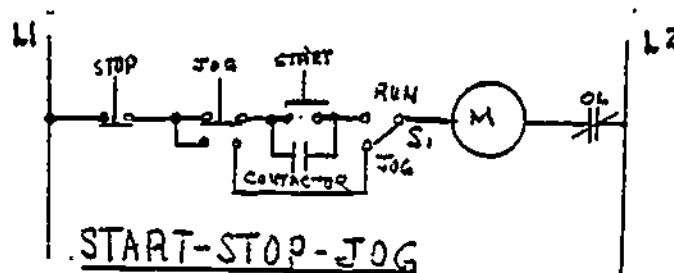

PERFORMANCE STANDARDS:

- Install a jogging control circuit that allows the circuit to function in the run position.
- In the jog (with jog button pressed) position, the control circuit will be energized only for that period of time.
- The circuit must be energized when the stop button is pressed and held down.

SUGGESTED INSTRUCTION TIME: 6 Hours

RELATED TECHNICAL INFORMATION:

- Define: Jogging or inching.
- Explain purpose of jogging controllers.
- Describe operation of a jogging control using a control relay.
- Describe operation of a jogging control using a control relay on a reversing starter.
- Describe operation of a jogging control using a selector switch.

UNIT 9.0 D

INDUSTRIAL ELECTRICAL
CONTROLS/DEVICES

TASK 9.13

INSTALL PLUGGING CONTROL CIRCUIT

PERFORMANCE OBJECTIVE:

Given a motor controller with plugging capability, a functional motor, the necessary tools, equipment, conductors, connectors, and materials; install a plugging control circuit. The motor will run in one direction. When plugging takes place, the motor will come to an abrupt stop and will not reverse. The plugging switch must open the instant the motor stops to prevent reversing.

PERFORMANCE ACTIONS: Install a plugging control circuit.

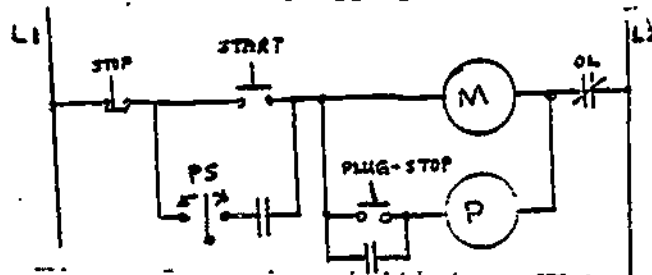

PERFORMANCE STANDARDS:

- Install a plugging control circuit that will cause a motor to come to a quick stop but will allow the motor to reverse.
- The plugging switch must open the instant the motor stops to prevent reversing.

SUGGESTED INSTRUCTION TIME: 3 Hours

RELATED TECHNICAL INFORMATION:

- Explain: Plugging a motor.
- Explain how a control circuit using a zero-speed switch operates to stop (plug) a motor. (Stator connections are reversed while motor is running to reverse the direction of flux rotation so motor is rotating in a direction opposite to that of its flux field. Countertorque is developed which exerts a retarding force on the motor. Advantageous when a motor driving a high inertia load has to be braked quickly.)
- Explain action of a time-delay in a plugging circuit.
- Explain antiplugging protection.
- Explain action of alternate circuits which used the zero-speed (plugging) switch.
- Identify safety consideration.

UNIT	9.0 D	INDUSTRIAL ELECTRICAL CONTROLS/DEVICES
TASK	9.14	INSTALL A LIMIT SWITCH

PERFORMANCE OBJECTIVE:

Given a machine needing a limit switch, the necessary equipment and materials, and standard electrical tools; install the limit switch. The machine must operate according to predetermined limits and performance and product must meet instructor's standards.

PERFORMANCE ACTIONS:

- 9.1401 Disconnect power from circuit.
- 9.1402 Check location of switch.
- 9.1403 Check switch for proper operation.
- 9.1404 Install the limit switch.
- 9.1405 Check installation for mechanical tightness and electrical continuity.
- 9.1406 Apply test voltage to machine; test for correct operation.
- 9.1407 Make necessary corrections to place circuit in desired operation.

PERFORMANCE STANDARDS:

- Install a limit switch to operate a circuit or machine in predetermined limits.
- Performance and product must be to instructor's standards.

SUGGESTED INSTRUCTION TIME: 3 Hours

UNIT	9.0 D	INDUSTRIAL ELECTRICAL CONTROLS/DEVICES
TASK	9.15 (OPTIONAL)	INSTALL DRUM SWITCH CONTROL STATION

PERFORMANCE OBJECTIVE:

Given a drum switch control station, a functional motor with reversing capability, the necessary conductors, connectors, tools, equipment, and materials; install a drum switch control station. The completed station will allow the motor to accelerate to its rated speed through all positions of the controller in both directions.

PERFORMANCE ACTIONS:

- 9.1501 Refer to drawing/schematic of circuit.
- 9.1502 Identify component and circuit requirements.
- 9.1503 Secure components (check catalogs for prices, etc.).
- 9.1504 Disconnect power, if applicable.
- 9.1505 Make mechanically preparations for installation of control.
- 9.1506 Mechanically, install control, fasten hardware.
- 9.1507 Fasten electrical conductors according to schematic and manufacturer's wiring instructions.
- 9.1508 Check installation and circuit.
- 9.1509 Energize circuit.
- 9.1510 Test operation.

PERFORMANCE STANDARDS:

- Install drum switch control station which will allow the motor to accelerate to its rated speed through all positions of the controller in both directions.

SUGGESTED INSTRUCTION TIME: 3 Hours

UNIT	9.0 D		INDUSTRIAL ELECTRICAL CONTROLS/DEVICES
TASK	9.15	(OPTIONAL)	INSTALL DRUM SWITCH CONTROL STATION

RELATED TECHNICAL INFORMATION:

- Explain uses of drum controller.
- Explain operation of movable contacts.
- Explain how speed control is obtained with the drum controller.
- Explain operation of drum controller when reversing of a motor is required.
- Identify safety considerations.

UNIT	9.0 D		INDUSTRIAL ELECTRICAL CONTROLS/DEVICES
TASK	9.16	(OPTIONAL)	REPLACE FLOW SWITCH

PERFORMANCE OBJECTIVE:

Given a fluid circuit with a defective flow switch, a replacement flow switch, and the required tools, equipment, and materials; replace the flow switch. The flow switch must detect movement of fluid within the fluid circuit.

PERFORMANCE ACTIONS:

- 9.1601 Disconnect power source from flow switch or circuit.
- 9.1602 If necessary, remove entire electro-mechanical component, turn fluid valves off, isolate location of the flow switch.
- 9.1603 Label and remove conductors.
- 9.1604 Remove defective flow switch.
- 9.1605 Install replacement flow switch.
- 9.1606 Connect conductors to proper terminals.
- 9.1607 Check installation for correctness and tightness.
- 9.1608 Turn fluid valves on, if previously shut off.
- 9.1609 Energize switch circuit.
- 9.1610 Check operation.

PERFORMANCE STANDARDS:

- Replace flow switch in a given circuit so that the flow switch operates as intended, detecting movement of fluid in circuit according to specifications.

SUGGESTED INSTRUCTION TIME: 3 Hours

UNIT	9.0 D		INDUSTRIAL ELECTRICAL CONTROLS/DEVICES
TASK	9.17	(OPTIONAL)	REPLACE RHEOSTAT CONTROL

PERFORMANCE OBJECTIVE:

Given a control circuit with a defective rheostat control, replacement control, necessary tools, equipment and materials including VOM; replace the rheostat control so that the circuit provides resistance through the required range and operates according to the manufacturer's specifications.

ALTERNATE TASK: Using VOM, electrician's tools, and instructor provided references, test a control circuit rheostat control and determine if it is defective or servicable.

PERFORMANCE ACTIONS: (To be determined by task)

- 9.1701 Disconnect power from circuit.
- 9.1702 Check rheostat control with VOM.
- 9.1703 If it is necessary to remove conductors from rheostat, label conductors.
- 9.1704 If rheostat must be remove:
 - a. Disconnect wires by loosening mechanical connectors or unsoldering.
 - b. Remove mounting hardware.
 - c. Remove control.
 - d. Replace with new control.
 - e. Fasten hardware.
 - f. Fasten conductors.
 - g. Check connections.
- 9.1705 Connect power.
- 9.1706 Test circuit for proper operation.

PERFORMANCE STANDARDS:

- Replace (or test) rheostat control in a given control circuit so that the circuit operates properly.

SUGGESTED INSTRUCTION TIME: 3 Hours

UNIT 9.0 D

INDUSTRIAL ELECTRICAL
CONTROLS/DEVICES

TASK 9.17

REPLACE RHEOSTAT CONTROL (Con't)

RELATED TECHNICAL INFORMATION:

- Identify a rheostat control.
- Explain how to test a rheostat.
- Demonstrate use of VOM to test a rheostat.

UNIT	9.0 D	INDUSTRIAL ELECTRICAL CONTROLS/DEVICES
TASK	9.18	TROUBLESHOOT CONTROLS

PERFORMANCE OBJECTIVE:

Given possibly defective controls, necessary references, VOM clamp-on amprobe, required tools and equipment; troubleshoot the control circuit and control devices to identify repair(s) needed or if controls should be replaced. Repaired circuits should operate as intended. Performance must be within given time and meet instructor's standards.

PERFORMANCE ACTIONS: (To be determined by problem)

- 9.1801 Follow standard or recommended troubleshooting procedures. (See accompanying "Motor Control Trouble-Remedy Guide.")
- 9.1802 Observe safety.

PERFORMANCE STANDARDS:

- Troubleshoot controls, identifying repair(s) needed and replacement situations.
- If required, make repairs or replacements so that controls operate as intended.
- Performance must be to the instructor's standards.

SUGGESTED INSTRUCTION TIME: 30 Hours

RELATED TECHNICAL INFORMATION:

- Identify typical control devices currently used in local industries.
- Describe how different control devices function.
- Interpret or draw required control circuits.
- Classify control problems by symptoms such as contact chatter, welding or freezing, overheating, etc.

MOTOR CONTROL TROUBLE-REMEDY GUIDE
(Magnetic Contactors and Starters)

SYMPTOMS	PROBABLE CAUSE	RECOMMENDED ACTION
CONTACTS		
Contact Chatter	<ol style="list-style-type: none"> 1. Broken shading coil. 2. Poor contact in control circuit. 3. Low voltage. 	<ol style="list-style-type: none"> 1. Replace magnet and armature. 2. Replace the contact device or use holding circuit interlock (3 wire control). 3. Correct voltage condition. Check momentary voltage dip during starting.
Welding or Freezing	<ol style="list-style-type: none"> 1. Abnormal inrush of current 2. Rapid jogging. 3. Insufficient tip pressure. 4. Low voltage preventing magnet from sealing. 5. Foreign matter preventing contacts from closing. 6. Short circuit. 	<ol style="list-style-type: none"> 1. Check for grounds, shorts or excessive motor load current or use larger contactor. 2. Install larger device rated for jogging service. 3. Replace contacts and springs, check contact carrier for deformation or damage. 4. Correct voltage condition. Check momentary voltage dip during starting. 5. Clean contacts with Freon. Contactors, starters, and control accessories used with very small current or low voltage, should be cleaned with Freon. 6. Remove short or fault and check to be sure fuse or breaker size is correct.
Short Tip Life or Overheating of Tips	<ol style="list-style-type: none"> 1. Filing or dressing. 2. Interrupting excessively high currents. 3. Excessive jogging. 4. Weak tip pressure. 5. Dirt or foreign matter on contact surface. 6. Short circuits. 7. Loose connection. 8. Sustained overload. 	<ol style="list-style-type: none"> 1. Do not file silver tips. Rough spots or discoloration will not harm tips or impair their efficiency. 2. Install larger device or check for grounds, shorts or excessive motor currents. 3. Install larger device rated for jogging. 4. Replace contacts and springs, check contact carrier for deformation or damage. 5. Clean contacts with Freon. 6. Remove short or fault and check to be sure fuse or breaker size is correct. 7. Clean and tighten. 8. Check for excessive motor load current or install larger device.

<u>COILS</u>		
Open Circuit	1. Mechanical damage.	1. Handle and store coils carefully.
Roasted Coil	1. Over voltage or high ambient temperature. 2. Incorrect oil. 3. Shorted turns caused by mechanical damage or corrosion. 4. Under voltage, failure of magnet to seal in. 5. Dirt or rust on pole faces increasing air gap.	1. Check application, circuit, and correct. 2. Install correct coil. 3. Replace coil. 4. Correct system voltage. 5. Clean pole faces.
<u>OVERLOAD RELAYS</u>		
Tripping	1. Sustained overload. 2. Loose connection on load wires. 3. Incorrect heater.	1. Check for grounds, shorts, or excessive motor currents and correct cause. 2. Clean and tighten. 3. Heater should be replaced with correct size.
<u>MAGNETIC & MECHANICAL PARTS</u>		
Noisy Magnet	1. Broken shading coil. 2. Magnet faces not mating. 3. Dirt or rust on magnet faces. 4. Low voltage.	1. Replace magnet and armature. 2. Replace magnet and armature. 3. Clean. 4. Check system voltage and voltage dips during starting.
Failure to Pick-up and Seal	1. Low voltage. 2. Coil open or shorted. 3. Wrong coil. 4. Mechanical obstruction.	1. Check system voltage and voltage dips during starting. 2. Replace. 3. Replace. 4. WITH POWER OFF check for free movement of contact and armature assembly.
Failure to Drop-Out	1. Gummy substance on pole faces. 2. Voltage not removed. 3. Worn or rusted parts causing binding. 4. Residual magnetism due to lack of air gap in magnet path.	1. Clean pole faces. 2. Check coil circuit. 3. Replace parts. 4. Replace magnet and armature.
<u>PNEUMATIC TIMERS</u>		
Erratic Timing	1. Foreign matter in valve.	1. Replace timing head complete or return timer to factory for repair and adjustment.
Contacts Do Not Operate	1. Maladjustment of actuating screw. 2. Worn or broken parts in snap switch.	1. Adjust as per instruction in service bulletin. 2. Replace snap switch.
<u>LIMIT SWITCHES</u>		
Broken Parts	1. Overtravel of actuator.	1. Use resilient actuator or operate within tolerances of the device.
<u>MANUAL STARTERS</u>		
Failure to Reset	1. Latching mechanism worn or broken.	1. Replace starter.
<u>COMPENSATORS (MANUAL)</u>		
Welding of Contacts on Starting Side	1. Inching, jogging, and operating handle slowly.	1. Excessive inching and jogging not recommended (caution operator). Move handle swiftly and surely to start position.

Welding of Contacts Running Side	<ol style="list-style-type: none"> 1. Moving handle slowly to run position. 2. Lack of sufficient spring pressure. 	<ol style="list-style-type: none"> 1. Move handle swiftly and surely to run position as motor approaches full speed. 2. Replace contacts and contact springs.
Damaged or Burned Transformer	<ol style="list-style-type: none"> 1. Repeated inching and jogging. 2. Holding handle in start position for long periods. 	<ol style="list-style-type: none"> 1. Excessive inching and jogging not recommended (caution operator). 2. Hold handle in start position only until motor approaches full speed.

Courtesy: Square D Company

UNIT 9.0 E

INTRODUCTION TO INDUSTRIAL ELECTRONICS

The purpose of this Introduction to Industrial Electronics unit is to provide the electricity graduate who may continue training at the post-secondary level or who may enter industrial electrical maintenance work with a orientation to basic electronic industrial control devices such as LED's, SCR's, etc.

Secondary graduates interested in careers in industrial electronics or related fields are encouraged to continue their training at the post-secondary level in Industrial Electricity/Electronics at Greenville Technical College.

References used in this unit include:

Driscoll, Edward F. Industrial Electronics: Devices, Circuits, and Applications, Alsip, IL: American Technical Publishers, Inc., 1976. (Includes a variety of projects and learning activities.)

ELECTRICITY
INTRODUCTION TO INDUSTRIAL ELECTRONICS
SUGGESTED INSTRUCTION TIMES

<u>ELECTRICITY</u> <u>MODULE/TASK</u>	SUGGESTED HOURS
Unit 9.0 E INTRODUCTION TO INDUSTRIAL ELECTRONICS	
9.01 Identify Basic Symbols and Components Used in Simple Industrial Electronic Circuits	3
9.02 Identify Considerations in Using Simple Electronic Components	3
9.03 Draw Diagrams of Industrial Electronic Control Circuits Using Solid State Relays	6
9.04 Install Solid State Relay in Circuit	6
9.05 Connect Diodes in Circuit	3
9.06 Connect/Replace Solid State Lamps (SSLs) (LEDs)	3
9.07 Construct a Basic SCR Speed Control Circuit	6
9.08 Construct a TRIAC Speed Control Circuit	6
9.09 Install Electronic Photoelectric Sensing Device	3
9.10 Construct a Photoelectric Relay Circuit	3
9.11 Install Electronic Proximity Sensing Device	3
Total	<u>3</u> 45

TASK LISTINGS
ELECTRICITY

MODULE/TASK	DESCRIPTION
Unit 9.0 E	INTRODUCTION TO INDUSTRIAL ELECTRONICS
9.01	(Identify Basic Symbols and Components Used in Simple Industrial Electronic Circuits) Given instruction and opportunity to match symbols with actual components, identify basic symbols and components used in simple industrial control circuits including the diode, LED, SCR, TRIAC, photoelectric and similar simple electronic devices.
9.02	(Identify Considerations in Using Simple Electronic Components) Given instruction, orientation to physical construction of simple electronic components used in industrial control circuits such as the diode, LED, SCR, TRIAC, photoelectric cell, etc.,; identify considerations in constructing circuits with electronic components.
9.03	(Draw Diagrams of Industrial Electronic Control Circuits Using Solid State Relays) Given a circuit to be operated by a low-voltage solid state device (relay), circuit components, and necessary tools and materials; draw a diagram of an electronic circuit using solid state relays or other devices. The diagram must be completed in representing the electronic control circuit and, if constructed, must operate as intended.
9.04	(Install Solid State Relay in Circuit) Given a requirement for a solid state relay such as between a computer programmable controller and AC controllers, solid state relay, relay specifications, and all necessary tools and materials; install the solid state control relay. The solid state relay must be selected and connected so that it properly isolates the controlling and controlled circuits.
9.05	(Connect Diodes in Circuit) Given a schematic of a circuit requiring one or more diodes for rectification and blocking, the specified diodes (for PIV and current ratings), a VOM, and AC power supply, and the required tools and materials; connect the diode(s) in the circuit. Desired rectification must be accomplished by the diodes. Voltage delivered from the diodes must be approximately that calculated. If diodes are used as blocking devices, the DC must be blocked out of the circuit.

- 9.06 (Connect/Replace Solid State Lamps (SSLs) (LEDs)) Given one or more light emitting diodes (LEDs), assortment of current limiting, circuit in which LED is to be used, and the necessary components, wire, tools and materials; connect or replace a solid state lamp in a circuit so that it operates as intended.
- 9.07 (Construct a Basic SCR Speed Control Circuit) Given a schematic diagram of a SCR speed control circuit, components, components list, motor or other device to be controlled, variable DC and AC power supplies, VOM, and the necessary tools and materials; construct a SCR speed control circuit. Circuit construction will be according to schematic diagram provided, components and wiring must be mechanically and electrically secure, and the control circuit must operate or control another device as intended.
- 9.08 (Construct a TRIAC Speed Control Circuit) Given a schematic diagram of a TRIAC speed control circuit, components, components list, signal generator, DC series motor, AC and DC power sources, VOM, and the necessary tools, and materials; construct a TRIAC speed control circuit. Circuit construction must be according to schematic diagram provided, components and wiring must be mechanically and electrically secure, and the control circuit must operate or control another device as intended.
- 9.09 (Install Electronic Photoelectric Sensing Device) Given a photoelectric electronic sensing device, the necessary material and equipment and tools; install the photoelectric sensing device in a circuit according to the schematic provided. The device must operate without fault through a complete testing cycle and be set to delay its operation according to the requirements of the installation.
- 9.10 (Construct a Photoelectric Relay Circuit) Given a schematic diagram of a photoelectric relay circuit, components, component list, AC and DC power sources, VOM, and the necessary tools and materials; construct a photoelectric relay circuit. The circuit constructed will be according to the schematic diagram, components and wiring will be mechanically and electrically secure, and the relay circuit will switch on or off according to exposure to the light source. Performance process and product must be to the instructor's standards.
- 9.11 (Install Electronic Proximity Sensing Device) Given a proximity sensing circuit and application, the necessary materials and equipment, and a standard tool kit; install the sensing device. The sensing circuit must activate relay switching circuit every time an object is passed within the preset distance of the pick-up element or coil.

UNIT	9.0 E	INTRODUCTION TO INDUSTRIAL ELECTRONICS
TASK	9.01	IDENTIFY BASIC SYMBOLS AND COMPONENTS USED IN SIMPLE INDUSTRIAL ELECTRONIC CIRCUITS

PERFORMANCE OBJECTIVE:

Given instruction and opportunity to match symbols with actual components, identify basic symbols and components used in simple industrial control circuits including the diode, LED, SCR, TRIAC, photoelectric and similar simple electronic devices.

PERFORMANCE ACTIONS:

- 9.0101 Review symbols used for diode, LED, SCR, TRIAC, and other simple electronic components common to industrial electrical control circuits.
- 9.0102 Match symbols with actual components.
- 9.0103 Discuss construction of components:
 - a. Positive/negative connections of diode.
 - b. Anode of LED.
 - c. SCR connections, etc.
- 9.0104 Identify the components in a simple schematic.

PERFORMANCE STANDARDS:

- Identify basic symbols and components used in simple industrial electronic circuits to include the diode, LED, SCR, TRIAC, etc.
- Performance must be to the instructor's standards.

SUGGESTED INSTRUCTION TIME: 3 Hours

RELATED TECHNICAL INFORMATION:

- Basic electricity symbols.
- Wiring techniques.

ELECTRONIC SYMBOLS
USED IN INDUSTRIAL ELECTRONICS UNIT

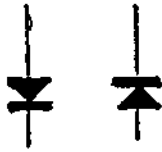

DIODE (HALF WAVE RECTIFIER)

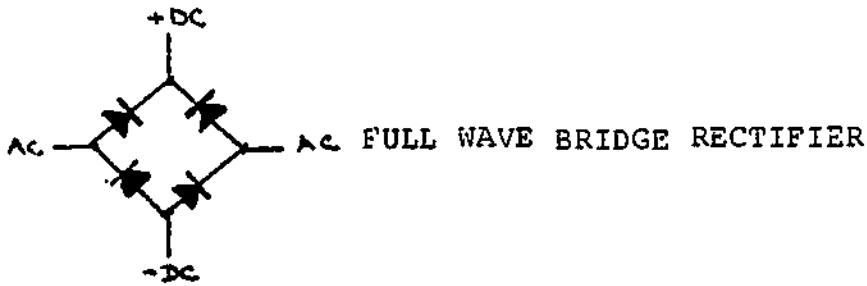

FULL WAVE BRIDGE RECTIFIER



UNIDIRECTIONAL BREAKDOWN ("ZENER") DIODE



SOLID STATE LAMP (LED) (SSL)



SILICON CONTROLLED SCR



PROGRAMMABLE UNIT - JUNCTION TRANSISTOR (PUT)



TRIAC (BIDIRECTIONAL TRIODE THYRISTOR)

UNIT	9.0 E	INTRODUCTION TO INDUSTRIAL ELECTRONICS
TASK	9.02	IDENTIFY CONSIDERATIONS IN USING SIMPLE ELECTRONIC COMPONENTS

PERFORMANCE OBJECTIVE:

Given instruction, orientation to physical construction of simple electronic components used in industrial control circuits such as the diode, LED, SCR, TRIAC, photoelectric cell, etc.; identify considerations in constructing circuits with electronic components.

PERFORMANCE ACTIONS:

9.0201 Identify important considerations for constructing circuits with the diode, LED, SCR, etc.

(NOTE: This action (sub-objective) may be expanded to include basic electronic theory for advanced students.

9.0202 Identify the positive and negative leads of diodes, the anode of LED's, etc.

9.0203 Discuss how to solder electronic components, including the use of heat sinks and proper methods of soldering sensitive electronic components such as the diode, LED, and SCR.

9.0204 Identify precautions when constructing circuits using simple electronic components.

PERFORMANCE STANDARDS:

- Identify considerations in using simple electronic components in industrial control circuits.
- Components must not be damaged from physical use or heat from soldering.
- Performance must be to the instructor's standards.

SUGGESTED INSTRUCTION TIME: 3 Hour (Integrated training with identifying electronic symbols)

UNIT 9.0 E

INTRODUCTION TO INDUSTRIAL
ELECTRONICS

TASK 9.02

IDENTIFY CONSIDERATIONS IN USING
SIMPLE ELECTRONIC COMPONENTS

RELATED TECHNICAL INFORMATION:

- Identify electronic components used in industrial controls by symbols.
- Use of hand tools in working with electronic components.
- Soldering techniques in working with electronic components including the use of heat sinks.

UNIT	9.0 E	INTRODUCTION TO INDUSTRIAL ELECTRONICS
TASK	9.03	DRAW DIAGRAMS OF INDUSTRIAL ELECTRON- IC CONTROL CIRCUITS USING SOLID STATE RELAYS

PERFORMANCE OBJECTIVE:

Given a circuit to be operated by a low-voltage solid state device (relay), circuit components, and the necessary tools and materials; draw a diagram of an electronic circuit using solid state relays or other devices. The diagram must be complete in representing the electronic control circuit and, if constructed, must operate as intended.

PERFORMANCE ACTIONS:

- 9.0301 Review schematic information and circuit description (to be drawn).
- 9.0302 Plan drawing:
 - a. Identify symbols to be used.
 - b. Rough sketch drawing.
 - c. Correct circuit, location of components, etc.
 - d. Finish rough sketch.
- 9.0303 Draw diagram to requirements.
- 9.0304 Check drawing.

PERFORMANCE STANDARDS:

- Draw diagrams of industrial electronic control circuits using solid state relays.
- Performance must be to the instructor's standards.
- The circuit drawn must be functional and, if constructed, must operate as intended.

SUGGESTED INSTRUCTION TIME: 6 Hours

RELATED TECHNICAL INFORMATION:

- Symbols: Electrical and electronic
- Reading schematic circuits.

UNIT 9.0 E

INTRODUCTION TO INDUSTRIAL
ELECTRONICS

TASK 9.04

INSTALL SOLID STATE RELAY IN CIRCUIT

PERFORMANCE OBJECTIVE:

Given a requirement for a solid state relay such as between a computer programmable controller and AC controllers, solid state relay, relay specifications, and all necessary tools and materials; install the solid state control relay. The solid state relay must be selected and connected so that it properly isolates the controlling and controlled circuits.

PERFORMANCE ACTIONS:

- 9.0401 Review circuit drawing and requirement(s) for solid state relay device(s).
- 9.0402 Select or check relay provided to ensure that it will properly operate in the circuit.
- 9.0403 Wire the relay in the circuit.
- 9.0404 Test the circuit for proper operation.

PERFORMANCE STANDARDS:

- Install solid state relay in circuit according to requirements so that a programmable controller is separated from the controlled circuit.
- Performance must be to instructor's standards.

SUGGESTED INSTRUCTION TIME: 6 Hours

RELATED TECHNICAL INFORMATION:

- Construction of solid state relays.
- Characteristics of solid state relays.

EXPANSION OF TASK:

- Given instruction, schematic, electronic components, tools, and materials; construct a functional optical coupling device that will buffer between a controlling circuit and controlled a circuit.
- Listen to instruction and read material concerning optically-coupled isolators and optoisolators SSL or LED, and phototransistor.
- Describe construction and uses of optical coupling devices including used as high-speed, contactless switching devices to couple between voltage levels, eliminating ground loops.

UNIT	9.0 E	INTRODUCTION TO INDUSTRIAL ELECTRONICS
TASK	9.05	CONNECT DIODES IN CIRCUIT

PERFORMANCE OBJECTIVE:

Given a schematic of a circuit requiring one or more diodes for rectification and blocking, the specified diodes (for PIV and current ratings), a VOM, an AC power supply, and the required tools and materials; connect the diode(s) in the circuit. Desired rectification must be accomplished by the diodes. Voltage delivered from the diodes must be approximately that calculated. If diodes are used as blocking devices, the DC must be blocked out of the circuit.

PERFORMANCE ACTIONS:

- 9.0501 Identify how to classify the ratings of diodes:
 - a. PIV.
 - b. Current rating.
- 9.0502 Describe/demonstrate how to test forward reverse bias resistance of all diodes.
- 9.0503 Mount diodes in heat sinks, if applicable.
- 9.0504 Connect diodes according to circuit schematic.
- 9.0505 Connect AC to diode(s).
- 9.0506 Check wiring.
- 9.0507 Apply AC to circuit and test rectified voltage.

PERFORMANCE STANDARDS:

- Connect diode(s) in given circuits including using the diode as a rectifier and as a blocking device in a DC circuit.
- The constructed circuit must operate as intended and to specifications.
- Performance must be to the instructor's standards.

SUGGESTED INSTRUCTION TIME: 3 Hours

RELATED TECHNICAL INFORMATION:

- Identifying diodes.

UNIT 9.0 E

INTRODUCTION TO INDUSTRIAL
ELECTRONICS

TASK 9.05

CONNECT DIODES IN CIRCUIT (Con't)

RELATED TECHNICAL INFORMATION (Con't):

- Identifying the bridge diode.
- Use of the ohmmeter for testing diodes (low resistance with lead to anode and high resistance with positive lead to cathode).
- Precautions in using proper scales for testing electronic solid state devices.
- Techniques of soldering diodes including the use of heat sinks.

UNIT	9.0 E	INTRODUCTION TO INDUSTRIAL ELECTRONICS
TASK	9.06	CONNECT/REPLACE SOLID STATE LAMPS (SSLs) (LEDs)

PERFORMANCE OBJECTIVE:

Given one or more light emitting diodes (LEDs), assortment of current limiting, circuit in which LED is used, and the necessary components, wire, tools and materials; connect or replace a solid state lamp in a circuit so that it operates as intended.

(NOTE: Instructor/student reference to LEDs included in "Reference Appendixes to Electricity Guide.")

PERFORMANCE ACTIONS:

- 9.0601 Review circuit.
- 9.0602 Determine current limiting resistor to be used.
- 9.0603 Select, test, and install LED.
- 9.0604 Install other components if required.
- 9.0605 Check LED operation in circuit.

PERFORMANCE STANDARDS:

- Connect/replace solid state lamps (LEDs) in given circuits, following schematic or circuit descriptions and computing the size of current limiting resistors to be used.
- Circuit LED must operate as intended.
- Performance must meet instructor's standards.

SUGGESTED INSTRUCTION TIME: 3 Hours

RELATED TECHNICAL INFORMATION:

- Explain and design the principles of LED construction and operation.
- Computation of current limiting resistor value.
- Techniques of installation of LEDs, precautions, etc.

UNIT 9.0 E

INTRODUCTION TO INDUSTRIAL
ELECTRONICS

TASK 9.06

CONNECT/REPLACE SOLID STATE LAMPS
(SSLs) (LEDs)

RELATED TECHNICAL INFORMATION (Con't):

- USES OF LEDs:
 - a. Pilot lamp (A)
 - b. Optical coupling device (B)
 - c. AC line-voltage indicator
 - d. Contactless potentiometer
 - e. Temperature sensor

A. Pilot Lamp

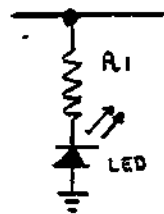

B. Optical Coupling

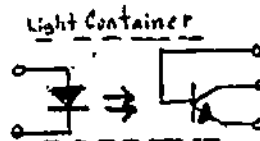

UNIT	9.0 E	INTRODUCTION TO INDUSTRIAL ELECTRONICS
TASK	9.07	CONSTRUCT A BASIC SCR SPEED CONTROL CIRCUIT

PERFORMANCE OBJECTIVE:

Given a schematic diagram of a SCR speed control circuit, components, components list, motor or other device to be controlled, variable DC and AC power supplies, VOM, and the necessary tools and materials; construct a SCR speed control circuit. Circuit construction will be according to schematic diagram provided, components and wiring must be mechanically and electrically secure, and the control circuit must operate or control another device as intended.

PERFORMANCE ACTIONS:

- 9.0701 Review drawing, schematic, etc.
- 9.0702 Assemble materials.
- 9.0703 Construct circuit according to schematic.
- 9.0704 Check circuit wiring.
- 9.0705 Apply voltage and test circuit operation.
- 9.0706 Test circuit control of device (as intended, to specifications).

PERFORMANCE STANDARDS:

- Construct a basic SCR speed control circuit according to schematic diagram with mechanically and electrically secure connections and so the control device operates as intended.
- Performance process and product must be to the instructor's standards.

SUGGESTED INSTRUCTION TIME: 6 Hours

RELATED TECHNICAL INFORMATION:

- Explain why a basic SCR speed control offers only limited control.
- Explain why a neon lamp is used in a basic SCR speed control circuit.
- Describe the operation of a SCR speed control.

UNIT 9.0 E

INTRODUCTION TO INDUSTRIAL
ELECTRONICS

TASK 9.07

CONSTRUCT A BASIC SCR SPEED CONTROL
CIRCUIT

RELATED TECHNICAL INFORMATION (Con't):

- Describe the construction features of a SCR speed control circuit.
- Identify safety considerations.

SPEED CONTROL

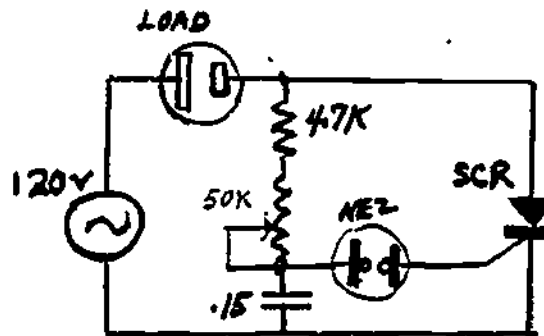

UNIT 9.0 E

INTRODUCTION TO INDUSTRIAL
ELECTRONICS

TASK 9.08

CONSTRUCT A TRIAC SPEED CONTROL
CIRCUIT

PERFORMANCE OBJECTIVE:

Given a schematic diagram of a TRIAC speed control circuit, components, components list, signal generator, DC series motor, AC and DC power sources, VOM, and the necessary tools, and materials; construct a TRIAC speed control circuit. Circuit construction must be according to the schematic diagram provided, components and wiring must be mechanically and electrically secure, and the control circuit must operate or control another device as intended.

PERFORMANCE ACTIONS:

- 9.0801 Review circuit description.
- 9.0802 Examine TRIAC device for specifications.
- 9.0803 Disconnect power, if applicable.
- 9.0804 Install TRIAC components in circuit or construct a TRIAC speed control circuit.
- 9.0805 Test as appropriate: Neon lamp, DIAC, triggering device.
- 9.0806 Check connections.
- 9.0807 Apply power.
- 9.0808 Check operation of circuit.
- 9.0809 Adjust circuit as needed.

PERFORMANCE STANDARDS:

- Construct a TRIAC speed control circuit to operate another device as intended.
- Circuit must operate according to schematic diagram provided, components and wiring must be mechanically and electrically secure.
- The control must function to specifications.
- Performance and process must be to instructor's standards.

SUGGESTED INSTRUCTION TIME: 6 Hours

UNIT 9.0 E

INTRODUCTION TO INDUSTRIAL
ELECTRONICS

TASK 9.08

CONSTRUCT A TRIAC SPEED CONTROL
CIRCUIT (Con't)

RELATED TECHNICAL INFORMATION:

- Explain advantage to TRIAC speed control over SCR speed control.
- Describe operation of TRIAC.
- Describe operation of DIAC.
- Describe construction features of a TRIAC speed control.
- Identify safety considerations.
- Techniques for testing TRIAC neon lamp, DIAC, etc.
- Connections to TRIAC.

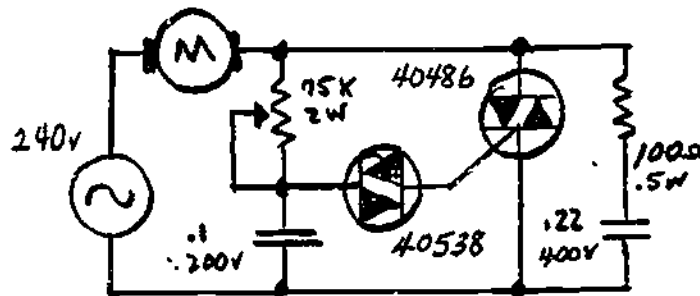

UNIT 9.0 E

INTRODUCTION TO INDUSTRIAL
ELECTRONICS

TASK 9.09

INSTALL ELECTRONIC PHOTOELECTRIC
SENSING DEVICE

PERFORMANCE OBJECTIVE:

Given a electronic photoelectric sensing device, the necessary material and equipment and tool; install the photoelectric sensing device in a circuit according to the schematic provided. The device must operate without fault through a complete testing cycle and be set to delay its operation according to the requirements of the installation.

PERFORMANCE ACTIONS:

- 9.0901 Review schematic or circuit application and the photoelectric control function the device will do.
- 9.0902 Check to be sure the sensor provided will meet the specifications of the circuit.
- 9.0903 If applicable, disconnect power from circuit.
- 9.0904 Install photoelectric sensing device.
- 9.0905 Check polarity of device, if applicable.
- 9.0906 Apply power to circuit.
- 9.0907 Check device through a complete cycle of light-dark-light.
- 9.0908 Observe operation of device and time delay, if applicable.

PERFORMANCE STANDARDS:

- Install electronic photoelectric sensing device according to schematic or circuit requirements.
- Operation must be without fault and according to installation requirements.
- Performance must be to instructor's standards.

SUGGESTED INSTRUCTION TIME: 3 Hours

UNIT	9.0 E	INTRODUCTION TO INDUSTRIAL ELECTRONICS
TASK	9.10	CONSTRUCT A PHOTOELECTRIC RELAY CIRCUIT

PERFORMANCE OBJECTIVE:

Given a schematic diagram of a photoelectric relay circuit, components, component list, AC and DC power sources, VOM, and the necessary tools and materials; construct a photoelectric relay circuit. The circuit constructed will be according to the schematic diagram, components and wiring will be mechanically and electrically secure, and the relay circuit will switch on or off according to exposure to the light source. Performance process and product must be to the instructor's standards.

PERFORMANCE ACTIONS:

(Instructor will issue schematic and instructions for completion of project.)

- 9.1001 Interpret circuit schematic.
- 9.1002 Assemble parts or components including wire.
- 9.1003 Assemble tools including solder.
- 9.1004 Construct circuit in a logical or recommended order/manner.
- 9.1005 All electrical connections must be mechanically and electrically secure. Soldered joints, if used, must meet instructor's standards.
- 9.1006 When completed, the circuit must operate as intended.

PERFORMANCE STANDARDS:

- Construct a photoelectric relay circuit according to schematic provided so that the circuit operates as intended.
- Performance process and product must meet instructor's standards.

SUGGESTED INSTRUCTION TIME: 3 Hours

UNIT	9.0 E	INTRODUCTION TO INDUSTRIAL ELECTRONICS
TASK	9.10	CONSTRUCT A PHOTOELECTRIC RELAY CIRCUIT

RELATED TECHNICAL INFORMATION:

- Identify relevant components and their operation.
- Explain the operation of a photoelectric device.
- Describe some variations of photoelectric relay applications in modern industries.
- Identify safety considerations.

EXPANSION TO TASK:

- Use photoelectric devices in specular (sensor-mirror-source) and retroreflective (source/sensor to mirror and return).
- Use solid-state lamps (SSLs and LEDs) to activate photoelectric devices. (See task or LEDs.)
- Use "optical coupling devices" to control circuits.

UNIT	9.0 E	INTRODUCTION TO INDUSTRIAL ELECTRONICS
TASK	9.11 (OPTIONAL)	INSTALL ELECTRONIC PROXIMITY SENSING DEVICE

PERFORMANCE OBJECTIVE:

Given a proximity sensing circuit and application, the necessary materials and equipment, and a standard tool kit, install the sensing device. The sensing circuit must activate relay switching circuit every time an object is passed within the preset distance of the pick-up element or coil.

PERFORMANCE ACTIONS:

- 9.1101 Review circuit drawing/description.
- 9.1102 Disconnect power from circuit, if applicable.
- 9.1103 Test circuit to be sure the power is off.
- 9.1104 If sensing device is in module form test sensing module to be sure it is operational.
- 9.1105 Install sensing device, mechanically and electrically.
- 9.1106 Inspect installation, check electrical connections.
- 9.1107 Apply power to circuit.
- 9.1108 Test circuit through a complete cycle of operation.
- 9.1109 Adjust as necessary.

PERFORMANCE STANDARDS:

- Install electronic proximity sensing device or module so that it operates properly every time an object is passed within the preset distance of the pick-up element or coil.
- Performance must meet instructor's standards.

SUGGESTED INSTRUCTION TIME: 3 Hours

RELATED TECHNICAL INFORMATION:

- Principles of proximity sensing devices.

INDUSTRIAL ELECTRICITY TASK OMITTED

Some task objectives that might be included in industrial electrical wiring and maintenance training have been omitted from this articulated guide on the recommendation of the secondary instructor participants of the Task Force Committee on Electricity.

The secondary electricity instructors suggested:

- Series and parallel circuits involving industries should be included in electronics training, however, the topic might be included in the secondary electricity program if there is sufficient instructional time, equipment and materials, and student interest and readiness.
- Transformers will be covered in an orientation manner since there is little opportunity for "hands on" training and since this training probably would be duplicated on the job for safety reasons.
- Communications and alarm circuits probably will be restricted to the installation and testing of low voltage control wiring although a new unit concerning the installation of telephone wiring will provide related training. Basically, public address, burglar and fire alarm, and other similar systems will be omitted from this guide since these tend to be specialized occupational areas which require on-the-job or specialized training.

MODULE 10.0

ESTIMATING AND PLANNING ELECTRICAL WORK

The purpose of this unit is to introduce the student to the fundamental practices in estimating and planning electrical work.

It is projected that some students may have to provide information used in estimating electrical work, although most students, as entry level workers, will not be involved in estimating tasks.

ELECTRICITY
ESTIMATING AND PLANNING ELECTRICAL WORK
SUGGESTED INSTRUCTION TIMES

<u>ELECTRICITY</u> <u>MODULE/TASK</u>	SUGGESTED HOURS
MODULE 10.0 ESTIMATING AND PLANNING ELECTRICAL WORK	
10.01 Estimate the Cost of a Specific Installation	*
10.02 Estimate Cost of Materials for a Specific Wiring Job	*
10.03 Estimate Costs of Labor Needed to do a Specific Wiring Job	*
10.04 Inventory Equipment, Materials, and Supplies	*
10.05 Complete a Trouble Report on Tools, Equipment, and Materials not Servicable	*
10.06 Plan a Sequence of Work Operations	30
	Total 30
* = See 10.06	

TASK LISTINGS
ELECTRICITY

MODULE/TASK	DESCRIPTION
MODULE 10.0	ESTIMATING AND PLANNING ELECTRICAL WORK
10.01	(Estimate the Cost of a Specific Installation) Given the drawings and specifications of a specific installation and all the necessary forms, schedules, and current pricing information; estimate the cost of the specific installation. The estimate must include the cost of materials, cost of labor, overhead cost, and expected profit and must be within 5 percent of the predetermined estimate of the instructor.
10.02	(Estimate Cost of Materials for a Specific Wiring Job) Given the drawings and specifications for a specific wiring job and the necessary materials, forms and schedules; estimate the cost of the materials for the specific wiring job. The estimate must include all of the materials needed to complete the job and contain prices effective at the time the estimate is submitted. The estimate must be within +/- 5 percent of the estimate of the instructor.
10.03	(Estimate Costs of Labor Needed to do a Specific Wiring Job) Given drawings and specifications for a specific wiring job and a list of all the needed materials, forms, and schedules; estimate the cost of the labor for the job based on labor rates provided by the instructor. The labor rates must represent the labor unit prices effective at the time the estimate is submitted. The estimate must be within +/- 5 percent of that figured by the instructor.
10.04	(Inventory Equipment, Materials, and Supplies) Given a supply room or any area containing quantities of equipment, materials, and supplies; inventory the equipment, materials, and supplies as directed by the instructor. The inventory must be accurate when compared to the control inventory and must be completed using the appropriate forms furnished by the instructor.
10.05	(Complete a Trouble Report on Tools, Equipment, and Materials not Servicable) Given an area containing equipment, tools, or materials to be maintained, the necessary forms and information; maintain a trouble report on the maintenance of the equipment. The report must be up to date and in accordance with the policy of the instructor.

10.06 (Plan a Sequence of Work Operations) Given a job description and designated results; plan the sequence of work operations that will achieve the desired results. The plan must involve all the tasks necessary to complete the job and the proper order in which they should be completed.

MODULE 10.0

ESTIMATING AND PLANNING ELECTRICAL
WORK

TASK 10.01

ESTIMATE THE COST OF A SPECIFIC
INSTALLATION

PERFORMANCE OBJECTIVE:

Given the drawings and specifications of a specific installation and all the necessary forms, schedules, and current pricing information; estimate the cost of the specific installation. The estimate must include the cost of materials, cost of labor, overhead cost, and expected profit and must be within 5 percent of the predetermined estimate of the instructor.

PERFORMANCE ACTIONS:

- 10.0101 Review all drawings and specifications provided.
- 10.0102 Draw up any or all of the following needed:
 - a. Branch circuit schedule.
 - b. Lighting fixture schedule.
 - c. Branch circuit materials schedule.
 - d. Service and feeder schedule.
 - e. Labor unit schedule.
- 10.0103 Transfer above information to an estimating form including:
 - a. Unit cost of materials.
 - b. Material cost.
 - c. Unit labor/hours.
 - d. Labor cost.
- 10.0104 Add all materials and labor costs.
- 10.0105 Add percentage of total to cover overhead. Use percentage factor given by the instructor.
- 10.0106 Add percentage of total to cover expected profit. Use percent factor provided by electricity instructor.
- 10.0106 Submit complete estimate to instructor.

PERFORMANCE STANDARDS:

- Estimate the cost of a specific electrical installation using the provided forms, schedules, and current pricing information showing the cost of materials, cost of labor, overhead cost, and expected profit.

SUGGESTED INSTRUCTION TIME: See 10.06

MODULE	10.0	ESTIMATING AND PLANNING ELECTRICAL WORK
TASK	10.02	ESTIMATE COST OF MATERIALS FOR A SPECIFIC WIRING JOB

PERFORMANCE OBJECTIVE:

Given the drawings and specifications for a specific wiring job and the necessary materials, forms, and schedules; estimate the cost of the materials for the specific wiring job. The estimate must include all of the materials needed to complete the job and contain prices effective at the time the estimate is submitted. The estimate must be within +/- 5 percent of the estimate of the instructor.

PERFORMANCE ACTIONS:

- 10.0201 Review drawings and specifications.
- 10.0202 List materials:
 - a. Branch circuit materials schedule.
 - b. Lighting fixture schedule.
 - c. Service and feeder materials schedule.
- 10.0203 Transfer the above information to an estimating form provided by the instructor and indicating the unit cost and extended cost of each item.
- 10.0204 Total all the extended costs listed.

PERFORMANCE STANDARDS:

- Estimate cost of materials for a specified wiring job using an estimating form prepared and showing unit cost, total cost of extended items, and total of extended costs listed.

SUGGESTED INSTRUCTION TIME: See 10.06

MODULE	10.0	ESTIMATING AND PLANNING ELECTRICAL WORK
TASK	10.03	ESTIMATE COSTS OF LABOR NEEDED TO DO A SPECIFIC WIRING JOB

PERFORMANCE OBJECTIVE:

Given drawings and specifications for a specific wiring job and a list of all the needed materials, forms, and schedules; estimate the cost of the labor for the job based on labor rates provided by the instructor. The labor rates must represent the labor unit prices effective at the time the estimate is submitted. The estimate must be within +/- 5 percent of that figured by the instructor.

PERFORMANCE ACTIONS:

- 10.0301 Study the drawings and specifications.
- 10.0302 Compile a labor units schedule. Total the hours needed to complete the job.
- 10.0303 Calculate the labor cost by multiplying the number of hours times the current cost per hour.

PERFORMANCE STANDARDS:

- Estimate costs of labor needed to do a specific wiring job using given information and materials/forms and using labor rates effective at the time the estimate is submitted.
- The estimate must be within +/- 5 percent of that figured by the instructor.

SUGGESTED INSTRUCTION TIME: See 10.06

MODULE	10.0	ESTIMATING AND PLANNING ELECTRICAL WORK
TASK	10.04	INVENTORY EQUIPMENT, MATERIALS, AND SUPPLIES

PERFORMANCE OBJECTIVE:

Given a supply room or any area containing quantities of equipment, materials, and supplies; inventory the equipment, materials, and supplies as directed by the instructor. The inventory must be accurate when compared to the control inventory and must be completed using the appropriate forms furnished by the instructor.

PERFORMANCE ACTIONS:

- 10.0401 Sort and separate pieces of equipment.
- 10.0402 Check equipment for servicable condition and check assigned/necessary accessories (such as test probe leads with VOM's).
- 10.0403 Sort and separate materials.
- 10.0404 Sort and separate supplies.
- 10.0405 Count and record numbers of each item of equipment, materials, and supplies.
- 10.0406 Recount number of each item comparing second count to record made of first count (or to master inventory).

PERFORMANCE STANDARDS:

- Inventory equipment, materials, and supplies as directed by the instructor, using furnished forms, and comparing the inventory to a master inventory provided by the instructor.

(RECOMMENDATION: Toolroom man may conduct an inventory of tool storage, etc., room daily or as directed by the instructor. This practice should contribute directly to the knowledge and skill development of the student providing the student with experience in inventory; equipment, tool, and component terminology; and an opportunity to check out the condition of tools and equipment.)

SUGGESTED INSTRUCTION TIME: See 10.05

MODULE	10.0	ESTIMATING AND PLANNING ELECTRICAL WORK
TASK	10.05	COMPLETE A TROUBLE REPORT ON TOOLS, EQUIPMENT, AND MATERIALS NOT SERVICABLE

PERFORMANCE OBJECTIVE:

Given an area containing equipment, tools, or materials to be maintained, the necessary forms and information; maintain a trouble report on the maintenance of the equipment. The report must be up to date and in accordance with the policy of the instructor.

PERFORMANCE ACTIONS:

- 10.0501 Review instructor's directions concerning reporting tools, equipment, or materials that are not servicable.
- 10.0502 Review report form.
- 10.0503 Note location of all tools, equipment, and materials to be inspected.
- 10.0504 Use forms to record trouble with tools, equipment, or material.
- 10.0505 Submit reports to instructor.

PERFORMANCE STANDARDS:

- Complete a trouble report on tools, equipment, or materials not servicable on the forms provided by the instructor, according to the instructor's directions, and the meeting standards of the instructor.

(NOTE: This task may be combined with toolroom duty to expand skill and knowledge development training in that learning experience.)

SUGGESTED INSTRUCTION TIME: See 10.06

MODULE	10.0	ESTIMATING AND PLANNING ELECTRICAL WORK
TASK	10.06	PLAN A SEQUENCE OF WORK OPERATIONS

PERFORMANCE OBJECTIVE:

Given a job description and designated results; plan the sequence of work operations that will achieve the desired results. The plan must involve all the tasks necessary to complete the job and the proper order in which they should be completed.

PERFORMANCE ACTIONS:

- 10.0601 Make a general analysis of the job to be completed.
- 10.0602 List all the operations (tasks) needed to complete the job.
- 10.0603 Arrange the operations in the proper sequence from beginning to completing the job.
- 10.0604 Review and examine the sequence listed for possible errors or omissions.
- 10.0605 Submit the proposed sequence to the instructor for review and critique.
- 10.0606 Complete sequence, if required.

PERFORMANCE STANDARDS:

- Plan a sequence of work operations for the most efficient and effective accomplishment of desired results, outlining or listing job task in the proper order in which they should be completed.
- Meet the instructor's standards.
- Complete the sequence of operations, if required.

SUGGESTED INSTRUCTION TIME: 10.01 - 10.06 = 30 Hours

MODULE 11.0

ELECTRICITY SHOP/FIELD PROJECTS

There is similar use of applied electricity shop projects at the secondary level for the purpose of allowing students to apply theory to practical situations and to develop competencies in basic skills.

The primary purposes of electricity shop projects includes:

- a. Providing individualized training in basic and advanced electricity training.
- b. Providing learning opportunities for the student according to the student's special abilities, career interests, or to meet potential needs of employers at a particular time.
- c. Providing opportunities for the instructor to test the student's knowledge and skills development in simulated or realistic situations ("hands on" examinations).
- d. Providing an opportunity where the instructor may conduct a "final examination" of basic electricity skills demonstrated in simulated or applied situations.
- e. Providing opportunities for each student to develop general competencies or special* electricity related skills and knowledge. Shop projects may be designed to help students gain advanced skills in electricity or expand their skill development beyond the typical electricity program.

*If individualized learning situations are offered, the following is RECOMMENDED:

"Individual learning situations should be accompanied by a written plan indicating the objective, major steps or student actions necessary to reach the objective, minimum standards expected of the student, and how the student will be evaluated. This individualized learning plan should be developed mutually by the instructor, other participating instructors as applicable, the student, and others directly involved."

Today, secondary level vocational programs such as Electricity are being taught in a more realistic manner and setting. Where student interest is high, basic electricity training may be followed up by applied live projects in the lab or in the field when practical.

A simulated or live project may involve only electricity students or may allow electricity students to work jointly with students from other vocational areas such as air conditioning-refrigeration-heating, carpentry, masonry, machining, etc. Some projects might involve students in secretarial science or accounting to simulate ordering and accounting of electrical materials.

Live electricity projects should be selected carefully so that there will be no direct competition with local businesses. The improvement of low-income family dwellings and the improvement of the community should be given high priority in the selection of wiring projects. Work involving motors and controls should be selected for its learning value to the students.

Typically, the production of the electricity student in a live field or shop project will be low and slow because the primary aim is teaching. Emphasis in applied training is placed on developing skills for the electrical construction or industrial maintenance trades. A job not done right may have to be done over by the student. Live electrical projects, however, provide a unique opportunity for students to encounter, in a controlled setting, day-to-day construction problems that never would occur in the classroom.

Well planned, field electricity projects may provide exceptional opportunities. Electricity instructors from two career centers might combine their students at one field training site. In addition to increasing student manpower, joint training might provide students with a situation where they would benefit from the diversified trade experience of two instructors instead of one instructor.

Live or simulated field electricity projects, however, require more instructor planning. Careful scheduling is necessary to ensure that students can reach the job site, learn, practice skills, and return to their home schools within given times. In addition, activities must be arranged in the proper sequence so that students do not become "bunched-up" on the job and so that the electricity project develops properly.

A side benefit that may result from live electricity projects is that students may develop good work habits and attitudes in addition to increasing their knowledge and skills in electricity.

Examples of electricity field projects might include installing wiring or rewiring residential or commercial structures, installing or troubleshooting controls or installing or troubleshooting motor in small industrial settings. These or other projects which might be brought into the shop provide realistic training for students. Typically, field electrical work for private individuals should involve a small fee to cover the cost of materials and expendibles and to provide the electricity program with a small fund to help support optimum training.

Field installations for private individuals should be certified by the instructor, etc., to ensure that the job is done correctly, meets NEC or other codes, and results in no fire or electrical hazard. Proper steps should be followed to ensure that the instructor or school is not placed in a situation where they may become liable as a result of training projects.

Shop projects such as the repair of controls or motors of electrical appliances such as washers, hot water heaters, stoves, small household appliances, electric tools and equipment, etc., should be organized to fit within the curriculum plan. Appliance repairs for the public should involve a small fee to ensure that instructional funds are not diverted for their primary purpose.

When undertaking shop or field electricity projects, a detailed plan outlining objectives, actions necessary to obtain objectives, standards of performance and production, and the criteria for evaluation should be developed and followed. (See accompanying form.)

SHOP PROJECTS: _____

RELATED CURRICULUM TOPIC: _____

TASK NOS: _____ / _____ / _____ / _____ / _____

PERFORMANCE OBJECTIVE:
 (What is student given? What behavior is expected of student? What standard of performance is expected?)

DESCRIBE MAJOR STEPS OF TASK (JOB):	STEPS COMPLETED WHEN BELOW STANDARDS DEMONSTRATED
1. _____	
2. _____	
3. _____	
4. _____	
5. _____	
6. _____	
7. _____	
8. _____	
9. _____	
10. _____	

STANDARDS (CRITERIA) OF PERFORMANCE THAT INDICATES THAT STUDENTS HAS COMPLETED TASK:

PLANNED INSTRUCTIONAL TIME: _____ Hours
 (Estimated travel to/from: _____ Hours On Job: _____ Hours)

DATE TASK STARTED: _____ DATE TASK FINISHED: _____

RELATED KNOWLEDGE TRAINING	RELATED SKILL TRAINING

NOTES/COMMENTS:

INSTRUCTOR: ATTACH PLANS, INSTRUCTIONS, TESTS, ETC.

TOOL ROOM WORKERS

(OPTIONAL)

Practical activities in the secondary electricity program may include related training and experiences in the shop (lab) tool room. Purposes that may be served by assigning the student to tool room duty on a rotating basis include the following:

1. Assigning the student to periodic duty in the tool room, on a rotating basis, provides a means of controlling expensive public property, essential to electricity training.
2. Through tool room duty, the student should learn responsibility, and important trait to successfully holding a job.
3. Tool room duty can contribute directly to a reduction in damaged or missing tools and equipment. Misuse of tools and equipment can be identified and a student can be held responsible for the loss of training tools or equipment.
4. Through maintaining a log of all tools and equipment signed out and returned, there will be a current inventory of the tool or equipment rooms. Tools and equipment in use or borrowed can be identified as to location and user.
5. The activities of the tool room duty student should include identifying tools, equipment, and parts by their proper names; proper storage of tools, equipment, and parts; and inspection, cleaning, and care of tools and equipment. This task should include a regular inventory of tool boxes or pouches to identify missing or unservicable components.
6. In addition, the tool room duty student may be assigned the task of assisting the instructor in observing the lab (shop) area for possible safety infractions and fire hazards. In this task, the student can help the instructor ensure that a safe training environment is maintained.

As a safety observer, the tool room duty student should take action to prevent obstructed aisles and cluttered storage areas that might cause injury to others.

The tool room duty student should review posted first aid directions and be prepared to alert the instructor concerning accidents and to assist fellow students who receive injuries.

The tool room duty student should aid fellow students in following prescribed safety practices of the shop. For example, the student might remind others concerning the use of safety eye goggles, "warning" markers or tags to indicate electricity should not be turned on while circuits are being repaired, etc.

The tool room duty student should observe the shop for potential fire hazards. The tool room duty student should assist in recovering oily rags and waste materials in proper containers and seeing that flammable solvent, oil, and chemicals are stored in fireproof areas.

The tool room duty student should observe the shop for potential electrical hazards such as exposed wires, switch boxes or breakers that are not marked and that might be thrown by accident while students are working on potentially dangerous circuits.

The tool room duty student should be prepared to notify the instructor of questionable situations, locate and use fire extinguishers, and assist students with first aid in cases of minor cuts, etc.

7. The knowledges and skills of the student assigned to tool room duty might be expanded through individualized study assignments or worksheets selected to prepare the student for career opportunities in counter or warehouse work in the electrical supply field.

PROFICIENCY REPORT

PROFICIENCY REPORT
for

Vocational Course

Student: _____

High School: _____

Career Center: _____

Date Training Initiated: _____

First Year Completed: _____

Second Year Initiated: _____

Second Year Completed: _____

Instructor: _____

DIRECTIONS: The purpose of the proficiency report is to communicate to the student, other instructors, or potential employers the abilities that a student has demonstrated to the instructor in vocational training. Mark each task as soon as possible after instruction or skills demonstrated. If instruction is not aimed as task proficiency, or if only an orientation or introduction to the task was provided, DO NOT mark a proficiency level or mark Level 0. Levels 1-4 indicate that instruction was given and the proficiency may be interpreted as follows:

- Level 0 No skill level demonstrated or proficiency training not given in the skill.
- Level 1 Individual's skill level is not that generally expected for entry level employment.
- Level 2 Individual's skill level probably is that generally expected for entry level employment, but the individual probably will need close on-the-job supervision for a while longer.
- Level 3 Individual's skill level is that generally expected for entry level employment.
- Level 4 Individual's skill level is equal to that of a worker with some on-the-job experience.

For further description of the levels of proficiency, see the "Credentialing Process and Proficiency Report" section of the Policies and Procedures Guide for Articulation Between The School District of Greenville County and Greenville Technical College.

STUDENT _____

PROFICIENCY REPORT

ELECTRICITY

			Proficiency						
			Level 0	Level 1	Level 2	Level 3	Level 4	Date	Completed
MODULE	1.0	INTRODUCTION							
UNIT	1.0 B	INTRODUCTION TO SAFETY							
	1.03-	Observed Safety Practices							
	1.05	and Applied Electrical Safety Rules and Procedures							
UNIT	1.0 C	INTRODUCTION TO LEADERSHIP/ JOB COMMUNICATIONS							
	1.01	Worked Cooperatively With Fellow Students							
	1.11	Identified Post-secondary Career Development Opportunities							
UNIT	1.0 E	INTRODUCTION TO DESIRABLE JOB/LEARNING CHARACTERISTICS/ HABITS/ATTITUDES							
	1.01	Exhibited Good Work Habits Important to Job Success							
	1.02	Exhibited Successful Job Performance Characteristics							
	1.03	Exhibited Desirable Work Attitudes							
	1.04	Demonstrated Respect for and Care of Property							
UNIT	1.0 G	BASIC MEASURING							
	1.01	Measured Accurately to 1/10 Inch							
UNIT	1.0 H	INTRODUCTION TO BLUEPRINT READING							
	1.01	Identified Working Drawings and Blueprint and Read Specifications							
	1.02	Interpreted Common Blueprint Symbols							
	1.03	Interpreted Dimensions from Blueprints							
	1.04	Read Blueprint and Specifications and Estimate Materials for Job							
MODULE	2.0	FUNDAMENTALS OF ELECTRICITY							
	2.06	Measured Voltage in Simple Circuit							
	2.07	Measured Amperage in a Simple Circuit							

		Proficiency							
		Level 0	Level 1	Level 2	Level 3	Level 4	Date	Completed	
2.08	Measured Resistance in Simple Circuit								
2.09	Tested Continuity								
2.10	Determined Wattage of Circuit								
2.11	Can Read Microfarad Rating of Capacitors								
2.12	Tested Capacitors								
2.13	Able to Draw a Series Resistive Circuit and Calculate Circuit Values								
2.14	Constructed a Resistive Series Circuit								
2.16	Able to Draw Parallel Resistive Circuit and Calculate Circuit Values								
2.17	Constructed a Parallel Resistive Circuit								
2.19	Able to Draw a Series-Parallel Resistance Circuit and Calculate Circuit Values								
2.20	Constructed a Series-Parallel Resistance Circuit								
2.21	Measured Resistance of a Single-Phase Motor								
MODULE	3.0 ELECTRICAL TOOLS AND EQUIPMENT								
3.01	Selected and Used Typical Pouch (Hand) Tools								
3.02	Selected and Used Typical Electricity Speciality Tools								
3.03	Used the Clamp-on Ammeter								
3.04	Used the VOM (Multimeter)								
MODULE	5.0 ELECTRICAL WIRE CONNECTIONS								
5.01	Crimped Wire to Terminal Using Crimping Tool								
5.02	Spliced Wires Using Solderless Connectors (Wire Nuts)								
5.03	Soldered Electrical Conductors and Connections to Industry Standards								
MODULE	6.0 BENCHWORK USING HAND TOOLS								
6.01	Exhibited Safe Working Practices at Workbench Area								
6.02	Cared for Hand Tools								
6.03	Identified and Properly Used a Bench Vice								
6.04	Cut Given Material in Required Time With Hand Hacksaw								

		Proficiency					Date	Completed
		Level 0	Level 1	Level 2	Level 3	Level 4		
	6.05	Identified Types of Fasteners						
	6.06	Assembled and Fitted Parts Correctly						
	6.07	Properly Used Hand Tools for Assembly/Disassembly						
	6.08	Bench Filed Workpiece						
	6.09	Drilled Holes With Portable Drill						
	6.11	Set Up a Drill Press						
	6.12	Drilled Holes to Size						
	6.14	Set Up Pedestal Grinder for Job						
MODULE	7.0	RESIDENTIAL WIRING & ELEC. MAIN.						
UNIT	7.0 A	COMPUTED SERVICE LOADS						
	7.01	Calculated Individual Circuit Load						
	7.02	Balanced Total Load Per Leg						
	7.03	Computed Size of Service Entrance Conductors						
UNIT	7.0 B	INSTALLED SERVICE ENTRANCE						
	7.01	Installed Main Service Panel						
	7.02	Grounded Service Entrance Equipment to NEC						
	7.03	Installed Circuit Breakers in Panel						
	7.04	Installed Main Service Disconnect						
	7.05	Installed Mast-type Through Roof Service						
	7.06	Installed Temporary Service Entrance						
	7.07	Installed Underground Service Entrance						
UNIT	7.0 C	INSTALLED SWITCH AND OUTLET BOXES (RESIDENTIAL)						
	7.01	Installed Bar-Hanger Mounted Box						
	7.02	Installed Flush Mount Junction Box						
	7.03	Installed Flush Mount Switch and Outlet Boxes in Dry Wall or Paneled Wall						
	7.04	Installed Gangable Boxes						
	7.05	Installed Octagon Outlet Boxes						
	7.06	Installed Recessed Fixture Housing in Ceiling						
UNIT	7.0 D	ROUGHED IN ELECTRICAL CIRCUITS (RESIDENTIAL)						
	7.01	Roughed in 120/240 Circuits to Distribution Panel Using Nonmetallic Sheathed Cable (N.M.C.)						

		Proficiency	Level 0	Level 1	Level 2	Level 3	Level 4	Date	Completed
	7.02	Roughed in Armored Cable to Outlet Box							
	7.03	Roughed in Cable Between Existing Box and Newly Installed Box							
	7.04	Roughed in Cable for Branch Circuits							
	7.05	Roughed in Circuit for Outlet Controlled by two Each Three-Way Switches With Feed to Switch Box							
	7.06	Roughed in Circuit for Outlet Controlled by two Each Three-Way Switches With Feed to Outlet Box							
	7.07	Roughed in Circuit for Outlet Controlled by two Three-Way Switches and one Four-Way Switch With Feed to a Three-Way Switch							
	7.08	Roughed in Circuit for Door Chime							
	7.09	Roughed in Circuit for Intercom							
	7.10	Roughed in Low-Voltage Thermostat Wiring							
	7.11	Installed Nonmetallic Cable in Outlet Boxes							
	7.12	Roughed in Circuit for Split Circuit Duplex Receptacle							
	7.13	Introduced to Installing Conduit Underground							
	7.14	Introduced to Installing Direct Buried Cable							
UNIT	7.0 E	ROUGHED IN TELEPHONE WIRE AND ACCESSORIES							
	7.01	Planned Wiring Job							
	7.02	Installed Telephone Outlets							
	7.03	Installed Telephone Wire							
	7.04	Connected Wires to Junction Boxes and Jacks							
UNIT	7.0 F	TRIMMED OUT (FINISHED) ELECTRICAL DEVICES (RESIDENTIAL)							
	7.01	Connected Door Chime System							
	7.02	Connected/Installed Duplex Receptacle Outlets							
	7.03	Connected/Installed 240 Volt Four-Wire Receptacle for Range or Dryer							
	7.04	Installed Ground Fault Interrupting Device (GFCI)							

		Proficiency	Level 0	Level 1	Level 2	Level 3	Level 4	Date	Completed
	7.05	Connected Hot Water Heater							
	7.06	Connected Low-Voltage Lighting Control							
	7.07	Connected Moisture Resistance Receptacle							
	7.08	Connected Single Pole Switch							
	7.09	Connected Split Circuit Duplex Receptacle							
	7.10	Connected Three-Wire 240 Volt Receptacle							
	7.11	Connected Wires from Junction Box to Appliance/Electrical Device							
	7.12	Connected 120/240 Circuits to Circuit Breaker Panel Using Nonmetallic Cable							
	7.13	Installed/Connected Three-Way Switches							
	7.14	Made Wire and Fixture Splices to NEC							
UNIT	7.0 G	MAINTAINED LIGHTING/WIRING SYSTEM (RESIDENTIAL)							
	7.01	Diagnosed/Repaired Florescent Fixtures Malfunction							
	7.02	Diagnosed Malfunctions and Repaired/Replaced Incandescent Lighting							
	7.03	Repaired Water Heater							
	7.04	Repaired/Replaced Frayed/Damaged Service Cord							
	7.05	Replaced Fuse							
	7.06	Replaced Pilot Light (Lamp) Bulb							
	7.07	Tested for Correct Voltage							
	7.08	Able to Troubleshoot a Branch Circuit							
	7.09	Serviced Electrical Motor/ Appliance							
	7.10	Installed/Maintained Emergency Lighting							
MODULE	8.0	COMMERCIAL ELECTRICAL WIRING							
	8.01	Identified and Read Electrical Wiring Information on a Commercial Floor Plan							
	8.02	Interpreted Commercial Electrical Wiring Installation Specifications							

		Proficiency	Level 0	Level 1	Level 2	Level 3	Level 4	Date	Completed
8.03	Constructed an Electrical Floor Plan for a Given Commercial Structure								
8.04	Calculated Commercial Service Entrance Requirements								
8.05	Installed and Secured Rigid Conduit								
8.06	Installed and Secured Thin-wall (EMT) Conduit								
8.07	Installed and Secured Flexible Conduit								
8.08	Installed and Secured PVC Plastic Conduit								
8.09	Pulled Wire Through Conduit and Terminate It								
8.10	Installed and Secured a Surface Raceway								
8.11	Installed Conductors in Conduit								
8.12	Installed Commercial Telephone Raceway								
8.13	Installed Commercial Single-Phase Receptacle Outlet								
8.14	Installed Commercial Three-Phase Circuit Receptacle								
8.15	Installed and Wired Commercial Lighting Circuit								
8.16	Installed and Wired Commercial Standby Emergency Lighting Circuit								
8.17	Installed and Wired Commercial Low-voltage Signal Communications or Control Circuit								
8.18	Calculated Total Commercial Job Installation Costs								
MODULE	9.0 INDUSTRIAL ELECTRICAL WIRING AND MAINTENANCE								
UNIT	9.0 A INDUSTRIAL ELECTRICAL WIRING								
9.01	Planned and Performed Sitework for Small Industrial Facility								
9.02	Calculated Branch Circuit Conductors and Overcurrent Protection								
9.03	Installed Outlet, Junctions, and Conduitlets								
9.04	Wired Transformers as Required								
9.05	Installed and Wired Commercial Emergency Alarm Circuit to Protect Workers Against Hidden Dangers								

			Proficiency					
			Level 0	Level 1	Level 2	Level 3	Level 4	Date Completed
UNIT	9.0 B	WIRING DIAGRAMS AND SCHEMATICS						
	9.01	Able to Draw Basic Schematic Wiring Diagrams						
	9.07	Able to Update Schematic Print Files of Given Machinery or Control Panel						
UNIT	9.0 C	ELECTRICAL MOTORS						
	9.01	Collected Motor Data Information from Motor						
	9.02	Connected Shaded-Pole Motor						
	9.03	Connected a Dual-voltage Motor in a Given Circuit						
	9.04	Disassembled and Assembled a Single-Phase Motor						
	9.05	Measured Resistance of Windings in a Split-Phase Motor and Identify Start/Run Windings						
	9.06	Connected a Split-Phase Motor in a Given Circuit						
	9.07	Reversed the Direction of Rotation of a Split-Phase Motor						
	9.08	Connected a Capacitor-Start Motor						
	9.09	Installed a Permanent-Split Capacitor Motor						
	9.10	Determined Condition of Starting Components of a CSR Motor						
	9.11	Disassembled/Assembled a Three-Phase Motor						
	9.12	Measured Resistance of Windings in a Single-Voltage, Single-Speed, Three-Phase Motor						
	9.13	Installed a Single-Voltage, Three-Phase, Squirrel-Cage Induction Motor						
	9.14	Connected a Dual-Voltage, Three-Phase Induction Motor for Low and High Voltage						
	9.15	Adjusted V-Belt Tension						
	9.16	Identified Motor Bearing and Bushing Problems						
	9.18	Installed Gear Motor Station						
	9.19	Installed Direct Drive Station						
	9.20	Correctly Serviced an Electrical Motor						
	9.21	Installed Motor Bearings and Bushings						
	9.22	Able to Troubleshoot a Given Motor						

			Proficiency					Date	Completed
			Level 0	Level 1	Level 2	Level 3	Level 4		
UNIT	9.0 D	INDUSTRIAL ELECTRICAL CONTROLS/DEVICES							
	9.01	Installed Manual Motor Control Station							
	9.02	Installed Magnetic Push-Button Motor Control Station							
	9.03	Installed a Three-Phase Control Magnetic Starter							
	9.04	Installed Two-Station, Push-Button Control Station							
	9.05	Installed Control Push-Button to Change Direction of Rotation of Motor							
	9.06	Installed Hand Sequence Control Station							
	9.07	Installed Timed Sequence Control Station							
	9.08	Installed Automatic Sequence Control Station (or Microcomputer Based Controller)							
	9.09	Programed a Programmable Controller (Minicomputer)							
	9.10	Installed Direct Current (DC) Motor Controllers							
	9.11	Connected Capacitor Timing Starter							
	9.12	Installed Jogging Control Circuit							
	9.13	Installed Plugging Control Circuit							
	9.14	Installed a Limit Switch							
	9.15	Installed Drum Switch Control Station							
	9.16	Replaced Flow Switch							
	9.18	Able to Troubleshoot Controls							
UNIT	9.0 E	INTRODUCTION TO INDUSTRIAL ELECTRONICS							
	9.01	Identified Elementary Symbols and Components Used in Simple Industrial Electronic Circuits							
	9.03	Able to Draw Diagrams of Industrial Electronic Control Circuits Using Solid State Relays							
	9.04	Installed Solid State Relay in Circuit							
	9.05	Connected Diodes in Circuit							
	9.06	Connected/Replaced Solid State Lamps (SSLs) /LEDs/							

		Proficiency					Date	Completed
		Level 0	Level 1	Level 2	Level 3	Level 4		
9.07	Constructed a Basic SCR Speed Control Circuit							
9.08	Constructed a TRIAC Speed Control Circuit							
9.09	Installed Electronic Photoelectric Sensing Device							
9.10	Constructed a Photoelectric Relay Circuit							
9.11	Installed Electronic Proximity Sensing Device							
MODULE 10.0	ESTIMATING AND PLANNING ELECTRICAL WORK							
10.01	Estimated the Cost of a Specific Installation							
10.02	Estimated Cost of Materials for a Specific Wiring Job							
10.03	Estimated Costs of Labor Needed to do a Specific Wiring Job							
10.04	Inventored Equipment, Materials, and Supplies							
10.05	Completed a Trouble Report on Tools, Equipment, and Materials not Servicable							
10.06	Planned a Sequence of Work Operations							
MODULE 11.0	CORRECTLY COMPLETED ELECTRICITY SHOP/FIELD APPLIED PROJECT(S) (Describe)							

COMMENTS: _____

INSTRUCTOR'S SIGNATURE _____

VOCATIONAL CENTER _____

DATE _____

BIBLIOGRAPHY

BIBLIOGRAPHY

- Ferm, Olaf G., Ferm's Fast Finder Index, Spokane, WA: Ross Printing Company, 1981
- Miller, Rex, Residential Electrical Wiring, Peoria, IL: Bennett Publishing Company, 1981
- Miller, Rex, Residential Electrical Wiring, Student Guide, Peoria, IL: Bennett Publishing Company, 1981
- Miller, Rex, Residential Electrical Wiring, Student Guide Answer Key, Peoria, IL: Bennett Publishing Company, 1981
- Miller, Rex, Industrial Electricity, Peoria, IL: Chas A. Bennett Co., Inc., 1978
- Miller, Rex, Industrial Electricity, Student Guide, Peoria, IL; Chas A. Bennett Co., Inc., 1978
- Miller, Rex, Industrial Electricity, Student Guide, Answer Key, Peoria, IL: Chas A. Bennett Co., Inc., 1978
- Miller, Rex, Industrial Electricity, Teacher's Guide, Peoria, IL: Chas. A. Bennett Co., Inc., 1980
- Seippel, Robert G., Fundamentals of Electricity, 6th Edition, Alsip, IL: American Technical Publishers, Inc., 1974
- Seippel, Robert G., Fundamentals of Electricity, 6th Edition, Answer Key, Alsip, IL: American Technical Publishers, Inc., 1974
- Seippel, Robert G., Fundamentals of Electricity, Student Guide, 6th Edition, Alsip, IL: American Technical Publishers, Inc., 1974
- Rockis, Gary and Mazur, Glen, Electrical Motor Controls, Alsip, IL; American Technical Publishers, Inc., 1982
- Rockis, Gary and Mazur, Glen, Electrical Motor Controls, Instructor's Guide, Alsip, IL: American Technical Publishers, Inc., 1982
- Rockis, Gary and Mazur, Glen, Electrical Motor Controls, Workbook, Alsip, IL: American Technical Publishers, Inc., 1982
- Industrial Electrician, Frankfort, KY: Kentucky State Department of Education (Bureau Of Vocational Education), 1980
- Appliance Repairer, Atlanta, GA: Georgia State Department of Education, 1980
- Electronic Mechanics, Atlanta, GA: Georgia State Department of Education, 1980
- House Electrician, V-TEC, Daniels, Nancy Carter, Tullahoma, TN: Motlow State Community College (Tennessee Department of Vocational-Technical Education) 1981

- Industrial Electricity Post-secondary, Atlanta, GA: Georgia Department of Education, 1981
- Electromechanical Technology Post-secondary, Atlanta, GA: Georgia Department of Education, 1981
- Electronic Technology Post-secondary, Atlanta, GA: Georgia Department of Education, 1981
- Articulation Agreement for Electricity/Electronics Technology, Bennettsville, SC: Marlboro Vocational School/Chesterfield-Marlboro Technical College, 1979
- Introduction to Industrial Electricity - Electronics, Stillwater, OK: State Department of Vocational and Technical Education, 1981
- Industrial Maintenance Mechanic, V-TEC, Madison, WI: Bureau of Research Student & Professional Development (Wisconsin Board of Vocational, Technical & Adult Education) 1981
- Curriculum Standards for Electricity, Montgomery, AL: State of Alabama, 1982.
- Colvin, Thomas S. Maintaining the Lighting and Wiring System, Athens, GA: American Association for Vocational Instructional Materials, 1980.
- Parady, W. Harold and Turner, J. Howard, How Electric Motors Start & Run, Athens, GA: American Association for Vocational Instructional Materials, 1980.
- Electric Motors Section/Production/Drives, 5th edition, Athens, GA: American Association for Vocational Instructional Materials, 1982.
- Allison, James M. Electric Motors Section/Protection/Drives, Teacher Guide, Athens, GA: American Association for Vocational instructional Materials, 1980.
- Allison, James M. Electric Motors Selection/Protection/Drives, Student Workbook, Athens, GA: American Association for Vocational Instructional Materials, 1980.
- Turner, J. Howard, Understanding Electricity & Electrical Terms, Athens, GA: American Association for Vocational Instructional Materials, 1981.
- Turner, J. Howard ed., Electrical Wiring Residential, Utility Buildings, and Service Areas, 2nd edition, Athens, GA: American Association for Vocational Instruction Materials, 1981.
- National Electrical Code 1981, Quincy, MA; National Fire Protection Association, 1980.
- Taylor, Mark Residential Wiring, Mid-American Vocational Curriculum Consortium, Inc., 1983.

- Gebert, Kenneth L., National Electrical Code Blueprint Reading, 8th Edition, Alsip, IL: American Technical Publishers, Inc., 1981.
- Gebert, Kenneth L., National Electrical Code Blueprint Reading, Answer Key, 8th Edition, Alsip, IL: American Technical Publishers, Inc., 1981.
- Driscoll, Edward F., Industrial Electronics Devices, Circuits, and Applications, Alsip, IL: American Technical Publishers, Inc., 1976.
- Driscoll, Edward F., Industrial Electronics Devices, Circuits, and Applications, Instructor's Guide, Alsip, IL: American Technical Publishers, Inc., 1976.
- Steinberg, William B., and Walter B. Ford, Electricity and Electronics Basic, Alsip, IL: American Technical Publishers, Inc., 1972.
- Masterton, Robert N., Electricity and Electronics--Basic, Student Guide, Alsip, IL: American Technical Publishers, Inc., 1972.
- Steinberg, William B., and Walter B. Ford, Examination Answer Key for Student Guide for Electricity and Electronics--Basic, Alsip, IL: American Technical Publishers, Inc. 1972.
- Kubala, Thomas S., Electricity 1 Devices, Circuits, Materials, 3rd Edition, Albany, NY: Delmar Publishers Inc., 1981.
- Kubala, Thomas S., Electricity 1 Devices, Circuits, Materials, 3rd Edition, Instructor's Guide, Albany, NY: Delmar Publishers Inc., 1981.
- Kubala, Thomas S., Electricity 2 Devices, Circuits, Materials, 3rd Edition, Albany, NY: Delmar Publishers Inc., 1981.
- Kubala, Thomas S., Electricity 2 Devices, Circuits, Materials Instructor's Guide, 3rd Edition, Albany, NY: Delmar Publishers Inc., 1981.
- Alerich, Walter N., Electricity 3 DC Motors & Generators Controls Transformers, 3rd Edition, Albany, NY: Delmar Publishers Inc., 1981.
- Alerich, Walter N., Electricity 3 DC Motors & Generators Controls Transformers, Instructor's Guide, 3rd Edition, Albany, NY: Delmar Publishers Inc., 1981.
- Alerich, Walter N., Electricity 4 AC Motors Controls Alternators, 3rd Edition, Albany, NY: Delmar Publishers Inc., 1981.
- Alerich, Walter N., Electricity 4 AC Motors Controls Alternators, Instructor's Guide, 3rd Edition, Albany, NY: Delmar Publishers Inc., 1981.

- Smith, Robert L., Electrical Wiring--Industrial, Albany, NY: Delmar Publishers Inc., 1982.
- Smith, Robert L., Electrical Wiring--Industrial, Instructor's Guide, Albany, NY: Delmar Publishers Inc., 1982.
- Mullin, Ray C., Electrical Wiring--Residential, Albany, NY: Delmar Publishers Inc., 1981.
- Mullin, Ray C., Electrical Wiring--Residential, Instructor's Guide, Albany, NY: Delmar Publishers Inc., 1981.
- Mullin, Ray C., and Smith, Robert L., Electrical Wiring--Commercial, Albany, NY: Delmar Publishers Inc., 1981.
- Mullin, Ray C., and Smith, Robert L., Electrical Wiring--Comercial, Instructor's Guide, Albany, NY: Delmar Publishers Inc., 1981.
- Alerich, Walter N., Electrical Construction Wiring, Alsip, IL: American Technical Publishers, Inc., 1982.
- Alerich, Walter N., Electrical Construction Wiring, Student Guide, Alsip, IL: American Technical Publishers, Inc., 1982.
- Alerich, Walter N., Electrical Construction Wiring, Answer Key to Student Guide, Alsip, IL: American Technical Publishers, Inc., 1982.
- The IBEW Leads to Electrifying Careers, Washington, DC: International Brotherhood of Electrical Workers,
- "Electrical Construction-A Career for Today and Tomorrow," Washington, DC: National Electrical Contractors Association, 1980.
- "What is an Electrical Contractor," Washington, DC: National Electrical Contractors Association, 1980.
- "DACUM Survey for Industrial Electronics Technician (Post-Secondary Level Graduate): Install, Troubleshoot, and Repair Electrical/Electronic Equipment," Prepared by Sumter Area Technical College, 1982.
- Palmquist, Ronald E., Questions and Answers for Electricians Examinations, Indianapolis, NY: The Bobbs-Merrill Company, Inc., 1982.
- Palmquist, Roland E., Electrical Course for Apprentices and Journeymen, Indianapolis, NY: The Bobbs-Merrill Company, Inc., 1982.
- Anderson, Edwin P., Home Appliance Servicing, Indianapolis, NY: The Bobbs-Merrill Company, Inc., 1983.

National Electrical Code Test, Portland, OR: Portland State University.

National Electrical Code Answer Key, Portland, OR: Portland State University.

Soares Grounding Electrical Distribution Systems for Safety, Park Ridge, IL: International Association of Electrical Inspectors, 1980.

Analysis of the 1984 NEC, Park Ridge, IL: International Association of Electrical Inspector, 1983.

National Electrical Code 1984, BatteryMarch Park Quinch, MA: National Fire Protection Association, 1983.

Stallcup, James G., Illustrated Changes of the 1984 NEC, Alsip, IL: American Technical Publishers, Inc., 1983.

Commercial Electricity, Natchitoches, LA: State of Louisiana Vocational Curriculum Development and Research Center, 1981.

Commercial Electricity, Units 1 & 2 Basic Electricity, Fundamentals of DC and AC Circuits, Natchitoches, LA: State of Louisiana Vocational Curriculum Development and Research Center, 1980.

Commercial Electricity, Lighting and Residential Wiring Methods, Instructor's Edition, Natchitoches, LA: State of Louisiana Vocational Curriculum Development and Research Center, 1980.

Tools, Equipment, and Safety, Instructor's Edition, Natchitoches, LA: State of Louisiana Vocational Curriculum Development and Research Center, 1979.

Basic Electricity Book 1, Fundamentals of Basic Electricity and Meters, Natchitoches, LA: State of Louisiana Vocational Curriculum Development and Research Center, 1979.

Basic Electricity Book 2, Fundamentals of DC and AC Circuits, Natchitoches, LA: State of Louisiana Vocational Curriculum Development and Research Center, 1979.

Industrial Electricity, Basic Electronics, Natchitoches, LA: State of Louisiana Vocational Curriculum Development and Research Center, 1980.

Industrial Electricity, Lighting and Residential Wiring Methods, Natchitoches, LA: State of Louisiana Vocational Curriculum Development and Research Center, 1980.

Industrial Electricity Test Book, Natchitoches, LA: State of Louisiana Vocational Curriculum Development and Research Center, 1980.

Industrial Electricity, Lighting and Residential Wiring Methods, Instructor's Edition, Natchitoches, LA: State of Louisiana Vocational Curriculum Development and Research Center, 1980.

CURRICULUM DEVELOPMENT REFERENCES

Defined Minimum Program for South Carolina School Districts,
Columbia, SC: South Carolina Department of Education, 1980.

Henderson, Wm. Edward, Jr., Introductory Guide to the Occupational Education Articulation Program, Greenville, SC: Occupational Education Articulation Program of The School District of Greenville County and Greenville Technical College, 1983.

Henderson, Wm. Edward, Jr., (ed.) Policies and Procedures Guide for Articulation, Greenville, SC: Occupational Education Articulation Program of The School District of Greenville County and Greenville Technical College, 1983.

Henderson, Wm. Edward, Jr., Workshop Guide I: Suggestions for Conducting a Task Analysis and Some Sources of Ready-made Task Lists and Objectives for CBVE, Greenville, SC: Occupational Education Articulation Program of The School District of Greenville County and Greenville Technical College, 1983.

Henderson, Wm. Edward, Jr., Workshop Guide II: Preparing Objectives, Performance Actions, and Standards for Articulated Performance-based Instruction, Greenville, SC: Occupational Education Articulation Program of The School District of Greenville County and Greenville Technical College, 1983.

Henderson, Wm. Edward, Jr., Workshop Guide III: Developing Outcome-referenced Tests, Greenville, SC: Occupational Education Articulation Program of The School District of Greenville County and Greenville Technical College, 1983.

High School Credit Courses for The School District of Greenville County, Greenville, SC: The School District of Greenville County (Instructional Services), 1981.

Industrial Division, Greenville Technical College, 1982-1984 (Catalog), Greenville, SC: Greenville Technical College, 1983-1984.

Outline of High School Credit Courses - State Department of Education, Columbia, SC: SC State Department of Education (Accreditation and Educational Improvement Section), 1980.

South Carolina Occupational Projections 1978-1985, Columbia, SC: South Carolina Employment Security Commission (Research & Analysis), 1982.

Technical Division, Greenville Technical College, 1982-1984, (Catalog), Greenville, SC: Greenville Technical College, 1983-1984.

TASKS OMITTED
FROM
SECONDARY GUIDE

Task omitted from this articulated, secondary level instruction guide for Electricity have been classified as optional areas of training and are omitted based on instructional time allocations the possibility that the tasks typically might be performed as a specialized service, or based on available shop facilities, equipment, materials, or funds.

Task omitted include:

- DC Electricity Fundamentals
- Wire Transformers
- Series and Parallel Capacitance Circuits
- Communications and Alarm Circuits (these are represented by low-voltage wiring)

Task included in guide but not emphasized:

- DC motors
- Raceways
- Rigid Conduit

Validation of the training objectives with local employers and future articulation may reveal that instruction should be expanded to include:

- DC Electricity Fundamentals
- Series and Parallel Capacitance Circuits
- DC Motors

SAMPLE
OUTCOME-REFERENCED TESTS

This articulated, performance-based instruction guide is designed to answer three critical questions necessary for quality instruction.

First, what should be taught?

The objectives of the articulated, performance-based vocational education program are based on extensive task analysis and validation.

The task objectives represent what employers in business and industry say is important for entry level job success.

Second, how should it be taught?

It should be taught using the latest "state-of-the-art" instructional technology incorporated into each unit.

Students are taught the knowledges, skills, and attitudes needed for successful and productive employment.

Third, how should students be evaluated?

Students are evaluated using a validated, competency-based approach to determine student proficiency in vocational knowledges and skills.

The minimum standards are those required for successful entry into the next higher level of training or for successful employment.

The sample tests in this guide are included to illustrate how a student's competency in vocational skills and knowledges may be measured with validity and reliability. In addition, the test samples should promote standardization in the evaluation of vocational students in similar programs.

Test items have been constructed solely from the objectives of the vocational program. The statement of the objectives indicate the level of knowledge or skill to be tested. Task force committee participants have attempted to develop tests that agree with objectives in the behavior requested, the given conditions, and the desired standards of performance.

NOTE: Unless a test is marked "Revised" or "R," the test should be considered a field trial edition currently under evaluation.

PROFICIENCY REPORT
0 / 1 / 2 / 3 / 4

COMPETENCY REPORT
0 / 1 / 2 / 3 / 4

The purpose of the proficiency rating is to communicate to the student, other instructors or potential employers the abilities that a student has demonstrated to the instructor in vocational training.

Circle the student's proficiency or competency rating as skill is demonstrated.

If instruction is not aimed at task proficiency/competency, or if only an orientation or introduction to the task was provided DO NOT mark a proficiency level or mark level 0.

Levels 1-4 indicate that performance was demonstrated and the demonstrated skill level was as follows:

LEVEL 0 No skill level demonstrated or proficiency not obtained

LEVEL 1 Skill level is not that generally expected for entry level employment

LEVEL 2 Skill level probably is that generally expected for entry level employment, but close on-the-job super-
vision probably will be needed for a while longer

LEVEL 3 Skill level is that genrally expected for entry level employment

LEVEL 4 Skill level is that equal to a worker with some on-the-job experience

UNIT 1.0 H OR BLUEPRINT READING

STUDENT: _____ DATE: _____

DIRECTIONS: Use the given electrical plan for a residential structure to answer the accompanying questions.

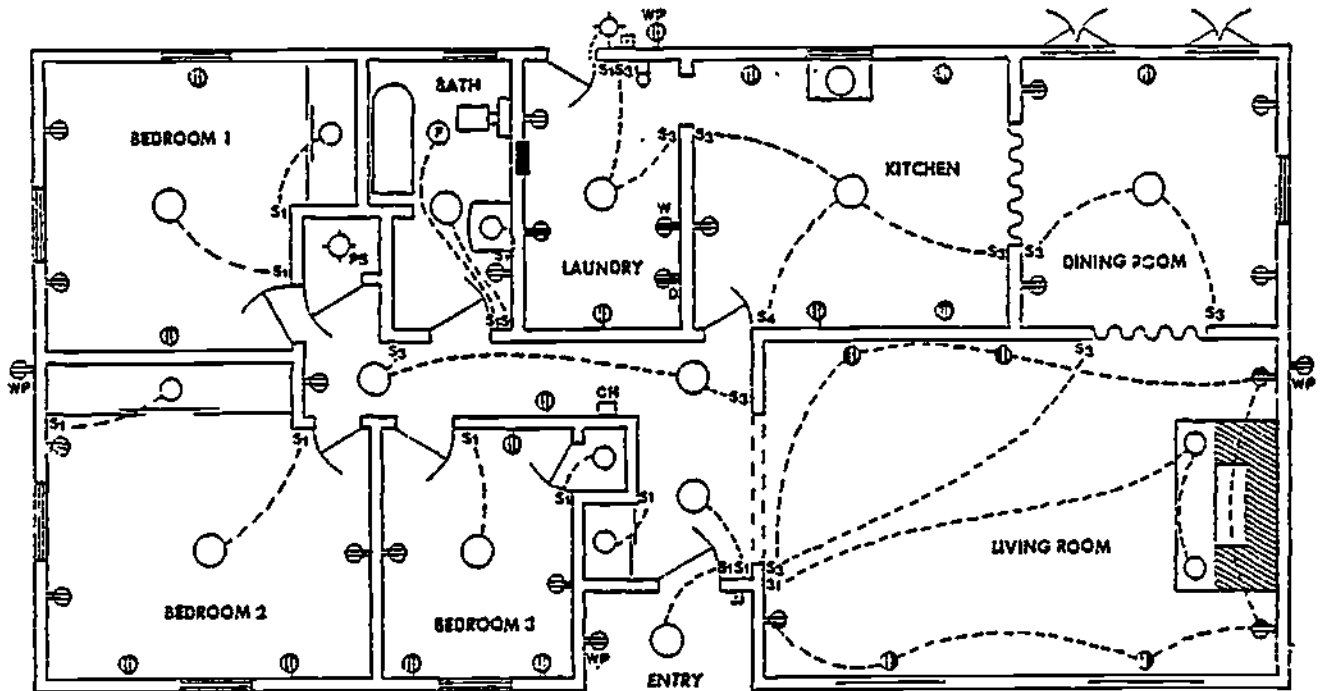

COMPLETE OR IDENTIFY:

1. Where is the panel box for the house located?



2. How many weatherproof outlets are there?

3. How many duplex, split-wire outlets are there?







4. How many heavy-duty special purpose outlets are there?

5. How many 4-way switches are there?

FILL IN THE NUMBERS INDICATING HOW MANY OF EACH TYPE OF OUTLET ARE NEEDED IN THE BATH AND IN THE LAUNDRY (USE THE DRAWING GIVEN):

		BATH	LAUNDRY
6.	S ₁		
7.	S ₂		
8.	S ₃		
9.	S ₄		
10.			
11.			
12.			
13.	○		
14.	Ⓡ		
15.	○ _{PS}		

USING THE GIVEN ELECTRICAL PLAN, FILL IN THE NUMBERS OF EACH TYPE OF OUTLET FOR EACH ROOM IN THE CHART BELOW:

	LIVING ROOM	DINING ROOM	KITCHEN	LAUNDRY	BR #1 (AND CLOSET)	BR #2 (AND CLOSET)	BR #3 (AND CLOSET)	BATH	FRONT ENTRY (AND CLOSET)	OUTSIDE OF HOUSE
16.	S ₁									
17.	S ₃									
18.	S ₄									
19.										
20.										
21.										
22.										
23.	○									
24.	□									
25.										
26.										
27.	PANEL BOX									
28.	Ⓡ									

USING THE GIVEN ELECTRICAL PLAN, ANSWER THE FOLLOWING QUESTIONS:

29. What does the pushbutton by the front door operate? _____
30. Where is the chime located? _____
31. What does PS mean? _____
32. Is there one located in the house? _____
33. If so, where is it located? _____
34. What does the S₄ in the kitchen operate? _____
35. Which switch controls the two lights by the fireplace? _____
36. Where is the switch located? _____
37. Where is the panel box located? _____
38. How many switches control the duplex outlets in the living room? _____
39. Are any outside outlets controlled from inside the house? If so, which? _____

SPELL OUT THE FOLLOWING ABBREVIATIONS:

1. C.B. _____
2. C.P. _____
3. GR _____
4. J.B. _____
5. M _____
6. N.E.C. _____
7. R.C. _____
8. S.D. _____
9. SW _____
10. T _____
11. UNG _____
12. VAC _____
13. WT _____
14. WP _____

SKETCH THE FOLLOWING SYMBOLS:

- | | | | |
|--------------------------------|-----------|----------------------------|-----------|
| 15. Pull switch | 15. _____ | 24. Thermostat | 24. _____ |
| 16. Fan | 16. _____ | 25. Duplex receptacle with | |
| 17. Clock | 17. _____ | switch | 25. _____ |
| 18. Duplex receptacle | 18. _____ | 26. Four-way switch | 26. _____ |
| 19. Split wired receptacle | 19. _____ | 27. Single pole switch | 27. _____ |
| 20. Weatherproof receptacle | 20. _____ | 28. Double pole switch | 28. _____ |
| 21. Range outlet | 21. _____ | 29. Three-way switch | 29. _____ |
| 22. Special purpose receptacle | 22. _____ | | |
| 23. Water heater | 23. _____ | | |

STUDENT: _____ DATE: _____

DIRECTIONS: FILL IN THE BLANK(S) WITH THE WORD OR WORDS THAT COMPLETE THE STATEMENT.

1. If the polarity is wrong when a voltmeter is connected to an electrical circuit, the needle will deflect to the _____ of zero.
2. If the range of the voltmeter is set too _____, the needle will deflect off scale to the right.
3. The needle of the voltmeter will deflect only a small amount if the range switch is set too _____.
4. If the voltage to be measured is unknown, the range switch should be set on its _____ scale.
5. For purposes of accuracy, it is best to read between ____% and ____% of scale.

DIRECTIONS: USE THE FOLLOWING DRAWING TO ANSWER QUESTIONS 6-10.

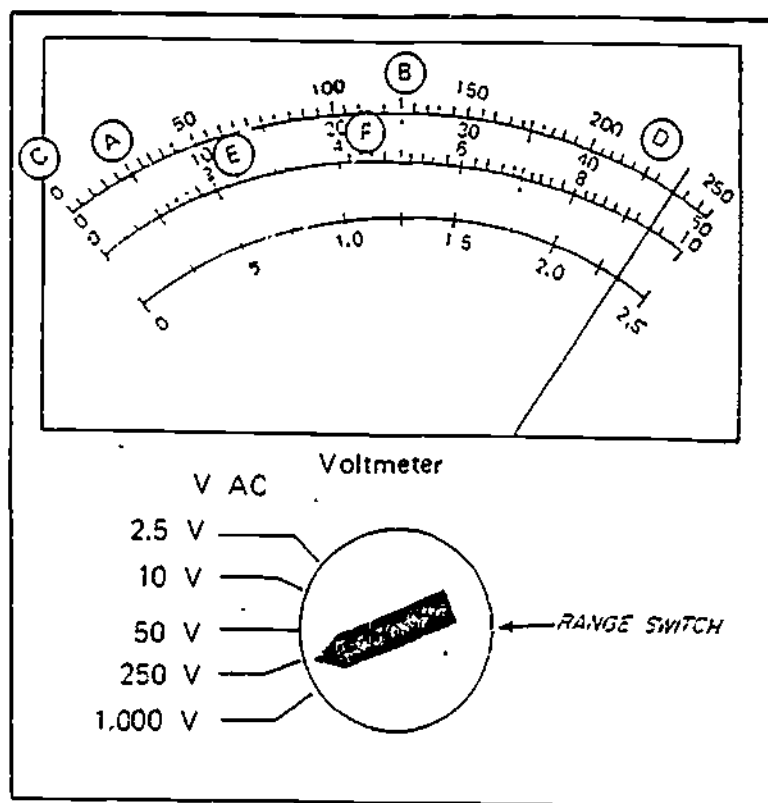

6. In a range setting of 10 v, point B = _____ volts.
7. If the range setting is 1,000 v, point D = _____ volts.
8. The range setting is 50 v, point F = _____ volts.
9. The range setting is 2.5 v, point A = _____ volts.
10. Range = 250 v, point E = _____ volts.

DIRECTIONS: USING THE DRAWING ON PAGE 2-1, ANSWER THE FOLLOWING QUESTION.

11. If the range switch is the 1,000 v position, and the needle is reading at point C, what should you do next?
-
-

PERFORMANCE TESTS:

12. Set a VOM up to measure AC voltages of less than 250 volts. The function and range switches must be pointing to correct function and range positions and the test leads must be correctly inserted in/connected to the meter. Performance must be acceptable to the instructor. Accuracy in inserting test leads and positioning function and range switches must be 100%.

COMPETENCY RATING

0 / 1 / 2 / 3 / 4

13. Accurately measure a voltage of less than 10 volts in a simple circuit. Performance and reading of voltage must be to the instructor's standards.

COMPETENCY RATING

0 / 1 / 2 / 3 / 4

14. Accurately measure an AC voltage between 100 and 250 volts using the VOM. Performance and reading of voltage must be to the instructor's standards.

COMPETENCY RATING

0 / 1 / 2 / 3 / 4

15. Accurately set the VOM up for a negative voltage measurement and measure a negative voltage to the standards of the instructor. Function and range switches must be accurately positioned and the test leads must be properly connected to the VOM and properly used in taking the measurement.

COMPETENCY RATING

0 / 1 / 2 / 3 / 4

INSTRUCTOR'S ANSWER KEY

- | | | |
|------------|----------|--------------------------|
| 1. Left | 6. 5 / | 11. Reduce range setting |
| 2. Low | 7. 900v | until an accurate |
| 3. High | 8. 22.5v | reading is obtained. |
| 4. Highest | 9. .25 v | |
| 5. 10 - 90 | 10. 60v | |

STUDENT: _____ DATE: _____

DIRECTIONS: MARK THE FOLLOWING STATEMENTS TRUE (X) OR FALSE (X):

- | T | F | |
|-----|-----|--|
| () | () | 1. A coulomb is a unit used to measure electric current. |
| () | () | 2. An ampere of current is a measurement of the rate at which electrons flow in a circuit. |
| () | () | 3. A milliampere is a unit of current equal to one-millionth of an ampere. |
| () | () | 4. A milliampere is smaller than a microampere. |
| () | () | 5. A good conductor is one which allows the flow of the electrons easily. |

DIRECTIONS: USE THE FOLLOWING DRAWING OF AN AMMETER SCALE TO ANSWER THE BELOW QUESTIONS:

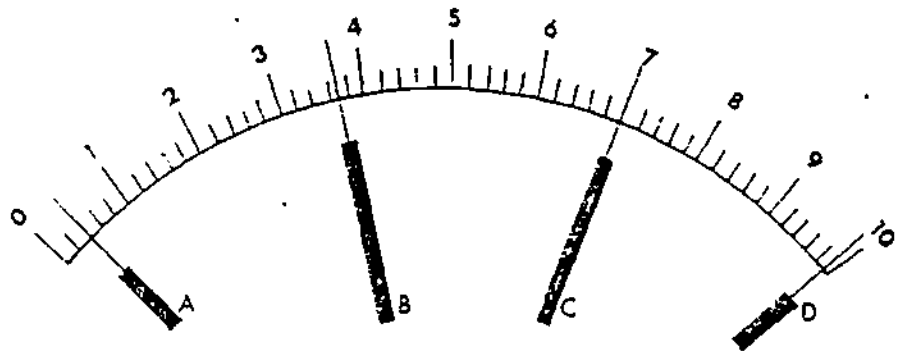

FOR QUESTIONS 7 - 10, FULL SCALE IS 10 AMPS.

7. The ammeter reading at point A = _____ amps.
8. Point B reading is _____ amps.
9. Point C reading is _____ amps.
10. Point D reading is _____ amps.

FOR QUESTIONS 11 - 14, FULL SCALE IS 1 AMPERE.

11. Reading at point A is _____ amps.
12. Reading at point B is _____ amps.
13. Reading at point C is _____ amps.
14. Reading at point D is _____ amps.

PERFORMANCE TEST:

15. Using the VOM or an ammeter, set the instrument up to measure current flow in a simple circuit or a circuit selected by the instructor . Performance must be to the instructor's standards. The instrument must be correctly prepared for measuring amperage. The function and range switches must be correctly positioned. The test leads must be inserted in the proper jacks.

Measure the amperage in a given circuit with 100% accuracy.

COMPETENCY RATING

Setting ammeter up:	0 / 1 / 2 / 3 / 4 .
Using ammeter:	0 / 1 / 2 / 3 / 4

INSTRUCTOR'S ANSWER KEY:

- | | |
|------------------------|-------------------------|
| 1. F | 11. .05 |
| 2. F | 12. .37 |
| 3. F | 13. .7 |
| 4. E | 14. .99 |
| 5. E | 15. Instructor's rating |
| 7. .5 or $\frac{1}{2}$ | |
| 8. 3.7 | |
| 9. 7 | |
| 10. 9.9 | |

DIRECTIONS: ANSWER THE FOLLOWING QUESTIONS TRUE (X) OR FALSE (X).

- | | | |
|-----|-----|---|
| T | F | |
| () | () | 1. To accurately measure the resistance of a component, it should be removed from the circuit. |
| () | () | 2. Most ohm meters (ohmmeters) have a linear scale. |
| () | () | 3. A weak battery is the most common cause for an ohm-meter not to zero properly. |
| () | () | 4. When the range is changed on an ohmmeter, it should be recalibrated. |
| () | () | 5. The normal position of an analog ohmmeter needle is zero (0) when the leads are not shorted or connected to a component. |

DIRECTIONS: USE THE FOLLOWING DRAWING TO ANSWER QUESTIONS 6 - 10.

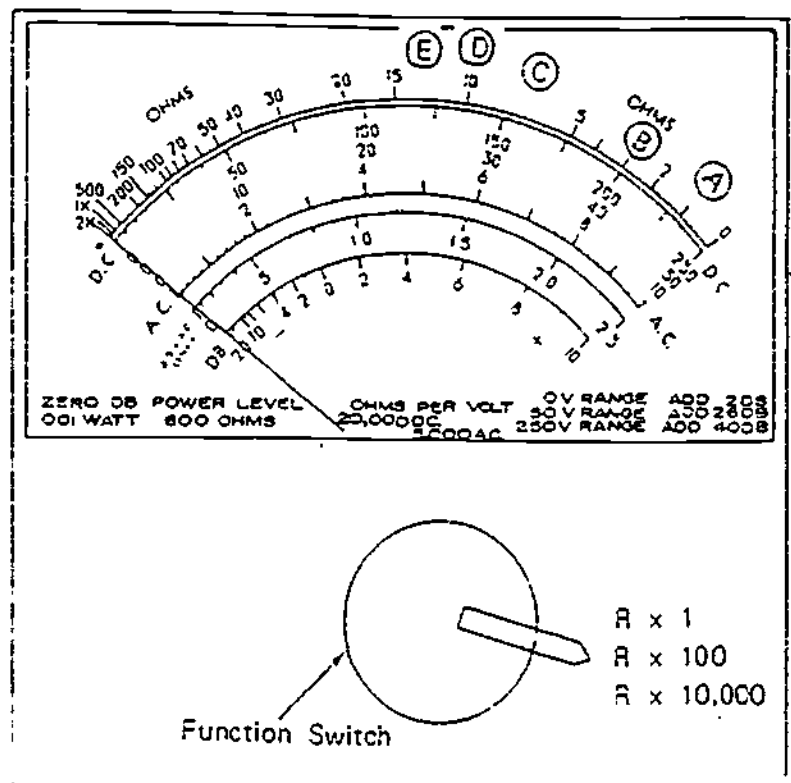

6. Read the resistance if the function switch is in the R x 100 position and the needle is at point D. Ans. _____ ohms.
7. Function switch in R x 10,000 position. Needle pointing to B on scale. Ans. _____ ohms.
8. Function switch in R x 1 position. Needle at point B. Ans. _____ ohms.
9. Function switch in R x 1 position. Needle at point A. Ans. _____ ohms.
10. Function switch in R x 100 position. Needle at point E. Ans. _____ ohms.

INSTRUCTOR'S KEY TO 2.08

- | | | | |
|----|---|-----|--------------------|
| 1. | T | 6. | 1,000 ohms, 1K |
| 2. | F | 7. | 30,000 ohms or 30K |
| 3. | T | 8. | 3 ohms |
| 4. | T | 9. | 100 ohms |
| 5. | F | 10. | 1,300 ohms, 1.3K |
-

PERFORMANCE TEST:

11. Given a VOM and a simple circuit in which to measure the resistance between two points, set the VOM up so function and range switches are properly positioned and so test leads are in correct jacks, then, measure the resistance as required. Performance must meet the instructor's standards.

COMPETENCY RATING

Set up ohmmeter properly: 0 / 1 / 2 / 3 / 4

Used ohmmeter correctly: 0 / 1 / 2 / 3 / 4

Measured accurately: 0 / 1 / 2 / 3 / 4

12. Using the VOM, measure the resistance of given components (such as carbon resistors, etc.) with 100% accuracy.

COMPETENCY RATING

0 / 1 / 2 / 3 / 4

13. Using the VOM, check for continuity in a given circuit.

COMPETENCY RATING

0 / 1 / 2 / 3 / 4

14. Using the VOM, locate "opens" and "shorts" in given circuits.

COMPETENCY RATING

0 / 1 / 2 / 3 / 4

15. Interpret "digital" scales or readings on a digital ohmmeter (DVM). (DVM may be simulated.)

COMPETENCY RATING

0 / 1 / 2 / 3 / 4

MODULE 2.0
 TASKS 2.13, 2.16, 2.19

DIRECTIONS: USING EQUATIONS GIVEN (OR FROM MEMORY IF REQUIRED) CALCULATE THE VALUE OF THE SINGLE EQUIVALENT RESISTANCE BETWEEN TERMINALS A AND B. SHOW ALL CALCULATIONS.

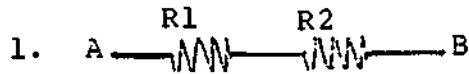

Answer: _____ ohms.

$R1 = 15$
 $R2 = 25$

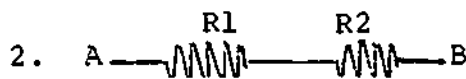

Answer: _____ ohms.

$R1 = 200$
 $R2 = 1.5K$

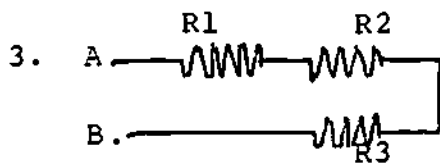

$R1 = 100$
 $R2 = 200$
 $R3 = 1.5K$

Answer: _____ ohms.

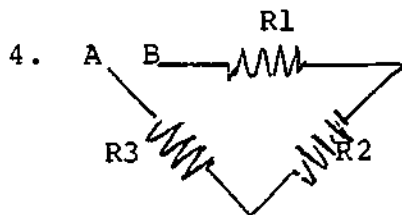

Answer: _____ ohms.

$R1 = 300$
 $R2 = 50$
 $R3 = 10$

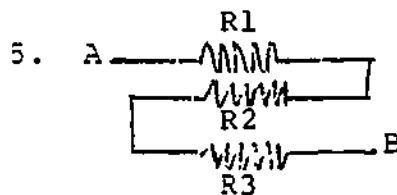

Answer: _____ ohms.

$R1 = 300$
 $R2 = 600$
 $R3 = 1,2K$

MODULE 2.0
TASKS 2.13, 2.16, 2.19

DIRECTIONS: DRAW THE REQUIRED SERIES OR PARALLEL CIRCUITS AS REQUIRED BY THE FOLLOWING SPECIFICATIONS. COMPUTE THE TOTAL RESISTANCE OF THE CIRCUIT FROM POINT A TO POINT B.

1. Series resistance of 400 ohms, 200 ohms, and 300 ohms.

Total resistance = _____ ohms.

2. Series resistance of 200, 100, and 5 ohms. The 5 ohm resistance is the result of two resistances in parallel and one of the parallel resistances is 10 ohms.

Total resistance = _____ ohms.

3. Resistance of 30 ohms in a series with parallel resistances of 10 ohms and a 10 ohm resistance made up of three resistances in a series-parallel circuit (series-parallel circuit consists of a 5 ohm resistance in series with a parallel resistance circuit with one resistance of 10 ohms): You compute remaining value that will result in a total resistance of 10 ohms for this series-parallel circuit. Finally, the circuit is terminated through a series resistance of 25 ohms.

You are working with the following resistances: 30, 10, 5, 10, unknown parallel resistance, and 25 ohms.

At least one series-parallel circuit is identified. The main circuit may be series, parallel, or series-parallel.

Total resistance = _____ ohms.
2-9 540

DIRECTIONS: THE FOLLOWING ILLUSTRATION REPRESENTS SOME TYPICAL HAND TOOLS THAT THE ELECTRICIAN MIGHT USE. IDENTIFY BY PROPER TERMINOLOGY. - IDENTIFY FIVE (5) HAND TOOLS OR ITEMS PICTURED.

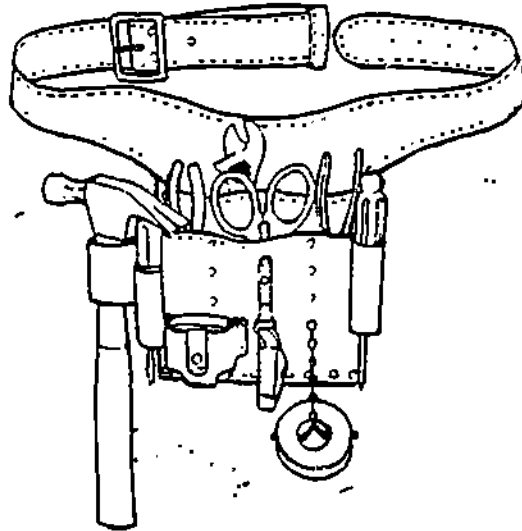

1. _____
2. _____
3. _____
4. _____
5. _____

ANSWER KEY:

- | | |
|-------------------------|------------------------------|
| 1. Flathead Screwdriver | 6. Adjustable Wrench |
| 2. Phillips Screwdriver | 7. Sissors |
| 3. Electricians Hammer | * Pliers are not visable for |
| 4. Electricians Knife | identification |
| 5. Steel Tape | |

TEST - MATCHING



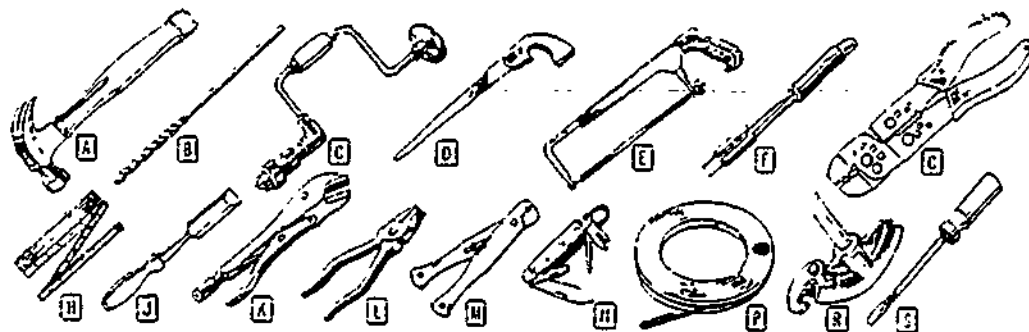



- ___ 1. For use with drill, screwdriver, reamer.
- ___ 2. To trace circuits, test fuses and lines.
- ___ 3. For notching studs, joists, plaster, flooring and lath.
- ___ 4. Wire cutter, stripper.
- ___ 5. To tighten screws, locknuts.
- ___ 6. A handy time-saver.
- ___ 7. For gripping locknuts, cutting wires.
- ___ 8. For measuring wire, openings.
- ___ 9. For cutting cable, plaster or laths.
- ___ 10. For boring wood, or soft metal.
- ___ 11. For driving staples, nails, fastening hangers.
- ___ 12. For cutting circles and irregular shapes.
- ___ 13. Cuts and skins wire, attaches terminals, etc.
- ___ 14. Use as plier, lock wrench, pipe wrench.
- ___ 15. For cutting insulation.
- ___ 16. Fish wire thru wall and conduit.



STUDENT: _____

DATE: _____

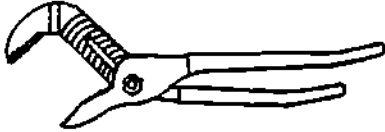
DIRECTIONS: IDENTIFY THE FOLLOWING TYPES OF PLIERS BY THE PROPER TERMINOLOGY (NAME).

1.  _____
2.  _____
3.  _____
4.  _____
5.  _____
6.  _____
7.  _____

Answer Key:

1. Locking Pliers
2. Lineman's Side Cutting
3. Slip Joint
4. Diagonal Cutting
5. End Cutting
6. Utility Pliers
7. Long Nose

STUDENT: _____

DATE: _____

DIRECTIONS: IDENTIFY THE FOLLOWING ELECTRICAL TOOLS. USE THE CORRECT TERMINOLOGY.

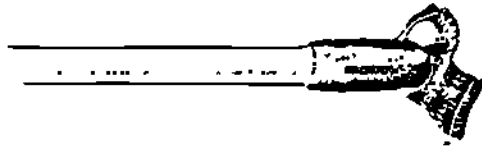

1. _____

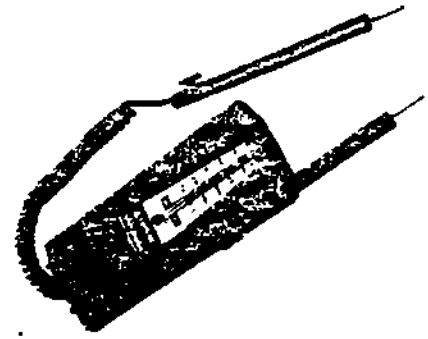

6. _____

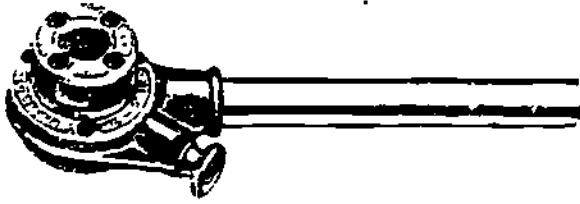

2. _____

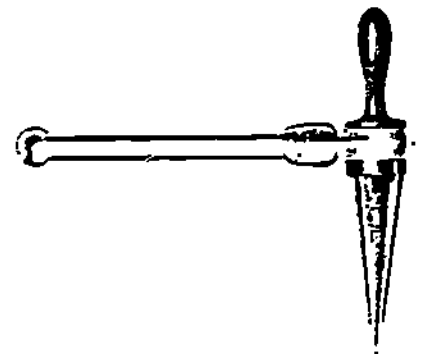

7. _____

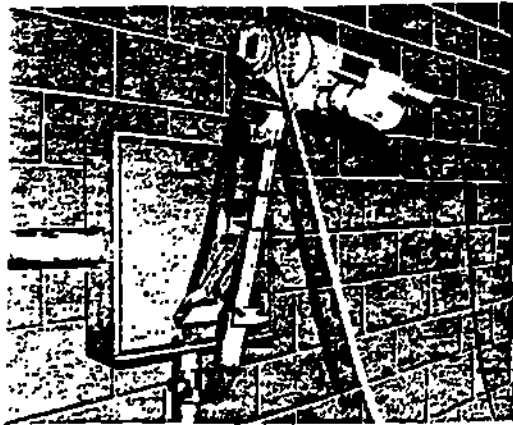

3. _____

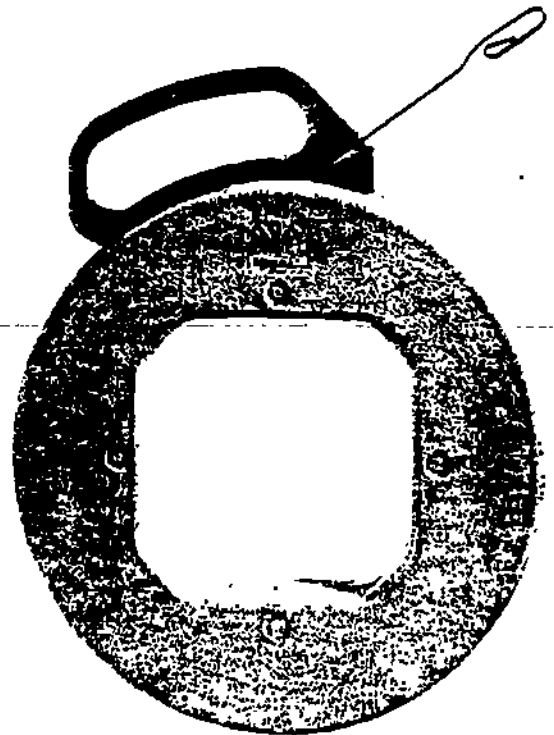

8. _____



4. _____

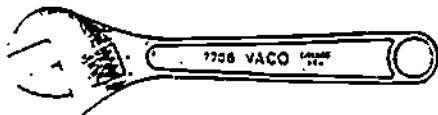

5. _____

ANSWER KEY:

1. Rigid Conduit Hickey
2. Hand Threader
3. Power Wire Puller
4. Folding Rule
5. Adjustable Wrench
6. Voltage Tester
7. Reaming Tool
8. Fish Tape (with Holder)

DIRECTIONS: IDENTIFY THE CONTROLS AND TEST JACKS ON THE TEST INSTRUMENTS ILLUSTRATED BELOW.

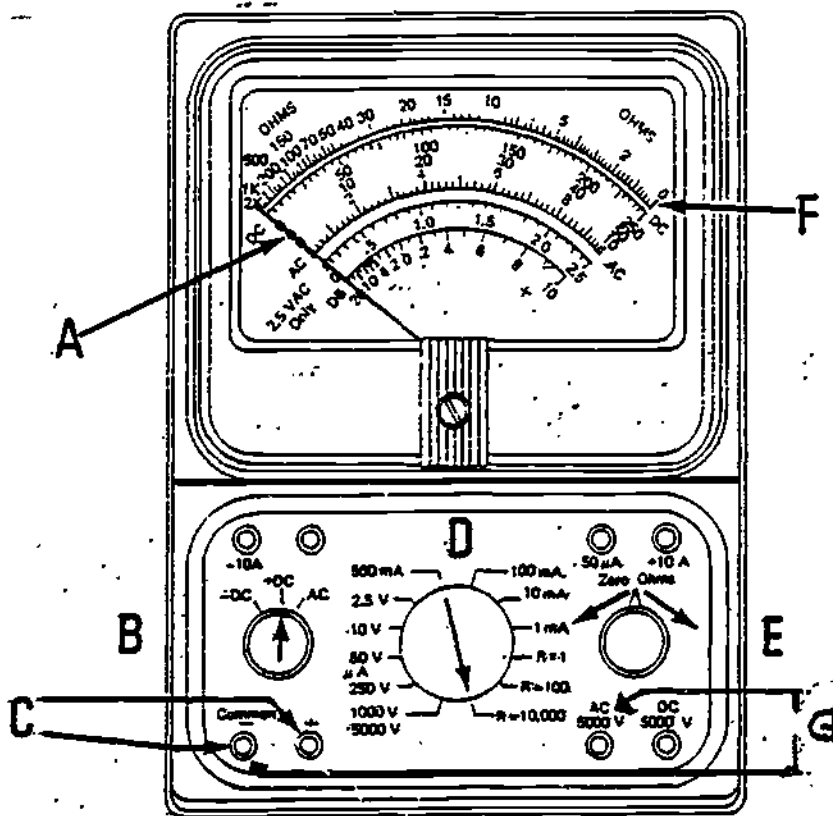

1. Switch B selects the _____.
2. Switch D selects the _____.
3. Control E is used for the "zero ohms" adjustment. When adjusting or checking the ohms range adjustment, the meter needle will be at A or F? Ans. = _____
4. The VOM illustrated is set to read what function? Ans. = _____
5. The range switch is set for what scale? Ans. = _____
6. To test/read 120VAC, test leads would be inserted/plugged into the jacks marked C or G? Ans. = _____
7. If you were reading continuity in a circuit and the meter needle was at A, would the circuit be "open" or "short"? Ans. = _____
8. If you were reading continuity in a circuit and the meter needle was at F, would the circuit be "open" or "short"? Ans. = _____

DIRECTIONS: FOR THE FOLLOWING QUESTIONS, REFER TO THE VOM ILLUSTRATION AT THE RIGHT.

9. Is the VOM reading amps, volts, ohms, or continuity?

Ans. = _____

10. With the VOM settings shown, what is the maximum measurement that can be made?

Ans. = _____

11. What numerical value is the VOM needle indicating (what is the measurement)?

Ans. = _____

12. The test leads are plugged into the correct jacks.

() Yes () No

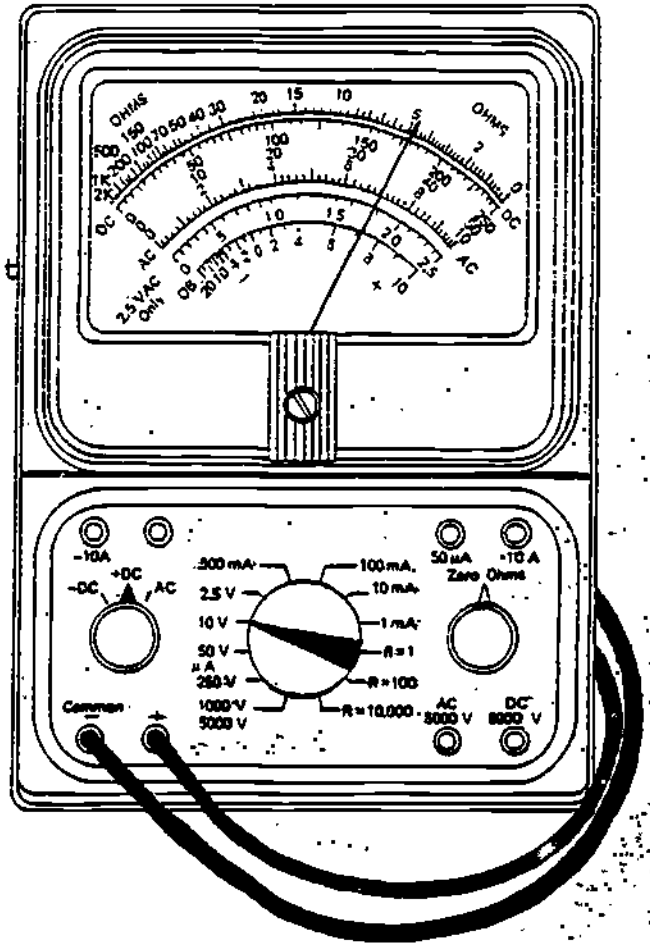

DIRECTIONS: FOR THE FOLLOWING QUESTIONS, REFER TO THE VOM ILLUSTRATION AT THE RIGHT.

13. Is the VOM reading volts, amps, or ohms?

Ans. = _____

14. Is the function in AC, DC, or ohms?

Ans. = _____

15. What is the numerical value of the reading (needle indicator)?

Ans. = _____

16. Are the test leads plugged into the correct jacks?

() Yes () No

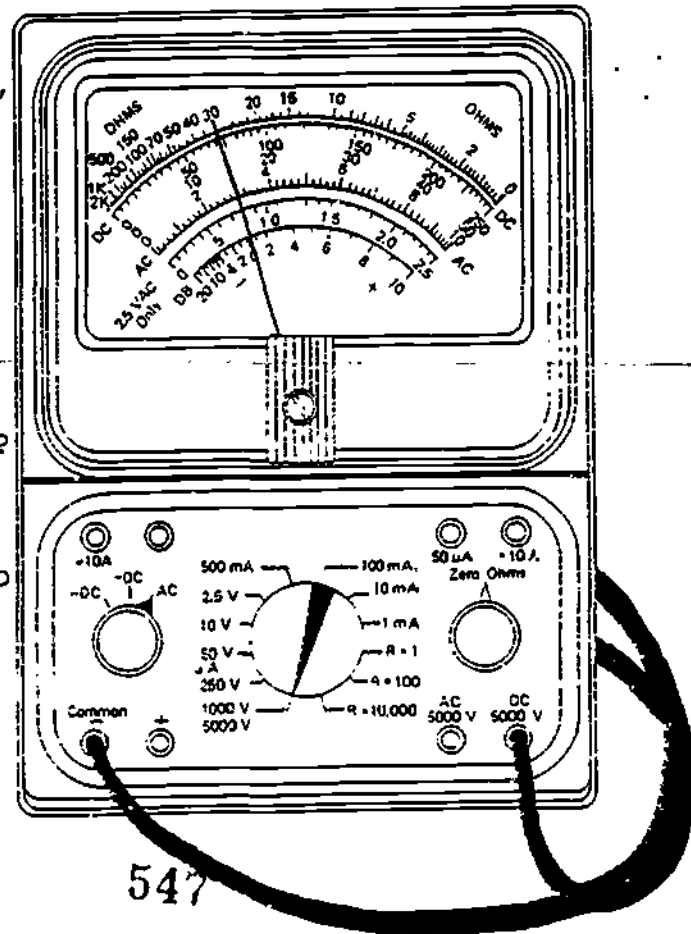

ILLUSTRATION TO THE RIGHT FOR USE WITH QUESTIONS 17-19.

17. Is the meter in amps, volts, or ohms function?

Ans. = _____

18. Is the range of function switch shown?

Ans. = _____

19. Based on the meter reading and the switch position, the reading is:

- 8.5
- 85
- 850
- 8,500

Ans. = _____

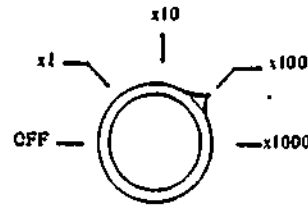
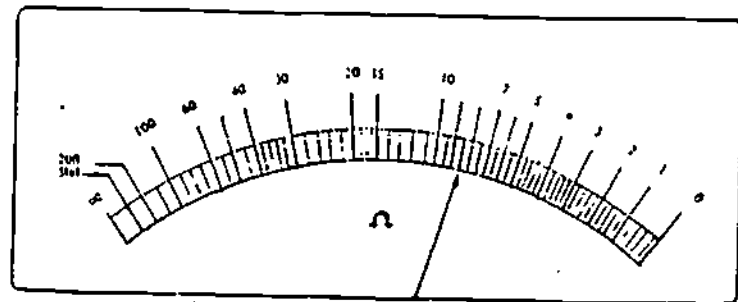

USE THE ILLUSTRATION BELOW FOR QUESTIONS 20-23.

20. Is the meter in the amps, volts, or ohms function?

Ans. = _____

21. Is the range or function switch shown?

Ans. = _____

22. Based on the meter reading and the switch position, the measurement is volts, amps, or ohms?

Ans. = _____

23. The numerical measurement is:

- 4.9
- 5.08
- 5.4
- 5.8

Ans. = _____

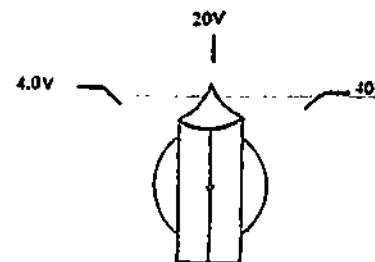
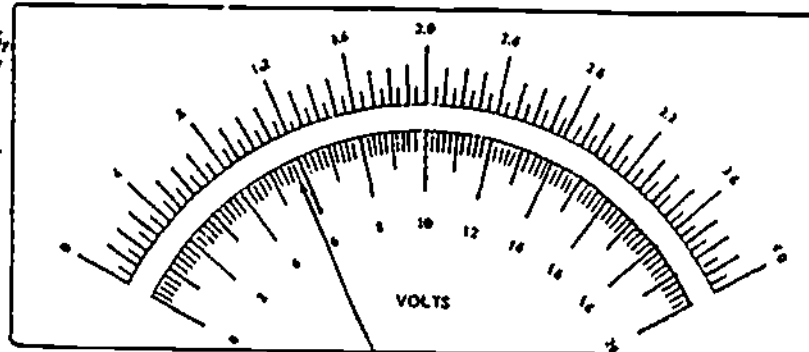

STUDENT: _____

1. Given a VOM, test leads, and a circuit in which measurements will be taken;
- a. Set the VOM up for AC voltage measurements of +/- 120 volts AC.

Action	CHECKLIST	
	Acceptable	Not Acceptable
Function switch properly set		
Range switch properly set		
Tests Leads in correct jacks		
Correct meter scale identified		

*All items must be acceptable.

- b. Set the VOM up for DC voltage measurements of +/- 12 volts DC.

Action	CHECKLIST	
	Acceptable	Not Acceptable
Function switch properly set		
Range switch properly set		
Test Leads in correct jacks		
Correct meter scale identified		

*All items must be acceptable.

- c. Set the VOM up for the measurement of resistances of 30-60 ohms.

Ac	CHECKLIST	
	Acceptable	Not Acceptable
Function switch properly set		
Range switch properly set		
Test Leads in correct jacks		
Correct meter scale identified		

*All items must be acceptable.

- . Set up the VOM for reading continuity in circuits.

Action	CHECKLIST	
	Acceptable	Not Acceptable
Function switch properly set		
Range switch properly set		
Test Leads in correct jacks		
Correct meter scale identified		



2. Set up the VOM for reading AC voltage and measure a minimum of three different AC voltages in given situations. Voltage readings must be +/- 2 percent depending on accuracy of meter and performance process and reading must be to the instructor's standards.

	<u>COMPETENCY RATING</u>			
Set up VOM	0	1	2	3 / 4
Reading #1	0	1	2	3 / 4
Reading #2	0	1	2	3 / 4
Reading #3	0	1	2	3 / 4

3. Set up the VOM for reading DC voltage and measure a minimum of three different DC voltages in given situations. Voltage readings must be +/- 2 percent depending on accuracy of meter and performance process and readings must be to instructor's standards.

	<u>COMPETENCY RATING</u>			
Set up VOM	0	1	2	3 / 4
Reading #1	0	1	2	3 / 4
Reading #2	0	1	2	3 / 4
Reading #3	0	1	2	3 / 4

4. Set up the VOM for reading the resistance of components such as carbon or wire resistors, relay coils, or motor windings. Readings must meet instructor's standards and must agree with predetermined readings, if applicable. A minimum of three different resistance measurements must be taken.

	<u>COMPETENCY RATING</u>			
Set up VOM	0	1	2	3 / 4
Reading #1	0	1	2	3 / 4
Reading #2	0	1	2	3 / 4
Reading #3	0	1	2	3 / 4

5. Set up the VOM for checking continuity in a given circuit and test three different parts of the circuit for "opens" or "shorts". Use of the VOM and readings must meet instructor's standards.

	<u>COMPETENCY RATING</u>			
Set up VOM	0	1	2	3 / 4
Reading #1	0	1	2	3 / 4
Reading #2	0	1	2	3 / 4
Reading #3	0	1	2	3 / 4

DIRECTIONS: USING THE FOLLOWING ILLUSTRATION OF A CLAMP-ON AMMETER, SUCH AS THE AMPROBE, READ THE BELOW SCALES.

With the clamp-on ammeter set up as illustrated on the right, read the following measurements.

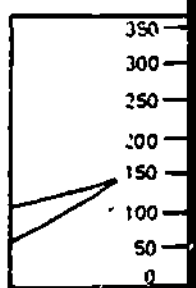
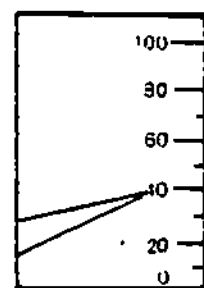
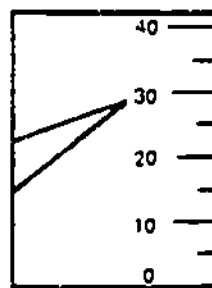
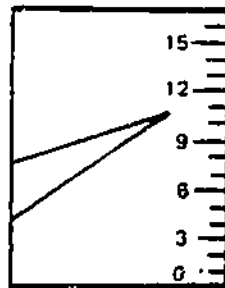
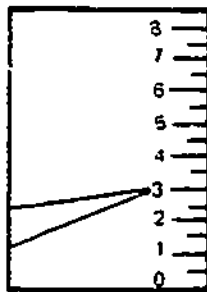
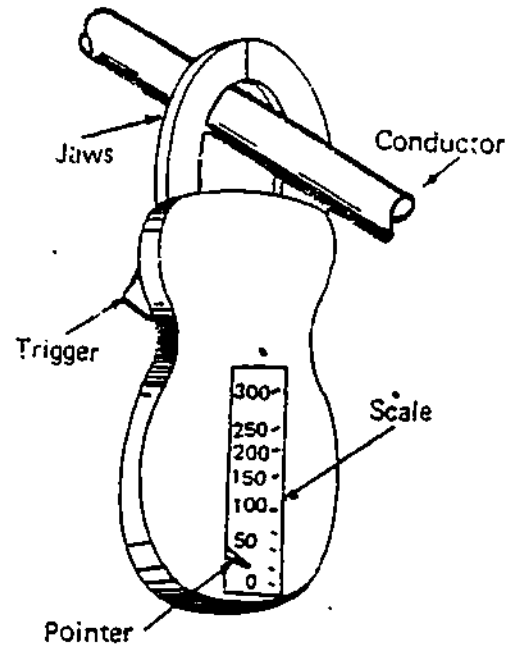

1. _____ 2. _____ 3. _____ 4. _____ 5. _____

DIRECTIONS: REFER TO THE ILLUSTRATION AT THE RIGHT FOR THE FOLLOWING QUESTIONS:

6. The ammeter reads 6 amps. 3 loops are passed through the ammeter jaws. What is the current in the wire?
7. If 10 loops of multiplier were used to read a current. Would the current be multiplied or divided by 10 as it is read.

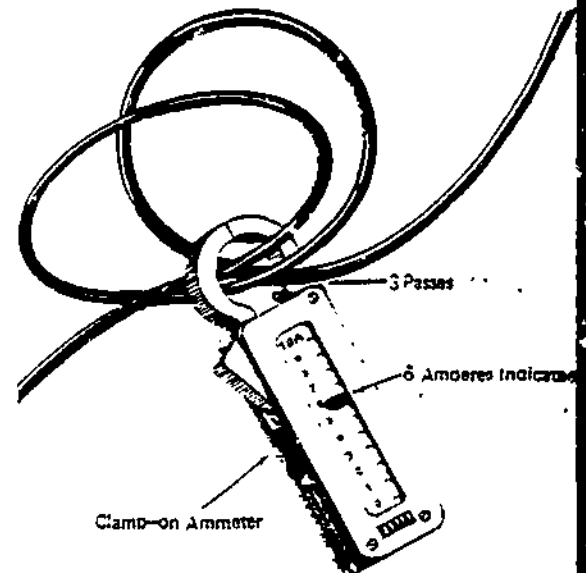

8. Given a clamp-on ammeter, multiplier wire if applicable, electric motor or other device connected to a line source; properly set-up the clamp-on ammeter to read the current used by the device. The ammeter must be properly operated. Correct use must be made of the scales. The current must be accurately measured. Performance and measurement must be to the instructor's standards.

	<u>COMPETENCY RATING</u>								
Set up Ammeter	0	/	1	/	2	/	3	/	4
Use of Ammeter	0	/	1	/	2	/	3	/	4

9. Given an electric motor or other device to test, a clamp-on ammeter, and other materials necessary; Use the clamp-on ammeter to determine if the device is operating properly and if it is the amount of current indicated on the product nameplate.

	<u>COMPETENCY RATING</u>								
Set up Ammeter	0	/	1	/	2	/	3	/	4
Use of Ammeter	0	/	1	/	2	/	3	/	4

TRUE-FALSE/COMPLETION: Indicate if the following statements are true or false. If the statement is false as it is worded, correct the statement in the blank provided. Indicate the appropriate NEC article.

- | <u>TRUE</u> | <u>FALSE</u> | <u>NEC</u>
<u>ARTICLE</u> | |
|-------------|--------------|------------------------------|---|
| () | () | _____ | 1. Soldered spliced conductors are first joined together mechanically and then are soldered for a good electrical connection.

_____ |
| () | () | _____ | 2. Splices in raceways must be covered with an insulation equivalent to that of the conductors or with an insulating device suitable for the purpose.

_____ |
| () | () | _____ | 3. Splices and taps shall be made only in junction boxes, outlet boxes, or conduit bodies.

_____ |
| () | () | _____ | 4. The ground electrode conductor may only be spliced with a conductor of the same type such as copper, aluminum, or copper-clad aluminum. The conductor may be solid or stranded, insulated, covered, or bare.

_____ |
| () | () | _____ | 5. During initial installation, a flexible cord that has been cut is not long enough for the requirement. It be spliced according to Section 110-14(b), if it is number 14 wire?

_____ |

Answer Key:

1. F 110-14 "Mechanically and electrically secure without solder, then soldered."
2. F 346-14 "No splices in raceway."
3. T 346-14
4. F 250-91a "No splices in grounding electrode conductor."
5. F 400-9 "No splices or tap when initially installing flexible cord."

STUDENT: _____ DATE: _____

PERFORMANCE TESTS:

1. Given necessary tools and materials, replace a damaged lamppcord plug with an attachment plug using the underwriter's knot to prevent strain on the connection when the cord is pulled. The wire must be mechanically secure and the proper underwriter's knot must be used. Performance must be to instructor's standards.
2. Given side cutting pliers, electrician's knife, lengths of #14 wire, length of fixture wire, and lengths of #6-#8 stranded cables and other materials as required, properly prepare and make various wire splices using the proper procedures, tools, and precautions. Performance must be to instructor's standards.
 - a. Make a Rattail or Pigtail Splice
 - b. Make a Tap or Tee Splice
 - c. Make a Fixture Splice
 - d. Make a Western Union Splice
 - e. Make a Cable Splice
3. Given an assortment of wire nuts, electrician's knife, lineman's side cutters, variety of electrical wire, and installation setting such as flourescent fixtures, switch and outlet boxes, etc.; Splice wire as required using wire nuts. The splice must be electrically and mechanically secure. The wire nuts must be firmly attached. No exposed wire should be present as a hazard. Performance and product must be to the instructor's standards.

CHECKLIST

	Acceptable	Not Acceptable
Wire cut appropriately		
Insulation properly removed		
Proper length of bare wire exposed		
Wire scraped until bright		
Proper techniques of splicing demonstrated		
Rattail/Pigtail		
Tap/Tee		
Fixture		
Western Union		
Cable		

PERFORMANCE TEST:

1. Given a soldering iron/gun and one or more projects to solder, select the proper type of solder and demonstrate the proper techniques of soldering so that the soldered electrical connections meet the instructor's standards

CHECKLIST

	Acceptable	Not Acceptable
Correct type solder selected		
Iron or gun tip properly tinned		
Workpiece properly supported on table		
If applicable, heat sink used		
Iron or gun held in a satisfactorily manner		
Soldering iron rest/holder used to protect work table		
Workpiece(s) properly heated for good solder joint		
Solder properly applied: Not to much, enough to provide acceptable solder connection		
Connection terminal, etc., not cooked		
Proper soldered joint: No cold solder, no pitting or holes, no damage to wire insulation if applicable		
Solder iron or gun tip cleaned after use		

SHORT ANSWER QUESTION:

1. A load connected to 120 volts consumes 200 watts of power. How much current flows through the load?

2. An appliance with a nameplate rating of 5 amps at 240 volts requires how much power?

3. Each small appliance branch circuit must be able to supply a minimum of how much power?

4. If a branch circuit supplies only one motor, the branch circuit ampacity should be what percent of the motor load current?

5. What is the maximum wattage that can be supplied by a 20 amp, 120 volt source?

PERFORMANCE TEST:

6. Given a residential electrical house plan, a list of appliances and the voltage and wattage requirements of each appliance, calculate the total load of the residence. Balance the given loads. Compute the size of the service entrance requirements. Computations must agree with predetermined calculations. Performance must be to the instructor's standards.

TRUE-FALSE:

- () () 1. The term "service-entrance conductors" includes the term "service drops."
- () () 2. The smallest permissible size of hard-drawn copper service drop is No. 10.
- () () 3. Service conductor connections for single-phase services may be made with the aid of solder lugs.
- () () 4. A No. 6 grounding which is secured to the building but is exposed to moderate physical damage must be run in metal conduit, rigid nonmetallic conduit, or cable armor.
- () () 5. The disconnecting means for a 3-wire, single-phase lighting service must open all ungrounded conductors simultaneously.

MULTIPLE CHOICE:

6. A bare copper neutral service-entrance conductor is permitted only if the voltage is not over:
- _____ a. 150 v
b. 300 v
c. 600 v
d. All of the above
7. The service rating for a single-family residence shall not be less than 100 amps, according to the NEC, when the initial load amounts to:
- _____ a. 7.5 kW
b. 10 kW
c. 12.5 kW
d. 15 kW
8. The minimum clearance of service drops above a public driveway on other than residential property is:
- _____ a. 10 ft.
b. 12 ft.
c. 16 ft.
d. 18 ft.
9. Typically, the minimum ampacity of the underground service entrance conductors of a service is:
- _____ a. 50 amps
b. 60 amps
c. 80 amps
d. 100 amps

10. The unit lighting load for a dwelling unit, expressed in "watts-per-square-foot", shall be:
- a. 2 watts
 - b. 1.5 watts
 - _____ c. 3 watts
 - d. 5 watts
11. The rating of a cord-and plug appliance used on a 20 amp branch circuit having two or more outlets shall not exceed:
- a. 16 amps
 - b. 15 amps
 - _____ c. 18 amps
 - d. 12 amps
12. The demand load for a 16 kW electric range should be assessed at:
- a. 8200 watts
 - b. 9600 watts
 - _____ c. 12600 watts
 - d. 14400 watts
13. The Code requires that metal enclosures for grounding electrode conductors shall be:
- a. not permitted
 - b. isolated
 - _____ c. electrically continuous
 - d. rigid conduit

SHORT ANSWER:

14. How should conductors larger than No. 6 be marked to indicate the grounded wire?
15. What is the voltage between the red and black wires in a typical residential installation?

PERFORMANCE TEST:

Given the materials and tools needed and a simulated residential situation, install the main service entrance panel, ground, meter base if applicable, and circuit breakers as required. The installation and performance must be to the instructor's specifications. The installation must be according to the following NEC articles: 230-26, 230-40, 230-41, 230-43, 230-54, and 300-18.

IDENTIFY: IDENTIFY THE PARTS OF A SERVICE ENTRANCE.

- A. _____
- B. _____
- C. _____
- D. _____
- E. _____
- F. _____
- G. _____
- H. _____
- I. _____
- J. _____
- K. _____
- L. _____
- M. _____
- N. _____

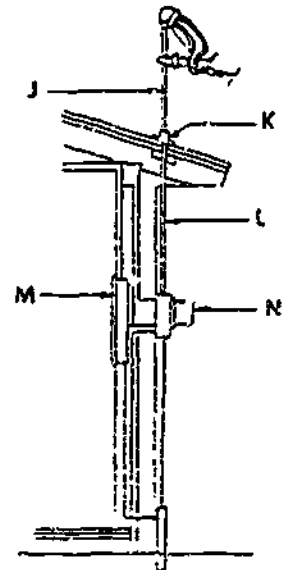
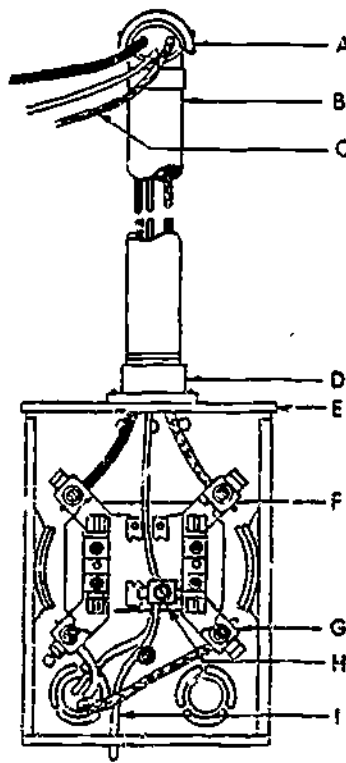

MULTIPLE CHOICE:

1. The internal depth of outlet boxes intended to enclose flush devices shall be at least:
- a. 1/2 inch
 - b. 7/8 inch
 - c. 15/16 inch
 - d. 1 1/2 inch
- Ans. _____
2. The maximum number of No.14 conductors permitted in a 1 1/2 inch x 4-inch octagon outlet box is:
- a. 5
 - b. 9
 - c. 8
 - d. 7
- Ans. _____
3. If a 1 1/2 x 4 inch octagon outlet box contains a fixture stud and a cable clamp, the number of No. 14 wires permitted in the box is:
- a. 6
 - b. 4
 - c. 7
 - d. 5
- Ans. _____
4. In combustible walls or ceilings, the front edge of an outlet box or fitting may set back from the finished surface:
- a. 1/4 inch
 - b. 1/8 inch
 - c. 1/2 inch
 - d. it must be flush
- Ans. _____
5. Threaded boxes and fittings which are threaded into two or more properly supported conduits from two or more sides and do not support fixtures or contain devices, need not to be further secured provided their volume does not exceed:
- a. 100 cu. in.
 - b. 125 cu. in.
 - c. 150 cu. in.
 - d. 200 cu. in.
- Ans. _____
6. The metal raceway enclosing tap conductors for recessed fixtures shall not be:
- a. over 2 feet long
 - b. over 3 feet long
 - c. less than 6 feet long
 - d. less than 4 feet long
- Ans. _____

7. The NEC requires that recessed portions of fixture enclosures shall be spaced from combustible material by at least:

- a. $3/8$ inch
- b. $1/2$ inch
- c. $5/8$ inch
- d. $3/4$ inch

Ans. _____

8. A handy box extension is used to:

- a. make the box large enough to hold more wire.
- b. make a covering for the box.
- c. make room for a receptacle.
- d. protect against shock hazards.

Ans. _____

9. The number of #14 wires allowed in a box with 29.5 cu. in. is:

- a. 14
- b. 13
- c. 11
- d. 9

Ans. _____

10. An underwriter's knot is used to:

- a. support a fixture.
- b. support a lamp.
- c. relieve stress on a plug where the cord is attached.
- d. support a switch.

Ans. _____

TRUE-FALSE: (Answers must agree with NEC.)

- () () 1. A handy box or utility box can be used only on thin-wall conduit.
- () () 2. You do not have to use a clamp in a non-metallic box.
- () () 3. The volume of the box is the determining element in the number of conductors that can be allowed in the box.
- () () 4. Splices are not allowed along the run of the cable unless the splice is housed in an appropriate box.
- () () 5. In a single-gang box, the nonmetallic cable does not have to be clamped to the box.
- () () 6. Any wire that comes into a box and is spliced is counted as two wires.

COMPLETION:

- 7. Outlets in a residence should be _____ inches above the floor.
- 8. Wall switches should be located at the _____ side of the door.
- 9. Wall switches normally are mounted approximately _____ inches above the floor.
- 10. One convenience outlet for every _____ linear feet of hallway is recommended.
- 11. The washing machine outlet should be connected to a _____ ampere, laundry-area branch outlet.
- 12. In the kitchen, one outlet for each _____ linear feet of work-surface frontage is recommended.

SHORT ANSWER:

13. What is the required distance between supports and from outlet boxes for armored cable?

14. How many wires are subtracted from the table of maximum number of conductors in a box if an outlet box contains a fixture stud?

15. What is the maximum number of No. 14 conductors allowed in a 4" x 1 1/2" round box with a fixture stud contained?

16. What is the maximum number of No. 12 conductors allowed in a 1 1/2" x 4" square outlet box with inside cable clamps?

17. A nonmetallic box has 32 cubic inches stamped on it. You must place four No. 12 conductors in it. How many No. 10 conductors can be placed in the junction box with the No. 12 conductors?

18. A junction box has a volume which will hold 10 conductors. If there is one fixture stud and one cable clamp in the box, what is the number of conductors that may be placed in the junction box?

PERFORMANCE TESTS:

1. Given the necessary materials and tools and a simulated setting, install bar-handger mounted box at the center of a ceiling location to meet specifications, NEC, and instructor's standards.
2. Given the necessary materials and tools and a simulated setting, install recessed fixture housing in ceiling according to manufacturer's specifications and NEC. Performance process and product must meet instructor's standards.
3. Using materials and tools provided, install flush mount junction box so that it is flush with the finished surface of a mock-up and so the location is according to plan and the box is accessible after installation. Performance process and product must be to the instructor's standards.
4. Using materials and tools provided, install flush mount switch and outlet boxes in dry wall or paneled wall so boxes are flush with finished wall and located to plan and installed according to NEC.
5. Using materials and tools provided, install gangable boxes in approved manner, meeting requirements of NEC, flush with finished surface and level on top. Performance process and product must meet the instructor's standards.
6. Using materials and tools provided, install octagon outlet boxes as required by plan and according to requirements of NEC and meeting instructor's standards for process and product.

CHECKLIST FOR PERFORMANCE TESTS

	Acceptable	Not Acceptable
Reviewed plan correctly before starting		
Determined boxes and materials needed		
Selected tools needed		
Correctly located installation points		
Correctly positioned and attached boxes to structure		
Flush with surface, if applicable		
Level across top		
Installation meets NEC and local code		
Safe working habits, etc., demonstrated		
Attitude toward job		

MULTIPLE CHOICE:

1. The NEC requires that recessed portions of fixture enclosures shall be spaced from combustible material by at least:
- a. 3/8 inch
 - b. 1/2 inch
 - c. 5/8 inch
 - d. 3/4 inch
- Ans. _____
2. A nineteen conductor cable is used to:
- a. control a three-way switch circuit
 - b. control a four-way switch circuit
 - c. make runs from master selector switches
 - d. make runs in residential circuits
- Ans. _____
3. All of the components of the GE low-voltage system operated on:
- a. 12 volts
 - b. 16 volts
 - c. 20 volts
 - d. 24 volts
- Ans. _____
4. Flexible appliance cords are considered adequately protected if the circuit overcurrent device is set at a maximum value of:
- a. 15 amps
 - b. 30 amps
 - c. 20 amps
 - d. 40 amps
- Ans. _____
5. The minimum diameter of a steel ground rod shall be:
- a. 3/8 inch
 - b. 1/2 inch
 - c. 5/8 inch
 - d. 3/4 inch
- Ans. _____
6. Wiring located above electric heating panels shall be spaced above the heated ceiling not less than:
- a. 5 inches
 - b. 4 inches
 - c. 3 inches
 - d. 2 inches
- Ans. _____

7. The NEC requires that heating panels be seperated from outlet boxes that are to be used for mounting fixtures not less than:

- a. 12 inches
- b. 8 inches
- c. 6 inches
- d. 10 inches

Ans. _____

8. The rating of any one cord-and-plug connected appliance used on a 30 amp branch circuit shall not exceed:

- a. 30 amps
- b. 24 amps
- c. 27 amps
- d. 20 amps

Ans. _____

9. The neutral conductor of a 3-wire branch circuit to a household electric range shall not be smaller than:

- a. No. 4 THW
- b. No. 6 THW
- c. No. 8 THW
- d. No. 10 THW

Ans. _____

10. A feeder supplying a 5-kW wall-mounted oven and a 7 kW counter-mounted cooking unit must have capacity for:

- a. 12 kW
- b. 9.2 kW
- c. 7.8 kW
- d. 7 kW

Ans. _____

SHORT ANSWER:

11. The smallest stranded copper conductor permitted for general wiring is No. _____.
12. A metal fixture shall be grounded if located within _____ feet vertically or 5 feet horizontally of a kitchen sink.
13. In general the voltage to ground on a branch circuit supplying 15 amp receptacles shall be not greater than _____ volts.
14. Except where fished or for flexibility, Type AC armored cable shall be supported with _____ inches of an outlet box.
15. The free length of a conductor at a switch outlet shall be not less than _____ inches.
16. A receptacle installed on a 15 amp or 20 amp branch circuit shall be of the _____ type.
17. In residential occupancies the NEC requires one 15 amp lighting circuit for every _____ square feet.
18. Receptacles connected to a 30 amp branch circuit supplying two or more outlets shall be rated not less than _____ amps.
19. What is the maximum rating that would be permitted by the NEC on a fixed appliance located on a 15 or 20 amp branch circuit on which there is a lighting fixture?

Answer: _____

20. What is the smallest splice wire permissible for a feeder circuit?

Answer: _____

TRUE FALSE:

- () () 21. Generally low voltage control systems are used only in industrial plants.
- () () 22. All relay switching circuits have low-voltage, low-current requirements.
- () () 23. Stranded grade relays are designed to operate on extended energized periods.
- () () 24. Electronic dimmers cannot be used to dim fluorescent lamps.
- () () 25. Wires used for low-voltage systems can be stapled with tackers.
- () () 26. Green color wire can be used for circuit wires when properly marked.
- () () 27. Unless otherwise specified, the material referred to as conductors in the NEC is copper coated aluminum.
- () () 28. Wooden plugs may be used for mounting equipment in masonry, concrete, and plaster.
- () () 29. Grounding conductors must be electrically and mechanically secure before soldering and then soldered with a noncorrosive flux.
- () () 30. EMT can be used to support a box that is above ground level.

PERFORMANCE TEST:

Make a materials list for the below drawing and submit the list to the instructor for evaluation. If required, price the materials. Performance must be to instructor's standards. Calculations must be accurate.

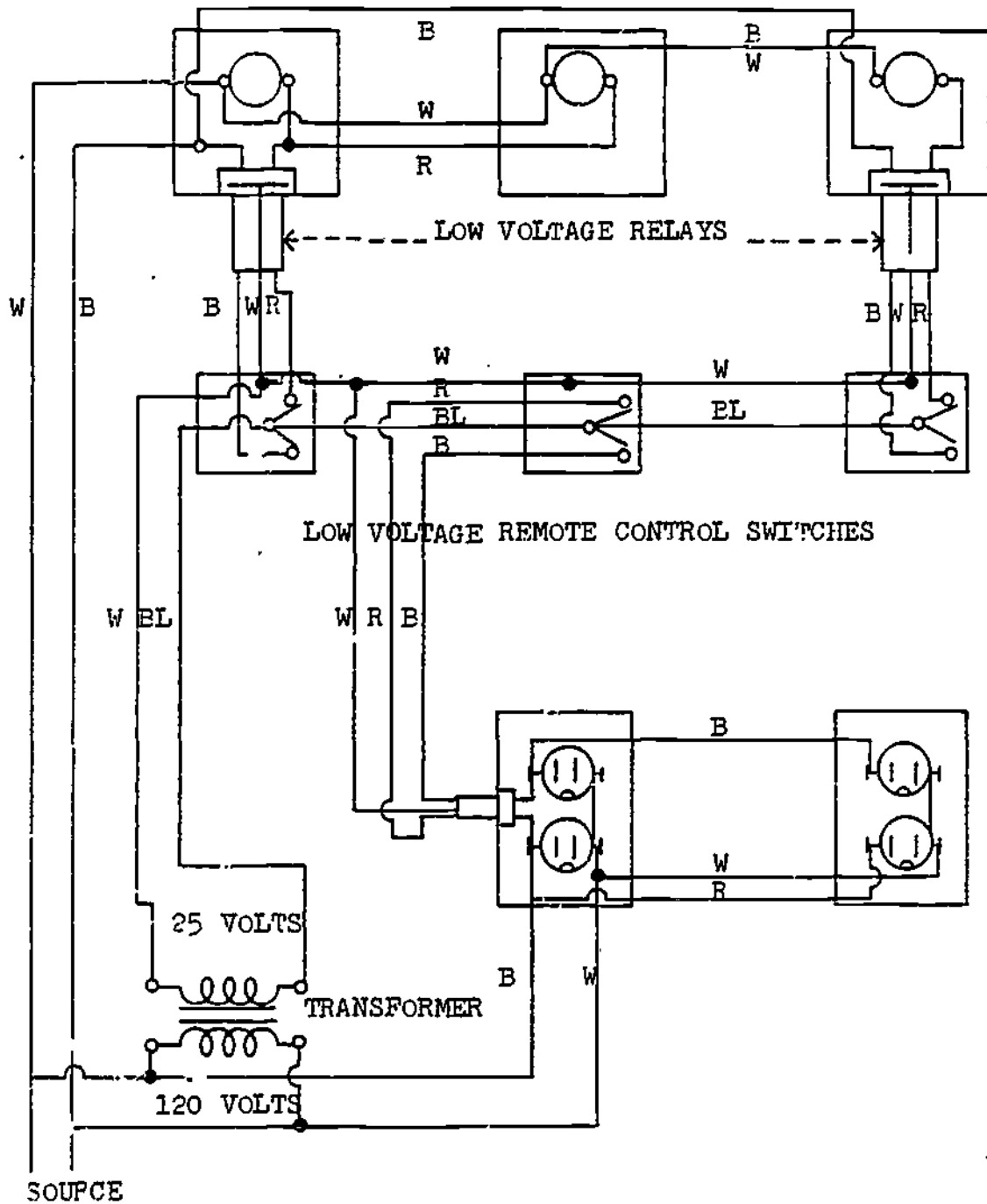

PERFORMANCE TEST:

1. Given electrical drawing, basic tool kit, electrical installation materials including fasteners, and a simulated residential setting; rough in 120/240 volt circuits to distribution panel (SEP box) using nonmetallic sheathed cable (N.M.C.) according to the NEC, plan, and the instructor's standards. (A checklist may be used to evaluate student performance.)

PERFORMANCE RATING

0 / 1 / 2 / 3 / 4

2. Given electrical drawing, basic tool kit, installation and electrical materials, including fasteners; rough in cable (or conduit, if required by plan) for branch circuits. Installation must be completed without damage to interior finish. Wire size must be appropriate for load to be serviced and cable must extend from power source to outlet box of load serviced and must be terminated in approved fittings. Installation must meet the NEC and plan. Performance and product must be to the instructor's standards. (A checklist may be used to evaluate student performance.)

PERFORMANCE RATING

0 / 1 / 2 / 3 / 4

3. Given electrical drawing, basic tool kit, simulated residential setting, installation and electrical materials including fasteners; rough in circuit for outlet controlled by two each three-way switches with the feed to the switch. The cable must be installed in the most direct path. Power source must terminate at one of the switch outlets. There must be sufficient conductors in each box for the circuit to function properly. Installation must be to NEC Ar. 300. Performance and product must be to the instructor's standards. The circuit must operate as designed. (A checklist may be used to evaluate student performance.)

PERFORMANCE RATING

0 / 1 / 2 / 3 / 4

4. Given a requirement for a low-voltage wiring circuit, wire boxes as necessary, basic tool kit, fasteners, and other material required; rough in the low-voltage circuit to plan or specification requirements. Wire must be the correct size and run in acceptable directions and locations. Sufficient number of conductors per cable to control devices being served. Devices such as thermostats, intercoms, chimes must be located to specified heights and properly installed. Appropriate NEC sections apply. Performance and product must meet the instructor's standards.

PERFORMANCE RATING

0 / 1 / 2 / 3 / 4

5. Given previously installed receptacle box, basic tool kit, and installation and electrical materials including fasteners; rough in a circuit for a split circuit duplex receptacle. The rough in circuit must meet NEC requirements (Ar. 210-4, 210-6, subs. C.1,2) The circuit must operate as designed. Performance and product must be to the instructor's standards.

PERFORMANCE RATING
0 / 1 / 2 / 3 / 4

TRUE-FALSE

- () () 1. In general, a building cannot have openings in its fire walls.
- () () 2. Lighting outlets, installed in other than dwelling occupancies, shall not be connected to 50 amp branch circuits.
- () () 3. The feeder demand factor for store lighting shall be 100% of the connected load.
- () () 4. The maximum rating of a 250 volt cartridge fuse is 600 amps.
- () () 5. The service overcurrent device is permitted to be located adjacent to the service disconnect means.
- () () 6. No. 18 copper wire may be used for grounding a portable device used on a 20 amp circuit.
- () () 7. Taps not over 18 inches long, for individual lamp-holders, may be smaller than the branch circuit conductors.
- () () 8. Splices under certain conditions are permitted in service conductors.
- () () 9. Conduit nipples not over 24 inches long may be filled to 60% of their cross-sectional area.
- () () 10. On electric discharge lighting systems of more than 1000 volts, transformers shall never be connected in series.

COMPLETION:

1. Circuit breakers used to switch 120 volt flourescent fixtures shall be approved for the purpose and marked _____
2. In commercial settings, each 5 feed or fraction of multioutlet assembly shall normally be considered as a load of _____ amps.
3. Total load on a branch circuit should not exceed its _____.
4. Threaded boxes not over 100 cubic inches in size need no additional support if two or more conduits, which are properly supported within _____ inches of the box, are threaded into the box from the same side.
5. Interior raceways installed between areas differing widly in temperatures shall be _____.

MULTIPLE CHOICE:

1. The minimum feeder allowance for show-window lighting expressed in watts-per-linear-foot shall be:
- a. 100
 - b. 200
 - c. 300
 - d. 500
- Ans. _____
2. The unit load for a store is listed _____ watts-per square-foot.
- a. 3
 - b. 3.75
 - c. 2
 - d. 2.5
- Ans. _____
3. The largest standard cartridge fuse rating is:
- a. 6,000 amps
 - b. 12,000 amps
 - c. 1,000 amps
 - d. 600 amps
- Ans. _____
4. Metal enclosures for grounding electrode conductors shall be:
- a. rigid conduit only
 - b. not less than 3/4 inch in diameter
 - c. bonded
 - d. electrically continuous
- Ans. _____
5. The size of copper grounding electrode conductors utilizing a water pipe electrode for a 120-208-volt service which has three 250 MCM copper conductors and a No. 3/0 neutral is:
- a. No. 8
 - b. No. 2
 - c. No. 6
 - d. No. 4
- Ans. _____
6. Underground service conductors carried up a pole must be protected from mechanical injury to a height of at least:
- a. 12 feet
 - b. 8 feet
 - c. 15 feet
 - d. 9 feet
- Ans. _____
7. Angle-pull dimensional requirements apply to junction boxes only when the size of conductor is equal to or larger than:
- a. No. 0
 - b. No. 4
 - c. No. 6
 - d. No. 000
- Ans. _____

MODULE 8.0

MULTIPLE CHOICE (Con't.)

8. The maximum number of overcurrent devices in one cabinet of a lighting and appliance panelboard shall be:

- a. 30
- b. 36
- c. 42
- d. 48

Ans. _____

9. Panelboards equipped with snap switches rated at 30 amps or less, shall have overcurrent protection not in excess of:

- a. 150 amps
- b. 300 amps
- c. 100 amps
- d. 200 amps

Ans. _____

SHORT ANSWER:

1. Does room temperature affect the operation of fluorescent lamps?
2. In what units is light measured?
3. Can the light output of incandescent bulbs be increased? Explain.
4. Does frequent starting and stopping of fluorescent lighting affect the bulb life?
5. Do the filaments stay lit during the operation of a fluorescent bulb? Explain.

PERFORMANCE TEST:

1. Given the materials needed, draw a master-control lighting system with one circuit with two groups of lamps. The drawing must be acceptable to the instructor.

TRUE-FALSE:

- () () 1. The rapid-start ballast circuit is the most popular fluorescent lamp circuit in use today.
- () () 2. The instant-start fluorescent lamp requires no starter.
- () () 3. Allowing failed lamps to stay in the circuit eventually will cause ballast troubles.
- () () 4. An SCR can be used to control lights.
- () () 5. The brightness of fluorescent lamps cannot be controlled.

PERFORMANCE TEST:

1. Given an electrical wiring plan and specifications for a commercial structure interpret the drawing and information to determine installation material requirements and calculate commercial service entrance requirements.

COMPETENCY RATING
0 / 1 / 2 / 3 / 4

2. Given a requirement for the installation of conduit (type to be determined by the instructor or specifications), hand and other tools as needed, and other materials required; install and secure conduit to specifications and to meet NEC and instructor's standards.

COMPETENCY RATING
0 / 1 / 2 / 3 / 4

3. Given a requirement to install conductors in conduit or raceways, conductors, hand tools and other materials as needed, and a copy of the NEC; install conductors in conduit. Terminate conductors as required by specifications or the instructor. Calculate the number of conductors according to the NEC.

COMPETENCY RATING
0 / 1 / 2 / 3 / 4

4. Plan a commercial lighting circuit using information provided by the instructor and the NEC. Calculations and plans must be acceptable to the instructor.

COMPETENCY RATING
0 / 1 / 2 / 3 / 4

5. Using given materials and tools and a simulated situation, install and wire a commercial lighting fixture to meet NEC or local codes. Performance must be to the instructor's standards.

COMPETENCY RATING
0 / 1 / 2 / 3 / 4

PERFORMANCE TEST:

Diagram a commercial surface metal raceway circuit containing a light fixture, a single pole switch, a duplex receptacle, and a multiple raceway receptacle. The diagram must be according to NEC standards and must be acceptable to the instructor.

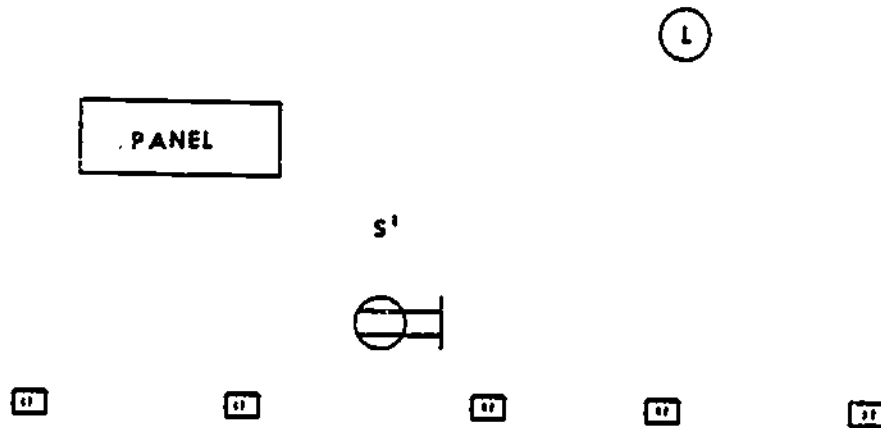
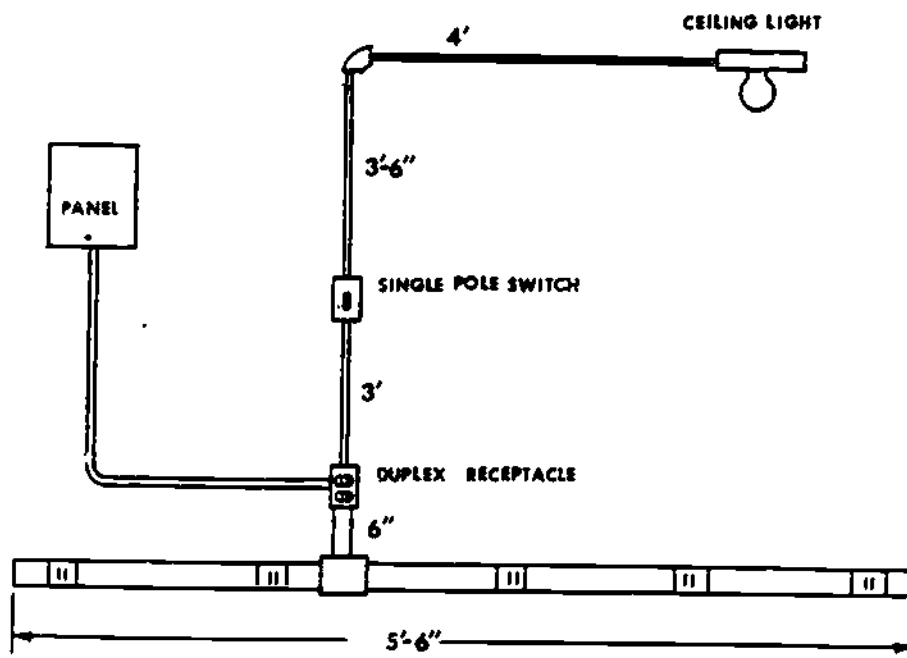

Fig. 1



LONG ANSWER:

1. Article 450-2 requires that transformers and transformer vaults be readily accessible to qualified personnel for inspection and maintenance. You often see 480 to 120-240 volt transformers for lighting, etc., mounted high on walls or columns. Are these situations violations of the NEC?
2. Is it acceptable to mount a 50 KVA dry type (completely enclosed except for ventilation openings) 480 volt transformer directly on a plywood wall?
3. Generally speaking, must all oil insulated transformers installed indoors be installed in vaults?
4. Above what voltage must Askarel-insulated transformers be installed in vaults?
5. What would be the minimum size combined natural ventilation opening for a 1,000 KVA bank of transformers located in a vault?

MODULE 9.0 - UNIT 9.0A

PERFORMANCE TEST:

1. Wire the circuit in illustration below to match the load voltage requirements. Drawing must be to instructor's standards.

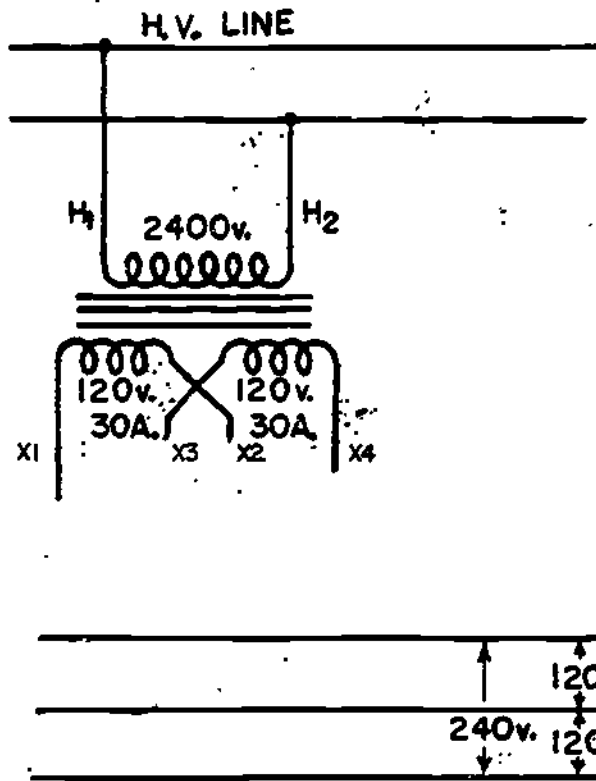

MODULE 9.0 - UNIT 9.0A

2. Wire the two single phase transformers illustrated below to provide the secondary voltages shown. The transformers have a 1:1 ratio and should be connected open-delta or V-V. Drawing must be 100% acceptable to instructor.

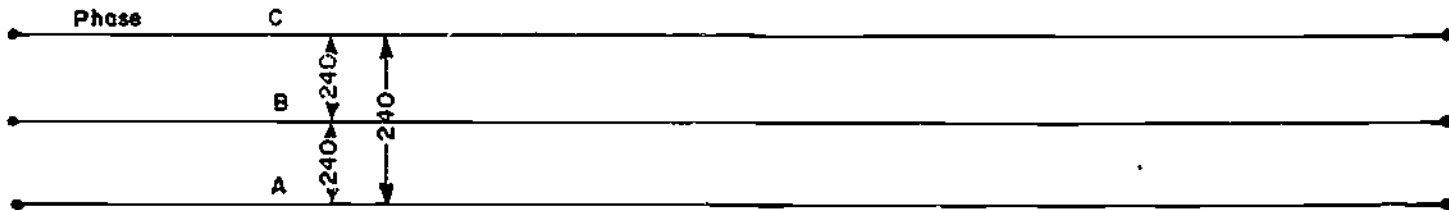

1:1 Ratio

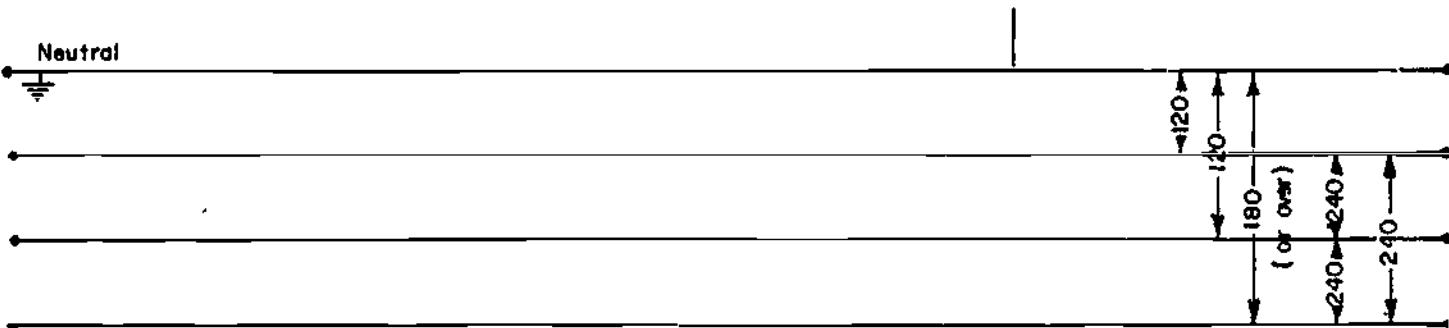
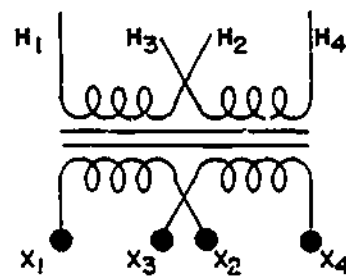
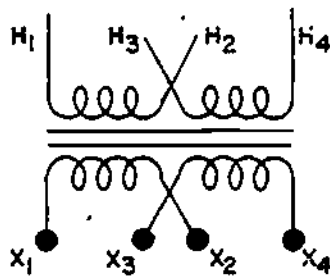

MODULE 9.0 - UNIT 9.0A

3. Wire the single phase transformer below for a delta-wye bank. The transformers have a 1:1 ratio and should be connected to provide the voltages shown. Drawing must be 100% acceptable to instructor.

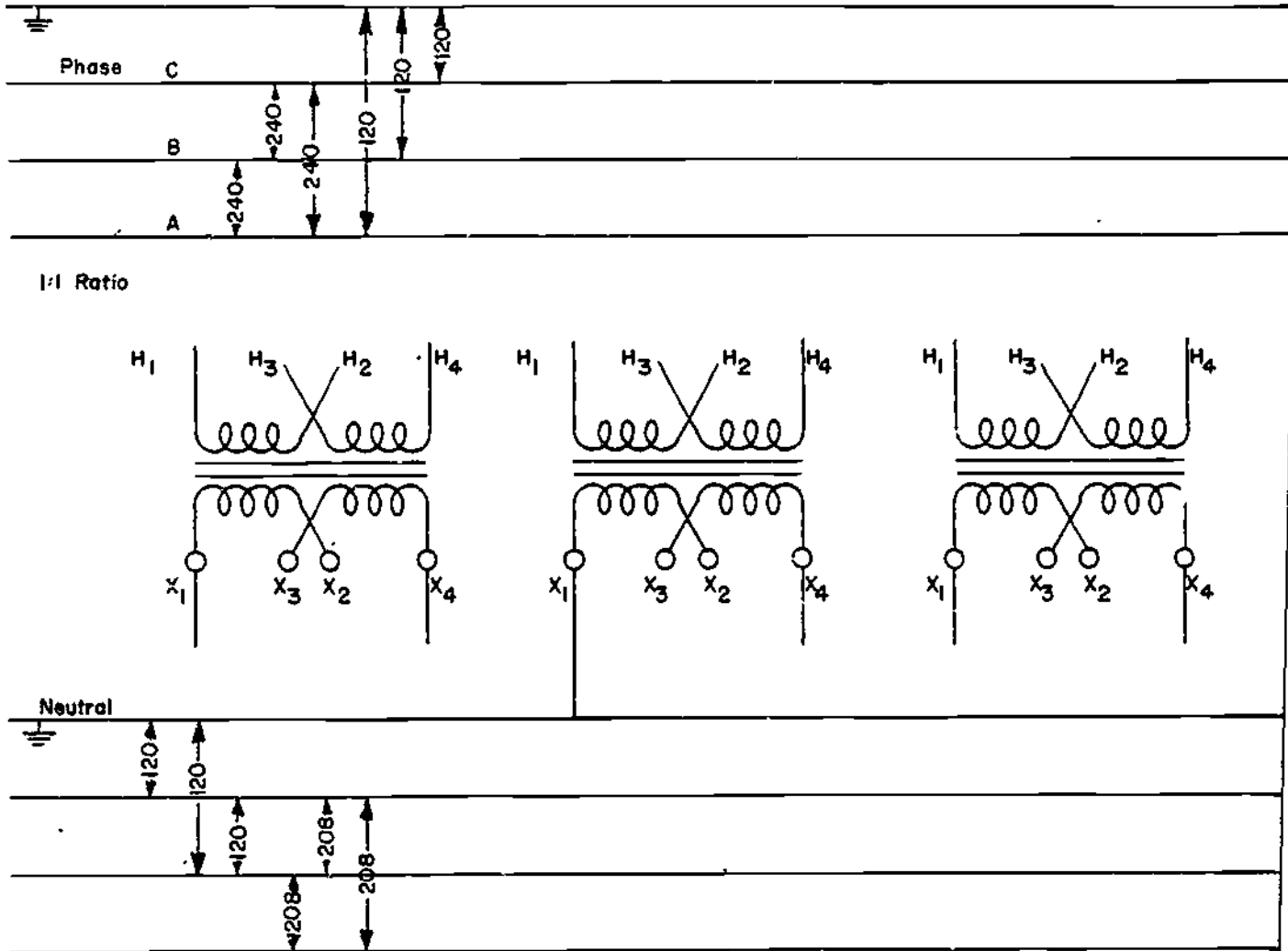

IDENTIFY:

1. Given standard symbols of electrical components used in industrial applications, identify the symbols with an accuracy of at least 80%. Terminology must be correct and acceptable to the instructor.
2. Given a diagram or schematic of an industrial electrical control circuit, interpret the circuit by indentifying the components with 100% accuracy and by identifying any errors that exists in the diagram/schematic.

PERFORMANCE TEST:

1. Draw a schematic wiring diagram of a low voltage control circuit described by the instructor. The circuit should be 100% accurate and should operate as designed if constructed.

COMPETENCY RATING
0 / 1 / 2 / 3 / 4

2. Draw control-panel diagrams (schematics) as specified in information provided by the instructor or to represent an actual circuit mock-up, etc. The drawing must be 100% accurate and must be to the standards of the instructor concerning the quality, use of symbols, use of parrallel and vertical lines, etc. The drawing must be neat and must communicate the circuit correctly to others.

COMPETENCY RATING
0 / 1 / 2 / 3 / 4

3. Update schematic print files for given controls or machinery based on given information, mock-ups, etc., provided by the instructor. The updated information must be correctly illustrated using proper vertical and horizontal lines, correct symbols, and must be neat. The circuit update must be 100% accurate.

COMPETENCY RATING
0 / 1 / 2 / 3 / 4

ANSWER KEY:

1.

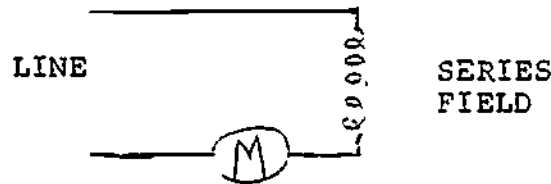

The field of a series-wound motor is wound in series with the armature.

2.

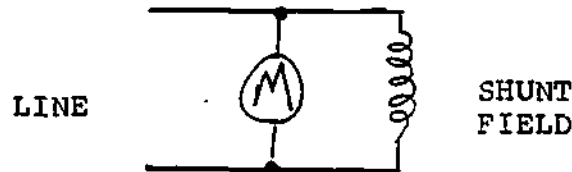

A shunt-wound motor has the field winding in shunt, or parallel, with the armature. The field consists of many turns of small wire, since it must be able to handle the line voltage that is connected across it.

3.

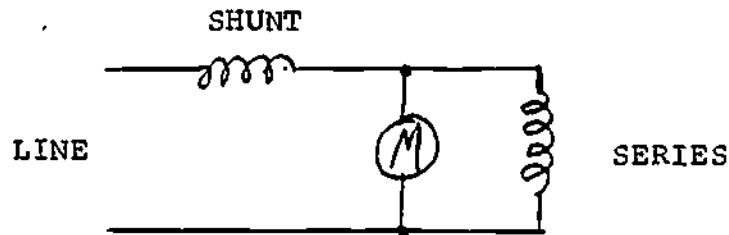

A compound-wound motor is a combination of series and a shunt-wound motor and has better speed regulations than either one.

4. A squirrel-cage motor is one with the winding on the stator, or line winding. The rotor consists of a winding made of bars that are permanently short circuited at both ends by a ring.

5. By reversing either the running or starting coil leads where they are connected to the line, the direction of rotation of a capacitor-start motor is reversed.

PERFORMANCE TEST:

1. Troubleshoot the circuit shown below according to the following information.

PROBLEM: Motor does not turn on. Assume that the motor has been checked and is good. Both the float switch and overload contacts have been jumped with a fuse jump wire and found to be good.

PROCEDURE: Circle the part of the circuit that probably contains the fault, both in the line diagram and wiring diagram.

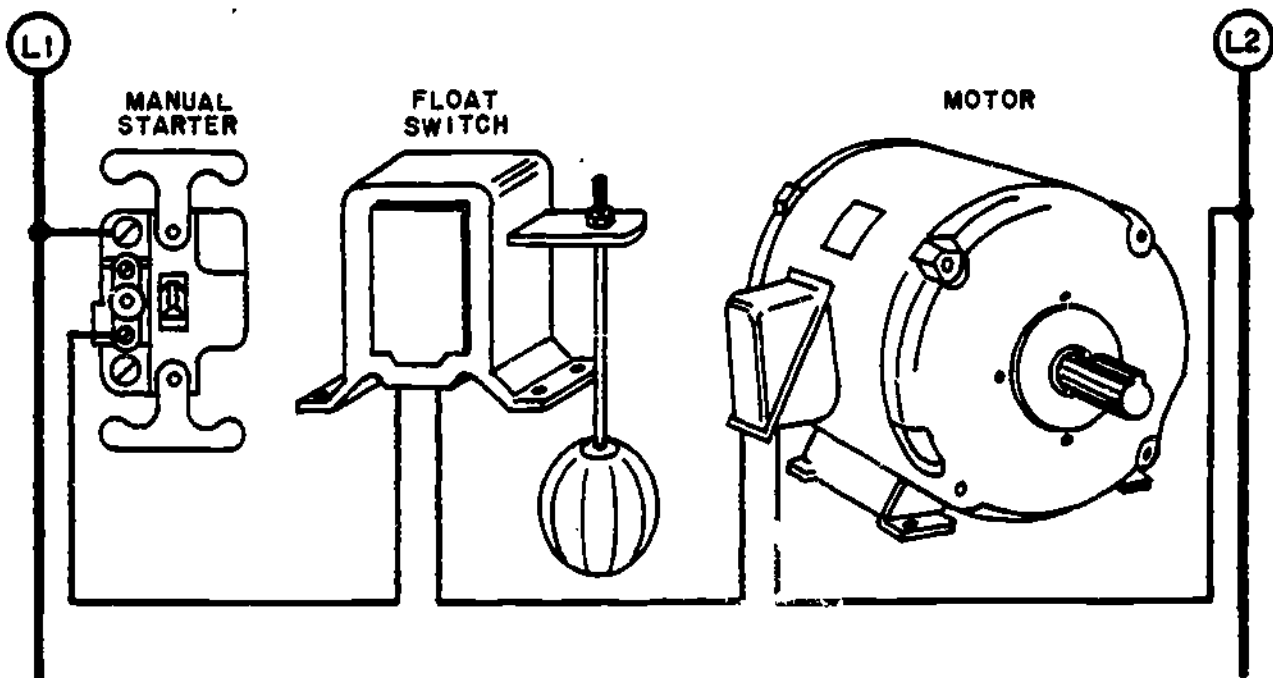
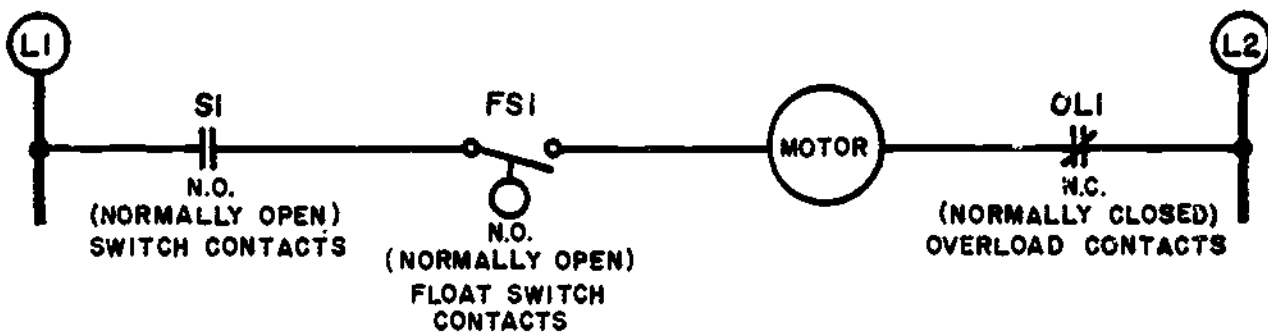

PERFORMANCE TEST:

1. The following diagrams illustrate the use of the Amprobe (Volt-ohm-ammeter) to test for _____ .
 - a. a grounded phase.
 - b. an open winding.
 - c. for a short.
 - d. all of the above.

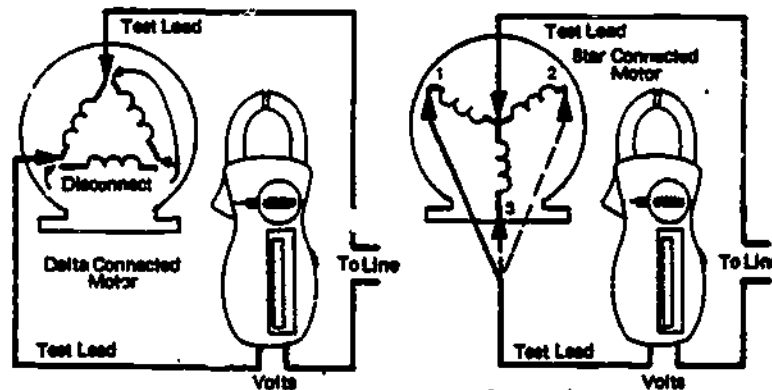

2. The following diagrams illustrate the use of the Amprobe (Volt-ohm-ammeter) to test for _____ .
 - a. grounded phase
 - b. an open winding
 - c. voltage to winding
 - d. none of the above
 - e. all of the above

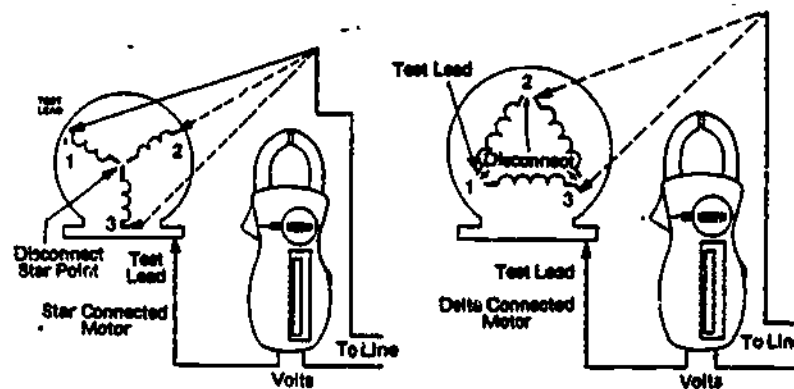

3. Review the diagram below. The test set-up is using the Amprobe connected as shown to test for a winding short circuit. A full line voltage reading on the Amprobe means _____.
- a. windings are good
 - b. windings are shorted
 - c. voltage is applied, no diagnosis possible
 - d. none of the above.

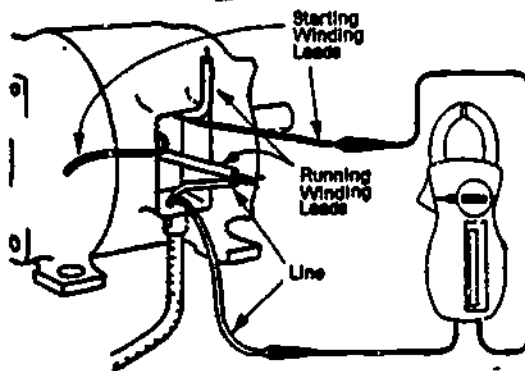

4. To test a centrifugal switch, the test set-up below results in a current indication after the motor is up to speed. The correct diagnosis is _____.
- a. the centrifugal switch opened
 - b. the centrifugal switch did not open
 - c. neither of the above
 - d. motor is operating properly.

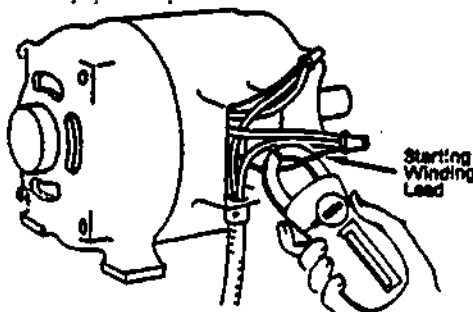

5. In the below diagram, the Amprobe is set up to check an AC electrolytic capacitor. If there is no current indication, the capacitor is _____.

- a. open
- b. short
- c. operating properly
- d. questionable

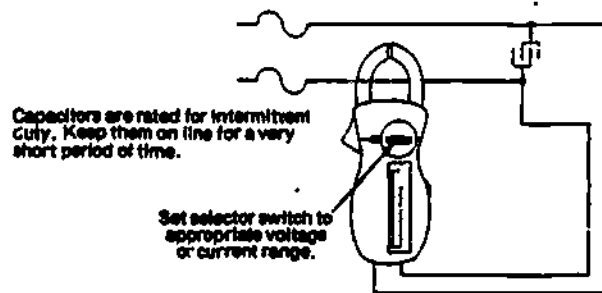

6. In the diagram above, if the set-up blew a fuse when the line voltage was applied, what would be the correct diagnosis?

- a. open capacitor
- b. shorted capacitor
- c. too much current drawn by set up
- d. none of the above

SHORT ANSWER:

1. What is the maximum allowable distance between a motor and its controller that can be considered "in sight"?
2. Where do you find important information about the motor?
3. What size wire is required for a circuit supplying a one 1-amp motor, one 7.5-amp motor, and two 5-amp motors?
4. What type of motor overload protection would be required by a 2hp hoist?
5. Would it be alright to connect two 6.5 ampere 3/4hp motors to a 120 volt 20 amp branch circuit?
6. Are motor overload relays as they are typically used capable of opening short circuits?
7. Would a portable air compressor with a 3hp motor require a horsepower rated disconnect?
8. Are junction boxes to house motor terminals always required by the NEC?
9. Calculate the rating of a disconnect switch needed for a combined load of two 5hp motors, one 2hp, one 1hp, and 2 amperes of resistance load at 460 volts 3 phase all starting at the same time.
10. Would it be permissible to use a 12 amp rated portable cord connected room air conditioner on a 20 amp circuit that also supplied a lighting unit?

TRUE-FALSE:

- () () 1. When the coil of a generator is not cutting lines of magnetic flux, no electricity is generated.
- () () 2. The shifting of the brush assembly of a DC generator will change its armature reaction.
- () () 3. The left-hand rule is used to determine the direction of current flow through a wire for the purpose of explaining the operation of DC motors.
- () () 4. A shunt motor will operate only on AC.
- () () 5. Direct current motors can be reversed by changing the polarity.
- () () 6. The series motor, according to the characteristics chart, draws more current when the speed decreases due to increasing the load.
- () () 7. The series motor increases its torque as its speed decreases.
- () () 8. Either three-phase or single-phase transformers can be used with three-phase power.
- () () 9. The shaded-pole motor will not start without external aid.
- () () 10. Split-phase motors are used where there is need to start under load.
- () () 11. A capacitor-start motor has a high starting current and the ability to start under load.
- () () 12. Generally, single-phase motors are more expensive to purchase and to maintain than three-phase motors.
- () () 13. The synchronous motor is self starting.
- () () 14. Synchronous motors can be used to correct power factor.
- () () 15. A synchronous motor depends upon its frequency rather than voltage for its speed.

MULTIPLE CHOICE:

1. Another name for a AC generator is:
- a. alternator
 - b. dynamo
 - c. shunt reactor
 - d. static generator
- Ans. _____
2. Alternating current generators produce a waveform called:
- a. sine wave
 - b. cosine wave
 - c. pulsations
 - d. pulsating DC
- Ans. _____
3. The rotating field in a generator is called the:
- a. rotator
 - b. rotor
 - c. revolver
 - d. regenerator
- Ans. _____
4. Which AC motor is the most widely used?
- a. synchronous
 - b. capacitor-start
 - c. induction
 - d. split phase
- Ans. _____
5. In a single-phase motor, the direction of rotation can be reversed by:
- a. reversing any two wires
 - b. reversing the start winding wires
 - c. reversing the run winding wires
 - d. reversing all wires
- Ans. _____

MULTIPLE CHOICE:

1. A _____ condition is one that will respond to changes in a system.
 - a. manual
 - b. automatic
 - c. standard
 - d. mechanical
2. One advantage of using a double break contact instead of a single break contact is that the double break contact _____.
 - a. has a higher contact rating in a smaller space.
 - b. has a higher contact rating when enclosed in a steel case.
 - c. is not made of soft copper.
 - d. does not present an electrical hazard.
3. Excessively noisy solenoids may be the result of _____.
 - a. broken shading coil.
 - b. voltage too low.
 - c. dirt, rust, or fillings on the magnetic face.
 - d. all of the above.
4. An actuator designed for applications where a direct thrust with a limited travel is accomplished is the _____.
 - a. pushroller actuator.
 - b. standard actuator.
 - c. wobble-stick actuator.
 - d. fork-lever actuator.
5. A limit switch is a control device used to switch an electrical circuit _____.
 - a. manually
 - b. mechanically
 - c. automatically
6. A logic module belongs to the _____.
 - a. signal part of the control circuit.
 - b. decision part of the control circuit.
 - c. action part of the control circuit.
 - d. power part of the control circuit.

7. The speed of an AC squirrel cage motor can be changed by _____.
- a. changing the number of poles.
 - b. changing the supply voltage.
 - c. changing the supply current.
 - d. adding interpoles connected to the armature.
8. Reduced voltage starting is used as a means of _____.
- a. reducing the starting current.
 - b. speed control.
 - c. full voltage starting.
 - d. starting difficult loads.
9. A pressure switch is a control device used to switch an electrical circuit. _____.
- a. manually
 - b. mechanically
 - c. automatically
10. In a photoelectric application, the operating point at which the level of light intensity will trigger the output is determined by the _____.
- a. sensitivity.
 - b. differential adjustment.
 - c. voltage adjustment.
 - d. current adjustment.

IDENTIFY:

1. The circuit below is an example of _____ control logic.

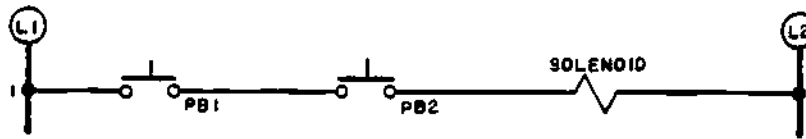

2. The circuit below is an example of _____ control logic.

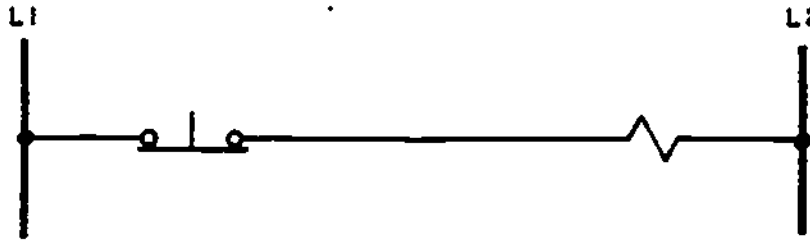

3. The circuit below is an example of _____ control logic.

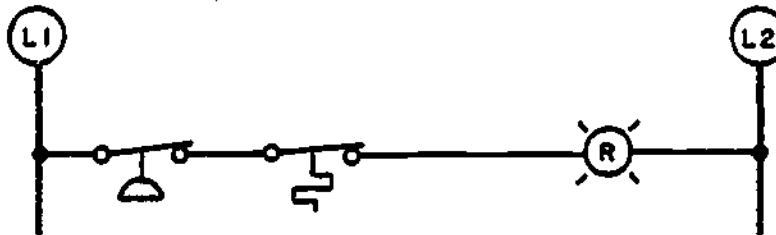

4. The circuit below is an example of _____ control logic.

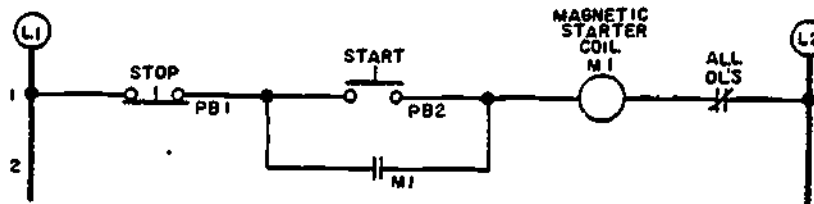

5. The circuit below is an example of a combination of _____ and _____ and _____ logic.

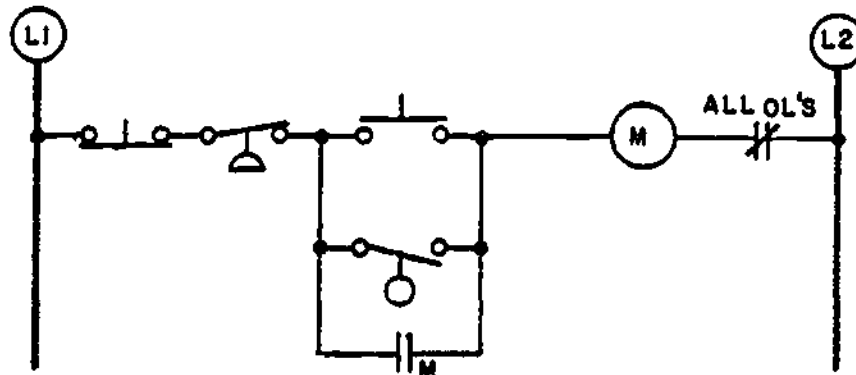

SHORT ANSWER:

1. How can you use low voltage to control a motor starter that is designed for use on high voltage?

2. What is plugging?

3. What is jogging?

4. What is a universal motor?

5. Calculate the speed of a 60 cycle, 4-pole AC motor.

DRAW SCHEMATICS

1. Draw a schematic of a low-voltage control using a control relay to energize the magnetic coil with full voltage.

2. Draw a schematic of a magnetic starter with three stop-start stations.

3. Draw a schematic of three motors that are all started and stopped from one start-stop station so that they will all stop if one overload trips.

4. Draw a diagram of a two-speed AC motor control with push-button control.

5. Draw a diagram of a magnetically operated DC motor started with three push-button control stations.

PERFORMANCE TEST:

1. Troubleshoot the circuit shown below to the following information.

PROBLEM: Magnetic starter coil M1 starts and remains engaged after the start pushbutton is pressed, regardless of the position of the selector switch.

PROCEDURE: Circle with red pencil the part of the circuit that probably contains the fault.

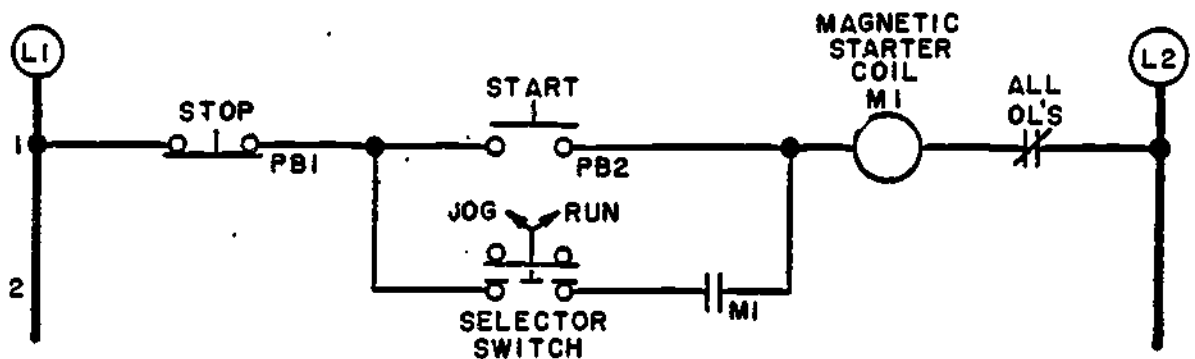

PERFORMANCE TEST:

2. Troubleshoot the circuit shown below according to the following information.

PROBLEM: The motor is running hot and does not seem to have much power. A test with a voltmeter indicates that there is only about one-half the required voltage at terminals T1, T2, and T3 of the motor.

PROCEDURE: (1) Illustrate how a fused jumper or jumpers could be connected to eliminate trouble with the control circuit.
 (2) Illustrate how a voltmeter could be connected to test the power circuit for the source of trouble.

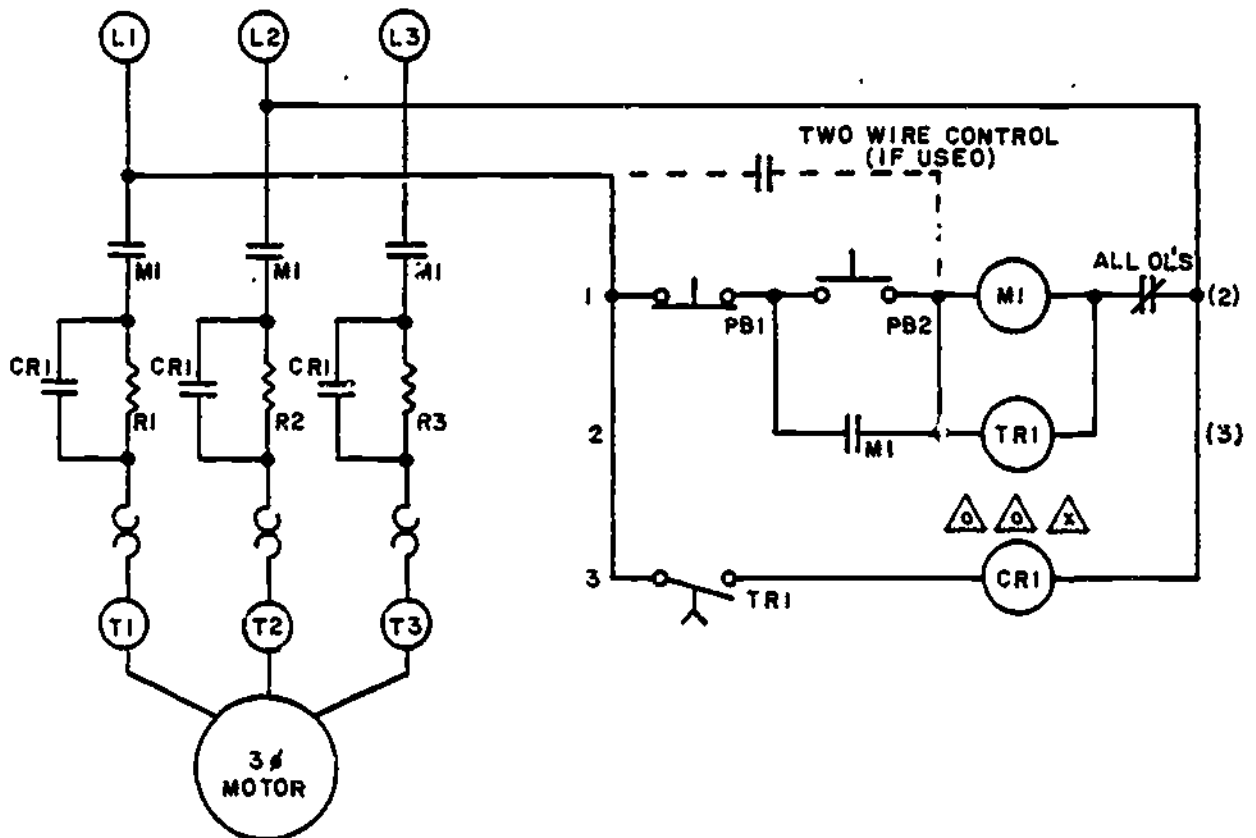

PERFORMANCE TEST:

1. Given a manual motor controller, a functional motor, the necessary equipment and materials; install a manual motor control station. The controller must cause the motor to accelerate through all positions until the motor runs at the rated speed and current.

PERFORMANCE RATING

0 / 1 / 2 / 3 / 4

2. Given the required components, work station, tools and all necessary materials; install a magnetic motor starter with two remote pushbutton controllers according to a diagram/schematic provided. The control station must be to specifications and must operate as intended. Performance and product must be to instructor's standards.

PERFORMANCE RATING

0 / 1 / 2 / 3 / 4

3. Connect a computer based controller to a series of devices using solid state relays or the equivalent and program the controller to operate the devices in a desired sequence. Performance and product must be acceptable to the instructor. No damage must occur to the programmable controller. Performance must be 100% accurate.

PERFORMANCE RATING

0 / 1 / 2 / 3 / 4

4. Given a motor control with jogging capability, functional motor, the necessary tools, equipment and materials; install a jogging control circuit. The completed circuit will function in the run position; but, when the jog button is pressed the control circuit will be energized only for that period of time. The circuit must not be energized when the stop button is pressed and held down. Performance must be to the standards of the instructor.

PERFORMANCE RATING

0 / 1 / 2 / 3 / 4

5. Given possibly defective controls, necessary references, VOM, clamp-on amprobe, required tools and equipment; troubleshoot the control circuit and control devices to identify repair(s) needed or if controls should be replaced. Repaired circuits should operate as intended. Performance must be within given time and must meet instructor's standards.

PERFORMANCE RATING

0 / 1 / 2 / 3 / 4

IDENTIFY:

Identify the following characteristics as related primarily to the electromechanical (EMR) or solid state relay (SSR).

EMR - SSR

- () () 1. Arcless switching of the load
- () () 2. AC and DC switching
- () () 3. Multipole and multithrow switching
- () () 4. Zero voltage turn-on

DRAW SYMBOLS FOR ELECTRICAL/ELECTRONIC COMPONENT AND IDENTIFY THE PARTS CORRECTLY.

1. Diode

2. SCR

3. TRIAC

4. LED

5. Carbon resistor

MULTIPLE CHOICE:

1. The below illustration is of a: Ans. _____
- a. direct control solid state relay.
 - b. transformer isolated solid state relay.
 - c. hybrid solid state relay.
 - d. optically isolated solid state relay.

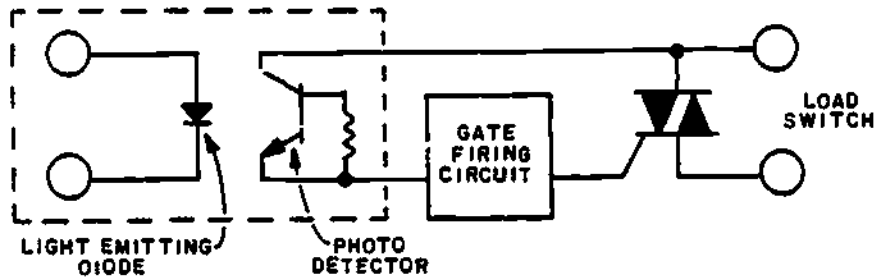

2. Below is an illustration of: Ans. _____
- a. direct control solid state relay.
 - b. transformer isolated solid state relay.
 - c. hybrid solid state relay.
 - d. optically isolated solid state relay.

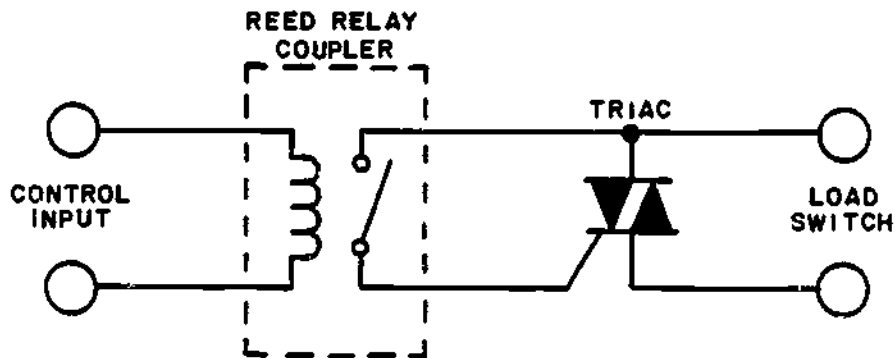

PERFORMANCE TEST:

1. Given the below schematic using the LED as a 120 VAC pilot lamp, LED, diode, and appropriate resistor, soldering iron, and all necessary tools and materials, construct the circuit so that it operates as intended. Measure the voltage to the LED with a VOM and adjust the resistor if the voltage is too high.

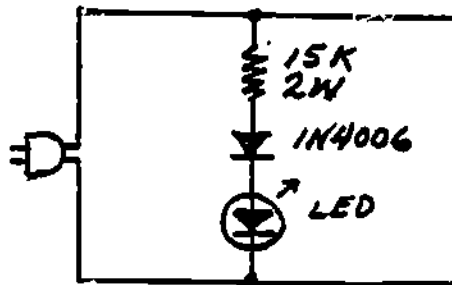

PERFORMANCE TEST:

2. Given a requirement for a solid state relay such as between a computer programmable controller and AC controllers, solid state relay, relay specifications and all necessary tools and materials; install the solid state relay. The solid state relay must be selected for the application and connected so that it properly isolates the controlling and controlled circuit.

PERFORMANCE RATING

0 / 1 / 2 / 3 / 4

3. Given a schematic diagram of a SCR speed control circuit, components, component list, motor or other device to be controlled, variable DC and AC power supplies/sources, VOM and the necessary tools and materials, construct a SCR speed control circuit. Circuit construction will be according to schematic diagram provided, components and wiring must be mechanically and electrically secure, and the control circuit must operate or control another device as intended.

PERFORMANCE RATING

0 / 1 / 2 / 3 / 4

4. Given a photoelectric electronic sensing device, the necessary material and equipment and tools; install the photoelectric sensing device in a circuit according to the schematic provided. The device must operate without fault through a complete testing cycle and be set to delay its operation according to the requirements of the installation.

PERFORMANCE RATING

0 / 1 / 2 / 3 / 4

1. Based on the following pricing information, and on the dimensions in the illustration below, complete the bill of materials.

Feeder busway duct	\$ 30 per foot	Crosses	\$200 each
Plug-in busway duct	35 per foot	50 amp breakers	150 each
Elbows.....	150 each	100 amp breakers	200 each
Tees	170 each		

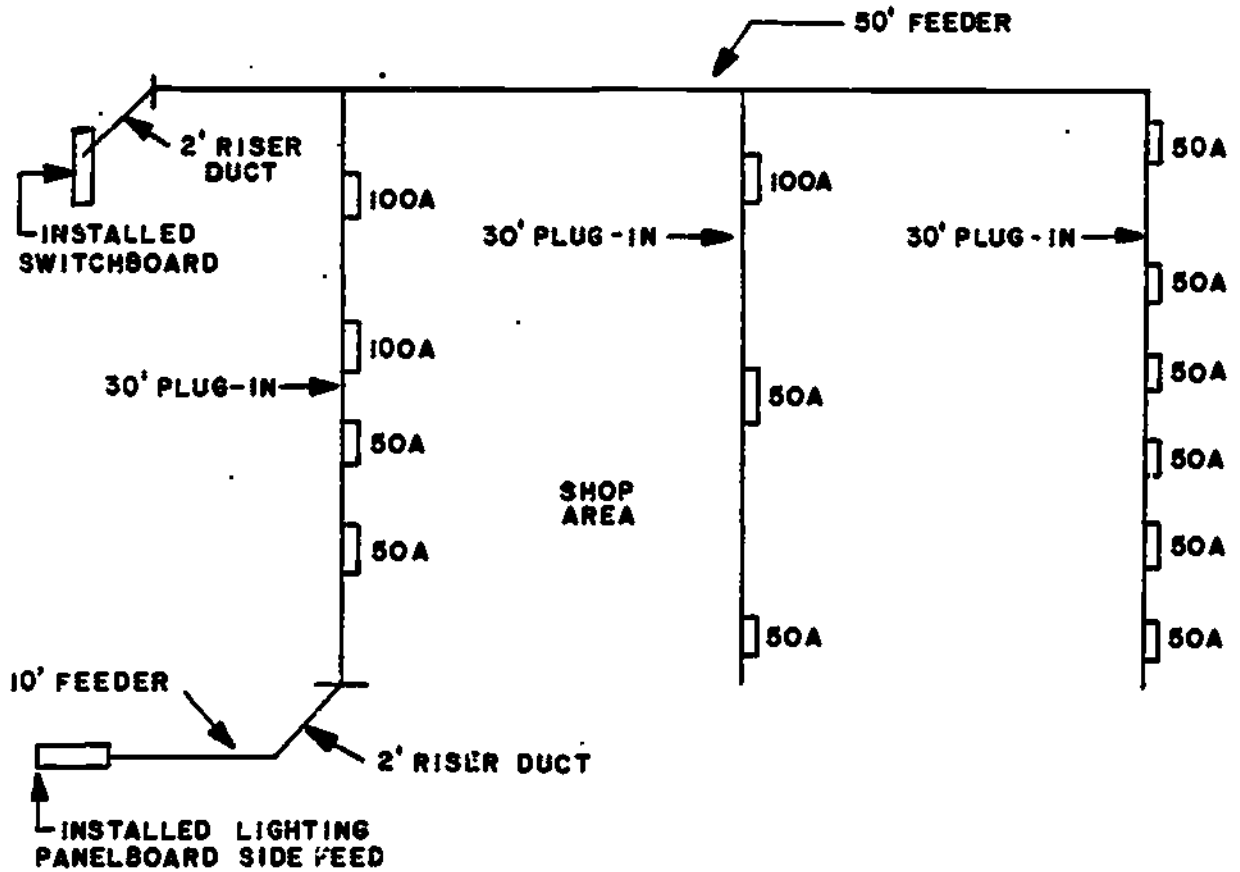

BILL OF MATERIALS

_____ feet of feeder duct @ \$ _____/ft.	Totals
_____ feet of plug-in duct @ \$ _____/ft.	\$ _____
_____ elbows @ \$ _____/ea.	\$ _____
_____ tees @ \$ _____/ea.	\$ _____
_____ crosses @ \$ _____/ea.	\$ _____
_____ 50 amp breakers @ \$ _____/ea.	\$ _____
_____ 100 amp breakers @ \$ _____/ea.	\$ _____
	\$ _____
TOTAL	\$ _____

2. Based on the simple sketch of the busway system shown below, fill in the bill of materials based on pricing information and dimensions given.

PRICING INFORMATION

Feeder busway duct	\$ 30 per foot	Crosses	\$200 each
Plug-in busway duct	35 per foot	50 amp breakers	150 each
Elbows.....	150 each	100 amp breakers	200 each

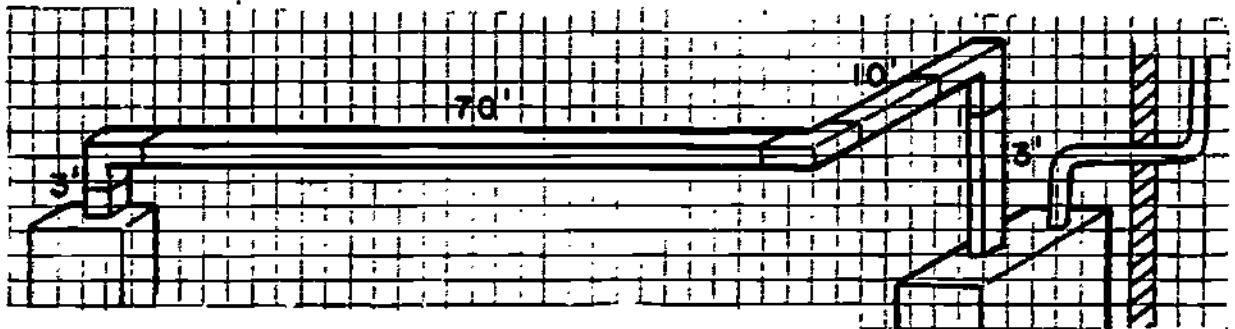

_____ feet of feeder duct # \$_____ per foot	Totals
_____ feet of plug-in duct # \$_____ per foot	\$ _____
_____ elbows # \$_____ each	_____
_____ tees # \$_____ each	_____
_____ crosses # \$_____ each	_____
_____ 50 amp breakers # \$_____ each	_____
_____ 100 amp breakers # \$_____ each	_____

PERFORMANCE TEST:

1. Given a blueprint of a structure such as a residence and the necessary information for estimating the job; determine the materials needed to complete the job and estimate the cost of the materials. Performance must be to the instructor's standards. Calculations must be accurate.

PERFORMANCE RATING

0 / 1 / 2 / 3 / 4

2. For the job described above, estimate the cost of labor needed to complete the job. Calculations must be accurate.

PERFORMANCE RATING

0 / 1 / 2 // 3 / 4

3. Given a electrical wiring job to complete, plan a sequence of work operations so that the job is accomplished in the minimum time, using the least labor, in a logical sequence. Performance will be rated by the instructor and must meet the instructor's standards.

PERFORMANCE RATING

0 / 1 / 2 / 3 / 4

4. As required by the instructor, inventory equipment, materials, and supplies in the electricity shop. Complete a trouble report on tools, equipment, and materials not servicable. Assist the instructor in accounting for electrical tools and other training equipment. Performance must meet the standards of the instructor.

PERFORMANCE RATING

0 / 1 / 2 / 3 / 4

APPENDIXES

APPENDIX A	JOINT ARTICULATION AGREEMENT
APPENDIX B	INSTRUCTOR'S SIGNED AGREEMENT TO ARTICULATE
APPENDIX C	PHILOSOPHY OF ARTICULATION GUIDE DESIGN
APPENDIX D	PURPOSES OF ARTICULATION GUIDE
APPENDIX E	DEFINITION OF TERMS
APPENDIX F	PREVIOUS ARTICULATION INFORMATION
APPENDIX G	CRITERIA FOR SCHOLARSHIP STUDENT
APPENDIX H	DIRECTIONS FOR TESTS
APPENDIX I	ANALYSIS OF SECONDARY INSTRUCTION TIMES
APPENDIX J	RESPONSIBILITY SHEET
APPENDIX K	BINDER DESIGN SHEET

THE SCHOOL DISTRICT
OF GREENVILLE COUNTY

GREENVILLE TECHNICAL COLLEGE

TO: All Administrators, Staffs and Faculties, The School District of
Greenville County and Greenville Technical College

SUBJECT: Application and Implementation of the Policies and Procedures for
the Articulation of Similar Vocational Training Programs of
Instruction

Since 1976, The School District of Greenville County and Greenville Technical College have been working toward making the articulation of vocational education programs a viable and valid reality. Through joint efforts in the Occupational Education Articulation Program. The School District of Greenville County and Greenville Technical College fully support the concept of articulation and agree upon the purposes of the articulation program.

This Policies and Procedures Guide has been developed as a joint effort of The School District of Greenville County and Greenville Technical College with the assistance of individuals representing the institutional administrative units, involved faculty, and the local business and industrial community. The Policies and Procedures Guide is designed to assist the articulation of very similar programs of vocational training between the secondary and post-secondary, public, vocational training institutions in Greenville County.

Appreciation is expressed to participants at both institutions for the joint effort of this endeavor.

J. F. Hall
Superintendent
The School District of
Greenville County

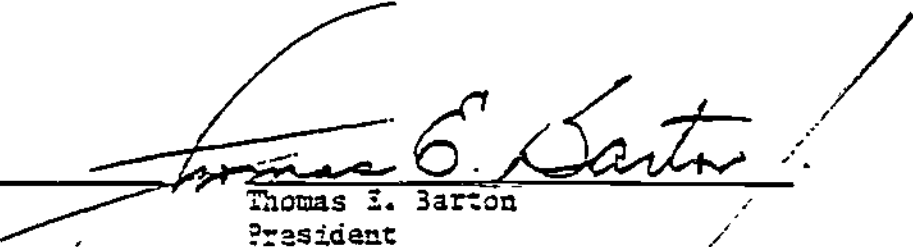
Thomas E. Barton
President
Greenville Technical College

TASK FORCE COMMITTEE
AGREEMENT TO ARTICULATE
VOCATIONAL EDUCATION

Articulation provides a system whereby secondary and post-secondary instructors can cooperate effectively in providing a continuous occupational development program where the level and type of vocational training that leads to entry-level employment skills will be clear to instructors, other educators, students, and potential employers.

The concept of articulation and the articulation program are supported fully by The School District of Greenville County and Greenville Technical College which have agreed upon a statement of purpose for the articulation of similar vocational education programs in Greenville County.

The articulation program in Greenville County is a joint effort of The School District of Greenville County and Greenville Technical College to develop a continuous program of vocational training so that students may continue their career preparation without loss of time or waste of effort in repeating tasks which have been learned previously and demonstrated. Articulation program activities are designed to help remove unnecessary gaps or overlap in student learning which may occur when a student completes a secondary vocational program and continues career development at the post-secondary level in a similar occupational field.

To implement articulation, instructor representatives from the participating institutions have met as a task force committee to develop this articulated, performance-based instruction guide which describes the secondary vocational program and which provides the parameters for vertical articulation.

Vertical articulation shall include recognition of the occupational competencies demonstrated by secondary graduates of articulated vocational programs.

It is agreed that...

The task force committee instructor representatives from The School District of Greenville County and Greenville Technical College mutually recognize the value of occupational education provided by each institution.

The task force committee instructor representatives will take the necessary actions, approved by their administrations, to ensure that this agreement to articulate is fulfilled including interpreting the program to students.

It is understood that periodic review of the articulated task objectives, performance actions, minimum standards, and outcome-referenced measures will be necessary to ensure that a valid training program is serving the needs of the community and the students.

PHILOSOPHY OF ARTICULATED, PERFORMANCE-BASED
INSTRUCTION GUIDE DESIGN

The design of the articulated, performance-based instruction guides and the articulation program is based on a philosophy that the vocational education curriculum should be for career training with few fringe or non-related subjects. The student should be given the basis to do useful skilled work upon graduation and employment. The vocational program graduate should have a background which will allow him/her to learn and advance as rapidly as possible on the job, but it should not include subject matter which will not be applicable to his/her work for years. When subject matter is introduced that will not be applicable to the graduate's work for years, it may put the graduate out of perspective. The result might be that the graduate may try to force applications which do not exist, simply because the information is in his/her repertoire. Thus, the purpose of vocational training by the articulated, performance-based instruction guides is to prepare graduates for successful entry into a skilled trade.

To ensure that the design of the articulated, performance-based instruction guides is conforming to the philosophies of both the secondary and post-secondary institutional participants, a periodic review of the guide design and philosophy is recommended.

PURPOSES OF THE ARTICULATED INSTRUCTION GUIDE

The articulated instruction objectives guide are is expected to serve the following purposes:

1. The guide serves as the primary vehicle for the articulation of subject matter in similar vocational training programs between the vocational education centers, high schools, and Greenville Technical College through use by instructors at both levels as a reference in preparing instruction.
2. The guide provides a listing of the minimum tasks that a student or worker is expected to perform in the conduct of a specific level job in the area of vocational training or work of concern.
3. The guides identify the primary detailed instruction objectives, performance objectives which are based upon the task listings. The tasks are listed in the sequence of complexity, with the least complex task being listed first, except where a task must be performed as a prerequisite to performance of another task.
4. The guides identify the tasks performed (actions, steps, sets of skills) and related technical information which must be taught and learned to accomplish each major instruction objective. The tasks performed represent the minimum skills and related information required for adequate occupational proficiency in the performance objectives.
5. The guides designate the instructional contact hours necessary to provide the required instruction, as required by appropriate educational agencies or offices and as estimated by the instructor-participants on the Vocational Articulation Project Task Forces, and based on the time required to teach the average learner to perform the task. The time estimated is based on having the essential equipment, facilities and instructional aids required to provide the instruction, whenever the class size is limited to an acceptable number.
6. The guides identify the performance standards to be met for occupational proficiency in the task. Performance standards used are those considered to be minimum business or industry standards. The ability to meet the listed standards of performance will be considered as qualification for advanced instruction in the vocational program.
7. The guides provide direction in the conduct of sequential vocational competency instruction by modules or job tasks, resulting in qualification by the learner to perform limited skill specialist jobs of

progressively higher skills until the program objective is reached (i.e., file clerk to executive secretary, etc.). As the student becomes proficient in the performance of tasks in successively more complex modules, more marketable competencies are gained and may be identified as the lower job qualifications of a specialist.

Through this procedure, even the slower student is provided an opportunity to eventually gain sufficient skills to perform adequately as a specialist at some level in the vocational field, even if the student is unable to complete the total program of training.

The standardized sequence of activities of the vocational instruction modules will facilitate lateral articulation between vocational education centers in the School District and will simplify vertical articulation when training is continued at Greenville Technical College articulating to employers.

8. The guides provide a descriptive listing of equipment required to conduct the program of vocational training. The equipment listed is considered to be the type and quantity essential for the conduct of instruction to prepare students for entry-level employment in the vocational field. It may be necessary to delay teaching some tasks involving special equipment, if that equipment is not available at all instructional sites, or to move students and equipment together as necessary to teach skills.
9. The guide provides information about requirements or limitations that typically are involved in the performance of the task, environmental conditions and physical demands, and able to perform the task.
10. The guides provide a list of standardized performance test items/ and outcome-referenced measures to be used in the determination of vocational proficiency. As long as the specifics are not provided, the test items listed cannot be compromised easily and could serve as study guides.
11. The tasks listed in the guide are the minimum requirements for job qualification under average circumstances in a regional market. It is understood that there may be unlisted tasks that some employers may require the worker to do in the occupation, when in their employment. In addition, there may be unlisted tasks, such as mental process tasks, that are not stated but that may occur and that should be considered in instructional planning or testing.

Instructors may teach skills and related technical information other than what is shown in the guides. Provision of additional information should be limited to the students who have completed the requirements for the tasks emphasized in the instructional guides. The change of tasks in the guides should be based on task force committee agreement to ensure lateral and vertical articulation.

12. It is expected that there will be updating and correction of items in the articulated instruction guide. Participants are to be sure that the contents are valid and consistent with business and industry requirements. Recommendations should be submitted to the Vocational Articulation Program office which will assemble and present them to the appropriate committee for review and possible adoption.
13. Typically, the teacher/instructor should not plan to conduct instruction in a given articulated module unless the capability exists to conduct all of the instruction to meet the instructional objectives, with the result that the successful student is qualified to perform the tasks identified within the module.
14. An underlying philosophy in vocational training is that it is better to prepare the student to be fully qualified to perform all of the tasks in a limited group of modules in a vocational field and be qualified at a lower job level rather than to be only familiar with a large number of task descriptions or duties and qualified to perform none of them fully. For higher levels of job qualification beyond the secondary level, the student or worker is encouraged to enroll at Greenville Technical College.
15. Generally, vocational programs will include certain basic modules or courses of instruction without which the student would not be considered vocationally qualified at any level. Basic modules typically will be identified and taught early in the program sequence.
16. The instruction guides provides information essential to help the vocational student who completes training at the secondary level and continues career development training at the post-secondary level in a similar program receive appropriate credit for the articulated vocational training that has been mastered at the secondary level.

DEFINITIONS OF TERMS

The following definitions of terms are applicable to the articulated, performance-based instruction guides developed as products of the Occupational Education Articulation Program.

- Behavior: The actions of a person (specifically, job or job training actions). Behavioral actions include both overt, those that can be observed, and covert, those not observable outwardly. Performance may be interchanged with behavior in the project. (See also Performance Actions).
- Concept: A group of ideas that may be classed together or that are similar.
- Criteria: A standard by which performance may be measured, usually considered the minimum standard.
- Domain: A cluster of related jobs.
- Duty: One of the distinct major activities involved in the work performed and comprising related tasks.
- Evaluation: When comparison is made between a measurement and a standard and judgment is passed on the comparison.
- Item: A single stimulus or stimulus pattern that calls for a single response or set of responses. It is one sample of behavior or performance. The response may be simple or complex.
- Job: The duties or tasks actually performed by a specified individual.
- Knowledge: In this project, knowledge refers to acquired covert behavior which facilitates skills and performance, such as the theoretical information of what should be done under given circumstances, and in what order of sequence performance should occur to accomplish the objective.
- Measurement: The process of determining the extent some characteristic is associated with the student.
- Module: Modules in the pilot Drafting and Business and Office Education curriculum modifications in the Occupational Education Articulation Program have been designed to

coincide secondary level training with post-secondary level similar areas of training.

Another method of developing modules might be for modules to represent an identifiable, complicated task or job area involving a number of sub-tasks such as "Electrical Systems" in Automotive Mechanics.

Norm-referenced Evaluation: In norm-referenced evaluation, measures are dependent on a relative standard. Measures compare the capabilities of one student to those of other students.

Objective: (See Performance Objective) A stated desired outcome of training or the end result of the job, task, or performance actions. Objectives referred to in this project will be terminal objectives, generally representing a specific job function.

Occupational Education: An organized sequence of learning experiences consisting of vocational theory, practice, and skills taught to students on a regular or systematic basis.*

*Reference: Standards of the Delegate Assembly (Atlanta: Southern Association of Colleges and Schools, Commission on Occupational Education, December, 1972) p. 12.

Outcome-referenced Evaluation: Outcome-referenced, or criterion-referenced, measurement provides a standard of achievement for the individual as compared with specific behavioral objectives and therefore provides information about the degree of competence attained by the student.

The outcome-referenced measure is a performance or other measure based upon a performance objective, the accomplishment of which measures attainment of that objective.

Performance: Performance is used in this project to refer to a job or task which results from a set of sequential actions or steps.

Performance Actions: A series of steps, generally arranged in a sequence ordinarily followed, which when completed may result in the accomplishment of a performance objective (performance of a task).

Performance actions may be referred to as a set or sets of skills, functions, or steps. V-TEC (Vocational-Technical Education Consortium of States) catalogs generally describe performance actions in the "performance guide" of their format.

Articulated. Performance-based Instruction Guide: A comprehensive collection of performance objectives, performance actions to obtain those objectives, suggested hours for instruction (for planning purposes), performance standards, related technical

information, and outcome-referenced measures, as well as general secondary level and post-secondary level descriptions of similar courses for the purposes of aiding lateral and vertical articulation concerning the subject area.

Performance-based Instruction: Performance-based (competence-based) instruction is based on the competencies or tasks performed by on-the-job workers. Everything in a performance-based instruction system is made public beforehand. There are no surprises for student, teacher, counselor, or employer. When the student begins a program, information is available to tell the student exactly what competencies are expected to be developed as a result of the instructional program, how and against what standards or criteria the student will be evaluated, and how the student's competencies will be communicated to the student, instructors, and to employers. A performance-based instructional system tells the student exactly what the student must learn, teaches the student that skill or knowledge, and then tests on mastery of that specific competence.

Performance Objective: A statement in precise, measurable terms of a particular behavior to be exhibited by a learner under specified conditions. It possesses each of the elements or characteristics specified below:

Conditions under which the performance is to take place.

Behavior Desired or expected of the student (things to be done, the performance desired).

Standards to determine how well the performance is to be done (criteria).

Performance Test: A performance test requires the student to demonstrate (master) the desired behavior of the objective (accomplish a job-like task) under controlled conditions and according to predetermined standards. The controlled conditions allow the student to demonstrate the desired behavior and the conditions remain consistent from student to student.

Skill: Primarily, skill refers to overt, observable performance, however, it is recognized that there are covert skills required in some performances.

Step: Step is used to refer to a task or action, generally as a sequence of steps involved in the accomplishment of a performance objective or job.

Systems Approach: The systems approach to instruction emphasizes the specification of instructional objectives, precisely controlled learning experiences to achieve the objectives, criteria for performance, and evaluative information.

Task: A task is a set of skills (set or sets of functions, actions, or steps) the student must perform to accomplish the job (training). A task may be described as a logically related set of actions necessary or required to complete the job objective. Several tasks could be referred to as a duty.

Task Analysis: Task analysis is breaking down a learning task (objective) into component tasks each of which must be mastered as a prerequisite to mastery of the total job.

Task List: A listing of tasks (performance objectives) performed by incumbent workers (students in training) within a domain of interest (course of study).

Test: An event during which the student is asked to demonstrate some aspect of knowledge or skill is a test. It can be a single test item, but usually it consists of several items.

TABLE OF CONTENTS

Overview	1
Flow Chart	2
Tuition Scholarships	3
Placement Tests	4
Guidance Form	5
Course Objectives	7

GREENVILLE TECHNICAL COLLEGE - ARTICULATION GRANT

INDUSTRIAL ELECTRONICS

MAY, 1976

OVERVIEW

The vocational school graduate will have the opportunity to exempt some of the Industrial Electronics courses at Greenville Technical College that are repetitive of his vocational school studies. The student may exempt a course after attaining an acceptable proficiency level on the appropriate placement test. Each placement test may be taken once a quarter with a limit of one retake during another quarter.

The course objectives that are covered in each placement test will be given to each vocational electricity instructor. They are also available for inspection at GTEC's Industrial Electronics department.

The first placement tests for exemptions will begin during the regular registration days just before fall quarter. They will continue to be offered during each pre-registration time in a testing center at Greenville Technical College. Mr. J.D. Warren, Industrial Division Chairman, or the Industrial Electronics department may be contacted for details.

Specifically, the following courses will be considered for exemption upon completion of the placement test:

<u>Course Title</u>	<u>Course Number</u>
Applied Electricity	EEM 101
Residential Electricity-Codes and Ordinances-A	EEM 345
Residential Electricity-Codes and Ordinances-B	EEM 346
DC Electricity	EEM 113
AC Electricity	EEM 123
AC Machines and Devices	EEM 127
Electrical Control Circuits	EEM 136
Electrical Math I	MAT 115
Electrical Math II	MAT 126

PROPOSED FLOW CHART OF ARTICULATION STUDENTS - EEM

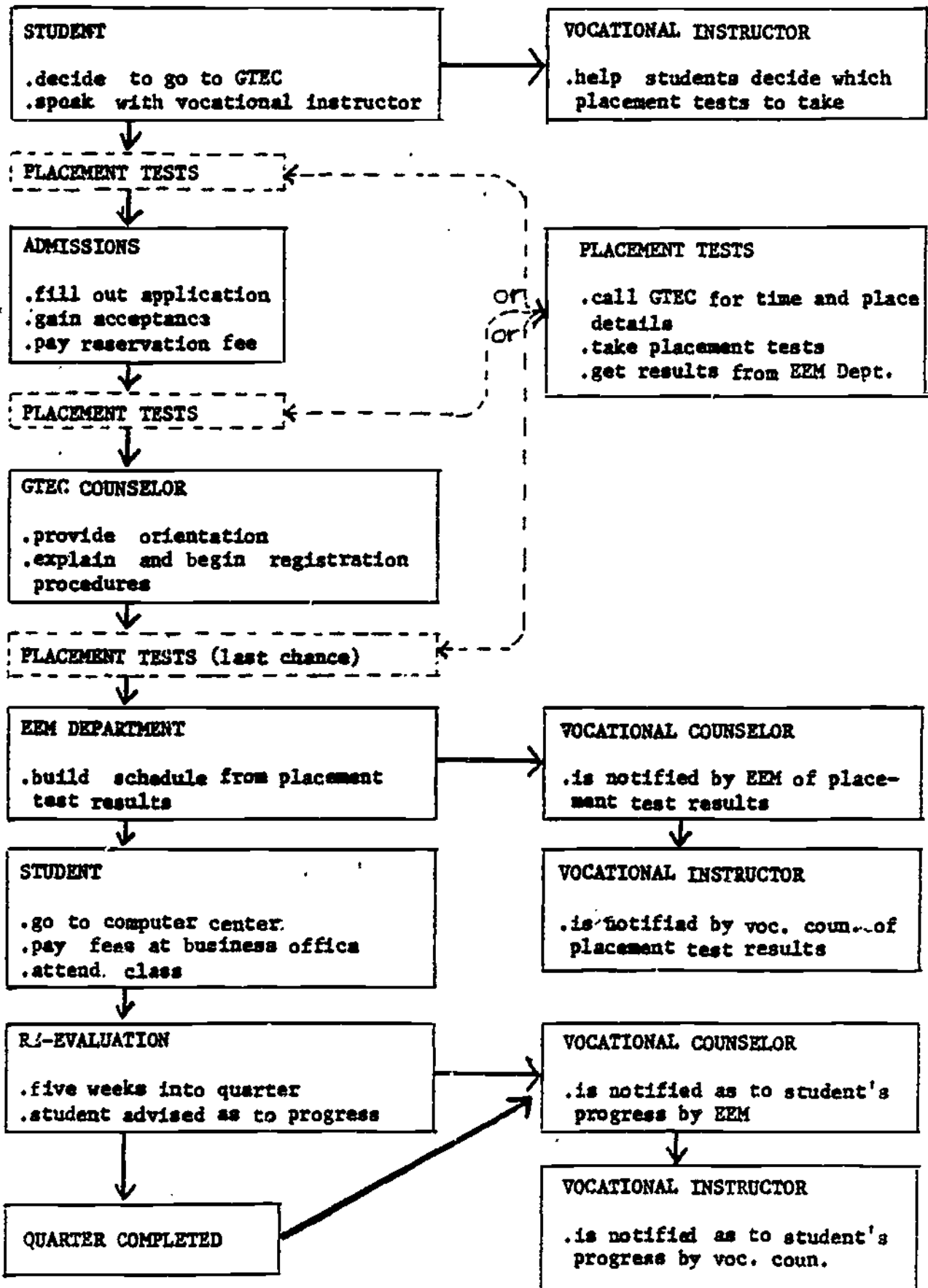

TUITION SCHOLARSHIP

Greenville Technical College is proud to offer tuition scholarships in each of the Articulation Grant programs: Machine Tool Technology, Industrial Electronics, and Engineering Graphics Technology. These scholarships were suggested at an Articulation Grant Advisory Committee meeting and hardly approved by the Greenville Technical College administration. It is hoped their inception will stimulate interest in continuing quality education and training in these fields.

The Donaldson, Enoree, and Foothills Vocational Centers will each select their most outstanding and/or worthy student in their drafting, electricity, and machine shop programs. Wade Hampton High School will select a student from their electricity program. The three scholarship students from each center will receive one quarter of tuition free study at Greenville Technical College. After their first quarter, each student may receive an extension for another quarter based upon review and approval by his or her instructors and department head.

After the selection of the students by their instructors, the director or principal of each school should send a copy of all the names to the heads of the Industrial and Technical Divisions, Mr. J.D. Warren and Mr. Lee Caraway. This is necessary to insure the tuition waiver be available when the student begins.

PLACEMENT TESTS

Course objectives for each course offering a placement test are in this booklet and on file in the Industrial Electronics department at Greenville Technical College. Each vocational instructor may review these objectives and advise his students as to which placement tests would be most appropriate to take.

The placement tests will be offered at Greenville Technical College during the registration days immediately preceding each quarter. They will begin just before fall quarter, 1976, and be offered each quarter thereafter.

It is the student's responsibility to find out the location of the testing center and schedule him/herself so that all the desired placement tests may be taken in the time the center is open. The Industrial Electronics department and Mr. J.D. Warren, Industrial Division Chairman, may be called for details. It is planned that the guidance counselors at TEC will also know specific details.

Tentative schedules for registration (and therefore the placement tests) for the next year are as follows:

Fall, 1976 - Sept. 1,2,3

Winter, 1976 - Nov. 29,30

Spring, 1977 - March 1,2

Summer, 1977 - May 24,25

It is hoped that through the urging of the vocational instructors that each vocational student will take full advantage of these placement tests.

GUIDANCE INFORMATION FORM

This form was designed to supply feedback to guidance counselors, instructors, and administrators. It will be sent by the Greenville Technical College department involved to the vocational center each time there is a horizontal line of asterisks. The information on the form will supply data to evaluate our effectiveness and suggest continuation or change in our procedures.

IT IS EXTREMELY IMPORTANT THAT THE STUDENT OR HIS/HER PARENT IF THE STUDENT IS UNDER 18 SIGNS THE PERMISSION BLANK ON THE SIDE OF THE FORM. IT WOULD BE ILLEGAL TO DISEMINATE THIS INFORMATION FROM GREENVILLE TECHNICAL COLLEGE WITHOUT THE PROPER SIGNATURE.

ARTICULATION STUDENT'S PROGRESS

Your student, _____, from _____

Vocational Center has exempted the following courses:

EEM _____, MAT _____

The student will be enrolling in the following EEM courses next quarter: _____, MAT course: _____

This placement was based on
_____ placement test score(s)
_____ vocational instructor's recommendation
_____ interview requested by _____ and conducted by _____

The student
_____ readily accepted placement
_____ requested a lower placement, outcome _____
_____ requested a higher placement, outcome _____

Date exemption(s) granted _____

The student at mid-term has been re-evaluated and is
_____ progressing satisfactorily
_____ not progressing satisfactorily

Student's signature _____

Instructor's signature _____

Date _____

The student at the end of the first quarter of work
_____ successfully completed the following courses in EEM / MAT
EEM _____ (grade _____) EEM _____ (grade _____)
EEM _____ (grade _____) EEM _____ (grade _____)
MAT _____ (grade _____)
_____ received an incomplete
_____ dropped out before the end of the quarter

Student's status at the end of the first year of work - _____

I GIVE MY PERMISSION FOR THE INFORMATION ON THIS PAGE TO BE SENT BACK TO THE GREENVILLE COUNTY PUBLIC SCHOOL SYSTEM.

PARENT'S SIGNATURE IF UNDER 18

LEGAL SIGNATURE

DATE

CONCEPT / PERFORMANCE

(Sometimes) Covered or Not Covered?

C, SC, or NC

When is it covered? 1-1, 1-2, 2-1, 2-2

Concept 1.0 Underwriters and Codes

1.1 State the function and purpose of UL.

1.2 State the function and purpose of NEC.

1.3 State the function and purpose of local electrical inspector and ordinances.

Concept 2.0 Basic Principles and Measurements

2.1 Use Ohm's Law to calculate values (amps, ohms, volts, watts) in a circuit.

2.2 State and contrast definitions of conductance and resistance.

Concept 3.0 AC and DC;
Power Factor; Transformers

3.1 Compare and contrast the generation, distribution, and usage of ac and dc.

3.2 Explain power factor - cause and correction.

3.3 Define alternation, cycle, hertz, phase, poly-phase, and frequency.

3.4 Given all values except one, solve for each element of the power formula in ac and dc circuits.

3.5 Explain how a transformer works and where it is used.

CONCEPT / PERFORMANCE

Concept 4.0 Basic Devices

- 4.1 Recognize differences between incandescent and fluorescent lights.
- 4.2 Recognize various wiring devices: switches, receptacles, and lighting outlets
- 4.3 Recognize various types of fuses and circuit breakers.
- 4.4 Explain the reason for, location of, and function of fuses and circuit breakers

Concept 5.0 Circuits

- 5.1 Define branch circuit and feeder
- 5.2 Recognize series and parallel circuit diagrams

Concept 6.0 Types and Sizes of Wires

- 6.1 Explain how to determine wire sizes with an American wire gauge.
- 6.2 Given load, ambient temperature, overcurrent protection, or use requirements, match size and type of wire and insulation appropriate for usage

Concept 7.0 Selection of Proper Wire Sizes

- 7.1 Given current, distance, or wire size, calculate voltage drop and determine type and size of conductor to overcome the drop.

Concept 8.0 Wire Connections and Joints

- 8.1 Given the devices or pictures of the devices, recognize and select proper application of UL listed splicing and terminating devices
- 8.2 Recall the restrictions on use of solder for service and grounding requirements.

CONCEPT / PERFORMANCE

(Sometimes) Covered or Not Covered?

C, SC, or NC

When is it covered? 1-1, 1-2, 2-1, 2-2

Concept 9.0 Theory and Importance of Grounding

9.1 State the purpose of grounding electrical equipment and systems and the consequences of the lack of good grounding.

9.2 State possible materials used for grounding, their color, and their installation.

9.3 Recognize proper and inferior basic grounding installations in light of NECode requirements.

9.4 Differentiate between a ground fault and short circuit.

9.5 State when G. F. C. I. (Ground fault circuit interrupter) should be used.

Concept 10.0 Outlet and Switch Boxes

10.1 Recognize and match usage of outlet boxes, junction boxes, and switch plates.

10.2 Use NEC table 370-6A & B to determine size of boxes needed.

Concept 11.0 Different Wiring Methods

11.1 State the usage of non-metallic sheath cable and armored cable

11.2 Given pictures or actual material, identify and list the advantages of and fittings used with the four basic types of conduit

11.3 Given pictures or actual material, identify and list the advantages of and fittings used with the two basic types of flexible conduit.

CONCEPT / PERFORMANCE	(Sometimes) Covered or Not Covered? C, SC, or NC When is it covered? 1-1, 1-2, 2-1, 2-2
<p>Concept 12.0 Adequate Wiring</p>	
<p>12.1 Explain the difference between minimum-standard and adequate wiring and lighting.</p>	
<p>Concept 13.0 Service Entrance and Branch Circuits</p>	
<p>13.1 List the main considerations in choosing electrical service and equipment for residential occupancies.</p>	
<p>13.2 Explain the usage of the Code demand factor tables for determining size of service and service entrance conductors</p>	
<p>13.3 Define branch circuit and feeder</p>	
<p>Concept 14.0 Good Lighting</p>	
<p>14.1 Define lumen and footcandle</p>	
<p>14.2 Compare suitability of various types of lighting in different occupancies.</p>	

CONCEPT / PERFORMANCE	(Sometimes) Covered or Not Covered? <u>C, SC, or NC</u> When is it covered? <u>1-1, 1-2, 2-1, 2-2</u>
<p>Concept 1.0 General Information for Electrical Installations</p>	
<p>1.1 Explain the purpose of (electrical) blueprints</p>	
<p>1.2 Given a specific set of specifications, explain how specifications are used in estimating costs and making electrical installations.</p>	
<p>1.3 Explain why symbols and notations are used on electrical drawings.</p>	
<p>Concept 2.0 Electrical Symbols and Outlets</p>	
<p>2.1 Identify and explain the electrical outlet symbols used in the plans of the single family dwelling.</p>	
<p>2.2 Identify the types of outlets, boxes, fixtures, and switches used in the residence.</p>	
<p>2.3 Explain the methods of mounting the various electrical devices used in the residence.</p>	
<p>Concept 3.0 Determining the Number of Circuits Required</p>	
<p>3.1 Given the dimensions of a dwelling, Calculate the occupied floor area of a dwelling.</p>	
<p>3.2 Given floor area or dwelling's dimensions, determine the total load requirements in amperes for general lighting.</p>	
<p>3.3 Given floor area or dwelling's dimensions, determine the minimum number of lighting branch circuits required.</p>	

CONCEPT / PERFORMANCE

(Sometimes) Covered or Not covered?
 C, SC, or NC
 When is it covered? 1-1, 1-2, 2-1, 2-2

3.4 Recall the number of small appliance circuits required in a residence.

3.5 Given the NECode and the floor area or dwelling's dimensions, use the NECode (Article 210 & 220) to determine the basic requirements for the various branch circuits in a dwelling.

Concept 4.0 Conductor Sizes and Types

4.1 Define the terms used to size and rate conductors.

4.2 Describe the types of cables used in the majority of residential installations.

4.3 List the basic installation requirements for wiring cables.

4.4 Describe the uses and installation requirements of electrical metallic tubing and rigid metal conduit.

4.5 Describe the requirements for grounding a service entrance.

Concept 5.0 Switch Control of Lighting Circuits

5.1 Distinguish between the various types of toggle switches for lighting circuit control.

5.2 Use Ohm's law to calculate circuit load and select a switch with the proper rating for the specific installation conditions.

5.3 Describe the operation that each type of toggle switch performs in typical lighting circuit installations.

CONCEPT / PERFORMANCE

(Sometimes) Covered or Not Covered?
C, SC, or NC
 When is it covered? 1-1, 1-2, 2-1, 2-2

5.4 Demonstrate the correct wiring connections for each type of switch per Code requirements.

Concept 6.0 Bedroom Lighting Branch Circuits

6.1 Explain the difference in determining circuit wattage requirements in residential versus other occupancies.

6.2 Given information from the residence plans, specifications, and Code requirements, draw a cable layout and a wiring diagram.

6.3 Select the proper wall box for a particular installation.

6.4 Explain how wall boxes can be grounded.

6.5 List the requirements for the installation of fixtures in clothes closets.

6.6 Explain the operation and connections of ground-fault circuit interrupters (GFCI).

Concept 7.0 More Bedroom Lighting Branch Circuits

7.1 Given a cable layout, draw a wiring diagram.

7.2 Explain how outlets in one room can be connected to a circuit in another room.

Concept 8.0 Bathroom and Passage Lighting Branch Circuits

8.1 Connect recessed fixtures, both prewired and nonprewired types, according to Code regulations.

8.2 Recall the separation regulations for installation of recessed fixtures.

CONCEPT / PERFORMANCE	(Sometimes) Covered or Not Covered? C, SC, or NC When is it covered? 1-1, 1-2, 2-1, 2-2
8.3 List the equipment grounding requirements for bathroom installations.	
Concept 9.0 Lighting Branch Circuit for Halls and Front Entrances	
9.1 Install 3-wire circuits, making the proper connections to prevent overloads.	
9.2 Demonstrate the proper methods of installing pilot light switches in circuits.	
9.3 Explain how outdoor lighting can be installed using UF type underground cable.	
9.4 Describe two methods of bringing conduit into a residence from an external location.	
9.5 Define a wet location.	
Concept 10.0 Lighting Branch Circuits for Kitchen and Rear Entry and Small Appliance Circuits for Kitchens	
10.1 List three methods of installing under-cabinet lighting fixtures.	
10.2 Explain the use of exhaust fans for humidity control.	
10.3 Install split circuit (two-circuit) convenience receptacles.	
10.4 Discuss the general grounding considerations for a residence.	

CONCEPT / PERFORMANCE

(Sometimes) Covered or Not Covered?
 C, SC, or NC
 When is it covered? 1-1, 1-2, 2-1, 2-2

Concept 11.0 Lighting Branch Circuit for the Living Room

11.1 Explain how to install multi-outlet assemblies.

11.2 Determine load restrictions of multi-outlet assemblies as per NEC.

11.3 Connect the proper dimmer controls for incandescent lamp circuits and for fluorescent lamp circuits.

11.4 Define incandescent inrush current.

11.5 Define a class P fluorescent ballast.

Concept 12.0 Lighting Branch Circuit for the Dining Room, Porch, Garage Storage Area, and Attic

12.1 Install a three-way switch and a dimmer control.

12.2 Restate the Code requirements for the installation of outlets and receptacles in damp or wet locations.

12.3 Describe the installation of attic wiring according to Code requirements.

Concept 13.0 Lighting Branch Circuit for the Garage

13.1 Given conditions in the cable layout and/or blueprints, select the proper wiring method (cable or conduit) based on the conditions of installation.

Concept 14.0 Lighting and Receptacle Branch Circuits for the Terrace, Recreation Room, and Utility Room

14.1 Select the proper size boxes for installation in areas where the construction makes it impossible to install deep boxes.

EEM 345 - Residential Wiring (Part A) - Greenville Technical College

CONCEPT / PERFORMANCE	(Sometimes) Covered or Not Covered C, SC, or NC When is it covered? <u>1-1, 1-2, 2-1, 2-2</u>
14.2 Describe the installation steps of conduit in concrete floors and on cinder block walls.	
14.3 List the basic requirements for the proper installation of conduit in an exposed location.	
14.4 Explain which convenience receptacles should be connected to separate circuits.	
Concept 15.0 Lighting and Convenience Receptacle Branch Circuits for the Bathroom, Workshop, and Storage Room	
15.1 Select the proper wiring method and outlet boxes for exposed wiring.	
15.2 Select the proper outlet box for surface mounting in a basement area.	
15.3 Given Code tables 310/16-19 and notes or ampacity, wattages, or load requirements for the load involved, determine the appropriate wire size for a specific ampacity and apply derating factors if necessary.	

CONCEPT / PERFORMANCE	(Sometimes) Covered or Not Covered? SC, C, or NC When is it covered? 1-1, 1-2, 2-1, 2-2
<p>● Concept 1.0 Special Purpose Outlets</p>	
<p>1.1 Given a blueprint, recognize special-purpose outlet designations.</p>	
<p>1.2 Given nameplate reading, or specs, or equipment, calculate the load to be connected to a special outlet and use configuration chart for selection of outlet.</p>	
<p>1.3 Illustrate the proper grounding connections when using armored cable and nonmetallic-sheathed cable.</p>	
<p>1.4 Illustrate the proper connections to insure grounding continuity between a grounded outlet box and the grounding circuit of the receptacle.</p>	
<p>Concept 2.0 Special Purpose Outlets for a Water Pump and Heater</p>	
<p>● 2.1 List the basic requirements for a motor to be used on deep-well jet pump.</p>	
<p>2.2 Given the rating of a motor, calculate the conductor size and over-current protection required for the pump circuit.</p>	
<p>2.3 List the basic steps in various water heating methods which can be used.</p>	
<p>2.4 Describe the operation of the water heating system, including the functions of the tank, the heating elements, and the thermostats.</p>	
<p>2.5 Illustrate the proper grounding connections for the water heater.</p>	
<p>Concept 3.0 Special Purpose Outlets for Dryers and Over. Garage Door Openers</p>	
<p>● 3.1 Illustrate the proper wiring and grounding connections for large appliances based on the type of wiring method to be used.</p>	
<p>3.2 List the requirements for using service entrance cable to connect large appliances.</p>	

CONCEPT / PERFORMANCE

(Sometimes) Covered or Not Covered
 SC, C, or NC
 When is it covered? 1-1, 1-2, 2-1, 2-2

3.3 Illustrate the proper connections involved in remote control switching such as in an overhead garage door opener based on manufacturer's installation recommendations.

3.4 Given Code tables, select the proper overcurrent protective device based on the amperage rating of the device.

Concept 4.0 Special Purpose Outlets for Kitchen Appliances

4.1 Interpret electrical plans and construction blueprints to determine any special installation requirements for electrical appliances.

4.2 Given NEC table 310/16-19 and notes and based on the ratings of appliances, select proper conductor sizes for wiring installation.

4.3 Illustrate how to ground all appliances properly regardless of the wiring method used.

4.4 Illustrate proper wiring of 7-heat control and 3-heat control for a dual element cooking unit-heating unit. (phasing out)

4.5 List the advantages of infinite over 7- and 3-heat control.

4.6 Illustrate the 3 options in the installation of various types of stove and oven units: group circuit, single circuit, and load center.

Concept 5.0 Telephone, Television, and Signal Systems

5.1 Describe the proper precautions to prevent line voltage interference with television signals.

5.2 Given specifications, describe the installation of outlet boxes, outlets, and provide cable or conduit to which the telephone installer will make final connections.

5.3 Define what is meant by signal circuit.

CONCEPT / PERFORMANCE	(Sometimes) Covered or Not Covered? SC, C, or NC When is it covered? 1-1, 1-2, 2-1, 2-2
5. Describe the operation of a two-tone chime and a four-tone chime with one or more extension chimes.	
Concept 6.0 Heating Systems	
6.1 List the advantages of electric heat.	
6.2 Describe the several types of electric heating systems.	
6.3 Describe the various thermostat control systems for electric heating units.	
6.4 Describe the installation of electric heaters with appropriate temperature controls according to NEC requirements.	
6.5 Interpret typical schematics provided by heating system control manufacturers.	
6.6 Describe the functions of the control devices provided in a typical system.	
6.7 Explain the principle of the thermopile and the thermocouple.	
6.8 Compare and contrast the electrical requirements for the following heating systems: oil, gas fire - water gravity, gas fire - self-contained.	
Concept 7.0 Service Entrances, Equipment, and Calculations	
7.1 Define these terms: electrical service, overhead service, service drop, and underground service.	
7.2 Describe the installation of a mast-type overhead service and an underground service.	
8. Discuss the NEC requirements for disconnecting the electrical service by means of a main panel and ad centers.	

CONCEPT / PERFORMANCE	(Sometimes) Covered or Not Covered? C, SC, or NC When is it covered? <u>1-1, 1-2, 2-1, 2-2</u>
7.4 Differentiate between the various types of fuses and select the proper fuse for a particular installation.	
7.5 Explain the operation of fuses and circuit breakers.	
7.6 Explain the term, "interrupting capacity".	
7.7 Determine available short-circuit current using a simple formula.	
7.8 Determine the total calculated load of a residence using the methods in Article 220 of the NEC.	
7.9 Calculate the size of the service entrance conductors, including the neutral conductor.	
Concept 8.0 Remote Control Systems for Lighting Control Circuits	
8.1 Explain the operation of the various components of a low-voltage, remote control system for lighting circuits.	
8.2 Interpret the wiring diagrams of various types of low-voltage, remote control circuits.	
8.3 Describe the installation of a low-voltage, remote control system using the proper conductors, wiring, and components according to NEC requirements.	

CONCEPT / PERFORMANCE	(Sometimes) Covered or Not Covered? C, SC, or NC When is it covered? <u>1-1, 1-2, 2-1, 2-2</u>
Concept 1.0 - Current	
1.1 List the fundamental atomic particles and label the parts of a model of the atom.	
1.2 Explain the role of the electron in carrying electricity and contrast it to random drift of electrons.	
1.3 Define a coulomb and explain the behavior of charged bodies in terms of Coulomb's law	
1.4 Given a diagram, label a diagram of a complete (closed) circuit and a schematic diagram of a simple circuit containing a power source, a load, a switch, and conductor wires.	
1.5 Given a diagram, label the diagram of the direction of current flow in a circuit.	
1.6 List the components of an electric circuit and compare them with those of a simple hydraulic system.	
1.7 Define an ampere as a rate of coulombs of charge per second and calculate current mathis.	
1.8 Write the common symbols for current, charge, and time, as distinguished from standard (SI) abbreviations for their units of measure.	
1.9 Calculate measurements in power of 10, express figures in scientific notation, and convert from one metric unit to another by means of 10.	
1.10 List the steps for placing and connecting an ammeter into a circuit to measure current.	

CONCEPT / PERFORMANCE

(Sometimes) Covered or Not Covered?
C, SC, or NC

When is it covered? 1-1, 1-2, 2-1, 2-2

2.0 - Voltage

2.1 Compare and contrast definitions of emf and potential difference as separate forms of the same force.

2.2 Define and calculate voltage.

2.3 Define voltage rise and voltage drop, and identify the symbols used to differentiate them.

2.4 Tell how dry cells produce emf.

2.5 Explain the process of separating charges in a battery.

2.6 Recognize a diagram of a series and parallel connection of cells, and calculate total voltage of each.

2.7 Tell how an opposing voltage affects total output voltage.

2.8 Given a voltmeter and components, connect a voltmeter to load and source of a circuit and make voltage measurements.

Concept 3.0 - Resistance

3.1 Define resistance, the parameters that vary it, and the effects of temperature upon it.

3.2 Given resistivity and dimensions, calculate resistance.

3.3 Identify the classes of resistors, circuit symbols that represent them, resistor ratings, and the codes by which they are designated.

3.4 Given an ohmmeter and components, connect an ohmmeter in a circuit and make resistance measurements.

CONCEPT / PERFORMANCE	(Sometimes) Covered or Not Covered? C, SC, or NC When is it covered? <u>1-1, 1-2, 2-1, 2-2</u>
<p>Concept 4.0 Measuring Voltage and Current in Series Circuits</p>	
<p>4.1 Define, compare, and contrast parallel and series circuits.</p>	
<p>4.2 State Kirchhoff's voltage law.</p>	
<p>4.3 Define the relation between voltage drop across a resistor and the ohmic value of its resistance.</p>	
<p>4.4 Given a multimeter and components, use a multimeter to measure voltage in a dc and ac circuit.</p>	
<p>Concept 5.0 - Relationships of Current, Voltage, and Resistance</p>	
<p>5.1 Tell how varying voltage or resistance in a series circuit effects current when the alternate element is held constant.</p>	
<p>5.2 Use Ohm's Law to calculate values and power expended in a series circuit.</p>	
<p>5.3 State, explain, and derive all equivalent equations for Ohm's law.</p>	
<p>5.4 List the effects of source internal resistance and how it can be determined.</p>	
<p>5.5 Define a short circuit and an open circuit, and locate each using an ohmmeter or voltmeter.</p>	
<p>Concept 6.0 - Parallel Circuits</p>	
<p>6.1 Define a parallel circuit.</p>	
<p>6.2 Define the relation of source voltage to parallel branches and source current to branch currents.</p>	
<p>6.3 State Kirchhoff's current law.</p>	

CONCEPT / PERFORMANCE	(Sometimes) Covered or Not Covered? <u>C, SC, or NC</u> When is it covered? <u>1-1, 1-2, 2-1, 2-2</u>
6.4 Given two of the following, current, resistance, or voltage, calculate source and branch currents, using Ohm's law.	
6.5 Calculate total circuit resistance.	
6.6 Reduce complex circuit schematics to simple form by redrawing.	
6.7 Given a multimeter and a problem circuit, use a multimeter to troubleshoot a given parallel circuits.	
6.8 Tell how a parallel circuit is fused.	
6.9 Use variational analysis as a tool in explaining how circuit quantities interact.	
Concept 7.0 Series - Parallel Circuits	
7.1 Find missing values and apply variational analysis to explain and compute values in a series-parallel circuit	
7.2 Define the concept of voltage reference.	
7.3 Define the terms ground and floating ground.	
7.4 Given voltage supply, design a voltage divider to give desired voltage.	
7.5 Practice complex circuit reduction by redrawing.	
Concept 8.0 Magnetism and Electromagnetics	
8.1 List the properties of a magnetic field.	
8.2 State the laws governing magnetic fields.	

CONCEPT / PERFORMANCE	(Sometimes) Covered or Not Covered? C, SC, or NC When is it covered? <u>1-1, 1-2, 2-1, 2-2</u>
8.3 Define 3 types of magnetism.	
8.4 Identify types of magnetic materials.	
8.5 Tell how magnetic shielding works.	
8.6 State the magnetic domain theory.	
8.7 Distinguish between various types of magnets.	
8.8 State the relationship between electricity and magnetism.	
8.9 Label a diagram of the magnetic field around a current carrying loop and coil.	
8.10 Tell how a solenoid and a relay (mechanical and electrical) work.	
8.11 List the factors affecting flux density in an inductor.	
8.12 State and interpret Lenz's law.	
8.13 State the principles of electromagnetic induction.	
8.14 List the factors affecting generated emf.	
Concept 9.0 Mutual Induction and RL Circuits	
9.1 Define mutual induction, including the direction of the induced emf in a conductor.	
9.2 Name the units of inductance and state the rules for solving total inductance.	
9.3 Tell how mutual inductance takes place between two coils.	
9.4 Explain the behavior of an idealized RL circuit.	

CONCEPT / PERFORMANCE	(Sometimes) Covered or Not Covered? C, SC, or NC When is it covered? 1-1, 1-2, 2-1, 2-2
9.5 Plot: a) current rise, b) resistor voltage, c) coil voltage, d) decay of current, e) collapse of flux lines, f) decay of voltage in an RL circuit from opening of the switch (time T=0) until steady state.	
9.6 Define the RL constant.	
9.7 Make calculations of energizing and decaying RL circuits using the universal time-constant chart.	
Concept 10.0 Capacitance	
10.1 Describe the different kinds of capacitors and how they charge and discharge.	
10.2 Tell how a capacitor charges and discharges in an RC circuit.	
10.3 Define capacitance.	
10.4 Define the unit of capacitance in terms of farads and micro-farads.	
10.5 Calculate capacitance from type and size of dielectric.	
10.6 Calculate the value of total capacitance for capacitors in series, parallel, and series-parallel	
10.7 Define and calculate the RC time constant	
10.8 Solve RC time-constant problems, using the universal time-constant chart.	

CONCEPT / PERFORMANCE

(Sometimes) Covered or Not Covered?

C, SC, or NC

When is it covered? 1-1, 1-2, 2-1, 2-2

Concept 1.0 - Generating AC Voltage, AC and DC Generators

1.1 Tell how ac voltage is generated.

1.2 Define the terms that describe an ac wave: amplitude, frequency, and phase relationship.

1.3 Given a diagram, label the parts of an ac generator

1.4 State the function of slip rings.

1.5 State the function of a commutator.

Concept 2.0 - AC Relationships

2.1 State how a coil reacts to ac.

2.2 Define and state the factors affecting inductive reactance.

2.3 Given circuit parameters, calculate inductive reactance and current in an inductive circuit.

2.4 Define a vector.

2.5 Given magnitude and direction, calculate the sum of two vectors and plot rotating vector sine wave.

2.6 Define the phase relationship between current and voltage in an inductive and capacitive ac circuit.

2.7 Define and state the factors affecting capacitive reactance.

2.8 Given circuit parameters, calculate capacitive reactance.

2.9 Add ac voltages vectorially.

2.10 Define and calculate impedance.

CONCEPT / PERFORMANCE	(Sometimes) Covered or Not Covered? C, SC, or NC When is it covered? <u>1-1, 1-2, 2-1, 2-2</u>
2.11 Define, real, apparent, and reactive power.	
2.12 Define and compute the power factor.	
Concept 3.0 The Transformer	
3.1 State and explain the function and construction of a transformer.	
3.2 Given a schematic of a transformer with multiple secondary windings, determine the stepdown ratios required for circuit voltages and loads.	
3.3 Draw the schematic symbols for the various kinds of transformers.	
3.4 Determine the direction of induced voltage in the secondary conditions.	
3.5 Define current and voltage relationships.	
3.6 Calculate power in a transformer.	
3.7 Define copper, eddy current, and hysteresis loss.	
3.8 State transformer efficiency.	
3.9 Name transformer ratings.	
3.10 Define transformer impedance relationships.	
3.11 Given typical circuit values, solve impedance matching problems for a transformer.	
3.12 Define the function of an auto transformer.	

CONCEPT / PERFORMANCE	(Sometimes) Covered or Not Covered? C, SC, or NC When is it covered? <u>1-1, 1-2, 2-1, 2-2</u>
Concept 4.0 Power Supplies	
4.1 State the functions of a power supply.	
4.2 Define the functions of a rectifier.	
4.3 Diagram a full and half-wave rectifier.	
4.4 Explain the rectification of ac input utilizing diode rectification.	
4.5 Define ripple frequency and its relationship to half and full-wave rectification.	
4.6 Diagram a 1) choke-input filter, 2) capacitor-input filter, and 3) pi filter and explain the relative advantages and disadvantages of each.	
Concept 5.0 AC Computations	
5.1 Define the trigonometric functions of sine, cosine, and tangent.	
5.2 Solve vectors by graphical analysis.	
5.3 Solve vectors by the Pythagorean Theorem.	
5.4 Solve circuit problems by trigonometry.	
5.5 Define rectangular coordinates.	
5.6 Define polar coordinates.	
5.7 Make impedance calculation using rectangular and polar coordinates.	
Concept 6.0 Series Resistive - Reactive Circuits	
6.1 Analyze a series RL circuit by varying frequency, resistance, applied voltage and inductance; prove the effects by mathematical calculations.	

CONCEPT / PERFORMANCE

(Sometimes) Covered or Not Covered?
 C, SC, or NC
 When is it covered? 1-1, 1-2, 2-1, 2-2

6.2 Define the terms cut-off and half-power point

6.3 Determine the cutoff frequency of an RL circuit.

6.4 Define an RL low-pass and high-pass filter.

6.5 Solve vector diagrams for series RC circuits.

6.6 Analyze a series RC circuit by variational analysis; prove the effects by mathematical calculations.

6.7 Determine the effects of frequency on RC circuits.

6.8 Define an RC low-pass and high-pass filter.

6.9 Solve mathematically for impedance in a series RLC circuit.

6.10 Define the figure of merit (Q) for a coil and determine its value mathematically.

6.11 Define skin effect.

6.12 Define proximity effect.

Concept 7.0 Series Resonance

7.1 Define the conditions for series resonance

7.2 Derive the expression for the resonant frequency.

7.3 Explain and calculate voltage gain across the reactive elements in resonance.

7.4 Diagram current and impedance curves at the resonant frequency.

CONCEPT / PERFORMANCE

(Sometimes) Covered or Not Covered?

C, SC, or NC

When is it covered? 1-1, 1-2, 2-1, 2-2

7.5 Define bandwidth and contrast it with voltage gain and explain their use in amplifiers and receivers.

7.6 Explain the effects of Q on bandwidth.

7.7 Tell how many series resonant circuits may be employed as filters.

Concept 8.0 Parallel-Reactive Circuits

8.1 Explain the current and voltage relationships of series versus parallel circuits.

8.2 Calculate current, impedance, power, and power factor in a parallel RL circuit.

8.3 Analyze a parallel RL circuit by varying frequency, resistance, applied voltage, and inductance; prove the effects by mathematical calculations.

8.4 Calculate current, impedance, power, and power factor in a parallel RC circuit.

8.5 Calculate current, impedance, power, and power factor in an RLC circuit.

8.6 Analyze an ideal parallel LC circuit.

8.7 Define the conditions for parallel resonance.

8.8 Diagram current and impedance curves at the resonant frequency.

8.9 Define a tank circuit.

8.10 Analyze a practical tank circuit.

8.11 Analyze circuit behavior above and below the resonant frequency.

CONCEPT / PERFORMANCE	(Sometimes) Covered or Not Covered? C, SC, or NC When is it covered? <u>1-1, 1-2, 2-1, 2-2</u>
8.12 Tell how parallel resonant circuits may be used as filters.	
8.13 Define when the effective resistance of the coil in an RL circuit must be considered.	
8.14 Calculate figure of merit, impedance, and current in a practical RL circuit.	

CONCEPT / PERFORMANCE

(Sometimes) Covered or Not Covered?

C, SC, or NC

When is it covered? 1-1, 1-2, 2-1, 2-2

● Concept 1.0 The Synchronous Motor and
Electrodynamometer (Intro.)

1.1 Explain how to connect a three-
phase synchronous motor.

1.2 Demonstrate how to connect the
electrodynamometer.

Concept 2.0 Split-Phase Induction Motor

2.1 Explain or disassemble and recon-
struct a split-phase motor.

2.2 Measure the resistance of split-
phase windings.

2.3 Explain the basic motor wiring con-
nections of a synchronous motor.

2.4 Given an ammeter, measure the
starting and operating characteris-
tics of the split-phase motor
under load and no-load conditions.

● 5 Calculate the power factor and
efficiency of the split-phase
motor.

Concept 3.0 Capacitor Start and Run
Motors

3.1 Given an ammeter, measure the
starting and operating characteris-
tics of the capacitor start motor.

3.2 Compare the capacitor-start motor's
starting and running performance
with the split-phase motor's.

3.3 Explain or disassemble and reas-
semble a capacitor run motor.

3.4 Determine the capacitor-run motor
running and starting characteris-
tics.

● 3.5 Compare the capacitor-run motor
running and starting performance
with the split-phase and capacitor
start motors.

CONCEPT / PERFORMANCE

(Sometimes) Covered or Not Covered?

C, SC, or NC

When is it covered? 1-1, 1-2, 2-1, 2-2

Concept 4.0 Universal Motor

4.1 Explain or disassemble and reconstruct a universal motor.

4.2 Given appropriate meters and equipment, determine a universal motor's no-load and full-load characteristics while on ac.

4.3 Given appropriate meters and equipment, determine a universal motor's no-load and full-load characteristics while on dc.

Concept 5.0 Repulsion-Start and Induction-Run Motors

5.1 Explain or disassemble and reconstruct a repulsion start - induction run motor.

5.2 State the properties of the repulsion start - induction run motor under no-load and full-load conditions.

5.3 Explain the construction of the three-phase wound rotor induction motor.

5.4 State the effect of the variation of the revolving field and rotor speed upon the voltage induced in the rotor of a wound rotor induction motor.

Concept 6.0 Wound Rotor Induction

6.1 Given appropriate meters and equipment, determine the starting characteristics of the wound rotor induction motor.

6.2 Given an ammeter, measure and record the rotor and stator currents at different motor speeds in a wound rotor induction motor.

CONCEPT / PERFORMANCE	(Sometimes) Covered or Not Covered? C, SC, or NC When is it covered? 1-1, 1-2, 2-1, 2-2
Concept 7.0 Squirrel Cage Motor	
7.1 Explain or disassemble and reconstruct a three-phase squirrel cage motor.	
7.2 Given an ammeter, determine the squirrel cage induction motor's no-load and full-load characteristics.	
Concept 8.0 The Synchronous Motor	
8.1 Explain or disassemble and reconstruct a three-phase synchronous motor.	
8.2 Demonstrate how a synchronous motor can act as a variable inductance or capacitance.	
8.3 Obtain the dc current versus ac current characteristics curve for the synchronous motor.	
8.4 Given an ammeter and tachometer determine the full-load characteristics of the synchronous motor.	
8.5 Given a dynamometer, determine the pull-out torque of the synchronous motor.	

CONCEPT / PERFORMANCE	(Sometimes) Covered or Not Covered? C, SC, or NC When is it covered? 1-1, 1-2, 2-1, 2-2
Concept 1.0 Fundamentals of Controls	
1.1 Define and recognize the difference between manual, semi-automatic, and automatic controls.	
1.2 Label components of manual, semi-automatic, and automatic controls on provided diagrams.	
Concept 2.0 Control of Motor Starting	
2.1 Explain low-voltage (3 types) and line voltage starting.	
2.2 Explain 3 types of acceleration control: current limit, definite time, and voltage drop.	
2.3 Identify components for the controls of squirrel-cage, wound-rotor, synchronous and dc motors on provided wiring diagrams.	
2.4 State the purpose and give one example of each of eight types of motor protection.	
Concept 3.0 Control Components	
3.1 Identify and list the limitations of switches, breakers, contactors, and relays as motor starters.	
3.2 Given diagrams, explain the functions of the various components in different types of motor controls.	
Concept 4.0 Pilot Devices	
4.1 Explain how a pilot device functions and its location in a circuit.	
4.2 Identify seven or more pilot devices.	

CONCEPT / PERFORMANCE

(Sometimes) Covered or Not Covered?

SC, C or NCWhen is it covered? 1-1, 1-2, 2-1, 2-2

Concept 5.0 Control Circuit Diagrams

5.1 Identify and explain control diagram symbols.

5.2 Identify and explain schematic, wiring, wireless, one-line, and block diagrams.

Concept 6.0 Development of Control Circuits

6.1 Compare and contrast two-wire and three-wire control.

6.2 Given a control problem, develop a control circuit to handle the problem, draw a schematic for that circuit, transfer that information into a wiring diagram, then wire the circuit with provided components. (There will be 37 such control problems to complete during the remainder of the quarter.)

Concept 7.0 Analysis of Control Circuits

7.1 Given a control diagram, analyze the function and relationships of component parts.

(Continue to develop control circuits.)

Concept 8.0 Maintaining Control Circuits

8.1 Discuss the value of proper and preventative maintenance of control equipment and how to avoid the most prevalent troubles.

Continue to develop control circuits.

Concept 9.0 Troubleshooting Control Circuits

9.1 Given electrical circuits or diagrams, locate problem(s) and correct or propose a correction for the malfunction(s).

Continue to develop control circuits.

CONCEPT / PERFORMANCE

(Sometimes) Covered or Not Covered

SC, C, or NC

When is it covered? 1-1, 1-2, 2-1, 2-2

Concept 10.0 Basic Concepts of Static Control (This concept is not always covered.)

10.1 Identify and state the function of basic logic circuit elements, and determine their appropriate function in given circuit diagrams.

Course Title: Electrical Mathematics I
Course Number: MAT 115
Quarter Credit Hours: 5
Contact Hours per Week: 5

Prepared by
James A. Barnes
November 11, 1975

Textbook: "Basic Mathematics for Electricity and Electronics" by B. B. Singer, Third Edition, Copyright 1972, Published by McGraw-Hill Book Co.

Prerequisite: Minimum grade level 8 in mathematics achieved on California or equivalent entrance test.

Course Description: A review of basic operations of arithmetic. An introduction to the principles and operations of elementary Algebra through simple equations in one unknown. Introduction to mathematical operations on vectors (phasors). Also, introduction to mathematical operations on pocket calculations.

Course Content (Topics):

1. Mathematical operations on decimals, common fractions, and mixed numbers.
2. Solving linear, pure quadratic, and radical equations in one unknown.
3. Changing numbers from ordinary form to scientific notation form (standard form), and changing numbers from scientific notation form (standard form) to ordinary form.
4. Expressing vectors in right triangle, rectangular form, and polar form. Also included is use of J-operator.
5. Multiplication, division, addition, subtraction, and finding of roots on pocket calculator with results expressed in scientific notation form (standard form).
6. Using pocket calculator to change vectors (phasors) from rectangular form to polar form; and from polar form to rectangular form. Also included is use of J-operator.
7. Addition and subtraction of vectors in rectangular form.
8. Multiplication and division of vectors in polar form.

Course Title: Electrical Mathematics II
Course Number: MAT 126
Quarter Credit Hours: 5
Contact Hours per Week: 5

Prepared by
James A. Barnes
November 11, 1975

Textbooks: "Basic Mathematics for Electricity and Electronics" by B. B. Singer, Third Edition, Copyright 1972, Published by McGraw-Hill Book Co.

Prerequisite: Successful completion of Electrical Mathematics I, MAT 115.

Course Description: Use of arithmetic, elementary algebra, vectors (phasors) with J-operator and pocket calculator in calculations of data in AC electrical circuits. Included, are series, parallel, and series--parallel circuits.

Course Content (Topics): Using arithmetic, algebra, vectors, and pocket calculator on series, parallel, and series--parallel AC circuits to find numerical values of:

- | | |
|-------------------------|---------------------|
| 1. Capacitive reactance | 4. Current |
| 2. Inductive reactance | 5. Voltage |
| 3. Impedance | 6. Electrical power |

SURVEY OF
ELECTRICITY SHOP EQUIPMENT/FACILITIES

Donaldson	Enoree	Foothills	Golden Strip	
(x)	(x)	()	(x)	BASIC ELECTRICITY TRAINER (Example Lab Volt, Use, (Type:) (1) 501 Basic, A-1000, A-500, A-2000 (2) SES 501 A (4) A-500, A-2000, PR-50
()	()	(x)	()	Don't use
(x)	()	()	()	Would like to have : (1) Motor trainer
(x)	(x)	(x)	(x)	WIRING: RESIDENTIAL Use mock-up house
()	()	(x)	(x)	Use bench trainer/training stations
()	()	(x)	(x)	WIRING: COMMERCIAL Special training station
(x)	()	()	()	No special training station
()	()	(x)	()	Training station for putting conduit and outlet, etc., in foundations
()	()	()	()	Commercial not separated from residential wiring
(x)	(x)	(x)	(x)	CONDUIT BENDING Bend EMT
()	()	()	(x)	Bend intermediate
(x)	()	(x)	(x)	Bend rigid
()	()	(x)	(x)	BENDER Rigid conduit wickey
(x)	(x)	(x)	(x)	EMT Bender
(x)	()	()	()	Other: (1) Heavy duty rigid bender (2) Hydraulic rigid bender
(x)	(x)	(x)	(x)	THREADER Hand
(x)	()	()	(x)	Power
(x)	(x)	(x)	(x)	VOLTAGES USED IN SHOP/TRAINING (HANDS ON) 120
(x)	(x)	(x)	(x)	208
(x)	(x)	(x)	()	230, 220, 230, 240)
()	()	(x)	(x)	277
()	(x)	(x)	()	460 (440, 460, 480)
(x)	()	(x)	(x)	INDUSTRIAL ELECTRICITY TRAINERS Motor trainer: Fundamentals
()	(x)	()	(x)	Motor trainers: Simulating plant/industrial motors
()	(x)	(x)	()	Industrial control circuits

INSTRUCTIONS FOR ANSWERING OUTCOME-REFERENCED TEST ITEMS

Typically, eleven (11) different types of outcome-referenced test items may be used in the competency test.

1. True-False
2. Completion (Fill-in Blanks)
3. A Combination of True-False and Completion
4. Multiple-Choice
5. Matching
6. Identification
7. Short Answer
8. Long Answer
9. Program Product of Performance Test
10. Simulated Performance Test
11. Actual Performance Test

An example of each type of test item is included. Carefully study the illustration test item and the directions for answering the question. These directions will not be given again. Your test questions may vary slightly in the format, however, the instruction should be applicable. Where necessary, the instructor will supplement these instructions for answering outcome-referenced test items.

Do not guess. Guessing does not add to your knowledge, even if you happen to guess right. If you do not know the answer skip the test item and go to the next question. Remember: Enter your answers in the blanks provided on the separate answer sheet, if used.

1. TRUE-FALSE

Directions: Read the statement carefully. Decide whether it is true or false. Answer by marking T or F in the blank provided to the right (or, if answer sheet requires, mark "X" in the appropriate (T) or (F) parenthesis, or "circle" T or F).

Example: Lumber shrinks across the grain of the board. (T) (F)

2. COMPLETION (Fill-in Blanks)

Directions: Complete the statement by printing on the blank line the word or words which make a complete and correct statement.

Example: Proper edge spacing will restrict _____ and ensure good weld penetration. distortion

TYPICAL EQUIPMENT STUDENT WILL BE SKILLED
IN USING AT END OF FIRST AND SECOND YEAR:
(Check only applicable)

1ST YEAR					2ND YEAR			
Donaldson	Enoree	Foothills	Golden Strip		Donaldson	Enoree	Foothills	Golden Strip
(x)	(x)	(x)	(x)	Tool pouch	(x)	()	(x)	(x)
(x)	(x)	(x)	(x)	Screwdriver	(x)	()	()	(x)
(x)	(x)	(x)	(x)	Lineman's pliers	(x)	()	(x)	(x)
(x)	(x)	(x)	(x)	Long nose pliers	(x)	()	(x)	(x)
(x)	(x)	(x)	(x)	Cutter pliers	(x)	()	(x)	(x)
(x)	(x)	(x)	(x)	Nut drivers	(x)	()	(x)	(x)
(x)	(x)	(x)	(x)	Adjustable/Crescent Wrench	(x)	()	(x)	(x)
(x)	(x)	(x)	(x)	Groove Joint/Utility/Pump/Tong & Groove pliers	(x)	()	(x)	(x)
(x)	(x)	(x)	(x)	Adjustable Wire Strippers	(x)	()	(x)	(x)
(x)	()	()	(x)	Six in One tool/Crimping. All-purpose tool	(x)	()	()	(x)
(x)	(x)	(x)	(x)	Electrician's Pocket Knife	(x)	()	(x)	(x)
()	(x)	()	(x)	Electrician's Hammer	()	()	()	(x)
(x)	(x)	(x)	(x)	Ball Peen Hammer	(x)	()	(x)	(x)
(x)	(x)	(x)	(x)	Folding Rule	(x)	()	(x)	(x)
()	()	()	(x)	Tap Tool	(x)	()	()	(x)
(x)	(x)	(x)	()	Neon Test Light	(x)	()	(x)	()
(x)	(x)	()	(x)	V.O.M., Analog	(x)	()	(x)	(x)
()	(x)	()	(x)	Voltage Tester, Voltprobe	()	()	(x)	(x)
()	(x)	()	(x)	Clamp-on Amp Meter, Amprobe, Snap-around Probe	(x)	()	(x)	(x)
()	(x)	()	()	Watt Meter	()	()	()	()
()	()	()	()	Insulation Tester, Meg-Meter, Megohmmeter	()	()	(x)	()
()	(x)	()	()	Oscilloscope for AC	()	()	()	()
()	()	()	()	Phase Sequence and Open Phase Tester	()	(x)	()	()
(x)	(x)	(x)	(x)	Soldering Gun	(x)	()	(x)	(x)
(x)	(x)	(x)	()	Soldering Iron	(x)	()	(x)	()
(x)	(x)	(x)	(x)	Hacksaw	(x)	()	(x)	(x)
()	()	()	(x)	Pipe Cutter	()	()	()	(x)
(x)	(x)	(x)	(x)	EMT Bender or Hickory Bender	(x)	(x)	(x)	(x)
()	()	(x)	(x)	Pipe Reamer	()	()	(x)	(x)
(x)	(x)	()	(x)	Files	(x)	()	(x)	(x)
()	(x)	(x)	(x)	Torpedo Level	(x)	(x)	(x)	(x)
()	(x)	(x)	(x)	Brace and Bit	()	()	(x)	(x)
()	(x)	(x)	(x)	Knockout Punches	()	(x)	(x)	(x)
()	(x)	(x)	(x)	Fish Tape and Reel	(x)	(x)	(x)	(x)
()	()	()	(x)	Plumb Bob	()	()	()	(x)
(x)	(x)	()	(x)	Electrician's Chisel	(x)	()	()	(x)
()	()	(x)	(x)	Keyhole Saw	()	()	(x)	(x)
()	()	()	(x)	Reciprocal Power Saw	()	()	()	(x)
()	()	()	(x)	Power Sabre Saw	(x)	()	(x)	(x)
(x)	(x)	()	(x)	Electric Hand Drill	(x)	()	(x)	(x)

3. COMBINATION OF TRUE-FALSE/COMPLETION

Directions: If the statement is correct, in the parenthesis mark (T) or answer true, as required. If the statement is incorrect, mark (F) in the parenthesis and fill in the blank provided with the appropriate word or term which, if substituted for the underlined word, would make the statement correct.

Example: A pantry chef usually is the head chef's first assistant. (T) (F)
sous

4. MULTIPLE-CHOICE

a. Directions: You are given three or four choices from which to make a complete and correct statement. In the blank answer space provided, write in the "letter" indicate the best choice.

Example: The head chef's first assistant is a ?.

- a. junior chef
- b. sous chef
- c. pantry cook

b. Negative Answer Multiple-Choice

Directions: If the multiple-choice question includes the word EXCEPT, you should look for the choice that does not fit the question. Read the entire question carefully before you choose your answer.

Example: All of these could cause high starter current draw EXCEPT:

- a. work starter bushing
- b. bad starter relay
- c. grounded field coils
- d. grounded armature

5. MATCHING:

Directions: For each given item in the left hand column, match it with the appropriate item from the right hand column. Write the letters of the correct or best answer in the appropriate blanks.

Example: Match these metric terms on the left with their proper equivalents.

<u>b</u>	deca	a.	thousands
<u>e</u>	meter	b.	tens
<u>a</u>	kilo	c.	units of length measurement

6. IDENTIFICATION

Directions: Identify each labeled part of the illustration below and write the name next to the appropriate letter in the blank provided.

Example:

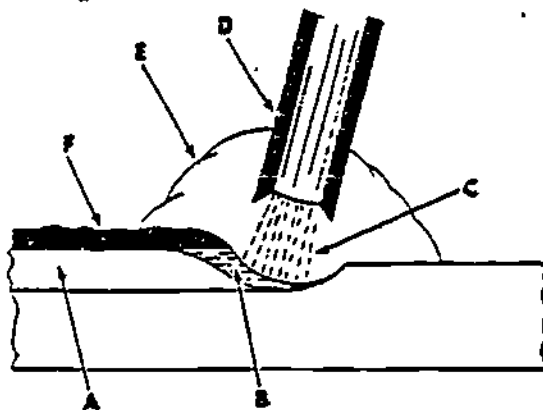

a.	<u>base metal</u>
b.	<u>molten metal</u>
c.	<u>arc</u>
d.	<u>electrode</u>
e.	<u>gas shield</u>
f.	<u>slag</u>

7. SHORT ANSWER

Directions: Write the correct answer in the blank provided.

Example: What type of electrode is best for vertical and overhead welding? fast-freeze

8. LONG ANSWER

Directions: Using as few words as possible, write the answer to the question in the blank provided.

Example: What should be done if the electrode welds fast to the work?

"Electrode should be broken loose by twisting or bending the holder."

9. PROGRAM PRODUCT OR PERFORMANCE TEST

Definition: Concrete project or production accomplishments during training are used to test knowledge or skill. Typically, test pressures are missing and the student may have had help in completing the task.

Directions: Instructor will observe student during training and by checklist or rating scale will rate student's performance or knowledge.

Example: Given an oven for baking, food items, and necessary implements and equipment; load the oven with foods to be baked. All items on a checklist used to rate performance must receive an acceptable rating. The task must be accomplished within 15 minutes.

CHECKLIST

(Load Oven Racks)

ACTIVITY	RATING	
	Acceptable	Unacceptable
1. Gathered needed supplies.		
2. Used needed supplies.		
3. Pulled oven rack partially out while loading.		
4. Stacked oven shelves 3 inches apart for baking.		
5. Placed food on rack so that heat circulated adequately.		
6. Followed appropriate safety precautions.		

10. SIMULATED PERFORMANCE

Definition: Contrived situation, resembling tasks the graduate will be required to do on the job. This form of test is useful for evaluating transferable skills such as reasoning, attitudes, and psychomotor skills necessary for occupational success.

11. ACTUAL PERFORMANCE TEST

Definition: Exhibits the advantage of realism, but may be too late to help either the student or the vocational program correct failures.

Example: Given an automobile with a leaking pinion seal, access to proper tools and equipment, replacement parts, and service manual; replace the pinion seal according to manufacturer's recommended procedures. The job should be completed within 2 hours. The manufacturer's specifications must be met and the completed job must meet the instructor's standards.

ANALYSIS OF SECONDARY INSTRUCTIONAL TIMES

Instructional times and tasks have been described based on a State of South Carolina requirement that 3-hour blocks of training total 540 hours per year or 1,080 hours for two year programs.

Currently vocational programs in career centers typically are conducted on the 3-hour block time frame. Most vocational programs currently are offered for a two year period. Some vocational courses, such as office occupations areas, may be offered for only one or two hours of training daily.

While the "suggested instruction times" for the tasks in this guide have been allocated based on a 3-hour vocational instruction day, many vocational students in reality are not in the classroom for a full three hours. Students, typically, must be bused to and from feeder high schools with transit times typically of about 15-30 minutes per trip one way. In addition, students typically are given at least one break during instruction and some instructional time is lost as students change clothes for shop work and then change back into regular school clothing. Add to this lost time the possible time lost to feeder high school activities such as 'pep rallies' and other activities and the resulting vocational instructional day probably is less than 1.5 to 2 hours per day of actual instruction or training.

Realistically, a total instruction time of from 270 to 360 hours of vocational training probably is more accurate for a 3-hour block program in one year than 540 hours.

It is important to recognize this potential situation as vocational instruction is planned and evaluated.

THIS DOCUMENT AND BINDER ARE THE PROPERTY OF THE SCHOOL DISTRICT
OF GREENVILLE COUNTY OR GREENVILLE TECHNICAL COLLEGE

The production of this curriculum guide and binder by the Occupational Education Articulation Program was funded through the South Carolina Appalachian Council of Governments. This guide and binder are the property of The School District of Greenville County or Greenville Technical College.

Except for document and binder copies that have been placed in libraries or shared with educational organizations, the documents and binders are issued on an accountability basis.

Documents and binders issued to instructor participants remain the property of the issuing institution. Should a vocational instructor leave the employment of The School District of Greenville County or Greenville Technical College, the document and binder must be returned to the principal, vocational center director, or department head so the instruction guide may be used by replacement personnel.

Corrections, modifications, and notes may be made on the pages of the documents for the purpose of modifying the field trial edition or to improve the instructional value of the document. Please share any corrections, modifications, and recommendations concerning this document with the Occupational Education Articulation Program.

Illegible or blank document page replacements may be requested at no cost through the Occupational Education Articulation Program. For replacement pages, please indicate:

Document Title
Module Number
Task Number or Page Number

Replacement costs for this document and binder are:

1" Binder - \$2.80
2" Binder - \$5.00
Document - .05¢ per page (1982)

Who to contact:

Occupational Education Articulation Program
The School District of Greenville County
c/o Donaldson Vocational Center
Donaldson Center
Greenville, SC 29605

(or)

Consultant, Vocational Education
The School District of Greenville County

(or)

Associate Vice President for Education
Greenville Technical College

BINDER DESIGN

(Occupational Education Articulation Program)

The binder design is simple and straightforward.

Two triangular figures, in balance, represent the two institutions participating in articulation.

Two levels of training are represented by the placement of the triangular figures and the identification of the two institutions.

Horizontal and vertical lines represent lateral and vertical articulation.

The diagonal across the design represents the progressive movement in career development for successful job performance.

The two figures are not closed when they face, but allow for interaction and are linked by the document title: Articulated, Performance-based Instruction Guide.