

DOCUMENT RESUME

ED 243 720

SE 044 494

AUTHOR Gardner, Anne, Ed.
 TITLE Sanitary Survey Training. The Need-to-Know Material: Instructor's Technical Manual.
 INSTITUTION Dynamac Corporation, Rockville, MD.
 SPONS AGENCY Environmental Protection Agency, Washington, DC; Office of Drinking Water.
 PUB DATE Oct 83
 CONTRACT 68-03-3130
 NOTE 393p.; For student's text see SE 044 495.
 AVAILABLE FROM EPA Instructional Resources Center, 1200 Chambers Rd., 3rd Floor, Columbus, OH 43212 (\$1.00 plus \$0.06 per page).
 PUB TYPE Guides - Classroom Use - Guides (For Teachers) (052)
 EDRS PRICE MF01 Plus Postage. PC Not Available from EDRS.
 DESCRIPTORS Drinking Water; Environmental Standards; Postsecondary Education; Public Health; Public Relations; Safety; *Storage; Surveys; *Training Methods; Training Objectives; *Water Quality; *Water Resources; *Water Treatment
 IDENTIFIERS Pumps; *Sanitary Surveys; *Water Distribution

ABSTRACT

This manual, developed as an aid to state agencies who provide instruction to inspectors of water systems, is based on the minimum information that an inspector with limited experience needs to know to successfully assess a public water system. The manual is designed for use by individuals who are experts in the field of water systems and sanitary surveys, but who may not be experienced in instructional techniques. The manual (which includes basic text material, audiovisuals, and evaluation exercises as well as detailed instructions for presenting the material and managing sanitary training activities) is divided into 13 units of varying length. Unit topics focus on water regulations; water sources (general, wells, springs, and surface sources), pumps, water treatment, storage (gravity storage and hydropneumatic tanks), water distribution (distribution systems and cross-connections), monitoring and recordkeeping, management and safety, surveys, communications and public relations, and technical assistance; an orientation unit and concluding information are provided in separate units. Each unit includes a summary, objectives, basic material (in outline format), instructional strategies, unit emphasis, student preparation, and pre-/post-tests. The outline approach used provides instructors with maximum flexibility in adapting the material to specific situations encountered during the conduct of a sanitary survey within a particular state. (JN)

 * Reproductions supplied by EDRS are the best that can be made *
 * from the original document. *



Sanitary Survey Training

ED 341 5720

U.S. DEPARTMENT OF EDUCATION
NATIONAL INSTITUTE OF EDUCATION
EDUCATIONAL RESOURCES INFORMATION
CENTER (ERIC)

This document has been reproduced as received from the person or organization originating it.
Minor changes have been made to improve reproduction quality.

Points of view or opinions stated in this document do not necessarily represent official NIE position or policy.

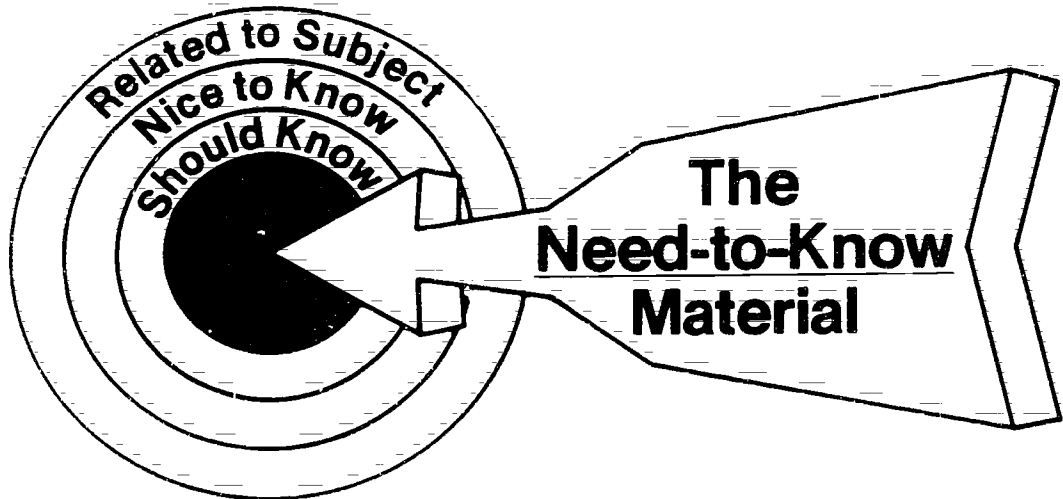

Instructor's Technical Manual

PERMISSION TO REPRODUCE THIS
MATERIAL IN MICROFICHE ONLY
HAS BEEN GRANTED BY

U.S.E.P.A.

TO THE EDUCATIONAL RESOURCES
INFORMATION CENTER (ERIC)."

SE 044 494

CREDITS

The U.S. Environmental Protection Agency gratefully acknowledges the Conference of State Sanitary Engineers for the development of the background materials for this training program made possible by an Agency grant.

This manual was developed and prepared for the USEPA Office of Drinking Water by Dynamac Corporation, Rockville, Maryland, under EPA Center for Environmental Research Information Contract No. 68-C3 3150. The Project Engineer and Technical Editor for the effort were Lloyd A. Hinkle, Jr., and Anne Gardner, respectively, of Dynamac Corporation.

Recognition is also due Robert Heckelman, EPA Project Officer, and Kenneth Hay, EPA Educational Specialist, who were particularly instrumental in the development of this training manual.

TECHNICAL ADVISORS

The following individuals assisted in selecting the need-to-know technical information provided in this manual. This was accomplished with a great deal of discussion, compromise, and ultimate agreement on the part of each of the individuals concerned with the development of this document.

M. K. Batavia	Director, Water Supply State of South Carolina
Bill Carpenter	Assistant Training Director National Rural Water Association
Peter Karalckas	Water Supply Branch USEPA Region I Boston, MA
Ken Kerri	Professor of Civil Engineering California State University of Sacramento
Don Kuntz	Chief, Drinking Water Division State of West Virginia
Don Moore	Office of Environmental Health Indian Health Service - Phoenix
William Price	Chief, Technical Services and Training Public Drinking Water Program State of Missouri
T. Jay Ray	Water Supply Branch USEPA Region VI Dallas, TX
R. Clough Toppan	Manager, Drinking Water Program State of Maine
Bob Williams	Water Supply Branch USEPA - Region II New York, NY

PREFACE

This Sanitary Survey Training Manual has been developed as an aid to State agencies who provide instruction to inspectors of water systems. It is based on the minimum information that an inspector with limited experience needs to know to successfully assess a public water system.

The Instructor's Manual and Student's Text are intended for use in conducting technical assistance seminars for State and local agency personnel responsible for State public water supply programs under the Federal Safe Drinking Water Act.

The overall objective of seminars conducted through the use of these materials is to provide the minimum training that, when complemented by on-the-job training, will enable personnel to perform effective evaluations of small public water supply systems. Personnel attending training where these manuals are used by an instructor should have a basic knowledge of water supply systems and some limited on-the-job experience of sanitary surveys conducted by experienced agency personnel. It must be stressed that these manuals provide only "need-to-know" information; that is, only the basic questions, and their rationale and importance; that an inspector needs to know to adequately evaluate a water system. These manuals do not provide technical detail on every facet of a water system, nor are they intended to provide an inspector with the ability to provide technical assistance.

CONTENTS

UNIT TITLE	PAGE
PROPOSED SCHEDULE	v
INSTRUCTION GUIDE	vii
UNIT 1. ORIENTATION	1-1
UNIT 2. WATER REGULATIONS	2-1
UNIT 3. WATER SOURCES	3-1
3a. General	3-2
3b. Wells	3-8
3c. Springs	3-12
3d. Surface Sources	3-15
UNIT 4. PUMPS	4-1
UNIT 5. WATER TREATMENT	5-1
UNIT 6. STORAGE	6-1
6a. Gravity Storage	6-2
6b. Hydropneumatic Tanks	6-5
UNIT 7. WATER DISTRIBUTION	7-1
7a. Distribution Systems	7-2
7b. Cross-Connections	7-5
UNIT 8. MONITORING/RECORDKEEPING	8-1
UNIT 9. MANAGEMENT/SAFETY	9-1
UNIT 10. SURVEYS	10-1
UNIT 11. COMMUNICATIONS/PUBLIC RELATIONS	11-1
UNIT 12. TECHNICAL ASSISTANCE	12-1
UNIT 13. CONCLUSION	13-9
SUGGESTED REFERENCES	13-9

PROPOSED SCHEDULE

DAY 1

Unit	Title	Contact Time	Schedule
1	ORIENTATION	60 minutes	8:30 am - 9:30 am
2	WATER REGULATIONS	30 minutes	9:30 am - 10:00 am
	Break	15 minutes	10:00 am - 10:15 am
3	WATER SOURCES		
4	General	30 minutes	10:15 am - 10:45 am
5	Wells	60 minutes	10:45 am - 11:45 am
	Lunch	60 minutes	11:45 am - 12:45 pm
6	Spring	45 minutes	12:45 pm - 1:30 pm
7	Surface Sources	45 minutes	1:30 pm - 2:15 pm
8	PUMPS	45 minutes	2:15 pm - 3:00 pm
	Break	15 minutes	3:00 pm - 3:15 pm
9	WATER TREATMENT	75 minutes	3:15 pm - 4:30 pm

PROPOSED SCHEDULE (Continued)

DAY 2			
Hour	Title	Contact Time	Schedule
6	STORAGE		
6a	Gravity Storage	20 minutes	8:30 am - 9:00 am
6b	Hydropneumatic Storage	30 minutes	9:00 am - 9:30 am
7	WATER DISTRIBUTION		
7a	Distribution Systems	45 minutes	9:30 am - 10:15 am
	Break	15 minutes	10:15 am - 10:30 am
7b	Cross-Connections	30 minutes	10:30 am - 11:00 am
8	MONITORING/RECORDKEEPING	45 minutes	11:00 am - 11:45 am
	Lunch	60 minutes	11:45 am - 12:45 pm
9	MANAGEMENT/SAFETY	45 minutes	12:45 pm - 1:30 pm
10	SURVEYS	60 minutes	1:30 pm - 2:30 pm
	Break	15 minutes	2:30 pm - 2:45 pm
11	COMMUNICATIONS/ PUBLIC RELATIONS	30 minutes	2:45 pm - 3:15 pm
12	TECHNICAL ASSISTANCE	30 minutes	3:15 pm - 3:45 pm
13	CONCLUSION	15 minutes	3:45 pm - 4:30 pm

INSTRUCTION GUIDE

A thorough understanding of this Instructor's Technical Manual is vital to the successful presentation of a sanitary survey training program. This manual, when complemented by on-the-job experience for the student under the guidance of the more experienced inspector, would enable the instructor to successfully provide the minimum training necessary to conduct a sanitary survey. In presenting such a program, the Student's Text must be utilized in conjunction with this manual.

This manual is designed for use by individuals who are experts in the field of water systems and sanitary surveys, but who may not be experienced in instructional techniques. The prerequisites for an individual utilizing this manual would be an academic background in public drinking water systems with a minimum of 3 years of experience in performing sanitary surveys.

This manual includes the basic text material, audiovisuals, and evaluation exercises as well as detailed instructions for presenting the material and managing sanitary training activities. The content of this manual is geared for presentation to students of varying educational backgrounds. Students being trained via this manual should be sanitary engineers, sanitarians, or technicians with some limited experience in performing sanitary surveys.

Manual Goals

The purpose of the Instructor's Technical Manual and Student's Text is to provide the basic outline, text, and materials for use in a State training program. The outline and text should be modified to present the specific situations encountered during the conduct of a sanitary survey within that particular State.

Of primary importance to such a presentation is the student's ability to relate course information to the activities of the sanitary survey. Insofar as possible, the instructor should explain how the information presented can be used during an actual survey.

The inspector should be able to determine not only that the water system is complete, but also that it is functioning in an approved manner.

The instructor can greatly enhance student understanding by relating anecdotes from personal experience demonstrating means of determining whether system activities such as disinfection and cross-connection control are, in fact, being adequately performed.

Presentation

To successfully present a sanitary survey training program utilizing this manual, the instructor must be thoroughly conversant with all types of small water systems and the activities of a sanitary survey. The information provided in brief outline form. The outlines are designed to serve as guidelines to ensure that all relative information is covered. The outlines in themselves are not complete sources of information but rather are notes designed to be expanded upon by the instructor. It is imperative to the successful presentation of this manual that all points in the outlines be covered.

This outline approach will provide the instructor with maximum flexibility in adapting the training program to the specific needs of a particular region. The points covered in the outline are general and will apply to most sanitary survey requirements.

Material

Instructor's Technical Manual

- o Instruction Guide
- o Proposed Schedule
- o Preparation Checklists
- o Basic Material (Units 1-13)
- o Evaluation Forms
- o Instructional Aids
(additional copies of each from which transparencies can be made)
- o Provisions for including specific State information

Student's Text (separate manual)

- o Introduction
- o Basic Material (Units 1-13)
- o Provisions for student's supplementary materials

Format

The Units. The manual is divided into 13 units of varying lengths. Each unit is organized into the following sections:

- o Unit Summary. This section gives the instructor an overview of the unit material.
- o Objectives. Each unit is based on specific objectives that state what the student should be able to do at the end of the material presentation. The objectives are based on information the inspector needs to successfully perform a sanitary survey. The instructor should make careful note of these objectives and use them to guide the presentation.

- o Basic Material. This section provides the basic information in outline form. The instructor should use the basic material section to guide the presentation, being sure to cover all points in the outline. Additional information and personal anecdotes should be presented as time allows. Transparencies and other graphics are included in this section as aids in presentation and as reinforcement of text material.
- o Basic Material Format. This manual presents basic material and instructional strategy in a two-column format on the right-hand page. The basic material, in outline form, is located in the right column. (Related material is included in the Student's Text.)

Specific instructions for presenting the material are located in the left column. These directions are designed to aid the instructor in varying the material presentations and in encouraging active student participation in the program.

The left hand page is provided for the outlining of specific State information pertinent to conducting sanitary surveys:

- o Unit Emphasis. Units dealing with system components and operations emphasize sanitary risks and means of assessing these risks. The sanitary risk factors listed in these units describe situations or conditions that can increase the risk of contamination. They can also be used to identify specific means of protection.
- o Student Preparation. Prior to the presentation of each unit, students should read the basic material in the Student's Text. This will familiarize students with topics to be covered in the unit so that they can contribute actively to unit sessions. Specific assignments for this preparation are listed both in the Instructor's Technical Manual and in the Student's Text. Instructors should assign each section in advance of the session and expect that students will come to class prepared.
- o The Pre- and Post-Tests. A pre-test and a post-test will be given to measure the level of progress each student has made during the training session.

Flexibility

The manual is designed to accommodate specific requirements of the participants and of the local circumstances. The instructor should carefully review the information regarding educational background and water supply experience received on the participant data questionnaires. The level of education and experience of the group will determine the amount and depth of technical information to be presented during a particular training program.

When at all possible, instructor materials such as site maps, well logs, and engineering plans should represent actual circumstances in the student's particular geographical area.

- o Content Modification. Changes in the content of the manual to reflect the types of systems or supplies that students will encounter in a particular area can be made simply without disruption to the overall organization of the manual. The lesson objectives and instructional strategies are sufficiently flexible to accommodate additions and deletions of material. Provisions are made in the Instructor's Technical Manual for these modifications.

Instructors are encouraged to add additional materials, visuals, examples and anecdotes to supplement the basic material of this manual. However, care should be taken to assure that additions relate directly to the instructional objectives and do not stray from the category of "need-to-know" information. Any changes should always relate directly to improving the student's ability to conduct a successful sanitary survey.

Schedule Modification. The Proposed Schedule is set up on a 2-day block of time. If such a schedule is impractical, the plan may be modified.

- o Each unit is independent, and one or more can be presented in an evening or in a program of consecutive evenings or weeks.

Units might be grouped to spread the program over a 2-week period of partial days.

EVALUATION (OPTIONAL)

At the close of the training, all participants (students and instructors) can be asked to evaluate the overall effectiveness of the presentation. Specifically, the instructional staff, training material, presentation organization, and facilities will be evaluated. These evaluations can be used to identify deficiencies and make improvements in the overall program.

Preparation Checklists

Preliminary Activities. Use this checklist in planning and preparing for the training sessions. Additional steps may be necessary to meet specific requirements.

- ___ Review all materials thoroughly, paying particular attention to the Instruction Guide in the Instructor's Technical Manual.
- ___ Set the dates for the program and schedule the facilities. Facility considerations include:
 - o Meeting room of adequate size
 - o Adequate number of tables and comfortable chairs
 - o Nearby facility for lunch
 - o Coffee and refreshments available
 - o Lodging for out-of-town participants
- ___ Prepare and mail letters of invitation and Participant Data Sheets (Form 1) to prospective participants.
- ___ Adjust course to meet specific requirements, if desired. Change Student's text, if necessary.
- ___ Prepare roster of participants. (See Form 2.)
- ___ Send Acknowledgment Form and Student's Text to participants 2 weeks in advance.
- ___ Make arrangements for equipment:
 - o Chalkboard/chalk
 - o Movie screen
 - o Overhead projector; spare lamp
 - o Instructional materials (see "Logistics" section of each lesson)
- ___ Duplicate all materials to be handed out to the students.
 - o Pre-test
 - o Simulation exercises
 - o Post-test
 - o Evaluation forms (optional)
 - o Other materials to be added by the instructor

Presentation Checklist: Use this checklist to prepare for each presentation.

- ___ Review entire lesson thoroughly, including material in Student's Text.
- ___ Study lesson objectives.
- ___ Study basic material. Clarify questions; insert specific State information.
- ___ Duplicate handouts (if any).
- ___ Prepare other material as needed to complete lesson.
- ___ Make sure necessary equipment is available and functional.

Form 1

Participant Data Sheet

Please complete this form and return it to this address by: _____

Please type or print the information requested below:

Your Name: _____

Employer: _____

Title: _____

Work Address: _____

Zip: _____

Phone: _____
(Area Code)

How long have you been in present job? _____

Brief summary of present job duties: _____

Previous experience pertinent to small water systems:

(1) Dates: from _____ to _____

Employer: _____

Duties: _____

(2) Dates: from _____ to _____

Employer: _____

Duties: _____

(3) Dates: from _____ to _____

Employer: _____

Duties: _____

Education:

High School Graduate? Yes ___ No ___

College(s) Attended: (1) _____

Major: _____

Years of Attendance: 19 ___ - 19 ___ Title of Degree: _____

College(s) Attended: (2) _____

Major: _____

Years of Attendance: 19 ___ - 19 ___ Title of Degree: _____

College(s) Attended: (3) _____

Major: _____

Years of Attendance: 19 ___ - 19 ___ Title of Degree: _____

Previous Training in Water Supply-Related Topics:

(1) Name of Course: _____

Units or CEUs ___ Year Conducted ___

(2) Name of Course: _____

Units or CEUs ___ Year Conducted ___

(3) Name of Course: _____

Units or CEUs ___ Year Conducted ___

Please supply the following information about the public water systems in your area of jurisdiction: Total Number: _____; of this, the:

No. of Well/Infiltration Gallery Sources _____

No. of Spring Sources _____

No. of Surface Sources _____

Roster of Participants

SANITARY SURVEYS OF WATER SYSTEMS

Course Location: _____ Course Sponsor: _____ Course Date: _____

Name and Address _____

Job Title/Position: _____

1. _____
2. _____
3. _____
4. _____
5. _____
6. _____
7. _____
8. _____
9. _____
10. _____
11. _____
12. _____
13. _____
14. _____
15. _____
16. _____
17. _____
18. _____
19. _____
20. _____

UNIT 1: ORIENTATION - "THE NEED TO KNOW"

Unit Summary

Registration and Introduction
Schedule and Format
Pre-Test
The Sanitary Survey

Unit Objectives

To conduct a successful sanitary survey, the student must know what a survey is and why it is being conducted.

At the close of this unit, the student should know:

1. What is a sanitary survey
 2. Why sanitary surveys are performed
 3. Who conducts such surveys
 4. What activities occur during a survey
-

Logistics

Approximate Presentation Time: 60 minutes

- o Registration (10 minutes)
- o Pre-Test (to be duplicated)
- o Answer Key
- o Basic Material
- o Transparencies 1-1 through 1-8

Student Materials

- o Student's Text, Unit 1

Student Preparation

- o Unit 1 should be read prior to the session.

Unit References

Report of a Sanitary Survey in the North Adams, MA, Water Supply System, January 8, 1982; by Peter C. Kuralekas, USEPA, Boston, MA

Register students.

Registration Form located in this unit
(10 minutes)

Personal Information

- o Home location
- o Previous experience

Introduce instructor(s);
give brief biographical
sketch to instill student
confidence in instructor
credentials.

Review schedule, format,
and logistical necessities.

Explain purpose of and
administer pre-test.

Have students code
identification on pre-
test (e.g., use last
four digits of driver's
license) to allow
students to remain
anonymous yet receive
evaluated test results.

Purpose of Pre-test (5 minutes)

- o Inventory student's knowledge of sanitary surveys
- o Highlight topics to be covered in training program
- o Provide instructor with guide to areas of students' knowledge that will need strengthening

Administration of Pre-test (20 minutes)

- o Pre-test should be administered and evaluated in the first period. This will allow instructor to determine where additional emphasis may need to be placed in the training program. This may be facilitated by giving the pre-test and allowing students to introduce themselves while another instructor grades pre-tests.

Introduce students. Ask each
to give some brief personal
background information. Try
to create informal atmosphere.
Have students briefly explain
what their job is. This in-
formation can be used to draw
anecdotes from actual student
experience.

Registration Form

SANITARY SURVEYS OF WATER SYSTEMS

Location: _____

Date: _____

Student

Address

1.	_____	_____
2.	_____	_____
3.	_____	_____
4.	_____	_____
5.	_____	_____
6.	_____	_____
7.	_____	_____
8.	_____	_____
9.	_____	_____
10.	_____	_____
11.	_____	_____
12.	_____	_____
13.	_____	_____
14.	_____	_____
15.	_____	_____
16.	_____	_____
17.	_____	_____
18.	_____	_____
19.	_____	_____
20.	_____	_____

SANITARY SURVEYS OF WATER SYSTEMS

PRE-TEST

This test is intended to assess your prior knowledge of water systems and their operations. At the conclusion of the training program, a post-test will be administered to evaluate your progress and the overall effectiveness of the program. There may be more than one correct answer to some of these questions.

1. Smaller water systems usually have
 - a. a greater variation between the average daily demand and the maximum daily demand than do larger water systems.
 - b. less variation between the average daily demand and the maximum daily demand than do larger water systems.
 - c. a variation between the average daily demand and the maximum daily demand similar to that of a larger water system.
2. A dimension with the unit of "feet of head" is measuring which of the following?
 - a. Velocity
 - b. Length
 - c. Pressure
 - d. Flow
3. Which of the following is a factor affecting the likelihood that a given source of pollution may contaminate a well?
 - a. Depth of well
 - b. Distance from well
 - c. Type of pollutant
 - d. Diameter of the well.
4. The results of fermentation tube method and membrane filter method
 - a. are directly comparable.
 - b. cannot be compared.
 - c. are a measure of the spore-forming bacteria present in the sample.
5. The two basic maintenance checks on the hydropneumatic storage system are
 - a. correct air volume.
 - b. correct air gap separation.
 - c. correct pressure range.
 - d. presence of a diaphragm.

6. The most effective cross-connection prevention device is
- an air gap.
 - a vacuum breaker.
 - reduced pressure zone backflow preventer.
 - a check valve.
7. The chlorine contact time for a free chlorine residual should be a minimum of
- 10 minutes.
 - 45 minutes.
 - 30 minutes.
 - 5 minutes.
8. A system is producing 500,000 gallons of water per day and utilizes 10 pounds of chlorine per day for disinfection. The estimated chlorine dose is
- 0.4 mg/l
 - 0.2 mg/l
 - 2.4 mg/l
 - 4.0 mg/l
9. Turbidity is of concern in water quality because
- it is a suspected carcinogen.
 - it interferes with disinfection.
 - it interferes with coagulation.
 - it causes corrosion.
10. The best reason intakes should be located at various depths in a surface impoundment is to
- withdraw the maximum amount of water.
 - withdraw the best quality water.
 - provide a backup in case of clogging of an intake.
11. The purpose of jar testing is
- to determine the minimum turbidity.
 - to determine the optimum chemical dosage for coagulation.
 - to determine corrosivity of raw water.
 - to determine alkalinity of finished water.
12. The accepted method for determination of turbidity is
- Nephelometric method.
 - Jackson Unit.
 - Amperometric method.

13. The application of granular activated carbon and chlorination at the same point as a means of pretreatment
- a. for the control of taste and odor.
 - b. for the removal of color.
 - c. a costly and ineffective means of treatment.
14. The primary purpose of rapid sand filtration is
- a. disinfection.
 - b. removal of color.
 - c. removal of taste and odors.
 - d. removal of turbidity.
15. An increase of turbidity in a spring collection chamber after a rain indicates
- a. a defective drain valve.
 - b. backflow of treated water.
 - c. surface water contamination of the source.
16. The AWWA-recommended procedure for disinfection of new water mains involves
- a. 300 mg/l chlorine dosage with a 10 mg/l residual after a 3-hour contact time.
 - b. 10 mg/l chlorine dosage with a 25 mg/l residual after a 1-hour contact time.
 - c. 2.0 mg/l chlorine dosage with a 2 mg/l residual after a 30-minute contact time.
 - d. 50 mg/l chlorine dosage with a 10 mg/l residual after a 24-hour contact time.
17. Common problems observed in gravity storage tanks are
- a. nonlocking manhole covers.
 - b. corrosion of metal tanks.
 - c. improper or lack of screens on vents.
 - d. sludge buildup in the tank bottom.
 - e. lack of disinfection after making repairs.
18. Samples for free chlorine residual
- a. can be stored up to 6 hours before analysis.
 - b. can be stored up to 1 hour before analysis.
 - c. can be stored up to 24 hours before analysis.
 - d. must be analyzed immediately after sampling.

Pre-test Key

- | | |
|------------|-------------------|
| 1. a | 10. b |
| 2. c | 11. b |
| 3. a, b, c | 12. a |
| 4. b | 13. c |
| 5. a and c | 14. d |
| 6. a | 15. c |
| 7. c | 16. d |
| 8. c | 17. a; b; c; d; e |
| 9. b | 18. d |

Explain objective of unit.

The Sanitary Survey (20 minutes)

Use questions to elicit responses prior to presenting material on specific areas:

Use Transparency 1-1.

1. What is a sanitary survey?
 - o Defined in National Interim Primary Drinking Water Regulations 40 CFR.
 - o No longer the classic "sanitary survey" of watershed.

Use Transparency 1-2.

2. Why should sanitary surveys be conducted?
 - o Required by law (NIPDWR 40 CFR).
 - o Determine adequacy of both quantity and quality of the water provided for public consumption.
 - o Identify problem areas and provide possible remedies.

Use Transparency 1-3.

3. Who conducts sanitary surveys?
 - o Competent personnel who are experienced in the identification of problems within a water system.

Use Transparency 1-4:

4. What are activities and their rationale of a sanitary survey?
 - o Inspect and Evaluate
 - a. Water source
 - b. Intake structure and wells
 - c. Treatment/conditioning facilities
 - d. Distribution system
 - o Review
 - a. Operations and maintenance practices
 - b. Records, files, maps, correspondence
 - c. Management practices and personnel needs
 - d. Competency of technical and ancillary personnel
 - e. Laboratory certification (if other than State lab)

Emphasize that the period of the survey is very short when compared with total time system must function.

o Sample

- a. Sample source and distribution for bacteriological, physical, chemical, and radiological properties and (as required) perform and evaluate field analyses.

Emphasize that this is the heart of the survey.

o Recommend

- a. Complete survey report and present data (both negative and positive comments) to operating personnel:
- b. Discuss problem areas and provide recommendations for their remedies. Provide an appropriate time schedule for remedies:

o Notify

- a. The owner/operator, public, State regulatory agency, and EPA of deficiencies (as required).

Emphasize that remainder of presentations will be spent answering these questions.

Use Transparency 1-5:

Use Transparency 1-6:

Briefly highlight components that will be discussed during course.

Use Transparencies 1-7 and 1-8.

Sanitary Risks

1. What conditions cause sanitary risks?
2. How can they be recognized?

Water System Components (5 minutes)

- o Source
- o Intake Structure/Wells
- o Treatment
- o Storage
- o Distribution

Instructor's Narrative

Introduction

During this training program we will be covering the basic "need to know" of sanitary surveys. This will neither prepare you for every situation.

nor will it make design engineers of you. You will merely be provided a starting point from which to develop competency in the field of water supply. Although this information is applicable to all systems, we will be addressing smaller systems serving less than 10,000 in population. But before we go further, we must ask ourselves some basic questions:

1. What is a sanitary survey? The classic "sanitary survey" was an inspection of a watershed to identify potential sources of contamination such as manure piles, septic tanks, pig farms, and a variety of other activities that could contaminate the source of water supply. This is not the type of survey we will be discussing. The basis for the survey we are considering is found in the National Interim Primary Drinking Water Regulations. This regulation defines sanitary surveys as "an onsite review of the water source, facilities, equipment, operation and maintenance of a public water system for the purpose of evaluating the adequacy of such source, facilities, equipment, operation and maintenance for producing and distributing safe drinking water." Essentially, it is a review of a public system from the source to the consumer's tap. The next question is then:
2. Why should sanitary surveys be conducted? In this day of high technology, it would seem that the problems of water supply would have by now been identified and solutions provided. There have been reports within recent history that would tend to cast doubt on this assumption. One of these reports was the Survey of Community Water Supply Systems carried out nationwide by the U.S. Public Health Service in 1969. The results published in 1970 showed that of 969 community water systems surveyed serving more than 18 million people, 41% were delivering water of inferior quality based on the U.S. Public Health Service Drinking Water standards, essentially the same standards utilized today.

The Community Water Supply Study also showed that, apart from quality, many other problems were apparent. About 56% of the water systems evidenced physical deficiencies including poorly protected sources, inadequate treatment, and inadequate system pressure. Operators were inadequately trained, with 77% lacking sufficient training in fundamental water microbiology and 46% deficient in chemistry. Other problems included inadequate inspection frequency of systems by State authorities and insufficient sampling of water supplies to measure bacteriological or chemical quality of the water. In many ways this was shocking to a public that rarely questioned the quality of a water supply system. Another factor that enters the picture is the development of new analytical methods that allow the measurement of contaminants in the parts per billion range. Results of studies by researchers in the Netherlands and by EPA scientists in Cincinnati and New Orleans showed that a variety of new contaminants were being found in water systems. Suddenly the organics were upon us. Early health and epidemiological studies indicated that some of these organic compounds were potential

cancer-causing agents. Has the quality of water improved since the implementation of the Safe Drinking Water Act? By its definition we are dealing with 60,000 community water systems. About 67% of the total number of community water systems serve populations of 500 or less but only 2.4% of the population. Furthermore, 88% of the community water systems are defined by EPA as small water systems (serving 3,300 or less), yet they serve only 10.7% of the population.

Having looked at this distribution of systems, a review of the FY 81 national microbiological violations is informative. Approximately 92% of the systems in violation of the MCL and/or monitoring/reporting standards are in the small and very small systems category. There has been general improvement in practically all categories with regard to the previous year's compliance data. As for the MCL violation, the national average for FY 81 was 8.5%. It is interesting to compare this figure with the results found in the 1969 Community Water Supply Study mentioned earlier. At that time more than 12% of the 969 systems surveyed failed to meet the microbiological MCL. A more significant comparison is the compliance with monitoring requirements. In the 1969 study, only 10% of the systems conducted a monitoring program sufficient to meet the standards. In FY 81, 74% of the systems carried out a regular monitoring program. The same type of trend follows for the turbidity violations as well.

These are only statistics. Perhaps a better way to illustrate the need to conduct sanitary surveys would be to provide a specific case study of a small water system in New England. This particular small water system was consistently in violation of the MCL for turbidity. Surprisingly, there were no violations of the MCL for coliform in over 3 years.

The water system itself has both reservoirs and wells as sources of supply. The watersheds on the reservoir were very well protected with no human habitation, farms, or other obvious sources of contamination. However, one must also consider the not so obvious sources such as wild animals that can certainly be sources of disease causing micro-organisms like *Giardia*. So, by the historic definition of the sanitary survey, the watershed was very clean and would be indicative of a very good water supply system. However, by applying our present definition of a sanitary survey that evaluates the entire water system from source to the consumer's tap, this particular water system was, as you will see, a disaster. Treatment consisted of only simple chlorination with chlorine gas. Among the deficiencies noted during our survey at the chlorination facility were:

- o The operator of the facility was a part-time employee with no training other than on-the-job training in water treatment.

- The building in which the chlorinator was housed was a wooden structure in which hay was also stored for use by the operator for feeding animals; an obviously serious fire hazard.
- Chlorine feed was interrupted when changing cylinders, allowing untreated raw water to enter the distribution systems.
- Only one Cl₂ cylinder was connected to the chlorinator and was not being weighed.
- There was no standby chlorinator in case of equipment breakdown.
- There was no emergency power to provide continuous chlorination during power failures.
- The existing gas chlorinator had inadequate capacity to chlorinate the water during conditions of high flow and high chlorine demand.
- There was no forced ventilation in case of chlorine leak and no chlorine alarm system.
- A World War II vintage gas mask was used that would threaten the life of the operator should the operator try to use it in repairing a serious chlorine leak.
- Chlorine feed was not proportional to chlorine demand.

There were a number of deficiencies in the operation, maintenance, and facilities used in the storage and distribution of water, which will be mentioned briefly:

- Water mains were not disinfected according to the AWWA standards:
- There were 40 deadends in the distribution system with no regular flushing to remove corrosion products, sediment, and poor quality water from the deadends.
- Lead goosenecks were used in service lines from the early 1900's to around World War II and many are still present. A corrosion study needs to be done to evaluate water quality at the consumer's tap to determine if lead is being imparted to water.
- There was no continuing program for cross-connection control:

- There were a number of areas of low pressure where pressure has been known to go to zero during peak usage of water.
- There was a 0.6 million gallon uncovered earthen distribution reservoir that is subject to airborne contamination, insects, and animals. Water receives no treatment after leaving the reservoir.
- Two other concrete distribution storage reservoirs had improper hatches and vents that could permit birds and animals to enter the reservoir and also leave them subject to vandalism and sabotage.
- A booster pumping station had no low pressure cutoff switch to shut the pump off in case of low pressure and lack of water.

In terms of water quality, there were supposedly no coliform violations in 3-1/2 years, but considering the magnitude of the noted problems, this would seem highly unlikely. Various check samples by the State have found coliforms where the utility found none, which adds further suspicion to these highly improbable results. Inorganic and organic chemical samples taken by the State revealed no other MCL violations.

This example points out the number and types of problems present in some of today's water systems. It also highlights "why" sanitary surveys are needed. After answering "why," then we move to "who."

3. Who conducts sanitary surveys? Obviously, the answer in the near future will be "you do sanitary surveys." The people conducting sanitary surveys are those individuals who, through a combination of knowledge and experience, are competent to assess sanitary risks. They are also able to make sound, adequate, and economical recommendations. These individuals have to realize the limits of their knowledge and be cautious about giving advice beyond this limit. The final question is, then:
4. What are the activities of a sanitary survey? The activities of a sanitary survey provide a comprehensive, accurate record of the component parts of small water systems; assess their operating conditions and adequacy as a water system; and determine the effectiveness of the implementation of past recommendations regarding the system. This program of instruction presents the information needed by the inspector to effectively carry out the following activities:

Inspect and Evaluate

- Water source
- Intake structure and wells
- Treatment/conditioning facilities
- Distribution system

Essentially this activity is an in-depth review of the facilities and processes involved with delivering potable water to the consumer.

Review

- o Operation and maintenance practices
- o Records, files, maps, correspondence
- o Management practices and personnel needs
- o Competency of technical and ancillary personnel
- o Laboratory certification (if other than State laboratory)

This activity allows the inspector to have a long-term look at the system. The inspector's visit will only be a few hours in duration, a very short period when considering that the system must be meeting requirements 24 hours/day, 365 days/year. This review will help identify problem areas.

Sample

- o Sample source and distribution for bacteriological, physical, chemical, and radiological properties, and (as required) perform and evaluate field analyses.

This sample will provide a look at the water quality for that brief moment when the sample was collected. The inspector may use this for comparison with data (for the same period) that was collected/analyzed by others.

Recommend

- o Complete the survey report and present data (both negative and positive comments) to operating personnel.
- o Discuss problem areas and provide recommendations for their remedy.

This activity can have the most positive impact of any performed during a survey. Communicating to the operating personnel what the inspector's findings were and discussing recommendations for alleviating noted problems is the heart of a sanitary survey. However, if the recommendations are erroneous due to snap judgments on the part of the inspector or a failure to recognize the limits of the inspector's own knowledge, the results can do great damage.

Notify

- o Notify the owner/operator, the public, State regulatory agency, and EPA of deficiencies (as required).

The inspector should communicate in writing the comments resulting from the survey to the appropriate individuals and organizations.

These have been the what, why, and who of sanitary surveys. For the rest of this program we will discuss the "need-to-know" details of how to conduct sanitary surveys. The questions that we will attempt to answer are:

1. What conditions might cause sanitary risks in each of the components of a water system?
2. How might these conditions be recognized?

We will be following the same path that the water would take through a system. We will be discussing the following:

Source: This water body, whether above or below ground, must provide water in adequate quantity and quality to meet requirements.

Intake structure or wells: The water must be collected in a manner to provide the best possible water without degrading the source.

Treatment: Water that is of inferior quality must be treated to meet standards. This treatment must not create further problems.

Storage: These components provide adequate quantities to meet short-term demands that may exceed the capabilities of the source or treatment units. Storage must be provided in a manner to prevent contamination.

Distribution: This component dispenses the purified water to the consumers in the necessary volume at adequate pressure. In providing water to the consumer, care is taken to minimize the possibility of quality degradation.

THE SANITARY SURVEY

What is a Sanitary Survey?

A sanitary survey is an onsite inspection of a public water system by competent personnel who use a standard form, procedure, and method to survey the effectiveness and maintenance of the system and to determine its ability to provide continuously safe water to the consuming public.

Why Conduct a Sanitary Survey?

Competent personnel must conduct sanitary surveys periodically to determine whether the construction, equipment, facilities, operation, and maintenance of the parts of a water supply system are adequate, effective, and efficient in producing adequate quantities of safe water for the consuming public, and whether the water quality meets acceptable standards.

Who Conducts a Sanitary Survey?

Sanitary surveys are conducted by sanitary engineers, sanitarians, and technicians who have experience, knowledge, and competence in the design, operation, and maintenance of water supply systems. These personnel must also be qualified to assess problems using hydrological, hydraulic, mechanical, and other basic engineering knowledge and be able to make sound, adequate, and economical recommendations.

What Occurs During a Sanitary Survey?

The activities of a sanitary survey provide a comprehensive, accurate record of the component parts of water systems, assess their operating conditions and adequacy as a water system, and determine if past recommendations regarding the system have been effectively implemented.

This program of instruction presents the information needed by the inspector to effectively carry out the following activities:

- Inspect and evaluate the water source.
- Inspect and evaluate the intake structure.
- Inspect and evaluate the treatment/conditioning facilities.
- Inspect and evaluate the distribution system.

- Sample source and distribution water for bacteriological, physical, chemical, and radiological properties, and (as required) perform and evaluate field analyses.
- Review operation and maintenance practices.
- Review records, files, maps, correspondence.
- Determine qualifications of engineering, sanitation, and ancillary personnel; review management practices and personnel needs.
- Complete the survey report.
- Present sanitary survey data to operating personnel and (as required) discuss onsite problems and provide recommendations.
- Notify the owner/operator, public, State regulatory agency, and EPA of deficiencies (as required).

(Specific inspection and reporting information is included in the basic material of the following units.)

Program Objective

For the remainder of this training program, we will be covering the components of a typical water system:

- Source
- Intake Structure
- Treatment
- Storage
- Distribution

We will be answering two questions about these components:

1. What conditions might cause sanitary risks in each of the components?
2. How might these conditions be recognized?

A Sanitary Survey is:

A Review of:

- **Source**
- **Facilities**
- **Equipment**
- **Operations & Maintenance**

A Sanitary Survey is:

A Review of:

- Source
- Facilities
- Equipment
- Operations & Maintenance

Why Do Sanitary Surveys?

- Required by Law
- Determine adequacy
- Identify problem areas

Why Do Sanitary Surveys?

- Required by Law
- Determine adequacy
- Identify problem areas

Who Does Sanitary Surveys?

- Personnel experienced in evaluating sanitary risks of water systems.

Who Does Sanitary Surveys?

Personnel experienced in evaluating sanitary risks of water systems.

Activities are:

- Inspect and Evaluate
- Review
- Sample
- Recommend
- Notify

Activities are:

- Inspect and Evaluate
- Review
- Sample
- Recommend
- Notify

What Conditions Cause Sanitary Risks?

1-20

TRANSPARENCY 1+5

What Conditions Cause Sanitary Risks?

How Can They Be Recognized?

How Can They Be Recognized?

Components of Typical Water System

- Source
- Intake Structure
- Treatment
- Storage
- Distribution

Components of Typical Water System

- Source
- Intake Structure
- Treatment
- Storage
- Distribution

Examples of Typical Water System

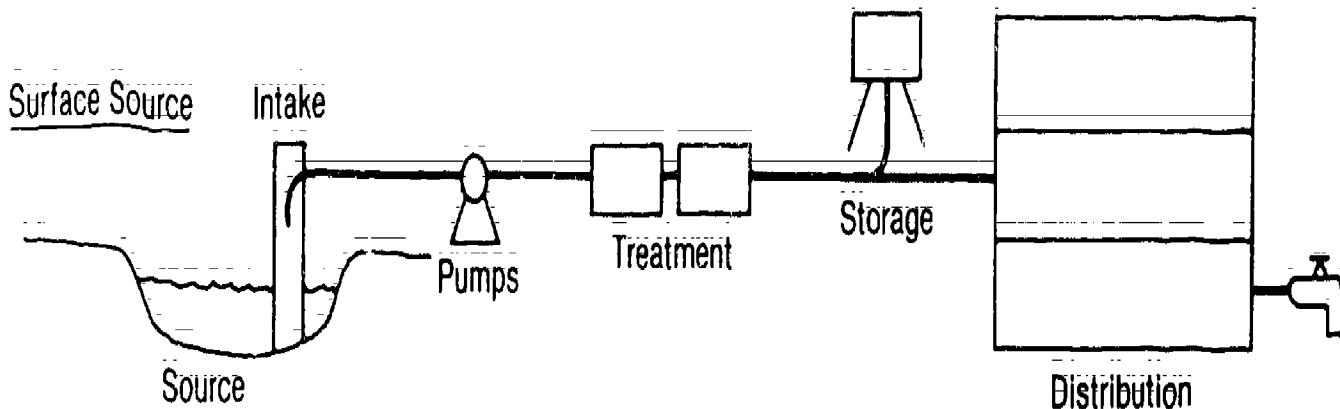

1-23

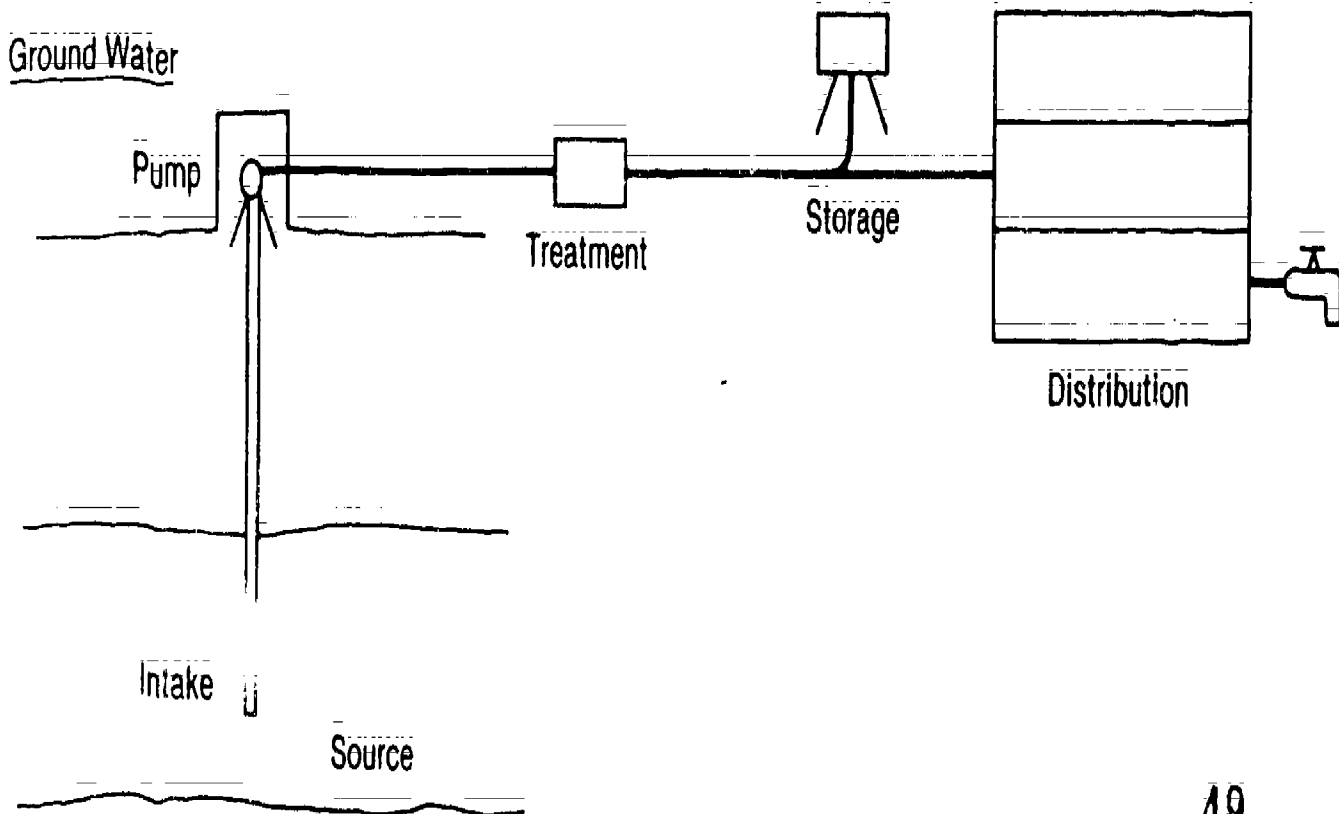

TRANSPARENCY 1-8

Examples of Typical Water System

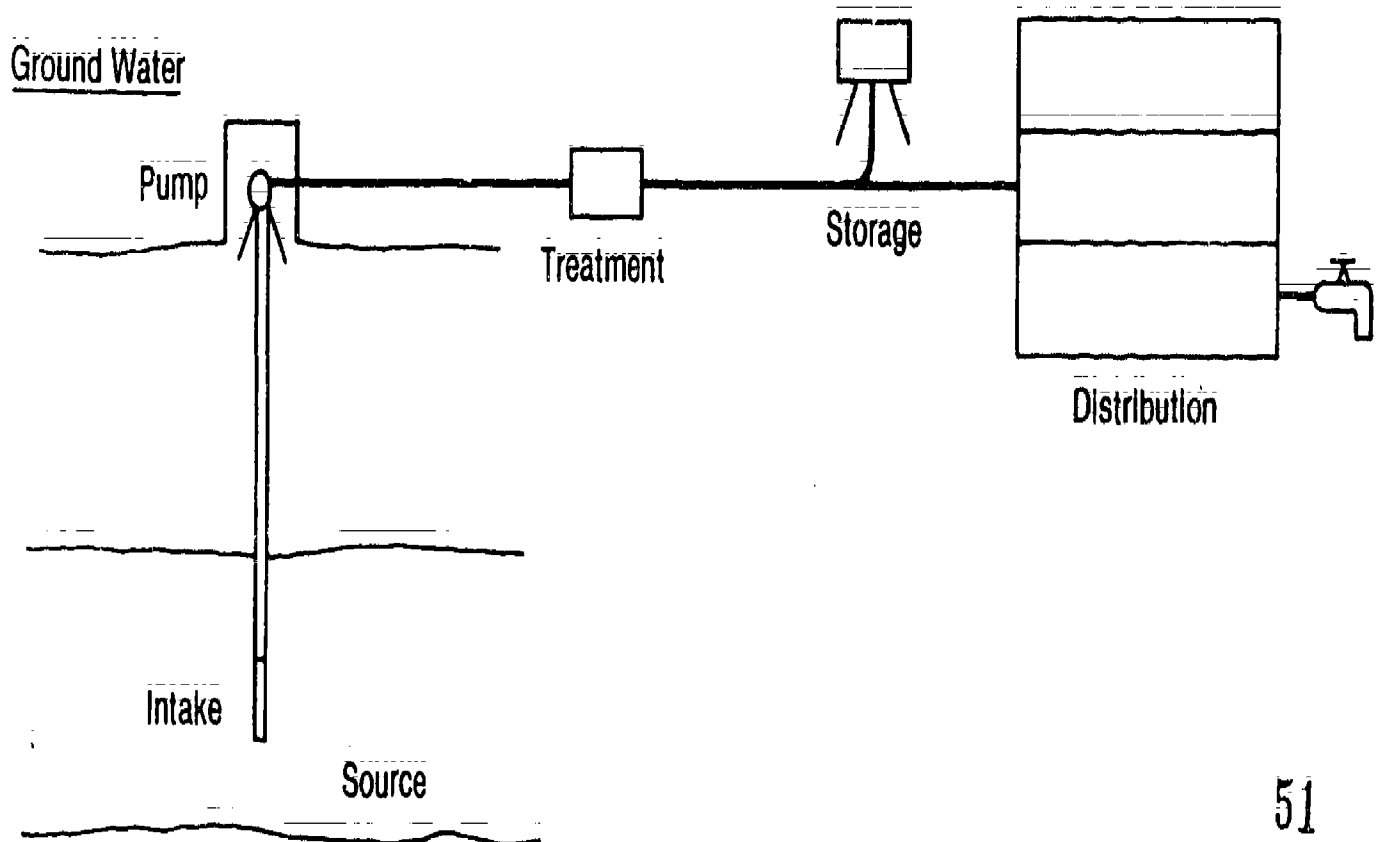
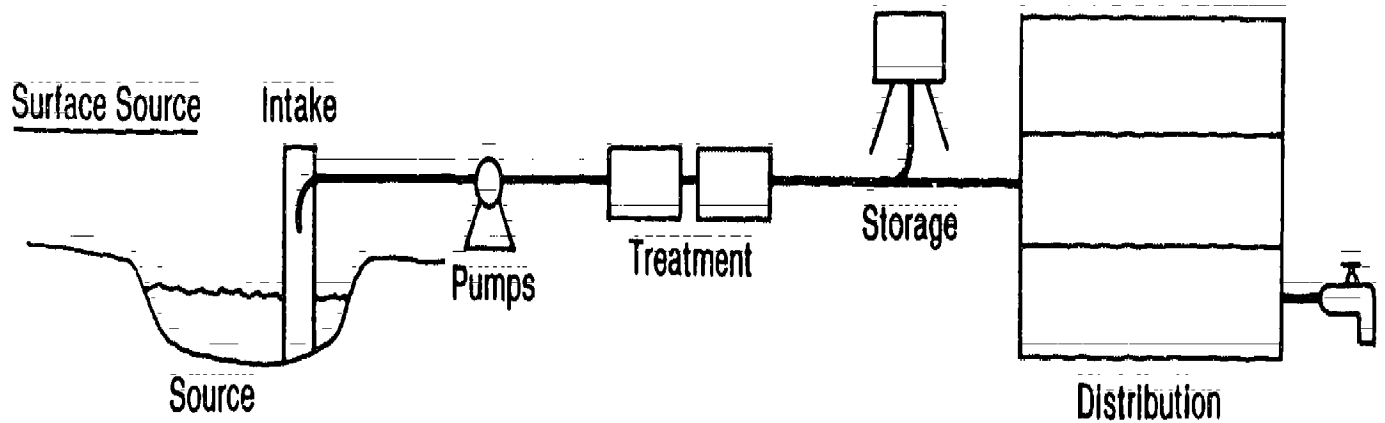

UNIT 2: WATER REGULATIONS - "THE NEED TO KNOW"

Unit Summary

- Safe Drinking Water Act
 - National Interim Primary Drinking Water Regulations
 - Implementation of NIPDWR
 - Applicability
 - Requirements
 - Responsibilities
 - National Secondary Drinking Water Regulations
 - Appropriate State Regulations and Standards

Unit Objectives

The Federal and State drinking water regulations form the basis for regulatory activity in public water supply systems. An inspector must be familiar with these regulations, their standards, and their implementation. This unit provides a brief overview of Federal regulations.

Logistics

Approximate Presentation Time: 30 minutes

Instructor Materials

- o Basic material
- o Transparencies 2-1 through 2-12
- o Overhead projector and screen
- o Chalkboard

Student Materials

- o Student's Text, Unit 2

Student Preparation

- o Unit 2 should be read prior to the session.

Unit References

- o National Interim Primary Drinking Water Regulations (40 CFR 141)
- o National Interim Primary Drinking Water Regulations Implementation (40 CFR 142)
- o National Secondary Drinking Water Regulations (40 CFR 143)
- o Water Treatment Plant Operation (Volume II, Chapter 22)

Use Transparency 2-1.

Briefly explain the development of the Act and its purpose.

Use Transparency 2-2.

Use Transparency 2-3.

Use Transparency 2-4.

Briefly explain a public water system.

Use Transparency 2-5.

Use Transparency 2-6.

Ask students why there would be a need for distinction between community and noncommunity systems.

Briefly describe requirements.

Use Transparency 2-7.

Explain that due to economics and geographic location siting requirements may not be able to be met.

Safe Drinking Water Act (5 minutes)

- o Resulted from concern over deteriorating public water.
- o Increased public awareness
- o Congress intended that the Act be a partnership:
 - EPA providing overall national guidance
 - States (by accepting "primary" enforcement responsibility) implementing the law within their borders
 - Water utilities complying with the regulations
- o Mandated:
 - Primary Drinking Water Regulations
 - Secondary Drinking Water Regulations

National Interim Primary Drinking Water Regulations (5 minutes)

- o Purpose - to protect human health
- o Enforceability - federally enforceable
- o Applicability - all public water systems

A public water system is a system that provides to the public piped water for human consumption. The system has at least 15 service connections or regularly serves an average of at least 25 individuals daily at least 60 days out of the year. This includes (1) any collection, treatment, storage, and distribution facilities under the control of such a system and used primarily in connection with such system, and (2) any collection or pretreatment storage facilities not under such control that are used primarily in connection with such a system.

Community Water System - a public water system that serves at least 25 service connections used by year-round residents or regularly serves at least 25 year-round residents. Permanent residents exposed to potential contaminants for extended periods.

Noncommunity Water Systems - a public water system that is not a community water system.

Requirements Under NIPDWR (5 minutes)

- o Siting - avoid areas of earthquakes, floods, fires, or other disasters

Use Transparency 2-8:

Tell students that specific contaminants are provided in Tables 2-1 through 2-3.

Use Transparency 2-9.

Ask students to identify public health implications of each.

Explain to students that records of these analyses could provide valuable information for surveying the system's water quality.

Use Transparency 2-10.

- Maximum Contaminant Levels Established for:
 - Inorganic chemicals
 - Organic chemicals
 - Turbidity
 - Microbiological contaminants
 - Radioactive contaminants
- Monitoring and Analytical
 - Frequency of sampling and water analysis
 - Analytical requirements
 - Record maintenance required
- Reporting
 - Outlines when water supplier must make reports to State agency
- Public Notification
 - Outlines when supplier for community water system must notify public and how
- Record Maintenance
 - Outlines what records must be kept and for how long

Responsibilities for Implementing NIPDWR

(10 minutes)

Federal

- Annual evaluation of State program
- Funding of State program elements
- Federal enforcement of standards if States have not instituted own program

State

- Adopt Federal, or equally stringent, standards
- Maintain program that meets conditions for "primacy." The most important for this course is a systematic program for conducting sanitary surveys.

Water Utility

- Monitor for contaminants.
- Keep records and report results.
- Public notification as required.
- Obtain prior approval of plans and specifications.

Emphasize that States have authority to implement more stringent standards than NIPDWR.

Stress that inspectors must be familiar with local (county, township, water district) and State regulations.

Use Transparency 2-11:

Explain purpose of NSDWR.

Use Transparency 2-12:

Ask students why standards are important from a health standpoint.

National Secondary Drinking Water Regulations
(5 minutes)

- o Purposes
 - Provide esthetically appealing water
 - Discourage consumers from using an unsafe source
- o Enforceability
 - Guidelines only
 - Not federally enforceable
 - Individual State may adopt and enforce standards
- o Maximum contaminant levels

Instructor's Narrative

Note: This training program is designed to provide the student with only "need-to-know" information. This discussion covers information pertinent to sanitary surveys. If the particular State presenting this training program has standards different from the Federal regulations, they should be emphasized.

As discussed in the last unit, the late 60's and early 70's were a period of revelation to the general public concerning drinking water supplies. Reports were identifying problem areas; technologies were measuring contaminants in the parts per billion range. Some of these contaminants were suspected or known carcinogens. The problems with water systems were being dealt with in an uneven manner across the Nation. Drinking water regulations and the appropriations necessary to implement them were an area that many State and local governments felt they could skimp upon, thus avoiding the political hazards of water rate increases. As public concern and anger grew, a movement for a Federal policy to provide a comprehensive means of addressing water supply problems gained impetus. This movement resulted in the passing of the Safe Drinking Water Act (PL 93-523) in December 1974.

Congress intended that the SDWA would be a partnership between the States, EPA, and local water utilities. EPA would provide the overall national guidance by determining health effects and establishing standards for contaminants, researching treatment technologies for contaminants, and monitoring State programs.

States, by accepting "primary enforcement responsibility" (primacy), would implement the law within their borders. The water utilities would have to meet the requirements of the law, thereby providing the day-to-day compliance.

The SDWA, among other things, mandated two further regulations: the Primary Drinking Water Regulations and the Secondary Drinking Water Regulations.

The National Interim Primary Drinking Water Regulations were an immediate attempt to meet the need for control of public water supplies. They established the basis for the overall program and outlined the responsibilities in implementing it.

Let's briefly discuss this regulation:

Purpose - The purpose was to protect human health by minimizing ingestion of specific contaminants:

Applicability - This regulation applies to all public water systems. Public water system means a system providing to the public piped water for human consumption. The system has at least 15 service connections or regularly serves an average of at least 25 individuals daily at least 60 days out of the year. This includes 1) any collection, treatment, storage, and distribution facilities under the control of such a system and used primarily in connection with such a system; and 2) any collection or pretreatment storage facilities not under such control which are used primarily in connection with such a system.

Public water systems were further divided into community and noncommunity systems.

Community Water System - A public water system that serves at least 25 service connections used by year-round residents or regularly serves at least 25 year-round residents.

Noncommunity Water System - A public water system that is not a community water system.

There is a difference in the standards applied to the two systems. This is based on the fact that permanent residents are exposed to potential contaminants for extended periods.

The regulations outline requirements that must be met for compliance. There is a siting requirement that restricts the areas in which a water system may be placed unless there is no alternative. Maximum contaminant levels were established for inorganic and organic chemicals, turbidity, microbiological contaminants, and radioactive contaminants. Turbidity and microbiological contaminants are of particular interest to the sanitary surveyor. The surveyor will most frequently be involved in evaluating the water supplier's methods for turbidity and free chlorine residual. Monitoring requirements were also established with respect to frequency of sampling, analytical procedures, and record maintenance of test results. A review of these records could provide the inspector with valuable information for surveying the system's water quality. They can point out problem areas and identify trends in water quality. Reporting requirements told water suppliers when they must routinely notify State agencies of analytical results. How soon a failure to comply with any primary water regulation had to be reported is delineated in the regulation.

There was a requirement for public notification in specific instances. The public would be told firsthand of the shortcomings of its water supply. How the general public and the everyday customer would be notified is outlined. This requirement assured that the public would not only be aware of the hazards of the particular shortcoming but also provide public support for corrective actions. A final requirement was for record maintenance, specifying what records were to be kept and for how long.

In addition to requirements of the regulation, responsibilities for each of the parties that were involved in the implementation were stated. Basically, the Federal responsibilities were an annual evaluation of State programs, funding of the State program elements, and Federal enforcement of standards if the States did not have primacy. The State requirements were to adopt standards that were equal or more stringent than Federal standards. The State was to maintain a program that met the conditions for receiving primacy. The most important condition with respect to this course was that the State must have a systematic program for conducting sanitary surveys; that is the reason for this course--to assist in providing personnel who are able to conduct sanitary surveys. Finally, the water supplier had responsibilities. Briefly these were to monitor for contaminants, keep records and report results, notify the public and/or consumers when required, and obtain prior approval of plans and specifications.

We have briefly been discussing the Primary Drinking Water Regulations. Before going into the core of this course, let's take a quick look at the Secondary Drinking Water Regulations. The purpose of this regulation was to provide an esthetically appealing water, thereby discouraging consumers from using a potentially unsafe source. The average consumer bases the evaluation of the quality of water on their senses. A water that is free of pathogens and contains no harmful chemicals yet has color, taste, and odor and stains clothes could very well be rejected by a consumer. These contaminant levels were guidelines and are not federally enforceable; however, the States can adopt them as enforceable standards.

Basic Material

In recognition of a decline in the quality of drinking water around the Nation, Congress passed the Safe Drinking Water Act designed to ensure the delivery of safe drinking water by public water systems and to protect underground water sources from contamination.

The Act required the Environmental Protection Agency to establish primary and secondary regulations limiting contaminants to a level where "no known or anticipated adverse effects on the health of persons occur and which allows an adequate margin of safety."

The National Interim Primary Drinking Water Regulations specify requirements and procedures for controlling contaminants in public water supplies.

Applicability

Although the Primary Regulations apply to all public water supply systems, the regulations make a distinction between community and noncommunity systems. Community systems generally supply drinking water to residential and institutional users who might be exposed to dangerous levels of contaminants for extended periods of time. Consequently, a wider range of contaminants is controlled by the regulations. The regulations define a "public water system" as a system for providing piped water to the public for human consumption if such a system has at least 15 service connections or regularly serves at least 25 people at least 60 days per year. The term includes any collection, treatment, storage, and distribution facilities under control of the system operator and used primarily in connection with such a system, and any collection or pretreatment storage facilities not under such control that are used primarily in connection with such a system.

Some classes and types of regulated water systems are listed below.

Community Water Systems

Municipal systems and public water utilities
Mobile home parks
Condominiums
Residential institutions and schools, including hospitals, nursing homes, homes for the aged, colleges
Housing developments, public and private
Multifamily housing complexes (all varieties)

Noncommunity Water Systems (with separate water systems)

Motels-hotels-resort areas	Campgrounds
Schools (nonresident)	Highway rest areas
Restaurant and other food service places	Marinas
	Airports

Parks
Recreation areas
Migrant labor and construction
camps
Children's and adult camps
Gasoline service stations
Industries
Churches

Medical care facilities
Shopping centers
Office and commercial buildings
Public buildings and public
assembly facilities
Social and recreation clubs
Swimming pools and beaches

Siting Requirements

The siting of a water system is of primary importance in ensuring safe water. The National Interim Primary Drinking Water Regulations encourage the avoidance of hazardous locations when constructing new or expanding public water systems. Sites to be avoided are areas subject to significant risks of:

- o Earthquakes*
- o Floods (100-year floodplain)
- o Fire or other disasters that could cause a breakdown in the water systems
- o In many areas, California for example, it is impossible to construct plants which are not subject to these hazards. In those cases, good designing is even more critically important to providing a continuous supply of water.

Maximum Contaminant Levels

The regulations include maximum contaminant levels for five properties of drinking water:

- o Inorganic chemicals
- o Organic chemicals
- o Turbidity
- o Microbiological contaminants
- o Radiological contaminants

The specific maximum contaminant levels are provided in Tables 2-1 through 2-3. Each category has specific sampling and analytical requirements.

Water Purveyor Requirements

The water purveyor must report to the State agency:

- o Results of all tests and analyses within the first 10 days following the month in which the result is received, or within the first 10 days following the end of the required monitoring period - whichever is the shortest.
- o Notice of failure to comply with any primary water regulations, including monitoring, within 48 hours.

- Notify public when a community water system fails to comply with:
 - An applicable maximum contaminant level
 - An applicable testing procedure
 - Scheduled corrections
 - Required monitoring
- Maintain the following records:
 - Bacteriological analyses - for at least 5 years.
 - Chemical analyses - for at least 10 years. Actual laboratory reports may be kept, or data may be transferred to tabular summaries, provided that the following information is included:
 - Date, place, time of sampling; name of person collecting
 - Identification of routine distribution system sample, check samples, raw or process water samples, special purpose samples; date of analysis
 - Lab and person responsible for performing analysis
 - Analytical method used
 - Results of analysis
 - Records of action taken to correct violations - for at least 3 years after last action was taken with respect to a particular violation.
 - Copies of written reports, summaries, or communications relating to sanitary surveys conducted by itself, private consultant, or local, State or Federal agency - for at least 10 years after completion of sanitary survey involved.
 - Records concerning scheduling of improvements - not less than 5 years following expiration of scheduling time.

Responsibilities for Implementing NIPDWRs

Federal

As already noted, the Federal Government through the Environmental Protection Agency has set the MCLs and Secondary MCLs for constituents to ensure that no adverse health effects occur. If a State desires primary enforcement authority (primacy), EPA will certify the program if the State meets requirements. Annual evaluations will be performed to ensure the quality of the State program.

Research, technical assistance, training programs, and funding are provided States. EPA may take action if States fail to adopt or properly implement the regulations.

State

Most States and territories have assumed primary enforcement responsibility for enforcement of the regulations. EPA would retain program responsibility only if a State is unable or unwilling to meet the minimum requirements for primacy. To attain primacy under the Act, a State must adopt standards at least as stringent as the Federal primacy standards. States are free to adopt and enforce more stringent standards appropriate to that State.

Additionally the States must:

- o Maintain an inventory of public water systems.
- o Have a systematic program for conducting sanitary surveys.
- o Establish a program for certification of water testing laboratories (unless testing is done by approved State laboratories).
- o Assure that new or modified public water systems are capable of compliance with State drinking water regulations.
- o Establish procedures for enforcement:
 - o Authority to sue in court for violations
 - o Right to entry
 - o Authority to require suppliers to keep accurate records and make appropriate reports to the State
- o Establish and maintain recordkeeping and reporting of its activities.
- o If variances or exemptions are permitted, they must be under the same conditions as granted under the Federal regulations.
- o Adopt and implement an adequate plan for providing safe drinking water under emergency conditions.

Water Utility Responsibilities

The responsibility of the water purveyor is to meet the primary standards set by EPA, or the more stringent State standards.

These responsibilities include the treatment and monitoring of bacteriological, chemical, and radiological contaminants; recordkeeping and reporting of results to State agencies; and notification of any noncompliance to consumers and the public.

The National Secondary Drinking Water Regulations are designed to control contaminants that affect the esthetic quality of drinking water. High concentrations of these contaminants may have health as well as esthetic implications. The federally set contaminant levels were set as guidelines for State regulations provided in Table 2-4.

ST 2-8

Table 2-1. Interim Primary Drinking Water Regulations (40 CFR 141)

Type of Contaminant	Name	Type of Water System	Maximum Contaminant Level mg/l (except as noted)
Inorganic chemicals	Arsenic	Community	0.05 mg/l
	Barium		1.
	Cadmium		0.010
	Chromium		0.05
	Lead		0.05
	Mercury		0.002
	Selenium		0.01
	Silver		0.05
	Fluoride		
	53.7° F & below		2.4
	53.8 to 58.3		2.2
	58.4 to 63.8		2.0
	63.9 to 70.6		1.8
70.7 to 79.2		1.6	
79.3 to 90.5		1.4	
Nitrate (as N)	Community & Noncommunity	10.	
Organic chemicals	Endrin	Community	0.0002 mg/l
	Lindane		0.004
	Methoxychlor		0.1
	Toxaphene		0.005
	2,4-D		0.1
	2,4,5-TP Silvex		0.01
Turbidity	Turbidity at representative entry point to distribution system	Community & Noncommunity	1 TU monthly avg. and 5 TU avg. of 2 consecutive days
Chloroorganics	Trihalomethanes	Greater than 10,000 population (if it chlorinates water)	0.1 mg/l

Table 2-2. Maximum Permissible Microbiological Contaminants (NIPDWR)

Coliform Method	Per Month	Less than 20 Samples per Month	20 or More Samples per Month
-----------------	-----------	-----------------------------------	---------------------------------

Number of coliform bacteria shall not exceed:

Membrane filter (100-ml portions)	1/100 ml average density	4/100 ml in one sample	4/100 ml in 5% of samples
--------------------------------------	-----------------------------	---------------------------	------------------------------

Coliform bacteria shall not be present in more than:

Multiple tube fermentation (10-ml portions)	10% of portions	3 portions in one sample	3 portions in 5% of samples
---	--------------------	-----------------------------	--------------------------------

Coliform Method	Per Month	Less than 5 Samples per Month	5 or More Samples per Month
-----------------	-----------	----------------------------------	--------------------------------

Coliform bacteria shall not be present in more than:

Multiple tube fermentation (100-ml portions)	60% of portions	5 portions in more than one sample	5 portions in more than 20% of samples
--	--------------------	---------------------------------------	--

Table 2-3. Maximum Permissible Radioactivity (NIPDWR)*

Contaminant	Maximum Contaminant Level Picocurie per liter (pCi/l)
<u>Natural</u>	
Combined Radium-226 and Radium-228 Gross alpha particle activity, including Radium-226 but excluding Radon and Uranium	5 15
<u>Man-Made</u>	
Tritium (total body)	20,000
Strontium-90 (bone marrow)	8
Gross beta particle activity (applicable to surface water sources)	50

*For full explanation refer to Part 141, National Interim Primary Drinking Water Regulations.

ST 2-13

Table 2-4: Special Monitoring Requirements Under National Interim Primary Drinking Water Regulations:

Contaminant	Frequency	
	Surface	Ground
Sodium	1 sample annually	1 sample at least every 3 years
Corrosivity	2 samples annually (1 mid summer) (1 mid winter)	1 sample annually

Table 2-5. National Secondary Drinking Water Regulations Maximum Contaminant Levels

Contaminants	Level
Chloride	250 mg/l
Color	15 Color Units
Copper	1 mg/l
Foaming Agents	0.5 mg/l
Hydrogen Sulfide	0.05 mg/l
Iron	0.30 mg/l
Manganese	0.05 mg/l
Odor	3 Threshold Odor Number
pH	6.5-8.5
Sulfate	250 mg/l
TDS (Total Dissolved Solids)	500 mg/l
Zinc	5 mg/l

Safe Drinking Water Act

**Public Law 93-523
as amended by Public Law 95-100**

Safe Drinking Water Act

Public Law 93-523

as amended by Public Law 95-100

SDWA

EPA: Provide Guidance

State: Implement the Law

Suppliers: Comply With the Law

SDWA

EPA: Provide Guidance

State: Implement the Law

Suppliers: Comply With the Law

National Interim Primary Drinking Water Regulations 40 CFR Parts 141 & 142

National Interim Primary Drinking Water Regulations 40 CFR Parts 141 & 142

NIPDWR

Purpose—Protect Human Health

Enforceability—Federally Enforceable

Applicability—All Public Water Systems

NIPDWR

Purpose—Protect Human Health

Enforceability—Federally Enforceable

Applicability—All Public Water Systems

Public Water System

15 or more service connections
or
25 people at least 60 days/year

Public Water System

15 or more service connections

or

25 people at least 60 days/year

Community Water System

- public system
- 25 year-round residents or 15 service connections

Community Water System

public system

25 year round residents or 15 service connections

Siting

Avoid areas of:
Earthquakes
Floods
Fires

Siting

Avoid areas of:

Earthquakes

Floods

Fires

Maximum Contaminant Levels

- Inorganic Chemicals
- Organic Chemicals
- Turbidity
- Microbiological Contaminants
- Radioactive Contaminants

Maximum Contaminant Levels

- Inorganic Chemicals
- Organic Chemicals
- Turbidity
- Microbiological Contaminants
- Radioactive Contaminants

Monitoring

- Frequency
- Analytical Requirements
- Records

Monitoring

- Frequency
- Analytical Requirements
- Records

Reporting

Public Notification
Record Maintenance

Reporting

Public Notification
Record Maintenance

National Secondary Drinking Water Regulations

Purposes—Provide Esthetically
Appealing Water

National Secondary Drinking Water Regulations

Purposes—Provide Esthetically
Appealing Water

NSDWR

- Enforceability—Not Federally Enforceable
- Maximum Contaminant Levels

NSDWR

Enforceability—Not Federally Enforceable
Maximum Contaminant Levels

UNIT WATER SOURCES "THE NEED TO KNOW"

Unit Summary

General
Wells
Springs
Surface Sources

Unit Contents

- 3a: General
 - o Hydrologic Cycle
 - o Adequate Quality
 - o Adequate Quantity
- 3b: Wells
 - o Sanitary Risks
 - o Surveying Wells
- 3c: Springs
 - o Sanitary Risks
 - o Surveying Springs
- 3d: Surface Sources
 - o Sanitary Risks
 - o Surveying Surface Sources

UNIT 3a: General - "The Need To Know"

Unit Summary

Hydrologic Cycle
Adequate Quality
Adequate Quantity

Unit Objectives

An inspector should be familiar with the hydrologic cycle and how it affects the quality of water. Additionally, to adequately evaluate a water source and system, the inspector should know the demands for quantity and how they are determined. This unit will briefly discuss the hydrologic cycle, factors affecting raw water quality, and the importance of various water demands.

Logistics

Approximate Presentation Time: 30 minutes

Instructor Material

- o Basic Material
- o Transparencies 3-1 through 3-4
- o Overhead projector and screens
- o Chalkboard

Student Materials

- o Student's Text, Unit 3a

Student Preparation

- o Unit 3a should be read prior to the session.
-

Unit References

Manual of Individual Water Supply System
(Part 1)
Water Systems Handbook
Water and Wastewater Engineering (Volume 1,
Chapter 6)
Water Treatment Plant Operation (Volume 1,
Chapters 2 and 3)
Water Supply and Distribution (Chapter 2)

Use Transparency 3-1.
Introduce a discussion of the hydrologic cycle by explaining how natural contamination may accumulate in water as it flows through the parts of the cycle. Define each component and indicate flow direction.

Use Transparency 3-2.

Describe both confined and unconfined aquifers.

Use Transparency 3-3.

Ask students to identify some major sources of pollution.

List sources on chalkboard as they are suggested by students.

Explain to students that these sources present hazards to drinking water, and, where possible, should be noted during a sanitary survey.

Use questions to promote discussion of water and how it might become contaminated.

Use Transparency 3-4.

Explain the various water demands.

Hydrologic Cycle (10 minutes)

- o Surface water
- o Ground water
- o Aquifers (confined and unconfined)
- o Sinkholes
- o Zone of saturation
- o Flow direction of.
 - evaporation
 - transpiration
 - runoff
 - percolation
 - infiltration

Sources of Water Contamination (5 minutes)

- o Proximity to:
 - nearby sewers
 - waste disposal
 - animal pasturing
 - chemically treated agricultural land
 - chemical storage areas
 - subsurface liquid waste disposal systems
- o Impact of high-flood runoff
- o Chemical constitution of soil above rock
- o Decomposition of organic matter

1. What are potential sources of contamination?
2. Which of the sources are relevant only to ground water; to surface water; to both?

Water Demand (10 minutes)

- o Average daily demand.
 - o What is average demand?
 - o How is it calculated?
 - o Importance to small water systems?
- o Impact of unaccounted-for water and unrealistic water rates

Refer to page 3-12 in Student's text for class for estimating average daily water requirements.

- o Maximum demand
 - o What is maximum daily demand?
 - o How it is figured?
 - o Importance to small water systems?
- o Peak demand
 - o What is peak demand?
 - o How it is estimated?
 - o Importance to small water systems?
- o Fire demand
 - o What is fire demand?
 - o How it is estimated?
 - o Importance to small water systems?

Discuss questions concerning sanitary risks.

Sanitary Risks (10 minutes)

1. What type of source (surface, ground or combination)?
2. What is the total design production capacity?
3. What is the present average daily production?
4. What is the maximum daily production?
5. Does system have an "operational" master meter?
6. How many service connections are there?
7. Are service connections metered?

Instructor's Narrative

In this unit we will be discussing sources of water, and its adequacy both in terms of quality and quantity. At a beginning we should discuss the hydrologic cycle. As the name implies there is a continuous circulation of moisture and water. As a start point and because of its size with respect to the total volume of water, let's pick up the cycle at the ocean. Radiation from the sun evaporates water from the ocean into the atmosphere. As the water vapor rises, it cools, creating clouds. From these clouds the moisture condenses and falls back to the earth's surface in the form of precipitation. Precipitation is essentially the source of all our fresh water. Part of this precipitation, after saturating the surface, runs off to streams. The water that enters the soil initially is detained in the plant root zone or zone of aeration; water not utilized by the plants continues on through the subsurface formations under the influence of gravity. Eventually water reaches a zone where all the formation pores are filled with water, the zone of saturation. The upper edge of this zone is what is referred to as a water table. Depending on topography, geology, and barometric pressure, the water moves through the saturated formation and may reappear where the surface intersects the water table. The formations of strata that are saturated with water and from which ground water may be obtained are called aquifers. To qualify as an aquifer, a geologic formation must contain pores or open spaces that

are filled with water and large enough to permit the water to move at a perceptible rate. Aquifers may be either confined or unconfined. Unconfined aquifers have a free water surface. Confined or artesian aquifers have the water surface restricted both vertically and horizontally by formations that are impermeable. The water pressure within these aquifers is such that when the upper confining layer is broken, either by a well or faultline, the water will rise above the top of the aquifer. In some cases, the water rises above the land surface and an artesian spring or well is created.

What impact does the hydrologic cycle have on a sanitary survey? The inspector must realize that from the moment of inception, water is being contaminated by natural and manmade sources. The raindrops are formed around dust particles. Falling through the air, the water picks up additional pollutants such as gases, plant seeds, and chemicals such as sulfur, nitrogen, and carbon dioxide. Upon reaching the surface, water becomes further contaminated by, for instance, domestic and industrial waste. As it passes through subsurface formations it dissolves materials that impact on the quality of the water. What are some potential sources of contamination?

Sources of Water Contamination

- o Proximity to:
 - nearby sewers
 - waste disposal
 - animal pasturing
 - chemically treated agricultural land
 - chemical storage areas
 - subsurface liquid waste disposal systems
 - highways
- o Impact of high-flood runoff
- o Chemical and physical characteristics of soil above rock
- o Decomposition of organic matter

As stated earlier, a survey for potential sources of contamination within a watershed or recharge zone is no longer a "sanitary survey." In fact, due to limited resources, time, and personnel, a detailed evaluation of these areas will be beyond the scope of survey. The inspector will be concerned with pollution in close proximity of the water supply source. The system owner should be questioned as to what provisions are made by the water system to limit contamination of the source (e.g., zoning restrictions, control of watershed, restricted use of impoundment, and periodic inspections).

Our discussion has thus far dealt with the "quality" aspects of sources. There is another equally as important factor of adequacy: quantity. In providing sufficient quantity of water to meet a system's requirements, we must evaluate not only the adequacy of the source, but such things as storage capacity, treatment unit capacities, pump capacities, and distribution systems. In speaking of adequate quantity we refer to various types of water demands. Water demand is the total water used by a system in a specified period of time. The components of demand are residential, industrial, commercial, industrial, public, fire, other water

utilities; main leakage; unaccounted-for water; and water used in treatment. We will briefly be discussing four types of demand: average daily demand; maximum demand; peak demand; and fire demand:

Average daily demand is the quantity of water utilized on an average day. Average daily demand is utilized in determining treatment unit capacities and raw water pump capacities. Average demand can be estimated by a combination of projected population figures and normal water usage requirements. Generally, a standard planning guide, such as Table 3-1 on page ST 3-12, is utilized in making the estimate. The fact cannot be overstressed that tables such as this give "estimates." This figure must be modified with regional and demographic considerations. As an example, the per capita consumption can be influenced by lawn irrigation and swimming pool usage, which would be a greater factor in the Southwest than in northeastern sections of the United States. The surveyor is well advised to review local information on water systems of comparable nature when evaluating water usage.

In speaking of maximum demand, we evaluate two types. The maximum daily demand is the greatest amount of water that a system will use in one day. Experience with small residential water systems suggests that the maximum day is 1.5 to 3 times the average day. However, this ratio may not apply to other types of water systems. In general, the smaller the water system, the greater the variation between the average and the maximum day. The other type is maximum hourly demand. The maximum hourly demand is the greatest amount of water that will be used in any hour during a day. Maximum hourly demand is sometimes referred to as the peak hourly demand, although there will be short-term peak demand rates lasting for several minutes that will exceed the maximum hourly demand rate. Each type of system exhibits its own maximum hourly and short-term peak demands and the hours of peak occurrence will vary. As an example, shopping centers usually experience hourly peaks in the early afternoon while residential communities may experience two peak hours, about 8:00 a.m. and 6:00 p.m. The maximum hourly demand is often expressed as a ratio of the average daily demand in gallons per minute. Generally speaking, the smaller the system, the greater the maximum hourly rate in respect to the average daily rate.

Maximum daily and hourly demands occur for those specified periods of time. Short-term demands are referred to as peak demands. This is the maximum amount of water necessary to meet the peak short-term demand rate that may occur several times during a day, but usually during the peak hour period. The instantaneous peak may last for several minutes. The rate is particularly important in considering the sizing of the storage tank in a hydropneumatic system. The effective storage capacity is usually designed to meet these short-term peaks. In the absence of sufficient effective storage to meet extended peak demands, the wells and pumps must be capable of meeting the peak demands. The smaller the system, the greater the ratio of the peak demand to the average demand. Experience with small residential communities suggests that the peak hourly demand may range from about 6 to 10 times the average daily demand.

The final type of demand is fire demand. An adequate system provides sufficient water to meet peak demands for domestic, commercial, and industrial purposes as well as for firefighting. Fire demand is the amount of water capacity that must be designed into a water system for firefighting purposes. Fire flow is not included in the definition of average daily and maximum daily demands and must be added if fire protection is desired. Fire flows are usually expressed as gallons per minute to fight a fire of a certain duration. Local fire underwriters will provide specific requirements on request.

A logical question at this point might be: "What does this discussion on demand have to do with a sanitary survey?" There are several sanitary or health-related impacts that these demands can have. Does the system or portions of it ever run out of water? This is one of the first questions that should be asked in determining adequacy of a system. If the answer is yes, then a definite health problem exists. How much water is being produced and for what? This may be a question that is difficult to answer, particularly for smaller systems. Many of these systems not only lack service meters but lack master meters as well. In these cases, the amount of water produced may be estimated from pump rating curves and either pump hour meters or electric meters. The impact of unaccounted-for water and leaks can increase the per capita demand to as much as 600 gpd. This puts a strain on the source and the mechanical units of the system. Unaccounted-for water can have sanitary significance in terms of service outages, low pressures, and contamination problems from cross connections.

These losses are also nonrevenue producing and therefore place a financial burden on the system. Coupled with unrealistic water rate structures, this can create real problems as required maintenance and replacements must be delayed because of lack of funds.

Basic Material

The two principal sources of water supplies are surface waters and ground waters. Both originate from precipitation. Some of the precipitation collects on the surface of the earth to form streams, lakes, and other surface waters. Some seeps downward through the earth where it accumulates in the pore spaces in the soils that overlay rock formations. The seepage continues downward and laterally to fill the interconnecting joints, cracks, solution channels, pore spaces, and other openings in these rock formations below the soils. Ground water is not static and tends to move slowly through the substrata, some of it reappearing at the edge of streams and lakes or as springs and seepage areas. Energy from the sun evaporates water from the earth, streams, lakes, and seas and promotes transpiration of moisture from growing plants to form water vapor in the atmosphere. The water vapor forms into clouds, which in turn produce rain and snow to replenish the surface and ground waters. This continuous process is called the hydrologic or water cycle; and by its very nature, water is exposed to both natural and man-induced contamination.

Ground Water

Ground water is the principal source of water for small water supply systems. Ground water generally has a more consistent good bacterial quality than surface water, having undergone considerable natural purification through straining and prolonged storage. However, a number of areas have suffered contamination of their ground water due to improper disposal of their wastes. Generally it requires little (if any) treatment prior to use, whereas surface waters invariably require rather sophisticated treatment. Furthermore, ground waters are readily available in most areas of the country in sufficient quantities to meet the needs of small water systems.

Surface Water

Precipitation that does not enter the ground through infiltration or is not returned to the atmosphere by evaporation flows over the ground surface and is classified as direct runoff. Direct runoff is water that moves over saturated or impermeable surfaces, and in stream channels or other natural or artificial storage sites. The dry weather (base) flow of streams is derived from ground water or snowmelt.

Runoff from ground surfaces may be collected in either natural or artificial reservoirs. A portion of the water stored in surface reservoirs is lost by evaporation and from infiltration to the ground water table from the pond. Transpiration from vegetation in and adjacent to ponds constitutes another means of water loss.

Because surface waters are exposed to potentially severe contamination by both man and nature and because the quality of the water varies considerably, a relatively high degree of treatment is required to ensure its

constant quality. The treatment is generally more sophisticated than with ground waters and requires more diligent operation and maintenance and more costs.

However, there are occasions when surface water is a source for a small water supply system because of the poor quality or lack of local ground water. When other factors being equal, impoundments such as natural lakes or ponds; and reservoirs, are preferred over streams since the quality of the water is usually less variable, reducing the extremes in quality.

Quality of Water

Precipitation in the form of rain, snow, hail, or sleet contains very few impurities. Trace amounts of mineral matter, gases, and other substances may be entrained as the precipitation forms and falls through the earth's atmosphere; however, the precipitation has virtually no bacterial content.

Once precipitation reaches the earth's surface, many opportunities are presented for the introduction of foreign substances into the water, which may lower its quality to the point that it constitutes a health hazard or impairs its usefulness.

Proximity of the water source to nearby sewers, waste disposal, construction projects, animal pasturing, chemically treated agricultural land, and chemical storage areas (such as salt or petroleum) increases the likelihood of contamination. Other sources of contamination are completely natural, such as the impact of high flood runoff, chemical composition of soil above the rock (e.g., the presence of iron); or decomposition of organic matter.

Substances that alter the quality of water as it moves over or below the surface of the earth may be classified as follows:

- o Organic
- o Inorganic
- o Biological
- o Radiological

Impurities in natural waters depend largely on the circumstances of the source and its history. Water destined for an aquifer picks up impurities as it seeps through soil and rock, including possible pollution. Pollution sources may include leaking sanitary sewers, septic systems, waste disposal sites, and accidental discharges. Uptake of minerals is common. The natural straining action does remove some of the particulate matter and, combined with a relatively long retention period in the ground, will often aid in removing micro-organisms. This long retention time can, however, create problems in that ground water once contaminated can be costly to purge in terms of both time and money. Ground waters have a fairly stable quality usually not highly affected by seasonal changes. Wells affected by seasonal changes tend to be very shallow and subject to easy contamination.

Water Demands

The projected average daily demand is the quantity of water projected to be used by a specific system or part of a system in an average day. This is based upon experience from water meter readings in similar water systems over an extended period of time and reflects the normal seasonal and daily variations. For design purposes, it is usually determined by estimating the population or units of housing or other units and multiplying by an average person or per unit water consumption derived from past experience. Other water demand terms frequently relate to this basic term. The average daily demand will be exceeded on many days so it is not appropriate to design merely for the average. For this reason other terms are used to express the probable greatest amount of water that may be used in one day, or other period of time.

Table 3-1 provides a guide for estimating the average daily demand for various types of establishments, in gallons per day per unit. The unit is persons per day unless otherwise indicated. The values shown may vary throughout the Nation, and the inspector is advised to review local information on water systems serving similar size establishments.

The maximum daily demand is the greatest amount of water that a system will use in one day. Experience with small residential water systems suggests that the maximum day is 1.5 to 2 times the average day. However, this ratio may not apply to other types of water systems. In general, the smaller the water system, the greater the variation between the average and the maximum day.

The maximum hourly demand is the greatest amount of water that will be used in any hour during a day. Maximum hourly demand is sometimes referred to as the peak hourly demand, although there will be short-term peak demand rates lasting for several minutes that will exceed the maximum hourly demand rate. Each type of system exhibits its own maximum hourly and short-term peak demands and the hours of peak occurrence will vary. As an example, shopping centers usually experience hourly peaks in the early afternoon while residential communities may experience two peak hours, about 8:00 a.m. and 6:00 p.m. The maximum hourly demand is often expressed as a ratio of the average daily demand, in gallons per minute. Generally speaking, the smaller the system, the greater the maximum hourly rate in respect to the average daily rate.

Peak demand is the maximum amount of water necessary to meet the peak short-term demand rate that may occur several times during a day, but usually during the peak-hour period. The instantaneous peak may last for several minutes. The rate is particularly important in considering the sizing of the storage tank in a hydropneumatic system. The effective storage capacity is usually designed to meet these short-term peaks. In the absence of sufficient effective storage to meet extended peak demands, the wells and pumps must be capable of meeting the peak demands. The smaller the system, the greater the ratio of the peak demand to the average demand. Experience with small residential communities suggests that the peak hourly demand may range from about 6 to 10 times the average daily demand.

Fire flow is the amount of water capacity that must be designed into a water system for firefighting purposes. Fire flow is not included in the definition of average daily and maximum daily demands and must be added if fire protection is desired. Fire flows are usually expressed as gallons per minute to fight a fire of a certain duration. Local fire underwriters will provide specific requirements on request.

Sanitary Risks

1. What type of source (surface, ground or combination)?

There are specific risks for each type of source, which will be covered in later sections of Unit 3.

2. What is the total design production capacity?

Comparison of this figure with present demand figures allows the inspector to determine if there is adequate treatment capacity.

3. What is the present average daily production?

Comparison of this figure with values for other similar systems on a per capita basis may point out problems within the system. An evaluation of average daily production trends may indicate problems as well. For example, if consumption is excessive or production trends are increasing without an accompanying population or use increase, leakage within the distribution system may be indicated.

4. What is the maximum daily production?

Comparison of this figure with design capacity allows determination of adequacy of treatment capacity.

5. Does system have an "operational" master meter?

Without an operational and calibrated master meter, it is difficult for the utility to accurately monitor production.

6. How many service connections are there?

This figure provides the inspector with an idea of the size of the system; this means the total number of homes and businesses served by the system. It should not include connections for vacant lots.

7. Are service connections metered?

This allows a water balance to be made. There is also a correlation between metered service and water conservation. If the system is metered, the per capita consumption is reduced.

A review of the system's records and operator responses should provide answers to these questions.

Table 3-1. Guide for Estimating Average Daily Water Requirements*
 (Adapted from various sources for small water systems)

Type of Establishment (The unit is per person unless otherwise stated)	Average Daily Use (gpd)
Airport (per passenger)	3-5
Assembly Halls (per seat)	2
Camps - Child, overnight, central facilities	40-50
- Construction	50
- Migrant labor	35-50
- Day type, no meals served	15
Churches (per member)	1
Cottages, season occupancy	50
Clubs - Residential	100
- Nonresidential	25
Factories, sanitary uses, per shift	15-35
Food Service - Restaurants	7-10
- With bars	9-12
- Fast food	2
Highway Rest Areas	5
Hotels (2 persons per room)	60
Institutions - Hospitals (per bed)	250-400
- Nursing Homes (per bed)	150-200
- Others	75-125
Office Buildings	15-30
Laundries, self service (per customer)	50
Motels (per bed)	60
Parks - Day use (with flush toilets)	5
- Mobile homes (per unit)	200
- Travel trailers (per unit)	90-100
Picnic Areas (with flush toilets)	5-10
Residential Communities	
- Multi-family (per bedroom)	120
- Rooming house and tourist homes type (per bedroom)	120
- Single family type (per house)	400
Resort Motels and Hotels	75-100
Retail Stores (per toilet room)	400
Schools - Day, no showers or cafeteria	15
- Day, with cafeteria	20
- Day, with showers and cafeteria	25
- Residential types	75-100
Shopping Centers, per sq. ft. sales area	0.16
Swimming Pools and Beaches	10
Theaters - Drive-in (per car)	3-5
- Others (per seat)	3

*The values listed in Table 3-1 are for normal water requirements and do not include special needs or unusual conditions. State and local requirements may vary from those provided in this table. Additional allowance should be made for frequent lawn watering, swimming pool maintenance, industrial or commercial process water, cooling water, firefighting, and other special uses.

UNIT 3b: Wells - "The Need To Know"

Unit Summary

Types and Characteristics
Sanitary Risk Factors
Exercise I: Identifying Sanitary Risk
Surveying Wells
Exercise II: Surveying Wells

Unit Objectives

A major function of the sanitary survey is to determine the degree of protection afforded the source. At the end of this unit the student should know:

1. Characteristics and components of wells
2. Sanitary risks to wells and how to identify them

Logistics

Approximate Presentation Time: 60 minutes

Instructor Materials

- o Basic material
- o Transparencies 3-5 through 3-11
- o Overhead projector and screen
- o Chalkboard

Student Materials

- o Student's Text, Unit 3b

Student Preparation

- o Unit 3b should be read prior to the session.

Unit References

- o Small Water Systems Serving the Public (Chapter 5)
- o Manual of Individual Water Supply Systems (Part II)
- o Groundwater and Wells
- o Well Drilling Operations
- o Water Supply System Operation (Chapter 3)

Briefly describe differences between each type of well.

Use Transparency 3-5:

Use Transparency 3-6 to discuss components:

Briefly describe importance of each question on checklist.

Provide personal experiences or anecdotes to relate course material to actual situations an inspector may encounter.

Explain to students that activities of a water utility immediately adjacent to a well can have adverse impact.

A. Types of Wells (5 minutes)

- o Drilled
- o Driven/Jetted
- o Bored
- o Dug

B. Components (10 minutes)

- o Casing
- o Sanitary seal
- o Grout
- o Pitless adapter
- o Screen
- o Pump
- o Vent

C. Sanitary Risks (30 minutes)

1. Recharge Area/Surface Area

a. Is recharge area protected?

- o Ownership
- o Fencing
- o Ordinances

b. What is nature of recharge zone?

- o Agricultural
- o Industrial
- o Residential
- o Other

Emphasize that activities on recharge zone can impact on the quality of ground water.

c. Is site subject to flooding?

- o Impact of drainage of immediate area.
- o Problems of well field in floodplain of less than 100-year flood.

d. Is well located in proximity of a potential source of pollution?

Table 3-2. Sample Minimum Distances Between Wells and Pollution Sources

Source	Feet from Well	Remarks
Watertight Sewers	50	
Other Sewers	100	Consult the State regulatory agency for special local requirements.
Septic Tanks	100	
Sewage Field, Bed or Pit	200	
Animal Pens and Yards	200	

Source: Small Water Systems Serving the Public, Chapter 5.

Use Transparency 3-7.

RISK EVALUATION

Points of Risk on Transparency:

1. Flooding from stream
2. Septic tanks
3. Filling station tanks
4. Sewers
5. Fuel storage on site
6. Proximity of highways
(salt and spills)

2. Well Data

- a. Depth of well
- b. Drawdown
 - o What is the well's drawdown?
 - o How is it measured?

Emphasize importance of measuring drawdown.

3. Construction

- a. Depth of casing
 - o Protection against surface waters and undesirable aquifers
- b. Depth of grout
 - o Protection against surface water contamination
 - o Minimum of 20 feet recommended
- c. Does casing extend at least 12 inches above the floor or ground?
 - o Protection against flooding
- d. Is well properly sealed?
 - o Concrete pad in good condition
 - o Well head seal
- e. Does well vent terminate 18 inches above ground/floor level or above maximum flood level with return bend facing downward and screened?
 - o Keeps contaminated water and animals from entering well.
- f. Does well have suitable sampling cock?
 - o Sampling cock at well point is helpful in identifying location of problems.
- g. Are check valves, blowoff valves, and water meters maintained and operating properly?

Use Transparency 3-8:

Explain importance of information requested by each question.

Explain that concrete pad by itself is not sufficient because of burrowing animals and erosion.

h. Is upper termination of well protected (housed, fenced, barrier)?

i. Is lighting protection provided?

4. Well Pumps

a. Is intake located below the maximum drawdown?

b. Are foot valves and/or check valves accessible for cleaning?

Use Transparencies 3-10 and 3-11 to discuss deficiencies:

D. Evaluation of Risks (15 minutes)

Deficiencies

1. Proximity of septic tank
2. Proximity of underground fuel tank and lines
3. Use of well pit
4. Improper well vent
5. Lack of lighting protection
6. Lack of drain in well pit

UNIT 3b: Wells

Unit Summary

Types and Characteristics
Sanitary Risk Factors
Surveying Wells

Unit References

Small Water Systems Serving the Public (Chapter 5)
Manual of Individual Water Supply Systems (Part II)
Ground Water and Wells
Well Drilling Operations
Water Supply System Operation (Chapter 3)

Basic Material

To reach the ground waters underlying the earth's surface, a well must be constructed to penetrate the desired water-bearing strata. These structures may be dug, driven, bored, jetted, or drilled, depending on the geological formations through which they must pass and the depth to which they must reach. Dug, driven, bored, and jetted wells are usually confined to relatively soft soils overlaying rock and to shallow depths normally less than 50 feet (15 meters). Wells using these sinking methods should not be constructed for use as public water sources unless specifically approved by the State regulatory agency. Drilled wells may be used in both soft and hard soil and in rock and may be sunk to depths of several hundred feet.

Drilled wells can be constructed in all instances where driven and jetted wells might otherwise be used and in many areas where dug and bored wells are constructed. The larger diameter of a drilled well, compared with a driven or jetted well, permits use of larger pumping equipment that can develop the full capacity of the aquifer.

There are various components of a well, many of which cannot be observed by the sanitary surveyor. Some of the more important ones follow:

Well casing is installed in wells to prevent the collapse of the walls of the bore hole; to exclude pollutants (either surface or subsurface) from entering the water source; and to provide a column of stored water and a housing for the pump mechanisms and pipes.

Cement grout is used to fill the annular open space left around the outside of the well casing during construction to prevent underground water and contamination from entering the well.

Screens are installed at the intake point of the well to hold back unstable aquifer material and permit free flow of water into the well. The well screen should be of good quality (corrosion-resistant, hydraulically efficient, and with good structural properties).

Well head covers or seals are used at the top of the casing or pipe sleeve connections to prevent contaminated water or other material from entering the well. A variety of covers and seals are available to meet the variety of conditions encountered, but the principles and the objective of excluding contamination are the same.

Pitless adapters are used to eliminate the need for a well pit. Because of the flooding and pollution hazards involved, a well pit to house the pumping equipment or to permit accessibility to the top of the well is not recommended. Some States prohibit its use. These units vary in design but generally include a special fitting designed for mounting on the side of the well casing. The well discharge and other piping are screw-threaded into the fitting, providing a tight seal. The pitless system permits the connection of the well piping to the casing underground below frost depth and, at the same time, provides for good accessibility to the well casing for repairs without excavation.

Sanitary Risks

1. Is the aquifer recharge area protected? What is the nature of the recharge area?

The nature of activities on the recharge zone and whether or not they are controlled can influence the quality of the water source. This information can assist the inspector in the identification of the potential source. The recharge area can be protected by means ranging from ownership of the area by the utility with restricted access to zoning laws prohibiting the use of subsurface waste disposal (septic tanks). The owner/operator should know this information.

2. Is the site subject to flooding?

The introduction of surface waters into the well should be avoided. Runoff in the immediate area should be drained away from the well site. The well field should not be placed in a floodplain (100-year flood). To protect a well is easier than to clean an aquifer once it is contaminated. Information on flooding and site drainage may be obtained from the owner/operator, visual inspection, and flood stage records. The exposed casing should terminate 18 inches above known flood level.

3. Is the well located in the proximity of a potential source of pollution?

The state regulatory agency should be consulted for its policy concerning well location, particularly the minimum protective distances between the well and sources of existing or potential pollution. Table 3-2 is an example of typical minimum distances. These distances are based on general experience and are not guarantees of freedom from contamination. The water purveyor should provide even greater protection where possible. The table applies to properly constructed wells with protective casing set to a depth of at least 20 feet below ground surface. Other types of wells will require special considerations.

Table 3-2. Sample Minimum Distances Between Wells and Pollution Sources

Source	Feet from Well	Remarks
Watertight Sewers	50	
Other Sewers	100	Consult the State regulatory agency for special local requirements.
Septic Tanks	100	
Sewage Field, Bed or Pit	200	
Animal Pens and Yards	200	

Source: Small Water Systems Serving the Public, Chapter 5.

4. What is the depth of the well?

The greater the depth of the aquifer utilized, the less chance of surface contamination degrading the water quality. Deeper aquifers generally have a more consistent quality of water.

5. What is the well drawdown?

Drawdown is the difference between static water levels and pumping water levels. Measuring drawdown is important since changes in drawdown can indicate problems in the aquifer (declining water levels) or well (incrustation, sand). The operator should be able to provide this information. If the operator is not measuring drawdown, he/she should be encouraged to do so.

6. What is the depth of the casing?

The casing must be strong enough to resist the pressures exerted by the surrounding materials and corrosion by soil and water environments. The casing must be of the proper length to provide a channel from the aquifer to the surface through unstable formations and through zones of actual or potential contamination. The casing should extend above potential levels of flooding and should be protected from flood water contamination and damage. In unconsolidated soils, the casing should extend at least 5 feet (1.5 meters) below the estimated maximum

expected drawdown level. In consolidated rock formations, the casing should extend 5 feet (1.5 meters) into firm bed rock and sealed into place. The operator should be able to provide this information.

7. What is the depth of grouting?

Specific grouting requirements of a well depend on the existing surface conditions, especially the location of sources of pollution, and the subsurface geologic and hydrologic conditions. To achieve the desired protection against contamination, the annular space must be sealed to whatever depth is necessary, but in no case less than 20 feet.

8. Does the casing extend at least 12 inches above the floor or ground?

This provides protection against surface runoff or drainage problems. The 12 inches is recommended when there is no potential for flooding.

9. Is the well properly sealed?

Well head covers or seals are used at the top of the casing or pipe sleeve connections to prevent contaminated water or other material from entering the well. A variety of covers and seals are available to meet the variety of conditions encountered, but the principles and the objective of excluding contamination are the same. Well covers and pump platforms should be elevated above the adjacent finished ground level and should be sloped to drain away from the well casing. Well pits should not be used, since they may result in contamination. Pitless adapters are used to eliminate the need for a well pit. Because of the flooding and pollution hazards involved, a well pit to house the pumping equipment or to permit accessibility to the top of the well is not recommended. Some States prohibit its use. A concrete slab around the well casing is not a completely reliable seal, since burrowing animals and insects can undermine it or it can be broken or cracked from frost heave or vehicles.

10. Does the well vent terminate 18 inches above ground/floor level or above maximum flood level with return bend facing downward and screened?

This is to keep water (from water cooled bearings for example), dust, insects, and animals from entering the well casing.

11. Does the well have a suitable sampling cock?

This is important when trying to isolate sources of contamination in a well field. If there is a well field and individual sample cocks are not provided, it is difficult to determine if one or all wells are the problem.

12. Are check valves, blowoff valves, and water meters maintained and operated properly?

Valves should be maintained and operated to prevent contamination from entering the well.

13. Is the upper termination of the well protected?

The upper termination of the well should be either housed or fenced to protect it from vandalism and vehicle damage.

14. Is lightning protection provided?

Lightning surges can develop in powerlines during thunderstorms. Such surges can damage pump motors, creating loss of water supply as well as costly repairs. To protect against this, lightning arrestors can be provided where service lines are connected to service entrance cables or at the motor control box. A multiground arrangement can be provided that grounds the entire pump and well against damage.

15. Is pump intake located below maximum drawdown?

This prevents the pump from running dry as well as protects against contamination in upper portion of water table from being pumped.

16. Are foot valves and/or check valves accessible for cleaning?

As with above-ground valves, these valves must be maintained in an operating manner to prevent flow of undesirable water into the well.

UNIT 3c: Springs - "The Need To Know"

Unit Summary

Spring Source Collection System Components
Sanitary Risk Factors

Unit Objectives

A major function of the sanitary survey is to determine the degree of protection afforded the source. Springs are sometimes used as public water sources. At the end of this unit, the student should know:

1. Characteristics of springs
 2. Sanitary risks to springs
-

Logistics

Approximate Presentation Time: 45 minutes

Instructor Materials

- o Basic material
- o Transparencies 3-12 through 3-16
- o Overhead projector and screen
- o Chalkboard

Student Materials

- o Student's Text, Unit 3c

Student Preparation

- o Unit 3c should be read prior to the session.

Unit References

- o Small Water Systems Serving the Public (Chapter 7)
- o Manual of Individual Water Supply Systems (Part II)

Use Transparency 3-12:

Use Transparency 3-13.

Point out major components of each type. Ask students to describe the function of each component. Explain as necessary.

Use Transparencies 3-14 and 3-15:

Point out major components:

Use personal experiences and anecdotes to relate the course material to actual situations an inspector may encounter during a sanitary survey.

Emphasize that activities on recharge area have greater impact on water quality of springs than of wells.

Use Transparency 3-13. Briefly explain importance of items.

A. Spring Collection System Components (10 minutes)

- o Spring flow interception
- o Storage tank/collection chamber
- o Screened overflow
- o Valved supply intake
- o Drain
- o Tank/chamber cover
- o Screened supply intake

B. Infiltration Galleries (5 minutes) Components

- o Screen
- o Collector pipes
- o Gravel and sand bed
- o Backfill
- o Sump
- o Drainage

C. Sanitary Risks (30 minutes)

1. Recharge Area/Surface Area

- a. Is recharge area protected?
 - o Ownership
 - o Fencing
 - o Ordinances
- b. What is nature of recharge area?
 - o Agricultural
 - o Industrial
 - o Residential
 - o Other
- c. Is site subject to flooding?

2. Construction

- a. Collection chamber
 - o Watertight
 - o Adequately covered and locked
 - o Drain provided for cleanout
 - o Proper overflow provided
- b. Supply intake
 - o Screened
 - o Properly located

3. Site Protection

- a. Diversion ditch for surface drainage
- b. Site fencing with secured access

4. Water Quality

What conditions cause changes to quality of the water?

Use Transparency 3-16.

Have students identify

deficiencies of illustration.

Evaluation of Springs

Deficiencies:

- o Inadequate cover (not tight fitting, not lockable)
- o Proximity to pollutant source
- o No site fencing
- o No drain
- o No exterior valves
- o Improper overflow (no screen, no overflow drainage provisions)
- o No surface drainage division
- o Improper intake (located on bottom, no screen)

UNIT 3c: Springs

Unit Summary

Spring Source Collection System Components
Sanitary Risks

Unit References

Small Water Systems Serving the Public
(Chapter 7)
Manual of Individual Water Supply Systems
(Part II)

Basic Material

To properly develop a spring supply, the natural flow of ground water must be captured below the ground surface, and the method used must not contaminate the water. Springs are subject to contamination by wastewater disposal systems, animal wastes, and surface drainage. Springs are also susceptible to seasonal flow variations, and the yield may be reduced by the pumping of nearby wells.

Springs may be gravity or artesian. Gravity springs occur where the water-bearing stratum overlays an impermeable stratum and outcrops to the surface. They also occur where the land surface intersects the water table. This type of spring is particularly sensitive to seasonal fluctuations in ground water storage, and frequently dwindles or disappears during dry periods. Gravity springs are characteristically low-yielding sources, but when properly developed they may be satisfactory for small water supply systems.

Artesian springs discharge from artesian aquifers. They may occur where the confining formation over the artesian aquifer is ruptured by a fault or where the aquifer outcrops at a lower elevation. Artesian springs are usually more dependable than gravity springs, but they are particularly sensitive to the pumping of wells developed in the same aquifer. As a consequence, artesian springs may be dried up by nearby well pumping.

Important criteria for spring sources include selection of a spring with acceptable water quality, development to the required quantity of water, and sanitary protection of the spring collection system. The measures taken to develop a spring must be tailored to the prevailing geological conditions.

Spring Source Collection System

Spring flow is intercepted by a system of perforated pipes driven into the water-bearing stratum or laid in gravel-packed trenches. The flow is directed into a storage tank. As an alternative, a watertight concrete collection chamber is constructed with openings in the bottom and/or a side wall to intercept the flow. This chamber may also serve as the storage tank. Where possible, the walls of the collection chamber should extend to bedrock or the impervious stratum. The watertight walls should extend 8 or more inches above ground to prevent entrance of surface water. An overlapping (shoe-box) cover will prevent entrance of debris.

The tank is usually constructed in place with reinforced concrete to intercept as much of the spring as possible. When a spring is located on a hillside, the downhill wall and sides are extended downward to bedrock or impervious soil to ensure that the structure will hold back water to maintain the desired level in the chamber. Supplementary cutoff walls of concrete or impermeable clay may be used to assist in controlling the water table in the vicinity of the tank. The lower portion of the uphill wall of the tank must have an open construction to allow water to move in freely while the aquifer material is held back. Backfilling with graded gravel will aid in restricting movement of aquifer material.

The tank cover should be cast in place to ensure a good fit. The cover should extend down over the top edge of the tank at least 2 inches, should be heavy enough to prevent dislodging by children, and should be lockable.

A drain pipe with an exterior valve should be placed close to a wall of the tank at the floor level to permit draining. The end of the pipe should extend far enough to allow free discharge to the ground surface, away from the tank. The discharge end of the pipe should be screened to prevent nesting by animals and insects.

The overflow is usually placed slightly below the maximum water-level elevation. The overflow should have a free discharge to a drain apron of rock to prevent soil erosion at the point of overflow and should be screened.

The supply intake should be located about 6 inches above the floor and should be screened. Care should be taken to ensure good bond between pipes and the concrete structure.

Infiltration Galleries

Recreational or other developments located in the mountains may have access to a head water mountain stream where the watershed is generally heavily forested and uninhabited by man. However, after periods of heavy rainfall or spring thaws, debris and turbidity may cause problems at the

water intake and will materially increase the required degree of treatment. If the conditions are suitable, this problem can be avoided by constructing the intake in an underground chamber (infiltration gallery) along the shore of the stream or lake.

Galleries may be considered where porous soil formations adjoin a stream or lake so that the water can be intercepted underground to take advantage of natural filtration. Any gallery access structure should be located above the level of severe flooding.

A typical installation generally involves the construction of an underdrained, sand filter trench located parallel to the stream bed and about 10 feet from the high water mark. The sand filter is usually located in a trench with a minimum width of 30 inches and a depth of about 10 feet, sufficient to intercept the water table. At the bottom of the trench, perforated or open joint tile is laid in a bed of gravel about 12 inches in thickness, with about 4 inches of graded gravel located over the tile to support the sand. The embedded tile is then covered with clean, coarse sand to a minimum depth of 24 inches, and the remainder of the trench backfilled with fairly impervious material. The collection tile drains to a watertight, concrete chamber from which water may flow to the distribution system by gravity or pump, whichever is appropriate. Chlorination is generally necessary and may be done in the chamber or at another place, but prior to any use.

Where soil formations adjoining a stream are unfavorable for the location of an infiltration gallery, the debris and turbidity that are occasionally encountered in a mountain stream may be controlled by constructing a modified infiltration gallery in the stream bed.

If a natural pool is not available in the stream bed, a dam is usually constructed across the stream to form a pool. The filter is installed in the pool by laying perforated pipe in a bed of graded gravel, which is then covered by at least 24 inches of clean, coarse sand. About 24 inches of freeboard should be allowed between the surface of the sand and the surface water level. The collection lines may terminate in a watertight, concrete basin located adjacent to the upstream face of the dam from where the water is diverted to chlorination facilities.

Sanitary Risks

1. Is the recharge area protected?
2. What is the nature of the recharge area?
3. Is the site subject to flooding?

The rationale for the above questions is the same as that for wells.

4. Is the collection chamber properly constructed?

The collection chamber should be watertight to prevent the inflow of undesirable water. The tank cover should be impervious and lockable. The drain should have an exterior valve and the exterior end screened. The overflow should have a free discharge to a drain apron to prevent soil erosion. This information may be obtained by inspection of the collection chamber.

5. Is the supply intake adequate?

The supply intake should be located 6 inches above the chamber floor and screened. This location reduces the withdrawal of the sludge that may build up in the chamber.

. Is the site adequately protected?

The following precautionary measures will help ensure spring water of consistently high quality:

- o Diversion of surface drainage from the site. A surface drainage ditch should be located uphill from the source to intercept surface water runoff and carry it away from the source. Springs in close proximity to agriculturally developed land treated by pesticides and herbicides may be particularly susceptible to contamination.
- o Protection from stray livestock and from tampering by means of site fencing, locked covers, and warning signs.

7. What conditions cause changes to quality of the water?

A marked increase in turbidity or flow after a rainstorm is a good indication that surface runoff is reaching the spring.

UNIT 3d: Surface Sources - "The Need To Know"

Unit Summary

Types and Characteristics

Sanitary Risks

Unit Objectives

A major function of the sanitary survey is to determine the degree of protection afforded the source. In this unit the sanitary risks of surface sources will be highlighted and the methods of evaluating these risks discussed.

Logistics

Approximate Presentation Time: 45 minutes

Instructor Materials

- o Basic Material
- o Transparencies 3-17 through 3-19
- o Overhead projector and screen
- o Chalkboard

Student Material

- o Student's Text, Unit 3d

Student Preparation

- o Unit 3d should be read prior to the session.
-

Unit References

- o Small Water Systems Serving the Public (Chapter 8)
- o Manual of Individual Water Supply Systems (Part III)
- o Water Treatment Plant Operation (Volume 1; Chapters 2 and 3)
- o Water Supply System Operation (Chapter 2)

Use Transparency 3-17.

Use Transparency 3-18.

Use the cistern as an example of how a controlled catchment functions.

Explain that use of cisterns should be discouraged if other adequate sources are available.

Use questions to guide class discussion.

Use Transparency 3-19.

Discuss potential problems involved in watershed use for small systems.

Use questions to guide class discussion.

Explain use of streams as source.

List pros and cons of system on chalkboard.

Draw rough sketch of a typical intake system on chalkboard.

A. Types and Characteristics (15 minutes)

Controlled Catchments (5 minutes)

- o Collects rainfall runoff from defined area
- o Water stored in cistern or reservoir
- o Predictable yield (historical data)
- o Pollutant exposure controllable
- o System components
 - Watertight collection chamber
 - Initial runoff diversion
 - Screened intake, overflow, drain lines
- o Larger systems involve paved ground area for collection

1. What is the purpose of a roof washer?
2. What potential pollution sources might contaminate this system?

Ponds/Lakes (5 minutes)

- o Collect runoff from watershed
- o Predictable yield
- o Large storage capacity
- o Watershed control essential
 - Protection from pollution sources
 - Protection against erosion, drainage from animal areas, etc.
- o System components (ponds)
 - Area; minimum 1-year storage
 - Fenced
 - Minimum depth: 8 feet
 - Screened inlet

1. What factors should be considered when describing a pond or lake?
2. Is control of activity or watershed necessary? If so, to what degree?
3. How might watershed control be accomplished?

Streams and Rivers (5 minutes)

- o Less desirable source
 - Large watershed
 - May require very high treatment levels
 - Sensitive to adverse temperature levels typical during low-water stages
- o High water stage best for diverting water to storage
- o System components
 - Screened intakes located upstream from pollutant sources
 - Storage reservoir

Use question to guide class discussion.

1. What factors are of particular importance in evaluating the use of streams as sources?

Sanitary Survey of Surface Waters (30 minutes)

Explain impact of watershed activities on water quality. Note hazards of types of land use.

1. What is the nature of the watershed?
 - o Industrial
 - o Agricultural
 - o Forest
 - o Residential

Give an example of a watershed control program (see Chapter 3, Water Treatment Plant Operation).

2. What is the size of the owned/protected area of the watershed?
 - o Importance of protecting watershed

Describe effectiveness of types of control.

3. How is the watershed controlled?
 - o Ownership
 - o Ordinances
 - o Zoning restrictions

Emphasize importance of contingency planning to students.

4. Has management had a watershed survey performed?
 - o Importance of utility to be concerned with land use of watershed
5. Is there an emergency spill response plan?
 - o Identification of potential spill sites and types of contaminants
 - o Need for spill plan
 - o Need for prior coordination
6. Is the source adequate in quantity?
 - o Present demands
 - o Future demands
 - o Trends

Use personal experiences and anecdotes to relate course material to actual situations an inspector may encounter.

7. Is the source adequate in quality?
 - o Present quality
 - o Trends

Describe necessity to control area immediately around intake.

8. Is there any treatment provided in the reservoir (algae control, insect control, chemical addition)?
9. Is the area around the intake restricted for a radius of 200 feet?
 - o Reduce bacterial and organic contamination

10. Are there any sources of pollution in the proximity of the intakes?
 - o Boat launching ramps
 - o Marinas
 - o Wastewater discharges

Draw examples of intake structures on blackboard. Discuss both stream and impoundment intakes.

11. Are multiple intakes, located at different levels, utilized?
 - o Spring/fall turnover
 - o Ability to draw best quality water
12. Is the highest quality water being drawn?
 - o Raw water testing
13. How often are intakes inspected?
 - o Screen integrity
 - o Periodic cleaning
14. What conditions cause fluctuations in quality?
 - o Rain
 - o Wind
 - o Currents
15. Review of dam inspection (if applicable in State)
 - o Burrowing animals
 - o Trees
 - o Sinkholes

Have students suggest conditions that might influence water quality.

UNIT 3d: Surface Sources

Unit Summary

Types and Characteristics
Sanitary Risks

Unit References

Small Water Systems Serving the Public
(Chapter 8)
Manual of Individual Water Supply Systems
(Part III)
Water Treatment Plant Operation
(Volume 1, Chapters 2 and 3)
Water Supply System Operation (Chapter 2)

Basic Material

Surface water sources used for small water supply systems require consideration of additional factors not usually associated with ground water sources. When small streams, open ponds, lakes, or open reservoirs must be used as sources of water supply, the danger of contamination and of the consequent spread of intestinal diseases such as typhoid fever and dysentery is generally increased. Clear water is not always safe, and the old saying that running water "purifies itself" to drinking water quality within a stated distance is false.

The physical, chemical, and bacteriological contamination of surface water makes it necessary to regard such sources of supply as unsafe for domestic use unless reliable treatment, including filtration and disinfection, is provided. The treatment of surface water to ensure a constant, safe supply requires diligent attention to operation and maintenance by the owner of the system. Principal sources of surface water that may be developed are controlled catchments, ponds or lakes, surface streams, and irrigation canals. Except for irrigation canals, where discharges are dependent on irrigation activity, these sources derive water from direct precipitation over the drainage area.

Controlled Catchments

In some areas, ground water is so inaccessible or so highly mineralized that it is not satisfactory for domestic use. In these cases, the use of controlled catchments and cisterns may be necessary. A properly located and constructed controlled catchment and cistern, augmented with a satisfactory filtration unit and adequate disinfection facilities, will provide a safe water. However, cisterns should be utilized only when no other source is available.

Ponds/Lakes/Reservoirs

The development of a pond as a supply source involves: (1) selecting a watershed that permits only water of the highest quality to enter the pond; (2) using the best water collected in the pond; (3) filtering the water to remove turbidity and reduce bacteria; (4) disinfecting filtered water; (5) properly storing the treated water; and (6) properly maintaining the entire water system.

The value of a pond or lake as a source is its ability to store water during wet periods for use during periods of little or no rainfall. A pond should be capable of storing a minimum of one year's supply of water. It must be of sufficient capacity to meet water supply demands during periods of low rainfall with an additional allowance for seepage and evaporation losses. The drainage area (watershed) should be large enough to catch sufficient water to fill the pond or lake during wet seasons of the year.

To minimize the possibility of chance contamination, the watershed should be:

- o Clean, preferably grassed
- o Free from barns, septic tanks, privies, and soil-absorption fields
- o Protected against erosion and drainage from livestock areas
- o Fenced

The pond should be:

- o Not less than 8 feet deep at the deepest point
- o Large enough to store at least one year's supply
- o Designed to have the maximum possible water storage area over 3 feet in depth
- o Fenced
- o Free of weeds, algae, and floating debris

In many instances, pond development requires the construction of an embankment with an overflow or spillway.

Streams and Rivers

Streams receiving runoff from large uncontrolled watersheds may be the only source of water supply. The physical, chemical, and bacteriological

quality of surface water varies and may impose unusually or abnormally high loads on the treatment facilities.

Stream intakes should be located upstream from wastewater discharges, storm drains, or other sources of contamination. The water should be pumped when the silt load is low. A low-water stage usually means that the temperature of the water is higher than normal and the water is of poor chemical quality. Maximum silt loads, however, occur during maximum runoff. High-water stages shortly after storms are usually the most favorable for diverting or pumping water to storage. These conditions vary and should be determined for the particular stream.

Irrigation Canals

If properly treated, irrigation water may be used as a source of domestic water supply. Water obtained from irrigation canals should be treated the same as water from other surface water sources.

Water from irrigation canals may contain large concentrations of undesirable chemicals, including pesticides, herbicides, and fertilizer. Periodic chemical analysis should be made.

Sanitary Risks

1. What is the nature of the watershed?

Industrial ____ Agricultural ____ Forest ____ Residential ____

As previously noted, the activities on the watershed will impact on the water quality of the runoff. The potential for spills from industrial activities, herbicides and pesticides from agricultural land uses, organics from plant decay, and animal-borne diseases are a few problems that may be indicated by land use on the watershed.

2. What is the size of the owned/protected area of the watershed?

To reduce the extent of contamination of the watershed, many utilities have chosen to purchase a portion of it. Another method is to restrict activities through zoning restrictions and ordinances.

3. How is the watershed controlled?

This question allows the inspector to evaluate the effectiveness of watershed control measures. Ownership with restricted access is the most stringent measure but it is also the most costly. If ordinances are used, the inspector may wish to know how they are enforced.

4. Has management had a watershed survey performed?

If the utility has had a watershed survey conducted, many of the above questions may be answered by referring to it. The fact that a utility has conducted such a survey would indicate a concern on its part for the protection of the supply.

5. Is there an emergency spill response plan?

Some industries (e.g., petroleum) are required to have emergency spill plans. Potential spill sites should be identified by the utility and contingency plans developed in the case of a spill. However, because a plan is only paper, the necessary equipment and personnel must be identified and coordination between respective agencies (fire, police, water utility) worked out prior to any emergency.

6. Is the source adequate in quantity?

To answer this question, the inspector should determine if the source is adequate for present as well as future demands. The source should be able to continuously meet the demands of the water system. Decreasing trends in quantity are also important to note. Operation records should provide this information.

7. Is the source adequate in quality?

A review of monitoring records should reveal this answer. As with quantity, any trends of decreasing quality should be noted.

8. Is there any treatment provided in the reservoir?

The addition of any chemicals to the reservoir should be noted. Particular concern is assuring that only approved chemicals be utilized and that they be properly applied.

9. Is the area around the intake restricted for a radius of 200 feet?

Restriction of contact sports (e.g., swimming and water skiing) and use of powerboats in the vicinity of the intake is important. This will reduce the coliform and organic pollution of the intake water.

10. Are there any sources of pollution in the proximity of the intakes?

Sources of pollution such as wastewater discharges, feedlots, marinas, and boat launching ramps should be identified. If the use of the reservoir is not restricted, the impact of activities should be minimized as much as possible by keeping them away from the intakes.

11. Are multiple intakes located at different levels utilized?

Because of fluctuations of the water surface elevation and the variability of water quality with depth, it is necessary that intakes be provided at different depths. Seasonal turnover of the reservoir, algal blooms, and thermal stratification can cause water quality problems. This applies to deep reservoirs, streams, and shallow reservoirs not subject to stratification commonly utilized at single-level intakes.

12. Is the highest quality water being drawn?

The operator should be performing monitoring tests to determine the water quality at the various depths in order to draw the best quality water. The operator should be questioned as to how the intake level is selected, what tests are accomplished, and at what frequency. Suggested tests are dissolved oxygen, metals, and nitrogen values.

13. How often are intakes inspected?

As with all components, maintenance must be periodically performed on the intake structure. Removal of debris and inspection of intake screen integrity will prevent damage to piping valves and pumps. This is particularly important during winter months due to the danger of sheet and frazzle ice buildup.

14. What conditions cause fluctuations in water quality?

Conditions such as stratification, algal blooms, ice formation, on-shore winds, and changing currents may create adverse changes to water quality. Conditions creating such problems should be noted as well as what measures are being taken to mitigate them.

15. Has the dam been inspected for safety (if applicable)?

Dams should be routinely inspected to avoid conditions that may endanger their integrity. Many States require that such inspections be performed. However, if not required, operators should be encouraged to look for such things as erosion, sinkholes, burrowing animals, and trees growing in the dam face.

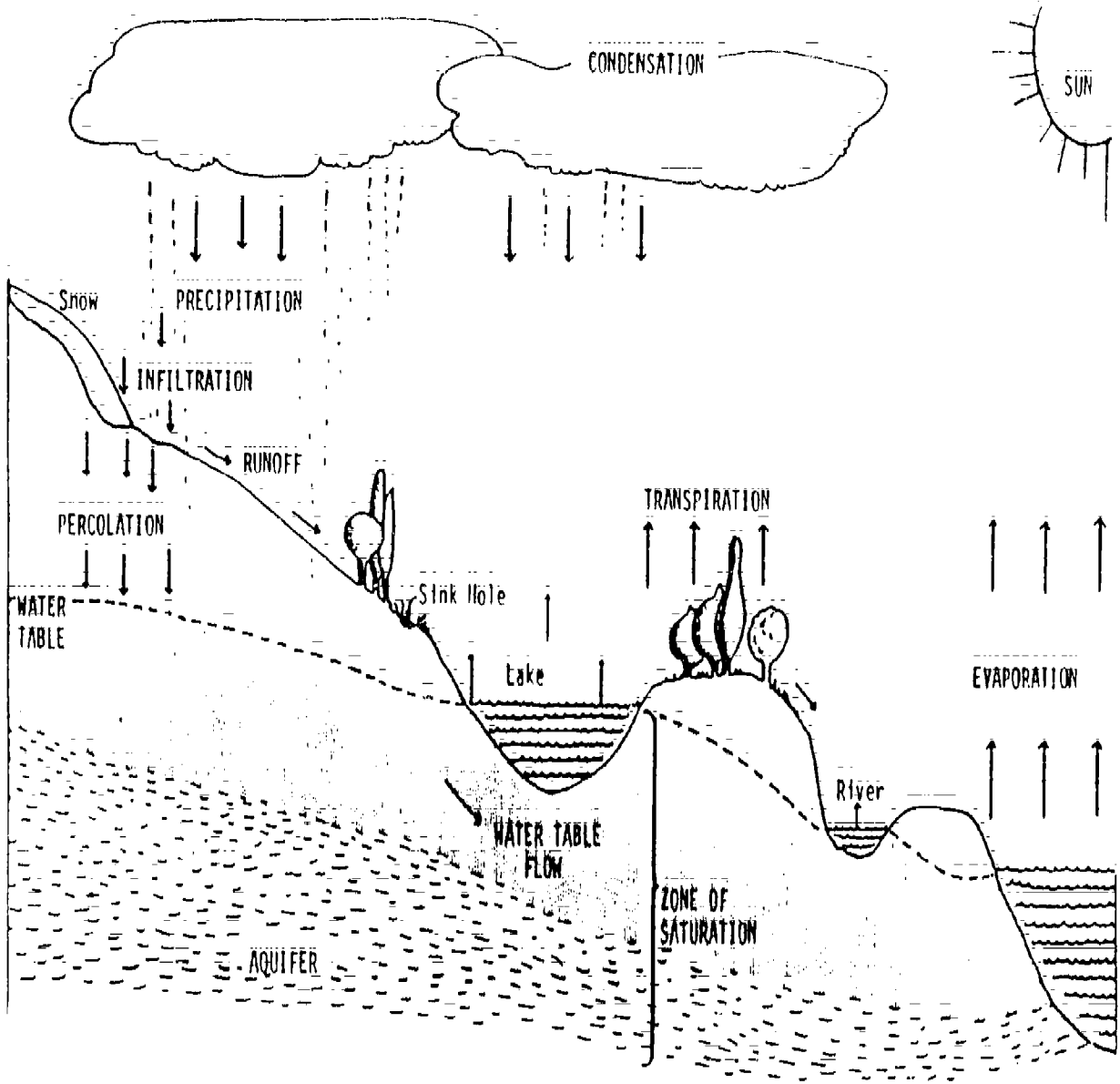

Hydrologic Cycle

13-119

TRANSPARENCY 13-1

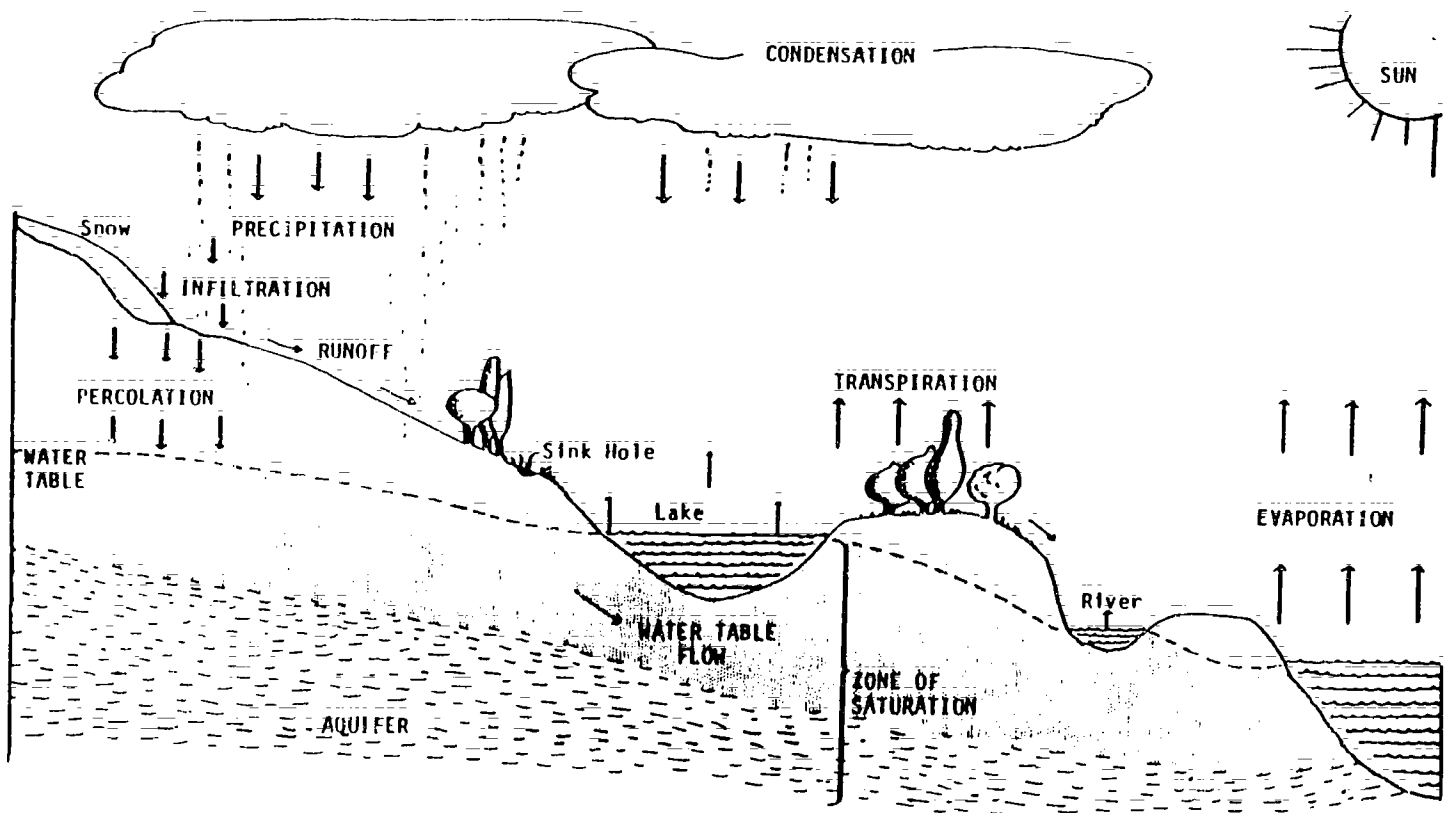

Hydrologic Cycle

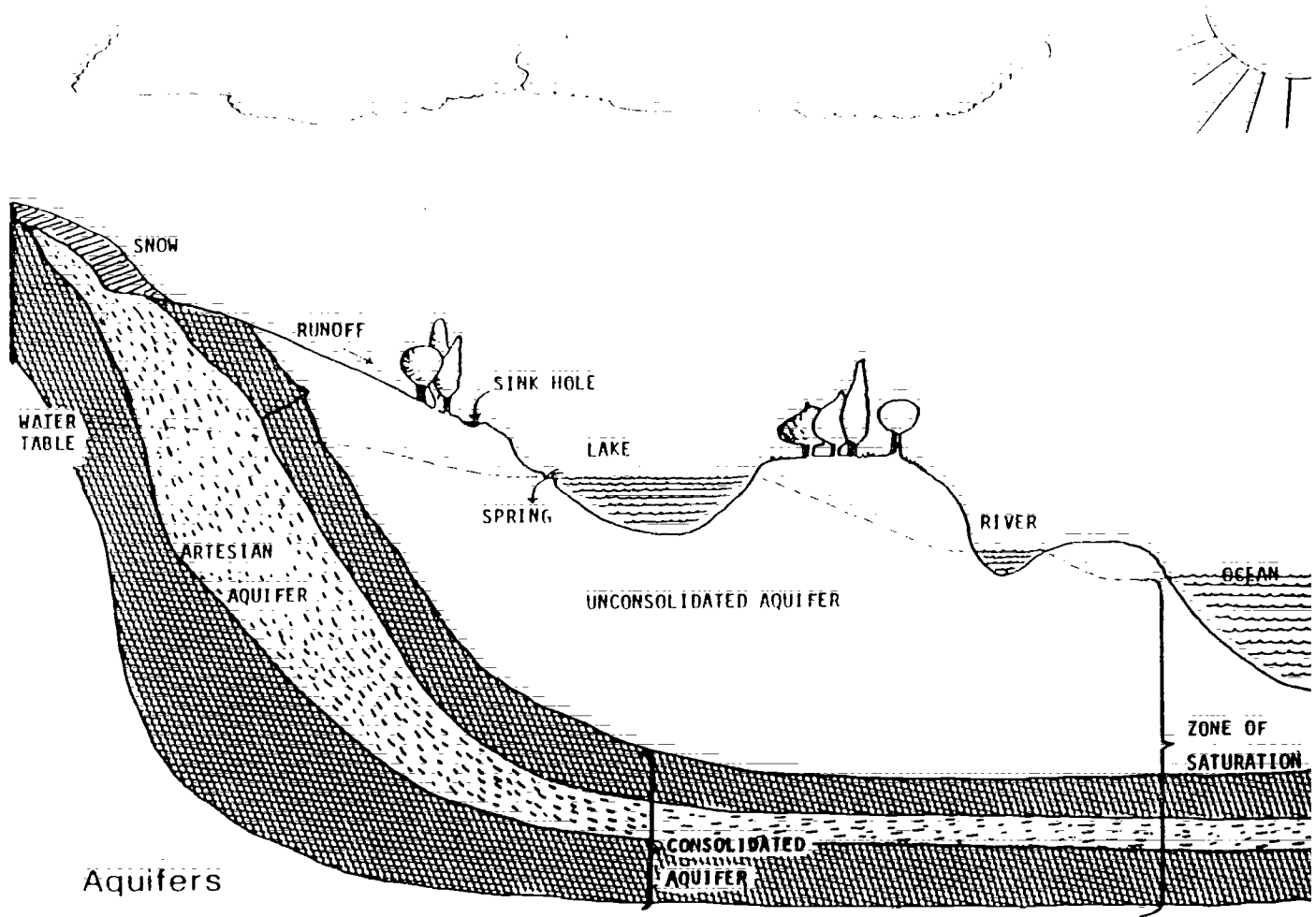

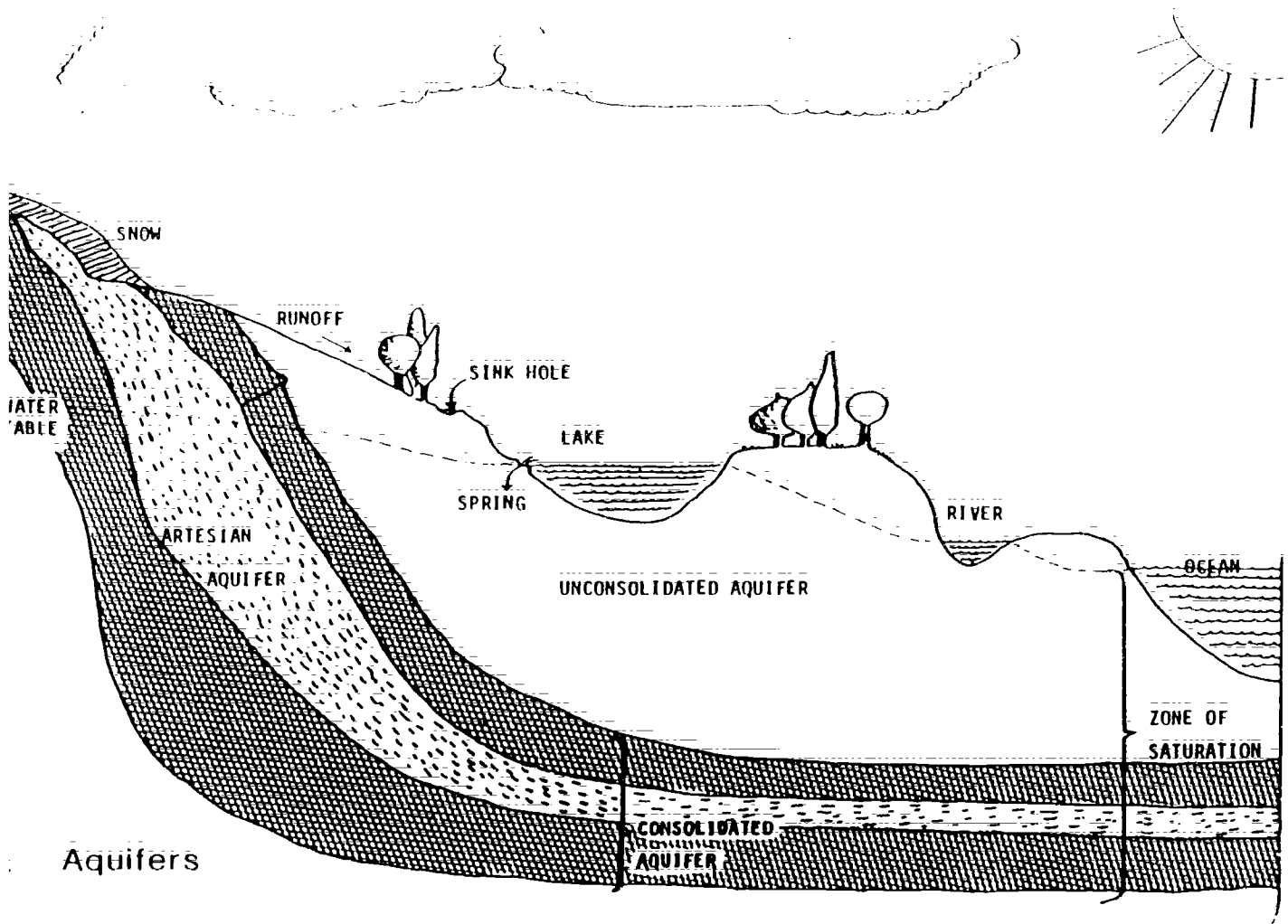

What Are Sources of Contamination?

3-21

TRANSPARENCY 3-3

132

What Are Sources of Contamination?

133

Water Demand

- Average Daily
- Maximum Daily
- Peak
- Fire

3-22

TRANSPARENCY 3-14

134

Water Demand

- Average Daily
- Maximum Daily
- Peak
- Fire

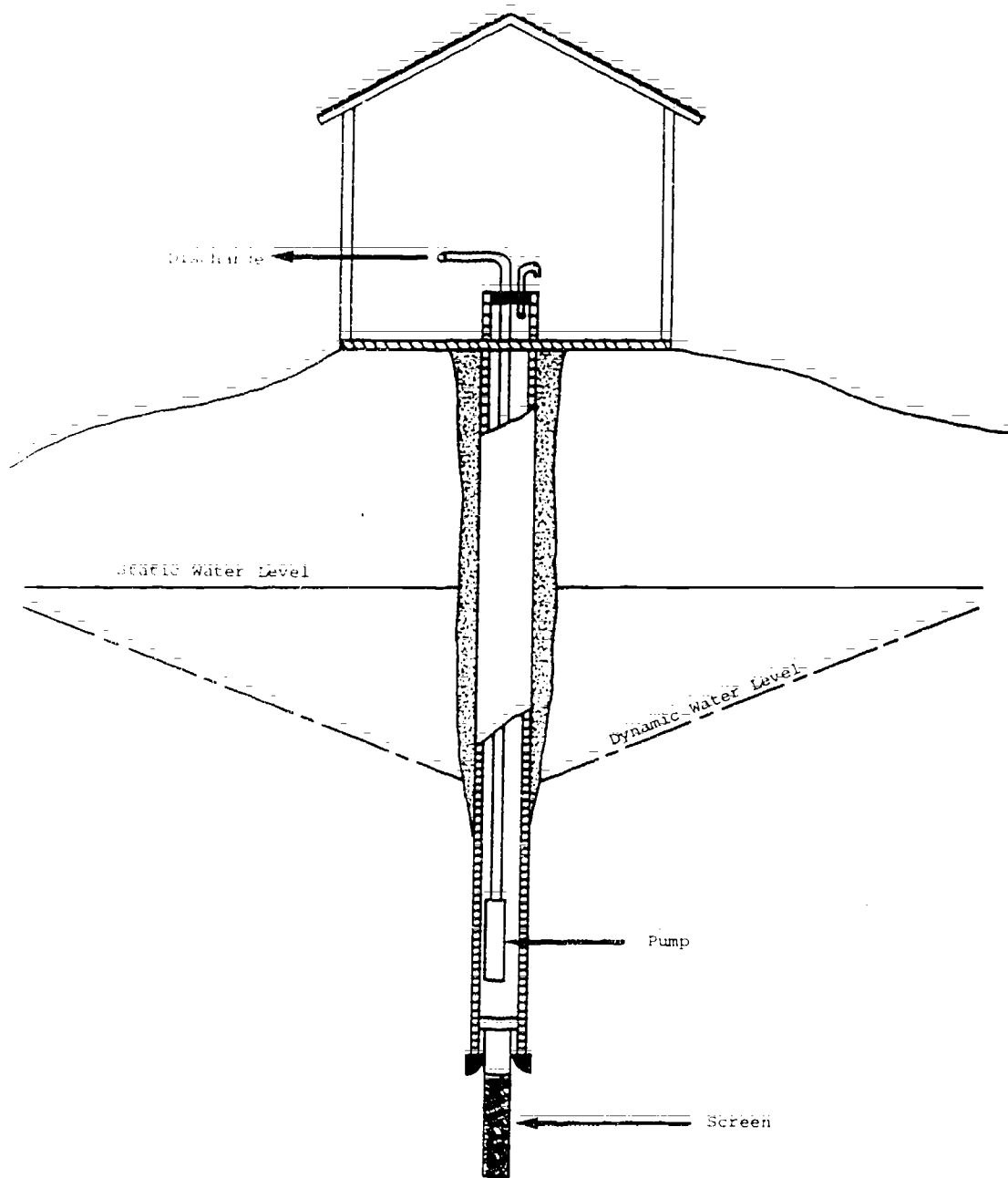

3-23

TRANSPARENCY 3-5

136

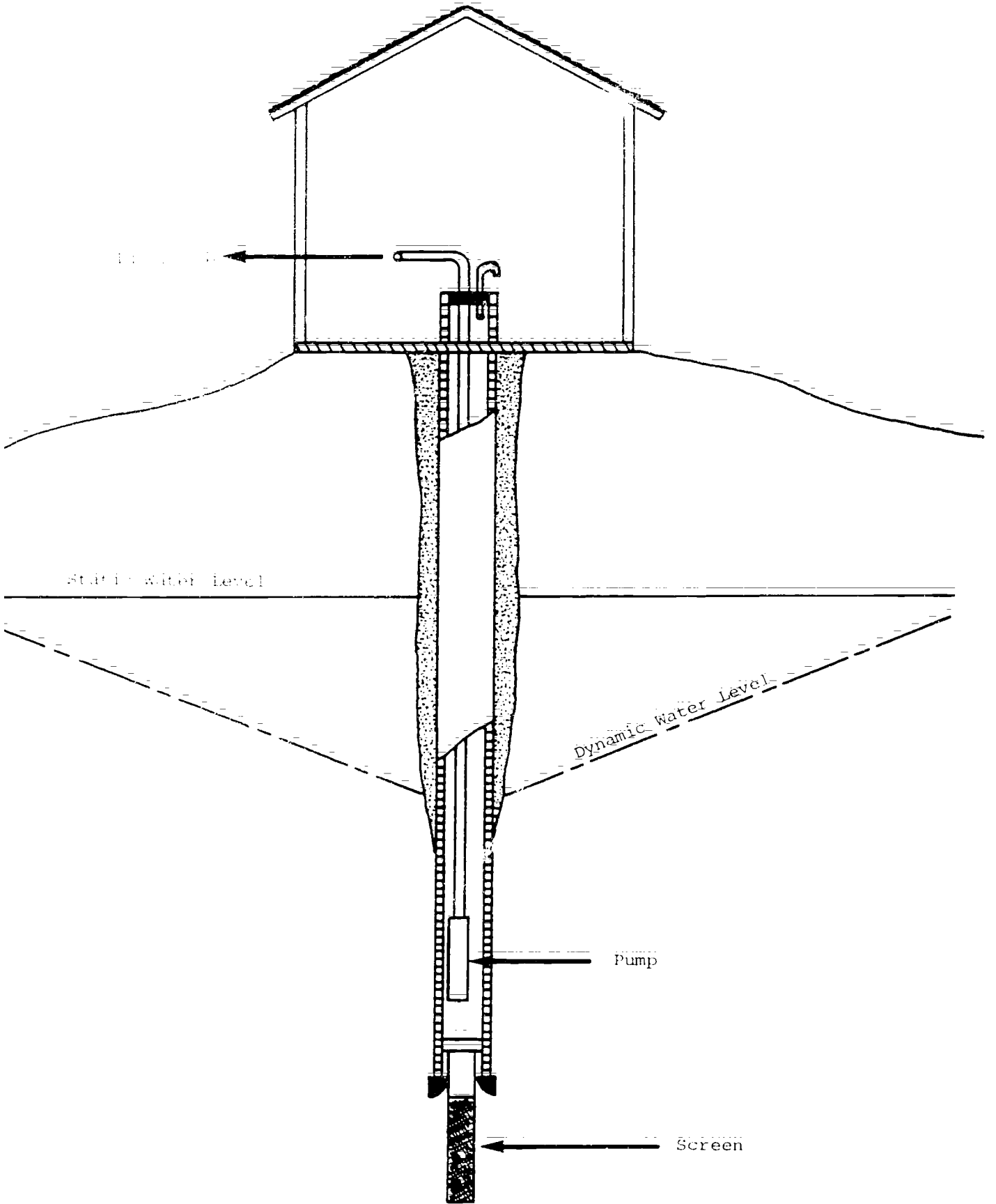

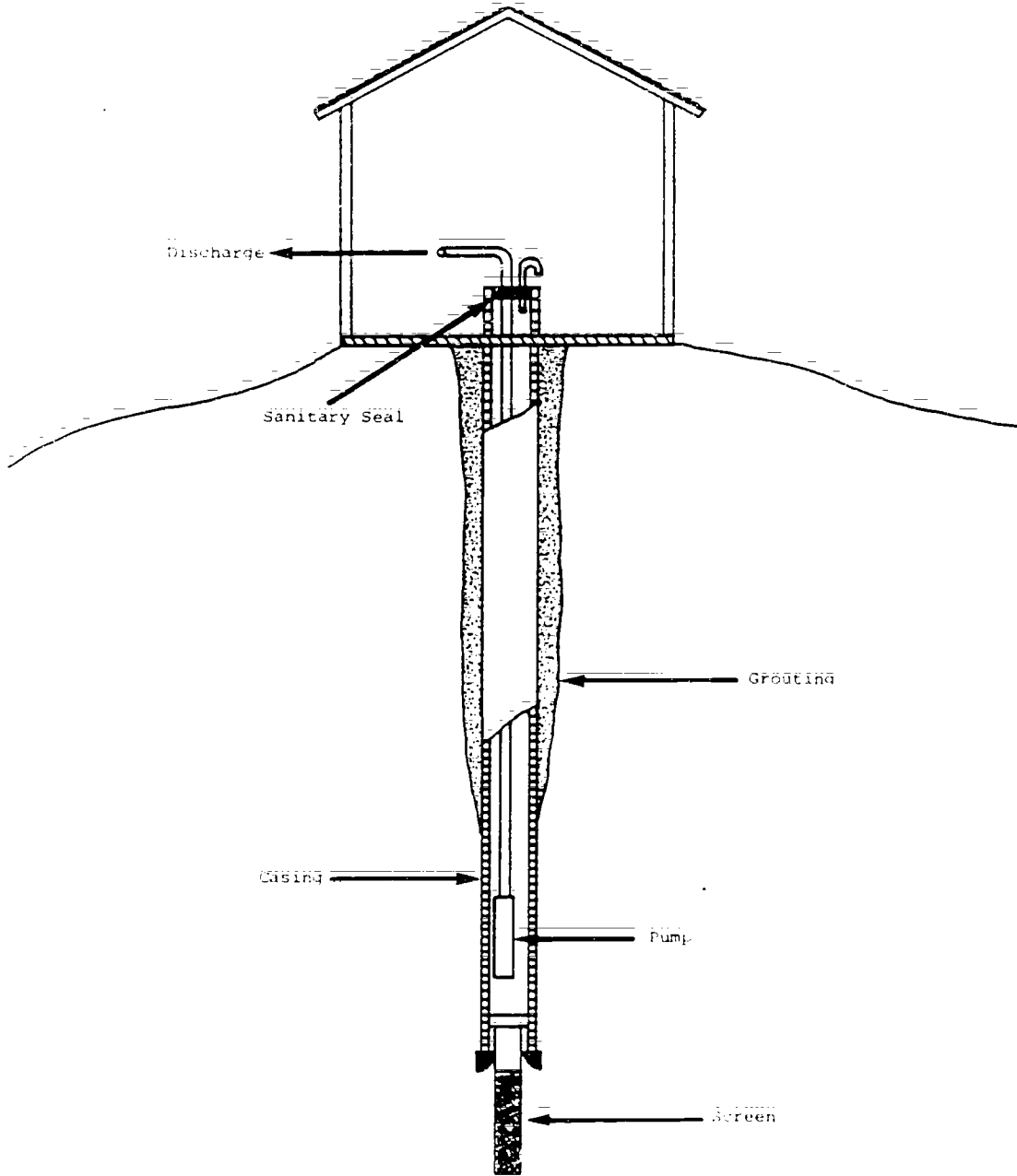

3-24

TRANSPARENCY 3-6

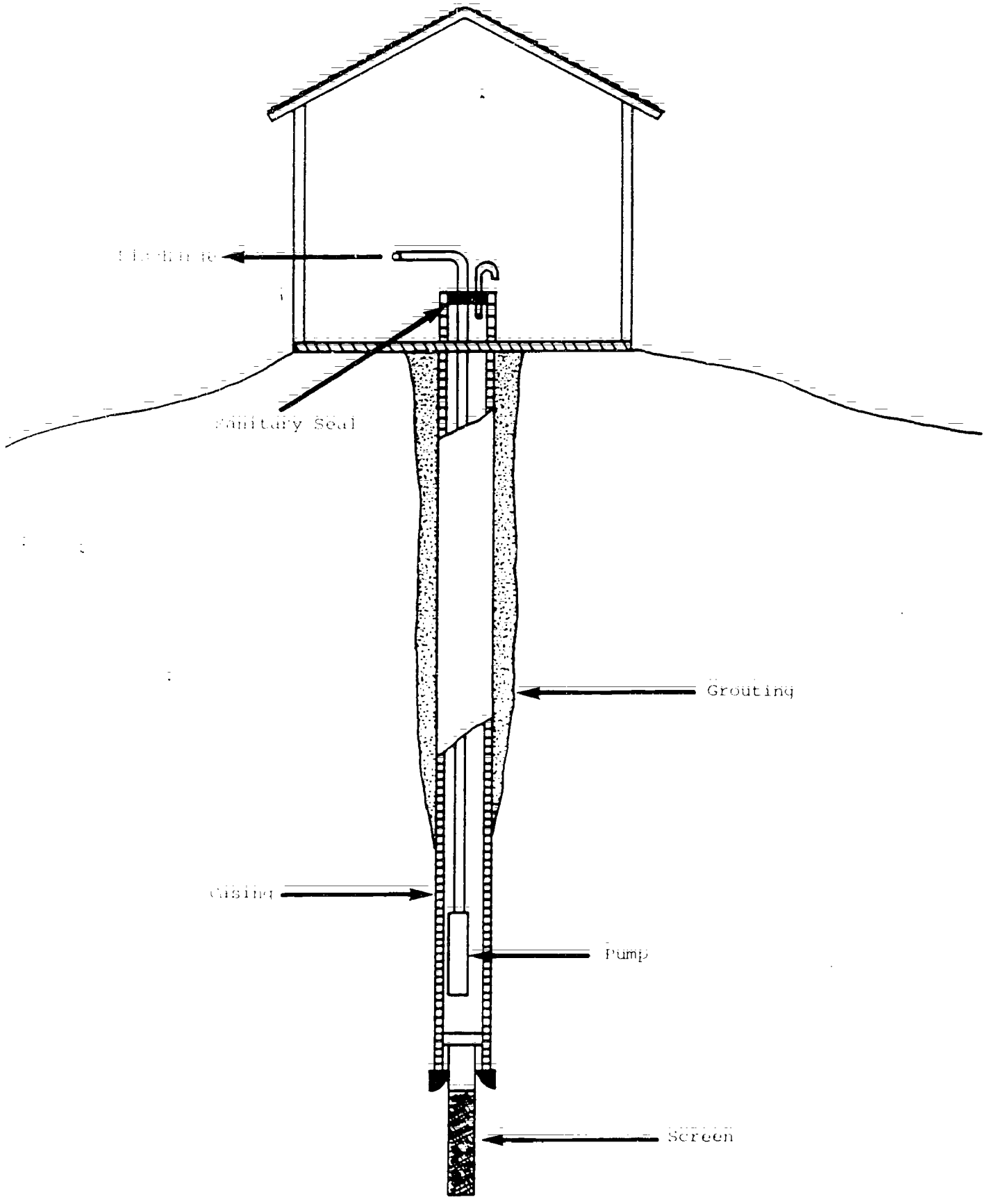

Typical Site Plan

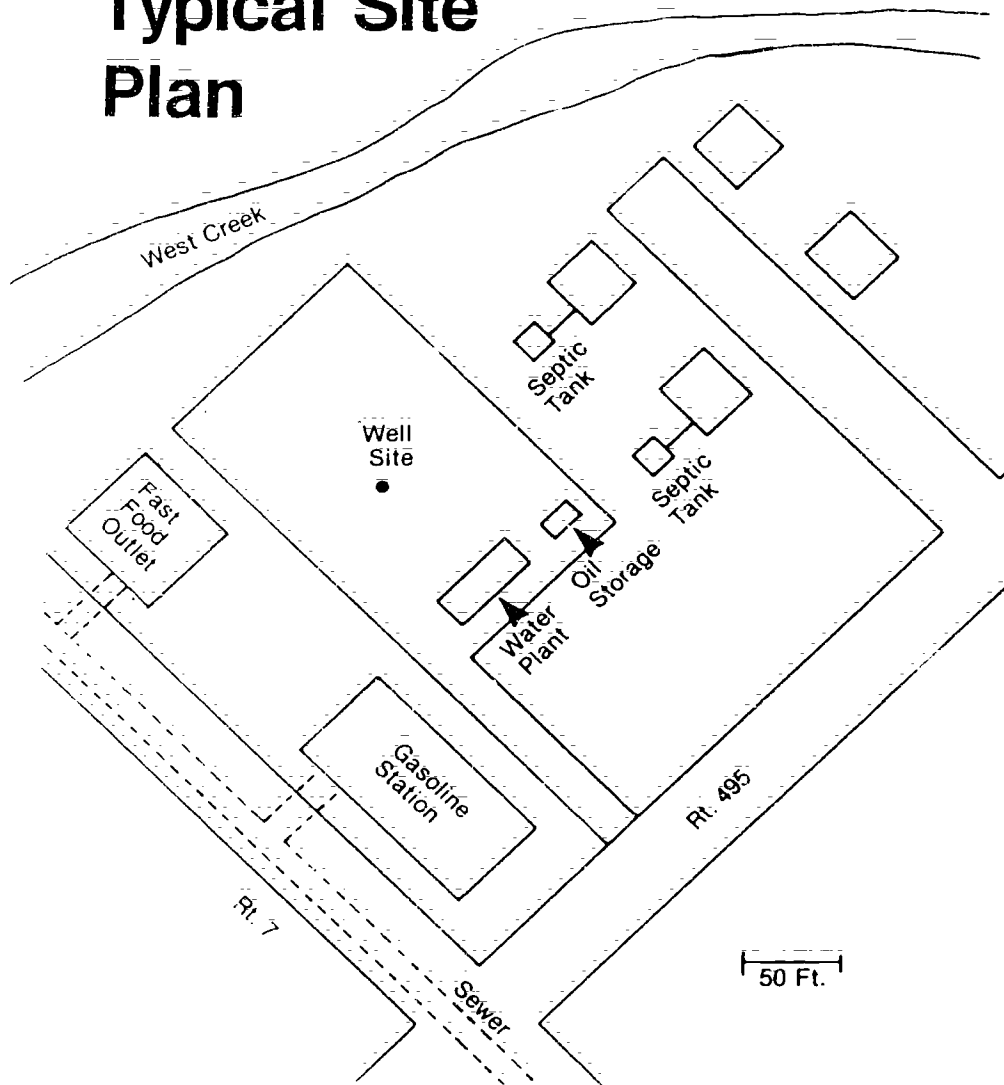

Typical Site Plan

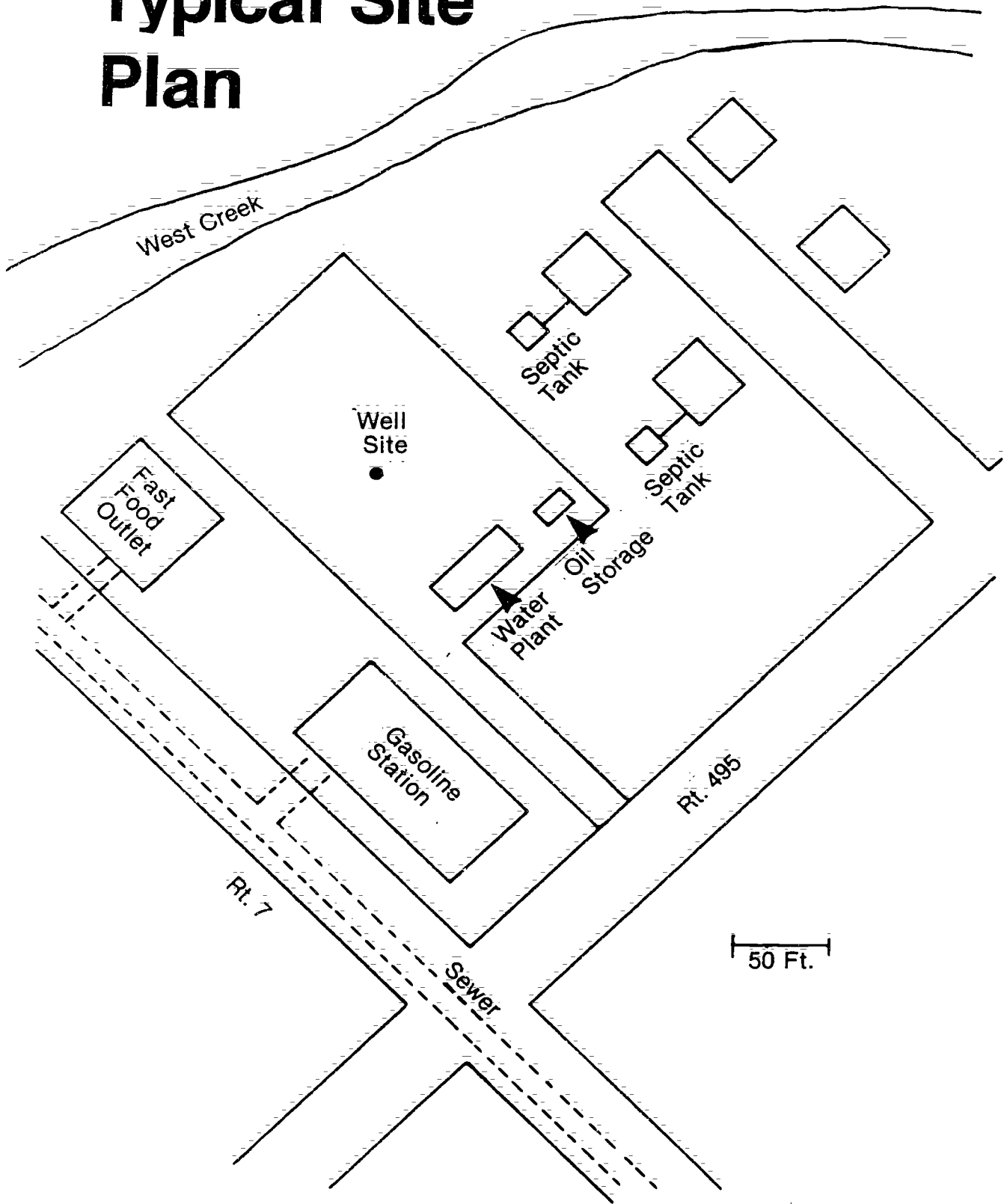

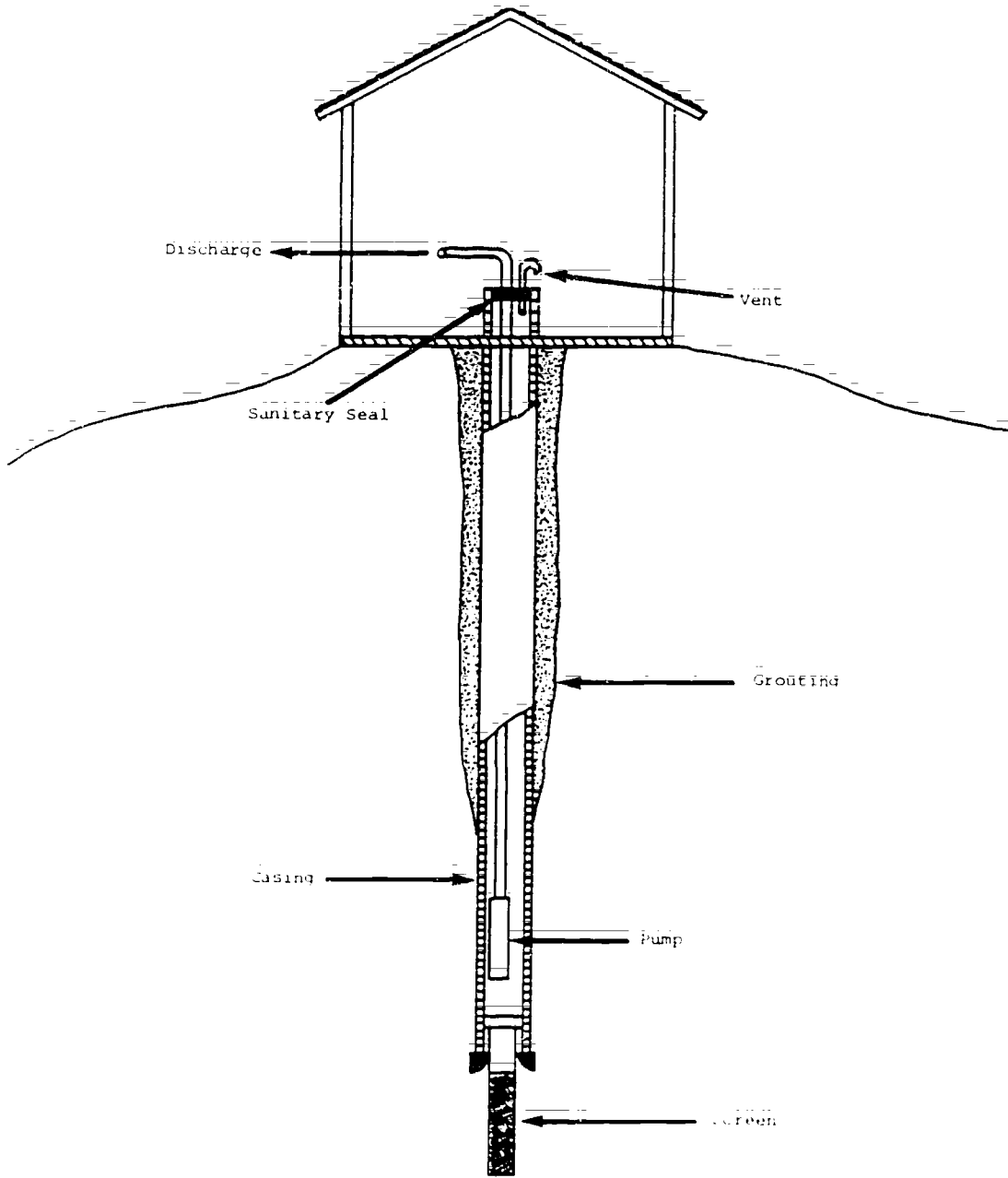

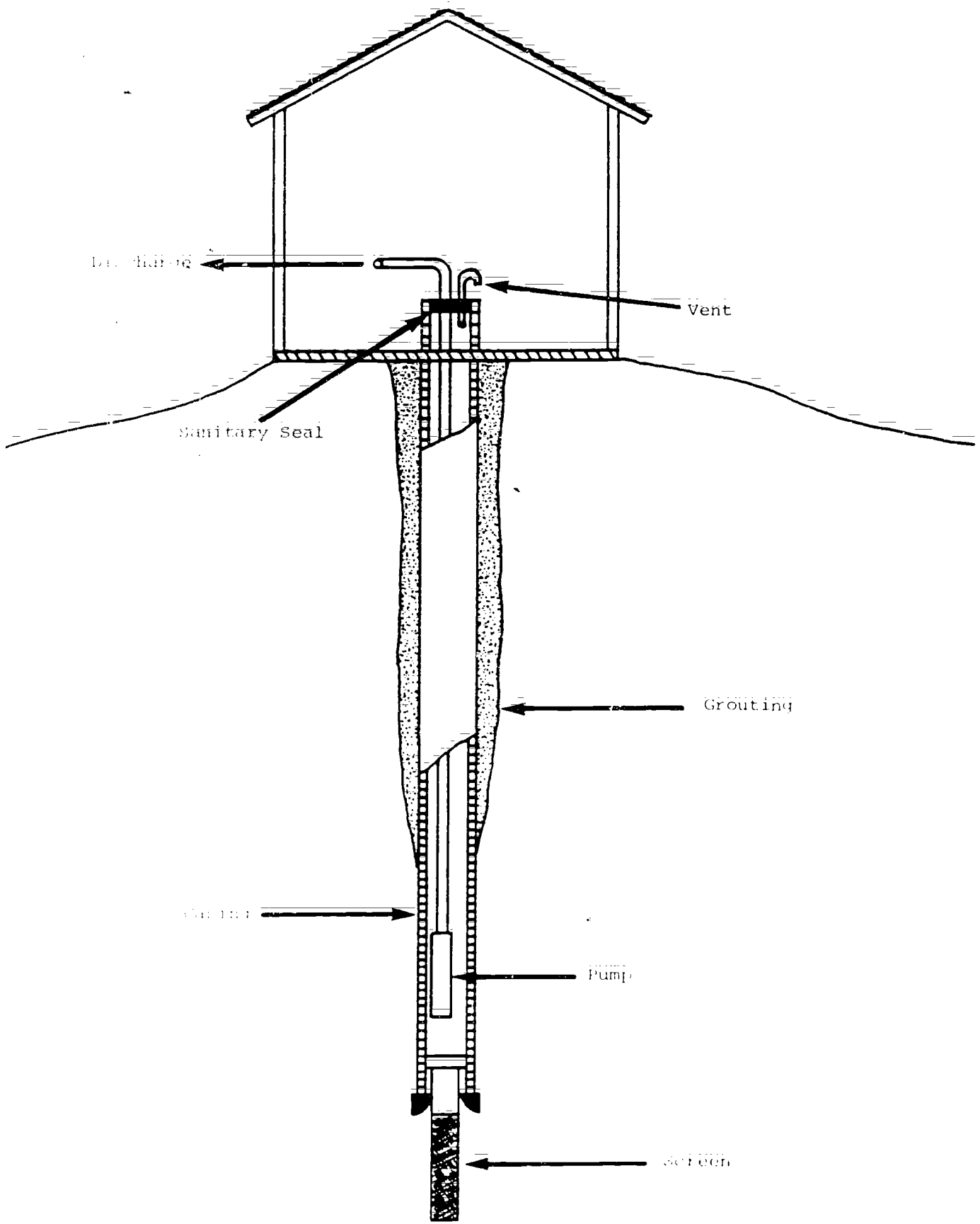

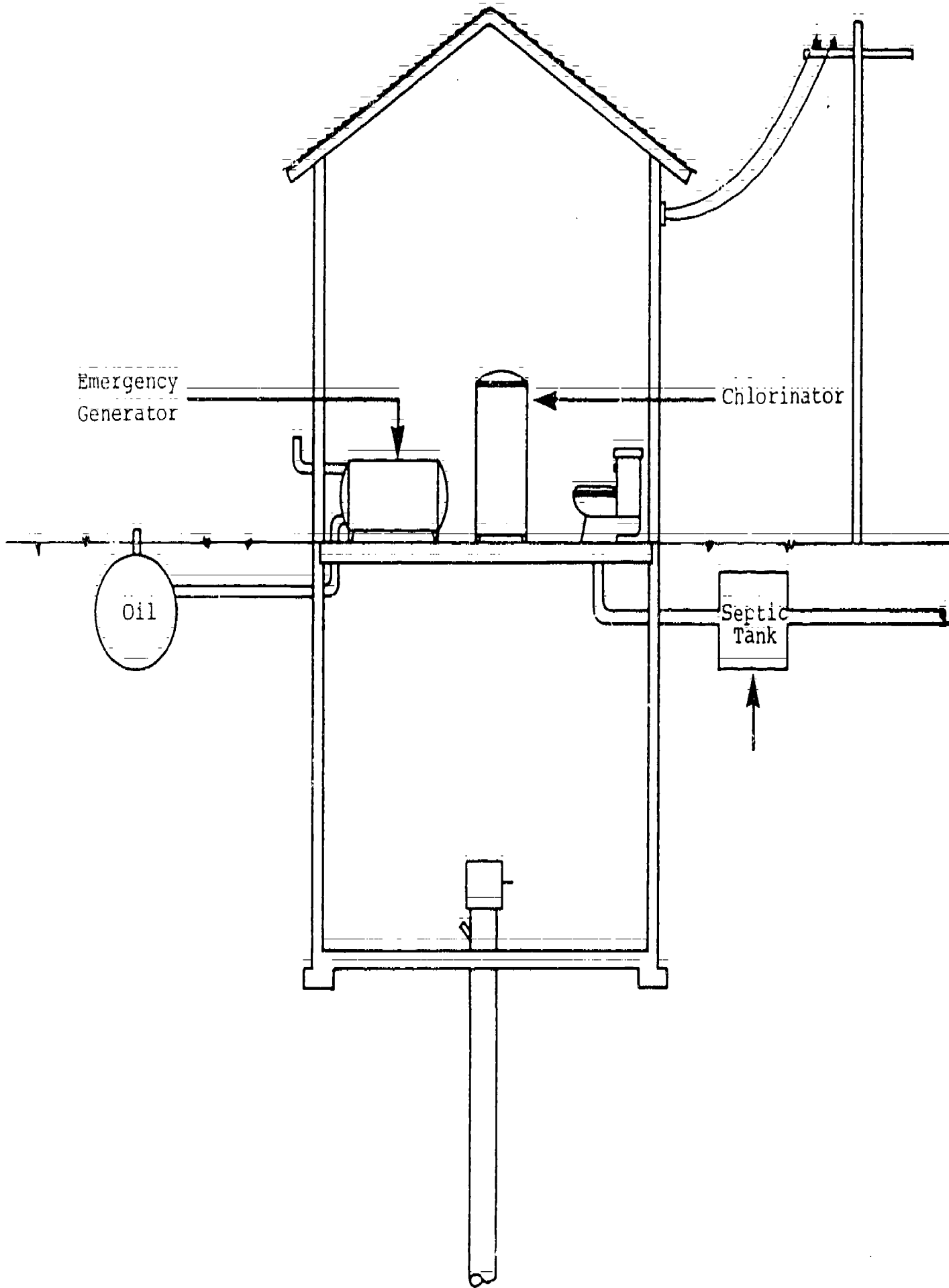

3-27

TRANSPARENCY 3-9

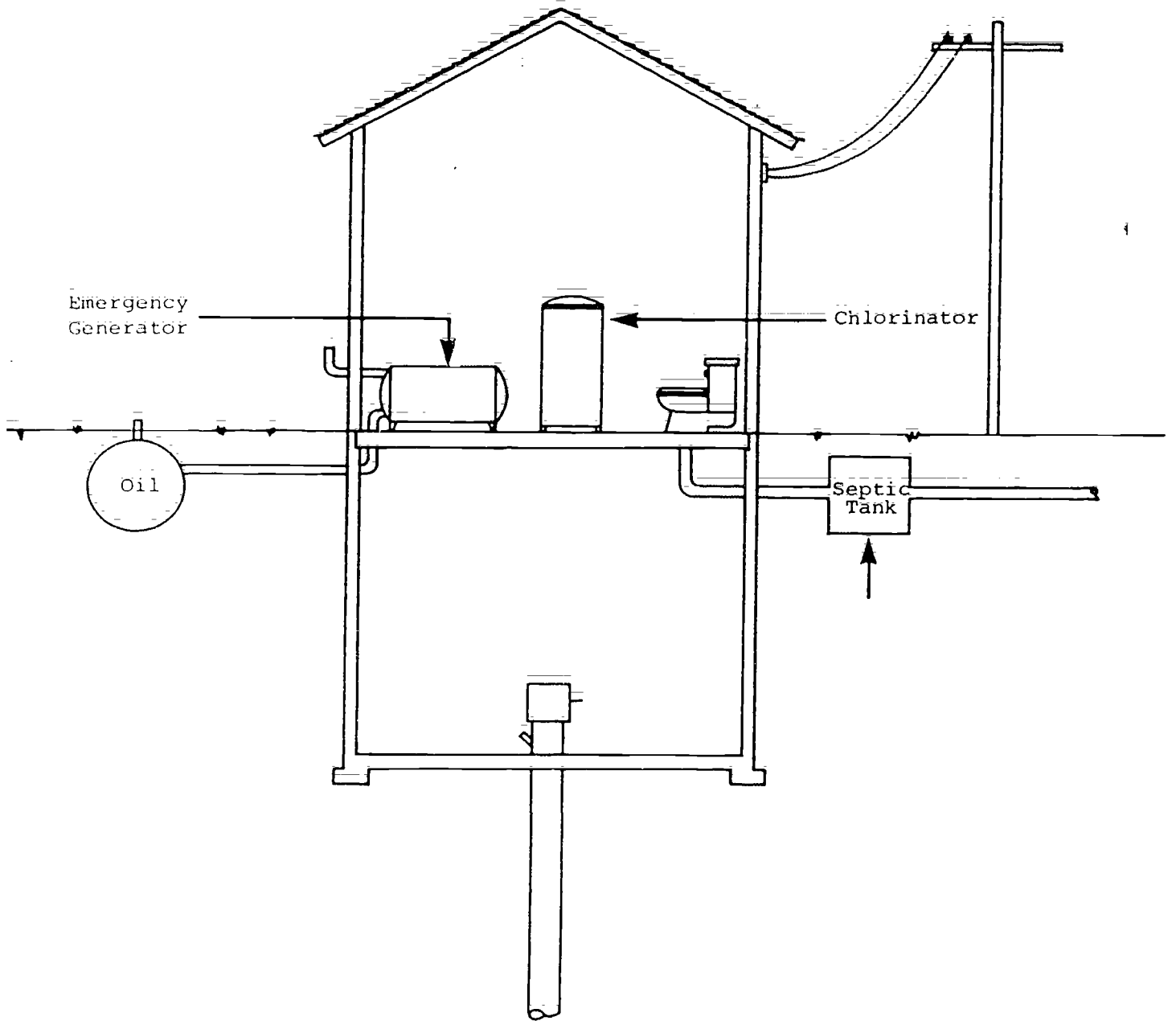

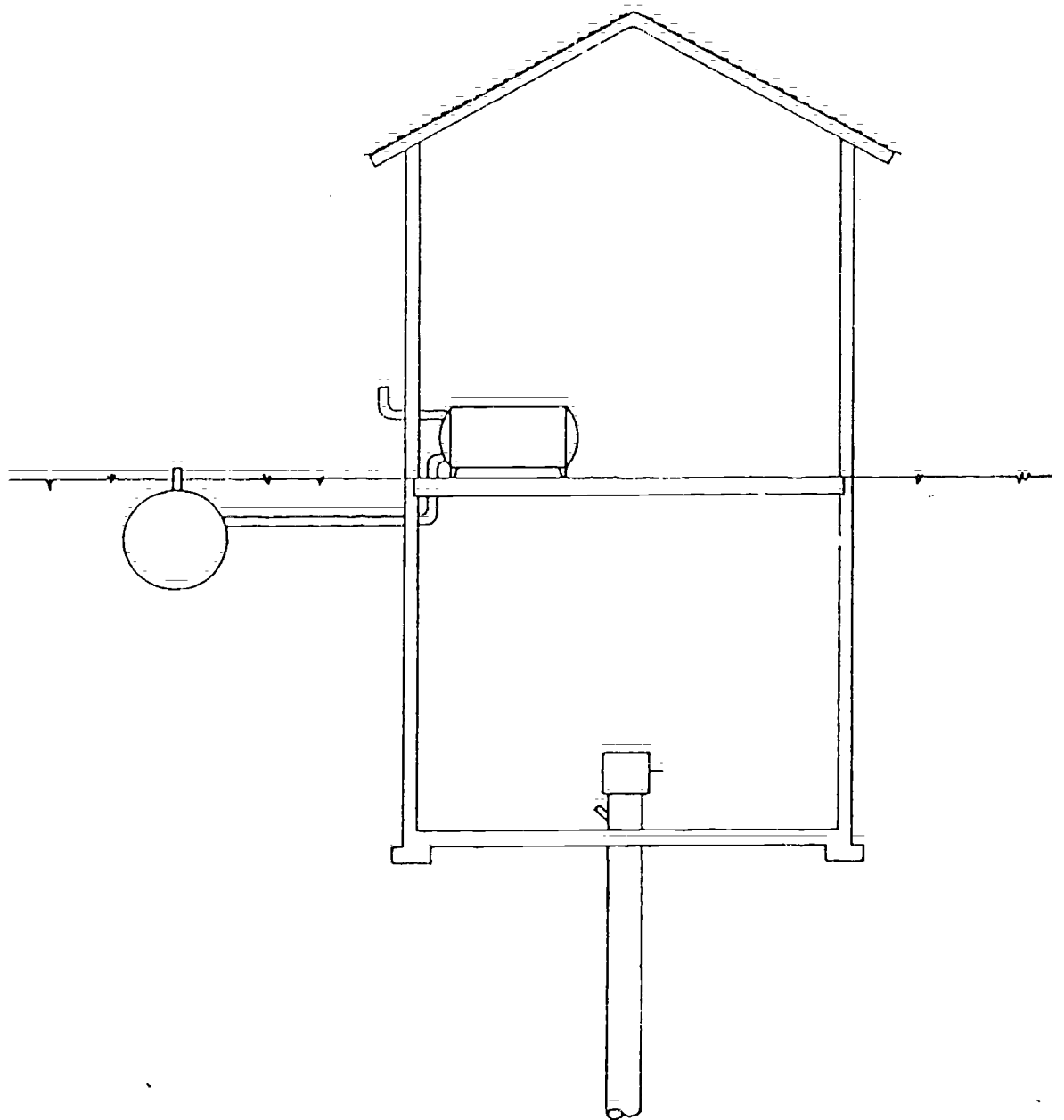

3-28

TRANSPARENCY 3-10

146

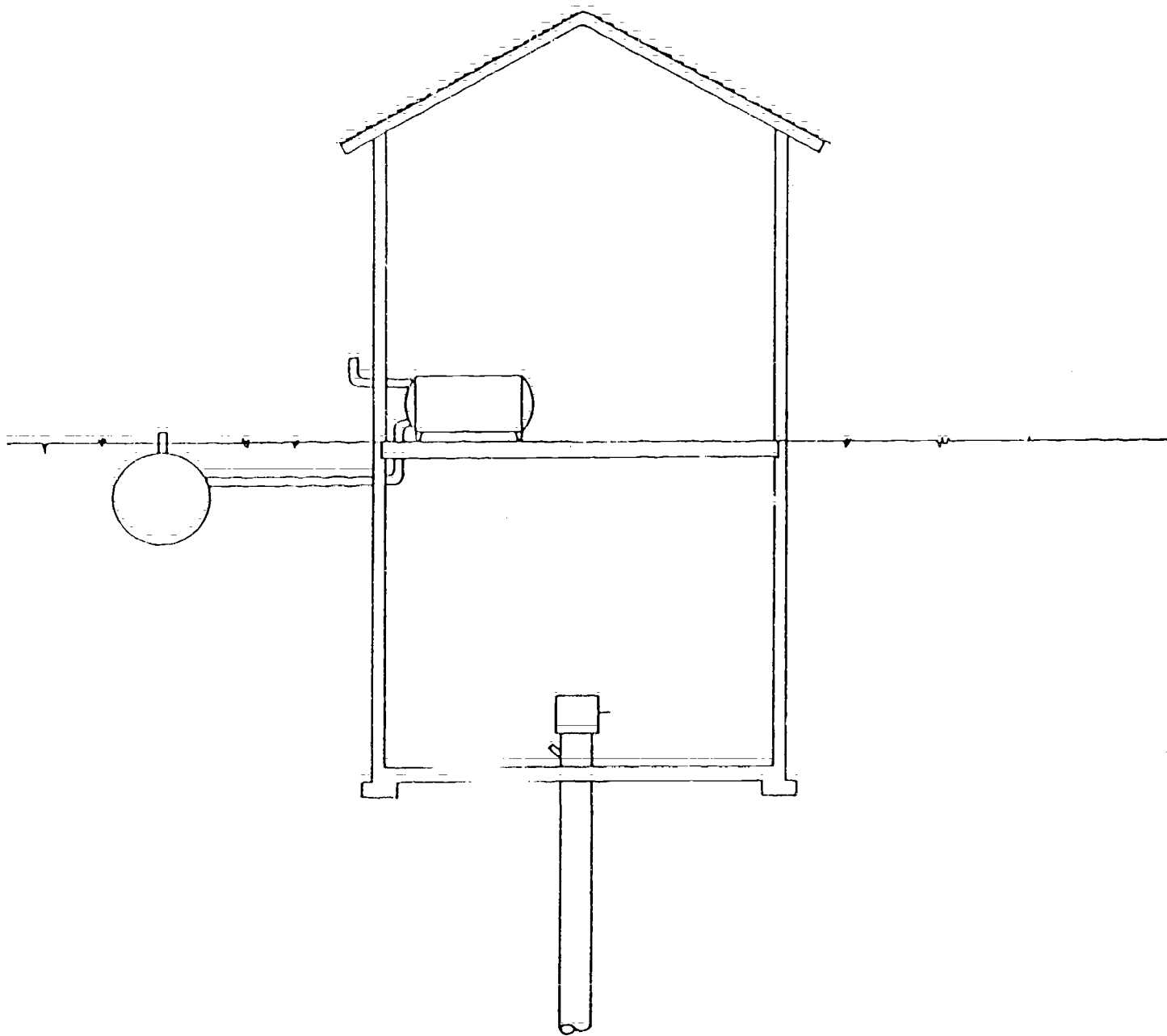

147

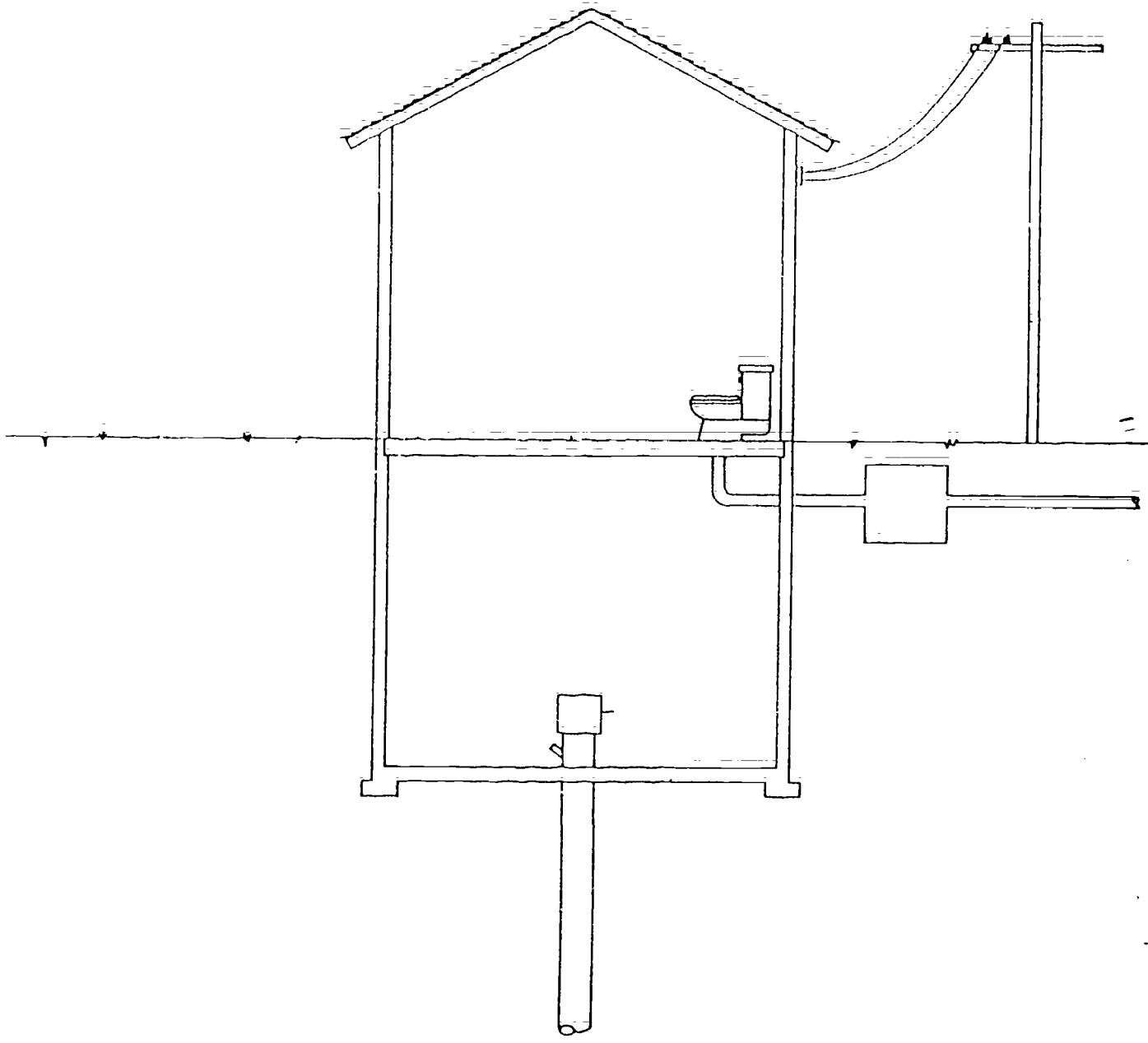

148

3-29

FRANSOUBENY 2-11

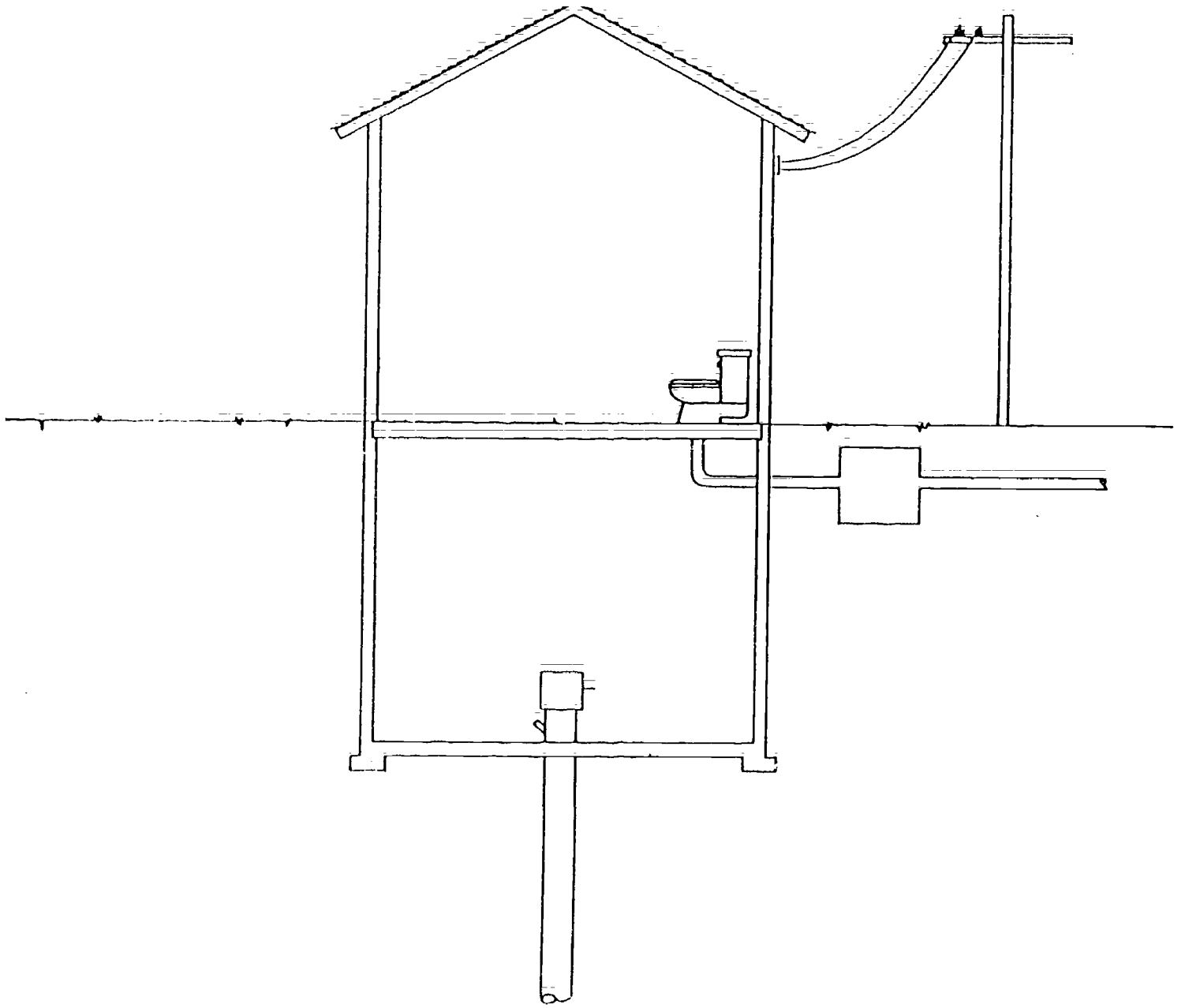

Springs

3-30

TRANSDUCTION 2-17

150

Springs

151

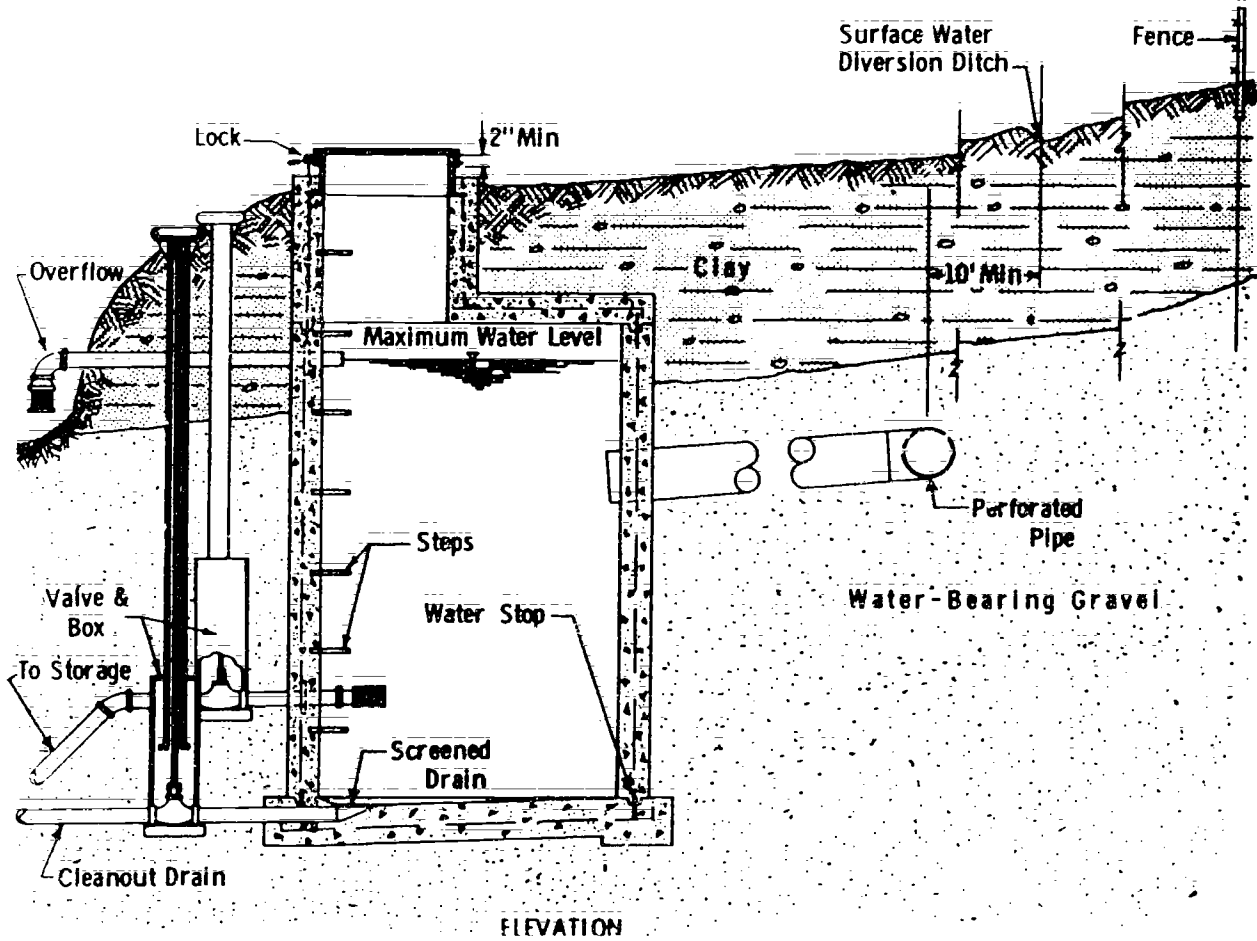

ELEVATION

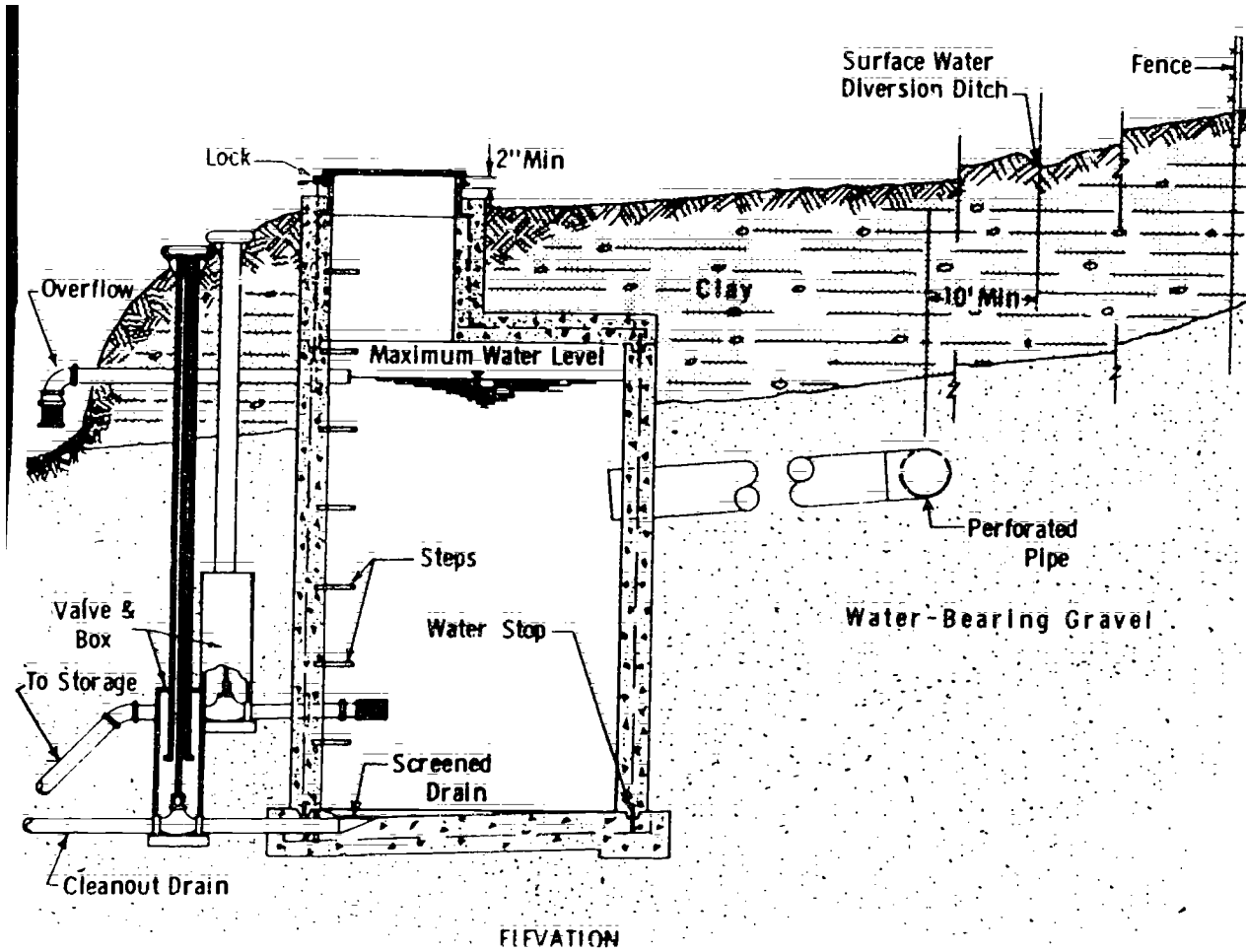

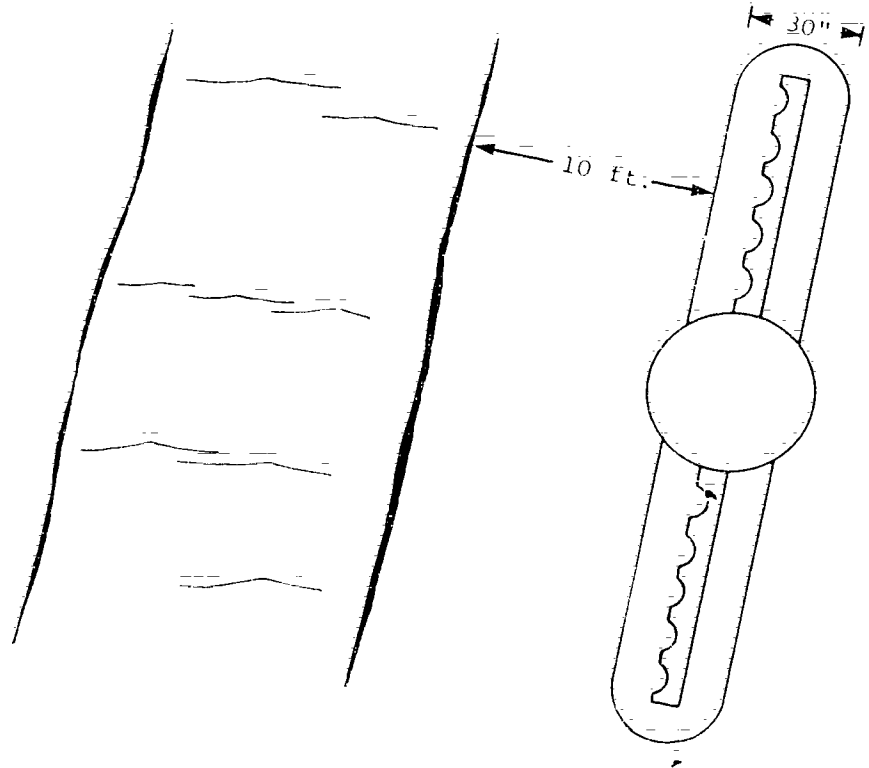

Infiltration Gallery

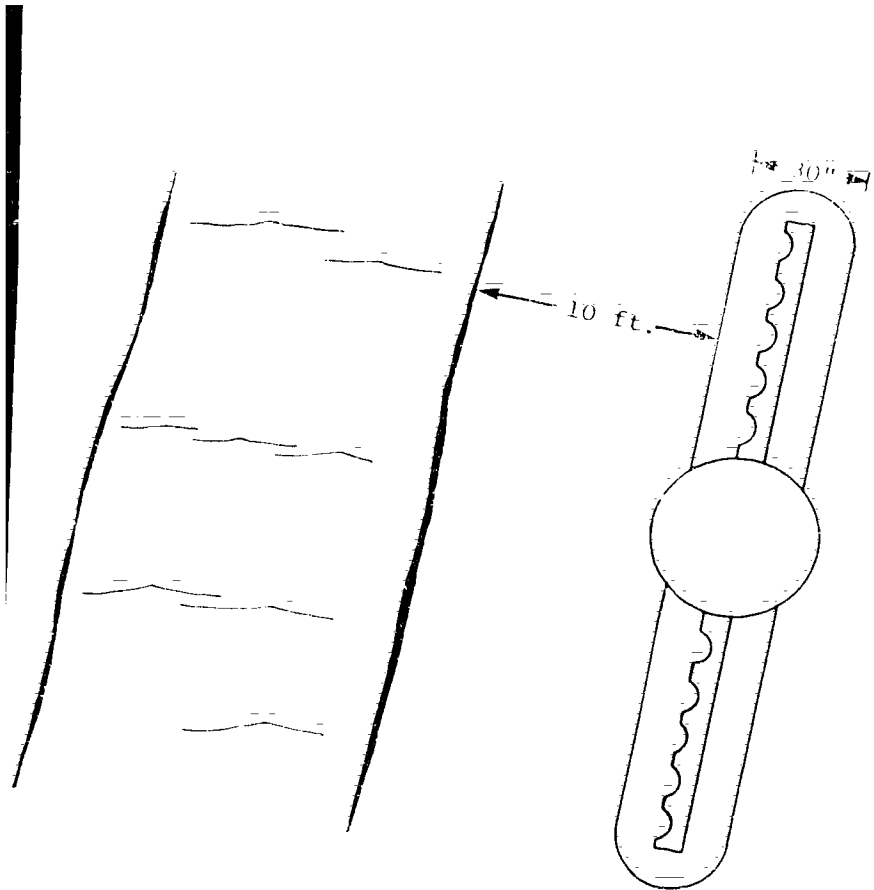

Infiltration Gallery

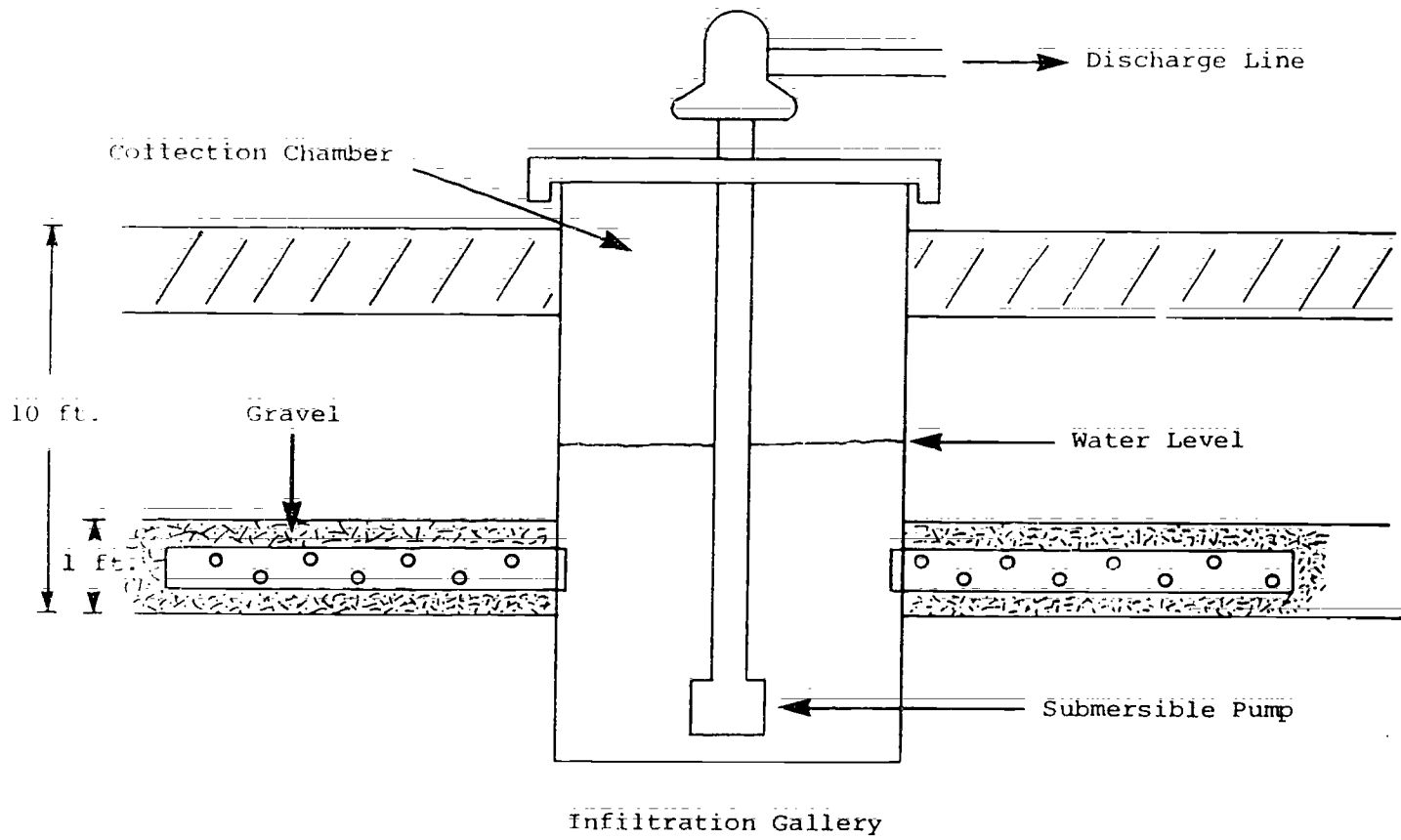

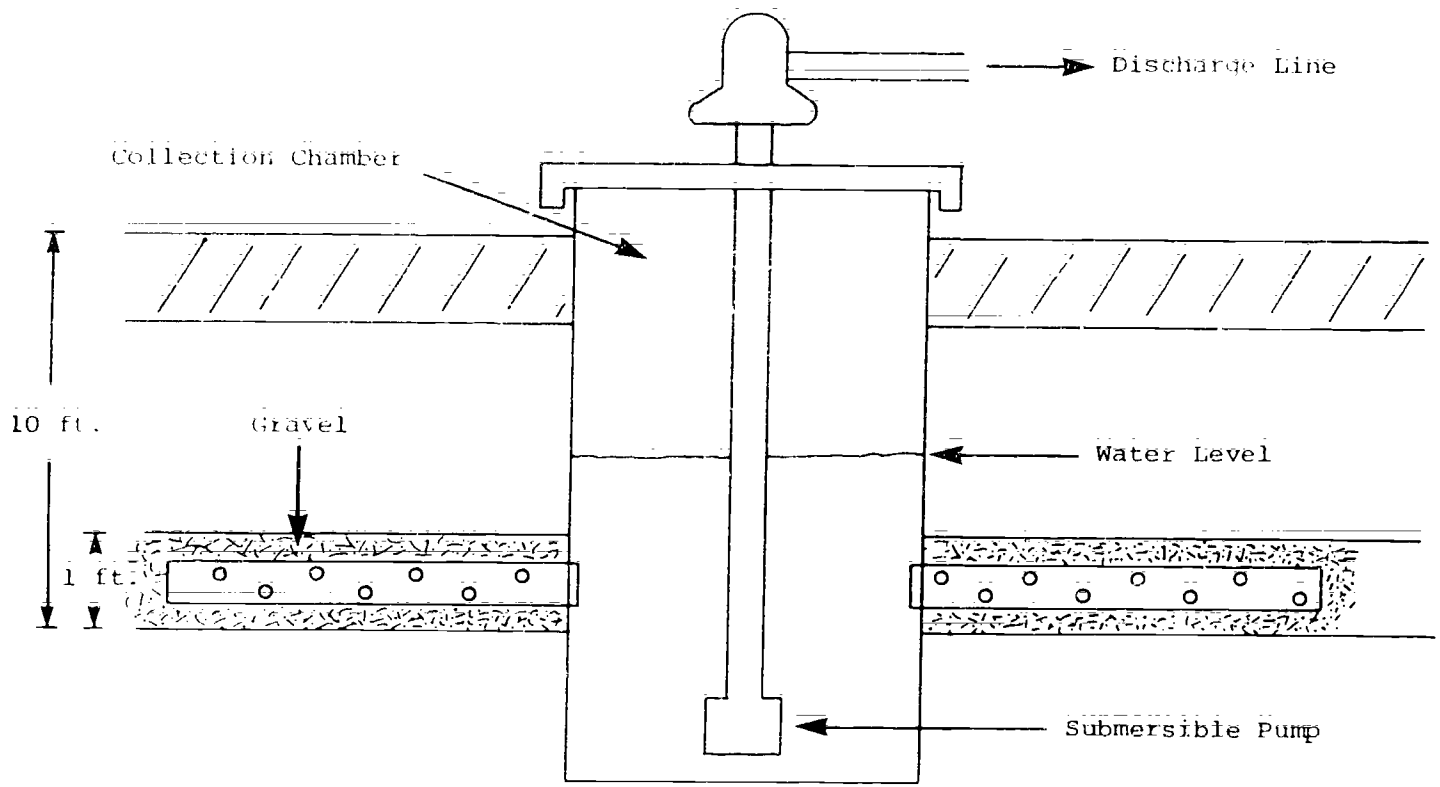

Infiltration Gallery

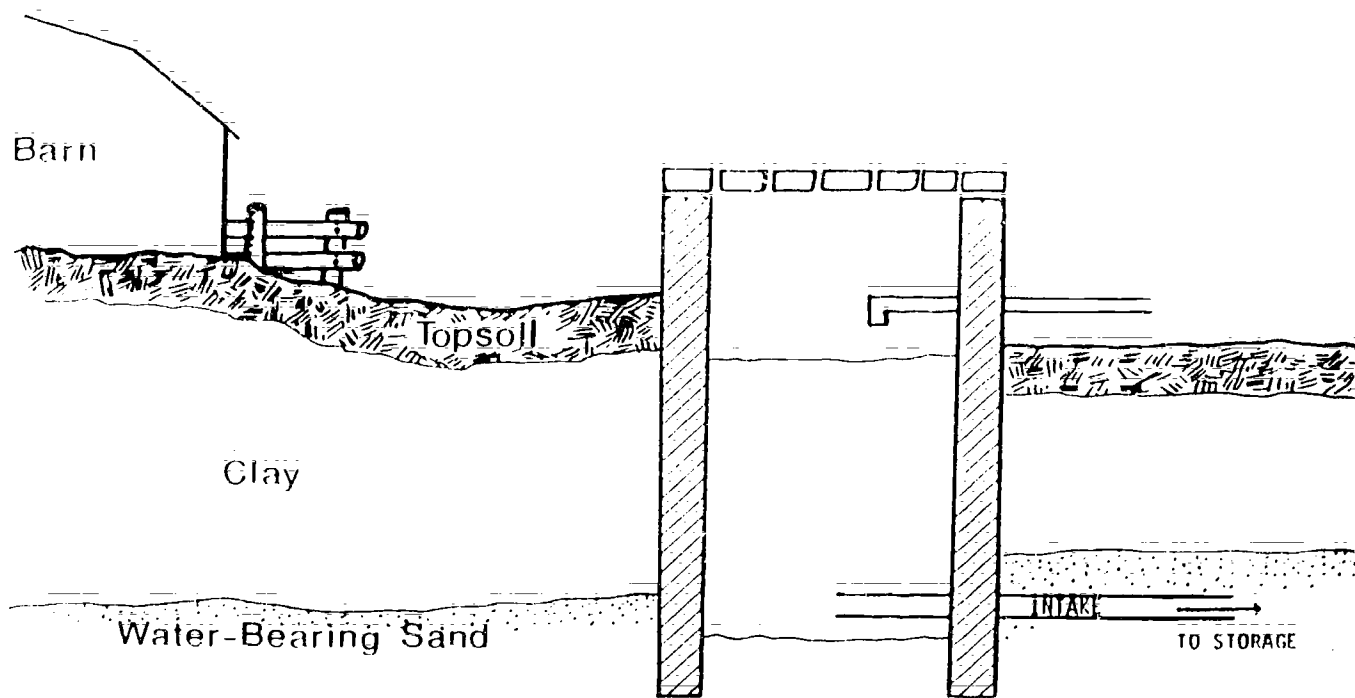

Identify Deficiencies

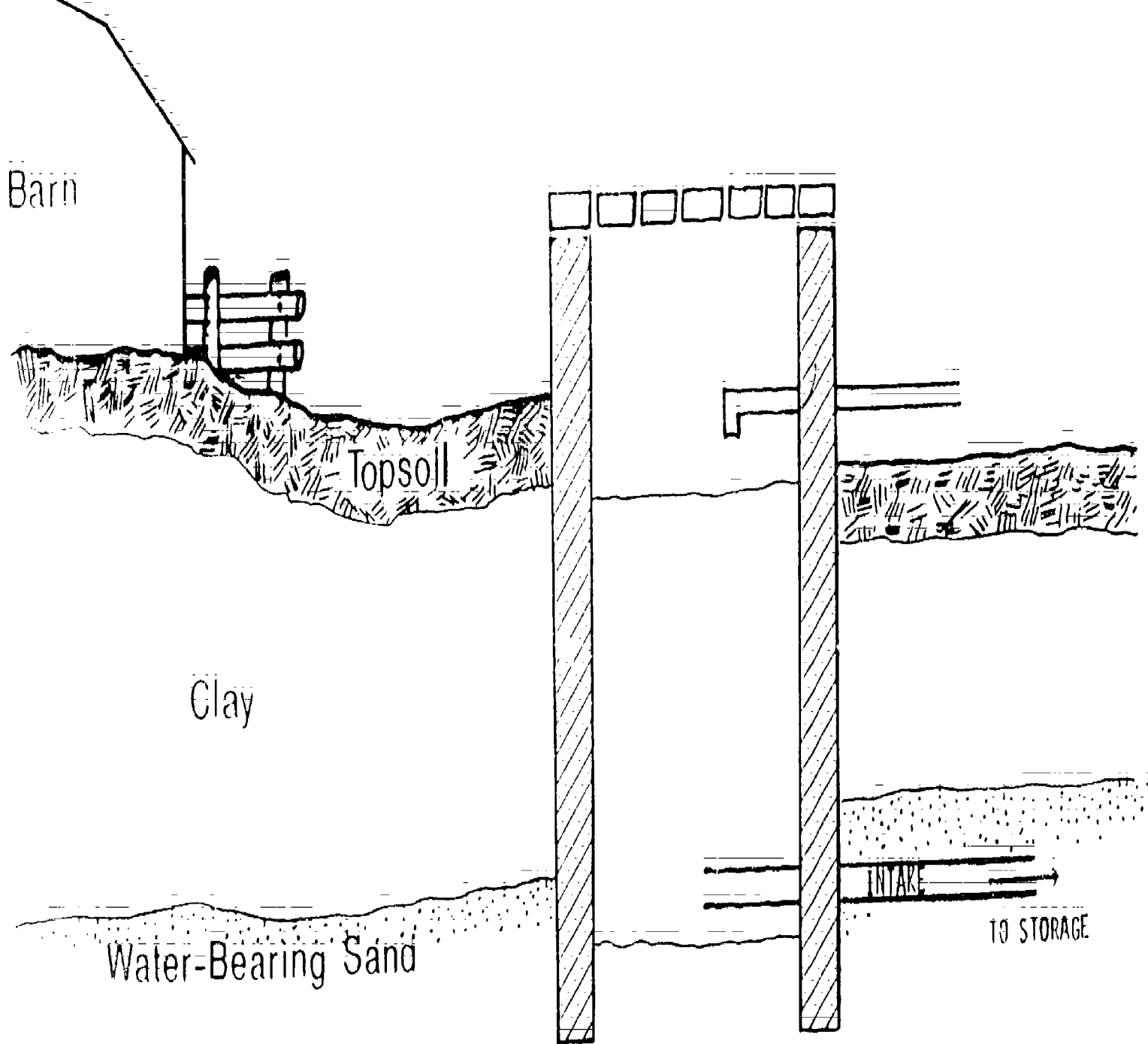

Identify Deficiencies

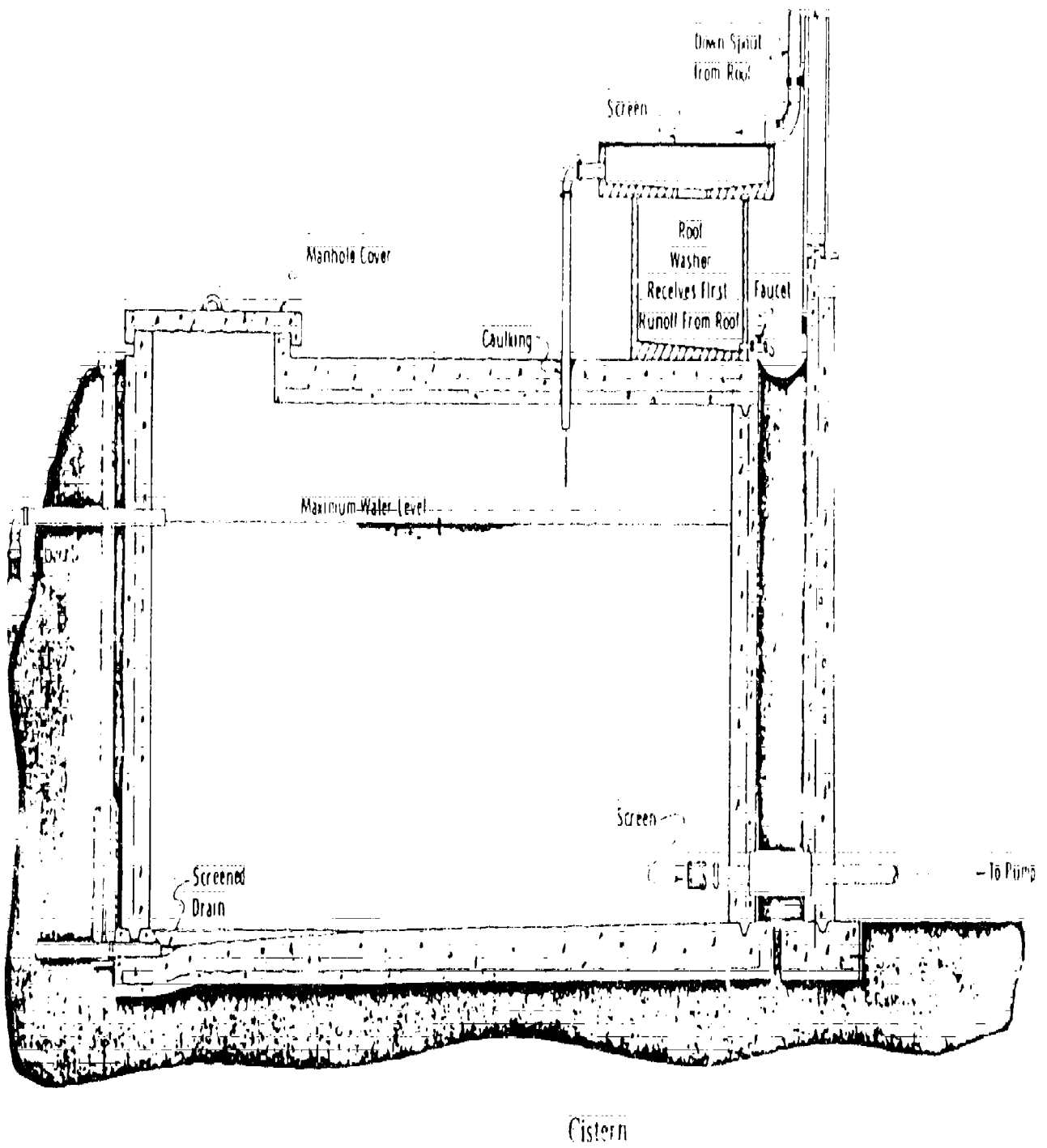

13-135

TRANSPARENCY 3-117

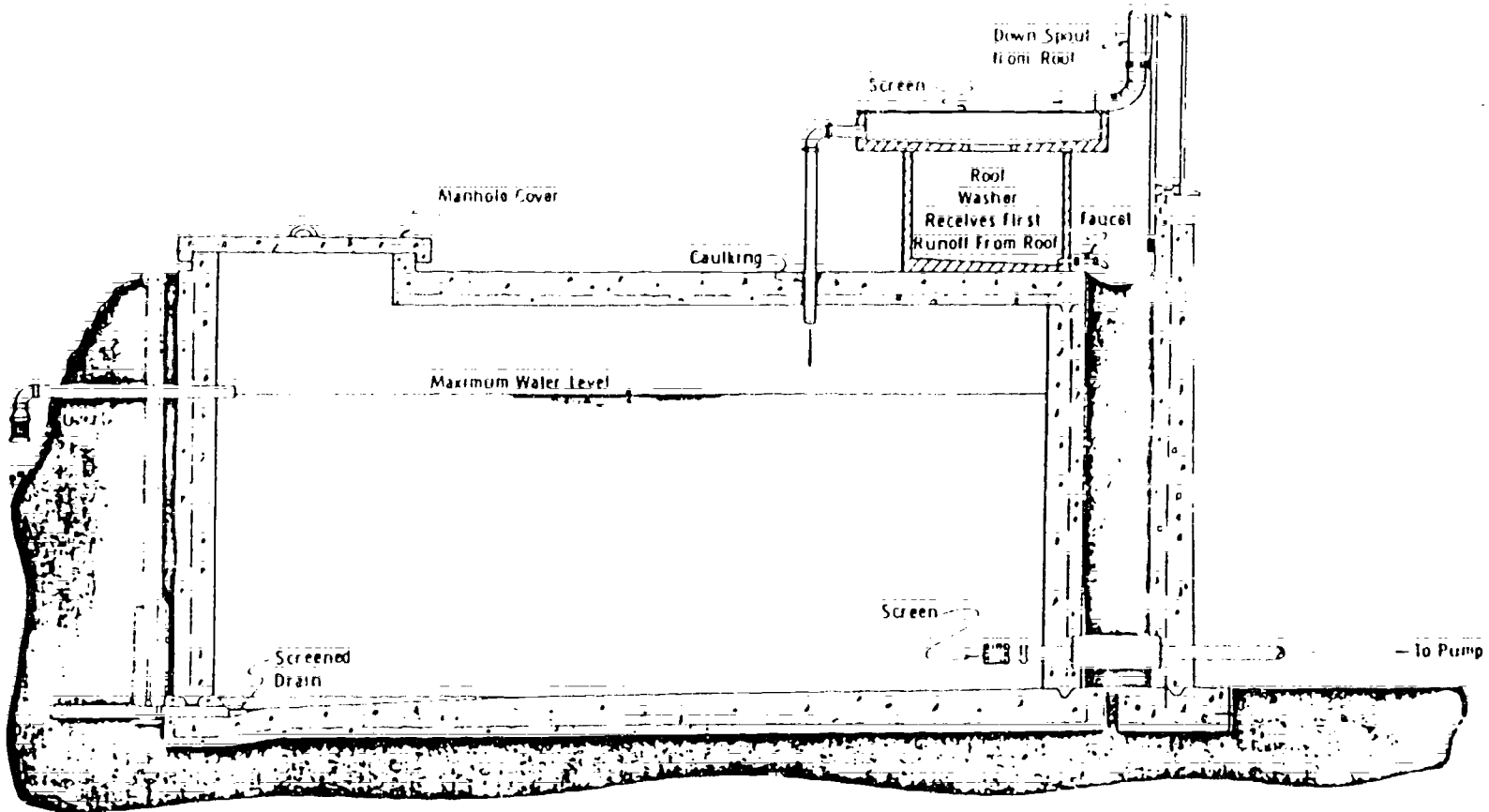

Cistern

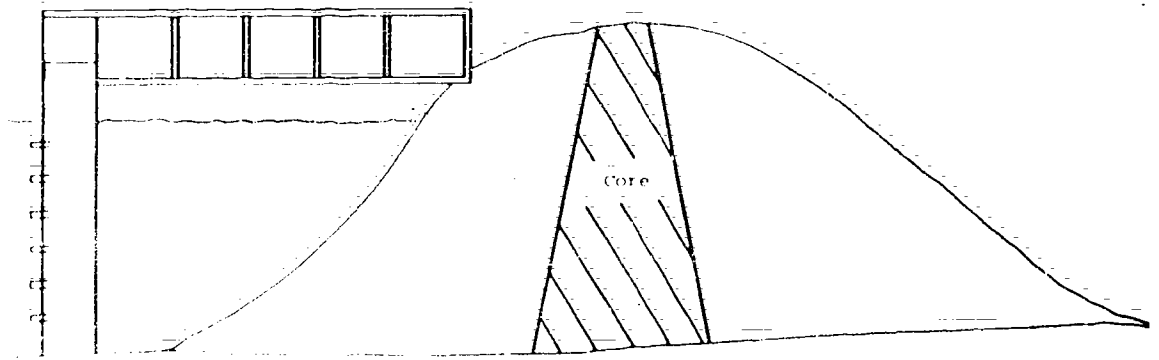

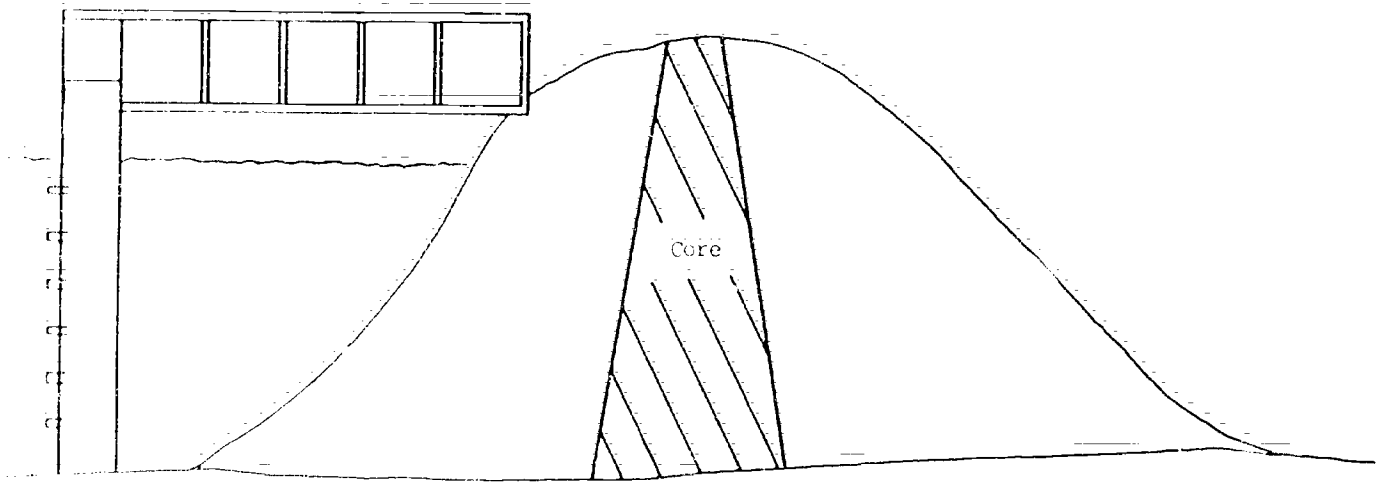

UNIT 4: PUMP FACILITIES - "THE NEED TO KNOW"

Unit Summary

Types of Pumps
Sanitary Risks

Unit Objectives

The adequacy of pumps and pump operation is an important factor in maintaining the sanitary integrity of a water system.

By the end of the unit the student should know:

1. Where pumps are commonly found in water systems
 2. What sanitary risks are involved with pumps and how to identify them
-

Logistics

Approximate Presentation Time: 45 minutes

Instructor Materials

- o Basic material
- o Transparency 4-1
- o Chalkboard

Student Materials

- o Student's Text, Unit 4

Student Preparation

- o Unit 4 should be read prior to the session.

Unit References

- o Manual of Instruction for Water Treatment Plant Operators (Chapter 19)
- o Environmental Engineering and Sanitation (Chapter 3)
- o Well Drilling Operations
- o Operation of Water Supply and Treatment Facilities
- o Water Supply Engineering (Chapter 15)
- o Water Supply System Operation (Chapters 3 and 5)

Use Transparency 4-1.

Explain pumps:

- o Types
- o Construction features
- o Operation

Make rough sketches on chalkboard for explanation when appropriate:

Use questions to encourage discussion and present additional information.

Ask students to suggest a sanitary risk in each of the factors, and a means of ensuring against the risk.

Make rough sketches on chalkboard for explanation when appropriate:

Use personal experiences and anecdotes to relate the course material to actual situations an inspector may encounter during a survey.

Point out: what problems can occur from lubricants. Oil contamination, non-potable water as lubricant.

Major Types and Characteristics (10 minutes)

A.

- o Positive Displacement
- o Centrifugal
- o Jet
- o Rotary

B.

- o Shallow Well
- o Deep Well

See Table 4-1 for instructor review information.

1. What are the advantages and disadvantages of each type?
2. For what situation is each type best suited?

Sanitary Risks (10 minutes)

A. General

1. Number (include reserve, location, and type)
2. Rated Capacity
 - o When was pump last rated?
 - o Is pump metered?
3. Condition of equipment
 - o Are pumps operable?
 - o What is state of repair of pumps?
4. What type of lubricant is used?
5. Emergency power system
 - o What type?
 - o Frequency of function testing?
 - o Record of primary power failures?
 - o Automatic or manual switchover?
 - o Are backup pumps/motors provided?

B. Pumping Stations

1. Is all electro/mechanical rotating equipment provided with protective guards?

Point out the importance of each of these items.

2. Are controls functioning properly and adequately protected?
3. Are underground compartments and suction wells waterproof?
4. Are permanently mounted ladders sound and firmly anchored?
5. Is facility properly protected against trespassing and vandalism?
 - o Vandalism
 - o Animals
 - o Flooding

Table 4-1. Types and Characteristics of Pumps

Type of Pump	Practical Suction Lift	Usual Well-Pumping Depth	Usual Pressure Heads	Advantages	Disadvantages	Remarks
Reciprocating 1 Shallow well 2 Deep well	22-25 ft. 22-25 ft.	22-25 ft. Up to 600 ft.	100-200 ft. Up to 600 ft. above cylinder.	<ul style="list-style-type: none"> • Positive action. • Discharge against variable heads. • Pumps water containing sand and silt. • Especially adapted to low capacity and high lifts. 	<ul style="list-style-type: none"> • Pulsating discharge. • Subject to vibration and noise. • Maintenance cost may be high. • May cause destructive pressure if operated against closed valve. 	<ul style="list-style-type: none"> • Best suited for capacities of 5-25 gpm against moderate to high heads. • Adaptable to hard operation. • Can be installed in very small diameter wells (2' casing). • Pump must be set directly over well (deep wells).
Centrifugal 1 Shallow well a) Straight centrifugal (single stage)	20 ft. max.	10-20 ft.	100-150 ft.	<ul style="list-style-type: none"> • Smooth, even flow. • Pumps water containing sand and silt. • Pressure on system is even and free from shock. • Low starting torque. • Usually reliable and good service life. <p>*****</p>	<ul style="list-style-type: none"> • Loses prime easily. • Efficiency depends on operating under design heads and speed. 	<ul style="list-style-type: none"> • Very efficient pump for capacities above 60 gpm and heads up to about 150 ft.
b) Repetitive vane turbine type (single stage)	28 ft. max.	28 ft.	100-200 ft.	<ul style="list-style-type: none"> • Same as straight centrifugal except not suitable for pumping water containing sand or silt. • They are self priming. <p>*****</p>	<ul style="list-style-type: none"> • Same as straight centrifugal except maintains priming easily. 	<ul style="list-style-type: none"> • Reduction in pressure with increased capacity not as severe as straight centrifugal.
2 Deep well a) Vertical line shaft turbine (multistage)	Impellers submerged	50-800 ft.	100-800 ft.	<ul style="list-style-type: none"> • Same as shallow well turbine. • All electrical components are accessible; above ground. 	<ul style="list-style-type: none"> • Efficiency depends on operating under design head and speed. • Requires straight well large enough for turbine bowls and housing. • Lubrication and alignment of shaft critical. 	

Table 4-1 (Continued)

Type of Pump	Practical Suction Lift	Usual Well-Pumping Depths	Usual Pressure Heads	Advantages	Disadvantages	Remarks
Centrifugal (cont.) b) Submersible turbine (multistage)	Pump and motor submerged.	50-400 ft.	50-400 ft.	<ul style="list-style-type: none"> Same as shallow well turbine. Easy to frost-proof. Short pump shaft to motor. Quiet operation. Well straightness not critical. 	<ul style="list-style-type: none"> Abrasion from sand. Repair to motor or pump requires pulling from well. Sealing of electrical equipment from water vapor critical. Abrasion from sand. 	<ul style="list-style-type: none"> 3500 RPM models, while popular because of smaller diameters or greater capacities, are more vulnerable to wear and failure from sand and other causes.
Jet: 1 Shallow well.....	15-20 ft. below ejector.	Up to 15-20 ft. below ejector.	80-150 ft.	<ul style="list-style-type: none"> High capacity at low heads. Simple in operation. Does not have to be installed over the well. No moving parts in this well. 	<ul style="list-style-type: none"> Capacity reduces as lift increases. Air in suction or return line will stop pumping. 	
2 Deep well.....	15-20 ft. below ejector.	25-120 ft. 200 ft. max.	80-150 ft.	<ul style="list-style-type: none"> Same as shallow well jet. Well straightness not critical. 	<ul style="list-style-type: none"> Same as shallow well jet. Lower efficiency, especially at greater lifts. 	<ul style="list-style-type: none"> The amount of water returned to ejector with increased lift - 50% of total water pumped at 50-ft. lift and 75% at 100-ft. lift.
Rotary: 1 Shallow well..... (gear type)	22 ft.	22 ft.	50-250 ft.	<ul style="list-style-type: none"> Positive action. Discharge constant under variable heads. Efficient operation. 	<ul style="list-style-type: none"> Subject to rapid wear if water contains sand or silt. Wear of gears reduces efficiency. 	
2 Deep well..... (helical rotary type)	Usually submerged.	50-500 ft.	100-500 ft.	<ul style="list-style-type: none"> Same as shallow well rotary. Only one moving pump device in well. 	<ul style="list-style-type: none"> Same as shallow well rotary except no gear wear. 	<ul style="list-style-type: none"> A cutless rubber stator increases life of pump. Flexible drive coupling has been weak point in pump. Best adapted for low capacity and high heads.

Types of Pumps

Positive Displacement Pumps. The positive displacement pump forces or displaces the water through a pumping mechanism. There are several types: reciprocating pumps; helical or spiral rotor; regenerative turbine pumps; and diaphragm pumps.

Centrifugal Pumps. Centrifugal pumps contain a rotating impeller mounted on a shaft turned by the power source. The rotating impeller increases the velocity of the water and discharges it into a surrounding casing shaped to slow down the flow of the water and convert the velocity to pressure. This decrease of the flow further increases the pressure.

Jet (Ejector) Pumps. Jet pumps are actually combined centrifugal and ejector pumps. A portion of the discharged water from the centrifugal pump is diverted through a nozzle and venturi tube. A pressure zone lower than that of the surrounding area exists in the venturi tube; therefore, water from the source (well) flows into this area of reduced pressure. The velocity of the water from the nozzle pushes it through the pipe toward the surface where the centrifugal pump can lift it by suction. The centrifugal pump then forces it into the distribution system.

Rotary Pumps. In the rotary pumps there are two cams or gears that mesh together and rotate in opposite directions. The gear teeth or cams fit closely to the casing so that the water will be drawn up the suction pipe and forced into the discharge pipe. Such pumps require no valves and are self-priming. They are positive displacement. They can be operated at high speeds and so obtain large capacity with small size. They have the disadvantage of showing considerable slip. Water containing grit is especially injurious to them.

Sanitary Risks

1. What is the number (including reserves) and location of pumps?

At least two pumping units should be provided (for both chemical feed and water applications of pumps). Pumps may be used for a variety of reasons within the system: raw water, chemical feed, finished water, and solids movement. The type of pump is important to assure proper application. For example, positive displacement-type solution pumps should be used to feed liquid chemicals but not to feed chemical slurries. The operator and a review of the plant schematic can provide this information.

2. What is the rated capacity of the pumps?

Pumps should have ample capacity to supply the peak demands with dangerous overload. The inspector should also ask when the pump was last rated. This is particularly important when the pumping time is used to estimate water production. The pump may have been rated 10 years ago for 200 gpm, but due to changes in the pump and system is

presently only pumping 125 gpm. The inspector should also note if the pump is metered. This can help the operator detect changes in the system and take corrective action before a serious problem develops.

3. What is the condition of the equipment?

The pumps should be operable! No benefit is provided the system when only one of its three raw water pumps is functional. The inspector should note the state of repair. Although packing gland seals require a constant drip of water, it should not be an excessive spray. The pumps should not be overgreased or overoiled. Excessive noise and vibration, particularly of centrifugal pumps, would indicate problems. Note the condition of the room; if it's dirty, operation cannot be satisfactory. Dirt will get into the lubricants and shorten the life of the bearings.

4. What type of lubricant is used?

In the case of well pumps, this is particularly important since oil contamination of the aquifer is possible from improperly maintained submersible pumps. In the case of water-lubricated pumps, the possibility of cross-connection exists.

5. Is the emergency power/backup system provided?

Emergency power is necessary for continuous operation of the water system. This may be provided by an auxiliary generator or by directly connected engines. The inspector should note how emergency power is provided, how frequently it is tested, and whether there is automatic or manual switchover. This inspector should also be concerned with the number of primary power failures. Availability of replacement pumps, motors, and critical parts should also be evaluated.

6. Are all electro/mechanical rotating equipment provided with protective guards?

The inspector should not only be concerned with the sanitary aspects of the equipment but safety as well. The inspector should check to see that belts, gears, rotating shafts, and electrical wiring are properly shielded to prevent injury.

7. Are controls functioning properly and adequately protected?

All controls should be functional. Jerry-rigging of controls presents both an electrical hazard and risk of failure of the pump.

8. Are underground compartments and suction wells waterproof?

Pump stations should be waterproofed to prevent flooding of the pump room. The suction wells should be protected to prevent entrance of undesirable water into the compartment either through the walls or surface water.

9. Are permanently mounted ladders sound and firmly anchored?

As previously stated, the inspector should be concerned with safety. This concern is not only for the operator's sake but for the inspector's own preservation. The inspector should follow safety procedures and inform the operator of unsafe conditions or acts (e.g., entering a confined space that is not properly ventilated).

10. Is the facility properly protected?

The site should be properly protected against fire, flood, vandalism, and other hazards. The location should be a minimum of one foot above the highest flood elevation. Runoff should drain away from the pumping station. Pumping facilities should be protected against vandalism and unauthorized entry by animals or people.

Pumps

4-6

BRANDENBURG 4-1

175

Pumps

176

UNIT 5: WATER TREATMENT - "THE NEED TO KNOW"

Unit Summary

Treatment Processes
Sanitary Risks

Unit Objectives

Treatment of water is often necessary to assure that water quality meets applicable standards. It is necessary for the surveyor to understand proper treatment for water quality problems. This unit provides a brief overview of treatment and sanitary risks.

Logistics

Approximate Presentation Time: 75 minutes

Instructor Materials

- o Basic Material
- o Transparencies 5-1 to 5-8
- o Chalkboard

Student Materials

- o Student's Text, Unit 5

Student Preparation

- o Unit 5 should be read prior to the session.
- o Scan Table 5-1.

Unit References

- o Small Water Systems Serving the Public (Chapters 9 and 10)
- o Manual of Instruction for Water Treatment Plant Operators (Chapters 5-15)
- o Manual of Water Utility Operations (Chapters 7-11)
- o Water Treatment Plant Operations (Volume 1 Chapters 4-9 and 11)
- o Manual of Water Treatment Techniques for Interim Primary Drinking Water Treatment (Chapters 1-3)
- o Water Treatment Plant System Operation (Chapter 4)

5-1

Use Transparency 5-1.

Draw a typical treatment process schematic on the chalkboard (see example).

Define each of the activities involved in water treatment.

Indicate on the diagram the activity point and the treatment process(es) involved.

Use questions to promote discussion and present additional information.

State that this section is only to assist the student in identification of sanitary risks. For a detailed discussion of a particular process, they will have to consult other references or programs.

Use Transparencies 5-2 and 5-3.

Suggest that students draw a schematic of plants when inspecting.

Briefly point out that application point and amount of chlorine addition can impact on TTHM generated.

Treatment Processes (10 Minutes)

Pretreatment - generally for removal of taste and odors.

Coagulation/Flocculation - treatment with certain chemicals for collecting nonsettleable particles into larger or other fine-grained materials to remove particulate matter too light or too finely divided for removal by sedimentation.

Sedimentation - removal of suspended matter.

Filtration - the process of passing a liquid through a filtering media for removal of suspended or colloidal matter usually of a type that cannot be removed by sedimentation.

Disinfection - destroying pathogenic organisms with chlorine, certain chlorine compounds, or other means.

1. How can effectiveness of treatment process(s) be determined?
2. What records would be helpful in making this determination?

Sanitary Risks (65 minutes)

A. Prechlorination/Pretreatment
(10 minutes)

1. What chemical is used?
2. What amount is used?
 - o Discuss commonly used chemicals/processes for pretreatment.
 - Chlorine, chlorine dioxide, ozone, potassium permanganate activated carbon
3. For prechlorination, has TTHM been evaluated?
4. What is point of application?
 - o Improper application
5. Is proper mixing achieved?
 - o Short circuiting
6. What other pretreatment is provided?

Final Report
Final Report
Final Report
Final Report
Final Report
Final Report
Final Report
Final Report
Final Report
Final Report

Final personal experiences
and anecdotes to relate
course material to
actual situations an
inspector may encounter
during a sanitary
survey.

Final Report
Final Report

Chemical Feed (10 minutes)

1. What chemical is used?
2. Where is it applied?
3. Stress that it will assist surveyor
to make a schematic diagram of
and chemical addition points.
4. What is a chemical feed equipment?
5. Are instrumentation and controls for
the process adequate, operational,
and being utilized?
 - o The operator's answers to questions
about process controls and equip-
ment will give inspector insight
into the operator's competency.
6. Is chemical storage adequate and
safe?
7. Are adequate safety devices avail-
able and precautions observed (dust
mask, safety goggles, gloves, pro-
tective clothing)?
 - o Emphasize the importance of the
surveyor observing correct safety
procedures while inspecting.

Mixing (10 minutes)

1. Is mixing adequate based on visual
observation?
 - o Problems with short circuiting
2. Is equipment operated properly and in
good repair?

Flocculation/Sedimentation (5 minutes)

1. Is process adequate based on visual
observation?
 - o Good floc formation
 - o No floc carryover from sedimentation
2. Is equipment operated properly and in
good repair?

Transparency 5-6:

Point out that inspector may wish to have operator forward filter.

These questions may be handled by other types of filters.

Transparency 5-7:

Explain that inspector should not only be concerned with sanitary aspects of chlorination but safety as well.

Transparency 5-8.

Discuss use of coliform bacteria as indicator and sampling. Discuss importance of confluent growth and colonies too numerous to count.

Use personal experience or anecdotes to relate material to actual situations an inspector may encounter during a sanitary survey.

Discuss need to stop flow of water when changing cylinders on a one-cylinder system.

Filtration (5 minutes)

1. Is process adequately observed or observation?
2. Are instrumentation and controls for the process adequate, operational, and being utilized?
 - o Rate of flow controllers
 - o Head loss indicators
3. Is equipment operated properly and in good repair?
 - o Presence of mudballs, leaks
 - o Backwash
 - o Possibility of cross-connections

Post-Chlorination (20 minutes)

1. Is adequate chlorine residual being maintained?
 - o Describe types of residual and their importance.
 - Combined - slower acting disinfectant
 - Free - faster acting
 - Breakpoint chlorination
2. Is there sufficient contact time (30 minutes minimum) between the chlorination point and the point of use?
3. Is the disinfection equipment being operated and maintained properly?
 - o Describe importance of contact time.
 - o Problems with short circuiting
4. Is operational standby equipment provided? If not, are critical spare parts on hand?
 - o Emphasize importance of continuous chlorination.
5. Is a manifold provided to allow feeding from more than one cylinder?
 - o Allows continuous chlorination
6. Are scales provided for weighing of containers?
7. Are chlorine storage and use areas isolated from other work areas?

Emphasize the importance of a good working safety program.

Ask students to explain importance of safety measures.

8. Is room vented to the outdoors by exhaust grilles located not more than 6 inches above floor level?
o One complete air change per minute recommended
9. Are all doors hinged outward; equipped with panic bars; and at least one provided with a viewport?
10. Is self-contained breathing apparatus available for use during repair of leaks?
11. Is a means of leak detection provided?
o Use of dilute ammonium hydroxide or chlorine detection devices
12. Are all gas cylinders restrained by chaining to wall or by other means.

Other Treatment (5 minutes or more depending on instructor's discretion)

Explain that Table 5-1 is a general overview of treatment techniques to remove contaminants having various other common water quality problems.

The instructor should discuss other treatment processes present in the area, such as:

- Ozone Disinfection
- Ultraviolet Light Disinfection
- Ion Exchange
- Chloramine Disinfection
- Chlorine Dioxide Disinfection
- Carbon Adsorption
- Iodine Disinfection
- Reverse Osmosis

APPENDIX 1. Water Quality Problems and Treatment

Problem Parameter	Standard	Typical Treatment
1. Bacteria	See page 59 p-7	1. Disinfection filtration; disinfect settling; filtration disinfection
2. Suspended Solids	1 mg/l	2a. Filtration sand, diatomaceous earth 2b. Complete treatment chemical addition, coagulation settling; filtration
3. Iron	0.05 mg/l	3a. As^{+5} Alum or Iron coagulation Line softening 3b. As^{+3} oxidizing to As^{+5} treating as above
4. Hardness	1.0 mg/l	4. Line softening
5. Chloride	0.010 mg/l	5. Line softening
6. Sulfate	mg/l	6. Cr^{+3} a. Alum coagulation b. Iron coagulation c. Line softening Cr^{+6} d. Ferric chloride coagulant
7. Fluoride	0.4-2.0 mg/l	7. Ion exchange using activated alumina or bone char
8. Cyanide	0.1 mg/l	8a. Chlorine or ozone coagulation 8b. Alum coagulation
9. Lead	0.05 mg/l	9a. Sulfate 9b. Sulfate coagulation 9c. Alum coagulation 9d. Ion exchange
10. Mercury	0.001 mg/l	10. Ion exchange 11. Activated carbon

Table 5-1 (Continued)

Parameter	Standard	Typical Treatment
10. Nitrate	10 mg/l (N)	10. Ion Exchange
11. Selenium	0.01 mg/l	11. Se ⁺⁴ <ul style="list-style-type: none"> a. Ferric sulfate coagulation b. Reverse osmosis c. Ion exchange Se ⁺⁶ <ul style="list-style-type: none"> d. Reverse osmosis e. Ion exchange
12. Silver	0.05 mg/l	12a. Alum coagulation b. Ferric sulfate coagulation c. Lime softening
13. Organic Chemicals	See specific chemical	13a. Activated carbon
14. Odors	--	14. Sulfide <ul style="list-style-type: none"> a. Aeration b. Oxidation c. Desulfuration Organics <ul style="list-style-type: none"> d. Clarification e. Oxidation f. Adsorption
15. Hardness	--	15a. Ion exchange b. Lime softening
16. Iron/Manganese	--	16a. Polyphosphate b. Ion exchange c. Oxidation/precipitation

UNIT 5: WATER TREATMENT

Summary

Treatment Processes
Sanitary Risks

Unit References

Small Water Supplies Serving the Public
(Chapters 9, 10)
Manual of Instruction for Water Treatment
Plant Operators (Chapters 5-15)
Manual of Water Utility Operations
(Chapters 7-11)
Water Treatment Plant Operations
(Volume 1; Chapters 4-9 and 11)
Water Supply System Operation (Chapter 4)

Basic Material

The purpose of water treatment is to condition, modify or remove undesirable impurities to provide a water that is safe, palatable, and acceptable to consumers. National standards (specified in the NPDWR with maximum contaminant levels) for some of the impurities that are considered important to the health of consumers are set under the Federal Safe Drinking Water Act. If these contaminants are present in excess of the established limits, the water must be treated to reduce the levels. Some impurities that affect the esthetic qualities of the water are listed in SDWR as guidelines. Treatment or modification of the water to achieve these desirable levels is highly recommended.

Some of the common treatment processes and their purposes are:

Pretreatment - generally for removal of taste and odors.

Coagulation/Flocculation - treatment with certain chemicals for collecting nonsettling particles into larger or other fine-grained materials to remove particulate matter too light or too finely divided for removal by sedimentation.

Sedimentation - removal of suspended matter.

Filtration - filtering through sand, anthracite, or other fine-grained materials to remove particulate matter too light or too finely divided for removal by sedimentation.

Disinfection - destroying pathogenic organisms with chlorine, certain chlorine compounds, or other means.

For specific information on the treatment process, the suggested references should be consulted. It is suggested that the inspector be familiar with:

Coagulation: Aluminum Sulfate and Iron Salts
Chlorination: Gas and Hypochlorite
Filtration: Rapid Sand
 Pressure
 Diatomaceous Earth
Ion Exchange
 Lime Softening
Sedimentation
Taste and Odor Control
Corrosion Control

Sanitary Risks

Prechlorination/Chemical Pretreatment

Although treatment for taste and odors can be performed at several locations in the treatment process, frequently it is conducted as a pretreatment. This allows the time in the pipe from the intake to the plant to be used as contact time. Chemicals commonly used are chlorine, activated carbon, potassium permanganate, ozone, and chlorine dioxide. There are other pretreatment processes such as aeration, presedimentation, and screening that may be encountered, but the following questions deal with processes utilizing chemical addition.

1. What chemical is used?

The inspector should determine what chemicals are utilized, if they are approved, and if they are being properly applied.

2. What is the amount used?

The amount utilized should be based on testing. The inspector should inquire as to how the dosage is determined and how frequently. In some cases the inspector will find that the dosage has been based on tests conducted in the distant past and has remained the same even though conditions have changed.

3. For prechlorination, has total trihalomethanes (TTHM) been evaluated?

Although TTHM control is not required for systems serving a population less than 10,000, the inspector should determine if the inspector is aware of their impact and causes. The dosage and/or application point may be changed to reduce their levels.

4. What is the point of application?

The inspector should determine what chemicals are being added at the best point to achieve the desired results. The inspector should alert the operator to improve application such as addition of powdered activated carbon and chlorine at the same point.

5. Is proper mixing achieved based on visual observation?

The inspector should be looking for evidence of short circuiting.

6. What other pretreatment is provided?

Other processes should be noted and evaluated as to their sanitary risks.

Chemical Feed

This section deals with chemical addition for such processes as coagulation, lime softening, activated carbon addition, and corrosion control. A good policy is for the inspector to draw a simple schematic of the plant systems and where chemicals are added. The following questions apply to chemical feed.

1. What chemical is used?

The inspector should determine what chemicals are utilized, and if they are approved. The question should be asked as to how the dosage is determined and frequency of this determination.

2. Where is it applied?

The inspector should note the application point and evaluate it in light of the purpose of the chemical addition.

3. What is the condition of the feed equipment?

The equipment should be functional and properly maintained. For example, with dry chemical feeders watch for problems with "bridging" of the chemical in the hopper. Liquid solution feeder lines should be observed to see that they are not clogged. The operator should be asked if a preventive maintenance program exists and is utilized. The care taken for the equipment of the facility could reflect the operator's attitude towards the system as a whole. Cross connections and the possibility of bacterial contamination of stock solutions should be noted.

4. Are instrumentation and controls for the process adequate, operational, and being utilized?

Controlling processes is difficult when instrumentation is not functional and/or properly calibrated. The instrumentation is useless if the operator does not know the significance of the measurement. The inspector should observe the controls and question the operator about calibration checks and what is done based on the measurement.

4. Is chemical storage adequate and safe?

At least a 30-day supply of chemicals on hand is recommended. Level indicators and overflow protection should be provided for liquid chemical storage. This is particularly important for tanks located near a well to prevent contamination of the aquifer. Chemicals stored together should be compatible. For example, hypochlorite and activated carbon should not be stored near each other. Strong acids should not contact chlorites. Chemicals should be stored in a manner that would preclude a spill from entering the water being treated or the source.

5. Are adequate safety devices available and precautions observed?

Safety goggles, gloves, hearing protection, and respirators should be provided for protection against injury by the particular chemicals. The inspector should observe safety procedures during the inspection. As stated previously, the inspector should be concerned with safety, the operator's and his own.

Mixing

1. Is mixing adequate based on visual observation?

Problems with short circuiting should be noted. Adequate solution water and agitation should be provided in the case of dry chemical addition.

2. Is equipment operated properly and in good repair?

Mixing can be accomplished by several means (mechanical mixers, diffusers, pump blenders, and baffles). The inspector should determine that the particular means utilized is functioning properly.

Flocculation/Sedimentation

1. Is the process adequate based on visual observation?

The inspector should observe if there is good floc formation prior to sedimentation. The best floc size ranges from 0.1 mm to about 3 mm. There should be little carryover of the floc from the sedimentation basin.

2. Is equipment operated properly and in good repair?

In the case of mechanical flocculators, the paddles should all be present and turning. The flocculators should not break up the floc.

3. Are jar tests being performed to determine optimum dosage of chemicals?

Proper regulation and flocculation cannot be routinely achieved without jar testing.

Filtration

Several types of filters are available for use in water systems such as diatomaceous earth, pressure sand filters, and rapid sand filters. As stated previously, this manual provides only the "need to know" of sanitary risks involved with the components. The inspector should consult the suggested references for specific operational considerations.

1. Is process adequate based on observation?

The primary purpose of filtration is to remove turbidity. The inspector should be concerned that the filtration process actually reduces the turbidity. If there are multiple filters, the effluent from each filter should be checked.

2. Are instrumentation and controls for the process adequate, operational, and being utilized?

Turbidity should be measured in the influent and effluent from the filters. Head loss through the filter is also important to filter operation, as is the use of flow rate controllers. The instruments for these measurements and controls should be present and functional. The operator should know the importance of the readings. The answers provided should indicate the operator's competence to the inspector.

3. Is equipment operated properly and in good repair?

For rapid sand filters, the inspector should look for problems such as: mudballs, cracks in the media, backwashing difficulties resulting in short filter runs and/or failure to clean media, and loss of media. If a problem is indicated, the inspector may wish to have the operator backwash the filter.

Post-Chlorination

The primary purpose of post-chlorination is disinfection. Disinfection is the process of destroying a large portion of the microorganisms in water with the probability that all pathogenic bacteria are killed in the process. In water treatment, disinfection is almost always accomplished by adding chlorine or chlorine compounds. Other processes that may be encountered are: ultraviolet disinfection and the use of iodine or ozone. The measure used to determine effectiveness of disinfection is the coliform group. The standard test for the coliform group is either the multiple-tube fermentation technique or the membrane filter technique. An in-depth discussion of these techniques may be found in "Standard Methods for the Examination of Water and Wastewater." The coliform group is used as an indicator of pathogenic organisms. The use of this indicator group has several advantages over testing for specific pathogenic organisms. Primarily these advantages are:

1. Ease of isolation: Using relatively unsophisticated analytical procedures and equipment, the presence of coliforms can be detected. The procedures can give results in 24 hours, making it a comparatively rapid bacteriological test.

2. Coliforms are present in large numbers in feces of all animals. Any fecal pollution results in the presence of coliform organisms in sufficient quantities to determine the degree of pollution with fair accuracy.
3. Coliforms are resistant to the forces of natural purification to a greater degree than commonly encountered pathogens. Consequently, the coliforms will normally still be present after the disease-producing pathogens may have died off and will continue to indicate the possible danger to the water.

Chlorination Terminology

Regardless of the form of chlorination, chlorine gas, or chlorine compounds, the reaction in water is basically the same. The standard term for the chlorine concentration is either milligrams per liter (mg/l) or parts per million (ppm).

- o Chlorine Dose: The total amount of chlorine fed into a volume of water by the chlorinator.
- o Chlorine Demand: Chlorine is a very active chemical oxidizing agent. When injected into water, it combines readily with certain inorganic substances that are oxidizable (hydrogen sulfide, nitrite, ferrous iron, etc.) and with organic impurities including micro-organisms and decay products. These reactions consume or use up some of the chlorine before it can fully destroy micro-organisms. This amount used up is the chlorine demand.

$$\text{Chlorine Demand} = \text{Chlorine Dose} - \text{Chlorine Residual}$$

- o Chlorine Residual: The amount of chlorine (by test) present in the water after the chlorine demand is satisfied and after a specified time period. The presence of a "free" residual, in contrast to a "combined" residual of at least 0.2-0.4 ppm (in relatively unpolluted, low turbidity water), after the chlorine demand is satisfied, usually provides a high degree of assurance that the disinfection of the water is complete.

A residual also provides some protection against any chance contamination that may inadvertently enter the system. The chlorine residual test sample is usually collected before the first point in the distribution system where water is consumed. However, it is also advisable to also test at the farthest point in the system to ensure that a residual exists throughout the whole system. The residual test is the basis for increasing or decreasing the chlorinator feed rate to achieve the desired value. Too much chlorine residual will be offensive to some consumers.

$$\text{Chlorine Residual} = \text{Chlorine Dose} - \text{Chlorine Demand}$$

- o Chlorine Contact Time: The contact time is the time interval (usually minutes) that elapses between the time when chlorine is added to the water and the time when that same slug of water passes by the sampling point. A certain minimum period of time is required for the disinfecting action to become completed. The contact time is usually a fixed condition dependent upon the rate of flow of the water and the time it takes the water to pass through the piping and storage facilities. Generally speaking, it is preferable that the contact period be not less than 30 minutes under the peak demand flow conditions. However, even more time may be necessary under unfavorable conditions.

Gas Chlorination

Chlorine gas is available in compressed gas form stored in steel pressurized cylinders. A gas chlorinator meters the gas flow and mixes it with water which is then injected as a water solution of pure chlorine. Chlorine gas is a highly toxic lung irritant and special facilities are required for storing and housing gas chlorinators. The advantage of this method is the convenience afforded by a relatively large quantity of chlorine available for continuous operation for several days or weeks without the need for mixing chemicals. Gas chlorinators have an advantage where variable water flow rates are encountered as they may be synchronized to feed chlorine at a variable rate.

Hypochlorination

Small system operators will find the use of liquid or dry chlorine compounds mixed with water and fed into the system with inexpensive hypochlorinators a satisfactory chlorination method. These small chemical feed pumps are designed to pump (inject under pressure) an aqueous solution of chlorine into the water system. They are designed to operate against pressures as high as 100 psi but may also be used to inject chlorine solutions at atmospheric or negative head (suction side of water pump) conditions.

The pumping rate is usually manually adjusted by varying the stroke of the piston or diaphragm. Once the stroke is set, the hypochlorinator feeds accurately at that rate. However, chlorine measurements should be made occasionally at the beginning and end of the well pump cycle because if the drawdown is high, the pumping rate varies considerably and the concentration will vary since the applied dose is constant. A metering device may be used to vary the hypochlorinator feed rate synchronized with the water rate. Where a well pump is used, the hypochlorinator is connected electrically with the on-off controls of the pump.

The following questions deal with the sanitary risks of chlorination.

1. Is adequate chlorine residual being maintained?

The answer to this lies in whether there have been any positive coliform counts. The next step in determination of adequacy would be to ensure that a detectable residual is present at the remotest

connection in the system. The inspector should review where the utility's sample points within the distribution system are located and/or how they were selected. If the inspector is to sample, a deadend portion of the system that is remote from the plant may be selected. A free residual of 0.2-0.5 mg/l or a combined residual of 1.0-2.0 mg/l should be maintained at the most distant points in the system and at the ends of deadend sections. The chlorinator should have sufficient capacity to provide adequate treatment under peak flow conditions.

2. Is there sufficient contact time between the chlorination point and the first point of use?

Contact time should be a minimum of 30 minutes for free residual and 2 hours for a combined residual. This may be determined by figuring detention time in the clear well, storage tank, and/or pipeline between point of chlorination and use.

3. Is the equipment properly operated and maintained?

The inspector should determine that all equipment is operational and preventive maintenance is routinely performed. Some indicators of problems for gaseous chlorination would be valves, piping and fittings that are damaged, badly corroded or loose, no gas flow to the chlorinator, or frost on valves and piping. For powdered disinfectants, some indicators are clogged feed lines and valves. A more detailed discussion of these problems and their solutions is provided in "Water Treatment Plant Operation," Chapter 7.

4. Is operational standby equipment provided? If not, are critical spare parts on hand?

Disinfection must be continuous! Standby equipment of sufficient capacity to replace the largest unit is recommended. Where it is not, flow to the water system should be halted and critical spare parts should be on hand for immediate replacement.

5. Is a manifold provided to allow feeding gas from one cylinder?

As stated above, chlorination must be continuous. A manifold should be provided to allow empty cylinders to be changed without stopping chlorination. If only one cylinder can be utilized, the inspector should determine what procedure is followed when it is changed. The operator could be allowing water to continue to flow into the system while he changes the cylinder, a process that could take 30 minutes. Such a situation could result in contamination of the entire system.

6. Are scales provided for weighing cylinders?

Scales should be provided and utilized to measure the amount of chlorine used each day and to determine when they are near empty so they can be changed. These scales should be located so that the cylinders will be cooler than the chlorinators to prevent condensing of the chlorine in the lines.

7. Is the chlorine storage and use area isolated from other work areas?

Operators should be well versed on the hazards of chlorine gas, proper handling of the gas and protective equipment, and the limitations of the protective equipment. The inspector should be knowledgeable in these areas as well. A brief overview of chlorine is that it is a heavier-than-air gas, which is corrosive in moist atmospheres and is extremely toxic. Its toxicity ranges from throat irritation at 15 ppm to rapid death at 1,000 ppm. Consequently, the storage and use areas for chlorine should be above ground, well ventilated, and separated by a gas-tight partition from other work areas. Both chlorine gas and particularly sodium chlorite should not be stored with organic compounds.

8. Is room vented to the outdoors by exhaust grilles located not more than 6 inches above the floor level?

The room should be vented at a rate of one air change per minute with exhaust grilles not higher than 6 inches above the floor. An inlet grille for the room should be located near the ceiling. The vapor-tight fan switch should be located outside the room and equipped with an indicator light. The inspector should ensure that the exhaust from the chlorine room will not enter into other interior areas. Problems have resulted from locating the exhaust grilles to the chlorine room in the vicinity of the makeup air inlet for other rooms.

9. Are all doors hinged outward, equipped with panic bars, and at least one provided with a viewport?

The need for doors to be hinged outward is based on the fact that someone in the room could be overcome and passed out against the door, making rescue difficult if the door has to swing into the room. The door should also have warning signs affixed, alerting personnel to the dangers.

10. Is a self-contained breathing apparatus available for use during repair of leaks?

The use of chlorine requires protective clothing. Chemical goggles should be worn by personnel entering the area for routine inspection. When cylinders are changed or adjustments made to the system, impervious gloves, chemical goggles, and a full face shield should be worn (unless a full facepiece respirator or hood is used). Chlorine canister-type gas masks are only acceptable if the known chlorine vapor concentration is less than 1% and oxygen level greater than 16%. Additionally, canister-type gas masks must be checked routinely and the canister changed when it has reached its expiration date or has been damaged. When a worker enters a heavily contaminated area for repair, a self-contained breathing apparatus is required. Use of protective equipment and emergency drills should be practiced. Emergency procedures should be coordinated with fire and police personnel. The inspector should ask if the utility has an emergency plan and if it has ever been practiced.

11. Are there means of leak detection?

The inspector should never enter a room containing chlorine gas without first opening the door slightly to check for the smell of chlorine. A squeeze bottle of dilute ammonium hydroxide can be used for leak detection by squirting a small amount into the room prior to entry. If a leak is present a "snow" will form. There are also continuous and portable chlorine detection devices that may be used.

12. Are all gas cylinders restrained by chaining to the wall or other means?

Cylinders should be restrained to an immovable object. They should be transported and stored in an upright position and kept away from direct heat and direct sun. Empty containers should be segregated from full containers.

13. Have there been any interruptions in chlorination during the past year due to chlorinator failure or feed pump failure?

Any interruptions in chlorination and their cause should be identified. The operator should be questioned as to what measures have been taken to preclude recurrence of the interruption.

Water Treatment

5-8

TRANSPARENCY 5-1

194

Water Treatment

195

Common Pretreatment Chemicals

- Chlorine
- Chlorine Dioxide
- Ozone
- Potassium Permanganate
- Activated Carbon

Common Pretreatment Chemicals

- Chlorine
- Chlorine Dioxide
- Ozone
- Potassium Permanganate
- Activated Carbon

Chemical Feed

5-110

TRANSPARENCY 5-3

193

Chemical Feed

199

Mixing

15-11

TRANSPARENCY 15-4

209

Mixing

201

Flocculation/ Sedimentation

5-12

TRANSPARENCY 5-5

202

Flocculation/ Sedimentation

203

Filtration

15-13

TRANSPARENCY 5-6

204

Filtration

205

Post-Chlorination

5-7

TRANSPARENCY 5-7

206

Post-Chlorination

207

Why the Coliform Group?

1. Ease of Isolation
2. Present in all Fecal Pollution
3. Greater resistance to Natural Purification

209

203

Why the Coliform Group?

1. Ease of Isolation
2. Present in all Fecal Pollution
3. Greater resistance to Natural Purification

UNIT 6: STORAGE - "THE NEED TO KNOW"

Unit Summary

Gravity Storage
Hydropneumatic Storage

Unit Contents

6a: Gravity Storage

- o Characteristics
- o Sanitary Risks

6b: Hydropneumatic Storage

- o Characteristics
- o Sanitary Risks

UNIT 6a: Gravity Storage - "The Need To Know"

Unit Summary

Characteristics of a Gravity Storage
System
Sanitary Risks

Unit Objectives

A major function of the sanitary survey is to determine that a storage system is free of and protected from contamination. Gravity storage will be discussed and sanitary risks outlined.

Logistics

Approximate Presentation Time: 45 minutes

Instructor Materials

- o Basic Material
- o Transparency 6-1 to 6-3
- o Chalkboard
- o Overhead projector and screen

Student Materials

- o Student's Text, Unit 6a

Student Preparation

- o Read Unit 6a prior to the session.

Unit References

- o Small Water System Serving the Public (Chapter 6)
- o Manual of Individual Water Supply Systems (Part V)
- o Water Supply System Operation (Chapter 5)

Use Transparency 6-1.

Identify on chalkboard diagram of the various components. Explain their functions.

Use Transparency 6-2.

Use personal experiences and anecdotes to relate material to actual situations an inspector may encounter during a sanitary survey.

Point out importance of information requested by each question.

Use Transparency 6-3.

General (10 minutes)

Components

- o Supply (generally a well)
- o Inlet
- o Reservoir
 - o Elevated
 - o Surface (on ground)
 - o In ground
- o Outlet
- o Pumps (if applicable)

Sanitary Risks (30 minutes)

1. Does surface runoff and underground drainage drain away from the storage structure?
2. Is the site protected against flooding?
 - o Provides protection against contamination by nonpotable water
3. Is storage tank structurally sound?
4. Are overflow lines, air vents, drainage lines, or cleanout pipes turned downward or covered, screened and terminated a minimum of 3 diameters above the ground or storage tank surface?
 - o Protection against birds, dust, and nonpotable runoff
5. Is site adequately protected against vandalism?
 - o Fenced
 - o Hatches lockable
 - o Ladders cut off 10 feet above ground
6. Are surface coatings in contact with water approved?
 - o Unauthorized surface coatings can degrade water quality through organic and inorganic contaminants

7. Is tank protected against icing and corrosion?

Corrosion

- o O₂, water, in contact with steel
- o Esthetic problems
- o Heavy metal solubility
- o Protection:
 - o Rust prevention barrier (paint, cement, other coatings)
 - o Carbonate film coating
 - o Cathodic (sacrificial anode)

8. Can tank be isolated from system?
- o Emphasize importance of being able to take tank out of system without shutting down entire system.

9. Is all treated water storage covered?

10. What is cleaning frequency for tanks?

Sludge

- o Buildup of organic, inorganic debris
- o Contributes to turbidity, esthetic problems
- o Protection
- o Periodic draining, cleaning

11. Are tanks disinfected after repairs are made?

Inadequate Disinfection

- o Following entry for service, repair
- o Protection
 - o Procedures to disinfect system
 - o Records of procedures, effectiveness

UNIT 6a: Gravity Storage

Unit Summary

Characteristics of a Gravity Storage System
Sanitary Risks

Unit References

Small Water Systems Serving the Public
(Chapter 6)
Manual of Individual Water Supply Systems
(Part V)
Water Supply System Operation
(Chapter 5)

Basic Material

Well supplies are often pumped directly to a gravity distribution reservoir (tank) from which water flows on demand to the points of use. The wells may also be pumped directly into the distribution system with the tank floating (riding) on the system. Either arrangement is acceptable. The pumps may be controlled by water level float controls or pressure switches. The storage tank is sufficiently elevated to ensure adequate operating pressures.

A gravity storage system offers several advantages over other (e.g., hydropneumatic) systems and should be considered where topographic conditions are favorable. The larger the water system, the greater the advantages. However, even smaller systems will have these advantages:

- o Less variation in pressure
- o Storage for firefighting use
- o One to two days' storage to meet water requirements
- o Greater flexibility to meet peak demands
- o Use of lower capacity wells (pumping not necessary to meet peak system demand)
- o Sizing of pumps to take better advantage of electric load factors
- o Reduced on and off cycling of pumps
- o Tie-in of several wells, each pumping at its optimal rate

Since the gravity reservoir provides the storage necessary to meet the peak system demands, the wells need not be developed to meet the peak system capacities, as is generally necessary with pressure tank systems.

The wells should be capable of meeting the maximum day demand within the period of time when water use is significant. For example, day schools usually exert a significant water demand only over a 10- to 12-hour day. The wells must, therefore, be pumped at a rate sufficient to meet the maximum day demand in a 10- to 12-hour period. Under these conditions, the reservoir (tank) should have an effective capacity equivalent to the average daily demand.

Gravity distribution reservoirs may be elevated tanks mounted on structural supports above ground, may be located partly below ground, or may be tanks placed on pads or cradles on the ground surface. Elevated tanks are necessary when high ground is not available within the service area. The operating water levels of the tank should be sufficiently above the distribution system to produce minimum operating pressures of 35 psi (about 81 feet of head) but preferably 50-75 psi (116 to 173 feet). Pressures should not exceed 100 psi (231 feet).

Shallow reservoirs with large diameters are preferred over deep ones with smaller diameters, other things being equal. Tanks with larger diameters have more water per foot of drawdown and are thus less prone to pressure fluctuations. They are also less costly to build.

Prefabricated standpipes and elevated tanks are readily available with a wide range of capacities. Prestressed concrete tanks are quite popular, since they require less maintenance.

Sanitary Risks

1. Does surface runoff and underground drainage drain away from the storage structure?
2. Is site protected against flooding?

Storage reservoirs should be located above probable ground water levels. Surface runoff and underground drainage should be away from the structure. Provisions should be included to guard against the sanitary hazards related to location; groundwater levels, movements, and quality; character of soil; possibility of wastewater pollution; and overtopping by floods. Sites in ravines or low areas subject to periodic flooding should be avoided. Any sewer located within 50 feet of a storage reservoir with a floor below ground level should be constructed of extra-heavy or service-weight cast iron pipe with tested, watertight mechanical joints. No sewer should be located less than 10 feet from the reservoir.

All storage reservoirs should be protected against flood waters or high water levels in any stream, lake, or other body of water. These reservoirs should be placed above the high water level, and the structure and its related parts should be watertight. The ground surface above the reservoir should be graded to drain surface water away from the reservoir and to prevent pooling of surface water within the vicinity. Walls or fencing should surround open reservoirs, and public access should be prohibited.

3. Is storage tank structurally sound?

The inspector should base the answer to this question on visual observation. Look for washouts and signs of foundation failure.

4. Are overflow lines, air vents, drainage lines, or cleanout pipes turned downward or covered, screened, and terminated a minimum of 3 diameters above the ground or storage tank surface?

Any overflow, blowoff, or cleanout pipe from a storage reservoir should discharge freely into an open basin from a point not less than three diameters of the discharge pipe above the top or spill line of the open basin. All overflow, blowoff, or cleanout pipes should be turned downward to prevent entrance of rain and should have removable #24-mesh screens to prevent the entrance of birds, insects, rodents, and contaminating materials. If the discharge pipes are likely to be submerged by surface or flood water, a watertight blind flange should be provided to attach to the pipe opening to prevent contaminated water backflow into the reservoir. If the reservoir must be emptied when the normal outlet is submerged by surface or flood waters, pumps with outlets above the flood water should be used for emptying.

5. Is site adequately protected against vandalism?

Manholes and manhole frames used on covered storage reservoirs and elevated tanks should be fitted with raised, watertight walls. Each manhole frame should be closed with a solid watertight cover and a sturdy locking device. The frame should be locked when not in use. The storage site should be fenced to prevent unauthorized entry. Ladders to tops of storage tanks should terminate 10 feet above the ground to deter unauthorized climbing.

6. Are surface coatings in contact with water approved?

Coatings that are in contact with water should be approved. Unauthorized coatings can create problems due to organic and inorganic contamination of the stored waters.

7. Is tank protected against icing and corrosion?

Cathodic protection may be provided for metal storage tanks. Icing can be a particularly traumatic problem in northern areas. Tanks have "blown their tops" due to the pressures that can result; in less severe cases, the cathodic protection and tank interiors may be damaged. Tanks should not be allowed to remain idle if freezing is a problem. Heaters may need to be used in tanks reserved for emergency purposes.

8. Can tank be isolated from the system?

Tanks should be able to be taken out of the system for repair without shutting down entire system.

9. Is all treated water storage covered?

Reservoirs should be covered to prevent airborne contamination (birds and algae growths that impart tastes and odors). Covers should be watertight, made of permanent material, and constructed to drain freely and to prevent contamination from entering the stored water. The surface of a storage reservoir cover should not be used for any purpose that may result in contamination of the stored water.

10. What is cleaning frequency for tanks?

Over a period of time, reservoirs may accumulate organic and inorganic debris, which settles to the bottom as a sludge. This sludge can contribute taste, odors, and turbidity to the systems when it accumulates to a depth approaching the outlet pipe. Periodic draining of the tank and cleaning is necessary. The tank should then be disinfected before reuse.

11. Are storage tanks disinfected after repairs?

Reservoirs and elevated tanks on the distribution system should be disinfected before being put into service or after extensive repairs or cleaning have been completed.

Unit Summary

Types and Characteristics Sanitary Risks

Unit Objectives

A major function of the sanitary survey is to determine that the storage system is free of and protected from contamination. Hydropneumatic storage will be discussed and sanitary risks outlined.

Logistics

Approximate Presentation Time: 30 minutes

Instructor Materials

- o Basic Material
- o Transparencies 6-4 through 6-8
- o Overhead projector and screen
- o Chalkboard

Student Materials

- o Student's Text, Unit 6b

Student Preparation

- o Read Unit 6b prior to the session.

Unit References

- o Small Water Systems Serving the Public (Chapter 6)
- o Manual of Individual Water Supply Systems (Part V)
- o Planning for an Individual Water System (Part V)
- o Water Supply System Operation (Chapters 3 and 5)

Use Transparencies 6-4, 6-5 and 6-6.

Explain principle of system.

Locate on the transparency the various system components. Ask students to describe the functions.

Use Transparency 6-7 to show various types of system tanks.

List terms on chalkboard. Ask students to define them. Explain as necessary.

Use questions to guide class discussion.

Explain purpose of controls and what to look for.

Types and Characteristics (10 minutes)

1. Principle: Air pocket at top; pump's energy pushes air down, water out; cycle repeats when energy dissipates

2. Components

- o Steel tank
 - o Conventional (air and water in contact)
 - o Floating wafer (wafer separates air and water)
 - o Flexible separator (diaphragm or bag separates air and water)
- o Air volume control
- o Relief valve
- o Inlet piping
- o Pressure gauges
- o Motor controls
- o High-low water level controls
- o Low pressure/flow controls
- o Discharge piping
- o Air compressor and controls
- o Pump

3. Terms

- o Cycle rate - frequency of pump start and stop per hour
- o Cut-in Pressure - predetermined low pressure level in system at which pump is activated
- o Cut-out Pressure - predetermined pressure level in system at which pump shuts off

1. What advantages/disadvantages do the various types of tanks offer?
2. Explain why hydropneumatic systems have less usable storage than gravity systems.
3. What might this mean in terms of sanitary protection?

Sanitary and Other Risks (15 minutes)

1. Does low pressure level provide adequate pressure?
 - o Backflow/back-siphonage potential
2. Are instruments and controls adequate, operational, and being utilized?
 - o Water level sight glass
 - o Pressure gauges
 - o Water level controls

Explain importance of each question and its rationale.

Use Transparency 6-8.

Explain how to estimate if storage capacity is adequate. Explain formula.

Work problem on chalkboard. Use other examples. Ask one or two students to work problem on chalkboard for class.

Describe a waterlogged tank.

3. Are the interior and exterior surfaces of the pressure tank in good physical condition?
 - o Hazards of improperly maintained tank; e.g., at 50 psi a tank has 3.5 tons of pressure per square foot. DO NOT TAP TANKS WITH METAL OBJECTS.
4. Tank supports should be structurally sound.
 - o Structurally sound and properly positioned
5. Is storage capacity adequate?

Storage Capacity Assessment

- o Formula for estimating appropriate tank size

$$Q = \frac{Q_m}{1 - (P_1/P_2)}$$

Q = Tank volume in gallons

Q_m = Peak demand rate gpm x desired minutes of storage

P₁ = Cut-in pressure + atmospheric pressure (14.7 psi)

P₂ = Cut-out pressure + atmospheric pressure (14.7 psi)

- o Data Sources

- o Operating records to determine peak demand and supply rates
- o Engineering records to determine system design pressures, capacity

1. What would be the minimum tank size needed to meet a peak demand of 30 gpm for 5 minutes and gauge pressures of 40-60 psi?

6. What is the cycle rate?
 - o Indicator of waterlogged tank

UNIT 6b: Hydropneumatic Tanks

Unit Summary

Types and Characteristics
Sanitary Risks

Unit References

Small Water Systems Serving the Public
(Chapter 6)
Manual of Individual Water Supply Systems
(Part V)
Planning for an Individual Water System
(Chapter V)
Water Supply System Operation
(Chapter 3 and 5)

Basic Material

Hydropneumatic systems are very common for use in storing and distributing small water supplies. They combine the energy from a pump with the principle of air pressure to force water into the distribution system. Understanding how the hydropneumatic system is susceptible to sanitary risks requires understanding basic system operation and the role of system components.

The system operates in the following manner:

- o The pump starts up at a certain pressure (cut-in pressure), and the energy from the pump moves through water to the pocket of air, air volume, at the top of the pressure tank.
- o When the pressure builds to a certain point (cut-out pressure), the pump stops and the air forces the water into the distribution system.
- o When the pressure becomes too low, the pump starts up again, and the cycle is repeated. The cycle rate is the number of times the pump starts and stops in 1 hour.

A typical hydropneumatic system is made up of the following parts:

<u>Item</u>	<u>Purpose</u>
○ Steel tank	Store water
○ Air volume control	Control air volume
○ Relief valve	Prevent excessively high pressure
○ Inlet piping	Allow flow of water into system
○ Pressure gauges	Monitor pressure
○ Motor controls	Control cut-in and cut-out points
○ High/low water level controls	Regulate water level
○ Low pressure or flow controls	Maintain balance between water and air pressure
○ Discharge piping/air compressor	Discharge water from tank; force additional air in to increase pressure: (<u>prepressurizing</u>)

Most systems differ only in the kind of pressure storage tank used. The pressure tank is a significant part of the system in that the methods of separating water and air and the tank size and placement vary. All these factors may contribute to the degree of vulnerability to sanitary risks. The three kinds of tanks are:

Conventional

- Air cushion in direct contact with water; air volume controls necessary
- Capacity ranges from a few to several thousand gallons
- Vertical or horizontal placement
- Outlet located near bottom of tank; combined inlet-outlet or separated on opposite sides of tank
- Air volume control located in upper portion of tank; provisions available for prepressurizing

Floating Wafer

- Floating wafer (rigid floats or flexible rubber or plastic) separates water and air, but separation not complete; some loss of air expected, requiring occasional recharging
- Vertical placement limits tank capacity
- Inlet and outlet combined at bottom of tank
- Internal air check valve to prevent premature loss of air due to electric outage or excess water demand

Flexible Separators

- Separator fastened around inside of tank for complete separation of air and water, either flexible diaphragm or bag type
- Vertical placement limits tank capacity
- Supercharged at factory to pressures just below pump starting pressure

Sanitary Risks

1. Does low pressure level provide adequate pressure?

Maintenance of adequate pressure is especially important. Too little pressure can cause a reversal in the flow of the water, allowing it to flow from a polluted source to enter a potable, stored water source. Too high pressure can strain system components, cause high leakage rates, and can force air out with water. Low pressure can indicate improper connections, or cross-connections, made from storage to serviced facilities. Adequate pressure is needed to keep the water flowing from storage to serviced areas. Backpressure backflow occurs when potable water pressure is less than nonpotable pressure; backsiphonage backflow is a reversal stemming from a vacuum at the potable supply. Backflow and backsiphonage are especially hazardous sanitary risks when they involve poisonous or harmful chemicals. Inspectors must be aware of proximity of polluted sources and must protect stored water against cross-connections.

To ensure against backflow and backsiphonage, minimum pressure must be maintained at all times.

System Pressures (Pounds Per Square Inch)

Optimum Working Pressure = 40-60 psi
Minimum Working Pressure = 35 psi

Maximum Pressure at Service Connections = 100 psi
Minimum Pressure at Service Connections = 20 psi

Inspectors should check engineering records to assess potential hazards in the water of facilities served by the system and consult operating records to see whether pressure is adequate at service connections.

2. Are instruments and controls adequate, operational, and being utilized?

Proper operation and maintenance of the storage system is also essential. Failure to adjust gauges and controls properly can lead to inadequate pressure and/or inadequate supplies of water. Also, pollution of the storage tank can occur from airborne or waterborne foreign matter. Careful installation and maintenance of pollution prevention devices can prevent their entry into the hydropneumatic system.

To ensure proper operation and maintenance of the system, the following components must be routinely checked and adjusted for changes in the peak demand:

- o Air volume control
- o Relief valve
- o Motor controls
- o High/low water level controls
- o Low pressure flow controls
- o Air compressor and controls

Frequently, controls are not adjusting after delivery of the system from the factory. Operating records will reveal original calibration and whether peak demand has changed.

3. Are the interior and exterior surfaces in good condition?

The interior and exterior should be in good physical condition. The inspector may not be able to inspect the interior surfaces but should emphasize the importance of regular inspections. The inspector may determine if they are being performed by reviewing maintenance records.

4. Are tank supports structurally sound?

The tank should be properly supported.

5. Is storage capacity adequate?

There are several formulas for determining required storage capacity. One method is presented.

In selecting and evaluating the tank, storage capacity must be matched to the peak demand (period of highest water use) of the system. Otherwise, the tank will supply neither sufficient daily water needs nor emergency needs, such as for firefighting.

To ensure against inadequate storage capacity (and straining facilities at peak demand), purveyors must know pumping capacity and peak demand rates, which can be used in the formula below to compute appropriate tank size. Engineering records list pump capacity, cut-in, and cut-out pressures. Operating records show current peak demand and whether peak demand has changed since the tank was installed, which could require a change in tank size.

Formula for Estimating
Appropriate Tank Size

$$Q = \frac{Q^m}{1 - (P_1/P_2)}$$

Q = Tank volume in gallons
Q^m = Peak demand rate, gpm x desired minutes of storage
P₁ = Cut-in pressure + atmospheric pressure (14.7 psi)
P₂ = Cut-out pressure + atmospheric pressure (14.7 psi)

6. What is the cycle rate?

The pressure pump should not cycle frequently (10-15 cycles/hour acceptable). Frequent or constant operation of the pressure pump indicates a "waterlogged" tank or improper settings on the pressure controls.

Gravity Storage

6-8

TRANSPARENCY 6-1

226

Gravity Storage

227

Top
Manhole

Vent

Overflow

Ladder

Splash Pad

Gravity Storage Tank

6-19

TRANSPARENCY 6-2

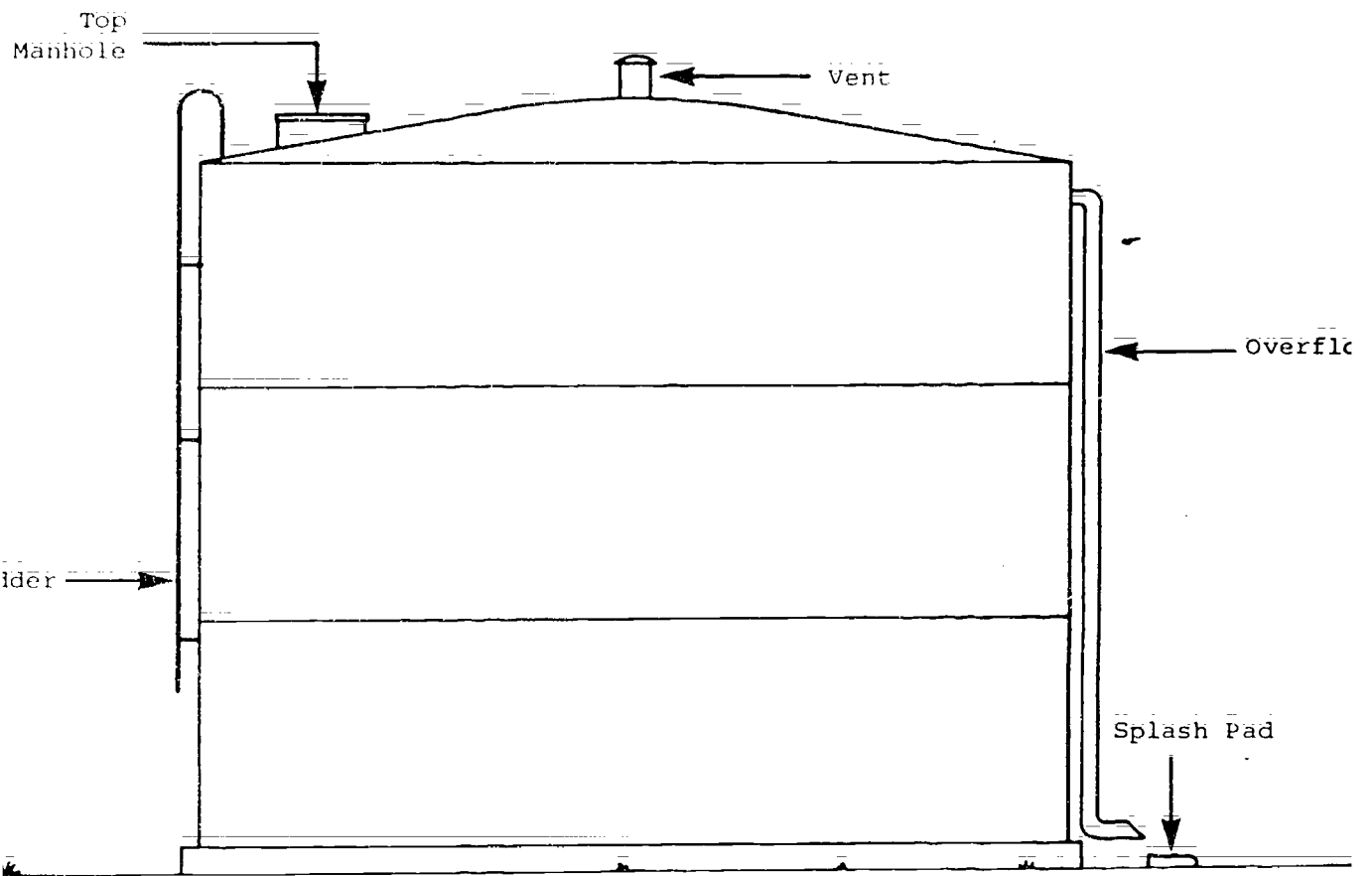

Gravity Storage Tank

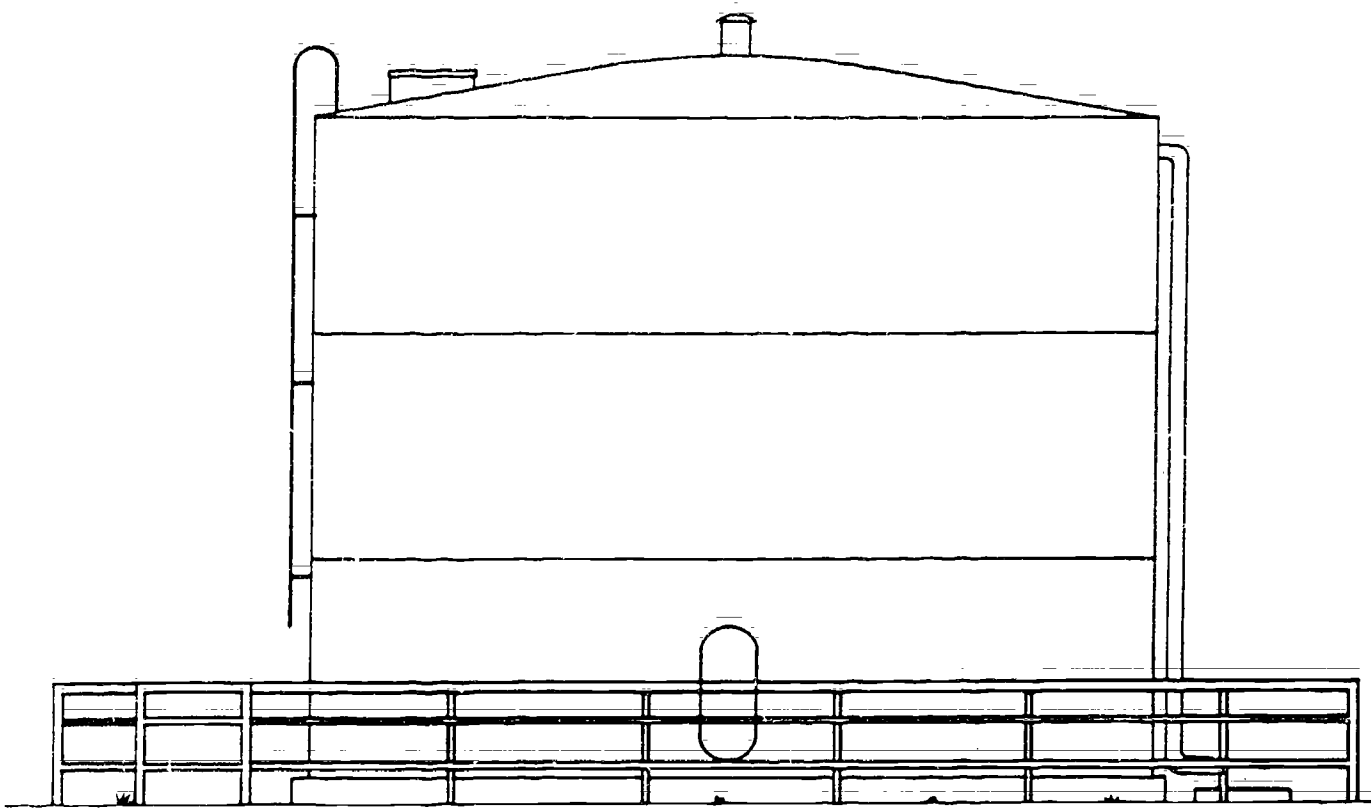

VANDALISM PROTECTION

231

6-10

TRANSPARENCY 6-3

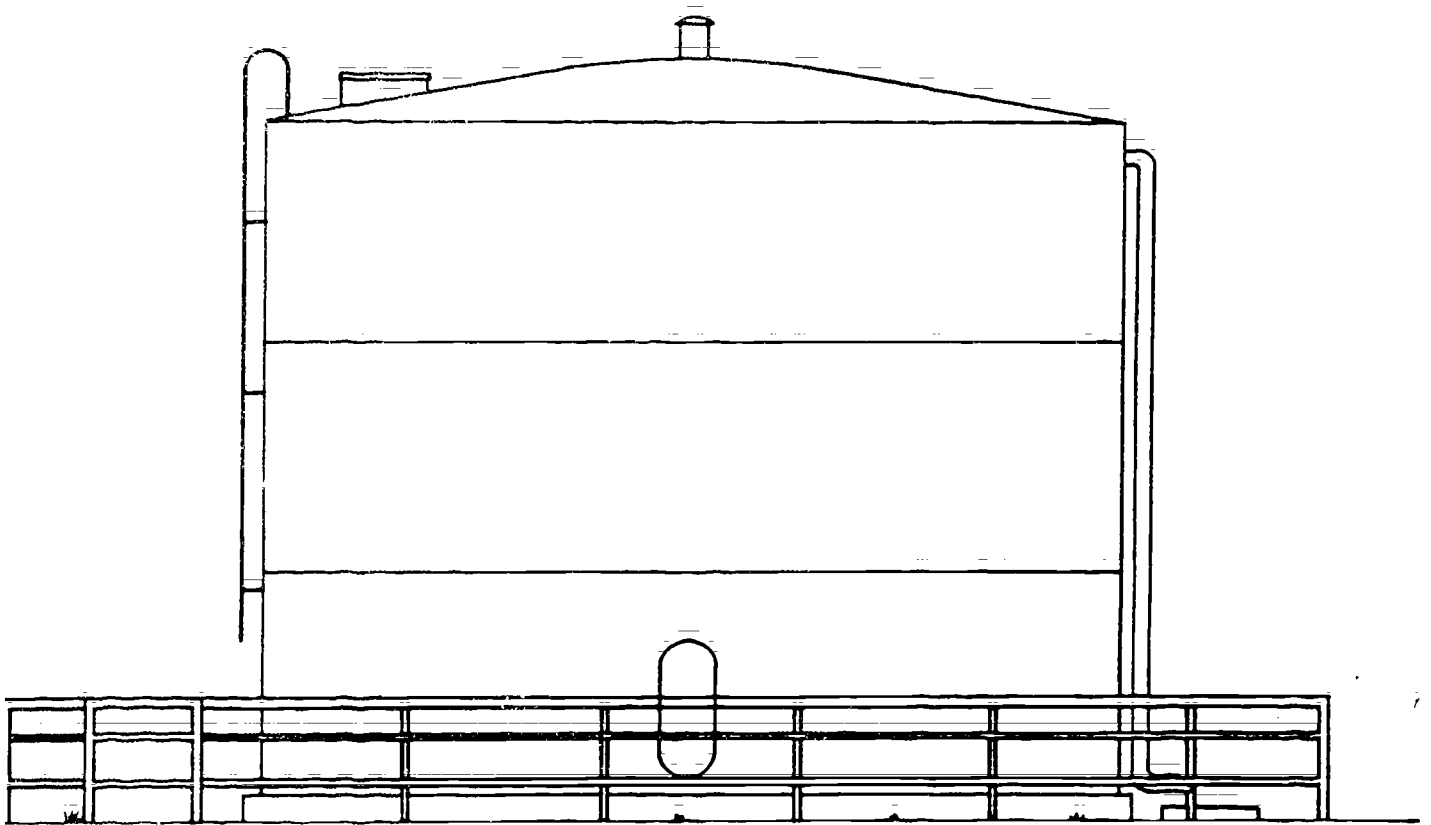

VANDALISM PROTECTION

232

Hydropneumatic Tanks

6-11

TRANSPARENCY 6-4

233

Hydropneumatic Tanks

234

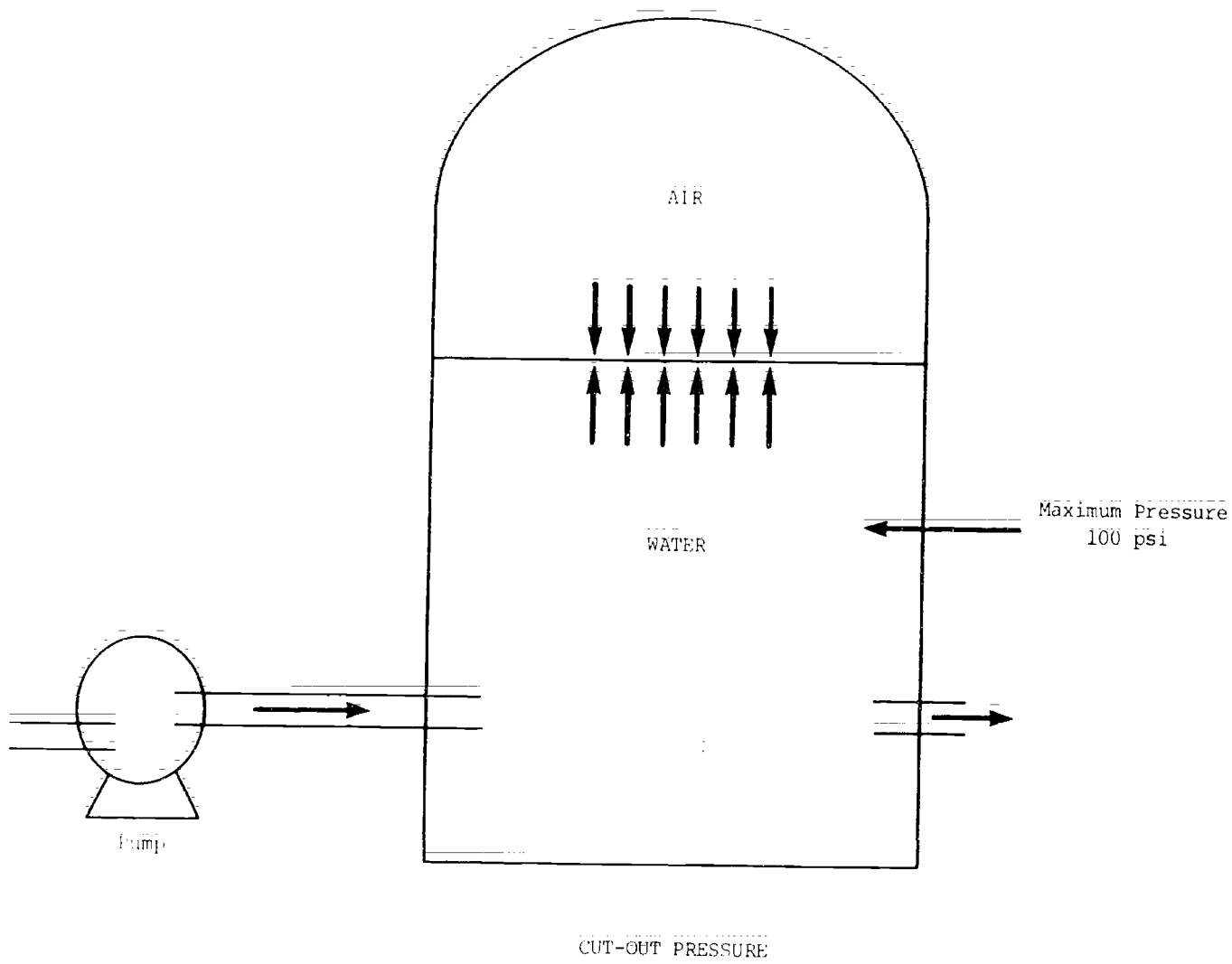

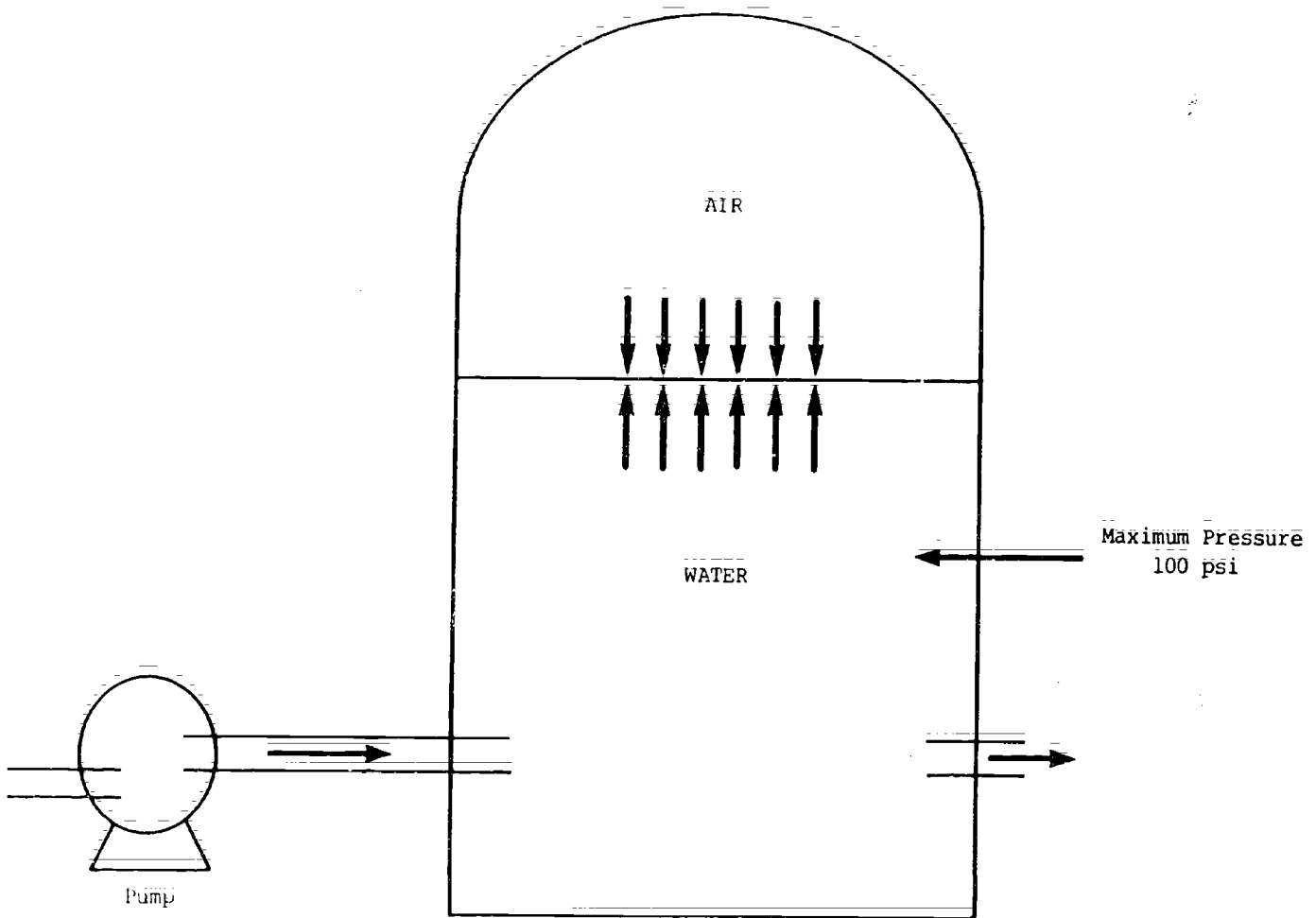

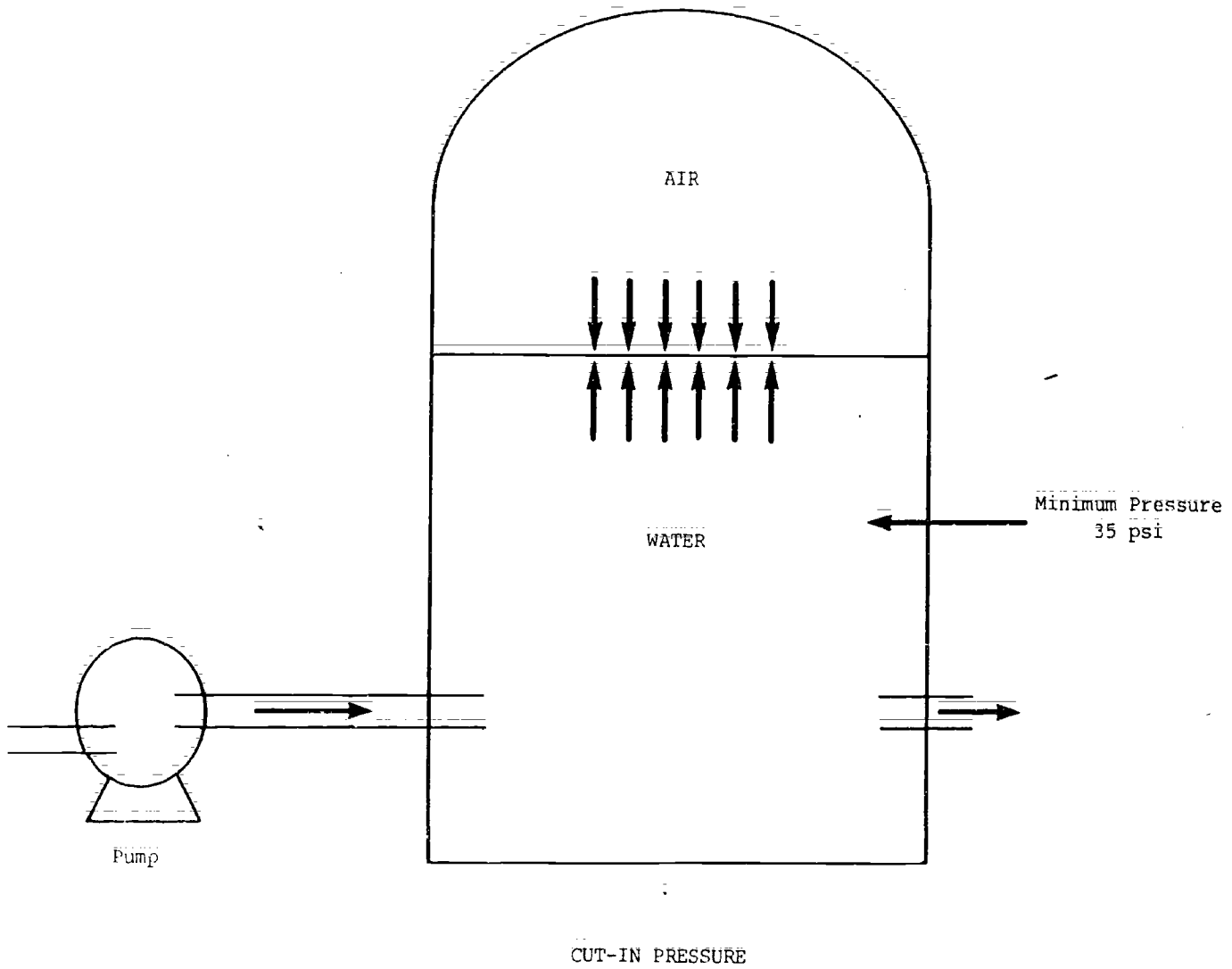

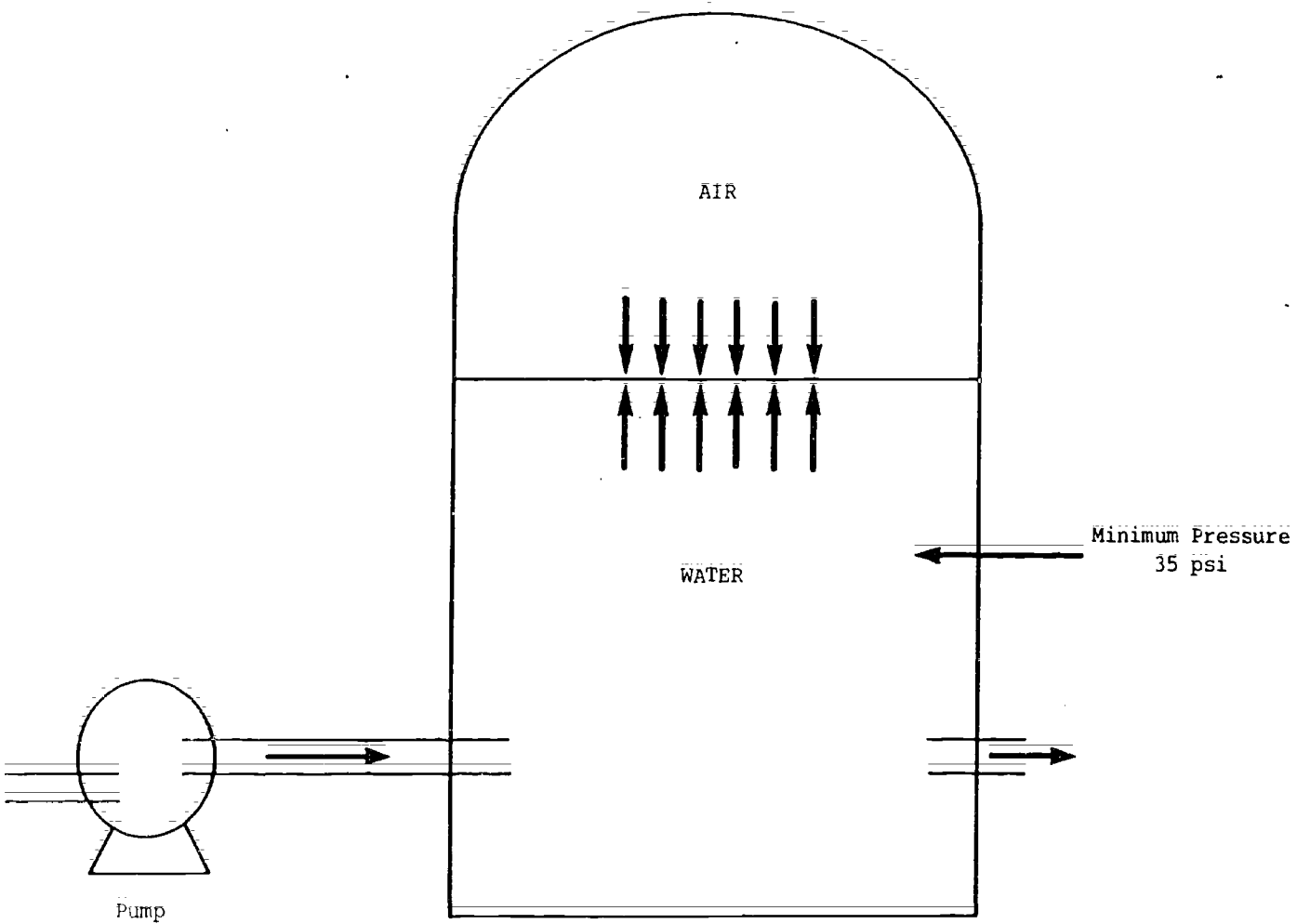

CUT-IN PRESSURE

Types of Pressure Tanks

CONVENTIONAL

WAFFER

DIAPHRAGM

WATER IN BAG

AIR IN BAG

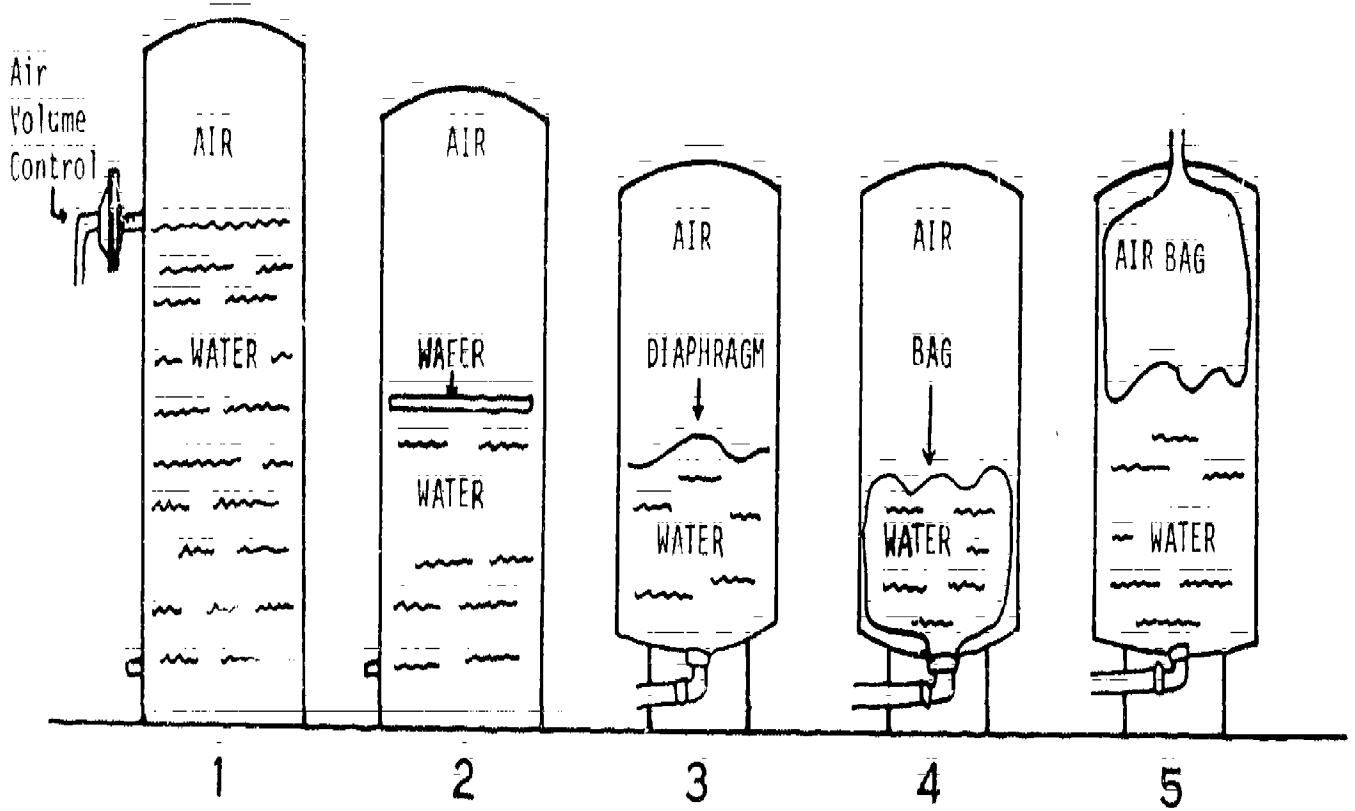

6-14

TRANSPARENCY 6-7

Types of Pressure Tanks

CONVENTIONAL

WAFFER

DIAPHRAGM

WATER IN BAG

AIR IN BAG

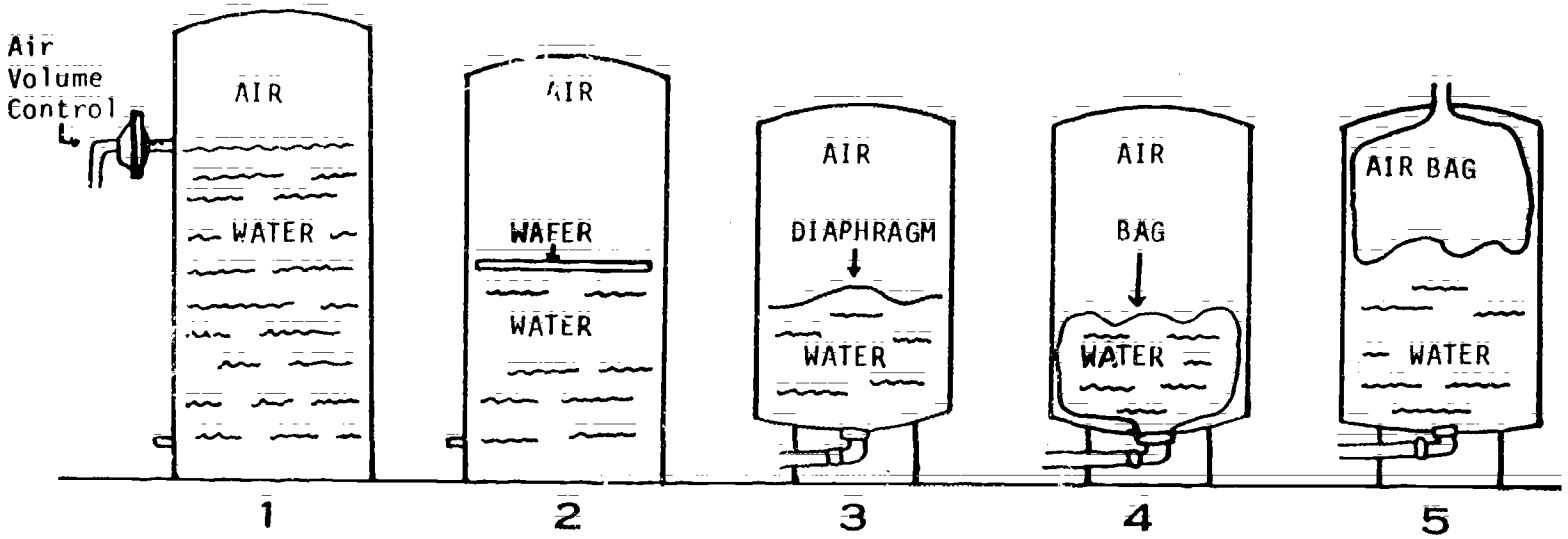

6-15

$$Q = \frac{Q_m}{1 - \left(\frac{P_1}{P_2} \right)}$$

TRANSPARENCY 6-8

$$Q = \frac{Q_m}{1 - \left(\frac{P_1}{P_2} \right)}$$

UNIT 7: WATER DISTRIBUTION - "THE NEED TO KNOW"

Unit Summary

Components of a Distribution System

Sanitary Risks

Types of Cross-Connections

Sanitary Risks

Unit Contents

7a: Distribution Systems

o Components

o Sanitary Risks

7b: Cross-Connections

o Types and Characteristics

o Sanitary Risks

UNIT 7a: Distribution Systems - "The Need To Know"

Unit Summary

Components of a Distribution System
Sanitary Risks

Unit Objectives

A knowledge of distribution system components and their interaction is essential in assessing the sanitary integrity of a system. This unit should familiarize the student with distribution system components and their risks.

Logistics

Approximate Presentation Time: 45 Minutes

Instructor Materials

- o Basic Material
- o Transparencies 7-1 through 7-3
- o Overhead projector and screen
- o Chalkboard

Instructor Preparation

- o During this presentation, the instructor will be asked to draw on the chalkboard a simple diagram of a typical distribution system. A rough sketch of this diagram should be prepared in advance.

Student Materials

- o Student's Text, Unit 7a

Student Preparation

- o Read Unit 7a prior to the session.

Unit References

- o Small Water Systems Serving the Public (Chapter 11)
- o Manual of Individual Water Supply Systems (Part V)
- o Manual for Evaluating Public Drinking Water Supplies (Part III)
- o Water Supply System Operation (Chapters 6 through 8)

Use Transparency 7-1:

Explain types and function of pipes.
Briefly discuss concept of pressure head loss relative to pipe sizing.

Use Transparency 7-2:

Use Transparency 7-3:

Explain types, functions, and purposes of valves.
Sketch a simple diagram of a distribution system on the chalkboard.
Ask students to identify locations where these valves might be used.

Components of a Distribution System (15 minutes)

Pipes

- o Convey supply to points of use
- o Pipe size relative to flow
gpm, distance
- o Types:
 - o Galvanized. Not recommended for underground use; subject to corrosion from soil, acid water
 - o Copper. Heavy types used underground; less sensitive to corrosion
 - o Plastic. Corrosion resistant; subject to puncture
 - o Cast Iron. Corrosion resistant; good hydraulic characteristics
 - o A/C. Lightweight; corrosion resistant
 - o Lead. Present in older systems. Can be a source of lead contamination in tapwater

Valves

- o Control water flow
- o Control backflow
- o Adjust water levels and pressures
- o Isolate sections of system for repair
- o Types:
 - o Shut-Off Valves stop flow of water.
 - o Check Valves permit water to flow in one direction only.
 - o Flow Control Valves provide uniform flow at varying pressures.
 - o Relief Valves permit water to escape from the system to relieve excess pressure.
 - o Float Valves respond to high water levels to close an inlet pipe.
 - o Altitude Valves shut off flow of water to storage tanks at a preset level to avoid overflow.
 - o Blowoff Valves provide a means to flush sedimentation from low points/deadends in the distribution system.
 - o Air Relief Valves are used at high points to release entrapped air.
 - o Pressure Reducing Valves are used for reducing pressure between a high and low pressure area.
 - o Hydrants provide water for fire-fighting as well as a means to flush system.

Explain other components and their purposes and functions. Use the diagram to demonstrate locations of all system components.

Use questions to guide class discussion.

Ask students what information would be desired on a distribution plan.

Describe the importance of each of these factors on the sanitary risks of the water system.

Briefly describe AWWA disinfection procedures.

Meters

- o Monitor flow through various sections to provide regulation, reimbursement, and maintenance.

Meter Vaults

- o Protect meters and controls

Thrust Blocks and Anchors

- o Protect against pipe movement

Sanitary Risks (30 minutes)

1. Is proper pressure maintained throughout the system?
 - o Inadequate working pressure
 - Backsiphonage/backflow potential
 - o Pressure maintenance during peak demand
1. Explain how low pressure or pressure fluctuation might contribute to backsiphonage.
2. Why must the pressure controls be adjusted to adapt the system to demand fluctuation?
3. What controls would be used to make these adjustments?
2. What types of construction materials are used?
 - o Pipes
 - o Caulking materials
3. Are plans of the water system available and current?
 - o Minimum of Plan
 - Locations
 - Main size
 - Valve location
 - o Ability to isolate sections without loss of service to the system
 - o Deadends
4. Does the utility have an adequate maintenance program?
 - o Frequency of main breaks
 - o Pressure testing
 - o Flushing program
 - o Valve maintenance program
 - o Corrosion control
 - o Disinfection procedures
5. Is the system interconnected with any other water system?
 - o Drought
 - o Emergency

7-4

UNIT 7a: Distribution Systems

Unit Summary

Components of a Distribution System
Sanitary Risks

Unit References

Small Water Systems Serving the Public
(Chapter 11)
Manual of Individual Water Supply Systems
(Part V)
Manual for Evaluating Public Drinking Water
Supplies (Part III)
Water Supply System Operation
Chapters 6, 7, and 8)

Basic Material

Many failures to meet the requirements of the drinking water standards are directly related to the use of poor operating and maintenance procedures for distribution systems or to the presence of sanitary defects in the system. Some causes that contribute to poor water quality are:

- o Insufficient treatment at the point of production
- o Cross-connections
- o Improperly protected distribution system storage
- o Inadequate main disinfection
- o Unsatisfactory main construction, including improper joint-packing
- o Close proximity of sewer and water mains
- o Improperly constructed, maintained, or located blowoff, vacuum, and air relief valves
- o Negative pressures in the distribution system

Components of the Distribution System

The following briefly describe some of the important components of a distribution system.

Pipes

- o Convey supply to points of use
- o Pipe size relative to flow gpm, distance
- o Types
 - o Galvanized. Not recommended for underground use; subject to corrosion from soil, acid water
 - o Copper. Heavy types used underground; less sensitive to corrosion
 - o Plastic. Corrosion resistant; subject to puncture
 - o Cast Iron/Ductile Iron. Corrosion resistant; good hydraulic characteristics; unlined pipe can be subject to iron tubercles
 - o Asbestos Cement. Lightweight, corrosion resistant; easily cut but easily broken
 - o Lead. Used in older systems, particularly as service lines. No longer approved under any circumstances due to possibility of contaminating tapwater.

Valves

- o Control water flow
- o Control backflow
- o Adjust water levels and pressures
- o Isolate sections of system for repair
- o Types
 - o Shut-Off Valves stop flow of water.
 - o Check Valves permit water to flow in one direction only.
 - o Flow Control Valves provide uniform flow at varying pressures.
 - o Relief Valves permit water to escape from the system to relieve excess pressure.
 - o Float Valves respond to high water levels to close an inlet pipe.
 - o Blowoff Valves provide a means to flush sediment from low points/deadends in the distribution system.
 - o Altitude Valves are used to shut off flow of water into storage tank at a preset level to avoid overflow and allows water to flow into tank after level drops.
 - o Air Relief Valves are used at high points to release entrapped air.
 - o Hydrants provide water for firefighting and are a means to flush the system.

Meters

- o Monitor flow through various sections to provide regulation, reimbursement, and maintenance

Meter Vaults

- o Protect meters and controls

Thrust Blocks and Anchors

- o Protect against pipe movement

Sanitary Risks

The questions that a surveyor should be asking with regard to the distribution system and their rationale follow:

1. Is proper pressure (40-70 psi) maintained throughout the system?

The system should be designed to supply adequate quantities of water under ample pressure and should be operated to prevent, as far as possible, conditions leading to the occurrence of negative pressure. Steps to prevent negative pressure should include minimizing planned shutdowns, providing adequate supply capacity, correcting undersized conditions, and properly selecting and locating booster pumps to prevent the occurrence of a negative head in piping subject to suction. Continuity of service and maintenance of adequate pressure throughout a public water supply system are essential to prevent backsiphonage. The inspector should determine if complaints about inadequate pressure have been registered. He or she should determine if there is a program to periodically monitor pressures throughout the system.

2. What types of construction materials are used?

The components of the distribution system should meet the current AWWA standards. The corrosive effects of finished water on nonferrous metal pipe used for water-service lines should be considered, together with possible toxicological effects on consumers, resulting from solution of the metals. Only nontoxic plastic pipe should be used, when plastic pipe is acceptable. Materials used for caulking should not be able to support pathogenic bacteria and should be free of oil, tar, or greasy substances. Joint packing materials should meet the latest AWWA specifications.

3. Are plans of the water system available and current?

The minimum record of a distribution system contains maps showing locations of all mains, main size, and the location in detail of every line valve. The pipe layout should be designed for future additions and connections to provide circulation where deadends are necessary in the growth state of the pipe system. The system should be provided with sufficient bypass and blowoff valves to make necessary repairs without undue interruption of service over any appreciable area. Blowoff connections to sewers or sewer manholes should be prohibited.

4. Does the system have an adequate maintenance program?

This is actually an overall evaluation of the answers to a series of questions, such as:

- a. What is the frequency of main breaks?

The majority of breaks are not due to age but to leaks. The leaks undermine the pipe, consequently causing it to fail under the weight of the overburden. To prevent main breaks, a routine program for leak detection should be conducted.

- b. Does the utility have a pressure testing program?

Such a program may be conducted in conjunction with the fire department to determine adequacy of fire flow. A record of pressures throughout the system may help to identify problems. If they are conducted both during the day and at night, they will indicate the hydraulic efficiency under common requirements.

- c. Does the utility have a flushing program?

The whole system should be flushed once or twice a year due to sediment deposition in the lines. The flushing should be well planned and carried out, beginning at points near the water plant/storage and moving to the outer ends.

- d. Does the utility have a valve maintenance program?

All valves in a system should be inspected on a routine basis. The frequency of inspection depends on type of valve, but an annual inspection is desirable for all valves. This should include completely closing, reopening to about one-quarter, and reclosing until valve seats properly. A record of valve maintenance and operation should be kept.

- e. Does the utility have a corrosion control program?

The utility should have a program to evaluate corrosion and the effectiveness of corrosion control particularly to control contaminants such as lead and cadmium.

- f. Are proper disinfection procedures used after repairs?

The procedure outlined in the AWWA Standard for Disinfecting Water Mains should be followed. The inspector should question the operator as to what procedures are used. The final determining factor should be that new mains and repaired main sections should demonstrate negative bacteriological results prior to being placed in service.

5. Is the system interconnected with any other water systems?

This is of concern for two reasons:

- a. The water systems to which it is connected may be of a lower quality and potentially pose a risk.
- b. The other water system may provide an alternate source in the case of drought, contamination of the primary source or a similar emergency.

The inspector should evaluate the answers to such questions and the availability of records to determine the adequacy of the maintenance program.

UNIT 7b: Cross-Connections - "The Need To Know"

Unit Summary

Types and Characteristics

Sanitary Risks

Surveying for Cross-Connection Hazards

Exercise I: Protection Against Cross-Connections

Unit Objectives

Cross-connections can be a major source of contamination of a water system. To determine the degree of protection afforded a water system, an inspector must understand cross-connection control. In this unit we will briefly describe cross-connections, their control and common location within the treatment plant.

Logistics

Approximate Presentation Time: 30 Minutes

Instructor Materials

- o Basic Material
- o Transparencies 7-4 through 7-9

Student Material

- o Student's Text, Unit 7b

References

- o Small Water Systems Serving the Public (Chapter 15)
- o Cross-Connection Control Manual
- o Water Supply System Operation (Chapters 6 and 8)

Use Transparency 7-4.

Define cross-connection.
Draw simple diagram on chalkboard showing the two types of connections.

Define backflow and backsiphonage.

For each case shown, ask students to identify contact point of connection, and to explain how reversed flow might result.

Use Transparency 7-5.

Use example situations; have students identify whether backflow or backsiphonage and recommend control.

Use questions to guide class discussion.

Use Transparencies 7-6, 7-7, and 7-8 to show various types of preventive devices. Ask students to explain how each would prevent reverse flow.

List underlined topics on chalkboard. Ask students to list possible sanitary risks to potable water supplies.

Explain how each factor is a potential risk. Discuss degree of risk.

Types and Characteristics (10 minutes)

Cross-connection: A connection between a drinking (potable) water system and an unapproved water supply

Types of Cross-Connections

- o Pipe-to-pipe
- o Pipe-to-water

Contamination Hazard

Contamination hazards result from polluted fluids entering the potable system through the cross-connection, generally when distribution pressure is inadequate.

- o Backsiphonage occurs when a negative pressure or partial vacuum is created in the potable system.
- o Backflow occurs when the pollution source pressure is greater than that in the potable system.

1. What is the major difference between backflow and backsiphonage?
2. How can a building be protected against backsiphonage?

Contamination Prevention

- o Removal of physical connection
 - o Air gap separators
 - o Surge tanks with air gaps
- o Double check, double gate valves
- o Approved backflow prevention devices
 - o Vacuum breaker
 - o Reduced pressure zone
 - o Swing connection
 - o Barometric loop

Locations (5 minutes)

Unauthorized Connections from Facility

- o To other systems, i.e., fire systems
- o To unapproved wells
- o Restricted uses
 - Fixtures and equipment regulated by ordinance

Use personal experiences and anecdotes to relate the course material to actual situations an inspector may encounter during a sanitary survey.

Ask students to explain why pressure maintenance is critical in preventing contamination. Ask how an inspector might determine that a facility is having pressure problems.

Ask questions that review sanitary risk factors and lead to detailed discussion of how risks occur.

Uncontrolled/Unmonitored Connections from Facility

- o To hazardous water uses
 - Wastewater treatment plants
 - Boiler plants
 - Chemical manufacturing plants
 - Hospitals (health care facilities)
 - Nuclear power plants
- o To intermediate hazards
 - Schools
 - Homes
 - Other
- o No airgap in service line
- o No backflow/back-siphonage prevention devices
- o Insufficient maintenance of devices
 - Inadequate for flow rate
 - Wrong devices
 - Breakdown

Pressure Fluctuations

- o Vacuum at facility
 - Inadequate pumping
 - Emergency-fire, drought, etc.
 - o Reduced pressure in service line
 - Blockage in pipes
 - Break in pipes
 - Hydrant breaks
1. Why must cross-connection control devices be carefully checked after a large fire?
 2. Does a link to a lesser hazard, such as a school, present as great a potential for a cross-connection hazard as a chemical plant?
 3. What should a plumber know about cross-connections before working in a community served by a water facility?

Sanitary Risks (15 minutes)

1. Does the utility have a cross-connection prevention program?

Requirements

- o Authority to establish program
- o Technical provisions relating to eliminating backflow and cross-connections
- o Penalty provisions for violations

Use personal experiences and anecdotes to relate the course material to actual situations an inspector may encounter during a survey.

2. Are backflow prevention devices installed at all appropriate locations and tested periodically?

- o Locations
 - o Wastewater treatment plants
 - o Boiler plants
 - o Chemical plants
 - o Hospitals
 - o Mortuaries, etc.
- o Periodic testing necessary

Use Transparency 7-9.

Emphasize importance of inspectors to point out problems at plant since cross-connections there can affect whole system.

3. Are cross-connections present at the treatment plant?

- o Submerged inlets to solution tanks (hypochlorite, fluoride, etc.) without backflow protection
- o Connections between solution tanks and sewers
- o Split chemical feed going to raw and finished water injection
- o Finished water and supply waterlines connected
- o Finished water used for priming raw water pumps without backflow prevention
- o Garden hoses in buckets, meter vaults, sinks filled with water

Protection Against Cross-Connections

Situation 1 - There is a submerged inlet in the second floor bathtub. An automobile breaks a nearby fire hydrant causing a rush of water and a negative pressure in the service line to the house, sucking dirty water out of the bathtub.

Situation 2 - A direct connection from the city supply to a boiler exists as a safety measure and for filling the system. The boiler water system is chemically treated for scale prevention and corrosion control. The boiler water recirculation pump discharge pressure or backpressure from the boiler exceeds the city water pressure and the chemically treated water is pumped into the domestic system through an open or leaky valve.

Situation 3 - Wastewater seeping from a residential cesspool pollutes a private well that is used for lawn sprinkling. The domestic water system, which is served from a city main, is connected to the well supply by means of a valve. The purpose of the connection may be to prime the well supply for emergency domestic use. During periods of low city water pressure, possibly when lawn sprinkling is at its peak, the well pump discharge pressure exceeds that of the city main and well water is pumped into the city supply through an open or leaky valve.

Situation 4 - A chemical tank has a submerged inlet. The plant fire pump draws suction directly from the city water supply line, which is insufficient to serve normal plant requirements and a major fire at the same time. During a fire emergency, reversed flow may occur within the plant.

Situation 5 - A single-valved connection exists between the public, potable water supply and the fire-sprinkler system of a mill. The sprinkler system is normally supplied from a nearby lake through a high-pressure pump. About the lake are large numbers of overflowing septic tanks. When the valve is left open, contaminated lake water can be pumped to the public supply.

1. Read the objectives/directions to the students.
2. Allow 10 minutes.
Review and determine acceptability of student responses. Clarify procedures/questions.

Suggested Key

- Situation 1 - The hot and cold water inlets to the bathtub should be above the rim of the tub.
- Situation 2 - As minimum protection, two check valves in series should be provided in the makeup water line to the boiler system. An airgap separation or reduced pressure principle backflow preventer is better.
- Situation 3 - The connection between the well water and city water should be broken.
- Situation 4 - The water service to the chemical tank should be provided through an airgap.
- Situation 5 - The potable water supply to the fire system should be through an airgap, or a reduced pressure backflow preventer should be used.

UNIT 7b: Cross-Connections

Unit Summary

Type and Characteristics of
Cross-Connections
Sanitary Risks

Unit References

Small Water Systems Serving the Public
(Chapter 15)
Cross-Connection Control Manual
Water Supply System Operation
(Chapters 6 and 7)

Basic Material

To prevent contamination of the community's water supply, the purveyor must make sure that service connections are properly made and are continually monitored for cross-connection hazards. A cross-connection is a physical connection or arrangement between otherwise separate piping systems containing potable and other water, whereby water may flow between the two systems. Hazards occur when water flows toward the potable supply instead of from it to the service outlets. Unless controlled, cross connections can result in contaminated water replacing potable water at various sites within a water system. If the contaminated water is unobstructed and its force is great enough, it can enter the potable supply at the water facility, endangering the health of the entire community.

A cross-connection link can be made either as a pipe-to-pipe connection, in which potable and contaminated water pipes are linked without the proper control valves, or as a pipe-to-water connection, in which the outlet from a potable water supply is submerged in contaminated water. Cross-connections are usually made unintentionally or are made because their hazards are not recognized. The two major types of cross-connection hazards--backpressure backflow and backsiphonage backflow--are distinguished by their origins. Backpressure backflow refers to the flow of water toward a potable supply when the contaminated water's pressure is greater than the potable water's pressure. Contaminated water pushes toward the potable supply. (Liquid flows from a place of high pressure to one of lower pressure.) Backsiphonage backflow is a type of backflow resulting from negative pressure (a vacuum) in the distributing pipes of a potable water supply. Contaminated water is sucked up toward the potable supply.

Plumbing defects can occur within any part of a water system, and cross-connection hazards can occur where outside water pressure can exceed potable water pressure. Therefore, cross-connections must be prevented or controlled at all service sites as well as at the water facility.

Successful control of cross-connection hazards depends not only on voluntary monitoring of connections by the water purveyor and water users, but also on an enforceable community control program. If a community subscribes to a modern plumbing code, such as the National Plumbing Code, its provisions will govern backflow and cross-connections. Still, the water facility must obtain authority to conduct a community inspection program through an ordinance or other means. A cross-connection control ordinance should have at least three basic parts:

- Authority for establishment of a program.
- o The technical provisions relating to eliminating backflow and cross-connections.
- o Penalty provisions for violations.

Protection Against Sanitary Risks

At Service Sites: Cross-connections that occur at sites serviced by the water facility can usually be controlled at the sites themselves. For example, a submerged water outlet in an apartment building could result in contamination of the water for the entire building (as well as threatening the water facility's supply) if the water pressure of the contaminated water exceeds that of the potable water. To prevent this cross-connection hazard, each fixture in the building should have a vertical airgap between its water outlet and its flow-level rim. This will eliminate the physical cross-connection link and protect the building (and the municipal supply) against backflow. An airgap separation may also be made at a point where the water service enters the building. (This protects only the municipal supply, however, and not the building system.) Backflow prevention devices, such as double-check, double-valve assemblies, can be installed when an airgap cannot be made. They can also provide backup when airgaps are made. Surge tanks, booster systems, and color-coding and labeling of pipes in dual water systems also protect buildings against cross-connection backflow. Backsiphonage can be prevented by installation of vacuum-breaking devices at water outlets where contaminated water is used and where a vacuum could occur in the water supply pipe.

At the Water Facility: To lessen the chances of hazardous cross-connections, water facilities should not be connected to unapproved systems or to private wells. If connections must be made to wastewater treatment plants, boiler plants, and other sites with inherently dangerous contaminants, the connections must be carefully monitored at the facility to prevent contamination from entering the water supply. An airgap in the service line to a premise at which extreme hazards exist may be warranted. Waterworks officials often prescribe the installation of a backflow prevention device in the service line to a premise where

hazardous use of water is found. Lesser hazards can often be prevented with backflow prevention devices in other locations. Backflow prevention devices are critical (used exclusively or as backup) in all water facilities because any water pressure greater than that of the facility could cause a flow reversal. Maintenance of systematic water pressure will prevent backsiphonage stemming from the water facility. The facility must also install and maintain devices that block backsiphonage flow as a backup in cases when pressure does drop. (This can occur if a main break or a fire overburdens the pumping capacity.)

Types of Devices:

Vacuum Breaker: A device that is activated by atmospheric pressure to block the water supply line when negative pressure develops in the line. This action admits air to the line and prevents backsiphonage. A vacuum breaker is not designed to provide protection against backflow resulting from backpressure, and should not be installed where backpressure may occur.

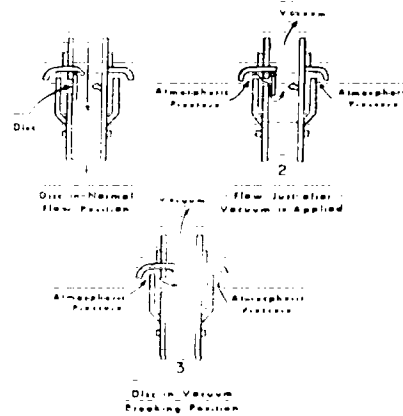

Pressure-Type Vacuum Breaker: This device is installed in pressurized systems and will operate only when a vacuum occurs. It is usually spring loaded, and should be specially designed to operate after extended periods under pressure because corrosion and deposition of material in the line might render it inoperable.

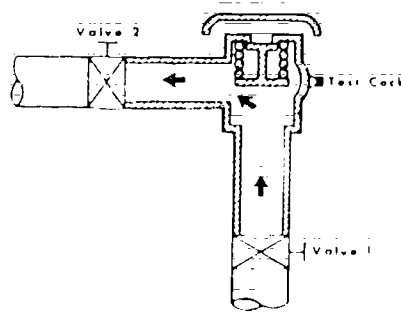

WT 2-14

Reduced Pressure Zone Backflow Preventer (RPZ): This device consists of two hydraulically or mechanically loaded pressure-reducing check valves, with a pressure-regulated relief valve located between the two check valves. Flow from the left enters the central chamber against the pressure exerted by the loaded check valve 1. The supply pressure is reduced by a predetermined amount. The pressure in the central chamber is kept lower than the incoming supply pressure through the operation of relief valve 3, which discharges to the atmosphere whenever the central chamber pressure is within a few pounds of the inlet pressure. Check valve 2 is lightly loaded to open with a pressure drop of 1 psi in the direction of flow and is independent of the pressure required to open the relief valve. In the event that the pressure increases downstream from the device, tending to reverse the direction of flow, check valve 2 closes, preventing backflow. Because all valves may leak as a result of wear or obstruction, the protection provided by the check valves is not considered sufficient. If some obstruction prevents check valve 2 from closing tightly, the leakage back into the central chamber would increase the pressure in this zone, the relief valve would open, and flow would be discharged to the atmosphere.

When the supply pressure drops to the minimum differential required to operate the relief valve, the pressure in the central chamber should be atmospheric. If the inlet pressure should drop below atmospheric pressure, relief valve 3 should remain fully open to the atmosphere to discharge any water that may flow back as a result of backpressure and leakage of check valve 2.

Malfunctioning of one or both of the check valves or relief valve should always be indicated by a discharge of water from the relief port. Under no circumstances should plugging of the relief port be permitted because the device depends on an open port for safe operation. The pressure loss through the device may be expected to average between 10 and 20 psi within the normal range of operation, depending upon the size and flow rate of the device.

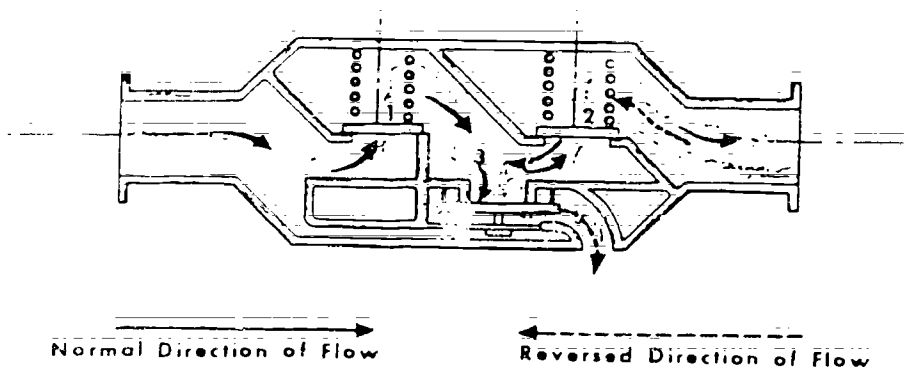

Double-Check, Double-Gate Valve Assembly: The double-check, double-gate valve assembly is a very useful and, when properly maintained, reliable means of backflow protection for intermediate degrees of hazard. As in the case of other backflow preventers, the double-check, double-gate valve assembly should be inspected at regular intervals. Some health authorities have established programs of annual inspection.

The double-check, double-gate system has the advantage of a low head loss. With the gate valves wide open, the two checks, when in open position, offer little resistance to flow.

Double-check, double-gate assemblies should be well designed and constructed. The valves should be all bronze or, for larger sizes, galvanized gray iron. The trim should be of bronze, or other corrosion-resistant material. Springs should be bronze, stainless steel, or spring steel covered with a coat of vinyl plastic. Valve discs should be of composition material with low water absorption properties. Test cocks should be provided.

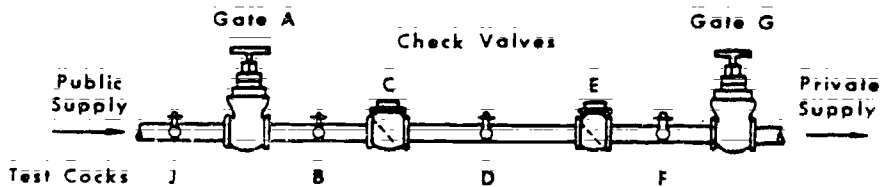

Sanitary Risks

To evaluate the potential risks of cross-connections, the inspector should determine the answers to the following:

1. Does the utility have a cross-connection prevention program?

The inspector should determine if the water facility has obtained authority to conduct a community inspection program through an ordinance or other means. A cross-connection control ordinance should have at least three basic parts:

- o Authority for establishment of a program
- o The technical provisions relating to eliminating backflow and cross-connections
- o Penalty provisions for violations

2. Are backflow prevention devices installed at all appropriate locations (wastewater treatment plants, hospitals, industrial locations)?

The threat of cross-contamination hazards is especially great at wastewater treatment plants, boiler plants, chemical manufacturing plants, hospitals, and nuclear power plants. Their water may contain inherently dangerous materials. These sites should be ensured against physical leaks and should be equipped with devices to prevent backflow and backsiphonage from contaminating water on the premises.

3. Are cross-connections present at the treatment plant?

The inspector should briefly discuss with the operator the importance of ensuring that there are no cross-connections at the plant either on a temporary or permanent basis. One way to help minimize the potential of cross-connections is to have the piping in the plant color coded. The primary sources of cross-connections in the treatment plant are submerged inlets to solution tanks, connections between potable water lines and process water lines, and at pumps. When using phosphate solutions, tanks must be kept covered and disinfected by carrying a 10 mg/l free chlorine residual to prevent the growth of bacteria.

Distribution Systems

268

Distribution Systems

269

Types of Pipe

- Galvanized
- Cast Iron/Ductile Iron
- Copper
- Abestos Cement
- Plastic
- Lead

Types of Pipe

- | | |
|------------|--------------------------|
| Galvanized | • Cast Iron/Ductile Iron |
| Copper | • Abestos Cement |
| Plastic | • Lead |

Valves

- Gate
- Check
- Flow Control
- Blowoff
- Altitude
- Air Relief
- Hydrants

Valves

Gate

Check

Flow Control

Blowoff

- Altitude
- Air Relief
- Hydrants

valves

Gate

Check

Flow Control

Blowoff

- Altitude
- Air Relief
- Hydrants

A Cross-Connection Is?

A Connection Between a Drinking Water System and Unapproved Water.

277

76

A Cross-Connection Is?

A Connection Between a Drinking Water System and Unapproved Water.

Types of Cross-Connections

- Backsiphonage Backflow
- Backpressure Backflow

Types of Cross-Connections

- Backsiphonage Backflow
- Backpressure Backflow

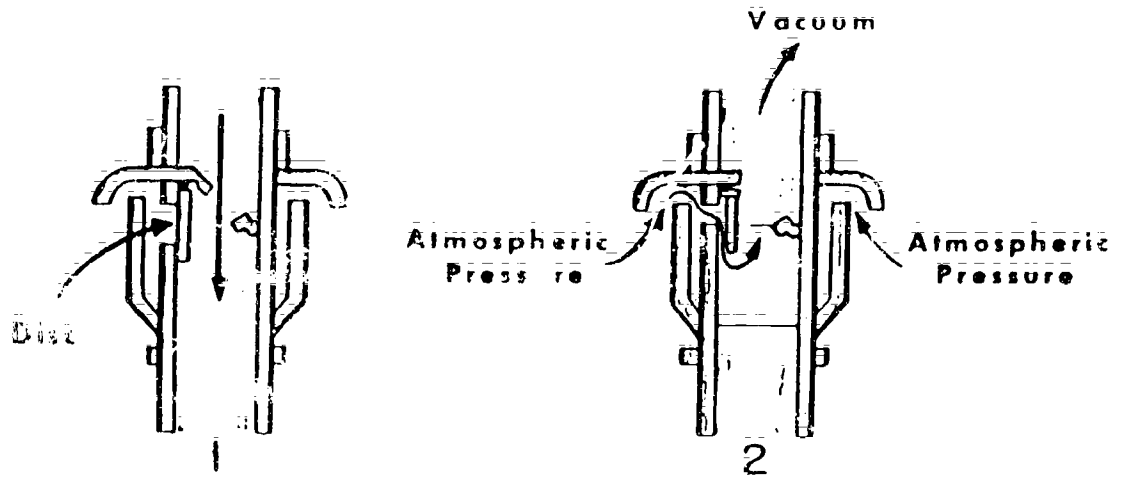

Disc in Normal
Flow Position

Flow Just after
Vacuum is Applied

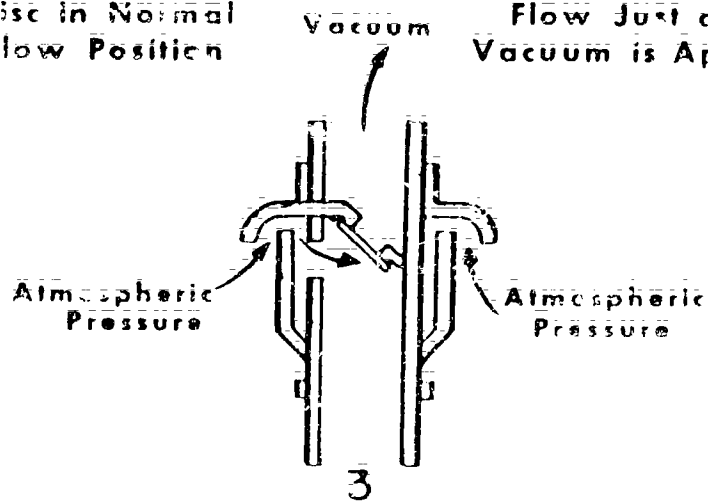

Disc in Vacuum
Breaking Position

Operation of a vacuum breaker.

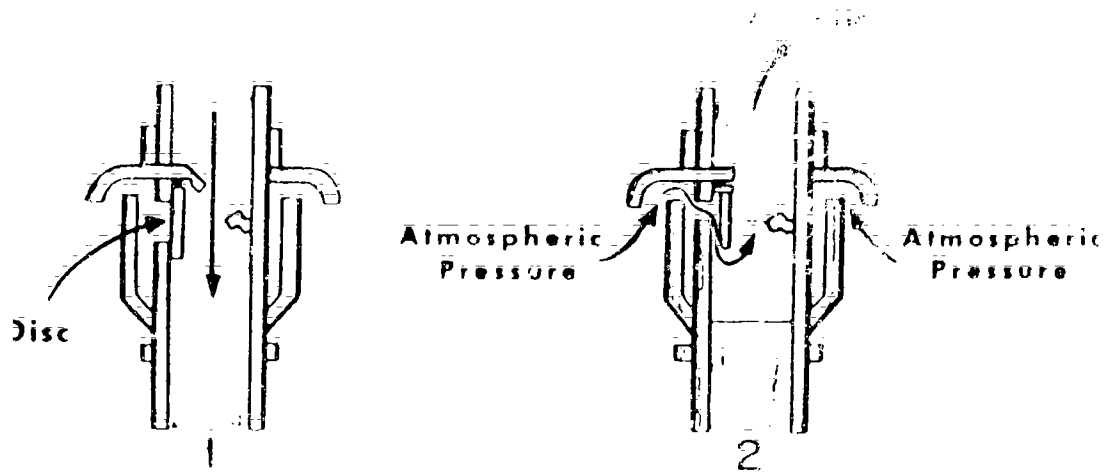

Disc in Normal Flow Position

Vacuum

Flow Just after Vacuum is Applied

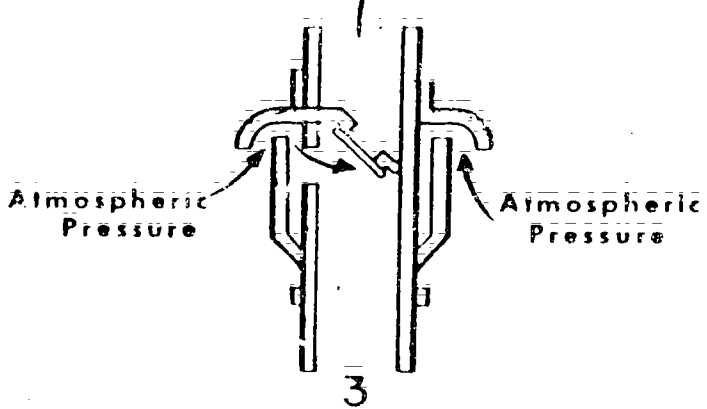

Disc in Vacuum Breaking Position

Operation of a vacuum breaker.

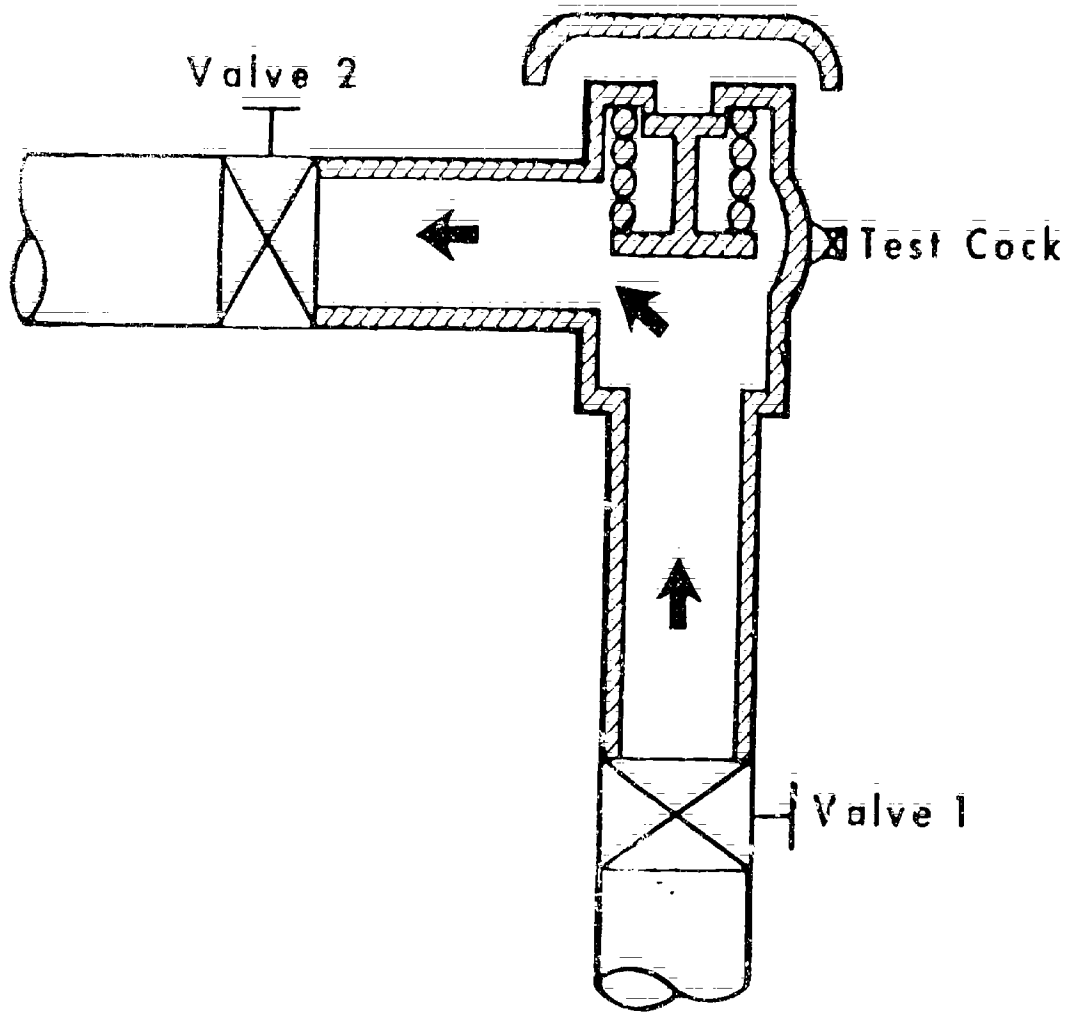

Pressure-type vacuum breaker installation

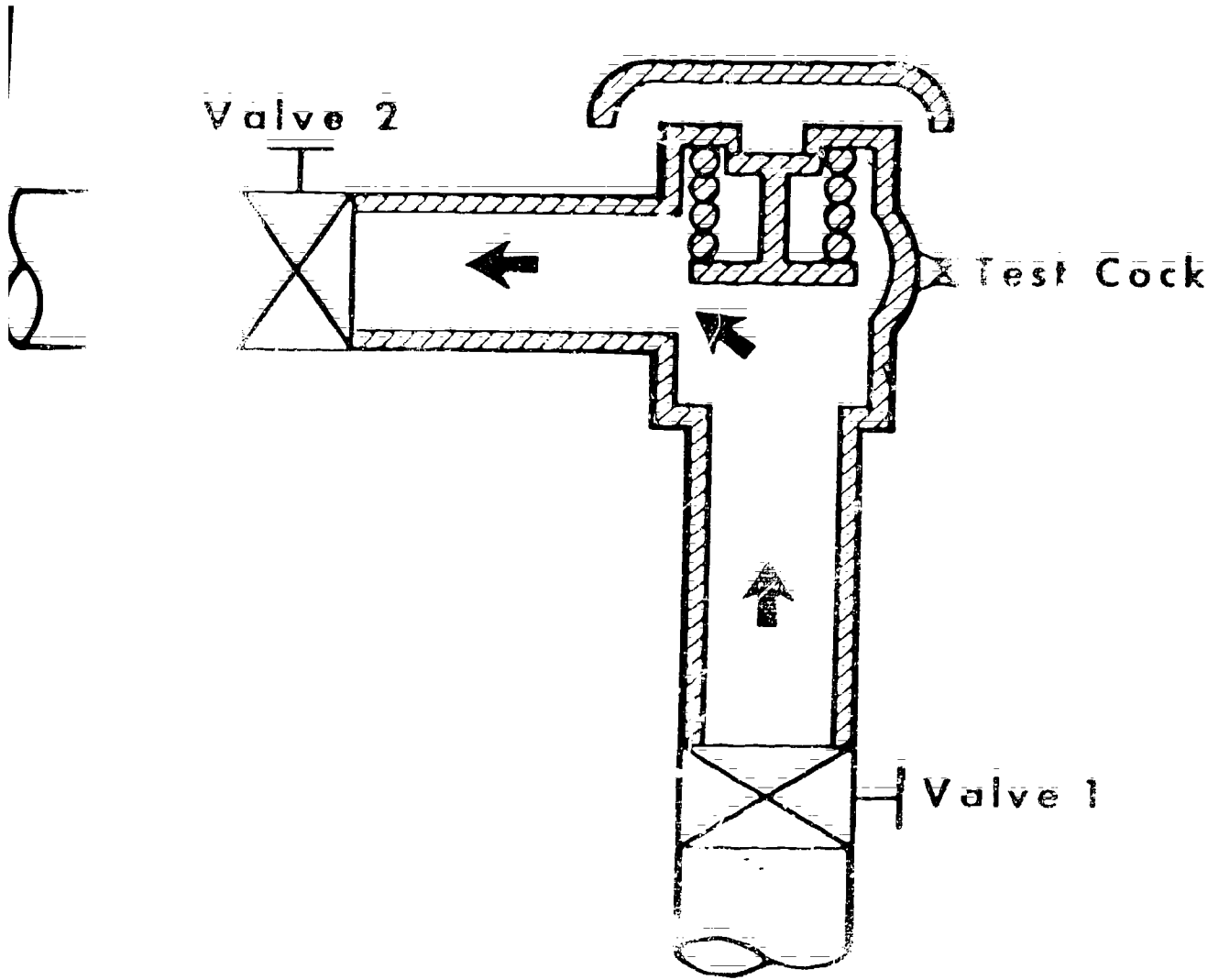

Pressure-type vacuum breaker installation.

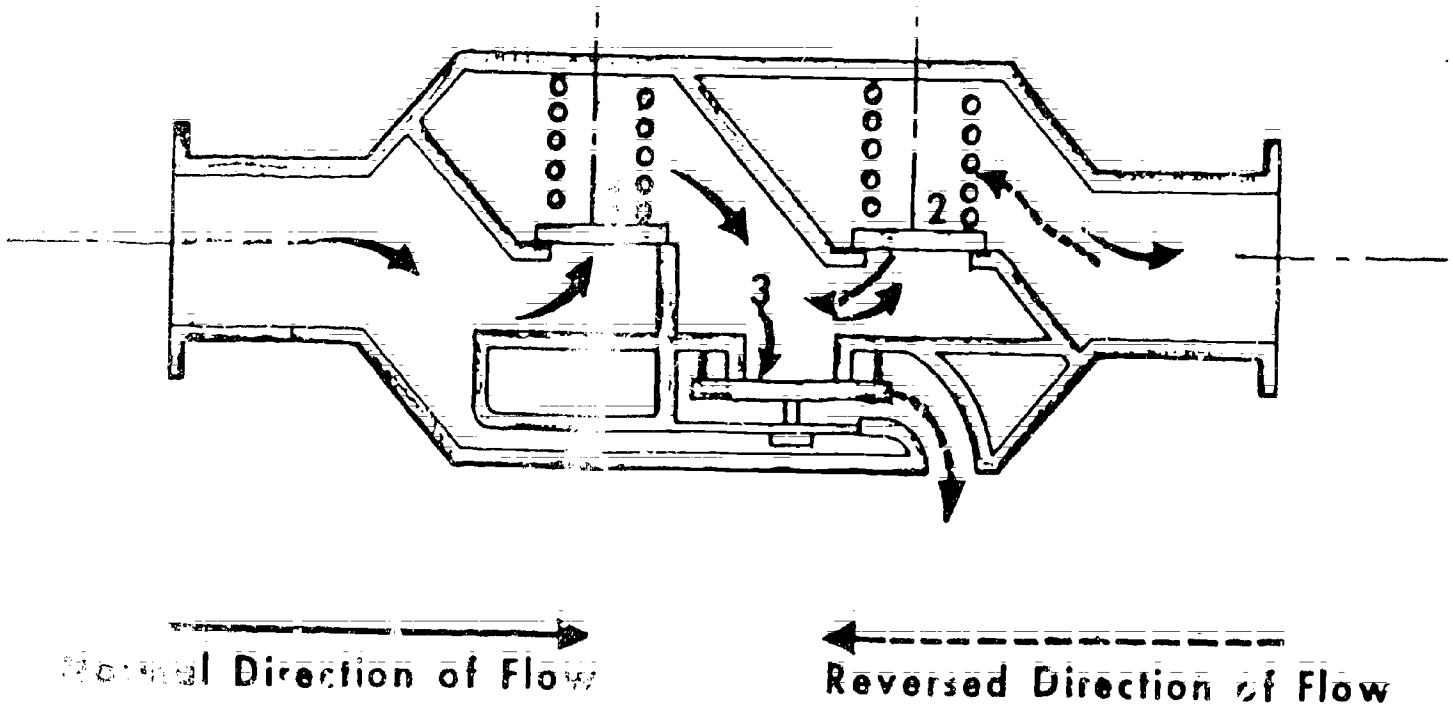

Reduced pressure zone backflow preventer – principle of operation.

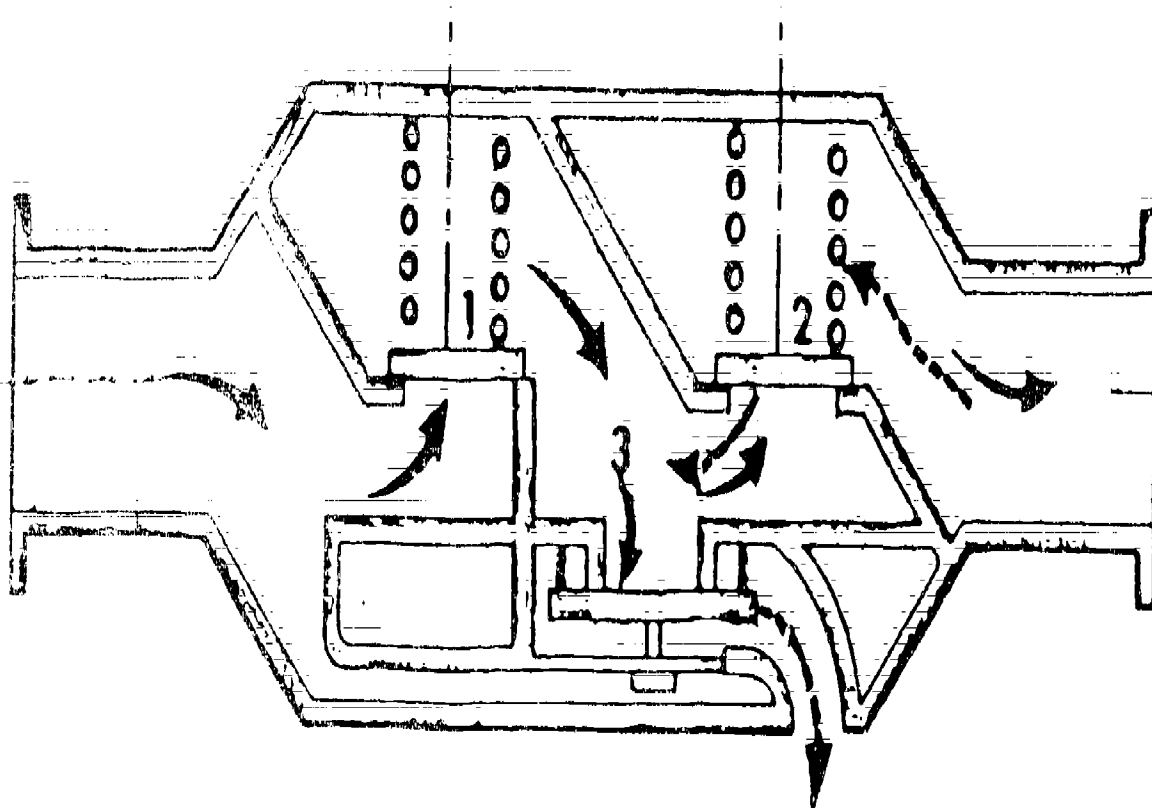

 Normal Direction of Flow

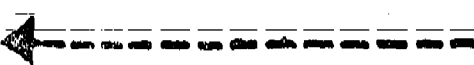
 Reversed Direction of Flow

Reduced pressure zone backflow preventer –
principle of operation.

Treatment Plant Situations:

- Submerged Inlets
- Solution Tank-Sewer Connections
- Split Chemical Feeds
- Finished Raw Water Connections
- Classic "Garden Hose" Situations

Treatment Plant Situations:

- Submerged Inlets
- Solution Tank-Sewer Connections
- Split Chemical Feeds
- Finished Raw Water Connections
- Classic “Garden Hose” Situations

UNIT 8: MONITORING/RECORDKEEPING - "THE NEED TO KNOW"

Unit Summary

Monitoring Responsibility
Monitoring Requirements
Recordkeeping
In-plant Monitoring

Unit Objectives

A function of a sanitary survey is to determine facility compliance with the monitoring requirements. In order to make this determination, an inspector must be familiar with the regulations, sampling and testing procedures, and laboratory report evaluation.

Logistics

Approximate Presentation Time: 45 minutes

Instructor Materials

- o Basic Material
- o Transparencies 8-1 through 8-5
- o NIPDWR

Student Materials

- o Student's Text, Unit 8

Student Preparation

- o Read Unit 8 prior to the session.

Unit References

- o National Interim Primary Drinking Water Regulations
- o Water Treatment Plant Operation (Volume I, Chapter 10)

Section 141.10(a)(1) 8-1.

Discuss the responsibilities for monitoring that exist with the water purveyor.

Section 141.10(a)(2) 8-2.

Monitoring (10 minutes)

Responsibilities of Water Purveyor:

- o Arrange for all applicable sampling required in the regulations.
- o Arrange for sample examinations at a State-approved laboratory.
- o Note: Some States may require the inspector to take samples and submit them to an approved laboratory as a routine part of a sanitary survey.

Frequency Requirements for Sampling and Analysis

MICROBIOLOGICAL

<u>Contaminant</u>	<u>Surface Source</u>	<u>Ground Source</u>
<u>Coliform Bacteria</u>	<p>Monthly, based on population served</p> <p>Community systems of less than 1,000 people, a minimum of one per month</p> <p>Noncommunity systems, a minimum of one per calendar quarter</p>	<p>Same as for surface sources except that State agency may reduce to one sample per calendar quarter</p>

INORGANIC CHEMICALS (Applies only to community systems except for nitrate, which applies to both community and non-community)

Contaminant	Surface Source	Ground Source
Arsenic Boron Cadmium Chromium Lead Mercury Selenium Silver Fluoride Nitrate	Analysis at 1-year intervals	Analysis at 3-year intervals

ORGANIC CHEMICALS

Contaminant	Surface Source	Ground Source
Dieldrin Dibane Methoxychlor Toxaphene 2,4-D 2,4-DDE Silver	Analysis at 3-year intervals	Analysis only if required by the State
Total Trihalo- methanes	Sampling and analysis conducted quarterly	
Individual States may require greater frequency of sampling and analysis.)		

RADIOACTIVITY (Applies only to community-type systems)

Contaminant	Surface Source	Ground Source
Natural Radioactivity	Analysis completed at 4-year intervals	Analysis completed within 3 years after effective date; thereafter at 4-year intervals

SODIUM (Applies only to community-type systems)

Surface Source	Ground Source
Sampling and analysis conducted annually	Sampling and analysis conducted every 3 years

CORROSIVITY CHARACTERISTICS (Applies only to community-type systems)

Surface Source	Ground Source	
(One round of sampling and analysis)	Two samples to be taken: one midwinter and one midsummer	Only one sample and analysis required

(NOTE: Individual States may require a greater frequency of sampling and analysis.)

TURBIDITY

Surface Source	Ground Source
Sampling of at least once per day	Not applicable

Use the question to promote class discussion:

Alert students that there are other contaminants than those covered by the regulations, and to be on the lookout for unusual conditions that might pose a risk of contamination.

Ensure that students have a copy of the National Interim Primary Drinking Water Regulations (EPA-570/9-76-003) and have them locate section on MCLs for future reference.

Use the question to promote class discussion.

Use Transparency 8-3.

Discuss requirements of NIPDWR for record-keeping.

1. How would an inspector determine that a facility has met the frequency requirements for sampling and analysis?

References (NIPDWR):

- o Inorganic Chemicals (141.11 and 141.23)
- o Organic Chemicals (141.13 and 141.24)
- o Coliform Bacteria (141.14 and 141.22)
- o Radioactivity (141.15, 141.16, and 141.26)

1. When would an inspector use MCL information?

Recordkeeping (5 minutes)

- o Bacteriological analyses - for at least 5 years
- o Chemical analyses - for at least 10 years

Actual laboratory reports may be kept or data may be transferred to tabular summaries, provided that the following information is included:

- date, place, time of sampling, name of person collecting
- identification of routine distribution system sample, check samples, raw or process water samples, special-purpose samples
- date of analyses
- lab and person responsible for performing analysis
- analytical method used
- results of analysis

- o Records of action taken to correct violations - for at least 3 years after last action was taken with respect to a particular violation

- o Copies of written reports, summaries, or communications relating to sanitary surveys conducted by the facility, private consultant, or local, State or Federal agency - for at least 10 years after completion of the sanitary survey involved
- o Records concerning scheduling of improvements not less than 5 years following expiration of scheduling time

Use Transparencies 8-4 and 8-5.

Discuss reasons for in-house monitoring.

Draw sample point scheme on blackboard. Ask students for reasons for particular analysis. See schematic provided.

In-house Monitoring (20 minutes)

Reasons for In-house Monitoring

- o Important for proper operation of treatment units
- o Identifies trends in water quality
- o Identifies problems in water treatment before finished water quality is affected

Sample Points and Parameters

- o Dependent on type of treatment
- o Frequency dependent on type of source, variability of source, importance of parameter

Monitoring Program Evaluation

1. Is operator competent and certified to perform the tests?
2. Are testing facilities and equipment adequate?
3. Do reagents used have an unexpired shelf life?
4. Are records of the test results being maintained?
5. Are tests and operational results being supplied to the state regulatory agency (as required)?

Sampling Points

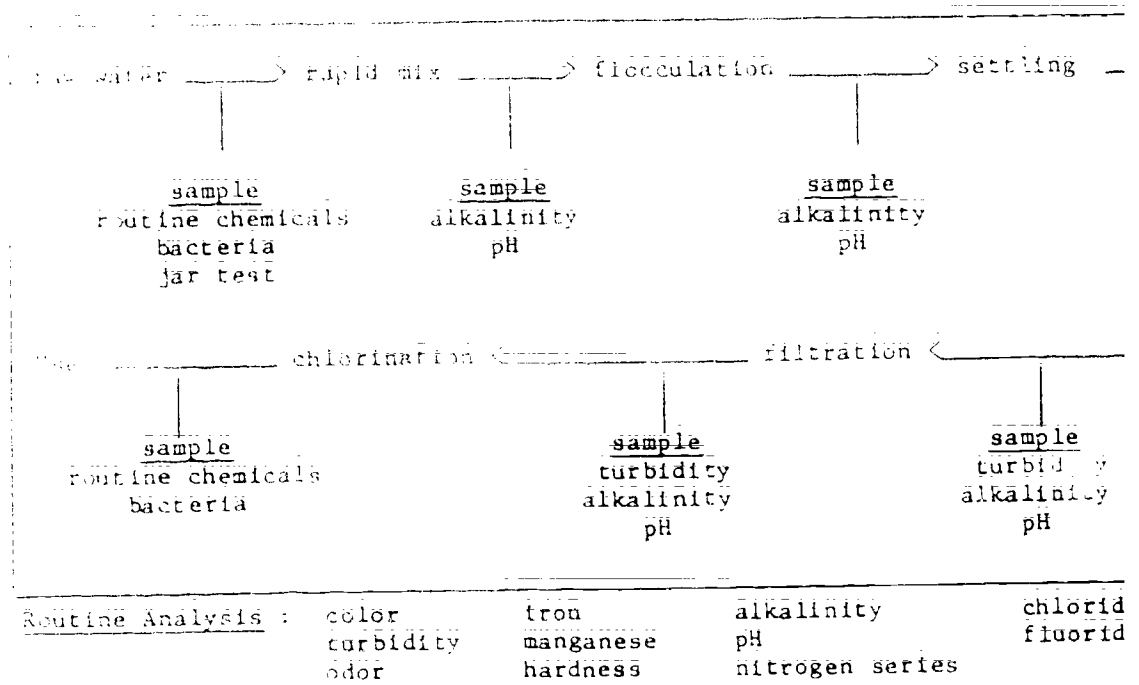

Sample Points and Analysis

UNIT 8: MONITORING/RECORDKEEPING

Unit Summary

Monitoring Responsibility
Monitoring Requirements
Recordkeeping
In-plant Monitoring

Unit References

National Interim Primary Drinking Water
Regulations
Water Treatment Plant Operation (Volume I,
Chapter 10)

Basic Material

The National Primary Drinking Water Regulations outline responsibilities and requirements of the water purveyor with respect to monitoring. The responsibilities for monitoring are:

1. Arrange for all applicable sampling required in the regulations.
2. Arrange for sample examinations at a State-approved laboratory.

The requirements for sampling frequency are provided in the tables included in this unit.

Frequency Requirements for Sampling and Analysis

MICROBIOLOGICAL

Contaminant	Surface Source	Ground Source
Coliform Bacteria	<p>Monthly, based on population served</p> <p>Community systems of less than 1,000 people, a minimum of one per month</p> <p>Noncommunity systems, a minimum of one per calendar quarter</p>	Same as for surface sources except that State agency may reduce to one sample per calendar quarter

INORGANIC CHEMICALS

(Applies only to community systems except for Nitrate, which applies to both community and noncommunity)

Contaminant	Surface Source	Ground Source
<p>Arsenic</p> <p>Barium</p> <p>Cadmium</p> <p>Chromium</p> <p>Lead</p> <p>Mercury</p> <p>Selenium</p> <p>Silver</p> <p>Fluoride</p> <p>Nitrate</p>	Analysis at 1-year intervals	Analysis at 3-year intervals

ORGANIC CHEMICALS

Contaminant	Surface Source	Ground Source
Endrin Lindane Methoxychlor Toxaphene 2,4-D 2,4,5-TP Silvex	Analysis at 3-year intervals	Analysis only if required by the State
Distal Trihalo-methanes	Sampling and analysis conducted quarterly	

(Individual States may require greater frequency of sampling and analysis.)

RADIOACTIVITY (Applies only to community-type systems)

Contaminant	Surface Source	Ground Source
Natural Radioactivity	Analysis completed at 4-year intervals	Analysis completed within 3 years after effective date; thereafter at 4-year intervals

SODIUM (Applies only to community-type systems)

	Surface Source	Ground Source
	Sampling and analysis conducted annually	Sampling and analysis conducted every 3 years

CORROSIVITY CHARACTERISTICS (Applies only to community-type systems)

	Surface Source	Ground Source
(One round of sampling and analysis)	Two samples to be taken: one midwinter and one midsummer	Only one sample and analysis required

(NOTE: Individual States may require a greater frequency of sampling and analysis.)

TURBIDITY

	Surface Source	Ground Source
	Sampling of at least once per day	Not applicable

The following records must be kept by the water supplier as outlined by NIPDWR:

- o Bacteriological analyses - for at least 5 years.
- o Chemical analyses - for at least 10 years. Actual laboratory reports may be kept, or data may be transferred to tabular summaries, provided that the following information is included:
 - o Date, place, time of sampling, name of person collecting
 - o Identification of routine distribution system sample, check samples, raw or process water samples, special purpose samples, date of analyses
 - o Lab and person responsible for performing analysis
 - o Analytical method used
 - o Results of analysis
- o Records of action taken to correct violations - for at least 3 years after last action was taken with respect to a particular violation.

- o Copies of written reports, summaries or communications relating to sanitary surveys conducted by itself, private consultant, or local, State or Federal agency - for at least 10 years after completion of sanitary survey involved.
- o Records concerning scheduling of improvements - not less than 5 years following expiration of scheduling time.

The inspector should ensure that the required monitoring is being conducted and that analysis is performed by a certified laboratory. Recordkeeping should also be evaluated to determine compliance with the regulation.

The previously discussed monitoring is required to comply with the regulations. The analysis for those samples, with the exception of turbidity and chlorine residual, must be conducted by an approved laboratory. The operator must establish an in-house monitoring program to properly evaluate the operation of the treatment system. The number of parameters and sample points is dependent on the type of treatment required. The frequency of the sampling will depend on the type of source, its variability of quality, and the importance of the parameter being evaluated. The chart below illustrates sampling points and suggested monitored parameters.

Sampling Points

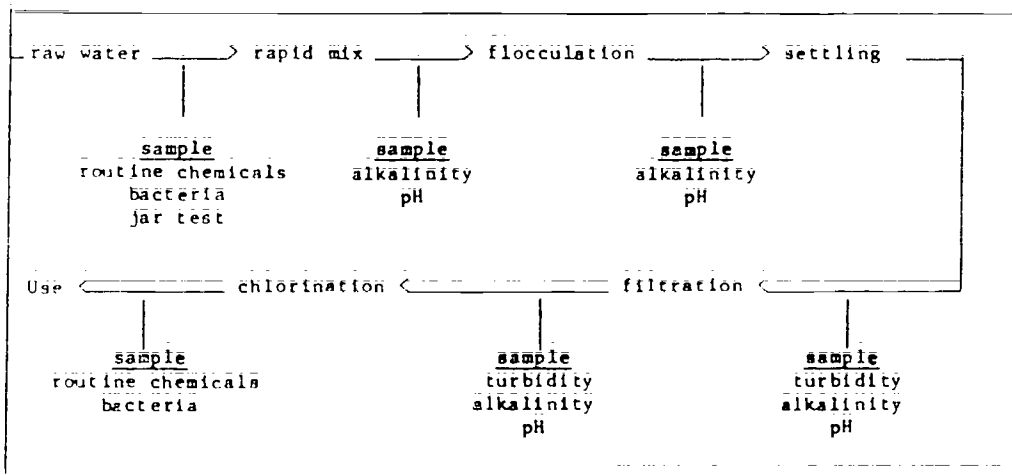

Routine Analysis: color iron alkalinity chloride
 turbidity manganese pH fluoride
 odor hardness nitrogen series

With respect to this in-house monitoring, the inspector should be concerned with the following points:

1. Is the operator competent in performing the tests?

The inspector may wish to observe the operator's technique in collecting samples and performing analyses. The operator should follow the correct procedures such as calibrating and zeroing specific ion electrodes. The operator should be aware of interferences that may cause incorrect readings.

2. Are testing facilities and equipment adequate?

The water utility should be encouraged to have equipment to enable proper operational monitoring. The equipment should be in working order. The inspector may wish to look at the equipment. The operation of the plant is not aided by a pH electrode that the operator has been using which has been dry for the last 6 months. The facilities should be adequate for the equipment utilized. Many of the electronic instruments are influenced by temperature and humidity.

3. Do reagents used have an unexpired shelf life?

The operator should be encouraged to mark the date of preparation on reagents and to discard when appropriate. The manufacturer-prepared reagents should be discarded when the expiration date is reached.

4. Are records of test results being maintained?

The records of test results should be kept so that trends may be observed. The inspector should determine what action is taken based on the test results. The operators should know the importance of the particular test and what the results mean.

Monitoring/ Recordkeeping

8-8

TRANSPARENCY 8-1

306

Monitoring/ Recordkeeping

307

Responsibilities:

- Arrange for Required Sampling
- Sample Examination at State-approved Laboratory.

Responsibilities:

- Arrange for Required Sampling
- Sample Examination at State-approved Laboratory.

Responsibilities:

Arrange for Required Sampling
Sample Examination at State-approved
Laboratory.

Recordkeeping

4-10

EDRS 311-100

311

Recordkeeping

312

In-House Monitoring

313

9-11

TRANSPARENCY R-4

In-House Monitoring

314

Why Monitor?

- Proper Operation
- Identify Water Quality Trends
- Identify Water Treatment Problems

Why Monitor?

Proper Operation

Identify Water Quality Trends

Identify Water Treatment Problems

UNIT 9: MANAGEMENT/SAFETY - "THE NEED TO KNOW"

Unit Summary

Personnel
Finance
Emergency Planning
Safety

Unit Objectives

The inspector, in order to evaluate the total system, must be concerned with its management and safety aspects. This unit briefly discusses points of importance in these two areas.

Logistics

Approximate Presentation Time: 45 minutes

Instructor Materials

- o Basic Material
- o Transparencies 9-1 to 9-3
- o Chalkboard

Student Material

- o Student's Text, Unit 9

Student Preparation

- o Read Unit 9 prior to the session.

Unit References

- o Manual of Water Utility Operation
- o Water Treatment Plant Operation (Volume I)
- o Water Supply System Operation

Use Transparency 9-1.

Use Transparency 9-2:

Discuss aspects of management that are important to the operation of the system.

Ask students for factors affecting personnel requirements.

Use Transparency 9-3.

Emphasize the importance of safety for both the inspector and the operator.

Briefly discuss hazards and safety precautions.

Management (15 minutes)

o Personnel

1. Are personnel adequately trained and/or certified?
 - o In-house training programs
 - o Correspondence courses
 - o Short courses
2. Are there sufficient personnel?
 - o State requirements
 - o Sickness, vacations
3. Are the financing and budget satisfactory?
 - o Present operation and maintenance
 - o Future replacements
 - o Future expansion
4. Is an emergency plan available and workable?

Safety (30 minutes)

- o Source of Hazards
 - Electrical shock
 - Exposure to chemicals
 - Drowning
 - Working in confined spaces
 - High-intensity noise
 - Sprains and strains due to lifting
 - Slips and falls
- o Safety Equipment
 - Helmets
 - Goggles
 - Gloves
 - Shoes
 - Respirators
 - Self-contained breathing apparatus
- o Safety Concerns
 - Is adequate safety and personal protective equipment provided?
 - Are the facilities free of safety hazards?

The management of the water system does not of itself represent a sanitary risk to the quality of the water. However, there are several aspects of management that will affect the overall capabilities of the system.

Personnel

1. Are personnel adequately trained and/or certified?

In order to properly operate a system, personnel must be adequately trained. This can be provided by an in-house training program conducted by more experienced personnel. Correspondence courses such as Water Treatment Plant Operation, Water Supply System Operation and AWWA courses are a means for a small system operator to receive training relatively inexpensively. Operators should also be certified by the appropriate state regulatory agency. Proof of certification should be prominently displayed or otherwise made available to the inspector.

2. Are there sufficient personnel?

There should be enough personnel to provide for operation during vacations or sickness as a minimum. The number of operators is dependent on the type and size of the treatment process.

Finance

3. Are the financing and budget satisfactory?

The system should be able to have sufficient funds for operation, maintenance, and future replacements.

Emergency Planning

4. Is an emergency plan available and workable?

The utility should have a contingency plan that outlines what action will be taken and by whom. The emergency plan should meet the needs of the facility, the geographical area, and the nature of the emergency likely to occur. Conditions such as storms, floods, and civil strife should be considered.

Another aspect of management is safety. This is a concern if the system has 1 operator or 50. It has been pointed out previously that safety should be a concern of the inspector, both his safety and that of the operator. There are a number of safety hazards including:

1. Electrical shock
2. Exposure to chemicals
3. Drowning
4. Working in confined spaces
5. High-intensity noise
6. Sprains and strains due to lifting
7. Slips and falls

The first choice in preventing accidents is to engineer out the exposure. An example of this is providing guards for all rotating equipment and belts. This choice is not always possible. The second choice is the use of protective equipment. The most frequently used equipment and a necessity of every plant are the following:

- o Safety Helmets - provide protection from falling objects in manholes and pipe galleries. Can be used as a means of identification.
- o Goggles - provide eye protection from chemicals and flying objects. They may need to be supplemented by full face shield when working with some chemicals.
- o Gloves - provide protection against injuries from chemicals and equipment.
- o Shoes - steel-toed safety shoes provide protection from falling objects.
- o Respirators - protect the wearer from inhalation of dust, organic vapors, and other chemicals. This equipment is only to be used where the atmosphere is known not to be oxygen deficient.
- o Self-contained Breathing Apparatus - provides protection in oxygen deficient atmospheres where the operator must work, such as repairing chlorine leaks.

With regard to safety the inspector should be concerned with:

1. Is adequate safety and personal protective equipment provided?
2. Are the facilities free of safety hazards?

Management/Safety

9-3

TRANSPARENCY 9-1

321

Management/ Safety

322

Management

- Personnel
- Finances

323

9-4

TRANSPARENCY 9-2

Management

- Personnel
- Finances

Safety

- Electrical Shock
- Chemicals
- Drowning
- Confined Spaces
- Noise
- Lifting
- Slips/Falls

Safety

Electrical Shock
Chemicals
Drowning
Confined Spaces

- Noise
- Lifting
- Slips/Falls

UNIT 10: SURVEYS - "THE NEED TO KNOW"

OBJECTIVES

Survey Techniques
Sample Survey Forms

UNIT DESCRIPTION

The inspector must know how to actually conduct a sanitary survey. This unit outlines the three phases of a sanitary survey and some activities that should occur in those phases. A set of sample survey forms is also presented.

ESTIMATED

Approximate Presentation Time: 60 minutes

Instructor Materials

- o Basic Material
- o Transparencies 10-1 to 1-5

Student Material

- o Student's Text, Unit 10

Student Preparation

- o Read Unit 10 prior to the session.

Unit References

None

Discuss transparencies 10-1 and 10-2.

Explain the purpose of a sanitary survey.

Transparency 10-3:

Explain the importance of this phase.

Transparency 10-4.

Use personal experiences and anecdotes to relate program material to information that inspectors will encounter.

Transparency 10-5:

Explain functions of a sanitary report.

Briefly discuss the sample forms.

Schedule

- Planning schedule
- o Estimating time
- o Phases of survey

Preparation Phase

- o Review of available records
- o Review of chemical and bacteriological files
- o Review of self-monitoring reports
- o Make contact with owner/operator and establish survey date and time
- o Notification of any schedule changes

Onsite Phase

- o Review of system complaints
- o Review of monthly operator reports and in-house monitoring
- o Complete investigation of the water supply, treatment, and distribution facilities
- o Make general description of the system and a flow diagram
- o Exchange of information between operator and inspector
- o Completion of form
- o Sampling
- o Debriefing

Report Writing Phase

- o Function
 - o Formal notification of deficiencies
 - o Motivate corrective action
 - o Provide records of compliance, future inspections
- o Activities
 - o Complete formal report
 - o Notification of appropriate organizations
 - o Followup on technical assistance/questions asked by owner
 - o Notification of variance of written evaluation from oral debriefing
- o Sample Forms
 - o Sample form compiled from this text
 - o State of Alaska
 - o State of Maine
 - o State of Missouri
 - o State of South Carolina

(Can be used to develop or compare forms.)

In the previous chapters, the concerns of a sanitary inspector have been outlined. In this unit a plan for doing the survey will be developed. As this plan is developed and the use of a standard form is discussed, it is important for the inspector to remember what the purpose of the survey is. The inspector is to perform an onsite review of the water source, facilities, equipment, operation, and maintenance of a public water system for the purpose of evaluating the adequacy of such source, facilities, equipment, operation, and maintenance for producing and distributing safe drinking water. This purpose is easy to forget and to let the survey become an exercise in completing the blanks in a particular form. As an inspector, you need to concentrate on identifying potential or existing problems and evaluating their risks.

In planning for a survey, an estimate of the time required will help in managing your schedule. The estimate should include time prior to, during, and after the survey. Although the time required will vary with the complexity and the experience of the inspector, a good rule of thumb would be 2 days in the office for every day in the field.

Prior to each survey the inspector should review all available file information concerning the system being surveyed. This review will assist you in being fully briefed on the system's past history and present conditions. Many times, if you are familiar with the past system history, past inspections, reports, memorandums, telephone communications, you can dispel remarks made concerning previous letters, conversations, etc., that are taken out of context, altered, or just misunderstood. This knowledge of the system's past conveys to the water system personnel a concern for the system and professionalism on your part. Once the owner, operator, or engineer realizes you are familiar with their operations and past dealings with your agency, they will normally take the inspecting party more seriously and the end result will be better, more accurate, and useful information concerning their operation and facilities. In this preparation period, the initial contact should be established with the water system. Telephone contact to establish a mutually acceptable date for the onsite visit is beneficial. A short notification letter giving the survey time and date should be forwarded with instructions for requesting changes to the schedule. This is also a good opportunity to reiterate the reasons for performing the survey and to inform them of specific information they will need to provide. This should be provided in sufficient time for the water system personnel to respond to the notice. If the inspector must change the schedule, it must be done at the earliest possible time. The survey must never be postponed or cancelled without prior notification.

A brief synopsis of activities during this period follows:

1. Detailed general file review.
2. Detailed review of chemical and bacteriological files.
3. Review self-monitoring reports.
4. Make contact with owner/operator to establish survey date and time.
5. Give early notice of any schedule change.

In performing the onsite survey, the first step is to be punctual. This will prevent getting off to a bad start because the operator had to wait.

This brings up the necessity of the successful survey. Imperative to a successful survey is having a representative of the water system, preferably the operator, accompany the inspector during the onsite survey. This will allow the inspector and operator to ask questions and develop a mutual confidence in each other's ability. Once this trust has been developed, the operator may be more willing to be open about the operations and problems of the system. This is the period of evaluating the system. In most cases it is good to use a standard form to help the inspector cover all the points of the system. Again it is not the primary function of the survey to complete the form. Many times system owners and operators are "put off" by someone filling out a form. They wonder if you know what you are asking or whether you are just filling out a form with information that may never be used or evaluated. The inspector should know why each question is asked. The judicious use of a form will (a) provide uniformity of inspections, (b) ensure completeness of the inspection by another inspector, (c) facilitate data record, and (d) allow followup inspection by another inspector. There is no best form since each system is different and each report must be tailored to the specific conditions of that system. There are several examples of survey forms provided at the end of this unit. The first is a compilation of the questions that have been asked in the previous chapters. Other examples are from the States of Alaska, South Carolina, Maine, and Missouri. These examples may be used in developing or comparing your own survey form.

Some of the activities that should be conducted at this point are:

1. Review of system complaints.
2. Review of monthly operator reports and in-house monitoring.
3. Complete investigation of the water supply, treatment, and distribution facilities.
4. A general description of the system and a flow diagram.
5. Establishment of an exchange of information between the operator and inspector.
6. Completion of the form as required.
7. Sampling as required.
8. Debriefing of the operator/owner at the end of the evaluation.

The last phase of the survey is the writing of the report. This represents the official notification of the results of the evaluation. The report should be done promptly and reflect the information provided to the operator at the end of the onsite visit. If the written evaluation is different from the oral debriefing, the operator should be advised telephonically of such changes. There is little that is more exasperating to the owner/operator than to receive a written report 6 months after the onsite visit listing deficiencies that he knows nothing about. The purpose of the report is (a) formal notification of deficiencies, (b) motivate corrective action, (c) provide records of compliance and future inspections. The report itself can be as brief as a letter or as detailed as necessary to convey to owners and operators of the system what deficiencies exist and what must be done to correct them.

Briefly, the activities during this period are:

1. Completion of formal report.
2. Notification of appropriate organizations of results
3. Followup on technical assistance/questions asked by owner/operator.
4. Notification of variance of written evaluation from that provided in the oral debriefing.

SURVEY SAMPLE FORM

Date of Survey _____

Name of Facility _____ System Identification _____

Owner _____ Telephone _____

Address _____

County _____

Treatment Plant Telephone Number _____

Name of Operator _____ Certification _____

Water Purchased From _____ Water Sold To _____
(other than system)

SOURCE

1. What type of source? _____
2. What is the total design production capacity? _____ MGD
3. What is the present average daily production? _____ MGD
4. What is the maximum daily production? _____ MGD
5. Does system have an operational master meter? Yes _____ No _____
6. How many service connections are there? _____
7. Are service connections metered? Yes _____ No _____

WELLS

Yes No

1. Is recharge area protected?
Ownership _____ Fencing _____ Ordinances _____
2. What is nature of recharge zones?
Agricultural _____ Industrial _____ Residential _____ Other _____
3. Is site subject to flooding? _____
4. Is well located in proximity of a potential source of pollution? _____
5. Depth of well _____ ft.
6. Drawdown _____ ft.
7. Depth of casing _____ ft.

	Yes	No
8. Depth of grout _____ ft.		
9. Does casing extend at least 12 inches above the floor or ground?	_____	_____
10. Is well properly sealed?	_____	_____
11. Does well vent terminate 18 inches above ground/floor level or above maximum flood level with return bend facing downward and screened?	_____	_____
12. Does well have suitable sampling cock?	_____	_____
13. Are check valves, blowoff valves, and water meters maintained and operating properly?	_____	_____
14. Is upper termination of well protected?	_____	_____
15. Is lightning protection provided?	_____	_____
16. Is intake located below the maximum drawdown?	_____	_____
17. Are foot valves and/or check valves accessible for cleaning?	_____	_____
	Yes	No

SPRINGS AND INFILTRATION GALLERIES

1. Is the recharge area protected? Ownership _____ Fencing _____ Ordinances _____		
2. What is the nature of the recharge area? Agricultural ___ Industrial ___ Residential ___ Other ___		
3. Is site subject to flooding?	_____	_____
4. Is collection chamber properly constructed?	_____	_____
5. Is supply intake adequate?	_____	_____
6. Is site properly protected?	_____	_____
7. What conditions cause changes to quality of the water? _____ _____ _____		

SURFACE SOURCES

1. What is nature of watershed?
 Agricultural ___ Industrial ___ Forest ___ Residential ___
2. What is size of the owned/protected area of the watershed?

3. How is watershed controlled?
 Ownership ___ Ordinances ___ Zoning ___
4. Has management had a watershed survey performed? _____
5. Is there an emergency spill response plan? _____
6. Is the source adequate in quantity? _____
7. Is the source adequate in quality? _____
8. Is there any treatment provided in the reservoir? _____
9. Is the area around the intake restricted for a radius of 200 feet? _____
10. Are there any sources of pollution in the proximity of the intakes? _____
11. Are multiple intakes, located at different levels, utilized? _____
12. Is the highest quality water being drawn? _____
13. How often are intakes inspected? _____
14. What conditions cause fluctuations in quality?

PUMPS

1. Number _____
 Type _____
 Location _____
2. Rated Capacity _____

- | | Yes | No |
|---|-------|-------|
| 3. Are pumps operable? | _____ | _____ |
| 4. What is state of repair of pumps? _____
_____ | | |
| 5. What type of lubricant is used? _____ | | |
| 6. Emergency power | | |
| o What type _____ | | |
| o Frequency of testing _____ | | |
| o Record of primary power failures: _____ in last year. | | |
| o Automatic _____ Manual _____ Switchover _____ | | |
| o Are backup pumps/motors provided? | _____ | _____ |
| 7. Is all electro/mechanical rotating equipment provided with guards? | _____ | _____ |
| 8. Are controls functioning properly and adequately protected? | _____ | _____ |
| 9. Are underground compartments and suction well waterproof? | _____ | _____ |
| 10. Are permanently mounted ladders for pumping stations sound and firmly anchored? | _____ | _____ |
| 11. Is facility properly protected against trespassing and vandalism? | _____ | _____ |
| | Yes | No |

TREATMENT UNITS (Note: Multiple units should have a separate information section completed for each unit.)

Prechlorination/Pretreatment Units

- | | | |
|--|-------|-------|
| 1. What chemical is used? _____ | | |
| 2. What amount is used? _____ lbs/day | | |
| 3. For prechlorination, has TTHM been evaluated? | _____ | _____ |
| 4. Where is point of application? _____ | | |
| 5. Is chemical storage adequate and safe? | _____ | _____ |
| 6. Are adequate safety devices available and precautions observed? | _____ | _____ |

Yes No

Mixing

1. Is mixing adequate based on visual observation? _____
2. Is equipment operated properly and in good repair? _____

Flocculation/Sedimentation

1. Is process adequate based on visual observation? _____
2. Is equipment operated properly and in good repair? _____

Filtration

1. Is process adequate based on visual observation? _____
2. Are instrumentation and controls for the process adequate, operational, and being utilized? _____
3. What type of filter is utilized? _____
4. Is equipment operated properly and in good repair? _____

Post-Chlorination

1. Is adequate chlorine residual being monitored? _____
2. Is the disinfection equipment being operated and maintained properly? _____
3. Is there sufficient contact time (30 minutes minimum) between the chlorination point and the first point of use? _____
4. Is operational standby equipment provided? If not, are critical spare parts on hand? _____
5. Is a manifold provided to allow feeding gas from more than one cylinder? _____
6. Are scales provided for weighing of containers? _____
7. Are chlorine storage and use areas isolated from other work areas? _____
8. Is room vented to the outdoors by exhaust grilles located not more than 6 inches above the floor level? _____
9. Is a means of leak detection provided? _____

- | | Yes | No |
|---|-------|-------|
| 10. Is self-contained breathing apparatus available for use during repair of leaks? | _____ | _____ |
| 11. Are all doors hinged outward, equipped with panic bars, and at least one provided with a viewport? | _____ | _____ |
| 12. Are all gas cylinders restrained by chaining to wall or by other means? | _____ | _____ |
| 12. Have there been any interruptions in chlorination during the past year due to chlorinator failure or feed pump failure? | _____ | _____ |

	Yes	No
--	-----	----

STORAGE

1. What type of water is stored?
Raw _____ Treated _____
2. What type of storage is provided?
Gravity _____ gals. Hydropneumatic _____ gals.
3. Total number of days of supply? _____ days

Gravity Storage

- | | | |
|--|-------|-------|
| 1. Does surface runoff and underground drainage drain away? | _____ | _____ |
| 2. Is the site protected against flooding? | _____ | _____ |
| 3. Is storage tank structurally sound? | _____ | _____ |
| 4. Are overflow lines, air vents, drainage lines or cleanout pipes turned downward or covered, screened, and terminated a minimum of 3 diameters above the ground or storage tank surface? | _____ | _____ |
| 5. Is site adequately protected against vandalism? | _____ | _____ |
| 6. Are surface coatings in contact with water approved? | _____ | _____ |
| 7. Is tank protected against icing and corrosion? | _____ | _____ |
| 8. Can tank be isolated from system? | _____ | _____ |
| 9. Is all treated water storage covered? | _____ | _____ |
| 10. What is cleaning frequency for tanks? _____ | | |
| 11. Are tanks disinfected after repairs are made? | _____ | _____ |

	Yes	No
<u>Hydropneumatic</u>		
1. Does low pressure level provide adequate pressure?	_____	_____
2. Are instruments and controls adequate, operational, and being utilized?	_____	_____
3. Are the interior and exterior surfaces of the pressure tank in good physical condition?	_____	_____
4. Are tank supports structurally sound?	_____	_____
5. Is storage capacity adequate?	_____	_____
6. What is cycle rate? _____		
<hr/>		
	Yes	No

DISTRIBUTION SYSTEM

1. Is proper pressure maintained throughout the system?	_____	_____
2. What types of construction materials are used? _____		
3. Are plans of the water system available and current?	_____	_____
4. Does the utility have an adequate maintenance program?	_____	_____
5. Is the system interconnected with any other system?	_____	_____
<hr/>		
	Yes	No

CROSS-CONNECTIONS

1. Does the utility have a cross-connection prevention program?	_____	_____
2. Are backflow prevention devices installed at all appropriate locations?	_____	_____
3. Are cross-connections present at the treatment plant?	_____	_____
<hr/>		
	Yes	No

MONITORING

1. Is the operator competent in performing necessary tests?	_____	_____
2. Are testing facilities and equipment adequate?	_____	_____

	Yes	No
3. Do reagents used have an unexpired shelf life?	_____	_____
4. Are records of test results being maintained?	_____	_____

	Yes	No
<u>MANAGEMENT</u>		
1. Are personnel adequately trained?	_____	_____
2. Are operators properly certified?	_____	_____
3. Are there sufficient personnel?	_____	_____
4. Are financing and budget satisfactory?	_____	_____
5. Is an emergency plan available and workable?	_____	_____
6. Is adequate safety and personal protective equipment provided?	_____	_____
7. Are the facilities free of safety hazards?	_____	_____

SITE PLAN

TREATMENT UNIT SCHEMATIC

ST 10-16 340



STATE OF ALASKA
DEPARTMENT OF ENVIRONMENTAL CONSERVATION
PUBLIC WATER SYSTEM SANITARY SURVEY

WATER SYSTEM INVENTORY INFORMATION		PWS ID Number	
Name of Water Supply		System Class	
Mailing Address (Street or P. O. Box)		Date of Survey	
City, State and Zip Code		Plant Location (if different than mailing address)	
Owner Name		Operator Name	
Owner Address (Street or P. O. Box)		Operator Address (Street or P. O. Box)	
City, State and Zip Code		Telephone	City, State and Zip Code
Telephone		Telephone	
Service Area Type (Resid., Indus., School, Restroom, etc.)		No. Serv. Connections	
Owner Type (Municipal, Commercial, State, Federal, etc.)		Source Type (Surface, ground, or combination)	
Resident Population	Non-Resident Population	Water Purchased From	
Water Sold To		Date System Began Operation	
Days per Year System in Operation		Seasonal Operation Dates	
Average Daily Production (gpd)		Start	End
Design Daily Production (gpd)		Maximum Daily Production (gpd)	
Storage (Type, Capacity, etc., Comments)			
Treatment Types Used			
<input type="checkbox"/> Disinfection <input type="checkbox"/> Softening <input type="checkbox"/> Ion Exchange <input type="checkbox"/> Fe & Mn Cntl. <input type="checkbox"/> Coagulation <input type="checkbox"/> Filtration <input type="checkbox"/> Fluoridation <input type="checkbox"/> Other			
Disinfection Method Used		In-House Tests Being Performed	
<input type="checkbox"/> Gas Cl ₂ <input type="checkbox"/> Sodium Hypochlorite <input type="checkbox"/> Calcium Hypochlorite <input type="checkbox"/> Other			

Well Data									
Well Number or Name	Date Drilled	Well Size (in.)	Total Depth (ft)	Depth of Casing (ft)	Depth of Grout (ft)	Well Yield (gpm)	Pump Capacity (gpm)	Date Last Chemical Analysis	Remarks

Surface Water Data						
Source Name	Location	Type of Intake Structure	Summ. Capacity (gpm)	Date Last Chemical Analysis	Remarks	

Form No. 10-17 (Rev. 1-78) State of Alaska Department of Environmental Conservation, P.O. Box 11060, Anchorage, Alaska 99511



WATER SYSTEM INSPECTION RESULTS

		WATER SYSTEM INSPECTION RESULTS				
SYMBOL	QUESTION	Yes	No	N/A	QUESTION	Yes
	WELL OR SPRING INFORMATION				OTHER TREATMENT	
	1. Is the source(s) adequate in quantity?	<input type="checkbox"/>	<input type="checkbox"/>	<input type="checkbox"/>	33. Is chemical storage adequate?	<input type="checkbox"/>
	2. Is the source(s) adequate in quality?	<input type="checkbox"/>	<input type="checkbox"/>	<input type="checkbox"/>	34. Are chemical feeders and pumps in operation, good condition and being properly maintained?	<input type="checkbox"/>
	3. Is the top of the well protected so that foreign matter or surface water cannot enter the well?	<input type="checkbox"/>	<input type="checkbox"/>	<input type="checkbox"/>	35. Are instrumentation and controls adequate for the process being utilized and in proper working order?	<input type="checkbox"/>
	4. Is the grouting or concrete pad surrounding the casing at the well head free from cracks or chips, and does it seal tightly to the casing?	<input type="checkbox"/>	<input type="checkbox"/>	<input type="checkbox"/>	36. Are accurate records being maintained (amount of water treated, amount of chemical usage)?	<input type="checkbox"/>
	5. Is the well site properly drained?	<input type="checkbox"/>	<input type="checkbox"/>	<input type="checkbox"/>	37. Are adequate safety devices available and precautions observed (dust mask, safety goggles, gloves, protective clothing)?	<input type="checkbox"/>
	6. Is the site protected against flooding?	<input type="checkbox"/>	<input type="checkbox"/>	<input type="checkbox"/>	STORAGE	
	7. Is there a sanitary seal on the well and properly installed?	<input type="checkbox"/>	<input type="checkbox"/>	<input type="checkbox"/>	38. Are storage reservoirs located above groundwater level?	<input type="checkbox"/>
	8. Are potential sources of contamination located far enough away from the well site?	<input type="checkbox"/>	<input type="checkbox"/>	<input type="checkbox"/>	39. Does surface run-off and underground drainage drain away from the storage structure?	<input type="checkbox"/>
	9. Does the casing extend at least 12 inches above the floor or ground?	<input type="checkbox"/>	<input type="checkbox"/>	<input type="checkbox"/>	40. Are the storage reservoirs protected against flooding?	<input type="checkbox"/>
	10. Is the well vent screened with the return bend facing downward and terminating 18 inches above ground level or above the maximum flood level, whichever is higher?	<input type="checkbox"/>	<input type="checkbox"/>	<input type="checkbox"/>	41. Are overflow lines, air vents, drainage lines or clean out pipes turned downward or covered, screened and terminated a minimum of 3 diameters above the ground or storage tank surface?	<input type="checkbox"/>
	11. If a pitless adapter or well-pit is used, are all entry points to the casing tightly sealed?	<input type="checkbox"/>	<input type="checkbox"/>	<input type="checkbox"/>	42. Are treated water storage reservoirs covered?	<input type="checkbox"/>
	12. Are the pressure tank, check valves, blow-off valves, water meters and other well system appurtenances maintained and operating properly?	<input type="checkbox"/>	<input type="checkbox"/>	<input type="checkbox"/>	43. Are the storage reservoirs clean and free from contamination?	<input type="checkbox"/>
	13. If standby or auxiliary power is available, is it in operable condition and well maintained?	<input type="checkbox"/>	<input type="checkbox"/>	<input type="checkbox"/>	44. Is the reservoir structurally sound?	<input type="checkbox"/>
	14. If a spring source is utilized, is it enclosed by a permanent structure with watertight seals?	<input type="checkbox"/>	<input type="checkbox"/>	<input type="checkbox"/>	DISTRIBUTION SYSTEM	
	15. Is direct surface drainage and contamination diverted around or away from the spring?	<input type="checkbox"/>	<input type="checkbox"/>	<input type="checkbox"/>	45. Are pressure and flows adequate throughout the system at all times of the year?	<input type="checkbox"/>
	16. Is the area around the spring fenced?	<input type="checkbox"/>	<input type="checkbox"/>	<input type="checkbox"/>	46. Are all services metered?	<input type="checkbox"/>
					47. Are plans of the water system available and current?	<input type="checkbox"/>
	SURFACE WATER SOURCE				MANAGEMENT	
	17. Is the source(s) adequate in quantity?	<input type="checkbox"/>	<input type="checkbox"/>	<input type="checkbox"/>	48. Are personnel adequately trained and/or certified?	<input type="checkbox"/>
	18. Is the source(s) adequate in quality?	<input type="checkbox"/>	<input type="checkbox"/>	<input type="checkbox"/>	49. Is an emergency plan available and workable?	<input type="checkbox"/>
	19. Does raw water remain free from excessive turbidity following rains?	<input type="checkbox"/>	<input type="checkbox"/>	<input type="checkbox"/>	50. Are supplies and maintenance parts inventories adequate?	<input type="checkbox"/>
	20. Are the waters entering the reservoir or source free from sources of industrial, domestic or other types of pollution?	<input type="checkbox"/>	<input type="checkbox"/>	<input type="checkbox"/>	51. Is the financing and budget satisfactory?	<input type="checkbox"/>
	21. Have the intake works been properly protected from ice buildup and siltation?	<input type="checkbox"/>	<input type="checkbox"/>	<input type="checkbox"/>	52. Are there sufficient personnel?	<input type="checkbox"/>
	22. Is human activity restricted in the watershed?	<input type="checkbox"/>	<input type="checkbox"/>	<input type="checkbox"/>	53. Are sufficient operation and maintenance records being kept?	<input type="checkbox"/>
	23. Is the raw water pumping capacity adequate?	<input type="checkbox"/>	<input type="checkbox"/>	<input type="checkbox"/>	54. Are routine maintenance schedules established and adhered to for all components of the water system?	<input type="checkbox"/>
	24. Is standby or auxiliary power available, is it in operable condition and well maintained?	<input type="checkbox"/>	<input type="checkbox"/>	<input type="checkbox"/>	55. Are all facilities and activities free from safety defects?	<input type="checkbox"/>
	25. If disinfection galleries are used, do they yield sufficient turning efficiencies?	<input type="checkbox"/>	<input type="checkbox"/>	<input type="checkbox"/>	CROSS CONNECTIONS	
					56. Was the system free from uncontrolled cross connections?	<input type="checkbox"/>
	DISINFECTION				57. Is the cross connection control program adequate and scheduled testing of backflow prevention devices?	<input type="checkbox"/>
	26. Is disinfection equipment being operated and maintained properly?	<input type="checkbox"/>	<input type="checkbox"/>	<input type="checkbox"/>	58. Are backflow prevention devices installed at all appropriate locations (wastewater plant, hospital, industrial locations, etc.)?	<input type="checkbox"/>
	27. Are critical spare parts on hand?	<input type="checkbox"/>	<input type="checkbox"/>	<input type="checkbox"/>	ANALYSES PERFORMED IN-HOUSE	
	28. If gas chlorination is used, are adequate safety precautions being followed, exhaust fan with interlock near floor gas mask with non-expired canister or full charge, ammonia leak bottle available, tanks chained to wall or otherwise secured?	<input type="checkbox"/>	<input type="checkbox"/>	<input type="checkbox"/>	59. Is the operator competent in performing the tests?	<input type="checkbox"/>
	29. If hypochlorite is used, are dilutions being made in proper manner?	<input type="checkbox"/>	<input type="checkbox"/>	<input type="checkbox"/>	60. Are testing facilities and equipment adequate?	<input type="checkbox"/>
	30. Are chlorine residual measurements being made and recorded?	<input type="checkbox"/>	<input type="checkbox"/>	<input type="checkbox"/>	61. Do reagents used have an unexpired shelf life?	<input type="checkbox"/>
	31. Is a free chlorine residual being maintained throughout the water system?	<input type="checkbox"/>	<input type="checkbox"/>	<input type="checkbox"/>	62. Are records of test results being maintained?	<input type="checkbox"/>
	32. Is adequate chlorine contact time, at least 30 minutes, between the chlorination point and first point of use?	<input type="checkbox"/>	<input type="checkbox"/>	<input type="checkbox"/>	SAMPLES TAKEN AT TIME OF SURVEY	
					Total Conform Result _____	
					_____ Inorganic	
					_____ Turb	
					_____ Fecal Conform Result _____	
					_____ Other _____	

DEFICIENCIES AND RECOMMENDATIONS (Indicates critical items needing immediate correction)

Inspector: _____ Date: _____

Inspector: _____ Date: _____





STATE OF ALASKA
DEPARTMENT OF ENVIRONMENTAL CONSERVATION

INSPECTION CONTINUATION

		Date of Inspection			
		Page of			
			Date	Inspected By	Date

DEPARTMENT OF HUMAN SERVICES
DIVISION OF HEALTH ENGINEERING
SANITARY SURVEY FORM

WATER SUPPLY _____ SOURCE _____
TOWN _____
SUPERVISOR _____ PERSON INTERVIEWED _____

ESTAB # _____ CLASS _____ INSP N/C _____ DATE _____ SCORE _____
S/O _____

SOURCE	01	PROTECTION: A. Ownership; B. Fencing; C. Easements; D. Ordinances	(4)
	02	HAZARDS: A. Oil Storage; B. Septic Systems; C. Swimming; D. Chemicals; E. Other	(5)
	03	ADEQUACY: A. Alt. Source; B. Ability to meet max. flow	(2)
	04	INTAKE: A. Screening; B. Depth; C. Location	(2)
DISINFECTION	05	FEED EQUIP.: A. Chlorinator; B. Spare; C. Scales; D. Antisiphons	(4)
	06	CONTROL: A. Pacing; B. Constant Pumping; C. Application Point	(3)
	07	SAFETY: A. Chlorine Room; B. Exhaust Fan; C. Gas Mask; D. Cannister; E. Air Pack; F. Restrainted Cylinders; G. Door to exterior; H. Window; I. Gloves; J. Apron	(4)
FLUORIDATION	08	CONTACT TIME: A. Residual	(1)
	09	FEED EQUIP.: A. Parts; B. Scales; C. Sone	(3)
	10	CONTROL: A. Soft Soaps; B. Pacing; C. Maintenance; D. Mixed	(3)
TREATMENT	11	SAFETY: A. Gloves; B. Goggles; C. Apron; D. Dust Mask; E. Eye Wash	(2)
	12	COMPLETE: A. Operation; B. Flash Mixer; C. Flocculation; D. Coagulation; E. Sedimentation; F. Filters; G. Backwash; H. Sludge Disposal	(2)
	13	SPECIAL: A. Softeners; B. Iron Removal; C. Nitrate Removal; D. Diatomaceous Earth; E. Corrosion Control; F. Other	(2)
OPERATOR	14	A. Certified	(4)
STORAGE	15	A. Covered; B. Rechlorination; C. Fencing	(2)
	16	MAINTENANCE: A. Painted; B. Cleaned; C. Grass Cut	(2)
DISTRIBUTION	17	A. Flushing; B. Disinfection; C. Pressure	(4)
LAB TESTING	18	CHLORINE: A. Daily; B. Location; C. Method; D. Chemicals	(3)
	19	FLUORIDE: A. Equipment; B. Technique; C. Chemicals; E. Daily Standard; Resent	(2)
	20	TURBIDITY: A. Equipment; B. Technique; C. Standard	(2)
	21	CHEK SAMPLES: A. Fluoride; B. Turbidity	(2)
PAR TEST	22	A. Equipment; B. Use; C. Application	(2)
	23	A. Daily	(2)
RECORDS	24	A. Lab Analysis	(2)
	25	A. Locks; B. Holes; C. Lightning Protection	(2)

NOT COPY AVAILABLE

MISSOURI DEPARTMENT OF NATURAL RESOURCES
DIVISION OF ENVIRONMENTAL QUALITY
PUBLIC DRINKING WATER PROGRAM

RECORD OF PUBLIC WATER SUPPLY ROUTINE SURVEY

1. Inspection: Initial 1
Final 2
Annual 3
Interim 4

DATE: _____

2. PWS ID No. (7) _____ 3. County Name: _____

4. PWS Name: _____

Check person(s) who should get analyses reports

Mayor/Board Chairman/President/Owner ()

5. Name: _____ 10. Name: _____

6. Address: _____ 11. Address: _____

7. City-State-Zip Code: _____ 12. City-State-Zip Code: _____

8. Office Phone Number: () - _____ 13. Office Phone Number: () - _____

9. Home Phone Number: () - _____ 14. Home Phone Number: () - _____

Clerk/Secretary () Other ()

15. Name: _____ 20. Name: _____

16. Address: _____ 21. Address: _____

17. City-State-Zip Code: _____ 22. City-State-Zip Code: _____

18. Office Phone Number: () - _____ 23. Office Phone Number: () - _____

19. Home Phone Number: () - _____ 24. Home Phone Number: () - _____

Mail Sample Bottle ID: ()

Operators and Certification Level

25. Name: _____

26. Address: _____

27. City-State-Zip Code: _____

28. Office Phone Number: _____

29. Home Phone Number: _____

30. People Served (7) _____

31. Service Connections (7) _____

32. Capacity - Primary (7) _____ MGD

33. Capacity - Secondary (7) _____ MGD

34. Finished Water Storage (7) _____ MG

35. No. of Secondary Systems Served (2) _____

36. Names of Secondary Systems _____

Average Daily Consumption

37. Own System (7) _____ MGD

38. Secondary Systems (7) _____ MGD

39. Total-Entire System (7) _____ MGD

Maximum Daily Consumption

40. Own System (7) _____ MGD

41. Secondary Systems (7) _____ MGD

42. Total-Entire System (7) _____ MGD

43. Report Date: _____

44. _____

BEST COPY AVAILABLE

SYSTEM SURVEY

ITEM	SATIS-FACTORY	UNSATIS-FACTORY	REMARKS
Source			
44 Surface Source Condition			
45 Ground Source Condition			
46 L.S. Pumps			
47 Other (Specify)			
Treatment			
48 Aeration			
49 Chemical Application			
50 Mixing			
51 Settling			
52 Filtration			
53 Control Equipment			
54 Laboratory Equipment			
55 Other (Specify)			
Distribution			
56 Plant Storage			
57 H.S. Pumps			
58 Distribution Storage			
59 Booster Pumps			
60 Cross Connection Control			
61 Metering			
62 Other (Specify)			
Record Keeping			
63 Analyses Records			
64 Violation Actions			
65 Inspection Reports			
66 Variance/Exemption Records			
67 Operational Records			
68 Systems Records			
Sample Submission			
69 Microbiological			
70 Chemical			
71 Fluoride			
72 Radiological			
Water Quality			
73 Microbiological			
74 Chemical			
75 Physical			
76 Radiological			

Rating Codes Satisfactory - 0; Unsatisfactory (use one or more) -- Construction Deficiency - 1; Operation and/or Maintenance Deficiency - 2; Capacity Deficiency - 3.

Plant Effluent Cl Free _____ Cl Total _____ pH _____ Alk. _____ Hard _____ F _____ Fe. _____ Turb. _____ Mn _____ Stability _____

Odor _____ Color _____ Phosphate _____ Other _____

Maximum Rate of Operation: L.S. _____ H.S. _____ Filters _____ Other _____

Previous Recommendations Carried Out _____

New Construction Proposed _____

Improvements _____

STATE OF SOUTH CAROLINA WATER SUPPLY DIVISION
 SANITARY SURVEY REPORT

Date: _____

Inspected By: _____
 (signature)

Station Code: _____

Name of Facility: _____ County: _____

Owner: _____ Telephone: _____

Address: _____

Name of Operator: _____ Certification No. and Grade: _____

Population Served: _____ No. of Services: _____

Number of unsatisfactory routine Bacteriological samples since last Sanitary Survey Report: _____

Number of routine Bacteriological samples since last Sanitary Survey Report: _____

Chemical: Health oriented parameters not meeting standards on last report: _____

Aesthetic oriented parameters not meeting standards on last report: _____

TREATMENT PLANT

Capacity: _____ (MGD) Average usage: _____ (MGD)

Emergency power _____ Capacity under emergency power _____ MGD

TREATMENT (sketch plant and locate injection points)

baffle mix _____	sedimentation _____	pH adjustment _____
mechanical mix _____	aeration _____	ion exchange _____
disinfection _____	filtration _____	sequestration _____
flocculation _____	lime softening _____	taste and odor control _____

TREATMENT CHEMICALS:

chlorine _____	lime _____	phosphate _____
alum _____	potassium permanganate _____	fluoride _____
caustic _____	activated carbon _____	ammonia _____
soda ash _____	polyelectrolyte _____	

Can operator conduct following tests (has knowledge and equipment)? Yes No

 pH chlorine iron phosphate fluoride turbidity

Does operator keep records of test results? Yes NO

 Certified operator on duty at all times plant is operating?

 Plant locked when operator not on duty? Chemicals kept under lock?

 Back-up feeders available. Chlorination room for gas chlorination.

 Gas mask, gloves, aprons, etc. available. General condition of plant.

WATER SUPPLY DIVISION
SANITARY SURVEY REPORT

Date: _____

Inspected By: _____
(initials)

Station Code: _____

Wells	#1	#2	#3	Comments
Well Driller				
Year Installed				
Type of Well				
Size				
Depth of Well				
Depth of Grout				
Type of Pump				
Depth of Water				
Yield				
Concrete Pad (3' in any direction)				
Casing extended 20" above pad				
Well Properly Sealed				
Screened Vent 40 mesh				
Check Valve				
Flow Off				
Gate Valve				
Sample Box				
House for Wells and Controls				
Nearest Source of Pollution				
Distance				
Site Susceptible of Surface Runoff				
General Condition of Well House and Surround Area				
Installation Equipment				

BEST COPY AVAILABLE

WATER SUPPLY DIVISION
SANITARY SURVEY REPORT

Date: _____

Inspected By: _____
(Initials)

Station Code: _____

Storage Facilities

Pneumatic Storage Tank	#1	#2	#3	Comments
Size				
Operating Pressure Range (PSI)	ON	OFF		
Adequate Drain (2")				
Sample Cock				
Controls Protected from Vandalism				
General Condition of Tank				
Observe Operation of Tank and note deficiencies (water logged, low pressure, etc.)				
Air Compressor (tank 5000 gal.)				

Size	Ground Storage		Elevated Storage		Comments
	#1	#2	#1	#2	
atches Watertight and Locked					
Screened Vent					
No Direct Connection with Storm Drain					
General Condition of Tank					
Site Susceptible to Flooding					
Valve to Isolate Tank	XXXXXXXX	XXXXXXXX			
Sample Cock					
Ladder Not 20' above ground	XXXXXXXX	XXXXXXXX			

BEST COPY AVAILABLE

ST 10-25

349

Surveys

10-3

TRANSPARENCY 10-1

350

Surveys

351

Schedule

10-14

TRANSPARENCY 10-2

352

Schedule

353

Preparation Phase

10-5

TRANSPARENCY 10-3

354

Preparation Phase

355

Onsite Phase

10-6

TRANSPARENCY 10-14

356

Onsite Phase

357

Report Writing

10-7

TRANSPARENCY 10-5

358

Report Writing

359

UNIT 11: COMMUNICATIONS/PUBLIC RELATIONS - "THE NEED TO KNOW"

Unit Summary

Communications
Public Relations of Survey

Unit Objectives

The inspector must know who to contact with regard to the sanitary survey being performed. The relationship of the inspector and the operator is important to the success of the survey. This unit briefly discusses the importance of these items.

Approximate Presentation Time: 30 minutes

Instructor Materials

- o Basic Material
- o Transparencies 11-1 to 11-3

Student Materials

- o Student's Text, Chapter 11

Student Preparation

- o Read Chapter 11 prior to the session.

Use Transparencies 11-1 and 11-2:

Ask for student suggestions on what should be accomplished in each phase of communication:

Briefly discuss activities involved with each item.

Use personal experiences and anecdotes to illustrate situations students may encounter during a survey.

Communications

Prior to Onsite Visit

- o Owner of Water System
 - o Obtain cooperation and established survey dates
 - o Explain purposes of survey
 - o Request that necessary information be available
- o Operator
 - o Coordinate gaining entry to site
 - o Ensure presence of operator during survey
- o Local Health Unit/Other Departments
 - o Ensure cooperation and coordination
 - o Obtain information pertinent to system

During Onsite Visit

- o Owner of Water System
 - o Obtain information pertinent to system
 - o Explain function of survey results
 - o Explain recommended actions
 - o Explain what action will result from survey
- o Operator
 - o Obtain information pertinent to system
 - o Exchange of technical information
 - o Explain survey results
 - o Explain recommended action

After Onsite Visit

- o Owner of Water System
 - o Notification of deficiencies
 - o Instructions on corrections
 - o Compliance schedule for corrections
- o State Regulatory Agency
 - o Case report where formal enforcement is indicated
- o U.S. Environmental Protection Agency
 - o Case report when State does not have primacy under SDWA

- o Public
 - o If system is not in compliance with:
 - applicable MCL
 - applicable testing procedure
 - required monitoring
 - scheduled corrections
 - an exemption or variance

Use Transparency 11-3:

Use personal experiences and anecdotes to illustrate actual situations students may encounter during a survey.

Public Relations

- o Importance of establishing good relationship with owner/operator

An area that the inspector of a water system must deal with is who to contact with regard to the sanitary survey. This contact is necessary for obtaining cooperation, gathering information, coordinating with other departments or agencies, and transmitting the results of the evaluation. Briefly, the persons/agencies the inspector should contact, and the purpose of the contact, are the following:

Prior to Onsite Visit

- o Owner of water system
 - o Obtain cooperation and established survey dates
 - o Explain purposes of survey
 - o Request that necessary information be available
- o Operator
 - o Coordinate gaining entry to site
 - o Ensure presence of operator during survey
- o Local Health Unit/Other Departments
 - o Ensure cooperation and coordination
 - o Obtain information pertinent to system

During the Onsite Visit

- o Owner of water system
 - o Obtain information pertinent to system
 - o Explain function of survey results
 - o Explain recommended actions
 - o Explain what action will result from survey
- o Operator
 - o Obtain information pertinent to system
 - o Exchange of technical information
 - o Explain survey results
 - o Explain recommended action

After the Onsite Visit (Survey Report)

- o Owner of water system
 - o Notification of deficiencies
 - o Instructions on corrections
 - o Compliance schedule for corrections
- o State Regulatory Agency
 - o Case report where formal enforcement is indicated
- o U.S. Environmental Protection Agency
 - o Case report when State does not have primacy under SDWA

o Public

- o If system is not in compliance with:
 - applicable MCL
 - applicable testing procedure
 - required monitoring
 - scheduled corrections
 - an exemption or variance

Briefly, we need to discuss communications with the owner/operator and with the public. There is not sufficient time in this course to fully discuss interpersonal relationships and how to deal with people. However, there are some points that inspectors should keep in mind. The establishment of a good relationship with the operator is important to the success of the survey. The operator of the small water system occupies a unique position in the water supply industry. In most cases the operator is responsible for all aspects of the system from operation of the plant to budgeting for equipment, and in small towns may also be responsible for the other services (wastewater treatment, road repair, etc.) in the community. Consequently, the operator will frequently have only a basic working knowledge of the treatment processes of that particular system. The fact that the operator may not be fully knowledgeable about the technical design criteria does not make the operator incompetent. Communicate with the operator in terms that can be understood, not by yourself or by an engineer, but by the operator. This is particularly true when providing assistance. An indepth discussion on the Brownian movement of colloidal particles may dazzle the operator with your brilliance but do little to foster a good relationship.

Communicating at the level of your audience is particularly important in dealing with the general public. A technical knowledge of water treatment and water quality cannot be assumed with the general public. Consequently, you must be careful to couch your communications in laymen's terms, particularly when dealing with problems in the system. The public should be made to realize the impact of the problem without having the dangers exaggerated.

Communications/ Public Relations

11-4

TRANSPARENCY 11-1

365

Communications/ Public Relations

366

Communications

- Prior to Onsite Visit
- During Onsite Visit
- Post Onsite Visit

Communications

- Prior to Onsite Visit
- During Onsite Visit
- Post Onsite Visit

Public Relations

- Inspector/Operator Relationship

Public Relations

Inspector/Operator Relationship

370

Providing Technical Assistance
Command Problems

Objectives

A significant element of the sanitary survey is the assistance that the inspector can render the operator in overcoming operational and procedural problems and in improving the operation of the system.

Activities

Approximate Presentation Time: 30 minutes

Instructor Materials

- o Basic Material
- o Transparencies 12-1 and 12-2

Student Material

- o Student's Text, Unit 12

Student Preparation

- o Read Unit 12 prior to the session

Unit References

None

and the primary filter.

Explain to the students that this section is designed as a checklist for investigating the possible cause(s) for low or low water pressure; unsatisfactory water quality, and aesthetically objectionable water. The information will be used to provide technical assistance to water system personnel.

Primary Filter

Investigate the problem.

Identify the health risks associated with the problem.

Draw on chalkboard map of distribution system, showing location of problem.

Identify the symptoms and probable causes of the problem relative to the problem.

Appropriate symptoms that be indicators that would alert the operator or inspector of the problem (i.e., vibrating equipment, blown fuses, water leaks, etc.).

Make student assignments relative to the problem.

Make pertinent notes on chalkboard under the appropriate heading.

Technical Assistance (15 minutes)

- o Importance of providing technical assistance
- o Small system frequently with technical staff
- o Can provide immediate resolution of a sanitary risk

Importance of how assistance is provided:

- o Factors of snap judgments
- o Request help from more experienced personnel
- o Make recommendations in terms that can be understood

Problem: _____ Water Pressure

Health Risk: Contaminated water (if cross-connected)

Location: _____

Water Source: _____

_____ (shallow well)

- o Choking of well screen
- o Spring flow diminished

Well or Intake Structure:

- o Piping blocked
- o Defective valves or valve setting
 - o Plugged foot valve and/or strainer
 - o Break in wall of collection chamber
 - o Water in collection chamber or pipes freezing
- o Well pipe installed above water table (shallow well with suction pump)

Treatment Equipment:

- o Electrical safety control activated to shut off water pump due to inoperative chemical feed pump

Pumping System:

- o Power failure
- o Low line voltage
- o Blown fuses

Use the basic material to guide the discussion and to present additional information.

Repeat the above procedures for problems 2 and 3 and

- o Shorted-out electric motor
- o Defective pressure switch
- o System valve off
- o Air lock in suction line
- o Leak on suction side of system
- o Plugged filter or ejector
- o Worn or defective pump
- o Discharge line check valve stuck back.
- o Lost prime in piston-type pump

Storage Tanks

- o Ruptured tank
- o Drain valve open
- o Float switches on gravity tank defective
- o Pressure switch on hydro-pneumatic storage tanks defective

Distribution System

- o Break in water main
- o Hydrant(s) open
- o Excessive demand over prolonged period

Problem 4

Problem 4. Water Quality Violates Standard (5 MGD or less)

Health Risk: disease and/or chemical poisoning of consumers

Possible Causes:

Water Source

Contamination by untreated water
toxic chemicals

Well or Intake Structure

Onsite contamination by wastes
toxic chemicals

Inoperative well seal

Welly covered or blocked

Leakage into well from broken
wire

Treatment Process

- o Contamination of treated water
- o Insufficient chlorine residual
- o Chlorine solution exhausted
- o Defective chemical feed device

Pumping System

- o Repair or replacement of pump parts without adequate disinfection
- o Use of contaminated water to lubricate packing

1 -

- o Improper sealing of pump to base
- o Improper pump drainage

Storage System

- o Debris in storage tank
- o Interior of tank coated with unapproved coating
- o Entry of birds through defective vent or open manhole

Distribution System

- o Cross-connection with source of sewage or toxic chemicals

Appendix A - Summary for Problem 1

Problem 1: Bad Taste; Color; Odor (5 minutes)

Health Risks:

- o Possible bacterial or chemical contamination
- o Use by consumer of a more palatable but less safe water supply

Possible Cause:

Water Source

- o Contamination by foreign substance

Well or Intake Structure

- o Entry of bird or animal through defective vent or open manhole
- o Inoperative well seal

Treatment Process

- o Production of chlorophenyls by reaction of chlorine on precursor substances

Pumping System

- o Repair or replacement of pump parts without adequate disinfection
- o Use of contaminated water to lubricate package
- o Improper sealing of pump
- o Improper drainage of pump

Storage System

- o Debris in storage tank
- o Interior of tank coated with unapproved coating
- o Entry of birds through broken vent or open manhole

Distribution System

- o Iron bacteria growth in pipes

TECHNICAL ASSISTANCE

Public Agency

Providing Technical Assistance
Common Problems

Objectives

Small Water Systems Serving the Public
(Chapter 13)
Handbook of Individual Water Systems
Water Systems Handbook
Water Treatment Plant Operation (Volumes I
& II)
Water Supply System Operation

Objectives

The primary survey is in part designed to assist the water purveyor in detecting any deficiencies in water quality or the water supply system. In order to provide this assistance, the inspector must be able to communicate to water system personnel the possible causes of problems. Problem solving should be approached in a systematic manner with a concept of the factors that might contribute to water problems and with insights into the solutions:

An effective maintenance and repair schedule is of primary importance in a water supply system. Every opportunity should be taken to provide guidance in the development of such a system and to supply technical assistance with potential and actual water system problems.

How the technical assistance is provided is equally important as the information given. Unless the solution is obvious, technical assistance should be given only after the entire system has been surveyed. There are two reasons for this procedure. First, the objective of your visit is to evaluate the entire water system. If you spend your time playing Sherlock Holmes in attempting to determine the cause of a problem, you have changed your objective and may very well overlook a serious sanitary risk. Isolating the cause of a water system problem is time consuming and without technical and analytical support, generally difficult. If the operator is competent, the more common causes will have been evaluated and will have been ruled out. The second reason for surveying the entire system is that the cause of a water system problem is not always immediately apparent. The cause should be observed and the problem has been resolved.

The operator should be asked what steps have been taken to evaluate and mitigate the problem. The inspector should determine if the problem has occurred before and what action was taken. A review of operating records may provide a clue to recent changes in the system or chemicals utilized which may be the cause.

The inspector should temper any advice with a realization of the operator's experience and knowledge of the problem. If erroneous information is provided, a loss of money and time can result while the hazard continues to exist. The classic "I'm from the Government and I'm here to help" attitude followed by assistance that intensifies the problem rather than provides a solution can be devastating. The inspector with limited experience is wiser to refer the problem to more experienced personnel.

Regulators have developed a means by which assistance can be provided to the system either by its request or a referral from a sanitary engineer. This is not to say that there should not be an exchange of information with the operator by an inspector. The inspector should identify sanitary problems to the operator, discuss their importance, and formulate a means of resolution, provide it.

Identify the following problems in light of the possible causes. Wherever possible, refer to the possible causes as indicators of the problem so as to assist in the water purveyor's diagnosis. Use the elements of the checklist to guide you.

Problem of low water in well

Well

Sanitary condition (see Exhibit 10.1)

Well condition

Water source

- Water table has dropped below well screen
- Clogging of well screen with debris
- Upward flow has been diminished

Well or Intake Structure

- Debris blocking pipe
- Defective valves or valve settings
- Plugged foot valve or strainer
- Block in well or collection chamber
- Water in collection chamber or pipes freezing
- Well screen plugged or broken
- Well pipe ruptured above water table (shallow well with surface pump)

Wellhead Equipment

- Electrical safety control activated to shut off water pump due to temperature chemical flow pump

Pump System

- o Power failure
- o Low line voltage
- o Blown fuses
- o Shorted-out electric motor
- o Defective pressure switch
- o System valved off
- o Air lock in suction line
- o Leak on suction side of system
- o Plugged ejector or impeller
- o Worn or defective pump
- o Discharge line check valve installed backward
- o Loss of prime in piston-type pump

Storage System

- o Ruptured tank
- o Drain valve open
- o Float switches on gravity tank defective
- o Pressure switch on hydropneumatic storage tank defective

Distribution System

- o Break in water main
- o Hydrants open
- o Excessive water demand over prolonged period

Problem 2: Water Quality Violates Standards

Health Risk

- o Disease or chemical poisoning of consumers

Possible Causes:

Water Source

- o Contamination of source by wastewater or toxic chemicals

Well or Intake Situation

- o Onsite contamination by wastewater or toxic chemicals
- o Inoperative well seal

Treatment Process

- o Contamination of treatment chemicals
 - o Insufficient chlorine feed rate
- o Chlorine solution exhausted
- o Defective chemicals feed equipment

Pump System

- o Repair or replacement of pump parts without adequate disinfection
- o Use of contaminated water to lubricate package
- o Improper sealing of pump to base during repair
- o Improper drainage of pump

Storage System

- o Debris in storage tanks
- o Interior of tank coated with unapproved coatings
- o Access of contaminants through broken vent or open manhole

Distribution System

- o Cross-connection with source of sewage or toxic chemical

Problem 3: The Water Has Bad Taste, Odor, or Color

Health Risk

- o Possible bacterial or chemical contamination
- o Use by consumer of a more palatable but potentially less safe water supply

Possible Causes:

Water Source

- o Contamination of source by foreign substance

Well or Intake Structure

- o Entry of contaminant into structure through defective vent, open manhole, or screen
- o Inoperative well seal, allowing entry of contaminant

Treatment Process

- o Production of chloro-pyrenyls by action of chlorine on precursor substances

Pump System

- o Repair or replacement of pump parts without adequate disinfection
- o Use of contaminated water to lubricate package
- o Improper sealing of pump to base, allowing entry of contaminants
- o Improper drainage of pump

Storage System

- o Debris in storage tank
- o Interior of tank coated with unapproved coatings
- o Entry of contaminants through broken vent or open manhole

Distribution System

- o Iron bacteria growth in pipes

Technical Assistance

12-5

TRANSPARENCY 12-1

379

Technical Assistance

380

When to Provide?

- After Survey is Complete
 - Objective is to Evaluate Entire System
 - Problem can be Caused Throughout System

When to Provide?

- After Survey is Complete
 - Objective is to Evaluate Entire System
 - Problem can be Caused Throughout System

1. Program Review

Program Review
Post-Test (Optional)
Program Evaluation (Optional)

Students should complete the post-test with 85% accuracy.

Approximate Presentation Time: 60 minutes

Instructor Materials

- o Post-test (to be duplicated)
- o Key to the post-test
- o Evaluation form (to be duplicated)

Unit References

- o Units 1 through 12 of this manual
-

1. Material

Review essential points
of unit.

Areas of emphasis will be determined by
instructor(s). (20 minutes)

Clarify any questions
students may have.

Administer post-test.

Review post-test.

Distribute evaluation
form and have students
evaluate the training
program.

NOTE: There may be more than one correct answer to some of the questions.

1. The primary purpose of rapid sand filtration is
 - a. disinfection.
 - b. removal of color.
 - c. removal of taste and odors
 - d. removal of turbidity.
2. The chlorine contact time for a free chlorine residual should be a minimum of
 - a. 15 minutes.
 - b. 45 minutes.
 - c. 30 minutes.
 - d. 3 minutes.
3. A chlorine dose of 1.0 mg/l is desired using a 2% hypochlorite solution; 1.5 million gallons of water are produced per day. The estimated number of gallons of sodium hypochlorite solution used per day is
 - a. 7.5.
 - b. 100.
 - c. 25.
 - d. 75.
4. An increase in turbidity in a well after a rain indicates
 - a. excessive drawdown.
 - b. possibility of surface water contamination.
 - c. faulty pump.
5. The best means of preventing a cross-connection between finished water and a chemical solution tank is
 - a. a reduced pressure zone backflow preventer.
 - b. a check valve.
 - c. a vacuum breaker.
 - d. an air gap.
6. The two basic maintenance checks on the hydropneumatic storage system are
 - a. correct air volume.
 - b. correct air gap separation.
 - c. correct pressure range.
 - d. presence of a diaphragm.

7. The National Interim Primary Drinking Water Regulations provide
 - a. maximum contaminant levels for certain parameters.
 - b. requirements for monitoring frequency and methods of analysis.
 - c. that States may not require more stringent standards than outlined in the Regulations.

8. Samples for free chlorine residual
 - a. can be stored up to 8 hours before analysis.
 - b. can be stored up to 12 hours before analysis.
 - c. can be stored up to 36 hours before analysis.
 - d. must be analyzed immediately after sampling.

9. The membrane filter method for coliform analysis
 - a. is the quickest acceptable method (if the test is negative).
 - b. does not require a large amount of incubator space.
 - c. allows comparison of results to those of fermentation tube technique.
 - d. does not require judgment on the part of the technician.

10. The pressure exerted by water standing in a pipe or tank is called
 - a. dynamic pressure.
 - b. pneumatic pressure.
 - c. head.

11. Proper disinfection may be determined by comparing which of the following two test results?
 - a. Jar test results
 - b. DPD test results
 - c. Bacteriological test results
 - d. Alkalinity test results
 - e. pH test results

12. The purpose of grouting in a well is to
 - a. prevent the casing from corroding.
 - b. prevent settling of the pump shaft.
 - c. prevent air binding of the well.
 - d. prevent entry of contaminated surface water.

13. The most common water treatment method for coliform reduction is
 - a. granular activated carbon.
 - b. chlorination.
 - c. lime-soda ash treatment.
 - d. neutralization.

Post-Test Key

1. d
2. c
3. d
4. b
5. d
6. a, c
7. a, b

8. d
9. a, b
10. c
11. b, c
12. d
13. b

Program Evaluation

Sanitary Surveys of Water Systems

Please rate the following by circling the appropriate number (1 = lowest, 10 = highest):

A. Instructional Staff: (Consider: organization and clarity of presentations, interest in assuring that learners assimilate material, preparation and knowledge of material, use and appropriateness of visual aids, etc.)

Instructor (list name)

1.	_____	1	2	3	4	5	6	7	8	9	10
2.	_____	1	2	3	4	5	6	7	8	9	10
3.	_____	1	2	3	4	5	6	7	8	9	10
4.	_____	1	2	3	4	5	6	7	8	9	10
5.	_____	1	2	3	4	5	6	7	8	9	10
6.	_____	1	2	3	4	5	6	7	8	9	10

Comments: _____

B. Instructional Material: (Consider: overall appropriateness of material to basic program objectives, i.e., provide training to enable completion of sanitary surveys of small water systems when complemented by on-the-job training; completeness of subject matter within each unit.)

<u>Unit No.</u>	<u>Name</u>	<u>Your Rating</u>										
1	Orientation	1	2	3	4	5	6	7	8	9	10	
2	Water Regulations	1	2	3	4	5	6	7	8	9	10	
3	Water Sources	1	2	3	4	5	6	7	8	9	10	
4	Pumps	1	2	3	4	5	6	7	8	9	10	
5	Water Treatment	1	2	3	4	5	6	7	8	9	10	
6	Storage	1	2	3	4	5	6	7	8	9	10	
7	Water Distribution	1	2	3	4	5	6	7	8	9	10	
8	Monitoring/Recordkeeping	1	2	3	4	5	6	7	8	9	10	
9	Management/Safety	1	2	3	4	5	6	7	8	9	10	
10	Surveys	1	2	3	4	5	6	7	8	9	10	
11	Communications/Public Relations	1	2	3	4	5	6	7	8	9	10	
12	Technical Assistance	1	2	3	4	5	6	7	8	9	10	
13	Conclusion	1	2	3	4	5	6	7	8	9	10	

Comments: _____

C. Overall Program Organization: (Consider: relationship of one unit to another, reinforcement of material from one lesson to the next, position of lessons within the program, length of presentation, etc.)

1 2 3 4 5 6 7 8 9 10

Comments: _____

D. Lesson Support Materials: (Consider: appropriateness of visual aids, adequacy and appropriateness of materials received prior to the program, etc.)

1 2 3 4 5 6 7 8 9 10

Comments: _____

E. Facility: (Consider: availability of media equipment, seating arrangement and comfort, lighting, temperature, etc.)

1 2 3 4 5 6 7 8 9 10

Comments: _____

F. Additional:

1. Was the course of benefit to you? Yes _____ No _____

2. Would you recommend the program to others who were entering careers
related to Sanitary Surveys of Water Systems?
Yes _____ No _____

Comments: _____

Program Evaluation

Instructor Feedback Report Form
(10 minutes)

Note to the instructor: These questions are presented only as a guide to assist you in organizing your impressions of the conduct and outcome of the program. Your report should include important subjective and observational information for use in continually upgrading the training program.

The Participants

1. Were they motivated?
2. Did the units meet their needs?
3. What was not covered that should have been?
4. What was their reaction to the Student's Text?

The Techniques

1. Were the techniques and methods appropriate for and helpful in presenting the material? Please explain.
2. What techniques were most effective? Least?
3. What changes would you suggest to the designers of the program?

REFERENCES

1. Water Treatment Plant Operations, Volume I
Water Treatment Plant Operations, Volume II
Water Supply System Operation
Available from: Kenneth Kerri
Department of Civil Engineering
Calif. State University, Sacramento
6000 J Street
Sacramento, CA 95810
(Phone: 916-454-6142)
Price: \$30.00 per manual
2. Manual of Water Utility Operations
Available from: Texas Water Utilities Association
6521 Burnet Lane
Austin, TX 78757
Price: \$17.00
3. A Manual of Instruction for Water Treatment Plant Operators
Available from: Health Education Services, Inc.
P.O. Box 7126
Albany, NY 12224
Price: \$3.13
4. Planning for an Individual Water System
Available from: American Association for Vocational
Instructional Materials
Engineering Center
Athens, GA 30602
Price: \$7.65
5. Water Systems Handbook
Available from: Water Systems Council
221 North LaSalle Street
Chicago, IL 60601
Price: \$6.00
6. Environmental Engineering and Sanitation
by Joseph A. Salvato
Available from: John Wiley & Sons, Inc.
Somerset, NJ 08873
Price: \$55.00
7. National Interim Primary Drinking Water Regulations
Available from: Superintendent of Documents
U.S. Government Printing Office
Washington, DC 20402
Stock No. 055-000-00157-0
Price: \$5.50

8. Manual of Individual Water Supply Systems
 Available from: Superintendent of Documents
 U.S. Government Printing Office
 Washington, DC 20402
 Stock No. 055-000-00229-1
 Price: \$6.00
9. "How to Conduct a Sanitary Survey" Procedures Manual
 Available from: New Mexico Health and Environmental
 Department
 Environmental Improvement Division
 P.O. Box 968
 Santa Fe, NM 87504-0968
 Price: \$4.00

ADDITIONAL READINGS

1. Water Treatment Plant Design, prepared jointly by the American Water Works Association, Conference of State Sanitary Engineers, and American Society of Civil Engineers
 Available from: Data Processing Department, AWWA
 6666 W. Quincy Avenue
 Denver, CO 80235
 Order NO. 10006
 Price: To members - \$14.40; nonmembers - \$18.00
2. Water Quality and Treatment: A Handbook of Public Water Supplies; American Water Works Association, Third Edition, McGraw-Hill, 1971
 Available from: Data Processing Department, AWWA
 6666 W. Quincy Avenue
 Denver, CO 80235
 Order No. 10008
 Price: To members - \$34.10; nonmembers - \$42.60
3. Manual of Treatment Techniques for Meeting the Interim Primary Drinking Water Regulation; EPA 600/8-77-005
 Available from: ORD Publications
 USEPA-CERI
 26 West St. Clair Street
 Cincinnati, OH 45268
 Price: Free