

DOCUMENT RESUME

ED 240 784

EC 161 854

AUTHOR Allen, William; And Others
TITLE Accessible Elementary Schools: A Renovation Planning and Design Manual. [Final Report].
INSTITUTION Peoples Housing, Inc., Topanga, Calif.
SPONS AGENCY Special Education Programs (ED/OSERS), Washington, DC.
PUB DATE Mar 81
GRANT G007902653
NOTE 378p.
PUB TYPE Guides - Non-Classroom Use (055)

EDRS PRICE MF01/PC16 Plus Postage.
DESCRIPTORS *Accessibility (for Disabled); *Building Design; Classroom Environment; Design Requirements; *Disabilities; Elementary Education; Environmental Influences; *School Buildings

ABSTRACT

The manual is intended to help school districts comply with federal mandates for physical accessibility and least restrictive settings for handicapped elementary school children. A general introduction to the accessibility concept in chapter 1 considers the historical background, the role of the physical environment, and existing federal guidelines and regulations. Results of a survey of over 50 schools are reported in chapter 2, along with illustrations of 22 common problems (such as inadequate fire safety provisions, circulation hazards, unsafe stairs, limited access in libraries, inadequate furniture and cabinetry, and playgrounds not designed with disability in mind). Chapter 3 focuses on accessibility implementation, noting planning factors, problem identification, and cost estimating procedures. The fourth chapter presents technical information for the design of barrier free renovations, presenting solutions to problems posed in chapter 2. In the final chapter, case studies illustrate actual schools' application of design guidelines in renovating facilities. (CL)

* Reproductions supplied by EDRS are the best that can be made *
* from the original document. *

ED240784

Accessible Elementary Schools

A Renovation Planning And Design Manual

[Final Report]

U.S. DEPARTMENT OF EDUCATION
NATIONAL INSTITUTE OF EDUCATION
EDUCATIONAL RESOURCES INFORMATION
CENTER (ERIC)
 This document has been reproduced as
received from the person or organization
originating it.
 Minor changes have been made to improve
reproduction quality.
• Points of view or opinions stated in this docu-
ment do not necessarily represent official NIE
position or policy.

7581912

Accessible Elementary Schools

A Renovation Planning And Design Manual

By Peoples Center For Housing Change

William Allen

Jeffrey Beer

Stephen M. Kerpen

David Marshall

Edward Steinfeld, Project Director

March, 1981

The research and studies forming the basis of this report were financed by grant no. G007902653 from the bureau of Education for the Handicapped, U S. Department of Education. The statements and conclusions herein are those of the grantee and do not necessarily reflect the views of the U.S. Government in general or the Department of Education in particular.

Table of Contents

	<u>Introduction</u>	1
<u>Chapter One:</u>	<u>The Purpose of Accessibility</u>	5
	Target Population	6
	Historical Background of Educational Approaches	7
	Problems with Segregation	9
	Role of the Physical Environment	11
	Existing Guidelines and Regulations	12
	Research on Accessibility	13
	References	17
<u>Chapter Two:</u>	<u>Nature of the Problem</u>	19
	Survey Description	21
	Range of Problems	22
<u>Chapter Three:</u>	<u>Accessibility implementation</u>	35
	Accessibility Plans	36
	Planning Process	37
	Issues in Program Accessibility	39
	Method of Problem Identification	44
	Cost Estimating	45
<u>Chapter Four:</u>	<u>Accessibility Guidelines</u>	49
	Accessible Paths of Travel	51
	Accessible Spaces and Facilities	95
	Accessible Building Elements	147
	Checklist of Design Criteria	181
<u>Chapter Five:</u>	<u>Case Studies</u>	193
	Process	194
	School One	195
	School Two	209
	<u>Appendix</u>	223

Introduction

This manual was created to fill an information gap. The Federal Rehabilitation Act of 1973-1974 required, among its many provisions, that schools receiving federal aid could not discriminate against providing educational services to children with physical disabilities due to the presence of architectural barriers in school buildings.

The Education for All Handicapped Children's Act mandated that schools provide an educational approach that creates the "least restrictive setting" for the education of handicapped children in their programs. Together, these two pieces of legislation have spurred public school districts into making many renovations to their physical facilities for the purposes of removing architectural barriers.

School districts must decide which buildings are to be made accessible and how accessible they are to be. They must design specific barrier-free renovations. And they must do both these tasks within the scope of their economic resources. Particularly in older cities with old buildings and declining tax bases, creating accessibility for handicapped children is no easy task. Before this manual no decision-making aids existed to help a school district plan their programs of renovation work. Even in relatively prosperous districts, the technical knowledge of barrier-free design necessary to insure adequate accessibility is not always available. In

fact, as we shall see, before this project was completed, there was no basic data base for barrier-free design specifically concerning elementary school age children. Finally, there is no technical material on the specific construction problems likely to be encountered in renovating elementary schools, including estimates of what barrier-free renovations would cost.

In the absence of decision making aids, technical knowledge of barrier-free design and technical information on construction problems and costs, a research project was undertaken to gather the necessary information and present it in a form that would be useful to planners and designers. The scope of the research was limited by both time and money. However, it was possible to include a survey of typical accessibility problems found in elementary schools, a study of handicapped children's abilities in using the physical environment and a study of typical construction problems in making renovations, including constraints imposed by existing buildings and technology as well as the costs of renovations.

This manual provides the results of the research in the most usable form for planners and designers. It is intended to be both a decision making aid and a source of technical information. It is not intended to give pat solutions to every problem encountered in making elementary schools accessible. Rather,

It is intended to demonstrate a range of solutions, provide the most comprehensive and reliable data base possible and provide a tool with which individual districts and designers can solve their own problems faster, more confidently and with the constraints of budget and technology.

The manual is organized into four Chapters. Chapter 1 provides a general introduction to the concept of accessibility in buildings with a specific focus on elementary schools. It includes a discussion of how accessibility to elementary schools grew out of the educational approach of "mainstreaming" and the historical background for that approach. The target population for barrier-free design is identified and psychosocial impact of inaccessibility is described. The Chapter also includes a description of existing Federal regulations and guidelines pertaining to accessibility of schools and a review of the state-of-the-art in and our knowledge of how handicapped people use buildings.

Chapter 2 is an overview of the problems of accessibility in existing buildings. It describes a survey of over 50 schools completed as part of the research leading to this manual and provides illustrated descriptions of common problems in existing schools. The Chapter concludes with a general discussion of constraints in making barrier-free renovations, including both construction problems and human problems.

Chapter 3 is a presentation of planning and implementation processes in making an accessible school environment on a district-wide level. It includes a discussion of the policy issues in providing accessibility to the educational program of a district. Several strategies are provided for deciding on the level of accessibility to be presented for identifying specific problems and making cost estimates for an entire accessibility plan.

Chapter 4 is the most extensive part of the manual and focuses on technical information for design of barrier-free renovations. This Chapter presents solutions to each accessibility problem identified in Chapter two. In most cases, several alternative solutions to each problem are presented, each described by associated impacts in terms of student's well being and cost estimates. This Chapter is extensively illustrated and covers all parts of elementary school buildings. It incorporates performance specifications based on the research conducted as part of this project and previous research on how handicapped people use buildings.

Chapter 5 is a series of case studies using actual schools to demonstrate how the design guidelines in Section 4 can be applied. Existing conditions and the proposed renovations are illustrated as well and cost estimates for their construction are provided.

The manual can be used in several ways. It is recommended that all readers skim through the entire document to become familiar with its contents. As a tool for the planning of accessibility renovations on a school district level readers are directed to Chapters 1-3. As a source of technical information for design of renovations, readers are directed to Chapters 4 and 5. In particular, the lists of technical criteria in Chapter 4 provide a handy checklist of design data.

The Appendix contains examples of a survey for inspecting buildings for barriers. Parents of disabled children and advocates of disabled people will find that Sections 1-3 provide a good background, however, they should also read Chapter 4 with specific attention to performance specifications, alternative solutions and their impact on children's well being.

Several abbreviations have been used in various places throughout the book. These included:

Action Alternative	AA
Board	BD
Concrete	CONC
Gypsum	GYP
Linear Foot	LF
Maximum	max.
Minimum	min.
Square Foot	SF
Square Yard	SY

Chapter One:

The Purpose of Accessibility

Target Population	6
Historical Background of Educational Approaches	7
Problems with Segregation	9
Role of the Physical Environment	11
Existing Guidelines and Regulations	12
Research on Accessibility	13
References	17

Since the 1950's, much attention has been focused on the social and environmental needs of disabled people. There have been numerous developments in the way of increasing social opportunities for disabled people, including actions aimed at removing architectural barriers in buildings. In 1961, the first ANSI standard, "Making Buildings and Facilities Accessible To and Useable by the Physically Handicapped" (ANSI 117.1, 1969-1971) was adopted. Since then, several federal laws have been adopted which require that public buildings and facilities be useable by disabled people. In 1968, PL90-480, "The Architectural Barriers Act" was passed. This act requires that all new, or newly renovated, federally-funded buildings comply with ANSI A117.1. Most states have implemented similar legislation which requires that publicly-funded buildings be accessible.

More recently, federal legislation has affirmed that disabled children have a right to complete educational opportunities and that architectural barriers in school buildings should not be cause for denying those opportunities to them. Section 504 of the Rehabilitation Act of 1973 establishes that school districts are responsible for providing access to their entire educational programs for disabled children. PL94-142, The Education for All Handicapped Children Act requires that to the maximum extent appropriate for each child disabled children are to be educated in the "least" restrictive

environment. Thus, the philosophy of "mainstreaming" has been adopted as federal law. Under mainstreaming principles, disabled and non-disabled children should be educated together to the greatest extent possible and segregated educational programs should be considered only for those children who have severe disabilities (Reynolds, 1962).

During the years since these laws were adopted, provisions have been made to provide accessibility in newly constructed or renovated schools. The effectiveness of such attempts have been limited since there has been very little information available regarding the accessibility needs of children. All of the existing accessibility standards and guidebooks present design criteria which are based on the size, strength and capabilities of adults. Even the recently revised ANSI A117.1 (1980) is based on the findings of research which was conducted solely with adults. Practically all of the commercially available equipment which is intended to improve accessibility, such as stairlifts, have been developed with adults in mind and use by children was not fully considered in their design.

TARGET POPULATION

Approximately .3% of all school-aged children in the United States have some sort of physical disabilities which limit their mobility and therefore, limit

their ability to participate in school activities (Chollet, 1979). There is a wide range of different disability types among the children who will be attending public schools under existing legislative mandates. Broadly, the different disability-types and their problems related to using the built-environment are as follows:

Non-ambulatory disabilities require a person to use a wheelchair in order to move around. Generally, non-ambulatory people have severe problems in attempting to use buildings. Problems which they typically encounter include stairs, walkways or doorways which are too narrow or do not have sufficient maneuvering clearances, narrow toilet stalls or lavatories which do not permit them to approach close. They cannot use furniture which has insufficient underside clearance or has built-in seats.

Semi-ambulatory disabilities require a person to use crutches, braces or walkers. People with semi-ambulatory disabilities have difficulty using stairs. They usually cannot travel long distances without tiring severely and have difficulties using doors which require a high amount of opening force.

Reaching and manipulation difficulties impair a person's ability to use their hands or arms in reaching or manipulation. These children have difficulties using standard door opening controls, sink hardware or other objects which require exerting a firm grasp, twisting,

or continuous hold or a high amount of force. They have difficulty using fixtures which require a high or distant reach.

Visual impairments which prevent people from using standard signals, signage or detecting hazardous obstructions.

Hearing impairments which prevent children from hearing their teachers or other conversations as well as prevent them from hearing emergency alarms.

In addition to those children who are primarily physically disabled, a large number of mentally impaired children also have secondary physical disabilities.

The object of "barrier-free design" guidelines is not to create buildings which are completely useable by all disabled people independently, regardless of the severity of their disability (Steinfeld, 1977). Rather, the intent of such guidelines is to expand the "normal" range of people for whom buildings are usually designed to include most disabled people. Some disabled people will always need assistance to complete certain tasks.

HISTORICAL BACKGROUND OF EDUCATIONAL APPROACHES

The movement towards mainstreaming disabled children is the most recent

development in the history of approaches towards educating disabled children.

In the Colonial period, disabled people were kept and cared for at home. For the most part, it was the responsibility of the family to care for family members who could not care for themselves. In some larger towns, almshouses were established to care for those aged, insane, or poor people who did not have family to care for them. (Rothman, 1971).

Rather than being run like institutions, as we know them today, almshouses were organized and run like households. They usually looked like any ordinary home and a "family" atmosphere was maintained. Informal routines and behavior were allowed and residents were permitted to dress as they liked. Residents were regarded as family, not inmates (Rothman, 1971).

It wasn't until the middle of the nineteenth century that large-scale institutions were first established in this country. One type of these institutions was for mentally impaired children. The main purpose of these initial institutions for children was to provide education. The establishment of separate institutions for mentally impaired children was justified by the argument that mentally-impaired people had to be concentrated in one place so that intensive expert services could be provided (Wolfsenberger, 1975). For the

most part, the residents of the institutions for the mentally impaired were only mildly disabled and were free from physical handicaps.

As the 19th century progressed, these institutions were no longer regarded as schools, but rather came to be regarded as asylums, where shelter rather than education became the primary purpose. The role of education at these institutions was further downplayed in some instances, as the need to invest money to educate retarded persons was questioned (Wolfsenberger, 1975).

With the adoption of compulsory education laws in the early 20th century, public schools found themselves compelled to provide educational services for disabled children. In some instances, educational programs were established at already existing residential institutions. In other cases, separate schools for the disabled students were opened (Hewett, 1974). The establishment of separate classes was a first step in the development of educational programs for disabled children. The practice continued unchanged for many years and they were lauded for their practicality in dealing with the problem of educating disabled children (Bates, et al, 1977).

Many educators today believe that segregation of disabled children restricted their social development, as well as educational development and contributed

to the continuation of prejudice and misconception towards people with disabilities.

Even as legislative reforms began to require that separate facilities for the disabled be eliminated whenever possible and that disabled and non-disabled children be educated together whenever possible, those who resisted integration continued to argue that separate facilities where homogeneous groupings could be maintained provided for better care and education (Bates, et al, 1977).

With the advancement of mainstreaming legislation, there has been some progress towards integrating disabled and non-disabled children. The "mainstreaming" approach towards integrating children follows a pattern whereby children are placed in schools according to their level of ability. This system is known as the "cascade".

According to the "cascade" approach, children with mild disabilities are educated together with non-disabled children in their regular classroom. When special services are required, such services may be provided in the regular classroom. If a special place or special equipment is needed, such as the equipment used in educating learning disabled or visually impaired children, then instruction may be given in "resource rooms" where the disabled children would go expressly to receive special services.

In the cascade approach, more severely disabled children are taught in "self-contained" classrooms. In "self-contained" classes, disabled children are taught together in their own rooms where they receive the bulk of their instruction. Children in "self-contained" classes join non-disabled children in certain classes or activities whenever appropriate for them to do so. Since "self-contained" classes are conducted in the regular school, contact between disabled and non-disabled children occurs at lunch, auditorium, playground and special activities.

Because emphasis had been placed on the provision of separate facilities for the disabled, accessibility issues were ignored at the time that most existing elementary schools were built. For this reason, creating integrated settings is more difficult than it would have been, if the needs of disabled children had been considered as part of the architectural program.

PROBLEMS WITH SEGREGATION

Because of their inability to perform "routine" tasks and differences in appearance and behavior, disabled people have long been regarded as being incompetent (Wolfensberger, 1977). Institutions for the disabled, including schools, have been designed around the incompetency of disabled people rather

than their abilities. Unlike the usual schoolhouse environment, institutions for disabled children often had features such as barred windows, switches and controls placed out of reach, drains in the middle of floors and "indestructible" wall and floor finishes. Features which elsewhere would be required by prevailing social norms, such as privacy screens in toilet rooms, were usually not provided. An important aspect of a child's growth is the development of their self concept. Positive self-concept development requires that a child feel good about themselves (Moore, et al, 1979). These environments communicated a message to disabled children that they were incompetent (Wolfensberger, 1977). Reinforcement of positive self-concept is difficult, if not in fact negated, when school programs are conducted in environments which continually remind children that they are "incompetent". Such environments also communicate to outsiders, that the children who are educated at these facilities are incompetent or deviants. Thus, the differences of the disabled and the resultant prejudices and stigmas are accentuated (Wolfensberger, 1977), creating a vicious cycle of stereotypical thinking.

An important contributor to the development of a child's self-concept is the quality of social interaction with other children. Social interaction between handicapped and non-handicapped children, can lead to the learning of appropriate behavioral norms by

disabled children and the non-disabled can come to know disabled children as individuals rather than viewing them collectively as a pitiful group or as the objects of prejudice and brutal jokes. Interaction can help all children learn about their differences and similarities as well as helping to foster cooperation, understanding and friendship. Unfortunately, as long as widespread separation continues, the opportunities for such interaction are very limited. If totally separate schools for disabled children are maintained, the opportunities for interaction are virtually nil. At schools where separate classes for disabled children are maintained in the same school building, there is some opportunity for interaction at lunch, and play, but usually in these situations, there are adults present when disabled children are together. Studies have found that adult presence can shatter the ambience needed for informal socialization among children (Moore & Rose, 1976).

When special classes for disabled children were established, an implicit assumption was made that children with similar disabilities have similar educational needs. All children with similar handicaps were thus assigned to the same class without regard to individual academic potential or needs (Bates, et al, 1977). The educational needs of disabled children are as varied as all other children. Some children need slower paced or individualized

instruction; others need accelerated programs and access to specialized learning equipment. If disabled children are to be kept in segregated, homogeneous, self-contained classes, and if the full-range of a school district's educational programs and facilities are not available to disabled children, then they are being deprived of these valuable educational opportunities.

ROLE OF THE PHYSICAL ENVIRONMENT

If physically-disabled children are to be able to participate in regular school programs, then the architectural barriers which limit these children's access to such programs must first be overcome.

At any school, there are usually many physical barriers which stand in the way of a disabled child's attempts to use school facilities. Among the common accessibility problems in elementary schools are:

- The location of important facilities, such as auditoriums, gymnasiums and cafeterias on different levels of multi-story buildings which are connected only by stairways.
- Steps along critical pathways such as along approaches to entry doors.

- Hazardous protruding objects and inadequate warnings of potential dangers that might harm visually-impaired children.
- Toilet rooms which do not have accessible facilities or the lack of accessible toilet rooms in needed locations, such as near cafeterias, locker rooms and playgrounds.
- Doors which require too much force to open for disabled children to be able to pass through them.

These architectural barriers are a two-edge sword. Not only do the barriers, in many cases, prevent disabled children from gaining access to school facilities, but these same barriers also contribute greatly to the stereotypical image of "incompetence" that surrounds disabled children. Not only is a flight of stairs a formidable physical barrier to a child in a wheelchair, but the presence of a flight of stairs bars a child from taking part in an activity, or aides are needed to help the child up or down staircases; the significance of the barrier is amplified as the child's disability is overtly called to the attention of all others present. Similarly, imagine the frustration, humiliation and stigma that is brought to a disabled child who wets himself because there is no accessible toilet room close to the cafeteria.

With growing movements towards "mainstreaming", existing school facilities will have to be renovated in order to minimize architectural barriers. Continued existence of such barriers in schools not only restricts physical accessibility for disabled children, but also helps seed an atmosphere where the disabled are poorly regarded. Rather than helping to reinforce the mainstreaming philosophy that children are more alike than different, inaccessibility continues to reinforce the stigma associated with disability.

EXISTING GUIDELINES AND REGULATIONS

Under ideal conditions, all educational programs would be available to both disabled and non-disabled children. All architectural barriers would be removed and modifications would be made to maximize disabled children's opportunities to use school facilities independently. Thus accessibility for all children would be achieved through a combination of modifying program regulations and minimizing architectural barriers.

Under existing Section 504 implementation guidelines, a distinction is made between the concepts of "program accessibility" and "physical accessibility". Section 504 guidelines call for program accessibility; all aspects of a school district's program should be

open to any child who is capable of participation in each activity. Section 504 guidelines do not require that all facilities of a school district be made "barrier-free", in fact, it allows programmatic adjustments to provide complete program accessibility as an alternative to physical modifications. Under Section 504 implementation guidelines, architectural changes are needed "only when there is no other feasible way to make a program or activity accessible" (Contract Research Corporation, 1978). New school construction, of course, must comply with the Architectural Barriers Act and state laws which require that public buildings be free from architectural barriers.

According to Section 504 guidelines, when a school district has more than one feasible option in making their programs accessible, the option selected "shall be the one that will result in the most integrated setting appropriate". In essence, under existing regulations, school districts have a substantial amount of flexibility in developing their accessibility plan.

This also applies to accessibility in the school itself since Section 504 Regulations have no specific guidelines on how accessible a school should be. The extent of accessibility at any school has to be determined by school districts, acting in the interest of providing the most "integrated setting feasible", depending on the specific conditions at

each school and the school district-wide program then viewed in its entirety. Therefore, depending on the specific circumstances, a school district has multiple options.

RESEARCH ON ACCESSIBILITY

Access and use of buildings includes the following tasks:

1. passing through openings
2. operating electronic and mechanical controls
3. moving along routes of travel
4. negotiating changes in level
5. transferring from one body posture to another
6. searching for direction-finding information
7. interpreting information displays
8. negotiating a series of movements within a confined space
9. negotiating through human and vehicular traffic
10. avoiding hazards in the path of access

To have reliable and generalizable information on the limits of human performance in these tasks, there must be carefully designed and controlled research. People vary considerably in their abilities, thus, basing design decisions on anecdotal information can be misleading and sometimes dangerous. Many of the tasks above have been studied by researchers. Although the re-

search was not always concerned with building design, much of the results are directly relevant to the design of buildings. Most of the research has used subjects who are not disabled. In some cases, data from such studies can be interpreted to the disabled population but it is not always possible. In recent years, due to the passage of legislation aimed at removing architectural barriers and the resulting demand for reliable technical information, there have been a number of research studies focusing on these tasks and completed with disabled subjects (see Steinfeld, 1979 for a review of previous research). Unfortunately, many of the codes and standards on barrier free design do not adequately reflect the extent of our research knowledge on the subject. The most reliable source of technical design criteria on accessibility is the American National Standards Institutes standard, ANSI A117.1 (1980) Specifications for Making Buildings and Facilities Accessible To and Usable By Physically Handicapped People. This document incorporates, to the greatest degree possible, design criteria based on controlled research. However, until now there had been no research with young children, only with adults. Thus, even the ANSI A117.1 (1980) standard does not contain technical criteria that are specific to the needs of children. The full details of the human performance research completed as part of this project are reported in another document. Below is a summary of the work and its main findings.

A total of 51 orthopedically handicapped children participated in the study. The sample was obtained from a total population of 179 orthopedically handicapped children of elementary school age in the Buffalo, NY, Public School District. Only those children participated whose parents gave permission and who were capable of following the instructions for the tasks based on the judgment of principals and teachers i.e. not severely mentally impaired. Children in the sample were representative of all ages below 13 years old, both sexes and several disability categories. They were selected from three schools at which all the research activities took place.

Although direct research was not conducted with hearing impaired children, discussions were held with administrators of schools for the deaf on special needs for deaf children. Since young children with severe sight impairments require specialized education not usually available in public schools, it was decided to omit research with that specific group.

A portable testing facility was designed that could be unassembled, transported and reassembled at each site. On-site observations of school activities were conducted prior to initiating the performance testing.

Trained staff supervised the children in the completion of standardized tasks and their performance was recorded

with standardized forms. A sample of 20 able-bodied children was used for comparison purposes. Each child was rated in their basic physical abilities and information on their medical diagnosis was obtained from the school records.

Topics were selected for research based on differences in stature, endurance and strength between adults and children. Some issues of accessibility were not studied since adult requirements would govern in design. For example, the dimensions and abilities to use wheelchairs determine space needs for maneuvering them. Data is available on the space needs of adults who use wheelchairs to make 90 and 180 degree turns. Since children are smaller and their chairs are smaller, it was assumed that they would not require any more space than adults. However, reaching abilities of children in a wheelchair were studied because the smaller stature of children is likely to result in lower maximum reaching abilities. The following design topics were investigated:

1. toilet height
2. lavatory height
3. grab bar height and width
4. type of controls (sink), dispensers (paper) and door openers
5. handrail height
6. door use maneuvers
7. travel rate and distance
8. ramp slopes and heights

9. stair use
10. basic anthropometric and biomechanic measurements, e.g. reach, strength, etc.

Generally, the results of the research demonstrated different needs for children compared to adults usually as a result of smaller stature and strength. The sample had a wide range of basic abilities, however, most of the subjects had cerebral palsy (60%). There were some differences in needs among the children based on age, specifically where stature was a critical factor in performance.

From the findings, it appears that a large proportion of severely disabled children in schools will have significant difficulty in using some parts of the environment (e.g. ramps, doors with self closers, toilets) without assistance, regardless of the degree of accommodation made. Comparing this finding with the research with adults subjects done as part of the development of ANSI A117.1 (1980) (Steinfeld, 1979) demonstrates considerable difference since, in that work only a few of the severely disabled people could not be accommodated. This difference can be attributed to the fact that the earlier research was conducted only with subjects who lived independently. Children in elementary schools are a population with a high degree of dependence upon teachers, aides, and other children. Many of the children will probably never be able to independently without some human

assistance. Some do not yet have sophisticated technical aids that will be available to them as adults, e. g. electric wheelchairs. Others have serious developmental conditions and are deteriorating in their physical abilities.

Perhaps the most important finding from this work is that the building itself cannot be expected to solve all the children's problems in obtaining access to physical resources. If there are doors with closers, ramps and long distances between origins and destinations, severely disabled children may need human assistance. Wheelchair users will often require assistance for toilet transfers. In fact, in the Buffalo School District, school policy prohibited children from transferring without assistance in order to reduce the liability for accidents. This means that wherever there are large concentrations of severely disabled children there will be a need for aides and assistants. With small concentrations, it may be possible to provide assistance without additional staff as long as the environment is accessible.

The slow rates at which many severely disabled children can move (1.5 ft/sec) has strong implications for planning and design. Although travel rates were found to be similar as among adults (Steinfeld, 1979) schools are a unique building type in that classes move from place-to-place as a group. If accessible facilities are not clustered in close proximity, considerable class time could be spent in circulation.

Large numbers of severely disabled children will result in greater losses of class time and/or greater needs for assistants or aides. With smaller numbers, teachers or other children can assist slow moving individuals.

It should be noted that these implications do not apply to children with less severe disabilities and those that are not related to stamina and strength. If they can maintain a rate of travel that is not significantly less than that of their classmates, barrier-free design alone can provide a great deal of independence.

The research results, then suggest decentralization and dispersion of severely disabled children throughout a school system to reduce the need for human resources for assistance although this approach may have to be qualified by the need to have critical masses for specialized therapy and health services. In addition, it is clear that barrier-free design renovations will not eliminate entirely the need for human assistance because of the nature of the population served by public elementary schools.



REFERENCES

- Bates, P., West, T.L., and Schmerl, R.S., (Eds.) Mainstreaming: Problems, Potentials and Perspective, National Support Systems Project, St. Paul, Minnesota, 1977.
- Chollet, Deborah J. A Cost-Benefit Analysis of Accessibility. U.S. Department of Housing and Urban Development, Washington, D.C., 1979.
- Contract Research Corporation. Civil Rights, Handicapped Persons, and Education: Section 504 Self-Evaluation Guide for Pre-school, Elementary, Secondary and Adult Education. U.S. Department of Health, Education and Welfare, Washington, D.C., 1978.
- Hewett, F. M. Education of Exceptional Learners. Allyn and Bacon, Inc., Boston, 1974.
- Moore, G.T., Cohen, V., et al. Designing Environments for Handicapped Children. EFL, New York, 1979.
- Moore, G.t., and Rose, P., "Evaluation and design of Children's environments: an example from three inner-city Sydney playgrounds". Paper presented at the Environmental Design Research Association 7th Annual Conference, Vancouver, Canada, May, 1976.
- Reynolds, Maynard C. "A Framework for Considering Some Issues in Special Education," Exceptional Children, March, 1962, p. 367-370.
- Rothman, David J. The Discovery of the Asylum: Social Order and Disorder in the New Republic, Little, Brown and Company, Boston, 1971.
- Steinfeld, Edward. "Developing Standards For Accessibility" in M.J. Bednar (ed.) Barrier-Free Environments, Dowden, Hutchinson & Ross, Inc., Stroudsburg, Pa., 1977.
- Steinfeld, Edward et al. Access to the Built Environment: A Review of the Literature. U.S. Department of Housing and Urban Development, Washington, D.C., 1979.
- Wolfenstenger, Wolf. The Origin and Nature of Our Institutional Models. Human Policy Press, Syracuse, N.Y., 1975.
- Wolfensberger, Wolf. "The Normalization Principle, and Some Major Implications to Architectural-Environmental Design" in M.S. Bednar (ed.) Barrier Free Environments. Dowden, Hutchinson & Ross, Inc., Stroudsburg, Pa., 1977.

Chapter Two:

Nature of the Problem

Survey Description	21
Range of Problems	22
Drop-off Zone	22
Obstructions on Circulation Paths	23
Stairs at Entries	23
Doorways	24
Inadequate Fire Safety Provisions	25
Circulation Hazards	25
Unsafe Stairs	26
Level Changes in Auditoriums	27
Hard-to-Use Ramps	27
Limited Access in Libraries	28
Inconvenient Cafeteria Seating and Lunch Lines	28
Hard-to-Use Elevators	29
Lack of Elevators and Lifts	29
Inadequate Furniture and Cabinetry	30
Inconvenient Classrooms	30
Playgrounds not Designed with Disability in Mind	31
Inadequate Lockers and Locker Room Facilities	31
Inadequate Toilet Facilities	32
Lack of Useable Signage and Signaling Systems	33
Lack of Handrails	33
Lack of Listening Systems	34
Inconvenient Drinking Fountains	34

The recognition of the wide range of existing problems in elementary schools is the first step towards a plan to resolve program accessibility.

There is generally an awareness of the most conspicuous set of barriers throughout the school, most notably, stairs between levels. Even these acknowledged barriers, when viewed from the capabilities of a child will reveal aspects previously not considered. In addition to the more obvious barriers and hazards there are problems which, although they don't prohibit use, will pose significant inconvenience or require the assistance of an able-bodied person, for the disabled child to satisfactorily perform.

An example of this might be the lack of a lowered counter in the library. A child in a wheelchair would not have the convenience of being able to fill out a card on a stable writing surface but would be forced to do this in their lap.

To enumerate and catalog such barriers, it was necessary to empirically record conditions at existing elementary school facilities. This was the purpose of the survey which is reviewed in the following discussion.

Survey Description

The survey of existing schools began with preliminary school visits. Approximately fifty schools were visited; general characteristics of these schools were recorded. These included the neighborhood, site topography, building configuration, building age and construction type and a general assessment of accessibility difficulties. The feedback from the preliminary visits allowed for a complete survey form to be developed. (See Appendix 1) Additionally these visits provided the basis for identifying a select group of schools for a subsequent complete and detailed survey.

Based upon the first visits a total of 24 schools were selected, these selections provided a sample of existing schools that represented a variety of different types of buildings and sites. For example, a mix of single and multi-story schools were selected; other variations included sloped sites and flat sites, or buildings of brick, concrete, and wood construction. Climatic variations were recognized by including schools from the Northeast, Southeast, and West Coast.

The survey itself involved a complete notation of all conditions at the schools as well as a photographic record of these conditions. This survey recorded dimensions, materials types or simply the existence of a particular condition. Accompanying the form would be sketches and diagrams.

Discussions were held with many school personnel in the course of explaining the project, while conducting the surveys, and in follow-up visits to the schools. The children at the schools also were willing to informally discuss the purpose of the surveys and their opinions of their school buildings.

The survey process accomplished several objectives. First, an accurate record of what conditions exist in the schools was obtained. This record produced increased awareness of the existent accessibility problems. Most importantly, the survey forced the recognition of the real constraints which will be incurred in the process of establishing criteria for future alternative modifications.

Range of Problems

To illustrate the results of the survey, a number of the more significant problems will be described. This is by no means a complete list of existing problems in the school environment. Hopefully, this sample will serve to foster consciousness to the total range of such difficulties.

Drop-off Zone

Most disabled children are brought to school by van, bus, or auto. At many schools, particularly those on small sites in urban areas, there is no special space set aside, for loading and unloading children which is protected from other traffic. Curbs in drop-off zones prevent non-ambulatory children from getting onto the sidewalk after they leave their vehicle. When the drop-off zone is located relatively distant from the building and there is no weather protected waiting area adjacent to that zone, children will have to wait inside during poor weather. This results in a rush when their transportation arrives.



Obstructions on Circulation Paths

Narrow circulation paths are difficult for wheelchairs to use because there may not be enough room for two wheelchairs to pass each other, or to allow turning maneuvers. Circulation paths which have loose or uneven surfaces, such as sand or cobblestone, require wheelchair users to exert a great deal of effort to move across them. Similarly, carpets which have high or loose pile, such as shag carpets, or which have soft cushions underneath are difficult to maneuver in wheelchairs. Finally, paths with abrupt changes in levels are obstructions to wheelchair users.

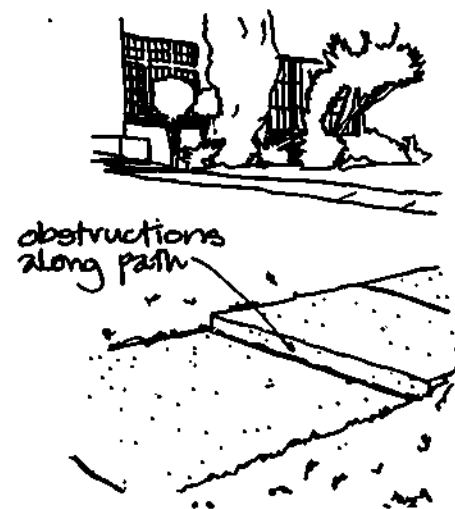

Stairs at Entries

Stairs, either inside or outside of entries may prevent many disabled children from participating in school activities because of the difficulties getting into the school buildings. If the only entries without stairs require that the disabled children have to enter the school through basements, kitchens, or mechanical rooms, then, not only are those children even more likely to be singled out from their classmates but they are also subject to possible injury from hazards in those areas.



Doorways

Doorways sometimes pose obstacles to disabled children's ability to move through school buildings. Children in wheelchairs cannot pass through doors if there is insufficient maneuvering space or if the doorway is too narrow for a wheelchair. Children with limited strength cannot exert enough force required to open doors if door closers with high closing forces are installed. Some closers shut doors so quickly that children who move slowly cannot move fast enough to pass through the doors even if they can open them.

The hardware found on most school doors, usually knobs, is difficult for children with impaired muscular coordination to operate because a firm grasp is needed and knobs must be twisted by wrist action. Automatic door activators which are located too far away from the door or are so close that they require a child to stand in the area where the door swings may make the doorway unuseable. Similarly, activator buttons which require a high amount of pressure to activate are not useable by many disabled children.

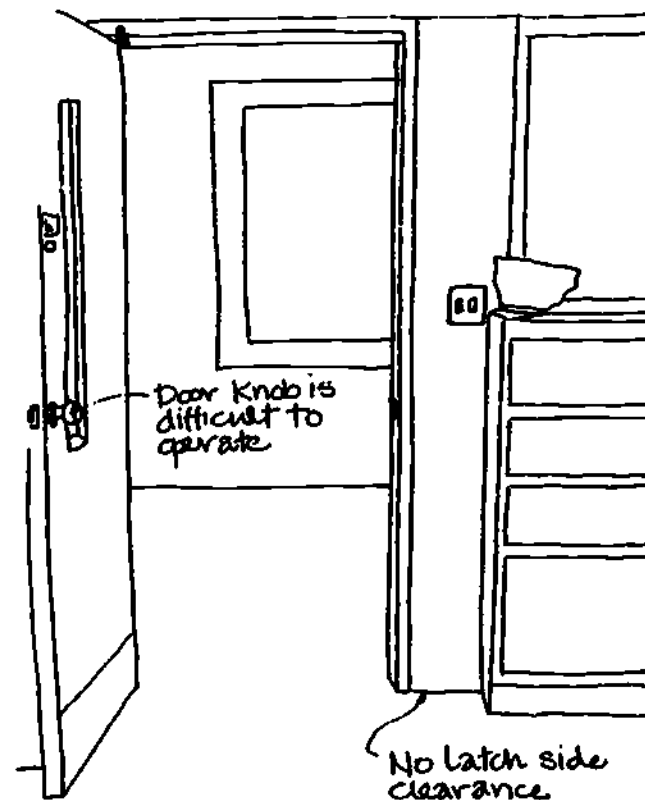

Inadequate Fire Safety Provisions

In multi-story buildings where there are elevators for access to upper floors, there is usually no provision for a fire protected area near the stairway. This is needed since an elevator is not acceptable as an emergency means of egress.



Circulation Hazards

There are many hazards to disabled children in schools, particularly along circulation paths. Children with visual impairments can easily bump into obstructions or trip and fall when path surfaces are uneven or unstable. Objects out of the range of detection by canes, yet protruding into a path of travel are very dangerous to severely visually impaired children. So are unexpected hazards such as stairs immediately in the path of travel. Children with semi-ambulatory disabilities can fall easily on uneven or slippery floor surfaces. Moreover, wheelchair users can roll off unprotected edges such as at walk and ramp edges.

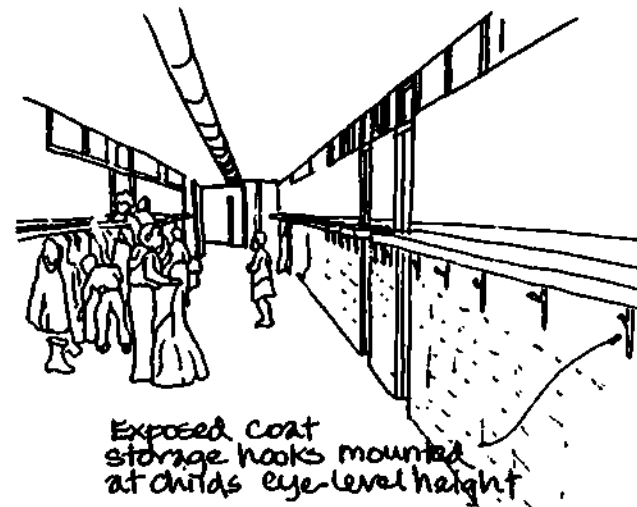

Unsafe Stairs

Some semi-ambulatory children are able to climb stairs. Many of these children rely on using handrails to help balance and give assistance in walking. If handrails are too high or too large, then children may not be able to grasp them firmly. Handrails without extensions at the top and bottom are difficult for some children to begin and end the climb.

Treads which have abrupt nosing are potentially hazardous because children with leg braces may catch their toes on the underside of the nosings and may trip. When the spaces under the bottom of stairs are exposed, visually-impaired children may accidentally walk into these areas and strike their head.

If the lighting level along stairways is insufficient or if there are shadows or glare, then all children, but especially those with partial visual impairments, may not be able to see their way in order to safely use the stairs.

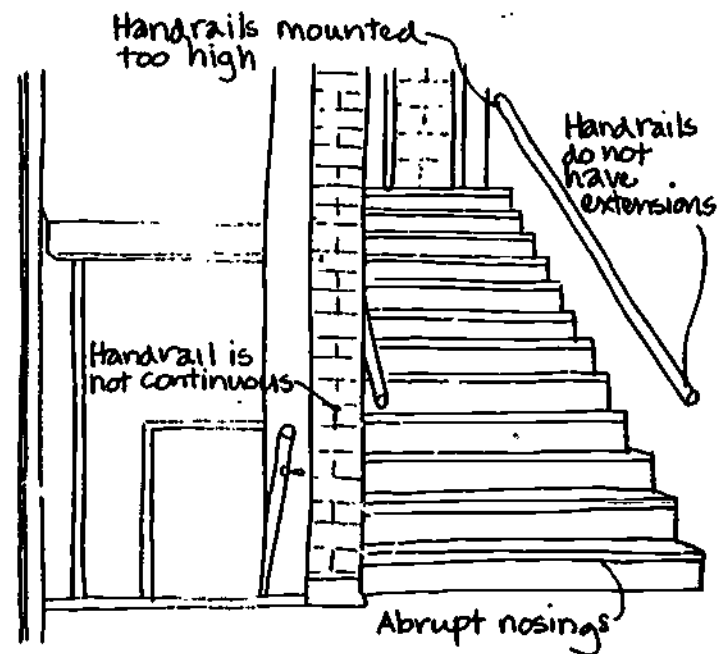

Level Changes in Auditoriums

Because of the design of most auditoriums, it is difficult for many disabled children to fully participate in events. Aisles are sloped to increase visibility but this prevents most disabled children to move independently from the rear to the front. When stages are raised and the only way to get to them is by climbing stairs, it is difficult, if not impossible, for children to take part in on-stage activities. In most auditoriums there is no space where children in wheelchairs can position themselves without being in circulation paths.



Hard-to-Use Ramps

Children, for whom it is impossible to climb stairs, may use ramps to move between levels in a building. Steep ramp slopes, 1:12 or greater, are not useable by non-ambulatory children. Shallow sloped ramps, 1:20, are still not useable by some disabled children. Additionally, by necessity, shallow slope ramps require a long time for children to move along them. Long ramps which do not have intermediate landings do not allow children to rest on a level spot during their trip. Handrails on ramps that are mounted too high or are too large do not allow children to get the firm grasp needed to support themselves safely. Handrails which do not have extensions at the top and bottom do not provide assistance upon mounting and dismounting the ramp.

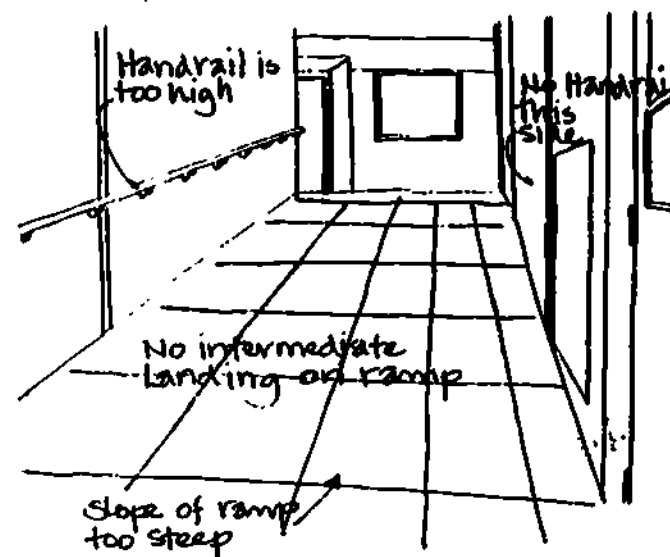

Limited Access in Libraries

Furnishings cause the most significant impediment to disabled children's use of libraries. High bookshelves are not within the reach of almost all elementary school children. Aisles between shelves are sometimes too narrow for wheelchairs to use. When there is no clearance under card catalogs and check-out counters, children in wheelchairs cannot make forward approaches to them.



Inconvenient Cafeteria Seating and Lunch Lines

Most cafeteria table seating consists of long benches which are attached to tables. In order to sit at these tables one has to first climb over the bench; a difficult task for most semi-ambulatory children. Lunch lines are usually too narrow for wheelchairs to pass through and the reach for food service can be both too high and too far.



Hard-to-Use Elevators

Elevators and lifts which are ordinarily found in schools can be hard to use by disabled children. Call buttons in lobbys and control buttons in the cabs are often mounted too high for children. In many cases the floor area of the cab is inadequate to permit either one or two wheelchairs. Due to either initial design or poor maintenance the leveling mechanism often results in a difficult entry condition.

Lack of Elevators and Lifts

Many schools, particularly older urban ones, are located in multi-story buildings and the centralized facilities (gymnasium, cafeteria, auditorium, etc.) are often on more than one floor. In other instances, where new additions have been connected to existing buildings, floor levels are sometimes not at the same elevation. Wheelchair users and many semi-ambulatory children cannot climb stairs and disabled children cannot use ramps, except very shallow ones for short distances.



Inadequate Furniture and Cabinetry

A great deal of school furniture is not useable by disabled children. For example, tables and desks with insufficient underside clearance or which have built-in seats. Built-in seating is also difficult to use by some semi-ambulatory children. Lift-up desk tops cannot be used by some children with motor control impairments. Counters in offices and classrooms are often too high and do not have underside clearance.

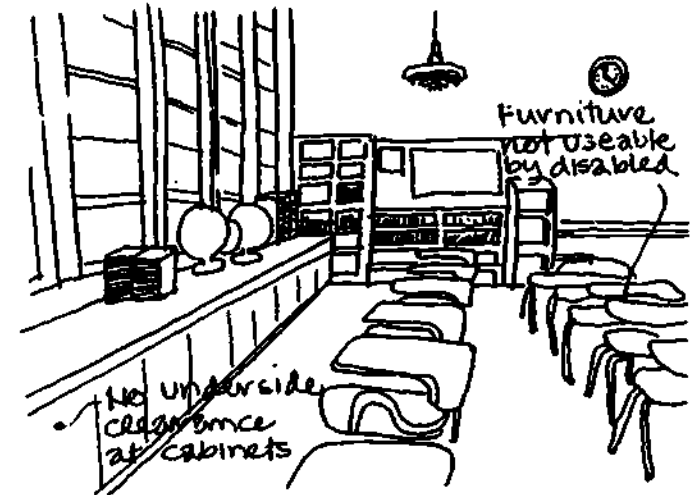

Inconvenient Classrooms

Some classrooms, especially in new schools, have raised or lowered areas where special activities such as storytelling, arts and crafts or science activities take place. Since wheelchair users and many semi-ambulatory children cannot climb steps, they cannot take part in these activities. Classroom storage shelves and coat hooks are often mounted out of reach of disabled children. Sinks with storage areas below them may not be useable to many children if there is no room for a side approach and the controls are too far a reach. Electrical switches can be mounted too high which will preclude a child in a wheelchair from aiding a teacher as other children can.

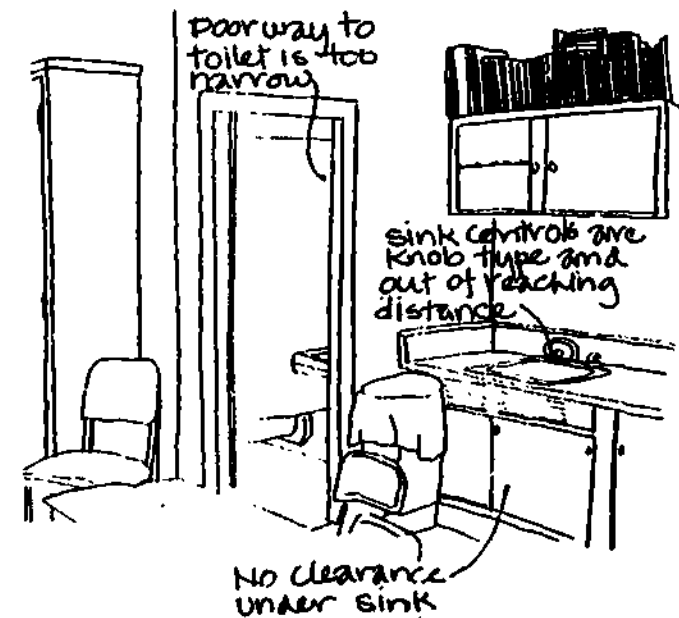

Playgrounds not Designed with Disability in Mind

Many school playgrounds are not designed with disabled children in mind. Often the paths which lead to playgrounds are not hard surfaced, nor do they have surfaces on which disabled children can walk easily. Usually there are no accessible toilets nearby. Most schools do not have play equipment which is useable by disabled children and there are no provisions in the area for these children to rest or escape from the sun

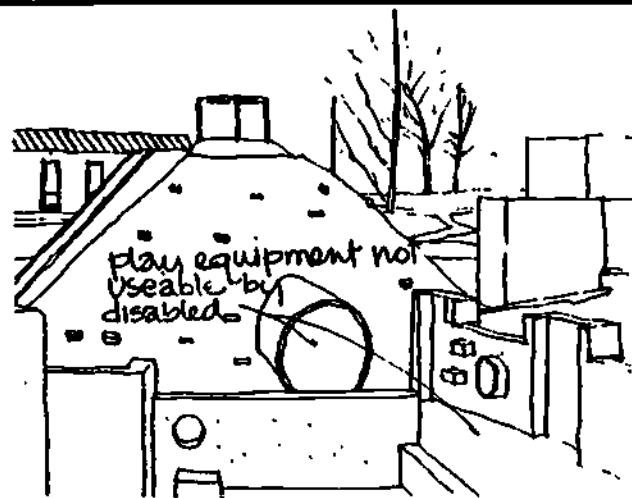

Inadequate Lockers and Locker Room Facilities

Often, locker room facilities are not easily useable by disabled children. Aisles are often too narrow for wheelchairs. Combination locks and thumb-latches on locker doors are difficult for children with motor coordination problems to operate. Locker stalls are usually narrow and, if adjacent ones are being used at the same time, there may not be enough space for disabled children to approach their own lockers. Hooks and shelving are frequently out of reach of disabled children. Toilet facilities are usually not accessible. When there are curbs in front of showers, they are not useable by many semi-ambulatory children and those in wheelchairs.



Inadequate Toilet Facilities

In most schools, toilet stalls are not useable by disabled children because the toilet is mounted too high, there are no grab bars and paper dispensers are difficult to use. There usually are no stalls which are large enough for an aide to accompany and assist a child. Traps under lavatories prevent wheelchair users from making a forward approach. Knob-type lavatory controls requiring the twist of the wrist are difficult to use. Mirrors and dispensers which are mounted too high are not easily used by children in wheelchairs. Often, toilet room lights are left off and due to the height of the switch a child in a wheelchair will not be able to turn the lights on. Some fixtures are only operable by foot controls. These are impossible for non-ambulatory and many semi-ambulatory children to use.

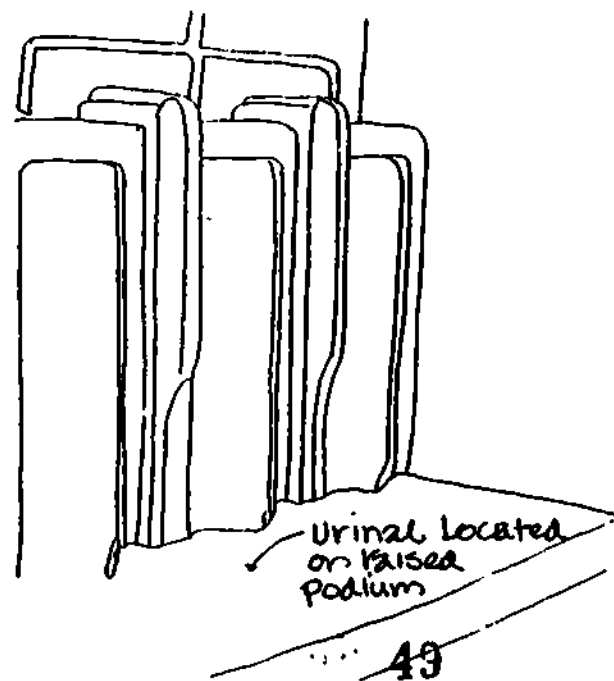

**Lack of Useable
Signage and Signaling
Systems**

Most of the signage in schools is not useable by visually impaired children. Existing signs are too small to be seen at a distance. The signage frequently does not have raised or indented characters for use by blind children. Since deaf children cannot hear auditory alarms such as bells or buzzers; visual alarms are needed to warn the children of emergencies.

Lack of Handrails

Semi-ambulatory children often use handrails along stairs and corridors when walking to help balance themselves or to lean on for rest. If corridors do not have handrails, then moving from one place to another is more difficult, especially if the travel distance is fairly long. If handrails are mounted too high, then they are not useable by young children and if too low, are unuseable by older children. If the space between the handrail and side wall is too large, then children's arms may slip into the gap. If handrails are too wide or otherwise shaped so that children cannot get an opposing grip of fingers and thumb then they cannot hold the handrail securely.



Lack of Listening Systems

Very few schools will provide listening systems, particularly where most needed such as in auditoriums and classrooms. Children with hearing impairments, even if they know how to read lips, can have difficulty because of low light levels or distance from the speaker.

Inconvenient Drinking Fountains

Most older drinking fountains have several accessibility problems. They might be mounted too high and have exposed piping below them which prevents safe use from a forward approach. Controls which require great force or twisting motions to activate are difficult for children with motor coordination disabilities to use. Spouts located at the rear of the fountain are not useable.

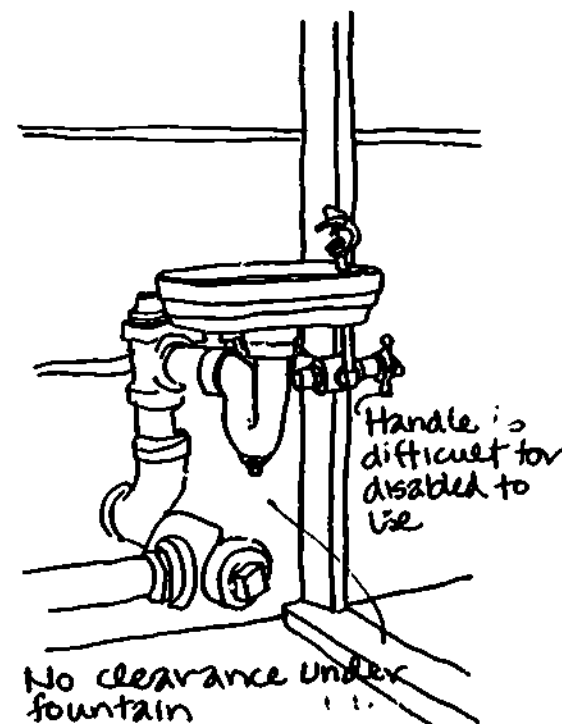

Chapter Three:

Accessibility Implementation

Accessibility Plans	36
Planning Process	37
Issues in Program Accessibility	39
Method of Problem Identification	44
Cost Estimating	45

Implementing accessibility requires a plan of action and a process for developing it. Both accessibility plans and the planning process should be considered; they should be responsive to both the needs of the disabled children in a district and to the resources available. This chapter describes the attributes of effective planning approaches and discusses the major issues in providing program accessibility.

ACCESSIBILITY PLANS

An accessibility plan is a working document used as a tool to achieve program accessibility in a school district. It is a process-oriented document that should never be considered complete; but rather, it should always be evolving to meet new needs and situations. A comprehensive accessibility plan should include these parts:

- a. description of process - persons responsible for developing and implementing the plan including roles, responsibilities and communication methods.
- b. needs assessment - an overview of the disabled population served by the district, specific educational and extra-curricula needs based on type of disability, age, residential location, etc.
- c. basic policy statement - the overall policy toward provision of accessibility as a response to the needs assessment including how the school program will be made accessible to meet variation in educational, social and support needs.
- d. evaluation of existing buildings - the degree of accessibility of the districts' physical plant.
- e. design objectives - identification of these schools that are currently accessible and/or are to be made accessible including the level of accessibility to be provided.
- f. description of modifications - drawings and specifications showing how changes will be made and estimates of their cost.
- g. schedule and budget - phasing of the modifications and dollar amounts requested or designated for each part of the work.
- h. evaluation - method and schedule for evaluating the success of the plan, identifying unmet needs and modifying the goals and objectives.

The most important aspects of accessibility planning is the attitude with which planners and decision makers view the planning process. If accessibility planning is viewed solely as a short term effort focused on minimal

compliance with Federal regulations at the least cost, it is unlikely to be truly successful and probably, in time, will not result in continued compliance. Cost and other concerns of feasibility cannot be ignored. However, the true success of accessibility planning is the degree to which it is integrated into the everyday management of a school district's facilities. There are always new needs developing since the student population is always changing. The success of a plan is actually measured by how it helps the district respond to new needs and to each and every disabled student. Inadequate response will result in formal complaints and government investigation. In a nutshell, an accessibility plan is a means to institutionalize concern, planning and action into management activities.

PLANNING PROCESS

In the initial stages of planning, specific individuals should be given responsibility for the planning work and the plan's implementation. The success of any organizational planning effort often hinges on the coordination between planning and implementation. It is best if the same people do both, but if that is not possible, clear lines of authority and communication should be instituted to insure follow-through. Even if one person within the organization is solely responsible, there will usually be many other people who

have useful information for planning or who will be effected by the implementation efforts. If all interested parties are involved from the start of planning and are kept informed about all the planning and implementation activities, the chances of success will be greater. Thus, setting up a planning committee is an important first step. It should consist of all those people who will be directly involved in planning, implementation and evaluation. The committee could include people with these responsibilities:

1. overall responsibility for programs serving disabled children, including health and social services.
2. direct responsibility for construction.
3. day-to-day responsibility for maintenance and repairs to the physical plant.
4. overall responsibility for scheduling.
5. overall responsibility for curriculum development.
6. overall responsibility for transportation.
7. parents of disabled school children.

The committee should also have liaison representatives at each school who can provide feedback as it develops its plan.

In a small school system, there may be no need for a formal committee--one person can be given responsibility for developing and implementing the accessibility plan. However, that person should maintain lines of communication with others and solicit information, opinions and ideas before finalizing a plan or action.

When developing an initial plan with a committee, meetings should be held on a regular basis until the plan is completed. In particular, each part of the accessibility plan should be reviewed and discussed in detail before finalization. During the early implementation phase, the committee should meet regularly to review and evaluate actions as well as to identify the need for minor changes to the plan. Usually during this phase, certain aspects of the plan may prove not to be totally effective. For example, it could be discovered that because of existing construction conditions, automatic door openers cannot be installed on some doors in a manner that would guarantee reasonable levels of reliability. The committee could consider whether they should be installed as planned and special maintenance actions instituted to keep them in working order or if the plan should be modified to replace

existing doors or make other entrances accessible. Another type of early implementation problem is the undiscovered need. For example, it might be discovered that an entry to a school is usually kept locked for security reasons. Children who arrive late to school must ring a bell to gain admittance. Handicapped children might not be able to reach the bell. Such problems are common, but, after the initial implementation phase, solving them will become a routine procedure. The committee should establish formal lines of communication, action steps and responsibilities for typical problems. Once this is done, there is probably no need to continue regular meetings unless problems are discovered that are new to the district. As part of the evaluation process, semi-annual meetings could be scheduled by the committee with representatives from the schools and parents to assess the success of the accessibility plan and identify new problems.

Additional problems could be the most difficult to resolve. For example, some parents may feel that children are not receiving enough staff assistance in using buildings and grounds while others may feel the opposite -- that because of limited accessibility, their children are not allowed to be as independent as they could be, or, even though school buildings are fully accessible, teachers and administrators may restrict the independent activities of disabled students to reduce the risk

of injury. As another example, maintenance staff may not respond quickly enough when accessible equipment breaks down, assuming there is other equipment available when, in reality, disabled children cannot use it. Such problems can best be resolved by meetings in which the viewpoints of those involved can all be heard and different ways of resolving them can be discussed.

In the planning stage, it can be very useful to have an awareness-raising workshop as an initial activity for the planning group, parents, teachers, administrative and maintenance staff. Such a workshop can utilize many available films and the services of an experienced consultant to uncover and correct prejudices, myths and mistaken beliefs held by parents, school staff and even planners. Although such attitudes are not changed overnight, it may help to reduce the impact of negative attitudes during both planning and implementation phases.

ISSUES IN PROGRAM ACCESSIBILITY

Perhaps the most important set of decisions to be incorporated in an accessibility plan are those concerning the basic policy of accessibility, the selection of schools that are to be made accessible and the level of accessibility to be provided at each school in which modifications will be made. In effect, set of decisions determines the

nature of program accessibility in a school district. The way program accessibility is achieved should be determined locally because the needs, existing conditions, available resources and costs will vary considerably from community to community. However, there are several major issues that are common to any plan. If the plan resolves these issues well, it should be successful in reaching the overall goal of program accessibility.

The issues are:

1. equality in access to educational programs.
2. normal social opportunities.
3. special supports where necessary.
4. cost effective allocation of resources.
5. community support.

Equality in access to educational programs means that disabled children are not denied participation in the full range of educational programs offered by a school district. Some districts have uniform elementary school programs in each school. With such an educational approach, a disabled child could attend any school in the district and would have equal access to the educational program. Other districts have

programs that vary, on a neighborhood basis, from one school to another. Programs are individualized by school to meet specific neighborhood needs. If a disabled child lived in a particular neighborhood and shared the same educational needs as others in that neighborhood, equality of access to the educational program could only be achieved if the neighborhood school or another school with a similar program was accessible. A third educational approach is the "magnet" school concept in which a few schools serve the district as a whole to provide programs with certain specific philosophic approaches e.g. Montessori or "traditional" teaching methods, or to serve children with specific intellectual interests or gifts. If each of the "magnet" schools were not accessible, a disabled child would not have equal access to the full range of educational opportunities in a district.

There is, of course, even greater variation in educational programs than described above. However, the basic issue, as illustrated in the examples, is to provide access for disabled children in a manner consistent with the opportunities available to able-bodied children. Resolving this issue has a great impact on the basic policy of accessibility and the selection of accessible schools. It also has an impact on the level of accessibility provided within each school.

With regard to the selection of

schools to be made accessible, resolving this issue means that schools which provide unique educational resources in the district should be made accessible. In addition, it indicates that there is flexibility in selecting schools to be accessible where educational programs are similar. Where there are spaces with specific educational resources that either are an integral part of an educational program at an accessible school or serve the district for specific educational activities e.g. swimming pool used for swimming classes by children in several schools, then those spaces should be accessible.

Schools provide education in more than academic subjects. The experience of going to school includes obtaining an education in social norms and social skills.

An accessibility plan should give consideration to these aspects of school as well as academics. Not only are they important in their own right but social abilities are indirectly related to academic performance through their effect on morale, emotional adjustment and self-image.

The chance to participate in normal social opportunities can be affected by accessibility plans. For example, if a school district uses the neighborhood school concept, the provision of only one accessible school in a district could reduce opportunities for disabled

children to make friends with their neighbors. If magnet schools were not accessible, disabled children may not have the opportunity to meet children who share special interests, e.g. music, art, science or math. Moreover, if special classes are small, several age groups are often lumped together, reducing opportunities for friendships to be based on age-related interests. The segregation of disabled children into one or more schools results not only in "labeling" by other children and parents but also added stigma such as the assumption that all children who attend the special school are not as "bright" as those who attend the "normal" schools. The stigma of being treated differently in a devalued sense can have a serious negative effect on self-esteem.

In an educational setting where all children are disabled, adults have to provide considerable assistance with tasks such as pushing a wheelchair or carrying a cafeteria tray. In a mainstreamed environment, such assistance is often provided spontaneously by other children. This assistance can lead to social bonds between the children. In comparison to adult aid, it is socially more acceptable because it represents acceptance into the peer-group structure and a sense of belongingness. As an example, during our survey of schools, we heard about a class that voted not to go to the lunchroom for an entire month because an elevator had broken. One of the students used a wheel-

chair and she would have had to eat alone in the lunchroom if the other students had not decided to join her.

Accessibility plans, then, should take the social life of children into consideration. Normal social opportunities can best be achieved by a plan in which disabled children can attend schools with other children with whom they could conveniently have out-of-school friendships. In a large city, this would mean decentralization of accessible facilities. In so far as possible, disabled children should be integrated into normal classes and particularly with children of their own age. Where special interests and talents are a basis for educational programs, the spaces that house those programs should be accessible.

There are many severely disabled children who need special supporting environments to insure the highest potential for intellectual development, safety and good health. Many of these children need extensive physical or occupational therapy. Others, such as those with severe hearing impairments, need special technology as a support for communication. A third group cannot keep up with the normal pace of school because they lack the energy and stamina or are heavily medicated. Finally, there are many physically disabled children who have mental impairments that prohibit their participation in regular classes. School districts

should recognize these special needs but should not use them to justify unnecessary segregation. The investment of extensive resources in one school for handicapped children can create a "magnet" based on dependency. Well meaning parents and health professionals may believe that such a school represents "the ultimate in care" for their children and patients. Such supports are, of course, necessary; however, they should be provided in a manner that holds the amount of segregation to a minimum. If a so-called "handicapped" school really has no special supports then there is unwarranted segregation. If it is feasible to provide special classes, equipment and services in a decentralized way through several schools in a district then the selection of one school to be the "handicapped" school may be overly restrictive.

On the other hand, some small school districts do not have the resources to provide special supports or have a very small number of severely handicapped students. By working with county or state agencies or by pooling resources with neighboring districts, programs can be set up to provide the supporting services and environments on a regional scale. Even at a regional level, it is possible to decentralize special facilities under regional management.

All accessibility plans must be developed within the context of economic

resources. Too often, however, the approach that costs the least on a first cost basis is the one that is selected. School districts should insure that a plan is cost-effective, not just inexpensive. If one plan option provides significantly greater equality in access to educational programs and more normal social opportunities for only a small difference in cost, then it may be worth spending the extra money.

Another aspect of cost-effective planning is the allocation of resources among schools. Given a fixed sum of money, several schools can be made partially accessible -- enough to accommodate the full program of accessibility by room changes, etc. This will often provide more normal social opportunities than making only one school in a district fully accessible.

In deciding how accessible a particular school building should be, planners must decide how to provide access to the facilities in which basic elementary school activities usually take place. Facilities which are common to most elementary schools, and therefore, must be considered in developing accessibility plans are:

- Classrooms
- Toilet Rooms
- Gymnasium & Locker Rooms
- Libraries

Cafeterias

Auditoriums

**Playgrounds & Athletic Sport
Fields**

Main Offices

There are several approaches which may be applied towards making a particular school accessible. At any one school, it may be necessary to apply several of these strategies when dealing with the different facilities, depending on the specific needs and constraints which are applicable in each situation. These general approaches are:

- Modify the existing facilities so that they are accessible.
- Provide alternative facilities within the school for use by disabled children. Depending on the situation, the provision of alternative space for disabled children may not be considered an acceptable response to the Section 504 Mandate.
- Build new, accessible facilities for use by all children.
- Use similar facilities which may be available elsewhere in a community for Special Education Programs.

Once it has been decided which facilities in a school are to be acces-

sible, decisions must be made regarding the location of these facilities within the school. Options which may be appropriate to a particular school include:

- Locate all accessible facilities on the ground floor of the same building.
- Locate all accessible facilities in the same building, even though it may be necessary to use several levels.
- Locate all accessible facilities on the ground floor even if this requires locating facilities in 2 or more buildings (campus-type schools).
- Distribute accessible facilities throughout the school.

The strategies above all have different costs and impacts.

Alternate plans and options for allocating funds to different schools should be developed and evaluated with respect to equality in educational programs, social opportunities, special supports and cost before a final decision is made.

Ultimately, whatever strategy is selected for implementation, the plan should have community support from parents of disabled children, health professionals, teachers and others interested in the welfare of disabled

children. The best way to insure that such support will be forthcoming is to involve these people in the planning process (see above).

It is not uncommon for parents, teachers and administrators to oppose integration of handicapped children into regular classes. Arguments against integration include:

1. teacher's attention directed to handicapped students at the cost of others,
2. increased administrative complexity,
3. risks to safety of handicapped children and liability problems,
4. myths about contagion - e.g. other children will "catch" the disability.

To overcome such opposition, planners must demonstrate that such arguments are fallacious or that there are reasonable solutions to the problems. If opposition becomes irrational, it may be necessary to call upon outside third parties such as administrators, teachers, parents and experts from other places who can demonstrate success by example or help change attitudes.

METHOD OF PROBLEM IDENTIFICATION

Problem identification is essentially a two step process. The first step in problem identification is to survey the existing conditions of the school building and site. The second step will be to compare those existing conditions to the design criteria; this will result in specific problems being identified.

A survey of school conditions can be conducted by two persons who have a basic ability of making accurate measurements and exercise attention to details. The most important aid in performing a clear and complete survey will be a designed written survey form. Examples of such survey forms are included in the Appendix of this book. The forms included will cover most conditions which occur in schools. Space is provided for noting dimensions, presence or absence of a feature, and remarks. Other materials necessary for performing a survey will include a tape measure (one 16' in length is adequate although a 50' tape is also helpful), clipboards, a watch with second hand and a door pressure measuring device. A small spring loaded scale which is made for weighing fish can be substituted for an actual door pressure testing device. Although plans of the school are not required they will make the survey easier. Such a survey can usually be done in one day depending upon the size and complexity of the school.

There will be no set way to move around the school for the survey. Each school's layout will dictate to some degree the most convenient route to take. The important factor is the thoroughness of the survey. A preliminary walk throughout the entire school and grounds can be helpful to start. Identification of typical spaces or building elements can be done on this preliminary walk. Based upon this it might be that there only exists two classroom types which require surveying. Other commonly repeated or typical items might be drinking fountains, toilet rooms and doors.

Once the existing conditions have been recorded a comparison to the design criteria can be made. The checklist of design criteria, in alphabetical order, page , will be the key to such a comparison. The survey forms should be first organized in an order which parallels the order of the checklist or the order following the outline of Chapter Four. As one compares the particular existing condition to the specific criteria or standard and a variance is recognized one can make a notation of the variance. This would best be done on a separate list. Before finalizing the list of identified problems, it would be a good idea to refer to the detailed discussion of relevant corresponding design standards.

COST ESTIMATING

The first step in preparing an estimate of the total cost for an accessibility plan in a school is to group the various improvements, together according to the sequence set out in Chapter Four. Generally this begins with circulation, both site and building, continues through the different use areas and ends with a review of individual elements. This will allow for the most direct use of the cost information which is provided in that chapter. This should also organize an estimate in such a way to prevent omission of necessary improvements and their costs.

Some accessibility modifications might entail only one task, others may involve a number of tasks or separate components. The simple addition of a guardrail along a sidewalk is an example of the first case, while construction of a fire refuge area near a stair is an example of the second. Such construction would likely require existing wall demolition and new wall or doorway installation; in addition, other work such as window relocation or floor refinishing might be needed. In the case of a multiple task modification the major tasks should be delineated and noted.

The next step in the cost estimating process is to select the appropriate units for estimating the labor and ma-

terial for each of the tasks. The most common of these units are "square foot" (SF) and "linear foot" (LF). Another common unit will simply be the number of items, such as towel dispensers or grab bars. Units can be identified by common sense and by using the cost discussion included in the action alternatives.

After units are determined a fairly complete framework for an estimate will have been established. It is possible, and probably desirable, to include in the list of modifications some alternative solutions to each improvement so that comparisons can be made regarding the least expensive solution to an accessibility problem. Once this framework is established, the completion of the estimate essentially involves "filling in the blanks". The actual quantity of work, which is determined in the field survey of the facility, and the unit cost, found in the cost sections of the Accessibility Guideline chapter, are entered. From this the total can be computed for each task. Finally, the subtotal and total sums are computed.

It should be noted that the costs provided in this book are based on several sources of data -- construction cost manuals, professional estimates, and talks with manufacturers or installers.

Costs in Chapter Four are usually divided into cost of materials and cost for Labor means installation. There

is often significant variance in local costs of labor. School districts may be able to eliminate labor costs since their own personnel could do the work as part of their regular work load. The costs used in this book are typically based on union wage rates. Material costs do not vary as much as labor costs; thus the divided costs allow someone using this book to substitute, or possibly eliminate the labor cost depending on the capabilities of the school's maintenance personnel or that of the district's physical facilities department. The labor figure that has been provided does include overhead and profit for those trades that are commonly sub-contracted.

The cost figures have been prepared with job size in mind. Depending on the particular school, the degree of modification required, and the number of such modifications, the cost will vary. Obviously, there is an economy of scale; the price to have one fire alarm lowered will be more per unit than if the same task is completed throughout the school in a number of locations. A rough job size was assumed based upon the average situation found in the schools surveyed. Therefore, a higher cost, or perhaps a half-day minimum, should be used if the job involves only one change while a lower figure could be used where the work is being estimated for more than one school, for example, on a district-wide basis.

As with all estimating, cost will vary

in different areas of the country and will obviously be increasing over time. These factors must be considered and recognized. The intent of the cost estimating process and actual figures in this book is to give general guidance while hopefully bringing some specificity to the difficult decisions regarding the preparation of an accessibility plan.

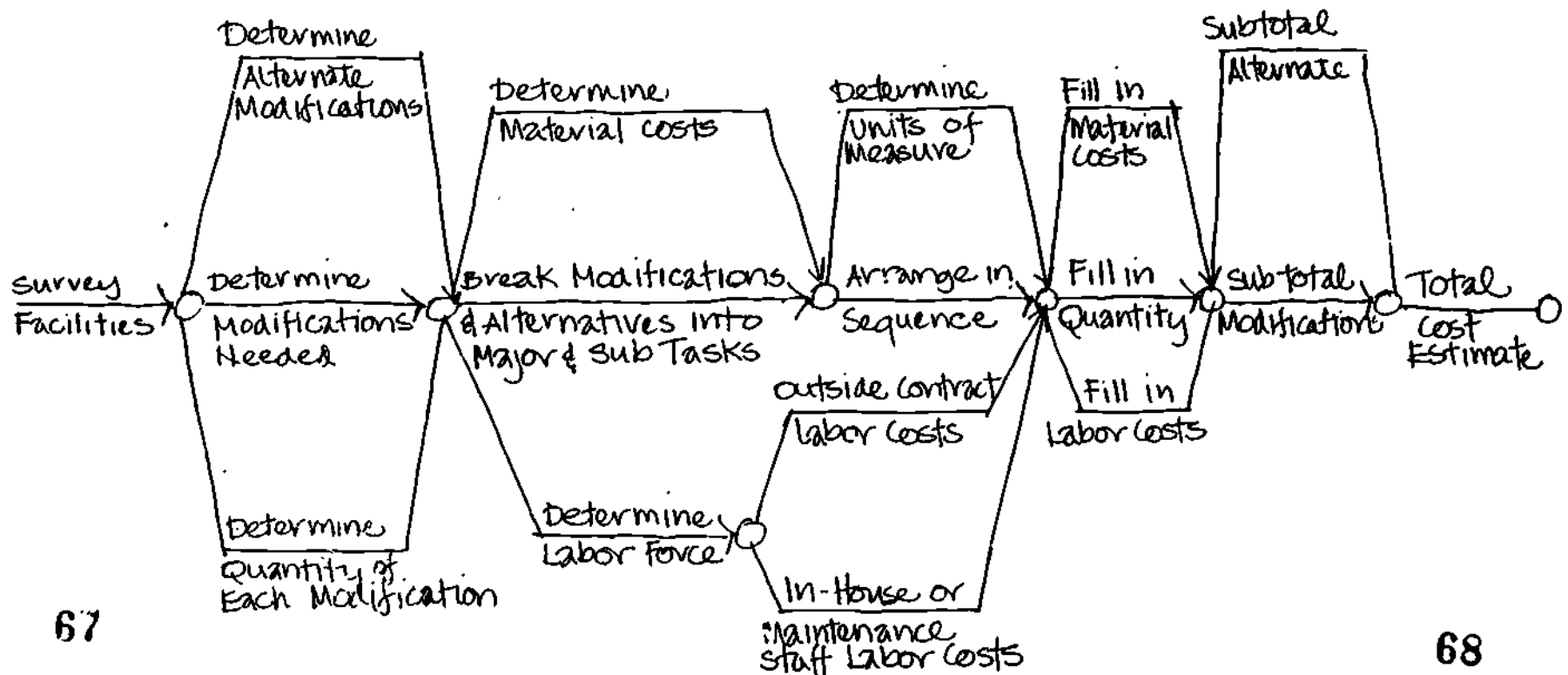

Chapter Four:

Accessibility Guidelines

Accessible Paths of Travel	51
Passenger Loading Zone	52
Walks and Corridors	57
Hazardous Objects and Areas	64
Accessible Entries	67
Life Safety Provisions	69
Vertical Circulation	70
Stairs	75
Ramps	81
Elevators, Platform Lifts and Chair Lifts	88
Accessible Spaces and Facilities	95
Auditoriums	96
Cafeterias	99
Classrooms	103
Libraries	109
Locker Rooms and Gymnasiums	112
Playgrounds and Athletic Fields	121
Toilet Rooms	127
Toilet Stalls	131
Grab Bars	135
Flush Controls	137
Urinals	139
Lavatories	141
Accessible Building Elements	147
Doorways	148
Door Hardware	153
Automatic Doors	157
Corridor Handrails	161
Personal Storage	163
Sinks	166
Drinking Fountains	168
Warning Signals	172
Signage	174
Telephones	176
Emergency Warning Systems	177
Listening Systems	178
Checklist of Design Criteria	181

This Chapter is composed of 28 performance guidelines and 121 action alternatives which the reader can use to identify possible solutions to existing accessibility problems within their school setting.

The performance guidelines present a brief rationale and statement of objectives in performance terms for design of each part of a school. They are followed by the action alternatives which present possible means to reach the objectives in the guidelines. Each of the action alternatives begin with a hypothetical problem statement. Normally it is framed as an "If" statement. Following this statement are a number of possible modifications or changes which can resolve the problem. These are labeled as (a) through perhaps (e). The discussion of each alternative initially identifies the constraints connected with the change and its possible impacts. Next, the specific technical criteria are noted; these act to establish the standards which the solution must meet to be accessible. Finally, estimated costs of the modifications are presented.

The guidelines are grouped into three major areas: accessible paths of travel, accessible spaces and facilities and accessible building elements.

All aspects of circulation are reviewed in the first section, from arrival at the school to use of elevator. This section includes action alternatives 1 through 44. The second group of al-

ternatives, 45 through 92, focuses on specific spaces or facilities. The sequence of spaces is alphabetical, starting with Auditoriums. The last group of actions respond to features found throughout the school, common to particular spaces or any area of circulation.

A concise checklist of the design standards and technical criteria follows the action alternatives. It provides an easy-to-use reference and index to the performance guidelines and action alternatives.

The intent of the guidelines and action alternatives is to provide options and flexible approaches to meet the objectives of accessibility. Each school district and school has different existing conditions and resources. Thus, prescription of appropriate solutions must be left to planners at the local level. The material presented here identifies a range of options, their associated impacts and their costs. School districts should use this information to develop plans that provide the greatest level of accessibility within the constraints of existing conditions and resources.

Accessible Paths of Travel

The basis of any accessibility plan is the establishment of a system of accessible routes which disabled children will use to reach the various school spaces and facilities. Accessible routes have to accommodate the mobility needs of children who use wheelchairs as well as those who have walking difficulties and those who have visual impairments.

Exterior accessible routes should extend from pedestrian approaches to the school sites drop-off zones, playgrounds and athletic fields to the accessible building entries. Accessible routes within buildings should connect the accessible entries with the accessible rooms and spaces.

The ease of movement between school facilities is greatly affected by the extensiveness of the accessible route system. Given the specific conditions found at a particular school, the following options may be considered:

- a. Develop an accessible route system which allows for continuity of movement between all accessible facilities.
- b. Provide routes which extend to a group of accessible facilities from central accessible entries.
- c. Provide routes directly from specific entries to specific accessible facilities.

PASSENGER LOADING ZONE

Since most disabled children are brought to school by bus or auto there should be a safe drop-off zone located near the main entrance which has weather protection if necessary.

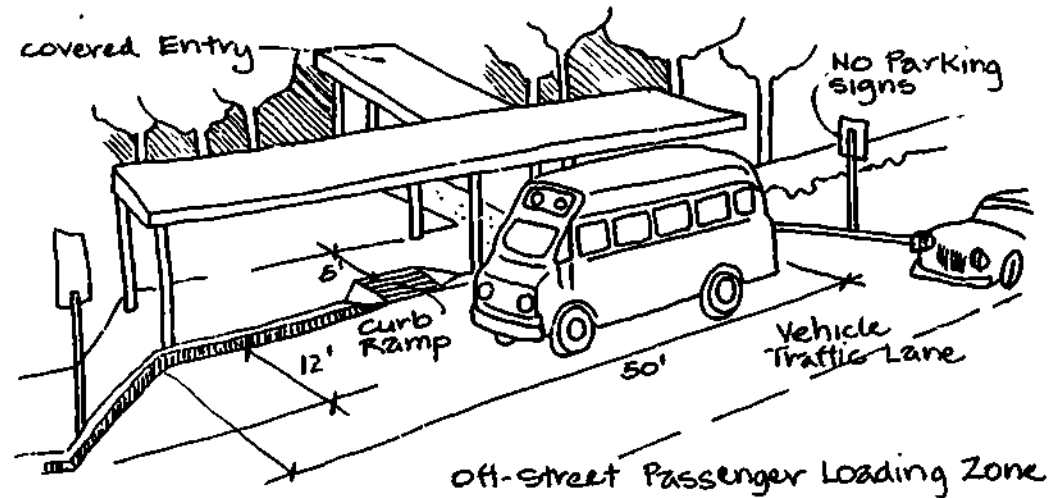

1 If an existing off-street passenger loading zone is not large enough to accommodate the prevailing traffic:

a Enlarge the loading zone.

This will be limited by the site layout and building configuration. Other factors requiring consideration are existing traffic patterns, street utilities, and landscaping.

The cost of an additional drop-off zone area is \$1.05/SF for asphaltic concrete paving and \$5.50/LF for concrete curb construction. Existing curb removal cost is \$1.13.

b Build a new, larger zone.

The limitations for this alternative would be the same as those noted for the enlargement of an existing zone.

The passenger loading zone should be at least 12' in depth and no less than 50' in length, based on a parallel parking scheme. The cost of a zone is between \$1700 and \$3000 (This figure does not include any cost for relocation of street utilities).

2 If passenger loading activities conflict with street traffic:

a Create designated loading zone on the existing street.

This is possible if there is a parking lane which can serve as the zone. It could be accomplished with signs and curb painting. This solution might be difficult to enforce.

The dimensions for the zone should be 12' wide by 50' long. Depending on the method of designation, this solution will vary in cost but will remain below that for an off-street solution. The cost of this type of zone would be between \$100-\$200.

b Relocate the loading zone to a place with less traffic.

This requires consideration of the traffic patterns on streets surrounding the school site. This solution may result in a longer distance to the primary entrance, and separation of disabled children from the main flow of entry to the school. It may be difficult to get parents to use this distant location.

The cost of the zone is between \$100 and \$200.

c Build an off-street passenger loading zone.

This alternative provides the safest condition but there must be adequate space on the site for a feasible auto and bus circulation pattern. This is primarily constrained by the building configuration and its location on the site.

A passenger loading zone should be at least 12' in depth and no less than 50' in length (this is based on a parallel parking scheme). The cost of a zone is between \$1700 and \$3000 as noted in Action Alternative 1b.

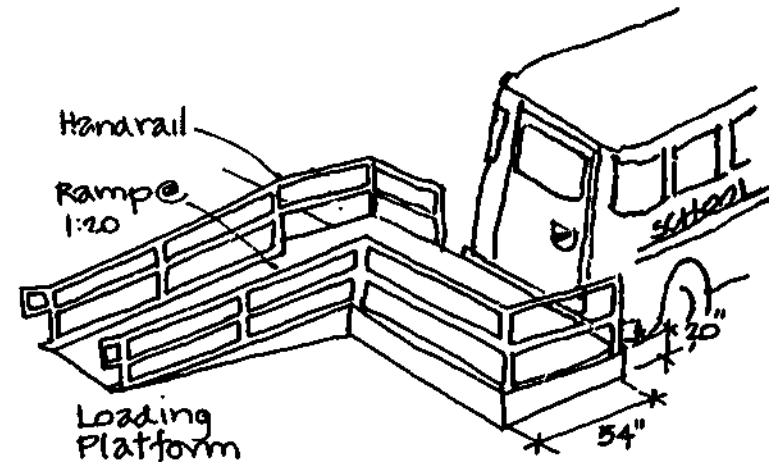
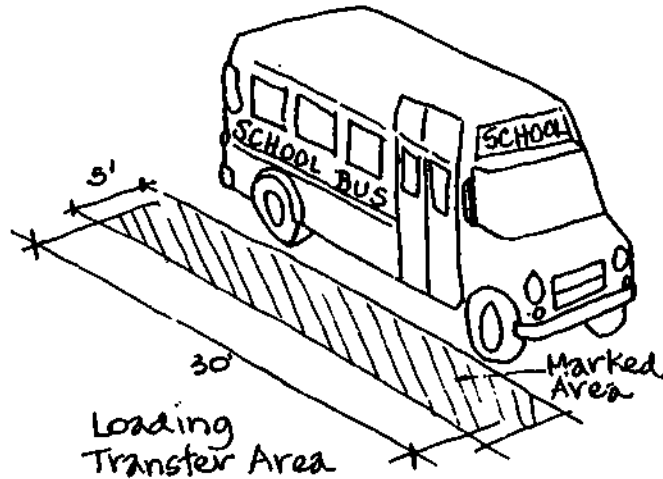

3 If the children are brought to school by bus or van:

a Provide sufficient space so that children can transfer from vehicle to ground.

This will be limited by site conditions and building layout adjacent to the loading area.

There should be a clear space. 5' x 30' of walk surface adjacent to the bus parking space. The cost for such paving is:

	Materials	Labor	Total
3" CONC	\$.90/SF	\$1.00/SF	\$1.90/SF

b Grade a portion of the zone to allow a level transfer to the ground level.

This solution must accommodate possible drainage, either by curbing or catch basins.

The drive would need to be lowered approximately 20". To remove existing paving and re-grade and replace paving would cost \$3.00/SF and new concrete curb installation of \$5.50/LF.

c Build a raised platform at curbside.

This requires a ramp or lift to allow children to reach ground level or direct access to the school via a loading dock. Adequate space for the ramp or a power source for lift would be required.

This alternative with a ramp or direct access should be used if buses are used to transport large numbers of disabled children since it reduces the unloading time required. Lifts can be satisfying with small numbers of children.

The depth of a raised platform should be enough for passage of two wheelchairs or 54". The height of the platform would be set at the level of the floor of the bus or van (approx. 20"). The cost of a platform is \$1.40/SF for the concrete surface and \$13.00/LF of perimeter. This does not include the means of reaching the ground level.

4 If the loading zone is not connected to an accessible building entrance:

a Construct an accessible path to the nearest accessible entrance.

This may be limited by building location and site conditions such as significant slopes. For requirements of an accessible entrance see Action Alternatives 93 through 96.

b Relocate loading zone in a more accessible location.

This will be limited by the site and building configuration in addition to all factors noted in AA 2a or 2c.

The cost of a relocated zone is between \$100 and \$200.

5 If an existing loading area does not have curb ramps:

a Build curb ramps at each loading spot.

The only limitation of this solution would be the need for adequate space to build the curb ramp at a slope of 1:20 and still have a clear area at the top of the ramp.

The slope of a curb ramp should be 1:20 with a minimum width of 36". The cost of a curb ramp with a straight run is:

Materials	Labor	Total
\$115	\$150	\$265

b Remove entire curb and make the drop-off zone sidewalk slope down to the street.

There must be adequate space for the sloping walk. With a normal curb height the space required would be 10'. This might cause problems for the blind who use curbs for orientation. If this alternative is used, see Signage and Warning Signals.

The cross slope of the walk in such a design should be 1:20 or less. The cost of curb removal is:

Materials	Labor	Total
\$.53/LF	\$.60/LF	\$1.13/LF

The cost of such a walk would be:

Materials	Labor	Total
\$.90/SF	\$1.00/LF	\$1.90/SF

73

80

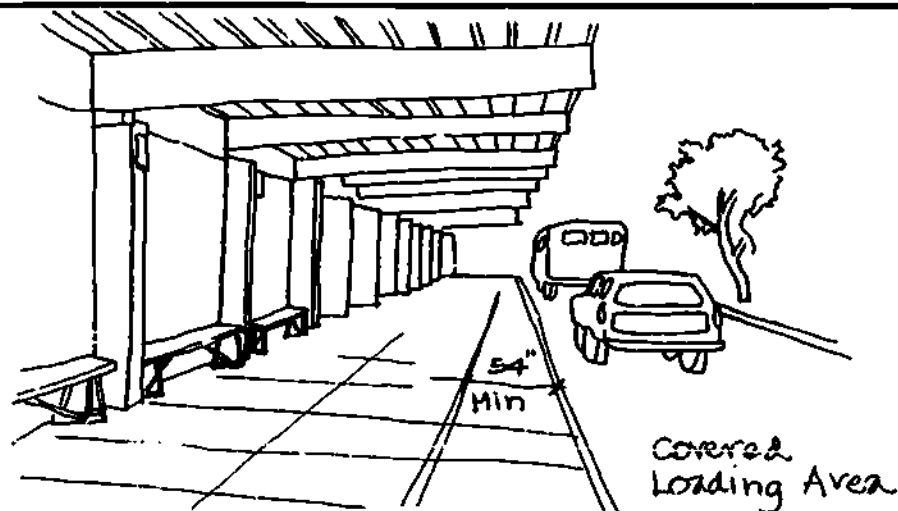

Covered Loading Area

6 If weather protection for the loading zone is required:

a Construct a shelter from rain and snow in cold or wet climates.

There are no apparent problems to this modification. Local codes regarding such construction should be consulted. Such a cover is preferable in all climates so that rain will never inhibit school access.

The shelter should be of sufficient width to cover the minimum area of 54". Supports should not present a hazard to circulation. The cost for a metal framed canopy with steel supports and built-up roof ranges between \$5-\$8/SF.

b Provide protection from the sun in hot, dry climates.

There are no constraints to this solution. If shade trees are used there must be adequate soil area so that in the future, roots will not damage adjacent sidewalks. Such planting would also call for irrigation in dry climates.

If a solid roofed shelter is provided, the cost is as in alternative 'a'. A wood trellis construction costs \$10/SF and 48" box trees are \$1150 EA.

WALKS AND CORRIDORS

Accessible paths are essential to provide mobility to disabled children. A path must be sufficiently wide, have a safe surface, and be free of projecting objects that might be dangerous.

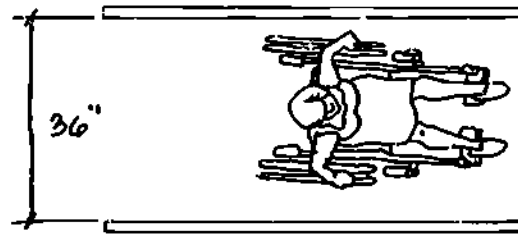

Minimum Path

7 If walks or corridors are not wide enough for using a wheelchair:

a Widen the walk surface.

This alternative can be limited by adjacent features such as the building structure, canopy supports, or substantial planting.

The minimum clear width for a corridor, walkway or aisle is 36". The cost of various types of walks are:

	Materials	Labor	Total
3" CONC	\$.90/SF	\$1.00/SF	\$1.90/SF
A/C paving	\$1.50/SF	\$.35/SF	\$1.85/SF
Compacted Clay	\$.45/SF	\$.30/SF	\$.75/SF

b Relocate walls or partitions to widen corridors.

This option will result in a reduction in the size of adjacent spaces. If adjacent walls are load bearing or retaining, substantial structural modification might be necessary. Electrical and mechanical systems might also need to be relocated.

Minimum width is in alternative 'a'; it is usually not a problem in corridors. Cost of various wall type demolition and new construction is as follows:

	Demolition	Materials	Labor	Total
Stud & GYP BD	\$.36/LF		\$3.00/LF	\$ 3.36/LF
6" CONC	\$28.00/LF		\$15.00/LF	\$43.00/LF (with vinyl)
DBL width brick	8.00/LF		\$35.00/LF	\$43.00/LF

New Wall Construction

	Materials	Labor	Total
Stud & GYP BD	\$15.00/LF	\$20.00/LF	\$35.00/LF
6" CONC	\$46.00/LF	\$42.00/LF	\$88.00/LF
DBL brick	\$70.00/LF	\$75.00/LF	\$145.00/LF

These figures are for an 8' high wall with some minor electrical work involved.

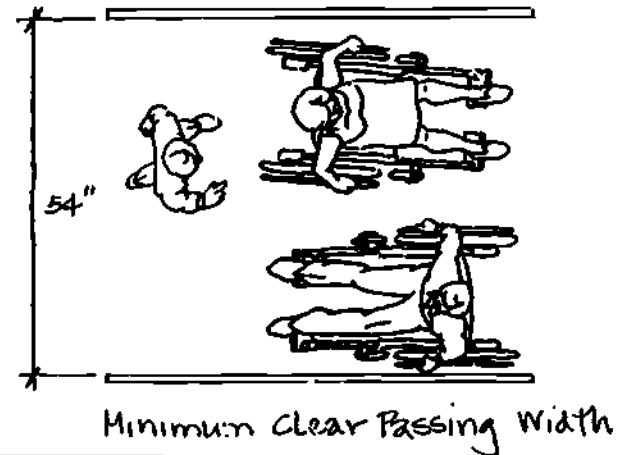

B If walks and corridors are not wide enough for wheelchairs to pass:

a Widen walks at intervals for passing spaces.

This solution may require persons to back-up at times to use the passing space.

Minimum clear passing width is 54" and should occur every 200'. A passing space should be 54" X 54", a "T" intersection of two walks is an acceptable passing space. cost of a passing space would be as in AA 7a.

b Use existing alcoves, landings, or intersections as passing spaces.

The space must be as per the standards in alternative "a". This solution can, on occasion, require one individual to back up. There would be no additional costs.

C Widen the walk along the entire length.

The limitations of this alternative are as those in AA 7a. It provides unrestricted passing with no waiting or back-ups.

Standards for width and costs of various types of paths are found in AA 7a.

9 If there is not sufficient space to permit wheelchairs to complete 180 degree turns on dead end paths:

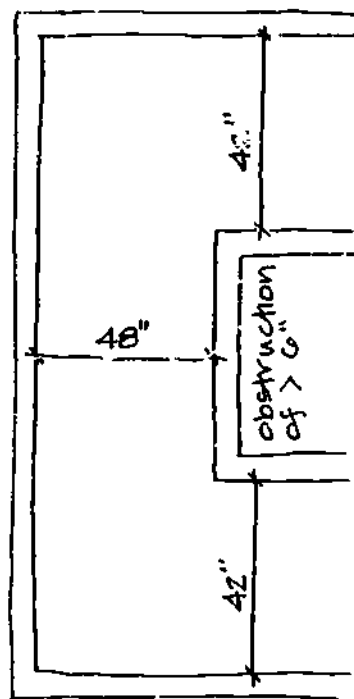

87A Turn Around an Obstruction

a Widen the path at the end only.

This alternative must take into consideration building configuration and site obstructions. Usually such a dead end path would be found leading out to playground areas.

An area at least 60" X 60" is required for such a turn. Space required for an "L" turn is 36" X 36", and a turn around an obstruction requires an area of 48" X 42". The costs for such areas for various path types is found in AA 7a.

b Widen the path at two or more places.

The constraints are the same as in alternative "a". This solution allows more flexibility of circulation.

Design criteria and cost estimates are as in AA 7a.

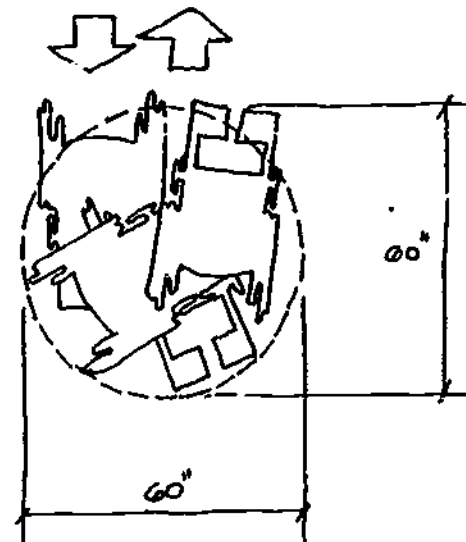

Minimum Turnaround

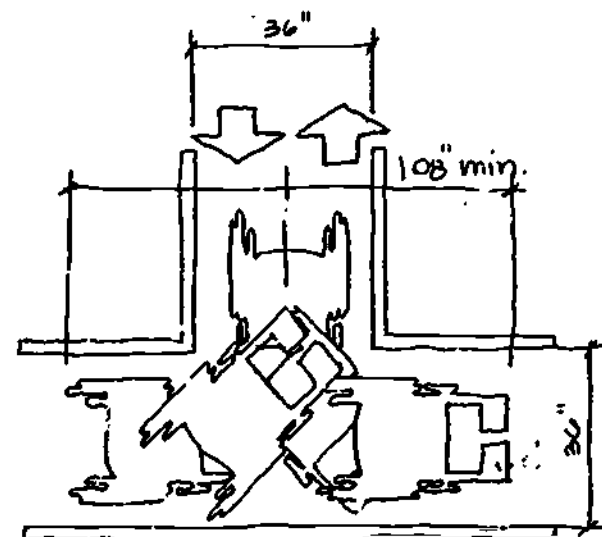

Minimum "L" Turn

10 If walks or corridors are surfaces with rough or irregular materials, such as cobblestones:

a Remove existing materials and resurface with an acceptable material.

There are no constraints to this option.

For design standards regarding materials and costs see AA 7a.

b Cover existing surface material with an acceptable material.

There might be difficulties in achieving a smooth surface over such an existing surface. Also, temperature changes can cause differential expansion or contraction of the materials and subsequent cracking.

This solution eliminates the cost of removal of the existing material. The cost of the surfacing is found in AA 7a.

c Fill the cracks so that a smooth, even walking surface is obtained.

This will require continued maintenance of the joints due to the effect of weather conditions on the materials. Thin patching will crack and need further repair.

There should be no level changes greater than $\frac{1}{4}$ " without edge treatment. Patching work can usually be done by school personnel.

d Construct a new accessible path alongside existing walk or corridor.

The limits on this solution will be the same as those noted in AA 7a. The separate path will reinforce the perception that disabled children are different.

The design criteria and costs associated with this solution are noted in AA 7a.

11 If the walk surfaces are of loose or unstable materials, such as sand or mud:

a Replace with firm materials such as clay or cinders.

Walks of these materials may break down due to weather or heavy use.

Walk surfaces should be of firm, stable, and non-slip materials. In exterior conditions walks should have a crown for drainage and the maximum crown should be 1:50. Cost of the walks of these materials is:

Materials	Labor	Total
\$.45/SF	\$.30/SF	\$.75/SF

b Pave with concrete, asphalt, or paving blocks.

These materials are easier to maintain and are more durable.

Design criteria are as noted in alternative "a" and the costs are found in AA 7a.

12 If a walk or corridor surface is unusually slippery e.g. vinyl, tile, or polished stone:

a Refinish surface with a non-skid wax.

The floor surface must be stripped and cleaned prior to the application of the new wax. A UL "non-slip" co-polymer wax will achieve this result.

The cost of such a job is about \$.30/SF.

b Cover or replace existing floor surface with a non-skid surface.

There are several products which can achieve this goal. Caution should be used in selection as there are some products which are not useable both inside and out. Most slippery surfaces can be treated to be covered.

Cost of covering the floor surface varies from product to product but generally is available for \$1/SF. This is for material only, it can be applied by school maintenance personnel.

13 If existing carpets do not allow wheelchairs to be easily maneuvered:

a Replace existing carpet with accessible carpet.

There are no difficulties with this solution, unless the existing carpet is glued down.

Carpet pile should be no higher than $\frac{1}{4}$ " and be securely attached to the floor. Carpet edge strips should be beveled, with slopes no greater than 1:2. A cost of \$14/SY for the new carpet could be expected. The cost for removal might be \$.25/SY unless glued, in which case it might run \$1/SY.

b Remove carpet.

If there is a poor surface below the carpet such as a slippery floor this is not a viable solution. Carpet is an easy surface for semi-ambulatory children to use.

The cost of the removal are as noted in alternative "a" for various conditions.

c Remove existing carpet and if the surface underneath is unacceptable, replace with an accessible floor surface other than carpet.

An accessible surface is one that is stable, firm, and relatively non-slip. The cost of such installations is \$.73/SF for vinyl asbestos tile and \$10.50/SY for sheet vinyl. This figure would not include carpet removal or any surface preparation which might be necessary in some situations.

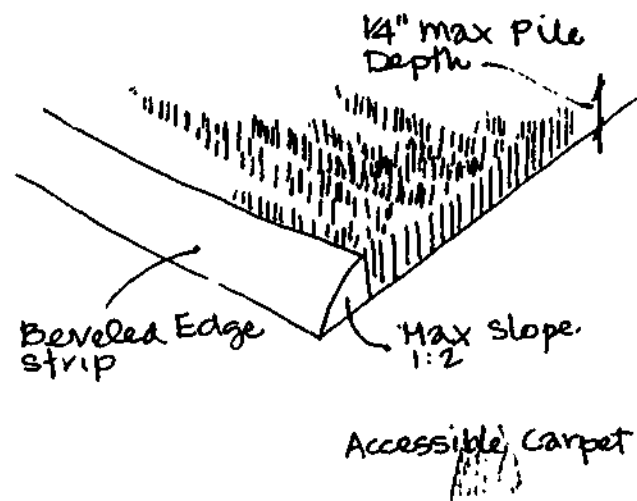

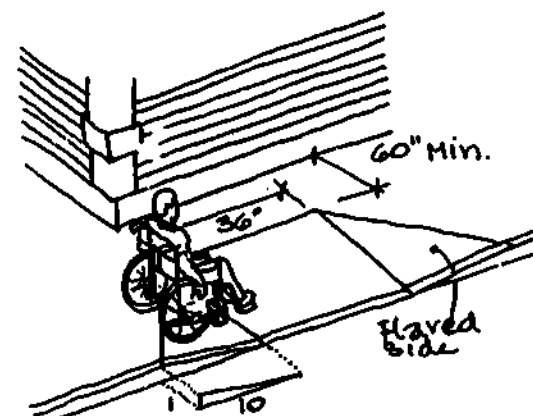
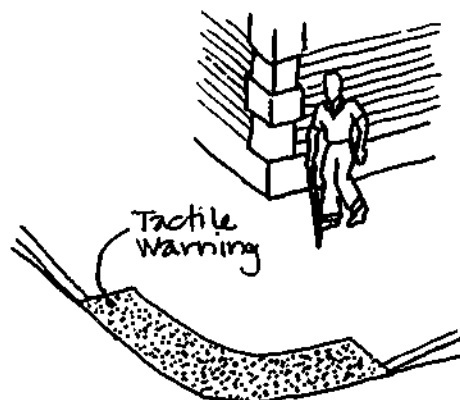
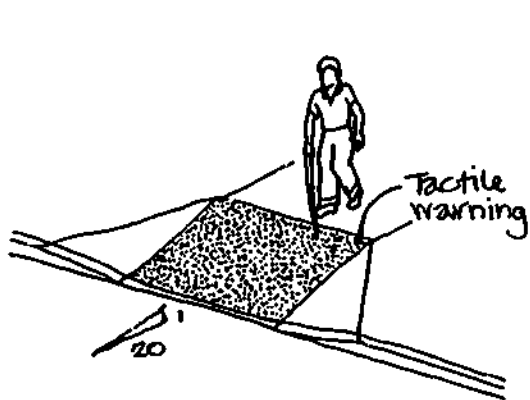

curb Ramp Designs

14 If there is a curb in the middle of a walk that should be accessible:

a Remove the curb across the entire width of the walk and ramp the full width of the walk with the appropriate warning signals. See AA 115.

There should be no difficulty in achieving this. It might cause problems for blind people who use curbs for orientation.

The slope of the curb ramp should be no more than 1:20. The tactile warning signal should extend the full width and depth of the ramp. The cost of the ramp and curb removal is:

	Materials	Labor	Total
Per Ramp	\$98	\$150	\$248

This assumes a 4' wide walk and a 6" high curb.

b Build a curb ramp as a portion of the width of the walk.

As with alternative 'a' there are no constraints to achieving this solution but some problem with orientation by the blind could be expected.

The design criteria are the same as in alternative 'a' with the addition that the sides of the ramp should have a slope no greater than 1:10, and the minimum width of the ramp should be 36". The cost of curb removal and a ramp construction would be approximately the same as in 'a'.

HAZARDOUS OBJECTS AND AREAS

Accessible paths and non-circulation, used as accessible paths, should be free of hazards which might result in injury to disabled children, particularly those with visual impairments. These hazards include edges of drop-offs and projecting objects.

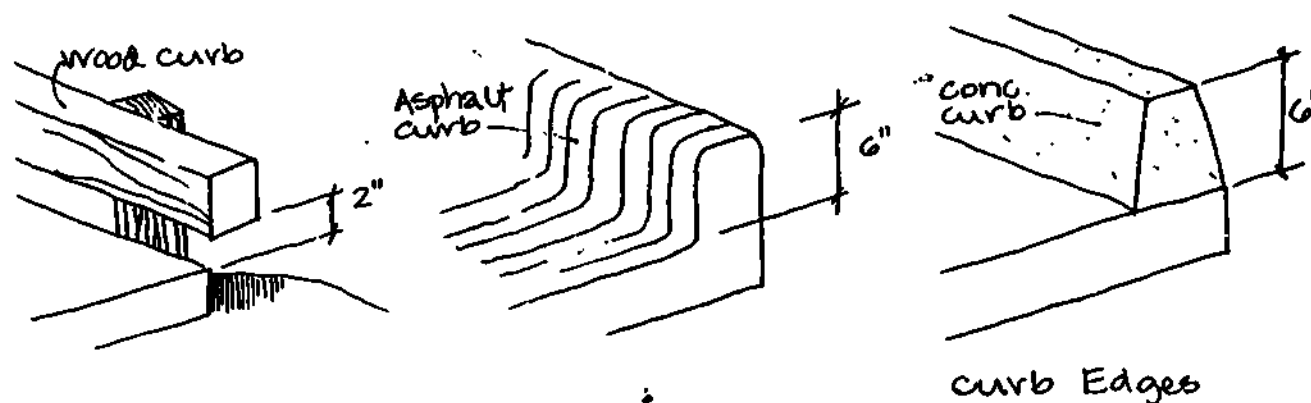

15 If there is a drop-off greater than 6" along side an accessible path of travel:

a Build a raised curb alongside the path.

There are no difficulties with this solution.

The protective edge curb should be at least 2" above path. The cost of a concrete formed curb is \$5.50/LF or approximately \$2/LF for asphalt. This will provide a curb beside the path with a total height of 6".

b Install a guardrail or wall.

This approach is best where a drop-off is steep and surrounding surfaces irregular or unsafe. Substantial footing work might be required to support such a barrier.

The cost of a metal guardrail (not including any footing cost) is \$16/LF and the cost of a concrete block wall (also without footing) is \$11/LF. These solutions are assumed to be 32" high. The cost for the block wall does not include footings which will vary depending on the particular site.

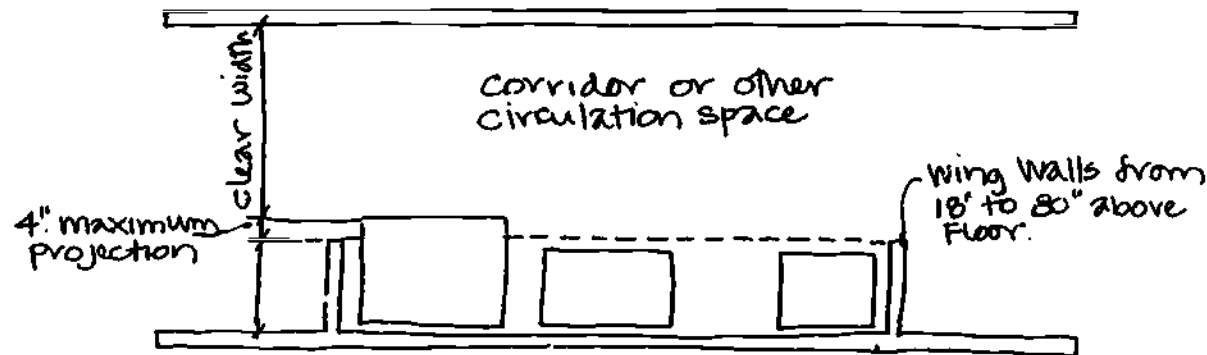

Protection from Projecting Objects

16 If there are dangerous projecting objects:

A Redesign or modify existing projecting objects so that they are not hazardous.

This is not usually a viable solution since the most commonly occurring objects are heaters, fire extinguishers, and drinking fountains. These objects tend to be formed pieces, not compatible to redesign.

A wall mounted object should not project further than 4" if its lower leading edge is between 18" and 80". This standard is based on the fact that people with severe visual impairments are trained to use a cane so that they move along about 6" away from the wall. Children with canes should be able to detect objects below 18". There should be a minimum 80" clear head room in all corridors and aisles.

B Build a wall or cabinetry to shield the projecting objects.

This does not pose any difficulties as a possible solution.

The leading edge of walls or cabinetry should be less than 18" from the floor. The cost of simple cabinetry would be \$2.60/SF (wall hung) including some labor cost. This cabinetry would be required on both sides of the object. This type of work might be performed by school personnel.

17 If there are steps or ramps along an accessible path:

a Install tactile warning signal at the top.

This can be done without any difficulties.

See AA 115 for the design and cost information regarding tactile warning signals.

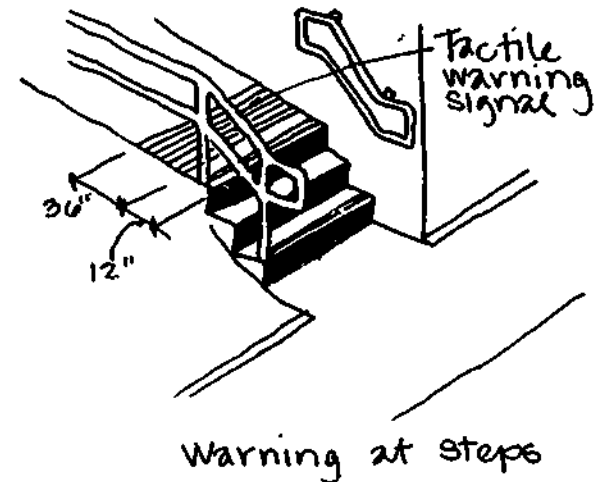

18 If service, or other non-circulation spaces are used for pathways:

a Schedule circulation so that it does not conflict with, and is not impeded or endangered by activities which usually occur in those areas.

Use of such spaces will probably be limited by building codes with respect to egress standards. This option may require additional environmental improvements such as lighting, in which case there would have to be adequate circuits. It may result in longer routes of travel and reinforce the differences of disabled children.

The design of such a path would need to meet the requirements of an accessible path as found in AA 7, 8, and 12. The cost of such a solution will depend on the particular situation and corresponding improvements required.

b Build partitions so that the circulation area is clearly separated from the remainder of the area where hazardous equipment or activities are located.

The constraints involved in this option are similar to those in alternative 'a'. This approach would be the only feasible one where the fire rating of an exit corridor is required.

Design and cost considerations are as noted in alternative 'a'. The cost of wall construction would be:

	Materials	Labor	Total
Stud/ GYP BD	\$15/LF	\$20/LF	\$35/LF

This cost assumes an 8' high wall.

101

ACCESSIBLE ENTRIES

A system of accessible entries is the key to providing movement into and throughout the school facilities. At least one entry from the exterior should be accessible and it should be joined to accessible corridors and accessible exterior walks.

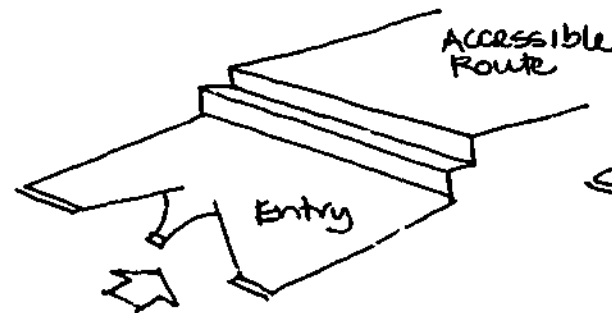

Existing Accessible Entry

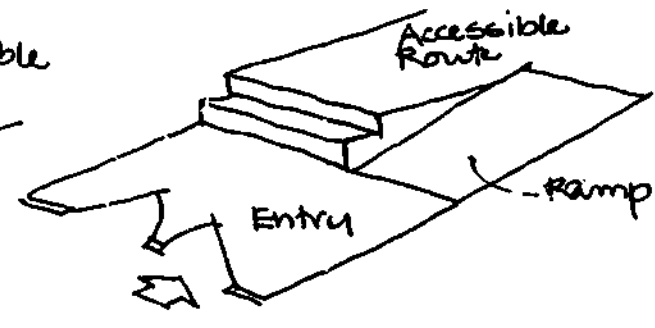

Modified Circulation at Entry

19 If an entry is accessible but does not connect to other accessible routes:

a Provide accessible vertical circulation immediately inside the entry, if the entry is not at the same level as the accessible corridors.

In most cases there will be sufficient space within an entry to accommodate a short ramp, wheelchair lift or stairway elevator. There are several possible difficulties with providing vertical access at such a point, including interference with mechanical and electrical systems. See AA 22 for a fuller discussion of these options.

If the entry needs to be enlarged to provide the vertical circulation one could expect such an addition to cost from \$50 to \$75/SF depending on the type of construction.

b Modify circulation or corridors to connect entry to other accessible corridors.

A more difficult element involved in modifying corridors would be the occurrence of steps in that corridor. See AA 7, 8, 12 and 17.

20 If one, or more, of the school entries need to be made accessible:

a Select entries which are used as the school's primary entries.

The primary entries could be situated in a way that presents significant constraints to making them accessible, e.g. a steep set of stairs. The choice of the primary entry can result in longer trips for disabled children due to location of interior facilities or the passenger loading zone.

Although the design and cost of an entry solution will vary depending on the existing conditions of a particular school several common conditions are worth noting. If the inaccessibility is the result of inadequate door opening the cost to install a set of new doors with proper hardware is \$400 to \$900. Often there will be one or two steps up to a set of entry doors and this can be solved with a shallow on grade ramp which can be provided for \$32.50/SF.

Perhaps the simplest problem to correct at an entry is an inaccessible threshold which can be corrected by maintenance personnel with a material cost of \$15.

b Select entries which are nearest to the school's accessible facilities.

If these entries are not the primary entries, it can create the need for additional security and supervision. The use of an ancillary entry by the disabled children will tend to reinforce the differences of those children.

c Select entries which are the easiest to make accessible.

These would not necessarily be the most accessible to the passenger loading zone. Security would have to be extended to these entries. As in alternative 'b', a stigma could be created.

For the design and cost of making doorways accessible see AA 93 through 102.

d Select entries which are on the same level as the accessible corridors.

This option might be the most feasible where in a multi-story building on a sloping site additional security could be required. If this entry is a different one than that used by most children it reinforces the differences of disabled children.

The design criteria and cost of making doorways accessible are in AA 93 through 102.

LIFE SAFETY PROVISIONS

As part of the circulation system there must be provision for exiting or refuge in event of fire, this is particularly important in multi-story buildings. Protection for such exiting should be part of the accessible corridor system.

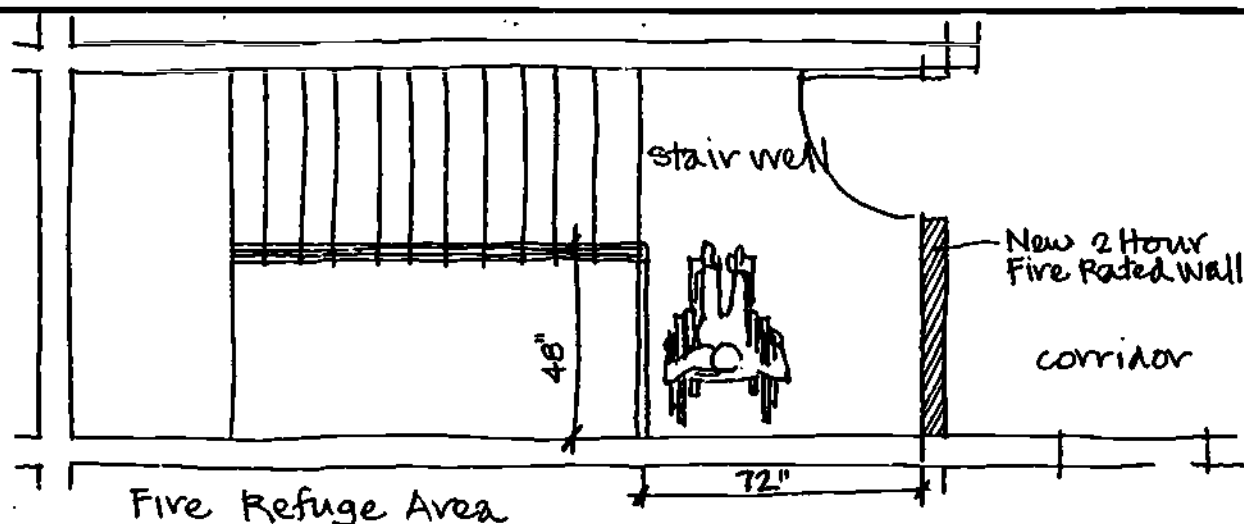

21 If fire refuge areas are needed:

a Enlarge landings in fire stair towers so that they can accommodate at least two children in wheelchairs.

Enlargement of the landing at the top of stairs usually requires a space enclosure projecting into the corridor. This might obstruct circulation in that corridor. Caution should be used so that the space needs do not interfere with the required door swings or circulation on the exit path.

An area 6' x 4' is required for two chairs and space for an aide to assist. The cost of such a modification depends to a great extent on the particular layout of the stairwell. Cost of stud and gypsum board wall construction to provide 2 hour resistance is \$38/LF. This assumes an 8' high wall. The cost of installing a new door in this type wall is \$565 per door.

b Install fire separation to break up the building into smaller fire areas.

This involves new wall and door construction at intervals along corridors. All code exiting requirements must be met. This modification can require modification of the mechanical air distributing system to retain balanced heating or cooling needs.

See AA 93, 94, 96, 98, and 99. The cost of this modification for two 3 hr. rated corridor doors and wall panels at each side is:

	Materials	Labor	Total
Per Set Doors	\$690	\$540	\$1,130

The doors are assumed to be 3' wide.

VERTICAL CIRCULATION

Movement between levels is one of the most difficult problems which will have to be resolved in order to make many schools accessible because major modifications may be necessary. Factors to be considered include the degree of overlap between accessible and regular circulation and the strain and time imposed on disabled children by the different vertical modes.

The basic ways of moving people up and down in a building are stairs, ramps, elevators, platform lifts, and chair lifts. Decisions regarding the appropriate means of accessible vertical circulation may be guided by:

a) The type and severity of the population: some semi-ambulatory children will be able to use existing stairs safely if proper modifications are made, however, most seriously disabled children cannot climb stairs and therefore, ramps or mechanical lifts are needed.

b) The size of the handicapped population at a school: the larger the handicapped population is, the more extensive the accessible vertical circulation system will have to be.

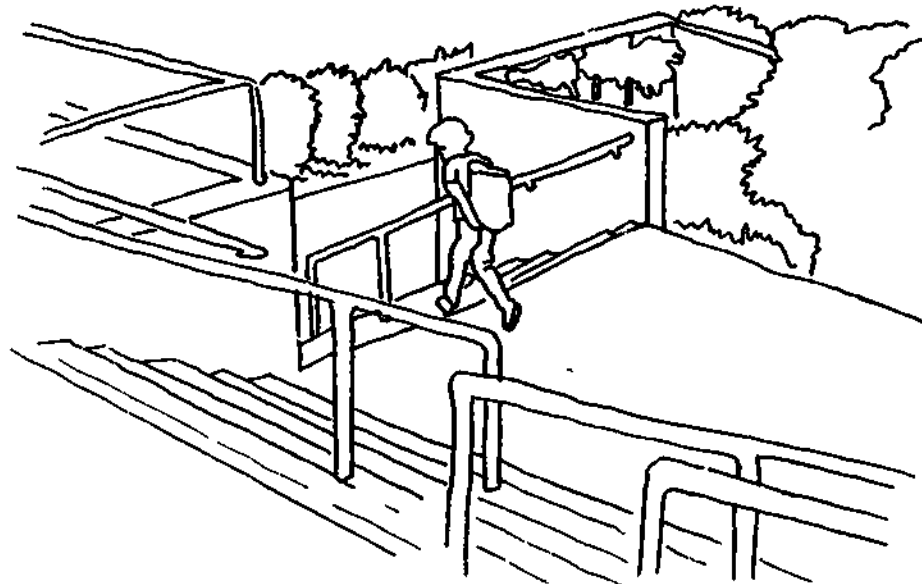

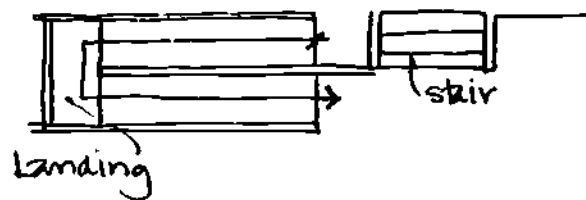

switch-back Ramp

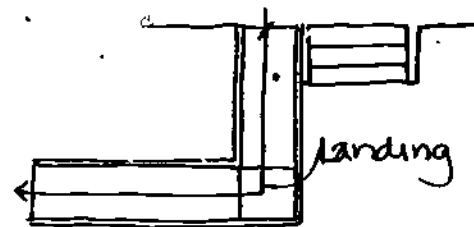

"L" Turn Ramp

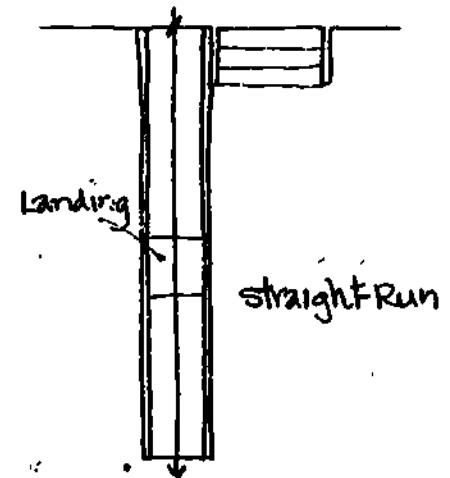

straight Run

Alternate Ramp Plans

22 If there are only a few steps between levels, possible actions are:

a Make stairs accessible for mildly disabled children.

This may include modification to both the treads and handrails of the existing stairs. This solution does not allow for access for severely disabled children. There are no significant constraints to this solution.

The design and cost for the various modifications can be found in AA 24 through 28.

b Construct a ramp.

There must be adequate space so that the ramp doesn't interfere with an intersecting corridor or any doorway into the corridor.

The design criteria and cost for various ramp constructions are found in AA 37.

C Install a stairway elevator.

There are two types of stairway elevator lifts, those that are equipped with a chair and those that have a platform. Both types move along a track which is mounted to the steps, a side wall or handrail of the stair.

The stairway elevator will require a source of power for the operation of the motor. Local code authorities may specify which models are acceptable. Although some of the platform types can be "folded away" when not in use, the stair will need a minimum width of approximately 42". There are several factors to consider when selecting a chair type unit; see AA 43 a for an additional discussion. Both types are available for straight-run or switchback stairs, but not all manufacturers make the switchback unit.

The minimum platform size should be 36" x 48" and the controls should be no more than 36" above the floor. The lift should provide smooth starting and stopping. The cost for the platform type stair elevator is between \$6,000 and \$8,000 for the equipment and labor to install it; this is based on a one story travel distance.

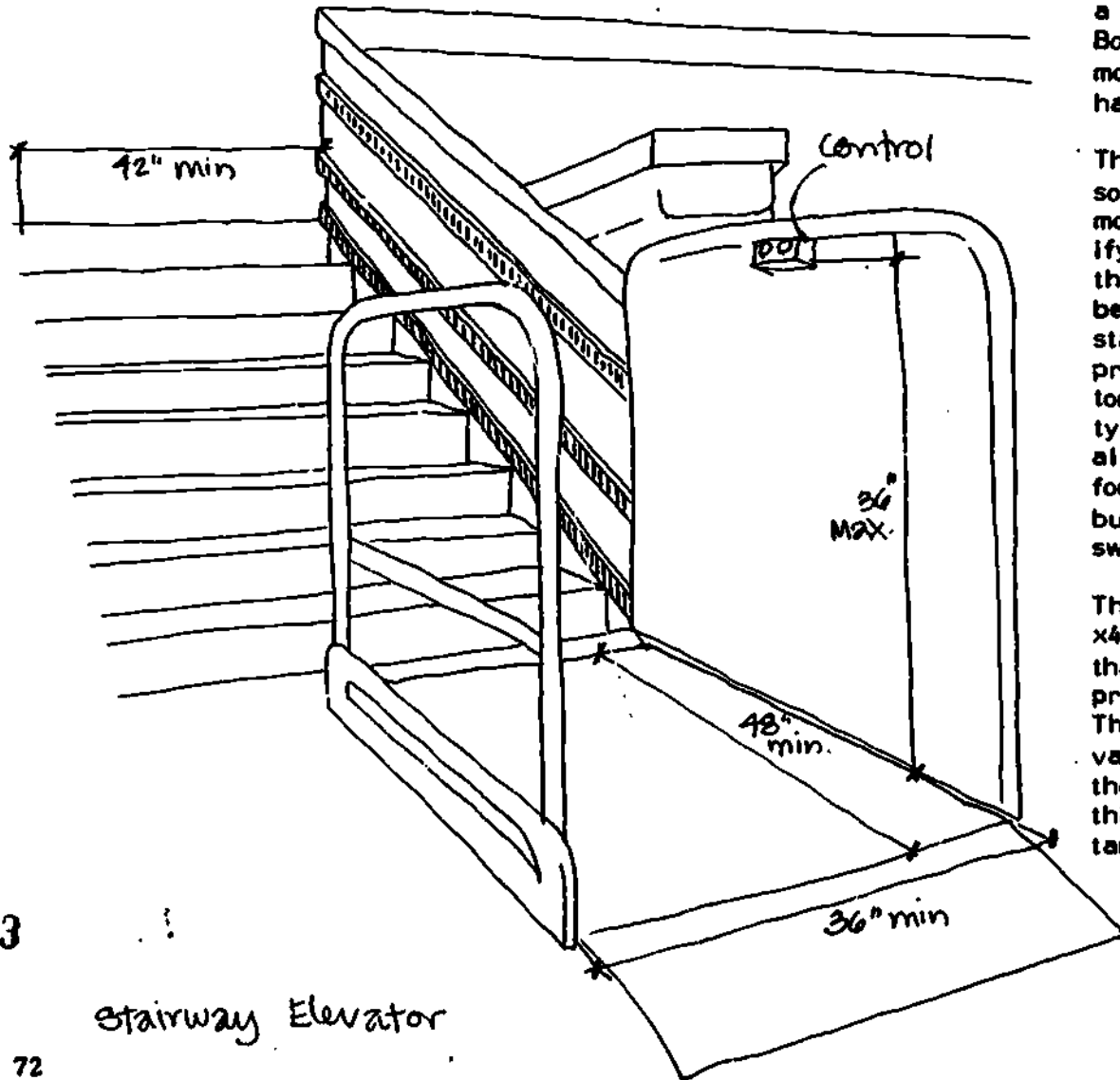

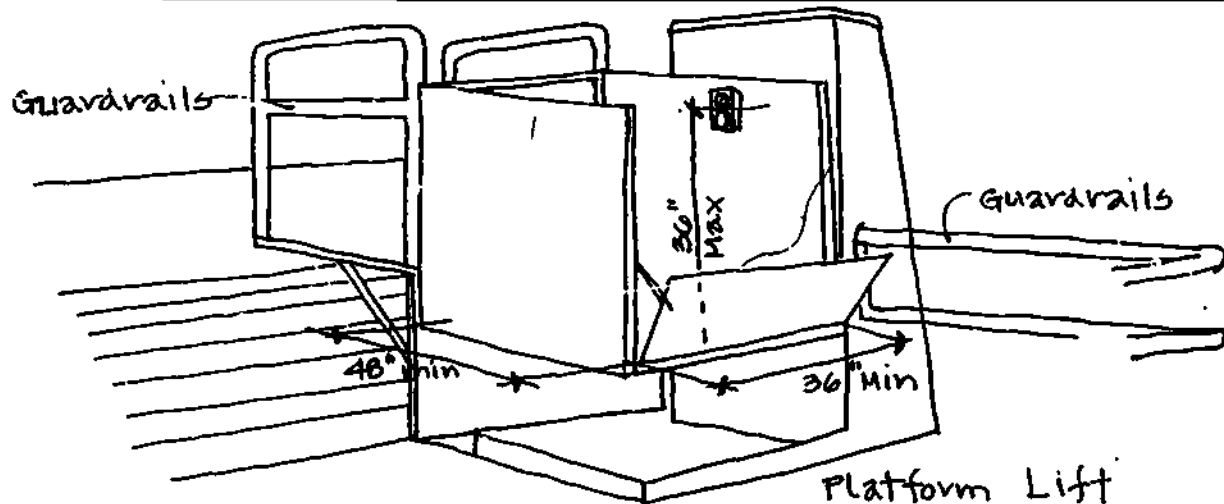

d Install a platform lift.

A platform lift travels vertically, and depending on the manufacturer, can accommodate level changes up to about 8'. 110v. power will be required for the operation. These lifts are made for both interior and exterior use and, in both cases, guardrails will be required for protection at the top and bottom. Local codes may limit the use of these lifts.

Design criteria for the platform lifts are the same as those for the stair elevator in alternative 'c'. The cost of the platform lift varies between \$1,600 and \$2,200. This figure is based on a 60" vertical travel and is for the equipment only. Site modifications will cause the cost of installation to vary depending on the adjacent ground or floor materials and extent of guardrails required. An installation requiring a new landing area of 30 sq ft and guardrails surrounding the upper and lower landings would cost about \$4,500.

e Have aides assist children.

This solution requires staff time and availability of personnel. It will limit the disabled child's independence and perpetuate a poor self-image.

f Develop an alternative route.

This solution is dependent on the layout of the circulation system in the school. It can create a longer route of travel which can be tiring for the children.

The features of an accessible path are found in AA 7, 8, 12, 13, and 17.

23 If there are full stories between levels with programs for disabled children on more than one floor:

a Modify existing elevators so that they are usable by disabled children.

This involves a number of possible modifications which range from enlargement of the cab to remounting the controls at an appropriate height. A general discussion of some feasible modifications is found in AA 38a. A service/sales person from the manufacturer of the existing elevators should be contacted to review feasible modifications.

The specific requirements for operation and controls are found in AA 40. As an example, one of the most common needs is modification of the controls at both the cab and landing, including lowering the controls, new symbols on cover plate, and audible signals; this set of modifications for a two stop elevator would cost approximately \$1,750.

b Construct a new elevator.

This can be done within the existing building or attached to the exterior, a fuller discussion of these options is found in AA 39. Either option will require extensive shaft and machine room construction. The machine room would be at the lower level for a hydraulic elevator and would, in addition, require sound insulation. In most cases, three phase electrical service is needed to power the elevator.

The elevator must be automatic in operation and self-leveling. Fuller discussion of design standards for the elevator are found in AA 39 and 40. The cost of a new elevator with installation would be approximately \$18,500. This is based on a light-use school quality two stop elevator.

c Install stairway elevators.

For a discussion of the limitations, design criteria, and the costs of the stairway elevators see AA 22c.

STAIRS

Stairs can be modified to be safely used by semi-ambulatory children with moderate disabilities. Modifications to handrails, stair treads, and lighting are often necessary. Stairs that are unprotected from below can be hazardous, particularly to children with severe impairments of vision.

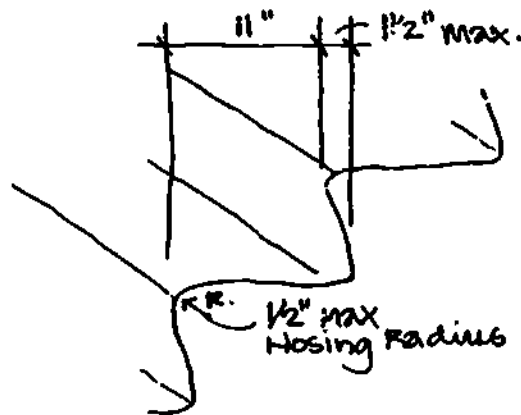

Flush Riser

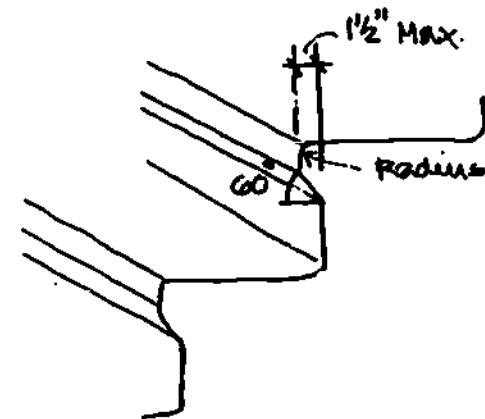

Angled Nosing

24 If existing treads on stairs connecting levels not served by elevators have abrupt nosings:

a Modify existing nosings so that they are not abrupt.

The nosing can be modified by either installation of a new nosing strip or a new full tread over the existing tread. The existing tread must first be leveled in the worn areas to adequately support the new overlay. If a nosing strip is used, as opposed to a full tread, there is a potential for the rear edge to trip someone. All treads should be replaced or there will be an irregular riser; this is a major cause of stairway accidents.

A tread should measure 11" min. from nosing to nosing. The nosing should not be abrupt and should have a $\frac{1}{2}$ " maximum radius. Material cost for the treads is \$3 to \$4/LF for rubber and approx. \$9/LF for a metal tread with a grit surface. This is a material cost only; the installation could be performed by school personnel.

b Replace existing treads with ones which have nosing that are not abrupt.

This does not seem feasible for most tread types. Only wood treads could be replaced easily. Even with replacement, wear will quickly cause an unsafe condition on wood stairs.

The design criteria of the tread is as in alternative 'a'.

25 If existing handrails are too high to be used by handicapped children:

■ Install new handrails on both sides of the staircase at an appropriate height.

There are no constraints to this solution. If stairs are not set-back at the top or bottom, handrails should be designed so that they do not project into corridors.

Handrails should be located on both sides and mounted 26"-28" above the leading edge of the tread. The higher dimension can be used where only older children (grades 4-6) use the stairs and the lower, where only younger children (grades K-3) use them. A compromise height may not be appropriate for tall or short children and adults. If two rails are installed, they should be mounted at 26" and 30".

The handrail size should be $1\frac{1}{4}$ "- $1\frac{3}{4}$ " diameter or gripping perimeter from 3"- $6\frac{1}{2}$ " with a minimum thickness of $\frac{1}{2}$ ". The clear space between the handrail and the wall should be $1\frac{1}{4}$ ".

The cost for handrails are:

Wall mounted wood	\$5.45/LF
" " metal	\$12.00/LF
Guardrail - wood	\$4.75/LF
" " - metal	\$10.50/LF

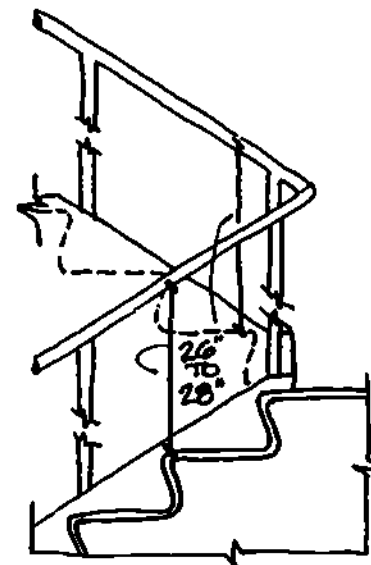

stair Handrails

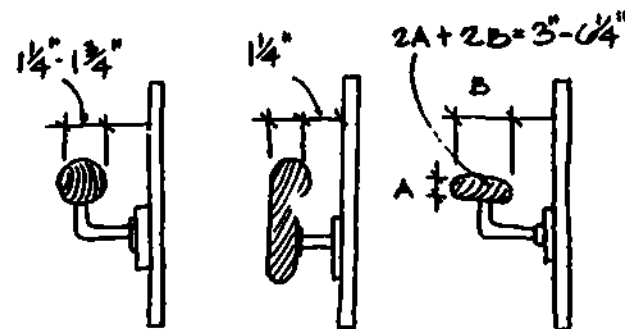

Handrail shapes

26 If there are existing handrails at appropriate heights which are not continuous or do not have extensions:

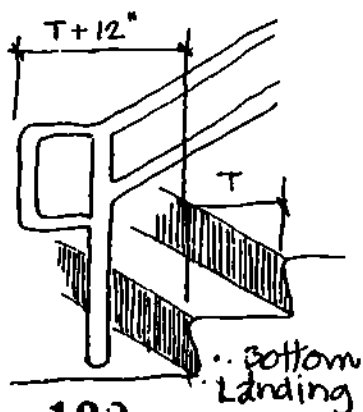
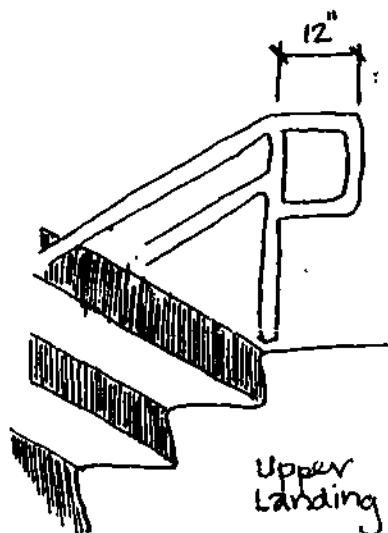

a Modify handrails so that they are continuous and have extensions.

To achieve continuity of existing handrails can be difficult at switchbacks where there are newell posts. Extensions should not project into corridors at the top or bottom; if necessary, they can wrap-around the corner.

The inside handrail of switchback or dogleg stairs should always be continuous. At the top, handrail extensions should be parallel with the floor or ground and continue 12" beyond the top riser.

At the bottom, handrails should continue to slope for a distance of the width of one tread from the bottom riser and then should be parallel to the floor for 12". The cost to provide a switchback rail section is \$14.00 for labor and \$15.00 for material per switchback. The cost to fabricate and install handrail extensions is:

	Materials	Labor	Total
Wood	\$8/LF	\$3/LF	\$11/LF
Metal	\$11/LF	\$6/LF	\$17/LF

b Install new handrails which are continuous and have extensions.

Adequate backing or appropriate attachment will be required at stud wall construction.

The design criteria for handrails are found in AA 25 and 26. The cost for the installation is found in AA 25.

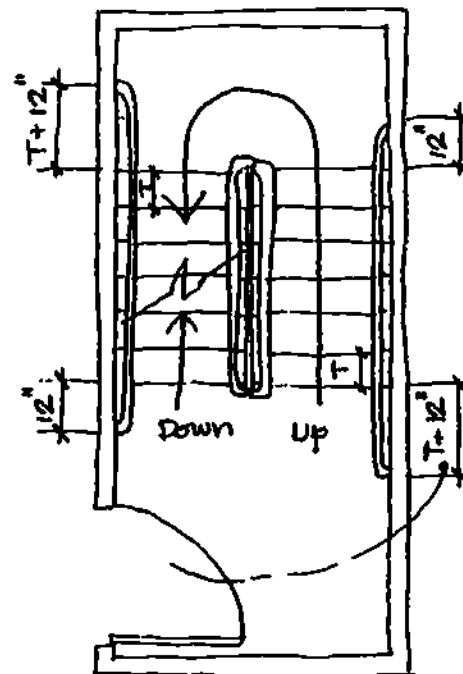

Handrail Plan

27 If lighting levels are too low (this would have to be determined on the basis of professional judgement, possibly including consultation with orientation and mobility trainers):

a Use higher intensity light bulbs.

This will pose no difficulties since its impact on an existing circuit is minimal for either incadescent or flourescent fixtures.

There are no specific light level requirements and the cost of the change is not significant except possibly slight increases in energy operating costs.

b Install additional lighting fixtures.

This alternative can be limited by the maximur load on all existing electrical circuits but there is likely to be sufficient capacity. The cost for additional fixtures is:

	Materials	Labor	Total
4' Flourescent fixture	\$65	\$40	\$105
2-bulb Incandescent fixture	\$45	\$20	\$65

c Construct more windows or skylights.

The skylight will only be useful where the stairwell runs to the roof. Both alternatives may be constrained by energy codes which limit glass areas or heat/cooling loads.

There are no specific light level requirements. The cost for the installation of a 3'x 6' window is:

	Materials	Labor	Total
Stud & stucco wall	180	300	480
Brick wall	565	920	1485



28 If there is glare or strong shadows on the stair treads or hand-rails:

a Install shades or blinds over the windows.

This solution can present maintenance difficulties in terms of operation and cleaning. Also, there could be vandalism problems if the shades or blinds are within reach.

The cost of venetian blinds is 1.80/SF and good quality shades are 1.14/SF. These are material costs only, it is presumed that they could be installed by school personnel.

b Modify existing artificial illumination system to correct lighting problems.

This modification can be the addition of light fixtures; the constraints to this solution are noted in AA 27b.

There are no specific criteria for the solution of these problems. The cost of additional fixtures is in AA 27b.

29 If there are exposed spaces under stairs where a child could hit his head:

a Build a solid wall.

If the space below the stairs is to be used for storage or some other use, it must be constructed to comply with fire resistance standards in building codes.

Cost of wall construction is:

	Material	Labor	Total
Stud & GYP. BD.	\$15/LF	\$20/LF	\$35/LF

b Install a guardrail or other low barrier. The barrier should establish 6'-8" as the lowest open space under a stair.

There are no difficulties with this solution. A guardrail might invite children to climb over or through it and thus create more of a hazard.

The primary criteria for solution of this problem is that there is no danger presented in circulating under the stair. The cost of a guardrail is:

	Materials	Labor	Total
Guardrail	\$12/LF	\$6/LF	\$18/LF

(this is for a 30" high metal rail.)

c Place planting, or a display case in front of the dangerous area.

Both these solutions present no particular difficulty and each would be appropriate in different circumstances. As with the guardrail solution, the solution should not create a greater hazard.

The cost would vary based on the particular design and existing conditions.

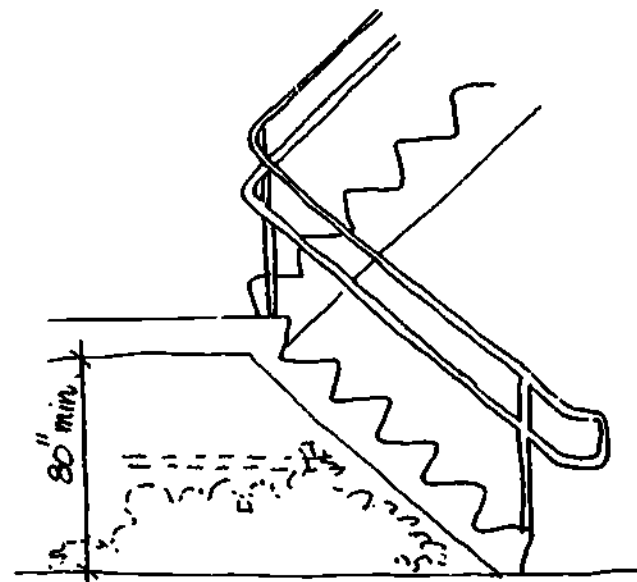

Protected Area Below Stairs w/ No Headroom

RAMPS

Accessible ramps allow semi-ambulatory children to move between two levels in a school. Most existing ramps are too steep and would require modification; shallower ramps however require the child to travel further and thus become tired. Ramps should have handrails, protective edges, and good light levels.

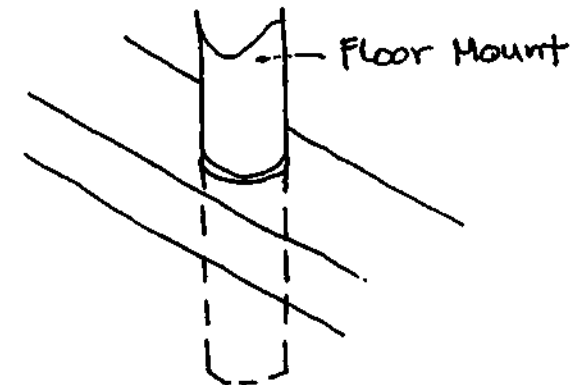
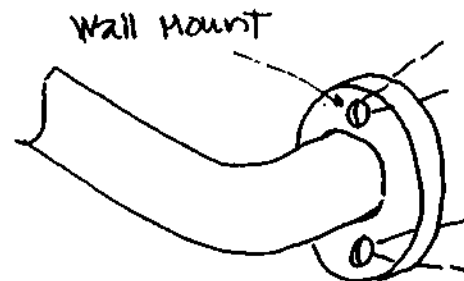

Handrail Mounting

30 If a ramp does not have handrails:

a Install handrails of appropriate size and at an appropriate height.

Floor mounted handrails must comply with structural safety requirements of building codes. Secure mounting devices must be used for wall attachment.

For design criteria with respect to height and size see AA 31 and 34. Handrails should be provided at both sides of the ramp. The cost of handrails is:

	Materials	Labor	Total
Stud & BYP BD	\$1.90/LF	\$7.25/LF	\$9.15/LF
Brick & CONC	\$1.90/LF	\$9.50/LF	\$11.40/LF

These costs are for wall mounted rails.

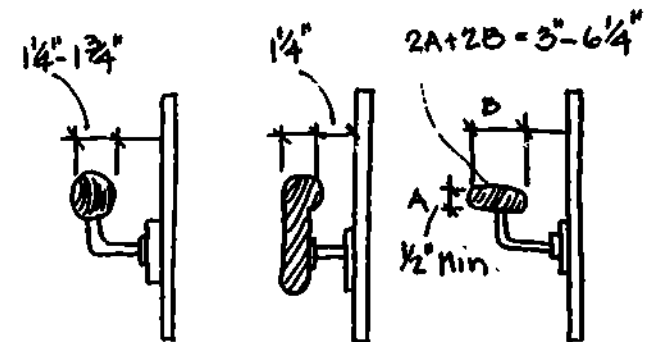

Handrail Shapes

31 If existing handrails are too wide or are mounted too high:

a Remount handrail at an appropriate height.

It must be possible to securely attach handrails to the wall; floor mounted handrails might be secured more easily.

The handrail should be mounted between 26" and 28". The higher dimension can be used where only older children (Gr. 4-6) use the stairs and the lower, where only younger children use them. A compromise height may not be appropriate for tall or short children and adults.

	Materials	Labor	Total
Stud & GYP BD	\$.50/LF	\$4.50/LF	\$5.00/LF
Brick & CONC	\$.50/LF	\$4.50/LF	\$5.00/LF

b Install a new handrail on the existing brackets or posts if the rail is not the correct size.

Brackets must have a shape compatible with the new rail.

The handrail should be between 1" - 1 3/4" or have a perimeter between 3" - 6 1/4" with a minimum thickness of 1/2". The cost of installing new rail on existing brackets is:

	Materials	Labor	Total
Wood or Metal	\$1.25/LF	\$6.00/LF	\$7.25/LF

c Retain the existing handrail and add a second rail.

The same constraints as in alternative 'a' apply. In addition, the top rail may interfere with a new rail.

For design see alternative 'a' and 'b', and for cost see AA 25 (cost is comparable with stair handrail costs).

d If the existing distance between the handrails and wall is too small, re-install the current handrail on new brackets.

Compatibility between the rail and new brackets is required to have a secure rail.

The clear space between the handrail and wall should be 1 1/4" minimum. The cost of modification is:

	Materials	Labor	Total
Stud & GYP BD	\$.90/LF	\$7.25/LF	\$8.15/LF
Brick & CONC	\$.90/LF	\$8.00/LF	\$8.90/LF

These costs assume metal brackets @ 4' on center.

32 If existing handrails are not continuous or do not have extensions:

a Modify existing handrails.

Achieving continuity with existing handrails can be difficult at switchbacks where there are newell posts. Extensions should not project into corridors at the top or bottom and, if necessary, they should wrap around corners.

The inside handrail on switchbacks and dogleg ramps should always be continuous. Handrails should extend at least 12" beyond the top and bottom of each ramp segment. The cost of an addition to achieve continuity is:

	Materials	Labor	Total
Metal	\$14/LF	\$15/LF	\$29/LF

To fabricate and install handrail extensions (per extension) the cost is:

	Materials	Labor	Total
Wood	\$3/LF	\$3/LF	\$6/LF
Metal	\$9/LF	\$6/LF	\$15/LF

b Install new handrails.

There are no additional constraints other than those listed in AA 30.

The criteria for the design of the handrails is found in AA 31 and in this section. The cost of the new handrail is noted in AA 25, however this figure does not include the cost of removing the existing railing which can be done in most cases, by school maintenance personnel.

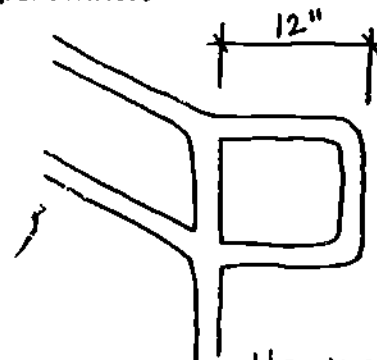

Handrail Extension

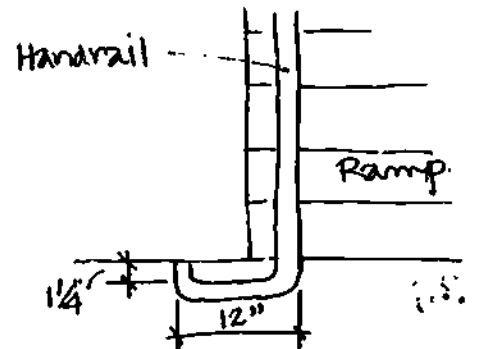

Handrail Return

33 If an existing ramp is too narrow:

a Widen ramp if there is enough space on at least one side.

If the ramp is used for required exiting, its construction must comply with fire resistance requirements of building codes. Because of settling, a break in the surface of the ramp could occur; adequate construction measures should therefore be taken to join the new portion with the existing ramp. The clear width of a ramp should be 36". The cost for a ramp addition is as follows:

	Materials	Labor	Total
CONC	\$24.50/SF	\$ 8.10/SF	\$32.50/SF
Wood	\$22.50/SF	\$10.10/SF	\$32.50/SF

These figures do not include a cost for a demolition of the handrail and edge condition on the existing ramp.

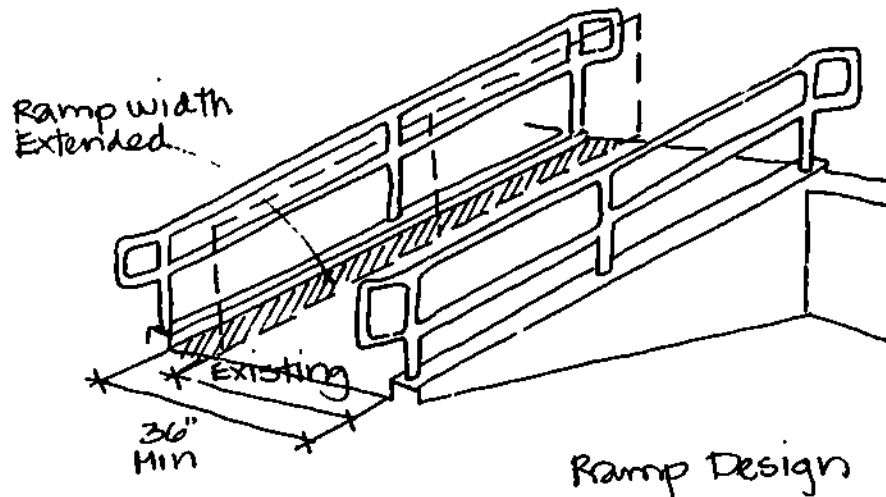

Ramp Design

b Remove one side wall in order to widen the ramp.

In addition to the constraints in alternative 'a', when a wall must be removed, mechanical and electrical services may have to be relocated and space is lost in the adjoining area. If the wall is structural, the feasibility of such a solution is questionable.

The design criteria and cost for the construction of the ramp are as in alternative 'a'. The demolition of an existing wall will vary according to the construction type as shown:

	Total
Stud & GYP B0	\$3.36/LF
6" CONC	\$43.00/LF
OBL Brick	\$43.00/LF

These costs are for an 8' high wall and assume no structural modification is required. There would be additional costs in an interior condition where adjacent floor removal would be required.

c Build a new, wider ramp.

This option will be limited by the layout of the circulation within the school and the site grades. The location which is most feasible in terms of construction might result in a longer path of travel for the disabled child.

For the design criteria and cost of a new ramp see AA 37.

34 If an existing ramp is too steep:

a Rebuild the ramp at a shallower slope.

The primary constraint to this alternative is the space available for the longer run of a shallower ramp. This might interfere with circulation, building placement, etc. The longer ramp will require children to use more energy and time to make the level change.

Any path with a slope equal to or greater than 1:20 should be considered a ramp. The maximum slope of any ramp should be 1:12. A slope of 1:20 is preferred; any ramp will be too steep for some disabled children; the steeper the ramp the more children will need assistance.

The cost of ramp construction will be found in AA 37. That figure will not include demolition of an existing ramp.

b Rely on an aide or another student to assist children who cannot manage the existing slope.

The availability of an aide is the constraint of this solution. The use of an aide can reinforce the stigma of disability as well as encourage poor self-concept and dependency in the child.

It would require the assistance of an aide every time the disabled child used the ramp; the cost of providing the aide is dependent on school district salaries.

c Retain the existing ramp and build a new ramp in another location.

The factors impacting this are found in AA 32c.

The design criteria and cost of an accessible ramp are in AA 37.

35 If an existing ramp does not have edge protection along its sides:

a Install a curb along the edge(s).

This would only be a problem if the curb reduced the clear dimension to less than the minimum required.

The minimum curb height should be 2". If a curb were constructed by the addition of a wood strip, the cost is \$1.80/LF on a concrete ramp. This would be less for application on a wood ramp.

b Install guardrails along the edge(s).

There are no apparent problems in providing edge protection by this method. Building codes will specify when a guardrail is required, i.e. when the height of the ramp is above 30".

The height of the guardrail would be the same as a handrail - 26" to 28". The cost of a new guardrail is:

	Materials	Labor	Total
Metal	\$12/LF	\$6/LF	\$18/LF

This assumes verticals @ 9" OC and some support work which would approximate that required for attachment on a ramp.

c Build a solid wall along the edge(s).

This solution will not be limited by any factors.

The criteria for the protection are similar to those in alternative 'a' and 'b'. The cost to provide solid wall protection is:

	Materials	Labor	Total
Stud and Stucco	\$4.25/LF	\$5.50/LF	\$9.75/LF

These costs assume a wall 30" high.

36 If lighting is too low or does not illuminate the entire ramp area (This would have to be determined as in AA 27):

a Install higher intensity light bulbs.

There is no constraint to this solution; most electrical circuits will accommodate the increased load.

There is no specific criteria for light levels. This modification can result in slight increases in energy costs.

b Install more lighting fixtures.

See AA 27b for a discussion of constraints and costs.

Construct more windows or skylights.

For discussion of constraints and costs of these alternatives see AA 27b.

37 If a new accessible ramp is to be built:

a Build a short relatively steep ramp.

Even the steep ramp will require significant space to allow for the necessary run. Any ramp (path over 1:20) will be too steep to be used independently by many disabled children.

The maximum distance of run on a ramp between landings should be 20'. Ramps should have level landings at the top and bottom of each run which are 60" long and as wide as the width of the ramp. If the ramp changes direction, the size of the landing should be 60" square. The cost of the ramp is:

	Material	Labor	Total
Conc.	\$24.50/SF	\$8/SF	\$32.50/SF
Wood	\$22.50/SF	\$10/SF	\$32.50/SF

These costs include handrails.

b Build the shallowest ramp.

This solution will require the greatest space to provide the necessary run. The long distance of travel will be strenuous and will require frequent resting and therefore, substantial time to negotiate.

The design criteria and costs of this ramp will be as those in alternative 'a'.

c Build a relatively short and shallow ramp.

The limits on this solution are generally the building layout and site configuration. Ramps would be usable by many if kept to within a 20' length and at a 1:20 slope.

The criteria and costs for new ramps are found in alternative 'a'.

ELEVATORS, PLATFORM LIFTS AND CHAIR LIFTS

For disabled children to have full access to multi-leveled or multi-storied schools, some type of mechanical device may be required to provide for vertical circulation.

33 If an existing elevator is to be used by handicapped children and is not accessible:

a Modify the deficiencies in the cab and/or the lobby.

There are a number of requirements for accessible elevators. The constraints on modification will depend on the age, model, and features of the existing elevator.

All elevators should be automatic operation and self-leveling. The likelihood of an existing elevator not having these is very slight. A new elevator would be the most feasible solution to this deficiency.

Automatic reopening devices should be installed on the elevator. The cost of this modification is approximately \$950.00 to \$1,350.00 per elevator.

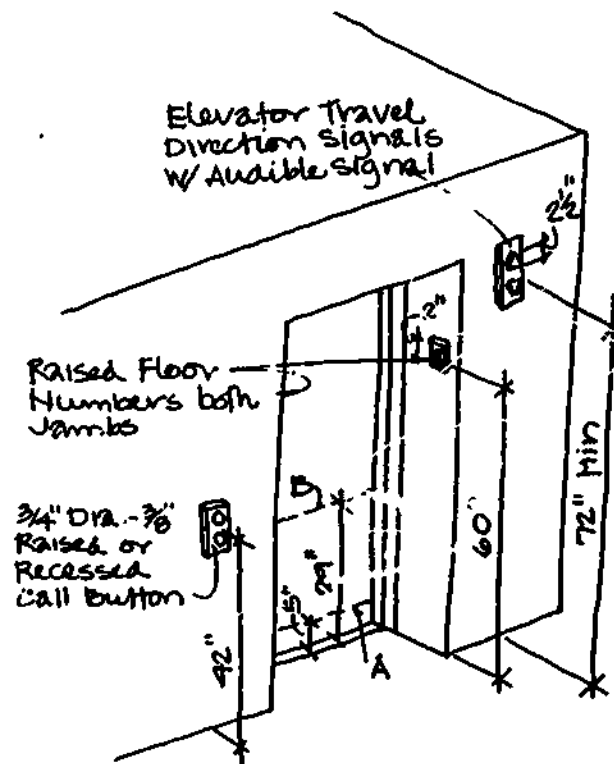

Elevator Controls & Signals

The automatic door reopening device is activated if an object passes through either line A or line B. Line A and line B represent the vertical locations of the door reopening device not requiring contact.

The elapsed time between onset of visible and audible signal of car arrival until doors start to close should be based upon the following formula:

$$T = \frac{D}{1.5 \text{ ft/s.}}$$

where T = total time in seconds and D = distance in feet from a point in the lobby or corridor 60 in. directly in front of the farthest call button controlling that car to the centerline at its hoistway door. The timing of the door closing after its arrival can almost always be modified in existing elevators.

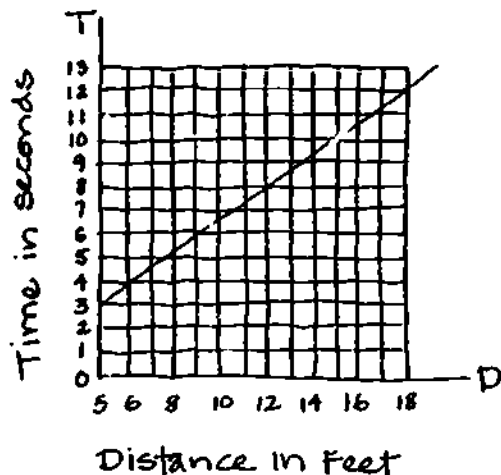

Doors should have a hold open time of 3 seconds minimum. Door timing can usually be adjusted on existing elevators.

Car arrival signals should be both audible and visible. The installation of these signals pose no difficulties. Additionally, there should be an audible signal in the car when it passes each floor. This is not needed in a two-story situation. The sound signal itself is an inexpensive device.

Raised floor numbers should be provided at both jambs of hoistway entrances; they should be at least 2" high and mounted 60" above the floor. The cost of these numbers would be \$8 each and they could be installed by school maintenance personnel.

Cars should be equipped with 2-way communications systems, the highest operable part should be no greater than 36" from the floor. Phones that are not the head-set type are preferable. This modification involves mostly labor with a cost of approximately \$900 to \$1,250.

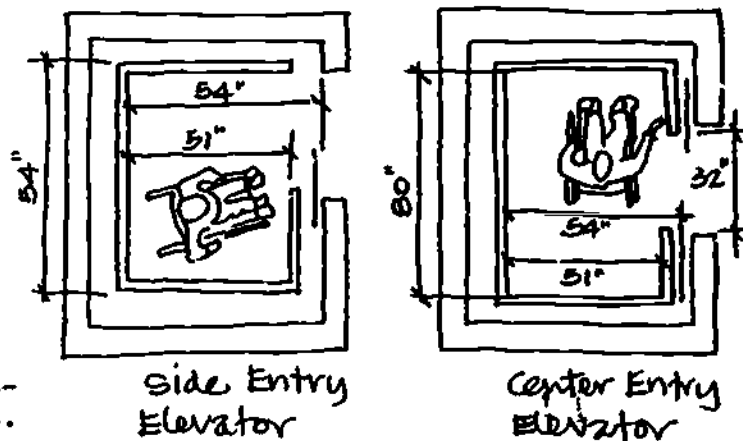

39 If a new elevator is to be added to a building:

a Construct the elevator within the building.

The most obvious constraint in placing an elevator within the existing building is the space available at the point where the elevator should be located. This space would be at minimum, 6' deep by 6.5' wide (9.5' for elevators with center opening doors), and approximately 5' X 7' for machine room. Depending upon whether the elevator is a hydraulic or traction machine, there will be either a pit or penthouse. The penthouse will usually require additional structural work beyond creating the elevator shaft. In most cases, there must be three phase electrical service to operate the elevator. Such service may or may not be presently available at the school. Providing three phase power will increase the cost. Interior installation might also involve the relocation of existing electrical and mechanical systems. It may not be possible to relocate them.

The minimum clear floor space in the cab should be 51" X 54". Criteria for other features required for accessibility are in AA 38 and 40. A basic total cost of \$18,500 for the installation can be used, keeping in mind that this is for a two stop elevator; add \$3,000 for each additional stop. This figure does not reflect specific conditions which could raise the cost such as additional structural work.

b Construct the elevator along an outside wall.

The construction of this option will not result in the disruption of existing spaces and systems but is limited by the layout of the existing circulation and the site configuration. There may be limitations related to building setbacks established by local building or zoning codes. Pit construction could undermine the existing foundations of the building and may require underpinning of existing footings.

Design criteria and costs are as in alternative 'a' with the same qualification that the cost can vary depending upon the particular structural or circulation modifications that might be required.

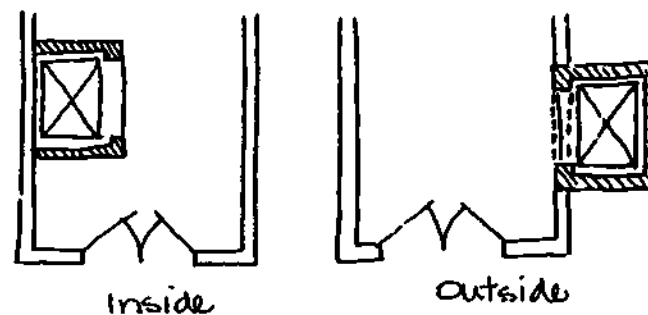

Elevator Locations

40 If the existing elevator controls are mounted too high for children to use:

a Install an additional set of controls at a lower height.

This can be done without great difficulty but it could confuse people using the elevator.

The controls should be mounted at a maximum height of 36"; they should be identified by raised numerals as well as tactile symbols for main floor, emergency alarm, emergency stop, door open and door close controls. These two modifications are often made at one time and are probably more expensive than if the controls themselves are lowered as described below.

Another similar approach is installation of a mechanical button transfer device. By mechanical means this surface-mounted mechanism activates the original upper control upon pushing the lower set of buttons. It has a possible cost saving in that the wall construction itself need not be disturbed. The cost can be less than the other options.

b Remount the existing controls at a lower height.

In this alternative, wiring to the controls is simply extended and a new larger cover is remounted. This does involve several days of down time for the elevator and the work should be done by the original manufacturer. The lower controls may cause some inconvenience to tall children or adults.

The criteria for the installation are as in alternative 'a'. The cost for the work and materials is between \$1,750 and \$2,500. This cost is based on modifying one cab and two landings. Variation in cost will occur depending on the lobby wall construction and the quality of the new cover panel.

c Assign an aide or another student to operate the elevator for everyone.

This solution is dependent on the availability of funds, staff or free time from studies. It will provide greater security against misuse but would limit the independence of the children.

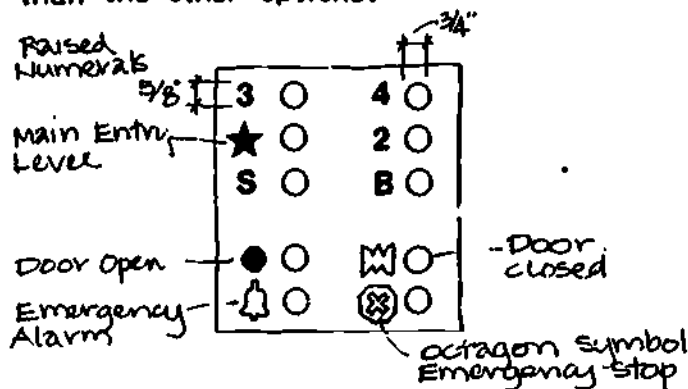
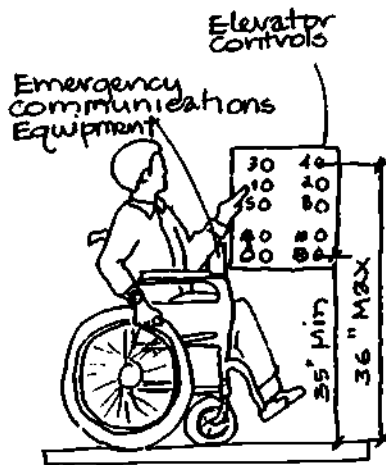

41 If an existing elevator is to be used to move disabled children between levels, but is not located along an accessible path:

a Connect an existing elevator to the accessible path.

There would be no general difficulty with this solution and most likely such an elevator would be connected to an accessible path. Depending on the specific circulation system of the school, there can be any number of specific constraints on achieving this alternative. Such a path, if connected to an existing exit corridor, should be of a construction type that would maintain that corridor's fire rating.

The criteria for an accessible path are found in AA 7, 8, 12 and 17. The cost of such a connection must be developed by totaling the various components of the required modifications such as wall construction, doorways, etc. The cost of wall construction is:

	Materials	Labor	Total
Stud & Gyp. bd.	\$15/LF	\$20/LF	\$35/LF
6" Conc.	\$46/LF	\$42/LF	\$88/LF
Brick (dbl)	\$70/LF	\$75/LF	\$145/LF

These figures are for an 8' high wall.

b Build a new elevator in an accessible location.

For a discussion of this option see AA 39, which addresses two alternative construction locations with their corresponding limitations and costs.

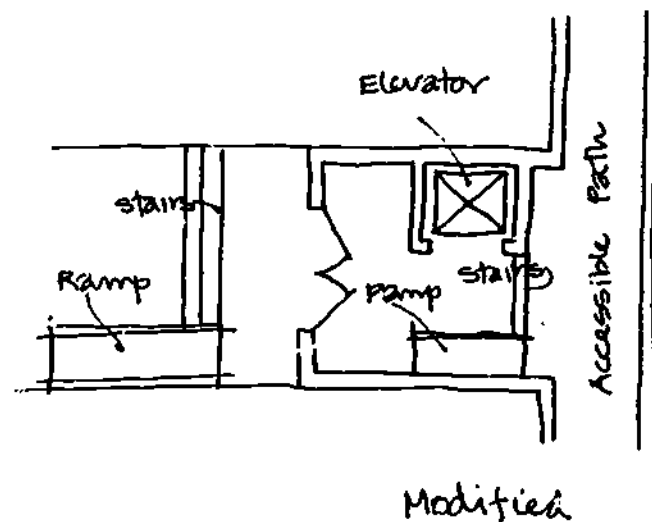
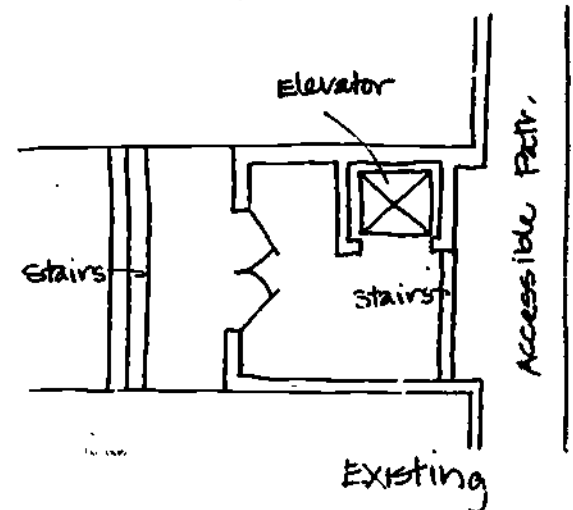

42 If lifts are not located in a secured area: a Issue keys to handicapped children and teachers.

Some method of controlling the use of lifts is necessary. Although the keyed control is often a standard feature with platform lifts, an optional keyed call-send control will probably be required. A call-send set of controls is a switch mounted at the top and bottom of the lift to activate the lift to come to the level where one wants to get on that lift. There could be unauthorized use of keys and also problems due to loss of keys by the children. Lifts should be equipped with pressure sensitive shut-off switches that automatically stop lifts if anyone gets in the way of their movement.

A control should be no higher than 36" if children are to use the lift themselves. The cost for the additional call-send controls is \$212 per set. These could be installed by school maintenance personnel.

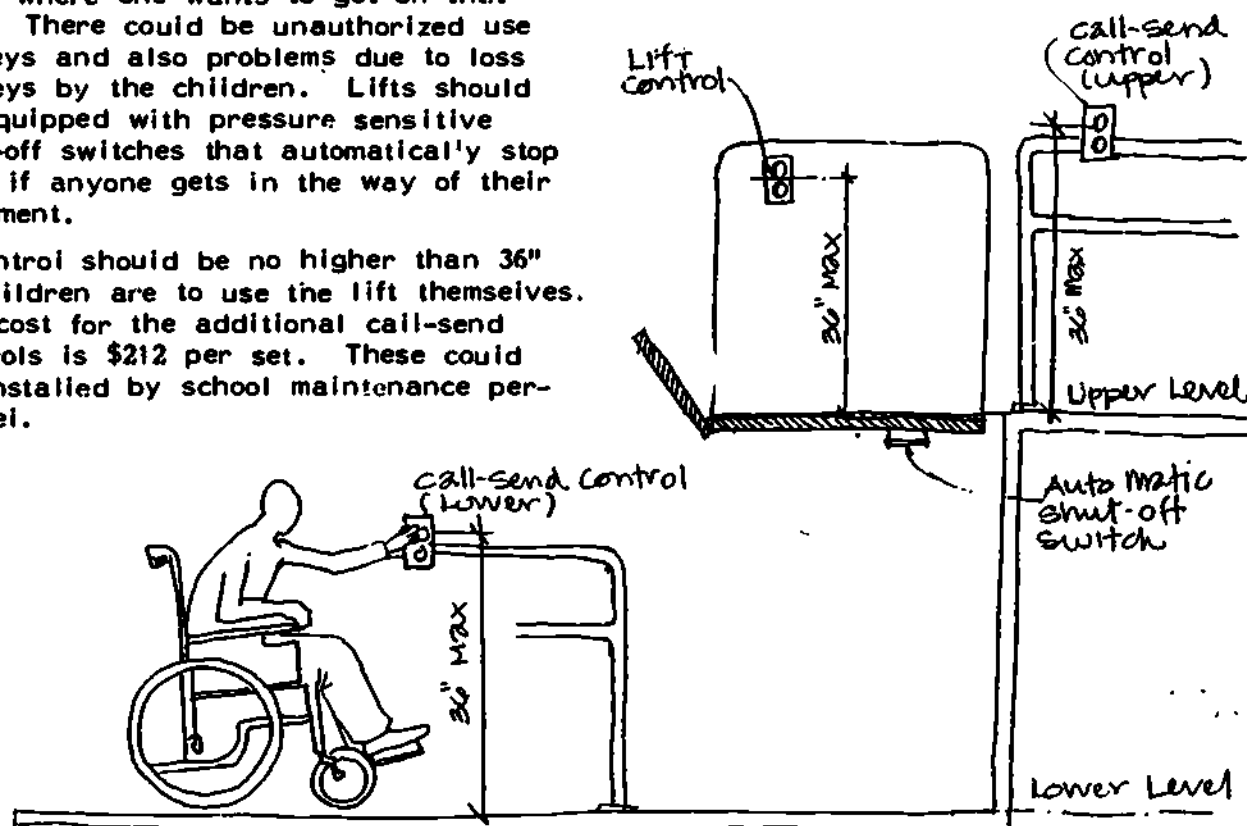

b Have an aide assist children who use lifts.

This solution is dependent on the availability of staff. It would provide more security and safety in use of the lift, but would limit the independence of the children.

43 If wheelchair users are to use chair-type stairway elevators:

a Use a model that allows the wheelchair to be taken along.

There are very few models which have this capability. The child will have to be able to transfer onto the chair and lift the wheelchair into position for it to be moved. Additional limitations are the same as found in AA 22c.

The cost for such an elevator is approximately that of the platform stair elevator or \$6,000-\$8,000 for a one floor rise.

b Use a model that does not allow the wheelchair to be taken along and rely on an aide to take wheelchairs up and down for the child.

This solution is dependent on the availability of staff. It would limit the independence of the children. Carrying a wheelchair up or down stairs is a potential safety hazard for the aide.

c Provide wheelchairs at both the top and bottom of the stair.

This solution also relies on an aide to assist with storing the abandon chair and supplying the chair at the other end of the stairway elevator. This would require storage space at the stair location. Also, children must be able to transfer from the wheelchair at the elevator chair.

This solution would include provision of the cost of extra wheelchairs and possibly the cost to construct storage or provide security of the chairs. An extra wheelchair costs about \$500 and a security storage cabinet would be approximately \$500 per location.

Accessible Spaces and Facilities

In addition to an accessible circulation system in the school there must be access to program spaces and service spaces at the school. Different facilities present unique difficulties which must be remedied to allow disabled children to fully participate in all programs which the school offers.

AUDITORIUMS

Most auditoriums have several lev. changes, sloped aisles and an elevated stage. These changes will restrict the participation of non-ambulatory children in observing or participating in school programs. Also, due to the typical seat layout, there is difficulty for semi-ambulatory children.

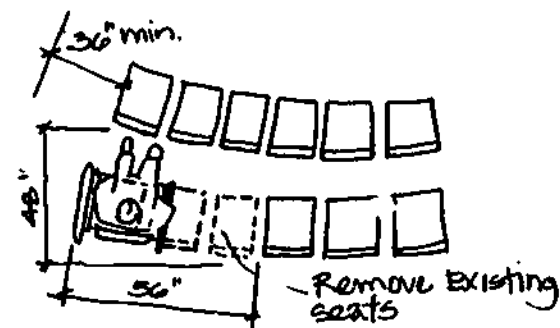
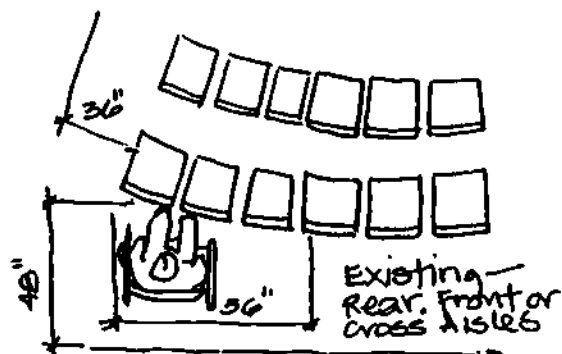

Auditorium Seating

44 If seating space is needed for wheelchair, crutch or leg brace users:

a Use the front or rear aisles of the auditorium, if these aisles are level and wide enough to seat children.

Possible conflicts with local fire codes could prohibit the use of front or rear aisles. Use of these aisles may make it difficult for children to see and hear any program being presented on stage.

A level clear floor space 56"x48" should be provided for two wheelchairs. This is a minimum; the actual number provided should accommodate the number of wheelchair users in the school. There should be a minimum clear aisle width of 36" throughout the auditorium.

b Remove part of a row of seats to create space for disabled children.

The removal of more than one row might be required to achieve the necessary clear space for wheelchairs. If the seating area is on a sloped surface, it may be necessary to level an area or to provide a curb to prevent wheelchairs from rolling forward before brakes can be set.

The criteria for this space are as in alternative 'a'. The cost to remove the seats would be based on the time needed by school maintenance personnel to complete the work.

The cost of leveling an area would be approximately \$10/SF or \$200 per two chairs; this includes a curb at the raised edges.

45 If access for disabled children is located only in the rear of the seating area:

a Modify sloped aisles so that they provide access to the front of the auditorium.

This alternative is not likely to be feasible for a number of several reasons. To rebuild the slope of the aisles only would restrict access at the entrance to any row of seating due to an increasing height of step as the aisle moved to the front. If the slope were such that it could work as a ramp, the necessary handrails and landings would either inhibit circulation or cause some steps into rows at the landing. If this alternative can be achieved, however, it would provide the greatest accessibility and integration of the disabled children.

Ramps to the front of the auditorium should comply with the criteria for ramps as found in AA 30 through 37.

b Provide an indirect accessible route from the rear to the front of the auditorium.

This method of solving the problem depends on the layout of adjacent corridors or walks to the auditorium. There must be sufficient distance to the ramp from back level to the front; this can result in obstruction of entry to rooms or spaces which adjoin those corridors. Such a route might be longer and circuitous, which can be tiring and focus more attention on the disabled child.

The criteria for this route are in AA 7, 8, 12 and 17. The cost for the modifications for the accessible path can be derived from the above sections. For paths connected with ramp requirements see AA 30 through 37.

c Have an aide assist the children when necessary.

This will require staff time. This solution will focus attention on the disabled child's problem and can perpetuate dependency.

46 If there is a raised stage:

a Install a ramp from the auditorium floor to the stage.

There are no particular factors which will prohibit such construction. The layout of the stage and backstage areas will establish the most appropriate location for the ramp. Most often the stages are wood construction and portions can be removed for the ramp. Such a solution will take away some stage area and could make set storage or gathering backstage difficult.

The criteria for the ramp are found in AA 37. Since most school stages are about 20" high, one could anticipate that the cost of a wood ramp is approximately \$2,500. This does not include demolition of existing platforms.

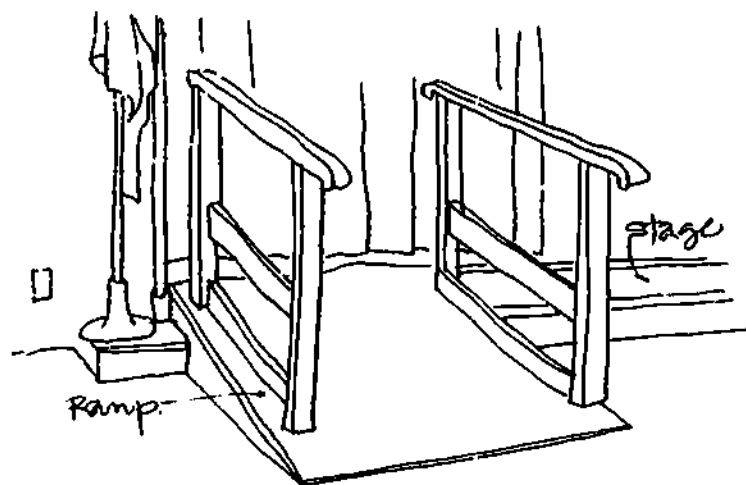

Accessible Raised stage

b Provide a lift from the auditorium floor to the stage.

The installation of a platform lift is a possible alternative. The particular constraints to its use are found in AA 22d. Specifically, for use to a stage it would be desirable to have the lift installed backstage to eliminate it as visual or audible interference with programs. It would take less floor area from the stage than a ramp solution.

This criteria for the platform lifts are in AA 22c. The equipment cost for such a lift is between \$1,600 and \$2,200 but this does not include installation and modifications to the stage which might be required. An overall installed cost would be about \$4,500.

c Provide an accessible route to the stage which leads through the backstage area.

If there are adjacent corridors which are on the same level as the stage this solution can be used. New doorways or wall removal may be necessary. This solution imposes an inconvenient or long trip on the disabled child and may also reinforce stigma.

The criteria for such a path are in AA 7, 8, 12 and 17. The cost for this solution will depend on the particular circulation layout of the school and the extent of the modifications necessary.

CAFETERIAS

The importance of normal socialization opportunities for the disabled child requires that there be access to cafeteria facilities. This will mean convenient access to serving lines and furniture which is useable by the children.

47 If there is no accessible toilet room near the cafeteria:

a Modify the nearest toilet room to the cafeteria so that it is accessible.

Depending on the layout of that toilet room, substantial modification might be necessary. The trip to even the nearest toilet room may be too far for some disabled children, particularly those with bladder control problems.

The criteria for accessibility in toilet rooms are in AA 74 through 92.

b Build a new accessible toilet room adjacent to the cafeteria.

This can involve significant construction and possibly demolition. The most important requirement would be to have access to existing water and waste lines.

The criteria for accessibility are in AA 74 through 92. A space approximately 5' X 5' would accommodate a minimum unisex toilet room.

The cost for this minimal toilet room (one lav and one toilet) is approximately \$2,000. This is a low figure which assumes minimal interior construction, no demolition of existing walls and immediate access to water and waste lines.

48 If the food serving aisle is too narrow:

a Relocate serving table.

Most serving tables are movable pieces of equipment and therefore pose no difficulty. This alternative can reduce space behind the table which might be designed already to a minimum criteria. Since the movement required will tend to not be significant this should be possible.

The clear width of a serving aisle should be 36" minimum. There would be no direct cost to make this modification, except for the time of the district staff.

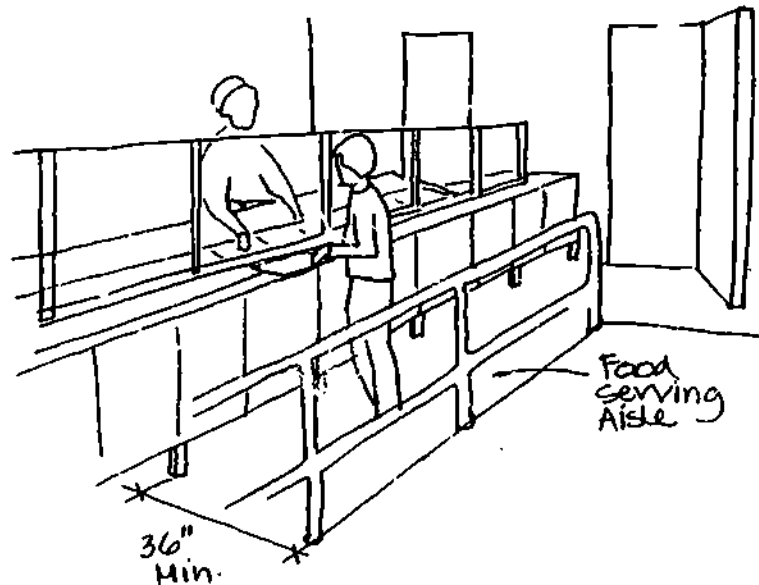

b Relocate railing or wall at side of line.

Relocating a railing poses no problems; however wall relocation could be complicated by structural considerations.

Design criteria appear in alternative 'a' for the aisle width. The total cost for removing and replacing a rail is:

	Materials	Labor	Total
Move rail	\$30	\$220	\$250

This figure assumes that the rail has 4 points of attachment to the floor and is based upon a total length of 24'.

The cost to demolish walls is:

	Materials	Labor	Total
Stud & GYP BU	\$.36/LF	\$ 3.00/LF	\$ 3.36/LF
6" CONC	\$46.00/LF	\$42.00/LF	\$88.00/LF
DBL brick	\$70.00/LF	\$75.00/LF	\$145.00/LF

These costs are for an 8' high wall.

49 If the serving tray slide is mounted too high:

a Lower the tray slide.

There should be no difficulties with this modification; these slides are either welded or screw attached.

The tray slide should be mounted no higher than 30". All food counters should be no higher than 30" above the floor and forward reach for food should be no more than 12". The cost to lower the slide would depend on the particular method of attachment and the length of the slide.

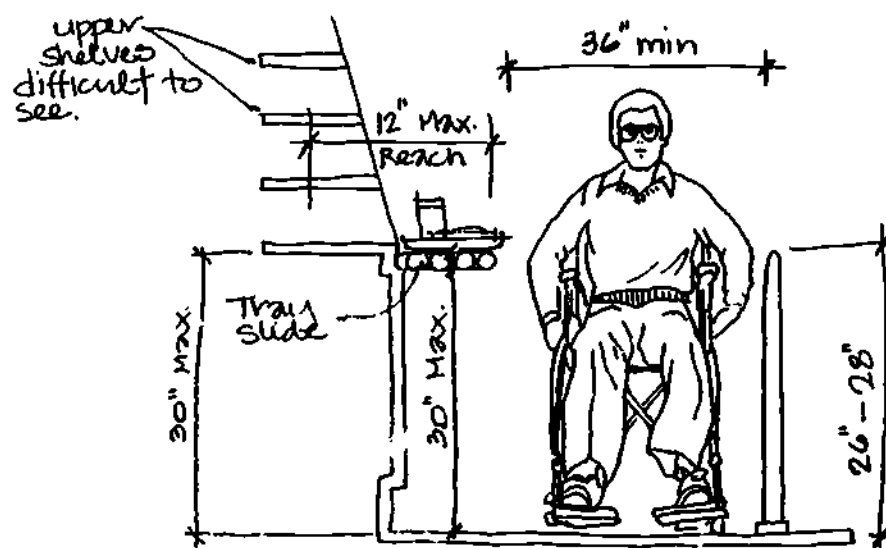

serving line

50 If cafeteria tables have built-in seats or other obstacles which prevent disabled children from eating at them:

a Remove some of the built-in seating to make some of the seating locations accessible.

Built-in seating is not common. It is more likely that there will be integral/tables which are difficult to modify. To replace or modify some some portion will not allow unlimited seating opportunities.

Accessible seating would preferably have arms, backs and a seat height of between 15" and 17". The cost to modify seating would be dependent on the particular construction and configuration of that seating.

b Provide some tables which are use-able by disabled as well as able-bodied children.

Most often there would be no difficulty adding some tables to a cafeteria. This will, as in alternative 'a', not allow for complete choice in seat location.

Tables should be no higher than 30" above the floor with a minimum of 24" clearance below. Moveable tables cost approximately \$250 each.

c Replace all inaccessible tables and seating with accessible furnishings.

This would provide the greatest choice in seating.

The criteria for these furnishings are in alternatives 'a' and 'b'. The cost of chairs is \$10 each in lots of 10 and \$8.50 in lots of 25.

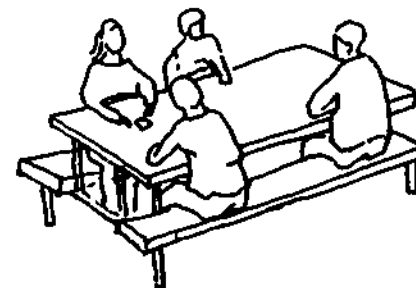

Existing Tables

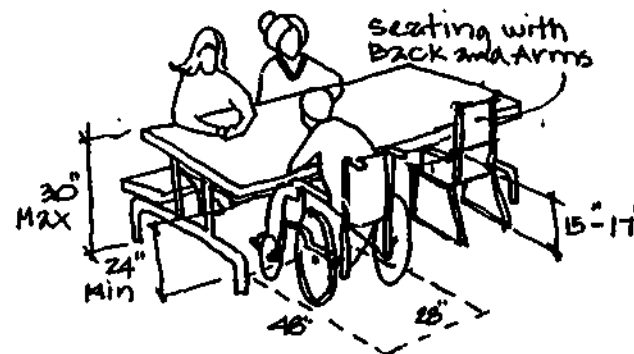

Accessible Seating

CLASSROOMS

Since the bulk of structured learning activity takes place inside classrooms, disabled children should have access to all classroom equipment and activity spaces. In some classrooms, special consideration should be given to the needs of children with hearing and visual disabilities.

51 if doors are too narrow or do not have adequate maneuvering clearances:

a Reverse direction of door swing.

For a full discussion of this approach see AA 93a. The most important constraint on this alternative is the application of exiting requirements in building codes for out-swinging doors.

The preferred clear opening width of an accessible door is 32" yet acceptable widths are between 28" and 32". For standards and illustrations of maneuvering clearances see AA 93. The cost for the pulling and reversing the frame and door is \$84 per door.

b Remove or relocate sidewalls, partitions, or storage closets which obstruct paths.

The feasibility of this option will depend on the layout of corridors or stairs and ramps which lead to the door.

Space planning criteria are found in AA 93c. These criteria specify both pull and push side clearances. The cost to provide the appropriate space can be estimated by computing the amount of wall needing removal and replacement. Figures for these modifications can be found in AA 93.

52 If there are raised or sunken floor areas in a classroom where activities take place regularly:

a Provide space for disabled children around the top of the sunken area.

Although there would not be any constraints to doing this, it could limit participation and reinforce separation and stigma.

b Install ramps or lifts to allow disabled children access.

Since these areas are almost always less than 30" higher or lower than the surrounding area, by most codes there would be no requirement for guardrails or handrails yet these features would be needed for the ramps. Within the confines of a classroom, it is not likely that there would be room for a ramp or a lift.

The design criteria and costs for ramps and lifts are in AA 22 and 37.

53 If built-in furniture restricts movement:

a Remove or relocate furniture as needed to provide accessible routes.

There should be no problems implementing this solution. In most schools there is very little built-in furniture. Most often it is along a wall. If there were a need for such modifications it might result in a predetermined and limited accessible path for disabled children.

The minimum aisle for circulation should be 36" clear. The construction work could typically be performed by school personnel with the cost being the corresponding wages.

b Replace built-in furniture with moveable furniture.

This would cause no foreseeable problems in implementation. It would allow for greater flexibility and freedom of movement for disabled children.

Typically, such furniture would be storage units; the design criteria are similar to those for lockers as found in AA 60 and 62.

Clear floor space in front of storage areas should be 28" x 48" minimum. The cost of a typical school-quality storage cabinet is \$110/Unit for a moveable, full-height design.

174

54 If there is an inaccessible toilet room as part of the classroom:

a Modify it so that it is accessible.

The changes will range from modifying circulation to lowering toilet access rises. The limits of the various changes will be found in AA 74 through 92. Often the toilet room in a classroom will be very small and difficult to modify.

The criteria and cost for the work to achieve accessibility are detailed in AA 74 through 92. The toilet room will have to be 5' square at a minimum.

b Use a nearby accessible toilet room.

There would be no particular constraints on solving the problem this way. It could create difficulty in supervision of children. Access distance would be increased and therefore make it more inconvenient for children with bladder control problems.

The path to the accessible toilet must meet criteria for an accessible path or corridor, as found in AA 7.

c Modify a nearby toilet room so that it is accessible.

The limitations on this are similar to those in Alternative 'a'. This also will mean a longer and more inconvenient trip to the toilet.

The standards and costs are noted in AA 74 through AA 92.

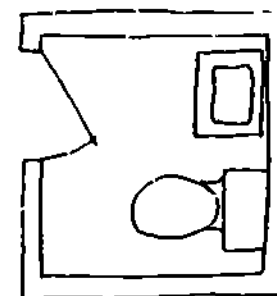

Existing

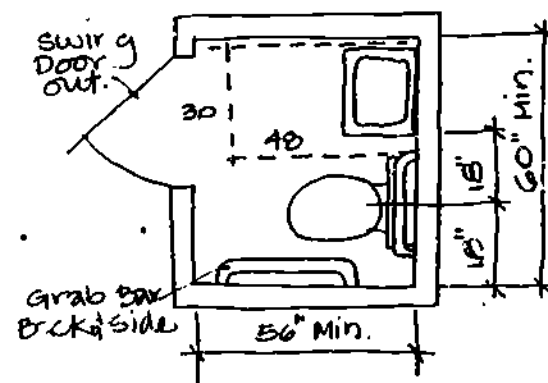

Modified

55 If activities, such as arts and crafts, take place in the raised or sunken areas where children actually have to be in the area to participate:

a Provide a lift.

This will require a minimum area of 5' x 6' for the lift and a source of electrical power. The operation of the lift and its physical space requirements will weigh against its use for this need.

The particular guidelines for lift features are found in AA 22. The cost for such equipment is between \$1600 and \$2200, not including installation.

b Rely on an aide to assist disabled children.

The feasibility of this approach depends on the program and availability of staff. Use of the aide may result in a poor self-image and stigma.

c Relocate the activities to an accessible area.

The major constraint on implementation of this approach is the availability of special equipment in other places. The relocation of special equipment can be done by school maintenance personnel.

56 If wall mounted objects (sharpeners, switches, tackboards, etc.) are mounted too high to be used by disabled children:

a Remount the objects at a height which allows use by both disabled and able-bodied children.

These changes can be made without much difficulty. It is unlikely that the lower heights will create inconvenience for able-bodied children.

The bottom edge of blackboards should be no higher than 24". If blackboards are higher one section can be lowered. All these tasks can be performed by school maintenance personnel.

All other wall-mounted objects should be mounted no higher than 36" maximum.

b Install additional equipment mounted at heights that are useable by disabled children.

There is almost always some location within the classroom which will permit the installation of one of these fixtures.

The height for the new fixture would be as in alternative 'a'. The cost for a new chalkboard with chalk rail is between \$5.40 and \$5.70/SF.

57 If a classroom is to be used by children with partial sight or children who lip read, lighting levels and glare should be controlled:

a Install shades or blinds to control natural lighting.

These tend to be common features of most schools. Most blinds and shades cannot be expected to last any great time. They can have impact on heating and cooling loads for the classroom.

There are no specific standards for the light levels in schools. Costs for such lighting control vary from \$1.15/SF for shades to \$2.50/SF for vertical blinds.

b Modify or replace light fixtures.

Replace the lens of the fixture with one that reduces brightness or add some type of screen to shield the source of light. The exact solution will depend on the fixture to be modified. Replacing a fixture poses no difficulty as long as it does not draw significantly greater current. This is unlikely since one would probably be searching for a fixture that has reduced brightness, thus uses equal power or less.

The cost of modifying a light fixture will depend on the fixture and exact modification to be made. To replace a light fixture, cost is as follows:

	Materials	Labor	Total
4' Fluorescent 2/bulb	\$65	\$40	\$105
Incandescent	\$45	\$20	\$65

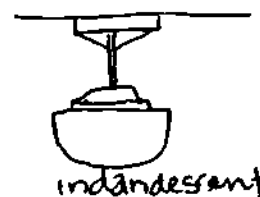

incandescent



Fluorescent

Existing

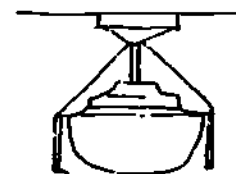

Ballie Fixtures

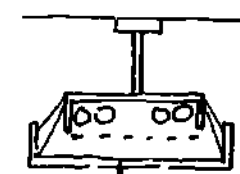

Modified

181

C Relocate light fixtures, blackboards or desks so that children do not have to look in the direction of glare.

Depending on the orientation of the windows any of these changes can solve the problem and can be implemented without difficulty. Glare is caused by either areas of extreme brightness directly in the field of view or indirectly through reflectance from a surface near the visual task. Generally, light sources set high above the line of vision will not create direct glare. By either reducing the brightness of the light source, increasing the surrounding (within limits) brightness, glare can usually be reduced.

Fixtures lighting the blackboard need some shield or recess so as not to be a source of glare when children are looking at the board. A lot can be accomplished to reduce the glare without much cost since this work can be done by school maintenance personnel.

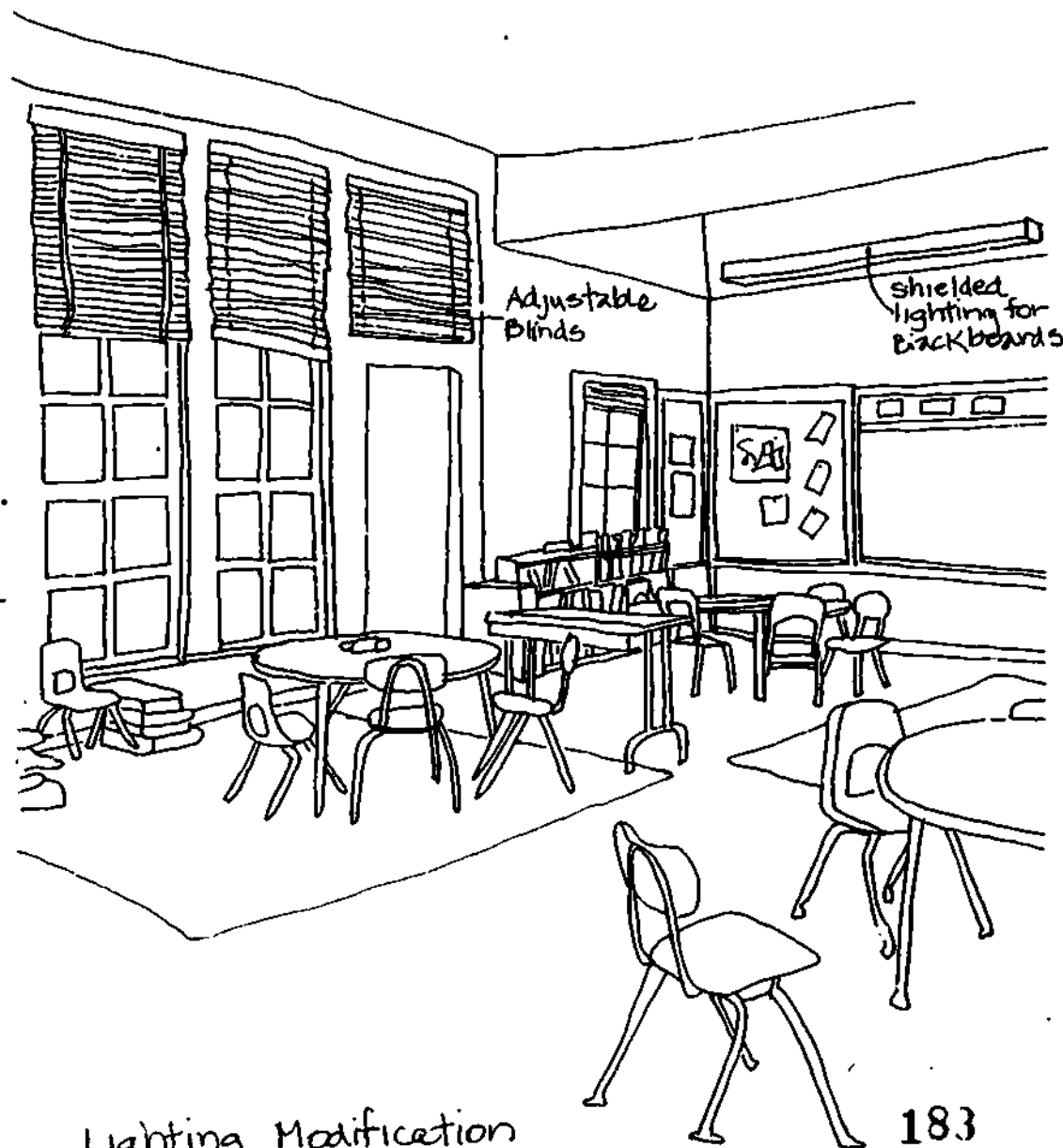

LIBRARIES

In addition to having the library centrally located and easily accessible, attention must be directed to furnishings which are useable by the disabled child. This includes tables, counters, card files, and any special listening stations.

§8 If the check-out counter is too high or does not have sufficient clearance for use by a child in a wheelchair:

a Modify the counter to provide sufficient knee clearance underneath.

In most cases this would require some finish carpentry and might diminish storage space or drawers beneath the counter.

There should be a clear floor space below the counter 24" high, 28" wide and 17" deep. One could expect such a modification to cost approximately \$175. This would include labor and materials.

b Lower a portion of the counter.

This would typically entail cutting down the finish wood cabinetry and replacing the countertop. It might result in the loss of some storage space.

The top of any counter should be no higher than 30; the minimum counter width should be 30". The labor and material costs are about \$150 to modify a counter.

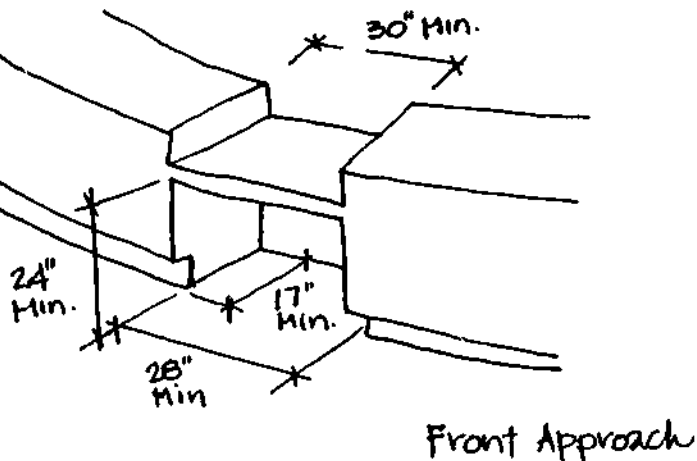

Side Approach

c Provide clear floor space to allow a side approach to counter.

In most cases there will be enough room for a side approach. A front approach is more desirable.

An area 28" deep by 48" wide is needed for this approach position. Maneuvering space must also be considered. The cost to provide the space would be derived from cost to either move the entire counter or remove the obstacle which restricts a side approach.

d Use an accessible table or other location as the check-out counter.

This may be inconvenient for certain tasks - storing supplies or file cards. The location should provide the same control feature that the existing check-out point provides.

The criteria as specified in alternatives 'a' and 'b' would apply for any table put to this use.

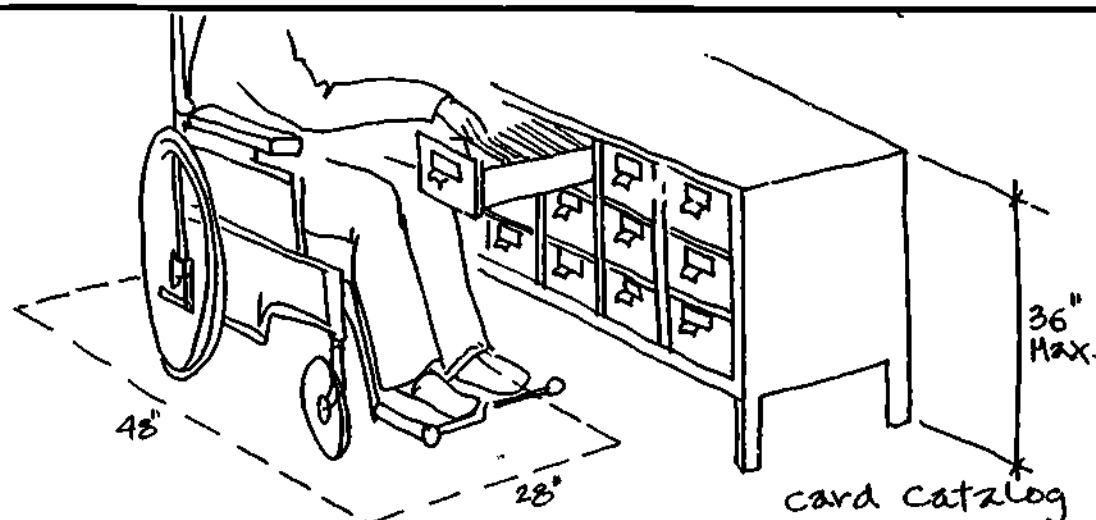

59 If the card catalog is too high or it is inaccessible for a child in a wheelchair:

a Modify the catalog so that it is lower.

Most catalogs do not allow a front approach with adequate knee clearance; a side approach, however, is acceptable. Top drawers of typical catalogs are higher than a child in a wheelchair could reach, let alone review the cards while in the drawer. Either the legs of the cabinet unit could be removed and the catalog set on a low table or the legs could be cut down.

The highest drawer should be 36" above the floor. These changes are simple and could most likely be done by school personnel capable of simple carpentry work.

b Provide sufficient clear floor space so that a child may maneuver up to the catalog.

The card catalogs usually are freestanding and space is usually available to accommodate such a change. If the catalog is located on the counter and is unapproachable, it could be moved to a table where it is accessible.

The necessary area for approach would be found in AA 57c and AA 58c.

LOCKER ROOMS AND GYMNASIUMS

Physical education instruction is an important part of a basic education. Some of the areas used for physical education pose many of the same difficulties as toilet rooms. There should be an accessible path between the two facilities. If there is a combined therapy program special adapted gym equipment should be provided.

60 If shelves or hooks in lockers are too high to be useable by disabled children:

a Lower some existing shelves or hooks to appropriate heights.

These would be relatively simple modifications to perform, fastening with screws being adequate. Lowered hooks could result in clothes dragging on the floor.

Accessible shelves and hooks should be without sharp edges and points and mounted no higher than 36". These modifications can be made by school maintenance personnel.

b Install additional shelves or hooks at a lower height.

Such accessories can usually be acquired from locker manufacturers and installed with ease. Higher hooks become unuseable if a lower shelf is installed, and reduce flexibility in use of the locker for other children.

The criteria of 36" maximum height applies. The cost of these parts will be higher if purchased individually rather than in large numbers.

61 If individual lockers are too narrow for access by disabled children including when other lockers are opened:

a Install wider lockers for disabled children.

This approach will be constrained by the layout of the locker room and the space left after circulations needs are met. The largest "standard" lockers are 18" wide although 24" and above are available on special order.

The criteria for size of such lockers are in alternative 'b'. A double door model might demand less space for use; there are such models available on special order, with a minimum order requirement, for approximately \$155/ea. not including installation.

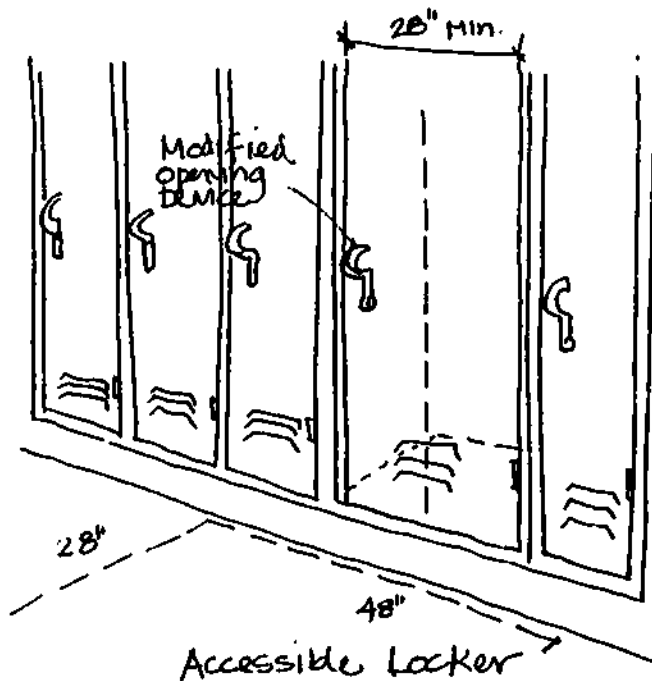

b Make a wide locker from two narrow ones by removing a side partition and replacing existing doors with a wider one.

Lockers come in varying widths, usually from 9" to 18". Two or more lockers can be combined. This will of course result in the loss of some lockers. The wider door might also require modification or movement of some adjacent seating to accommodate the larger door swing.

A locker should have a clear opening width of 28" min. If the locker is deeper than 12". There would have to be corresponding space in front of the locker for a child to approach it in a wheelchair, open it, and then get situated in front of it for use. This space would be 28" deep by 48" wide, minimum. The cost to join two lockers is:

	Materials	Labor	Total
Per locker	\$85	\$185	\$270

62 If locker opening devices require a good fingering ability, firm grasp or high force to operate, such as required by thumb slides or combination locks:

a Modify existing devices so that they are easier to open.

The device should not require firm grasping but work with a light and openhand. Any need for twisting of the wrist to operate should be avoided.

This can present quite some difficulty as there is no simple pre-made part which could accomplish this end. Any addition of a lever type handle to the existing device would start to solve the problem. Such an addition would result in a protruding object that may be a hazard in the locker room.

The cost for such custom devices would have to be individually established.

b Install new opening devices which are easy for disabled children to operate.

There doesn't seem to be any particular device made specifically for lockers that solves this problem. Perhaps a standard lever door handle most closely matches the handle requirements; installation of such a handle would be the best solution. Another possibility is the addition of a loop pull handle in conjunction with modification of the latch catch mechanism.

The cost of the particular handle must be added to the cost for custom modification and installation. This would be the type of modification school personnel with shop facilities could perform.

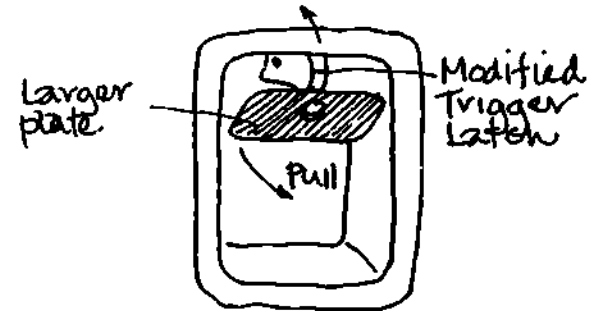

Recessed Type

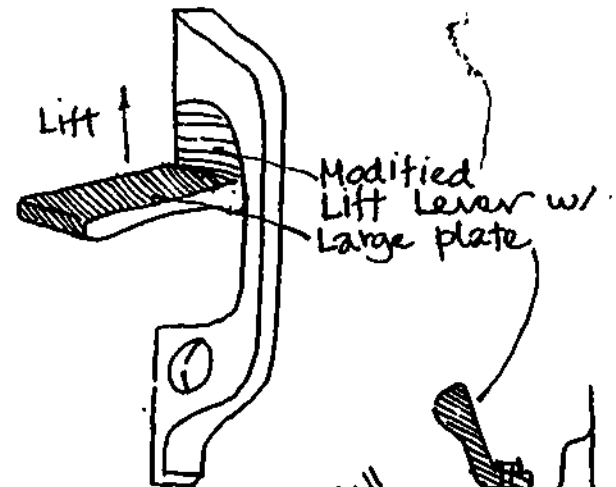

Lift Type

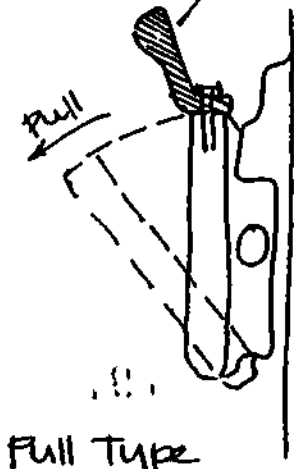

Full Type

63 If toilet facilities are not accessible:

a Modify toilet room facilities.

Generally toilet room facilities in locker rooms will accommodate a larger number of children and are therefore designed with generous space and fixtures. This usually means that fewer and simpler changes are necessary than in other toilet rooms. For a full discussion of all criteria and costs see AA 74 through AA 92.

b Construct an accessible toilet room adjacent to the locker room.

The primary constraint on the feasibility of this alternative is the proximity and capacity of existing water and waste lines. The space available and its configuration will also be factors to consider.

Such an addition would minimally include one lavatory and one toilet. The minimum space in which they could be constructed is 5' x 5' and the cost would be about \$2000 (this assumes there is available space which doesn't require significant modification). For detailed criteria on the needs of an accessible toilet room see AA 74 through 92.

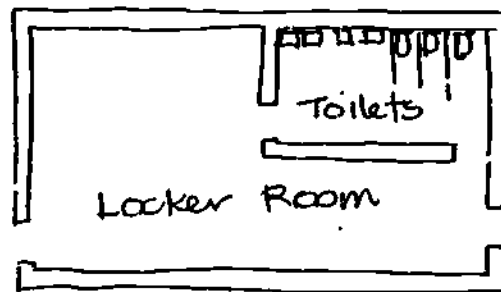

Existing

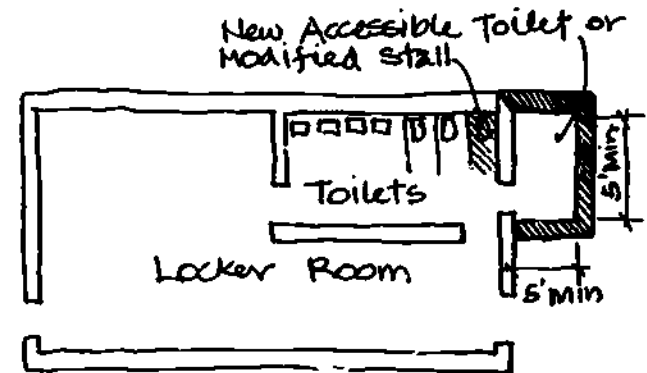

Modified

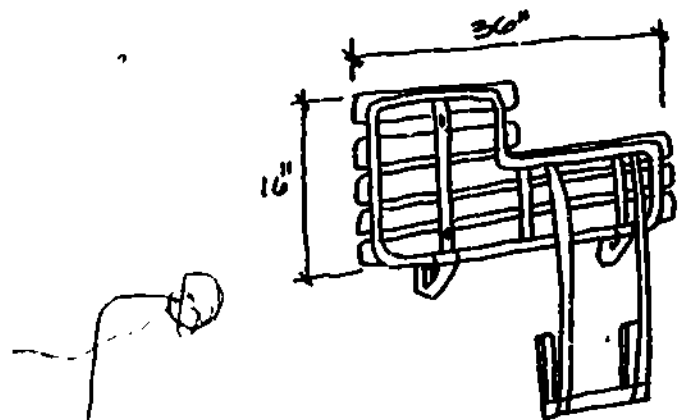

Fold down Shower Seat

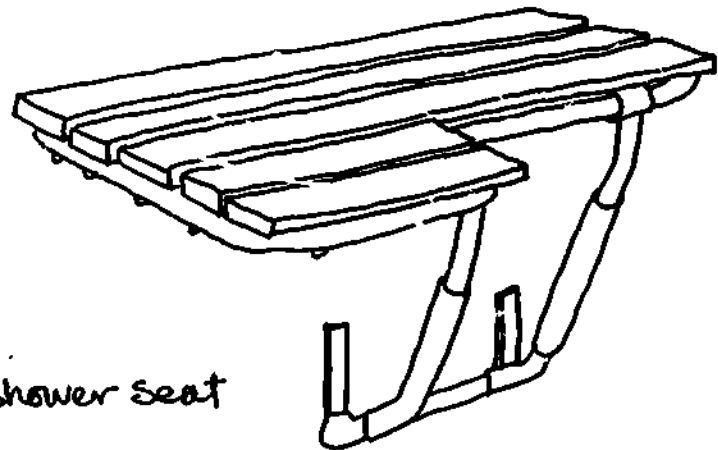

64 If showers are not accessible, modify any of the following deficiencies for at least one individual shower stall or at least one shower in a gang shower room.

a Install a fold down seat.

There would be no real restrictions to adding a folding shower seat in an existing shower. The widest models appear to be 32" which falls short of the optimum but is acceptable. Secure attachment is necessary.

There should be at least one shower with grab bars and a shower seat. The seat should be as wide as the stall (36" min.) and 16" deep. It should be mounted 15" above floor for younger children (k-3) and 17" maximum for older children (k-4 thru k-6).

The cost for a seat is between \$150-\$250 each, the variance is due to materials i.e. cushioned seat or wood. The seats could be installed by school personnel.

b Remove curbs.

If the floor level of the shower is above the outside floor, removal of the curb will still leave an offset which would require a ramped approach. The curb, depending on the slope of the shower floor and location of the drain, serves to prohibit water from spilling out and creating a slippery floor surface. A small offset ($\frac{1}{2}$ " max.) could be left and depending on the drainage of the shower floor this may be adequate to eliminate spillage.

The cost to remove a shower curb (conc. with tile over) and repair the floor is approximately \$50. This assumes ceramic tile floor and a curb 6" h. x 36" w.

c Lower controls.

There would be no constraints to this modification.

Shower controls should be between 28" and a maximum of 36". The cost to lower controls (reusing existing fixtures) is:

	Materials	Labor	Total
Per shwr.	\$120	\$580	\$700

This assumes a tiled wall finish.

d Modify controls.

The preferable modifications in this case is to change to lever handle controls. The most desirable control would be a single lever mixer control.

Controls should be operable with one hand and easy to activate without twisting of the wrist or tight grasping. The cost to make this change is:

	Materials	Labor	Total
Per set	\$80	\$120	\$200

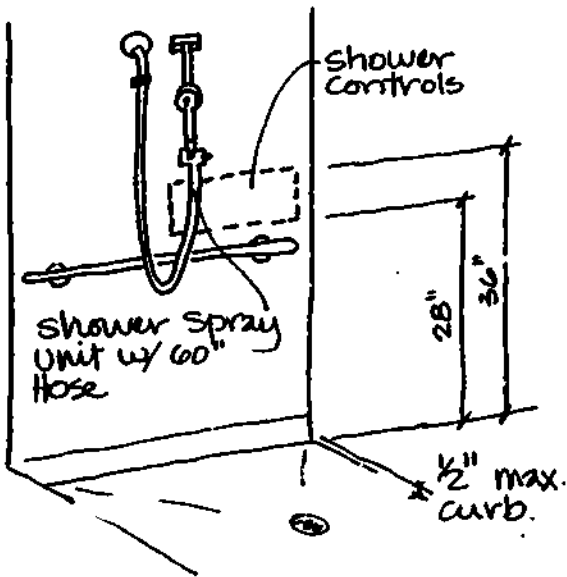

shower controls

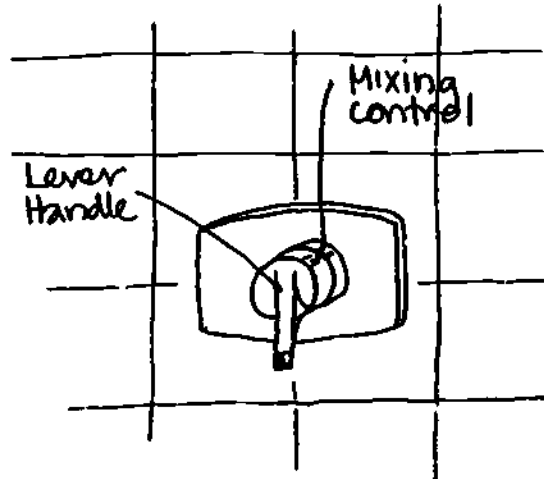

● Install separate accessible showers.

This option will require adequate water and drain capacity. Construction close to existing showers will be least expensive.

In addition to the requirements listed in alternatives 'a' thru 'd', the shower should have 36" x 36" or 30" x 60" minimum clear floor space. Horizontal grab bars should be mounted between 23"-26" above the floor on all walls except behind or immediately next to attached seats. The cost to install a new shower meeting these criteria is:

	Materials	Labor	Total
Per stall	\$360	\$1150	\$1510

This is based on a tile wall finish. There are some prefabricated shower units available; they are usually fiberglass with ramp, controls, and bars built-in. One such model costs \$2450 exclusive of installation.

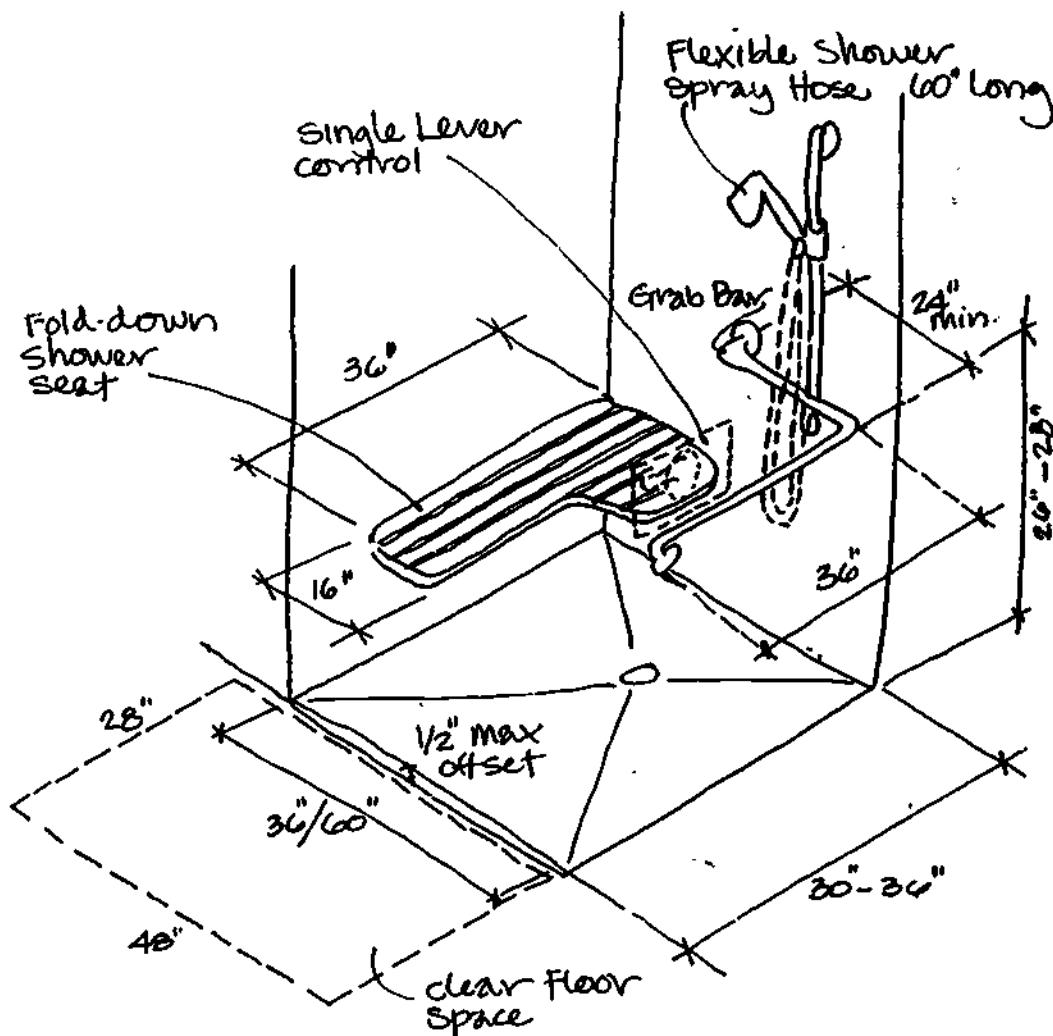

200

201

Accessible Shower

65 If there is not an accessible path to all essential parts of the locker room and between the locker room and gym:

a Relocate some locker room equipment to an accessible location:

This option means losing space for the existing use. As the distance from the locker room to gymnasium increases the inconvenience will become greater, for instance, the children may be embarrassed to use corridors in gym attire. Moreover this approach could prohibit use of shower rooms by disabled children.

There should be an accessible path to the equipment. The criteria for a path are found in AA 7, 8, 12, 13 and 17. The cost of this solution would be based on the time required to relocate equipment.

b Remove or relocate obstructing walls, partitions, or equipment.

The ability to accomplish this will depend on the existing conditions within the locker room. The relocation of walls may require structural, electrical, and mechanical systems.

The criteria for the corridors would be found in AA 7, 8, 12, 13 and 17. Cost is dependent on the extent and type of walls or equipment which must be moved.

c Modify doors:

This can include widening doors, reversing their swings or other changes. There would be no particular limitations in modifying doorways in the locker and gym setting other than those that apply to doorways in general.

Design criteria and costs for doorways are in AA 93 through 99.

d Provide separate accessible lockers in a place where an accessible path to the gym can easily be created.

This might be some accessory space such as a storage room off the gym or a teacher's office. This approach will segregate the disabled children and may perpetuate stigma but it can provide some additional privacy. The use of toilet and shower facilities may be limited.

The criteria for accessible lockers are in AA 60, 61 and 62. Cost of lockers and installation is in AA 60.

66 If the gym is located in an inaccessible location:

a Construct an accessible path between the gym and the rest of the school.

This may include new corridors, doorways, or other circulation elements. The feasibility of these will depend on the particular gym location.

The criteria for an accessible path are found in AA 7, 8, 12, 13 and 17.

b Provide an alternative setting to be used as a gym for both disabled and able-bodied children.

A classroom is one possibility; multi-purpose area is another. The size or configuration may not allow for use of the full range of sports equipment and therefore limit instruction.

The floor surface under the play equipment should preferably be covered by mats or rubber pads for protection of children.

67 If therapy programs take place in the gym:

a Provide equipment which can be used for physical therapy, e.g. raised exercise platforms, balance beams, etc.

The provision of this equipment poses no problems. It will obviously support the greatest amount of integration for the disabled child in the school program.

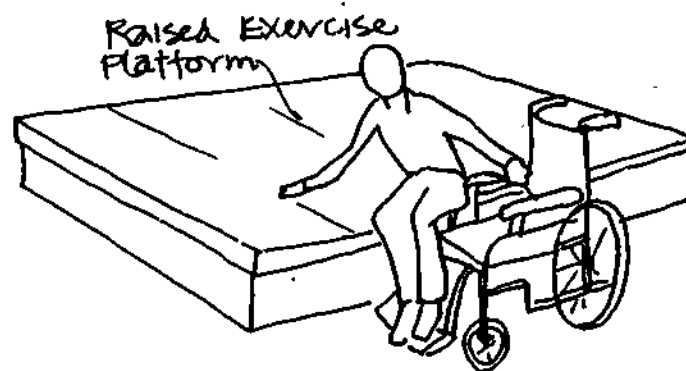
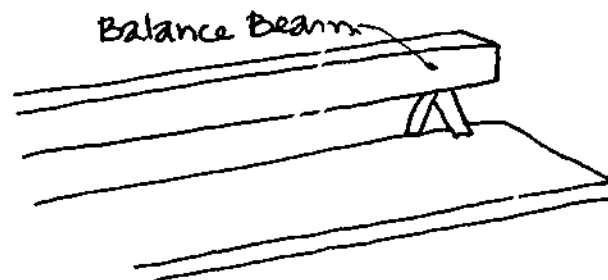

204

205

Accessible Gym Equipment

PLAYGROUNDS AND ATHLETIC FIELDS

Participation in play and athletic activities is important to the social and physical development of all children. To meet this objective both able-bodied and disabled children should be able to play together (with some exceptions, for example, hemophiliacs) Appropriate equipment should be provided in an accessible location.

68 If accessible play equipment is to be provided:

a Locate accessible play equipment adjacent to existing equipment.

There should be no constraints to siting the equipment this way. This provides close contact during play while being safer for disabled children than playing on the same equipment as other children.

Design features of such equipment are noted in alternatives 'c' and 'd'. The cost is dependent on the particular pieces installed.

b Locate accessible equipment in its own area.

Lack of space on the school site and existing steep site slopes would be the only factors to limit this possibility. Proximity to the building would be advantageous. This solution would, more than the others, continue a sense of separation.

There should be an accessible path to the play area that meets the requirements of AA 7 and 8.

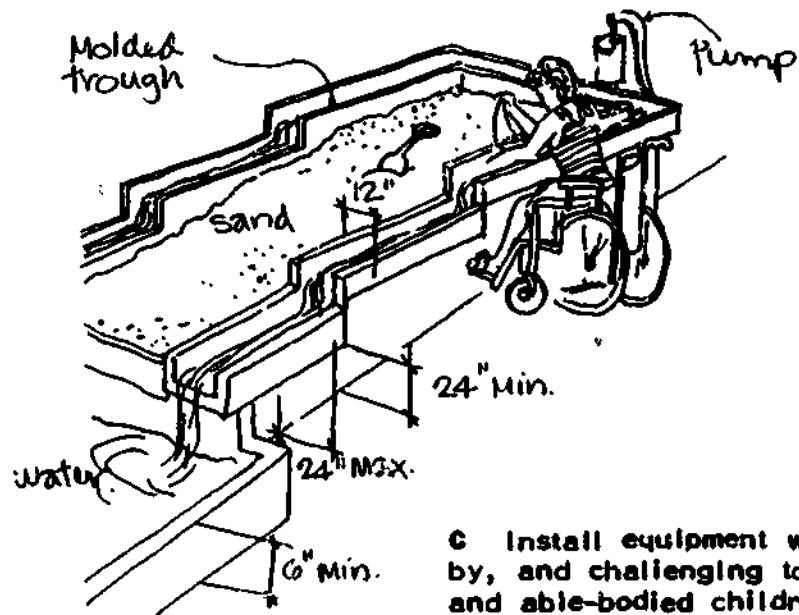

challenging Equipment

c Install equipment which is useable by, and challenging to both disabled and able-bodied children.

Challenging accessible play equipment may have to be custom designed. These designs should pose no problems in construction. Equipment for both able-bodied and disabled will promote socialization yet does require adequate supervision to see that rough play won't endanger disabled children.

Accessible play equipment should have raised manipulative play surfaces, incorporate sloping circulation surfaces, soft ground materials or provide several levels of challenge. Lowered basketball backstops and raised sandboxes are examples of these pieces. Cost for these solutions will vary depending on the particular design and size of the units.

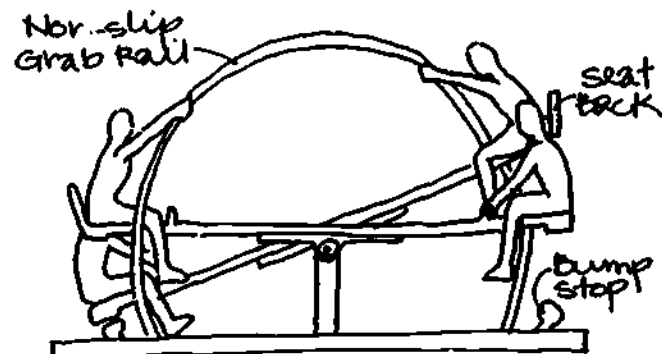

Modified Equipment

d Modify some existing play equipment so that it is useable by, and challenging to disabled and able-bodied children.

An example of this approach would be the addition of free-standing arched rails on either side of a see-saw to serve as handrails. A bumper below the point of impact would also be needed. This option has the same advantages and disadvantages as noted in alternative 'c'.

Generally, design criteria for these modifications would be to soften ground surfaces, create protective barriers such as hand rails, and remove sharp edges or shapes.

69 If there is no accessible path between school and existing play area:

a Modify existing path(s) so that they are accessible.

Often the greatest accessibility problem is a steep level change along this path. Adequate space is usually available to provide an accessible path. Most other barriers can be remedied easily.

The criteria for an accessible path are found in AA 7, 8, 10 and 11. The cost of such a path will be based on the particular circumstances.

b Build an accessible path to an existing play area.

Some play areas are separated from the school building by only dirt or grass areas. There are usually no barriers to building a firm surfaced path to those areas.

See AA 7 and 8 for design criteria and details. Such a path costs approximately \$2/SF.

c Relocate play area to an accessible location.

A location close to the school is more accessible, however, it may increase noise and create distraction from classroom activities.

The criteria referenced in alternatives 'a' and 'b' apply to this option as well. New surfaces and equipment relocation would be the major expenses. The cost for surfaces is:

	Materials	Labor	Total
A.C. Paving	\$1.50/SF	\$.35/SF	\$1.85/SF

School maintenance personnel could move existing play equipment; there would be a need for excavation and concrete pouring.

210

211 - 1

70 In order to provide weather protection, especially relief from sun and heat:

a Relocate play areas close to the school building so that advantage can be taken of shade offered by the building as well as the interior of the building.

To do this the site must be compatible in slope and available space. Location of play areas near classrooms or libraries can be distracting to those activities.

There should be weather protection in a playground. The cost of such a relocation will depend on the type and number of pieces of relocated equipment.

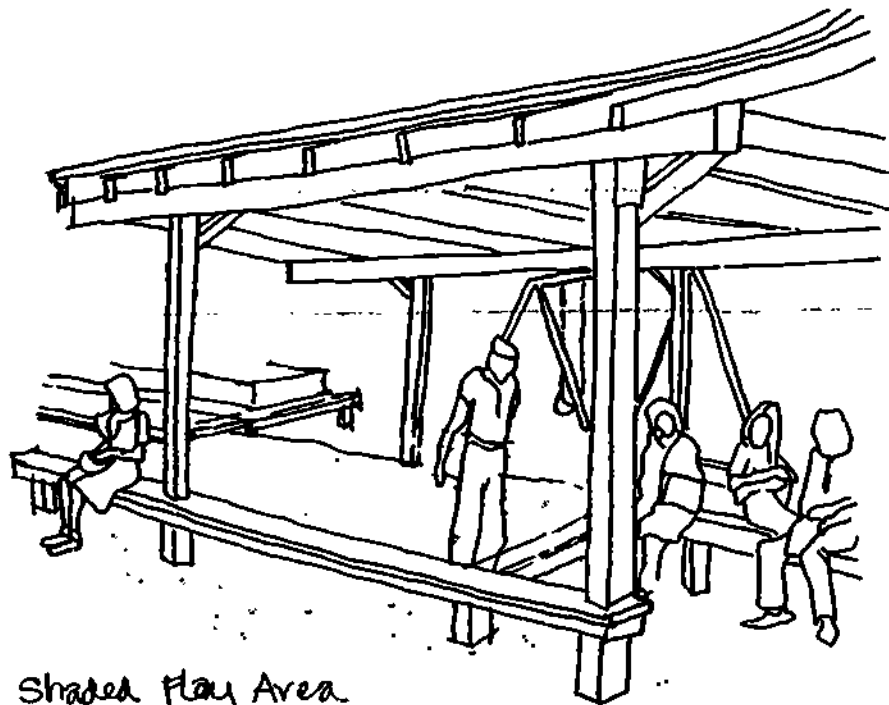

212

Shaded Play Area

b Plant large shade trees in the play area.

This may require removal of a hard ground surface prior to the tree planting. Irrigation and maintenance will be ongoing and require time from school personnel. Droppings from the tree can be a hazard. Planting a large tree is not always possible; a smaller tree will not provide shade for an adequate number of children until some years after it is planted.

The cost to plant a shade tree is:

	Materials	Labor ¹	Total
Per tree	\$950	\$200	\$1150

This is for a 48" boxed tree.

c Erect an awning or tent in the play area during the hot weather or a permanent shade-producing structure.

The short life of temporary structures will be their primary drawback. A permanent structure will not have this disadvantage but will cost considerably more.

The cost of a temporary shade structure is approximately \$1.50/SF of the area covered. This would be canvas on aluminum frame. One could expect a cost for a permanent structure to be between \$5/SF - \$8/SF.

213

71 if there is no accessible seating near the play area:

a Modify existing seating area so that it is accessible.

The most important consideration for accessibility seating is access to the seats; this means firm ground surface and adequate clearances for approach to the seats.

Accessible seating should have a seat height no more than 17" and provide back support and arm rests to aid children in raising themselves. These modifications can usually be done by school personnel if the existing seating is constructed from wood.

b Construct an accessible seating area.

There would be no constraints on building such a seating area. It would be advantageous to provide this seating in a shaded place.

The needs, as noted in alternative 'a', should be met. Manufactured seating can be installed or custom seating constructed. The cost of manufactured seating for a 6' seat is:

	Materials	Labor	Total
Conc.	\$109	\$44	\$153
Wood	\$99	\$32	\$131

This is for the seating alone, surrounding ground surface material is not included.

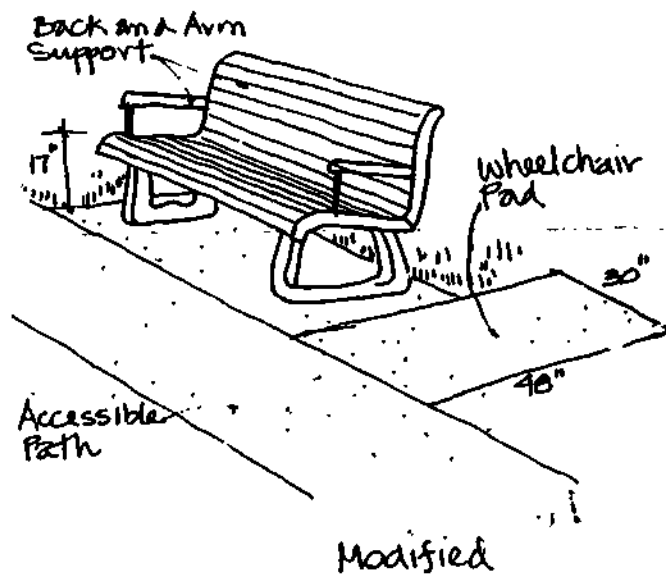
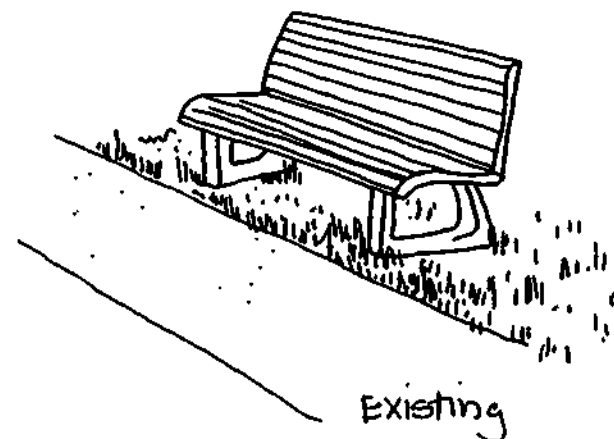

72 If there are existing toilet rooms near the playground:

a Modify them to be accessible.

Accessibility to toilet rooms involves several factors and many potential constraints. Outdoor toilet rooms will tend to be of more substantial construction and therefore changes to walls or partitions might be more difficult.

A detailed discussion of toilet rooms is found in AA 74 through 92.

73 If there are no existing toilet rooms near the playground:

a Construct an accessible toilet room near the playground.

The most significant constraint to this option will be availability of water and sewer connections.

Criteria for a new toilet room are in AA 74 through 92. The cost to build such a toilet room would be approximately \$4,000 to \$5,000. This is based on two minimal toilet rooms, each with a lav and toilet.

b Modify the nearest toilet within the building.

In addition to all the factors related to any toilet modification, a major constraint on this alternative is the entry condition at the nearest entrance. In selecting entrances to make accessible, consideration should be given to the location of toilet rooms in relation to playgrounds.

The criteria and costs for this work are in AA 74 through 92.

TOILET ROOMS

Accessible toilet rooms must be conveniently located. In addition to being along accessible circulation paths, they must have internally accessible circulation. Fixtures of all types should be useable by disabled children. More than elsewhere in schools, the spaces and equipment in the toilet rooms are likely to require a great deal of modification.

74 If accessible toilets are needed at a school:

a Modify existing toilet rooms to be accessible.

This includes making one of each type of fixture available for disabled children. Generally, some fixtures will have to be changed, plumbing modified and wall and floor surfaces replaced. If there is generous circulation space in the existing toilet room, the task will be easier. The greatest convenience will be afforded if all toilet rooms are accessible.

The toilet room is accessible if the various components are; design criteria for each individual component and the costs for their replacement or modification are provided in the following sections.

b Build new toilet rooms with accessible equipment in convenient locations.

This major constraint to creating a new toilet room is providing it with water and sewage connections. The capacity of mechanical and electrical systems must be great enough to handle the new loads or modification must be possible. These constraints will be minimized if the new facility is located near an existing toilet room. If the room is not added to the exterior then there will be a loss of some space which may serve another purpose.

The criteria for the new room are presented in the following section. One could expect a cost in excess of \$1,200 per fixture for new toilet rooms. This would not include the cost of additional space or any additional runs to existing water and sewer connections.

75 If the path within the toilet room is not accessible:

a Remove or relocate privacy partitions.

Privacy screens are typically used near the toilet room entry. There is usually no difficulty relocating them but the new location can restrict the use of some fixtures near the entry.

When there is a privacy partition in an existing toilet room, the partition should be 48" from the entry door if the door swings into the toilet room and 42" if the door swings out of the room. The work required to relocate such a partition could be completed by school maintenance personnel but if performed by contract it would cost approximately \$200.

b Modify doorways.

This can be accomplished in a number of ways ranging from changing the direction of door swing to widening the door. For a full discussion see AA 93 through 99. Toilet rooms often use a one-way circulation scheme or a sequential set of doors and this can result in doubling costs; however, sometimes these types of circulation are not really necessary particularly if the size of the student body is lower than the total capacity of the building or the school day schedule is different than when the building was originally planned.

c Remove or relocate walls.

There are often walls at the entry. If the wall is structural its removal could require extensive work to remove and provide substitute structure. If the wall is non-structural, it could be replaced with a partition, a less expensive proposal.

The same clearances as alternative 'a' apply. The cost of wall demolition would be:

	Materials	Labor	Total
Stud & GYP BD	\$15/LF	\$20/LF	\$35/LF

These figures are for an 8' high wall.

The cost for a sight screen (3' X 7') is:

	Materials	Labor	Total
Plastic Laminate	\$89 EA	\$27 EA	\$116 EA
Porcelain Enamel	\$133 EA	\$27 EA	\$160 EA

These are floor mounted partitions.

220

221

76 If any of the facilities are on raised podiums:

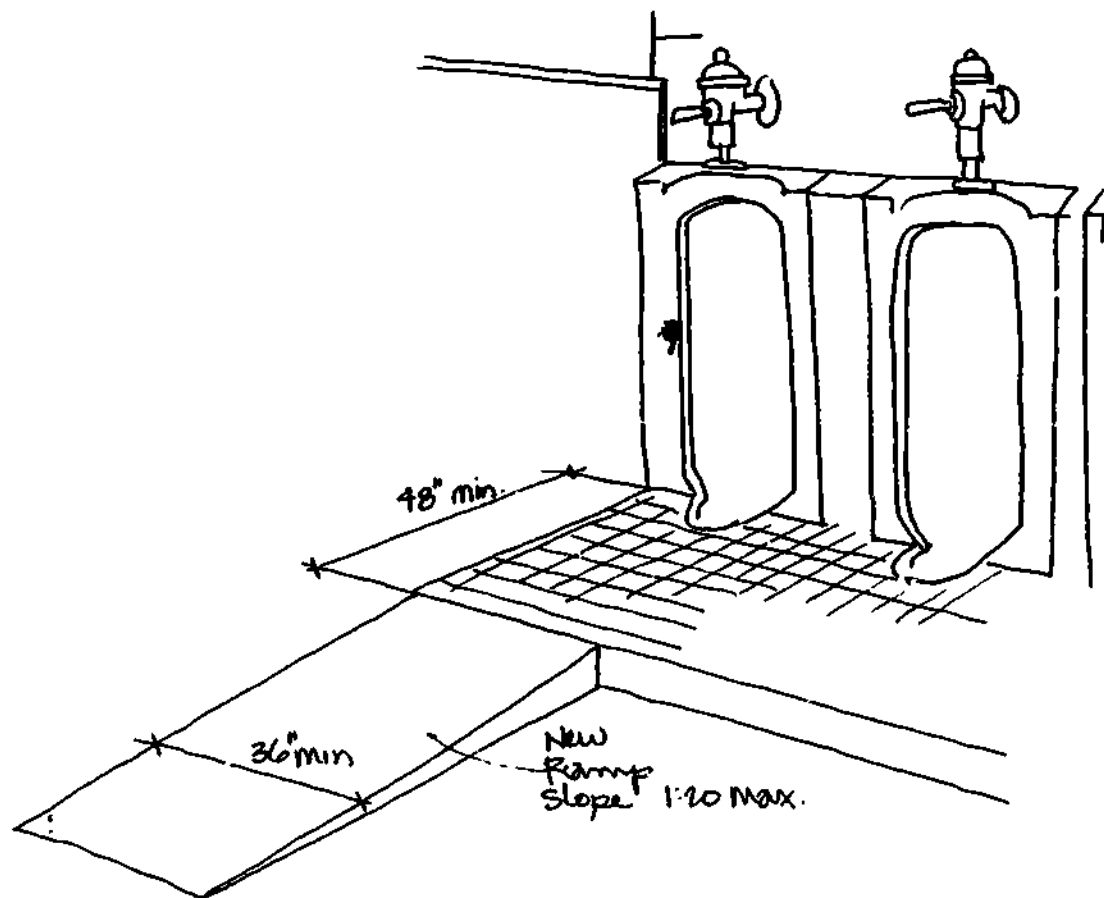

8 Build a ramp to the podium and, if necessary, enlarge the podium so that it can accommodate wheelchairs.

These podiums are rarely greater than 6" high, in which case a ramp of 6' would be required. Having the space necessary to build a ramp that size will be the limiting factor. Other circulation must not be obstructed by the ramp.

The ramp would have to have a 1:12 slope maximum and be 36" wide. The podium, in front of the fixture, must be a minimum of 48" deep (measured from the face of the fixture). The cost of such a ramp would be about the same as the cost to add to the podium.

The cost to add to an existing podium or build a ramp is:

Materials	Labor	Total
\$1.50/SF	\$13.50/SF	\$15.00/SF

This assumes a ceramic tile floor and a concrete ramp with no handrails.*

* Handrails are not needed for ramps 6' long or shorter that have a rise equal to or less than 6 inches.

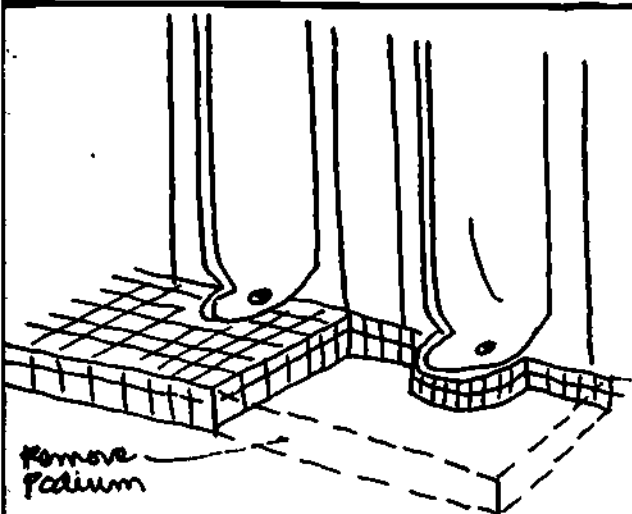

B Remove the podium and lower equipment to appropriate heights.

Such a podium is usually constructed with a slope for drainage either to a drain in the podium itself or sometimes towards floor mounted urinals. If there is a floor drain, the success of this approach depends on the flexibility available to lower the drain and trap within the floor or below it. Covered urinals would also require a new drainage scheme.

In terms of access, one fixture of each type should be available for use. For a full discussion of the constraints, criteria and costs of lowering particular fixtures see AA 80, 85, and 87. The cost to remove a podium and refinish the floor is:

Materials	Labor	Total
\$2.50/SF	\$4.20/SF	\$6.80/SF

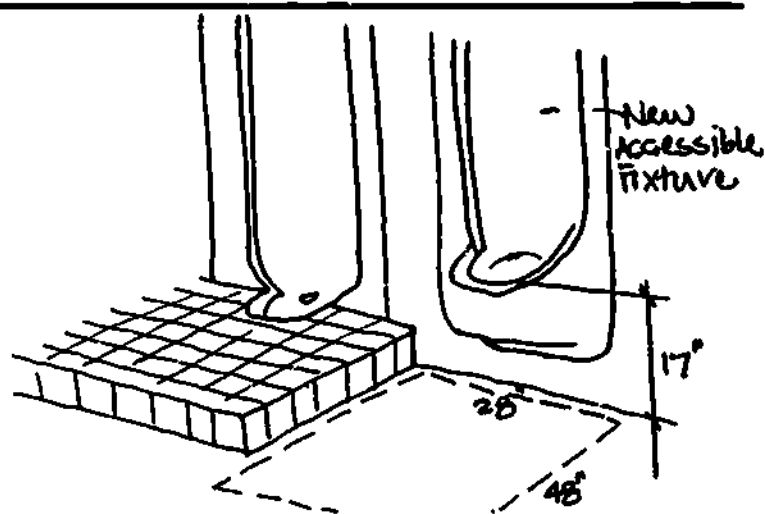

C Install additional facilities in accessible locations within the toilet room.

Typically there would be adequate capacity for additional fixtures but two items should be evaluated to establish the feasibility of this option: the size of existing waste lines and the pitch of those lines. Both of these can have bearing on this alternative.

The cost to install an additional fixture ranges from \$420 to \$660. See AA 85c, 87b, 78c and 80c for details.

TOILET STALLS

77 If the toilet stall is to be for non-assisted use only:

a Modify an existing standard-width stall so that it is accessible.

The non-assisted stall is a narrow stall which the disabled child can use independently. Many severely handicapped children, however require assistance in making toilet transfers. The narrow stall works better for the ambulatory and semi-ambulatory child because they can use the grab bars on both sides. There should be no difficulty in modifying a typical stall for this use.

The non-assisted stall should be 30" wide by 66" deep. The typical existing stall will usually meet the width standard but the depth will likely need to be extended. This can interfere with aisle circulation in the room.

Any minor widening of the stall could be done by school personnel but depth extension and door widening would likely need to be contracted. The cost to perform this work would be:

	Materials	Labor	Total
Plastic	\$180	\$185	\$365
Laminate			
Porcelain	\$225	\$185	\$410
Enamel			

This does not include the costs for grab bars which are found in AA 81.

b Build a new accessible stall.

If there is enough space, the provision of the larger assisted stall is a better alternative since the severely disabled child will need assistance. The addition of a stall will be contingent on available space within the toilet room. A more significant constraint can be the addition or relocation of a toilet as discussed in AA 78c.

The design criteria are as in alternative 'a'. The cost of adding a stall is:

	Materials	Labor	Total
Plastic	\$160	\$37	\$197
Laminate			
Porcelain	\$201	\$37	\$238
Enamel			

The cost to add a toilet would be:

Materials	Labor	Total
\$385	\$275	\$660

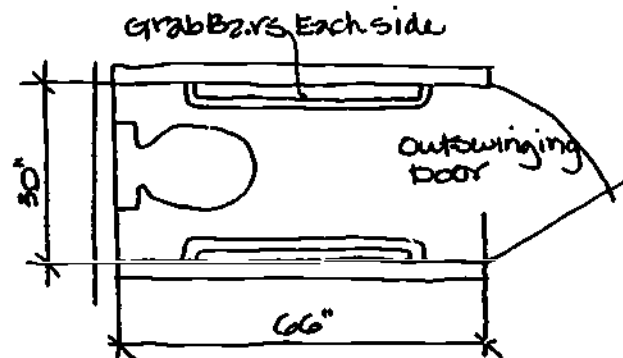

Non-assisted stall

78 If an accessible stall is to be for both assisted and non-assisted use, a widened stall is needed.

a Modify an end stall of a row by moving the end partition.

This is contingent on there not being walls at either one end of the row or another. If, in moving the end partition, circulation is made inaccessible, this option would not be satisfactory.

The assisted stall should be 60" w. x 56" d.; the toilet should be 15" from either of the two side walls. The cost to accomplish this is:

	Materials	Labor	Total
Plas. lam.	\$180	\$185	\$365
Porc. eman.	\$225	\$185	\$410

These figures include widening the stall door.

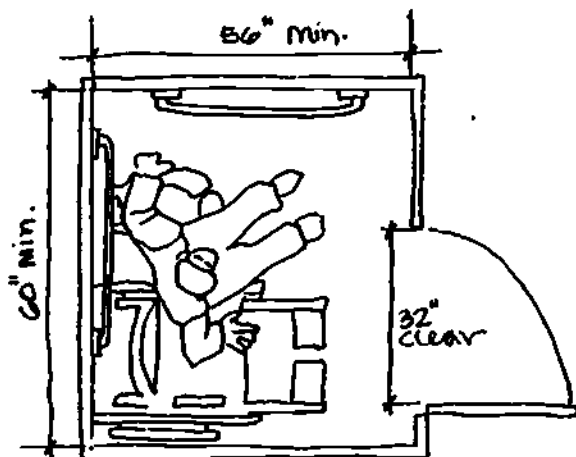

Assisted/Non-assisted stall

b Among a row of stalls, remove a side partition and the toilet from the adjacent stall in order to combine two standard stalls into one wide stall.

There would be no physical constraints to this alternative; if there are code requirements specifying a certain ratio of toilets per student the loss of one toilet might be problematical; however, the overall number of toilets in a school will usually exceed the minimum number required.

The criteria for the stall width are as in alternative 'a'. In addition to the cost for the similar modification in 'a', there will be a cost for removing a toilet and wall/floor patching which could be approximately \$100.

c Build a new stall large enough for assisted use.

This alternative can be implemented if space permits and capacity for a new toilet fixture is available.

The design criteria are as in alternative 'a'. The cost to add stall and toilet is:

	Materials	Labor	Total
Toilet	\$385	\$275	\$660
Partitions	\$201	\$37	\$238
Per Stall	\$586	\$312	\$898

Partitions figures are for porcelain enamel partitions.

79 If the existing toilet in the accessible stall is mounted too high or too low:

a Remount toilet at an appropriate height.

This will be easy to accomplish for wall hung toilets but the solution for a floor mounted toilet would be to replace the toilet.

Toilet heights should be between 15" and 17", the first being preferable for younger children (k-3) and second for older children (grades 4-6). The cost to modify the height is:

	Materials	Labor	Total
Per Toilet	\$35	\$420	\$455

This also includes wall refinishing as required.

b Install a seat height spacer:

There are seat spacers available with varying heights. Most standard school toilets comply with the criteria in alternative 'a'. In some cases, a 2" high lifter would result in the criteria set in 'a'. The lifter will require more maintenance than a standard seat.

The design criteria are in alternative 'a'. The cost for such a spacer is approximately \$100 and it could be installed by school personnel.

c Change the toilet to a new model.

The existing fittings would have to match those required by the new fixture.

The height for the seat is in alternative 'a'. The cost to do this is:

	Materials	Labor	Total
Floor mtd.	\$245	\$105	\$351

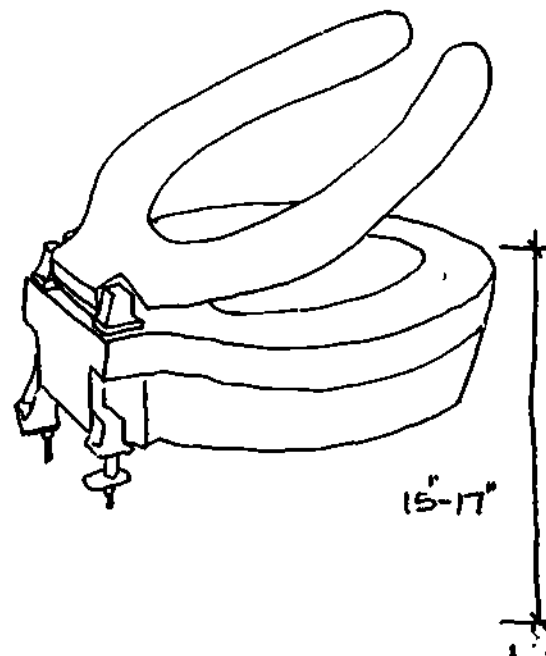

seat spacer

80 If existing stall door swings inward:

a Rehang door so that it swings outward:

There would not be any difficulty in rehanging the door; however, there might not be enough room or the swing might block circulation in the toilet stall area.

The door should be 28"-32" wide and swing out. The cost to do this is:

	Materials	Labor	Total
Per Stall	\$38	\$65	\$100

b Remove door.

This would of course not provide the privacy afforded users of other stalls. A curtain could be installed as a replacement; however, curtains are easy to remove and/or rip down. Moreover, they cannot be locked to insure privacy.

The cost to remove the door would be minimal and could be accomplished by school personnel. The cost to install a curtain is approximately \$25.

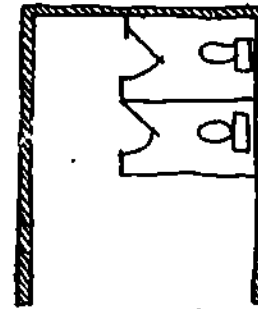

Existing

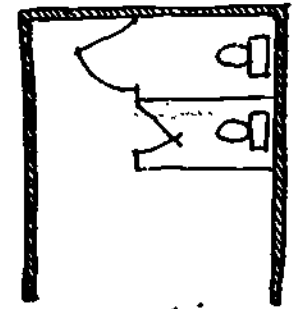

This

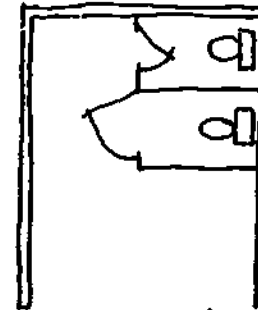

Not This

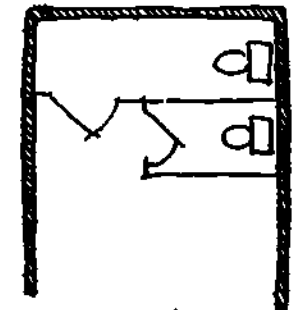

or This

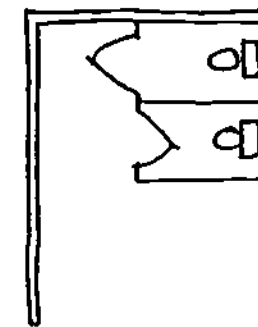

Not This

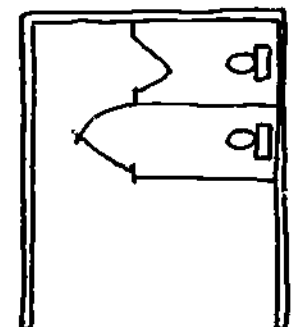

Not This

GRAB BARS

81 If a toilet stall which is to be accessible does not have grab bars:

a Mount grab bars on wall or partitions.

Grab bars can be mounted with a number of alternative devices, each applicable for different wall constructions. Refer to toilet stall illustration for required bar locations. Either attachment to solid material or through-bolting will be required.

Bars should have a non-slip surface or material. The clearance between grab bar and wall should be $1\frac{1}{4}$ " minimum. Its thickness should be between 1" and $1\frac{3}{4}$ " ($1\frac{1}{2}$ " optimal) or perimeter of gripping area between 3"-6.25" with minimum thickness in one direction of $\frac{1}{2}$ ". The bars should extend at least to within 12" from the rear wall to within 4" of the front partition. For additional criteria see AA 82a. The cost for a metal 43" grab bar is \$48 for material alone. Wood handrails are acceptable but because of added mounting difficulties their cost is about the same as metal.

b Mount grab bars to floor.

In a situation where the toilet is too far from the side partition or a wall, this solution is desirable.

The same design criteria as in alternative 'a' applies to this alternative. The cost of a floor-mounted bar is roughly the same as a wall-mounted bar, or \$48.

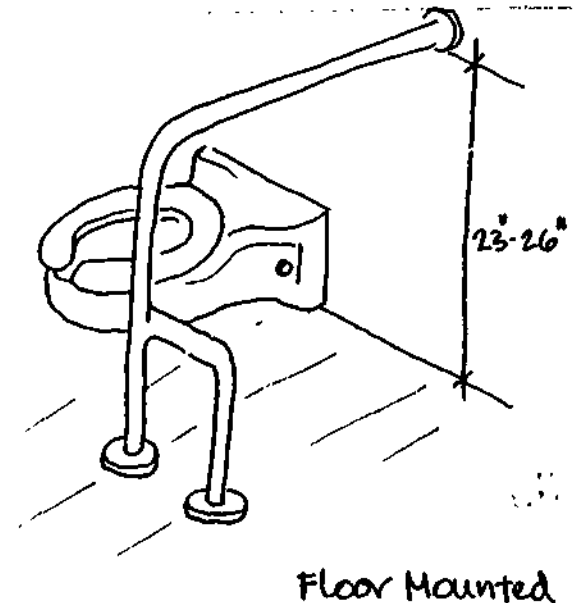
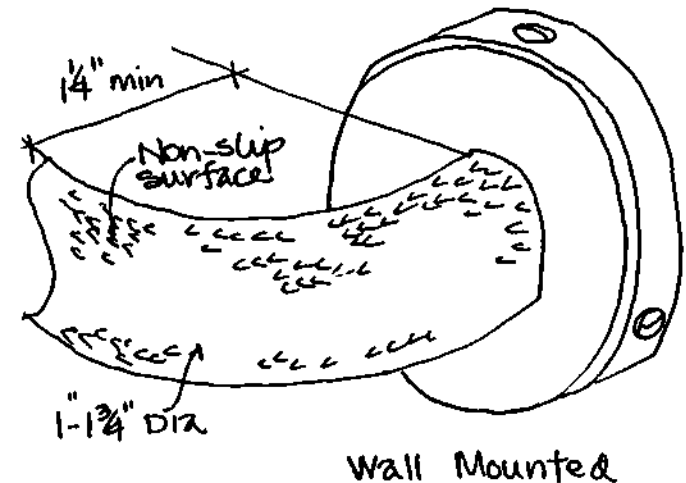

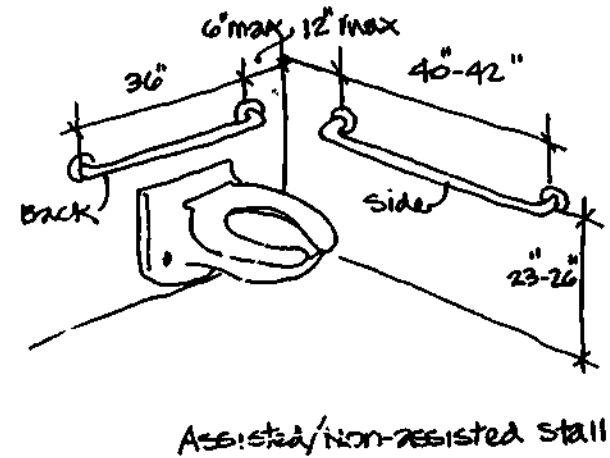
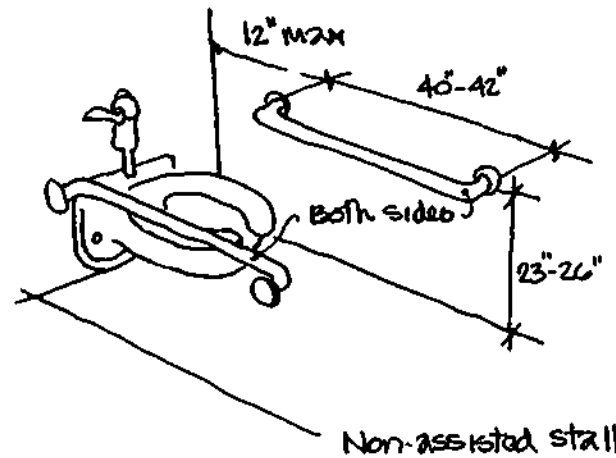

82 If a stall has grab bars which are not useable by children:

A Remount existing bars at the appropriate height.

If the bars are an appropriate width and length then they only have to be relocated.

Grab bars should be horizontally mounted between 23" and 26" above the floor on the side walls of non-assisted stalls or on the rear wall and close side wall of assisted-use stalls. See AA 81.

This task can be completed by school maintenance personnel.

B Replace existing bars with ones which are useable by children.

This will be done when the length or width of the existing bars is not acceptable. There should be no problems with replacement. See AA 81a.

This task can be completed by school maintenance personnel.

235

236

FLUSH CONTROLS

83 If toilet flush controls or paper dispensers are mounted at heights which make them unuseable by children:

• Remount the equipment at appropriate heights.

Neither modification poses significant problems. However, it will be difficult for children in wheelchairs to reach flush controls in the unassisted 30" stall.

The flush controls should be mounted between 20" and 36" above the floor. Most controls will be mounted somewhere between these heights but if a control needs to be lowered one could expect the following cost:

	Materials	Labor	Total
Per toilet	\$55	\$60	\$115

This assumes an exposed flush lever being lowered approximately 6".

A toilet paper dispenser should be mounted on the near stall wall between 12" and 24" from back wall and 19" above the floor maximum. This can be easily accomplished by school maintenance personnel.

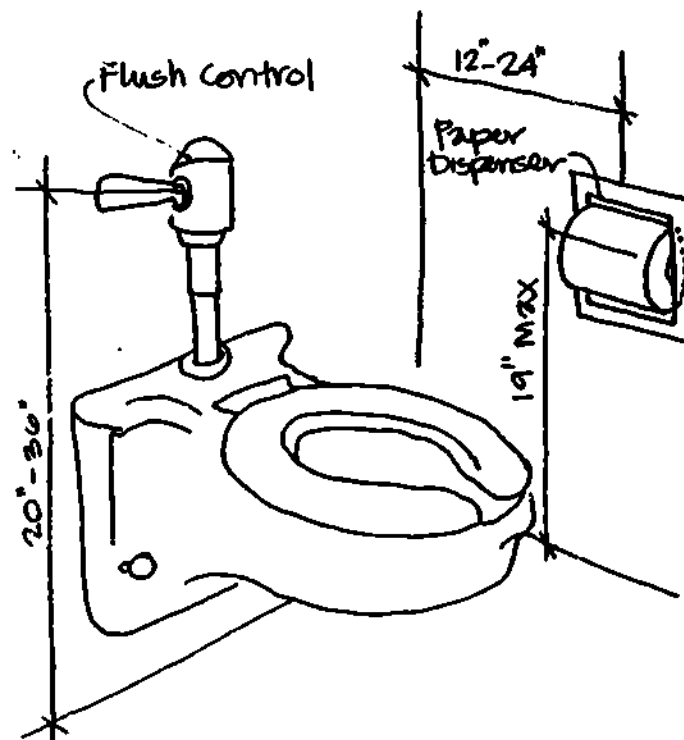

84 If flush controls are difficult for disabled children to use (e.g. foot activation):

a Modify existing equipment so that it is easier to use:

Non-ambulatory children cannot use foot controls and many children with impairments affecting hands have difficulty grasping and twisting. Knobs should have rods applied to provide lever action. Foot activated controls can have hand operated extensions applied. Push plates requiring more than 3 lb. force to activate can be adjusted sometimes.

There are no manufactured items for this purpose. Costs would depend on the particular situation.

b Replace existing equipment with equipment that is easier to use.

Non-ambulatory children cannot use foot controls and many children with impairments affecting hands have difficulty grasping and twisting.

This will involve changing from a twist type push type or foot operated control to a handle or push plate flush control. These changes can be made easily.

The standard as in 'a' applies. The cost to change these controls is:

	Materials	Labor	Total
Foot-handle	\$180	\$290	\$470
Twist-handle	\$180	\$280	\$460
Push-type	\$180	\$280	\$460

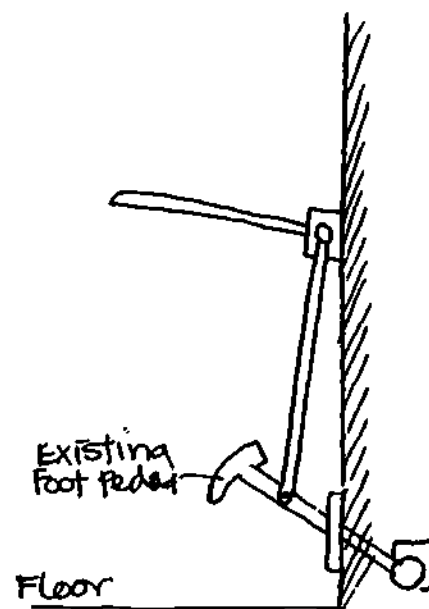
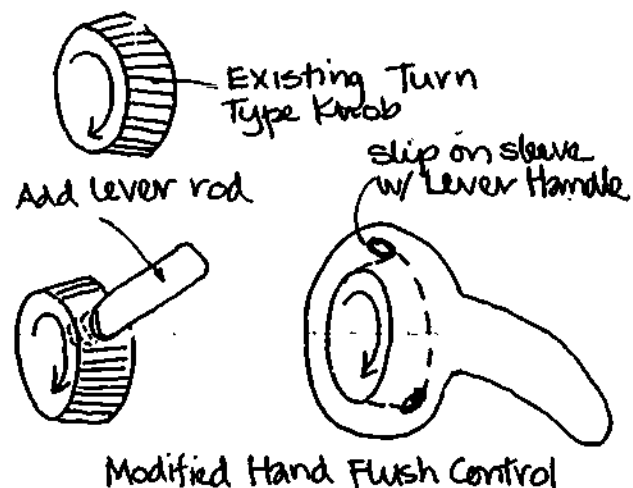

Modified Foot Flush control
240

URINALS

85 If existing urinals are mounted too high:

a Lower an existing urinal.

In most cases the drain pitch will allow such a change. The lowered urinal may be inconvenient for tall able-bodied children or result in increased maintenance.

The urinal rim should be a maximum of 17" above the floor.

The cost to lower a urinal is:

	Materials	Labor	Total
Per Urinal	\$35	\$420	\$455

b Replace an existing urinal with a floor mounted urinal.

This would be difficult to achieve since the drain would have to be relocated to the floor and have to tie-in to existing drain lines. Also the flush control would likely be above or at the upper limit for reach. The floor mounted urinal could improve maintenance.

c Install an additional urinal which is useable by handicapped children.

The constraints on this alternative are ones common to the addition of any fixture; available space, and water or waste line capacity.

The urinal should have a clear space in front of 28" X 48" which does not overlap an adjoining circulation path. The cost to add an additional urinal is:

	Materials	Labor	Total
Per Urinal	\$250	\$235	\$285

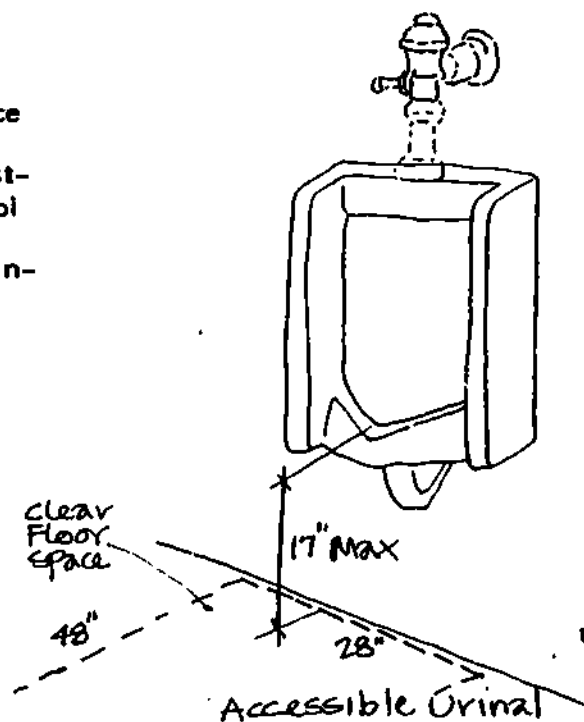

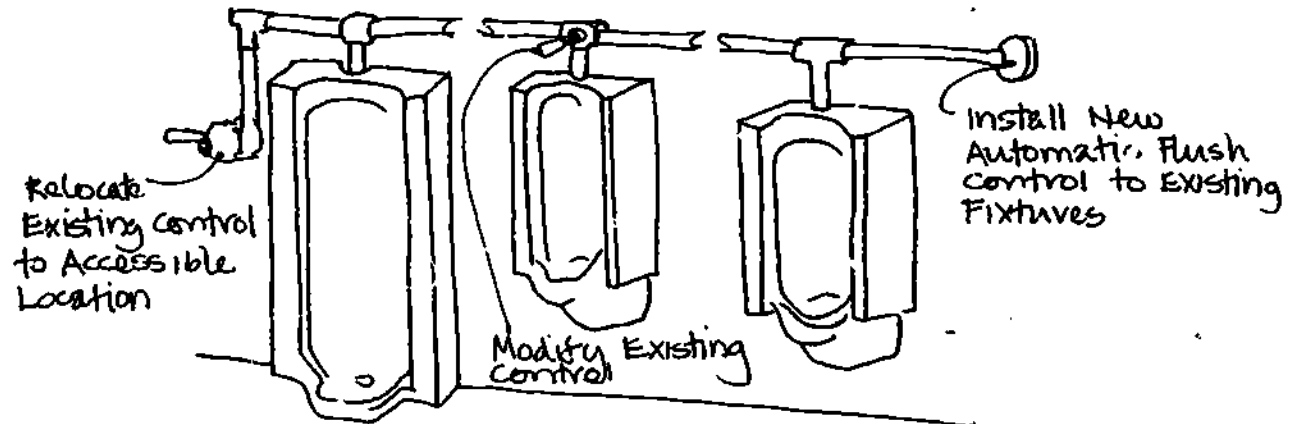

Accessible Flush Controls

86 If urinal flush controls are too difficult for disabled children to use because they require a firm grasp or high amount of force to operate:

a Modify existing flush controls.

Although the most commonly occurring control is the handle type, if another exists some modification might be possible. See discussion in AA 84.

b Replace existing flush controls with ones that are easier to use.

The modifications would be similar to those in AA 84 for toilet flushes. The costs would be approximately the same.

c Replace flush control with an automatic flush system.

This system will require a higher water pressure. Existing water lines must provide this pressure.

This will provide the easiest use by disabled children but will be wasteful of water.

The cost to connect four urinals to an automatic flush system is:

	Materials	Labor	Total
4 Urinals	\$880	\$550	\$1,430

LAVATORIES

87 If existing lavatories are mounted too high:

a Remount one existing lavatory so that it is useable by a child in a wheelchair.

A lavatory can be raised or lowered without great difficulty.

The preferred height of a lavatory should be 30" to the rim from the floor. The bottom at the leading edge should be 24" minimum above the floor. The cost is:

	Materials	Labor	Total
Per lavatory	\$35	\$420	\$455

b Install additional lavatories at appropriate heights.

The constraints on this would be available space and capacity of existing water and waste lines. Most plumbing systems would have flexibility designed in at least one fixture.

The lavatory needs a clear floor space at 28" X 48" in front. The cost to add a lavatory is:

	Materials	Labor	Total
Per lavatory	\$210	\$210	\$420

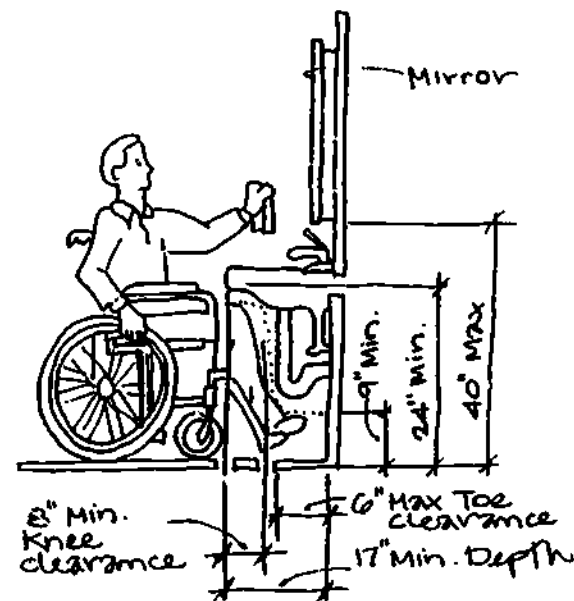

Lavatory Mounting

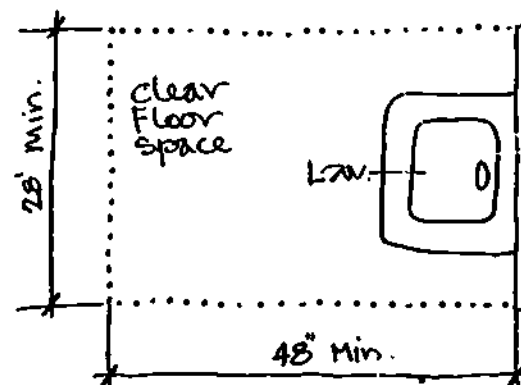

Lavatory Manuvering

88 If there is insufficient knee clearance under the lavatories, or if there are sharp edges:

a Modify existing equipment so that sufficient clearance is provided and sharp edges are eliminated.

The clearance required here is for knee and toe space to allow wheelchair users to approach the lavatory. The drain location and trap will establish this clearance. One modification is to change the stem to a shorter one and provide an immediate horizontal run for some distance before the trap. Also change the trap by turning it 90 degrees (parallel to the wall).

There are no constraints to wrapping the drain and water pipes below the sink with a foam or fiberglass covering.

See the accompanying drawing for required clearances. The distance between front edge of lavatory and back wall should be 17" minimum. There should be no sharp edges or abrasive surfaces under the lavatories. The cost for modifications and a shallower trap is:

	Materials	Labor	Total
Per lavatory	\$37	\$100	\$137

The cost to cover the pipe is about \$1.30 LF in materials and could be performed by school personnel.

b Install a new accessible lavatory.

See AA 87 for a discussion regarding constraints, criteria and costs for adding such a fixture.

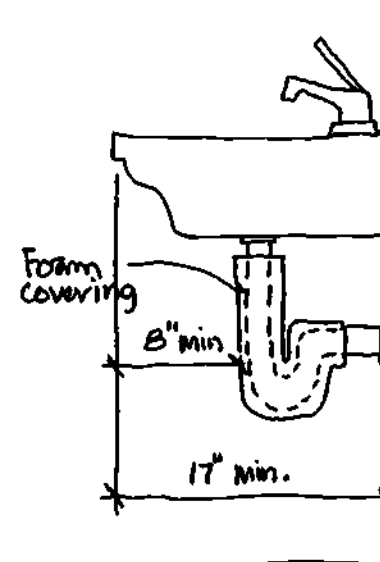

Knee Protection

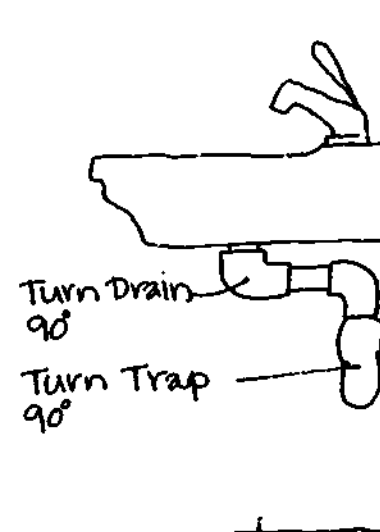

Knee Clearance

89 If the reach required to operate the sink controls is too great:

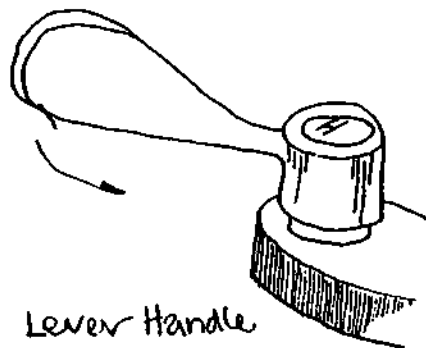

90 If existing sink controls are too difficult for disabled children to operate:

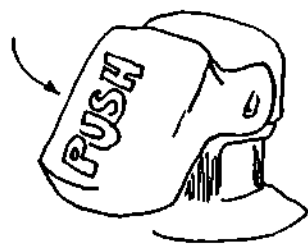

a Eliminate or replace the existing lavatory.

This might require some modification of plumbing fittings for water and drain.

The criteria for the lavatory are in AA 88. The cost to remove the existing lavatory and replace it with a new unit would be approximately the same as adding a new one.

	Materials	Labor	Total
Per lavatory	\$210	\$210	\$420

b Replace existing controls.

The controls could be replaced with lever handles to provide a closer reach.

The distance from the front of the sink to the back wall should be no less than 17". The cost to change to lever handles would be:

	Materials	Labor	Total
Each control:	\$30	\$20	\$50

a Modify existing controls so that they are easier to use.

About the only modification possible is changing springs in self-closing controls. Controls should be easily operable with one hand and not require a firm grip.

The cost of modifying existing faucets is as much or more than replacing them with new faucets.

b Replace existing controls with ones that are easier to use.

These would be self-closing controls or time-flow controls. Some valves can be operated by a photoelectric switch, but maintenance of these valves is a problem. These types of controls should be used in conjunction with tempering valves on the hot water supply.

If a timed or meter-flow control is used, water flow should continue for at least 10 seconds. The cost of various types of controls are:

	Materials	Labor	Total
Self-closing	\$80	\$150	\$230
Tempering	\$75	\$75	\$150
Time Flow	\$100	\$150	\$250

91 If soap or paper towel dispensers are not easily operable, mounted out of reach, or are located in inaccessible locations:

a Modify existing equipment to make it easier to use.

Crank-type paper towel dispenser could be modified by adding a larger more useable handle. The valve on a soap dispenser can be replaced if the old one has become difficult to use.

Dispensers should be operable with one hand and not require twisting of the wrist or tight gripping. The cost to modify dispensers with custom parts might exceed the cost to replace them.

b Relocate existing equipment at appropriate heights or in accessible locations.

Neither of these solutions pose any difficulty. At accessible heights, there might be inconvenience for older, tall children. However, only one item of each type needs to be relocated.

The highest operable part of any dispenser should be no greater than 36" above the floor. There should be a 28" X 48" clear space next to the dispenser. Either of these changes can be made by school personnel.

c Retain existing equipment and install additional equipment which is useable by disabled children.

Provided there is adequate space, this can be a viable solution. Pull-type towel dispensers with folded towels will be simplest to use. Powder spray dispensers can be used with one hand and operated more easily than liquid push-type valves. Surface mounted fixtures will obviously require less mounting effort and expense than recessed ones.

The design criteria for these units are in alternatives 'a' and 'b'. The cost for these items is approximately \$15 for a soap dispenser and \$110 for a towel dispenser. These can be installed by school personnel.

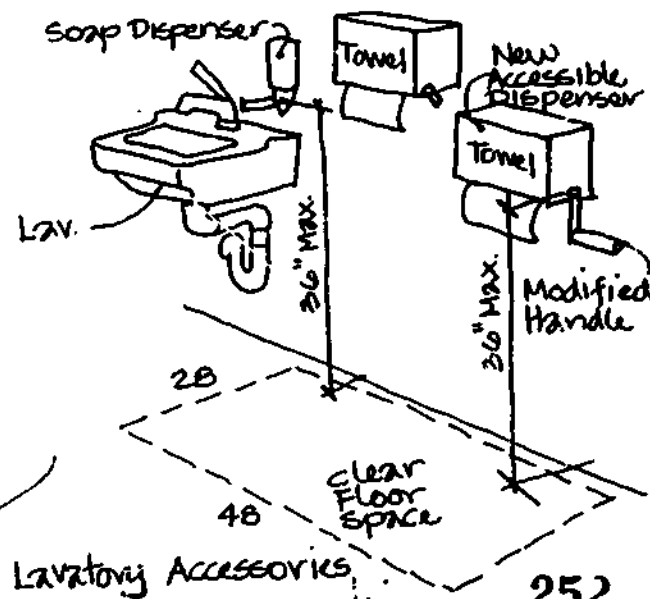

92 If existing mirrors are mounted too high to be useable by disabled children:

a Remount one mirror at a lower height.

This can be done easily in most toilet rooms. If there is only one mirror, the lowered height may be inconvenient for older children.

The bottom edge of the mirror should be no more than 24" from the floor for grades K to 3 and 30" for grades 4 to 6. The work to lower the mirror will involve remounting wall brackets and can be performed by school personnel.

b Install a full height mirror.

There would have to be a space which would allow the mirror to be used without interfering with the circulation in the toilet room. This type of mirror would be high enough to be useable by all children.

The criteria in alternative 'a' applies to this section. The cost of a 24" X 60" mirror would be \$45 and would be installed by school personnel.

c Install a standard size mirror at the appropriate height.

The comments and criteria in alternative 'a' and 'b' are applicable here. The cost for a 16" X 20" mirror is approximately \$20.

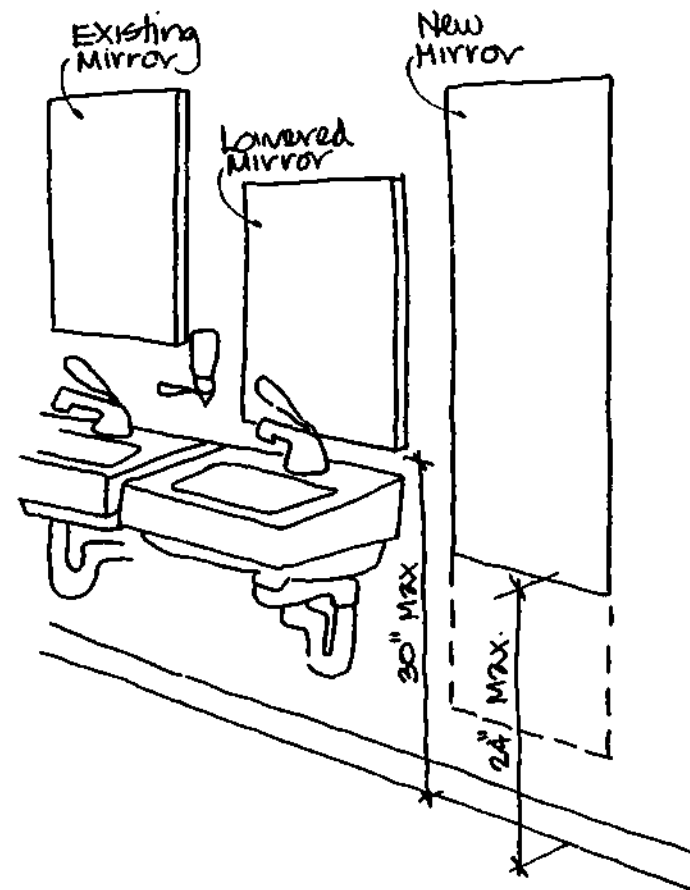

Mirror Mounting

Accessible Building Elements

There are a number of essential features within the school environment which must be considered in conjunction with accessible paths of travel and accessible spaces and facilities. These features are found throughout the school building.

DOORWAYS

Doorways can pose a number of difficulties for a disabled child in moving freely through the school. Door width, maneuvering clearances opening devices are the more critical problems.

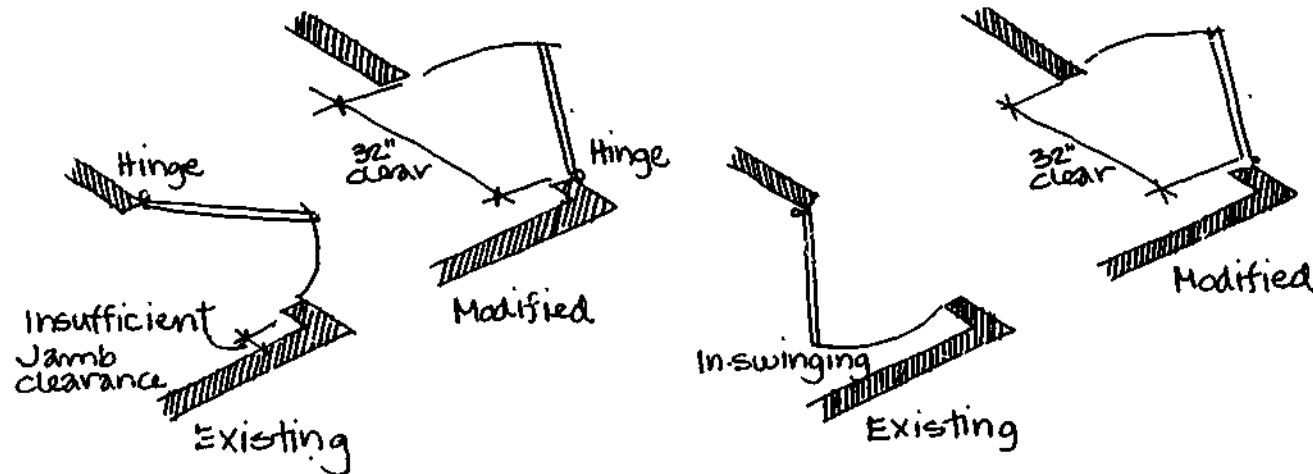

93 If there is not sufficient maneuvering space at a doorway*:

a Locate the hinges on the opposite side and keep the direction of swing the same.

This involves turning the door around so that handle and hardware locations aren't changed. This will result in the door finish being reversed, not of concern with an interior door. A kickplate might possibly need to be changed.

See illustration for the approach criteria. The cost to make this modification is:

	Materials	Labor	Total
Per door	\$62	\$70	\$132

b Reverse the direction of the door swing.

This conflicts with code requirements calling for doors to swing in the direction of exits. Assuming a frame has a typical integral stop, if the door swing is reversed it would necessitate reversing the frame also.

By reversing the swing from in to out or vice versa the maneuvering space requirements can be met and the need to enlarge landings or move walls can be avoided.

The criteria for approach requirements in front of doorways and beside door latches are shown in the illustration. the cost to reverse the swing (and reverse frame) are:

	Materials	Labor	Total
Per door	\$ 0	\$84	\$84

* If doors have closers see AA 97.

257

C Remove, relocate, or modify adjacent partitions or walls which restrict maneuvering clearance.

This can intrude upon the available space in an adjacent room. Structural, electrical and mechanical modifications may have to be made with such a solution. New walls must comply with fire resistance requirements of building code.

Costs for wall removal are:

	Materials	Labor	Total
Stud/GYB	\$.36/LF	\$3.00/LF	\$3.36/LF
DBL Brick	\$8.00/LF	\$35.00/LF	\$43.00/LF
6" CONC	\$28.00/LF	\$15.00/LF	\$43.00/LF

These are for 8' high walls.

New wall construction would cost:

	Materials	Labor	Total
Stud/GYB	\$15.00/LF	\$20.00/LF	\$35.00/LF
6" CONC	\$46.00/LF	\$42.00/LF	\$88.00/LF
DBL Brick	\$70.00/LF	\$75.00/LF	\$145.00/LF

These are for 8' high walls.

D Install a new doorway in a more accessible location.

This alternative can usually be implemented easily; its constraint is the actual layout of existing spaces and corridors may need to be constructed which would have to meet exit standards of building codes.

In addition to the approach standards illustrated, the maneuvering clearance area should be level at the interior and have no more than a 1:50 slope at the exterior. The costs of installation of various interior door constructions are:

	Materials	Labor	Total
Stud wall	\$255	\$340	\$565
Brick	\$250	\$535	\$785
Concrete	\$260	\$665	\$925
For an exterior door addition (this is for panic hardware)	\$220	\$ 60	\$280

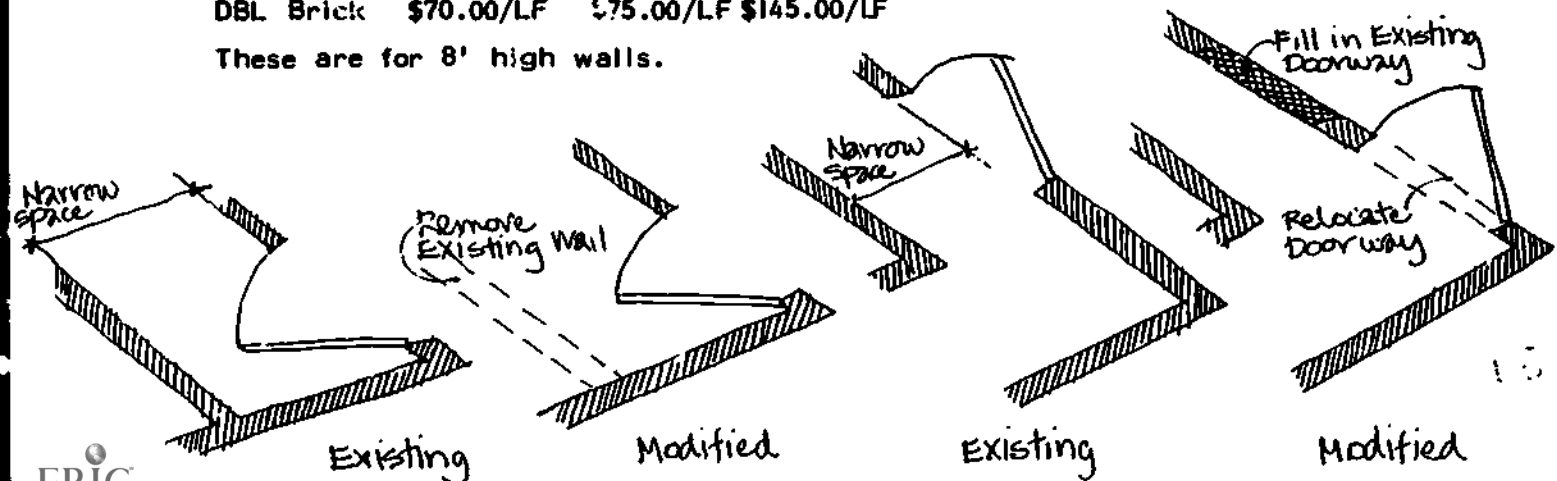

94 if doorways are not wide enough to allow wheelchairs to pass through them:

a Remove door stops at the critical wheelchair passage points.

There are several constraints that may restrict use of this solution. With the loss of the stop (either entirely or partially) there will be increased noise, moisture, and air infiltration. This last element can result in the loss of a door's required fire rating due to smoke infiltration. Security will also be reduced. In metal frames, the stop is integral and modification would be impossible.

The preferred clear door width would be 32" with widths down to 28" being acceptable. Where the above-mentioned problems do not exist (i.e. an interior toilet room) it would be possible for school personnel to modify a wood door jamb to allow a wider passage.

b Replace existing hinges with ones which allow for fuller door opening.

There are several manufacturers of such hinges and there would be no problem with their installation. These hinges will provide about 1½" greater width when the door is in the normal 90 degree open position.

The clear width as in alternative 'a' applies. The cost to install a set of these hinges would be:

	Materials	Labor	Total
Per door	\$105	\$25	\$130

c Replace existing door and frame with one which allows for sufficient clearance.

There could be a need for some minor electrical work if light switches are situated beside the door.

If this approach is taken, the costs are approximately \$50.00 less than the totals listed for a new doorway in AA 93c.

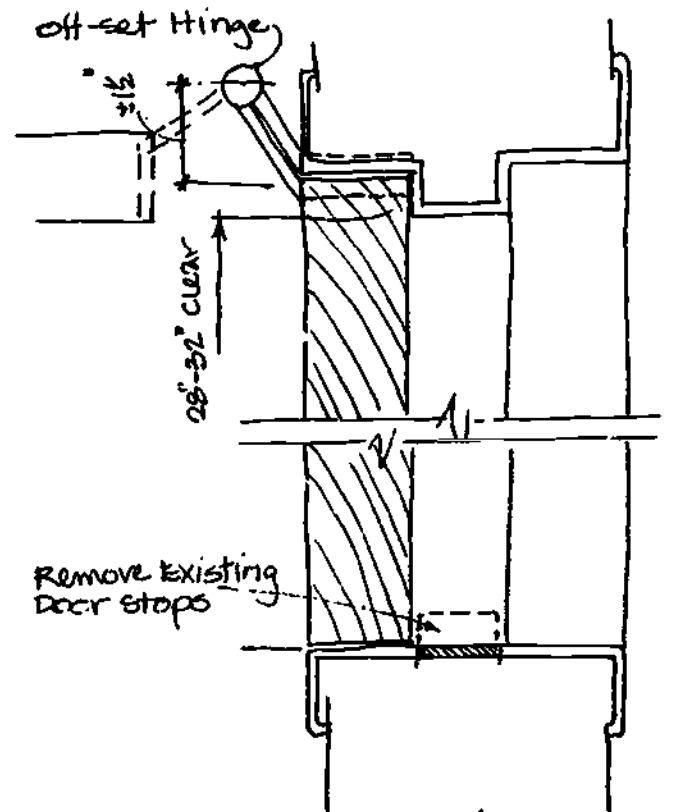

Doorway Modifications for Clearance

95 If neither side of a double leaf door is wide enough to allow wheelchair clearance:

a Remove door stops on the center post.

This alternative presents the same problems as in AA 93d. For these reasons it is not likely to satisfy the clearance problem. It would be possible where few of the concerns raised are relevant, but this is not likely to be the case for essential doorways in a circulatory scheme.

b Remove the center post and replace one door with a wider door or replace both doors.

This will require modification of the hardware on the existing door. Since most of these doors are required exits, with panic hardware, the existing door would require vertical rod panic hardware added to replace the latch into the post. The new wider door would also have to be fitted with this type of hardware.

If the need is for only several inches in additional clearance, both doors could be changed. This allows more flexibility in use and therefore is more desirable.

The standard acceptable 28"-32" clearance would apply to one of the two doors. The cost to do this is:

	Materials	Labor	Total
Per door	\$750	\$150	\$900

To only change one door with hardware changes on both doors, the total cost would be \$400 less.

c Replace existing hinges with ones which allow for fuller openings. This provides some additional clearance. See AA 94b.

The cost to modify a set of doors is:

	Materials	Labor	Total
Per set of doors	\$205	\$50	\$255

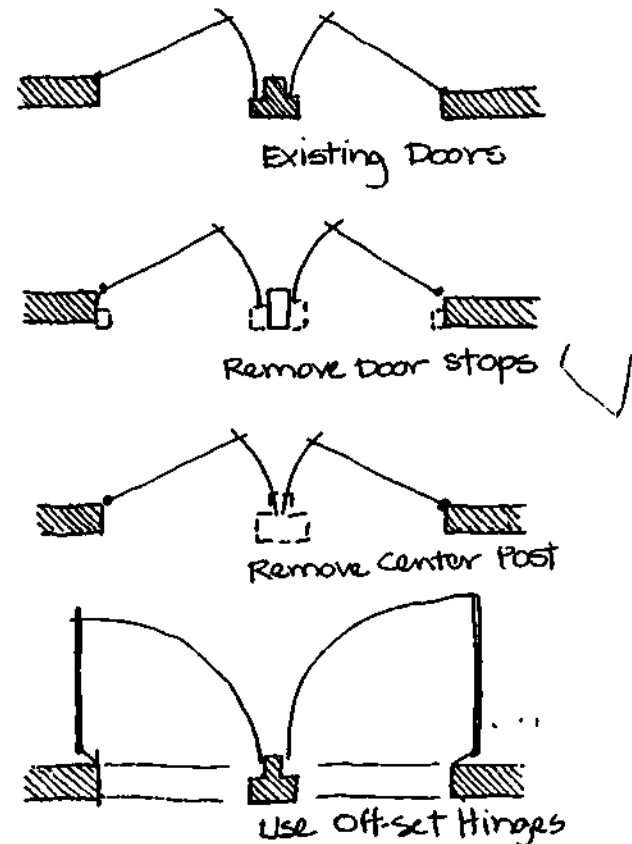

96 If thresholds in doorways obstruct accessible movement:

a Remove thresholds.

Some thresholds are formed with an integral anchor and set in concrete; this can be extremely difficult to remove. At exterior doors there will often be an offset which is covered by the threshold. This is also a barrier. The removal of the threshold may expose unfinished floors or a joint of two materials which would not be desirable. Additionally, air and moisture infiltration can occur possibly conflicting with energy conservation measures.

Thresholds up to $\frac{1}{4}$ " may be abrupt but between $\frac{1}{4}$ " and $\frac{1}{2}$ " will require a bevel with a slope no greater than 1:2. The typical threshold could be removed by school personnel.

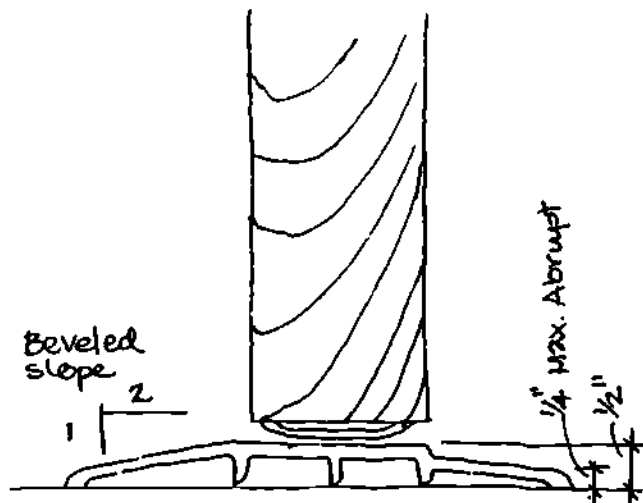

Doorway Thresholds

b Modify the existing threshold.

One possibility would be to remove the stops. Some stops are integral with the threshold itself. Their removal would be difficult; if they are screw-attached there would not be any difficulty and the loss in height could be modified by a door sweep strip. A beveled threshold section can be placed against an abrupt edge. These are available from several manufacturers and can easily be set in place.

The criteria in alternative 'a' will apply to this modification. The cost for an additional beveled threshold would be about \$10. It can be installed by school personnel.

c Replace thresholds with one that is easier to maneuver over.

There might be difficulty in removing the existing threshold discussed in alternative 'a'.

Many shapes of thresholds are available which meet the criteria. The cost of this option is approximately \$15 for material but will involve school personnel time to remove the existing threshold.

DOOR HARDWARE

One of the most difficult tasks for many disabled children is opening doors. Door opening hardware devices should be easy to use for children with impairments to handling and arm movement.

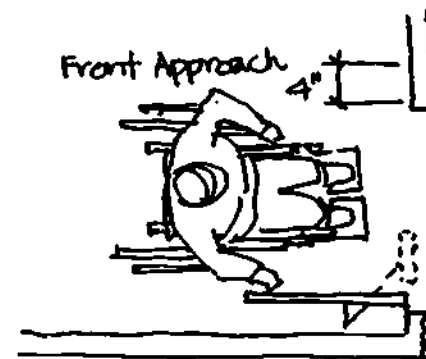
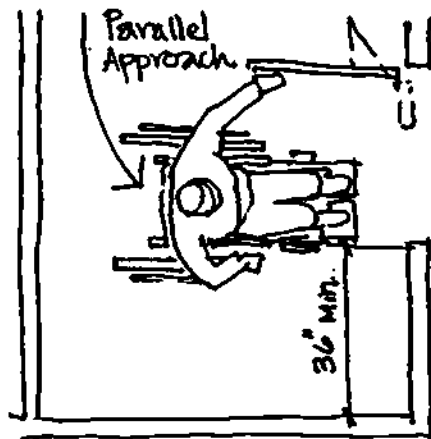

Maneuvering Clearances

97 If a door equipped with a closer does not have adequate maneuvering space to allow its opening from the pull side:

a Remove the closers.

This problem will not be found in most school doors since these doors are into or out of corridors which have adequate approach space. Codes will invariably require most interior doors to have a self-closing device which would prohibit this alteration. At the exterior door, the self-closer could be removed but security and weather protection will be compromised.

Wheelchair clearance at the latch side should be 4" for a front approach and 36" for a parallel approach from the hinge side. The closer removal can be accomplished by school maintenance personnel.

b Modify adjacent walls and partitions to provide maneuvering space.

The location of structural, electrical and mechanical systems may restrict use of this solution. Adjacent space can be lost when such modifications are made.

The clearances established in alternative 'a' apply to this modification. The cost to demolish existing walls is:

	Materials	Labor	Total
Stud/GYP	\$.36	\$3.00	\$ 3.36
6" CONC	\$28.00	\$15.00	\$43.00
DBL Brick	\$ 8.00	\$35.00	\$43.00

98 If the force required to open a door which has a closer is too high:

A Remove the existing door closers.

The constraints on this option are discussed in AA 97a. Basically, this solution will be limited to very few situations due to code requirements.

The maximum force which should be necessary for pushing or pulling doors equipped with a manual door closer is 8.5 lb. force for exterior doors and 5 lb. force for interior doors. Closing speed should be 3 sec. minimum. A closer can be removed by school maintenance personnel.

B Install new low-force door closers.

There are a number of available closers which can be adjusted to the standards and will operate more efficiently than older models (thus resulting in greater closing force). Surface mounted models are easiest to add. The model should be properly sized for the particular door.

The criteria in alternative 'a' apply to such an installation. The cost to have a new manual closer added would be:

	Materials	Labor	Total
Per closer	\$75	\$25	\$100

C Reduce the force exerted by the door closers and/or reduce the closing speed of the door.

In attempting to reduce the opening force of doors one can first make repairs such as correcting sticking doors, warped frames, worn or rusted hinges, and broken latches. After this, most door closers can have their closing force adjusted. The most serious constraint is meeting the opening force criteria while also getting the door to close properly. The efficiency of the closer, pressures created by air-conditioning systems and wind drafts at exterior doors may make it difficult to do both. Balancing of air conditioning system and closer maintenance can help to provide proper closing.

The design criteria are in alternative 'a'. These adjustments, when possible, can be done by school personnel. Testing opening of the force should be done with a push-pull gauge and should register the maximum force required for a 90 degree opening. Make several measurements applying the gauge to the opener or a push plate in a smooth movement. Average all the measurements. Closing speed is adjustable on almost all closers.

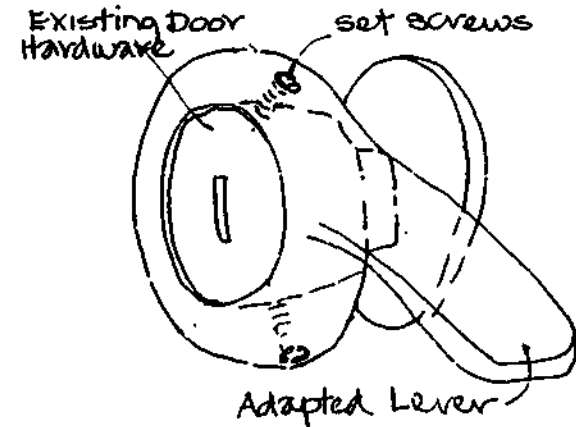
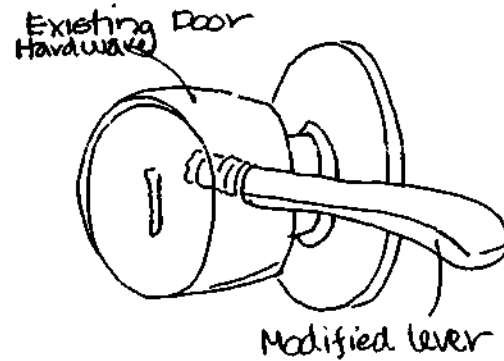

99 If existing door hardware is difficult for disabled children to use:

a Modify existing door hardware.

There will be difficulty modifying an existing turn knob to meet the criteria for accessible hardware. This would be a custom modification which could well cost more than replacing the knob hardware.

Door opening devices should be easy to use with one hand and should not require firm grasping or twisting of wrist to operate. Maximum force required to operate door hardware should be 3 lbs.

b Install lever-handle adaptors over door knobs.

There are several such devices which might be viable for limited-use applications. These adaptors can be easily vandalized or stolen and would require periodic adjustment.

The addition of such a device would comply with the criteria in 'a' and would cost approximately \$5.00 each. School personnel could install them.

26J

27J

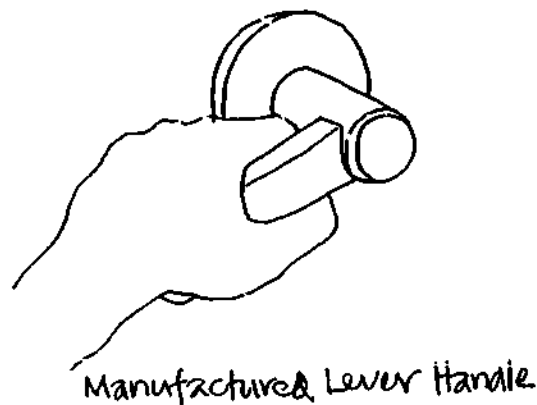
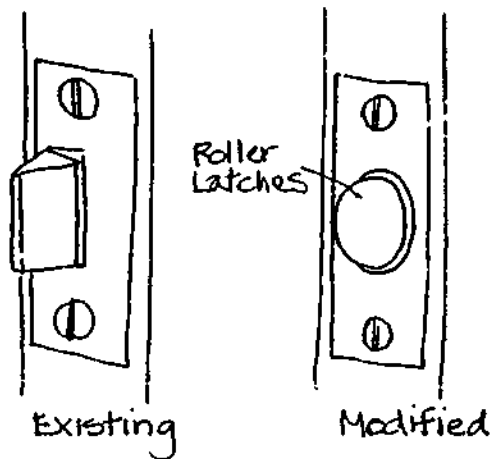

c Replace existing latches with roller latches.

There are roller latches manufactured which are typically used in residential applications. They consist of a spring loaded ball bearing or a roller which catches in an indented strike plate. The knob is a dummy and opening is accomplished by simply pushing the door or pulling the handle.

The fit is not very tight and therefore not secure. A separate locking device, such a deadbolt, would be required if needed. This application would be most compatible for limited use doors such as on closets.

The criteria are in alternative 'a'. The cost for this modification is \$50, including separate locking device, for materials; the work can be done by school personnel.

d Replace existing hardware with accessible equipment.

This is the preferable modification. Lever type handles should be used. Lever handled hardware is not available with cylinder locks.

The criteria in alternative 'a' apply here. The cost to remove existing hardware and replace with lever lockset hardware is about \$75 per door. This varies depending on the fitting which might be required to accommodate the backset of existing and new hardware.

AUTOMATIC DOORS

Under certain conditions it may be impossible to reduce the closing force on manual doors to a level suitable for children to operate and still meet fire code regulations and energy conservation objectives. Automatic door closers can be the solution. Low force, low speed, intentionally activated swing doors are preferred for safety and economy.

100 If an automatic door is needed:

a Install a fast opening door.

Fast opening automatic doors are electrically operated. A constraint on their use is the availability of electrical power. The load of such an opener would not likely overburden existing current. The fast opening door is not necessary for school use; it is commonly used in heavy commercial applications such as at airports. Additionally, the high speed door will operate with greater force. Because of this speed and the forces involved, greater maintenance is required. The speed and force of closing could be a hazard in elementary school settings.

The maximum force required to stop a fast opening automatic door movement should be 15 lbs. Such doors should be equipped with safety controls e.g. mats and guardrails. The cost for the door opener is discussed in AA 101.

b Install a slow opening door.

Slow opening door closers are preferable to the fast ones. These will be better for children due to slow speed and low force. They can be operated by electric motors or pneumatics. The pneumatic operation will allow for greater flexibility in adjustment for door opening speed and force. Since the pneumatic operators use less force, in some situations strong drafts may retard closing. Either pneumatic or motorized units are available in surface mounted models.

The motorized type will need 110 v. power and the pneumatic will require a source of compressed air.

The slow opening automatic door should have a minimum opening speed of at least 3 seconds and a hold open time of 8 seconds. The closing speed should be at least 3 seconds also. The stopping force should be 15 lb. force or less.

101 When automatic doors are installed:

a Install sliding doors.

Sliding doors will require space for installation. To retain an existing double door opening width an equal amount of space would be needed at the sides of the opening. Some sliding door equipment requires the purchase of new doors and side panels while other equipment can be applied to an existing door. The sliding doors can be either motorized or pneumatic type with the corresponding constraints as discussed in AA 100. Additional constraints on the sliding door option are code requirements for fire and panic exiting and increased maintenance on some types of equipment. There is less likelihood of danger or accident with the sliding doors especially when there is heavy two-way use.

The standards for timing and force are as those specified in AA 100. The cost for a sliding door installation, either pneumatic or motorized will range between \$1500 and \$2000 depending on the type of equipment.

b Install swinging doors.

The swinging door installation will be possible to install in more locations than sliding doors. The moving equipment is simpler and can be added to existing doors. The constraints will be those discussed for either motorized or pneumatic operation in AA 100. Swinging doors have the potential of hitting a child when approaching it from the outswing side.

The speed and force standards in AA 100 apply. The costs for a swing installation will be less than sliders. This would be approximately \$1200 with pneumatic being about another \$400.

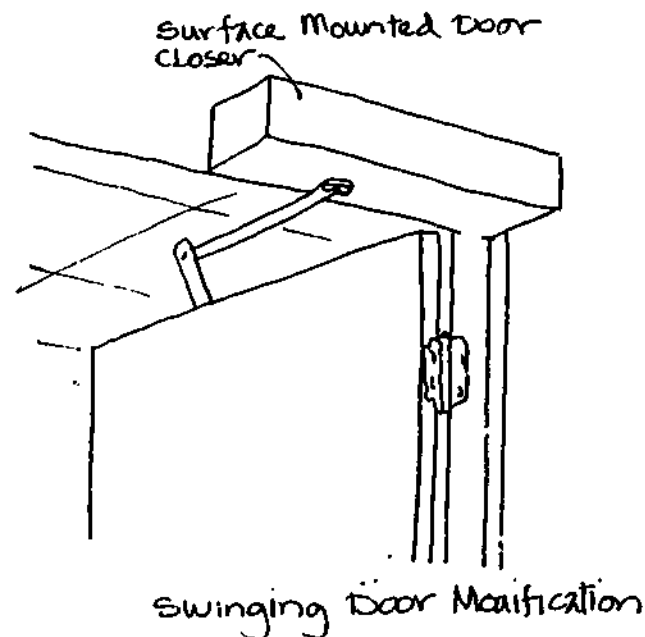

102 If automatic doors are installed, there are three possible methods of activation:

a Push plates.

Although acceptable, this method is the least desirable of the three. The location of the push device can vary and therefore should adapt to varying circumstance .

The push type activator should operate within the maximum pressure of 3 lbs. A push plate should be 3" in the smallest dimension; it should be mounted no higher than 36" above the floor. Controls are best if door mounted. Illustrations of criteria for the location of wall mounted devices are shown. If the wall control is located further than the minimum dimension, add one second to the hold open time for each foot beyond that recommended dimension.

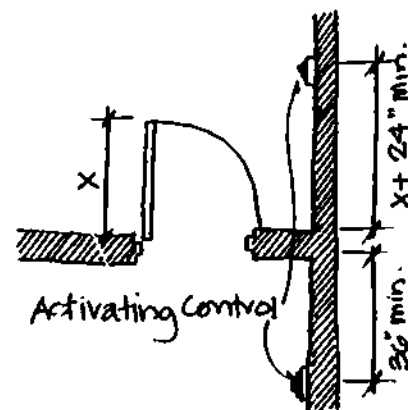
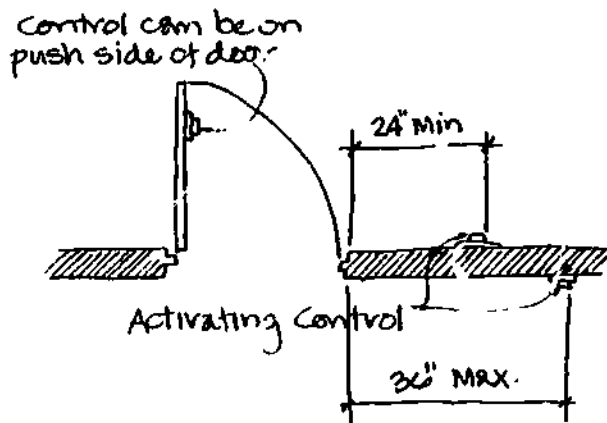
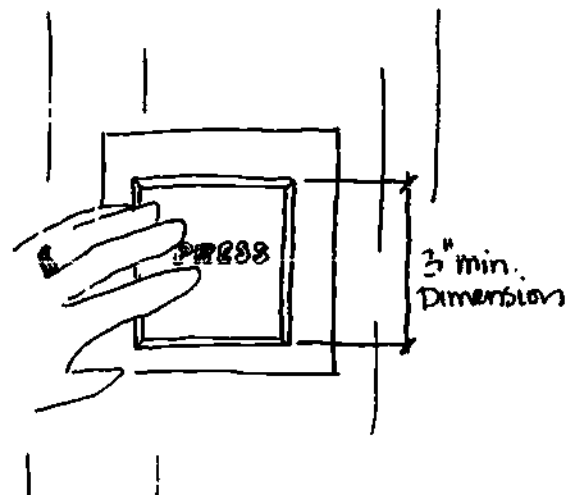

278

Automatic Door Activating Devices

277

159

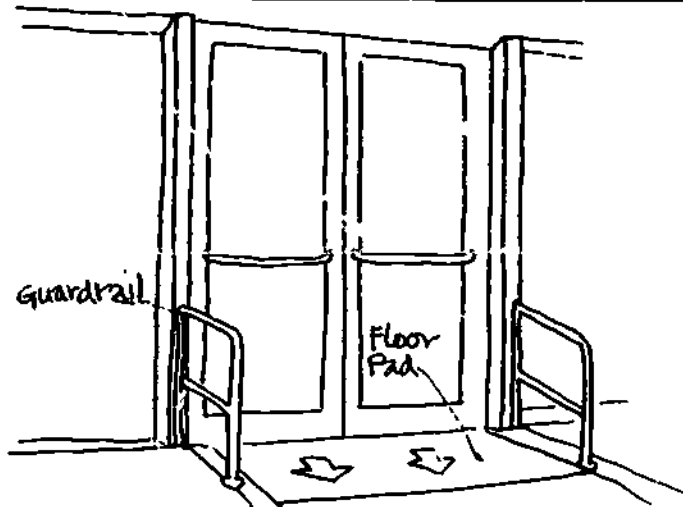

b Floor pressure pad.

It is preferred that such a pad be recessed; this can present problems in some locations.

If a floor mat is installed with swinging doors, guardrails should also be set up; this will prevent the possibility of a child being hit by the door as it opens. The mat edge should meet the threshold criteria in AA 96.

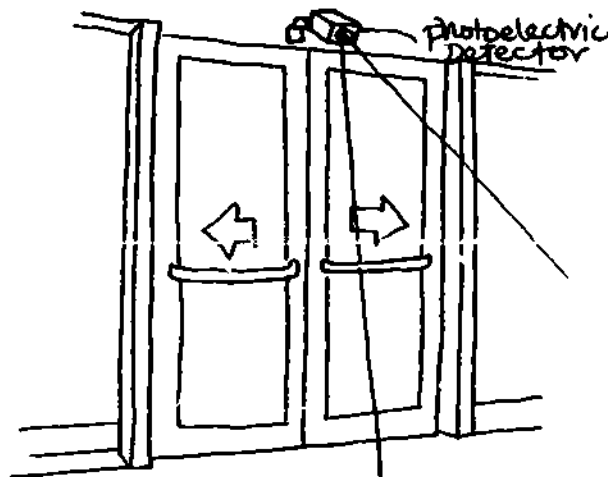

c Photoelectric cell or motion detector.

This would be the most desirable method. These devices can be either mounted above the doors or on posts near the doors. The motion detector can only be used in conjunction with sliding doors. A source of electricity will be required.

The costs for any of the door activating methods are approximately the same and represent about the same percentage of total cost for the automatic doors.

If there is a lot of movement around the door, it can open even if no one wants to go through it, e.g. bottom of stairway. This could be a hazard.

CORRIDOR HANDRAILS

Although not an absolute necessity, corridor handrails help prevent accidents and can reduce the need for some children to use walking aids. Handrails should be at a comfortable height and be easy to grasp. In facilities where many severely disabled children are present, handrails should be installed in all corridors.

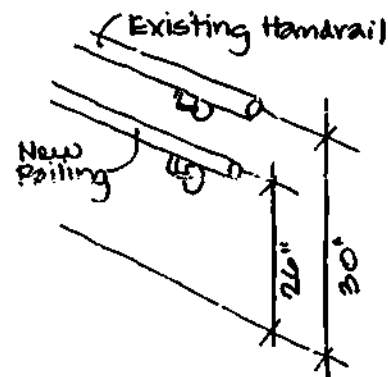
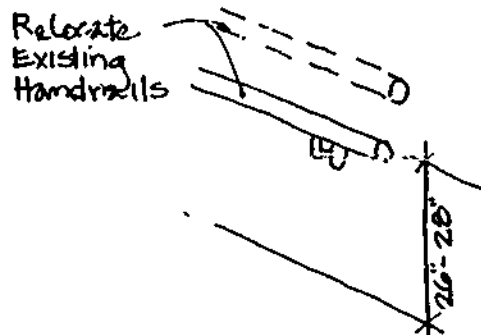

103 if existing handrails are not useable by disabled children:

a Remount existing handrail at an appropriate height.

Given secure attachment to available solid wall surfaces there should be no difficulty completing this modification. A compromise handrail height may not be appropriate for tall and short children or adults.

A single rail should be mounted between 26" and 28". The cost to remount such a handrail is:

	Materials	Labor	Total
All Walls	\$.90/LF	\$4.50/LF	\$5.00/LF

b Retain the existing handrail and add a second handrail.

The top handrail may interfere with the use of the lower rail.

If there are two rails the preferable heights would be 26" for the low one and 30" for the higher. The cost to add a new handrail is:

	Materials	Labor	Total
Stud/GYP	\$1.90/LF	\$7.25/LF	\$9.15/LF
CONC/brick	\$1.90/LF	\$9.50/LF	\$11.40/LF

273

161

280

161

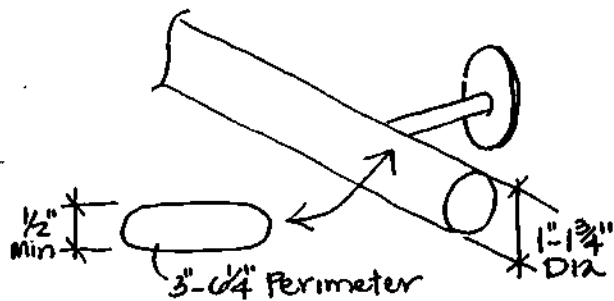

Handrail shapes

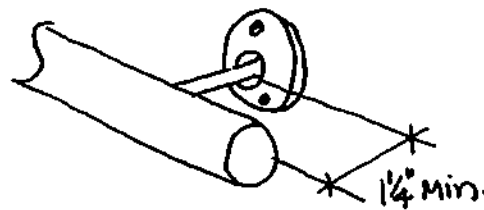

Handrail spacing

c Install a new handrail on the existing brackets or posts if the current handrail is not an appropriate size.

There are no constraints if the shape of the new rail is compatible with the existing brackets.

The handrail thickness should be between 1" and $1\frac{3}{4}"$ ($1\frac{1}{2}"$ optimal) or have a perimeter of gripping area between $3"-6\frac{1}{4}"$ with minimum thickness in one direction of $\frac{1}{2}"$. The cost to make such a change is:

	Materials	Labor	Total
Per LF	\$1.25	\$6.00	\$7.25

d Reinstall the current handrail on new brackets if the existing distance between the handrail and wall is not appropriate.

There should be a minimum $1\frac{1}{4}"$ clearance between the handrail and walls. The cost to remount the handrail on new brackets would be:

	Materials	Labor	Total
Stud/GYP	\$.90/LF	\$7.25/LF	\$8.15/LF
Brick/CONC	\$.90/LF	\$8.00/LF	\$8.90/LF

These costs assume brackets @ 4' on center.

PERSONAL STORAGE

All children need personal storage space. Storage space should be along accessible paths and have equipment that is useable by disabled children.

104 If storage room doors are not accessible:

a Modify them.

Most storage areas are either cabinets or small rooms adjacent to the classroom. If the doorway (there usually isn't a door) to the area is too narrow then widening the opening would be necessary. This can be done easily if there are no structural members at the jambs

The doorway should have a 32" clear width. For constraints and costs see AA 93, 94 and 99.

b Build new accessible doors.

The installation of a new doorway to a storage area is possible only if there is adequate space to approach the door. This can be more difficult than in other locations due to the limited size of the storage space.

For a full discussion of doors and doorways see AA 93, 94 and 99.

c Use an alternate accessible space for storage for handicapped children's belongings.

Assuming such a space is available, this is a viable alternative. This might be some other storage closet, a teacher's room off the classroom or a free standing rack. This approach may result in an inconvenient trip for the disabled child.

The door should comply with standards set in AA 93, 94 and 99. Some minor cabinet work would be required if other storage spaces were adapted for this use.

105 If individual storage lockers are not accessible:

a Modify them.

See AA 61.

Modify the opening devices.

See AA 62 and AA 99. Roll latches or magnetic catches with loop handles will meet these requirements.

b Install some lockers which are accessible.

The feasibility of this approach will be based upon the availability of additional floor space for the lockers and approach clearances. Design criteria for lockers and costs are found in AA 61b.

106 If aisles within the storage room are not accessible:

a Modify the aisles.

Narrow width of the circulation space within the storage room is the most commonly occurring obstruction. Enlarging the space necessitates moving walls and possibly cabinets; this results in reduced classroom space. If there are excess closets or racks, their elimination could solve the circulation problems.

An aisle should be 36" wide minimum and the space needed for a 180 degree turn is 60" x 60". The cost will vary depending upon the particular layout of storage space.

b Provide storage facilities in an accessible part of storage rooms.

There should be constraints on allocating some storage space near an entry to the storage area for disabled children.

The standards for aisles and corridors apply, e.g. minimum width, projecting objects, etc.

c Use an alternative accessible space for storage of handicapped children's belongings.

This is contingent on the availability of some suitable space. Of course, if the space is at too great a distance from the classroom it will result in an inconvenience for these children. The addition of storage units into the classroom can serve this purpose.

The cost of a portable storage cabinet would be \$200-\$400 depending on materials and quality.

284

107 If shelves or hooks have sharp edges or corners:

a Eliminate hazards.

Hazardous conditions are not common in most storage situations. An end wall or cabinetry can serve to protect a shelf which projects. Hooks which are mounted back at the wall surface will rarely project into the path of travel.

Any of these changes can be made by school personnel.

b Replace dangerous shelves and hooks with safe ones.

These replacements can be done easily. They may involve minor cabinetry construction. Usually school maintenance personnel can perform the required work.

108 If shelves or hooks are too high in storage rooms or lockers:

a Remount some at lower heights.

The two most common situations are where storage is in cabinets and where the storage area is partitioned within the classroom. Either situation lends itself to simple modification by lowering shelves and hooks.

Accessible shelves and hooks should be mounted no higher than 36" above the floor. This work can be done by school personnel.

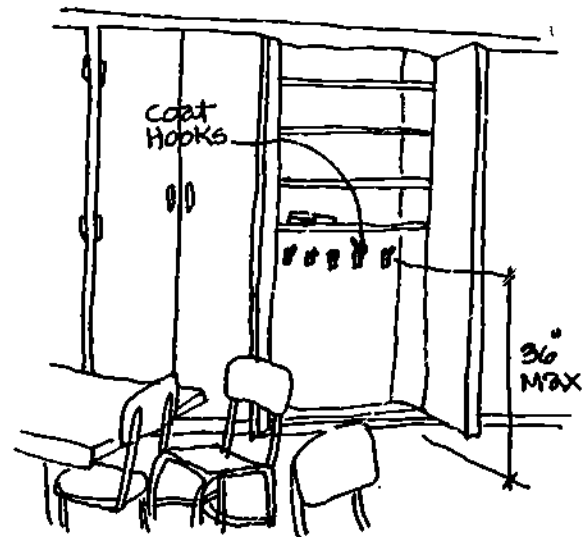

SINKS

These occur in various locations throughout schools, commonly in the classroom. They are used during arts and craft activities. For the disabled child, the use of such a fixture is important. Difficulties with sinks will be similar to those noted for lavatories and drinking fountains with respect to controls and knee clearance.

109 If there is insufficient clear floor space around the sink to allow a side approach:

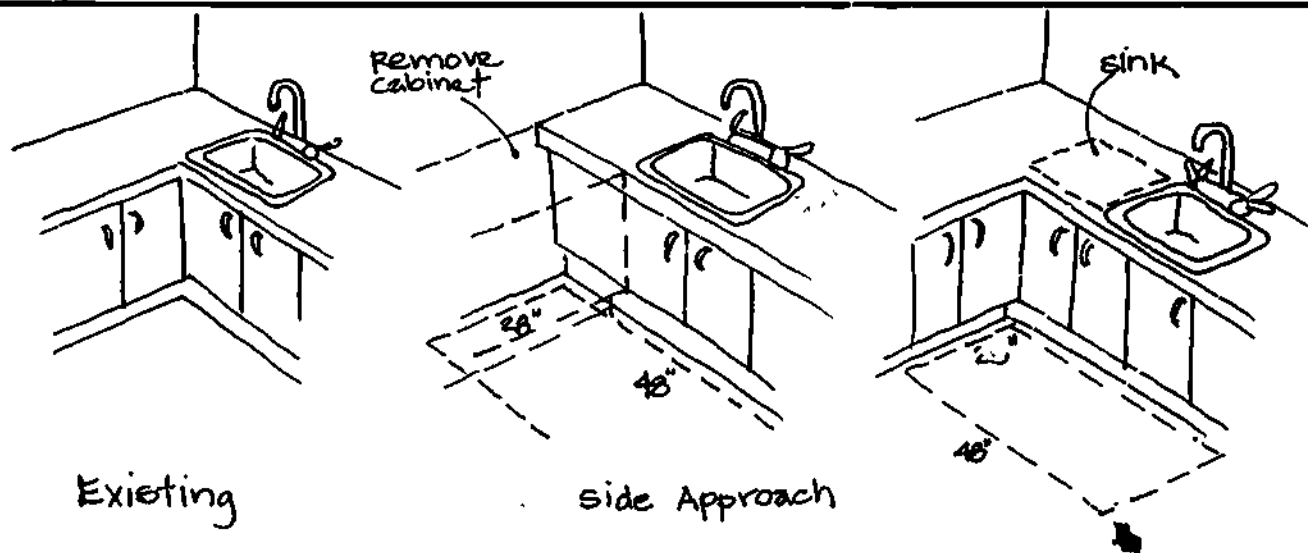

a Remove built-in furniture which restricts clear floor space.

The side approach will be impossible when the sink is next to a corner cabinet. There should be no problem to removing any adjacent cabinetry; it can be replaced with portable cabinetry.

A side approach would require a space of 28" deep by 48" long (parallel to the counter).

The cost of portable cabinetry would be slightly higher than the cost of conventional fixed cabinetry or about \$60/LF.

b Install an additional sink.

This should be located as close as possible to the existing sink in order to minimize expense. For additional notes, criteria and costs, see AA 87 through 90.

c Remount the sink in an accessible location.

If space permits, a horizontal movement of the sink is feasible. Surface plumbing, which could be covered, can be used to tie in to existing supply and drainage.

The cost to move a wall-mounted or counter mounted sink, not including the cost to modify cabinetry, would be approximately the same as that for lowering a sink, or \$445. If cabinet and counter top work is required, the cost will be greater.

110 If there are shelves or cabinets under sinks which restrict front approaches:

a Remove them.

This can usually be done without great difficulty. The loss of the storage space will not be significant.

There should be a minimum of 24" clear height under the sink. See accompanying illustration for further details. The cost to do this will be based on the labor expense of minor cabinet work which can usually be done by school maintenance personnel.

b Modify cabinets to be adaptable, removable or replaced as needed.

This alternative would allow for the cabinet or shelves to be removed. This is not convenient on an as needed basis but is a solution to be used when a disabled student will be using the classroom for a good part of the school year.

The criteria for clearance will be as referred to in alternative 'a'. The cost of these changes will vary depending on particular design of the below sink shelves or cabinets, however a figure of \$160 can serve as an average.

Basically an adaptable sink would have cabinets, including doors that could be slid out from under the sink leaving the space clear.

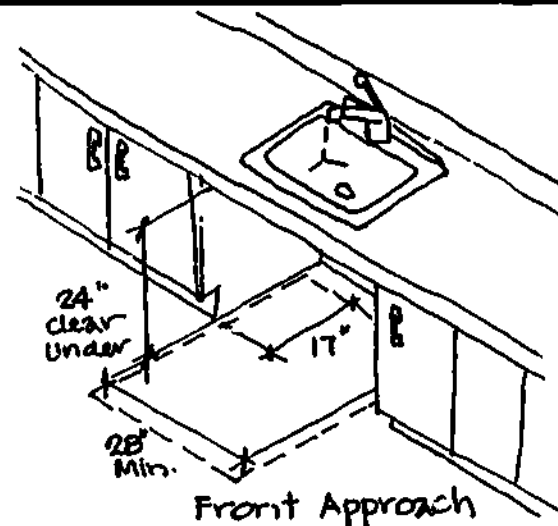

c Provide adequate clear floor space to allow a side approach.

Although this is a less desirable solution, it should rarely present any constraints.

A side approach would require a space 28" deep by 48" long (parallel to the counter).

d Install an additional accessible sink.

This can only be done if there is adequate capacity for drainage on the existing line.

For standards regarding an accessible sink, rev. w AA 87 through 90. The cost to add another sink will approximate the cost of adding a lavatory as set forth in AA 87b.

DRINKING FOUNTAINS

The problems in making drinking fountains accessible are similar to those for lavatories, phones, or other wall mounted devices which have hand controls. Approach, height and controls all must allow for use by disabled children.

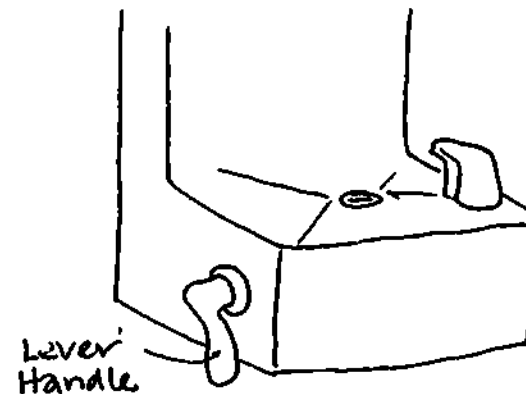
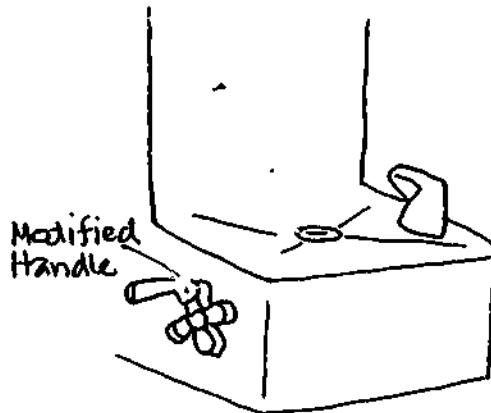

111 If existing controls are difficult to use:

a Modify the existing control so that firm grasping, twisting of the wrist or high operating force is not required.

Modification of an existing control would be a custom change which is not likely to be feasible. Although the valve spring in a control could be replaced with one having a reduced force but it might not, given other design factors, re-close the valve or it could cause the valve to operate improperly.

Manufacturers representatives could be contacted to explore this option.

b Replace with accessible controls.

There are several controls which provide good accessibility. The lever handle or push bar would be two desirable types. The push button provides ease of operation but can require greater dexterity and control. Installing a lever handle is feasible, particularly if specific fountain manufacturers have a design with an interchangeable control valve. This could also be feasible with push button controls that are not integral with the spout. The push bar would be almost impossible to install as a retrofit.

The cost to change to a lever control valve from a cross handle knob is:

	Materials	Labor	Total
Per Valve	\$30	\$20	\$50

293

112 If controls or spouts on drinking fountains are not within reach:

a Modify controls to reduce reach required.

It would be possible to change an existing knob control to a lever control. Most controls will be within reach if they are on the spouts or on the side of the fountain. Only controls below the basin would present distant reaches and these would likely conflict with knee clearance.

The cost to replace an existing turn knob control with a lever type control is:

	Materials	Labor	Total
Per Fountain	\$30	\$20	\$50

The cost varies depending on the particular model of fountain but this can be used as an estimate.

b Relocate spout to the front of the basin.

This will only be practical in the metal case-type fountain. The cost to do such custom work will in most cases equal cost for replacement of the fountain.

Spouts should be located in the front of the fountain with a water flow parallel to the front edge. The cost to relocate the spout is:

	Materials	Labor	Total
Handle integral w/spout	\$76	\$50	\$126
Handle not integral w/spout	\$101	\$120	\$221

c Replace existing fountain with one that has the control and spout in an accessible location.

There are many accessible drinking fountains available which should present no difficulty being substituted for existing fountains. This applies to either interior or exterior locations.

The maximum height of the fountain spout should be 30" above the floor. The cost to remove an existing fountain and replace it with an accessible one is:

	Materials	Labor	Total
Per Fountain	\$185	\$50	\$235

This is a fountain only, without cooling.

d Provide a separate accessible fountain.

Access to the water supply and tie-in to existing drainage will limit the use of this alternative. If the fountain is located close to the existing drainage there should be no problems with this alternative.

Criteria in alternatives 'a' through 'c' should be considered as well as others in this section. The cost to do this, assuming there is plumbing available, would be \$50 more than in 'c'. This additional cost would be for wall patching.

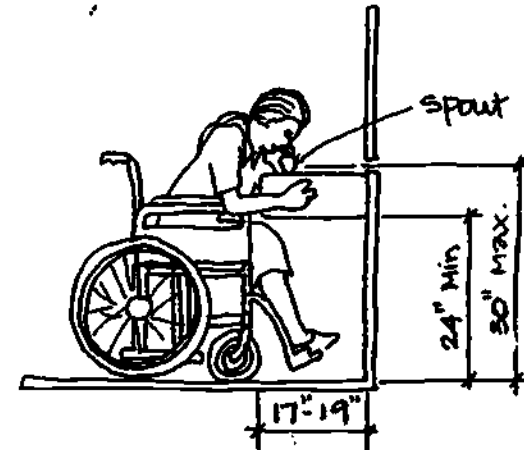

Drinking Fountain Mounting

113 If the fountain is mounted too high:

a Remount existing equipment at an appropriate height.

b Install additional equipment at appropriate heights.

The profile of the existing fountain will establish the viability of this possible change.

For a discussion of this alternative see AA 112d.

The maximum spout height should be 30" above the floor and the minimum clearance below should be 24" high. The cost to lower the fountain will vary depending on the wall construction as follows:

	Total
Stud wall	\$200
Brick	\$400
Concrete	\$450

114 If there is insufficient knee clearance space under fountains located in recessed alcoves:

a Remount fountains higher.

As in the case of lowering a fountain, this option will be limited by the maximum spout height and fountain profile.

The standards and costs are found in AA 113a.

b Extend fountain out from the wall to increase knee clearance depth.

This is possible with a fountain that has a shallow depth. Wall and plumbing work would be necessary. This solution is only feasible if the wall extension is above the minimum knee clearance height.

The clear depth of space needed for knee clearance should be 17". To build out the wall and reconnect a fountain costs approximately \$350, most of this being labor costs.

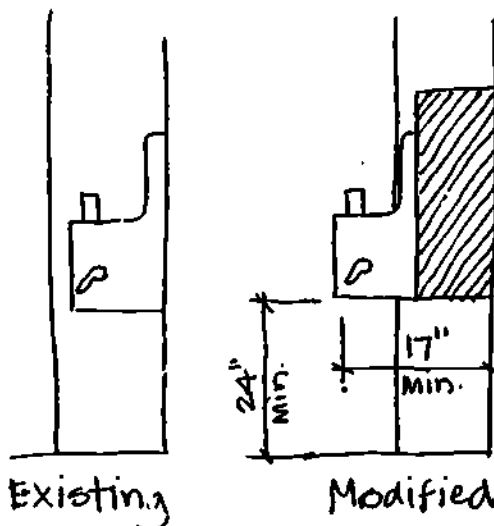

c Modify traps under fountains.

It is possible to provide a shallower trap. The amount of clearance gained will depend on the depth of the existing trap.

The clear height needed is 24" and, as in lavatories there should be protection over the plumbing to prevent injuring a disabled child. Ideally, as in new models, a cover plate would suit this purpose. The cost to replace the existing trap is:

	Materials	Labor	Total
Per Fountain	\$37	\$100	\$137

d Enlarge alcoves so that a side approach can be made.

The side walls of an alcove can be moved. The degree of difficulty in doing this would depend on the type of wall construction and its structural or non-structural character.

Even with the front approach, the clear space in front of the fountain should be a minimum of 28" wide. The side approach requires a space 48" wide and a depth of 28". The cost to enlarge the side walls or one wall will vary depending on the materials and extent of modification.

WARNING SIGNALS

Tactile warning signals are necessary for children with visual problems to allow them to anticipate possibly hazardous conditions. They are necessary at the top of stairs (except enclosed fire stairs), along the edge of paths where there are no curbs between vehicular and pedestrian areas, at curb ramps and at doors to hazardous areas.

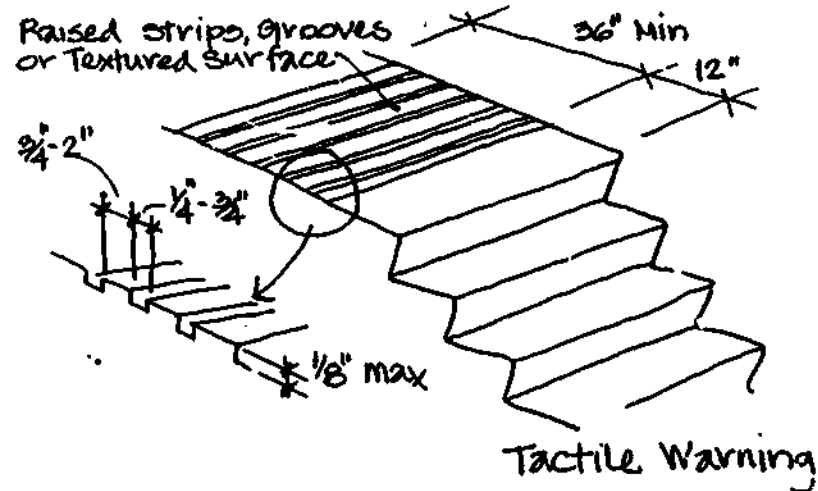

115 If tactile warning signals need to be installed:

a Re-do warnings, as needed, so that they are standardized.

The standardization applies to the form and material at the warning signal. Obviously inconsistent signals will generate confusion and a resultant hazard.

Standardization should apply throughout each building and each site. The cost to achieve such standardization varies depending on the existing type and extent of signals.

b Change floor surface to create a warning signal.

A floor material or mat can be applied to the existing floor. The thickness cannot be greater than 1/8" and edges should be firmly attached; if not, a tripping hazard could be created.

The texture of the material used should be significantly different than the surface to which it is applied.

The area of the covering should be as wide as the path and at least 36" deep. The cost for vinyl asbestos tile is \$.75/SF and \$10.50/SY for sheet viny. This includes materials and labor.

300

301

© Use textured surfaces on the door openers of doors leading to dangerous areas, e.g. loading docks.

Textured surfaces can be obtained by knurling, plastic coating with abrasive material imbedded in it, tape, etc.

The cost to apply this material to panic hardware would be:

	Materials	Labor	Total
Per door	4.50	17.50	22.00

d Use exposed aggregate or broom finish concrete, cushioned plastic, or applied strips for warning signals.

Concrete finishing is obviously a technique which can be used easily in new walk or floor construction whereas applied strip or cushioned plastic can be retrofitted. The concrete finishes will last longer and not incur any maintenance. Over time the edges of applied abrasive strips will be worn.

Strips should run perpendicular to the direction of prevailing travel. The size of warning area is specified in alternative 'a'. See illustration for width, depth and spacing of strips. The cost for exposed aggregate concrete finish would be \$.43/SF and a broom finish \$.23/SF or about equal to a typical trowel finish. The cost of abrasive strips would be between \$.13 and \$.30/SF. The low figure is for continuous rolls and for pre-cut strips.

● Use indented grooves in the floor to create a warning signal.

Grooves can be cut in most existing floors as warning signals. They cannot be used outdoors because they can be mistaken for cracks or joints in paving.

Grooves should be of depth, width and spacing as illustrated. The area of coverage should be as in alternative 'a'. The cost to establish a 36" wide set of grooves is:

	Materials	Labor	Total
Wood	1.00	7.50	8.50
Conc.	3.00	15.00	18.00

These costs are per LF of warning area.

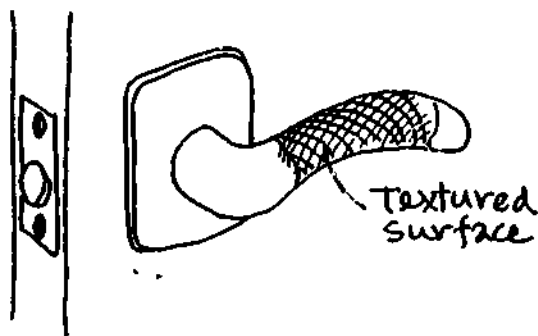

Tactile warning

SIGNAGE

Some disabled children have impairments of sight that limit their ability to read small print. Signs should have large, easily readable print. Children with severe impairment of sight cannot read signs. If a school has students who are legally blind, tactile signage should be installed.

116 If existing signage is not useable by visually impaired children:

a Supplement existing signage with easily readable signage.

Surface mounted signage can easily be applied. All letters and numbers should have a width to height ratio between 3:5 and 1:1. The stroke width to height ratio should be 1:5 to 1:10.

The cost for the most economical signage, engraved in plastic plate, is approximately \$5 per plate. This would be for room names or numbers. While these standard type signs do not provide the most desirable lettering (in terms of width/height ratio or stroke/height ratio) they do provide an acceptable sign. Symbols or different letter styles will increase this cost. These signs can be mounted by school personnel.

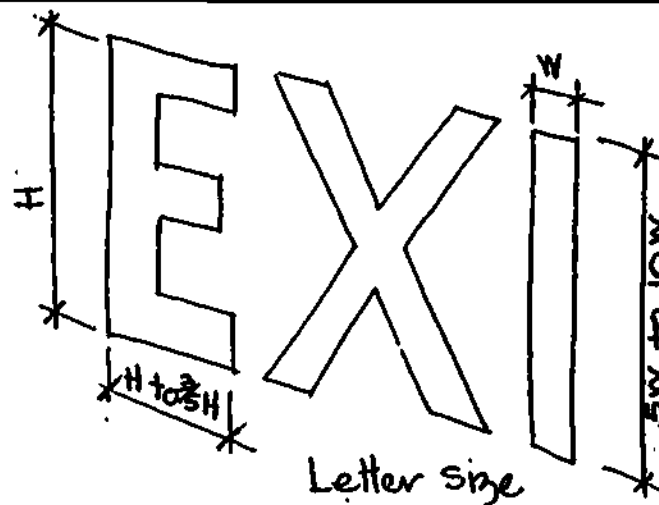

b Replace existing signage with readable signage.

Removal of existing signage, as opposed to simply adding some new, is a good idea since multiple signage can be confusing.

The standards and costs noted in alternative 'a' are applicable to this alternative.

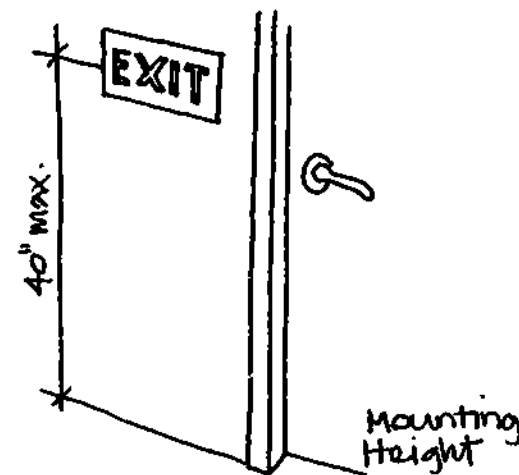
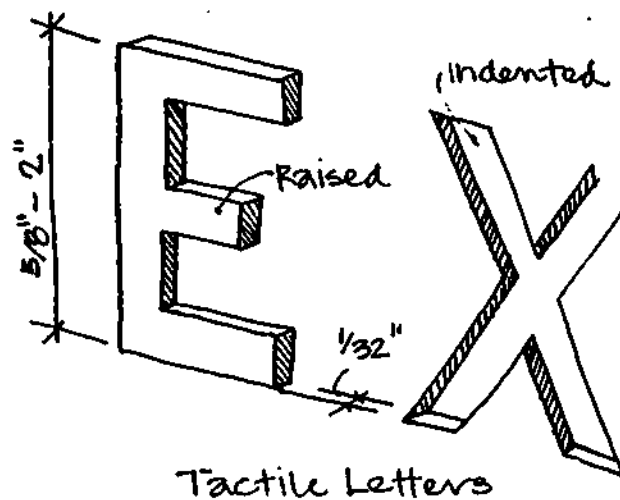

117 If a school has students who are legally blind:

a Install new tactile signage to identify all room names and numbers.

Existing signage will usually not meet raised or indented criteria.

Signage should be raised or indented at least 1/32". Signs should be mounted no more than 40" above the floor. All characters should be between 5/8" and 2" high. Width to height ratios of characters and stroke widths to be as in AA 116.

The cost of this type signage will be as in AA 116.

b Install new tactile signage throughout the facility including all directional and informational signage.

Criteria and costs are as in alternative 'a'.

305

TELEPHONES

Although public phones rarely occur in elementary schools, there are several features which should be available if a phone does exist. Volume control and touch-tone dialing are desirable features which the phone installer can provide.

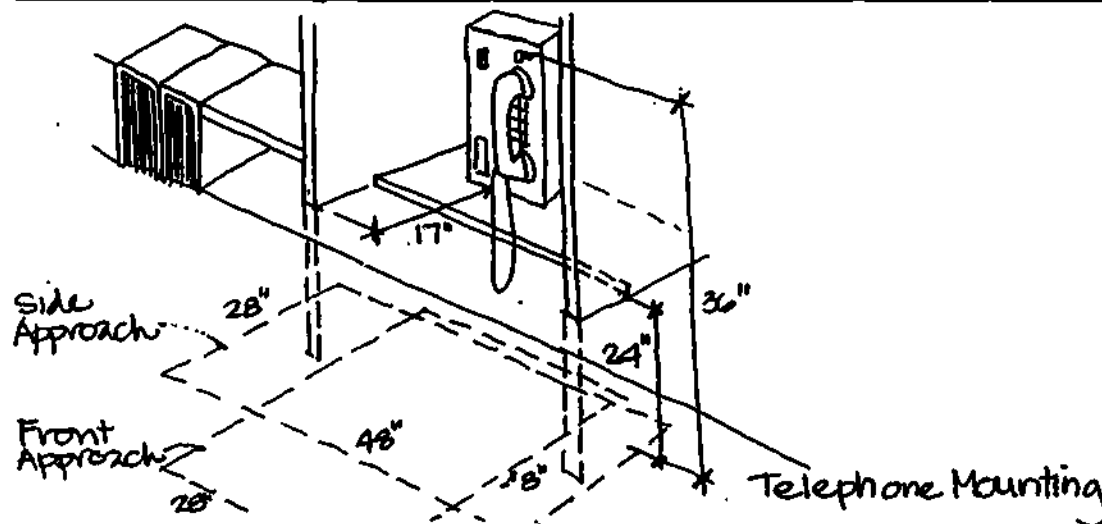

118 If a telephone is mounted too high or there is not sufficient clear area to approach and use it:

a Lower the phone.

This modification can be easily performed by the phone company.

The highest operable part of the phone should be 36" above the floor.

b Modify the wall behind the phone or adjacent walls to provide adequate clearance.

There should be no difficulty with these changes providing that such walls are non-structural. Most wall booths will meet the criteria. For a front approach, the desired projection can be provided by building the wall out or making a recess below the phone; this is because the depth of the phone itself will not meet the projection standard.

Provide a clear floor space of at least 28" x 48" to allow a parallel approach or a clear space 24" high by 28" wide under the phone. The face of the telephone should be no more than 17" behind the leading edge of an enclosure.

EMERGENCY WARNING SYSTEMS

For children with hearing impairments there should be a visual alarm system coupled to the audible alarm system. This is only needed if children with such disabilities attend a given school.

119 If there is no visual alarm system:

a Install permanent flashing lights.

They should be installed in all areas of the school and connected to the alarm system and an emergency power system. High frequency flashing may trigger epileptic seizures. Flashing frequency should be 5HZ or slower. Strobe lights are most effective in attracting attention.

The visual alarms should be located wherever children will not be with teachers such as toilet rooms and corridors. Flashing alarm lights cost about \$30 for regular light and \$60 for strobe light equipment and would require installation by an electrician.

b Use a flashing illuminated exit sign.

This will probably provide adequate warning. Usually there will be other people around and this limited application will provide warning where needed.

The cost to add a flasher unit to an illuminated sign and connect it to the emergency warning system will cost approximately \$20-\$40 per installation depending on the number provided and particular wiring conditions.

LISTENING SYSTEMS

These systems are used to aid hearing impaired students where individual hearing aids will not be satisfactory. They should be provided in selected classrooms and assembly areas. They are only needed if children with hearing impairments are present in a school.

120 If a listening system is needed to assist hearing-impaired children:

a Install a "hard wire" system.

The hard wire system consists of a transmitting station and any number of permanently installed listening stations which are connected by permanently installed wiring.

This type, as well as all others, should be capable of providing 125 dbs. A suitable number of listening stations should be provided in the room.

The basic cost for this type system includes an amplifier at \$100 and a wired microphone at \$30. Each station would require a booth amplifier at \$65 and a head set at \$12. The wiring, if installed in thin walled conduit, would cost about \$2/LF and would run from the base amplifier to each listening stations booth amplifier.

b Install a "loop" system.

The loop system creates a magnetic field by passing electrical current through a wire loop. The wire may be temporarily or permanently installed. The signals are received by those with hearing aids or headphones with special transducers.

Loops should cover a large enough area to serve the expected number of hearing impaired children. Loop locations should fit with nature of activity patterns and activity locations.

Loops should be installed so that interference caused by overlapping signals of separate loops would not occur. The cost of this system includes a transmitter at \$350, a wired microphone at \$10 or \$330 for a remote microphone. Each set of headphones cost \$65 and wiring the loop is about \$500 for the average classroom.

311

c Install a FM (or RF) system.

The FM (or RF) system includes use of wireless FM transmitters and receivers which may be worn by people who ordinarily do not use hearing aids as well as those who do.

The system should be capable of producing a sound level as in alternative 'a'.

The cost of this system is approximately the same as the loop system in alternative 'b'.

d Install an infra-red radiation system.

The infra-red system uses infra-red light to transmit signals to people who are wearing special receivers which convert the light signals to electrical signals which then are converted to sound by head phones or hearing aids.

Infra-red radiators should be located in positions where their signal would not be inadvertently blocked. A sufficient number of radiators would be installed in each room where the system is used to insure signal coverage throughout the entire room.

The basic cost for this type system is about \$1,500 for a radiator/transmitter which would be capable of serving an average classroom. Receiving head sets or receivers for those with hearing aids cost about \$135 each.

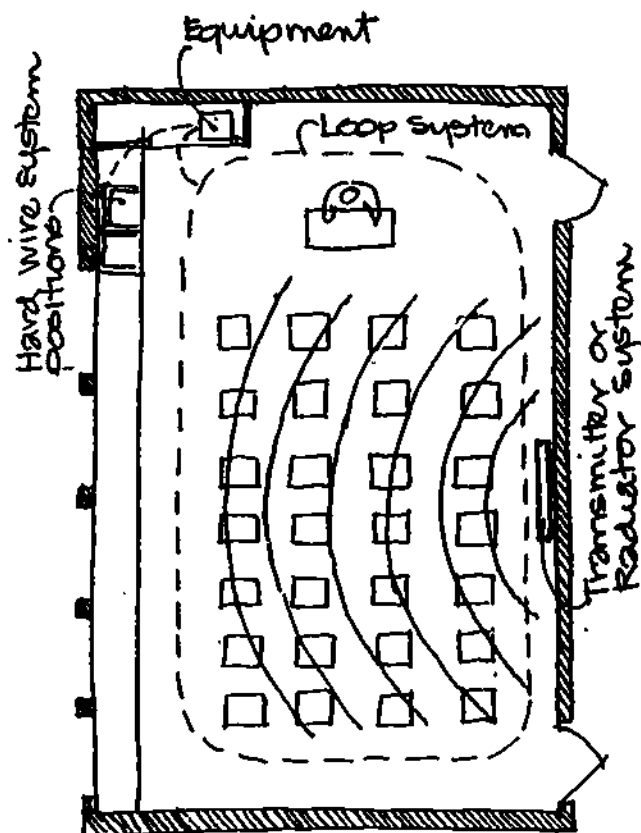

classroom Listening Systems

Checklist of Design Criteria

<u>Issue</u>	<u>Criteria</u>	<u>References</u>
Accessible Entries	<ul style="list-style-type: none"> • provide access from entries to other accessible routes 	Action Alternatives 19 and 20
Auditoriums - seating and circulation stage (also see Vertical Circulation)	<ul style="list-style-type: none"> • provide wheelchair seating min. size area 48" X 56" for two wheelchairs • provide access to front and rear of auditorium • provide access to stage area 	Action Alternatives 44 to 46
Automatic Doors	<ul style="list-style-type: none"> • max. stopping force 15 pounds • equip with safety controls and guard-rails • slow opening doors: opening and closing speed of 3 seconds with hold open time of 8 seconds • provide easily used activating devices • push plates: - min. dimension 3" mounted 36" above floor • locate controls for easy use 24" - 36" from control to door 	Action Alternatives 100 to 102
Cafeterias	<ul style="list-style-type: none"> • provide accessible toilets near cafeteria • food serving aisle width 36" min. • tray slide and food counters max. 30" high • max. forward reach for food 12" • provide accessible seating tables with max. height of 30", 	Action Alternatives 46 to 50

314

315

Issue	Criteria	References
Classrooms	<ul style="list-style-type: none"> min. clearance under table 24" seating 15"-17" high with backs & arms • accessible doors 28" - 32" width • make entire classroom accessible • make circulation and furnishings accessible • make toilet rooms accessible • make classroom equipment accessible; • make blackboards with bottom at 24" • max. ht. to controls, etc. 36" • control lighting levels and glare 	Action Alternatives 51 to 57
lighting		
Corridor Handrails	<ul style="list-style-type: none"> • mounting height 26" - 28" • handrail shapes 1" - 1 3/4" diameter or 3" - 6 1/4" perimeter with 1/2" min. thickness • mounted 1 1/4" from wall surface 	Action Alternative 103
Door Hardware - door closers	<ul style="list-style-type: none"> • provide maneuvering space at doors with closers • max. operating force 8.5 pounds for exterior doors, 5.0 pounds for interior doors, closing speed of 3 sec. min. • provide easily used opening hardware • provide easily operated latching hardware 	Action Alternatives 97 to 99
Doorways	<ul style="list-style-type: none"> • provide maneuvering space at doorways 	Action Alternatives 93 to 96

Issue	Criteria	References
Drinking Fountains	<ul style="list-style-type: none"> • provide accessible doorways 32" clear preferred, 28" min. • modify doorway thresholds $\frac{1}{4}$" max. abrupt change, $\frac{1}{2}$" max. vertical height with 1:2 bevel slope • provide easily used controls • spout located at front of fountain • control mounted within easy reach • height of spout 30" max. • height clearance under fountains 24" max. • clear depth for knee clearance under fountains 17" min. 	Action Alternatives 111 to 114
Elevators, Platform Lifts and Chair Lifts operation	<ul style="list-style-type: none"> • automatic operation • self leveling • automatic re-opening with 3 sec. hold open time • provide two-way communications system with operable parts at max. height of 36" 	Action Alternatives 37 to 43 (Also see Vertical Circulation)
cab size	<ul style="list-style-type: none"> • 51" X 54" for side opening doors • 51" X 80" for center opening 	
controls	<ul style="list-style-type: none"> • max. height 54" • min. height 35" • tactile numerals and symbols for operation identification 	

Issue	Criteria	References
location	<ul style="list-style-type: none"> • elevators connected to accessible path of travel 	
Platform Lifts & Chair Lifts	<ul style="list-style-type: none"> • provide call-send controls at max. 36" height • provide safety shut-off controls • provide stairway elevators capable of carrying wheelchairs 	Action Alternative 42 and 43
Emergency Warning System	<ul style="list-style-type: none"> • provide visual alarm system with flashing frequency of 5 Hertz 	Action Alternative 119
Flush Controls	<ul style="list-style-type: none"> • flush control at 20" - 36" above floor • paper dispenser 19" above floor 12" - 24" from rear wall • modify flush controls for easy use 	Action Alternatives 83, 84 and 86
Grab Bars	<ul style="list-style-type: none"> • 1 - 1 3/4" in diameter or 3" - 6 1/4" perimeter • 1 1/2" min. from wall • 2, 40" to 42" grab bars 12" max. from rear wall - both sides of non-assisted • 36" back grab bar 6" from side wall • 40" - 42" side grab bar 12" max. from back wall 	Action Alternatives 81 and 82
unassisted stalls assisted stalls	<ul style="list-style-type: none"> • protective edge 2" min. above path 	Action Alternatives 15 to 18

Issue

Criteria

References

- dangerous projecting objects max. projection 4" between 18" and 80"
- exposed under stair areas protect areas under 80", (Also see Vertical Circulation AA 29)
- tactile warning signals at steps or ramps
- circulation spaces: separation of pathways from hazardous areas

Lavatories

- mount lavatories at 30" max.
- clearance under leading edge 24", 8" deep from front of lav
- 17" min. total depth
- 6" deep 9" high toe clearance
- 40" max. to bottom of mirror
- maneuvering space at lav 28" X 48"
- trap clearance & protection under lavatories
- modify lavatory controls for easy use
- highest operable part at 36" above floor
- provide maneuvering space of 28" X 48"
- mirrors mounted at 24" and 30"

Action Alternatives 87 to 92

lavatory accessories

Libraries - checkout counter

- max. height counter 30"
- min. width counter 30"

Action Alternatives 58 and 59

Issue	Criteria	References
card catalogs	<ul style="list-style-type: none"> • front approach requires 28" min. width 17" min. depth with min. clearance 24" below counter • side approach requires clear area at counter 28" X 48" • 36" max. to highest drawer 	
Life Safety Provisions	<ul style="list-style-type: none"> • provide fire refuge area min. size 4' X 5' at each floor in protected fire stairs 	Action Alternative 21
Listening Systems	<ul style="list-style-type: none"> • provide listening systems for hearing-impaired 	Action Alternative 120
Locker Rooms and Gymnasiums - lockers	<ul style="list-style-type: none"> • max. height of shelves and hoods 36" above floor • provide larger lockers min. 28" wide if over 12" deep • modified locker opening devices 	Action Alternatives 60 to 67
toilet facilities	<ul style="list-style-type: none"> • modify existing toilets to made the accessible 	
shower	<ul style="list-style-type: none"> • provide at least one accessible shower stall 36" min. dimension; See AA 64e shower seat 16" X 36" mounted 15" - 17" above floor, eliminate curbs; maximum height difference of $\frac{1}{2}$" 	
controls	<ul style="list-style-type: none"> • mounted 28" - 36" above floor • shower spray with 60" hose • single lever mixing control 	

Issue	Criteria	References
accessible path gymnasiums	<ul style="list-style-type: none"> • provide accessible path from lockers to toilets to gymnasium • provide accessible gym equipment 	
Passenger Loading Zone bus and van unloading	<ul style="list-style-type: none"> • zone size 12' depth 50' length • on grade: clear space 5' X 30' • sunken grade: height 20" • raised grade: height 20" • minimum depth of platform 54" • accessible route to entry see AA 4 • curb ramps where accessible path • crosses curb: slope 1:20 width 36" cross slope 1:20 • sheltered loading zone width 54" 	Action Alternatives 1 to 6
Personal Storage	<ul style="list-style-type: none"> • provide accessible storage areas • 32" min. clear doorways • provide easily used opening devices • 36" min. aisle • turn around space 60" X 60" • eliminate hazardous conditions • mount shelves and hooks at 36" 	Action Alternatives 104 to 108
Playgrounds and Athletic Fields	<ul style="list-style-type: none"> • provide accessible and challenging play equipment 	Action Alternatives 68 to 73

Issue	Criteria	Reference
toilet	<ul style="list-style-type: none"> • provide accessible path from school to play area • provide weather protected areas near play area • provide accessible seating areas near play • seating with back and arm support with 17" seat height • 30" X 48" wheelchair pad • provide accessible toilet near play area 	
Ramps (see also Vertical Circulation) handrails	<ul style="list-style-type: none"> • secure mounting to wall or floor mounting height 26" to 28"; size is 1" - 1 3/4" diameter or gripping area of 3" - 6 1/4" with 1/2" min. thickness; distance from handrail to wall 1 1/4" • handrails to be continuous, 12" extensions at top and bottom landing 	Action Alternatives 27, 30 to 37
width	• minimum ramp width 36"	
slope	• max. slope of ramp 1:20	
edge protection	<ul style="list-style-type: none"> • min. curb at edge of 2" • guardrail required on ramps of 30" or more in height 	
new ramps	<ul style="list-style-type: none"> • provide adequate lighting • max. run 20' • landing size 60"; landings at ramp direction change 	

Issue	Criteria	References
Signage	<ul style="list-style-type: none"> • provide signs with easily readable letters • width to height ratio between 3:5 and 1:1 • stroke width to height ratio 1:5 and 1:10 • tactile signs raised or indented 1/32" • height of letters 5/8" - 2" • signs mounted max. of 40" above floor 	Action Alternatives 116 to 117
Sinks	<ul style="list-style-type: none"> • for side approach provide maneuvering space 28" X 48" • for front approach provide space 28" wide with clear space under sink a min. 24" high and min. of 17" deep 	Action Alternatives 109 to 110
Stairs	<ul style="list-style-type: none"> • uniform risers rise and tread; min. tread 11" nose to nose; nosing max. radius 1/2" 	Action Alternatives 24 to 29
handrails	<ul style="list-style-type: none"> • handrails both sides, inside handrail continuous mounted at 26" - 28" above leading edge of nosing; handrail extension top and bottom; handrail size 1" - 1 3/4" diameter and perimeter gripping area 3" - 6 1/4", min. thickness 1/2"; distance from handrail to wall 1 1/4" min. • handrail extension parallel to landing; 12" extension at top landing; 12" and tread width extension at bottom landing 	

Issue	Criteria	References
lighting safety	<ul style="list-style-type: none"> • check with professional consultant • modify light sources to eliminate glare • eliminate dangerous conditions 	
Telephones	<ul style="list-style-type: none"> • highest operable part of phone at 36" above floor • distance from face of phone to edge of enclosure max. 17" • provide clear floor space of 28" X 48" for side approach • provide 28" wide by 24" high clearance for front approach 	Action Alternatives 118
Toilet Rooms	<ul style="list-style-type: none"> • provide accessible toilet rooms • provide maneuvering space at entry doors: 48" clear for in-swinging door and 42" clear for out-swinging door • provide access to raised facilities 	Action Alternatives 74 to 76
Toilet Stalls	<ul style="list-style-type: none"> • non-assisted stall 30" min. width, 66" min. depth • alternate stall - 60" wide 56" deep with wall mount toilet, toilet 15" from side wall • toilet height 15" - 17" from floor • stall door to swing out • door opening 28" - 32" clear 	Action Alternatives 77 to 80
assisted/non-assisted stalls		

Issue	Criteria	References
Urinals	<ul style="list-style-type: none"> • urinal rim at 17" max. above floor • clear floor space in front of urinal 28" X 48" 	Action Alternative 85
Vertical Circulation ramps stairway elevators platform lift	<ul style="list-style-type: none"> • provide connecting ramps • min. width stair 42" • min. platform 36" X 48" • control at max. 36" above floor • even start and stop • guardrails required at top and bottom 	Action Alternatives 22, 23, 38 to 40, 42 and 43
elevators	<ul style="list-style-type: none"> • min. cab size 51" X 54" • automatic doors, min. 3 sec. hold open • controls at 36" max., tactile symbols 	
Walks and Corridors	<ul style="list-style-type: none"> • walks min. width 36" • passing areas width 54", frequency 200' • passing space 54" X 54", dead end area 60" X 60", "L" turn 36" X 36" and min. leg 108", around obstruction 46" X 42" (obstructions greater than 6") 	Action Alternatives 7 to 13
surfaces	<ul style="list-style-type: none"> • smooth regular surfaces, firm surfaces, and non-slip surfaces 	
carpets	<ul style="list-style-type: none"> • pile no higher than $\frac{1}{2}$"; beveled edge strips with slopes 1:2 	

Issue**Criteria****References**

Warning Signals

- provide tactile warnings at hazardous conditions
- warning as wide as a path min 36" wide, a min. 12" from hazard
- max. height of warning 1/8"
- alternating pattern of strips 3/4" - 2" wide and 1/4" - 3/4" wide
- provide texture surfaces on door openers to hazardous areas

Action Alternative 115

Chapter Five:

Case Studies

Process	194
School One	195
Problem Identification	196
Problem Solution	199
Costs	205
School Two	209
Problem Identification	210
Problem Solution	214
Costs	220

To illustrate the method for establishing an accessibility plan for a school two examples were selected.

An attempt was made to present several alternative possible schemes to achieve program accessibility as discussed in Chapter Three, Accessibility Implementation. The distinction between building accessibility and program accessibility will be made and illustrated by these alternatives. The greatest economy in achieving accessibility will likely be through the program accessibility approach. This generalization is subject to the particular conditions at a school such as the characteristics of the handicapped population served and the range of programs available. These factors are not considered in the two case studies presented in any more than a summary way.

The most important use of the case studies is to demonstrate the steps in the development of an accessibility plan and the application of the action alternatives and guidelines put forth in Chapter Four, Accessibility Guidelines.

Each case study begins with a general description of the school, both the building and the site. After this, a brief analysis follows which gives initial shape to an overall scheme of accessibility. The program accessibility and building accessibility approaches will be outlined. A detailed review of each category of problem is then described. The sequence by which the problems are reviewed parallels that of the action alternatives in Chapter Four. Solutions to the identified problems are then proposed. The solution is chosen after consideration of the most appropriate action alternatives. A reference to the action alternatives which address this solution will be given where appropriate. To conclude each case study, the cost for the solutions are estimated first by item, then by subgroup (circulation, spaces and facilities, and building elements), and lastly in total. Also, a total will be estimated for each of the proposed schemes to illustrate a low figure corresponding to program accessibility and a higher one for complete building accessibility.

School One

School One is located in a dense and older section of a Northeastern city. This neighborhood school consists of two buildings. A four level "main" building which is approximately 80 years old, and a three level 50 year old addition. The basement, first and second floors of the two buildings are connected. Classrooms are on the first, second, and third floors. The gym, locker rooms, cafeteria, and industrial arts shops are in the basement. The library and auditorium are on the second floor. There is no elevator at the school.

The site slopes down five feet from the east to the west. Due to the slope of the site and the design of the building, the basement floor is at the same elevation as the sidewalk on the west side of the building. Leading from both sidewalks are stepped paths to the entries; these entries are at a level midway between the first floor and the basement. Once inside those entries, a half flight of stairs leads to either of the two floors.

The first major consideration in developing an accessibility plan for this school is providing access to either of two possible floor levels. Various alternatives exist to achieve this, basically requiring ramps either to the first floor or to the basement. The actual selection of any of the possible alternatives depends upon weighing the advantages, disadvantages and cost of the alternatives. These factors will be discussed in greater detail in the Problem Solution portion of this case study. Since the common facilities occur on all floors, some form of accessible vertical circulation will be required. If an elevator is used, its location becomes significant in the circulation scheme. Such an installation would also eliminate the need for several stairwell modifications.

A particular strategy for accessibility grows out of a discussion of the itemized problems in the following section.

PROBLEM IDENTIFICATION

The sequence of problem identification follows the action alternatives in Chapter Four; this is Accessible Paths of Travel, Spaces and Facilities, and then Building Elements.

Passenger Loading Zone

- 1 Presently the children are dropped off at the curbside and there is no weather protection to the entry.
- 2 There are no curb cuts at the drop-off point.

Accessible Entries

- 3 Entry to either the first floor or basement is by stairs.
- 4 Paths to the entries have steps without any handrails.

Vertical Circulation

- 5 Circulation to all floors is restricted by stairwells; classrooms and common facilities are scattered on these floors.

Stairs

- 6 There is a hazardous area below the stairs on the basement floor.

Life Safety Provisions

- 7 There are no fire refuge areas at the exits and at the stairs on the upper floors.

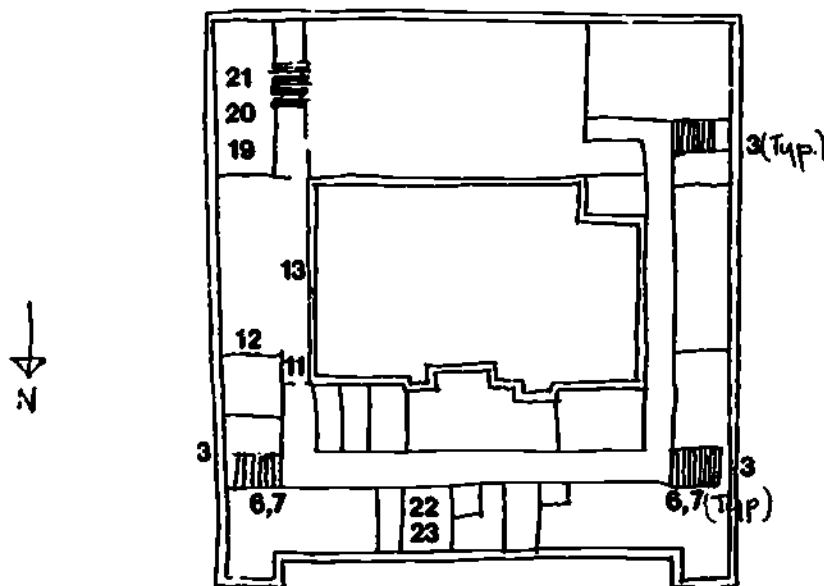

341

Basement Floor Plan

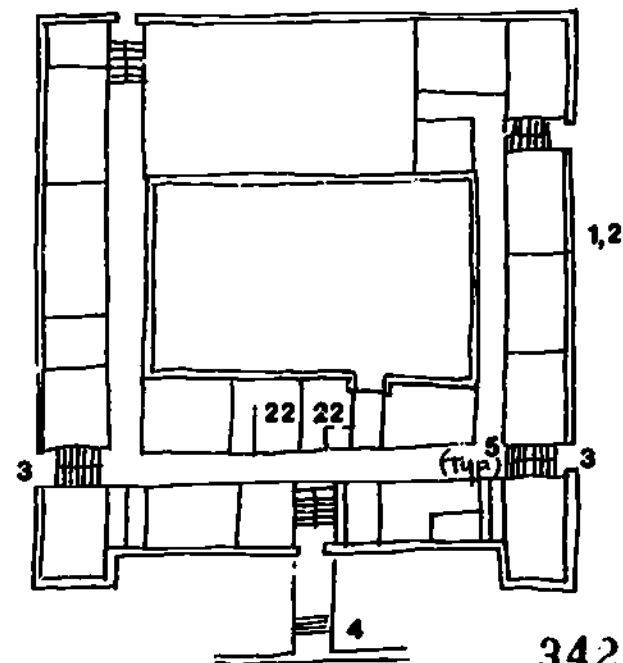

342

Partial Site and First Floor Plan

Auditorium

- 8 The entry doors are too narrow.
- 9 The entire floor of the auditorium is sloped and doesn't provide for wheelchair seating.
- 10 There is a raised stage with a very long and circuitous path to get up to it.

Cafeteria

- 11 The entry doors are too narrow.
- 12 The food serving line is too narrow.
- 13 Most seating is fixed and attached to the tables and therefore difficult to use.

Classrooms

- 14 The entry doors have knob handle hardware which is difficult to use.
- 15 Desks in most classrooms have built-in seats.
- 16 The door closers at the new building require too great a force to open.
- 17 The doors to the classroom closets are difficult to open.
- 18 Shelves and hooks are mounted too high.

Library

- 19 Library doors have too high an opening force to operate easily.

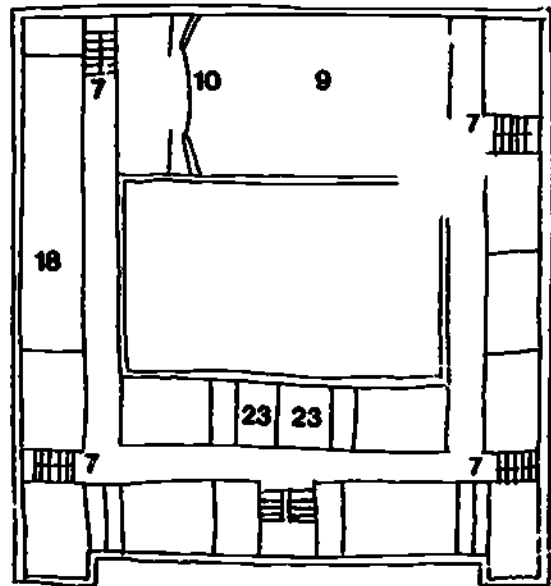

Second Floor Plan

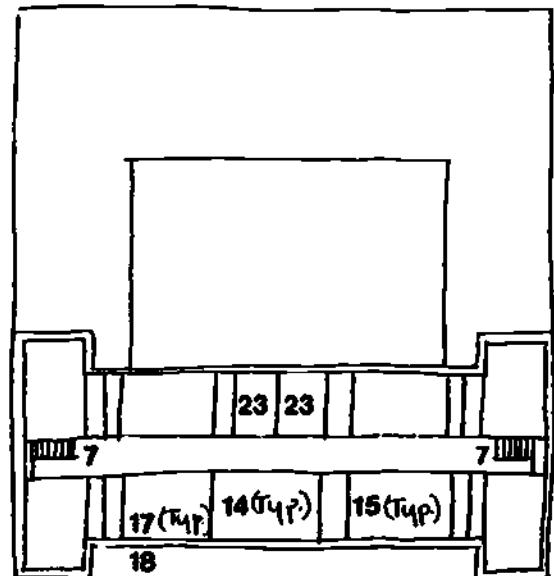

Third Floor Plan

Locker Rooms

20 The privacy partitions don't allow adequate entry space.

21 Curbs at the showers prevent their use by disabled children. There are no features such as grab bars and shower seats.

22 Thumb latches on lockers are difficult to operate.

23 There are no shower stations designed for the disabled.

Toilet Rooms

24 The following problems occur in the boys and girls toilet rooms on all floors:

The closing force on entry doors is too great.

The lavatories have support posts and traps below which prevent a front approach for their use.

The lavatory controls are spring loaded and difficult to use.

Existing toilet stalls are too narrow for assisted use and have in-swinging doors.

At the boys toilet room in the basement the urinals are set on a podium.

Door Hardware

25 All interior doors have turn knob hardware.

Signage

26 Existing signage is too small and mounted too high for the visually impaired to easily read.

Telephones

27 The phones are mounted too high.

Emergency Warning Systems

28 The fire alarm boxes are mounted too high.

29 There are no visual alarm systems.

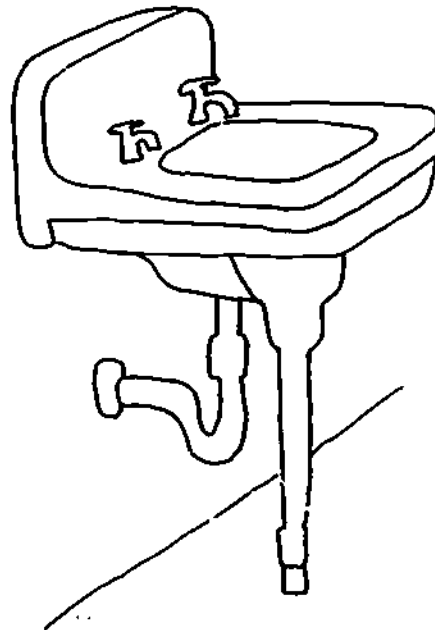

Inaccessible Lavatory

PROBLEM SOLUTION

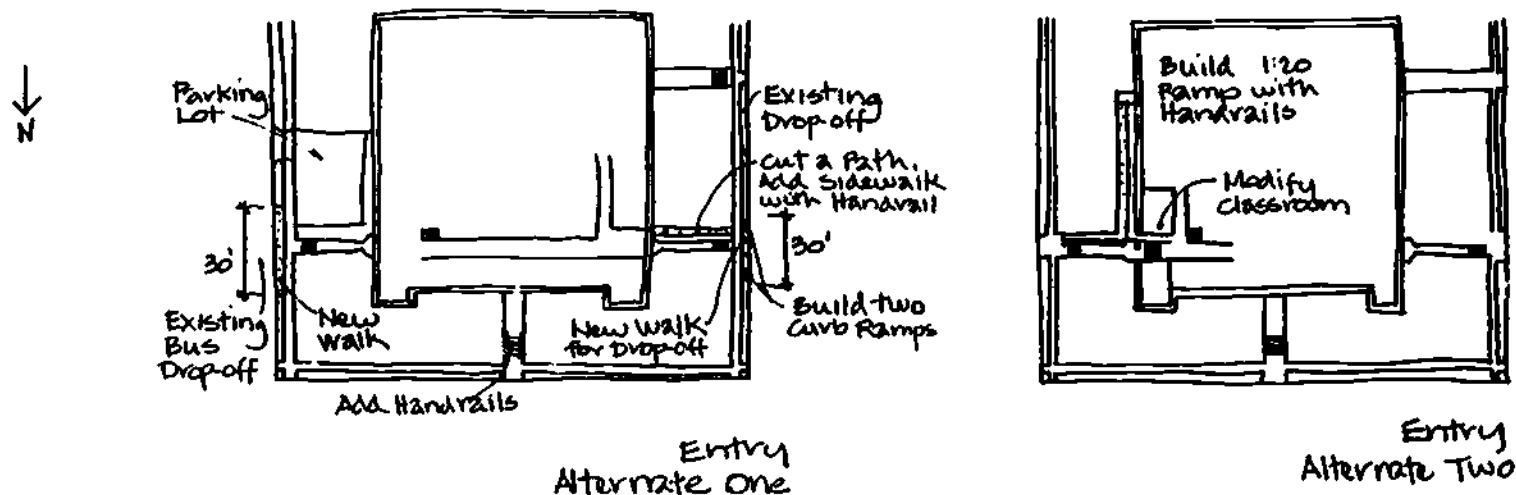

Passenger Loading Zone

- 1 At the existing bus drop-off area build a new portion of sidewalk for unloading/loading of students and designate the zone with signs and striping. Create a new drop-off on the west side of the building as an auto drop-off area. This would require new walk surface. See AA 1.
- 2 Build four curb ramps with two at each drop-off. See AA 14.

Accessible Entries

- 3 To solve the entry problem one of four solutions is possible:

Alternate One Cut a path to the basement floor from the sidewalk on the west side of the building. This path should be 60" wide and made of concrete. A new entry doorway would be built at the existing stair and the wall of the girls'

locker room moved. This could result in the loss of some of the lockers. There is a psychological disadvantage to this solution in that the disabled child will have to enter at a different location than the able-bodied child. A curb cut would be required and also, designation of a second drop-off zone west of the site.

Alternate Two Construct a shallow ramp 1:20, at the east side of the building from the sidewalk to the first floor. This long ramp would be tiring for many disabled children and impinge on the parking lot, therefore, limiting its use as a drop-off. As with **Alternate One** a new doorway would be needed.

Alternate Three Construct a moderately sloped ramp, 1:12, at the east side of the building to the first floor. Since the ramp is steeper than the one in Alternate Two it can be sited so that it runs on the opposite side of the entry and therefore doesn't impinge on the parking lot. This ramp will be of such a slope that it cannot be used independently by many disabled children. This solution will entail the movement of one classroom wall and change its entry. This solution has the advantage of bringing all children to the same entry point.

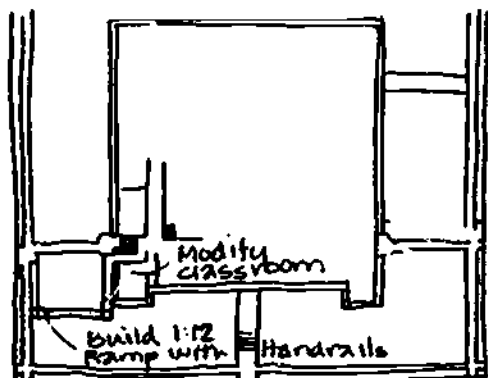

Entry
Alternate Three

Alternate Four This alternate, as in the first one, will bring the disabled children to the basement floor and therefore has the same disadvantage as that option. A ramp slope of 1:20 would be cut to the basement floor on the east side of the building. The landing of the entry at the first floor would require reconstruction. A new doorway would be cut below it and one stair wall moved. The drop-off would be common for all children. See the Action Alternatives for Walks and Corridors, Accessible Entries and Ramps.

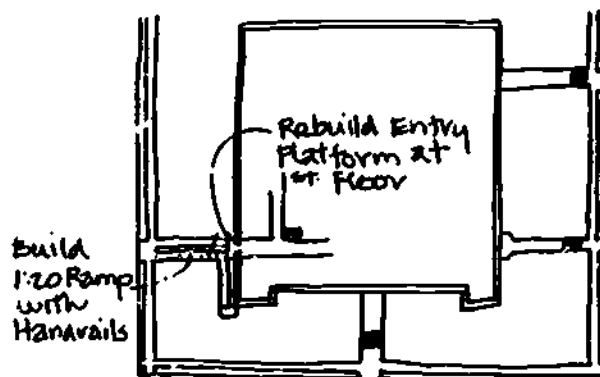

Entry
Alternate Four

Selection of a particular alternate would be best made after consideration of the school handicapped population and budget.

With respect to a covered path and loading area, this would be a desired modification with Alternates 2, 3, and 4 due to the length of time to travel from the school to a vehicle. It would not be necessary for program accessibility.

4 Add handrails at the steps on the southeast and west paths to the building. See AA 25 and 26.

Vertical Circulation

5 Since the common facilities are on the basement and second floor there is need for circulation among those levels at a minimum. Optimally the classrooms on the third floor would also be included in an accessibility plan. This vertical circulation can be remedied by either an elevator or a stairway elevator.

In the previous discussion of Accessible Entries, it suggests that the northeastern entry is the most appropriate location for vertical circulation. The proximity of the common facilities to that entry also supports the choice of this corner of the building as one for vertical circulation.

Alternate One If a stairway elevator is installed, it would be best in the stairwell in the northeast. This is also the stairwell likely to have the heaviest use by all children. This piece of equipment, although competitive in cost, would need greater supervision during its use. Since it operates in the stairwell there could be conflict between its users and others. For this reason it is suggested that an elevator be installed.

Alternate Two The elevator installation could be at the exterior or interior. Exterior construction would call for modifications in the corridor at that point to connect it to other circulation. If it were constructed at the interior intersection of the two corridors only small changes would be required to several classrooms. An equipment room could be provided in the basement. On this basis only (not considering possible electrical and mechanical systems) the interior solution appears to be a viable solution. See AA 22, 23, and 39.

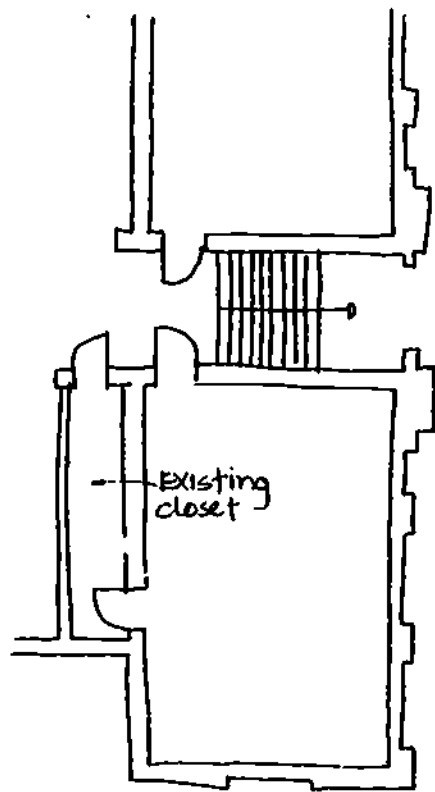

Existing Floor Plan

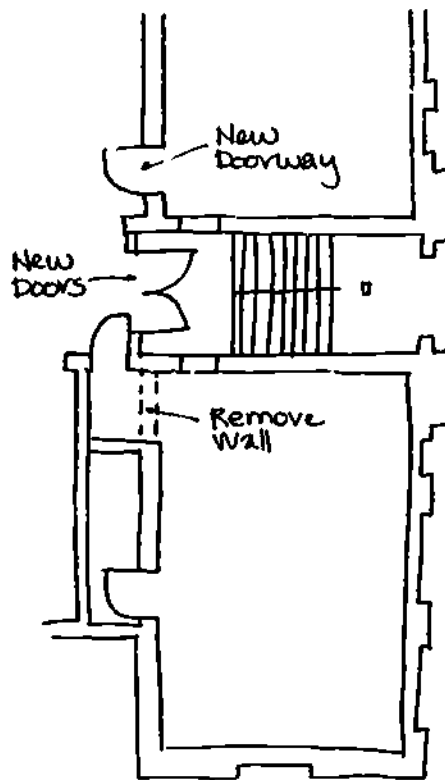

New Floor Plan with Fire Refuge

Life Safety Provisions

6 Build fire refuge areas at all four stairwells on all floors. This involves doorway and wall construction. An example of the change at the northwest stairwell is illustrated. See AA 21.

Stairs

7 Build a wall below the stairs in the basement. See AA 29.

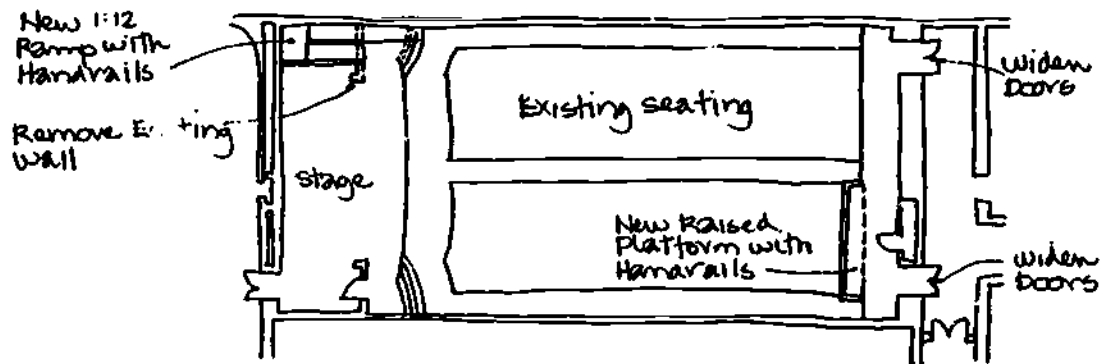

Auditorium

Auditorium

8 Remove the two entry doors and replace with two new doors, one of which has a clear opening of 32". See AA 95.

9 Remove the rear row of seats on one half of the auditorium and build a level platform. There should be a guard-rail on either side. The platform should be 48" deep. See AA 44.

10 Remove a portion of the stage and build a ramp up to the performing level. The slope should be 1:12. See AA 46.

Cafeteria

11 Remove the double doors at the cafeteria entry and replace with two new ones, one of which is a min. of 32" clear. See AA 44.

12 Remove the serving line railing and

move it elsewhere. See AA 48.

13 Remove some of the existing cafeteria seats. See AA 47.

14 Remove the existing classroom door knobs and replace with lever hardware.

15 Install some accessible desks in classrooms.

16 Adjust the closing force on the doors in the newer building.

17 Remove the door from the closet rooms in the classrooms.

18 Add lowered hooks and shelves in the storage closets.

Library

19 Adjust the closing force on the library door.

Locker Room

- 20 remove the existing privacy screens in the locker rooms, enlarge it, and replace it to allow adequate clearance.
- 21 Remove the shower curbs at the shower room. Install grab bars and shower seat for one station.
- 22 Replace the thumb latches with a lever type handle on the lockers.
- 23 Install grab bars and seats at two shower stations.

Toilet Rooms

24 In all the toilet rooms do the following changes:

- Adjust the closing force of the entry door.
- Remove one lavatory and replace it with a wall-hung one which allows for proper knee clearance.
- Change the spring-loaded lav controls to stay-open by adding a self-closing valve.
- Join two existing stalls to make one wide stall for assisted use. Add grab bars.
- Lower one mirror.
- At the first, second, and third floor boys toilet room, add one new wall mounted urinal.
- In the basement, remove part of the existing podium, remove the urinal and replace with a new one.

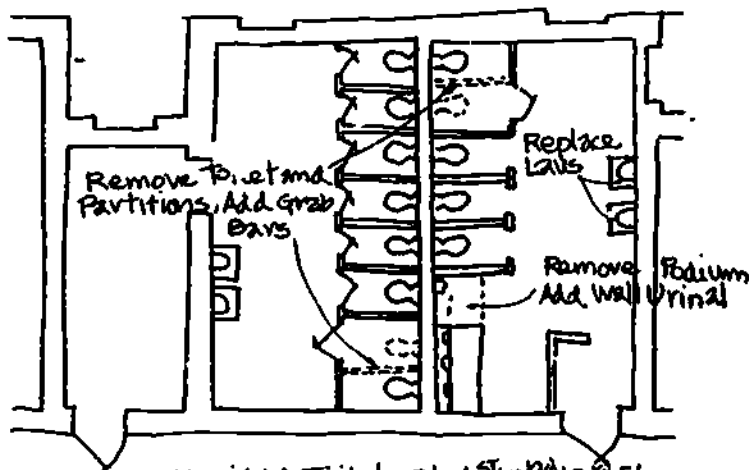

Modified Toilets at 1st, 2nd & 3rd Floor

Door Hardware

25 Replace all interior entry doors with lever type handle hardware; includes library, office, classrooms.

Signage

26 Install new signage throughout the school at the appropriate height.

Telephones

27 Have the telephone company remount the phones so that no operable part is above 36".

Emergency Warning Systems

28 Lower the existing fire alarm boxes to a maximum height of 36".

29 Install a flasher unit to all existing exit signs.

COSTS

The first estimate below will be one that provides for complete program accessibility. Following this will be an estimate which adds or replaces items in the first one with substituted or additional modifications. There is a corresponding total estimated cost based on the second estimate. The second estimate will represent a cost for complete building accessibility, an option which, depending on the handicapped population and budget considerations, would provide the greatest flexibility of accessible design.

Footnotes, i.e. (1), (2) appear at the end of the estimate.

	<u>Amount</u>		<u>Unit Cost</u>	<u>Total Cost</u>
Passenger Loading Zone				
1 Conc Load- ing Area	300 SF	@	1.90	= 570
2 Curb ramps: Ramps	4	@	248.00	= 992

Accessible Entry

3 build one of the following entry solutions:

Alternate 1:

Cut grade	40 CY	@	9.00	= 360
Sidewalk	300 SF	@	1.90	= 570
Retaining Wall	420 SF	@	4.80	= 1,216
Doorway	1	@	1205.00	= 1,205
Wall demol.	25 LF	@	43.00	= 1,075
New Wall	20 LF	@	35.00	= 700
			<u>Subtotal =</u>	<u>5,926</u>

	<u>Amount</u>		<u>Unit Cost</u>	<u>Total Cost</u>
<u>Alternate 2:</u>				
Ramp	1100 SF	@	32.50	= 35,750
Ext. door	1	@	1065.00	= 1,065
Wall demol.	6 LF	@	43.00	= 258
New wall	25 LF	@	35.00	= 875
Int. door	1	@	565.00	= 565
			<u>Subtotal =</u>	<u>38,513</u>

Alternate 3:

Ramp	625 SF	@	32.50	= 20,312
Ext. door	1	@	1065.00	= 1,065
Wall demol.	6 LF	@	43.00	= 258
New wall	25 LF	@	35.00	= 875
			<u>Subtotal =</u>	<u>22,510</u>

Alternate 4:

Cut grade	130 CY	@	9.00	= 1,197
Sidewalk	625 SF	@	1.90	= 1,188
Retain wall	1015 SF	@	4.80	= 4,872
Handrail	250 LF	@	1140.00	= 2,850
Ext. door	1	@	1065.00	= 1,065
Entry slab	64 SF	@	50.00	= 3,200
			<u>Subtotal =</u>	<u>14,372</u>

4 Handrails at steps	48 LF	@	18.00	= 864
-------------------------	-------	---	-------	-------

Vertical Circulation

5 New elevator installation at the interior of the building.

Three stop	1	@	21500.00	= 21,500
------------	---	---	----------	----------

Stairs

6 Wall below stairs	4 LF	@	35.00	= 140
------------------------	------	---	-------	-------

353 A

	<u>Amount</u>	<u>Unit</u> <u>Cost</u>	<u>Total</u> <u>Cost</u>
--	---------------	----------------------------	-----------------------------

Life Safety Provisions

7 Construct fire refuge areas at the four stairs.

Northwest stairs

DBL doors at corridor	3	@ 1130.00 =	3,390
New doors	1	@ 925.00 =	925
New wall	24 LF	@ 35.00 =	840
Wall demoi.	2 LF	@ 43.00 =	516

Southwest stairs

DBL doors at corridor	3	@ 1130.00 =	3,390
-----------------------	---	-------------	-------

Southeast stairs

DBL doors at corridor	3	@ 1130.00 =	3,390
New doors	1	@ 925.00 =	925
New wall	3	@ 35.00 =	105

Northeast stairs

DBL doors at corridor	3	@ 1130.00 =	3,390
New doors	1	@ 925.00 =	925
New wall	27 LF	@ 35.00 =	945
Wall demol.	12 LF	@ 43.00 =	516

Auditorium

8 DBL doors at entry	2	@ 900.00 =	1,800
9 Seating area	80 SF	@ 10.00 =	800
Guardrail	28 LF	@ 18.00 =	504

	<u>Amount</u>	<u>Unit</u> <u>Cost</u>	<u>Total</u> <u>Cost</u>
--	---------------	----------------------------	-----------------------------

10 Stage access:

Wall demol.	10 LF	@ 43.00 =	430
Stage demol.	120 SF	@ 3.36 =	403
Ramp	120 SF	@ 3250.00 =	3,900

Cafeteria

11 New doors	1	@ 900.00 =	900
12 Move serv	30 LF	@ 10.40 =	312

Classroom

14 Door hardware	3	@ 75.00 =	225
15 New desks & chairs	2	@ 23.50 =	47

16, 17, 18 Adjusting closers, removing doors, lowering hooks and shelves are jobs which can be performed by school personnel.

Library

19 Adjusting closers can be done by school personnel.

Locker Rooms

20 New privacy screens	2	@ 200.00 =	400
21 Remove curb at showers	8 LF	@ 16.61 =	133
22 Replace latches	6	@ 30.00 =	180
23 Add bars & seats	4	@ 48.00 =	192
	2	@ 200.00 =	400

	<u>Amount</u>	<u>Unit</u>	<u>Cost</u>	<u>Total</u>	<u>Cost</u>
Toilet Rooms					
24 New closers	8	@	100.00 =	800	
New lavs	8	@	420.00 =	3,360	
Combine stall	8	@	610.00 =	4,880	
Podium re- moval	48 SF	@	6.80 =	326	
New urinal	4	@	485.00 =	1,940	

(Mirrors can be lowered by school personnel.)

Doors

25 New hardware	10	@	75.00 =	750	
-----------------	----	---	---------	-----	--

Signage

26 New signs	80	@	5.00 =	400	
--------------	----	---	--------	-----	--

Telephone

27 The phone can be lowered by the telephone company.

Emergency Warning Systems

28 Lower boxes	16	@	25.00 =	400	
29 Add flashers	14	@	20.00 =	280	

Total cost for Program accessibility is:
\$72,961. (1)

To achieve complete Building accessibility the following estimates should be substituted for the previous ones:

	<u>Amount</u>	<u>Unit</u>	<u>Cost</u>	<u>Total</u>	<u>Cost</u>
Vertical Circulation					
5 Four Stop	1	@	24,500 =	24,500(2)	

Life Safety Provisions (3)

7 Fire refuge areas

Northwest Stairs

DBL doors	4	@	1130.00 =	4,520	
New doors	2	@	925.00 =	1,850	
New wall	29 LF	@	35.00 =	840	
Wall demol.	2 LF	@	43.00 =	516	

Northeast Stairs

DBL doors at corridor	4	@	1130.00 =	4,520	
New doors	2	@	925.00 =	1,850	
New wall	27 LF	@	35.00 =	945	
Wall demol.	12 LF	@	43.00 =	516	

Classroom

14 Door Hardware	35	@	75.00 =	2,625(4)	
15 New desks & chairs	35	@	23.50 =	825(5)	

With these revised estimates the total cost for complete Building accessibility is:
\$83,436.

(1) This estimate is based on Alternate 1 for an entry solution.

-
- (2) Program accessibility would only necessitate the elevator going to thesecond floor and therefore only three stops. This is because classrooms are available on the lower floors and those on the third floor need not be accessible.
 - (3) If the third floor is accessible, additional life safety provisions would be required at the Northwest and Northeast stairs.
 - (4) To achieve complete school accessibility all classrooms should have new hardware; for Program accessibility only one classroom per floor would need such a change.
 - (5) This provides for one chair/desk set in each classroom as opposed to only two sets necessary for Program accessibility.

School Two

This school is located in a residential area and runs the full length of a tree lined block. Adjacent to the school is a pre-school center which was not included in the survey.

The buildings fall into three different dates of construction. The oldest, built in the 1920's, is a group of classrooms (Bldg. D & E) and an auditorium which are joined by covered, but not enclosed, corridors. The circulation among these facilities has a slope to the corridors which runs in the north-south direction. Also joined to these covered walks is the cafeteria. On the south of these structures are portable classrooms which are from two to three risers above the grade. These are set on asphalt paving. To the west of these classrooms is a newer "open" classroom building (Bldg. A) built in the early 1970's. It is placed at the street level and therefore requires steps on the south to connect to the lower covered walks.

All the buildings are of stud and stucco construction with an exterior tile on the lower portion of the walls at Bldg. A. There are four playground areas, one in a court of the old buildings, one among the portable classrooms, one at an upper level near the new building, and a large one covering the western end of the site. The library sits in a separate portable building on the south and is several steps above grade.

The major common facilities (auditorium, cafeteria, outdoor eating, and library) are all central to the three classroom types. Generally it would be possible to make several modifications to this central area and therefore provide accessibility for the entire school. One factor which supports this attempt at centralization is that access to the auditorium entry is limited by steps and internally the aisle slope from the rear to the front is too great to be used by disabled children. A number of options exist with respect to classroom and toilet accessibility; these options address the question of program accessibility.

A particular strategy grows out of the discussion of the itemized problems in the following section.

PROBLEM IDENTIFICATION

The sequence of problem identification follows the action alternatives in Chapter Four; this is Accessible Paths of Travel, Spaces and Facilities, and then Building Elements.

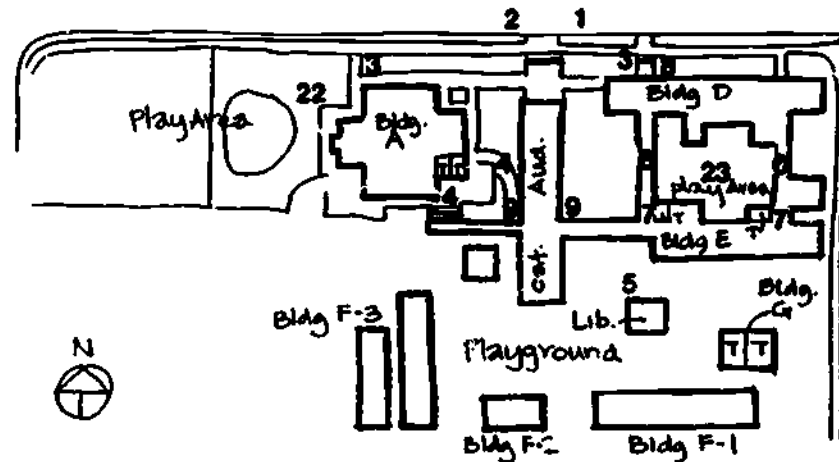

Passenger Loading Zone

1 Presently the drop-off of children is along the curb in the parking lane of a main street fronting the school. It is unmarked.

2 There are no curb ramps at the present drop-off.

3 Although there are large trees which provide shade, there is no weather protection in case of rain.

Walks and Corridors

4 Access from the new classroom Building A to the common facilities is limited by either steps or a steep path. Either way is not covered for protection from the weather.

5 The path to the library is not covered.

6 Open corridors between the older classrooms at Buildings D and E are sloping and become wet during the rain.

7 There is a gutter drain in each of the above corridors that has a grate which is hazardous.

Accessible Entries

8 There are steps along the path from the curb to Building D.

9 Entry to the auditorium at the stage end is restricted by four risers at both doorways.

Auditorium

10 Aisle slope is 1:15 from the entry doors at the rear to a level area at the front of the space. The slope starts immediately inside the doors.

11 There is no level seating area at the rear of the auditorium.

12 There is an elevated stage which can only be reached by steps with 5 risers of 7" each.

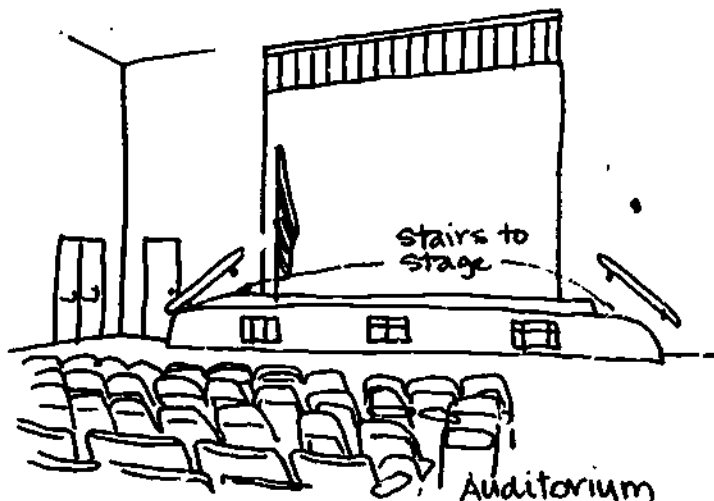

Cafeteria

13 The serving line is only 22" wide at the checkout point.

14 The nearest toilet rooms to the cafeteria and on the same level are in Building E.

Classrooms

15 All classrooms have turn knob door hardware.

16 Classrooms at Building D and E have too narrow an opening into the coat storage area.

17 Portable classrooms, the F buildings, are entered by anywhere from one to three risers. Entry doors swing out onto the landing; this makes an approach difficult.

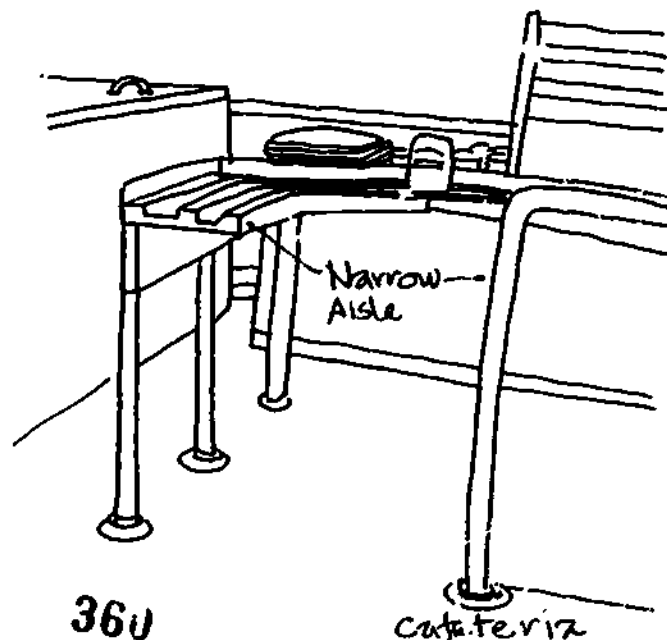

18 The sinks in classrooms at Building D and E are not accessible due to cabinets below them.

19 There is a $\frac{1}{2}$ " high carpet edge trim in classrooms in Building A.

20 There is a $\frac{1}{2}$ " offset at the entry doors of classrooms in Building A.

Library

21 The library is elevated and reached only by steps with 5 risers at 6" each.

Playgrounds and Athletic Fields

22 The play area adjacent to Building A is inaccessible due to a path across dirt.

23 Play equipment is separated from an asphalt surface by sand at the playground situated between Buildings D and E.

24 Toilet facilities which are near the playgrounds are not accessible.

Toilet Rooms

25 Boy's toilets at Building E have a step at the entry, narrow entry doors, inaccessible lavatories, and mirrors mounted too high. There are no stalls suitable for assisted use.

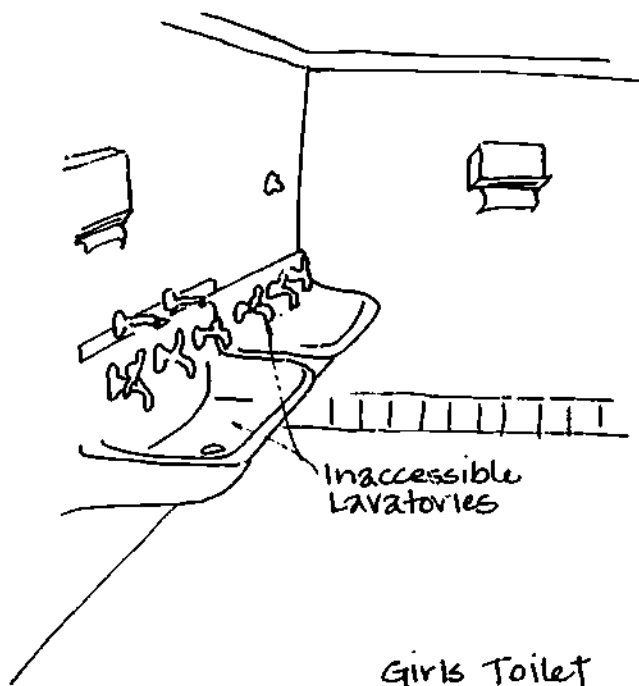
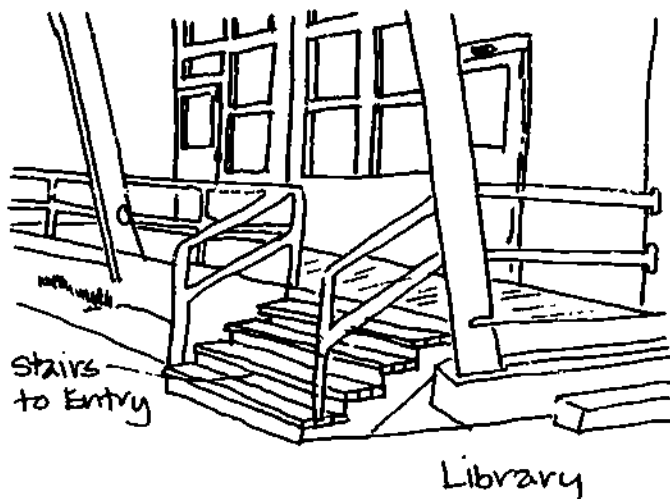

26 Girl's toilets at Building E have the same problems as those of the Boy's.

27 The Boy's and Girl's toilets at Building A have the same difficulties as those noted for Building E above with the exception of the step at the entry. Two single toilets in this building have been adapted for handicapped use. These toilets have entry doors that provide only 29" clearance and the mirrors are mounted too high.

28 Toilets at portable Building G have steps at the entry and privacy screens which prohibit entry.

Signage

29 The existing signage is diverse, mounted too high, and small in character size.

Drinking Fountains

30 The fountains at Building A, E, and the Cafeteria are inaccessible due to insufficient clearance below them and the type of controls.

Emergency Warning Systems

31 There are no visual alarm systems in the school.

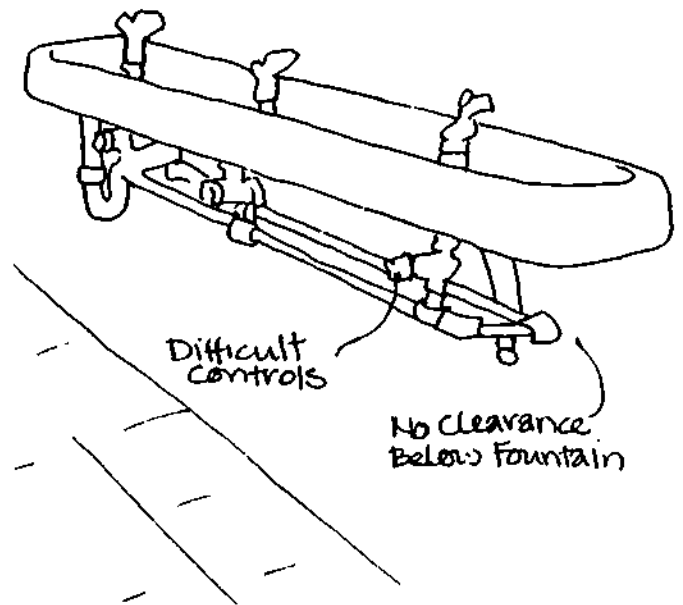

PROBLEM SOLUTION

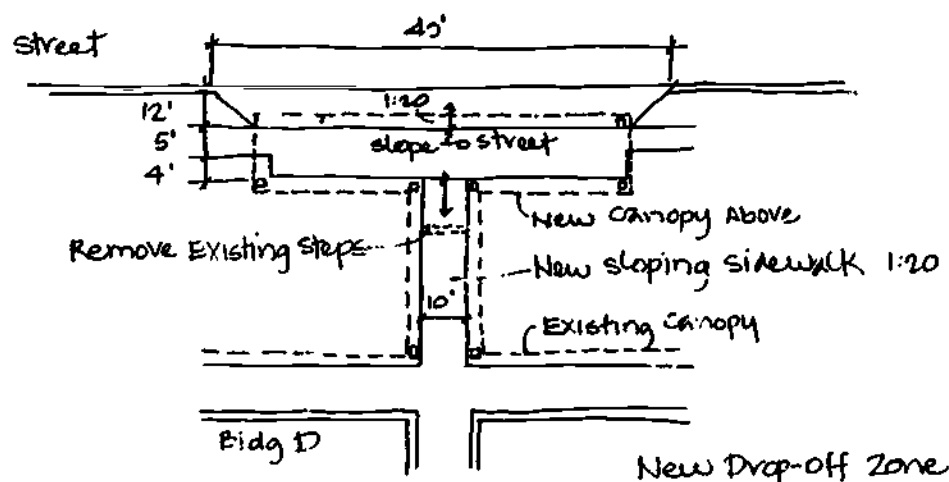

Passenger Loading Zone

1 Construct a drop-off for autos and 2 buses at the west end of Building D which has curb ramps. This location was selected due to its proximity to the mildest sloped path to the common facilities and its closeness to a covered path. This would be an essential improvement. See AA 1 and 5.

3 The distance from the loading area to covered protection is approximately 25'. Although rain is not a significant factor in this locale, a covered path to the canopy of Building D from the drop-off would be desirable for optimum building accessibility.

Walks and Corridors

4 Construct a ramp in the area between

Building A and B. This will provide an accessible path between Building A and the common facilities (cafeteria, auditorium, and library) while also providing access to the front level area of the auditorium which is not restricted by steps on the exterior and a sloping aisle at the interior. See AA 22 and 37.

5 For optimum accessibility to allow complete flexibility of building use, a covering could be constructed. From a program perspective, use of the library facilities could also be achieved by relocating the library to a classroom in Building D and E. This also would resolve any problem raised by the steps at the entry as described in problem 21.

6 Resurface the sloping exterior corridors between Building D and E with a slip-resistant material.

7 Replace the grating over the two gutter drains.

Accessible entries

8 Construct a sloping sidewalk at 1:20 from the drop-off to Building D. See AA 20 and 22.

9 The ramp constructed to solve problem 4 also provides entry to the auditorium.

Auditorium

10 Access to the auditorium is achieved by the solution described in Solution 9. Level seating area is available in the front and in that location children with hearing disabilities can best hear any presentations.

12 Install a platform lift at the west side of the stage. This solution was chosen over a ramp due to the configuration of the stage; a ramp would have needed to be approximately 36' long. The lift is proposed for the western side since the accessible ramp proposed in Solution 8 and 9 will serve this side of the auditorium. See AA 46.

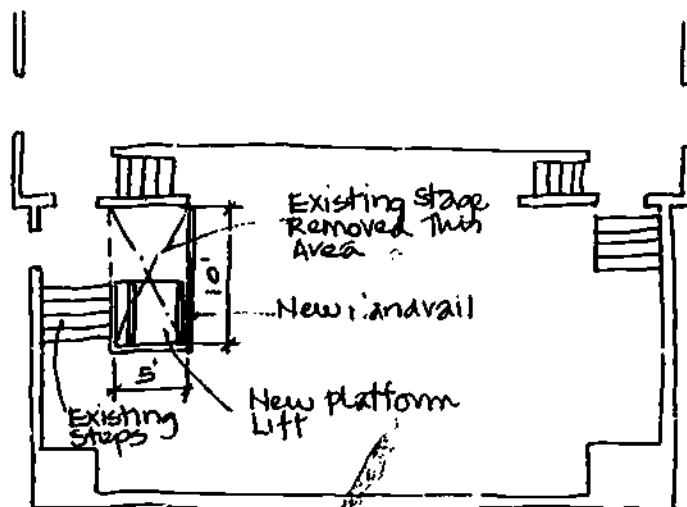
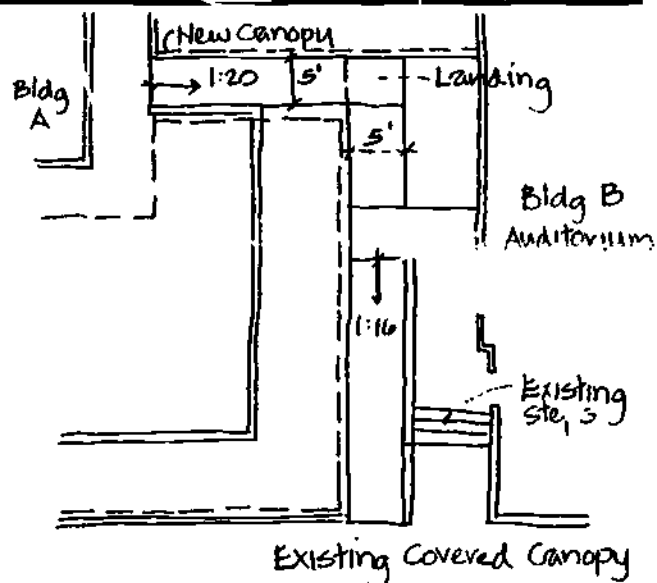

Modified stage Area

Cafeteria

13 Cut back a portion of the serving line rail at the checkout point. This should be done for both lines. See AA 48.

14 For a discussion of the solution to the toilet needs of the cafeteria see Solutions 24 through 28.

Classrooms.

15 Install new lever type door hardware at all classrooms.

16 Widen the opening into the coat storage approximately 6" at classrooms for Buildings D and E. See AA 94.

17 To resolve the accessibility of the portable classrooms, several options can be designed.

First, since there exists a number of classrooms at Building A, D, and E which are accessible, the children or grades served by the portable can be relocated to one or several of those classrooms. No special learning programs exist in the portables which can't be supported by the other classrooms. This is obviously a less expensive proposition than making physical modifications as outlined in the other options. This also solves for circulation difficulties that could be encountered in inclement weather.

Second, one or several classrooms could have an entry porch and ramp constructed which would allow for a disabled child to use these classrooms. If all upper grades, for example, use these classrooms, a child in one of those grades would be attending class in an area with their peers.

Lastly, one could remove the existing steps and landings at all portable classrooms in Buildings F-1, F-2, and F-3. These could be replaced with a continuous raised platform which has a ramp at one end. Steps could be placed at several points along the platform. This solution works particularly well due to the existing site slope along the front of the buildings. This solution is obviously the most expensive yet would provide complete building accessibility.

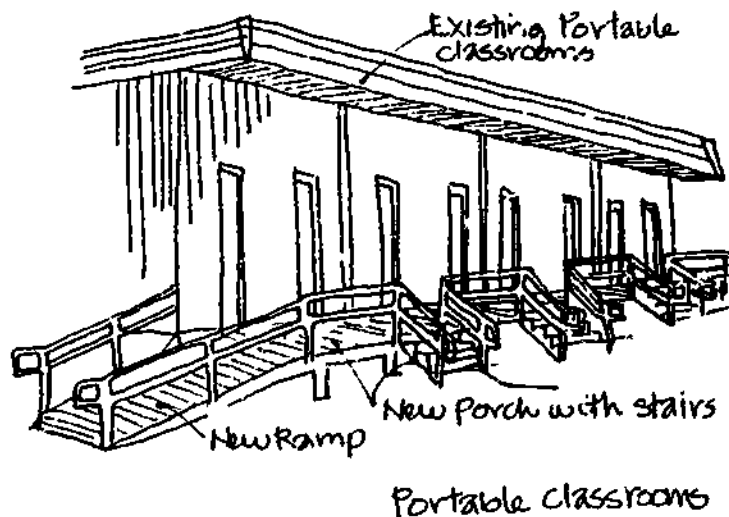

18 Remove the cabinets below classroom sinks in Buildings A, D and E. See AA 110.

19 Replace existing carpet edge trim with one which is beveled. See AA 13.

20 Install a beveled threshold at the entry doors for classrooms in Building A. See AA 96.

Library

21 The library has no physical facilities which can not be accommodated in a typical classroom space. Shelves would have to be relocated. This would provide program accessibility.

As an alternative to this, one could construct a ramp up to the library deck near the east end of that deck. The ramp should be at 1:12 slope. See AA 37.

Playgrounds and Athletic Fields

22 Build a concrete path from the sidewalk on the west side of Building A to the play area in that location. The path should be 3'-6" wide. This is a newer play area with accessible equipment. See AA 69.

23 Build a concrete path to the slide and bars in the playground between Buildings D and E. The path should be 3'-6" wide. See AA 69.

24 See solutions below.

Toilet Rooms

25, 26, 27, 28 The solution to accessible toilets in the school is best presented as several possible alternatives.

The only toilets which offer basic accessibility are two single ones in Building A. All other toilets will need multiple modifications. A preferred solution would provide some accessible toilet facilities near the cafeteria and the main playground based on AA 47, 72 and 73.

New toilets constructed at the west side of the cafeteria would meet this goal but in themselves would not provide close accessible toilets for the classrooms in Building D and E.

Based on this the two options are as follows:

First, as a minimally acceptable solution, the slight changes in the single toilet at Building A could be made. This involves adding a lowered mirrors and widening the doors.

Additionally, the Boy's and Girl's toilets at Building E should be modified. The changes at Building E toilets would be to widen doors, add accessible lavatories, join two existing toilet stalls to form an assisted one, and a new lower mirror. Additionally, modifications illustrated are required to solve for a 5" step at the entry to the Boy's toilet. Any solution must change conditions inside the vestibule since a ramp outside would interfere with circulation in the corridor.

Second, to meet a preferred level of accessibility and to avoid a longer trip from the cafeteria and playgrounds, a new toilet could be constructed at the west end of the cafeteria. These toilets would include two lavatories, two toilets for the girls, and one toilet with a urinal for the Boy's. See AA 74 - 92.

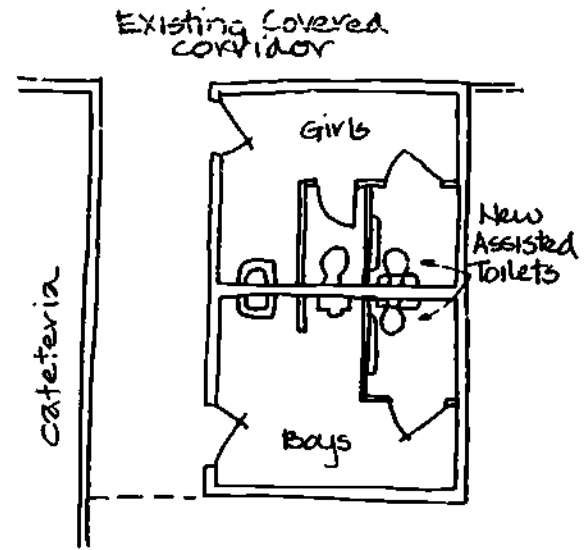
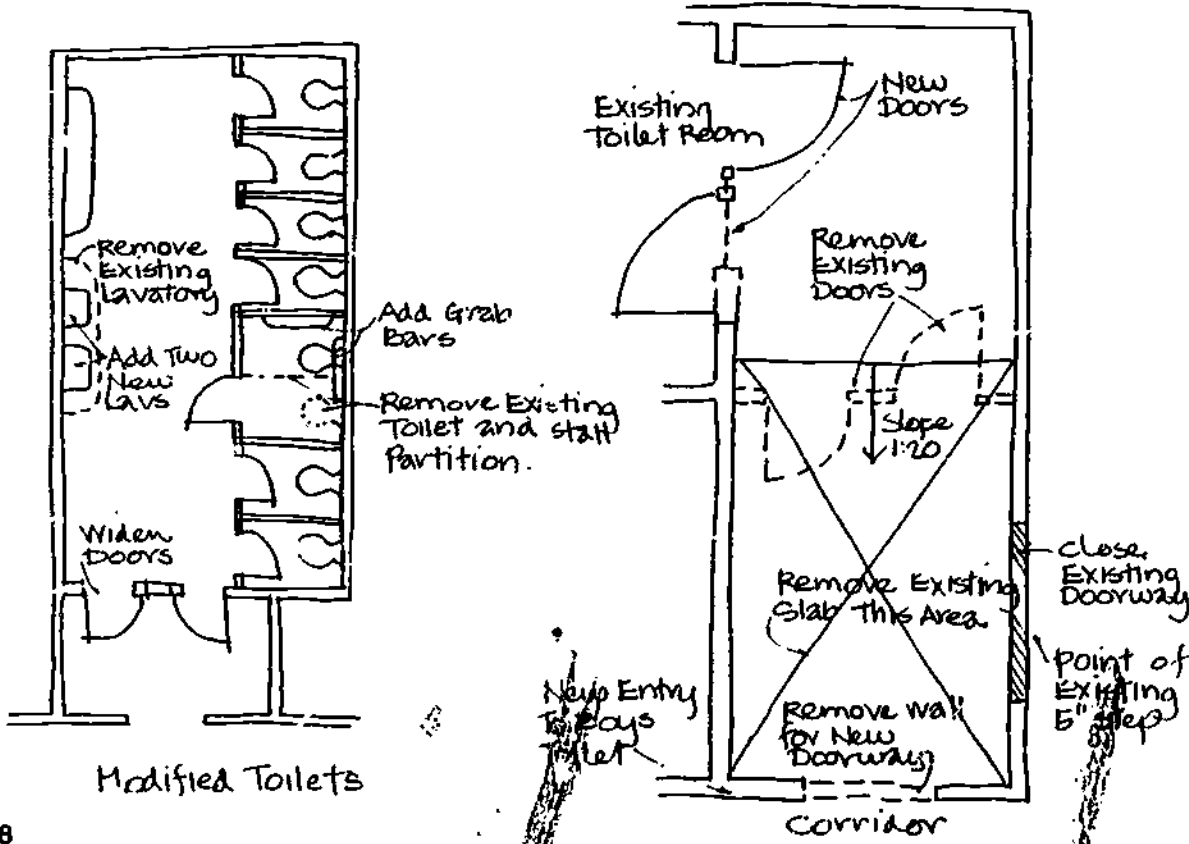

363

Modified Toilets

New Accessible Toilets at Cafeteria

Signage

29 Install new room identification throughout the school. See AA 117.

Drinking Fountains

30 Replace the drinking fountains at the cafeteria and in the corridor of Building E. The fountain in Building A has controls which are adequate and although necessary clearance is not available below the fountain, there is a lowered fountain with the required space for a side approach and use.

Emergency Warning Systems

31 Since the corridors of this school are on the exterior and there would always be supervision present in all spaces, it is not necessary to install visual alarms.

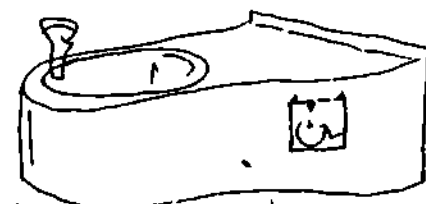

Add
New Accessible
Drinking Fountain

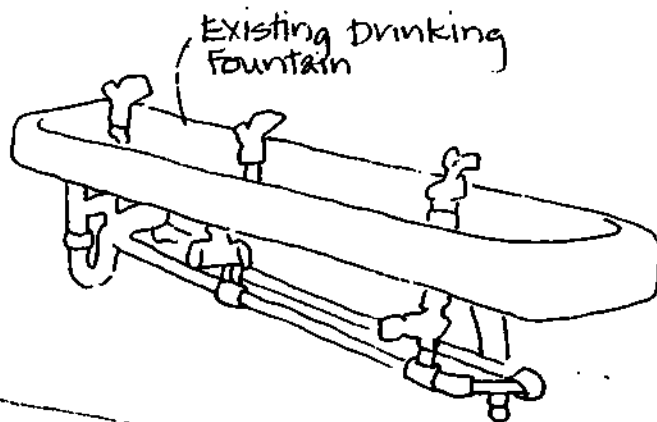

Drinking Fountain

COSTS

The first estimate below will be one that provides for complete program accessibility. Following this will be an estimate which adds or replaces items in the first one with substituted or additional modifications. There is a corresponding total estimated cost based on the second estimate. The second estimate will represent a cost for complete building accessibility, an option which, depending on the handicapped population and budget considerations, would provide the greatest flexibility of accessible design.

	<u>Amount</u>	<u>Unit</u>	<u>Cost</u>	<u>Total</u>	<u>Cost</u>
Passenger Loading Zone					
1 Curb re- moval	40 LF	@	1.13	=	45
2 Walk	480 SF	@	1.90	=	912
Entries and Corridors					
4 Sidewalk	540 SF	@	1.90	=	1,026
5 Sidewalk	280 SF	@	1.90	=	532
6 Ramp	140 SF	@	32.50	=	4,550
8 Resurface	2200 SF	@	1.00	=	2,200
9 Grate	20 SF	@	8.25	=	165
Auditorium					
12 Lift	1	@	2200	=	2,200
Stage demo	50 SF	@	3.36	=	168(1)

	<u>Amount</u>	<u>Unit</u>	<u>Cost</u>	<u>Total</u>	<u>Cost</u>
Cafeteria					
13 Modify rail	3 LF	@	10.40	=	31.20(2)
Classrooms					
15 Door levers	40	@	75.00	=	3,000
16 Widen door	7	@	38.35	=	268(3)
18 Cabinets	9	@	160.00	=	1,440
19 New Trim	180 LF	@	2.00	=	360
20 Threshold	.13	@	15.00	=	195
Playground					
22 CONC path	60 SF	@	1.90	=	114
23 CONC path	44 SF	@	1.90	=	84
Toilet Rooms 24, 25, 26, 27, and 28					
Girls					
Modify door	2	@	515.00	=	1,130
New mirror	1	@	20.00	=	20
Add lav.	2	@	420.00	=	840
Combine stall	1	@	610.00	=	610(4)
Boys					
New doors	2	@	565.00	=	1,130
New slab	48 SF	@	2.00	=	96
New wall	12 LF	@	35.00	=	420

	<u>Amount</u>	<u>Unit Cost</u>	<u>Total Cost</u>
New Mirror	1	@ 20.00	= 20
Add lav.	2	@ 420.00	= 840
Combine stall	1	@ 610.00	= 610

Signage

29 New Signs 60 @ 5.00 = 300

Drinking Fountains

30 New fountain 2 @ 235.00 = 470

Total cost for Program Accessibility is \$23,776.

To solve for complete Building accessibility the above estimate would be supplemented by the following items. The number preceding the item corresponds to that preceding both the problem identification and problem solution.

Passenger Loading Zone

3 Canopy 540 SF @ 8.00 = 4,320

Walks and Corridors

7 Canopy to Library 192 SF @ 8.00 = 1,536

Cafeteria

14 New toilets at cafeteria 240 SF @ 55.00 = 13,200(5)

	<u>Amount</u>	<u>Unit Cost</u>	<u>Total Cost</u>
Classrooms			
17 Wood Ramps	108 SF	@ 32.00	= 3,456(6)
Raised Platform	2,100 SF	@ 10.00	= 21,000(7)

Library

21 Wood ramp 54 SF @ 32.00 = 1,728

Additional cost for complete Building accessibility,

with ramps to three portable classrooms is \$24,40 and

with raised platform continuous at all portable classroom entries is \$45,240.

Total cost for complete Building accessibility is \$69,016.

(1) The demolition unit cost used is the figure for demolition of a gypsum-board and stud wall.

(2) This figure is appropriate for the work if it is done in conjunction with other work. If the work is done separately a minimum of \$75 could be anticipated.

(3) This figure is based on the cost of wall demolition and construction. At

each doorway it was estimated as one foot of work.

- (4) The cost of two grab bars is included.
- (5) This is estimated on a per square foot basis; the figure corresponding to a detached toilet facility with institutional finishes.
- (6) This estimate would provide for access to three separate portable classrooms with a ramp and a necessary platform at the doorway.
- (7) This provides for a continuous platform along the front of all portable classrooms with one ramp and several points with stair access.

Appendix

Sample Survey Forms

225

375

Corridor

		Yes/ No	Dimen- sions	Type &/or Material	Problems / Remarks
A	Clear Width @ Narrowest Point				
B	Clear Floor Width @ 90 degree Turn				
C	Corridor Slopes (changes vertical level)				
D	Floor Surface				
E	Floor Surface Changes Cue				
F	Objects Not Recessed or Protected by Wing Walls Extend to Floor or w/in 8" of Floor				
G	Objects Project from Above				
H	Lighting Avg. Illumination Level Glare/Distortion				
I	Drinking Fountain				

SKETCHES

Door

	Yes/ No	Dimen- sions	Type &/or Material	Problems / Remarks
•Type				
•Adjacent Material				
•Level on Both Sides				
•Clear Width				
•Clearance in Front				
•Clearance Behind				
•Clearance Between Latch Side & Wall				
•Tactile Cue(s) in Front				
•Swing				
•Threshold				
Ht.				
•Kickplate Ht.				
•Opening Hardware				
Operable Easily w/1 Hand				
Opening Force Required				
Ht. Inside				
Ht. Outside				
Tactile Identification				
•Closing Speed (if self-closing)				
•View Panel				
Ht. to Bottom				
Dimensions				

SKETCHES

STAIRS

	Yes/ No	Dimen- sions	Type &/or Material	Problems / Remarks
• Clear Width				
• Risers				
No. on Poth				
Average Ht.				
Non-Uniform Risers				
• Treads				
Average Depth				
Non-Uniform Treads				
• Nosing				
Depth				
• Surface Material				
• Tactile Cues @ Top &/or Bottom				
• Objects Project from Top or Sides				
• Handrails				
Shape				
Dimensions				
No. per Stair				
Top Ht.				
Continuous/Interrupted				
Extensions @ Top & Bottom				
• Circulation Space Under Stairs				
Barrier to Prevent Hitting Head				
• Landings or Floor Levels				
Dimensions of Clear Floor Area				
• Interior Only: Lighting				
Avg. Illumination				
Glare/Distortion				
• Exterior Only:				
Begin or End Where Water Pools				
Water Drains Across Treads				

SKETCHES