

DOCUMENT RESUME

ED 238 904

TM 830 852

AUTHOR Hill, Clifford; Larsen, Eric
 TITLE What Reading Tests Call For and What Children Do.
 INSTITUTION Columbia Univ., New York, N.Y. Inst. for Urban and
 Minority Education.
 SPONS AGENCY National Inst. of Education (ED), Washington, DC.
 PUB DATE Oct 83
 GRANT NIE-G-78-0095
 NOTE 558p.
 PUB TYPE Reports - Research/Technical (143)

EDRS PRICE MF02/PC23 Plus Postage.
 DESCRIPTORS Elementary Education; Grade 3; Grade 4; *Item
 Analysis; *Minority Group Children; Multiple Choice
 Tests; *Reading Comprehension; Reading Difficulties;
 *Reading Processes; Reading Research; *Reading Tests;
 Testing Problems; *Test Items
 IDENTIFIERS Gates MacGinitie Reading Tests

ABSTRACT

This study examines how third and fourth grade children work with a representative sample of test items designed to measure reading comprehension. The developmental and ethnocultural problems that children experience (whether they are rooted in the passage, the tasks, or the entire item) are discussed. From a passage-based perspective, the items are presented according to the various kinds of incomplete narratives that the passages convey and the various kinds of shifts that the passages (expository as well as narrative) require readers to make. From a task-based perspective, ways of classifying the tasks are developed with particular attention to the functional demands that they make. This developed framework helps to examine more broadly the passage-based perspective. The passage/task configurations are delineated that are particularly troubling from developmental and ethnocultural perspectives. This presentation allows for a cumulative grounding of the theoretical points made, and the detailed exposition of 22 items (consisting of nearly 400 pages) demonstrates how much goes into reading what is an apparently simple passage. (PN)

 * Reproductions supplied by EDRS are the best that can be made *
 * from the original document. *

ED238904

SCOPE OF INTEREST NOTICE

The ERIC Facility has assigned this document for processing to W.

In our judgement this document is also of interest to the clearinghouses noted to the right. Indexing should reflect their special points of view

Institute for Urban and Minority Education
Teachers College, Columbia University

WHAT READING TESTS CALL FOR
AND WHAT CHILDREN DO

Clifford Hill and Eric Larsen

Program in Applied Linguistics
Teachers College, Columbia University

Final Report for Grant #G-78-0095

National Institute of Education

October, 1983

U.S. DEPARTMENT OF EDUCATION
NATIONAL INSTITUTE OF EDUCATION
EDUCATIONAL RESOURCES INFORMATION
CENTER (ERIC)

- X This document has been reproduced as received from the person or organization originating it.
Minor changes have been made to improve reproduction quality.
- Points of view or opinions stated in this document do not necessarily represent official NIE position or policy.

7M 830 852

For

Jeremy

who has taught us
who a child-reader is

and

Kathleen

who has taught us
who the child-reader becomes

ACKNOWLEDGEMENTS

We would like to thank the following persons for their help:

- Walter MacGinitie, who first gave us the idea for the study, provided the wherewithal to execute it, and generously answered many questions about how standardized tests of reading comprehension are constructed
- Neal Grove, who helped to prepare the initial proposal that we sent to the National Institute of Education
- Robert Aronowitz, who got the study off the ground by conducting the initial interviews (in taking the research to the children, he turned up many of the questions that proved to be most fundamental in this study)
- Sharon Goldstein, Kate Parry, Enid Pearsons, and Paula Schwartz, who provided many different kinds of help (they analyzed test items, made suggestions on how to conduct interviews and experimental probes, conducted a number of each, and analyzed the results of many more
- Robert Schwarz, Word Processing Supervisor at Teachers College, Columbia University, and staff members Betty Engel, Catherine Gabriel, and Gabriella Oldham, for patient and intelligent help with the manuscript in its various stages
- Saiki Kawade and Susan Price for help in producing graphics

In addition, we would like to thank all the persons--mostly graduate students at Teachers College, Columbia University--who conducted interviews or experimental probes with children:

Ayuba Abubakar
Jose Adames
Kamal Ahmed
David Armstrong
Elizabeth Asch
Shirley Be
Catherine Biggins
Terri Bush
Haekyong Chang
Harold Chester
Michelle Cohoy
Diane Coassin-Conti
Beatrice Crowell
Victor Cummings
Brian Devlin
Car_n Dewhirst
Susan Dicker
Ruth Dorfman
Alyse Elias
Myrna Elliot-Lewis
Anne Friedman
Joyce Fuller
Pat Gallagher
Maureen Gannon
Salihu Garba
Susan Gausby
Doreen Gollman
Lois Glock
Clyde Griffin
Winnifred Hall
Peter Hastorf
Helen Hecken
Ilona Henderson
Warren Herendeen
Andrea Herrmann

Carol Janda
Wendy Jean
Edward Jones
Joyce Jui
Mary Karahalios
Ab Libdeh
Wendy Maloney
Yoko Maruki
Ronald Mason
Maureen McCann
Sally Mettler
Betty Msonda
Eugenia Perez
Gloria Peterson
Kathleen Prager
Conrad Reina
Maritza Reyes
Johanna Ridgeway
Yuri Shimizu
Kathleen Slowik
Charlotte Stearns
Betsy Stokes
Barbara Strassman
Terry Tchaconas
Judith Torres
Halima Toure
Kathy Van Nice
Susan Varenne
Olivia Villagra
Susan Wawrose
Ellen Weighart
Eva Weiss
Roslyn Wexler
Donna Wilson-King
Anne Wintergerst

Finally, we would like to thank the hundreds of children in metropolitan New York who participated in the study during the past years. We hope that their participation will help them to do better on standardized tests.

TABLE OF CONTENTS

Chapter 1: Introduction 1-1

 Methodological Remarks 1-10

 Interviewing 1-12

 Group Probes 1-19

 The Gates-MacGinitie Reading Tests 1-22

 Definition of Terms 1-27

 Presentation of Research 1-30

Chapter 2: Expanding Narratives 2-1

 Truncated Narratives 2-5

 SHOP SIGN 2-5

 LEAVING HOME 2-36

 Excerpted Narratives 2-47

 BLACK BONNET 2-49

 ALICE AND THE FAWN 2-71

 LEARNING TO READ 2-92

 Gapped Narratives 2-129

 HURRICANE 2-131

 CHEE TONG 2-153

 ADVERTISING TAILOR 2-177

Chapter 3: Testing Flexibility 3-1

 Frame Items 3-5

 MINNESOTA 3-5

 JAYS AND CROWS 3-17

 WHITE CIRCLES 3-27

Polarity Items	3-35
PENCILS	3-49
BACTERIA	3-66
RAISINS	3-86
ICEBERGS	3-98
GEORGE WASHINGTON BRIDGE	3-109
Register Items	3-141
GREEN CEDARS	3-145
MOTHER ALLIGATOR	3-161
Chapter 4: Task Characteristics	4-1
Formal Properties of Tasks	4-1
Functional Properties of Tasks	4-13
Literal Tasks	4-17
Repeating Tasks	4-22
Rephrasing Tasks	4-28
Inferential Tasks	4-36
Content-oriented	4-40
Factual versus Fictional	4-40
Passage-Dependent versus Passage-Independent	4-44
Structure-oriented	4-57
Discourse	4-57
Vocabulary Item	4-62
Stylistic Feature	4-70
Figurative Language	4-70
Non-Figurative Language	4-73
Summary	4-79

Chapter 5: Summary of Findings	5-1
Incomplete Narratives	5-3
Reader Flexibility	5-7
Ethnocultural Variation	5-13
Content-oriented Differences	5-14
Structure-oriented Differences	5-15
Oral versus Literate	5-16
Structural Divergence Between Spoken and Written Language	5-17
Dialogic Incompleteness of Everyday Speech	5-18
Holistic Processing of Dialogic Experience	5-20
Gap-based Processing of Monologic Experience	5-21
References	R-1

Chapter 1

INTRODUCTION

In recent years a good deal of public attention has been brought to bear on the standardized tests of reading comprehension that are regularly given to students in primary and secondary schools. By and large, this attention has not focused on the tests themselves; in the public mind their reliability and efficacy as a tool for the mass evaluation of students, teachers, and programs have been largely accepted on faith. What the public expects to find in the yearly reports are the results of these tests, numbers that give some overall assessment of how well students have done. In New York City, for example, scores on the city-wide tests are made public, and while reports in the broadcast media are cursory, the New York Times publishes the results in detail, giving a breakdown of scores by grade level, school district, and even individual school. Accompanying these results are various articles that attempt to explain why scores have improved or declined. During the last decade, these articles have usually dealt with decline, though the past two years have seen a modest upturn.

Those who have actually worked with the tests have often been less willing to accept them on faith. Many teachers, particularly those who work in urban ghetto schools, have expressed a number of reservations about them. Deborah Meier (1973), for example, published a report about minority students' difficulties with

various tests that she had administered over the years. Here is an item for third-grade children that she includes in her report:

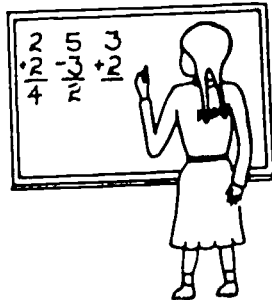

below the blackboard
before the blackboard
beside the blackboard
behind the blackboard

Meier points out how unnatural the target response (i.e., before the blackboard) sounds to any child--or even to an adult for that matter--and describes the particular difficulties that minority children experience with it (see Hill, 1977:36-39, for a discussion of how these difficulties are related to culturally variant uses of spatio-temporal constructs).

Added to these first-hand reports from teachers is a more formal body of research that emerged during the early 1970s. A number of researchers, responding to a concern for educational equity within the larger society, investigated minority students' performance on reading tests (see, for example, Flaugher, 1970; Williams, 1971; Cicourel, 1974; MacKay, 1974; Jennings and Jennings, 1974; Breland et al., 1974; and Sullivan, 1974). By and large, this research was oriented to problems having to do with language structure. These researchers surveyed different reading tests,

attempting to identify phonological and syntactic problems like the ones that had been delineated in Teaching Black Children to Read (Baratz and Shuy, 1969).

Our own work in this area began in 1975, when we participated in a research seminar sponsored by the Institute of Urban and Minority Education, then based jointly at Teachers College, Columbia University, and the Educational Testing Service. As an outgrowth of work in that seminar, we published Urban Minority Students, Language, and Reading.^{*} Walter MacGinitie, then in charge of applied psycholinguistics at Teachers College, read this monograph and suggested that we might like to examine the performance of mainstream and minority students on a pilot test that he and his associates had just completed. In preparing a new edition of the Gates-MacGinitie Reading Tests, they had tried out more than twice the number of items needed for each grade level; and for each item statistical data were available on the proportion of mainstream and minority students who had selected each of the available choices.^{**}

In examining the results of the pilot testing, we became interested in developmental problems as well as ethnocultural ones; for we discovered that a surprising number of items piloted for tests at the early grade levels were difficult for all the children

^{*}This seminar led to other publications as well (Nix and Schwartz, 1978; Freedle, 1978).

^{**}The students who participated in this pilot test were largely drawn from urban areas. The minority students were, for the most part, Afro-American.

who were tested.* Hence we decided that it would be useful to investigate the two kinds of problems together. Such an approach would, in principle, allow us to sort out more clearly differences between developmental and ethnocultural problems. We had often been struck that a good deal of research, particularly within the language-deficit framework, merged the two, with the consequence that minority children's problems were viewed largely as developmental.

After examining items at various levels, we finally decided to work with those that had been prepared for the third grade. The items at this level reflected a promising balance of developmental and ethnocultural problems. Moreover, this is the time that children first encounter the kind of item that is widespread in standardized testing: a brief passage followed by multiple-choice tasks.** This is also the point in the school curriculum at which children are expected to do independent reading. In principle, they have mastered basic decoding skills and are ready to use reading for learning.

Having decided to deal with development problems as well as ethnocultural ones, we began to work out an approach that would allow us to deal with three major limitations of our earlier

*For adults, these items are quite easy. We tested a group of 30 adults and found that only one item gave them any trouble (see MOTHER ALLIGATOR, chap. 3, p. 161).

**At earlier grade levels, the Gates-MacGinitie tests use a combination of pictures and words.

research:*

- (1) the analysis of the language used in test items was conducted primarily at the micro-level rather than at the macro-level
- (2) even when the macro-level was taken into account, the analysis dealt primarily with text structures rather than with how readers understand these structures
- (3) even when reader response was taken into account, the analysis dealt primarily with response to individual test items

Let us briefly describe each of these limitations and our plans for dealing with it.

It was natural that as linguists we had initially focused on problems at the micro-level (i.e., those having to do with the lexical and grammatical properties of individual sentences). In the late 1970s, however, there was a good deal of ferment in linguistics: the Chomskyan paradigm was under attack, and linguists, working with psychologists in fields such as artificial intelligence, were beginning to deal with problems at the macro-level (i.e., those having to do with logical and pragmatic relations between connected propositions). The extensive work of Halliday

*Our earlier research had not been funded and its goal was largely heuristic: to discover by sampling test items at different grade levels a range of problems that minority students experience. Having obtained funding from the National Institute of Education, we were now in a position to investigate these problems more thoroughly.

and Hasan on discourse cohesion had just been published, and it was particularly helpful to linguists who wished to bridge the gap between the micro- and the macro-levels; for it shifted the analytic perspective from a single sentence to extended discourse, while maintaining sharp focus on details of lexis and grammar.

To our way of thinking, linking the micro- and the macro-levels was crucial to achieving comprehensive discourse analysis. It was clear that linguists had traditionally neglected the macro-level, but we felt that a number of researchers, particularly psychologists, were now neglecting the micro-level (i.e., they often focused on the logical structure of discourse without showing how language was used to express it). It was our hope that in our own work on test items we would be able to work out powerful links between the two levels:

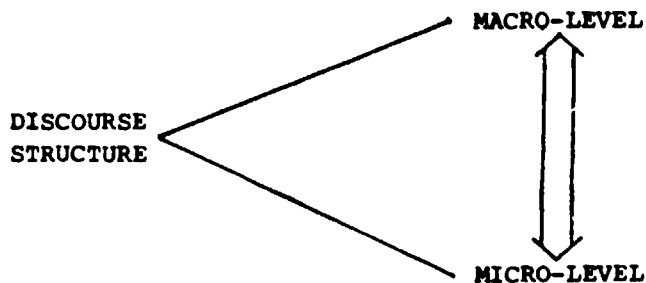

In dealing with the second limitation of our previous research, we drew on the emerging body of schemata research in cognitive science. We cannot here present this research in any detail (for a number of useful papers, see Spiro, Bruce and Brewer, 1980). We can, however, observe that its central concern is to delineate the

different kinds of schemata--stored bodies of knowledge--that readers use in making sense out of their experience. With respect to reading, this research generally distinguishes schemata having to do with knowledge of the real world from those having to do with knowledge of textual properties. We can illustrate these two kinds of schemata by considering what readers need to draw on in comprehending the following bit of prose (of all the passages that we worked with, this is the briefest):

Cats won't trouble to learn tricks as a rule.
But there have been some famous performing
cats, like the one that walked the tightrope
at the Lilienkron circus.

The various real-world schemata that readers of this passage may use include what a cat is, how it behaves in ordinary life, how it behaves in a circus, what a circus is like, and so on. On the other hand, they might use textual schemata like the following: expository prose often begins with a general observation; this observation may be followed by an exception; and an adversative connective is likely to be used in signaling this exception.

In order to document the various kinds of schemata that readers actually use, researchers in cognitive science have developed a range of experimental methods. Many of these go far beyond the scope of the research that we envisioned. We did, however, want to use certain of their methods in comparing how representative groups of readers respond to various features of the items we were concerned with. In order to identify developmental

factors, we planned to conduct experimental probes that would allow us to compare the responses of children and adults; and in order to identify ethnocultural factors, we planned to conduct probes that would allow us to compare the responses of mainstream children and minority children. Working with these various probes, we hoped that we might be able to identify various developmental and ethnocultural factors that influence children's responses to test items, and even to show how these two kinds of factors interact:

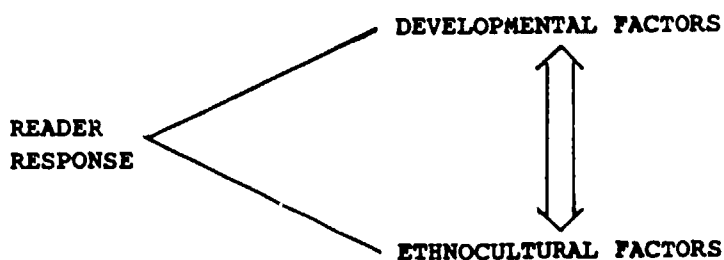

In adapting the methods of those who work in cognitive science, we did have certain reservations. Earlier we pointed out how text-centered researchers sometimes concentrate on the macro-level of discourse at the expense of the micro-level. Reader-centered researchers often reflect a comparably limited focus: they often focus on how readers respond to macro-features and neglect the powerful ways in which they use micro-features to understand the higher level of structure. It was our hope that we could link children's responses to both levels of discourse, or to put the matter more precisely, their responses to the interaction between the two levels:

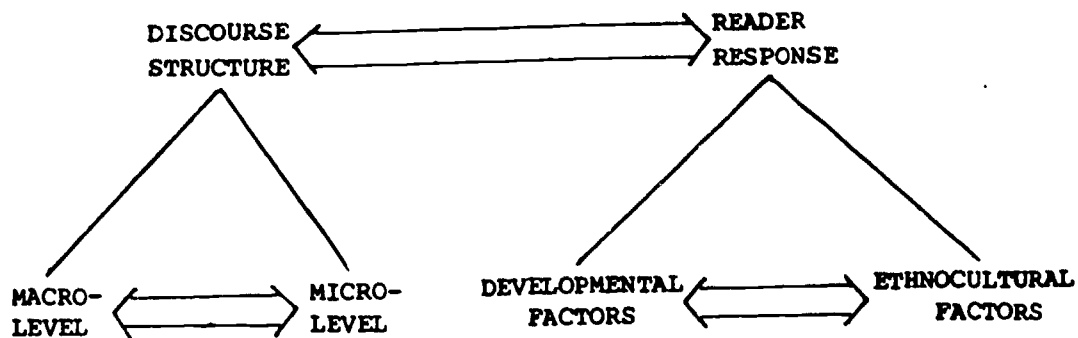

We also had reservations about the extent to which those who work in cognitive science rely on experimental data. Generally speaking, they have not used ethnomethodological techniques such as individual interviews to complement experimental ones. Hence it has often been difficult to interpret just what their data mean.*

Let us now turn to the third limitation of our earlier research, the one having to do with a focus on item-specific difficulties. To overcome this limitation, we planned to work with items at a single level so that we might be in a position to describe the range of passages and tasks to be found at this level. Moreover, we hoped that insightful categorizing of passages and tasks would help us to establish various kinds of passage-task configurations:

*It is only fair to note, however, that, in the case of research on reading tests, the major ethnomethodological critique of experimental methods loses much of its force (i.e., that people are forced to perform tasks that they do not ordinarily do); for the experimental tasks used in probing children's understanding of reading tests closely resemble the tests themselves. In each case, children are generally required to read a short passage and then respond to tasks.

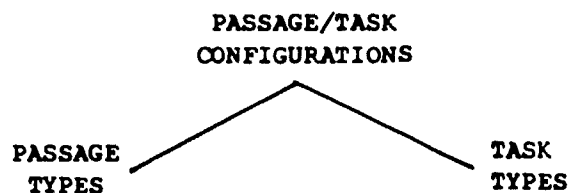

Once these broader classifications were worked out, they could, in principle, be used in accounting for developmental and ethnocultural difficulties that children experience:

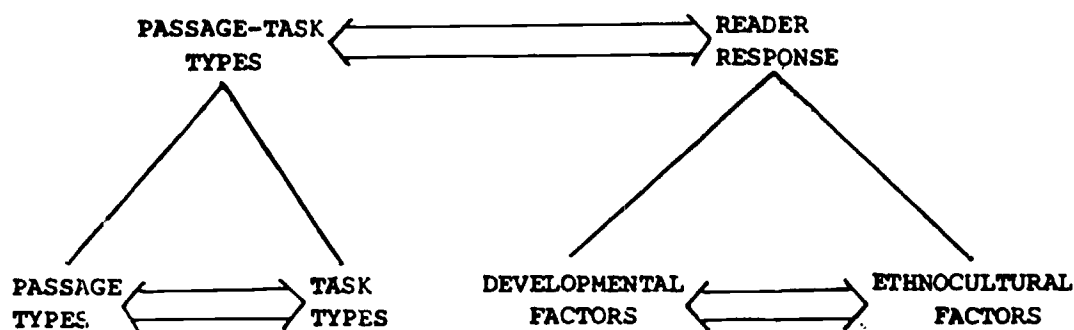

Hence our ultimate goal was to relate developmental and ethnocultural dimensions of children's responses to the various kinds of passages, tasks, and passage-task configurations that they are faced with.

Methodological Remarks

We began our research by establishing a seminar in which both mainstream and minority doctoral students participated. Our initial work was two-fold: (1) comprehensive discourse analysis of the corpus of items that had been pilot-tested at the third-grade level and (2) exploratory interviewing. These two activities were, in fact, closely related, for our analyses led us to anticipate various developmental and ethnocultural influences to be explored

through the interviewing. The interviewing supported some of these expectations, led us to modify or even discard others, and, in some instances, turned up effects that had not been anticipated: there were more things in children's heads than were dreamt of in our discourse analysis.

We were then faced with the task of synthesizing what we had learned from the exploratory interviews and what we had worked out in our preliminary analyses of the items. This synthesis took several months, for we were working out, item by item, the key issues that we would explore during the main stage of our research. It was during this period that we narrowed our corpus of items from 46 to 22. Our rationale for reducing the corpus was three-fold: first, we wanted to highlight the items in which developmental or ethnocultural problems were particularly pronounced; second, we had come to realize that certain items were more useful than others at uncovering what children do; and third, we had discovered that children can effectively discuss only a limited number of items in a single interview.

We were now ready for the main stage of our research, in which we would interview individual children and administer experimental probes to groups of children and adults.

Interviewing

Our interviewing usually involved three steps:

- (1) we administered to the individual child a mock-exam made up of the 22 items that constituted our final corpus*
- (2) after the mock-exam, one of us analyzed the child's responses in preparation for the interview, while the other took the child for something to eat and drink
- (3) the interview itself was conducted

The first step usually took about 30 minutes, the second about 15 minutes, and the third about 45-60 minutes. Hence children were usually with us for less than 2 hours.

We would like at this point to characterize our basic orientation to interviewing, first noting that it shifted a good deal during the course of the research. We began with notions about interviewing that owed much to Piaget. We were sympathetic to his reactions against experimental psychologists' demands that a standardized format of exactly worded questions be followed to insure comparability of results. Eleanor Duckworth has conveniently summarized Piaget's reactions to these demands:

*The mock-exam had the same number of items as the Gates-MacGinitie test for the third-grade level. We did not, however, set any time limit, for we did not want to create a pressured atmosphere that might carry over into the interview.

Piaget and his researchers engage in a rather loose discussion with a child. The researcher has a number of key questions in mind, to be brought up in the standard order. But the phrasing of the questions and the ensuing discussions with the child depend on the child's reactions. Piaget is criticized by many psychologists for not having a standardized format--a fixed set of questions phrased in a fixed way so that exactly the same words are used with each child. The point of this standardization is to guarantee that each child is dealt with in the same way. But from Piaget's point of view standardizing the words has little to do with standardizing the problem for the children. The words are only a way to get the thinking going. There is no guarantee that the same words will cue in in the same way for every child. It is important to vary the words used until they make contact with the child's thinking. Reaching the child is what has to be standard. Sticking rigidly to a fixed formula can almost guarantee a lack of standardization. (1971:27)

At the beginning of our interviewing, we, too, were strongly committed to the notion of having "key questions in mind, to be brought up in a standard order." We, in fact, approached each interview with a list of questions and tasks to be explored with the child. It was understood, of course, that a certain flexibility was needed in order to take account of each child's responses. Questions varied, for example, according to whether the child selected the target response or one of the distractors. Here is a typical item from the corpus followed by the list of questions initially used for interviewing:

The fawn looked at Alice with its large, gentle eyes. It didn't seem at all frightened.
"Here, then! Here, then!" Alice said, as she

held out her hand and tried to stroke it. It moved back a little and then stood looking at her again.

A. How did the fawn's eyes look?

sad

tired

gentle

frightened

B. What did Alice try to do to the fawn?

help it

pet it

hug it

hide it

GUIDE FOR INTERVIEWING

1. Ask children to read the passage aloud.
2. Ask children to retell the story without looking at the passage.
3. Ask children to read (A) and (B) and respond to each.
4. Returning to (A), ask children why they picked the answer they did.
5. Explore the process by which children arrived at their response by asking follow-up questions. Some possibilities are:
 - a. Does the story say so or did you just know?
 - b. Do you think any of the other answers are good ones?
 - c. What does the word it refer to in the story?
 - d. Who does she refer to?
 - e. When did the fawn's eyes look _____?
(insert in the blank the word(s) chosen by children)

6. Now explore the process by which children arrived at the answer to (B). Possible follow-up questions include the following:
 - a. Does the story say so or did you just know?
 - b. Are any of the other answers good ones?
 - c. What does stroke mean? Can you use it in a sentence?
 - d. Do you know what a fawn is?

7. When you think you have gotten as much information as you can with specific questions, ask broader questions such as the following:
 - a. If there were no answers here to choose from, if there was just the question by itself, what answer would you give? (first for (A) and then for (B))
 - b. Do you remember ever reading this story before?
 - c. What does the story say about the fawn's eyes?
 - d. What do you think the fawn's eyes really looked like?
 - e. What does the story say that Alice tried to do to the fawn?
 - f. What was Alice really trying to do to the fawn?

We found these guides to be invaluable, but as we progressed with the interviewing, we became less concerned with bringing up "key questions" in a "standard order." We increasingly came to rely upon the interpersonal relations that emerged with the individual child. We came to appreciate that the kinds of

questioning appropriate with some children were not necessarily appropriate with others. Moreover, we came to realize that many children were aware of whether we were responding to what they had experienced or were merely working through our list of questions. In analyzing our interviews, we became aware that we often lost valuable information when we attempted to pursue a list of questions rather than working with what children gave us.

Moreover, we became aware that children have a limited capacity for reflecting upon their own experience. While they may at first be attracted to a certain kind of adult talk, they soon lose patience; and so we began to concentrate on those areas where children seemed to have access to their experience. This meant that other areas simply had to be ignored.

In effect, we arrived at a point where we no longer insisted on a list of key questions to be worked through in a standard order. We were still committed to the notion that, as interviewers, we should be maximally aware of all the problems inherent in the test item under discussion, but we realized that our interviewing would be more effective if we were free to pursue whatever emerged with the individual child. Moreover, we found that often, at the end of such interviewing, we had managed to deal with the key questions, but that these questions had emerged collaboratively. Once our control had been lessened, it was the children who often brought up the questions that we were concerned with. The fact that they did so confirmed that our questions were, in fact,

meaningful for third and fourth graders.

We should note here our sympathy for the ethnomethodological critique (Garfinkel, 1967; Cicourel, 1974; Mehan and Wood, 1975) of interviewing within traditional paradigms of research (i.e., such interviewing does not sufficiently draw on the indigenous categories of those being interviewed). Accommodating these categories is clearly fundamental to interviewing; and yet we have reservations about the strong version of the ethnomethodological position, namely, that interviewers are to eschew their own categories, working only with those provided by the interviewees. Total avoidance of one's own categories is, of course, a methodological fiction and even to pursue it as an ideal may only lead interviewers to introduce their own categories more deviously. Moreover, those being interviewed may well perceive such avoidance as violating the give-and-take norms of conversation and so avoid introducing their own categories as well. An interview is, after all, a form of conversation, and any radical deviation from the norms of everyday talk may have unwanted effects.*

There is an additional point that we would like to make about our interviewing methods. Initially, we were committed to the principle of working strictly with what the child brought to the test item. In practice, this meant that when children had not

*All the above complications are increased whenever those being interviewed lack well-developed categories about the subject matter of the interview. Certainly most third and fourth graders have not done much thinking about standardized tests of reading.

understood an item, we resisted our instincts to guide them toward a better understanding. We found, however, that "the teacher" in us was unhappy with this approach, and we eventually allowed ourselves to guide children to a better understanding of the passage as the interview unfolded. In doing so, we found that some children were better able to benefit from this help than others. In fact, children's differing capacities for gaining help from an interview became a matter of some interest to us, and we will have occasion to analyze these differences when we present the results of our research. We will also deal, in our concluding remarks, with certain provocative analogies between this method of doing research and clinical approaches to teaching.

One final word about interviewing: we have no illusions that children--or, for that matter, adults--can report accurately on what takes place when they read. Reading is such a complex activity that most of it necessarily lies beyond consciousness; and so readers are not able to reconstruct what happens during their original experience.* Even if children could perform such

*When making this claim in public, we have discovered that it is sometimes assimilated to the one that has been advanced by Bettelheim and Zelan (1982): namely, that the unconscious, as it is defined psychoanalytically, exercises powerful constraints upon what children understand as they read. This may well be the case, but it is not what we are here claiming. Our own claim is that language itself is so complex, given its many levels of structure, that it generates more information than we can process when we read. We are thus not conscious of most of the information that we work with as we read, nor can we readily retrieve it when we later reflect upon what we initially experienced. Nevertheless

reconstruction, they would not necessarily be able to talk about it during an interview. An interview makes its own demands on what is said and what is left unsaid, and these demands are radically shaped by the interaction between the child and the interviewer. Despite all these constraints, we still find that children's struggle during an interview to reconstruct their initial act of reading provides rich information; and if this information is used judiciously, it opens up possibilities of understanding that can be gained in no other way.

Group Probes

We conducted two major kinds of group probes:

- (1) those concerned with what children do when a test item is presented in a different way (hereafter referred to as performance probes)
- (2) those concerned with what children know about some particular feature of an item (hereafter referred to as knowledge probes)

The first kind of probe dealt primarily with children's textual schemata, the second with their real-world schemata. The probes were administered to children who had not been previously exposed to the test items. Indeed, with knowledge probes, the children did not confront the test item at all, since this would contaminate

this information continuously impinges upon that which we can be conscious of, and so we prefer to describe it as preconscious rather than unconscious.

their relevant real-world knowledge.

We may use the item about Alice and the fawn to illustrate these two kinds of probes. As performance probes, we asked children to provide either an oral or a written recall after reading just the passage. As knowledge probes, we asked children who had not seen the item to define words like fawn and stroke. In probing for children's knowledge of stroke, we used two different approaches. First, we used a relatively unstructured probe, simply asking children to use the word stroke in a sentence. We then used a more structured probe to find out whether children would find a sentence acceptable in which the word stroke is used in the same way as it is in the test passage:

Here are some sentences. In each sentence you will find the word stroke. Put C in front of each sentence which uses the word stroke in a correct way.

Homer's granddad had a stroke.

Homer went out on the golf course to practice his strokes.

Homer ate all the delicious strokes on his plate.

Homer's mother told him to stroke the kitten gently.

The recipe said to beat the cake batter 100 strokes.

The following list will give an idea of the kinds of performance probes used in the research:

- (1) children draw the scene they imagined while reading
- (2) children read the initial portion of a passage and then complete it
- (3) children recall a passage and/or tasks
- (4) children make up tasks after reading the passage
- (5) children do an item with some feature changed in a task

In the case of the last kind of probe, we sometimes presented the task stem with different choices or even without any choices at all. At other times, we varied the stem itself. In the item about Alice and the fawn, for example, we presented the second task with a stem that showed more clearly the underlying intent:

What did Alice try to do to the fawn? ———> In the story, the word "stroke" means _____.

Here is a representative sample of the different kinds of knowledge probes used:

- (1) children draw a picture or describe a picture that is already drawn
- (2) children tell what they know about some feature of punctuation such as quotation marks
- (3) children tell what they know about a particular topic
- (4) children interpret what a particular sentence means
- (5) children evaluate whether a particular sentence sounds all right, and if not, try to explain why it doesn't

A final word about probes. So many of them were conducted

that we were unable to insist upon the standards that would be used in conducting more formal experiments. We were generally not able to pilot test them in order to improve their substance or design; nor did we select participants according to random procedures. The probes with children were mostly conducted by teachers in public schools in and around New York City.* In general, these teachers were not able to take account of factors other than the ethno-cultural one (e.g., gender or socioeconomic class).

Hence we caution the reader to bear all this in mind when evaluating the results of the various probes. They were designed to provide working ideas about what third and fourth graders know and do with respect to certain features of the test items. Used judiciously, they can provide insights into differences, on the one hand, between children and adults and, on the other, between mainstream children and minority children.

The Gates-MacGinitie Reading Tests

At this point a brief overview of the Gates-MacGinitie Reading Tests may be helpful. They are one of a handful of comprehensive standardized testing programs that are widely used to compare the reading achievement of individual students, classes, schools, and school districts with national norms. The different

*The adult probes were generally conducted with graduate students in either the Applied Linguistics Program or the Language and Reading Program at Teachers College, Columbia University.

tests provided are described in the following table:

<u>Test Level (Forms)</u>	<u>Designed for Grade</u>	<u>Number of Items</u>	<u>Testing Time (in minutes)</u>
R (1,2)	1.0 - 1.9	54	about 65 minutes (given in 2 sessions)
A (1,2)	1.5 - 1.9	Vocabulary 45 Comprehension 40	20 35
B (1,2)	2	Vocabulary 45 Comprehension 40	20 35
C (1,2)	3	Vocabulary 45 Comprehension 44	20 35
D (1,2,3)	4 - 6	Vocabulary 45 Comprehension 43	20 35
E (1,2,3)	7 - 9	Vocabulary 45 Comprehension 43	20 35
F (1,2)	10 - 12	Vocabulary 45 Comprehension 43	20 35

(MacGinitie, 1978:1)

The items which constitute our corpus were prepared for the comprehension section of Level C, which is intended primarily for use with third graders or beginning fourth graders, but is also used "out of level" with older classes or children whose reading is below average. This section consists of 22 passages, each followed by two multiple-choice tasks. The test is not intended to reward speed. It has been formulated so that "most children will have time to try all the items" in the 35 minutes allowed. The comprehension sections of Levels D, E, and F are similar except that they contain fewer passages and the number of tasks per passage varies.

Form 2 of Level F, for example, contains 14 passages and there are from two to five tasks for each. Considering the difference in reading speed between third graders and high school students, it is surprising that the total number of words in the passages in Level F(2) is only slightly higher than the total for Level C(1)--1,272 as opposed to 1,098. Clearly, even a slow reader will use only a fraction of the time available in the initial reading of the passages. The bulk of the time spent on a test is taken up with its mechanics--reading the tasks, considering alternative answers, rereading passages for crucial information, and so forth.

The format of a standardized reading test is a compromise between several objectives. The fundamental goal is that the test be valid and reliable. Other things being equal, the validity and reliability of a test increase when there are more items and a greater variety of item types, since the result depends less on any particular item. Pressures to make tests longer and more complex are counterbalanced, however, by practical considerations. To maintain validity, a test must be uniformly administered by teachers who have no special training beyond the directions in the manual, and this is more likely to be achieved if a test uses a simple format that is familiar to teachers and students. With respect to length, the longer a test becomes, the more difficult it is to fit it into the school routine. The ideal is a test that takes no longer than a class period, including the 10 to 15 minutes necessary for distributing materials, giving instructions, and completing practice items.

One effect of these various constraints on format is that the texts to be comprehended are extremely brief. If it has been decided that there must be 44 tasks and that there should only be two tasks per item and that the total number of words should not be much over 1,000, there is no alternative. The average length of a passage in Forms 1 and 2 of Level C is just under 50 words, with the longest containing 73 words and the shortest only 23 words.

The passages used are intended to reflect the "kinds of material that most communities hope their children will learn, will read, and will enjoy reading" (MacGinitie, 1978:31). The subject matter of the passages has been selected according to the following general plan:

Distribution of Subject Matter Content

Test Level	Percentage of Comprehension Passages					
	A	B	C	D	E	F
Content Area						
Narrative-Descriptive	85	70	55	40	32.5	32.5
Social Sciences Community Life, Social, Economic History & Technology	10	15	20	27.5	32.5	32.5
Natural Sciences Plants and Animals Natural Phenomena Biological and Physical Sciences	5	15	20	27.5	25	25
The Arts	0	0	5	5	10	10

(MacGinitie, 1978:59)

Narrative-descriptive is presumably a cover term for fictional passages. In the plan outlined above, the amount of narrative-descriptive material decreases with each level, while the amount of expository material from the social sciences, the natural sciences, and the arts increases. From our point of view, this plan confounds two different principles of classification: one based on discourse mode--narrative, descriptive, expository--and one based on the status of the information conveyed--fictional or factual. We would prefer a system of classification that kept these two principles separate:

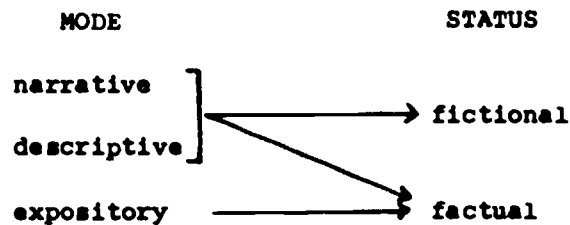

This classification makes clear that while expository passages can be presumed to be factual, narrative-descriptive passages are not necessarily fictional. Indeed, the historical anecdote, which is both narrative and factual, appears frequently on reading comprehension tests, probably because it is a form that can be kept brief (for further discussion of this matter, see chap. 4, pp. 40-44).

The tasks in the Gates-MacGinitie Tests are divided into two general categories, literal and inferential. A literal task is concerned with "something that is explicitly stated in the passage; it involves a retatement or a paraphrase." An inferential task, on

the other hand, is concerned with "something that is only implied in the passage." The two kinds of tasks have been distributed so that the proportion of inferential tasks increases with each level, as shown in the following table:

Distribution of Types of Comprehension Questions

Test Level	Percentage of Questions					
	A	B	C	D	E	F
Type of Question						
Literal	90	80	65	55	55	55
Inferential	10	20	35	45	45	45

(MacGinitie, 1978:59)

The terms literal and inferential are widely used in categorizing comprehension tasks, and yet the criteria used to decide which category a task belongs in are not very clear. In Chapter 4 we explore a number of alternative ways for talking about the differences between tasks.

Definition of Terms

There is no agreed upon terminology for referring to the machinery of reading comprehension tests. We have sought to use the following terms, some of which have been introduced already, in a consistent way. The combination of an individual text and the questions that follow it is referred to as an item. The text part of an item is called a passage. We have chosen to refer to the two "questions" that follow each passage as tasks, since fewer than

half of them are actually interrogative in form. We distinguish between the two tasks in an item by referring to them simply as (A) and (B). The suggested answers in each task will be referred to generally as choices or responses or alternatives. The choice designated as correct by the testmakers is called the target response; choices regarded as incorrect are referred to as distractors.

From a formal point of view, the various tasks can be divided into two groups: completion tasks, in which the student is given the initial part of an incomplete statement and the four choices represent possibilities for completing the statement; and question tasks, in which the student is asked a question and the four choices represent possible answers. The following item provides an example of each type:

The trap-door spider lives in a burrow that it digs in the ground. It lines the burrow with silk that it has spun. A tightly fitting door of silk and mud closes the burrow at the entrance.

A. This spider lines its burrow with

mud	silk
grass	cotton

B. What part of the burrow gives this spider its name?

the entrance	the web
the floor	the lining

In completion tasks the incomplete statement is referred to as the stem, and the word or phrase used to complete it is called the completer. When the target response is used as a completer, the stem and the completer together form the target proposition. The target proposition for (A) above would be

This spider lines its burrow with silk.

Correspondingly, when a distractor is the completer, the incomplete statement and the distractor form a distractor proposition. The three possible distractor propositions for (A) above are

This spider lines its burrow with mud.
This spider lines its burrow with grass.
This spider lines its burrow with cotton.

With a question task, the target proposition consists of the "long answer" to the question that uses the target response (i.e., the answer that is maximally redundant). For (B) above the target proposition would be

The entrance is the part of the burrow that gives this spider its name.

The distractor propositions for (B) would be

The floor is the part of the burrow that gives this spider its name.

The web is the part of the burrow that gives this spider its name.

The lining is the part of the burrow that gives this spider its name.

Presentation of Research

Perhaps a word is in order about how we have organized the chapters that follow. As we carried out this study, a range of themes emerged around which it could be organized. There were the developmental themes: for example, the various ways in which literate--even literary--features in the test passages affect children's understanding; and there were the ethnocultural themes: for example, the ways in which minority student's experience of oral narrative shapes their notions of what constitutes a story. Such themes were fundamental to the study and could have been used as the basis for presenting it. In order to develop these themes appropriately, however, we would have had to assemble supporting material for each from a number of the test items; and generally such material is not well assimilated unless the full items themselves are immediately available to the reader.

For this reason, we decided to organize the study around the individual test items. We take up the items consecutively, and while each is under consideration, we deal with it exhaustively. The various problems--developmental and ethnocultural--that children experience with it are together explicated, whether they are rooted in the passage, the tasks, or the entire item. In each exposition we weave together results of the initial pilot test, the individual interviews, and the group probes. At the same time, we provide cross-references so that multiple themes can be traced throughout the study.

Once we decided to take up the items one at a time, we were faced with the question of how to order them. After some deliberation, we decided to order them according to certain passage characteristics that they display. In Chapter 2 we present items according to the various kinds of incomplete narratives that the passages convey. In Chapter 3 we present items according to various kinds of shifts that the passages--expository as well as narrative--require readers to make (the final part of that chapter is concerned with a shift that involves the tasks as well).

From the passage-based perspective in Chapters 2 and 3, we move to a task-based perspective in Chapter 4. There we develop various ways of classifying the tasks, with particular attention to the functional demands that they make. In Chapter 5, we conclude our study, by using the framework developed in Chapter 4 to examine more broadly what we presented in Chapters 2 and 3. At that point we delineate passage-task configurations that are particularly troubling from developmental and ethnocultural perspectives.

This way of presenting the study has two main advantages. First, it allows for a cumulative grounding of the theoretical points that we make. These points emerge gradually rather than en masse, and each is introduced only as it is needed in clarifying some particular aspect of children's experience with a test item. Second, our detailed exposition of the 22 items--it runs for nearly 400 pages--materially demonstrates how much goes into reading what is an apparently simple passage. We bring to the surface and

examine closely all the fine detail that ordinarily remains out of awareness during an act of reading. This is one of the reasons why the analysis of an individual item may seem a bit overwhelming. Another reason is that each analysis conflates the experience of hundreds of children of varying ethnocultural backgrounds. It is as though, for each item, we observe many readers reading at once.

One final word of caution. We have often discovered, when presenting our research in a public forum, that there are people who assume that comprehensive analysis of test items and reader response can solve the problems of reading tests. Certainly it is our hope that what lies in the pages ahead will help testmakers to improve the tests that they prepare, but our own experience in doing the research has made us aware of how difficult it is to prepare a test item. It has led us to accept that any item, no matter how carefully it is prepared, is subject to varying interpretive frames. Indeed, one of the major goals of our research has been to demonstrate how rich and varied children's responses are to test items, how much their understanding of language is bound to ethnocultural bodies of knowledge, experience, and values.

Chapter 2

EXPANDING NARRATIVES

In Chapter 1 we remarked on the brevity of the passages used in the items of our corpus. We suggested that this brevity results from an effort to achieve a balance between two antithetical goals: the statistical goal of maximum validity and reliability and the practical goal of providing a test that can be easily and uniformly administered in a single class period. In this chapter we will present eight items from our corpus that contain narrative passages. We will begin by considering how narratives are made brief enough to fit the test format.

The shortest of the eight passages is only 37 words long, while the longest contains 78 words. A question that naturally occurs is "What kind of story can you tell in 78 words, let alone 37?" A brief answer is "Not a very exciting one." But before we consider the consumer's point of view, let us speculate on the options open to those who prepare test items.

Ideally, test passages should represent the kinds of reading that children are expected to do in school and at home. Since narratives of less than a hundred words are not common in these

environments, passages are frequently taken from longer pieces. There are two possibilities. One is that a passage will consist of the beginning of a longer narrative. Here is an example:

One day many years ago, Dr. Wye came along the Salem Road. Dust was all over the buggy top, all over the big gray plodding horse, and all over the doctor's hat and coat. He was tired and drowsy, but you would not have guessed it, for he sat up straight and solid.

The formulaic One day many years ago clearly marks this passage as the inception of a narrative. The total effect is to set a scene:

TIME: many years ago before automobiles were common

PLACE: a rural area

PROTAGONIST: Dr. Wye, the kind of man who sits up straight even when nodding off

Setting up the scene leaves little space for actual narration and so the reader is left wondering what might happen next. We will describe this kind of passage as TRUNCATED.

The second possibility for drawing a test passage from a longer piece is that it will represent something besides the beginning:

Hans found himself in a pretty pickle in the chimney. The soot got into his eye and set it to watering, and into his nose and set him to sneezing, and into his mouth and his ears and his hair. Still he struggled on, up and up. "Every chimney has a top," said Hans to himself, "and I am sure to climb out somewhere or other."

Here readers wonder not only what will happen next but also what has already happened. Certainly they are justified in feeling that they should have been told how Hans came to be in this predicament. Passages like this one that force the reader to speculate about what information has been given will be described as EXCERPTED.

An alternative to selecting a test item from a larger narrative is to construct one that seems to be complete. Here is a passage that manages to convey to the reader the sense of a whole story:

Using wires, magnets, and electric batteries, Alexander Graham Bell began to build models of an invention he called the telephone. None of his ideas worked. Then one day Bell's assistant happened to pull a small spring connected to their latest model. In another room, listening into the receiver, Bell heard a faint "twang." It was the first sound ever heard over a telephone line.

We cannot be certain whether the testmaker wrote this passage from scratch or adapted it from already existing material. Whichever strategy was followed, the result is much the same: a narrative resembling what people often call an anecdote. First the reader is told what happened--the faint "twang"--and then why it's remembered--it was the first sound ever heard over a telephone line.

Clearly something must be sacrificed if the semblance of a complete story is to be achieved with so few words. What tends to be left out is the kind of connecting detail that a reader is accustomed to. Consider, for example, the relations between the first two sentences. Sentence 1 reports that Bell began to build

models of a telephone. The use of began to leads a reader to expect some information about what these models were like, how they differed from each other, or at least the amount of time that Bell worked on them. But sentence 2 does not build on these expectations, reporting only the schematic notion that none of Bell's ideas worked. It is as though a large gap emerges between the two sentences, one that a reader must fill in (and as the writer moves ahead at a rapid pace, the reader is left behind to fill in a comparable gap between sentence 2 and sentence 3). It is for this reason that we describe a narrative like the above one as GAPPED.*

Of the eight items presented in this chapter, the first two contain truncated narratives, the middle three excerpted narratives, and the final three gapped narratives.

*Given the brevity of the passages in our corpus, it follows that all of them are necessarily gapped and so this term must be understood relatively. Generally speaking, the truncated and excerpted passages do manage to provide the kind of sensate detail that a child needs in order to imagine the physical scene. In the truncated passage above, dust is everywhere:

All over the buggy top, all over the big gray plodding horse, and all over the doctor's hat and coat.

In the excerpted narrative, it is soot rather than dust that is everywhere:

The soot got into his eye and set it to watering, and into his nose and set him to sneezing, and into his mouth and his ears and his hair.

Truncated Items

SHOP SIGN

We will begin with the following example of a truncated narrative:

Its first appearance sent a flutter of excitement through the street. It was only a shop sign, made up of white lettering on a sky-blue background. It announced that Mrs. Doyle was a dealer in candies, homemade taffies, confectionery, and sundries. The "sundries" was a mystery to most of the admirers of the sign, but they assumed it meant something at least as delicious as caramel.

A. What was the mystery?

an appearance	the caramel
a woman	a word

B. The story is mainly about

candies	a shop
a sign	Mrs. Doyle

Rather than telling a story, this passage only manages to get one underway. In fact, the entire passage can be viewed as an example of a fictional technique that is commonly used to launch a story. A single object--in this instance a shop sign--is introduced, leaving readers to wonder why it is there. Their curiosity is heightened by the way in which the object is presented. It is evoked in the first sentence, but not actually named until the second. Moreover, the message conveyed by the shop sign is rather

obscure. The final word on the sign--sundries--is described as "a mystery to most of the admirers of the sign." This bit of mystery is emblematic of larger ones circulating in the air: who, for example, is Mrs. Doyle and why has she become a dealer in candies?

Once their curiosity has been aroused, children are liable to misunderstand the task that immediately follows the passage. It may be difficult for them to think of the single word sundries as constituting a "mystery," and so they may be led to choose any one of the distractors. They might, for example, choose a woman, given that the candy-shop owner has been so thinly--and provocatively--identified. Mrs. Doyle is described as a dealer in various things that must sound strange to children. The very use of this word is suggestive to the ear of a child who lives in the inner city.

In certain ways, children's misunderstanding of (A) is prototypical of what we encountered in our work, and so it is useful, at the outset, to identify its two major sources. First, children often use larger patterns of meaning in responding to a task that calls for a local detail. This tendency can become heightened whenever a particular word--like mystery in this passage--readily cues such larger patterns (for another example, see WHITE CIRCLES, chap. 3, p. 27, where children are expected to link the word surprise with a minor detail, even though the larger scene is fraught with surprise). Second, children may use their own reactions in responding to a task that is, in fact, concerned with

the reaction of people who have been identified in the passage. In this item, for example, some children applied the word mystery to their own experience as readers rather than to the townspeople's experience. As we will see, the highly elliptical form of a task may encourage this kind of response (e.g., What was the mystery? rather than What did the townspeople find mysterious?). In effect, this misunderstanding, like the previous one, arises from children actively identifying with the material (i.e., establishing links between the world that it presents and the one that they inhabit).

We might note that all three of the distractors--each of which can be identified as a mystery within the larger ambience of the story--were more attractive during the pilot testing than the target response:

		MAINSTREAM	MINORITY
DISTRACTORS	[the caramel	34%	36%
	[an appearance	31%	36%
	[a woman	20%	22%
TARGET RESPONSE	a word	16%	7%

As can be seen, mainstream and minority children's patterns of response were similar on this task. Children in both groups were attracted most strongly to the caramel and an appearance, even though, on the surface, these two choices seem less a mystery, with respect to the story itself, than does a woman. Moreover, the proportion of children in both groups who selected the target response fell well below chance (which is, of course, 25%, given

that there are four choices). The proportion of minority children selecting the target response was particularly low.*

Before discussing reasons for children selecting the individual distractors, we should note that the form of the task itself can be viewed as eliciting a choice based on story content. As suggested earlier, the brevity of the task stem encourages children to select what is a mystery to themselves as readers as well as what was a mystery to the townspeople. The task does not, for example, end with a phrase such as to the admirers of the sign, thereby making clear that it is concerned with the mystery in the story itself. The form of the verb--was is used rather than is--does convey this intention, but children are likely to overlook this kind of signal,

*In (B) as well, the proportion of mainstream and minority children selecting the target response fell below chance (see p. 25). It is rare that this happened on tasks in our corpus--it occurred three other times (see LEARNING TO READ, p. 92; GREEN CEDARS, chap. 3, p. 145; and MOTHER ALLIGATOR, chap. 3, p. 161; note that any reference without chapter is to material located within the same chapter).

Whenever the proportion of children selecting a given choice--whether a distractor or the target response--falls well below chance, we can presume that there were certain factors that led to active elimination of that choice. In principle, test-takers approach a multiple-choice task by eliminating one or more choices at the same time that they select a single one. Some test-takers claim that they depend heavily upon the former aspect of this process and do not feel secure unless they have been able to eliminate all but one choice. This approach can be conveniently referred to as a backing-into-the-answer strategy. Throughout this study we will apply the term strategy to a number of such approaches. The use of this term should not suggest that children are necessarily conscious of what they do: the degree to which they are varies considerably from child to child. Moreover, the different approaches described by this term vary in the degree to which they are likely to operate at a conscious level.

particularly given that they are disposed to work off their own perspective whenever possible. During the interviewing, we discovered that children are prone to work from their own perspective, unless one represented in the passage is clearly demarcated by the task; and, of course, the brevity of the task militates against such demarcation (see *LEARNING TO READ*, pp. 110-113 for further discussion of this matter).

Two other features of the task stem encourage a choice based on story content. To begin with, a wh-word, particularly when it is the head of a nominal group, tends to be content-oriented (e.g., What happened?). Even more importantly, however, the word mystery does not usually refer to a word but rather to elements in a larger narrative. The identity of Mrs. Doyle, for example, might well be considered a mystery, but a word would ordinarily be described as unknown or unfamiliar.

We initially expected a woman to be a more attractive distractor than either the caramel or an appearance, and so wondered why these two had been more widely selected during the pilot testing. Once we began to interview children, however, we discovered a number of reasons for the greater popularity of these two. To begin with, the words caramel and appearance are both used in the passage, whereas woman and word are not. Throughout this study we will have occasion to observe how a passage word constitutes a particularly attractive distractor; and in Chapter 4 we will provide extended discussion of what can be described as a REPETITION DISTRACTOR

(see chap. 4, pp. 20-22). Here we will only call attention to two strategies that can lead children to select a repetition distractor. The first may be described as a desperation strategy. It is used by children who are so confused by a passage that they have no idea of what a task calls for and so latch on to any choice that contains a passage word. Even children who lack effective decoding skills can use visual-matching techniques to identify some word in a task choice as having already occurred in the passage (it may be that a rather long word like caramel or appearance is more noticeable and so is easier to match up in this way). During the interviewing we came across a number of readers who, when asked their reasons for a particular choice, would simply say, "Cause it says so." This justification was used even more by children whose efforts at oral reading indicated that they were not able to decode effectively.*

The other strategy that leads to the choice of a repetition distractor can be described as a stick-to-the-passage strategy. In preparing children for tests, teachers often admonish them to work only with what is in the passage. This advice is based on a good deal of wisdom and experience, for children are prone--as this study amply documents--to expand passage content as they respond. Some children may, however, carry this advice further than it is intended and develop a strategy that can be summarized by the

*This kind of response can, of course, be viewed as simply defensive, a formula used in responding to a question that the child feels unable to deal with. This was one of the main reasons we tried to avoid why-questions during the interviews.

following maxim: a choice containing a passage word is to be preferred to one that does not. It may be noted that a wide range of test tasks do call for children simply to recycle a passage word, and so it is easy to understand how they overgeneralize their teacher's advice.

In the case of the caramel, an additional feature may have led children astray for much the same reason. In examining the pattern of article use in the four choices, we can see that only caramel is preceded by the--the other three nominals are all preceded by a. The major function of the is, of course, to signal OLD INFORMATION; that is to say, information that can be presumed to be contextually available. Hence, it is only natural for children to take the as a kind of pointer toward the preceding passage and so any distinctive use of this article among the four choices, particularly if it is coupled with a passage word, is likely to attract children who wish to stick to the passage.*

*It appears that children are more prone to select any choice that formally differs from the others. This may be simply because it is thereby more salient, but then, too, they are likely to suspect that it differs for some reason. Certainly testmakers strive to achieve formal equivalence among the four choices for a given task (see chap. 4, pp. 4-12 for a discussion of various parameters for judging formal equivalence among task choices). In this instance, they presumably avoided the use of a before caramel, because this word is used as a mass noun in the passage. From our vantage point it would have been preferable to use no article at all to signal mass-noun status, given the old-information function that children may supply for the (i.e., caramel rather than the caramel). We should further note that caramel is sometimes used as a count noun and so a caramel is, in fact, a permissible form, though one not in keeping with the use of caramel in the passage.

The form of the task stem may also have contributed to the choice of the caramel. Earlier we pointed out how the word what tends to call for a response at a content level. Hence it can lead children away from the target response toward one of the distractors. But it is more likely to lead them toward the choice of the caramel or an appearance than to a woman, given that the question-word what tends to call for a 'non-person' response.* In addition, the caramel may be viewed as a particularly apt response to the question (i.e., what is marked not only for a 'non-person' response, but more specifically, a 'thing' response).

In addition, caramel may have been attractive to readers who interpreted the word mystery with reference to their own experience as readers. The use of caramel in this passage was, in fact, mystifying to many readers. A number of children, even skilled oral readers, stumbled over this word when they were asked to read the passage aloud (one even pronounced it as camel). The word tends to be familiar to children in its spoken form, but for many that form is /karmɹ/ and so it is not easily connected with the written form.

*What can function more generically, eliciting a 'person' response as well as a 'non-person' one:

--what made Sarah late again?

--Well, it must have been her father.

This greater latitude is, however, more associated with the informality of everyday conversation than with the formality of school prose.

The use of caramel in the passage was mystifying for an additional reason. It is the final word of the passage, coming at the end of a rather long and arduous sentence. This sentence is not only compound in structure, but its second part requires children to understand that the townspeople used caramel as a base of comparison in evaluating what the word sundries meant. Many children simply did not understand this sentence. For example, a number of them associated the final it with shop sign rather than sundries. The three previous uses of it in the passage do, in fact, refer to the sign and, as we will see, many children failed to understand that sundries was referring to a word rather than the things that the word stands for. In fact, some children even associated they in the final sentence with sundries rather than with the admirers of the sign. Given such confusions, it is not surprising that many children failed to understand how caramel was used in the passage. It is interesting that when children were asked to say what was in the passage, a number of them included caramel along with the other kinds of candies that were advertised on the shop sign.* One child who did understand the final sentence nevertheless wondered why townspeople had used caramel as a base

*One of us came across a girl more than a year after she had been interviewed about the test items. She began to talk about what she remembered from this experience. SHOP SIGN was rather high on the list of items that she could recall, and she managed to supply a good deal of information about it. She claimed that the sign advertised "taffies, caramels, and sundaes." In fact, a number of children actively misread sundries as sundaes.

for comparison. She felt that "chocolate would have been a whole lot better," and so she, too, was mystified by the use of caramel in the passage.

Let us now consider specific factors that led children to choose an appearance. To begin with, the appearance of a shop sign is highly thematic to the passage. We asked a group of 22 adults* to identify what the passage was "mainly about" (i.e., we gave them (B) but without the multiple choices), and more than half made responses that involved the shop sign's appearance--as opposed to simply a sign which is the target response provided for (B). An appearance may have thus been selected simply because it is so central to the passage, which, as already pointed out, is itself full of mystery.

It might be argued that the appearance of the shop sign, considered only as an event, is the least mysterious element in the narrative. Readers are directly told that it was hung so that the townspeople would know about the opening of Mrs. Doyle's candy shop and about what kinds of candies she would deal in. Still, the manner in which the sign conveys this information is mysterious. The townspeople do not know the word sundries that is written on

*Throughout this study we make reference to adults who participated in various group probes. Generally speaking, these adults were drawn from programs that deal with language study at Teachers College, Columbia University (e.g., Applied Linguistics or Language and Reading). Hence, in evaluating their performance it is important to bear in mind that they are probably more analytic about language than the average adult is.

it. Nor do they know--at least not necessarily--who Mrs. Doyle is, why she is referred to as a dealer, what confectionery refers to, and so on. In choosing an appearance, a reader can attempt to encompass the multiple mysteries associated with the sign. Hence, this choice can be viewed as constituting an even more holistic response to mystery at the story level than does a woman. When one child was asked why she had chosen an appearance, she replied, "Well, I think that sign had a very strange appearance." She first talked about its coloring but went on to discuss its rather bizarre display of information. It is evident that she viewed sundries as only one among many mysterious words on the sign.

At least two other factors seem to have contributed to children's selecting an appearance. To begin with, the words appearance and mystery are closely connected. Both convey a sense of 'irrealis,' and they often occur together in narrative genres that children are familiar with (e.g., the ghost story). We might note that other words in the passage can be similarly associated with mystery, though, at least in certain instances, to a lesser degree: flutter, excitement, dealer, announced, and even assumed. In effect, a substantial network of lexical resources sustain an aura of mystery in the passage. Secondly, appearance is a word somewhat bookish in flavor and so tends, as one child put it, "to sound right as a test answer." We will often point out how distractors are attractive to children for much the same reason (see, for example, arrangement in CHEE TONG, pp. 168-169).

We have already mentioned reasons for children's attraction to a woman and so will not reiterate them here. We will rather note factors that may have somewhat dampened their attraction. As already mentioned, the word what in the task stem tends to call for a 'non-person' response. Perhaps more importantly the use of a rather than the may have prevented children from properly associating woman with Mrs. Doyle. A use of the could have effectively guided this association, given that the passage mentions only one woman.*

Children seem to have experienced a similar difficulty in selecting the target response a word. Just as they failed to associate Mrs. Doyle with woman, so they failed to associate "sundries" with word. With regard to both choices, a more specific word must be linked to a more general one. In the case of the target response, however, the could not have been used to guide the linkage since a number of words on the sign are listed.

The difficulty of associating sundries and word is perhaps best described as metalinguistic. This term has been bandied around a good deal and just what it means is often not all that clear. At times, its scope of reference is so far-ranging that it can be used to identify any formal measurement of language knowledge or skills (those trained in psychology or education often use the term in this way; see, for example, Ellis, 1980, or Bracken,

*The was not, of course, avoided for consistency's sake, since it is used before caramel.

1981). Obviously we do not intend the term to have this scope, for it would then describe all the tasks in our corpus and so could not be used to distinguish any subset of them. In order to restrict metalinguistic, we adopt a familiar posture among linguists and apply the term to any use of language that itself refers to language. Perhaps the prototype of such use is the defining of a vocabulary item, and a number of tasks in our corpus call for just that:

In the story, the word "abated" means died down.

HURRICANE (chap. 2, p. 131)

One bit of language is established as synonymous to another, at least with reference to a particular context.

The task under consideration is obviously not metalinguistic in this sense. It does not, for example, require children to provide a bit of language to establish what the word mystery means. The task is simply 'What was the mystery?' rather than 'In the story, the word "mystery" means _____. ' The task does, however, require children to identify that mystery is used to refer to a verbal entity (i.e., the word sundries). Hence, the task can still be described as metalinguistic in that it requires children to use language in a self-referring way.

As has been often pointed out (e.g., Olson, 1976), one of the major demands of formal schooling is that children learn to use language in a self-referring way. Early on in their school careers, children are exposed to exercises such as the following:

Reading is fun.

Which word begins with a vowel in the above sentence?

Here the word to be identified is in the immediate text and, of course, it is explicitly referred to (i.e., which word).

In the case of (A), however, mystery does not refer to a word as it occurs in the immediate text but rather to one written on the shop sign, which is, of course, itself a non-verbal entity in the constructed world that the text mediates. In effect, children must locate a verbal entity not in the passage where they might expect it, but rather in the world that they imaginatively construct from the passage.

We cannot be certain how this added demand affected children, but it may well have been the proverbial straw. As we will often point out, children have enough difficulty dealing with the more ordinary kind of metalinguistic task

From an adult perspective, (A) can seem to be a relatively straightforward task. The passage does, after all, use the word mystery to refer to "sundries":

The "sundries" was a mystery . . .

In principle, a reader has access to two major cues that the mystery was simply a word (i.e., sundries) rather than what the words itself refers to (i.e., 'sundries'):

- (1) the placing of sundries in quotation marks
- (2) the use of was--a singular form of the verb--after the word sundries.

These cues are not, however, necessarily available to an inexperienced reader. To begin with, quotation marks can be used in a number of different ways. By far the most familiar use is to indicate quoted speech. We asked 30 children what quotation marks are used for, and 26 of them made reference to quoted speech in some form or another. Another familiar use is, however, to indicate some kind of special use of language (i.e., what is often described as figurative use). Given that children generally do not know the word sundries, they are inclined to think of it as a special word and so do not find the use of quotation marks strange. Some children even pointed out that the quotation marks indicate special use of this word.

By the same token, the use of the singular verb--the other major cue--can be readily accommodated as well. Sundries, as an unfamiliar word, can be analogized to a word such as series, which, even though it ends in -ies, is singular. From a broader perspective, we can observe that children of this age are generally not attentive to formal cues such as quotation marks and number agreement; and in the case of minority children, the cue for subject-verb agreement may be even less salient because it differs from those to which they are accustomed.

Added to the lack of saliency of these cues is the absence of

word between the and "sundries." Such an absence can be misleading, as illustrated by the following sentences:

- (1) Hey, [the word books] shouldn't have a c before the k.
- (2) Hey, [books] shouldn't have a c before the k.
- (3) Hey, [the books] shouldn't have a c before the k.

As can be seen by examining the bracketed material, sentence (3), in comparison to sentences (1) and (2), seems somewhat ill-formed. The combination [the + nominal], even though the latter is placed in quotation marks, leads readers to think of a real-world entity rather than a purely verbal one.

We suspect that word may have been removed from the passage in its original form in order to set up (A):

The ~~word~~ "sundries" was . . .

If this is the case, it was a misleading omission. It would have been preferable to remove the as well, leaving simply sundries as the subject:

"Sundries" was . . .

As indicated by the group of three sentences above, a simple nominal placed in quotation marks more readily refers to a verbal entity than the plus a nominal placed in quotation marks. As we earlier pointed out in regard to the mystery, the word the tends to point away from language toward the world that it represents.

It is obvious that other factors interfered with the choice of a word. To begin with, many words were potentially unfamiliar in this passage (e.g., confectionery), and so it was difficult for children to focus on any one word as a mystery, particularly if they were concerned with what was mysterious to themselves as readers. Perhaps even more troubling is the use of mystery to describe a word that is not known. As already suggested, a term such as unknown or unfamiliar would be more appropriate. The use of mystery tends to evoke a real-world situation rather than a mere word; and given children's unfamiliarity with the word sundries, it was easy for them to imagine that whatever it refers to is quite mysterious. We are able to observe, once again, their focus on the world rather than the word.

We interviewed some adults who reasoned in a similar way. They claimed that the townspeople would, in fact, know the word sundries, but would associate it with various odds and ends that can be purchased in a drugstore (e.g., sewing goods such as needles). These goods would be viewed as inedible and so the townspeople would wonder why Mrs. Doyle planned to sell them in her candy shop. One adult even went so far as to make a provocative association between the selling of needles and Mrs. Doyle's work as a dealer. This provides a suggestive example of how even experienced readers hold on to the core meaning of a word, although the context encourages them to extend that meaning (i.e., sundries in a candy shop would presumably refer to edible goods).

Inexperienced readers are, of course, even more reluctant to extend word meaning in a novel context. In this study we will often show how children are misled by holding on to a fixed meaning for a word (see RAISINS, chap. 3, pp. 92-94 for a particularly vivid example of this phenomenon).

Most children did not have any idea of what the word sundries means, given the highly restricted contexts in which it generally occurs (these contexts, can be generally characterized as literate rather than oral). Hence, they processed the word more at the level of form than of meaning. As already mentioned, one child, when asked later to recall the passage, talked about how Mrs. Doyle sold "sundaes" as well as taffies and caramels. When first reading the passage orally, several children pronounced sundries as "sundaes" and went on to mention various kinds of ice-cream concoctions (e.g., hot fudge sundaes). One child said,

they sound like something you treat yourself to
on Sunday.

Other children pronounced the word as "sun-dries" so that it rhymed with mudpies.^{*} Some went on to explain how Mrs. Doyle

*In treating sundries as a compound word, children were following the conventional advice to "look for little words in big ones." Many children also followed this advice in another item when they pronounced vineyard so that it resembled barnyard (see RAISINS, chap. 3, p. 86). Here a spelling pronunciation was helpful to them in understanding the passage. Most of them would have been quite mystified by the word if they had heard it pronounced correctly. Realizing that a word is a compound is no help, however, if the familiar components are taken too literally.

wanted to include dried fruit in her repertoire of goods so that, as one child put it, "parents wouldn't get angry about all that candy." One ten-year-old minority child associated "sun-dries" specifically with raisins:

--What does "sun-dries" mean? (The interviewer adopts the child's pronunciation)

--Dry in the sun.

--Uh-huh. Okay, how could that word be the mystery?

--'Cause some people don't know how the raisins was dried.*

And an eleven-year-old mainstream child made the same association:

--What do you think of when you hear the word sundries?

--It's like a kind of candy, I guess, and it's dried by the sun probably.

--Have you heard this word before or was this the first time?

--Probably the first time, but it probably means raisins.**

One child, for example, thought that a cockpit was a large, scooped-out area where cocks fight each other, an interpretation that led her far afield in dealing with WHITE CIRCLES (see chap. 3, p. 27).

*We can here observe the use of was with raisins in the speech of this girl. This illustrates the point that we made earlier about differing patterns of subject-verb agreement in the speech of black children, which thus can neutralize the cue provided by the use of was after sundries (we might note that, semantically speaking, raisins can be treated, like rice, as a mass noun).

**This child was addicted to the word probably, using it three times in two brief utterances. Many children studied their speech with "grown-up words" during an interview, no matter how much the interviewer tried to put them at ease. By the same

This association of "sun-dries" with raisins provides a clear example of what may be described as INTER-ITEM LEAKAGE. Before children worked with SHOP SIGN (it was #5 on the mock-test), they had just worked with RAISINS (it was #4 on the test). The major theme of that item (see chap. 3, p. 86) is how grapes are dried in the sun in order to produce raisins. We will observe item leakage at various points in the study. It is clear that the extreme brevity of these test items conspires with time constraints to produce a good deal of such leakage. It is difficult to assess how far-reaching the effects of such leakage might be on children's performance.

Let us now turn to the other task and first examine the results of the pilot testing. As already pointed out, the proportion of mainstream and minority children selecting the target response in (B) is, once again, below the level of chance. As indicated by the following figures, minority children performed slightly better than mainstream children:

	MAINSTREAM	MINORITY
a sign	17%	23%

token, we could often detect the use of "child words" on the part of the adult conducting the interview. At first, we were troubled by such mutual dislocation; but the more we observed it, the more we came to view it as inevitable. It manifests the accommodating patterns basic to any communication, and the greater the distance between interlocutors, the more transparent their signals of accommodation will be.

The major distractor for both groups was Mrs. Doyle, with mainstream children preferring this choice even more:

	MAINSTREAM	MINORITY
Mrs. Doyle	40%	32%

With respect to the remaining distractors, candies was a somewhat more attractive choice than a shop.*

	MAINSTREAM	MINORITY
candies	28%	23%
shop	14%	22%

Before examining the specific patterns of choice for (B), let us note certain intertask influences. The most noticeable was that children who selected a woman in (A) tended to select Mrs. Doyle in (B). In addition, less pronounced influences could be observed between

- (1) the choice of the caramel in (A) and candies in (B)

*We can observe that the pattern of choice among minority children does not vary greatly from that dictated by chance itself. A similar pattern--though it is usually less dramatic--is reflected in minority children's choices on other tasks that are intrinsically difficult. This pattern can also be reflected in mainstream children's choices, though it is usually less pronounced. On the basis of our interviewing, we were able to determine that a number of children were unable to deal with certain of these tasks and so resorted to guessing. Hence, the element of chance needs to be borne firmly in mind in evaluating the results of the pilot testing.

(2) the choice of the two target responses--a word in (A)
and a sign in (B).

Throughout this study we will call attention to intertask influences. We have presumed that their direction is primarily from (A) to (B), since children generally first do (A) and then (B).^{*} When analyzing children's performance on (B), we thus view (A) as integral to the discourse that they work with.

As indicated by the results of the pilot testing, children are far more attracted to Mrs. Doyle in (B) than to a woman in (A). At first glance, this may seem surprising since the truncated quality of the passage can encourage an extension whereby Mrs. Doyle is viewed as a mysterious figure who will be central to the story's development. Yet when the form of the individual tasks is examined more closely, it is easy to understand why Mrs. Doyle is a more popular choice. First of all, the target response in (B) actually occurs in the passage, whereas the one in (A) does not. Moreover, the task stem in (B), unlike (A) which begins with what, does not discourage the choice of a person. Rather, it may actively encourage such a choice, depending largely on how children respond to the expression the story. If they take it as referring to the larger narrative that the passage has initiated, they are likely to expect Mrs. Doyle to play a major role. Most stories that children

^{*}We administered a questionnaire about the order in which tasks are performed, and almost all children as well as adults claim that they tend to work with the tasks in the given order.

encounter are, after all, about a person.

When children were interviewed about the passage, their talk often gravitated to Mrs. Doyle. One child was directly asked, "What's the story mainly about?" and was quick to reply:

Oh, the lady that makes candy for the kids.

Another defended his choice of Mrs. Doyle by saying that she "was the one who invented that sign." He went on to claim that she had also "invented a new name for some ice cream...." Like the children mentioned earlier, he associated sundries with sundaes.

We should note that use of the term story can be problematical in a task stem. For all the tasks in our corpus it is the standard term used to refer to the preceding passage, whether it is a narrative, like this one, or expository prose (see, for example, (A) in MINNESOTA, chap. 3, p. 5). This usage seems to be reflected in many elementary classrooms where the more usual descriptive term passage is avoided.*

It is not at all clear, however, that children suppress their more usual associations with the word when they encounter it in a task. For children, story is a powerful word. It can conjure up a

*We wonder whether this avoidance is as necessary as teachers and test-makers assume it is. Both are likely to shy away from a word that they think might be confusing to children. Yet as we will see, this practice may itself lead to even greater confusion. Not only can it mislead children in unpredictable ways--it can even lead to patterns of usage that linger in adult life. In our own teaching experience, we have found that it is not unusual for college students to refer to an expository essay as a story.

wide range of experiences--a father reading a fairy tale, a grandmother telling a ghost story, a brother spreading a rumor, a sister telling a lie, or a friend describing something special that happened. Given such associations, children may be inclined, when applying the word to the preceding passage, to focus on the larger narrative that the passage has initiated. In effect, the use of the word story may encourage children to extend an incomplete passage and so choose a distractor which, like Mrs. Doyle, accords with the larger narrative that they think is likely to develop. Children do not, of course, think through such an extension--they do it automatically in response to powerful cues such as the word story itself.

Let us briefly consider children's responses to the other two distractors. Their reasons for selecting candies are fairly obvious. Not only is this word actually used, but a number of different kinds of candies are mentioned; and then, of course, children have a special fondness for candies. One interviewer asked a child what he found most interesting about the "story," and the answer was simple and forthright: "Candy." Another child claimed that she was initially attracted to candies, but decided to reject it because of an equal attraction to Mrs. Doyle. When she was questioned about this decision, she sketched with her hands a spatial image to represent her sense of the information structure of the passage: candies and Mrs. Doyle are on the same level, each subordinate to sign on a higher level:

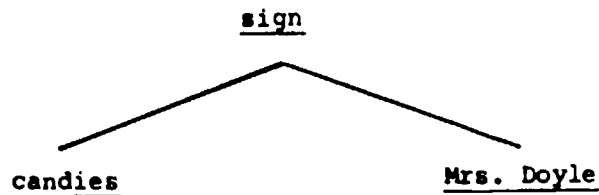

She brought forward this eliminate-if-equal strategy when discussing other items as well (e.g., LEAVING HOME, the next item that we present).

A shop was the least widely selected distractor, but even it competed favorably with a sign during the pilot testing (minority children, in fact, preferred a shop). Viewed most broadly, the passage is about the opening of a shop that sells candy. As already mentioned, we asked 22 adults to read the passage and to respond to (B) with the multiple choices removed. 12 did, in fact, refer to the shop sign's appearance. Out of the other 10, however, 8 referred to the shop itself in some way.* Most of the 8 focused on the opening of the shop, although some included the townspeople's reaction to the opening. We should note that, within these free responses, the word store was used more widely than a shop. We might also note that most children are unfamiliar with the kind of candy store described in the passage. They tend to buy candy in other settings--drugstores, grocery stores, supermarkets--but seldom in a shop that sells only candy. This lack of familiarity may help to account for the relatively low proportion

*The other 2 referred to candy.

of children who selected a shop during the pilot testing.

In considering children's difficulties in selecting the target response, let us begin by noting that (B) is comprised of a formulaic stem that occurs widely on standardized tests of reading. In our own corpus, for example, this stem is used three times (for the other two, see MINNESOTA, chap. 3, p. 5, and JAYS AND CROWS, chap. 3, p. 17). This kind of task is often described as one concerned with the main idea, but such a characterization can be misleading. It is, at best, a task concerned with main subject matter, but even this description can be misleading. Subject matter does describe more accurately than idea the nature of the response that children are required to make. The use of either term, however, suggests that this kind of task is oriented to passage content (i.e., it functions at the level of meaning). In point of fact, it functions more at the level of wording, and so it, too, can be described as metalinguistic. This position may be somewhat surprising, so let us explain just what we mean.

In selecting a sign as the target response, children are required to suppress attention to passage content, which, given its incompleteness, is likely to lead them, as we have shown, to infer a larger narrative frame. Rather, they need to focus on actual patterns of wording in the passage to determine which bit of information provided by the choices is both persuasive and prominent. Consider, for example, the display of one wording pattern that supports the choice of a sign in (B):

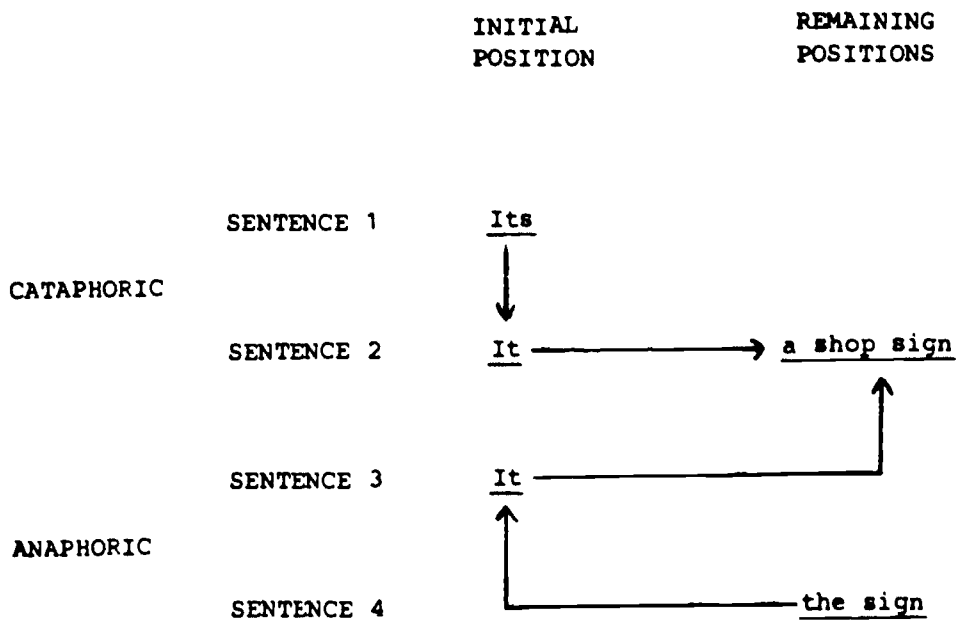

This display is based on the model of COHESION developed by Halliday and Hasan (1976). In essence, this model is concerned with representing various threads of presupposition that run through a text. One of the familiar threads is, of course, formed by a sequence of nominals(s) and pronominal(s), as illustrated by the arrows in the above display. The model deals not only with how one language element presupposes another but with matters such as the extent and direction of presupposition. Let us illustrate these terms with reference to the above table. As can be seen, a single thread of reference to 'shop sign' is extended across the five sentences. In each of the four sentences, some unit referring to 'shop sign' occurs. The distribution of units, however, shows that presupposition can run forward or backward. In the first two sentences, the movement is forward from a pronominal unit to

a nominal one. Hence, the cohesive relations are described as CATAPHORIC since information is anticipated. Once the nominal unit, a shop sign, is established in sentence 2, the ensuing cohesive relations are described as ANAPHORIC since information can now be retrieved (i.e., the direction of the presupposition is now backward).*

This analysis shows that a sign is both more pervasive and prominent in the passage than any of the other choices. It is more pervasive in that it is distributed evenly throughout the entire passage; and it is more prominent in that each of the first three sentences opens with a pronominal referring to the sign. Moreover, the cataphoric pattern found in the first two provides dramatic focus on a shop sign; or to use the term frequently used by discourse analysts, it is the shop sign which is staged within the passage.

The above analysis is, in many ways, elegant and satisfying; and once it is carried out, it leads inexorably to the choice of a sign in (B). This kind of analysis, however, presupposes that

*This is a fairly quick sketch of the inherent complexity of this cohesive thread. Any adequate description would have to note features such as

- (1) the lexical repetition of sign in sentence 4 is preceded by the to indicate its anaphoric relation to a shop sign in sentence 2
- (2) once the initial presupposition has been satisfied (i.e., with the emergence of a shop sign in sentence 2), the entire cohesive chain is presupposed with the emergence of each new link.

readers have highly developed metalinguistic skills that enable them to focus on the level of wording apart from the level of meaning; and it is precisely these kinds of skills that are not ordinarily well in place among children at this grade level. At this point in their development, children, while reading, tend to focus almost exclusively on the level of meaning. It is only later, if at all, that they acquire the skills that allow them to deal effectively with the level of wording. Hence, we would like to question whether metalinguistic tasks are appropriate for measuring reading comprehension at a third grade level. Judging from children's performance on (A) and (B), we might well recommend that they be avoided.

Before leaving (B), we wish to note a further complication that makes it more directly comparable to (A). While discussing (A), we pointed out that it is difficult for inexperienced readers to separate a word from what it refers to. In effect, they tend to experience the levels of wording and meaning as a seamless web. They may experience a similar kind of confusion when dealing with sign, given what this word means. From a semiotic perspective, it, like an individual word, is emblematic. Its only function is to stand for something else. In the case of the sign in the passage, it stood for any number of things in the minds of the townspeople: the shop, the owner of the shop, the candies to be sold inside the shop. Any one of the three distractors represents various aspects of the reality that the sign stands for and so could be readily

substituted for the sign itself. We can thus view (B) as meta-linguistic in a double sense. At the level of wording, children are required to isolate the most pervasive and prominent subject matter; and at the level of meaning, they are required to maintain a separation between the shop sign and that which it stands for.

In concluding our discussion of the target response in (B), we would like to note a couple of problems associated with the use of particular words. First, some children took the word only (in the sentence It was only a shop sign) as indicating that the sign was not, as one child put it, "really important." The downgrading effects of this word may have been particularly potent, given that a sign is not a very likely topic for any story.* Secondly, the use of the word mainly in (B) suggests that various topics compete for the central place in the passage. Hence, readers may be prone to view the shop sign as only a fictional device for getting the story underway, and that the real topic will emerge only when the rhetorical one disappears. In effect, the very use of mainly may lead readers to think of the sign, given that it is so clearly an initiating mechanism, as only a minor topic. When we come to

*This point is similar to the one we made in (A) when we pointed out that a word is not likely to be described as a mystery. In this study we will frequently make such claims so that at this point we would like to characterize them briefly. They are based on our intuitive notions about dominant patterns of language use, and, as far as we can see, these claims could be substantiated only by massive studies of various text structures. We did, however, check them out with a number of native speakers, and so are inclined to think that they are not based simply on our own idiosyncratic intuitions.

MINNESOTA (chap. 3, p. 5) and JAYS AND CROWS (chap. 3, p. 17),
we will provide evidence for such responses to the word mainly.

Both of these passages contain competing topics, for in each what
initially appears to be the main topic is replaced as further
information emerges.

LEAVING HOME

Let us turn to another item in which the passage presents a truncated narrative:

Jim and his family were going away for a week. They took a bus across town to the train station and then settled down for a long trip. First they passed by many tall buildings and busy streets. Later they went by farms and woods. They went through other cities, too, before they reached the little town near the sea.

A. Where is Jim's home?

by the sea on a farm

in a little town in a city

B. Most of the trip was by

train car

bus boat

The passage describes the journey of someone named Jim--whom most readers take to be a young boy--and his family from a city to a small town near the sea. It opens with an overview sentence, and then moves on to describe the journey itself. Once this journey has been described, the passage comes to an abrupt end with no mention of what Jim and his family did by the sea.

It is possible, of course, for a story to be about what happens on a journey, but the journey described here is not at all eventful. All that we learn about it is that Jim saw the most predictable scenery as he went along. Hence readers are likely to regard this bland journey as mere prologue and to think of what

happens after Jim and his family arrive in the little town as constituting the real story.

In many items the two tasks contrast in some way. One deals with content and the other with some aspect of vocabulary; or if they do both deal with content, one requires that information be recycled and the other that it be inferred. In this item, however, the two tasks are of a similar type; they both require readers to use their powers of inference, to take information directly stated in the passage, and to derive from it that which is not directly stated.

These tasks are also unusual in that the same tense is not used in both of them:

Where is Jim's home?

Most of the trip was by _____.

Following a narrative passage, the norm is for both tasks to be in the past tense. Presumably (A) has been put in the present tense because it is not part of the narrative sequence but rather is concerned with background information. On the other hand, (A) would work perfectly well if it were put in the past tense:

Where was Jim's home?

It is not clear what, if any, are the effects of such shifts in tense.

From the perspective of ethnocultural variation, this item is

of particular interest. During the pilot testing, mainstream children performed significantly better than minority children on both tasks. Here are the proportions of children selecting the target response for each:

	MAINSTREAM	MINORITY
(A) <u>in a city</u>	35%	24%
(B) <u>train</u>	56%	43%

Hence in analyzing children's responses to these tasks, we will be particularly concerned with showing how differing ethnocultural norms affect the understanding of this passage.

In order to select the target response for (A)--in a city--it is necessary to establish two points: (1) that Jim's home is in the place that he starts out from, and (2) that this place is more appropriately characterized as a city than as a little town. The relevant information for the first point can be found in the initial sentence of the passage:

Jim and his family were going away for a week.

To go away ordinarily indicates 'moving from a home base.' In this case, the absence is to be a temporary one, lasting only for a week. Hence there is the implication that where Jim is leaving from and returning to is more permanent than where he is going and thus should be considered his 'home.'

But the initial sentence did not function this way for many

readers. One reason may be that in certain parts of the country, "going away" has a more specific meaning than 'moving from home base.' In New York City, for example, it is a common way of referring to a vacation. During May and June one is likely to be asked

When are you going away?

For readers who are familiar with this use, the succeeding details in the passage concerning the trip and its seaside destination mesh neatly to form a vacation-theme. From inside such a frame, it is easy to see that 'home' is where Jim started out from. For those readers who speak of "taking a vacation" rather than "going away," the situation is not as immediately clear.*

Another difficulty with the initial sentence is that it is not as salient as one might suppose, given its position. When we asked children to recall the content of the passage, this sentence was almost always left out, no doubt because it is not part of the narrative sequence.

Two separate pieces of information in the passage provide evidence for the second point that must be established in order to answer (A) successfully, namely, that where Jim leaves from is a 'city' rather than a 'town':

*It has been our experience that these contrasting usages often reflect contrasting lifestyles. New Yorkers who "go away" usually end up in a pleasant, quiet place, often the same place year after year, in which they proceed to vegetate. People who "take vacations," on the other hand, are likely to take trips in which they keep moving, often at a fast pace.

SENTENCE 3: First they passed by many tall buildings and busy streets.

SENTENCE 5: They went through other cities, too. . . .

If at the beginning of the trip they passed by tall buildings and busy streets, they must have been in a city when they started out.* Likewise, the passage could not say they passed other cities unless a city had already been mentioned, either explicitly or, as in this case, by implication.

This evidence seems reliable enough, but for many third and fourth grade readers, terms like town and city that have relative and overlapping meanings are not very well differentiated. Besides this, there are many special usages which carry these words beyond their normal meaning. The Town of Hempstead on Long Island has almost a million inhabitants, while Vatican City is exceedingly small, to choose two extreme examples. One of these special uses even occurs in the passage, where the word town is actually used to refer to the city where Jim lives:

They took a bus across town. . . .

An inability to distinguish clearly between 'city' and 'town' may account for the 34% of mainstream children and 32% of minority children who selected the distractor in a little town during the

*Some adult readers of the passage have felt that the chronology of the trip is so vague that the word first may reasonably be taken as representing the first scenery mentioned rather than that seen right at the beginning of the trip.

pilot testing.*

We would also like to suggest that this same difficulty may also explain why so many children selected the distractor by the sea (23% mainstream; 32% minority). For children who think of city and town as referring to the same sort of thing, the strategy that we mentioned in our discussion of SHOP SIGN (see pp. 28-29)--namely, when two choices are equal, choose neither--may have led to a third possibility:

in a city = in a little town by the sea

This same strategy, applied differently, led other children to the target response. Since the passage says that the trip ended in a little town near the sea, these children reasoned that the distractors in a little town and by the sea were equal in that they refer to the same location. Consequently, they selected in a city as their answer.

in a little town = by the sea in a city

*There is a question of theoretical interest concerned with whether the unmarked representation of movement in natural discourse is from home base to some other point, or vice-versa. There are cogent arguments for either view which we cannot enter into here. If, however, unmarked representation is 'return' rather than 'departure'--and we think that it is--it might contribute, in some measure, to the surprising number of readers who selected in a little town. In effect, we picture ourselves more easily as 'returning' rather than 'leaving'--it is as though we view ourselves, when reporting motion, as located away from home base.

During the interviewing, we came across several children whose understanding of this item was affected by whether they tended to view 'home' as in a city or in a small town. For those who live in a small town, a city may well be viewed as a place to visit rather than to live in. But for those who live in cities, the question seems to be more complicated. One might think that they would view the city as the place where home is and a small town, particularly one by the sea, as the place for a holiday. Because of distinctive patterns of ethnocultural experience, however, some children who "live" in the city do not think of it as 'home,' at least not in the sense that a person has just one home, a sense that is implicitly assumed by this task.

The word home itself is not often used to describe an apartment, at least not in Manhattan. When we asked children what expressions they use to invite friends to where they live, they used place, house, and apartment much more than home. However, some children whose parents own country houses did report themselves as using the word home whenever they invite friends to these places. It is possible that they are adopting the non-urban speech patterns that can be found where the country houses themselves are. Moreover, some of these children viewed the country house, often located in a "little town near the sea," as their true home. Adopting the cultural values of their parents, they viewed their city apartment as simply a pied-à-terre. One of the members of the research team asked his high school daughter, who regularly goes to a country

--Jim and his family, they was in the city and they was gonna go to his home. So they took the bus to the train station and took the train through little towns and cities* till they got to their town.

--why did you decide he was going home?

--I guess he was going home. They was going away** for a week so they was either going to his mother's house or his grandmother's house or his relative's house.

--But what were they doing in the city?

--I don't know.

The interviewer, reflecting his own ethnocultural vantage point, asks for clarification:

--Do you have any idea why you thought he was going home?

--Probably he was going to visit his family.

--when he goes to visit his family, would you think of that as home?

--Mmhmm.

--Even relatives? Can a person have more than one home?

*Notice the linking of little towns and cities in her recall.

**At this point she actually uses the expression going away, but it does not affect her notion of where home is, presumably because she sees both the departure point and the destination point as 'home.'

house, to respond to the various items on the mock test. She did all of them rapidly without any problem except for this one task. When he asked her why she had circled in a little town, she used the expression "country house" in referring to the place "near the sea." He then invoked the principle, "When two answers are equally good, choose neither," and asked her how she had decided between in a little town and by the sea. She said that this problem had bothered her, but she finally resolved it by figuring out that by the sea had been included as a "trick choice." She pointed out that Jim's home was "just near the sea and not actually by it." When he asked her whether she thought tests actually force such refined distinctions upon the reader, she responded, "Of course."

Having dealt with mainstream children's cultural attitudes, let us now consider those of minority children. To begin with, many of these children have families who maintain connections with relatives in small towns. When interviewing these children, we discovered that they often hear about "going back home," and, indeed, some of them do actually go back home during the summer months. We discovered, in fact, that for these children the experience of an extended family is so strong that many do not possess the notion of a single home that this item assumes.

To illustrate the effects of ethnocultural experience, let us examine what a young girl said when asked to recall what was in the passage:

--Mhmm.

--So--do you have more than one home?

--Mhmm.

--How many?

--I have a lot of homes--my grandmother's, my mother's, my aunts', my cousins', my grandfather's house.

Let us now examine children's responses to (B). As we have already reported, about half (mainstream, 56% and minority, 43%) selected the target response train. The main distractor was bus, which was chosen by 27% of both mainstream and minority children. The power of this distractor results from a striking gap in sentence 2 of the passage:

They took a bus across town to the train station and then settled down for a long trip.

The reader begins this sentence with the protagonists on a bus and ends with them preparing themselves for a long trip. From the destination of the bus--the train station--and from the fact that these characters are experiencing locomotion in the succeeding sentence, a reader must infer that they got off the bus, walked through the station, and got on a train between the compound predicates in sentence 2.

A writer cannot tell everything, of course; in fact, an important aspect of skillful writing is knowing what must be said

and what it is safe to leave out. The omissions in this sentence, however seem perverse. We suggest that the missing information has been arbitrarily withheld in order to provide the foundation for (B).

In closing our discussion of this task, we would like to note that for many urban children, particularly those belonging to an ethnic minority, the implied transfer from bus to train is directly counter to the one they are likely to make. When they leave the city, they generally take the train (i.e., the subway) to the bus terminal and then take a bus to the small town where their relatives live. In fact, since long-distance travel by train is moribund in our culture, this item, no doubt, strikes children as somewhat old-fashioned. We will discuss this matter further as we present BLACK BONNET, the very next item in this chapter.

Excerpted Narratives

When we described our three-way classification of narrative passages--truncated, excerpted, and gapped--we did not mean to imply that it would always be easy to decide which category to place a particular passage in. In the final analysis, what is important is not what a passage is, but rather how individual readers take it, what they do in response to its inherent incompleteness. LEAVING HOME is a case in point. We suspect that it was written for the test rather than taken from a longer narrative, and one can think of it as telling a complete story, though certainly not a very compelling one. By these criteria it should have been considered gapped. However, when we talked to children we found that many regarded it as preamble. They were left to wonder what happened after Jim and his family got to the little town near the sea.

With some passages it is difficult to tell whether they are truncated or excerpted. Many writers try to capture a reader's attention by starting in medias res--in the middle of things--and then later give the background information that is needed for a fuller understanding. Consider the following passage:

The thunder rumbled again, almost as though it were in the earth instead of the sky, making the house tremble a little. And then slowly, one by one, as if someone were dropping pennies on the roof, came the raindrops. A noise of wind stirred in the leaves, and then the rain burst strong and loud upon the world.

This passage could well be the beginning of a story--and therefore truncated. Or it could just as well be an internal paragraph, which would make it excerpted. It is impossible to decide on the basis of the available evidence.

The first of the narratives to be treated in this section may occasion some disagreement. We think that the way it is written demonstrates that it is not an initial paragraph, but the evidence is subtle and there may well be those who think it is an example of in media res. There is not likely to be any disagreement about the other two narratives that follow in this section.

BLACK BONNET

Our first example of an excerpted passage, like the one in LEAVING HOME, presents a train scene:

The train stopped. Miss Esther stood far back to get away from the smoke and roar. As the cars pulled away, she took a few steps forward to scan the platform. There was no black bonnet with a worn lace veil, no old lady with a burden of bundles. There were only the stationmaster, a boy or two, and a clean-faced bent old man with a bird cage in one hand and an old carpetbag in the other.

A. What did Miss Esther expect to see?

a lot of people	an old man
a black bonnet	a bird cage

B. Miss Esther stepped forward when the

crowd left	crowd arrived
train left	train arrived

This scene, like the previous one, comes out of a world that no longer exists. The two differ, however, in their manner of evoking this world. Here it is captured by sensate detail: the train, for example, emits smoke and roar; and Miss Esther--the name itself is dated--searches for an old lady wearing a black bonnet with a worn lace veil. The very language used to render this detail itself evokes the past, at least for a reader who is accustomed to literary nuances.

LEAVING HOME, on the other hand, is written in the bland, colorless style that was once the bane of children's schoolbooks.

It provides readers little detail with which they can establish a former world. Rather they must infer such a world, reasoning that a family, at least in this country, would no longer be likely to make a vacation trip by train.*

We would like to note, in passing, that these two items, despite stylistic differences, illustrate well testmakers' tendency to avoid contemporary materials. They do this presumably in the interests of fairness and neutrality, but in light of the pilot test results one might question whether these interests are served. Mainstream children seem to have an advantage in dealing with such material. Consider, for example, how readily a suburban child went from the detail of smoke to a dated world:

--It was an old-fashioned train because they'd
have smoke.

This greater ease may, of course, be largely due to the particular kind of worlds that are presented in passages like BLACK BONNET and LEAVING HOME.

The sensate detail, important in establishing the dated setting, is not particularly helpful in establishing the central point of the passage--the contrast between what Miss Esther expected

*Other bits of passage information also support this inference. The understated "tall buildings and busy streets" hardly seems adequate to describe the scale and congestion of a modern city. Moreover, the implied quick transition from the center of a city to farm and woods does not seem to take into account modern urban sprawl.

to see (described in sentence 3) and what she actually saw (described in sentence 4). Most of the children whom we interviewed had difficulty in retrieving this point. It tended to get lost in the smoke and roar of peripheral detail, as their performance on a recall task clearly shows. The passage was displayed on a screen for 30 seconds, and then 34 children wrote down what they could recall of the passage (the number of children who mentioned the various bits of sensate detail is placed in parentheses):

--black bonnet (9)*

--smoke and/or roar (15)**

--bird cage and/or carpetbag (16)

--Miss Esther's standing back and/or stepping forward (18)

Only two children actually mentioned the contrast central to the passage:

--The lady didn't see a black bonnet all the lady saw was a oldman a bird cage and a carpetbag....

--She didn't see the black bonnet. She only saw a station master and a bend old man with one hand in the bird cage and the other in the old bag.

*Among these various bits, black bonnet, the one recalled least frequently, is the one most closely linked to the central point. It is as though the bath water was thrown out with the baby.

**One child mentioned the roar but mislocated its source:

The story was about a lady who got off the train and moved far back and roared.

And neither reproduced the syntactic cue for this contrast that the passage provides: there was no/there were only. Instead each rendered the contrast by referring to Miss Esther and her act of seeing: she didn't see/she only saw.*

We might note that the sheer bulk of detail that some children managed to get down on paper made their omission of this contrast even more striking. One girl, for example, wrote the following:

The train was coming and the train stopped and she stepped back so the smoke and the roar won't bother her. And she stepped forward and stepped in the train. She saw a man with a bird cage in his hand and a bag in his other hand. And she saw two boys with clean face.

We then asked adults to do the same recall task. In general, they focused on the central contrast rather than the peripheral patterns of detail. Thirty-two of them mentioned this contrast, and a number of these even used some form of the word expect, as illustrated by the following response (note the discursive commentary that emerges in adult recall):

Miss Esther was waiting at the train station. She was expecting an elderly lady (probably a widow, if we can guess from her dress) and instead saw an old man carrying a bird cage and another object. This probably took place sometime early in this century or in the last,

*The first child used old lady instead of she and the ungrammatical sequence didn't saw.

as it appears to be a steam locomotive that is pulling the train.*

Just why did children--as opposed to adults--have so much trouble in recalling the central point of the passage? A number of factors are obviously at work. To begin with, children are inclined to be drawn to sensate detail--as evidenced by their responses to the recall task--but they are less inclined to establish pattern in that detail. Perhaps more basic is the oblique manner in which sentences 4 and 5 express the central point. First, these sentences contrast sharply with the previous three. Sentences 1-3 represent events and actions from what might be called an external point of view:

train stopped

Miss Esther stood back

train left

Miss Esther stepped forward

This point of view, however, suddenly vanishes, and an internal one--presumably belonging to Miss Esther--emerges in its place. Sentence 4 merely registers the absence of a certain person and the

*More than half of the adults, however, preserved some form of the oblique language in the passage. A number of them, in fact, produced the there was no/there were only-contrast verbatim:

There was no black bonnet with wilted yellow lace worn by a figure burdened with candles. There were only the stationmaster and a boy or two. An elderly man....

reader is left to make two closely related inferences: first, that Miss Esther did not see the old lady and, second, that she had been expecting to see the old lady. If the external point of view had been maintained, these propositions might have been overtly expressed (e.g., "She did not see the old lady whom she had been expecting"); and sentence 5, of course, would have begun with she saw only rather than there was only. It is obvious that children would have understood the passage better if sentences 4 and 5 had maintained she as subject. It is noteworthy that the two children who actually recalled the contrast did, in fact, represent it in just this way.

Children's difficulties, however, did not arise merely from the shift between the first three sentences and the last two. Many of them came directly from the internal complexity of the last two. We have already pointed out how sentence 4 syntactically parallels sentence 5 in order to convey the central contrast:

There was no...



There were only...

In addition, the complement of each sentence itself contains parallel nominals. We might, in fact, use the image of Chinese boxes to represent how these sentences fit together:

Sentence 4:

--	--

Sentence 5:

--	--	--

Notice that the inmost boxes themselves vary in size, for we have wished to show that some of the nominals have a complexity of their own. Moreover, it is the last nominal--one that has nothing to do with Miss Esther's expectations--that is the most complex:

SENTENCE 4:

--no black bonnet with a worn lace veil

--no old lady with a burden of bundles

SENTENCE 5:

--the stationmaster*

--a boy or two

--a clean-faced bent old man with a bird
cage in one hand and an old carpetbag in
the other

As young readers attempt to process all this embedded detail, they easily lose a grip on the larger whole that the two sentences

*Children's real-world knowledge might lead them to assume that Miss Esther would expect to see the stationmaster in a train station. Such an assumption could then interfere with their working out what the first task requires, namely, that she was expecting to see an old lady with a black bonnet.

express. By the time they wade through all the lace and bundles, the birdcage and the carpetbag, they may no longer be aware of the overarching frame signaled by the contrast between there was no and there were only. That frame does, after all, extend over a good deal of syntactic space and so is not easily processed (i.e., there was no and there were only are quite distant from each other).

Added to all the foregoing complexity is the fact that sentence 4 can be interpreted in two ways. From a pragmatic point of view, it is clear--at least to an adult reader--that the parallel nominals refer to the same entity (i.e., the nominals are in an appositive relation):*

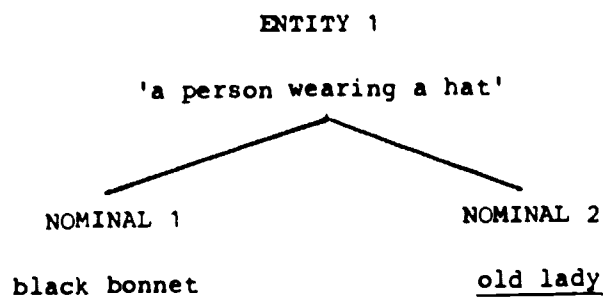

From a strictly linguistic point of view, however, there is nothing to prevent a reader from assuming that the parallel nominals refer to separate entities (i.e., the nominals are in a serial relation):

*This is a familiar kind of literary parallelism in which a person is first described synecdochically (i.e., a part stands for the whole), and then the figurative language is explicated by an appositive.

ENTITY 1	ENTITY 2
'a hat'	'a person'
NOMINAL 1	NOMINAL 2
<u>black bonnet</u>	<u>old lady</u>

One child, for example, wrote:

She was looking for a black bonnet with blue
lace and veil. and a lady with bags.

Given this confusion, we decided to test which interpretation children would make when faced with a comparable parallelism. We gave the following task to 24 children in the fourth grade:

Read the following sentence and tell how many children Mrs. Smith saw on the merry-go-round.

Mrs. Smith smiled as she saw that red cap,
that smiling little boy waving from the
best wooden horse on the merry-go-round.

Twelve answered that she saw 2 children, 10 that she saw 1 child (the other 2 wrote red cap and I don't know). These results suggest that children of this age do not readily understand this kind of parallelism, which is, of course, hardly surprising in light of its literary character.*

At this point it might be useful to summarize the various

*It may be that the wording how many children in the task led to a greater choice of 2 children.

complexities that could have prevented children from grasping the central point of the passage:

SENTENCE 1-3: EXTERNAL PERSPECTIVE

SENTENCE 4-5: INTERNAL PERSPECTIVE

} SHIFT IN
DISCOURSE
FRAME

SENTENCE 4: NOMINAL PARALLELISM: FIGURATIVE

SENTENCE 5: NOMINAL PARALLELISM: NON-FIGURATIVE

} SYNTACTIC
PARALLELISM
EXPRESSING
THE CENTRAL
POINT

In responding to (A), the task concerned with what Miss Esther expected to see, mainstream children selected the target response-- a black bonnet--more frequently than minority children did (35% to 21%). We should note, at the outset, that we consider this a misleading choice. We would have much preferred an old lady--which was not provided as one of the four choices--in that it describes more precisely the target of Miss Esther's expectations. Many of the children whom we interviewed expressed the same preference. Minority children, in particular, seemed to think that a black bonnet was a trap. Consider, for example, the wariness of a ten-year-old girl:

--Was there anything in the passage that mentions what she was expecting to see?

--A black bonnet was in there, but I don't think she was expecting to see a black bonnet.

She went on to explain, somewhat scoffingly, that Miss Esther obviously was not expecting to see a black bonnet, but rather an old lady wearing one.

What is particularly troubling about this child's failure to select the target response is that she did, in fact, understand the figurative language of the passage. She felt, however, that merely recycling this bit of language would be misleading, for it would indicate that Miss Esther was really looking for just a black bonnet. This child--as well as many others--seemed to have developed an uncanny sense of a test norm that might be stated in the following way: whenever a task deals with figurative language, it calls for a literal response (see chap. 4, pp. 70-72 for tasks that exemplify this norm).*

It is equally troubling that other children selected the target response, and yet did not understand the figurative language in the passage. When we asked one child about his choice of black bonnet, he said that Miss Esther had expected to see a black bonnet "somewhere on the platform." Upon further questioning, he was unable to provide any explanation as to why she might expect to see an unattached bonnet there.** Still he had chosen the response for

*Children's sense of one other test norm might have contributed to their rejecting a black bonnet, namely, that a task calls for information to be retrieved holistically rather than partially (see chap. 4, pp. 26-28 for discussion of tasks that follow this norm).

**He did know what a bonnet is, as indicated by his response to our follow-up question:

which he would be given full credit in a normal testing situation. On the basis of our interviewing, we have discovered that children often choose--or, for that matter, avoid--the target response for reasons not envisioned by the testmakers.

Let us now turn to the distractors and begin by observing that, during the pilot testing, mainstream and minority children were pulled in opposing directions:*

	MAINSTREAM	MINORITY
<u>a lot of people</u>	35%	25%
<u>an old man</u>	16%	32%

Usually, as we have seen, the two groups are most attracted, though to a different degree, to the same distractor (see SHOP SIGN, p. 00, where we point out that all four of the choices are usually ranked in the same order for both groups).

Let us first consider mainstream children's greater attraction to a lot of people. As we observed in LEAVING HOME, they may have more experience of train travel than minority children do, and so are more likely to be misled by what an experienced train traveler knows--a train station tends to be crowded at the moment a train

--Well, what do you think a bonnet is?

--It's like--it's a hat--like--and with a--cloth attached to the top of it and you can pull it. You can put it up over the hat or down to cover your face.

*When we come to (B), we will see a similar pattern of opposition.

arrives. In fact, a number of mainstream children used this bit of real-world knowledge to justify their choice of a lot of people:

--So why do you think she was expecting to see
a lot of people there?

--'Cause at the train station usually there's
a lot of people.

--Why did you pick that?

--Well, if there is--if--usually on trains
there's a lot of people waiting.

--So why were there a lot of people there?

--There are a lot of cars so if there's a lot
of cars, there should be a lot of people
that--aaah--come to use cars.

Certain children may have taken the excessive attention to the lonely few at the station as itself indicating that Miss Esther had anticipated a crowd.

Finally, some children--minority as well as mainstream--seem to have selected a lot of people as a last resort, eliminating, one by one, the other choices. One child articulated this backing-into-the-answer strategy nicely. He started by saying that the answer couldn't be an old man or a bird cage, because Miss Esther did not see them; and it couldn't be a black bonnet because the idea of

looking for a bonnet was "crazy." He then concluded that it had to be a lot of people, but gave no reason for his choice.

Minority children's preference for an old man is probably best traced to two sources. First, they seem to respond more to the incipient dramatic structure of the passage. The old lady, presented first, is barely sketched in; and then the stationmaster and the boy or two are given short shrift. Finally, the old man is described as if he is somehow the point of the story and as if whatever drama is about to unfold will center around him as the major character. He is clean-faced, bent, and old; and he carries a bird cage in one hand and an old carpetbag in the other. For the child attentive to the dramatic functions of language, surely it must be the old man whom Miss Esther was expecting to see.

Secondly, some minority children seem to have been influenced by all the mention of old in the passage--old lady, old man, old carpetbag (even the lace veil is described as worn). It is as though they saw old everywhere and so wanted to pick a choice that included it--if not old lady, at least old man. We will have other occasions to observe how minority children are particularly misled by an oft-repeated word or concept.*

Let us now turn to (B) and first note that it, like (A), is best described as a recycling task; that is to say, one that calls

*It is clear that testmakers, when constructing task-distractors, exploit any material thematic to the passage (see HURRICANE, p. 131, for a particularly vivid example).

for information already in the passage. In the case of (B), however, this information must be rephrased (cars pulled away train left) whereas in (A) it needs only to be repeated. In this instance, it was minority children (49%) who selected the target response more frequently than the mainstream children did (43%). Mainstream children's weaker performance can be directly linked to their stronger attraction to a particular distractor. If they take cars as referring to automobiles rather than individual parts of the train, it is only natural for them to select crowd left (i.e., all the people got in their cars and drove away from the station). Mainstream children were, in fact, pulled toward this distractor (we can observe, once again, opposing patterns of attraction):

	MAINSTREAM	MINORITY
<u>crowd left</u>	35%	12%
<u>train arrived</u>	9%	23%

When first considering mainstream children's attraction to crowd left, we felt that it probably had more to do with what pulled them toward a lot of people in (A) rather than with any limited knowledge of how the word car can be used. Nevertheless, we decided to check up on their knowledge of this word. We first consulted Dale's Living Vocabulary which states that 92% of children at this age level know that car can refer to a 'train part' (only 94% are listed as knowing that car can refer to an 'automobile').

Here is a sketch of the train. Please label each part.

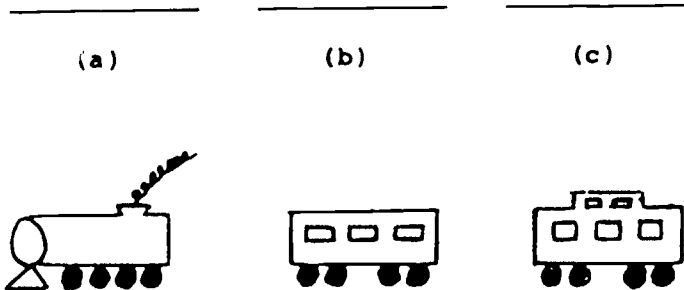

Nearly half--nine children--filled in the second blank with an answer that contained car:

- cars (2)
- box cars (2)
- o: cars (1)
- flat cars (1)
- carrier cars (1)
- freight cars (1)
- passenger cars (1)

Given that they actually had to produce the word car, this is a relatively high proportion.*

We then gave a receptive task to the same children and found that all but one associated car with (b)--the number choosing each letter is placed in parentheses immediately after:

*Consider, for example, that only 13 wrote engine in the first blank.

Which parts of a train are called cars? Circle all the letters you choose.

(a) (2)

(b) (19)

(c) (7)

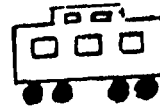
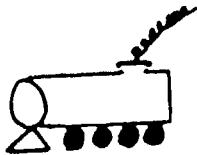

We were thus left with an intriguing question: if third and fourth graders know that the word cars can refer to train parts, why did so many--particularly mainstream children--interpret it as referring to automobiles? The passage is obviously about a train--it even opens with The train stopped.

In responding to this question, we would like to call attention to two factors. First, we discovered on a number of items that children drew on the central meaning of a word, even though the passage activated a peripheral one. This tendency, common to mainstream and minority children alike, will emerge as one of the major themes in Chapter 3. Second, there is the matter of inter-task influence. A large number of mainstream children selected a lot of people in (A) for various reasons that we outlined. Having made this choice, they were likely in (B) to make a congruent one.

If they think of cars as referring to automobiles, they may picture a sequence in which passengers who have rapidly descended from the train are whisked away by waiting cars, while Miss Esther, trying to orient herself, scans the platform; or they may imagine a scene in which the cars are driven by people who have brought to

the station passengers who wish to board the train and that the drivers have not waited for the train to leave before they themselves leave the station; perhaps they may even imagine a scenario that combines elements of the above two. Whatever scene they do imagine, the station is likely to resemble those in suburbia, where an adjacent parking lot makes a large number of arriving, waiting, or departing automobiles seem an integral part of the station. Indeed, it is this item, perhaps more than any other in our corpus, that demonstrates how ethnocultural norms of experience can be misleading to mainstream children as well as to minority children.*

In closing our discussion of this task, we would like to point out that children's difficulty in locating Miss Esther at a precise point may have adversely affected their performance. When reading this passage, most adult readers picture Miss Esther as standing on the station platform, mainly because of the words Miss Esther stood far back. For them, she could not be inside the train, because its aisle would not be sufficiently wide to allow her to stand far back. Nevertheless, a reader can construct a scenario--and, in fact, a number of children did**--in which Miss Esther stood inside

*In pointing out this fact, it is important to remember that a large number of mainstream children still managed to select the target response for both tasks. It is simply that ethnocultural experience seems to have strengthened the choice of a particular distractor, thereby contributing to the mainstream and minority divergence that is so salient on this item.

**When examining responses to the recall tasks, we discovered that even some adults pictured Miss Esther on the train. Consider, for example, one adult's use of greet in the following sentence:

the train, far back from the exit, to avoid the smoke and roar. Consider, for example, what one child said as the interviewer questioned him about Miss Esther's location:

--What was the relationship between smoke and
roar and where she stood?

--It went past the window.

--Oh so you thought she was inside the train.

--Yeah....She had to be in the train because
mostly the smoke doesn't get--Have you ever
seen an old-fashioned train in the movies--
the smoke doesn't--It never goes in the place
where the people are sitting down.

--No, you're right about that.

--It always goes the other way round; and
that's why they have stations on one side
and some on the other.

--O.K. I think we need to draw pictures on
this one.

The child and the interviewer then proceeded to draw pictures of
the scene they had imagined:

There was no one with a black bonnet to greet
the person, just someone holding a carpet-bag.

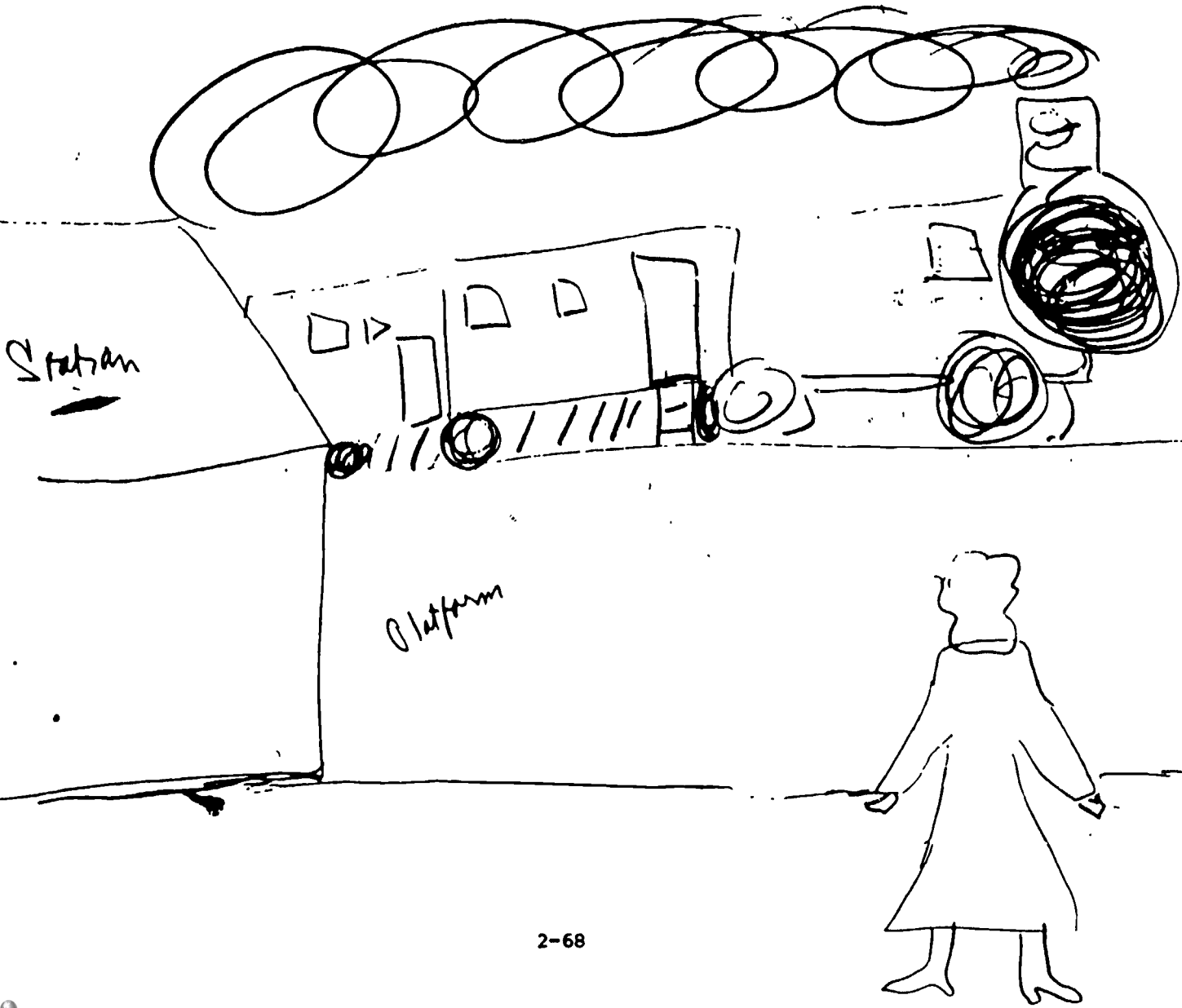
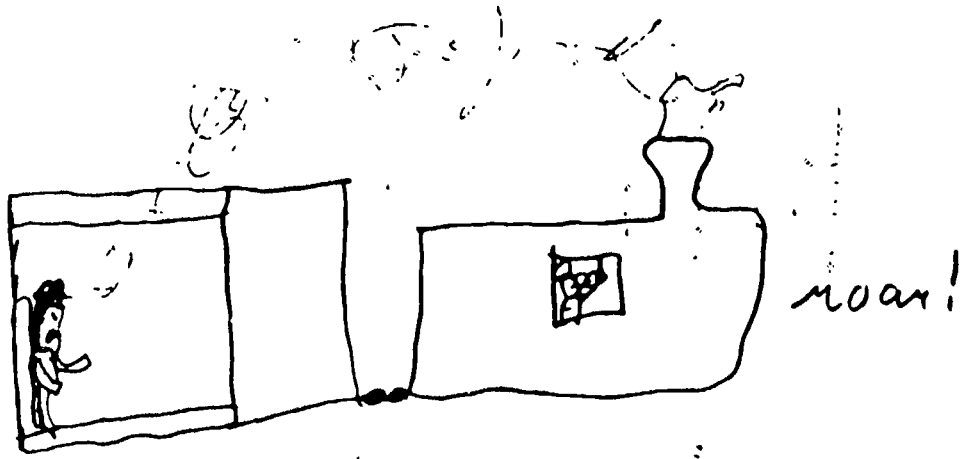

2-68

If Miss Esther is pictured as arriving on the train, there is a further indeterminacy as to whether she gets off at the station or stays on the train. If she does get off, then her few steps forward are on the platform; if not, they are inside the train itself. One child reasoned that she must have stayed on the train since the old lady had not come to meet her.

We would like, at this point, to summarize the various possibilities that we have outlined:

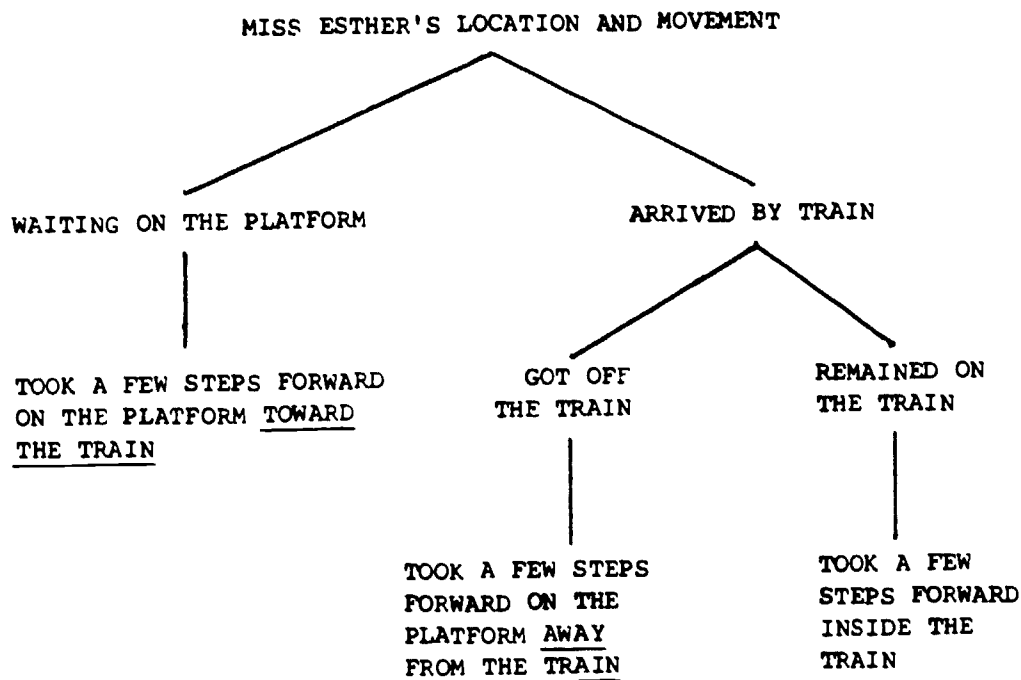

None of these interpretations, in and of itself, prevents a reader from selecting the target response for (B)--or, for that matter--for (A) as well. Nevertheless, we have discovered that even the slightest indeterminacy in a passage can lead inexperienced readers to think that they are failing to understand something that

they should. It is as if one blurred detail causes the whole picture to go out of focus (see GEORGE WASHINGTON BRIDGE, chap. 3, pp. 113-114 for further discussion of this point).

2-70

ALICE AND THE FAWN

We can verify that one of the items contains an excerpted narrative, since four sentences have been taken from Through the Looking Glass with only slight modifications. They tell of Alice meeting the fawn.

The fawn looked at Alice with its large, gentle eyes. It didn't seem at all frightened. "Here, then! Here, then!" Alice said, as she held out her hand and tried to stroke it. It moved back a little and then stood looking at her again.*

A. How did the fawn's eyes look?

sad	gentle
tired	frightened

B. What did Alice try to do to the fawn?

help it	hug it
pet it	hide it

During our interviewing, we discovered that a few children-- mostly those belonging to the cultural mainstream--knew that this

*It is instructive to compare the excerpted passage with the original. Below is the paragraph from which the passage was taken. It includes (1) brackets to indicate the beginning point and end point of the excerpt, and (2) underlining to indicate the various points at which changes were made:

Just then a Fawn came wandering by: [it looked at Alice with its large, gentle eyes, but didn't seem at all frightened. "Here then! Here then!" Alice said, as she held out her hand and tried to stroke it; but it only started back a little, and then stood looking at her again.]

passage was taken from Through the Looking Glass. One child whose father is a professor of English literature was even able to locate just where in the larger story this scene occurs. One minority child did describe reading Alice in Wonderland, though he seems to have fused it, given his description of the fawn, with some classical tale:*

I read a story about Alice and the Wardrobe, right, and then she went into this wardrobe, that's like a key passing through time or something like that and she finded a faun and the faun had some horns on his head. It had two horns. And starting at the neck or back was like a horse or goat and then its neck and head; it was human.

Here is a list of the changes, except for those involving punctuation:

	ORIGINAL	TEST PASSAGE
SENTENCE 1:	<u>It</u>	<u>The fawn</u>
SENTENCE 2:	<u>but</u>	∅
	∅	<u>it</u>
SENTENCE 4:	<u>but</u>	∅
	<u>only started</u>	<u>moved</u>

The changes seem to be designed not only to make the text more readable for young readers but to reduce any sense they might have that the fawn was frightened. The but removed from sentence 2 seems to work off the assumption that 'large, gentle eyes' would be thought of as frightened. In addition, the verb started is replaced with moved: started carries the sense of sudden movement and, by virtue of phonetic similarity, tends to be associated with startled.

*He also fuses the title, replacing Wonderland with Wardrobe. He may have been thinking of C. S. Lewis' The Lion, The Witch, and the Wardrobe.

The interviewer then asked:

--And you remember how that word faun was spelled in that story?

--Yes.

--How?

--F-A-W-N.

One child, recently arrived from Jamaica, claimed to have seen a movie entitled Alice and the Fawn. The interviewer tried to find out what movie he was referring to, but did not have much success. From the description that the child provided, it may have been Bambi.

Most readers are not familiar with the larger story from which the passage has been excerpted, but still are led to invent a context in which to place the brief encounter between Alice and the fawn. Indeed, the nature of the detail, and the imaginative manner in which it is reported, leads most children to thicken the texture of the encounter; and as we will see, such thickening is likely to lead children to pass over the target response and select a distractor in each of these tasks.

The tendency to expand this passage can be traced to three main sources: (1) the internal relations among the various actions and states that are reported, (2) children's real-world knowledge of how a fawn behaves in the presence of a human being, and (3) children's textual knowledge of what constitutes a narrative.

Let us first examine the sequence of action and states:

- (1) the fawn looks at Alice
- (2) the fawn does not seem frightened
- (3) Alice speaks and acts
 - (a) she says, "Here, then! Here, then!"
 - (b) she tries to stroke the fawn
- (4) the fawn moves back
- (5) the fawn looks at Alice again

These actions and states seem innocent enough, and yet when placed together they are likely to activate children's real-world knowledge that an undomesticated animal is likely to be skittish in the presence of a human being. This knowledge, in turn, leads them to view the fawn as frightened of Alice. Such an interpretation provides a dynamic connection--one involving cause-and-effect relations--between actions and states that would otherwise be viewed as static and without any real point. Hence readers are likely to draw upon a familiar narrative frame for binding the various elements in the passage together:

- (1) CONFRONTATION: A girl meets a young deer that appears not to be frightened.
- (2) ACTION: The girl tries to pet the deer.
- (3) RESULT: The deer now appears as frightened to the girl.

This is a simple frame, and yet it has considerable generative power. Consider, for example, the relation between the 'confrontation'

and the 'action': the first can be viewed as providing a motive for the second. The girl acted in the way that she did because she thought that the fawn really was frightened, even though it seemed not to be. Or consider the relation between the 'action' and the 'result': what the little girl did enabled her to confirm her original belief--the fawn was indeed frightened. Such fleshing out of the frame gives it the rounded contours that children often experience when they are imaginatively engaged with a real story.

We should further observe that the frame is so powerful that not only do children richly interpret what is present but they tend to extend it as well. Any real story would hardly end with a deer, frightened, stepping back from a little girl. Consider, for example, how one young girl responded when she was asked to recall what she had just read:

Once upon a time Alice was walking through the forest and she saw a fawn. It was beautiful and she saw how gentle it was looking at her. So she went over there and walked to it and tried to pet it. Then the fawn jerked back. She was wondering why did the fawn jerk back.* So she went over there and she went to get her friend. Her friends came They all surrounded the fawn and then suddenly she got to it. And then she realized that the fawn had a broken leg.

*Note this child's use of jerked back rather than moved back. Note also her use of the Black English feature of embedding a question in its verb-initial form:

She was wondering why did the fawn jerk back.

The use of formulaic Once upon a time signals that this child wishes to produce a story, not merely repeat what she has read; and yet she manages to retain the detail of the passage, weaving it into a larger narrative. It is of interest that this child selected the target response for both tasks, even though her expanded narrative provided a context, which, in the case of many children, led to the choice of a distractor. It seems as though her performance for the interviewer was one thing, her responses to the tasks quite another. We should also note that she thought that a fawn was a dog and so was less likely to think of it as being frightened of a little girl.

There were other children who did not know that the fawn was a deer. As we have seen, one thought that it was a faun, the mythical beast. Some simply described it as an animal, although a number did try to specify its identity, describing it variously as

a person
a forest animal
like a bird
an elephant
a squirrel of some kind
something like a goose
like a duck

The child who describes it as a duck later talked about how Alice stroked "the fawn's feathers."

Knowing what a fawn is may have adversely affected children's performance on either one of the tasks. Some of the children who selected frightened for (A) or help it for (B) were prone to talk about how a little deer acts around people: it is frightened and so needs to be helped. It seems clear that a fawn is more vulnerable than, say, an elephant.

Let us now turn to the tasks. (A), like the tasks in BLACK BONNET, is a recycling task; it asks readers to affirm that the passage described the fawn's eyes as gentle, as opposed to sad, tired, or frightened. (B) can be termed a VOCABULARY-DEFINING task, since its function is to determine whether readers know the meaning of the word stroke. Both of these tasks can be described as ACOMMUNICATIVE in that they ask readers to use language in a way that runs counter to everyday communicative norms, mainly those associated with conversation, but not excluding the norms that develop around real-world reading. Thus, (A) requires readers to abandon their emerging understanding of the passage as a whole in order to locate and recycle a trivial detail. (B) requires readers to move from the level of meaning to the level of wording, from what is being said to how it is being said.

When recycling or definition do occur in everyday interaction, it is because the audience has indicated in some way that communication has not taken place. With (A) and (B), however, there is no such implication. They are examples of "teacher questions"-- questions that arise not from a need to know, but from a desire to

find out whether somebody else knows. As has frequently been pointed out, the psychological dynamics of such questions are different from anything that occurs in everyday interaction. The place where they flourish is, of course, the classroom.*

Sometimes the acommunicative nature of a task is cued by the use of expressions like In the story or The story says that. Such locutions are evidently meant to imply that the answer should come from attending to the details, even the exact words, of the passage. Consider, for example, how (A) and (B) might have been written:

(A) How did the fawn's eyes look?	→	The story says that the fawn's eyes looked _____.
-----------------------------------	---	---

(B) What did Alice try to do to the fawn?	→	In the story, what does Alice try to do to the fawn?
---	---	--

Notice, however, that even with these cues readers still do not know, strictly speaking, whether these tasks are recycling or vocabulary-defining. It is only when they get to the choices that

*Some parents assume the teacher role--in loco magistri, so to speak--and ask their children teacher-questions. Frequently, their children find these acommunicative intrusions into a normally communicative relationship irritating. Many adults also find the Socratic style trying: "Don't play cat and mouse; just give it to me straight." Indeed, his addiction to teacher questions may have been the real reason why Socrates was so unpopular in Athens.

Teacher questions are just one aspect of school language. Some analysts--notably Bernstein and his colleagues--have claimed that the domain of formal schooling has a pervasive effect on everyday language use, particularly in middle-class settings (see Hill and Varenne, 1981, for a discussion of these claims).

they can tell one from the other. If there is a choice that recycles the relevant part of the passage, they select it as the target response. In the absence of such a choice, they must search for another kind of relationship with that part, namely, synonymy. Thus we could turn (A) into a vocabulary-defining task by substituting a synonym like soft or quiet for the target response gentle. Similarly, we could turn (B) into a recycling task by substituting stroke it for the target response pet it.

In the case of a vocabulary-defining task, however, one can introduce further wording that makes the vocabulary-defining status of the task altogether clear. Consider, for example, how (B) might have been written:

What did Alice try to do to the fawn?

In the story the word "stroke" means _____.

The presence of the word "stroke" means leaves no doubt as to what the point of the task is.*

In our own thinking about the form of a communicative task, we

*Notice also that in the story has an additional implication once the entire task stem has become formulaic. It implies that the word stroke has several senses and that the one referred to is, in fact, the one that it has in the passage. In other words, the answer should be based on the passage rather than on general knowledge of word meanings. However, the fact that stroke has different senses is not exploited in this item, that is, none of the distractors activate alternative senses of stroke (for tasks which do include alternative senses, see NERVOUS HORSE, chap. 3, p. 176, and GEORGE WASHINGTON BRIDGE, chap. 3, p. 109; for further discussion of vocabulary-defining items, see HURRICANE, pp. 132-134).

have found the terms OVERT and COVERT to be useful. We use overt to describe an acommunicative task that contains a formula, covert to describe one that does not. We then use the terms FOCUSED and UNFOCUSED to describe the two kinds of overtness that we have distinguished above. These terminological distinctions are illustrated by various transformations of (A) and (B) in the following display:

COVERT		OVERT
<p>THE READER DOES NOT KNOW THAT THE TASK IS ACOMMUNICATIVE.</p>		<p>UNFOCUSED: THE READER KNOWS THE TASK IS ACOMMUNICATIVE BUT NOT WHETHER IT IS RECYCLING OR VOCABULARY-DEFINING.</p>
<p>(A) How did the fawn's eyes look?</p>	<p>→</p>	<p>The story says that the fawn's eyes looked _____.</p>
<p>(B) What did Alice try to do to the fawn?</p>	<p>→</p>	<p>In the story what does Alice try to do to the fawn?</p>
		<p>FOCUSED: THE READER KNOWS THAT THE TASK IS VOCABULARY-DEFINING.</p>
<p>(B) What did Alice try to do to the fawn?</p>	<p>→</p>	<p>In the story the word "stroke" means _____.</p>

Given the frequent use of formulaic material to cue an acommunicative response, its absence may not be as neutral as the previous display suggests. As children become familiar with

the language of standardized testing, they may come to rely on such cueing. If they then encounter a task that lacks it, they may not recognize the acommunicative intent, particularly when a distractor has been included that fits with--indeed motivates--a communicative response.

Both (A) and (B) provide such a distractor; and as shown by the table below, minority children, in comparison to mainstream children, were more drawn to it (they were also less drawn to the acommunicative response):

		MAINSTREAM	MINORITY
(A)	ACOMMUNICATIVE TARGET RESPONSE: <u>gentle</u>	64%	46%
	COMMUNICATIVE DISTRACTOR: <u>frightened</u>	17%	25%
(B)	ACOMMUNICATIVE TARGET RESPONSE: <u>pet it</u>	52%	26%
	COMMUNICATIVE DISTRACTOR: <u>help it</u>	30%	47%

Let us examine (A) in more detail. To select the target response gentle, the reader must not only locate the nominal its large, gentle eyes in the passage but also realize that a portion of it can be expanded into "the fawn's eyes looked gentle."* Theoretically, such recycling tasks are easy, but careful analysis

*In a number of tasks information that is presented as a syntactic whole in the passage is used only in part (for a general discussion of this matter and further examples, see chap. 4, pp. 26-28).

often uncovers unexpected difficulties. We have already pointed out a major difficulty: that such a task, by its very nature, forces readers to work within an acommunicative framework, something which many third and fourth graders are unprepared for, because they either cannot do such a task or even recognize what is called for.

Still another difficulty with (A) is its use of the word looked. This word is used twice in the passage, where it combines with the particle at to form a transitive phrasal verb. In (A), however, looked is a copula, meaning 'seemed' or 'appeared,' that links the fawn's eyes with a predicate adjective. We found that some children, instead of taking looked as a copula, tried to use it in the same sense that they found in the passage. In other words, they thought that the task was concerned with stating "how the fawn looked at Alice." They selected frightened, intending something like "The fawn looked at Alice in a frightened way."*

The major stimulus for choosing frightened, however, comes from the narrative expansion that we described earlier. Using the narrative frame provided on page 74, we can identify two separate points--stage 1 (confrontation) and stage 3 (result)--at which the fawn's eyes could be described as frightened. In interviewing

*Some children who selected gentle seem to have understood look in the same way. Note, for example, the words uttered by the little girl whose recall of the passage was given on page 75:

It was beautiful and she saw how gentle it was looking at her.

children, we discovered that most who selected frightened were thinking of the fawn's eyes at stage 3. Consider, for example, what one minority child says in defense of her response:

--It must have been frightened.

--Okay, why do you think that's the right answer?

--Because when she tried to stroke her, he moved back.

Another minority child elaborated on the same theme, though he did remain close to the passage content:*

--Why did you pick frightened as the answer to the first question?

--Because it say in the story when she tried to stroke it, it moved back and looked at her. His eyes, I think, were wide open so it must be frightened.

There are at least two reasons for readers assuming that (A) is concerned with the appearance of the fawn's eyes at stage 3 rather than at stage 1. First, they might feel that the fawn's

*Some children departed from the passage content, speculating on what the fawn expected Alice to do:

--Maybe it thought that she was gonna throw a stone and that's why it moved back.

eyes have already been described at stage 1 and that there would be no point in repeating this description. Secondly, readers tend to assume that questions following a story are concerned with the state of affairs at the end of the narrative rather than at some point within it. This assumption is strengthened by the way in which this particular story ends (i.e., the explicit mention of the fawn's looking at her again). This final focus on a second act of looking might have contributed to its selection by some readers as that with which (A) is concerned. If the passage and tasks are viewed as forming sequential discourse, it is noteworthy that (A) immediately follows the statement that represents the fawn's second act of looking. In interviewing young readers, we have discovered that a "last-in, first-out" principle often accounts for the way they chunk information.

Before leaving (A), we should note that readers who are communicatively oriented to tasks are more likely to focus on the fawn's second act of looking. Such orientation strengthens the tendencies that we have just described: (1) viewing the passage and tasks as continuous and (2) focusing on where the passage ends up rather than where it begins. A communicative orientation even led some readers to assume that the fawn's eyes looked frightened at stage 1 as well as at stage 3. This interpretation opposes the actual state of the fawn's eyes to an apparent state. In effect, sentence 2--It didn't seem at all frightened--can be taken as a

cue that it was, in fact, frightened.* Hence a reader might feel that (A) was concerned with how the fawn's eyes "really looked," since Alice, after attempting to pet the fawn, discovered that it was, indeed, frightened.**

As we turn to (B), we can see that it, too, is difficult for a child with a communicative orientation. The target response pet it presupposes a literal approach to the question, one which might be paraphrased in the following manner: Which of the following responses results in a proposition that would most closely parallel the one in the passage which states that Alice tried to stroke it? In other words, which of the following phrases contains a verb roughly synonymous to stroke? This metalinguistic intent, as already mentioned, could have been made overt by changing the task stem:

In the story, the word "stroke" means _____.

The presence of the lexical item try in (B) should, in

*To use this cue, the reader needs somehow to equate the fawn with its eyes, but this is not hard to do. The eyes are the place where we look if we wish to know whether a person--or some creature--is frightened.

**Many students undoubtedly selected frightened simply because it was present in the passage. Certainly those who construct reading tests often assume that children are attracted to such words. For example, inclusion of the distractor tired is apparently related to the presence of tried in the passage. In effect, it is assumed not only that readers may select a word because it is present in the passage but that they may even select a word closely related in graphic form to one that is in the passage.

principle, cue this search for a synonym, since to stroke functions as an infinitival complement to the verb try in the passage. But for some readers, particularly those prone to seek an interpretive response, the presence of try led to a search for a response which would represent what Alice was "actually trying" to accomplish with her act of stroking the fawn. In effect, these readers understood the intent of the question as "What was Alice really trying to do for the fawn when she tried to stroke it?" In response to this question the most appropriate answer might well be help it; that is to say, the act of stroking is viewed as an effort to help the fawn, e.g., by making it feel good.

Some children, however, defended their choice of help it by referring to an expanded version of the passage. For example, one minority child, when asked why he thought Alice was trying to help the fawn, responded:

--Because it says right here--here it is [he
then reads from the passage, replacing stroke
with help] and tried to help it.

--how do you know she tried to help it?

--She tried to stick her hand out for her to
reach it.

--How come you think that's a way of helping
the fawn?

--Save its life.

Here is how another minority child explained his choice of help
it:

--Because the fawn was hurt.

--Does the story say that it was hurt?

--No, but that's what I think.

Apparently, this child was not bothered by responding to a task with what was in his head rather than in the passage.

The multiple senses of the word stroke provide one other source of interference, especially for minority students. The word can refer to a movement which is either 'hard and quick' or 'soft and caressing.' Most dictionaries list the sense of hard, quick movement in the initial entries for stroke as a noun. For example, the American Heritage Dictionary initially defines the noun stroke as

1. An impact: blow: strike.
2. An act of striking.

This sense is reflected in such special uses as

Any of a series of movements of a piston from one end of the limit of its motion to another.

The sudden severe onset of a malady, as apoplexy or sunstroke.

This latter use would probably be salient for those whose primary experience of language is oral (e.g., "Be quiet now! You know Grandpa's had a stroke"). By way of contrast, the use of stroke as

a verb to indicate 'soft, caressing movement' would appear to occur more frequently in literate uses of language. For example, children might encounter this use of the word in fairy tales: "And then Sir Gawain gently stroked the princess' golden hair."

During the interviewing, we discovered that many children did, in fact, associate stroke with 'a blow.' One boy, for example, thought it meant "to grab something and push it forward." Another boy said:

Like when you row a boat, you stroke it.

The interviewer then asked him to act out what stroking a fawn means, and he responded with some rapid, jerky gestures. When the interviewer then asked whether it was "a nice action or a bad one," the boy replied, "A bad one." One child, while reading the passage orally, stopped and asked the interviewer:

--Stroking, is that to hit, right?

--No.

--No? But in a baseball bat, when you got to stroke somebody, you stroke him like that [takes a violent swing]. That's the meaning I have of stroke.

--So that's what made you feel--

--A stroke. Like this wood, and I stroke it at the tree or something. Stroke means like vroom, vroom, like that.

This child chose help it for (B). When asked for his reason, he said:

--Well, I think I just had to guess that word because I didn't find out about the stroke that I was thinking of.

Given these responses during the interviewing, we decided to ask a group of children what the word stroke means. Here's how the children--32 of them--responded:

illness (13)*	paddle a boat (2)	pencil stroke (1)
swimming (5)	skim the water (2)	brush stroke (1)
a movement (3)	hit swiftly (1)	golf (1)
sunstroke (2)	12-stroke engine (1)	

Only two children defined stroke as roughly synonymous with pet, both using the expression soft pat. During the interviewing, we discovered that the children who did know this meaning preferred pat to pet (i.e., they would make a vertical movement rather than a horizontal one to illustrate the meaning of stroke). It is as though the sense of piston-like movement lingers even in their understanding of stroke as a soft gesture.**

*Many of the 13 mentioned heart attack.

**One girl freely mingled the soft and the hard as she tried to define stroke:

--What does stroke mean?

--Stroke means--sort of--pet or pat--sort of--very hard, something like that.

In another attempt to find out how children understand stroke, we presented the following task to a group of 20 children (the number of children who placed a C in front of each sentence is placed in parentheses immediately after it):

Here are some sentences. In each sentence you will find the word stroke. Put C in front of each sentence which uses the word stroke in a correct way.

Homer's granddad had a stroke. (17)

Homer went out on the golf course to practice his strokes. (10)

Homer ate all the delicious strokes on his plate. (1)

Homer's mother told him to stroke the kitten gently. (2)

The recipe said to beat the cake batter 100 strokes. (10)

These two probes suggest that children of this age do not readily associate stroke with pet.

In closing our discussion of this item, we would like to reproduce a story written by one ten-year-old minority child. He was a good reader who talked freely about his approach to the various items. When the interviewing was over, he wrote down the following story:

--Can you describe it in words?

--I could describe it as you stroke your bunny lovingly or dog lovingly.

I was walking in the woods when suddenly I saw something move in the bushes. I went to see what it was and it was a deer it looked at me and it was a sad look. I looked back and saw it was caught in a trap, I jiggled the trap but it wouldn't open, so I took a rock and smashed it. I opened and the deer was free, it looked at me again and then it ran away.

This child selected a communicative distractor for each of the tasks on this item--sad for (A) and help it for (B).

LEARNING TO READ

Let us now consider a third item that contains an excerpted narrative:

She looked at the calendar. "Only two more days and I go to school. In three days I can read!"
Mama chuckled. "Not quite that soon, dear!"
"How many days?"
"Some children learn to read in a few months. Some learn in about a year."
A year? A whole year? Maybe not till she was seven? That would be awful!

A. How old is the girl in this story?

six eight

four seven

B. At first, how long did the girl think it would take her to learn to read at school?

three days a few months

one day a year

This passage differs from all others in our corpus in that it consists mainly of dialogue. It opens with an exchange between a 'she' and a 'Mama.'* Two statements in quotation marks are introduced respectively by (1) She looked at the calendar and (2) Mama chuckled (we will hereafter refer to such statements as introducers). After the initial exchange, a second one ensues, but this time no introducers are used: two statements are simply enclosed in

*The 'she' is not named at any point in the passage: the reader can, however, assume that this person is Mama's daughter from the content of the interaction and, of course, from the expression Mama as well.

quotation marks. The reader is able to attribute them to the daughter and mother respectively by drawing upon normative rules of turntaking (and, of course, the content of the utterances as well). Then follows a statement that has neither an introducer nor quotation marks. In certain respects, it resembles direct speech (e.g., use of fragments such as A year? A whole year?). In other respects, it resembles reported speech (e.g., use of the third person pronominal she). This hybrid statement--which we can describe as free indirect speech*--is not used to represent what the girl said but what she thought. We can summarize the overall structure of the passage in the following way:

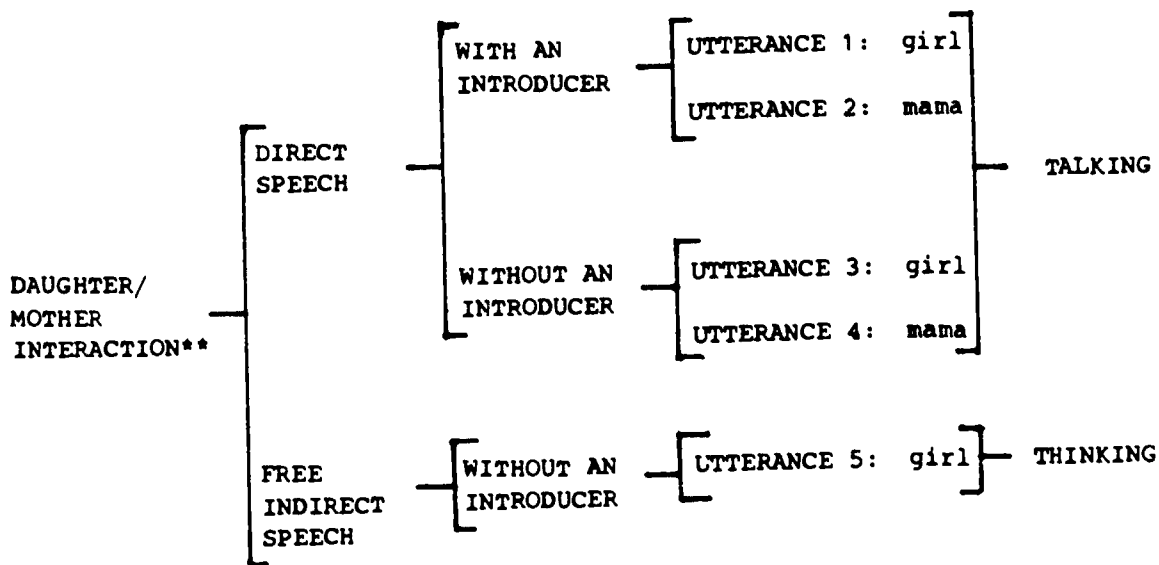

*A direct translation of the more familiar French expression style indirect libre.

**Placing daughter before mother violates an expected ordering, and yet the ordering does correspond to the actual sequence of turntaking. It also captures the nature of a good deal of parent/child interaction (notice how the normal ordering parent/child

To adult readers, this structure presents no real difficulty. We automatically make the various transitions from one utterance to the next; and when we come to the free indirect speech, we know that the writer is now reporting on the girl's thoughts rather than her speech. But to inexperienced readers, the structure of the passage can present a number of problems. They are not able to make the various transitions with ease, and, in fact, many are unable to make the final transition at all. Their oral experience of language has not prepared them to deal with the literate device--free indirect speech--used to represent the girl's internal reaction and so they are not able to extract the information needed for responding to (A).*

Before we consider children's difficulties with this task, let us first note what it shares with (B). Each calls for a response that involves a calculation. Neither calculation in, and of itself, is difficult--for (A) $7 - 1 = 6$ and for (B) $3 - 2 = 1$; and

predisposes us to set up the parent as initiating the interaction (see Ochs, 1981, for discussion of how such conventions influence the study of human interaction).

*Most children were able to deal with the direct speech without difficulty, whether or not an introducer was present. As we pointed out in SHOP SIGN, quotation marks are generally sufficient to cue even young readers that speech is being represented directly. We did discover a few children who seemed unable to work with the initial pair of introducers. It is as though they expected an introducer to contain a verb that refers to an act of speaking (e.g., She said or Mama replied). It appears that one child thought Mama's chuckling constituted one speech act, the quoted words that followed a separate act to be attributed to the little girl.

yet setting up each one is. During the interviews a number of children were surprised to learn that these tasks actually call for a calculation. Upon making this discovery, one child exclaimed, "Oh, now I get it. This is like a logic test!" He went on to explain that he expected to do "word problems" only on math tests.*

It is not, however, simply a matter of what children expect to encounter on a reading test: it is also a question of what kind of response a passage that presents a fictional world is likely to elicit. Upon confronting the report of an intimate exchange between a daughter and mother, even experienced readers are not likely to feel the need to make explicit the information that these calculations lead to. They are more likely to wonder about, say, the relations between the mother and daughter or what they meant by what they said: for example, just what did the daughter have in mind when she said that she would be able to read in three days?

In order to determine to what extent readers make these calculations after an initial reading, we displayed this passage on a screen for 25 seconds to small groups. We then displayed the two tasks without the multiple choices. Among the 18 adults and 34 children--the latter were evenly divided among mainstream and minority--the following proportions selected the target responses:

*His reaction gave us the idea for a group probe that we still have not carried out. This item would be included among word-problems on a mathematics test in order to determine whether students, operating on a set of tasks where they expect to exercise computational skills, might be able to provide the target responses.

		ADULT	CHILDREN	
			MAINSTREAM	MINORITY
(A)	<u>six years</u>	56%	12%	12%
(B)	<u>one day</u>	56%	0%	0%

As can be seen, the children were almost totally unable to provide the target responses. None, in fact, did provide it in (B). On the other hand, the adults performed somewhat better than might be expected. Their superior performance may be traced to a number of factors. They are, as already pointed out, graduate students specializing in language study. Moreover, the test-like situation seems to have prompted them to process more low-level detail than they ordinarily would. Finally, the amount of time allotted, in principle, allows for at least one re-reading; and adults have learned how to use extra time in a testing situation to ferret out the kinds of detail they are likely to need.

Added to the unexpected nature of the two calculations is one other feature that makes them difficult for children. Both require that children chunk together bits of information that they have obtained from disparate syntactic structures that represent the elliptical language of thought--in the case of (A)--and of speech--in the case of (B); and yet the major distractor for each task is one that recycles numerical information to be found in a single syntactic structure. In selecting a response to (A), the wording she was seven is available at the end of the passage; and

in selecting a response to (B), the wording In three days I can read is available at the beginning. If these expressions are considered apart from context, they can be viewed as justifying the choice of seven and three days respectively. In effect, the tasks would be constituted as acommunicative--requiring only that information be recycled--rather than as communicative--requiring that an actual calculation be made. Here are the proportions of children who selected the acommunicative distractors during the pilot testing:

		MAINSTREAM	MINORITY
(A)	<u>seven</u>	41%	41%
(B)	<u>three days</u>	49%	42%

As can be seen, mainstream and minority children do not differ in the degree to which they are attracted to an acommunicative distractor in (A). In (B), however, mainstream children are somewhat more prone to constitute the task as merely a recycling one. It might well be that their greater capacity for an acommunicative approach, which often works in their favor, here leads them to choose three days.*

The above pattern is reversed when one examines the proportion of children selecting the target response on the two tasks:

*A similar pattern is reflected in children's performance on the group probe in which the tasks were presented without choices. Mainstream children were, once again, more attracted to the acommunicative distractor in the second task (even in the first they were slightly more attracted):

		MAINSTREAM	MINORITY
(A)	<u>six</u>	40%	26%
(B)	<u>one day</u>	17%	19%

In this instance, it is (A) that reflects the ethnocultural difference-- a significantly larger proportion of mainstream children selected six. With respect to (B), children in the two groups did not differ, at least not significantly. In fact, the proportion in both groups fell below chance, as was the case in SHOP SIGN (see p. 5).*

As already pointed out, the information that (A) calls for is buried in the final entry, the one that uses free indirect speech to represent the girl's internal reactions. We cannot here enter into the complex ways in which free indirect speech differs from, yet overlaps with direct speech (see Quirk, Greenbaum, Leech, Svartik, 1973, for such discussion). We would like, however, to note two shifts that take place whenever a writer moves from one

		MAINSTREAM	MINORITY
(A)	<u>seven</u>	61%	57%
(B)	<u>three days</u>	72%	57%

We should further note that, under these conditions as compared to normal ones, a higher proportion of children in both groups were attracted to an acommunicative distractor. This is not surprising, for they are more likely, once the passage has been taken away, to repeat any numerical information that it provided. They need the passage physically before them in order to carry out the required calculations.

*Even in (A) the proportion of minority children selecting the target response is barely at chance.

mode to the other:

DIRECT SPEECH:	I	will + <u>Ø</u>	come next year
	↓	↓	
FREE INDIRECT SPEECH:	She	[will + -d] = would	come next year

The second shift is often referred to as backshifting in that it parallels a shift from present tense to past tense (i.e., Ø to -d). As we will see, backshifting can be confusing to children because of this parallelism.*

With these shiftings in mind, let us return to the passage and consider how they might have confused an inexperienced reader. We may observe that the passage, until the final entry, has included only two kinds of sentences:

- (1) those containing the features of [+third person] and [+past tense] which describe actions:
 - (a) She looked at the calendar.
 - (b) Mama chuckled.
- (2) those enclosed in quotation marks which represent speech:
 - (a) "Only two more days and I can go to school. In three days I can read."
 - (b) "Not quite that soon, dear."
 - (c) "How many days?"

*Both shifts are at the propositional core--subject and verb. At the adverbial periphery, next year could shift to the following year, but it doesn't have to (see Banfield, 1976, for discussion of delicate constraints on peripheral shifting in free indirect speech).

- (d) "Some children learn to read in a few months.
Some learn in about a year."

Hence, we may view the passage, until the final entry, as consisting only of descriptive statements and direct speech.

Upon encountering the final entry, children may view the initial fragments A year? A whole year? as continuing the direct speech, even though no quotation marks are present. These fragments contain neither pronoun or verb, so they cannot themselves signal the shift to free indirect speech; and given the absence of pronoun or verb, they do not appear to be descriptive statements containing the features of [+third person] and [+past tense]. Yet as readers move to the next fragment Not till she was seven, they may assume, upon processing the two words she was, that the mode of descriptive statement has reappeared. On the surface, she was appears to be expressing past tense, much as she looked and Mama chuckled does. The likelihood of readers assuming this textual consistency is, no doubt, increased by their lack of familiarity with the use of verb backshifting to signal free indirect speech; and as we have already suggested, no introductory clause such as she thought alerts them to the presence of this mode.

What do children make of this final entry as they deal with these confusing signals? Some made very little of it, having no idea to whom it should be attributed. Others took the pronoun cue--she instead of I--as signaling that the final entry belongs to the writer of the passage rather than to the characters:

--I think it was the writer, probably.

--Is there any way you can tell?

--Because it said she and not I.

Still others used the same cue to ascribe the words to the daughter:

--I think it's the girl in the story. She was
just thinking this over in her mind or
something.

--She was thinking this over in her mind?

--She was thinking, A year? A whole year?

Maybe not till she was seven? She probably
was thinking that in her mind.

It is, of course, possible that children could extract from the final entry the information needed for responding to (A), without attributing it to any one person. The words are, after all, the same, whether they are ascribed to the little girl, the mother, the writer, or to no one at all. The children whom we interviewed, however, were generally not able to make much sense out of any stretch of language that they could not meaningfully situate in the larger discourse.

Children's difficulty with this final entry is, of course, intensified by its fragmentary nature. Many do not possess a sufficiently mature knowledge of syntax to form a meaningful whole out of the various fragments. In order to perform the calculation called for by (A), children have to combine the first two fragments--

essentially conveying the same information--with the third. In effect, they need to know that together the three convey the following information:

Maybe not till she was seven, a whole year
[from now,] [would she be able to read.]

As indicated by the brackets, two bits of information have been supplied so that the fragments can be chunked together to form a syntactic whole:

(1) from now

(2) would she be able to read

Before discussing how a reader supplies these bits, let us first note how unnatural either would have sounded if it had actually been in the final entry. As writers of imaginative fiction have long known, the technique of syntactic fragmentation is particularly appropriate for conveying the texture of the language that we think in. Our thinking strains toward a state of pure predication, one in which words that convey old information are continuously suppressed.

In examining how the bracketed words represent old information, we must, of course, work from the little girl's perspective, for it is in her consciousness, at a particular point in the narrative, that certain information may be viewed as old. Let us first examine the second bit of bracketed information, would she be able to read. This information has been provided by what the mother has

just said, and so the little girl needn't supply it. Here we see a well-known discourse principle at work: that which is on the front-burner can be dispensed with.

The second bit of bracketed information--from now--is not retrievable from the immediate discourse. Rather it expresses a frame of reference that human beings take for granted in external speech as well as internal.* Some linguists such as Bennett (1976) and Fillmore (1975) have used the term DEICTIC to describe the use of one's own spatio-temporal location (i.e., the 'here and now' of communication itself) as an unspecified reference point. We will, however, use the term ANCHORED rather than deictic, contrasting it with UNANCHORED, to distinguish the two modes of interpreting an utterance like the following:**

ANCHORED: I'll do the job in a week [from now].

UNANCHORED: I'll do the job in a week [∅].

In the anchored mode, the point at which the job will be done is seven days from the speaker's now, but the job itself may take a day, a month, or even a year. In the unanchored mode, however, the job itself will take a week to do, but it may be started the next

*Even if the little girl had been talking, she would not have bothered to specify her own temporal location.

**The term deictic is more frequently used to characterize any language element (e.g., a pronominal) whose meaning is dependent upon the situation in which it is used--see chap. 4, pp. 5-14 for this more familiar use).

day, a month later, or even a year later. In effect, the anchored mode is inception-oriented, the unanchored mode extent-oriented. When we come to (B), we will see that both modes were used by children in interpreting the little girl's statement In three days I can read. Some anchored it in the little girl's now, but others--particularly minority children--took this statement as describing the extent of the time period that the little girl thought would be required for learning to read.

There is an accumulating body of research that suggests mainstream children are more prone to use an anchored mode of interpretation than are minority children whose ethnocultural heritage is in West Africa (see Hill, 1982, for a review of this research). Hitherto this difference has been demonstrated in a spatial domain rather than a temporal one. Mainstream children are, for example, more likely to work off their own 'here' in interpreting an utterance like That's my pen in front of the telephone. They are prone to envision the pen as located in an orientational field that takes its source from the point where they are:

ANCHORED

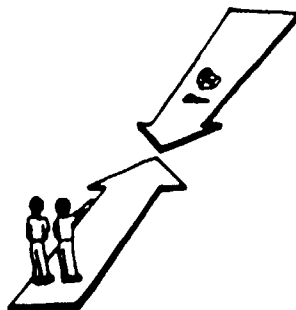

Minority children, however, are more prone to locate the pen in an orientational field that takes its source from the point where the

telephone 18:

UNANCHORED

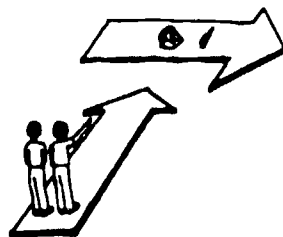

We are not yet certain whether minority children's lesser use of 'here' is paralleled by a lesser use of 'now.' If, however, it is, this may help to explain why they experienced more difficulty in dealing with both tasks in this item.*

We should note--apart from these cultural differences--that all children, when reading, have difficulty in anchoring spatial and temporal phrases. Such difficulty is particularly noticeable, given the ease with which they supply the 'here and now' in their oral experience of language. Consider, for example, the little girl's language in the passage. It provides three examples of anchored temporal phrases--only two more days, in three days, and a year? a whole year?--and each fits naturally with what she is saying. As readers we take such language use to be normal for a six-year-old child. Moreover, children of this age are competent in interpreting their interlocutors' deictically anchored language (i.e., they can decenter to the 'here and now' of the person they

*It is, of course, ironic that many researchers (e.g., Bereiter and Englemann, 1968) have claimed that minority children reflect a language deficit precisely because they are more limited to their own 'here and now' in verbal communication.

are talking to).* This decentering skill, however, is less in evidence when they are reading, for children often fail to supply the 'here and now' that is needed to make sense of an anchored phrase (e.g., a year? a whole year?). It is as though children's decentering skills are limited to the immediate world of space and time that they experience during human interaction.**

Before leaving (A), we would like to discuss two other factors that may help to account for minority children's greater difficulty with it. We will first discuss reasons why they may have had even greater difficulty than mainstream children in shifting from external speech to internal speech. As research by Labov (1974) suggests, narrative style in black speech communities tends to focus on external events, avoiding, for the most part, overt psychologizing within the narrative itself. Moreover, those who use this style will often report internal experience as though it were external (i.e., that which was merely thought will be

*Influenced by Piaget's notions of egocentrism, some researchers have claimed that children have difficulty in decentering to the 'here and now' of their interlocutors. These claims are, however, generally based on children's performance of artificially constructed tasks. Tanz has shown that in everyday talk children do effectively decenter to another's 'here and now.' In fact, she points out that children's competence in using deictically anchored language can come only from observing others using it (i.e., children learn to use their own 'here and now' only by decentering to another person's).

**We initially believed that children would be better able to infer a textually mediated 'here and now' when it is embedded in the human interaction. Children's difficulties with this passage, however, have led us to doubt this notion.

reported as if it were spoken).^{*} According to Labov, this style is embedded in a cultural system of communication that places greater reliance on bodies of shared information. This system also relies heavily on paraverbal and nonverbal channels in transmitting information concerning how people feel about experience. In effect, speakers directly display emotion, both their own and that belonging to the people they talk about, and so they have less need to express it verbally.

Given these cultural patterns, minority children may be less familiar with the narrative structure of the passage, one that requires them to move from external events to internal ones; that is to say, from activities such as looking at a calendar, speaking, and chuckling which are potentially available to any observer present at the scene to an activity such as thinking which is not directly available to such an observer.

It is ironic that minority children's attraction to four may have been strengthened by their having participated in various school programs designed to give them a head start. Minority children are often four years old when they begin such programs and so they readily associate this age with beginning school. One

^{*}In this sense, black narrative style resembles that traditionally found in oral culture wherein the storyteller focuses largely on external events, leaving the audience to infer the characters' various reactions to these events. Upon completion of the narrative, however, the audience, along with the narrator, can then talk freely about these reactions. In fact, one of the major purposes of oral narrative is to stimulate such talk.

girl, when asked to justify her choice of four, put the matter simply:

'Cause at four years old you go to school.

The Haitian child provided unexpected commentary on the little girl's age:

She is four years old in Haiti. But in New York she is five years old.

He went on to explain that children begin school earlier in Haiti.

Other children made similar responses, though they were less explicit in formulating the reason for their choice. One boy, for example, focused on the fact that at the age of four the little girl would not be able to read:

If she's four, she maybe can't read.

He went on to point out that if the little girl were six, she would already be able to read.

The children who made these claims had generally been exposed to reading-related activities from the age of four on in special programs such as Operation Headstart. Moreover, they were adamant in insisting that the word school should be used to describe these programs. It was as if they felt the term pre-school would be slighting.*

*We did find a contrary attitude in one black girl who chose eight in (A). When talking about this choice, she seems to have been

By way of contrast, mainstream children tended to reserve the word school for only post-kindergarten experience. One girl, for example, made this point in explaining her rejection of the choice four:

'Cause she would only be in kindergarten if she was four.

By the same token, a number of mainstream children justified their choice of six by identifying it as the age at which children begin school. One boy, for example, said:

That means that she is going--like--to first grade; and if someone's got to go to first grade, they got to be six.*

It is instructive to compare this statement to the one made by the minority child ('cause at four years old you go to school). The

unduly influenced by the word awful that ends the passage:

It was awful that she would not go to school till she was eight. She wouldn't learn to read till she was eight.

The interviewer then asked her whether that wasn't a bit late for learning to read, and she replied:

I don't know, 'cause when I was seven, I couldn't be able to read.

*He also made the ingenious point that, in one sense, the little girl already knew how to read. When she looked at the calendar, she was able to "figure out what it said."

boy's statement is more verbose, but it boils down to the same thing. Both children were unable to understand the passage's final entry, and so resorted to their own ethnocultural norms of language (i.e., what the word school means to them) and experience (i.e., at what age reading-related activities began for them). In one case, the child was credited with selecting the target response; in the other case, the child received no credit at all. Yet, each had followed a similar pathway, one that might be characterized as PASSAGE-INDEPENDENT (we will use this term more technically in Chapter 3 when we deal with tasks that accompany expository passages). During the interviewing we detected that some children were predisposed to view tests as measuring the extent of their general knowledge. This predisposition led them to focus less on the specific information conveyed by the passage, concentrating instead on what might constitute an appropriate response to the task considered apart from the passage.

Let us now move on to (B), bearing in mind the substantial comparison of the two tasks that has been already made. It should be remembered that, despite the apparent similarity of the two tasks, more children had difficulty with (B) during the pilot test. The repetition distractor three days was particularly attractive to children in both groups (see page 97 for the results). It was as if children, failing to understand the real point of the task, grabbed on to whatever they could.

The greater difficulty of this task may be partly attributed

to its syntactic complexity. Whereas (A) has only one verb, (B) has four--think, take, learn, and read--each functioning at a different structural level. A version of the sentence somewhat closer to the deep structure would be

The girl thought that for her to learn to read would take so long.

In addition, a further level of structure is represented by at first, the initial adverbial that modifies all of the remaining sentence.

In reading (B) aloud, a number of children were not able to render clearly the tone groups that signal the underlying syntactic relations. Evidently, the syntactic complexity prevented their chunking the words into meaningful groups. This was all the more striking in that all the individual words could be pronounced easily. All 18 of them--the most used in any task in our corpus--are monosyllabic words that can be found in the most ordinary kind of talk.

We have already pointed out how testmakers tend to write a task as simply as possible (e.g., in SHOP SIGN, p. 5, they wrote What was the mystery? rather than, say, What did the townspeople think was a mystery?). Hence it is interesting to speculate on why they made this one so complex. To begin with, they probably added at first so that children would focus on what the girl thought at the beginning of the passage rather than at the end. If the children

focused on the end, they would choose a year rather than one day.*

Let us now speculate on why they included at school, the at-initiated phrase at the end of the task. At first glance, this final spatial phrase seems less motivated than the initial temporal one. In fact, the testmakers probably would have preferred--had it not made the task even wordier--another temporal clause like once she went to school:

At first, how long did the girl think it would take her to learn to read once she went to school?

This version of the task manages to focus on what is crucial--the point in time at which she thought she would begin to learn to read.**

We cannot be certain why the testmakers included this final phrase, but we suspect that it had to do with their concern that children might anchor how long in the girl's now:

How long [from the point at which she was talking] did the girl think it would take her to learn to read)?

*In ALICE AND THE FAWN, p. 71, we pointed out how, in the absence of a comparable specifier, a number of children, particularly those disposed toward a communicative approach, naturally gravitated toward the passage end while responding to the first task.

**Once learning to read has begun at school, it is, of course, immaterial whether it takes place at school or at home.

The form of the question, strictly considered, does not allow for such expansion, for the how long focuses only on the unanchored duration that the girl projects for learning to read. To allow for the above expansion, the task would have had to be written differently:

How long [from the point at which she was talking] would it be until, in the girl's thinking, she learned to read?

Such refinements are not readily available to young readers, and so it is not surprising that many were confused about whether how long should be anchored or not.

When we presented (A), we pointed out a number of reasons why young readers tend to become confused about now-anchoring (at that time we also pointed out that minority children have particular cause for confusion). In this instance, there are specific factors that heighten the possibilities for confusion. To begin with, how long focuses on an imagined temporal extent--as opposed to an actual one--and this fact alone may have led some children to anchor it. Given that the act of imagining is itself anchored in the little girl's now, it is as if the content of that act comes, by a kind of osmosis, to be anchored there as well.

More important, however, is the fact that in order to interpret how long at all, readers must anchor the two temporal phrases that the little girl uses in her initial utterance. In the case of the first, this anchoring flows naturally from the presence

of only . . . more:

Only two more days [from now] and I go to school.

The second phrase, however, contains no specific markers that call for anchoring:

In three days I can read.

Rather anchoring is signaled by the position of in three days. This phrase, like the preceding one, receives tonic stress and, concomitantly, semantic foregrounding:

Only two more days and I go to school.

In three days I can read.

This parallelism leads the reader to process the two as a single unit of discourse, and so anchoring spreads from the first to the second:

Only two more days [from now] and I go to school.

In three days [from now] I can read.

We might note that, apart from the parallelism, the mere fact that in three days is frontshifted favors anchoring. Notice that sentence 1 is more likely to be anchored than sentence 2:

(1) In three days I can read.

(2) I can read in three days.

Even in (1), however, the effects of front-shifting are at least partially offset by the presence of can. This auxiliary tends to block the anchoring of any concomitant temporal phrase. Notice, for example, how a simple change from can to will be able strengthens the possibility for anchoring:

(1) In three days I can read.

(2) In three days I will be able to read.

The echo of from now can be heard more strongly in (2), and it becomes even stronger when in three days is placed at the end of the sentence:

I will be able to read in three days [from now].

We suspect that can may, in fact, have been a powerful factor in many children's choice of three days in (B). Inexperienced readers allow a local cue to exercise more power than it should (we have already seen how the core meaning of a word like stroke in ALICE AND THE FAWN takes over when it is not effectively integrated into the larger discourse). It is only as readers place can in the larger discourse that they are able to suppress its misleading effects. It is as though the signal for anchoring gets stronger as readers chunk more information:

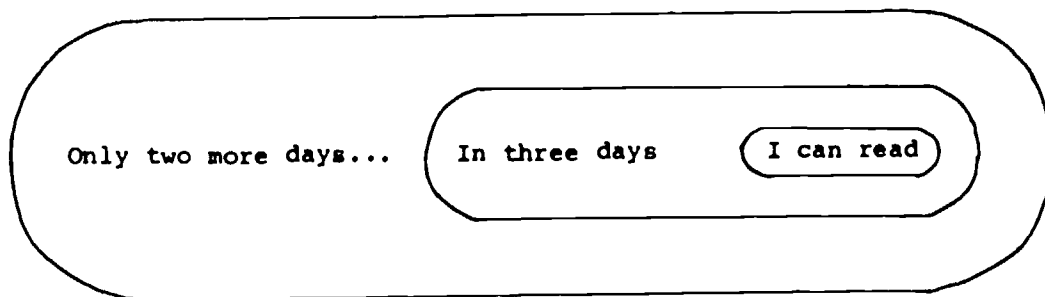

We might, in fact, add even another layer to the concentric image:

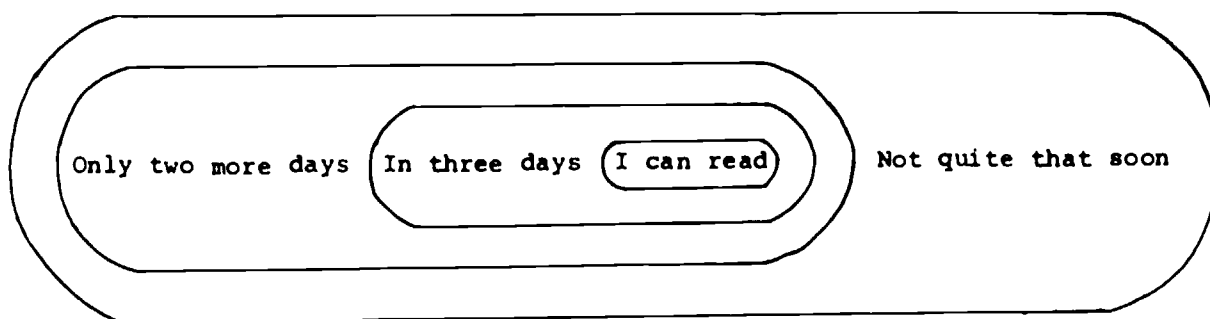

The fact that the mother uses soon rather than a word like fast shows that she herself treats the daughter's utterance as anchored:*

	DAUGHTER	MOTHER
ANCHORED:	In three days [from now] I can read	Not quite that <u>soon</u>
UNANCHORED:	In three days [Ø] I can read.	Not quite that <u>fast</u>

*: reader does not, of course, have to accept the mother's interpretation as the only valid one. But given that the daughter does not subsequently challenge the mother's interpretation, it tends to be viewed as normative.

Obviously this kind of cue is accessible only to a reader who is able to chunk discourse delicately. Most children were, of course, not even able to chunk the two sentences that the daughter uttered, as indicated by the small numbers who were able to choose one day as a response in (A).

There are, however, other ways of chunking the two temporal expressions in the girl's utterance that we came across when we conducted the group probe in which adults and children responded to the tasks without the multiple choices. First of all, both groups included two individuals who responded to (B) with five days, a choice not among the four actually provided in the task.* These individuals obviously chunked the two temporal expressions. They did not, however, anchor both in the girl's now:

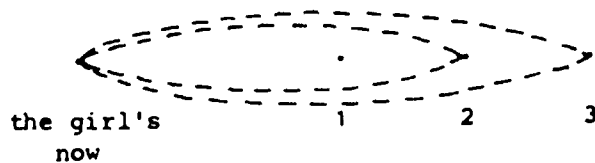

Rather they anchored only the first there:

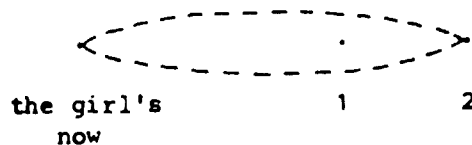

and then anchored the second at the point where the first temporal

*The adult probe was extended to a separate group of graduate students who were not native speakers of English. Among the 12 who participated, 4 chose 5 days (3 of these 4 spoke an Asian language).

period ends (i.e., the girl's 'then'):

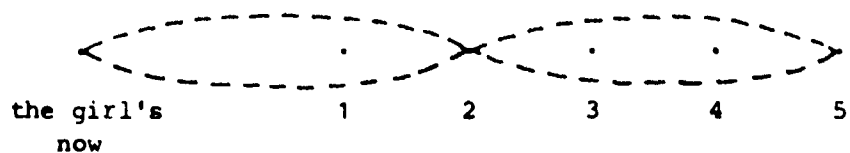

We may describe this mode as THEN-ANCHORING, thereby contrasting it with the NOW-ANCHORING that was called for.*

During the group probe there were also individuals--1 child and 3 adults--who provided the answer two days to (B). We can, once again, assume that the individuals making this choice did, in fact, chunk the two phrases. Moreover, they anchored both in the girl's now, unlike the individuals who chose five days. They failed, however, to understand that only two more days and in three days actually refer to the same day--the little girl's first day at school. Only two more days refers to a point in time at the beginning of that day and in three days to a point at the end of it (readers can then subtract two from three in order to arrive at the target response one day--i.e., the amount of time actually spent in school learning). Hence, with respect to the school day itself, the two temporal expressions call for different interpretive modes. The first calls for an EXCLUSIVE mode:

*Some linguists (e.g., Bennett, 1976) would use the term deictic to describe both kinds of anchoring. Others (e.g., Fillmore, 1975) would restrict this term to only now-anchoring.

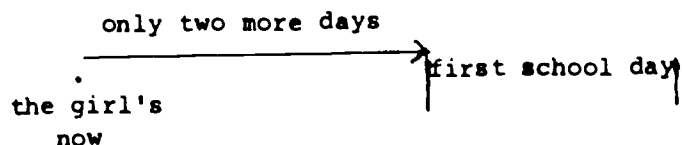

whereas the second calls for an INCLUSIVE one:

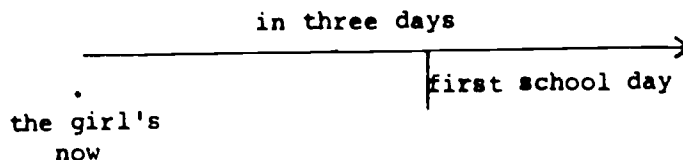

Presumably the individuals who chose two days extended the exclusive mode from the first phrase to the second (i.e., a second school day has to be added if in three days is interpreted exclusively):

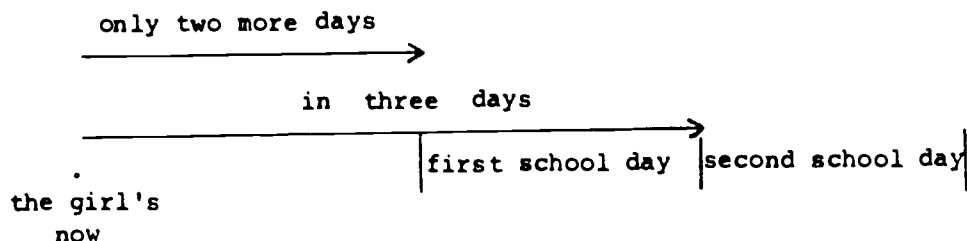

It is as though the extension of the exclusive mode leads them to overshoot the first school day and land on a second.

It is not surprising that children, when interpreting temporal phrases, are not certain about whether to include the day on which the counting ends (hereafter ED for 'end-day') or, for that matter, the day on which it begins (hereafter BD for 'beginning-day'). Many factors can determine whether these days are included in the counting: the time of day at which the utterance takes place, the

time of day at which the predicated event is expected to take place, and, of course, the nature of the temporal expression (we have pointed out the effects of only . . . more in the first phrase).

In order to get a clearer idea of how English speakers actually interpret the first temporal phrase that the little girl used, we gave the following task to 30 children and 30 adults:

While looking at a calendar, a little girl says to her mother:

Only two more days and I can go to school.

The date on the calendar is September 1. What is the date when the little girl will start school?

Here is how they responded to this task:

	CHILDREN	ADULTS
September 2	1	0
September 3	13	24
September 4	16	6

As can be seen, more children chose September 4 which means that they had to exclude both BD and ED from the counting:

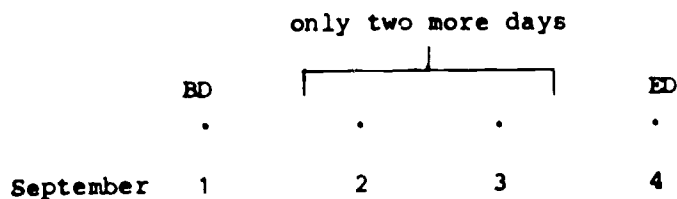

A number of children were quite articulate about the fact that they were excluding SD as well. Consider, for example, what one child had to say:

--You wouldn't count the day you're speaking on. You always start with the next day.
Only two more days after that day.*

The child who chose September 2 did just the opposite of what these children did. Ignoring the cue of only . . . more, he included both BD and ED in the counting:

*Those who chose September 3--the preferred choice among adults--presumably included BD rather than ED in the counting:

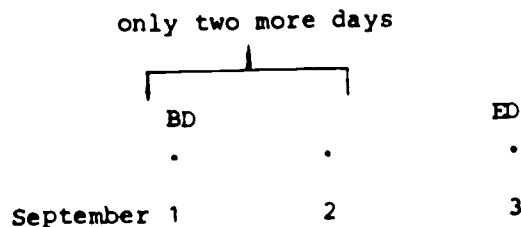

As already pointed out, only . . . more leads readers to exclude ED.

We presented another version of the same task to 30 children, simply adding the words One morning at the breakfast table. Children now preferred the choice of September 4 (23 selected it). They could now locate the little girl's utterance at an early point in BD and so they chose to include that day in the counting.

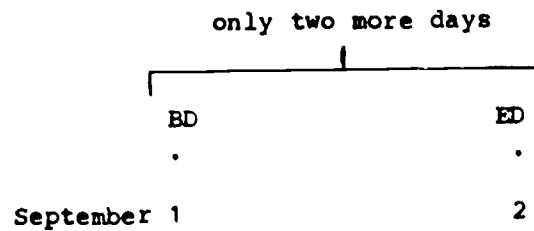

From the interviewing it was difficult to understand why he did this. His mother, however, reported that he is prone to foreshorten the time period involved in any event that he is looking forward to. In this way he is able to make the event seem closer than it actually is.

It is difficult to imagine how this difficulty of actually counting the days might have affected children's performance on (B). It would not, of course, lead directly to a distractor, since a choice such as two days is not available. However, it might, when joined with the complications already noted, lead children to avoid anchoring altogether and thus opt for the three days, unanchored choice.

At this point it might be useful to retrace our steps and summarize all the decisions that a reader has to make about how to chunk in three days with only two more days. We represent these decisions in the form of a flow-chart:

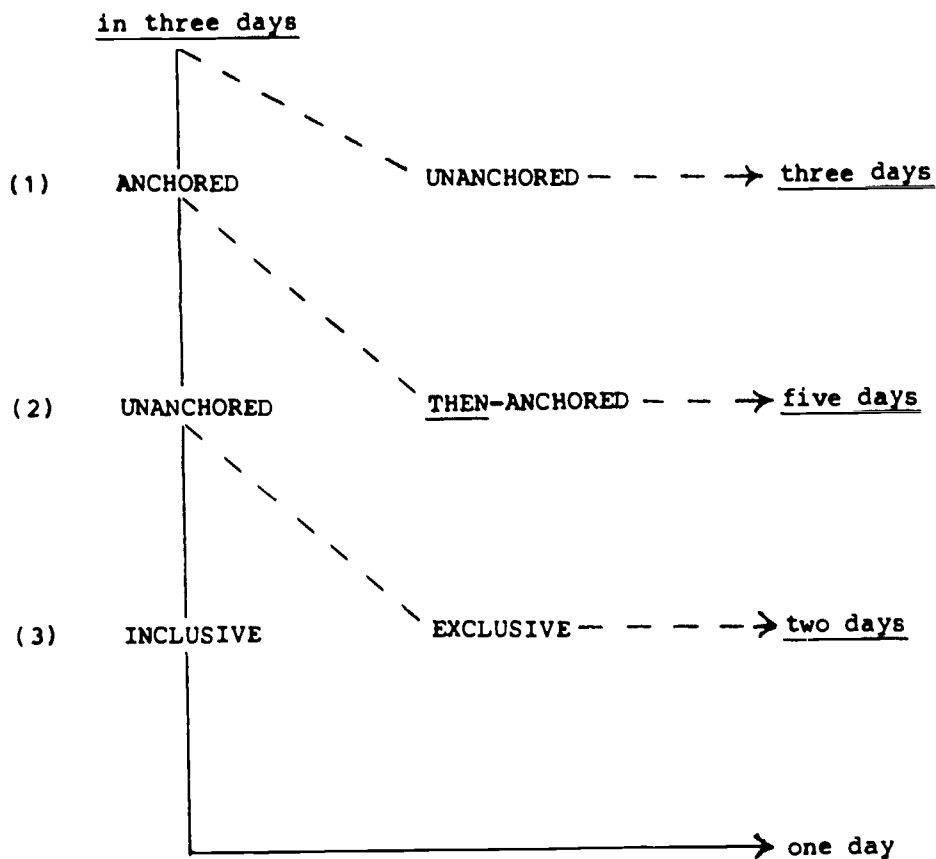

As can be seen, readers may make a decision at any of three points that will lead them away from the target response one day. It is only at the first point that a distractor (three days) is actually provided; and yet as we have seen, when children and adults are free to choose their own responses, they make decisions at both points (2) and (3) that lead away from the target response.

The testmakers were probably wise in not providing all four of the choices listed in the flow-chart. There is, after all, a cut-off point in how many demands a task can legitimately make. It is clear that providing all four choices would have been well beyond that point, particularly for children who are bright enough

to envision all the decision points represented in the flow-chart.*

Let us now turn to a final set of problems, much less technical than the preceding ones, but nevertheless potentially troubling to children in their approach to (B). These problems are probably best characterized as pragmatic, for they have to do with how children respond to what (B) assumes about what the little girl meant when she first spoke--that she really would learn to read on the first day of school.

Given what we know about the elliptical nature of human speech, we are inclined to question whether this was what the little girl really meant. She may have thought that the process of learning to read would begin on the first day of school; or she may have simply intended to convey that she would be in the place (i.e., the school) which is associated with reading; and in using the word read she may have had in mind the whole range of school activities rather than the activity of reading per se. Whatever she had in mind, she must have known that actually learning to read would take much longer.

Now it is true that the mother interpreted the utterance as if her daughter thought that she could learn to read on the first day of school. And it is further true that the daughter then responded as if

*Nevertheless, we would like, at some point, to risk such cognitive overload by conducting a group probe in which these four choices are included in the task. Such a probe might lead to a clearer picture of how children make decisions about chunking temporal phrases.

she accepted the legitimacy of the mother's interpretation. But even these two facts do not necessarily support what (B) assumes, namely, that she was at first thinking that she would learn to read on the first day. In everyday conversation, we often accept the meanings that others ascribe to our words, even though these meanings may not have been present in our own minds at the time of speech. This would appear to be particularly the case when a child is talking with some authority figure such as a teacher or a parent. It is as if the child assumes that the interpretation of this person has a certain legitimacy and should be appropriately respected. Moreover, we need to bear in mind what ethnomethodologists such as Sacks have taught us about conversation: we often are not aware of what we mean when we speak and hence take our meanings to be what others take them to be.

Strangely enough, the children who did not worry about what the little girl actually meant seemed to have a certain advantage in responding to (B). By accepting what this task assumed, they were then in a position to accept one day as a perfect expression of the little girl's naivete. As one child put it,

--That's crazy to think you can learn to read
in one day.

It is as though this child was able to back into the target response without even worrying about all the temporal complications that we

have described.*

By way of contrast, certain children who did worry about what the little girl meant had difficulty in selecting the target response. It is as though they took (B) as concerned with what the little girl really thought and so felt that the choice of one day would result in a misleading statement.** The daughter of the English professor provides an interesting case study. She failed to choose the target response for (B)--this happened on only one other task in our corpus, and in that instance her failure is probably best viewed as a success (see our discussion in MOTHER ALLIGATOR, chap. 3, pp. 164-178).

When she realized that she had not selected the target response, she was obviously disappointed. But she struggled gamely to make sense out of the little girl's initial statement:

--I guess she meant a word here and there,

'cause you can't learn how to read a paragraph that fast. She was just thinking about a few tiny words like it, the, and art.

*Focusing on the little girl's naivete did not, however, lead this child to the target response in (A). There he chose four on the assumption that a six-year-old child would not be so naive to think that she could learn to read straightaway. As he put it:

--Anybody who's been to kindergarten knows better.

**In ALICE AND THE FAWN we saw a similar pattern of response: some children took (B) as concerned with what Alice was really trying to do for the fawn.

It was her father who was conducting the interview, and even he was incredulous at her having included art in the list of easy words:

--It, the, and what?

--It, the, and art. A-R-T. Art.

--A-R-T. Art. I see. Uhmm.

--And small words like that. And her name.

She goes on to tell about her own experience of learning to read:

--I learned to read when I was about three-and-a-half. We had these easy reader books, like Foot Book. It's all about foot, like F-O-O-T; and it tells all about foot; and like the small words, you know, I learned how to read them even before I went to school. And so I was...I could read pretty clearly, but not really the hard words like, let's see, items, for example. But I could read small little words--it, the, is, my, and words like that.

The father then points out that he didn't know how to read when starting school, but thought he would learn to read straight-away:

--I thought a short time later I'd be able to read all the comic books.

The daughter cannot resist a mild reprimand:

--Yes. Anyway, you shouldn't have even read comic books.

She uses this bit of parent-child exchange as a springboard for commenting on the fact that the mother in the story did not understand what her own daughter had meant when she was talking about learning to read:

--The mother thinks the girl means that she could read some really hard book like that... like The Count of Monte Cristo.

In effect, she has returned to her original point--that adults really don't understand what the little girl meant.

In closing our discussion of this item, we would like to suggest that any assessment of comprehension, ideally, should be concerned with children's capacity to work out pragmatic meaning for what they read; and yet here the child's legitimate concern with such meaning led her away from more purely referential meaning. It is as though her concern with what the little girl actually meant prevented her from sufficiently processing the temporal detail that (B) calls for.

Gapped Narratives

We come now to the final section of this chapter that deals with narrative incompleteness. We are aware that describing only narratives in this section as gapped may be misleading. Any narrative--and certainly the brief kind found in a test item--contains many different kinds of gaps that the writer expects the reader to fill in. Consider, for example, all the gaps that were present in BLACK BONNET--the reader doesn't know what Miss Esther's relation was to the old lady, why the old lady was expected, why she didn't show up, and so on.

Still the narratives presented so far differ from the ones that we are about to present in one fundamental respect: they were taken from some larger whole--or, at least, they lead the reader to respond as if they were. As a consequence, their most striking gaps are best described as external than internal; that is to say, they are located at the margins of the narrative rather than within its fabric. In the case of truncated narratives, it was the ending that is absent. In the case of excerpted narratives, it was both the beginning and the ending.

The narratives that we now present were not taken from a larger whole; or if they were, they were so substantially rewritten that they seem to have an ending as well as a beginning and middle. This holistic quality has, however, been purchased at high cost. In order to pack a whole story into 50 words or so, the writer has

to push out the kind of transitional detail that readers are accustomed to as they move from one part to the next. Hence they often becomes confused as they try to supply this detail.

We have already observed how children, when extending a truncated or excerpted narrative, often end up with too much of a story--at least for the purposes of test-taking. Here we will observe the opposite. As children patch together a gapped narrative, they often end up with not enough of a story.

HURRICANE

The first gapped passage that we will consider is a narrative about a hurricane:

The hurricane dumped huge amounts of rain on the island. Its strong winds knocked down trees and blew away houses. The island's streams and rivers began to overflow, flooding the towns. Luckily, the mighty storm soon abated.

A. This story says that trees were

flooded

strong

blown over

blown away

B. In the story, the word "abated" means

died down

got worse

rained

blew

The content of the passage can be conveniently summarized as follows:

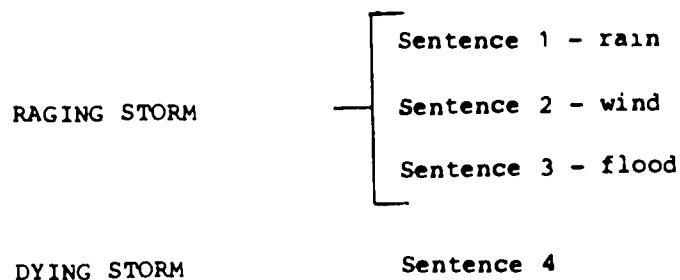

Although this narrative is only 37 words long, it conveys a holistic quality, a sense that it is not part of anything else. In order to achieve this, however, a major gap has been left between sentences 3 and 4. At the end of sentence 3, the discourse has given readers

no reason to suspect--other than the visual clue that they are only one brief sentence away from white space--that the storm--and the narrative--are almost over. In fact, the use of cataphoric the in the hurricane and the island has implied that more specific information will be supplied in due course. The failure to fulfill this legitimate reader expectation makes it startling to find that the six words of sentence 4 conclude the narrative. It is as though the writer, having just launched his subject, for some unknown reason interrupted it and added a brief conclusion. The resulting gap is so peculiar that we are led to think that this passage was written especially for this test item rather than adapted from existing prose.

Before discussing the two tasks in detail, it will be useful to point out certain similarities between them. To begin with, both are acommunicative and can be described with the terms introduced in ALICE AND THE FAWN (see pp. 77-81). Thus, each task can be phrased in three different ways:

	(A)	(B)
COVERT	Trees were _____.	The storm finally _____.
OVERT (unfocused)	The story says that trees were _____.	The story says that the storm finally _____.
OVERT (focused)	In the story, "knocked down" means _____.	In the story, the word "abated" means _____.

Unlike the tasks in ALICE AND THE FAWN, both tasks in HURRICANE have been made overtly acommunicative by including the formula the

story, which implies that the answers should be found by paying close attention to the details of the passage. From the standpoint of vocabulary-defining, however, (A) is left unfocused; readers do not find out until they do the task whether it is recycling or vocabulary-defining. In (B), the vocabulary-defining function is made explicit with the formula the word . . . means.*

(A) and (B) are also similar in the patterning of their choices, a patterning that is reflected in the responses of both mainstream and minority children. For example, there is a considerable gap between the two groups in selecting the target response for each task:

	MAINSTREAM	MINORITY
(A) blown over	47%	33%
(B) died down	47%	23%

*No doubt the testmakers expressed the vocabulary-defining intent of these tasks in different ways because they wished to avoid using the same form for two consecutive tasks. We can speculate that (A) was made unfocused and (B) focused because the alternative in each case requires an adjustment to the usual formula. In (A), an exact adherence to the overt form produces the word "knocked down". The obvious solutions to this problem are all awkward: the phrase "knocked down" or the words "knocked down" or just "knocked down". In (B), following the established form exactly produces

The story says that the storm _____.

Unless the task makes clear that it is referring to the state of affairs at the end of the passage, three of the four choices--blew, rained, and died down--would be defensible answers. One solution is to add a word like finally to the usual formula, as was done above; the other is to use the focused formula, which requires no adjustments.

This item provides further evidence that the gap between mainstream and minority children tends to widen on communicative tasks. The gap on (B) is, in fact, greater than any other in our corpus.

Turning now to the distractors, we find that each task has a choice that expresses 'intensity':

	MAINSTREAM	MINORITY
(A) strong	14%	27%
(B) got worse	17%	37%

If we add the percentages for the target responses and the 'intensity' distractors together, we find that the gaps, which are inverse to each other, are nearly the same size:

	MAINSTREAM	MINORITY
(A) blown over + strong	61%	60%
(B) died down + got worse	64%	60%

When we discuss (A) and (B) in detail, we will try to account for the appeal that these 'intensity' distractors have for minority children.

The responses of the two groups were much closer on the remaining two distractors. By far the more attractive were the 'blowing' distractors:

	MAINSTREAM	MINORITY
(A) blown away	28%	27%
(B) blew	19%	25%

2-134

Finally, the 'water' distractor on each task was the least favored:

	MAINSTREAM	MINORITY
(A) flooded	11%	13%
(B) rained	16%	15%

Let us now consider (A) in detail. Its apparent aim is to find out whether a child knows that knocked down as used in the passage is equivalent to blown over. But there were some children who did not realize that the task was vocabulary-defining. Perhaps this is because there is no obvious "hard" word that seems to need defining. Or perhaps some of them found blown over and knocked down too different to be synonymous. As one girl put it:

--I would have said flattened or something, because blown over is not exactly a synonym for knocked down. Some people who, you know, aren't really with it wouldn't really get that.

--Why? What's the difference between knocked down and blown over?

--Well blown over is like, well it could snap back up, you know, like a clown could be blown over and then just snap back up. But when it is knocked down, it is knocked down.

Those who thought of this task as calling for recycling were faced with three choices that come from the passage: strong, flooded, and blown away. In fact, the only new material in (A) is the target response blown over. If one responds to the passage holistically, a case can be made for either flooded or strong. To begin with, each embodies a theme that is well-represented in the passage:

flooded	rain--streams and rivers--overflow--flooding
strong	hurricane--huge amounts--strong winds--knocked down--blew away--mighty storm

It is also possible to support each of these choices logically. With flooded, for example, one might reason that the passage says that towns were flooded, and the towns must have had trees in them, and therefore the trees must have been flooded too. With respect to storm, one can reason that the trees must have been strong, because strong winds knocked them down but were unable to blow them away like they did the houses. Since most children probably think of houses as stronger than trees--particularly if they are urban and are thinking of apartment houses--the fact that the trees hung on and the houses didn't might be taken as an especially dramatic illustration of their strength.

Now let us consider the children who selected blown away. Most of them undoubtedly understood the vocabulary-defining nature of the task, but were unable for some reason to select blown over

and ended up with the nearly identical blown away. Since we are dealing with vocabulary, we might begin by asking how unfamiliar knocked down, blown over, and blown away are likely to be. This is not easy to establish, since frequency lists--together with dictionaries in general--have fragmentary coverage of lexical items that are not single words orthographically. Our intuition is that while knock down is considerably more frequent than blow over, both items are likely to be familiar to most third and fourth graders.* Here is how one fourth grader who had the relevant knowledge negotiated the task:

--Why did you say blown over?

--Oh, boy!

--Well?

--You see the story? It says that a strong wind knocked down trees and blew away houses. So it blows over trees because if it was knocked down it should say knocked down, but there wasn't.

--Okay, if it said knocked down down here, you'd say that.

--Yup.

--But you said blown over because why?

*If this intuition is correct, then this vocabulary-defining task reverses the usual order by placing the less familiar of two synonyms in the task rather than in the passage.

that wires will become crossed, giving

blew away trees

Its strong winds

and

knocked down houses.

For children who conceive of houses as generally being stronger than trees, it would be natural to think of them as less likely to be blown away.

Since the actions expressed by the two verbs could be sequential, some children may reformulate the original information in still another way:

Its strong winds knocked down and blew away
trees and houses.

Even when readers have located the relevant information and separated it accurately from its context, they may still have difficulty in matching it with the task sentence:

Its strong winds
knocked down trees.

Trees were
blown over.

The shift from active to passive, together with the suppression of the agent of the action, produces a sentence that looks and sounds quite different, even though the meaning is similar. The shift to passive also makes it hard to use the substitution strategy to validate a particular choice:

*Its strong winds blown over trees and blew away houses.

Even those who are able to change the form of blown over appropriately will obtain a problematic result:

Its strong winds blew over trees and blew away houses.

This double use of blow is so unlikely in this context that it could well cause readers to reject blown over as an answer.

Added to these syntactic pitfalls is the difficulty of distinguishing between phrasal verbs that begin with the same word.* Blow is quite productive in this role. Using storm as a subject, here are some of the possibilities:

INTRANSITIVE

They expect a storm to blow in tonight?

Do you think the storm will blow out anytime soon?

I hope a storm does not blow up after we go to sleep.

The storm will blow over before we have to leave.

TRANSITIVE

The storm blew over my pot of geraniums.

The storm blew down the water tower?

*These verbs are sometimes referred to as two-word verbs or verb-adverb combinations.

The storm blew off the shutters?

The storm blew away the barn?

Thus, we have two senses of blow over. The image behind the transitive use is a vertical object which becomes horizontal. The image behind the intransitive use is movement along a horizontal plane. Blow and over also occur together in sentences in which blow has a double complement, an object and a prepositional phrase:

The wind blew her hat over the fence.

The wind blew my hair over my eyes.

The wind blew the balloon over the lake.

In the first sentence, the hat ended up beyond the fence; in the second, the hair ended up covering the eyes; in the third, the balloon ended up directly above the lake. Each of these sentences has a briefer form:

Her hat blew over the fence.

My hair blew over my eyes.

The balloon blew over the lake.

These examples demonstrate the semantic principle that high-frequency words are polysemic, that is, they are used in a wide variety of contexts and tend to cover large, diffuse areas of meaning. They are given a precise sense only when used in a particular context. Thus, in the last three examples, shifts in the meaning of over are cued by the physical characteristics of the

objects it is relating to one another:

hat/fence = 'beyond'

hair/eyes = 'covering'

balloon/lake = 'directly above'

Another characteristic of polysemic items is that when they are encountered out of context, a core meaning seems to take over, and many of the senses they have in particular contexts recede and become psychologically unavailable.* Let us exemplify this process by describing two probes that were carried out during the investigation of HURRICANE.

In the first probe, 22 third graders were given the following task:

*We have often observed this process when discussing the English personal pronouns. Native speakers often resist the idea that they is used to refer to objects as well as people. Yet they use they this way themselves dozens if not hundreds of times a day:

Where are the forks? They're in the top drawer.

The core meaning of they is strongly associated with animate entities. When it occurs in isolation, this core meaning is so pervasive that it is difficult to conceive of they as also being used in connection with inanimate entities, even though this second use is ubiquitous.

Here are two sentences. Circle the number of the sentence which describes the picture.

- (1) The hurricane blew over both trees.
- (2) The hurricane blew away both trees.



17 of them circled (2), indicating that in a supportive context, pictorial as well as linguistic, they were able to distinguish between blow over and blow away.

In the second probe, 55 third and fourth graders were asked to use the words blow over in a sentence. The results varied greatly. Only two supplied sentences in which blow over clearly had the 'cause to be horizontal' meaning required by (1):

The house blew over.

The boat got blow over.*

A few others wrote sentences in which over might have this interpretation:

The storm blew over the house.

The storm blow over the ship.

*Most of the children were so intent on having blow over present in letter as well as spirit in their sentences that they neglected to use blew and blown where required.

When children are asked to supply a sentence in this way, their first instinct is probably to start with a personal subject such as I, he, or my mother. Several children combined a personal subject and blow over with interesting results:

I blow over the leaves.

Blow over that bug.

Blow that ant thats on you.

I can blow over a feather.

I will blow over that napkin because it was over here.

I blow over the lamp.

I blow over a chair.

I will blow over the statue.

I told my brother to blow over the men.

In the first group, the reader gets an image of someone causing a light object to move by blowing on it. In the second, vertical group, objects are 'caused to be horizontal' but they are too heavy to be moved by someone's breath. The more appropriate lexical item would appear to be knock over. The sentence in which the brother is asked to "blow over the men" might, of course, refer to small figures such as toy soldiers.

It is particularly interesting that some children were so constrained in producing a sentence using blow over that they actually used it in place of other phrasal verbs beginning with blow:

The boat's engine had a blow over. (blow out?)
I blow over the paper bag. (blow up?)
The wind blow over my hat. (blow off?)
The wind blow over my scarf. (blow away?)
The boy had a big blow over. (blow up? blow out?)
I blow over my door. (blow open???)

In addition, there were sentences representing some of the meanings of blow over that we have mentioned.

Blow my hair over my ears.
The wind could blow over the fence.
The storm will blow over in an hour.

And there were a considerable number that are inexplicable:

I was blow the sky.
That blow over is very windy.
A blow over is the kind of that is blows over the hill.
You blown you over santa?

All in all, this probe turned out to be difficult for these children. Only about a fifth were able to place blow over in a context that resulted in a viable sentence.

Let us now turn to an interview in which the child chose blown away because he was working with a sense of over that blocked him from seeing that blown over could be matched with knocked down:

--Show me in the story where it says blown
away.

--OK. Its strong winds knocked down trees and
blow away houses. It should say blow away,
blow away houses and trees.

--So you think blown away?

--Yeah. No! Knocked down, but here it doesn't
say knocked down.

--No. What about blown over?

--I don't think it fits blown, blown ... I
don't think it fits knocked down.

--Why not?

--Because blown over doesn't mean knocked down,
cause if it were knocked down it just fell on
the floor.

--And if it's blown over?

--If it blows over something.

--What does knocked down mean?

--That the trees will fall down.

--OK. What does blow over mean?

--It means that the tree flies over something
else.

Notice that in the beginning, this child is so far from seeing how
blown over might fit in that he actually suggests that the passage
is wrong, that it means to say that both trees and houses were

blown away. Further on, the nature of this block becomes clear. When over is taken out of context, the core meaning of 'above' is all he can conceive of. After further discussion with the interviewer, he was able to see how over could mean something else in the context of 'wind' and 'blow' and 'trees.'

When a lexical item is used in a text, it has a syntagmatic relationship with other items that are present, that is, it plays a role along with them in forming the meaning of the whole. When a lexical item appears in isolation, such as it does when it is one of the four choices in a test task, it has a paradigmatic relationship with the other three; and each of the choices is also related paradigmatically to the part of the passage that is relevant to the task. Breaking up syntagmatic wholes and looking for synonymous relationships among paradigmatic items, as children must do in completing a vocabulary-defining task, puts a special strain on their capacity to process language.* When children deal with phrasal verbs, the situation becomes even more difficult. Once a phrasal verb is removed from a syntagmatic relationship, the bond between its two components is loosened, and they begin to be affected by their roles as individual words. And since phrasal verbs like the ones used in this item as well as the single words that form them are all high-frequency lexical items, the

*Word-association tasks have demonstrated that children draw more on syntagmatic relations in their early years. As they grow older, they increasingly draw on paradigmatic ones.

possibilities for polysemous combinations are multiplied. To put this more generally, as long as phrasal verbs operate syntagmatically, we can handle them perfectly well. It is when we are forced to deal with them paradigmatically that we become aware of their anomalous nature and may lose our grip on them.

Phrasal verbs began to be a noticeable part of the lexicon almost five hundred years ago. Since then their number has increased enormously, becoming a torrent in the twentieth century, especially in American English. Yet we still feel they are awkward--not when we are using them, nothing could be more natural--but when we are forced to think about them. This lack of ease in dealing with these verbs is manifested in several ways. They were not taken account of in commercial dictionaries until the 1950s, and coverage is still fragmentary. Indeed, dictionaries designed for those learning English often are more comprehensive in this area because they have a mission to explicate "idioms." Moreover, these verbs have often been thought of as being especially informal or slangy. Until recently, writers were often advised to replace them systematically with "more precise" single words. As yet, however, linguistic investigations have not turned up any simple principles that would enable us to feel more comfortable with this unruly area of the lexicon.

This contrast between syntagmatic ease and paradigmatic vertigo is perhaps another example of a principle that has been frequently cited in recent years, most notably in such popular

books as The Inner Game of Tennis and Zen and the Art of Motorcycle Maintenance. We are most skillful when we can do something holistically and keep it on the margins of awareness; any tendency to be analytic or even turn our full attention on what we are doing is likely to break our natural rhythm and be counterproductive.

To return now to (A)--perhaps we can demonstrate these matters concretely by substituting single words for blown over and blown away:

PASSAGE . . . Its strong winds knocked down
trees and displaced homes

(A) The story says that trees were
 flooded strong
 flattened displaced

Flatten and displace are not entirely satisfactory as substitutes, but perhaps this alternative version does provide a useful perspective on how the presence of phrasal verbs makes this task more complicated than it appears to be.

To sum up, the apparent function of (A) is to see whether children know that knocked down and blown over can mean the same thing. But there is a paradox. Most children seem to know the meaning of these terms, yet many of them were not able to complete the task successfully. From an operational point of view, (A) seems to test whether children can negotiate the syntactic and semantic complexities that we have described.

(B) contrasts sharply with (A). Where (A) is perplexing, (B)

is transparent. Its vocabulary-defining function is unmistakable; in fact, it meets the two conditions that ideally should be present in any vocabulary-defining task: (1) the word that children are to define is unlikely to be known at this grade level;* and (2) the passage contains clues that enable readers to figure out what the word means.

It was clear that many children were able to use the passage clues effectively in figuring out what abated means. Consider, for example, the following exchange:

--Why do you think died down?

--Because it says Luckily, the mighty storm soon abatted.

--Okay. Now wait a minute. You could pronounce that better.

--Abated.

One can presume from this child's mispronunciation of the key word that it was unfamiliar to him. His special emphasis on luckily when he read from the passage showed that he considered it the major clue.

In order for children to utilize luckily as a clue, they must share, at least for the moment, a world view in which it is considered fortunate for a violent and destructive storm to come to an end.

*In an explicit vocabulary task, if the child knows what the word means, the task becomes, in principle passage-independent, that is, it can be answered without reading the passage and does not therefore function as a test of text comprehension. According to Dale & O'Rourke (1976), even at the twelfth-grade level, abated is familiar to only 41%.

When we first analyzed this item, we wondered whether certain children might subscribe to the opposite world view, one in which observers are "lucky" when things get worse, because they are then able to experience maximum excitement. Much that occurs on television, in movies, and while playing videogames would seem to encourage such a stance. However, we did not find any children who responded in this way--or, at least, not any who were able--or willing--to say that they did. Whatever their predilections when playing Missile Command or watching James Bond, when children reacted to this passage, they seemed to follow the rules. Nevertheless, a fairly large number of children--particularly those belonging to minority culture--did, in fact, select got worse.*

This attraction is not surprising, given the way in which (B) exploits the gap in this passage. Indeed, children who do not know what abated means and who are unable to interpret luckily in the expected way will probably not realize that a gap exists.** They

*We thought about doing a group probe in which children would respond to a slightly adjusted version of the passage, one in which a more neutral word would be used in place of luckily. We were not able, however, to replace luckily as easily as we thought we could--a simple connective like but somehow sounded too blunt. This limitation itself provides further evidence that the gap is so substantial that it is not easily negotiated.

**A fourth grader pointed out to us another possible clue to the gap. She didn't know the meaning of abated and she seemed to miss the significance of luckily, yet she got the right answer. She said that the presence of mighty before storm in the final sentence made her think that the storm was first described as especially bad to provide a more vivid contrast to when it was later described as getting better. She claimed that writers

are more likely to think that the last sentence continues the theme of the first three, and they might well select got worse for their answer. After all, in the ordinary course of things, it is to be expected that a story will continue to build for a while before there is a turn of events. To put this another way, for children who miss the relevant clues, this passage is likely to seem truncated (i.e., lacking an ending) rather than gapped (i.e., lacking a middle).

We noted at the beginning of our discussion of HURRICANE that the 'intensity' distractor for each task (i.e., strong and got worse) was surprisingly attractive to minority children. We have suggested certain aspects of the passage and the tasks that might have led children to select these distractors. We suspect, though, that something further is operating here. Various bits of evidence lead us to speculate that members of minority culture are more likely to have a macro-frame--we might call it strength-in-the-face-of-adversity--that makes strong salient for them in (A). There may be a similar frame operating in (B) that points toward got worse. We might even relate these frames by suggesting that one needs strength in the face of adversity because things are always likely to get worse. We will have occasion to note other tasks in which minority children seem to be operating with such frames (see, for example, both of the tasks in RAISINS, chap. 3, p. 86).

"like to set things up this way." After reflection, we think that she is probably right, that mighty does indeed contain a subtle clue of this kind.

CHEE TONG

The second item that we will consider in this section differs markedly from the first. HURRICANE was largely characterized by one large gap, but the passage below reflects a number of gaps, both large and small.

During the day, Chee Tong traveled around the city with his stove. The boatman took his boat up and down the river, but at night he always tied up at the same place. There they met, and together they ate the evening meal, prepared and cooked by Chee Tong. It was a most satisfactory arrangement--the boatman provided shelter, Chee Tong the meals.

A. What did the two men do together?

cook	tie up
go up the river	eat

B. What was the shelter?

a boat	a house
a stove	an arrangement

This narrative is fundamentally unlike the ones that we have examined thus far. The sequence of events that it establishes occur habitually rather than uniquely. As a consequence, the narrative feels a bit more like exposition. It moves, for example, toward an overtly formulated generalization--that Chee Tong and the boatman have "a most satisfactory arrangement." Moreover, lurking at each point in the story is an unformulated generalization--both Chee Tong and the boatman faithfully follow a diurnal schedule.

It is, of course, this fidelity that makes possible a description of their activities from a habitual perspective.

The pervasive gapping in this passage can be approached in a number of ways. To begin with, it is useful to point out how culturally alien its world is. An intelligible rendering of this world would require more textual space than is available in a test item. Consider, for example, what the first sentence presents. Any reader, particularly an inexperienced one, is likely to wonder who Chee Tong is, why he travels around the city with a stove all day, or, for that matter, what kind of object the word stove refers to. A number of children whom we interviewed were unable to imagine a stove so small that a man might be able to carry it around all day. For them, stove refers only to the Hotpoint range in their kitchen; it cannot be extended to, say, the hibachi used on a cookout. Some resolved this problem by picturing Chee Tong as a large man. But making the man bigger is in many ways just as difficult as making the stove smaller. In children's thinking, an oriental man tends to be small, at least when compared to a westerner.

The kinds of problems that the opening sentence presents multiply as children continue with the passage. By the time they reach its end, many are so disoriented that they cannot provide a coherent account of what they have read.*

*Some of the narratives we have considered--for example, SHOP SIGN, LEAVING HOME, and BLACK BONNET--are distant in time rather

The information in this passage, however, is not only culturally distant: it is also structured in a way that is potentially confusing. Consider, for example, the use of Chee Tong and the boatman. These two nominals are intended to refer to separate persons, as indicated by the use of they in sentence 3. But before readers reach this sentence, they may decide that the two refer to a single person. This is the converse of the process that we observed in BLACK BONNET. There some children mistakenly interpreted two appositional nominals as representing two persons rather than one (see pp. 56-57):

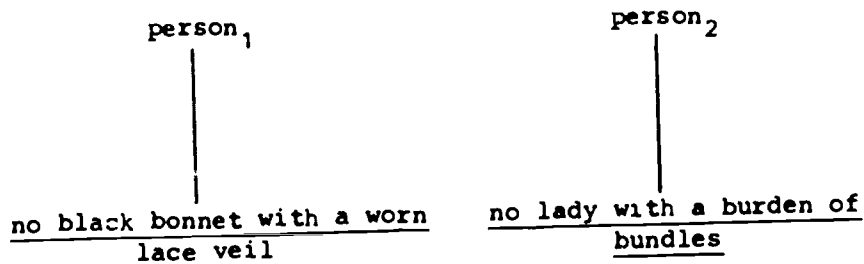

Here some children mistakenly interpreted two nominals as referring to one person rather than two:

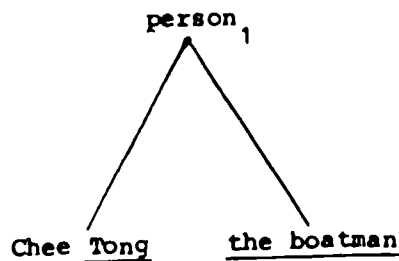

than in space, presenting cultural wor... t have largely
 vanished from the American scene. Mc... ren can enter these
 worlds more easily than they can the world of CHEE TONG.

In listening to children's oral reading of this passage, we came to suspect that many were, in fact, misframing the first two sentences. In order to find out more about what children make of these sentences, we presented them as a "story opening" to 55 third and fourth graders. After the children read the two sentences, we asked them to complete the story. Judging from the stories that the children constructed, 36 viewed Chee Tong and the boatman as referring to one person, 15 viewed them as referring to two people, and in the case of 4 children, we were not able to determine whether they had one or two persons in mind. Moreover, mainstream children were even more prone than minority children to think that Chee Tong and the boatman referred to the same person:

	MAINSTREAM	MINORITY
one person	23	13
two persons	7	8
third persons	2	2

We might take a moment to compare what kinds of stories the two groups of children wrote. Minority children tended to write about various kinds of disaster. Here are some of their story-endings in which a single person is involved:

Next morning [he] untied boat to go for [a] ride but a storm come and recked the boat but he stayed alive.

Somebody stold the boat at night. Then he called the poilice. Ofter Dan picked up the phone.

Everytime he went some place he end in the same place. When he took his stove it gave him bad lock. Everybody uset to think that he was crazy.

Always hurt fm his arm because he rowed to long. Kept trying to get another place but he couldnt. Soon caught in rain storm and was scared, and stopped traveling with boat and stove.

And here are some endings in which two people are involved:

One day when he was in his boat he got lost. The boatman saw him and rescue him. Then they went home and never got lost again.

So it will not get away. The next day the boat was gone. They maad a boat and look for the other

When he goes some place he come back the same day. His boat sunk with the stove on it. The boatman had to take his boat up and down the river.

The man who wood always take his boat up and down was not nice and chee tong was always stuck in the house all day he did not like it.

Mainstream children also included a certain amount of disaster in their endings, but they were more inclined to incorporate fantasy:

Traveled for hours with stove. Landed on island. Woke up and noticed it was only a dream.

Then the stove fell off of his hands. And then he started chasing it. And then it sank in the water and he never got it again.

Another common element for mainstream children was commerce:

He finally sold his boat and got out of that place.

Chee Tong selling his stove. One woman bought it for \$50. Chee Tong went home to relax. His troubles were over.

We then asked 20 adult readers to do the same task: 7 constructed a story-ending in which Chee Tong and the boatman are the same person, while all the other 13 thought two people were involved. Let us consider a couple of these endings to get some idea of how even adults were able to view the two sentences as the opening of a one-person story:

Chee Tong tried to catch as many fish as he could. He would then cook the fish and sell them as he went up and down the river. He always felt good about his work at the end of the day.

He tied his boat here because it was close to where he lived. In the morning he would untie the boat and go up and down the river again and sell hot food to many people.

There are a number of factors in the first two sentences that lead readers to adopt a one-person interpretive frame. First of all, Chee Tong in sentence 1 and the boatman in sentence 2 can be viewed as constituting a coreferential sequence rather than an additive one. Certainly a story often opens with a person's name and then describes what that person does. Consider, for example, how the main character in F. Scott Fitzgerald's "The Camel's Back" is introduced:

I want you to meet Mr. Perry Parkhurst, twenty-eight, lawyer, native of Toledo.

Here the proper name is followed directly by the person's age, profession, place of birth.

This misframing may have been encouraged by the temporal framing in the first two sentences. During the day provides the time frame not only for sentence 1, but for the first half of sentence 2. Then but at night provides a contrasting frame for the rest of sentence 2:

		TIME	PERSON
SENTENCE 1		d	Chee Tong
SENTENCE 2	PART 1	a	b o a t m a n
	PART 2	y night	

There is no temporal separation of sentence 1 from sentence 2 to help the reader establish that Chee Tong and the boatman are different people. Or to put it another way, the time-meshing of sentence 1 with sentence 2 may have encouraged a person-meshing as well. Furthermore, when presented with the two contrasts in rapid succession, readers are more likely to process the one that is overtly marked (i.e., but separates 'day' and 'night,' whereas

'Chee Tong' and 'the boatman' are not separated formally).

Added to these local cues is readers' tendency to assume identity of reference, unless they encounter a firm signal to the contrary (this tendency represents what might be described as an inertia principle in text interpretation). One might claim that the first two sentences provide just such a signal--two patterns of movement that presumably call for the reader to establish a separate person for each:

SENTENCE 1: . . . travelled around the city with his stove

SENTENCE 2: . . . took his boat up and down the river

Some children, however, viewed these two patterns as complementary aspects of a single movement, the first describing what Chee Tong carried--a stove--and the second how he carried it--by means of a boat. Such a merger helps, in fact, to solve the problem of picturing Chee Tong as himself transporting the stove. It does, however, raise, at least potentially, another problem: How can Chee Tong move around the city in a boat? This problem is not difficult to solve if readers imagine a city with canals. Some children, in fact, claimed that they had seen such a city in movies about China.*

One might assume that any reader would eventually overcome any

*No child actually mentioned a Chinese city by name, although one did refer to Venice. He told about how he had bought food from a boat vendor there.

initial confusion, given that the they in Sentence 3 provides clear evidence that Chee Tong and the boatman are, in fact, two different people. In working with children of this age, we have discovered that many have difficulty, once an interpretive frame is in place, in using later information that calls for that frame to be abandoned. This discovery is, of course, not novel. Piaget often discussed this difficulty (see, for example, The Language and Thought of the Child, 1926, where he used the term syncretism to describe children's assimilation of ill-fitting information to an already existing frame). We did not discover many children who persisted in thinking that Chee Tong and the boatman were the same person. Nevertheless, many ended up confused by the passage and we suspect that an initial misframing may have led them so far astray that they never recovered. When these children were asked to recall what they had read, they were reduced to silence or, at best, managed a few halting phrases that did not make much sense.*

In spite of this relatively global breakdown, a substantial

*One adult reader described her reading of this passage in the following way:

I processed the first two sentences as referring to one individual. I pictured a Chinese vendor traveling around an island like Manhattan, by boat, cooking and selling some Chinese version of a fast-food shish-kebab. I was not prepared for they in the third sentence. It created a kind of dissonance which wasn't resolved until the fourth and final sentence when the role of each of the story characters was delineated.

In Chapter 3 we will deal more extensively with items that result

number of children were still able to select the target responses for the two tasks. In responding to (A), for example, 40% of mainstream children and 41% of minority children selected eat. From a certain perspective, the task is quite straightforward--it calls for children to recycle that which is overtly expressed in sentence 3:

PASSAGE PROPOSITION ...Together they ate the evening meal...

TASK PROPOSITION What did the two men do together? eat

Many children, however, seem to have difficulty in understanding sentence 3. It reports a sequence of three activities--the first two involve both men, but the third only Chee Tong.* The order in which the activities are reported, however, do not match the one in which they occur. Activity 3 in the TEXT SEQUENCE is activity 2 in the PREDICATED SEQUENCE:**

in an initial misframing (see pp. 3-34). As we will see, certain items are deliberately constructed to determine whether children can first construct one frame and then replace it with another as ill-fitting information emerges. In responding to these items, some children erroneously hold on to the initial frame until the end, while others, in attempting to shift, experience a general breakdown in comprehension. During the interviewing, we discovered that children who were confused by CHEE TONG were often confused by these items.

*For economy's sake, we will consider preparation and cooking of the evening meal to constitute a single activity.

**Halliday and Hasan (1976) use the terms internal and external to distinguish these two. The terms deictic and non-deictic, first introduced in LEARNING TO READ (see pp. 103-105), are sometimes used as well.

SENTENCE 3

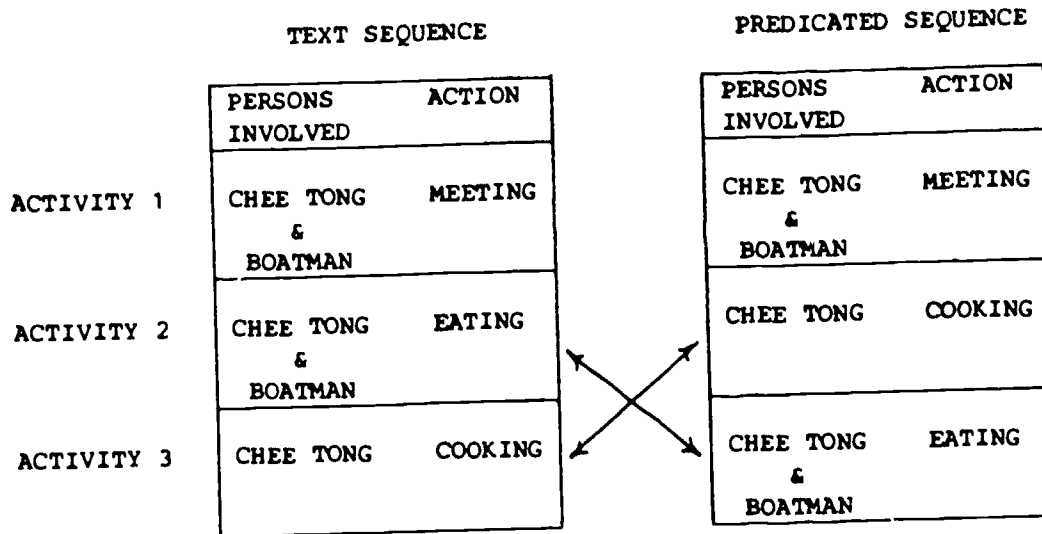

We might note that this lack of matching arises directly from a sentence structure in which a participial modifier follows a main clause. This kind of sentence is common in modern prose--it was, for example, a hallmark of Hemingway's style--but we suspect that it is rare in the materials that children read. In responding to (A), readers are required to deal directly with this temporal discrepancy. They must identify that what the two men did together was eating--activity 2 in text-time, but activity 3 in predicative-time.

The major distractor was not, as might be expected, cook, the activity interchanged with eat. Both mainstream and minority children were more attracted to go up the river, though, as indicated below, the difference between these two was negligible in the case of the minority children:*

*As we pointed out with reference to deictic confusions in LEARNING TO READ, minority children are, in general, less accustomed to dealing with more literate forms of text structure.

	MAINSTREAM	MINORITY
go up the river	33%	29%
cook	20%	27%

It is not easy to explain the greater popularity of go up the river. Some of it may have to do with its idiomatic flavor--it has a familiar ring, paralleling an expression such as send up the river. Then, too, some of the attraction may be traced to its length. When discussing the choice of caramel in SHOP SIGN (see p. 11), we suggested that any formal difference between one choice and the others may cause it to be more attractive.

Perhaps an even more compelling reason for its popularity can be found in the explanation offered by one eleven-year-old minority child. When defending her choice of go up the river, she appealed to discourse structure at large:

When there is a story, it always has the body part. That's the middle part and I think that this part is more important than the part where they ate.

For her, the story was mainly about two men's experience in a boat, and so she preferred an answer dealing with their movement in water. The fact that they ate together seemed an incidental detail. Upon further questioning, she conceded that the passage did not actually describe their going up the river together. She claimed, however, that they must have, for, as she put it:

If you invite somebody on a boat, you're sure
to give him a ride.

Before leaving (A), we might note that many children were confused by the use of tied up in sentence 2, even though not many chose the distractor tie up in (A). One child, however, who did choose it, defended his answer by saying that "Chee Tong and the boatman tied their feet together." Upon hearing this, the interviewer was so nonplussed that she was unable to pursue what the child had in mind. Presumably he had been stimulated by some tale or movie of ancient China--say, the magical world of Fu Manchu--which he was bringing to bear on the world of Chee Tong.

In this passage the use of tie up without a complement represents a nautical idiom that children are not likely to know. We were curious as to what children would make of the sentence, At night he always tied up at the same place, apart from any specific context. So we asked a group of 20 children what this sentence meant to them. Here's a sampling of the responses:

he was doing homework

there were traffic jams all over the city and
bridges

He is always tied up in his bedroom. He is
doing homework, and he looks tired. His
mother is yelling at him too.

I think that he is tying a horse up at
night

It sounds like he is always in the same bed

his blankets under his arms and legs twisted
around

He's tied at a top of a tree at night

that his parents tie the person to his bed
all night.

Smoking, drinking out with another women.

None of the children mentioned a boat.

Let us now turn to (B), a task which, at least on the surface,
directs children's attention to sentence 4, just as (A) directs
their attention to sentence 3. As already suggested, sentence 4
provides a summary of that which has preceded. Structurally
speaking, it is a difficult sentence for young readers to understand.
It can perhaps be best described as cataphorically structured. It
begins by stating that it was a most satisfactory arrangement and
then goes on to specify what constituted the arrangement. This
specification is, however, gapped in that it consists of two
sentences with the verb missing in the second:

(1) S V O

(2) S \emptyset O

The verb in (2) is, of course, to be supplied from (1), but this
involves an operation that not all children are able to perform.
It was evident from oral reading that a number of children were
unable to expand Chee Tong \emptyset the meals to Chee Tong provided the
meals.

This structural ellipsis is symptomatic of a deeper ellipsis

in the information base that underlies sentence 4. If we were to represent the overtly expressed information, we might do so in the following way:

PERSON	CONTRIBUTION
the boatman	shelter
Chee Tong	meals

The sentences do not express, however, the agent by which each made his own contribution:

PERSON	AGENT	CONTRIBUTION
the boatman	∅	shelter
Chee Tong	∅	meals

Using information from the previous sentence, the reader has to infer that the boatman uses his boat to provide shelter and Chee Tong his stove to provide meals:

PERSON	ENTITY INFERRED AS AGENT	CONTRIBUTION
the boatman	boat	shelter
Chee Tong	stove	meals

The first of the two inferences is precisely the one that (B) calls for, but substantially less than half of the children were able to make it during the pilot testing--only 42% of mainstream children and 34% of minority children selected a boat. Mainstream and

minority children followed the same pattern in their choice of the distractors, as indicated by the table below:

	MAINSTREAM	MINORITY
an arrangement	24%	28%
a stove	20%	24%
a house	13%	14%

As can be seen, a slightly higher proportion of minority children selected the distractor in each case.

The overall pattern suggests that many children may have been floundering on this task. As already mentioned, an arrangement represents a choice of a word that tends to "sound right" for a test task: children are not sure of its meaning and by virtue of this uncertainty are attracted to it. Moreover, the greater attraction to an arrangement and a stove may have been due to the fact that they were actually used in the passage. Whenever children are confused by a passage, repetition distractors tend to make a strong showing.

In some ways, it is surprising that a house was not more widely selected, given its close association with the word shelter. But then, of course, this choice presupposes that children know what shelter means, and a number of children whom we interviewed seemed not to. In order to understand better third and fourth graders' sense of the word shelter, we asked 20 children to use the word in a sentence. Only 2 responded that they did not know the word. Most

of the other 18 were able to use the word in an acceptable way, though some of the sentences were a bit strange:

a preting place to stay

ah, something to live in

food, clothes, house

I have alot of shelter space in my house.

The Indians took shelter before they attacked.

As illustrated by the last sentence, many associated the word with the threat of violence. Consider, for example, the following sentences that refer to a bomb shelter:

We will go to see a nuclear shelter.

He lives near a bombshelter.

Let's use the bomb shelter as a play for tomorrow.

Many also associated it with a storm:

When the hurricane came, we ran for shelter.

The shelter kept them safe from the storm.

Head for shelter, guys.

I found shelter in a cave.

We best get or go to shelter or our hair will get wet.

From the results of this probe, it seems that most children at this age do have a reasonably good sense of how to use the word shelter.

During the interviewing, we came across two children who provided a rather ingenious justification for their choice of house in (B). One of these children, when describing his choice of eat in (A), referred to how the two men always ate together "in the sailor's house." When the interviewer asked the child what he meant by this expression, he responded, "Oh, that's the boatman's house where they store boats." He went on to describe this house in some detail:

It's a log cabin and has one stove and they live there and that's where he keeps his boat. It's like a shed where he keeps his boat and they don't have any lights and he lives next to a river.

The interviewer then asked him if this house was mentioned in the passage. He replied, "No," but went on to explain that the reason the boatman "tied up at the same place" each evening was so that he and Chee Tong could stay at his house.

One other child followed the same line of reasoning. He, too, pointed out how the boatman returned to the same place each night so that he could meet Chee Tong in his house; and he, too, pictured the house with Chee Tong's stove inside:

It was a small house but quite comfortable where Chee Tong put his stove and cooked, and it was near the harbor where these two men tied the boat up together.

These children's choice of house, apart from their ingenious use of the textual cue ties up at the same place, comes largely from their difficulty in imagining a boat as a place of shelter. One of them pointed out how two men would not be able to cook, eat, and sleep in a boat. This problem was, in fact, widespread and, no doubt, helped to explain the relatively low proportion of children who selected a boat during the pilot testing. During the interviewing we asked children to draw the boat described in the story.

Most drew a rather skeletal picture of a boat, as evidenced by the following:

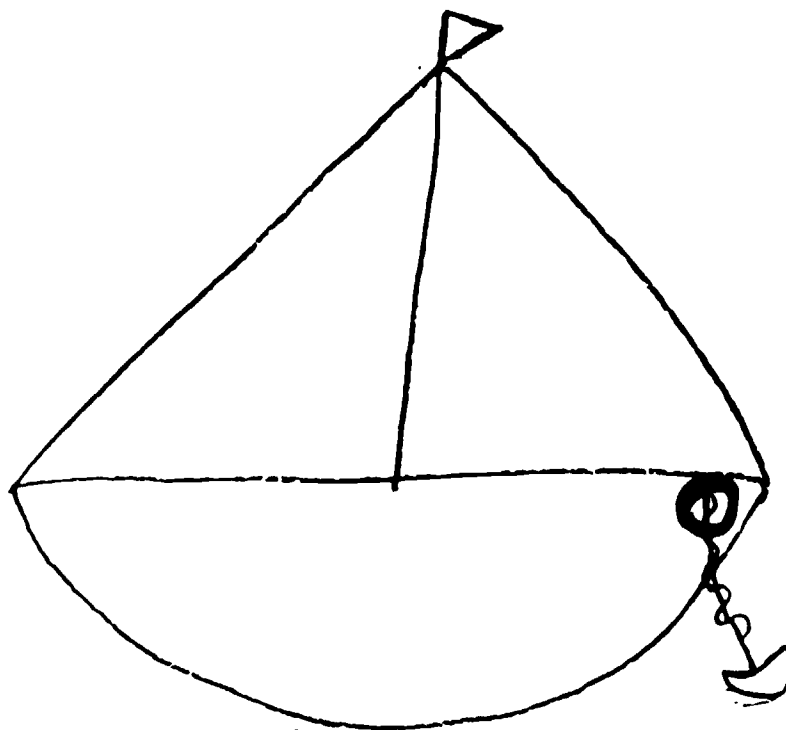
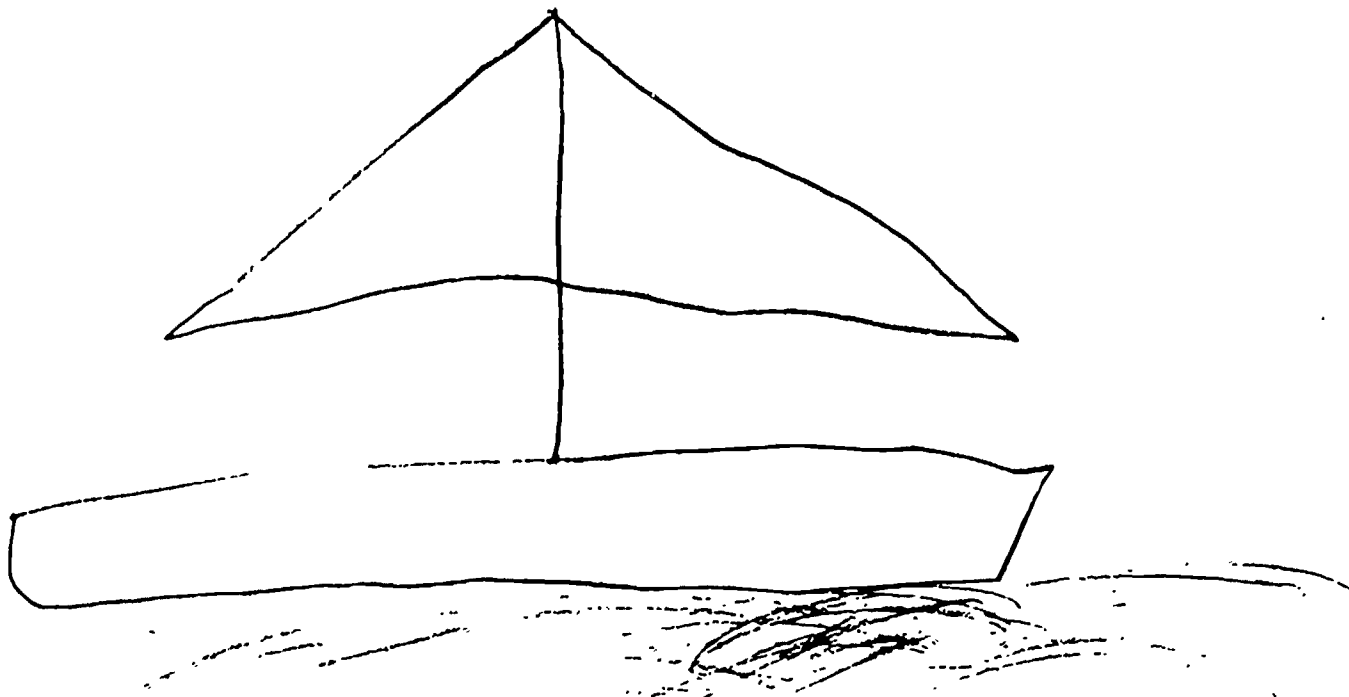

BOATS LACKING SHELTER

A few did manage to draw some semblance of a boat that could provide shelter:

2-172

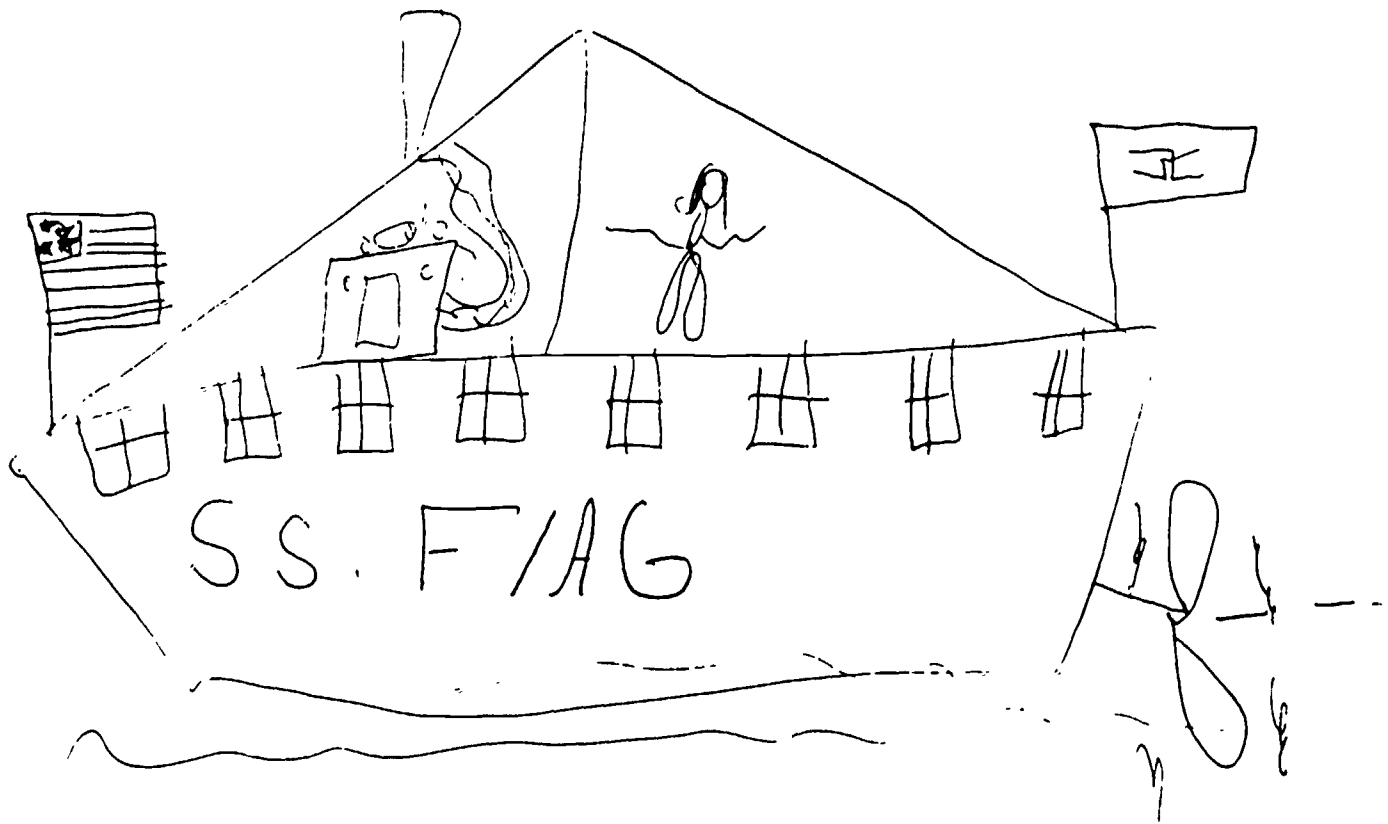
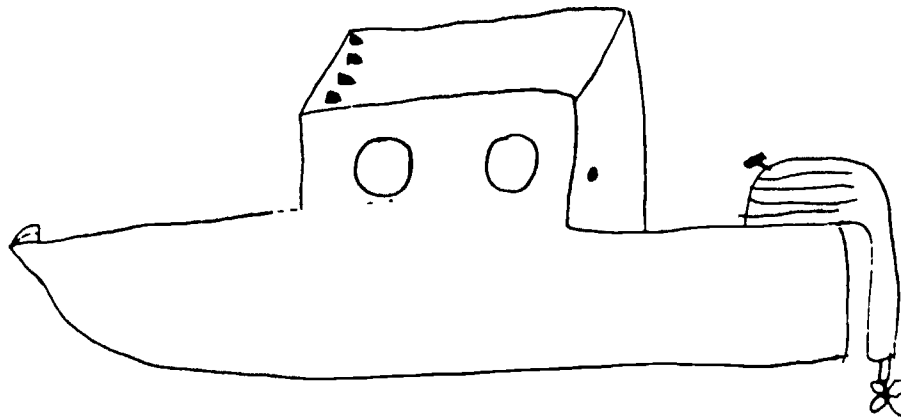

BOATS WITH SHELTER*

*As can be seen, the second drawing represents not only shelter, but the stove as well. Generally speaking, children placed only one person in the boat, though a few placed a second person as well:

2-173

We noticed that a higher proportion of the children who drew houseboats also managed to select a boat in response to (B). In order to test the strength of such a correlation, we asked 55 third and fourth graders to read the passage, do the two tasks, and then "draw a picture of the boat in the story." The following table shows the results of this probe:*



It is interesting that when this child was given the first two sentences and asked to complete the passage, he included two persons in his story.

*Mainstream and minority children did not vary much in their performance on this probe, but third and fourth graders did:

	MAINSTREAM	MINORITY
an arrangement	24%	28%
a stove	20%	24%
a house	13%	14%

These results are quite suggestive, though they must, of course, be interpreted with caution. Clearly many children lack drafting skills, and so resort to some kind of a boat-prototype--much like those pictured above--when faced with this task. But these results indicate, no doubt, another lack that we have repeatedly called attention to: namely, children's lack of skill in adapting a word to a novel context. For most children, the word boat is best used

	those who chose <u>a boat</u>		those who did not choose <u>a boat</u>	
	3rd grade	4th grade	3rd grade	4th grade
those who drew a boat with shelter	2	9	1	4
those who drew a boat without shelter	7	6	21	8

The difference between third and fourth graders is more sharply delineated on this probe than on any we conducted throughout the entire course of the research.

to describe a small, unenclosed structure and so they do not readily use it in reference to a Chinese houseboat.*

*There were, of course, children who could use the word in this way. A number of children, in fact, reported firsthand experience of a houseboat. One child, for example, explained that

a lot of people live on boats. They have houseboats and sailboats. My grandfather has a houseboat and he keeps it in the garage.

2-176

ADVERTISING TAILOR

We have saved for last the passage that constitutes the most dramatic example of a gapped narrative:

An advertising tailor put a sign on the ballpark fence. The sign announced that he would give away a suit of clothes for each home run. Biff took notice. He began to hammer out a wardrobe at such a terrific pace that the owner of the little shop trembled when he heard the news of the game.

A. Biff "hammered out a wardrobe" by making

a closet a notice

home runs suits

B. The tailor was surprised to see how much he had

made trembled

sold promised

At first glance, Biff and the advertising tailor's world might not seem so alien as Chee Tong and the boatman's. It is, after all, situated on home soil, and it is even concerned with our national sport, one that many children--at least boys--learn to play at an early age. One might, then, expect young readers to be in a better position to fill in the many gaps in the passage; yet as we interviewed children, we became aware that, for many, this world was even more confusing than Chee Tong's. Among the many questions that it raised were:

- (1) What does an advertising tailor do? and why does he want to give away suits for home runs? Is he a baseball fan who wishes to support the local team? Does he see this as a way to improve his business?
- (2) Who's Biff? a baseball player or the tailor's assistant? and what does hammer out a wardrobe mean? Did Biff build a closet, make suits, hit home runs, or what?
- (3) Who is the owner of the shop? the advertising tailor? Biff? or perhaps even the tailor's boss? and why is he trembling when he hears the news of the game? Is he afraid he's going to lose money or is he excited by the team's performance?

It is evident that most of these questions revolve around the identity of the characters. This passage, like CHEE TONG, lightly sketches in two people whose relations are difficult to work out. In both passages, one person is identified by profession, the other by proper name; and neither of the names is a familiar one.* In this passage, even the profession is named in a peculiar way. The

*The name Chee Tong, of course, signals automatically that the character is Chinese. In this connection, we thought that the name Biff might signal, at least to some degree, that the character is an athlete of some kind; and so we asked 25 third and fourth graders to select from a list any word that they might associate with the name Biff. Here are the selections they made:

word tailor itself is not all that familiar to children, but when it is preceded by advertising, the result is downright bizarre. It is as though some tailor with a specialty in advertising is being introduced, much as the phrase suit tailor would identify someone whose specialty is suitmaking. An opening sentence such as the following would have been less awkward:

In order to advertise his business, a tailor decided to put a sign on the ballpark fence.

We might further note how odd it is to shift from advertising tailor to the owner of the little shop. Within such a brief passage we expect a character's identity to be more firmly established before such a shift takes place. It is not surprising that some children thought another person was being introduced. In order to link the two expressions to a single person, children need some notion of the 'self-employed person' (i.e., they have to picture the owner of the shop as doing his own work). During the interviewing, we became aware that certain children do not think of a shop owner in this way (a number of children who live in the inner city thought of this person as someone who appears once a month to collect the rent).

woman - 1	man - 6	boy - 17	girl - 2	young - 13
old - 6	tall - 4	short - 15	weak - 14	strong - 7

Hence our expectations were proven wrong, at least with respect to this group of children. They tended to think of someone named Biff as a young boy who was short and weak rather than tall and strong.

By the same token, it would have been more natural to introduce the baseball player with greater specificity. The first two sentences are concerned solely with the tailor's world, and then suddenly three words--Biff took notice--plunge the reader into some other world. A mediating phrase such as one of the star players would have guided the reader more gently, but, as we have pointed out, testmakers often construct a passage to fit with the tasks that they wish to set. In this instance, the capacity of (A) to discriminate among children would be reduced if Biff were overtly identified as a baseball player. We can see, once again, how normative patterning in discourse may have been skewed in order to set up a task that will have sufficient discriminatory power.

How children sort out the various ways of referring to the characters--an advertising tailor, Biff, the owner of the little shop--is fundamental to how they respond to the two tasks. Consider, for example, (A) which requires children to figure out what the expression hammered out a wardrobe means. What they think this expression means is directly controlled by who they think Biff is. If they picture him as a baseball player, they are then in a position to choose the target response home runs. If, however, they think of him as the tailor's assistant, they are likely to choose either a closet or suits. It is instructive to examine a chart that displays the AGENT, INSTRUMENT, and ACTIVITY that each of these three choices entails (the results of the pilot testing are also included in this chart):

	AGENT	INSTRUMENT	ACTIVITY	MAINSTREAM	MINORITY
TARGET RESPONSE					
<u>home runs</u>	a baseball player	a baseball bat	hitting home runs	38%	35%
DISTRACTORS					
<u>suits</u>	the tailor's assistant	a sewing machine	making clothes	22%	21%
<u>a closet</u>	the tailor's assistant	a hammer	making furniture	11%	16%

The other distractor, a notice, is not included in the chart, since it does not neatly entail a particular set of choices for AGENT, INSTRUMENT, and ACTIVITY. It was, however, a relatively popular distractor during the pilot testing: 28% of both mainstream and minority children selected it (that the word notice occurs at the major gap in the passage seems to have made it a prime target for misinterpretation). During the interviewing, we discovered that children provided vague explanations for their choice of a notice. Some reasoned that Biff was a baseball player who made the tailor notice him; others thought that Biff was the tailor's assistant who helped put up the notice on the ballpark fence; and one even said that Biff was actually the tailor who had first put up the notice.

As indicated by the results of the pilot testing, children selected a choice--either suits or a closet--that potentially sets up Biff as the tailor's assistant about as often as they selected the target response home runs. In evaluating these results, it is important to bear in mind that not all the children who chose suits or a closet necessarily thought that Biff was the tailor's assistant. Some children were so confused by the passage that they had no clear idea of who Biff was. Moreover, some were attracted to one of the two choices, and having selected it, were forced, for consistency's sake, to view Biff as the tailor's assistant. Consider, for example, what one girl said who chose suits:

Well, the tailor promised all these suits . . .
and his apprentice or little assistant or
whatever--decided that he would start making
a lot of suits because he wanted them to give
away a lot--or something like that . . . and
then the tailor was surprised--or trembling--
when he heard how many suits he had made
because he didn't plan to give away that many.

She seems to have ignored the equation, suit = home run, and so operated solely in the tailor's world. For her, Biff had to be the tailor's apprentice or little assistant--or whatever (this girl later confessed to utter ignorance of baseball).

We may thus conclude that children's response to (A) could be the cause as well as the result of their decision about Biff's identity. In such instances, the relations between a passage decision and a task decision are best viewed as reciprocal (we have already hinted at such reciprocity in our discussion of SHOP SIGN and ALICE AND THE FAWN).

Before we consider children's approach to hammered out a wardrobe, let us first consider their understanding--or lack of it--of the two lexical items that this predicate contains. The collocation of hammered out and wardrobe--in the secondary senses used here--is, to say the least, unusual. This may, in fact, be the sole instance in the world of English prose that the two have ended up together. The items themselves, moreover, are likely to

be unfamiliar. The verb hammer out is not listed in Dale's Living Vocabulary at all. Wardrobe is listed but not until the sixth grade level, and then children's knowledge of its meanings is represented thus:

'all one's clothes'	86%
'a place to put clothes'	85%

In order to get a clearer picture of how younger children handle these items, we gave the following tasks to 55 third and fourth graders:

- (1) What is a wardrobe?
- (2) Use the words hammer out in a sentence.

The children's responses to the first task are represented in the following table:

	A PLACE TO STORE CLOTHING	A COLLECTION OF CLOTHING	OTHER*
3rd Grade	19	0	9
4th Grade	22	4	1

*Most responses classified as OTHER mentioned something to be worn on the body: a boot, a kind of gown, something to put on, something you wear under your clothes, something like to cover yourself. Two responses, however, had no apparent connection to a sartorial domain: a cart and something that is in a lease.

As we expected, it was the more concrete meaning--a piece of furniture--that children in metropolitan New York drew on when dealing with wardrobe apart from any specific context.*

In dealing with the second task, a surprising number of the 55 children--10 to be exact--ignored the word out and simply used hammer as a noun to refer to a physical object:

A hammer is usuaful.

I used the hammer to hang up my picture.

I used a hammer & a nail to hang up the picture.

I use a hammer to put the nail on the wall.**

Even among the children who used the lexical item as a verb, the majority--87%--imagined an activity in which an actual hammer is used. Most of these children--25 out of 35--drew on the familiar combination of hammer and nail evidenced in the last two sentences above:

*This more concrete meaning would, however, be relatively unknown to children in certain parts of the country (e.g., the Midwest). We would question the wisdom of including on a nation-wide test any word that has markedly variant patterns of usage in different parts of the country. Dialect lexicography is sufficiently advanced that test-makers should be able to avoid such words.

**One child did try to incorporate out into the noun:

A hammer out is a tool.

Another child came up with an even more ingenious solution, constructing a sentence in which the noun hammer was followed by the word outside written as out side:

He needed a hammer out side.

I hammered out a nail.

He hamerout the naile.

Did you hammer out the nail yet

I hammered out the nail on the wall.*

Children's use of this combination may have been motivated by more than just the frequency with which hammer and nail occur together. Some children apparently felt the need to justify the presence of the word out in hammer out. One child, in fact, included the phrase out of the wall to make explicit the direction in which the nail was being hammered:

He hammered out the nail out of the wall.

Another child presumably had directionality in mind when he indicated which part of the hammer was to be used:

I will use the back of the hammer to hammer
the nail.

Both sentences manage to convey the image of a nail being removed; and yet in each a verb such as pull out would have done so more naturally. It is, in fact, not easy to construct a plausible

*Some of these children also omitted the word out, allowing hammer and nail to nestle together:

He hammered a nail.

He used a hammer to hammer the nail.

scenario for the phrase hammer out a nail. Presumably it might be used if one person were asking another to remove a nail that was sticking through a thin board (i.e., by hammering the nail out from the 'point end' rather than from the 'head end').

A handful of children did manage a somewhat figurative use of the verb hammer out (i.e., one in which a physical hammer is not necessarily present). Consider, for example, the following sentences:

I hammered his faced out.

Say like if I want to hammer you out.

We can hammer out our way from the store.

The use of a physical hammer is not, strictly speaking, ruled out by any of these sentences, and yet it does not immediately spring to mind as in the case of the hammer-and-nail sentences. There were two sentences, however, that activate a domain in which the use of an actual hammer has no role:

--You use hammer out for base words.

--Don't use the word hammer because dad will get mad.*

None of these figurative uses clearly expresses the notion 'constructing a framework' that is basic to adult use of the verb hammer out. We asked 30 adults to use this verb and the majority

*The word hammer--but not hammer out--is used to describe sexual activity by certain members of minority speech communities.

supplied an abstract complement as in:

The lawyers hammered out the divorce agreement.

I hammered out an outline for my paper.*

Given the nature of these complements, the verb conveys the notion of sustained activity which, like carpenter's blows, produce a rough scaffolding so that work can proceed. Hence we may conclude that normative use of hammer out in the adult world is figurative rather than non-figurative (i.e., it does not involve a physical hammer).

It is clear that the use of hammer out in the passage does not closely parallel the examples that we have just considered. In the first place, its complement wardrobe, unlike agreement or outline, does not refer primarily to a verbal domain. Moreover,

*It is instructive to replace hammer out with hammer away at in the above sentences:

The lawyers hammered away at the divorce agreement.

I hammered away at the outline for my paper.

One can almost hear a but trailing each of these sentences, introducing some statement that closure was not actually reached. It is interesting to note that out often conveys the notion of 'closure' in phrasal verbs:

I'm all tired out.

Count me out.

I really bombed out on that exam.

Biff struck out.

hammer out, when joined with wardrobe, does not, strictly speaking, convey the idea of constructing a framework that allows further work to proceed. It does manage to convey some notion of 'closure,' for wardrobe describes a collection of clothing which can be viewed as complete; and then, too, wardrobe fits within the figurative pattern since it does not entail the use of a physical hammer.

In analyzing hammered out a wardrobe, readers need, of course, to take account of what the tailor promised (i.e., a suit = a home run). Hence they are to understand that Biff was really hammering out home runs rather than suits; and given baseball idiom, the linking of hammer out and home runs is not unusual (this idiom, of course, exploits the powerful analogy between the swinging of a hammer and the swinging of a bat).* We may represent this impacted predicate in the following way:

*It would perhaps be more accurate to say that the linking of hammer with singular home run is not unusual:

Reggie has just hammered his 30th home run of the season.

The linking of hammer out with plural home runs would be less usual simply because of the constraints on the two-word verb that we identified earlier, namely, the repeating of some action to achieve a goal:

During September Hank Aaron hammered out home runs at an even faster pace than Babe Ruth had.

Hammer out may be occasionally used with singular home run, given that the ball actually does go out of the playing field. In this sense, a home run, compared to, say, a single or a double, does represent a kind of closure.

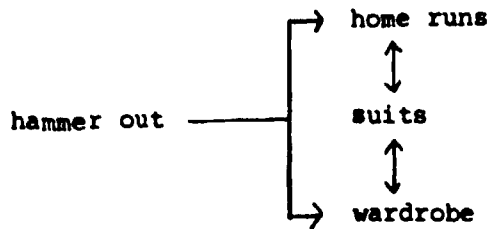

It is of interest that hammer out cannot readily be joined with suits. Unlike plural home runs, it does not activate the image of a hammer-like object; and unlike singular wardrobe, it does not activate the notion of closure. In effect, the verb can collocate with the chain's end points, but not the mediating link itself.

The relations that we have just identified are, in fact, only a portion of a larger network which, ideally, the reader is to work out in responding to (A). Given the complexity of these relations, we will display them in two stages. First, we will show their PHYSICAL LOCUS. In the following diagram, the textual source of each relation is on the left, the relation itself on the right.

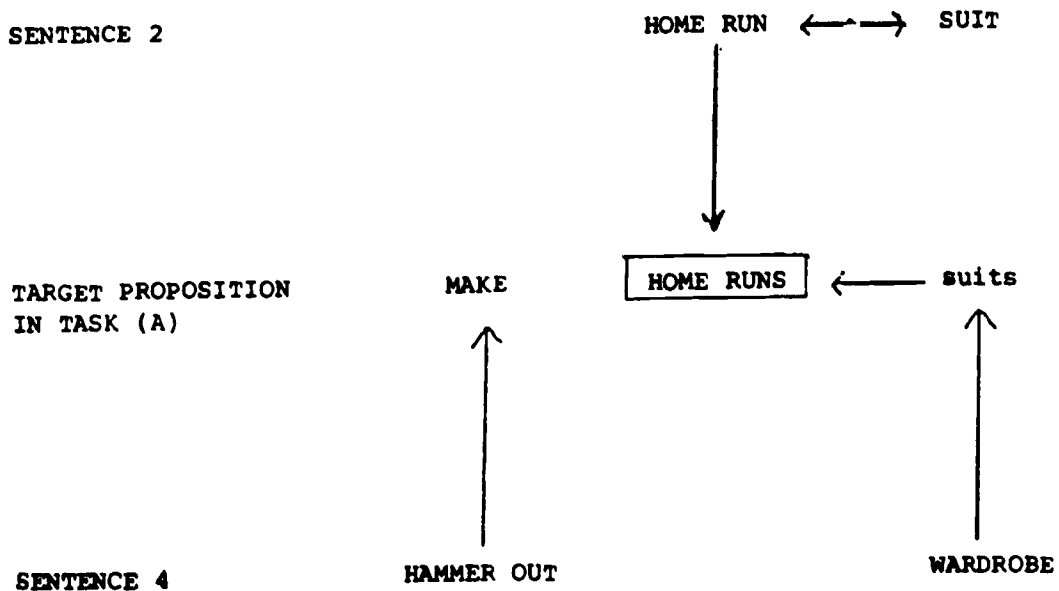

Having established the physical locus for these relations, let us now consider their COGNITIVE LOCUS. We will use the terms TEXT-DEPENDENT, LANGUAGE-DEPENDENT, and READER-DEPENDENT to identify the primary information source for each relation. The topmost relation in the diagram, HOME RUN = SUIT, is described as text-dependent* that

- (1) it does not hold beyond the text under consideration
- (2) it cannot be inferred by the reader from other relations.

By way of contrast, a relation such as WARDROBE → suits is described as language-dependent in that it does, in fact, hold beyond the text (it cannot, of course, be inferred by the reader). In effect, wardrobe and suits function within the same lexical set and so their relation can be viewed as fundamentally anchored in language itself.*

Reader-dependent relations are illustrated by the two arrows converging onto the target response:

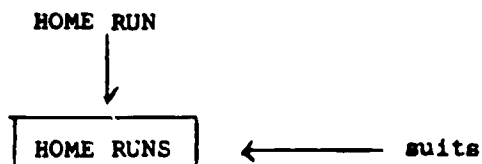

*Some text-dependency is, of course, at work in that the passage mentions a suit of clothes rather than a piece of furniture. In this sense, a text always narrows the range of what individual words can mean, but the reader is, of course, the one who must activate these narrowed meanings.

Neither of these relations is directly given by the text, nor do they constitute meaning-relations within language. Rather they represent the inferences that readers have to make if they are to integrate text-dependent and language-dependent information. In fact, one arrow runs from the text-dependent portion of the network, the other from the language-dependent portion. This convergence of the two arrows graphically illustrates how readers must chunk disparate bits of information if they are to arrive at the target response. One adult reader put the matter well when he said,

I had the distinct sense of a number of things clicking into place when I selected home runs as the right answer.

To summarize what we have just outlined, let us reproduce the network displayed on page 190. This time, however, we have included labels for the cognitive locus of information as well as for the physical locus:*

*In a number of instances we have found this three-way distinction to be more useful than the usual two-way distinction between passage-dependent and passage-independent. In other instances, however, this greater differentiation was difficult to work out and so we caution the reader not to assume that it can be generally used. Where it is motivated, however, we find its greater precision to be particularly attractive.

SENTENCE 2

HOME RUN ↔ SUIT

TARGET PROPOSITION
IN (A)

make

HOME RUNS

← suits

SENTENCE 4

HAMMER OUT

↑
WARDROBE

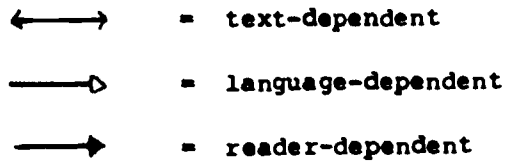

In examining the network in its new form, we can see that the relation HAMMER OUT → MAKE is to be identified as language-dependent. This labeling is not altogether satisfying, for hammer out and make are not parallel in the same way as are, say, wardrobe and suits; and yet these two verbs can be included in the same lexical set. It is only that make is far more general; that is to say, it can collocate with a wider range of complements. Note, for example, the range illustrated by the four choices provided in (A): a notice, a closet, suits, home runs.* It is, however, ironic that home runs, the target response, is the one that fits least well with this verb. To someone who knows baseball, making a home run sounds very odd.

*In fact, make, along with do, is the verb that most generally represents activity in the English language.

It is interesting that boys, while discussing this task, tended to use hit with home runs. Consider, for example, the following excerpts from interviews:

They are going to need a lot of clothing because a lot of home runs would be hit during the game.

Hammer means hit a home run.

--What does hammer out mean?

--Hit the ball as hard as he could and hit a home run.

A few boys were so troubled by this lack of fit that they apparently rejected the target response. As one 10-year-old boy put it,

That's stupid. Nobody would ever say make a home run.

In the case of most boys, however, the inherent elasticity of make seemed to allow them to accommodate this odd usage.

By way of contrast, girls were more prone to talk about making home runs:

So I was thinking about Biff . . . how many home runs Biff had made.

You know, he made a lot of home runs for the upcoming game.

Oh, you mean 'cause he kept making home runs.

So someone heard of the many home runs he was making . . .*

This provides evidence, once again, of children possibly benefiting from not having sufficient knowledge of the passage content (see, ALICE AND THE FAWN, pp. 76-77 where we discuss children's greater proclivity to respond acommunicatively by virtue of not knowing what a fawn is).

There is another way in which baseball knowledge might interfere with the expected understanding of the passage. One of the major clues that Biff is a baseball player comes from the temporal adjunct that ends the passage--when he [the owner of the little shop] heard the news of the game. The owner is presented as hearing the news of a single game, and yet Biff is presented as hammering out so many home runs that the owner trembles. For anyone with much knowledge of baseball it is difficult to imagine Biff hitting enough home runs in a single game to cause the

*One girl even used do with home runs:

Well, he hadn't made any clothes yet because he didn't know how many home runs a person was going to do.

tailor to tremble. A more extended temporal frame seems to be required so that the reader can imagine a series of games over which Biff maintains the "terrific pace."

From a broader perspective, however, girls' greater ignorance of baseball probably did more harm than good, for it meant that they had less access to certain cues. Compare, for example, their responses to "What does hammer out mean?" to the boys' responses cited above. Many girls were confused by the question, making vague references to the hammer-and-nail scenario discussed earlier:

Hammer out means . . . let me think . . . he
put it up on the wall. . . .

One did manage to suggest that hammered out a home run should have been used in the passage:

. . .instead of saying he hammered out a
wardrobe, [it should] say he hammered out a
home run, and then it wouldn't be confusing.

Even she, however, has not quite mastered the idiom, for she uses hammer out with singular home run.*

*Note how boys tend to use hammer rather than hammer out:

Hammer is hit . . . in baseball.

When you hit a ball, you usually call that
hammering it.

One boy even directly switched from hammer out to hammer, and

In closing our discussion of (A), we would like to present what one nine-year-old minority child volunteered during an interview. An ardent baseball fan, he began, with no apparent provocation, to mimic how a baseball announcer might describe Biff at bat:

Biff was up to bat and the first pitch came and he swung and missed. The second pitch came and he swung and missed; the third pitch came and was a ball; the fourth pitch came and was a ball; the fifth pitch came and was a ball. And the fourth pitch--the sixth pitch--came and he swung as hard as he could and he hit--he hit it either over the fence or hit it over everybody's heads. He ran and well, he got it all on errors. Maybe lots of homeruns are on errors-- at least in our league they are.

Incidentally, he was able to do this task--and the next--with apparent ease.

went on to associate the word with the man who hit more home runs than any other baseball player in history:

To hammer out a wardrobe, to hammer, the word is associated with hammering Hank Aaron of baseball.

This boy was obviously a baseball fan--Hank Aaron's nickname was "the hammer."

Let us now move on to (B), one of the most difficult tasks in the entire corpus. The following table shows the results of the pilot test:

	MAINSTREAM	MINORITY
made	37%	39%
sold	26%	26%
trembled	24%	18%
promised	13%	17%

As can be seen, children in both groups selected all four of the choices in similar proportions. Moreover, mainstream and minority children alike were least attracted to the target response promised.

Many of the difficulties that we discussed in connection with (A) are also present in (B). For example, children are, once again, led astray by assuming that Biff is the tailor's assistant. Two new problems, however, emerge that account for children's dismal performance on (B):

- (1) To whom does the word he in the task stem refer?
- (2) How is the word promised, one of the four choices, to be understood?

When we began to interview children, we were surprised to discover that many of them--particularly minority children--thought he referred to Biff. So we decided to present the two tasks without the passage to third and fourth graders--17 mainstream and

17 minority--and then ask them to whom he refers. Here are the results:

	MAINSTREAM	MINORITY
<u>Biff</u>	8	11
<u>tailor</u>	8	6
unclear	1	0

The results were so unexpected that we decided to give the same task to 30 adults. Their pattern of response was similar, though members of the minority group were not so strongly attracted to Biff:

	MAINSTREAM	MINORITY
<u>Biff</u>	8	6
<u>tailor</u>	8	5
unclear	0	2

We were puzzled by these results, having assumed that test-takers--at least adult ones--understand that the language of a task tends to be self-contained (and so the antecedent for any pronominal is included in the same task).^{*} Nevertheless these

^{*}Some children seemed to think quite the opposite, that the two tasks should be linked:

Given the first question, it is natural for me to assume that he refers to Biff because the second question follows the first question.

I was relating (B) to (A) so I was thinking about Biff . . . how many home runs Biff had made.

responses did help us interpret the pilot test results: for the most popular choices--made and sold--make sense if he refers to Biff, while the two least popular choices--trembled and promised--only do so if he refers to the tailor. As we progressed with the interviewing, we began to discover why children tend to link he with Biff. Perhaps the major reason was succinctly expressed by a ten-year-old girl:

It had to be Biff because the tailor was surprised.

This child--and apparently many others--followed an interactional pattern that might be stated roughly as follows: within narrative, characters tend to be surprised by what others do rather than by what they themselves do.

This pattern seems to have controlled the responses of one nine-year-old girl. She claimed that she would accept promised in (B), only if the task began with Biff rather than The tailor (i.e., he could refer to the tailor if the sentence began with Biff):

[tailor]
↑
Biff . . . he

In working with the actual task, she had, in fact, linked he

with Biff:*

[Biff]
↑
the tailor . . . he

There is, however, a further reason for linking he with Biff which was articulated by one student.** He pointed out how the passage itself has already focused on the tailor's surprise at what Biff did:

It is more natural to think of he as referring to Biff because in the prose passage at the top, the tailor was surprised on account of Biff, or something that Biff did.

*Children might have been less influenced by this pattern if the notion of 'promise' had been somehow included in the task stem itself. In that case, they would have been more likely to focus on the open-ended commitment that the tailor had made when posting the sign. It is not uncommon that people promise more than they can fulfill.

One might like to argue that, even apart from the specific domain of promising, people are surprised by their own actions. All of us have a great deal of evidence that we do, in fact, surprise ourselves by what we do. But we take such surprises as belonging more to untold worlds of interior life than to the told worlds of human experience that we read about (writers such as Proust, of course, surprise us by making known these untold worlds).

**We use the word student since the person interviewed was in high school. One member of the research team interviewed four students at the high school level in order to contrast their responses with children's in regard to this task. She wanted to find out whether older students would be better able to understand the word promised in the way that (B) calls for.

In effect, the passage has predisposed the reader to associate the tailor's surprise with what Biff did, and so it is only natural that this association will carry over to the task.

What is particularly disturbing about this lack of fit between passage and task is that it is more a matter of wording than of actual substance. The student goes on to point out that the tailor knew what he had offered and so, in the strict sense, is not surprised by what he had said he would do:

To take he as the tailor doesn't make sense because he was fully aware of what he had promised. He wrote it and put it on the fence.

In effect, the tailor is not really surprised by his "promise"--to use this task's word--but rather by Biff's response to it.

Once readers have linked he to Biff, they are not in a position to select the target response. Rather they must choose between made and sold; and the choice between these two is, in turn, constrained by whether they view Biff as a baseball player or the tailor's assistant. If they view Biff as a player, they can choose only made, in which case the unspecified grammatical object of made must be a mass noun like hitting [of home runs] or clothing (the latter describing the reward for the former). If, however, they view Biff as the tailor's assistant, they can select either made or sold, in which case the unspecified grammatical object could be

only a mass noun like clothing (referring to the actual suits made or sold by the assistant).

It is surprising how many students selected sold on the pilot test (more than a quarter of both mainstream and minority students). As was the case with notice in (A), this choice seems to reflect an inability to cope with the gapped passage. A confused reader might be forced to resort to merely associating words--tailor, the grammatical subject of (B), goes best with the verb sold. Consider, for example, what one child said who chose sold:

--Who's Biff?

--It could be the one that works for the owner of
the shop.

--What does he do?

--He sells.

On the other hand, made is a motivated choice, once a reader has decided that the he in (B) goes with Biff. As already suggested, this choice allows a reader to view Biff as either a baseball player or as the tailor's assistant, and for this very reason it may be attractive to any child who is inclined to choose a response that can fit in with multiple frames.

The major block to choosing made comes from the presence of the modifier how much in (B). As already pointed out, its unspecified grammatical subject must be a mass noun. Readers, however, prefer to supply one of the count nouns--home runs or

suits--actually present in the passage. A number of children who selected made were aware of this tension between the two kinds of noun, but managed to deal with it ingeniously. Consider, for example, the response of the student we have just quoted:

If it [the task] was referring to either home runs or suits, then it would have to be how many. So the tailor was surprised to see how much of a wardrobe Biff had made.

On the other hand, some children rejected made simply because they could not fit how many with home run. One girl, who was initially attracted to made, finally decided against it:

Well, it makes no sense then. . . . If you are talking about he [as] Biff, it would be how many he had made instead of much. So since it is much, it must be promised.

In effect, this lack of grammatical fit helps the girl to back into the choice of promised.

Let us now turn to the second major difficulty that children experienced with this task, namely, describing what the tailor did as a promise. The notion of promise for many children was limited to the domain of face-to-face interaction (presumably this is where they hear the word most frequently). As one child put it:

A promise is like something that your mommy
and daddy do.

Another child made a similar point:

--Why wouldn't you have used the word promise?

--Because a promise is--like--more direct.

For her, a promise was a direct commitment from one person to another and so she was unable to absorb the more generic notion of promise called for by the task (i.e., one that encompassed a public commitment as well as a personal one).*

Certain children, in fact, suggested that other words should have been used in place of promise in (B). One girl, for example, suggested gave:

--Well, gave came to my mind. I looked to see how much he had gave, you know. I was gonna check to see how much he had gave, because he gave a lot of clothes. But I didn't find it.

--But you couldn't find gave here.

--No, so I just settled for trenbled.

Another girl said that promise

*In RAISINS, chap. 3, pp. 92-94, we will further illustrate how children, by virtue of the personal context in which they have learned a particular word, are unable to understand its generic use.

didn't really sound right. I couldn't put anything else--I sounded out the most likely answer. The tailor was surprised to see how much he had given away would have been better.

A boy suggested that the word offered would have been better.

When the interviewer asked why he preferred this word, he replied:

It just isn't...promise sounds more like...
I don't know...not like a business deal really.
A promise would be more--like--I promise not to tell somebody or something. Offer has more to do with a deal than promise...A promise sounds more like...I mean you're really a bastardly person if you break a promise. And an offer...if you break that you might be a lousy business man....If you break a promise you really mentally wound someone.

Some children spouted familiar criticisms of advertising:

You know how a lot of advertisements, they say--like--how great the thing is. Most advertisements always say how great everything is and, you know, most of them, how good their product is. They often tell of lot of lies.

All advertisers lie so that in an ad they can't really be considered to have promised anything. Promising means that you really will do something; advertisers shouldn't be assumed to be making promises.

One child went so far as to characterize the tailor's posting of the sign as a bribe. She claimed that, for her, the word promise could be used only to describe what "one person says to somebody he knows well."

Given all these comments, we decided to ask 24 third and fourth graders to evaluate whether certain sentences use promise in an acceptable way (the number of children accepting a given sentence is placed in parentheses in the blank next to it):

- (20) Homer promised his mother that he would be back by 5:00.
- (3) The weather promises to be good today.
- (9) The advertisements for games promise us a lot of fun.
- (4) This movie promises to be exciting.

As can be seen, more than twice as many children preferred the interpersonal context to the commercial one.*

*We might note here that the high school students who were interviewed were better able to extend promise to the commercial context. At some point we would like to give this same probe to a group of older students.

In closing the discussion of this item, we would like to point out a difficulty with (B) that completely escaped our notice until we talked with a nine-year-old boy who knew by heart all the Yankees' batting averages. This child did not view the tailor's posting of the sign as business advertising. Rather he assumed the tailor made the offer as a baseball fan because "he wanted that team to win and be able to give out suits." This child selected trembled as the response to (B), because it describes well the state of a baseball fan as he listens to a game. The child did not go on to explore why the tailor was surprised by his own trembling excitement as a fan.

His response does, however, highlight the fact that the task assumes that children will interpret the use of trembled in the passage as indicating that the tailor was afraid that he would have to give away too many suits. This child makes an entirely different assumption--that the tailor must have been a baseball fan even to have made the offer and so his trembling expresses excitement rather than fear. He wanted Biff to hit home runs and so would be happy to give away suits. In this sense, the child is dealing with a question that the passage raises but fails to answer, namely, what motivated the tailor to post the sign? There are, after all, easier ways to advertise a business. His own answer to this question, however, got in his way when it came time for him to deal with (B). We can observe, once again, how a gapped narrative leads children to fill in missing information which then confuses them as

they deal with a highly constrained task. In effect, a gapped passage, by its very nature, encourages children to expand the story, and their expansions may follow lines not envisioned by the testmakers.

Chapter 3

TESTING FLEXIBILITY

In Chapter 2 we described different ways in which the narrative passages used on standardized tests of reading comprehension are incomplete. We began by pointing out that, given the brevity required by the test format, incompleteness is inevitable. We went on to distinguish various kinds of incompleteness and classified narrative passages as truncated, excerpted, or gapped. The main concern of our discussion was to show how children tend to fill in an incomplete narrative and then use this fuller version when responding to a task. We discussed several tasks in which the incompleteness of the narrative stimulated constructive processes that worked against selecting the target response.

In this chapter we will consider the kinds of cognitive demands that test items make on readers. We will be mainly concerned with three kinds of items that are well-represented in our corpus and that occur frequently on the tests we have examined:

- (1) items that lead readers to construct one frame--either a content frame or a discourse frame--and then to abandon it as further information is presented that requires the construction of a different frame
- (2) items that require readers to move back and forth between the two poles of multiple pairs of semantic oppositions such as 'hot'/'cold,' 'wet'/'dry,' 'light'/'dark,' 'hard'/'soft,' etc.

(3) items that require readers to shift from a highly evocative passage to tasks that are decidedly analytic. As a convenient shorthand, we will refer to these three kinds of items as FRAME ITEMS, POLARITY ITEMS, and REGISTER ITEMS.

The cognitive abilities required by these three kinds of items are quite different, but the items do have something in common. They can all be seen as attempts to test flexibility in reading. The idea that a reader should be flexible is hard to fault. A reader should obviously be able, when the situation calls for it, to shift frames in order to accommodate incoming information, to adapt the general notions conveyed by lexical polarities to a specific context, to shift from an evocative register to one that is brass-tacks. It should be remembered, however, that in real-world reading such cognitive flexibility, by its very nature, functions over an expanse of text; and there is no reason to think that flexibility can be adequately demonstrated in the reading of one brief paragraph. Indeed, our interviewing has led us to believe that the cognitive abilities required by the items discussed in this chapter are quite different from those that underlie flexible reading in the real world.

In the items discussed in Chapter 2, the passages seemed to be primary, with the tasks developing out of them. The items that will be discussed in this chapter are rather different: the tasks appear to be primary and the passages secondary. This is no doubt related to the fact that, as we have suggested, these items have

been shaped by certain convictions about how reading comprehension should be tested.* That these items result from a preconceived theory is further demonstrated by the fact that most of the passages appear to have been composed for the test, while most of the passages in Chapter 2 were adapted from existing prose. We are thus dealing with two contrasting aspects of the relation between language in school and language in the real world. The passages in Chapter 2 have been adapted from real-world prose to serve a school function, and as we have pointed out, language tends to become unnatural when it is shifted from one context to another in this way. On the other hand, for most of the items in this chapter, the challenge has been to make the passages sufficiently natural that they might conceivably function in the real world, even though they have actually been written for a school purpose.

All the passages in Chapter 2 were, by definition, narrative. Most of the passages in this chapter are expository. This does not seem surprising when we consider the purposes that underlie these items, especially those that we are calling polarity items. The differences between narration and exposition will become significant when we consider incompleteness in the passages in this section, especially the kind of incompleteness that we have referred to as a

*With respect to the register items, we are unsure about the degree of premeditation. To a certain extent, a shift in register between passage and task is dictated by the test format. The sharp breaks in register that we will discuss in this chapter may simply be especially vivid examples of this more general pattern of shifting and may not involve deliberate planning.

gap. The kinds of gapping that we will observe in these expository passages are comparable to those noted in the previous section, but because of the differing norms for narrative and expository prose, they do not have the same effect. Writers of narration aim to be arresting and evocative, and one of the techniques for attaining these effects is ellipsis, not saying everything at once, but rather leaving some things for readers to figure out. The communicative assumptions that writers of exposition make are quite different. They, too, wish to be interesting, even provocative, but their chief obligation is to be as clear and as readable as their skill and subject matter will allow. Thus, while gaps are, to a certain extent, expected in narration, they are likely, in exposition, to be regarded as violations of communicative norms.

Frame Items

MINNESOTA

The passage in a frame item can be either expository or narrative. We will begin with an expository passage.

So much flour and so many dairy products come from Minnesota that it is often called the Bread and Butter State. It is also called the Gopher State because of all the gophers that live in the prairies. The name of the state comes from the Indian words meaning "sky-tinted water."

A. This story is mainly about Minnesota's

products prairies

names history

B. When the Indians said "Minnesota," they were talking about

gophers water

a state bread

The passage above consists of three sentences. Each of the first two explains a different name for the state of Minnesota; the final sentence accounts for the name Minnesota itself. It is significant that there is no sentence that provides a general statement of what the paragraph is about; in effect, there is nothing that functions as a "topic sentence." In this respect, the paragraph deviates from what might be called the CANONICAL PARAGRAPH in English, which might be characterized as follows:

A paragraph usually begins with a topic sentence that expresses the main idea of the paragraph. The succeeding sentences support or develop this main idea.

In detailed treatments of the paragraph, the "usually" in the above characterization is enlarged upon to include a good many variations and exceptions. In simpler treatments, such as are found in materials designed to improve reading comprehension, the "usually" tends to get transformed into "almost always." There is convincing evidence, however, that the topic sentence, insofar as it is intended as an explanation of how writers actually write, has been overemphasized. In a careful study of a large corpus of contemporary expository prose, Braddock (1974) found that only 13% of the paragraphs began with a topic sentence. Evidently, the appropriate word for the frequency of the canonical paragraph is "occasionally" rather than "usually."*

An interesting aspect of MINNESOTA is that the first sentence does look very much like a topic sentence. As readers proceed through the rest of the paragraph, however, they discover that the expectations raised by the initial sentence are not in fact satisfied. In order to investigate these expectations further, we presented the initial sentence to a group of skilled adult readers, telling them that it was the first sentence in a paragraph. We

*Whether writers should use the canonical paragraph more frequently is, of course, another matter, one that people concerned with the writing curriculum should consider. Those concerned with improving reading comprehension must necessarily deal with how something has been written rather than with how it ought to be written.

then asked what they thought the paragraph was likely to be about. Out of 45 responses, only 2 people mentioned 'names': one thought that the paragraph might be about the names of different states; the other guessed that it was about Minnesota's nicknames. Of the remaining responses, about two-thirds thought that the paragraph would be about Minnesota's agriculture or its products; one-third suggested that the paragraph was likely to be about Minnesota as a whole.

In the pilot testing, 46% of the mainstream children and 30% of the minority children chose products; only 22% of the mainstream and 25% of the minority children chose the target response names. Whether those who chose products had been taught that there was a high-frequency relationship between the first sentence in a paragraph and the main idea, or whether they had set up a frame in reading the first sentence that the succeeding sentences did not dislodge, we were not able to determine. It is interesting to note that the mainstream children were more susceptible to the influence of the first sentence; perhaps this was because they had been exposed more to school norms for expository prose.

Having established 'names' as much less important than 'products' in the first sentence, we wondered how salient it was for readers in the passage as a whole. To find out, we gave the passage to a group of children and a group of adult readers and asked them what it was "mainly about." Without prompting from multiple choices, only one-third of the children mentioned 'names' in their responses; of the adults, only two-thirds mentioned 'names.'

Part of the focus on 'products' results from the unusual way the information is structured in the initial sentence of the passage. This sentence begins by stating a variable--the production of flour and dairy products--and goes on to state what happens when that variable reaches a critical point--the producing area gets a nickname that refers to the products (there was a similar sentence in ADVERTISING TAILOR in which the variable was home runs and the result was a trembling tailor; see chap. 2, p. 177). The focus on 'products' is also reinforced by temporal ordering. Instead of mentioning the products first, the sentence might well have begun with the nickname:

Minnesota is called the Bread and Butter State because it produces so much flour and so many dairy products.

Apart from the focus on 'products' in the initial sentence, there are two additional factors that may have contributed to children's difficulty in selecting the target response to (A). Even with a limited experience of expository prose, children presumably have developed a sense that 'commercial products,' much more than 'names,' is the kind of subject matter that they are likely to read about in a school setting. In such prose, an etymological explanation of a name is usually only incidental, providing a bit of local color. If 'names' were to be the central subject, the writer would probably indicate this by some general statement like

We can learn a great deal about the state of Minnesota from its many names.

But even with this sentence, a reader might justifiably consider the focus on 'names' as only a means for fulfilling a more basic purpose--giving information about Minnesota. To focus on 'names' unambiguously, one would need to write something like:

The state of Minnesota has been given many names.

Another source of difficulty may have been a restricted notion of the term names. Some children may have viewed only the last sentence of the passage as dealing with the 'real name' of Minnesota, and the first two sentences as being concerned only with the 'nicknames.' In other words, they may have worked with a distinction between what the state is 'called' and what it 'is.'

Before leaving (A), we should note that it opens with This story is mainly about, a confusing expression that we have already discussed (see chap. 1, pp. 34-35). The use of the term story may have been particularly confusing here, given that the passage is expository rather than narrative.

Let us turn to (B), which also proved to be difficult in the pilot testing--only 28% of mainstream children and 26% of minority children selected water. There was no one distractor that was especially attractive. The one most frequently selected by both mainstream children (30%) and minority children (31%) was gophers. It is difficult to understand just why nearly a third of

the children selected this word, other than that it is an unusual word and so may have been associated with what Indians might have said. In fact, dealing with 'what the Indians said' proved to be a particularly vexing metalinguistic problem for most children. To choose the target response, they have to understand that the name Minnesota comes from Indian words which refer to water of a particular hue, and this presents at least two problems. In the first place, children have to think of the word Minnesota, which is for them an ordinary name in English--much like John, Paul, New York, or Ohio--as constituting a group of words in another language. Secondly, they have to think of "sky-tinted water" as a way of translating into English what the Indians said rather than as what they actually said. It is at this point that the metalinguistic process seems to break down, for the phrase sky-tinted water is so unusual that it comes to be associated with what the Indians actually said. Thus, it is easy for children to think that what the Indians said was "sky-tinted water"--an expression that sounds exotic--rather than "Minnesota," which, to their ears, sounds like an ordinary English word.

To illustrate how these confusions work, let us consider an interview with a child who initially selected "grasshoppers" as a response to (B). (When reading the passage, he pronounced Gopher State as "Grasshopper State" and gophers as "grasshoppers," and when responding to (B), he once again pronounced gophers as "grasshoppers.") In general, this child did not have serious

decoding problems, but he did have a tendency to read too quickly and would occasionally make such an error. Having once made an error, he would tend to repeat it if not corrected. In this instance the interviewer did not correct the error immediately, but he did re-read the passage at one point in the interview, and from then on, the child, with no overt recognition of the change, pronounced gophers correctly.

After a good deal of discussion with the interviewer, the child did manage to select water, but certain confusions still remained, as evidenced by the following exchange:

-- What's the Indian name for the state?

-- Sky-tinted water--so they were talking about water.

-- What's the Indian name for the state? Sky-tinted water is English; what's the Indian?

-- I don't know. I don't know--I only know one Indian word.

At this point the interviewer attempted to shift the child's attention to the larger discourse structure in an effort to resolve the confusion:

-- There are three names here. Why's it called the Bread and Butter State?

-- Because of that dairy--the dairy products?

- Why's it called the Gopher State?
- I don't know. They don't even say. Because
of all the gophers that live in the prairies.
- Yeah, so it's called the Gopher State
because there are lots of gophers.
- Yeah, that live in the prairies.
- So why's it called Minnesota?
- Because of--uh--water.
- So what do the Indians call it?
- Sky-tinted water. (with assurance)
- But those are English words.
- I don't know what the Indians called it.
(with exasperation)
- The Indians don't know English.
- Yes, they do.
- Not these Indians.
- The American Indians do.
- Okay.

At this point, the interviewer, sensing that the confusion is well-entrenched, decides to explain directly to the child:

- Minnesota is an Indian name and in the
Indian language Min-ne-so-ta means 'sky-
tinted water,' so that's what they mean.
The name of the state--meaning Minnesot' -

comes from the Indian words meaning 'sky-
tinted water.'

The child, at last, understands the metalinguistic problem and
exclaims:

-- So Minnesota should really be called sky-
tinted water.

The interviewer responds:

-- If they translated the words instead of using
the Indian words--

The child interrupts with a series of high-pitched and impatient
exclamations:

-- Yeah, yeah, yeah, yeah. Instead of using
the Indian words, they could use sky-tinted
water.

Encouraged by his success in dealing with this problem, the child
decided to establish just who these Indians were, and the following
exchange ensued:

-- But is this from the Indians from India or
the American Indians?

-- Well, what do you think?

-- Indians from India.

-- Where's Minnesota?

-- In America, but it's gotta be the Indians
because the Indians in America know--uh--
English.

Here we can observe an anachronistic dimension in the child's thinking that might have contributed to his earlier difficulty. This failure to think historically is of particular interest in light of the subsequent exchange, for it becomes clear, as the interviewer presses the child to work with a historical perspective, that he does have potentially relevant information:

-- Did they know English when Columbus got
off the boat?

-- Yes, they did. No, they didn't. But
they knew it when Columbus--

-- Did Columbus know English?

-- Yeah, he was the one who taught it to them.
If Columbus hadn't been there, we would've
never known any English.

-- Was Columbus an Englishman?

-- Yes.

-- Where was he born?

-- He was born in Genoa.

-- Where's Genoa?

-- In Italia.

-- Okay, and where did Columbus--

- So he was Italian.
- and where did Columbus go after he was in Italy?
- He went to--uh--Spain--and then he went to the New World.
- Did he ever go to England?
- No, he never set a foot in England.
- Well, we don't really know. He might've, but I've never heard of it if he did.

The child, feeling himself trapped, claims:

- But he did know English.

At this point a long exchange takes place in which the child stubbornly defends his original position that Columbus did, in fact, know English and even taught it to the American Indians. In listening to this exchange, one recognizes the familiar human propensity to defend, even in the face of overwhelming odds, some position that has been staked out. What is important to notice throughout this discussion, however, is that the child possesses knowledge that would be useful in dealing with this task but is seemingly unable to make use of it. This illustrates a point that is often overlooked when the use of real-world knowledge in reading is discussed: namely, that reading depends not simply upon children's possessing certain bodies of real-world knowledge but also upon their capacity to use that knowledge appropriately.

We have dealt with this interview at some length because it illustrates how children of this age can be quite ingenious in their use of verbal skills and yet not be in a position to deal with the tasks that are set for them on reading tests. This child, for example, did not select either of the target responses: in (A) he chose products rather than names and in (B) he initially selected "grasshoppers" rather than water. Even when he changed his response to water, he was unable to say what the Indian name was. When he finally solved this problem, he still worked with the erroneous assumption that the American Indians spoke English. Throughout the interview, however, he displayed considerable verbal skill in discussing the passage and the accompanying tasks. It is clear that he had understood a good deal from the passage, and yet he was not able to approach either task effectively.

JAYS AND CROWS

Let us consider a second item in which readers are led to construct one content frame, but then are required to abandon it and replace it with another:

It was the season of jays and crows. Their harsh voices pierced the silent air. From everywhere in the woods came the hollow drilling of woodpeckers and the dropping of acorns. Small creatures moved about the floor of the woods noisily. In the dry, crackling ocean of leaves the running squirrel sounded like a man, the hopping sparrow like a dog.

A. This story is mainly about

birds	voices
sounds	trees

B. The story says that the air was

harsh	cold
silent	clear

This passage, like many others on reading tests for these grade levels, deals with the natural world. Some of these passages are expository, evidently drawn from the science curriculum (see MOTHER ALLIGATOR and the following discussion on pp. 161-164 of this chapter). Others are descriptions of nature that have been extracted from narratives. The passage above appears to be the initial paragraph in a story, but it does not actually initiate the story, as does, say, SHOP SIGN (chap. 1, p. 5), in which the focus on the sign does not preclude mention of Mrs. Doyle, the "dealer in mysteries" who promises to play a significant

role in the events to follow. Rather, the opening scene of noisy, busy nature serves as a backdrop. Soon--perhaps in the next paragraph--the "real story" will begin: Mother Bear and her cubs will enter the scene, or perhaps even Prince Albrecht and his huntsmen. Thus, when children are asked in (A) to decide what "this story is mainly about," they haven't been given a story--in the narrative sense of the word--only the expectation of one (for a discussion of story, see chap. 2, pp. 27-28).

For someone who sees this passage as--to use the categories of Chapter 2--a truncated narrative, the main point will be that the story to come takes place, or at least begins, in some wooded area in the fall. As is often the case in imaginative writing, background information is presented with a certain indirection, through an accumulation of detail rather than a summary statement. For those who do not know when the season of jays and crows is, the passage gives hints: woodpeckers preparing winter homes, dropping acorns, lots of dry and crackling leaves.* All the details in the passage help to establish the woods as the scene of the events to come.

If this passage is viewed as establishing the setting for an imminent narrative, none of the alternatives in (A) is likely to be satisfying. No choice that refers to time or place is offered;

*When we gave the first sentence of the passage to a group of 20 adults and asked them what time of year the "season of jays and crows" was, only 7 thought it was autumn; 9 voted for spring and 4 for summer.

instead the choices recycle details that the writer has used to help the reader infer this information.

In an attempt to discover what interpretive frames children might develop without the influence of multiple choices, we presented this passage to a group of fourth graders and asked them to "tell what you think it is about." The children's written answers refer to five themes that they find in the passage: 'the season,' 'sounds,' 'birds,' 'animals,' 'nature.' Of the 11 children who mentioned a single theme, 3 mentioned a season (2 summer, 1 spring), 4 mentioned either kinds of birds or birds in general, 2 mentioned animals, and 2 mentioned nature. Four children gave answers that combined two of these themes. All the answers that mentioned sounds combined this theme with one or two of the others:

It's about seasons. Little animals wondering
and the sound of acorns dropping to the ground.

how jays and crows sing and wood pecker eats

sounds from all kinds of birds

About jay, crow and other animals making
different noises

It is about forest and the sound and the
animals.

About the sounds of animals

All the sounds of spring are coming back

The sound of the fall in the woods

Clearly these children's conception of what the passage is about is too rich to be expressed in a single word. What happens when children bring conceptions like these to a task like (A) and must

funnel their thoughts into a single word? To take an individual example, notice the last item in the list above. Given the level of generalization that the writer has chosen, it would be hard to improve upon it as a statement of what the passage is about. This child has activated and related three of the themes in the passage, and he would probably be uncomfortable if we asked him to choose whether the passage was more about 'fall' or 'woods' or 'sounds.' When he comes to the choices for (A), he will probably choose sounds because 'woods' and 'fall' aren't given. He is likely, however, to feel that the answer he has chosen is not adequate for expressing his comprehension of the passage.*

Having suggested that, from a certain point of view, none of the choices for (A) is very satisfactory, we will turn to a discussion of what readers do with the choices as they are given. In the pilot testing 43% of the mainstream children and 52% of the minority children chose birds; only 30% of the mainstream and 26% of the minority children selected the target response sounds. How can we account for the fact that birds was so much more attractive than sounds?

It is instructive to compare this passage with SHOP SIGN (chap. 2, p. 5), where children were also asked to decide what

*When we gave the passage without suggested answers to a group of adults attending a lecture on reading tests, two-thirds of the 22 native speakers in the group thought that the passage was about sounds. The fact that so many were able to get the target response even when the choices were not given may be explained by the nature of the occasion and the fact that most of the respondents were reading teachers. It is interesting that of the 9 non-native speakers in the group, only one gave sounds as an answer.

"this story is mainly about." In that passage, sign was the target response because it permeated the passage more than any other concept, appearing in every sentence. If we consider the present passage from this perspective, we observe that 'birds' does persist beyond the first sentence. In fact, some kind of bird is referred to in all five sentences. (The fourth sentence refers only to small creatures . . . on the floor of the woods, but we discover in the final sentence that among these creatures is the hopping sparrow.) By way of contrast, the concept 'sounds' is not present in the initial sentence. It might be claimed that jays and crows are known to be noisy birds and that the initial focus on them has already raised the theme of sounds, but such a claim is clearly based on hindsight. When we presented the initial sentence of the passage to a group of 49 adults and asked them to speculate on what a paragraph that began with this sentence would be about, not a single one mentioned sounds.

The way the passage is structured also tends to favor birds. The initial sentence provides an overview of the scene into which it is possible to fit all the concrete details that follow. Since this sentence encompasses in some way the other sentences, it is easy to think of it as expressing what the passage is "mainly about." To put this another way, there is a rough analogy between the structure of this passage and that of the canonical paragraph, in which a "topic sentence," usually the initial sentence, expresses the "main idea."

'Birds' is also a much more accessible concept for children

than is 'sounds.' In the first place, a bird is an entity that can be experienced through all sensory channels: it can be seen, touched, smelled, and tasted as well as heard, whereas a sound can only be heard. In addition, we think of a bird as an entity whose form persists over time, whereas a sound has no comparably permanent form; we tend to think of it as fleeting and momentary. We also tend to think of a sound as existing only by virtue of our perceptual experience, and so have traditionally posed such conundrums as "Does a tree falling in the forest make any noise if no one is there to hear it?" In contrast, we think of a bird as existing independently of our perception, and hence do not think to pose a question such as "Is a bird really in the forest if no one is there to see it?"

These differences between the concepts 'birds' and 'sounds' seem to be related to the typical ways in which the two are represented in an ordinary piece of discourse. Consider, for example, the diagrams on the facing page, which show the various ways in which these concepts are manifested in the passage under consideration.

All the references to birds are expressed by nominals, for the most part nouns referring to species of birds--jays, crows, woodpeckers, and the sparrow. Just as the general category of 'birds' is quite familiar to children, so these more specific categories are familiar as well. Moreover, they can be easily grouped together to support the general category. By way of contrast, the references to 'sounds' form a diverse set of

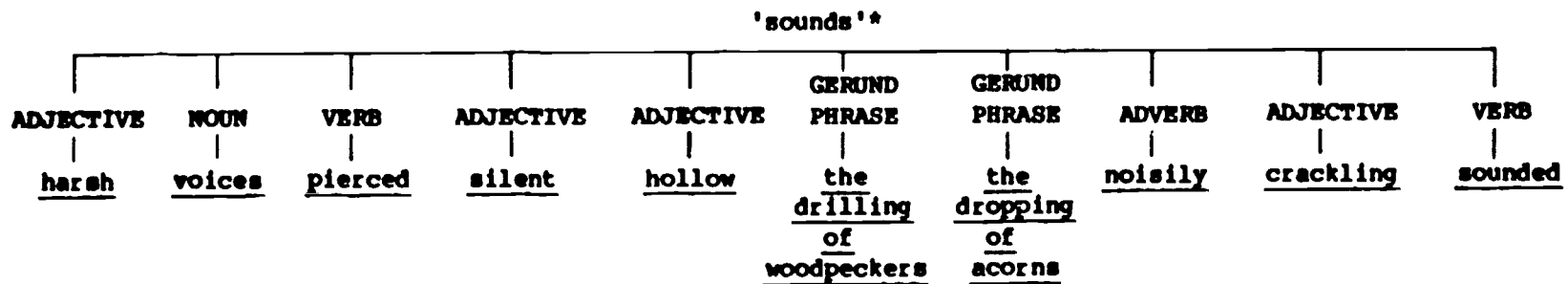
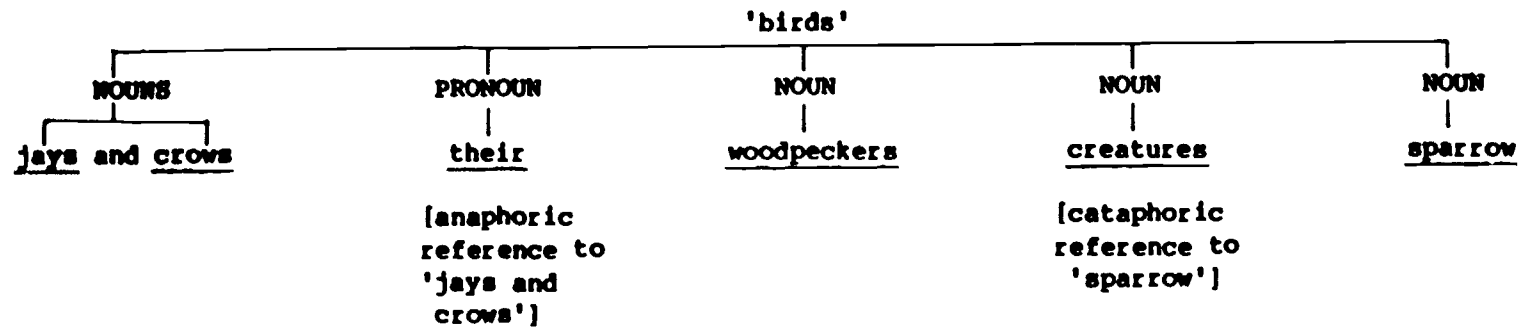

3-23

*In listing words and phrases that suggest 'sounds,' we have been as inclusive as possible. Perhaps some justifications are in order. In isolation, a word like pierced would not ordinarily suggest 'sounds,' but the related word piercing is frequently used in two senses that refer to 'sounds': 'loud' and 'shrill.' Silent has been included because it has the semantic feature [-sound], or to put it another way, one cannot refer to the absence of sound without necessarily bringing up the concept 'sound.'

The two gerund phrases form an interesting contrast. Every element in the hollow drilling of woodpeckers suggests 'sounds.' Hollow describes a kind of sound; drilling is a noisy process; and woodpeckers are known as noisy birds (even if most children haven't heard a real woodpecker at work, they probably are acquainted with Woody Woodpecker cartoons on Saturday morning television; many of Woody's adventures are concerned with how much noise he makes). In contrast, the dropping of acorns is so quiet that our processing of this phrase in isolation is likely to be totally visual. Yet, anything that drops a certain distance must make some sound, however slight, and once one gets the idea that this passage is organized around 'sounds,' it becomes clear that the author meant the sound of acorns falling into dry leaves to be taken as yet another contribution to the soundscape.

linguistic units--adjectival, adverbial, and verbal as well as nominal--and it is difficult to group them. In effect, the concept 'birds' is more easily retrieved from the passage, and this presumably contributes to children's selection of it as a response to (A).

The foregoing discussion raises the intriguing question of the degree to which a successful reading of this passage, at least as measured by children's response to (A), depends on their capacity for what might be called "sensate response" to language. Presumably, readers differ as to how much and how vividly they imaginatively "see" and "hear" as they read. Children who "heard" the various sounds represented in the passage while reading might be in a better position to select 'sounds' as a response to (A). However, we do not know any way of investigating the auditory sensations that children experience while reading.

Hitherto, our comparison of 'sounds' and 'b'irds' as conceptual themes in the passage has tended to be merely descriptive. Another way to approach this problem is to consider how information about the two domains fits together. Information about 'birds' is given first, but in the very next sentence, the focus shifts to the sounds that they make. As researchers such as Grimes (1975) and Meyer (1975) have pointed out, an appropriate analysis of discourse must deal not just with the linear order of the concepts conveyed but also with the hierarchical relations among them. Using their techniques of analysis, it is possible to view 'birds' as conceptually subordinated to 'sounds':

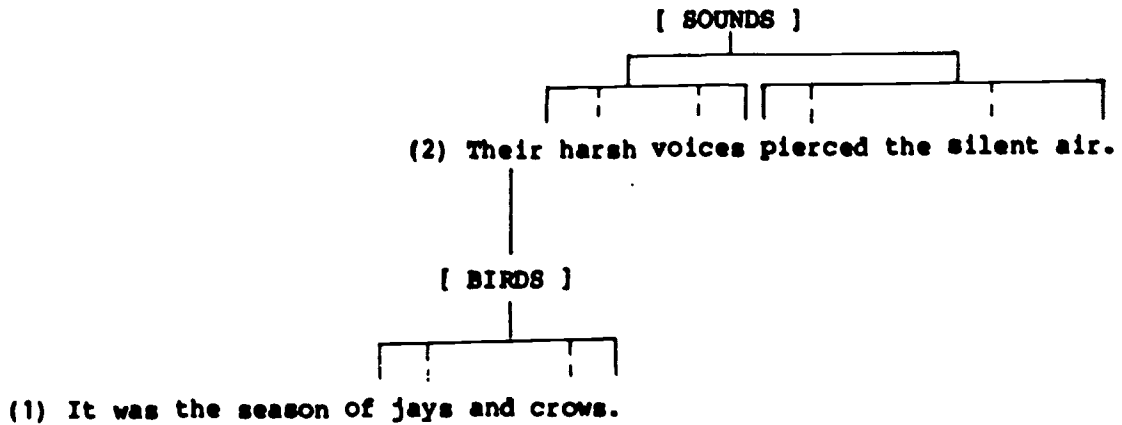

This kind of hierarchical analysis is strengthened by the fact that jays and crows are thought of as noisy birds. We discovered that many children do not know this, and we suspect that this lack of information may have contributed to their difficulty in subordinating 'birds' to 'sounds.' But apart from this, the process of subordinating one concept to another in actual discourse is a demanding task, one not easily carried out by children of this age. They are prone to rely on more superficial cues such as saliency ('birds' is more salient than 'sounds') or temporal ordering ('birds' comes before 'sounds') in developing a conceptual hierarchy, if they develop one at all. It appears that they do not, in fact, experience the same need as older readers to organize concepts hierarchically while reading.

With regard to ordering, it should be noted that the passage builds toward an ever greater concern with 'sounds.' It culminates in a sentence that presents this concern with considerable rhetorical flourish, stating that, in the ocean of leaves, a squirrel sounded like a man, a sparrow like a dog. This final pair of similes

captures powerfully the ways in which silent nature magnifies the crackling of leaves. Furthermore, this figurative language can itself be viewed as a signal, at least for adult readers, that 'sounds' is what the passage is mainly about, for figurative language is often used to highlight thematic concerns.

Before leaving the discussion of this item, we would like to make a point similar to the one we made in regard to the previous passage. Just as we claimed that 'products' is more likely than 'names' to be a subject of expository prose, so we would claim here that 'birds' is more likely than 'sounds' to be a subject of descriptive prose; and presumably even at a fairly early age, readers develop some sense of the degree to which prose is likely to be concerned with one kind of subject matter as opposed to another.

WHITE CIRCLES

We have considered two passages in which the initial sentence is misleading if it is interpreted as providing orientation for what is to follow. In each instance, readers are led to construct a general frame of what the passage is about. As they accumulate further bits of information, they are required to abandon this frame and replace it with one that is less probable in the kind of discourse they are dealing with. Let us now turn to a passage that has no general sentence that orients readers to the material that follows. Even in this case, however, the initial sentence leads readers to construct a content frame that they must later repudiate if they are to respond appropriately to (A). We recommend that, as an experiment, you read just the first sentence of the passage and then pause to consider what frame it has suggested to you:

As she rolled to a stop in the center of the business district, she quickly was surrounded by townspeople.

Now start the same passage from the beginning and notice what happens to your original frame as you read the succeeding sentences:

As she rolled to a stop in the center of the business district, she quickly was surrounded by townspeople. They were surprised when a woman stood up in the cockpit. When she raised her goggles they were even more surprised. She had been flying into the sun all day and her face was sunburned a bright red except for white circles around her eyes where her goggles had protected her. She blinked out at the assembled population of Hobbs like a boiled owl.

- A. She came into town by
 airplane car
 motorcycle parachute
- B. The people were surprised by her
 owl blinking
 goggles white circles

This passage is clearly narrative. Using the descriptive categories of Chapter 2, we would describe it as EXCERPTED. The first sentence presents some woman, referred to only as she, entering an unidentified town. We know only (1) that she has entered an urban area in some kind of vehicle (she rolled to a stop in the center of the business district), and (2) that her entry into this area is noteworthy (she quickly was surrounded by townspeople). In general, the verb rolled to is used with a subject that refers to a wheeled vehicle rather than a person (e.g., the car rolled to a stop rather than she rolled to a stop). In this passage, the naming of a specific vehicle may have been deliberately avoided in order to make (A) possible. Indeed, if existing prose was edited to produce this passage, we suspect that she was substituted for the plane in the first sentence. Since a business district is ordinarily entered by a street, most readers will, after reading the initial sentence, think of the vehicle involved as a car. Readers are less likely to picture a woman driving a truck or riding a motorcycle. Imagining the woman on a train is also unlikely, even though railroads do run to the center of business districts. The fact

that she is used as the subject of rolled to leads readers to see the woman as herself in control of the vehicle.

The other major piece of information in this sentence-- that the townspeople gathered around her--suggests that her entry is unusual in some way. It might be noteworthy because she entered the town in an unexpected way. We discovered, however, that no reader, whether adult or child, to whom we gave the first sentence in isolation, interpreted the noteworthiness in this way. As they added sentences "to complete the passage," the major tendency was to view the woman as a celebrity entering some town on a special occasion. In effect, they tended to construct a content frame that might be described as CELEBRITY ARRIVAL.

Although this frame works well in the first sentence, it begins to falter in the second. At this point, readers discover that the townspeople were surprised when a woman stood up in the cockpit. If the arrival had been planned in advance, the townspeople would have known that the celebrity was a woman. The fact that the vehicle has a cockpit is also unexpected. Many children, particularly the girls, did not know the meaning of this word. Many of those who did know the meaning were not able to make use of this information. Instead, they tried to devise a special meaning for cockpit that would fit the picture they had formed of a woman in a car. One girl, a quite skilled reader, defined the word as 'a large pit where cocks fight.' In responding to (A), she selected parachute, since it seemed to allow most effectively for a vertical descent into such a pit.

Some readers found still another way to deal with the word cockpit. They pictured a special kind of vehicle in which the driver sits in an enclosed glass bubble, like something that they might see in a comic book or a film. Others thought of a less extreme way of reconciling cockpit with the concept 'land-vehicle.' The woman might have entered the town in a racing-car with a glass bubble on top; and since women are not ordinarily racing-car drivers, the townspeople would have been surprised.

Once a racing-car has been imagined, readers are able to assimilate effectively the other cues--goggles and flying--that would ordinarily be regarded as leading to the target response airplane. In fact, children are more likely to associate goggles with a racing-car driver than with an airplane pilot. An appropriate understanding of this passage seems to require some knowledge of pilots in the early days of aviation--Amelia Earhart, for example. The children we interviewed, however, tended to picture the kind of pilot who is at the controls of a 747. Only one of them realized that the incident described in this passage probably happened some time ago.

Having managed to work in goggles, readers who have pictured a racing-car must then deal with the verb flying in the next sentence:

She had been flying into the sun all day.

This cue would seem to be more difficult to assimilate than goggles, and yet, once a racing-car has been imagined, a metaphorical interpretation of flying is quite possible. Certainly the

verb is used in everyday speech to describe the movement of an ordinary car at high speed:

After getting stuck in the traffic jam, I had to fly once I hit the turnpike.

A figurative use is even more motivated when describing the movement of a racing-car:

He was flying around the track at an unbelievable speed when his rear tire blew out.

To summarize all of this, readers are able to provide a plausible interpretation of the passage by imagining the woman in a racing-car. And of course this interpretation has the additional advantage that it does not require readers to imagine an airplane entering the center of a town.

In the pilot testing, the mainstream children favored airplane over car by a margin of 47% to 26%; the minority children found these choices equally attractive, with 33% choosing each one. A surprising number selected parachute--16% of the mainstream children and 21% of the minority children. For some children this was a way of resolving a contradiction. The passage seemed to be about an airplane, and yet they could not picture an object of such magnitude--a jetliner was the only kind of airplane they seemed to know about--as actually entering the center of a town. A parachute, however, which is, after all, closely associated with an airplane, could be used to enter a town's center. Moreover, such an entry would lead the townspeople to gather around, keeping alive the

theme of 'surprise' as well as that of 'airplane.'

(B) was even more difficult for young readers than (A)--during the pilot testing only 25% of both mainstream and the minority readers selected the target response white circles. The reasons for this difficulty are of a quite different kind from those we have been discussing. With (B), it does not seem to matter whether readers picture the woman as having entered the town by airplane or car, or, for that matter, by parachute or motorcycle. Rather, the major difficulty seems to be that if they select the target response--white circles--they produce a sentence which, as one child put it, "really sounds weird":

The people were surprised by her white circles.

Even children who selected white circles were bothered by the way in which it completed the sentence. One child justified her choice of white circles by laboriously working through her reasons for rejecting the other responses. She ended by pointing out that she didn't like "the way white circles sounds." She was saying, in effect, that while white circles might be the "best answer," it was not a very good one.

The children are certainly correct when they say that the target proposition for (B) is not English. There are firm constraints on the use of personal possessives like his, her, its, your, my, their. Just as we can't say her bags when we mean the bags under her eyes, so we cannot use her white circles as an equivalent to the white circles around her eyes. To produce

something acceptable, we would have to provide something fuller,
perhaps a sentence such as:

The people were surprised when they saw the
white circles around her eyes.

But this would violate the test format in two ways. First, it
would result in a target response that is much longer than the
three distractors. Second, ending the stem with the word the would
make the other completers sound less plausible:

The people were surprised when they saw the

[owl
goggles
blinking]

Let us now briefly consider another item--HUNG BRIDGES--in
which selecting the target response produces an ill-formed sentence:

Suspension bridges are hung from towers by
strong cables. Golden Gate Bridge in San
Francisco is one of the world's longest sus-
pension bridges. The world's smallest such
bridge may be in the Boston Public Garden. No
great ocean liners sail under Tiny Bridge, but
Swan Boats do.

A. These bridges are

towers long

small hung

B. Where is Tiny Bridge?

in London in San Francisco

at Golden Gate in Boston

Selecting the target response for (A) results in a target proposition that would be very difficult to interpret if it were considered in isolation:

These bridges are hung.

Again, a crucial modifying phrase--from towers--has been omitted in order to have completers that are equally brief. It may have been assumed that the modifying phrase would be carried over from the passage. If so, it was an assumption that children are uncomfortable with. As with the previous item, many complained about how the sentence sounded, and those children who did not complain may have also been bothered. During the pilot testing, only 31% of mainstream children and 22% of minority children selected hung.

The problem of an ill-formed task sentence occurs with some frequency. As we have suggested, it seems to result from the constraints that testmakers work with. They must provide four relevant completers, all of similar length, that can function as the final element of the same stem. These pressures occasionally result in an ill-formed target proposition that can work only if readers supply certain words from the passage. Unfortunately, it may be the children most sensitive to language who are prone to reject such odd-sounding sentences.

Polarity Items

Let us now turn to polarity items, the second kind of item that we are considering in this part of our study. In certain ways, these items can be analogized to the "word problems" that children encounter in mathematics. In making this comparison, we do not wish to call attention only to the more obvious resemblances. As already illustrated by LEARNING TO READ (see chap. 2, pp. 00-00), certain tasks on reading tests require children to make actual calculations; and as we pointed out at that time, many children faced with these tasks do not realize that they must carry out a straightforward calculation, one that they would do easily in a context where they understood more clearly what they were expected to do. This difficulty is even more dramatically illustrated by children's performance on the following item--17 TO 7--which indicates the necessity for calculation more clearly than did LEARNING TO READ:

The class became very quiet as Joan opened the last few ballots. The count was 17 to 17. Then she opened the final ballot. "Our new president," she said, "is Pat Morris!"

- A. They were voting for
- | | |
|----------------|-----------------|
| a new club | class president |
| club president | a class name |
- B. The final count was
- | | |
|------------|--------------|
| 18 to 17 | 17 to 17 |
| Pat Morris | Joan and Pat |

In order to select the target response for (B), children must understand that when Joan "opened the final ballot," the count, which had been 17 to 17, became 18 to 17. In effect, they only need to perform the simplest of calculations:

$$\begin{array}{r} 17 \text{ to } 17 \\ + \frac{1}{18 \text{ to } 17} \end{array}$$

This calculation is obviously easy for children at these grade levels, but for some reason they are not able to understand that this is the point of the task. During the pilot testing, only 25% of the mainstream children and 20% of the minority children selected this response. When we interviewed children, they were, for the most part, unable to focus on the need for the above calculation. Many children accepted the overt mention of 17 to 17 as representing the final count (on the whole, these children seemed to be unfamiliar with the ballot-counting scene evoked by the passage). Since no numeral was used in reference to the final ballot, it may be difficult for children to integrate this information with the numerically encoded information that precedes it. In math problems all relevant information is, of course, numerically specified.

Having noted this rather obvious resemblance between certain reading test items and word problems in mathematics, we would like to identify a deeper kind of resemblance that sometimes occurs (none of the items that we will analyze in this section require children to perform calculations). Word problems characteristically

require readers to extract crucial bits of information from prose, represent them in some kind of formula, and then carry out a sequence of operations that results in further information--the answer. The items that we are here concerned with make similar demands: (1) the crucial bits of information to be extracted are represented by pairs of lexical oppositions; (2) these bits must be aligned with each other in a configuration, which can usually be represented spatially; (3) certain logical operations must be performed so that some unstated bit of information can be derived.

There is a further sense in which polarity items resemble word problems: neither provides much supporting detail to facilitate the tasks they require. This is an acceptable practice in constructing word problems because the bits of information to be extracted have stable values and can be stated numerically. But in the case of reading items, where the bits of information to be extracted are often represented by lexical oppositions, the absence of supporting detail can be confusing. As we have already suggested, one of the most important requirements of expository prose is adequate support for the information that is conveyed; and the need for such support tends to increase whenever there is a dependence on lexical oppositions. In the absence of such support, lexically opposed terms can be difficult to process, for such terms convey semantic opposition in variable ways. Unlike opposing numbers, opposing words are not stable in their meaning. They are, in fact, protean, and their polarities reverse with little apparent

motivation.

To illustrate how lexical pairs can reverse polarities, let us consider a familiar problem: the resetting of our clocks each spring and fall as we move between standard time and daylight saving time. We can be confused as to whether to set clocks at an earlier point or a later one; and our way of talking about this problem does little to dispel the confusion. If anything, it may make matters worse. Consider, for example, our reliance on words such as forward and back to indicate the direction of the change. These words are commonly used in expressions such as

Please be sure to set your clock back before
you go to bed tonight.

Yet many people do not understand whether, at midnight, the hands of the clock should be moved to 11:00 P.M. or to 1:00 A.M. Because of the confusion generated by the terms forward and back, attempts have been made to standardize their use in such expressions. For example, in mnemonic phrases such as Spring forward and fall back, forward indicates movement to a later time and back to an earlier; and in published information these terms are generally used in this way as well. Despite these efforts at standardization, the opposing use still creeps in. We know a person who continues to say, "Spring back and fall forward," even though he has often been told that he is reversing the phrase; and in a brochure put out by a telephone company to aid its customers in resetting their clocks, we discovered a slip in the use of the term back in the final

sentence. Back had been used consistently to indicate earlier time throughout the brochure, but at the very end it was used to indicate movement to a later time.

These confusions provide clear support for what we will be claiming throughout this section: that lexical pairs such as forward and back are easily reversed; therefore, a good deal of supporting detail is needed to specify the particular meanings that they convey in any given situation.

Let us now take a closer look at why the polarities expressed by forward and back are so easily reversed in expressions that deal with time. We will begin by considering the more standard interpretation, the one in which back is viewed as signalling that the clock should be set at an earlier time. If time is viewed as having a direction, one in which it progresses from an earlier point to a later one, a movement from, say, 12 to 11 would be against the flow of time, and so would be expressed by back:

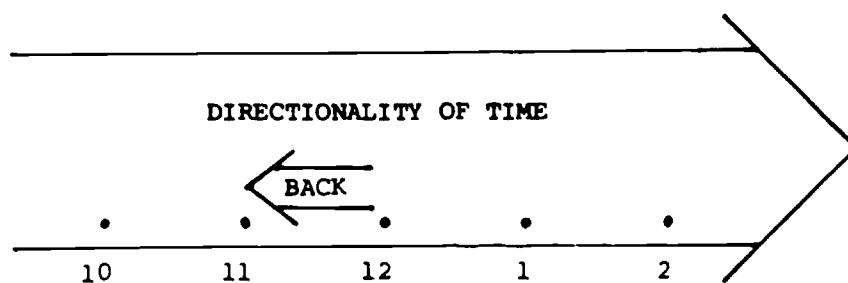

Drawing upon the terms introduced in *LEARNING TO READ* (see chap. 2, pp. 103-105), we could describe this interpretation as non-deictic, as free from any reference to the orientation in time of speaker or

listener. In effect, it is based upon the orientation that time itself is thought to possess.

This interpretation of back can be conceived of in another way, one that does not depend upon viewing time as having inherent directionality. If speaker and/or listener are thought of as facing toward the future, then a movement from a later point to an earlier one would be seen as contrary to this orientation and would be encoded as back. This interpretation is deictic in that the movement is described in relation to speaker/listener orientation:

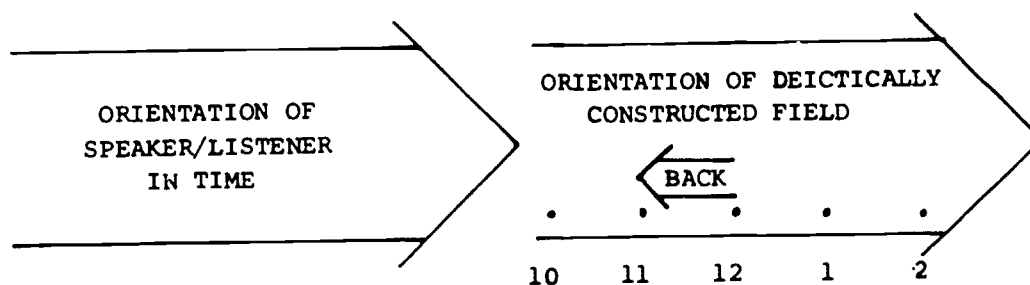

This deictic interpretation--in which speaker/listener and time have a common orientation--is based on an image that might be described as IN-TANDEM.

Yet, as we have seen, there is a considerable tendency for back to be viewed as representing the opposite movement in time--from an earlier point to a later one; and it is instructive to see just why this is so. To begin with, it is significant that the word back is involved in two sets of lexical opposition, one with forward and the other with front:

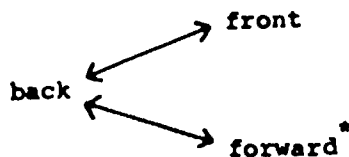

In general, the lexical opposition of front to back is used to describe spatial phenomena; the opposition of forward to back, temporal phenomena. The deictic use of front and back to describe spatial relations presupposes that an orientational field is constructed around some controlling center, ordinarily the location of speaker and listener:

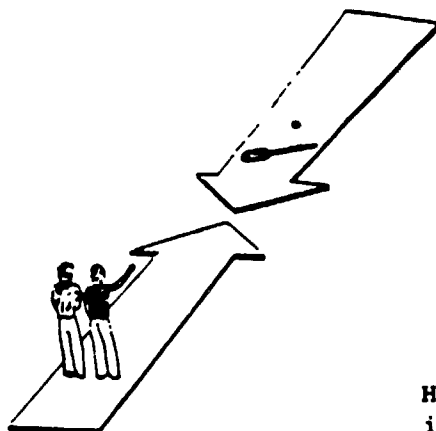

Hey, there's my squash ball
in back of that racket.

We can describe this deictic interpretation as based on a FACE-TO-FACE image, one that is directly opposed to the deictic interpretation based on an in-tandem image.

*We might note that forward is also involved in two sets of lexical opposition, one with back and the other with backward:



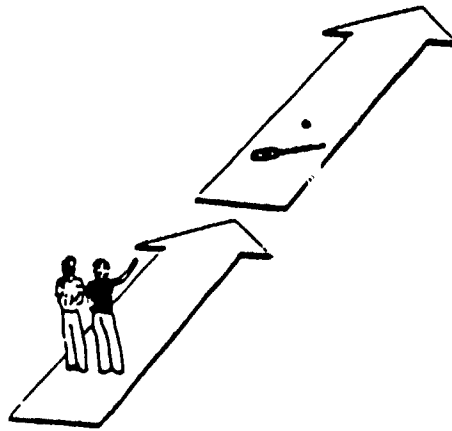

Hey, there's my squash ball
in front of that racket.

As illustrated by the following chart, the term back participates in two sets of opposition, one used for representing static relations and the other for representing dynamic relations.

CONSTRUCTED MODE OF EXPERIENCE	LEXICAL OPPOSITION	INTERPRETIVE IMAGERY
STATIC:	<u>front/back</u>	FACE-TO-FACE
DYNAMIC:	<u>forward/back</u>	IN-TANDEM

Hence the overlapping sets can be best represented in the following configuration:

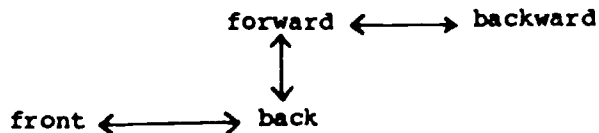

The fact that comparable patterning can be found in many languages provides further evidence for the claims that we are making here: (1) a lexical opposition is by no means absolute, but is rather a formal device for encoding varying sets of oppositions which occur at a deeper level; and (2) lexically opposed terms cannot be readily processed unless these deeper oppositions are well specified by the verbal context.

We tend to associate the statically conceived face-to-face image with space and the dynamically conceived in-tandem image with time, but these associations are by no means absolute. Consider, for example, a situation in which we are moving in space and hence make use of an in-tandem image to identify the relations between, say, a fire hydrant and a basketball that can be seen ahead:

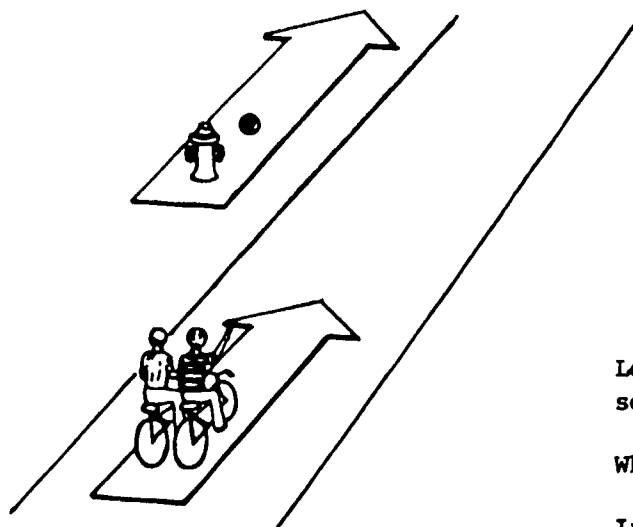

Look, somebody's left their soccer ball.

Where?

In front of the fire hydrant.

By the same token, the face-to-face image can be drawn on in representing temporal relations, which helps to explain why back can be used to describe movement from an earlier point to a later one:

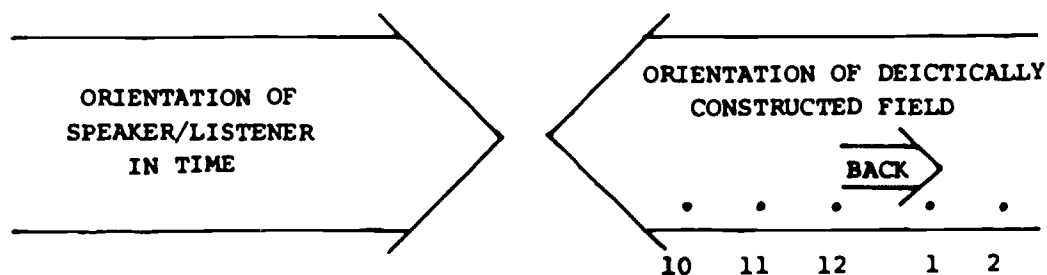

The use of a face-to-face image seems to occur more frequently with back than with forward; and we can think of various factors that may account for this. To begin with, the word back, as we have seen, does participate in two sets of oppositions, and so, in itself, does not indicate, as does front or forward, which kind of experience, static or dynamic, it should be associated with. But apart from this formal factor is a pragmatic one that seems to have even more weight. One of the primary uses of forward and back in the temporal domain is with reference to the rescheduling of an event or meeting. Given that human affairs ordinarily run behind schedule, a meeting is ordinarily moved to a later time when it is rescheduled. So upon hearing that a meeting has been rescheduled, we are likely to assume--whether forward or back is used--that it has been postponed. If forward is used, then the description of the movement is consonant with an in-tandem image:

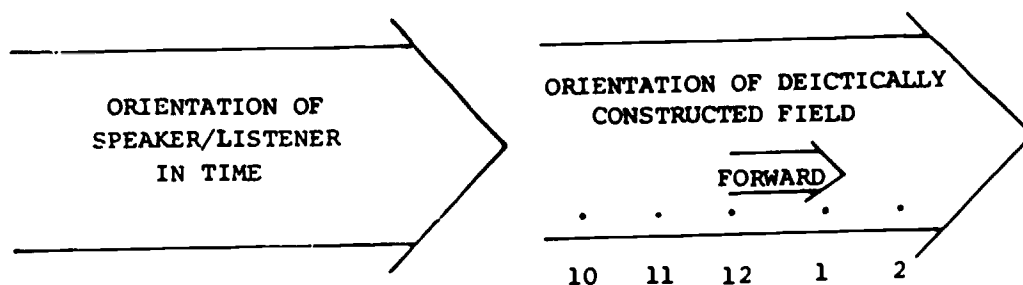

If back is used, however, the description reflects the use of a face-to-face image:

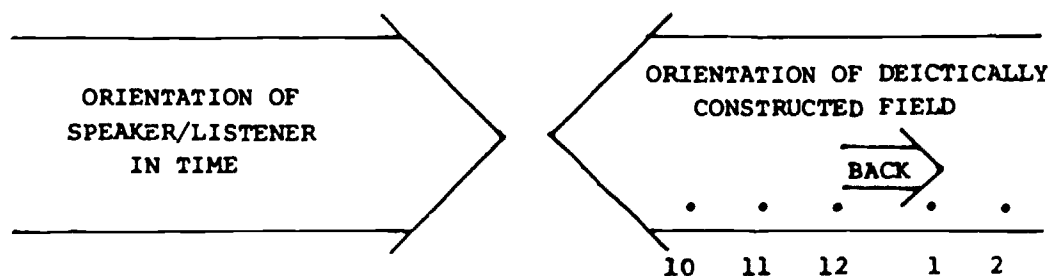

It is not difficult to see how this usage could carry over to the RESETTING CLOCK scene and how back could be used to indicate movement to a later hour rather than an earlier one.

We would like to call attention briefly to one other confusion that attends this scene, for it too bears on our analysis in the pages that follow. This confusion has to do with predictable associations made across pairs of opposing terms. Consider, for example, pairs such as big/small and strong/weak: everyone would agree that big goes with strong, because each is associated with the positive pole of some scale; correspondingly, small goes with weak, because both terms are associated with the negative pole of some scale.

Such associations are quite common and they control language--and thinking--a good deal more than we realize. Consider, for example, the confusion that we experience when we try to decide, after resetting our clocks, whether we have thereby gained or lost an hour. If we have used forward to indicate a change to a later time, we are prone to think that we have thereby gained an hour, given our ready association of 'moving forward' with 'gaining.' This association is, however, misleading; for when we set our

clocks forward from, say, midnight to one in the morning, we skip over that hour, a loss clearly registered in our bodies as we awake the next morning to begin our day with an hour's less sleep.

We could pursue the multiple confusions that surround the use of terms such as forward and back at greater depth, for as soon as developmental and cross-cultural considerations are introduced, the picture becomes more complicated (see Hill, 1982). But our discussion has been sufficient, we think, to show that opposing terms such as forward and back can be conveniently thought of as place-holders. They signal a potential opposition, but just how that opposition is to be used depends upon factors that operate at a deeper level. Unless these factors are adequately specified, it is possible that opposing terms will fail to carry any opposition at all. As we have seen with forward and back, each can indicate movement to either an earlier or a later point in time. The RESETTING CLOCK scene provides an especially vivid example of the instability of lexical oppositions. Although we could not demonstrate these confusions so clearly for every opposition, we are convinced that the processes involved are quite general.

Before leaving this subject, we should mention one other way in which lexical oppositions depend upon context. It has often been noted that many of these terms are relative, with their meanings dependent upon the situation in which they are used. Consider, for example, how the use of a term like big to describe, say, a German shepherd standing next to a beagle must be modified when a Saint Bernard enters the scene.

These observations may help to account for the experience most people have had of saying the opposite of what they mean, or even thinking one word and discovering later that they have written down its opposite. When people hear others make these reversals, they usually adjust for them automatically, and proceed as though no mistake has been made. Indeed, it is often annoying when someone feels compelled to interject something like, "Oh, you mean scarce, don't you, rather than plentiful?" in a context where it is clear that plentiful is what was meant.

Given the powerful role of context, there is considerable motivation for language users to elaborate what they mean when they make use of lexically opposing pairs. To return to our example of forward/back, let us examine, for a moment, the following sentence, excerpted from a faculty memorandum:

In order to accommodate earlier discussion of the budget, we shall be bringing the next scheduled faculty meeting forward by one week.

Here we encounter a use of forward based on a face-to-face image rather than an in-tandem one. This less ordinary usage is, however, buttressed by two additional cues: (1) the use of earlier and (2) the use of bringing, a verb that signals orientation toward the earlier point in time at which the audience is located.

Such supporting information should not be viewed as redundant, but rather as what we need from writing where the main purpose is to inform. Yet in the items that follow an undue burden has been

placed on opposing terms. A number of such terms are packed into two or three sentences, and not much detail is provided to specify how these terms are to be understood. It is as though testmakers have deliberately set out to measure whether children can comprehend impacted prose. We suspect that such measurement doesn't tell very much about how well children comprehend more natural writing.

HARD LEAD

Let us begin with an item in which readers are required to work with three sets of lexical oppositions--hard/soft, thick/thin, and dark/light. Initially we would like to point out that hard and light are both members of other common lexical oppositions:



Bennett (1976) has suggested that a term involved in more than one opposition is more difficult to process than one involved in a single pairing. As children read the passage and think about (A), they may expend a good deal of energy in maintaining focus on the oppositions that are relevant to this context.

Near the top of most pencils there is a symbol, usually a letter or number. It tells you whether the pencil lead is soft or hard. If you want your writing to be thick and dark, you select a pencil with a soft lead.

A. You choose a hard lead to make lines that are

thick	red
hard	light

B. The letters or numbers near the tops of pencils are

useless	dates
symbols	lead

Let us first examine the structure of this expository passage.

Its "main idea"--that pencils are marked in some way to indicate whether they have hard or soft lead--is spread across the first two sentences. The first sentence states that pencils are marked with a symbol, usually a letter or number; it is only in the second sentence that readers find out what the symbol stands for. In effect, readers are required to chunk together the first two sentences in order to come up with the main idea. By this time, they have only one sentence left to read, and it deals with the relationship between pencil lead and the physical characteristics of writing. But it does this in only a partial way. It tells only of the kind of writing that results from using soft lead, not the kind that results from hard lead. This piece of contrasting information is saved, as it were, for (A). The fact that this task forces readers to take the reasoning in the passage one step further may encourage them to do the same with other incomplete passages; as we have already pointed out (see, for example, the discussion of ALICE AND THE FAWN, chap. 2, p. 71), such an expansion can introduce information that leads away from the target response.

That it does not provide closure for the discourse is not the only problem associated with the third sentence. This sentence conveys information in a way that can be difficult to understand. To begin with, it is a conditional sentence, and both the if-clause and the then-clause* contain a good deal of internal complexity.

*The word then does not actually appear in the surface of this sentence. We use it as a convenient way of referring to the apodosis of a conditional sentence, just as if has been used to refer to the protasis.

The if-clause, for example, is composed of two underlying clauses:

(1) you want your writing and (2) your writing to be thick and dark.

Moreover, the if-clause contains the coupled terms thick and dark that must be associated with the single term soft in the then-clause. This association is especially difficult because it works against the conventional association of thick and dark with hard, the opposite of soft. This is a point that we will shortly take up in greater detail.

There is a further unconventional association in sentence three that is even more fundamental. The result of a certain action has been expressed in the if-clause, whereas the action itself is expressed in the then-clause, as illustrated below:

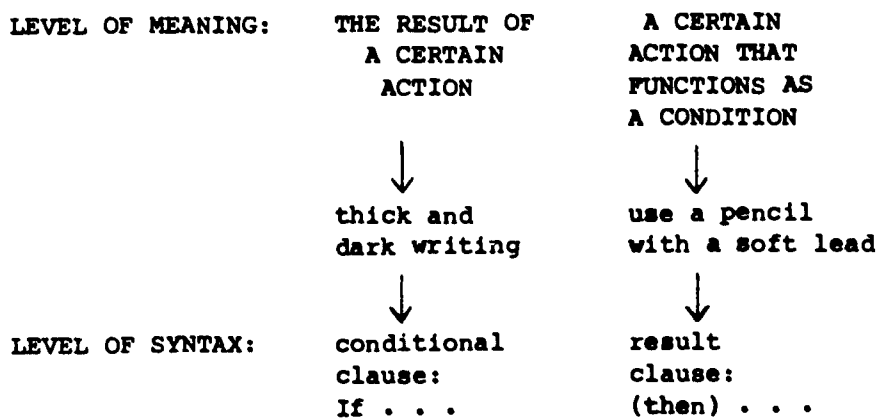

This reversal is made possible by placing the result of the action under the scope of you want in the if-clause (i.e., if you want a certain result, there is a certain condition that you must observe). The more conventional association of 'condition' with an if-clause and 'result' with a then-clause is illustrated by a sentence like

If you use a pencil with soft lead, you will get thick and dark writing.

This version of the sentence is clearly easier to read than the one in the passage, given the iconic relation between its meaning and syntax:

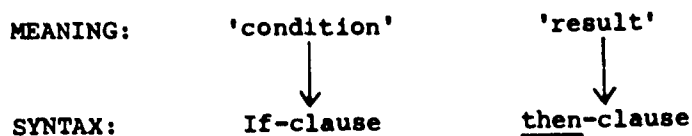

The difficulty of extracting information from sentence three is compounded by the form of (A), which, in fact, follows the conventional order outlined above. The task for (A), which is not overtly conditional, begins with the 'condition'--you choose a hard lead--and ends with the 'result'--to make lines that are light. (since to make can be expanded to in order to make, the second part of the sentence would ordinarily be described as expressing 'purpose'). In effect, (A) reverses the order of information in sentence three, as illustrated by the following diagram:

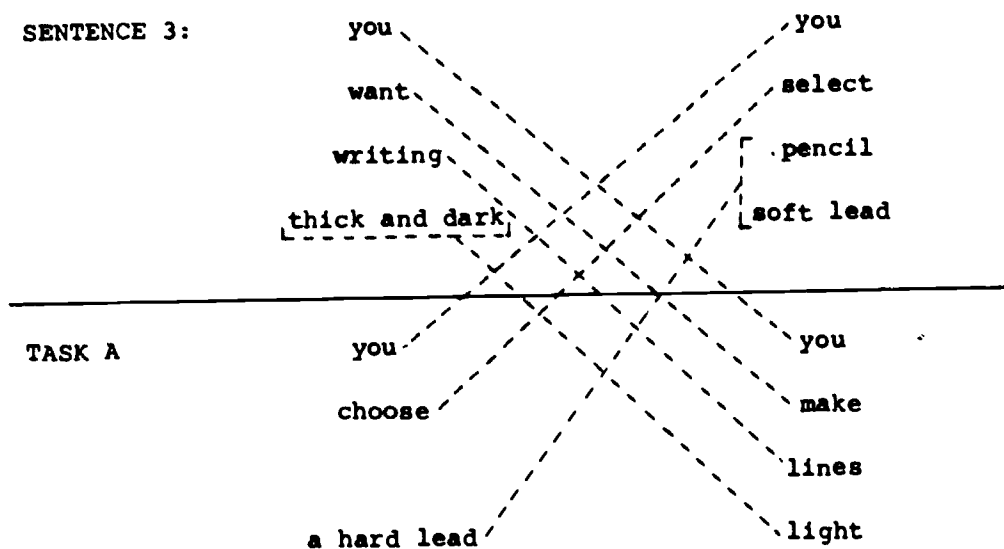

The diagram above also indicates a number of discrepancies in

the two versions that are potentially confusing. (A) talks about choosing "a hard lead" rather than "a pencil with hard lead." There is also the rather strange use of make lines in (A). This shift from writing in sentence three was necessary because it is not possible to use thin and light in describing writing, at least not to refer to its physical characteristics. For example, it is possible to say the first of the following phrases, but not the second:

If you want your writing to be thick and dark

If you want your writing to be thin and light

This contrast demonstrates how lexically opposed categories often function asymmetrically in language use.*

There is a further difficulty in (A). Given the information in sentence three, readers anticipate an answer opposing both thick and dark; yet each of the choices in this task consists of a single word. Here is a diagram of the strategy that leads to the selection of the target response:

*In linguistic theory such asymmetries have generally been accounted for by categorizing semantically opposed terms as marked or unmarked. In general, the unmarked term has a wider pattern of distribution. Thus, in the following sentences we are much more likely to use the unmarked terms thick and dark than the marked terms thin and light:

How thick is that board over there?
How dark is your new gray suit?

In fact, thin and light would only be used in cases where the entities being talked about are, in some way, presupposed to be 'thin' or 'light.'

LEAD

WRITING

SENTENCE 3:

soft

thick and dark

TASK A:

hard

'thin' and 'light'

CHOICES:

light

The solid arrow shows the relationship between 'lead' and 'writing' that is set up in the passage. The dotted arrows indicate the relationships that readers are led to infer in (A), causing them to anticipate the target response thin and light. In scanning the four choices, however, they discover that such a choice is not available and so are forced to settle for the partial response light (for a discussion of the difficulties associated with choosing a partial response, see BLACK BONNET, Chap. 2, p. 00). During the pilot testing only 34% of mainstream children and 29% of minority children selected light. The partial nature of the target response certainly contributes to the difficulty of this task, but perhaps an even greater problem is the unconventional associations that we alluded to earlier. Apart from any specific context, soft tends to be associated with thin and light and hard with thick and dark. It is as though all the former are somehow 'less' and all the latter somehow 'more.' The broken-line arrows in the diagram below indicate the reversal of conventional associations that readers need to make when they are dealing with the relationship between

pencil lead and the physical characteristics of the writing it produces:

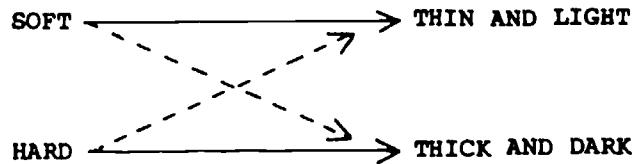

In order to ascertain children's knowledge of these matters, we asked 25 fourth graders who had not been exposed to this test item what they knew about numbers on pencils and kinds of lead. Of these, 17 knew that the numbers had something to do with the lead. Their answers were distributed as follows:

- 3 - the kind of lead
- 4 - how hard or soft the pencil is
- 10 - how dark or light the pencil is

The other 8 thought the numbers had to do with such matters as

- 5 - the quality of the lead (how good it is)
- 1 - the amount of lead
- 1 - what company made the pencil
- 1 - whether the pencil can be used on a test (presumably a machine-scored answer sheet)

When the children were asked what kind of line they thought hard lead makes, 15 circled thick and 10 circled thin. When they were asked what kind of line soft lead makes, 17 circled light and 8 circled dark. So about 60% did not make the necessary reversal of conventional associations.

This reversal is much easier for readers to handle if they understand the physical processes that motivate it. If pencil lead is soft, more of it rubs off on the page, leaving thicker and darker writing. But if lead is hard, then less of it rubs off, leaving "lines" that are, relatively speaking, "thin and light." The passage, of course, provides no hint of this explanation, so if readers are to grasp it, they must work it out on their own. In principle, they could have brought such knowledge to their reading of the passage, but none of the children we interviewed did. Moreover, they did not carry such knowledge away from their reading of the passage. Even the children who managed to choose the target response light were unable to explain why a pencil with hard lead makes light lines.

These children's performance demonstrates that there can be a sharp separation between (1) manipulating verbal symbols, and (2) gaining knowledge about the world referred to by those symbols. Many of the activities associated with formal schooling encourage this separation, but our methods of testing especially do, since they require students to move rapidly if they are to succeed. Once students have worked out the oppositions represented in the diagram on page 54, they are forced to go on to the next item without pausing to wonder why pencils with hard lead make light lines. We think that it is fruitful to distinguish between two levels of comprehension, one that is PURELY VERBAL and another that is KNOWLEDGE-BUILDING. We choose this latter term deliberately, for we suspect that children are not likely to remember the informa-

tion presented in this item very long. If, however, the item had enabled them to work out why hard lead makes light lines, they might have added to their stock of permanent knowledge.*

*BURBANK'S CACTUS provides another example of how a child can arrive at a correct answer through logical associations that sidestep the main issues in the information structure of a passage:

Animals would destroy cactus plants if it were not for their forbidding spines. A plant experimenter, Luther Burbank, produced a spineless variety of prickly-pear cactus. But cattle and other animals devoured it so rapidly that the spineless cactus did not have a chance to survive long in nature.

A. Burbank's new plant did not live long in nature because it

was too weak needed water

had no seeds was eaten up

B. Burbank's plant had no

juice taste

spines fruit

It is possible to arrive at the target response for (B) by establishing certain relationships between the stem and sentence 2 in the passage:

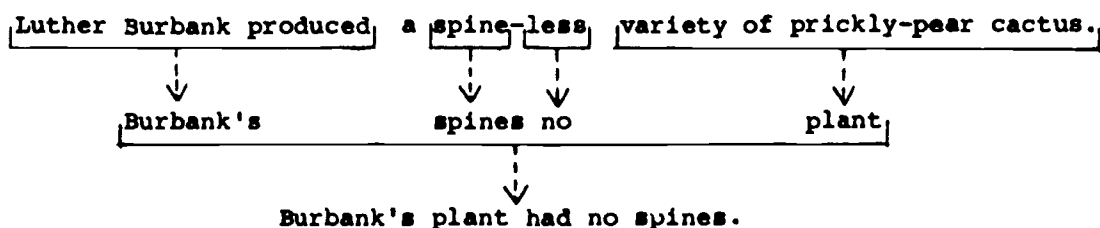

Thus, if children perceive certain parallels between (B) and sentence 2, they can select the target response through a purely

As it stands, of course, the passage lacks anything that would encourage such knowledge-building. In the real world, writers who address a subject like this are primarily concerned with informing their readers, with helping them make sense out of a part of their environment, however minor. Thus, they would take account of the cognitive traps that make this material hard to explain, to understand, or to remember. They would be especially careful to supply additional information to help anchor slippery relationships. They would certainly explain the physical characteristics that underlie the relationship of hard lead to light lines, and they would make clear, as the passage we have been discussing does not, that the hard-soft contrast is not an either-or but a continuum. They would certainly want to enable their audience to use their new knowledge--or the newly reorganized bits of previous knowledge and experience--by explaining at least the most common system used to express degrees of hardness or softness. And they would seek to concretize all this by explaining what tasks the different kinds of lead are most appropriate for.

There is a further problem in this area that we have not mentioned. Even if one understands that hard lead goes with "light" writing and that the numbers on pencils indicate the degree

verbal association of spineless and no spines. This strategy enables them to get the right answer without comprehending any of the ecological processes that unify the content of the passage and make it potentially knowledge-building. They might not realize that spines are prickles; they could conceivably even think of the spines as "backbones" and still be able to do (B) successfully.

of hardness, there is still the problem of whether a numerical increase indicates an increase in hardness or an increase in softness. In one class of graduate students--mostly reading teachers--half thought that a #1 pencil was harder than a #2 and half thought that it was softer. Clearly, any writer who could come up with a memorable mnemonic--something along the lines of "Thirty Days Hath September"--would earn lasting gratitude.

As we have sought to demonstrate, one of the reasons that HARD LEAD seems unnatural is that it neglects--seemingly perversely--numerous opportunities for being helpfully explanatory. Another reason for its unnaturalness is the odd way in which it addresses the reader:

If you want your writing to be thick and dark,
you select a pencil with a soft lead.

How are readers to take this? The author has assumed a good deal: that readers have noticed the difference between light and dark writing; that they are concerned about whether their own writing looks light or dark, at least on certain occasions; that they have the knowledge that enables them to produce light or dark writing as they wish. In fact, this author goes so far as to tell readers what they customarily do in a particular situation.

Perhaps the you in the passage is meant to be indefinite. We can test this possibility by using another way of expressing an indefinite actor:

If we want our writing to be thick and dark,
we select a pencil with a soft lead.

If people want their writing to be thick and dark, they select a pencil with a soft lead.

This is better in that it doesn't necessarily include the reader in its assertions, but there is still the implicit assumption that people are generally knowledgeable about these matters, and many readers will realize that this is not the case. As we have seen, a more accurate assessment of the situation is that people do not know very much about pencils and lead, that, indeed, they are confused, and that they need information and guidance. Perhaps the most usual way of expressing the advisor/advisee relationship between writer and reader utilizes the word should:

If you want your writing to be thick and dark, you should select a pencil with a soft lead.

And similarly for (A):

You should choose a hard lead to make lines that are light.

The gap between what would normally be written in this situation-- if you want a certain result, then you should do thus--and the way the passage is actually written provides another example of how difficult it is to write something for a school task without inadvertently producing aberrant prose. The connections between language and its functional context are so various, and operate on so many different levels, that it is inordinately difficult to shape words for a school function and at the same time provide real-world camouflage. As we have pointed out, the alternative of

adapting existing language for a school purpose is also problematic, but perhaps it more often achieves a satisfactory result.

Let us now turn to (B), which does not deal with lexical oppositions but is interesting in several other ways. (B) is based on the first sentence of the passage, and it is evidently meant to be a vocabulary task: do the children know something about how the word symbols is used? The most straightforward way to ascertain this would be a target proposition like

Letters and numbers
are symbols.

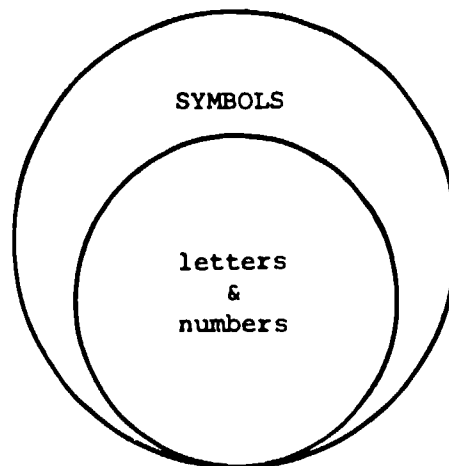

In other words, as illustrated above, the class of 'letters and numbers' is included in the larger class of 'symbols.' But such a target proposition would not be sufficiently dependent upon the passage. It would make sense apart from the passage, and it could be answered on the basis of general vocabulary knowledge. This is perhaps why the target proposition used in this task includes extra material from the passage:

The letters and numbers near the tops of pencils are symbols.

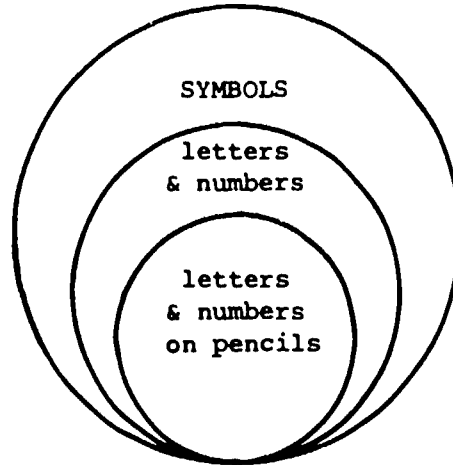

Notice that this target proposition, as shown in the illustration, refers to three different classes: the class of 'letters and numbers on pencils' is included in the larger class 'letters and numbers,' which, in turn, is part of the class 'symbols.'

That near the tops of pencils has been included to satisfy a requirement of the test format is not likely to occur to readers. For them, a more likely interpretation will be that some letters and numbers, specifically those that appear on pencils, are symbols, while other letters and numbers are not, as illustrated below:

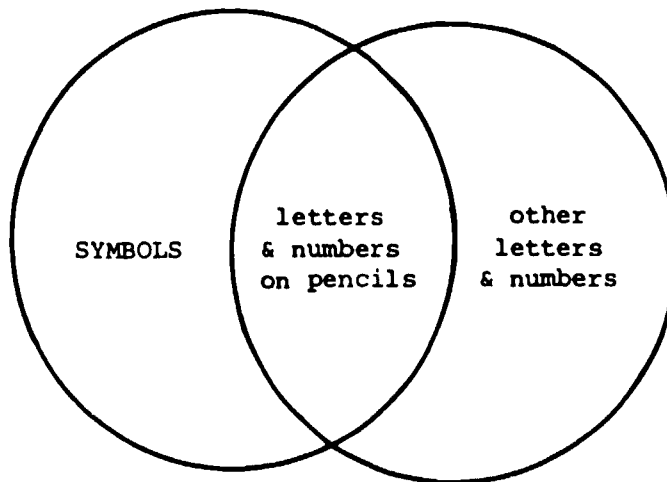

For readers who don't have much idea of how the word symbols is used, the fact that this interpretation is not accurate will present no problem, and they are likely to select the target response. Those who do have some prior knowledge of how this word is used are likely to think further. The most likely direction for them to go is to restrict the scope of 'symbols' so that it matches the restriction placed on 'letters and numbers.' Thinking along this line might produce something like the following:

The letters or numbers near the tops of pencils are symbols that indicate the kind of lead a pencil contains.

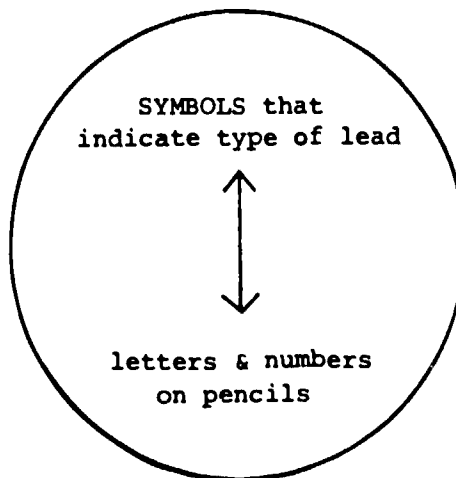

This proposition sets up a single class which can be described in either of two ways:

- (1) numbers and letters on pencils
- (2) symbols that indicate the kind of lead a pencil contains

Readers who have come this far may well begin to consider the choice lead as having some merits. This would produce the target proposition

The letters or numbers near the tops of pencils are lead.

This is not very precisely stated; it would be more accurate to say that these letters and numbers represent the type of lead. It should be remembered, however, that this kind of all-purpose use of the verb be is frequent in speech and by no means unknown in writing. Consider, for example, the following:

--What's this little number here mean?

--That's the lead. It tells you whether the pencil is hard or soft.

So readers who have come this far are faced with the choice between two dissonant target propositions:

The letters or numbers near the tops of pencils are symbols.

The letters or numbers near the tops of pencils are lead.

Taken out of context in this way the first seems preferable. But one can certainly sympathize with those who pick the second. After all, using information from the passage to flesh out a target proposition so that it sounds reasonable is just what is required in some of the items we have discussed.

At this point, it may be instructive to see how some of these considerations match up with the results from the pilot testing. (B) was answered by 92% of the mainstream children and 77% of the minority children. Those who completed the task were distributed among the choices as follows:

	MAINSTREAM	MINORITY
useless	9%	35%
symbols	56%	38%
dates	9%	8%
lead	26%	19%

Symbols was favored by both groups, though not to the same degree.

For each group approximately half as many chose lead as chose symbols. There is a remarkable divergence between the two groups on useless; proportionately, it was selected by four times as many minority children as mainstream children.

How can we account for this divergence? Certainly most of the children who selected useless knew they were picking the wrong answer, but they couldn't resist it. It's funny; it's irreverent; and for those who have been struggling with this item it is, no doubt, God's truth. On a more general level, useless represents a chance to talk back to the test, to say what one really feels. It is impossible to say just why minority children were so much more attracted by this opportunity. One possibility is that, as we have often suggested, they are especially attracted to responses that are communicative, that do not merely recycle the content of the passage. None of the children we interviewed actually chose this answer, but all of them found it tantalizing and laughed at its communicative possibilities. It perhaps goes without saying that testmakers should avoid distractors that encourage children to go beyond the usual confines of the test situation.

BACTERIA

Let us now examine a passage which, at least on the surface, reflects the conventional characteristics of expository prose. Indeed, it is an example of what we have called the canonical paragraph (see page 000).

From the earliest times, people have found ways to keep food from spoiling. The ancient Egyptians kept grain in dry, cool storehouses. They added salt to fish and meat or dried them in the sun. For centuries people have also kept meat from spoiling by smoking it. All of these methods kill bacteria that cause rotting.

A. Which will keep meat from spoiling?

water	grain
bacteria	salt

B. Bacteria grow best when food is

smoked	dry
warm and damp	cool and dry

The passage begins with a "topic sentence," which states the "main idea" that human beings have known ways to preserve food from the earliest times. The next three sentences support this proposition by citing specific examples. Sentences two and three describe methods used by the ancient Egyptians: dry, cool storehouses; the addition of salt; drying in the sun. It should be noted that these sentences contain no indication that they are examples of "ways to keep food from spoiling." The author has depended upon the reader to infer this connection. In contrast, the example supplied in

sentence four--preservation through smoking--does make this relationship explicit by repeating the words keep . . . from spoiling. The passage ends with a "summary sentence" that tells why the previously mentioned methods are effective.

Yet despite this orderliness, a careful reading of the passage results in a level of uncertainty that is unusual for simple informative prose. How, for example, should one interpret the shift from past tense in sentences two and three to present perfect in sentence four? The also in sentence four is perhaps meant to reassure the reader that this change in direction is reasonable, but the shift from definite to indefinite between the two sentences--from Egyptians to people and from ancient to for centuries--makes it difficult to know just what also is meant to imply. Are the methods of preservation mentioned in sentences two and three still used? Are the ancient Egyptians included in "people" or was preservation by smoking unknown to them? Careful readers might further wonder if they should infer something from the fact that both meat and fish are mentioned in sentence three but only meat in sentence four. Is smoking somehow inappropriate for preserving fish?

Logically considered, these indeterminacies do not prevent a reader from answering either task correctly. It is likely, however, that for many third and fourth graders, such woolly writing, added to the inevitable difficulties that result from trying to deal with a subject like this in five brief sentences, contributes to a general breakdown in comprehension. Even a skilled reader is often

affected by the indeterminacies in a text, though they usually remain below the level of consciousness. These indeterminacies may not prevent comprehension, but the static they introduce certainly makes it less efficient and enjoyable.*

The diagram on page 69 represents one way of looking at the structure of BACTERIA, a way that focuses on what the test-taker is asked to do in the two tasks that follow. The three areas into which the diagram is divided--initial sentence, middle sentences, and final sentence--reflect the basic structure of the passage.

The initial sentence, given at the left, is divided into its basic parts. The nominals--people, ways, food, spoiling--are given in brackets. The words that relate the nominals to each other--found, keep, and from--are boxed. From is labeled "adversative," because it expresses a basic disjunction in the passage between the concepts of 'food' and 'preservation' and the concept of 'spoiling.' Since the passage presents 'food' and 'preservation' as desirable, the elements representing these concepts are preceded by a plus sign. Correspondingly, since 'spoiling' is presented as undesirable, the elements representing it are preceded by a minus sign. Thus, an adversative indicates that the elements on each side are opposed in some way that is significant in a given discourse.

*Given the nature of language and meaning, it is probably true that any piece of writing will wobble and fall apart under intensive analysis. Nevertheless, skilled writers are able to keep indeterminacies at a level where they are unlikely to impede the reader's progress.

Initial Sentence (1)

Middle Sentences (2-4)

Final Sentence (5)

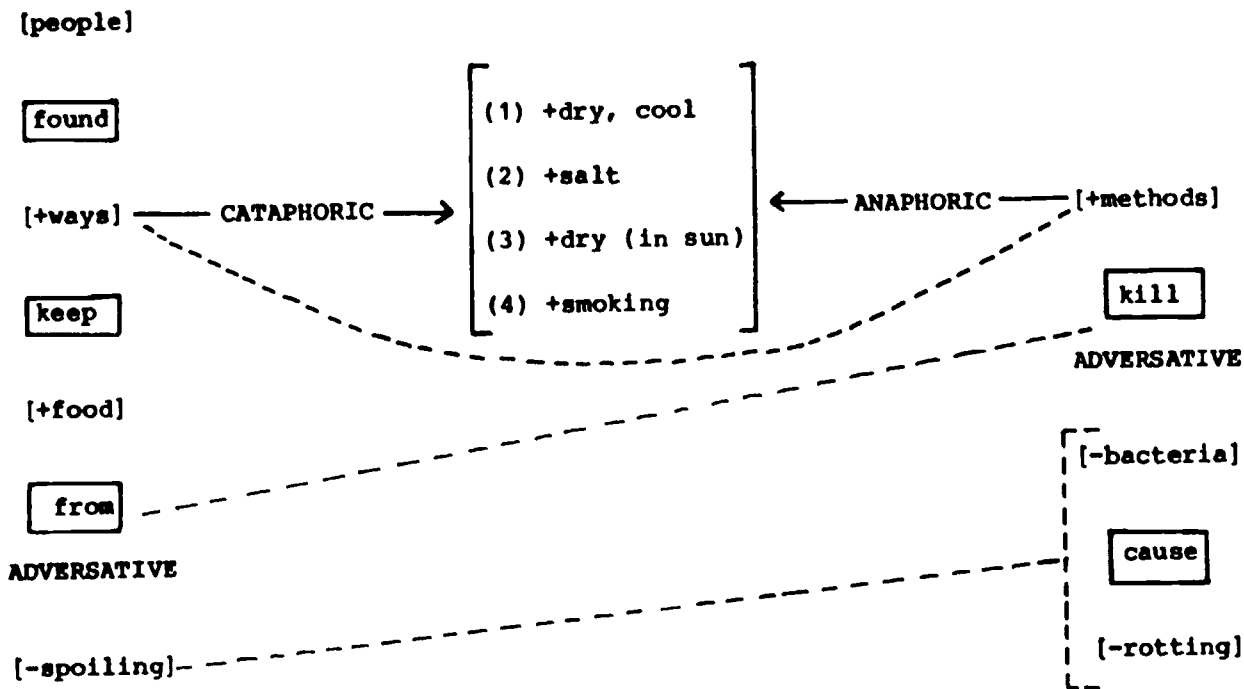

The word ways functions cataphorically to tie the initial sentence to the middle sentences. In other words, ways presupposes information that follows. What is presupposed is expressed in the middle sentences, namely, four techniques for preserving food. These techniques are represented in the diagram by the significant component(s) of each one: (1) dry, cool; (2) salt; (3) dry in sun; (4) smoking. Thus, ways may be viewed as a placeholder in the initial sentence for material that is subsequently expressed in the middle sentences.

The diagramming of the final sentence starts with another placeholder--methods--which presupposes the same material in the middle sentences as was presupposed by ways, only this time, of course, the relationship is anaphoric. Methods is related to bacteria by the word kill, which is adversative. Bacteria, in turn, is related to rotting by the word cause. As in the initial sentence, the elements on either side of the adversative are given opposing signs.

Presented in this way, the initial and final sentences can be seen to have a similarity in structure that is not readily apparent in their surface form:

- (1) both sentences contain a general word which refers to the material in the middle sentences: ways, methods
- (2) both sentences contain an adversative: from, kill
- (3) both sentences are divided into plus and minus sections: ways, foods, methods versus spoiling, bacteria, rotting

In the diagram, these similarities are indicated with dotted lines.

Since (A) is based on the initial sentence of the passage and (B) on the final sentence, there are similarities between the two tasks. In fact, they are much more alike than is usual for a reading test item, where there is often a conspicuous contrast between adjacent tasks as to type or difficulty. We can summarize the similarities between (A) and (B) by pointing out that the target response for each can be arrived at by searching the middle sentences of the passage. Yet, before readers can evolve this strategy, they must gain an understanding of how the passage as a whole is structured.

The most "logical" way of answering (A) is to take each of the choices and search the "ways" and "methods" of food preservation given in the passage for information that will either agree or disagree with it. Since the task asks for something that will "keep meat from spoiling," the search will be for attributes that are on the 'desirable' side in the passage, that is, those marked with a plus in the diagram on page 69.

Let us go through each of the choices and see what inferences are necessary to validate or disqualify it. Water (16% mainstream; 23% minority) is not mentioned in the passage, but it can be disqualified in the following way. 'Dryness' is an attribute of two of the four methods of preservation given. Since it has a plus value in the passage, anything that expresses its opposite-- 'wetness'--must be regarded as having a minus value with regard to food preservation. Water expresses 'wetness,' so it must be disqualified as having the wrong polarity; it is on the

'undesirable' side in the passage, and the target response must be on the 'desirable' side.

Continuing this strategy, it should be easy to disqualify bacteria. The passage states quite directly that they cause spoiling, and in this task the reader is searching for something that prevents spoiling. The relative attractiveness of bacteria (20% mainstream; 28% minority) can perhaps be explained by the fact that it is an unusual word (see chap. 2, p. 15 for a discussion of distractors that contain low-frequency lexical items).

Grain (19% mainstream; 16% minority) can be disqualified because it is one of the foods needing protection from spoiling, not a way of preventing spoiling. In the interviewing we came across one child who chose grain because she read the sentence in which it appears in an unexpected way. She interpreted it as paralleling the clause that directly follows it, as shown below:

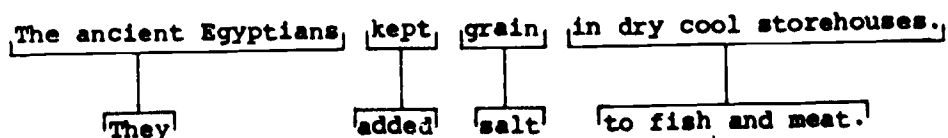

Thus, to this child, grain was something put in the storehouses to keep whatever was there from spoiling.

For readers who realize that the middle sentences of the passage are concerned with ways to prevent spoiling, the target response salt (45% mainstream, 33% minority) can be validated directly.

This route to the target response is, of course, only theoretical, for it makes two assumptions that may be unwarranted:

(1) that readers have sufficient language skills to decipher the passage; and (2) that they do not have any knowledge of food preservation that can replace or supplement their understanding of the passage. Certainly most older readers would not meet this second requirement. Those with even an elementary knowledge of what causes and prevents food spoilage would be able to choose the target response for either (A) or (B) without reading the passage. But even with readers who have never thought about this subject, a reading of the passage is bound to activate certain frames--coolness might be associated with refrigeration, for example, or drying in the sun with TV commercials for raisins--and these could affect their path toward a response in unpredictable ways.

For third and fourth graders, the assumption of ignorance is mostly justified. This item is hard for them and few had any real-world knowledge that could help them out. Still there were some who were able to use prior knowledge to select the target response. As an example, let us quote from a joint interview with two step-brothers, both of whom had selected salt for (A):

--Now how did you go about getting that answer?

J --I saw it on a film in my fourth grade--we had the film on people going across the seas--the Pilgrims--on the seas--and how they had to keep their meat--they preserved it in salt--so I just--

--I remembered that--

R --Well, I just knew--

--You just knew that it was salt. Okay.

R --I just knew.

--So you didn't even have to go back--

R --That's why all the explorers went out--because
they needed salt and spices to keep the meat
good, because--

J --The Roman soldiers got paid--

--So you really didn't have to even go back to the
passage here.

J&R --Naah.

--Just something you know.

J&R --Yeah.

Although both boys maintained that their answers came from general knowledge rather than from their reading of the passage, this claim should not be taken entirely at face value. For one thing, they were both good readers and would probably have selected the target response even if they hadn't been able to make use of knowledge gained from their social studies class. A more important consideration is that they had, in fact, read the passage. Once readers have negotiated a text, activating high-speed and automatic responses that are largely out of consciousness, their evaluation of what part of their understanding came from the text and what part from prior knowledge can only be suggestive, not definitive. Still another consideration is that there were two interviewees, and as they talked with each other, the interview began to take on

some of the characteristics of ordinary conversation. As many have observed, conversational norms as to what is relevant to a matter at hand are looser and more inclusive than the norms associated with comprehending a written text. Thus, the interview itself rather than the passage may have stimulated the wide-ranging historical references to the Pilgrims, medieval trade with the East, and how Roman soldiers got paid.

Let us consider briefly the effects of real-world knowledge on the functioning of test items. Certainly an item in which a reader can choose the target response without having read the passage is defective in some way; such a reader is getting credit for possessing skill that he has not in fact demonstrated. No doubt testmakers strive to use material that will be unfamiliar to their intended audience, but given their goal of using passages that are typical of the kinds of reading that children do in school, they can hardly succeed in neutralizing the effects of prior knowledge altogether. This is particularly difficult with passages like BACTERIA, which deal with generic knowledge, with concepts and principles rather than individual facts, whether they be historical or fictional (see chap. 4, pp. 00-00 for further discussion). It is paradoxical that we should seek to neutralize the effects of real-world knowledge in testing reading comprehension, and at the same time advise readers that their comprehension can be increased--that is, they will achieve "critical reading"--if they maximize the number of connections they make between a text and their existing knowledge and experience.

Let us now return to a consideration of (B). We have pointed out that the initial and final sentences of the passage are similar in many ways, and that this similarity is transmitted to the two tasks which are based on them. Yet, only half as many children were able to select the target response for (B) as were able to select it for (A). How can this divergence be explained?

One possible reason for this discrepancy is the nature of the final sentence, which provides the basis for (B). There are several aspects of this sentence that make it more difficult than the initial sentence, which was the basis for (A). To begin with, in our analysis of the structure of the passage, we called the final sentence a summary sentence, but it is a summary sentence of a special kind; for while it provides closure for what has gone before, it does so by bringing up a new aspect of the subject--causation. If this passage were followed by more text, readers would ordinarily expect it to expand on causation in some way. Perhaps a succeeding paragraph would begin with something like

Bacteria are tiny living things that . . .

Such a paragraph would probably continue by describing how bacteria cause spoilage and end up with a statement of the information that is called for in (B), and which this task requires the test-taker to deduce from the passage, namely, that bacteria flourish in the presence of heat and moisture. Thus, (B) does not recycle the information in the passage but rather anticipates

what, according to the ordinary expectations of discourse, would eventually be stated in an explicit way.

A second difficulty with the final sentence is the presence of the word bacteria. Almost half of the fourth graders we asked said they didn't know what it meant. Most of those who found the word familiar defined it as 'germs,' or less frequently as 'disease.' Only one child seemed to know that the meaning was broader than this; he suggested that bacteria was "a living thing inside bodys." Another difficulty with bacteria is its form. Both the passage and the task treat it as plural (using cause and grow rather than causes and grows), yet it does not end in -s, and children are almost certainly unfamiliar with its singular form bacterium. About one-third of the children who gave us definitions of bacteria construed it as singular, going counter to a context that marked it as a plural (What are bacteria? What do they do?). It may well be that bacteria is the first Latinate plural that most children come across.

Still another difficult aspect of the final sentence is that it verges on being ill-formed. If we take the relative clause as explaining bacteria, it should be nonrestrictive:

All of these methods kill bacteria, which
cause rotting.

On the other hand, if this clause is taken as restrictive, as dividing bacteria into two groups, those that cause food to rot and those that don't, the sentence would, according to the usual

rules of English, contain a definite article:

All of these methods kill the bacteria that
cause rotting.

Let us now turn to the target proposition for (B):

Bacteria grow best when food is warm and
damp.

To select the target response, readers must evaluate the choices
to find one that is regarded as 'undesirable.' A more straight-
forward way to present this task would be

Food spoils fastest when . . .

With a stem like this, children would understand more easily
that they are to look for attributes opposed to the ones associated
with food preservation in the passage, whereas in (A) they sought
attributes congruent with the passage. To put it another way, they
would see how much alike the two tasks are, how these tasks deal
with the same content and how an answer can be arrived at in the
same way. The important exception to this similarity is, of
course, that a polarity has been reversed between the two tasks:
the target response for (A) is [+food preservation] while for (B)
it is [-food preservation].

Another effect of the peculiar wording of the target proposi-
tion is that it makes bacteria and their activities sound so
positive (grow and best are certainly weighted toward the
favorable side in the subjective lexicon). An actual discussion

of food preservation would never say "bacteria grow best." It would instead use some such phrasing as "bacteria multiply most rapidly." If our analysis of the passage into 'desirable' and 'undesirable' elements separated from each other by adversatives is on the right track, this presentation of something from the 'undesirable' side in favorable terms may be disorienting. We might even think of it as reversing the polarity of the passage, changing minuses to pluses and pluses to minuses. Perhaps the confusion that this shift in values may cause can be better conveyed by an analogous sentence in a more familiar area. How might readers react, for example, to a discussion of the perils of smoking that contained the following assertion?

Lung cancer grows best when you smoke
nonfilter cigarettes.

Thus, as readers approach the choices in (B), some of them may be in a vertiginous state. Ideally, they will realize that dry, cool and dry, and smoked are all represented in the passage as favoring food preservation, while the target response must represent something that encourages food spoilage. By process of elimination, the target response must be warm and damp (see chap. 2, p. 00-00 for a discussion of the strategy of arriving at the target response by eliminating other choices).

Another "logical" way of arriving at the target response is to work through the oppositions around which the task is structured. Such reasoning might go something like this:

I am looking for something associated with food spoilage, which is the opposite of food preservation. If I go through all the things that I have been told favor food preservation, and think of their opposites, I may get the right answer. Smoking and salt don't have opposites. The opposites of cool and dry are warm and damp. Aha!

These relationships can be diagrammed as follows:

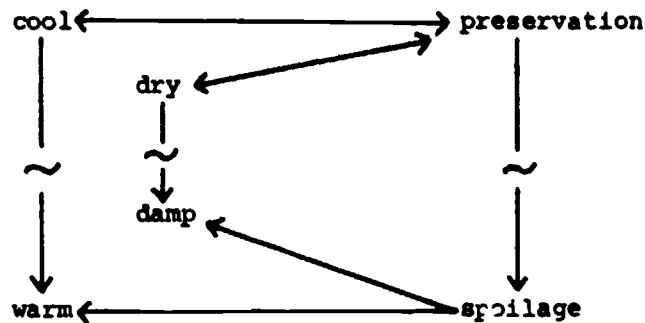

Assuming that the opposites of opposites are opposite is by no means respectable reasoning from the logician's point of view, but it is on such rough assumptions that we build much of our everyday thinking, and much of our writing as well.

There is one bit of evidence from our interviewing that this kind of strategy is not wholly theoretical. The child involved was one of the least promising of the comprehenders we talked to. While most children were able to go through twenty-two items in about twenty minutes, at the end of an hour he had only managed to complete seven. His reading aloud of the passages was painfully slow and he resisted talking about the items or how he had handled them, though he was willing to talk about almost anything else. Yet he got most of the answers right, including

warm and damp.

--Okay, now does it say that in the passage?

--No.

--How did you figure that out?

--I guessed it.

--I don't believe that you guessed it. It's
the answer that you were expected to get.

--Because the opposite of smoke and dryness--
that's what it says.

However this child arrived at warm and damp, he was unusual; in the pilot testing this was the least favored response among minority children, with only 15% selecting it. Among mainstream children only 23% selected it. We have already suggested several characteristics of the stem and its relationship to the passage that are likely to cause children difficulty. We would now like to point out additional difficulties that are associated with choices made available to them.

Contributing to this difficulty is the fact that three of the four choices involve the oppositions cool/warm and dry/damp, which we will refer to as the temperature scale and the humidity scale, respectively. Moreover, two of the responses involve pairing one member from each of the two scales:

warm and damp

cool and dry

Following up on our conviction that polarities are inherently difficult to process, we investigated what associations of temperature terms and humidity terms children find most natural. Independent of any context, 92% of the children we asked thought that warm and dry "sounds better" than warm and damp; and 80% were more comfortable with cool and damp than with cool and dry.* It is hard to know how much it matters that these preferred sequences are the opposite of those used in the choices for (B). Certainly many children depend upon whether something "sounds right" when they are deciding on a response to a task.

Cool and dry (selected by 27% of majority children and 32% of minority children) was favored somewhat more than warm and damp. This may be due to the fact that cool and dry can be found in the passage, though in a different sequence--dry, cool storehouses. It is possible that readers who tried to get the opposite of dry, cool became confused and reversed the sequence (after all, in one sense cool and dry is does represent the opposite of dry and cool). When we asked children which of these sequences was more natural to them, about 75% favored dry and cool. Recent research by Ross and Cooper (1980) suggests that orderings of this kind are often fixed and that they provide evidence for deeper principles of information-processing. Hence, these reversals may have greater consequences for young readers than we would ordinarily suspect.

*Climatic conditions may influence these pairings considerably. If we were to test a similar group of children in, say, Arizona rather than New York, the results might be different.

Another difficulty in choosing a response for (B) is that the dividing line that the passage establishes between 'warm,' 'damp,' 'bacteria,' and 'rotting,' on the one hand, and 'dry,' 'cool,' and 'preservation,' on the other, is not impermeable. This was pointed out to us by one of the children. After she had heard an explanation of why warm and damp was the target response, she pointed to dry in the sun in the passage and asked, "Why would the Egyptians have put their food in the sun if they didn't want it to get warm?" Once we gained this insight, we could see that smoking, another of the methods of preservation, presents a similar problem. Everyone, including third and fourth grade children, has heard about the one-to-one relationship between smoke and the intense kind of warmth called fire.

Smoking was, in fact, the most attractive of the choices; 30% of the mainstream children and 34% of minority children selected it. It is difficult to say why this should be so. It may be significant that three of the simplest test-taking strategies all lead to smoking: (1) it can be found in the passage; (2) it contrasts with the other three choices, all of which contain temperature or humidity terms; (3) its meaning is mysterious. With respect to this last strategy, we have here not an unknown word but a familiar word that is used to refer to something that is unfamiliar to many children. According to Dale and O'Rourke (1976), smoke is known to 94% of fourth graders in the meaning 'to puff tobacco'; the meaning 'to preserve with fumes' is not widely known until high school.

In order to find out how children would put together their usual meaning of smoking with the context of food preservation, we asked a class of fourth graders, "How would you smoke meat or fish?" Many of the children had a fairly accurate idea:

with a stick and put the meat on the stick and
turn it around

hang it up and put a fire under it

when the meat absorbs the smoke from the fire

you cook it in smoke

put it in a smokehouse

Other answers ranged from the unhelpfully general to the ingenious:

it is from the market

with fire

by a fire

put it on a grill

you would put fish in pan and keep it over a fire

burn it and smoke it

make it very hot and it will smoke

people open it up and put smoke in it

light it and put it in your mouth

you smash up the meat or fish put it in the pipe
and light it

We were particularly interested in the last two responses. In a preliminary analysis of this item, one of us had ended his

speculations on how children might assimilate the passage to their concept of 'smoking' by asking: "Will some children imagine a frankfurter lighted like a cigar, or a pipe filled with chopped chicken livers?"

RAISINS

Let us now examine another item that manipulates polar terms from the temperature and humidity scales:

Raisins are made from sweet varieties of grapes. The ripe fruit is usually placed on trays right in the vineyard. There, it dries in the sun. Drying may take several weeks.

- A. Raisins are made from grapes that have a lot of

water	varieties
skin	sugar

- B. What kind of climate is best for making raisins?

warm and dry	warm and wet
cool and dry	cool and wet

From the point of view of structure, this passage divides into two parts. The first sentence tells what kind of grapes are used for making raisins. The final three sentences describe the procedure that is followed. Contributing to the sense that there are two separate parts is the nature of the cohesive chain that links grapes in the first sentence with each of the following sentences as well as the first task:

	COHESIVE CHAIN	KIND OF COHESION*
(I) Sentence 1:	grapes	
(II) Sentence 2:	↓ the ripe fruit	Lexical (superordinate)
Sentence 3:	↓ it	Reference
Sentence 4:	↓ Ø	Ellipsis
Task A:	↓ grapes	Lexical (repetition)

In order to understand the passage, a reader must realize that the 'fruit' in the second part is actually 'grapes,' that instead of repeating the word grapes, the writer has used a superordinate term. An unfortunate side-effect of this shift is that readers must switch from plural in the first part (grapes) to singular in the second part (fruit is, it dries) and then back to plural in (A) (grapes that have), while their sense of what is being referred to remains plural throughout.

Although the passage is divided into two parts, they are not related in an explicit way. That is left up to the reader. For most readers this connection will be automatic, since the passage fits neatly with the familiar discourse frame PROCESS DESCRIPTION. In terms of this frame, the first part of the passage will be taken as describing raw material, the second as describing a procedure for

*For a description of these categories, see Halliday and Hasan (1976). They would not, however, regard sentence 4 as a case of ellipsis. We have extended the term to include a situation like this, in which the reader must carry over information from the preceding text:

Drying [of the fruit/grapes] may take several weeks.

transforming this raw material. Thus, the two parts are easily related under the general theme "how raisins are made," or as it is often expressed at the elementary school level, "where raisins come from":

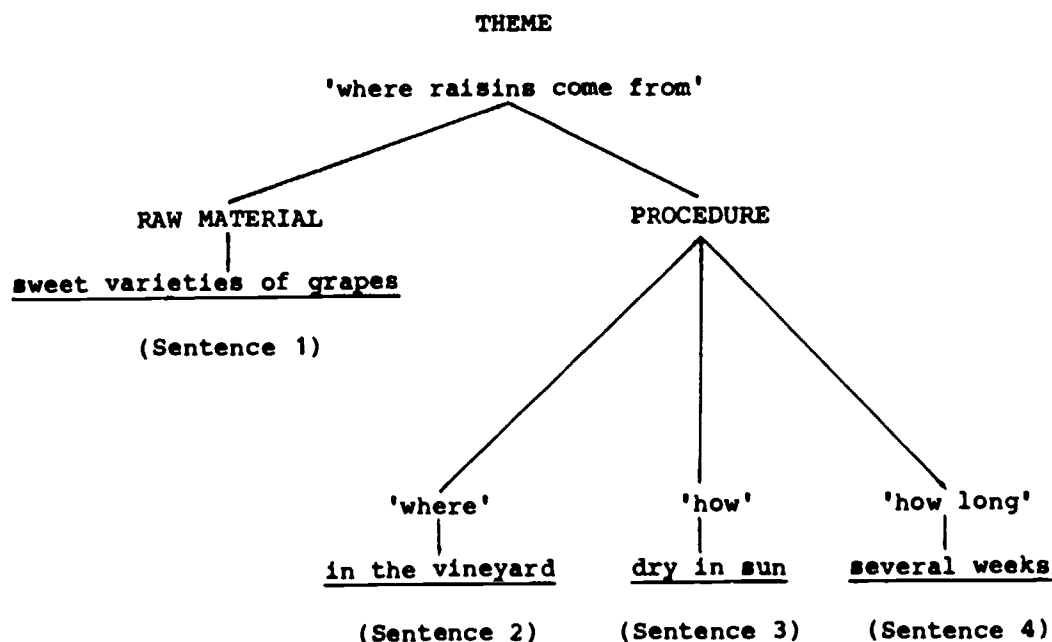

The two-part structure is also relevant to the two tasks, for (A) is based on the first part and (B) on the second. We will first discuss (B), because it is the task that deals with polarities, our major focus in this section.

In order to answer (B), a reader must decide, on the basis of the information given in the passage, which climate is best for making raisins. All four of the choices consist of a temperature term followed by a humidity term. Given this fixed ordering, all possible combinations of the terms cool/warm and wet/dry are realized, as can be seen in the following diagram:

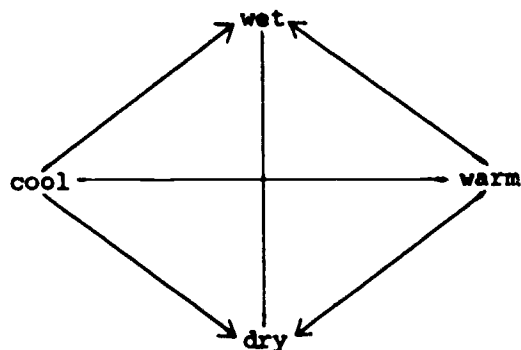

As indicated by the arrows, each term on the horizontal axis, cool and warm, is combined with each term on the vertical axis, wet and dry, to produce four pairs of terms: cool and wet, cool and dry, warm and wet, warm and dry.

We might anticipate that children would have a good deal of difficulty handling multiple pairings of opposing terms from two different scales. But such was not the case. In fact, (B) was one of the easiest tasks in our corpus. During the pilot testing, 61% of mainstream children and 57% of minority children selected the target response warm and dry; each of the three distractors was chosen by about 15%. The ease with which children did this task was probably due, at least partly, to two factors: (1) all four of the choices reflect the preferred ordering of temperature term followed by humidity term, and (2) the target response pairs warm with dry, which, as we reported in discussing BACTERIA (see p. 82), sounds more natural to the great majority of children than does the pairing of warm with wet. It is likely that their experience has led many children to establish a schema in which an increase in temperature is associated with faster evaporation, as

in drying clothes, for example.

A few children found support in the passage for warm and wet. They reasoned that since grapes take a long time to dry, the climate must be wet. Here is how one girl, a native speaker of Spanish, explained this reasoning:

Look, first I didn't understand so much so I picked [warm and] dry because of this [points to dries in text]. But then when I read it now I think--uhm--warm and wet, because here it says, "There, it dries in the sun. Drying may take several weeks." Weeks. I think weeks are very long. So, I don't think dry is very good.

This ingenious inference seems to result from a nervousness about "trick questions." It provides an example of how "test-taking strategies," whether taught or learned through experience, may turn out to be counterproductive.

When we were putting together the twenty-two items that comprised our test for children, it occurred to us that RAISINS deals with food preservation, that, in fact, it is an example of the "dry in the sun" method that is mentioned in BACTERIA (see p. 66). We decided to place it soon after BACTERIA in order to see whether there would be any carryover from one passage to the other. More specifically, we wondered whether the association that is set up between warm and damp in BACTERIA would cause children any problem in associating warm with dry in this item. Only one child mentioned the similarity between items during the interviews. Perhaps children did not think of raisin-making as a form of preservation. Probably more important was the fact that BACTERIA was so

difficult that, for most children, no relationship was established between warm and damp. It is now clear that we should have placed RAISINS--the easy item--first, and then looked for evidence that children brought in the relationship established in RAISINS when they subsequently had trouble in understanding BACTERIA. A surprise was a carry-over from RAISINS to the following item--SHOP SIGN. One child said that he pronounced sundries "sun dries" because he was thinking they might be something like the raisins in the passage he had just read (see SHOP SIGN, chap. 2, p. 00).

Although we have not turned up a great deal of evidence, we still suspect that leakage from one item to another does occur when children are forced, as they are in reading tests, to move rapidly from one discrete text to another. Some children may not understand that every item is to be considered apart from the other items. A more common source of leakage may occur when readers are in trouble, when they cannot make sense of a text. This leads to a search for further information that can be brought to bear on the problem at hand. We have given examples of how children bring in elements of their experience in surprising ways. We suspect that, for some children, a source of further information is the items that they have just completed.

We would now like to consider children's responses to (A), which turned out to be a considerably more difficult task than (B). During the pilot testing, the target response sugar was selected by only 14% of mainstream children and 17% of minority children; the

major distractor was varieties, selected by 60% of mainstream children and 45% of minority children. Let us first consider children's difficulty in selecting sugar, before we discuss the possible reasons for their attraction to varieties.

In order to select sugar, children must be able to see that the words following Raisins are made from both in the passage and in the target proposition for (A) have the same referent, that they are different ways of talking about the same thing:

SENTENCE 1

TASK A

Raisins are made from

Raisins are made from

sweet varieties
of grapes

=

grapes that have
a lot of sugar

One difficulty in establishing the relationship between 'sweetness' and the 'presence of sugar' may be that the word sweet is understood too broadly as a general term of approval.* This may be encouraged by its low profile in the passage; the text doesn't even directly state that the grapes themselves are sweet but rather that the varieties are. Here is what one child said when he was asked what sweet means:

*Even when it refers to taste, sweet is not always connected with sugar: butter is sweet when it has no salt in it; milk is sweet when it hasn't turned sour. Sweet is used to describe other kinds of sensation as well: air can smell sweet, music can sound sweet, little girls can look sweet, and things like 'success' can even feel sweet.

--Tastier.

--How do things get sweet? If you had some food that wasn't sweet enough, what would you do?

--Add salt or something like that.*

In considering the connection between 'being sweet' and 'containing sugar,' we can note certain trends in the culture that tend to break down this relationship. Sugar has gained a bad reputation: it contributes to tooth decay, it encourages obesity, and it may be implicated in a host of other ills. Yet it is hard to do without sweetness. Nonsugar sweeteners make it possible to solve this problem, to have 'sweetness' without 'sugar,' and food products that taste sweet are widely advertised as being "sugar-free" or having "no sugar." A related development is the concern about products that contain "hidden sugar." These products don't taste sweet, yet they contain a surprising amount of sugar.

*This child's idea of sweet is surprising, but it is not difficult to see how he has arrived at it. From all the contexts in which he has encountered the word, he has generalized that it refers to a taste that is "good" in some way rather than one that is specifically associated with sugar or honey. When food doesn't taste quite to one's satisfaction, a common solution is to put salt on it. This is likely to give it a "good" taste, or, from this child's point of view, a "sweet" one. Research in idiosemantics turns up numerous discontinuities of this sort. Words that are used to talk about sounds, smells, tastes, and feelings (both physical and psychological) are especially likely to develop such idiosyncratic meanings. They don't occur frequently enough in contexts that support precise, mutually verifiable discriminations. In contrast, our experience usually does enable us to achieve fairly uniform meanings for words that refer to visual concepts. It is of interest that a number of languages have one word for visual sensation and another that covers other kinds of sensations.

Consumer worries about hidden sugar are allayed with such slogans as "all natural, no sugar added."

All of this concern with sugar contributes to the idea that it is a manmade additive, one that is prototypically associated with the white, crunchy stuff that is sprinkled over food or stirred into beverages. If one thinks of sugar only in this way, it is difficult to see how it can get inside the skin of a grape. Clearly, completing (A) successfully depends upon having a more generic understanding of the word sugar, namely, one in which it is seen as a chemically defined substance that may be present in natural products as well as refined ones.*

Thus, the difficulties that prevented many children from selecting sugar seem to have been largely developmental. They had concepts of sweet (too general) or sugar (too specific) that were not sophisticated enough to establish the necessary relationship between these two terms.

As we have already mentioned, most children ended up selecting varieties. This choice results in the following proposition:

Raisins are made from grapes that have a lot of varieties.

*One child who was knowledgeable about both sorts of sugar was upset with the passage because it seemed to him to ignore this vital distinction:

I wasn't sure about the first question. Because sugar could be natural or--uh--refined sugar. So I put sugar because it said "sweet." But, I mean, it could be natural sugar--they should've said natural or refined sugar.

In our interviewing, we found that only a few children are bothered by this sentence. This includes those who seemed particularly sensitive to language and who used their sense of syntactic deviancy as a tactic in making their choices in other items--rejecting These bridges are hung, for example, because it didn't "sound right" (see HUNG BRIDGES, p. 33). We are evidently dealing here with a syntactic constraint that most children of this age have not learned, but it is difficult to specify its exact nature. We might, however, notice the following parallels:

The seeds of grapes are numerous.

The varieties of grapes are numerous.

Grapes' seeds are numerous. *Grapes' varieties are numerous.

Grapes have numerous seeds. *Grapes have numerous varieties.

Grapes have a lot of seeds. *Grapes have a lot of varieties.

The reason that varieties cannot go through the possessive transformations (phrasal genitive, attributive genitive, have genitive) in the same way that seeds can is that the underlying relationship between grapes and varieties is existential:

There are a lot of varieties of grapes.

We might also point out that it is possible to devise a situation in which a combination of have and a lot of varieties would occur naturally:

--Where's the best place to buy grapes?

--Oh, the fruit stands on Broadway have a lot of varieties.

Interacting with this syntactic problem is confusion about what the word varieties means. By the fourth grade, children tend to be familiar with this word. They may, however, confuse its different senses: 'type,' 'assortment,' and 'diversity.' These senses are so closely related that it was often difficult during the interviewing to tell whether a particular child didn't know all these senses or was just unable to decide which one was suitable in this context. Here is what one ten-year-old girl said when asked what the word varieties means:

--It means different kinds.

--And why did you choose the word varieties?

--Because I thought that raisins could be made out of--like every kind of grape.

This child seems to be thinking of variety as 'assortment' instead of as 'type.' In the following interview another young girl seems to be operating with variety as 'diversity':

--Okay. What are varieties?

--A lot of mixtures.

--Could you say that all grapes have varieties?

--No.

--Why not?

--Because all grapes don't have all kinds of mixtures.

--I don't really know what you mean by mixtures of grapes.

--They don't have a lot of things added into the grapes.

--I see. So varieties are things that are in the grapes?

--Mhmm.

--Now if you had a bunch of grapes, would they all be the same or would they--

--Sometimes they'd be different.

This child seems to be interpreting varieties as somehow referring to the mixture of ingredients that might be inside a grape, and evidently the grapes that are used for raisin-making are those with a sufficient number of internal ingredients.

It should perhaps go without saying that an important reason why varieties was so often chosen is that in the context of sugar, water, and skin it is the least known item. In addition, it is abstract and somewhat learned and so seems like an appropriate response to a test item.

ICEBERG

In the polarity items that have been presented so far, the opposing categories have been explicitly named, if not in the passage, at least in one of the tasks. There are other items in which only one member of a set of opposing categories is referred to, yet the reader has to work with both parts of the opposition in order to respond to the tasks successfully. We will consider two of these items, beginning with one that is concerned with natural phenomena:

An iceberg is a large chunk of frozen fresh water that floats in the sea. Most of the iceberg is below the surface. Just the top part is visible.

A. Icebergs are made mostly of

sea water	fresh water
salt	rock

B. Most of the iceberg is

hidden	visible
surface	top

The first sentence states that an iceberg is frozen fresh water and that it floats in the sea. This information may be surprising to readers, since it runs counter to the common-sense assumption, based on an iceberg's surroundings, that it consists of frozen sea water. However, the passage does not pause to explicate this apparent contradiction, to explain "where icebergs come from." Instead it proceeds to give another surprising fact about icebergs:

most of an iceberg (actually 87-90%) cannot be seen, because it is under the water. In contrast, most children think what they can see of a floating object is the major part. Again, there is no attempt to remove a quandary through further explanation. Thus, we might think of this passage as iconic with its subject: only the tip of the information it deals with is actually visible.

(A), which is based on the first sentence of the passage, is a simple recycling task, and during the pilot testing over half the children selected the target response fresh water. About a third, however, chose the distractor sea water. In thinking about how this task works, it is useful to compare the target proposition for (A) with its source in the passage:

SENTENCE 1: An iceberg is a large chunk of frozen
fresh water . . .

TASK A: Icebergs are made mostly of fresh water.

The two versions are clearly not equivalent. First, the passage says that an iceberg consists of "frozen water," that is, it is made of ice, while the target proposition says that it is made of water. Second, the passage says that an iceberg is frozen fresh water, while the target proposition says that it is mostly fresh water, implying that it also contains other ingredients. Children who are anxious about "trick questions" sometimes fasten on discrepancies such as these. For example, one child who picked sea water equated mostly in (A) with most of the iceberg in the second sentence in the passage. His reasoning seemed to go something like this:

The part of an iceberg that floats [the part that can be seen] is made of fresh water. The other part, the larger part that can't be seen, is sea water. QED, an iceberg is made mostly of sea water.

In order to achieve a better fit between passage and task, the task stem might be recast as follows:

Icebergs are made from _____.

The substitution of from for of makes clear that an essential process--namely, freezing--intervenes between water and its presence in an iceberg.

Another variation between the target proposition for (A) and its source in the passage is the way in which they indicate that their subject is generic rather than particular: the passage refers to an iceberg, while (A) refers to icebergs. In between these two generic references, however, is a non-generic one. Most of the iceberg in the second sentence of the passage necessarily refers to a particular iceberg. This unmotivated shift, which is repeated in (B), weakens the coherence of the item considerably.

The opposing categories that can be found in this item are illustrated on page 101. Those that are referred to specifically in the passage are given in capital letters; those that are only mentioned in one of the tasks are underlined. Opposing categories that the reader must infer from the text are given in small letters.

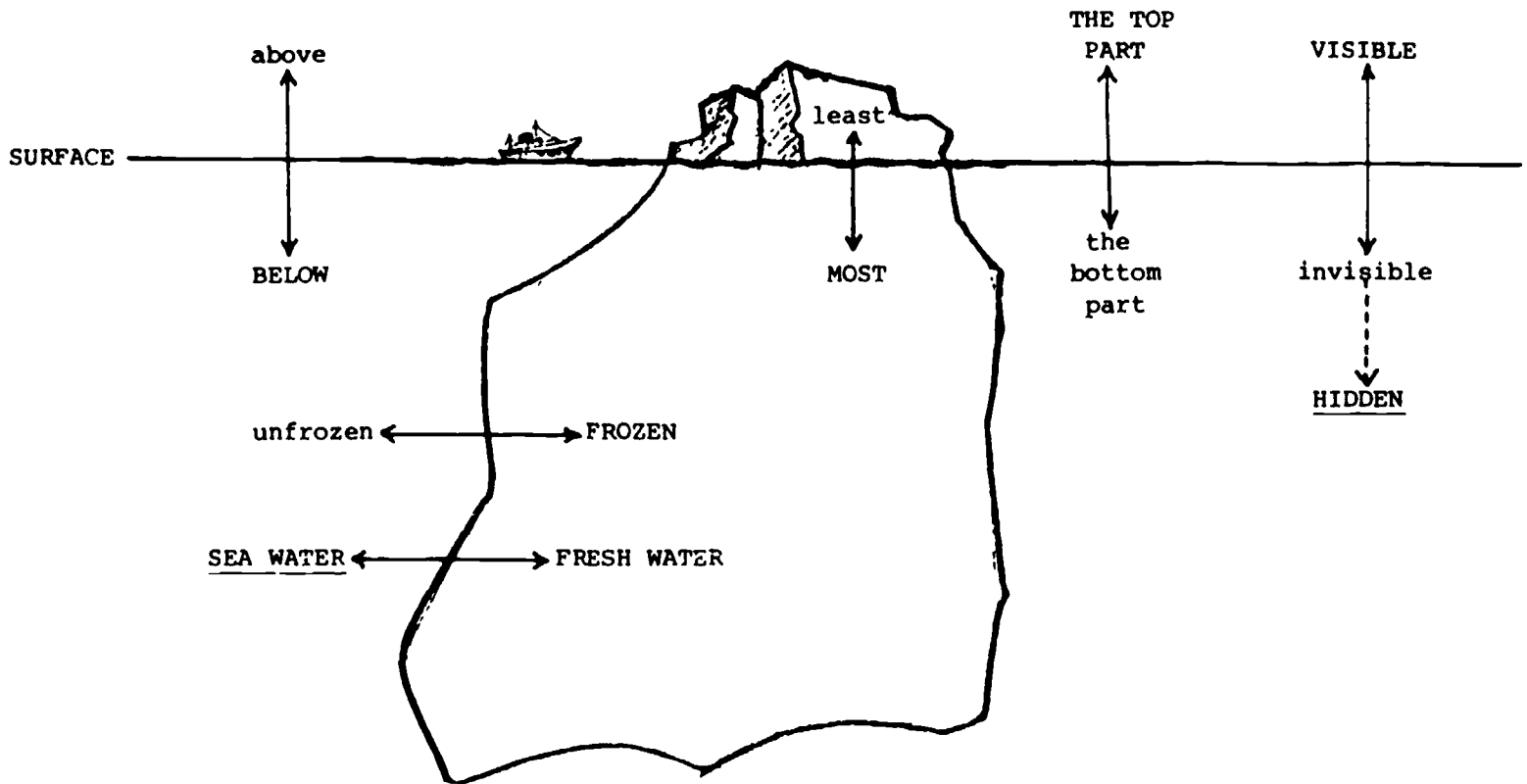

Two of the oppositions in this item are relevant to (A):

FROZEN \longleftrightarrow unfrozen
FRESH WATER \longleftrightarrow SEA WATER

From one point of view, answering (A) is simply a mechanical operation, one requiring neither previous knowledge nor even any knowledge gained from the passage. As a practical matter, however, it is probably necessary to have the framework suggested by the above oppositions in order to see that recycling is what is called for. In other words, to complete this task easily, children probably need to understand (1) that water and ice are different forms of the same substance, and (2) that there are important differences that distinguish water in the sea from other water. Otherwise it may be difficult to see that it is all right to regard frozen fresh water and fresh water as equivalent, and to ignore the fact that the verb used in the task--made--is so much more active-sounding than the is that appears in the passage.

Four of the opposing categories represented on page 101 are relevant to (B). Two of these are mentioned in sentence 2 and two in sentence 3. In order to make any further headway toward responding to (B), the reader must realize that these sentences divide the iceberg into two parts and that sentence 2 refers to one part and sentence 3 to the other. The information that is presented about the two parts is displayed in the following table:

KIND OF INFORMATION	FIRST PART (Sentence 2)	SECOND PART (Sentence 3)
proportion	MOST	
location	BELOW	
orientation		TOP
sensory status		VISIBLE

To proceed beyond this point, the reader must infer from the partial opposition between below and top (indicated with an arrow in the table above) that the two parts of the iceberg are being presented in opposing terms. Once this inference has been made, it is possible to fill in the "holes" in the above table, producing the following:

KIND OF INFORMATION	FIRST PART (Sentence 2)	SECOND PART (Sentence 3)
proportion	MOST	less
location	BELOW	above
orientation	bottom	TOP
sensory status	invisible	VISIBLE
	↓	
	<u>HIDDEN</u>	

It is now possible to evaluate the choices in (B). None of the words listed is in the first-part column above. Hidden, however, expresses sensory status, and is a synonym of invisible, one of the words in the first-part column. In order to align all these oppositions accurately, it is probably also necessary for the reader to

realize that the dividing line between the two parts of the iceberg is the surface of the sea, and further, that it is impossible to see under the surface.

In the pilot testing, somewhat over a third picked the distractor visible; somewhat less than a third selected the target response hidden. The rest were divided between surface and top, with mainstream children favoring the former and minority children the latter.

In addition to working with multiple oppositions, readers of ICEBERG must negotiate two structural ellipses that require them to retrieve information across sentence boundaries:

- (1) below the surface in sentence 2 must be expanded to below the surface of the sea by retrieving information in sentence 1
- (2) Just the top part in sentence 3 must be expanded to Just the top part of the iceberg by retrieving information from the previous sentence

Although these ellipses may appear inconsequential, they can be confusing to inexperienced readers. Some children interpreted below the surface as meaning 'below the surface of the iceberg.' The passage focuses so exclusively on an iceberg that it is understandable that young readers may not realize that there is more than one thing involved that can have a surface. It was difficult, however, to keep track of how, once this misunderstanding

had occurred, they proceeded. Here is how one young girl explained her choice of the distractor visible:

--It says, "just the top part is visible."

--And that tells you that most of it is visible?

--Yeah, because it says that the top, and like most of the top could be visible.

Another child who selected visible was blocked from selecting hidden because she was convinced that if the larger part of a floating body was under the water, it would necessarily keep sinking down and eventually disappear. It appears that many children of this age may share this misconception, one which, as far as we know, has not been precisely delineated within the Piagetian scheme.

When we asked a group of 25 fourth graders to draw a picture of an iceberg, 19 drew only the part above water; of the remaining 6, 4 drew the part under the water smaller than the part above, and only 2 drew it bigger. We then asked two more classes to draw a picture of an iceberg, but this time we added, "Be sure to include the part that is under the water." Out of 39 children, 16 drew the two parts about the same size; 15 made the top part larger; and only 8 made the part under the water larger.

Certainly most readers have no difficulty in understanding that the other elliptical expression--the top part--refers to the iceberg, but it is not at all clear just which part of the iceberg

they understand as being the top. Readers are expected to oppose this information to below the surface in the preceding sentence and interpret it as 'that part which is above the surface of the sea.' But since the preceding information is expressed elliptically, they may become confused and interpret it as (1) the very tip of the iceberg, (2) the part above the water, or (3) the top half, either with reference to (a) the entire iceberg or (b) the part that is visible. These four possibilities are indicated in the following diagram:

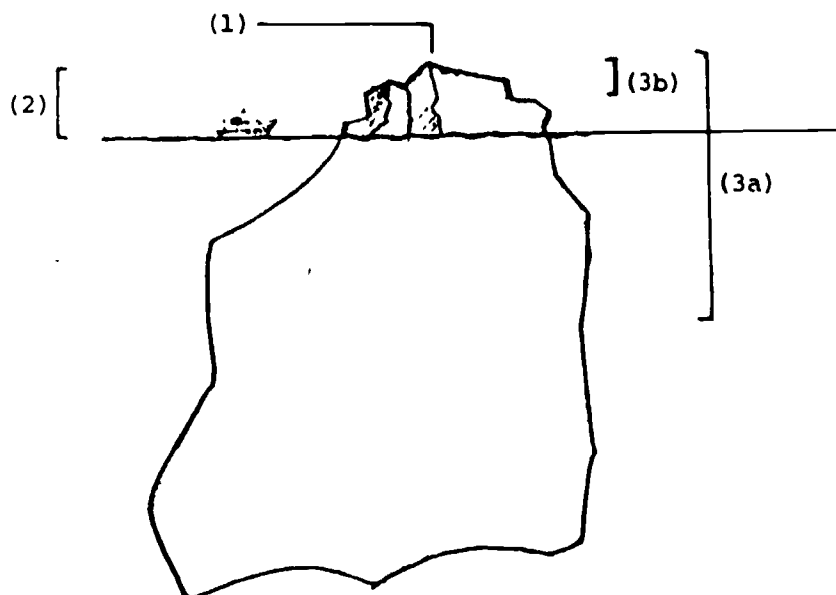

Our analysis of this item would indicate that it is quite difficult, yet children did relatively well on it, with over half being successful in (A) and almost a third in (B). The explanation may be that children were able to work with a good deal of real-world knowledge. During the interviews, a number of children described how they used such knowledge. One girl, for example, said:

3-106

Well, I didn't have to read the paragraph for this one because there was an article in my Cricket magazine about it.

Two boys who were not native speakers of English chose the target response entirely on the basis of real-world knowledge. We can say this with some confidence because the interviewing demonstrated that they did not know the meaning of either visible or surface. The source of their reading power was a recent viewing of the movie Raise the Titanic. One of these boys also mentioned that his father had told him "all about icebergs." It was evidently a subject of great interest to him. According to the interviewer, "I couldn't have held him back if I had wanted to. He went wild and started drawing sharks in the water and really became involved in the situation." Here is the drawing he made after reading this pared-down item:

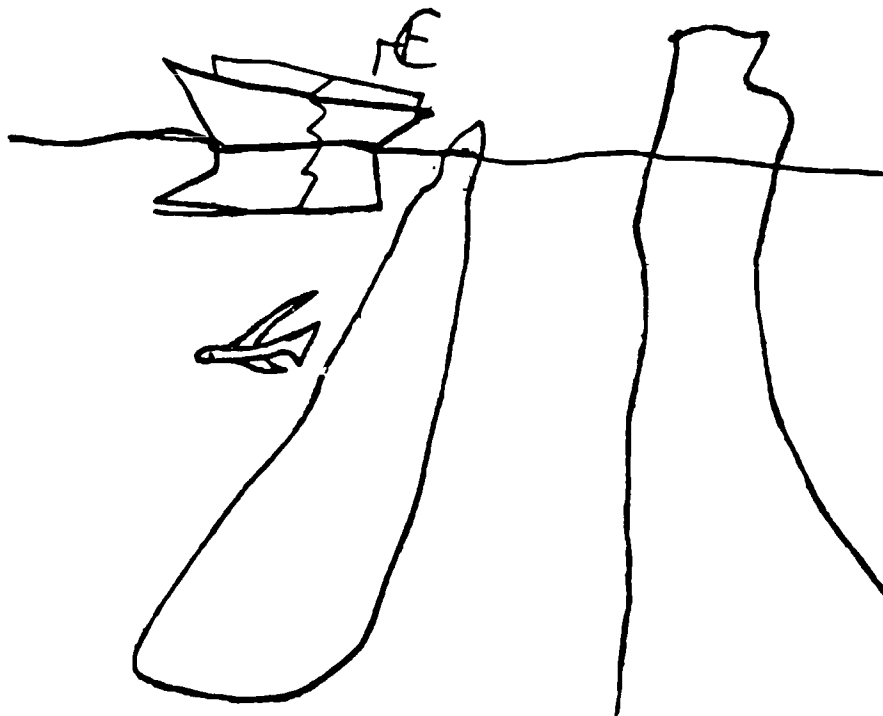

3-107

Notice how much contextualization he has provided for an iceberg that has been presented to him in a generic way: not just one iceberg, but two, with considerable emphasis on how much is hidden under the water; the Titanic with a fissure running from top to bottom; and even a rather benign-looking shark.

One striking feature of polarity items is the way they combine a high cognitive load with limited textual space. The oppositions that they contain and the kinds of inferences that they require are not unusual in themselves, but in the real world, we would expect to find them distributed over much larger expanses of text. ICEBERG provides a remarkable example of this compression. In just 29 words it implies six sets of opposing terms, and all of these oppositions must, in principle, be activated in order to complete the tasks successfully. If one knows something about icebergs, these brief references can be fitted easily enough into pre-existing frames. In fact, it is difficult for someone who has these frames in mind even to imagine the problems that this item poses to readers who do not have them. In our analysis we have tried to give some sense of this by displaying the great number of connections that this item requires a reader to make.

GEORGE WASHINGTON BRIDGE

Let us now consider the other item which, like ICEBERG, forces the reader to work with opposing categories that are not overtly realized:

The George Washington Bridge, completed in 1931, spans the Hudson River between New York and New Jersey. The plan for the bridge called for stone coverings over the two towers. But the steel structure itself was beautiful, so the towers stayed as they were.

A. In this story, "called for" means

picked up	telephoned
realized	required

B. The finished towers are made of

stone	steel over stone
steel	stone over steel

At first glance, this passage appears to be easier to understand than ICEBERG. It too consists of three sentences, but they are more fully developed. Moreover, the relations between them are more explicit. Sentence 1 provides spatial and temporal information as an orienting frame for this bit of narrative about the construction of the George Washington Bridge. Sentence 2 tells what materials were planned for in constructing its towers, and sentence 3 provides the reason for a departure from this plan. On the surface, the relationship between sentences 2 and 3 seems to be effectively rendered. The adversative connective but initiates sentence 3, signaling that some piece of information in

the sentence will contrast with what has come before. The word steel then plays against sentence 2's stone, with stone describing the covering that was planned and steel the structure that was actually built.

Despite these overtly signaled contrasts, most children seemed to lack the larger framework that would support an appropriate understanding of the passage. They needed to be aware of two further contrasts not overtly signaled: (1) the contrast between 'plan' and 'execution,' and (2) the contrast between 'structure' and 'ornament.' To make the larger framework of the passage explicit, these underlying contrasts can be used to create a four-cell matrix, which can then be filled in with stone and steel, the words that carry the overt contrast:

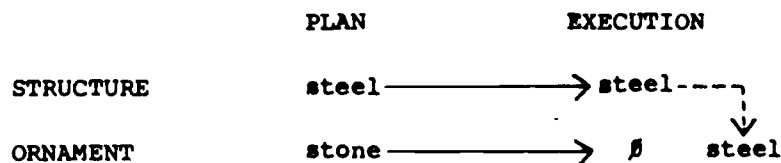

As indicated by the solid arrows, the plan for the steel structure was executed, but the one for the ornamental stone covering was not. The reason is given in sentence 3: once the steel structure was in place, it was considered beautiful and so the stone was not added. In the diagram the dotted arrow is used to indicate steel's takeover of stone's ornamental function. It is worth noting that the contrast between 'plan' and 'execution' is more overtly realized than the one between 'structure' and 'ornament,'

with the former signaled by the but-relation between sentence 2 and sentence 3. The latter contrast is merely suggested by the word covering and by the reference to an esthetic criterion, and many readers seemed unable to use these cues. A number of them thought of the stone as integral to the support system of the bridge; we will shortly describe how this affected their response to (B).

As is often the case with a polarity item, one task deals with the content of the passage, the other with vocabulary. (A) represents a typical pattern for a vocabulary-defining task: a more frequent sense of a vocabulary item is given in a distractor, while the target response represents a less familiar sense that fits with the passage. (A), in fact, included two distractors--picked up and telephoned--that are more familiar than required, the target response. One nine-year-old girl who selected required was, however, uneasy about her choice. She claimed that it does not accurately represent the way called for is used in the passage. The flavor of her reasoning is conveyed in the following exchange:

--In this story, called for means--well, I don't think required is a very good word, but it was the closest to the one that I think would fit.

--What's that?

--. . . The planner of the bridge asked for [the underlined words are pronounced with heavy stress] stone coverings over the two

towers.

--Uh-huh.

--Because required is not a good word. Because they could change plans. Because, well, it is sort of like a command; that's the final thing; this is what's going to happen.

--And what would happen if you didn't include the stone covering?

--Well, I don't know. Plans would get all messed up. They would have to change the plans or something, or somebody would sue somebody, and there would be a big problem. . . . Required isn't a really good word because a lot of architects change their plans in mid-building.

We will begin our discussion of (B) by observing that, like its counterpart in RAISINS, its four completers all manipulate contrasting words. In this case, the construction materials, stone and steel, are first presented alone and then combined in opposing ways (stone over steel and steel over stone). Here are the results of the pilot testing:

	MAINSTREAM	MINORITY
stone	26%	35%
steel	30%	38%
steel over stone	17%	8%
stone over steel	27%	19%

3-112

Notice that on this task a higher percentage of minority children than mainstream children selected the target response. It is also interesting that mainstream children were more attracted to the distractors that contain pairs of terms. Before commenting on these results, let us first discuss some of the inherent complexities of this task.

During the interviewing we discovered that children experience three major comprehension gaps in this item:

- (1) a failure to understand that the steel structure is to be associated with the two towers
- (2) a failure to understand which part of the bridge the word towers refers to
- (3) a failure to understand that (B) is concerned with the towers as 'executed' rather than as 'planned'

Any one of these failures is sufficient to disorient a child, but working together, they lead to so much confusion that a child's response becomes largely a matter of guesswork. Let us take a look at some of the reasons for these gaps.

In order to link the steel structure with the two towers, readers need to establish the following cohesive chain within the passage:

SENTENCE 2:	the two towers	
SENTENCE 3:	the steel structure	(clause 1)
	the towers	(clause 2)

This linkage is difficult to establish on both formal and functional

grounds. From a purely formal perspective, the shift from singular to plural seems to have weakened the link for many children.

How can towers be a single structure? We may further note that repeating towers in sentence 3 may have alleviated the need for linking towers and structure: it is as though the linkage, having been made at one point, is not necessary at the other.

From a functional perspective, it is not clear what the steel structure refers to--the entire bridge, the suspended horizontal span, or only the two towers. Readers cannot, strictly speaking, decide purely on the basis of the passage. If they turn to their real-world knowledge, they are likely to think of the steel structure as constituting the entire bridge. If the towers are perceived as part of the bridge, such indeterminacy need not in itself be confusing, yet we have found that it often is. The very fact that a bit of information floats can give children the sense that they are failing to understand something that they should; and this sense can lead them to doubt whether they have understood even that which seems to be clear. In effect, a single indeterminacy can cause an entire text to wobble.

Not only do children fail to link steel structure and two towers appropriately, they fail to identify which parts of the bridge two towers refers to. This failure is understandable, given that (1) tower is a word that can represent a number of different entities, and (2) it is not a word frequently used in connection with a bridge. To find out how children might handle these problems, we carried out a number of probes. To begin with, we asked 30 children

in a suburban school what they think of when they hear the word tower. Nearly all of them mentioned some kind of building, many making reference to the World Trade Center in lower Manhattan, which is often called the "Twin Towers." In describing the characteristics of a tower, most used the modifier tall, some used big, and a few used round or circular. Moreover, a number of children characterized it as a high place, using expressions like

look out place

a tall gall

a thing that sort of sticks up alone

something on top of a building

We also asked 30 children in a Manhattan school to draw a picture of the George Washington Bridge. Many of their drawings reflect quite accurate perceptions of the bridge: for example, the first one on page 125 represents four of the bridge's most salient features: (1) the presence of two towers, (2) a criss-crossing pattern in the towers, (3) multiple cables that hang parallel to the towers, and (4) the two levels of roadway.

After they had completed their drawings, we asked them to draw a circle around the part(s) that could be called a tower. Nearly all the children were reluctant to complete this second step: they claimed that they didn't think of any part as a tower. Some claimed that bridges cannot have towers, since towers are really, as it was variously put, "monuments," "tall buildings," or "places

to store water." Nevertheless, 25 of the children did eventually circle various parts of the bridges that they had drawn: 13 of them circled the very top of the bridge (for examples of "bird's-nest towers", see pages 125-128); 8 circled a structure rising from the roadway (for examples of "flagpole towers," see pages 129-132); and only 2 circled the structure that is, in fact, the tower, one that rises from the river bed up past the roadway (for these drawings of "real towers," see pages 133-134). We should also note that certain children, responding to some image associated with tower, actually inserted various tower-like shapes into the drawing (for examples of "stuck-in towers", see pages 135-138). As we observed in the use of smoked in BACTERIA (pages 83-85), the prototypical meaning of an individual word can exercise considerable power over children's imagination, causing them to resist its absorption into an unfamiliar context.

We also asked a group of 30 adults in Manhattan to draw a picture of the George Washington Bridge. In general, their drawings were much less detailed than those of the children. Here, for example, is how one person responded to the task:

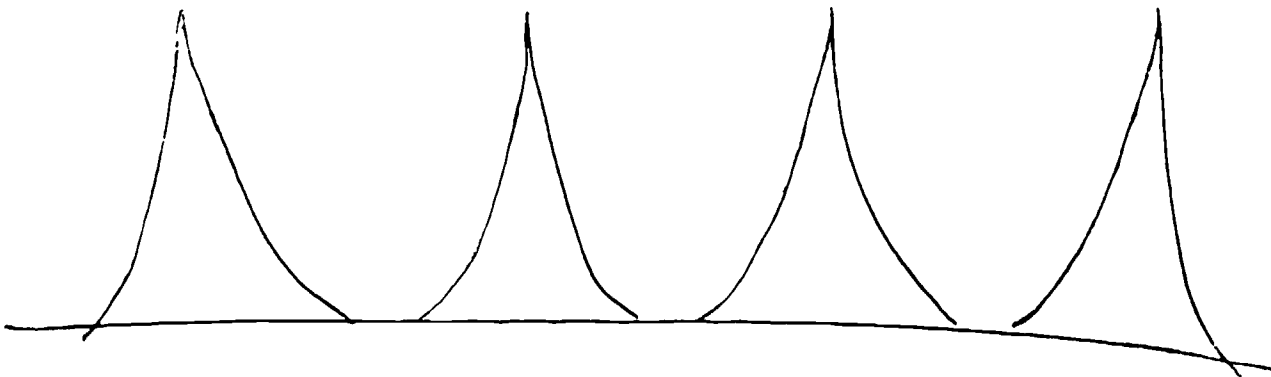

3-116

Many adults were embarrassed by their drawings, making comments like the following:

I don't know what it looks like. I drive by it on the West Side Highway twice a day to and from work.

I drive by it everyday and have no idea.

For the drawings that these two people made, see page 139.

We also asked these adults to respond to two questions:

- (1) What is the name of the support structures for the bridge?
- (2) How many of these support structures are there?

In responding to (1), only one person used the word tower. It turned out that this person had once taken a course in bridge design (see the top of page 140 for his drawing). In responding to (2), only 6 thought the George Washington Bridge has two support structures. Many claimed that the bridge has 6 or even more of these structures (see the bottom of page 140 for the drawing of someone who claimed that it has 12). We can think of several factors that might help to account for the greater detail in the children's drawings. For one thing, they practice drawing more. It would also seem, on the basis of the drawings that we have examined, that they are better observers of the real world. It is also possible that their memories are less cluttered and that they have more access to their store of visual experience, perhaps due to the fact that they depend less on print for getting information.

Let us now turn to the third gap--children's failure to understand that (B) is concerned with the towers as executed rather than as planned. In order to understand this failure, we need to examine more closely the temporal framing of the passage. The initial sentence is set in the present (The George Washington Bridge . . . spans . . .), leading the reader to think of the bridge as it is today. The rest of the passage, however, uses only the simple past tense, even though at least three points can be distinguished in a temporal sequence:

VERB	POINT IN A SEQUENCE
SENTENCE 2: <u>called for</u>	time ¹ : prior to bridge construction
SENTENCE 3: (Clause 1) <u>were</u>	time ² : <u>immediately</u> subsequent to bridge construction
(Clause 2) <u>stayed*</u>	time ³ : subsequent to bridge construction

This formal leveling of temporal sequence in sentences 2 and 3 may have led inexperienced readers to blur the distinction between 'plan' and 'execution.' Hence in approaching (B), they may not have framed the task as concerned with time³ rather than time¹. Two features in the task stem itself may have contributed to this blurring: (1) the use of finished to modify towers, and (2) the use of present tense.

*Stayed suggests a certain volition that could have been avoided with a verb like remained (i.e., the towers remained as they were).

The modifier finished is, of course, intended to identify the towers as they were actually constructed (i.e., made only of steel). From the vantage point of the plan, however, the towers can be viewed as still unfinished. In a finished state, the towers would have consisted of stone over steel. Readers presumably had greater access to the 'plan' frame by virtue of the use of present tense in the task stem. Such tense marking can be interpreted as neutral, allowing a reader to supply whatever temporal frame is motivated by other discourse features. We should observe that, generally, a content-oriented task that follows a narrative passage reflects past-tense marking (see chap. 4, pp. 10-11). Certainly such marking would have provided sharper focus on the state of the towers at the time they were built. The use of present tense in this task is, no doubt, motivated by the fact that, even today, the towers consist only of steel. This present relevance also serves to key the task to the opening statement of the passage.*

We have deliberately refrained from discussing how children's real-world knowledge may have affected their response to (B). Most of the children we interviewed live in metropolitan New York and so could be presumed to have some idea about how the bridge actually

*From time to time, we have noticed the effects of one task upon the other. As a vocabulary-defining task, (A) necessitates present tense; and this marking may have exercised some influence upon the choice of tense for (B).

looks;* and, in fact, during the interviews a number of children did talk about how such knowledge affected their responses. Let us examine a discussion that involved two boys. The interviewer begins by asking them how they got the answer steel:

M --Well, I drive over the bridge every other weekend.

--Imagine kids in Omaha, Nebraska, who have never been on the George Washington Bridge.

They might get a question like this, too.

You think they'd be able to answer it?

M --No. They'd be--they wouldn't know.

P --Yeah, it says it in the paragraph.

At this point the two boys begin to argue about whether Omaha kids would be able to answer (B) purely on the basis of the passage (they were both talking at once and so what they said was difficult to transcribe). Finally, the interviewer breaks in with the following question:

*In a primary school about 25 miles from New York City, 25 children made the following responses to a pair of questions about the bridge:

- (1) Have you ever seen the George Washington Bridge?
(all answer yes)
- (2) What is the George Washington Bridge made of?
(all mentioned steel, iron, or metal--some also mentioned materials such as cables, concrete, and asphalt)

--You don't think they could get the answer
from what's here?

M --No.

At this point, P begins to give way a bit, conceding that the passage does lack details and so may be difficult for the child lacking real-world knowledge:

P --You should put in more, like you should say:

"They were putting stone over the steel
skeleton on the bridge first."

M is not prepared to make a similar concession. He persists with this point:

M --But if we were going to answer the question--

say they [the kids in Omaha] have the
Scarlet Red Bridge, or something like that.
How would we answer? We don't know anything
about it.

P --Yeah, we have to answer about the Golden
Gate Bridge.*

The interviewer decides to recycle the question of real-world knowledge:

--So, you think you really have to know the
bridge to answer the--

*A reference to HUNG BRIDGES (see p. 33).

P knows where the question is going and so, once again, makes the point that the passage lacks detail:

P --Yeah, but you should really put in more details.

He then analyzes the passage, showing how difficult it is to extract the needed information. He concludes:

P --So it would be a fat chance. If somebody doesn't notice that, they wouldn't get it right.

Listening to P's concession, M asserts his initial point:

M --It's a New Yorker's test.

And P counters, again seeking the middle ground:

P --Well, New York Stater's.

We have quoted at some length from this interview because P establishes effectively the point that we have emphasized throughout our analysis of polarity items: a passage involving multiple sets of opposing categories needs a good deal of supporting detail if readers are to be in a position to understand these categories.

Although we concur with P's evaluation, we do not concur with M's that real-world knowledge necessarily leads to the target response. We would like to cite three separate cases where the knowledge either had no effect or was positively misleading. Let

us begin with a child whose bedroom window looks out on the George Washington Bridge, but who still chose stone over steel. He apparently did not care whether his response was congruent with his real-world knowledge, showing more concern that his response encompass as much information in the passage as possible. He seemed to feel some need to choose an answer that included stone and steel, simply because they were both present in the passage.* On many of his responses to other tasks he showed the same inclination to account for as much passage information as possible.

Let us consider the case of a young girl who chose steel over stone, even though she passes the bridge frequently and knows that it is made of steel. She explained that only its "outer covering" is made of steel and that underneath is "solid stone," adding that towers are always made of stone so that they will be strong. In the schema constructed by this girl, the builders had planned to add even more stone to hide the steel covering and to make the bridge even stronger. But since the steel turned out to be beautiful, they decided not to do so. We might note that this interpretation is not actually contradicted by any of the passage information. Moreover, it is congruent with the familiar notion that a tower is an object made of stone. When we asked 30 children to describe what a tower is made of, nearly two-thirds responded with stone or a stone-like material such as bricks or concrete.

*A number of children--particularly mainstream--seemed to select one of the compound responses for the same reason. It is as though they were seduced by the opposing categories in the passage and so felt that their response should incorporate an opposition.

Finally, let us examine the response of a young girl whose real-world knowledge actually misled her. Each day she rides to and from school on the Henry Hudson Parkway in Manhattan. At the point where she passes underneath the George Washington Bridge, massive stone bulwarking undergirds the approach to the bridge. As she looks up, she can see the steel of the bridge looming above this stone. It is apparently this image that she had in mind when she selected steel over stone (i.e., steel supported by a stone base). The manipulation of steel over stone and stone over steel may have encouraged her to shift from the sense of over as used in the passage to the sense 'higher in vertical space.'

Let us end with an observation that applies to all the polarity items. We have often resorted to diagrams and pictures in discussing these items, and we have noticed that a number of children who do well on such items have the same technique. This seems to help children properly align the various bits of information that are necessary for completing these tasks, and so we would like to suggest that all children be encouraged to resort to pencil and paper when they encounter such tasks.

3-125

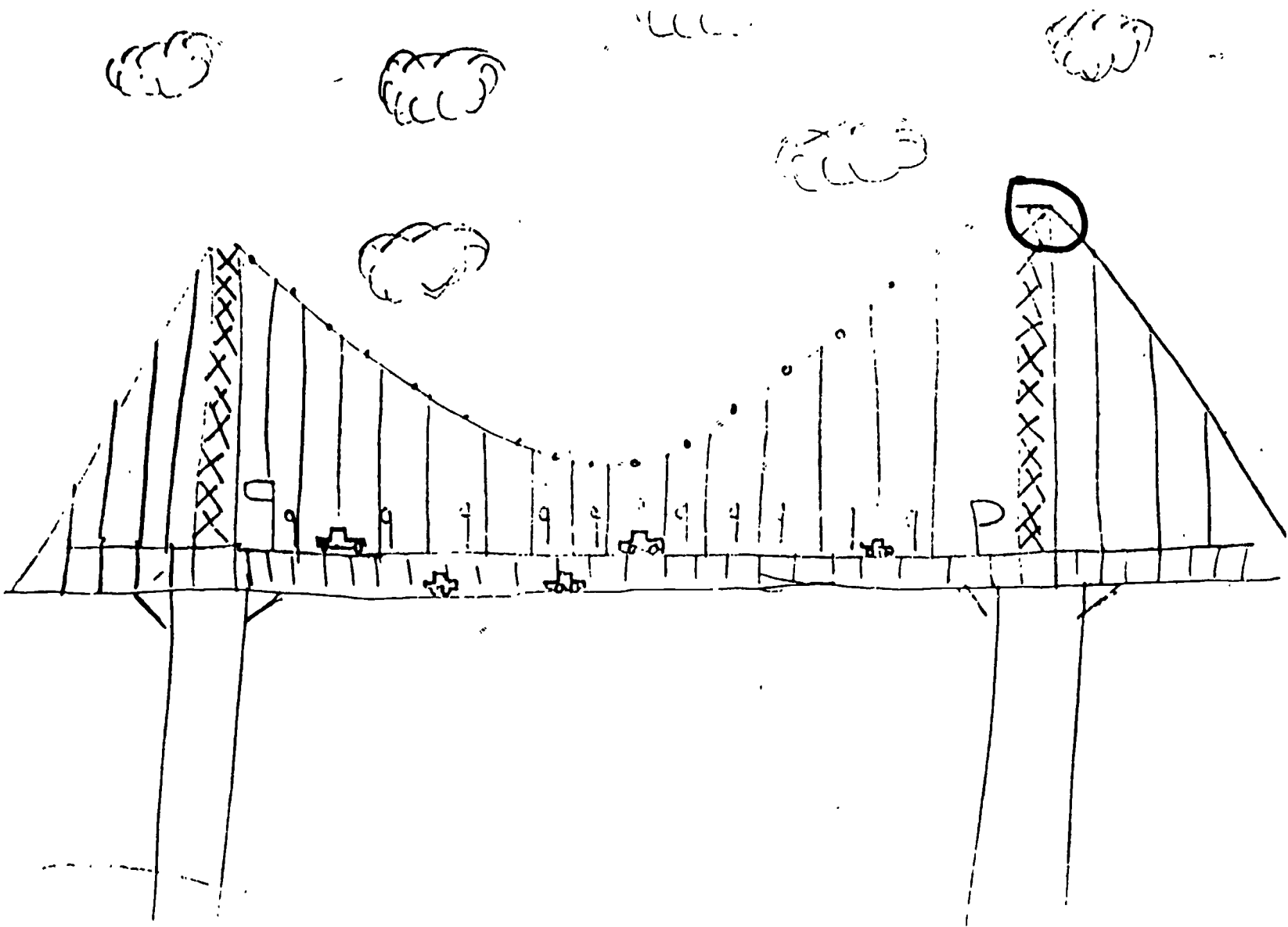

Gorge Washington Bridge

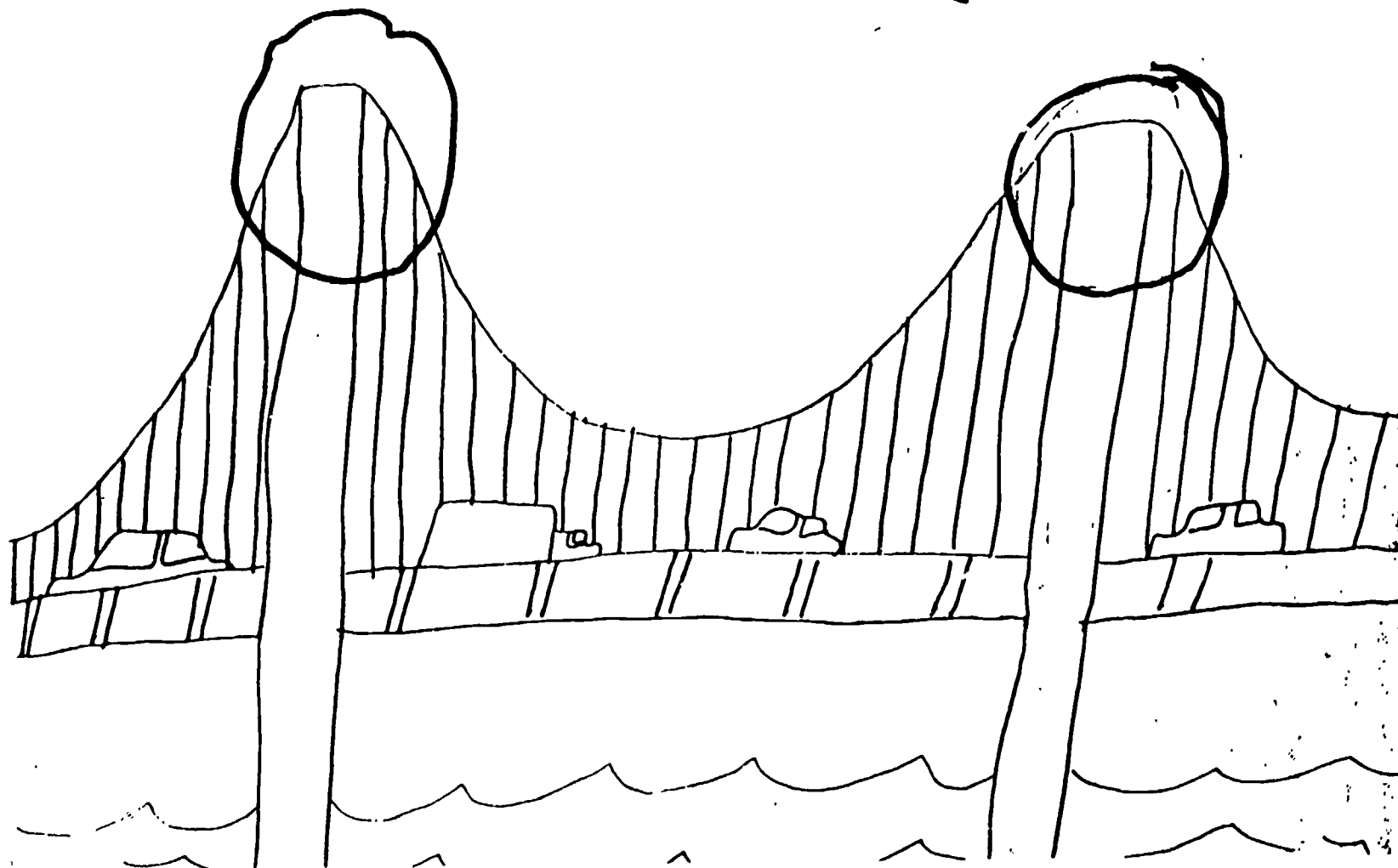

3-126

377

378

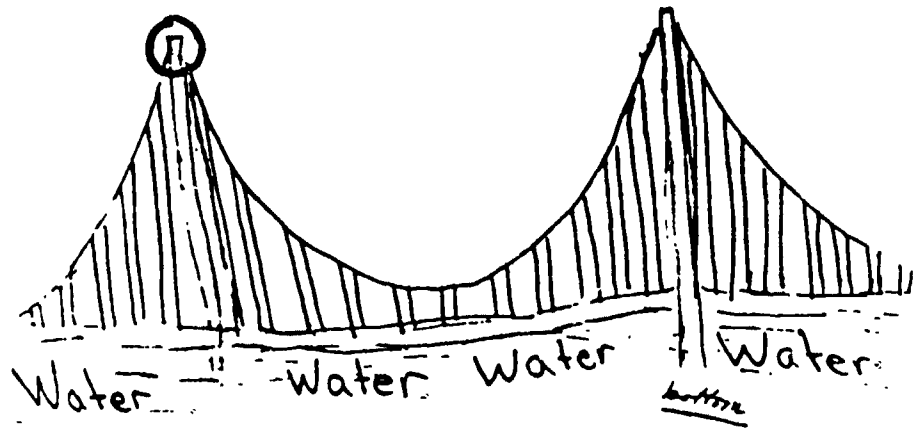

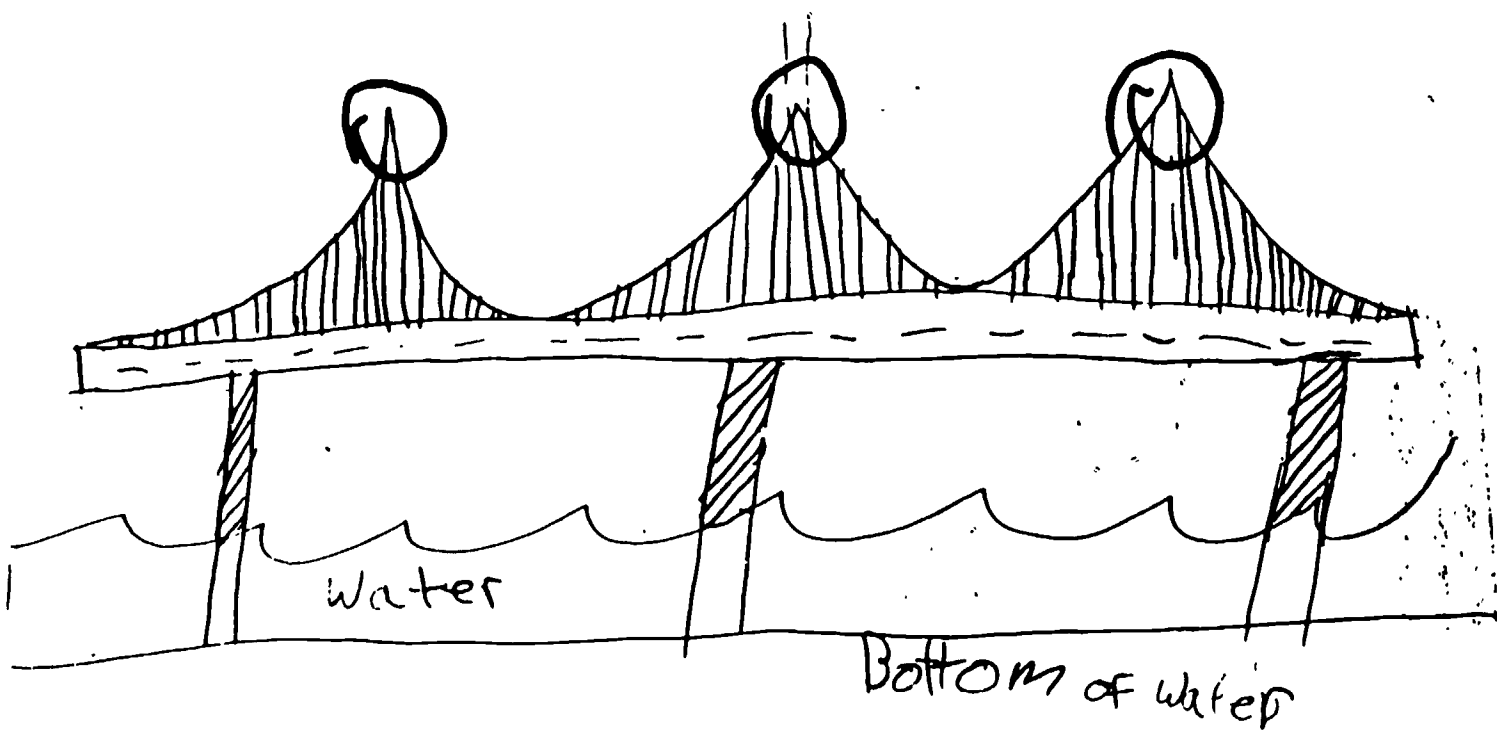

389

3-129

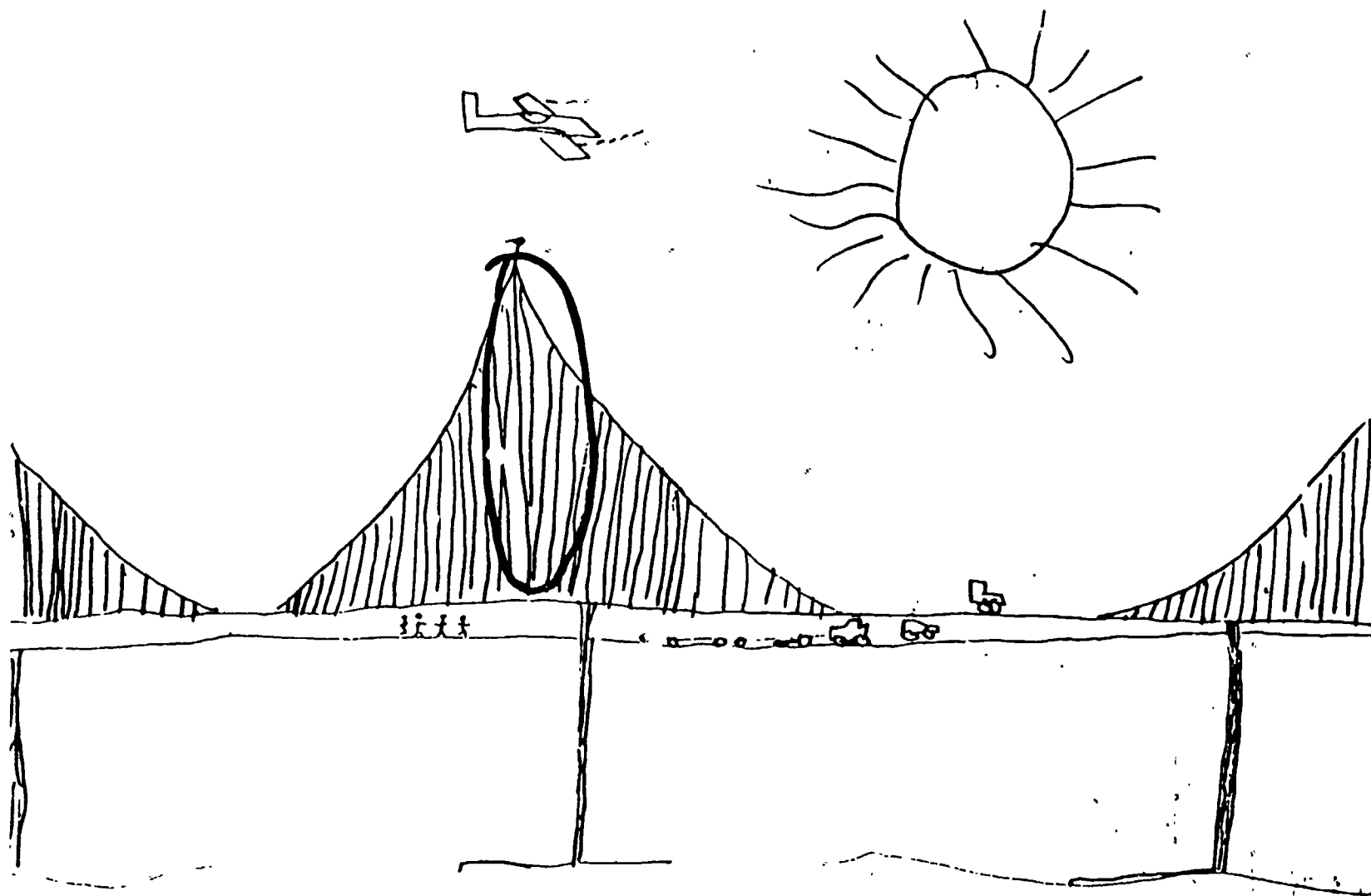

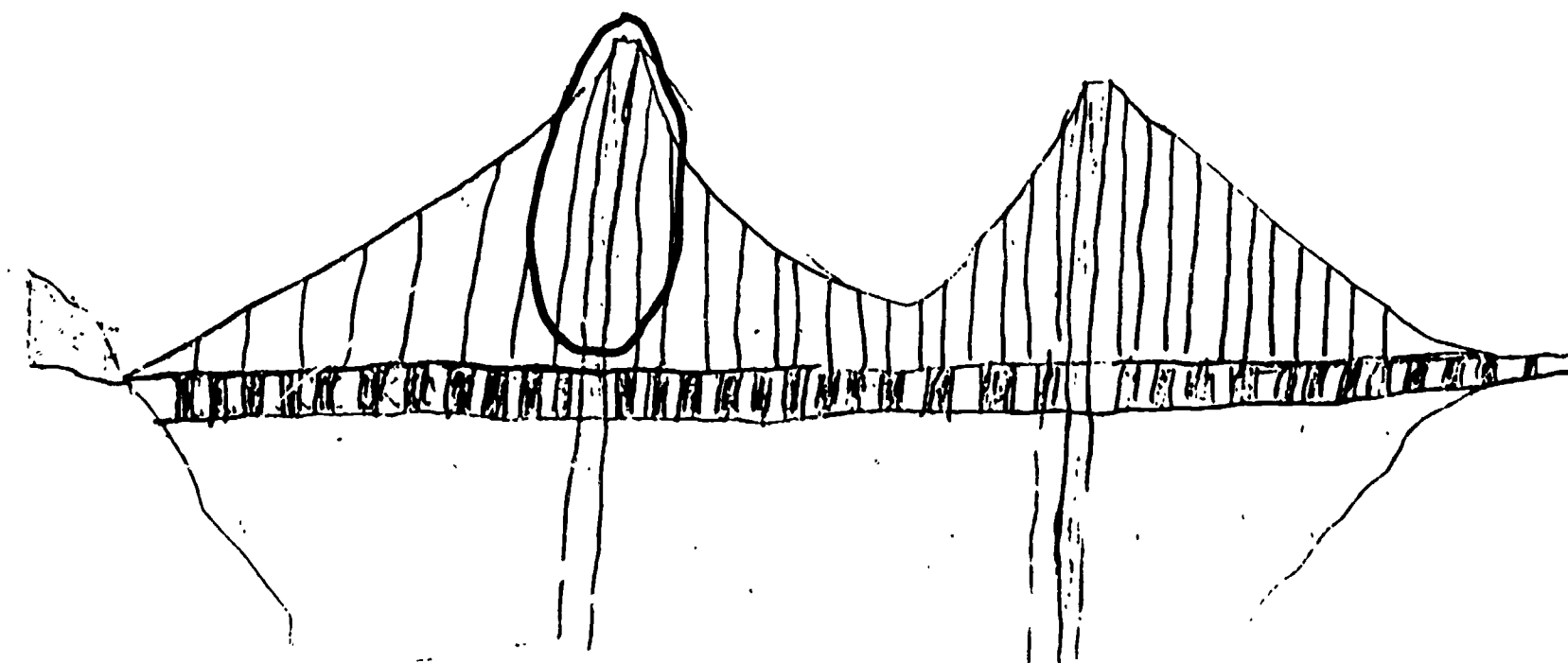

3-130

383

384

3-131

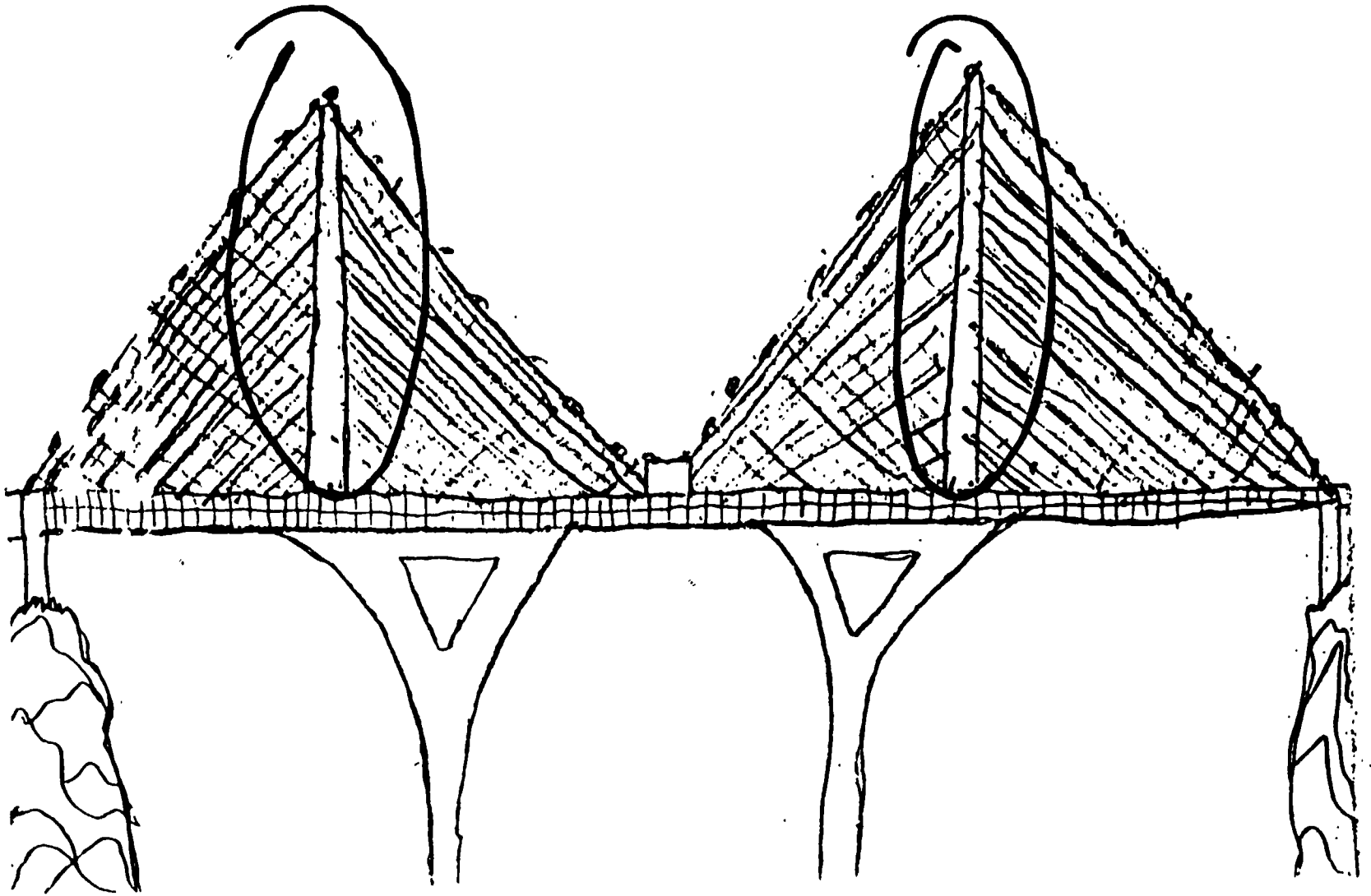

385

386

3-132

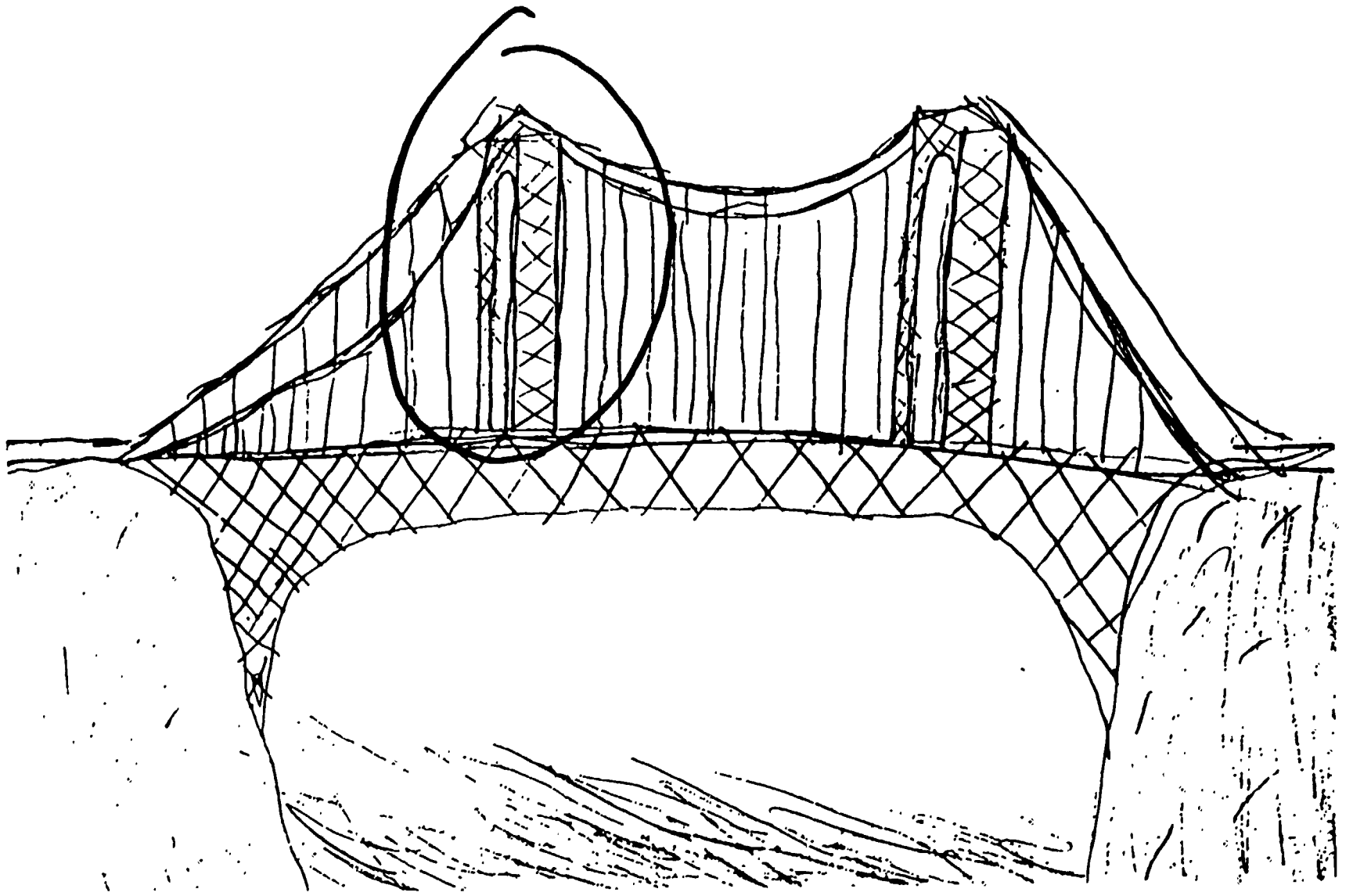

387

388

3-133

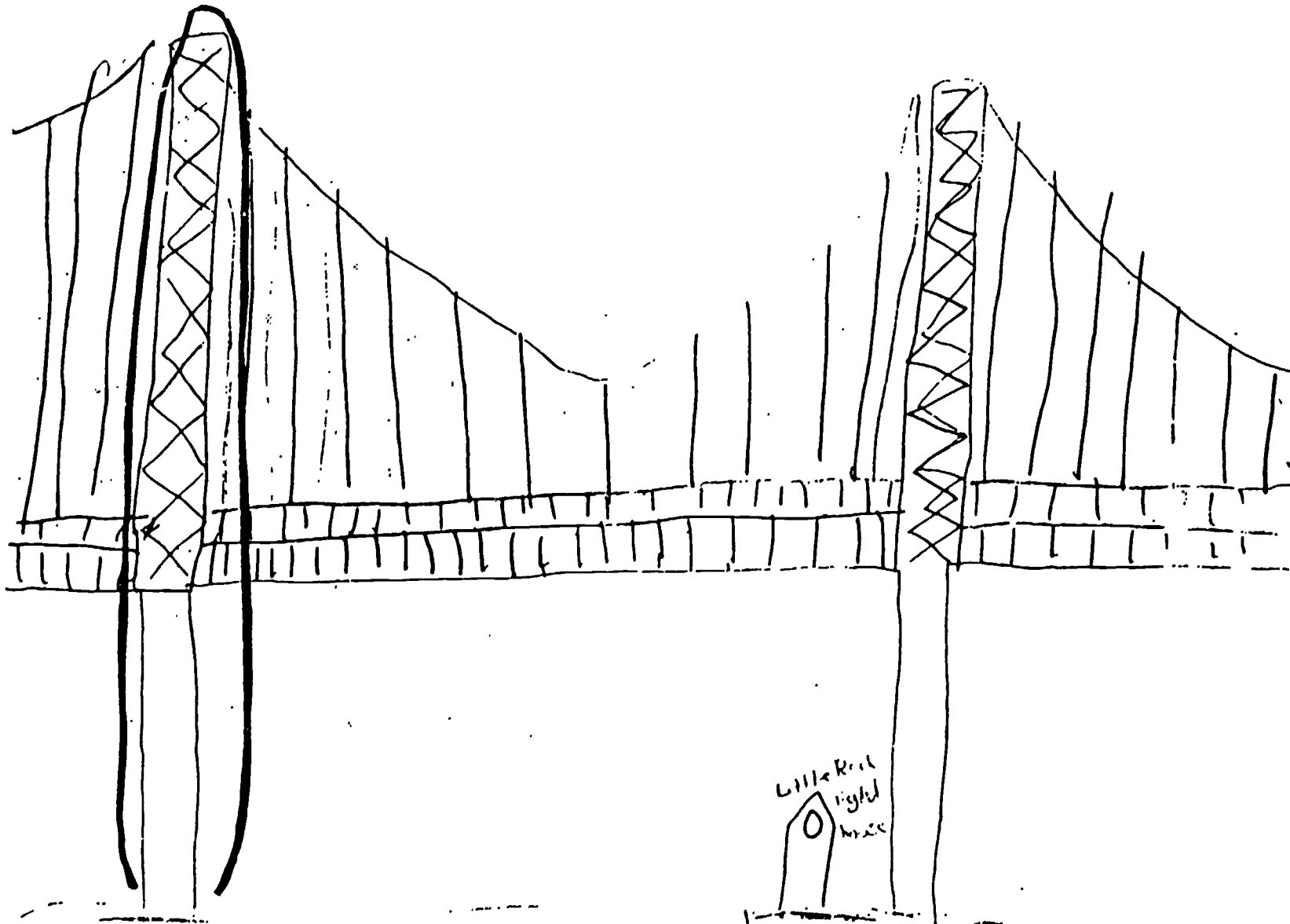

389

Little Rock
right
base

390

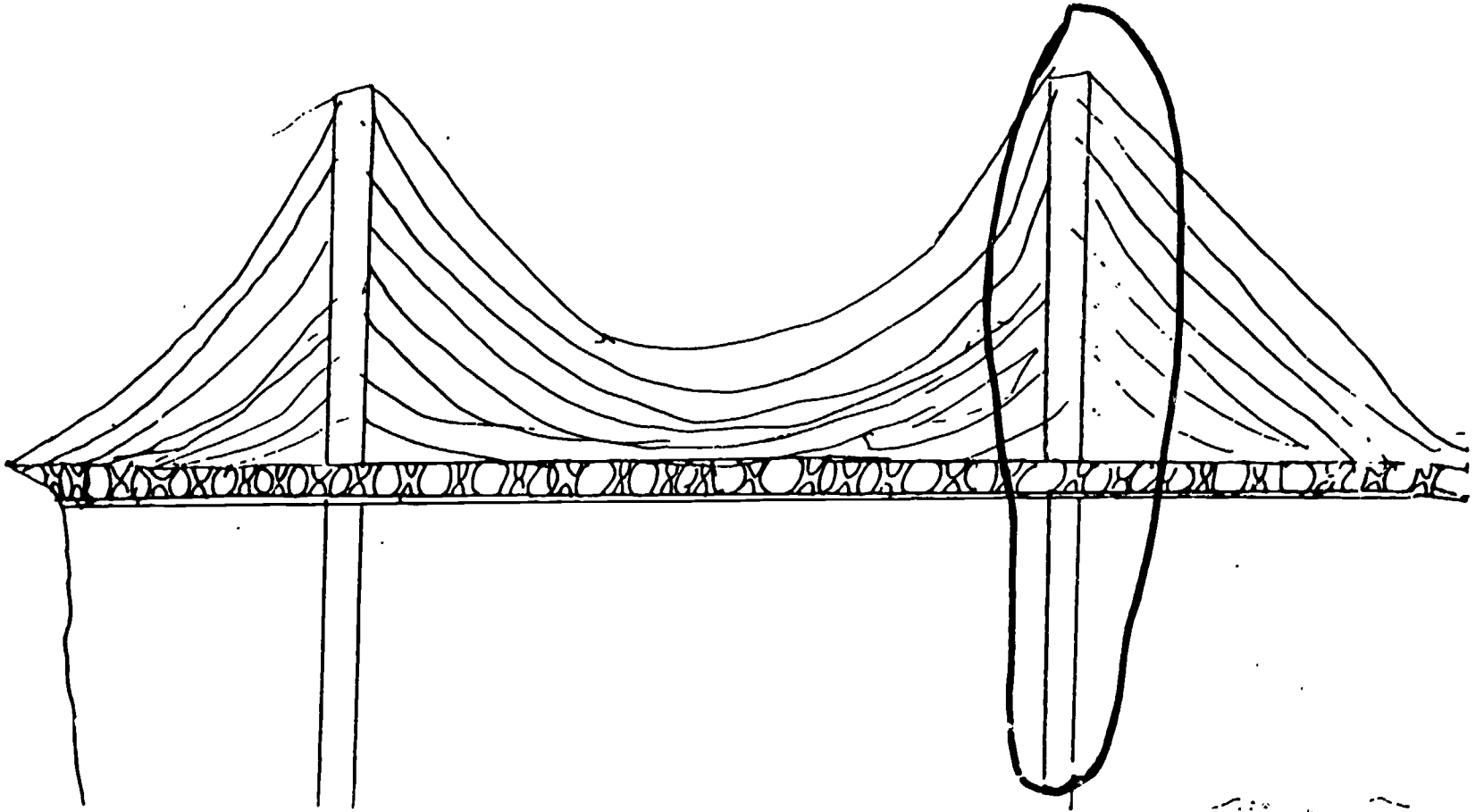

3-134

391

392

3-135

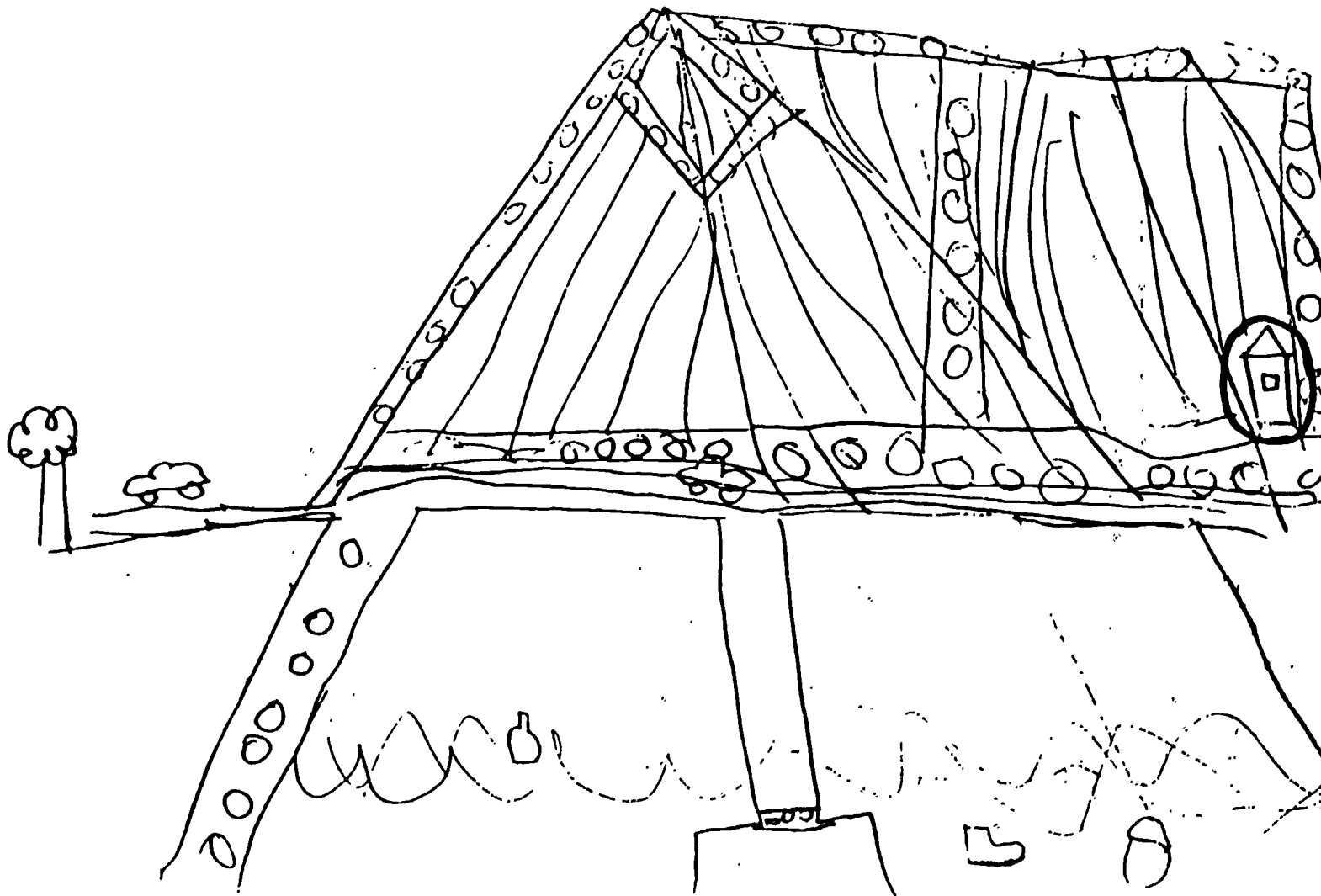

393

394

3-136

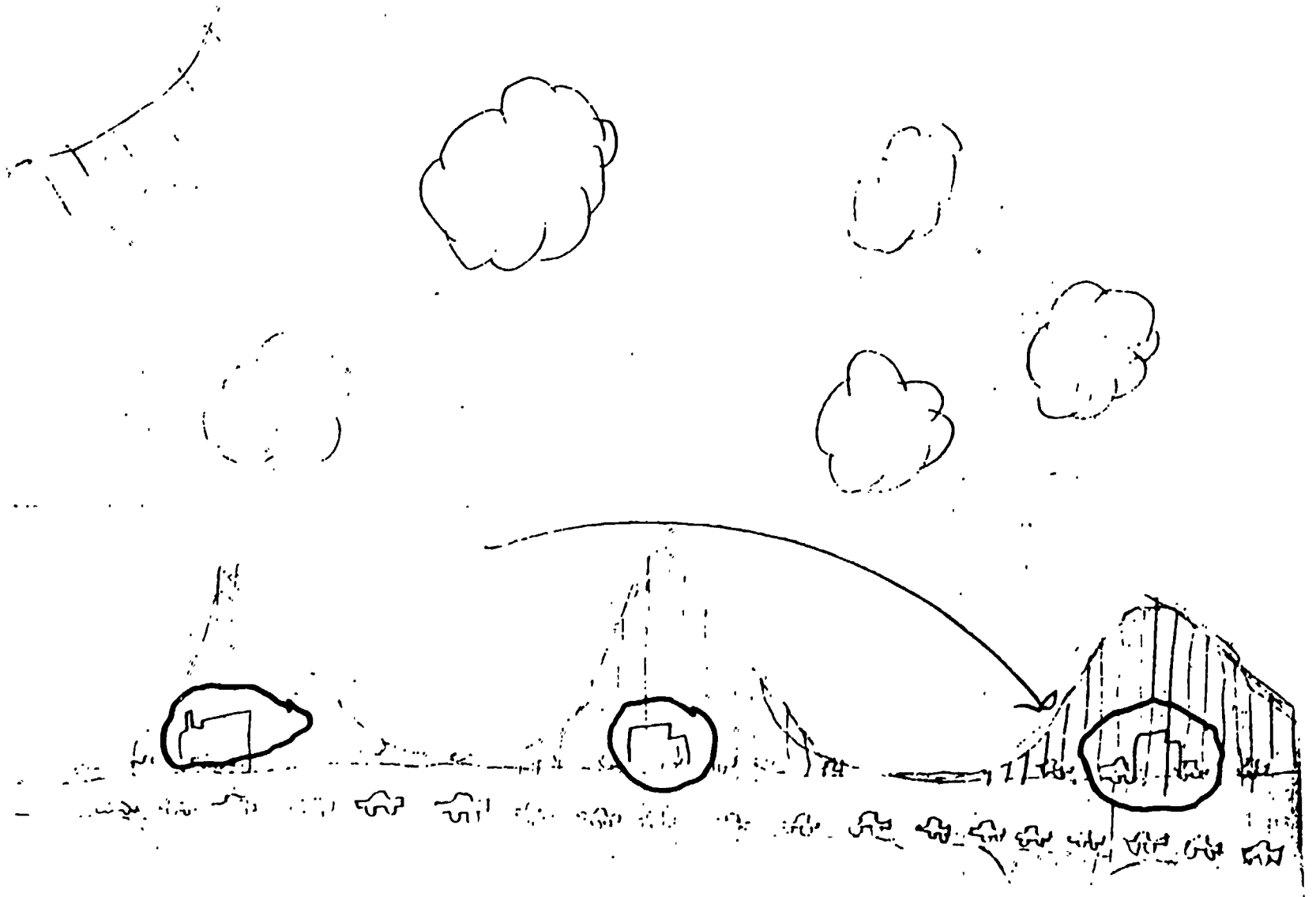

395

396

a lot more buildings.

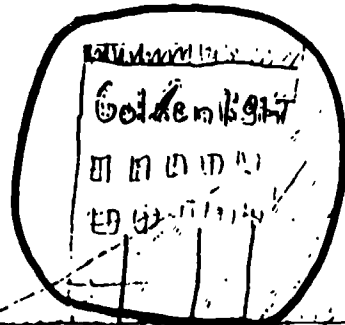

3-137

397

398

Michael

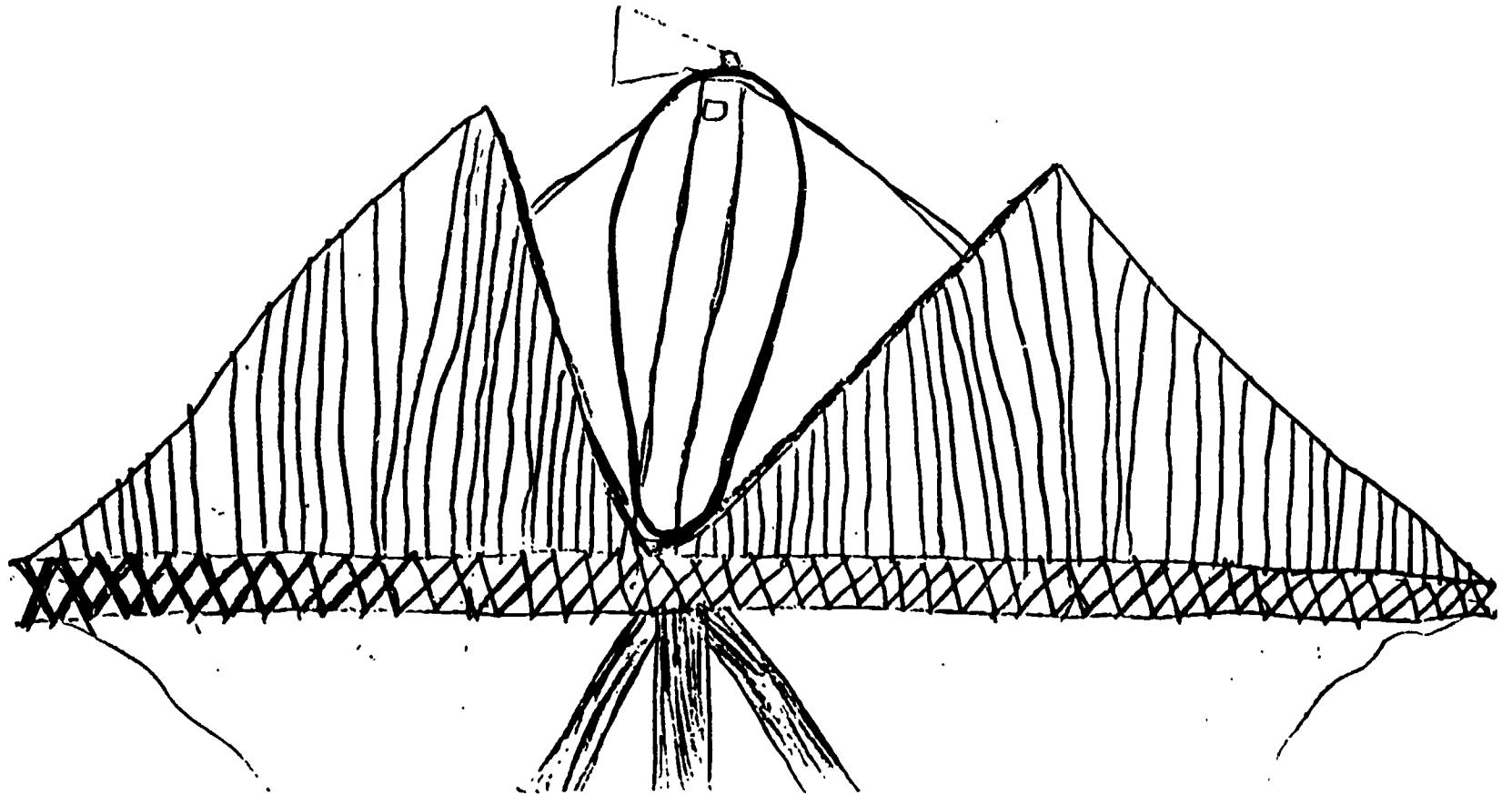

3-138

399

400

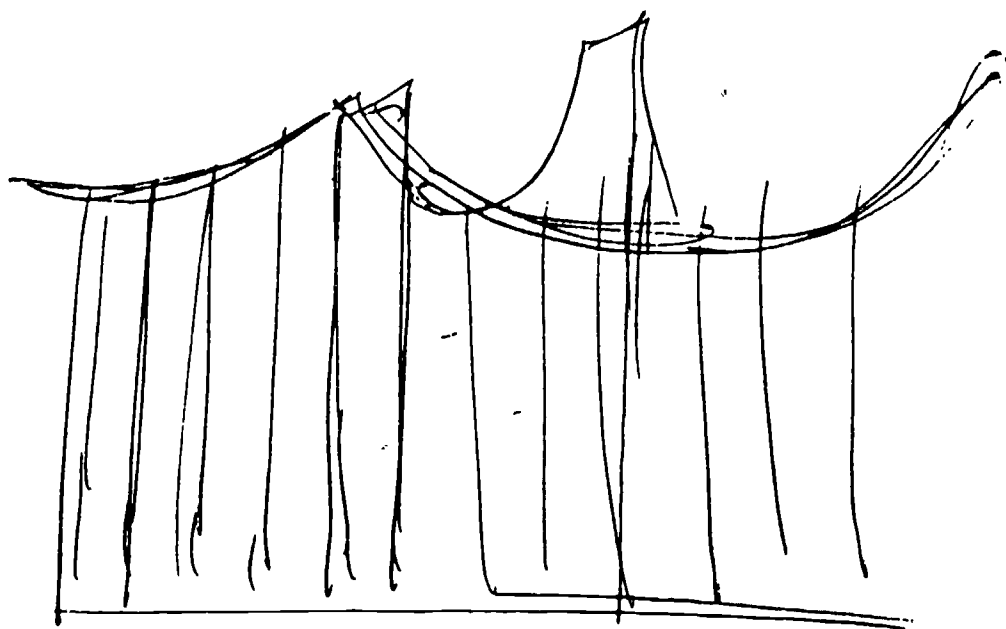
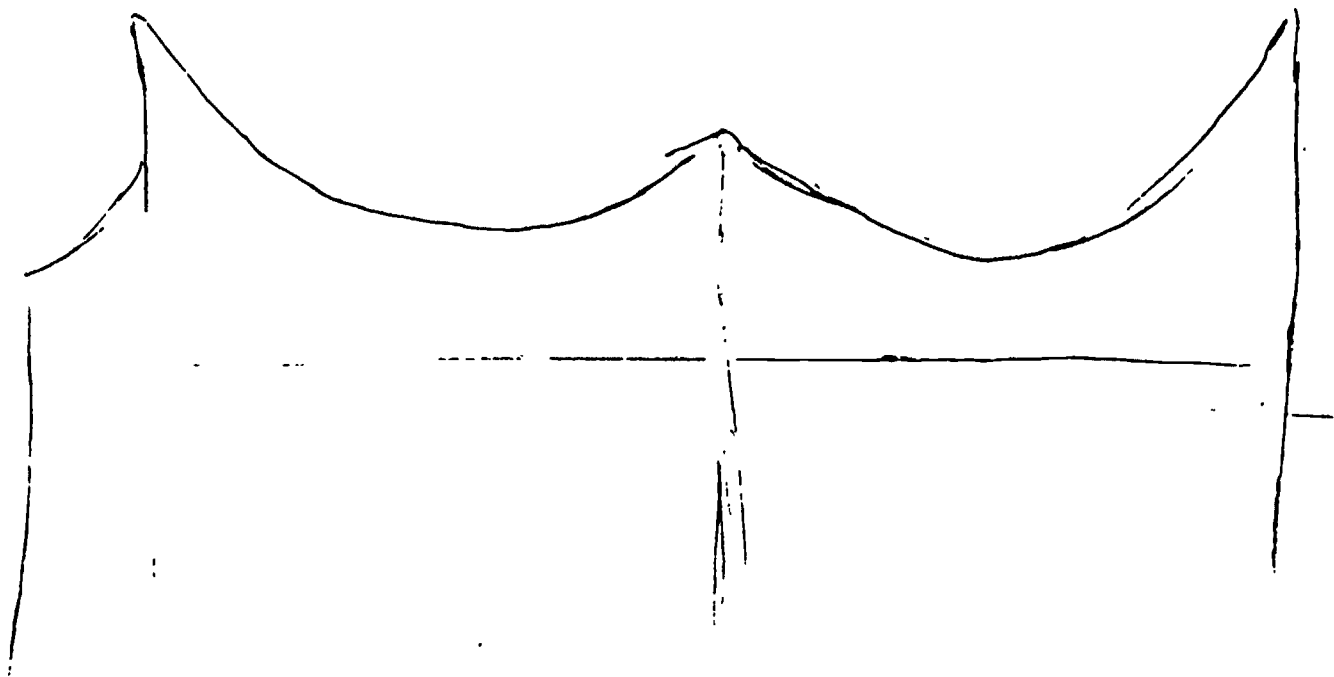

3-139

401

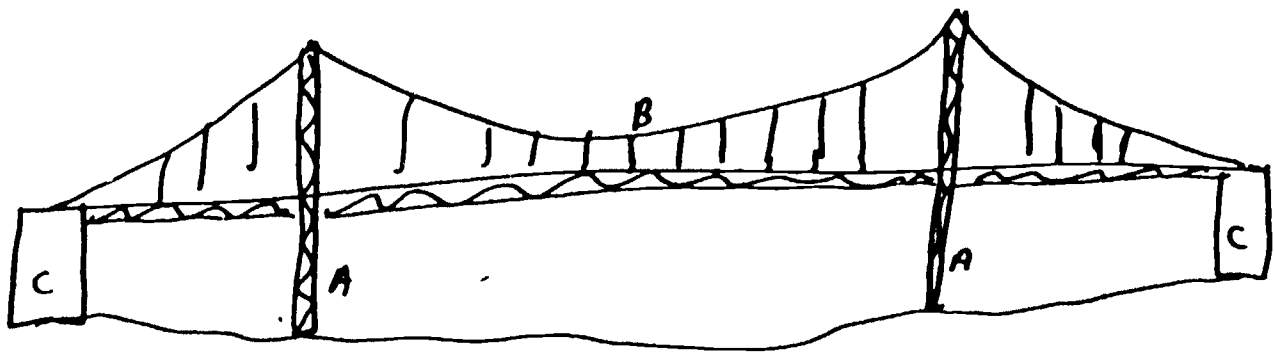

1) Main support systems are: Towers (A);
Cables (B); Anchorage (C).

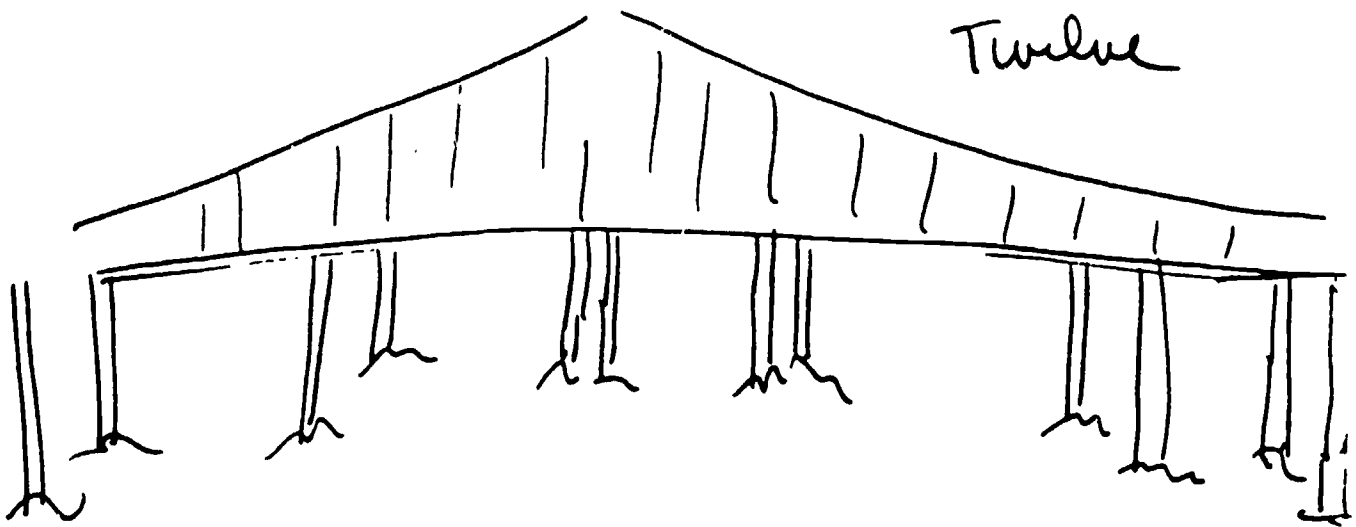

Register Items

Items in all three sections of this chapter require some kind of basic shift in the reader's stance. In this final section, however, the items to be considered differ in one fundamental respect from those in the previous two: the shifting that they call for is not motivated by the passage itself, but by its relations to the tasks that follow. The passage is written in one register--an imaginative, even evocative one--and the tasks are written in another--one that can be described as simple and straightforward. In order to negotiate these items successfully, children are required to shift between the two registers.

Considered broadly, this kind of shift is inevitable in a test item and, for that matter, in any school activity that moves from a sample of language to tasks that deal with the sample. Students are required to move, as it were, from language-in-use to language-about-language. Such movement is, of course, a fundamental aspect of school discourse--it is present not only in tests and textbooks but also in a good deal of teacher talk.* We often assume that children, early on, become aware of this boundary and learn how to negotiate it. On the basis of our interviewing, we suspect that this awareness is poorly developed in many children. We

*In teacher talk, this movement may be, at times, difficult to discern, particularly if it is not overtly signaled. In oral discourse, we have no standardized device for indicating this movement, as we do in written discourse (i.e., leaving a blank space between the language sample and tasks). We do, of course, possess a rich variety of verbal and paraverbal resources for marking this movement.

encountered a few cases in which children seemed to process the passage and tasks as though they formed continuous discourse.

Even if children are aware of this boundary, they still may not know how to negotiate it. They may, for example, be uncertain as to whether their response to a task should reflect the style of the passage. In effect, their surface response to a task can be viewed as reflecting a deeper one to an unstated but unavoidable question: to what degree is the boundary between a passage and a task permeable with respect to matters of style?

In Chapter 2 we observed numerous examples of style carryover in children's response to a task. In dealing with ALICE AND THE FAWN, for example, a number of children, in the case of both tasks, seemed to choose a distractor because it led to a proposition more consonant with the imaginative style of the writing.* Before dismissing such responses, we should remind ourselves that a compelling theory of reader response, one that can be traced to antiquity, holds that writing style and reading style cannot be separated, that our interpretive stance as readers is necessarily determined by the stylistic texture of what we read.

Having claimed that style carryover takes place on many items, we would like to take a moment to characterize the two examples of this phenomenon that will be discussed in this section.

*We should note that children seem to develop sensitivity to stylistic matters at an early age. Recent research by Georgia Green (1982) suggests that children, even from the age of 5 or 6, show a remarkable capacity for distinguishing one writer's style from that of another.

Both represent a familiar conjoining of a certain kind of material with a certain kind of style. One is written in a narrative-descriptive mode:

Far back in the deep woods, the limbs of a large tree stretched gray among the green cedars. Once that tree, too, had been green, but now the leaves were gone, and the tree was dead. Low, near the ground, a black hole opened into the hollow trunk of the tree. Inside the hole a mother bear and her two babies lay on a nest of grass and leaves.

The other is written in an expository mode:

The first time a mother alligator hears her babies she cannot see them. Their little grunts are coming from a pile of mud and old leaves. That is where the mother alligator laid her eggs many weeks ago.

Both passages present a nature scene in an imaginative style that could be characterized as anthropomorphic. Each, for example, uses a MOTHER-AND-BABIES frame in presenting the non-human.

This style is common among writers who present the natural sciences to children. It is as though they intend not only to inform children about nature but to inspire them to view it as related to their own lives. We will not consider here the advisability of encouraging children to think of a creature like an

alligator as filled with "mother love."*

There is one other reason for our reserving these two items for the final section. Each contains a task whose target response was inaccessible to virtually all children at these grade levels, and it is clear that in both instances the style of the passage plays a crucial role in leading children toward a communicative distractor and away from an acommunicative target response. Hence we will be concerned with showing how various stylistic features work together to create an interpretive frame that this distractor strongly reinforces. In both cases, however, this frame is incongruent with some local detail in the passage. In effect, the reader is forced to choose between holistic pattern and local detail in formulating a response, and it will be our claim that the stylistic texture of these passages strongly encourages the holistic response.

*There are, of course, writers such as Loren Eiseley and Annie Dillard who use an imaginative style in presenting the natural world to adults. An anthropomorphizing quality can be detected here as well, but its effects tend to be different. These writers are generally committed to the idea that poetry and science are ultimately indissoluble, and so they use one as a means to the other.

GREEN CEDARS

We will first consider the item that contains the narrative-descriptive passage:

Far back in the deep woods, the limbs of a large tree stretched gray among the green cedars. Once that tree, too, had been green, but now the leaves were gone, and the tree was dead. Low, near the ground, a black hole opened into the hollow trunk of the tree. Inside the hole a mother bear and her two babies lay on a nest of grass and leaves.

A. The green trees were

gone	dying
cedars	hollow

B. Where was the nest?

inside a tree	on a dead limb
in a cave	on a green tree

This passage parallels JAYS AND CROWS in that each describes a nature scene that holds the promise of a story to come. The promise is even stronger, however, in GREEN CEDARS. The passage begins with a long-range shot of a dead tree among green cedars and ends with a close-range shot of a mother bear and two babies nesting in the tree. By the end of the passage, the bear family is

in sharp focus.*

Both tasks in GREEN CEDARS call for the recycling of relatively unimportant information from the passage. (A) requires that the green trees surrounding the more salient dead tree be identified as cedars, whereas (B) requires that the bear nest be identified as inside a tree. In both instances, readers are required to engage in a "hunt-and-find" operation, an activity which, as it were, goes against the grain of the imaginative register of the passage. In effect, the style of the passage invites readers to "open out" onto a larger scene, but that of the tasks forces them to "close in" on local detail. This search for low-level detail is particularly difficult to conduct in the case of (A), for readers have good reason to reject the target response even if they do manage to locate it. Moreover, other choices, particularly dying, present their own attractions, given the imaginative register of the passage. In fact, cedars was the least attractive choice for children during the pilot testing. Only about one-seventh

*We asked 23 children what they thought the passage was mainly about and left them free to respond as they wished. We were curious to see whether they would write something connected to the trees, the bears, or some combination of the two. 15 of the children wrote about the trees, 3 about the bears, and 4 managed to write about both. This combining was difficult, since 'trees' and 'bears' were not woven together throughout the passage, as were 'birds' and 'sounds,' the competing themes in JAYS AND CROWS. One of the 4 children who combined the two wrote the following: "A tree gave its life for a mother bear and cubs."

We also asked these children what they thought "the rest of the story would be about." Here is how they responded to the three choices provided: what the bears do (16), how bears make nests (2), how trees die (5).

selected it, whereas about one-fifth selected gone. The remaining children were almost evenly divided between dying and hollow.*

The stem of (A) consists of only four words. In selecting the target response, readers need only to locate in the initial sentence the nominal in which green modifies cedars, and then use this overtly expressed modification to formulate a response. This operation would seem to be easy, and yet few children managed to do it.

In accounting for the difficulty of the task, we should first point out that surprisingly few children seem to know what a cedar is. When we asked 24 children to describe a cedar, only 6 identified it as a tree; 4 said that it was "wood" and 14 didn't know. This lack of vocabulary knowledge contributed, no doubt, to the poor performance on (A).

Even if children know the word cedars, however, the task is still difficult. It is important to recall that the other tasks in which information had to be retrieved from a single nominal were also difficult for children (see, for example, JAYS AND CROWS, p. 17, and ALICE AND THE FAWN, chap. 2, p. 71). When engaged in this kind of retrieval, children seem to view the modifying information as so trivial that they cannot accept it as constituting the point

*The results of the pilot testing were striking for this task in that mainstream and minority performance was virtually indistinguishable for all four choices. Hence we are able to report the results for the two groups together.

of the task.

Moreover, selecting cedars results in a sentence that is not only trivial but, on pragmatic grounds, peculiar. Given that trees are prototypically green, it is strange to use this color to identify a particular group of them. It's a bit like saying, "The birds that fly are crows." One bright, ten-year-old girl went so far as to claim that the green trees were cedars "doesn't sound like English."* She made a similar claim when dealing with target propositions such as "These bridges are hung" and "The people were surprised by her white circles. It can be argued that the target proposition in (A) is motivated on pragmatic grounds, if the reader assumes that the dead, non-green tree is not a cedar (i.e., the green trees are being identified as cedars so that they might be contrasted to the non-green tree that is not a cedar). The passage does, in fact, provide information that supports this assumption. The second sentence states that the tree's leaves were gone; and, of course, a cedar is not ordinarily thought of as having leaves.**

Most of the children whom we interviewed thought that the dead

*Some of the awkwardness of (A) would have been alleviated if it had been prefaced with "The story says that," the formulaic expression that is sometimes used to introduce a recycling task (see JAYS AND CROWS, p. 17).

**The word leaves can, of course, be used to refer to any greenish growth on a tree. In fact, Christmas-tree vendors in New York City often use it in this way. In the survey already mentioned, the 6 children who knew that a cedar was a tree were asked what was on the top part. All six used the word leaves in their answer.

tree was, in fact, a cedar. When we asked them why they thought so, several adduced the information that once that tree, too, had been green. In addition, some claimed that the trees must have been cedars since they were growing together. No child whom we interviewed called attention to "leaves" as a reason for thinking that the dead tree was not a cedar.*

There is one other problem with "The green trees were cedars" that we would like to mention. The form of this sentence tends to call for an exclusive interpretation; that is to say, "All the green trees were cedars." In imagining the scene described by the passage, readers are likely to picture an extended forest--the passage opens with the expression Far back in the deep woods. Hence readers might well imagine a forest with different kinds of green trees and so experience dissonance in choosing cedars.

Having suggested factors that may have prevented children from

*One child did justify his choice of dying by referring to leaves:

I wrote dying because they were writing all that stuff about the leaves falling off. That also could have been just the effects of fall. I wasn't sure.

This response may reflect some leakage from JAYS AND CROWS in which "the dry, crackling ocean of leaves" is used in describing the nature scene.

We asked one group of children to make a drawing of the scene they envisioned while reading GREEN CEDARS. Some of their drawings suggest that they viewed the dead tree as a different kind of tree from the surrounding cedars (see, for example, the drawing on page 157). This difference may, of course, be attributed simply to the child's wish to contrast the dead tree with the living ones.

choosing the target response, let us now consider those that may have led them toward one of the distractors. As noted earlier, all three were more attractive than cedars during the pilot testing, and, surprisingly, hollow was the most attractive of all. Much of its appeal seems to be related to the form of the task stem. A sentence that begins with a nominal plus the verb to be is more likely to be completed by an adjective than by a verb or a noun. When we asked children to complete the sentence "The people were _____," over three-quarters filled in an adjective. This proportion did not change when such other words as bears, cars, trees, and houses were substituted for people. The other one-quarter filled in the blanks with a verb form; no child completed a sentence with a nominal or an adverbial.

Finally, we should note that the choice of hollow, like the verbs gone and dying, are all more congruent with an active, text-making role for the reader, one that the stylistic texture of the passage calls for. Consider, for example, the opening sentence. Readers are confronted with the image of a tree whose limbs "stretched gray among the green cedars." The tree is not overtly identified as dead: the reader has to infer this from the contrast between gray and green, an inference which is confirmed in the

second sentence.* This kind of text structure, continuously forcing the reader to go beyond what is given, creates a style of response, which, if carried over to the tasks, encourages the reader to select whatever is associated with an active, holistic, inference-based interpretation of the passage.

Certainly the selection of dying can be based on such an interpretation. To begin with, it is the only choice that represents an ongoing process, and many children seem to be disposed toward any choice that represents such a process. The statement "The green trees were dying" can be viewed as providing a poignant commentary on the passage, one in which the dead tree is viewed as emblematic of the fate of its neighbors. In the second sentence, the reader learns that once that tree, too, had been green, but now the leaves were gone and the tree was dead and so may be led to infer that the other trees, which are now green, will one day be dead, too. As one child put it, "The green trees will die, too."**

A number of stylistic features work together to encourage such active reading: the stark use of too provides the haunting

*We presented 25 children with only the first sentence and asked them what they knew about the tree with gray limbs. Only 8 of them said that it was dead. We should note, however, that the 25 were all urban children for whom the 'green'/'gray' polarity may be less operative in symbolizing life and death with reference to trees. To begin with, urban children generally have less experience with trees. Moreover, urban conditions can dull considerably the green of living trees.

**From a biological point of view, it is, of course, accurate to describe any living thing as "dying," though such a description does not accord with our everyday way of thinking.

sense that the dead tree had once belonged to the community of the living but is now cut off; and the contrast between once/now and had been/was suggests that time itself destroys the living, and so the green trees, too must one day die.*

We might note how a formal aspect of the sentence "The green trees were dying is consonant with the interpretive frame that we are here developing. The verb die carries past progressive marking (were . . . dying) but there is no specification of a larger temporal frame in which to interpret this marking.** In the absence of such a marker, a past progressive verb is apt to suggest a process so gradual that it cannot be readily marked off in time (e.g., "We finally became aware that the river bottom was shifting"). Hence the sentence "The green trees were dying" has a particular resonance in describing ongoing processes of nature which, having touched one green tree, will inexorably touch the others as well.

*The first sentence provides detail that could even lead a reader to imagine a scene of infection, one in which the gray tree is actively spreading death to its green neighbors. The dead tree is pictured as penetrating the space of the living ones and its limbs are among the green cedars. An active sense of penetration is conveyed by the verb stretched, and the drawings of some children seem to reflect this (see, for example, the ones on pages 157-158). None of the children whom we interviewed talked about these details, but some did seem to feel that contagion was in the air. At the end of some interviews, we asked children if they had ever heard of Dutch elm disease and discovered that many had and could talk intelligently about it. As one child put it, "Once one tree dies, they're all going to."

**it is common for such a frame to be specified when a past progressive verb is used (e.g., The fog was coming in while we rowed across the lake.)

To sum up, "The green trees were dying" provides more appropriate commentary on the passage than "The green trees were cedars." The former provides a poignant truth that is consonant with the register of the passage, whereas the latter merely provides information about a detail that has no interpretive import. Hence any reader sensitive to the mood created by the first two sentences may well prefer dying to cedars as a response to (A).

The choice of gone, the other distractor, is able to express, though with considerably less finesse, the same interpretive frame. From a temporal perspective, gone is, of course, an inaccurate choice; and yet the finality of this verb provides a peculiar heightening of the feeling that the green trees are doomed to die. One black child who chose gone orally read the stem of (A) as "The green tree was" rather than "The green trees were." When questioned, he seemed to take (A) as a comment on the dead tree, the one that had once been green.

It is tempting to relate this confusion between singular and plural to dialect interference; and yet even in a "deep creole" it is unusual for the plural marker to be phonologically neutralized in a monosyllabic, vowel-final word like tree. It may be that the plural -s was simply not noticed, and that the boy speaks a version of the dialect in which was and were are grammatically interchangeable. Be that as it may, this incident did remind us of the substantial interference that speakers of a non-standard dialect can encounter as they read material written in standard language.

Let us turn to (B), the task concerned with the location of

the bear family's nest. As was the case with (A), readers are required to retrieve relatively insignificant information from the passage. In this instance, however, the target response does not occur as such in the passage. In order to arrive at inside the tree, readers need to combine information in the final two sentences. In effect, they have to carry over of the tree from sentence 3 to sentence 4:

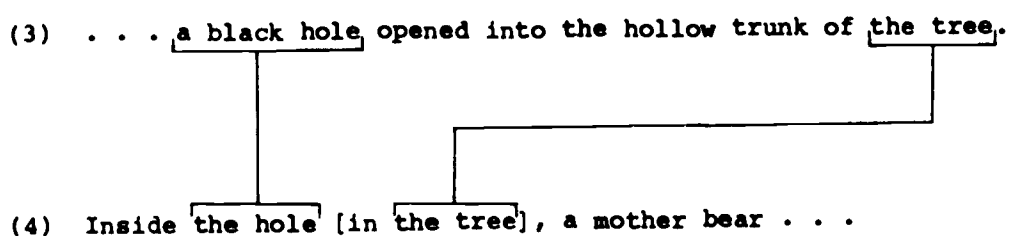

Perhaps the most difficult aspect of this task is that it forces children to work against various kinds of real-world knowledge that they possess. To begin with, most children do not think of a nest as a place where bears live. A nest is a place where birds live and so children tend to think of it not only as too small for three bears, but as located high in a tree, as illustrated by the drawing on page 159.* A young girl who made a similar drawing put the matter well:

*Some children were troubled by the fact that bears would have difficulty climbing up to where a nest should be, and so pictured the dead tree as lying on the ground (see, for example, the drawing on page 160). We can detect here the use of another bit of real-world knowledge: a dead tree is often stretched out on the ground (notice that the nest is still placed far from the tree base).

--It says, "laid on a nest of grass and leaves." I thought you gotta make the nest up here, but the nest gonna be on the ground.

--Why did you think you had to make the nest up here?

--I forgot. I thought they was talking about birds.*

At this point she and the interviewer burst into laughter, mutually recognizing the strange power the word nest had exerted on her. She did not necessarily mean that she had misread bears as birds, only that the word nest had led her to picture the kind of place where birds live. We suspect that young readers are often not able to contextualize an individual word that is used with an extended meaning. Older readers can, of course, have this problem as well, but on the basis of our work with children, we have come to believe that their more limited use of context is perhaps what distinguishes them most markedly from more mature readers.

To return to (B), it is not simply that children think that a nest is too small for three bears--they think that a tree is too small as well. This led some children to avoid drawing the hole in the dead tree. Examine, for a moment, the drawing on page 158. The dotted line represents the place where the hole was first drawn. It was only toward the end of the interview, when the child became aware that the bears were actually inside the dead tree,

*Notice that she uses was with they. She also used was when reading (A): "The green trees was cedars."

that she drew the hole there.

Her response was typical of other children who chose Cave simply because they could not imagine any tree large enough to hold a bear family in its hollow trunk. As one child put it, "Three bears can't fit inside a tree so they must have been in a cave or something." It was as if these children were blocked from absorbing information not congruent with their real-world knowledge (see Kimmel, 1981, for discussion of such interference).

There were other children, however, who seemed to have selected cave because it was an appropriate word for characterizing any hollow space inside a tree that would be large enough to hold three bears. It was as if they were using cave metaphorically in order to account for the sheer magnitude of the tree. The imaginative texture of the writing may have encouraged such figurative extension of cave. Certainly children often encounter in the imaginative literature that they read a metaphorical extension of some word that enables them to negotiate a disjunction between their real-world knowledge and the strange world that the text is creating.



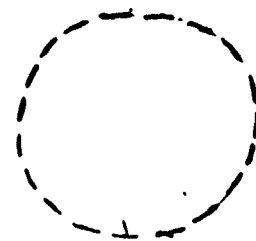

420

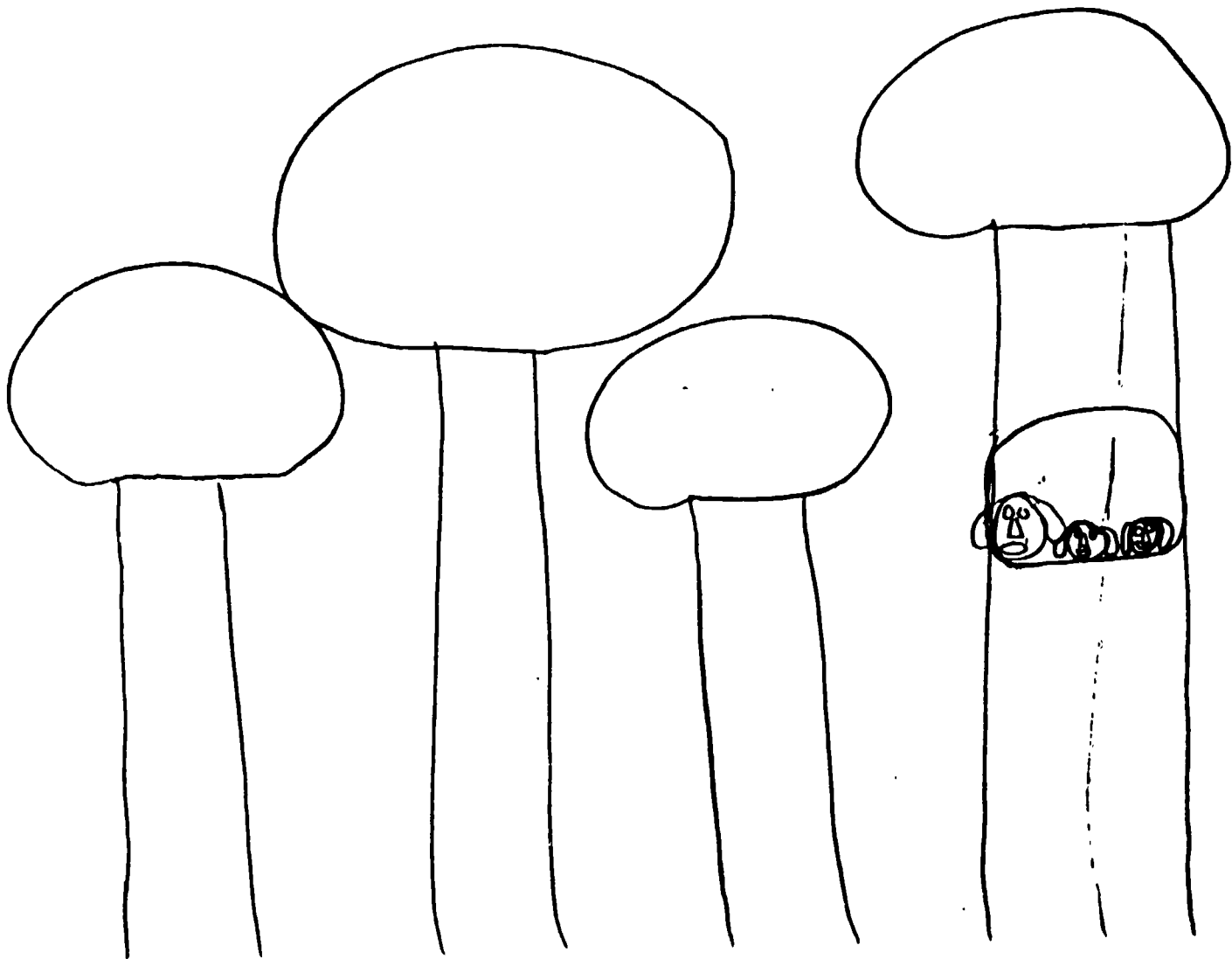

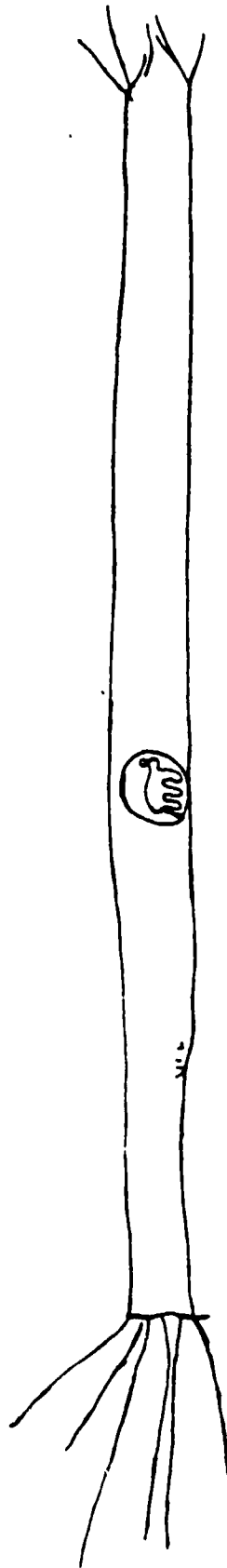

3-160

422

MOTHER ALLIGATOR

Let us turn to the other item in which the passage deals with the natural world. In this case, the underlying purpose seems to be expository--to convey certain information about alligator reproduction. The style, however, contains elements that are usually associated with fictional narrative.

The first time a mother alligator hears her babies she cannot see them. Their little grunts are coming from a pile of mud and old leaves. That is where the mother alligator laid her eggs many weeks ago.

- A. Alligators lay their eggs in
- | | |
|-------|------------|
| mud | the night |
| water | the winter |
- B. The "little grunts" in the story are
- | | |
|------------|-----------------|
| old leaves | baby alligators |
| eggs | noises |

The passage is quite brief, consisting of only three sentences, each of which is, in turn, relatively short. The first provides a generic description of an alligator's initial experience of its offspring--it can hear them but not see them. The sentences that follow provide supporting detail--and yet the level of this detail seems to sever them from the initial sentence. It is difficult for readers to retain the generic conception of an alligator while processing the "pile of mud and old leaves . . . where the mother alligator laid her eggs many weeks ago." The specificity of detail tends to sweep them into the world of a particular alligator.

We have pointed out that in many items an easy task is paired with a hard one. This pattern is more conspicuous in MOTHER ALLIGATOR than in any other item in our corpus. If we judge by the proportion of children who selected the target response during the pilot testing, this item contains both the hardest and the easiest task of the 44 that we have considered. The following table shows the percentage of children who selected the target responses mud in (A) and noises in (B):

	MAINSTREAM	MINORITY
TASK A	78%	64%
TASK B	4%	3%

How can we account for such a striking divergence in the performance of both mainstream and minority children? On the surface, these tasks parallel the ones in ALICE AND THE FAWN. In both items, (A) calls for information-recycling and (B) for vocabulary-defining. In dealing with ALICE AND THE FAWN, children did poorly on both tasks. We have suggested an explanation for this: both (A) and (B) juxtaposed an acommunicative task with an imaginative passage, and each of these tasks, in turn, contained a communicative distractor that was congruent with the imaginative texture of the passage.

We might have expected to find a similar result here. The passage, though not fictional, has some of the characteristics of imaginative writing. In the case of (B), this perspective is a crucial factor in children's responses, but in the case of (A) it

seems to have had little or no effect. In accounting for this difference, it is important to observe that (A), unlike (B), includes no distractor highly congruent with the imaginative perspective of the passage. In fact, the failure of children to select the target response seems to have been more related to their discomfort with its partial nature than with the inherent attraction of any other choice. The passage identifies mud and old leaves as the place where an alligator lays its eggs, whereas (A) includes only mud as a choice. Certain children called attention to this discrepancy. Here is how one boy defended his rejection of mud:

Because right here [pointing to the choices] it doesn't say anything about leaves.

We can observe, once again, the effects of task form--mud and old leaves would be excessively long as a choice (see chap. 4, pp. 26-28 for a summary of the various ways in which tasks call for a partial response).

We might note that the attraction of water, the most widely selected distractor in (A), seems to be partially motivated by children's thinking of an alligator as a "water creature." One child claimed that an alligator lays its eggs while swimming, and so they have to float down before they come to rest in the mud. This child seemed unable to picture the alligator as "getting eggs out" while its body was lying flat against the mud. She had a number of other difficulties in visualizing the scene. How does an alligator manage to lay eggs at all? And even if it does lay them,

how does it get them under a pile of mud and old leaves? And why does it put them there? In order to hatch its eggs, doesn't it have to sit on them the way a hen does? We can see, once again, how a conflict between real-world experience and passage information leads to probing questions, the very kind that are critical if reading is to become a knowledge-building activity, but which, in the context of a standardized text, only led this young girl to flounder on what should have been an easy task.

Let us now turn to (B). Not only did the fewest number of children select its target response, but the largest number selected one of the distractors: during the pilot testing 61% of mainstream children and 46% of minority children selected baby alligators. As we might suspect, this task is difficult for adults as well as for children. When we presented this item to 21 graduate students, all majoring in some field of language study, only one-third selected noises, while the other two-thirds selected baby alligators. Many of the students who selected noises claimed that they, in fact, would have preferred to choose baby alligators. When asked to explain why they chose noises, they tended to focus on the way in which their precedes little grunts in the second sentence of the passage:

Their little grunts are coming from a pile of mud and old leaves.

Here is how one student commented on this sentence:

Unfortunately, the word "their" refers to a plural subject and the mother alligator is singular. Cohesion blocks imagination.

It is clear from the initial unfortunately and the final sentence, which the writer carefully underlined, that she was attracted to baby alligators. Another student made a similar comment:

Little grunts is bound by the referent of their and so cannot refer to baby alligators.

He went on to point out that if little grunts were taken as referring to baby alligators, the sentence, if expanded, would read:

The baby alligators' baby alligators were coming from a pile of mud and old leaves.

Another student speculated that if mother alligator had been plural in the first sentence, he would have chosen baby alligators (i.e., their would have been interpreted as referring to mother alligators and little grunts to the baby alligators themselves).*

It would be difficult to fault the above reasoning, but readers--adults as well as children--did not avail themselves of it. Why did they ignore it? The passage was, after all, brief,

*There were also foreign students among the adults who responded to this item. Their responses are not included in the tally reported above, but it is interesting that those who selected noises tended to provide the same reason for their choice. One Japanese student wrote the following:

First I thought it might be baby alligators.
Then I reconsidered the words their and grunts.
When we use their in this sentence, it means
baby alligators. So I decided to circle noises.

and it was not difficult to locate their little grunts in the second sentence, and then analyze it as necessarily referring to the sounds the baby alligators made. Why did even those who did this bit of logical reasoning still experience a strong pull toward baby alligators? In order to deal with these questions adequately, we must bear in mind what is central to this passage: the mother alligator's restricted experience of her babies--she can experience them only as auditory sensation. The baby alligators are, for her, only the little grunts they make; and so the reader, identifying with the mother alligator's point of view, equates baby alligators and little grunts. As one child put it, "The mother doesn't hear noises--she hears her babies."

Why should this reader have adopted the mother alligator's point of view as his own? Is this empathetic response improper, or is it what the text calls for? To address these questions appropriately, we need to examine the stylistic texture. To begin with, the alligator's experience, as we have already noted, is anthropomorphized. Fundamental to this anthropomorphizing style is the use of pronouns that express gender and nouns such as mother and babies. It is instructive to examine the original passage alongside a version in which the "human" markers have been removed:

The first time a mother alligator hears her babies she cannot see them. Their little grunts are coming from a pile of mud and old leaves. That is where the mother alligator laid her eggs many weeks ago.

The first time an alligator hears its offspring, it cannot see them. Their little grunts are coming from a pile of mud and old leaves. That is where the alligator laid its eggs many weeks ago.

It is not, however, only certain nouns and pronouns that stimulate a reader's identification with the mother alligator's experience: a number of other features contribute as well. To begin with, there are the temporal expressions. Many weeks ago, as compared to, say, many weeks earlier, presupposes a personal center; and, perhaps to a lesser degree, the first time does as well. Then there are the verbs hear and see. These verbs can, of course, be used to describe non-human forms of sensation, but their use does tend to impart a human coloring to the situation.* Finally, we can observe that the use of progressive aspect in the second sentence (i.e., are coming) suggests the immediate and personal. Consider, for example, how the use of simple come would have tended to dampen these effects.

Their little grunts come from a pile of mud and old leaves.

Hence the entire passage is shot through with a human perspective, leading readers to identify with the mother alligator's experience.**

We would like to claim that, given the cumulative effect of these features, it is only natural that a reader empathizes with the mother alligator's point of view and so is in a position to

*There is, of course, no real alternative to these verbs. One cannot draw upon such periphrastic expressions as auditory stimuli and visual stimuli when writing for third and fourth graders.

**Notice how even the use of the word experience tends to anthropomorphize the sensate world that an alligator inhabits, illustrating, once again, a certain inevitability in the imposition of the human--this vantage point is taken as given in our ordinary use of language.

equate baby alligators and little grunts. We would further claim that such equating is not merely a possible response, but one that is fundamental to any real engagement with what the passage is concerned with.

It is not simply the passage that stimulates this response: the task stem does as well, particularly through its use of quotation marks around little grunts. Quotation marks are, of course, used for a variety of reasons: for example, they could, in principle, be used merely to indicate that little grunts is being recycled from the passage. However, quotation marks are not used for this purpose in any test tasks that we have examined. Rather, they are used primarily to indicate that certain words have a special status. In ADVERTISING TAILOR, for example, hammered out a wardrobe is enclosed in quotation marks in (A) to indicate that it was used figuratively in the passage (see chap. 2, ^{p. 177} ~~pp. 00-00~~). Extrapolating from this use of quotation marks, we might suppose that they have the same function here. If we search the passage for signs that little grunts is used in a special way, we are led to the thematic focus on how the mother alligator equates the little grunts with her babies.

Another effect of the quotation marks is that it makes little grunts seem like a familiar name, particularly given the frequency of little as a component in such naming (consider, for example, Little Bo Peep, Chicken Little, or L'il Abner). The quotation marks also highlight the parallelism between little grunts and

baby alligators. Each begins with a modifier signifying 'diminished status.' We will shortly present material from the interviews that shows both adults and children using these expressions interchangeably.

Even if it does not lead to the effects that we have noted, the use of quotation marks does signal that the words little and grunts are to be taken as a unit, and processing them as such makes it more difficult to select noises. From a pragmatic point of view, it would be more natural to think of grunts rather than little grunts as a kind of 'noise,' since conceptual classification generally involves a stripping away of extraneous information. Preserving such information is particularly confusing in this instance because little modifies grunts in a peculiar way. In its core meaning, little refers to entities that possess 'bodily extension,' but it is often used in semantic domains where such extension is lacking. Consider, for example, the domain of 'sounds.' It appears that little is extended to this domain almost by default: no other modifier is readily available to signify diminished status for 'sounds.' But notice the effects of this extension in an utterance like

Hear those little squeaks coming from the kitchen? The mice must be at it again.

Little indicates diminished status with respect to not merely the sounds (i.e., the squeaks) but also the creatures emitting those sounds (i.e., the mice). It is as though little retains something of its central function even as it assumes a more peripheral one.

We would, in fact, claim that these "osmotic" effects are not accidental but rather reflect a fundamental property of language, one that helps us resolve the paradox that we initially posed: how can a reader take little grunts as referring to both the baby alligators and the sounds that they make?*

To return to the matter of the task stem, we would suggest that both quotation marks and the modifier little be removed if noises is intended as the target response. This would leave the following stem:

The grunts in the story are _____.

Even this form of the stem, however, is likely to favor baby alligators. The pre-modifier the and the post-modifier in the story work together to focus attention on what grunts refers to in the passage; and so the thematic focus still pulls the reader toward baby alligators. If the initial the is removed and in the story takes its place, the attraction to baby alligators is substantially reduced:

In the story, grunts are _____.

The expression in the story is, in fact, ordinarily placed in this sentence-modifier position, and there is no clear reason why it has been placed after the head noun in this task.

*Apart from these osmotic effects of little, there is a natural tendency for us to associate a sound with what emits it: the siren with the fire engine, the loud roar overhead with the jet plane, night-time crying with the hungry baby, and so on.

We might further suggest that the expression in the story be totally removed, since, even in initial position, it may encourage the reader to imagine how the mother alligator experiences the little grunts. In this case, the stem would be ultimately stripped down to

Grunts are _____.

In this form, of course, the task has become independent of the passage. Once the metalinguistic status of the task is made transparent, it seems as though it should be made part of a vocabulary test, thereby avoiding the confusion that so often results from the insertion of a vocabulary-defining task in a comprehension item (we will deal with these confusions more systematically in Chapter 4).*

Before leaving this item, we would like to examine some of the reasons that readers provide for rejecting noises, for they indicate basic dispositions toward testing that are important to document. To begin with, let us consider a simple exchange between an interviewer and a ten-year-old boy:

*Strictly speaking, this task is not vocabulary-defining, but concept-categorizing. If it were to be a vocabulary-defining task, it would take the form

The word "grunts" means _____.

Such a stem would, of course, preclude the choice of noises as the target response.

--What do you think little grunts are?

--Noises, but baby alligators is right.

The word noises was uttered with such disdain that the effect was "any fool knows that grunts are noises, so clearly it cannot be the answer." This supports a point that Aronowitz (1982) has made: if children think of a particular word as familiar, it may be difficult for them to understand a task that calls for this word to be defined. In effect, the very familiarity of the word precludes their considering it to be a target response.*

Fillmore (1981) has made a related point with respect to vocabulary-defining tasks: namely, that the definition that they call for is often not exact. To illustrate this point, he provides the following example:

To seek is to _____.
find see settle search

The target response is search, but Fillmore points out that it differs substantially from seek. We can say, for example, I seek my fortune or I searched the room, but not I search my fortune or I sought the room. The careful reader might well reject search on

*Adult readers may experience the same difficulty, as indicated by the following response:

In a literal sense, the "little grunts" are noises, but that would seem too obvious and uninformative.

these grounds.*

The adults who wrote about their response to this task gave various reasons for feeling that noises was not an appropriate word for defining little grunts. One pointed out that it lacked specificity:

I was going to choose noises, but then decided baby alligators was more specific.

Another pointed out that it lacked thematicity:

Baby alligators was tempting. I've been trained to focus on what's most important in a passage. Noises are not important to me. Baby alligators are.

Another adult identified both of these lacks in a more extended statement:

Since grunts literally are 'noises,' I thought that perhaps noises was the answer. On the other hand, since noises was never mentioned in the selection, I decided that the phrase little alligators** was the only thing in the text that grunts referred to. By noises I assumed the questioner means something more general than 'baby alligator sounds' and that baby alligators were better because that answer located the source of the "noise" more specifically.

*Fillmore makes the further point that selecting find results in a "meaningful, if not particularly wise, proverb: To seek is to find." We can observe, once again, the conflict between the communicative and the acomunicative that we have noted throughout this study (this conflict will be presented more systematically in the chapter that follows).

**Note the conjoining of little with alligators, suggesting that the parallel expressions little grunts and baby alligators have somehow merged.

Lest one think that only adults rejected noises for these reasons, let us observe the thinking of a nine-year-old girl:

--And the little grunts in the story were baby alligators because it says the mother alligator heard her babies but could not see them, the little grunts. They were grunt babies.*

--Ummmm. And why couldn't the answer be anything else?

--Well, it certainly couldn't be eggs. Very unusual for eggs to make grunts. But they could have been noises.

--Why didn't you choose noises?

--Well, baby alligators were much more to the point.

--If someone wished to choose noises, could you say they were wrong?

--Well, I would think that they didn't read very well.

--Well, what if the person said that the grunting sound isn't a baby alligator?

The child now becomes aware that noises is, in fact, the target response and mouths the word in an almost pouting manner (this child prided herself on being a star reader):

*Here is a further example of the tendency to merge little grunts and baby alligators.

--Noises.

Having absorbed this blow to her pride, she quickly counters:

--Okay, they are, but they are also baby alligators. That's more to the point because it didn't say anything about noises.

This child did not initially consider noises and then consciously reject it, as did the adults who are quoted above. When she does, however, formulate her reasons against selecting noises, they are very much like those of the adults: she considers it to be lacking in specificity (i.e., baby alligators is "more to the point") and thematicity (i.e., the passage "didn't say anything about noises").*

In rejecting noises, all these readers evoke, in some form or another, the principle of "lack of exact fit." The use of this principle is somewhat ironic since it was intended to be the basis for choosing noises. Readers were expected to return to the passage, try out the different choices, and select the one that could be directly substituted for little grunts.

*Their baby alligators are coming from a pile of mud and old leaves.

Their noises are coming from a pile of mud and old leaves.

*This child loved to analyze test items and became adept at identifying various problems. We were dismayed to discover that the following year she began to have difficulties with standardized tests. Her teacher observed that she, almost as a matter of principle, would choose a distractor and then defend it passionately. We hope that her participation in our research has not spoiled her as a test-taker. If it has, our only defense is that it has made her a more critical reader.

Such a procedure blocks baby alligators, but as we have demonstrated, because of the way the passage is written, it does not necessarily validate noises. As a further test of the influence of the passage, we gave certain children an altered version of this item in which the crucial sentence was changed to

The baby alligators' little grunts are coming from a pile of mud and old leaves.

Even in this form, every child still chose baby alligators.

This principle of substitutability is supposed to lead the reader to the target response in many test items, but it can, at times, be misleading. Consider NERVOUS HORSE, for example:

Her horse was a little nervous, so she let it trot along slowly. Suddenly, something in the bushes rustled. The horse broke into a canter, then into a full gallop. She held on tightly, talking quietly to try to calm it.

A. Which pace is the slowest?

a canter a rustle

a gallop a trot

B. In the story, "broke into" means

robbed ran into

started tamed

If started, the target response for (B), is substituted for broke into, an ill-formed sentence results:

*The horse started a canter, then a full gallop.

By replacing a with to, one can, of course, achieve a structurally acceptable sentence:

The horse started to canter, then to gallop.

But even this sentence would reflect a certain semantic discontinuity with the original one. The verb broke into introduces an activity that functions in a contrastive relation with a preceding one (i.e., the horse was already trotting when it began to canter, and it was already cantering when it started to gallop). But the use of started does not necessarily carry this presupposition (i.e., you can start up an activity from "scratch"). As a consequence, when started is substituted for broke into, the notion is not preserved that the horse was doing something else before it began to canter.

Using a similar principle, we could claim that noises does not substitute effectively for little grunts in MOTHER ALLIGATOR. Given the stylistic texture of the passage, readers are forced to identify with the mother alligator's point of view, and, as we have suggested, she does not experience the little grunts as 'noises,' but as her own 'baby alligators.' Hence the use of noises is quite inappropriate in representing her experience. The word noises can also be judged as inappropriate, simply by virtue of its generality. The passage reflects a highly specific texture and so cannot readily absorb a word like noises.

Before leaving this item, we would like to note that one of us ran into a child nearly a year and a half after she had taken the

mock-test and participated in an interview. As she reminisced about the test, she began to talk about "mother crocodile" and her babies who were blind at birth but who opened their eyes once they began to move about. The transfer of 'lack of sight' from mother to babies is, of course, motivated by real-world knowledge, but it also provides a further example of leakage from one item to another. One of the practice items on the mock-test began in the following way:

Kittens are blind at birth but once their eyes are open they begin to go adventuring.

As we continued to talk, it became apparent that other items had run together in her memory as well.

Chapter 4

TASK CHARACTERISTICS

The items discussed in Chapters 2 and 3 were classified according to the kind of passage they contained. In Chapter 2, we were concerned with narrative passages. In Chapter 3, we considered three kinds of passages that are used to test reader flexibility. Beyond this major classification, we discussed the items one at a time, providing cross-references whenever important themes recurred.

In this chapter we will use the store of concepts and observations that have accumulated throughout Chapters 2 and 3 to take a systematic look at the tasks that these items contain and to consider these tasks, insofar as we can, apart from the passages they follow. We will first present the formal properties of these tasks and then their functional properties.

Formal Properties of Tasks

As pointed out in Chapter 1, tasks can be divided, purely on the basis of form, into two classes: (1) question tasks and (2) completion tasks. In Chapters 2 and 3, we have pointed out a number of ways in which task form affects what readers must do. We would now like to summarize these observations.

To begin with, in question tasks the question and answer form a natural discourse unit. By contrast, a completion task, in which the first part of a sentence is separated from its

conclusion, has no comparable relationship to everyday experience of language.* One consequence of this difference is that the choices in a question task are always grammatically parallel, as answers must be, while the choices in a completion task can be drawn from different grammatical classes. Here are some of the tasks in which the completers display grammatical variety:

The green trees were

gone dying cedars hollow

GREEN CEDARS (chap. 3, p. 145)

The people were surprised when they saw her

owl blinking goggles white circles

WHITE CIRCLES (chap. 3, p. 27)

The story says that the trees were

flooded strong blown over blown away

HURRICANE (chap. 2, p. 131)

Most of the iceberg is

hidden visible surface top

ICEBERG (chap. 3, p. 95)

*Sometimes speakers pause before the last part of a sentence, searching for words; if they take too long to finish, they may find that someone has finished their sentence for them. Such experiences do not, of course, form a systematic pattern as questions and answers do.

These bridges are

towers long small hung

HUNG BRIDGES (chap. 3, p. 33)

In framing these tasks, readers are unable to work paradigmatically with the stem but are forced to reparse it as they move from one completer to the next. We have accumulated evidence that such reparsing does, in fact, complicate a task considerably.*

A further contrast between question tasks and completion tasks is that only the latter seem to lead to ill-formed target propositions. Consider, for example, the following:

The people were surprised when they saw her
white circles.

WHITE CIRCLES (chap. 3, p. 27)

These bridges are hung.

HUNG BRIDGES (chap. 3, p. 33)

That sentences such as these occur only with completion tasks is probably related to the fact that stems and completers do

*Other tasks could be listed in which the completers require readers to recast the stem semantically:

Biff hammered out a wardrobe by making
a closet a notice home runs suits

ADVERTISING TAILOR (chap. 2, p. 177)

Here the various completers, even though each is a nominal, force readers to interpret making in different ways.

not have a consistent grammatical relationship as questions and answers do (for further discussion of these sentences, see chap. 3, pp. 32-34).

When tasks are examined from the perspective of formal dependence on the passage, a number of other problems emerge. Most prominent are those associated with syntactic elements that we can describe as deictic. We here use this term to refer to elements such as a determiner, a pronominal, or a tense marker, which are used to signal dependence on OLD INFORMATION, that is to say, dependence on information located elsewhere, either in surrounding text or in the larger communicative context.*

Let us first consider the ways in which tasks use determiners and pronominals. In general, information that is encoded nominally in the passage is recycled in fairly explicit form. In certain instances, the plus a noun is sufficient (in the following examples, the the-initiated nominals are bracketed):

What was [the mystery]? a shop sign

SHOP SIGN (chap. 2, p. 5)

Where was [the nest]? inside a tree

GREEN CEDARS (chap. 3, p. 145)

*The way the term deictic is used here differs from the way it was used in Chapters 2 and 3, where it describes a strategy that presupposes use of the 'here-and-now' in processing spatio-temporal information (see Hill, 1982, for a more detailed discussion of the multiple, often conflicting, uses of the term deictic and the confusions that they can engender).

What was [the shelter]? a boat

CHEE TONG (chap. 2, p. 153)

A more refined category can be established by placing a modifier before the head noun:

[The finished towers] are made of steel.

GEORGE WASHINGTON BRIDGE (chap. 3, p. 109)

How did [the fawn's eyes] look? gentle

ALICE AND THE FAWN (chap. 2, p. 71)

Such a category can also be established by realizing the the-initiated nominal as a partitive genitive:

Most of [the trip] was by train.

LEAVING HOME (chap. 2, p. 36)

Most of [the iceberg] is hidden.

ICEBERG (chap. 3, p. 98)

In general, the use of a more reduced form such as a pronominal is avoided, unless the task itself provides an antecedent, ordinarily a nominal introduced by the (in the following tasks both the pronominal and its antecedent are bracketed):

When [the Indians] said "Minnesota," [they] were talking about water.

MINNESOTA (chap. 3, p. 5)

[The people] were surprised when [they] saw her white circles.

WHITE CIRCLES (chap. 3, p. 27)

At first, how long did [the girl] think it would take [her] to learn to read at school? one day

LEARNING TO READ (chap. 2, p. 92)

[The tailor] was surprised to see how much [he] had promised.

ADVERTISING TAILOR (chap. 2, p. 177)

In principle, pronominals whose antecedent is in the same sentence should be easy for children; and yet, as we have seen, many were confused by the use of he in the last task above, aligning it with Biff--who was mentioned in the preceding task--rather than with the tailor (see chap. 2, p. 198-201 for a discussion of this misunderstanding).

There are some pronominals for which the task does not provide an antecedent. Consider the following, for example:

[She] came into town by airplane.

WHITE CIRCLES (chap. 3, p. 27)

In this task the use of a pronominal preserves the style of the passage, which itself opens with As she rolled to a stop (this she is later identified as a woman). In LEARNING TO READ (chap. 2, p. 92), on the other hand, the little girl is referred to only as she in the passage, both tasks then shifting to the girl.

Here is another use of a pronominal without an antecedent within the task itself:

[They] were voting for class president.

CLASS ELECTION (chap. 3, p. 35)

If this task had followed the more explicit pattern, it would look like this:

[The class members] were voting for class president.

The use of the pronominal they avoids use of the word class, thereby allowing it to be used, without redundancy, in the completers:

class president club president a class name a new club

In examining these completers together, we can also observe that they do not use the determiner a consistently: it is used to introduce only two of them, though, in principle, it could have introduced all four.

There are other tasks in which the inconsistent use of determiners in completers has more serious consequences. Consider, for example, the following task, in which three completers are introduced by a or an and the other one is introduced by the:

What was the mystery?*

an appearance the caramel a woman a word

SHOP SIGN (chap. 2, p. 5)

*Apparently a is not used with caramel because this word functions in the passage as a mass noun rather than a count noun. To preserve this sense, it would be preferable, in our opinion, simply

Both mainstream and minority children selected the caramel most frequently--the completer introduced by the--even though, on substantive grounds, it is not a particularly attractive choice. We suspect that the contrast between the and a played a substantial role in this popularity (see chap. 2, p. 11 for a discussion of this point). We suggest, moreover, that, as a working principle, the completers for a given task should make use of the same determiner so as to neutralize the highlighting effects of such a contrast.

Finally, we should note that there may be potential confusion even when completers are consistent with respect to determiner use. Consider, for example, the following task in which all completers are presented without a determiner:

Which pace is the slowest?

canter rustle gallop trot

NERVOUS HORSE (chap. 3, p. 175)

All these choices could well have been preceded by a, given that a full response to the question would be "A trot is the slowest pace." The children we interviewed, however, did not seem to be bothered by this formal discrepancy.

to use caramel rather than the caramel. Certainly the use of the in a completer is odd when the question reflects the form

What was the + [NOMINAL]?

Such a question ordinarily elicits only completers initiated by a.

We would like to end this discussion of determiner use by briefly noting a potential problem in the use of these in the following task:

[These bridges] were hung.

HUNG BRIDGES (chap. 3, p. 175)

These is intended to identify suspension bridges in general; and yet the passage dealt prominently with two suspension bridges in particular--the world's longest and the world's shortest--and the demonstrative these could feasibly refer to these two bridges exclusively. Certainly the use of the full form suspension bridges would have been more in keeping with the explicit style characteristic of these tasks.

While considering deictic elements in these tasks, we would like to note certain inconsistencies in the use of tense markers as well. In general, present tense is used more widely than past tense. To begin with, it is used in all tasks that follow expository passages written in the present tense. Consider, for example, the two tasks in RAISINS (chap. 3, p. 86):

Raisins ARE made from grapes that have a lot of sugar.

What kind of climate IS best for raisin-making?
warm and dry

Present tense is also used in certain kinds of tasks that follow narrative passages written in the past:

(1) tasks that call for recycling of information:

The story SAYS that the air WAS silent.

JAYS AND CROWS (chap. 3, p. 17)

(2) tasks that call for definition of a vocabulary item:

In the story, the word "abated" MEANS died down.

HURRICANE (chap. 2, p. 131)

(3) tasks that call for what the passage is concerned with:

This story IS mainly about sounds.

JAYS AND CROWS (chap. 3, p. 17)

In (1), we can notice that while the main verb is indeed in the present tense, the narrative information represented in the embedded clause is in the past: e.g., "the air WAS silent." When such narrative information is in the main--and only--clause of a task, it is ordinarily encoded in the past tense:

What WAS the mystery? a word

SHOP SIGN (chap. 2, p. 5)

What WAS the shelter? a boat

CHEE TONG (chap. 2, p. 153)

Where WAS the nest? inside a tree

GREEN CEDARS (chap. 3, p. 145)

She CAME into town by airplane.

WHITE CIRCLES (chap. 3, p. 27)

Burbank's plant HAD no spines.

BURBANK'S CACTUS (chap. 3, p. 57)

How DID the fawn's eyes look? gentle

ALICE AND THE FAWN (chap. 2, p. 71)

There are, however, certain tasks in which this pattern is violated. This violation is particularly noticeable when it occurs in only one of the two tasks attached to a narrative passage. In both of the following pairs of tasks, the first uses present tense and the second past, even though narrative information is presented directly in each:

A. Where IS Jim's home? in a city

B. Most of the trip WAS by bus.

LEAVING HOME (chap. 2, p. 36)

A. How old IS the girl in the story? six

B. At first, how long DID the girl think it would take her to learn to read at school? one day

LEARNING TO READ (chap. 2, p. 92)

In each of these items, the shift to present is probably motivated by the feeling that the information conveyed is not part of the narrative flow of the story, but rather part of the background against which the narrated events take place.

In the following task, present tense is used to represent narrative information encoded in the past:

The finished towers ARE made of steel.

GEORGE WASHINGTON BRIDGE (chap. 3, p. 109)

In this case, however, the initial frame of the passage is in the present tense:

The George Washington Bridge . . . SPANS . . .

And, of course, it is still true that the towers of the George Washington Bridge are made of steel.

We may complete this discussion by noting that there is a greater latitude in the use of tense markers in tasks when the passage itself reflects such latitude. In BACTERIA (chap. 3, p. 66), for example, the passage begins with present perfect, shifts to simple past, and then ends with simple present. The first task uses the future and the second the simple present:

- A. Which WILL keep meat from spoiling? salt
- B. Bacteria GROW best when food IS warm and damp.

The use of the future in (A) probably reflects an underlying conditional:

If you add salt to meat, it will keep it from spoiling.

The use of the present in (B) repeats its use in the final sentence

of the passage, which is the source of (B).

It can thus be seen that a number of deictic elements--determiner, pronominal, and tense marker--play roles in determining the relation of a task to a passage, and that it is difficult to use these elements in a totally consistent way. In general, they are used so as to make a task DISCOURSE-CONTINUOUS* and yet the use of a more reductive element such as a pronominal tends to be avoided unless the task itself provides an antecedent. It is clear that children develop some sense of how these deictic elements work in tasks and come to use them heuristically; that is to say, these elements serve to guide children toward an appropriate framing of the task, and so any inconsistency in their use can lead to confusion.

Functional Properties of Tasks

Throughout this study, we have used a wide range of terms in describing the functional characteristics of tasks, and, at times, our analysis has led us to characterize the same task in different ways. There are a number of reasons for this. To begin with, the descriptive terms that we have used function at different levels of generality. Some, for example, refer

*We will later use this same term--discourse-continuous--when we consider whether tasks present information that naturally extends the passage. In certain instances they do--and this can be misleading to children when they deal with tasks that do not, particularly if these tasks follow a passage that the children are naturally inclined to expand.

to functions that are quite specific: vocabulary-defining directly describes a task that requires children to define a word:

In the story, the word "abated" means died down.

HURRICANE (chap. 2, p. 131)

At a more general level, however, the same task can be described as metalinguistic, for it is included in a larger group of tasks that measure some aspect of children's knowledge of language rather than their understanding of the content of a passage. At an even more general level, this task can be described as acomunicative, a term used not only for metalinguistic tasks but for all tasks that do not deal meaningfully with passage content (e.g., those that require only information-recycling).

There is, however, another reason for using different terms with the same task. Given the multiple-choice format, any task can be thought of as, in a sense, actually constituting four tasks. Consider, for example, the various propositions that could result from the following tasks:

What kind of climate is best for raisin-making?

- (a) A warm and dry climate is best for raisin-making.
- (b) A warm and wet climate is best for raisin-making.
- (c) A cool and dry climate is best for raisin-making.
- (d) A cool and wet climate is best for raisin-making.

RAISINS (chap. 3, p. 86)

At first, how long did the girl think it would take her to learn to read at school?

- (a) At first, the girl thought it would take her three days to learn to read at school.
- (b) At first, the girl thought it would take her one day to learn to read at school.
- (c) At first, the girl thought it would take her a few months to learn to read at school.
- (d) At first, the girl thought it would take her a year to learn to read at school.

LEARNING TO READ (chap. 2, p. 92)

Only an inefficient reader would be forced to evaluate each proposition independently and in full; and yet we should recognize that, no matter what cognitive short-hand readers use, they must try out each choice in some form or another; and the task can change in important ways as they move from one choice to the next. We may examine, for example, the alternative choices for a task such as the following:

What did Alice try to do to the fawn?

- (a) Alice tried to help the fawn.
- (b) Alice tried to pet the fawn.
- (c) Alice tried to hug the fawn.
- (d) Alice tried to hit the fawn.

ALICE AND THE FAWN (chap. 2, p. 71)

Most readers are able to dismiss the last two choices quite rapidly, but many linger on the first two. In experimenting with

the target response pet it, readers must decide whether or not the goal of the task is vocabulary-defining, therefore metalinguistic, and therefore acommunicative. It should be pointed out that this goal is not overtly indicated, as it could have been. Drawing on a widely used formula, the task could have been presented as

In the story, the word "stroke" means pet.

In fact, children who select pet it are required, in some sense, to make this adjustment.*

In experimenting with the alternative choice, help it, readers must decide whether or not the task is communicative, i.e., concerned with what Alice was really trying to do in petting the fawn (for a fuller discussion of the difficulty in deciding between these choices, see chap. 2, pp. 85-87). As readers work with these two choices, they are required to alternate between constituting the task as communicative and constituting it as acommunicative; at some point, however, they must decide which, in fact, it is. Such a decision is metacognitive, reflecting, in large measure, a reader's own understanding of how tasks function on a standardized test. The strategies that readers develop for making these metacognitive decisions about various tasks is a subject that we will not explicitly deal with in this study. Here we will be concerned with describing what it is that tasks require

*We will deal with these matters more fully when we come to consider vocabulary-defining tasks.

readers to do in order to select the target proposition.*

There is one final point that we wish to make about the use of multiple terms for a single task. Even in attending only to what is required to select the target response, we still find that certain tasks, even at the most specific level, are not readily described with a single term. Consider, for example, the following task:

Raisins are made from grapes that have a lot of sugar.

RAISINS (chap. 3, p. 86)

As we will shortly see, this task can be categorized as literal, given that it requires certain information to be recycled (i.e., Raisins are made from sweet varieties of grapes). But it can also be categorized as vocabulary-defining, given that it requires children to understand that the word sugar can be used generically.

Literal Tasks

Let us begin our work on functional categories of tasks with the familiar distinction between literal and inferential. As we pointed out in Chapter 1, these are the terms that are generally

*We do plan, along with Enid Pearsons, to deal with these strategies in a forthcoming article entitled "Reading Tests and Children's Metacognitive Decisions." In this article we raise the question of what the relation is between children's metacognitive decisions about a multiple-choice task and their ability to comprehend what they read.

used in characterizing tasks. Here, for example, is what the manual for the Gates-MacGinitie tests has to say:

The question types can be grouped into two general categories: literal questions and inferential questions. A literal question asks about something that is explicitly stated in the passage; it involves a restatement or a paraphrase (in Levels A and B, it involves a picture of something described in the passage). An inferential question asks about something that is only implied in the passage. Examples of inferential questions are those that ask the student to see logical relationships between different parts of a passage, to summarize a situation, to choose the main idea, to infer the feelings of a character or the author, or to understand the purpose or the reason for an action, when these are not directly stated.

It is useful to examine more closely the use of the word literal in this passage. This word is used to describe a "question" that "involves a restatement or a paraphrase" of "something that is explicitly stated in the passage." Presumably restatement and paraphrase, when conjoined in this way, are intended to distinguish between REPEATING something word for word and REPHRASING it. In making this distinction, however, it is important to bear in mind that no task, whether in our corpus or in the standardized tests that we have examined, repeats something in the passage word-for-word. There are, however, tasks that do parallel some passage segment quite closely. Notice the relation between the target proposition and the source sentence for the following tasks:*

*Within the source, the following conventions are used: the words to be selected as target response are capitalized, whereas words repeated in the task stem are bracketed.

TARGET PROPOSITION:

These bridges are hung.

SOURCE:

[Suspension bridges are HUNG] from towers
by strong cables.

HUNG BRIDGES (chap. 3, p. 33)

TARGET PROPOSITION:

Raisins are made from grapes that have a
lot of sugar.

SOURCE:

[Raisins are made from] sweet varieties of
grapes.

RAISINS (chap. 3, p. 86)

In the first example, the target proposition repeats the first four words of the source sentence except for replacing suspension with these. In the second example, the first four words in each are exactly the same:

Raisins are made from . . .

And yet, considered as repetition tasks, these two are strikingly different. In the first, the word to be chosen as the target response occurs in the passage, whereas in the second it does not. In fact, linking sugar, the target response, with sweet is one of the major difficulties that children have with this task. As already suggested, the task may be better understood as a vocabulary-defining task requiring children to extend their everyday understanding of the

word sugar (see chap. 3, pp. 93-94 for discussion of this point).

In our categorizing of literal tasks, we will use the term REPEATING to describe tasks in which the target response actually repeats a word or phrase in the passage; and the term REPHRASING to describe tasks in which the target response does not repeat such a word or phrase.

This focus on the target response, as opposed to the task stem, may seem somewhat arbitrary. We believe, however, that it is motivated, given what we have observed of children working with multiple choice tasks. They know that these tasks often require a kind of hunt-and-find operation; and so when they have difficulty with a task, they become attracted to whatever choice repeats some word or phrase in the passage.

Let us recall, for example, how powerful these repetition distractors were in the following tasks:

DISTRACTOR PROPOSITION:

At first, how long did the girl think it would take her to learn to read at school? three days

SOURCE:

In THREE DAYS I can read.

LEARNING TO READ (chap. 2, p. 92)

DISTRACTOR PROPOSITION:

The final count was 17 to 17.

SOURCE:

The count was 17 TO 17.

CLASS ELECTION (chap. 3, p. 35)

Both of these tasks--but particularly the first--present complications that may force children to settle for a hunt-and-find operation; but even when the complications in a task are less severe, children select a repetition distractor with surprising frequency. In evaluating this frequency, we need, of course, to bear in mind that these distractors are ubiquitous on reading tests. It is only natural for testmakers to select words and phrases from a passage as distractors. This is illustrated in our corpus by canter and gallop in NERVOUS HORSE; eggs and old leaves in MOTHER ALLIGATOR; lead, hard, and thick in HARD LEAD; top, surface, and visible in ICEBERG; Golden Gate, towers, long, and small in HUNG BRIDGES; gophers, prairies, products, and bread in MINNESOTA; candies, Mrs. Doyle, a shop, and an appearance in SHOP SIGN; and cook, tie up, go up the river, and a stove in CHEE TONG.*

Children are often inclined to choose a repetition distractor when they are having difficulty with a task. Such a distractor seems to be particularly seductive when it is an abstract word whose meaning children are unsure of: for example, words such as

*We might note here that distractors such as tie up or go up the river have considerable appeal. They lead to rather provocative sentences that some children seem unable to resist:

The two men tied up together.
The two men went up the river together.

arrangement in CHEE TONG or an appearance in SHOP SIGN. We have pointed out a couple of reasons why these words may be tempting. To begin with, they are "big words," and so seem to be appropriate for reading tests. In effect, they sound like words to be used on a school task. Moreover, children seem to be motivated by a strategy familiar to all. Whenever they are in trouble, they assume that the unfamiliar is the source of that trouble. It is as though they view these unknown words as providing some kind of key with which they can unlock a task.

Repeating Tasks

Let us now turn to the actual tasks that we have classified as repeating. In analyzing both repeating and rephrasing tasks, we will be particularly concerned with whether they recycle passage information whose locus is COMPACT or DIFFUSE. We will first consider three tasks that repeat passage information that is highly compact:

- (1) The story says that the air was silent.

JAYS AND CROWS (chap. 3, p. 17)

- (2) The green trees were cedars.

GREEN CEDARS (chap. 3, p. 145)

- (3) How did the fawn's eyes look? gentle

ALICE AND THE FAWN (chap. 2, p. 71)

The target proposition for all three merely expands a modifier-head combination that can be found in a single nominal in the passage:

TARGET PROPOSITION	SOURCE
(1) The <u>air</u> was <u>silent</u> .	the <u>silent air</u>
(2) The <u>green</u> trees were <u>cedars</u> .	the <u>green cedars</u>
(3) Its <u>eyes</u> look <u>gentle</u> .	its large <u>gentle eyes</u>

We might note, in passing, that (1) uses the formula The story says to signal overtly that information is to be recycled; and we suspect that the presence of this formulaic expression may have contributed to children's performing somewhat better on this task than on the other two.

On the surface, these tasks appear to be easy, and yet the children performed surprisingly poorly on all three. It may be that repeating tasks are, in some sense, too easy. It is clear from our interviewing that some children viewed the expansion of a modifier-head relation as too trivial to be the target response, particularly since, in the context of the passage, the modifier does not seem to carry crucial information. In the case of (2) and (3), this triviality is accentuated by the possibility of selecting an alternative response--dying and frightened--which results in a communicative proposition far more congruent with the tone of the passage (see ALICE AND THE FAWN, chap. 2, pp. 82-85 and GREEN CEDARS, chap. 3, pp. 150-158 for further discussion). We might add that the tendency to provide communicative alternatives seems to be heightened on literal tasks that call for recycling of what appears to be quite incidental information. We doubt that such heightening is merely accidental, for we have noticed, in our own experience of

plant a more speculative distractor alongside a target response that might be considered matter-of-fact.

We would like to point out how misleading the term literal can be in describing these tasks, for children must do a good deal of inferencing in deciding whether they should respond communicatively or acommunicatively. We can describe such inferencing as tactical in order to distinguish it from the content inferencing involved in dealing with the actual substance of the target proposition. It is somewhat ironic that tactical inferencing for literal tasks often makes far greater demands on children than the content inferencing they must do for inferential tasks.*

There are other repeating tasks that call for the retrieval of more diffusely spread information (and, we might add, information that is less incidental than that expressed by a modifier-head combination in a nominal). In the following tasks, for example, the target proposition recycles information located in a single sentence:

TARGET PROPOSITION:

Icebergs are made mostly of fresh water.

SOURCE:

[An iceberg is a large chunk of frozen
FRESH WATER] that floats in the sea.

ICEBERG (chap. 3, p. 98)

*This point will be dealt with in our forthcoming article on children's metacognitive strategies.

TARGET PROPOSITION:

These bridges are hung.

SOURCE:

[Suspension bridges are HUNG] from towers
by strong cables.

HUNG BRIDGES (chap. 3, p. 33)

In some cases, the target proposition even recycles information
spread over two or three sentences:

TARGET PROPOSITION

The people were surprised when they saw her
white circles.

SOURCE:

[When she raised her goggles they were even
more surprised.] She had been flying into
the sun all day and [her face was sunburned
a bright red except for the WHITE CIRCLES
around her eyes where the goggles had
protected her].

WHITE CIRCLES (chap. 3, p. 27)

TARGET PROPOSITION:

Which will keep meat from spoiling? salt

SOURCE:

From the earliest times, [people have found
ways to keep meat from spoiling]. The
Ancient Egyptians kept grain in dry, cool
storehouses. [They added SALT to fish and
meat] or dried them in the sun.

BACTERIA (chap. 3, p. 66)

It can be seen that the tasks described earlier as formally

infelicitous surface here as well. It is not surprising that they do, for these tasks call for a recycling of information embedded in an extended context. Thus the larger pattern of detail that allows readers to make sense of that information may be lost in the very process of trimming it to fit the task format, and what remains may be so partial that some readers are unable to accept it.

There is another sense in which the target proposition may be fragmentary with respect to the source information that it recycles. In the first example on page 24, the target proposition includes the word mostly, and is thus more restricted than the source information. Careful readers who notice this discrepancy are forced to decide whether it is significant enough to affect their response (see chap. 3, pp. 99-100 for discussion of this matter).

Throughout Chapters 2 and 3, we pointed out how certain tasks require readers to deal with only part of a larger whole within the passage. In these instances, however, our focus was on extracting one bit of information structurally linked to another bit within a single nominal (in the examples below, the bit of information to be recycled is capitalized, the structural link is underlined, and the nominal is bracketed):

TARGET PROPOSITION:

Alligators lay their eggs in mud.

SOURCE:

Their little grunts are coming from a pile
of [MUD and old leaves].

MOTHER ALLIGATOR (chap. 3, p. 161)

TARGET PROPOSITION:

What was Miss Esther expecting to see?
a black bonnet

SOURCE:

There was no [BLACK BONNET with a worn
lace veil], no old lady with a burden
of bundles.

BLACK BONNET (chap. 2, p. 49)

TARGET PROPOSITION:

You choose a hard lead to make lines
that are light.

SOURCE:

If you want your writing to be [thick
and DARK], you select a pencil with a
soft lead.

HARD LEAD (chap. 3, p. 49)

It is not difficult to see how the loss of information on these tasks parallels that on tasks such as These bridges are hung. Both kinds of losses were, at times, troubling to children, who apparently worked with a heuristic that might be stated like this: A task proposition is not acceptable if it recycles information in only partial form.

Formal schooling provides a ready source for such a heuristic. Teachers often set up tasks that invite partial answers, and then mark them wrong in order to teach children to be thorough. This traditional practice has been promoted into an educational philosophy by curriculum specialists such as Bereiter and Englemann (1966), whose program for children with a "language deficit" involved

having them recycle language in its "full form." Questions such as Where is the book? are to be answered with the "logical form" The book is on the table rather than the "non-logical form" on the table, thus violating the communicative norms of everyday conversation. Bereiter and Englemann claimed that persistent use of such logical form in school tasks would help to develop a capacity in language-deficit children for processing the "formal properties [of] written language necessary for the organization of thought" (p. 113). It is not surprising that, under the influence of such educational thought and practice, a good number of children may come to believe that any partial response can work against them on a school task--that it must be rejected by virtue of its incompleteness, however attractive it may seem in other respects.

Rephrasing Tasks

In general, rephrasing tasks recycle information whose locus is less compact than it is in repeating tasks. There is, however, one rephrasing task that does bear some resemblance to those repeating tasks that recycle the information in a single nominal:

TARGET PROPOSITION:

Burbank's plant had no spines.

SOURCE:

a plant experimenter, [Luther Burbank],
produced [a SPINELESS variety of prickly-
pear cactus].

BURBANK'S CACTUS (chap. 3, p. 57)

Clearly readers have to work with a good deal of information beyond the bracketed material in order to carry out this task; but once they do, this material can be recoded as "Burbank's spineless plant" so that it parallels the task. From this version the modifier-head combination can be expanded into the target proposition:

TARGET PROPOSITION	SOURCE
Burbank's <u>plant</u> had <u>no spines</u> .	Burbank's <u>spineless plant</u>

As can be seen, this expansion differs somewhat from those elicited by repeating tasks: it involves the verb have rather than be as well as a transformation of a negative suffix to a separate word negative. This rephrasing task was a good deal easier for children than the repeating tasks that merely expanded a modifier-head combination. The need to equate no spine with spineless seems to give some point to the task. Some children, in fact, felt that this task was "really to find out what the word spineless means," and, in fact, it might be more appropriately classified as a vocabulary-defining task. We should also note that children's greater success with this task may have to do with the nature of the information it recycles. In contrast to repeating tasks, it recycles information that is central to the passage.

Let us examine one other task that requires readers to rephrase information located compactly in the passage:

TARGET PROPOSITION:

Miss Esther stepped forward when the train left.

SOURCE:

[As the cars pulled away, she took a few steps forward] to scan the platform.

BLACK BONNET (chap. 2, p. 49)

The target proposition, as the arrows indicate, reverses the order of the two clauses underlined in the source sentence. But apart from this reversal, there is a good deal of resemblance. The main clause, for example, is much the same in each:

TARGET: Miss Esther stepped forward

SOURCE: She took a few steps forward

Even the subordinate clauses are somewhat parallel in form:

TARGET: When the train left

SOURCE: As the cars pulled away

Nevertheless, many children who failed to connect cars with train were unable to select the target response. This failure further illustrates how a task classified as literal inevitably involves some kind of inferencing; for in order to select the target response, children must infer that since a train itself comprises cars, the particular cars that pulled away from the station were not individual automobiles, but segments of the train (see chap. 2, pp. 63-69 for a discussion of how contextual features cue this inference).

The need for inferencing becomes even more pronounced as we consider literal tasks that require readers to rephrase information

located diffusely in the passage. Whenever readers chunk together bits of information located in separate sentences, they have to make certain kinds of inferences, which we will describe as DISCOURSE INFERENCES, to distinguish them from the content inferences and tactical inferences we have discussed so far. Perhaps the most familiar kind of discourse inference is one based on an assumption of referential stability across sentences. To illustrate, let us consider the following tasks:

(1) TARGET PROPOSITION:

Where is Tiny Bridge? in Boston

SOURCE:

[The world's smallest such bridge may be in the Boston Public Garden. No great ocean liners sail under Tiny Bridge], but Swan Boats do.

HUNG BRIDGES (chap. 3, p. 33)

(2) TARGET PROPOSITION:

Where was the nest? inside a tree

SOURCE:

Low, near the ground, a [black hole opened into the hollow trunk of the tree. Inside the hole a mother bear lay on a nest of grass and leaves.]

GREEN CEDARS (chap. 3, p. 145)

In (1), readers need to assume that the same bridge is referred to by The world's smallest such bridge in the first sentence and Tiny Bridge in the second; and in (2), they need to assume that the same hole is referred to by a black hole in the first sentence and

the hole in the second. Such assumptions are so automatic that adult readers are hardly conscious of making them; and yet we found that they were difficult for some children. In (1), for example, children were unable to draw on a familiar cue such as deictic the in relating Tiny Bridge to the previously mentioned bridge; rather they had to make a lexical connection between Tiny and smallest, which, however, many were unable to do. It is as though Tiny ceased to have any lexical meaning because it was part of a proper name.

There are, in addition, inferences based on more general principles of DISCOURSE COHERENCE. These principles, which perhaps have been best articulated by Grice (1980), lead readers to assume that contiguous bits of information are meaningfully related. To illustrate these, let us consider, once again, the repeating tasks that require readers to recycle diffusely located information:

TARGET PROPOSITION:

Which will keep meat from spoiling? salt

SOURCE:

From the earliest times, [people have found ways to keep food from spoiling]. The ancient Egyptians kept grain in dry, cool storehouses. [They added salt to fish and meat] or dried them in the sun.

BACTERIA (chap. 3, p. 66)

When readers process the general statement that begins this passage,

they are disposed to assume that the more specific statements that follow are intended as exemplification. Hence the activity of adding salt to meat is taken to be a way of keeping meat from spoiling.

The repeating task below illustrates another kind of inference:

TARGET PROPOSITION:

The people were surprised when they saw her white circles.

SOURCE:

[When she raised her goggles they were even more surprised.] She had been flying into the sun all day and [her face was sunburned a bright red except for the white circles around her eyes where the goggles had protected her.]

WHITE CIRCLES (chap. 3, p. 27)

When readers learn that the townspeople were surprised, they are disposed to process all the details that follow as explaining that surprise. The nature of the task requires them to make a further inference. In examining all these details (the goggles, the white circles around the woman's eyes, the blinking), they must identify the white circles as the particular feature that best explains the surprise. This second inference would probably not be so difficult to make, if the choice of white circles did not result in such an odd-sounding sentence. As it is, however, this sentence provides further evidence for the claim that we made earlier: literal tasks that require information to be recycled are more likely to result in ill-formed sentences.

We would like to close our discussion of literal tasks by making two observations. First, there is so much inferencing involved in these tasks that the very use of the term literal can be called into question. We have identified a variety of inferences, distinguishing primarily between those that are tactical and those concerned with content. We did not pursue tactical inferencing in any great depth, for it rapidly leads into the complex world of metacognitive strategies that children work with on these tests, and, as mentioned, we plan to deal with this subject in a separate publication. We did, however, discuss content inferences in more detail, distinguishing between those used in working with relatively isolated bits of information and those used in chunking together such bits. We identified the latter set as comprising discourse inferences; and they were divided, in turn, into those assuming referential stability in particular chains and those assuming coherence relations between contiguous items of information.

Our second observation has to do with whether the information to be recycled in these literal tasks has a compact or diffuse locus within the passage. As we have seen, each kind of locus presents its own difficulties. It can be argued, for example, that the more compact the information, the greater the ease with which it can be retrieved. We have seen, however, that this is not always the case, and we have suggested reasons for the difficulties that children experience. In the first place, the more compact the information to be recycled, the more acommunicative the target

proposition; and, as we have pointed out, certain children may resist going back to pull out some isolated bit of information, particularly when a more communicative alternative is available. Moreover, they may have difficulty in even finding that bit of information. This difficulty is obviously greater when the information is not central to the passage; and as we have seen, the highly compact bits of information to be recycled often seem quite trivial when considered within the larger discourse.*

By way of contrast, the argument can be made that it is the more diffusely located information that should be easier to retrieve, since it tends to be more salient; and yet, this too is not necessarily the case. Clearly there is some kind of trade-off, for the retrieval of diffusely located information presents difficulties of its own. As we have pointed out, a variety of discourse inferences are necessary to facilitate retrieving such information; and children can experience a good deal of difficulty in making these inferences.** Even if they do make them, they may carry the inferencing process

*We should note that as test passages increase in length, this problem of finding the information becomes more severe. We can remember our experience with recycling items on standardized tests at the secondary level, where we often had the sense of looking for "a needle in a haystack."

**We would like to note that children can apparently make these kinds of inferences more easily as listeners. This is, no doubt, partly due to their experience in using the rich supply of paraverbal and nonverbal cues that make these inferences clear. It takes time for children to develop competence in using the compensatory mechanisms that written discourse provides to replace such cues. It would be most useful to study the different ways in which children make discourse inferences as they listen and as they read.

too far, ending up with more information than they need. The process of discourse inferencing can easily get out of hand, particularly given the oral norms of interpretation that children tend to work with.

By thus claiming that all literal tasks can be inherently difficult, we do not wish to minimize the importance of distinguishing between a compact and a diffuse locus for the information that needs to be recycled. As we have seen, a particular difficulty can often be better understood once the nature of the locus has been clearly identified. Hence, we believe that the distinction between the two kinds of loci has many potential uses. Testmakers, for example, can use this distinction to help evaluate the various kinds of recycling tasks that they set for children; and teachers can use it to prepare children to work more efficiently with the recycling tasks that they must face, not only on standardized tests but in larger texts as well.

Inferential Tasks

In reviewing the difficulties children experience when trying to process literal tasks, we were able to observe that even these tasks require a good deal more inferencing than might be expected. Tactical inferencing, content inferencing, and discourse inferencing all play crucial roles in the processing of literal tasks, and so it is clear that we can justify our use of the term inferential to delimit some other group of tasks

only if we establish differentiating criteria, identifying inferential properties that differ substantively from those we have described in the preceding section.

We can begin, as we did with the term literal, by examining how inferential is defined in the Gates-MacGinitie Teacher's Manual, (quoted on p. 18) where the term is applied to any "question" that "asks about something...only implied in the passage," and is then illustrated by five kinds of tasks. These tasks require students

- (1) "to see logical relationships between different parts of a passage"
- (2) "to summarize a situation"
- (3) "to choose the main idea"
- (4) "to infer the feelings of a character or the author"
- (5) "to understand the purpose or the reason for an action."

This list, obviously not an exhaustive one, exemplifies only a few of the varied inferential tasks encountered on the Gates-MacGinitie tests. Moreover, the list includes tasks that occur at all levels of these tests, and is thus not particularly applicable to tasks at the lower levels. Categories (4) and (5), for example, do not occur in our corpus or in the Level C tests that we have examined. This is true, at least, if only the target responses are considered. The distractors, however, are another matter. They often lead children to make exactly these kinds of inferences with unfortunate results. In working with MOTHER

ALLIGATOR, children, inferring the "feelings" of the mother alligator, identify "little grunts" as baby alligators rather than noises (for fuller discussion, see chap. 3, pp. 164-166); and in working with ALICE AND THE FAWN, children, looking for Alice's purpose in stroking the fawn, choose help it instead of pet it, (for fuller discussion, see chap. 2, pp. 85-87). We might question whether it is fair, at these early grade levels, to allow the sort of inferencing that is elsewhere legitimately encouraged to lead only to distractors.* This problem is particularly pronounced when such distractors are included in tasks that follow imaginatively written passages, as they do in the two cases mentioned above. We could, in fact, imagine a test whose main purpose was to find out whether children could make these kinds of inferences in response to a certain imaginative style of prose.

In moving from categories (4) and (5) to examine the first three categories of inferential tasks, we can see that (1), seeing "logical relationships," is so general that it, in some sense, encompasses the others. Certainly the ability to "see logical relationships" is a necessary component in "summarizing a situation" or "choosing the main idea." Indeed, the very generality of

*It is not at all clear just how widely reading tests at more advanced levels do, in fact, reward these inferences. Categories (4) and (5) describe the kinds of questions that are often encountered in 'language arts' textbooks but not on standardized tests. We might note that such gaps between "the curriculum" and "the tests" can easily confuse students, who are trying to establish analytical and imaginative patterns of response that relate to both.

(1) means that it cannot be easily operationalized as a descriptor for a specific group of inferential tasks; it is certainly not sui generis with the two descriptors that follows. Their greater specificity makes them more useful in delineating subsets of inferential tasks. In fact, two of the categories that we have delineated match these two quite closely.

Since the list provided by the manual is not well-suited for sorting out the tasks that we are here concerned with, we have developed our own categories. Before presenting them, we would like to recycle our "working criterion" for sorting tasks into the larger, superordinate categories: literal and inferential. We have said that only if a task recycles overtly expressed information can it be described as literal, and that if it does not, it is to be described as inferential. This principle, although easily stated, can be difficult to apply. Many of the tasks we have classified as literal can be considered to go beyond mere recycling. At the same time, given the stringency of our criterion, the inferential category tended to become a place where we could, so to speak, "sweep the leftovers." The work of further sorting has, in consequence, been quite difficult.

In our initial sorting, we found a distinction between content-oriented and structure-oriented tasks to be particularly useful. This distinction readily led to another that has been fundamental to this study, the one between communicative and acommunicative: for it is the structure-oriented inferential tasks, when combined

with literal tasks, that form the acommunicative class, thus leaving the content-oriented inferential tasks to form the communicative class (we will return to this distinction in the summary of this chapter and suggest a more refined way in which to classify tasks as communicative and acommunicative).

Content-Oriented

In our further sorting of content-oriented tasks, we have been concerned, in particular, with (1) the kinds of passages to which these tasks are attached and (2) the kinds of information that they call for. The first may be thought of as constituting the inference base and the second the inference result.*

Factual versus Fictional. In examining the inference base, we have found the distinction between a factual passage and a fictional passage to be fundamental. We can distinguish between these two kinds of passages in the following way: a factual passage presents information belonging to a general stock of knowledge whereas a fictional passage does not.** The information

*Our focus on content-oriented inferencing should not be surprising, given our global orientation to discourse analysis. Indeed, we are often ill at ease with the purely formal classifications of inference found in current theories of discourse-processing. Many of them seem not to be sufficiently constrained by the content on which inferencing operates. To our mind, a "psychological" characterization of inferencing needs to be carefully balanced by a "texto-logical" one. For it is the text itself-- a particular body of subject matter encoded in a particular sequence of words-- that ultimately generates the inferential processes.

**This distinction between information fields should not be confused with the distinction between expository and narrative as modes of discourse.

presented by a factual passage may be generic, specific, or some combination of the two.

GENERIC:

Raisins are made from sweet varieties of grapes.

RAISINS (chap. 3, p. 86)

SPECIFIC:

The plan for the bridge [the George Washington Bridge] called for stone coverings over the two towers.

GEORGE WASHINGTON BRIDGE (chap. 3, p. 109)

COMBINED:

GENERIC: Suspension bridges are hung from towers by strong cables.

SPECIFIC: Golden Gate Bridge in San Francisco is one of the world's longest suspension bridges.

HUNG BRIDGES (chap. 3, p. 33)

Generic information deals with a class of entities (e.g., raisins or suspension bridges) whereas specific information deals with a particular entity (e.g., the George Washington Bridge or the Golden Gate Bridge). Given this distinction, a statement such as Alligators lay their eggs in mud qualifies as generic since it is concerned with what all alligators do, not with what a single alligator does.*

*We should note that such a statement is often thought of as specific, since it is concerned with low-level information.

The factual passages in our corpus generally present only generic information.* Hence, they tend to omit the kinds of specific information that play such important roles (e.g., exemplification, substantiation, contrast, etc.) in more extended bodies of factual discourse. We can thus observe again how externally imposed brevity distorts these passages.

If the factual passages in tests can, theoretically, make use of generic or specific information, the fictional ones in our corpus present, by way of contrast, only specific information:

SPECIFIC:

An advertising tailor put a sign on the
ballpark fence.

ADVERTISING TAILOR (chap. 2, p. 177)

Here we are in a particular world, where one person does a particular act at a particular point in space and time. This claim of invariant specificity should, however, be qualified. First of all, fictional passages can vary a good deal as to how much specification they provide, and of what kind. Passages like JAYS AND CROWS and GREEN CEDARS, while readily perceived as fictional, do not so much tell a story as set the scene for action to follow (for fuller discussion, see chap. 3, pp. 17-18 and 145-146). Nevertheless, our criterion holds: these passages do take us to a particular place, a particular time. Secondly, it is important to

*The combining of generic and specific in HUNG BRIDGES should thus be considered an exception.

remember that however much fictional and factual passages may differ, brevity is as much a constraint in the fictional passages as in the expository ones. Unlike more extended bodies of fiction, these passages contain no "Proustian moments," no moments of larger generalization in which they leave behind their particular worlds. In effect, they suffer from a lack of generic information. Both kinds of exclusion remove us from the more hybrid forms of discourse that ordinarily enrich fact and fiction alike.

We can summarize the foregoing with the following diagram:

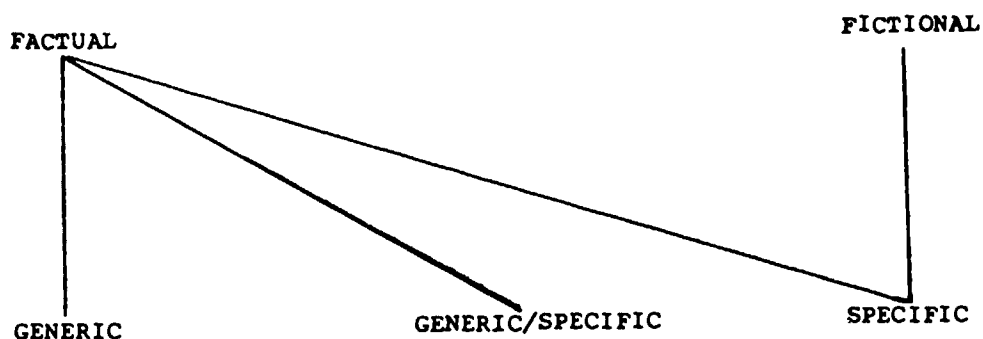

This diagram can, in point of fact, function as a heuristic for identifying the kind of information that any task calls for, whether it is classified as literal or inferential. Various tasks that we have already classified as literal can, for example, be viewed as recycling

(1) generic information from a factual passage:

These bridges are — 2.

HUNG BRIDGES (chap. 3, p. 33)

(2) specific information from a factual passage:

Where is Tiny Bridge? in Boston

HUNG BRIDGES (chap. 3, p. 33)

(3) specific information from a fictional passage:

The green trees were cedars.

GREEN CEDARS (chap. 3, p. 145)

But while this framework might have provided a useful perspective for literal tasks, it proves to be particularly illuminating when applied to inferential ones. Readers are necessarily more actively involved in producing information for an inferential task, since they are required to do much more than merely retrieve it from the passage.

Passage-Dependent versus Passage-Independent. The extent to which readers rely on their own experience varies greatly, according to the kinds of information they are required to infer. If that information is fictional, the reader is, in principle, confined to working from within the passage, as in the following task:

At first, how long did the girl think
that it would take her to learn to
read? one day

LEARNING TO READ (chap. 2, p. 92)

If children do not understand the passage--and many didn't--they cannot draw on any general body of knowledge in working out a response. In effect, the passage is their only recourse if they

want to respond to the task at all. We can refer to such a task as passage-dependent.

On the other hand, when children deal with a task that follows a factual passage, particularly one that contains generic information, they can, in principle, deal with the task independently of the passage; and so we will refer to this kind of task as passage-independent.* A typical example is

Bacteria grow best when food is warm and damp.

BACTERIA (chap. 3, p. 66)

Because this information is generic, children still have the possibility of dealing with the task as a self-contained unit even if they do not understand the passage. Whether or not they have any firm knowledge about bacteria and food spoilage, they can, working with their own experience, make some kind of guess that may, in fact, pan out.

Let us recall, with reference to BACTERIA, how two children we interviewed responded to the question: "How did you get the answer

*The passage-independence of factual information is, of course, only potential. In point of fact, an individual reader does not necessarily possess that information (we suspect, on the basis of our interviewing, that children at these grade levels seldom possess, at least not firmly, the factual information contained in the passages).

The use of the term passage-dependence for fictional information also needs qualification. This information may be drawn from material that children have read (e.g., ALICE AND THE FAWN is taken from Through the Looking Glass), and so they may possess it independently of the passage.

warm and damp? One child said,

Well, I think I had a sock that got all wet and I left it out somewhere for a long time....

As we pointed out, he presumably associated bacteria with his once having gotten athlete's foot, and it was a wet sock which caused that infection. The other child said,

Well, bacteria's all bad when it's wet and damp, and moldy food's the same way.

As we pointed out, she presumably worked off some set of intuitions that might be represented in the following way:

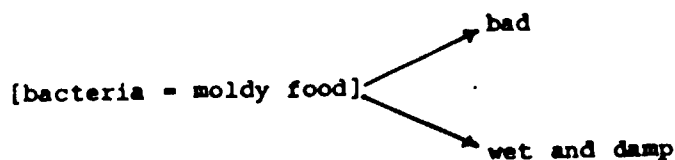

This strategy of drawing upon personal experience works less well when specific information is called for, as it is in the following task:

Where is Tiny Bridge? in Boston

HUNG BRIDGES (chap. 3, p. 33)

Children who are confused by this passage are not in a position to work out any kind of response; they either know or don't know that Tiny Bridge is in Boston. We should perhaps qualify this statement. First of all, children with a certain level of literate

experience may be far more likely to have access to the "factual base" of fictional discourse. Tiny Bridge, for example, figures prominently in Make Way for Ducklings, a children's book that is widely read in middle-class homes. Once again, we can document an advantage that accrues to children raised in literate households, a foothold on reading tests that other children do not have. A second qualifying point is that children can often guess intelligently and effectively, even on a task that calls for a specific fact, if that fact is, in turn, rooted in generic information. Such is potentially the case in the following task:

The finished towers were made of steel.

GEORGE WASHINGTON BRIDGE (chap. 3, p. 109)

Even if children are confused by the passage (and, again, many were), and even if they know nothing about the George Washington Bridge as such, they can draw on a body of more general knowledge in order to make a reasonable guess. As one child put it, "I chose steel because that's what bridges are made of." In effect, this child was able to exploit generic information (i.e., suspension bridges are usually made of steel) to produce valid specific information (i.e., the towers of the George Washington Bridge are made of steel).

Researchers have often noted the kind of distinction that we are drawing here. Some have even questioned whether reading tests should include factual passages at all, given that children

may be able to respond to a task appropriately, without having clearly understood the passage. On the basis of our own experience with children and reading tests, we can appreciate why this question is posed. But in responding to this question, there are a number of factors that need to be borne in mind. First of all, we should not lose sight of the substantial ways in which children draw on general knowledge, even in dealing with fictional passages. Children's use of such knowledge is particularly noticeable when they are asked to cope with what we have termed a gapped narrative. In working, for example, with ADVERTISING TAILOR (chap. 2, p. 177), they need a fairly clear understanding of baseball to fill in the various gaps. It is also helpful if they are aware that in the world of advertising, a commercial offer can be described as a "promise." To pull together any sensible picture of CHEE TONG (chap. 2, p. 153), another gapped narrative, the occidental child needs to construct what may seem to be a rather bizarre world, perhaps out of bits and pieces of knowledge gleaned from classes in social studies, from television, or from other examples of fiction. And consider how difficult it is for children to understand the worlds of, say, SHOP SIGN (chap. 2, p. 5) or WHITE CIRCLES (chap. 3, p. 27) without drawing on general knowledge. A child's ability to process the language of the text is simply not enough.

But it is not just that children need to use general knowledge in order to provide an intelligible context for a fictional passage. Even here they may be able to make use of such knowledge, such as

they might with a factual passage to frame a response to a task independently of the passage. It is quite possible to do so, for example, in responding to the following task:

How old was the girl when she went to school? six

LEARNING TO READ (chap. 2, p. 92)

Many children were not able to infer the target response six from the passage itself, given the complexity of the final sentence (see chap. 2, pp. 110-112 for discussion). Nevertheless, they were able to use general knowledge in selecting this response. As one child put it, "I chose six because that's how old kids are when they go to school." Of course, general knowledge is not very reliable in this particular situation; other children chose four for the very same reason. Obviously, in our culture, with its proliferation of options like nursery school, kindergarten, or other pre-school programs before first grade, there is no single age at which children necessarily begin school. Depending on how the word school is interpreted, children could select four, six, or even some other age if it had been provided. Such inherent variability should itself have been a cue to avoid using general knowledge in responding to this task (contrast, for example, the task dealing with Wynne Bridge's location, for which only one response can be "factually correct"). Children who were confused by LEARNING TO READ, however, had to make use of whatever knowledge they could bring to bear on the task.

One other inferential task from our corpus can be used to illustrate much the same point, i.e., that generic knowledge--even accurate generic knowledge--can hinder as well as aid one's choice of a target response. The subject is horse's paces and the task is

Which is the slowest? trot

NERVOUS HORSE (chap. 3, p. 175)

The confusion in this task is compounded by an odd use of verb tense that appears to shift the focus of the task away from its apparent goal--away from a quest for specific information. That is, we would expect a request for specific, passage-dependent information to make use of the simple past, as in, "What was the slowest (pace used by the horse in the story)?" The verb is calls instead for generic information (i.e., the slowest pace that any horse uses), thereby priming children who have some equestrian background to reject the target response. One eleven-year-old girl, with experience of horses, was able to choose correctly in any case. Wise in the way of tests, she commented that she had chosen trot in spite of the fact that it is not really the slowest gait, because "it's the slowest one they give here."

It seems clear, then, that general knowledge plays an important, if unpredictable, role in children's responses to a fictional passage. But factual passages present peculiar problems of their

own. In our experience these problems have less to do with the risk that children independently possess the specific knowledge needed to respond to the tasks than with the fact that they often lack the kind of framing-knowledge that would allow them to comprehend various factual passages, particularly those that we have described as polarity-passages. As we have claimed, such passages are highly elliptical; and while adult readers may lack the information that polarity-tasks call for, they can, using their ability to frame, to contextualize, somehow flesh out the passage to obtain that information. In effect, they are able to work with the gapped structure of the passages, patching in the missing bits of information that the tasks call for.

What we are claiming is that child readers are not in a position to do this very effectively. As a consequence, the children we interviewed often had to resort to bodies of personal experience so as to make sense out of an elliptical, factual passage. This strategy could work for them at times (e.g., on BACTERIA a child's reference to his "wet sock", but at other times it only led them astray (e.g., on RAISINS a child's reference to keeping raisins in the refrigerator).

Interestingly enough, it is often thought that one reason children are likely to misunderstand a fictional passage is that it motivates them to draw inappropriately on personal experience. But in our own interviewing we found that children were just as likely to misuse personal experience in dealing with a factual

passage (indeed, in the case of polarity-passages such misuse seems even greater).*

We have previously raised doubts about the legitimacy of including factual passages in the reading tests that are created for early grade levels. The possibility that these tasks may be dealt with quite apart from the passages raises serious questions about their efficacy as tests of reading at any age. But the developmental issue that we have raised is, in our own thinking, an even more basic one at these early levels. We seriously question whether children at this age can reasonably be expected to comprehend factual information when it is presented so elliptically that the communicative norms of expository prose seem to be violated. The difficulties inherent in such elliptical texts are exacerbated in the polarity items, and, as we have seen, it was the tasks following these items that most frequently forced children to draw on their personal experience in quite misleading ways.

A major claim in this study has been that a good number of

*It is not particularly surprising that children may misuse personal experience even more in interpreting factual passages. To begin with, such passages are ordinarily in an expository mode and it is clear that children have less experience in dealing with this mode. But it is not simply that they deal more efficiently with a narrative mode; for even when factual information is presented in this mode they tend to have difficulty in handling it. This difficulty can presumably be traced to a lack of the general knowledge they need for framing factual information. As a consequence, they must resort to personal experience as a means of framing such information. By way of contrast, they have better access to the kinds of general knowledge that allow them to frame fictional information intelligibly. Moreover, their personal experience can fit better within these general frames, and so they are more likely to use such experience reliably.

children's aberrant choices come from their tendency to extend a passage further than the task warrants, and we have pointed out how a fundamental characteristic of the passages--externally imposed brevity--contributes to this tendency. We have seen, too, how the presence in a task of certain deictic elements--determiners, pronominals, and tense markers--can also encourage readers to view tasks as passage-continuous. But there is yet another kind of passage-task relationship that fosters and rewards this general tendency. In this case, tasks do, in fact, present information that is meant to extend the passage, by focusing on generic information that grows out of the passage, but is not actually contained in it. We may illustrate this by placing together the final sentence and the first task of HARD LEAD (chap. 3, p. 49):

FINAL SENTENCE: If you want your writing to be thick and dark, you select a pencil with a soft lead.

TASK (A): You choose a hard lead to make lines that are light.

We can see that the final sentence and (A) form a natural sequence. None of the other polarity items includes a task that so directly extends the passage, but each does include a task leading to a target proposition that might be described as "summarizing": and these propositions, too, can be considered as extending the passage:

Bacteria grow best when food is warm and damp.

BACTERIA (chap. 3, p. 66)

What kind of climate is best for raisin-making?
warm and dry

RAISINS (chap. 3, p. 86)

Most of the iceberg is hidden.

ICEBERG (chap. 3, p. 98)

The finished towers are made of steel.

GEORGE WASHINGTON BRIDGE (chap. 3, p. 109)

If what we have here are tasks that naturally require extensions of a passage, it is clear that they contribute to habits of thinking that encourage the very activity for which children are so often penalized; namely, viewing tasks as calling for information that extends a passage rather than information to be recycled from some portion of the passage. We suggest that this is a matter to which testmakers should give serious attention.

We would like to raise one other matter, while dealing with the misleading effects of passage-task relations. All three of the following tasks require that children perform an arithmetical operation in order to infer specific information from a fictional passage:

How old is the girl in the story? six

LEARNING TO READ (chap. 2, p. 92)

At first, how long did the girl think it would take her to learn to read? one day

LEARNING TO READ (chap. 2, p. 92)

The final count was 18 to 17.

CLASS ELECTION (chap. 3, p. 35)

As already suggested, the operation required by each is relatively simple, and yet children had a good deal of difficulty in setting up these calculations. This difficulty is understandable in the case of the two tasks in LEARNING TO READ, for the passage includes verbal complexities that effectively prevent children from figuring out how to set up the calculations (see chap. 2, pp. 94-98 for discussion). In the case of CLASS ELECTION, however, the passage presents no comparable complexities, and still children did poorly. We suspect, as already suggested, that some of this difficulty results from the fact that children simply do not expect calculations to be a requirement in a reading test, particularly for a task based on a fictional passage. It is perhaps worth mentioning that none of the tasks based on factual passages required any similar kind of calculation, although such passages might offer a more expected context for numerical manipulations.

At this point, it may be useful to point out that few of the inferential tasks we have classified as content-oriented do, in fact, follow fictional passages. In addition to the three listed above, there were only three others:

Where is Jim's home? in a city

LEAVING HOME (chap. 2, p. 36)

Most of the trip was by train.

LEAVING HOME (chap. 2, p. 36)

She came into town by airplane.

WHITE CIRCLES (chap. 3, p. 27)

It should be remembered that there are 13 fictional passages in our corpus and so among the 26 tasks that accompany them only 6 can be readily classified as requiring that specific information be inferred (as we have seen, even half of these required that some calculation be performed). At the same time, we would like to point out that 5 of the 6 tasks included at least one distractor that might have been selected if children had done the kinds of inferencing naturally associated with fictional prose. We are not quite clear about the significance of this distribution. To begin with, we are not at all certain how representative our own corpus is. We did, however, examine the Level C tests, Forms 1 and 2, and found roughly the same patterns of distribution: only 15 out of the 50 tasks based on fictional passages required that specific information be inferred. We would like to point out, however, that children are naturally disposed to do a good deal of inferencing when reading a fictional passage. Consider, for example, the rich variety of inferences that we have documented on a passage such as ALICE AND THE FAWN. Much of this inferencing seems to be naturally motivated by the imaginative quality of the passage itself. Hence, we might raise the question of whether fictional passages in tests should be followed by so few content-oriented

These tasks are often thought of as belonging to the third category of inferential tasks identified by the Teacher's Manual; namely, those that require readers "to infer the main idea." The main idea-category seems to be largely cued by their use of a standard formula that includes "mainly about:"

The/This story is mainly about _____.

The use of the term main idea is, however, misleading in describing these tasks. In the first place, none of them follows a passage that actually has a well-articulated main idea as does, say, BACTERIA, which, following the canonical model for expository paragraphs, opens with what is clearly a main idea:

From the earliest times, people have found ways to keep food from spoiling.

and then goes on to provide supporting detail.

It is, of course, possible to identify a main idea that has not been explicitly stated, at least for an expository passage.* For MINNESOTA, for example, the following might serve as a statement of its main idea:

The state "M_nnesota" has many different names.**

*As we have suggested, it is quite confusing even to use the term main idea with reference to narrative passages such as SHOP SIGN or JAYS AND CROWS.

**As already pointed out, this proposition is not readily identified as a main idea. It seems rather to be the kind of idea

These tasks are often thought of as belonging to the third category of inferential tasks identified by the Teacher's Manual; namely, those that require readers "to infer the main idea." The main idea-category seems to be largely cued by their use of a standard formula that includes "mainly about:"

The/This story is mainly about _____.

The use of the term main idea is, however, misleading in describing these tasks. In the first place, none of them follows a passage that actually has a well-articulated main idea as does, say, BACTERIA, which, following the canonical model for expository paragraphs, opens with what is clearly a main idea:

From the earliest times, people have found ways to keep food from spoiling.

and then goes on to provide supporting detail.

It is, of course, possible to identify a main idea that has not been explicitly stated, at least for an expository passage.* For MINNESOTA, for example, the following might serve as a statement of its main idea:

The state "M_nnesota" has many different names.**

*As we have suggested, it is quite confusing even to use the term main idea with reference to narrative passages such as SHOP SIGN or JAYS AND CROWS.

**As already pointed out, this proposition is not readily identified as a main idea. It seems rather to be the kind of idea

This task, strictly speaking, does not articulate the passage's main idea; it merely indicates its subject matter.* This limitation is of course, dictated by test-format: the subject matter of a passage can be represented by a nominal group--the kind of language structure called for by a completer--whereas an entire clause is needed to represent a main idea.

All three tasks of the mainly about-tasks were extremely difficult for children, and we have already discussed a number of factors that may have contributed to this difficulty. To begin with, the term story, as used in these tasks can be misleading. From a technical point of view, the term is not even appropriate for MINNESOTA, but even more to the point, "story" is likely to suggest more extended discourse. In addition, the truncated quality of these passages suggests, in each case, that more is to come. We have shown how both SHOP SIGN and JAYS AND CROWS are merely setting the scene for a larger story (see chap. 2, pp. 5-7 and chap. 3, pp. 17-18 for discussion); and as we have suggested, even MINNESOTA, given its subject matter, is best viewed as a kind of "expository preamble." Hence, certain children had difficulty in believing that "the story" was about just a shop

used rhetorically to initiate some other set of more central concerns.

*We would prefer to use the term topic, but it does not work well for the other two tasks. They are both based on a fictional passage, and neither SHOP SIGN nor JAYS AND CROWS can be easily described as having a topic. Even the more neutral term subject matter does not work particularly well for these narrative-descriptive passages.

sign, sounds, or Minnesota's names. None of these seemed sufficiently weighty to be the "real subject matter" of "the story." Given that these tasks are designed to elicit an all-encompassing generalization about discourse structure, it is quite easy for children to generalize about what is implied as well as what is actually present.

In considering the three tasks together, we have shown how they share a certain property that may be misleading to children: they all follow passages that are conspicuously truncated. But this common property of the passages exists only at the level of content. At the level of discourse-structure, these passages, given the demands of the mainly-about tasks, have to be processed in quite opposing ways; and this opposition can itself be misleading to children. In processing SHOP SIGN, readers have to hold on to an initial discourse frame, even though incoming information threatens to dislodge it; but in processing MINNESOTA and JAYS AND CROWS, readers have to do the opposite: they must abandon one discourse frame and replace it with another as they work cumulatively with various bits of information in the passage. Hence, the discourse-processing strategy rewarded in SHOP SIGN is penalized in both MINNESOTA and JAYS AND CROWS and the strategy rewarded in the latter two is penalized in the former. This constitutes a further inconsistency among tasks that can be misleading to children.

Hence, these mainly about-tasks are not what they seem to be. Judging from their surface, they appear to be tasks concerned

directly with content, asking what "the story is mainly about;" and so they are generally classified as sui generis with all the other inferential tasks that we have considered thus far. But, in actuality, they can be better understood as requiring readers to generalize about the discourse structure of the passage rather than its content. Hence, we will refer to them as metalinguistic, and include them with the other tasks whose primary concern is to ascertain whether readers can deal with some aspect of language structure represented in the passage. This language structure may range from the level of discourse--as represented by the mainly about-tasks--to the level of an individual word--as represented by the vocabulary-defining tasks.

Before turning to the latter tasks, we would like to consider a particularly troubling aspect of mainly about-tasks: they belong to a whole genre of school tasks that include actual main idea-tasks (e.g., "What is the main idea of this paragraph?") as well as best title-tasks (e.g., "What is the best title for this story?"). These tasks are so firmly established in school curricula and testing that their role is seldom questioned. We are willing to grant that such tasks have value in training children to examine discourse from a highly general perspective. But we would like to raise another issue: to what degree do these tasks measure any of the comprehension skills that we actually use in real-world reading? In reflecting upon our own experience as readers, we find little evidence for the particular kinds of generalizing processes that

these tasks call for. And while such processes are crucial in reading, they do not ordinarily lead to isolating a single topic or a single main idea, but rather to constructing what might best be described as an information network, in which idea and fact are finely intermeshed at various levels of generality. From our vantage point, both the teaching and testing of reading skills should be more oriented to these networks rather than to a single topic or main idea.

Vocabulary Item. Among the other structure-oriented tasks are vocabulary-defining tasks, which can, in principle, be viewed as inferential, requiring readers to use passage context in order to establish the meaning of a vocabulary item that they do not know. The following task can illustrate how this inferencing process works:

In the story, the word "abated" means died down.

HURRICANE (chap. 2, pp. 131)

This task satisfies both of the conditions identified above:

- (1) it calls for the definition of a word that children can be presumed not to know (and, in fact, none of the children whom we interviewed could give the meaning of abated before reading the passage)
- (2) children can use context to infer the meaning of this word (see chap. 2, pp. 151-152 for discussion of how the

connective luckily can be used to infer the meaning of abated).

These two conditions are, however, rarely achieved together on vocabulary-defining tasks. It is more common for tasks to focus not on a vocabulary item that is altogether unknown, but on some lesser known sense of a relatively familiar item. Such is the case in the following two tasks:

In this story, "called for" means required.

GEORGE WASHINGTON BRIDGE (chap. 3, p. 109)

In the story, "broke into" means started.

NERVOUS HORSE (chap. 3, p. 175)

Both called for and broke into are familiar items, but the particular use of each activates a lesser known meaning.* Moreover, this meaning cannot be readily traced to any one isolable feature of the passage content (as in HURRICANE where the particular use of luckily as a connective leads directly to the meaning of abated). Rather, it comes from the general framing that is necessary in processing each passage. This framing is activated, in the first passage, most directly by the word plan; and in the second by the collocative patterning of the words horse, trot, canter, and gallop.

*The most familiar definition of each is provided as a distractor: picked up in the case of called for and robbed in the case of broke into.

Although in the last two items meaning is to be derived from context, these tasks are clearly not passage-dependent in the same way as the HURRICANE-task is. For each, the passage functions mainly as a vehicle for placing a certain vocabulary item before children. And while the passage is used to determine whether children can identify one among several possible meanings for the item, a single sentence could have served this purpose equally well:

The horse broke into a canter

or, for that matter, even a single phrase:

break into a canter

Once again, we may raise the question of whether a particular kind of task should be included on tests of reading comprehension. Vocabulary defining tasks might be more appropriately reserved for some separate testing procedure, unless they are, like the HURRICANE-task, dependent on the passage in a more radical sense.

However this question is responded to, we should in all fairness point out that all the above tasks do indicate clearly that they require some vocabulary item to be defined. All make use of the same formulaic stem:

In the story (the word) "....." means _____.*

*The expression the word is included only when the vocabulary item consists of a single word (e.g., abated).

But not all vocabulary-defining tasks signal this requirement overtly. Consider what is really being called for in the following tasks:

What did Alice try to do to the fawn? pet it

ALICE AND THE FAWN (chap. 2, p. 71)

The story says that trees were blown over.

HURRICANE (chap. 2, p. 131)

Burbank's new plant did not live long in nature because it was eaten up.

BURBANK'S CACTUS (chap. 3, p. 57)

On the surface, these tasks do not resemble the ones that we have just considered; and yet at a deeper level they, too, require children to define a particular vocabulary item: stroke in the first, knocked down in the second, and devoured in the third. These tasks might well have directly reflected this intent, by using the formulaic stem identified above:

- (1) In the story, the word "stroke" means _____.
- (2) In the story, "knocked down" means _____.
- (3) In the story, "devoured" means _____.*

Had they been formulated in this way, the tasks would, no doubt, have been easier for children.

*This overt form of the task calls for an "active" definition of devoured (i.e., eat up), whereas the covert form actually used called for a "passive" definition.

In fact, we presented the three items with the tasks in this form to 25 children in the fourth grade with the following results: 18 selected the target response for (1), 19 the target response for (2); and 21 the target response for (3). This high rate of success is not surprising; for, as already pointed out, most children who select an alternative response on one of these tasks actually know the meaning of the vocabulary item that is called for. Indeed, the very fact that they know the meaning seems to work against their constituting the task as merely vocabulary-defining. This perspective has been developed by Aronowitz in an article on children's test-taking strategies (1982). He illustrates it with the following sentence-completion task taken from a well-known test:

If you capture a rabbit, you _____.
hurt it kill it tease it catch it

Aronowitz makes it clear that the choice of catch it, the target response, results in a sentence whose two clauses have "virtually identical propositional content." By way of contrast, the choice of the other responses--hurt it, kill it, tease it--result in an information structure that we are more likely to associate with a conditional sentence (i.e., one part of the sentence expresses a condition, the other a result). Hence children need to know that the goal of this task is to test their knowledge of the word capture, or else they are likely to prefer a response that leads to a more normal use of a conditional sentence. But Aronowitz

goes on to point out that children are less likely to detect this goal if they know the meaning of the word capture (i.e., this knowledge prevents their perceiving this word as "test-worthy").

We would like to make one other point about these tasks that call for vocabulary-definition in covert form. Given the frequent use of the formulaic stem in vocabulary-defining tasks, it may be that children come to rely on it, and so whenever it is not used, they have difficulty in perceiving the metalinguistic intent. And just as the absence of the formulaic stem may be misleading to children, the absence of only its core--the verb means--may be misleading as well. Consider, for example, the use of are in the following task:

~~The "little grunts" in the story are noises.~~

MOTHER ALLIGATOR (chap. 3, p. 161)

This task does not call for the kind of definition ordinarily found in a dictionary, and so the stem cannot incorporate the verb means:

The "little grunts" in the story means noises.

*As linguists, we place an asterisk before a sentence to indicate that it is judged to be grammatically unacceptable. Such a judgment is often a matter of degree. In this regard, it is interesting to note how certain changes lead to an ever greater acceptability of the sentence even when it contains means rather than are:

(1) move in the story to sentence-initial position:

In the story the "little grunts" means noises.

The task is, however, metalinguistic in that it requires children to deal with the expression "little grunts" as purely a linguistic item, selecting a term for the more general category to which this expression belongs. They are thus forced to ignore a communicative interpretation, one based on the expressive power of "little grunts" as a means of identifying the baby alligators themselves (see chap. 3, pp. 168-171 for a more extended discussion of this task).

There is one task in the corpus that requires metalinguistic recategorizing directly opposed to that required by the MOTHER ALLIGATOR-task:

What was the shelter? a boat

CHEE TONG (chap. 2, p. 153)

Here readers must move from the general to the particular (i.e., they must begin with a general category and then select the entity which, on the basis of the passage, best fits into this category). This movement from general to particular was somewhat less

(2) remove the word the preceding "little grunts:"

In the story, "little grunts" means noises.

(3) remove both the and little:

In the story, "grunts" means noises.

We take this increasing acceptability as further evidence for our essential claim: the form of this task is strongly marked for a content-oriented response rather than a structure-oriented one.

difficult than the one from particular to general required by the MOTHER ALLIGATOR-task. But then the CHEE TONG-task presented no comparably compelling distractor. In this instance the most attractive distractor was a house, that which is most readily associated with shelter in ordinary usage.

We would like, at this point, to raise again the difficulty that children have in extending the meaning of a vocabulary item beyond the one that they use in their everyday experience. In the following tasks, neither of which is, strictly speaking, vocabulary-defining, the word set up as the target response must be extended beyond its most familiar meaning:

- (1) Raisins are made from grapes that have a lot of sugar.

RAISINS (chap. 3., p. 86)

- (2) The tailor was surprised to see how much he had promised.

ADVERTISING TAILOR (chap. 2, p. 177)

In the first, children must be able to understand sugar as referring to a substance in natural products as well as in artificial ones; and in the second they must be able to understand promise as referring to a commercial commitment as well as to a personal one (see chap. 3, pp. 92-94 and chap. 2, pp. 204-207 for further discussion of these extensions). From a developmental perspective, it is not at all clear that third and fourth grade children can reliably extend the meaning of these words, many

seemed unable to abandon an experiential understanding of familiar words for a more generic understanding.

Stylistic Feature. The third group of metalinguistic tasks, from a structural vantage point, may be perceived as intermediary to the two groups considered thus far in that tasks in this group are concerned with a level of structure more local than discourse as a whole and yet more global than a vocabulary item. Unfortunately, there is no one term that easily describes the variety of features that operate at this level. Nevertheless, we have found the term stylistic, if taken in its generic sense, to be useful in characterizing these features.

Figurative Language. As we have seen, a good number of tasks require children to work with figurative language. In general, such tasks require them to identify what some figurative expression in the passage actually means, as in the following task:

Biff "hammered out a wardrobe" by making
howe runs.

ADVERTISING TAILOR (chap. 2, p. 177)

(see chap. 2, pp. 189-193 for the various complications that children face in working out what the expression "hammered out a wardrobe" means).

What was Miss Esther expecting to see?
a black bonnet

BLACK BONNET (chap. 2, p. 49)

In order to select the target response, children must understand that a black bonnet stands for the old lady who was wearing it, the person Miss Esther was expecting to see. As already pointed out, however, some of the children who selected this response did not have any such understanding, and yet they received the same credit as the children who did (see chap. 2, pp. 58-60 for fuller discussion).

Not only does this task fail to discriminate adequately between children who understand the figurative expression and those who do not, it also fosters and reinforces the expectation that a figurative interpretation is perfectly permissible in a target proposition. As illustrated by the register-items in Chapter 3, this is the very kind of expectation that can lead children to accept distractor propositions such as "The green trees were dying" or "The 'little grunts' in the story are baby alligators." We found, in fact, that sensitive readers preferred these propositions, and whether they actually selected them or not was largely a matter of judging whether a given task could tolerate a figurative interpretation.

There are other tasks in which figurative language potentially plays a role in children's responses, even though such language does not appear in the surface of the task itself. In JAYS AND CROWS (chap. 3, p. 17), for example, figurative language in the final sentence is, as it were, the culminating cue that motivates the target response in 'The story is mainly about sounds.' Moreover, we have suggested that overly figurative language in a

passage may encourage children to supply a figurative interpretation where it is not expressly called for. In WHITE CIRCLES (chap. 3, p. 27), for example, the final simile like a boiled owl seems to have encouraged some children to interpret the verb flying in a figurative way, thereby supporting their choice of the distractor car in the task "The woman in the story arrived by _____." As we pointed out, the choice of car is already a logical possibility for this task; and this choice is substantially encouraged if a child assumes that the passage is written in a figurative register.

We might note that children can be misled in a comparable way on the following task:

The story is mainly about a shop sign.

SHOP SIGN (chap. 2, p. 5)

The target response shop sign is not used figuratively, if we consider only its referential function (i.e., it is used to refer to an actual sign hanging in front of the newly opened shop). But if we consider its rhetorical function it might indeed be described as figurative (i.e., the initial focus on shop sign is merely a rhetorical means of getting the discourse underway, and it is clear that the sign is not the real subject of this discourse or any discourse that might follow). Understanding shop sign as functioning figuratively at a rhetorical level may prevent a child from responding with the target answer to the above task (see chap. 2, pp. 5-6 for fuller discussion).

Non-Figurative Language. Not all tasks categorized under stylistic feature involve figurative language. A number of tasks may be included here if we think broadly of the various ways in which a task can presuppose children's knowledge of stylistic features. The following task provides a graphic example:

How old is the girl in this story? six

LEARNING TO READ (chap. 2, p. 92)

In responding to the task, children, should, in principle, work with information in the final sentence of the passage:

A year? A whole year? Maybe not till she was seven? That would be awful!

But as we have pointed out many cannot do so. They are unfamiliar with the style indirect libre in which this sentence is written. They fail to understand that this style can be used to express a world of unspoken thoughts. Missing are the familiar signposts that set off what a person says or thinks--quotation marks and an expression like She said or She thought.*

This is a clear example of how a task that requires children to work with a stylistic feature associated primarily with written expression can be enormously confusing for children whose primary experience of language is oral, for nothing in that experience will have prepared them to process that feature. As we have

*Such expressions are totally absent in LEARNING TO READ, even though direct quotation is used three times.

suggested, many children with adequate decoding skills (i.e., children who can readily convert written language to speech) still lack various kinds of knowledge that written discourse calls for. Consider what might appear to be a relatively straightforward demand, the processing of quotation marks. Children tend to view these marks as exclusively setting off quoted speech, and yet only two of the passages, in addition to LEARNING TO READ, use them in this way:

"Our new president," she said, "is Jason Brandt!"

CLASS ELECTION (chap. 3, p. 35)

"Here, then! Here, then!" said Alice....*

ALICE AND THE FAWN (chap. 2, p. 71)

In addition, one task uses quotation marks in this way:

When the Indians said "Minnesota," they were talking about water.

MINNESOTA (chap. 3, p. 5)

The most frequent use of quotation marks in tasks is to identify words that are being referred to as words. This metalinguistic use is present in all three tasks that we have identified as overtly vocabulary-defining:

*The use of quotation marks is not dialogic in either passage in that a single utterance is represented.

In this story, the word "abated" means died down.

HURRICANE (chap. 2, p. 131)

In this story, "called for" means required.

GEORGE WASHINGTON BRIDGE (chap. 3, p. 109)

In the story, "broke into" means started.

NERVOUS HORSE (chap. 3, p. 175)

Apart from the above uses, there are only two other tasks in our corpus that use quotation marks:

- (1) The "little grunts" in the story are noises.

MOTHER ALLIGATOR (chap. 3, p. 161)

- (2) Biff "hammered out a wardrobe" by making home runs.

ADVERTISING TAILOR (chap. 2, p. 177)

In dealing with the first task, certain children treated the quotation marks as signaling that "little grunts" was "like a nickname" for the baby alligators. This is, from our vantage point, a more plausible understanding than the one that test-makers would presumably provide in justifying the target response noises: namely, that the quotation marks merely indicate that the expression little grunts is being recycled from the passage. There are two problems with this latter position. To begin with, quotation marks are not generally used in tasks that recycle passage material. In the following tasks, for example, neither

mystery nor shelter is placed in quotation marks:

What was the mystery?

SHOP SIGN (chap. 2, p. 5)

What was the shelter?

CHEE TONG (chap. 2, p. 153)

Moreover, the other task that uses quotation marks to set off passage material encloses a figurative expression (i.e., "hammered out a wardrobe"); and extrapolating from this use, it is not difficult to view the quotation marks setting off little grunts in much the same way. A child who reasoned this way would be in a position to maintain a powerful heuristic, at least with respect to the tasks in our corpus: namely, that tasks use quotation marks in recycling passage material only when it is to be interpreted figuratively.*

Before leaving the matter of quotation marks, let us briefly return to the task that uses them to indicate direct speech:

When the Indians said "Minnesota," they were talking about water.

MINNESOTA (chap. 3, p. 5)

*We should note that it is not necessary, strictly speaking, to choose between these two functions. It would be possible to view quotation marks as indicating (1) that passage material is being recycled and (2) that it is to be interpreted figuratively. A similarly dual function could be set up for the use of quotation marks in vocabulary-defining tasks: (1) passage material is being recycled and (2) this material is to be treated as a "language example."

Not only does the task stem include "Minnesota," but the target response has to be retrieved from passage material which is itself placed between quotation marks: "sky-tinted water." Here quotation marks are used to indicate a translation of the Indian word Minnesota. We should reiterate that children at these grade levels are not very familiar with the multiple uses of quotation marks. In this instance they are likely to take these marks as indicating what the Indians "really said," and since Minnesota seems like an English word, it is hard to imagine that it needs translation. In addition to this, children are likely to experience the phrase "sky-tinted water" as sounding much more "un-English" than the "ordinary English" word Minnesota. Upon the basis of our interviewing, we are willing to venture that most children were totally turned around on this matter of "what the Indians said."*

It seems appropriate to conclude this section by re-examining a task, that, in many respects, can be considered the prototype for all the metalinguistic tasks:

What was the mystery? a word

SHOP SIGN (chap. 2, p. 5)

Both the passage and the task possess features that encourage

*From a functional point of view, it is, of course, only the strange-sounding sky-tinted water that provides the children meaningful entry into what the Indians said.

children to view any number of the major elements in the passage as mysterious: the shop, its owner--that "dealer in candies"--and what she was dealing in--"candies, homemade taffies, confectionery, and sundries" (see chap. 2, pp. 7-15 for discussion of how these various elements seem "mysterious" to children). Hence it is difficult to restrict the term mystery to the one word sundries that was written on the shop sign. And yet this is precisely what children must do in order to respond to the task appropriately. They need, in short, to understand that it is a mere word that is the "mystery."

This separating of language, as transmitting vehicle, from what it transmits is a feature shared by all the tasks that we here describe as metalinguistic. Children's difficulty with such tasks can be traced, in part, to a natural disposition, while reading, to deal with what language refers to rather than language itself; or to put it another way, they tend to experience the two as a seamless web. For young readers, the shop is, at the same time, a word and a thing; and Mrs. Doyle is both a name and a person.

This meshing of the two levels seems, in part, due to the way in which meaning is mediated by written language. In the case of writing, the entire world of meaning to be communicated is, in some sense, language-dependent; that is to say, it takes its source directly from language, though it may, of course, extend far beyond what is seemingly present in the words themselves. In most

experiences of oral language, on the other hand, a good deal of the meaning is mediated by channels other than purely verbal ones: for the information provided by the paraverbal and nonverbal channels so richly amplifies, restricts, and contradicts that which is verbally mediated. Moreover, speech is often quite incidental to quite complex worlds of experience, sensate and otherwise. In writing, on the other hand, any such worlds must, in some sense, be summoned by language. They are not, as is so often the case with speech, simply there.

Given that meaning is more language-dependent in written communication, it is not surprising that children, while reading, may have difficulty in consistently maintaining the distinction between words and what they refer to. It is as though they blur these two levels and so cannot easily deal with metalinguistic tasks that require them to view language as merely a formal tool, separated from the meaning that it transmits.

Summary

In this chapter we have examined tasks in our corpus from a number of perspectives and would now like to summarize the various classifications that we have made. Our main system of classifying tasks, which takes as its point of departure the distinction between literal and inferential tasks provided by the Teacher's Manual, is displayed on page 80.

TASK CLASSIFICATION

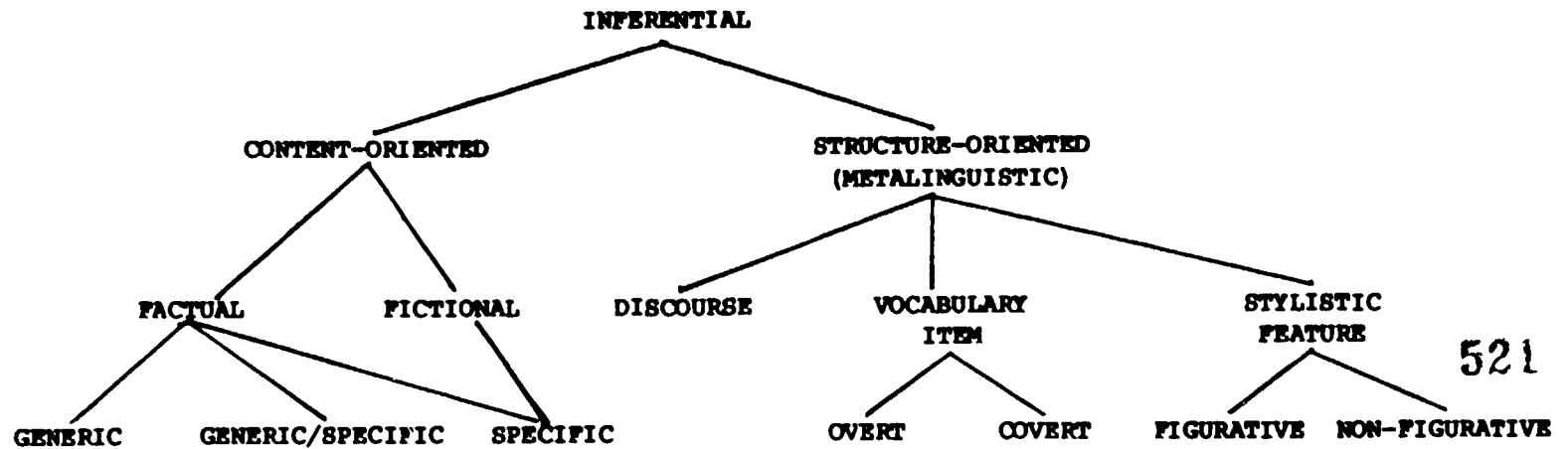
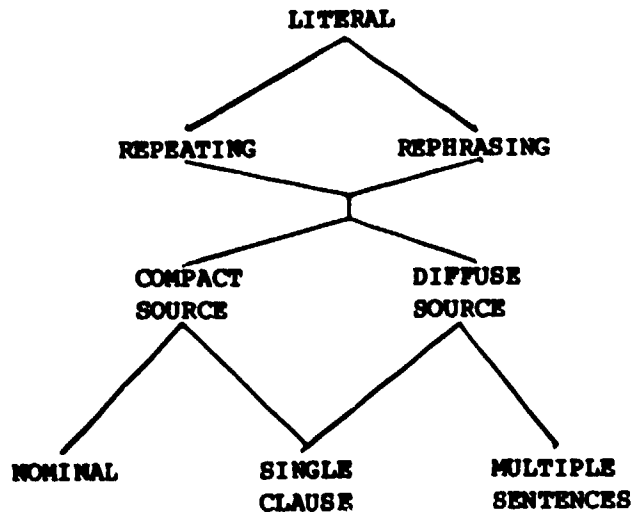

520

521

In addition to our main system, we have suggested two regroupings that cut across the distinction between literal and inferential. First, we regrouped tasks as either passage-dependent or passage-independent, as illustrated on page 82. In working with this distinction, the following points need to be borne in mind:

- (1) a passage-dependent approach to a given task is merely potential and individual readers do not necessarily avail themselves of it, but even if they do not, the fact that they can tends to affect whatever approach they do work out
- (2) tasks classified as passage-dependent (i.e., content-oriented inferential tasks) may, in fact, be approached in a passage-independent way (e.g., "Which is the slowest? a trot")

Second, we regrouped tasks as either communicative or acom-
municative, as illustrated below:

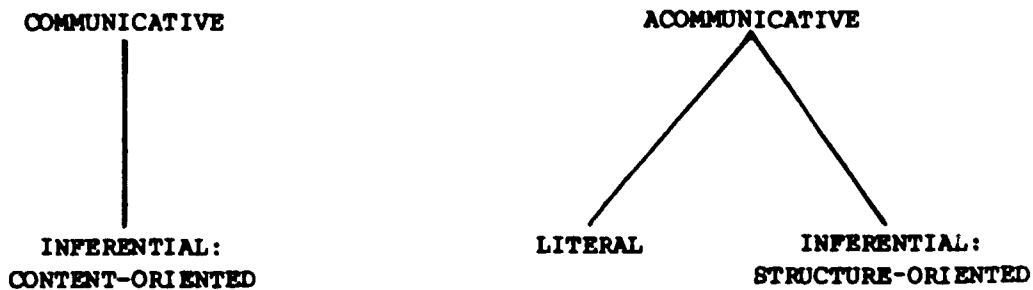

This distinction between communicative and acommunicative could be extended to lower levels of the classificatory system, in which case the more specific categories of tasks could be placed along a

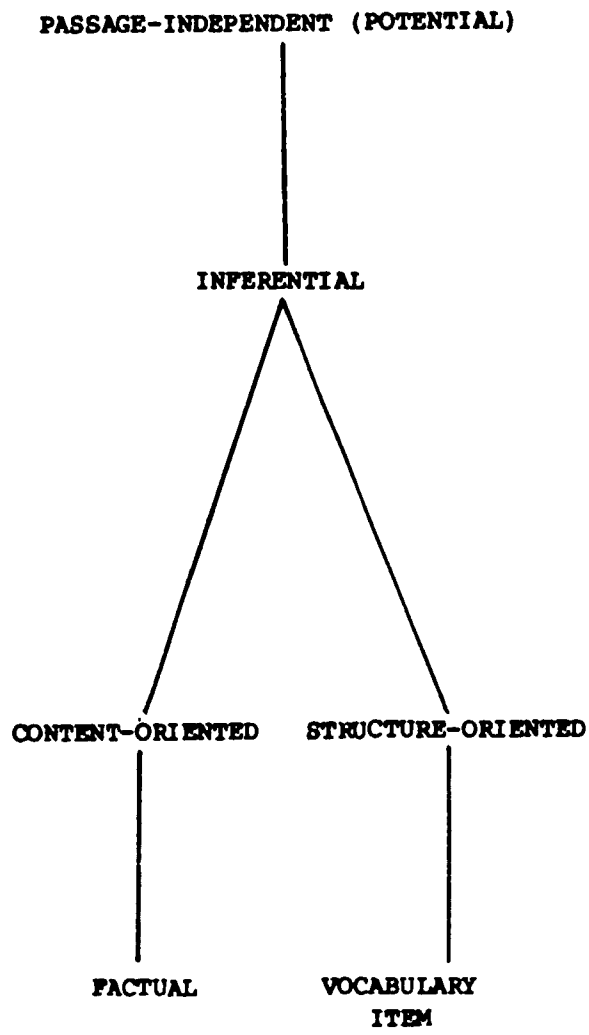
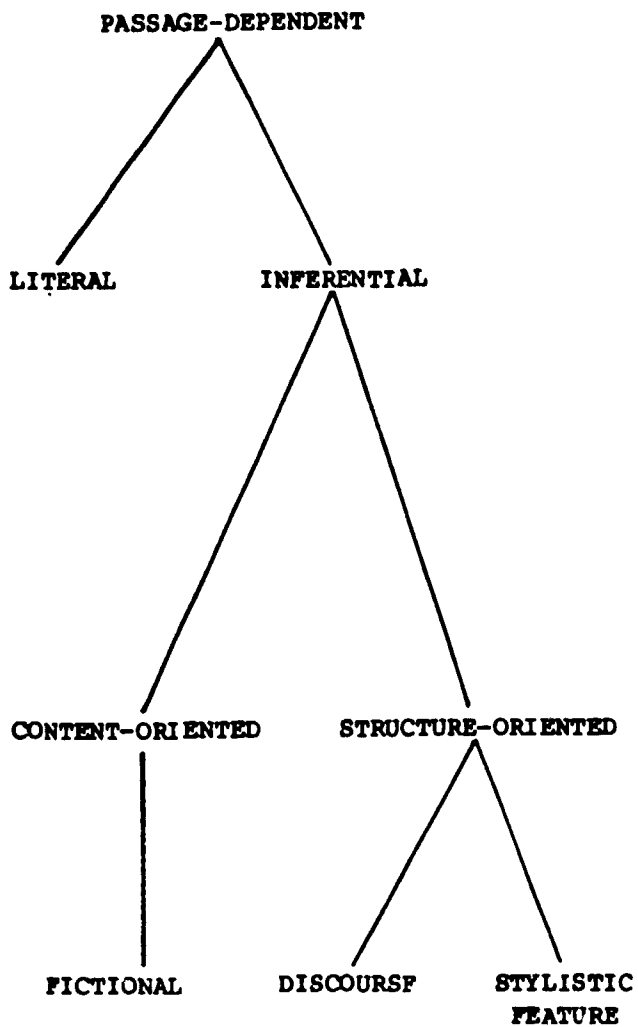

most communicative/least communicative continuum (such a continuum is displayed on page 84).

We would like to caution readers that such a continuum should be viewed more as a heuristic than as a strict classificatory scheme. In fact, any such continuum is necessarily limited, for the degree to which an individual task is either communicative or acommunicative depends upon many factors (e.g., the relative saliency of the information it deals with). Moreover, the interplay of these factors is so complex that the degree to which a task is either communicative or acommunicative varies considerably from reader to reader. If these limitations are, however, borne in mind, a continuum like the one displayed on page 84 can serve as a useful guide for a number of activities: for example, testmakers' evaluating the tasks that they construct, teachers' helping children understand how tasks function on reading tests, or researchers' evaluating children's performance on reading tests. In future research, for example, we could use the continuum to explore in a more refined way the notion that minority children whose primary experience is in oral culture have more difficulty with acommuni-
cative tasks than communicative ones.

Finally, we would like to summarize various indeterminacies in task form or function that have been noted throughout this chapter. In the table on page 86, the contrasting poles of these indeterminacies are represented by a pair of statements: a positive statement on the left and a negative one on the right (page

TASK CONTINUUM

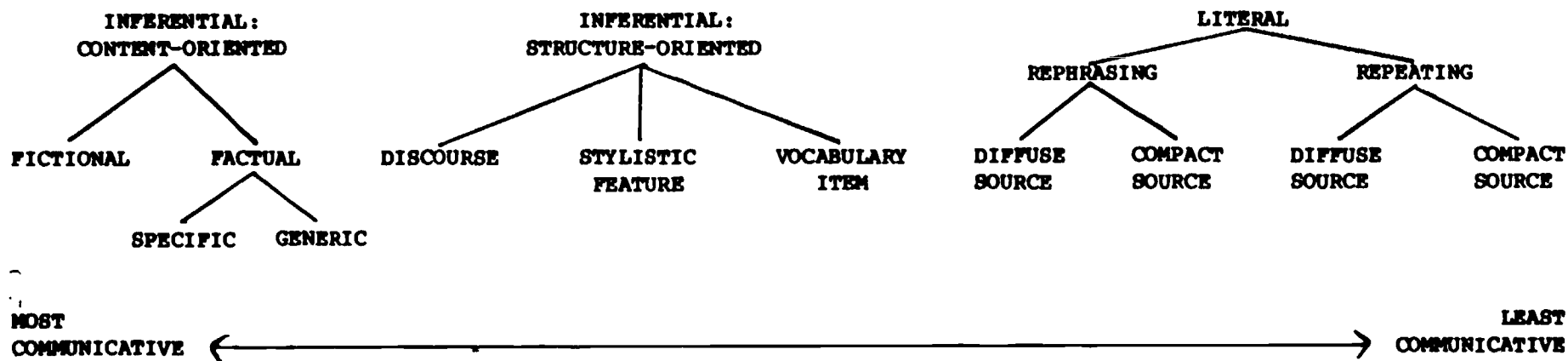

The placement of tasks along this continuum represents the following set of generalizations:

(1) INFERENTIAL AND LITERAL TASKS

- (a) Inferential tasks tend to be more communicative than literal tasks
- (b) Inferential tasks that are content-oriented tend to be more communicative than inferential tasks that are structure-oriented

(2) INFERENTIAL TASKS: CONTENT-ORIENTED

- (a) tasks dealing with fictional information tend to be more communicative than those dealing with factual information
- (b) with respect to tasks dealing with factual information, those that call for specific information tend to be more communicative than those that call for generic information

(3) INFERENTIAL TASKS: STRUCTURE-ORIENTED

- (a) tasks dealing with the entire discourse tend to be more communicative than those dealing with a stylistic feature
- (b) tasks dealing with a stylistic feature tend to be more communicative than those dealing with a vocabulary item

(4) LITERAL TASKS

- (a) tasks that call for rephrasing of information tend to be more communicative than those that call for repeating of information
- (b) with respect to both repeating and rephrasing tasks, those that recycle diffusely located information tend to be more communicative than those that recycle compactly located information.

numbers are listed to the right of each pair in order to identify where each of these indeterminacies is discussed).

As we have already observed, these indeterminacies vary a good deal as to (1) the degree to which either children or testmakers are likely to view one of the two poles as normative, and (2) assuming that one of the poles is viewed as a norm, the degree to which children and testmakers are likely to agree. It is not easy to assess what either children or testmakers view as normative in these matters, but, upon the basis of our work, we have formed certain judgments that we would like to represent in the following way:

- (1) a pair of statements is left unbracketed whenever neither children or testmakers are likely to view one of the poles as normative
- (2) one statement in a pair is bracketed whenever it represents a pole that is likely to be viewed as normative
 - (a) if both children and testmakers are likely to view that pole as normative, a C and a T are placed after the bracketed statement
 - (b) if only children are likely to view that pole as normative, a C is placed after the bracketed statement
 - (c) if only testmakers are likely to view that pole as normative, a T is placed after the bracketed statement

INDETERMINACIES IN TASK FORM OR FUNCTION

- | | |
|--|---|
| <p>1) [The goal of a task is overtly expressed.]_C</p> <p>2) A task preserves the use of figurative language from the passage.</p> <p>3) [A mainly about-task calls for information that rhetorically initiates a passage.]_C</p> <p>4) A task calls for information that involves arithmetical operation.</p> <p>5) [A task calls for retrieval of information in holistic form.]_C</p> <p>6) [On a vocabulary-defining task, the target response can be substituted for the vocabulary item in the passage.]_{C,T}</p> <p>7) [A task calls for information that extends the passage.]_C</p> <p>8) A task uses quotation marks to identify word(s) used in the passage.</p> <p>9) [In its use of deictic elements, a task signals that information recycled from the passage is to be viewed as "given."] _T</p> <p>10) [In its use of deictic elements, a task recycles information from the passage in lexically explicit form.] _T</p> | <p>1) The goal of a task is <u>not</u> overtly expressed. (pp. 64-67)</p> <p>2) [A task does <u>not</u> preserve the use of figurative language from the passage.]_{C,T} (pp. 70-72)</p> <p>3) A mainly about-task does <u>not</u> call for information that rhetorically initiates a passage. (pp. 59-60)</p> <p>4) [A task calls for information that does <u>not</u> involve an arithmetical operation.]_C (pp. 54-55)</p> <p>5) A task calls for retrieval of information in <u>partial</u> form. (pp. 26-28)</p> <p>6) On a vocabulary-defining task, the target response <u>cannot</u> be substituted for the vocabulary item in the passage. (pp. 62-63)</p> <p>7) A task calls for information that does <u>not</u> extend the passage. (pp. 52-54)</p> <p>8) A task does <u>not</u> use quotation marks to identify word(s) used in the passage. (pp. 74-76)</p> <p>9) In its use of deictic elements, a task does <u>not</u> signal that information recycled from the passage is to be viewed as "given." (pp. 4-13)</p> <p>10) In its use of deictic elements, a task does <u>not</u> recycle information from the passage in lexically explicit form. (pp. 4-9)*</p> |
|--|---|

*We should note that the source of children's norms in these matters is not so much the tests themselves as school materials in general. It is only fair to point out that tests tend to be more consistent than textbooks in formulating the tasks that they present.

These indeterminacies can perhaps be better remembered if they are grouped according to their most characterizing feature: for the first four it is the degree to which the verbal surface of a task matches its underlying purpose, for the middle two it is the degree to which a task demands exact fit with passage information, and with the final four it is the degree to which a passage and a task can be viewed as forming integral discourse.

As we have pointed out, these indeterminacies may seem to be of little consequence when viewed separately. But they do have a cumulative weight that can affect children's performance in ways not easily understood. We discovered that children are forced to develop strategies, no matter how rough and ready, for dealing with these indeterminacies, and that these strategies can play a crucial role in the metacognitive decisions that children make as they choose among various alternatives for a given task.

Chapter 5

SUMMARY OF FINDINGS

We have traversed a good deal of territory in examining how third and fourth grade children work with a representative sample of test items designed to measure reading comprehension. We have dealt with twenty-two items, the very number that children in these grade levels must work through on a Gates-MacGinitie Reading Test. We have looked at eighteen of these items as whole, multi-faceted units, though not all of them have been explored in equal depth. In the case of four items, we examined a single facet in order to amplify a point that we were making.

We hope that the welter of detail that has emerged in our analysis may provide a more comprehensive understanding of what children face as they work with a reading test; for they, too, must work through twenty-two worlds, each with multiple problems, each quite different from the others, and each potentially unfamiliar. There are the many worlds of nature, ranging from icebergs to cedar forests to mother alligators, and there are the many worlds of human affairs--the public ones that deal with bridge construction or food preservation and the more personal ones that tell of a class election or of a young girl's anxieties about learning to read. Children must enter and leave each of these worlds rapidly and efficiently if they are to complete a test in the allotted time. Moreover, having absorbed the considerable detail of one world, they must abandon it--and abandon

it thoroughly--or risk contaminating the worlds they have yet to enter.

Our strategy in presenting these twenty-two worlds has been to confront the teeming detail of each, while at the same time maintaining a larger perspective on dominant characteristics of individual passages. As a consequence, we dealt in Chapter 2 with items that contain incomplete narratives; in Chapter 3 we discussed items that test reader flexibility in various ways. Our discussion of each item was thus organized around whatever dominant characteristic we were concerned with at the time, but as each individual item was brought into focus, we took the occasion to examine the variety of problems that children experienced with it. Hence, we might deal in a single item with passage characteristics, task characteristics, passage-task relations, and even task-task relations, all the while detailing how a wide range of readers, belonging to both mainstream and minority cultures, responded to various features. Having worked holistically with the various items throughout Chapters 2 and 3, we then turned in Chapter 4 to the tasks themselves, describing their major characteristics from both formal and functional perspectives.

In summarizing our research findings, we would like to re-examine what we have described in Chapters 2 and 3 from the analytical perspective developed in Chapter 4. Using the various classifications of tasks developed there, our focus will now be

on dominant passage-task configurations.*

Incomplete Narratives

In Chapter 2 we examined items that contained three major kinds of incomplete narrative, the first two telling a partial story and the third a more holistic one:

(1) Truncated Narratives

SHOP SIGN (p. 5)

LEAVING HOME (p. 36)

(2) Excerpted Narratives

BLACK BONNET (p. 49)

ALICE AND THE FAWN (p. 71)

LEARNING TO READ (p. 92)

(3) Gapped Narratives

HURRICANE (p. 131)

CHEE TONG (p. 153)

ADVERTISING TAILOR (p. 177)

Throughout Chapter 2, our major concern was with particular problems children might experience as a result of narrative incompleteness. We looked at these problems not so much as difficulties planned by the testmakers but as impediments to comprehension arising from the incompleteness itself (we pointed out, early on,

*Readers who wish a summary of Chapter 4 may refer to the series of charts and tables provided on pages 79-87, which display our major findings concerning task form and function.

that the incompleteness could be viewed as stemming from various constraints on format that test-makers work with). We were concerned with identifying how narrative incompleteness stimulates interpretive modes that lead children to choose a distractor rather than the target response. Hence, we showed how a partial narrative stimulates modes that can be described as narrative-extending (see the truncated narrative SHOP SIGN, chap. 2, p. 5, and the excerpted narrative ALICE AND THE FAWN, chap. 2, p. 71, for striking examples of how these modes can mislead children). And we showed how a holistic but gapped narrative stimulates modes that can be described as narrative-patching (see ADVERTISING TAILOR, chap. 2, p. 177, for an example of how these modes can mislead children).

From a broader perspective, however, it is not simply the passage that stimulates these modes, but rather the particular relations between the passage and the tasks that follow. It is at this point that we can usefully draw on the analytic perspective provided by Chapter 4, for there we described a number of tasks as containing an acommunicative target response along with a communicative distractor (see pp. 15-16 for discussion of this kind of task); and it is the conjoining of such a task with an incomplete passage that encourages most fully the constructive processes that we were concerned with in Chapter 2. In effect, they are motivated not simply by a passage but by a passage and a communicative distractor taken together. Indeed, it appears that if the distractor were not present, the passage, by itself, would not

have stimulated some of the processes that children reported on. Be that as it may, the choice of the target response requires that certain constructive processes be suppressed; and it is this requirement that creates, for many children, what can be best described as a "double bind." In effect, one choice for the task activates particular processes, but another requires that they be suppressed.

To illustrate how this works, let us examine, once again,

ALICE AND THE FAWN:

The fawn looked at Alice with its large, gentle eyes. It didn't seem at all frightened. "Here, then! Here, then!" Alice said, as she held out her hand and tried to stroke it. It moved back a little and then stood looking at her again.

A. How did the fawn's eyes look?

sad	tired
gentle	frightened

B. What did Alice try to do to the fawn?

help it	pet it
hug it	hide it

This item is, in many ways, a classic example of what we are concerned with. The passage has been excerpted from imaginative literature and no attempt has been made to produce a self-contained story through editorial adjustments. Moreover, its tasks represent the two major kinds of communicative tasks that we described in Chapter 4: (1) those that recycle relatively unimportant

information from the passage, and (2) those that merely define a word from the passage. Each of the tasks contains a distractor that leads to a communicative proposition, one consonant with certain processes that the incomplete narrative stimulates. In responding to (A), children may choose frightened to indicate how they think the fawn "really looked," particularly at the end of the narrative, where it is pictured as "moving back" when Alice tries to touch it. In responding to (B), children may choose help it to indicate what Alice was "really trying to do" while petting the fawn. In each case, the constructive processes that lead to the distractor are the very kind that teachers encourage children to make in response to imaginative literature.

In responding to the two tasks, however, children are expected to suppress these processes for technical reasons. To begin with, each of the distractors leads to a proposition that does not fit exactly with certain information in the passage. In considering frightened as a response to (A), children should, in principle, be aware of the explicit statement that the fawn did not seem at all frightened,* and in considering help it as a response to (B), they should be aware that the passage does not indicate in any way that the fawn was in need of assistance. Hence any inference that Alice was helping the fawn is not directly motivated by the passage.

*As we have pointed out, the use of the word seem in this statement can actually encourage children to select frightened (see chap. 2, pp. 84-85 for discussion).

It is not, however, simply a matter of a communicative distractor not fitting with passage information. It is also a question of some other response not contradicting anything in the passage, even though this response is not itself motivated by a dominant pattern in the passage. If this other response is technically correct, it is to be preferred to the distractor which, though fitting a larger frame within the passage, does not fit with some local feature. Hence, the technically correct responses, gentle and pet it, are to be preferred. There is a kind of unwritten rule that a response not contradicting any passage information is to be preferred, no matter how a communicative it may be (see Aronowitz, 1982, for a suggested hierarchy of such unwritten rules).

Reader Flexibility

In Chapter 3 we turned our attention to items that test various kinds of reader flexibility. We focused on three kinds of items:

(1) Frame Items

items that lead readers to construct one frame--either a content frame or a discourse frame--and then to abandon it as further information is presented that requires the construction of a different frame

MINNESOTA (p. 5)

JAYS AND CROWS (p. 17)

WHITE CIRCLES (p. 27)

(2) Polarity Items

items that require readers to move back and forth between the two poles of multiple pairs of opposing categories, such as 'hot'/'cold,' 'wet'/'dry,' 'light'/'dark,' 'hard'/'soft,' etc.

HARD LEAD (p. 35)

BACTERIA (p. 66)

RAISINS (p. 86)

ICEBERG (p. 98)

GEORGE WASHINGTON BRIDGE (p. 109)

(3) Register Items

items that require readers to shift from a highly evocative passage to tasks that are analytic

GREEN CEDARS (p. 141)

MOTHER ALLIGATOR (p. 145)

Most of the passages in the first two groups are expository, and given their brevity, are necessarily incomplete. But this expository incompleteness differs substantially from narrative incompleteness in its effects on children's responses. As we have seen, children often deal with narrative incompleteness by extending or patching a story; and these expansions, on the whole, fit well with the original narrative frame, even though they can mislead children as they respond to an acommunicative task. Children were less successful, however, in expanding expository incompleteness. At times, they became confused and were unable to

make much sense of these passages. At other times, they expanded these passages in idiosyncratic ways, drawing upon personal experience only loosely associated with the material at hand.

As we have noted, it is generally assumed that children are more likely to be misled by personal experience when dealing with narrative passages, but in our own work, we discovered that the risk was just as great, perhaps even greater, when children were dealing with expository passages. This is not surprising when one considers that third and fourth grade children have had a good deal more experience in dealing with narrative prose than expository prose. They are thus more familiar with the various discourse frames that it uses, understanding better, for example, the transitional devices that signal event-relations as opposed to those that signal idea-relations. But perhaps even more important is their greater capacity for understanding the content frames that narrative prose typically introduces. Children were better able to imagine the world of, say, SHOP SIGN--strange as it may seem--than that of BACTERIA; and lacking the real-world knowledge and concepts needed to deal with bacteria and food spoilage, certain children drew on their own worlds of personal experience in idiosyncratic ways.

We would now like to draw on the framework of Chapter 4 to re-examine, from a broader perspective, the passage-task configurations of the items in Chapter 3. Register items have the same kind of passage-task configuration that we suggested

was common to narrative items, namely, an imaginatively written passage followed by a task that combines a communicative distractor with an acommunicative target response. However, we treated these items separately because few children, either mainstream or minority, managed to focus on the crucial local detail that leads to the target response.

Frame items and polarity items, on the other hand, each display a distinctive passage-task configuration. In frame items, one of the tasks is designed to determine whether the reader is able to shift from one frame to another. Thus, one distractor automatically fits with the initial frame while the target response fits with the frame that follows. The stem of this task invariably consists of the following formulaic structure:

The story is mainly about _____.

It is generally assumed that a mainly-about task is content-oriented and is thus to be viewed as communicative. We have claimed that it is, in fact, structure-oriented (i.e., it requires children to generalize about the discourse structure of the passage) and is thus better understood as acommunicative. Hence, this passage-task configuration is, on the surface, similar to the one identified for items in Chapter 2 in that both culminate in an acommunicative task, but, in fact, the two contrast sharply if the salient distractor for each is considered. We might claim that in the case of the earlier configuration, the distractor encourages

the children to take the passage too far (i.e., they extend an incomplete narrative), but in the case of this configuration, the distractor encourages them not to take the passage far enough (i.e., they hold on to what they first encounter). As might be expected, children who are misled by one configuration are not necessarily misled by the other. It is interesting to consider, as a case in point, the pilot-test performance of mainstream and minority children on these contrasting kinds of items. The gap between children in these two groups decreases substantially on items involving the not-far-enough configuration.

Let us now examine the dominant passage-task configuration in polarity items. For the most part, the tasks that follow these factual passages can be viewed as communicative in that they are content-oriented. In each of these items, at least one of the tasks--and sometimes both--requires readers to infer some particular bit of information that results in a generic statement about the factual world that the passage presents. These tasks can thus be considered as potentially passage-independent, given that readers may already possess the information to be inferred. We have pointed out, however, that most of the children whom we interviewed did not possess the information called for, or at least they were not able to produce it in response to a direct question. As we have suggested, the very way in which generic information is stored may prevent children from recovering it easily.

These passages were difficult for children for a number of reasons. First, they present fairly technical information that children tend to be unfamiliar with. Moreover, these passages may be viewed as reflecting a technical style, at least when one considers the audience for whom they are intended. As we have pointed out, they strain the communicative norms of expository prose by using multiple pairs of opposing categories without providing detail as to how they are to be understood. This lack of detail often leads children to neutralize these oppositions, or even worse, to reverse them. Such neutralizations and reversals are not surprising, given that opposing pairs, by their very nature, are subject to multiple interpretive frames (see chap. 3, pp. 35-48 for a discussion of this matter).

It is only natural that, given these difficulties, children often prefer to work directly with the tasks, virtually ignoring the passages; and as we have seen, the particular character of the tasks also encourages a passage-independent approach. Since these tasks call for generic factual information, children are in a position to make a good guess, even when they do not possess the requisite knowledge.*

Hence, we may claim that the dominant passage-task configuration

*Even when the task calls for specific factual information, children still may be able to guess successfully. In GEORGE WASHINGTON BRIDGE, for example, one task asks what the towers of the bridge are made of. One child answered steel, basing his response on generic information: "that's what bridges are usually made of."

for a polarity item couples a technical, hard-to-read passage with a task calling for information that children can reason out independently of the passage. Such a combination encourages children to minimize the role of the passage in approaching a polarity task. Consequently, such a task may tell us more about children's test-taking skills than about their understanding of a given passage. The gap between mainstream and minority children also widens on a polarity task, which, like an acommunicative task, is easier for those who have test know-how.

We would like to comment on one other aspect of polarity tasks. They seem to encourage in certain children a disposition that might be best described as getting by "on the sly," which in the long run may be detrimental to developing the skills needed for reading the kind of technical material to be found in these passages. Material of this kind calls for a patient, systematic approach, one that these items, given the dominant passage-task configuration, are not likely to encourage.

Ethnocultural Variation

A concern with ethnocultural variation has been at the heart of this research, both in the original pilot testing and in the subsequent interviewing. When mainstream and minority children's responses are compared, the variation that emerges is more a matter of degree than of kind. With respect to most of the task, children in the two groups are attracted by the same

distractors, with minority children often being attracted more strongly.

Content-oriented Differences

We have not concentrated, as have many researchers, on ethnocultural differences stimulated by the content of test items. We did, of course, come across item-specific differences. Consider, for example, children's responses to LEAVING HOME. Mainstream children were better able to frame the experience of leaving an urban home by train for a seaside holiday (see chap. 2, pp. 43-45 for a discussion of ethnocultural variation with respect to (1) whether the notion of 'home' is singular or multiple, and (2) whether movement from an urban to a rural scene constitutes 'return to' or 'departure from' a home base).

It has been often pointed out that the dominant frames embedded in reading tests tend to favor mainstream children. This is, of course, true, but the major efforts to solve this problem have not been very successful. Removing mainstream content from test-items has, in some cases, led to peculiarly denuded material, which often favors mainstream children even more, given their greater experience in dealing with artificially constructed, decontextualized material. On the other hand, introducing minority content into test items has not solved the problem either. Finding familiar content in an alien setting has often led to cognitive dissonance, such like that which may come from incorporating dialect features into classroom material (see Fasold, 1979, for a discussion of the difficulties

that minority children can experience when working with dialect-based materials in school). Many of the efforts to solve content-oriented problems in testing have reflected rather simplistic notions about how ethnocultural norms of thought and experience are verbally transmitted. Moreover, these problems are rather idiosyncratic, varying from item to item, and so we have preferred to direct our major attention to structure-oriented problems.

Structure-Oriented Differences

In addressing structure-oriented differences in mainstream and minority performance, we have focused on the dominant passage-task configuration introduced in Chapter 2 and then discussed more fully in Chapters 3 and 4: the combination of an incomplete passage with a task calling for an acommunicative target response but including, at the same time, a communicative distractor that encourages readers to do one or even both of the following:

- (1) to use constructive processes to complete the discourse and content frames activated by the passage
- (2) to focus holistically on a pattern of features while neglecting to take account of a single feature that does not fit within the pattern and thus invalidates it

Either response can lead a reader away from an acommunicative target response.

Both the pilot testing and the subsequent interviewing indicate that the gap between mainstream and minority children widens

considerably when they are confronted with items built on this passage-task configuration.* In attempting to account for this gap, we have claimed that a crucial factor is minority children's greater transfer of information-processing strategies from oral experience. In the pages that follow we will elaborate on what we mean by this claim. We will delineate differences between oral and literate experience, while recognizing that the emerging electronic, computer-based culture is heightening certain of these differences and neutralizing others.

Oral Versus Literate

We will begin by listing four aspects of oral experience to be dealt with in this section:

- (1) structural divergence between spoken and written language
- (2) dialogic incompleteness of ordinary speech
- (3) holistic processing of dialogic experience
- (4) gap-based processing of monologic experience

All these can--and obviously do--interfere with any child's reading, particularly the kind called for by a standardized test; but as we have suggested, the first two tend to interfere more in the case of minority children. In the case of the last two--particularly the

*As we have pointed out, this widening did not take place in the case of GREEN CEDARS or MOTHER ALLIGATOR, the register items presented in Chapter 3. Each of these contained a task in which almost no children, mainstream or minority, were able to focus on the local detail that leads to the target response.

very last--the interference may be just as great, and perhaps even greater, for mainstream children.

Structural Divergence Between Spoken and Written Language. We will begin with the most familiar factor, the one promulgated by the "language difference" researchers of the late '60's and early '70's. Briefly put, these researchers claimed that minority children's oral experience of language diverges more sharply from the standard language transmitted by formal schooling than does mainstream children's. Initially, this research focused on phonological and grammatical differences, but as linguists have become more concerned with discourse and pragmatic norms, it has come to describe differences more directly related to reading problems. This research suggests that minority students, because of the cumulative effect of these differences, experience a significant loss of information when they work with school tasks that involve standard language.* In order to compensate for this loss, they are forced to do more active inferencing with the information that they do obtain. Since this inferencing is based on more limited, and often quite different, information, it is likely to lead to the holistically constructed worlds of meaning characteristic of ordinary speech. Such worlds of meaning clearly

*We would like to stress, once again, that our interviews with mainstream children indicate that they, too, lose a good deal of information because of unfamiliarity with the discourse and pragmatic norms of standard language.

favor the selection of a communicative distractor rather than an acommunicative target response.

Dialogic Incompleteness of Everyday Speech. We first described the transfer of a dialogic frame to a test-taking situation five years ago (see Hill, 1977, pp. 64-66, for an earlier discussion), but subsequent research has deepened our sense of the influence of this transfer. Before dealing with this influence, it will be useful to discuss what we mean by a dialogic frame.

Perhaps the chief characteristic of everyday talk is its dialogic character. One person's speech is, by its very nature, incomplete, and so the other person is called upon to respond. This response is, in turn, incomplete, the initial person responds in kind, and so dialogue is born. The incompleteness of everyday talk can be traced to various sources--physical constraints (those having to do with bodily mechanisms for producing speech, bodily rhythms for sustaining it, etc.), cognitive constraints (those having to do with the fact that we do not know in advance what we are going to say), and of course, social constraints. In order for human beings to experience mutual satisfaction in talk, they must make clear that they view each other's utterances as incomplete. For any given utterance, they need to signal a number of things:

- (1) they have interpreted the preceding utterance as
incomplete
- (2) they are responding to this incompleteness

(3) they regard their own response as incomplete

(4) they anticipate an incomplete response to their own

Clearly this list could be elaborated, but it does suggest how basic our perception of incompleteness is to the achievement of dialogue. Indeed, it is this mutual and ongoing perception of incompleteness that fuels conversation.

It is not difficult to see how children, who have limited reading experience, may transfer this dialogue frame to the test-taking situation. As we have suggested, the binary format of a test item--first passage and then task--encourages such transfer, for the passage and task can be experienced as constituting a dialogic frame of interaction. The passage becomes, as it were, another person's voice calling for the child to respond; and the task becomes the child's voice, in which a response is to be given that advances the other's incomplete utterance. Hence, the child is inclined to create a response that will pick up what was left incomplete in the passage and advance it in some way. It is for this reason that children who operate within a dialogic frame are attracted to any distractor that leads them to expand the passage; and conversely, they tend to resist any response that merely recycles an unimportant detail from the passage or defines one of the words that has been used.

In claiming that minority children are more likely to transfer this frame to test-taking, we are not claiming that their oral experience of language is more dialogic than mainstream children's.

It may well be, but that is a matter that needs investigation. Rather, our claim is simply that they are more prone to transfer to the test-taking situation the dialogic framing that is basic to any conversation, regardless of the ethnocultural identity of its participants.

Holistic Processing of Dialogic Experience. There is another kind of transfer from dialogic experience that encourages children to select a communicative distractor rather than an acommunicative target response: the transfer of the mode we adopt as listeners, which concentrates on holistic pattern rather than local detail. This receptive mode of attending to holistic pattern can be viewed as closely linked to the productive mode of generating incompleteness. We have learned, as listeners, that we cannot find in speech all the detail that we need to understand what someone is saying. Hence, we learn to search for holistic patterns of meaning that are only partially supported by what a speaker says. We fill in the missing detail from many sources: the speaker's nonverbal and paraverbal behavior, our shared experience with the speaker, our general stock of knowledge. When we externalize this filling-in process, we are, in effect, responding dialogically to the inherent incompleteness of conversation.

Whenever this mode of information-processing is transferred to the test-taking situation, it contributes substantially to the selection of communicative distractors, because it encourages readers to attend to holistic patterns of meaning within the

passage. The task, however, frequently requires readers to forego these patterns in order to focus on local detail that does not fit within it. Thus, if young readers are to become aware of such detail, they must work against the grain of the listening habits they have developed in everyday talk.

Gap-based Processing of Monologic Experience. The fourth kind of transfer that we will deal with is closely related to the third, differing primarily with respect to its source. It does not arise from conversation, but from the massive amount of television viewing that children in our society undergo, no matter what ethnocultural group they belong to. We use the verb undergo deliberately in describing children's experience of television; for unlike their experience of conversation, they are not called upon to articulate any response.* Rather they simply monitor a continuous flow of information. Given the one-way flow of this information, we can describe it as monologic, thereby contrasting it with the two-way flow of information in dialogic experience.

Children do, of course, participate in other modes of monologic experience: for example, listening to a teacher give a talk on some subject. But within such experience they generally

*The medium can, of course, be adapted so that such responses are called for (e.g., a dialogic component is fundamental to developing an instruction program for microcomputer use). Even when the medium has not been adapted, such responses are still often made when children watch and listen to television together. In this instance, however, the dialogic interaction occurs between persons, not between a person and a machine.

have the right, as they do in conversation, to interrupt and focus on some particular bit of information that they wish to explore. In watching television, children cannot intervene in this way; nor can they physically stop the flow of information, as they can in reading, and go back to ponder what they have processed at earlier points. They do, of course, track back, in memory, to these points, particularly when what has come later leads them to new understanding of what has come before. Much of this back-tracking is preconscious and virtually instantaneous, but sometimes it is more extended; and since the stream of information continues to flow on, children are forced to re-enter it at a later point and so may lose a good deal of information. Hence they are forced to develop gap-based strategies in order to accommodate the information they lose.

From a certain point of view, these strategies may be viewed as akin to the information-processing mode that we identified for dialogic experience, namely, focus on holistic patterns. As we have observed, there are ordinarily a number of gaps in any pattern of information that we hear. There is, however, a crucial difference between our modes of attending to monologic and dialogic experience. In the case of dialogic experience, children can obtain the information that they need to fill out a pattern, and indeed, a great deal of the questioning they do in everyday conversation is motivated by this need. In the case of monologic experience, they have no comparable way of obtaining the information

that they lack; and given their massive experience of machine-produced, monologically-structured information, children rely heavily on gap-based strategies to accommodate the information that they lose. As children increasingly use these strategies, they come to appreciate the luxury of tuning in and out of the flow. In effect, they accept information loss as a normal state of affairs and thus settle for partial rather than holistic patterning.

In interviewing both mainstream and minority children, we were often struck by their willingness to justify a response to a task with some stray detail from the passage, even though it contradicted other details. We were even more struck by the passivity that some children displayed when they were asked to confront these contradictions. They did not seem to feel that a response had to be consistent with all the information present.

It has been claimed that a principle of internal consistency in information-processing is, after all, an acquired one--largely fostered by literate experience itself--and so we can hardly expect third and fourth grade children to be in full possession of it. We would agree that literacy is an important factor in developing this principle, and certainly literate societies have made it the cornerstone of scientific and hermeneutic modes of inquiry. We would suggest, however, that there are fundamental aspects of early childhood experience that foster this principle. As Piaget has observed, the very foundations of perceptual experience can be

viewed as motivating a principle of internal consistency in information-processing (e.g., whole-form closure of a partially formed structure). With respect to verbal experience, it is not simply literacy that nurtures a style of reasoning that takes account of all the information present. In traditional cultures, the orally transmitted curriculum--riddles, proverbs, dilemma tales--is concerned with fostering this style as well.*

In closing this discussion, we would like to note that most readers are likely to accommodate oral influences in their ordinary experience of reading. In effect, they tend to focus on holistic pattern, tolerate the loss of detail, and construct extended fields of information. Indeed, the following images can be used to contrast the information fields constructed in real-world reading with those called for in test reading:

*It is interesting to note that many of the children whose test-taking performance is adversely affected by transfer from oral experience have not been in a position to benefit from a more traditional curriculum. These children seem to be stranded somewhere between traditional oral culture and literate culture and thus are unable to draw appropriately on either. This is a matter that we need to address more seriously in our schools.

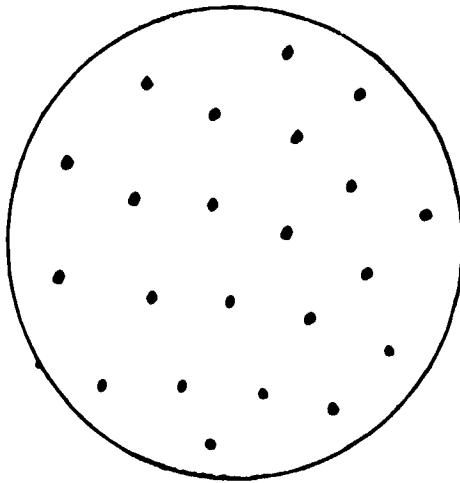

Information fields
constructed in real-
world reading

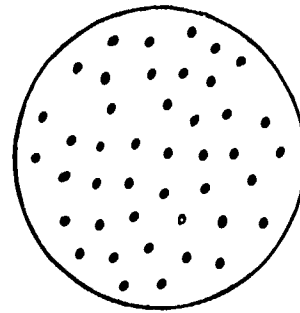

Information fields
called for in test
reading

Moreover, real-world reading is likely to take place within a dialogic frame, particularly in the case of imaginative writing. In his essay "Sur Lire," Proust claims that we cannot claim even to have read, unless the text, as it were, reads us, calling forth the vast worlds of experience that lie buried within us.

The question naturally arises as to whether standardized tests should be more concerned with evaluating comprehension processes characteristic of real-world reading, or whether they should focus, as do standardized tests in general, on the kinds of analytic operations that we have identified in this study. However we respond to this question, we need to do ethnographically oriented studies. If reading tests are to move in the direction of real-world reading, we need to know more about how children read both at home and in school. If, however, reading tests continue as they are, we need to learn more about how children deal with them and how they affect children's sense of what reading is. It is our

hope that this study has provided useful questions with respect to the former issues and some knowledge with respect to the latter ones.

REFERENCES

- Aronowitz, R. Reading tests as texts. In D. Tannen (Ed.), Spoken and Written Language. Norwood, N.J.: Ablex, 1983.
- Baratz, J.C. & R.W. Shuy (Eds.). Teaching Black Children to Read. Washington, D.C.: Center for Applied Linguistics, 1969.
- Bennett, D. Spatial and Temporal Uses of English Prepositions: An Essay in Stratificational Semantics. London: Longmans, 1976.
- Bereiter, C. & S. Engelmann. Teaching Disadvantaged Children in the Pre-school. Englewood Cliffs, N.J.: Prentice-Hall, 1966.
- Bettelheim, B. & K. Zelan. On Learning to Read: The Child's Fascination with Meaning. New York: Knopf, 1982.
- Breland, H.M., M. Stocking, B.M. Pinchak, & N. Abrams. The Cross-cultural Stability of Mental Test Items: An Investigation of Response Patterns for Ten Socio-cultural Groups. Princeton, N.J.: Educational Testing Service, 1974.
- Cicourel, A. Cognitive Sociology: Language and Meaning in Social Interaction. New York: Free Press, 1974.
- Cicourel, A.V., K.H. Jennings, S.M.H. Jennings, K.C.W. Leiter, R. Mackay, H. Mehan, & D.R. Roth. Language Use and School Performance. New York: Academic Press, 1974.
- Dale, E. & J. O'Rourke. The Living Word Vocabulary. Elgin, Ill.: Dome, 1976.
- Fillmore, C.J. Santa Cruz Lectures on Deixis. Bloomington, Indiana: Indiana University Linguistics Club, 1975.
- Flaughner, R.L. Testing Practices, Minority Groups and Higher Education: A Review and Discussion of the Research. Research Bulletin 70-41. Princeton, N.J.: Educational Testing Services, 1970.
- Freedle, R.O. (Ed.). Discourse Processes: Advances in Research and Theory (Vol. 1). Hillsdale, N.J.: Ablex, 1978.
- Garfinkel, H. Studies in Ethnomethodology. Englewood Cliffs, N.J.: Prentice-Hall, 1967.

- Gates-MacGinitie Reading Tests, 2nd ed. Boston: Houghton Mifflin Company, 1978.
- Grice, H.P. Logic and conversation. In P. Cole & J. Morgan (Eds.), Syntax and Meaning. New York: Academic Press, 1975.
- Grice, H.P. Further notes on logic and conversation. In P. Cole (Ed.), Syntax and Semantics. New York: Academic Press, 1978.
- Grimes, J.E. The Thread of Discourse. The Hague: Mouton, 1975.
- Hill, C. Urban minority students, language, and reading. ERIC/CU Urban Diversity Series, 51 and CAL.ERIC/CLL Series on Languages and Linguistics, 55, 1977 (monograph published jointly by ERIC Clearinghouse on Urban Education, Teachers College, Columbia University and ERIC Clearinghouse on Languages).
- Hill, C. Up/down, front/back, left/right: A contrastive study of Hausa and English. In J. Weissenborn & W. Klein (Eds.), Here and There: Cross-Linguistic Studies on Deixis and Demonstration. Amsterdam: John Benjamins Press, 1982.
- Hill C. & H. Varenne. Family language and education: The Socio-linguistic model of elaborated and restricted codes. Social Science Information, 1981, 20(1):187-228.
- MacGinitie, W.H. Teacher's Manual, Gates-MacGinitie Reading Tests, 2nd ed. Boston: Houghton Mifflin Company, 1978.
- Mackay, R. Standardized tests: Objective/objectified measures of competence. In Cicourel et al., Language Use and School Performance. New York: Academic Press.
- Mehan, H. & H. Wood. The Reality of Ethnomethodology. New York: Wiley, 1975.
- Meier, D. Reading Failure and the Tests. An Occasional Paper of the Workshop Center for Open Education, 1973.
- Meyer, B. The Organization of Prose and its Effects on Memory. New York: American Elsevir Company, 1975.
- Nix, D. & M. Schwarz. A phenomenology of reading comprehension. In R.O. Freedle (Ed.), Discourse Processes: Advances in Research and Theory (Vol. 1). Hillsdale, N.J.: Ablex.
- Ochs, E.K. Transcription as theory. In E. Ochs & B. Schieffelin (Eds.), Developmental Pragmatics. New York: Academic Press, 1979.

- Olson, D.R. Review of Jeanne Chall & John B. Carroll (Eds.), Toward a Literate Society. Proceedings of the National Academy of Education, 1975, 2:109-178.
- Olson, D.R. From utterance to text: The bias of language in speech and writing. Harvard Educational Review, 1978, 47: 257-281.
- Piaget, J. Language and Thought of the Child. New York: Harcourt, Brace, and Company, 1926.
- Spiro, R.J., Bruce, B.C., & Brewer, W.F. (Eds.). Theoretical Issues in Reading Comprehension: Perspectives from Cognitive Psychology, Linguistics, Artificial Intelligence, and Education. Hillsdale, N.J.: L. Erlbaum, 1980.
- Sullivan, J. A sociolinguistic review of the Iowa Tests of Basic Skills. Language and Linguistics Working Papers, Georgetown University, 1974, 4.
- Williams, R.L. Abuses and misuses in testing black children. The Counseling Psychologist, 1971, 2:62-73.