



DOCUMENT RESUME

ED 234 268

CE 037 085

TITLE Career Preparation Program Curriculum Guide for:  
Metal Fabrication, Millwright.

INSTITUTION British Columbia Dept. of Education, Victoria.  
Curriculum Development Branch.

REPORT NO ISBN-0-7719-9260-2

PUB DATE 83

NOTE 435p.; For related documents, see CE 037 083-086.  
Except for section 3, contents are duplicated by the  
related documents.

PUB TYPE Guides - Classroom Use - Guides (For Teachers) (052)

EDRS PRICE MF01/PC18 Plus Postage.

DESCRIPTORS Behavioral Objectives; Bibliographies; \*Career  
Education; Cooperative Education; Course  
Descriptions; Curriculum Guides; Equipment; High  
Schools; Learning Activities; Learning Modules;  
\*Machine Tool Operators; \*Machine Tools; Maintenance;  
\*Metal Industry; \*Metal Working; Postsecondary  
Education; Program Descriptions; Secondary Education;  
Welding

IDENTIFIERS \*Millwrights

ABSTRACT

This curriculum outline provides secondary and postsecondary instructors with detailed information on student learning outcomes for completion of the millwright metal fabrication program requirements. A program overview discusses the aims of education; secondary school philosophy; and career preparation programs and their goals, organization, and evaluation. Sections two and three provide the curriculum format for programs in grades 11 and 12, respectively. Each program is divided into units containing from 1 to 19 modules. Both course and unit general aims are first cited. Modules consist of these components: goal statements, learning outcomes, and student activities to support the learning outcomes. Topics covered in the 18 units in the grade 11 program and the 25 units in the grade 12 program include cooperative career preparation; shop practices, human relations, and safety; mechanical drawing; soldering; welding; metallurgy; power saws, shapers, and milling machines; hot metals; sheet metal; grinding, polishing, and surface finishing; drilling, reaming, and tapping; lathes; applied trade mathematics; trade science; screw threads; rigging and material handling; shafts, hubs, and keys; bearings; couplings; clutches and brakes; lubrication; packing and seals; pumps; gears; belts; chain; hydraulics; pneumatics; machine installation; preventative maintenance; electricity; and metallurgy. Section 4 lists resource material and contains a chapter on rigging and erection. (YLB)

\*\*\*\*\*  
\* Reproductions supplied by EDRS are the best that can be made \*  
\* from the original document. \*  
\*\*\*\*\*

ED234268

# CAREER PREPARATION PROGRAM CURRICULUM GUIDE FOR : METAL FABRICATION - MILLWRIGHT

PROVINCE OF BRITISH COLUMBIA

MINISTRY OF EDUCATION

U.S. DEPARTMENT OF EDUCATION  
NATIONAL INSTITUTE OF EDUCATION  
EDUCATIONAL RESOURCES INFORMATION  
CENTER (ERIC)

✓ This document has been reproduced as received from the person or organization originating it.

Minor changes have been made to improve reproduction quality.

- Points of view or opinions stated in this document do not necessarily represent official NIE position or policy.

"PERMISSION TO REPRODUCE THIS MATERIAL HAS BEEN GRANTED BY



TO THE EDUCATIONAL RESOURCES INFORMATION CENTER (ERIC)."

1983

CURRICULUM DEVELOPMENT BRANCH

© MINISTRY OF EDUCATION, PROVINCE OF BRITISH COLUMBIA, CANADA

No part of this publication may be reproduced in any form without permission in writing from the publisher.

45 011 000

### **Canadian Cataloguing in Publication Data**

Main entry under title:

Career preparation program curriculum guide for metal  
fabrication, millwright

Cover title.

ISBN 0-7719-9260-2

1. Mills and mill-work - Outlines, syllabi, etc.
2. Millwrights - Vocational guidance - British Columbia - Outlines, syllabi, etc. I. British Columbia: Schools Dept. Curriculum Development Branch.

TJ1040.C37

621.8'16'0712711

C83-092201-6

### ACKNOWLEDGEMENTS

- The Ministry of Education gratefully acknowledges the work of the Metal Fabrication curriculum committee members for their contribution to this Career Preparation Program and curriculum guide:

John Bigley	Vancouver (S.D. #39)
Dan Bradford	Selkirk College, Castlegar
Wayne Fagrie	Pacific Vocational Institute, Burnaby
Ted Marchant	Pacific Vocational Institute, Burnaby
Howard Thompson	North Vancouver (S.D. #44)
Fred Packford	Greater Victoria (S.D. #61)
Doug Podetz	Surrey (S.D. #36)
Mickey Zoyetz	Cariboo College, Kamloops

- The Ministry of Education personnel involved in this project was:  
Ken Douglas
- The B.C. Teachers Federation and those numerous persons in the field who contributed to and supported the production of this document.

TABLE OF CONTENTS

	PAGE
ACKNOWLEDGEMENTS: . . . . .	iii
INTRODUCTION . . . . .	1
<u>SECTION ONE</u> - PROGRAM OVERVIEW. . . . .	5
PART 1.0 - AIMS OF EDUCATION . . . . .	7
PART 2.0 - SECONDARY SCHOOL PHILOSOPHY . . . . .	8
PART 3.0 - CAREER PREPARATION PROGRAMS . . . . .	9
PART 4.0 - GOALS OF CAREER PREPARATION PROGRAMS. . . . .	15
PART 5.0 - ORGANIZATION: . . . . .	17
PART 6.0 - EVALUATION: . . . . .	22
<u>SECTION TWO</u> - C P 11 - METAL FABRICATION . . . . .	35
UNIT 1.0 - COOPERATIVE CAREER PREPARATION (SCHOOL BASED). . . . .	36
MODULE 1.01 - CAREER DEVELOPMENT AND COMMUNICATION. . . . .	37
MODULE 1.02 - WORK ETHIC AND WORK OBSERVATION . . . . .	40
MODULE 1.03 - ORGANIZATIONAL STRUCTURES AND ROLE OF MANAGEMENT AND LABOUR . . . . .	41
MODULE 1.04 - WORKING CONDITIONS AND LABOUR LEGISLATION . . . . .	43
MODULE 1.05 - JOB SEARCH SKILLS AND JOB INTERVIEWS. . . . .	44
MODULE 1.06 - FIELD TRIPS AND RESOURCE SPEAKERS . . . . .	46
MODULE 1.07 - EDUCATIONAL REQUIREMENTS FOR CAREER PLANNING. . . . .	47

	PAGE
UNIT 2.0 - SHOP PRACTICES, HUMAN RELATIONS AND SAFETY PROCEDURES . . . . .	48
MODULE 2.01 - SHOP RULES AND PRACTICES. . . . .	48
MODULE 2.02 - HUMAN RELATIONS AND PERSONAL ATTRIBUTES .	51
MODULE 2.03 - GENERAL SHOP ADMINISTRATION . . . . .	54
MODULE 2.04 - EMERGENCY PROCEDURES (FIRE AND MEDICAL ROUTINES) : . . . . .	55
UNIT 3.0 - TECHNICAL - READING, WRITING AND REPORTING . .	57
MODULE 3.01 - TECHNICAL REPORTS AND WORK SHEETS . . . .	57
UNIT 4.0 - FASTENERS. . . . .	59
MODULE 4.01 - TYPES OF FASTENERS. . . . .	59
UNIT 5.0 - TOOLS AND EQUIPMENT. . . . .	61
MODULE 5.01 - USE AND CARE OF HAND TOOLS. . . . .	61
MODULE 5.02 - MEASURING TOOLS . . . . .	62
MODULE 5.03 - LAYOUT TOOLS. . . . .	65
MODULE 5.04 - USE AND CARE OF PORTABLE POWER TOOLS AND ACCESSORIES . . . . .	68
UNIT 6.0 - MECHANICAL DRAWING CONCEPTS. . . . .	69
MODULE 6.01 - BASIC CONCEPTS. . . . .	69
MODULE 6.02 - MEASUREMENT . . . . .	71
MODULE 6.03 - PICTORIAL DRAWINGS. . . . .	72
MODULE 6.04 - ORTHOGRAPHIC DRAWINGS . . . . .	73
MODULE 6.05 - CONVENTIONAL LINES AND SYMBOLS. . . . .	75
MODULE 6.06 - CONVENTIONAL CONCEPTS . . . . .	77

	PAGE
UNIT 7.0 - SOFT AND SILVER SOLDERING. . . . .	80
MODULE 7.01 - SOFT SOLDER . . . . .	80
MODULE 7.02 - SOFT SOLDER APPLICATION . . . . .	82
MODULE 7.03 - SILVER SOLDER . . . . .	83
UNIT 8.0 - GAS WELDING OPERATIONS . . . . .	84
MODULE 8.01 - WELDING SAFETY PRACTICES. . . . .	84
MODULE 8.02 - STORAGE AND HANDLING OF OXYGEN AND FUEL GAS CYLINDERS. . . . .	85
MODULE 8.03 - HANDLING AND OPERATING OXY-ACETYLENE EQUIPMENT . . . . .	86
MODULE 8.04 - ASSEMBLY OF OXY-ACETYLENE EQUIPMENT .	87
MODULE 8.05 - TESTING FOR LEAKS . . . . .	88
MODULE 8.06 - CORRECTLY LIGHT AND SHUT DOWN THE OXY-ACETYLENE UNIT. . . . .	89
MODULE 8.07 - TORCH LINE EXPLOSIONS . . . . .	90
MODULE 8.08 - FIRE PREVENTION . . . . .	91
MODULE 8.09 - FIRE EXTINGUISHERS. . . . .	92
MODULE 8.10 - VENTILATION . . . . .	93
MODULE 8.11 - WELDING AND CUTTING CONTAINERS. . . .	94
MODULE 8.12 - PROTECTIVE EQUIPMENT. . . . .	95
UNIT 9.0 - OXY-ACETYLENE EQUIPMENT. . . . .	96
MODULE 9.01 - OXY-ACETYLENE WELDING EQUIPMENT PROCESSES AND APPLICATIONS. . . . .	96
MODULE 9.02 - CONSTRUCTION OF OXYGEN AND FUEL GAS CYLINDERS . . . . .	97
MODULE 9.03 - CONSTRUCTION OF PRESSURE REGULATORS .	98



	PAGE
MODULE 9.04 - OXYGEN AND FUEL GAS HOSE. . . . .	99
MODULE 9.05 - OXY-ACETYLENE TORCHES . . . . .	100
MODULE 9.06 - MANIFOLD SYSTEMS. . . . .	101
MODULE 9.07 - SELECTION OF FLAMES . . . . .	102
MODULE 9.08 - TIP SELECTION AND MAINTENANCE . . . . .	103
UNIT 10.0 = OXY-ACETYLENE WELDING, BRAZING AND CUTTING (O.A.W.). . . . .	104
MODULE 10.01 = WELDING POSITIONS. . . . .	104
MODULE 10.02 = SELECTION OF FILLER METALS . . . . .	105
MODULE 10.03 = FOREHAND WELD. . . . .	106
MODULE 10.04 = BEADING. . . . .	107
MODULE 10.05 = CORNER JOINT . . . . .	108
MODULE 10.06 = LAP JOINT. . . . .	109
MODULE 10.07 = EDGE JOINT . . . . .	110
MODULE 10.08 = TEE JOINT. . . . .	111
MODULE 10.09 = BUTT JOINT . . . . .	112
MODULE 10.10 = FUSION WELD OF CAST IRON . . . . .	113
MODULE 10.11 = BRAZE WELDING. . . . .	114
MODULE 10.12 = BRAZE WELDING. . . . .	116
MODULE 10.13 = BRAZE WELDING. . . . .	117
MODULE 10.14 = BRAZE WELDING. . . . .	118
MODULE 10.15 = BRAZE WELDING. . . . .	119
MODULE 10.16 = BRAZE WELDING. . . . .	120
MODULE 10.17 = BRAZE WELDING. . . . .	121
MODULE 10.18 = GAS CUTTING OXY-FUEL CUTTING-ACETYLENE	122
MODULE 10.19 = GAS CUTTING OXY-FUEL CUTTING-ACETYLENE	126

	PAGE
UNIT 11.0 - SHIELDED METAL ARC WELDING . . . . .	130
MODULE 11.01 - FUNDAMENTALS OF ARC WELDING . . . . .	130
MODULE 11.02 - ARC WELDING SAFETY: . . . . .	132
MODULE 11.03 - ARC WELDING EXERCISES . . . . .	134
UNIT 12.0 - METALLURGY . . . . .	139
MODULE 12.01 - FERROUS METALS. . . . .	139
MODULE 12.02 - NON-FERROUS METALS. . . . .	141
MODULE 12.03 - WELDABILITY OF STEELS . . . . .	142
MODULE 12.04 - HEAT TREATMENT. . . . .	143
MODULE 12.05 - SHAPES OF METALS. . . . .	144
UNIT 13.0 - POWER SAWS, SHAPERS AND MILLING MACHINES . . . . .	145
MODULE 13.01 - POWER SAWS. . . . .	145
MODULE 13.02 - SHAPERS . . . . .	147
MODULE 13.03 - MILLING MACHINES (VERTICAL, HORIZONTAL) . . . . .	148
UNIT 14.0 - HOT METALS . . . . .	150
MODULE 14.01 - TOOLS AND EQUIPMENT . . . . .	150
MODULE 14.02 - FORGING AND BENDING . . . . .	151
MODULE 14.03 - FOUNDRY . . . . .	152
UNIT 15.0 - INTRODUCTION TO SHEET METAL: . . . . .	155
MODULE 15.01 - SHEET METAL TRADES: . . . . .	155
MODULE 15.02 - SAFETY IN THE SHEET METAL SHOP. . . . .	156
MODULE 15.03 - COMMON SHEET METALS . . . . .	157
MODULE 15.04 - HAND TOOLS: . . . . .	158
MODULE 15.05 - SHEET METAL MACHINES. . . . .	159

	PAGE
MODULE 15.06 - APPLIED GEOMETRY . . . . .	160
MODULE 15.07 - SIMPLE PATTERN LAYOUT. . . . .	162
MODULE 15.08 - PARALLEL LINE DEVELOPMENT. . . . .	163
MODULE 15.09 - RADIAL LINE DEVELOPMENT. . . . .	164
MODULE 15.10 - HEAVY GAUGE AND STRUCTURAL FABRICATION .	165
UNIT 16.0 - GRINDING, POLISHING AND SURFACE FINISHING . .	166
MODULE 16.01 - GRINDING MACHINES. . . . .	166
MODULE 16.02 - SAFETY PRECAUTIONS . . . . .	167
MODULE 16.03 - BUFFING AND POLISHING. . . . .	168
MODULE 16.04 - PAINTING . . . . .	169
MODULE 16.05 - PLATING AND COLOURING METAL SURFACES . .	170
UNIT 17.0 - DRILLING, REAMING, TAPPING. . . . .	171
MODULE 17.01 - DRILLING MACHINES. . . . .	171
MODULE 17.02 - DRILLING MACHINES. . . . .	172
MODULE 17.03 - REAMING. . . . .	174
MODULE 17.04 - TAPS AND DIES. . . . .	175
UNIT 18.0 - LATHES. . . . .	176
MODULE 18.01 - LATHE NOMENCLATURE . . . . .	176
MODULE 18.02 - WORK HOLDING . . . . .	177
MODULE 18.03 - LATHE CUTTING TOOLS. . . . .	178
MODULE 18.04 - FEEDS AND SPEEDS . . . . .	179
MODULE 18.05 - OPERATIONS . . . . .	180

	PAGE
<u>SECTION THREE - C P 12 MILLWRIGHT . . . . .</u>	<u>191</u>
UNIT 1.0 - INTRODUCTION TO MILLWRIGHT TRAINING. . . . .	192
MODULE 1.01 - MILLWRIGHT TRAINING PROGRAM . . . . .	192
UNIT 2.0 - COOPERATIVE CAREER PREPARATION (COMMUNITY BASED)	195
MODULE 2.01 - PREPLACEMENT ROUTINE: . . . . .	195
MODULE 2.02 - PLACEMENT (EXTERNAL TO SCHOOL). . . . .	197
MODULE 2.03 - POSTPLACEMENT ROUTINE . . . . .	198
MODULE 2.04 - STUDENT REPORTING PROCESS . . . . .	199
MODULE 2.05 - LETTER OF THANKS TO EMPLOYER. . . . .	200
UNIT 3.0 - SAFETY AWARENESS . . . . .	201
MODULE 3.01 - PERSONAL ATTITUDES. . . . .	201
MODULE 3.02 - GENERAL SAFETY KNOWLEDGE. . . . .	202
MODULE 3.03 - SAFETY PRACTICES. . . . .	203
MODULE 3.04 - CAUSES OF ACCIDENTS . . . . .	205
MODULE 3.05 - FIRE PREVENTION . . . . .	206
UNIT 4.0 - APPLIED TRADE MATHEMATICS: . . . . .	208
MODULE 4.01 - BASIC MATHEMATICS . . . . .	208
MODULE 4.02 - DECIMALS . . . . .	210
MODULE 4.03 - FRACTIONS . . . . .	211
MODULE 4.04 - POWERS, SQUARE ROOTS AND CUBES. . . . .	213
MODULE 4.05 - RATIOS AND PROPORTIONS. . . . .	214
MODULE 4.06 - PERCENTAGE. . . . .	215
MODULE 4.07 - CIRCUMFERENCE AND AREA OF PLANE FIGURES . . . . .	216
MODULE 4.08 - VOLUME OF SHAPES. . . . .	219

	PAGE
UNIT 5.0 - TRADE SCIENCE. . . . .	221
MODULE 5.01 - SOLIDS . . . . .	221
MODULE 5.02 - LIQUIDS . . . . .	222
MODULE 5.03 - GASES . . . . .	223
MODULE 5.04 - PROPERTIES OF MATERIALS . . . . .	224
MODULE 5.05 - SIMPLE MACHINES . . . . .	225
MODULE 5.06 - HEAT. . . . .	227
MODULE 5.07 - MECHANICS . . . . .	228
UNIT 6.0 - LAYOUT AND BLUEPRINT READING . . . . .	230
MODULE 6.01 - GEOMETRIC CONSTRUCTION. . . . .	230
MODULE 6.02 - DIMENSIONING, TOLERANCES AND FITS . . . . .	233
MODULE 6.03 - WORKING DRAWINGS. . . . .	236
MODULE 6.04 - BLUEPRINT READING . . . . .	237
UNIT 7.0 - TRADE TOOLS. . . . .	238
MODULE 7.01 - HAND TOOLS. . . . .	238
MODULE 7.02 - MEASURING TOOLS . . . . .	241
MODULE 7.03 - PORTABLE POWER TOOLS. . . . .	245
UNIT 8.0 - SCREW THREADS. . . . .	246
MODULE 8.01 - PURPOSE AND GENERAL TERMS . . . . .	246
MODULE 8.02 - TYPES OF THREADS. . . . .	248
MODULE 8.03 - FASTENERS . . . . .	249
MODULE 8.04 - LOCKING DEVICES . . . . .	251
MODULE 8.05 - THREAD LOADING. . . . .	253
MODULE 8.06 - EXTERNAL AND INTERNAL THREADS . . . . .	255

	PAGE
UNIT 9.0 - RIGGING AND MATERIAL HANDLING . . . . .	256
MODULE 9.01 - SAFETY REGULATIONS ON RIGGING. . . . .	256
MODULE 9.02 - MATERIAL HANDLING EQUIPMENT. . . . .	259
UNIT 10.0 - SHAFTS, HUBS AND KEYS. . . . .	261
MODULE 10.01 - KEYS. . . . .	261
MODULE 10.02 - HUBS. . . . .	264
MODULE 10.03 - SHAFTS. . . . .	265
UNIT 11.0 - BEARINGS . . . . .	266
MODULE 11.01 - INTRODUCTION TO BEARINGS. . . . .	266
MODULE 11.02 - FRICTION BEARINGS . . . . .	267
MODULE 11.03 - ANTI-FRICTION BEARINGS. . . . .	269
UNIT 12.0 - COUPLINGS. . . . .	271
MODULE 12.01 - INTRODUCTION TO COUPLINGS . . . . .	271
MODULE 12.02 - RIGID COUPLINGS . . . . .	273
MODULE 12.03 - FLEXIBLE COUPLINGS. . . . .	275
MODULE 12.04 - CENTRIFUGAL COUPLING. . . . .	277
UNIT 13.0 - CLUTCHES AND BRAKES. . . . .	278
MODULE 13.01 - PURPOSE OF A CLUTCH . . . . .	278
MODULE 13.02 - CLUTCHES. . . . .	279
MODULE 13.03 - PURPOSE OF BRAKES . . . . .	280
MODULE 13.04 - BRAKES. . . . .	281

	PAGE
UNIT 14.0 - LUBRICATION . . . . .	282
MODULE 14.01 - THE PURPOSE OF LUBRICATION . . . . .	282
MODULE 14.02 - OILS . . . . .	283
MODULE 14.03 - GREASE . . . . .	285
UNIT 15.0 - PACKING AND SEALS . . . . .	287
MODULE 15.01 - SEALS: . . . . .	287
MODULE 15.02 - STATIC SEALS . . . . .	288
MODULE 15.03 - NON-CONTACT SEALS: . . . . .	289
MODULE 15.04 - SINGLE CONTACT SEALS . . . . .	290
MODULE 15.05 - PACKING: . . . . .	292
UNIT 16.0 - PUMPS . . . . .	294
MODULE 16.01 - PURPOSE OF PUMPS . . . . .	294
MODULE 16.02 - PUMP GROUPS. . . . .	295
MODULE 16.03 - PUMP INSTALLATION AND MAINTENANCE: . . . . .	296
UNIT 17.0 - GEARS AND GEAR DRIVES . . . . .	297
MODULE 17.01 - GEARS. . . . .	297
MODULE 17.02 - GEAR REDUCERS. . . . .	299
UNIT 18.0 - BELTS . . . . .	300
MODULE 18.01 - V-BELTS. . . . .	300
MODULE 18.02 - CONVEYOR BELTS . . . . .	302
UNIT 19.0 - CHAIN . . . . .	304
MODULE 19.01 - CHAIN TERMINOLOGY: . . . . .	304
MODULE 19.02 - ROLLER CHAIN . . . . .	305
MODULE 19.03 - CONVEYOR CHAIN . . . . .	309
MODULE 19.04 - LUBRICATION: . . . . .	311
MODULE 19.05 - PREVENTATIVE MAINTENANCE . . . . .	312

	PAGE
UNIT 20.0 - HYDRAULICS . . . . .	313
MODULE 20.01 - HYDRAULIC THEORY. . . . .	313
MODULE 20.02 - HYDRAULIC FLUIDS. . . . .	314
MODULE 20.03 - HYDRAULIC COMPONENTS. . . . .	315
MODULE 20.04 - HYDRAULIC CIRCUITS. . . . .	317
MODULE 20.05 - HYDRAULIC TROUBLESHOOTING . . . . .	318
UNIT 21.0 - PNEUMATICS : : . . . . .	319
MODULE 21.01 - PNEUMATIC THEORY. . . . .	319
MODULE 21.02 - PNEUMATIC COMPONENTS. . . . .	320
MODULE 21.03 - PNEUMATIC CIRCUITS. . . . .	322
MODULE 21.04 - PNEUMATIC SYSTEM MAINTENANCE. . . . .	323
UNIT 22.0 - MACHINE INSTALLATION . . . . .	324
MODULE 22.01 - CONCRETE AND GROUT. . . . .	324
MODULE 22.02 - FORMS . . . . .	325
MODULE 22.03 - BASE BOLTS. . . . .	326
MODULE 22.04 - LAYOUT. . . . .	327
UNIT 23.0 - PREVENTATIVE MAINTENANCE . . . . .	329
MODULE 23.01 - SCHEDULE AND REPORTS. . . . .	329
MODULE 23.02 - NON-DESTRUCTIVE TESTING . . . . .	331
UNIT 24.0 - ELECTRICITY. . . . .	332
MODULE 24.01 - BASIC ELECTRICITY . . . . .	332
MODULE 24.02 - GENERATORS AND MOTORS . . . . .	336



	PAGE
UNIT 25.0 - METALLURGY . . . . .	337
MODULE 25.01 - FERROUS MATERIALS . . . . .	337
MODULE 25.02 - PHYSICAL PROPERTIES . . . . .	339
MODULE 25.03 - HEAT TREATMENT. . . . .	340
<u>SECTION FOUR</u> - RESOURCE MATERIALS. . . . .	345

## INTRODUCTION

The purpose of this career preparation curriculum outline is to provide the secondary school teachers and post-secondary instructors with detailed information on student learning outcomes for completion of the career preparation program requirements. Information contained in this outline may be used as reference by students, counsellors, school administrators, employers and the general public. Performance standards and guidelines for instruction will be established according to the criteria developed by teachers for the modules and courses which comprise each career preparation program.

# Section One

## Program Overview

CAREER PREPARATION PROGRAM  
CAREER PREPARATION PROGRAM  
CAREER PREPARATION PROGRAM  
CAREER PREPARATION PROGRAM  
CAREER PREPARATION PROGRAM  
CAREER PREPARATION PROGRAM  
CAREER PREPARATION PROGRAM  
CAREER PREPARATION PROGRAM  
CAREER PREPARATION PROGRAM  
CAREER PREPARATION PROGRAM  
CAREER PREPARATION PROGRAM  
CAREER PREPARATION PROGRAM  
CAREER PREPARATION PROGRAM  
CAREER PREPARATION PROGRAM  
CAREER PREPARATION PROGRAM  
CAREER PREPARATION PROGRAM  
CAREER PREPARATION PROGRAM  
CAREER PREPARATION PROGRAM  
CAREER PREPARATION PROGRAM  
CAREER PREPARATION PROGRAM

PAGE

SECTION ONE      PROGRAM OVERVIEW

PART 1.0 - AIMS OF EDUCATION . . . . .	7
PART 2.0 - SECONDARY SCHOOL PHILOSOPHY. . . . .	8
PART 3.0 - CAREER PREPARATION PROGRAMS . . . . .	9
PART 4.0 - GOALS OF CAREER PREPARATION PROGRAMS . . . . .	15
PART 5.0 - ORGANIZATION . . . . .	17
PART 6.0 - EVALUATION . . . . .	22

## PART 1.0 AIMS OF EDUCATION

The basic function of the British Columbia system of public education is to serve society and to meet the needs of individual students. School personnel have the primary responsibility to educate everyone by enabling each student to pursue excellence, to experience success and to realize maximum potential in every course. The curriculum should enable each student to achieve educational and vocational goals in the development of their interests, skills and abilities.

Central to that responsibility is the promotion of learning, the acquisition of knowledge and the mastery of skills. This is essential to provide the student with a solid base upon which a successful future may be built. This responsibility implies an obligation to go beyond the provision of a learning opportunity and to link instruction and learning through activities that make it possible for the pupil to become a purposeful, effective and competent learner. Students should be encouraged to develop a sustained interest in learning and a confidence in their ability to learn by the realization that any study becomes effective through an orderly and sustained approach.

The primary responsibility of school personnel should be complemented by the many other facets of school life which contribute to the development of the maturing student. Teachers should encourage sportsmanship, good health and fitness, promote a willingness to serve the school and community, and provide opportunities to appreciate and share in the social customs of the school and society. Students should be encouraged to be active participants in the community by meeting their obligations and responsibilities as citizens.

The philosophy of the school is best achieved in a purposeful and challenging environment which motivates the best performance of students and staff. The environment should be safe, supportive, rewarding and satisfying; and should reflect mutual respect and courtesy among students, staff and parents. The facilities, equipment materials and organization should enable students and staff to pursue stated educational goals. The environment must also be conducive to effective participation by the staff in decisions affecting them and their students. Such participation is fostered by open, flexible and cooperative patterns of organization and communication based on a spirit of mutuality.

Teachers, parents and the community share the responsibility for fostering the optimum growth and development of each student. Shared responsibility should be directed to the end that each student will become a knowledgeable, self-reliant, self-disciplined, adaptive human being with a sense of enduring values and social and civic responsibility, able to communicate and participate effectively in a technologically advancing and increasingly mobile, complex and changing society.

## PART 2.0 SECONDARY SCHOOL PHILOSOPHY

Secondary schools are primarily concerned with the development of the individual in a changing society. Organization of the secondary school system is based on the belief that students should be provided with a meaningful sequence of courses directed toward a particular purpose which they themselves consider valuable and which lies within their abilities. Motivation of adolescents to maintain a positive attitude with commitment to their studies is a challenging task for teachers. Students need educational experiences that will help them to cope with their responsibilities in society; to prepare for further education at a college, Provincial institute or university; and/or to enter employment with a marketable skill.

General goals of the secondary school system should be incorporated into the educational philosophy of each school. Secondary school curriculum goals should:

- a. provide opportunities for all students to achieve a maximum of general and basic preparatory education,
- b. emphasize those subjects needed for individual intellectual development for future career goals,
- c. enable students to arrange subjects into broad patterns or programs on the basis of their interrelationships and usefulness for further education and employment,
- d. permit individual choice of school programs according to alternatives that are available,
- e. include opportunities for students to develop personal interests and avocational values,
- f. increase opportunities to relate course offerings to the needs of the school population and the community, and
- g. allow students to select for themselves educational goals and patterns of study in accord with their proven interests and abilities.

As students acquire and develop their skills and talents at the secondary school educational level, interest in future careers becomes increasingly important. The need to improve the transition between schools, colleges, Provincial institutes and employment has been addressed through the introduction of career preparation programs.

## PART 3.0 CAREER PREPARATION PROGRAMS

### 3.1 Aims and Purpose

Career preparation is vitally important to every individual in their choice of lifestyle and their economic security. In conjunction with the provision of basic education for all citizens, the school system should ensure that all students are provided the opportunity to increase their awareness of career planning leading to vocational choices. The general education acquired through the public school system should complement the personal and intellectual development of individuals for success in the world of work.

Occupational needs are never static and students should have the opportunity to increase their awareness of the world of work while attending public schools. The influence of modern technology has altered individual and family lifestyles and many students recognize the need for preparatory training that will lead toward success in a vocation of their choice. This increased emphasis on education and training will help students to understand the increasingly complex world of business and industry. Pertinent questions should be considered. What are the qualifications for particular occupations? Which occupations require a post-secondary education or other credentials? Which vocations require work related experiences? How should the school experience provide for student needs as they consider their future careers?

The last question is being partially answered through Career Preparation Programs. Students who enroll in a career preparation program will gain a broad overview of a particular industry and will be provided with vocational experiences in a career area of their choice. Essential components of the total program include specialized courses with cooperative career preparation studies and the completion of all requirements leading to a secondary school graduation certificate. Examples of some career areas are the hospitality/tourism industry, general mechanics and business education. Graduates of a career preparation program may be qualified to pursue further studies toward a profession, attend a college or Provincial institute to acquire further specialized education, or proceed directly to employment with some marketable skills. Secondary school teachers will need to cooperate with employers and post-secondary instructors to effectively integrate the career preparation programs.

Adults at the school and community level have a responsibility to ensure that all students will achieve a basic understanding and awareness of the world of work to prepare for emerging trends in society. Increased school and community cooperation through the career preparation program will provide appropriate educational and career development experiences to help students acquire marketable skills for future employment. This new program for the secondary schools is consistent with the general aims of the British Columbia school system in striving to meet the needs of all students.

The development of students who can think for themselves and learn on their own is one of the more important educational goals. In career preparation programs, practical experiences that combine methods, resources and activities provide an important teaching strategy to enhance learning and thinking abilities. Both individual and group problem solving strategies help students to utilize abstract thinking abilities through practical learning activities.

In the grade 11 and 12 school terms, students in career preparation programs have opportunities to apply basic skills and abilities gained from earlier educational experiences. Learning outcomes become more effective when students can develop abilities and talents with new applications and a wider variety of resources.

The career preparation programs in British Columbia senior secondary schools are designed to provide students with options that enable students to enter the work force, proceed to a college or Provincial institute or to pursue further academic studies leading to a professional career. Courses related to career fields at the senior secondary level are intended to improve the transition of students between school and employment and between school and post-secondary institutions. Students enrolled in a career preparation program will participate in cooperative career preparation studies to spend part of their school time in a learning situation in the community at a training station. This experience is designed to provide practical experience for a student in an occupational field directly related to a program specialty in the school.

All students will ultimately enter the work force in some capacity and career preparation programs will assist students to recognize current occupational practices and the avenues for advancement toward career goals. From these experiences, students can be encouraged to recognize the spectrum of employment within an occupational cluster.



### 3.2 Core Curriculum

Many of the core curriculum learning outcomes are integral parts of the learning outcomes that comprise a career preparation program. Students will be encouraged to relate their basic education experiences to practical experiences through the application of talents, skills, abilities and competencies to simulated roles relative to future employment responsibilities.

Career preparation programs provide opportunities for students to apply the following aspects of the core curriculum to their school experiences: (a) reading; (b) writing; (c) speaking; (d) principles of measurement; (e) roles, responsibilities and rights of the individual in society; (f) research and study skills; and (g) inquiry, analysis and problem solving. Practical application of the skills and purposes of the core curriculum to the career preparation program will help students to function effectively as active and responsible citizens.

### 3.3 Responsibility of the School Staff

Preparation for employment concerns everyone and the educational experiences of a student have a direct impact on each person's selection of a career path. One's choice of an occupation is closely aligned with the desires for a particular lifestyle. Teachers in our schools have a major responsibility to assist students in the development of attitudes toward work and the rewards that one may expect from future employment. School experiences should help people to prepare for satisfying and successful employment. From this premise, there is increasing recognition of the need for students to relate their school experiences to career goals and the benefits that can be derived from the completion of courses for career advancement.

The school experience for students should include the acquisition of career information, the development of skills and talents for specific occupations and the opportunity to gain practical experience along with completion of general education requirements. The purpose of career preparation is to provide students with information and generalized skills which apply to a broad series of interrelated occupations. Students will then be able to make meaningful decisions concerning the advantages and disadvantages of occupations. Along with the general education requirements a student on a career preparation program will complete the following studies in grades 11 and 12.

Grade 11: General orientation to an occupational cluster will be provided in school by practical experience in a career field and cooperative career preparation studies. To understand the occupational competencies required in vocations, students will have access to resource people and to information that will help them select a career. This cooperative approach to the involvement of community personnel is designed to broaden the students' educational background and perspective of possible career paths.

Development of skills and talents is the primary purpose of the practical experiences. Courses that comprise the specialty area of study must be directly related to occupational requirements for future employment and to the related programs offered at colleges and Provincial institutes.

Each course is divided into units and modules with student experiences described in terms of learning outcomes. Students will have the opportunity to explore a wide variety of core skills in an occupational field and the expected performance levels will be identified from the curriculum outline.

Grade 12: Student attendance in these courses will lead to the acquisition of skills and talents which may qualify them for entry level employment in related occupations and/or for advanced standing at a post-secondary institution. Emphasis is on career preparation; not on training for specific jobs. As students build on the earlier experiences from grade 11, they will be better prepared to focus on their future career goals.

Classroom experiences will be supplemented by cooperative career preparation studies which provide for community based learning external to the school. Teachers in each career preparation program will arrange with employers in the community for each student to acquire practical experience and will then conduct visitations to the training station to assess this learning experience. The external practical component of the program must be scheduled for a minimum of 100-120 hours with a well defined training plan. The personal contact between teacher/employer/student will strengthen the program. Teachers should assume the responsibility for coordinating the activities both at the school and the training station.

### 3.4 Definitions

**Career Preparation Program:** A Career Preparation Program is defined as a selection and arrangement of courses in general education subjects and courses in major vocational fields to form a systematic pattern leading to graduation from a senior secondary school with advanced admission to a post-secondary program and/or direct entry to employment. Requirements to complete a program consists of six approved specialty courses (including cooperative career preparation studies) together with prescribed constant courses and electives to meet the criteria for secondary school graduation in British Columbia.

**Career Preparation Program Teacher:** A suitably qualified teacher employed by a school to teach a specialty subject and who, in addition, has the responsibility of coordinating and supervising related job experience.

**Cooperative Career Preparation:** The process of integrating the instructional, administrative and organizational activities of career preparation experience into a cooperative relationship between the school and the community.

**Cooperative Education:** A comprehensive term used to describe shared responsibilities and roles of teachers and employers in the provision of educational experiences that will prepare people for employment.

**District Work Experience Coordinator:** A teacher employed by a school board to direct, coordinate and supervise work experience and cooperative career preparation studies for the whole school district.

**Training Plan:** A written outline indicating what is to be learned by the student at the training station and what is to be taught in the school.

**Training Sponsor:** The individual at the training station directly responsible for the supervision of the student's activities external to the school.

**Training Station:** The location external to the school where the student receives training related to an individual career development plan.

**Work Experience:** Activities at a training station undertaken by a student as an integral part of an approved school program under the cooperative supervision of a qualified work experience teacher and an employer.

### 3.5 Definition of Curriculum Terms

**Learning Package:** A self-contained package, comprised of a series of modules sequenced in a logical way to progressively build knowledge and skills which will enable attainment of an intended learning outcome. The package should include a diagnostic pretest and a posttest.

**Learning Outcome:** A learning outcome stated in behavioural, measurable, or performance terms is an assertion of what is expected to happen as a result of learning having taken place. The statement usually defines what the activity and subject matter will be, the conditions under which it will take place, and the minimum performance standard required. The purposes of the learning outcomes are:

- a. The student and teacher know what is expected upon completion of an instructional unit.
- b. The most appropriate instructional materials and strategy can be chosen in order to ensure achievement of the learning outcome.
- c. The statements provide a basis for measuring student progress related to the learning tasks.

**Module:** A combination of goals, instructions, content, and activities which facilitate the development of a desired competency. Each module focuses on a specific job task and learning outcome. Modules may focus on the need for essential knowledge, or hands-on practice, or integration of knowledge and skills to perform a job task.

**Modules for Self-paced Instruction:** The students can work through the modules, with the supervision of the teacher, at their own pace, instead of an imposed time schedule. The module is completed when the student demonstrates mastery of the intended learning outcome.

**Vocational Education:** The educational experiences offered at the secondary and post-secondary school levels that provide individuals with skills and talents to develop capacities for: (a) entry level employment, or (b) upgrading in an occupation, or (c) retraining in a new occupation, leading to qualifications for employment requiring less than a university degree upon completion of the program.

## PART 4.0 GOALS OF CAREER PREPARATION PROGRAMS

### 4.1 Review Process

From a review in 1977 of the effectiveness of secondary programs to adequately prepare students for future employment, three conclusions were made:

- a. There was a need to undertake a more efficient and relevant use of student time for the grade 11 and 12 years.
- b. There was a lack of realistic orientation to the world of work and this was deemed to contribute to the poor employment situation for many students.
- c. There was evidence from the Report of the Commission on Vocational, Technical and Trades Training in British Columbia, (1977) that more effective vocational training was needed in grades 11 and 12 to adequately prepare some students for direct entry into the work force.

Pilot programs in career preparation were undertaken in various areas of the province between 1977 and 1980 and the results of these programs supported assumptions that:

- a. in addition to the present provisions for secondary school graduation, the school may extend the opportunity in grades 11 and 12 for a student to gain marketable skills and/or advanced standing in post-secondary courses or programs;
- b. the provision of employment skills should not reduce the percentage of graduating students when compared to the school population generally;
- c. the provision of marketable skills should have a positive effect upon the graduates' employment opportunities when compared to the total graduate population;
- d. the monitoring of the pilot projects would provide information on the effects of the projects on the number of students choosing to further their full time studies;
- e. the pilot projects would have a positive effect upon the total integration process between secondary and post-secondary education (including the Apprenticeship Branch of the Ministry of Labour);
- f. the funding arrangements for the pilot project would provide the information necessary to establish a rational system of funding if the projects are extended to the whole province;
- g. monitoring of the pilot projects would provide information on the effects of the project on:
  - i. the basic comprehensive graduation programs offered in the schools;
  - ii. the standards and expectations of post-secondary courses and programs with respect to secondary schools, and
  - iii. the possible areas of conflict regarding the responsibilities of the secondary school and teachers and the post-secondary institutions and instructors.

#### 4.2 Recommendations

In 1980, the Ministry of Education agreed to the recommendations of a steering committee that the career preparation program receive formal endorsement. Four goals for the program were established.

The Ministry of Education should:

- a. foster career training in the schools without sacrificing the general education function of the school,
- b. increase the articulation of programs between secondary schools and post-secondary institutions through joint development of relevant curriculum units in career and vocational areas,
- c. define the career preparation program and monitor career training in order to assure the status, quality and provincial credibility of such training, and
- d. develop, through joint consultation, the administrative framework which will guide the general and specific conditions for course recognition by post-secondary institutions.

The primary goal for the career preparation program is to provide students at secondary schools with the opportunity to gain increased awareness of career and employment needs without sacrificing the general educational function of the schools. Courses are designed to integrate with the business and industrial community and with post-secondary colleges and Provincial institutes.

#### 4.3 Student Outcomes

Goals for student outcomes in career preparation programs are:

- a. to develop competencies and marketable skills for some individuals to prepare for an entry level job;
- b. to acquire prerequisite qualifications for some individuals who may pursue further training and/or advanced placement in an integrated program at a post-secondary school;
- c. to attain skills necessary to locate, read and comprehend material or literature related to their particular field of career interest;
- d. to attain a basic level of skills and talents needed for employment in a particular vocation (occupation);
- e. to achieve the competencies necessary for critical thinking and problem solving in a specialized area of study;
- f. to develop self-discipline for constructive work and study habits;
- g. to develop feelings of pride and self-confidence in achievement and progress;
- h. to acquire a sense of respect and concern toward personal property as well as the property of others;
- i. to increase personal and social competencies and acquire a sense of social responsibility; and
- j. to increase cooperative work skills to attain group goals.

## PART 5.0 ORGANIZATION

A career preparation program has been defined as a selection and arrangement of courses in general education subjects and in major vocational fields to form a systematic pattern leading to secondary school graduation with qualifications for direct entry to employment and/or advanced admission to a post-secondary school program.

### 5.1 Goals and Outcomes

General goals are provided for each program, each course, and for each module within the course. These goals are intended to provide general direction to the teachers, students and employers to indicate the broad parameters at each level.

Learning outcomes are specified for each module in terms that will indicate the performance levels that students are expected to achieve for completion of each unit and course. Criterion referenced tests may be developed by teachers to ensure that projected competencies for students are similar in various regions of the province.

### 5.2 Program Requirements

Requirements to complete a career preparation program consist of four constant courses, six provincially approved specialty courses and at least two additional elective courses for a minimum of twelve courses to meet the requirements for secondary school graduation. Within the six specialty courses of approximately 120 hours each (minimum of 700 hours), students will complete units in cooperative career preparation studies in grades 11 and 12.

Courses in the sample outline that follows for a student program in grades 11 and 12 should be regarded as the basic requirements for graduation with a career preparation specialty. There will be situations where it will be necessary, and to the student's advantage, to apply the elective courses to subjects as mathematics, physics or general business to acquire adequate preparation for a vocational choice or for requirements of a post-secondary institution. Students planning on a career in trades related to general mechanics will benefit from a mathematics course while another student may require a business education course for a career in the hospitality industry. The student program should be organized to provide the most useful background for entry into a chosen career field.

CAREER PREPARATION PROGRAM FOR  
METAL FABRICATION

CONSTANTS  
(4)

English 11  
English 12  
Social Studies 11  
Physical and Health Education 11

SPECIALTY  
(6)

C P 11 Metal Fabrication	)	
C P 11 Metal Fabrication	)	
C P 11 Metal Fabrication	)	Minimum
	)	of
C P 12 Metal Fabrication	)	700
C P 12 Metal Fabrication	)	hours
C P 12 Metal Fabrication	)	
	)	
	)	

ELECTIVES  
(4)

4 courses

SECONDARY SCHOOL REQUIREMENTS - completion of a minimum of twelve courses for graduation. For further details, refer to the Administrative Handbook 1981.



### 5.3 Guidelines

The fundamental purpose in the foregoing organization is to ensure that students complete the general education constants and acquire some specialized experiences that will prepare them for employment or continuing education. When students enter a career preparation program in grade 11, they will concentrate on the acquisition of core skills related to an occupational field or industry. Development of personal and interpersonal skills and an orientation to the organization of business and labour will be an integral part of the learning process.

In grade 12, the students will move from the core skills acquired in grade 11 to more specific skills related to an occupational/vocational choice. During this school year, students will gain practical experience in community based learning activities at a job site for a minimum period of 100 - 120 hours. Teachers of the specialty courses will arrange for the external practical experience with various business firms and visit each student at the training station as part of the cooperative career preparation studies. Teachers should prepare information that will assist the employer in assessing the performance of the student at a training station.

Practical experience is an integral part of the educational program for students enrolled in career preparation. School credit is granted for the cooperative career preparation component at a job site but the student should not be paid wages while working under the supervision of school personnel. The student must not displace a regular employee and should recognize that there is no assurance of a job at the conclusion of the training period.

In addition to Workers' Compensation Board coverage for school arranged cooperative career preparation with an employer, a student or their parents may choose to purchase personal accident insurance. Any student under the age of majority requires parent or guardian approval in writing before participating in a learning situation external to the school. Further details and approval forms are available from the Ministry of Education (Career Programs).

### 5.4 Advisory Committees

Advisory committees can perform a valuable role in the development of career preparation programs. The advice and guidance provided to teachers by representatives of employers, employees and the community is extremely important. The function of the advisory committee is not to establish policy or to make financial decisions but this voluntary group can provide a vital communication link between the school and the community. Recommendations for action will represent the best advice available to plan viable programs for the benefit of the student.

Functions of advisory committees as they relate to career preparation programs are:

- a. to assist in determining and evaluating the needs which the program is designed to meet;
- b. to assist in defining relevant program objectives;
- c. to assist in promoting public awareness of the instructional program by colleges, unions, professional associations, employers and appropriate community groups and government;
- d. to assist in securing community support of the instructional program, including formal recognition by industry and regulatory bodies, as well as government approval;
- e. to assist in the placement of graduates; and
- f. to assist in obtaining and coordinating student field experience in the community.

Advisory committees should have representation, where appropriate, from the secondary school, school district, local industry, unions or related associations, and post-secondary institutions in the region. A suggested composition for the advisory committee would include: Superintendent of Schools or representative; school principal or representative; teacher(s); college or Provincial institute representative; employer representative(s); employee representative; district career coordinator (work experience coordinator); labour representative; school trustee.

#### 5.5 Cooperative Education

Education is currently viewed as the way to prepare people for their lifework and the need for experiential learning is evident. One of the proven methods for the student to develop responsibility and dependability within the educational process is to arrange for organized learning experiences with an employer. Opportunities can be provided for the student to gain practical experience with an employer under the concept of cooperative education. The primary purpose of cooperative education is to provide the student with planned and evaluated practice/experiences which will enhance the integration of theory learned in the classroom with pragmatic requirements of the work situation. Acceptance of this premise implies that there are definite procedures that must be followed for implementing cooperative education practices.

Primary responsibility rests with the teacher to:

- a. design an overall plan for the student to participate in cooperative education;
- b. involve the advisory committee to validate proposed plans before implementation;
- c. consult with teachers, counsellors and CHOICES specialists concerning career goals for students;
- d. establish and maintain training stations;

- e. outline parameters of student experiences to be provided by employers;
- f. develop a training plan of proposed experiences and how these activities relate to school based courses;
- g. provide guidelines that may be used by the employers;
- h. outline the legal requirements that apply to students for compliance with guidelines from Ministry of Education, Ministry of Labour and the Workers' Compensation Board;
- i. contact the local office of the appropriate labour organization (where applicable);
- j. conduct visits with each student at the training stations; and
- k. determine and implement the evaluation procedures that will be used for each student in the course.

In conducting the cooperative education component of a career preparation program, the teacher coordinator is of vital importance to the operation of a successful plan. Detailed planning and evaluation procedures will enable all the affected parties to contribute to the learning experiences of each student. All activities between the school and a business must be coordinated in a manner that allows maximum opportunity for each student to practice what they learn. When evaluation techniques are well designed, the teacher and the advisory committee will be able to analyze the results and consider changes for improving this aspect of experiential learning.

Educational planning for cooperative career preparation experiences are incorporated as an integral part of this curriculum guide. The provision of the cooperative career preparation studies cannot be implemented as a separate component in isolation to approved courses. When people from the education system develop a cooperative approach with the business community to the learning needs of students, the transition from school to work will be more effective for all students who participate in cooperative career preparation.

Teachers of career preparation programs will need to coordinate their planning with a district staff person assigned to coordinate activities between the schools and employers. In large school districts there will be greater need to develop procedures between schools to organize the efforts of teachers who provide general work experience for students in any subjects and for students in the cooperative career preparation studies. The district coordinator will be responsible for maintaining consistency in policy and ensuring that all legal requirements are complied with according to school board policies.

## PART 6.0 EVALUATION

### 6.1 Evaluation Process

One of the important components of the Career Preparation Program that is critical to the successful acceptance by the community and post-secondary institutions is the matter of evaluation. Criteria within a curriculum guide for student performance must be established to indicate student progress. Evaluation must be consistent to provide the necessary documentation of the student achievement. Each program is organized in units and modules to indicate expected performance in terms of intended learning outcomes. On the basis of the statements concerning student performance, various testing methods may be employed to validate the achievement for the benefit of the students, parents, post-secondary teachers and potential employers.

Included in the evaluation process will be tests to consider progress in the affective, cognitive, psychomotor and perceptive domains. Terminal performance should consider theoretical knowledge, practical skills and the personal and interpersonal attributes that contribute to successful employment. Students are expected to affirm their understanding of the learning outcomes for each module through valid expression of their skills and talents. Indications of their cooperation with others and attitudes to work and future learning needs are an important consideration of the evaluation process for career preparation.

Students can be encouraged to judge their own progress in relation to the established objectives for the modules comprising a course outline. Rigid time limits for each module are not prescribed since there is recognition of the variable abilities of individuals to acquire skills and talents necessary for acceptable performance.

Learning outcomes and criteria have been stated according to the perceived needs of the students, employers and instructors of related courses and programs in colleges and Provincial institutes. Evaluation techniques and methods must be flexible but the results should indicate the standard of performance that has been achieved. Collaboration between teachers at secondary schools and instructors at post-secondary institutions is essential to ensure that the goals of the program are being met to effectively integrate courses which comprise each career preparation program. Regular meetings of advisory committees will help facilitate reviews of the goals and objectives and ensure that the interests of the concerned individuals are being considered.

Evaluation processes should be designed to assist students to acquire the necessary skills and talents that will be useful for a vocational goal. Performance criteria can be reviewed at appropriate intervals to ensure that standards are realistic and that employers and post-secondary instructors are satisfied with the graduates of the programs. Students should acquire a broad view of an employment field before they select an occupation that will require concentrated study and preparation. Qualifications for one job are often related to other jobs and the evaluation process must be designed to enhance student growth for employability in related occupations. Procedures for testing in any career area should help and not hinder student growth in the realization of personal goals that will lead to gainful employment. Evaluation should clarify the capabilities of individuals and provide essential information to students, parents and employers.

## 6.2 Determination of Performance Criteria

Part of the learning process concerns the evaluation process and various methods may be used by teachers to determine the progress of students. Teacher strategies will be employed in the affective, cognitive, psychomotor and perceptive domains. Performance levels in the cognitive domain will usually be assessed by formal written exams. In addition, there will be procedures to determine performance in the practical demonstration of abilities and other tests that will require the professional expertise of the teacher to assess performance levels. There are at least six evaluation procedures that teachers may apply to assess student progress toward the learning outcomes in this curriculum guide.

A bank of evaluation resource materials, including curriculum referenced tests and procedures for evaluating manipulative skills, will be developed and made available on a provincial basis to assist the classroom teacher and to serve as external benchmarks. At the same time, within the six categories below, it is expected that teachers will develop and share other materials that may be applied to the instructional process.

- Comprehensive written examination (on the cognitive level for all aspects of subject matter)
- Practical demonstration (on manipulative skills)
- Oral examination (on verbal descriptions of processes)
- Team or group examination (on activities that involve two or more students)
- Observation
- Questionnaire/opinionnaire instrument (on reactions from cooperative education experiences)

## CURRICULUM FORMAT

The following sections of this curriculum guide consist of:

- Aims and purposes for students enrolled in a Career Preparation Program for Metal Fabrication.
- Course/unit general aims which indicate the general knowledge/skill required to achieve a satisfactory level of performance.
- Goal statements and learning outcomes for each module with student outcomes for the expected levels of achievement.
- Student activities designed to support the learning outcomes of each module, and
- Bibliography and resources that may be used to assist the student achieve the learning outcomes.

The learning outcomes specify the minimum levels that are essential for the satisfactory completion of each module. This information is compiled under particular topics but the sequence of teaching any aspect of the program is the responsibility of the teacher. Professional expertise should be applied to plan instruction and to expand and enhance student performance without undue reliance on tests to measure cognitive knowledge. In the process of evaluation the teacher should consider all aspects which contribute to the effective mastery of skills for each occupation. Evaluation should include assessment of skills, knowledge, talents, personal and interpersonal behaviour related to a vocation. The development of attitudes toward the work ethic should be considered in the provision of experiences leading to successful employment.

Essential components to support the learning experiences outlines in courses will be cooperative career preparation studies. Teachers should develop procedures with business personnel in the community to ensure that cooperative activities at school and in the community are provided for all aspects of the career preparation program. Organized learning experiences away from the school building should be related to particular goals and learning outcomes stated in the following sections of this curriculum guide.

PROGRAM:

General Aims and Purpose

COURSE/UNIT:

General Aim

General Aim

General Aim

General Aim

MODULES:

Goal Statements

Goal Statements

Goal Statements

Can you test the performance level?

Learning Outcomes

Student Activities

Learning Outcomes

Student Activities

Learning Outcomes

Student Activities

What activities will support the desired performance?

Directly related to learning outcome statements

Criterion Referenced Tests

Criterion Referenced Tests

Criterion Referenced Tests

Criterion Referenced Tests

Criterion Referenced Tests

125

Section Two  
CP 11 - Metal Fabrication

CAREER PREPARATION PROGRAM  
CAREER PREPARATION PROGRAM  
CAREER PREPARATION PROGRAM  
CAREER PREPARATION PROGRAM  
CAREER PREPARATION PROGRAM  
CAREER PREPARATION PROGRAM  
CAREER PREPARATION PROGRAM  
CAREER PREPARATION PROGRAM  
CAREER PREPARATION PROGRAM  
CAREER PREPARATION PROGRAM  
CAREER PREPARATION PROGRAM  
CAREER PREPARATION PROGRAM  
CAREER PREPARATION PROGRAM  
CAREER PREPARATION PROGRAM  
CAREER PREPARATION PROGRAM  
CAREER PREPARATION PROGRAM



	PAGE
<u>SECTION TWO - C P 11 - METAL FABRICATION.</u> . . . . .	35
UNIT 1.0 - COOPERATIVE CAREER PREPARATION (SCHOOL BASED) . . . . .	36
MODULE 1.01 - CAREER DEVELOPMENT AND COMMUNICATION. .	37
MODULE 1.02 - WORK ETHIC AND WORK OBSERVATION . . . .	40
MODULE 1.03 - ORGANIZATIONAL STRUCTURES AND ROLE OF MANAGEMENT AND LABOUR . . . . .	41
MODULE 1.04 - WORKING CONDITIONS AND LABOUR LEGISLATION . . . . .	43
MODULE 1.05 - JOB SEARCH SKILLS AND JOB INTERVIEWS. .	44
MODULE 1.06 - FIELD TRIPS AND RESOURCE SPEAKERS . . .	46
MODULE 1.07 - EDUCATIONAL REQUIREMENTS FOR CAREER PLANNING. . . . .	47
UNIT 2.0 - SHOP PRACTICES, HUMAN RELATIONS AND SAFETY PROCEDURES . . . . .	48
MODULE 2.01 - SHOP RULES AND PRACTICES. . . . .	48
MODULE 2.02 - HUMAN RELATIONS AND PERSONAL ATTRIBUTES	51
MODULE 2.03 - GENERAL SHOP ADMINISTRATION . . . . .	54
MODULE 2.04 - EMERGENCY PROCEDURES (FIRE AND MEDICAL ROUTINES) . . . . .	55
UNIT 3.0 - TOOLS AND EQUIPMENT. . . . .	57
MODULE 3.01 - USE AND CARE OF HAND TOOLS. . . . .	57
MODULE 3.02 - MEASURING TOOLS . . . . .	58
MODULE 3.03 - LAYOUT TOOLS. . . . .	61
MODULE 3.04 - USE AND CARE OF PORTABLE POWER TOOLS AND ACCESSORIES . . . . .	64

	PAGE
UNIT 4.0 - FASTENERS. . . . .	65
MODULE 4.01 - TYPES OF FASTENERS. . . . .	65
UNIT 5.0 - TECHNICAL - READING, WRITING AND REPORTING . . . . .	67
MODULE 5.01 - TECHNICAL REPORTS AND WORK SHEETS . . . . .	67
UNIT 6.0 - MECHANICAL DRAWING CONCEPTS. . . . .	69
MODULE 6.01 - BASIC CONCEPTS. . . . .	69
MODULE 6.02 - MEASUREMENT . . . . .	71
MODULE 6.03 - PICTORIAL DRAWINGS. . . . .	72
MODULE 6.04 - ORTHOGRAPHIC DRAWINGS . . . . .	73
MODULE 6.05 - CONVENTIONAL LINES AND SYMBOLS. . . . .	75
MODULE 6.06 - CONVENTIONAL CONCEPTS . . . . .	77
UNIT 7.0 - SOFT AND SILVER SOLDERING . . . . .	80
MODULE 7.01 - SOFT SOLDER . . . . .	80
MODULE 7.02 - SOFT SOLDER APPLICATION . . . . .	82
MODULE 7.03 - SILVER SOLDER . . . . .	83
UNIT 8.0 - GAS WELDING OPERATIONS . . . . .	84
MODULE 8.01 - WELDING SAFETY PRACTICES. . . . .	84
MODULE 8.02 - STORAGE AND HANDLING OF OXYGEN AND FUEL GAS CYLINDERS. . . . .	85
MODULE 8.03 - HANDLING AND OPERATING OXY-ACETYLENE EQUIPMENT . . . . .	86
MODULE 8.04 - ASSEMBLY OF OXY-ACETYLENE EQUIPMENT . . . . .	87
MODULE 8.05 - TESTING FOR LEAKS . . . . .	88
MODULE 8.06 - CORRECTLY LIGHT AND SHUT DOWN THE OXY-ACETYLENE UNIT. . . . .	89

	PAGE
MODULE 8.07 - TORCH LINE EXPLOSIONS . . . . .	90
MODULE 8.08 - FIRE PREVENTION . . . . .	91
MODULE 8.09 - FIRE EXTINGUISHERS. . . . .	92
MODULE 8.10 - VENTILATION . . . . .	93
MODULE 8.11 - WELDING AND CUTTING CONTAINERS. . . . .	94
MODULE 8.12 - PROTECTIVE EQUIPMENT. . . . .	95
UNIT 9.0 - OXY-ACETYLENE EQUIPMENT. . . . .	96
MODULE 9.01 - OXY-ACETYLENE WELDING EQUIPMENT PROCESSES AND APPLICATIONS. . . . .	96
MODULE 9.02 - CONSTRUCTION OF OXYGEN AND FUEL GAS CYLINDERS . . . . .	97
MODULE 9.03 - CONSTRUCTION OF PRESSURE REGULATORS . . . . .	98
MODULE 9.04 - OXYGEN AND FUEL GAS HOSE. . . . .	99
MODULE 9.05 - OXY-ACETYLENE TORCHES . . . . .	100
MODULE 9.06 - MANIFOLD SYSTEMS. . . . .	101
MODULE 9.07 - SELECTION OF FLAMES . . . . .	102
MODULE 9.08 - TIP SELECTION AND MAINTENANCE . . . . .	103
UNIT 10.0 - OXY-ACETYLENE WELDING, BRAZING AND CUTTING (O.A.W.). . . . .	104
MODULE 10.01 - WELDING POSITIONS. . . . .	104
MODULE 10.02 - SELECTION OF FILLER METALS . . . . .	105
MODULE 10.03 - FOREHAND WELD. . . . .	106
MODULE 10.04 - BEADING. . . . .	107
MODULE 10.05 - CORNER JOINT . . . . .	108
MODULE 10.06 - LAP JOINT. . . . .	109

MODULE 10.07 - EDGE JOINT . . . . .	110
MODULE 10.08 - TEE JOINT. . . . .	111
MODULE 10.09 - BUTT JOINT . . . . .	112
MODULE 10.10 - FUSION WELD OF CAST IRON . . . . .	113
MODULE 10.11 - BRAZE WELDING. . . . .	114
MODULE 10.12 - BRAZE WELDING. . . . .	116
MODULE 10.13 - BRAZE WELDING. . . . .	117
MODULE 10.14 - BRAZE WELDING. . . . .	118
MODULE 10.15 - BRAZE WELDING. . . . .	119
MODULE 10.16 - BRAZE WELDING. . . . .	120
MODULE 10.17 - BRAZE WELDING. . . . .	121
MODULE 10.18 - GAS CUTTING OXY-FUEL CUTTING-ACETYLENE	122
MODULE 10.19 - GAS CUTTING OXY-FUEL CUTTING-ACETYLENE	126
UNIT 11.0 - SHIELDED METAL ARC WELDING. . . . .	130
MODULE 11.01 - FUNDAMENTALS OF ARC WELDING. . . . .	130
MODULE 11.02 - ARC WELDING SAFETY . . . . .	132
MODULE 11.03 - ARC WELDING EXERCISES. . . . .	134
UNIT 12.0 - METALLURGY. . . . .	139
MODULE 12.01 - FERROUS METALS . . . . .	139
MODULE 12.02 - NON-FERROUS METALS . . . . .	142
MODULE 12.03 - WELDABILITY OF STEELS. . . . .	143
MODULE 12.04 - HEAT TREATMENT . . . . .	144
MODULE 12.05 - SHAPES OF METALS . . . . .	145

	PAGE
UNIT 13.0 - POWER SAWS, SHAPERS AND MILLING MACHINES. . . . .	146
MODULE 13.01 - POWER SAWS . . . . .	146
MODULE 13.02 - SHAPERS. . . . .	148
MODULE 13.03 - MILLING MACHINES (VERTICAL, HORIZONTAL). . . . .	149
UNIT 14.0 - HOT METALS. . . . .	151
MODULE 14.01 - TOOLS AND EQUIPMENT. . . . .	151
MODULE 14.02 - FORGING AND BENDING. . . . .	152
MODULE 14.03 - FOUNDRY. . . . .	153
UNIT 15.0 - INTRODUCTION TO SHEET METAL . . . . .	156
MODULE 15.01 - SHEET METAL TRADES . . . . .	156
MODULE 15.02 - SAFETY IN THE SHEET METAL SHOP . . . . .	157
MODULE 15.03 - COMMON SHEET METALS. . . . .	158
MODULE 15.04 - HAND TOOLS . . . . .	159
MODULE 15.05 - SHEET METAL MACHINES . . . . .	160
MODULE 15.06 - APPLIED GEOMETRY . . . . .	161
MODULE 15.07 - SIMPLE PATTERN LAYOUT. . . . .	163
MODULE 15.08 - HEAVY GAUGE AND STRUCTURAL FABRICATION . . . . .	164
MODULE 15.09 - RADIAL LINE DEVELOPMENT. . . . .	165
MODULE 15.10 - HEAVY GAUGE AND STRUCTURAL FABRICATION . . . . .	166
UNIT 16.0 - GRINDING, POLISHING AND SURFACE FINISHING . . . . .	167
MODULE 16.01 - GRINDING MACHINES . . . . .	167
MODULE 16.02 - SAFETY PRECAUTIONS . . . . .	168
MODULE 16.03 - BUFFING AND POLISHING. . . . .	169
MODULE 16.04 - PAINTING . . . . .	170
MODULE 16.05 - PLATING AND COLOURING METAL SURFACES . . . . .	171

	PAGE
UNIT 17.0 - DRILLING, REAMING, TAPPING. . . . .	172
MODULE 17.01 - DRILLING MACHINES. . . . .	172
MODULE 17.02 - DRILLING MACHINES. . . . .	173
MODULE 17.03 - REAMING. . . . .	175
MODULE 17.04 - TAPS AND DIES. . . . .	176
UNIT 18.0 - LATHES. . . . .	177
MODULE 18.01 - LATHE NOMENCLATURE . . . . .	177
MODULE 18.02 - WORK HOLDING . . . . .	178
MODULE 18.03 - LATHE CUTTING TOOLS. . . . .	179
MODULE 18.04 - FEEDS AND SPEEDS . . . . .	180
MODULE 18.05 - OPERATIONS . . . . .	181

### C P 11 - METAL FABRICATION

The primary aim of the Metal Fabrication is to provide learning experiences for students to develop marketable skills for employment or to qualify for advanced standing in a related program at a post-secondary college or provincial institute. Part of the program includes an integral component of cooperative career preparation studies which is designed to orient students to the requirements of employment through work study experiences. This component can be organized by the specialist teacher to use various resource persons who can provide the expertise necessary to help students understand aspects of career preparation studies.

Student should acquire knowledge of:

- a. career opportunities and educational requirements in the metal fabrication industry;
- b. basic practices in the development of generic skills;
- c. theory and operation of fitting, machining and fabrication of metals;
- d. concepts applicable to the mathematics, layout and measuring of the metal trades;
- e. practice of clean, safe and orderly work habits;
- f. employment opportunities and occupational qualifications needed for initial job entry levels;
- g. continuing education opportunities at various post-secondary institutions;
- h. job satisfaction concepts and an appreciation of work ethics for successful employment;
- i. attitudes and skills required for entry and advancement in occupations related to metal fabrication; and
- j. surveys of industrial shops through field trips to develop an appreciation of actual working conditions.

## UNIT 1.0 COOPERATIVE CAREER PREPARATION (SCHOOL BASED)

Career planning and preparation involves a combination of educational experiences that will enhance the individual's personal development and provide practical experiences leading to a vocational field of interest. Cooperative educational experiences are designed to provide opportunities for students to become involved in career related experiences through community participation. In grade 11 the students will have opportunities to:

- a. learn about career development within the course requirements,
- b. observe employees at work in the community,
- c. participate in discussion with resource persons from the community,
- d. acquire knowledge of proven procedures for job searching and interviewing, and
- e. become aware of educational requirements for particular careers.

These educational experiences are intended to be an integral part of the learning experiences within the career preparation program. Students will gain further experiences in cooperative education in grade 12 through actual work experience in the community.

### General Aims

The student will:

- a. gain practical assistance in making the transition from school to a career field of interest,
- b. develop skills and abilities that are needed for employment in a career field of the student's choice,
- c. be prepared to enter the world of work with an increased measure of competence,
- d. develop respect for other people and the work that they do,
- e. develop a systematic approach to solving problems,
- f. participate in discussions related to career choice and life style to increase the student's awareness of the importance to health, happiness and economic security.



MODULE 1.01 CAREER DEVELOPMENT AND COMMUNICATION

Goal Statements

The learning experiences in this module are designed to help each student:

- a. increase awareness of the job opportunities in the community;
- b. gain insight into the aptitudes and skills required for various occupations;
- c. develop a relationship between immediate experiences and decisions that influence their evolving career development;
- d. understand factors that influence the choice of a vocation or profession;
- e. develop suitable, realistic and personally desirable career goals;
- f. enter the world of work with an increased measure of competence;
- g. gain experiences in decision-making skills;
- h. understand communication processes and barriers;
- i. learn and practice good work habits for employment situations;
- j. acquire skills in writing reports in a specified format.

Learning Outcomes

Student Activities

The student should be able to:

1.01.01

identify reasons that lead people to work

- consider why people work
- discuss work ethic, social values, economic independence

1.01.02

analyze and list tentative vocational choices in the metal trades

- compare vocational family grouping of occupations

- machinist
- millwright
- tool and die maker
- machinist fitter
- sheet metal worker
- boiler maker
- plater and fitter
- welder
- plumber
- pipe fitter
- iron worker
- structural steel worker

- blacksmith and farrier
- foundry worker
- production fabricator
- auto body man
- refrigeration mechanic
- saw filing fitter
- aircraft sheet metal worker
- gas fitter
- oil burner mechanic
- roofer

1.01.03

analyze factors to consider in career selection

- discuss reasons for people to work
- examine job cluster charts
- discuss educational requirements of jobs
- identify factors to consider in career decisions
- discuss career 'payoffs'

1.01.04

convey positive attitudes toward punctuality, honesty, courtesy, responsibility and cooperation

- discuss company losses due to theft, absenteeism, shoplifting, material wastage
- discuss employee responsibilities and personal relations.

1.01.05

identify factors that influence the student's vertical and horizontal mobility in a selected career field

- analyze qualifications for job entry
- use examples from industry

1.01.06

practice communication skills in an employment situation

- view films or read examples and react
- discuss importance of clear communication

1.01.07

describe successful work behaviour  
- attitudes, skills and responsibilities

1.01.08

participate and use communication skills in group interaction situations

1.01.09

use verbal and non-verbal communication skills

1.01.10

list three things that influence how one makes a decision

1.01.11

speak clearly and confidently in situations involving another individual or a group and using a telephone

1.01.12

participate and use communication skills in group interaction situations

1.01.13

prepare a brief report or memo from prepared examples of occupational situations

1.01.14

prepare a report of a work situation in school

- participate in small and large group discussions
- listen to instructions and restate them accurately and interpret them

- react to problem situations
- discuss communication techniques to resolve a problem situation

- work with other students in class

- review and discuss types of reports used in various employment situations, e.g. accident reports, evaluation, communications, etc.

- discuss reports

MODULE 1.02 WORK ETHIC AND WORK OBSERVATION

Goal Statements

The learning activities in this module are designed to:

- a. review the concept of 'work ethic' in relation to the economy,
- b. provide each student with various methods of conducting observation (shadowing) session, and
- c. increase the student's ability to interview and gather information from people.

Learning Outcomes

Student Activities

<u>Learning Outcomes</u>	<u>Student Activities</u>
The student should be able to:	
<u>1.02.01</u> describe positive work habits and attitudes	<ul style="list-style-type: none"><li>- class discussion</li><li>- discuss job/career satisfaction</li></ul>
<u>1.02.02</u> conduct an informational gathering analysis of a particular occupation	<ul style="list-style-type: none"><li>- discuss the nature of work tasks and social skills</li><li>- examine the impact of technology change</li></ul>
<u>1.02.03</u> prepare a brief oral report on a selected career that outlines advantages and disadvantages for employment in the field	<ul style="list-style-type: none"><li>- review social and economic aspects of various occupations</li><li>- examine present and future demands for employment in particular jobs.</li></ul>
<u>1.02.04</u> list the safety factors that are critical to a particular job	<ul style="list-style-type: none"><li>- consider training needs</li><li>- discuss "external" dangers, and jobs with high degree of risk in maintenance, e.g. mine sites</li><li>- research importance of "safety attitude"</li><li>- categorize "risk" factors</li></ul>
<u>1.02.05</u> list training requirements for three specific careers in area of interest	<ul style="list-style-type: none"><li>- use related resource information and sources of career information</li></ul>

MODULE 1.03 ORGANIZATIONAL STRUCTURES AND ROLE OF  
MANAGEMENT AND LABOUR

Goal Statements

The learning experiences in this module are designed to:

- a. help each student relate individual jobs to various organizational structures,
- b. provide examples of the inter-relationships of occupations and functions in a company related to mechanical trades,
- c. help each student to understand the function and responsibility of management,
- d. help the student recognize the role of the labour organizations in company operations,
- e. orient the student to the respective roles of labour and management personnel,
- f. provide the student with a brief overview of the process of contract negotiations,
- g. increase student awareness of the contribution of labour to economic growth and development in the country,
- h. provide information that outlines the contribution of the labour movement to the social and economic growth of the country, and
- i. examine the organizational structure and development of the major unions.

Learning Outcomes	Student Activities
The student should be able to:	
<u>1.03.01</u>	
prepare a chart to outline a typical company organization	- discuss the importance of various roles in a company - review organizational plan for small and large companies, identify "essential" positions
<u>1.03.02</u>	
compare the essential differences between management roles and workers	
<u>1.03.03</u>	
list some of the attributes of a manager and a leader	

1.03.04

list some of the methods used to accomplish company goals

- discuss social and consumer goals and needs

1.03.05

outline the steps that are followed for contract negotiations

- group discussions and guest speaker

1.03.06

debate an issue concerning any of these topics: unionism, capitalism, equal rights, sexual equality or employee benefits

- discuss with resource speakers

1.03.07

discuss the concept of the labour market in a career field and project conditions that would affect them

- discuss job stability
- project employment needs and the role of labour

1.03.08

list the procedures to be followed in a grievance procedure

- use resource people from labour organizations

1.03.09

define common terminology, e.g. shop steward, local, grievance, negotiation process

- review prepared materials
- read case studies (print, tape)

1.03.10

describe background for developments in the labour movement

- discuss handouts and films

1.03.11

make a flow chart on the labour organizational structure.

- group discussions and activities

MODULE 1.04 WORKING CONDITIONS AND LABOUR LEGISLATION

Goal Statements

The learning experiences in this module are designed to help each student:

- a. become familiar with common requirements and responsibilities of an employee,
- b. become aware of employee/employer rights under legislation,
- c. develop an awareness of the legislative process and laws that protect employee rights, and
- d. become familiar with the sources of information relative to employee rights and responsibilities.

Learning Outcomes	Student Activities
The student should be able to:	
<u>1.04.01</u>	
list examples of proper care of company equipment and materials	- differentiate between routing maintenance and careless breakage
<u>1.04.02</u>	
list reasons for employee punctuality in five occupations	- discuss different occupational requirements
<u>1.04.03</u>	
define 'overtime' in two different occupations	- discuss labour laws - relate concept of overtime to salary
<u>1.04.04</u>	
complete various types of applications forms, income tax forms, time cards etc.	- practice completion of basic forms that employees use - calculate salary by day, week, month and year
<u>1.04.05</u>	
analyze desirable and non-desirable considerations that relate to a specific geographical location for employment	- discuss particular jobs in urban, rural and remote areas

MODULE 1.05 JOB SEARCH SKILLS AND JOB INTERVIEWS

Goal Statements

The learning experiences in this module are designed to help each student:

- a. become familiar with a disciplined and methodical approach to the job search process,
- b. review examples of proven processes in preparing resumes and qualifications briefs,
- c. analyze some non-traditional job search skills,
- d. prepare for job interviews,
- e. practice methods of conducting job interviews, and
- f. review and clarify various methods of arranging and participation in an interview for employment.

Learning Outcomes	Student Activities
The student should be able to:	
<u>1.05.01</u>	
identify the 'hidden' job market	- review methods used by people to find jobs
<u>1.05.02</u>	
complete two resume outlines for simulated situations	- use various formats; chronological, functional, qualifications brief - organize information in an approved format and style
<u>1.05.03</u>	
draft a covering letter for resume	- write letters and compare with others in class
<u>1.05.04</u>	
examine procedures used to screen applicants for employment	- discuss various company personnel procedures
<u>1.05.05</u>	
follow detailed instructions to complete an application form	- use and complete sample application forms



1.05.06

outline basic steps to follow for initial contact with an employer

- prepare a letter that requests an application form
- discuss pros and cons of contracts by phone, letter or interview

1.05.07

apply successful job search techniques

- use resource personnel from Canada Employment and Immigration Commission (CEIC)
- list agencies and organizations that may be contacted for jobs

1.05.08

list employment opportunities for a metal trades occupation from a search of:

- newspaper classified sections
- personal contacts
- informational interviews (friends)
- Canada Employment and Immigration Commission

- discuss terms and occupational titles for various occupations
- interpret information from printed employment want ads

1.05.09

practice interviewing skills

- tape a simulated interview situation with other students
- demonstrate appropriate manners and etiquette
- writing letters of thanks where appropriate

1.05.10

prepare a job prospect card

- review examples and complete a sample

MODULE 1.06 FIELD TRIPS AND RESOURCE SPEAKERS

Goal Statements

The learning experiences in this module are designed to:

- a. provide the opportunity for occupational observation by utilizing the resources of the community, and
- b. involve the community in the educational career development of students.

Learning Outcomes	Student Activities
The student should be able to:	
<u>1.06.01</u>	
write a synopsis of a film or article on a career field of the student's choice	- view films or articles and discuss in class
<u>1.06.02</u>	
contact and arrange for a guest speaker to visit the class for a discussion	- discuss procedures and act as host/hostess
<u>1.06.03</u>	
interview three employers to record opinions and requirements that are deemed to be important to effective employment	- conduct interviews and make oral report to class
<u>1.06.04</u>	
prepare an outline of specific items on working conditions that should be observed during a plant visit	- complete written evaluation outline

MODULE 1.07 EDUCATIONAL REQUIREMENTS FOR CAREER PLANNING

Goal Statements

The learning experiences in this module are designed to:

- a. enable the student to enter the world of work with an increased measure of competence;
- b. help each student increase their awareness of a wide variety of career and educational options; and
- c. provide the student with an understanding of opportunities for continuing education - university, college or Provincial institute programs.

Learning Outcomes	Student Activities
The student should be able to:	
<u>1.07.01</u>	
identify the most powerful reinforcers to their proposed career choices	- class discussions
<u>1.07.02</u>	
list the names and locations of post-secondary institutions offering courses in three career fields	- review entry requirements, program offerings, length of terms for specific courses - select one career field and prepare an educational plan for report to class
<u>1.07.03</u>	
demonstrate an ability to define career ladders and how to reach more advanced positions	- review a line diagram of a company organization pattern - work from prepared samples to design a career ladder in a particular field of interest - interview people at different levels in a career area and assess opinions regarding job satisfaction

UNIT 2.0 SHOP PRACTICES, HUMAN RELATIONS AND SAFETY PROCEDURES

General Aim

The student should develop and apply positive attitudes toward the application of standard shop practices, interpersonal relations and observance of safety rules and regulations.

MODULE 2.01 SHOP RULES AND PRACTICES

Goal Statements

The learning experiences in this module are designed to:

- a. help enable the student to acquire sufficient skills to identify, select, maintain and to safely operate shop equipment;
- b. increase student awareness of the construction and operating principles of various items of shop equipment;
- c. help each student acquire a sensitivity for determining stress and strain in certain lifting operations; and
- d. safe use of compressed air and gas.

Learning Outcomes

Student Activities

The student should be able to:

2.01.01

identify safety and health hazards

- locate safety and health equipment and discuss reasons for safety and health protection

2.01.02

demonstrate good housekeeping habits

- list areas that require housekeeping and various methods used

2.01.03

maintain a clean and safe work area

- review both safe and unsafe work areas

2.01.04

use safety glasses, shields, guards, and other protective clothing according to prescribed standards

- discuss proper applications of protective equipment

2.01.05

identify and use proper cleaning agents

- study and discuss the characteristics of different cleaning agents and their applications

2.01.06

safely handle and store cleaning agents

- examine safety storage provided and consider applicable regulations

2.01.07

describe the design, safe operating procedures, and maintenance for general shop equipment

- proper cleaning and maintenance of equipment

2.01.08

explain first aid for common injuries; lay out procedure of response in any injury for your work situation

- discuss basic procedures for reporting and disposition of injuries

2.01.09

describe the need for the use of safety tags

- discuss the need for the use of safety tags

2.01.10

identify and explain the procedure to follow when finding a safety tag on a piece of equipment

- discuss the procedure to follow when finding a safety tag on a piece of equipment

2.01.11

state the basic steps to follow in filing a claim with Workers' Compensation Board

- discuss the importance of W.C.B. and their role in worker safety

2.01.12

list examples of legal protection  
for employees within Workers'  
Compensation Board

- discuss legal role of  
W.C.B.
- consider limitations of  
first aid and importance  
of adequate training  
before treating injured  
persons

MODULE 2.02 HUMAN RELATIONS AND PERSONAL ATTRIBUTES

Goal Statements

The learning experiences in this module are designed to help each student:

- a. develop an awareness of their own potential, a sense of pride in accomplishment and confidence in their own ability;
- b. develop an awareness of appropriate standards of human relations for various occupations;
- c. become familiar with techniques for improved interpersonal relations;
- d. develop positive attitudes in relations with teachers and students;
- e. appreciate the continuing importance of good human relations;
- f. make an inventory of interests and capacities;
- g. develop a sense of personal identity and worth;
- h. consider the theories of perceiving people as individuals rather than identification by traditional sex roles in society;
- i. prepare information regarding interests, temperaments and aptitudes required for various jobs;
- j. recognize the importance of appearance and personal ethics to employment success; and
- k. become aware of their own individual values and reactions toward people, situations and themselves.

Learning Outcomes

Student Activities

The student should be able to:

2.02.01

exhibit positive behaviour towards other students

- role playing
- display approved techniques for interpersonal relationships

2.02.02

display acceptable manners in all activities

- discuss need for appropriate manners

2.02.03

demonstrate individual differences in perception

- use examples of good and poor relations between employers and employees; teachers and students

2.02.04

complete a self-appraisal outline on personal traits and attitudes

- discuss importance of personality, attitudes and health to occupations
- assess personal traits and talents

2.02.05

assess strengths, capabilities and weaknesses of people

- consider and discuss problems in relation to employment roles
- discuss the need to conform in specific situations
- review the importance of health for employment
- list positive and negative personal attributes

2.02.06

use particular skills necessary to gather, process and act upon information about self in relation to their environment

- discussion of self-development

2.02.07

recognize the importance of standards in appearance, dress and grooming, manners; and correct use of the English language

- observe films
- review safe working conditions concerning dress

2.02.08

list factors that influence discrimination, i.e. race, religion and sex

- discuss equality of individuals
- react to examples of prejudice
- discuss ways to overcome discrimination



2.02.09

identify five important reasons  
for appropriate dress for an  
occupation

= group discussions

2.02.10

provide an example of a conflict  
situation created by employee/  
employer attitudes toward dress

= group discussions

MODULE 2.03 GENERAL SHOP ADMINISTRATION

Goal Statements

The learning experiences in this module are designed to:

- a. provide each student with a working knowledge of fundamental principles of shop systems, and
- b. help each student recognize the need for efficiency in shop administration procedures.

<u>Learning Outcomes</u>	<u>Student Activities</u>
<p>the student should be able to:</p> <p><u>2.03.01</u></p> <p>outline tool check out system in use</p> <p><u>2.03.02</u></p> <p>recognize areas where specific types of work may take place</p> <p><u>2.03.03</u></p> <p>direct responsibilities in a supervisory capacity during clean up</p> <p><u>2.03.04</u></p> <p>list responsibilities required to maintain assigned area</p>	<ul style="list-style-type: none"><li>- become familiar with area for tool storage and check out system</li> <li>- sketch a simplified shop layout</li></ul>

MODULE 2.04 EMERGENCY PROCEDURES (FIRE AND MEDICAL ROUTINES)

Goal Statements

The learning experiences in this module are designed to:

- a. introduce the student to approved processes for dealing with emergencies in shop situations; and
- b. describe the basic operation of four types of fire extinguishers (A B C D)

Learning Outcomes	Student Activities
The student should be able to:	
<u>2.04.01</u>	
demonstrate proper procedures for assigned emergency situations	<ul style="list-style-type: none"><li>- discuss common injuries</li><li>- review available safety films and procedures</li></ul>
<u>2.04.02</u>	
distinguish between various classes of fires	<ul style="list-style-type: none"><li>- in group activities, use the correct fire fighting equipment and describe correct use of an oil fire (in a controlled environment)</li></ul>
<u>2.04.03</u>	
describe the basic operation of four types of fire extinguishers (A B C D)	<ul style="list-style-type: none"><li>- examine all fire extinguishers</li><li>- local fire department involvement</li></ul>
<u>2.04.4</u>	
use appropriate fire extinguishers on different types of fires	<ul style="list-style-type: none"><li>- discuss school emergency exit procedures</li><li>- practice prescribed exit procedures</li><li>- inspect any given piece of fire fighting equipment and state the type of fire on which it may be used</li><li>- review locations of extinguishers (refer to sketch of shop layout)</li></ul>

2.04.05

identify basic first aid procedures and telephone numbers for emergency assistance

- locate the required first aid equipment and discuss use

UNIT 3.0 TECHNICAL - READING, WRITING AND REPORTING

General Aim

The student should further develop skills for reading, writing and reporting information.

MODULE 3.01 TECHNICAL REPORTS AND WORK SHEETS

Goal Statements

The learning experiences in this module are designed to:

- a. help each student read and interpret technical information,
- b. increase student ability to use English in communication,
- c. encourage neatness and legibility in all written work, and
- d. to develop the abilities to record and maintain accurate work done.

Learning Outcomes

Student Activities

The student should be able to:

3.01.01

interpret technical text books and other reference sources

- review various manuals

3.01.02

complete a neat and legible report on an assigned reporting task

- at task completion, a short concise report is to be forwarded to the instructor for evaluation

3.01.03

maintain a neat and legible notebook on activities

3.01.04

use correct English in verbal and written communications

- practice completion of daily work sheets

3.01.05

record information in a neat and legible format

3.01.06

describe in appropriate terms, work performed during a day

3.01.07

complete a basic 'time card' or record a work form

- compare samples of worksheets

- compare various formats and assess need for accuracy and neatness

## UNIT 4.0 FASTENERS

### General Aim

The student should develop an understanding of fastening devices and their selection, installation and maintenance.

### MODULE 4.01 TYPES OF FASTENERS

#### Goal Statements

The learnings experiences in this module are designed to:

- a. help each student identify and select common fasteners,
- b. increase ability to classify into categories various types of fasteners,
- c. make students aware of the types and uses of adhesives, and
- d. make students aware of the consequences of using dissimilar metals in fasteners.

#### Learning Outcomes

#### Student Activities

The student should be able to:

##### 4.01.01

identify and classify types of threads according to:

- a. size
- b. pitch
- c. thread series
- d. thread classes
  - S.I. metric
  - unified
  - Imperial
- e. pipe threads

- study and discuss the reasons for using different types of threads
- identify threads for a variety of fasteners from a large assortment

##### 4.01.02

identify and classify

- a. types of bolts and machine screws
- b. types of bolt heads
  - hex
  - square
  - Allen or socket
  - Phillips
  - Robertson
  - slotted

- use pitch gauge, steel rule and calipers to measure bolts and nut sizes
- compare common uses of bolts and screws

4.01.03

identify and classify various types of nuts:

- hex
- square
- slotted hex
- castellated
- acorn
- pal
- interference
- self locking

- common use of nuts

4.01.04

identify and classify types of:

- flat washers
- lock washers
- snap rings

- compare common uses of washers

4.01.05

identify and classify self tapping screws:

- type A sheetmetal screws
- drive screws
- head shapes

- compare thread configurations and common uses  
- compare various types and uses

4.01.06

identify and classify various types of pins:

- cotter
- spring
- dowels
- aligning
- taper

- compare common uses



UNIT 5.0 TOOLS AND EQUIPMENT

General Aim

The student should develop an understanding of the proper use and care of tools used in the metal trades.

MODULE 5.01 USE AND CARE OF HAND TOOLS

Goal Statement

The learning experiences in this module are designed to help student identify, select, use and maintain hand tools necessary use in the metal trades.

Learning Outcomes	Student Activities
<p>The student should be able to:</p> <p><u>5.01.01</u></p> <p>identify and select appropriate hand tools required for use in the metal trades</p> <p><u>5.01.02</u></p> <p>demonstrate a knowledge of metric and imperial tool sizes</p> <p><u>5.01.03</u></p> <p>explain the construction, safe handling and techniques of hand tools such as:</p> <ul style="list-style-type: none"><li>- hammers, punches</li><li>- wrenches, pliers</li><li>- chisels, files, hacksaws, drills</li><li>- vises, clamps</li></ul>	<ul style="list-style-type: none"><li>- list usage of hand tools</li>          <li>- use hand tools:<ul style="list-style-type: none"><li>- hammers, punches</li><li>- chisels, pliers, wrenches</li><li>- files, hacksaws</li><li>- screwdrivers</li><li>- clamp, vises</li></ul></li></ul>

MODULE 5.02 MEASURING TOOLS

Goal Statement

The learning experiences in this module are designed to help each student identify, select and become proficient in handling non-precision and precision instruments, and interpreting their readings (both S.I. metric and Imperial).

Learning Outcomes

Student Activities

The student should be able to:

5.02.01

state the necessity of measuring instruments such as:

- steel scales
- tapes
- inside calipers
- outside calipers
- squares
- hermaphrodite calipers
- dividers
- drill gauge
- wire gauge
- micrometers (outside, inside)
- vernier calipers
- dial indicators
- feeler gauges
- telescoping gauges
- thread gauges

- discuss why exact measurements are required
- use S.I. metric and Imperial
- apply proper handling and manipulation techniques

5.02.02

identify the specified steel measuring rules (flexible or non-flexible) in terms of:

- types
- values of graduations
- obtainable measuring accuracy
- measuring range
- holding techniques for measuring, checking and layout operations
- applications
- determine and apply the correct methods of handling, storing and maintaining steel measuring rules

- discuss and use measuring instruments on sample pieces
- use S.I. metric and Imperial

5.02.03

identify precision steel squares

- types
- sizes
- holding techniques for checking and layout operations
- applications

- discuss and use instruments on sample pieces

5.02.04

identify the micrometer (outside, inside, depth) measuring tools

- types
- components and working principles
- attaching and securing extension rods
- holding techniques for measuring operations
- setting, locking and measuring micrometers at determined values
- handling, storing and maintaining micrometers

- discuss and in small groups use micrometers on sample pieces

5.02.05

identify vernier calipers

- types
- components and working principles
- holding techniques for measuring operations
- setting and measuring calipers at determined values
- handling, storing and maintaining calipers

- discuss and in small groups use vernier calipers on sample pieces.

5.02.06

identify dial indicators

- types
- components and working principles
- obtainable measuring accuracy
- handling, storing and maintaining dial indicators

- discuss the use of dial indicators

5.02.07

- identify feeler gauges
- types
  - overall checking range
  - using individual and combination blades to determine the correct measurement
  - holding techniques for checking operations
  - handling, storing and maintaining thickness gauge sets

- discuss and in small groups use feeler gauges on sample pieces

5.02.08

- identify telescoping gauges
- overall checking range
  - applications
  - holding techniques for checking operation
  - setting, locking and measuring the overall valve with the outside micrometer
  - handling, storing and maintaining telescoping gauges

- discuss the use of telescoping gauges on sample pieces

5.02.09

- identify check gauges
- drill gauges
  - wire gauges
  - pitch gauges - S.I. metric
  - Imperial

- discuss and use check gauges where applicable

5.02.10

- identify calipers
- outside calipers
  - inside calipers
  - hermaphrodite calipers

- discuss and use calipers where applicable

5.02.11

- identify dividers

- discuss and use dividers

5.02.12

- select proper measuring devices for specific jobs

- study and discuss the reasons and advantages of each instrument
- study and discuss the different measuring systems

MODULE 5.03 LAYOUT TOOLS

Goal Statements

The learning experiences in this module are designed to:

- a. help each student identify, select and become proficient in the use of layout tools, and
- b. help each student use layout tools to produce accurate layouts to specification.

Learning Outcomes

Student Activities

The student should be able to:

5.03.01

identify and list various layout tools:

- scribes (hook, pocket, straight)
- steel rules (metric and imperial)
- precision square
- combination set
- plain steel protractor
- hook rule
- dividers
- angle-plates
- hermaphrodite calipers
- surface-gauge
- trammels
- centre punch
- prick punch
- surface plate
- toolmakers clamp
- vee blocks
- scratch awl

- list basic layout tools

5.03.02

scribe a line parallel to a datum edge using various tools and methods

- steel rule and scribe
- combination set square and scribe
- hermaphrodite calipers
- surface plate, angle plate and surface gauge
- tool makers clamp and surface gauge

5.03.03

scribe a line at 90° to a datum edge using various methods and tools

- combination square
- precision square
- angle plate, precision square and surface gauge

5.03.04

scribe circles, arcs and tangent lines using various tools and methods

- dividers or compass
- trammels
- dividers and steel rule

5.03.05

scribe angles to specification using various tools and methods

- protractor
- protractor head (combination set square)
- vee block and surface gauge
- bevel vernier protractor

- layout a project or projects to include layout activities outlined in Modules 3.03.02 to 3.03.10 to specification

5.03.06

layout equal distances with various tools and methods to specification

- dividers, layout equal distances around a circumference
- dividers, trammels, layout equal distances along a scribed line
- layout parallel lines with dividers
- layout perpendicular lines with dividers and trammels
- bisect an angle with dividers

5.03.07

find the centre of circles using various tools and methods

- hermaphrodite calipers
- dividers
- centre-head (combination set square)
- vee blocks and surface gauge

5.03.08

prick punch accurately around a finished layout

5.03.09

prepare a layout for drilling by prick punching, then centre punching

5.03.10

layout a double circle with centre lines to facilitate accurate drilling

MODULE 5.04 USE AND CARE OF PORTABLE POWER TOOLS AND ACCESSORIES

Goal Statement

The learning experiences in this module are designed to help each student identify, select, use and maintain portable power tools and accessories for use in the metal trades.

Learning Outcomes	Student Activities
<p>The student should be able to:</p> <p><u>5.04.01</u></p> <p>recognize the purpose, type and application of electrical and air power tools, i.e.:</p> <ul style="list-style-type: none"><li>- portable drill presses</li><li>- portable hand drills</li><li>- portable hand grinders and polishers</li></ul>	<ul style="list-style-type: none"><li>- study and discuss power tools and accessories</li><li>- discuss the effect of ferrous and non-ferrous metals on grinding wheels</li></ul>
<p><u>5.04.02</u></p> <p>demonstrate the safe and correct use of electrical and air power tools</p>	<ul style="list-style-type: none"><li>- after instruction, use appropriate equipment</li></ul>
<p><u>5.04.03</u></p> <p>point out and list the care and service required for electrical and air power tools</p>	<ul style="list-style-type: none"><li>- review manuals and assigned materials</li></ul>



UNIT 6.0 MECHANICAL DRAWING CONCEPTS

General Aim

The student should develop skills to read, sketch, draw and interpret basic methods used for graphic representation.

MODULE 6.01 BASIC CONCEPTS

Goal Statements

The learning experiences in this module are designed to:

- a. help the student recognize the necessary instruments used in to prepare accurate drawings;
- b. help the student practice gothic lettering and numbering techniques; and
- c. develop skills in sketching.

Learning Outcomes

Student Activities

The student should be able to:

6.01.01

identify types of pencils

- discuss basic types of pencils
  - hard - 9H, 8H, 4H
  - medium - 3H, 2H, H, F, HB, B
  - soft - 2B, 3B, 4B, 7B

6.01.02

identify types of instruments and their use

- discuss types and uses of instruments
  - T square
  - set square 30°-60°, 45°
  - triangular architects scale
  - triangular engineering scale
  - triangular metric scale
  - irregular curves
  - protractor
  - erasing shield
  - drawing paper
  - tape
  - other

6.01.03

identify the reasons for  
- accuracy  
- neatness

- discuss

6.01.04

perform gothic lettering and  
numbering

- complete gothic lettering  
and numbering sheets

6.01.05

identify the need for spacing and  
use of guide lines on drawings

- discuss and practice

6.01.06

sketch  
- horizontal lines  
- vertical lines  
- circles  
- angles

- discuss and complete  
drawing sheets

MODULE 6.02 MEASUREMENT

Goal Statements

The learning experiences in this module are designed to:

- a. improve measuring skills with the use of triangular scales, and
- b. help each student recognize and interpret scale drawings.  
simple components.

Learning Outcomes	Student Activities
<p>The student should be able to:</p> <p><u>6.02.01</u></p> <p>identify and use the following triangular scales</p> <ul style="list-style-type: none"><li>- architect's scale</li><li>- mechanical engineers' scale</li><li>- metric scale</li></ul> <p><u>6.02.02</u></p> <p>explain the use of scaled engineering or blueprint drawings</p>	<ul style="list-style-type: none"><li>- discuss and use each on line measurement exercises</li>          <li>- discuss</li></ul>

MODULE 6.03 PICTORIAL DRAWINGS

Goal Statements

The learning experiences in this module are designed to:

- a. help each student to recognize and develop the basic principles of pictorial drawings; and
- b. develop in each student the ability to freehand sketch and also accurately develop instrument drawings of machine parts.

Learning Outcomes	Student Activities
The student should be able to:	
<u>6.03.01</u>	
identify pictorial drawings	- discuss
<u>6.03.02</u>	
do isometric drawings <ul style="list-style-type: none"><li>- freehand sketching</li><li>- with drafting instruments</li></ul>	- discuss and complete isometric drawings
<u>6.03.03</u>	
do perspective drawings <ul style="list-style-type: none"><li>- one-point perspective</li><li>- two-point perspective</li></ul>	- sketch perspective drawings
<u>6.03.04</u>	
identify and sketch oblique drawings <ul style="list-style-type: none"><li>- cavalier</li><li>- cabinet</li></ul>	- sketch oblique drawings

MODULE 6.04 ORTHOGRAPHIC DRAWINGS

Goal Statements

The learning experiences in this module are designed to:

- a. help each student recognize and develop concepts or orthographic drawings,
- b. develop in each student the ability to freehand sketch and develop instrument drawings machine parts, and
- c. increase student ability to read orthographic drawing and relate them to actual components.

Learning Outcomes

Student Activities

The student should be able to:

6.04.01

identify orthographic drawings

- discuss

6.04.02

complete a one-view drawing

- freehand sketching
- instrument drawing

- discuss and complete one-view drawings

6.04.03

complete a two-view drawing

- freehand sketching
- instrument drawing

- discuss and complete two-view drawings

6.04.04

complete a three-view orthographic drawing in third angle projection

- freehand sketching
- instrument drawing

- discuss and complete three-view orthographic drawings

6.04.05

relate lines and surfaces between  
pictorial and orthographic  
drawings

- discuss and complete unfinished views
- reference text (blueprint reading for industry)

MODULE 6.05 CONVENTIONAL LINES AND SYMBOLS

Goal Statement

The learning experiences in this module are designed to help each student to understand and interpret the meaning of conventional lines and symbols used in graphic representation.

Learning Outcomes	Student Activities
The student should be able to:	
<u>6.05.01</u>	
identify basic lines used in graphic representation	- discuss and list basic lines
<ul style="list-style-type: none"><li>- border or visible lines</li><li>- section</li><li>- hidden</li><li>- centre</li><li>- extension</li><li>- dimension</li><li>- cutting plane</li><li>- short break</li><li>- long break</li><li>- leaders</li><li>- phantom</li><li>- other</li></ul>	
<u>6.05.02</u>	
identify basic symbols used in graphic representation	- discuss and list basic symbols
<ul style="list-style-type: none"><li>- arrowheads</li><li>- diameter symbol (D) (Ø)</li><li>- radius symbol (R)</li><li>- countersink (C'SK)</li><li>- cold roll steel (C.R.S.)</li><li>- hot roll steel (H.R.S.)</li><li>- hexagon (HEX)</li><li>- others</li></ul>	

6.05.03

identify surface finish ratings

- 1000 very rough (torch cut)
- 500 rough machining (heavy cut on mill machine)
- 250 coarse (coarse machining operation with sharp tool)
- 125 medium (fine machining operation with sharp tool)
- 63 good machine finish (extra fine feeds)
- 32 high grade machine finish (extremely fine feed on lathe or mill)
- 16 high quality machine finish (surface grinding)
- 8 very fine machine finish (fine honing or lapping)
- 2-4 extremely smooth (extra-fine honing or lapping)

= recognize and list symbols



MODULE 6:06 CONVENTIONAL CONCEPTS

Goal Statements

The learning experiences in this module are designed to:

- a. help each student acquire competency in conventional concepts of dimensioning and use of symbols,
- b. help students understand auxiliary views, and
- c. help each student understand the use of different types of sectional views.

Learning Outcomes	Student Activities
The student should be able to:	
<u>6.06.01</u>	
identify material symbols <ul style="list-style-type: none"><li>- brick</li><li>- concrete</li><li>- rubble and stone</li><li>- steel</li><li>- wood</li><li>- perforated metal</li><li>- marble</li><li>- coarse wire mesh</li><li>- fine wire mesh</li><li>- cast iron</li><li>- bronze, brass</li><li>- aluminium</li><li>- white metal, babbitt</li></ul>	- discuss and list section linings
<u>6.06.02</u>	
identify schematic threading symbols <ul style="list-style-type: none"><li>- external</li><li>- internal</li></ul>	- discuss

6.06.03

select proper placement of dimension and extension lines on a drawing

- discuss rules for dimensioning drawings
- identify the
  - unidirectional
  - aligned system

6.06.04

dimension

- figures
- angles
- arcs
- fillets and rounds
- holes
- threads
- tapers
- chamfers
- keyways
- knurls
- other

- discuss and complete drawings

6.06.05

identify special methods in dimensioning

- baseline
- point to point
- datum
- tolerancing
- fits
- other

- recognize and list special dimensioning methods

6.06.06

identify the purpose of an auxiliary view

- discuss and complete a drawing using an auxiliary view

6.06.07

identify the purpose of sectional views

6.06.08

identify the types of sectional views

- full section
- half section
- broke-out section
- revolved section
- removed section
- other

- discuss and complete sectional views of parts

6.06.09

identify welding symbols

- recognize and list welding symbols

6.06.10

identify architectural symbols and schedules

- mechanical
- electrical
- structural

- recognize and list symbols and schedules

UNIT 7:0 SOFT AND SILVER SOLDERING

General Aim

The student should gain experience using approved practices for the safe management and operation of soft and silver soldering equipment and gain proficiency in various soldering operations.

MODULE 7.01 SOFT SOLDER

Goal Statements

The learning experiences in this module are designed to:

- a. develop skills in the proper preparation of soldering coppers for soft soldering;
- b. help each student select proper fluxes for various soldering operations;
- c. make the student aware of the composition of tin-lead solder;
- d. help the student understand the uses of soldered joints; and
- e. make the student aware of the potential danger of fluxes.

Learning Outcomes	Student Activities
The student should be able to:	
<u>7.01.01</u>	
forge a soldering copper	<ul style="list-style-type: none"><li>- discuss various soldering copper shapes such as pointed and bottom copper</li><li>- heating and mechanical cleaning of coppers</li></ul>
<u>7.01.02</u>	
tin a copper	<ul style="list-style-type: none"><li>- chemically clean and tin copper</li></ul>
<u>7.01.03</u>	
select fluxes for specific operations	<ul style="list-style-type: none"><li>- discuss purposes of a flux corrosive and non-corrosive fluxes, safe handling and storage</li><li>- use fluxes for plated and bright steels and nonferrous metals</li></ul>

7.01.04

discuss the composition and forms on tin-lead solders

- discuss solders for various applications = 50-50, 60-40, 95-5, body leads etc.
- study various forms:
  - wire
  - cored wire
  - bar
  - sheet

7.01.05

explain the various uses of soft solder joints

- discuss soldering for water-tight joints in sheet metal and plumbing, airtight joints for blowpiping, sweat soldering for parts assembly.

MODULE 7.02 SOFT SOLDER APPLICATION

Goal Statements

The learning experiences in this module are designed to:

- a. make the student aware of the safe procedures in soldering,
- b. help the student become proficient in applying soft solder, and
- c. help the student become proficient in surface cleanup after soldering.

<u>Learning Outcomes</u>	<u>Student Activities</u>
The student should be able to:	
<u>7.02.01</u>	
explain the safe procedures for soldering	<ul style="list-style-type: none"><li>- study and discuss dangers inherent in various fluxes</li><li>- lighting firepots, furnaces and torches safely</li><li>- handling hot work safety</li></ul>
<u>7.02.02</u>	
properly apply soft solder with soldering coppers and open flame torch	<ul style="list-style-type: none"><li>- prepare and solder various joints such as:<ul style="list-style-type: none"><li>- lap</li><li>- rivetted</li><li>- seamed</li><li>- pre-tinned</li><li>- plumbing</li></ul></li></ul>
<u>7.02.03</u>	
clean metal surfaces after soldering operations	<ul style="list-style-type: none"><li>- remove corrosive fluxes and restore surface finish of various metals such as:<ul style="list-style-type: none"><li>- bright steel</li><li>- nonferrous</li><li>- stainless steel</li></ul></li></ul>

MODULE 7.03 SILVER SOLDER

Goal Statements

The learning experiences in this module are designed to:

- a. assist the student to understand the need for silver soldering.
- b. help the student to safely apply silver solder to metal joints.  
and
- c. help the student become proficient in surface cleaning up after silver soldering.

Learning Outcomes	Student Activities
The student should be able to:	
<u>7.03.01</u>	- discuss applications of silver soldering
select and prepare joints for silver soldering	- discuss and fabricate scarf and butt joints and sweat solder joints
<u>7.03.02</u>	
apply silver solder using open flame torch	- apply silver solder in proper amounts to various joints
<u>7.03.03</u>	
clean metal surfaces after silver soldering	- remove corrosive fluxes and restore surface finishes on ferrous and nonferrous metals

UNIT 8.0 GAS WELDING OPERATIONS

General Aim

The student should gain experience using approved practices for the safe management and operation of gas welding equipment.

MODULE 8.01 WELDING SAFETY PRACTICES

Goal Statements

The learning experiences in this module are designed to:

- a. help each student appreciate the importance of applying safe practices in the use of gas welding equipment;
- b. introduce the student to methods of checking gas welding equipment before operating on welding or heating tasks; and
- c. increase student awareness of the characteristics of gases used for heating and welding operations.

Learning Outcomes

Student Activities

The student should be able to:

8.01.01

identify the safety regulations for gas welding, cutting and heating to ensure a safe working environment

- read and discuss Workers' Compensation Board Sections 14, 17, 18.





MODULE 8.02 STORAGE AND HANDLING OF OXYGEN AND FUEL GAS CYLINDERS

Goal Statement

The learning experiences in this module are designed to ensure that each student can safely handle and store oxygen and fuel gas cylinders.

Learning Outcomes	Student Activities
<p>The student should be able to:</p> <p><u>8.02.01</u></p> <p>demonstrate the correct storage and handling practices of oxygen and fuel gas cylinders</p>	<ul style="list-style-type: none"><li>- identify correct storage practices for empty Oxygen cylinders</li><li>- identify correct storage practices for empty Acetylene cylinders</li><li>- identify correct handling practices for full Oxygen cylinders</li><li>- identify correct handling practices for full Acetylene cylinders</li><li>- identify correct procedure in removal of defective Acetylene cylinder from service</li><li>- identify correct mode of transporting cylinders in shop</li><li>- transport to and store empty cylinders in storage area</li></ul>

MODULE 8.03 HANDLING AND OPERATING OXY-ACETYLENE EQUIPMENT

Goal Statement

The learning experiences in this module are designed to enable each student to correctly handle and operate oxy-acetylene equipment.

Learning Outcomes	Student Activities
<p>The student should be able to:</p> <p><u>8.03.01</u></p> <p>describe correct handling and operating practices of oxy-acetylene equipment</p>	<ul style="list-style-type: none"><li>- crack cylinder and purge valve with appropriate wrench</li><li>- identify appropriate regulator to be used</li><li>- identify types of threads on acetylene equipment</li><li>- describe why an Oxygen regulator is set facing away from a acetylene regulator</li><li>- describe how oxy-acetylene fuel gas hose is stored</li><li>- describe correct method in purging oxy-acetylene</li><li>- describe the effect of oil and grease in contact with oxygen</li><li>- describe correct equipment handling practices</li><li>- describe correct equipment operating practices</li></ul>

MODULE 8.04 ASSEMBLY OF OXY-ACETYLENE EQUIPMENT

Goal Statement

The learning experiences in this module are designed to enable the student to correctly and safely assemble oxy-acetylene equipment.

Learning Outcomes	Student Activities
<p>The student should be able to:</p> <p><u>8.04.01</u></p> <p>correctly assemble a portable oxy acetylene unit</p>	<ul style="list-style-type: none"><li>- select place and secure cylinders in cart</li><li>- remove cap and crack cylinder valves</li><li>- attach regulators and hoses with proper wrench</li><li>- release regulator adjusting screw, open cylinder valve and set pressure to blow out hose</li><li>- open needle valves, attach torch assemble and blow out torch assembly</li><li>- attach welding or cutting apparatus to torch body securely.</li></ul>

MODULE 8.05 TESTING FOR LEAKS

Goal Statement

The learning experiences in this module are designed to enable the student to safely test oxy-acetylene equipment for leaks.

Learning Outcomes	Student Activities
<p>The student should be able to:</p> <p><u>8.05.01</u></p> <p>demonstrate correct procedures and methods in testing for leaks</p>	<ul style="list-style-type: none"><li>- describe methods employed in detecting leaks in oxygen and fuel gas systems</li><li>*- pressurize oxy-acetylene equipment and adjust regulator to working pressure</li><li>*- close cylinder valve and observe high pressure gauge on regulator</li><li>*- determine pressure drop, if any</li><li>*- apply nondetergent soap suds with brush to joints and connections</li><li>*- depressurize oxy-acetylene equipment and make necessary repair</li><li>- repeat * and determine outcome of repair</li></ul>

\*star denotes repeat of operation

MODULE 8.06 CORRECTLY LIGHT AND SHUT DOWN THE OXY-ACETYLENE UNIT

Goal Statement

The learning experiences in this module are designed to enable the student to correctly light and safely shut down the oxy-acetylene unit.

Learning Outcomes

Student Activities

The student should be able to:

8.06.01

correctly light an oxy-acetylene unit

- employ general and personal safety precautions
- identify tip size and select appropriate oxygen and acetylene pressures
- test connections for leaks using detergent, soapy water
- open acetylene valve on torch and light with striker. Adjust acetylene flow until smoke disappears
- open oxygen needle valve until complete combustion of acetylene occurs
- adjust torch to neutral flame setting

8.06.02

shut down the oxy-acetylene unit safely

- review general safety precautions
- close acetylene needle valve on torch body
- close oxygen needle valve on torch body
- close acetylene cylinder valve, open acetylene needle valve on torch body
- turn out pressure adjusting screw on acetylene regulator, then close needle valve
- close oxygen cylinder valve, open oxygen needle valve on torch body
- turn out pressure adjusting screw on oxygen regulator then
- close needle valve
- coil oxy-acetylene hose on unit.

101

MODULE 8.07 TORCH LINE EXPLOSIONS

Goal Statement

The learning experiences in this module are designed to enable the student to identify the causes of torch line explosions.

Learning Outcomes

Student Activities

The student should be able to:

8.07.01

identify the causes of flashback, backfire, burnback

- describe conditions and causes for a flashback
- describe conditions and causes for a backfire
- identify equipment maintenance procedures to eliminate explosions
- describe gas speed and speed of flame propagation
- identify the purpose of a reverse flow check valve (RFCV)
- identify conditions causing a burnback

Information note

- Backfire - the flame backs up into the tip and generally reestablishes itself with a bang or popping noise
- Burnback - combustion takes place steadily in the tip and mixer
- Flashback - occurs when one gas backs up into the other line forming an explosive mixture. Flashback always occurs in the line carrying the lower pressure.

MODULE 8.08 FIRE PREVENTION

Goal Statement

The learning experiences in this module are designed to enable the student to identify the requisites in fire prevention.

Learning Outcomes	Student Activities
<p>The student should be able to:</p> <p><u>8.08.01</u></p> <p>identify the requisites in fire prevention</p>	<ul style="list-style-type: none"><li>- define the term fire prevention</li><li>- describe the welder's responsibilities for fire prevention</li><li>- describe the employers' responsibilities for fire prevention</li><li>- describe conditions creating fire hazards and explosions</li><li>- identify remedies to eliminate fire hazards and explosions</li><li>- identify the importance of a fire watcher</li></ul>



MODULE 8.09 FIRE EXTINGUISHERS

Goal Statement

The learning experiences in this module are designed to enable the student to identify the components of a fire, types of fires, and extinguishers.

<u>Learning Outcomes</u>	<u>Student Activities</u>
<p>The student should be able to:</p> <p><u>8.09.01</u></p> <p>identify pressurized A, B, and C type fire extinguishers</p>	<ul style="list-style-type: none"><li>- describe the requisites for a fire</li><li>- describe the types of fires</li><li>- describe the classes of fires</li><li>- describe the types of fire extinguishers</li><li>- describe the classes of fire extinguishers</li><li>- identify the types of fire extinguishers used to extinguish rubbish and paper fires</li><li>- identify types of fires combated with CO2 fire extinguishers</li><li>- identify the uses of A, B, C, fire extinguishers</li></ul>

## MODULE 8.10 VENTILATION

### Goal Statement

The learning experiences in this module are designed to give a simulated working environment to enable the student to identify ventilation requirements for welding, cutting and general shop work.

Learning Outcomes	Student Activities
<p>The student should be able to:</p> <p><u>8.10.01</u></p> <p>identify ventilation requirements for welding, cutting and general shop work</p>	<ul style="list-style-type: none"><li>- review Section #17, Workers' Compensation Board Regulations for ventilation requirements</li><li>- identify conditions that require ventilation</li><li>- identify materials that emit toxic fumes when heated, welded or cut with torch</li><li>- identify precautions required when working in confined areas</li></ul>

MODULE 8.11 WELDING AND CUTTING CONTAINERS

Goal Statement

The learning experiences in this module are designed to enable the student to identify the correct and safe methods for welding and cutting containers.

Learning Outcomes	Students Activities
<p>The student should be able to:</p> <p><u>8.11.01</u></p> <p>identify the <u>extreme hazards</u> involved in <u>welding or cutting containers that are sealed or containers that have held combustibles</u></p>	<ul style="list-style-type: none"><li>- study and discuss safe methods of welding or cutting containers<ul style="list-style-type: none"><li>a. steam cleaning</li><li>b. purging using inert gases</li><li>c. filling with water</li></ul></li></ul>

MODULE 8.12 PROTECTIVE EQUIPMENT

Goal Statement

The learning experiences in this module are designed to enable the student to select and use protective equipment in welding.

Learning Outcomes	Student Activities
<p>The student should be able to:</p> <p><u>8.12.01</u></p> <p>identify and select proper protective equipment</p>	<ul style="list-style-type: none"><li>- describe the reason for wearing safety glasses</li><li>- describe uses and types of goggles in welding and cutting</li><li>- describe the uses and types of welding helmets</li><li>- describe the use of tinted or coloured lenses in welding and cutting and their shade description</li><li>- identify types of hearing protection equipment used</li><li>- identify the advantage of using leather jackets in welding and cutting</li><li>- identify the advantages of using leggings and aprons in welding and cutting</li></ul>

UNIT 9.0 OXY-ACETYLENE EQUIPMENT

General Aim

The student should identify, understand, and use oxy-acetylene welding equipment.

MODULE 9.01 OXY-ACETYLENE WELDING EQUIPMENT PROCESSES AND APPLICATIONS

Goal Statement

The learning experiences in this module are designed to provide introductory experiences that will enable the student to identify, understand, and use basic oxy-acetylene welding equipment.

Learning Outcomes

Student Activities

The student should be able to:

9.01.01

describe the production and properties of oxygen and acetylene gas

- describe the nature of oxygen
- describe the properties of oxygen
- describe the production of oxygen
- describe the nature of acetylene
- describe the properties of acetylene
- describe the production of acetylene

MODULE 9.02 CONSTRUCTION OF OXYGEN AND FUEL GAS CYLINDERS

Goal Statement

The learning experiences in this module are designed to provide introductory experiences that will teach the student to identify, understand, and use basic oxy-acetylene welding equipment.

Learning Outcomes

Student Activities

The student should be able to:

9.02.01

describe the construction of oxygen and fuel gas cylinders

- state agencies that govern standards in cylinder construction
- describe the construction of an oxygen cylinder
- describe the function of the oxygen cylinder valve
- describe the function of the oxygen cylinder valve cover
- describe the construction of an acetylene cylinder
- describe the construction of an acetylene cylinder valve
- describe the construction of a fusible plug and its location
- describe the construction of a mapp-gas cylinder and valve

MODULE 9.03 CONSTRUCTION OF PRESSURE REGULATORS

Goal Statement

The learning experiences in this module are designed to provide introductory experiences that will enable the student to identify, understand, and use basic oxy-acetylene welding equipment.

Learning Outcomes	Student Activities
<p>The student should be able to:</p> <p><u>9.03.01</u></p> <p>identify the construction and application of regulators on oxy acetylene equipment</p>	<ul style="list-style-type: none"><li>- state purpose of a pressure-reducing device in oxy-acetylene equipment</li><li>- describe the construction of the single and double stage regulator</li><li>- identify the limitations of a single stage regulator</li><li>- identify the operating characteristics of a two-stage acetylene regulator</li><li>- identify correct maintenance procedures for regulators</li></ul>

MODULE 9.04 OXYGEN AND FUEL GAS HOSE

Goal Statement

The learning experiences in this module are designed to provide introductory experiences that will teach the student to identify, understand, and use basic oxy-acetylene welding equipment.

Learning Outcomes	Student Activities
<p>The student should be able to:</p> <p><u>9.04.01</u></p> <p>identify the correct maintenance practices for oxygen and fuel gas hoses</p>	<ul style="list-style-type: none"><li>- describe the construction of twin design oxygen and fuel gas hose</li><li>- identify the colouring scheme employed to separate oxygen and fuel gases</li><li>- identify the thread design employed in the fuel gas hose connector fittings</li><li>- identify correct practices in splicing of oxygen and fuel gas hose</li><li>- identify correct practices in coiling and storing oxygen and fuel gas hoses</li></ul>



MODULE 9.05 OXY-ACETYLENE TORCHES

Goal Statement

The learning experiences in this module are designed to provide introductory experiences that will enable the student to identify, understand, and use basic oxy-acetylene welding equipment.

Learning Outcomes	Student Activities
<p>The student should be able to:</p> <p><u>9.05.01</u></p> <p>identify and describe two types of oxy-acetylene torches</p>	<ul style="list-style-type: none"><li>- describe the function of a balanced pressure type mixing chamber</li><li>- describe the function of an injector type mixing chamber</li><li>- identify the limitations of a one-piece torch</li><li>- identify the advantages and disadvantages of a two-piece torch</li><li>- identify correct methods in installing heating, cutting and welding tips</li><li>- identify correct maintenance practices for one and two-piece torches</li></ul>

MODULE 9.06 MANIFOLD SYSTEMS

Goal Statement

The learning experiences in this module are designed to provide introductory experiences that will enable the student to identify, understand, and use basic oxy-acetylene welding equipment.

Learning Outcomes	Student Activities
<p>The student should be able to:</p> <p><u>9.06.01</u></p> <p>identify the application of a manifold system</p>	<ul style="list-style-type: none"><li>- identify types of manifold systems</li><li>- identify regulations and standards governing construction and operation of manifold systems</li><li>- identify and define the term 'pickled pipe'</li><li>- explain the requirements for a hydraulic back pressure valve</li><li>- identify the purpose of pigtails and check valves</li><li>- identify the purpose of a master regulator</li><li>- identify the advantages and disadvantages of a manifold system</li></ul>

MODULE 9.07 SELECTION OF FLAMES

Goal Statement

The learning experiences in this module are designed to provide introductory experiences that will enable the student to identify, understand, and use basic oxy-acetylene welding equipment.

Learning Outcomes	Student Activities
<p>The student should be able to:</p> <p><u>9.07.01</u></p> <p>identify the use of neutral, oxidizing, and carburizing flames in oxy-acetylene welding and cutting</p>	<ul style="list-style-type: none"><li>- identify the types of flames</li><li>- identify the temperature ranges for neutral, oxidizing and carburizing flames</li><li>- identify and define the 3X flame system</li><li>- determine the use of a 3X flame</li><li>- identify the type of flame employed in oxy-acetylene cutting and welding of plain carbon steel</li></ul>

MODULE 9.08 TIP SELECTION AND MAINTENANCE

Goal Statement

The learning experiences in this module are designed to provide introductory experiences that will enable the student to identify, understand, and use basic oxy-acetylene welding equipment.

Learning Outcomes	Student Activities
The student should be able to:	
<u>9.08.01</u>	
identify and select the correct welding or cutting tip	<ul style="list-style-type: none"><li>- identify types of cutting tips</li><li>- identify purpose of numbering systems used</li><li>- install selected tip employing accepted methods</li></ul>
<u>9.08.02</u>	
perform tip cleaning procedure	<ul style="list-style-type: none"><li>- identify condition of models</li><li>- identify maintenance procedures employed for tip cleaning</li></ul>

UNIT 10.0 OXY-ACETYLENE WELDING, BRAZING AND CUTTING (O.A.W.)

General Aim

The student should gain experience using approved practices for the safe management and operation of oxy-acetylene welding, brazing and cutting.

MODULE 10.01 WELDING POSITIONS

Goal Statement

The learning experiences in this module are designed to provide the student with the letter identification for groove (G) and fillet (F).

Learning Outcomes	Student Activities
The student should be able to: <u>10.01.01</u> identify the accepted positions of welding	- review handout on positions of welding - identify the -F- positions - identify the -G- positions

MODULE 10.02 SELECTION OF FILLER METALS

Goal Statement

The learning experiences in this module are designed to enable the student to select filler metals.

Learning Outcomes	Students Activities
The student should be able to:	
<u>10.02.01</u>	
identify and select proper filler rod	<ul style="list-style-type: none"><li>- review gas welding filler metals</li><li>- identify type of steel to be joined</li><li>- identify types of gas welding rods</li></ul>
<u>10.02.02</u>	
select an R.G. 60 rod	<ul style="list-style-type: none"><li>- select one filler rod from stock and match with properties of steel</li><li>- identify selected filler rod</li></ul>

MODULE 10.03 FOREHAND WELD

Goal Statement

The learning experiences in this module are designed to enable the student to become proficient in using the forehand method of welding.

Learning Outcomes

Student Activities

The student should be able to:

10.03.01

forehand weld with the oxy-acetylene welding process (O.A.W.)

Refer to:

Provincial Welding Curriculum  
Level "C"  
Forehand Weld  
Module: P 3  
Goal 11  
Performance Objective: #2

- employ general and personal safety precautions
- select piece of M.S. 1/8" x 6" x 8", remove oxides and place in flat position
- select tip, install, choose and set correct oxy-acetylene pressures and light torch
- right handed person, hold torch with flame pointing to left, lower flame onto plate
- hold flame 1/6" over plate, preheat and create puddle
- oscillate torch and move from right to left in a straight line holding torch at 45°
- review progress and repeat procedure

MODULE 10.04 BEADING

Goal Statements

The learning experiences in this module are designed to enable the student to become proficient in bead welding with the O.A.W. process.

Learning Outcomes

Student Activities

The student should be able to:

10.04.01

deposit beads with the O.A.W. process

Refer to:

Provincial Welding Curriculum  
Level "C"  
Gas Welding Practical  
Module: P 3  
Goal 11  
Performance Objective #3

- read specification sheet and employ general safety precautions
- select base metal and filler material
- select tools and equipment for job
- determine sequence of operation and employ personal safety precautions
- \*- clean metal surfaces and place metal in flat position
- \*- heat to desired temperature
- \*- apply filler metal with the dipping method and employ forehand technique
- \*- let cool and perform specification check
- repeat process and follow \* tasks

\*star denotes repeat of operation



MODULE 10.05 CORNER JOINT

Goal Statement

The learning experiences in this module are designed to enable the student to weld a corner joint with the O.A.W. process.

Learning Outcomes	Student Activities
<p>The student should be able to:</p> <p><u>10.05.01</u></p> <p>fusion weld a <u>corner joint</u>, with the O.A.W. process</p>	<ul style="list-style-type: none"><li>- read specification sheet and employ general safety precautions</li><li>- select base metal and filler material required</li><li>- select tools and equipment for job</li><li>*- determine sequence and position of operation</li><li>*- clean metal surfaces, assemble and support parts to be joined</li><li>*- employ personal safety precautions</li><li>*- heat to desired temperature, tack weld in appropriate places and place joint into position</li><li>*- apply filler metal into joint, employ forehand welding technique</li><li>*- let cool and perform specification check</li><li>- follow repeat procedures on handout and follow * tasks.</li></ul>
<p>Refer to:</p> <p>Provincial Welding Curriculum Level "C" Gas Welding Practical Module: P 3 Goal 11 Performance Objective: #4</p>	

MODULE 10.06 LAP JOINT

Goal Statements

The learning experiences in this module are designed to enable the student to perform a lap weld with the O.A.W. process.

Learning Outcomes

Student Activities

The student should be able to:

10.06.01

fusion weld a lap joint with the O.A.W. process

- read specification sheet and employ general safety precautions
- select base metal and filler material required
- select tools and equipment for job
- \*- determine sequence and position of operation
- \*- clean metal surfaces, assemble and support parts to be joined
- \*- employ personal safety precautions
- \*- heat to desired temperature, tack weld in appropriate places and place joint into position
- \*- apply filler metal into joint, employ forehand welding techniques
- \*- let cool and perform specification check
- follow repeat procedures on handout and follow \* tasks.

Refer to:

Provincial Welding Curriculum  
Level "C"

Module: P 3

Goal 11

Performance Objective: #4

MODULE 10.07 EDGE JOINT

Goal Statement

The learning experiences in this module are designed to enable the student to fusion weld an edge joint with the O.A.W. process.

Learning Outcomes

Student Activities

The student should be able to:

10.07.01

fusion weld an edge joint with the O.A.W. process

- read specification sheet and employ general safety precaution
- select base metal and filler material required
- select tools and equipment for job
- \*- determine sequence and position of operation
- \*- clean metal surfaces, assemble and support parts to be joined
- \*- employ personal safety precautions
- \*- heat to desired temperature, tack weld in appropriate places and place joint into position
- \*- apply filler metal into joint, employ forehand welding technique
- \*- let cool and perform specification check
- follow repeat procedures on handout and follow \* tasks.

Refer to:

Provincial Welding Curriculum  
Level "C"  
Gas Welding Practical  
Module: P 3  
Goal 11  
Performance Objective: #6

MODULE 10.08 TEE JOINT

Goal Statement

The learning experiences in this module are designed to enable the student to fusion weld a tee joint with the O.A.W. process.

Learning Outcomes	Student Activities
<p>The student should be able to:</p> <p><u>10.08.01</u></p> <p>fusion weld a <u>tee joint</u> with the O.A.W. process</p>	<ul style="list-style-type: none"><li>- read specification sheet and employ General Safety Precautions</li><li>- select base metal and filler material required</li><li>- select tools and equipment for job</li><li>*- determine sequence and position of operation</li><li>*- clean metal surfaces, assemble and support parts to be joined</li><li>*- employ personal safety precautions</li><li>*- heat to desired temperature, tack weld in appropriate places and place joint into position</li><li>*- apply filler metal into joint, employ forehand welding technique</li><li>*- let cool and perform specification check</li><li>- follow repeat procedures on handout and follow * tasks.</li></ul>
<p>Refer to:</p> <p>Provincial Welding Curriculum Level "C" Gas Welding Practical Module: P 3 Goal 11 Performance Objective #5</p>	

MODULE 10.09 BUTT JOINT

Goal Statement

The learning experiences in this module are designed to enable the student to fusion weld a butt joint with the O.A.W. process.

Learning Outcomes

Student Activities

The student should be able to:

10.09.01

fusion weld a butt joint with the O.A.W. process

- read specification sheet and employ general safety precautions
- select base metal and filler material required
- select tools and equipment for job
- \*- determine sequence and position of operation
- \*- clean metal surfaces, assemble and support parts to be joined
- \*- employ personal safety precautions
- \*- heat to desired temperature, tack weld in appropriate places and place joint into position
- \*- apply filler metal into joint, employ Forehand welding technique
- \*- let cool and perform specification check
- follow repeat procedures on handout and follow \* tasks

Refer to:

Provincial Welding Curriculum  
Level "C"  
Gas Welding Practical  
Module: P 3  
Goal 11  
Performance Objective #7

## MODULE 10.10 FUSION WELD OF CAST IRON

### Goal Statement

The learning experiences in this module are designed to enable the student to fusion weld cast iron using the O.A.W. process.

### Learning Outcomes

### Student Activities

The student should be able to:

#### 10.10.01

fusion weld grey cast iron with the O.A.W. process.

Refer to:

Provincial Welding Curriculum  
Level "C"  
Gas Welding Practical  
Module: P 3  
Goal 11  
Performance Objective #13

- read specification sheet and employ general safety precautions
- bevel joints and assure accurate fitup of cast iron
- clean metal surfaces, assemble and support cast iron
- sear metal surfaces and apply appropriate preheat
- preheat cast iron to desired temperature
- heat filler metal and apply fluxing agent
- apply heat to attain melting temperatures, add filler metal
- continue fusion welding in the forehand method and complete weld
- cool slowly to room temperature and perform specification check.

### Information Note:

Cast iron should not be quenched. But be cooled under controlled conditions

MODULE 10.11 BRAZE WELDING

Goal Statement

The learning experiences in this module are designed to:

- a. define the braze welding process,
- b. identify filler metals,
- c. identify types of fluxes,
- d. identify flame type in braze welding, and
- e. identify types of edge preparations.

Learning Outcomes	Student Activities
<p>The student should be able to:</p> <p><u>10.11.01</u></p> <p>define the braze welding process</p>	<ul style="list-style-type: none"><li>- read handout</li><li>- explain what occurs in liquid-solid phase joining</li><li>- describe 2 types of processes</li><li>- identify the types of heat required for braze welding</li><li>- identify correct surface preparations in braze welding</li><li>- identify the properties of filler metals in braze welding</li><li>- identify the nature of the braze bond</li></ul>
<p><u>10.11.02</u></p> <p>identify filler metals</p>	<ul style="list-style-type: none"><li>- read handout</li><li>- identify type of base metal to be joined</li><li>- identify the main constituent metal in a copper base alloy welding rod</li><li>- identify the properties of zinc in the braze welding process</li><li>- identify a low fuming bronze alloy in braze welding</li><li>- identify a common type of filler metal used in braze welding</li></ul>

10.11.03

identify types of fluxes

- read handout
- define the term flux
- identify types of fluxes and their properties
- identify two types of flux employed in braze welding
- identify the type of flux on the coated non fuming RCUZN-C filler metal

10.11.04

identify flame type used in braze welding

- read handout
- identify the effect of a reducing flame in braze welding
- identify the effect of a highly oxidizing flame

10.11.05

define the types of edge preparations

- read handout
- describe the nature of the braze bond
- identify the effect of searing
- identify the desired bevel angle in braze welding
- identify the purpose of fluted bevels
- identify the effect of unbroken edges on the braze bond



MODULE 10.12 BRAZE WELDING

Goal Statement

The learning experiences in this module are designed to provide the student with the opportunity to deposit beads with RCUZN-C filler metal on M.S. plate. (Mild Steel Plate)

Learning Outcomes	Student Activities
<p>The student should be able to:</p> <p><u>10.12.01</u></p> <p>deposit beads with RCUZN-C filler metal on M.S. plate</p>	<ul style="list-style-type: none"><li>- read specification sheet and employ general safety precautions</li><li>- identify filler metal and select base metal</li><li>- clean metal surface and employ personal safety precautions</li><li>- choose correct O.A. flame and heat base metal to desired temperature</li><li>- employ forehand technique, add filler, observe tinning action</li><li>- proceed to deposit filler metal</li></ul>
<p>Refer to:</p> <p>Provincial Welding Curriculum Level "C" Braze Welding Practical Module: P 3 Goal 12 Performance Objective #1</p>	

MODULE 10.13 BRAZE WELDING

Goal Statement

The learning experiences in this module are designed to provide the student with the opportunity to perform braze welds to lap joints.

Learning Outcomes

Student Activities

The student should be able to:

10.13.01

perform braze welds on lap joints

Refer to:

Provincial Welding Curriculum  
Level "C"  
Braze Welding Practical  
Module: P 3  
Goal 12  
Performance Objective #2

- read specification sheet and employ general safety precautions
- select base metal and filler material required
- select tools and equipment for job
- \*- determine sequence and position of operation
- \*- clean metal surfaces, assemble and support parts to be joined
- \*- employ personal safety precautions
- \*- heat to desired temperature, tack weld in appropriate places and place joint into position
- \*- apply filler metal into joint, employ Forehand welding technique
- \*- let cool and perform specification check
- follow repeat procedures on handout and follow \* tasks

MODULE 10.14 BRAZE WELDING

Goal Statement

The learning experiences in this module are designed to provide the student with the opportunity to braze weld tee joints.

Learning Outcomes	Student Activities
<p>The student should be able to:</p> <p><u>10.14.01</u></p> <p>Braze weld tee joints</p>	<ul style="list-style-type: none"><li>- read specification sheet and employ general safety precautions</li><li>- select base metal and filler materials required</li><li>- select tools and equipment for job</li><li>*- determine sequence and position of operation</li><li>*- clean metal surfaces, assemble and support parts to be joined</li><li>*- employ personal safety precautions</li><li>*- heat to desired temperature, tack weld in appropriate places and place joint into position</li><li>*- apply filler metal into joint, employ forehand welding technique</li><li>*- let cool and perform specification check</li><li>- follow repeat procedures on handout and follow * tasks</li></ul>
<p>Refer to:</p> <p>Provincial Welding Curriculum Level "C" Braze Welding Practical Module: P 3 Goal 12 Performance Objective #3</p>	

MODULE 10.15 BRAZE WELDING

Goal Statement

The learning experiences in this module are designed to provide the student with the opportunity to braze weld M.S. plate.

Learning Outcomes	Student Activities
<p>The student should be able to:</p> <p><u>10.15.01</u></p> <p>braze weld M.S. plate</p>	<ul style="list-style-type: none"><li>- read specification sheet, employ general safety precautions</li><li>- bevel joint and assure proper fitup of plate</li><li>- clean metal surfaces, assemble, space and support plate</li><li>- employ personal safety precautions</li><li>- heat to desired temperature</li><li>- tin joint and proceed to fill groove</li><li>- let cool and apply final cleaning</li><li>- perform specification check</li></ul>
<p>Refer to:</p> <p>Provincial Welding Curriculum Level "C" Braze Welding Practical Module: P 3 Goal 12 Performance Objective #4</p>	

MODULE 10.16 BRAZE WELDING

Goal Statement

The learning experiences in this module are designed to provide the student with the opportunity to braze weld cast iron.

Learning Outcomes	Student Activities
<p>The student should be able to:</p> <p><u>10.16.01</u></p> <p>braze weld grey cast iron</p>	<ul style="list-style-type: none"><li>- read specification sheet and employ general safety precautions</li><li>- prepare joint and assure proper fitup</li><li>- clean metal surfaces, assemble, space and support cast iron</li><li>- employ personal safety precautions</li><li>- sear metal or joint surface and preheat to desired temperature</li><li>- assure good tinning and proceed to fill groove</li><li>- cool slowly and apply final cleaning</li><li>- perform specification check</li><li>- do not quench</li></ul>
<p>Refer to:</p> <p>Provincial Welding Curriculum Level "C" Braze Welding Practical Module: P 3 Goal 12 Performance Objective #5</p>	

MODULE 10.17 BRAZE WELDING

Goal Statement

The learning experiences in this module are designed to provide the student with the opportunity to weld dissimilar metals.

Learning Outcomes	Student Activities
<p>The student should be able to:</p> <p><u>10.17.01</u></p> <p>braze weld dissimilar metals</p>	<ul style="list-style-type: none"><li>- read specification sheet and employ general safety precautions</li><li>- prepare joint to given dimensions and assure proper fit-up</li><li>- clean metal surfaces, assemble, space and support metals</li><li>- employ personal safety precautions</li><li>- sear cast iron surface and preheat metals</li><li>- heat to desired temperature, assure good tinning action and proceed to fill groove</li><li>- let cool and apply final cleaning</li><li>- perform specification check</li></ul>
<p>Refer to:</p> <p>Provincial Welding Curriculum Level "C" Braze Welding Practical Module: P 3 Goal 12 Performance Objective #5</p>	

MODULE 10.18 GAS CUTTING O.F.C.-A. (OXY-FUEL CUTTING - ACETYLENE)

Goal Statement

The learning experiences in this module are designed to provide knowledge and experience that will help the student understand and use gas cutting equipment, efficiently and safely.

Learning Outcomes

Student Activities

The student should be able to:

10.18.01

define the oxy-fuel gas cutting process and its application

- describe how chemical reactions generate heat
- explain an exothermic reaction
- explain an endothermic reaction
- identify the most efficient methods in thermal cutting

10.18.02

define and apply terminology used in O.F.C.-A

- identify the term O.F.C.-A
- read and study reference material
- define the term "cutting attachment"

10.18.03

identify Worker's Compensation Board standard governing cutting

- identify and read section 17 of Worker's Compensation Board Industrial Health and Safety regulations

10.18.04

describe three types of cutting equipment

- describe manual cutting equipment
- describe types of portable O.F.C.-A machines
- list advantages and disadvantages of portable O.F.C.-A machines
- describe types of stationary O.F.C.-A machines
- list advantages and disadvantages of stationary O.F.C.-A machines

10.18.05

identify a two-piece oxy-acetylene cutting torch

- describe the function of an injector type mixing chamber
- identify the limitations of a one-piece cutting torch
- identify the advantages and disadvantages of a two-piece cutting torch
- identify correct maintenance practices for one and two-piece cutting torch
- identify correct methods in installing heating, cutting and welding tips

10.18.06

install a four-hole oxy-acetylene cutting tip

- identify types of cutting tips
- identify purpose of numbering systems used
- select a #2 four-hole oxy-acetylene cutting tip
- identify condition of various tips
- install selected tip employing accepted methods
- identify maintenance procedures employed for tip cleaning

10.18.07

correctly assemble a portable oxy-acetylene cutting unit

- select, place and secure cylinders in cart
- remove cap and crack cylinder valves
- attach regulators and hoses with proper wrench
- release regulator adjusting screw; open cylinder valve and set pressure to blow out hose
- open needle valves, attach torch assembly and blow out torch assembly
- insert cutting tip into torch and tighten snugly with proper wrench



10.18.08

correctly light a cutting torch

- employ general and personal safety precautions
- identify tip size and select appropriate oxygen and acetylene pressures
- test connections for leaks using appropriate medium
- open acetylene valve on torch and light with striker; adjust acetylene flow until smoke disappears
- open oxygen needle valve until complete combustion of acetylene occurs

10.18.09

identify the use of the neutral oxy-acetylene flame in cutting

- identify the types of flames
- identify the temperature range of an oxidizing flame
- identify the type of flame employed in oxy-acetylene cutting of plain carbon steel

10.18.10

shut-down the oxy-acetylene unit

- review general safety precautions
- close acetylene needle valve on torch body
- close oxygen needle valve on torch body
- close acetylene cylinder valve; open oxygen needle valve on torch body
- turn out pressure adjusting screw on acetylene regulator then close needle valve
- close oxygen cylinder valve; open oxygen needle valve on torch body
- turn out pressure adjusting screw on oxygen regulator then close needle valve
- coil oxy-acetylene hose on unit

10.18.11

identify the six main factors governing oxy-acetylene cutting

- identify material thickness
- determine surface conditions
- determine size of cutting tip
- determine condition of cutting tip
- assure proper flame setting and select correct cutting oxygen pressure
- determine speed of travel
- identify conditions determining a good quality cut

10.18.12

identify the metals that can be cut with O.F.C.-A process

- list the ferrous alloys that cannot be cut
- describe what occurs when non-ferrous alloys are subjected to the cutting torch
- describe the behaviour of various elements when exposed to the cutting process
- list the high alloy steels that cannot be cut with the O.F.C.-A
- identify the ferrous metals that can be cut with the O.F.C.-A process

MODULE 10.19 GAS CUTTING O.F.C.-A (OXY-FUEL CUTTING - ACETYLENE)

Goal Statements

The learning experiences in this module are designed to:

- a. enable the student to become proficient in using gascutting equipment.

Learning Outcomes

Student Activities

The student should be able to:

10.19.01

cut sheet steel with the O.F.C.-A process

- employ general and personal safety precautions
- mark a straight line with scribe, soapstone, chalk-line, or employ centre punch
- proceed with cutting employing correct angle and speed
- perform specification check and review quality of cut

10.19.02

cut mild steel plate with the O.F.C.-A process

- employ general safety precautions
- read specifications sheet
- employ personal safety precautions
- light cutting torch selecting appropriate flame
- proceed with cutting operation; employ correct angle and speed
- shut down oxy-acetylene unit
- perform specification check and review quality of cut
- follow repeat procedures

Refer to:

Provincial Welding Curriculum  
Level "C"  
Module: P 2  
Goal 6  
Performance Objectives #3

10.19.03

cut structural sections with the O.F.C.-A process

Refer to:  
Provincial Welding Curriculum  
Level "C"  
Module: P 2  
Goal 6  
Performance Objective #7

- employ general safety precautions
- read specification sheet
- measure and mark member to be cut in appropriate places
- employ personal safety precautions
- light cutting torch selecting appropriate flame
- identify sequence of cutting operation
- proceed with cutting operation employing correct angle and speed
- shut down oxy-acetylene unit
- perform specification check and review quality of cut

10.19.04

cut round stock with the O.F.C.-A process

Refer to:  
Provincial Welding Curriculum  
Level "C"  
Module: P 2  
Goal 6  
Performance Objective #8

- employ general safety precautions
- read specification sheet
- measure and mark selected piece of stock
- employ personal safety precautions
- light cutting torch selecting appropriate flame
- identify sequence of cutting operation
- proceed with cutting operation employing correct angle and speed
- shut down oxy-acetylene unit
- perform specification check and review quality of cut

10.19.05

perform bevel cuts on mild steel plate with the O.F.C.-A process

Refer to:  
Provincial Welding Curriculum  
Level "C"  
Module P 2  
Goal 6  
Performance Objectives #5

- employ general safety precautions
- read specification sheet
- determine degree of bevel, measure and mark selected mild steel plate
- employ personal safety precautions
- light cutting torch selecting appropriate flame
- identify sequence of cutting operation
- proceed with cutting operation employing correct angle and speed
- shut down oxy-acetylene unit
- perform specification check and review quality of cut

10.19.06

pierce holes in mild steel plate with the O.F.C.-A process

Refer to:  
Provincial Welding Curriculum  
Level "C"  
Module: P 2  
Goal 6  
Performance Objectives #6

- employ general safety precautions
- read specification sheet
- determine size of holes, measure and mark selected mild steel plate
- determine thickness of metal, select and install appropriate size cutting tip
- identify sequence of piercing operation
- employ personal safety precautions
- proceed with piercing operation, employing correct starting technique
- perform specification check and review quality of cut

10.19.07

gouge weldments with the O.F.C.-A process

Refer to:  
Provincial Welding Curriculum  
Level "C"  
Module P 2  
Goal 6  
Performance Objective #9

- employ general safety precautions
- read specification sheet and obtain weldment sample
- determine width and depth of gouge required
- select and install appropriate size gouging tip
- determine and select correct oxygen and acetylene pressures
- identify sequence of gouging operation
- employ personal safety precautions
- proceed with gouging operation, employing correct starting technique
- stop gouging and restart lost cut
- perform specification check and review quality of cut

10.19.08

fit structural members with the O.F.C.-A process

- read specification sheet
- determine type of structural member to be fitted
- measure and mark sections to be cut in appropriate places
- allow for cutting loss, and identify sequence of cutting operation
- proceed with cutting operations employing correct angle and speed
- clean cutting surfaces, remove slag and oxides
- fit cut members and determine quality of cuts
- perform specification check

UNIT 11.0 SHIELDED METAL ARC WELDING (S.M.A.W.)

General Aim

The student should gain experience using approved practices for the safe management and operation of arc welding equipment.

MODULE 11.01 FUNDAMENTALS OF ARC WELDING

Goal Statement

The learning experiences in this module are designed to provide introductory experiences that will help the student to understand the fundamentals of arc welding.

Learning Outcomes

Student Activities

The student should be able to:

11.01.01

demonstrate a working knowledge of basic electricity as applied to shielded metal arc welding

- study and discuss:
  - voltage, amperage, current flow characteristics
  - directional flow, straight and reverse polarity and effects of each

11.01.02

identify types of arc welding machines

- define the uses of an A.C. transformer
- define the uses of a rectifier
- define the uses of an AC/DC rectifier
- define the uses of an electrical motor generator
- define the uses of an engine driven generator

11.01.03

demonstrate a working knowledge of electrodes

- identify the types of covered arc welding electrodes in S.M.A.W.
- study the classification system of carbon steel electrodes
- identify the application and characteristics of mild steel

11.01.04

understand and identify basic joints and variations in joint design

- electrodes, i.e.: sizes, diameters
- identify the function of electrode coatings
  
  - identify and sketch the following basic joints:
    - butt
    - corner
    - tee
    - edge
    - lap



MODULE 11.02 ARC WELDING SAFETY

Goal Statement

The learning experiences in this module are designed to help each student understand the importance of applying safe practices in the use of arc welding equipment.

Learning Outcomes

Student Activities

The student should be able to:

11.02.01

describe the need and use of personal protective equipment

- identify and discuss the use of the following:
  - protective clothing, i.e. boots, gloves, leathers
  - welding helmets
  - helmet lenses (shade numbers)
  - flash goggles
  - hearing protection
  - extreme hazards of contact lenses
  - butane lighters

11.02.02

identify electrical hazards in shielded metal arc welding (.S.M.A.W.)

- discuss electric shock and the effects on the body
- describe the effects of damaged cables and leads
- identify the cause of electrical fires

11.02.03

identify corrective measures to eliminate electrical hazards

- inspect and repair welding cables and leads
- demonstrate correct steps in maintenance of S.M.A.W. machines
- select proper fire extinguisher for electrical fires
- importance of a proper ground connection

11.02.04

explain the effects of arc flash and identify first aid treatment

- identify and discuss the three types of radiation:
  - ultra violet
  - infra-red
  - visible light rays

11.02.05

describe the effects of hot metal burns

- discuss burns and the first aid treatment for burns:
  - first degree
  - second degree
  - third degree

11.02.06

describe the effects of inadequate ventilation

- identify toxic fumes and discuss their effect:
  - lead
  - zinc
  - cadmium
  - painted surfaces
- ozone (the product of intense arc amperage)

11.02.07

identify acceptable noise levels in a welding environment

- discuss and identify the need for hearing protection
- study Workers' Compensation Board Handbook, Section 13

### MODULE 11.03 ARC WELDING EXERCISES

#### Goal Statements

The learning experiences in this module are designed to:

- a. develop manipulative skills in basic competency of arc welding (S.M.A.W.); and
- b. demonstrate arc welding techniques on various types of joints and weld positions, 1-2-3 groove, fillet, 1-flat, 2-horizontal, 3-vertical.

#### Learning Outcomes

#### Student Activities

The student should be able to:

##### 11.03.01

strike an arc using the S.M.A.W. process when given the equipment, materials, tools and a procedure sheet

Refer to:

Provincial Welding Curriculum Level "C"

Module: P 4

Goal 11

Performance Objective #2

##### 11.03.02

run beads by applying single and multipass stringer beads on 1/4 plate when given the equipment, materials, tools, and a procedure sheet

Refer to:

Provincial Welding Curriculum Level "C"

Module: P 4

Goal 11

Performance Objective #3

- read procedure sheet and select electrode
- cut and clean M.S. plate
- secure plate in flat position and attach ground
- select polarity and amperage (welding current)
- insert electrode in stinger, apply personal safety precautions and start machine
- strike electrode on pre-determined spot on plate using scratch method
- strike electrode on plate using tap method

- define the term Stringer bead
- read specification sheet
- select materials, welding machine and welding current
- attach ground to plate, insert electrode into stinger and apply personal safety precautions
- start welding machine
- apply stringer bead
- remove slag and spatter
- apply second stringer bead
- compare to model
- remove slag and spatter

11.03.03

weave a bead by producing deposits with the Weave methods when given the equipment, materials, tools and a procedure sheet

Refer to:

Provincial Welding Curriculum  
Level "C"

Module: P 4

Goal 11

Performance Objective #4

11.03.04

produce tack welds when given the equipment, materials, tools and a procedure sheet

Refer to:

Provincial Welding Curriculum  
Level "C"

Module: P 4

Goal 11

Performance Objective #5

11.03.05

arc weld lap joints by following all the procedures

- apply third stringer bead
- compare to model
- remove slag and spatter
- perform specification check

- define the term weave method of weave bead
- read specification sheet
- select materials, welding machine and welding current
- attach ground to plate, insert electrode into stinger and apply personal safety precautions
- start welding machine
- apply filler material in the screscent weave method
- remove slag and spatter
- compare deposit to model
- apply second weave bead adjacent to previous pass employing herringbone weave
- remove slag and spatter
- compare deposit to model

- define the term tack weld
- read procedure sheet
- identify and locate M.S. plate
- cut plate, clean metal surfaces, and assure proper fit-up
- assemble and support plates
- select welding machine and welding current
- apply tacks in prscribed places on joints
- remove slag and spatter
- perform specification check

- read specification sheet and employ general safety precautions
- identify and locate plate and electrode
- cut plate, clean metal surfaces and assure proper fit-up

Refer to:

Provincial Welding Curriculum  
Level "C"

Module: P 4

Goal 11

Performance Objective #6

11.03.06

arc weld a corner joint by  
following all the procedures

Refer to:

Provincial Welding Curriculum  
Level "C"

Module: P 4

Goal 11

Performance Objective #6

11.03.07

arc weld a tee joint (2F) by  
following all the procedures

Note: Filler metal - E6012,  
E6010/11, 5/32" dia. E7018, 1/8"  
dia.

Refer to:

Provincial Welding Curriculum  
Level "C"

Module: P 4

Goal 11

Performance Objective #6

- employ personal safety precautions
- assemble, support and tack weld plates in prescribed position
- apply filler material in sequence, clean between passes
- final cleaning
- perform visual specification check
- perform destructive bend test and evaluate

- read specification sheet and employ general safety precautions
- identify and locate plate and electrodes
- employ personal safety precautions
- cut plate, clean metal surfaces, tack weld plates in prescribed position
- apply filler metal in sequence, clean between passes
- final cleaning of completed weldment
- perform specification check

- read specification sheet and employ general safety precautions
- identify and locate flat bar and electrodes
- employ personal safety precautions
- cut plate, clean metal surfaces, tack weld plates in prescribed position
- apply filler material
- final cleaning
- perform visual specification check and evaluate
- perform physical specification check and evaluate

11.03.08

arc weld a corner joint (3G)  
vertical down by following all the  
procedures

Refer to:

Provincial Welding Curriculum  
Level "C"

Module: P 4

Goal 11

Performance Objective #8

11.03.09

arc weld a tee joint (2F)  
12.GA.MS. plate by following all  
the procedures

Refer to:

Provincial Welding Curriculum  
Level "C"

Module: P 4

Goal 8

Performance Objective #8

- read specification sheet and employ general safety precautions
- identify and locate material and electrodes
- cut material to size, clean metal surfaces and assure accurate fit-up
- employ personal safety precautions
- use scrap sheet metal to adjust amperage, select electrode angle, arc length and speed of travel
- assemble, support and tack weld material in prescribed position
- strike electrode in weld joint, apply filler metal with single pass
- final cleaning of completed weldment
- perform specification check

- read specification sheet and employ general safety precautions
- identify and locate material and electrodes
- cut material to size, clean metal surfaces and assure accurate fit-up
- employ personal safety precautions
- use scrap sheet metal to adjust amperage, select electrode angle, arc length and speed of travel
- assemble, support and tack weld material in prescribed position
- strike electrode in weld joint, apply filler metal with single pass
- final cleaning of completed weldment
- perform specification check

11.03.10

arc weld a lap joint (1F) by following all the procedures

Refer to:

Provincial Welding Curriculum  
Level "C"

Module: P 4

Goal 11

Performance Objective #8

- read specification sheet and employ general safety precautions
- identify and locate material and electrodes
- cut material to size, clean metal surfaces and assure accurate fit-up
- employ personal safety precautions
- use scrap sheet metal to adjust amperage, select electrode angle, arc length and speed of travel
- assemble, support and tack weld material in prescribed position
- strike electrode in weld joint, apply filler metal with single pass
- final cleaning of completed weldment
- perform specification check

UNIT 12.0 METALLURGY

General Aim

To teach the student the fundamentals of basic metallurgy as applied to the metal trades.

MODULE 12.01 FERROUS METALS

Goal Statements

The learning experiences in this module are designed to:

- a. introduce each student to basic processes used in making ferrous metals,
- b. introduce to the student the various types of ferrous metals, and
- c. help the student acquire sufficient skills to identify and select the proper types of ferrous metals.

Learning Outcomes

Student Activities

The student should be able to:

12.01.01

introduce basic metallurgy

- read and study handout on terminology

12.01.02

describe the furnaces used in the process of making ferrous metals:

- blast
- open hearth
- basic oxygen process
- electric arc

- discuss the types of furnace and their products

12.01.03

describe the types of ferrous metals

- cast
  - grey
  - white
  - malleable
  - ductile
  - steel

- discuss the various types of casts



12.01.03 (Cont'd.)

- carbon steels
  - low carbon steel
  - medium carbon steel
  - high carbon steel
- alloy steels
  - high speed steel
  - stainless steel
  - nickel steel
  - chromium steel
  - others

- discuss the various types of carbon steels
- discuss the various types of alloy steels

12.01.04

describe the procedures for classifying and identifying different types of ferrous metals

- spark test
- Society of Automotive Engineers numbering
- American Iron and Steel Institute numbering

- discuss and individually perform practise tests on sample pieces of ferrous metals

12.01.05

describe the effects of alloying elements on the weldability of steel

- describe the elements affecting weldability
- identify carbon steels requiring pre and post heating to improve weldability
- identify alloy steels requiring control welding heat
- define the causes and effects of the Heat Affected Zone

12.01.06

describe mechanical and physical properties as applied to the weldability of steel

- identify and study mechanical properties such as hardness and malleability
- identify and study physical properties such as carbon and alloying

MODULE 12.02 NON-FERROUS METALS

Goal Statements

The learning experiences in this module are designed to:

- a. introduce the student to the various types of non-ferrous metals, and
- b. introduce the student to the skills to identifying and selecting the proper types of non-ferrous metals for a given application.

Learning Outcomes

Student Activities

The student should be able to:

12.02.01

describe the types of non-ferrous metals

- aluminum
- babbitt
- brass
- bronze
- copper
- lead
- magnesium
- nickel
- zinc
- others

- discuss the various types of non-ferrous metals

12.02.02

describe the procedures for classifying and identifying different types of non-ferrous metals

- discuss and identify samples of various pieces of non-ferrous metals

MODULE 12.03 WELDABILITY OF STEELS

Goal Statement

The learning experiences in this module are designed to teach the student the heat effects in welding on the weldability of steel.

Learning Outcomes	Student Activities
<p>The student should be able to:</p> <p><u>12.03.01</u></p> <p>understand the influence of heat effects in welding</p>	<ul style="list-style-type: none"><li>- study and discuss heat effects of a single bead arc weld<ul style="list-style-type: none"><li>- to the weld</li><li>- to the surrounding base metal</li></ul></li><li>- identify the effects of<ul style="list-style-type: none"><li>- electrode size</li><li>- current</li><li>- welding speed</li></ul></li><li>- discuss the effect of atmospheric temperatures (freezing) on welds made outdoors</li></ul>

MODULE 12.04 HEAT TREATMENT

Goal Statements

The learning experiences in this module are designed to:

- a. introduce the student to the basic principles of heat treatment, and
- b. introduce to the student the methods to determine the hardness of heat treated metals.

Learning Outcomes	Student Activities
The student should be able to:	
<u>12.04.01</u>	
describe the different types of heat treating methods <ul style="list-style-type: none"><li>- hardening</li><li>- tempering</li><li>- annealing</li><li>- normalizing</li><li>- surface hardening</li><li>- various methods</li></ul>	- discuss and in small groups perform heat treating processes on sample pieces of metal
<u>12.04.02</u>	
describe the method to determine the hardness of a heat treated metal <ul style="list-style-type: none"><li>- Brinell method</li><li>- Rockwell method</li><li>- others</li></ul>	- discuss and in small groups perform hardness tests on heat treated sample pieces

MOOULE 12.05 SHAPES OF METALS

Goal Statement

The learning experiences in this module are designed to introduce the student to the various shapes of metals.

Learning Outcomes	Student Activities
<p>The student should be able to:</p> <p><u>12.05.01</u></p> <p>identify various shapes of metals</p> <ul style="list-style-type: none"><li>- H-beam</li><li>- I-beam</li><li>- Channel</li><li>- Rail</li><li>- Angle</li><li>- T</li><li>- Square</li><li>- Hexagon</li><li>- Octagon</li><li>- Round</li><li>- Pipe</li><li>- Tubing</li><li>- Bar</li><li>- Half oval</li><li>- others</li></ul>	<ul style="list-style-type: none"><li>- discuss the various shapes of metals and their manufacture</li></ul>

UNIT 13.0 POWER SAWS, SHAPERS AND MILLING MACHINES

General Aim

The student should develop a basic understanding of power saws, shapers, and milling machines, their nomenclature and safe operation.

MODULE 13.01 POWER SAWS

Goal Statements

The learning experiences in those module are designed to:

- a. enable the student to recognize the various types of power saws,
- b. introduce the student to the nomenclature of power saws, and
- c. help the student operate a power saw in a correct and safe manner.

Learning Outcomes

Student Activities

The student should be able to:

13.01.01

identify and list various types of power saws

- horizontal reciprocating
- horizontal bandsaw
- vertical bandsaw
- cutoff saw
- abrasive wheel
- saw wheel

- list various types of power saws

13.01.02

identify and list the operating parts of a

- vertical band saw
- horizontal reciprocating

- list operating parts of a vertical band saw
- list operating parts of a horizontal reciprocating saw

13.01.03

adjust and operate a horizontal power saw in a correct and safe manner

- adjust and operate a horizontal saw

13.01.04

clamp and saw a workpiece to a specified length

- saw a workpiece to length

13.01.05

adjust and operate a vertical saw in a correct and safe manner

- saw to a layout line

MODULE 13.02 SHAPERS

Goal Statements

The learning experiences in this module are designed to:

- a. introduce each student to the nomenclature of the shaper,
- b. help the student operate the shaper in a correct and safe manner, and
- c. enable the student to shape a component accurately and to specification.

Learning Outcomes	Student Activities
The student should be able to:	
<u>13.02.01</u>	
identify and list the operating parts of a shaper	- list operating parts of a shaper
<u>13.02.02</u>	
adjust and operate the shaper in a correct and safe manner	- operate the shaper safely
<u>13.02.03</u>	
clamp workpiece in place on the shaper table using various tools and fixtures	- clamp a workpiece to the table
- T bolts - parallels - vice - angle plates - strap clamps - vee blocks - lead hammer - round bar	
<u>13.02.04</u>	
shape surfaces square to each other and to specification	- shape all four sides of a block



MODULE 13.03 MILLING MACHINES (VERTICAL, HORIZONTAL)

Goal Statements

The learning experiences in this module are designed to:

- a. introduce the student to the nomenclature of the milling machine;
- b. help the student operate the milling machine in a correct and safe manner; and
- c. enable the student to mill a component accurately and to specification.

Learning Outcomes

Student Activities

The student should be able to:

13.03.01

identify and list the operating parts of various types of milling machines

- list operating parts of a milling machine

13.03.02

adjust and operate the milling machine in a correct and safe manner

- operate the milling machine safely

13.03.03

clamp a workpiece on the milling table using various tools and fixtures as needed

- T-bolts
- vice
- parallels
- lead hammer
- angle plates
- strap clamps
- packers
- round bar

- clamp a workpiece to the table

13.03.04

mount a vise on the milling table, square with table travel using a dial indicator and parallel

- dial in a vise

13.03.05

identify and list various types of cutters

- list various types of cutters

13.03.06

select and mount a cutter correctly and safely

- mount a cutter

13.03.07

touch on workpiece and zero dials (table)

- touch on and zero dials

13.03.08

mill surfaces square to each other and to specification

- mill all four sides of block

UNIT 14.0 HOT METALS

General Aim

The student will develop an awareness of the types and characteristics of hot metal forming in relation to the metal trades.

MODULE 14.01 TOOLS AND EQUIPMENT

Goal Statement

The learning objectives in this module are designed to identify, select and use tools and equipment related to hot metal forming.

Learning Outcomes	Student Activities
The student should be able to:	
<u>14.01.01</u>	
describe the types of tools used in hot metal forming	- discuss the types of tools used in hot metal forming
- anvils - forging hammers - tongs - vices - fullers - swage blocks - swages	
<u>14.01.02</u>	
describe the equipment used in hot metal forming	- discuss the types of equipment used in hot metal forming
- gas fired forges - drop hammer - press forges - coal fired forges - oil fired forges	

## MODULE 14.02 FORGING AND BENDING

### Goal Statement

The learning experiences in this module are designed to introduce the student to the operations and procedures involved with forging and bending hot metals.

Learning Outcomes	Student Activities
The student should be able to:	
<u>14.02.01</u>	
identify the safety equipment and procedures dealing with hot metal forming	- discuss the needs for proper use of safety equipment and procedures dealing with hot metal forming
<u>14.02.02</u>	
describe the procedures involved in bending hot metals <ul style="list-style-type: none"><li>- angle bending</li><li>- circular bending</li><li>- etc.</li></ul>	- discuss and, in small groups, bend hot metal sample pieces
<u>14.02.03</u>	
illustrate the necessary calculations for bending metals <ul style="list-style-type: none"><li>- arcs</li><li>- circles</li><li>- L-angle</li><li>- radius</li></ul>	- discuss and demonstrate the necessary calculation for bends on flat bar and round metal material,
<u>14.02.04</u>	
draw out a point, change sections, hot twist	- forge hot metal work pieces

MODULE 14.03 FOUNDRY

Goal Statement

The learning experiences in this module are designed to:

- a. help each student appreciate the importance of applying safe practices in the foundry;
- b. introduce the student to the operations and procedures of a foundry;
- c. introduce the student to methods in forming a mold; and
- d. introduce the student to methods of cleaning a casting.

Learning Outcomes

Student Activities

The student should be able to:

14.03.01

describe the equipment used in foundry melting processes

- gas fired furnaces
- electric-arc furnaces

- discuss and, where possible, show the process in operation

14.03.02

identify the safety procedures on proper and approved safety equipment for foundry pouring

- face shields
- leather or heat resistant aprons
- heat resistant gloves
- heat resistant legging
- leather shoes
- others

- discuss the needs for wearing proper safety equipment for foundry pouring

14.03.03

describe the various metals used in the casting process

- aluminum
- brass or bronze
- iron
- steel
- etc.

- discuss metals for casting

14.03.04

identify safety procedures for handling and making a pour

- crucibles
- pre-heating metals
- pouring tongs
- others

- discuss and perform a demonstration for proper handling and pouring procedures

14.03.05

describe the types of tools used in foundry work

- riddles
- flasks
- rammers
- slick and spoon
- trowel
- bellows
- others

- discuss the use of the different types of tools used

14.03.06

illustrate the different types of materials used for making patterns

- wood
- metals
- plaster of Paris
- wax
- plastic
- others

- discuss the different types of materials used for making patterns, their advantages and working life

14.03.07

explain the use of the different types of patterns used in foundry work

- solid patterns
- split patterns
- matched plate patterns

- discuss the use and cost of different types of patterns used

14.03.08

describe the techniques used in making and finishing a pattern

- discuss the problems that the pattern maker must encounter when making a pattern

- draft
- shrinkage
- etc.

14.03.09

demonstrate the making of a mold

- green sand
- waterless sand
- shell molding
- investment

- discuss the uses of different sand for forming a mold

14.03.10

explain sand preparation and control

- refractoriness
- cohesiveness
- permeability
- collapsibility
- moisture content

- discuss the importance of proper sand preparation in forming a mold

14.03.11

discuss the use and design of cores

- discuss and make a core

14.03.12

illustrate the purpose of

- gates
- risers
- sprues
- others

- discuss and in small groups use a pattern and ram up a mold

14.03.13

illustrate the importance of pouring temperatures of metals

- pyrometers

- discuss melting and pouring temperatures of metals

14.03.14

explain the different methods for cleaning castings

- sand blasting
- shot blasting
- tumbling

- discuss and in a small group, where possible, demonstrate the different methods for cleaning a casting

UNIT 15.0 INTRODUCTION TO SHEET METAL

General Aim

The student should gain an insight into the scope and demands of the sheet metal trades.

MODULE 15.01 SHEET METAL TRADES

Goal Statements

The learning experiences in this module are designed to:

- a. provide the student with an insight into the sheet metal industry, and
- b. describe the qualifications required for entry into the metal trades.

Learning Outcomes

Student Activities

The student should be able to:

15.01.01

recognize the special demands placed on tradesmen in the various sheet metal trades

- study and discuss various aspects of the metal trades

15.01.02

explain and list the qualifications required for entry into the various sheet metal trades

- visit shops and work sites (field trips)

15.01.03

explain and list the types of work performed by the various sheet metal trades in:

- blow pipe
- ventilation
- stainless steel
- marine work
- architectural



MODULE 15.02 SAFETY IN THE SHEET METAL SHOP

Goal Statement

The learning experiences in this module are designed to develop an appreciation for the special precautions involved in handling plate and sheet metal, and for the use of specialized machines related to sheet metal fabrication.

Learning Outcomes	Student Activities
The student should be able to:	
<u>15.02.01</u>	
properly handle thin sheet metal and plate to avoid injury from edges, burrs and notches	- study and discuss the specialized problems inherent in the materials and machines used in the metal trades
<u>15.02.02</u>	
avoid tearing clothing and shoes on materials stacked on floors and benches	
<u>15.02.03</u>	
operate all types of shears safely and properly	
<u>15.02.04</u>	
avoid crushing fingers in forming machines	
<u>15.02.05</u>	
be aware of the hazards to eyes caused by fluxes and acid cleaning baths	
<u>15.02.06</u>	
remove all mushroom heads on impact tools	- grind and remove mushroom heads on rivet sets, groovers, chisels, punches, etc.
<u>15.02.07</u>	
illustrate the danger of carrying objects in pockets	

MODULE 15.03 COMMON SHEET METALS

Goal Statements

The learning experiences in this module are designed to:

- a. enable the student to gain an understanding of the characteristics of common sheet metals such as base metals, coated metals and alloys;
- b. enable the student to understand and select the appropriate thickness of materials needed according to the correct gauge schedules; and
- c. enable the student to learn the various standard sheet sizes.

Learning Outcomes	Student Activities
<p>The student should be able to:</p> <p><u>15.03.01</u></p> <p>demonstrate a working knowledge of hot and cold rolled steel, copper and aluminum</p> <p><u>15.03.02</u></p> <p>understand the need for coatings such as galvanized, tin, and terne plate</p> <p><u>15.03.03</u></p> <p>explain the purpose and uses of common alloys such as aluminum, brass and stainless steel</p> <p><u>15.03.04</u></p> <p>select sheet stock according to size, gauge, and composition:</p> <ul style="list-style-type: none"><li>- U.S. Standard gauge for steels</li><li>- the Brown &amp; Sharpe gauge for non-ferrous metals</li></ul>	<ul style="list-style-type: none"><li>- study and discuss the finishes on steel sheet, hot and cold rolled</li><li>- study and discuss the characteristics and uses of copper and aluminum sheet</li><li>- study and discuss the various coating methods and uses of coated metals</li><li>- discuss how alloying affects the characteristics and uses of sheet metals</li><li>- practise selecting sheet according to gauge and appearance</li></ul>

MODULE 15.04 HAND TOOLS

Goal Statement

The learning experiences in this module are designed to help the student identify, select, use and maintain the hand tools specific to the sheet metal industry.

Learning Outcomes	Student Activities
The student should be able to:	
<u>15.04.01</u>	
recognize, maintain, and use correctly the following hand tools:	- select proper hand tools for specific jobs - maintain and sharpen hand tools as required
- scratch awl - tinners and riveting hammers - tin snips - aviation snips - mallets - hole punches - rivet sets - hand groovers - circumference rulers - protractors - layout and testing squares - dividers - compasses - trammels - bevel gauges - bending tongs - pliers - nippers - vice grips - cold chisels and punches - forming stakes and drift pins - others	

MODULE 15.05 SHEET METAL MACHINES

Goal Statement

The learning experiences in this module are designed to enable the student to recognize, use, and maintain sheet metal machinery.

Learning Outcomes

Student Activities

The student should be able to:

15.05.01

describe the adjustment, correct use and maintenance of:

- barfolds
- standard and pan brakes
- roll forming machines
- squaring shears and circle shears
- Beverly and bench shears
- bending and crimping machines
- turning machines
- burring machines
- Pittsburgh, button lock, and Acme lock machines
- others

15.05.02

recognize ineffective or damaged machinery and initiate necessary repairs

- discuss, dismantle, service, and set up sheet metal machinery
- study operations and practice skills towards mastery of sheet metal machinery

- discuss methods of blade replacement and repair of damage

MODULE 15.06 APPLIED GEOMETRY

Goal Statement

The learning experiences in this module are designed to help the student become proficient in practical applied geometry required for pattern layout.

Learning Outcomes

Student Activities

The student should be able to:

15.06.01

define and name all parts of geometric shapes such as:

- squares
- rectangles
- circles
- triangles
- pyramids
- cylinders
- cones

15.06.02

Bisect a line or arc

15.06.03

divide a line or circumference into equal parts

15.06.04

construct a right angle using proportions of 3-4-5

15.06.05

bisect an angle

15.06.06

draw an angle equal to a given angle

15.06.07

erect a perpendicular to a line or arc from a point on that line or arc

15.06.08

erect a perpendicular to a line or arc from a point off that line or arc

- learn the formula for calculating  
perimeter  
area  
volume  
of various geometrical shapes

- use dividers and straight edges to construct and solve geometric problems 15.06.02 to 15.06.16  
- learn the definitions, relationships and names of all parts of geometric shapes such as:  
- squares  
- rectangles  
- circles  
- triangles  
- pyramids  
- cylinders  
- cones

15.06.09

draw lines parallel and at set distances apart using dividers

15.06.10

divide a circle into 12 equal parts

15.06.11

divide a circle into 16 equal parts

15.06.12

construct a right triangle within a circle

15.06.13

draw an arc through three points

15.06.14

find the centre of an arc or circle

15.06.15

from a point on a circle circumference draw a line tangent to the circle

15.06.16

from a point outside of a circle draw a line tangent to that circle

- solve problems involving geometric formulae

MODULE 15.07 SIMPLE PATTERN LAYOUT

Goal Statements

The learning experiences in this module are designed to:

- a. enable the student to become proficient in pattern development based on flat surfaces and right angles;
- b. develop an understanding of seam and edge treatments as applied to sheet metal; and
- c. help the student develop proper layout of notches.

<u>Learning Outcomes</u>	<u>Student Activities</u>
<p>The student should be able to:</p> <p><u>15.07.01</u></p> <p>develop patterns and fabricate workpieces involving simple layout of angular shapes</p> <p><u>15.07.02</u></p> <p>apply proper techniques involving selection, development and fabrication of lap, rivetted, single and double seams, hems and wire edges</p> <p><u>15.07.03</u></p> <p>develop and apply notching techniques for correct fits</p>	<p>- lay out and fabricate light gauge workpieces such as boxes, pans, trays, garbage boxes, tool boxes, and wash-up pans</p>

MODULE 15.08 PARALLEL LINE DEVELOPMENT

Goal Statements

The learning experiences in this module are designed to:

- a. enable the student to become proficient in parallel line development based on cylinders;
- b. develop an understanding of seams and edge treatment for as applied to cylindrical shapes; and
- c. help each student understand the importance of proper notching techniques.

Learning Outcomes

Student Activities

The student should be able to:

15.08.01

develop patterns and fabricate workpieces involving parallel line development

15.08.02

apply proper techniques involving selection, development, and fabrication of lap, rivetted, and groove single and double seams, hems, and wire edges as applied to cylinders

15.08.03

develop and apply notching techniques for correct fits

- lay out and fabricate light gauge workpieces such as cans, pails, oil measurers, elbows, tees and branches



MODULE 15.09 RADIAL LINE DEVELOPMENT

Goal Statements

The learning experiences in this module are designed to:

- a. enable the student to become proficient in radial line development in right cones and pyramids;
- b. develop an understanding of seams and edge treatments as applied to conic and pyramid shapes and
- c. help the student develop proper notching techniques.

Learning Outcomes	Student Activities
The student should be able to:	
<u>15.09.01</u>	
develop patterns and fabricate workpiece involving radial line development of round and square based objects	- lay out and fabricate light gauge workpieces such as pipes, funnels, and/or cones, pyramid shaped projects
<u>15.09.02</u>	
apply proper techniques involving selection, development and fabrication of lap, rivetted, single and double seams, hems and wire edges	
<u>15.09.03</u>	
develop and apply notching techniques for correct fits	

MODULE 15.10 HEAVY GAUGE AND STRUCTURAL FABRICATION

Goal Statements

The learning experiences in this module are designed to:

- a. enable each student to become proficient in working heavy gauge sheet and miscellaneous bar, pipe and structural shapes;
- b. teach each student to safely handle heavy materials; and
- c. teach each student to develop patterns making allowances for metal thickness and inside and outside measurements.

Learning Outcomes	Student Activities
<p>The student should be able to:</p> <p><u>15.10.01</u></p> <p>develop patterns and fabricate workpieces in heavy sheet involving problems of fits due to metal thickness</p> <p><u>15.10.02</u></p> <p>cut, bend, form, twist, and fabricate jobs using miscellaneous sectional shapes</p> <p><u>15.10.03</u></p> <p>develop proper techniques for applying rivetted, welded, and bolted joints to heavy gauge sheet, bar, and structural shapes</p>	<p>- lay out and fabricate workpieces such as tanks, containers, furniture, guards, railings and wrought iron work</p>

UNIT 16.0 GRINDING, POLISHING AND SURFACE FINISHING

General Aim

The students should gain experience in methods of grinding, polishing and surface finishing.

MODULE 16.01 GRINDING MACHINES

Goal Statements

The learning experiences in this module are designed to:

- a. introduce the student to the proper use and various applications of grinders and sanders, and
- b. assist the student to select grinding wheels and belts of various grits and abrasives for particular operations.

Learning Outcomes

Student Activities

The student should be able to:

16.01.01

demonstrate a working knowledge of bench and pedestal grinders for offhand grinding

- sharpen tools
- grind edges to a reference line

16.01.02

demonstrate a working knowledge of angle grinders using cloth backed and fibre wheels

- grind welds, remove oxides and surface finishes

16.01.03

demonstrate a working knowledge of belt sanders for grinding and surface cleaning

- grind welds, finish edges, remove burrs and oxides, and polish surfaces

MODULE 16.02 SAFETY PRECAUTIONS

Goal Statement

The learning experiences in this module are designed to emphasize the safety precautions which must be practised while grinding and polishing.

Learning Outcomes

Student Activities

16.02.01

describe the safe operation and maintenance procedures for grinders and buffing machines, disk sanders, angle grinders and belt sanders

- study and discuss the following precautions and procedures:
  - adequate eye protection
  - clothing hazards
  - tool rest adjustment
  - suitable guards
  - work positions in relation to the wheel, grind up rather than down
  - excessive wheel vibration
  - clamping devices to hold small work while grinding
  - heat generated while grinding and polishing
  - even wheel wear
  - catching work in wire wheels and buffing wheels
  - setting down disk sanders on the disk
  - flying grit from portable grinders and sanders
  - excessive noise
  - belts breaking while in use
  - getting tangled up in disk sanders and belt sanders
  - cracked or chipped wheels and disks and cut belts
  - loading the wheel
  - truing grinding wheels
  - rotation of wheels and correct belt rotation
- always grind and polish towards and edge

17J

MODULE 16.03 BUFFING AND POLISHING

Goal Statments

The learning experiences in this module are designed to:

- a. teach the student the proper use and various applications of surface polishing on metals.
- b. assist the student to select buffing and polishing processes for particular applications

<u>Learning Outcomes</u>	<u>Student Activities</u>
The student should be able to:	
<u>16.03.01</u>	
mount and properly use cloth buffing wheels and wire wheels	- discuss various buffing and polishing processes
<u>16.03.02</u>	
select buffing and polishing materials and compounds according to the type of material and the degree of polish required either by hand or by machine process	- buff and polish metal surfaces as required

MODULE 16.04 PAINTING

Goal Statements

The learning experiences in this module are designed to:

- a. prepare metal surfaces for paint finishes;
- b. introduce the student to the various types of paint finishes and application in common use; and
- c. develop an understanding of safe procedures used in cleaning, etching, dipping and finish applications.

Learning Outcomes	Student Activities
The student should be able to:	
<u>16.04.01</u>	
properly clean and prepare metal surfaces for paint finishes	<ul style="list-style-type: none"><li>- discuss industrial cleaning, dipping and etching processes</li><li>- clean and prepare metal surfaces using various etching and washing methods</li></ul>
<u>16.04.02</u>	
select suitable paints according to job requirements	<ul style="list-style-type: none"><li>- discuss various paints and plastic finishes</li></ul>

MODULE 16.05 PLATING AND COLOURING METAL SURFACES

Goal Statements

The learning experiences in this module are designed to:

- a. introduce the student to the various plating techniques used in industry, and
- b. give the student an understanding of the use of heat and various chemicals to colour metal surfaces.

<u>Learning Outcomes</u>	<u>Student Activities</u>
The student should be able to:	
<u>16.05.01</u>	
outline the different techniques used in electro-plating and hot dipping	- discuss plating methods, heat treating, and acid and chemical colouring of metals
<u>16.05.02</u>	
describe the use of heat to colour metal surfaces through various oxidation rates	- plate and colour metals as required
<u>16.05.03</u>	
select elementary chemical combinations or substances such as of sulphur to color metal surfaces	

UNIT 17.0 DRILLING, REAMING, TAPPING

General Aim

The student should develop an awareness of the safe operation and setups of drilling, reaming and tapping procedures.

MODULE 17.01 DRILLING MACHINES

Goal Statement

The learning experiences in this module are designed to help the student become conversant with the different types of drilling machines.

Learning Outcomes	Student Activities
The student should be able to:	
<u>17.01.01</u>	
identify the various types of drilling machines and their uses	- review notes, textbooks and handouts
<u>17.01.02</u>	
identify various parts of drilling machines and their uses	- maintain and operate available drilling machines



MODULE 17.02 DRILLING MACHINES

Goal Statements

The learning experiences in this module are designed to:

- a. familiarize the student with the basic theory of drill feeds and speeds relative to the material being drilled;
- b. demonstrate the correct method of work holding;
- c. familiarize the student with twist drills and their holding and drive methods;
- d. help the student select the correct setup for drilling holes, and
- e. familiarize the student with the types and uses of countersinks, counterbores, circle cutters and reamers.

Learning Outcomes	Student Activities
The student should be able to:	
<u>17.02.01</u>	
calculate the required R.P.M. when given a cutting speed and drill diameter	- calculate the correct R.P.M. using the drill speed formula
<u>17.02.02</u>	
apply the correct pressure depending upon material and drill size	- drill holes within a given tolerance, using different drill diameters
<u>17.02.03</u>	
select the correct vise or work holding device to safely secure workpiece	- select from a group of work holding fixtures the correct device for a specific application

17.02.04

select the correct drill holding device with respect to straight or taper shank

- mount straight or taper shank drills according to job requirements

17.02.05

select the correct setup for various drilling operations

- drill - thin metals
  - deep holes
  - large holes

17.02.06

recognize the various types of drills

- straight shanks
- taper shanks
- counterbore
- countersink

- review notes, textbooks and handouts

17.02.07

identify various types of drill size methods

- Imperial
- S.I. metric
- number
- letter

- review notes, textbooks and handouts

MODULE 17.03 REAMING

Goal Statement

The learning experiences in this module are designed to familiarize the student with the types and uses of machine reamers.

Learning Outcomes	Student Activities
The student should be able to:	
<u>17.03.01</u>	
recognize the various types of reamers - straight flute - helical flute	- review notes, textbooks and handouts
<u>17.03.02</u>	
determine drilling allowances for machine reaming	- calculate drill size for reaming
<u>17.03.03</u>	
determine speeds and feeds for reaming	- calculate speeds and feeds for reaming
<u>17.03.04</u>	
ream an accurate hole on the drill press	- set up a drill press and ream a hole

MODULE 17.04 TAPS AND DIES

Goal Statement

The learning experiences in this module are designed to familiarize the student with taps, dies and their use.

Learning Outcomes	Student Activities
The student should be able to:	
<u>17.04.01</u>	
identify various thread systems - metric (I S O) - Imperial (Unified) - pipe	- review notes, textbooks and handouts
<u>17.04.02</u>	
select the correct drill size from a tap drill chart	- study classroom notes and the prescribed text description
<u>17.04.03</u>	
identify the various types of taps - taper - plug - bottoming - pipe - straight pipe	- review notes and handouts
<u>17.04.04</u>	
identify various types of dies	- review notes and handouts
<u>17.04.05</u>	
tap a hole with a hand tap	- drill and tap a hole
<u>17.04.06</u>	
thread a rod with a solid or adjustable die	- thread a rod to size
<u>17.04.07</u>	
thread and tap pipe fittings with hand threading tools	- thread and tap pipe fittings

UNIT 18.0 LATHES

General Aim

The student should develop a basic understanding of types of lathes, tools and operations which can be performed; and become proficient in basic lathe operations.

MODULE 18.01 LATHE NOMENCLATURE

Goal Statement

The learning experiences in this module are designed to help the student become conversant with the different types of lathes and their parts.

Learning Outcomes	Student Activities
The student should be able to:	
<u>18.01.01</u>	
identify the various types of lathes and uses	- review notes and handouts - shop tour
<u>18.01.02</u>	
identify the various parts of an engine lathe and their uses	- review notes and handouts - shop tour

MODULE 18.02 WORK HOLDING

Goal Statement

The learning experiences in this module are designed to provide the student with experiences with various work holding methods.

Learning Outcomes

Student Activities

The student should be able to:

18.02.01

identify the following spindle noses

- camlock
- threaded
- taper and key
- flange

- review notes and handouts
- shop tour

18.02.02

identify the following work holding devices and their uses

- universal three jaw
- independent four jaw
- combination
- face plate
- driving plate
- collets

- review notes and handouts
- shop tour

18.02.03

demonstrate the care and knowledge necessary to mount chucks on the various types of spindle noses

- mount and dismount chucks on various spindle noses

18.02.04

mount a workpiece in a universal three jaw chuck

- mount a workpiece in a three jaw chuck

18.02.05

mount a workpiece in a four jaw universal chuck

- mount a workpiece in a four jaw chuck

18.02.06

mount work between centres

- mount a workpiece between centres using the correct dog and dead centre pressure

MODULE 18.03 LATHE CUTTING TOOLS

Goal Statement

The learning experiences in this module are designed to familiarize students with the various types of high speed steel cutting tools.

Learning Outcomes	Student Activities
<u>18.03.01</u> identify the various shapes of cutting tools	- review textbook information
<u>18.03.02</u> identify the various tool bit cutting and clearance angles	- review textbook information and handout
<u>18.03.03</u> grind a high speed steel tool bit for turning steel	- practice grinding on cold rolled steel before attempting to grind a high speed bit

MODULE 18.04 FEEDS AND SPEEDS

Goal Statement

The learning experiences in this module are designed to enable the student to recognize the need for different feeds and speeds.

Learning Outcomes	Student Activities
The student should be able to:	
<u>18.04.01</u>	
determine factors that affect speeds and feeds	- review textbook information relating to feeds and speeds
<u>18.04.02</u>	
calculate speed and feeds for basic lathe operations	- review textbook materials relating to cutting speeds of metals



MODULE 18.05 OPERATIONS

Goal Statement

The learning experiences in this module are designed to introduce the student to the basic operations which can be performed on an engine lathe.

Learning Outcomes	Student Activities
The student should be able to:	
<u>18.05.01</u>	
prepare a workpiece for mounting between centres	- face and centre drill a workpiece and mount between centres
<u>18.05.02</u>	
turn a cylindrical workpiece	- set up and turn the cylindrical workpiece parallel
<u>18.05.03</u>	
bore a through hole to size	- select the correct tools and set up to bore a through hole
<u>18.05.04</u>	
knurl a workpiece for size and appearance	- set up and knurl a workpiece
<u>18.05.05</u>	
cut a 60° thread	- set up and cut a thread
<u>18.05.06</u>	
drill and machine ream a hole	- review reaming speeds and operations in the textbook - set up and ream a hole



18.05.07

part off a workpiece

18.05.08

turn a taper using

- compound rest
- taper attachment
- offset method

- set up and part off a workpiece

- turn three tapers using:

- compound rest
- taper attachment
- offset method

# Section Three

## CP 12 ~ Millwright

CAREER PREPARATION PROGRAM  
CAREER PREPARATION PROGRAM  
CAREER PREPARATION PROGRAM  
CAREER PREPARATION PROGRAM  
CAREER PREPARATION PROGRAM  
CAREER PREPARATION PROGRAM  
CAREER PREPARATION PROGRAM  
CAREER PREPARATION PROGRAM  
CAREER PREPARATION PROGRAM  
CAREER PREPARATION PROGRAM  
CAREER PREPARATION PROGRAM  
CAREER PREPARATION PROGRAM  
CAREER PREPARATION PROGRAM  
CAREER PREPARATION PROGRAM  
CAREER PREPARATION PROGRAM  
CAREER PREPARATION PROGRAM  
CAREER PREPARATION PROGRAM  
CAREER PREPARATION PROGRAM  
CAREER PREPARATION PROGRAM

	PAGE
<u>SECTION THREE - C P 12 MILLWRIGHT</u> . . . . .	191
UNIT 1.0 - INTRODUCTION TO MILLWRIGHT TRAINING. . . . .	192
MODULE 1.01 - MILLWRIGHT TRAINING PROGRAM . . . . .	192
UNIT 2.0 - COOPERATIVE CAREER PREPARATION (COMMUNITY BASED)	195
MODULE 2.01 - PREPLACEMENT ROUTINE. . . . .	195
MODULE 2.02 - PLACEMENT (EXTERNAL TO SCHOOL). . . . .	197
MODULE 2.03 - POSTPLACEMENT ROUTINE . . . . .	198
MODULE 2.04 - STUDENT REPORTING PROCESS . . . . .	199
MODULE 2.05 - LETTER OF THANKS TO EMPLOYER. . . . .	200
UNIT 3.0 - SAFETY AWARENESS . . . . .	201
MODULE 3.01 - PERSONAL ATTITUDES. . . . .	201
MODULE 3.02 - GENERAL SAFETY KNOWLEDGE. . . . .	202
MODULE 3.03 - SAFETY PRACTICES. . . . .	203
MODULE 3.04 - CAUSES OF ACCIDENTS . . . . .	205
MODULE 3.05 - FIRE PREVENTION . . . . .	206
UNIT 4.0 - APPLIED TRADE MATHEMATICS. . . . .	208
MODULE 4.01 - BASIC MATHEMATICS . . . . .	208
MODULE 4.02 - DECIMALS . . . . .	210
MODULE 4.03 - FRACTIONS . . . . .	211
MODULE 4.04 - POWERS, SQUARE ROOTS AND CUBES. . . . .	213
MODULE 4.05 - RATIOS AND PROPORTIONS. . . . .	214
MODULE 4.06 - PERCENTAGE. . . . .	215
MODULE 4.07 - CIRCUMFERENCE AND AREA OF PLANE FIGURES . .	216
MODULE 4.08 - VOLUME OF SHAPES. . . . .	219

	PAGE
UNIT 5.0 - TRADE SCIENCE. . . . .	221
MODULE 5.01 - SOLIDS. . . . .	221
MODULE 5.02 - LIQUIDS . . . . .	222
MODULE 5.03 - GASES . . . . .	223
MODULE 5.04 - PROPERTIES OF MATERIALS . . . . .	224
MODULE 5.05 - SIMPLE MACHINES . . . . .	225
MODULE 5.06 - HEAT. . . . .	227
MODULE 5.07 - MECHANICS . . . . .	228
UNIT 6.0 - LAYOUT AND BLUEPRINT READING . . . . .	230
MODULE 6.01 - GEOMETRIC CONSTRUCTION. . . . .	230
MODULE 6.02 - DIMENSIONING, TOLERANCES AND FITS . . . . .	233
MODULE 6.03 - WORKING DRAWINGS. . . . .	236
MODULE 6.04 - BLUEPRINT READING . . . . .	237
UNIT 7.0 - TRADE TOOLS. . . . .	238
MODULE 7.01 - HAND TOOLS. . . . .	238
MODULE 7.02 - MEASURING TOOLS . . . . .	241
MODULE 7.03 - PORTABLE POWER TOOLS. . . . .	245
UNIT 8.0 - SCREW THREADS. . . . .	246
MODULE 8.01 - PURPOSE AND GENERAL TERMS . . . . .	246
MODULE 8.02 - TYPES OF THREADS. . . . .	248
MODULE 8.03 - FASTENERS . . . . .	249
MODULE 8.04 - LOCKING DEVICES . . . . .	251
MODULE 8.05 - THREAD LOADING. . . . .	253
MODULE 8.06 - EXTERNAL AND INTERNAL THREADS . . . . .	255

	PAGE
UNIT 9.0 - RIGGING AND MATERIAL HANDLING . . . . .	256
MODULE 9.01 - SAFETY REGULATIONS ON RIGGING. . . . .	256
MODULE 9.02 - MATERIAL HANDLING EQUIPMENT. . . . .	259
UNIT 10.0 - SHAFTS, HUBS AND KEYS. . . . .	261
MODULE 10.01 - KEYS. . . . .	261
MODULE 10.02 - HUBS. . . . .	264
MODULE 10.03 - SHAFTS. . . . .	265
UNIT 11.0 - BEARINGS . . . . .	266
MODULE 11.01 - INTRODUCTION TO BEARINGS. . . . .	266
MODULE 11.02 - FRICTION BEARINGS . . . . .	267
MODULE 11.03 ANTI-FRICTION BEARINGS. . . . .	269
UNIT 12.0 - COUPLINGS. . . . .	271
MODULE 12.01 - INTRODUCTION TO COUPLINGS . . . . .	271
MODULE 12.02 - RIGID COUPLINGS . . . . .	273
MODULE 12.03 - FLEXIBLE COUPLINGS. . . . .	275
MODULE 12.04 - CENTRIFUGAL COUPLING. . . . .	277
UNIT 13.0 - CLUTCHES AND BRAKES. . . . .	278
MODULE 13.01 - PURPOSE OF A CLUTCH . . . . .	278
MODULE 13.02 - CLUTCHES. . . . .	279
MODULE 13.03 - PURPOSE OF BRAKES . . . . .	280
MODULE 13.04 - BRAKES. . . . .	281

	PAGE
UNIT 14.0 - LUBRICATION . . . . .	282
MODULE 14.01 - THE PURPOSE OF LUBRICATION . . . . .	282
MODULE 14.02 - OILS . . . . .	283
MODULE 14.03 - GREASE . . . . .	285
UNIT 15.0 - PACKING AND SEALS . . . . .	287
MODULE 15:01 - SEALS: . . . . .	287
MODULE 15:02 - STATIC SEALS . . . . .	288
MODULE 15:03 - NON-CONTACT SEALS. . . . .	289
MODULE 15:04 - SINGLE CONTACT SEALS . . . . .	290
MODULE 15.05 - PACKING. . . . .	292
UNIT 16.0 - PUMPS . . . . .	294
MODULE 16.01 - PURPOSE OF PUMPS . . . . .	294
MODULE 16.02 - PUMP GROUPS. . . . .	295
MODULE 16.03 - PUMP INSTALLATION AND MAINTENANCE: . . . . .	296
UNIT 17.0 - GEARS AND GEAR DRIVES . . . . .	297
MODULE 17.01 - GEARS. . . . .	297
MODULE 17.02 - GEAR REDUCERS. . . . .	299
UNIT 18.0 - BELTS . . . . .	300
MODULE 18.01 - V-BELTS. . . . .	300
MODULE 18.02 - CONVEYOR BELTS . . . . .	302
UNIT 19.0 - CHAIN . . . . .	304
MODULE 19:01 - CHAIN TERMINOLOGY: . . . . .	304
MODULE 19:02 - ROLLER CHAIN . . . . .	305
MODULE 19:03 - CONVEYOR CHAIN . . . . .	309
MODULE 19:04 - LUBRICATION. . . . .	311
MODULE 19.05 - PREVENTATIVE MAINTENANCE . . . . .	312



	PAGE
UNIT 20.0 - HYDRAULICS . . . . .	313
MODULE 20.01 - HYDRAULIC THEORY. . . . .	313
MODULE 20.02 - HYDRAULIC FLUIDS. . . . .	314
MODULE 20.03 - HYDRAULIC COMPONENTS. . . . .	315
MODULE 20.04 - HYDRAULIC CIRCUITS. . . . .	317
MODULE 20.05 - HYDRAULIC TROUBLESHOOTING . . . . .	318
UNIT 21.0 - PNEUMATICS . . . . .	319
MODULE 21.01 - PNEUMATIC THEORY. . . . .	319
MODULE 21.02 - PNEUMATIC COMPONENTS. . . . .	320
MODULE 21.03 - PNEUMATIC CIRCUITS. . . . .	322
MODULE 21.04 - PNEUMATIC SYSTEM MAINTENANCE. . . . .	323
UNIT 22.0 - MACHINE INSTALLATION . . . . .	324
MODULE 22.01 - CONCRETE AND GROUT. . . . .	324
MODULE 22.02 - FORMS . . . . .	325
MODULE 22.03 - BASE BOLTS. . . . .	326
MODULE 22.04 - LAYOUT. . . . .	327
UNIT 23.0 - PREVENTATIVE MAINTENANCE . . . . .	329
MODULE 23.01 - SCHEDULE AND REPORTS. . . . .	329
MODULE 23.02 - NON-DESTRUCTIVE TESTING . . . . .	331
UNIT 24.0 - ELECTRICITY. . . . .	332
MODULE 24.01 - BASIC ELECTRICITY . . . . .	332
MODULE 24.02 - GENERATORS AND MOTORS . . . . .	336

	PAGE
UNIT 25.0 - METALLURGY . . . . .	337
MODULE 25.01 - FERROUS MATERIALS . . . . .	337
MODULE 25.02 - PHYSICAL PROPERTIES . . . . .	339
MODULE 25.03 - HEAT TREATMENT. . . . .	340
<u>SECTION FOUR</u> - RESOURCE MATERIALS. . . . .	345

C P 12 - MILLWRIGHT

General Aim and Purpose

The primary aim of this Millwright program in grade 12 is to provide learning experiences that will help students develop marketable skills or qualify for advanced standing in a related program at a college or provincial institute. At the grade 12 level, an integral part of the learning experience involves practical experience in a working situation external to the school. This cooperative career preparation component involves at least 100 hours of activities that are community based to provide actual work experience organized through the cooperation of employers and union organizations.

Students should acquire a comprehensive knowledge of:

- a. basic requirements for successful employment in millwright vocations;
- b. practices necessary for clean, safe and orderly work habits;
- c. theory of operation and construction of mechanical equipment;
- d. maintenance, repair and adjustments related to the millwright occupation;
- e. concepts applicable to trouble-shooting techniques;
- f. employment opportunities and occupational qualifications needed for job entry levels;
- g. procedures and opportunities available for continuing education;
- h. employers expectations for a positive attitude toward the work ethic and good relations in working with others; and
- i. tools and machinery used in the industry.

UNIT 1:0 INTRODUCTION TO MILLWRIGHT TRAINING

General Aim

The student will develop an awareness of the training program and the employment opportunities in the millwright trade.

MODULE 1.01 MILLWRIGHT TRAINING PROGRAM

Goal Statements

The learning experiences in this module are designed to:

- a. help students develop an awareness of post-secondary training institutions that are available in the province of British Columbia,
- b. identify the procedure, responsibilities and obligation of the apprenticeship program,
- c. identify areas of employment in the millwright field,
- d. help the student to understand the organizational structure of the industrial field,
- e. teach the student to develop positive attitudes with others in a working environment,
- f. introduce the student to time card arrangements.

Learning Outcomes

Student Activities

The student should be able to:

1.01.01

name the post-secondary institutes that offer millwright training programs

- review and discuss institutions that offer millwright training programs
- e.g. - Pacific Vocational Institute (Burnaby Campus)
- Selkirk College
- others

1.01.02

explain the millwright apprenticeship program

- discuss the apprenticeship program
  - e.g. - TRAC
    - four year apprenticeship
    - obligation and responsibilities of the employee and employer
    - salary

1.01.03

list the employment opportunities in the field

- discuss areas of employment
  - mining
  - sawmills
  - pulp mills
  - foundries
  - manufacturers
  - other

1.01.04

describe the obligations of the employee

- to his employer
- to his union or employee organization
- to the demands of work

- discuss and examine various types of
  - management organizations and responsibilities
  - employee associations
  - contact obligations and responsibilities

1.01.05

describe the working conditions in the field

- discuss and examine working conditions and industrial demands

1.01.06

describe the responsibilities and reliability factors of the employee

- discuss
  - necessity of punctual and regular attendance
  - necessity for trust and reliability between fellow employees

1.01.07

understand the need for positive attitudes and employee confidence:

- to himself
- to his superiors
- to his fellow employees

1.01.08

demonstrate a working knowledge of the bookkeeping requirements

- time card
- job description
- purchase order forms
- other

- discuss the beneficial effects that positive attitudes have on employer or employee relationships

- discuss and have each student complete individual records of
  - time cards
  - job descriptions
  - material orders to suppliers

UNIT 2.0 COOPERATIVE CAREER PREPARATION (COMMUNITY BASED)

General Aims

The student should:

- a. develop an increased understanding of the employment opportunities in the community, province and country;
- b. gain practical experience relating to employment responsibilities;
- c. benefit from the knowledge and experience of resource persons from business and industry.

Community representatives should participate in organized activities connected with the program.

MODULE 2.01 PREPLACEMENT ROUTINE

Goal Statements

The learning experiences in this module are designed to:

- a. provide an opportunity for the student to review appropriate regulations of Workers' Compensation Board;
- b. review all necessary procedures for student transportation to and from a placement work site;
- c. increase student responsibility to school and employer;
- d. acquaint the student with documentation, forms, contracts, and the reports of employer, teacher, and student.

Learning Outcomes	Student Activities
The student will be able to:	
<u>2.01.01</u>	
dress appropriately for the type of employment experience	- discuss appropriate dress for different occupations
<u>2.01.02</u>	
describe the transportation procedures necessary to reach the job site	- consider public or private means

2.01.03

list the important factors related to behaviour on the job

- review introductory procedures to contact employers
- discuss manners, speech, things to observe
- discuss significance of reports
- read examples of reports that will be written by the employer and the teacher



MODULE 2.02 PLACEMENT (EXTERNAL TO SCHOOL)

Goal Statements

The learning experiences in this module are designed to:

- a. provide the student with experiences that will relate school experiences with actual working conditions;
- b. provide students with actual job experience in a working environment;
- c. increase student awareness and understanding of employee responsibilities;
- d. have the student practise increased responsibility within a work environment
- e. facilitate effective transition of students between school and employment;
- f. assist the student to see value in education and training;
- g. create a student awareness of the opportunities for further training.

Learning Outcomes	Student Activities
The student will be able to: <u>2.02.01</u> function effectively in a job situation  <u>2.02.02</u> work cooperatively with other students or employees	- follow directions mutually agreed to by employer and teacher  - ask questions related to career goals - maintain good relations with others - acquire training experiences in the community

MODULE 2:03 POSTPLACEMENT ROUTINE

Goal Statements

The learning experiences in this module are designed to:

- a. assist the student to make a job analysis of an occupation related to the placement;
- b. review employment and career possibilities related to actual job experiences.

Learning Outcomes	Student Activities
<p>The student will be able to:</p> <p><u>2.03.01</u></p> <p>prepare a job analysis of an occupation where work experience was obtained</p> <p><u>2.03.02</u></p> <p>list safety factors that must be observed in a chosen occupation</p>	<ul style="list-style-type: none"><li>- review format of sample analyses</li><li>- discuss career paths</li> <li>- review safety aspects related to self and others</li></ul>

MODULE 2.04 STUDENT REPORTING PROCESS

Goal Statements

The learning experiences in this module are designed to:

- a. provide the student with a format for reporting on their field experiences with an employer,
- b. examine the role of employee duties in an occupation and relate to particular school experiences,
- c. have the student prepare a formal list of contacts and practical job experiences.

Learning Outcomes	Student Activities
The student should be able to:	
<u>2.04.01</u>	
complete a report of the job placement and discuss in detail the positive (and negative) aspects of the experience	<ul style="list-style-type: none"><li>- review content of reports and prepare details on the work experience</li><li>- prepare an oral report to the class on the experience at a job site</li></ul>
<u>2.04.02</u>	
explain the various advantages and disadvantages of an occupation	<ul style="list-style-type: none"><li>- discussions in class</li></ul>
<u>2.04.03</u>	
list criteria for effective job performance	<ul style="list-style-type: none"><li>- discussions in class</li></ul>
<u>2.04.04</u>	
discuss unsatisfactory job performance	<ul style="list-style-type: none"><li>- discussions in class</li></ul>

MODULE 2.05 LETTER OF THANKS TO EMPLOYER

Goal Statement

The learning experiences in this module are designed to provide the student with a format for preparing a letter of thanks to employers who provided work experience.

Learning Outcomes	Student Activities
<p>The student will be able to:</p> <p><u>2.05.01</u></p> <p>organize and write a letter of thanks to the business firm where job experience was obtained</p>	<ul style="list-style-type: none"><li>- prepare a draft for the consideration of the teacher</li><li>- type or write a neat letter using correct grammar</li><li>- mail or deliver to business within one week of return to school</li></ul>

UNIT 3.0 SAFETY AWARENESS

General Aim

The student will develop a high degree of understanding of safety and safety practices.

MODULE 3.01 PERSONAL ATTITUDES

Goal Statement

The learning experiences in this module are designed to help the student develop a good personal attitude toward safety.

Learning Outcomes

Student Activities

The student should be able to:

3.01.01

explain the necessary personal attitudes related to the millwright trade

- discuss the willingness to accept safety programs
- discuss the willingness to learn from others
- discuss the willingness to work with others as a team

MODULE 3.02 GENERAL SAFETY KNOWLEDGE

Goal Statements

The learning experiences in this module are designed to help the student to:

- a. protect himself on the job,
- b. realize he has to protect others on the job,
- c. identify and understand various types of safety equipment.

Learning Outcomes	Student Activities
The student should be able to:	
<u>3.02.01</u>	
explain the need for personal protection on the job	<ul style="list-style-type: none"><li>- discuss various methods of protecting yourself on the job<ul style="list-style-type: none"><li>- proper dress</li><li>- awareness</li><li>- no horseplay</li><li>- other</li></ul></li></ul>
<u>3.02.02</u>	
explain how to protect others on the job	<ul style="list-style-type: none"><li>- discuss how a workman is responsible for others in and around a work area<ul style="list-style-type: none"><li>- rope off hazard areas</li><li>- safety signs</li><li>- installation of guards</li><li>- other</li></ul></li></ul>
<u>3.02.03</u>	
explain various types of safety equipment	<ul style="list-style-type: none"><li>- discuss safety equipment<ul style="list-style-type: none"><li>- safety shoes</li><li>- hard hats</li><li>- glasses</li><li>- other</li></ul></li></ul>

MODULE 3.03 SAFETY PRACTICES

Goal Statements

The learning experiences in this module are designed to:

- a. help the student maintain good housekeeping practices,
- b. increase student understanding of material handling,
- c. familiarize the student with Workers Compensation Board procedures and regulations,
- d. develop proper methods of tagging out equipment in industrial plants.

Learning Outcomes

Student Activities

The student should be able to:

3.03.01

develop good housekeeping practices

- discuss the need for cleanliness in the general work area
- discuss the need for removal of metals after welding, drilling, grinding, etc.
- discuss the need for removal of spilled oils or liquids
- discuss the need for removing any projecting materials from walkways or projecting sharp objects which might injure a workman
- discuss reasons for returning equipment to storage
- other

3.03.02

develop proper handling techniques

- discuss the need to maintain proper posture when handling materials
- discuss the awareness of physical limits when handling materials
- discuss accepted moving methods in rolling, prying, pushing and lifting
- discuss ways in assessing work to be done and material available for the job (weight, bulk, fragility of article, corrosiveness or other considerations in which safety plays a part)
- other

3.03.03

familiarize themselves with Workers Compensation Board regulations

- discuss the Workers Compensation Board booklet
- discuss the need for workers to comply with all regulations
- discuss the need for adequate guarding techniques
- other

3.03.04

develop proper tag out procedures

- discuss tag out routine
- discuss the need for strict observation for tag outs
- discuss the need for the importance of removal of own tag at the end of each job



MODULE 3.04 CAUSES OF ACCIDENTS

Goal Statement

The learning experiences in this module are designed to help the student become aware of the causes of accidents.

Learning Outcomes	Student Activities
The student should be able to: <u>3.04.01</u> identify causes of accidents	<ul style="list-style-type: none"><li>- discuss why the following could result in accidents:<ul style="list-style-type: none"><li>- poor attitudes toward work and safety</li><li>- lack of cooperation with a fellow worker</li><li>- improper use of tools</li><li>- ineffective guarding</li><li>- horseplay on the job</li><li>- other</li></ul></li></ul>

MODULE 3.05 FIRE PREVENTION

Goal Statements

The learning experiences in this module are designed to:

- a. acquaint the student with the various causes of fires,
- b. acquaint the student with the various types of fires,
- c. enable the student to identify methods of extinguishing the various types of fires,
- d. familiarize the student with safety practices in conjunction with fire prevention.

Learning Outcomes	Student Activities
The student should be able to:	
<u>3.05.01</u>	
state or list some of the major causes of fires	<ul style="list-style-type: none"><li>- review and list some major causes of fires<ul style="list-style-type: none"><li>- welding sparks</li><li>- electrical sparks</li><li>- matches or cigarettes</li><li>- spontaneous combustion</li></ul></li></ul>
<u>3.05.02</u>	
state or list the types of fires	<ul style="list-style-type: none"><li>- discuss and list the types of fires<ul style="list-style-type: none"><li>- Class A - wood and paper</li><li>- Class B - grease, solvents, paints or any combination of A or B</li><li>- Class C - electrical involved with any combination of A and B</li><li>- Class D - metals, magnesium, phosphorus, sodium</li></ul></li></ul>

3.05.03

identify and list the various extinguishing methods

- discuss the proper application of protective equipment
  - Class A - water as a jet spray or fog or any chemical extinguisher for small spot fires
  - Class B - soda acid, CO<sub>2</sub>, drychemical nozzle without water
  - Class C - CO<sub>2</sub>, dry chemical, leave alone if high voltage is involved
  - Class D - dry compounds

3.05.04

identify some safe fire prevention practices

- discuss and list some fire prevention rules
  - proper waste disposal
    - oil, rags and waste
    - used oil
    - used solvent
    - metallic chips
  - proper storage
    - oil and grease
    - dry materials away from heat
    - chemicals
    - fire pairs for fire only

UNIT 4.0 APPLIED TRADE MATHEMATICS

General Aim

The student will develop a degree of competency in the field of applied trade mathematics.

MODULE 4.01 BASIC MATHEMATICS

Goal Statements

The learning experiences in this module are designed to:

- a. provide opportunities for the student to review basic fundamental principles of simple and complex computation of addition, subtraction, multiplication and division with whole numbers;
- b. develop student skills in solving problems related to the trade.
- c. enable the student to convert measurements from metric to imperial or vice versa.

Learning Outcomes

Student Activities

The student should be able to:

4.01.01

perform addition, subtraction, multiplication and division calculations with:

- simple and complex mathematical computations with whole numbers
- problems

4.01.02

perform a mixer of addition, subtraction, multiplication and division calculations on:

- mathematical computations with whole numbers
- problems

- discuss and perform
  - mathematical computations with whole numbers
  - problem calculations

- discuss and perform
  - mathematical computations with whole numbers
  - problem calculations

4.01.03

identify the metric and imperial units of:

- length
- mass
- volume
- temperature

4.01.04

state the conversion factors for converting

- discuss and perform mathematical computations

- discuss and perform mathematical computations

MODULE 4.02 DECIMALS

Goal Statements

The learning experiences in this module are designed to:

- a. provide opportunities for the student to review basic fundamental principles of simple and complex computations of addition, subtraction, multiplication and division with decimal numbers,
- b. develop student skills in solving problems related to the trade.

Learning Outcomes	Student Activities
The student will be able to:	
<u>4.02.01</u>	
perform addition, subtraction, multiplication and division calculations with: <ul style="list-style-type: none"><li>- simple and complex mathematical computations with decimal numbers</li><li>- problems</li></ul>	<ul style="list-style-type: none"><li>- discuss and perform<ul style="list-style-type: none"><li>- mathematical computations with decimal numbers</li><li>- problem calculations</li></ul></li></ul>
<u>4.02.02</u>	
perform a mixer of addition, subtraction, multiplication and division calculation on: <ul style="list-style-type: none"><li>- mathematical computations with decimal numbers</li><li>- problem</li></ul>	<ul style="list-style-type: none"><li>- discuss and perform<ul style="list-style-type: none"><li>- mathematical computations with decimal numbers</li><li>- problem calculations</li></ul></li></ul>

MODULE 4.03 FRACTIONS

Goal Statements

The learning experiences in this module are designed to:

- a. provide opportunities for the student to review basic fundamental principles of simple and complex computations of addition, subtraction, multiplication and division with fractional numbers;
- b. help the student compute decimal equivalents of fractions by using tables;
- c. develop student skills in solving problems related to the trade;
- d. convert simple imperial measurements to S.I. metric equivalents and vice versa through the use of tables.

<u>Learning Outcomes</u>	<u>Student Activities</u>
The student will be able to:	
<u>4.03.01</u>	
identify fractions - proper fractions - improper fractions - mixed numbers	- discuss
<u>4.03.02</u>	
convert whole or mixed numbers to improper fractions and reducing improper fractions to whole or mixed numbers	- discuss and perform mathematical calculations
<u>4.03.03</u>	
reduce fractions to lowest terms	- discuss and perform mathematical calculations
<u>4.03.04</u>	
find lowest common denominators of: - common fractions - mixed numbers	- discuss and perform mathematical calculations

4.03.05

change common fractions or mixed numbers to decimals

- computations
- table of decimal equivalents of fractions

- discuss and perform:
  - mathematical calculations
  - by using table of decimal equivalents of fractions

4.03.06

perform addition, subtraction, multiplication and division calculations with:

- simple and complex mathematical computations with:
  - common fractions
  - improper fractions
  - mixed numbers

- discuss and perform
  - mathematical computations with fractional numbers
  - problem calculations

4.03.07

identify measurement systems

- Imperial
- S.I. Metric

- discuss

4.03.08

convert imperial measurements to S.I. metric equivalents or vice versa through the use of tables

- discuss and perform conversion



MODULE 4.04 POWERS, SQUARE ROOTS AND CUBES

Goal Statement

The learning experiences in this module are designed to provide opportunities for the student to learn the basic fundamental principles of computing powers and square roots of numbers using tables.

Learning Outcomes	Student Activities
The student will be able to:	
<u>4.04.01</u>	
explain and compute powers of numbers	- discuss and perform mathematical calculations
<u>4.04.02</u>	
explain and compute square roots of numbers	- discuss and perform mathematical calculations
<u>4.04.03</u>	
use power and square root tables	- discuss and use power and square root tables
<u>4.04.04</u>	
use tables for computing cube roots	- discuss and use cube root tables

MODULE 4.05 RATIOS AND PROPORTIONS

Goal Statements

The learning experiences in this module are designed to:

- a. provide opportunities for the student to learn the basic fundamental principles of computing ratios and proportions,
- b. help the student relate ratios and proportions to simple gear, belt and chain drive arrangements.

Learning Outcomes	Student Activities
The student will be able to:	
<u>4.05.01</u>	
identify and set up ratios	- discuss and perform ratio computations
<u>4.05.02</u>	
reduce simple ratios	- discuss and perform ratio computations
<u>4.05.03</u>	
use ratios to set up direct proportions	- discuss and perform problems related to setting up direct proportions
<u>4.05.04</u>	
use ratios to set up inverse proportions	- discuss and perform problems related to setting up inverse proportions
<u>4.05.05</u>	
relate ratios as applied to simple drives	- discuss and perform problems related to drive units
- ratio of sizes - ratio of speeds	- ratio of sizes - ratio of speed - other

MODULE 4.06 PERCENTAGE

Goal Statement

The learning experiences in this module are designed to help the student to learn the basic fundamentals and computation of percentage problems.

Learning Outcomes	Student Activities
<p>The student will be able to:</p> <p><u>4.06.01</u></p> <p>perform computations involving the changing of:</p> <ul style="list-style-type: none"><li>- decimals to percentages</li><li>- percentages to decimals</li></ul>	<ul style="list-style-type: none"><li>- discuss and perform calculations</li></ul>
<p><u>4.06.02</u></p> <p>perform computations involving the changing of:</p> <ul style="list-style-type: none"><li>- fractions to percentages</li><li>- percentages to fractions</li></ul>	<ul style="list-style-type: none"><li>- discuss and perform calculations</li></ul>
<p><u>4.06.03</u></p> <p>perform computations involving problems related to percentage</p>	<ul style="list-style-type: none"><li>- discuss and perform calculations</li></ul>

MODULE 4.07 CIRCUMFERENCE AND AREA OF PLANE FIGURES

Goal Statements

The learning experiences in this module are designed to:

- a. provide the opportunities for the student to learn the basic fundamental principles of computing circumferences and area of plane figures,
- b. help the student compute circumference and area through the use of tables,
- c. help the student relate circumference and area problems to the trade, e.g. pulleys, belt drives, double sided cylinders, etc.

Learning Outcomes	Student Activities
The student will be able to:	
<u>4.07.01</u>	
identify shapes of figures	<ul style="list-style-type: none"><li>- discuss and identify figures<ul style="list-style-type: none"><li>- squares</li><li>- rectangles</li><li>- parallelograms</li><li>- right angled triangles</li><li>- acute angled triangles</li><li>- trapezoids</li><li>- hexagons</li><li>- octagons</li><li>- polygons</li><li>- circles</li><li>- circular rings</li><li>- fillets</li><li>- ellipses</li></ul></li></ul>
<u>4.07.02</u>	
practical methods of locating centres of some plane figures	<ul style="list-style-type: none"><li>- discuss and perform methods of:<ul style="list-style-type: none"><li>- squares</li><li>- rectangles</li><li>- circles</li><li>- other</li></ul></li></ul>

4.07.03

identify radius of circles

- discuss and have the student draw circles from given radii

4.07.04

identify diameters of circles

- discuss and have the student draw circles from a given diameter

4.07.05

identify circumference formulas for:

- circles
- squares

- discuss and perform circumference
  - computations
  - problems

4.07.06

identify the method of computing areas for various shapes

- shapes
- rectangles
- right angled triangles
- acute angled triangles
- trapezoids
- hexagons
- octagons
- circles
- circular rings
- other

- discuss and perform area calculations on various shapes

4.07.07

use tables for computing circumferences and areas of various shapes

- discuss and use tables for computing circumferences and areas

4.07.08

use circumference and areas in problem solving

- discuss and perform calculation on problems related to the trade

4.07.09

use formulas of circumference and areas to compute diameters of shapes in:

- computation
- problem solving

- discuss and perform calculations

4.07.10

use of Pythagoras' Theorem

- discuss and perform calculations on
  - right angled triangles
  - other

MODULE 4.08 VOLUME OF SHAPES

Goal Statements

The learning experiences in this module are designed to:

- a. provide the opportunities for the student to learn the basic fundamental principles to compute volumes of shapes,
- b. help the student compute volumes through the use of tables,
- c. help the student relate volume problems to the trade, and
- d. help the student convert U.S. Fluid to Imperial Fluid measurement or Imperial Fluid to S.I. Metric measurement.

Learning Outcomes

Student Activities

The student should be able to:

4.08.01

identify shapes of figures

- discuss and identify figures
  - cubes
  - square prisms
  - prisms
  - pyramids
  - wedges
  - cylinders
  - portion of cylinders
  - hollow cylinders
  - cones
  - frustum of cones
  - spheres
  - other

4.08.02

identify volume formulas for:

- cubes
- prisms
- cylinders
- other

- discuss and perform volume calculations on various shapes

4.08.03

use volume formulas in solving problems

- discuss and perform calculations on problems related to the trade

4.08.04

use formulas of volume to compute:  
- height or diameters of shapes  
- height or lengths of shapes

- use problems to discuss and perform calculations

4.08.05

compute or use tables to convert U.S. Fluid (gallons) to Imperial Fluid (gallons) or vice versa

- discuss and use tables for computing problems

4.08.06

compute or use tables to convert Imperial Fluid (gallons) to S.I. metric measurements (liters) or vice versa

- discuss and use tables for computing problems



UNIT 5.0 TRADE SCIENCE

General Aim

The student will develop a degree of competency in the field of applied millwright trade science.

MODULE 5.01 SOLIDS

Goal Statement

Familiarize the student with some of the necessary terms related to solids.

Learning Outcomes

Student Activities

The student should be able to:

5.01.01

identify the following terms which are related to solids:

- hardness
- ductility
- machinability
- other

- discuss the following terms

- hardness
  - Brinell
  - Rockwell
- ductility
- machinability
- density
- other

MODULE 5.02 LIQUIDS

Goal Statement

The learning experiences in this module are designed to familiarize the student with some properties related to liquids.

Learning Outcomes	Student Activities
<p>The student should be able to:</p> <p><u>5.02.01</u></p> <p>identify the following terms which are related to liquids</p> <ul style="list-style-type: none"><li>- cohesion</li><li>- viscosity</li><li>- specific gravity</li><li>- incompressibility</li><li>- other</li></ul>	<ul style="list-style-type: none"><li>- discuss and note the properties of liquids</li><li>- discuss and measure the viscosity properties of liquids</li><li>- discuss and measure the specific gravities of liquids</li><li>- note that liquid compresses 0.5 to 1% at 1000 psi</li></ul>

MODULE 5.03 GASES

Goal Statements

The learning experiences in this module are designed to:

- a. familiarize the student with Boyle's law;
- b. help the student compute problems related to pressure of gases.

Learning Outcomes	Student Activities
The student should be able to:	
<u>5.03.01</u>	
describe why gases compress	- discuss why gases compress
<u>5.03.02</u>	
measure the pressure of gases	- discuss Boyle's Law <ul style="list-style-type: none"><li>- Pressure = Force X Area</li></ul> - discuss how heat effects pressure (Charles law) <ul style="list-style-type: none"><li>- compute pressures of gases<ul style="list-style-type: none"><li>- calculate the force created in a cylinder if the area and pressure are known</li><li>- calculate the area of a cylinder if the force and pressure are known</li></ul></li></ul> - when volume changes
<u>5.03.03</u>	
identify the imperial and metric units of pressure	- discuss

MODULE 5.04 PROPERTIES OF MATERIALS

Goal Statements

The learning experiences in this module are designed to help the student identify:

- a. different types of stress on materials,
- b. the properties of some common metals.

Learning Outcomes

Student Activities

<u>Learning Outcomes</u>	<u>Student Activities</u>
<p>The student should be able to:</p> <p><u>5.04.01</u></p> <p>identify and demonstrate the different types of stress</p>	<ul style="list-style-type: none"><li>- discuss the demonstrate the following:<ul style="list-style-type: none"><li>- tension</li><li>- compression</li><li>- bending</li><li>- shearing</li><li>- torsional</li><li>- other</li></ul></li></ul>
<p><u>5.04.02</u></p> <p>identify the properties of common metals</p> <ul style="list-style-type: none"><li>- cast iron</li><li>- malleable iron</li><li>- steel</li><li>- brass</li><li>- aluminum</li><li>- copper</li></ul>	<ul style="list-style-type: none"><li>- discuss the difference between common metals<ul style="list-style-type: none"><li>- colour</li><li>- density</li><li>- elasticity</li><li>- tensile strength</li><li>- effect of heat on metals</li><li>- conductivity</li><li>- failure point</li><li>- yield point</li><li>- oxidation</li><li>- reduction</li><li>- conduction</li><li>- insulation</li><li>- others</li></ul></li></ul>
<p><u>5.04.03</u></p> <p>describe how the following materials oxidise</p> <ul style="list-style-type: none"><li>- stainless steel</li><li>- copper</li><li>- lead</li><li>- others</li></ul>	<ul style="list-style-type: none"><li>- discuss</li></ul>

MODULE 5.05 SIMPLE MACHINES

Goal Statements

The learning experiences in this module are designed to;

- a. familiarize the student with types of simple machines, and
- b. help the student complete problems related to simple machines.

Learning Outcomes

Student Activities

The student should be able to:

5.05.01

explain what a simple machine is

- discuss what a simple machine is
  - anything that makes it easier or more convenient to do work

5.05.02

identify the different types of simple machines

- levers
- pulleys
- inclined plane
- wedge
- wheel and axles
- screws

- discuss different types of levers
  - Class I
  - Class II
  - Class III
- discuss the formula for levers
  - $EXED = R \times RD$
  - actual
  - theoretical
- discuss the use of pulleys
  - calculate the mechanical advantages of different pulley arrangements
  - discuss the gain in effort with a loss in distance
  - application to:
    - rope blocks
    - hoisting equipment
- discuss the use of an inclined plane
  - discuss formula for inclined plane
  - $EXED = R \times RD$

Cont'd

5.05.02 Cont 'd

- discuss the use of wedges
- discuss the use of a wheel and axle
- discuss the use of a screw as a simple machine
  - jack screw is like an inclined plane
  - other

MODULE 5.06 HEAT

Goal Statement

The learning experiences in this module are designed to help the student understand the effect of temperature on metal.

Learning Outcomes	Student Activities
The student should be able to:	
<u>5.06.01</u>	
define the following terms <ul style="list-style-type: none"><li>- specific heat</li><li>- temperature</li><li>- expansion</li><li>- heat of fusion</li><li>- boiling</li><li>- vaporization</li><li>- mechanical equivalent of heat</li><li>- contraction</li><li>- induction</li><li>- absolute zero</li><li>- radiation</li><li>- calorie</li></ul>	- discuss
<u>5.06.02</u>	
explain the effect of heat in relation to: <ul style="list-style-type: none"><li>- density</li><li>- volume</li><li>- expansion</li><li>- contraction</li></ul>	- discuss
<u>5.06.03</u>	
describe how heat is transferred	- discuss

MODULE 5.07 MECHANICS

Goal Statements

The learning experiences in this module are designed to:

- a. familiarize the student with the following mechanical terms:
  - force
  - friction
  - work
  - power
  - horsepower
  - torque, and
- b. help the student compute problems related to the trade.

<u>Learning Outcomes</u>	<u>Student Activities</u>
The student should be able to:	
<u>5.07.01</u>	
define the term force	<ul style="list-style-type: none"><li>- discuss the term force<ul style="list-style-type: none"><li>- push or pull of an object</li><li>- identify metric and imperial units</li><li>- Newtons</li><li>- pounds - force</li></ul></li></ul>
<u>5.07.02</u>	
define the term friction	<ul style="list-style-type: none"><li>- discuss what causes friction</li></ul>
<u>5.07.03</u>	
identify the different types of friction	<ul style="list-style-type: none"><li>- discuss the different types of friction<ul style="list-style-type: none"><li>- sliding</li><li>- rolling</li><li>- fluid</li><li>- internal</li></ul></li></ul>
<u>5.07.04</u>	
define the term work	<ul style="list-style-type: none"><li>- discuss the term work<ul style="list-style-type: none"><li>- Work = Effort X Distance</li><li>- Work In = Work Out</li><li>- other</li></ul></li><li>- perform calculations relating to work</li></ul>



5.07.05

define the term power

5.07.06

define the term horsepower

5.07.07

define the term torque

- discuss the term power

- Power =  $\frac{\text{Work}}{\text{Minute}}$

- perform calculations relating to power

- discuss the term horsepower

- Horsepower =  $\frac{\text{Work}}{\text{Given time}}$

- Horsepower =  $\frac{\text{Work} \times \text{Distance}}{\text{Time}}$

- Horsepower =  $\frac{F \times S}{550 \text{ t}}$

Imperial

Power =  $\frac{FS}{t}$  S.I. Metric

- perform calculation relating to horsepower

- discuss the term torque

- twisting force necessary to turn a shaft

- expressed in the Imperial system (ft-lbs or in-lbs) or the S.I. metric system (Newton metres)

UNIT 6.0 LAYOUT AND BLUEPRINT READING

General Aim

The student will develop a degree of competency in blueprint reading.

MODULE 6.01 GEOMETRIC CONSTRUCTION

Goal Statements

The learning experiences in this module are designed to:

- a. familiarize the student with geometrical constructions, and
- b. help the student acquire the necessary techniques in forming geometrical constructions.

Learning Outcomes	Student Activities
The student should be able to:	
<u>6.01.01</u>	
identify different types of angles <ul style="list-style-type: none"><li>- completed circle (<math>360^\circ</math>)</li><li>- straight angle (<math>180^\circ</math>)</li><li>- right angle (<math>90^\circ</math>)</li><li>- acute angle (<math>&lt;90^\circ</math>)</li><li>- obtuse angle (<math>&gt;90^\circ</math>)</li><li>- complementary angles</li><li>- supplementary angles</li><li>- other</li></ul>	- discuss and list different types
<u>6.01.02</u>	
identify different types of triangles <ul style="list-style-type: none"><li>- equilateral triangles</li><li>- isosceles triangles</li><li>- scalene triangles</li><li>- right triangle</li><li>- other</li></ul>	- discuss and list different types

6.01.03

identify different types of quadrilaterals

- square
- rectangle
- rhombus
- rhomboid
- trapezoid
- trapezium
- other

- discuss and list different types

6.01.04

identify different types of polygons

- pentagon
- hexagon
- heptagon
- octagon
- other

- discuss and list different types

6.01.05

identify the following

- circle
- arc
- tangent
- concentric circle
- eccentric circle

- discuss and list different types

6.01.06

identify the different types of solids

- prisms
- pyramids
- cones
- sphere
- cylinders
- ellipsoid
- other

- discuss and list different types

6.01.07

perform the following geometric constructions

- bisecting a line or circle arc
- bisecting an angle
- transferring an angle
- divide a line into equal parts
- draw an equilateral triangle
- draw a square
- draw a pentagon
- enlarge or reduce a drawing
- other

- discuss and perform the required skills

MODULE 6.02 DIMENSIONING, TOLERANCES AND FITS

Goal Statements

The learning experiences in this module are designed to:

- a. help the student acquire the necessary skills in dimensioning techniques,
- b. familiarize the student with tolerance procedures used when mating parts
- c. acquaint the student with the different types of fits on mating parts,
- d. familiarize students with the use of reference tables.

Learning Outcomes

Student Activities

The student should be able to:

6.02.01

perform basic dimensioning techniques used on conventional drawings

- circular features
  - rounded ends
  - spherical surfaces
  - slotted holes
  - cylindrical holes
  - countersink holes
  - countebore holes
  - spot faces
- common features
  - tapers
  - chamfers
  - knurls
  - undercuts
  - threads
  - other
- dimensioning methods
  - rectangular coordinate dimensioning system
  - true position dimensioning
  - polar coordinate dimensioning
  - chordal dimensioning system
  - arrowless dimensioning
  - tabular
  - chain
  - datum
  - other

- discuss and perform required skills in drawings

6.02.02

explain the purpose of tolerancing

- discuss

6.02.03

identify the following terms

- tolerance
- allowance
- limits

- discuss

6.02.04

identify and use the different methods of expressing tolerances in dimensions

- limit dimensioning
- plus and minus dimensioning
- single limit dimensioning
- angular tolerances

- discuss and perform required skills on drawings

6.02.05

identify the following geometric symbols for tolerances

- flatness
- straightness
- roundness
- cylindricity
- parallelism
- perpendicularity
- angularity
- concentricity
- symmetry
- other

6.02.06

explain the purpose of an accurate fit between two or more parts

- discuss

6.02.07

explain the difference between types of fits on mating parts

- running and sliding fit
  - class 1 9
- clearance locational fit
  - class 1 11
- transition locational fit
  - class 1 7
- interference locational fit
  - class 2 and 3
- force and shrink fit
  - class 1 5

- discuss and show examples of different types of fits

6.02.08

use reference tables for determining required fits between mating parts

- shafts
- holes
- key and keyways
- other

- discuss and use reference tables where required

MODULE 6.03 WORKING DRAWINGS

Goal Statement

The learning experiences in this module are designed to help the student acquire the necessary skills for completing a working drawing.

Learning Outcomes	Student Activities
<p>The student should be able to:</p> <p><u>6.03.01</u></p> <p>explain the purpose and techniques involving the completion of a working drawing</p> <p><u>6.03.02</u></p> <p>complete a working drawing</p>	<p>- discuss</p>  <p>- complete working drawings of a simple machine component containing two or more parts</p>



MODULE 6.04 BLUEPRINT READING

Goal Statement

The learning experiences in this module are designed to familiarize and help the student acquire the necessary concepts for interpreting working drawings.

<u>Learning Outcomes</u>	<u>Student Activities</u>
The student should be able to:	
<u>6.04.01</u>	
identify the difference between engineering drawings and architectural drawings	- discuss
<u>6.04.02</u>	
interpret basic working drawings	- discuss and practice interpreting working drawings
<u>6.04.03</u>	
identify and interpret the following <ul style="list-style-type: none"><li>- title block</li><li>- drawing numbers</li><li>- parts and material lists</li><li>- zoning</li><li>- checking</li><li>- drawing revisions</li><li>- sheet numbering</li><li>- scale</li><li>- drawing notes</li><li>- other</li></ul>	- discuss and interpret working drawings

UNIT 7.0 TRADE TOOLS

General Aim

The student will develop a degree of competency in the use of tools and shop practices.

MODULE 7.01 HAND TOOLS

Goal Statement

The learning experiences in this module are designed to help the student develop a skill in the area of hand tools.

Learning Outcomes

Student Activities

The student should be able to:

7.01.01

maintain and explain the use of all basic hand tools

- hammers
  - ball peen
  - sledge
  - clipping
  - other
- clamps
  - C-clamps
  - bar clamp
  - other
- punches
  - prick
  - centre
  - drift
  - other
- files
  - mill
  - flat
  - rounding
  - pillar
  - square
  - round
  - half round
  - three corner
  - other

- discuss
  - each tool is designed to perform a specific range of functions. The correct tool must be selected for each job to ensure safe and efficient work
  - each tool is designed to perform its function only if it is used correctly
  - tools must be adequately maintained to retain their capacities to perform their intended function
- use the tools in various shop projects

7.01.01 Cont'd

- wrenches
  - adjustable
  - box
  - open end
  - pipe
  - other
- pliers
  - slip joint
  - water pump
  - side cutting
  - vise grips
  - needle nose
  - other
- screwdrivers
  - regular
  - Phillips
  - clutch head
  - Allen
  - Bristle
  - Robertson
  - other
- chisels
  - flat
  - cape
  - round nose
  - diamond point
  - other
- twist drills
  - straight shank
  - taper shank
- saws
  - hacksaw
  - rip
  - crosscut
- sockets and ratchet
  - six point
  - twelve point
- torque wrench

7.01.01 Cont'd

- vises
- pullers
  - gear
  - seal
  - other
- taps and tap wrench
  - taper
  - bottom
  - plug
- dies and diestock
  - adjustable
  - split
  - solid
- screw extractor
- reamers
  - pipe
  - hand
  - machine
  - other
- other

MODULE 7:02 MEASURING TOOLS

Goal Statement

The learning experiences in this module are designed to help each student identify, select and become proficient in handling non-precision and precision instruments, and interpreting their readings (both S.I. metric and Imperial).

Learning Outcomes

Student Activities

The student should be able to:

7.02.01

state the necessity of measuring instruments such as:

- steel scales
- tapes
- inside calipers
- outside calipers
- squares
- hermaphrodites calipers
- dividers
- drill
- wire gauge
- micrometers (outside, inside)
- vernier calipers
- dial indicators
- feeler gauges
- telescoping gauges
- thread gauges

- discuss why exact measurements are required
- use S.I. Metric and Imperial
- apply proper handling and manipulation techniques

7.02.02

identify the specified steel measuring rules (flexible or non-flexible) in terms of:

- types
- values of graduations
- obtainable measuring accuracy
- measuring range
- holding characteristics for measuring, checking and layout operations
- applications
- determine and apply the correct methods of handling, storing and maintaining steel measuring rules

- discuss and use measuring instruments on sample pieces
- use S.I. metric and Imperial

7.02.03

- identify precision steel squares
- types
  - sizes
  - holding characteristics for checking and layout operations
  - applications

- discuss and use instruments on sample pieces

7.02.04

- identify the micrometer (outside, inside, depth) measuring tools
- types
  - components and working principles
  - attaching and securing extension rods
  - holding characteristics for measuring operations
  - setting, locking and measuring micrometers at determined values
  - handling, storing and maintaining micrometers

- discuss, and in small groups use micrometers on sample pieces

7.02.05

- identify vernier calipers
- types
  - components and working principles
  - holding characteristics for measuring operations
  - setting and measuring calipers at a determined values
  - handling, storing and maintaining calipers

- discuss, and in small groups use vernier calipers on sample pieces

7.02.06

- identify dial indicators
- types
  - components and working principles
  - obtainable measuring accuracy
  - handling, storing and maintaining dial indicators

- discuss the use of dial indicators

7.02.07

identify feeler gauges

- types
- overall checking range
- using individual and combination blades to determine the correct measurement
- holding characteristics for checking operations
- handling, storing and maintaining thickness gauge sets

- discuss and in small groups use feeler gauges on sample pieces

7.02.08

identify telescoping gauges

- overall checking range
- applications
- holding characteristics for checking operation
- setting, locking and measuring the overall valve with the outside micrometer
- handling, storing and maintaining telescoping gauges

- discuss and in small groups use telescoping gauges on sample pieces
- discuss the use of telescoping gauges on sample pieces

7.02.09

identify check gauges

- drill gauges
- wire gauges
- pitch gauges - S.I. metric
- Imperial

- discuss and use check gauges where applicable

7.02.10

identify calipers

- outside calipers
- inside calipers
- hermaphrodites calipers

- discuss and use calipers where applicable

7.02.11

identify dividers

- discuss and use dividers

7.02.12

select proper measuring devices  
for specific jobs

- study and discuss the  
reasons and advantages of  
each instrument  
- study and discuss the  
different measuring  
systems



MODULE 7.03 PORTABLE POWER TOOLS

Goal Statement

The learning experiences in this module are designed to help the student develop skills in the use of portable power tools.

Learning Outcomes

Student Activities

The student should be able to:

7.03.01

safely handle and maintain all portable power tools used in the trade

- drills
  - air
  - electric
- grinders
  - air
  - electric
- impact wrenches
  - air
  - electric
- gear pullers
- jacks
  - hydraulic
  - screw
  - ratcheting
- air hammers
  - chisels
  - chipping
  - other
- air tuggers
- other

- discuss the safety, use and maintenance of the listed tools

UNIT 8:0 SCREW THREADS

General Aim

The student will develop a basic understanding of screw threads.

MODULE 8.01 PURPOSE AND GENERAL TERMS

Goal Statement

The learning experiences in this module are designed to familiarize the student with:

- a. the necessary terms in threaded fasteners, and
- b. the types of fits used on threaded fasteners.

Learning Outcomes

Student Activities

The student should be able to:

8.01.01

identify the purpose of a thread

- discuss that a thread is used for:
  - fastening parts
  - transmitting motion

8.01.02

explain the necessary thread terms

- discuss
  - diameter
    - nominal
    - major
    - minor
    - major and minor with nuts
  - pitch
    - definition
    - means of expressing
      - North American standard
      - S.I. metric
- calculation

8.01.02 Cont'd

8.01.03

identify and explain the necessary thread designations

8.01.04

identify and explain thread class

- lead
  - definition
  - calculation (lead and pitch are equal on a single start thread)
- thread angle
  - definition
  - thread angle variation on different types of thread forms
    - American National standard
    - Whitworth
    - Amce
    - S.I. metric
    - other
- discuss the following designations for threads
  - external threads - A
  - internal threads - B
  - basic major diameter and pitch
    - 1/2" - 13
    - M10 x 1.25
- discuss and identify
  - Class I thread
  - Class II thread
  - Class III thread

MODULE 8.02 TYPES OF THREADS

Goal Statement

The learning experiences in this module are designed to help the student identify and explain the types of threads.

Learning Outcomes	Student Activities
<p>The student should be able to:</p> <p><u>8.02.01</u></p> <p>identify and explain different types of thread forms.</p> <p><u>8.02.02</u></p> <p>identify the different styles of American National Standard thread forms</p> <p><u>8.02.03</u></p> <p>identify different styles of thread forms for</p> <ul style="list-style-type: none"><li>- special fasteners</li><li>- bearing nut threads</li></ul>	<ul style="list-style-type: none"><li>- discuss and explain the different types of thread forms<ul style="list-style-type: none"><li>- American National Standard</li><li>- S.I. metric</li><li>- British Standard Whitworth</li><li>- American National Acme</li><li>- buttress</li><li>- square</li><li>- other</li></ul></li> <li>- discuss the following styles<ul style="list-style-type: none"><li>- Unified National Coarse (UNC)</li><li>- Unified National Fine (UNF)</li><li>- Unified National Extra Fine (UNEF)</li><li>- other</li></ul></li> <li>- discuss</li></ul>

MODULE 8.03 FASTENERS

Goal Statements

The learning experiences in this module are designed to familiarize the student with:

- a. the types of fasteners.
- b. the methods of installing and removal of fastening devices.

Learning Outcomes

Student Activities

The student should be able to:

8.03.01

identify the different types of fasteners available

- review Section Two, Unit 4.0 Fasteners (page 65)
  - types of bolts
  - types of screws
  - types of set screws
  - types of nuts

8.03.02

properly select fasteners for purpose required

- discuss identification procedures
  - type of bolt
  - type of thread
  - type of fit
  - length of bolt
  - other

8.03.03

properly select nuts for the required purpose

- discuss identification procedures
  - type of nut
  - type of thread
  - type of fit
  - necessity for locking (high vibration etc.)
  - other

8.03.04

explain the methods of installing  
fasteners or nuts

- discuss

8.03.05

explain the methods of removing  
fasteners or nuts

- discuss

MODULE 8.04 LOCKING DEVICES

Goal Statements

The learning experiences in this module are designed to:

- a. help the student identify the purpose of locking devices,
- b. familiarize the student with non-destructive and destructive methods of locking,
- c. familiarize the student with the installation and removal procedures of locking devices.

Learning Outcomes

Student Activities

The student should be able to:

8.04.01

identify the purpose of locking devices

- discuss the reason for maintaining tension
- prevent loss of parts

8.04.02

identify destructive methods of locking

- discuss methods in locking and problems with this method
  - weld
  - destroy threads
  - other

8.04.03

identify non-destructive methods of locking

- lock nuts
- lock washers

- discuss methods in locking
  - lock nuts
  - lock washers
  - special nut design
  - cotter keys
  - other

8.04.04

explain the installation of  
locking devices

- discuss

8.04.05

explain the removal of locking  
devices

- discuss the removal  
procedures for locking  
devices  
- whole  
- broken



MODULE 8.05 THREAD LOADING

Goal Statements

The learning experiences in this module are designed to:

- a. familiarize the student with the forces involved in locking threads,
- b. help the student identify the reasons for locking or torquing threads,
- c. familiarize the student with torquing procedures.

Learning Outcomes

Student Activities

The student should be able to:

8.05.01

identify forces involved on thread loading

- discuss forces involved
  - tension
  - safe load
  - yield
  - failure
- compression
- shear
- dilation

8.05.02

identify the purpose of thread loading (torque)

- discuss torque

8.05.03

identify the factors affecting torque/tension relationship

- discuss the factors involved
  - = friction
  - = alignment
  - = other

8.05.04

perform torquing procedure

- discuss the use of reference tables for torquing
- discuss the procedure for using a torque wrench

8.05.05

describe the forces which separate loaded assemblies

- discuss the factors involved
  - vibration
  - surface wear
  - dilation
  - others

MODULE 8.06 EXTERNAL AND INTERNAL THREADS

Goal Statements

The learning experiences in this module are designed to help the student identify:

- a. the procedures used in cutting an external or internal thread,
- b. methods in thread recovery.

Learning Outcomes	Student Activities
The student should be able to:	
<u>8.06.01</u>	
review procedures from Module 17.04 from Metal Fabrication 11	<ul style="list-style-type: none"><li>- discuss types of dies etc.</li><li>- cut an external thread</li></ul>
<u>8.06.02</u>	
review procedures from Module 17.04 from Metal Fabrication 11	<ul style="list-style-type: none"><li>- discuss correct drill size</li><li>- discuss tap styles and proper usage</li><li>- drill and cut an internal thread</li></ul>
<u>8.06.03</u>	
identify methods of thread recovery	<ul style="list-style-type: none"><li>- discuss methods of thread recovers<ul style="list-style-type: none"><li>- die nuts</li><li>- tap</li><li>- other</li></ul></li></ul>
<u>8.06.04</u>	
identify the necessary precautions when tapping or threading various metals	<ul style="list-style-type: none"><li>- discuss</li></ul>

UNIT 9.0 RIGGING AND MATERIALS HANDLING

General Aim

To familiarize the student with safe practices in rigging, staging and material handling.

MODULE 9.01 SAFETY REGULATIONS ON RIGGING

Goal Statements

The learning experiences in this module are designed to:

- a. develop safe practices in material handling,
- b. increase the student's awareness of types of material handling equipment,
- c. familiarize the students with crane hand signals and their application,
- d. familiarize the student with types of scaffolds and their safe use.

Learning Outcomes

Student Activities

The student should be able to:

9.01.01

list and identify Workers Compensation Board Accident Prevention Regulations on rigging

- identify and study Section 8.50 on housekeeping
- identify and study Section 8.56 - 62 on storage of materials
- identify and study Section 14.02 - 20 on personal protective equipment
- identify and study Section 54.02 - 22 on rigging
- identify and study Section 56.80 - 100 on hoisting equipment
- identify and study Appendix D on hand signals
- identify and study Section 30.12 - 16 on ladders
- identify and study Section 32.12 - 82 on scaffolds and stages

9.01.02

identify the principles governing hoisting

- determine weight to be lifted
- determine type and shape of material to be involved
- determine methods of hoisting to be employed
- identify the safety precautions employed in the process
- identify correct piling or blocking methods

9.01.03

identify types of material handling equipment and their use

- identify the types of rope
- identify condition and load capacities of fibre rope and wire rope
- identify condition and load capacities of chains
- identify types of grab chains and their uses
- identify the correct usage of crosby clips
- identify the correct methods in using plate clamps and plate hooks
- identify the correct methods in using come-a-longs and chain hoists
- identify the correct methods in using hydraulic jacks
- identify the correct methods in applying cable clamps
- identify the procedures of slinging
  - regular shaped objects
  - irregular shaped objects
  - for holding loads horizontally
  - for holding loads vertically with a snatch block

9.01.04

identify the application of hand signals

- identify conditions requiring a signaller
- identify types of signalling systems
- identify authorized hand signals

9.01.05

identify and describe various types of scaffolds

- identify the general requirements for construction of scaffolds
- describe a wooden scaffold
- describe a bracket scaffold
- describe a needle beam scaffold
- describe a thrust out scaffold
- identify the limitations of ladder jack scaffolds

9.01.06

identify types of staging and their usage

- identify the general requirements for construction of staging
- identify the application of common stages
- identify the application of a swing stage

9.01.07

identify safety procedures employed in checking scaffolding and stages

- identify type of work area to be inspected
- check grade and condition of material
- check correct footing or mounting and tie-in to other members
- check for correct spacing of members
- determine if material sizes meet specifications

MODULE 9.02 MATERIAL HANDLING EQUIPMENT

Goal Statement

The learning experiences in this module are designed to familiarize the student with safe methods of using material handling equipment.

Learning Outcomes

Student Activities

The student should be able to:

9.02.01

identify types of material handling equipment

- define the term material handling equipment
- identify methods of material handling
- identify limitations of human model in material handling
- identify limitations of fork lifts
- identify limitations of hydraulic hoists
- identify limitations of overhead cranes

9.02.02

given a shop model, the learner will be able to demonstrate the safe methods of operating material handling equipment

- identify shop model used for material handling
- identify relevant section in Workers Compensation Board Industrial Health and Safety Regulations Section 26.24 - 50 all.
- identify operating instructions of model
- observe shop rules for operation of material handling equipment
- demonstrate correct use of model

9.02.03

identify safe lifting methods in material handling

- list limitations related to lifting materials manually

9.02.04

identify and list safe and unsafe lifting methods

- list and describe lifting methods



UNIT 10.0 SHAFTS, HUBS AND KEYS

General Aim

The student will develop a degree of competency in the field of shafts, hubs and keys.

MODULE 10.01 KEYS

Goal Statement

The learning experiences in this module are designed to help the student become familiar with keys.

Learning Outcomes

Student Activities

The student should be able to:

10.01.01

explain the purpose of keys

- discuss the purpose of keys
- transmit motion

10.01.02

explain the different styles of keys

- square
- flat
- gib head
- taper
- Pratt and Whitney
- Woodruff
- Kennedy
- Louis
- other

- discuss and list the different styles of keys

10.01.03

explain and use reference tables to determine the size of keys in relation to the size of shaft

- discuss and use reference tables

10.01.04

explain the different styles of keyway in:

- shaft
  - run out
  - round end
  - Woodruff
- hub
  - parallel (keyseat)
  - tapered

- discuss the different styles of keys

10.01.05

explain and use reference tables to determine the size and depth of keyway seats in the:

- shaft
- hub

- discuss and use reference tables

10.01.06

explain the advantages and disadvantages of different types of keys

- discuss and list advantages and disadvantages of the types of keys

10.01.07

demonstrate the installation or removal procedure of a hub attached to a shaft by means of a key

- discuss and have student practice installing and removing hubs

10.01.08

identify the reasons for using different types of material for keys

- discuss key materials

10.01.09

explain the importance in a tolerance fit between a key and keyway on both shaft and hub

- discuss key fits

10.01.10

fabricate a key and keyway slot in hub and shaft in reference to working drawings

- discuss and have students fabricate a keyway slot in shaft to fit manufacture key and hub

MODULE 10.02 HUBS

Goal Statements

The learning experiences in this module are designed to help the student:

- a. identify the different styles of hubs,
- b. distinguish between hub to shaft fits.

Learning Outcomes	Student Activities
The student should be able to:	
<u>10.02.01</u>	
identify and explain the different styles of hubs	<ul style="list-style-type: none"><li>- discuss the various styles of hubs<ul style="list-style-type: none"><li>- A hub</li><li>- B hub</li><li>- C hub</li><li>- D hub</li></ul></li></ul>
<u>10.02.02</u>	
identify and explain interference fits	<ul style="list-style-type: none"><li>- discuss interference fits</li></ul>
<u>10.02.03</u>	
identify and explain non-interference fits	<ul style="list-style-type: none"><li>- discuss non-interference fits</li></ul>
<u>10.02.04</u>	
identify the hazards associated with installing hubs	<ul style="list-style-type: none"><li>- describe and demonstrate the precautions and safe work procedures to use when installing hubs</li></ul>

MODULE 10.03 SHAFTS

Goal Statement

The learning experiences in this module are designed to help the student gain an understanding about shafts.

Learning Outcomes	Student Activities
The student should be able to:	
<u>10.03.01</u>	
identify and explain the sizing of shafting	- discuss the sizing of shafts
<u>10.03.02</u>	
explain the stresses relating to shafts	- discuss the stresses relating to shafts <ul style="list-style-type: none"><li>- deflection</li><li>- bending</li><li>- compression</li><li>- stretching</li><li>- torsion</li><li>- other</li></ul>
<u>10.03.03</u>	
explain the various types of shafts	- discuss the various types of shafts <ul style="list-style-type: none"><li>- solid</li><li>- hollow</li><li>- steel</li><li>- aluminum</li><li>- hollow</li><li>- flexible</li><li>- others</li></ul>
<u>10.03.04</u>	
identify various pieces of shafting	- discuss and identify various pieces of shafting from a given selection

UNIT 11.0 BEARINGS

General Aim

The student will develop a degree of competence in the field of bearings.

MODULE 11.01 INTRODUCTION TO BEARINGS

Goal Statements

The learning experiences in this module are designed to help the student:

- a. realize the purpose for the use of bearings,
- b. identify the loads that are to be overcome.

Learning Outcomes	Student Activities
The student should be able to: <u>11.01.01</u> explain the purpose of bearings  <u>11.01.02</u> explain the types of loads	- discuss the purpose of bearings - to reduce friction  - discuss the types of loads - radial - axial - combination

MODULE 11.02 FRICTION BEARINGS

Goal Statements

The learning experiences in this module are designed to help the student:

- a. understand the theory of friction bearings,
- b. identify the various styles of friction bearings,
- c. identify the various friction materials,
- d. identify the maintenance required for friction bearings.

Learning Outcomes	Student Activities
The student should be able to:	
<u>11.02.01</u>	
explain the theory of friction bearings	<ul style="list-style-type: none"><li>- discuss the theory of friction bearings</li><li>- sliding friction</li></ul>
<u>11.02.02</u>	
identify and explain the different types of friction bearings	<ul style="list-style-type: none"><li>- discuss types of friction bearings<ul style="list-style-type: none"><li>- bushings</li><li>- shells</li><li>- pillow blocks</li><li>- other</li></ul></li></ul>
<u>11.02.03</u>	
describe the materials used in bearing housings	<ul style="list-style-type: none"><li>- discuss various types of material<ul style="list-style-type: none"><li>- cast iron</li><li>- cast steel</li><li>- fabricated</li></ul></li></ul>
<u>11.02.04</u>	
identify the various friction bearing material	<ul style="list-style-type: none"><li>- discuss the various friction bearing material<ul style="list-style-type: none"><li>- babbitt</li><li>- brass</li><li>- nylon</li><li>- sintered metals</li><li>- other</li></ul></li></ul>
<u>11.02.05</u>	
explain friction bearing maintenance	<ul style="list-style-type: none"><li>- discuss friction bearing maintenance<ul style="list-style-type: none"><li>- lubrication- oil wedge</li><li>- adjustment</li><li>- other</li></ul></li></ul>

11.02.06

instal a friction bearing onto a shaft :

- discuss the hazards of pouring babbit
- describe the methods used to prepare and position the mandrel
- describe the methods used to prepare surfaces and dams before the babbit is poured
- describe the procedure for pouring babbit bearings
- describe the fitting of the bearing to the shaft



MODULE 11.03 ANTI-FRICTION BEARINGS

Goal Statements

The learning experiences in this module are designed to help the student:

- a. learn the theory of anti-friction bearings;
- b. identify the loading of an anti-friction bearing;
- c. learn the procedures to install and remove anti-friction bearings;
- d. identify the maintenance procedures concerning anti-friction bearings.

Learning Outcomes

Student Activities

The student should be able to:

11.03.01

explain the theory of anti-friction bearings

- discuss the theory of anti-friction bearings
  - rolling friction

11.03.02

explain the types of loading with the use of anti-friction bearings

- discuss the types of loading concerning anti-friction
  - point loading
  - line loading

11.03.03

explain the various types of anti-friction bearings

- discuss the various types of anti-friction bearings
  - roller
  - ball
  - taper-roller
  - thrust bearings
  - radial bearings
  - other

11.03.04

identify the parts of anti-friction bearings and the purpose of each

- discuss

- outer ring
- outer race
- rolling element
- separator
- inner race
- inner ring
- cone
- cup

11.03.05

explain, install and remove an anti-friction bearing

- discuss the dangers of removing and installing anti-friction bearings
- discuss installation and removal procedures dealing with anti-friction bearings
- install an anti-friction bearing
- remove an anti-friction bearing

11.03.06

explain and identify maintenance procedures concerning anti-friction bearings

- discuss anti-friction bearing maintenance procedures
  - lubrication
  - vibration testing
  - other

UNIT 12.0 COUPLINGS

General Aim

The student will develop a degree of competence in the handling of couplings and coupling alignment.

MODULE 12.01 INTRODUCTION TO COUPLINGS

Goal Statements

The learning experiences in this module are designed to help the student identify:

- a. the purposes of couplings,
- b. the types of couplings.

Learning Outcomes

Student Activities

The student should be able to:

12.01.01

identify the purpose of a coupling

- discuss the purpose of couplings

12.01.02

identify the classifications of couplings

- rigid
- flexible
- centrifugal

- discuss the classifications of couplings

12.01.03

identify necessary alignment tools for aligning couplings

- steel line
- shaft level
- calipers (inside and outside)
- straight edge
- feeler gauge
- taper gauge
- dial indicator
- other

- discuss the alignment tools

12.01.04

identify purpose of shimming material:

- raise
- tilt
- levelling
- other

- discuss shims and shimming procedures

12.01.05

explain conditions of shaft misalignment:

- angular
- eccentricity
- combination of both
- end float

- discuss shaft alignment  
- complete an alignment project

MODULE 12.02 RIGID COUPLINGS

Goal Statement

The learning experiences in this module are designed to help the student gain a knowledge of rigid couplings.

Learning Outcomes	Student Activities
The student should be able to:	
<u>12.02.01</u>	
explain areas of suitability for rigid couplings <ul style="list-style-type: none"><li>- line shafting</li><li>- should be used only when driving and driven shaft are on a common rigid base</li></ul>	- discuss where rigid couplings are used
<u>12.02.02</u>	
identify the types of rigid couplings <ul style="list-style-type: none"><li>- sleeve</li><li>- flange</li><li>- other</li></ul>	- discuss the types of rigid couplings
<u>12.02.03</u>	
identify size of coupling to suit <ul style="list-style-type: none"><li>- R.P.M.</li><li>- H.P.</li><li>- torque applied</li></ul>	- discuss coupling specification
<u>12.02.04</u>	
perform installation and removal procedures of rigid couplings	- discuss and have student practice installation and removal procedures of rigid couplings

12.02.05

perform routine maintenance checks  
on rigid coupling joints

- alignment check
- bearing check
- check on base bolts
- other

- discuss maintenance of  
rigid couplings

12.02.06

explain problems or failure of  
rigid coupling joints as to wear

- misalignment
- overload
- bearing failure
- other

- discuss coupling failure

MODULE 12.03 FLEXIBLE COUPLINGS

Goal Statement

The learning experiences in this module are designed to help the student gain an understanding of flexible couplings.

Learning Outcomes	Student Activities
The student should be able to:	
<u>12.03.01</u>	
identify the purpose of flexible couplings	- discuss flexible couplings
<u>12.03.02</u>	
identify the types of flexible couplings	- discuss and list the different types of flexible couplings
<ul style="list-style-type: none"><li>- flange with pin and separator</li><li>- jaw style with separator</li><li>- chain and sprocket</li><li>- nonflex</li><li>- rubber ball</li><li>- sure-flex</li><li>- other</li></ul>	
<u>12.03.03</u>	
identify size of coupling to suit <ul style="list-style-type: none"><li>- R.P.M.</li><li>- H.P.</li><li>- torque applied</li></ul>	- discuss flexible coupling specifications
<u>12.03.04</u>	
perform installation and remove procedures of flexible couplings	- discuss and have student practice installation and removal procedures of flexible couplings

12.03.05

perform routine maintenance checks on flexible coupling joints

- lubrication where required
- alignment checks
- bearing checks
- replacement of worn separators or parts
- check on base bolts
- other

12.03.06

explain problems or failure of flexible coupling joints due to wear

- misalignment
- overload
- bearing failure
- other

- discuss flexible coupling failure



MODULE 12.04 CENTRIFUGAL COUPLING

Goal Statement

The learning experiences in this module are designed to help the student gain an understanding of centrifugal couplings.

Learning Outcomes	Student Activities
The student should be able to:	
<u>12.04.01</u>	
identify the purpose of centrifugal couplings	- discuss the purposes of centrifugal couplings
<u>12.04.02</u>	
explain the operational procedures of a centrifugal coupling	- discuss the principles of centrifugal couplings
<u>12.04.03</u>	
explain the various types of centrifugal couplings	- discuss the various types of centrifugal couplings

UNIT 13.0 CLUTCHES AND BRAKES

General Aim

The student will develop an understanding of clutches and brakes.

MODULE 13:01 PURPOSE OF A CLUTCH

Goal Statement

The learning experiences in this module are designed to help the student understand the purposes of clutches.

Learning Outcomes	Student Activities
<p>The student should be able to:</p> <p><u>13.01.01</u></p> <p>explain the reasons for the use of clutches</p>	<ul style="list-style-type: none"><li>- discuss the reasons for the use of clutches<ul style="list-style-type: none"><li>- to engage</li><li>- to disengage (while in motion)</li></ul></li></ul>



MODULE 13.02 CLUTCHES

Goal Statements

The learning experiences in this module are designed to help the student identify:

- a. the types of clutches,
- b. the various methods of engagement,
- c. the various methods of contact.

Learning Outcomes	Student Activities
<p>The student should be able to:</p> <p><u>13.02.01</u></p> <p>identify and explain the types of clutches</p> <p><u>13.02.02</u></p> <p>identify and explain the methods of clutch engagement</p> <p><u>13.02.03</u></p> <p>identify and explain the various methods of contact</p>	<ul style="list-style-type: none"><li>- discuss the types of clutches<ul style="list-style-type: none"><li>- positive contact</li><li>- friction</li></ul></li><li>- discuss the methods of clutch engagement<ul style="list-style-type: none"><li>- mechanical</li><li>- pneumatic</li><li>- electrical</li><li>- hydraulic</li></ul></li><li>- discuss the methods of clutch contact<ul style="list-style-type: none"><li>- material</li></ul></li></ul>

MODULE 13.03 PURPOSE OF BRAKES

Goal Statement

The learning experiences in this module are designed to help the student understand the purposes of brakes.

Learning Outcomes	Student Activities
The student should be able to: <u>13.03.01</u> explain the reasons for the use of brakes	- discuss the reasons for the purpose of brakes

MODULE 13.04 BRAKES

Goal Statements

The learning experiences in this module are designed to help the student identify:

- a. the types of brakes
- b. the various methods of engagement,
- c. the methods of contact.

Learning Outcomes	Student Activities
The student should be able to:	
<u>13.04.01</u>	
identify and explain the types of brakes	- discuss the types of brakes - positive contact - friction
<u>13.04.02</u>	
identify and explain the methods of brake engagement	- discuss the methods of brake engagement - mechanical - pneumatic - electrical - hydraulic
<u>13.04.03</u>	
identify and explain the methods of contact	- discuss the methods of contact - material

UNIT 14.0 LUBRICATION

General Aim

The student will develop a degree of competence in the field of lubrication.

MODULE 14.01 THE PURPOSE OF LUBRICATION

Goal Statement

The learning experiences in this module are designed to help the student to identify the reasons for the use of lubricants.

Learning Outcomes	Student Activities
The student should be able to;	
<u>14.01.01</u>	
explain how lubrication minimizes friction	<ul style="list-style-type: none"><li>- discuss the types of friction<ul style="list-style-type: none"><li>- solid friction</li><li>- fluid friction</li></ul></li></ul>
<u>14.01.02</u>	
explain how lubrication dissipates heat	<ul style="list-style-type: none"><li>- discuss the reasons why friction causes heat</li><li>- discuss how lubrication will dissipate heat</li></ul>
<u>14.01.03</u>	
explain how lubrication will wash away contaminants	<ul style="list-style-type: none"><li>- discuss how lubrication will wash away contaminants</li></ul>
<u>14.01.04</u>	
explain the theory of the oil wedge	<ul style="list-style-type: none"><li>- discuss the oil wedge theory in relation to:<ul style="list-style-type: none"><li>- friction bearings</li><li>- anti-friction bearings</li></ul></li></ul>

MODULE 14.02 OILS

Goal Statement

The learning experiences in this module are designed to help the student identify, select and maintain oils and oil systems properly.

Learning Outcomes	Student Activities
The student should be able to:	
<u>14.02.01</u>	
explain the various types of oil	<ul style="list-style-type: none"><li>- discuss<ul style="list-style-type: none"><li>- petroleum oils</li><li>- water oil emulsions</li><li>- synthetic oils</li></ul></li></ul>
<u>14.02.02</u>	
explain how oils are graded	<ul style="list-style-type: none"><li>- discuss<ul style="list-style-type: none"><li>- viscosity</li><li>- viscosity index</li><li>- SAE and SUS</li><li>- pour point</li><li>- flash point</li><li>- fire point</li></ul></li></ul>
<u>14.02.03</u>	
explain the characteristics of oil additives; where and when they should be used	<ul style="list-style-type: none"><li>- discuss<ul style="list-style-type: none"><li>- anti-foam</li><li>- anti-rust</li><li>- anti-oxident</li><li>- extreme pressure</li><li>- emulsifier</li><li>- detergent</li><li>- dispersant</li></ul></li></ul>



14.02.04

explain the advantages and disadvantages of oils

- discuss
  - advantages
    - removes heat
    - other
  - disadvantages
    - seals
    - other

14.02.05

explain the various methods of oil lubrication

- discuss
  - once through applications (wasted)
  - application to enable recycling

14.02.06

demonstrate a knowledge of maintaining oiling systems

- discuss
  - proper lubrication levels
  - proper filtering of lubrication oils
  - the necessity of cleanliness concerning oil lubrication systems

14.02.07

explain the proper procedures for the handling and storage of oils

- discuss how to handle and store oils properly

MODULE 14.03 GREASE

Goal Statement

The learning experiences in this module are designed to help the student identify, select and maintain greases and greasing system.

Learning Outcomes

Student Activities

The student should be able to:

14.03.01

explain the various types of greases and how they are made

- discuss the different types of bases used for grease
  - calcium
  - sodium
  - lithium
  - other

14.03.02

explain how greases are graded

- discuss
  - penetration number
  - drop point
  - other

14.03.03

explain the characteristics of grease additives and their applications

- discuss additives
  - extreme pressure
  - other

14.03.04

explain the advantages and disadvantages of grease

- discuss
  - advantages
  - disadvantages

14.03.05

explain the various methods of grease lubrication

- discuss
  - grease guns
  - pumps
  - other

14.03.06

demonstrate a knowledge of maintaining greasing systems

- discuss proper lubrication procedures and levels
- discuss the necessity of cleanliness when working on grease system

14.03.07

explain the proper procedures for the handling and storage of greases

- discuss how to handle and store grease properly

UNIT 15.0 PACKING AND SEALS

General Aim

The student will develop a degree of competency in the application of seals and gaskets.

MODULE 15.01 SEALS

Goal Statement

The learning experiences in this module are designed to:

- a. help the student become familiar with the purpose of seals.
- b. help the student identify the different types of seals.

Learning Outcomes	Student Activities
The student should be able to:	
<u>15.01.01</u>	
identify the purpose of seals	- discuss the purpose of seals for the prevention of leakage
<u>15.01.02</u>	
identify the different types of seals	- discuss the different types of seals <ul style="list-style-type: none"><li>- static seals</li><li>- non-contact seals</li><li>- contact seals</li></ul>

MODULE 15.02 STATIC SEALS

Goal Statements

The learning experiences in this module are designed to:

- a. help the student identify the various types of gaskets,
- b. familiarize the student with removal and installation procedures of static seals.

Learning Outcomes	Student Activities
The student should be able to:	
<u>15.02.01</u>	
identify the different types of static seals	- discuss the different types of gaskets <ul style="list-style-type: none"><li>- non-metallic</li><li>- metallic</li></ul>
<u>15.02.02</u>	
explain how gaskets seal	- discuss
<u>15.02.03</u>	
demonstrate methods of removal	- perform removal of old gaskets <ul style="list-style-type: none"><li>- scraping</li><li>- other</li></ul>
<u>15.02.04</u>	
demonstrate methods in replacing gaskets	- discuss replacement methods <ul style="list-style-type: none"><li>- manufactured gaskets</li><li>- field constructed gaskets</li><li>- other</li></ul>
<u>15.02.05</u>	
demonstrate methods of installation of gaskets	- list the hazards associated with installing gaskets - discuss methods in stabilizing gasket before installing - discuss the use of gasket sealers - discuss methods of bolt tightening procedures

MODULE 15.03 NON-CONTACT SEALS

Goals Statements

The learning experiences in this module are designed to:

- a. help the student identify the various types of non-contact seals,
- b. familiarize the student with removal and installation procedures of non-contact sealing units.

Learning Outcomes	Student Activities
The student should be able to:	
<u>15.03.01</u>	
identify the different types of non-contact seals	<ul style="list-style-type: none"><li>- discuss the different types of non-contact seals<ul style="list-style-type: none"><li>- annulus</li><li>- labyrinth</li><li>- combination (annulus and labyrinth)</li></ul></li></ul>
<u>15.03.02</u>	
identify the factors when selecting an oil seal	<ul style="list-style-type: none"><li>- discuss the following when selecting an oil seal<ul style="list-style-type: none"><li>- the environment in which the seal will operate</li><li>- type of fluid to be sealed in</li><li>- type of fluid to be sealed out</li><li>- mean temperature of the environment</li></ul></li></ul>
<u>15.03.03</u>	
demonstrate methods of removal	<ul style="list-style-type: none"><li>- discuss and perform removal techniques of different types of non-contact sealing units</li><li>- list the hazards associated with installing seals</li></ul>

MODULE 15.04 SINGLE CONTACT SEALS

Goal Statements

The learning experiences in this module are designed to:

- a. help the student identify the various types of single contact seals,
- b. familiarize the student with the removal and installation of single contact sealing units.

Learning Outcomes	Student Activities
The student should be able to:	
<u>15.04.01</u>	
identify the different types of single contact seals	<ul style="list-style-type: none"><li>- discuss the different types of single contact seals<ul style="list-style-type: none"><li>- lip contact seals<ul style="list-style-type: none"><li>- commercial</li><li>- felt</li><li>- other</li></ul></li><li>- piston ring seals<ul style="list-style-type: none"><li>- O-rings</li><li>- rubber cup</li><li>- other</li></ul></li></ul></li></ul>
<u>15.04.02</u>	
identify the factors when selecting an oil seal	<ul style="list-style-type: none"><li>- discuss the following when selecting an oil seal<ul style="list-style-type: none"><li>- the environment in which the seal will operate</li><li>- type of fluid to be sealed in</li><li>- type of fluid to be sealed out</li><li>- mean temperature of the environment</li><li>- the type of shaft on which the sealing element runs</li><li>- other</li></ul></li></ul>

15.04.03

demonstrate the procedure for removing single contact seals

- lip contact seals
- piston ring seals

- discuss removal procedures
- discuss the hazards involved

15.04.04

demonstrate the procedure for installing different types of single contact seals

- discuss and perform installation techniques of different types of single contact sealing units
- discuss the hazards involved



MODULE 15.05 PACKING

Goal Statements

The learning experiences in this module are designed to:

- a. help the student identify the types and uses of various packing materials;
- b. familiarize the student with the removal and installation of packing.

Learning Outcomes

Student Activities

The student should be able to:

15.05.01

identify the different types of packing material

- PAC-1
- PAC-2
- PAC-3
- PAC-4
- PAC-5
- PAC-6
- PAC-7

- discuss the various uses of each type of packing material
  - PAC-1 - clear water or cold sewage slurries, maximum temperature 212°F
  - PAC-2 - clear hot or cold water; maximum temperature 400°F
  - PAC-3 - acid slurries maximum temperature 250°F
  - PAC-4 - alkali slurries maximum temperature 250°F
  - PAC-5 - food products
    - beverage and any liquid where non-contamination is the governing factor maximum temperature 180°F
  - PAC-6 - solvent, oils and kerosene slurries, maximum temperature 250°F
  - PAC-7 - where metallic packing is preferred for cold and hot liquids, maximum temperature 450°F and suction pressure exceeds 50 psi

15.05.02

identify the factors when selecting packing material

- discuss the following factors
  - stuffing box design
  - temperature
  - pressure
  - type of fluid being pumped

15.05.03

demonstrate the procedures for removing packing

- discuss the hazards involved in removing and installing packing
- discuss and perform installation procedures

UNIT 16.0 PUMPS

General Aim

The student will develop an understanding of pumps and pumping.

MODULE 16.01 PURPOSE OF PUMPS

Goal Statement

The learning experiences in this module are designed to help the student understand the purpose of pumps.

<u>Learning Outcomes</u>	<u>Student Activities</u>
The student should be able to; <u>16.01.01</u> explain the purposes of pumps	- discuss the purpose of pumps - move fluid from one location to another - other

MODULE 16.02 PUMP GROUPS

Goal Statement

The learning experiences in this module are designed to help the student identify the two pump groups.

Learning Outcomes

Student Activities

<u>Learning Outcomes</u>	<u>Student Activities</u>
The student should be able to:  <u>16.02.01</u>  explain and identify positive displacement pumps  <u>16.02.02</u>  explain and identify non-positive displacement pumps	   <ul style="list-style-type: none"><li>- discuss positive displacement pumps<ul style="list-style-type: none"><li>- hydrostatic</li><li>- positive seal</li></ul></li> <li>- discuss non-positive displacement pumps<ul style="list-style-type: none"><li>- hydrodynamic</li><li>- non-positive seal</li></ul></li></ul>

MODULE 16.03 PUMP INSTALLATION AND MAINTENANCE

Goal Statement

The learning experiences in this module are designed to help the student install and maintain pumping systems.

Learning Outcomes	Student Activities
The student should be able to:	
<u>16.03.01</u>	
explain and install pumps	<ul style="list-style-type: none"><li>- discuss pump installation</li><li>- install a pump<ul style="list-style-type: none"><li>- set pump higher than prime mover</li><li>- other</li></ul></li></ul>
<u>16.03.02</u>	
explain and identify pump maintenance	<ul style="list-style-type: none"><li>- discuss various pump maintenance programs<ul style="list-style-type: none"><li>- lubrication</li><li>- vibration testing</li><li>- stuffing boxes</li><li>- mechanical seals</li><li>- other</li></ul></li></ul>

UNIT 17.0 GEARS AND GEAR DRIVES

General Aim

The student will develop an understanding of gears and gear drives.

MODULE 17.01 GEARS

Goal Statement

The learning experiences in this module are designed to help the student gain an understanding of:

- a. the purpose of gears,
- b. gear terms,
- c. gear materials.

Learning Outcomes

Student Activities

The student should be able to:

17.01.01

explain the purpose of gears

- discuss the purpose of gears
  - to transmit positive motion

17.01.02

explain and identify the gear terms

- discuss gear terms
  - addendum
  - dedendum
  - pitch circle
  - other

17.01.03

explain and identify the different types of gear materials

- discuss the different types of gear materials
  - steel
  - brass
  - bronze
  - plastics
  - other

17.01.04

explain and identify the different  
tooth forms and pressure angles

- discuss gear tooth forms  
and pressure angles

MODULE 17.02 GEAR REDUCERS

Goal Statement

The learning experiences in this module are designed to help the student gain an understanding of gear drives.

Learning Outcomes	Student Activities
The student should be able to:	
<u>17.02.01</u>	
explain purposes of gear reducers	<ul style="list-style-type: none"><li>- discuss the reasons for the use of gear reducers<ul style="list-style-type: none"><li>- force increaser</li><li>- speed increaser</li></ul></li></ul>
<u>17.02.02</u>	
explain and identify the construction of gear reducers	<ul style="list-style-type: none"><li>- discuss the construction of gear reducers<ul style="list-style-type: none"><li>- single reduction</li><li>- double reduction</li><li>- other</li></ul></li><li>- discuss the types of reducers<ul style="list-style-type: none"><li>- internal gear</li><li>- external gear</li><li>- worm and wheel</li><li>- other</li></ul></li></ul>
<u>17.02.03</u>	
explain the maintenance procedures regarding gear reducers	<ul style="list-style-type: none"><li>- discuss maintenance of gear reducers<ul style="list-style-type: none"><li>- lubrication</li><li>- gear wear</li><li>- mesh</li><li>- other</li></ul></li></ul>



UNIT 18.0 BELTS

General Aim

The student will develop an understanding of belting.

MODULE 18.01 V-BELTS

Goal Statement

The learning experiences in this module are designed to help the student understand the uses of V-belts.

Learning Outcomes

Student Activities

The student should be able to:

18.01.01

explain the theory of V-belts

18.01.02

identify the following terms

- arc of contact
- area of contact
- creep
- pitch

18.01.03

explain the construction of V-belts

18.01.04

explain the different types of V-belts

- discuss how V-belts transmit motion
- wedging action

- discuss

- discuss the construction of V-belts
  - cover
  - load carrying section
  - wedging section
  - pitch line
  - others

- discuss the different types of V-belts
  - A-E
  - 3V-5V-8V
  - light duty 2L-5L
  - banded V-belts
  - wide V-belts
  - others

18.01.05

explain and identify the V-sheaves

- discuss sheaves

- V-V

- V-flat

- variable drive

18.01.06

explain the installation and removal procedures concerning V-belts

- discuss the hazards associated with removing and installing V-belts

- discuss installation and removal procedures

18.01.07

explain the maintenance procedures concerning V-belts

- discuss the maintenance procedures concerning V-belts

18.01.08

describe the operational limits of V-belts

- discuss

- belt speed

- pulley sizes

- pulley construction

- temperature

MODULE 18.02 CONVEYOR BELTS

Goal Statement

The learning experiences in this module are designed to help the student gain an understanding of conveyor belts.

Learning Outcomes

Student Activities

The student should be able to:

18.02.01

explain the purpose of conveyor belts

- discuss the purposes of conveyor belts

18.02.02

explain the construction of conveyor belts

- discuss the construction of conveyor belts
  - cover
  - load carrying section

18.02.03

explain the types of conveyors

- discuss the types of conveyors
  - roll conveyers
  - slide conveyers

18.02.04

identify the different types of materials used in flat belt construction

- discuss the types of materials used
  - leather
  - synthetic
  - rubber
  - others

18.02.05

explain the splicing procedures concerning conveyor belts

- discuss splicing procedures
  - vulcanizing
  - mechanical fasteners
  - other

18.02.06

identify the different types of pulleys used with flat belts

- discuss the different types of pulleys
  - flat
  - crown
  - flange

18.02.07

explain conveyor belt take-ups

- discuss various methods of conveyor belt take-ups

18.02.08

explain conveyor belt maintenance

- discuss the hazards involved when working around conveyor belts
- discuss conveyor belt maintenance
  - scrapers
  - skirts and skirting
  - other

UNIT 19.0 CHAIN

General Aim

The student will develop an understanding of the uses of chains and chain drives.

MODULE 19.01 CHAIN TERMINOLOGY

Goal Statement

The learning experiences in this module are designed to help the student identify chain terminology.

Learning Outcomes

Student Activities

19.01.01

identify the purpose of chain drives

- discuss the purpose of chain drives
  - to transmit motion

19.01.02

identify the advantages of chain drives

- discuss and list advantages
  - power transmitted is 90-99% efficient
  - no slippage on overload
  - shaft centre distance is not critical
  - one length of chain will drive several sprockets without slippage
  - other

19.01.03

identify the chain terminology

- discuss the following:
  - pitch
  - roller link
  - connector link
    - rivet type
    - key type
  - single pitch offset link
  - chain width
  - pin diameter
  - offset links

MODULE 19.02 ROLLER CHAIN

Goal Statements

The learning experiences in this module are designed to:

- a. familiarize the student with the different types of roller chains,
- b. help the student practice safety when repairing, installing or removing chain drives,
- c. familiarize the student with installation or removal procedures of chains and sprockets,
- d. familiarize the student with alignment techniques, and
- e. make the student aware of the various types of design factors in chain drive units.

Learning Outcomes

Student Activities

The student should be able to:

19.02.01

identify the different types of roller chains

- discuss and list different types of roller chains
  - single
  - double
  - multiple
  - offset
  - inverted tooth
  - double pitch
  - other

19.02.02

identify the different types of roller chain

- discuss
  - roller link
  - pin link
  - offset link

19.02.03

identify and explain roller chain pitch variations

- discuss pitch variation of roller chain
  - variation by 1/8" units

19.02.04

identify and explain the number system used on roller chain

- discuss roller chain numbering system
  - standard chain
  - American Standard

19.02.05

identify and explain the procedure in determining the length of roller chain needed for installation

- discuss the procedures used to determine the length of roller chain needed for installation
  - formula
  - quick approximate calculation
  - other

19.02.06

identify the need for safety when working near or around roller chain

- discuss and list all safety procedures when working around roller chain
  - correct lock out procedures are carried out during repair, installation or removal of roller chain
  - guard installation around drive units
  - during inspection or lubrication
  - other

19.02.07

demonstrate the procedure used for installation and removal of roller chain

- discuss repair procedures
  - disconnection
  - repaired rivet type chain
  - other
- discuss tightening procedure
- other

19.02.08

identify the different types of sprockets

- discuss and list the different types of sprockets
  - type A - steel
  - type B - steel
    - solid hub
    - split hub
    - taper lock bushing
    - other
  - type C - cast iron
    - single strand
    - offset
    - other
  - other

19.02.09

identify the required safety procedures in installation or removal of sprockets

- discuss and list safety procedures
  - correct lock out procedure carried out
  - use of gear or sprocket pullers
  - other

19.02.10

demonstrate the procedures for installation or removal of sprockets

- discuss and list the procedures
  - removal procedures
  - the need to have driver and driven shafts securely mounted
  - the need to have sprockets as close as possible to shaft support bearing
  - the need for proper alignment
  - slack - allowance 1% - 5% of shaft centres
    - too tight overloads bearings
    - too loose chain slops
  - other

19.02.11

identify purpose of good alignment

- discuss why poor alignment increases chain wear
- discuss why poor alignment increases sprocket wear
- other

19.02.12

identify the necessary equipment required for alignment of roller chain drives

- discuss and list the equipment
  - shaft level
  - straight edge
  - chalk line
  - other



19.02.13

demonstrate the necessary procedure for aligning roller chain drives

- discuss and list the procedure for alignment
  - bringing shafts to a parallel plane with a shaft level
  - aligning sprockets
  - other

19.02.14

identify the necessity in designing a chain drive system

- discuss the designing procedures of chain drives
  - chain wrap  $120^\circ$  of smaller sprocket
  - centre distance of 30 to 50 pitches is good practice
  - extra long distances between shafts should be avoided
  - methods of chain adjustment
  - idlers for removing slackness in the drive unit
  - supporting chain on guide rails
  - position of drives
  - other

MODULE 19.03 CONVEYOR CHAIN

Goal Statements

The learning experiences in this module are designed to:

- a. familiarize the student with different types of chains or chain drives,
- b. help the student practice safety when repairing, installing or removing chain link or sprockets,
- c. familiarize the student with installation or removal procedures of chain links or sprockets,
- d. make the student aware of the various types of design factors in conveyor chain drives.

Learning Outcomes

Student Activities

The student should be able to:

19.03.01

identify the purpose of conveyor chain

- discuss purpose
- to transfer material

19.03.02

identify the different types of conveyor chain

- discuss and list the different types of conveyor chains
  - mill chain
  - pintle
  - H class
  - combination chain
  - transfer chain
  - camel
  - long link chain
    - forged
    - cast
  - drag chain
  - fabricated chain
  - other

19.03.03

identify the need for safety when working on conveyor chains

- discuss and list all safety procedures
  - correct lock out procedures
  - other

19.03.04

identify the different types of sprockets used on conveyor chains

- discuss the different types of sprockets
  - long link chain
  - extended rim
  - log haul
  - other

19.03.05

demonstrate the procedures for installation or removal of conveyor chain or sprocket

- discuss the necessary procedures for installation or removal
  - the need to have driver and driven sprockets securely mounted
  - the need to have sprockets as close as possible to shaft support bearing
  - removal of worn link
  - removal of slackness in a chain
  - procedure to shorten each type of chain
  - other

19.03.06

identify the necessity in designing a conveyor chain system

- discuss the following
  - parallel strand system
  - gravity drop system
  - S-drive system
  - control of slack
    - take up bearings on tail drum
    - take up on idler arm of S-drum
    - cutting out links
  - need for controlling amount of slack in conveyor chain
  - other

MODULE 19.04 LUBRICATION

Goal Statement

The learning experiences in this module are designed to familiarize the student with various methods of lubrication.

Learning Outcomes	Student Activities
The student should be able to:	
<u>19.04.01</u>	
identify the purpose of chain lubrication	- discuss the need to minimize chain and sprocket wear
<u>19.04.02</u>	
identify types of oil used on chain drives	- discuss and list types of oil <ul style="list-style-type: none"><li>- mineral oil</li><li>- SAE 10</li><li>- SAE 20</li><li>- SAE 40</li><li>- SAE 50</li><li>- other</li></ul>
<u>19.04.03</u>	
identify the different methods of lubricating chain drives	- discuss the means of lubricating chain drives <ul style="list-style-type: none"><li>- oil can</li><li>- drip cup</li><li>- bath</li><li>- oil stream</li><li>- other</li></ul>

MODULE 19.05 PREVENTATIVE MAINTENANCE

Goal Statement

The learning experiences in this module are designed to help the student identify the necessary routine or preventative maintenance techniques that can be used on chain or conveyor drive units.

Learning Outcomes	Student Activities
<p>The student should be able to:</p> <p><u>19.05.01</u></p> <p>identify preventative maintenance measures for chain drives</p>	<ul style="list-style-type: none"><li>- discuss the following<ul style="list-style-type: none"><li>- check chain for wear<ul style="list-style-type: none"><li>- elongation</li><li>- side plate wear</li></ul></li><li>- check sprockets for wear<ul style="list-style-type: none"><li>- side wear</li></ul></li><li>- check tooth wear<ul style="list-style-type: none"><li>- normal wear</li><li>- chain too long</li></ul></li><li>- check for broken plates</li><li>- check for broken pins</li><li>- regular lubrication procedures</li><li>- other</li></ul></li></ul>

UNIT 20.0 HYDRAULICS

General Aim

The student will develop an understanding of hydraulic systems.

MODULE 20.01 HYDRAULIC THEORY

Goal Statement

The learning experiences in this module are designed to help the student gain knowledge about the theory of hydraulics.

Learning Outcomes

Student Activities

The student should be able to:

20.01.01

explain the reasons for the use of hydraulics

20.01.02

explain the compressible properties of fluids

- discuss the reasons for using hydraulics
- discuss the principles of hydraulics

- discuss the compressible properties of fluids
- 0.5 to 1% at 1000 psi

MODULE 20.02 HYDRAULIC FLUIDS

Goal Statement

The learning experiences in this module are designed to help the student identify different hydraulic fluids.

Learning Outcomes	Student Activities
<p>The student should be able to:</p> <p><u>20.02.01</u></p> <p>explain and identify the different hydraulic fluids</p> <p><u>20.02.02</u></p> <p>explain the additives required in hydraulic fluids</p>	<ul style="list-style-type: none"><li>- discuss the different hydraulic fluids<ul style="list-style-type: none"><li>- petroleum</li><li>- water - oil emulsions</li><li>- synthetic</li><li>- other</li></ul></li><li>- discuss hydraulic fluid additives</li></ul>

MODULE 20.03 HYDRAULIC COMPONENTS

Goal Statements

The learning experiences in this module are designed to help the student identify and understand the basic hydraulic components.

Learning Outcomes	Student Activities
The student should be able to:	
<u>20.03.01</u>	
identify and explain the reasons for the parts of a reservoir	<ul style="list-style-type: none"><li>- discuss the reason for and the parts of the reservoir<ul style="list-style-type: none"><li>- baffle plate</li><li>- amount of fluid held</li><li>- other</li></ul></li></ul>
<u>20.03.02</u>	
identify and explain the various types of filters and their uses	<ul style="list-style-type: none"><li>- discuss filters and strainers<ul style="list-style-type: none"><li>- active</li><li>- inactive</li><li>- other</li></ul></li></ul>
<u>20.03.03</u>	
identify and explain the various types of pumps used in hydraulic systems	<ul style="list-style-type: none"><li>- discuss the various types of hydraulic pumps<ul style="list-style-type: none"><li>- gear</li><li>- vane</li><li>- piston</li></ul></li></ul>
<u>20.03.04</u>	
identify and explain the three different groups of valves used in hydraulic systems	<ul style="list-style-type: none"><li>- discuss the three groups of valves<ul style="list-style-type: none"><li>- flow control</li><li>- pressure control</li><li>- directional control</li></ul></li></ul>



20.03.05

identify and explain the different actuators used in hydraulic systems

- discuss the actuators used in hydraulic systems
  - linear (cylinders)
  - rotary (motors)

20.03.06

identify and explain the use of accumulators in hydraulic systems

- discuss accumulators and why they are used in hydraulic systems
  - types
  - reasons for use

MODULE 20.04 HYDRAULIC CIRCUITS

Goal Statement

The learning experiences in this module are designed to help the student understand basic hydraulic symbols and circuits.

Learning Outcomes	Student Activities
The student should be able to:	
<u>20.04.01</u>	
identify and understand basic hydraulic symbols	- discuss and draw basic hydraulic symbols
<u>20.04.02</u>	
identify and understand basic hydraulic circuits	- discuss and draw basic hydraulic symbols - simple (basic) - meter-in - meter-out - bleed-off - accumulator

MODULE 20.05 HYDRAULIC TROUBLESHOOTING

Goal Statement

The learning experiences in this module are designed to help the student understand the reasons for good hydraulic troubleshooting techniques.

Learning Outcomes	Student Activities
<p>The student should be able to:</p> <p><u>20.05. 1</u></p> <p>explain why a hydraulic troubleshooting technique is necessary</p> <p><u>20.05.02</u></p> <p>demonstrate the proper procedure of hydraulic troubleshooting</p>	<ul style="list-style-type: none"><li>- discuss the reasons for hydraulic troubleshooting</li> <li>- follow a hydraulic system through from reservoir to actuator<ul style="list-style-type: none"><li>- check for flow</li><li>- check for pressure</li><li>- other</li></ul></li></ul>

UNIT 21.0 PNEUMATICS

General Aim

The student will develop an understanding of pneumatic systems.

MODULE 21.01 PNEUMATIC THEORY

Goal Statement

The learning experiences in this module are designed to help the student gain knowledge related to the theory of pneumatics.

Learning Outcomes

Student Activities

The student should be able to:

21.01.01

explain the reasons for the use of pneumatic systems and also their advantages and disadvantages

21.01.02

explain that gases are compressible

- discuss the advantages and disadvantages of pneumatics
- discuss the principles of pneumatics

- discuss that gases are compressible
  - Boyle's Law
  - Charles' Law

MODULE 21.02 PNEUMATIC COMPONENTS

Goal Statement

The learning experiences in this module are designed to help the student identify and understand the different pneumatic components.

Learning Outcomes	Student Activities
The student should be able to:	
<u>21.02.01</u>	
explain the reservoir for a pneumatic system	- discuss the atmosphere - atmospheric pressure
<u>21.02.02</u>	
identify and explain the various types of air filters used in pneumatic systems	- discuss pneumatic air filters - mesh - micron - other
<u>21.02.03</u>	
identify and explain the various types of compressors	- discuss the types of compressors - piston - lobe - screw - other
<u>21.02.04</u>	
identify and explain the groups of valves used in pneumatic systems	- discuss the groups of valves - pressure control - flow control - direction control

21.02.05

identify and explain the actuators used with pneumatic systems

- discuss the actuators used in pneumatic systems
  - cylinders
  - rotary devices

21.02.06

identify and explain intercoolers, aftercoolers and receivers

- discuss intercoolers, aftercoolers and receivers

MODULE 21.03 PNEUMATIC CIRCUITS

Goal Statement

The learning experiences in this module are designed to help the student understand basic pneumatic symbols and circuits.

Learning Outcomes	Student Activities
The student should be able to:	
<u>21.03.01</u>	
identify and understand basic pneumatic symbols	- discuss and draw basic pneumatic symbols
<u>21.03.02</u>	
identify and understand basic pneumatic circuits	- discuss and draw basic pneumatic circuits

MODULE 21.04 PNEUMATIC SYSTEM MAINTENANCE

Goal Statement

The learning experiences in this module are designed to help the student understand the reasons for pneumatic system maintenance.

Learning Outcomes

Student Activities

The student should be able to:

21.04.01

explain the reasons for a daily maintenance program on a pneumatic system

- discuss the procedures to be followed each day when maintaining a pneumatic system
  - check filters
  - drain receivers
  - other

21.04.02

demonstrate the maintenance procedure on a pneumatic system

- follow a pneumatic system completely through from filter to actuators
  - check pressure
  - check flow
  - check lubricators
  - other



UNIT 22.0 MACHINE INSTALLATION

General Aim

The student will develop a general understanding in the field of machine installation.

MODULE 22.01 CONCRETE AND GROUT

Goal Statement

The learning experiences in this module are designed to help the student gain an understanding of concrete and grout.

Learning Outcomes	Student Activities
The student should be able to:	
<u>22.01.01</u>	
explain the composition and properties of concrete	<ul style="list-style-type: none"><li>- discuss the use of reinforced concrete</li><li>- discuss the composition of concrete</li><li>- discuss the properties of concrete<ul style="list-style-type: none"><li>- rate of expansion</li><li>- contracts when dried</li></ul></li><li>- discuss the curing of concrete</li></ul>
<u>22.01.02</u>	
explain the composition and properties of grout	<ul style="list-style-type: none"><li>- discuss the composition of grout</li><li>- discuss the properties of grout<ul style="list-style-type: none"><li>- it expands when dried</li></ul></li></ul>
<u>22.01.03</u>	
discuss the factors involved in designing a foundation <ul style="list-style-type: none"><li>- weight of machine</li><li>- force exerted by machine</li><li>- vibration exerted by machine</li></ul>	<ul style="list-style-type: none"><li>- discuss</li></ul>

MODULE 22.02 FORMS

Goal Statement

The learning experiences in this module are designed to help the student construct forms for machine installation.

Learning Outcomes	Student Activities
The student should be able to:	
<u>22.02.01</u>	
identify the types of materials used for constructing forms	<ul style="list-style-type: none"><li>- discuss the materials available for form construction<ul style="list-style-type: none"><li>- plywood</li><li>- sound lumber</li><li>- steel</li></ul></li></ul>
<u>22.02.02</u>	
explain and construct forms for machine installation	<ul style="list-style-type: none"><li>- discuss methods of form construction<ul style="list-style-type: none"><li>- basic form construction</li><li>- setting pier form to a centre line</li><li>- bracing a form</li><li>- other</li></ul></li></ul>

MODULE 22.03 BASE BOLTS

Goal Statement

The learning experiences in this module are designed to help the student gain an understanding of the types and ways of installing base bolts.

Learning Outcomes	Student Activities
<p>The student should be able to:</p> <p><u>22.03.01</u></p> <p>identify the types of base bolts used for machine installation</p> <p><u>22.03.02</u></p> <p>explain the method of template design for base bolts</p>	<ul style="list-style-type: none"><li>- discuss the different types of bolt anchors<ul style="list-style-type: none"><li>- cast in concrete</li><li>- boxed</li><li>- piped anchor bolts</li><li>- other</li></ul></li> <li>- discuss purpose of template</li><li>- discuss methods of making a template</li><li>- other</li></ul>

MODULE 22.04 LAYOUT

Goal Statements

The learning experiences in this module are designed to help the student:

- a. gain an understanding of machine installation on concrete using working drawings,
- b. instal a machine on concrete.

Learning Outcomes

Student Activities

The student should be able to:

22.04.01

explain the procedure for machine installation by using working drawings

- discuss the hazards of installing a machine on concrete
- discuss lay out procedures for machine installation when using a drawing
  - from reference point
  - measured heights and sizes of forms
- installation of base bolts (template)
- pouring concrete
- dam construction for grouting
- pouring grout to height
- installation of machine on base
- other

22.04.02

explain the procedure for machine installation with the machine already in position

- discuss layout procedures for machine installation with the machine in position
  - concrete poured to minus elevation of 3/4" to 1 1/2"
  - machine lowered in position on bolts then brought up to desired height and level by metal shims and slow tapered wedges
  - tightened bolts and level
  - construct dam
  - pour grout to desired level
  - installation using pipe to allow for anchor bolt movement should have the pipe filled with grout before grouting under base

UNIT 23.0 PREVENTATIVE MAINTENANCE

General Aim

The student will develop an understanding of preventative maintenance programs.

MODULE 23.01 SCHEDULE AND REPORTS

Goal Statements

The learning experiences in this module are designed to help the student understand:

- a. scheduling and reporting procedures used in a preventative maintenance program,
- b. that management enforces company policies on preventative maintenance programs.

Learning Outcomes

Student Activities

The student should be able to:

23.01.01

identify the purpose of a preventative maintenance program

- discuss the need for a scheduled routine inspection of various machines or machine parts
- discuss the need for records of each inspection

23.01.02

identify and explain reasons for a preventative maintenance program

- discuss and list the necessary reasons
  - less time lost in mechanical breakdown during operation
  - analysis of parts giving most trouble
  - better estimation of maintenance costs per machine
  - other

23.01.03

identify methods in setting up a preventative maintenance program

- discuss the format used in setting up a card or sheet file system
  - times of inspection
    - weekly
    - monthly
  - note condition of part or machine
  - remarks on parts or machines
  - initials by inspector
  - list of parts to be checked on machine
  - list of times for lubrication
  - other

MODULE 23.02 NON-DESTRUCTIVE TESTING

Goal Statements

The learning experiences in this module are designed to:

- a. familiarize the student with methods of non-destructive testing on machines or machine parts;
- b. help the student proceed with safe non-destructive testing techniques.

Learning Outcomes

Student Activities

The student should be able to:

23.02.01

identify methods of non-destructive testing with machine down

- discuss means of testing with machine down
  - visual observation
  - dye check
  - other

23.02.02

identify methods of non-destructive testing with machine running

- discuss means of testing with machine running
  - visual observations
  - vibration analysis



UNIT 24.0 ELECTRICITY

General Aim

The student will develop an understanding of basic electricity.

MODULE 24.01 BASIC ELECTRICITY

Goal Statement

The learning experiences in this module are designed to familiarize the student with the concepts of basic electricity.

Learning Outcomes	Student Activities
The student should be able to:	
<u>24.01.01</u>	
identify the need for caution when working with electrical systems	<ul style="list-style-type: none"><li>- discuss<ul style="list-style-type: none"><li>- the safety precautions that must be taken when working around electric circuits</li><li>- Workers Compensation Board regulations</li></ul></li></ul>
<u>24.01.02</u>	
explain electric current	<ul style="list-style-type: none"><li>- discuss</li></ul>
<u>24.01.03</u>	
identify means of producing electric current	<ul style="list-style-type: none"><li>- discuss</li></ul>
<ul style="list-style-type: none"><li>- water current</li><li>- steam</li><li>- nuclear power</li><li>- wind</li><li>- sunlight</li><li>- other</li></ul>	

24.01.04

explain the difference between a conductor and a non-conductor of electricity

- discuss

24.01.05

identify materials which are conductors or non-conductors of electricity

- discuss and list materials as conductors or insulators

24.01.06

identify the two kinds of electric currents

- alternating current
- direct current

- discuss and explain the difference between alternating and direct current

24.01.07

explain the difference between an open and a closed circuit

- discuss

24.01.08

demonstrate the difference between a series and parallel circuit

- discuss and set up a series and a parallel circuit

24.01.09

identify the size of electrical wire

- discuss and check sizes of electrical wire

24.01.10

perform the necessary connection of wires according to the National Electrical Code

- pigtail splice
- branch splice
- end splice
- other

- discuss and perform wire connections

24.01.11

explain the sizing and installation of wire nuts on jointing connections

- discuss

24.01.12

identify the need for using electrical conduit

- rigid conduit
- flexible conduit

- discuss the reasons for using conduit

24.01.13

identify the purpose of electrical:

- outlet box
- junction box

- discuss

24.01.14

identify the purpose of electrical switches

- cord switch
- toggle switch
- breaker box

24.01.15

explain the procedure for calculating and measuring:

- voltage
- amperage
- resistance

- discuss and perform measurement on electrical circuits with

- voltmeters
- amp meters
- ohm meters

- perform calculations on electrical circuits

24.01.16

perform calculations of wattage on electrical circuits

- discuss and perform calculations on electrical circuits

24.01.17

identify the purpose of a fuse

- discuss the purpose of a fuse

24.01.18

identify the different types of fuses

- plug fuse
- cartridge fuse
- knife fuse

- discuss the list the types

24.01.19

identify the purpose of a ground system

- discuss the reasons for a ground system

24.01.20

identify the purpose of transformers

- discuss the need for using an electrical transformer

MODULE 24.02 GENERATORS AND MOTORS

Goal Statement

The learning experiences in this module are designed to help the student gain an understanding of electrical generators and motors.

Learning Outcomes	Student Activities
The student should be able to:	
<u>24.02.01</u>	
identify the purpose of electrical generators	- discuss the purpose of an electrical generator
<u>24.02.02</u>	
explain why a generator produces electrical current	- discuss the reasons why a generator produces electrical current
<u>24.02.03</u>	
identify the purpose of electrical motors	- discuss the purpose of an electrical motor
<u>24.02.04</u>	
identify the size of electrical motors	- discuss the methods used in determining the size of an electrical motor <ul style="list-style-type: none"><li>- measure the h.p.</li><li>- read the tag</li><li>- other</li></ul>

UNIT 25.0 METALLURGY

General Aim

To introduce the student to the methods used in the manufacture of iron and steel and the methods of classification and coding.

MODULE 25.01 FERROUS MATERIALS

Goal Statements

The learning experiences in this module are designed to:

- a. introduce the student to the production of iron and steel,
- b. enable the student to identify steels.

Learning Outcomes

Student Activities

The student will be able to:

25.01.01

identify the materials and process used in the production of pig iron

- describe the production of pig iron

25.01.02

identify the processes used for the production of steel

- open hearth
- basic oxygen process
- electric

- describe the various processes and their uses

25.01.03

recognize the difference between hot and cold rolled steels

25.01.04

recognize the difference between plain carbon and alloy steels and their applications

- identify and list the uses of plain carbon and alloy steels

25.01.05

describe different types of steels  
according to

- spark test
- numbering system

- identify steels by using  
SAE and AISI systems
- identify steels using the  
spark test

MODULE 25.02 PHYSICAL PROPERTIES

Goal Statement

The learning experiences in this module are designed to introduce the student to the basic physical properties associated with steels.

<u>Learning Outcomes</u>	<u>Student Activities</u>
The student will be able to:	
<u>25.02.01</u>	
describe the following physical properties	- list and define the physical properties
<ul style="list-style-type: none"><li>- tensile strength</li><li>- ductility</li><li>- malleability</li><li>- hardness</li><li>- toughness</li><li>- machinability</li><li>- corrosion resistance</li></ul>	
<u>25.02.02</u>	
identify the effects of the following elements	- list and identify the effects
<ul style="list-style-type: none"><li>- tungsten</li><li>- molybdenum</li><li>- manganese</li><li>- vanadium</li><li>- carbon</li><li>- lead</li><li>- chrome</li><li>- nickel</li></ul>	



MODULE 25.03 HEAT TREATMENT

Goal Statements

The learning experiences in this module are designed to:

- a. introduce the student to the various heat treating operations,
- b. enable the student to describe the purpose of the heat treating operations.

Learning Outcomes	Student Activities
The student will be able to:	
<u>25.03.01</u>	
recognize the purpose and methods of stress relieving	- identify and describe the methods of and purposes for stress relieving
<u>25.03.02</u>	
recognize the method and purpose of a full annealing operation	- identify and describe the method of and purposes for a full anneal - perform an annealing operation on a sample piece
<u>25.03.03</u>	
recognize and understand the steps required to perform a hardening operation	- identify and describe the hardening process - perform a hardening operation on a sample piece
- heating - soaking - cooling	
<u>25.03.04</u>	
recognize the various methods of surface hardening	- identify and describe the purposes of and methods used for surface hardening
- cyaniding - carburizing - nitriding - flame hardening - induction hardening	

25.03.05

recognize the method and need for a tempering operation

- identify the methods of and the purposes for tempering
- perform a tempering operation on a sample piece

25.03.06

recognize the methods used to determine the hardness of a heat treated material

- file test
- Rockwell
- Brinell
- other

- identify and describe the various methods of hardness testing
- perform a hardness test on a sample piece

## Section Four Resource Materials

CAREER PREPARATION PROGRAM  
CAREER PREPARATION PROGRAM  
CAREER PREPARATION PROGRAM  
CAREER PREPARATION PROGRAM  
CAREER PREPARATION PROGRAM  
CAREER PREPARATION PROGRAM  
CAREER PREPARATION PROGRAM  
CAREER PREPARATION PROGRAM  
CAREER PREPARATION PROGRAM  
CAREER PREPARATION PROGRAM  
CAREER PREPARATION PROGRAM  
CAREER PREPARATION PROGRAM  
CAREER PREPARATION PROGRAM  
CAREER PREPARATION PROGRAM  
CAREER PREPARATION PROGRAM  
CAREER PREPARATION PROGRAM  
CAREER PREPARATION PROGRAM  
CAREER PREPARATION PROGRAM  
CAREER PREPARATION PROGRAM  
CAREER PREPARATION PROGRAM

Technical Drawing Giesecke, Mitchell, Spencer and Hill Fifth Edition  
MacMillan

Basic Mathematics Simplified Olivo and Olivo Van Nostrand Reinhold  
Ltd., Toronto

Manual of Instruction for the Millwright Trade, Pts. I and II Michener,  
R. A. British Columbia Ministry of Education

Audel's Pumps, Hydraulics Graham General Publishing Co. Ltd.

Industrial Hydraulics Pippenger and Hicks McGraw-Hill Ryerson Ltd.

Hydraulic and Pneumatic Power for Production Stewart, H. L. Industrial  
Press, N. Y.

Machinery Handbook Oberg, E. and Jones, F. D. (Industrial Press Inc.)  
General Publishing Co.

Machine Tool Operation Burghardt McGraw-Hill Ryerson Ltd.

Handbook for Riggers Newberry, W. G. "Handbook for Riggers", Box 299,  
Calgary, Alberta

Advanced Blueprint Reading for Machine Trades Delmar, Thos. Nelson &  
Son Ltd.

Reading Engineering Drawings O'Donell E. I. Dupont de Nemours & Co.

Basic Physics Eubank, Ramsay & Rickard MacMillan Ltd. 1963

Practical Fundamentals of Electricity Lacey, A. L. Northern Miners  
Press Ltd.

Industrial Hydraulics Handbook Vickers

Boilermaking Manual Canadian Cataloguing Publications

Fasteners Handbook Soled, J. Reinhold Publishing Co.

Elementary Metallurgy Erier, W. T. McGraw-Hill Ryerson Ltd.

Metal Properties A. S. M. E. McGraw-Hill Ryerson Ltd.

Steel & Its Heat Treatment Bullens Wiley Ltd.

Maintenance Engineering Handbook Morrow McGraw-Hill Ryerson Ltd.

### INTRODUCTION

The field Boilermaker relies upon a variety of lifting and support mechanisms to transfer and secure material and equipment on the jobsite. At one extreme, immense, sophisticated cranes perform massive lifting and moving operations while at the other, simple systems of ropes and pulleys having sufficient mechanical advantage manage smaller operations to enable "man-power" to provide the required energy. In both cases, the fundamental unit of the system is the line or rope, and the Boilermaker must have a complete understanding of the composition, characteristics, capabilities and uses of all types of line and rope. This chapter describes natural fibre, synthetic fibre and

### KNOTS AND HITCHES

Both natural and synthetic fibres can be tied in various ways to produce knots and hitches to serve specific functions in rigging and erection operations

In making knots and hitches, the rope (Figure 7-1) is described as having three parts:

1. The **running end** or free end used when making a knot or hitch.
2. The **standing part** is the main line or inactive length of rope
3. The **bight** is the part, usually a loop, between the running end and the standing part.

### SECURING LINE ENDS

When a rope is cut, the raw end(s) tends to unravel or untwist and should be secured to

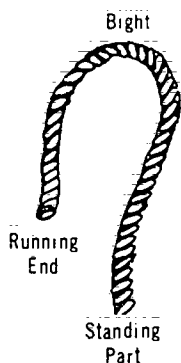

Figure 7-1. Parts of the Rope

prevent losing functional cord. Knotting the raw end is simple, but whipping has several advantages:

1. It does not significantly increase the rope's circumference and thus will still thread through openings.
2. It is a more durable and secure fastening.
3. It can be applied before a rope is cut to prevent any untwisting.

### WHIPPING A LINE END

Figure 7-2 illustrates the steps involved in whipping a line end:

- Step 1. Using a small cord, make a bight near the end and lay the doubled cord along a groove in the rope between two strands. The bight should project about 1/2 beyond the end of the rope.
- Step 2. Begin wrapping the standing part of the cord tightly around the line and cord.
- Step 3. Continue to wrap toward the end of the rope, ending about 1/2 from the cut. The wrapped portion should be as long as the equivalent of 1-1 1/2 times the rope diameter.
- Step 4. At the end of the wrap, slip the cord end through the bight. Then pull the free end of the cord until the bight is drawn under the whipping and the cord is tightened.
- Step 5. Cut off ends at the edge of the wrapping leaving a finished termination.

### KNOTS AT THE END OF A LINE

1. The **overhand knot** (Figure 7-3) is the simplest knot to make, but should be used only with small cord or twine on parcels. On a larger rope used in handlines and rope blocks this knot jams when pulled tight and damages the fibres of the rope.
2. The **figure eight knot** (Figure 7-4) does not injure the rope fibres and is larger than an overhand knot for tying on the end of a rope to prevent it from slipping through a fastening or a loop in another line.

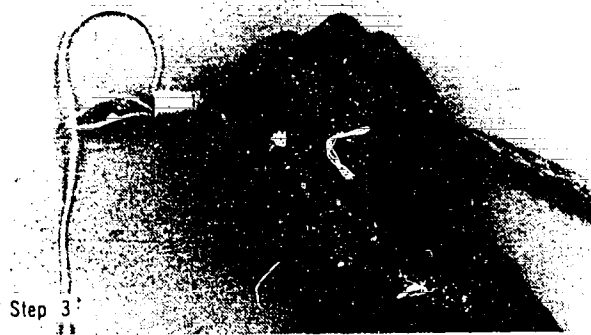
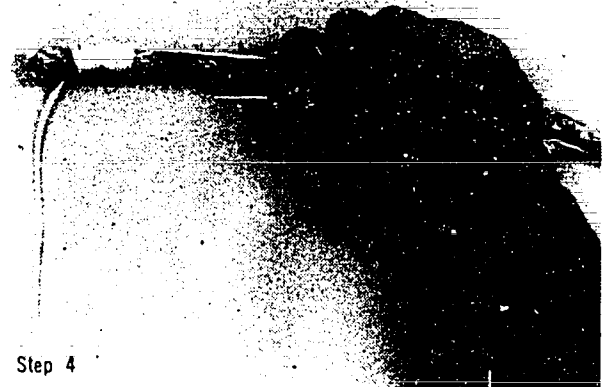

Figure 7-2: Whipping a Line End

### KNOTS FOR JOINING TWO LINES

1. The **square or reef knot** (Figure 7-5) is used for tying together two ropes of the same size, or for tying together the ends of a short rope to make a temporary endless sling. Properly tied, a square knot will not slip when the rope is dry and has 50% of the rope strength.

When tying a square knot, the standing part and the running end of each rope must pass

through the bight of the other rope in the same direction. A square knot is easily untied by grasping the ends of the two bights and pulling the knot apart.

2. The **granny knot** or the **thief knot** (Figure 7-6) looks like a square knot, but will slip and jam under a load.
3. A **single sheet bend** (sometimes called a **weaver's knot**) is used to tie together two dry ropes of unequal size. Figure 7-7



Figure 7-3. Overhand Knot



Figure 7-6. Granny Knot



Figure 7-4. Figure Eight Knot

illustrates the method of tying a single sheet bend. The knot will draw tight under light loads but will loosen or slip when the lines are slackened.

4. A **double sheet bend** (Figure 7-8) is used to join wet or dry lines of equal or unequal size. It will not slip or draw tight under heavy loads.

First tie a single sheet bend (do not pull it tight), then take one extra turn around the bight passing the running end under the

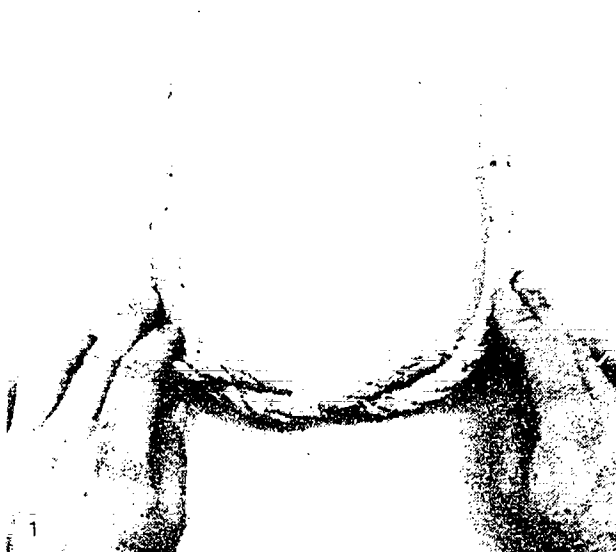

Figure 7-5. Tying a Square Knot



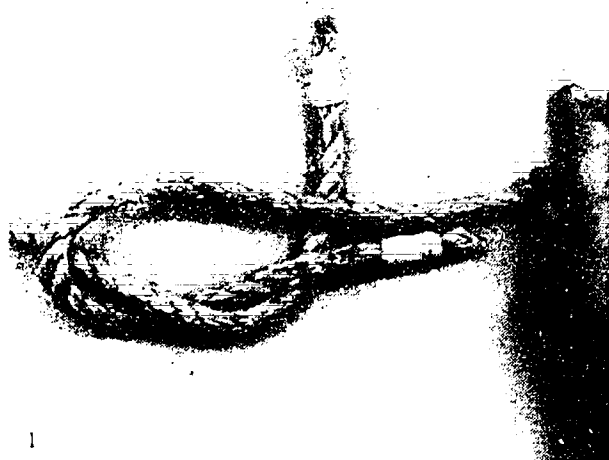

Figure 7-7. Tying a Single Sheet Bend



Figure 7-8. Double Sheet Bend

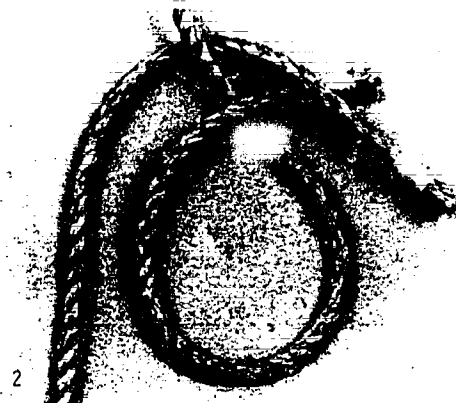
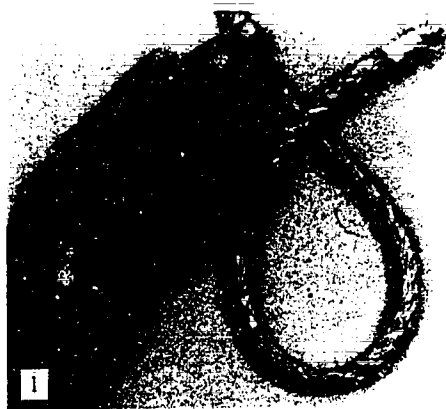

Figure 7-9. Tying a Carrick Bend



smaller line and over the larger line as for the single short bend.

5. The **carrick bend** is used for heavy loads and for joining heavy line. It will not draw tight under a heavy load. Figure 7-9 illustrates the steps in tying a carrick bend.

#### KNOTS FOR MAKING LOOPS

1. The **bowline knot** makes a non-slip loop that will not tighten under straining and can be untied easily when the tope is slack. Figure

7-10 illustrates the steps in tying a bowline knot.

2. The **double bowline knot** (or **French bowline**) provides a secure, two-loop sling that can serve as a seat for an operator (by passing a small, notched board through the loops) or as spreaders to sling a load. Figure 7-11 illustrates the steps in tying a double bowline.
3. The **running bowline knot** is the basic knot used in rigging for raising or lifting loads as it produces a choker type sling at the end of

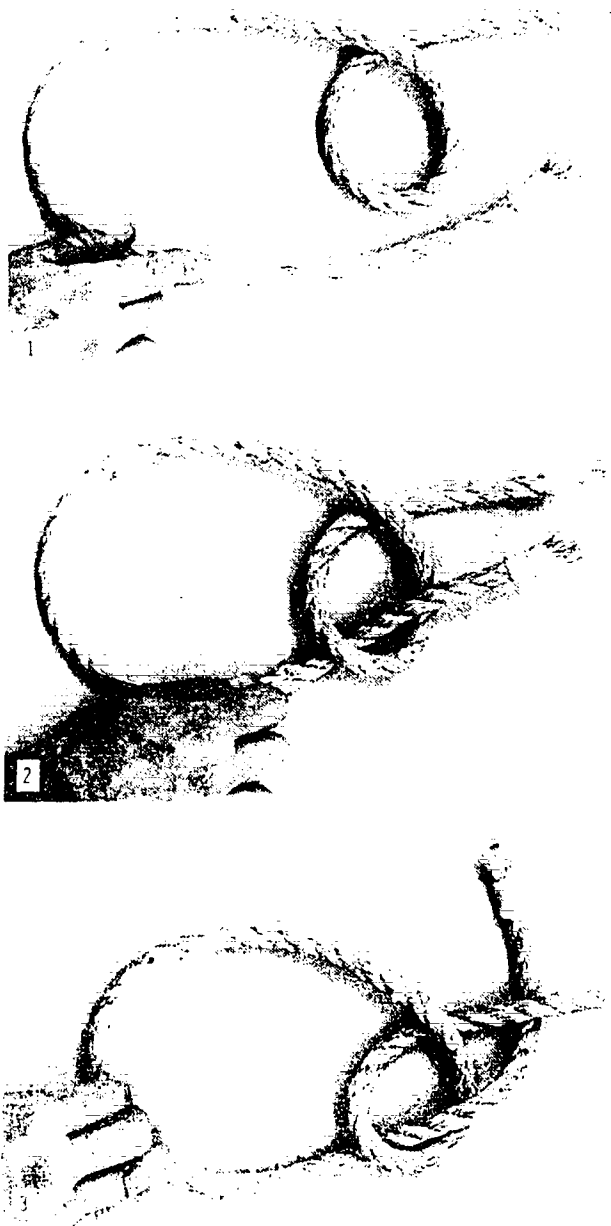

Figure 7-10. Tying a Bowline Knot

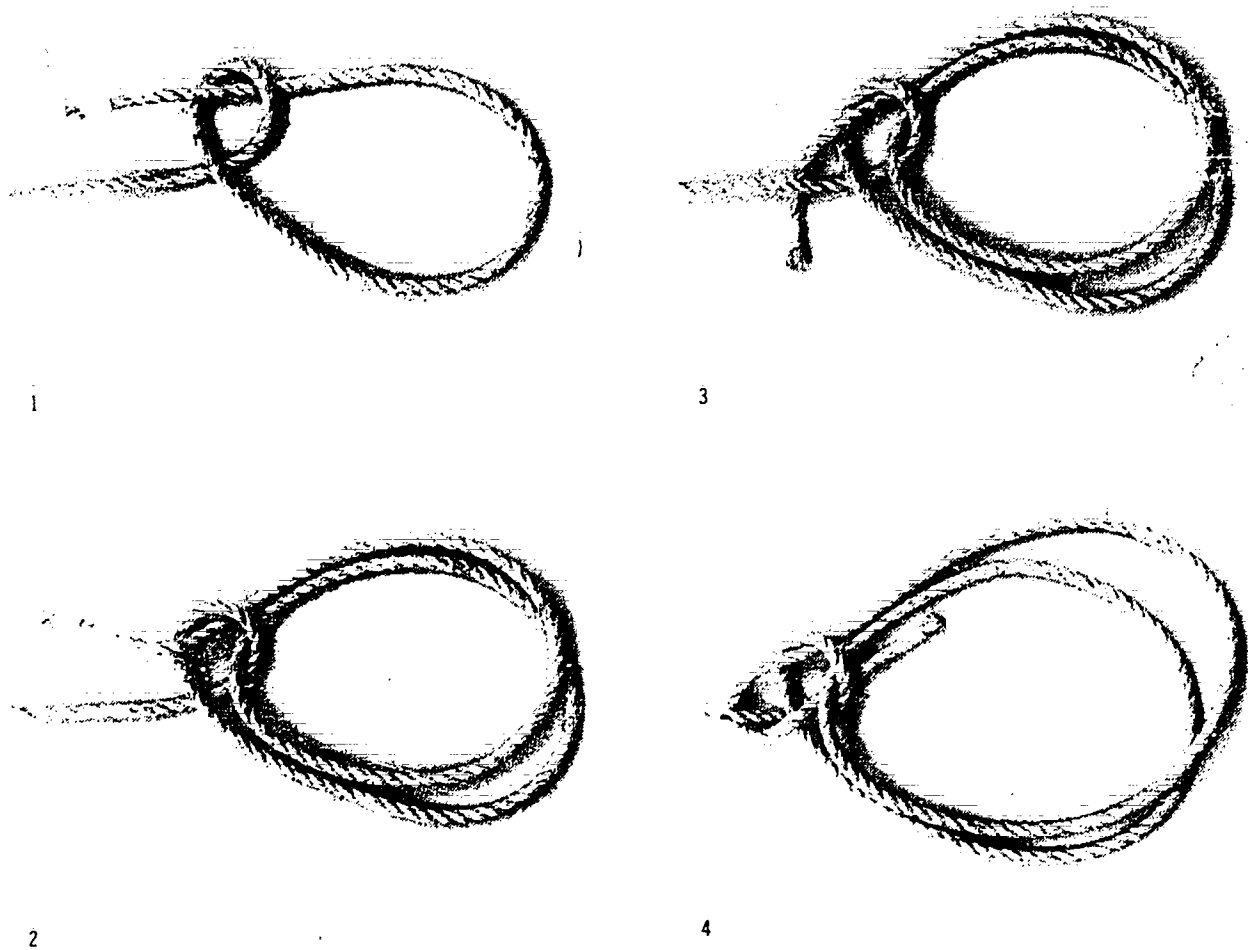

Figure 7-11. Tying a Double Bowline Knot

- a single line. Figure 7-12 illustrates the steps in tying a running bowline knot.
4. A **bowline on the bight** is tied to form a double loop in the middle of a line that can be used as a seat or as a spreader to sling a load. Figure 7-13 illustrates the steps in tying a bowline on the bight.
  5. A **Spanish bowline** forms two loops or "rabbit ears" providing a double sling for lifting round objects or for rescue work. Figure 7-14 illustrates the steps in tying a Spanish bowline.
  6. The **harness hitch** produces a loop in a line which will not slip. Figure 7-15 illustrates the steps in tying the harness hitch.

### HITCHES

1. The **half hitch** is used to secure the free end of a line to a timber or to another larger line. Figure 7-16 shows unsafe and safe half hitches.  
Two half hitches (Figure 7-17) provide a more secure fastening to a pole or timber. It is important that the second half hitch is made by passing the running end around the standing part and back under itself again as shown in Figure 7-17.
2. A **round turn and two half hitches** is an alternative method of fastening a line to a timber or pole, and involves passing the running end of the line in two complete

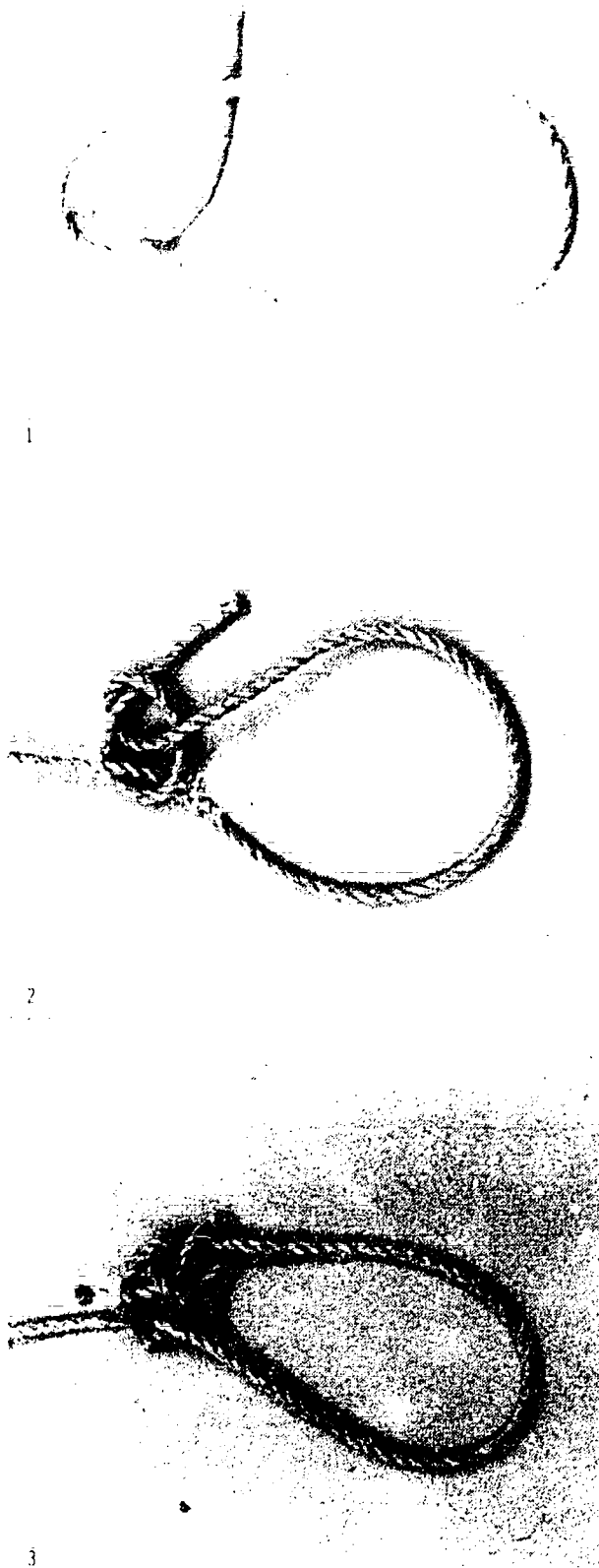

Figure 7-12. Tying a Running Bowline Knot

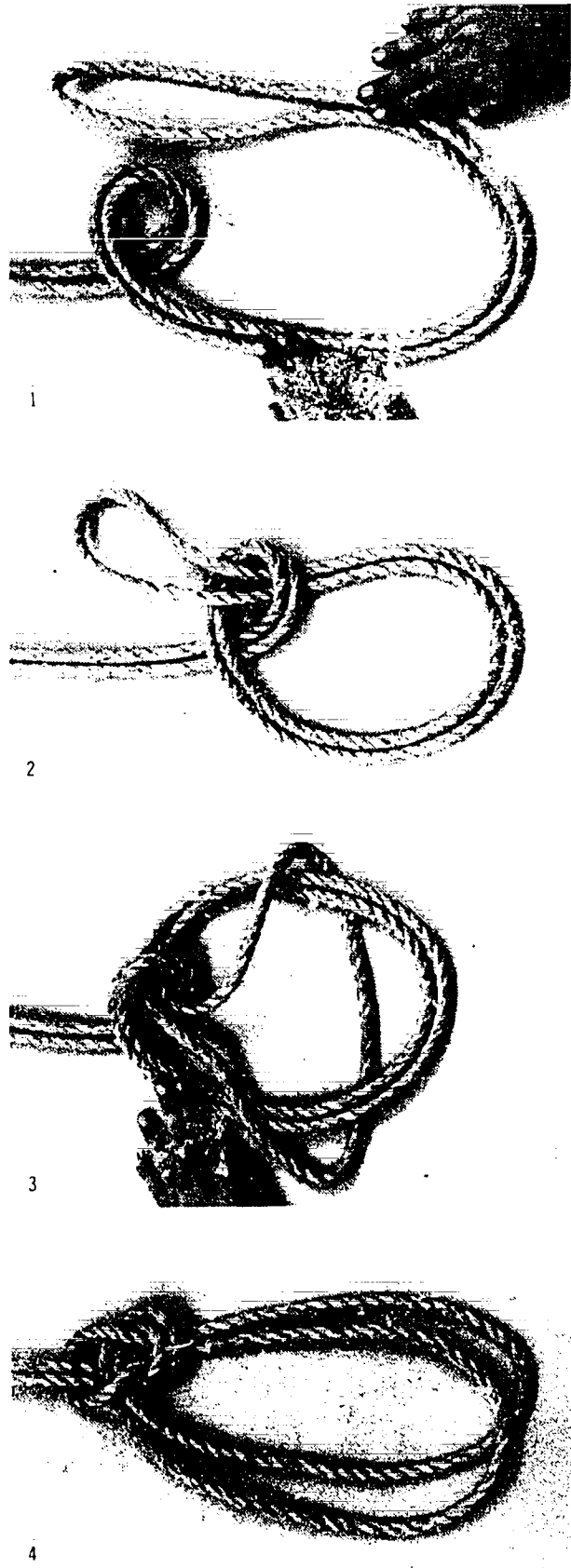

Figure 7-13. Tying a Bowline on the Bight

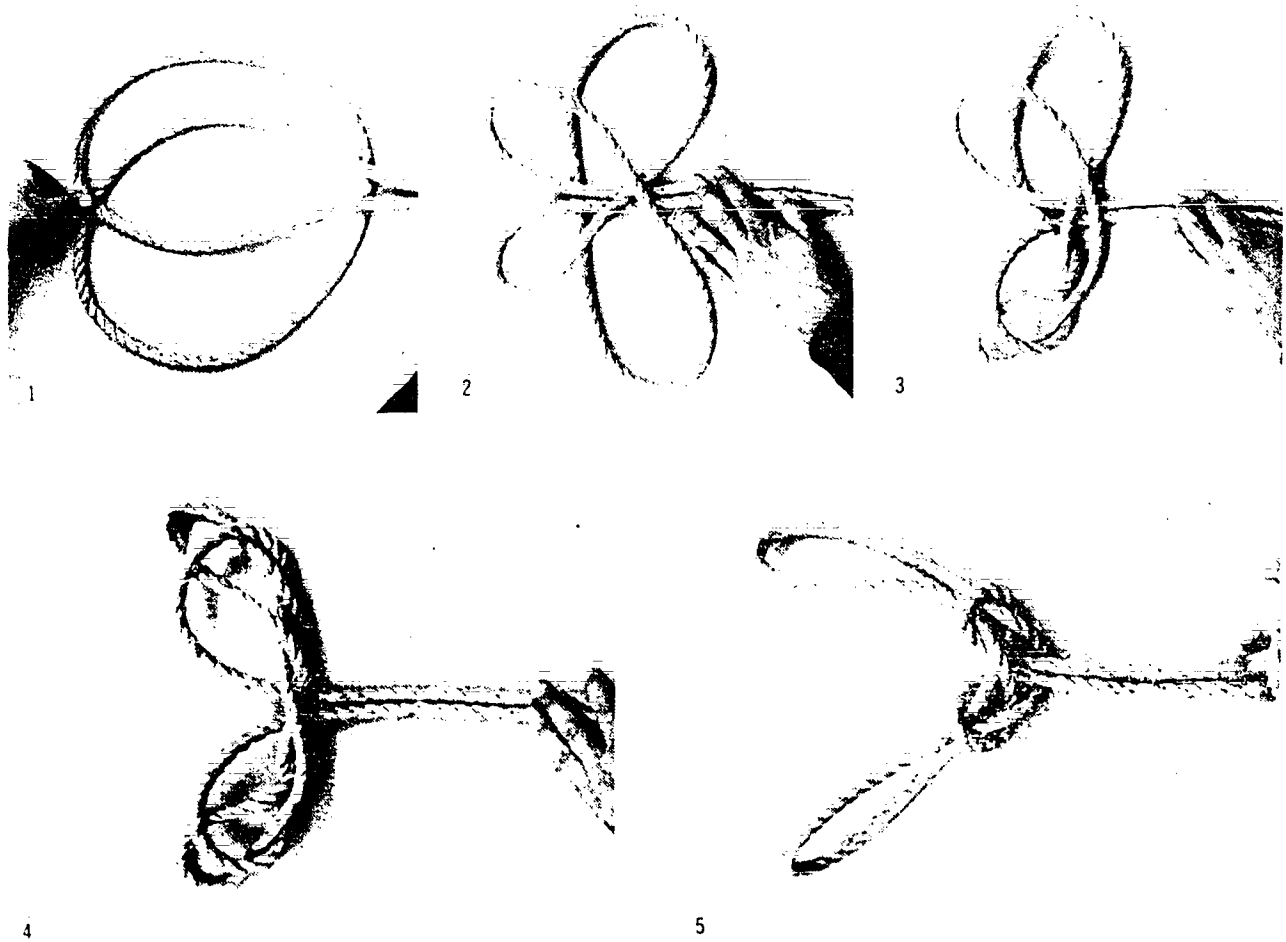

Figure 7-14. Tying a Spanish Bowline

- turns around the pole before making the two half hitches as shown in Figure 7-18.
3. The **clove hitch** offers a fast, simple way of fastening a line to a post, timber or pipe and can be tied at any point in the line. To tie a clove hitch in the middle of the line, make two turns close together in the line and twist them to bring them back to back as shown in Figure 7-19. Slip the loops over the post. To tie a clove hitch at the end of the line, two underhand loops are tied around the post as shown in Figure 7-20.
  4. The **rolling** or **Magnus hitch** is used to fasten a line to another line, cable, timber or post and it will remain tight under tension or pull. This hitch is also known as the **mooring hitch**. Figure 7-21 illustrates the steps in tying the rolling hitch.
  5. A **sheepshank** is used to shorten a rope as a temporary measure. This may be necessary to take the load off a weak or damaged part of the line before replacement can be accomplished. Figure 7-22 illustrates the steps in tying the sheepshank.
  6. The **timber hitch** is used to fasten rope to steady loads of posts, planks, timbers and pipes. The knot will loosen when the tension or pull is relieved. The hitch begins with a half hitch and is completed by turning or twisting the running end around itself two or three times following the lay of the rope (Figure 7-23).
  7. A **timber hitch and half hitch** provides a more secure hold on heavy poles or timbers for lifting or hauling. This involves tying one or two half hitches around the load, and further along tying a timber hitch with the running end of the line (Figure 7-24).
  8. A **catspaw** (Figure 7-25) is a particularly useful method of attaching the middle of a

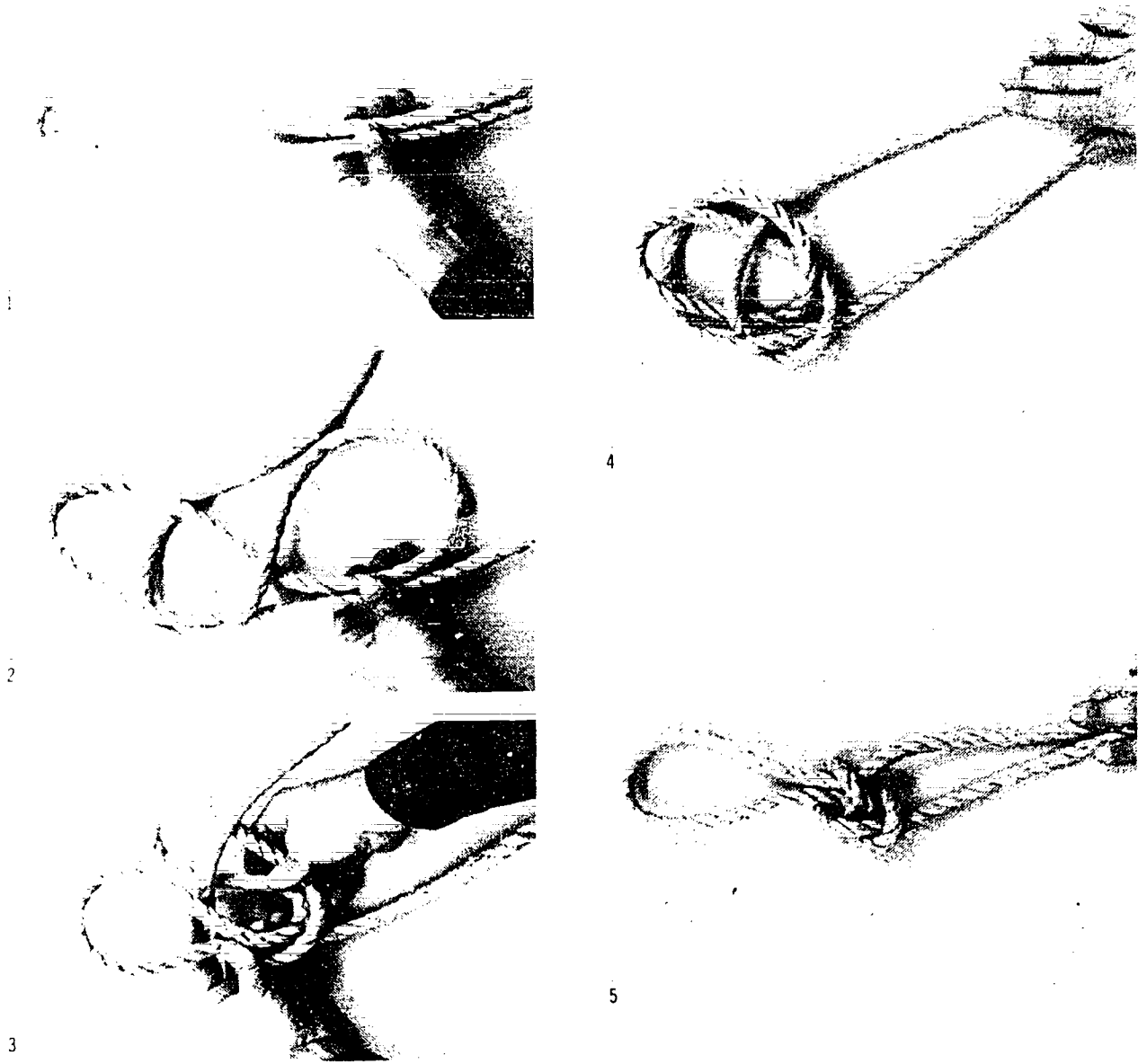

Figure 7-15. Tying a Harness Hitch

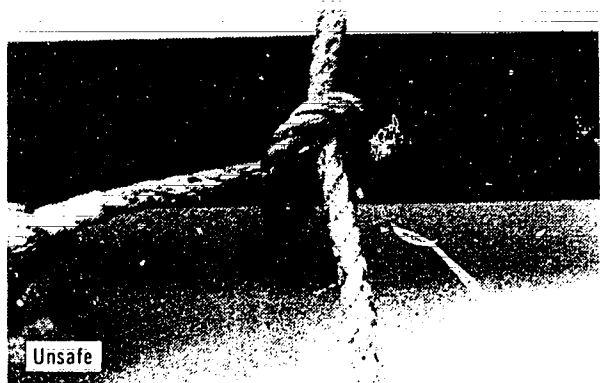

Figure 7-16. Safe and Unsafe Half Hitches

262



Figure 7-17. Two Half Hitches



Figure 7-18. Round Turn and Two Half Hitches

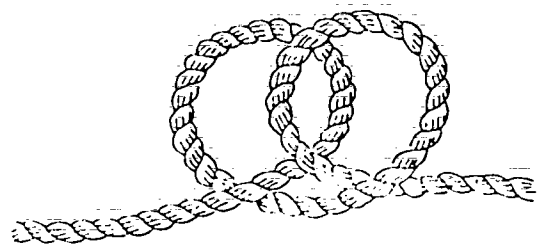

Figure 7-19. Tying a Clove Hitch in the Middle of a Line

line to a hook. When removed from the hook, it unties itself.

9. The **fisherman's bend** provides a secure fastening for a line or cable to an anchor or other situations where alternate tightening and slackening in the line occurs. Figure 7-26 illustrates a fisherman's bend. With the running end, take two turns through or around the object to be fastened, then around the standing part and through the loop formed by the turns. Finally, make a half hitch around the standing part and seize the running end to the standing part.

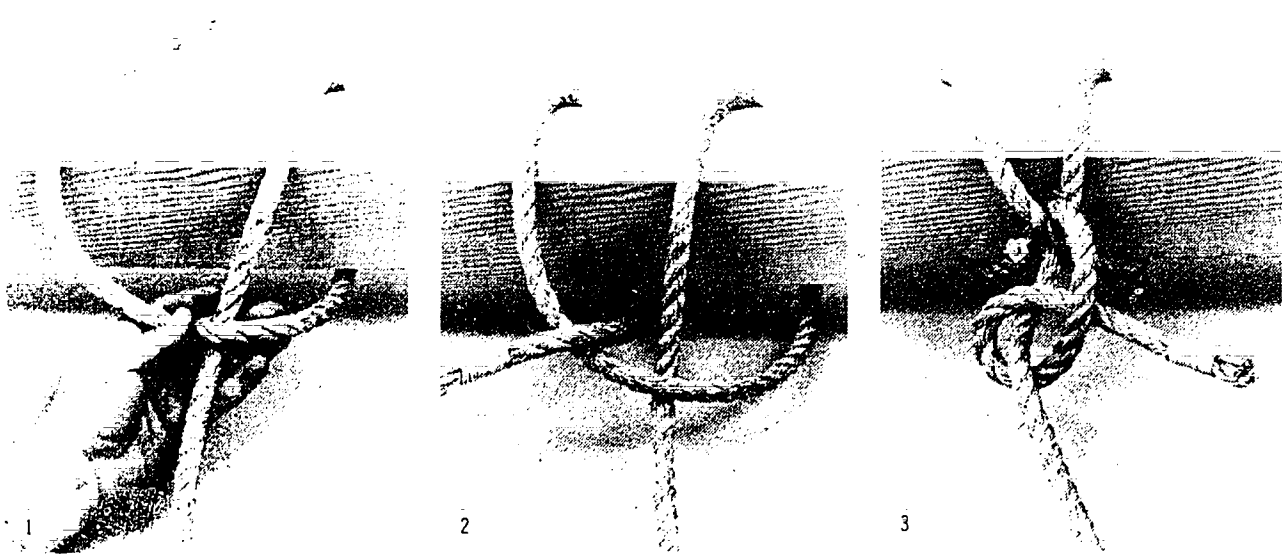

Figure 7-20. Tying a Clove Hitch at the End of Line

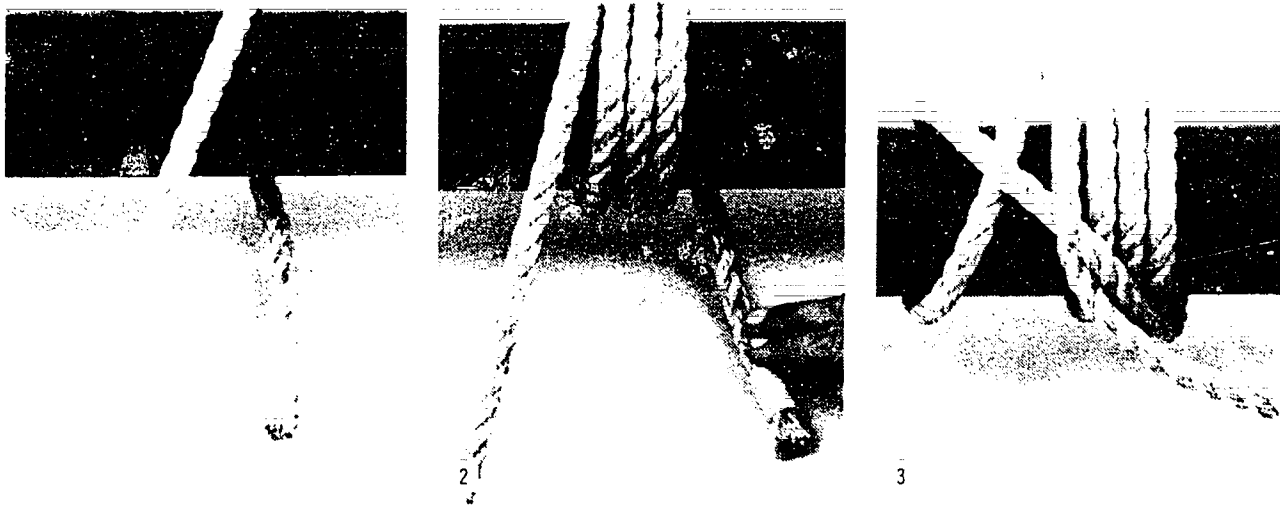

Figure 7-21. Tying a Rolling Hitch

10. The **scaffold hitch** is used to support single scaffold planks so they will hang level and be unable to tilt. Figure 7-27 illustrates the steps in tying a scaffold hitch.
11. The **Speir knot** provides a constant loop with a non-slipping knot and can be released easily by a pull on the running end. Figure 7-28 illustrates the steps in tying a Speir knot.
12. The **becket hitch** provides a secure means of fastening a line to a ring such as the becket of a block. Figure 7-29 illustrates the steps in tying a becket hitch. Pass the running end of the line through the eye of the ring, back around the standing part of the line, then over both sides of the loop and up through the bottom half of the loop as shown. Pull tight.
13. **Barrel slings** can be tied to hold barrels horizontally or vertically. The **horizontal sling** (Figure 7-30) is made by tying a bowline with a long loop. Make two "ears" by bringing the line at the bottom of the loop up over the sides of the loop and slide

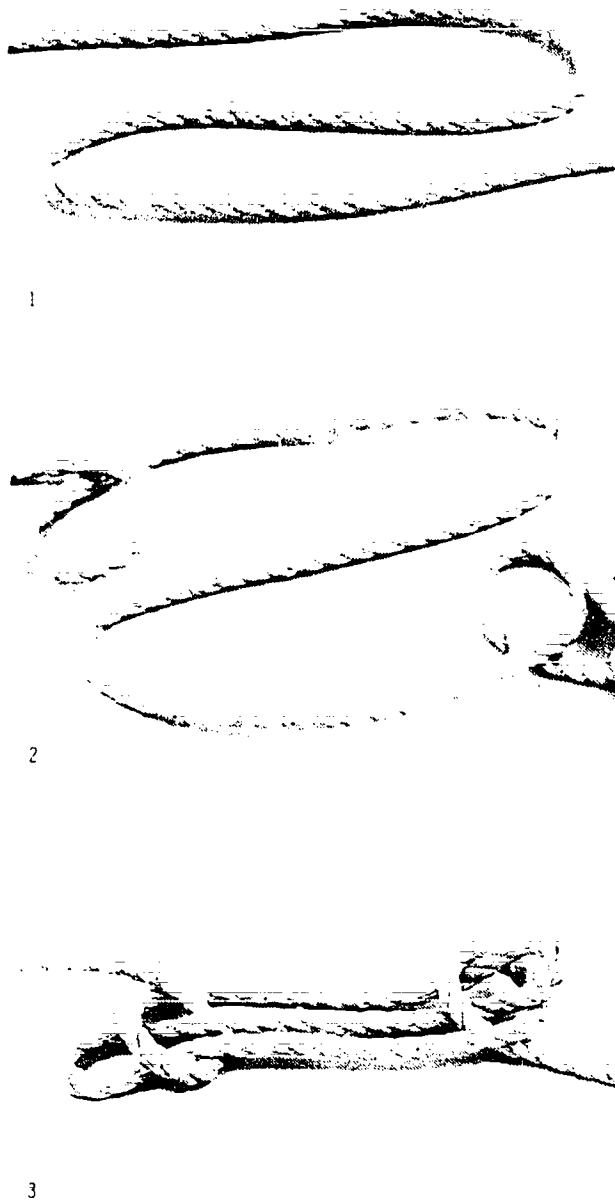

Figure 7-22. Tying a Sheepshank

the "ears" over the ends of the barrel. The **vertical sling** is made as illustrated in Figure 7-31.

**Note:** Rope strength is reduced to 50% when a knot or bend is tied anywhere along its length.

Rope strength is reduced to 75% when a hitch is tied anywhere along its length.

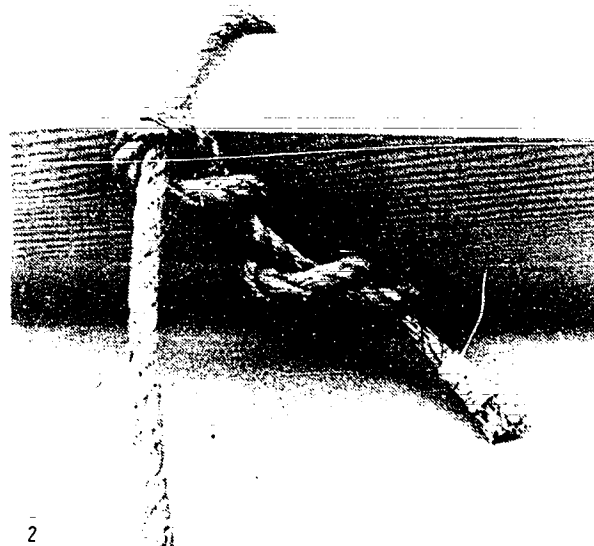
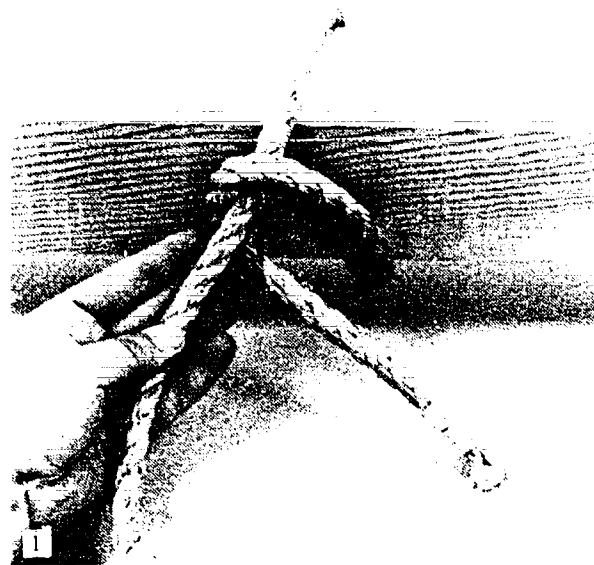

Figure 7-23. Tying a Timber Hitch

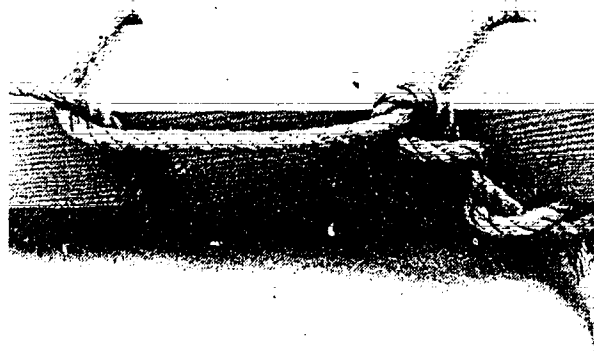

Figure 7-24. Tying a Timber Hitch and Half Hitch





1



2

Figure 7-25. Catspaw Hitch



Figure 7-26. Fisherman's Bend

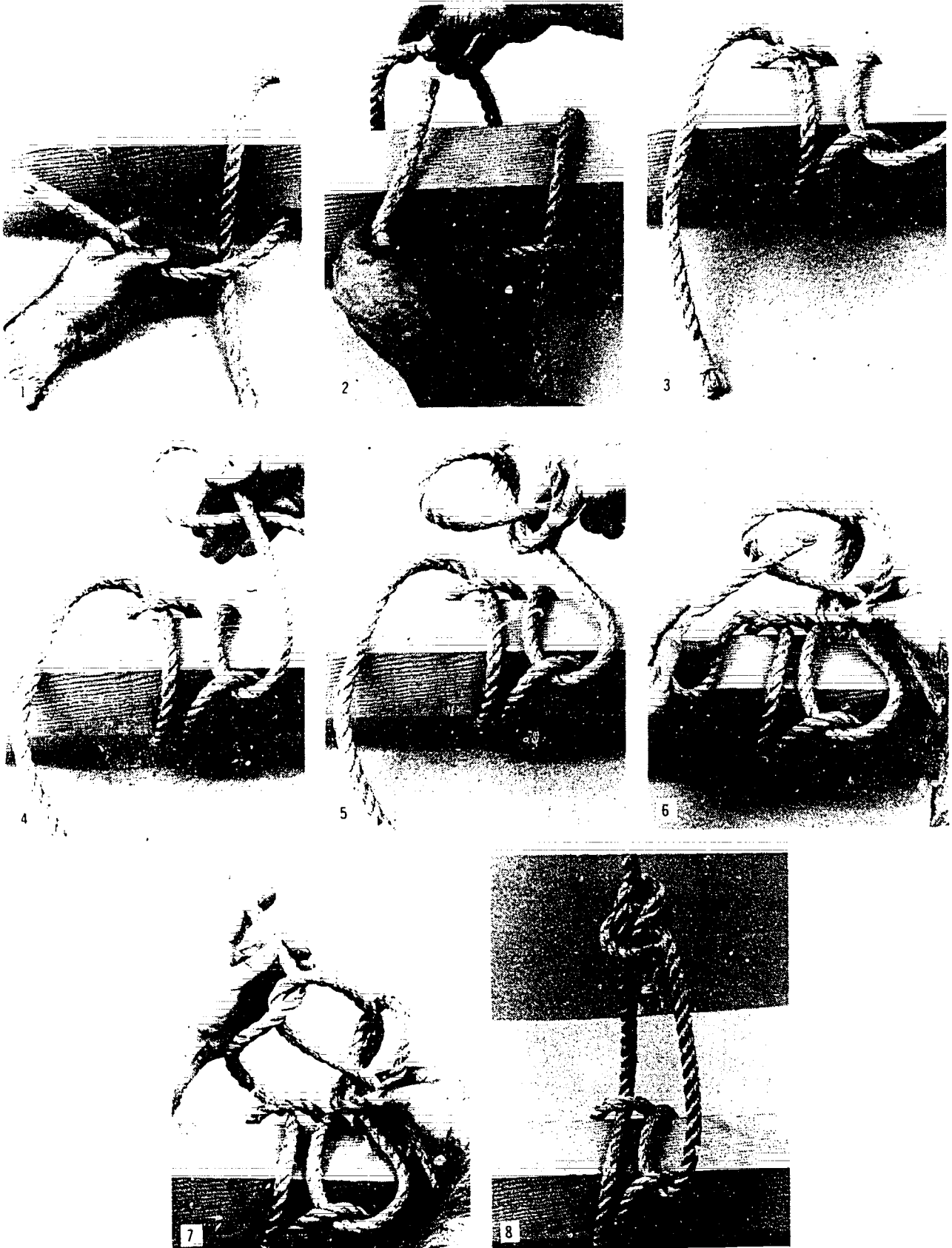

Figure 7-27. Tying a Scaffold Hitch



1



2



3



4



5



6

Figure 7-28. Tying a Speir Knot

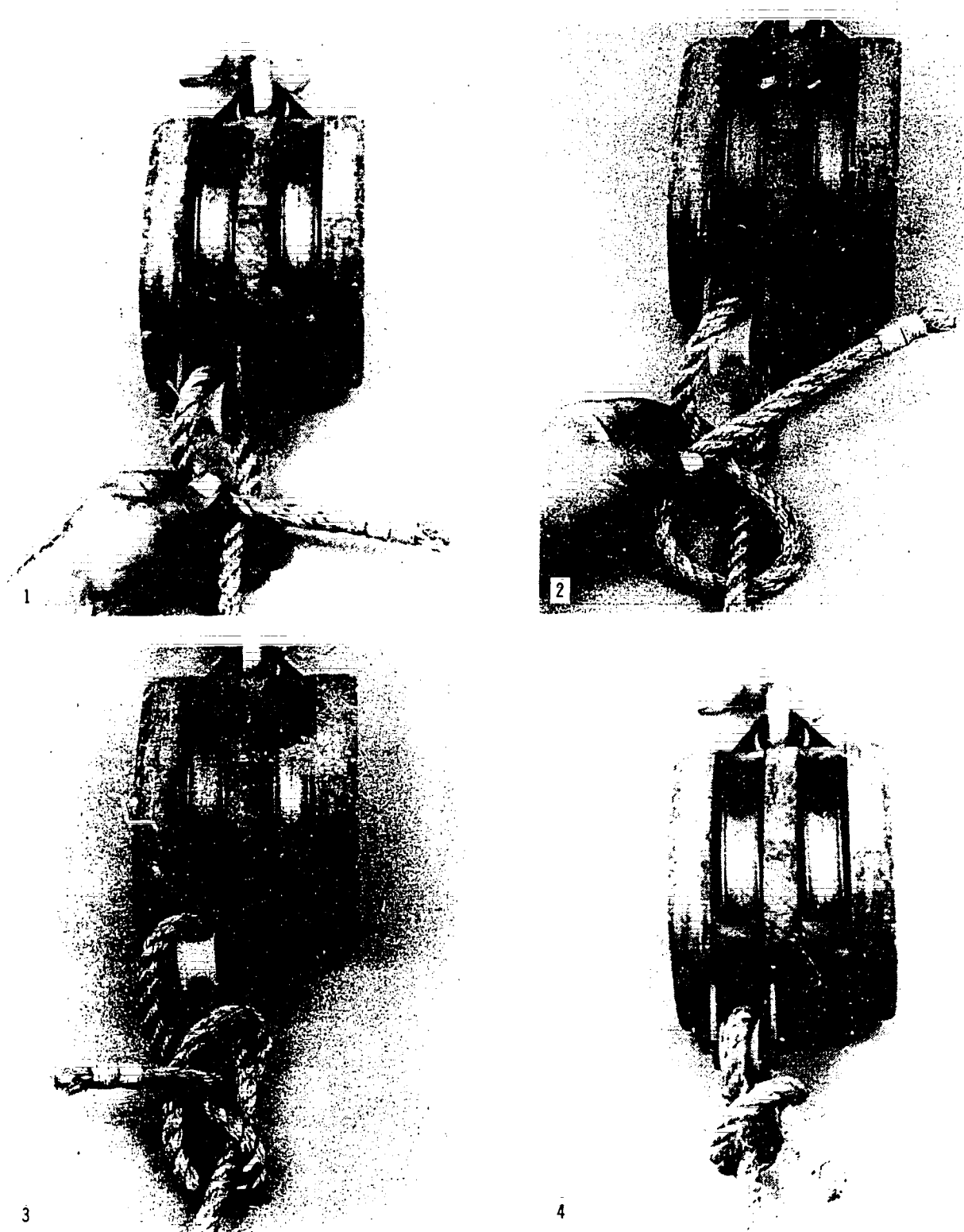

Figure 7-29. Tying a Becket Hitch



Figure 7-30. Horizontal Barrel Sling

### SPLICES

Splicing is a process of joining two ropes together, or joining the end of a rope to a point on the standing part. Splicing reduces the rated strength of the rope by 10-15%. Both natural and synthetic fibre ropes can be spliced, but for all types of splices, two or more extra tucks are required for synthetic fibre rope. An important consideration in making splices is the care that must be taken in unlaying the rope and reweaving the strands so that the form and lay of the rope are not disrupted.

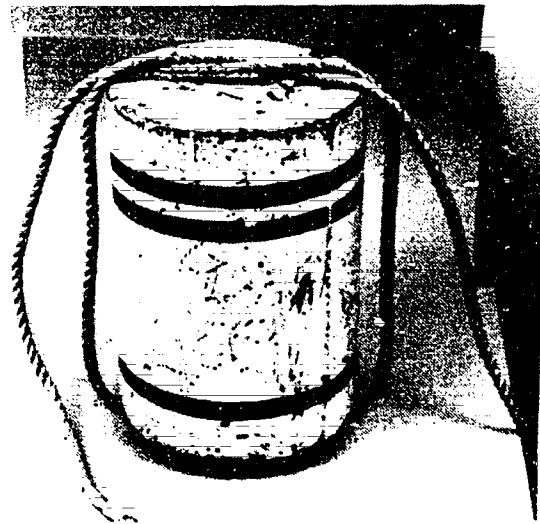

1



2



3

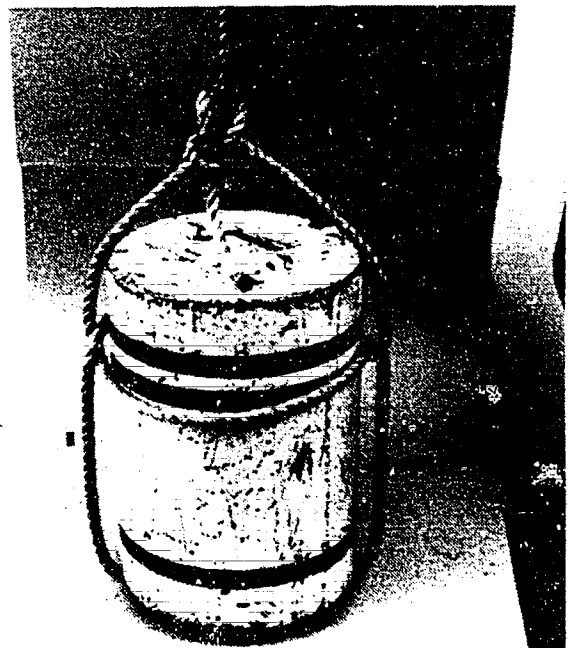

4

Figure 7-31. Making a Vertical Barrel Sling

## SHORT SPLICE

The Short Splice is the strongest type of splice; however, it has the disadvantage of increasing the diameter of the rope to such an extent that it is unsuitable for some uses such as running through blocks or sheaves.

### Procedure

- Step 1: Unlay the strands at end of each rope for six or eight turns. Whip the ends of the strands to prevent their untwisting, and bring together so that each strand of one rope alternates with a strand of the other (Figure 7-32, Step 1).
- Step 2: Bring the ends tightly together and apply a temporary seizing where they join (Figure 7-32, Step 2).
- Step 3: Take any one strand and begin tucking, the sequence being over one and under one. Figure 7-32, Step 3, shows how Strand A is passed over the strand nearest to it, which is Strand D, and then under the next strand, Strand E.
- Step 4: Rotate the splice away from you one-third of a turn and make the second tuck; Strand B is passed over Strand E and then under Strand F (Figure 7-32, Step 4).
- Step 5: Before making the third tuck, rotate the splice again one-third of a turn away from you. Strand C is then passed over Strand F, and under the next one, Strand D. The splice now appears as in Figure 7-32, Step 5.
- Step 6: This completes the first round of tucks in the left hand half of the splice. Each strand should now be tucked at least twice more, always over one and under one as before, making sure that each strand lies snug and is without kinks.
- Step 7: To finish the splice, reverse the rope end for end so that Strands D, E and F are now at the left instead of the right (in the same position of Strands A, B and C in the illustrations) and repeat the tucking operation on their side of the rope. Each of the six strands will now have had at least three tucks. A tapered splice is made by taking two more tucks with each strand, cutting
- away some of the threads from each strand before each extra tuck.
- Step 8: When tucking is finished, remove the centre seizing and cut off the ends of all strands, leaving at least 3/4" on each end. To give a smooth appearance, roll the splice back and forth, either under your foot or between two boards. The completed Short Splice should look something like the illustration in Figure 7-32, Step 8.

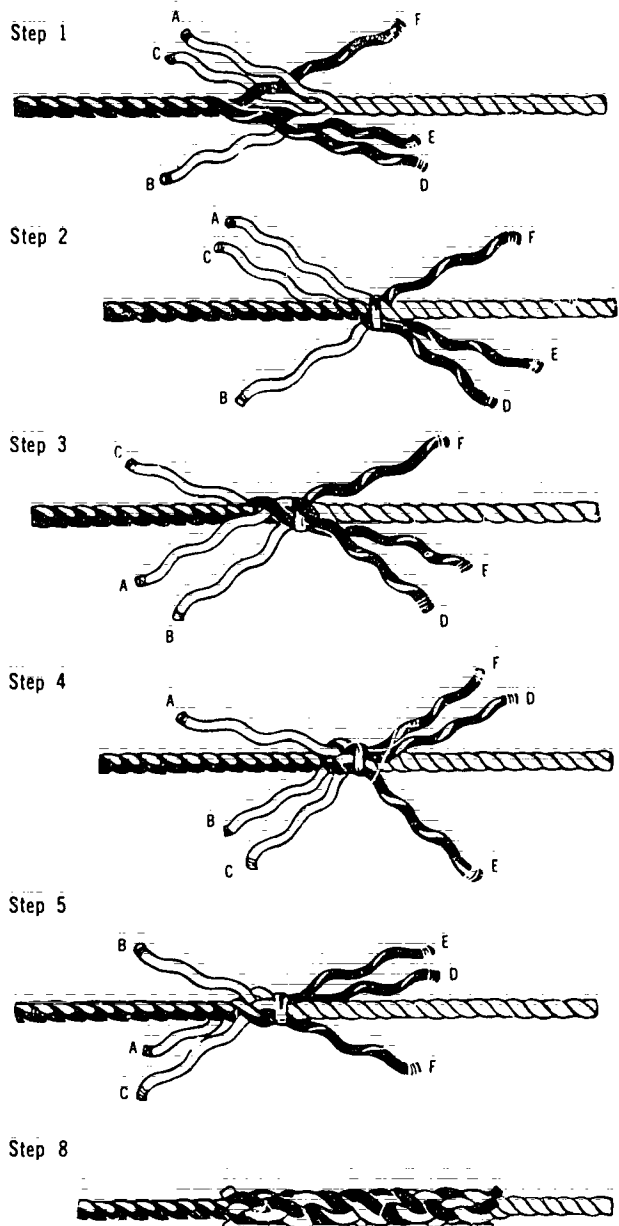

Figure 7-32. Making a Short Splice

### LONG SPLICE

The Long Splice is used for pulley work since it permits ropes that have been spliced to be run through sheave blocks without jamming or chafing. Unlike the short splice, the diameter of the spliced rope is increased very slightly.

#### Procedure

- Step 1. To make this splice, begin by unlaying one strand of each rope for 10 or 15 turns, and whip the ends of each strand to prevent untwisting. Then lock the two ropes together by alternating the strands from each end as illustrated in Figure 7-33, Step 1.
- Step 2. Starting at one end, take an opposite pair of strands, A and B, and unlay Strand A. Follow it with Strand B, turn by turn, continuing until only 1' or less of Strand B remains. Keep Strand B tight during this step and pull it down firmly into Strand A's former place. Repeat this operation with Strands C and D. Strand D is unlayed and Strand C is laid in its place. The splice at this stage is illustrated in Figure 7-33, Step 2.
- Step 3. Now each pair of strands is tied loosely together with a simple overhand knot, as indicated by Strands A and B in Figure 7-33, Step 3. Each knot is then pulled down into the rope like Strands C and D.
- Step 4. Each strand is now tucked twice, over and under, as done in making the Short Splice. Figure 7-33, Step 4 shows Strands C and D after tucking. If a smaller diameter splice is desired, tapering can be done by tucking each strand twice more, cutting away some of the threads for each additional tuck.
- Step 5. When tucking is finished, cut all strands off close to the rope and roll the splice on the floor under your foot to smooth it out. The completed Long Splice is illustrated in Figure 7-33, Step 5.

### SIDE SPLICE

The Side Splice is also called the Eye Splice because it is used to form an eye or loop in the end of a rope by splicing the end back into its

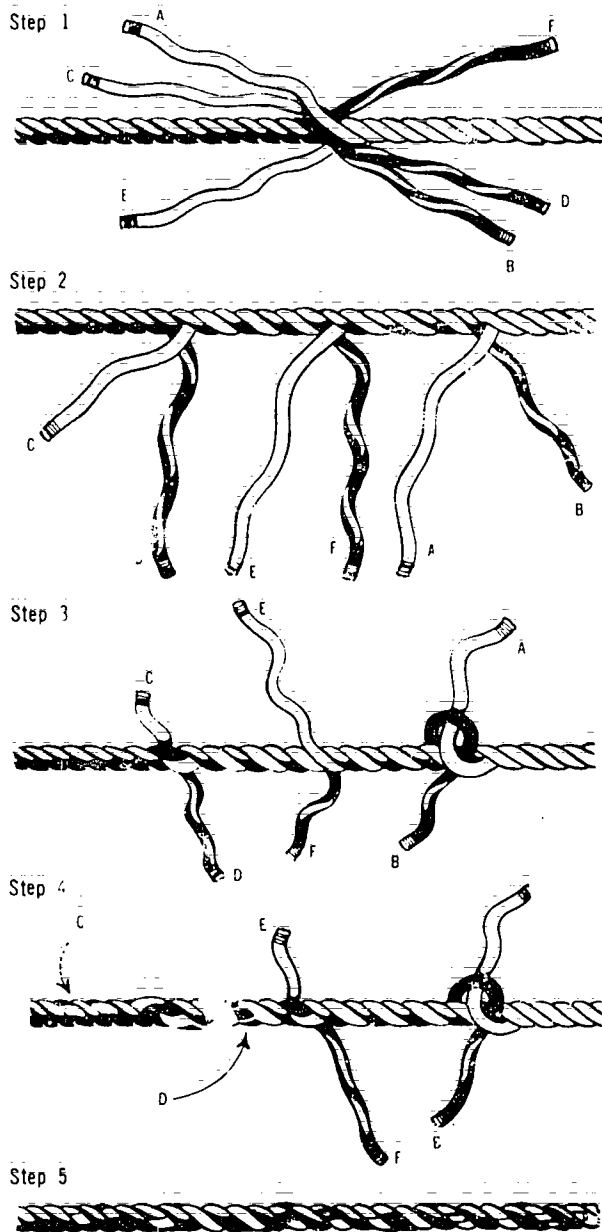

Figure 7-33. Making a Long Splice

own side. This splice is made like the Short Splice except that only one rope is used.

#### Procedure

- Step 1. Start by seizing the working end of the rope. Unlay Strands A, B and C, to the seizing and whip the end of each strand. Then twist the rope slightly to open up Strands D, E and F of the standing part of the rope, as indicated in Figure 7-34, Step 1:
- Step 2. The first tuck is shown in Figure 7-34, Step 2. The middle strand is always

tucked first, so Strand B is tucked under Strand E, the middle strand of the standing part.

Step 3. The second tuck is now made as illustrated in Figure 7-34, Step 3. Left Strand A of the working end is tucked under Strand D, passing over Strand E.

Step 4. Figure 7-34, Step 4 illustrates how the third tuck is made. To make Strand F easy to get at, the rope is turned over. Strand C now appears on the left side.

Step 5. Strand C is then passed to the right of and tucked under Strand F, as illustrated in Figure 7-34, Step 5. This completes the first round of tucks.

Step 6. Figure 7-34, Step 6 illustrates the second round of tucks started, with the rope reversed again for ease in handling. Strand B is passed over Strand D and tucked under the next strand to the left. Continue with Strands A and C, tucking over one strand and then under one to the left. To complete the splice, tuck each strand once more.

Step 7. Remove the temporary seizing and cut off the strand ends, leaving at least 1/2" on each end. Roll the splice back and forth under your foot to even up and smooth out the strands. The completed Eye Splice is illustrated in Figure 7-34, Step 7.

## NATURAL FIBRE LINE

### MANUFACTURE OF NATURAL FIBRE LINE

Natural fibre line is constructed by a process of twisting vegetable fibres together. Individual fibres are grouped and twisted to form yarns, and yarns are grouped and twisted together to form strands (Figure 7-35). Finally, a number of strands are twisted to form a line. The line twist is balanced by reversing the direction of twist for each set of components: fibres and strands are twisted opposite to yarns.

### TYPES OF NATURAL FIBRE LINE

Fibre line is classified on the basis of the kind of vegetable fibres used to manufacture it:

Step 1

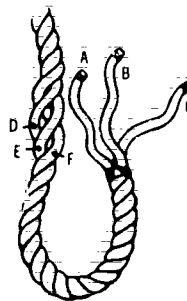

Step 2

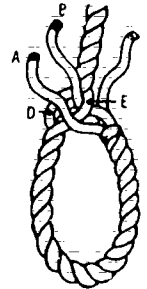

Step 3

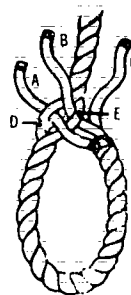

Step 4

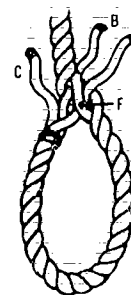

Step 5

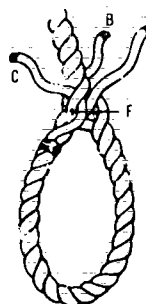

Step 7

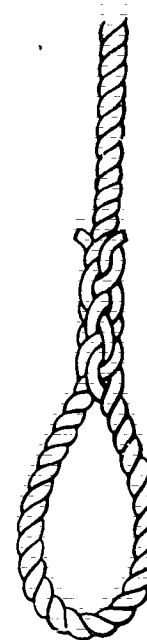

Step 6

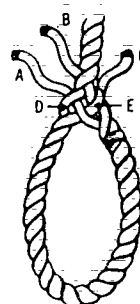

Figure 7-34. Making a Side Splice



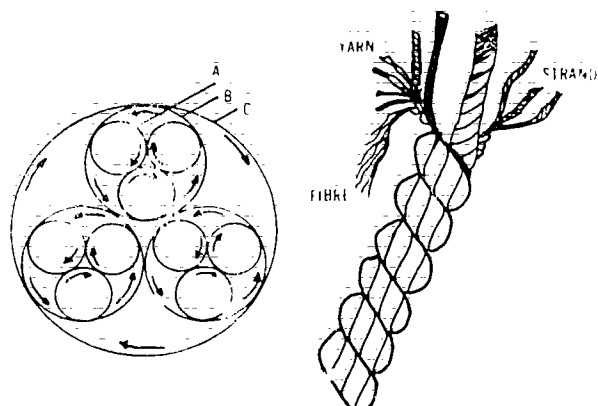

Figure 7-35. Construction of Natural Fibre Line

**Manila** fibres are made from plantain leaves. Superior quality manila line is made from long fibres of light colour, as it is softer, more elastic, stronger, durable and water resistant. Its smoothness makes it preferable for running over blocks and sheaves.

**Sisal** line has a harsher feel than manila and is about 80% as strong. It has the advantage of tolerating exposure to sea water very well.

**Hemp** fibres are short and soft, but it produces a strong, rough line. Tar soaking, although, reducing the line's strength and flexibility, is necessary to reduce deterioration from dampness.

**Coir and Cotton** Coir line is rough and elastic and floats on water. It is only 25% as strong as hemp. Cotton can tolerate a great deal of bending and running, but is too light for most uses.

**Forms of Natural Fibre Line**

The arrangement of strands in a line is an important feature of its construction. The three principal forms are: hawser laid, shroud laid and cable laid line.

**Hawser laid** line is composed of three strands in a right hand lay (Figure 7-36).

**Shroud laid** line is composed of four strands in a right hand lay around a centre core (Figure 7-36).

**Cable laid** line is composed of three lines (right hand Hawser) arranged in a left hand lay (Figure 7-36).

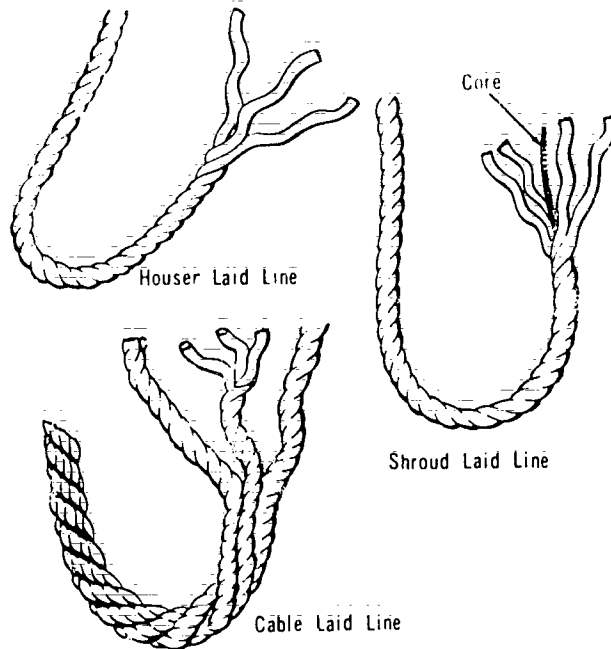

Figure 7-36. Forms of Natural Fibre Line

**CHARACTERISTICS OF NATURAL FIBRE LINE**

**Size** Fibre line is designated by diameter and circumference (in inches).

**Weight** The number of feet per pound of line can be estimated with the following formula within 12% accuracy:

$$\frac{3.4}{(\text{diameter})^2}$$

**Example:** for 5/8 inch line

$$\frac{3.4}{(5/8)^2}$$

= 8.7 feet per pound

**Strength** Line strength is described in terms of: 1) breaking strength and 2) safe working capacity. The breaking strength divided by the factor of safety gives the safe working capacity which should **never** be exceeded. Excess loads damage the fibres and reduce the strength and life of the line. The condition of the line, in terms of exposure, wear, use and bending, must be considered in estimating its strength, as these factors over time will greatly reduce the line's capability.

Rated capacities for safe loads are listed in tables for **new line only**. (See, for example, Table 7-1.)

A rule of thumb for estimating the safe working capacity (in tons) of manila line is to square the diameter (in inches); for example, a 1 1/8" manila line would have a safe working capacity of 1<sup>17</sup>/<sub>64</sub>; or approximately 1 1/4 tons.

**CARE AND MAINTENANCE OF NATURAL FIBRE LINE**

The functional life of natural fibre line can be extended with proper care in handling and maintenance. Knowledge of the characteristics and limitations of each kind of line will provide guidelines for good handling practices.

Inspect lines frequently to determine the actual condition of the inner fibres, which is not evident on the surface. Grasping the line firmly with two hands, untwist it slightly to expose the inner portion, and look for the following:

1. Mildew — inner fibres are dark and stained and have a musty odour
2. Broken strands or yarns

3. Chafing residue — dirt and sawdust-like material inside the line
4. Fragmentation of the core — core breaks away in small pieces, indicating overstrain.

Examine the line in this way in a number of places and finally pull out and stretch a few random fibres to test for breakage resistance. Any line found to be deficient should be destroyed or cut into pieces too short for hoisting.

**Protection of Line Ends** Raw or cut ends of line should be secured to prevent unlaying. Tying a knot at the end of a line, or whipping will secure the lay.

**Storage** Deterioration of natural fibre line can be prevented by good storage practices. These include the following conditions:

1. Storage areas should be dry.
2. Lines should be dried before storing.
3. Circulation of air around coiled line should be provided such as gratings to support the coils.
4. Fibre line should not be covered unless absolutely required.

Nominal diameter (inches)	Circumference (inches)	Weight per 100' (pounds)	No. 1 Manila			Sisal
			Breaking Strength (pounds)	Safe Load (pounds) F.S. :4	Breaking Strength (pounds)	Safe Load (pounds) F.S. :4
1/4	3/4		550	150	440	120
2/3	1 1/8		1,275	325	1,020	260
1/2	1 1/2		2,650	660	2,120	520
3/5	2	13.1	4,400	1,100	3,520	880
3/4	2 1/4	16.4	5,400	1,350	4,320	1,080
7/8	2 2/4	22.0	7,700	1,920	6,160	1,540
1	3	26.5	9,000	2,250	7,200	1,800
1 1/8	3 1/2	35.2	12,000	3,000	9,600	2,400
1 1/4	3 3/4	40.8	13,700	3,380	10,800	2,700
1 1/2	4 1/2	58.8	18,500	4,620	14,800	3,700
1 3/4	5 1/2	87.7	26,500	6,625	21,200	5,300
2	6	105.0	31,000	7,750	24,800	6,200
2 1/2	7 1/2	163.0	46,500	11,620	37,200	9,300
3	9	237.0	64,000	16,000	51,200	12,800

NOTE: Breaking strength and safe loads given are for new line used under favorable conditions. As line ages or deteriorates, progressively reduce safe loads to one-half of values given.



Rigging and Erection

**Prevention of Moist Damage** Since fibre line will contract when wet, it should be slackened before exposure to rain or dampness.

**Prevention of Damage to Strands** Although continued use will result in some fibre damage, this can be minimized by

1. Washing line that is muddy or sandy
2. Using softeners to pad sharp corners over which the line must be pulled
3. Keeping line out of sand and dirt as much as possible
4. Using knots that are easy to untie
5. Repairing broken strands in the line as soon as possible.

**Coiling and Uncoiling** New natural fibre line is delivered in coils of 600'-1200' and lashed or bound. Generally an instruction tag will accompany the coil. After cutting the bindings or lashings, grasp the line end inside the coil at the bottom and pull it up through the middle to prevent kinks from forming (Figure 7-37).

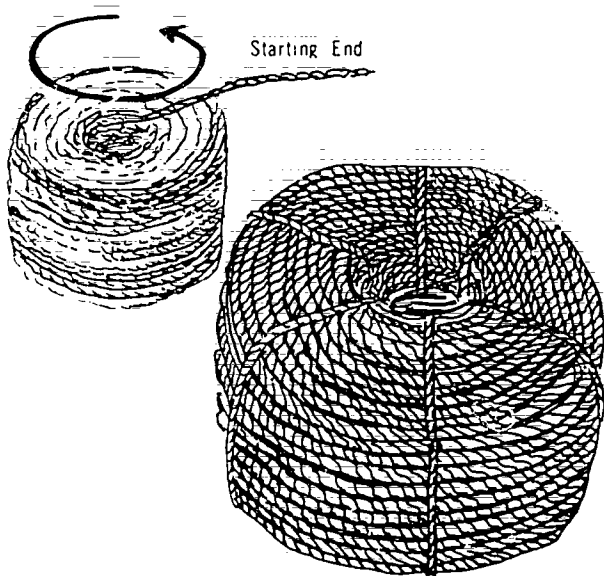

Figure 7-37. Uncoiling a Coil of Fibre Line

**SYNTHETIC FIBRE ROPE**

**CHARACTERISTICS OF SYNTHETIC FIBRE ROPE**

Synthetic fibre ropes, particularly nylon and polypropylene, are becoming more widely used, replacing manila rope in many instances. These ropes have individual fibres running the entire

length of the line rather than short, overlapping fibres as in natural fibre rope. This accounts for the greater strength of synthetic fibre line (See Table 7-2).

**TABLE 7-2. RELATIVE STRENGTH OF FIBRE ROPES (DRY)**

Type of Rope	Relative Capacity (Related to Nylon)
Nylon	100%
Polyester	94%
Polypropylene	81%
Polyethylene	73%
Manila	67%

Synthetic fibre ropes are generally impervious to rot, mildew and fungus and have good resistance to chemicals. They are lighter and easier to handle, and have excellent impact, fatigue and wear resistance, outwearing manila ropes by four or five times. They are liable to melt at high temperatures, however, and should not be used where heat is excessive or friction is high enough to melt the fibres. They should not be used near welding operations. Generally, synthetic fibre rope is abrasion resistant and can tolerate long exposure to water without any noticeable loss of strength or change in appearance.

**TYPES OF SYNTHETIC FIBRE ROPES USED IN RIGGING**

**Nylon Rope** Nylon rope is two and one half times stronger than manila and is the most widely used of the synthetic rope family. It is chalky white in colour, has a smooth surface, is soft and pliant and has a feeling of elasticity.

Some properties of nylon ropes are:

1. High breaking strength (wet or dry)
2. Light weight per unit of strength
3. Excellent elasticity and tensile recovery
4. Superior absorption of impact and shock loads
5. Excellent flex and abrasion resistance
6. Good flexibility
7. Excellent resistance to rot
8. Good sunlight and weather resistance
9. High melting point.

Due to its continuous fibre construction, nylon rope is strong and resistant to creep under sustained load. Its elasticity recommends its use where high energy absorption is needed or where shock loading is a factor. The high degree of stretch can be a serious disadvantage if headroom for lifting is restricted and slings must be as short as possible. Under actual service conditions, nylon rope will stretch to about 16% under working loads and over 40% under breaking loads. The initial loading of a nylon rope produces a permanent elongation of approximately 8%, but recovery is complete from subsequent stretching under load. Therefore, nylon ropes should be broken in prior to field use.

Nylon rope tolerates heat without loss of strength or physical properties up to 300°F (melting point 482°F.). Nylon ropes absorb moisture and lose approximately 10% of their strength when wet as well as becoming very slippery. Full recovery occurs when the rope

dries out. Table 7-3 compares nylon and manila ropes under a heavy sustained load.

Store nylon rope away from heat and exposure to sunlight. Nylon is highly resistant to alkalis, but can be degraded by most acids, paints and linseed oil, and all contact with chemicals should be avoided. If contact is suspected, wash the rope thoroughly in cold water and then carefully examine the fibres for evidence of weakening.

**Braided Nylon Rope** Braided nylon rope provides the highest possible strength since the load is divided equally between a braided sheath and a braided core. The rope is soft and flexible and does not twist or kink. Twisted three strand rope transmits a turning, twisting motion under load while braided nylon does not.

Braided nylon presents approximately 50% more surface area for wear and grip, is stronger for size and more stable, exhibits less stretch when

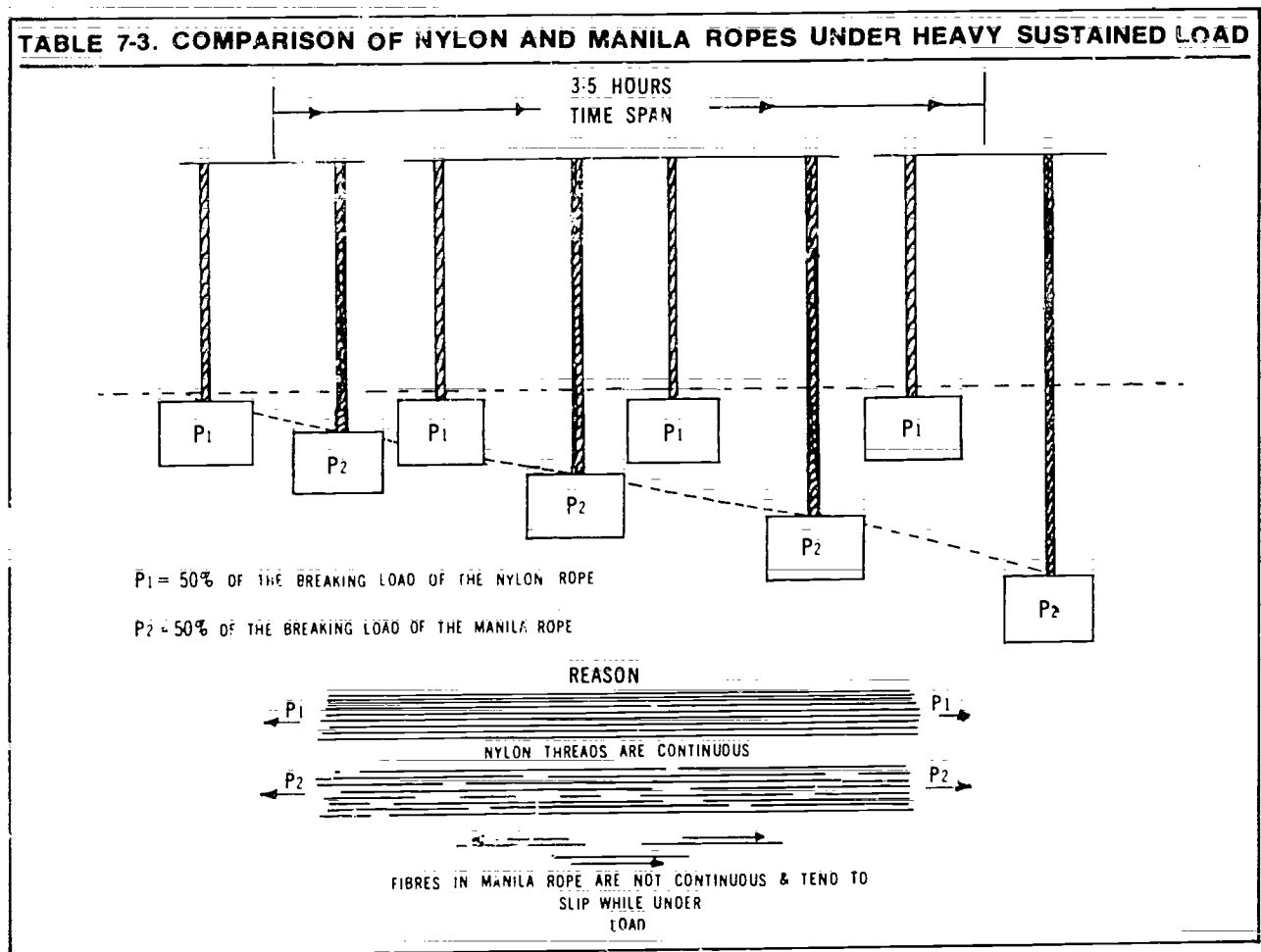

## Rigging and Erection

working, has less permanent stretch and greater flexibility than three strand nylon ropes.

The braided sheath and core construction is available in synthetic combinations in addition to nylon:

1. Nylon core/nylon cover — high strength, more stretch, good wearing qualities
2. Polypropylene core/nylon cover — lower strength, lower stretch
3. Polypropylene core/polyester cover — very low stretch, high strength and good abrasion resistance.

For example, a nylon core/nylon cover rope with a nominal diameter of 7/8 inch carries a safe working load of 4,800 pounds, while a polypropylene core/nylon cover rope will carry a safe working load of 4,150 pounds. A polypropylene core/polyester cover rope will support a safe working load of 3,800 pounds. The safety factor for braided synthetic combinations is 5.

**Polyester Rope** Polyester rope (Trade names: Dacron, Terylene) is nearly identical to nylon in appearance but has little or no elastic feeling. Size for size, it is heavier and not as strong as nylon rope, although similar in construction. This is a continuous filament rope and resists creep under sustained loads. The low stretch properties of polyester rope represent a considerable advantage where headroom is limited since, after the initial permanent stretch of approximately 6%, subsequent loads produce a temporary lengthening of approximately 5.9% (compared to 16% for nylon). Polyester ropes should be broken in before field use.

Abrasion resistance is similar to nylon rope. Like nylon, polyester rope is unaffected by temperatures up to 300° F. It absorbs much less water than nylon. It does not lose strength when wet. Polyester rope resists sun and weather damage as well as attack by rot and mildew, however, precautionary storage practices are recommended. Polyester is more resistant to chemicals than nylon, but exposure and contact should be avoided. Slings should be washed frequently in cold water.

**Polypropylene Rope** Polypropylene and polyester ropes are almost identical in appearance; they are available in various colours and are smooth and pliant and somewhat slippery, particularly polypropylene.

A singular advantage of polypropylene rope is its ability to float on water; however, it is not as strong as nylon or polyester and ranks between natural fibre ropes and the more sophisticated nylon and polyester.

Stretch properties of polypropylene ropes vary with the type of construction; however, they generally exceed those of polyester. Energy absorption is approximately half that of nylon.

Polypropylene ropes have a heat tolerating capacity comparable to nylon and polyester; however, some deterioration occurs in sunlight. Chemical resistance is generally good as is resistance to rot and mildew. An important feature is polypropylene rope's safety around electricity as it is a non-conductor because it absorbs no water.

**Polyethylene Rope** Polyethylene ropes are low in strength compared with the other synthetic fibre ropes. They tolerate heat only up to 250° F and undergo some deterioration in sunlight. They are, however, resistant to chemicals except sulphuric acid.

## WIRE ROPE

### CHARACTERISTICS OF WIRE ROPE

Wire rope is used for so many purposes today that it is not practical to enumerate them all. Because of this widespread use it cannot be expected that one type or construction of rope, varying only in size and strength, will meet all requirements.

Listed below are some common terms and their abbreviations used to designate types of construction of wire rope:

R.L.	Regular Lay
L.L.	Lang Lay
F.C.	Fibre Core
I.W.R.C.	Independent Wire Rope Core
6-19	6 strands 19 threads
6-24	6 strands 24 threads
6-37	6 strands 37 threads
M.S.	Mild Steel
C.C.	Cast Crucible
I.P.	Improved Plow
S.I.P.	Special Improved Plow
Gal	Galvanized

To determine the breaking strengths and safe working loads for the various types of wire rope used in the Boilermaking trade it is essential to know the construction of the rope. The most commonly used wire rope is 6-19 and 6-24 Low Steel in Ordinary Lay. Galvanized wire rope is used under certain unusual environmental conditions such as near salt water or chemical plants and pulp mills. Lang Lay wire rope is mostly used on shovels and drag lines. Under ordinary conditions Fibre Core is used, but where additional strength or resistance to compression is required Independent Wire Rope Core is chosen.

A process called Preforming of wire rope permanently shapes the fibres into the position they will occupy in the finished rope. This makes the rope more stable and more resistant to unstranding by reducing internal stresses.

#### GRADES OF WIRE ROPE

**Grade 120/130 Special Improved Plow Type II** is used in the manufacture of wire ropes for special installations where maximum rope strength is required and conditions permit use of this heavy grade rope with existing hoisting equipment.

**Grade 115/125 Special Improved Plow Type I** is also used for special applications when breaking strengths in excess of those obtained with Grade 110/120 are required and existing equipment can handle the rope size.

**Grade 110/120 Improved Plow** has high tensile strength, tough wearing qualities and fatigue resistant properties. This is the most frequently used wire rope.

Three further grades of wire rope are in less frequent use. Their capabilities make them suitable only in situations where strength is secondary to fatigue resistance. These grades are Grade 100/110 Plow, Grade 90/100 Mild Plow and Grade 80/90 Cast Crucible.

**Galvanized wires** are coated with zinc at finished size either by the "hot dip" or "electro" process.

**Drawn Galvanized wires** (sometimes called Drawn After Galvanized or DAG) are coated with zinc at an intermediate size and the zinc-coated wire cold-drawn to the final or required finished size.

**Bryanzed wire** is zinc-coated by a special process employed by a British company, whereby the zinc becomes an integral part of the wire itself. Note that galvanized finishes can be applied to any grade of rope wire except phosphor bronze and copper wires.

**Corrosion Resisting wire** is usually a chromium-nickel steel alloy with high resistance to corrosion. It is used under conditions where galvanized wire will rust and fail.

**Phosphor Bronze and Copper wires** are used only where corrosion resistance and non-sparking qualities are required as in marine and hazardous industrial applications.

#### WIRE ROPE LAYS

**Regular Lay (Ordinary Lay) ropes** have the wires in the strands laid in one direction while the strands in the rope are laid in the opposite direction. This results in the wire crowns running approximately parallel to the longitudinal axis of the rope. These ropes resist kinking and twisting and can withstand considerable crushing and distortion due to the short length of exposed wires.

**Lang Lay ropes** have the wires in the strands and the strands in the ropes laid in the same direction. Thus the outer wires run diagonally across the rope and are exposed for longer length than in Regular Lay ropes, providing greater wearing surface and greater resistance to abrasion. Lang Lay ropes are more flexible than Regular Lay and resist fatigue better. Lang Lay ropes are more liable to kink and untwist and will not tolerate the same degree of distortion and crushing. The ends of Lang Lay Ropes should be permanently fastened to prevent untwisting.

**Right Lay or Left Lay ropes** have strands "rotating" to the right, while a Left Lay rope is the opposite. Most ropes in use are Right Lay ropes. (See Figure 7-38).

**Preformed wire rope** is constructed of strands and fibres shaped permanently into the contour they will take up in the completed rope. In Non-Preformed rope the wires are forcibly held in position throughout the life of the rope, as can be seen by cutting such a rope at any point, when strands and wires will immediately fly apart. Preforming the wires and strands prevents this as they all lie naturally in their true



Left Lay LANG LAY



Right Lay LANG LAY



Left Lay REGULAR LAY



Right Lay REGULAR LAY

**. Types of Wire Rope Lays**

free from internal stress. The advantages of Preformed wire rope are:

flexible and limber and easy to handle. It runs smoothly and evenly over sheaves.

Lang Lay construction is practical for many applications. Preformed rope in Lang Regular Lay is completely inert.

It has a considerably longer life than other Lay rope of equivalent size due to its even and uniform distribution of internal stresses.

It is the only wire rope that evenly balances the load on individual strands and wires. The distribution on the single wires is also uniformly uniform.

It is preferred to use as broken wires do not pull out to tear at hands and clothing. It is more easily spliced, since there is no need to seize the strands as they fall into position more easily.

It is kinking better than other ropes.

It resists many of the abuses to which wire rope is often unavoidably subjected.

**WIRE ROPE**

Round ropes are the simplest of the true ropes and are almost universal in their use. They consist of from 3 to 36 strands laid in various arrangements concentrically around a central core. The use of round wires laid in geometric patterns results in a round strand. Figures 7-39 show only two of many round strand wire rope types available.

Each strand is made up of two or more wires. The wires in the strands are laid in a helical pattern. That is the pitch of lay will be larger for the outer

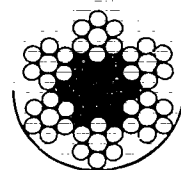

6 x 7 Round Strand  
Fibre Core

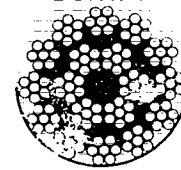

18 x 7 Round Strand  
Fibre Core

**Figure 7-39. Round Strand Rope**

layers as related to the next inner layer. This construction is limited to small ropes and cords, but is used for some ship ropes and for standing ropes in larger sizes.

For all other purposes ropes of equal-laid construction are preferable. By this method all layers of wires have the same pitch or length of lay. Each wire in each layer therefore lies either in a bed formed by the valleys between the wires of an underlayer or alternatively along the crown of an underlying wire. Because no layer of wires ever crosses over another an equal-laid rope maintains its diameter in service; has more solid cross section and improved fatigue life as compared to cross-laid ropes.

**Flattened Strand ropes** are built up of triangular shaped strands or strands of oval shape. Certain types, specifically non-rotating ropes, are built up of a combination of oval around triangular, or sometimes oval around round. In the case of triangular shaped strands the wires forming the strand are laid on a triangular shaped core formed of a single triangular shaped wire or of three or more round wires. The wires forming an oval strand are laid on an oval shaped centre ribbon or around a group of usually four round wires laid parallel. Because of the triangular shape of the strands, flattened strand ropes

have smaller fibre cores than do round strand ropes. Hence, size for size, flattened strand ropes have approximately 10% greater metallic area with comparable increased breaking strength. Figure 7-40 illustrates two of the various flattened strand wire arrangements available.

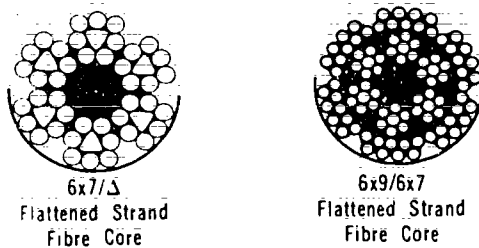

Figure 7-40. Flattened Strand Rope

With ropes of this type frictional wear is spread over a greater number of outer wires of the rope as compared with a round strand rope. In the flattened strand construction, with the friction distributed over a greater external surface, wear is more even and the loss of sectional area of the vital outside wires much reduced. Because of the smooth surface and circular cross section obtained with flattened strand ropes the wear on sheaves and pulleys is materially reduced and in the case of ropes used for endless haulage systems the increased external bearing surface enables grips and clips to be more securely employed. Also, owing to its more solid construction, this type of rope is less likely to be forced out of shape by such clips.

**Locked Coil rope** differs completely from both round strand and flattened strand rope. Instead of a group of individual strands closed around a central core member it is a single strand built up of layer upon layer of wires. The centre or core of the locked coil rope consists of a concentric laid strand of round wires. Around this core are laid one or more layers of shaped wires, the outer layer always being interlocking. The shape or shapes of all shaped wires in a locked coil rope depend on the rope diameter and its end use. Typical locked coil wire arrangements are illustrated in Figures 7-41.

Locked coil ropes have a higher breaking strength than stranded ropes for equal diameter and the same nominal strength grade. Because of their smooth external surface depreciation in

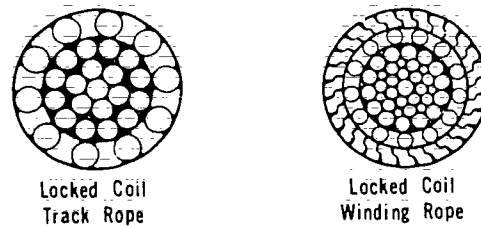

Figure 7-41. Locked Coil Rope

strength caused by frictional wear on drums or pulleys is greatly reduced. Because of their design locked coil ropes are less subject to rotation and stretch than stranded ropes.

**Concentric Strand rope** as its name implies consists of round wires laid layer upon layer around a centre wire. This simple strand construction is used exclusively for static purposes such as bridge suspension ropes, standing rigging and similar purposes. (See Figure 7-42).

Two general arrangements of wires are used. The first consists of concentric layers of wires of one size around a somewhat larger centre wire. The second consists of one or more concentric layers of wires of one size around a core group made up of an equal laid strand.

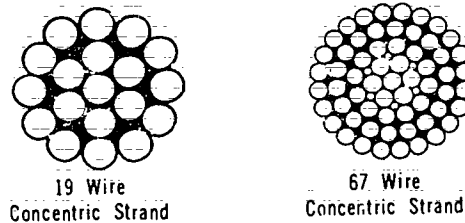

Figure 7-42. Concentric Strand Rope

### WIRE ROPE CORES

The core forms the heart of the rope and is the component about which the main rope strands are laid. The core supports the strands and is intended to keep them from jamming against or contacting each other under normal loads and flexings. The core may take one of several forms depending on the conditions under which the rope will be used.

**Fibre Core** (Figure 7-43) is adequate for many types of service providing maximum flexibility and elasticity to the wire rope. Generally made of hard fibres, usually sisal and occasionally manila, it may also be manufactured from man-



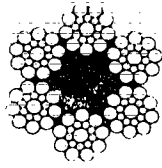

Figure 7-43. Fibre Core

made fibres such as polypropylene or nylon. These latter cores are useful where conditions surrounding the rope's use could result in premature failure of vegetable fibre cores. Sisal and manila fibre cores are impregnated during the cordage process with a suitable lubricant having preservative properties. Cotton and jute fibres are frequently used in cores for small cords such as sash cords, etc.

**Independent Wire Rope Core (IWRC)** (Figure 7-44) consists of a 6 x 7 stranded steel wire rope with a 7 wire centre strand. Its greatest use is where ropes are subjected to severe pressure while running over sheaves or winding on to drums. This core should be used when rope operates in temperatures damaging to natural or man-made fibres. It provides additional strength and less stretch with less resilience.

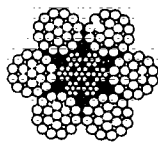

Figure 7-44. Independent Wire Rope Core

**Strand Core** (Figure 7-45) consists of a strand of steel wires, nominally 7, 19 or 37. It is occasionally used in running rope of smaller diameters rather than IWRC. It may also be used in standing ropes, guys, suspender ropes, etc. where extra strength, reduced stretch and maximum resistance to weathering are required.

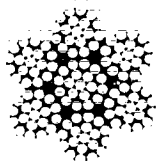

Figure 7-45. Steel Strand Core

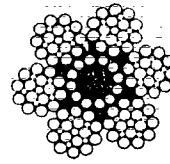

Figure 7-46. Armoured Core

provides superior wire-to-wire contact with the main rope strands as compared to IWRC's. The armoured core provides greater strength and resistance to crushing than fibre core.

**WIRE ROPE CLASSIFICATIONS**

**6 x 19 Classification** This classification covers ropes with 6 strands closed around a fibre or steel core and includes ropes having 17 to 26 wires per strand; an example is shown in Figure 7-47. Rope of 6 x 19 classification is used on a greater variety of applications than any other. Such ropes will be found on bridge cranes and gantrys, shop cranes and mobile cranes, hoists and derricks, dredges and clam shells, drag lines and scrapers, power shovels and trench hoes, blast-holes drills and in industry generally.

Ropes in this class are available in regular lay or lang lay, with fibre core or with independent wire rope core. While usually right lay, left lay is made for special purposes as, for instance, blast-hole drilling. The use of lang lay rope, where possible, also improves flexibility, and provides additional resistance to abrasive wear.

A wide choice of wire arrangements in the strands is available, giving varying combinations of flexibility and resistance to abrasive wear. This adaptability is primarily achieved through the number of outer wires in each strand, ranging from 8 to 12.

The diameter of wire rope is the main factor in the size of load that the rope can safely take. Table 7-4 gives the breaking strains and safe working loads for 6 x 19 plowsteel F.C. wire rope.



Figure 7-47. 6 x 26 Right Regular Lay, Fibre Core

TABLE 7-4. BREAKING STRAINS AND SAFE WORKING LOADS		
6 x 19 Plowsteel F.C. Wire Rope		
Diameter	Breaking Strain in Tons	S.W.L., Tons
3/8	6.0	1.1
1/2	10.7	2.4
5/8	16.5	3.3
3/4	23.8	4.7
7/8	32.0	6.2
1	41.7	8.3
1-1/8	53.0	10.6
1-1/4	65.5	13.2
1-1/2	96.0	19.1
2	169.0	53.8

**6 x 37 Classification** This classification covers ropes with 6 strands closed around a fibre or steel core and includes ropes having 27 to 49 wires per strand. This rope is designed for maximum flexibility with a reasonable degree of resistance to crushing and is in general use on applications such as overhead shop cranes where high rope speeds and multiple reeving are encountered and where layer-on-layer winding is normally involved. Such ropes also find wide-spread use in their larger sizes on power shovels, dredges, drag lines, etc. where, for considerations of mobility and weight, winch drums and main rope sheaves must be limited in size.

Ropes in this class are available in regular lay (Figure 7-48) or lang lay, with fibre core or independent wire rope core. While usually made right lay, left lay is made for special purposes, as, for instance, where ropes operating in pairs may consist of one right lay and one left lay to cancel out torque.

A wide choice of wire arrangements in the strands is available, thus giving varying degrees



Figure 7-48. 6 x 36 Right Regular Lay, Fibre Core

of flexibility and resistance to abrasion and wear. All rope sizes are not necessarily manufactured in every strand construction? Adaptability is primarily achieved through the number of outer wires, ranging from 12 to 13 per strand. The use of lang lay rope, where possible, also improves flexibility and provides additional resistance to wear.

**6 x 7 Galvanized Rigging and Guy Rope** This group includes ropes with 6 strands closed around a fibre core and having 6 or 7 wires per strand. These ropes are used as standing ships' rigging and for guying of towers, derricks, smoke stacks, etc. on shore. Individual wires are galvanized before being fabricated into ropes in accordance with Canadian Standard Association Standard G-4 requirements for Galvanized Wire (Figure 7-49).



Figure 7-49. 6 x 7 Galvanized Right Regular Lay, Fibre Core

### SPLICING WIRE ROPE

The length of a long splice in wire rope is governed by the size of the rope. The length of splice for 6-strand ropes of various diameters is calculated as follows:

**Multiply the diameter of the rope by 80** (gives length of splice in feet)

**Example:**

$$\text{For } 3/4 \text{ " rope: } 3/4 \times 80 = 60'$$

### PROCEDURE FOR SPLICING WIRE ROPE

- Step 1. Mark off 1/2 the total splice length from each of the two rope ends. These marks represent the point of marriage (Figure 7-50).
- Step 2. Unlay two strands from each piece to the marks and interlay the pairs as shown in Figure 7-51. Pull the ropes together snugly at the marry.
- Step 3. Unlay Strands 1 and 2 back to the 15' mark and lay Strands A and B in their

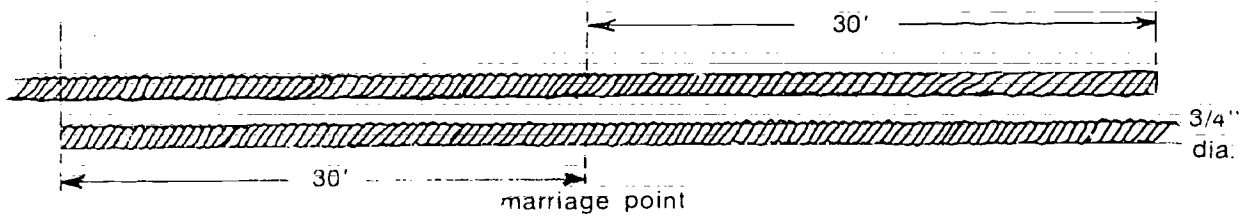

Figure 7-50. Marriage Point of Two Ropes

place. Then take Strand 1 and unlay it further back to the 25' mark and lay Strand A in its place (Figure 7-51).

Step 4 Unlay Strands C and D back to the 15' mark (in the opposite rope) and lay Strands 3 and 4 in their place. Then take Strand C and unlay it further back to the 25' mark and lay Strand 3 in its place (Figure 7-51).

Step 5 Unlay Strand 5 back to the 5' mark and lay Strand E in its place. Then unlay Strand F back to the 5' mark (in the opposite rope) and lay Strand 6 in its place. The splice should now be laid out as in Figure 7-52.

Step 6 Cut all ends, leaving 5' on each end for tucking; the ends are laid into the rope replacing the core. To open the rope for cutting the core and tucking, divide the rope in half with a marlin spike which enters the rope from the opposite side to the position of the strand to be tucked. With a smaller marlin or pliers, pull out the core and cut, pulling the end out slightly in the direction in which the tuck will be made. With the end of the tucking strand underneath the large marlin, rotate the marlin in the direction of the tuck to force the tucking end into the centre of the rope as the core is being pulled out at the end of the tuck; cut off the core so it does not abut the end of the tucked strand.

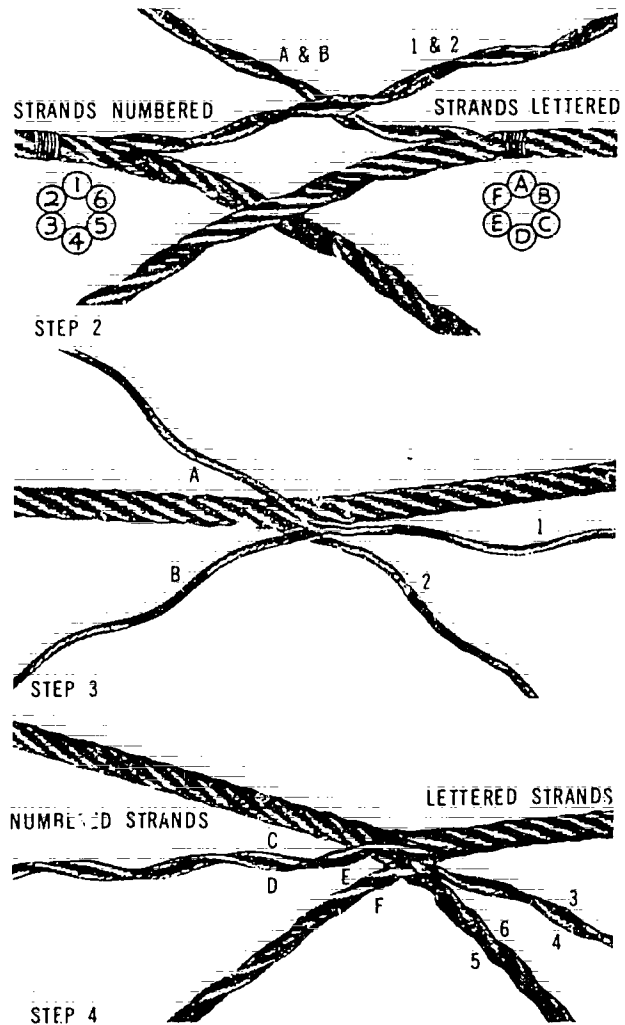

Figure 7-51. Splicing Wire Rope

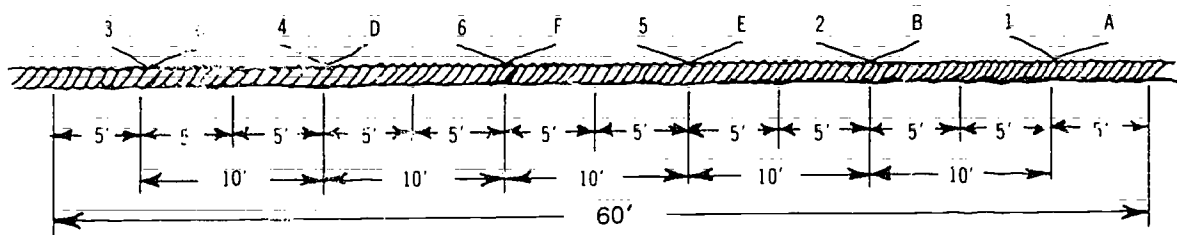

Figure 7-52. Splicing Wire Rope — Step 5

1

---

Step 7. Repeat this procedure for all tucks. A slight bulge will be noticeable where each tuck begins but this can be tapped down with a wooden mallet and will disappear entirely as soon as the rope is used.

A competent long splice in wire rope produces 95% of the rope's rated capacity.

### EYE SPLICE IN WIRE ROPE

A number of acceptable variations of the wire rope eye splice are in common use. The method set out here represents a logical step by step procedure resulting in a smooth splice of maximum strength.

In Figure 7-53 the cross-sectional illustrations with lines indicate the direction and placement of strands entering the main rope. The solid arrow illustrates the point of entry and direction of the marlin spike.

#### Procedure:

- Step 1. Secure the rope in the vise with the desired eye below and the required length of dead rope alongside the main rope above (Figure 7-53, step 1).
- Step 2. If an upper suspension vise can be secured to the main rope, and the lower vise can rotate, take one complete turn against the lay of the rope to loosen the tension of the strands in the lay. At this time unlay the strands of the dead end of the rope as illustrated in Figure 7-53 step 2.
- Step 3. Drive marlin **from front to back** at the point of entry passing under two strands to the left of the entry point (keep the main core to the right of the spike). Rotate the spike upward with the lay for a half turn around the rope (Figure 7-53, step 3).
- Step 4. Enter Strand 1 under the marlin, pull through, and rotate the spike back down toward the vise (in a direction against the lay) forcing the strand down with the left hand at the same time to nest the strand well down.
- Step 5. Determine Strand 2 on the dead end (next strand up the lay); unlay and separate.
- Step 6. Drive the marlin **from front to back** entering over the top of Strand 1 but coming out behind the next strand to the right at the back (keep the main core to the right of the spike). Rotate the spike upward as before (Figure 7-53, step 8).
- Step 7. Enter Strand 2 under the marlin and nest it well down as with Strand 1.
- Step 8. Select and unlay Strand 3.
- Step 9. Drive marlin **from the back** passing under two strands to the right of the initial entry point. (Keep main core on opposite side of marlin from previous paths.) Rotate upward as before. (See Figure 7-53, step 9.)
- Step 10. Enter Strand 3 from front under marlin and nest it well down.
- Step 11. Select and unlay Strand 4.
- Step 12. Drive marlin **from the back** passing under one strand to the right of the initial entry point. Rotate upward. (See Figure 7-53, step 12.)
- Step 13. Enter Strand 4 from front under marlin and nest.
- Note:** Four strands are now tucked and note that all four enter at the same place but come out between four consecutive strands from left to right at the back of the main rope.
- Step 14. Drive marlin **from the front** at the entry point passing under one strand to the left of the spike. Do not drive the spike in too far.
- Step 15. Force the spike hard to the left and at the same time force the core of the dead end of rope under the back of the spike. Rotate the spike upward for the usual half turn to run the dead core up alongside the main core (Figure 7-53, step 15).
- Step 16. Select and unlay Strand 5.
- Step 17. Enter Strand 5 under marlin and nest as before but do not withdraw spike. Continue upward for three more tucks with Strand 5 in the same manner.

Rigging and Erection

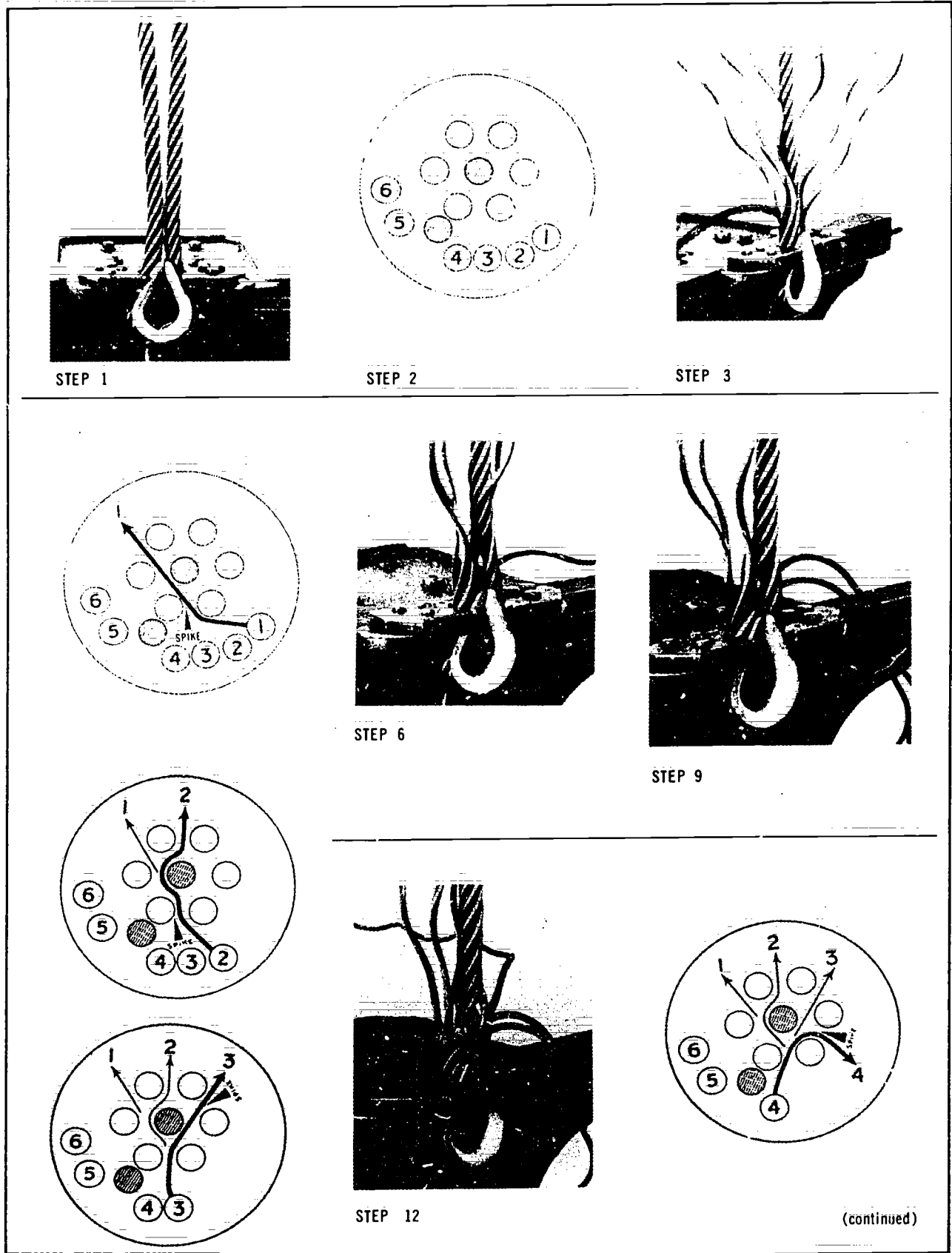

Figure 7-53. Making an Eye Splice

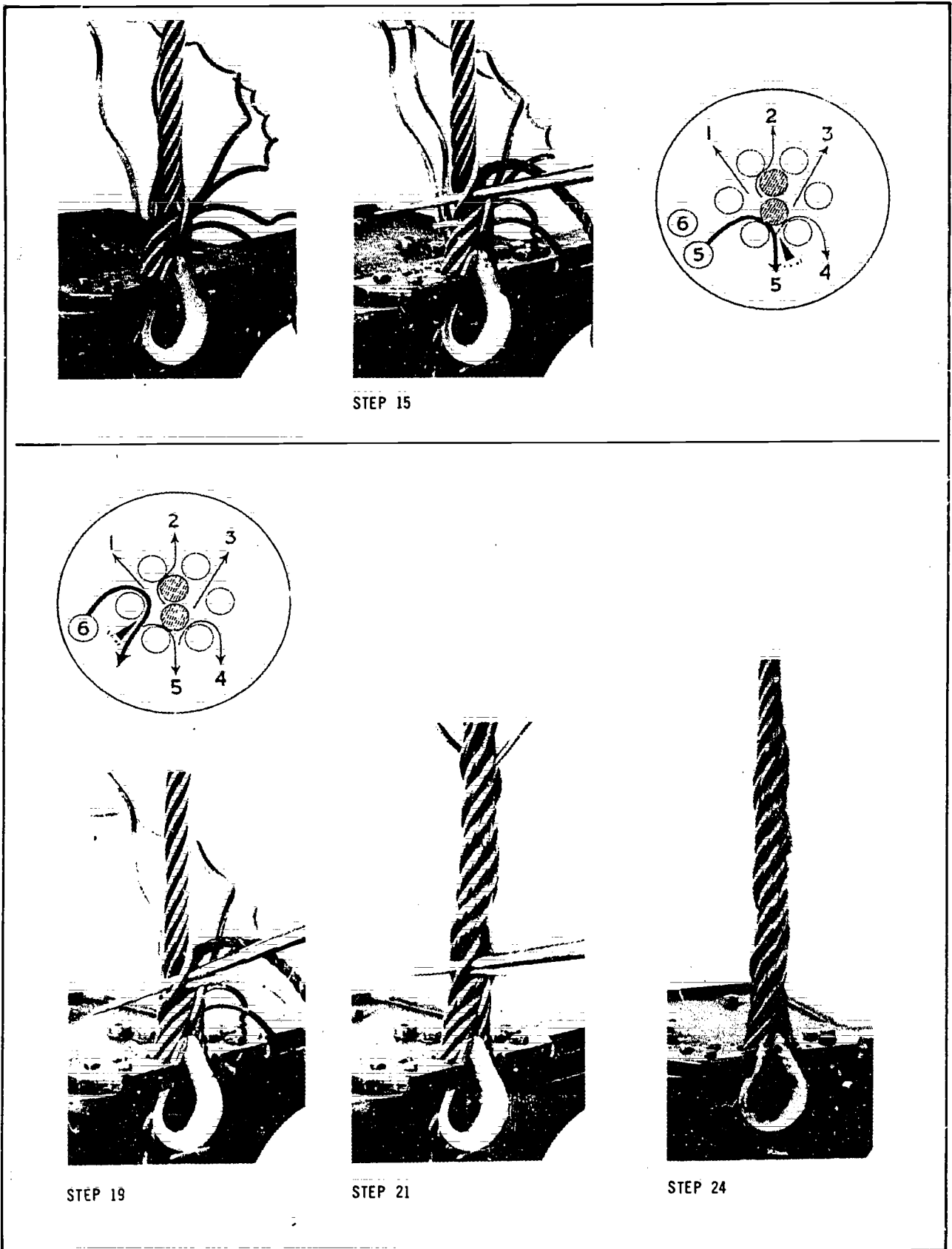

Figure 7-53. Making an Eye Splice (continued)

Rigging and Erection

- keeping the core ahead of the spike, forcing it into the centre.
- Step 18. Cut core short at this point and lay the end into the centre of the main rope.
- Step 19. Drive marlin **from the front** under the second strand to the left of the initial entry point (keep cores to the right) rotate upward as before (Figure 7-53, step 19).
- Step 20. Enter Strand 6 under marlin and nest as before, without withdrawing the spike. Continue upward for three more tucks, nesting each tuck in turn.
- Step 21. Complete three additional tucks for Strands 4, 3, 2 and 1 in the same manner (Figure 7-53, step 21).
- Step 22. Check the splice for uniformity of tucks around the main rope. If any strands are buried, drive the marlin under the strands at the top of the splice and rotate the spike downward to ease them into position.
- Step 23. Remove the eye splice from the vise and lay it on a flat wooden surface and shape it by pounding it on all sides with a wooden or soft faced metal mallet.
- Step 24. Cut off excess from tucked strands (Figure 7-53, step 24).

**FLEMISH EYE LOOP IN WIRE ROPE**

The Flemish Eye Loop is a quick method of creating a temporary eye at the end of a wire rope.

**Procedure:**

- Step 1. Unlay the rope into two sections for a distance equal to the length of the loop plus ten times the diameter of the rope (Figure 7-54, step 1).
- Step 2. Tie an overhand knot with the two parts at the top of the eye (Figure 7-54, step 2).
- Step 3. Take Part 2 and lay it into the grooves of Part 1 down to the throat of the eye (Figure 7-54, step 3).
- Step 4. Take Part 1 and lay it into the grooves of Part 2 down to the throat of the eye.

- Step 5. Bring Parts 1 and 2 together and recombine them as in the original lay (Figure 7-54, step 5).
- Step 6. Apply a U-bolt and Saddle clip to secure the dead end to the main rope at a point approximately eight times the rope diameter below the throat of the eye (Figure 7-54, step 6).

**END ATTACHMENTS FOR WIRE ROPE**

Steel wire ropes may be terminated for convenient attachment to hooks, pulley blocks, equipment, etc. by several satisfactory methods.

**Zinc (Spelter) Socket** A properly attached zinc-type socket will develop 100% catalogue rope strength. This socket is available in both open and closed types (Figure 7-55).

**Swaged Socket** Swaged sockets are applied by pressure to the rope end and will develop 100% of catalogue rope breaking strength. These are available in both open and closed types (Figure 7-55).

**Mechanically Spliced Eye** These are generally of two types: the Flemish Rolled Eye and the Fold Back Eye.

For satisfactory life the eye should be protected by a wrought steel or a cast steel thimble. Either

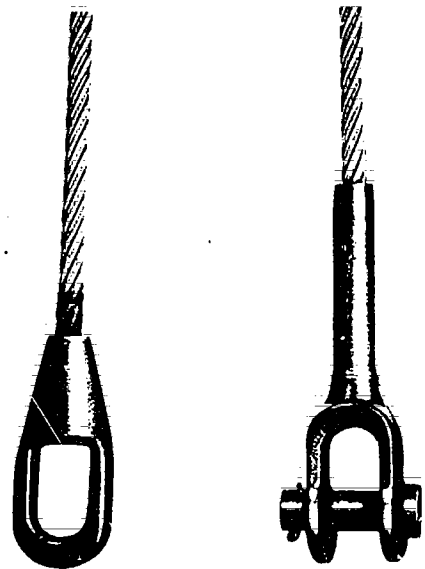

SPELTER SOCKET (closed type)

SWAGED SOCKET (open type)

Figure 7-55. Socket End Attachments





STEP 1

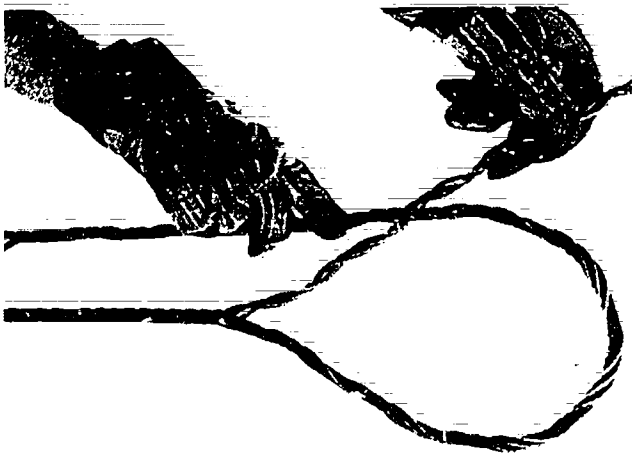

STEP 2

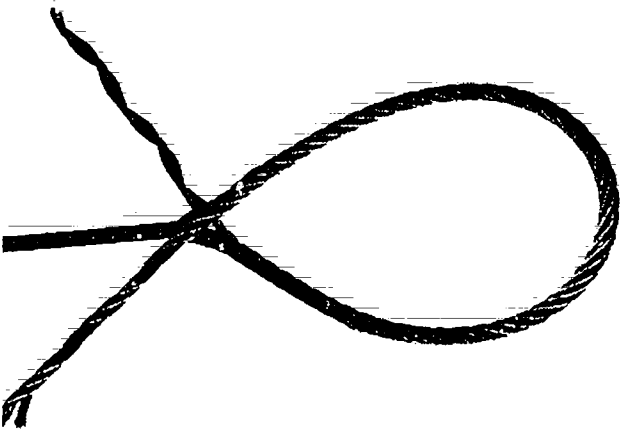

STEP 3

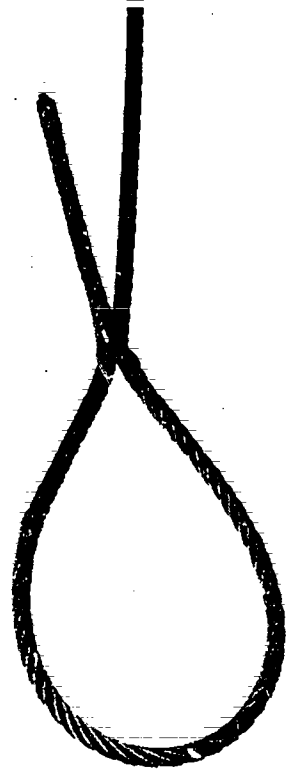

STEP 5

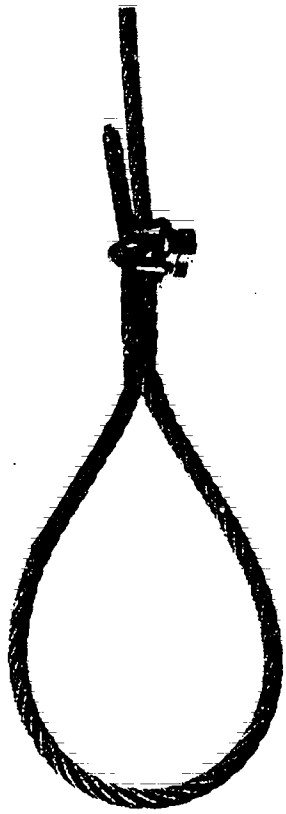

STEP 6

Figure 7-54. Making a Flemish Eye Loop

of these splices will develop strengths better than 95% of catalogue rope strength.

**Flemish Rolled Eye**

A flemish rolled eye (Figure 7-56) is made and the strand ends secured against the live portion of the rope by means of a steel or aluminum sleeve set in place with an hydraulic press under specified pressures.

**Fold Back Eye**

A fold back eye (Figure 7-56) is made simply by bending the rope to the eye dimension required and securing the free or dead end of the rope against the live portion of the rope by means of a steel or aluminum sleeve set in place with an hydraulic press under specified pressures.

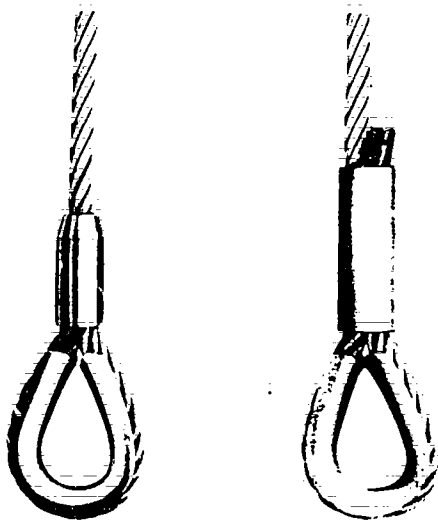

FLEMISH ROLLED EYE

FOLD-BACK EYE

**Figure 7-56. Mechanically Spliced Eye End Attachments**

**Swaged or Zinced Ferrule** The swaged or zinced ferrule (Figure 7-57) is used mainly in the



**Figure 7-57. Swaged or Zinced Ferrule End Attachment**

logging industry to provide a fast means of securing chokers to logs or tag lines. These end fittings are used in conjunction with "Bardon" type choker hooks, butt hooks, arch hooks, etc. Such ferrules are also used to anchor hoisting ropes to drums on small overhead electric- and air-powered hoists.

**HANDLING AND CARE OF WIRE ROPE**

**UNLOADING**

Ropes should be unloaded from trucks, trailers, railway cars, etc. with care (Figure 7-58). The reel should never be dropped because the impact could fracture or separate the reel drum from the reel flanges. The best way to lift a reel of rope is to place a bar or heavy pipe through the central hole of the reel and connect by slings to a suitable hoist. If a hoist is not available, improvise a ramp of heavy planks and trestles and roll the reel down under control at all times.

**UNREELING AND UNCOILING**

When removing wire rope from the shipping reel or from the coil in which it is received it is essential that the reel or the coil rotate as the rope unwinds. Any attempt to remove a rope from a stationary reel or coil will almost inevitably result in a kinked rope and the rope will be ruined beyond repair at that point.

**Unreeling** To unwind a rope from a reel one of three methods may be used.

Method 1. Pass a shaft through the reel, mounting the shaft on two jacks, one on either side. Grasp the free end of the

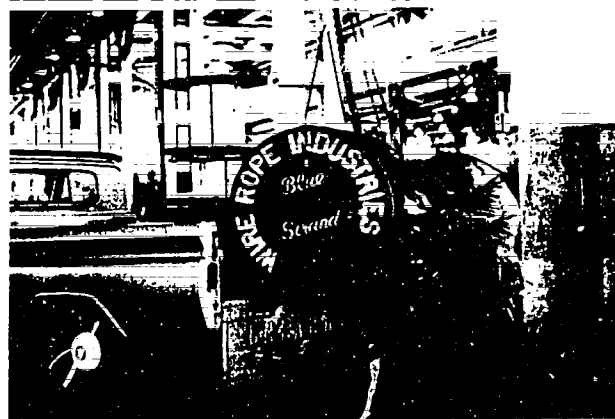

**Figure 7-58. Unloading Wire Rope**

rope and walk away from the reel which rotates as the rope unwinds. Apply a piece of planking as a lever to one of the flanges to act as a brake to keep the rope tight and the reel from overwinding (Figure 7-59).

Method 2. Hold the free end of the rope while the reel is rolled along the ground or floor (Figure 7-60).

Method 3. Upend the reel with one flange on a turntable. Unwind the rope in a similar manner to Method 1. Extra braking must be maintained to keep the rope under sufficient tension so that slack will not accumulate resulting in the rope's dropping below the lower reel-flange or turntable (Figure 7-61).

When re-reeling rope from the rope reel as in Method 1 to a drum on a piece of equipment, the

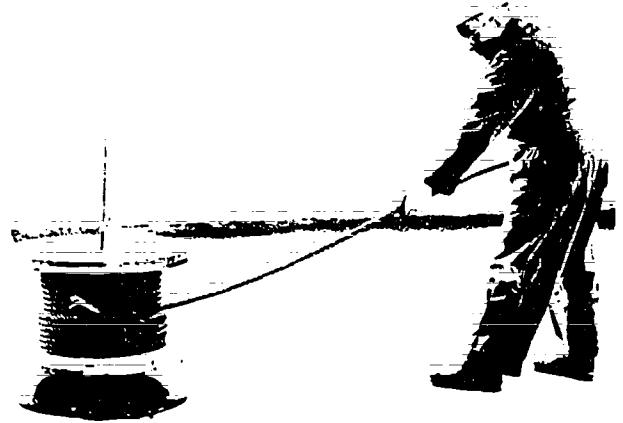

Figure 7-61. Unwinding Wire Rope-Method 3

rope should travel from the top of the reel to the top of the drum or from the bottom of the reel to the bottom of the drum (Figure 7-62). This avoids putting a reverse bend into the rope as it is being installed. A reverse bend would make the rope livelier and harder to handle.

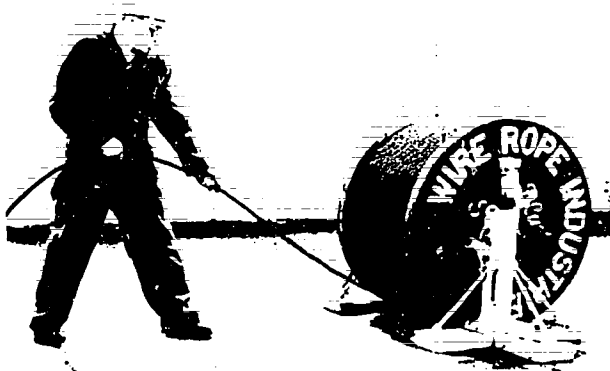

Figure 7-59. Unwinding Wire Rope-Method 1

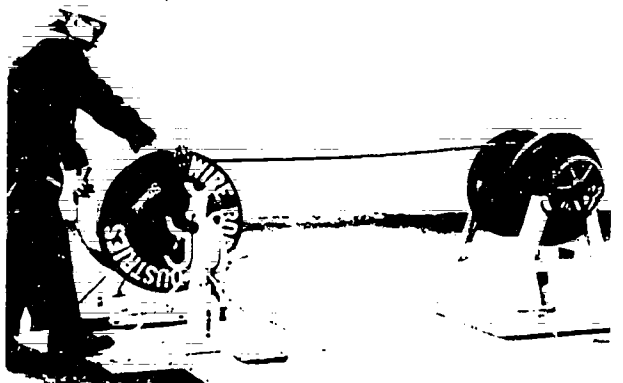

Figure 7-52. Re-Reeling Wire Rope

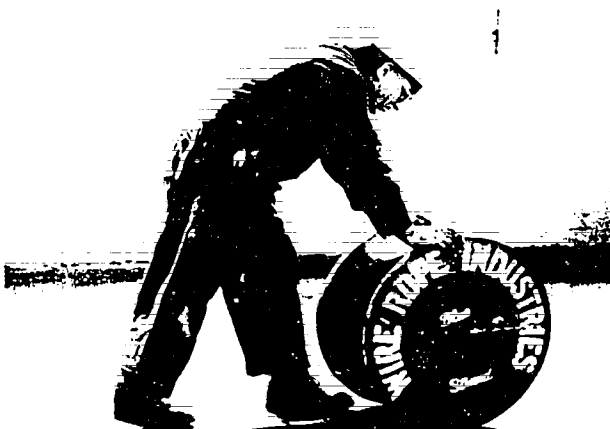

Figure 7-60. Unwinding Wire Rope-Method 2

**Uncoiling** To unwind a rope from a coil, either of two methods may be used.

Method 1. The preferred method is to secure the free end of the rope and then roll the coil of rope along the ground like a hoop (Figure 7-63). Exercise care at all times to ensure that all rope remaining in the coil is held together so that no tight coils or kinks will occur.

Method 2. The coil of rope may be laid on a turntable and the free end pulled out as the turntable and coil revolve (Figure 7-64). The turntable should



Figure 7-63. Uncoiling Rope-Method 1



Figure 7-64. Uncoiling Rope-Method 2

have a centre of approximately the same diameter as the eye in the coil and some means should be provided to ensure that the turns of the rope will not flip up and fall over this centre. Apply a wooden plank brake to the periphery of the turntable to prevent overwinding.

**STORAGE**

Unwrap and examine new rope immediately after delivery. Apply a fresh coating of rope dressing if necessary. Rewrap rope and store under cover in a clean, dry area, keeping the reel off the ground by steel or timber cribbing (Figure 7-65). Examine rope periodically and renew dressing as required.

**SEIZING THE ENDS OF WIRE ROPE**

It is most important that tight seizings of annealed iron wire or strand be maintained on the

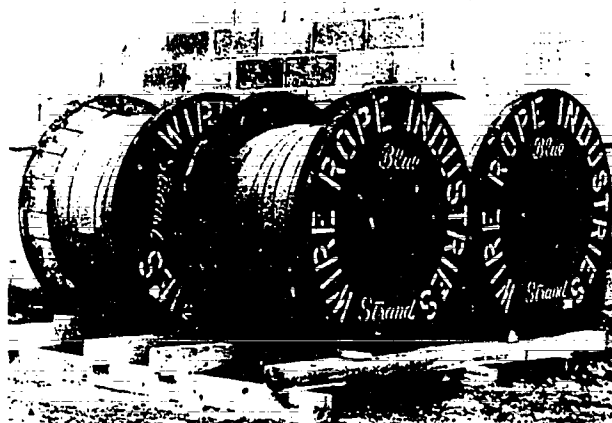

Figure 7-65. Wire Rope Stored on Cribbing

ends of ropes, whether Preformed or not. If ropes are not properly seized prior to cutting, wires and strands are apt to become slack with consequent upsetting of uniformity of tensions in the rope. This could result in overloading of some wires and strands and underloading of others, leading to high strands, birdcaging of wires or breakage of wires and strands. Non-rotating ropes, regardless of construction, depend on retention of built-in torsional balance to resist rotation under load.

There are two approved methods of seizing.

Method 1. This method is generally used on ropes larger than 1" diameter. Place one end of the seizing wire in the valley between two strands (Figure 7-66); then turn its long end at right angles to the rope and wind back over itself and the rope in a close, tight winding, in a direction opposite to the lay of the rope, until a length of seizing not less than a rope diameter has been wound. Twist the two ends together and by alternately tightening and twisting these ends, draw the seizing tight. Best results are obtained when the seizing is applied with a serving bar.

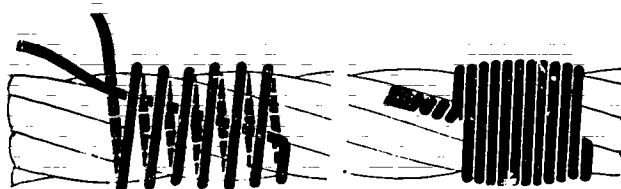

Figure 7-66. Stranding Rope-Method 1

Method 2. This method is usually used on ropes and strands of 1" diameter and smaller. Wrap the seizing wire around the rope in a close, tight winding in a direction opposite to the lay of the rope (Figure 7-67). Each seizing should consist of from 8-10 closely wound wraps of seizing wire. Twist the two ends together by hand in a counter-clockwise direction approximately at the centre of the seizing and about 1/2" from the rope. Using cutters, alternately twist and take up the slack until the serving is tight on the rope. Twist seizing ends tightly against the serving, wind twisted ends into a knot and cut off the ends of seizing wire.

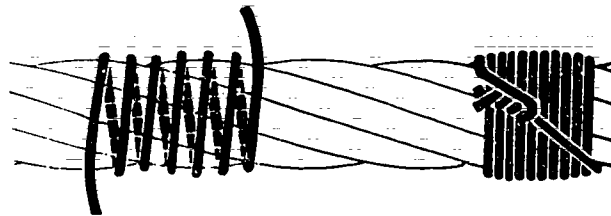

Figure 7-67. Stranding Rope-Method 2

Seizings on locked coil ropes will range in length from 10-20 rope diameters and their number will vary with rope diameter and construction. Should it be necessary to cut off a piece of rope containing one or more original seizings, apply an equal number further up the rope before making the cut. Seizings on locked coil ropes must be applied with a serving bar or mallet and soldered in place. The seizing wire or strand must hence be either tinned or

galvanized. Table 7-5 lists the number of recommended seizings for various types of ropes.

**LUBRICATING METHODS**

Whether stationary or in motion, steel wire ropes must be protected from corrosion. When in motion they must be lubricated to minimize wear between the metal-to-metal (wire-to-wire) surfaces. During manufacture a lubricant that will satisfy both these requirements at least for a time is built into the strands of wire and the core. Exposure to the elements and normal rope operation over sheaves and on and off drums will gradually deplete and contaminate the lubricant. Most ropes should be lubricated at intervals depending on the type of service to minimize corrosion and wear and extend rope life.

Clean a used rope with wire brushes, scrapers, compressed air or superheated steam. In some

**TABLE 7-5. RECOMMENDED NUMBER OF SEIZINGS AND SIZE OF SEIZING WIRE OR STRAND**

Rope Diameter inches	Minimum Number of Seizings				Approx. Diameter of Seizing, Inches		
	6 and 8 Strand Ropes Round and Flattened Strand		Non-Rotating Ropes Round and Flattened Strand		Stranded Ropes		Locked Coil Ropes
	Reg. Lay, Fibre Core Preformed Elevator	Lang Lay, Fibre Core Reg. Lay, Steel Core Lang Lay, Steel Core	Preformed and Non-Preformed		Wire	Strand	Wire*
			Groups	Seizings per Group			
3/32 & smaller	2	2	2	3	.020		
1/8 to 1/4	2	3	2	3	.024		
5/16 to 1/2	3	4	2	3	.032		
9/16 to 7/8	3	4	2	3	.040	1/16	.052
15/16 to 1-1/2	3	4	3	3	.080	3/32	.062
1-9/16 to 2	4	5	3	3	.106	1/8	.072
Larger than 2	4	5	3	3	.128	5/32	.072

\* Seizing wire for Locked Coil Ropes must be tinned or galvanized.

## Rigging and Erection

instances it may be necessary to soften the old lubricant and accumulated dirt with a penetrating oil or a good grade kerosene.

Then apply a lubricant suited to the conditions under which the rope is operating. Several methods are suggested; choose the one most suited to the installation and the lubricant being used. It is better to lubricate lightly and frequently than heavily and infrequently.

A suitable rope lubricant should have the following properties:

1. Freedom from acids and alkalis
2. Sufficient adhesive strength to stay on the rope without throw-off at maximum rope speed
3. Ability to penetrate between strands and reach the core
4. Non-solubility under conditions of rope use

5. Resistance to oxidation

6. High film strength is an advantage.

When a wire rope is taken out of service for storage against possible future use, first clean and then lubricate it. Then cover and store the rope in a dry location and protect against mechanical damage.

Figure 7-68 illustrates some simple methods of lubricating ropes externally while in use. Other lubricators and cleaning devices are, of course, available commercially or readily fabricated in a plant or local workshop.

### CONDITION OF WINDING DRUMS AND SHEAVES

Flat faced drums with roughly worn surfaces and grooved drums with rough and scored grooving

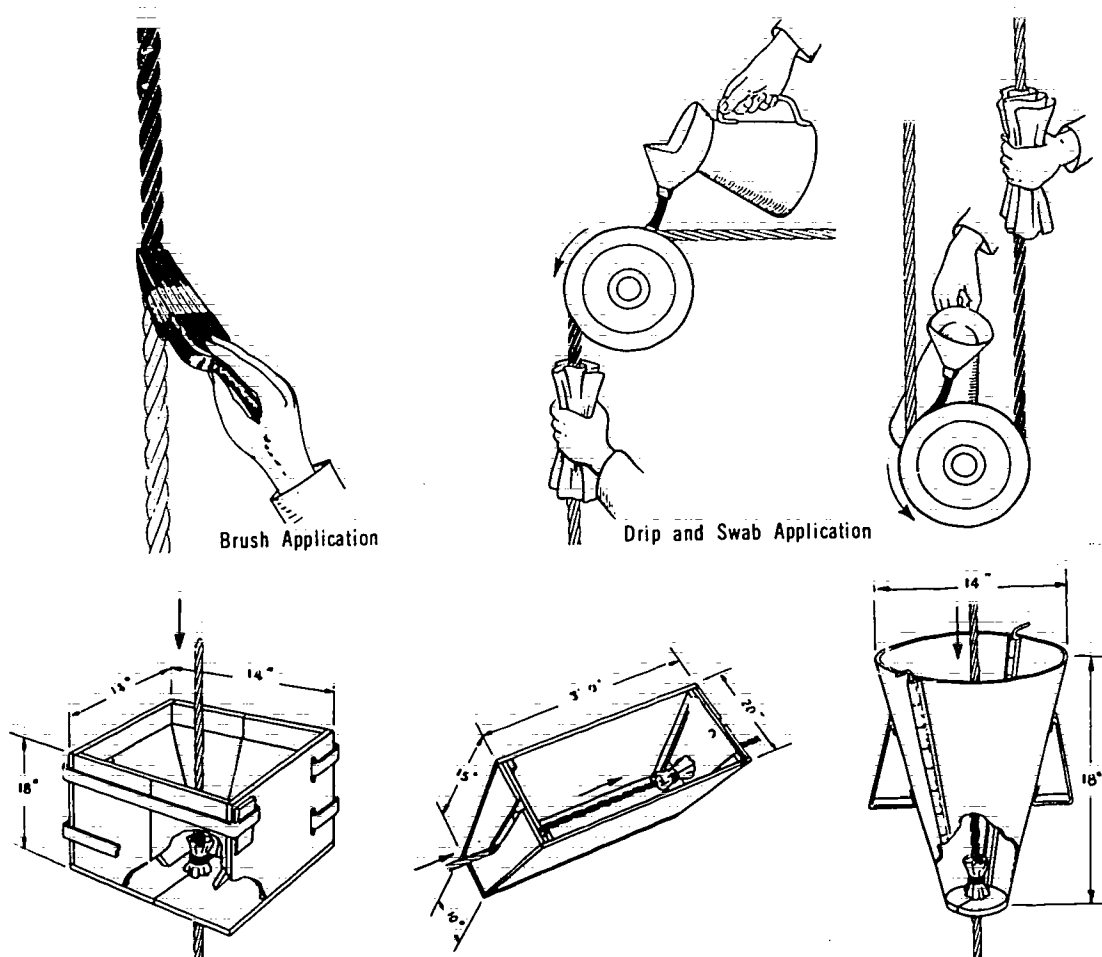

Split wooden or metal boxes.  
Rope passes through burlap or similar wiper at outlet end of box.

Figure 7-68. Methods of Lubricating Wire Rope In Use

or chipped groove separations can cause excessive rope wear.

Condition and contour of sheave grooves have a major influence on rope life. Grooves should be maintained in a smooth condition and be slightly larger than the rope to avoid pinching and binding of the rope in the groove. Since ropes are usually made slightly larger than their nominal size, new grooves for new rope should just accommodate the full over-size of the rope. Where the rope approaches the sheave at a specific angle of sheet, as for instance  $1^{\circ}$ - $20^{\circ}$  maximum for mine shaft hoisting, the head sheave groove diameter should be equal to the nominal rope diameter plus 8%. The bottom of the groove should have an arc of support of from  $120^{\circ}$ - $150^{\circ}$ , with the sides of the groove tangent to the ends of the bottom arc.

Note that the more closely the contour of the groove approaches that of the wire rope the greater the area of contact between the two. The greater this area of contact, the less the wear on both the groove and the wire rope. The greater area of contact lessens deformation of the rope in the groove, thus increasing its resistance to fatigue from bending.

**Fleet Angle** The fleet angle is that angle between the centre line through the first fixed sheave perpendicular to the axis of the drum shaft and the centre line of the rope leading to the drum (Figure 7-69). Excessive fleet angles can cause serious damage to wire rope, sheaves and grooved drums. Severe scuffing results when rope wears against groove walls, grinding them down and causing the rope to become bruised or crushed.

Maximum fleet angles on equipment should be kept small and preferably between  $1^{\circ}$  and  $1^{\circ}$ - $30'$ . To ensure the rope crossing back and starting the second layer properly without assistance the fleet angle should not be less than  $0^{\circ}$ - $30'$ .

The angle should not exceed  $1^{\circ}$ - $30'$  for smooth faced drums and  $2^{\circ}$  for grooved drums, except that in mine shaft hoisting the angle should not exceed  $1^{\circ}$ - $20'$ . Excessive drum wear and poor spooling or winding will result if these angles are exceeded.

**WINCH DRUM CAPACITY**

To determine the capacity in feet of steel wire rope of a winch drum or reel:

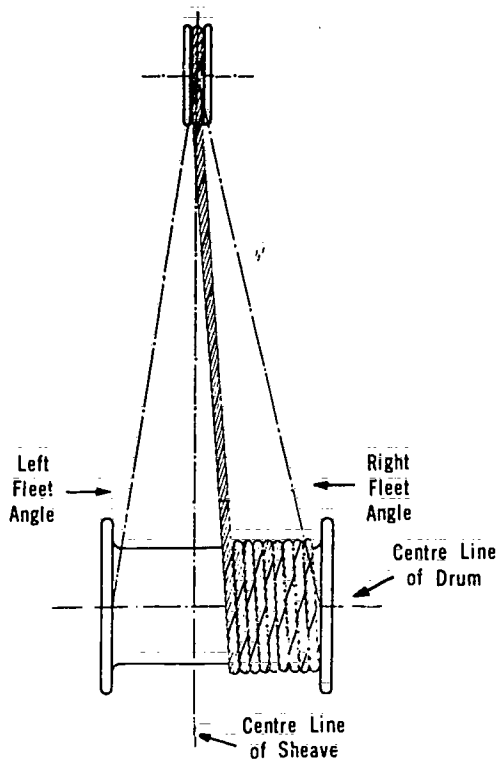
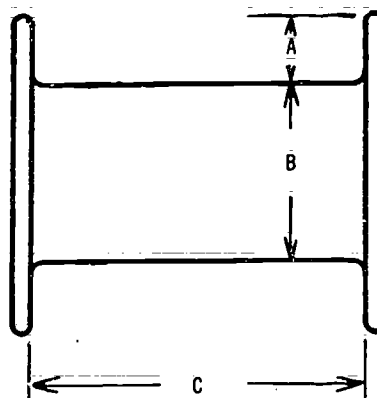

Figure 7-69. Fleet Angles

Refer to Figure 7-70. Add the diameter of the drum (B) to the depth of the flange (A). Multiply the sum by the depth of flange (A). Multiply the result by the length between the flanges (C), all in inches. Multiply the product by the factor in the right hand column opposite the size of rope required. The result will be the amount of rope in feet that the drum will hold.

Table 7-6 gives the factor F for "on-size" rope and level wind. Since new ropes are usually over-size by  $1/32"$  per  $1"$  of rope diameter the result obtained by the formula should be



395 Figure 7-70. Determining Winch Drum Capacity

**TABLE 7-6. "F" FACTOR FOR "ON-SIZE" ROPE**

Nominal Rope Diameter Inches	F	Nominal Rope Diameter Inches	F
1/4	4.16	1-1/4	.167
5/16	2.67	1-3/8	.138
3/8	1.86	1-1/2	.116
7/16	1.37	1-5/8	.099
1/2	1.05	1-3/4	.085
9/16	.828	1-7/8	.074
5/8	.672	2	.066
3/4	.465	2-1/8	.058
7/8	.342	2-1/4	.052
1	.262	2-3/8	.046
1-1/8	.207	2-1/2	.042

decreased as follows: for rope over-size decrease by from 0% to 6%; for random or uneven winding decrease by from 0% to 8%

Formula:  $(B + A) \times A \times C \times F$  for required size of rope.

**SHEAVE ALIGNMENT**

Align sheaves so that the axis of the rope travelling over the sheaves will coincide with a line drawn from centre to centre of sheave grooves. Poor alignment will result in severe wear on both the rope and the sheave flanges. Even the slightest misalignment accelerates rope wear and shortens rope life. Poor alignment of the first sheave off the drum may result in poor winding. A ready indication of poor alignment will be the rapid wear of one flange of the sheave.

**RADIAL PRESSURE ON SHEAVES AND DRUMS**

Radial pressure of the rope on the sheave or drum will cause wear in the groove or the drum face. Too great a radial pressure will cause excessively fast wear and result in shortened rope life. Radial pressure can be reduced by decreasing the load on the rope or by increasing the diameter of the sheave or drum. The amount of wear will vary with the material from which these are made. Table 7-7 specifies acceptable radial pressures for different wire rope types.

**ROPE OPERATION**

**Overwinding and Crosswinding** While the ideal winding condition would be a single layer

**TABLE 7-7. SUGGESTED MAXIMUM RADIAL PRESSURES (in pounds per square inch)**

Rope Construction	Sheave and Drum Materials		
	Cast Iron	Cast Steel	Manganese Steel 11-13% Mn.
6x7 Reg. Lay	300	550	1500
6x7 Lang. Lay	350	625	1700
6x19 Reg. Lay	500	900	2500
6x19 Lang Lay	575	1025	2850
6x37 Reg. Lay	600	1075	3000
6x37 Lang Lay	700	1250	3500
8x19 Reg. Lay	600	1075	3000
6x8 Flat. Strand	500	900	2500
6x25 Flat. Strand	800	1450	4000
6x33 Flat. Strand	975	1800	4900
Locked Coil	or application		

of rope on the drum, this is not always possible. Where it can not be avoided the succeeding layers should not cross-wind but should wind regularly in the groove formed between successive turns of the preceding layer of rope.

**Initial Operation** After installing a new rope it is advisable to run through its normal operating cycle for a number of trips under light load and at reduced speed. This permits the new rope to adjust gradually to working conditions and enables the strands to become seated and some stretch to occur. The rope will then be less liable to damage when the full load is applied.

**Shock Loading** Never lift or stop a load with a jerk; the load so imposed may equal the static working load several times and jerking may break a rope. Jerks that do not break the rope cause rapid deterioration and result in reduced rope life.

**Rope Speed** Experience indicates that rope wear increases with speed. Rope economy results from moderately increasing the load and reducing rope speed. Some authorities suggest that when ropes are running light, rope speed should not exceed 4,000' per minute whether hoisting or lowering.

**INSPECTING WIRE ROPE FOR WEAR**

Inspect the entire length of rope frequently paying particular attention to those sections experience indicates to be areas showing greatest wear. Watch for broken wires, excessive wear and lack of lubrication. Where drum capacity



will permit and winding conditions are such that "drum crushing" of the rope is minimal, it may be wise to install a slightly longer length of rope than absolutely necessary. This extra length will permit cutting a few feet of rope at either load end or drum end to change those areas of maximum wear over drums and sheaves.

In installations where rope wear is excessive at one end or the other the life of the rope may be extended by changing the drum end for the load end, that is, by turning the rope "end for end." This must be done before wear becomes too severe.

A rope may have to continue in operation with broken wires, but these wires should be removed as soon as possible. The method often used to get rid of a broken wire — nipping it off with pliers — is not recommended as this leaves a jagged end. It is preferable to bend the broken ends backwards and forwards with the fingers if possible, or if the ends are short or the wire large use a marlin spike or a piece of wood. In this way, the wire breaks inside instead of outside the rope. The ends are left tucked away between the strands where they will do no harm. (See Figure 7-71).

#### THREATS TO SAFE OPERATION AND MAXIMUM SERVICEABILITY

1. Drums and sheaves of too small diameter
2. Reverse bends in the rope
3. Overloading the rope
4. Incorrect rope construction for the job
5. Overwinding or incorrect winding on drums
6. Lack of lubrication
7. Handling or kinking damage
8. Insufficient or faulty guides or rollers
9. Sheaves out of alignment
10. Deeply worn grooves in drums
11. Broken rims or grooves on sheaves
12. Sheaves that turn hard or wobble
13. Displaced rope guides
14. Stones or other objects lodged in equipment
15. Sticking or grabbing clutches
16. Uneven or jerky pull on the rope from loose bearings
17. Lines whipping
18. Improper line spooling
19. Incorrect installation of clamps, ferrules, sockets or splices



Figure 7-71. Breaking Off a Loose Strand of Wire Rope

## Rigging and Erection

### SAFETY PRECAUTIONS

**Hand Protection** Gloves must be worn by all workmen handling wire rope.

**Use of Wire Rope Clips** Tighten wire rope clips of the "U" bolt type immediately after the initial load carrying use, and frequently thereafter. Malleable iron clips should not be used for hoisting lines.

**Running Line Safety** Running lines of hoisting equipment located within 7' of the ground or working level must be rapid off, or otherwise guarded, or the operating area restricted.

### INSPECTION AND ASSESSMENT OF WIRE ROPE

Wire rope or cables should be inspected by a competent person at the time of installation and once each week thereafter when in use. Wire rope or cables must be removed from hoisting or load carrying service when detrimental corrosion is present or when **one** of the following conditions exist:

1. Three broken wires are found in one lay of 6 x 7 wire rope.
2. Six broken wires are found in one lay of 6 x 19 wire rope.
3. Nine broken wires are found in one lay of 6 x 37 wire rope.
4. Eight broken wires are found in one lay of 8 x 19 wire rope.
5. Marked corrosion appears.
6. Four broken wires are found adjacent to each other or when sixteen broken wires are found in one lay.
7. Wire rope of a type not described here should be removed from service when 4% of the total number of wires composing such rope are found broken in one lay.
8. Wire rope should be removed from service when the wires in the crown of the strand are worn to less than 60% their original diameter.
9. Wire rope should be removed from service when there is a marked reduction in the diameter, even though the wires in the crown of the strand show no sign of wear. This condition can result from inner corrosion and indicates a serious weakening in the rope.

### CHAIN

A chain consists of a number of interlocking sections of oval metal pieces. Each section or link has one or more visible welds. For rigging jobs, the most common chain metals are wrought iron and steel alloys. Heat-treated carbon steel is used for chain slings because of its high abrasion resistance.

Certain properties of chain in operation make it preferable to wire rope: corrosion resistance, abrasion resistance, sharp bending tolerance. Since rope will stretch to some extent it has a greater shock load tolerance than chain.

Chain will fail abruptly when overloaded or if it has a faulty weld. Wire rope, on the other hand, will evidence failure more gradually as wires and strands break individually with unmistakable sounds.

Hooks are matched to chains by the manufacturer or on the basis of fit between the chain link size and the hook connector. Such a matched hook should fail before the chain fails.

### CARE AND MAINTENANCE

Do not leave chains where they will be run over by tractors, trucks or other equipment. Never point load a link of chain with the beak of a hook as this may damage both and cause the load to drop. Never shorten a chain by twisting or knotting or with nuts and bolts.

Store chain in a clean, dry, ventilated area with a light coating of oil on it to prevent rust.

### INSPECTION AND ASSESSMENT

Inspect all hoisting chains at frequent intervals for such defects as stretch, deformity, twist, cut, nicks, gouge marks, arc burns, open welds or fractures as indicated by very fine surface cracks. Remove chains from hoisting service when such defects are found.

Discard chains that have stretched more than 5% in any five link sections. Chains that show wear greater than 25% of the thickness of the metal in any individual link should be removed from service.

Alloy chains should be subjected to stricter scrutiny as some degree of damage or defect will weaken the chain more than that of a proof or BBB coil chain.

## SLINGS

A sling is a means of connecting a load to a power source for lifting. Different materials used in rigging may be adapted to create slings: fibre and wire rope, chain, synthetic or wire webbing, in conjunction with hooks, shackles, turn-buckles.

### SLING MATERIALS

#### Manila Rope

Advantages:

1. Flexibility
2. Easy to handle
3. Does not tend to slip from choke position
4. Will not scratch a load
5. Relatively low cost.

Disadvantages:

1. Limited strength
2. Subject to moisture, heat and chemical damage.

#### Synthetic Fibre Rope

Advantages:

1. Stronger than manila rope
2. High abrasion resistance
3. Provides secure grip to the load
4. Will not scratch a load
5. Resistant to moisture, heat and most chemical damage
6. Stretch increases absorption of impact and shock loads.

Disadvantages:

1. Not as strong as wire rope

#### Wire Rope

Advantages:

1. Strongest type of lifting material
2. Flexible
3. Abrasion resistant.

Disadvantages:

1. Will slip from choke position on metal loads
2. Will scratch fragile loads

3. Subject to sharp bend damage
4. High cost factor.

#### Chain

Advantages:

1. Not subject to sharp bend damage
2. Good lifting strength

Disadvantages:

1. Heavy material
2. Lack of stretch produces poor shock loading tolerance
3. Subject to failure if kinked or twisted while under load
4. Will slip from choke position unless softeners are used
5. Becomes brittle in cold temperatures over long periods.

**Note:** Use only alloy chain slings for overhead lifting. Proof Coil, BBB Coil, and High-Test chain grades are not recommended for overhead lifting.

### SLING ARRANGEMENTS

Figures 7-72 illustrate various sling arrangements.

#### TYPES OF SLINGS

**Flat Slings** Flat slings are manufactured from synthetic fibre webbing and wire mesh in a variety of constructions. The design of flat slings provides the following advantages:

1. Load is protected from damage at the point of contact
2. Wide surface will hug any shape load and reduce slippage
3. Apparatus is light in weight, clean to work with and easy on the hands.

Safe working loads for flat slings should always reflect manufacturer's specifications.

**Synthetic Fibre Web Slings** Web slings are available in nylon and polyester with various design and treatment features that adapt the slings to specific lifting requirements.

#### Features of Synthetic Web Slings

1. Resistant to alkalies but do not tolerate acids
2. Can be used in temperatures up to 200°F

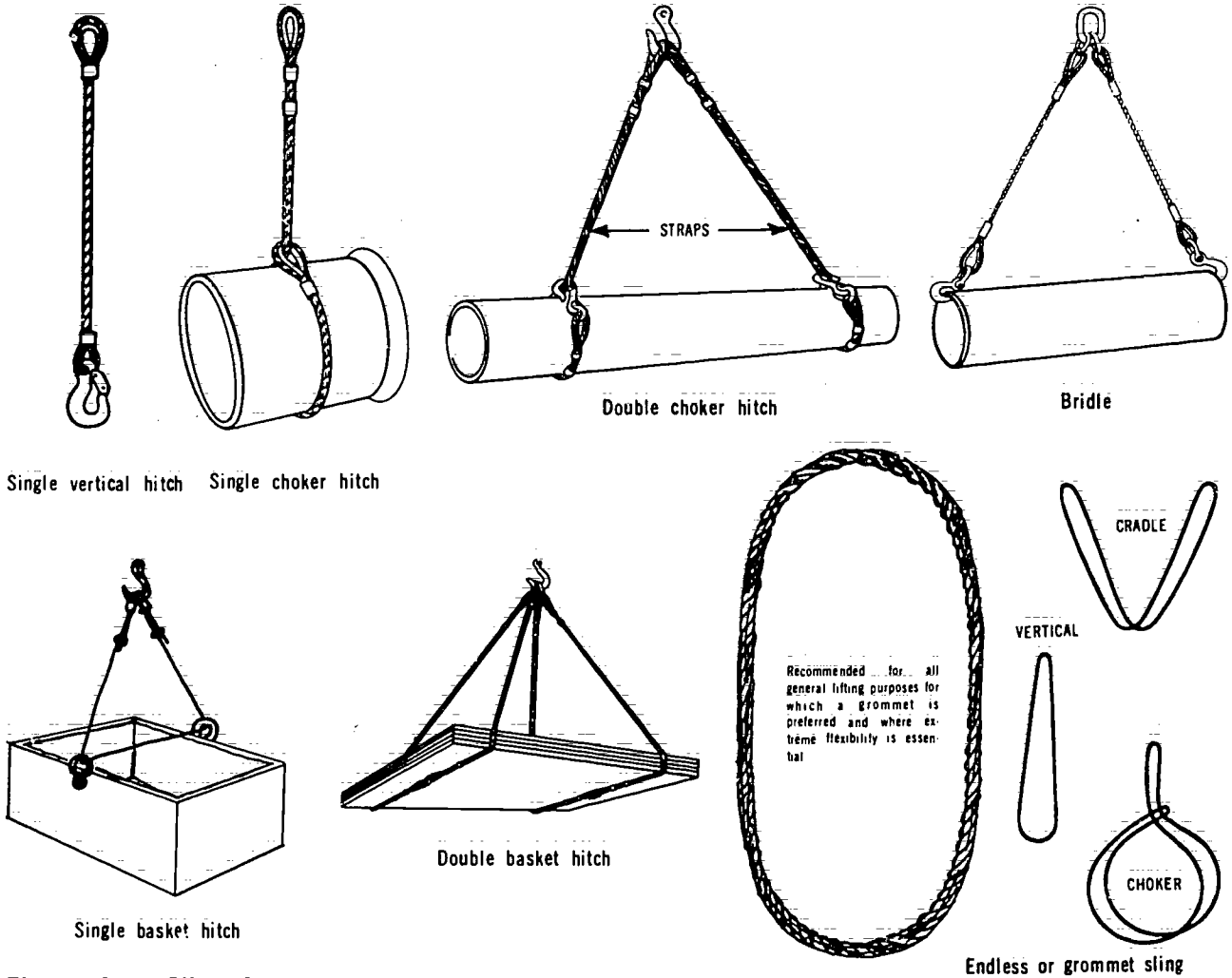

Figure 7-72. Sling Arrangements

3. Will stretch 10% rated capacity
4. Some designs are manufactured with a reinforcing core of inner load bearing yarns which carry 80% of the load and are protected from wear by the outer fibres.

Figures 7-73 illustrate the various constructions of synthetic web slings. The slings are shown in operation in Figure 7-74.

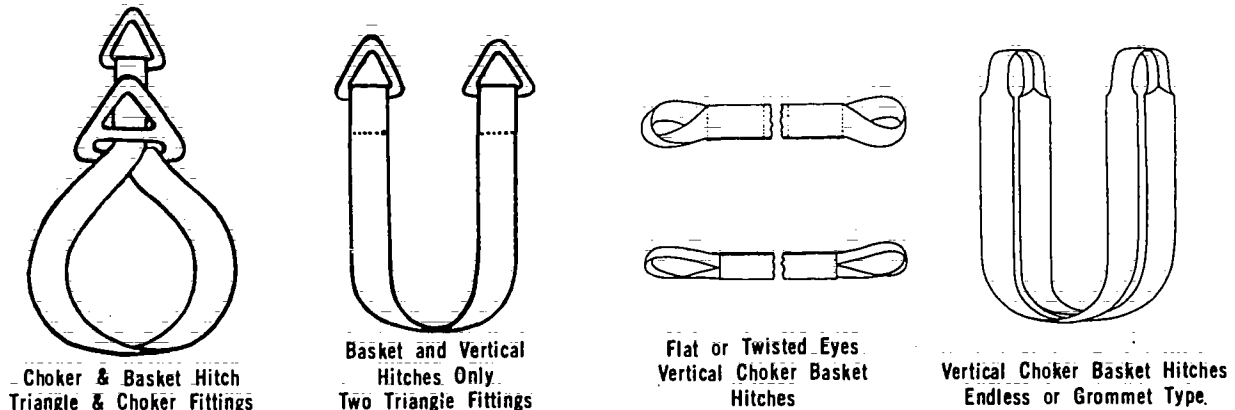

Figure 7-73. Synthetic Web Sling Constructions

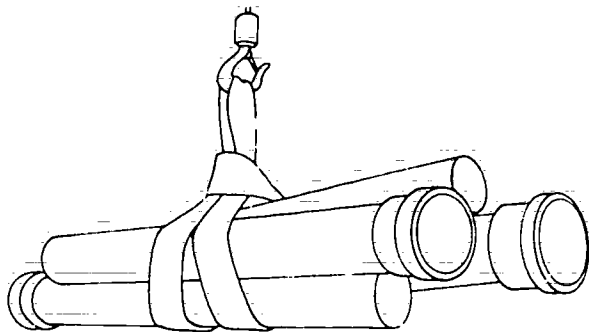
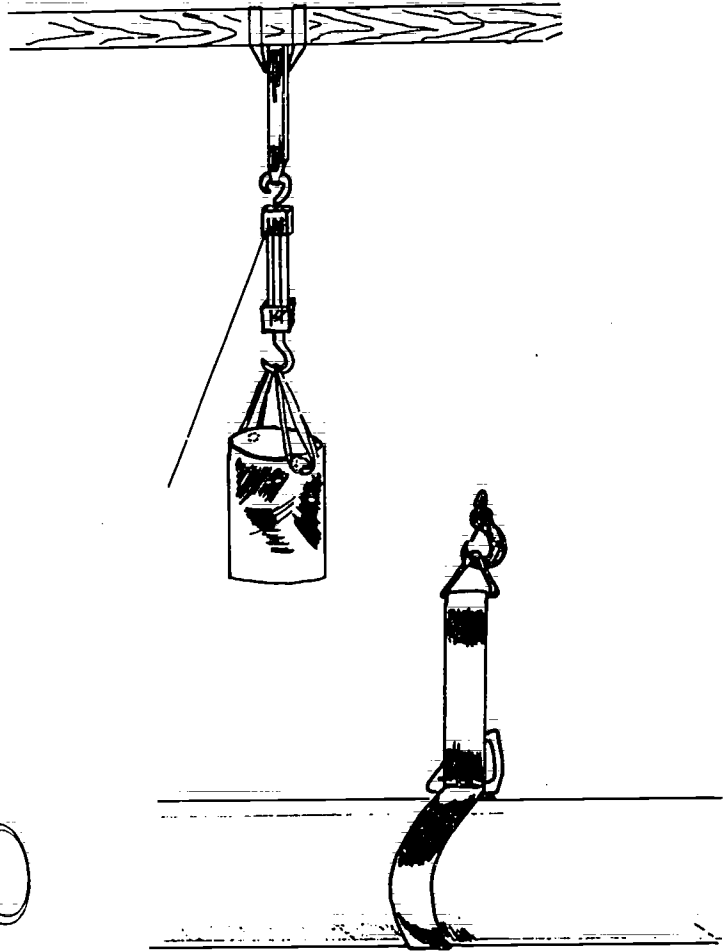
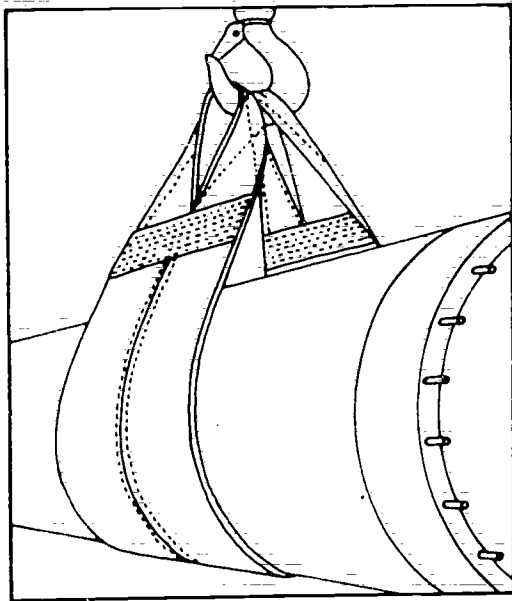

Figure 7-74. Synthetic Web Slings in Operation

**Wire Mesh Slings** Wire mesh slings are widely used in industries where loads are abrasive, hot or will tend to cut slings.

**Features of Wire Mesh Slings**

- 1. Resistant to abrasion and cutting
- 2. Firm grip maintains balanced load

- 3. Can withstand temperatures to 550°F
- 4. For handling materials that would damage wire mesh or for loads with soft finishes, slings can be coated with plastic.

Wire mesh is available in a range of gauges as illustrated in Figure 7-75. Wire mesh sling arrangements are shown in Figure 7-76.

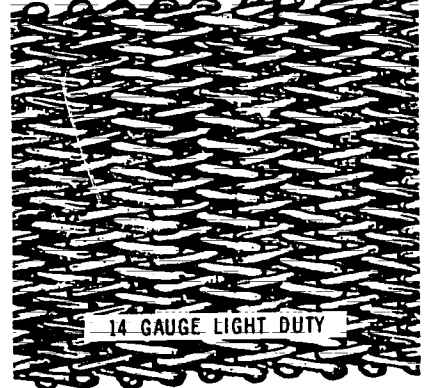
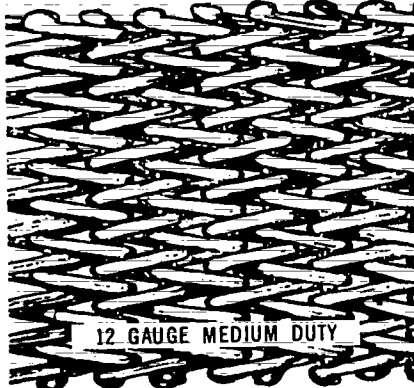
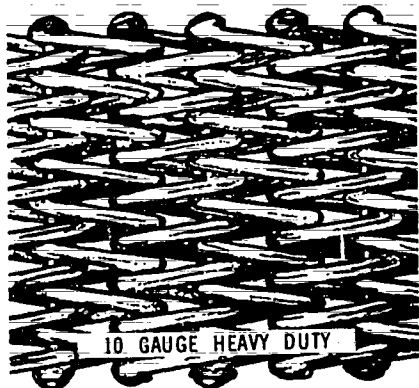

Figure 7-75. Wire Mesh Gauges

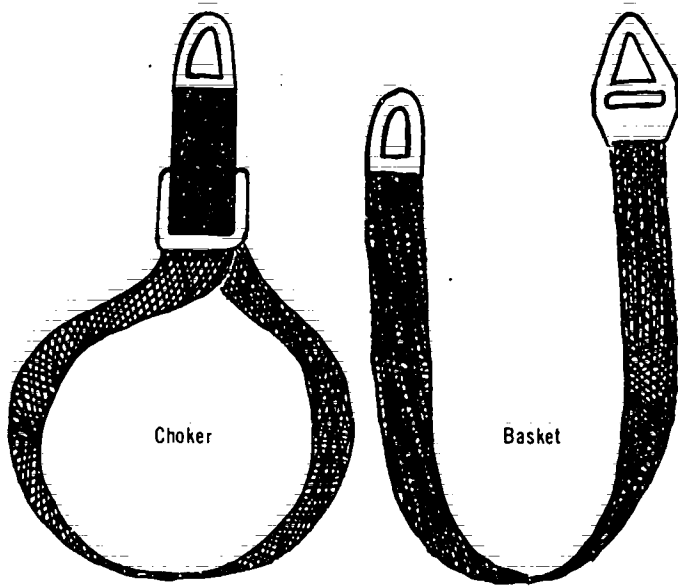

Figure 7-76. Wire Mesh Sling Arrangements

**SAFE WORKING LOADS FOR SLINGS AT VARIOUS ANGLES**

Different weights of pull are exerted on slings of various angles for the same load. The load on the rope equals the weight of the load **only** with a straight or vertical pull.

**Example:**

A load of 2,000 lbs. suspended from a single vertical hitch places 2,000 lbs. strain on the line.

Where a sling having two legs is involved, the angle of pull places a significantly greater strain on the sling. If the angle between the load and the sling leg is only 30°, the strain on the sling is nearly **twice** the actual weight of the load.

The maximum recommended angle between the load and the sling is 45°. If the angle is less than 45°, the danger of the sling failing is greatly increased.

Figures 7-77 illustrate the principle of sling angles.

**MEASURING AND CUTTING WIRE ROPE FOR CHOKERS**

**Procedure** (See Figure 7-78).

Step 1. Measure and mark splicing end and put on wire stop.

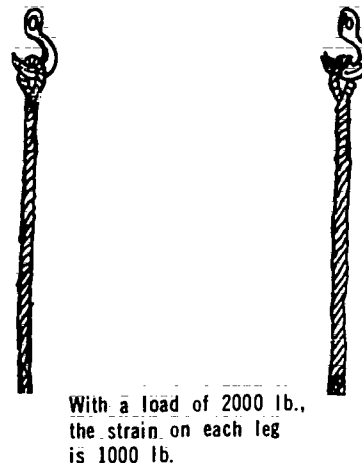
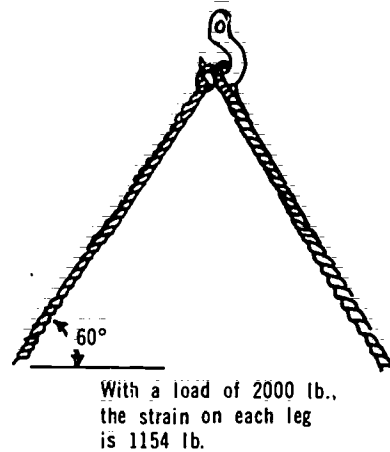
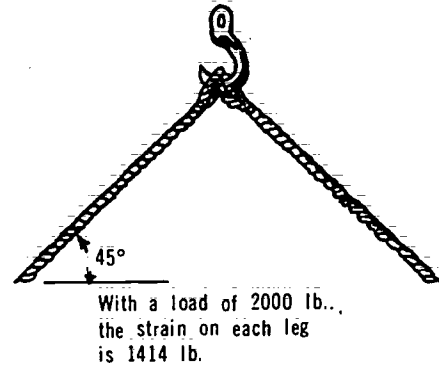
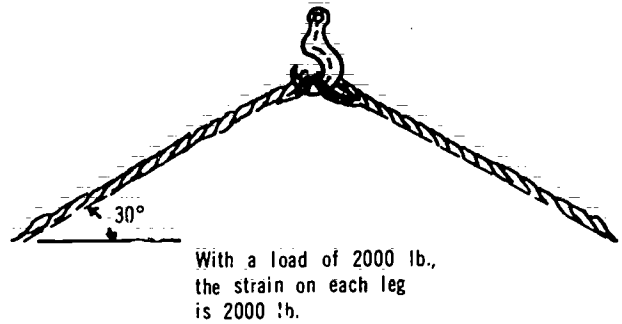

Figure 7-77. Sling Angle Principles

402

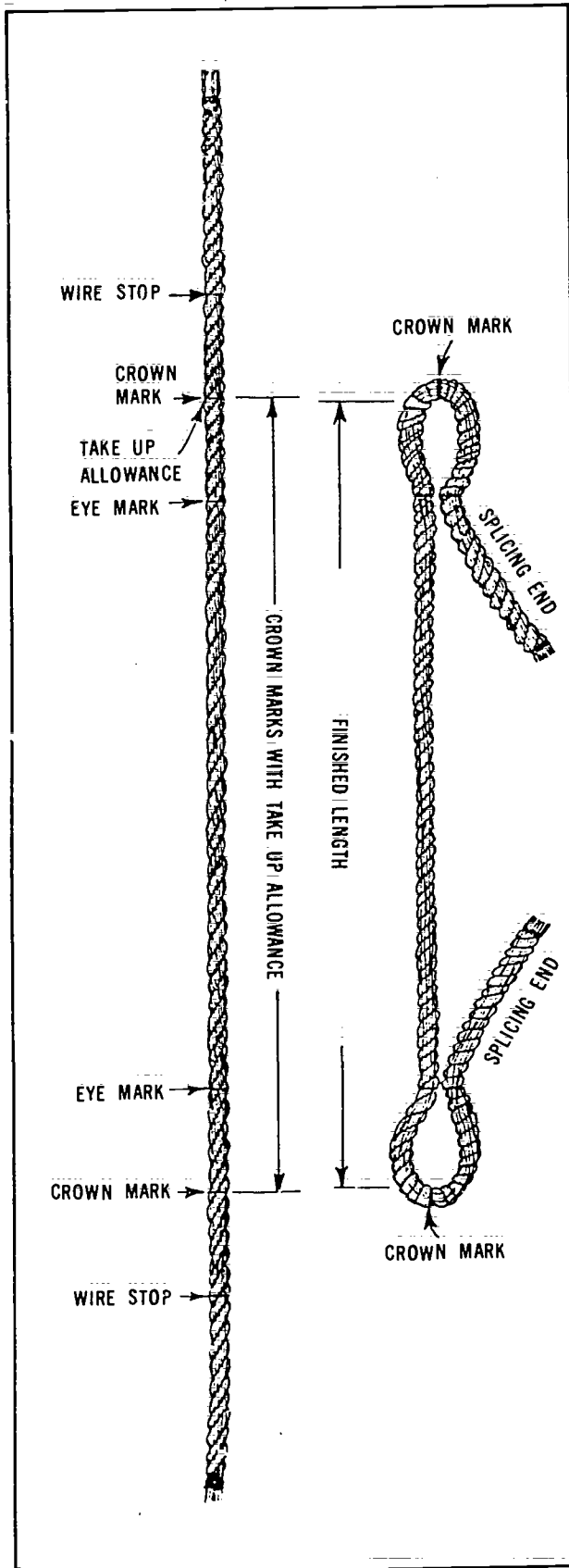

Figure 7-78. Making a Choker

- Step 2. Measure and mark crown and eye marks.
- Step 3. Measure required length between crown marks and add twice the circumference of the wire rope for take up allowance at top as shown in Table 7-8 and then mark off eye, wire stop and splicing end.

DIA. OF WIRE ROPE	TAKE UP ALLOWANCE	SPLICING END	EYE
3/8"	2"	12"	8"
1/2"	3"	14"	10"
5/8"	4"	16"	12"
3/4"	5"	18"	14"
7/8"	6"	24"	16"
1	6-1/4"	30"	18"
1-1/8"	6-1/2"	36"	20"
1-1/4"	7-1/4"	44"	22"

**SAFE USE OF SLINGS**

1. Determine the weight of the load to be lifted.
2. Do not use the sling for any load exceeding its Rated Safe Working Load.
3. When using multi-leg sling Assemblies, remember that the angles between the legs will reduce the Safe Working Load of the Assembly. Consult the Sling Chart and Safe Working Load Tables available.
4. Endless wire rope slings are prone to misuse, and in practice they are often found to be difficult to handle. They should be used only when they have been purposely made for applications requiring a very short effective length, or for heavy lifts where a single sling of the required Safe Working Load is not available.
5. Examine all slings before use, and discard any that are defective.
6. Do not use a sling that contains a severe kink.
7. Slings found to be unfit for use should be destroyed, not on a refuse dump.
8. When loads are being carried on a crane hook, slings not in use should not be carried on the same hook.
9. "Hooking Back" to the leg of a sling is not recommended.

## Rigging and Erection

---

10. Avoid bending wire rope slings around sharp corners of the load as it could effectively reduce their Safe Working Load.
11. A sling "doubled" around a shackle has a Safe Working Load equivalent only to that of a single part of the rope.
12. When using a halting sling or reeving sling do not force the bight down on to the load. The included angle formed by the bight should not exceed 120°.
13. Protect Wire Rope Slings by suitable softeners from sharp edges of the load.
14. Do not drag wire rope slings along the floor.
15. Check that the crane hook is positioned over the load's centre of gravity to prevent swinging when the load is being raised.
16. Make sure that the load is free before lifting, and that all sling legs have a direct lead.
17. Take your hands away from slings before the crane takes the load and stand clear.
18. Correct signals, according to the recognized code, should be given the crane driver. The signals must be given by the person responsible for the lift and nobody else.
19. Never allow the load to be carried over the heads of other persons.
20. Do not ride on a load that is being slung, or allow any other person to do so.
21. Steady application of the load at the start of each lift will avoid risk and prolong the life of the sling. Beware of snatch loading.
22. Always lower the load on to adequate dunnage to prevent damage to the sling.
23. After use, riggers should stow slings tidily on a suitable rack off the floor.
24. Keep wire rope slings away from welding and flame cutting operations.
25. Keep wire rope slings in a dry store when not in use, to prevent corrosion.
26. Good practice requires all lifting tackle to be examined by a competent person at regular intervals. This includes the wire rope slings. Riggers should not stow away slings and regard them as their own private property as this could lead to their being overlooked at inspection time.
27. Slings may not be made from Lang Lay wire rope.

## RIGGING

Attaching loads to lifting devices is a serious and complex responsibility and therefore, only the supervisor in charge can designate persons competent to do this. The assigned workman is fully responsible for the safety of the procedure:

- 1) The equipment (slings, chokers, chains, spreader bars, etc.) is of sufficient strength to lift, suspend and support the load.
- 2) The load must remain in a safe and stable situation while stationary or moving.
- 3) The total overall weight of the load to be moved must be less than the rated safe load capacity of the hoisting device.

In determining the safe working loads for cordage wire rope, chains and other rigging equipment, the manufacturers' published safe working load ratings must not be exceeded. Remember that these specifications apply to rigging in new or nearly new condition. These items must therefore be examined so that their condition can be considered in selecting the correct size and construction for a given load. Where special considerations of safety factors or special risks are involved, government regulations apply in selecting the correct size and construction to be used.

## RIGGING ACCESSORIES

For ropes and lines to be used efficiently in rigging operations, certain auxiliary devices can be included in the system.

## HOOKS AND SHACKLES

Hooks and shackles are manufactured from forged steel or built up steel plate, however special materials may be used where certain electrical or chemical conditions demand it, e.g. bronze hooks which have anti-spark properties.

1. **A Standard Eye Hook** is illustrated in Figure 7-79. The different dimensions are labelled for reference to the dimension and load charts to follow.
2. **Mousing Hooks** No open hook shall be used in any situation where accidental dislodgement of the load could cause a risk of injury to workers. In these circumstances a safety hook or a shackle must be used, or if permitted by government regulations, mousing as shown in Figure 7-80 could be applied.

404



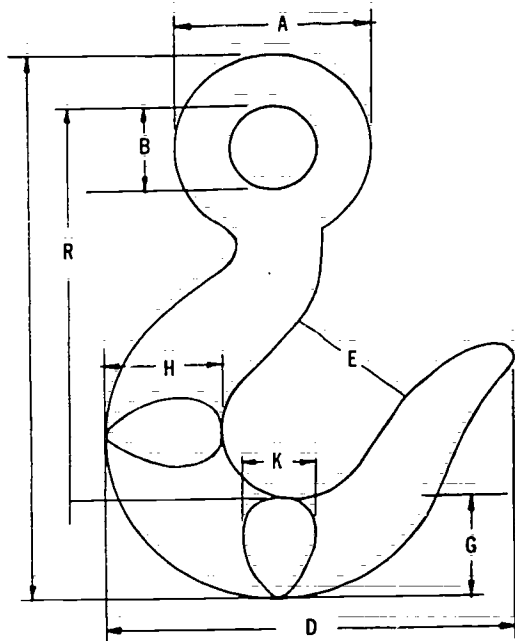

Figure 7-79. Standard Eye Hook

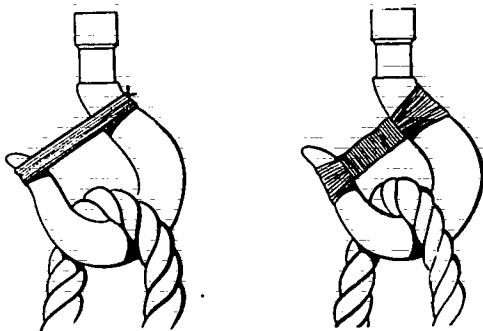

Figure 7-80. Mousing Hooks

3. A Standard Safety Eye Hook is illustrated in Figure 7-81.
4. **Shank Hooks** shall be considered to be of equal strength characteristics to eye hooks where the thickness at "G" is the same on both hooks. Open and Safety Shank Hooks are illustrated in Figure 7-82. Hooks must be inspected regularly with particular attention to load carrying sections (e.g., dimension G) and stress related areas (dimension E). Any hook showing a loss of material of 20% or more of the original thickness at any section must be destroyed and replaced. Similarly **any** increase in the throat opening E beyond stated specification indicates overstress, and the hook must be destroyed. Table 7-9 specifies important dimensions for eye type

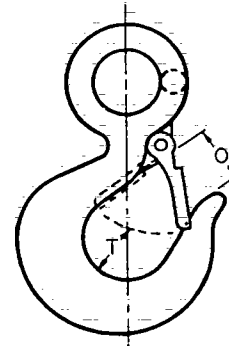

Figure 7-81. Standard Safety Eye Hook

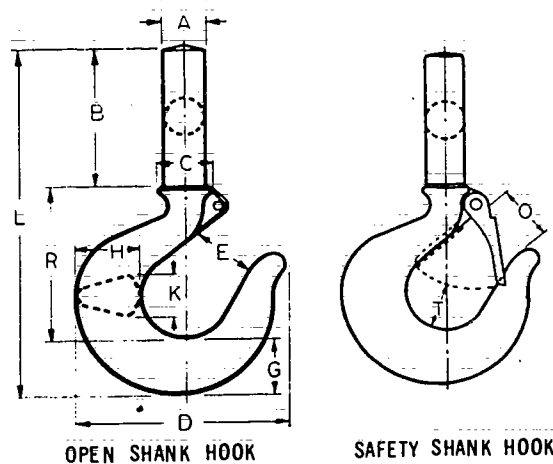

Figure 7-82. Shank Hooks

hooks along with the rated load capacity for each size.

5. **Shackles** are available in Screw Pin, Round Pin and Safety Type construction, as illustrated in Figure 7-83.

In determining safe working loads, the critical dimensions are the width between the eyes and the pin diameter. For example, the maximum width between eyes for a 3/4" diameter pin is 1 1/16". The rated safe working load for this shackle is 5,600 pounds. A 1 1/4" diameter pin can span a maximum of 1 7/8" between eyes, with a safe working load of 16,000 pounds.

All shackle pins must be straight, and all pins of screw pin type must be screwed in all the way. The use of rebar, bent or straight, as a substitute for pins is not permitted under any circumstances.

Shackles must be inspected regularly, and if the width between the eyes exceeds the listed

Rigging and Erection

**TABLE 7-9. CRITICAL DIMENSIONS FOR LOAD CARRYING HOOKS**

Size No	Rated Capacity Tons 2000 Lbs	HOOK DIMENSIONS IN INCHES											Approx. Weight Each Lbs.
		A	B	D	E	G	H	K	L	O	R	T	
22	46	1 1/2	1/4	2 7/8	1	2 5/32	1 5/16	9/16	4 13/32	7/8	3 1/4	2 5/32	.54
23	56	1 1/4	3/8	3 1/16	1 1/16	2 1/32	1	5/8	4 29/32	3 1/32	3 5/8	1 5/16	.75
24	74	2	1	3 1/16	1 1/8	1	1 1/8	1 1/16	5 15/32	1 1/32	4	1 5/16	1.1
25	1.4	2 1/4	1 1/8	4	1 1/4	1 1/8	1 11/32	2 7/32	7 7/32	1 1/8	4 1/2	1 1/8	1.7
26	1.7	2 1/2	1 1/4	4 9/16	1 3/8	1 5/16	1 9/16	3 1/32	6 7/8	1 7/32	4 15/16	1 1/8	2.5
27	2.1	2 3/4	1 3/8	5 1/16	1 1/2	1 1/2	1 29/32	1 1/8	7 3/4	1 5/16	5 9/16	1 15/32	3.5
28	2.5	3 1/8	1 1/2	5 7/8	1 3/4	1 11/16	2	1 1/4	8 11/16	1 5/8	6 1/4	1 1/2	4.9
29	3.2	3 3/8	1 5/8	6 1/2	1 7/8	1 7/8	2 3/16	1 3/8	9 5/8	1 3/4	6 15/16	1 5/8	7.3
30	4.2	3 5/8	1 3/4	7 3/16	2 1/16	2 1/32	2 13/32	1 17/32	10 1/2	1 7/8	7 5/8	1 7/8	9.1
31	4.7	4 1/4	2	7 11/16	2 1/4	2 7/32	2 5/8	1 21/32	11 23/32	2 1/16	8 1/2	2 1/8	12.0
32	7.0	4 7/8	2 3/8	8 9/16	2 1/2	2 15/32	2 31/32	1 13/16	13 3/32	2 5/16	9 7/16	2 5/32	17.6
33	8.0	5 1/2	2 1/4	9 9/16	3	2 29/32	3 9/32	1 15/16	14 13/16	2 25/32	10 3/4	2 1/2	23.5
34	9.4	6 1/8	3 1/8	11 1/16	3 3/8	3 7/32	3 13/16	2 7/32	16 29/32	3 5/32	12 5/16	2 13/16	35.1
34A	12	6 3/8	3 1/8	11 7/16	3 5/8	3 7/32	3 13/16	2 7/32	16 29/32	3 5/32	12 5/16	2 13/16	35.1
35	16	7	3 7/8	13 7/8	4	4 3/16	4 15/16	2 5/8	19 15/16	3 3/4	14	3 1/16	57.6
35A	19	7	3 1/2	13 7/8	4	4 3/16	4 15/16	2 5/8	19 15/16	3 3/4	14	3 1/16	57.6
36	20	8 1/2	4	15 5/8	4 1/2	4 11/16	5 7/32	3 1/16	2 15/16	4 3/16	15 7/8	3 11/16	86.8
36A	24	8 1/2	4	15 5/8	4 1/2	4 13/16	5 21/32	3 1/16	2 15/16	4 3/16	15 7/8	3 11/16	86.8

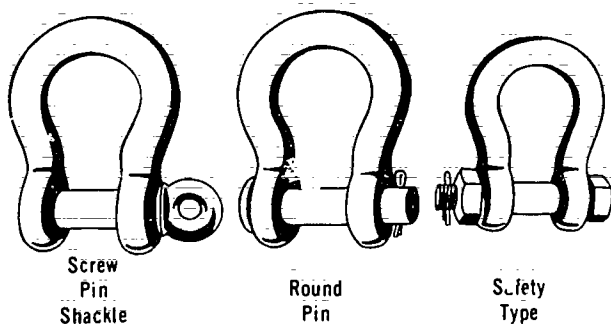

Figure 7-83. Types of Shackles

specification, the shackle has been overstrained and must be destroyed.

**Caution:** When using any of the above equipment, never under any circumstances exceed the safe working load. When in use all gear should be inspected daily and any parts showing excessive wear or distortion should be discarded immediately. All hooks should be used with caution and watched closely for excessive wear or any distortion.

**WELDED LUGS**

Specifications for welded lugs are illustrated in Figure 7-84 and in Tables 7-10 and 7-11.

**END ATTACHMENTS FOR WIRE ROPE**

**Eye Using Wire Rope Clips** Wire rope clips may be of the U-Bolt and Saddle type or of the Double Integral Saddle and Bolt type (Safety or Fist Grip). (Figure 7-85).

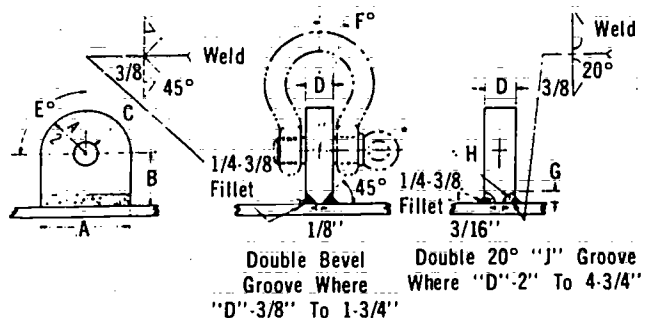
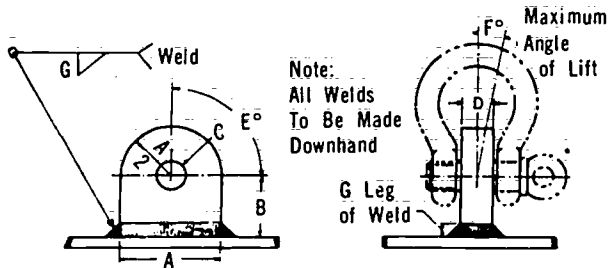
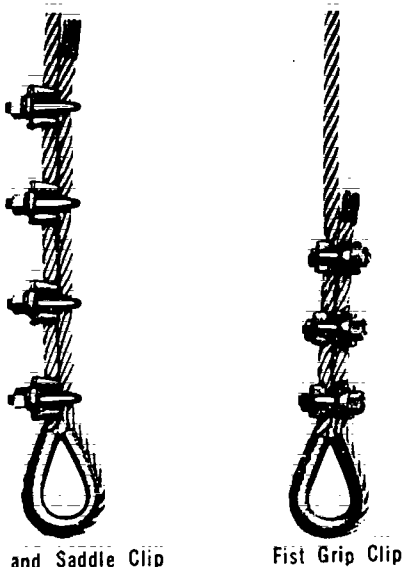

Figure 7-84. Dimensions for Welded Lugs

406

TABLE 7-10. STANDARDS FOR FILLET WELDED WELD-ON LIFT LUG FOR LIGHT DUTY USE							
Safe Load Tons	A	B	C	D	Load Angle		G
					E°	F° Max.	
1/3	1/4	7/8	3/8	3/8	0° to 90°	20°	3/8
1/2	13/4	1 1/8	7/16	3/8	"	"	3/8
3/4	2	1 1/4	1/2	1/2	"	"	1/2
1	2	1 1/4	5/8	5/8	"	"	1/2
1 1/2	2 1/4	1 3/8	3/4	3/4	"	"	1/2
2	2 1/2	1 1/2	7/8	7/8	"	"	1/2
3	3	1 5/8	1	1	"	"	1/2
4	3 1/2	2	1 1/8	1 1/4	"	"	1/2
5 1/2	4	2 1/8	1 1/4	1 1/2	"	"	1/2
6 1/2	4 1/4	2 1/4	1 3/8	1 1/2	"	"	3/4
8	4 3/4	2 1/2	1 1/2	1 3/4	"	"	3/4
10	5	2 3/4	1 5/8	2	"	"	3/4
12	5 1/2	2 7/8	1 3/4	2 1/4	"	"	3/4
16	6 3/4	3 1/4	2 1/4	2 1/4	"	"	7/8
21	7 1/2	3 3/4	2 1/2	3	"	"	7/8
27	8 1/4	4 1/4	2 3/4	3 1/2	"	"	1
34	9	4 1/4	3	4	"	"	1
40	9 3/4	4 1/4	3 1/4	4 1/4	"	"	1
50	10 1/2	4 3/4	3 1/2	4 3/4	"	"	1



U-Bolt and Saddle Clip

Fist Grip Clip

Figure 7-85. Clips For Wire Rope

When applied with proper care, following the regulations for number and spacing of clips, the formed eye will have 80% of the rated strength of the rope.

Never use fewer than the recommended number of clips and turn back the correct amount of rope for dead ending to permit proper spacing of the clips. (See Table 7-12.) The use of a thimble in the loop will prevent rope wear in the eye and provide a safer connection.

**Application of Rope Clips** U-bolt clips must be attached so the "U" part of the clip is over the dead end of the rope as shown in Figure 7-86.

- Step 1. Apply first clip one clamp diameter from dead end of wire rope. Tighten nuts.
- Step 2. Apply second clip nearest thimble. Do not tighten nuts.
- Step 3. Apply all other clips leaving equal space between each clip.
- Step 4. Take up rope slack and tighten all nuts evenly on all clips.
- Step 5. Inspect fastenings periodically. When load is placed on rope it will stretch and decrease in diameter. Tighten nuts to compensate.

**TABLE 7-11. STANDARDS FOR GROOVE WELDED WELD-ON LIFT LUG FOR HEAVY DUTY USE**

Safe Load Tons	A	B	C	D	Load Angle		G	H RAD
					E°	F° Max.		
1/3	1/4	7/8	3/8	3/8	0° to 90°	15°		
1/2	1 3/4	1 1/8	7/16	3/8	"	15°		
3/4	2	1 1/4	1/2	1/2	"	15°		
1	2	1 1/4	5/8	5/8	"	15°		
1 1/2	2 1/4	1 3/8	3/4	3/4	"	20°		
2	2 1/2	1 1/2	7/8	7/8	"	20°		
3	3	1 5/8	1	1	"	20°		
4	3 1/2	2	1 1/8	1 1/4	"	20°		
5 1/2	4	2 1/8	1 1/4	1 1/2	"	20°		
6 1/2	4 1/4	2 1/4	1 3/8	1 1/2	"	20°		
8	4 3/4	2 1/2	1 1/2	1 3/4	"	20°		
10	5	2 3/4	1 5/8	2	"	20°	3/4	1/2
12	5 1/2	2 7/8	1 3/4	2 1/4	"	20°	3/4	1/2
16	6 3/4	3 1/4	2 1/4	2 1/4	"	20°	3/4	1/2
21	7 1/2	3 3/4	2 1/2	3	"	20°	7/8	1/2
27	8 1/4	4 1/4	2 3/4	3 1/2	"	20°	1	1/2
34	9	4 1/4	3	4	"	20°	1 1/8	1/2
40	9 3/4	4 1/4	3 1/4	4 1/4	"	20°	1 1/8	1/2
50	10 1/2	4 3/4	3 1/2	4 3/4	"	20°	1 1/4	1/2

**TABLE 7-12. SPECIFICATIONS FOR ATTACHING WIRE ROPE CLIPS**

Rope Diam. Inches	U-Bolt and Saddle Type			Integral Saddle and Bolt Type		
	Minimum No. of Clips	Amount of Rope to turn back in inches from Thimble	Torque in Lbs. Foot	Minimum No. of Clips	Amount of Rope to turn back in inches from Thimble	Torque in Lbs. Foot
1/4	2	4 3/4	15	2	3 1/4	30
5/16	2	5 1/2	30	2	4	30
3/8	2	6 1/4	45	2	5	45
7/16	2	6 3/4	65	2	5 3/4	65
1/2	3	11	65	2	6 1/2	65
9/16	3	11 1/4	95	3	7 1/4	130
5/8	3	12	95	3	8	130
3/4	4	18	130	3	14	130
7/8	4	21 1/2	225	4	23	225
1	4	21	225	4	26	225
1 1/8	5	28	225	4	29	225
1 1/4	5	30	360	5	40	360



Figure 7-86. Applying U-Bolt Clips

**Wedge Socket** Wedge sockets are intended for "on the job" attachment and for quick rope replacement. Efficiencies will range from 80% to 90% of rated rope strength. These are available in both open and closed types (Figure 7-87).

**Application of Wedge Socket** The wedge socket must be applied so that the line of stress follows the live portion of the rope (Figure 7-88).

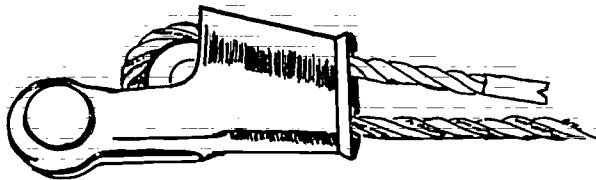

Figure 7-87. Wedge Socket (Open Type)

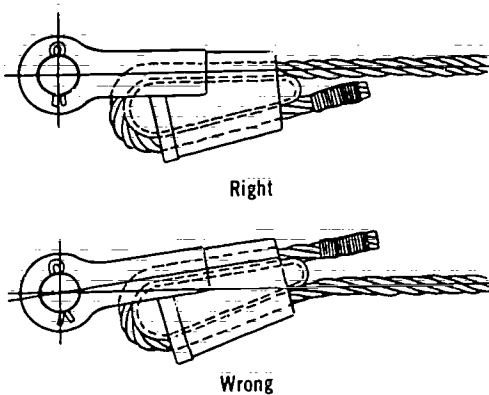

Figure 7-88. Applying a Wedge Socket

## TURNBUCKLES

A turnbuckle is a device used to tighten or loosen a stress on a rope by using right and left handed threads at opposite ends of a matching threaded centre piece. It is used where precise load balancing is required or as a temporary measure on offset loads.

Turnbuckles used in rigging should be steel drop forgings. They are available with a variety of end fittings or combinations of fittings (Figure 7-89).

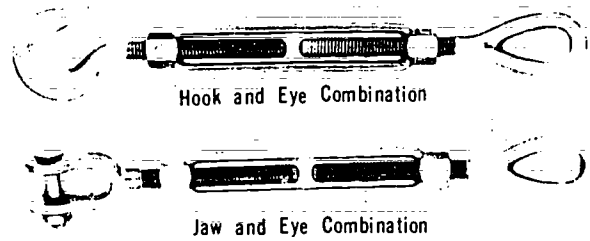
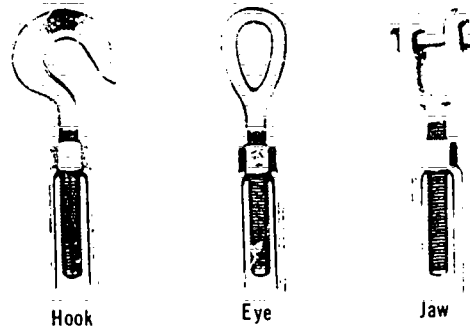

Figure 7-89. Types of Turnbuckles

### Using Turnbuckles:

When using turnbuckles with multi-leg slings, the following guidelines must be observed:

1. No more than one turnbuckle per leg should be used.
2. The angle of the leg at the horizontal should never be less than 30°.
3. The turnbuckle must be of sufficient size and strength to support the entire load since each leg of a two-leg sling at 30° carries tension equal to the full load.

### General Precautions:

1. Welding to repair damage on a turnbuckle is not permitted.
2. Never turn turnbuckles with long levers such as bars or pipes.
3. The maximum torque applied to turn a turnbuckle should be equal to that required to tighten a bolt of comparable size.
4. Avoid shockloading when using turnbuckles.
5. Turnbuckles must be free from contact with any other stationary object when supporting a load.
6. Turnbuckles must be secured to prevent unscrewing under load tension; threaded portions must be fully engaged.

Rigging and Erection

**Inspection and Assessment:**

1. If a turnbuckle does not turn easily on the threads, this indicates overloading. Replace the turnbuckle by one of adequate size.
2. Turnbuckles should be inspected for:
  - a) Nicks in the body
  - b) Signs of abuse or overloading
  - c) Corrosion
  - d) Wear or distortion of jaws, hooks or eyes
  - e) Distortion of male and female threads
  - f) Straightness of the rod.
3. Refer to Table 7-13 to determine safe working loads for turnbuckles.

TABLE 7-13. SAFE WORKING LOADS FOR TURNBUCKLES		
Stock Diameter of End Fitting (inches)	Safe Working Load of Turnbuckle having any combination of jaw, or eye end fittings (pounds)	Safe Working Load of Turnbuckle having hook end fitting (pounds)
1/4	500	400
5/16	800	700
3/8	1,200	1,000
1/2	2,200	1,500
5/8	3,500	2,250
3/4	5,200	3,000
7/8	7,200	4,000
1	10,000	5,000
1 1/4	15,200	5,000
1 1/2	21,400	7,500
1 3/4	28,000	not applicable
2	37,000	
2 1/2	60,000	
2 3/4	75,000	



Figure 7-90. Chain Fall — Spur-Gear Hoist

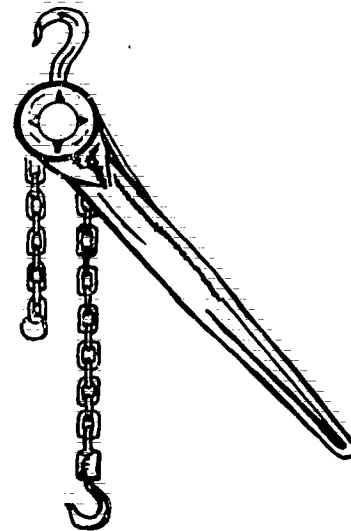

Figure 7-91. Come Along Hoist

**CHAIN FALLS**

The chain fall or chain hoist (Figure 7-90) is a dependable and economical device for lifting loads. The most commonly used chain fall is the spur-gear hoist. This hoist uses an endless chain to drive a pocketed sheave. This sheave in turn drives a gear reduction unit that is fitted with a second chain, the load chain. A brake is built into the gear box that engages when the hoisting or lowering action on the hand chain ceases. The brake disengages when the hand chain is operated.

**COME ALONGS**

The come along (Figure 7-91) is a type of chain operated hoist for raising and lowering loads as

well as pulling loads horizontally. A ratchet operated by a lever drives the gear reduction unit to power the load chain.

**TIRFOR JACKS**

The tirror jack (Figure 7-92) is a hand operated pulling or lifting device with an unlimited amount of rope travel. It operates by a direct pull on the rope, the pull being applied by two pairs of self-energizing, smooth jaws. These exert a grip on the rope in proportion to the load being lifted or pulled. The initial pressure causing the jaws to grip the rope starting the self-energizing action is derived from springs that give an initial pressure of about 120 lb. Two levers operate

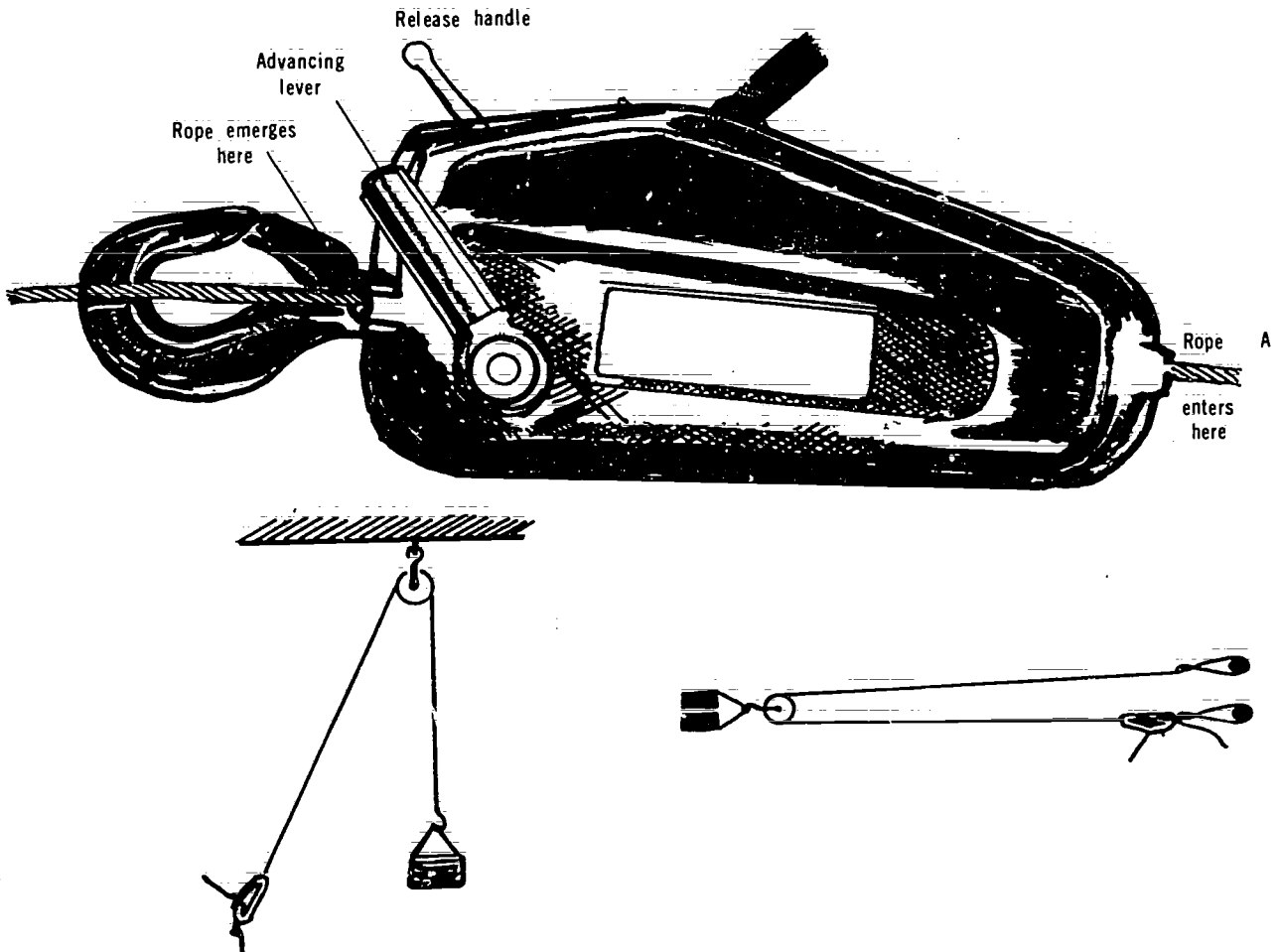

Figure 7-92. Tirfor Jack

these jaws which provide a forward or backward motion depending on the lever used.

**JACKS**

Jacks are used to raise or lower heavy loads over short distances. Smaller jacks are often of the screw or ratchet type while larger jacks are usually hydraulic, operated with either a hand or power assisted pump. Jacks are of various types (Figure 7-93).

Advantages of Hydraulic Jacks:

1. Small size relative to lifting capability
2. Ability to raise and lower loads precisely
3. Several jacks can be connected to one pump so that loads can be lifted with uniform tension on each jack.

Lever jacks with foot lift (sometimes called a railroad jack or track) are designed to lift loads

from a low position. They are used for lifting rails or for raising a tank float from ground level for placing shims under it. The steam boat ratchet is capable of pulling loads together or pushing them apart.

**BEAM CLAMPS**

A beam clamp is a stationary device that permits safe, easy suspension of hoists from beams or girders, eliminating the use of nuts, bolts, shackles, slings. Figure 7-94 illustrate beam clamps.

**Guidelines for Safe Use**

1. Obtain approval before applying a beam clamp to any structural member to ensure that the member is capable of supporting the load being raised.
2. The clamp must fit the beam and be fastened securely to it.

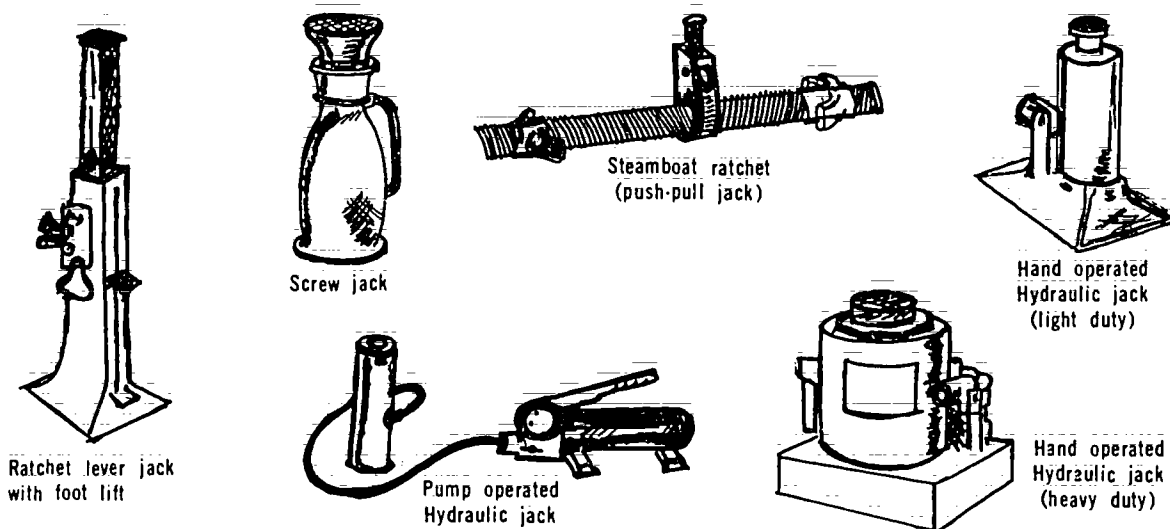

Figure 7-93. Types of Jacks

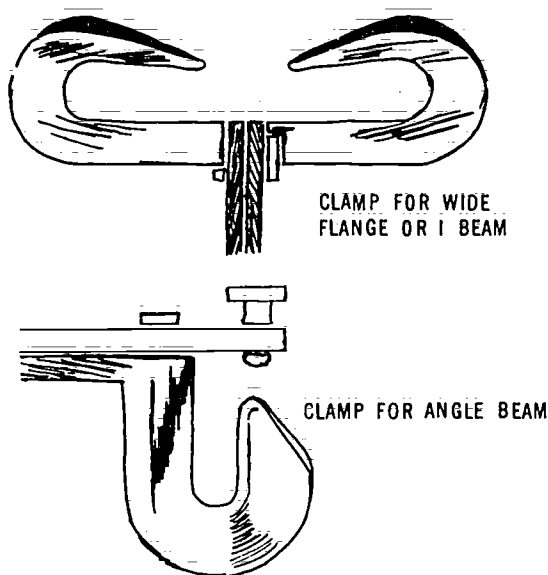

Figure 7-94. Beam Clamps

3. The clamp must be adequate to support the load being raised.
4. Beam clamp capacity ratings are based on **straight lifts only**. Angle lifts will place the beam flange under multiple stresses and the beam clamp under a point of load concentration that is liable to exceed design capacity.
5. Never use plate grips, tongs, girder hooks, pipe clamps, etc. as substitutes for beam clamps.
6. Use a shackle to attach rigging to a beam clamp. Never place a hoist hook directly into the lifting eye of a beam clamp.

### BEAM TROLLEYS

A beam trolley serves the same purpose as a beam clamp with the added advantage of being moveable along the beam by means of a wheel assembly that rides along both flanges of the beam. The wheel system may be designed for push travel or geared travel. Some models are manufactured specifically for straight lift while others are provided with a flexible lug that will permit a side pull. (See Figure 7-95.)

#### Procedure for Mounting

- Step 1. The bolt and nut arrangement connecting the wheels must be separated.
- Step 2. The wheels are set on the beam flanges.
- Step 3. The bolt and nut assembly is secured.

### PLATE CLAMPS

Plate clamps (Figure 7-96) are rigging devices with a serrated jaw designed to grip pieces of plate for hoisting. Plate clamps may be locking or non-locking; however, locking grips are recommended for maximum safety. **Plate clamps are designed to grip only one plate for each hoist.**

### SPREADER BEAMS

The spreader beam (Figure 7-97) also known as a spreader bar or rocker beam is most commonly used to support long or flimsy loads during lifting. The load cannot tip, slide or bend because of the support provided at two or more points along the load (Figure 7-98).



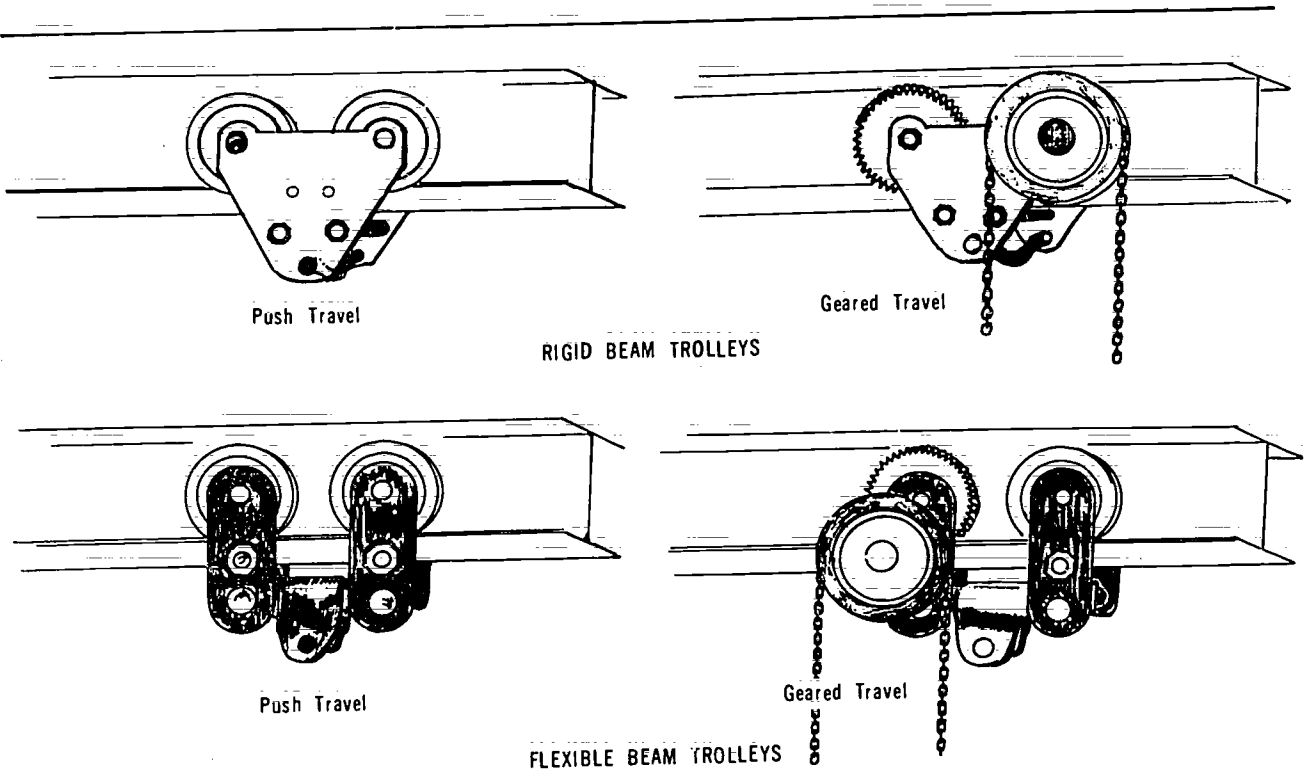

Figure 7-95. Beam Trolleys

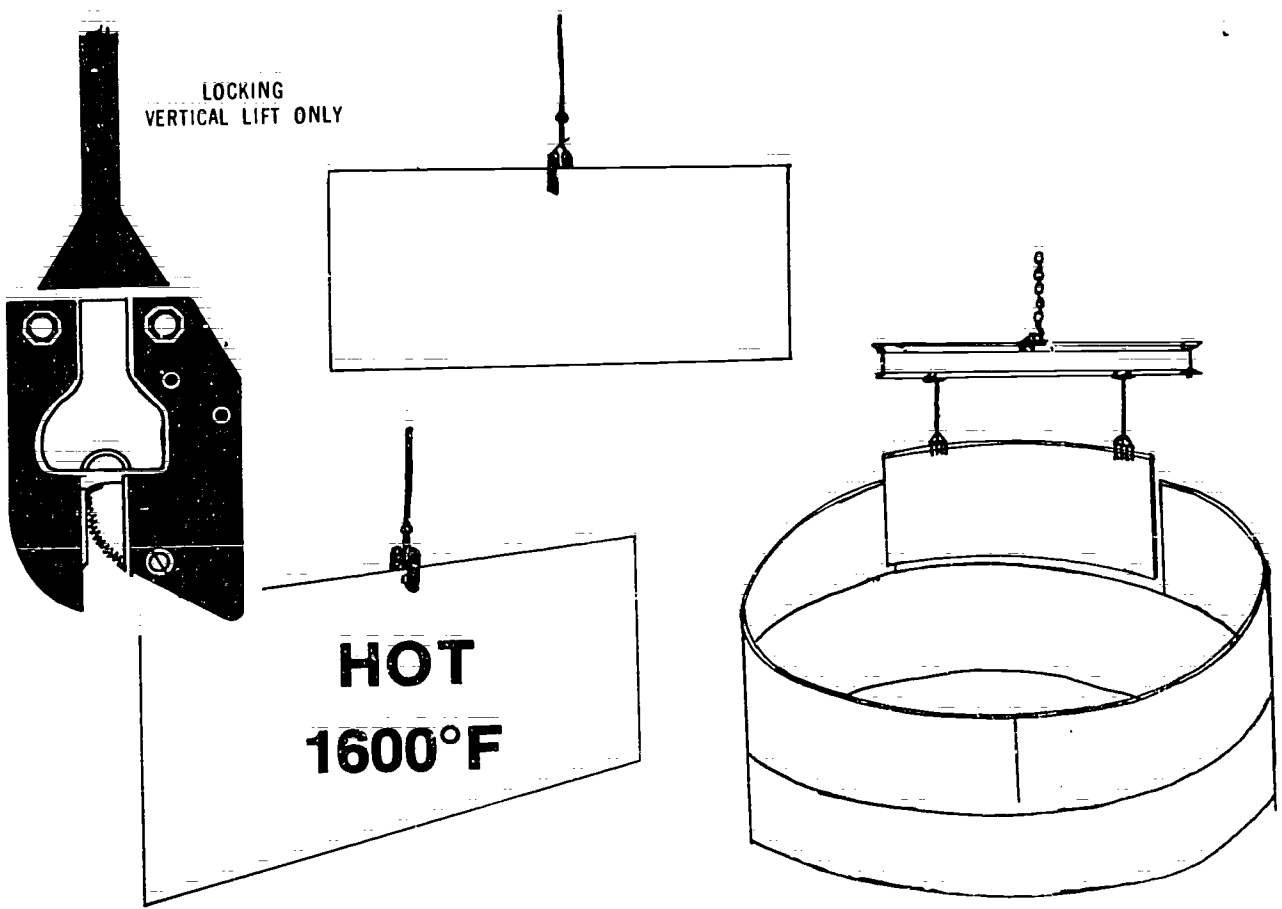

Figure 7-96. Uses of Plate Clamps

413

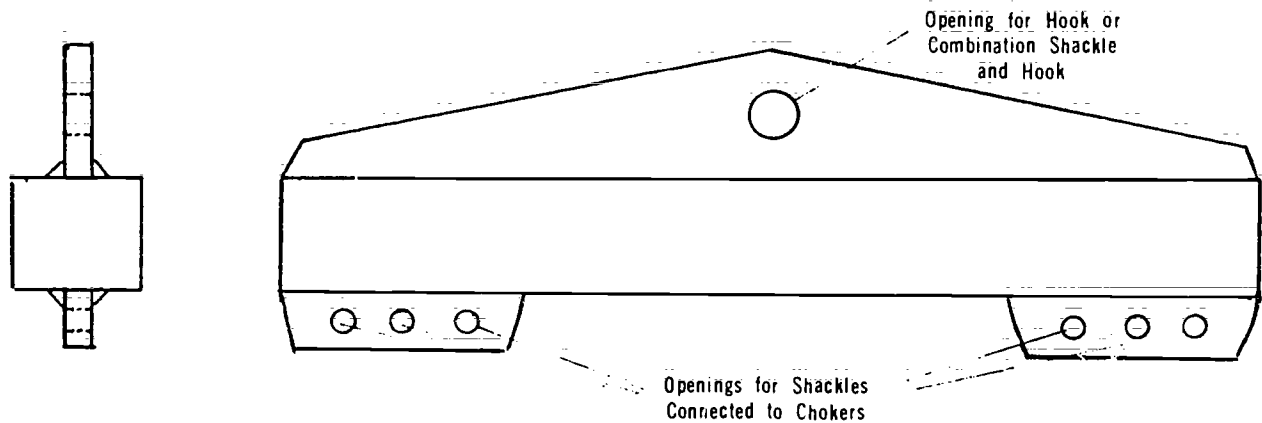

Figure 7-97. Spreader Beam or Bar

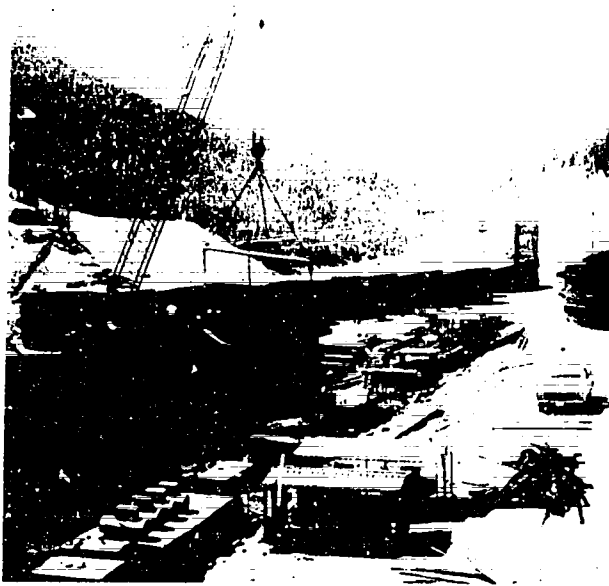

Figure 7-98. Spreader Beam in Use

involved, it is advisable to use a tugger or a tirlor jack as a holdback.

Rollers made of pipe or, less frequently, hardwood provide a rolling platform over the skids. The rollers must extend beyond the outside dimensions of the vessel. To ensure continuous support for the rollers along the moving distance, the skid joints should butt securely together or the ends be arranged in a side by side overlap. Skid joints should also be staggered so that the rollers pass over only one joint at a time.

To move the vessel, four or five rollers are positioned underneath and several additional rollers placed ahead. As the vessel rolls forwards, the rollers left behind are moved in position in front of it. If the moving path involves a turn, the skid timbers must be positioned to describe the turn angle in stages. As the vessel approaches the turn, its course can be redirected by knocking the leading rollers toward the required angle.

### SKIDS, ROLLERS, CRIBBING AND JACKS

It is not always feasible to hang rigging or use cranes to move heavy objects such as vessels where, for example, overhead wiring or piping limit the work space. Under these circumstances an arrangement of skids, rollers, cribbing and jacks can provide a safe means of transporting and/or raising large objects.

Timber skids can be set out longitudinally to distribute the weight of the vessel over a larger area. The skids also serve to make a smooth surface over which the vessel may be moved or to make a runway if rollers are used. The angle of incline of the skids should be kept as low as possible to prevent the vessel from "running away" or getting out of control. If any incline is

Cribbing is a layered arrangement of uniform sized, clean blocking timbers that distributes the weight of the vessel safely on the crib platform. The blocking is cribbed in alternate directions at each level, either tightly packed or spaced at even intervals, depending upon the requirements of the vessel weight. Where the cribbing is spaced, all layers of blocking must be in a direct vertical line with other members cribbed in the same direction in the system. The foundation for cribbing must be solid and level.

Cribbing may be required to provide a level, stable platform for a load that cannot be placed directly on rollers. It is also used to raise loads

in stages using jacks. The raising procedure is as follows:

- Step 1. Using jacks on a stable footing, raise the load to the maximum stable height.
- Step 2. Place one or more rows of cribbing under the load and lower the jacks to rest the load onto the crib platform.
- Step 3. Set the jacks on blocking and raise the load further, adding more rows of cribbing under the load. Repeat the stepwise jacking and cribbing until the required elevation is reached.

The weight of the load and the rated capacities of the jacks determine the number and type of jacks required for the lifting operation.

## TACKLE BLOCKS

Like any piece of equipment, tackle blocks cannot be abused or neglected without loss of effectiveness and life. Keep them clean. Remove sheaves occasionally and clean and oil the centre pins. Inspect sheaves for wear, and, store them in a dry place when not in use. Throwing them around carelessly will damage them and is injurious to the rope. With reasonable maintenance, replacements and repairs will be minimal.

In theory the mechanical advantage of a set of tackle blocks is determined by the number of parts of rope at the moving block. For example, with four parts of rope, 1 lb. pull on the lead line should lift 4 lbs. Friction reduces this advantage, however. For practical purposes a loss of approximately 10% occurs for each sheave in manila rope blocks and about 3% for each sheave in wire rope blocks. Each snatch block must be considered an additional sheave.

Many factors govern the selection and use of tackle blocks. Trouble will result from:

1. Overloading
2. Undue friction
3. Angle of pull
4. Condition of rope
5. Sudden application of load
6. Lack of lubricant.

The actual weight of the load to be moved does

not necessarily determine the stress on the blocks. Avoid obstruction to the free movement of the load, twisted ropes due to improper reeving or rigging, or improper angle of the tackle in relation to the load. Moving heavy loads over rough ground or on an incline or without rollers or rollers that are too small can introduce severe stresses.

A load suspended on two sets of tackle blocks should be evenly distributed or one set will be subjected to more than its calculated share of the load. Careless preparation may result in any or all of these conditions to such a degree that the load on a set of blocks will greatly exceed the actual weight of the load itself.

## TERMINOLOGY OF TACK BLOCK OPERATION

**Parts of Line** — a term used in multiple reeving for heavy loads. The number of parts of line can easily be determined by counting the number of cables reeved in movable blocks, including the dead end if applicable.

**Sheave** — a grooved pulley over which the rope passes.

**Snatch Block** — a block to maintain a straight pull on a line or to decrease the strain on cables.

### Mechanical Advantage

As previously stated, the mechanical advantage of the system is determined by the number of parts of rope at the moving block. (Figures 7-99 and 7-100).

## OPERATION OF SHEAVES

As illustrated in Figure 7-101, to raise a load 1' the lower block must be raised 1', and in accomplishing this, each working rope must be shortened 1'.

In the example in Figure 7-101, Ropes 1 must be shortened 1' to raise the load 1'. Assuming that the circumference of each sheave is 1', Sheave No. 1 must make one revolution to shorten Rope 1; Sheave No. 2 must make one revolution to take up the one foot slack from Rope 1 and one additional revolution to shorten Rope 2; Sheave No. 3 must make two revolutions to take up the 2' slack from Ropes 1 and 2 and one additional revolution to shorten Rope 3 and so on for each succeeding sheave.

Thus: Rope 1 must travel 1' on Sheave No. 1  
Rope 2 must travel 2' on Sheave No. 2

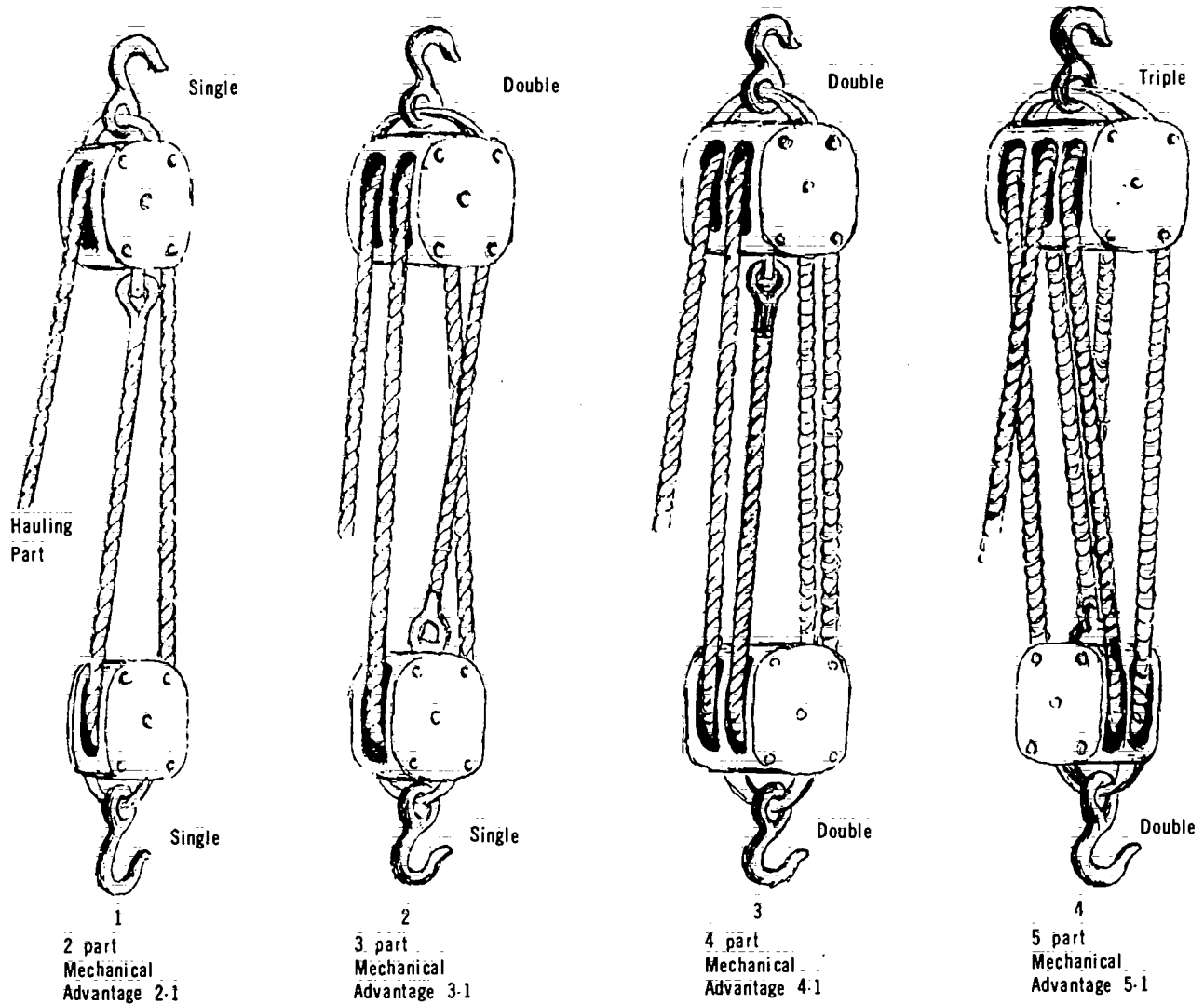

Figure 7-99. Mechanical Advantage of Tackle Block Systems

- Rope 3 must travel 3' on Sheave No. 3
- Rope 4 must travel 4' on Sheave No. 4
- Rope 5 must travel 5' on Sheave No. 5

Therefore all the sheaves in a set of blocks revolve at different rates of speed. Sheave No. 2 rotates twice as fast as sheave No. 1, Sheave No. 4 four times as fast as Sheave No. 1, etc. Consequently, the sheaves nearest the lead line, rotating at a higher rate of speed, wear out more rapidly.

All sheaves should be kept well oiled when in operation to reduce friction and wear.

### REEVING TACKLE BLOCKS

In reeving a pair of tackle blocks one of which has more than two sheaves, the hoisting rope should lead from one of the centre sheaves of the upper block.

When so reeved, the hoisting strain comes on the centre of the blocks and they are prevented from toppling, with consequent injury to the rope by cutting across the edges of the block shell.

To reeve by this method, the two blocks should be placed so that the sheaves in the upper block are at right angles to those in the lower one, as illustrated in Figure 7-102.

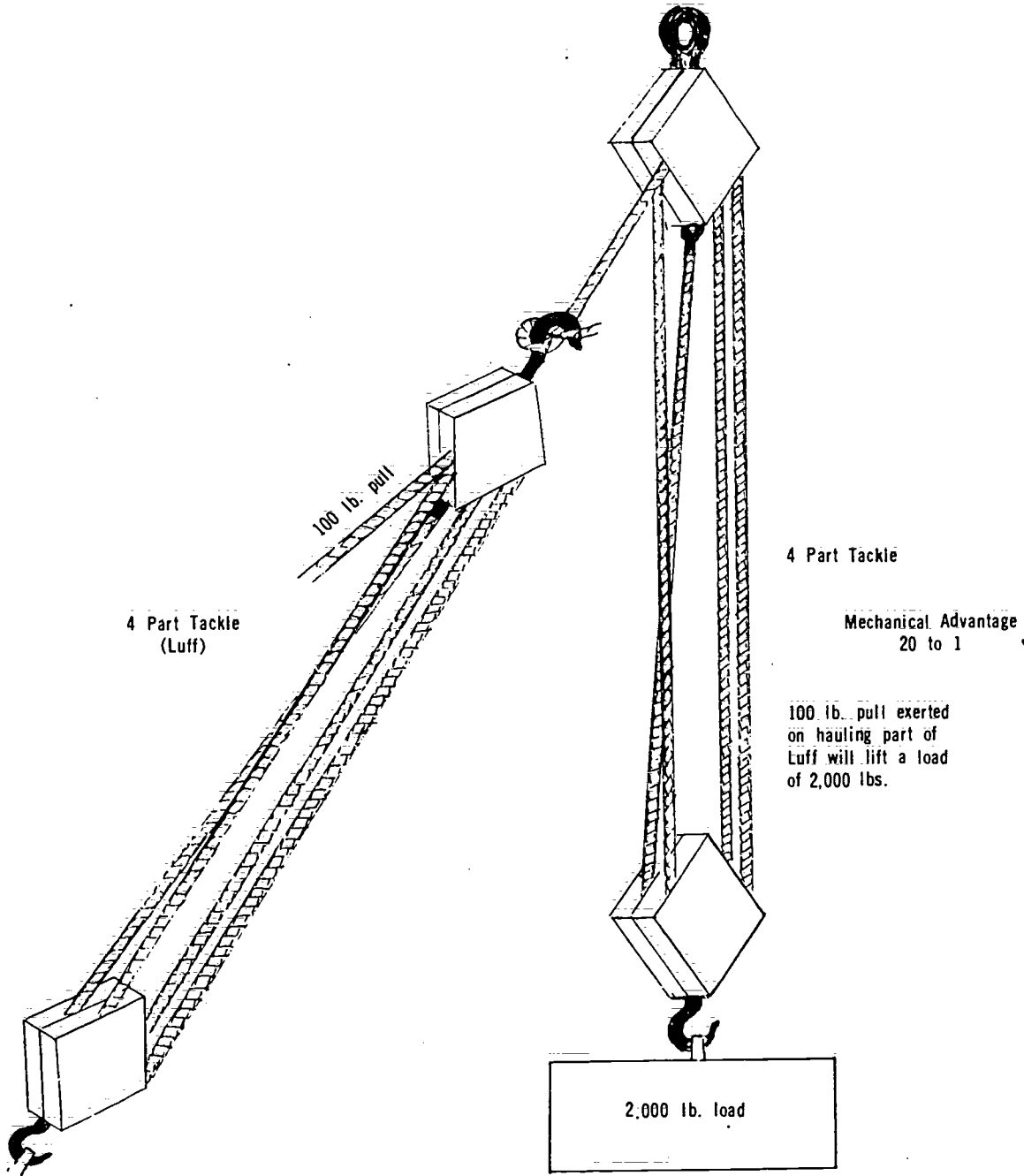

Figure 7-100. Compound Tackle (Luff)

**General Rules for Reeving**

1. Always reeve tackle right-handed.
2. If the number of sheaves in each block is equal, fasten the rope to the becket of the standing block.

If the number of sheaves is unequal, fasten the rope to the becket of the block with the smaller number of sheaves.

3. To determine the maximum size of fibre rope that can be used to reeve a tackle, divide the length of the shell of the block by 3, which will give the circumference of the rope to be used.

**Example:**

6" shell divided by 3 = 2 which is the circumference of 5/8" rope.

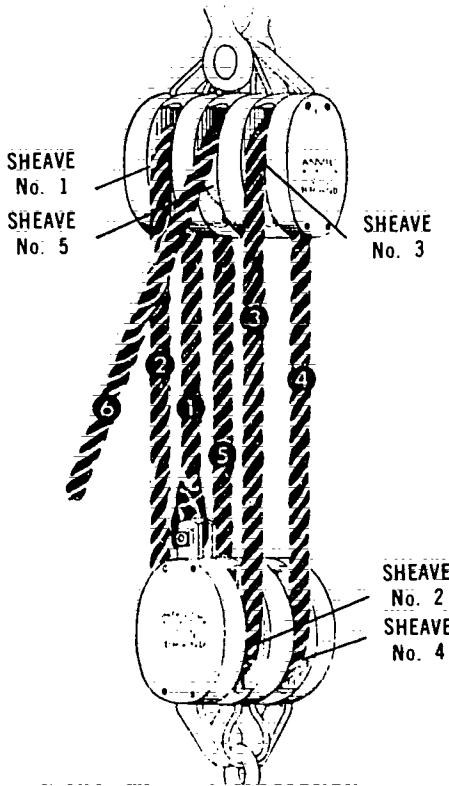

Figure 7-101. Sheave Operation

**DETERMINING LINE PARTS OR REQUIRED LINE PULL**

To help figure the number of parts of line to be used for a given load or the line pull required for a given load, the ratio table is provided with examples of how to use it (Table 7-14).

$$\frac{\text{TOTAL LOAD TO BE LIFTED}}{\text{SINGLE LINE PULL IN POUNDS}} = \text{RATIO}$$

**Example 1:**

To find the number of parts of line needed when weight of load and single line pull is established:

**Sample Problem:**

$$\frac{72,480 \text{ lbs. (load to be lifted)}}{8,000 \text{ lbs. (single pull)}} = 9.06 \text{ RATIO}$$

Refer to ratio 9.06 in table or number nearest to it, then check column under heading "Number of Parts of Line" — 12 parts of line to be used for this load.

**Example 2:**

To find single line pull needed when weight of load and number of parts of line are established.

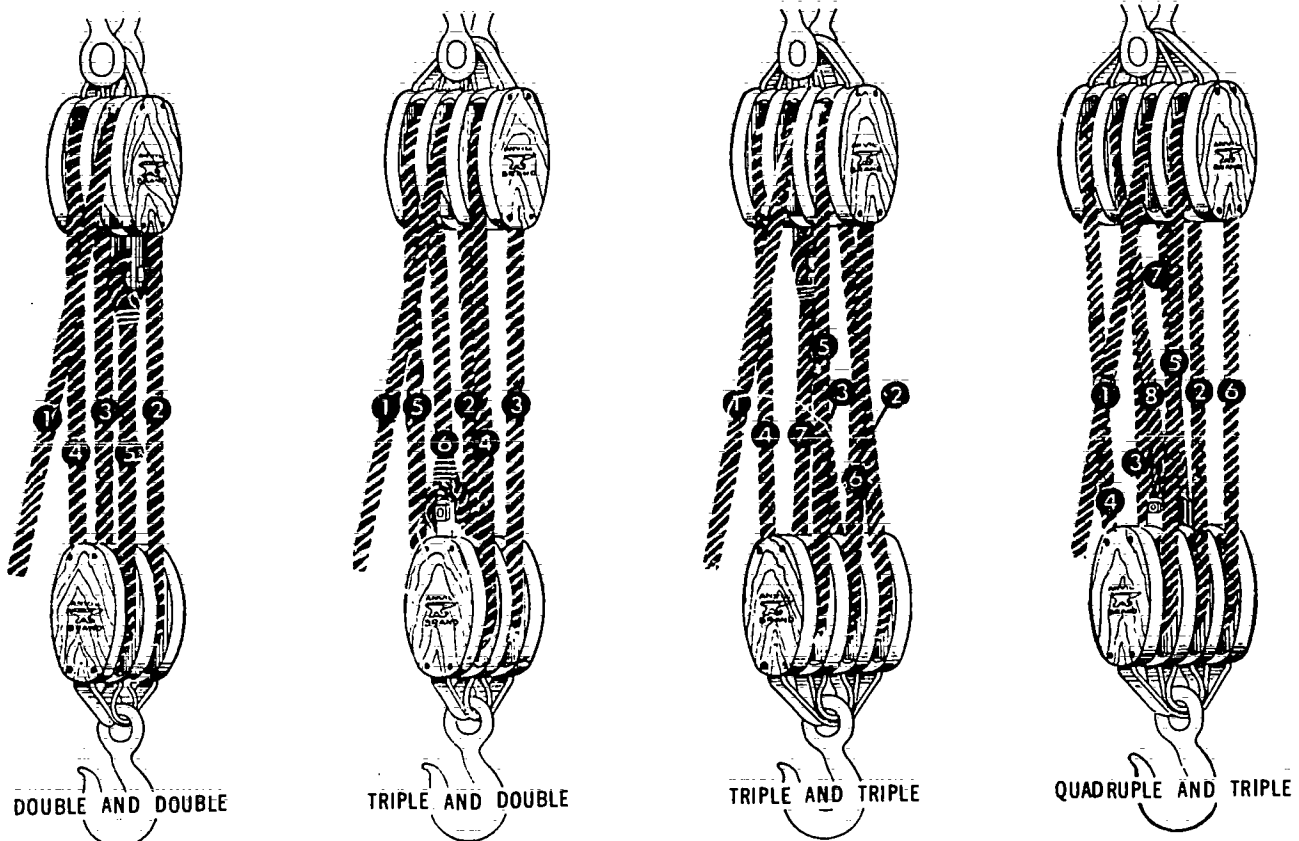

Figure 7-102. Tackle Blocks Placed at Right Angles to One Another

Number of Parts of Line	Ratio for Bronze Bushed Sheaves	Ratio for Anti-Friction Bearing Sheaves
1	.96	.98
2	1.87	1.94
3	2.75	2.88
4	3.59	3.81
5	4.39	4.71
6	5.16	5.60
7	5.90	6.47
8	6.60	7.32
9	7.27	8.16
10	7.91	8.98
11	8.52	9.79
12	9.11	10.6
13	9.68	11.4
14	10.2	12.1
15	10.7	12.9
16	11.2	13.6
17	11.7	14.3
18	12.2	15.0
19	12.6	15.7
20	13.0	16.4
21	13.4	17.0
22	13.8	17.7
23	14.2	18.3
24	14.5	18.9

hook. As the angle between the lines increases, the stress on the hook is reduced as illustrated in Figure 7-103. To determine the stress on a hook, multiply the pull on the lead line by a suitable factor from Table 7-15 adding 10% for friction.

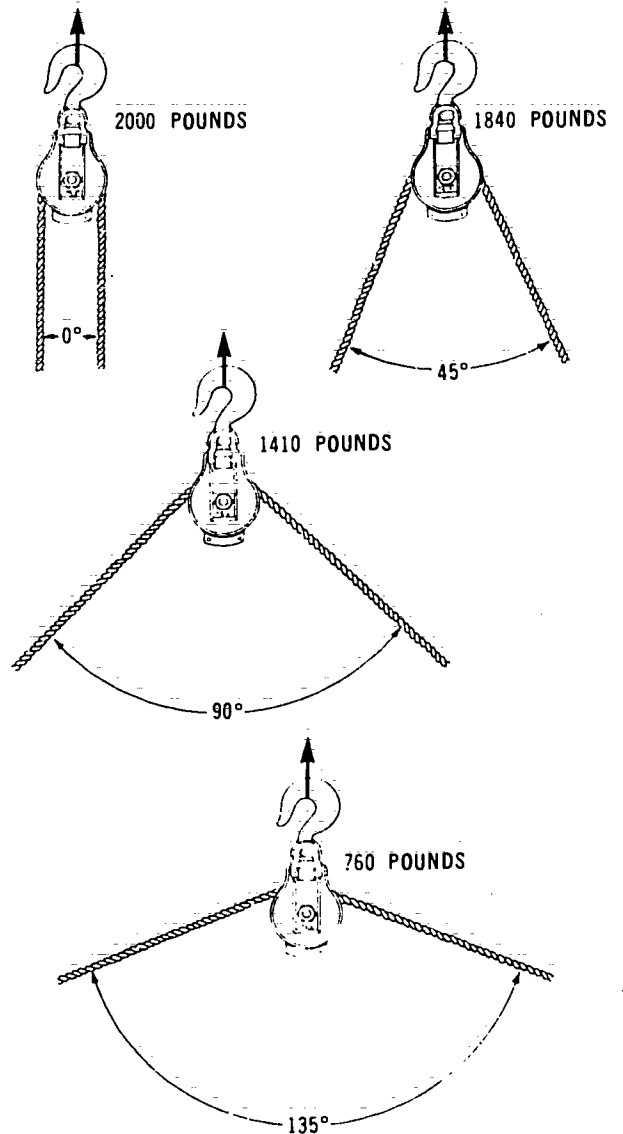

Figure 7-103.

**Sample Problem:**

68,000 lbs. (load to be lifted)  
 6.60 (ratio of 8 part line)  
 = 10,300 lbs. (single line pull)

10,300 lbs. single line pull required to lift this load on 8 parts of line.

**LOADS ON SNATCH BLOCKS**

The stress on a snatch block varies with the degree of angle between the lead and load lines. When the two lines are parallel, 1,000 lbs. on the lead line results in a load of 2,000 lbs. on the

Angle	Factor	Angle	Factor	Angle	Factor	Angle	Factor	Angle	Factor	Angle	Factor
5°	1.998	35°	1.90	65°	1.69	95°	1.35	125°	.92	155°	.43
10°	1.99	40°	1.87	70°	1.64	100°	1.29	130°	.84	160°	.35
15°	1.98	45°	1.84	75°	1.58	105°	1.22	135°	.76	165°	.26
20°	1.97	50°	1.81	80°	1.53	110°	1.15	140°	.68	170°	.17
25°	1.95	55°	1.77	85°	1.47	115°	1.07	145°	.60	175°	.08
30°	1.93	60°	1.73	90°	1.41	120°	1.00	150°	.52	180°	.00

415

Rigging and Erection

**Pressure on Sheave or Pulley Bearings** When a rope path is deflected by means of a sheave, pulley or roller, pressure is placed on the bearings. The pressure will vary depending on the angle of deflection of the rope.

**Placement of Shackle Block and Hook Block** It is good practice to use a shackle block as the upper one of a pair and a hook block as the lower one. A shackle is much stronger than a hook of the same size, and the strain on the upper block is much greater than on the lower one. The lower block supports only the load, while the upper block carries the load as well as the hoisting strain. A hook is more convenient on the lower block because it can be attached to or detached from the load more readily.

**RIGGERS RULES OF THUMB**

It is much easier to learn a simple formula than to memorize complex tables and graphs.

These "Rules of Thumb" are reasonably accurate and most are on the "safe side" of recognized safety practices. **But, it must be remembered, these formulas are only close estimates and are not intended to replace manufacturer's specifications in critical situations.**

**FIBRE LINE**

**The lay of rope** can be determined by running your thumb away from you along the strands in the line. (If strands go to the right, it is a right lay, etc.).

**Coil line** in the direction of the lay. (E.g., right lay, clockwise, etc.).

**Uncoil** a new bail counterclockwise to avoid kinks.

**Natural Fibre — (Manila)**

- 1. Breaking strength in tons =  $\frac{\text{Dia.}^2 \times 4}{10}$
- 2. Safe working load in tons =  $\frac{\text{Dia.}^2 \times 4}{10}$

(safety factor = 10)

**Synthetic Fibre — (Nylon, Polypropylene)**

- 1. Nylon = Approximately 2 1/2 times the strength of manila.

- 2. Polypropylene = Approximately 1 1/2 times the strength of manila.

**TACKLE SYSTEMS**

- 1. **Friction** in a tackle system = Approximately 8% per sheave @ 180° bend, 4% per sheave @ 90° bend. (For wire rope tackle — approximately 6% for bronze bushed sheaves and 3% for ball bearing sheaves)
- 2. **A Simple Tackle System** = 1 line and one or more blocks.  
Mechanical advantage = Number of lines on travelling block.
- 3. **A Compound Tackle System** = Two or more simple tackle systems compounded.  
Mechanical advantage = The M.A. of each system multiplied in series.

**WIRE ROPE**

(Determine lay, and coil like "Fibre Line")

- 1. **Lang Lay** — Wire laid up in same direction as strands of rope.  
**Regular Lay** — Wires layed up in opposite direction as strands of rope.
- 2. **Wire Core** (I.W.R.C.) is approximately 10% stronger than fibre core.  
**Galvanizing** reduces strength approximately 10%.
- 3. **Breaking Strength in Tons** =  $(\text{Dia.})^2 \times 40$  (For 6 x 19 I.P.S. F.C.)
- 4. **Safe Working Load in Tons** =  $(\text{Dia.})^2 \times 40 \div \text{Safety Factor}$ .
- 5. **Safety Factors** = Slings = 8  
Non rotating lines = 8  
Cranes and Derricks = 6  
Derrick Guys = 5  
Hoisting Tackle = 5  
Guy Lines = 3.5
- 6. **Broken Wires** = Unsafe when 4% of total wires in the rope are broken within the length of one rope lay.
- 7. **Choker Stress** —  $\frac{W}{N} \times \frac{L}{V} = T$   
N = Number of Chokers  
W = Weight of load in pounds  
V = Vertical distance in feet  
L = Choker leg length, in feet  
T = Tension, in pounds
- 8. **Sheaves** — The critical diameter of a sheave is 20 times the diameter of the rope.





9. **Drums** — For spooling a drum you face the lead block and place the right or left hand, which ever corresponds with the lay of the rope, palm down on the top of the drum for overwind and the bottom of the drum for underwind. The thumb will point to the flange where spooling begins.

10. **Drum Capacity** — in feet = 
$$\frac{25.8}{\text{Rope Dia.}^2} \times (A + B) \times A \times C.$$
 (in inches)

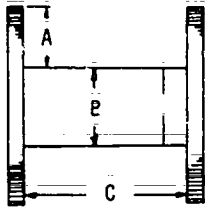

11. **Fleet Angle** — Maximum 4° on grooved drums and 2° on smooth drums. The distance to the lead block should never be less than 10 times the width of grooved drums or 20 times the width of smooth drums.

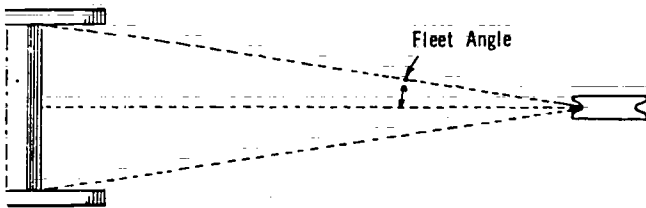

**WIRE ROPE ATTACHMENTS** — (Safety factor of 5 included)

- Crosby Clips**  
Number of clips required —  $4 \times \text{rope diameter} + 1$ .  
Minimum spacing —  $6 \times \text{rope diameter}$ .
- Hooks** — S.W.L. in tons =  $(\text{Dia.})^2$  where hook begins to curve or Diameter of eye in inches squared.
- Shackles** — S.W.L. in tons = Diameter of pin in one fourth inches squared and divided by three. (or select shackle pin one-eighth inch larger than choker size.)
- Chains (Alloy Steel)** — S.W.L. in tons = chain stock  $(\text{Dia.})^2 \times 6$ .
- Turn Buckles** — S.W.L. in tons = bolt  $(\text{Dia.})^2 \times 3$ .

**ESTIMATING WEIGHT OF STRUCTURAL STEEL:** — (One cubic foot = approximately 490 lbs.)

- Round Stock** — Approximate weight per lineal foot =  $(\text{Dia.})^2 \times \frac{8}{3}$
- Plate, Flat Bar, or Square** — Approximate weight per lineal foot = thickness times width  $\times \frac{10}{3}$  (All measurements in inches.)  
(Angles, Tees, or Wide Flange Beams can be calculated in the same manner by measuring the legs, or web and flange individually as Flat Bar or Plate.)

**SCAFFOLD PLANKS**

Two inch planks (2 x 8, 2 x 10, or 2 x 12) of fir or spruce in first class condition can be considered safe to support the weight of an average man for a "Span in Feet" that is equal to, or less than the plank "Width in Inches".

**DERRICKS**

**GUY DERRICK**

A guy derrick consists of a mast, a boom pivoted at the foot of the mast, guys and tackle (Figure 7-104). The mast is generally longer than the boom and is mounted on vertical pins at the foot and top so that the assembly of mast and boom may be rotated about a vertical axis. If the guys to the top of the mast clear the end of the boom the derrick can be rotated through a full circle. The mast and boom may be made of timbers or structural steel. Large derricks are made of hollow built up sections generally consisting of four angles and lacing bars forming a truss.

Hoisting tackle is suspended from the end of the boom and tackle is also provided for raising or lowering the boom in a vertical plane. Power is supplied by hand operated or engine driven hoists. The derrick is rotated by a bull wheel located at the base of the mast.

**STIFF LEG DERRICK**

The mast of the stiff leg derrick is held in the vertical position by two rigid inclined struts connected to the top of the mast (Figure 7-105). The struts are spread apart 60°-90° to provide support in two directions and are attached to sills extending from the bottom of the mast. The mast is mounted on vertical pins at its foot and top as in the case of the guy derrick. The mast and boom can swing through an arc of about 270°. The tackles for hoisting loads and raising the boom are similar to those for the guy derrick. Figure 7-106 illustrates a stiff leg derrick with long sills.

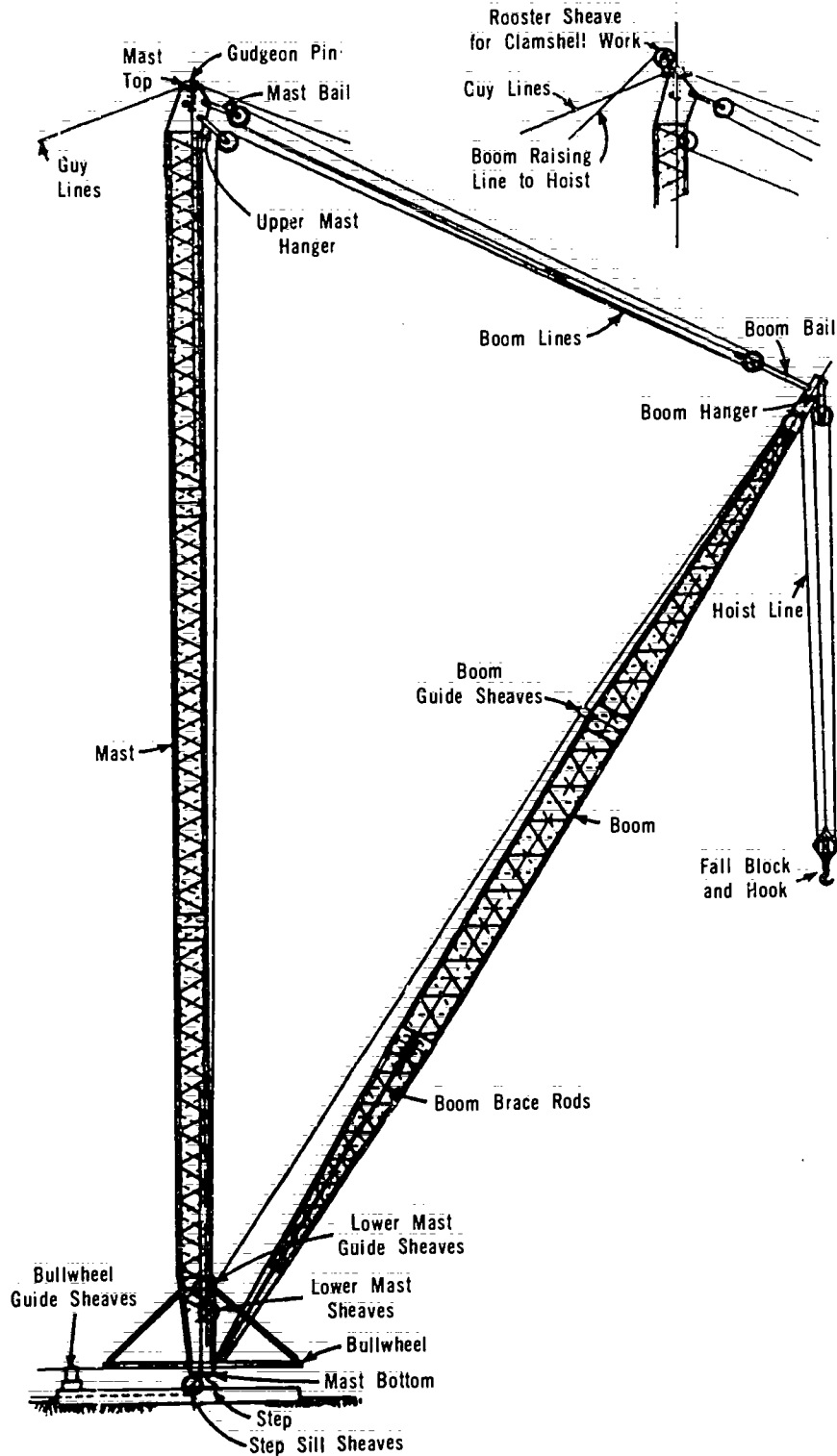

Figure 7-104. Sections of a Guy Derrick

A stiff leg derrick equipped with a boom is suitable for yard use for unloading and transferring material whenever continuous operations are carried on within reach of its

boom. They are sometimes used in multi-story buildings surmounted by towers to hoist materials to the roof of the main building to supply guy derricks mounted on the towers.

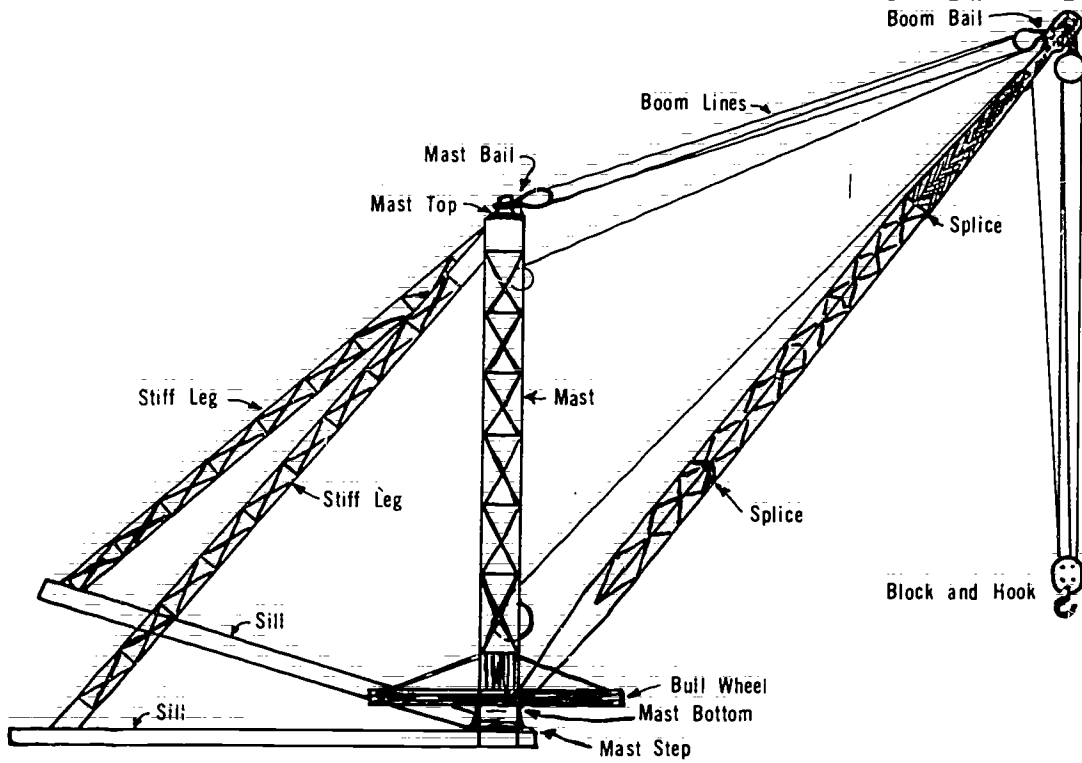

Figure 7-105. Stiff Leg Derrick

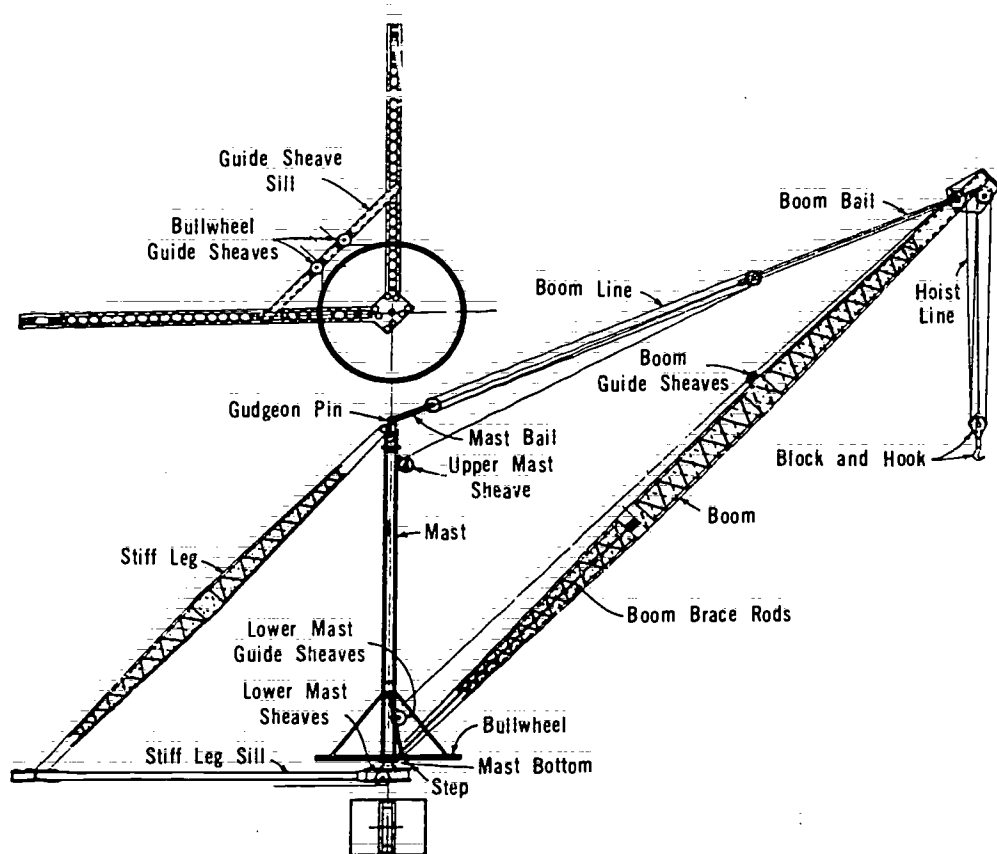

Figure 7-106. Section of Stiff Leg Derrick with Long Sills

### GIN POLE

The gin pole (Figure 7-107) consists of an upright spar guyed at the top to maintain it in a vertical position and is equipped with suitable hoisting tackle. The spar may be of round or square timber, heavy wall pipe, a wide flange beam section or a built up section consisting of angles and lacing bars. The load may be hoisted by hand tackle or by hand or engine driven hoists.

A gin pole is a very handy and versatile piece of equipment for lifting all types of comparatively light loads. To get maximum use out of a gin pole, it should be rigged with a minimum of four guys, with wire rope pendants and manila rope tackles between the pendants and the anchorages and swivel plates top and bottom. These can then be leaned at various angles and turned to lift from all sides.

The gin pole is used mostly for erection work of ease of rigging, moving and operating. It is

suitable for raising loads of medium weight to heights of 10'-50' where a vertical lift is required.

#### Procedure

Refer to Figure 7-108 for Steps in this procedure.

Step 1: Using any suitable scale, draw a sketch as shown in A.  
Line TS represents the guy  
Line RS represents the gin pole

Step 2: With a given load of 4,000 lb., let  $1/4" = 1,000$  lb. and draw a vertical line VU representing the load (1" long) as in B.

From U, extend a line UW parallel to TS (from A) to represent the guy, and a line VW parallel to RS (from A) to represent the gin pole

Step 3: To develop C, draw a line VW parallel to, and the same length as VW (from B). Drop a vertical line down from W, and draw the line VX parallel to TR (from A).

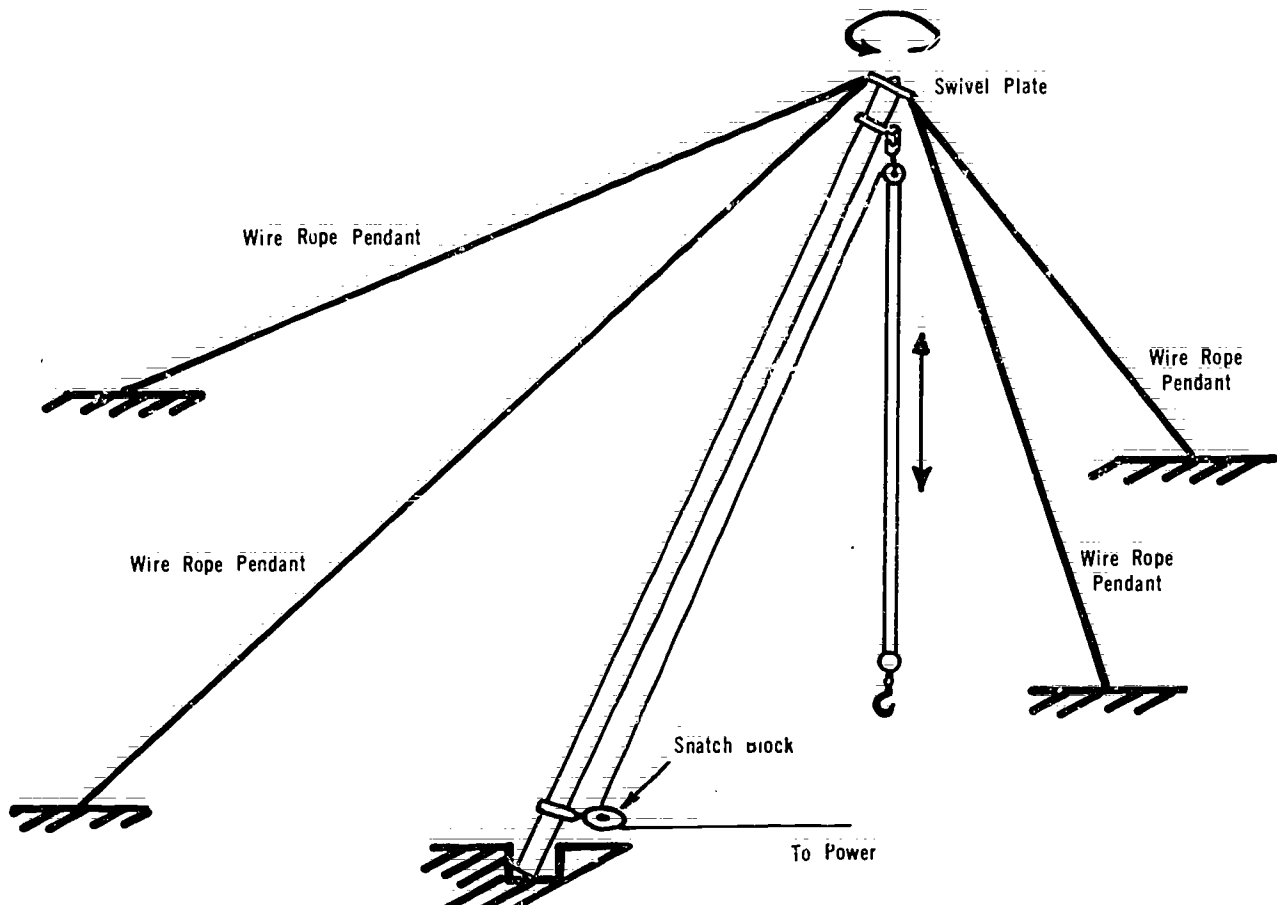

Figure 7-107. Gin Pole

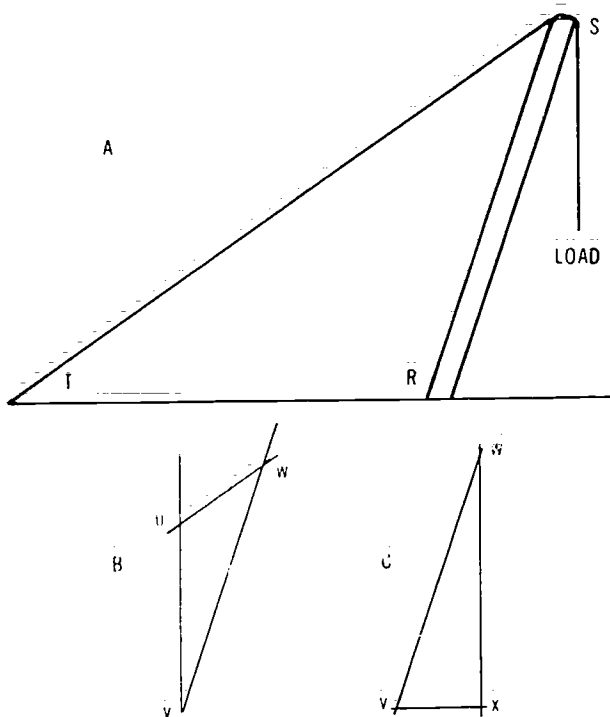

Figure 7-108. Determining the Kick at the Heel of a Gin Pole

Measure the length VX; and, using the scale  $1/4'' = 1,000 \text{ lb.}$ ; calculate the amount of kick on the pole.

### A-FRAME DERRICK

An A-Frame (or Shear Leg) derrick is a versatile hoisting device, requiring only two back guys and one lazy guy in front for support (Figure 7-109).

For light loads, a small A-Frame derrick can be quickly constructed by drilling a hole through two pieces of square timber and bolting through the holes. A wire rope choker is put around the top of the poles with the eye hanging down to attach the block. When a load is suspended from the block, the choker tightens to hold the crossed members more securely.

### MOBILE CRANES

Mobile cranes are mechanical lifting devices that can be relocated without disassembly. They may be classified into two main types: 1. those mounted on metal tracks (Figure 7-110) and 2. those mounted on rubber tires (Figure 7-111). Figure 7-112 illustrates the parts of a mobile crane.

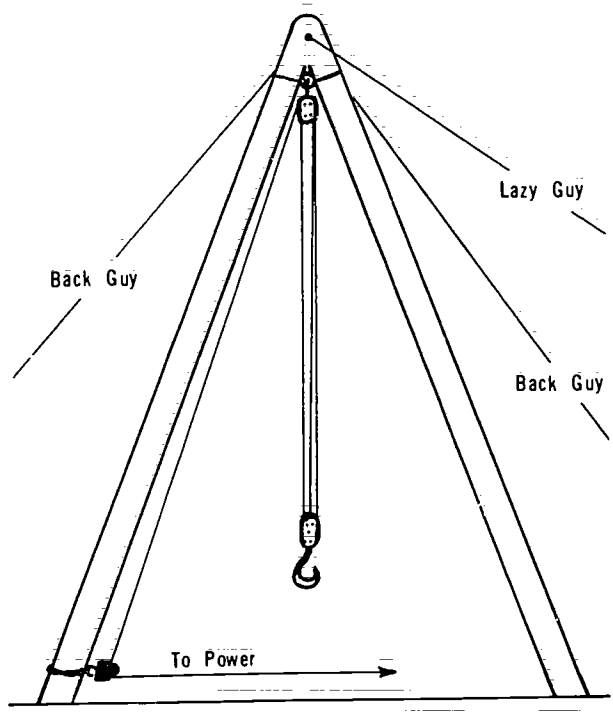

Figure 7-109. A-Frame Derrick

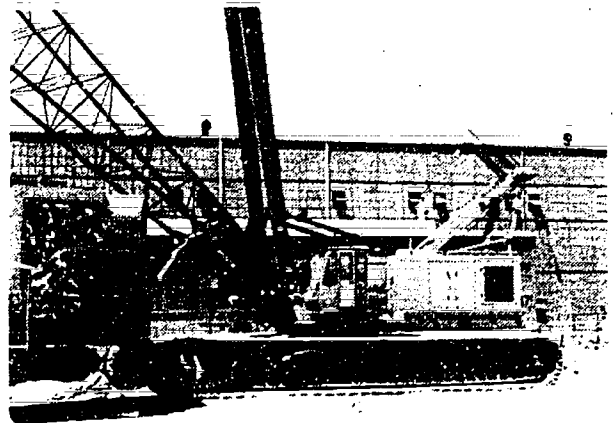

Figure 7-110. Mobile Crane on Tracks

Two types of booms (Figure 7-113) with respect to the capability on the crane are identified:

1. Conventional booms may be lowered, raised or swung sideways; however, the assembled length does not change.
2. Hydraulic booms may be lowered, raised or swung sideways, and the length can be extended or retracted without reassembly.

The choice of boom is based upon the functional requirements of the crane for the job. Where

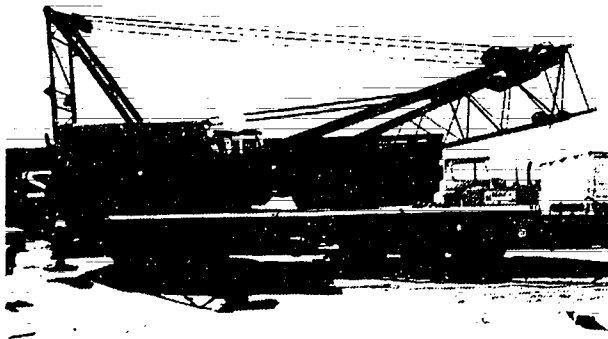

Figure 7-111. Mobile Crane on Tires

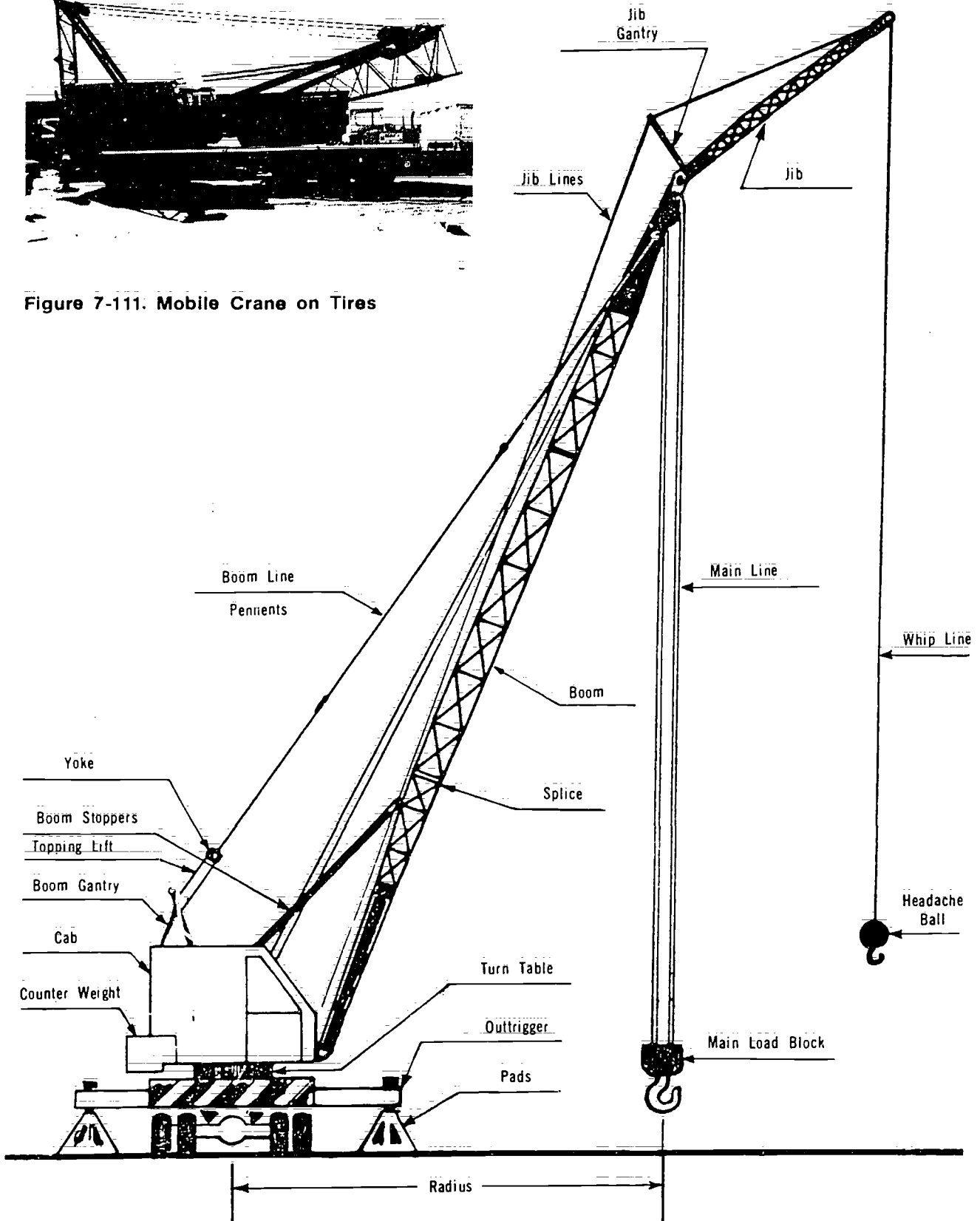
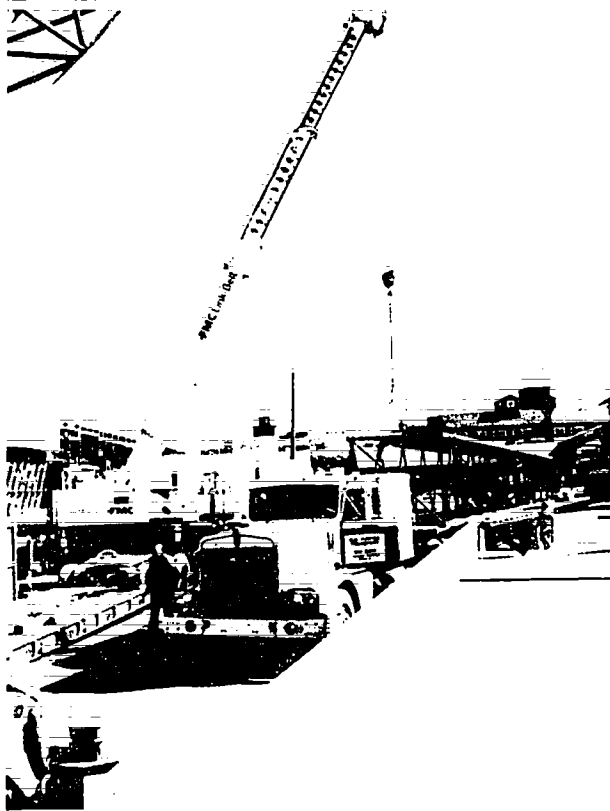
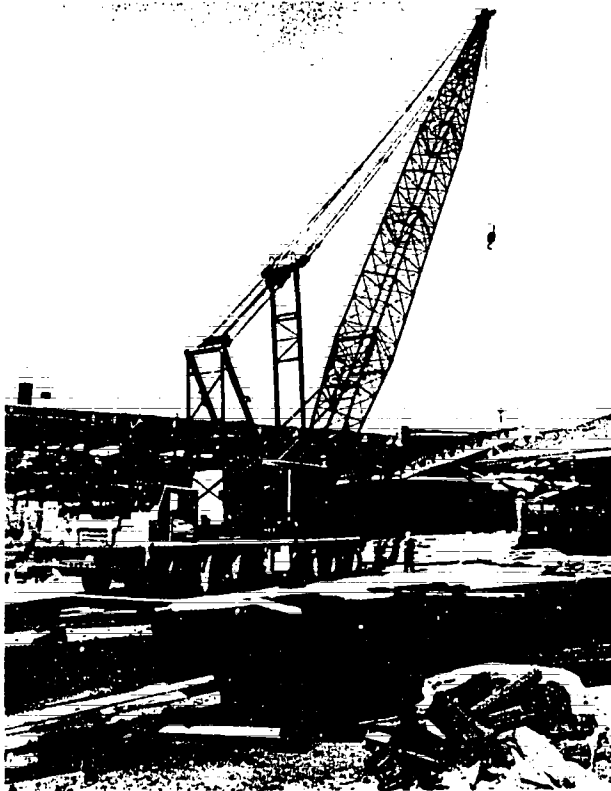

Figure 7-112. Parts of a Mobile Crane



HYDRAULIC BOOM



CONVENTIONAL BOOM

Figure 7-113. Crane Booms

heavy or exceptionally high lifts are involved, the conventional boom is used. Where the loads are lighter and more set-ups are required for shorter lifts, the hydraulic boom is more suitable.

When an hydraulic mobile crane is delivered to a jobsite, it is almost immediately ready to go into operation (Figure 7-114). It need only be "spot-

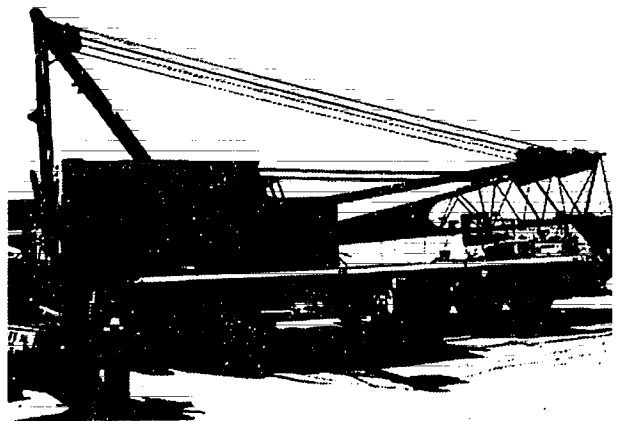
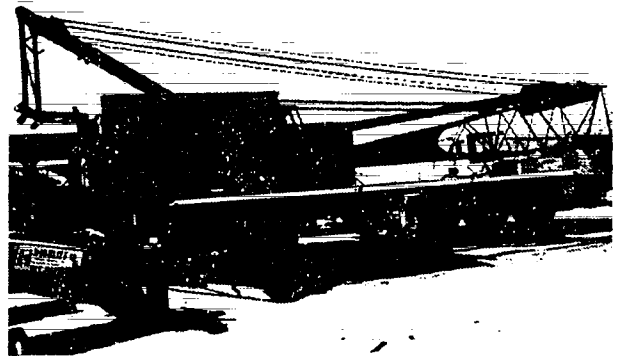
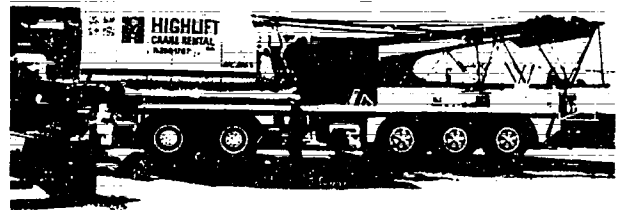

Figure 7-114. Crane Arriving on The Job, Raising Gantry to Operating Position

## Rigging and Erection

ted," the outriggers extended and the crane levelled, before the first load can be lifted.

### BOOM ASSEMBLY

On the other hand, a conventional type mobile crane arrives in separate units. The boom components, outriggers, counterweights and main block must be offloaded (usually assisted by an on-site hydraulic crane), and assembled on the

job location. Crane assembly at the jobsite falls within the jurisdiction of the erection Boilermaker.

Figures 7-114 to 7-118 illustrate a typical sequence in the assembly of a conventional mobile crane, from arrival on the job to work-ready.

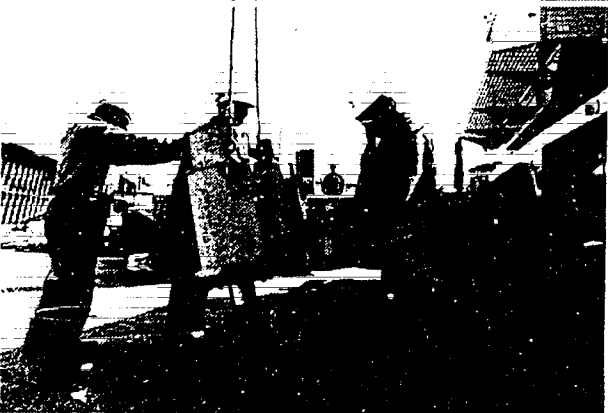
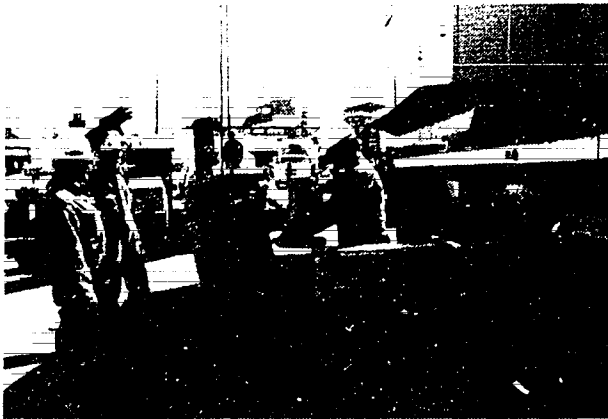

INSTALL FLOAT PADS

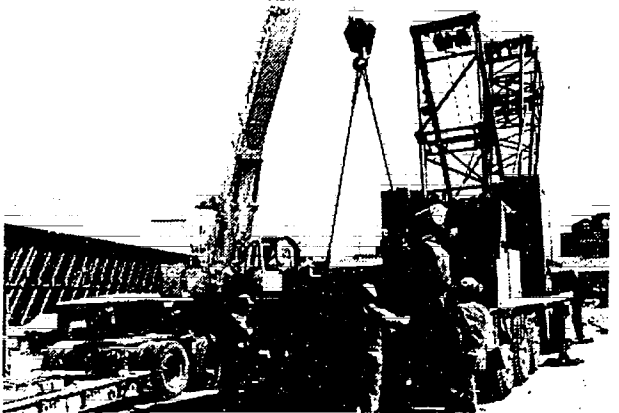

INSTALLING FRONT COUNTERWEIGHT

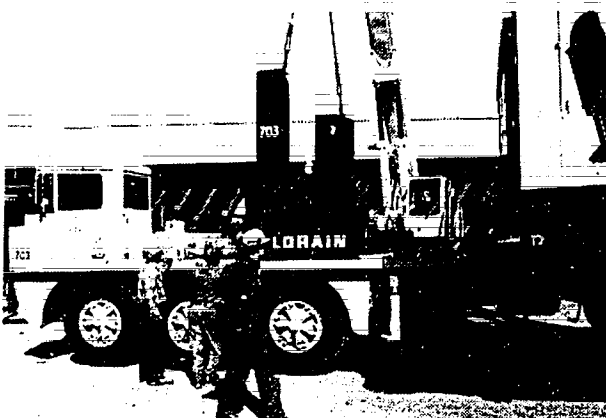

INSTALLING REAR COUNTERWEIGHT WITH SECOND RIG

Figure 7-115. Floatpads and Counterweights

### CRANE SAFETY AND SIGNALS

#### Assembly Precautions

1. Check all outrigger assemblies.
2. Check all boom sections for damage.
3. Always install boom pins from the inside of the boom to the outside.
4. Ensure all boom pins are secured with cotter pins.
5. Before raising boom, machine must be levelled, outriggers fully extended and rubber off the ground.
6. When disassembling boom sections, block the section to be removed.



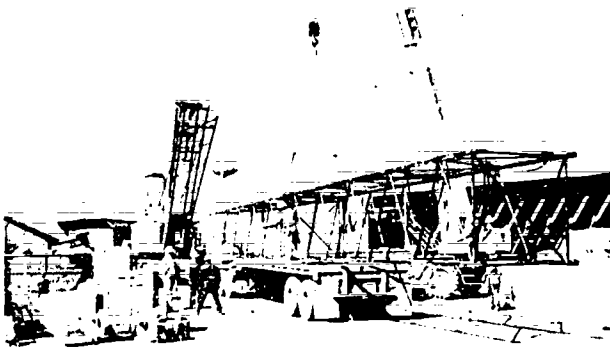

MOVING BOOM OFF TRUCK

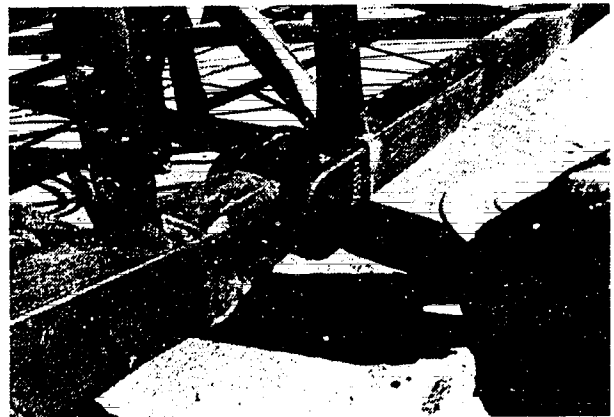

INSERTING BOTTOM PINS

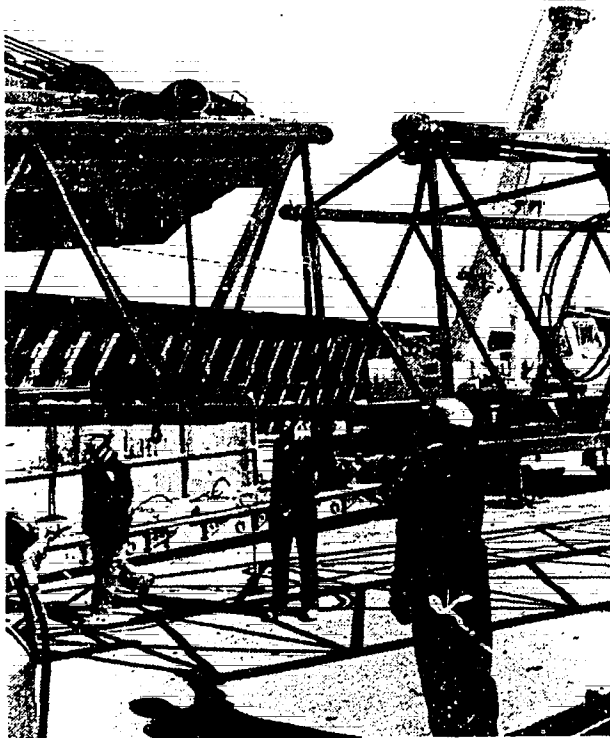

POSITIONING FOR PINNING



PINS SECURED BY COTTER PIN



INSERTING TOP PINS FIRST

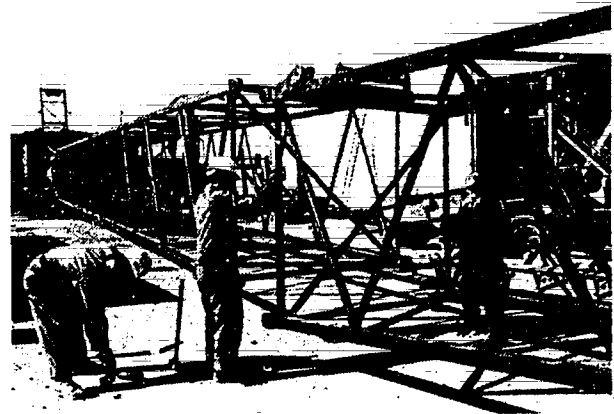

JOINING OTHER SECTIONS

Figure 7-116. Assembling the Boom

Rigging and Erection

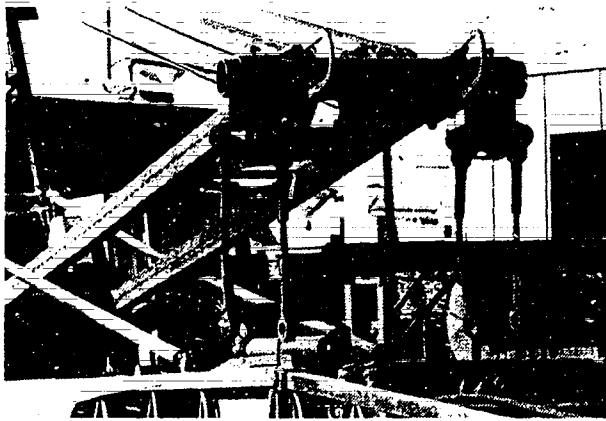

YOKE READIED FOR PENDANT LINES



WEDGE SOCKET ATTACHED TO MAIN BLOCKS

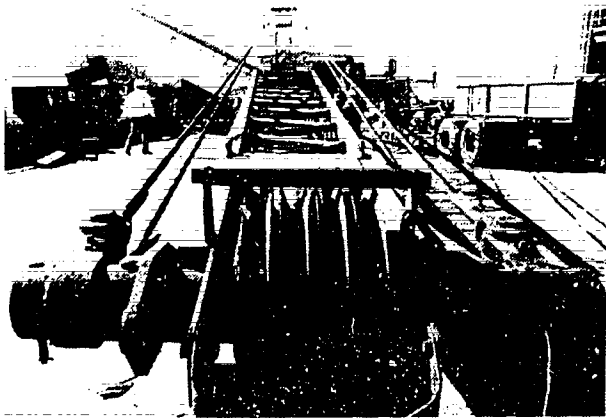

PENDANT LINES ATTACHED



MAIN LINE REEVED TO MAIN BLOCK



TERMINAL END OF MAIN LINE FITTED TO WEDGE SOCKET

Figure 7-117. Attaching the Lines

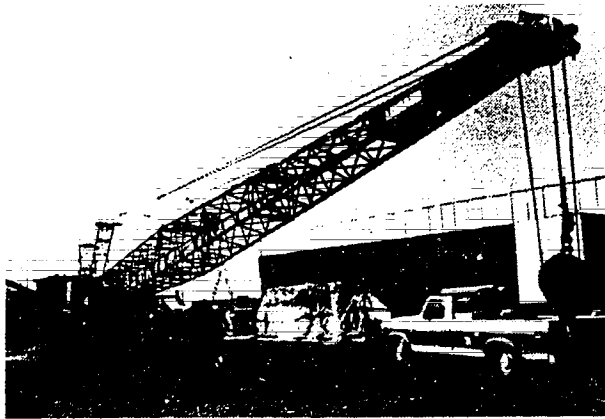

Figure 7-118. Boom Raised and Crane Moved to Area of Lift

### Safety During Crane Operation

1. **One man only** will be designated as signalman. The signalman must be in full view of the crane operator at all times. Crane signals are illustrated in The W.C.B. material in Figure 7-119.
2. When locating the machine, the following must be observed:
  - a. As level a path as possible must be followed when moving the machine; avoid slopes and rough terrain.
  - b. The boom must be in a raised position when the crane is travelling.
  - c. Particularly for larger machines, the speed of travel must be slow.
  - d. When "spotting" the crane, to ensure full rated capacity, the machine must be levelled, outriggers fully extended and all rubber off the ground.
  - e. Be aware of all power lines in the area where the crane is spotted.
3. Know the weight of all loads (including weight of any rigging accessories).
4. Measure (rather than estimate) the machine's load radius when making capacity lifts.
5. Avoid effects of "shock loading" to rigging and equipment, by raising and lowering loads slowly.
6. Always use a tag line to control the load when in the air.
7. When booming down, or swinging with a load, always keep the load as close to the ground as possible.
8. When swinging, always ensure that the counterweight area of swing has:
  - a) sufficient clearance to clear obstructions.
  - b) been barricaded wherever there is a possibility of a worker being crushed.
9. Keep all personnel out from under load.
10. **No one** is allowed to ride the load under any circumstances.
11. Snub heavy loads to the machine when travelling with a load.
12. When operations cease for the day, it is advisable to "tie down" the boom by attaching a choker from the hook in use to a stationary object with only enough tension to immobilize the boom.

432

**Standard Hand Signals for Controlling  
Crane Operations, Crawler, Locomotive and Truck Cranes**

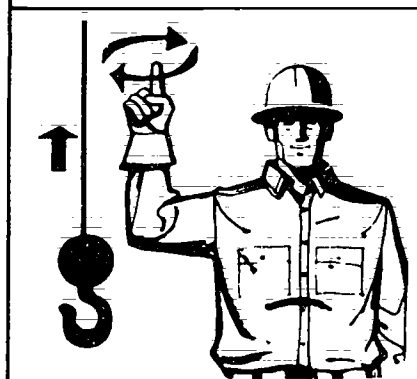

**HOIST** With forearm vertical, forefinger pointing up, move hand in small horizontal circles.

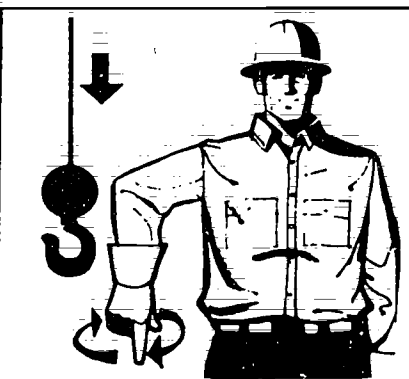

**LOWER** With arm extended downward, forefinger pointing down, move hand in small horizontal circles.

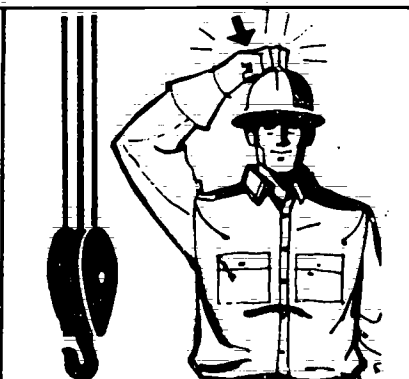

**USE MAIN HOIST.** Tap fist on head; then use regular signals.

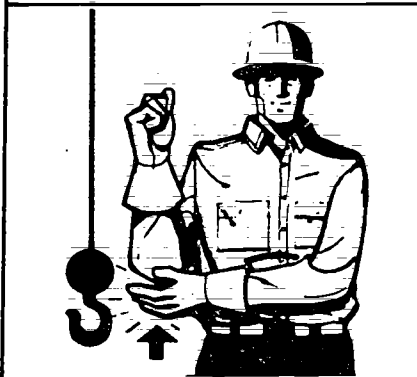

**USE WHIPLINE (Auxiliary Hoist).** Tap elbow with one hand; then use regular signals.

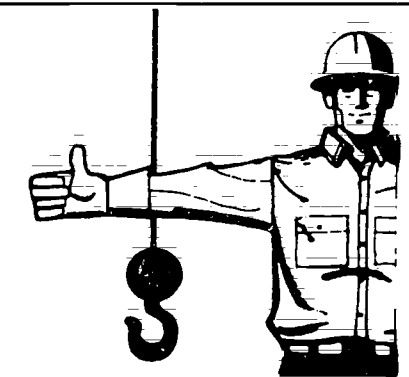

**RAISE BOOM.** Arm extended, fingers closed, thumb pointing upward.

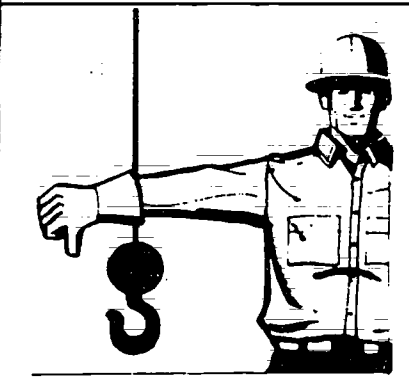

**LOWER BOOM.** Arm extended, fingers closed, thumb pointing downward.

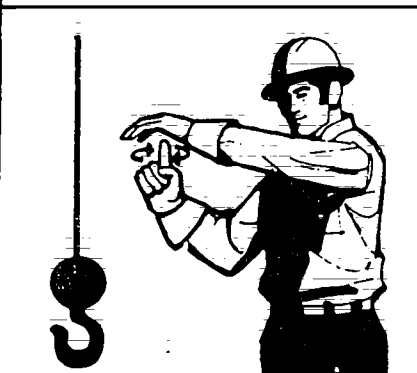

**MOVE SLOWLY.** Use one hand to give any motion signal and place other hand motionless in front of hand giving the motion signal. (Hoist slowly shown as example).

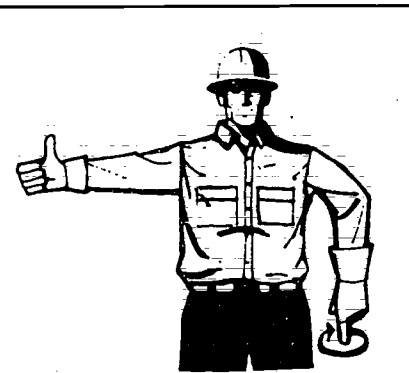

**RAISE THE BOOM AND LOWER THE LOAD.** Arm extended, fingers closed, thumb pointing upward, other arm bent slightly with forefinger pointing down and rotate hand in horizontal circles.



**LOWER THE BOOM AND RAISE THE LOAD.** Arm extended, fingers closed, thumb pointing downward, other arm with forearm vertical, forefinger pointing upward and rotate hand in horizontal circles.

(continued)

Figure 7-119. Crane Signals

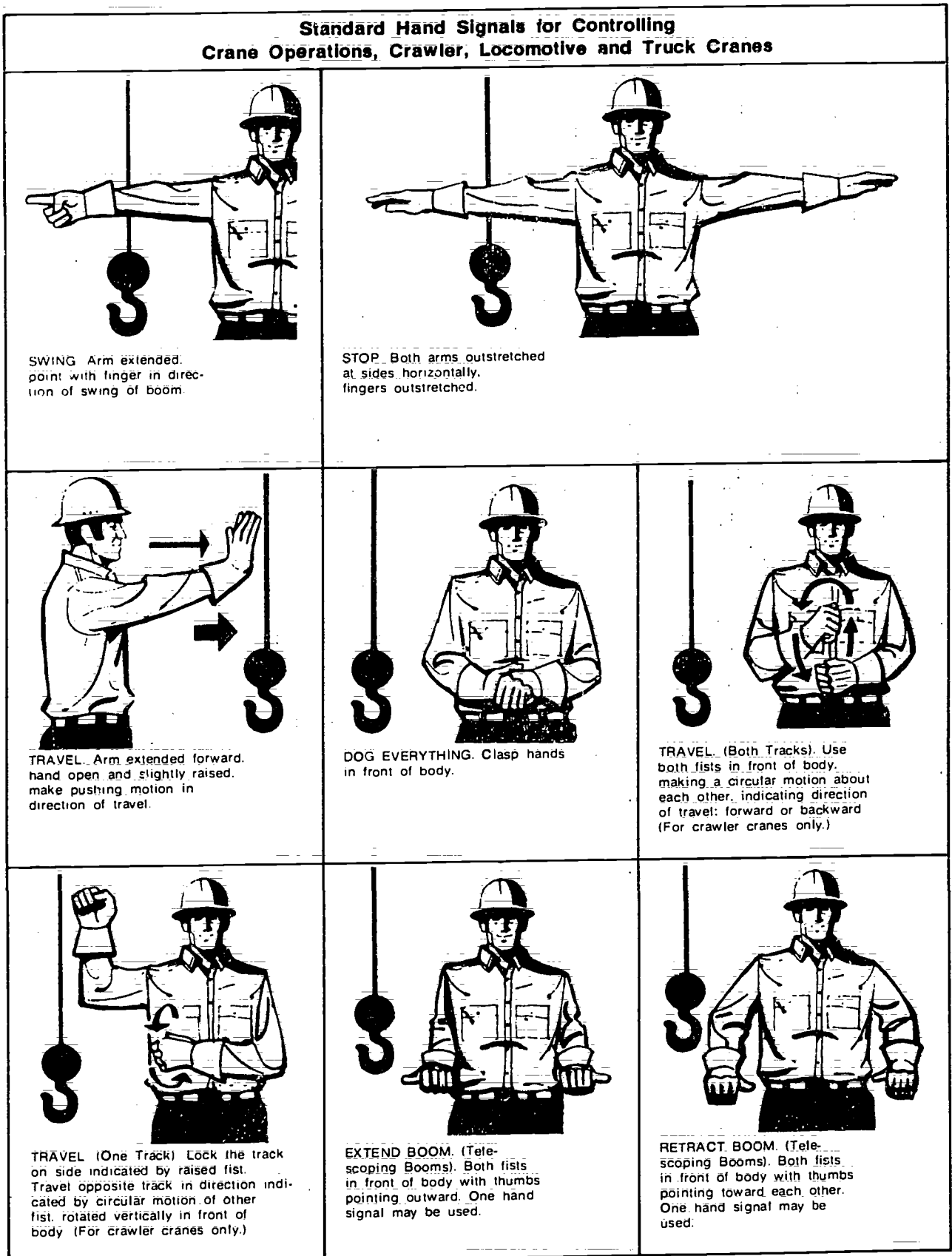

Figure 7-119. Crane Signals (continued)



<b>Standard Hand Signals for Controlling Crane Operations, Crawler, Locomotive and Truck Cranes</b>		
 <p><b>HOIST</b> With forearm vertical, forefinger pointing up, move hand in small horizontal circles.</p>	 <p><b>LOWER</b> With arm extended downward, forefinger pointing down, move hand in small horizontal circles.</p>	 <p><b>BRIDGE TRAVEL</b> Arm extended forward, hand open and slightly raised, make pushing motion in direction of travel.</p>
 <p><b>TROLLEY TRAVEL</b> Palm up, fingers closed, thumb pointing in direction of motion, jerk hand horizontally.</p>	 <p><b>STOP</b> Both arms outstretched at the sides horizontally, fingers outstretched.</p>	
 <p><b>MULTIPLE TROLLEYS</b> Hold up one finger for block marked "1" and two fingers for block marked "2". Regular signals follow.</p>	 <p><b>MOVE SLOWLY</b> Use one hand to give any motion signal and place other hand motionless in front of hand giving the motion signal. (Hoist Slowly shown as example.)</p>	 <p><b>MAGNET IS DISCONNECTED</b> Crane operator spreads both hands apart — palms up.</p>

Figure 7-119. Crane Signals (continued)

### Standard Hand Signals for Controlling Crane Operations, Overhead and Gantry Cranes

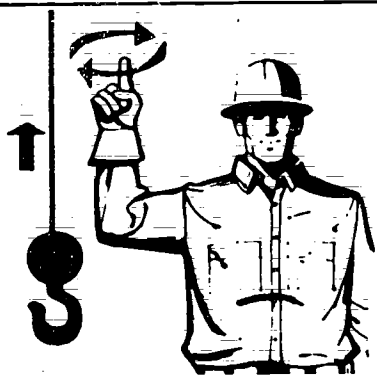
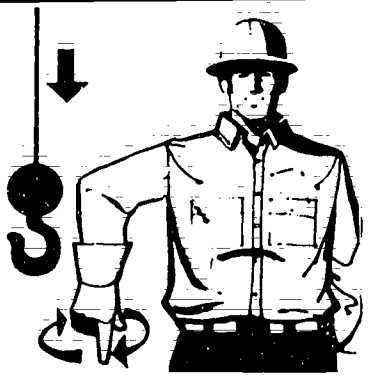
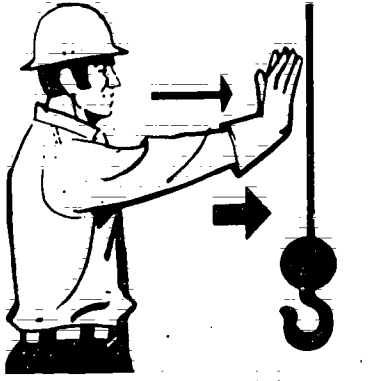
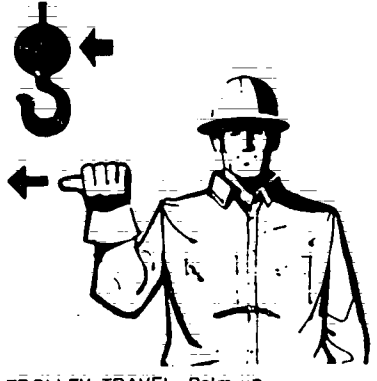
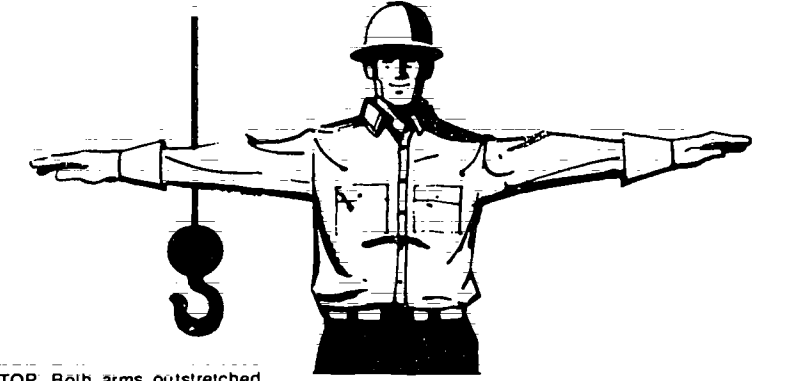
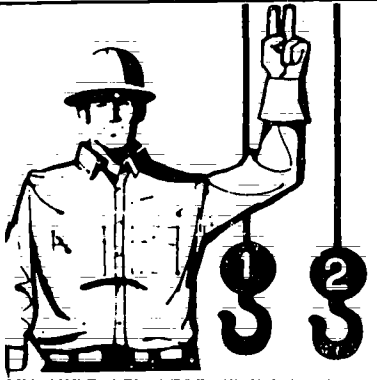

**MAGNET IS DISCONNECTED.**  
Crane operator spreads both hands apart — palms up.

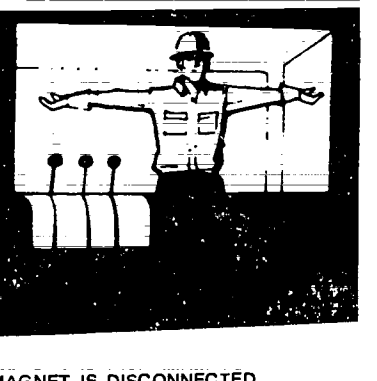
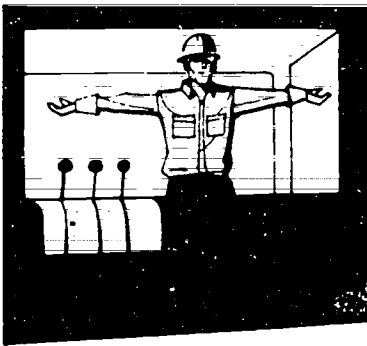
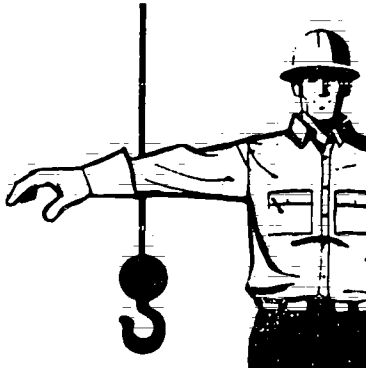

**OPEN CLAM SHELL BUCKET.**  
Arm extended, palm down, open hand.



**CLOSE CLAM SHELL BUCKET.**  
Arm extended, palm down, close hand.



**HOIST SLOWLY TO CLEAR FOULED LINE.** Hands crossed in front, above shoulders, fingers relaxed.

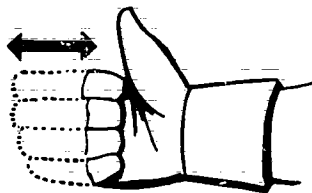

**BOOM UP AND LOWER THE LOAD.** One hand.

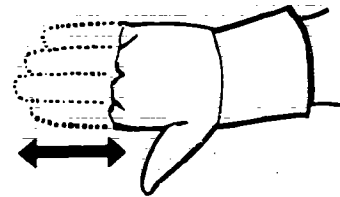

**BOOM DOWN AND RAISE THE LOAD.** One hand.



**STOP** One hand.

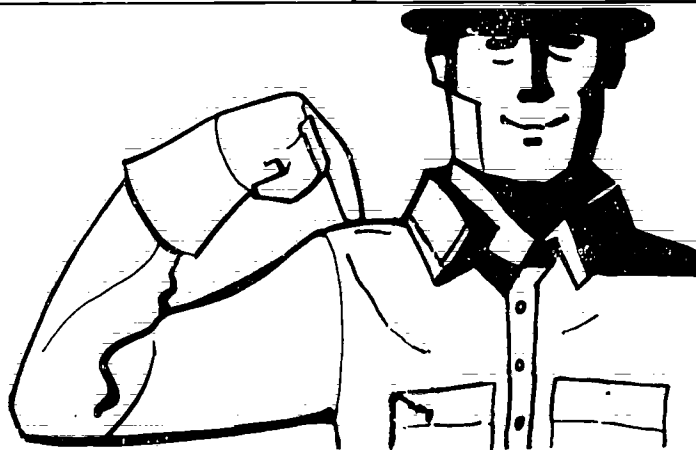

**WHIP LINE.** One hand.

Figure 7-119. Crane Signals (continued)