

DOCUMENT RESUME

ED 233 231

CE 036 788

**AUTHOR** Biondo, Ron; And Others  
**TITLE** Core III Materials for Metropolitan Agriculture/Horticulture Programs. Units J-M.  
**INSTITUTION** Illinois Univ., Urbana. Dept. of Vocational and Technical Education.  
**SPONS AGENCY** Illinois State Board of Education, Springfield. Dept. of Adult, Vocational and Technical Education.  
**PUB DATE** Jun 83  
**CONTRACT** R-33-13-D-0362-466  
**NOTE** 307p.; Not available in paper copy due to colored paper. For related documents, see ED 208 148-153, ED 220 689-690, ED 222 663-664, and CE 036 785-787.  
**PUB TYPE** Guides - Classroom Use - Guides (For Teachers) (052)  
**EDRS PRICE** MF01 Plus Postage. PC Not Available from EDRS.  
**DESCRIPTORS** Agricultural Education; \*Agricultural Production; Behavioral Objectives; Conservation (Environment); Core Curriculum; Curriculum Guides; Equipment; \*Floriculture; Grade 11; Grounds Keepers; High Schools; \*Horticulture; \*Landscaping; Learning Activities; Ornamental Horticulture; Ornamental Horticulture Occupations; \*Soil Science; Tests; \*Urban Areas; Visual Aids; Vocational Education

**ABSTRACT**

This second volume of a two-volume curriculum guide contains 11 problem areas selected for study to be included in a core curriculum for 11th grade or third-year students enrolled in a metropolitan agricultural program. The 11 problem areas are divided into four units: Soil Science and Conservation of Natural Resources (Understanding Soils, Selecting Soil Sites for Urban Use, and Attracting Birds to Your Backyard); Horticultural/Agricultural Products (Selecting and Buying Horticultural Tools and Equipment); Landscape Design, Establishment, and Maintenance (Pruning Evergreens; Surveying, Grading and Tiling; Constructing Fences and Retaining Walls; and Interior Plantscaping); and Retail Floriculture (Handling and Preparing Cut Flowers; Ordering and Buying Cut Flowers; and Making Corsages, Nosegays, and Table Arrangements). Each problem area includes some or all of the following components: suggestions to the teacher, a teacher guide (objectives, suggested interest approaches, anticipated student problems and concerns, suggested learning activities and experiences, application procedures, an evaluation, references and aids), information sheets, student worksheets or assignment sheets with a key, job sheets or laboratory exercises, transparencies, a discussion guide for transparencies, and sample test questions with a teacher key. (YLB)

\*\*\*\*\*  
 \* Reproductions supplied by EDRS are the best that can be made \*  
 \* from the original document. \*  
 \*\*\*\*\*

IL 8313306

CORE III MATERIALS  
FOR METROPOLITAN  
AGRICULTURE/  
HORTICULTURE  
PROGRAMS

UNITS **J-M**  
Project Staff

Sponsored by  
ILLINOIS  
STATE BOARD OF  
EDUCATION

DEPARTMENT OF  
ADULT,  
VOCATIONAL AND  
TECHNICAL EDUCATION

Edward Copeland  
Chairman

Research and  
Development Section

Co-directors:  
Paul Hemp  
Roger L. Courson

Donald G. Gill  
State Superintendent  
of Education

June, 1983

Developers:  
Ron Biondo  
Jim Ethridge  
Kallie Grobstein  
Paul Hemp  
Susie Osborne  
Jerry Pepple  
Marianne Ringger  
Marcia Watman-Lauchner

Department of  
Vocational and  
Technical Education  
and Vocational  
Agriculture Service,  
University of Illinois  
at Urbana-Champaign

ED233231

8  
036788

U.S. DEPARTMENT OF EDUCATION  
NATIONAL INSTITUTE OF EDUCATION  
EDUCATIONAL RESOURCES INFORMATION  
CENTER (ERIC)

- This document has been reproduced as received from the person or organization originating it.
- Minor changes have been made to improve reproduction quality.

• Points of view or opinions stated in this document do not necessarily represent official NIE position or policy.

"PERMISSION TO REPRODUCE THIS  
MATERIAL HAS BEEN GRANTED BY

C. Reisinger

TO THE EDUCATIONAL RESOURCES  
INFORMATION CENTER (ERIC)."

## UNIT J: SOIL SCIENCE AND CONSERVATION OF NATURAL RESOURCES

### PROBLEM AREA: UNDERSTANDING SOILS

#### SUGGESTIONS TO THE TEACHER:

This problem area is designed for use with eleventh-grade or third-year students enrolled in a horticultural occupations program. The recommended time for teaching this problem area is during the early fall or late spring. The estimated time for teaching this problem area is 3 to 5 days depending on how much time the teacher wishes to spend on discussion and conducting the suggested exercises. The materials in this problem area were selected and written with the following assumptions;

1. Student's have already received related instruction in soil science through Core I materials.
2. Students will have an opportunity to observe a soil profile and perform a land-use evaluation project.

The instructor is encouraged to conduct a local search to locate other supplementary materials. The items in this problem area are for reference or modification as the teacher adapts this problem area to his/her local situation.

#### CREDIT SOURCES:

These materials were developed through a funding agreement, R-33-13-D-0362-466 with the Illinois State Board of Education, Department of Adult, Vocational and Technical Education, Research and Development Section, 100 North First Street, Springfield, Illinois 62777. Opinions expressed in these materials do not reflect, nor should they be construed, as policy or opinion of the Illinois State Board of Education or its staff.

The teacher's guide, worksheets, job sheets, and sample test questions were developed by Chris Mower and Jerry Pepple, Department of Vocational and Technical Education, University of Illinois. The transparency masters were prepared by Vocational Agriculture Service, University of Illinois.

Suggestions and guidance in the development of these materials were provided by Paul Hemp, Project Director and by the Metropolitan Core Curriculum Field Test Teachers.

## TEACHER'S GUIDE

- I. Unit: Soil science and conservation of natural resources
- II. Problem area: Understanding soils
- III. Objectives: At the end of this problem area, the student will be able to:
  1. Define soil.
  2. Identify physical properties of the soil, including color, structure, texture.
  3. Determine soil class and associated limitations.
  4. Recommend management practices for different soils.
- IV. Suggested interest approaches:
  1. Discuss local soil types or have students name as many local soil types as they can. Keep a list on the board.
  2. Ask students what effect different soil types have on different crops.
  3. Ask if anyone has ever seen an exposed soil profile, like the side of a basement at a construction site, or along a ditch bank.
  4. Ask the lead questions:
    - a. "Why do dark soils yield more than light soils?"
    - b. "What is erosion?"
    - c. "Why do we say some soils are 'old' and some are 'young'?"
    - d. "What soil types are on your own home site?"
    - e. "What do we need to know about soil to manage it well?"
  5. Bring in soil samples. Discuss the differences between them.
  6. Ask students why soils located on the tops of hills are lighter in color than soils located at the base (bottom) of hills.
- V. Anticipated problems and concerns of students:
  1. What is soil?
  2. What is a soil profile?
  3. How were soils formed?
  4. What can I tell from the color of the soil?

5. What is the difference between organic and inorganic matter?
6. What is soil texture and how do you determine it?
7. What are the common soil structures?
8. Why do some soils drain or dry faster than others?
9. How do I figure slope?
10. What is soil position?
11. What are land classes?

VI. Suggested learning activities and experiences:

1. Have class identify their problems and concerns and record them on a chalkboard.
2. Distribute reference materials to students and discuss tentative answers to problems and concerns.
3. Have students complete Student Worksheet 1, using VAS Subject Matter Unit 4052 - Understanding Soils as a reference.
4. Demonstrate ribbon test and have students practice and complete Laboratory Exercise 1.
5. Plan various field trips. Suggestions for possible field trips are:
  - a. To examine soil profile, color, structure and texture at a basement construction site or pit dug for that purpose.
  - b. To ASCS conservation project.
  - c. To where land tile is being installed.
6. Develop a soil map of selected urban sites and discuss findings. Include soil type, class, and suggested management practices.
7. Show and discuss VAS Soil Science Transparencies. Selected transparency masters and discussions are included in this problem area.
8. Use a resource speaker such as a representative from the Soil Conservation Service or Extension Office. Possible topics include "use of drainage tile," "conservation structures," "using the soil loss equation," etc.
9. Explain the parts of the soil judging score cards and how each section is used to determine soil types.

10. Show VAS Slidefilm 708 - Soil Color and have students complete Student Worksheet 2 - Soil Color.
11. Show and discuss VAS Slidefilm 690-1 - Soils for Plant Growth: Air and Water Soils.
12. Show and discuss VAS Slidefilm 690-2 - Soils for Plant Growth: Container Soils.
13. Discuss various methods of improving soils, including garden soils, container soils, et cetera.

VII. Application procedures:

1. The purpose of this problem area is to identify some causes of soil limitations and develop proper management practices.
2. This knowledge and understanding should be applied to developing management and approved practices in the students' S.O.E. projects.

VIII. Evaluation:

1. Evaluate and grade work of students.
2. Administer test.
3. Grade performance in land use selection contest.

IX. References and aids:

1. Vocational Agriculture Service, University of Illinois, 1401 South Maryland Drive, Urbana, Illinois 61801.

A. Subject Matter Units:

1. VAS 4028 Soil Structure
2. VAS 4029 Soil Color
3. VAS 4030 Soil Texture
4. VAS 4052 Understanding Soils
5. VAS 4053 Using the Illinois Soil Judging Scorecard

B. Slidefilms

1. VAS F708 - Soil Color
2. VAS F690-1 - Soils for Plant Growth: Air and Water Soils
3. VAS F690-2 - Soils for Plant Growth: Container Soils

- C. VAS Soil Science Transparencies (a complete set can be obtained from VAS)

## STUDENT WORKSHEET 1

### SOIL FORMATION

(Reference - VAS Unit 4052 - Understanding Soils)

1. What is soil?
2. What is soil made up of?
3. Soils are composed of one or more layers or \_\_\_\_\_.
4. Most soils have \_\_\_\_\_ principal horizons, which are designated by capital letters: the \_\_\_\_\_ or A horizon, the subsoil or \_\_\_\_\_ horizon, and the \_\_\_\_\_ underlying the subsoil or \_\_\_\_\_ horizon.
5. Parent materials. Write the name of the material in the blank provided.

#### glacial origin

- a. finely ground rock, "glacial flour" distributed by wind.  
\_\_\_\_\_
- b. glaciers carried large amounts of rocky material, grinding much of it into a mixture of gravel, sand, silt and clay.  
\_\_\_\_\_
- c. deposited during mild periods by glacial runoff water, deposited in layers. \_\_\_\_\_

#### water deposited

- a. sediments in floodplains. \_\_\_\_\_
6. Topography refers to \_\_\_\_\_.
  7. Soils on steep topography are likely to be subject to severe \_\_\_\_\_.
  8. Native vegetation determines the \_\_\_\_\_ and \_\_\_\_\_ of organic matter in the soil.
  9. Under forest cover, the organic matter is in the form of \_\_\_\_\_. Since the material is on the surface, it decays \_\_\_\_\_ and leaves only a small residue. Total organic matter, therefore, is quite \_\_\_\_\_.
  10. Most prairie soils have a \_\_\_\_\_ surface layer that is fairly \_\_\_\_\_. Wild prairie grasses and other plants have abundant \_\_\_\_\_ which filled the top of the soil 1 or 2 feet down. Partial decay of these roots over a long period of time gave us the high \_\_\_\_\_ content of prairie soils, and along with it, the \_\_\_\_\_ color.
  11. Soils at different stages in the \_\_\_\_\_ process will differ widely.

12. Many soils are now \_\_\_\_\_ because the calcium originally in them has been \_\_\_\_\_ away.
13. When the soil is young, \_\_\_\_\_ accumulates, but as soils get older, organic matter and production decline, and clay accumulates in the \_\_\_\_\_.
14. Weathering depends on \_\_\_\_\_.
15. As a rule, the surface of the soil is darker than the subsoil because it contains more \_\_\_\_\_.
16. The darker the surface soil, the \_\_\_\_\_ the organic matter.
17. Subsoil colors of Illinois soils are due to the status of \_\_\_\_\_ compounds. Well-drained soils have \_\_\_\_\_ colored subsoils because the iron compounds are \_\_\_\_\_. Soils with poor natural drainage have dull gray or olive gray subsoils because the iron has been \_\_\_\_\_.

### Texture problems

To what textural class do the following soils belong?

18. 40% sand, 40% silt, 20% clay \_\_\_\_\_
19. 20% sand 60% silt, 20% clay \_\_\_\_\_
20. 50% sand, 10% silt, 40% clay \_\_\_\_\_
21. If you can form a long, pliable ribbon, the soil is \_\_\_\_\_ textured.
22. If a ribbon forms, but breaks into pieces, 3/4 inch to 1 inch long, the soil is \_\_\_\_\_ textured.
23. Define structure as it relates to soils.
24. Structure does not change soil \_\_\_\_\_, but a desirable structure may greatly improve \_\_\_\_\_ and the ease with which \_\_\_\_\_ and \_\_\_\_\_ can move through the soil.
25. Try to draw a picture of each of the 6 main kinds of structures.

granular

subangular blocky

platy

prismatic

angular blocky

columnar



26. The moisture holding capacity of a soil is closely related to its \_\_\_\_\_. As the clay content increases, there are \_\_\_\_\_ soil particles to hold water. So a soil high in clay holds \_\_\_\_\_ water than a sandy soil.
27. While moisture holding capacity is important, too much water will crowd the \_\_\_\_\_ out of the soil. If water moves freely through the profile, air can fill the empty \_\_\_\_\_ spaces. When water moves too fast, however, the result is a \_\_\_\_\_ soil.
28. Water drains very slowly from the small \_\_\_\_\_; therefore, fine textured soils have \_\_\_\_\_ permeability unless the structures of the surface and subsoil permits water to pass through.
29. If crops are to produce heavily, they must have a \_\_\_\_\_ system so that they can get nutrients and water from a large volume of \_\_\_\_\_. Coarse \_\_\_\_\_ and \_\_\_\_\_ discourage root growth because they have little \_\_\_\_\_ or plant nutrients.
30. Slope of the land influences the \_\_\_\_\_ with which water runs off a field and the amount of \_\_\_\_\_ that washes off with the water. Usually slope is expressed in \_\_\_\_\_ or feet of fall in each 100 feet of horizontal distance.

Problem: The soil drops 6 inches in 25 ft. of horizontal distance. Calculate the percent slope. \_\_\_\_\_

31. The \_\_\_\_\_ is the most valuable part of the soil profile since it contains more \_\_\_\_\_ and organic matter, and can often absorb more moisture than the other layers.
32. The principal loss of soil is usually by \_\_\_\_\_ erosion.
33. In assigning soils to various classes, soil scientists are concerned with 3 questions. What are they?

## STUDENT WORKSHEET 2

### SOIL COLOR

(Reference - VAS Slidefilm 708 - Soil Color)

1. What gives the surface soil its dark color?
2. What caused the thick, dark surface layer in prairie soils?
3. Why is the surface layer thinner on timber soils?
4. Why are the prairie soils of Southern Illinois lighter than those of Northern Illinois?
5. Why is erosion more hazardous on timber soils than on prairie soils?
6. Other than organic matter, what influences subsoil colors?
7. Why do soils that are poorly drained tend to be dull colored?
8. What colors are found in subsoils that are wet part of the time?
9. What names are used to describe surface soil colors? Subsoil colors?

## LABORATORY EXERCISE 1

### DEMONSTRATING RIBBON TEST FOR SOIL TEXTURE

- Objective: To learn how to determine soil texture.
- Materials:
1. Soil samples of various textural groups (fine, moderately fine, medium, etc.)
  2. Water for moistening samples, if needed.
- Procedures:
1. Moisten a sample of soil to the consistency of a workable putty.
  2. From this sample, make a ball about  $\frac{1}{2}$  inch in diameter.
  3. Hold the ball between the thumb and forefinger, and gradually press the thumb forward, forming the soil into a ribbon.
  4. If a ribbon forms easily, and is long and pliable, the soil is fine-textured.
  5. If a ribbon forms but breaks into pieces  $\frac{3}{4}$  to 1 inch long, the soil is moderately fine-textured.
  6. If no ribbon is formed, and soil feels smooth and talc-like with little grittiness, the soil is medium textured.
  7. If no ribbon is formed, and the soil feels very gritty, the soil is moderately coarse textured.
  8. If the sample consists almost entirely of gritty material and leaves little or no stain on the hand, it is coarse textured.
- Exercise:
1. Have students practice the procedure.
  2. Have students identify the textural group of each of the various soil samples.
- Questions:
1. Which sample formed the longest ribbon? \_\_\_\_\_
  2. Which sample had the highest clay content? \_\_\_\_\_
  3. Which sample felt grittiest? \_\_\_\_\_
  4. What is the textured class of that sample? \_\_\_\_\_
  5. Why should soil be moist to do this test? \_\_\_\_\_
-

TEACHER'S KEY

STUDENT WORKSHEET 1 - SOIL FORMATION

(Reference - VAS Unit 4052 - Understanding Soils)

1. What is soil? (See VAS Unit 4052, part 1)
2. What is soil made up of? mineral matter, organic matter, water and air.
3. Soils are composed of one or more layers or horizons.
4. Most soils have three principal horizons, which are designated by capital letters: the surface or A horizon, the subsoil or B horizon, and the substratum underlying the subsoil or C horizon.
5. Parent materials. Write the name of the material in the blank provided.  
glacial origin
  - a. finely ground rock, "glacial flour" distributed by wind. loess
  - b. glaciers carried large amounts of rocky material, grinding much of it into a mixture of gravel, sand, silt and clay. glacial till
  - c. deposited during mild periods by glacial runoff water, deposited in layers. outwash  
water deposited
  - a. sediments in floodplains. alluvium
6. Topography refers to slope characteristics of a soil.
7. Soils on steep topography are likely to be subject to severe erosion.
8. Native vegetation determines the kind and amount of organic matter in the soil.
9. Under forest cover, the organic matter is in the form of duff. Since the material is on the surface, it decays rapidly and leaves only a small residue. Total organic matter, therefore, is quite low.
10. Most prairie soils have a dark surface layer that is fairly deep. Wild prairie grasses and other plants have abundant roots which filled the top of the soil 1 or 2 feet down. Partial decay of these roots over a long period of time gave us the high organic matter content of prairie soils, and along with it, the black color.
11. Soils at different stages in the weathering process will differ widely.

12. Many soils are now acid because the calcium originally in them has been leached away.
13. When the soil is young, organic matter accumulates, but as soils get older, organic matter and production decline, and clay accumulates in the B horizon.
14. Weathering depends on climate.
15. As a rule, the surface of the soil is darker than the subsoil because it contains more organic matter.
16. The darker the surface soil, the higher the organic matter.
17. Subsoil colors of Illinois soils are due to the status of iron compounds. Well-drained soils have bright colored subsoils because the iron compounds are oxidized. Soils with the poor natural drainage have dull gray or olive gray subsoils because the iron has been reduced.

#### Texture problems

To what textural class do the following soils belong?

18. 40% sand, 40% silt, 20% clay loam
19. 20% sand, 60% silt, 20% clay silt loam
20. 50% sand, 10% silt, 40% clay sandy clay
21. If you can form a long, pliable ribbon, the soil is fine textured.
22. If a ribbon forms, but breaks into pieces, 3/4 inch to 1 inch long, the soil is moderately fine textured.
23. Define structure as it relates to soils.  
(Refer to VAS Unit 4052 - pp. 12 and 13.)
24. Structure does not change soil texture, but a desirable structure may greatly improve tilth and the ease with which air and water can move through the soil.
25. Try to draw a picture of each of the 6 main kinds of structures. (Refer to VAS Unit 4052 - p. 14)

granular	subangular blocky
platy	prismatic
angular blocky	columnar

26. The moisture holding capacity of a soil is closely related to its texture. As the clay content increases, there are more soil particles to hold water. So a soil high in clay holds much more water than a sandy soil.
27. While moisture holding capacity is important, too much water will crowd the air out of the soil. If water moves freely through the profile, air can fill the empty pore spaces. When water moves too fast, however, the result is a drouthy soil.
28. Water drains very slowly from the small poras; therefore, fine textured soils have low permeability unless the structures of the surface and subsoil permits water to pass through.
29. If crops are to produce heavily, they must have a large root system so that they can get nutrients and water from a large volume of soil. Coarse sand and gravel discourage root growth because they have little moisture or plant nutrients.
30. Slope of the land influences the speed with which water runs off a field and the amount of soil that washes off with the water. Usually slope is expressed in percent or feet of fall in each 100 feet of horizontal distance.

Problem: The soil drops 6 inches in 25 ft. of horizontal distance. Calculate the percent slope. 2%

31. The top soil is the most valuable part of the soil profile since it contains more nutrients and organic matter, and can often absorb more moisture than the other layers.
32. The principal loss of soil is usually by sheet erosion.
33. In assigning soils to various classes, soil scientists are concerned with 3 questions. What are they?  
(Refer to top of p. 19, VAS Unit 4052)

## TEACHER'S KEY

### STUDENT WORKSHEET 2 - SOIL COLOR

(Reference - VAS Slidefilm 708 - Soil Color)

1. What gives the surface soil its dark color?  
(Refer to frame 9)
2. What caused the thick, dark surface layer in prairie soils?  
(Refer to frame 13)
3. Why is the surface layer thinner on timber soils?  
(Refer to frame 17)
4. Why are the prairie soils of Southern Illinois lighter than those of Northern Illinois.  
(Refer to frame 19)
5. Why is erosion more hazardous on timber soils than on prairie soils?  
(Refer to frame 21)
6. Other than organic matter, what influences subsoil colors?  
(Refer to frame 26)
7. Why do soils that are poorly drained tend to be dull colored?  
(Refer to frames 28 & 29)
8. What colors are found in subsoils that are wet part of the time?  
(Refer to frame 30)
9. What names are used to describe surface soil colors? Subsoil colors?  
(Refer to frames 31 and 33)

# WHY SOILS ARE IMPORTANT

1. Plants grow in and on soil
2. Plants support animal life
3. Plants and animals support human life
4. World population is rapidly increasing
5. A large part of the world's population has inadequate nutrition
6. World supply of productive soil is limited
7. Improved soil management could feed more people

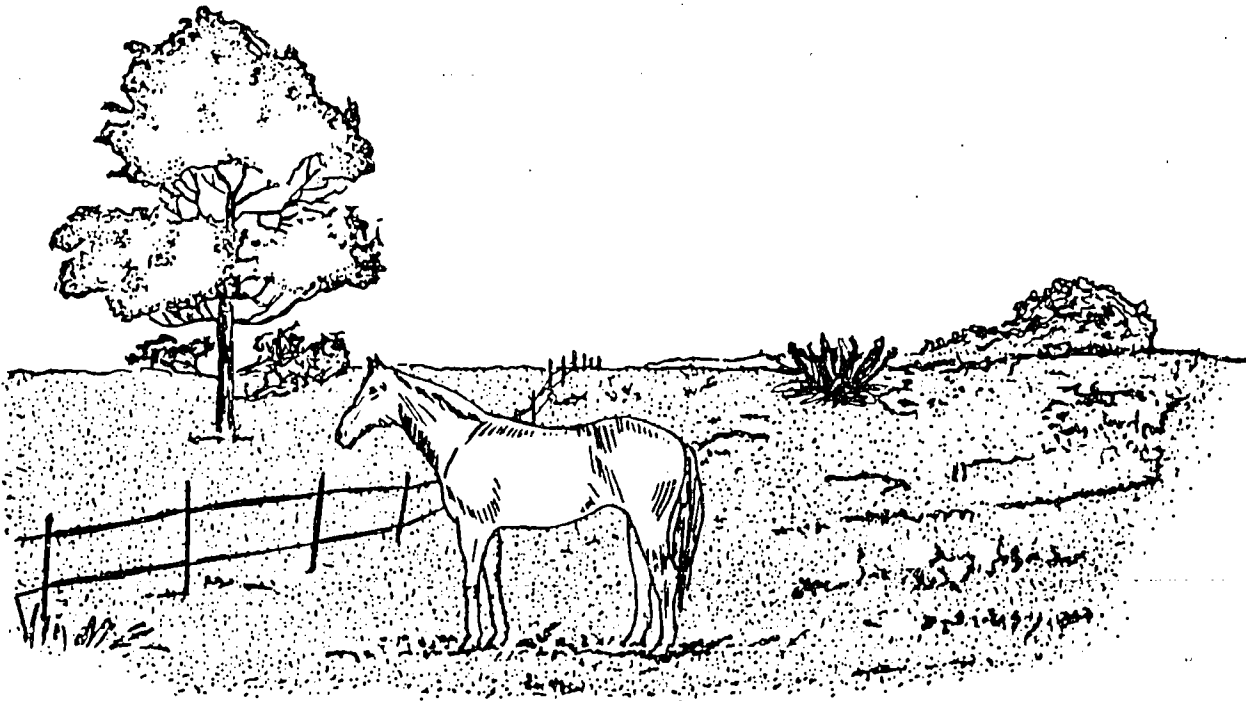



# SOIL PROFILE

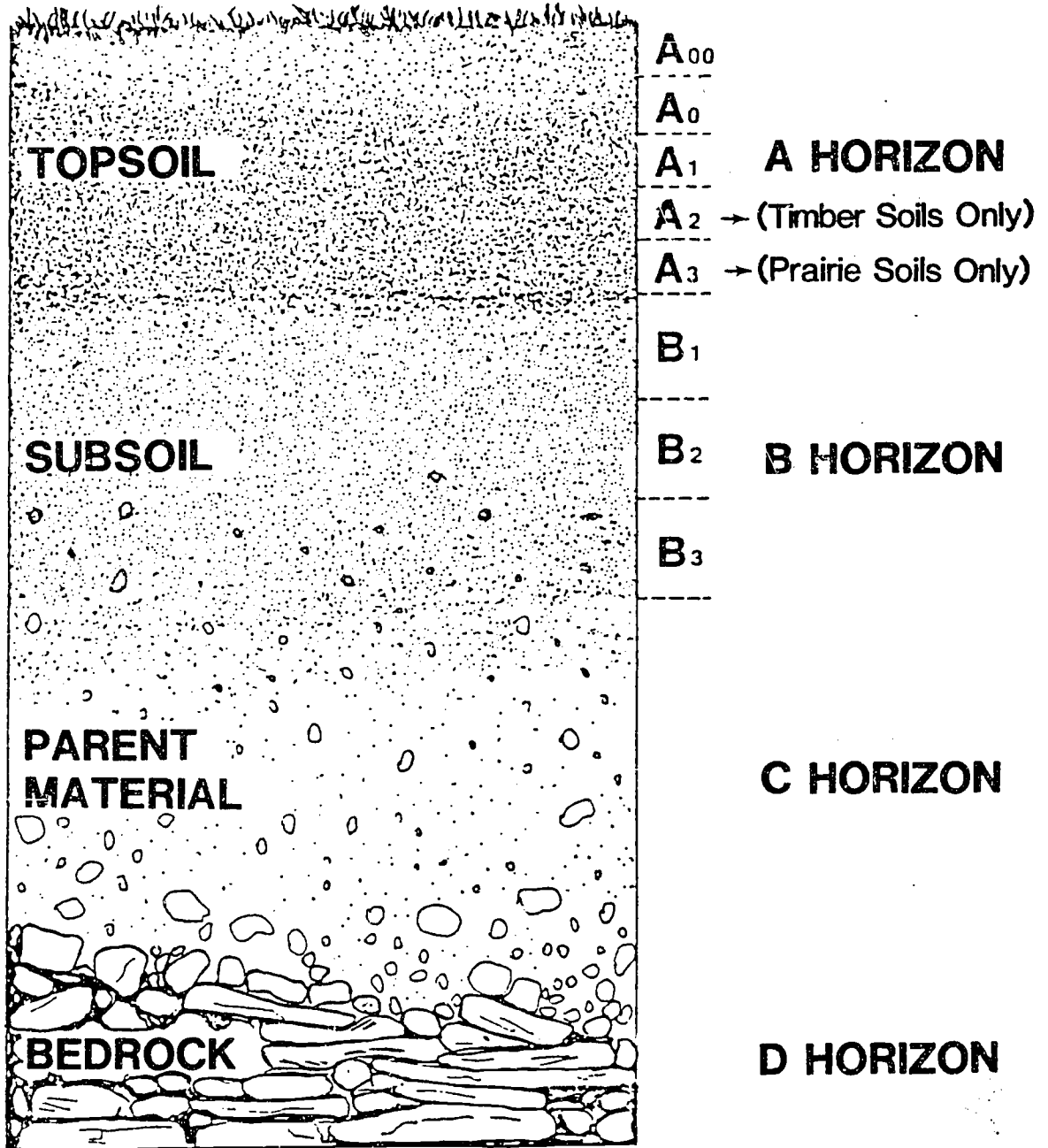

# CHARACTERISTICS OF THE VARIOUS SOIL CLASSES

<u>Characteristics</u>	<u>Sand</u>	<u>Silt</u>	<u>Clay</u>
LOOSENESS	Good	Fair	Poor
AIR SPACE	Good	Fair to Good	Poor
DRAINAGE	Good	Fair to Good	Poor
TENDENCY TO FORM CLODS	Poor	Fair	Good
EASE OF WORKING	Good	Fair to Good	Poor
MOISTURE HOLDING CAPACITY	Poor	Fair to Good	Good
FERTILITY	Poor	Fair to Good	Fair to Good

# THE RELATIVE SIZES OF SAND, SILT, AND CLAY PARTICLES

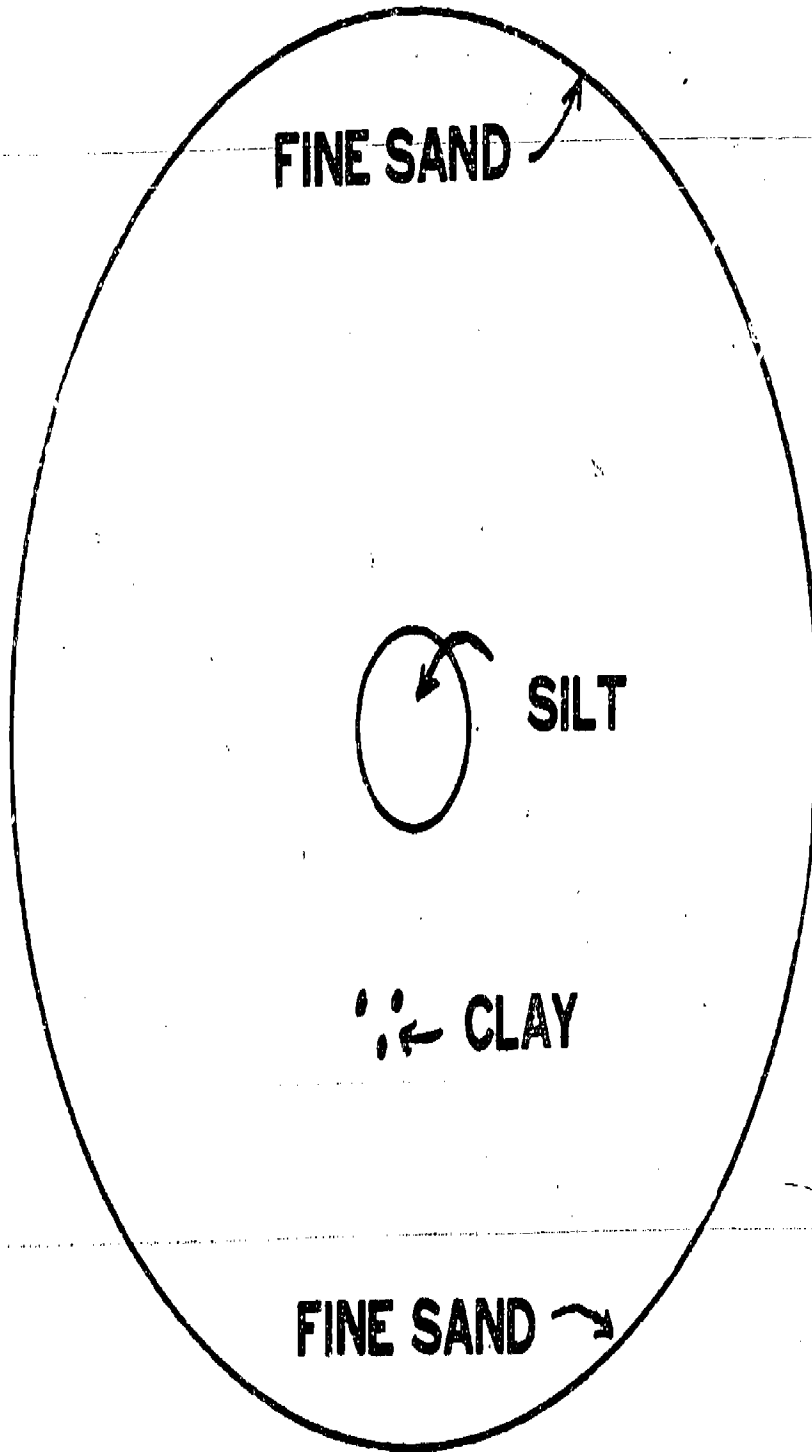

M-111-J-1-20

## SOIL TEXTURAL CLASSES

**SAND** -- DRY: LOOSE AND SINGLE GRAINED; FEELS GRITTY. MOIST: WILL FORM VERY EASILY-CRUMBLLED BALL. SAND--85-100%, SILT--0-15%, CLAY--0-10%.

**LOAMY SAND** -- DRY: SILT AND CLAY MAY MASK SAND; FEELS LOOSE, GRITTY. MOIST: FEELS GRITTY; FORMS EASILY-CRUMBLLED BALL; STAINS FINGERS SLIGHTLY. SAND--70-90%, SILT--0-30%, CLAY--0-15%.

**SANDY LOAM** -- DRY: CLODS EASILY BROKEN; SAND CAN BE SEEN AND FELT. MOIST: MODERATELY GRITTY; FORMS BALL THAT CAN STAND CAREFUL HANDLING; DEFINITELY STAINS FINGERS. SAND--43-85%, SILT--0-50%, CLAY--0-20%.

**LOAM** -- DRY: CLODS MODERATELY DIFFICULT TO BREAK; MELLOW, SOMEWHAT GRITTY. MOIST: NEITHER VERY GRITTY NOR VERY SMOOTH; FORMS A FIRM BALL; STAINS FINGERS. SAND--23-52%, SILT--28-50%, CLAY--7-27%.

**SILT LOAM** -- DRY: CLODS DIFFICULT TO BREAK; WHEN PULVERIZED FEELS SMOOTH, SOFT AND FLOURY, SHOWS FINGERPRINTS. MOIST: HAS SMOOTH OR SLICK "BUTTERY" OR "VELVETY" FEEL; STAINS FINGERS. SAND--0-50%, SILT--50-88%, CLAY--0-27%.

**CLAY LOAM** -- DRY: CLODS VERY DIFFICULT TO BREAK WITH FINGERS. MOIST: HAS SLIGHTLY GRITTY FEEL; STAINS FINGERS; RIBBONS FAIRLY WELL. SAND--20-45%, SILT--15-53%, CLAY--27-40%.

**SILTY CLAY LOAM** -- SAME AS ABOVE BUT VERY SMOOTH. SAND--0-20%, SILT--40-73%, CLAY--27-40%.

**SANDY CLAY LOAM** -- SAME AS FOR CLAY LOAM. SAND--45-80%, SILT--0-28%, CLAY--20-35%.

**CLAY** -- DRY: CLODS CANNOT BE BROKEN WITH FINGERS WITHOUT EXTREME PRESSURE. MOIST: QUITE PLASTIC AND USUALLY STICKY WHEN WET; STAINS FINGERS. (A SILTY CLAY FEELS SMOOTH, A SANDY CLAY FEELS GRITTY.) SAND--0-45%, SILT--0-40%, CLAY--40-100%.

# SOIL TRIANGLE

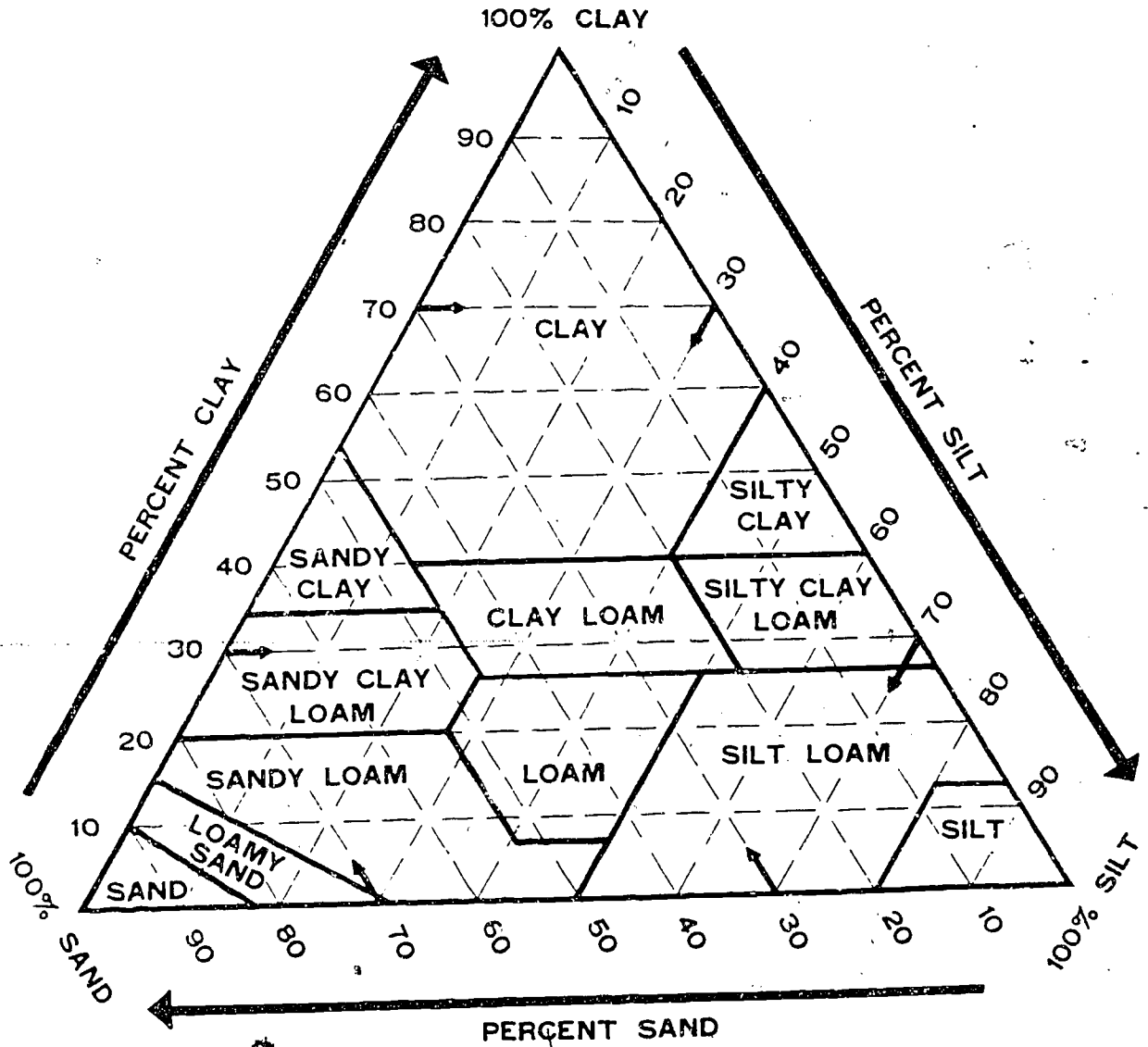

## TRANSPARENCY DISCUSSION GUIDE

### UNDERSTANDING SOILS

#### I. Transparency--WHY SOILS ARE IMPORTANT

- A. Use this transparency to supplement student's ideas and to promote further class discussion.
- B. Ask students to identify places in the community, state, or world where soil is being abused.
- C. Point out the importance of soil to the Illinois economy.
- D. Point out the fact that Illinois has the best soil in the world for crop production.

#### II. Transparency--SOIL PROFILE

- A. Vertical section of soil which extends through all the horizons.
- B. Soils can be identified and classified by studying the soil profile.
- C. Horizons vary in depth and often mix with one another.
- D. Major horizons are A-B-C and these are then further divided--

- A<sub>00</sub> - undecomposed plant and animal material, loose leaves, grass, etc.
- A<sub>0</sub> - partially decomposed organic matter
- A<sub>1</sub> - dark colored high organic matter and mineral matter
- A<sub>2</sub> - light colored only found in timber soils
- A<sub>3</sub> - changing to B, only found in prairie soils
- B<sub>1</sub> - a lot like A<sub>3</sub>--sometimes absent
- B<sub>2</sub> - high in clay content or iron
- B<sub>3</sub> - changing to C--mixed with C

- E. Point out that the A and B horizons are the major parts of a soil profile.
- F. The C horizon is loose parent material.
- G. The D horizon is not parent material but can physically affect the characteristics of the soil above it.

#### III. Transparency--CHARACTERISTICS OF VARIOUS SOIL CLASSES

- A. Point out the characteristics of each soil particle.

- B. Use the soil triangle to discuss how the proper amounts of each particle contribute to the makeup of a desirable soil.
- IV. Transparency -- THE RELATIVE SIZES OF SAND, SILT, AND CLAY PARTICLES
- A. The size of soil particles is important because it influences water intake, water-holding capacity, drainage, tillage, erosion, and the ease with which organic matter and fertility can be maintained.
- B. Note that these particles are greatly enlarged. For example, clay particles are so fine that you cannot see them with your unaided eye and many of them are too small to be seen even under a microscope. Silt can barely be seen with the naked eye and sand grains can be seen easily.
- V. Transparency -- SOIL TEXTURAL CLASSES
- A. Each of the soil particles has a distinctive feel. The best way to estimate texture in the field is to feel the soil with your fingers. The following procedure is recommended:
- B. Moisten a sample of soil to the consistency of workable putty. From this sample make a ball about  $\frac{1}{2}$  inch in diameter. Hold the ball between the thumb and index finger. Then gradually press your thumb down and forward, forming the soil into a ribbon.
- VI. Transparency -- SOIL TRIANGLE
- A. Illinois soils can be divided into 12 main classes on the basis of texture. The corners of this texture triangle represent 100 percent sand, clay, or silt as indicated. (Gravel and organic soils are not included). The triangle is divided into 10-percent portions of clay, silt, and sand. Heavy lines show the divisions between the 2 basic soil textural classes. The triangle can be used only when the percentages of clay, silt, and sand have been determined in the laboratory by mechanical analysis. If you know that a soil is 20 percent clay and 40 percent silt, you can follow the 20-percent line from the left-hand (clay) side of the triangle to the point where it meets the 40-percent line from the right-hand (silt) side of the triangle. You will see, then, that the soil is a loam.

SAMPLE TEST QUESTIONS AND TEACHER'S KEY

UNDERSTANDING SOILS

TRUE OR FALSE

- True 1. Soil is the outer portion of the earth's crust that supports the growth of plants.
- False 2. 90% of the total volume of the soil is made up of mineral and organic matter. The rest is pore space filled with air and water.
- True 3. Three soil particles are sand, silt, and clay.
- False 4. Ideally soil should be composed of 50% water, 25% air, 15% organic matter and 10% mineral matter.
- False 5. Timber soils tend to be higher in organic matter than prairie soils.

MULTIPLE CHOICE

- a 6. A surface soil with a high organic matter content (5%) will be a \_\_\_\_\_ color.
- a. very dark      c. light  
b. dark            d. very light
- b 7. A well drained soil would be expected to have a subsoil with a \_\_\_\_\_ color.
- a. dark            c. dull  
b. bright         d. mottled
- a 8. A soil that is mostly clay would be considered \_\_\_\_\_.
- a. fine-textured      c. moderately coarse-textured  
b. medium-textured    d. coarse textured
- c 9. When testing a soil's texture, the sample will not form a ribbon and feels smooth and talc-like. The soil is
- a. fine-textured      c. medium textured  
b. moderately fine textured    d. moderately course textured
- d 10. Which soil structure is most desirable for a surface soil?
- a. platy            c. single grain  
b. sub-angular blocky    d. granular or crumb



- b   11. What is it called when there is no structure, but soil particles cling together in large uniform masses?
- a. angular blocky      c. prismatic  
b. massive              d. columnar
- b   12. What kind of soil has the highest capacity to hold water for use by plants?
- a. soils high in clay    c. soils high in sand  
b. soils high in silt    d. soils high in gravel
- a   13. Course textured soils tend to have \_\_\_\_\_.
- a. rapid permeability      c. slow permeability  
b. moderate permeability    d. texture doesn't affect permeability
- d   14. What influences the type of soil formed?
- a. native vegetation      c. topography  
b. climate                  d. all of the above
- b   15. If the B Horizon is yellowish in color, this means it
- a. is weak in structure and falls apart  
b. drains well  
c. holds water  
d. is ready to grow vegetables for that year
- b   16. Soil water content is greater
- a. in soils with more large pores  
b. in soils with more small pores  
c. in soils with aeration  
d. in soils made of coarse materials
- d   17. Capillary water is held in the soil
- a. by a magnetic force  
b. by the gravel in soils  
c. by the sand particles  
d. by the small pores
- c   18. Adhesion is
- a. the force between two like substances  
b. created by the water vapor bonds  
c. the force between two different substances  
d. created by gravitational force

- a 19. Cohesion is
- a. the force between two like substances
  - b. created by the water vapor bonds
  - c. the force between two different substances
  - d. created by gravitational force
- d 20. Soluble salts "build up" in soils is caused by
- a. watering from the base of containers
  - b. fertilizing the plant
  - c. using rain water to water plants
  - d. both a and b
- c 21. Salts can be lowered in soils by
- a. changing the pH
  - b. adding sulfur
  - c. leaching
  - d. adding fertilizer
- d 22. The B Horizon is viewed for its ability to
- a. retain fertilizer
  - b. hold water
  - c. supply CO<sub>2</sub>
  - d. drain
- a 23. A dark A Horizon soil is an indication of
- a. high organic matter and nitrogen content
  - b. a river bed location
  - c. a non-aged soil
  - d. low fertility content and low organic matter
- d 24. Illinois parent material is mainly
- a. loess
  - b. bedrock
  - c. outwash
  - d. both a and c
- c 25. Two types of vegetation that covered Illinois are
- a. forest and bluegrass
  - b. bluegrass and vines
  - c. prairie and forest
  - d. soil and water

## UNIT J. SOIL SCIENCE AND CONSERVATION OF NATURAL RESOURCES

### PROBLEM AREA: SELECTING SOIL SITES FOR URBAN USE

#### SUGGESTIONS TO THE TEACHER:

This problem area is designed for use with eleventh grade or advanced students enrolled in a horticultural occupations program. The time recommended for teaching this problem area is during the fall semester before the soil freezes. The estimated time for teaching this problem area is 2 to 5 days depending on how much time the teacher wishes to spend on discussion and conducting the suggested exercises. The materials in this problem area were written with the following assumptions:

1. Each student will have the opportunity to evaluate soil sites for urban use.
2. Students will have completed a basic problem area on soils before beginning this problem area.

The instructor is encouraged to conduct a local search to locate other supplementary materials. The items in this problem area are for reference or modification as teachers adapt these materials to their local situation.

#### CREDIT SOURCES:

These materials were developed through a funding agreement, R-33-13-D-0362-466 with the Illinois State Board of Education, Department of Adult, Vocational and Technical Education, Research and Development Section, 100 North First Street, Springfield, Illinois 62777. Opinions expressed in these materials do not reflect, nor should they be construed as policy or opinion of the State Board of Education or its staff.

The true/false and multiple choice sample test questions were developed by The Ohio Agricultural Education Curriculum Materials Service. Other sample test questions and the teacher's guide were developed by James Ethridge, Joliet Junior College, and Susie Osborne, Department of Vocational and Technical Education, University of Illinois. Transparency masters were prepared by the Vocational Agriculture Service, University of Illinois. Suggestions and guidance in the development of these materials were provided by the Metropolitan Core Curriculum Field Test Teachers.

## TEACHER'S GUIDE

- I. Unit: Soil science and conservation of natural resources
- II. Problem area: Selecting soil sites for urban use
- III. Objectives: At the close of this problem area, students will be able to:
  1. Determine the physical properties and urban uses of land and soil
  2. Evaluate land and soil for urban use.
- IV. Suggested interest approaches:
  1. Ask the class one of the following lead questions:
    - A. Did any of you have flooding in your home during the past year?
    - B. Does anyone have a vegetable garden, turf or landscape that grew poorly last year?
  2. Ask the class to identify reasons why they think soil might have an effect on land use selection.
  3. Ask the class to identify the best areas to build houses and why.
  4. Visit several sites where land has been properly selected for its use and explain why. Also, consider the opposite option.
- V. Anticipated problems and concerns of students:
  1. What are the physical properties of soils?
  2. How do you determine the physical properties of soils?
  3. How do you determine slope?
  4. What is a subsoil?
  5. What is a flooding hazard?
  6. What is sediment?
  7. What is a water table?
  8. What is soil stability?
  9. What is permeability?
  10. What is porosity?

11. How can the permeability and/or porosity of the soil be improved?
12. Why should physical properties of the land and soil be considered when selecting an area for urban use?

VI. Suggested learning activities and experiences:

1. Using the transparencies, Physical Properties of Land and Soil and Urban Uses of Land and Soil, ask students what physical characteristics of land and soil should be considered when selecting a site for each of the urban uses listed.
2. Have students read VAS Subject Matter Unit 4053 - Using the Illinois Soil Judging Scorecard. Discuss the importance of slope, position, texture and permeability when selecting soil sites for urban use.
3. Discuss the limitations of various soil sites in regard to building homes and septic-tank filter fields. Use VAS Subject Matter Unit 4053 - Using the Illinois Soil Judging Scorecard, pages 13-16, and Information Sheet I - Land and Soil Judging Scorecard for Urban Uses as references.
4. Have students determine slope by use of a hand level or clinometer.
5. Have students complete Laboratory Exercise 1 - Determining Soil Permeability. Repeat this lab exercise with soil samples brought in from the students' home sites and/or school grounds.
6. Have students determine the texture of various soil samples using the ribbon technique. Refer to the previous problem area in this unit entitled "Understanding Soils" for an explanation of this method.
7. Show slide set, Selecting Soil Sites for Urban Land Use.
8. Have students evaluate various urban land sites using the "Land and Soil Judging Scorecard for Urban Uses" included in this problem area or the "Illinois Soil Judging Scorecard" (A copy is included in VAS Subject Matter Unit 4053).
9. Conduct a soil judging and land use selection contest. Award prizes to top students.
10. Invite a representative from the Soil Conservation Service to speak to the class regarding selection of land for urban uses.
11. Give students information about various building sites, and have them determine possible urban uses. Refer to the sample test questions on land use situations included in this problem area for possible ideas.

VII. Application procedures:

1. Skills learned in this problem area should be used when selecting land sites for urban use.
2. The skills learned in this problem area will be valuable for students who plan to maintain landscapes and turf areas and plant vegetable gardens.

VIII. Evaluation:

1. Evaluate laboratory exercise.
2. Evaluate student performance level when selecting land for the proper use. The land and soil judging scorecards can be utilized for this purpose.
3. Administer and grade an exam using the sample test questions included in this problem area.
4. Evaluate students' ability in a land selection and use contest.

IX. References and aids:

1. Slide Set and Script "Selecting Soil Sites for Urban Land and Soil Use," Ohio Agricultural Education Curriculum Materials Service, The Ohio State University, Room 254 Agricultural Administration Building, 2120 Fyffe Road, Columbus, Ohio 43210-1099
2. "Judging Land and Soil for Urban Use." Ohio Agricultural Education Curriculum Materials Service, The Ohio State University, Room 254 Agricultural Administration Building, 2120 Fyffe Road, Columbus, Ohio 43210-1099
3. VAS Subject Matter Unit 4053 - Using the Illinois Soil Judging Scorecard available from Vocational Agriculture Service, University of Illinois, 1401 South Maryland Drive, Urbana, Illinois 61801.

INFORMATION SHEET 1  
LAND AND SOIL JUDGING SCORECARD FOR URBAN USES

Name \_\_\_\_\_ Site No. \_\_\_\_\_

PHYSICAL PROPERTIES OF THE LAND SITE AND THEIR LIMITATIONS FOR URBAN USE

SLOPE - Check one

- |       |                           |                                                                             |
|-------|---------------------------|-----------------------------------------------------------------------------|
| _____ | Nearly level (0-2%)       | SLIGHT all uses                                                             |
| _____ | Gently sloping (2-6%)     | SLIGHT for all uses except 5 and 7 which are MODERATE                       |
| _____ | Sloping (6-12%)           | MODERATE for all uses except 5 and 7 which are SEVERE and 8 which is SLIGHT |
| _____ | Moderately steep (12-25%) | SEVERE for all uses except 8 which is SLIGHT                                |
| _____ | Steep (25%+)              | SEVERE for all uses except 8 which is SLIGHT                                |

FLOODING HAZARD OR POSITION - Check one

- |       |                         |                                              |
|-------|-------------------------|----------------------------------------------|
| _____ | Subject to Flooding     | SEVERE for all uses except 8 which is SLIGHT |
| _____ | Not subject to flooding | SLIGHT for all uses                          |

SURFACE SOIL TEXTURE - Check one

- |       |                             |                                                        |
|-------|-----------------------------|--------------------------------------------------------|
| _____ | Very sandy or very gravelly | SLIGHT for all uses except 4, 6 and 7 which are SEVERE |
| _____ | Coarse (sandy)              | SLIGHT for all uses except 4 which is MODERATE         |
| _____ | Medium                      | SLIGHT for all uses                                    |
| _____ | Fine (clayey or muck)       | SLIGHT for all uses except 4, 6 and 7 which are SEVERE |

LAND AND SOIL JUDGING SCORECARD FOR URBAN USES - Continued

PERMEABILITY OF SUBSOIL - Check one

- |                          |          |                                                          |
|--------------------------|----------|----------------------------------------------------------|
| <input type="checkbox"/> | Rapid    | SLIGHT for all uses*                                     |
| <input type="checkbox"/> | Moderate | SLIGHT for all uses except 1, 4 and 7 which are MODERATE |
| <input type="checkbox"/> | Slow     | SLIGHT for all uses except 1, 4 and 7 which are SEVERE   |

DEPTH TO SEASONAL WATER TABLE - Check one

- |                          |                   |                                                                      |
|--------------------------|-------------------|----------------------------------------------------------------------|
| <input type="checkbox"/> | More than 3 feet  | SLIGHT for all uses                                                  |
| <input type="checkbox"/> | 1½ - 3 feet       | MODERATE for all uses except 6 and 8 which are SLIGHT                |
| <input type="checkbox"/> | Less than 1½ feet | SEVERE for all uses except 6 which is MODERATE and 8 which is SLIGHT |

DEPTH TO BEDROCK - Check one

- |                          |                  |                                                                      |
|--------------------------|------------------|----------------------------------------------------------------------|
| <input type="checkbox"/> | More than 6 feet | SLIGHT for all uses                                                  |
| <input type="checkbox"/> | 4 - 6 feet       | MODERATE for all uses except 4 and 8 which are SLIGHT                |
| <input type="checkbox"/> | 1 - 4 feet       | SEVERE for all uses except 4 which is MODERATE and 8 which is SLIGHT |
| <input type="checkbox"/> | Less than 1 foot | SEVERE for all uses except 8 which is SLIGHT                         |

SOIL STABILITY - Check one

- |                          |                         |                                              |
|--------------------------|-------------------------|----------------------------------------------|
| <input type="checkbox"/> | Not subject to slippage | SLIGHT for all uses                          |
| <input type="checkbox"/> | Subject to slippage     | SEVERE for all uses except 8 which is SLIGHT |



LAND AND SOIL JUDGING SCORECARD FOR URBAN USES - Continued

URBAN USES	Summary Rating For Each Use		
	Slight	Moderate	Severe
1) Septic tank filter fields	_____	_____	_____
2) Homesites with basements	_____	_____	_____
3) Homesites without basements	_____	_____	_____
4) Lawns, gardening and landscaping	_____	_____	_____
5) Subdivision roads and parking lots	_____	_____	_____
6) Playgrounds and picnic areas	_____	_____	_____
7) Athletic fields	_____	_____	_____
8) Natural areas	_____	_____	_____

Total Possible Score - 150  
 (10 Points for each correct answer)

Tie scores may be untied by written or oral questions or by other more expedient methods.

\* Possible pollution hazard with septic tank filter fields where substratum is porous.



**LABORATORY EXERCISE 1**  
**DETERMINING SOIL PERMEABILITY**

**INTRODUCTION:** Permeability refers to the rate of water movement through the soil profile. Soil permeability is measured in inches per hour and can be classified as rapid (more than 6 inches per hour), moderate (.6 to 2 inches per hour), and slow (.06 to .2 inches per hour). A moderate rate of water movement is desirable to enable soils to dry after a rain and for flow of septic-tank effluent through a soil. Rapid permeability may mean a droughty homesite or a potential problem from pollution of water by septic-tank effluent.

**PURPOSE:** The purpose of this laboratory exercise is to determine the permeability of various soils. Students can compare the permeability of peat moss, perlite and sand as described in the procedures below or they can use soil samples brought from home.

**MATERIALS NEEDED:**

3 small plastic pots	3 rubber bands	Peat moss
3 large cans with plastic lids	Measuring cup	Perlite
3 pieces of cheesecloth	Water	Sand

**PROCEDURES:**

1. Cover the bottom half of a plastic pot with cheesecloth and secure tightly with a rubber band. Be sure the holes in the pots are covered with cheesecloth to prevent the soil samples from leaking.
2. Fill one pot with peat moss, one with perlite and one with sand. Label each pot according to its contents.
3. Cut a hole in the plastic lids of the large cans so that the plastic pots will fit inside. Secure the lids on the cans.
4. Hold each pot above the hole cut in the plastic can lid and pour in  $\frac{1}{2}$  cup of water. Record the time when the water was poured into each pot and also when the water first begins to drip from the pot.
5. Place each pot securely in the lid of the metal cans allowing the water to drain. After 10 minutes remove the pots and measure the amount of water left in each can.

## LABORATORY EXERCISE 1 - Continued

### OBSERVATIONS:

1. How long did it take the water to begin dripping from the pot containing peat moss \_\_\_\_\_, perlite \_\_\_\_\_, and sand \_\_\_\_\_?
2. After 10 minutes, how much water was left in the can with the pot containing peat moss \_\_\_\_\_, perlite \_\_\_\_\_, and sand \_\_\_\_\_?
3. Which soil sample is the most permeable?
4. Which soil sample is the least permeable?

---

# **Urban Uses Of Land And Soil**

**1. Septic Tank Filter Fields**

**2. Homesites with Basements**

**3. Homesites Without Basements**

**4. Lawns, Gardening, and Landscaping**

**5. Subdivision Roads and Parking Lots**

**6. Playground and Picnic Areas**

**7. Athletic Fields**

**8. Natural Areas**

---

# Physical Properties Of Land And Soil

1. Slope

2. Flooding Hazard

3. Surface Soil Texture

4. Permeability of the Subsoil

5. Depth to Seasonal Water Table

6. Depth to Bedrock

7. Soil Stability

# FIGURING PERCENT SLOPE

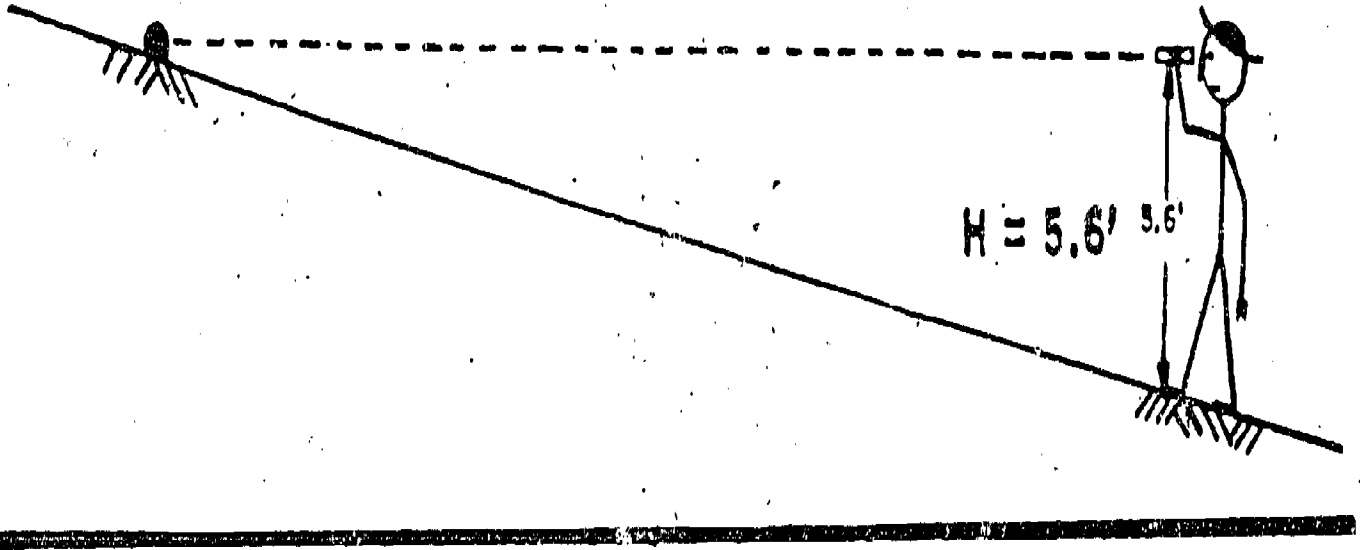

SAMPLE TEST QUESTIONS AND TEACHER'S KEY

SELECTING SOIL SITES FOR URBAN USE

SHORT ANSWER:

1. List the seven physical properties of land and soil.
  - A. Slope
  - B. Flooding hazard
  - C. Surface soil texture
  - D. Permeability of the subsoil
  - E. Depth to seasonal water table
  - F. Depth to bed rock
  - G. Soil stability
  
2. Define the following terms:
  - A. SLOPE: Slope is the difference in elevation between two points 100 feet apart.
  - B. FLOODING HAZARD: A flooding hazard exists when the soil is subject to stream overflow.
  - C. SEDIMENT: Sediment is soil particles that are deposited along the banks of streams in places where the stream overflows.
  - D. SOIL TEXTURE: Soil texture refers to the size of soil particles.
  - E. PERMEABILITY OF SUBSOIL: Permeability of the subsoil refers to the rate by which air and water are able to move within the subsoil.
  - F. DEPTH TO SEASON WATER TABLE: Depth to season water table refers to the shallowest depth to which the soil is saturated with water during the year.
  - G. BED ROCK: Bed rock is rock formations near the soil surface.
  
3. Name the four texture groups for surface soil.
  - A. Very Sandy or Very Gravelly
  - B. Course (Sandy)
  - C. Medium (loamy smooth)
  - D. Fine (clayey and sticky when wet)
  
4. What are the three rates of permeability of subsoil?
  - A. Rapid
  - B. Moderate
  - C. Slow

TRUE OR FALSE:

- True 5. The physical properties of land and soil determine whether or not land is suitable for specific urban purposes.
- False 6. The physical properties of land and soil are of equal importance for all urban uses.
- True 7. Land that is very steep presents few, if any, limitations for natural areas.
- True 8. The importance of soil texture varies with the use of the land.
- False 9. Soils with very slow permeability are suitable for septic tank filter fields.
- True 10. Soils with high water tables may result in wet basements.
- True 11. Limitations of land for urban uses are rated as slight, moderate, or severe.

MULTIPLE CHOICE:

- C 12. The starting point to assess the cost of construction for specific urban uses of land is the:
- a. location.
  - b. nearness to highways.
  - c. physical properties.
- B 13. The construction costs on steep land or moderately sloping land are:
- a. less costly.
  - b. more costly.
  - c. about the same.
- C 14. Permeability of soil refers to:
- a. structure of the subsoil.
  - b. texture of the subsoil.
  - c. the rate at which air and water moves through the soil.
- A 15. The shallowest depth at which soil is saturated with water is known as the:
- a. seasonal water table.
  - b. bedrock depth.
  - c. high water table.



- A 16. A 6 - 12% slope is a severe limitation for:
- subdivision roads and parking lots.
  - septic tank filter fields.
  - natural areas.
- A 17. Very sandy or gravelly soil texture is a severe limitation for:
- lawns, garden, and landscape plants.
  - home sites.
  - septic tank filter fields.
- A 18. A seasonal water table with a depth of more than three feet is a slight limitation for:
- all urban uses.
  - no urban uses.
  - five urban uses.

LAND USE SITUATIONS: Refer to the "Land and Soil Judging Scorecard for Urban Uses" to answer the following questions.

CHARACTERISTIC	SITE 1	SITE 2	SITE 3
Slope	Sloping (6-12%)	Nearly level (0-2%)	Nearly level (0-2%)
Soil Surface Texture	Medium	Fine	Medium
Permeability of the Subsoil	Rapid	Slow	Rapid
Depth to Seasonal Water Table	1½ - 3 feet	More than 3 feet	More than 3 feet
Depth to Bedrock	More than 6 feet		
Flooding Hazard	Not subject to flooding		
Soil Stability	Not subject to slippage		

Considering the physical properties of Land Sites 1 through 3 in the chart above answer yes or no to the following questions.

- No 19. Is Site 1 an excellent location for an athletic field?
- Yes 20. Should a house be built on Site 1?
- Yes 21. Would Site 1 be a nice place for a playground or picnic area?
- Yes 22. Would Site 1 be suitable for gardening and landscaping?
- No 23. Site 1 has a porous substratum. Is it a good site for a septic tank filter field?
- No 24. Is Site 1 the best site for a parking lot?
- No 25. Would you use Site 2 as a septic tank filter field?
- Yes 26. Is Site 2 the best site for a football field?
- No 27. Could you build a parking lot on Site 2?
- No 28. Would Site 2 be a good place for a garden?
- Yes 29. Is Site 2 suitable for a natural area?
- Yes 30. Is Site 3 the best site for a football field?
- Yes 31. Is Site 3 a good site for a septic tank filter field?
- Yes 32. Could you build a house with a basement on Site 3?
- Yes 33. Could you use site 3 for any of the 8 urban uses of land and soil?

## UNIT J: SOIL SCIENCE AND CONSERVATION OF NATURAL RESOURCES

### PROBLEM AREA: ATTRACTING BIRDS TO YOUR BACKYARD

#### SUGGESTIONS TO THE TEACHER:

This problem area is designed for use with eleventh grade or advanced students in a horticultural occupations program. The recommended time for teaching this problem area is during the late fall.

The estimated instructional time for this problem area is 3 days, depending on how far the teacher wishes to go in developing skills at the third year level. If the teaching plan is limited to classroom discussion with little or no practice or observation, the instructional time can be 2 days or less. If the students are to be involved in other activity exercises, the instructional time will need to be increased.

The instructor is encouraged to conduct a local search to locate other supplementary materials for use with this problem area. The items in this problem area are for reference or modification as instructors adapt this problem area to their local situation.

#### CREDIT SOURCES:

These materials were developed through a funding agreement R-33-13-D-0362-446 with the Illinois State Board of Education, Department of Adult, Vocational and Technical Education, Research and Development Section, 100 North First Street, Springfield, Illinois 62777. Opinions expressed in these materials do not reflect, nor should they be construed as policy or opinion of the State Board of Education or its staff.

The teacher's guide, information sheets, student worksheets and sample test questions were developed by Marcia Watman-Lauchner, Department of Vocational and Technical Education. Suggestions and guidance in the development of these materials were provided by the Metropolitan Core Curriculum Field Test Teachers.

## TEACHER'S GUIDE

- I. Unit: Soil science and conservation of natural resources
- II. Problem area: Attracting birds to your backyard
- III. Objectives: At the close of this problem area students will be able to:
  1. Recognize the various trees and shrubs that can be integrated into the home landscape to attract birds.
  2. Select suitable structures, feeders, and feed for attracting birds.
- IV. Suggested interest approaches:
  1. Ask student if they currently try to attract birds to their backyard and if so, what methods have been successful.
  2. Ask students if anyone has built a bird feeder or watering source for birds. Have them describe the feeders.
  3. Ask students if they have ever gone bird-watching. Do they know the names of the most common birds in their area?
- V. Anticipated problems and concerns of students:
  1. What can I do to attract birds to my home site?
  2. What types of birds are most common to my area?
  3. What do birds eat?
  4. What type of nest or birdhouse do different types of birds prefer?
  5. What types of plants do birds like?
- VI. Suggested learning activities and experiences:
  1. Have students find a simple plan and make a birdhouse. Wood or recyclable materials such as milk cartons, detergent or bleach bottles, coffee cans, pie tins, et cetera can be used.
  2. Take the students on a walk around the school to identify what species of birds live in the area. A separate walk may be needed to identify the winter birds. Once the birds have been identified, the students can suggest a feeding schedule.
  3. Arrange a field trip to a local park district nature center. Have the park ranger or manager discuss methods used to attract and protect birds.

4. The Illinois Conservation Department has many excellent free resources concerning birds. Have students contact the department and order materials most relevant to their home situation. A few resources are listed in the References and Aids section.
5. Have students read pages 32-34, 36-39 in the Illinois Wildlife Conservation Manual and answer Student Worksheet 1 - Birds.
6. Have students read the reprint article from National Wildlife Magazine entitled "Invite Wildlife to Your Backyard.", and answer Student Worksheet 2 - Invite Birds to Your Backyard.
7. Bring in different landscaping materials (or slides of these materials) that attract birds, and have students identify them.
8. Have students draw a landscape plan for their home or school grounds which is intended for the purpose of attracting birds. Students should use the information sheets on the different types of trees and shrubs which attract birds.
9. Compare store-bought and natural feeds (from trees and shrubs which attract birds) to see what birds prefer. Also compare different types of birdhouses and feeders.
10. Have students list the trees and shrubs in their yard. Check to see if these trees and shrubs are suitable for attracting birds by using Information Sheets 2 through 8.

VII. Application procedures:

1. Skills learned can be applied to the student's home situation.
2. Students working for a nursery, landscape company or garden center will be able to advise customers as to appropriate landscaping materials for attracting birds to their home site.

VIII. Evaluation:

1. Evaluate student worksheets.
2. Evaluate the birdhouses or bird feeders that students have built.
3. Administer and evaluate test using sample test questions included in this problem area.

IX. References and aids:

1. Illinois 4-H Wildlife Conservation Manual  
Cooperative Extension Service  
College of Agriculture  
University of Illinois  
Urbana, Illinois 61801

2. Reprint: "Invite Wildlife to Your Backyard"  
Available from: National Wildlife Magazine, April-May 1973  
1412 16th Street, N.W.  
Washington, D.C. 20036
3. A Complete Guide to Bird Feeding, by John V. Dennis and Alfred A. Knopf, New York 1976 (available at many bookstores or the local library)
4. Invite Birds to Your Home, by Wade H. Hamor. Soil Conservation Service, United States Department of Agriculture
5. Selected information sheets
6. Selected student worksheets

## INFORMATION SHEET 1

### ATTRACTING BIRDS TO YOUR HOME SITE

"Bird-watching" is an interesting hobby for many people. Why not take a bird-watching hike through your neighborhood? You can, if all the necessary items are available for attracting birds. To maintain a population of birds in your backyard, you should have a feeding area with the proper food, a place with water for drinking and bathing and a place for shelter in poor weather. Each species of birds are particular as to the type of feed they like, whether they nest in trees or a nest box and how much sunlight they enjoy.

If you have enough room in your home landscape, you may want to plant a special garden for attracting birds. A home grounds planting with decorative trees, shrubs and vines will usually furnish food and shelter for many species of birds. Select plants with healthy foliage, fruits, attractive flowers and interesting branches, as well as a neat general appearance.

In addition, you may wish to build nesting boxes to attract birds. The chart on the next page gives the dimensions of nesting boxes which attract various species of birds.

8-8-111-W  
 INFORMATION SHEET 1 - continued

DIMENSIONS OF NESTING BOXES

Species	Floor of Nesting Box	Depth of Nesting Box	Entrance Above Floor of Box	Diameter of Entrance	Height Above Ground
	Inches	Inches	Inches	Inches	Feet
Bluebird	5x5	8	6	1-½	5-10
Robin	6x8	8			6-15
Chickadee	4x4	8-10	6-8	1-1/8	6-15
Nuthatch	4x4	"	"	1-¼	12-20
House Wren	4x4	6-8	1-6	"	6-10
Carolina Wren	4x4	"	"	1-½	"
Violet Green or Tree Swallows	5x5	6	1-5	"	10-15
Barn Swallow	6x6	"			8-12
Purple Martin	6x6	"	1	2-½	15-20
Song Sparrow	6x6	"			1-3
House Finch	6x6	"	4	2	8-12
Phoebe	6x6	6			8-12
Crested Flycatcher	6x6	8-10	6-8	2	8-20
Flicker	7x7	16-18	14-16	2-½	6-20
Golden Fronted or Red-Headed Woodpeckers	6x6	12-15	9-12	2	12-20



INFORMATION SHEET 2

LARGE TREES THAT ATTRACT BIRDS

NAME	FOOD QUALITY	FOOD AVAILABILITY	COVER	NESTING	HARDINESS	REMARKS
Betula lutea Yellow Birch	Good	Late Winter	Fair	Fair	3	Attracts Finches
Celtis occidentalis Common Hackberry	Good	Winter	Fair	Fair	2	
Larix decidua European Larch	Good	Winter	Fair	Fair	2	
Picea glauca White Spruce	Fair	Winter	Excel.	Excel.	2	Evergreen
Pinus strobus Eastern White Pine		Winter	Good	Good	3	Evergreen
Prunus serotina Black Cherry	Excel.	Fall	Fair	Fair	3	35 species of birds
Tsuga canadensis Canadian Hemlock	Good	Winter	Excel.	Good	3	Evergreen; Finches

M-111-J-3-9

## INFORMATION SHEET 3

## MEDIUM SIZE TREES THAT ATTRACT BIRDS

NAME	FOOD QUALITY	FOOD AVAILABILITY	COVER	NESTING	HARDINESS	REMARKS
Morus rubra, Morus alba Red, White Mulberry	Excel.	Summer	Good	Good	4	Use in back of planting 50 species of birds
Tnuja occidentalis Eastern Arbovitae	Fair		Good	Good	2	Evergreen
Malus species Crabapple	Good	Fall	Good	Good		Very ornamental May attract up to 30 species of birds
Elaeagnus angustifolia Russian Olive-tree	Fair	Fall/Winter	Fair	Fair	2	Good in salty areas

INFORMATION SHEET 4

SMALL TREES THAT ATTRACT BIRDS

NAME	FOOD QUALITY	FOOD AVAILABILITY	COVER	NESTING	HARDINESS	REMARKS
Amelanchier asborea Serviceberry	Excel.	Summer	Fair	Fair	4	Many species
Cornus alternifolia Pagoda Dogwood	Excel.	Summer/Fall	Fair	Good	3	Crested Flycatcher
Crataegus crusgalli Cockspur Hawthorne	Good	Fall/Winter	Good	Good	4	Fruit all winter
Crataegus phaenopyrum Washington Hawthorne	Good	Fall/Winter	Good	Good	4	Fruit lasts
Juniperus virginiana Eastern Red cedar	Excel.	Winter	Excel.	Good	2	Do not use near apples or crabapples
Malus floribunda Japanese Flowering Crabapple	Excel.	Winter	Good	Fair		
Prunus virginiana Common Chokecherry	Good	Summer	Fair	Fair	2	70 species of birds
Sorbus aucuparia European Mountain Ash	Good	Fall/Winter	Fair	Fair	3	Robins/Waxwings Sus. to Fireblight

M-111-J-3-11

## INFORMATION SHEET 5

## LARGE SHRUBS THAT ATTRACT BIRDS

NAME	FOOD QUALITY	FOOD AVAILABILITY	COVER	NESTING	HARDINESS	REMARKS
Cornus ammomum Silky Dogwood	Good	Fall	Fair	Fair	5	80 species of birds
Cornus mas Cornelian Cherry Dogwood	Good	Spring	Fair	Good	4	
Cornus racemosa Gray Dogwood	Excel.	Fall	Fair	Fair	4	
Cornus sericea Redosier Dogwood	Good	Fall	Fair	Fair	2	does well in wet soils
Lonicera tatarica Tatarian Honeysuckle	Good	Summer	Fair	Good	3	15 species of birds
Rhus typhina Staghorn Sumac	Good	Winter	Fair	Fair	3	15 species
Sambucus canadensis American Elder	Excel.	Summer/Fall	Good	Good	3	100 species good in wet areas
Viburnum dentatum Arrowwood Viburnum	Good	Summer/Fall	Good	Good	2	
Viburnum lentago Nanhyberry Viburnum	Good	Fall/Winter	Good	Good	2	Cardinals
Viburnum trilobum American Cranberrybush Viburnum	Fair	Fall/Winter	Fair	Fair	2	Cardinals
Viburnum prunifolium Blackhaw Viburnum	Good	Fall/Winter	Good	Good	3	Good fall color attract 29 species

MEDIUM SIZE SHRUBS THAT ATTRACT BIRDS

NAME	FOOD QUALITY	FOOD AVAILABILITY	COVER	NESTING	HARDINESS	REMARKS
Aronia Arbutifolia Red Chokeberry	Good	Fall	Fair	Fair	5	
Ilex verticillata: Common Winterberry	Good	Fall/Winter	Fair	Fair	3	Good for wet areas
Lonicera morrowii Morrow Honeysuckle	Good	Summer/Fall	Good	Fair	3	Will do well just about anywhere

INFORMATION SHEET 7

SMALL SHRUBS THAT ATTRACT BIRDS

NAME	FOOD QUALITY	FOOD AVAILABILITY	COVER	NESTING	HARDINESS	REMARKS
Juniperus communis Common Juniper	Good	Fall/Winter	Good	Good	2	Ground cover
Rhus aromatica Fragrant Sumac	Good	Winter	Good	Good	3	Nice fall color
Rubus idaeus Red Raspberry	Excel.	Summer/Fall	Poor	Poor		
Rubus occidentalis Black Raspberry	Good	Summer/Fall	Fair	Fair		
Symphoricarpus orbiculatus Indian-current Coralberry	Good	Winter	Fair	Fair	2	Full of fruit in the winter

INFORMATION SHEET 8

VINES THAT ATTRACT BIRDS

NAME	FOOD QUALITY	FOOD AVAILABILITY	COVER	NESTING	HARDINESS	REMARKS
Campsis radicans Trumpet Creeper	Good	Summer	Fair	Poor	4	Nectar used by hummingbirds
Parthenocissus quinquefolia Virginia Creeper	Excel.	Fall/Winter	Fair	Good	4	Usually clings to walls of buildings
Vitis labrusca Fox Grape	Excel.	Fall/Winter	Good	Fair		Can be used on an arbor

65

66

INFORMATION SHEET 9

ENDANGERED AND THREATENED BIRDS IN ILLINOIS

I. ENDANGERED SPECIES - those which are in danger of extinction as a breeding species:

Double-crested Cormorant	Black Rail
Snowy Egret	Purple Gallinule
Great Egret	Piping Plover
Little Blue Heron	Eskimo Curlew
American Bittern	Upland Sandpiper
Black-crowned Night Heron	Wilson' Phalarope
Mississippi Kite	Forster's Tern
Cooper's Hawk	Common Tern
Red-shouldered Hawk	Least Tern
Swainson's Hawk	Black Tern
Bald Eagle	Barn Owl
Osprey	Long-eared Owl
Marsh Hawk	Short-eared Owl
Peregrine Falcon	Brown Creeper
Greater Prairie Chicken	Bachman's Warbler
Yellow Rail	Yellow-headed Blackbird
	Bachman's Sparrow

II. THREATENED SPECIES - those which are likely to become an endangered species within the foreseeable future:

Swainson's Warbler	Common Gallinule
Brewer's Blackbird	Bewick's Wren
Henslow's Sparrow	Veery
	Loggerhead Shrike



## STUDENT WORKSHEET 1

### BIRDS

(Reference - Illinois 4-H Wildlife Conservation Manual, Pages 32-39)

1. How many species of birds exist today worldwide?
2. How many years ago do fossil records indicate that birds may have existed?
3. How many species of birds are found in North America?  
How many species of birds are found in Illinois?
4. How many species of birds nest in Illinois in the spring and summer?
5. When trying to attract birds to your backyard, what is the one item they need, especially in the spring and summer months?
6. What is needed to attract birds on a year-round basis?
7. Where can you find natural plantings created by birds and why?

STUDENT WORKSHEET 2  
INVITE BIRDS TO YOUR BACKYARD

(Reference - "Invite Wildlife to Your Backyard", reprint from National Wildlife Magazine, April-May 1973)

1. Name four characteristics of Stage I.
  - 1.
  - 2.
  - 3.
  - 4.
  
2. Name five characteristics of Stage II.
  - 1.
  - 2.
  - 3.
  - 4.
  - 5.
  
3. Name two characteristics of Stage III.
  - 1.
  - 2.
  
4. How many years does it take to reach Stage I, Stage II, and Stage III?
  1. Stage I -
  2. Stage II -
  3. Stage III -

5. What are the four basic elements birds and other wildlife need?

1.

2.

3.

4.

If your yard is not large enough to plant trees and shrubs, how can you attract birds to your home site.

7. Name one method of supplying water for birds.

## TEACHER'S KEY - STUDENT WORKSHEET 1

### BIRDS

(Reference - Illinois 4-H Wildlife Conservation Manual, Pages 32-39)

1. How many species of birds exist today worldwide.

8,600 species of birds exist today, worldwide.

2. How many years ago do fossil records indicate that birds may have existed?

Fossil records indicate that birds may have existed 10-15 million years ago.

3. How many species of birds are found in North America?  
How many species of birds are found in Illinois?

750 species of birds can be found in North America and 350 species in Illinois.

4. How many species of birds nest in Illinois in the spring and summer?

Approximately 170 species of birds nest in Illinois in the spring and summer months.

5. When trying to attract birds to your backyard, what is the one item they need, especially in the spring and summer months?

Birds need a nesting place, especially in the spring and summer months.

6. What is needed to attract birds on a year-round basis?

A watering place is needed to attract birds on a year-round basis.

7. Where can you find natural plantings created by birds and why?

Natural plantings created by birds can be found along fence rows. Birds eat seeds of various plants as they feed, and many of these seeds grow after they pass through the bird's digestive system. Seeds deposited in the bird droppings may grow if they fall on suitable ground.

TEACHER'S KEY STUDENT WORKSHEET 2

INVITE BIRDS TO YOUR BACKYARD

(Reference - "Invite Wildlife to Your Backyard", reprint from National Wildlife Magazine, April-May 1973)

1. Name four characteristics of Stage I.
  1. low shrubs
  2. trees scattered
  3. need to supplement food and water
  4. may need to take out undesirable plants and relocate others
2. Name five characteristics of Stage II.
  1. 5-10 year growth
  2. shrubs just reaching mature height
  3. trees have gained considerable height
  4. birds attracted by annual flowering and fruiting
  5. birds can nest naturally in the shrubbery
3. Name two characteristics of Stage III.
  1. most trees have reached mature height
  2. shrubs have reached mature height
4. How many years does it take to reach Stage I, Stage II, and Stage III?
  1. Stage I - First year planting
  2. Stage II - 5-10 years
  3. Stage III - 30-40 years
5. What are the four basic elements birds and other wildlife need?
  1. food
  2. water
  3. shelter
  4. nesting area

6. If your yard is not large enough to plant trees and shrubs, how can you attract birds to your home site?

in addition to landscaping the home to attract birds, you can hang bird feeders and waterers and use window boxes.

7. Name one method of supplying water for birds.

A bird bath or ground watering device would be a simple method of supplying water for birds.

SAMPLE TEST QUESTIONS AND TEACHER'S KEY

ATTRACTING BIRDS TO YOUR BACKYARD

TRUE OR FALSE:

- True 1. Evergreen trees provide excellent cover and nesting sites for birds.
- True 2. Mulberry trees are a favorite of many birds because of its soft fruit.
- False 3. There are more threatened bird species than endangered bird species in Illinois.
- True 4. The bald eagle is an endangered bird species in Illinois.
- False 5. Bird baths come only in one form; a pedestal base with bath three feet off the ground.
- True 6. The best way to attract birds is to naturalize the setting as much as possible.
- True 7. Birdhouses should have roofs with sufficient pitch to avoid water leakage into the food area.
- False 8. There are only 5000 bird species worldwide today.

SHORT ANSWER:

9. 8,600 species of birds exist worldwide today.
10. 350 species of birds are found in Illinois.
11. What should be provided in order to attract birds to your home site?  
To attract birds you should provide the following:
1. a nesting place
  2. a watering source
  3. food, and
  4. a sheltered area.
12. Low shrubs and scattered trees are characteristics of Stage I.
13. A 5-10 year growth is a characteristic of Stage II.
14. In Stage III trees have reached their mature height. This takes place over 30-40 years.
15. A bird bath is used by birds for water and bathing purposes.

## UNIT K: HORTICULTURAL/AGRICULTURAL PRODUCTS

### PROBLEM AREA: SELECTING AND BUYING HORTICULTURAL TOOLS AND EQUIPMENT

#### SUGGESTIONS TO THE TEACHER:

This problem area is designed for use with eleventh-grade or advanced students in a horticultural occupations program. The recommended time for teaching this problem area is during the spring semester.

The estimated instructional time for this problem area is 8 to 10 days, depending on how far the teacher wishes to go in developing selection, identification, and purchasing skills at the third year level. If the teaching plan is limited to classroom discussion with little or no practice or observation, the instructional time can be 8 days or less. If the students are to be involved in additional activity exercises, the instructional time will need to be increased.

Instructors are encouraged to conduct a local search to locate other supplementary materials for use with this problem area. The items in this problem area are for reference or modification as instructors adapt this problem area to their local situation.

#### CREDIT SOURCES:

These materials were developed through a funding agreement R-33-13-D-0362-466 with the Illinois State Board of Education, Department of Adult, Vocational and Technical Education, Research and Development Section, 100 North First Street, Springfield, Illinois 62777. Opinions expressed in these materials do not reflect, nor should they be construed as policy or opinion of the State Board of Education or its staff.

The teacher's guide, information sheets and sample test questions were developed by Marcia Watman-Laughner, Department of Vocational and Technical Education, University of Illinois. Transparency masters were prepared by the Vocational Agriculture Service, University of Illinois. Information included in the transparency discussion guide was developed by John E. Smith, Vocational Agriculture Service. Suggestions and guidance in the development of these materials were provided by the Metropolitan Core Curriculum Field Test Teachers and Paul Hemp, Division of Agricultural Education, University of Illinois.



## TEACHER'S GUIDE

- I. Unit: Horticultural/agricultural products
- II. Problem area: Selecting and buying horticultural tools and equipment
- III. Objectives: At the close of this problem area, students will be able to:
  1. Identify common horticultural hand and power tools and equipment.
  2. Select and purchase proper horticultural tools and equipment to match their intended use.
  3. Use horticultural tools and equipment in a proper and safe manner.
- IV. Suggested interest approaches:
  1. Display various tools and equipment and have students identify them by name and indicate intended use.
  2. Ask students what tools and equipment they have used at home.
  3. Ask students if they have been involved in any accidents when using hand or power tools and equipment. Have students discuss what safety practices could have been used to avoid the accidents.
  4. If students have not had any accidents with hand or power tools and equipment, discuss with them the safety procedures that must be taken to insure safe and proper operation.
  5. Have students get current prices on the tools and pieces of equipment they have at home.
  6. Identify students' current knowledge of tool identification and use with a pre-test. Examples for the pre-test may be taken from the final identification tests included in this problem area.
- V. Anticipated problems and concerns of students:
  - A. Digging, raking and weeding tools and equipment
    1. What is the difference between a front tine and rear tine rotary tiller?
    2. Why do shovels, spades and forks have different handles? Is there any one handle that is best?
    3. Does a higher price always mean the best tool?
    4. Which tools are best for weeding and which tools are best for loosening the soil?
    5. What factors should I look for when selecting quality tools?

6. What is the difference between a D-handle and a reinforced D-handle?
7. What is the purpose of a dibble?
8. Is a mattock the same as a pick? Can both be used for the same purposes?
9. Can I use a bowhead garden rake for raking leaves or grass?
10. Is there any difference between a steel tine and polypropylene rake other than what they are made of?

B. Lawn tools and equipment

1. What is the minimum number of tools one would need to maintain a lawn and garden plot?
2. What factors should I consider when comparing push, electric and gasoline powered lawn mowers?
3. If I mow my lawn regularly, do I still need grass shears?
4. Do the electric edger and trimmer perform basically the same function?
5. Why would I want a self-propelled lawn mower?
6. Can I use the same spreader for fertilizer and grass seed or do I need two separate spreaders?
7. What is the difference between a drop and rotary broadcast spreader?
8. Is a lawn sweeper really necessary or can I accomplish the same thing with a garden rake?
9. When is the best time to buy lawn equipment?

C. Pruning tools and equipment

1. What kinds of cutting blades are best for pruning tools?
2. Are there different pruning tools for different types of wood thicknesses?
3. Which pruner is best for the plant, a bypass blade or anvil blade?
4. Loppers are fairly expensive. Could I use a hand pruner in place of loppers?

5. How do I know whether to purchase a large or small bowsaw?
6. What factors should I consider when comparing a gas engine and electric chainsaw?
7. Do I need a special extension cord for electric powered tools and equipment?
8. Can I use hedge shears in place of an electric hedgetrimmer?
9. Is the pole pruner adjustable for various heights?
10. Will a double-edge pruning saw cut two branches at one time?

D. Watering and pest control tools and equipment

1. How large a watering can do I need if I already have a garden hose?
2. What size and type of garden hose should I purchase?
3. Is a hose reel really necessary to have?
4. What are the different uses for pistol grip, spray and fan nozzles?
5. Does the size of the lawn dictate the type of sprinkler to be used?
6. Does each type sprinkler put out the same amount of water?
7. Can the hose end sprayer be used for all types of chemicals? Is it best to have different sprayers for different types of chemicals?
8. Do I need to buy an expensive sprayer to make sure it will work the best?
9. What safety precautions must I take when using chemical sprayers?

VI. Suggested learning activities and experiences:

1. Have students make a picture collection of horticultural hardware on 3x5 index cards. Pictures can be cut out of catalogs.
2. Using the transparencies on tool and equipment identification included in this problem area, have students identify each horticulture tool. Refer to Information Sheet 2 for other ways to use the transparencies.
3. Have students take the Safety tests in Core 1, pp. M-I-D-3-24, M-I-D-3-25.

4. Have each student or pair of students demonstrate how to select, use, and maintain one horticultural tool. Have the class members keep a collection of these demonstrations in their notebooks.
5. Demonstrate to students the proper use of each tool available and identify the safety procedures to follow when using the tools.
6. Have students review safety rules in Core 1, pp. M-I-D-2-39,41, 43,44,45,46.

VII. Application procedures:

1. The information in this problem area will enable students to properly select and purchase the most suitable and appropriate horticultural tools and equipment.

VII. Evaluation:

1. Administer and grade safety test for general shop and horticultural tools.
2. Collect and grade worksheets.
3. Administer and grade test on completion of this problem area.
4. Have students take the student tests in Core 1, pp. M-I-D-2-62,64, 66,67,68,69. These tests are specific to one tool or piece of equipment and only necessary if covered in class.

IX. References and aids:

1. VAS Safety Test - Vocational Agriculture Service  
1401 S. Maryland Drive  
Urbana, IL 61801
2. How to Select, Use and Maintain Garden Equipment\* - Ortho Books  
Chevron Chemical Co.  
575 Market St.  
San Francisco, CA 94105

\*This publication is usually available at the local garden center.

## INFORMATION SHEET 1

### SUGGESTED LIST OF HORTICULTURAL TOOLS AND EQUIPMENT

This is a broad outline of the common horticultural tools and equipment referred to in this problem area. Select from the list below the tools and equipment you wish your students to identify.

#### Digging, raking and weeding tools and equipment:

- garden trowel
- dibble
- general purpose shovel with D-handle
- general purpose shovel with long handle
- garden spade with a D-handle or a reinforced D-handle
- garden fork
- mattock
- posthole digger
- front-tine rotary tiller
- rear-tine rotary tiller
- bowhead garden rake
- lawn rake (steel tine or polypropylene)
- garden hoe
- onion hoe
- warren hoe
- hand-held three-pronged cultivator
- hand-held knife weeder

#### Lawn tools and equipment:

- push reel mower
- gasoline-powered rotary mower
- self-propelled mower
- electric mower

INFORMATION SHEET 1 - Continued

hand-held grass shears  
rotary edger  
electric edger  
electric trimmer (weed-eater)  
hand-held plastic spreader  
rotary broadcast spreader  
drop spreader  
push-type lawn sweeper  
push broom

Pruning tools and equipment:

bypass blade pruner  
anvil blade pruner  
bypass loppers  
anvil loppers  
curved-blade pruning saw  
folding curved-blade pruning saw  
straight double-edge pruning saw  
bow saw  
pole pruner  
hedge shears  
electric hedge trimmer  
electric chainsaw  
gas-engine chainsaw

Watering and pest control tools and equipment:

watering can  
garden hose

INFORMATION SHEET 1 - Continued

hose reels

spray nozzle-brass

pistol grip nozzle

fan sprayer

oscillating sprinkler

revolving sprinkler

impulse sprinkler

hose-end sprayer

compression 3-gallon sprayer

INFORMATION SHEET 2  
USE OF THE HORTICULTURAL TOOLS AND  
EQUIPMENT IDENTIFICATION SHEETS

Fifty-four horticultural tools are pictured on the following sheets. The sheets are free from supplemental information so they can be modified by the teacher according to the abilities of the students. Suggested ways to use these sheets are listed below.

1. Overhead Transparencies

Use these sheets as masters to produce transparencies. Have students give the correct name of each tool or piece of equipment and discuss how each item is used. Use the transparency discussion guide as a teacher's guide and key.

2. Flash Cards

Cut and paste each individual tool illustrated on a piece of cardboard. Write the tool name and function on the back of the card. Have students test themselves and each other. Students can also make their own collection.

3. Student Worksheets

In the spaces provided, the student can write the name and function of each tool or piece of equipment. The student can obtain the information from classroom references, interviewing various persons with knowledge of these tools, or from class instruction.



# HORTICULTURE TOOL AND EQUIPMENT IDENTIFICATION



1. \_\_\_\_\_

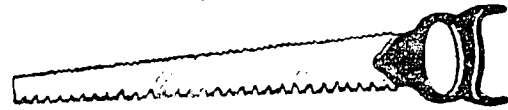

2. \_\_\_\_\_

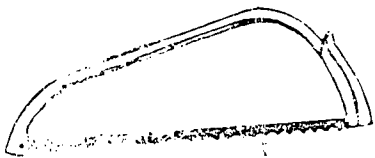

3. \_\_\_\_\_

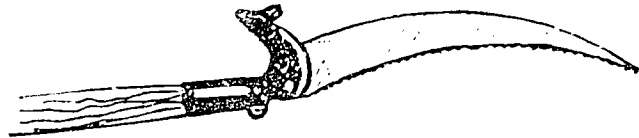

4. \_\_\_\_\_

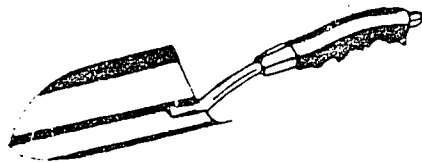

5. \_\_\_\_\_

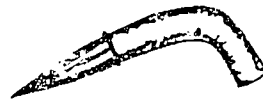

6. \_\_\_\_\_

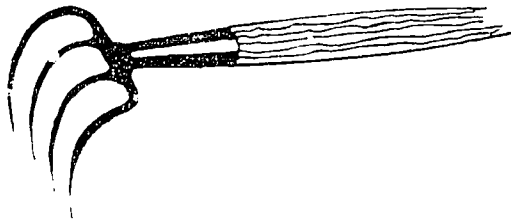

7. \_\_\_\_\_

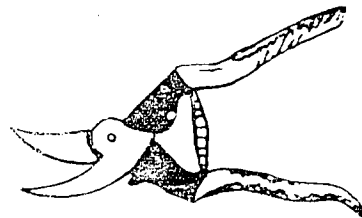

8. \_\_\_\_\_



9. \_\_\_\_\_

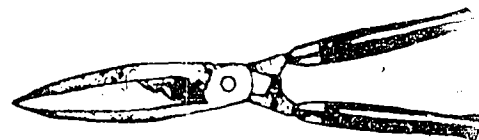

10. \_\_\_\_\_

# HORTICULTURE TOOL AND EQUIPMENT IDENTIFICATION

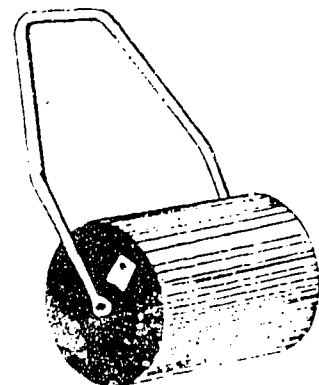
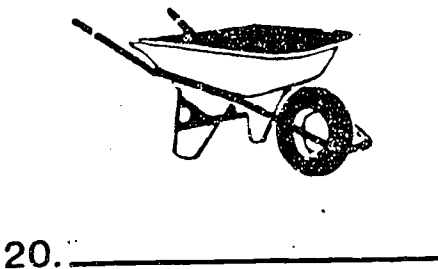
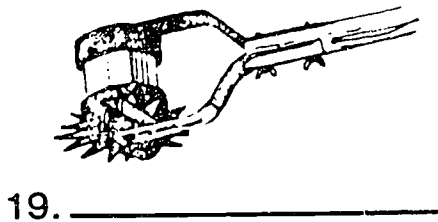
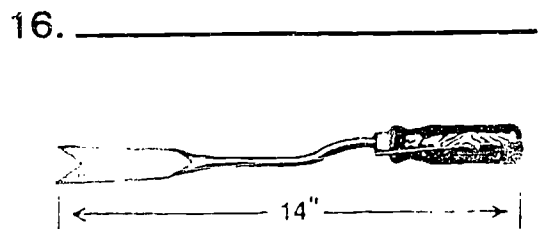
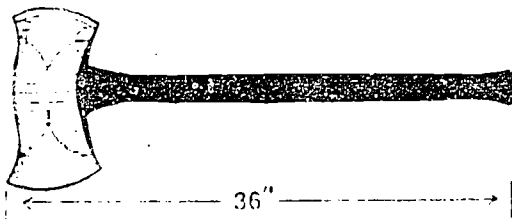
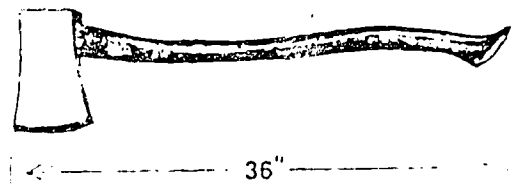
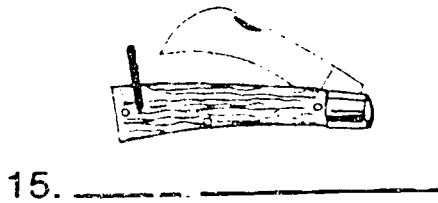
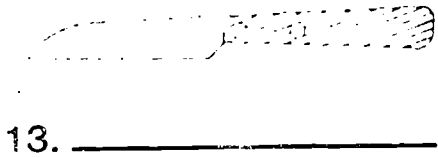
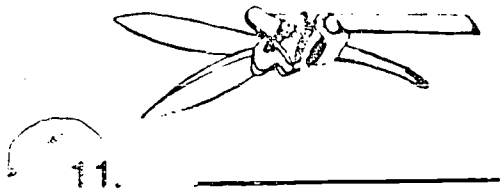

# HORTICULTURE TOOL AND EQUIPMENT IDENTIFICATION



22. \_\_\_\_\_



23. \_\_\_\_\_



24. \_\_\_\_\_

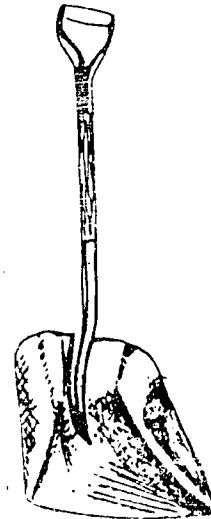

25. \_\_\_\_\_



26. \_\_\_\_\_



27. \_\_\_\_\_

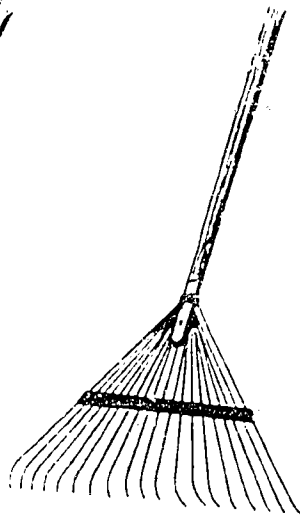

28. \_\_\_\_\_

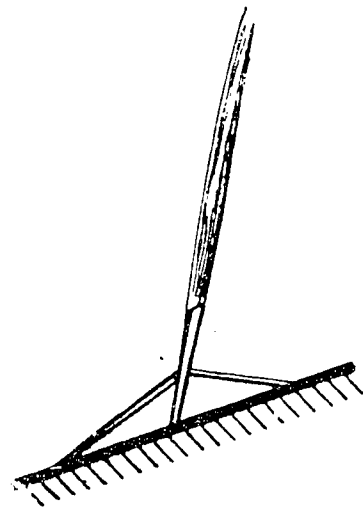

29. \_\_\_\_\_

# HORTICULTURE TOOL AND EQUIPMENT IDENTIFICATION

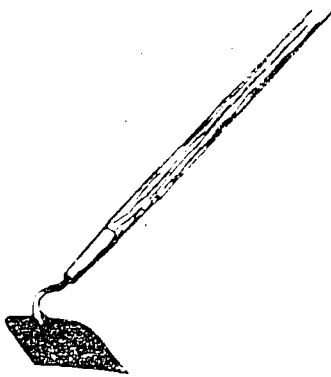

30. \_\_\_\_\_



31. \_\_\_\_\_



32. \_\_\_\_\_

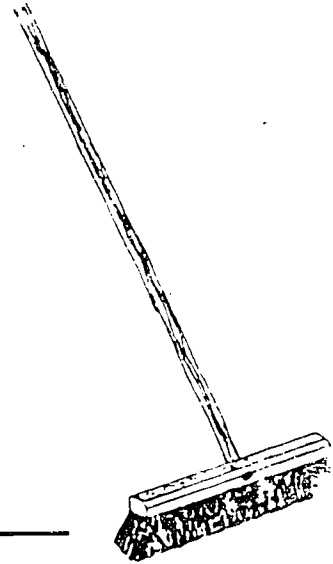

33. \_\_\_\_\_

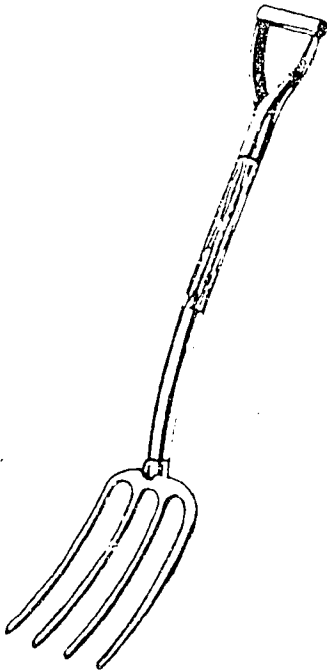

34. \_\_\_\_\_

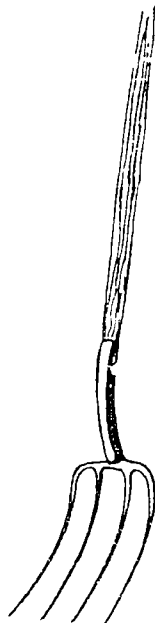

35. \_\_\_\_\_



36. \_\_\_\_\_

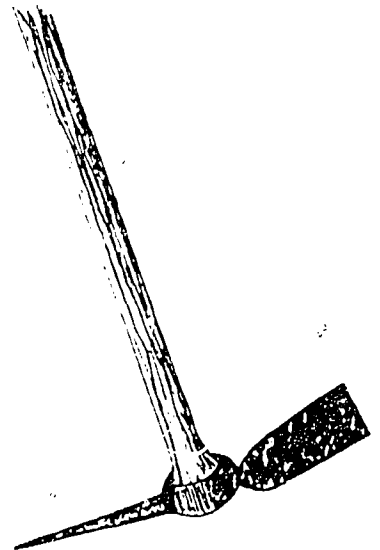

37. \_\_\_\_\_

# HORTICULTURE TOOL AND EQUIPMENT IDENTIFICATION

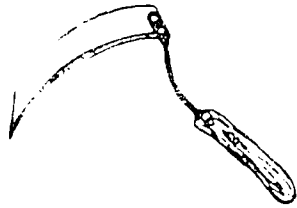

38. \_\_\_\_\_

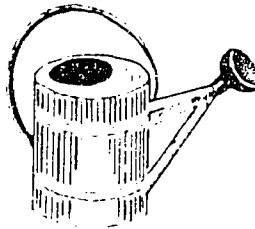

39. \_\_\_\_\_

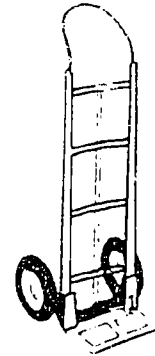

40. \_\_\_\_\_

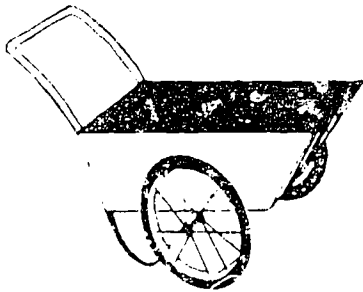

41. \_\_\_\_\_



42. \_\_\_\_\_



43. \_\_\_\_\_

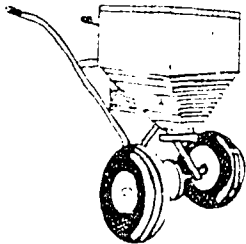

44. \_\_\_\_\_

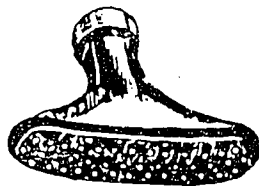

45. \_\_\_\_\_

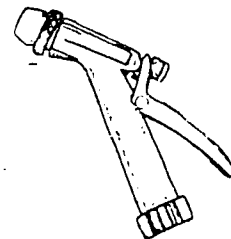

46. \_\_\_\_\_

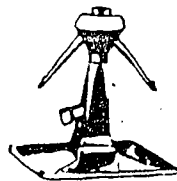

47. \_\_\_\_\_

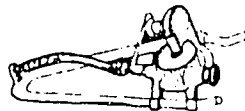

48. \_\_\_\_\_

# HORTICULTURE TOOL AND EQUIPMENT IDENTIFICATION

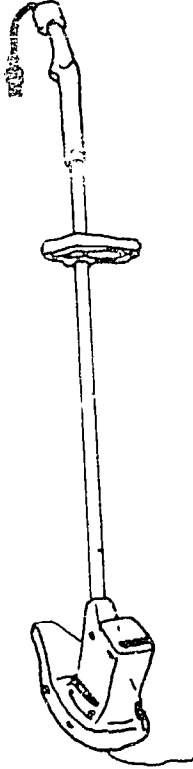

49. \_\_\_\_\_

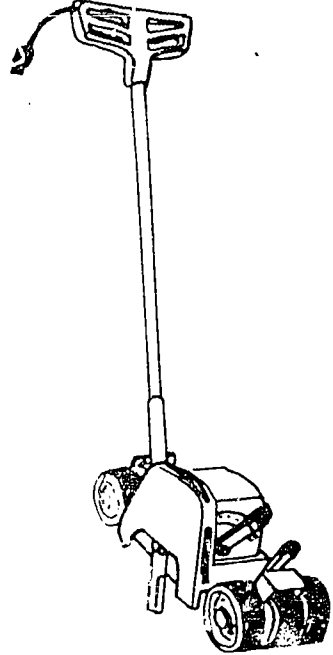

50. \_\_\_\_\_

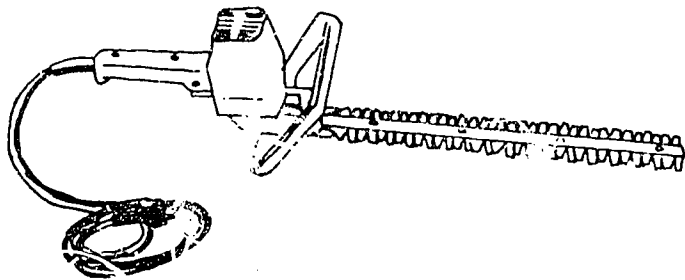

51. \_\_\_\_\_

---

# HORTICULTURE TOOL AND EQUIPMENT IDENTIFICATION

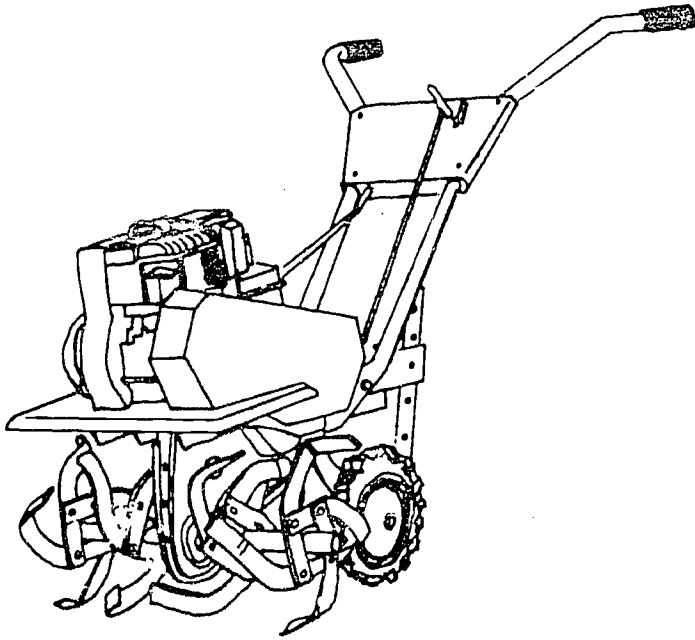

52. \_\_\_\_\_

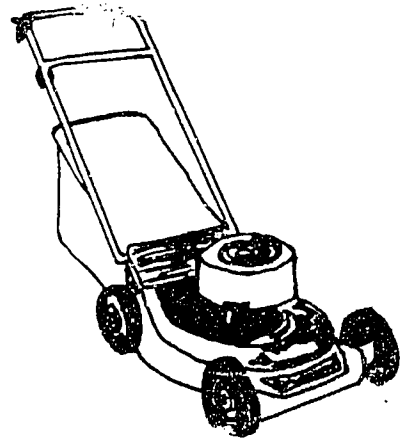

53. \_\_\_\_\_

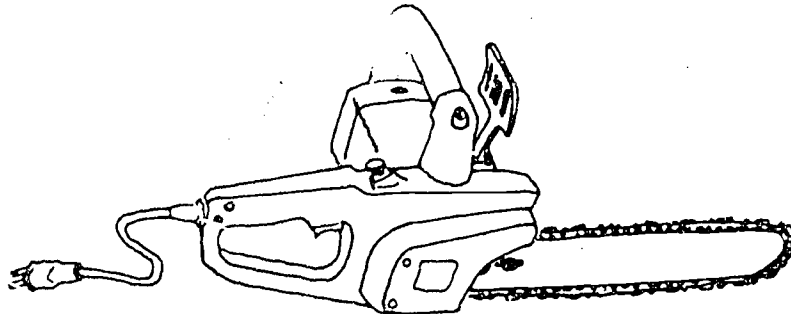

54. \_\_\_\_\_

## TRANSPARENCY DISCUSSION GUIDE

### HORTICULTURAL TOOLS AND EQUIPMENT IDENTIFICATION

This set of transparencies have been developed to use with the problem area "Selecting and Buying Horticultural Tools and Equipment." They may be used to practice identification and to point out the function or use of these tools and equipment.

#### Transparency - Items 1 - 10

1. Curved pruning saws usually cut on the draw stroke. They are very commonly used.
2. Straight pruning saws are used on larger limbs. They usually cut on both draw and push strokes.
3. Bow saws cut fast and blades are replaceable.
4. Pole pruning saws are useful for cutting limbs too far away to prune with a hand saw.
5. Trowels for light garden work are available in many designs.
6. Dibbles are used for transplanting.
7. The four tine cultivator is useful for seeding and cultivating. It usually has a long handle.
8. Pruning shears are available in many designs. Select one with a comfortable grip and heavy-duty construction.
9. Anvil-type pruning shears crush the stem being cut.
10. Hedge shears are often 24 to 36 inches long.

#### Transparency - Items 11 - 21

11. Grass shears are used for trimming grass near foundations and fences, or for light foliage pruning.
12. Lopping shears are recommended for pruning branches up to a diameter of  $1\frac{1}{2}$  inches.
13. Budding knives are available in many designs.
14. Grafting knives of many designs are 3 to 4 inches long. This is a typical design.
15. Pruning knives are recognized by a curved or hooked blade.
16. Single bit axes have a striking face on one side.



17. Double bit axes have two cutting edges and a straight handle.
18. Weeders of this type are for close work.
19. Rotary edgers are used along sidewalks.
20. Wheelbarrows are useful for moving dirt or stone.
21. Turf rollers help keep lawns level.

Transparency - Items 22 - 29

22. Spades of various types tend to be long and narrow.
23. D-handle shovels are easy to grip.
24. Long-handle shovels allow longer reach.
25. Scoop shovels are convenient for moving large amounts of relatively lightweight material.
26. Bow garden rakes are lightweight.
27. Level head garden rakes help level soil surfaces.
28. Spring rakes are handy for raking grass or leaves.
29. Grading rakes are used to spread and level topsoil, especially when seeding lawns.

Transparency - Items 30 - 37

30. The garden hoe shown is a typical, lightweight design.
31. Turf edgers have a curved blade to cut through turf.
32. Walk scrapers have straight blades.
33. Garage brooms are available with several different grades of bristle stiffness.
34. Spading forks have flat or square tines.
35. Manure forks have round tines.
36. Post hole diggers of this type may have two round handles as shown or two half-round handles with the flat sides together.
37. Pick mattocks are used for heavy work with hardened earth, stone, or roots.

Transparency - Items 38 - 48

38. Grass hooks may be more curved than the one shown, and may have long handles.
39. Sprinkler cans prevent flooding the soil surface.
40. Nursery trucks should be sturdy and easy to roll.
41. Lawn carts may be designed to be pulled behind a riding lawn mower or pushed by hand.
42. Hose reels permit easier handling of long hoses.
43. Compression sprayers help in controlling plant insects and diseases.
44. Spreaders are best for seeding and fertilizing.
45. Rose nozzles provide a very fine spray.
46. Lever nozzles are suited for general use.
47. Rotating sprinklers provide a circular pattern.
48. Oscillating sprinklers provide even coverage at low pressure.

Transparency - Items 49 - 51

49. Electric trimmers can handle small to medium trimming of weeds and light brush. The long handle helps avoid stooping.
50. Electric-powered edgers are used to trim grass next to sidewalks and driveways.
51. Electric hedge trimmers can trim branches up to  $\frac{1}{4}$  inch thick and can be used to shape bushes and hedges.

Transparency - Items 52 - 54

52. Front-tine rotary tillers can be used to cultivate, mulch or turn under soil in the garden or other areas. Rear-tine tillers are also available.
53. Rotary mowers have blades which move perpendicular to the wheels and cut the lawn surface. Bags or other receptacles can be attached to catch the cut grass.
54. Mini-electric chain saws can be used to cut small diameter logs and heavy brush or to prune small limbs.

SAMPLE TEST QUESTIONS AND TEACHER'S KEY  
HORTICULTURAL TOOLS AND EQUIPMENT

MULTIPLE CHOICE:

- D 1. When shopping for garden tools, what rules should be followed?
- A. Buy the best you can afford
  - B. Buy the most expensive to insure quality
  - C. Don't buy what you don't need
  - D. A and C
- D 2. Once you know the quality and price range of garden tools and equipment you want, you can find the best choice at
- A. Garage sales
  - B. Flea markets
  - C. A reputable garden center
  - D. All of the above
- B 3. A file is used to
- A. Clean your tools
  - B. Sharpen your tools
  - C. Take off one season's rust
  - D. Clean the mud off your shoes
- D 4. Which factors should be considered when selecting a tool for digging?
- A. How rust-proof the steel is
  - B. How the handle is attached to the tool
  - C. The length of the handle
  - D. All of the above
- B 5. What type handle can be found on a shovel, spade and fork?
- A. An A handle
  - B. A D handle
  - C. An E handle
  - D. An I handle
- C 6. Which of these tools is best for use in a confined area?
- A. A square nose shovel
  - B. A tree planting spade
  - C. A border spade
  - D. An Irish garden spade

- A 7. Which of these forks is not meant for digging?
- A. Hayfork (pitchfork)
  - B. Border fork
  - C. Heavy duty garden fork
  - D. Medium garden fork
- D 8. Which factors should be considered when selecting a garden rake?
- A. The head of the rake should be loose enough to be flexible in hard soil
  - B. Stay away from high carbon steel - cast iron is best
  - C. Always buy the most expensive
  - D. None of the above
- D 9. Which of these materials are used to make a lawn rake?
- A. Bamboo
  - B. Polypropylene
  - C. Steel
  - D. All of the above
- A 10. The best nozzle for watering roses is a
- A. Fan sprayer
  - B. Revolving sprinkler
  - C. Pistol grip
  - D. Sweeper nozzle

TRUE OR FALSE:

- False 1. The warren hoe is best used for weeding between onion rows.
- True 2. The eye hoe is a long lasting hoe.
- True 3. The hand cultivator has 3 tines and the long-handled cultivator has 4-5 tines.
- True 4. The asparagus knife weeder and the forked-shaft weeder are used for the same purpose.
- False 5. It is best to keep the load in a wheelbarrow nearest to you to avoid an accident.
- False 6. When selecting a mower, price should be the primary concern.
- True 7. A lawn mower should be easy to adjust.
- True 8. Most professional lawn cutters use the power reel mower.
- False 9. A push reel-mower will cut just about anything including wet grass and weeds several feet high.

- True 10. A mower-mulcher saves you the trouble of raking or bagging the grass clippings.
- True 11. A rotary edger is an optional lawn tool.
- True 12. When using a nylon string trimmer, one should wear sturdy shoes or boots as a safety precaution.
- False 13. A broadcast spreader is preferred for applying granular pesticides to the lawn.
- True 14. Hand pruners should cut wood up to a 3/4 inch thickness.
- False 15. Anvil hand pruners allow you to cut closer to the tree trunk.

MATCHING:

- |          |                          |    |                                                             |
|----------|--------------------------|----|-------------------------------------------------------------|
| <u>F</u> | 1. Bypass loppers        | A. | used to remove soil for fence posts                         |
| <u>L</u> | 2. Bypass blade pruner   | B. | eliminates the need for a ladder when pruning tall trees    |
| <u>H</u> | 3. Pistol grip nozzle    | C. | speciality tool to clear lawn of matted grass               |
| <u>K</u> | 4. Hose-end sprayer      | D. | medium duty garden tilling hard to use in rocky soils       |
| <u>G</u> | 5. Watering can          | E. | light-duty cutting, also need a power outlet                |
| <u>J</u> | 6. Rear-tine rototiller  | F. | cuts wood 3/4" or greater and cuts closer to the tree trunk |
| <u>B</u> | 7. Pole pruner           | G. | used to water plants and apply liquid fertilizers           |
| <u>M</u> | 8. Hose reel             | H. | easy to handle and is easy to change the spray type.        |
| <u>D</u> | 9. Front-tine rototiller | I. | works by a spring mechanism, water broken into particles    |
| <u>E</u> | 10. Electric chainsaw    | J. | good for breaking ground that is compacted                  |
| <u>C</u> | 11. Thatching rake       | K. | glass or plastic and fits on hose to spray concentrate      |
| <u>I</u> | 12. Impulse sprinkler    | L. | cuts wood 3/4" or smaller and cuts closer to the tree trunk |
| <u>A</u> | 13. Posthole digger      | M. | keeps hoses kink-free                                       |

SHORT ANSWER:

1. List 3 types of nozzles for watering.
  1. pistol grip
  2. adjustable brass
  3. fan sprayer
2. List 3 types of sprinklers.
  1. oscillating
  2. revolving
  3. impulse
3. List the function of a bow saw, pole saw and straight double-edged saw.
  1. bow saw - for pruning large limbs in an uncrowded condition
  2. pole saw - for pruning inaccessible branches
  3. straight double-edged saw - for medium and heavy pruning
4. List 3 types of hoes and their functions.
  1. onion hoe - for weeding between onion rows
  2. general garden hoe - for general purpose weeding
  3. scuffle hoe - for weeding and tilling
5. List the function of each tool.
  1. dibble - makes holes in the ground for transplanting seedlings
  2. garden trowel - makes holes for transplanting
  3. three-pronged cultivator - to loosen soil and to incorporate materials into the soil

IDENTIFICATION TEST OF HORTICULTURAL TOOLS AND EQUIPMENT:

Teachers' note: Horticultural tools and equipment used for this exam should be arranged in a neat and orderly manner. Each item should be tagged with a number.

Instructions: Have each student list the name and major use of the items to be identified.

Horticultural tools and equipment to be identified:

Refer to Information Sheet 1 - Suggested List of Horticultural Tools and Equipment for a list of possible tools and equipment to identify. If the actual item is not available the teacher may use pictures. The transparencies included in this problem area can be used for this purpose.

## UNIT L: GROWING HORTICULTURAL CROPS

### PROBLEM AREA: PRUNING EVERGREENS

#### SUGGESTIONS TO THE TEACHER:

This problem area is designed for use with eleventh grade or advanced students in a horticultural occupations program. The recommended time for teaching this problem area is during the late winter or early spring months.

The estimated instructional time for this problem area is 8 to 10 days, depending on how far the teacher wishes to go in developing evergreen pruning skills at the third year level. If the teaching plan is limited to classroom discussion with little or no practical experiences or observations, the instructional time can be less than five days. If the students are to be involved in other activity exercises, the instructional time will need to be increased.

The instructor is encouraged to conduct a local search to locate other supplementary materials for use with this problem area. The items in this problem area are for reference or modification as instructors adapt this problem area to their local situation.

#### CREDIT SOURCES:

These materials were developed through a funding agreement R-33-13-D-0362-446 with the Illinois State Board of Education, Department of Adult, Vocational and Technical Education, Research and Development Section, 100 North First Street, Springfield, Illinois 62777. Opinions expressed in these materials do not reflect nor should they be construed as policy or opinion of the State Board of Education or its staff.

The information sheet, student worksheet, and laboratory exercises were developed by Marianne Riegger, Department of Vocational and Technical Education, University of Illinois. The teacher's guide and sample test questions were developed by James Ethridge, Joliet Junior College. Transparency masters and the transparency discussion guide were prepared by the Vocational Agriculture Service, University of Illinois. Suggestions and guidance in the development of these materials were provided by the Metropolitan Core Curriculum Field Test Teachers.

## TEACHER'S GUIDE

- I. Unit: Growing horticultural crops
- II. Problem area: Pruning evergreens
- III. Objectives: At the close of this problem area students will be able to:
  1. Identify the reasons for pruning
  2. Use pruning terminology
  3. Prune narrow leaf and broadleaf evergreen trees, shrubs and ground covers properly
  4. identify the proper technique for pruning hedges.
- IV. Suggested interest approaches:
  1. Tour the local area around the high school and observe proper and improper pruning of evergreens.
  2. Have students demonstrate practical applications of pruning other plants by using Metropolitan Core Curriculum I - Unit G.
  3. Take a trip to a local nursery to observe the pruning of evergreens.
  4. Ask the students if they have pruned evergreens, what types of pruning techniques and tools they used when pruning. Have the students discuss problems they encountered while pruning evergreens.
- V. Anticipated problems and concerns:
  1. What are the reasons for pruning?
  2. When should I prune evergreens?
  3. Are different evergreens pruned in different ways?
  4. How should you prune taxus?
  5. How should you prune arborvitae?
  6. How should you prune junipers?
  7. How should you prune pines and spruce?
  8. How should you prune broadleaf evergreens?
  9. How should you prune ground covers?



10. How should you prune hedges?
11. Are tree forms pruned differently than shrub forms?
12. Are pruning practices different in the nursery than in the landscape?

VI. Suggested learning activities and experiences:

1. Show VAS Slidefilm 643 - Pruning Evergreens or other appropriate slide materials.
2. Have a local nursery person describe how he or she prunes evergreen plants for development and future sales.
3. Identify a plant for students and have them react as to how it should be pruned, keeping in mind its characteristics, shape, form and intended use.
4. Have students complete Student Worksheet 1 - Pruning Evergreens using Cooperative Extension Circular 1033 - Pruning Evergreens and Deciduous Shrubs as a reference.
5. Demonstrate the proper techniques of pruning evergreens. Have students prune actual plant material. Utilize the laboratory exercises included in this problem area for this purpose.
6. Spend a day at a local nursery practicing pruning techniques on evergreen plant materials. Discuss the difference between pruning practices done in the nursery and in the home landscape.
7. Prune an evergreen hedge.

VII. Application procedures:

1. The main purpose of this problem area is to develop skills in the pruning of evergreen landscape plant materials. Skill level for entrance into the job market should be emphasized. On-the-job training should be encouraged.
2. Additional performance should be emphasized in a supervised occupational experience program and work on the home landscape.

VIII. Evaluation:

1. Prepare and administer an exam using the sample test questions included in this problem area.
2. Evaluate the student worksheet.
3. Evaluate students on actual performance when pruning evergreens.

IX. References and aids:

1. VAS Slidefilm 643 - Pruning Evergreens, available from Vocational Agriculture Service, 1401 South Maryland Drive, Urbana, Illinois 61801.
2. All About Pruning, Ortho Book, Chevron Chemical Company, Ortho Division, 57 Market Street, San Francisco, CA 94105, available at most local garden centers.
3. Cooperative Extension Service, College of Agriculture, University of Illinois, 61801
  1. Circular 1033 - Pruning Evergreens and Deciduous Trees and Shrubs
  2. Horticultural Facts LH 480 - Planting and Caring for Hedges

## INFORMATION SHEET 1

### PRUNING EVERGREENS

#### WHY PRUNE?

Before pruning, know what you want to accomplish. Prune evergreens to control their size or shape, to remove dead, diseased, or damaged wood and to remove old branches to allow for new growth. Proper pruning practices will enhance the natural beauty of evergreens as well as improve their health.

#### PRUNING PRINCIPLES:

- \* Pruning can dwarf a plant or make it grow taller.
- \* "Heading back" a plant produces denser, stronger vegetative growth while reducing its size. Heading back refers to removing the terminal part of a branch or stem to a bud. This pruning method usually stimulates the growth of shoots below the cut, thus creating a denser, more formal looking plant.
- \* "Thinning out" produces a taller, more open, and natural looking plant. Thinning out involves cutting off a branch at its point of origin to the parent stem or to a lateral side branch or to a "Y" of a branch junction.
- \* Older evergreens develop "dead zones" in the center where heavy shade has caused the plants to lose their foliage. New growth will not develop from these areas unless there are surviving green twigs or foliage. Therefore, pruning into the dead zone should be avoided.
- \* Two branches growing close together are in competition with each other. Removal of one will allow the other to grow and mature.
- \* When making pruning cuts choose to cut 1/8 to 3/8 of an inch above the bud or lateral branch and slightly slanted away from the bud. Avoid leaving stubs by making all cuts flush with the parent stem when removing branches.
- \* As a general rule, evergreens should be pruned in the late winter or early spring before new growth starts, with the exception of pines, spruce, rhododendrons and azaleas. Pines and spruce are pruned in mid-June and early July, respectively. Heading back may be necessary in late July or early August to shape plant growth produced during the summer season. Rhododendrons and azaleas should be pruned after flowering.
- \* In the nursery it is common practice to shear evergreens to produce tightly shaped compact plants. This practice is not recommended in landscape maintenance as plants pruned only by this method will actually gain in height, spread each year, and may outgrow their spaces.

# STUDENT WORKSHEET 1

## PRUNING EVERGREENS

REFERENCE - Cooperative Extension Circular 1033 - Pruning Evergreens and Deciduous Trees and Shrubs

PLANT	PRUNING TIME	PRUNING METHOD	SPECIAL CONSIDERATIONS
Upright Arborvitae			
Oval Arborvitae			
Upright Juniper			
Spreading Junipers			
Upright Yew			
Spreading Yew			
Pines			
Spruce			
Rhododendron			
Ground Covers			

M-111-L-1-9

LABORATORY EXERCISE 1  
PRUNING ARBORVITAE, JUNIPERS AND YEWS

PURPOSE:

To practice pruning techniques specific to arborvitae, junipers, and yews.

MATERIALS NEEDED:

1. Hand pruners
2. Chlorine bleach
3. Large branches of arborvitae, junipers, and yews
4. Upright and spreading forms of arborvitae, junipers and yews when available

PROCEDURES:

1. Sterilize the pruner cutting blade with chlorine bleach
2. Practice cutting to lateral buds or branches on the large branches of arborvitae, junipers, and yews. Make sure cuts are 1/8 -3/8 inch above the bud or branch, and slightly slanted away from the bud or branch. Note the direction the new growth will take in choosing your cuts. Avoid cutting into the dead zone.
3. Selectively prune upright and spreading forms of arborvitae, juniper, and yews using the above technique.

OBSERVATIONS:

LABORATORY EXERCISE 2  
PRUNING PINES AND SPRUCES

PURPOSE:

To practice pruning techniques specific to pines and spruce. NOTE: This exercise should only be done in mid-June for pines and early July for spruce.

MATERIALS:

1. Hand pruners
2. Chlorine bleach
3. Large branches of pines and spruce
4. Pine and spruce plant material when available

PROCEDURES:

1. Sterilize the pruner cutting blade with chlorine bleach.
2. Practice cutting candle growth by cutting the leader candle leaving an 8 to 10 inch stub. Prune the lateral candles of the cluster 2 to 4 inches shorter than the leader.
3. Cut side branches in the same manner, but cut back the main candles 1/3 to 1/2 instead of 8 to 10 inches.
4. Prune pine and spruce plant material using the above technique.

OBSERVATIONS:

106

LABORATORY EXERCISE 3  
PRUNING RHODODENDRONS

PURPOSE:

To practice pruning techniques specific to rhododendrons. NOTE:  
Pruning should be done after flowering.

MATERIALS NEEDED:

1. Hand pruners
2. Chlorine bleach
3. Rhododendron plant material

PROCEDURES:

A. Method 1 - (Maintenance)

1. Clip or pinch flower heads off after blooming. Avoid damaging new leaf buds.
2. Pinch 1 inch of sticky new growth when approximately 4" long to produce more flower trusses for next year and create bushier plants.

B. Method 2 - (Renewal)

1. Remove dead wood cutting back to the main stem or a green bud.
2. Cut back to one or two whorles to renew a leggy plant. NOTE: Severe pruning should be done in the spring where winters are severe. This will hinder the flowering potential of the plants, but may be necessary to improve their health and appearance.

OBSERVATIONS:

---

# PRUNING TOOLS

Pruning Knife



Hand Pruners

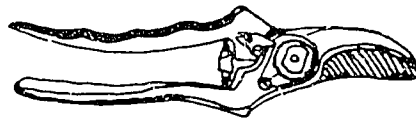

Electric Hedge Shears

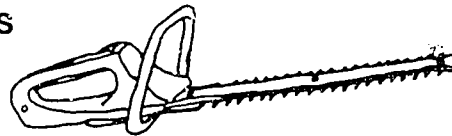

Hedge Shears

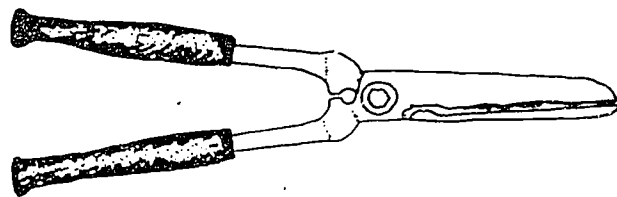

Lopping Shears

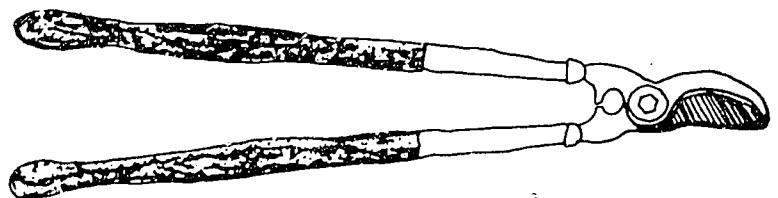



# PRUNING PINES

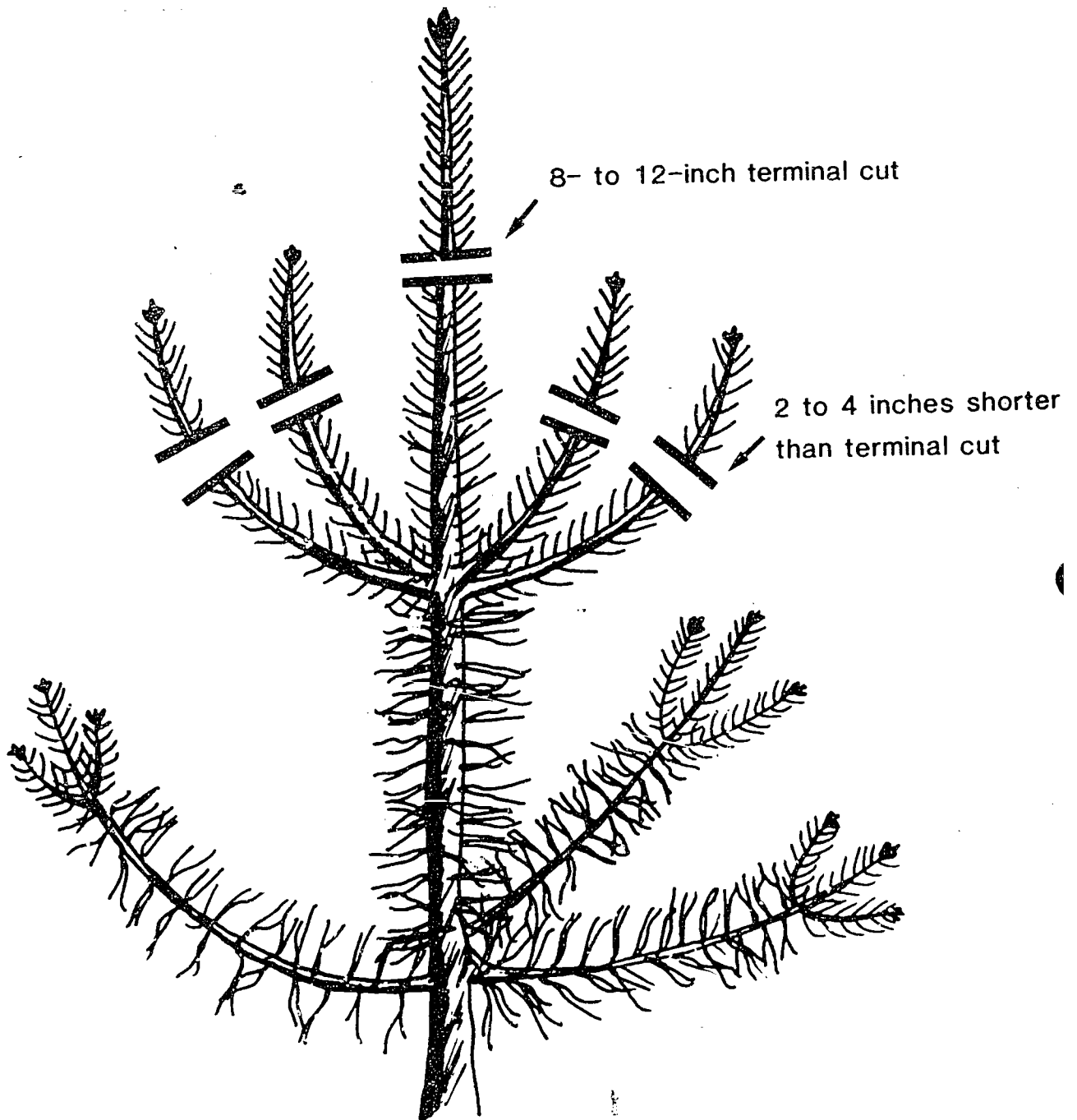

Prune pines to maintain a thick, compact appearance and pleasing shape.

# PRUNING SPRUCE

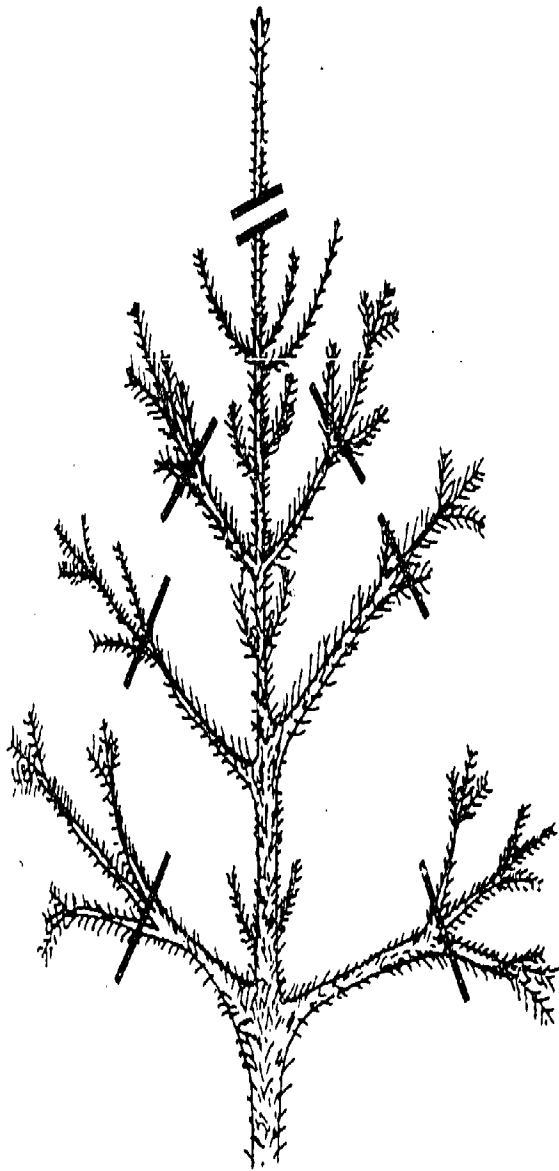

Lines indicate where annual pruning cuts should be made.



This is the same plant after annual pruning. The line indicates where a cut could be made to reduce the plant's size.

# PRUNING RHODODENDRONS

1. Remove faded flower trusses

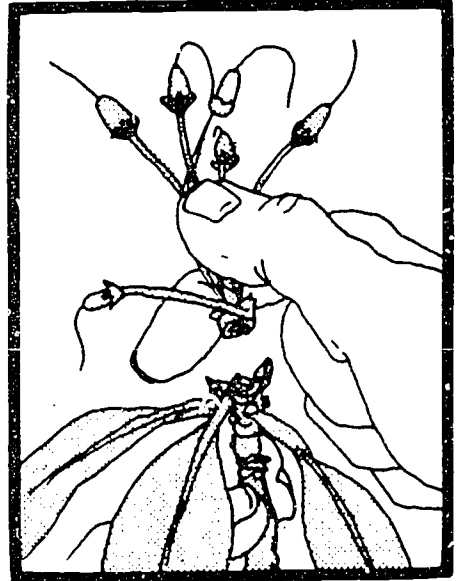

2. Pinch back sticky new growth



3. New shoots will sprout 113



M-III-L-1-18

---

# PRUNING FORMAL HEDGES

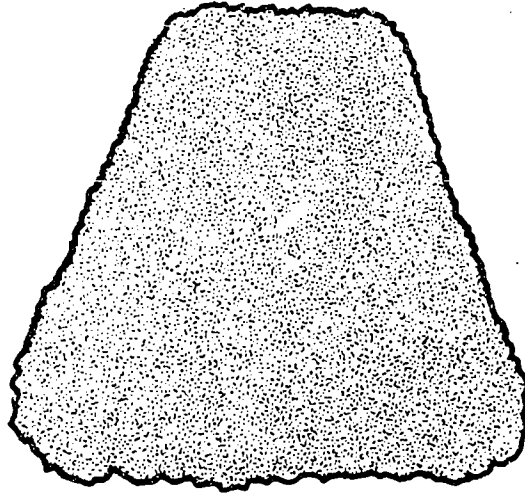

CORRECTLY SHAPED HEDGE

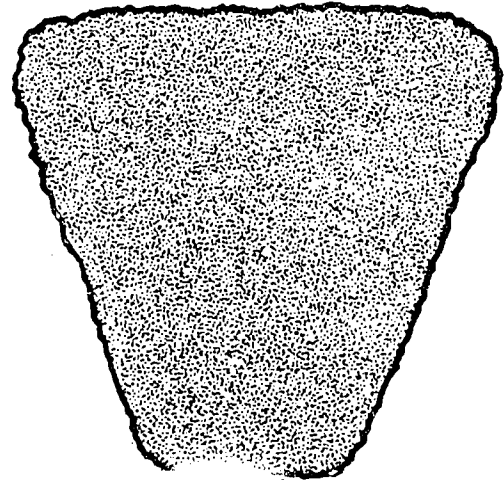
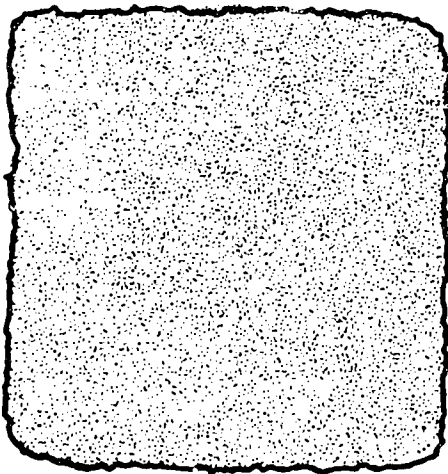

INCORRECT SHAPES

## TRANSPARENCY DISCUSSION GUIDE

### PRUNING EVERGREENS

#### I. Transparency -- PRUNING TOOLS

- A. Hand Pruners - Use on stems up to 3/4 inches in diameter. They come in two main types:
1. Scissors-style pruners have sharpened blades that overlap in making the cut
  2. Anvil-style pruners have a sharpened top blade that snaps onto a flat plate of softer metal. Though lighter and easier to handle than the scissor type, this pruner always crushes the bark on the anvil side and cannot cut as close as the scissor type.
- B. Pruning Knife - Use to smooth the rough edges on the trunk or large branch after making a large cut. Smoothing the edges helps the tree heal more quickly.
- C. Lopping Shears - Use on branches up to 1 1/4 inches in diameter. Heavy duty loppers are available for cutting through wood 1 3/4 inches thick.
- D. Hedge Shears - Use on all hedges except those with protruding stems over 1/2 inch in diameter. To prevent the foliage from slipping away, buy the kind that has one blade notched.
- E. Electric Hedge Shears - Use on all hedges except those with stems.

#### II. Transparency -- PRUNING PINES

- A. Prune central leader back to an 8-10" stub.
- B. Prune side candles 2-4 inches shorter than the central candle.
- C. Avoid cutting into two-year wood because shock can be severe. Pruning in June allows buds to develop in the surviving needle bundles and will develop new shoots the following spring.

### III. Transparency -- PRUNING SPRUCE

- A. The leader should be cut leaving at least 3 buds.
- B. Lateral shoots should be 1-2 inches shorter than the leader.
- C. Prune lateral branches in the same manner or cut out terminal shoots.
- D. Prune in early July.

### IV. Transparency -- PRUNING RHODODENDRONS

- A. Remove faded flower trusses from rhododendrons by bending over and pulling gently. Be careful not to damage new leaf buds.
- B. Pinch off about 1 inch of the sticky new growth when that new growth is about 4 inches long.
- C. Two or three new shoots will sprout on each shoot you pinch. The second shoot shown in the transparency is now ready for pinching.

### V. Transparency -- PRUNING FORMAL HEDGES

- A. Prune evergreen hedges in June when the new spring growth has hardened or matured.
- B. An inverted "V" is the recommended shape for a formal hedge. For example, a hedge 5 feet high should be 2  $\frac{1}{2}$  feet at the base and about 1 foot at the top to be in good proportion. This allows sunlight to reach the lower branches.

## SAMPLE TEST QUESTIONS AND TEACHER'S KEY

### PRUNING EVERGREENS

#### SHORT ANSWER:

1. List the reasons for pruning.

Pruning is done to control the size and shape of an evergreen, or to remove dead, diseased, damaged, or old wood.

2. Define thinning out.

Thinning out is the removal of a branch to its point of origin or a lateral side branch or a "Y" of a branch junction.

3. Define heading back.

Heading back is the removal of the terminal part of a branch or stem to a bud.

4. Define the dead zone.

The dead zone is the center of a plant where shade has caused the foliage to die.

5. How do pruning practices done in the nursery differ from those done in the landscape?

Evergreens are sheared in the nursery, but selective pruning is done in the landscape.

6. What pruning techniques are commonly used on arborvitae, junipers and yews?

Thinning out and heading back are pruning practices done on arborvitae, junipers and yews.

7. Describe the two pruning methods used on rhododendrons.

Maintenance is done by removal of flower heads and 1 inch of new growth.

Renewal is done by cutting back to one or two whorles.

8. How are ground covers pruned?

Ground covers are pruned by cutting back or shearing in early spring. Long, straggling, diseased or damaged stems should be removed to encourage new growth and ensure the health of the plant.

9. How should hedges be pruned?

Hedges should be pruned in an inverted "V" shape in June when the new spring growth has hardened or matured.

M-III-L-1-23

## UNIT L: LANDSCAPE DESIGN, ESTABLISHMENT AND MAINTENANCE

### PROBLEM AREA: SURVEYING, GRADING AND TILING

#### SUGGESTIONS TO THE TEACHER:

This problem area is designed for use with eleventh grade or advanced students in a horticultural occupations program. The recommended time for teaching this problem area is during the Fall or Spring of the year.

The estimated instructional time for this problem area is 8-10 days, depending on how far the teacher wishes to develop surveying, grading and tiling skills at the third year level. If the teaching plan is limited to classroom discussion with little or no practice or observation, the instructional time can be decreased. If the students are to be involved in other activity exercises, the instructional time will need to be increased.

The instructor is encouraged to conduct a local search to locate other supplementary materials for use with this problem area. The items in this problem area are for reference or modification as instructors adapt this problem area to their local situation.

#### CREDIT SOURCES:

These materials were developed through a funding agreement, R-33-13-D-0362-466, with the Illinois State Board of Education, Department of Adult, Vocational and Technical Education, Research and Development Section, 100 North First Street, Springfield, Illinois 62777. Opinions expressed in these materials do not reflect, nor should they be construed as policy or opinion of the State Board of Education or its staff.

The teacher's guide, information sheet, laboratory exercises, student worksheets and sample test questions were developed by Ron Biondo, High School District 214 and Jerry Pepple, Department of Vocational and Technical Education, University of Illinois. Transparency masters and the transparency discussion guide were prepared by the Vocational Agriculture Service, University of Illinois. Suggestions and guidance in the development of these materials were provided by the Metropolitan Core Curriculum Field Test Teachers.



## TEACHER'S GUIDE

- I. Unit: Landscape design, establishment and maintenance
- II. Problem area: Surveying, grading and tiling
- III. Objectives: At the close of this problem area, students will be able to:
  1. Identify the materials and equipment used in surveying, grading and tiling.
  2. Understand the terminology used in surveying, grading and tiling.
  3. Identify the steps necessary in order to establish final grade.
  4. Demonstrate how to correctly install drainage tile.
  5. Perform surveying skills for grading and tiling purposes.
- IV. Suggested interest approaches:
  1. Bring sections of clay and corrugated plastic drain tile to class and ask the class a series of questions:
    - a. What are the uses of these items?
    - b. What are the advantages of each?
  2. Ask the students if any of them live on lots which flood after rain. Then, ask how the flooding or standing water could be prevented.
  3. Ask the students if any of them are interested in landscaping. Then, ask them what are the first tasks of a landscape project.
  4. Show the class actual tractor implements (box scraper, rake, etc.) or pictures of them and ask the students how they could be used for grading and tiling.
- V. Anticipated problems and concerns of students:
  1. What is drainage tile?
  2. What are the different kinds of drainage tile?
  3. Can drain tile be connected to downspouts?
  4. Should drain tile be set at a slope?
  5. How deep should drain tile be placed?

6. What are the different attachments used with tractors for grading purposes?
7. What is the rough grade?
8. What is meant by the finished grade?
9. Should the grade slope away from the house?
10. What is a swale?
11. What is a berm?
12. How can a higher grade be established around a tree?
13. How is grading related to surveying?
14. What equipment is used for determining the slope?
15. How do I use a hand level?
16. How will surveying help me when grading or tiling?
17. How do I use a hand level?
18. How do I read a target rod?
19. What is differential leveling?
20. What is profile leveling?
21. How do I use surveying equipment to place drainage tile?

VI. Suggested learning activities and experiences:

1. Have the students read pages 26-35 in Cooperative Extension Circular 1111 - Landscaping Your Home.
2. Take a field trip to homes being constructed. Observe rough grades and finished grades.
3. The building trades departments of some high schools build homes as a class project. Gain permission from the administration to landscape the home. Determine the need for grading and tiling, and the best way to provide adequate drainage.
4. Have the students measure the slope of the land surrounding the school.
5. Distribute and discuss Information Sheet 1 - Recommended Slopes for Residential Landscapes.
6. Visit an implement dealer, and discuss the tractor implements commonly used to establish a grade.

7. Give the students the opportunity to operate a tractor with various implements attached.
8. Have the students practice changing tractor implements.
9. Discuss how to save a tree from either a cut or fill operation. This is illustrated in Cooperative Extension Service Circular 1061 - Tree Damage Around Construction Sites.
10. Have students read pages 14-16 in Part 5 of VAS Subject Matter Unit 3010a - Agricultural Surveying. Show VAS Slidefilm 437a - Field Notes for Surveying, frames 1-29. If necessary, conduct a supervised study to assist students in properly completing the exercises. Refer to Laboratory Exercise 1 - Setting Up and Adjusting the Level.
11. Have students complete Student Worksheet 1 - Differential Leveling.
12. Distribute the necessary surveying equipment to students and have them complete Laboratory Exercise 2 - Differential Leveling for field experience.
13. Distribute Student Worksheet 2 - Profile Leveling. Have students read pages 16-18 in Part 5 of VAS Subject Matter Unit 3010a - Agricultural Surveying. Show and discuss VAS Slidefilm 437a - Field Notes for Surveying, frames 30-40. Conduct a supervised study or use small groups to assist students in completing and understanding the techniques of profile surveying.
14. Distribute the necessary surveying equipment to assigned student groups and distribute Laboratory Exercise 3 - Profile Leveling. Have students complete the exercise to obtain "hands-on" experience in doing profile surveys.
15. Assign Part 4 in VAS Subject Matter Unit 3010a - Using the Hand Sighting Level, and show and discuss frames 7-15 of VAS Slidefilm 438a - The Level in Farm Surveying. Distribute Student Worksheet 3 - Using the Hand Level, and have students complete the assignment for evaluation and discussion.
16. Distribute Laboratory Exercise 4 - Using the Hand Level, and have students perform the assigned exercise to obtain practical field experience in using a hand level.
17. Visit with the school's groundskeeper and ask about drainage on school property.

VII. Application procedures:

1. The main purpose of this problem area is to learn to establish proper grades and install drainage tile.

2. The students should use their knowledge and understanding learned in field exercises in their place of employment.

#### VIII. Evaluation:

1. Prepare and administer a pencil and paper test covering identification and proper use of surveying equipment using sample test questions included in this problem area.
2. Collect and grade student worksheets.
3. Grade laboratory exercises.

#### IX. References and aids:

1. Vocational Agriculture Service, 1401 South Maryland Drive, University of Illinois, Urbana, Illinois 61801.
  - A. VAS Subject Matter Unit 3010a - Agricultural Surveying
  - B. VAS Slidefilms: 437a - Field Notes for Surveying  
438a - The Level in Farm Surveying
  - C. Survey Kit available on a loan basis.
2. Cooperative Extension Service, College of Agriculture, University of Illinois, Urbana, Illinois 61801
  - A. Circular 1111 - Landscaping Your Home
  - B. Circular 1061 - Tree Damage Around Construction Sites
3. Selected student worksheets
4. Selected laboratory exercises
5. Selected transparencies

INFORMATION SHEET 1

RECOMMENDED SLOPES FOR RESIDENTIAL LANDSCAPES

	<u>PERCENT SLOPE</u>		<u>RATIO</u> <u>HORIZONTAL:VERTICAL</u>		<u>DESIRABLE SLOPE</u>	
	Minimum	Maximum	Minimum	Maximum	Minimum	Maximum
	Patios/Decks	.5	2	200:1	50:1	1
Entrance Walks	1	4	100:1	25:1	1	4
Driveways	.5	15	200:1	67:1	1	12
Drainage Swales	1	10	100:1	10:1	2	10
Ramps	---	20	-----	5:1	10	15
Grass Banks	---	33.3	-----	3:1	16.6	33.3
Planted Banks	---	50	-----	2:1	20	50
Steps	---	66.5	-----	15:1	33.3	50

STUDENT WORKSHEET 1  
DIFFERENTIAL LEVELING

1. What is differential leveling?
2. Explain the process of differential leveling.
3. What is allowable error?
4. How is allowable error calculated?
5. Record the following data in standard form as it would appear in a field notebook. These statements represent brief descriptions of the activities performed by the surveying party.
  - a. Prepare to do differential leveling on the Holly Horticulture Nursery located in the E 1/2 of the NW 1/4, Section 24, T6N, R3E, 3rd Prin. Meridian.
  - b. Set up instrument and leveled it.
  - c. Took sight on bench mark #1. . . .5.24'
  - d. Took sight on turning point #1. . . .6.35'
  - e. Moved instrument and leveled it.
  - f. Took sight on T.P. 1. . . .4.83'
  - g. Took sight on T.P. 2. . . .5.03'
  - h. Moved instrument
  - i. Took sight on T.P. 2. . . .1.31'
  - j. Took sight on T.P. 3. . . .3.52'
  - k. Moved instrument
  - l. Took sight on T.P. 3. . . .5.07'
  - m. Took sight on T.P. 4. . . .4.73'
  - n. Moved instrument
  - o. Sighted on T.P. 4. . . .4.61'
  - p. Sighted on point A. . . .3.57'

- q. Sighted on T.P. 5. . . 2.32'
- r. Moved instrument
- s. Sighted on T.P. 5. . . 3.11'
- t. Sighted on T.P. 6. . . 2.46'
- u. Moved Instrument
- v. Sighted on T.P. 6. . . 5.91'
- w. Sighted on B.M. 1. . . 6.65'

The following is a sketch of the location of the bench marks and turning points. This information is to be appropriately recorded and also used to determine if the error is a reasonable amount.

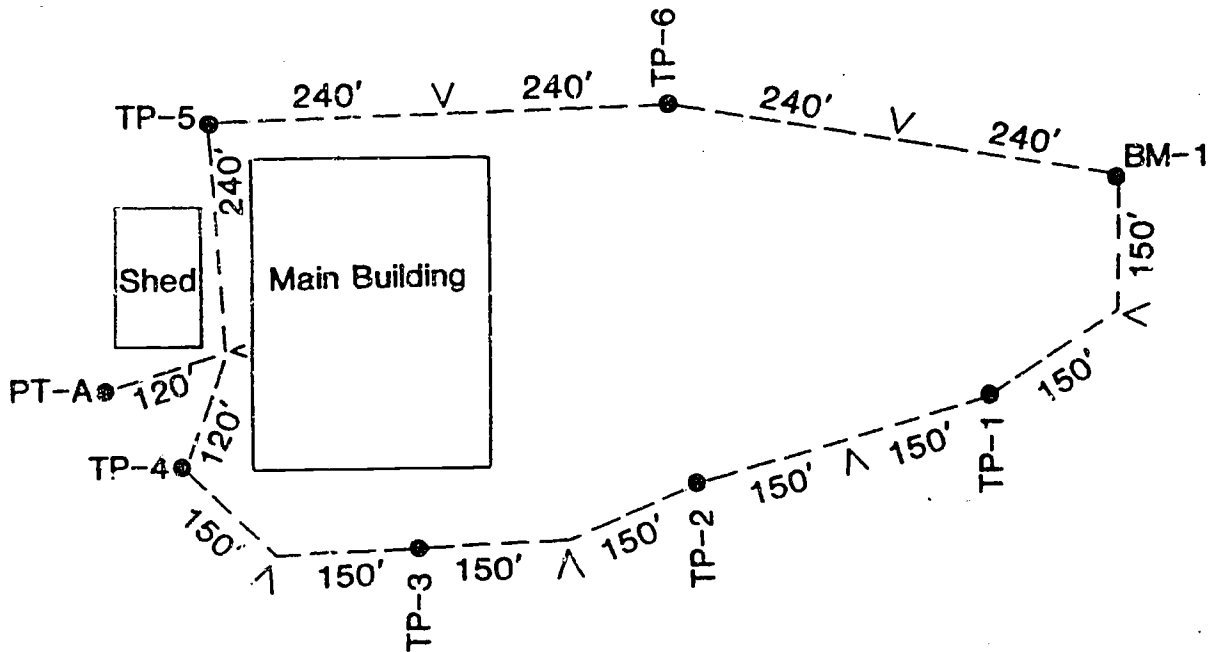

124

6. From the following descriptive notes, make appropriate entries in standard form. (Vocational Agriculture Service field notes for surveying). Label columns correctly and make all calculations necessary to complete a differential leveling problem.

- a. Set up the instrument and leveled it.
- b. Took a sight on bench mark 1 . . .4.36'
- c. Took a sight on turning 1. . .5.32'
- d. Moved instrument
- e. Sighted on T.P. 1. . .5.81'
- f. Sighted on T.P. 2. . .3.41'
- g. Moved instrument
- h. Sighted on T.P. 2. . .7.33'
- i. Sighted on point A. . .4.25'
- j. Sighted on T.P. 3. . .6.23'
- k. Moved instrument
- l. Sighted on T.P. 3. . .4.20'
- m. Sighted on B.M. #1. . .6.73'



STUDENT WORKSHEET 2  
PROFILE LEVELING

1. What is meant by profile leveling?
2. Where is profile leveling used?
3. Explain the process of profile leveling.
4. Work out the following profile survey and figure the grade elevation, cut and width of a surface drain to drain point 4+00 into point 0+00 using a 5:1 side slope on the ditch.

Station	Back Sight	Height Instrument	Fore Sight	Elevation	Grade Elevation	Cut	Width
BM - 1	2.60			50.00			
0+00		6.60					
0+50		6.40					
1+00		6.10					
1+50		5.40					
2+00		5.20					
TP - 1	8.05	9.65					
2+50		3.40					
3+00		2.80					
3+50		3.10					
4+00		3.40					
TP - 2	7.94	5.86					
BM - 1		3.08					

5. Work out the following profile survey and figure the grade evaluation cut or fill and width of a surface drain to drain from 3+00 to 0+00 using a 5:1 side slope on the ditch.

Station	Back Sight	Height of Instrument	Fore Sight	Elevation	Grade Elevation	Cut/ Fill	Width
BM - 1	5.62			100.00			
0+00			3.12				
0+50			3.80				
1+00			4.46				
1+50			5.06				
TP - 1	5.32		4.62				
2+00			2.93				
2+50			1.68				
3+00			0.82				
TP - 2	4.16		6.32				
BM - 1			4.16				

6. Work out the following profile survey for a surface drain using a 5:1 side slope on the ditch.

Station	Back Sight	Height of Instrument	Fore Sight	Elevation	Grade Elevation	Cut/ Fill	Width
BM - 1	4.50			100.00			
0+00			8.02				
0+50			7.85				
1+00			6.42				
TP - 1	7.28		7.77				
1+50			5.03				
2+00			4.72				
2+50			4.31				
3+00			4.07				
TP - 2	5.37		3.91				
BM - 1			5.42				

STUDENT WORKSHEET 3

USING THE HAND LEVEL

1. Explain how a contour line can be found with the hand level.
2. Explain how slopes can be measured using the hand level.
3. If your eye level is 5 feet, determine the percent slopes on the following readings: The distance read is 25 feet.

A - 5'6"

B - 4'8"

C - 3'

D - 4'1"

E - 5'0"

F - 4'10"

G - 2'1"

H - 1'3"

I - 2'6"

J - 1'4"

LABORATORY EXERCISE 1  
SETTING UP AND ADJUSTING THE LEVEL

OBJECTIVES:

1. To become familiar with the procedures involved in setting up a tripod.
2. To develop the skills needed to adjust a level.

TOOLS AND EQUIPMENT

1. Instrument
2. Tripod

PROCEDURES:

1. Grasp the two legs of the tripod that are nearest you and set the leg shoes in the ground about three feet apart.
2. Swing the third leg out to form a triangle (NOTE: If the ground is not level, you may have to change the position of the tripod in order to keep the head plate level. Always place two legs on down-hill or unlevel).
3. Tighten leg thumb nuts.
4. Check head plate to see if it is level.
5. Remove the instrument from carrying case by lifting the level bar. (CAUTION: Keep a firm grip on the instrument until it is securely in position on tripod).
6. Remove the dust cap from front lens. (NOTE: The dust cap should be kept in place in order to protect the lens from dust or scratches.)
7. Attach sun shade to the instrument.
8. Align telescope barrel directly over one pair of leveling screws. (NOTE: The leveling screws will be used to level the instrument.)
9. Rotate screws under the leveling head to bring bubble to the center of the leveling tube. (NOTE: Move your thumbs in opposite directions!)
10. Check bubble to see if it is centered.
11. ~~Turn instrument clockwise through 90 degrees to align with other pair of leveling screws.~~

12. Bring bubble to center of marks by rotating leveling screws.
13. Turn instrument clockwise through 90 degrees to bring it parallel with first pair of leveling screws.
14. Center bubble again.
15. Turn instrument clockwise through 90 degrees to bring it parallel with second pair of leveling screws.
16. Center bubble again.  
(NOTE: Bubble should stay in center regardless of what direction telescope is pointing. If bubble does not stay centered, the instrument is out of level and should be adjusted by competent personnel.)
17. Focus cross hairs so that they appear sharp and clear.  
(NOTE: Focusing is accomplished by looking through the eye piece ring until the cross hairs become sharp or "clear.")
18. Rotate the focusing screw to bring target into sharp focus.  
(NOTE: When cross hairs and targets are in sharp focus, you should be able to read a rod accurately. Always tie level shots back to starting bench mark to check for error in rod shots or in field notes.)

(CAUTION: After instrument is level, keep hands off tripod. Use the instrument only. If instrument creeps off level or is bumped, stop, reset tripod, relevel instrument, and start again from the last known good bench mark.)

LABORATORY EXERCISE 2  
DIFFERENTIAL LEVELING

OBJECTIVES:

1. To understand the process of differential leveling.
2. To develop the skills used in differential leveling.

MATERIALS:

1. Tripod and level
2. Target rod
3. Map of area
4. Field notebook and pencil

PROCEDURES:

1. The teacher will place 6 stakes at intervals around the survey field.
2. Use the top of stake #1 as BM 1 (100' elevation).
3. Find the elevation of the top of the stakes to which your group is assigned.
4. Use a turning point between the two stakes farthest apart, otherwise one instrument set-up between each pair of stakes will be sufficient.
5. Close the traverse of returning to stake 1 to check the accuracy of your work.
6. Record all notes in the standard form in a field notebook as the work progresses. This should include an appropriate sketch, weather conditions, date, survey party members, etc. on the right page as well as the title and record the data on the left page. (Rotate jobs to obtain practice).

QUESTIONS:

1. How is differential leveling used by the landscaper?
2. What other industries or persons might use these skills?
3. What are the sources of error in a differential leveling survey?

**OBSERVATIONS:**

Correctly measure the difference in elevation between two points. Become familiar with the skills and techniques used to do a differential leveling survey.



## LABORATORY EXERCISE 3

### PROFILE LEVELING

#### OBJECTIVES:

1. To become familiar with the techniques involved in profile leveling.
2. To develop the ability to accurately run a profile survey.

#### MATERIALS:

1. 100 foot tape
2. Marking pins
3. Tripod level
4. Target rod
5. Range poles

#### PROCEDURES:

1. Refer to pages 16 and 17 of VAS Subject Matter Unit 3010a - Agricultural Surveying for instructions for profile leveling.
2. The teacher will place stakes along the area to be surveyed.
3. Students will begin at stake #1 and designate this as station O. Then, they should proceed along that line taking readings at 25 foot intervals. When the survey team has reached the end point designated by the instructor they should then sight back to station O. (Rotate jobs to gain experience).
4. These data should be properly entered in the field notebook.
5. Survey for surface ditch
6. Record in proper form, showing cut for each station
7. Upper end of ditch is at 0+00. Outlet at 4+50.

#### QUESTIONS:

1. How and when can profile leveling be used?
2. How can errors in the survey be avoided?

#### OBSERVATIONS:

Become proficient at the skills involved in profile leveling.

LABORATORY EXERCISE 4  
USING THE HAND LEVEL

OBJECTIVES:

1. To become proficient with the use of the hand level.
2. To be able to determine slope with the hand level.
3. To be able to lay out contours with the hand level.

MATERIALS:

1. Hand level
2. Target rod or range pole

PROCEDURES:

SLOPES

1. The instructor must locate the slopes to be measured and place stakes at 25 foot intervals.
2. The students must determine eye level.
3. The student may now read the slope, subtracting his or her eye level from the reading.
4. Multiply the remainder by 4. This represents the inches per 100 feet of slope. 12 inches = 1%
5. Remember it is always best to take your readings from the downhill position.

CONTOURS

1. Select an area to be contoured.
2. Select a starting point. The rodman then proceeds at 25-50 foot intervals to locate that same elevation in the slope.
3. When the proper location is found drive a stake at that point and move on.
4. Continue this process until the contour is complete.

QUESTIONS:

1. In what type landscaping operations can use of the hand level be beneficial?

2. What things must be done to assure accuracy?
3. What can you do to improve your skills?

**OBSERVATIONS:**

Become familiar with the equipment and procedures used in determining slope and laying out contours.

Learn how to lay out a contour and determine percent slope correctly.

TEACHER'S KEY - STUDENT WORKSHEET 1

DIFFERENTIAL LEVELING

1. What is differential leveling?

The process by which relative elevations of several points may be determined.

2. Explain the process of differential leveling.

See Page 14 of VAS Subject Matter Unit 3010a

3. What is allowable error?

A reasonable error made in surveying

4. How is allowable error calculated?

Allowable error = .14 times the square root of the length of traverse in feet divided by 100.

5. Record the following data in standard form as it would appear in a field notebook. These statements represent brief descriptions of the activities performed by the surveying party.

a. Prepared to do differential leveling on the Holly Horticulture Nursery located in the E 1/2 of the NW 1/4, Section 24, T6N R3E 3rd PM.

b. Set up instrument and leveled it.

c. Took sight on bench mark #1. . . 5.24'

d. Took sight on turning point #1. . . 6.35'

e. Moved instrument and leveled it.

f. Took sight on T.P. 1. . . 4.83'

g. Took sight on T.P. 2. . . 5.03'

h. Moved instrument

i. Took sight on T.P. 2. . . 1.31'

j. Took sight on T.P. 3. . . 3.52'

k. Moved instrument

l. Took sight on T.P. 3. . . 5.07'

m. Took sight on T.P. 4. . . 4.73'

- n. Moved instrument
- o. Sighted on T.P. 4. . .4.61'
- p. Sighted on point A. . .3.57'
- q. Sighted on T.P. 5. . .2.32'
- r. Moved instrument
- s. Sighted on T.P. 5. . .3.11'
- t. Sighted on T.P. 6. . .2.46'
- u. Moved instrument
- v. Sighted on T.P. 6. . .5.91'
- w. Sighted on B.M. 1. . .6.65'

The following is a sketch of the location of the bench marks and turning points. This information is to be appropriately recorded and also used to determine if the error is a reasonable amount.

HOLLY HORTICULTURE NURSERY

E 1/2 of the NW 1/4  $\odot$   
 Section 24  $\wedge$   
 T6N R3E 3rd P.M. Rec.

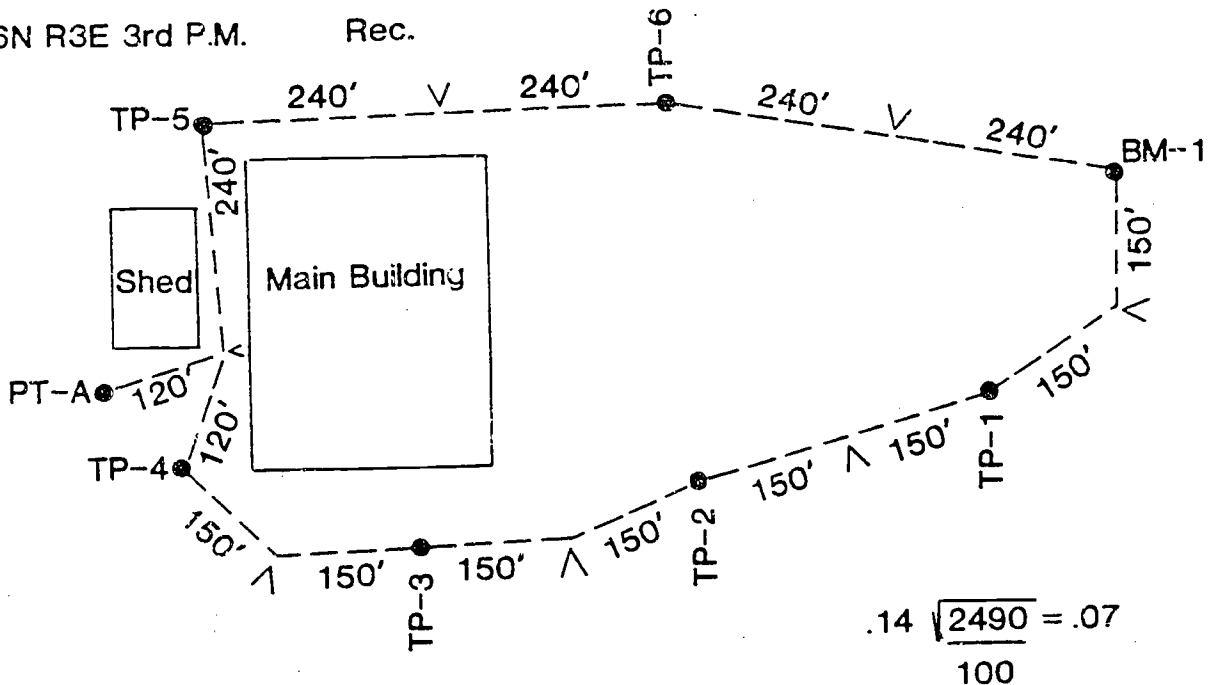

STA	BS	HI	FS	ELEV
BM-1	5.24			100
		105.24		
TP-1	4.83		6.35	98.89
		103.72		
TP-2	1.31		5.03	98.69
		100.00		
TP-3	5.07		3.52	96.48
		101.55		
TP-4	4.61		4.73	96.82
		101.43		
PointA			3.57	97.86
TP-5	3.11		2.32	99.11
		102.22		
TP-6	5.91		2.46	99.76
		105.67		
BM-1			6.65	99.02

6. From the following descriptive notes, make appropriate entries in standard form. (Vocational Agriculture Service field notes for surveying). Label columns correctly and make all calculations necessary to complete a differential leveling problem.
- a. Set up the instrument and leveled it.
  - b. Took a sight on bench mark 1. . . 4.36'
  - c. Took a sight on turning point 1 . . . 5.32'
  - d. Moved instrument
  - e. Sighted on T.P. 1. . . 5.81
  - f. Sighted on T.P. 2. . . 3.41'
  - g. Moved instrument
  - h. Sighted on T.P. 2. . . 7.33'
  - i. Sighted on point A. . . 4.25'
  - j. Sighted on T.P. 3. . . 6.23'
  - k. Moved instrument
  - l. Sighted on T.P. 3. . . 4.20'
  - m. Sighted on B.M. #1. . . 6.73'

140

STA	BS	HI	FS	ELEV
BM-1	4.36			100
		104.36		
TP-1	5.81		5.32	99.04
		104.85		
TP-2	7.33		3.41	101.44
		108.77		
Pt-A			4.25	104.52
TP-3	4.20		6.23	102.54
		106.74		
BM-1			6.73	100.01



## TEACHER'S KEY - STUDENT WORKSHEET 2

### PROFILE LEVELING

1. What is meant by profile level? Determines elevation of a series of points at measured intervals along a line.
2. Where is profile leveling used?  
Tile lines and drainage ditches
3. Explain the process of profile leveling.  
See Page 16 VAS Unit 3010a
4. Work out the following profile survey and figure the grade elevation, cut and width of a surface drain to drain point 4+00 into point 0+00 using a 5:1 side slope on the ditch.

Station	Back Sight	Height of Instrument	Fore Sight	Elevation	Grade Elevation	Cut/ Fill	Width
BM - 1	2.06	52.60		50.00			
0+00			6.60	46.00	46.00	0	0
0+50			6.40	46.20	46.20	0	0
1+00			6.10	46.50	46.40	.10	1.0
1+50			5.40	47.20	46.60	.60	6.0
2+00			5.20	47.40	46.80	.60	6.0
TP - 1	8.05	51.00	9.65	42.95			
2+50			3.40	47.60	47.00	.60	6.0
3+00			2.80	48.20	47.20	1.00	10.0
3+50			3.10	47.90	47.40	.50	5.0
4+00			3.40	47.60	47.60	0	0
TP - 2	7.94	53.08	5.86	45.14			
BM - 1			3.08	50.00			

5. Work out the following profile survey and figure the grade elevation cut or fill and width of a surface drain to drain from 3+0 to 0+00 using a 5:1 side slope on the ditch.

Station	Back Sight	Height of Instrument	Fore Sight	Elevation	Grade Elevation	Cut/ Fill	Width
BM - 1	5.62	105.62		100.00			
0+00			3.12	102.50	102.50	0	0
0+50			3.80	101.82	103.00	+1.18	11.8
1+00			4.46	101.16	103.50	+2.34	23.4
1+50			5.06	100.56	104.00	+3.4	34.0
TP - 1	5.32	106.32	4.62	101.00			
2+00			2.93	103.39	104.50	+1.11	11.1
2+50			1.68	104.64	105.00	+0.36	3.6
3+00			0.82	105.50	105.50	0	0
TP - 2	4.16	104.16	6.32	100.00			
BM - 1			4.16	100.00			

6. Work out the following profile survey for a surface drain using a 5:1 side slope on the ditch.

Station	Back Sight	Height of Instrument	Fore Sight	Elevation	Grade Elevation	Cut/ Fill	Width
BM - 1	4.50	104.50		100.00			
0+00			8.02	96.48	96.480	0	0
0+50			7.85	96.65	97.056	+ .40	0
1+00			6.42	98.08	97.632	+ .448	4.48
TP - 1	7.28	104.01	7.77	96.73			
1+50			5.03	98.98	98.208	.772	7.72
2+00			4.72	99.29	98.784	.506	5.06
2+50			4.31	99.70	99.360	.340	3.40
3+00			4.07	99.94	99.936	.004	.04
TP - 2	5.37	105.47	3.91	100.10			
BM - 1			5.42	100.05			

TEACHER'S KEY - STUDENT WORKSHEET 3

USING THE HAND LEVEL

1. Explain how a contour line can be found with the hand level.

See Pages 11-12 VAS, Unit 3010a

2. Explain how slopes can be measured using the hand level.

See Pages 11-12 VAS, Unit 3010a

3. If your eye level is 5 feet determine the percent slopes on the following readings: The distance read is 25 feet.

A - 5'6"      2%

B - 4'8"      1%

C - 3'      8%

D - 4'1"      4%

E - 5'0"      0%

F - 4'10"      71%

G - 2'1"      12%

H - 1'3"      15%

I - 2'6"      10%

J - 1'4"      15%

# TYPES OF LEVELS

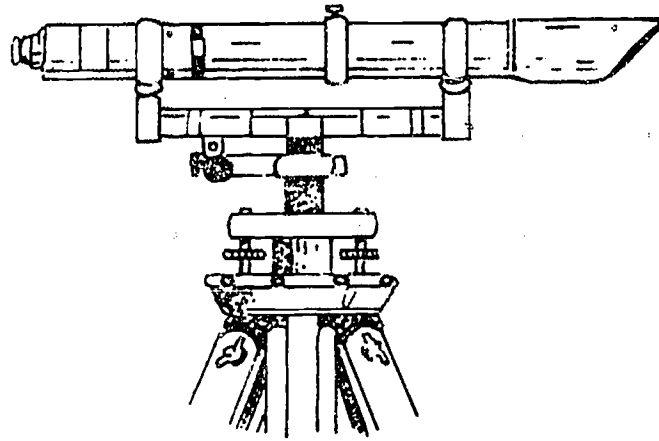

**Engineer's Dumpy**

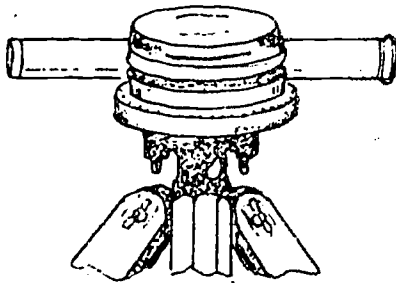

**Turret**

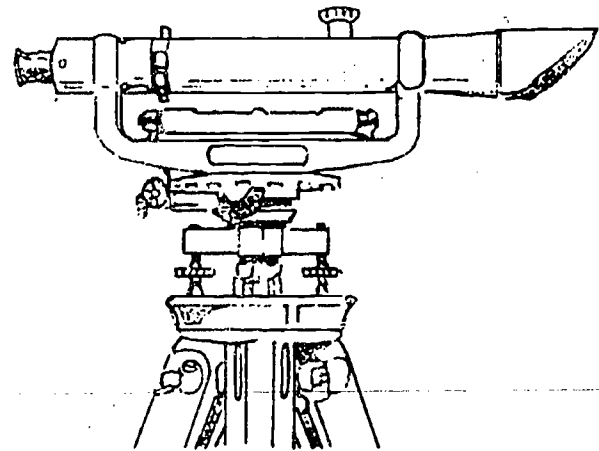

**Builder's**

# PARTS OF THE LEVEL

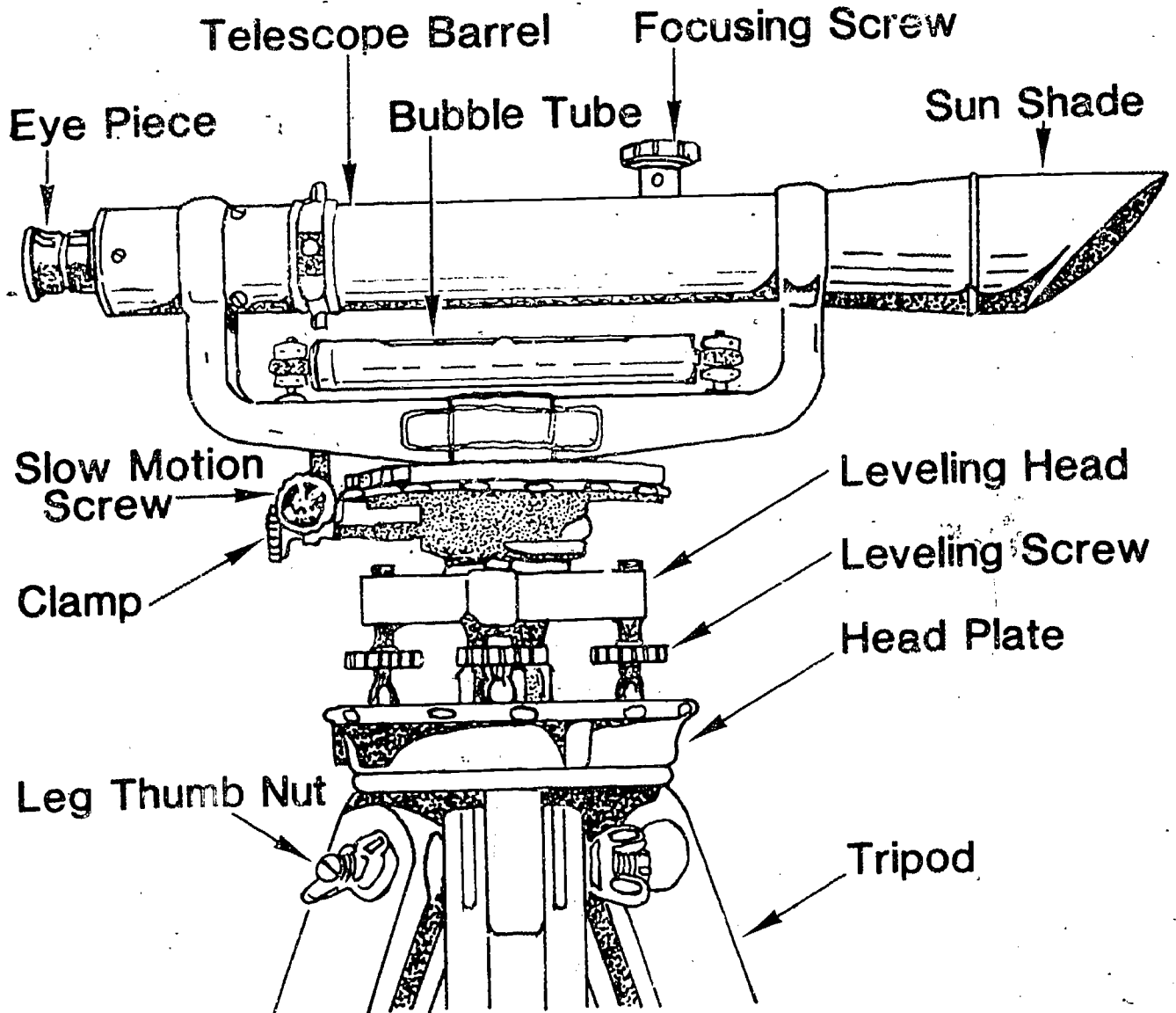

# SELF-READING ROD

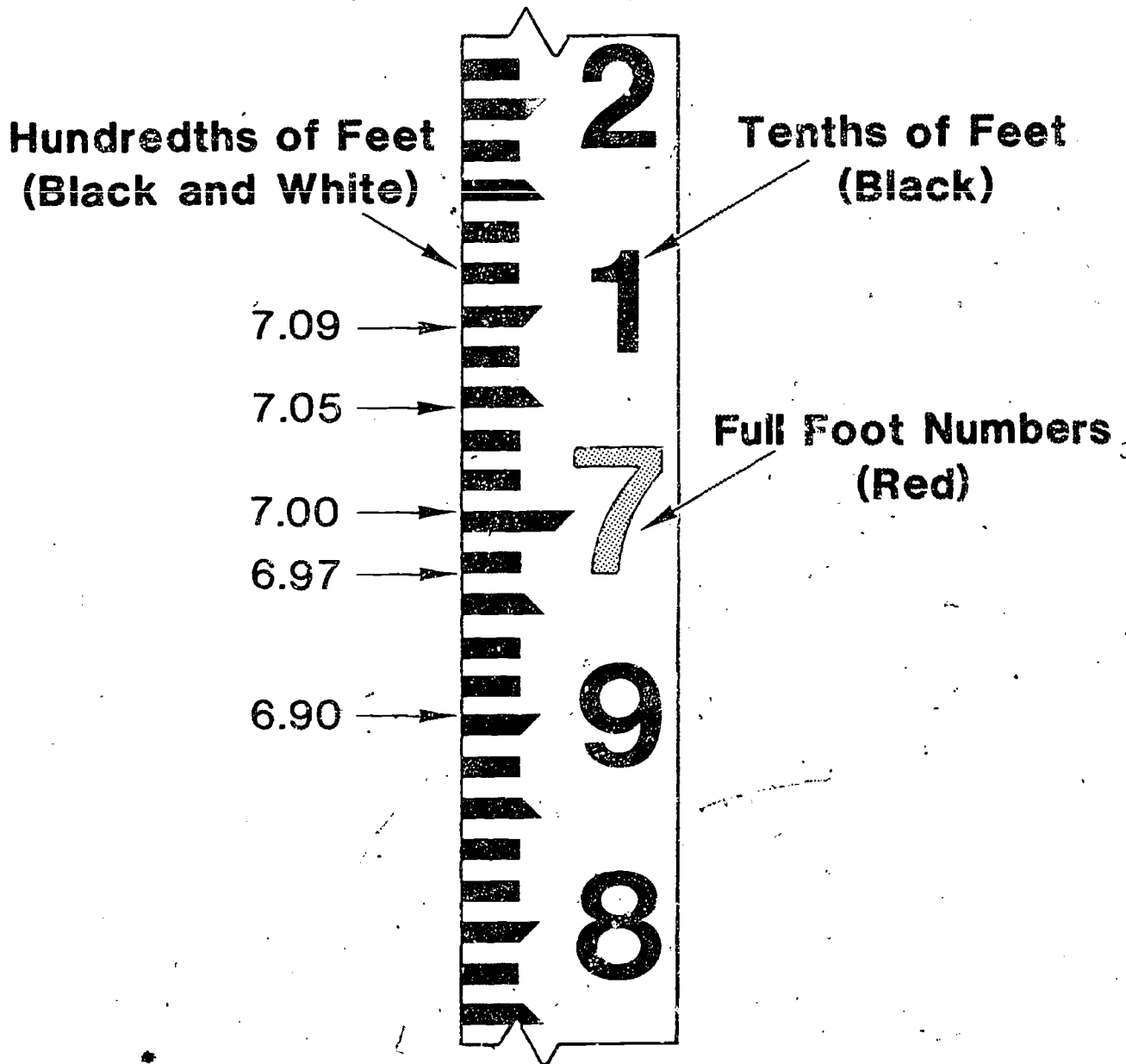

# SELF-READING ROD WORKSHEET

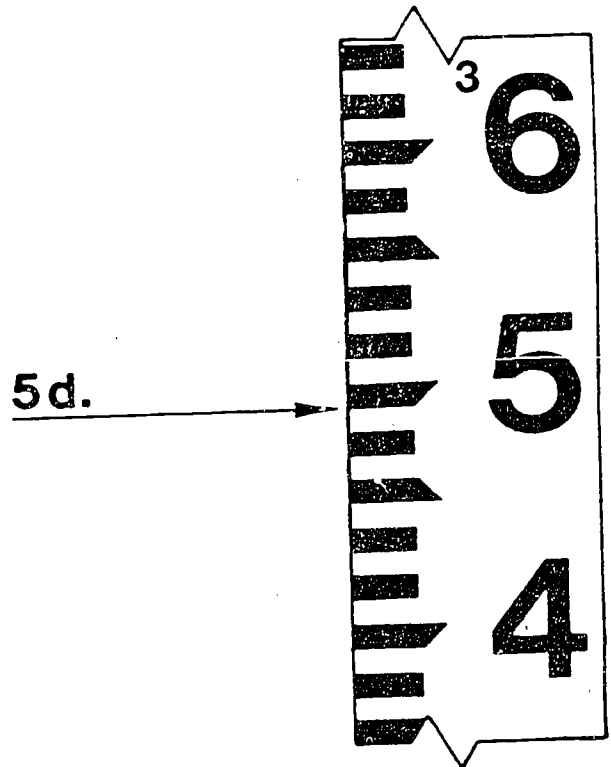
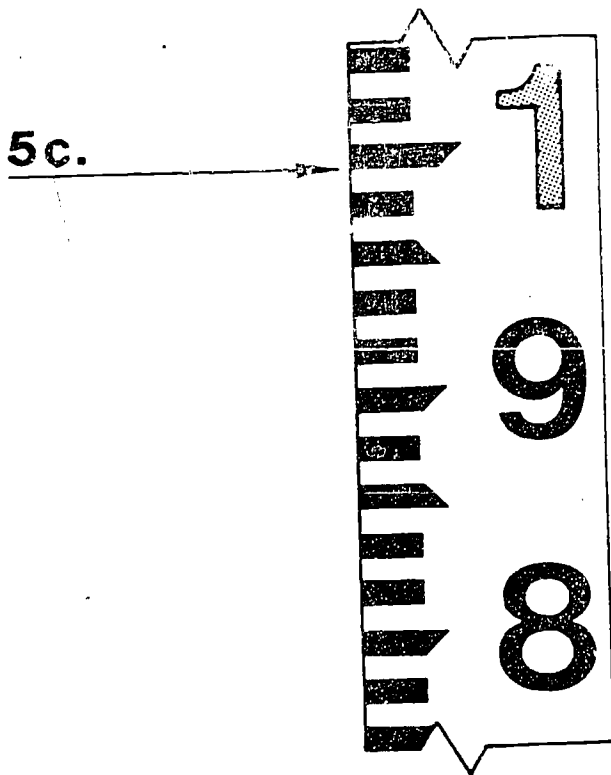
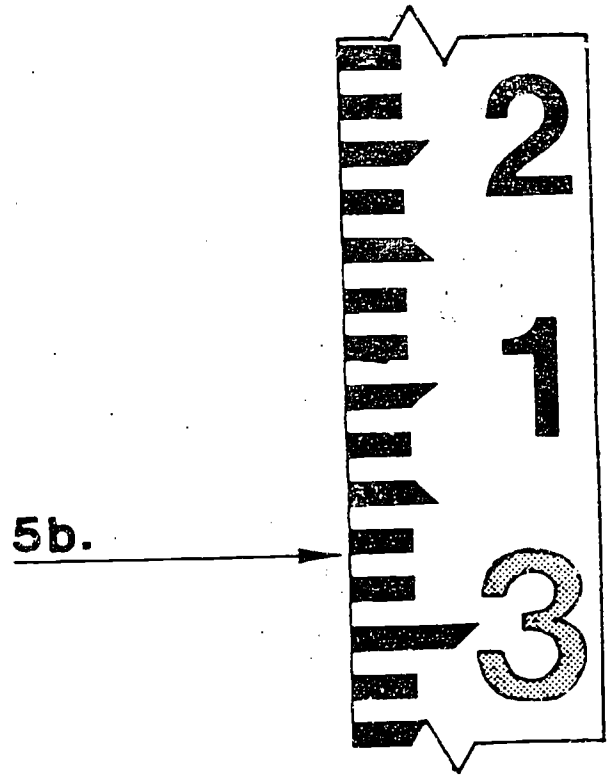
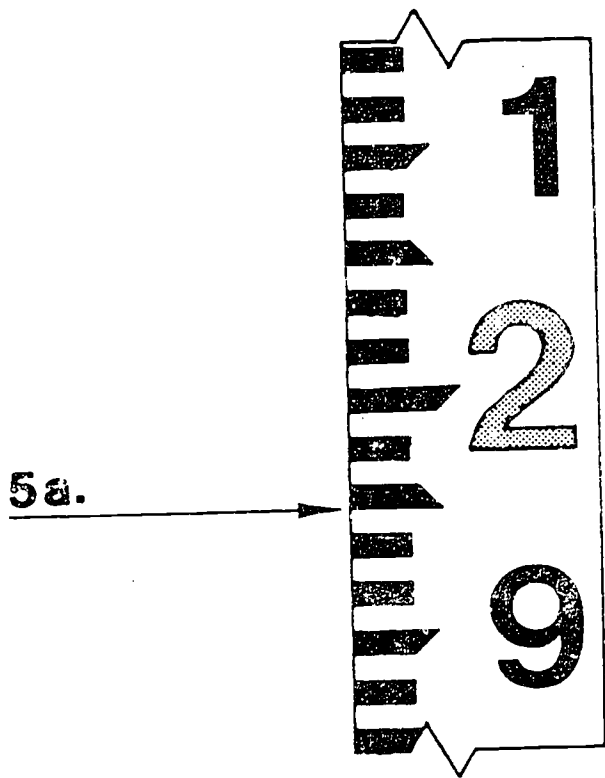



# HAND MOTIONS



**Move up**

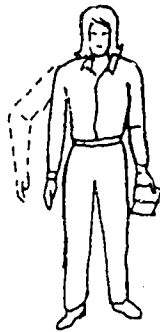

**Move down**

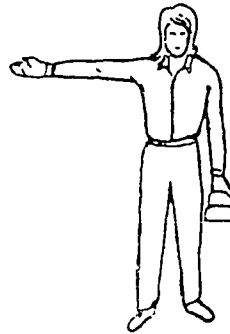

**Move rod  
to the right**

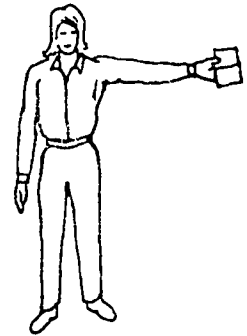

**Move rod  
to the left**

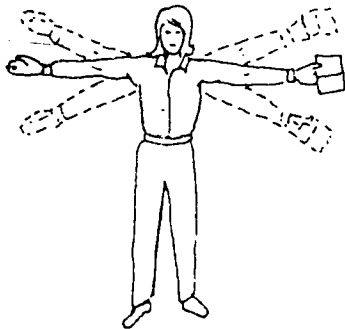

**Observation completed  
or Move on  
or Understood**

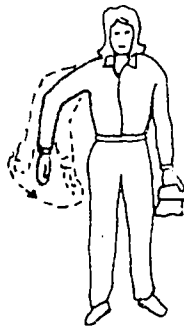

**Come in**

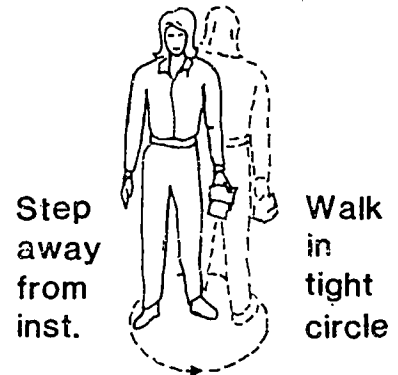

**Step  
away  
from  
inst.**

**Walk  
in  
tight  
circle**

**Wrong face  
or Check clamp  
or Rod upside down**



**Use long rod**

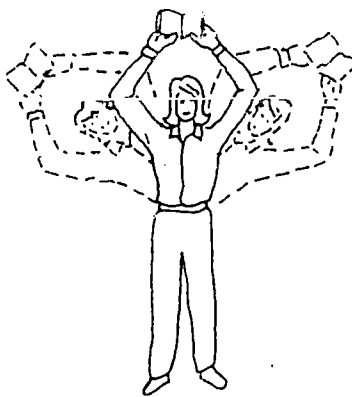

**Wave rod from  
side to side**

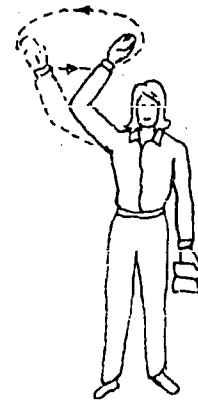

**Turning point**

# INCORRECT AND CORRECT METHODS OF LOWERING GRADE AROUND TREES

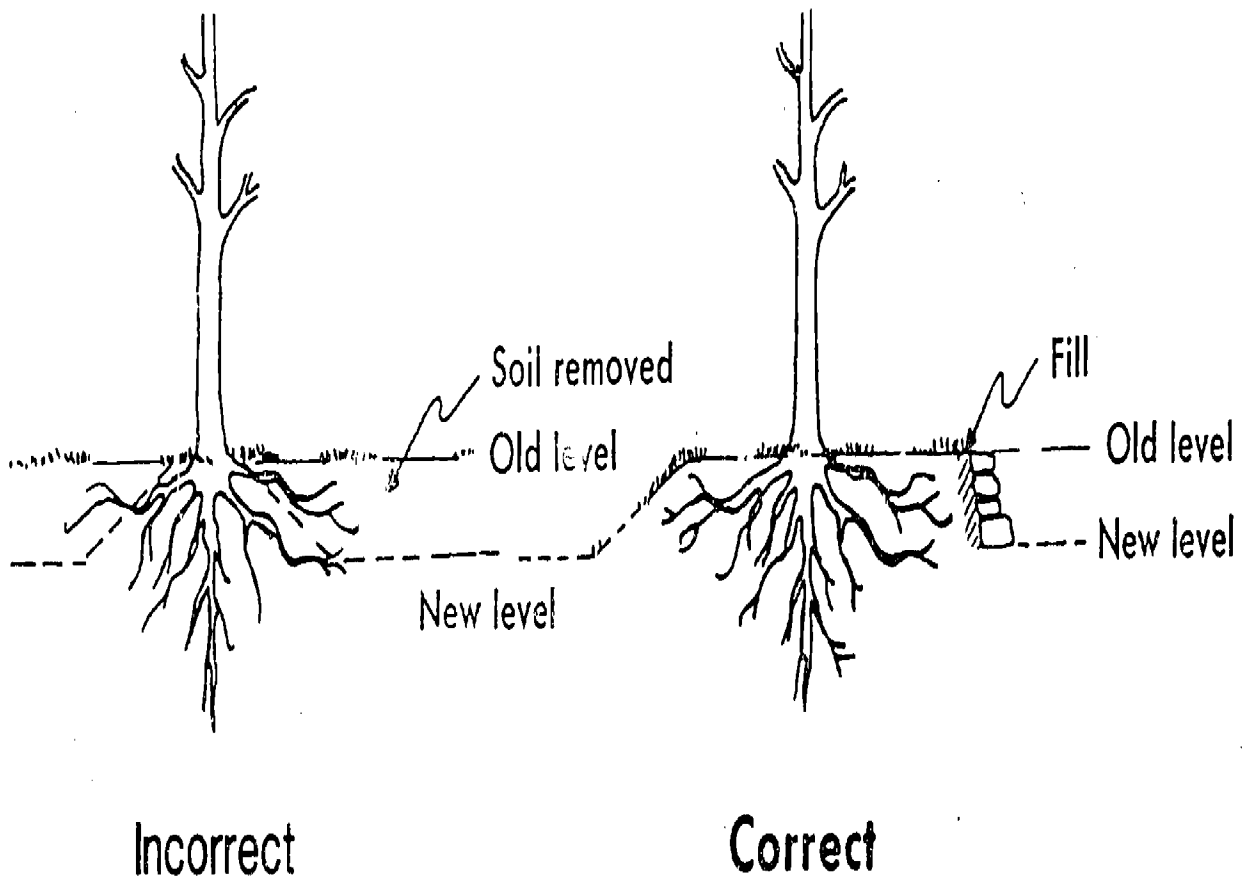

# CORRECT METHOD OF CUT AND FILL WHEN A TREE IS LOCATED ON SLOPE

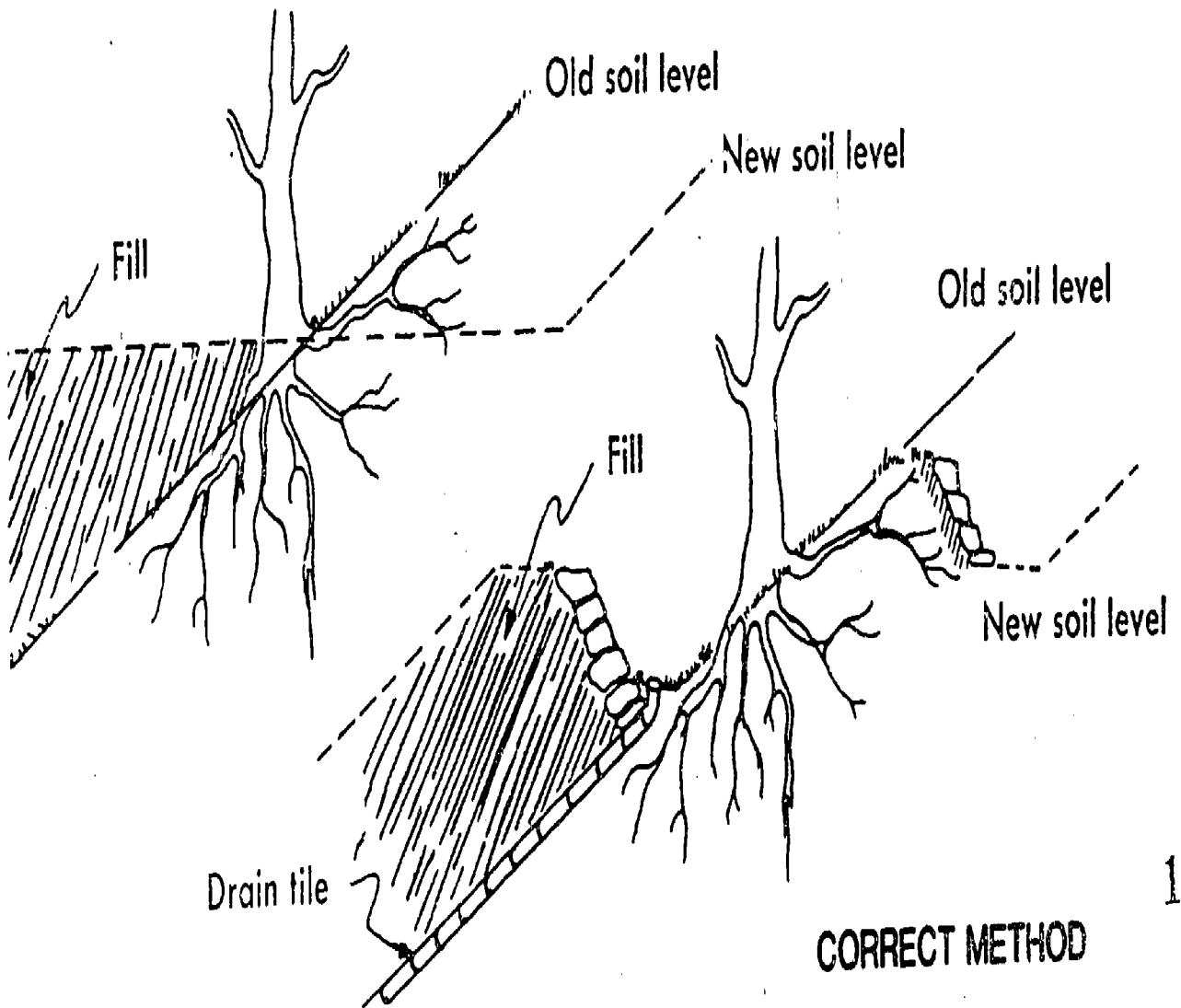

154

153

TRANSPARENCY DISCUSSION GUIDE  
SURVEYING, GRADING AND TILING

I. Transparency - SURVEYING LEVELS

A. Types of Levels:

1. Identify the common types of levels.
2. Point out that levels vary considerably in cost.
3. The types range from the simple farm level, to the builder's level, to the engineer's level.

B. Parts of the Level:

1. Point out that it is necessary to be familiar with the parts of a level so you will know how to set it up and adjust it.
2. Discuss how all levels have essentially the same parts;
  - a. telescope
  - b. leveling device (point out screws)
  - c. leveling plate
  - d. tripod
3. Point out that the wye level has a removable telescope and the dumpy level's telescope cannot be removed.

II. Transparency - SURVEYING RODS

A. Parts of the Surveying Rod:

1. Point out that the distance between each black and white line is  $1/100$  of a foot in width.
2. Top of black lines are even 100ths of a foot.
3. The rod is graduated in feet, tenths, and hundredths.
4. The red numbers are feet and the black numbers are tenths of a foot and not inches.

B. Reading the Rod:

1. Use these transparencies to explain and demonstrate how to read a surveying rod.
2. Explain how to determine a percent slope using a hand level, height or a tripod height of instrument.

III. Transparency - HAND SIGNALS

- A. Demonstrate each hand signal.
- B. Explain why hand signals are used in surveying.

IV. Transparency - LOWERING GRADE AROUND TREES

- A. Point out the differences between the correct and incorrect methods of lowering the established grade around trees.

V. Transparency - METHOD OF CUT AND FILL WHEN A TREE IS LOCATED ON SLOPE

- A. Point out the proper method for protecting a tree from cut-and-fill damage.

SAMPLE TEST QUESTIONS AND TEACHER'S KEY  
SURVEYING, GRADING AND TILING

MATCHING:

- |                                |                                                                        |
|--------------------------------|------------------------------------------------------------------------|
| 1. <u>  B  </u> Swale          | A. Condition of landscape before landscape construction begins         |
| 2. <u>  F  </u> Berm           | B. A concave depression that forms a drainage channel for runoff water |
| 3. <u>  G  </u> Slope          | C. Rainwater which flows across the site                               |
| 4. <u>  C  </u> Runoff         | D. Material used to build existing elevations                          |
| 5. <u>  D  </u> Fill           | E. Top of material on which surface construction rests                 |
| 6. <u>  J  </u> Finished Grade | F. A small hill                                                        |
| 7. <u>  E  </u> Subgrade       | G. Height divided by width                                             |
| 8. <u>  A  </u> Rough Grade    | H. Underground cavity in which water is collected                      |
| 9. <u>  I  </u> Cut            | I. Excavated material                                                  |
| 10. <u>  H  </u> Catch Basin   | J. Final surface after all construction has been completed             |

SHORT ANSWER:

11. Drain tile should be placed at a depth below the frost line (2.5'-3').
12. Drain tile should be placed at a slope of .5% to 1%
13. Vertical Distance ÷ Horizontal Distance = Slope
14. Grading should not be done if the soil is wet.
15. Water flowing over sidewalks is known as sheeting.
16. A benchmark is a permanent point of known or assumed elevation from which leveling surveys are started.
17. The operation by which the relative elevation of several points the same distance apart are determined is known as differential leveling.
18. A backsight is a reading taken on a point of known elevation.

19. Subtract the foresight from height of instrument to determine elevation at a location.
20. Add the backsight to the elevation of a location to determine height of instrument.
21. Profile leveling is the process of determining the elevations of a series of points at measured intervals along a line.
22. Profile leveling is used to determine grade elevations for drainage ditches, tile lines, etc.

## UNIT L: LANDSCAPE DESIGN, ESTABLISHMENT AND MAINTENANCE

### PROBLEM AREA: CONSTRUCTING FENCES AND RETAINING WALLS

#### SUGGESTIONS TO THE TEACHER:

This instructional packet is designed for use with advanced students in a horticultural or agricultural occupations program. The recommended time for teaching this problem area is during the spring semester when outdoor projects can be carried out.

The estimated instructional time for this problem area is 3 to 7 days, depending on how far the teacher wishes to go in developing construction skills of students. If the teaching plan is limited to classroom discussion with little or no practice or observation, the instructional time can be 3 days or less. If the students are to be involved in other activity exercises, the instructional time will need to be increased. It is recommended that the teacher plan a hands-on learning activity involving the construction of fences and retaining walls.

This problem area is based on materials available from Vocational Agriculture Service and two Sunset Books available from most local centers or building supply stores.

#### CREDIT SOURCES:

These materials were developed through a funding agreement 833-13-De 0362-466 with the Illinois State Board of Education, Department of Adult, Vocational and Technical Education, Research and Development Section, 100 North First Street, Springfield, Illinois 62777. Opinions expressed in these materials do not reflect, nor should they be construed as policy or opinion of the State Board of Education or its staff.

The teacher's guide, student worksheet, and sample test questions were developed by Ron Biondo and Marcia Watman-Lauchner. Transparency masters were prepared by the Vocational Agriculture Service, University of Illinois, using drawings by Floyd Giles and William R. Nelson, Jr., Department of Horticulture. Suggestions and guidance in the development of these materials were provided by the Metropolitan Core Curriculum Field Test Teachers and Paul Hemp, Division of Agricultural Education, University of Illinois.



## TEACHER'S GUIDE

- I. Unit: Landscape design, establishment and maintenance
- II. Problem area: Constructing fences and retaining walls
- III. Objectives: At the close of this problem area, students will be able to:
  1. Identify different types of fence and explain where each type might be used.
  2. Set posts and install braces.
  3. Erect a section of fence.
  4. Lay out and construct a retaining wall.
- IV. Suggested interest approaches:
  1. Survey the class to find out if any students have experience in constructing retaining walls or building fence. Raise the following questions:
    - a. Have any of you built fence? What kind did you build? How did you get started?
    - b. Have any of you constructed a retaining wall? How did you do it?
  2. Take class on a short walking tour to show the students examples of different types of fence and retaining walls.
  3. Find out if any students in the class are planning to build fence or construct walls at home.
  4. Show slides of fences and retaining walls which have been improperly constructed or misplaced. Then, ask a series of questions such as the following:
    - a. What is wrong with the structures?
    - b. How should the structures have been constructed?
    - c. Have the correct materials been used?
- V. Anticipated problems and concerns of students:
  1. Why do people build fences? Why are they used?
  2. What types of fences can be built?
  3. What are the advantages of each type?
  4. What steps are involved in building a fence?

5. How should fence posts be set?
6. What kinds of braces should be used and how are they erected?
7. What is a "dead-man"?
8. How should fence posts be treated?
9. What type of fence materials should I use?
10. How do you build and hang a gate?
11. Why are retaining walls used in landscape construction?
12. What types of walls may be erected and what are the advantages of each type?
13. What steps are involved in building a wall?
14. What effect does freezing and thawing have on retaining walls?
15. What laws regarding fences should we know about?

VI. Suggested learning activities and experiences:

1. Conduct an interest approach to accomplish the following:
  - a. Find out what students know about this area.
  - b. Find out how much experience they have in this area.
  - c. Create interest and develop a feeling of need to learn about this area.
2. Work with the class to develop student objectives.
3. Identify problems and concerns of students by asking the following questions:
  - a. What do we need to know and be able to do in order to plan and build yard fences?
  - b. What do we need to know and be able to do to construct a retaining wall?
4. Have students search out answers to the problems and concerns by reading reference materials.
5. Show VAS Slide Set 629, "Fencing and Patios." Use the first 27 frames which cover fences.
6. Show VAS Slide Set 628, "Walks, Steps, and Retaining Walls." Use the last 24 frames which cover retaining walls.

7. Show and discuss transparencies included with this problem area. Use the Transparency Discussion Guide as a reference.
8. Bring samples of fencing materials to class or arrange a field trip to observe different types of fences and walls.
9. Arrange one or more construction projects involving fence building or wall construction. Use Student Worksheet 1--Planning Construction Projects to outline plans.

VII. Application procedure.

1. Skills learned in constructing fences and retaining walls should be applied in the student's home situation.
2. Skills learned in this problem area will aid students working for landscape contractors, garden centers, and city or park district forestry divisions.
3. The students should use the skills learned to complete SOEP's.

VIII. Evaluation:

1. Provide a written test at the end of this problem area.
2. Administer a lab test on the identification of materials used in constructing fences and retaining walls.
3. Evaluate students' performance on construction projects.

IX. References and aids:

1. University of Illinois Cooperative Extension Circular 1111, Landscaping Your Home, Chapter 5.
2. Slide Sets (S) and supplementary study guides (G), available from Vocational Agriculture Service, 1401 S. Maryland Drive, Urbana, IL 61801.

S,G-628 Walks, Steps and Retaining Walls  
80 Frames (the last 24 frames are concerned with retaining walls only)

S,G-629 Fencing, Patios  
73 Frames (only the first 27 frames are concerned with fencing)

3. References available at most garden centers or local bookstores:

Reader's Digest Practical Guide to Home Landscaping

How to Build Fences and Gates - a Sunset Book

How to Build Walks, Walls and Patio Floors - a Sunset Book

STUDENT WORKSHEET 1  
PLANNING A CONSTRUCTION PROJECT

1. Name of project \_\_\_\_\_

2. Purpose of the project:

3. Materials needed to complete the job:

	<u>Name</u>	<u>Quantity</u>	<u>Cost</u>
1.			
2.			
3.			
4.			
5.			

4. Tools required to complete the job:

- 1.
- 2.
- 3.
- 4.
- 5.

5. Estimation of hours of labor required to complete the job:

6. Miscellaneous costs (rentals, equipment, etc.)

7. Total costs:

NOTE: Costs for materials, labor, and equipment should be current prices in the industry.

# FENCE FRAMEWORK AND BRACING

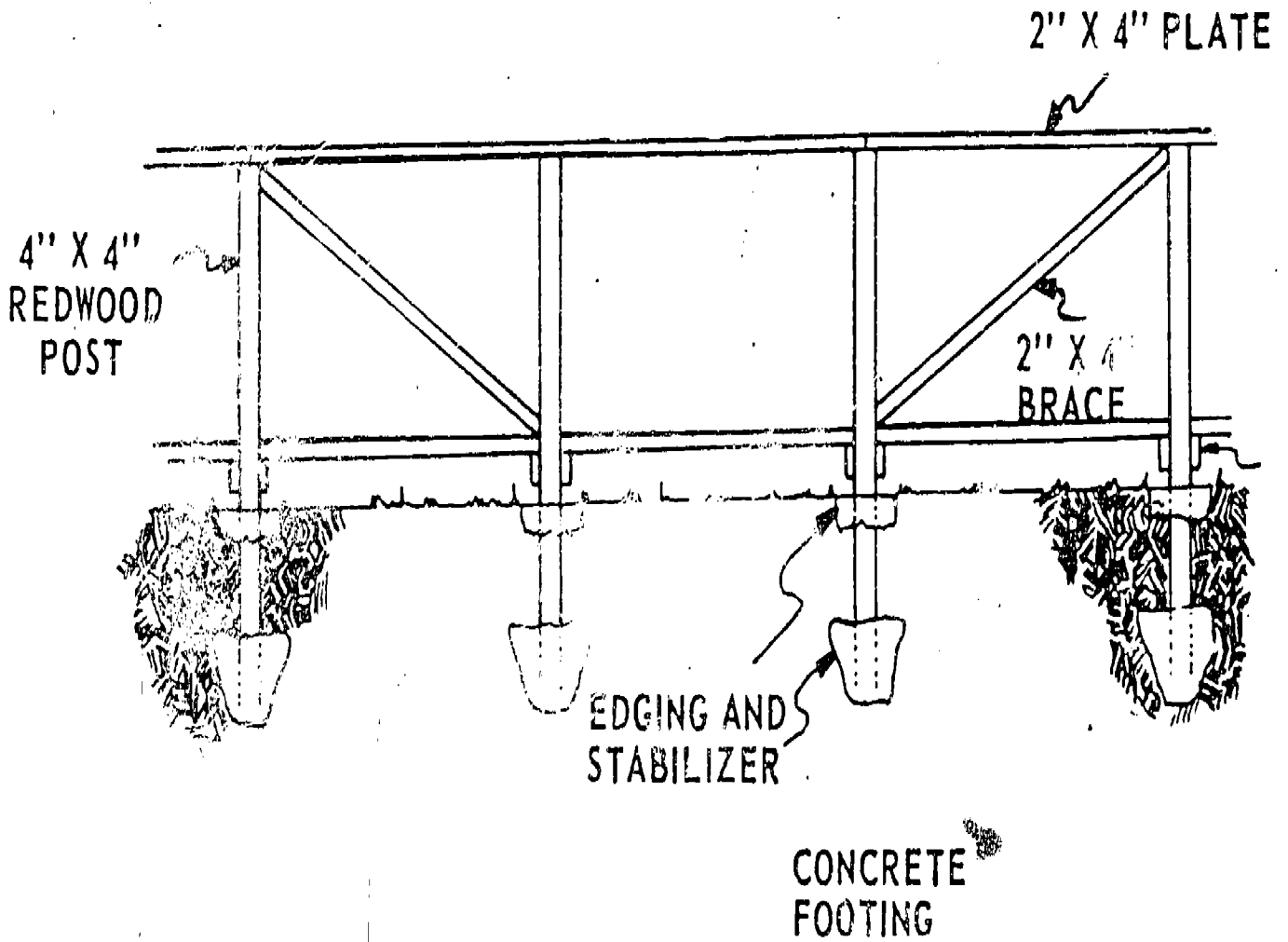

164

165

# CORNER BRACING

CORNER LAP JOINT

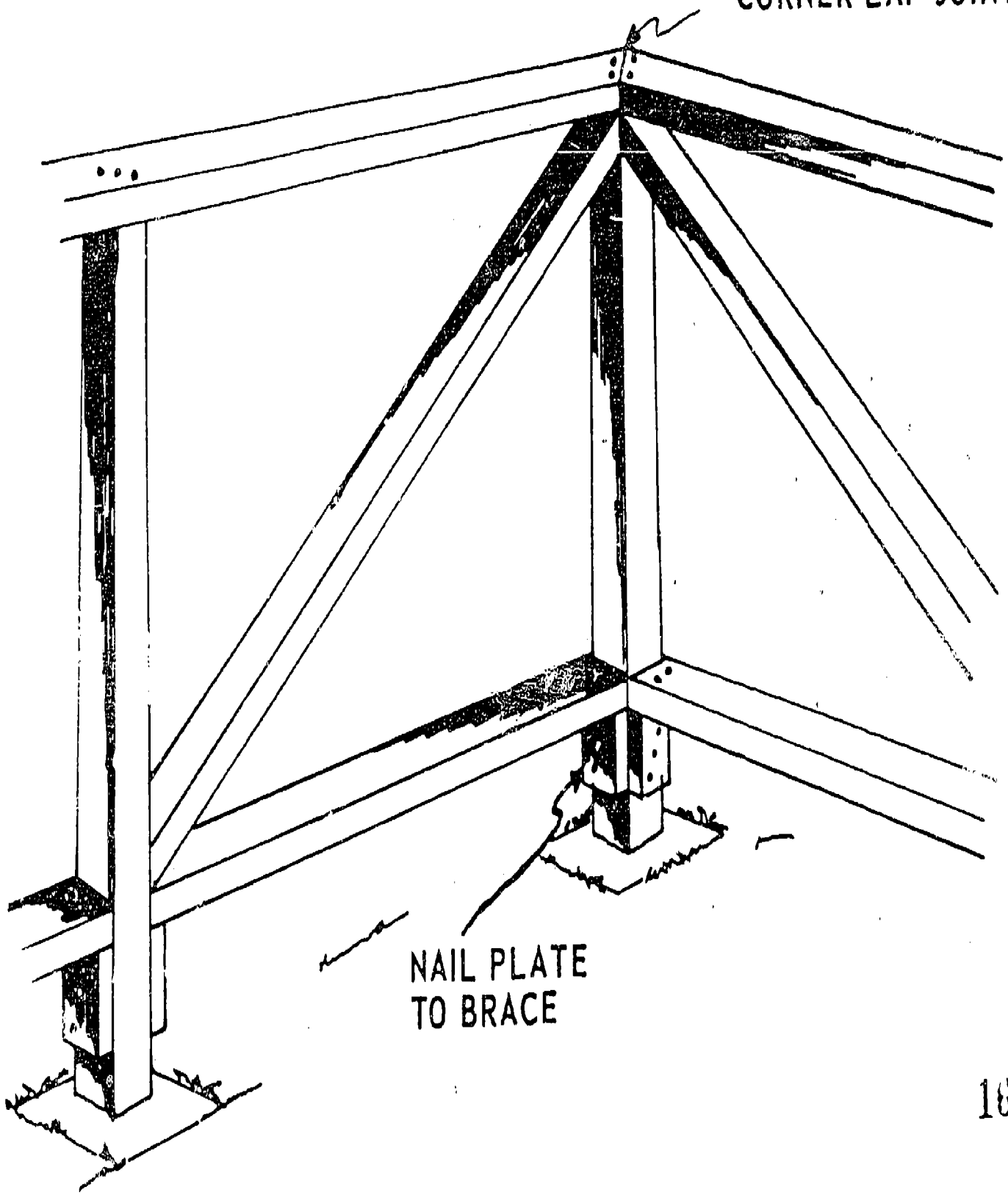

NAIL PLATE  
TO BRACE

# SETTING POST ON HILLS

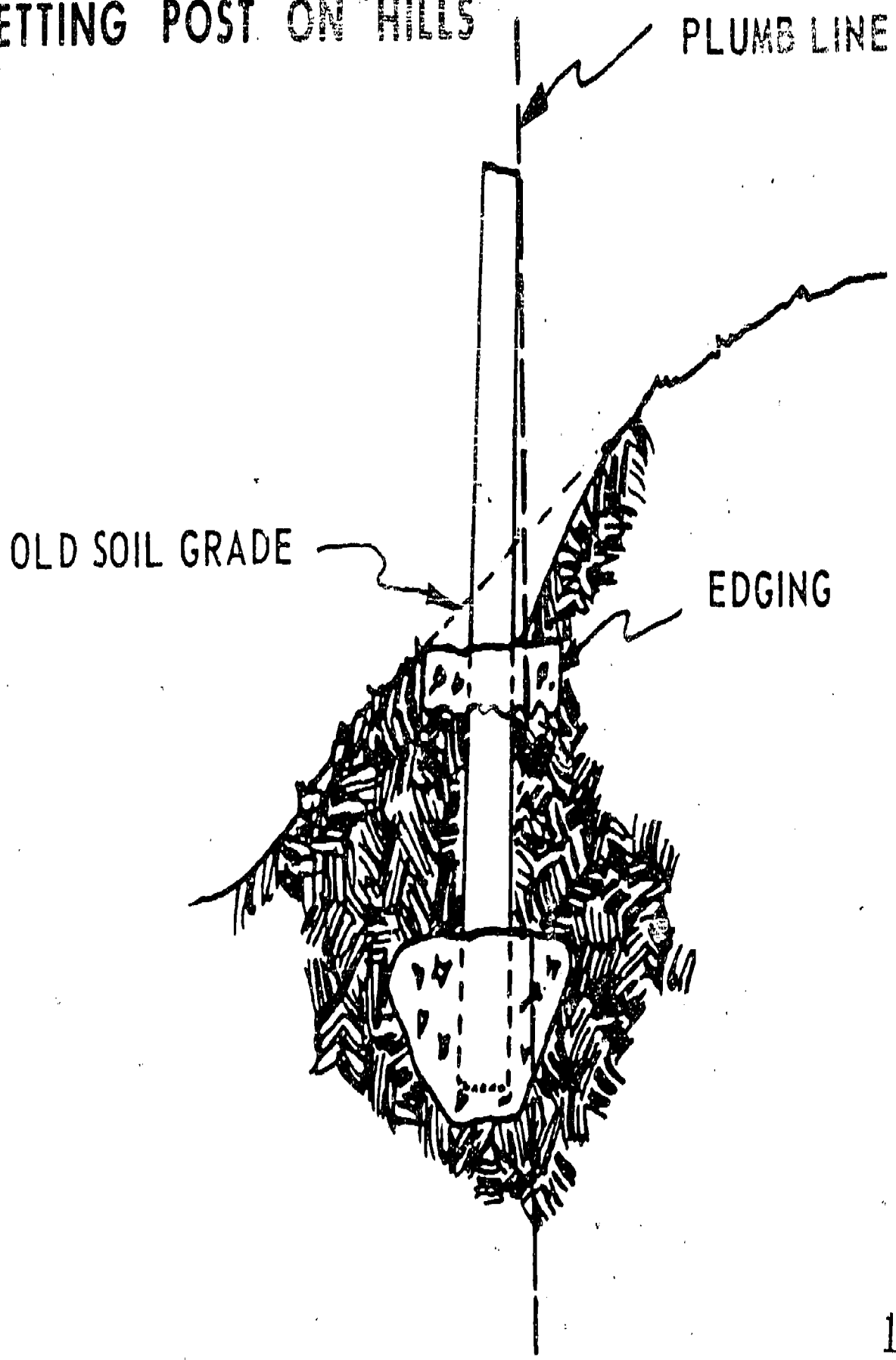

# CHALK LINING A FENCE

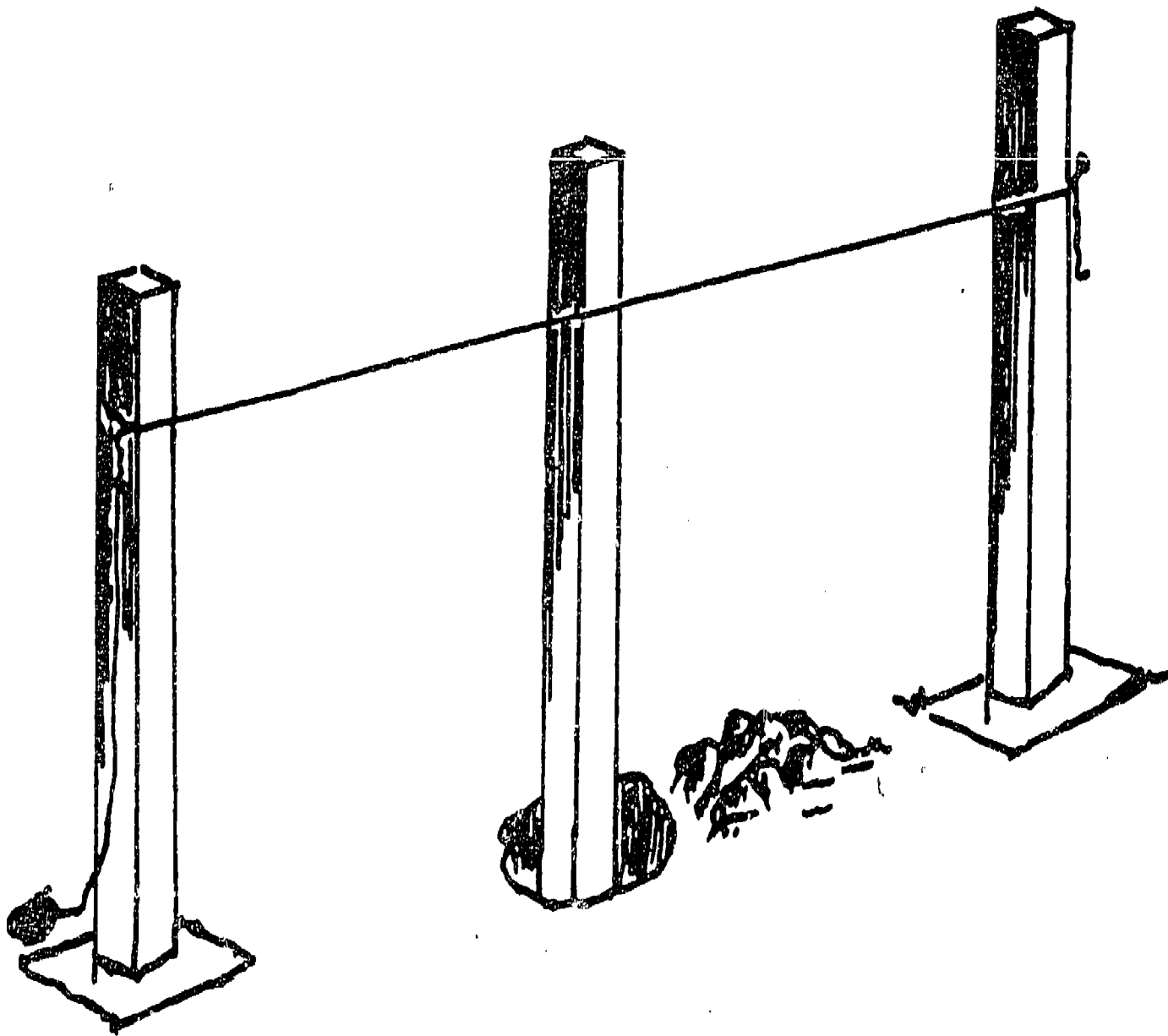



# FENCING OVER A HILL

MAKE FENCE SECTIONS  
CLOSE TOGETHER WHERE  
GRADE DROPS SHARPLY

NORMAL SECTIONS CAN BE  
USED ON GRADUAL SLOPE

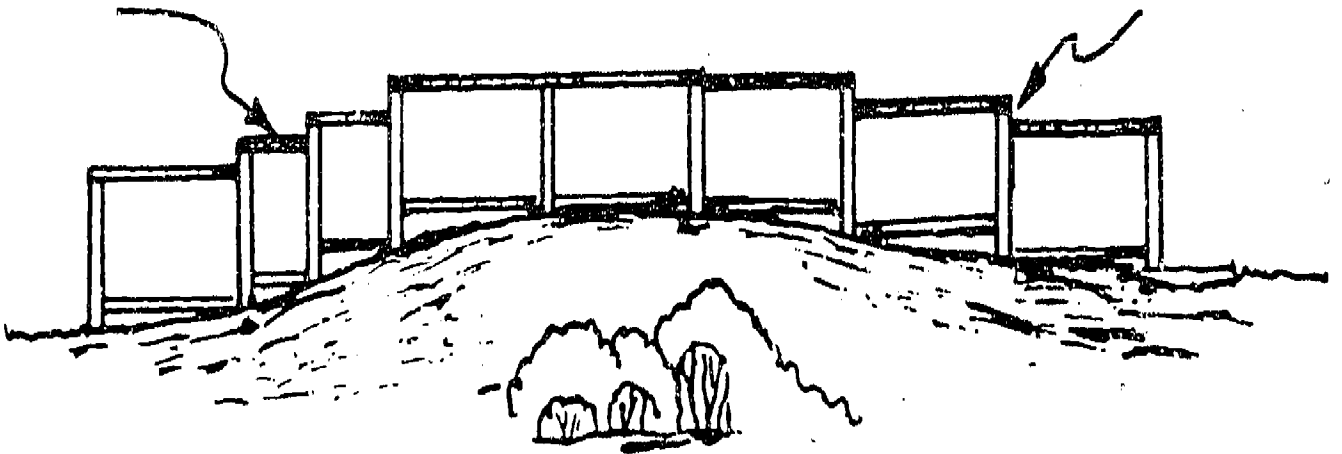

172

173

# RAIL FENCING

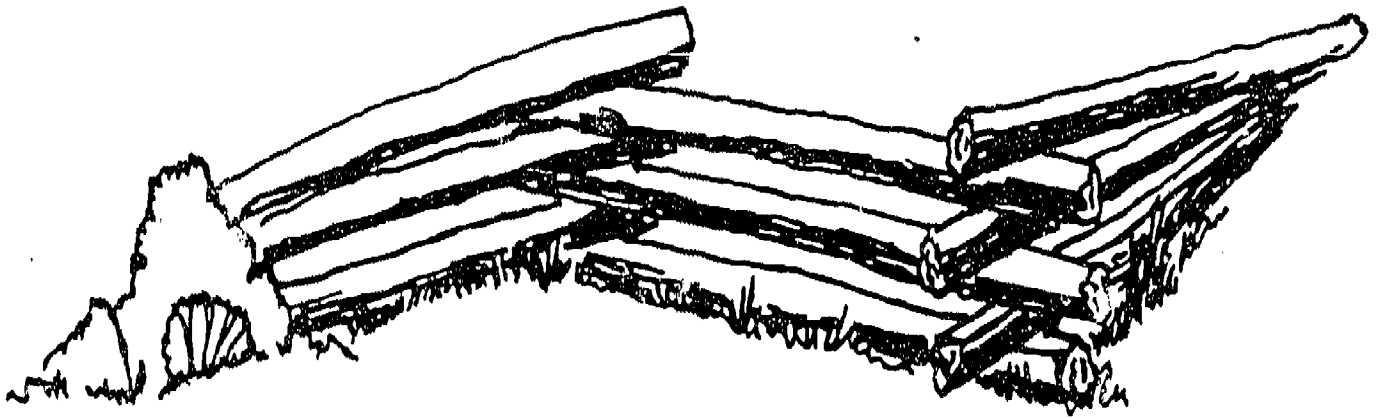

# MOWING CLEARANCE UNDER FENCING

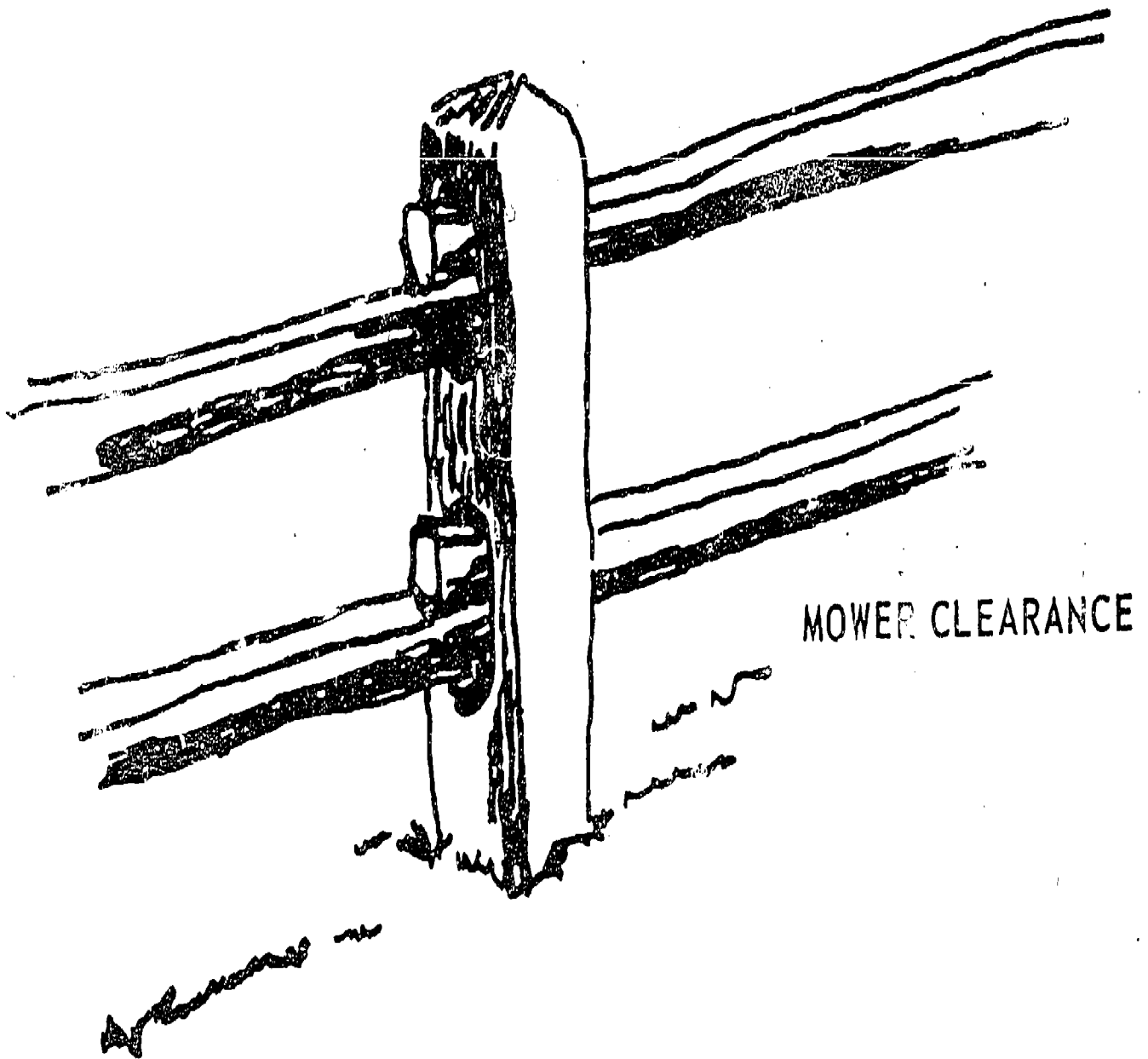

# FENCE POST JOINTS

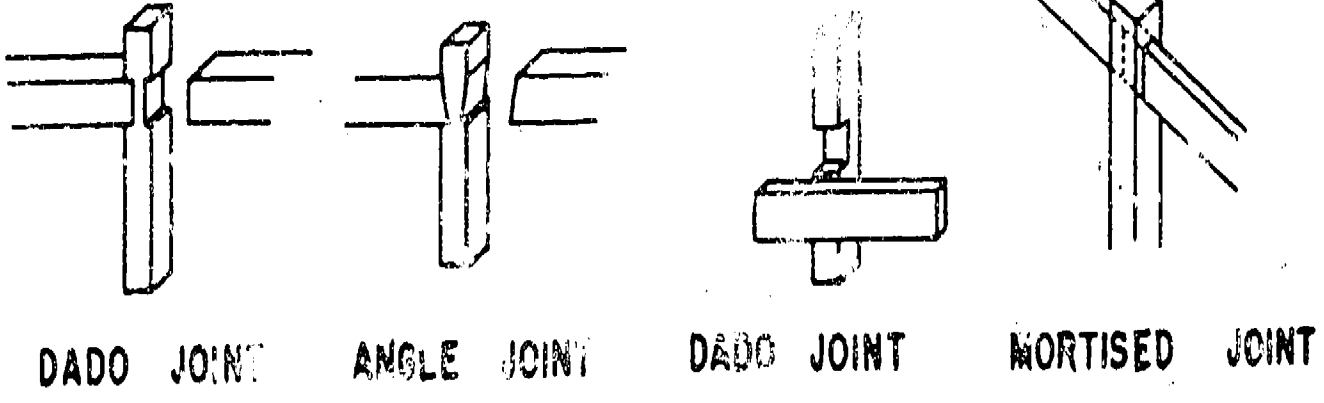
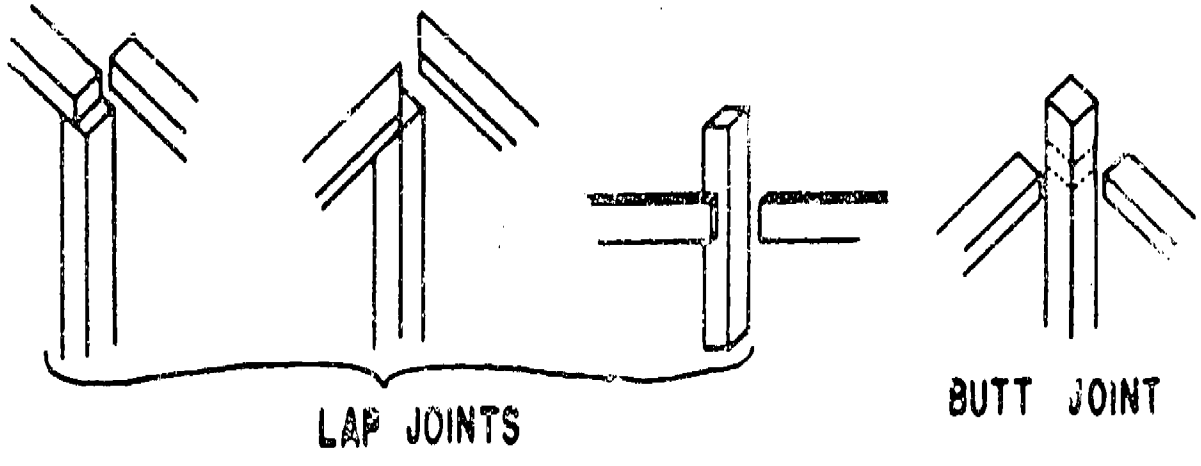

# CONCRETE RETAINING WALL

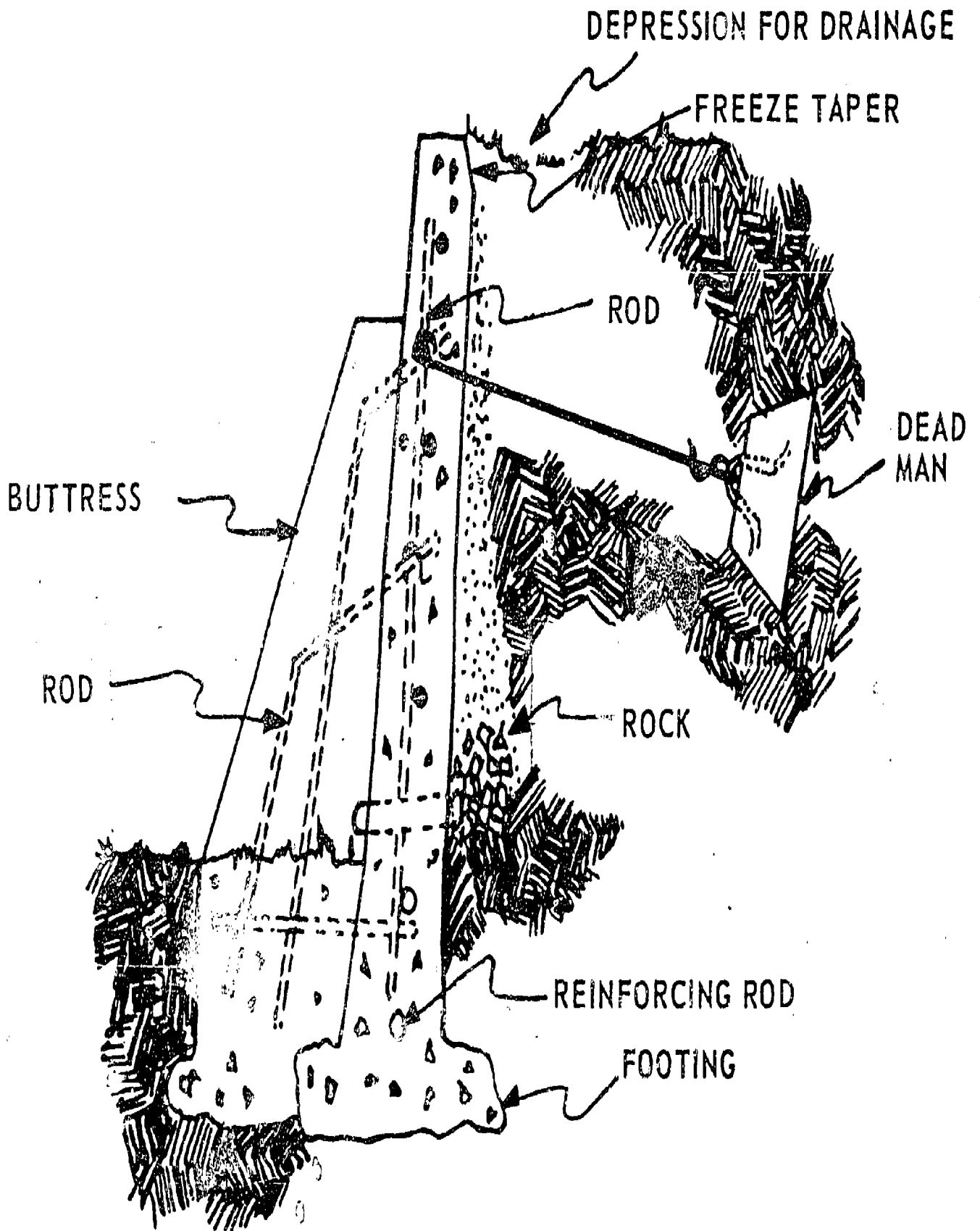

M-111-L-3-17

# FREE LAID STONE RETAINING WALL

DEPRESSION FOR DRAINAGE

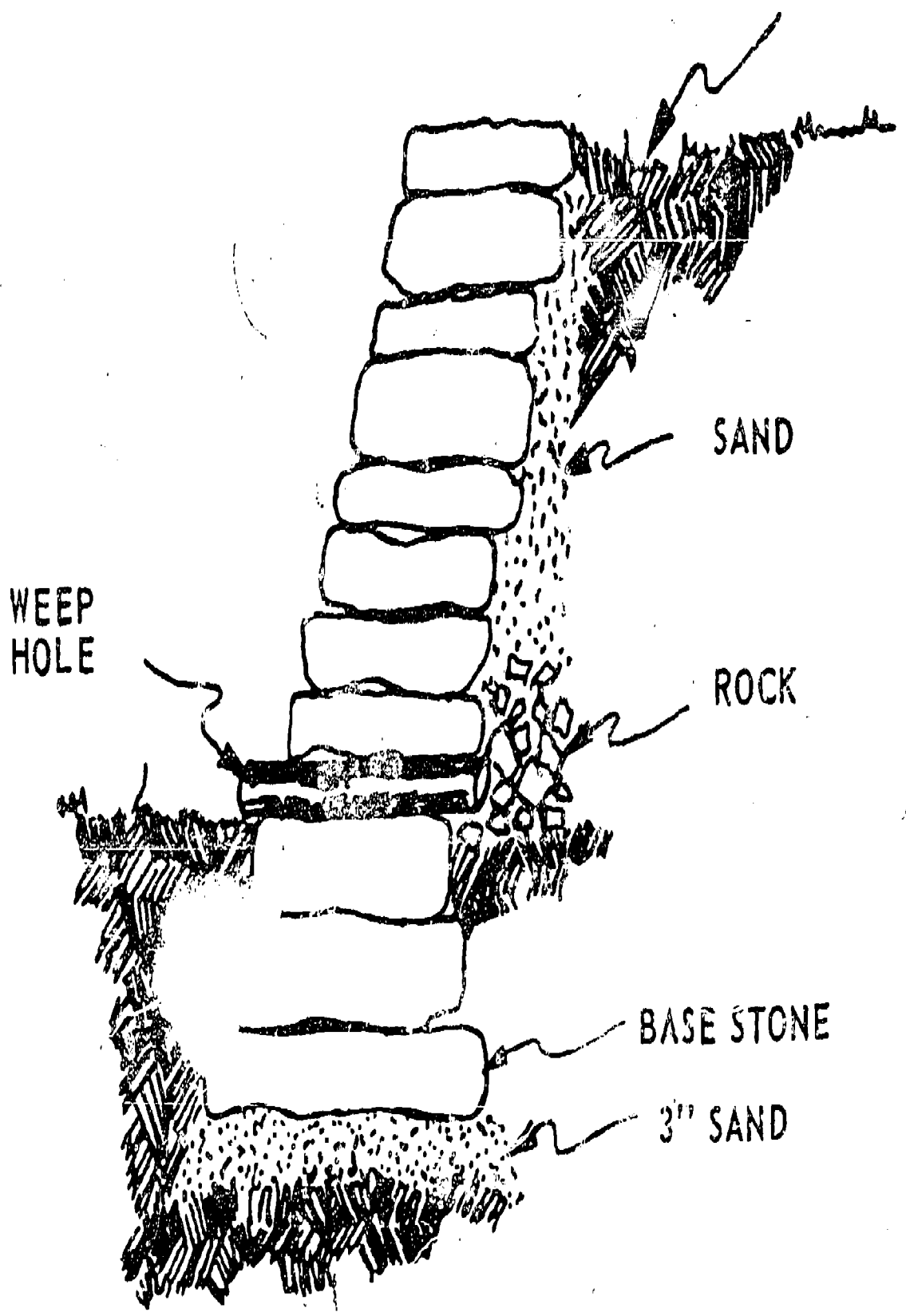

# POST WALL

CLUSTER OF POST FOR STRENGTH

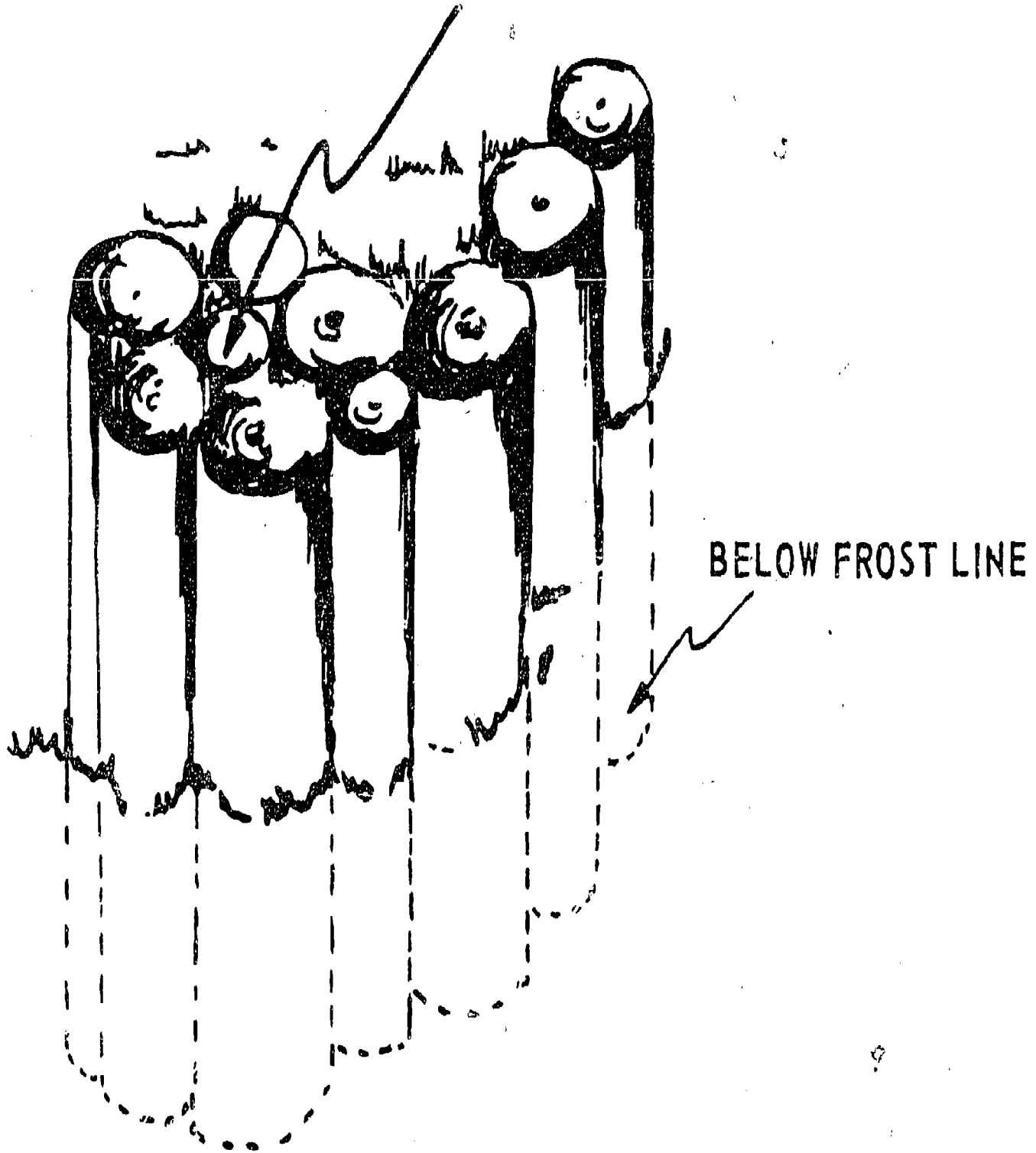

M-111-L-3-19

# RAIL ROAD TIES

BLUNT END SO IT WILL NOT PULL THROUGH

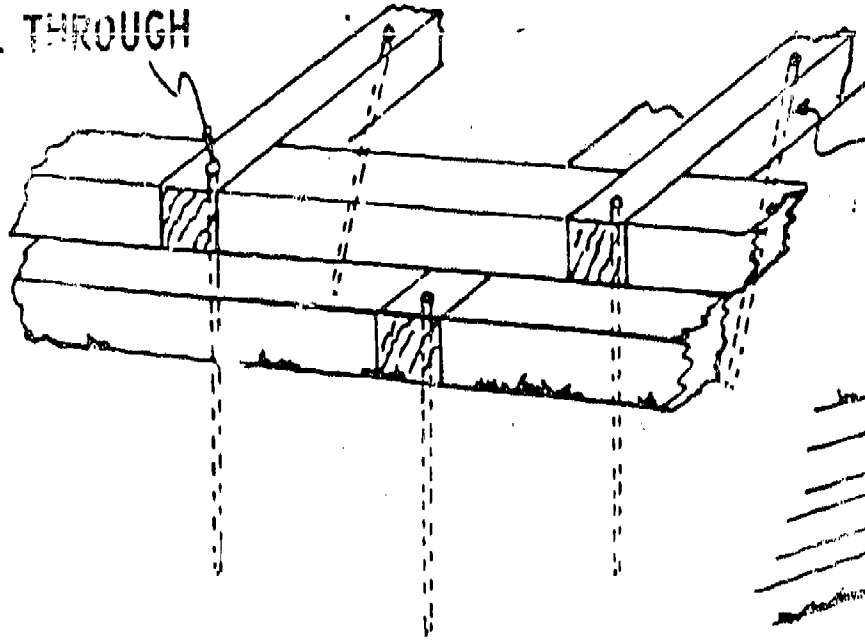

METAL STAKE AT AN ANGLE

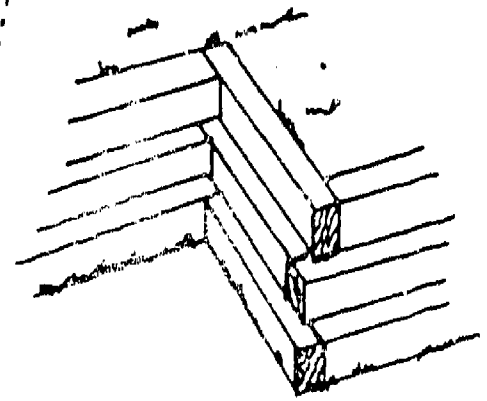



# BRICK WALL

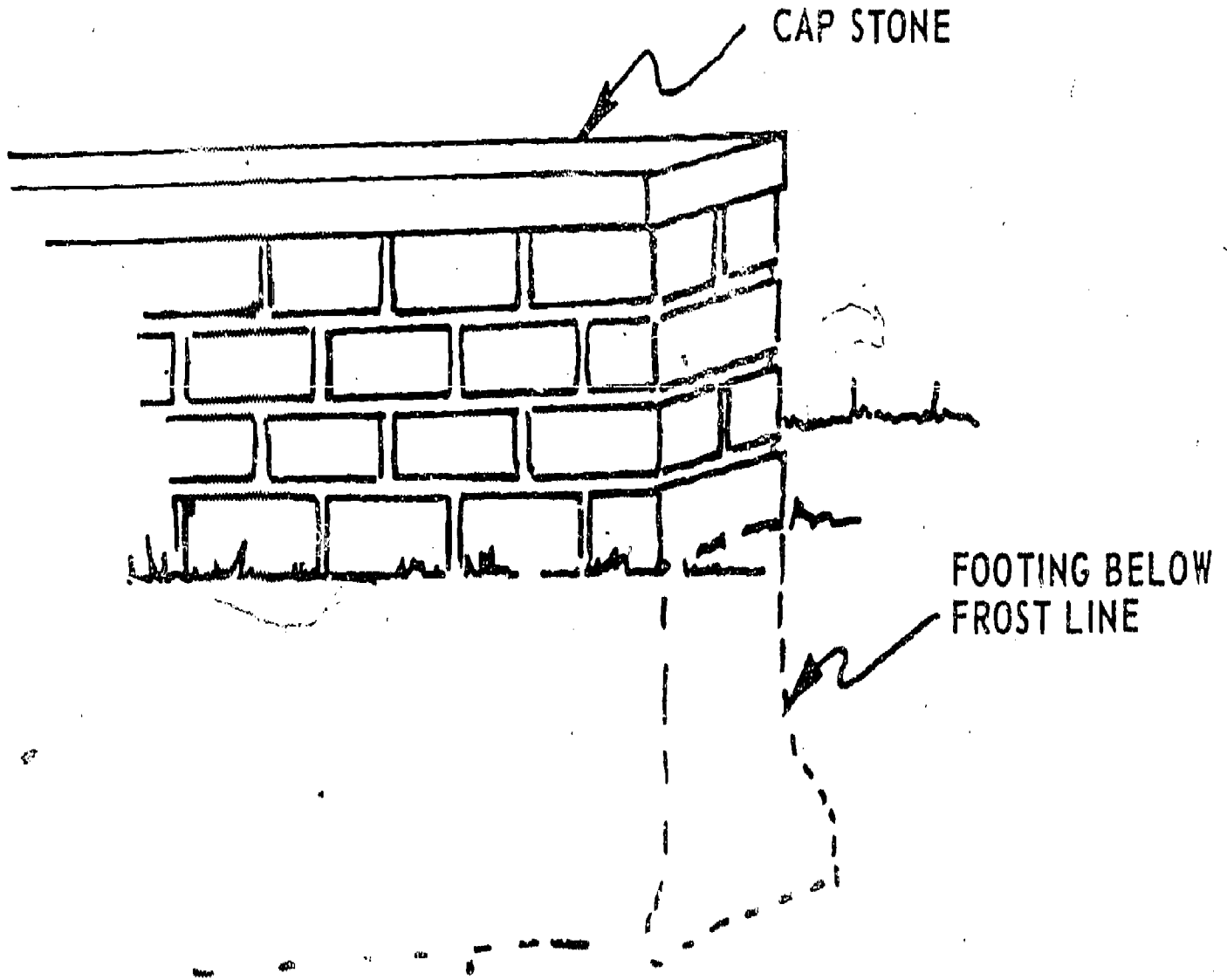

180

180

## TRANSPARENCY DISCUSSION GUIDE

### FENCES AND RETAINING WALLS

This discussion outline has been taken from Landscape Construction Series No. 3 and No. 4, prepared by Floyd Giles and Roger Courson and published by Vocational Agriculture Service, University of Illinois.

#### I. Transparency - FENCE FRAMEWORK AND BRACING

- A. Here is a section of fence frame work properly done. The posts are set in concrete and a concrete edge is used at the surface. Such a frame can be used to support almost any kind of fence material that can be nailed or attached.

#### II. Transparency - CORNER BRACING

- A. Bracing should be done as illustrated. Brace to the corner top to apply pressure at the fence's weakest point and at the point of most stress.

#### III. Transparency - SETTING POST ON HILLS

- A. Posts set on a hillside should be tilted a few degrees back toward the hill at the time of setting. When all settling ends, the post will be plumb.

#### IV. Transparency - CHALK LINING A FENCE

- A. Set the corner post and use a chalk line to assure a straight fence and to keep a straight topline.

#### V. Transparency - FENCING OVER A HILL

- A. When fencing a small area on a changing grade, use the method illustrated. The arrows indicate where the span between posts has been shortened to allow a drop. If the grade does not change too rapidly, adjust the spans to give the same amount of drop at each post.

#### VI. Transparency - RAIL FENCING

- A. Rail fencing gives a rustic effect and should be kept in an appropriate setting. Keeping rail fences clean of weeds can be a full-time job. If this fence is used to border a natural area and allowed to blend into the surroundings, it can be a useful fence.

#### VII. Transparency - MOWING CLEARANCE UNDER FENCING

- A. When building fences, leave mower clearance if possible.

## VIII. Transparency - FENCE POST JOINTS

- A. These are some examples of joints used in fencing. The butt joint is the weakest.

## IX. Transparency - CONCRETE RETAINING WALL

- A. This is the design for a concrete retaining wall. Any one wall might not have all of these features, such as the buttress and dead men, but one would be enough, except in extreme cases. The freeze taper can be of great assistance in relieving the pressure of quick freezing and thawing in spring.

## X. Transparency - FREE LAID STONE RETAINING WALL

- A. Retaining walls are built to retain soil. If this were the only force that had to be retained, construction would be no problem. However, the force of winter heaving, sluff, and water all work together and do as much damage as soil pressure.
- B. Proper back slant of the wall will take care of the soil pressure and sluff. Walls much over 4 feet should have a dead man, buttresses, or ledger rocks. Ledgers are used only with free-laid stone. They are long stones laid with the length sticking back into the retained soil area.
- C. The water can be taken care of by a slight depression or channel just behind the top of the wall. Underground water or seepage can be collected in a stone pocket of grout at the base of a sand shaft. This water can, then, be drained off through a pipe, called a weep hole. If there is a considerable amount of water to carry off, a field tile can be installed at the base of the wall in the area of the rock or grout. This tile would run the length of the wall and drain at the end of the wall or into a storm sewer.
- D. Freeze damage can be taken care of with the sand backfill and proper back tilt. Free-laid walls are often planted, and this is also a help in controlling freeze damage. The minimum back tilt is 1 foot back for every 3 feet of height.

## XI. Transparency - POST WALL

- A. Posts can be used, but they have a height limit of about 4 feet. At this height, there must be as much post underground as above.

## XII. Transparency - RAILROAD TIES

- A. Railroad ties have long been used for retaining walls. All of the same factors that were mentioned previously apply here plus one--the weight of the material. Ties are much lighter than stone or concrete and, therefore, need to be more securely anchored to the retained soil. This can be done by using a tie placed back

into the back at even intervals and pinned to the wall with 1/2 inch reinforcing rods. Walls over 4 feet should use this method without fail. Rod is also used to pin tie to tie. A change in direction also adds strength and interest.

### XIII. Transparency - BRICK WALL

- A. Free standing walls must be capped off to stop freeze damage. This is called a cap stone or coping. This stone should be extended slightly over the edge so water will not run down the side of the wall.

SAMPLE TEST QUESTIONS AND TEACHER'S KEY  
CONSTRUCTING FENCES AND RETAINING WALLS

TRUE OR FALSE:

- T   1. Materials used in landscape construction should fit the overall design.
- T   2. In Illinois, freezing and thawing is a major force causing the destruction of many retaining walls.
- F   3. Railroad ties are not recommended for retaining walls due to the fact that they rot within 3-4 years.
- T   4. The concrete used to set fence posts should extend below the frost line.
- F   5. Most woods are decay-resistant and do not need to be treated with preservatives for use outside.
- T   6. Timbers, field stone and flagstone are commonly used for retaining walls.

SHORT ANSWER:

1. Retaining walls are built to retain soil.
2. A weep hole under a retaining wall is for underground water drainage.
3. The minimum back tilt for retaining walls is 1 foot back for every 4 feet of height.
4. If a retaining wall is not tilted enough the materials will dislodge and come apart.
5. When changing directions of a retaining wall made with railroad ties, the corners should interlock.
6. Fence posts should be set below the frost line.
7. Fence posts should be set in concrete for best support.
8. Butt joints are the weakest joints used in fencing.
9. The frost line in our geographical area is \_\_\_\_\_ inches below the surface.

## UNIT L: DESIGNING, ESTABLISHING AND MAINTAINING THE LANDSCAPE

### PROBLEM AREA: INTERIOR PLANTSCAPING

#### SUGGESTIONS TO THE TEACHER:

This instructional packet is designed for use with third year or advanced students in a horticultural occupations program. The recommended time for teaching this problem area is during the winter months when outdoor activities are limited.

The estimated instructional time for this problem area is 3 to 6 days, depending on how far the teacher wishes to develop interior plantscaping skills at the third year level. If the teaching plan is limited to classroom discussion with little or no practice or observation, the instructional time can be 3 days or less. If the students are to be involved in other activity exercises, the instructional time will need to be increased.

The instructor is encouraged to conduct a local search to locate other supplementary materials for use with this problem area. The items in this problem area are for reference or modification as instructors adapt this problem area to their local situation.

#### CREDIT SOURCES:

These materials were developed through a funding agreement, R-33-13-D-0362-466 with the Illinois State Board of Education, Department of Adult, Vocational and Technical Education, Research and Development Section, 100 North First Street, Springfield, Illinois 62777. Opinions expressed in these materials do not reflect, nor should they be construed as policy or opinion of the State Board of Education or its staff.

The teacher's guide, information sheets, student worksheets, and sample test questions were developed by Marcia Watman-Lauchner, Department of Vocational and Technical Education, University of Illinois. Suggestions and guidance in the development of these materials were provided by the Metropolitan Core Curriculum Field Test Teachers and Marianne Ringger, Division of Agricultural Education, University of Illinois.

## TEACHER'S GUIDE

- I. Unit: Landscape design, establishment and maintenance
- II. Problem area: Interior plantscaping
- III. Objectives: At the end of this problem area, students will be able to:
  1. Demonstrate the ability to account for several important factors when designing an interior landscape including 1) the needs of the plants, 2) the indoor climate, 3) how sunlight exposures change from season to season, and 4) the floor plan and aesthetic elements of the room.
  2. Identify water and light requirements, proper conditions, sunlight exposure, and humidity and temperature levels for houseplants and outdoor plants that can be grown indoors.
  3. Identify containers and creative ways to display plants.
- IV. Suggested interest approaches:
  1. Ask students about the placement of their houseplants at home. Try to identify what reasons they had for placing the plants in their particular location.
  2. Ask students why houseplants are popular.
  3. Show students pictures of rooms with and without plants and have them list ways in which plants enhance the interior of a room.
  4. Bring in sample foliage plants and ask which ones would grow best in the home.
- V. Anticipated problems and concerns:
  1. What environmental factors affect the use of plants indoors?
  2. Which plants survive best in an indoor climate?
  3. Which plants do best in specific exposures indoors?
  4. What kind of problems will occur when introducing new plants to the indoor environment and how do we deal with the problems?
  5. How can we tell if a plant is not suited to its room placement?
  6. What design elements should we consider when decorating a room with plants?
  7. Which plants are not suited for an indoor climate?

8. How can natural and artificial lighting best be used?
9. What types of containers and plants stands or props can be used to enhance the use of plants in the interior of a room?

VI. Suggested learning activities:

1. Have students read and discuss Information Sheets 1 through 5 on the various aspects of interior plantscaping.
2. Have students complete Student Worksheet 1 - Plants Commonly Used in Interior Plantscaping. References will need to be supplied. Plants can be added or deleted at the teacher's discretion.
3. Have students complete Student Worksheet 2 - Interior Plantscaping. A plant list should be compiled by the student unless the instructor would rather choose the plants beforehand. Other worksheets can be devised for interior plantscaping. Examples could be public places such as bank lobbies, offices with and without natural light or other rooms in the home.
4. Have students bring in pictures or examples of different containers and plant stands and evaluate how they could be used in the home.
5. Visit a site which has been plantscaped such as an office building, restaurant, or mall. Have students draw the design and critique it on the basis of design and plant suitability.

VII. Application procedures:

1. The skills learned in this problem area should be applied to the student's home situation.
2. The skills learned in this problem area will aid students working in garden centers, florist shops and with interior plantscaping companies.

VIII. Evaluation:

1. Administer a written exam using sample test questions included in this problem area.
2. Evaluate student worksheets.

IX. References and aids:

1. Vocational Agriculture Service, 1401 S. Maryland Drive, University of Illinois, Urbana, Illinois 61801.

VAS Subject Matter Units: 5019 - Care of Flowering Pot Plants In the Home  
5007 - Growing Plants Indoors



VAS Slide Sets:    S613   - Planting and Care of Hanging Baskets  
                          S614-1 - Care of Flowering House Plants  
                          S614-2 - Care of Gift Plants in the Home

2. University of Illinois, Cooperative Extension Service, Horticultural Facts, FL-1-79 - Indoor Gardening
3. All About Houseplants - An Ortho Book
4. Decorating with Plants - A Time-Life Book
5. Growing Foliage Plants - A Time-Life Book

## INFORMATION SHEET 1

### DESIGN CONSIDERATIONS IN INTERIOR PLANTSCAPING

#### CREATE A FEELING:

Using plants in interior areas can achieve several different effects to enhance the aesthetic value of the area. Plants have a way of softening and blending contrasts within an interior to create a pleasant and restful environment. They also can be used to accent or brighten an area. Whatever the room, plants can be used to create a feeling of freshness, restfulness, excitement, or beauty depending on how they are used and arranged with the existing elements of the room. When decorating with plants concentrate on the feeling you want to create and use plants to create the feeling.

#### DEALING WITH SPECIAL PROBLEMS:

Plants can be used to relieve a sterile look in the home or office by setting plants around on tables or dishes to soften the cold look of some interiors.

Instead of hanging pictures, break up an expanse of wall with groups of plants of varying heights, widths, leaf shapes and colors to break the monotony. The same elements of landscape design would apply here. Remember to gradually change the height and texture of plants using tall, large, or colorful plants as focal points.

Tall, narrow plants placed in corners of small rooms will emphasize vertical lines and create a feeling of space in an otherwise cramped room. In addition, plants placed in front of mirrors can create the same effect.

Plants used on book shelves or mantles can soften the blocky effect often created by the rectangular shape of books and shelves.

Using plants in an empty space will soften the starkness of a room when the plants fill the space adequately. Avoid using plants too small or too large for a space.

#### CONTAINERS AND PLANT STANDS

The types of containers and plants stands available for use are only limited by your imagination and budget. When choosing containers be sure they will provide adequate drainage. Beyond this the only other consideration is how the container will blend with the decor of the room and the size of the plant. Plant containers should not be too large or too small proportionately to the size of the plant. Also, they should compliment the plant and decor of the room, not detract from it.

Plant stands should fit with the decor of the room and enhance the displaying of the plant, as well as be sturdy and stable.

## INFORMATION SHEET 2

### CREATING THE PROPER ENVIRONMENT

There is no such thing as a native "houseplant." All plants are native to an outdoor environment somewhere. Given the proper environmental conditions, almost anything that grows outdoors can be considered a houseplant.

Gardening indoors allows for pure imagination. Flowers, shrubs or trees growing in containers indoors allows for easy rearrangement according to the design of the room, the season and one's creativity. With careful selection indoor plants can be combined effectively with the overall interior design.

For those interior spaces where natural light is at a minimum, artificial lighting can increase the types of plants that can be grown indoors.

Eight points to remember when placing plants indoors are listed below.

1. An indoor environment usually has a relatively constant temperature and humidity.
2. Containers restrict root growth and the soil may fluctuate in moisture and fertility.
3. All movement is minimal and there is no refreshing rain to cleanse the foliage.
4. Plants are easily over or under-watered.
5. Feeding is concentrated to only certain times.
6. Natural light usually is from one direction only.
7. The time of darkness is shorter.
8. There is much less light indoors than found in the plant's native environment.

There are two kinds of light in the interior plantscape, natural (from the sun) and artificial (man-made by the use of fluorescent and incandescent lighting fixtures). Natural and artificial light can be used separately or together.

The four seasons have a definite effect on the interior plantscape. The amount of light entering a room through a window increases after December 22 and decreases after June 22. The angle of natural sunlight also changes throughout the seasons. To allow for these changes, the interior plantscape may need to be shifted each season.

## INFORMATION SHEET 3

### THE NEEDS OF PLANTS.

#### LIGHT:

Light is what plants rely on for photosynthesis to occur. Plants vary as to how much light they actually need to grow satisfactorily. Four light categories apply to interior plantscapes:

1. Sunny - at least 5 hours of direct sunlight in winter south, southeast or southwest exposures
2. Semi-sunny - 2-5 hours of sun in the winter east or west window exposures
3. Semi-shady - bright sunlight, but little or no direct sunlight
4. Shady - no direct sunlight, but enough to cast a shadow

There are many factors that affect the amount of sunlight allowed to enter the inside. They include the geographical area you live in, surrounding industries that emit smoke, the amount and type of trees and shrubs outside and in front of the window, the amount of dirt on windows inside and out, and the presence of window screens.

Artificial light can supplement or serve as a substitute for natural sunlight in the interior plantscape. Artificial light can extend the growing season. There are two types of artificial light, incandescent and fluorescent.

Incandescent light comes from the common household lightbulb. This type of light carries the red and infra-red rays, the same as emitted from the sun. However, incandescent light does not emit the blue and violet rays of the spectrum. Incandescent lights also give off heat. This heat can damage or burn the plant if it is left too close. It is best to keep incandescent lights at least one foot from the top of the plant(s).

Fluorescent light is usually found in school classrooms, offices and public places. This type of light is long lasting, more economical and energy efficient than incandescent and distributes its light more evenly. Fluorescent light emits the blue and violet rays of the spectrum and a very small amount of the red rays. The cool-white fluorescent tube is the most common type used in interior plantscapes, although the deluxe warm white is more flattering to indoor furnishings. This type of light can be placed as close as 1 inch to the plants because the amount of heat given off is minimal. Any distance past 18 inches is too far to warrant a significant amount of growth.

Fluorescent and incandescent lights can be combined in order to provide the full spectrum of natural sunlight. Another source used to achieve the proper proportion of light rays is "plant growth" lamps. This is the easier method of the two. These are modified fluorescent lamps that provide the blue and red rays and are sold under many trademark names.

## INFORMATION SHEET 3 - Continued

### HUMIDITY:

Humidity is the amount of moisture in the air. An average house has a humidity range of 30-45%. A moist atmosphere is 45-60% and Very moist is above 60%.

A cool vapor humidifier is an excellent way to increase humidity. Portable units can be placed where needed. Some homes have a humidifier installed as part of the heating system. Setting potted plants on trays of pebbles or frequent misting can also increase the humidity.

### TEMPERATURE:

Most plants do best in a temperature range of 65°-75°F. Tropical plants may be harmed at temperatures below 60°F, whereas some plants do best at a 60°-65°F range. All plants should be kept away from cold or hot air drafts.

Cool-loving plants prefer day temperatures of 55°-60°F and 40°-50°F at night. The warm-loving plants prefer day temperatures of 80°-85°F and 62°-65°F at night. The average indoor plant does best at 70°F in the day and 50°-55°F at night.

### WATER:

Different plants need varying amounts of water depending on the size of the plant, the container used and the season. On short, cloudy, humid days, the plants will use less water than on long, clear, sunny days. Most plant roots do best when they are moist, not extremely dry or wet. The best way to tell if a plant needs water is to insert your finger about 1 inch into the soil.

Water softened by the zeolitic system can be very harmful to your plants. This kind of softener replaces the calcium (which makes the water hard) in the water with sodium which settles and accumulates in houseplant soil. If your water is softened by this method, have one tap in the water line for unsoftened water. Otherwise, it is best to collect rainwater to water your plants.

201

## INFORMATION SHEET 4

### THE FOUR EXPOSURES

#### THE NORTH:

The northern exposure receives the least amount of light and heat year-round. However, northern light is fairly constant throughout the day and has less variation than the other three exposures.

There is a wide variety of foliage plants that do well with the low light exposure from the north. Plants with colored foliage may lose some of their color when placed in a northern exposure. Plants grown for their flowers will generally not do well in a northern exposure.

#### THE EAST:

The eastern exposure receives direct morning light until midday. Eastern exposure light does not create the heat that a southern or western exposure does. Therefore, the light is less dehydrating. Most houseplants will generally do well when placed in an eastern exposure.

#### THE SOUTH:

The southern exposure receives light most of the day. Southern exposure light may create some heat and sometimes more humidity is needed.

#### THE WEST:

The western exposure creates the most heat of all four exposures, especially in the summer. Some plants may die from staying in a western exposure for too long a time. If the only exposure available for growing houseplants is from the west, humidity, air circulation and a light-filtering curtain should be provided during the months of April through October.

Cacti, succulents and annuals do best in a western exposure. Other plants should be placed 2 - 3 feet away from a western window to protect them from the sometimes intense heat.

INFORMATION SHEET 5

COMMONLY USED INTERIOR PLANTS

COMMON PLANT NAME	BOTANICAL NAME
Aluminum plant	<u>Pilea cadierei</u>
Aralia, false	<u>Dizygotheca elegantissima</u>
Areca palm	<u>Chrysalidocarpus lutescens</u>
Arrowhead	<u>Syngonium</u> species
Asparagus fern	<u>Asparagus</u> species
Bamboo palm	<u>Chamaedora</u> species
Boston fern	<u>Nephrolepis exaltata</u> 'Bostoniensis'
Bromeliad	<u>Cryptanthus</u> species
Chinese evergreen	<u>Aglaonema</u> species
Coleus	<u>Coleus</u> species
Crossandra	<u>Crossandra infundibuliformis</u>
Dieffenbachia	<u>Dieffenbachia</u> species
Dracena	<u>Dracena</u> species
English ivy	<u>Hedera helix</u>
Monstera	<u>Monstera</u> species
Norfolk Island pine	<u>Araucaria heterophylla</u>
Parlor Palm - dwarf	<u>Chamaedorea elegans</u>
Peperomia	<u>Peperomia</u> species
Philodendron	<u>Philodendron</u> species
Piggyback plant	<u>Tolmiea menziesii</u>
Pothos, Devil's ivy	<u>Epipremnum</u> species and <u>Scindapsus</u> species
Purple velvet plant	<u>Gynura scandens</u>
Rubber plant	<u>Ficus elastica</u>
Schefflera	<u>Schefflera</u> and <u>Brassaia</u> species
Snake plant	<u>Sanseveria</u> species
Spider plant	<u>Chlorophytum</u> species
Wandering Jew	<u>Tradescantia</u> species
Wax plant	<u>Hoya</u> species
Weeping fig	<u>Ficus benamina</u>
Yucca	<u>Yucca</u> species
African violet	<u>Saintpaulia</u> species
Amaryllis	<u>Hippeastrum</u> species
Azalea	<u>Rhododendron</u> species
Begonia-Rex	<u>Begonia rex-cultorum</u>
Calceolaria	<u>Calceolaria</u> species
Christmas cactus	<u>Schlumbergera</u> species
Cape primrose	<u>Streptocarpus</u> species
Chrysanthemum	<u>Chrysanthemum</u> species
Cineraria	<u>Senecio hybridus</u>
Cyclamen	<u>Cyclamen</u> species
Easter lily	<u>Lilium longiflorum</u>
Gloxinia	<u>Sinningia</u> species
Goldfish plant	<u>Nematanthus</u> species
Hibiscus	<u>Hibiscus rosa-sinensis</u>
Moses in the cradle	<u>Rhoeo</u> species
Poinsettia	<u>Euphorbia pulcherrima</u>
Zebra plant	<u>Aphelandra</u> species

# STUDENT WORKSHEET 1

## GREEN PLANTS COMMONLY USED IN INTERIOR PLANTSCAPING

INSTRUCTIONS: Fill in the chart for selected plants commonly used in interior plantscaping. Refer to the listed references on plants in the References and Aids section.

Plant Name	Height and Width of plant	Light Requirement	Sunlight Exposure	Water Requirement	Temperature Requirement	Special Considerations
6						205



STUDENT WORKSHEET 2

INTERIOR PLANTSCAPING

INSTRUCTIONS: Select and arrange appropriate plants to fit the following floor plan. Select 10 to 15 different plants considering plant needs, the interior climate, and the design elements of the room.

FIRST LEVEL

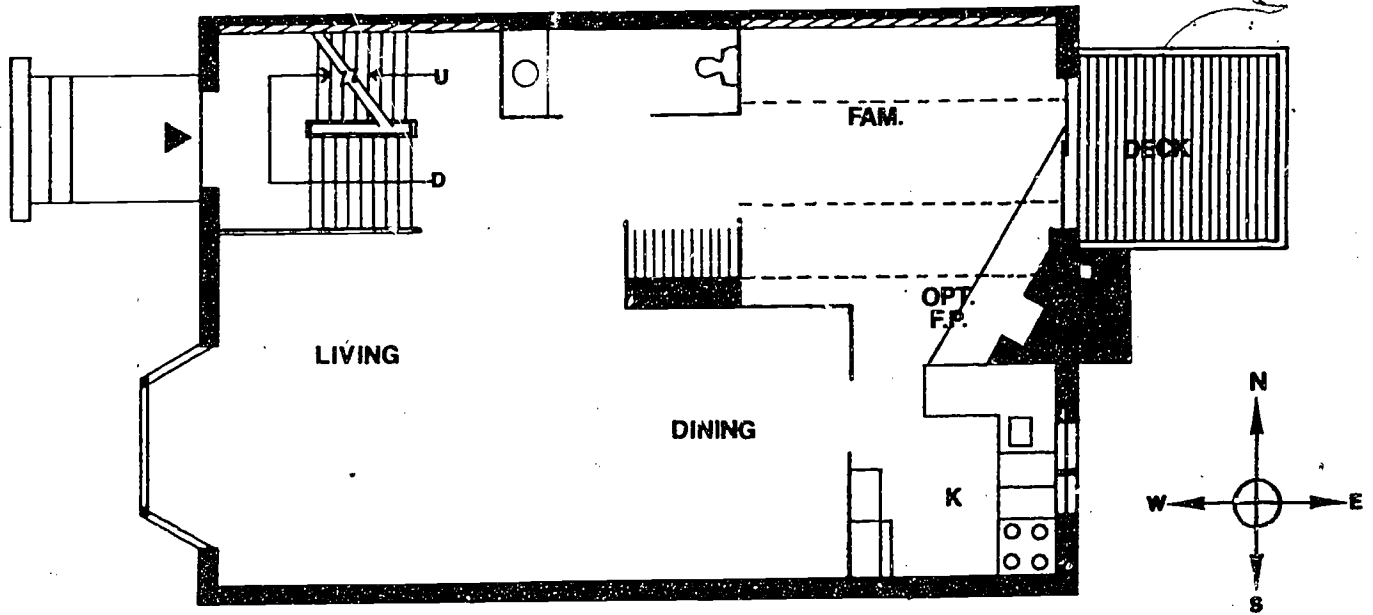

293

# SECOND LEVEL

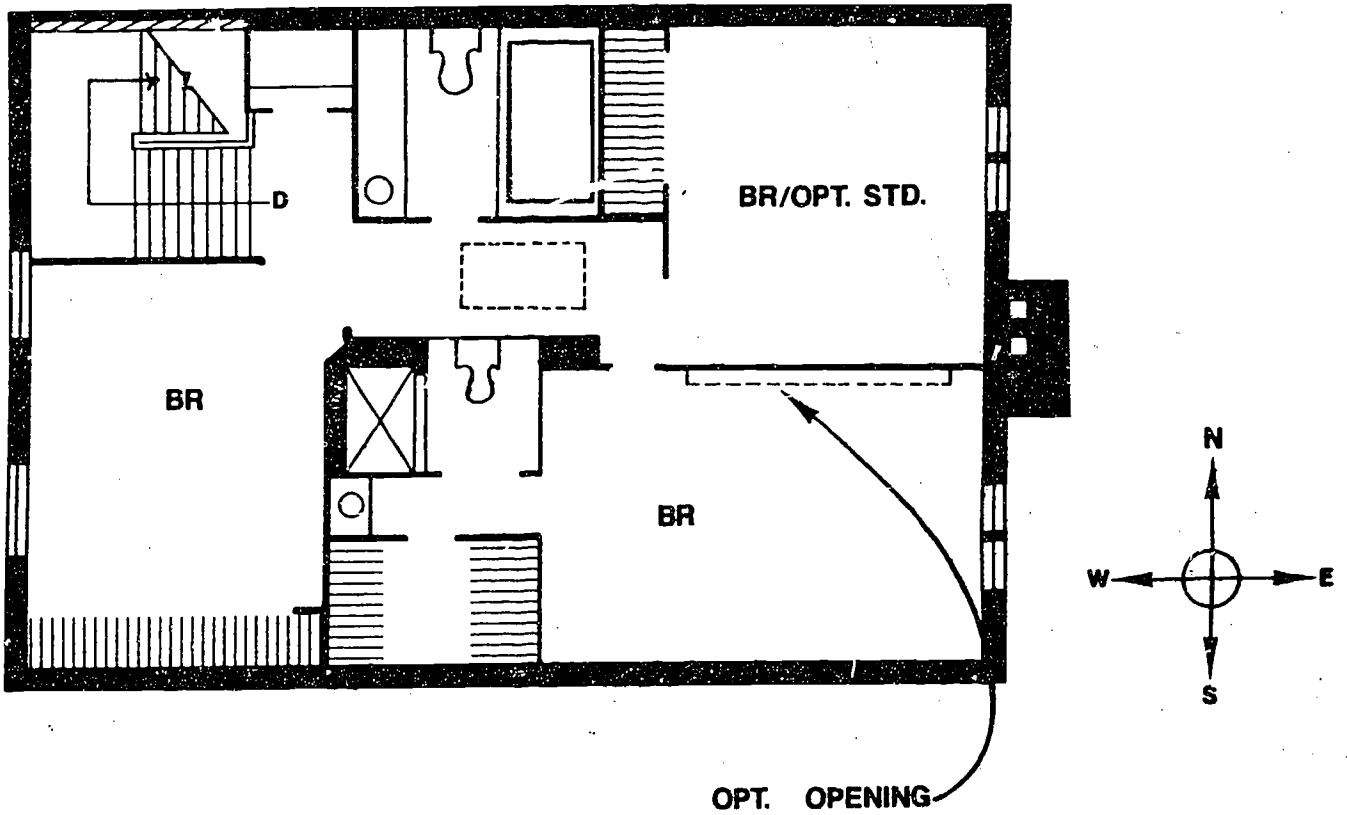

207

M-III-L-4-15

## SAMPLE TEST QUESTIONS AND TEACHER'S KEY

### INTERIOR PLANTSCAPING

#### SHORT ANSWER:

1. What are the four light exposures for growing plants indoors?

North	East
South	West

2. Name four points to remember when placing plants indoors.

- indoor environments have relative constant temperature and humidity
- soil may fluctuate in moisture and fertility
- air movement is minimal
- plants may be easily over/under-watered
- feeding is concentrated
- natural light usually from one direction
- shorter dark hours
- less light indoors

3. What types of light are available in interior plantscapes?

- natural or man-made

4. Why do plants need light?

- Light is needed for photosynthesis to occur

5. Name the 4 light categories and the hours of direct sunlight they receive.

- sunny - at least 5 hours
- semi-sunny - 2-5 hours
- semi-shady - little or no direct sunlight
- shady - 0 hours

6. Name five factors that affect the amount of sunlight entering a room.

- part of the world one lives in
- surrounding industries
- amount and type of outdoor plants in front of the windows
- amount of dirt on the windows
- presence of window screens

7. What are two types of artificial light?

- incandescent, fluorescent

8. Which type of artificial light emits red and infra-red light rays?

- incandescent

9. Which type of artificial light emits blue and violet light rays?
  - fluorescent
10. Which type of artificial light gives off the most heat?
  - incandescent
11. What is a "plant growth" lamp?
  - a modified fluorescent lamp that provides blue and red light rays.
12. What is humidity?
  - the amount of moisture in the air.
13. What is the percent of humidity of an average house, a moist area and a very moist area?
  - average house -- 30-45%
  - moist -- 45-60%
  - very moist -- 60%+
14. What is one way to increase humidity?
  - Using a cool vapor humidifier
  - Setting potted plants on a tray of pebbles
  - Frequent misting
15. Cool-loving plants prefer day temperatures of 55° - 60°F .
16. Warm-loving plants prefer day temperatures of 80° - 85°F .
17. The average indoor plant does best at 70°F in the day and 50° - 55°F at night.
18. What is a quick way to tell if a plant needs to be watered?
  - Insert your finger 1 inch into the soil
19. Which exposure creates the warmest temperatures?
  - West
20. Which exposure receives light most of the day?
  - South

# **UNIT M: Retail Floriculture**

## **PROBLEM AREAS:**

- 1. Handling and preparing cut flowers**
- 2. Ordering and buying cut flowers**
- 3. Making corsages, nosegays and table arrangements**

## UNIT M: RETAIL FLORICULTURE

### PROBLEM AREA: HANDLING AND PREPARING CUT FLOWERS

#### SUGGESTIONS TO THE TEACHER:

This problem area should be taught to advanced horticultural occupations students. The area may be taught at any time during the year and therefore, may be incorporated in the winter months when no outdoor horticultural activities are possible. The instructor may wish to integrate the problem area with floral design so that the cut flowers needed may serve a dual purpose.

The estimated instructional time for this problem area is 5 to 10 days, depending on the teacher's perception of the students' needs. If the instruction is limited to classroom discussion with no outside field trips, resource persons, or experiments, the instructional time can be reduced to 3 to 4 days. If the students are to be involved in activity exercises, the instructional time will need to be increased.

The instructor is encouraged to conduct a local search for resource speakers and experts in post-harvest physiology. It is imperative that a relationship be established with a retail or wholesale florist so materials may be purchased or donated for classroom use. Greenhouse growers of cut flowers, wholesale florists, and retail florists have adapted their own practices of cut flower care and handling which would enrich and localize the problem area. The items in this problem area are for reference and modification as instructors adapt these materials to their local situation.

#### CREDIT SOURCES:

These materials were developed through a funding agreement, R-33-13-D-0362-466, with the Illinois State Board of Education, Department of Adult, Vocational and Technical Education, Research and Development Section, 100 North First Street, Springfield, Illinois 62777. Opinions expressed in these materials do not reflect, nor should they be construed as policy or opinion of the State Board of Education or its staff.

The teacher's guide, information sheets, student worksheets, laboratory exercises and sample test questions were developed by Christine Townsend, Illinois State University and Kallie Grobstein, Department of Vocational and Technical Education, University of Illinois. Transparency masters were prepared by the Vocational Agriculture Service, University of Illinois. Suggestions and guidance in the development of these materials were provided by the Metropolitan Core Curriculum Field Test Teachers.

## TEACHER'S GUIDE

- I. Unit: Retail floriculture
- II. Problem Area: Handling and preparing cut flowers
- III. Objectives: At the close of this problem area, students will be able to:
  1. Prepare and condition cut flowers received from a wholesale florist or grower in order to create longest vase life for consumer use.
  2. List requirements for 3 different flowers in terms of temperature, humidity, ventilation, and lighting.
  3. Recognize and prevent ethylene gas damage to floral products.
  4. Identify the components and proper use of floral products.
  5. Identify the availability, vase life, handling and conditioning procedures, and storage of at least 5 cut flowers used in the retail floriculture industry.
  6. Eliminate the environmental factors that affect cut flower problems such as botrytis, bent neck, and geotropic response in order to increase the vase life of the cut flowers.
- IV. Suggested interest approaches:
  1. Bring in a "dead" floral design and ask students, "What happened to these flowers?"
  2. Have students discuss the times they have purchased flowers and how long they lasted.
  3. Take a trip to observe the care of cut flowers. Visit a floral shop, greenhouse, or wholesale florist and compare techniques of 2 different establishments.
  4. Have students predict the vase-life of various cut flowers, record the guesses, and begin an experiment to see who is "closest".
  5. Bring in a snapdragon that has been laid down for a day and shows geotropic response at the tip.
  6. Bring in 2 refrigerator cans, one dirty and one clean. Ask students, "Which is best for cut flower storage and why?"
  7. Compare 2 vases filled with flowers, 1 with preservative and one without, to demonstrate the effectiveness of floral preservatives.

8. Have students discuss times they have received flowers as a gift, and how they cared for them.

V. Anticipated problems and concerns of students:

1. What cut flowers last the longest after they are harvested?
2. Can something be added to the water to make flowers last longer?
3. Why do snapdragons, tulips, and gladiolus tips turn up when the flowers are laid in a horizontal position?
4. What temperatures are best for storage of different cut flowers?
5. Why shouldn't flowers and fruit be stored in the same refrigerator?
6. What equipment is needed to properly prepare cut flowers for consumer use?
7. Do light and humidity affect the vase-life of cut flowers like they affect the life of foliage plants?
8. What are the causes of quick death of cut flowers?
9. What are bullets?
10. What 2 methods are used to revive bent neck roses?
11. What are the most common mistakes the consumer makes when receiving flowers as a gift?
12. How long can flowers be stored "dry"?
13. How does one prepare newly purchased flowers?
14. Should flower stems be cut, broken or snapped?
15. How do I prepare the water to receive cut flowers?

VI. Suggested learning activities and experiences:

1. Discuss the myths of cut flower care after students have completed Student Worksheet 1 - Flower Care...Myths or Fact.
2. Have a florist demonstrate his/her techniques for increasing the vase-life of cut flowers.
3. Outline the procedure for immediate cut flower care with the aid of Information Sheet 1 - Steps to Follow When Flowers Arrive.



4. Compare the effects of cutting procedures of cut flowers including sharp knife, scissors, crushing stems, no fresh cut.
5. Identify a good preservative for cut flowers by comparing substances containing the necessary components (sugar, bactericide) using Laboratory Exercise 1 - Preservatives Experiment.
6. Set up a chart for general fresh flower care using Information Student Worksheet 2 - Fresh Flower Care.
7. Bring in examples of ethylene damage and discuss with the aid of Information Sheet 2 - Effects of Ethylene Gas on Cut Flowers.
8. Test the effect of ethylene gas on crops by placing high ethylene producing fruit (apples, oranges, etc.) in a plastic bag with various types of cut flowers.
9. Record the temperature of various coolers in retail or wholesale floral shops.
10. Draw the layout of the best example refrigerator or design your own according to the styles you have seen.
11. Clean roses according to industry standards using Laboratory Exercise 2.
12. Revive a wilted, bent neck, and/or bullet rose according to Information Sheet 3 - Post Harvest Care of Roses.
13. Examine the effect of geotropism on different cut flowers including snapdragons and gladiolus. Place the flowers horizontally. Record your observations, and present solutions to prevent this unattractive response in certain flowers.
14. Discuss how foliage can be stored with flowers after reviewing Information Sheet 4 - Decorative Foliage.
15. Have students set up experiments illustrating post-harvest handling procedures and then present the results to other classes.

VII. Application procedures:

1. The main purpose of this problem area is to teach information and procedures to increase the vase life of cut flowers and foliage.
2. Students should practice the procedures during future handling of cut flowers (i.e., during Floral Design Problem Area) at the school greenhouse and/or laboratory facility.

3. Students will be able to practice proper handling procedures while on the job at wholesale or retail floral outlets.

VIII. Evaluation:

1. Prepare and administer a pencil and paper test using sample test questions included in this problem area.
2. Collect and grade laboratory exercises and student worksheets.
3. Continuously observe and grade students on their post-harvest handling of all cut flowers and foliages brought into the school laboratory.
4. Have students complete the Competency Inventory Sheet included in this problem area to assess their progress.

IX. References and aids:

1. "Special Issue: Cut Flower Care Guide.", Florist, 1979, Florist Transworld Delivery Association, 29200 Northwestern Highway, P.O. Box 2227, Southfield, Michigan 48037.
2. "Proceedings of National Floricultural Conference on Commodity Handling.", 1976, George L. Staley, Jerry L. Robertson, and D. C. Kiplinger Department of Horticulture, The Ohio State University, The Ohio Florists' Association, 2001 Fyffe Court, Columbus, Ohio 43210.
3. Selected information sheets.
4. Selected student worksheets.
5. Selected laboratory exercises.

215

## COMPETENCY INVENTORY

### HANDLING AND PREPARING CUT FLOWERS

1. Student has no knowledge of competency.
2. Student has read about competency.
3. Student has seen competency performed.
4. Student has performed competency.
5. Student has performed competency without supervision.
6. Student does possess skill.
7. Student does not possess skill.

Competency	Circle One				
1. Prepare preservative solution for cut flowers	1	2	3	4	5
2. Revive a "bent neck" rose	1	2	3	4	5
3. Demonstrate proper preparation of flowers	1	2	3	4	5
4. Maintain a clean refrigerator	1	2	3	4	5
5. Receive a shipment of cut flowers	1	2	3	4	5
6. Demonstrate post-harvest care of roses	1	2	3	4	5
7.					
8.					
9.					
10.					
11.					
12. Recognize ethylene damage to carnations					6 7
13. Place an order to a wholesale florist correctly					6 7
14. Describe the vase-life of 5 flowers					6 7
15. Recognize geotropic response in flowers					6 7

These competencies outlined in the National Agricultural Occupations Competency Study are for entry level positions in horticulture.

\_\_\_\_\_  
Name Date

## INFORMATION SHEET #1

### STEPS TO FOLLOW WHEN FLOWERS ARRIVE

#### 1. LOOSEN WRAPPINGS

- A. Blooms will expand as they open
- B. Remove wilted, damaged blooms
- C. Report damage to wholesaler

#### 2. AVOID BLOCKAGES

- A. Stems blocked by bacteria or minerals from water
- B. Cut 1/2-1" from bottom of stem
- C. Quickly place in water to prevent air block

#### 3. ANGLE CUT BEST

- A. Prevents stem from "sealing" to bottom of container
- B. Remove all foliage which will be under water as it rots under water and will release harmful bacteria and ethylene
- C. Use a glove or rag to remove foliage so not to injure bark and prevent water uptake

#### 4. CLEAN CONTAINERS

- A. Clean with hot, detergent solution, disinfect with bleach, and rinse it should be "clean enough to drink from"
- B. Use non-metallic containers: no rust, ions of metal may interrupt positive actions of preservatives
- C. Use 100°-110° water with preservative

#### 5. PRESERVATIVES

- A. 1-4% sugar + anti-microbial agent like hydroxy-quinoiine citrate (HQC)
- B. De-ionized (DI) water can increase longevity if natural water contains over 200 PPM soluble salts
- C. Example preservative = 200 PPM HQC + 3% sugar

#### 6. KEEP FLOWER BLOOMS DRY

- A. Wet blooms encourage botrytis (a fungus which turns petals brown)

## INFORMATION SHEET #2

### EFFECTS OF ETHYLENE GAS ON CUT FLOWERS

#### FACTS ABOUT ETHYLENE GAS:

1. Ethylene gas speeds up the maturation of plants, therefore, causes cut flowers to wilt faster.
2. Ethylene is given off during respiration of mature fruits, flowers and foliage. Fungus and bacteria also give off ethylene gas.
3. Damaged fruit, flowers and foliage give off ethylene gas which will cause all plants nearby to age faster.
4. Ethylene gas affects cut flowers and foliage.
  - A. Carnations go to "sleep"
  - B. Roses turn "blue"
  - C. Snapdragons drop their florets
  - D. Leaves turn downward (Epinasty)

#### PREVENTING ETHYLENE DAMAGE:

1. Do not store fruit with flowers.
2. Do not store old cut flowers with new ones.
3. Use preservatives on fresh cut flowers.
4. Keep the cooler clean.
5. Use commercial ethylene "scrubbers".

210

## INFORMATION SHEET 3

### POST HARVEST CARE OF ROSES

Since cut roses are one of the most expensive, requested, and fragile cut flowers utilized in the floriculture industry, extreme care should be noted during post harvest preparation. The following key points are integral to extending the vase life of roses.

1. Roses should be cut underwater so a small drop of water remains on the newly cut stem at all times. This water bubble insures the stem won't be blocked by an air bubble to prevent future water uptake.
2. If blockage does occur, recut another inch from the base of the stem.
3. "Bent Neck" occurs when the rose evaporates more water than it takes up through the stem. Since roses are woody and evaporate water through stomates under the leaves, the less leaves the less evaporation.
4. "Bullets" are roses cut too tight. Place these roses in a tall container with the rose submerged to the base of the bud in a 110°-120° F preservative/water solution. Cover the top of the can with translucent waxed paper or a plastic bag. Place in good, but not direct sunlight. If roses were not cut "too green", they should open to desired bud stage.
5. To revive wilted roses, remove 1/2 foliage, recut stem, and place in warm preservative water (entire stem submerged) 20 minutes to 1 hour.
6. Store roses at 34° F.
7. Avoid letting water drip on rose petals to prevent botrytis, a fungus disease.
8. Preservatives can increase rose vase life 30 to 50 percent.

INFORMATION SHEET 4

DECORATIVE FOLIAGE\*

COMMODITY	STORAGE TEMPERATURE	
	F	C
Anthurium . . . . .	40-45	4-7
Asparagus . . . . .	32-40	0-4
Boxwood . . . . .	32	0
Camellia . . . . .	40	4
Cedar . . . . .	32	0
Croton . . . . .	35-40	2-4
Dieffenbachia . . . . .	55	13
Dracaena . . . . .	35-40	2-4
Eucalyptus . . . . .	35-40	2-4
Ferns:		
Adiantum (Maidenhair) . . . . .	32-40	0-4
Brake . . . . .	32	0
Dagger and Wood Ferns . . . . .	30-32	1-0
Leatherleaf (Baker) . . . . .	34-40	1-4
Staghorn . . . . .	55	13
Woodwardia . . . . .	32-40	0-4
Galax . . . . .	32	0
Holly . . . . .	32	0
Huckleberry . . . . .	32	0
Ivy, English . . . . .	32	0
Juniper . . . . .	32	0
Magnolia . . . . .	35-40	2-4
Mistletoe . . . . .	32	0
Mountain-laurel . . . . .	32	0
Palm . . . . .	45	7
Peperomia . . . . .	35-40	2-4
Philodendron . . . . .	35-40	2-4
Pittosporum . . . . .	35-40	2-4
Podocarpus . . . . .	40-45	4-7
Pothos . . . . .	35-40	2-4
Rhododendron . . . . .	32	0
Salal, Lemon Leaf . . . . .	32	0
Scotch-broom . . . . .	40	4
Smilax, southern . . . . .	40	4
Ti (Palm Lily) . . . . .	40	4

\*USDA Handbook No. 66, "The Commercial Storage of Fruits, Vegetables and Florist and Nursery Stocks".

## STUDENT WORKSHEET 1

### FLOWER CARE ... MYTHS OR FACT

DIRECTIONS: Mark the following statements as either true or false. Explain your reasons in the space provided below each statement.

\_\_\_\_\_ 1. Stems cut straight across take up less water than stems cut on an angle.

\_\_\_\_\_ 2. One may extend the life of cut flowers by adding a penny and/or aspirin.

\_\_\_\_\_ 3. Flowers will store longer when they are kept in water.

\_\_\_\_\_ 4. Flowers will drink more water if the container is full, than if the container is half full.

\_\_\_\_\_ 5. Sprite and 7-up are effective floral preservatives.

\_\_\_\_\_ 6. It is better to smash the ends of woody stems than to cut them.



STUDENT WORKSHEET 1 - Continued

- \_\_\_\_\_ 7. Roses with petals slightly open will not last as long as roses with very tight buds.

220

## STUDENT WORKSHEET 2

### FRESH FLOWER CARE\*

DIRECTIONS: Fill in the squares with the correct information

TYPE OF FLOWER	HANDLING	CONDITIONING	VASE-LIFE
ROSE			
ORCHID			
CARNATION			
DAISY			
MUM			
SPRING FLOWERS			

M-111-M-1-15

LABORATORY EXERCISE 1  
PRESERVATIVES EXPERIMENT

**OBJECTIVE:** After testing three preservatives (commercial or homemade) the students will be able to recommend the best of the three to consumers.

**CONDITIONS FOR THE TEST:**

1. Select area free from clutter which will be out of the way from daily activities.
2. Be sure there are no drafts, excessive heat or cold or any other obvious environmental factors which will affect the test.
3. Each preservative's content should be known to you. Be sure you know whether it has sugar, acid, and germicide in it.
4. Use only one type flower for each test.
5. Use freshest flowers and try to estimate age of flower from cut.

**EQUIPMENT AND MATERIALS:**

1. Vases
2. Flowers
3. Water
4. Preservatives (2 commercial, 7-up, aspirin, sugar)
5. Chart for recording data (i.e., Floralife, Crystal)

**PROCEDURES:**

1. Count out 4 flowers for each preservative testing.
2. Place 2 flowers in each vase and add preservative; you will have 6 vases--2 for each type preservative.
3. Set up another vase with plain water and 2 flowers for your control group.
4. On a sheet of paper make a chart to record the following: color change of flower, strength of stem, time of day when data taken, date of data taken, etc.
5. For at least 10 days take data twice daily (except weed ends).
6. At end of test, list conclusions and which of three was best, which was worse, how control group compared and other factors.

**PRECAUTIONS:**

1. Avoid using flowers of different ages.
2. Be sure to give each flower good, clean cuts at beginning of test.
3. Record any operation you do to interrupt test (cutting of stems, movement, drafts, etc.).

## LABORATORY EXERCISE 2

### CLEANING ROSES

**INTRODUCTION:** Roses are one of the most expensive flowers available at the retail floral shop. They will last between 3 to 6 days in a customer's home if they have been properly prepared by the florist.

**OBJECTIVE:** To prepare cut roses after harvest for the longest possible vase life.

**MATERIALS:**

1. Cut roses purchased from wholesale florist, retail florist, or rose grower
2. Sharp knife and heavy duty gloves
3. Storage can -- glass or plastic
4. Preservative and water

**PROCEDURE:** (Read through all items before beginning operation.)

1. Prepare 2 preservative solutions according to package directions, one in sink or deep dishpan for cutting, the other in the storage container. Use 100° F water.
2. Unpack roses from delivery protection wrapping.
3. Put on heavy duty gloves.
4. Hold a rose near the bud end and with your other hand, pull down over the lower 1/3 of the foliage and thorns with a light grip.
5. Remove the lower 1/3 of the foliage or any foliage which will be underwater.
6. Avoid using knives or thorn strippers which may cut the bark and cause the stem to dry out if the cut is above water level.
7. Using a sharp knife, recut about 1 inch from the stem ends while holding in a 100° F (37.8° C) preservative solution.
8. After cutting stems, immediately transfer to storage container.

**OBSERVATIONS:**

## TEACHER'S KEY - STUDENT WORKSHEET 1

### FLOWER CARE ... MYTHS OR FACT

**DIRECTIONS:** Mark the following statements as either true or false. Explain your reasons in the space provided below each statement.

- False 1. Stems cut straight across take up less water than stems cut on an angle.

Stems cut both ways take up the same amount of water. Angle cutting is recommended because it makes it easier to insert flowers into floral foam. It also prevents stem ends from sealing to the bottom of the container.

- False 2. One may extend the life of cut flowers by adding a penny and/or aspirin.

Both additives are supposed to act as floral preservatives. However, there is no evidence that either does any harm or good for the flowers.

- False 3. Flowers will store longer when they are kept in water.

Flowers must be conditioned in water before they are used. But, for long-term storage many flowers last longer stored dry. Stored dry at temperatures down to 31° F, the flowers are kept in almost a suspended state. Some species can be dry-stored for up to 4 weeks.

- False 4. Flowers will drink more water if the container is full, than if the container is half full.

The flower's vascular system sucks up water as it is needed. Filling containers to the top will not force more water into the stem. Use just enough water to prevent the container from running dry.

- True 5. Sprite and 7-up are effective floral preservatives.

Both soft drinks provide sugar for the flower as well as citric acid and carbonation to control microorganisms. The recommended mixture is equal parts of water and soft drink plus ½ teaspoon of chlorine bleach to each quart of solution. The bleach helps to cut bacterial growth.

- False 6. It is better to smash the ends of woody stems than to cut them.

Woody stems are poor water carriers and mashing them doesn't make them any better. The best way to get them to take up water is to cut the woody part off the stem.

STUDENT WORKSHEET 1 - Continued

False 7. Roses with petals slightly open will not last as long as roses with very tight buds.

According to "Roses, Inc.", vase life is not lost if a rose is allowed a day or two more time on the plant after it reaches the bud stage. If allowed this extra time, the bloom has a greater chance of opening without bent neck and it will last just as long as the one cut very tight. Some very tight buds may have been cut too early and may never open.

22

TEACHER'S KEY - STUDENT WORKSHEET 2

FRESH FLOWER CARE\*

DIRECTIONS: Fill in the squares with the correct information

TYPE OF FLOWER	HANDLING	CONDITIONING	VASE-LIFE
ROSE	Unpack immediately, or place closed boxes in the refrigerator for a few hours. Avoid scraping stems when dethorning. Cut off $\frac{1}{2}$ " of stem.	Place processed flowers in very warm water (100-110°F) at 40°F, with 90-94% humidity for at least 3 hours before use.	3-6 days
ORCHID	If delivered dry, cut ends of the stems & place in water tubes. Check water level if they arrive in tubes.	Mist orchids & place in plastic bags.	4-5 days if kept cool & sprayed with water
CARNATION	Cut off $\frac{1}{2}$ "-1" stems.	Place in 100-110° F preservative solution at 40° F, 90-94% humidity for several hours before use.	5-7 days, doubled with the use of a preservative
DAISY	Cut off 1"-2" of stem.	Place in 100-110° F preservative solution at 40° F, 90-94% humidity several hours before use. Change water daily when a preservative is not used.	3-7 days doubled with the use of a preservative
MUM	Break or cut off 2-3" of stem.	Place in 101-110° preservative solution at 40° F, 90-94% humidity for several hours before use.	7-14 days pompons 10 days
SPRING FLOWERS	Cut off $\frac{1}{2}$ "-1" of stem.	Place in 80-100° F preservative solution. Use 100-110° F solution for several hours before use of iris.	3-6 days Freesia 5-10 days

\*Based on "Special Issue: Cut Flower Care Guide"

## SAMPLE TEST QUESTIONS AND TEACHER'S KEY

### HANDLING AND PREPARING CUT FLOWERS

#### TRUE OR FALSE:

- False 1. A metal container is the best choice for flower storage since it is unbreakable.
- True 2. Flowers that respond to "geotropism" will turn their tips up if shipped laying down.
- False 3. The addition of preservatives to the water will increase epinasty occurrence in carnations.
- True 4. Botrytis mold is deterred when water is not allowed to drip on flower blooms.
- False 5. When new flowers arrive, after proper preparation, place them in containers of older flowers of the same type.

#### MATCHING:

<u>Flower</u>	<u>Average Vase Life</u>
<u>C</u> 1. Rose	A. 5-7 days (doubled with preserv.)
<u>A</u> 2. Carnation	B. 1-2 days
<u>D</u> 3. Chrysanthemum	C. 3-6 days
	D. 7-14 days

#### SHORT ANSWER:

- Name 3 symptoms of ethylene gas damage.
  - carnations go to sleep
  - roses turn blue
  - snapdragons drop florets
  - leaves turn downward (epinasty)
- What are 2 sources of ethylene gas?
  - old fruit
  - old flowers
  - bacteria
  - fungus
- What are "bullets" in floral shops?
  - roses cut too green

M-III-M-1-23



4. How can wilted roses be revived?
  - remove  $\frac{1}{2}$  foliage,
  - recut stem,
  - place entire stem in warm preservative water for 20 minute to 1 hour
5. What is the general storage time for florist greens?
  - 1-4 weeks
6. List the major components and functions of the ingredients of 7-Up or sprite soft drinks when they are used as floral preservatives.
  - sugar - food or nutrients for flowers
  - citric acid - bactericide or antimicrobial agent
7. What are 2 reasons florists use an angle cut when preparing flowers for the cooler?
  - stem won't seal on base of container
  - easier to insert into floral foam
  - knife cut at angle does not mash stem, and therefore, water up-take is not prevented

## UNIT M: RETAIL FLORICULTURE

### PROBLEM AREA: ORDERING AND BUYING CUT FLOWERS

#### SUGGESTIONS TO THE TEACHER:

This problem area is designed for use with eleventh grade or advanced students in a horticultural occupations program. This problem area may be taught at any time during the year and therefore may be incorporated in the winter months when few outdoor horticultural activities are possible.

The estimated instructional time for this problem area is 5-7 days, depending on how far the teacher wishes to develop purchasing skills at the third-year level. If the teaching plan is limited to classroom discussion with little or no practice or observation, the instructional time can be four days or less. If the students are to be involved in other activity exercises, the instructional time will need to be increased.

The instructor is encouraged to conduct a local search for resource persons and experts in wholesale flower operations who might assist with the teaching of this area. Greenhouse growers and wholesale florists have adapted their sales techniques to the needs of the local retail florists, and therefore, can enrich and add a community emphasis to this problem area. The items in this problem area are for reference and modification as instructors adapt this material to their local situation.

#### CREDIT SOURCES:

These materials were developed through a funding agreement R-33-13-D-0362-466 with the Illinois State Board of Education, Department of Adult, Vocational and Technical Education, Research and Development Section, 100 North First Street, Springfield, Illinois 62777. Opinions expressed in these materials do not reflect, nor should they be construed as policy or opinion of the State Board of Education or its staff.

The teacher's guide, student worksheets, sample test questions, and transparency discussion guide were developed by Dr. Christine Townsend, Illinois State University and Kallie Grobstein, Department of Vocational and Technical Education, University of Illinois. Transparency masters were prepared by the Vocational Agriculture Service, University of Illinois. The Cut Flower Care Guide information sheet was reprinted with permission from Florist Magazine, Copyright March, 1979. Suggestions and guidance in the development of these materials were provided by the Metropolitan Core Curriculum Field Test Teachers.

## TEACHER'S GUIDE

- I. Unit: Retail floriculture
- II. Problem area: Ordering and buying cut flowers
- III. Objectives: At the close of this problem area, the students will be able to:
  1. Identify the common name of at least 15 cut flowers used in the retail floriculture industry
  2. Identify the common name of at least 5 cut foliages used in the retail floriculture industry
  3. Judge the best quality flowers for purchase from a wholesale florist
  4. Identify and list at least 10 non-perishable products available through wholesale floral operations
  5. Describe the differences between retail florist purchases from decentralized growers and local wholesale florists
  6. Properly place an order to a wholesale florist
  7. Identify the standard marketing quantities of flowers
  8. Accept a delivery from a wholesale florist, check it in and correct any problems concerning quantity and quality.
- IV. Suggested interest approaches:
  1. Develop an advertisement for your school flower shop showing all the types of flowers you could sell. This activity could be a class project for a bulletin board or individual advertisements from each student.
  2. Bring in flowers and have students guess where they were grown. Use Student Worksheet 2 - Crop Growing Sites to label countries and the floral exports which are important to each country.
  3. "Judge" some flowers as to their visual appeal. Without any supporting information, which would you buy and why?
  4. Record the keeping quality of different types of flowers (both commercial and non-commercial types) in the classroom environment. If you were a florist, which would you want to sell to your customers, and why?
  5. Visit a local wholesale florist. Determine the organizational pattern, flower prices, and products sold.

6. Invite a retail florist to the class so he/she can explain the buying process.
7. Bring in a box of flowers from a wholesale florist. Have the students look for clues as to the origin and contents of the box and the route it took to reach the final destination (note growers' labels, shipping labels, foreign newspapers that the flowers are wrapped in).

V. Anticipated problems and concerns of students:

1. In what countries/states are floral products produced?
2. What types of transportation are utilized to ship floral products to the terminal markets?
3. Who can buy flowers from a local wholesale florist?
4. Why do wholesale flower prices fluctuate throughout the year?
5. What types of flowers are available for daily purchase by retail florists?
6. How do most retail florists buy cut flowers that they need for daily operations?
7. What should I look for when purchasing flowers?
8. Why can't a florist buy the exact quantity of flowers he/she needs to fill an order?
9. What is the difference between a standard carnation and a fancy carnation?
10. What is a #2 rose?
11. Why do we import many of our flowers from foreign countries?
12. Who can buy flowers from a grower?
13. What do I do when the flowers I receive from the wholesale florist are in poor condition?
14. What do I do if I am "shorted" part of my order?

VI. Suggested learning activities and experiences:

1. Visit a retail flower shop and record the names of the flowers for sale. Have students write on the chalkboard a compiled list of all their findings and record the names for their notes.

2. Have students practice judging flowers using Laboratory Exercise 1 - Judging Flowers.
3. Set up a flower judging contest. Use 4 specimens of one type of flower for each class. Have a retail florist serve as judge. Award prizes for the top students.
4. Use Student Worksheet 1 - Field Trip Report Guide as a guide for a trip to a wholesale floral operation or as a guide for questions to a wholesale florist invited into the classroom.
5. Identify non-perishable products and supplies needed in the floral trade. Students should be prepared to investigate trade journals, such as Florist Review Magazine, to determine what supplies are important to florists. The John Henry Company catalog lists a variety of floriculture supplies. (See References and Aids section.)
6. Distributive Information Sheet 2 - Florist Supply List. Have students determine the cost of these items to the retail florist. Discuss how florists determine the "mark up price" of these items when sold to the consumer.
7. Make an identification display chart or bulletin board showing florist supplies.
8. Use Information Sheet 1 - Cut Flower Care Guide and transparencies included in this problem area to help students become aware of how flowers eventually end up at the florist's shop. Ask preliminary questions like, "How does the local wholesaler obtain all the flowers to sell to the retail florists?" "Is it possible for the florist to by-pass the wholesaler (and save money) and buy direct from the grower?" "What happens if flowers are shipped by air and bad weather closes the airports?" Assign students the part of wholesaler, grower, and retail florist. Conduct a role play session acting out these types of situations.
9. Place an order to a wholesale florist using Laboratory Exercise 2 - Placing an Order and Information Sheet 3 - Wholesale Cut Flower Prices. Determine the total cost of the order.
10. Write an order that a florist has placed to the wholesaler on the chalkboard.

On a table set up the bunches of flowers received from this order. Have the students check the flowers to determine:

- 1). Did all the flowers ordered arrive?
- 2). Are they the proper colors and sizes?

3). Are they in good condition?

4). Did I receive full bunches?

If anything is wrong with the order received, have the students explain (or write a summary) how they would handle the situation.

Suggestions for errors in the order:

- 20 carnations in a bunch instead of 25
- old bunch of roses
- wrong color of flowers.

11. Distribute Student Worksheet 2 - Crop Growing Sites. On a map of the world locate the sites of major floriculture crop producers.

12. Show slide sets Cut Flowers and Design Greens.

VII. Application procedures:

1. The purpose of this problem area is to introduce students to the operation of purchasing cut flowers, foliages, and non-perishable supplies as a retail florist.
2. A floriculture judging team may be formed to apply the concepts which would be used by florists to purchase the best products.
3. Subscriptions to trade journals allow students to keep current with new innovations within the floral industry concerning new varieties of cut flowers and foliages and non-perishable products.
4. A working relationship should be opened with the local wholesale florist in order that flowers may be obtained for future floriculture problem areas or supervised occupational experience programs.
5. Students should serve as managers for the floriculture laboratory on a rotation basis under the supervision of the instructor, so they may gain practice in ordering flowers and supplies.

VIII. Evaluation:

1. Administer and grade a written examination using the sample test questions included in this problem area.

2. Evaluate student worksheets and laboratory exercises.

I X. References and aids:

1. Manual for Flower Judging, Second Edition, Pi Alpha Xi National Horticulture Fraternity in Floriculture, Department of Horticulture and Landscape Architecture, Washington State University, Pullman, Washington 99164 (Minimal cost)
2. Ohio Agricultural Curriculum Materials Service, Room 254 Agricultural Administration Building, 2120 Fyffe Road, Columbus, Ohio 43210
  - A. Cut Flowers (slides)
  - B. Design Greens (slides)
  - C. Retail Floriculture: Book 1, Sales, Service, and Promotion
3. Florist Review Magazine, 310 South Michigan Avenue, Suite 302, Chicago, Illinois 60604, Phone number (312) 922-9011.
4. John Henry Company, 5800 West Grand River, P. O. Box 17099, Lansing, Michigan 48901-7099, Phone number (517) 323-9000.
5. Selected information sheets
6. Selected student worksheets
7. Selected laboratory exercises
8. Selected transparencies

## INFORMATION SHEET 1

### FLORIST MAGAZINE "SPECIAL ISSUE: CUT FLOWER CARE"

All the care in the world can't save a flower that, because of improper care in its immediate post-harvest life, is destined for premature "old age." The care taken by the retailer is only one step in a continuing process which starts before the flower is even cut and ends when it is in the hands of the consumer.

While retail florists have little control over how cut flowers are handled by the grower and supplier, they can assure high quality flowers in their shop by shopping shrewdly and purchasing only good quality flowers.

Florists today have several choices when it comes to cut flower suppliers. Flowers can be purchased locally or from suppliers in different states or even countries. Florists can buy flowers out of warehouses or trucks, or they can order them by the phone. Florists in some areas can even bid on flowers at auctions.

At one time, these choices weren't available. During the late 1800s, when the floral industry was in its infancy, retailers either grew their own flowers or bought them directly from growers. As the number of customers increased, growers had trouble handling the volume of bookkeeping which resulted. It was then that wholesalers emerged, taking some of the pressure off the growers and helping distribute flowers to different parts of the country.

But during the late '50s and early '60s, as communication and transportation improved, growers again began to ship directly to retailers, in many cases eliminating the wholesaler in the process.

Today, there are so many different types of suppliers and so many functions that they each perform, that it is often hard to categorize them. Many growers are selling directly to retailers. Some wholesalers have begun growing their own product.

Another type of wholesaler, called a wholesale shipper, sells flowers to other wholesalers as well as retailers. Some operations have growing wholesaling and retailing divisions. Because of the variety of sources, a retailer's decision on where and how cut flowers are purchased must be based on the available sources, prices and quality. And these factors vary from market to market.

#### Wholesalers

The local wholesaler is the only source through which many retailers will purchase flowers. They like the convenience and security of having the supplier nearby. Especially in an emergency, it's comforting for retailers to be able to pick up the phone, order flowers and have them delivered within a few hours. Such service is available only through local sources.



Wholesalers get their products from many growers in different parts of the U.S. and also from foreign countries. The flowers arrive by truck or air and all come together in the wholesale house, where they are conditioned, and sold to the retailer.

Wholesalers offer retailers the opportunity to come in and pick out their merchandise or order over the phone and have the flowers delivered. Some wholesalers operate refrigerated trucks which make regular trips to retail shops, allowing florists to make purchases right outside their front door.

Retailers usually do not have problems with the quality of the product obtained through a wholesaler. Wholesalers normally ship through major airports--something not all retailers can do because of their location. By shipping through major airports, the flowers are more likely to have been shipped on a direct flight from the grower, eliminating excessive handling.

Having received merchandise from a variety of different sources, a wholesaler is assured a constant inventory of products. If one grower's crops are poor because of weather or the time of the growing season, the wholesaler should still be able to provide good quality from another grower. The same principle holds true in problems related to transportation. If, for some reason, flowers can't arrive by air, the wholesaler will still have flowers that were transported by truck.

If there ever is a problem with quality in flowers purchased from a wholesaler, the retailer can handle it on a local level by merely calling or visiting the wholesaler himself.

Wholesalers welcome standing orders and the retailer who takes advantage of this opportunity is often rewarded with priority prices, selection and guaranteed supplies at peak periods. Standing orders also can be an advantage in quality because flowers that are pre-sold by the box are delivered directly to the retailer in the box in which they were shipped to the wholesaler. The conditioning is left to the retailer. The speed in delivery and lack of handling by the wholesaler makes for fresher quality flowers than those that were kept at the wholesale house waiting to be purchased.

One of the biggest advantages of buying cut flowers from a local wholesaler is the ability to buy flowers in small quantities. This is especially important for small retailers. For them, small purchases will assure freshness since flowers won't have to be stored long. It is also convenient for purchasing unusual or off-beat items which the retailer doesn't need a lot of.

## DIRECT SHIPPING

Increasingly though, retailers are depending on wholesalers only to fill in items that they don't receive from direct shippers. The flowers shipped directly to the retailer from a grower are the same flowers that are shipped to wholesalers and then sold to retailers. By eliminating the middleman, the flowers go through less handling and therefore suffer less damage. The result is flowers that arrive in the retail shop quicker, fresher and at a lower cost than if they went through a wholesaler.

The cost of shipping direct is often dominated by freight charges. For that reason, those who ship by air must be able to purchase in large quantities or buy cooperatively in order to reduce the price per stem of the flowers with freight. Shipment by truck is cheaper than shipment by air. But depending on where the flowers are coming from and the airline, air freight can be quite reasonable. A retailer is wise to experiment to find the cheapest rate for the best quality flowers.

Flowers shipped directly must be picked up at a wholesale house or airport. Sometimes though, arrangements can be made for delivery right to the retail shop. It all depends on the shipper.

One thing to keep in mind when ordering direct-shipped flowers is to find the most direct route between grower and retailer. If shipped by air, florists should find a direct flight to avoid unnecessary delays and additional handling. Picking up the flowers yourself can also assure careful handling and prompt delivery.

If damage does occur in shipment, it is the retailer's responsibility to determine whether it is the fault of the airline or the grower. Long distance damage claims can be bothersome, but once a reliable shipper is found, such problems usually don't occur.

Finding a reliable grower-shipper is often a trial and error experiment. Because of the distance involved, a retailer can't always visit the grower's operation and must depend on experience or the advice of peers to choose a supplier. After finding a long distance supplier, many retailers enjoy the reliability, economics and quality that comes with direct shipping.

#### WISE SHOPPING

No matter where or how flowers are purchased, there are procedures that can help assure that the flowers received are of the best quality. The biggest help in obtaining flowers in the proper quality and quantity is careful planning.

Know what kinds of flowers you use regularly and make commitments, through standing orders, to purchase them regularly from the same suppliers. Base your standing orders on the minimum (not the maximum) amount of flowers you expect to use.

Many retailers have found that by giving suppliers regular business--and paying the bills promptly--the suppliers can be counted on when an emergency arises. That security is important, especially during high-volume periods or on hard to fill orders. In such situations, it's not only important to be a regular customer, but to have a good rapport with the salespeople. If you get to be known as someone who demands a certain quality and variety of flower, and someone with good credit, the salespeople will help in a crisis.

If there is a market report in your area, it can also offer information on what's available at what price.

Before committing yourself to a supplier, find out if it's a stable business --one that will be around tomorrow. Compare prices and quality with other

suppliers. If you're not satisfied with what you find at one place, go somewhere else.

Such comparative shopping has been effective in some markets where retailers were not pleased with the quality and prices of local suppliers. They started to buy from direct shippers. The competition forced the local businesses to better serve their customers' needs.

Visit the facilities at which your flowers are handled, especially when you're first deciding whether to do business with a certain supplier. Check to see that the methods of shipping and storing used extend vase life. Temperature control is essential throughout the flower's life.

A new method of maintaining cool temperatures in shipping is called pre-cooling. With it, a grower cools flowers soon after harvest by drawing warm air out of boxes of flowers. The boxes are then transported in refrigerated trucks which maintain the low temperature.

### JUDGING QUALITY

Fresh flowers can be judged by their firm foliage and flowers and their bright, uniform color. Foliage should be green, with no signs of damage, spots, wilting or yellowing. The stems should be straight and symmetrically developed.

The flowers should be bright and turgid with the center petals tight and unopened. Feel the calyx to see if it's firm. This is an indication that the flower and stem are full of water. Don't buy flowers with split calyxes. The supporting tissue around the petals will easily give way and the flower will lose its petals quickly.

Look for colorful flowers, especially when shopping for roses. But don't be fooled by lighting: Some suppliers display their flowers under warm-colored lights, which can distort the actual hue of the flowers.

Consider when the flowers will be used. Flowers that have been dry-stored will have to be conditioned before they are sold. So buy flowers that have already been conditioned if the flowers must be used immediately.

Finally, don't hesitate to return anything that isn't satisfactory or change suppliers if quality or service is consistently below par. If you're known as a stickler for quality, suppliers will think twice before unloading a bad batch of merchandise on your shop.

---

"Special Issue: Cut Flower Care" was reprinted with permission from Florist Magazine, Florists' Transworld Delivery Association, 29200 Northwestern Highway, Southfield, Michigan, 1979.

INFORMATION SHEET 2

FLORIST SUPPLY LIST

Artificial Flowers (silk, plastic & dried)
Novelty Containers (Baby, special occasion, holiday)
Baskets
Boxes
Card Tie
Cards/Tags
Corsage Bags
Chenille Stems
Chicken Wire
Colonial Shields PNL
Colonial Holders BHO
Easels/Wire/Wood
Envelopes
Fern Pins
Floral Adhesive
Floral Foam
Floratape
Floral Preservative
Foil
Glass Vases
Gold Letter & Script
Knives/Scissors/Snips
Moss
Order Pads
Paper Mache Containers
Picks
Pins/Bank/Corsage
Picks/Wire/Water
Plant Polish
Pot Labels
Ribbon
Satin Hearts/Pillows
Styrofoam Products

Tissue Paper/Rolls/Reams

Wire - various gauges

Wrapping Paper

Wrist Clips

Misc.

INFORMATION SHEET 3

WHOLESALE CUT FLOWER PRICES

	PRICE*	QUANTITY	SEASON	COLORS
ROSES (each)			all year	yellow, white,
22" & Longer	.50-1.25	25 per bunch	"	pink, red,
18" to 22"	.40-1.05	"	"	orange, and
14" to 18"	.30-.90	"	"	lavendar
10" to 14"	.20-.75	"	"	
Sweethearts	.50-.60	"	"	
CARNATIONS (each)			all year	pink, red,
Selects	.20-.35	25 per bunch	"	white, yellow,
Fancies	.15-.25	"	"	lavendar,
Standards	.12-.20	"	"	orange, and
Shorts	.10-.15	"	"	variegated
MIN. CARNS (bch)	1.50-5.00	bunch (varies)	"	
CHRYSANTHEMUMS			all year	
ExLge to Lge (bch)	5.00-10.00	25 per bunch	"	white, yellow
Spiders (10)	2.50-5.00	10 per bunch	"	lavendar,
Rovers (10)	3.00-6.00		"	bronze
POMPON MUMS (bch)	1.25-3.00	approx. 6 stems/bhc	"	
DAISIES			"	
Killians (10)	2.00-4.00	10/bunch	"	pink, yellow, white
Gerberas (10)	5.00-8.00	10/bunch	"	pink, white, red
Majestics (10)	.85-3.50	10/bunch	"	yellow, white
Marguerites (20)	.80-2.00	20/bunch	"	yellow, white
ORCHIDS (each)			all year	
Cattleyas	1.75-3.00	each	"	white, lavendar
mbidiums	1.25-2.50	each	"	pink, white, lavendar, green
Japhets	1.25-2.50	each	"	white
Phalaenopsises	1.25-2.50	each	"	white
GLADIOLI (10)	2.50-4.50	10/bunch	all year	all colors

	PRICE*	QUANTITY	SEASON	COLORS
ALSTROEMERIAS (bch)	4.50-12.00	10/bunch	"	pink, burgandy, yellow, white
ANTHURIUMS (each)	.60-1.50	each	"	red, pink, white
BIRDS OF PARA- DISE (each)	.80-1.50	each	"	blue and orange
FREESIAs (10)	3.00-6.00	10/bunch	winter/ spring	yellow, white lavendar
GARDENIAS (each)	1.00-3.50	3/box	all year	white
GINGER (blm)	1.50-2.25	each	all year	burgandy
GYPSOPHILA (bch)	3.00-6.00	bunch	all year	white
PROTEAS (each)			all year	
Pink Mink	1.00-2.00	each	"	pinks
Pin Cushion	1.50-2.00	each	"	
STATICE (bch)	1.75-4.00	bunch	all year	blue, rose, white, yellow
STEPHANOTISES (each)	.30-.40	25/box	all year	white
SNAPDRAGONS (10)	2.50-5.00	10/bunch	all but summer	pink, yellow, white
STOCKS (10)	2.50-6.00	10/bunch	all but winter	lavendar, pink, white

\*PRICE FLUCTUATES

## STUDENT WORKSHEET 1

### FIELD TRIP REPORT GUIDE

1. Before you listen to the manager of the wholesale floral operation, walk around and list the non-perishable products available for sale.
  
2. Who does the wholesale florist sell to?
  
3. Are there any requirements you must meet if you want to purchase products from the wholesale florist?
  
4. Where do wholesalers obtain the flowers they sell?
  
5. What type of transportation is used to
  - A. get flowers in from the growers?
  
  - B. send flowers out to the retail florists?
  
6. Why do flower prices increase at holiday times?
  
7. What is consignment and does this wholesaler take products in on consignment?
  
8. How many persons work at this wholesale operation? What are the jobs?
  
9. Can florists charge their purchases? What happens if a florist does not pay the bill?



## STUDENT WORKSHEET 2

### CROP GROWING SITES

Locate the sites of the following major producers of these floriculture crops on a map of the world.

CARNATIONS	Columbia, Colorado, California, Israel
POMPONS (mums)	Ecuador, Florida, California
STANDARD MUMS	Guatemala, California
ROSES	Colorado, California, Israel, Illinois
BULB FLOWERS	Netherlands
CYMBIDIUM ORCHIDS	Australia, Hawaii, California, Illinois
ANTHRIRUM	Hawaii
BIRD OF PARADISE	Hawaii
GLADIOLAS	Florida, California
LEATHERLEAF	Florida
HUCKLEBERRY-BOXWOOD	Oregon, Washington

## LABORATORY EXERCISE 1

### JUDGING FLOWERS

**OBJECTIVE:** The students will begin to rate flowers as to their quality and value and become familiar with the judging process.

**PROCEDURE:**

- A. Bring in samples of cut flowers and show them to the class.
- B. Have the students rank the flowers on paper, then ask a representative few why they ranked them in that particular order.
- C. Write on the chalkboard the items considered in the judging (size, color, quality, etc.).
- D. Next, bring in some other examples of cut flowers and ask what criteria can be used for judging them.
- E. An example judging criteria is outlined by Pi Alpha Xi, the National Honorary Fraternity in Floriculture (see Reference and Aids section).

CONDITION	25	(uniformity 10, freedom from bruise and blemish 5, substance 10)
FORM	20	(uniformity 5, maturity 5, correct shape 5, regular petalage 5)
STEM & FOLIAGE	10	(uniformity 5, strength and/or straightness 5, foliage quality 5, size and proportion 5)
COLOR	20	(uniformity 5, intensity 5, clarity 5, trueness to variety 5)
SIZE	15	(uniformity 5, deduct points in relation to development and condition of oversized or undersized)
TOTAL	100	

## LABORATORY EXERCISE 2

### PLACING AN ORDER

**OBJECTIVE:** The following exercise is designed to help the student place an order to a wholesale florist.

**PROCEDURE:** Read the following paragraph and answer the questions below.

The local flowershop has seven orders that will go out the day after tomorrow. What flowers will the florist have to order from the wholesale florist to cover these orders. Assume that he has all of the supplies and greens that he needs.

- Order #1 1 Doz. Red Roses arranged with Baby's Breath
- Order #2 1 round centerpiece with  $\frac{1}{2}$  doz. yellow Sweetheart Roses, white Daisy Poms, 3 Iris, blue Stattice and Baby's Breath
- Order #3 12 white Carnations and 6 red Roses arranged (1 sided) with Baby's Breath
- Order #4 1 Corsage: 3 Red Roses and Baby's Breath  
1 Bout.: 1 Red Rose
- Order #5 1 Doz. Red Roses - boxed
- Order #6 1 Cymbidium Orchid corsage with Baby's Breath (any color is OK)
- Order #7 A funeral arrangement with 7 red Gladiolas, 1 Doz. white Carnations, greens and Baby's Breath

#### FILL IN THE BLANK:

The local florist placed the following order:

1. \_\_\_\_\_ Long stem red roses (18-20 in. length)
2. \_\_\_\_\_ Baby's breath
3. \_\_\_\_\_ Daisy pompons
4. \_\_\_\_\_ Blue stattice
5. \_\_\_\_\_ White select carnations
6. \_\_\_\_\_ Cymbidium orchid
7. \_\_\_\_\_ Yellow sweetheart roses
8. \_\_\_\_\_ Blue iris
9. \_\_\_\_\_ Red fancy gladiolas

LABORATORY EXERCISE 2 - continued

After the florist filled the seven orders, there were some flowers left over. List the number of extra flowers below:

1. \_\_\_\_\_ Red roses
2. \_\_\_\_\_ Gladiolas
3. \_\_\_\_\_ Iris
4. \_\_\_\_\_ White carnations
5. \_\_\_\_\_ Cymbidium orchid
6. \_\_\_\_\_ Sweetheart roses

After the florist has filled the seven orders, a last minute customer comes into the shop. The customer would like a dozen sweetheart roses and baby's breath boxed. Are there sufficient flowers to cover the request?

TEACHER'S KEY - LABORATORY EXERCISE 2

PLACING AN ORDER

FILL IN THE BLANK:

The local florist placed the following order:

1. 2 bunches or 50 Long stem red roses (18-20 inch length)
2. 1 bunch Baby's breath
3. 1 bunch Daisy pompons
4. 1 bunch Blue stattice
5. 1 bunch or 25 White select carnations
6. one Cymbidium orchid
7. 1 bunch or 25 Yellow sweetheart roses
8. 1 bunch or 10 Blue iris
9. 1 bunch or 10 Red fancy gladiolas

After the florist filled his seven orders, he had some flowers left over. List the number of extra flowers below:

1. 16 Red roses
2. 3 Gladiolas
3. 7 Iris
4. 1 White carnations
5. 0 Cymbidium orchid
6. 15 Sweetheart roses

After the florist has filled his seven orders, a last minute customer comes into the shop. The customer would like a dozen Sweetheart Roses and Baby's Breath boxed. Are there sufficient flowers to cover his request?

Yes

# How flowers reach the consumer

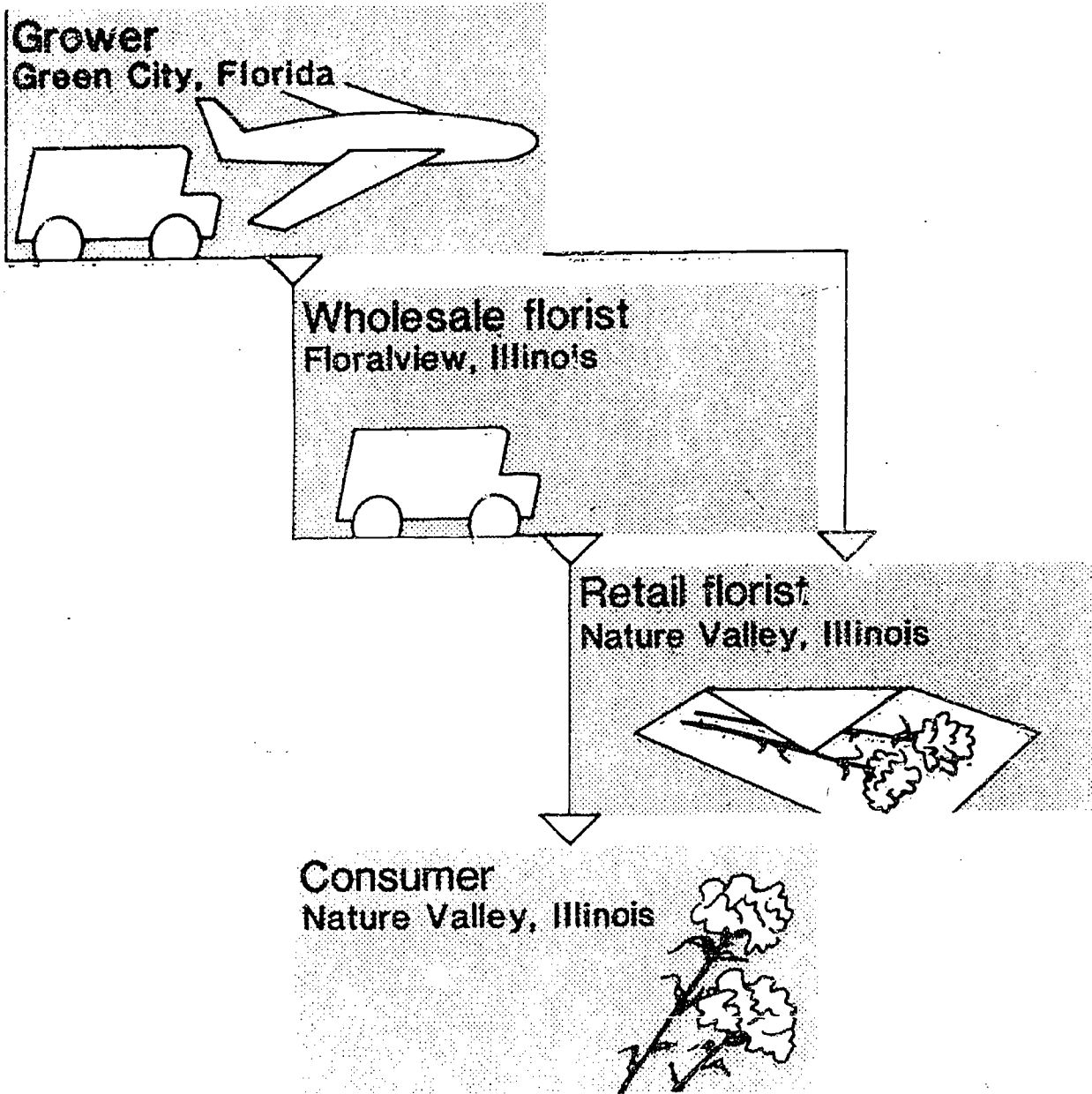

# How flowers reach the consumer

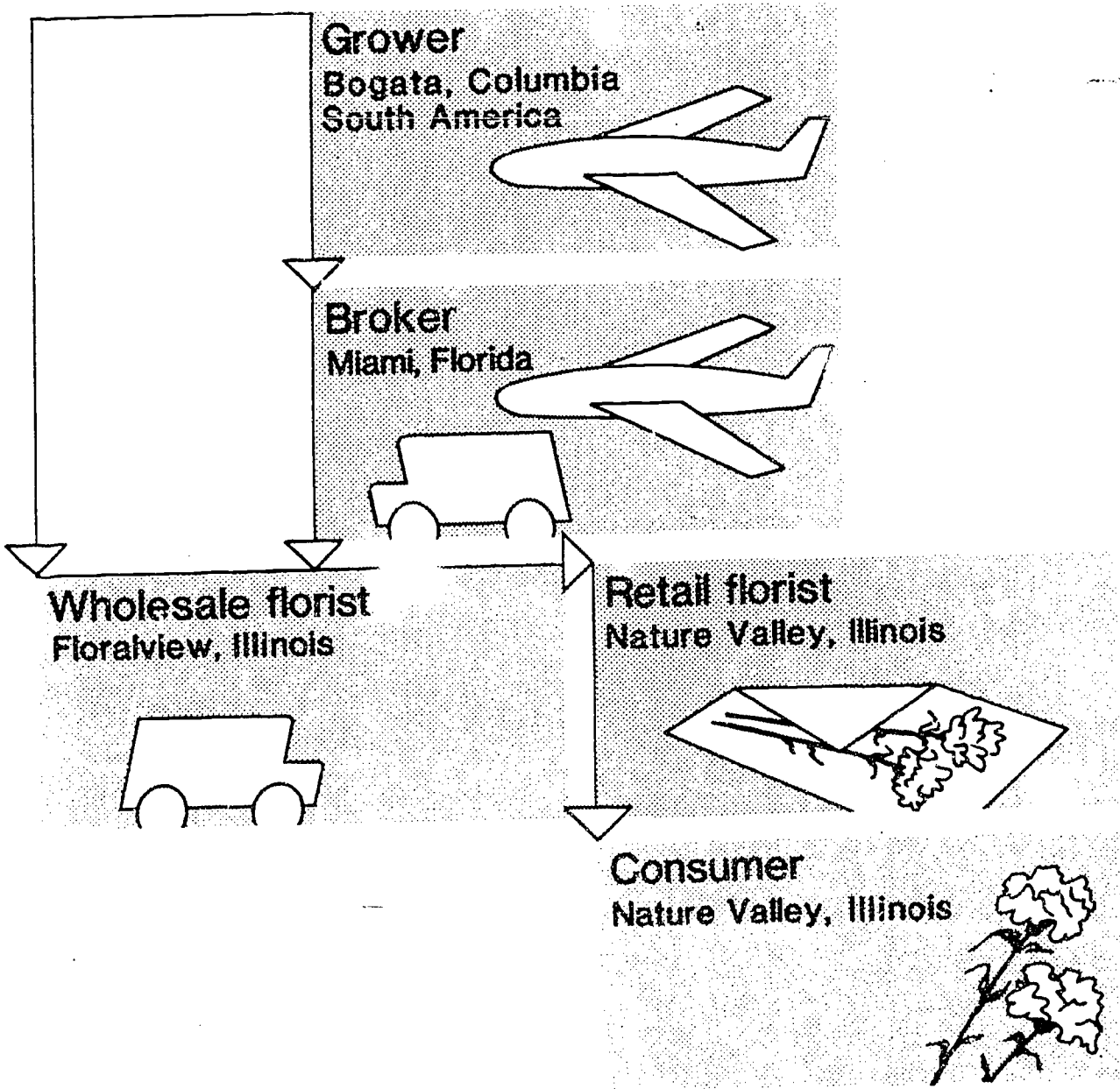

# How many flowers are in a bunch?

1 bunch of roses



Roses from Israel are packaged in bunches of 20's.

25 stems



Other common flowers and greens packaged in bunches of 25 include:

Carnations

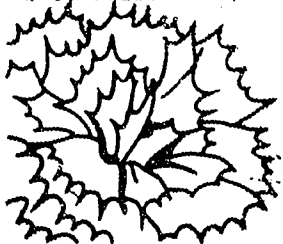

Stephanotis



Leather leaf



Plumosa

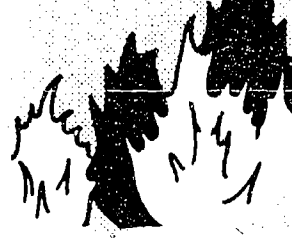



How many flowers are in a bunch?

Gladiolas 1 bunch

10 stems

Most bulb  
grown flowers  
are also  
packaged in  
10's

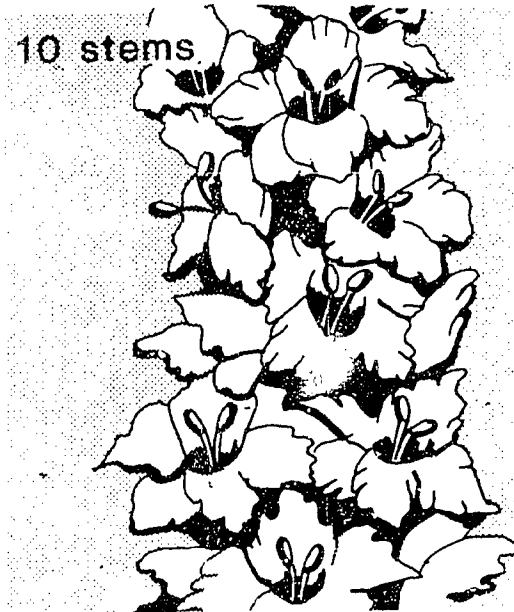

Tulip

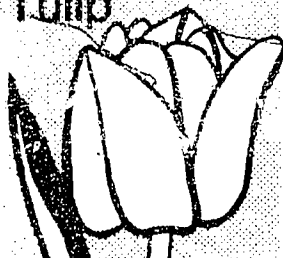

Jonquil



Iris



Alstroemeria

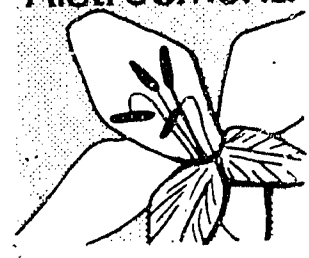

Gardenias 1 box

1 box

3 flowers

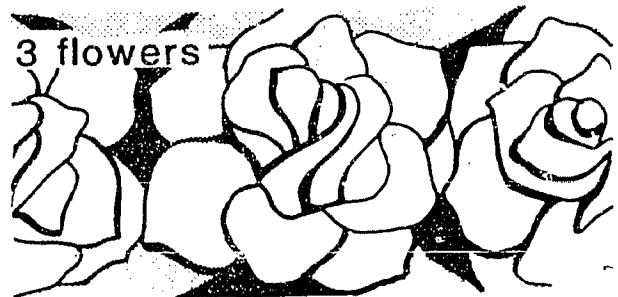

---

# How many flowers are in a bunch?

Some flowers and greens can not be counted exactly when packaged.

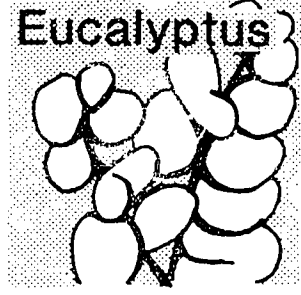
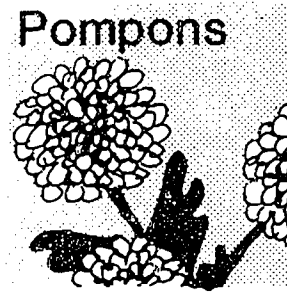
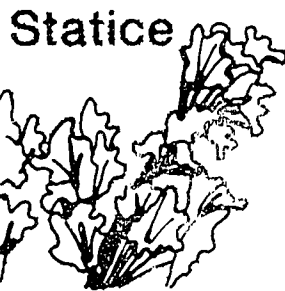
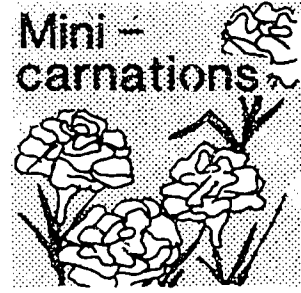
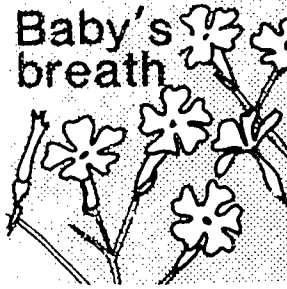

The size of the bunch can vary - depending on the time of the year and the grower it came from.

Florists are aware of this fact and learn to plan their orders accordingly.

---

# Are mixed orders possible?

We have learned that carnations are packaged in bunches of 25.



A florist has an order for :

12 white carnations  
5 red carnations  
8 pink carnations

---

25 carnations

Can the florist call the wholesaler and order one bunch of mixed carnations to fill his order?

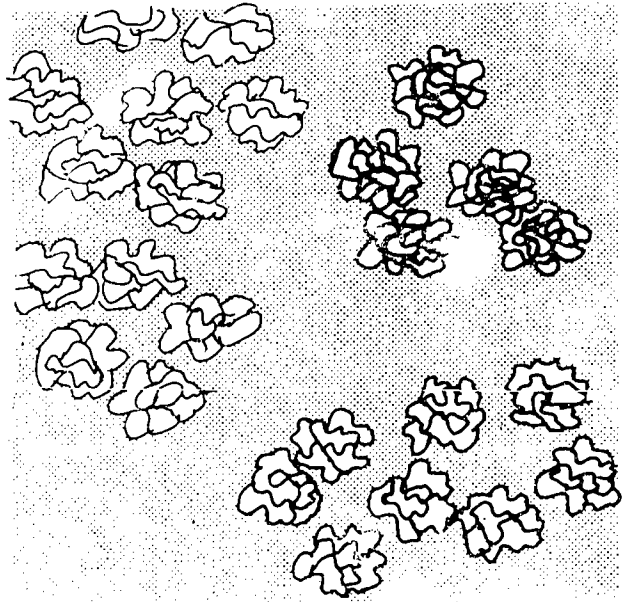

255

---

## How roses are graded

Roses are graded according to stem length. The price of roses increases or decreases according to the grade.

### Grades of roses

Extra fancy.....26" or more

Fancy.....22" to 26"

Long.....18" to 24"

Medium.....12" to 18"

Specials or

#2's..... under 12": odds and ends  
from the cutting bench:  
twisted stems.

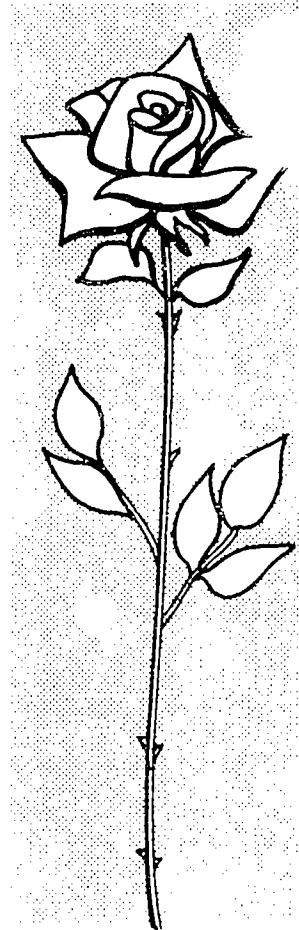

## How carnations are graded

Carnations are graded according to stem length and flower quality.

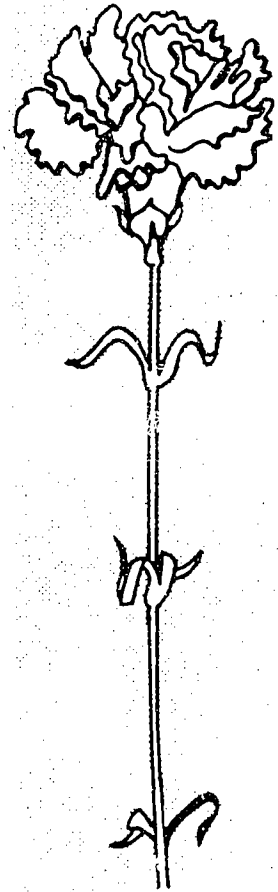

### Grades of carnations

- Fancy..... longest stems: largest flower head and best color quality
- Select..... long stems: average flower head and color quality.
- Standard..... approximately 14" stems, smaller flower head and average color quality
- Shorts..... approximately 10" stems.
- Splits..... split calyx on flower

TRANSPARENCY DISCUSSION GUIDE  
ORDERING AND BUYING CUT FLOWERS

I. Transparency--HOW DO FLOWERS REACH THE CONSUMER?

- A. Point out that flowers are perishable and must reach their destination quickly.
- B. The two main methods of transporting flowers are by airplane and by truck.
- C. Explain how a florist places an order. Note that he can purchase the flowers directly from the grower, as well as the wholesale florist, but larger minimum quantities must be purchased from the grower.
- D. Point out that flowers are grown all over the world. Sometimes a broker will act as a middleman or a wholesale shipper between a wholesale florist and a grower of a foreign country.
- E. Discuss why all our flowers are not grown in the United States.

II. Transparency--HOW MANY FLOWERS ARE IN A BUNCH?

- A. Point out that flowers must be purchased in set quantities on the wholesale level.
- B. List several common flowers and greens that are packaged in 25's.
- C. Many flowers are now being bunched in 10's. Eventually most growers will be packaging flowers according to the metric system.
- D. Gardenias are sold 3 to a box.
- E. Bird of Paradise are sold 5 to a bunch.
- F. Certain varieties cannot be bunched according to an exact number of blossoms, because the plant varies so much in nature.
- G. The size of the bunch can also vary due to 1) time of the year, and 2) discretion of the grower.

III. Transparency--ARE MIXED ORDERS POSSIBLE?

- A. Certain varieties of flowers are packaged with only 1 color per bunch. Some of these include roses, carnations, poinsons, mums, and alstroemaria.

- B. Tulips may be sold in solid bunches and in mixed bunches.
- C. Depending on the growers relationship with the wholesaler, and the quantity involved, orders may be custom packed.

I V. Transparency--HOW ROSES AND CARNATIONS ARE GRADED

- A. The florist can be very selective in the size and quality of the flower he/she is buying.
- B. The two most common flowers sold by grade as well as color and variety are carnations and roses.

TEACHER'S KEY  
SAMPLE TEST QUESTIONS

SHORT ANSWER:

1. From the examples or slides shown, write the common name of the cut flowers in the blanks.

- |     |     |
|-----|-----|
| 1.  | 11. |
| 2.  | 12. |
| 3.  | 13. |
| 4.  | 14. |
| 5.  | 15. |
| 6.  | 16. |
| 7.  | 17. |
| 8.  | 18. |
| 9.  | 19. |
| 10. | 20. |

2. Write the names of the cut foliages shown.

- 1.
- 2.
- 3.
- 4.
- 5.

3. Match the floral crop with the country or state which produces large quantities of it.

<u>E</u>	1. Anthiriums	A. Ecuador
<u>A</u>	2. Pompons	B. Netherlands
<u>B</u>	3. Bulb Flowers	C. Colorado
<u>C</u>	4. Carnations	D. Texas
<u>F</u>	5. Gladiolas	E. Hawaii
		F. Florida

4. A customer has requested flowers for an arrangement that is generally available in only the Spring. Name 5 possibilities you could use.

- |    |            |                      |
|----|------------|----------------------|
| 1. | Agapanthus | - Iris               |
| 2. | Anemone    | - Lily of the Valley |
| 3. | Daffodil   | - Narcissus          |
| 4. | Freesia    | - Tulip              |
| 5. | Heather    |                      |

5. Define commission as it relates to wholesale florist operations.

Growers bring in flowers to a wholesale operation. If the flowers are sold, the grower is paid a percentage of the selling cost. The wholesaler keeps the remainder of the selling cost.



6. List three advantages of dealing with a local wholesale florist.
1. Variety of merchandise
  2. No hassels with transportation from grower
  3. No minimum order
  4. Retailers can pick out flowers
7. Why would a florist prefer to deal with the grower rather than the wholesaie florist?
1. Flowers go through less handling and have less damage
  2. Middleman costs are cut for saving to retailer
  3. Flowers arrive at floral shop quicker
8. List two types of flowers that are packaged 25 stems to a bunch.
1. Roses
  2. Carnations
  3. Stephanotis
9. List two types of flowers that are packaged 10 stems to a bunch.
1. Gladiolas
  2. Iris
  3. Most bulb flowers
  4. Fuji or spider mums
  5. Marguerite daisies

TRUE OR FALSE:

- True 10. Orchids can be purchased individually.
- False 11. The average consumer can buy flowers from a wholesale florist.
- False 12. You can mix colors in 1 bunch of carnations.
- False 13. Select carnations are the highest quality.
- True 14. Extra fancy roses are between 26 inches and up.

MULTIPLE CHOICE:

- D 15. Your order arrives from the wholesale florist and your roses are "soft". You will
- A. stop buying roses from that grower
  - B. call the wholesale florist when you are not busy to inform him of the probiem
  - C. not worry about it and sell them anyway
  - D. call your salesman immediately to inform him/her of the prob-lem
- C 16. The best time to place an order is
- A. the day you need the flowers
  - B. between 9:00 a.m. and 11:00 a.m.
  - C. 2 days before you need the flowers
  - D. when the wholesale florist calls you

- E 17. Cymbidium orchids may be grown in
- A. Hawaii and California
  - B. Australia
  - C. Illinois
  - D. a & b only
  - E. all of the above
- D 18. Stock is available
- A. spring and fall
  - B. winter
  - C. summer
  - D. a & c
  - E. all of the above
- B 19. The highest quality carnation is
- A. select
  - B. fancy
  - C. standard
  - D. none of the above
- D 20. Bergena Daisy is available in
- A. yellow and white
  - B. red
  - C. pink
  - D. all of the above

## UNIT M: RETAIL FLORICULTURE

### PROBLEM AREA: MAKING TABLE ARRANGEMENTS, CORSAGES, AND NOSEGAYS

#### SUGGESTIONS TO THE TEACHER:

This problem area should be taught to advanced horticultural occupations students. The area may be taught at any time during the year, and therefore, may be incorporated in the winter months when no outdoor horticultural activities are possible. The instructor may wish to integrate this problem area with the area of "Handling and Preparing Cut Flowers" so the flowers used may serve a dual purpose.

The estimated instructional time for this problem area is 10 to 20 days, depending on the teacher's perception of the students' needs. If the instructor is limited to classroom discussion with no outside field trips, resource persons, or laboratory exercises, the instructional time can be reduced to 5 to 7 days. If the students are to be involved in other activity experiences, the instructional time will need to be increased.

Floral Design is an art. It would be unrealistic to believe one unit of floral design would produce an accomplished designer--just as one art class does not make an artist. Also, every designer develops a particular style similar to, yet different from, the teacher. This unit is written to give the basics of one style of floral design. It is suggested you solicit demonstrations from the local florist adapting the worksheets to that person's style of floral design. Before you give a demonstration be sure to practice the floral design.

This problem area is expensive to teach if all the materials must be purchased. Use whatever is appropriate from this unit. Substitute pom poms for roses if the cost of materials is too great. It would be wise to purchase, through a wholesale florist, a stock container which can be used for all arrangements by each student. (Mark each container with identification so they do not get lost and can be re-used throughout the instruction.) Students should be encouraged to bring containers from home to transfer arrangements into after class. Also, schedule the instruction so the flowers may be utilized twice. For example, the same flowers can be used for

Symmetrical Triangle -- then -- Asymmetrical Triangle  
Centapice -- then -- Nosegay -- Corsages  
Nosegay in the foam holder -- then -- Nosegay wired and taped

The arrangements must be stored in a cooler between sessions to maintain their quality.

The instructor is encouraged to conduct a local search to locate other supplementary materials for use with this problem area. The items in this problem area are for reference or modification as instructors adapt these materials to their local situation.

## CREDIT SOURCES:

These materials were developed through a funding agreement, R-33-10-D-0362-466, with the Illinois State Board of Education, Department of Adult, Vocational and Technical Education, Research and Development Section, 100 North First Street, Springfield, Illinois 62777. Opinions expressed in these materials do not reflect, nor should they be construed as policy or opinion of the State Board of Education or its staff.

The teacher's guide, information sheets, student worksheet, laboratory exercises and sample test questions were developed by Christine Townsend, Illinois State University, and Kallie Grobstein, Department of Vocational and Technical Education, University of Illinois. Transparency masters were prepared by the Vocational Agriculture Service, University of Illinois. Suggestions and guidance in the development of these materials were provided by the Metropolitan Core Curriculum Field Test Teachers.

## TEACHER'S GUIDE

- I. Unit: Retail floriculture
- II. Problem area: Making table arrangements, corsages, and nosegays
- III. Objectives: At the close of this problem area, students will be able to:
  1. Utilize various color schemes in a floral design.
  2. Display proper principles of floral design.
  3. Construct the following floral designs:
    - a. circle or colonial arrangement
    - b. oval arrangement
    - c. triangular arrangement (and variations of this design)
    - d. carnation corsage
    - e. pom pom mum corsage
    - f. nosegay: wired and taped and floral foam holder
  4. Critique floral designs as to their quality and adherence to the principles of design.
  5. Identify the tools and hard goods utilized in floral design.
- IV. Suggested interest approaches:
  1. Bring in a floral arrangement displaying poor design principles and ask if students would buy it.
  2. Pass around pictures of interior designs and see if students can identify color schemes.
  3. Visit a floral shop and observe a floral designer at work.
  4. Take an opinion poll on what types of designs the students like the best. Use pictures or slides for this activity.
  5. Have students list on the chalkboard why people buy flowers and when they think they (the students) will use them.
  6. Have a local florist discuss the opportunities for young people in the floral industry.
  7. Collect FTD brochures.
  8. Cut out pictures from trade journals as a source of good designs.
- V. Anticipated problems and concerns of students:
  1. What are the principles of floral design?

2. What colors can be combined to create a "warm" or "cool" feeling within an arrangement?
3. Why do some arrangements look like they are falling over?
4. How can you make a design look expensive without using an overall abundance of flowers?
5. How is a nosegay constructed?
6. What are the "mechanics" of floral designs so they will not fall apart?
7. What tools are necessary for the floral designer?
8. How do you wire flowers?

VI. Suggested learning activities and experiences:

1. Introduce color used in floral design by using Information Sheet 1 - Which Color Fits You? Take a poll on favorite colors in the class and then discuss the possible personality indications given. You may wish to have a student hold up a color wheel in front of the class while that color is discussed.
2. Make your own color wheel by mixing water colors as indicated on Information Sheet 2 - Simple Color Formulas.
3. Follow the floral design rules for color shown on the transparency entitled "Floral Design Rules for Color" while constructing arrangements.
4. Bring in some samples or pictures of floral arrangements and discuss the functions of different flowers within an arrangement using Student Worksheet 1 - Types of Flowers for a Design.
5. Discuss the principles of floral design with Information Sheet 3 - Basic Rules and Principles of Floral Design. Have a student make a design in front of the class breaking as many principles as possible and have class identify which principles were broken.
6. Show slides or magazine pictures of different types of floral designs and have students write down the geometric shapes of the designs (triangle, oval, circle, etc.).
7. Use the transparencies included in this problem area to show the mass floral designs most common within the floriculture industry.
8. Use a critique or evaluation form similar to Information Sheet 4. All designs should be critiqued by the students, as well as the instructor.

9. Utilize the laboratory exercises included in this problem area. Other possibilities for floral design laboratory exercises are given on Information Sheet 5 - Ideas for Types of Floral Designs.
10. Suggested materials for setting up a floral design laboratory are given on Information Sheet 6 - Setting Up the Floral Design Laboratory.
11. Visit industry floral conventions to investigate new innovations in floral design.
12. Subscribe to floral industry publications and search articles for floral design techniques.

VII. Application procedures:

1. Floral arrangements can be designed for FFA or school activities.
2. Design arrangements for holiday sales to students and faculty.
3. Demonstrate floral design activities to other classes or schools.
4. Plan additional activities for school laboratory and work experience practice.

VIII. Evaluation

1. Prepare and administer a pencil and paper test using the sample test questions included in this problem area.
2. Administer a practical exam in the lab on construction of floral designs utilizing Information Sheet 4 - Critique Sheet for Evaluating Floral Arrangements.
3. Critique laboratory exercises.
4. Observe and grade performance on demonstrations and sales of floral designs.
5. Have students evaluate their progress by completing the Competency Inventory Sheet included in this problem area.

IX. Reference and aids:

1. Vocational Agriculture Service, University of Illinois, 1401 South Maryland Drive, Urbana, Illinois 61801
  - A. Subject Matter Unit U5009 - Arranging Flowers in Vases and Bowls
2. Pennsylvania State University, Department of Agricultural Education, 102 Armsby Building, University Park, Pennsylvania, 16802.

- A. Retail Flower Shop Operation and Management (manual)
  - B. Designing with Flowers and Decorative Materials (slides)
  - C. Floral Design Task Sheets (packet)
3. Vocational Education Productions, California Polytechnic State University, San Luis Obispo, California, 93407.
    - A. Care and Handling of Cut Flowers and Foliage (filmstrip)
    - B. Flower Arranging: Beginning Techniques (filmstrip)
  4. Ohio Agricultural Education Curriculum Materials Service, Room 254, 2120 Fyffe Road, Columbus, Ohio 43210.
    - A. Cut Flowers (slides)
    - B. Design Greens (slides)
    - C. Flower Arranging (slides)
    - D. Dried Materials (slides)
    - E. Retail Floriculture: Book 2, Design and Care of Flowers and Foliages (manual)
  5. Florists' Transworld Delivery Association, 29200 Northwestern Highway, P.O. Box 2227, Southfield, Michigan, 48037.
    - A. Write "Educational Services Division" for current industry information.
  6. Teleflora, 2400 Compton Boulevard, Redondo Beach, California, 90278.
    - A. Write "Educational Services Division" for current industry information.
  7. McDaniel, Gary L. Floral Design and Arrangement. Reston Publishing Co., Reston, Virginia, 1981.
  8. Selected information sheets
  9. Selected laboratory exercises
  10. Selected transparencies



## COMPETENCY INVENTORY

### MAKING TABLE ARRANGEMENTS, CORSES, AND NOSEGAYS

1. Student has no knowledge of competency.
2. Student has read about competency.
3. Student has seen competency performed.
4. Student has performed competency.
5. Student has performed competency without supervision.
6. Student does possess skill.
7. Student does not possess skill.

Competency	Circle One				
1. Demonstrate proper use of florist's equipment	1	2	3	4	5
2. Demonstrate 3 methods of wiring flowers	1	2	3	4	5
3. Demonstrate proper use of floral tape	1	2	3	4	5
4. Construct a corsage	1	2	3	4	5
5. Construct a centerpiece	1	2	3	4	5
6. Construct a nosegay in a foam holder	1	2	3	4	5
7. Construct a nosegay that is wired	1	2	3	4	5
8. Construct a bow	1	2	3	4	5
9.					
10.					
11.					
12.					
13.					
14.					
15.					
16.					
17. Recognize various line mass filler and focal flowers					6 7
18. Describe effective color combinations					6 7
19. Summarize the basic principals of design					6 7
20. Recognize a properly constructed arrangement					6 7

These competencies outlined in the National Agricultural Competency Study are for entry level positions in horticulture.

Name \_\_\_\_\_

Date \_\_\_\_\_

INFORMATION SHEET 1  
WHICH COLOR FITS YOU???\*

If Your Favorite Color is---

Then You--

RED

have an urge to achieve results or succeed.  
are impulsive, competitive, enterprising, aggressive, forceful.

YELLOW

have intellectual appeal, energy, vitality, cheerfulness, & liveliness.  
are a person who likes change & has a desire to escape difficult situations.  
are optimistic and future oriented.

BLUE

like emotional tranquility, calm, peace, & harmony.  
seek environments free from upsets & disturbances.  
are passive, dreamy, cool, sincere, hopeful, aloof, & loyal.

GREEN

want your own opinion to prevail and you place yourself on a pedestal to moralize and lecture others.  
need recognition.  
are organic, calming, refreshing, restful, faithful, & immature.

GRAY

wall everything off.  
remain uncommitted & uninvolved.  
are sedate, passive, humble.

BROWN

need physical ease and contentment & release from a discomforting situation.  
are earthy, solid, firm, matter-of-fact, warm, somber & sad.  
may forfeit your creative impulse.  
see the importance of having roots.

VIOLET

are sensitive and believe whatever is desired should become reality.  
are magical, enchanting, & mentally immature.  
show a feeling of meditation, mystery, melancholy.

BLACK

exhibit extremes in behavior and protest everything.  
are subdued, depressed, solemn, sorrowful, secretive, and formal.

270

M-III-M-3-9

INFORMATION SHEET 1 - Continued

WHITE

are positive, stimulating, humane,  
eerie, delicate.  
appear to denote purity, innocence,  
and truth.

\*Rae, Barb, "Are You Tickled Pink or in a Blue Mood?", Ethos, Vol. 34,  
No. 3, Spring 1981, Iowa State University, Ames, Iowa, page 4.

INFORMATION SHEET 2  
SIMPLE COLOR FORMULAS

1 PRIMARY	+	1 PRIMARY	=	1 SECONDARY COLOR
blue	+	red	=	violet
blue	+	yellow	=	green
yellow	+	red	=	orange

1 PRIMARY	+	1 SECONDARY	=	1 TERTIARY COLOR
blue	+	violet	=	blue-violet
violet	+	red	=	red-violet
red	+	orange	=	red-orange
orange	+	yellow	=	yellow-orange
yellow	+	green	=	yellow-green
green	+	blue	=	blue-green

TINTS = add WHITE to original color

SHADES = add BLACK to original color hue

## INFORMATION SHEET 3

### BASIC RULES AND PRINCIPLES OF FLORAL DESIGN

#### RULES:

1. An arrangement should be  $1\frac{1}{2}$  times the height or width of the container.
2. Use an uneven number of flowers.
3. Never cross stems; all stems should look like they are "growing" out of the center of the design.

#### PRINCIPLES:

1. Balance - equal distribution of weight on either side of a central axis in a horizontal plane.
  - A. Symmetrical - the two halves look exactly the same.
  - B. Asymmetrical - unequal visual weight on each side; the long line on one side must be balanced with material on the other side.
2. Stability - equal distribution of weight on either side of a central axis in a vertical plane; arrangement does not look like it would fall forward or backward.
3. Rhythm -
  - A. Facing - change flowers from looking upwards at the top, to side facing, to forward facing at the focal point
  - B. Spacing - change spaces between flowers gradually from farther apart at the top to close at the focal point
  - C. Size - change sizes of flowers from small at the top to largest at the focal point
4. Focal point - the spot which first attracts the eye
  - A. all lines seem to converge
  - B. largest flowers, strongest colors, unusual foliage
  - C. keep low in arrangement
  - D. only one focal point in one view
5. Proportion - size relationship between various parts of the arrangement

INFORMATION SHEET 3 - Continued

6. Scale - size relationship between the arrangement and the surroundings
7. Repetition - repeat a character with slight changes gives emphasis (green and white foliage to repeat white of flower)

INFORMATION SHEET 4

CRITIQUE SHEET FOR EVALUATING FLORAL ARRANGEMENTS

DESIGNER \_\_\_\_\_

Balance/stability	(4)	_____
Proportion	(4)	_____
Rhythm	(4)	_____
Color	(4)	_____
Focal Point	(2)	_____
Creativity	(2)	_____
TOTAL	(20)	_____

Comments:

\_\_\_\_\_  
Evaluator

275

## INFORMATION SHEET 5

### IDEAS FOR TYPES OF FLORAL DESIGNS

These additional types of floral designs may be used for instructing individual or advanced students. The materials have been listed and it is suggested you seek help from a local floral designer for the steps to completion.

1. Funeral Arrangement (large inverted-T)
  - A. container large enough for 1 floral foam
  - B. 1 floral foam block thoroughly soaked
  - C. 5 pieces Emerald or Jade foliage
  - D. 1/3 bunch leatherleaf
  - E. 5 standards
  - F. 7 carnations
  
2. Dried and Silk Arrangement (mass: all around)
  - A. small basket
  - B. 1/3 "Sahara" or other dry floral foam
  - C. 1/2 bunch stardust gypsophilia ("Angel Lace")
  - D. 1 pick silk daisies with 5-7 flowers
  - E. 1 pick silk gypsophilia (baby's breath) with 7-9 groups of flowers
  - F. glue gun, wood picks, or picking machine
  - G. sheet moss and ferning pins
  
3. Hogarth Curve Arrangement
  - A. compote-type container
  - B. 1/3 block floral foam soak
  - C. 1/4 bunch of leather
  - D. 5 pieces scotch broom or eucalyptus
  - E. 5 carnations or 3 fugi mums
  
4. Standard Mum/Vertical Design
  - A. container
  - B. soaked 1/3 floral foam block
  - C. 1/3 bunch leatherleaf
  - D. 3 standard mums
  - E. 7 carnations
  
5. Glamellia Nosegay or Corsage
  - A. #30 gauge wire
  - B. 3 gladiolus with open florets
  - C. camillia foliage
  - D. #26 or #28 gauge wire
  - E. floral tape
  - F. corsage ribbon



INFORMATION SHEET 5 - Continued

6. Standard Mum Corsage (Football Mum)
  - A. #20 or #18 gauge wire
  - B. cardboard circle for behind flower head
  - C. standard mum
  - D. floral tape
  - E. corsage ribbon
  
7. Creative Arrangement (designed with non-traditional materials)
  - A. weeds
  - B. paper flowers, fabric flowers
  - C. wood flowers

255

INFORMATION SHEET 6  
SETTING UP THE FLORAL DESIGN LABORATORY

Equipment (long term)

1. 1 refrigerator or cooler (80 sq. ft.)
2. Design tables (4' X 6' and 33" - 45" high)
3. Double sink
4. Floral knives
5. Wire cutters or snips
6. Wire rack
7. Electric glue gun
8. Picking machine
9. Plastic buckets

Supplies

1. Floral preservative
2. Flora' foam
3. Floral tape for corsages (green)
4. Floral adhesive tape for arrangements ( $\frac{1}{2}$ " or  $\frac{1}{4}$ " )
5. Stock, inexpensive containers
6. Ribbon (#3)
7. Wire (18 or 20, 24, 28 or 30 gauge)
8. Ribbon sheers
9. Pins
10. Corsage bags

## STUDENT WORKSHEET 1

### TYPES OF FLOWERS FOR A DESIGN

**PROCEDURE:** List the various types of flower shapes (ex: line and mass) and describe how each contributes to an arrangement. Give 3 examples of each type.

Type	Purpose	Examples
1. Line Flowers		1. 2. 3.
2. Mass Flowers		1. 2. 3.
3. Form Flowers		1. 2. 3.
4. Filler Flowers		1. 2. 3.

## LABORATORY EXERCISE 1

### MAKING A BOW

#### MATERIALS:

1. #3 width corsage ribbon
2. #30 gauge wire
3. green floral tape

#### PROCEDURES:

1. It is best to watch someone make a bow before you try so you can see the method first.
2. Hold a #30 wire in one hand and attach the end of the floral tape to one end.
3. Twirl the wire while pulling the tape down until the whole wire is taped.
4. Cut the taped wire in half with wire cutters.
5. Form a small loop (2" or so) with the corsage ribbon. The shiny side should be facing out. Pinch the base of the loop so the ribbon is crimped where the loop meets the rest of the ribbon.
6. Form a second loop opposite the first one, being sure the shiny side still shows outward. You have to twist the ribbon in order to keep the shiny side out.
7. Continue making loops and crimping the center until you have 3 to 4 loops on each side.
8. Now you are ready to add a very small loop in the center of the bow to hide the holding wire. Whatever happens next, do not let go of the center of the bow or it will unravel!
9. Place your thumb on top of the bow in the center where the ribbon is crimped. Take the ribbon and make a small loop around your thumb holding the loop with your thumb and forefinger underneath.
10. Insert the taped holding wire under your thumb between your thumb and loop.
11. Bring the 2 sides of the wire down and tightly twist behind the bow. The wire should secure the bow and be available to attach to a corsage.

LABORATORY EXERCISE 2  
WIRING AND TAPING METHODS

1. PIERCING:

- A. Break stem of carnation leaving at least  $\frac{1}{2}$ ".
- B. Insert #24 wire crosswise through calyx.
- C. Bend ends down to start stem.

2. HOOK:

- A. Break off stem of pom-pom mum leaving  $\frac{1}{2}$ ".
- B. Insert #24 or #26 wire up through center of stem and flower head.
- C. Bend top of wire into hook.
- D. Pull the hook down into the flower head until it is almost invisible.

3. HAIRPIN:

- A. Bend #26 or #28 wire into shape of hairpin.
- B. Hold the ends of the hairpin close together. Insert both ends down through the center of a pom-pom and along shortened flower stem.
- C. Pull wire ends down. The wire should not be visible in the center of the flower.

4. STITCH METHOD FOR HEAVY LEAVES:

- A. Insert #26 wire under main vein from back side of leaf.
- B. Bring both wire ends down along the back of the leaf.
- C. Carefully wrap the natural stem of the leaf for a couple of turns with each end of the wire.
- D. Tape with floral tape from the top of the natural stem.

5. WRAPPING METHOD FOR LEATHERLEAF AND OTHER LEAVES:

- A. Use a hairpin shaped wire (#26 or #28).
- B. Wind the wire carefully around the natural stem as high as you need to support the leaf.
- C. These leaves are fragile and may break but if you are careful, you add great support with the wiring.
- D. Tape the wire from the top of the natural stem.

6. TAPING:

- A. Since floral tape stretches, be sure to stretch it as you tape a wire.
- B. Wrap a little of the tape around the top of a wire to secure.
- C. Twirl the wire in one hand and pull the tape as it is wrapped around the wire.

## LABORATORY EXERCISE 2 - Continued

**NOTE:** Florist wire is usually green and comes in 12" or 18" lengths. It is gauged according to its weight and commonly runs between #18 (heavy) to #30 (light). The heavy gauges are used for heavy flower heads and light gauges are used for fragile or lightweight flowers.

Floral tape is available in 2 widths and many colors. Different florists use different tapes, but for these exercises using the  $\frac{1}{2}$ " width and a green color (as it matches the stems natural color) is suggested.

## LABORATORY EXERCISE 3

### OVAL CENTERPIECE

**PURPOSE:** Students will construct an oval centerpiece. The following illustration shows a two-dimensional placement of the flowers from a side view.

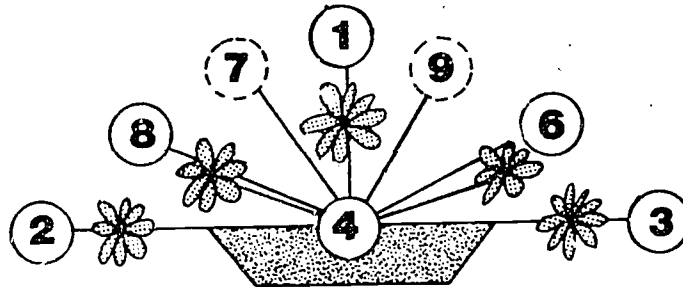

#### MATERIALS:

1. container
2. floral foam (thoroughly soaked): 1/3 block or 1 #5 cylinder
3. 9 carnations
4. 2 stems of pom pom chrysanthemums
5. 1/3 bunch of leatherleaf

#### PROCEDURES:

1. Since this arrangement will be seen from all sides, what you do on one side, you will repeat on the other.
2. Place a leatherleaf tip in the top center of the foam. This piece will set the height of the design so make it about 4-5" tall.
3. At the rim of the container, insert a piece of leatherleaf on each of the 4 sides. These pieces will determine the length and width of the design. The 2 side pieces should run at least 5 inches beyond the container and the front and back pieces should run only 2-3" beyond the container. (These greens have created an oval shape if you look down at the arrangement from a bird's-eye-view).
4. Back to the top of the foam; insert pieces of leatherleaf at each corner. Remember all stems go into an imaginary point in the center of the foam! These pieces should be a length to create a curve from the center leatherleaf to the side leatherleaves.
5. Now, fill in with leatherleaf pieces so the foam is hidden. Follow the rules of design carefully.

### LABORATORY EXERCISE 3 - Continued

6. Placement of carnations: 1 in the top center just shorter than the leatherleaf, 1 at each side, 1 in front and 1 in back at the container rim. These flowers should be just a bit shorter than the leatherleaf in those areas. One carnation is placed at an angle in each corner on the top of the foam.
7. Place the pom pon mums at the places where "holes" exist. Use all sizes, even buds, to add depth to arrangement. Some of the mums should be "hidden" in the arrangement to create a movement for the eye.

#### APPLICATION:

The oval centerpiece is used in situations where the flowers will be viewed from all sides and people must be able to see over the top. It may be placed in the center of an oblong or rectangular table or towards the front as in the case of a head table. Many holiday arrangements are oval centerpieces, so they may be used at the family meal.

#### OBSERVATIONS:



## LABORATORY EXERCISE 4

### THE INVERTED-T ARRANGEMENT

**PURPOSE:** Students will construct an inverted-t floral design. The following illustration shows a two-dimensional placement of the flowers from a front-view.

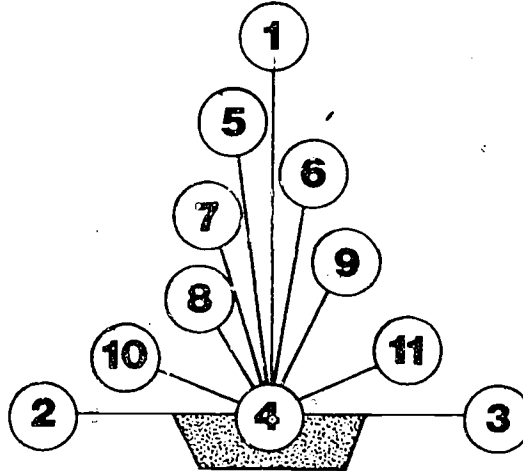

#### MATERIALS:

1. container
2. floral foam (thoroughly soaked): 1/3 block or 1 #5 cylinder
3. 1/3 bunch leatherleaf (9 pieces)
4. 1/2 bunch pom pon chrysanthemums (3 stems)
5. 6 carnations
6. 6 pieces of #20 or #22 gauge wire

#### PROCEDURES:

1. Secure the foam in the container with adhesive floral tape. Use  $\frac{1}{4}$ " width tape and cross the top of the foam. Bring the tape down over the container about  $\frac{1}{2}$ -1". (This tape should be hidden from view at the completion of the design.)
2. Develop your triangle with the leatherleaf. Place one piece vertically in the middle rear of the foam and 1 piece to each side (horizontal and parallel to the table or bending down slightly).
3. Add one small piece to break the rim of the front of the container.
4. Now you are ready to complete the 3 dimensional qualities of your triangle. Place pieces of the leatherleaf inside the line of the triangle with all ends heading to a central point in the middle of the oasis. Remember the rules and try to use just enough foliage to cover the foam and develop the line and mass of the design.
5. Place the flowers using the numerical sequence suggested in the 2-dimensional picture.

## LABORATORY EXERCISE 4 - Continued

6. Some of the carnations (or roses) may not be sturdy enough to stand straight. You may use a #18 or #20 gauge wire to support the flower. Leaving the natural stem attached, insert the end of the wire vertically into the calyx. Twist the wire around the stem and cut the wire just above where your flower stem will be cut. (Do not tape this wire and be sure to leave the whole natural stem attached!)

### APPLICATION:

The inverted-t design is useful when the arrangement is seen from only 3 sides. Example situations include buffet tables, entryway tables, hospital gifts. By adding more flowers, the inverted-t becomes appropriate for funeral designs, grand opening arrangements, and other larger styles. Many holiday styles are constructed with the inverted-t design.

### OBSERVATIONS:

## LABORATORY EXERCISE 5

### ASYMMETRICAL TRIANGLE

**PURPOSE:** Students will construct an L-shape floral design. The following illustration shows a two-dimensional placement of the flowers.

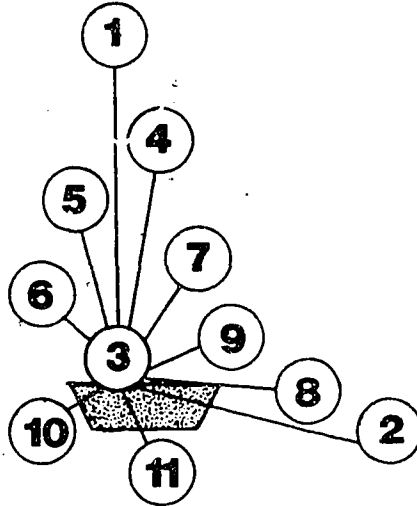

#### MATERIALS:

1. container
2. floral foam (thoroughly soaked): 1/3 block or 1 #5 cylinder
3. 11 or 9 carnations
4. 1/3 bunch leatherleaf (9 pieces)
5. 1/3 bunch pittosporum (optional)
6. 1/4 bunch baby's breath or statice (optional)

#### PROCEDURES:

Use the same procedure as the Inverted-T except start your vertical piece of leatherleaf to one rear side corner of the oasis. Your design should look like an "L".

#### APPLICATION:

The L-shape designs are used where only 3 sides of the arrangement is viewed and asymmetrical balance is desired. An example for 2 L-shaped arrangements might be to the sides of a fireplace mantel. Two L-shapes can "frame" a situation if the L's face each other (i.e., a wedding altar). This design may be especially good for Christmas when needed greens are used.

#### OBSERVATIONS:

## LABORATORY EXERCISE 6

### POM PON MUM OR SWEETHEART ROSE CORSAGE

**PURPOSE:** Students will construct a pom pon and/or sweetheart rose corsage. The following illustration shows a 2-dimensional placement of the flowers.

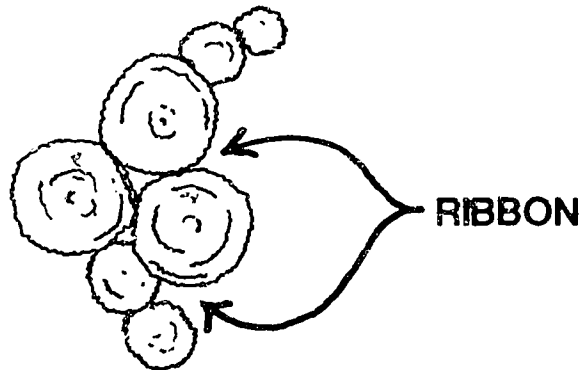

#### MATERIALS:

1. 3 larger and 4 smaller pom. pon mums or 7 sweetheart roses
2. 5 small pieces of foliage
3. 2 corsage bows
4. #24 gauge wire
5. #30 wire
6. #28 wire
7. floral tape

#### PROCEDURES:

1. Cut 3-#24 wires in half.
2. Wire each daisy pomp using the hook method.
3. Wrap wire for each flower with floral tape. Stretch tape tightly and tape to the end of the wire.
4. Construct the 2 corsage bows.
5. Wire and tape the leatherleaf foliage using the hairpin method.
6. Using the bow as a center point, place the 3 large pomps in a triangle around it. You will have to bend the flowers so that they would face out when placed on the shoulder.
7. Tape the 2 small pomps together in a line.
8. Wrap the 2 groups of pomps together with a #30 wire. This wire should be close to the lower flowers.

## LABORATORY EXERCISE 6 - Continued

9. Place the foliage in the "spaces" formed by the design of the corsage and attach with your #30 wrapping wire.
10. Cut the wrapping wire and tape over it so not to scratch the wearer.
11. Place the second bow under the 2 lowest flowers.
12. Place completed corsage in bag with corsage pins. Refrigerate until time of wearing.

NOTE: The sweetheart corsage procedure is the same except all the sweethearts are wired with the pierce method.

### APPLICATION:

This corsage is used wherever a pin-on corsage is required (dance, wedding, special event). It can be adapted as a wrist corsage by adding a commercial "wristlet" and cutting the stem short.

### OBSERVATIONS:

295

## LABORATORY EXERCISE 7

### CARNATION CORSAGE

**PURPOSE:** Students will construct a carnation corsage. The following illustration shows a 2-dimensional placement of the flowers.

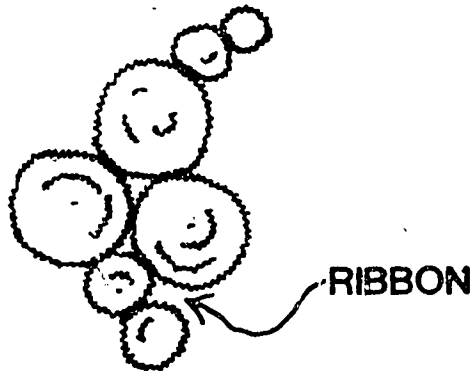

#### MATERIALS:

1. 4 carnations
2. 7 #24 gauge wires
3. 9 #28 gauge wires
4. 2 #30 gauge wires
5. 5 small pieces from leatherleaf
6. floral tape
7. corsage ribbon

#### PROCEDURES:

1. The assembly procedure is the same as for the pom pon mum corsage except:
  - A. no bow is placed in the center
  - B. small carnations are either miniature carnations or split from whole carnations.
2. Splitting or feathering carnations:
  - A. Carefully cut carnations into 2 or 3 pieces leaving the calyx on each piece. It is easiest to slice the carnations while they are laying flat on the table.
  - B. Wrap each piece with a #28 wire.
  - C. Pierce each piece with a #24 wire.
  - D. Tape securely from the base of the petals down to the end of the wire.

## LABORATORY EXERCISE 7 - Continued

### APPLICATION:

This corsage is useful in situations where pin-on corsages are requested (dances, weddings, etc.). It can be adapted to a wrist corsage by adding a commercial "wristlet" and cutting the stem short.

LABORATORY EXERCISE 8  
NOSEGAY IN FLORAL FOAM HOLDER

**PURPOSE:** Students will construct a nosegay using a floral foam holder.

**MATERIALS:**

1. 3 standard carnations
2. 6 miniature carnations
3. 7-9 pom poms
4. 4 sweetheart roses
5. 1/3 bunch leatherleaf
6. nosegay foam holder (thoroughly soaked)

**PROCEDURES:**

1. Use the leatherleaf to green the foam holder. Use the technique similar to a round centerpiece (See Laboratory Exercise 3 for review of an oval centerpiece.). Some of the leatherleaf can be used under the foam to hide the holder from the back side.
2. Place 1 sweetheart rose in the top center of the foam.
3. Place 3 carnations around the sweetheart rose at about a 45° angle into the foam.
4. Place 3 or 4 of the poms at a 90° angle to the sweetheart rose at the base of the holder. These flowers form the bottom of the nosegay.
5. Fill in the 3 spaces created by the carnations with the 3 sweetheart roses. Be sure these flowers can be seen as they are usually the most expensive flower of the 3.
6. Use the rest of the poms to fill in holes in the nosegay.
7. Attach a bow at the point between the top of the handle and base of the foam holder.

**APPLICATION:**

This nosegay is useful when working ahead and flowers need to be stored for a time. It is not recommended for a wedding "throw-away" bouquet as it will shatter on impact. The floral foam nosegay is used whenever a handheld bouquet is required (dances, weddings, etc.).

**OBSERVATIONS:**



LABORATORY EXERCISE 9  
WIRED AND TAPED NOSEGAY

PURPOSE: Students will construct a wired and taped nosegay.

MATERIALS:

1. 3 standard carnations
2. 6 miniature carnations (or 3 standard carnations split in two)
3. 7 pom poms
4. 4 sweetheart roses
5. 10 pieces pittosporum: approx. 2" long
6. #26 gauge wire
7. #24 gauge wire
8. #30 gauge wire
9. floral tape
10. corsage ribbon

PROCEDURE:

1. Wire carnations and sweethearts using whole #24 wire
2. Wire poms with  $\frac{1}{2}$  #24 wire using "hook" method
3. Wrap carnations and sweetheart roses with floral tape. Stretch tape tightly and tape to end of wire.
4. Set aside completed taped flowers. Place them in a vase so they will not become bruised.
5. Cut your pittosporum so that each stem has one row of foliage.
6. Bend the poms directly under the flower. Place a piece of pittosporum under the flower head so that the leaves back the flower. Tape these pieces together. Use only 3 or 4 turns of the tape.
7. Tape a small piece of wired pittosporum around your best sweetheart rose. Place in the center of a bow similar to the size nosegay you desire.
8. Place the 3 standard carnations around the sweetheart. Bend the carnations outward.
9. Use a #30 wire to hold the bouquet together. Always wrap the wire at the same point--point where the "handle" begins. Be sure to use your wrapping wire with each addition.
10. Add the 3 sweethearts between the carnations at the outer edges.
11. Place all the poms with pittosporum around the carnations and sweetheart roses.

## LABORATORY EXERCISE 9 - Continued

12. Add the miniature carnations at intervals around the pomps.
13. Tape the whole stem. Arrange spaces among the flowers and tuck a bow at the base of the flowers. Cut the stem so it's long enough to hold. Some designers wrap the stem with ribbon and attach another bow at the top of the stem.
14. Be sure all the flowers are in excellent condition. Your nosegay should be a design you would carry.

NOTE: For a larger bouquet use 4 whole carnations around the sweetheart rose and increase the number of other flowers.

### APPLICATION:

This design is utilized for weddings and other occasions where a hand-held bouquet is desired. It is timely to construct and short-lived, but is flexible and may be easily adapted to different styles.

### OBSERVATION:

TEACHER'S KEY - STUDENT WORKSHEET 1

TYPES OF FLOWERS FOR A DESIGN

PROCEDURE: List the various types of flower shapes (ex: line and mass) and describe how each contributes to an arrangement. Give 3 examples of each type.

Type	Purpose	Examples
1. Line Flowers	form framework; give height	1. snapdragon 2. gladiolus 3. delphinium stock
2. Mass Flowers	placed inside of line flowers to fill in the arrangement	1. carnation 2. chrysanthemum 3. aster 4. daisy
3. Form Flowers	use at focal point--have exceptional beauty and distinctive shapes	1. rose 2. iris 3. orchid 4. bird-of-paradise 5. anthurium
4. Filler Flowers	small sprays of flowers to fill open spaces, add fullness and gentleness	1. baby's breath 2. statice 3. pom pon mum

---

# FLORAL DESIGN RULES FOR COLOR

1. 1/3 dark + 2/3 light  
Example: 12 carnation arrangement = 4 red + 8 pink

2. Lighter colors toward outside of design, darker colors toward center!

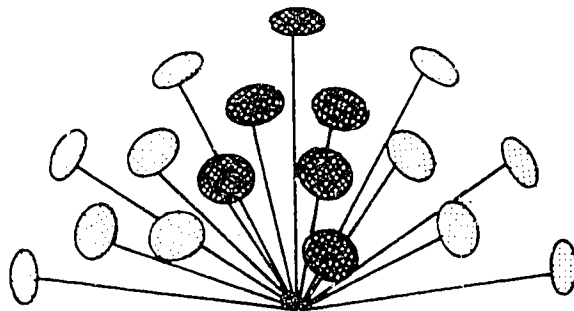

3. Strong warm colors create a focal point. Be careful not to let one color become a dominant element.
4. Gradually change from one hue to another for color rhythm.

# TYPES OF COLOR SCHEMES

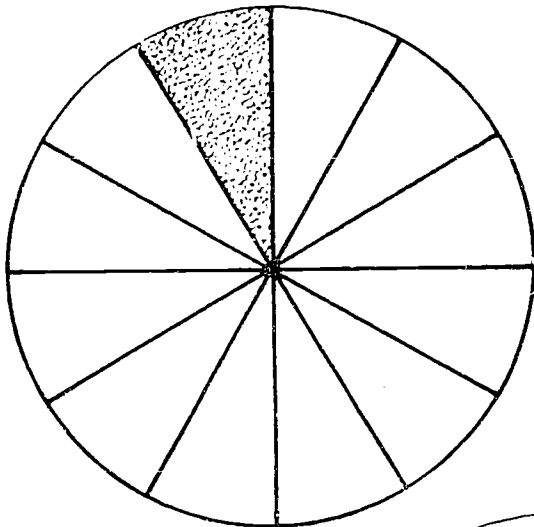

MONOCHROMATIC

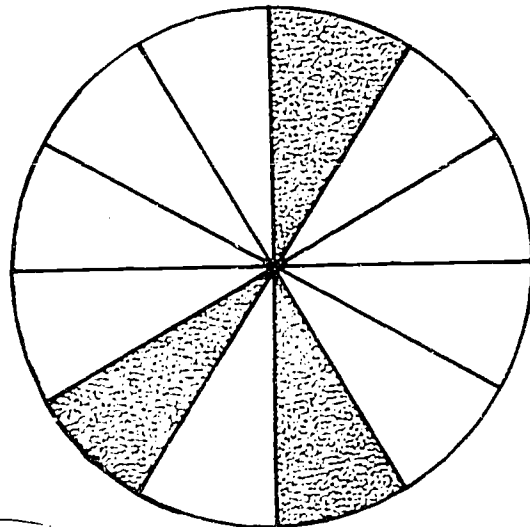

SPLIT COMPLEMENTARY

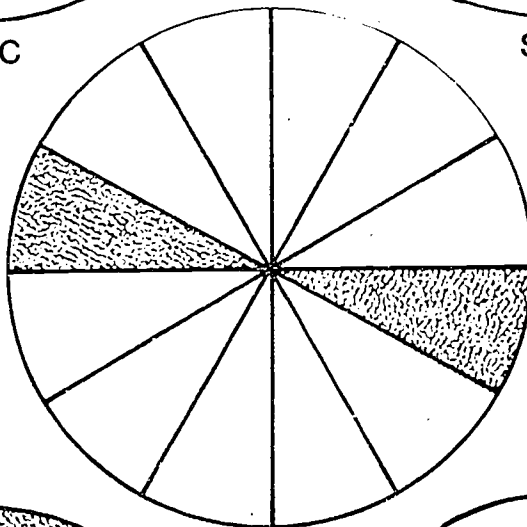

COMPLEMENTARY

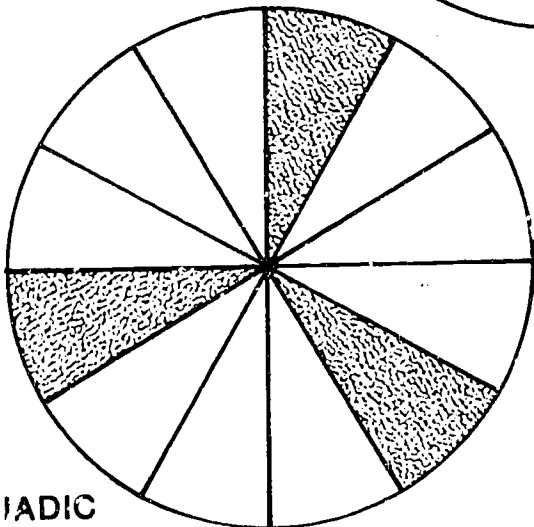

TRIADIC

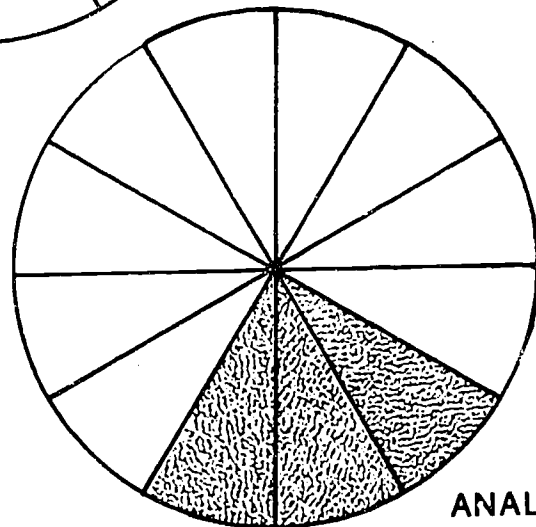

ANALOGOUS

300

5-

---

# THE CIRCLE OR COLONIAL ARRANGEMENT

- THE BASIC SHAPE OF A COLONIAL ARRANGEMENT IS A CIRCLE.

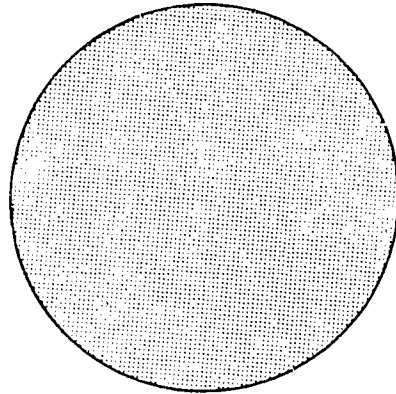

- SIDE VIEW

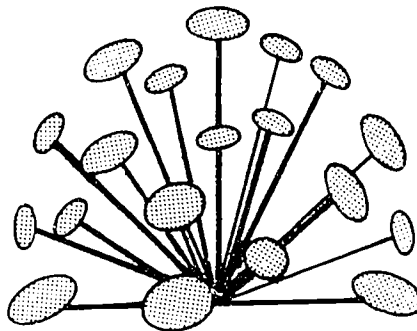

- TOP VIEW

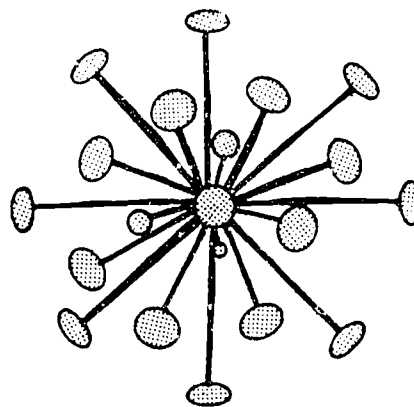

# THE OVAL OR OBLONG ARRANGEMENT

- THE BASIC SHAPE OF AN OBLONG ARRANGEMENT IS AN OVAL.

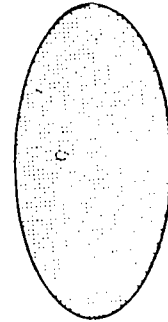
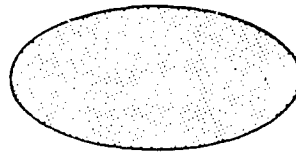

- SIDE VIEW

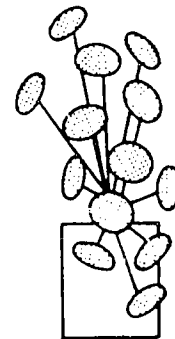
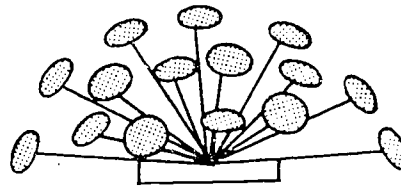

- TOP VIEW

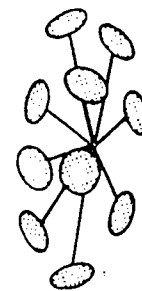
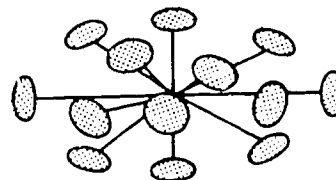

---

# THE SYMMETRICAL TRIANGLE ARRANGEMENT

▲ ONE TYPE OF FLORAL DESIGN IS THE SYMMETRICAL TRIANGLE

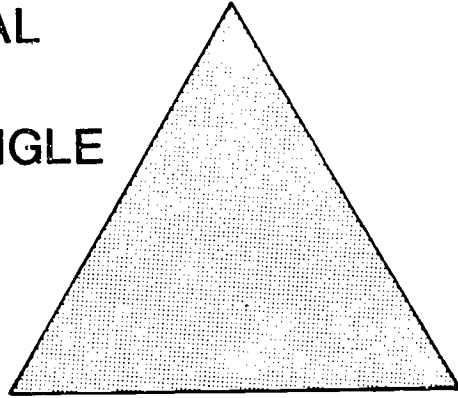

▲ SIDE VIEW

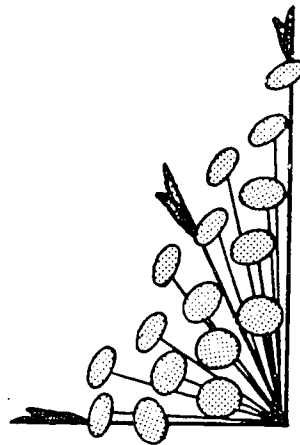

▲ FRONT VIEW

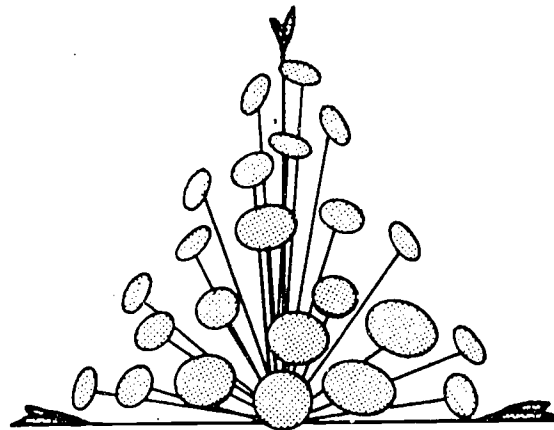



# THE ASYMMETRICAL TRIANGLE ARRANGEMENT

Variations of the asymmetrical triangle arrangement include

(A) the inverted "T"

(B) a right 

(C) a left 

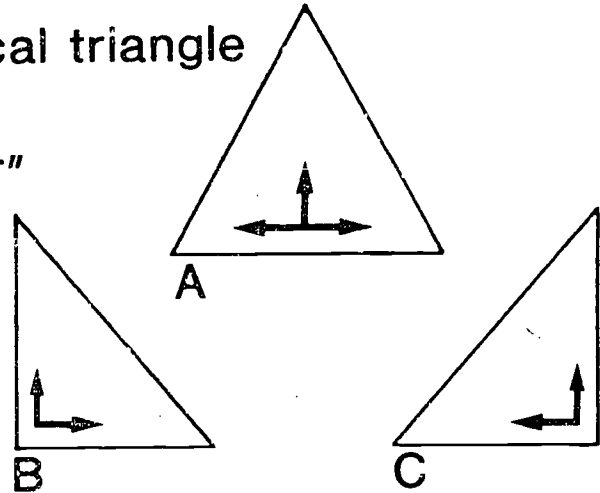

## FRONT VIEWS

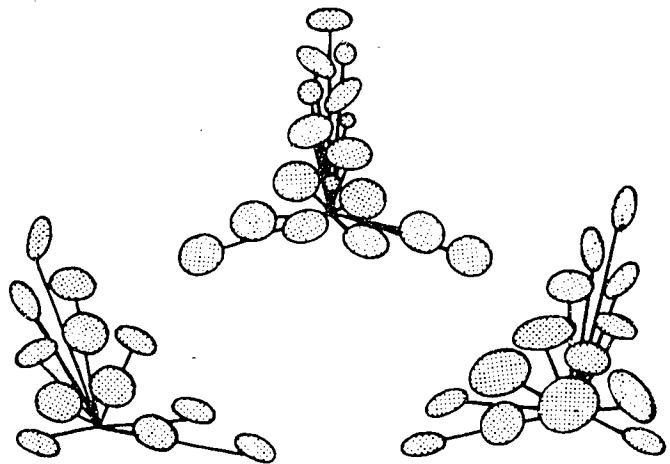

## TRANSPARENCY DISCUSSION GUIDE

### MAKING TABLE ARRANGEMENTS, CORSAGES, AND NOSEGAYS

- I. Transparency -- FLORAL DESIGN RULES FOR COLOR
  - A. Use the correct proportions of light and dark flowers when constructing an arrangement. Lighter colors belong towards the outside of the arrangement and deeper colors towards the center. Strong or warm colors tend to dominate, and should be used sparingly. To create color rhythm use a variety of hues.
- II. Transparency -- TYPES OF COLOR SCHEMES
  - A. By noting the position of the colors on a color wheel, students can learn the basic color scheme relationships.
    - P = Primary
    - S = Secondary
    - T = Tertiary
- III. Transparency -- BASIC TYPES OF FLORAL ARRANGEMENTS
  - A. Floral arrangements can be created in a wide variety of shapes and sizes; however, it is important to learn the basic shapes and design principals before attempting to be too creative.
  - B. Note the direction your eye takes when looking at the various arrangements. Observe the size and shape of the flowers utilized in the design. Identify the focal point in each arrangement. Discuss when and where various styles of arrangements are appropriate.
  - C. Use these transparencies to assist students in the actual construction of floral arrangements.

SAMPLE TEST QUESTIONS AND TEACHER'S KEY  
MAKING TABLE ARRANGEMENTS, CORSAGES, AND NOSEGAYS

SHORT ANSWER:

1. Secondary colors are created by mixing certain colors. Name the secondary colors found on the color wheel.

A. Orange

B. Violet

C. Green

2. How are tertiary colors created?

Mix 1 Primary + 1 Secondary Color

Ex: Red-Violet = Red + Violet

3. What factors distinguish a tint from a shade?

Tint = Hue (color) + White

Shade = Hue + Black

4. Name the type of balance for the following arrangements.

A. L-shape or right triangle: Asymmetrical

B. Crescent Asymmetrical

C. Inverted-T Symmetrical

5. How is color balance achieved?

-2/3 light + 1/3 dark colors  
-dark at base; light at top

6. How does a floral designer create spacing rhythm?

-More space between flowers at outer edges

7. How does a floral designer create facing rhythm?

-Flowers point up at top of design  
-Flowers angle to the side in the middle of the design  
-Flowers point forward at focal point

8. Explain a situation where multiple focal points might be possible in one floral design.

-a centerpiece where the sides are in different viewing areas

TRUE OR FALSE:

True 9. Avoid using the inverted triangle with greater width at the top than at the base.

True 10. Break the rim line of the container with a few flowers or leaves.

False 11. It is alright to cross stems of flowers in a floral arrangement.

True 12. Plan for interesting voids and spaces in your design.

False 13. Push your focal point in and let it hide under taller flowers.

True 14. Cover your mechanics with--oasis, floral foam, styrofoam, etc.

False 15. Have your tallest flowers the same length as the height of the container.