

DOCUMENT RESUME

ED 230 821

CE 036 370

AUTHOR Henderson, William Edward, Jr.
 TITLE Articulated, Performance-Based Instruction Objectives Guide for Building Construction/Carpentry. Final Document. Revised.
 INSTITUTION Greenville County School District, Greenville, S.C.; Greenville Technical Coll., S.C.
 SPONS AGENCY South Carolina Appalachian Council of Governments, Greenville.
 PUB DATE 28 Feb 83
 CONTRACT ARC-211-B
 NOTE 423p.; For related documents, see ED 220 579-585, CE 036 366-368, and CE 036 371-372.
 PUB TYPE Guides - Classroom Use - Guides (For Teachers). (052) -- Tests/Evaluation Instruments (160)

EDRS PRICE MF01/PC17 Plus Postage.
 DESCRIPTORS Articulation (Education); Behavioral Objectives; Blueprints; *Building Trades; *Cabinetmaking; *Carpentry; Competency Based Education; *Construction (Process); Criterion Referenced Tests; Curriculum Guides; Finishing; Flooring; Floor Layers; High Schools; Industrial Arts; Secondary Education; *Trade and Industrial Education

ABSTRACT

Developed during a project designed to provide continuous, performance-based vocational training at the secondary and postsecondary levels, this instructional guide is intended to help teachers implement a laterally and vertically articulated secondary level building construction/carpentry program. Introductory materials include descriptions of Building Construction I and II, descriptions of the postsecondary carpentry program, postsecondary course descriptions, standards applicable to Building Construction I and II, discussion of sample tests provided in the guide, and suggested instructional time. Topics covered in the 25 units include an introduction; safety; math; blueprint reading; hand tools; fasteners, finishing, and hardware; power tools; site layout; footings and foundations; framing; roofing; finishing; stair construction; cabinets and built-ins; cabinetmaking, built-ins, and finishing specialization; mechanical and masonry rough-ins, finishing, and completion; finished carpentry tasks; estimating materials and costs; practical application projects; job leadership; and career opportunities. Suggested instructional time and task listings begin each unit. For each task in a unit, some or all of the following are provided: performance objectives, performance actions, performance standards, recommended sources, related technical information, and other information the teacher might need. Suggested outcome-referenced tests have been interspersed throughout the text, immediately following the unit to which they apply. Appendixes include proficiency reports, articulation materials, definitions, and test directions. (YLB)

FINAL DOCUMENT FOR
ARTICULATION OF BUILDING CONSTRUCTION/CARPENTRY

ED230821

Project No. 82-1361
Contract No. ARC 211-B

Wm. Edward Henderson Jr., Coordinator
Occupational Education Articulation Program
The School District of Greenville County
P. O. Box 2848 - 301 Camperdown Way
Greenville, SC 29602

ARTICULATED, PERFORMANCE-BASED INSTRUCTION OBJECTIVES GUIDE FOR BUILDING
CONSTRUCTION/CARPENTRY

U.S. DEPARTMENT OF EDUCATION
NATIONAL INSTITUTE OF EDUCATION
EDUCATIONAL RESOURCES INFORMATION
CENTER (ERIC)

✓ This document has been reproduced as
received from the person or organization
originating it
Minor changes have been made to improve
reproduction quality

- Points of view or opinions stated in this docu-
ment do not necessarily represent official NIE,
position or policy

February 28, 1983

"PERMISSION TO REPRODUCE THIS
MATERIAL HAS BEEN GRANTED BY

W E Henderson

TO THE EDUCATIONAL RESOURCES
INFORMATION CENTER (ERIC) "

Occupational Education Articulation Program
of The School District of Greenville County
and Greenville Technical College
Funded in part by
South Carolina Appalachian Council of Governments

00036370

ARTICULATED, PERFORMANCE-BASED CURRICULUM GUIDE

THE SCHOOL DISTRICT OF GREENVILLE COUNTY

DR. J. FLOYD HALL
SUPERINTENDENT

DR. NORMAN MULLINS
ASSOCIATE SUPERINTENDENT FOR EDUCATIONAL DEVELOPMENT

MRS. DORIS CLANTON
DIRECTOR, INSTRUCTIONAL SERVICES

MR. O. RICHARD COTHRAN, JR.
CONSULTANT, VOCATIONAL EDUCATION

ARTICULATION GUIDE

THE SCHOOL DISTRICT
OF GREENVILLE COUNTY

AND

GREENVILLE
TECHNICAL COLLEGE

THE SCHOOL DISTRICT OF GREENVILLE COUNTY
GREENVILLE, SOUTH CAROLINA

REVISED 1983

Henderson, Wm. Edward Jr., ed. Articulated, Performance-based Instruction Guide for Building Construction/Carpentry, Greenville, SC: The School District of Greenville County (Occupational Education Articulation Program funded in part by the South Carolina Appalachian Council of Governments), 1983.

ACKNOWLEDGEMENT

This Articulated, Performance-based Instruction Guide for Building Construction/Carpentry is the product of the work of the following instructors representing the secondary program of The School District of Greenville County and the post-secondary similar program at Greenville Technical College.

Donaldson Vocational Center
Enoree Vocational Center
Foothills Vocational Center
Golden Strip Vocational Center

James E. Christie
Earl K. Bentley
Theron H. Giles
Kenneth Kirkland

Greenville Technical College

Jim Bowen, Department Head

The cooperation of these instructors and others representing The School District of Greenville County and Greenville Technical College is appreciated.

DISCRIMINATION PROHIBITED - Title VI of the Civil Rights Acts of 1964 states: "No person in the United States, shall, on the grounds of race, color, or national origin, be excluded from participants in, be denied the benefit of or be subjected to discrimination under any program or activity receiving federal financial assistance." Therefore, the Occupational Education Articulation Program, like all other programs or activities receiving financial assistance from the Appalachian Council of Governments, must be operated in compliance with this law.

The opinions expressed hereina do not necessarily reflect the position or policy of the Appalachian Council of Governments and no official endorsement by that agency should be inferred.

BIAS STATEMENT

This articulated, performance-based instruction guide has been developed based upon the tasks (objectives) and task actions (enabling objectives) important to the success of entry level workers in the vocation. The objectives were derived from task analysis and available tasks lists such as V-TEC Catalogs. The standards of performance are those expected by local businesses and industries for job success. Test samples are included to represent valid and reliable measures of the mastery of objectives.

This articulated, performance-based instruction guide has been designed to comply with the requirements of PL 94-482 Educational Amendments of 1976, Title II, which is intended to "...ensure that...curricula do not reflect stereotypes based upon sex, race, or national origin..."

COPYRIGHTED DISCLOSURE STATEMENT

Every effort has been made to appropriately document any copyrighted material used in this articulated, performance-based instruction guide.

The objectives and task actions in this guide were developed or contributed by task force committee (instructor) participants based on their expertise and on task lists from resources such as V-TEC Catalogs. Standards included in this guide are those identified by local businesses and industries as important to the success of entry level workers. Sample knowledge and performance tests are included for the purpose of representing valid and reliable test items that may be used to measure mastery of objectives. Test samples taken from texts or workbooks typically are those being used locally and appropriate documentation has been included.

Wm. Edward Henderson Jr., Coordinator
Occupational Education Articulation Program
The School District of Greenville County

ABSTRACT

Title of Project: Occupational Education Articulation Program:
Building Construction/Carpentry

Project Coordinator: Wm. Edward Henderson Jr.

Contracting Agency: The School District of Greenville County P. O.
Box 2848 - 301 Camperdown Way Greenville, SC
29602

Program Period: March 1, 1982, through February 28, 1983

PURPOSE: To develop a continuous line of vocational training in similar Building Construction and Carpentry programs so that students may continue their education at the secondary and post-secondary levels without loss of time or waste of effort in repeating tasks that have been mastered previously.

To provide a system where teachers can cooperate effectively in providing a continuous occupational development program where the level and type of training that leads to entry-level employment skills will be clear to students, teachers, other educators, and employers.

METHOD: Building Construction teacher representatives from four secondary level vocational centers of The School District of Greenville County and post-secondary level Building Construction teacher representatives from the Industrial Division, Greenville Technical College were brought together in task force committee meetings and workshops to survey very similar vocational courses of training to identify possible overlap or gaps as students continued carpentry training from the secondary level to the post-secondary level. In addition, there was interest in lateral articulation of similar programs at the secondary level. This articulated, performance-based (competency-based) instruction objectives guide was developed by the Task Force Committee on Building Construction to facilitate articulation. The Task Force Committee on Building Construction, by the task analysis process, identified the essential competencies for Building Construction for a student to continue training or for initial entry into the labor market in a Building Construction related field. Major objectives for competency were stated, performances to obtain the objectives were stated, performances to obtain

the objectives were identified and placed in sequential order, instruction time was estimated, and performance standards were stated. Finally, outcome-referenced (criterion-referenced) measures of competence were developed as a guide in articulating.

RESULTS: As a result of this project, the Articulated, Performance-based Instruction Objectives Guide for Building Construction/-Carpentry was developed. This articulation guide, however, is not a final product since it must be field trial tested and revised. Modifications and improvements to the guide are expected since the process of education must be continually reviewed to ensure that objectives are valid and are being met as best they can be met under given conditions.

A Policies and Procedures Guide was developed to aid articulation activities in an earlier phase of the project and has been used to direct program activities.

Two workshop guides, developed during the earlier phase of the project were used to assist task force committee participants in writing performance-based objectives, performance actions to reach the objectives, performance standards, and outcome-referenced tests. These guides contain how-to-do-it sections distributed to teacher participants. The workshop standards for performance evaluation guides and the Policies and Procedures Guide were revised during this phase of the articulation program.

CONTENTS

Building Construction I Secondary	1
Building Construction II Secondary	2
State Department of Education Recommendations	5
Post-Secondary Description	6
Post-Secondary Course Description	7
Potential Articulation.	9
Standards Applicable to Building Construction I and II	10
Outline of Articulated, Performance-based Instruction Guide	11
A Typical Residential Construction Work Sequence	12
Sample Outcome-Referenced Test.	13
Suggested Instruction Time	14
Task Listings	21
Unit 1.0 - Introduction to Building Construction	46
Review School Policies and Procedures	47
Orientation to Shop	48
Review Course Objectives and Standards	49
Identify Typical Building Construction Career Opportunities	50
Job Performance	51
Work Attitudes	53
Unit 2.0 - Carpentry Safety	55
Classroom Safety	56
Use Personal Protective Equipment	62
Practice Safety In Using Power Tools	63
Ladder and Scaffolding Safety	65
Unit 3.0 - Building Construction I	66
Carpentry Math	67
Carpentry Math - Fractions	68
Carpentry Math - Decimals	69
Carpentry Math - Volumes	70
Carpentry Math - Areas	71
Carpentry Math - Angular Measurement	72
Unit 4.0 - Blueprint Reading	74
Identify Working Drawings and Blueprints and Read Specifications	76

Unit 4.0 - Blueprint Reading (Con't.)	
Interpret Common Blueprint Symbols Used in Residential Construction	77
Interpret Dimensions From Blueprints	78
Read Blueprint and Specifications and Estimate Lumber Materials	79
Unit 5.0 - Carpentry Hand Tools	80
Identify and Demonstrate Proper Use of Carpentry Hand Tools	81
Read and Measure With Rules and Squares	85
Check Whether a Surface is Level or Plumb	87
Unit 6.0 - Fasteners, Finishing, and Hardware	88
Fasten Stock Using Glue, Nails, Staples, Screws, and Bolts	89
Install Wood Plugs in Prepared Holes	92
Fill and Finish Nail and Screw Holes	93
Sand Surfaces For Finishing	94
Unit 7.0 - Portable Power Tools	95
Drill or Bore Holes With Portable Electric Hand Drill	96
Cut Stock With Portable Electric Saws (Circular, Sabre, and Reciprocating)	97
Rout Irregular Edges With Portable Router	99
Plane Stock With Portable Electric Plane	100
Sand Surfaces and Edges With Belt Sander and Finishing Sander	101
Unit 8.0 - Stationary Power Tools	104
Demonstrate Use of Table Saw	105
Demonstrate Use of Radial-Arm Saw	109
Demonstrate Use of Drill/Drill Press	113
Demonstrate Use of Jointer	115
Demonstrate Use of Planer	118
Demonstrate Use of Band Saw	120
Demonstrate Use of Router and Shaper	122
Demonstrate Use of the Belt Sander	125
Unit 9.0 - Site Layout (Site Planning)	127
Establish Site Property Lines	129
Demonstrate Use of Leveling Instrument	130
Locate Building Site in Relation to Property Line	131
Locate and Square Building Corners Using Builder's Level	133
Locate and Mark Excavation Lines	134
Supervise Site Preparation (Dual Tasks)	135
Unit 10.0 - Footings and Foundations	138
Install Batter Boards for Rough Excavation and Footings	140
Set Grade Stakes at Proper Elevations	141

Unit 10.0 - Footings and Foundations (Con't.)

Align Form Walls	142
Brace Foundation Wall Forms	143
Calculate Concrete for Footings and Foundation Walls	144
Clean and Repair Form.	145
Construct Concrete Step and Stair Forms	146
Construct Single Wall Foundation Forms	147
Build Side Forms	149

Unit 11.0 - Floor and Sill Framing 150

Construct Models to Illustrate Scaled Floor, Wall, and Roof Framing	152
Layout a Floor Frame	155
Cut and Install Sill Plates to Foundation Wall	156
Frame and Install a Buildup T-type Sill	158
Frame and Install a Box Sill	159
Install Posts and Columns	160
Frame and Install a Buildup Girder	161
Install Floor Joists	163
Install Bridging Between Joists	164
Frame Floor Openings	165
Install a Subfloor	166

Unit 12.0 - Wall and Partition Framing 168

Layout a Wall Frame	170
Construct Corner Posts and T-Posts	171
Frame a Wall Opening	172
Install Door and Window Frames	173
Build Box Beams	174
Install Furring	175
Install Firestop	176
Install Structural Sheathing	177

Unit 13.0 - Roof Framing 178

Layout, Cut, and Install Common Rafters for Equal Pitch Roofs	181
Layout, Cut, and Install Ceiling Joist	183
Layout Common Roof Plan.	184
Layout, Cut, and Install Cripple Jack Rafters for Hip and Valley Installations	186
Cut and Install Valley Rafters	188
Layout, Cut, and Install Hip Rafters for Equal Pitch Roofs	190
Cut and Install a Ridgeboard	192
Frame Roof Openings	194
Frame a Dormer	196
Frame Gable Ends	198
Cut and Install Collar Ties	200
Layout, Construct, and Install Roof Trusses.	202

Unit 14.0 - Roofing	204
Apply Insulation (Underlay) for Asphalt Shingles	207
Install Composition Shingles	209
Layout for Bonding Shingles Over Dormers (Or other Roof Appendages)	211
Install Valley Shingles	213
Flash Chimney and Roof Vents	214
Flash Valleys	216
Unit 15.0 - Exterior Finishing	217
Install Exterior Sheathing (Fiberboard or Plywood)	219
Frame a Boxed Cornice	220
Install Double-Hung Windows	221
Install Exterior Doors	222
Install Prefabricated Storm Doors and Windows	223
Install Exterior Trim	224
Cut and Install Furring	225
Cut and Install Wood Paneling	226
Install Exterior Siding	227
Unit 16.0 - Interior Finishing	228
Fit and Install Flexible Insulation	230
Install Prefinished Paneling	232
Cut and Install Furring	233
Cut and Install Solid Wood Paneling	234
Install Prefinished Hardboard	235
Install Drywall Board (Sheetrock) (Gypsum Wallboard)	236
Install Interior Doors	238
Install Door Lock Sets	239
Cut and Install Finish Flooring	240
Cut and Install Baseboards, Trim, and Molding	242
Cut and Install a Fireplace Mantel	244
Construct a Storage Closet	245
Unit 17.0 - Stair Construction	246
Calculate Riser Height	248
Layout, Cut, and Install a Straight Run Stringer	249
Layout and Install Stair (Carriage)	250
Layout, Cut, and Install Treads for Open Riser Stairs	251
Cut, Fit, and Install Balusters and Handrails	252
Fit Newel Posts in Open Stairs	253
Assemble and Erect Prefabricated (Mill-built) Stairs	254
Unit 18.0 - Cabinets and Built-ins	255
Install Built-in Shelving and Cabinets	256
Assemble Cabinet Frame	258
Install Prefabricated Cabinets	259
Unit 19.0 - Cabinetmaking, Built-ins, and Finishing Specialization (Optional)	261
Cut and Shape Casework Components	262
Assemble and Install Casework Components	265

Unit 20.0 - Mechanical and Masonry Rough-in, Finishing, and Completion (Optional Units)	267
Electrical - Mechanical	268
Heating and Cooling - Mechanical	269
Plumbing - Mechanical	270
Masonry	271
Thermal Insulation	272
Interior Finishing	273
Exterior Finishing	274
Unit 21.0 - Finish Carpentry Task (Optional Task)	276
Finish Carpentry	277
Unit 22.0 - Estimating Materials and Costs	279
Estimating	280
Unit 23.0 - Practical Application Project	289
Residential Field Construction	290
Field Trips Training Orientation	293
Unit 24.0 - Job Leadership.	294
Developing Leadership Characteristics.	295
Career Opportunities.	297
Identify Post-Secondary Career Development Opportunities.	297
Proficiency Report Form	298
References	305

APPENDIXES

- A Joint Articulation Agreement
- B Instructor's Signed Agreement to Articulate
- C Philosophy of Articulation Guide Design
- D Purposes of Articulation Guide
- E Definitions of Terms
- F Directions for Tests
- G Responsibility Sheet
- H Binder Design

BUILDING CONSTRUCTION I

LEVEL: Secondary

TITLE: Building Construction I

DESIGNATION: BUILD CONST I COMPUTER NUMBER: 747

DESCRIPTION: Graduates of Building Construction are prepared for successfully entry into carpentry work. Training includes construction of structures in wood, plywood, and wallboard using hand and power tools. Reading and interpreting blueprints, sketches, and building plans, different methods of construction, and types of building materials are taught. Generally, students receive familiarization training in masonry and all mechanical systems as they relate to carpentry and residential construction. Practical carpentry work on residential is emphasized.

OBJECTIVES: Upon completing Building Construction I, the student should have acquired basic knowledges and skills in carpentry careers, carpentry safety, carpentry math, blueprint reading, job planning, and estimating, the use and care of carpentry hand and power tools, use of fasteners and assembling jobs by various means, identifying correctly types and grades of lumber and cutting stock to dimensions, as well as the basic carpentry phases of residential construction.

Building Construction I prepares the student for continuation of training in Building Construction II which will be concerned with increasing the students knowledge of carpentry and providing opportunities for the development of acquired and new skills.

PREREQUISITES: None
Suggested Grade Level: 11

RECOMMENDED: For optimum success, the carpenter should have a working knowledge of basic math and be able to solve simple problems in fractions, percentages, ratio, and proportions, typical of the carpentry business.

Carpenters should have above average finger and manual dexterity, good hand-eye-foot coordination, physical strength, mechanical aptitude, and form perception.

REQUIRED/SUGGESTED INSTRUCTIONAL HOURS:

System	Year		
	Class	Lab	Total
Credits	3	-	3
Hours	540	-	540

LEVEL: Secondary

TITLE: Building Construction II

DESIGNATION: BUILD CONST II COMPUTER NUMBER: 748

DESCRIPTION: Building Construction II reviews, expands, and applies the principles learned in Building Construction I. Building Construction II emphasizes more specific and advanced phases of the trade. During the second year of vocational training, the student will become more knowledgeable concerning various phases of foundations, framings, coverings, trimming, and finishing. Each student will have the opportunity to gain specialized skills and knowledges through individual or team activities.

OBJECTIVES: Upon successful completion of two years of training the graduate should be competent for entry level employment in the field of carpentry. Carpentry work typically involves the general erection of buildings. In addition, carpentry work may include putting up shelves, hanging doors, framing windows, laying flooring, and building walls and partitions. The finished carpenter may construct cabinets, install molding, and panel room interiors.

The carpenter is able to do simple mathematical problems, estimate jobs, and read blueprints. A general knowledge of related fields is necessary when the carpenter works with plumbers, bricklayers, roofers, and others.

Building Construction I and II provides the student with the basic skills and knowledge necessary for entry into carpentry work. The second year high school level program provides additional advances or specialized skills and knowledges to better prepare the student for work, to qualify the student for entry in related field of carpentry, or for continued career preparation at the post-secondary level.

PREREQUISITES: Building Construction I
Suggested Grade Level: 12

REQUIRED/SUGGESTED INSTRUCTIONAL HOURS:

System	Year		
Division	Class	Lab	Total
Credits	3	-	3
Hours	540	-	540

PERFORMANCE
EVALUATION:

Given basic carpentry tools and equipment, the will demonstrate competency in reading and interpreting blueprints, specifications, sketches, and building plans by fulfilling the carpentry requirements according to applicable standards.

JOB
QUALIFI-
CATIONS:

Carpentry, D.O.T. 860.381. Entry level generally will be as an apprentice carpenter. The carpenter may advance to the position of foreman, job superintendent, and general superintendent. Work may be as rough carpenter, or finish carpenters typically in residential construction.

The "Rough Carpenter," D.O.T. 860.761 generally follows sketches or oral instructions and builds rough wooden structures that might include concrete forms or house framing. The rough carpenter interprets specifications to determine dimensions, measures boards, timbers, or plywood using a square, measuring rule or tape, and marks wood for cutting. Cutting wood by hand or power saw to dimensions, the rough carpenter fastens wood by nails or other means for forming a structure. Other typical jobs include installing door and window frames, subflooring, or sheathing on walls and roofs. Primarily, the rough carpenter deals with wooden framework in construction such as subflooring, sheathing, partitions, floor joists, studding, and rafters.

"Finish carpenters" may specialize in installing molding, paneling, cabinets, window sashes, door frames, and hardware.

Related work might include sales and service in lumber businesses, cabinetmaking, or prefab housing manufacturing.

Although cabinetmaking is a specialized vocational program, some cabinetmaking skills are taught to prepare the carpenter to build, install, or finish kitchen cabinets and similar built-ins. In addition, vocational programs suitably equipped for teaching cabinetmaking may allow students who wish to specialize in cabinetmaking to develop skills and knowledge that will help them enter that field. Training might include production of window frames, molding, trim, and panels; making products such

as furniture, store fixtures, kitchen cabinets, and office equipment. Skills typically acquired would include cutting, shaping, and assembling parts by means of hand tools and woodworking machines; refinishing furniture, installing hardware; planning layouts; and working with various types of woods.

WORKING
CONDITIONS:

Carpentry work involves some manual dexterity. The carpenter may have to lift moderate weights such as wood stock, frames, or assemblies. Some of the disadvantages found in carpentry work are dangers from falls, strains, or cuts. Work in construction industry may involve layoffs caused by poor weather or shortage of materials.

Carpentry work, in the business world, seldom waits on the weather. Since the Building Construction/Carpentry is designed to prepare graduates to make their living in the construction business, students should be prepared to work in cold and hot environments, sometimes in the rain or mud. Exposure to elements such as sharp winds or sunlight should be expected. Typically, training will not expose the student to harsh environmental conditions that may be experienced in the trade.

In some work, carpenters may be required to provide their own hand tools.

STATE DEPARTMENT OF EDUCATION RECOMMENDATIONS
FOR SECONDARY BUILDING CONSTRUCTION

Building Construction prepares the graduate for entry level work in the field of carpentry. Training includes constructing and repairing structures of wood, plywood, and wallboard, using hand and power tools. The reading and interpreting of blueprints, sketches, and building plans is taught also. The graduate has knowledge of basic mathematics, methods of construction, and types of building materials. Practical work on residential or commercial structures is emphasized in training. Generally, Building Construction includes an introduction to electrical installation, masonry, and plumbing related to building construction.

Recommended course content includes:

1. Safety
2. Blueprint reading
3. Measurements and problem-solving
4. Hand and power tools
5. Layout
6. Foundations
7. Floor
8. Framework:
 - Floor joists
 - Studding
 - Partitions
 - Rafters
9. Sheeting
10. Shingling
11. Window
12. Door frame
13. Insulation
14. Interior trim
15. Paneling
16. Cabinets
17. Estimating

POST-SECONDARY DESCRIPTION

CARPENTRY

The purpose of the program is to prepare the graduate to enter the construction trade as an advanced apprentice enabling the worker to become a journeyman carpenter at an accelerated rate. A diploma is awarded upon successful completion of this one year program.

Carpentry teachers the fundamentals of the carpentry trade as well as the basic procedures of cabinetmaking. Included in the curriculum are tools of the trade, their care and use, safety materials, codes and specifications, foundations and layout, concrete formwork, floor, wall, and roof framing, scaffolding, exterior and interior materials and trim exterior and interior finishes, basic cabinetmaking, and related trades.

Suggested Sequence of Required Courses:

FIRST QUARTER

<u>COURSE NUMBER</u>	<u>COURSE TITLE</u>	<u>CLASS CREDIT</u>	<u>LAB</u>	
MAT 112	Applied Mathematics	5	0	5
CAR 111	Carpentry I	3	18	9
CAR 112	Construction Blueprint Reading	5	0	5
		<u>13</u>	<u>18</u>	<u>19</u>

SECOND QUARTER

CAR 121	Carpentry II	4	18	10
CAR 117	Construction Layout	2	3	4
PSY 112	Industrial Human Relations	3	0	3
		<u>9</u>	<u>21</u>	<u>17</u>

THIRD QUARTER

CAR 131	Carpentry III	2	18	8
CAR 132	Estimating and Quantity Take-Off	3	0	3
CAR 145	Foremanship	2	0	2
ECO 100	Consumer Economics	3	0	3
		<u>10</u>	<u>18</u>	<u>16</u>

FOURTH QUARTER

CAR 141	Carpentry IV	4	18	10
CAR 142	National and Local Building Codes	2	0	2
ENG 151	Language Applications I	3	0	3
		<u>9</u>	<u>18</u>	<u>15</u>

Industrial Division Catalog, Greenville Technical College, Greenville,
SC: Greenville Technical College, p. 10-11, 1980.

POST-SECONDARY DESCRIPTION

CARPENTRY

CAR 111 CARPENTRY I

"A study of the care and safe use of hand tools, portable power tools and general operation of stationary woodworking machinery. The student will be able to identify and match common power woodworking machines with their intended use and complete safety measuring and be able to read a rule in feet, inches, and fractions of an inch to one-sixteenth of an inch. (3-18-9)

CAR 112 CONSTRUCTION BLUEPRINT READING

"Course will cover architectural working drawings and shop drawings, including concrete form work, foundations, framing and wood structural members. All standard symbols, details, sections, etc., will be covered. (5-0-5)

CAR 117 CONSTRUCTION LAYOUT

"A course designed to teach persons in the carpentry trade how to locate and lay out building corners and elevation. The use of transits, levels, tapes, rules, etc., will be taught. (2-3-4)

CAR 121 CARPENTRY II

"A study of framing a building from foundation to roofline. The student will be able to define terms and know the purpose of each framing member. He will be able to lay off, compute the length, and install each framing member and apply subflooring and sheathing. (4-18-10)

CAR 131 CARPENTRY III

"A study of the various types of roof construction and insulation for light commercial and residential structures. Student should be able to compute, cut, and assemble the various roof members and determine suitable roofing materials. (4-12-8)

CAR 132 ESTIMATING AND QUANTITY TAKE-OFF

"A study of practical work in quantity survey for construction trades. The student should be able to list the size, amount, styles, grades and cost of materials and list the man-hours and labor cost. The estimation will be based on local and Southern standard building codes. (3-0-3)

CAR 141 CARPENTRY IV

"The study of carpentry interior and exterior finish work. Includes wall covering, flooring, doors, windows, molding, and trims, and stairs and cornices.

CAR 142 NATIONAL AND LOCAL BUILDING CODES

"An analysis of the Southern Standard Building Code, HUD, and VA standards and local building codes. After completion of this course, the student should be able to apply the requirements of codes and standards to building construction. (2-0-2)

CAR 145 FOREMANSHIP

"Course is designed to expose students to the duties and responsibilities required to hold positions of leadership in the career field." (2-0-2)

Industrial Division Catalog, Greenville Technical College, Greenville,
SC: Greenville Technical College, pp. 38-39, 1980-82.

POTENTIAL ARTICULATION
BUILDING CONSTRUCTION/CARPENTRY
(Similar Training)

ARTICU- LATED	GTC COURSE	TOPIC	SECONDARY UNIT(S)	TOPIC(S)
<u>yes</u>	CAR 111	Care and use of hand tools Care and use of portable power tools General operation of stationary woodworking machines Identify and match woodworking machines with intended use Complete safety rules for each machine Define measuring Read a rule to 1/16 inch accuracy	# 5 # 7 # 8 # 7, 8 # 7, 8, 2 # 5 # 5, 3	Carpentry Hand Tools Portable Power Tools Stationary Power Tools "above two" "above" + Carpentry Safety Carpentry Hand Tools "above" + Carpentry Math
<u>N/A</u>	CAR 121	Framing - Foundation Floor Wall Partitions Know purpose of each framing member Able to lay off, compute length, install--- Framing members Sub-flooring Sheathing Sitework	# 10 # 11 # 12 # 12 # 10, 11, 12 # 10, 11, 12 # 10, 11, 12 # 10, 11, 12 # 10, 11, 12 # 9	Footings & Foundations Floor & Sill Framing Wall & Partition Framing "above" "above" + Foundations-wall "above" "above" "above" "above" Site layout
<u>N/A</u>	CAR 131	Roof construction: Styles, support, trusses, layouts, ridges, common rafters, hip, valley, & jack rafters Insulation Compute, cut, assemble roof members Determine suitable roofing materials	# 13 # 14 # 13, 14 # 13, 14	Roof Framing Roofing "above two" "above two"
<u>N/A</u>	CAR 141	Interior and exterior finish work including wall covering, flooring, doors, windows, molding, & trims Constructing stairs Constructing cornices	# 15 # 16 # 17 # 15	Exterior finishing Interior finishing Stair construction Cornice (box)
<u>N/A</u>	CAR 117	(Construction Layout) Locate, layout building corners and elevations Use of transits, levels, & rules	# 9 # 9, 10 # 9 # 9 # 9, 5, 3	Site Layout " + Footing & Foundations Site Layout Site Layout " + Hand Tools, & Math
<u>N/A</u>	CAR 112	(Construction Blueprint Reading)	# 4	Blueprint Reading

Unless otherwise specified, secondary level courses are based on the 180 day school year system and post-secondary level courses are based on the quarter system.

N/A Although similar, currently not articulated because GTC program involves more field instruction/work or encompasses more subjects in more depth.

STANDARDS
APPLICABLE TO
BUILDING CONSTRUCTION I & II

- i. a. Layout lines on lumber should be accurate within the width of a sharp pencil line. Tolerances associated with framing are $\pm 1/16$ inches unless otherwise noted. A reliable general guide is to leave the penciled line when cutting.
- b. At the suggestion of secondary carpentry instructors, the typical standard of $\pm 1/16$ inch is replaced by the standard of $\pm 1/8$ inches for framing and rough carpentry work. It is the opinion of the secondary instructors that the revised standard is more realistic for the type of training being conducted.
- c. All materials will be marked accurately for cutting according to specifications $\pm 1/8$ inches minimum, and $\pm 1/16$ inches preferred, unless otherwise stated.
2. Materials must be marked to indicate maximum use of wood stock and dimensioned lumber.
3. Specifications of the Southern Standard Building Code apply unless superseded by standards included in task description.
4. Upright, 90 degree walls or posts must be plumb ± 12 degrees.
5. Construction will reflect local building code requirements and local building practices.
6. Construction must be completed according to given specifications, architectural or working drawings or sketches.
7. Proper safety, use and care of carpentry hand tools, power hand tools, and stationary carpentry machinery will be practiced at all times.

OUTLINE
OF
ARTICULATED, PERFORMANCE-BASED
INSTRUCTION GUIDE FOR BUILDING CONSTRUCTION
(Secondary Level Carpentry)

This performance-based instruction guide has been developed based on the recommendations of the S. C. State Department of Education, secondary level carpentry training being conducted at the writing of this guide, a task analysis survey of potential employers of secondary level graduates, a survey of V-TEC and other articulation or competency-based program task lists as well as the recommendations from the participating post-secondary institution and current curriculum research data.

This curriculum guide has been prepared along the traditional lines of "stick building" but omitting certain tasks that have been replaced by the growing use of pre-cuts or other current practices.

While this description is applicable to the carpentry program presently being conducted at the secondary level, a change of a secondary level instructor or varying requirements from potential employers might necessitate revision of this guide.

The articulated, performance-based description of the secondary level Building Construction (Carpentry) program is outlined on the following pages.

(See: Suggested Instruction Time and Task Listing)

A TYPICAL RESIDENTIAL CONSTRUCTION WORK SEQUENCE

JOB SEQUENCE	WORKING DRAWINGS USED (SPECIFICATIONS ALWAYS USED)	See Below	
Site Survey	Plot Plan		
Building Permit			
Ground Graded			
Building Excavation Made		*	+
Trenches for Permanent Plumbing or Power Cut			
Temporary Power and Water Brought In (For workers on job)			
Footings Formed and Placed	Foundation Plan		
Drainage Laid	Elevation Plan		
Foundation Walls Put In	Sections and Details	*	
Slabs Placed (With heating, plumbing, & electrical pipe as needed)			
Floor Framing Put In	Floor Plan		
Rough Floor Installed	Sections		
Backfilling Around Foundation (After floor is in)		*	
Rough Walls Constructed	Elevations		
Ceiling Framed In	Floor Plan Sections	*	
Roof Framing Erected	Roof Framing Plan		
Roof Insulation Panels Put On	Elevations	*	
Roof Finished Off	Sections		
Flashing Applied			
Stairs Erected	Interior Elevations		
Brick or Stone Fireplace Built	Sections and Details	*	
Chimney Built			
Sheathing, Windows, and Doors Installed	Elevations		
Flashing Installed Around Openings (House closed in at this point)	Schedules Sections	*	
Heating Ventilating and Air Conditioning Ductwork or Pipes Installed (Rough In)	Floor Plan Heating and Cooling Plan Sections and Details	-	+
Plumbing Runs (Rough In)	Floor Plans Plumbing Plans Plumbing Schematics & Diagrams Sections and Details	-	+
Electrical Runs (Rough In)	Floor Plans Elevations Electrical Plans	-	
Siding, Exterior Finish Applied (Anytime after sheathing in place)	Elevations	*	
Insulation Installed	Sections		
Windows and Other Openings Caulked	Details	*	
Interior Finish Applied	Interior Elevations		
Finish Floor Applied	Schedules	*	+
Cabinet Work Installed			
Heating Fixtures Installed (Finish)	Details		
Plumbing Fixtures Installed (Finish)	Schedules		
Electrical Fixtures Installed (Finish) (Tested)		-	*
Painting As Needed	Schedules	-	+
Exterior Sidewalks and Driveways (Anytime after foundation is Backfilled)	Plot Plan	-	+
Landscaping and Sodding	Plot Plan Landscaping Plan	-	+

- * Carpentry Training
- Orientation
- + Related Trade

This outline of a typical work flow on a small residential construction job has been used for the purpose of carpentry curriculum planning. Practice will vary and this sequence is suggested only as a rough planning guide.

SAMPLE
OUTCOME-REFERENCED TESTS

CARPENTRY

This articulated, performance-based instruction guide is designed to answer three critical questions necessary for quality instruction.

First, what should be taught?

The objectives of the articulated, performance-based education vocational education programs are based on extensive task analysis and validation.

The task objectives represent what employers in business and industry say is important for entry level job success.

Second, how should it be taught?

It should be taught using the latest "state-of-the-art" instructional technology incorporated into each unit.

Students are taught the knowledges, skills, and attitudes needed for successful and productive employment.

Third, how should students be evaluated?

Students are evaluated using a validated competency-based approach to determine student proficiency in vocational knowledges and skills.

The minimum standards are those required for successful entry in the next high level of training or for successful employment.

The sample tests are included to illustrate how the student's competency in vocational skills and knowledges may be measured with validity and reliability. In addition, the test samples are included to promote standardization in the evaluation of vocational students in similar programs.

Test items have been constructed solely from the objectives of the vocational program. The statement of the objectives indicate the level of knowledge or skill to be tested. Task force committee participants have attempted to write tests that agree with objectives in the behavior requested, the given conditions, and the desired standards of performance.

NOTE: Unless the test page is marked "Revised" or "R," the test should be considered a field trial edition currently under review and revision.

SUMMARY
CARPENTRY
SUGGESTED INSTRUCTION TIMES

<u>CARPENTRY</u> <u>UNIT/TASK</u>		<u>SUGGESTED</u> <u>HOURS</u>
Unit 1.0	INTRODUCTION TO BUILDING CONSTRUCTION (CARPENTRY)	(16)
1.01	Review School Policies and Procedures	3
1.02	Orientation To Shop	1
1.03	Review Course Objective and Standards	3
1.04	Identify Typical Building Construction Career Opportunities	3
1.05	Job Performance	3
1.06	Work Attitudes	3
Unit 2.0	CARPENTRY SAFETY	(54)
2.01	Classroom Safety	3
2.02	Use Personal Protective Equipment	3
2.03	Practice Safety In Using Power Tools (and Machinery)	6-45
2.04	Ladder and Scaffolding Safety	3
Unit 3.0	BUILDING CONSTRUCTION I	(60)
3.01	Carpentry Math	24
3.02	Carpentry Math - Fractions	12
3.03	Carpentry Math - Decimals	6
3.04	Carpentry Math - Volumes	6
3.05	Carpentry Math - Areas	6
3.06	Carpentry Math - Angular Measurement	6
Unit 4.0	BLUEPRINT READING	(21)
4.01	Identify Working Drawings and Blueprints and Read Specifications	6

4.02	Interpret Common Blueprint Symbols Used In Residential Construction	6
4.03	Interpret Dimensions From Blueprints	3
4.04	Read Blueprint and Specifications and Estimate Lumber Materials	6
Unit 5.0	CARPENTRY HAND TOOLS	(49)
5.01	Identify and Demonstrate Proper Use of Carpentry Hand Tools	30
5.02	Read and Measure With Rules and Squares	15
5.03	Check Whether a Surface is Level or Plumb	4
Unit 6.0	FASTENERS, FINISHING, AND HARDWARE	(27)
6.01	Fasten Stock Using Glue, Nails, Staples, Screws, and Bolts	15
6.02	Install Wood Plugs in Prepared Holes	3
6.03	Fill and Finish Nail and Screw Holes	6
6.04	Sand Surface for Finishing	3
Unit 7.0	PORTABLE POWER TOOLS	(40)
7.01	Drill or Bore Holes With Portable Electric Hand Drill	6
7.02	Cut Stock With Portable Electric Saws (Circular, Sabre, and Reciprocating)	12
7.03	Rout Irregular Edges With Portable Router	10
7.04	Plane Stock With Portable Electric Plane	6
7.05	Sand Surfaces and Edges With Belt Sander and Finishing Sander	6
Unit 8.0	STATIONARY POWER TOOLS	(66)
8.01	Demonstrate Use of Table Saw	15
8.02	Demonstrate Use of Radial-arm Saw	15
8.03	Demonstrate Use of Drill/Drill Press	6
8.04	Demonstrate Use of Jointer	6

8.05	Demonstrate Use of Planer	6
8.06	Demonstrate Use of Band Saw	6
8.07	Demonstrate Use of Router and Shaper	9
8.08	Demonstrate Use of the Belt Sander	3
Unit 9.0	SITE LAYOUT (SITE PLANNING)	(45)
9.01	Establish Site Property Lines	6
9.02	Demonstrate Use of Leveling Instrument	9
9.03	Locate Building Site in Relation to Property Line	9
9.04	Locate and Square Building Corners Using Builder's Level	9
9.05	Locate and Mark Excavation Lines	6
9.06	Supervise Site Preparation (Dual Tasks)	6
Unit 10.0	FOOTINGS AND FOUNDATIONS	(54)
10.01	Install Batter Boards for Rough Excavation and Footings	12
10.02	Set Grade Stakes at Proper Elevations	6
10.03	Align Form Walls	3
10.04	Brace Foundation Wall Forms	3
10.05	Calculate Concrete for Footings and Foundation Walls	6
10.06	Clean and Repair Forms	3
10.07	Construct Concrete Step and Stair Forms	6
10.08	Construct Single Wall Foundation Forms	6
10.09	Build Side Forms	6
Unit 11.0	FRAMING - Floor and Sill Framing	(60)
11.00	Construct Models to Illustrate Scaled Floor, Wall, and Roof Framing	*

11.01	Layout a Floor Frame	6
11.02	Cut and Install Sill Plates to Foundation Wall	*
11.03	Frame and Install a Built-up T-Type Sill	**
11.04	Frame and Install a Box Sill	12
11.05	Install Posts and Columns	**
11.06	Frame and Install a Built-up Girder	**
11.07	Install Floor Joists	24
11.08	Install Bridging Between Joists	6
11.09	Frame Floor Openings	6
11.10	Install a Subfloor	6
Unit 12.0	FRAMING - Wall and Partition Framing	(60)
12.01	Layout a Wall Frame	30
12.02	Construct Corner Posts and T-Posts	12
12.03	Frame a Wall Opening	6
12.04	Install Door and Window Frames	6
12.05	Build Box Beams	*
12.06	Install Furring	*
12.07	Install Firestop	*
12.08	Install Structural Sheathing	6
Unit 13.0	ROOF FRAMING	(79)
13.01	Layout, Cut, and Install Common Rafters for Equal Pitch Roofs	15
13.02	Layout, Cut, and Install Ceiling Joist	9
13.03	Layout Common Roof Plan	12

* Optional
** See Task 11.02

13.04	Layout, Cut, and Install Cripple Jack Rafters for Hip and Valley Installations	12
13.05	Cut and Install Valley Rafters	6
13.06	Layout, Cut, and Install Hip Rafters for Equal Pitch Roofs	6
13.07	Cut and Install a Ridgeboard	3
13.08	Frame Roof Openings	2
13.09	Frame a Dormer	3
13.10	Frame Gable Ends	3
13.11	Cut and Install Collar Ties	2
13.12	Lay Out, Construct, and Install Roof Trusses	6
Unit 14.0	ROOFING	(18)
14.01	Apply Insulation (Underlay) for Asphalt Shingles	3
14.02	Install Composition Shingles	6
14.03	Lay Out for Bonding Shingles Over Dormer (or Other Roof Appendages)	3
14.04	Install Valley Shingles	2
14.05	Flash Chimney and Roof Vents	3
14.06	Flash Valleys	1
Unit 15.0	EXTERIOR FINISHING	(80)
15.01	Install Exterior Sheathing (Fiberboard or Plywood)	5
15.02	Frame a Boxed Cornice	10
15.03	Install Double-Hung Windows	8
15.04	Install Exterior Doors	10
15.05	Install Prefabricated Storm Doors and Windows	8
15.06	Install Exterior Trim	20

15.07	Cut and Install Furring	3
15.08	Cut and Install Wood Paneling	8
15.09	Install Exterior Siding	8
Unit 16.0	INTERIOR FINISHING	(90)
16.01	Fit and Install Flexible Insulation	6
16.02	Install Prefinished Paneling	6
16.03	Cut and Install Furring	3
16.04	Cut and Install Solid Wood Paneling	3
16.05	Install Prefinished Hardboard	3
16.06	Install Drywall Board (Sheetrock) (Gypsum Wallboard)	15
16.07	Install Interior Doors	6
16.08	Install Door Lock Sets	6
16.09	Cut and Install Finish Flooring	15
16.10	Cut and Install Baseboards, Trim, and Molding	15
16.11	Cut and Install a Fireplace Mantel	6
16.12	Construct a Storage Closet	6
Unit 17.0	STAIR CONSTRUCTION	(20)
17.01	Calculate Riser Height	20
17.02	Layout, Cut, and Install a Straight Run Stringer	**
17.03	Layout and Install Stair (Carriage)	**
17.04	Layout, Cut, and Install Treads for Open Riser Stairs	***
17.05	Cut, Fit, and Install Balusters and Handrails	***
17.06	Fit Newel Posts in Open Stairs	***
17.07	Assemble and Erect Prefabricated (Mill-Built) Stairs	-

* Optional

** See Task 17.01

*** For advanced students

Unit 18.0	CABINETS AND BUILT-INS	(30)
18.01	Install Built-in Shelving and Cabinets	9
18.02	Assemble Cabinet Frame	15
18.03	Install Prefabricated Cabinets	6
Unit 19.0	CABINETMAKING, BUILT-INS, AND FINISHING SPECIALIZATION (OPTIONAL)	(40)
19.0	Part A - Cut and Shape Casework Components	*
19.0	Part B - Assemble and Install Casework Components	*
Unit 20.0	MECHANICALS AND MASONRY ROUGH-IN, FINISHING, AND COMPLETION (OPTIONAL UNITS)	(21)
20.0	Part A - Electrical - Mechanical	*
20.0	Part B - Heating and Cooling - Mechanical	*
20.0	Part C - Plumbing - Mechanical	*
20.0	Part D - Masonry	*
20.0	Part E - Thermal Insulation	*
20.0	Part F - Interior Finishing	*
20.0	Part G - Exterior Finishing	*
Unit 21.0	FINISH CARPENTRY TASKS (OPTIONAL TASK)	
21.0	Finish Carpentry	*
Unit 22.0	ESTIMATING MATERIALS AND COSTS	(30)
22.0	Estimating	*
Unit 23.0	PRACTICAL APPLICATION PROJECT	(120)
23.0	Residential Field Construction	*
Unit 24.0	JOB LEADERSHIP	3

* Optional

TASK LISTINGS

CARPENTRY

UNIT/TASK

DESCRIPTION

Unit 1.0

- 1.01 (Review School Policies and Procedures) Given information on school policies and procedures, apply these policies and procedures on a day-to-day basis.
- 1.02 (Orientation to Shop) Given information on school shop or instructor's policies and procedures, apply these policies and procedures. The policies and procedures will be adhered to on a day-to-day basis. Meet standards of the instructor 100 percent.
- 1.03 (Review Course Objectives and Standards) Given an introduction to the Building Construction program, a review of the course objectives and minimum standards of performance; describe the course objectives and the minimum performance expected to demonstrate competency in the objective.
- 1.04 (Identify Typical Building Construction Career Opportunities) Given instruction, data on the local building construction industry, primarily carpentry, and opportunities to study the construction and related industry; identify the major categories of potential employers in the local community (and the key characteristics of each).
- 1.05 (Job Performance) Given instruction, demonstrate job performance characteristics that are considered important to entry-level career success in the vocational field. A "Job Performance Rating Sheet" will be used to evaluate performance and all items must be rated "frequently" or above.
- 1.06 (Work Attitudes) Given instruction, demonstrate work attitudes that the majority of potential employers prefer in an entry-level worker. Performance will be evaluated on a "Work Attitudes Score Card" and a minimum of 90 percent should be attained. Performance will be rated through training and should improve to 100 percent by the end of the training period.

Unit 2.0

- 2.01 (Classroom Safety) Given a typical building Construction (carpentry) shop or job situation, exhibit an awareness of safety practices, safe work habits, and a positive attitude concerning job safety and accident prevention and meet standards established by the instructor.

- 2.02 (Use Personal Protective Equipment) Given personal protective equipment guidelines, personal protection equipment, and a working situation, use personal protection equipment to meet the instructor's standards or other applicable standards such as OSHA.
- 2.03 (Practice Safety In Using Power Tools and Machinery) Given proper instructions, power tools used in carpentry; use power tools safely according to manufacturer's specifications/ instructions and meet instructor's standards (or local codes, OSHA Standards).
- 2.04 (Ladder and Scaffolding Safety) Given proper instructions, various types of ladders used in construction, jobs that require the use of the ladder; select the appropriate type of ladder and use it correctly in accomplishing the job. Selection and use of the ladder must meet the instructor's standards.

Unit 3.0

- 3.01 (Carpentry Math) Given a pretest by the instructor, perform basic mathematical calculations in whole numbers, addition, subtraction, multiplication, and division with an accuracy of 95 percent on written knowledge typical of basic math in the carpentry field.
- 3.02 (Carpentry Math - Fractions) Given instructor or text provided carpentry shop or job math problems involving the addition, subtraction, multiplication, or division or fractions; select the proper operation or operations to solve the problems with 90 percent accuracy. Able to conduct following operations with fractions:
1. Change any fraction to a decimal number, and any terminating decimal number to a fraction.
 2. Arrange in order...unit and simple nonunit fractions.
 3. Write equivalent fractions in higher, lower, and lowest terms.
 4. Write improper fractions as whole or mixed numbers, and mixed numbers as improper fractions.
 5. Multiply fractions and mixed numbers, expressing answers in simplest form.
 6. Divide fractions and mixed numbers, expressing answers in simplest form.
 7. Add and subtract unlike fractions, expressing answers in simplest form.
 8. Add and subtract mixed numbers with unlike fractions, expressing answers in simplest form.
 9. Use rational numbers to solve simple work problems.
 10. Solve typical carpentry problems involving fractions.
 11. Read typical flat ruler fractions.

- 3.03 (Carpentry Math - Decimals) Given a pretest or examples by the instructor, conduct the following decimal math operations:
1. Name the place value of digits in decimal numbers of up to three digits before the decimal and three digits after the decimal.
 2. Compare decimal numbers and arrange them in order.
 3. Write the numeral for any decimal number of up to four decimal places.
 4. Round decimal numbers to any designated place value up to thousandths.
 5. Add and subtract decimal numbers of up to three digits.
 6. Multiply decimal numbers by whole numbers or decimal numbers.
 7. Divide a number by a three-digit decimal number.
 8. Multiply and divide decimal numbers by powers of ten, by inspection.
 9. Solve simple carpentry problems involving decimals.

3.04 (Carpentry Math - Volumes) Given a pretest or examples by the instructor, find the volume of given rectangle, in cubic feet or yards as required, for the purpose of removing earth or filling with concrete.

3.05 (Carpentry Math - Areas) Given a pretest or examples by the instructor, find the area of a given rectangle (minimum performance).

3.06 (Carpentry Math - Angular Measurement) Given a pretest or examples by the instructor which involve the four basic math processes* in angular measurement, perform math operations changing degrees, minutes, and seconds to whichever one of the three units will expedite the mathematical processes involved.

*Four basic math processes: Addition, Subtraction, Multiplication, and Division.

Unit 4.0

4.01 (Identify Working Drawings and Blueprints and Read Specifications) Given an orientation to working drawings, blueprints, and specifications; differentiate between working drawings, blueprints, and specifications.

4.02 (Interpret Common Blueprint Symbols Used in Residential Construction) Given instruction concerning building symbols, a set of simple blueprints using the symbols, and an assignment to identify common symbols; recognize different building symbols typically used in residential construction. Meet instructor's standards in recognizing and interpreting symbols.

- 4.03 (Interpret Dimensions From Blueprints) Given instructions, Architect's Scale or drawings, blueprint representations, and an assignment to interpret the blueprint with 1/8 inch accuracy.
- 4.04 (Read Blueprint and Specifications and Estimate Lumber Materials) Given residential blueprints, a requirement to layout carpentry work from the blueprints and specify lumber material needed to complete the work. Accuracy of 1/8 inch in measuring is expected and final work must meet instructor's standards.

UNIT 5.0

- 5.01 (Identify and Demonstrate Proper Use of Carpentry Hand Tools) Given proper instructions and a display of 20 common carpentry hand tools, identify and demonstrate proper use of a minimum of 10 different hand tools.
- 5.02 (Read and Measure With Rules and Squares) Given a rule, square, and stock; measure and record the dimensions of the three different sizes of stock to the nearest 1/16 inch and draw four lines to predetermined length (+/- 1/16 inch).
- 5.03 (Check Whether a Surface is Level or Plumb) Using a level*, chalk line, proper instructions, and a project; check whether a surface is level or plumb. Findings must agree with instructor's findings.

UNIT 6.0

- 6.01 (Fasten Stock Using Glue, Nails, Staples, Screws, and Bolts) Given instructions, specifications, pre-cut wood stock; fasten the wood (using wood glue and clamps, nails, staples, screws, and bolts) by the required procedures and meeting instructor's standards.
- 6.02 (Install Wood Plugs in Prepared Holes) Given wood stock with screw holes prepared for wood plugs, a selection of wood plugs, wood glue, and the necessary tools and materials; install wood plugs in prepared holes. The plugs must be the correct type, kind, and size for the hole, glued securely, and free of excess glue.
- 6.03 (Fill and Finish Nail and Screw Holes) Given wood stock with nails and screws installed and recessed at least 1/8 inch below surface, and the necessary tools and materials; fill and finish the nail and screw holes so that the filler projects above the surface and then is finished flush with the surface and is free of voids or low spots.

- 6.04 (Sand Surfaces for Finishing) Given wood stock or casework ready for finish sanding, an assortment of sandpaper, finish sander, and the necessary tools and materials; sand the surface for finishing. All surfaces must be smooth with no cross grain sanding marks or scratches. Edges must be eased, and all surfaces and edges must be free of loose particles.

Unit 7.0

- 7.01 (Drill or Bore Holes With Portable Electric Hand Drill) Given a portable hand drill, a complete set of power bits 1/4 inch through 1 1/8 inch, a five dimensioned layout showing the specific location and size of a series of five holes, and wood stock; layout, mark, and bore the holes. The holes must match the layout, with locations accurate, holes square to the surface, and the back of the stock free of splinters.
- 7.02 (Cut Stock With Portable Electric Saws [Circular, Sabre, and Reciprocating]) Given stock to cut, sawhorses, helper, specifications concerning the desired cut, and a portable electric saw (or saws); make the desired cut(s) according to specifications with the cut 90 degrees to the surface of the stock (unless a bevel cut is required) and on the waste side of the line.
- 7.03 (Route Irregular Edges With Portable Router) Given a piece of stock or project with curved or irregular edges to be routed, a portable electric router, assorted router bits, wrenches, and other necessary tools, specifications concerning the finished product; route edges of the stock according to instructions. The finished product must be fully shaped with no run-off, smooth with no torn grain or burn marks, and must meet specifications.
- 7.04 (Plane Stock With Portable Electric Plane) Given a power hand plane, stock, and stock specifications, plane stock with power hand plane to specifications. The finished stock must be planed with the grain, be straight and true, and cut at the prescribed angle.
- 7.05 (~~Sand Surfaces and Edges With Belt Sander and Finishing Sander~~) Given stock, belt sander, and assortment of belts; sand the surface and edges of stock so that the finished stock has a smooth surface, is to the predetermined size and shape, is free of cross grain scratches, and does not contain burn marks.

Unit 8.0

- 8.01 (Demonstrate Use of Table Saw) Given operator's manual or instructions, a table saw and appropriate saw blades, dado head, rip fence, miter gauge or mitering jig, and the necessary tools, equipment, attachments, specifications and wood stock; perform the following tasks to demonstrate the use of the table saw.

- 8.02 (Demonstrate Use of Radial-Arm Saw) Given a radial-arm saw blade, operator's manual, (mitering jig or miter gauge for miter cut), and necessary tools, equipment, and attachments, as well as wood stock and specifications...demonstrate use of radial-arm saw.
- 8.03 (Demonstrate Use of Drill/Drill Press) Given operator's manuals or instructions, an electric drill or drill press, wood stock (if applicable), specifications, and the necessary tools and attachments; demonstrate the following use of the drill/drill press.
- 8.04 (Demonstrate Use of Jointer) Given an operator's manual or instructions, the necessary tools, equipment, attachments, stock, and specifications; demonstrate the use of the jointer by the required performances.
- 8.05 (Demonstrate Use of Planer) Given an operator's manual or instructions, the necessary tools, equipments, attachments, stock, and specifications; demonstrate the use of the planer by the required performances.
- 8.06 (Demonstrate Use of Band Saw) Given an operator's manual or instructions, the necessary tools and equipment, wood stock, and specifications; demonstrate the use of the band saw.
- 8.07 (Demonstrate Use of Router and Shaper) Given operator's manual or instructions, necessary tools, materials, and attachments (such as bits), wood stock, and specifications; demonstrate the use of the router and shaper.
- 8.08 (Demonstrate Use of the Belt Sander) Given an operator's manual or instructions, the necessary tools, equipment, and accessories; operate a portable belt sander, longbelt sander, or abrasive belt sander.

Unit 9.0

- 9.01 (Establish Site Property Lines) Given a residential building property site, working drawings, residential construction specifications, and all necessary equipment; set property (boundary) lines to an accuracy of +/- 1/2 inch.
- 9.02 (Demonstrate Use of Leveling Instrument) Given a builder's level (transit or optical level), instructions, leveling rod, measuring tape, and a helper; demonstrate use of the instrument to layout a building.
- 9.03 (Locate Building Site in Relation to Property Line) Given a set of working drawings for a residential structure, and the necessary tools and materials; locate the corners of the proposed structure within the property boundaries so that the proper setback is maintained, according to code and so the corner stakes are positioned within 1/4 inch.

- 9.04 (Locate and Square Building Corners Using Builder's Level*) Given a builder's level, building lot, building plans and hub (2 inch x 2 inch stake), set the level over the center of the hub and level instrument so corners can be located:
- With center points at 90 degrees to hub.
 - So leveled before corners are squared.
 - So instrument is centered directly above hub.
- 9.05 (Locate and Mark Excavation Lines) Given necessary tools, equipment, and working drawings for a residential building; locate and accurately layout excavation area with a stretched line or with visible material (such as lime) spread on the ground. Clearance for form work will be maintained (2 feet beyond building line). Line will be visible by means of a line, stakes, or string.
- 9.06 A (Supervise Site Preparation [Dual Tasks]) (Supervise Excavation of Building Site to Specifications) Given building lines, excavating equipment with operator, vertical section views and plot plan (including contour elevations) from the working drawings, supervise the excavation of a building site to the following standards:
- Correct depth maintained over entire area within building lines.
 - Depth maintained 2 feet beyond building perimeter for form work.
 - Batter boards not altered by excavation activities.
 - Drainage provide to allow water to run away from excavation.
- 9.06 B (Supervise Site Preparation [Dual Tasks]) (Supervise Site Preparation for Slab-on-ground Construction) Given site, worker, proper equipment, working drawings, and specifications for slab-on-ground construction:
- Site should be level.
 - Grading to proper elevation +/- 1 inch.
 - Grading to proper dimensions +/- 1 inch.

Unit 10.0

- 10.01 (Install Batter Boards for Rough Excavation and Footings) Given a building site, working drawings, and specifications for a residential structure, necessary carpentry tools, materials, finished grade, and the desired rod length; erect the rough excavation. The building lines and batter boards will be the same elevation +/- .01 foot. Corners will be square +/- 0 degrees one minute. Length of lines will be correct according to the drawing +/- 1/32 inch.

- 10.02 (Set Grade Stakes at Proper Elevation) Given a set of working drawings, specifications, and the necessary tools and materials; set the stakes according to drawings and specifications.
- 10.03 (Align Form Walls) Given a section of concrete wall form, the necessary carpenter tools, bracing materials, specifications, a helper, and instructions; align the wall to the required specifications, installing braces and support devices. There will be no more than $1/8$ +/- inch deviation in 6 foot sections both horizontally and vertically.
- 10.04 (Brace Foundation Walls Forms) Given a foundation wall form, bracing lumber, appropriate tools and equipment, construct and secure braces to foundation wall form. The poured wall must conform horizontally and diagonally to the working drawings. The form must be rigid enough so that it does not bulge or twist when filled with concrete. Joints must be tight enough to prevent mortar leakage.
- 10.05 (Calculate Concrete for Footings and Foundation Walls) Given a complete detailed set of footing and foundation plans for a single family residential structure, calculate the total number of cubic yards of concrete required for the job. Mathematical calculations must be accurate.
- 10.06 (Clean and Repair Forms) Given used concrete forms, a helper, and instructions; clean and repair the forms by plugging all holes, replacing damaged parts and resetting loose nails. Eighty percent or more of the used forms must be acceptable for reuse.
- 10.07 (Construct Concrete Step and Stair Forms) Given detail plans for a typical two- or three-step concrete stair, a helper, lumber, tools and equipment; construct and install the concrete step/stair forms complete and ready to receive mixed concrete.
- 10.08 (Construct Single Wall Foundation Forms) Given the necessary tools, a helper, detailed plans, and required materials; construct a single wall foundation form. The foundation wall form must be without gaps, be fastened together with appropriate fasteners, be positioned at 24 inch intervals, and the tongue edge of all boards must be in an up position.
- 10.09 (Build Side Forms) Given form lumber, previously erected batter boards, appropriate tools, a helper, and foundation detail plans, make and set a build side form. The inside line of form wall will coincide with building line. All stakes will be secure, spreaders will be used to ensure uniform footing width. Form ties will be securely fastened to form boards. Distance between stakes will be that distance twice the width of the footing. Bracing will be sufficient to prevent movement of forms.

Unit 11.0

- 11.00 (Construct Models to Illustrate Scaled Floor, Wall, and Roof Framing) (NOTE: This is an "optional task" for Floor, Wall, and Roofing Framing units / Units 11, 12, and 13 /. The task may be used for any of the framing units or all of them to introduce the student to the concept of framing.)

Given plans and specifications, stock, carpentry tools, equipment, and a scale to use; cut framing members to given sizes according to scale and construct models to illustrate floor, wall, and roof framing techniques. All framing should be within specifications required by the instructor.

- 11.01 (Layout a Floor Frame) Given working drawings, specifications for a floor frame, wood stock and lumber, and the necessary layout tools and materials, layout a floor frame. All materials must be marked accurately for cutting and installing the floor according to specifications $\pm 1/8$ inch. Materials must be marked to indicate maximum use of wood stock and dimensioned lumber.

- 11.02 (Cut and Install Sill Plates to Foundation Wall) Given working drawings and specifications for a floor frame, wood stock and dimensioned lumber, a foundation wall or slab ready to receive sill plates, necessary tools and equipment, and sufficient materials; cut and install a sill plate to the top of a foundation wall. The following standards apply:
- Joints in the sill must not be over an opening in the foundation wall.
 - Sills must be cut square so they butt together closely at the corners of the foundation or slab. (Square ± 2 degrees).
 - All members will be level and straight ($\pm 1/8$ inch) and must be anchored according to Southern Building specifications.

- 11.03 (Frame and Install a Built-up T-Type Sill) Given working drawings and specifications for a floor frame, wood stock and dimensioned lumber, a foundation wall or slab with sill plate installed, and the necessary tools, equipment, and materials; frame and install a built-up T-type sill. Floor joists must have a minimum of 4 inches bearing seat on the sill plate. The sill header must be centered on the sill plate $\pm 1/8$ inch, cut to specified length $\pm 1/8$ inch, and square at the ends.

- 11.04 (Frame and Install a Box Sill) Given working drawings and specifications for a floor frame, wood stock and dimensioned lumber, a foundation sill or slab with sill plate installed, and the necessary tools, equipment, and materials, frame and install a box sill. The sill header must be flush with the outside edge of the plate, cut specified length $\pm 1/8$ inch, and square at the ends.

- 11.05 (Install Posts and Columns) Given working drawings and specifications for a floor, frame, a foundation sill installed and footings for posts or columns, steel or wood columns, of the correct size and shape, and the necessary tools, equipment, and materials, install the posts or columns. The posts or columns must be installed to Southern Building specifications and positioned to receive bearing members.
- 11.06 (Frame and Install a Built-up Girder) Given working drawings and specifications for a floor frame, a foundation wall with sill, columns, and beams installed, dimensioned lumber for a built-up girder, and the necessary tools, equipment, and materials, and a helper if required; set and align girder to columns and foundation wall. The following specifications apply:
- Girder will be cut to specified length +/- 1/8 inch.
 - Ends of girder will be cut square.
 - Girder will be secured to foundation wall and columns as specified.
 - Bearing plate will be two inches wider than girder on each side of girder.
 - Installed girder will be level.
- 11.07 (Install Floor Joists) Given working drawings and specifications for a floor frame, a foundation wall or slab with support members installed, dimensioned lumber, and the necessary tools, equipment, and materials; cut and install floor joists as specified. The joists must be cut to +/- 1/8 inch of length specifications, positioned 16 or 24 inches O.C., and fastened to specifications with crowns facing upward.
- 11.08 (Install Bridging Between Joists) Given working drawings and specifications for a floor frame, a frame with installed, wood stock or dimensioned lumber suited for bridging and the necessary tools, equipment, and materials; cut and install the joist bridging. The type of bridging must correspond to the requirements of the working drawings. All bridging must be cut to length specifications and installed straight and plumb +/- 1/8 inch. Cross bridging must be cut to specified angles +/- 2 degrees.
- 11.09 (Frame Floor Openings) Given working drawings and specifications for a floor frame, frame with full joists installed, dimensioned lumber, and the necessary tools, equipment, and materials; frame floor openings for a basement or fireplace. The opening must be square and within size specifications +/- 1/8 inch and installed straight and plumb with the required fastening.
- 11.10 (Install a Subfloor) Given working drawings and specifications for a floor frame, a frame with all joists and openings installed, subfloor material (plywood, particle-board, tongue-and-groove stock), and the necessary tools, equipment,

and materials; install a subfloor. The subfloor must be installed to specifications $\pm 1/8$ inch with the required fastening pattern. Floor openings must be allowed, and joints must be staggered. Waste of material must be maintained at 10 percent or less.

Unit 12.0

- 12.01 (Layout a Wall Frame) Given working drawings and specifications for an exterior or interior wall frame, wood stock and dimensioned lumber, and the necessary tools and materials; lay out a wall frame. All materials must be marked accurately for cutting and framing the wall frame according to specifications $\pm 1/8$ inch. Materials must be marked to indicate maximum use of wood stock and dimensioned lumber.
- 12.02 (Construct Corner Posts and T-Posts) Given working drawings, and specifications for an exterior wall frame, wood stock, dimensioned lumber, and the necessary tools, equipment, and materials; construct corner posts and T-posts. The dimensioned lumber must be straight, sound material cut to specified length $\pm 1/16$ inch. Ends must be flush for fastening to plates. Blocking must be positioned according to the drawing specifications $\pm 1/16$ inch, and members must be fastened in the required pattern. All blocks or pieces will be nailed according to Southern Standard Building Codes.
- 12.03 (Frame a Wall Opening) Given working drawings and specifications, necessary tools and equipment, and sufficient materials; frame a window or door opening. The following standards will apply:
- Framing members will be flush $\pm 1/16$ inch.
 - Members will be positioned and nailed as according to specifications. (Southern Standard Building Codes.)
 - Members will be cut to exact dimensions $\pm 1/8$ inch.
 - Installed header will be plumb and level.
 - Cripple studs will be carried through the O.C. spacing.
- 12.04 (Install Door and Window Frames) Given working drawings and specifications, an erected wall frame with door and window openings, a door, window frame, braces, and the necessary tools, equipment, and materials, install the door and window frames. The frames must be set plumb and in alignment with the wall frame. Clearance for the door must assure that the door moves without binding.
- 12.05 (Build Box Beams) Given working drawings and specifications, wood stock and dimensioned lumber, and the necessary tools, equipment, and materials, frame and build a box beam in accordance with drawings, specifications, and the following standards:
- Measurements must be accurate to $\pm 1/8$ inch.
 - Glue bond between various members must be strong.

- Beams must not sag or webbing buckle under specified load.
- Joints must be staggered and fastened according to required patterns.

12.06 (Install Furring) Given working drawings and specifications necessary tools and equipment, and sufficient materials, furr masonry walls. The following standards apply:

- Furring strips will be the required length (+/- 1/8 inch).
- Furring strips will be fastened to masonry wall with appropriate fasteners.
- Furring strips will be located 16 inches on center +/- 1/16 inch.
- Furring strips will be plumb.

12.07 (Install Firestop) Given working drawings, specifications, necessary tools, equipment, and sufficient materials; install firestops between wall studs. The following standards apply:

- Firestops will be required length +/- 1/16 inch.
- Firestops will be firmly secured in place.
- Firestops will be located as specified.

12.08 (Install Structural Sheathing) Given working drawings, specifications, an erected wall frame with door and window openings, wood stock (plywood, particleboard, or fiberboard), and the necessary tools, equipment, and materials, install structural sheathing. The sheathing must be installed with required patterns. Caps between sheets must not exceed 1/8 inch. Openings must be cut after the sheets are nailed.

Unit 13.0

13.01 (Layout, Cut, and Install Common Rafters for Equal Pitch Roofs) Given working drawings (including roof layout), for a typical residential dwelling, required carpentry tools, a helper, and materials; layout, cut, and install common rafters for an equal-pitch roof.

13.02 (Layout, Cut, and Install Ceiling Joist) Given a typical residential structure with the bearing walls erected ready to receive the ceiling joists, a helper, tools, and materials; layout, cut, and install the ceiling joist.

13.03 (Layout Common Roof Plan) Given working drawings, specifications for a gable (*or hip) roof frame (plan), wood stock and dimensioned lumber, and the necessary layout tools and materials; layout a gable (or hip) roof frame. All materials must be marked accurately for cutting and framing the rafters, ridgeboard, gables, formers, purlins, and collar beams according to specifications +/- 1/16 inch. Materials must be marked to indicate maximum use of wood stock and dimensioned lumber.

- 13.04 (Layout, Cut, and Install Cripple Jack Rafters For Hip and Valley Installations) Given hip and valley rafters installed, tools, materials, and a helper; layout, cut, and install the required cripple jack rafters. The following standards apply:
- Determined roof pitch.
 - Determined cripple jack rafter run.
 - Calculated length of cripple.
 - Deducted one-half of 45 degrees thickness of hip or valley.
 - Laid out top and bottom cuts.
 - Laid out locations on hip and valley.
 - Nailed cripple jack in place.
 - Checked alignment, spacing, and nailing.
- 13.05 (Cut and Install Valley Rafters) Given working drawings, specifications for a roof frame (equal or unequal pitch), a structure with an intersecting roof frame and floor, wall, and ceiling frames and ridge and common rafters installed, dimensioned lumber, and the necessary tools, equipment, and materials; cut and install valley rafters for an unequal pitch intersecting roof. The valley rafters must extend diagonally from plate to ridge. The rafter lengths, including allowances for overhang and ridgeboard must be accurate to $\pm 1/8$ inch. Plumb and plate cuts must be installed plumb and straight $\pm 1/8$ inch. (For equal pitch roofs).
- 13.06 (Layout, Cut, and Install Hip Rafters for Equal Pitch Roofs) Given working drawings, specifications for a roof frame equal or unequal pitch, a hip roof structure with floor, wall, and ceiling frames and ridgeboard installed, dimensioned lumber, and the necessary tools, equipment, and materials; cut and install hip rafters for an equal or unequal pitch roof. The hip rafters must extend diagonally from plate to ridge. The rafter lengths, including allowances for overhang and ridgeboard, must be accurate to $\pm 1/8$ inch. Plumb and plate cuts must allow for a tight fit, and the rafters must be installed plumb and straight $\pm 1/8$ inch.
- 13.07 (Cut and Install a Ridgeboard) Given working drawings, specifications for a roof frame a structure with floor, wall, and ceiling frames installed, two sets of pre-cut common rafters, dimensioned lumber, and the necessary tools, equipment, and materials; cut and install the ridgeboard with required assistance. The ridgeboard must be marked to receive rafters, cut to specified length $\pm 1/8$ inch, and positioned plumb and level. The ridge must be installed with the required fastening pattern.
- 13.08 (Frame Roof Openings) Given working drawings, specifications for a roof frame, a structure with rough frame installed, dimensioned lumber, and the necessary tools, equipment, and materials; frame roof openings for a chimney. The openings must be square and within size specifications $\pm 1/8$ inch. All frame members and tail rafters must be cut to required

length \pm 1/8 inch and installed straight and plumb with the required fastening pattern.

- 13.09 (Frame a Dormer) Given working drawings, specifications for a roof frame, a structure with rough frame and roof openings installed, a dimensioned lumber, and the necessary tools, equipment, and materials; frame a dormer. The dormer must include double headers and trimmers, and all frame members must be cut to required length \pm 1/8 inch. Plumb and plate cuts must allow for a tight fit, and the members must be installed plumb and straight \pm 1/8 inch.
- 13.10 (Frame Gable Ends) Given working drawings, specifications for a roof frame, a structure with rafters and ridgeboard installed, dimensioned lumber, wood stock, and the necessary tools, equipment, and materials; frame the gable ends. Gable studs must be notched (if appropriate), cut to length, and installed to specifications \pm 1/8 inch. Angle cuts must allow for a tight fit of plumb, straight gable studs.
- 13.11 (Cut and Install Collar Ties) Given working drawings, specifications for a roof frame, a structure with rafters and ridgeboard installed, wood stock, or dimensioned lumber, and the necessary tools, equipment, and materials; cut and install the collar ties. The ties or beams must be cut to required length \pm 1/8 inch. End cuts must be flush with rafters.
- 13.12 (Layout, Construct, and Install Roof Trusses) Given working drawings, specifications for roof trusses, wood stock and dimensioned lumber, and the necessary tools, equipment, and materials; layout, and build roof trusses. Chord and web length must be accurate to \pm 1/8 inch. Truss members must be fastened and reinforced with trusses or plates in the required pattern.

Unit 14.0

- 14.01 (Apply Insulation Underlay for Asphalt Shingles) Given roofing specifications, a roof frame with decking installed, roofing felt paper (insulation and underlayment), and the necessary tools, equipment and materials; apply the roofing felt paper. The entire surface of the decking must be covered. Edges must be fastened with nails or staples 8-10 inches apart, and center sections 18-24 inches apart. Strips must be installed at lap lines or chalk snapped 2 inches from each upper edge. The felt paper must be marked and trimmed for maximum use of materials.
- 14.02 (Install Composition Shingles) Given roofing specifications, a roof frame with decking and felt paper installed, strip shingles in bundles, and the necessary tools, equipment, and materials; install the shingles to manufacturer's specifications. Unless superseded by manufacturer's specifications,

chalk lines must be snapped to indicate vertical starting lines on the outside edge of the cornice trim. The first layer of shingles must be laid with slots upside down, and successive course must not allow for overlapping joints or slots. The amount of exposure for each course must not exceed specifications $\pm 1/8$ inch. Shingles must be fastened using the required pattern and type of fasteners, and end tabs must be sealed to prevent wind damage. All runs or courses must be completed until the entire roof surface is covered. Hip and ridge cap shingles must be installed securely with the required fastening pattern and type of fasteners, and cap tab fasteners must be sealed.

- 14.03 (Layout for Bonding Shingles Over Dormer or Other Roof Appendages) Given a roof with a dormer that has been prepared for shingle installation, a helper, and the necessary tools; layout the roof for bonding the shingles over the dormer.
- 14.04 (Install Valley Shingles) Given manufacturer's installation plans for the type shingles, a valley flashed and ready for shingle installation, tools, materials, and a helper; install the valley shingles.
- 14.05 (Flash Chimney and Roof Vents) Given a chimney or vent that extends through roof structure, tools and materials, flash the chimney or vent. All items on the instructor's checklist must be acceptably completed. Flashing material must be cut to specified lengths $\pm 1/8$ inch and installed securely with the required fastening pattern. Roof vents and chimney must be flashed with counterflashing cap strips and roofing sealer to prevent water leaks. All flashing joints must be lapped to specifications $\pm 1/8$ inch.
- 14.06 (Flash Valleys) Given a previously decked roof with valley, a helper, tools, and materials; flash the valley for asphalt shingle installation. Flashing material must be cut to specified lengths $\pm 1/8$ inch and installed securely with the required flashing pattern. Valley flashing must be at least 14 inches wide and laid on top of asphalt sealer.

Unit 15.0

- 15.01 (Install Exterior Sheathing Fiberboard or Plywood) Given working drawings, specifications for exterior walls, a structure with plywood or fiberboard structural sheathing installed exterior sheathing material (fiberboard, plywood, or insulated sheathing), and the necessary tools, equipment, and materials; install the exterior sheathing. The sheathing must be installed with joints centered on studs $\pm 1/4$ inch and fastened using required patterns. Joints must be staggered and spaces between sheets must not exceed $1/8$ inch. Openings must be cut after the sheathing is nailed.

- 15.02 (Frame a Boxed Cornice) Given working drawings, specifications for exterior trim, a residential structure with roof decking installed, wood stock and dimensioned lumber, and the necessary tools, equipment, and materials; frame the boxed cornice. Fascia boards, soffits or planciers (horizontal or sloping), lookouts, ledgers, and frieze boards must be cut and installed to specifications +/- 1/16 inch. Fascia board; must be jointed with required end and corner joints for a tight fit +/- 1/16 inch. All cornice members must be fastened using required pattern.
- 15.03 (Install Double-Hung Windows) Given working drawings, specifications for exterior trim and windows, a framed structure, double-hung windows, wood stock and dimensioned lumber, and the necessary tools, equipment, and materials; install the double-hung windows (wood frame). The windows must be installed from the outside. Side jambs must be plumb, frames must be level, and corners must be square +/- 1/16 inch. Windows must be installed so that the sashes operate smoothly. Fasten with aluminum or galvanized casing nails approximately 16 inches O.C. Nails must penetrate well into the rough frame and must be countersunk with a nail set.
- 15.04 (Install Exterior Doors) Given working drawings, specifications for exterior trim and doors, a framed structure, exterior doors with prefabricated frames, wood stock and dimensioned lumber, and the necessary tools, equipment, and materials; install the exterior doors. The doors must be installed with plumb jambs, level sills, and square corners +/- 1/16 inch. Hung doors must operate smoothly, and the frame must be fastened with aluminum or galvanized casing nails 16 inches O.C. The nails must penetrate well into the rough frame and must be countersunk with a nail set.
- 15.05 (Install Prefabricated Storm Doors and Windows) Given working drawings, specifications for exterior trim, a door and window schedule, a framed structure with exterior doors and double-hung windows installed, storm windows and doors, and the necessary tools, equipment, and materials; install the storm doors and windows. The storm doors and windows must be installed to specifications +/- 1/16 inch. All mechanisms must operate smoothly, and the doors and windows must be installed with the required fasteners.
- 15.06 (Install Exterior Trim) Given working drawings, specifications, a structure with exterior doors and windows installed, exterior molding and trim material, and the necessary tools, equipment, and materials; install the exterior trim for windows, doors, and cornice. The molding or trim must be cut to required lengths +/- 1/16 inch and installed with required fasteners and right-fitting joints.
- 15.07 (Cut and Install Furring) Given working drawings, specifications, a room requiring installation of furring strips for

ceiling panels or horizontal solid wood interior walls, wood stock or dimensioned lumber, and the necessary tools, equipment, and materials; install the furring. The furring strips must be cut to required lengths $\pm 1/8$ inch and installed level as a nailing base for the suspended ceiling or interior wall. Furring strips must be attached securely with the required fasteners.

- 15.08 (Cut and Install Wood Paneling) Given working drawings, specifications, a room requiring installation of solid wood paneling, installed furring strips, board-and-batten shiplap, or tongue-and-groove paneling material, and the necessary tools, equipment, and materials; cut and install the wood paneling. The material must be cut to required lengths $\pm 1/16$ inch and installed securely with staggered, tight joints $\pm 1/32$ inch. Fasteners must be nailed in the required pattern and countersunk or blind-nailed.
- 15.09 (Install Exterior Siding) Given working drawings, specifications for exterior walls, a structure with exterior sheathing applied, exterior siding material (metal, vinyl, or wood), and the necessary tools, equipment, and materials; install exterior siding. The siding must be installed to manufacturer's standards $\pm 1/16$ inch with joints staggered and positioned on stud centers. The siding must be fastened using the required pattern and type of fasteners or adhesives. End, corner, and trim joints must fit tightly, and the installed material must be free of splits, dents, or chips.

Unit 16.0

- 16.01 (Fit and Install Flexible Insulation) Given specifications, rough frame walls and ceiling ready for insulation, rolls of batts or rock wool or fiberglass insulation, staple tacker/staples, and other necessary tools and equipment; cut and install insulation according to manufacturer's instructions.
- 16.02 (Install Prefinished Paneling) Given working drawings, specifications, a framed structure requiring installation of wall paneling for one or more rooms, plywood paneling material, and the necessary tools, equipment, and materials; install the paneling.
- 16.03 (Cut and Install Furring) Given working drawings, specifications, a room requiring installation of furring strips for ceiling panels or horizontal solid wood interior walls, wood stock or dimensioned lumber, and the necessary tools, equipment, and materials; install the furring.
- 16.04 (Cut and Install Solid Wood Paneling) Given working drawings, specifications, a room requiring installation of solid wood paneling, installed furring strips, board-and-batten, shiplap, or tongue-and-groove paneling material, and the necessary tools, equipment, and materials; cut and install the solid wood paneling.

- 16.05 (Install Prefinished Hardboard) Given working drawings, specifications, a framed structure requiring installation of wall paneling in one or more rooms, hardboard paneling material, and the necessary tools, equipment, and materials; install the hardboard paneling.
- 16.06 (Install Drywall Board [Sheetrock] [Gypsum Wallboard]) Given working drawings, specifications, a room requiring installation of drywall board (sheetrock), a wall and ceiling drywall material, taping and corner material, and the necessary tools, equipment and materials; install the drywall board.
- 16.07 (Install Interior Doors) Given working drawings, specifications for interior trim and doors, a door schedule, a structure requiring installation of interior doors and frames, interior doors with prefabricated frames, wood stock, dimensioned lumber, and the necessary tools, equipment, and materials; install the interior doors.
- 16.08 (Install Door Lock Sets) Given working drawings, specifications, installed interior and exterior doors requiring installation of lock sets, an assortment of door lock sets, and the necessary tools, equipment, and material; install the door lock sets.
- 16.09 (Cut and Install Finish Flooring) Given working drawings, specifications, a room with installed subfloor and building paper or vapor barrier, strip or plank flooring material, and the necessary tools, equipment, and materials; install the finish flooring.
- 16.10 (Cut and Install Baseboards, Trim, and Molding) Given working or detail drawings, baseboard, trim, and molding specifications, a room or rooms requiring installation of door, window, and wall trim, an assortment of baseboard, trim, and molding material, and the necessary tools, equipment, and materials; cut and install the baseboards, trim, and molding. Install molding with coped joints, on inside corners, and miter joints on outside corners.
- 16.11 (Cut and Install a Fireplace Mantel) Given a detailed drawing of a fireplace, mantel specifications, dimensioned lumber, and the necessary tools, equipment, and materials; install the fireplace mantel.
- 16.12 (Construct a Storage Closet) Given working or detailed drawings, specifications, a structure or room requiring a storage closet, cupboard, or clothes closet, wood stock and dimensioned lumber, and the necessary tools, equipment, and materials; construct the closet.

Unit 17.0

- 17.01 (Calculate Riser Height) Given working drawings and specifications, calculate riser height.
- 17.02 (Layout, Cut, and Install a Straight Run Stringer) Given working drawings, specifications, sufficient materials, necessary tools and equipment; frame a built-up stair stringer.
- 17.03 (Layout and Install Stair Carriage) Given a stairway ready to receive stringers, plans and specifications, finished lumber, nails, glue, tools and other necessary materials; prepare and install outside and wall stringer according to Southern Standard Building Code.
- 17.04 (Layout, Cut, and Install Treads for Open Riser Stairs) Given drawings, specifications, installed stringers, necessary materials, tools, and equipment; cut and install treads for open riser stairs.
- 17.05 (Cut, Fit, and Install Balusters and Handrails) Given drawings, specifications, necessary materials, tools and equipment; cut, fit, and install balusters and handrails.
- 17.06 (Fit Newel Posts in Open Stairs) Given stairs ready to receive newels, drawings, specifications, and necessary tools, equipment, and materials; fit and install starting and landing newels.
- 17.07 (Assemble and Erect Prefabricated Mill-built Stairs) Given working drawings and specifications, a milled stairway, fasteners, and necessary tools, and equipment; assemble and install mill-built stairs.

Unit 18.0

- 18.01 (Install Built-in Shelving and Cabinets) Given plans and specifications, a supply of materials and hardware, necessary tools and equipment; layout and install cabinets and shelving according to details and specifications at the wall or space provided.
- 18.02 (Assemble Cabinet Frame) Given pictorial exploded detail drawing, assembly specifications, necessary tools, equipment, fasteners, adhesive and cabinet frame; assemble cabinet frame to specifications.
- 18.03 (Install Prefabricated Cabinets) Given mill-built cabinets, working drawings and specifications, areas in which cabinets are to be installed, and necessary tools and equipment; install cabinets to specifications.

Unit 19.0 Cabinets and Built-ins (OPTIONAL)

Part A

- 19.01A (Cut Face Frame Stiles and Rails) Given a radial arm saw, drill press, working drawing, specifications, wood stock, and necessary tools, equipment, and materials; cut face frame stiles and rails. Stock must be cut to specified dimensions $\pm 1/32$ inch* with no splinters or chips.
- 19.02A (Cut End, Top and Bottom Panels) Given a table saw, radial arm saw, jointer, working drawing, specifications, wood stock, and necessary tools, and materials; cut end, top and bottom panels. Stock must be cut to specified dimensions $\pm 1/32$ inch with no splinters or chips.
- 19.03A (Cut Partitions and Sleepers) Given a table saw, radial arm saw, jointer, working drawing specifications, wood stock, and the necessary tools and materials; cut partitions and sleepers. Stock must be cut to specified dimensions $\pm 1/32$ inch with no splinters or chips.
- 19.04A (Cut Shelf Panels) Given radial arm saw, working drawing, specifications, wood stock, and necessary tools, equipment, and materials; cut shelf panels. Stock must be cut to specified dimensions $\pm 1/32$ inch with no splinters or chips.
- 19.05A (Cut Skelton Frame Stiles and Rails) Given table saw, radial arm saw, shaper, working drawing, specifications, wood stock, and necessary tools and materials; cut skeleton stiles and rails. Stock must be cut to specified dimensions $\pm 1/32$ inch with no splinters or chips.
- 19.06A (Cut Toe Board and Back Panel) Given a radial arm saw, table saw, working drawing, specifications wood stock, and necessary tools, equipment, and materials; cut a toe board and back panel. Toe board and back panel must be cut to specified dimensions $\pm 1/32$ inch with no splinters of chips.
- 19.07A (Cut Casework Top or Countertop and Backsplash) Given a radial arm saw, sabre saw, belt sander, working drawing, specifications, wood stock, necessary tools and materials; cut a casework top or countertop and backsplash. Casework top or countertop and backsplash must be cut to specified dimensions $\pm 1/32$ inch with no splinters or chips.
- 19.08A (Cut Drawer Front, Sides, Back, and Bottom) Given a table saw, radial arm saw, jointer, planer, detailed drawing, specifications, wood stock, casework with face frame, necessary tools, equipment, and materials; cut drawer front, sides, back, and bottom. Stock must be cut to specified dimensions $\pm 1/32$ inch, with no splinters or scarred surfaces on exposed drawer front or sides.

- 19.09A (Cut Wood Drawer Guides). Given a radial arm saw, table saw, jointer, planer, detailed drawing, specifications, wood stock, casework with face frame, necessary tools, and materials; cut wood drawer guides. Stock must be cut to specified dimensions $\pm 1/32$ inch with no splinters or chips.
- 19.10A (Cut Solid Doors) Given a table or radial arm saw, jointer, shaper, working drawings, specifications, wood stock, and the necessary tools and materials; cut solid doors. Stock must be cut square to specified dimensions $\pm 1/32$ inch with no splinters, chips, or chatter marks.
- 19.11A (Rout or Shape Casework Components) Given a router or shaper with attachments, working or detailed drawing, specifications, solid doors, drawer fronts, and necessary tools, equipment, and materials; rout or shape casework components. Doors and drawer fronts must be routed or shaped to specified design and dimensions $\pm 1/32$ inch and must be free of burn marks, splinters, and chips.
- 19.12A (Cut, Trim, Molding, and Edge Banding) Given a radial arm saw or miter box, working or detailed drawings, specifications, casework, panel or solid doors, drawer fronts, trim, molding, edge banding, and necessary tools, equipment, and materials; cut trim, molding, and edge banding. Edges must be cut evenly with no splintering at 45 or 90 degree angles and to specified dimensions $\pm 1/64$ inch.
- 19.13A (Cut Sink Opening in Countertop) Given a sabre saw or circular saw, electric drill, working drawing, specifications, base cabinet with countertop, sink, necessary tools, and materials; cut a sink opening in countertop. Opening must be cut to specified dimensions $\pm 1/8$ inch and free of chips or gouges.

Part B

- 19.01B (Assemble Face Frame, Panels, Toe Board and Skeleton Frame) Given a detailed drawing, specifications, clamps, glue, precut casework, components, and necessary tools, equipment, and materials; assemble face frame, panels, toe board, and skeleton frame. All casework components must be in specified location with joints tight, square, and free of excess glue. Components must be fastened according to drawing specifications with no visual openings or gaps between stock. Overall dimensions must be within $\pm 1/16$ inch.
- 19.02B (Fasten Top or Countertop and Backsplash to Casework) Given a working drawing, specifications, casework top or countertop and backsplash, and necessary tools, equipment, and materials; fasten top or countertop and backsplash to casework. The top must be fastened squarely and securely and be level and flush with the wall. No damage will be caused to the top or countertop and backsplash or casework and fasteners will be in specified locations.

- 19.03B (Assemble Drawers) Given a detailed drawing, specifications, and necessary tools, equipment, and materials; assemble drawers. Drawer fronts must be assembled to specified dimensions +/- 1/16 inch. Joints must be secured and free or visual openings or gaps between stock. Sides and end must be square and parallel.
- 19.04B (Install Drawer Guides) Given specifications and a detailed drawing, a framed cabinet, drawer guides, and the necessary tools, equipment, and material; install drawer guides to specified dimensions +/- 1/16 inch. The guides must form a 90 degree angle with the face frame, be fastened securely, and be level to allow the drawer to move without bending.
- 19.05B (Hang Casework Doors) Given a working drawing, specifications, assemble solid or paneled doors, casework with the face frame attached and the necessary tools, equipment, and materials; hand casework doors. The doors must be plumb with the casework and mounted securely in specified locations +/- 1/16 inch. Doors hinges must be installed with correct number and type fasteners.
- 19.06B (Install Shelving) Given a working drawing, specifications, casework, pre-cut shelving, and the necessary tools, equipment, and materials; install shelving. The shelves must fit securely in specified locations +/- 1/16 inch and be level.
- 19.07B (Attach Trim, Molding, and Edge Banding) Given a working drawing, specifications, assembled casework, doors and the necessary tools, and materials; attach trim, molding, and edge banding. The trim, molding, and banding must be in the specified locations +/- 1/16 inch.
- 19.08B (Install Casework Hardware) Given a working detailed drawing, specifications, assembled casework, and the necessary tools, equipment, and materials; install casework hardware. Hinges, pulls, latches, tracks, and sides must be installed in specified locations +/- 1/16 inch and must allow for smooth opening and closing of casework doors and drawers.

Unit 20.0

- 20.0A-G (Rough-in, Finishing, and Completion /Optional Units/) This optional unit concerning Rough-in, Finishing, and Completion tasks may be used to introduce the carpentry student to related building construction duties in interior and exterior finishing; electrical, plumbing, and heating and cooling mechanical areas; as well as to basic masonry tasks.

- 20.0A Electrical
 20.0B Heating and Cooling
 20.0C Plumbing
 20.0D Masonry
 20.0E Thermal Insulation

20.0F Interior Finishing
20.0G Exterior Finishing

Unit 21.0

- 21.01 (Remove Old Finish) Given furniture needing refinishing or repair, necessary tools, equipment, and supplies; remove old finish by stripping, washing, or sanding or other appropriate methods.
- 21.02 (Clean Wood Surfaces) Given furniture or wood stock ready for finishing and the necessary cleaning tools, equipment, and materials; clean the wood surfaces so that all surfaces are free of loose particles, foreign materials, lint, fingerprints, grease, and smudges.
- 21.03 (Swell a Soft Wood Dent) Given soft wood furniture with a surface dent that can be repaired, steaming equipment (household steam iron and damp pad), and necessary tools and materials; swell the dent. No warpage or water marks should be caused by wetting procedures. No glazing, discoloration, or burning of the wood surface should result from heating. The dent should be raised to the surface and sanded to match the adjacent areas.
- 21.04 (Repair Furniture) Given furniture to repair, necessary tools, equipment, and materials; remove old glue, replace broken dowels and parts, and patch veneers. Repaired furniture should match original design and finish.
- 21.05 (Finish Stock) Given unfinished furniture or stock to finish, necessary tools, equipment, and materials; finish the furniture by filling, staining, toning, shading, coating, rubbing, and polishing as necessary to make the finished stock match in appearance.
- 21.06 (Paint Casework) Given paint, casework needing painting, specifications, and the necessary tools and materials; apply the paint. The paint must be mixed according to specifications and applied for a uniform finish and color. The finished surfaces must be free of scratches, bubbles, and sanding marks.
- 21.07 (Fabricate Furniture) Given specifications or drawings, necessary stock, tools, equipment, and materials; fabricate simple furniture such as cabinets, tables, etc. This task may be undertaken at the discretion of the instructor to provide furniture for the school district or student needs and as a training exercise to expand skills in cabinetmaking and carpentry tool use.

Unit 22.0

- 22.01 (Interpret Blueprints) Given a blueprint that includes all dimensions and information necessary to construct an object or structure; interpret the lines, symbols, and notations on the blueprint. A detail description of the object or structure must be provided including: (1) overall dimensions, (2) notations, (3) symbols, and (4) abbreviations.
- 22.02 (Draw a Set of Shop Plans) Given a set of plans for a structure, room, or wood casework, the necessary drafting tools and equipment to construct the items must be provided without dimensional error, including: (1) necessary dimensions, (2) views, (3) details, and (4) designated scale.
- 22.03 (For Casework /Make a Rod Layout/) Given rod stock, a set of working drawings, and necessary tools, equipment, and materials; make a rod layout. The rod layout must be full size for each part of the casework within a tolerance of +/- 1/16 inch.
- 22.04 (Draw a Detailed Plan) Given a scale drawing and the necessary drafting tools, equipment, and materials; draw a detailed plan that includes all dimensions and information necessary to construct the structure or casework. The detailed plan must be drawn to 1 1/4 inch scale or larger, and all dimensions must be located on the drawing to 100 percent accuracy.
- 22.05 (Estimate Materials From a Blueprint or Layout) Given dimensioned blueprint or layout for a structure or a type of casework, specifications and other essential information, and a bill of materials form, estimate materials from the blueprint or layout. All materials necessary to construct the casework must be provided, including: (1) the quantity of pieces needed, (2) the size and footage of each piece, and (3) the type of material to be used. The quantity and footage figures must be within +/- 5 percent of predetermined calculations and the total must include allowances for waste material.
- 22.06 (Estimate Materials Costs) Given a detailed drawing of a structure of casework, a materials list, cost per unit information, and estimated cost per linear foot; estimate materials costs to within +/- 5 percent of predetermined calculations. (Materials 40 percent, labor 60 percent)
- 22.07 (Estimate Labor Costs) Given a detailed drawing of a structure of casework, a materials list, and materials costs; estimate labor costs to within +/- 5 percent of predetermined calculations. (Materials 40 percent, labor 60 percent)
- 22.08 (Extension of Estimating) Given an estimated list of needed materials, (a) select lumber (stock) for framing, (b) select lumber (stock) for finishing, and (c) stack the lumber or stock and store building materials.

Unit 23.0

- 23.01 (Plan Practical Application Project With Instructor or Others) Given identified student or program (potential employer) needs for a practical application project, the student should participate in planning the training project so that the student can explain the purpose, the student's role, and the potential benefits from the project with 100 percent accuracy.
- 23.02 (Participate In Practical Application Project) Given a written plan for a special application project, the student should participate in the training program in an agreed upon manner, meeting minimum standards of performance as outlined.
- 23.03 (Successfully Pass Knowledge or Written Tests on Project) Given a written plan for a special application project, mutually agreed upon minimum standards, and a process for testing knowledges or performance skills in the special training program, the student should meet the necessary minimum standards to indicate competency in the desired carpentry skills and knowledges required by the practical application project.
- 23.04 (Participate in Practical Training Situations) Given a practical training situation such as participating in remodeling, new construction, etc.; perform the required carpentry or carpentry related duties identified by the instructor, to the instructor's satisfaction.

Unit 24.0

- 24.01 (Developing Leadership Characteristics) Given instruction, identify at least five important characteristics of a good leadership and demonstrate positive leadership characteristics in working with other students to accomplish carpentry jobs. A student self-rating checklist may be used in evaluation and evaluation may include ratings by other students as well as be instructor.

UNIT 1.0

INTRODUCTION TO BUILDING CONSTRUCTION
(Carpentry)

UNIT	1.0	INTRODUCTION TO BUILDING CONSTRUCTION
TASK	1.01	REVIEW SCHOOL POLICIES AND PROCEDURES

PERFORMANCE OBJECTIVE:

Given information on school policies and procedures, apply these policies and procedures on a day-to-day basis.

PERFORMANCE ACTIONS:

- 1.0101 Review school policies and procedures.
- 1.0102 Review philosophy of school and state.
- 1.0103 Review relevant safety policies and procedures under unit concerning safety and practice good safety behavior.

PERFORMANCE STANDARDS:

- Using information and materials, supplies, review and apply school policies and procedures daily.

SUGGESTED INSTRUCTION TIME: 3 Hours

RELATED TECHNICAL INFORMATION:

- Student Handbook.
- Authorization and "release" forms (such as safety release).
- Written Policies and Procedures of the School District.

UNIT	1.0	INTRODUCTION TO BUILDING CONSTRUCTION
TASK	1.02	ORIENTATION TO SHOP

~~PERFORMANCE OBJECTIVE:~~

Given information on school shop or instructor's policies and procedures, apply these policies and procedures. The policies and procedures will be adhered to on a day-to-day basis. Meet standards of the instructor 100 percent.

PERFORMANCE ACTIONS:

- 1.0201 Review with instructor the shop policies and procedures.
- 1.0202 Apply, with 100 percent accuracy, the policies and procedures of the shop.

PERFORMANCE STANDARDS:

- Apply information/instructions given during orientation and throughout training period to comply with all policies and procedures of the shop (instructor) on a day-to-day basis.
- Standards of the State, School District, Vocational Center or high school, and instructor apply.

SUGGESTED INSTRUCTION TIME: 1 Hour

RECOMMENDED:

- Shop Policies and Procedures should be written and posted or distributed to students.

UNIT	1.0	INTRODUCTION TO BUILDING CONSTRUCTION
TASK	1.03	REVIEW COURSE OBJECTIVES AND STANDARDS

PERFORMANCE OBJECTIVE:

Given an introduction to the Building Construction program, a review of the course objectives and minimum standards of performance; describe the course objectives, and the minimum performance expected to demonstrate competency in the objective.

(NOTE: This task may be accomplished in general at the beginning of the first year and in detail over the two year training period.)

Possible Action: Instructor may require students to identify objectives and standards as the initiation of each new unit of instruction.

PERFORMANCE ACTIONS:

- 1.0301 Review each major objective of the Carpentry program.
- 1.0302 Review the minimum performance standards of the objectives.

PERFORMANCE STANDARDS:

- Using information provided, explain the objectives of the course and describe the minimum performance standards for each objective.

SUGGESTED INSTRUCTION TIME: 3 Hours

RECOMMENDED:

- Course objectives, such as the Task Listing, should be written and posted or distributed to students.

UNIT	1.0	INTRODUCTION TO BUILDING CONSTRUCTION
TASK	1.04	IDENTIFY TYPICAL BUILDING CONSTRUCTION CAREER OPPORTUNITIES

PERFORMANCE OBJECTIVE:

Given instruction, data on the local building construction industry, primarily carpentry, and opportunities to study the construction and related industry; identify the major categories of potential employers in the local community (and the key characteristics of each).

PERFORMANCE ACTIONS:

"Performance actions may vary from center to center due to the potential employers served and the emphasis of the individual carpentry program."

PERFORMANCE STANDARDS:

- Identify typical types of building construction jobs, businesses in the local community, and the major characteristics that distinguish them based on given instruction, local market data, and student observation.

SUGGESTED INSTRUCTION TIME: 3 Hours

UNIT	1.0	INTRODUCTION TO BUILDING CONSTRUCTION
TASK	1.05 (Optional)	JOB PERFORMANCE

PERFORMANCE OBJECTIVE:

Given instruction, demonstrate job performance characteristics that are considered important to entry-level career success in the vocational field. A "Job Performance Rating Sheet" will be used to evaluate performance and all items must be rated "frequently" or above.*

PERFORMANCE ACTIONS:

- 1.0501 Review important work characteristics for the vocational field.
- 1.0502 Review the "Job Performance Rating Sheet" with the instructor.
- 1.0503 Demonstrate those work characteristics that are considered important to success in the vocational field.

PERFORMANCE STANDARDS:

- Demonstrate by personal performance the work characteristics that are considered important to success in construction work.
- A "Rating Sheet" will be used to evaluate performance and all items must be rated "frequently" (observed) or above.

SUGGESTED INSTRUCTION TIME: 3 Hours

Accompanied by addendum page (Rating Sheet)

Rating sheet includes the following categories:

- | | |
|-------------------------|------------------------------------|
| - Accuracy of work | - Attitude toward fellow workers |
| - Care of working space | - Attitude toward teacher |
| - Care of equipment | - Observance of safety rules |
| - Speed | - Use of materials |
| - Use of working time | - Responsibility |
| - Initiative | - Accident report |
| - Attendance | - Personal appearance, cleanliness |

*NOTE: It is the general recommendation of instructor task force committees that employer-recommended "job performance characteristics" and "work attitudes" be included as part of the vocational student's overall training and that demonstrated performance in these areas be included in the total evaluation of the student.

JOB PERFORMANCE RATING SHEET

Student _____ Job Performed _____
 Dates from _____ to _____
 Place of work _____ Supervisor _____

DIRECTIONS: Circle the number that best fits your opinion of the student's performance using the following factors:

	Never	Seldom	Frequently	Usually	Always
1. Gets to work on time	1	2	3	4	5
2. Uses time properly	1	2	3	4	5
3. Shows interest in work	1	2	3	4	5
4. Shows dependability	1	2	3	4	5
5. Is ambitious	1	2	3	4	5
6. Is neat (work and self)	1	2	3	4	5
7. Works well with others	1	2	3	4	5
8. Follows directions	1	2	3	4	5
9. Works without supervision	1	2	3	4	5
10. Shows good manners	1	2	3	4	5
11. Meets people well	1	2	3	4	5
12. Uses knowledge on the job	1	2	3	4	5
13. Seeks assistance, when necessary	1	2	3	4	5

Does the worker have the skills for doing satisfactory work? Yes _____
 No _____

List the skills or characteristics that need to be developed or improved upon:

Additional comments:

Date _____ Supervisor _____



UNIT	1.0	INTRODUCTION TO BUILDING CONSTRUCTION
TASK	1.06	WORK ATTITUDES

PERFORMANCE OBJECTIVE:

Given instruction, demonstrate work attitudes that the majority of potential employers prefer in an entry level worker. Performance will be evaluated on a "Work Attitudes Score Card" and a minimum of 90 percent should be attained. Performance will be rated through training and should improve to 100 percent by the end of the training period.*

PERFORMANCE ACTIONS:

- 1.0601 Review work attitudes considered important to success in the vocational field.
- 1.0602 Review the "Work Attitudes Score Card."
- 1.0603 Demonstrate the type of work attitudes that potential employers in the local industry report as important to job success.

PERFORMANCE STANDARDS:

- Demonstrate to 80 percent acceptable rating on a "Work Attitude Score Card", to be completed by the instructor those work attitudes considered important by local potential employers for entry-level job success.

SUGGESTED INSTRUCTION TIME: 3 Hours

Accompanied by addendum page (Work Attitudes Score Card)

*NOTE: It is the general recommendation of the instructor task force committees that employer-recommended "job performance characteristics" and "work attitudes" be included as part of the vocational student's overall training and that demonstrated performance in these areas be included in the total evaluation of the student.

WORK ATTITUDES SCORE SHEET

DIRECTIONS: Score the student on the following attitudes and work behavior by circling the appropriate description either "yes" (+) or "no" (-). Indicate any comments to support the rating or recommendations.

	Circle		Comments/ Recommendations
	(No)	(Yes)	
Cooperative	-	+	
Courteous	-	+	
Loyal	-	+	
Tackful	-	+	
Self Disciplined	-	+	
Respectful	-	+	
Alert	-	+	
Motivated	-	+	
Responsible	-	+	
Trustworthy	-	+	
Dependable	-	+	
Cheerful	-	+	
Polite	-	+	
Interest	-	+	
Friendly	-	+	
Sympathetic	-	+	
Accepts changes	-	+	
Follows rules and regulations	-	+	
Does share of work	-	+	
Helps others, if needed	-	+	
Works regularly	-	+	
On time	-	+	
Shows pride in work	-	+	
Keeps promises	-	+	
Does not waste time	-	+	
Controls anger	-	+	
Accepts criticism	-	+	
Follows superior's directions	-	+	

28 Items total

TOTAL (+'s) _____

Interpretation

- 28 = 100% = Level 4
- 25 = 90% = Level 3
- 22 = 80% = Level 2
- 20 = 70% = Level 1
- 17 = 60% = Level 0
- 14 = 50%

Student: _____

TRUE/FALSE

1. Rough carpentry includes the building of concrete forms. _____
2. Carpenters work only on building homes. _____
3. The carpenter works only with wood. _____
4. The installation of cabinets, paneling, and molding typically is the job of the finished carpenter. _____
5. Upon graduation from high school, a student who has completed a carpentry program typically may enter the construction field as a journeyman carpenter. _____

COMPLETION

1. A _____ carpenter usually is responsible for installing hardware in a residential structure. _____
2. Typically, at the beginning, the apprentice carpenter will be paid approximately _____ percent of the wages received by the journeyman. _____
3. Typical zoning categories that are used in most cities include: Industrial, commercial, multi-family, and _____ . _____
4. Generally a building permit is not issued until after a _____ is made. _____
5. Two utilities typically are turned on before construction work begins: One is water and the second one is _____ . _____

RATING SCALES AND CHECKLISTS

- a. "Job Performance Rating Sheet"
- b. "Work Attitudes Score Sheet"

These rating or score sheets may be used by the instructor, the student, or fellow students to critique the desirable characteristics that the ideal carpenter might demonstrate. The rating scale may be used to assist the student's professional development in the affective domain, in desirable work habits, and in skill performance. The scales are applicable for the entire two year secondary carpentry program.

UNIT 2.0

CARPENTRY SAFETY

While safety training is described at the beginning of the articulation guide and in major units of instruction, safety is integrated throughout the entire course of training on a daily basis.

UNIT	2.0	BUILDING CONSTRUCTION I
TASK	2.01	CLASSROOM SAFETY

PERFORMANCE OBJECTIVE:

Given a typical building construction (carpentry) shop or job situation, exhibit an awareness of safety practices, safe work habits, and a positive attitude concerning job safety and accident prevention and meet standards established by the instructor.

PERFORMANCE ACTIONS:

- 2.0101 Develop an awareness of hazards and become more safety conscious.
- 2.0102 Develop a serious attitude toward the use of safety procedures.
- 2.0103 Prepare for safety before entering the work area.
- 2.0104 Prepare for safety on entering the work area.
- 2.0105 Prepare for safety at the work station.
- 2.0106 Demonstrate knowledge of safety color coding.
- 2.0107 Practice safe procedures.
- 2.0108 Prepare for safety on leaving the work environment.

SUGGESTED INSTRUCTION TIME: 3 Hours

PERFORMANCE STANDARDS:

- "Zero-Level" accident record.
- Instructor's standards based on recommended resources.
- Applicable OSHA Standards.

POSSIBLE RESOURCES:

Current vocational program safety guide publication of The School District of Greenville County.

Jacobs, Clinton O., and Howard J. Turner, Developing Shop Safety, Skills, Athens, GA: American Association for Vocational Instructional Materials. Approximately 80 pages of brief, visually clear suggestions concerning a variety of shop safety situations. Good student or resource manual.

UNIT	2.0	BUILDING CONSTRUCTION I
TASK	2.01	CLASSROOM SAFETY

RECOMMENDED RESOURCES (Con't.):

Safety Handbook, A Guide for Trade and Industrial Programs, Clemson University, SC: Vocational Education Media Center, 1968. (No 13/2/70, \$2.25; Accompanying 31 Transparencies, No. 9/8/68, \$5.75.) Available from Trades and Industries District Supervisors, Office of Vocational Education South Carolina State Department of Education or from the Vocational Education Media Center, Clemson University, SC.

Planning for Emergencies, Occupational Safety and Health Short Course Number Seven, Columbia, SC: SC State Board for Technical and Comprehensive Education.

Notgrass, Troy. Safety Handbook for ICT, Austin, TX: The University of Texas at Austin: Center for Occupational Curriculum Development, Division of Continuing Education, 1978.

RELATED TECHNICAL INFORMATION:

- Regulations of individual school or classroom.
- Regulations of The School District of Greenville County.
- Codes, laws, and ordinances.
- Materials, and equipment, handbooks, and manuals.
- OSHA Regulations.
- E.P.A. Regulations.

Accompanied by addendum pages:

- Suggested Shop Safety Rules.
- Suggestions for maintaining a clean and orderly shop.
- Suggested Personal Safety Guide.
- Student Safety Pledge Form.

Suggested Shop Safety Rules

- A. Keep all hand tools sharp, clean, and in safe working order.
- B. Report any defective tools, machines, or other equipment to the instructor.
- C. Retain all guards and safety devices except with the specific authorization of the instructor.
- D. Operate a hazardous machine only after receiving instruction on how to operate the machine safely.
- E. Report all accidents to the instructor regardless of nature or severity.
- F. Operator turns off power and makes certain the machine has stopped running before leaving.
- G. Make sure all guards and barriers are in place and adjusted properly before starting a machine tool.
- H. Disconnect the power from machine tools before performing the maintenance task of oiling or cleaning.
- I. Use a solvent only after determining its properties, what kind of work it has to do, and how to use it.
- J. Use correct, properly fitting wrenches for nuts, bolts, and objects to be turned or held.
- K. Keep the shop or laboratory floor clear of scraps and litter.

Suggestions for Maintaining a Clean and Orderly Shop

- A. Arrange machinery and equipment to permit safe, efficient work practices and ease in cleaning.
- B. Stack materials and supplies safely or store them in proper place.
- C. Store tools and accessories safely in cabinets, on racks, or in other suitable devices.
- D. Clear working areas and work benches of debris and other hazards.
- E. Clean and free floors from obstructions and slippery substances.
- F. Free aisles, traffic areas, and exits of materials and other debris.
- G. Dispose of combustible materials properly or store in approved containers.
- H. Store oily rags in self-closing or spring-lid metal containers.
- I. Know the proper procedures to follow in keeping the work area clean and orderly.
- J. Keep sufficient brooms, brushes, and other housekeeping equipment readily available.
- K. Clean up any spilled liquids immediately.
- L. Oily rags or oily waste should be stored in metal containers.
- M. Clean the chips from a machine with a brush--not with a rag or the bare hand.
- N. Do not use compressed air to clean yourself or clothing.
- O. Use only approved scaffolding.

Suggested Personal Safety Rules

- A. Wear shop clothing appropriate to the work activity being performed.
- B. Always wear safety glasses, face protection, or suitable hard hats as needed.
- C. Confine long hair before operating rotating equipment.
- D. Remove ties when working around machine tools or rotating equipment.
- E. Remove rings and other jewelry when working in the shop.
- F. Always conduct yourself in a manner conducive to safe shop practices.

SAFETY

STUDENT SAFETY PLEDGE FORM

_____, who is enrolled in Vocational Building Construction (Carpentry), will operate machines as part of training, and equipment providing that the student's parent or guardian has given written permission.

It is understood that each student will be given proper instruction, both in the use of the equipment and in correct safety procedures concerning it, before being allowed to operate it. The student must assume responsibility for following safe practices, and therefore the student is asked to subscribe to the following safety pledge.

1. I promise to follow all safety rules for the shop.
2. I promise never to use a machine without first having permission from the instructor.
3. I will not ask permission to use a particular machine unless I have been instructed in its use, and have made 100 percent on the safety test for that machine.
4. I will report any accident or injury to the teacher immediately.

Date _____ Student's Signature _____

I hereby give my consent to allow my son/daughter to operate all machines and equipment necessary in carrying out the requirements of the course in which enrolled.

Date _____ Parent's Signature _____

Parents are cordially invited to visit the shop to inspect the machines and to see them in operation.

77

UNIT	2.0	BUILDING CONSTRUCTION I
TASK	2.02	USE PERSONAL PROTECTIVE EQUIPMENT

PERFORMANCE OBJECTIVE:

Given personal protective equipment guidelines, personal protection equipment, and a working situation, use personal protection equipment to meet the instructor's standards or other applicable standards such as OSHA.

PERFORMANCE ACTIONS:

- 2.0201 Wear approved hard hat as required by standards.
- 2.0202 Wear approved eye and face protection when warranted.
- 2.0203 Wear special equipment such as safety belts, dust respirators, or other clothing, etc., as recommended by the instructor.

PERFORMANCE STANDARDS:

- Wear personal protective equipment to meet specified work situation requirements, to instructor's standards (or OSHA Standards).

SUGGESTED INSTRUCTION TIME: 3 Hours

RELATED TECHNICAL INFORMATION:

- Care of lenses and side shields of safety glasses.
- Nail aprons free from holes.

UNIT	2.0	BUILDING CONSTRUCTION I
TASK	2.03	PRACTICE SAFETY IN USING POWER TOOLS (and Machinery)

PERFORMANCE OBJECTIVE:

Given proper instructions, power tools used in carpentry; use power tools safely according to manufacturer's specifications/instructions and meet instructor's standards (or local codes, OSHA Standards).

PERFORMANCE ACTIONS:

- 2.0301 Able to identify principles of operations, methods of use, and general and special safety precautions of any power tools prior to operating it.
- 2.0302 Check to be sure all power tools are grounded (unless approved double insulated). Power tools should have a 3-wire conductor cord. If an adaptor plug is used to allow a 3-ground plug to be plugged in a 2-hole outline, use separate ground wire. Use correct voltage.
- 2.0303 (a) Unplug power tool when changing belts, blades, bits, etc.
(b) Don't leave a power tool until it stopped running "while machine is coasting."
- 2.0304 Always use safety guards provided with power tools.
- 2.0305 When work is completed, unplug power plug. Always turn switch of power tool to "off" prior to connecting power plug. Always turn switch to "off" when work is completed.
- 2.0306 If extension cord is needed, use recommended cord size. Cord should not run through water or be placed so damage may occur.
- 2.0307 Inspect power tools for worn power cords, proper adjustments.
- 2.0308 Store power tools properly or label and remove from use power tools which are defective.

PERFORMANCE STANDARDS:

- Able to properly and safely use carpentry power tools to manufacturer's instructions/specifications or instructor's standards (applicable code or OSHA Standards), without damage to tools, and with "ZERO" accidents.

UNIT	2.0	BUILDING CONSTRUCTION I
TASK	2.03	PRACTICE SAFETY IN USING POWER TOOLS (and Machinery) (Con't.)

SUGGESTED INSTRUCTION TIME: 6-45 Hours*

RELATED TECHNICAL INFORMATION:

- Manufacturer's instructions/specification on each power tool.
- Electrical codes and safe practices of electrical use.
- Safety guard use with power tools.

NOTE: Obtain competency qualification (instructor's) approval prior to operation of power hand tools or machinery.

*Power tool safety is an ongoing skill development task.

Additional safety instruction is given as an integral part of instruction on individual power tool operation.

UNIT	2.0	BUILDING CONSTRUCTION I
TASK	2.04	LADDER AND SCAFFOLDING SAFETY

PERFORMANCE OBJECTIVE:

Given proper instructions, various types of ladders used in construction, jobs that require the use of the ladder; select the appropriate type of ladder and use it correctly in accomplishing the job. Selection and use of the ladder must meet the instructor's standards.

PERFORMANCE ACTIONS:

LADDER SAFETY

- 2.0401 Select ladder size and type appropriate for job.
- 2.0402 Inspect ladder prior to use.
- 2.0403 Slant ladder at safe angle: 1 to 4 recommended.
- 2.0404 Check for secure footing. (Use swivel safety feet as appropriate.)
- 2.0405 Be sure ladder is clear of doors or passageways.
- 2.0406 Top of ladder should clear support by a minimum of 3 feet.
- 2.0407
 - a. Face ladder going up or down.
 - b. Use both hands in climbing.
 - c. Don't over-reach, over-load a ladder.
- 2.0408 Label and remove from use an unservicable ladder.

SCAFFOLDING SAFETY

- 2.0409 Wood or metal scaffolding require specific safety precautions. See "Scaffolding Safety Rules" recommended by Scaffolding and Shoring Institute or see, Fundamentals of Carpentry, Durbahn and Putman.

PERFORMANCE STANDARDS:

- Able to select proper ladder for job, use ladder according to recommended safety procedures and instructor's standards.
- "ZERO" accidents using ladder.

SUGGESTED INSTRUCTION TIME: 3 Hours

TRUE/FALSE

1. Students must wear approved eye protection at all times while in the carpentry shop, except in safe areas or when designated by _____ instructor. _____
2. All fixed machine guards must _____ in place and be operating correctly before the machine is used. _____
3. Before working alone in the shop using power equipment, the student should be checked out on the power tools to be used. _____
4. Students must at all times have permission from the instructor to work in the carpentry laboratory. _____
5. A "running" machine must never be left unattended. _____
6. It is recommended that a ladder clear the support by 3 feet. _____
7. A ladder should be selected by size and type according to the job. _____
8. A recommended safe angle of ladder slant is 1 to 4. _____
9. In climbing _____ ladder, face the ladder, and carry your carpentry tools in one hand to your side. _____
10. To refinish a wooden ladder, the preferred material to use would be varnish rather than paint. _____

MULTIPLE CHOICE

1. Clean the chips from a machine with _____.
a. a rag
b. your hand
c. brush
2. To clean yourself or clothing, do not use _____.
a. brush
b. hands
c. compressed air
3. Before oiling or cleaning a machine tool, _____.
a. disconnect the power
b. place rag or paper under the machine to catch the oil
c. tell others not to use the machine while you are working on it

MULTIPLE CHOICE (Con't.)

4. Defective tools, machines, or other equipment ____.
- a. should be returned to the tool room
 - b. reported to the instructor
 - c. repaired if you have the tools and parts necessary
5. To help prevent head injuries on the job you should wear ____.
- a. insulated cap
 - b. steel toe shoes
 - c. hard hat
 - d. safety belt
6. Eye protection should be worn ____.
- a. at all times
 - b. only when grinding metal
 - c. when using hand saw
 - d. when reasonable possibility of eye injury exists
7. A respirator should be worn ____.
- a. when using radial arm saw
 - b. while spraying paint
 - c. when using sanding block
 - d. while sweeping floors
8. Combustible material should be stored ____.
- a. in metal cabinets
 - b. in plastic containers
 - c. in glass containers
 - d. in wire cages
9. When you are working around power tools, your clothing should ____.
- a. be loosely fitted
 - b. fit snugly
 - c. be new
 - d. be left unbuttoned
10. Before operating any power tool, you need to ____.
- a. know who the manufacturer is
 - b. know how old it is
 - c. unplug the power supply
 - d. be familiar with the way it operates

MULTIPLE CHOICE

11. Shop and work area should be cleared of debris _____. _____
 - a. once a week
 - b. before inspections
 - c. once a day
 - d. at all times

12. Tools and equipment not being used should be _____. _____
 - a. stored away
 - b. carried in pockets
 - c. spread out on table
 - d. piled on floor

13. Scaffolds and ladders should be checked for defects _____. _____
 - a. beginning of year
 - b. monthly
 - c. daily before use
 - d. weekly

14. While on a construction site, be especially cautious of _____. _____
 - a. salesmen
 - b. wet cement
 - c. wet lumber
 - d. overhead work activity

15. When lifting heavy objects _____. _____
 - a. bend your knees
 - b. bend your back
 - c. twist your body
 - d. shift weight to one leg

16. A fire extinguisher with a class C chemical should be used _____. _____
 - a. on all fires
 - b. on burning wood
 - c. paint and oil fires
 - d. on electrical fires

UNIT 3.0

BUILDING CONSTRUCTION I

Upon completing this unit, the carpentry student should have gained the skills and knowledge necessary to perform the following carpentry mathematical functions:

- a. Addition, subtraction, multiplication, and division of whole numbers.
- b. Addition, subtraction, multiplication, and division of fractions. Changing fractions to a decimal number and a decimal number to a fraction. Reading typical flat ruler fractions.
- c. Working with three digit decimals.
- d. Calculating the volume of a rectangle.
- e. Estimating the area of a rectangle.
- f. Determining angular measurement.

UNIT 3.0

BUILDING CONSTRUCTION I

TASK 3.01

CARPENTRY MATH

PERFORMANCE OBJECTIVE:

Given a pretest by the instructor, perform basic mathematical calculations in whole numbers, addition, subtraction, multiplication, and division with an accuracy of 95 percent on written knowledge typical of basic math in the carpentry field.

PERFORMANCE ACTIONS:

- 3.0101 Demonstrate basic math skills in the addition of whole numbers with 95 percent accuracy.
- 3.0102 Demonstrate basic math skills in the subtraction of whole numbers with 95 percent accuracy.
- 3.0103 Demonstrate basic math skills in the multiplication of whole numbers with 95 percent accuracy.
- 3.0104 Demonstrate basic math skills in the division of whole numbers with 95 percent accuracy.

PERFORMANCE STANDARDS:

- Demonstrate with 95 percent accuracy on a given pretest, basic math skills in the addition, subtraction, multiplication, and division of whole numbers.

(NOTE: The level of this math skill is eighth grade.)

SUGGESTED INSTRUCTION TIME: 24 Hours

RELATED TECHNICAL INFORMATION:

- Any good basic arithmetic book, oral presentation, and demonstration of basic math as necessary.

UNIT	3.0	BUILDING CONSTRUCTION I
TASK	3.02	CARPENTRY MATH - FRACTIONS

PERFORMANCE OBJECTIVE:

Given instructor or text provided carpentry math problems involving the addition, subtraction, multiplication, or division of fractions; select the proper operation or operations to solve the problems with 90 percent accuracy. Able to conduct following operations with fractions:

1. Change any fraction to a decimal number, and any terminating decimal number to a fraction.
2. Arrange in order...unit and simple nonunit fractions.
3. Write equivalent fractions in higher, lower, and lowest terms.
4. Write improper fractions as whole or mixed numbers, and mixed numbers as improper fractions.
5. Multiply fractions and mixed numbers, expressing answers in simplest form.
6. Divide fractions and mixed numbers, expressing answers in simplest form.
7. Add and subtract unlike fractions, expressing answers in simplest form.
8. Add and subtract mixed numbers with unlike fractions, expressing answers in simplest form.
9. Use rational numbers to solve simple word problems.
10. Solve typical carpentry problems involving fractions.
11. Read typical flat ruler fractions.

PERFORMANCE ACTIONS:

Consult: Curriculum Guide for High School General Mathematics, Greenville, SC: The School District of Greenville County, 1979.

SUGGESTED INSTRUCTION TIME: 12 Hours (Recommended that actual hours of instruction be determined by students math skills as level indicated by pretest. Remedial instructions may be at initiation of Building Construction I or as the actual skill is required.)

PERFORMANCE STANDARDS:

- Student should be able to complete pretest in Math Curriculum Guide with 90 percent accuracy.
- Consult the Math Curriculum Guide for pretests, suggested exercises, and references.

(NOTE: The level of this math skill is eighth grade, General Math I.)

UNIT	3.0	BUILDING CONSTRUCTION I
TASK	3.03	CARPENTRY MATH - DECIMALS

PERFORMANCE OBJECTIVE:

Given a pretest or examples by the instructor, conduct the following decimal math operations:

1. Name the place value of digits in decimal numbers of up to three digits before the decimal and three digits after the decimal.
2. Compare decimal numbers and arrange them in order.
3. Write the numeral for any decimal number of up to four decimal places.
4. Round decimal numbers to any designated place value up to thousandths.
5. Add and subtract decimal numbers of up to three digits.
6. Multiply decimal numbers by whole numbers or decimal numbers.
7. Divide a number by a three-digit decimal number.
8. Multiply and divide decimal numbers by powers of ten, by inspection.
9. Solve simple carpentry problems involving decimals.

PERFORMANCE ACTIONS:

Consult: Curriculum Guide for High School General Mathematics, Greenville, SC: The School District of Greenville County, 1979.

SUGGESTED INSTRUCTION TIME: 6 Hours (Actual hours of instruction will be determined by the students math skills level as indicated by pretest. Remedial instruction may be at initiation of Building Construction I or as the actual skill is required.)

PERFORMANCE STANDARDS:

- Student should be able to complete pretest in Math Curriculum Guide with 90 percent accuracy.
- Consult: Curriculum Guide for High School General Mathematics, 1979, for pretests, suggested exercises, and references.

(NOTE: The level of this math skill is eighth grade, General Math I.)

RELATED TECHNICAL KNOWLEDGE:

- Student should be able to add, subtract, multiply, and divide.

RECOMMENDED: Carpentry mathematic text and workbook should be available for use as needed. Such texts include:

Reband, P., Related Mathematics for Carpentry, 2nd ed., Alsip, IL (60658): American Technical Publishers, Inc., 1981.

UNIT 3.0

BUILDING CONSTRUCTION I

TASK 3.04

CARPENTRY MATH - VOLUMES

PERFORMANCE OBJECTIVE:

Given a pretest or examples by the instructor, find the volume of given rectangle, in cubic feet or yards as required, for the purpose of removing earth or filling with concrete.

PERFORMANCE ACTIONS:

Consult: Curriculum Guide for High School General Mathematics, Greenville, SC: The School District of Greenville County, 1979.

SUGGESTED INSTRUCTION TIME: 6 Hours (Actual hours of instruction will be determined by the student's math skill as indicated by pretest. Remedial instruction may be at initiation of Building Construction I or as the actual skill is required.)

PERFORMANCE STANDARDS:

- Student should be able to complete pretest in Math Curriculum Guide with 90 percent accuracy.
- Consult: Math Curriculum Guide for pretests, suggested exercises, and references.
- Able to find volume of a given rectangle to be filled with concrete.
- Able to estimate tonage.

(NOTE: The level of this math skill is eighth grade, General Math 1.)

UNIT 3.0

BUILDING CONSTRUCTION I

TASK 3.05

CARPENTRY MATH - AREAS

PERFORMANCE OBJECTIVE:

Given a pretest or examples by the instructor, find the area of a given rectangle (minimum performance).

PERFORMANCE ACTIONS:

Consult: Curriculum Guide for High School General Mathematics, Greenville, SC: The School District of Greenville County, 1979.

SUGGESTED INSTRUCTION TIME: 6 Hours (Actual hours of instruction will be determined by the student's math skill as indicated by pretest. Remedial instruction may be at initiation of Building Construction I or as the actual skill is required.)

PERFORMANCE STANDARDS:

- Student should be able to complete pretest in Math Curriculum Guide with 90 percent accuracy.
- Consult the Math Curriculum Guide for pretests, suggested exercises, and references.

(NOTE: The level of this math skill is eighth grade, General Math I.)

UNIT 3.0

BUILDING CONSTRUCTION I

TASK 3.06

CARPENTRY MATH - ANGULAR MEASUREMENT

PERFORMANCE OBJECTIVE:

Given a pretest or examples by the instructor which involve the four basic math processes* in angular measurement, perform math operations changing degrees, minutes, and seconds to whichever one of the three units will expedite the mathematical processes involved.

*Four basic math processes: Addition, Subtraction, Multiplication, Division.

PERFORMANCE ACTIONS:

- 3.0601 Identify the parts of an angle.
- 3.0602 Locate rules for:
 - a. Changing degrees to minutes
 - b. Changing minutes to seconds
 - c. Changing an angle expressed in degrees and minutes to seconds
 - d. Changing minutes to degrees
 - e. Measuring length of an arc (circular length)
- 3.0603 Using given references, determine the degrees in various parts of a circle.
- 3.0604 For given problems, determine equivalent values of angles: Degrees, parts of a circle, angular measurement to degrees, minutes, or seconds. "Reference data given."
- 3.0605 Compute circular and angular measurements arriving at the appropriate combination of measurements required for the process involved. "Reference data given."
- 3.0606 Measure angles by the direct method and by computation. "Reference data given."

SUGGESTED INSTRUCTION TIME: 6 Hours

PERFORMANCE STANDARDS:

- 80 percent accuracy in basic angular measurements necessary for the completion of tasks in Building Construction I. Reference book or data given to aid student.

UNIT 3.0

BUILDING CONSTRUCTION I

TASK 3.06

CARPENTRY MATH - ANGULAR MEASUREMENT
(Con't.)

SUGGESTED REFERENCES:

- Curriculum Guide for High School General Mathematics, Greenville, SC: The School District of Greenville County, 1979.
- Olivo, S. Thomas, and Olivo, Thomas P., Basic Mathematics Simplified, 3rd edition, Albany, NY: Delmar Publishers, 1972.

I. Add the following numbers.

1.
$$\begin{array}{r} 5 \text{ gal. } 2 \text{ qt.} \\ \underline{4 \text{ gal. } 3 \text{ qt.}} \end{array}$$

2.
$$\begin{array}{r} 3 \text{ yd. } 2 \text{ ft. } 9 \text{ in.} \\ 1 \text{ yd. } 1 \text{ ft. } 8 \text{ in.} \\ \underline{3 \text{ yd. } 2 \text{ ft. } 6 \text{ in.}} \end{array}$$

II. Subtract the following numbers.

1.
$$\begin{array}{r} 4 \text{ ft.} \\ \underline{1 \text{ ft. } 9 \text{ in.}} \end{array}$$

2.
$$\begin{array}{r} 8 \text{ yd. } 1 \text{ ft.} \\ \underline{5 \text{ yd. } 2 \text{ ft.}} \end{array}$$

3.
$$\begin{array}{r} 3 \text{ qt. } 1 \text{ pt.} \\ \underline{2 \text{ qt. } 2 \text{ pt.}} \end{array}$$

4.
$$\begin{array}{r} 29 \text{ yd.} \\ \underline{13 \text{ ft. } 7 \text{ in.}} \end{array}$$

III. Convert the following measurements.

1. 40 in. = _____ ft. _____ in.

2. 3 yd. 2 ft. = _____ ft.

3. The fraction $\frac{1}{3} = \frac{\quad}{6}$.

4. _____ ft. 4 in. = _____ in.

5. 84 in. = _____ ft. _____ in.

IV. Compute the total board feet for the following pieces of lumber.

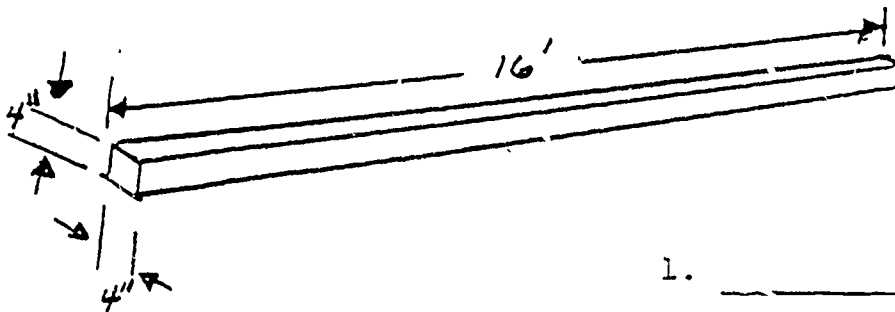

1.

1. _____

2.

2. _____

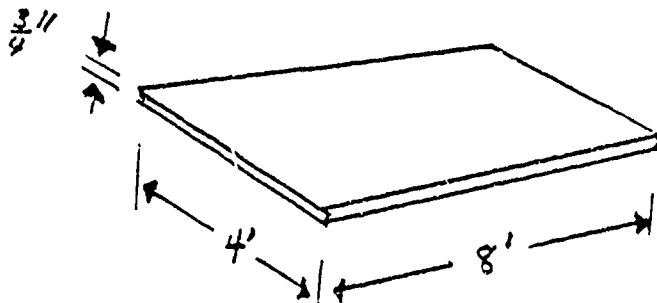

V. Calculate total board feet in each of the following problems.

1. $7' 2'' \times 4'' \times 12' =$ _____

2. $12' 1'' \times 8'' \times 8' =$ _____

3. $1' 1'' \times 6'' \times 10' =$ _____

4. $8' 2'' \times 4'' \times 20' =$ _____

5. $3' 2'' \times 8'' \times 8' =$ _____

VI. Calculate the cost of lumber using the following information. Round your answer to the nearest cent. (M = 1,000 board feet.)

1. Ten boards $4'' \times 4'' \times 15'$ at \$245.00 per M.

Ans. _____

2. Six boards $2'' \times 6'' \times 14'$ at \$75.00 per M.

Ans. _____

3. Twenty boards $1'' \times 12'' \times 6'$ at \$60.00 per M.

Ans. _____

4. A contractor ordered the following for framing a garage:

- 36 studs, $2'' \times 4'' \times 8'$
- 9 sills, $1'' \times 4'' \times 20'$
- 4 plates, $2'' \times 6'' \times 20'$
- 24 rafters, $2'' \times 8'' \times 14'$
- 60 $1'' \times 6'' \times 22''$ for sheathing

a. Calculate the total number of board feet ordered.

Ans. _____

b. If the material is priced at \$135.00 per M, calculate the cost of the order.

Ans. _____

VII. Add the following fractions:

1. $2/5 + 1/7 =$ _____

2. $1/9 + 1/6 =$ _____

VIII. Subtract the following fractions:

1. $5/7 - 2/9 =$ _____

2. $2/9 - 3/18 =$ _____

3. $7/8 - 2/5 =$ _____

IX. Multiply the following fractions:

1. $8/9 \times 3 =$ _____

2. $1/6 \times 3/5 =$ _____

3. $3/4 \times 6/7 =$ _____

X. Divide the following fractions:

1. $\frac{5 \frac{1}{2}}{6} =$ _____

2. $\frac{2 \frac{2}{3}}{3} =$ _____

MULTIPLE CHOICE

1. The formula for calculating the number of cubic yards of concrete is ____.

a. $\frac{\text{Width} \times \text{length} \times \text{thickness}}{27} =$ cubic yards of concrete

b. $\frac{\text{Width} \times \text{length} \times \text{thickness}}{12} =$ cubic yards of concrete

c. $\text{length} \times \text{width} \times \text{thickness} =$ cubic yards of concrete

d. $3.14 \times \text{thickness} \times \text{length} =$ cubic yards of concrete

2. To determine the number of board feet for a lumber order, use the following formula:

a. $\frac{\text{No. pcs.} \times 12}{27} =$ Bd. ft.

b. $W \times T \times 16 =$ Bd. ft.

c. $\frac{\text{No. pcs.} \times T \times W \times L}{12} =$ Bd. ft.

d. $L \times W \times T \times 12 =$ Bd. ft.

MULTIPLE CHOICE (Con't.)

3. One square of shingles will cover:
- a. 1,000 sq. ft.
 - b. 75 sq. ft.
 - c. 100 sq. ft.
 - d. 100 sq. ft.
4. The labor cost for installing 13 sq. of shingles @ 5.75 per sq.:
- a. \$50.00
 - b. \$76.00
 - c. \$747.50
 - d. \$74.75
5. The number of pieces of 4' x 8' plywood to cover a floor 12' x 32':
- a. 12 pcs.
 - b. 10 pcs.
 - c. 384 pcs.
 - d. 44 pcs.
6. The number of 8" x 16" concrete blocks for a wall 8' high and 52' long using the stack bond:
- a. 312
 - b. 900
 - c. 468
 - d. 416
7. The cost of 1750 board feet of siding at \$380.00 per thousand would be:
- a. \$285.00
 - b. \$665.00
 - c. \$550.00
 - d. \$66.60
8. The actual size of a dressed 1 x 4 is:
- a. 3/4" x 3-1/2"
 - b. 5/8" x 3-3/4"
 - c. 3/4" x 3-1/4"
 - d. 7/8" x 3-7/8"
9. The crown of a piece of stock is the same as:
- a. the cup
 - b. the twist
 - c. the bow
 - d. the crook

MULTIPLE CHOICE (Con't.)

10. The abbreviation for a board which has been surfaced both sides and both edges is:
- a. SISIE
 - b. S4S
 - c. S2S
 - d. STD

UNIT 4.0
BLUEPRINT READING

Upon completing this unit, the student should be qualified to:

- Identify AIA building symbols
- Determine dimensions from a plan
- Interpret building specifications
- Interpret building codes
- Interpret a multi-view drawing
- Sketch a working drawing

SUGGESTED MINIMUM TERMINOLOGY

BLUEPRINT READING

Alphabet of Lines	"Set of conventional symbols covering all lines needed to depict an object to size and shape."
Architect's Scale	Rule divided so a fraction of an inch is proportionally equal to one foot. EX. 3, 1/2; 1/4, 1/8 inch to 1 foot
Architectural Drawings	Construction drawings showing step by step instructions.
Blueprint	Copy of the original detailed drawing.
Detail view	Drawing that includes the complete detailed information for construction.
Dimensions	Lines and symbols that indicate the actual sizes to be followed in construction.
Elevation View	Drawings representing the front, sides, or rear face of a structure.
Plan View	"Horizontal cut through a building showing foundation, rooms, partitions, windows, doors, and stairs."
Scale Drawing	"Drawing made to size either portionally larger or smaller than the actual size of the object represented."
Section View	Drawing that has been cut to show internal construction.
Specifications	"Detailed set of written instructions which explains the drawings and becomes a part of the construction contract."
Working Drawings	"Technical drawing which includes all dimensions and procedures to guide workers building a structure."

These definitions were adopted in part from the following publication:
Residential Carpentry, Stillwater, OK: State Department of Vocational and Technical Education, p. 5 E., 1973.

UNIT	4.0	BLUEPRINT READING
TASK	4.01	IDENTIFY WORKING DRAWINGS AND BLUEPRINTS AND READ SPECIFICATIONS

PERFORMANCE OBJECTIVE:

Given an orientation to working drawings, blueprints, and specifications; differentiate between working drawings, blueprints, and specifications.

PERFORMANCE ACTIONS:

- 4.0101 Identify working drawings.
- 4.0102 Identify blueprints. Explain the relationship between blueprints and working drawings.
- 4.0103 Identify specifications.
- 4.0104 Read Specifications (orientation training).
(*As an integrated task during training, "Extract specific information from a prepared set of building specifications.")

PERFORMANCE STANDARDS:

- On a written knowledge test, identify with 70 percent accuracy a working drawing, blueprint, and specifications and the relationship between working drawings and blueprints.
- (Integrated task: Extract specific information with 100 percent accuracy from given residential construction specifications, meeting instructor's standards.)

SUGGESTED INSTRUCTION TIME: 6 Hours

RELATED TECHNICAL INFORMATION:

- Identify:

a. Plot plan	e. Right side elevation
b. Foundation plan	f. Rear elevation
c. Front elevation	g. Roof plan
d. Left side elevation	h. Auxiliary detail
- Identify sections.
- Introductory related training (Orientation) to zoning, building permits, building codes, and inspections.
- Working drawings: Orthographics, Pictorials, Sections.
- Interpret Alphabet of Lines.

UNIT 4.0

BLUEPRINT READING

TASK 4.02

INTERPRET COMMON BLUEPRINT SYMBOLS
USED IN RESIDENTIAL CONSTRUCTION

PERFORMANCE OBJECTIVE;

Given instruction concerning building symbols, a set of simple blueprints using the symbols, and an assignment to identify common symbols; recognize different building symbols typically used in residential construction. Meet instructor's standards in recognizing and interpreting symbols.

PERFORMANCE ACTIONS:

- 4.0201 Identify common building symbols used in residential construction:
- a. Types of lines
 - b. Wall openings
 - c. Common material symbols
 - d. Common electrical and lighting symbols
 - e. Common plumbing symbols
 - f. Common heating symbols
- 4.0202 Interpret symbols used in simple residential construction blueprint (symbols that apprentice carpenter at entry level should be prepared to identify to meet minimum standard of industry.
- 4.0203 Identify commonly used abbreviations in building construction drawings. (Familiarization)

PERFORMANCE STANDARDS:

- Interpret common building symbols used in residential construction to the standards of the instructor. Identify commonly used abbreviations used in building construction drawings.

SUGGESTED INSTRUCTION TIME: 6 Hours

RELATED TECHNICAL INFORMATION:

- American Institute for Architects (AIA) building symbols.
- American standard plumbing symbols.

UNIT	4.0	BLUEPRINT READING
TASK	4.03	INTERPRET DIMENSIONS FROM BLUEPRINTS

PERFORMANCE OBJECTIVE:

Given instruction, Architect's Scale or drawing, blueprint representations, and an assignment to interpret the blueprint with 1/8 inch accuracy.

PERFORMANCE ACTIONS:

- 4.0301 Identify Architect's Scale and its use.
- 4.0302 Identify methods of dimensioning on blueprints.
- 4.0303 Interpret dimensions on blueprints and sketches.

PERFORMANCE STANDARDS:

- Interpret dimensions on blueprints and sketches within 1/8 inch.
- Meet instructor's standards.

SUGGESTED INSTRUCTION TIME: 3 Hours

RELATED TECHNICAL INFORMATION:

- Scales used on blueprints.
- Scaling drawings in residential construction.
- Measure scaled lines.

(NOTE: Task 4.0303 may be interpreted as including reading and interpreting structural details.)

UNIT	4.0	BLUEPRINT READING
TASK	4.04	READ BLUEPRINT AND SPECIFICATIONS AND ESTIMATE LUMBER MATERIALS

PERFORMANCE OBJECTIVE:

Given residential blueprints, a requirement to layout carpentry work from the blueprints and specify lumber material needed to complete the work. Accuracy of 1/8 inch in measuring is expected and final work must meet instructor's standards.

PERFORMANCE ACTIONS:

- 4.0401 From given residential blueprints, layout (chalk) carpentry work (walls, cabinets, etc.). Layout must meet dimensions measured by instructor (within 1/8 inch).
- 4.0402 From blueprints and specifications, specify the lumber required to complete the work.
- (NOTE: This action may be integrated with estimating. Estimating may be treated as a separate task or integrated with carpentry math.)
- 4.0403 "As an extenuation of this task," take the lumber specifications, determine how the lumber should be purchased, and obtain purchase estimated (from local suppliers or from information given by the instructor).

PERFORMANCE STANDARDS:

- Given blueprints and specification, determine the lumber requirements and estimate the cost of the material.

SUGGESTED INSTRUCTION TIME: 6 Hours

RELATED TECHNICAL INFORMATION:

- Reading blueprints.
- Reading specifications.
- Measuring.
- Layout (elementary chalk line).
- Building material suppliers.

(NOTE: Task 4.0101 may be interpreted as reading and interpreting Southern Building Code specifications cited in specifications. Also, read and interpret "notations" on plans.)

MULTIPLE CHOICE

1. The three basic drawings used in industry are:
 - a. foundations, plot, and elevation
 - b. elevations, sections, and scale
 - c. pictorial drawings, diagrams, and working drawings
 - d. surface drawings, cabinet, and oblique

2. The purpose of using abbreviations in blueprints is:
 - a. to save time and space
 - b. to reduce the chance of error
 - c. to assist the carpenter
 - d. to show the building elevations

3. A shop drawing contains:
 - a. a drawing of an object made by hand
 - b. a drawing which shows only the plumbing and heating layout of a structure
 - c. a drawing showing only the front elevation
 - d. detail drawings and information covering specific parts of a structure

4. A set of working drawings with the stamp A.I.A.:
 - a. has been prepared by an apprentice architect
 - b. has been prepared by a licensed architect
 - c. is the preliminary sketch of a building
 - d. includes only the foundation plan

5. A set of specifications contains:
 - a. all paint colors to be used
 - b. the specific directions for installing a piece of equipment
 - c. written instructions which explain the working drawings, and describes the quality material and equipment used in a building
 - d. the prices and quantity of material used in building

6. Standardized symbols are used in drawing to represent:
 - a. building information
 - b. the quality of material to be used
 - c. location of the building
 - d. dimensions of the building

MULTIPLE CHOICE (Con't.)

7. To find out what the lot and exterior of the building looks like:
- a. refer to the detail drawing
 - b. refer to the plot plan
 - c. refer to the cross section
 - d. refer to the elevation drawing
8. An isometric drawing shows:
- a. top and front of an object
 - b. three-dimensional effect
 - c. four sides of an object
 - d. lists all dimensions in metric measurements
9. A floor plan contains:
- a. the type of floor to be used
 - b. the elevation of the floor level
 - c. the room sizes and location of the openings
 - d. the type of doors to be used
10. The only requirement for constructing a building is:
- a. a complete set of working drawings
 - b. a complete set of tools
 - c. a complete floor plan
 - d. a detailed set of specifications

UNIT 4.0

BLUEPRINT READING

TASK 4.01

COMPLETION

1. The two scales commonly used for dimensions in working drawings are ___" = 1' and ___" = 1'. _____

2. _____ and _____ schedules are usually found with the floor plans. _____

3. A set of building plans usually shows _____ elevations. _____

4. Cutaways of parts of the building, such as walls, foundations, or fireplaces, are called _____ views. _____

UNIT 4.0
 TASK 4.02

BLUEPRINT READING

IDENTIFICATION

1. On the given drawing below match the proper terminology with the symbols identified. Select answers from list.

- | | |
|------------------------------------|---------------------|
| a. cutting plane line | m. firebrick |
| b. sectional line | n. toilet |
| c. fixed glass | o. recessed bathtub |
| d. double-hung windows | p. lavatory |
| e. door | q. single sink |
| f. double-action door | r. double sink |
| g. bi-fold doors | s. recessed light |
| h. according door | t. floor drain |
| i. sliding doors | u. refrigerator |
| j. two-units of double-hung window | v. range |
| k. double-unit casement | w. built in |
| l. common brick | x. partition window |

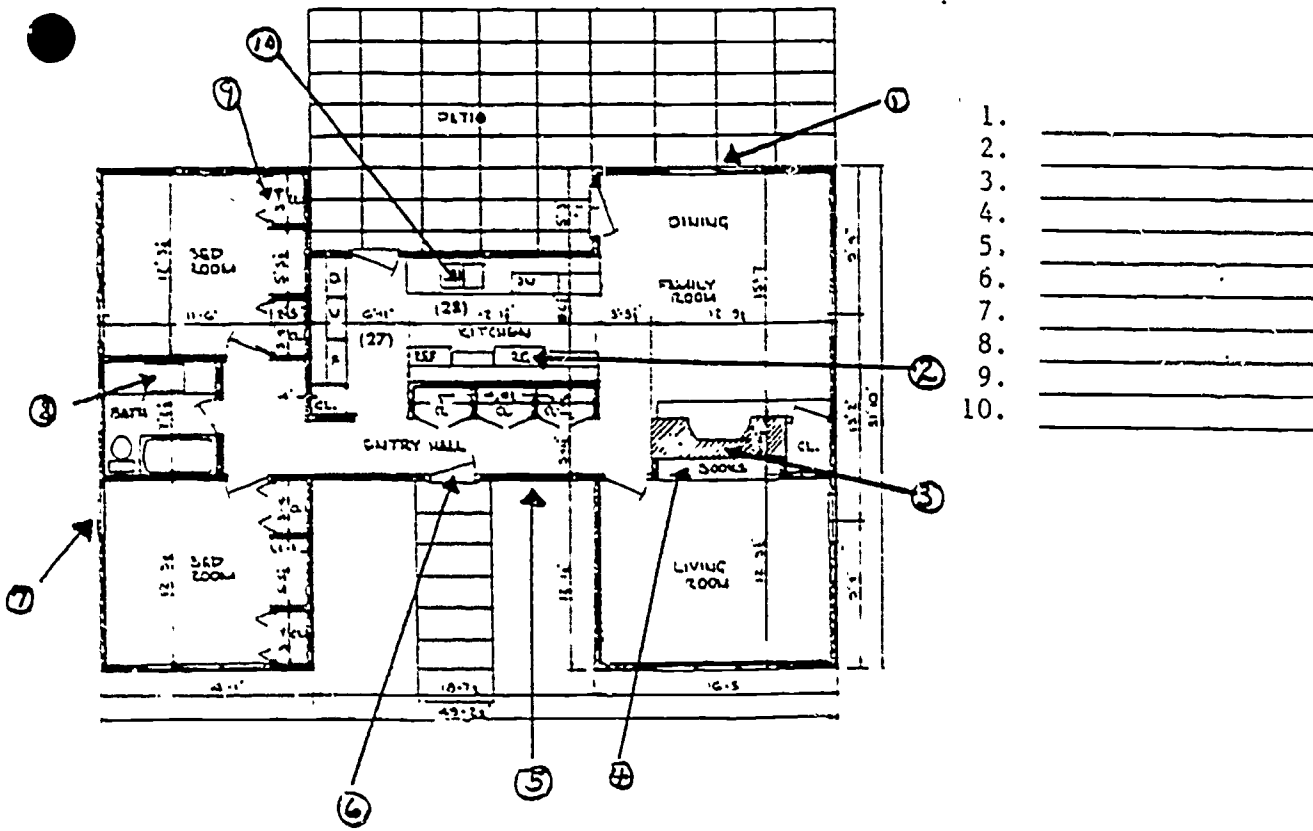

1. _____
2. _____
3. _____
4. _____
5. _____
6. _____
7. _____
8. _____
9. _____
10. _____

UNIT 4.0

BLUEPRINT READING

TASK 4.02

IDENTIFICATION (Con't.)

2. Identify the following lines.

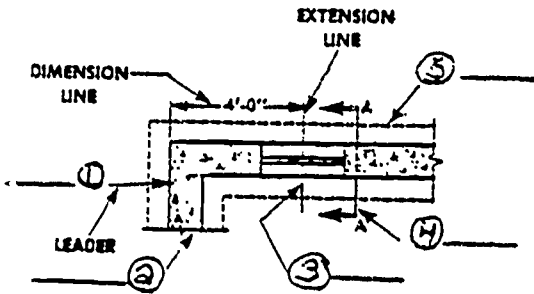

1. _____
2. _____
3. _____
4. _____
5. _____

UNIT 4.0
TASK 4.03

BLUEPRINT READING

MULTIPLE-CHOICE

1. A structure 48 feet by 32 feet when drawn at a scale of $1/4'' = 1'-0''$ would be drawn on a blueprint _____
- a. 8" x 6"
 - b. 12" x 8"
 - c. 16" x 12"
 - d. 9" x 12"
2. A plot 32 feet by 96 feet when drawn at a scale of $1/8'' = 1'-0''$ would be drawn on a blueprint _____
- a. 4" x 16"
 - b. 8" x 24"
 - c. 8" x 12"
 - d. 4" x 12"
3. A foundation wall 9 feet high when drawn at a scale of $3/4'' = 1'0''$ would be drawn on a blueprint _____
- a. 6 3/4"
 - b. 7 1/4"
 - c. 4 3/4"
 - d. 12"

COMPLETION

4. A 26 foot retaining wall on a plot plan when drawn at a scale of $1/16'' = 1'-0''$ would be drawn _____ inches long. _____
5. Six feet, six and one-half inches would be written _____ on a blueprint. _____

UNIT 5.0
CARPENTRY HAND TOOLS

Upon completing this unit on carpentry hand tools, the student should be able to demonstrate the proper use and care of given hand tools used in carpentry. The student should be able to identify common carpentry hand tools and describe their use.

UNIT 5.0

CARPENTRY HAND TOOLS

TASK 5.01

IDENTIFY AND DEMONSTRATE PROPER USE
OF CARPENTRY HAND TOOLS

PERFORMANCE OBJECTIVE:

Given proper instruction and a display of 20 common carpentry hand tools, identify and demonstrate proper use of a minimum of 10 different hand tools.

PERFORMANCE ACTIONS:

- 5.0101 Identify given common hand tools used in carpentry (building construction) and explain its use.
- 5.0102 Properly demonstrate use of given hand tools.
- 5.0103 Describe safety precautions in using the individual hand tools.
- 5.0104 Describe or demonstrate care of hand tools.

PERFORMANCE STANDARDS:

- Identify and demonstrate proper use and care of a minimum of 10 different given common carpentry hand tools.

SUGGESTED INSTRUCTION TIME: 30 Hours

RELATED TECHNICAL INFORMATION:

- Common hand tools:

- Steel rule
- Combination square
- Framing square
- Crosscut saw
- Rip saw
- Keyhole saw
- Hand plane
- Block plane
- Chisel
- Wood file
- Ladders
- Pliers, wrenches
- Wood rasp
- Brace
- Claw hammer
- C-clamp
- Bar-clamp
- Scrape
- Level (Carpenter's level)
- T-bevel
- Hack saw
- Plumb bob
- Screwdrivers

CHECKLIST

SUGGESTED MINIMUM TASKS FOR GIVEN HAND TOOLS

		S	U
Straight rule	Make simple linear measurements.		
Folding rule (Zig-zag rule)	Make linear measurements less than 2 inches, greater than 2 inches, and make inside measurements.		
Flexible tape Rule, Steel rule	Measure irregular shapes. Make longer linear measurements.		
Try Square	Test surface for levelness. Check surface for squareness. Make lines across face or edge of stock.		
Combination square	Test a level or plumb surface. Check squareness. Mark and test a 45-degree miter. Mark a line with a pencil.		
Framing or Rafter square	Check for squareness. Mark a line across a board. Layout rafters and stairs.		
Carpenter's level	Check whether a surface is level or plumb.		
Plumb bob and line	Establish a vertical line.		
Back saw	Make fine cuts for joinery. Miter box use.		
Crosscut saw	Cut across grain.		
Rip saw	Cut with the grain.		
Keyhole saw	Cut small openings or fine work.		
Coping saw	Cut curves. Shape ends of molding for joints. Cut scroll work.		
Miter box saw	Used in miter box, cut miters or square ends.		
Block plane	Plane end grain. Plane ends of molding, trim, and siding.		
Jointer plane	Plane edges of doors or long boards.		
Brace and bits	Auger bit: Bore holes to specified size and depth.		
Hack saw	Cut metal fasteners, hardware, and metal parts.		
Cold chisel	Cut off a nail.		

S = Satisfactory
U = Unsatisfactory

All cuts, depths of holes, and measurements or angles, etc., must be made to instructor's standard or standards for entry level employment in industry. Demonstrate safe use and care of hand tools.

USE OF THE CLAW HAMMER

Given a 20 ounce, curved or straight claw hammer, stock, and appropriate nails; demonstrate the proper use of the hammer for driving nails and for pulling a nail.

1. Inspect to ensure that the handle of the hammer is sound. The handle should be securely attached to the head.
2. The hammer (head) face should be clean, not damaged, mushroomed and burrs should be ground off.

A. DRIVING WITH THE HAMMER

3. Attention should be focused on the work.
4. Select an appropriate nail for the stock to be joined.
5. Grasp the hammer firmly and using a light blow, set the nail and "determine the aim." Strike the nail squarely.

(NOTE: Do not use the nail hammer to strike a hardened steel surface such as a cold chisel; use a ball peen hammer. To drive masonry nails or hardened steel-cut nails, use a heavy hammer with a large striking face (not a nail hammer!).

6. Use a nail set to drive nails below the surface of all fine work.

B. PULLING NAILS WITH THE HAMMER

7. To draw a nail, slip the claw under the nail head and pull until the handle is nearly vertical and the nail partly drawn.
8. To continue the pull, without exerting unnecessary force that will bend the nail, mar the wood, or even break the hammer handle. Use a piece of stock under the head of the hammer to increase leverage and continue pulling the nail.

(NOTE: Pull spikes using a wrecking bar.)

9. Clean and store the hammer properly when the work is completed.

USE OF THE RIP AND CROSSCUT HAND SAW

Given stock to saw, rip and crosscut handsaws, and necessary sawhorses or tables; demonstrate the proper use of the handsaw for cutting.

1. Identify which saw will be needed to make the required cut on the stock.
 - a. Crosscut saw, 8 point (10-11 point for finished stock).
 - b. Ripsaw, 7-8 point (10-11 point for finished stock).
2. Inspect to be sure the saw blade is sharp and set properly.
3.
 - a. Make sure the material being cut is free from nails and other obstructions.
 - b. Draw a pencil line to indicate the cut.
4. Start the cut by drawing the saw backward. Saw steadily with the thumb held high on the blade. Allow the saw to make the cut... avoiding hacking at the wood.
 - a. When making a cross cut, use an angle of about 45 degrees between the saw teeth side of the blade and the stock.
 - b. When making a rip cut, the best angle is about 60 degrees.
5.
 - a. If the saw leaves the line of cut, twist the handle and draw the saw back to the line.
 - b. If the blade is not square to the stock, bend it a little and gradually straighten it, avoiding damage to the blade.
6. After the job is completed, wipe a thin film of oil on the blade to prevent rust. Store the saw properly to protect the teeth.

UNIT	5.0	CARPENTRY HAND TOOLS
TASK	5.02	READ AND MEASURE WITH RULES AND SQUARES

PERFORMANCE OBJECTIVE:

Given a rule, square, and stock; measure and record the dimensions of the three different sizes of stock to the nearest 1/16 inch and draw four lines to predetermined length (+/- 1/16 inch).

PERFORMANCE ACTIONS:

- 5.0201 Describe operation of rules, tapes, and squares used for linear measurement.
- 5.0202 Identify basic tools used by the carpenter in measuring.
- 5.0203 Read a rule to the nearest 1/16 inch.
 - a. Measure objects to nearest 1/16 inch.
 - b. Draw lines and objects to specified dimensions (1/16 inch accuracy).
- 5.0204 Demonstrate marking stock, using a framing square.
- 5.0205 (Possible additional task): Interpret dimensions from blueprints or drawings and measure and mark wood material.

PERFORMANCE STANDARDS:

- With rule or square, measure objects to nearest 1/16 inch and draw lines and objects to specified dimensions with 1/16 inch accuracy, meeting instructor's standards.
- Score 80 percent on written knowledge tests which will include reading and measuring drawn figures.

SUGGESTED INSTRUCTION TIME: 15 Hours

RELATED TECHNICAL INFORMATION:

- Measuring devices:
 - Straight rule
 - Folding rule
 - Tape rule
 - Measuring tape or steel tape
 - Try square or combination square
 - Framing square

115

UNIT	5.0	CARPENTRY HAND TOOLS
TASK	5.02	READ AND MEASURE WITH RULES AND SQUARES (Con't.)

RELATED MEASURING DEVICES:

- Dividers
- Calipers
- Trammel points
- Sliding T-bevel
- Marking gage
- Butt gage

UNIT	5.0	CARPENTRY HAND TOOLS
TASK	5.03	CHECK WHETHER A SURFACE IS LEVEL OR PLUMB

PERFORMANCE OBJECTIVE:

Using a level*, chalk line, proper instruction, and a project; check whether a surface is level or plumb. Findings must agree with instructor's findings.

PERFORMANCE ACTIONS:

- 5.0301 Given a chalk line, properly mark a surface with a straight line.
- 5.0302 Given a level, determine whether given surfaces are:
 - a. level
 - b. plumb

PERFORMANCE STANDARDS:

- Mark a chalk line properly, determine whether given surfaces are level and plumb with the level. Performance must be the instructor's standards.

SUGGESTED INSTRUCTION TIME: 4 Hours

RELATED TECHNICAL INFORMATION:

- (orientation) Plumb a corner with the plumb bob.
- Chalk line.
- Line level.
- Carpenters level (Spirit level).

*Level refers to carpenter's level, spirit level, aluminum level, etc., generally a 2 or 4 foot level.

MULTIPLE CHOICE

1. The most common carpenter's hammer is: _____
 - a. ripping claw
 - b. curved claw
 - c. ball peen
 - d. soft face

2. All finish nails should be set below the surface: _____
 - a. 1/32 inch
 - b. 1/4 inch
 - c. 1/16 inch
 - d. half-way through board

3. A 2-D nail is: _____
 - a. 1 inch long
 - b. 6 inches long
 - c. 2 inches long
 - d. 3 inches long

4. The tools most commonly used to check vertical and horizontal planes is called: _____
 - a. framing square
 - b. tri-square
 - c. spirit level
 - d. chalk line

5. A surface on a perfect vertical plane is said to be: _____
 - a. level
 - b. square
 - c. straight
 - d. plumb

6. Each inch on the carpenter's rule is divided into: _____
 - a. 1/32
 - b. 1/12
 - c. 1/16
 - d. 1/8

7. The square used to transfer any angle from one piece to another is the: _____
 - a. T-bevel
 - b. Tri-square
 - c. combination square
 - d. framing square

MULTIPLE CHOICE (Con't.)

8. When using a smoothing plane one should cut: _____
- a. across the grain
 - b. against the grain
 - c. up the grain
 - d. with the grain
9. The jointer plane is used to cut off the: _____
- a. low spots first
 - b. ends first
 - c. sides first
 - d. high spots first
10. When a plane is not in use the blade should be: _____
- a. removed
 - b. retracted
 - c. replaced
 - d. reversed
11. Two pieces of stock cut at 45 degree angles and joined together form a: _____
- a. butt joint
 - b. lap joint
 - c. coped joint
 - d. miter joint
12. The miter saw is used to cut: _____
- a. only 45 degree angles
 - b. only 90 degree angles
 - c. any angle
 - d. only 180 degree angles
13. The keyhole or compass saw is used for cutting: _____
- a. long miter cuts
 - b. long bevel cuts
 - c. accurate square cuts
 - d. irregular or close cuts
14. The coping saw is used for cutting: _____
- a. accurate straight cuts
 - b. molding
 - c. 3/4 inch plywood
 - d. miter cuts

MULTIPLE CHOICE (Con't.)

15. To avoid splintering on the backside of stock when boring with a brace and bit:
- a. slow down boring process
 - b. speed up boring process
 - c. remove bit and cut with knife or chisel
 - d. when point protrudes through backside, remove and bore from backside

READING AN INCH SCALE

1. Write the correct readings in the circles above the rulers.
Each small subdivision is 1/16 inch.

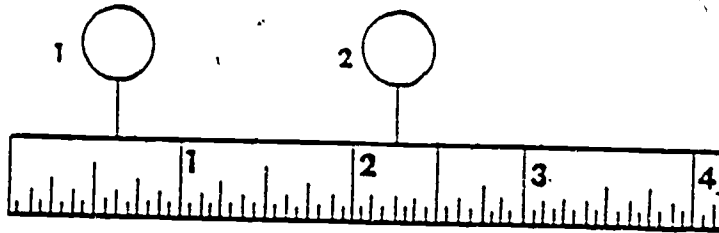

INCH SCALE READS LEFT TO RIGHT

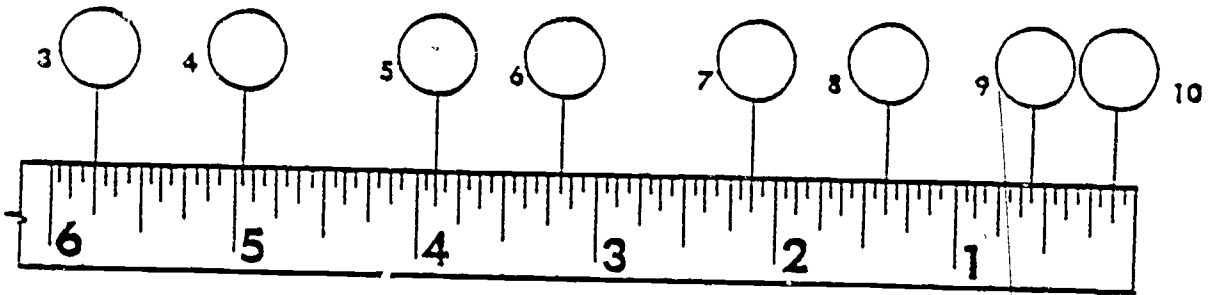

INCH SCALE READS RIGHT TO LEFT

1. _____
2. _____
3. _____
4. _____
5. _____

6. _____
7. _____
8. _____
9. _____
10. _____

2.

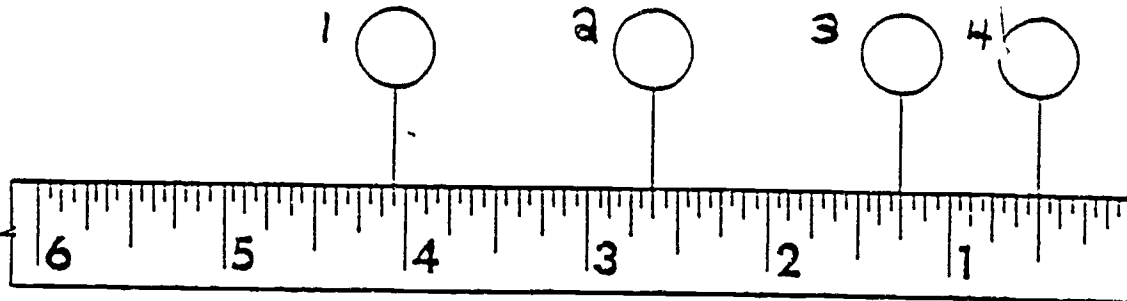

1. _____
2. _____

3. _____
4. _____

UNIT 5.0

IDENTIFY AND DEMONSTRATE PROPER
USE OF CARPENTRY HAND TOOLS

TASK 5.01

Tool Identification

MATCHING:

- a. Bench Rule
- b. Combination Rule
- c. Zigzag Rule
- d. Framing Square
- e. Carpenter's Square
- f. Combination Square
- g. T-Bevel
- n. Try Square
- i. Compass Saw
- j. Crosscut Saw
- k. Ripsaw
- l. Backsaw
- m. Keyhole Saw
- n. Dovetail Saw
- o. Router Plane
- p. Jointer Plane
- q. Smooth Plane

1. _____

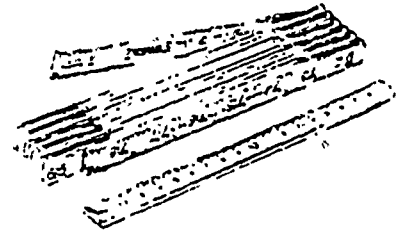

2. _____

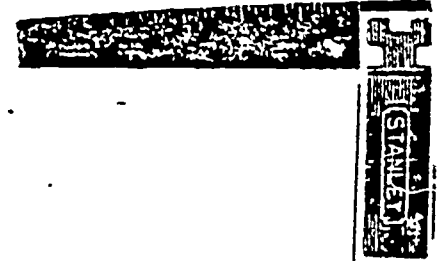

3. _____



4. _____

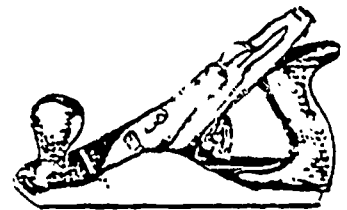

5. _____

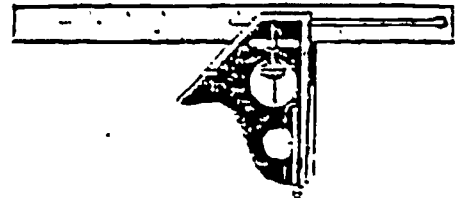

UNIT 6.0

FASTENERS, FINISHING, HARDWARE

Upon completing this task, the student will be able to identify common types of fasteners used in general carpentry work including glue, nails, staples, screws, and bolts and will be able to select the most appropriate method or methods of fastening stock and demonstrate the correct procedures of fastening and finishing.

Cabinet hardware may be included in this section or may be featured in the unit concerning cabinetmaking.

UNIT 6.0

FASTENERS

TASK 6.01

FASTEN STOCK USING GLUE, NAILS,
STAPLES, SCREWS, AND BOLTS

PERFORMANCE OBJECTIVE:

Given instructions, specifications, pre-cut wood stock; fasten the wood (using wood glue and clamps, nails, staples, screws, and bolts) by the following procedures and meeting instructor's standards.

SUB-OBJECTIVES AND PERFORMANCE ACTIONS:

1. FASTEN STOCK WITH WOOD GLUE

Using clamps, wood glue, and the necessary tools, equipment, and materials; fasten stock so it is free of excess glue and all joints form 90-degree angles that fit securely with no visual openings or gaps between the stock.

- (a) Identify appropriate types of natural and synthetic wood glue.
- (b) Identify the following types of clamps: parallel, bar, C-clamp, edging, spring, band, and miter clamps.
- (c) Explain why moisture content of wood is important in gluing.
- (d) Explain the importance of allowing glued stock to cure.

2. FASTEN STOCK WITH NAILS

Using a selection of nails and braids, and the necessary tools and materials fasten stock so the nails or braids are countersunk with no hammer marks on the stock, and the stock fits securely.

- (a) Identify the following kind of nails: common, box, finishing, braids, tacks, masonry, and T-nail.
- (b) Explain the method used for nailing in hardwood or close to an edge.
- (c) Demonstrate the use of a hammer.
- (d) Demonstrate the use of a power nailer.
- (e) Describe the procedure for fastening stock with nails.

3. FASTEN STOCK WITH STAPLES

Using a pneumatic or manual stapler, staples, and the necessary tools and materials; fasten stock so all staples are countersunk with no tool marks on the stock and the stock must fit securely.

UNIT	6.0	FASTENERS
TASK	6.01	FASTEN STOCK USING GLUE, NAILS, STAPLES, SCREWS, AND BOLTS (Con't.)

SUB-OBJECTIVES AND PERFORMANCE ACTIONS (Con't.):

- (a) Demonstrate procedure for loading a stapler.
- (b) Demonstrate use of a pneumatic or manual stapler.
- (c) Demonstrate procedure for fastening stock with staples.

4. FASTEN STOCK WITH SCREWS

Given a selection of screwdrivers, and electric or pneumatic drill with driving attachments, screws and specialized screw-type fasteners, and the necessary tools and materials; fasten stock with screws within +/- 1/16 inch of specifications and countersunk without splitting the wood. The stock must fit with no visual openings or gaps between the stock.

- (a) Explain why sheet metal screws are recommended for fastening hardboard and particleboard.
- (b) Explain why pre-drilling is done when fastening with screws.
- (c) Identify screws by type and length.
- (d) Explain why a stop is often used on a drill for pre-drilling.
- (e) Describe the procedures for fastening stock with screws.
- (f) Identify uses for specialized screw-type fasteners such as T-nut and tight joint fasteners.

5. FASTEN STOCK WITH BOLTS

Given an assortment of wrenches, bolts, nuts, lags and washers, and the necessary tools and materials; fasten the stock with bolts so the bolts or lags are within +/- 1/16 inch of specifications, without splitting or damaging the wood. The stock must fit securely with no visual openings or gaps between the stock.

- (a) Explain the purpose of washers when fastening stock with bolts.
- (b) Identify applications of bolts and lags.
- (c) Demonstrate the procedure for fastening stock with bolts.

UNIT 6.0

FASTENERS

TASK 6.01

FASTEN STOCK USING GLUE, NAILS,
STAPLES, SCREWS, AND BOLTS (Con't.)

PERFORMANCE STANDARDS:

- +/- 1/16 inch measuring accuracy with stock joints and fastener holes, etc.
- Stock must be fastened securely.
- No visual openings or gaps between stock.
- No wood splitting, tool marks on stock, and fasteners must be properly countersunk, as appropriate.
- Fastened stock must be to specifications.
- Procedures and fastening must meet instructor's standards.

SUGGESTED INSTRUCTION TIME: 15 Hours*

* Skill development during full two years of training.

RELATED TECHNICAL INFORMATION:

- Measuring.
- Use of hand or hand power tools.
- Identification of types of woods.
- Relevant safety precautions.

UNIT	6.0	FASTENERS
TASK	6.02	INSTALL WOOD PLUGS IN PREPARED HOLES

PERFORMANCE OBJECTIVE:

Given wood stock with screw holes prepared for wood plugs, a selection of wood plugs, wood glue, and the necessary tools and materials; install wood plugs in prepared holes. The plugs must be the correct type, kind, and size for the hole, glued securely, and free of excess glue.

PERFORMANCE ACTIONS:

- 6.0201 Determine the size and depth of various screw holes.
- 6.0202 Identify types of plugs and wood glues.
- 6.0203 Describe gluing techniques.
- 6.0204 Explain how a plug is installed.
- 6.0205 Identify tools used to install wood plugs.
- 6.0206 Describe the procedure for installing a wood plug.

PERFORMANCE STANDARDS:

- Install wood plug in prepared holes so the plug is glued securely and free of excess glue.
- The plug must match the wood material and be the proper size.

SUGGESTED INSTRUCTION TIME: 3 Hours

RELATED TECHNICAL INFORMATION:

- Relevant safety precautions.

UNIT	6.0	FINISHING
TASK	6.03	FILL AND FINISH NAIL AND SCREW HOLES

PERFORMANCE OBJECTIVE:

Given wood stock with nails and screws set and recessed at least 1/8 inch below surface, and the necessary tools and materials; fill and finish the nail and screw holes so that the filler projects above the surface and then is finished flush with the surface and is free of voids or low spots.

PERFORMANCE ACTIONS:

- 6.0301 Explain why nails and screw holes should be cleaned before filling.
- 6.0302 Explain why depth of a hole is important to a good bond and a smooth finish.
- 6.0303 Demonstrate selection, preparation, and application of wood filler.
- 6.0304 Determine drying time for various sizes of holes and types of fillers.
- 6.0305 Demonstrate the procedure for installing sandpaper on a finish sander.
- 6.0306 Demonstrate the use of a portable finish sander.

PERFORMANCE STANDARDS:

- Fill and finish nail and screw holes so that the filler projects above the surface and then is finished flush with the surface and is free of voids or low spots.
- Completed project should meet standards of industry and instructor's standards.

SUGGESTED INSTRUCTION TIME: 6 Hours

RELATED TECHNICAL INFORMATION:

- Relevant safety precautions.
- Types of filler.

UNIT	6.0	FINISHING
TASK	6.04	SAND SURFACES FOR FINISHING

PERFORMANCE OBJECTIVE:

Given wood stock or casework ready for finish sanding, an assortment of sandpaper, finish sander, and the necessary tools and materials; sand the surfaces for finishing. All surfaces must be smooth with no cross grain sanding marks or scratches. Edges must be eased, and all surfaces and edges must be free of loose particles.

PERFORMANCE ACTIONS:

- 6.0401 Identify grit sizes of sandpaper required for various materials and finishes.
- 6.0402 Demonstrate hand and power sanding techniques.
- 6.0403 Describe the procedures for sanding surfaces in preparation for finishing.
- 6.0404 Identify and describe the use of cleaning materials.
- 6.0405 Explain the relevant safety precautions.

PERFORMANCE STANDARDS:

- Sand surfaces for finishing so that the surfaces are smooth with no cross grain sanding marks or scratches, edges eased, and all surfaces and edges free of loose particles.

SUGGESTED INSTRUCTION TIME: 3 Hours

TRUE/FALSE

1. Clamping is usually used in gluing operations. _____
2. Cabinet work and molding joints should be glued. _____
3. Contact cement is used to apply cabinet tops to wood base. _____
4. Gluing is a highly technical procedure and the kind of glue, temperature, materials to be glued, and the characteristics of the glue must be considered before gluing. _____
5. There are only a very few kinds of nails available. _____
6. The letter "d" is used as a symbol for the penny system of nail size. _____
7. Staples are sometimes used for installing insulation, roof sheathing, and building kitchen cabinets. _____
8. Common screws have flat, oval, or round heads. _____
9. Screw sizes are also based on the penny system. _____
10. In selecting a screw about 2/3 of the screw should go into the second member. _____
11. Brass screws are always used with oak. _____
12. The depth of the average plug over a screw should be about 3/8" deep. _____
13. The grain of the plug should match the grain of the wood. _____
14. All nail holes, screw holes, and dents must be filled and sanded before applying final finish. _____
15. Sanding should be done with the grain. _____
16. Sanding for a natural or transparent finish should be with the grain and use a fine sandpaper, such as garnet 6/0 or 7/0. _____

UNIT 7.0

PORTABLE POWER TOOLS

Upon successfully completing the tasks in this unit, carpentry students will be qualified: (a) to identify common power hand tools used in carpentry work, (b) to select the appropriate power tool for a given task, and (c) demonstrate proper use of, care of, and safety precautions used with the power tool to accomplish given jobs.

- Portable Hand Drill
- Circular, Sabre, and Reciprocating Saws
- Portable Router
- Portable Plane
- Belt Sander, Finishing Sander

UNIT	7.0	PORTABLE POWER TOOLS
TASK	7.01	DRILL OR BORE HOLES WITH PORTABLE ELECTRIC HAND DRILL

PERFORMANCE OBJECTIVE:

Given a portable hand drill, a complete set of power bits 1/4 inch through 1 1/8 inch, a five-dimensioned layout showing the specific location and size of a series of five holes, and wood stock; layout, mark and bore the holes. The holes must match the layout, with locations accurate, holes square to the surface, and the back of the stock free of splinters.

PERFORMANCE ACTIONS:

- 7.0101 Determine location of holes from job sheet.
- 7.0102 Mark location of each hole on stock.
- 7.0103 Clamp stock to horizontal surface.
- 7.0104 Select correct size drill bit.
- 7.0105 Install drill bit in chuck. Use depth stop, if appropriate.
- 7.0106 Start perpendicular hole with nutset or punch.
- 7.0107 Drill holes to correct angle and depth.
(NOTE: Avoid splintering by placing a waste piece of stock beneath the piece being bored.)

PERFORMANCE STANDARDS:

- Layout, mark, and bore holes in given stock, using portable hand drill, power bits, and specifications provided so that hole sizes are to specifications, locations are accurate, holes are square to the surface, and the back of the stock is free of splinters.
- Hole must be drilled perpendicular to face of stock.

SUGGESTED INSTRUCTION TIME: 6 Hours

*Layout (hole sizes and dimensions) accompanies task description.

UNIT	7.0	PORTABLE POWER TOOLS
TASK	7.02	CUT STOCK WITH PORTABLE ELECTRIC SAWS (CIRCULAR, SABRE, AND RECIPROCATING)

PERFORMANCE OBJECTIVE:

Given stock to cut, sawhorses, helper, specifications concerning the desired cut, and a portable electric saw (or saws); make the desired cut(s) according to specifications with the cut 90 degrees to the surface of the stock (unless a bevel cut is required) and on the waste side of the line.

PERFORMANCE ACTIONS:

PORTABLE CIRCULAR SAW

1. Rip stock with portable circular saw.
 - a. Check dimensions on specifications.
 - b. Place stock in horizontal position with sawhorses at appropriate locations.
 - c. Mark line of cut according to specifications.
 - d. Connect saw to electrical source, using proper extension cord and safety practices.
 - e. Put on safety glasses.
 - f. Adjust saw for proper cut.
 - g. Turn saw on and cut stock on waste side of line.
 - h. Turn saw off and hold saw until blade stops its motion.
 - i. Check work.

PORTABLE SABRE SAW

1. Make straight and irregular cuts following the above steps.
2. Make plunge or internal cuts with the sabre saw.
 - a. Mark area of cut.
 - b. Select convenient starting place inside waste stock.
 - c. Tip saw forward with shoe resting on surface of stock and top of blade clearing surface.
 - d. Start saw. Allow saw to reach full speed. Slowly lower back of saw until the blade cuts through the material to the desired depth. Next, cut the opening to specifications.
3. Make bevel cut with portable sabre saw. Follow previous steps with straight cut, adjusting bevel cut as desired.

UNIT	7.0	PORTABLE POWER TOOLS
TASK	7.02	CUT STOCK WITH PORTABLE ELECTRIC SAWS (CIRCULAR, SABRE, AND RECIPROCATING) (Con't.)

PERFORMANCE ACTIONS (Con't.):

4. Make circle cuts.
 - a. Follow above steps, adjusting guide and setting it into position for the radius desired. Secure the guide with a nail.
 - b. Make a pocket cut or drill a pilot hole.
 - c. Make circle cut allowing the saw to do the cutting following the guide.

RECIPROCATING SAW

1. Make plunge cut with the reciprocating saw.

PERFORMANCE STANDARDS:

- Using the portable electric saw provided or required, cut stock to given specifications so the cut is 90 degrees (unless bevel cut) to the surface and is on the waste side of the line.
- Cuts must be free of splinters, top and bottom.

SUGGESTED INSTRUCTION TIME: 12 Hours

RELATED TECHNICAL INFORMATION:

- Follow appropriate safety steps when handling electric power saws.
- Properly adjust power saws for the cut desired.
- Measurement and layout.

UNIT 7.0

PORTABLE POWER TOOLS

TASK 7.03

ROUT IRREGULAR EDGES WITH PORTABLE
ROUTER

PERFORMANCE OBJECTIVE:

Given a piece of stock or project with curved or irregular edges to be routed, a portable electric router, assorted router bits, wrenches, and other necessary tools, specifications concerning the finished product; rout edges of the stock according to instructions. The finished product must be fully shaped with no run-off, smooth with no torn grain or burn marks, and must meet specifications.

PERFORMANCE ACTIONS:

- 7.0301 Check details for required profile.
- 7.0302 Select proper bit and check its condition.
- 7.0303 Place in router chuck and fasten securely with wrench or appropriate tool.
- 7.0304 Check electrical cord and attach extension cord as necessary.
- 7.0305 Put on safety glasses.
- 7.0306 Secure work and place router in position.
- 7.0307 Turn on motor and advance router into stock at moderate speed.
- 7.0308 Use firm steady feed until routing is complete.
- 7.0309 Turn off switch and hold until router motor stops turning.
- 7.0310 Check work for quality of cut and repeat operation if necessary.
- 7.0311 Sand edges smooth without losing molding detail.

PERFORMANCE STANDARDS:

- Rout edges of given stock with the portable router so that the edges are fully shaped with no run-off, are smooth with no torn grain or burn marks, and meet specifications.

SUGGESTED INSTRUCTION TIME: 10 Hours

135

UNIT	7.0	PORTABLE POWER TOOLS
TASK	7.04	PLANE STOCK WITH PORTABLE ELECTRIC PLANE

PERFORMANCE OBJECTIVE:

Given a power hand plane, stock, and stock specifications; plane stock with power hand plane to specifications. The finished stock must be planed with the grain, be straight and true, and cut at the prescribed angle.

PERFORMANCE ACTIONS:

7.0401 Secure stock.

7.0402 Adjust plane:

- a. Set cutter at zero setting depth of cut.
- b. Set desired depth of cut by rating depth-adjustment lever.

7.0403 Plane stock to specifications.

(Optional Task Expansion)

Use Power Block Plane to bevel edges of laminates, plane, or cut stock to specifications. Task actions are similar to above.

PERFORMANCE STANDARDS:

- Using the portable hand plane, plane given stock to specifications and so that the finished stock is straight and true, planed with the grain, and is cut at the prescribed angle.

SUGGESTED INSTRUCTION TIME: 6 Hours (May be orientation task.)

UNIT	7.0	PORTABLE POWER TOOLS
TASK	7.05	SAND SURFACES AND EDGES WITH BELT SANDER AND FINISHING SANDER

PERFORMANCE OBJECTIVE:

Given stock, belt sander, and assortment of belts; sand the surface and edges of stock so that the finished stock has a smooth surface, is to the predetermined size and shape, is free of cross grain scratches, and does not contain burn marks.

PERFORMANCE ACTIONS:

BELT SANDER

1. Secure work in horizontal position.
2. Select appropriate belt sander for specific job.
3. Select appropriate abrasive belt for sanding job.
4. Sand work to requirements.

FINISHING SANDER

1. Secure and position work for sanding.
2. Select appropriate abrasive sheet and attached sandpaper to sander.
3. Select appropriate movement of sanding machine, if applicable.
(NOTE: Straight-line action is least likely to cause cross grain scratches.)
 - a. orbital
 - b. straightline
 - c. multi-motion

PERFORMANCE STANDARDS:

- Sand the surface and edges of given stock so that the finished product is to the predetermined size and shape, has a smooth surface, is free of cross grain scratches, and does not contain burn marks.

SUGGESTED INSTRUCTION TIME: 6 Hours

137

UNIT	7.0	PORTABLE POWER TOOLS
TASK	7.05	SAND SURFACES AND EDGES WITH BELT SANDER AND FINISHING SANDER (Con't.)

RELATED TECHNICAL INFORMATION:

- Abrasive sandpaper: Selection.
- Installation of sandpaper on sander: Varies according to machine.
- Safety precautions applicable to sanding.

~~ADDITIONAL HAND POWER TOOLS~~

THAT MAY BE INCLUDED IN TRAINING AS AVAILABLE/APPLICABLE

- Power Nailer
- Motorized Miter Box

MULTIPLE CHOICE

1. The size of a circular saw is determined by: _____
 - a. its horsepower
 - b. weight
 - c. size of arbor hole
 - d. diameter of blade

2. The type of circular saw blade that lasts longer is: _____
 - a. rip blade
 - b. crosscut blade
 - c. plywood blade
 - d. carbon tip

3. When cutting with portable circular saw: _____
 - a. turn stock face down
 - b. turn stock face up
 - c. cut with grain
 - d. cut across grain

4. When cutting with portable circular saw, always cut on the: _____
 - a. right side of line
 - b. left side of line
 - c. waste side of line
 - d. center of line

5. To determine the depth of cut on a portable power plane: _____
 - a. adjust rear shoe
 - b. adjust fence
 - c. adjust front shoe
 - d. adjust handle

6. The portable power plane can be used to make square cuts and also: _____
 - a. round cuts
 - b. mortise cuts
 - c. irregular cuts
 - d. bevel cuts

7. The portable router is used to cut irregular shapes and: _____
 - a. contours
 - b. smooth surfaces
 - c. crosscut sawing
 - d. boring large holes

MULTIPLE CHOICE (Con't.)

8. When cutting around circular pieces of stock with a portable router:
- a. counterclockwise direction
 - b. clockwise direction
 - c. fast
 - d. back and forth
9. When sanding stock with a portable belt sander, it will:
- a. stay still
 - b. pull backwards
 - c. pull forward
 - d. pull sideways
10. When sanding with a portable belt sander, move it:
- a. 1/2 belt with back stroke
 - b. width of belt each stroke
 - c. six inches each time
 - d. two strokes and move sideways

MATCHING

Identify the following portable power tools:

- a. Portable Drill
- b. Belt Sander
- c. Finishing Sander
- d. Portable Router
- e. Portable Plane
- f. Circular Saw
- g. Reciprocating Saw
- h. Sabre Saw

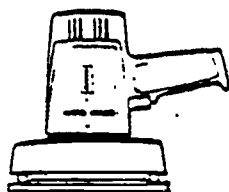

1. _____

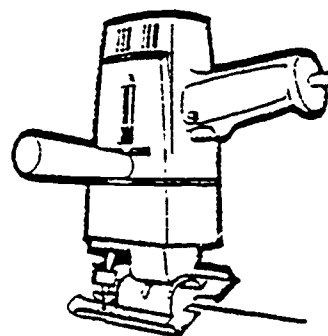

2. _____

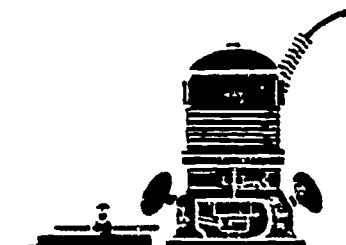

3. _____

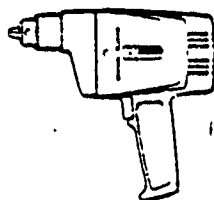

4. _____

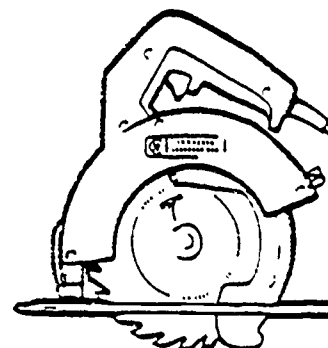

5. _____

UNIT 8.0

STATIONARY POWER TOOLS

Upon successfully completing the tasks in this unit, carpentry students will be qualified to identify common stationary power tools used in building construction work, be able to select the appropriate power tools for a given task, and demonstrate the proper use and care of given stationary power tools to accomplish given jobs.

Typical stationary power tools may include:

- Table Saw
- Radial Arm Saw
- Drill and Drill Press
- Jointer and Planer
- Band Saw
- Router and Shaper
- Belt Sander

The extent to which the student is introduced to stationary power tools used in carpentry work may depend on the degree to which the individual carpentry shop is equipped.

UNIT 8.0

STATIONARY POWER TOOLS

TASK 8.01

DEMONSTRATE USE OF TABLE SAW

PERFORMANCE OBJECTIVE:

Given operator's manual or instructions, a table saw and appropriate saw blades, dado head, rip fence, miter gauge or mitering jig, and the necessary tools, equipment, attachments, specifications and wood stock; perform the following tasks to demonstrate the use of the table saw:

SUB-OBJECTIVES AND PERFORMANCE ACTIONS:

1. CROSSCUT WITH THE TABLE SAW

Layout and crosscut with table saw to specified dimensions within 1/8 inch, with edges at a 90 degree angle to the face of the stock.

- a. Layout the crosscut on wood stock.
- b. Install crosscutting, hollow-ground, or combination blade.
- c. Set blade 1/8 inch above thickness of stock.
- d. Remove ripping fence.
- e. Set miter gauge to proper angle. (Use stop rod to help prevent stock from moving while cut is made.)
- f. Use support roller stand or helper for long pieces to cut.
- g. Turn on machine. Place board on table.
- h. Cut wood stock or plywood to specifications.
- i. Cut machine off after cut is made.

(NOTE: The actions of turning on the machine, using helper if required, using safety precautions, and turning off machine typically will be omitted from description.)

PERFORMANCE STANDARDS:

- Properly adjust saw blade (1/8 inch above stock thickness).

RELATED TECHNICAL INFORMATION:

- Table saw safety precautions and practices for crosscutting.
- Use helper or roller stand for long stock.
- Adjust blade to reduce splintering when sawing plywood.
- Explain functions of miter gauge or fence.

UNIT	8.0	STATIONARY POWER TOOLS
TASK	8.01	DEMONSTRATE USE OF TABLE SAW

SUB-OBJECTIVES AND PERFORMANCE ACTIONS (Con't.):

2. RIP CUT WITH TABLE SAW

Layout and rip cut stock to specified dimensions +/- 1/8 inch with edges at a 90 degree angle to the face of the stock.

- a. Layout stock for rip cut.
- b. Adjust fence and blade accordingly.
- c. Turn on machine. Place board on table. Feed stock into blade.
- d. Rip cut must be made to specifications.

PERFORMANCE STANDARDS:

- Rip cut stock to specifications with 1/8 inch, with edges at a 90 degree angle to the face of the stock.

RELATED TECHNICAL INFORMATION:

- Procedures for cutting wide and narrow stock.
- Explain functions of miter gauge or rip fence.

3. CUT A MITER WITH THE TABLE SAW

*Using mitering jig or miter gauge, miter stock to a 45 degree angle and to specified dimensions with 1/8 inch.

- a. Layout miter cut on wood stock.
- b. Adjust miter gauge as required.
- c. Make flat miter cut.
- d. Make miter cut on edge.
- e. Cuts must meet specifications.

PERFORMANCE STANDARDS:

- Make required miter cuts to specifications, at 45 degree angle or as specified by instructor, with 1/8 inch accuracy.

RELATED TECHNICAL INFORMATION:

- Flat and combination miter cuts.
- Adjustment of miter:
TO FIND CORRECT ANGLE FOR MITER CUT
- Divide 180 by number of sides
- Subtract that number from 90
- The result will be the number of degrees for each miter cut.

UNIT	8.0	STATIONARY POWER TOOLS
TASK	8.01	DEMONSTRATE USE OF TABLE SAW

RELATED TECHNICAL INFORMATION (Con't.):

- Example: $180 \div 5 = 36$
 $90 - 36 = 54$
 Make cuts at 54 degree angle
- Explain functions of miter gauge or mitering jig.
- Relevant safety precautions. Importance of using push blocks.

4. LAYOUT AND CUT A DADO WITH THE TABLE SAW

Layout and cut a dado so the stock is to specified dimension +/- 1/8 inch and at a 90 degree angle to the face.

- a. Identify difference between a dado, rabbet, and groove.
- b. Layout a dado on wood stock.
- c. Adjust miter gauge or fence.
- d. Adjust for proper dado thickness.
- e. Make dado cut to specifications.

PERFORMANCE STANDARDS:

- Make dado cut to specifications with 1/8 inch, at a 90 degree angle to the face.

RELATED TECHNICAL INFORMATION:

- Dado = groove cut against grain.
- Procedures for cutting a groove.

5. CUT A GROOVE WITH THE TABLE SAW

Using the dado head, rip fence, etc., layout and cut a groove so it is to specified dimensions +/- 1/8 inch.

- a. Layout groove cut on stock.
- b. Differentiate that the dado head is the safest and fastest method of cutting grooves. Alternate methods are making two or more cuts with a standard blade and using wobble washers.
- c. Observe dado blade: Two outside cutters with chippers between them.
- d. Adjust chippers for desired width. Adjust for proper positioning.
- e. Install proper throat plate.
- f. Adjust dado head and fence as required.
- g. Make cut.

UNIT 8.0

STATIONARY POWER TOOLS

TASK 8.01

DEMONSTRATE USE OF TABLE SAW (Con't.)

PERFORMANCE STANDARDS:

- Cut a groove with the table saw using a dado head with the final cut being to specifications +/- 1/8 inch.
- Methods of making groove cuts.

SUGGESTED INSTRUCTION TIME: 15 Hours

UNIT	8.0	STATIONARY POWER TOOLS
TASK	8.02	DEMONSTRATE USE OF RADIAL-ARM SAW

PERFORMANCE OBJECTIVE:

Given a radial-arm saw, saw blade, operator's manual, (mitering jig or miter gauge for miter cut), and necessary tools, equipment, and attachments, as well as wood stock and specifications...demonstrate use of radial-arm saw.

SUB-OBJECTIVES AND PERFORMANCE ACTIONS:

1. INSPECT AND CLEAN RADIAL-ARM SAW

Inspect and clean radial-arm saw (given cleaning fluid) according to manufacturer's specifications with the saw and surrounding area free of sawdust, scrap wood, and foreign material.

- a. Identify procedures for inspecting radial-arm saw.
- b. Interpret reasons for performing routine.
- c. Inspect and clean radial arm saw.

2. REMOVE AND REPLACE RADIAL-ARM SAW BLADES

Remove and replace the saw blade so that the blades are mechanically secure and set at a depth of cut 1/16 inch below the table surface and 90-degrees to the table surface. No damage must be caused to the saw guard, arbor, shaft, arbor nut, or blade.

- a. Identify conditions requiring replacement of a radial-arm saw blade.
- b. Identify high-speed steel and carbide tipped radial-arm saw blades.
- c. Identify on/off, cutting depth, and angle adjustment controls.
- d. Describe or demonstrate procedures for removing and replacing saw blades.

3. LAYOUT AND MAKE A CROSSCUT

Layout and make a crosscut so that the finish cut is to specified dimensions +/- 1/8 inch with edges at a 90-degree angle to the face of the stock.

- a. Layout crosscut on wood stock.
- b. Mount a crosscutting or combination saw blade on the arbot.
- c. Adjust the radial-arm to zero (right angle to guide fence) and set the motor so that the blade is a right angle to the table top. Lock radial-arm with the miter clamp handle.

UNIT 8.0

STATIONARY POWER TOOLS

TASK 8.02

DEMONSTRATE USE OF RADIAL-ARM SAW

SUB-OBJECTIVES AND PERFORMANCE ACTIONS (Con't.):

- d. Turn elevating handle down until the teeth are about 1/16 inch below the surface of the work table (blade should follow the saw kerf already cut in the table).
- e. Adjust anti-kickback fingers about 1/8 inch above wood surface.
- f. Position stock for cutting.
- g. Turn on machine and grasp motor yoke handle, and pull saw behind guide fence and turn motor off.

4. LAYOUT AND MAKE A RIP CUT

Layout and make a rip cut with the stock ripped to specified dimensions +/- 1/16 inch with edges at a 90 degree angle to the face of the stock.

- a. Explain why ripping is usually done on a table saw rather than a radial-arm saw.
- b. Explain actions of blade and stock during ripping.
- c. Layout a rip cut on wood stock.
- d. Identify inrip and outrip positions.
- a. Make rip cut.
 - (1) Mount proper blade.
 - (2) Pull entire motor carriage to front of arm.
 - (3) Pull up on locating pin above yoke.
 - (4) Rotate yoke 90 degrees clockwise until blade is parallel to guide fence. Motor should be "outboard" (away from column) so not to obstruct cutting. *Ripping wide panels may require rotating the yoke counterclockwise to place the motor "inboard" (toward the column) to increase ripping capacity.
 - (5) Move motor assembly along radial-arm until correct width is shown on rip scale. Tighten rip clamp (opposite of radial-arm from locating pin). Lower saw until blade just touches wood table.
 - (6) Adjust guard so that infeed end clears the work slightly (1/8 inch +/-). Adjust anti-kickback so that the points are 1/8 inch below surface of workbench.
 - (7) Turn on power. Make sure saw is rotating up-wards toward operator. Hold work against guide fence and feed it into the blade. (Never feed work from the anti-kickback end.) Use push stick to complete cut.

UNIT 8.0

STATIONARY POWER TOOLS

TASK 8.02

DEMONSTRATE USE OF RADIAL-ARM SAW

SUB-OBJECTIVES AND PERFORMANCE ACTIONS (Con't.):

5. LAYOUT AND CUT A MITER

Layout and cut a miter so that the stock is mitered to a 45-degree angle and to specified dimensions +/- 1/8 inch.

- a. Layout a miter cut on wood stock.
- b. Loosen miter clamp handle and lift miter latch.
- c. Make the cut as described in crosscutting. (Flat miter cut can be made by clamping or nailing a piece of stock on the table top at the required angle.)
- d. Swing arm to desired angle. Reclamp.

6. LAYOUT AND CUT A PLAIN DADO

Layout and cut a dado with the radial-arm saw so that stock is dadoed to specified dimensions +/- 1/8 inch at a 90 degree angle to the fence.

- a. Layout a dado on wood stock.
- b. Identify difference between dado, end rabbet, blind dado, and groove.
- c. Mount dado head on saw, adjusting blade for proper thickness.
- d. Make certain saw teeth next to table top are pointed back toward column, replace guard, and rotate dado head by hand to make sure it turns freely.
- e. Prior to making a plain dado cut, lower the blade until it touches the surface of a scrap stock the same thickness as the desired finish stock. Remove scrap.
- f. Make plain dado cut as in crosscutting.

7. LAYOUT AND CUT A GROOVE

- a. Layout groove on wood stock.
- b. Adjust table fence.
- c. Adjust radial-arm saw for groove cut. Lower guard on infeed side and adjust kickback assembly.
- d. Install dado head.
- e. Rotate motor unit counterclockwise as for ripping.
- f. Proceed as in ripping.
- g. Cut groove.

UNIT 8.0

STATIONARY POWER TOOLS

TASK 8.02

DEMONSTRATE USE OF RADIAL-ARM SAW
(Con't.)

PERFORMANCE STANDARDS:

- Demonstrate proper use of radial-arm saw (inspect, clean, change blades, crosscut, rip cut, miter cut, dado cut, and groove cut) following manufacturer's instructions, meeting instructor's standards, with relevant safety precautions emphasized, and meeting specifications with final cut.
- +/- 1/8 inch, 90-degree angle to fence or face of stock as applicable, or 45-degree miter angle as applicable.

SUGGESTED INSTRUCTION TIME: 15 Hours

RELATED TECHNICAL INFORMATION:

- Manufacturer's instruction manual.
- Instructor's requirements and standards concerning machine operation.
- Relevant safety precautions.

UNIT 8.0

STATIONARY POWER TOOLS

TASK 8.03

DEMONSTRATE USE OF DRILL/DRILL PRESS

PERFORMANCE OBJECTIVE:

Given operator's manuals or instructions, an electric drill or drill press, wood stock (if applicable), specifications, and the necessary tools and attachments; demonstrate the following uses of the drill/drill press.

SUB-OBJECTIVES AND PERFORMANCE ACTIONS:

1. INSPECT AND CLEAN A DRILL AND DRILL PRESS

Using cleaning fluid, inspect and clean a portable electric drill and drill press. The bench or pedestal mounted drill and drill press must be free of sawdust, scrap wood, and foreign material.

- a. Explain reasons for performing routine inspection and cleaning electric drills and drill presses.
- b. Describe the procedure for inspecting an electric drill or drill press.
- c. Identify materials and describe procedures for cleaning an electric drill/drill press.

2. DRILL AND BORE HOLES

Drill and bore holes in wood stocks so that the locations are within a tolerance of 1/64 inch for diameter, location, and depth. No damage is to be caused to the cutting tool and the stock will not be splintered or chipped.

- a. Explain why stock must be clamped securely to the drill press table.
- b. Explain how splintering and chipping of the stock can be prevented.
- c. Explain how to avoid damage to a drill bit.
- d. Describe the procedure for drilling and boring with a portable drill.
- e. Describe the procedure for drilling and boring with a drill press.

3. COUNTERBORE HOLES IN STOCK

Using necessary attachments, counterbore holes in wood stock so that the holes meet specified dimensions +/- 1/64 inch for location, diameter, and depth. No damage will be caused to the cutting tools and the stock will not be splintered or chipped.

UNIT 8.0

STATIONARY POWER TOOLS

TASK 8.03

DEMONSTRATE USE OF DRILL/DRILL PRESS

SUB-OBJECTIVES AND PERFORMANCE ACTIONS (Con't.):

- a. Repeat items a-c, above.
- b. Describe the procedures for counterboring (drilling and boring) with the:
 - (1) portable drill
 - (2) drill press

4. COUNTERSINK HOLES IN STOCK

Countersink holes in wood stock meeting specified dimensions within a tolerance of 1/64 inch for location, diameter, and depth. No damage is to be caused to the cutting tool and the stock will not be splintered or chipped.

- a. Explain the purpose of countersinking holes.
- b. Describe the procedure for countersinking a hole.

PERFORMANCE STANDARDS:

- Demonstrate proper use of electric drill/drill press (inspecting and cleaning, drill and bore holes in stock, counterbore holes, and countersink holes) following manufacturer's instructions, meeting instructor's standards, with relevant safety precautions observed, and meeting specifications to within 1/64 inch tolerance.

SUGGESTED INSTRUCTION TIME: 6 Hours

RELATED TECHNICAL INFORMATION:

- Relevant safety precautions.
- Selection of cutting bits.

UNIT 8.0

STATIONARY POWER TOOLS

TASK 8.04

DEMONSTRATE USE OF JOINTER

PERFORMANCE OBJECTIVE:

Given an operator's manual or instructions, the necessary tools, equipment, attachments, stock, and specifications; demonstrate the use of the jointer by the following performances.

SUB-OBJECTIVES AND PERFORMANCE ACTIONS:

1. INSPECT AND CLEAN A JOINTER

Using cleaning fluid, inspect and clean a jointer so it is free of sawdust, scrap wood, and foreign material.

- a. Identify the various uses of a jointer.
- b. Explain the reasons for performing routing inspection and cleaning of the jointer.
- c. Describe the procedure for inspecting a jointer.
- d. Identify materials and describe the procedures for cleaning a jointer.

2. FACE ROUGH STOCK

Face rough stock so that all warp is removed from the stock by using consecutive 1/16 inch cuts and no damage is caused to the jointer and so that the stock is smooth and free of nicks, splinters, and cuts.

- a. Describe the procedures for:
 - (1) adjusting the outfeed table
 - (2) adjusting for parallel planes
 - (3) adjusting cutting depth
 - (4) adjusting the fence to a 90-degree angle to the table
- b. Describe the position of the operator while facing rough stock.
- c. Describe the procedure for facing rough stock.
- d. Explain the reason for using a push stick or block.
- e. Explain why stock less than 12 inches in length should not be faced.
- f. Define face and warp.

UNIT 8.0

STATIONARY POWER TOOLS

TASK 8.04

DEMONSTRATE USE OF JOINTER

SUB-OBJECTIVES AND PERFORMANCE ACTIONS (Con't.):

3. SQUARE EDGE FACE STOCK

Using the table saw, as necessary, square edge faced stock on the jointer. All crook must be removed from the stock by using a table saw or jointing with consecutive 1/16 inch cuts. No damage will be caused to the jointer. The stock edge must be smooth and free of nicks, splinters, and cuts.

- a. Define crook.
- b. Describe the position of the operator while square edging stock.
- c. Describe the procedures for square edging faced stock.
- d. Explain the reasons for using a push stick or block.
- e. Explain why stock less than 12 inches in length should not be square edged.
- f. Describe the procedure for square edging stock with extreme crook by using a table saw.

4. BEVEL OR CHAMFER STOCK

Using the Jointer (or planer), bevel or chamfer stock so that the finished wood is smooth and free of nicks, splinters, and cuts. The chamfer or bevel must be accurate within +/- 1 degree.

ACTIONS FOR BOTH JOINTER OR PLANER (See also planer)

- a. Define bevel.
- b. Define chamfer.
- c. Describe the position of the operator while beveling or chamfering stock.
- d. Describe the procedures for beveling stock.
- e. Describe the procedure for chamfering stock.

PERFORMANCE STANDARDS:

- Cleaning of machine must be to manufacturer's specifications or standards of the instructor.
- No damage will be caused to jointer.
- Stock face or edge must be smooth and free of nicks, splinters, and cuts.
- Finish wood must be to specifications.
- Chamfer or bevel (if appropriate) must be accurate with +/- 1 degree.

UNIT 8.0

STATIONARY POWER TOOLS

TASK 8.04

DEMONSTRATE USE OF JOINTER

SUGGESTED INSTRUCTIONAL TIME: 6 Hours

RELATED TECHNICAL INFORMATION:

- Relevant safety precautions.
- Manufacturer's instructions on machine adjustment.

UNIT 8.0

STATIONARY POWER TOOLS

TASK 8.05

DEMONSTRATE USE OF PLANER

PERFORMANCE OBJECTIVE:

Given an operator's manual or instructions, the necessary tools, equipments, attachments, stock, and specifications; demonstrate the use of the planer by the following performances.

SUB-OBJECTIVES AND PERFORMANCE ACTIONS:

1. INSPECT AND CLEAN A PLANER

Using cleaning fluid, inspect and clean a planer so it is free of sawdust, scrap wood, and foreign material.

- a. Describe the various uses of a planer.
- b. Explain the reasons for performing routing inspection and cleaning of the planer.
- c. Describe the procedure for inspecting a planer.
- d. Identify materials and describe the procedure for cleaning a planer.
- e. Identify the up/down and brake controls.

2. PLANE STOCK

Plane stock to required thickness +/- 1/16 inch with the grain and so it is free of chip impressions, splinters, and blemishes.

- a. Identify foreign materials that can cause blemishes when planing stock.
- b. Determine the direction of grain in wood stock.
- c. Describe set-up and feeding procedures for planing.
- d. Describe procedures for adjusting the planer.
- e. Describe the position of the operator when planing stock.
- f. Explain the dangers of planing stock of different thicknesses.

UNIT	8.0	STATIONARY POWER TOOLS
TASK	8.05	DEMONSTRATE USE OF PLANER (Con't.)

PERFORMANCE STANDARDS:

- Cleaning of machine must be to manufacturer's specifications or standards of the instructor.
- No damage will be caused to planer.
- Stock must be planed with the grain and must be free of chip impressions, splinters, and blemishes.
- Chamfer or bevel, if applicable, must be accurate within +/- 1 degree.

SUGGESTED INSTRUCTION TIME: 6 Hours

RELATED TECHNICAL INFORMATION:

- Relevant safety precautions.
- Manufacturer's instruction book or instructions.

UNIT 8.0

STATIONARY POWER TOOLS

TASK 8.06

DEMONSTRATE USE OF BAND SAW

PERFORMANCE OBJECTIVE:

Given an operator's manual or instructions, the necessary tools and equipment, wood stock, and specifications; demonstrate the use of the band saw.

SUB-OBJECTIVES AND PERFORMANCE ACTIONS:

1. INSPECT AND CLEAN BAND SAW
Using cleaning fluid, inspect and clean a band saw so it is free of sawdust, scrap wood, and foreign material.
 - a. Describe the various uses of the band saw.
 - b. Explain the reasons for performing routing inspection and cleaning of the band saw.
 - c. Describe the procedures for inspecting a band saw.
 - d. Identify materials and describe the procedures for cleaning a band saw.

2. REMOVE AND REPLACE BAND SAW BLADE (Under instructor's supervision)
Given a replacement blade, remove and replace a band saw blade.
 - a. Describe procedures for removing and replacing a band saw blade.
 - b. Describe the conditions requiring replacement of a band saw blade.
 - c. Identify the on/off brake, table adjustment, and tension controls.

3. LAYOUT AND MAKE A STRAIGHT CUT
Layout and make a straight cut so the stock is to specified dimensions +/- 1/16 inch with edges at a 90-degree angle to the face of the stock.
 - a. Describe how to layout a straight cut.
 - b. Describe the procedures for feeding the stock into the blade.
 - c. Describe the procedures for making a straight cut.

UNIT	8.0	STATIONARY POWER TOOLS
TASK	8.06	DEMONSTRATE USE OF BAND SAW

SUB-OBJECTIVES AND PERFORMANCE ACTIONS (Con't.):

4. LAYOUT AND MAKE A FREEHAND CUT

Layout and make a freehand cut to the specified dimensions $\pm 1/8$ inch with edges at a 90-degree angle to the face of the stock.

- a. Describe the procedures for laying out a freehand cut.
- b. Describe the procedures for feeding the stock into the blade.
- c. Explain the reason to avoid backing up.
- d. Describe the procedures for making a freehand cut.

5. LAYOUT AND CUT A RECTANGULAR OPENING

Layout and cut a rectangular opening to specified dimensions $\pm 1/8$ inch with edges at a 90-degree angle to the face of the stock.

- a. Describe the procedures for laying out a rectangular opening.
- b. Describe the procedures for cutting a rectangular opening.

PERFORMANCE STANDARDS:

- Demonstrate use of band saw.
- By operating, maintaining, laying out, and performing straight, freehand, and rectangular opening cuts to specifications.

SUGGESTED INSTRUCTION TIME: 6 Hours

RELATED TECHNICAL INFORMATION:

- Relevant safety precautions.
- Manufacturer's operator's manual.

UNIT . 8.0

STATIONARY POWER TOOLS

TASK 8.07

DEMONSTRATE USE OF ROUTER AND SHAPER

PERFORMANCE OBJECTIVE:

Given operator's manual or instructions, necessary tools, materials, and attachments (such as bits), wood stock, and specifications; demonstrate the use of the router and shaper.

SUB-OBJECTIVES AND PERFORMANCE ACTIONS:

1. INSPECT AND CLEAN A ROUTER (INSPECT AND CLEAN A SHAPER)

Using cleaning fluid, inspect and clean a router in accordance with the manufacturer's specifications so it is free of sawdust and foreign material.

- a. Describe procedures for inspecting the router or shaper.
- b. Identify materials and describe the procedures for cleaning a router (or shaper).
- c. Explain the reasons for performing routine inspection and cleaning of a router (or shaper).

2. REMOVE AND INSTALL CUTTING BITS

Given cutting bits, remove and install cutting bits. The cutting bits must be mechanically secure in the router chuck (shaper spindle) and the cutting edges should project equally.

- a. Describe the procedures for removing and installing router bits and shaper cutters.
- b. Describe the conditions requiring replacement of cutting bits.
- c. Identify the on/off, cutting depth, and spindle brake/lock controls.
- d. Identify the following types of router bits and shaper cutters:

- | | |
|---------------------|-------------------|
| (1) straight | (8) chamfering |
| (2) veining | (9) cove |
| (3) V-grooving | (10) beading |
| (4) core box | (11) corner round |
| (5) hinge mortising | (12) ogee |
| (6) dovetail | (13) panel pilot |
| (7) rabbeting | (14) trimming |

UNIT 8.0

STATIONARY POWER TOOLS

TASK 8.07

DEMONSTRATE USE OF ROUTER AND SHAPER

SUB-OBJECTIVES AND PERFORMANCE ACTIONS (Con't.):

- e. Identify the following parts of a router bit:
 - (1) shank
 - (2) cutting edge
 - (3) pilot
 - f. Explain why three-wing cutters are safest to use on a shaper.
3. ROUT STOCK WITHOUT A TEMPLATE
Route stock without a template to specified dimensions +/- 1/16 inch and free of burns, splinters, or chips.
- a. Explain the method for adjusting depth of cut.
 - b. Explain the method for controlling the motion of the router.
 - c. Describe the procedures for routing stock without a template.
4. ROUT STOCK WITH A TEMPLATE
Using a template, rout stock to specified shape and dimensions +/- 1/16 inch and free of burns, splinters, or chips.
- a. Explain how the router motion is controlled when using a template.
 - b. Describe the procedure for routing stock with a template.
5. MOLD STOCK WITH A FENCE
Using a table mounted shaper or router, mold stock with a fence to specified dimensions +/- 1/8 inch and free of burns, splinters, or chips.
- a. Explain the adjustments possible on the shaper fence.
 - b. Describe procedures for adjusting the spindle height and installing hold-downs and feather boards.
 - c. Describe the procedures for feeding the stock into the cutter.
 - d. Describe the procedures for molding stock with a fence.

UNIT	8.0	STATIONARY POWER TOOLS
TASK	8.07	DEMONSTRATE USE OF ROUTER AND SHAPER

SUB-OBJECTIVES AND PERFORMANCE ACTIONS (Con't.):

6. MOLD STOCK WITH A MITER GAUGE
Using a table mounted shaper or router, mold stock with a miter gauge to specifications +/- 1/8 inch and free of burns, splinters, or chips.
 - a. Describe the set-up of a miter gauge.
 - b. Describe the procedures for molding stock with a miter gauge.

7. SHAPE STOCK WITH COLLARS
Using collars, shape stock to specified dimensions +/- 1/8 inch and free of burns, splinters, or chips.
 - a. Explain the purpose of collars in shaping.
 - b. Demonstrate the procedures for installing collars.
 - c. Explain how to avoid burning the stock edge when shaping with collars.
 - d. Describe the procedures for shaping stock with collars.
 - e. Explain how to feed stock into a shaper with collars.

PERFORMANCE STANDARDS:

- Rout or shape wood stock to specifications to a tolerance of +/- 1/8 inch with no burns, splinters, or chips and performing the necessary adjustments to the router or shaper to accomplish the job and leave the machine clean after use.
- The finished stock must meet the instructor's standards.

SUGGESTED INSTRUCTION TIME: 9 Hours

RELATED TECHNICAL INFORMATION:

- Relevant safety precautions.
- Measurement and layout to specifications.

UNIT 8.0

STATIONARY POWER TOOLS

TASK 8.08

DEMONSTRATE USE OF THE BELT SANDER

PERFORMANCE OBJECTIVE:

Given an operator's manual or instructions, the necessary tools, equipment, and accessories to operate a portable belt sander, long-belt sander, or abrasive belt sander.

SUB-OBJECTIVES AND PERFORMANCE ACTIONS:

1. INSPECT AND CLEAN A BELT SANDER

Inspect and clean a belt sander so it is free of sawdust, scrap wood, and foreign material.

- a. Identify the following types of belt sanders:
 - (1) portable belt sander
 - (2) long-belt stroke sander
 - (3) abrasive belt sander
- b. Explain the reasons for performing routing inspections and cleaning of belt sanders.
- c. Describe the procedures for inspecting a belt sander.
- d. Identify materials and describe procedures for cleaning a belt sander.
- e. Define abrasive and grit.

2. REMOVE AND REPLACE SANDING BELTS

Remove and replace sanding belts on each type of belt sander so the belt is mechanically secure, placed so it will move in the correct direction, and adjusted for correct tension and tracking. (Possible types of sanders: portable belt sander, long-belt sander, abrasive belt sander).

- a. Describe conditions that require replacement of sanding belts.
- b. Identify various grades of abrasive used for sanding belts.
- c. Describe the procedures for removing and replacing sanding belts.

3. SAND STOCK

For given wood stock, select the appropriate sander for the job and sand stock to a smooth and even finish with no streaks, uneven surfaces, or scratch marks.

125164

UNIT 8.0

STATIONARY POWER TOOLS

TASK 8.08

DEMONSTRATE USE OF THE BELT SANDER

SUB-OBJECTIVES AND PERFORMANCE ACTIONS (Con't.):

- a. Describe procedures for sanding stock.
- b. Explain the importance of sanding with the grain.
- c. Sand stock to specification and industry standards.

PERFORMANCE STANDARDS:

- Inspect, clean, lace sanding belts, and demonstrate use of given sanders, selecting best sander and belt type for job.
- Sanded surface must be smooth and even; finished with no streaks, uneven surfaces, or scratch marks.

SUGGESTED INSTRUCTION TIME: 3 Hours

RELATED TECHNICAL INFORMATION:

- Relevant safety precautions.
- Manufacturer's Operator's Manual.

MULTIPLE CHOICE

1. When using the table saw, set the blade...
 - a. $1/32''$ above the thickness of the stock
 - b. $1/8''$ above the thickness of the stock
 - c. $1/2''$ above the thickness of the stock
 - d. $1''$ above the thickness of the stock

2. Holes drilled into wood with the drill press should be located within a tolerance of...
 - a. $1/64''$
 - b. $1/16''$
 - c. $1/4''$
 - d. $\pm 1/2''$

3. When ripping with a radial arm saw, fingers are kept away from the saw blade by using...
 - a. the fence
 - b. radial arm
 - c. a push stick
 - d. an antikickback device

4. When replacing or installing a circular saw blade, the teeth should point...
 - a. toward the person operating the saw
 - b. away from the person operating the saw
 - c. away from the table of the saw
 - d. none of the above

5. To cut bevels and chamfers on a table saw, you typically would use...
 - a. stop rod
 - b. dado set
 - c. miter gage
 - d. mortise template

TRUE/FALSE

1. The acceptable procedure for cleaning the radial-arm saw is to receive the instructor's permission, switch the machine to off, and tell your classmates not to touch the machine while it is being cleaned.

2. When using the jointer, stock less than 12 inches should not be faced.

TRUE/FALSE (Con't.)

3. A planer can be used to bevel or chamfer stock to an accuracy of +/- 1 degree. _____
4. The stationary band saw typically is used to cut out openings such as circles in stock. _____
5. Generally, the hand router can do about the same job as the stationary router for the residential carpenter. _____
6. The motor on a radial-arm saw may be tilted 90 degrees in either direction. _____
7. Warped stock should be ripped only with the radial-arm saw. _____
8. The rotation of the saw blade on the radial-arm saw should be determined by the type of cut being made. _____
9. The fence on a table saw should never be used as a length gage because the stock might slip, causing a bind between the blade and fence and resulting in a kickback. _____
10. Grooves differ from dado joints in that they are cut with the grain of the wood, while dado joints are cut across the grain of the wood. _____
11. When using the jointer, a small-width end cut should be made using the face to stabilize the stock. _____
12. The guard of the jointer is not used during the operations of rabbeting and stop chamfering. _____
13. Goggles should be worn primarily when cutting plywood. _____
14. The minimum thickness of material that should be jointed on the jointer is 1/2 inch. _____
15. Freehand cutting may not be done on the circular table saw when ripping but is permissible when doing cross cutting. _____

UNIT 8.0

STATIONARY POWER TOOLS

Given a task completion sheet for the following stationary power tools, scrap lumber, and access to machines the student will safely complete tasks required on the task sheet for each power tool. The student will have as much time as needed to complete the tasks safely and accurately. Required mill work must be completed to $\pm 1/8"$.

TOOLS:	Table saw	Planer
	Radial arm saw	Band saw
	Drill and drill press	Router and shaper
	Jointer	Belt sander

Match the operations or jobs on the right to the power tools. There may be one or more answers per question.

- | | |
|-------------------------------|---------------------------------|
| _____ a. Band saw | 1. Crosscutting |
| _____ b. Jointer | 2. Drilling and boring |
| _____ c. Planer (surfacer) | 3. Edge planing |
| _____ d. Electric hand drill | 4. Ripping |
| _____ e. Table saw | 5. Planing to uniform thickness |
| _____ f. Portable belt sander | 6. Cutting curved objects |
| _____ g. Router | 7. Face planing |
| _____ h. Shaper | 8. Dadoing |
| _____ i. Radial arm saw | 9. Mitering |
| | 10. Grooving |
| | 11. Shaping molding |
| | 12. Edge sanding |

Identify the following stationary power tool drawings from the list provided.

- a. Table saw
- b. Radial arm saw
- c. Drill press
- d. Jointer
- e. Planer
- f. Band saw
- g. Router
- h. Shaper
- i. Belt sander
- j. Jig saw

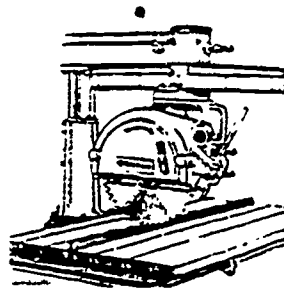

1. _____

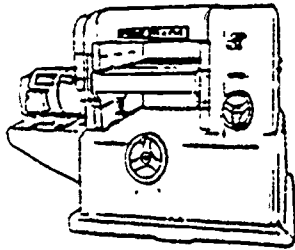

2. _____

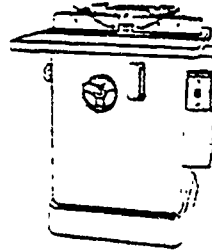

3. _____

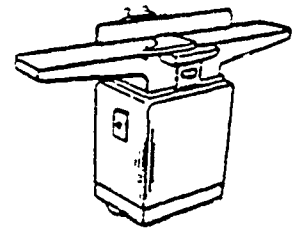

4. _____

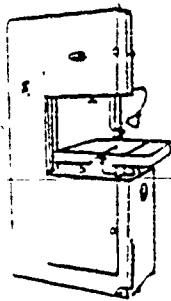

5. _____



6. _____

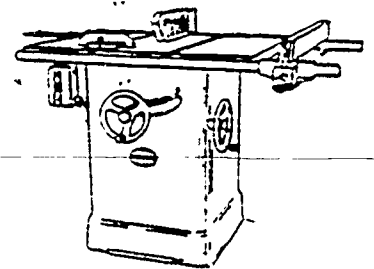

7. _____

UNIT 9.0
SITE LAYOUT (SITE PLANNING)

Upon satisfactory completion of this unit on Site Layout, the student will be qualified to:

- Establish property lines, reference points, and setbacks
- Layout a building site
- Install batter boards
- Locate and square corners
- Locate and mark excavation lines
- Set grade stakes

In addition, the student will have mastered entry-level skills in:

- Using the Builder's Level (line level)
- Using carpentry tools and equipment for layout
- Building layout procedures including use of the transit or line level

SUGGESTED MINIMUM TERMINOLOGY

SITE LAYOUT

Bench mark	A metal or stone marker placed in the ground by a surveyor with the elevation indicated on it; this is the reference point for determining lines, grades, and elevations in the area.
Building permit	An agreement between the builder and a city that specifies the type, quality, and extent of construction to be done.
Builder's level	An instrument consisting of a telescope, leveling bubble, and tripod used primarily for establishing grade levels and building lines.
Excavate	To remove soil for a footing or to establish a uniform grade.
Fall	Pertaining to the slope of the line such as inches of fall per foot of run.
Fill	Soil or other substance used to raise the grade level.
Grade line	The level of the ground at the building line.
Grade stake	A stake driven into the ground that located the finished level of the ground at that point (as read from the bench mark).
Leveling rod	A rod used in leveling with the builder's level and usually graduated in tenths and hundredths of a foot.
Ordinance	A regulation governing the construction of buildings within a municipality.
Site	A plot of ground on which a building is to be erected.

UNIT	9.0	SITE LAYOUT
TASK	9.01	ESTABLISH SITE PROPERTY LINES

PERFORMANCE OBJECTIVE:

Given a residential building property site, working drawings, residential construction specifications, and all necessary equipment; set property (boundary) lines to an accuracy of +/- 1/2 inch.

PERFORMANCE ACTIONS:

- 9.0101 Check plot plan for reference points.
- 9.0102 Check property for existing hubs.
- 9.0103 Establish first property lines using datum points along one side of the property.
- 9.0104 Establish opposite property line.
- 9.0105 Mark third property line.
- 9.0106 Mark fourth property line, etc.
- 9.0107 Check accuracy of measurements.

PERFORMANCE STANDARDS:

- Set property (boundary) lines within 1/2 inch according to plot plan and bench mark.
- Boundary lines must agree with instructor's findings +/- 1/2 inch.

SUGGESTED INSTRUCTION TIME: 6 Hours

RELATED TECHNICAL INFORMATION:

- Reading property descriptions, working drawings.
- Measuring with 100 foot tape.

UNIT	9.0	SITE LAYOUT
TASK	9.02	DEMONSTRATE USE OF LEVELING INSTRUMENT

PERFORMANCE OBJECTIVE:

Given a builder's level (transit or optical level), instructions, leveling rod, measuring tape, and a helper; demonstrate use of the instrument to layout a building.

(NOTE: This task may be learned as a separate task or in conjunction with another task, such as locating a building site.)

PERFORMANCE ACTIONS:

- 9.0201 Identify parts of the leveling instrument.
- 9.0202 Set up and adjust the leveling instrument.
- 9.0203 Level the instrument.
- 9.0204 Demonstrate sighting with the instrument.
- 9.0205 Read the leveling rod.
- 9.0206 Read the instrument scales.
- 9.020C Perform leveling jobs selected by instructor.

PERFORMANCE STANDARDS:

- Demonstrate the proper use of the builder's level (transit or optical level) by locating points $\pm 1/4$ inch of specifications.

SUGGESTED INSTRUCTION TIME: 9 Hours

RELATED TECHNICAL INFORMATION:

- Instrument manufacturer's instruction manual or instructions.
- Measuring with 100 foot tape.
- Using level rod.
- Reading circle scale and vernier on instrument.
- Identify site preparation terminology.

UNIT	9.0	SITE LAYOUT
TASK	9.03	LOCATE BUILDING SITE IN RELATION TO PROPERTY LINE

PERFORMANCE OBJECTIVE:

Given a set of working drawings for a residential structure, and the necessary tools and materials; locate the corners of the proposed structure within the property boundaries so that the proper setback is maintained, according to code and so the corner stakes are positioned within 1/4 inch.

PERFORMANCE ACTIONS:

- 9.0301 Check plans for location of structure on property.
- 9.0302 Locate lot stakes.
- 9.0303 Measure and mark setback line and side yard distance requirements, with 1/4 inch. (Suggestion: First mark with stake, then with nail.)
- 9.0304 Set up and level instrument directly over a reference nail.
- 9.0305 Using helper, stretch measuring tape from corner to opposite front corner, in from and at right angles to front property line. Measure and mark.
- 9.0306 Loosen lock on level transit to permit telescope to move in both horizontal and vertical planes. Align scope so the sight falls as close as possible to the mark established above. Lock instrument, make vernier adjustments to set vertical cross hair of scope on setback distance.
- 9.0307 Move instrument in vertical plane to establish the line which can be extended as necessary for locating stakes.
- 9.0308 Layout remaining lines.

PERFORMANCE STANDARDS:

- Using working drawings for a residential structure, stake out the building site on the property.

UNIT	9.0	SITE LAYOUT
TASK	9.03	LOCATE BUILDING SITE IN RELATION TO PROPERTY LINE (Con't.)

SUGGESTED INSTRUCTION TIME: 9 Hours

RELATED TECHNICAL INFORMATION:

- Use of Builder's level.
- Measuring with 100 foot tape.

UNIT	9.0	SITE LAYOUT
TASK	9.04	LOCATE AND SQUARE BUILDING CORNERS USING BUILDER'S LEVEL*

PERFORMANCE OBJECTIVE:

Given a builder's level, building lot, building plans and hub (2 inch x 2 inch stake), set the level over the center of the hub level instrument so corners can be located:

- With center points at 90 degrees to hub.
- So leveled before corners are squared.
- So instrument is centered directly above hub.

PERFORMANCE ACTIONS:

- 9.0401 Set up instrument with plumb bob centered over point. Adjust to level.
- 9.0402 Locate reference points.
- 9.0403 Establish points on a line.
- 9.0404 Layout right angles.
- 9.0405 Stake out building. Establish corners +/- 1/4 inch, +/- 1 degree.
- 9.0406 Check building layout.

(*NOTE: Locate and square building task may be by builder's level, triangulations, parallel, and diagonal methods.)

PERFORMANCE STANDARDS:

- Locate and square building corners using builder's level.
- Maintain setback +/- 1 inch.
- Maintain allowable side and rear boundary lines +/- 1 inch.
- Corners must be 90 degrees.
- Footlines must be level and parallel to corresponding building lines.
- Check layout by alternate method.

SUGGESTED INSTRUCTION TIME: 9 Hours

RELATED TECHNICAL INFORMATION:

- Using builder's level.
- Triangulation, parallel, and diagonal methods of layout.

UNIT	9.0	SITE LAYOUT
TASK	9.05	LOCATE AND MARK EXCAVATION LINES

PERFORMANCE OBJECTIVE:

Given necessary tools, equipment, and working drawings for a residential building; locate and accurately layout excavation area with a stretched line or with visible material (such as lime) spread on the ground. Clearance for form work will be maintained (2 feet beyond building line). Line will be visible by means of a line, stakes, or string.

PERFORMANCE ACTIONS:

- 9.0501 Review plot and foundation plans.
- 9.0502 Determine distance on outside of building lines required for working clearance in forming for footings and in building foundation forms.
- 9.0503 Plans will indicate if foundation wall is to be block or poured concrete. Determines the amount of clearance required on the outside of the building line.
- 9.0504 Plans will indicate if drain tile is to be laid on outside of the footing and the amount of gravel fill needed for proper drainage.
- 9.0505 Use building lines as reference for driving stakes for excavation lines.
- 9.0506 Use builder's level or diagonal method to check layout accuracy.
- 9.0507 Remove building lines for excavation.

PERFORMANCE STANDARDS:

- Mark excavation lines according to plan specifications.

SUGGESTED INSTRUCTION TIME: 6 Hours

UNIT	9.0	SITE LAYOUT
TASK	9.06A and 9.06B	SUPERVISE SITE PREPARATION (DUAL TASKS)

9.06A PERFORMANCE OBJECTIVE:

SUPERVISE EXCAVATION OF BUILDING SITE TO SPECIFICATIONS:

Given building lines, excavating equipment with operator, vertical section views and plot plan (including contour elevations) from the working drawings, supervise the excavation of a building site to the following standards:

- Correct depth maintained over entire area within building lines.
- Depth maintained 2 feet beyond building perimeter for formwork.
- Batter boards not altered by excavation activities.
- Drainage provided to allow water to run away from excavation.

PERFORMANCE ACTIONS:

- 9.06A Supervise:
- a. Check drawings and specifications.
 - b. Earth is removed to specified width, length, and depth.
 - c. Stock pile required amounts of earth according to specifications.

PERFORMANCE STANDARD:

- Supervise excavation activities of a building site to specifications.

9.06 B PERFORMANCE OBJECTIVE:

SUPERVISE SITE PREPARATION FOR SLAB-ON-GROUND CONSTRUCTION:

Given site, worker, proper equipment, and working drawings and specifications for typical residential structure; supervise site preparation for slab-on-ground construction.

- Site should be level.
- Grading to proper elevation +/- 1 inch.
- Grading to proper dimensions +/- 1 inch.

PERFORMANCE ACTIONS:

- 9.06B Supervise:
- a. Check plans for slab size.
 - b. Locate and stake corners for slab construction.

UNIT	9.0	SITE LAYOUT
TASK	9.06A and 9.06B	SUPERVISE SITE PREPARATION (DUAL TASKS) (Con't.)

PERFORMANCE ACTIONS (Con't.):

- c. Grade to specified dimensions.
- d. Compact area that has been disturbed by grading.
- e. Check final grade for accuracy.

PERFORMANCE STANDARD:

- Take equipment and prepare site for slab construction.

SUGGESTED INSTRUCTION TIME: 6 Hours

NOTE

Site preparation may include other tasks such as (1) set grade stakes at proper elevation, (2) prepare applications for required construction inspections, and (3) supervise filling operations around foundation walls. These will be considered optional tasks since they may or may not be taught in secondary vocational center programs.

For additional information on site preparation tasks, see references.

150

Match the following list of layout terms to the correct definitions.

- | | |
|--------------------------|--|
| _____ a. Batter boards | 1. Removing soil for a footing or to establish a uniform grade. |
| _____ b. Builder's level | 2. An enlargement at the lower end of a foundation wall, pier, or column to distribute the load. |
| _____ c. Excavating | 3. A temporary framework used to assist in locating corners when laying out a foundation. |
| _____ d. Footing | 4. The level of the ground at the building line. |
| _____ e. Grade line | 5. A graduated rod used with the builder's level in leveling. |
| | 6. An instrument consisting of a telescope, leveling bubble, and tripod used primarily for establishing grade levels and building lines. |
| | 7. A stake driven into the ground that locates the finished level of the ground at that point. |

PRACTICAL TEST

Job Sheet for the Erection of Batter Boards and Location of Building Lines.

Given the shape, size, building line elevation, and a bench mark; erect batter boards and locate building lines on blueprint or instructor's drawing for this structure.

- I. A. Tools
 - 1. Sledge hammer
 - 2. Claw hammer
 - 3. Handsaw
 - 4. Electric handsaw
 - 5. Builder's level
 - 6. Plumb bob
 - 7. Cord

- B. Materials
 - 1. Lumber
 - 2. 8D box nails

- II. Procedure
 - A. Cut material to size.
 - B. Locate property boundary lines.
 - C. Locate approximate building lines on lot inside boundary lines.
 - D. Erect batter boards.
 - E. Locate building lines.
 - F. Locate and drive stakes at building lines to establish grade.
 - G. Remove cord from property lines.

TASK 9.02

1. Identify the numbered parts of a builder's level shown below.

1. _____
2. _____
3. _____
4. _____
5. _____

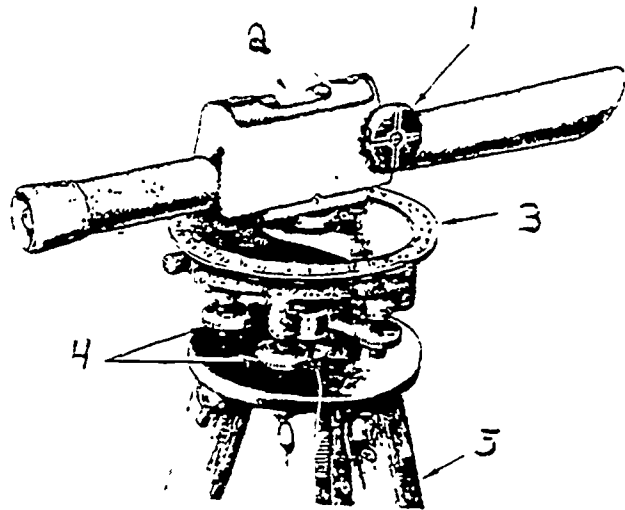

2. Read the following builder's level instrument scale in degrees and minutes.

1. This instrument shows a reading of ____°-____'.

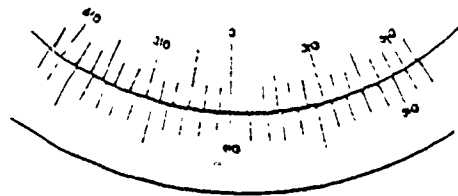

2. This instrument shows a reading of ____°-____'.

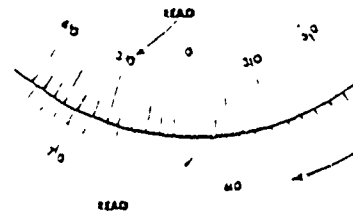

3. This instrument shows a reading of ____°-____'.

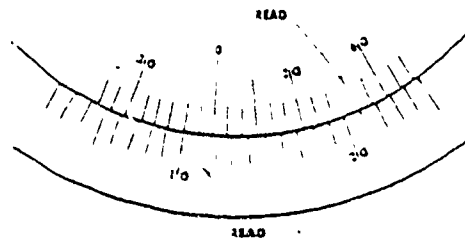

UNIT 10.0

FOOTINGS AND FOUNDATIONS

Upon satisfactorily completing this unit on footings and foundations, the student will be prepared to plan and prepare for different methods of constructing footings and foundations for residential construction. Emphasis will be on the construction of forms used for footings and foundations and meeting architectural specifications.

(NOTE: Some building construction tasks that may be associated with footings and foundations work are omitted because (a) the task actions represent supervisory level work or (b) the task actions are typically accomplished by the mason and probably would not be required of the entry level carpenter apprentice.)

SUGGESTED MINIMUM TERMINOLOGY

FOOTINGS AND FOUNDATIONS

Brace	Wood stock or other material used to support weight or pressure.
Cleat	Wood stock or metal fastener across a form to add additional strength.
Duplex Nail	Double headed nail used in forming and designed for ease in removing.
Footing	Enlarged area at base of a wall or other object to distribute the weight of the superstructure.
Foundation	Portion of a wall including the footing on which the building rests.
Pier	Column beneath a foundation which rests on firm soil or rock which is used as an additional means of support when the soil is unstable.
Pier and Beam	Foundation poured on top of piers with no support in between.
Whaler	Horizontal bracing member used in form construction.

UNIT	10.0	FOOTINGS AND FOUNDATIONS
TASK	10.01	INSTALL BATTER BOARDS FOR ROUGH EXCAVATION AND FOOTINGS

PERFORMANCE OBJECTIVE:

Given a building site, working drawings, and specifications for a residential structure, necessary carpentry tools, materials, finished grade, and the desired rod length; erect the batter boards to establish building lines and elevation points necessary for rough excavation. The building lines and batter boards will be the same elevation +/- .01 foot. Corners will be square +/- 0 degrees one minute. Length of lines will be correct according to the drawing +/- 1/32 inch.

PERFORMANCE ACTIONS:

- 10.0101 Drive batter board stakes as necessary around corners of excavation.
- 10.0102 Set up level.
- 10.0103 Make a grade rod, according to height of forms, to establish a to-or-batter-board mark, usually above and out of the way of the forms. Mark this height on all the stakes that will support the batter boards.
- 10.0104 Nail horizontal batter boards to these established heights and brace securely. Working lines may now be stretched between batter boards over the corner stakes. Use a level or plumb bob to make line adjustments over the points on top of the stakes.
- 10.0105 Make a saw kerf in the top of each batter board and mark the kerf "Building Line" (BL). This will preserve the location of lines during construction and keep the lines from slipping out of place. After the corner batter boards have been kerfed, points along intermediate batter boards can be located by measurement.

PERFORMANCE STANDARDS:

- Using materials provided, erect batter boards at correct locations on a real or simulated building lot.

SUGGESTED INSTRUCTION TIME: 12 Hours

RELATED TECHNICAL INFORMATION:

- Layout irregular building by a series of square and rectangles with builder's level, etc.
- Preliminary tasks:
 - a. Locate building corners.
 - b. Indicate outside line of foundation walls by nails in stakes.
 - c. Check squareness of corners.

UNIT	10.0	FOOTINGS AND FOUNDATIONS
TASK	10.02	SET GRADE STAKES AT PROPER ELEVATIONS

PERFORMANCE OBJECTIVE:

Given a set of working drawings, specifications, and the necessary tools and materials; set the stakes according to drawings and specifications.

PERFORMANCE ACTIONS:

- 10.0201 Refer to plot and foundation plans.
- 10.0202 Drive stake to establish first floor level at highest corner or existing grade for beginning point.
- 10.0203 Layout necessary stakes along building lines.
- 10.0204 Place one end of straight edge on top of reference stake and drive other stakes to corresponding grade using the builder's level.
- 10.0205 After driving all stakes to grade, check back to starting grade stake to determine accuracy of grade.
- 10.0206 Establish grade for batter boards level with top of grade stakes.
- 10.0207 Check work.

PERFORMANCE STANDARDS:

- Set grade stakes for given building lot to specifications meeting instructor's standards.

SUGGESTED INSTRUCTION TIME: 6 Hours (Optional)

UNIT	10.0	FOOTINGS AND FOUNDATIONS
TASK	10.03 (OPTIONAL)	ALIGN FORM WALLS

PERFORMANCE OBJECTIVE:

Given a section of concrete wall form, the necessary carpenter tools, bracing materials, specifications, a helper and instructions; align the wall to the required specifications, installing braces and support devices. There will be no more than 1/8 +/- inch deviation in 6 foot sections both horizontally and vertically.

PERFORMANCE ACTIONS:

- 10.0301 Using a plumb bob, mark points on the footing directly below the established building line (outside wall).
- 10.0302 From these points, locate the inside of the wall on the footing by snapping a chalk line on the footing. These lines should extend the full length of the footing.
- 10.0303 Set the wall form in position and install bottom braces to hold the form secure on the footing line.
- 10.0304 Plumb the wall vertically at each end to +/- 1/8 inch in every 6 feet and install top braces at corners.
- 10.0305 Use block gauge and line to align top and center section of wall form.
- 10.0306 Locate stakes for top braces and install braces to provide 30 degrees or less angle to horizontal.
- 10.0307 Nail all braces and support devices with double-headed form nails for ease of wrecking form.

PERFORMANCE STANDARDS:

- With helper, given tools and materials, set and align the form on the footing, +/- 1/8 inches deviation in 6 foot horizontal and vertical sections.

SUGGESTED INSTRUCTION TIME: 3 Hours (Optional)

UNIT	10.0	FOOTING AND FOUNDATIONS
TASK	10 04 (OPTIONAL)	BRACE FOUNDATION WALL FORMS

PERFORMANCE OBJECTIVE:

Given a foundation wall form, bracing lumber, appropriate tools and equipment, construct and secure braces to foundation wall form. The poured wall must conform horizontally and diagonally to the working drawings. The form must be rigid enough so that it will not bulge or twist when filled with concrete. Joints must be tight enough to prevent mortar leakage.

PERFORMANCE ACTIONS:

- 10.0401 Refer to working drawings and specifications.
- 10.0402 Check building layout lines on surface of footing.
- 10.0403 Set the sections of the outside wall form on the footing to conform to the layout lines.
- 10.0404 Level top of forms by bringing shims under the sole plate of the forms.
- 10.0405 Drive stakes and set braces to hold wall form in place.
- 10.0406 Add walers to make outside wall form rigid.
- 10.0407 Complete bracing on foundation wall forms.
- 10.0408 Check the forms for accuracy before inserting the ties and spreaders.
- 10.0409 On taller forms, ties and spreaders must be inserted as inside form is built in place.

PERFORMANCE STANDARDS:

- Brace foundation wall forms with provided material. Form must not bulge or twist when filled with concrete and joints must be tight to prevent mortar leakage.

SUGGESTED INSTRUCTION TIME: 3 Hours (Optional)

UNIT	10.0	FOOTING AND FOUNDATIONS
TASK	10.05	CALCULATE CONCRETE FOR FOOTINGS AND FOUNDATION WALLS

PERFORMANCE OBJECTIVE:

Given a complete detailed set of footing and foundation plans for a single family residential structure, calculate the total number of cubic yards of concrete required for the job. Mathematical calculations must be accurate.

PERFORMANCE ACTIONS:

- 10.0501 Determine size of footings. (Thickness x Width x Length).
- 10.0502 Determine size of foundation walls. (Thickness x Width x Length).
- 10.0503 Calculate the required amount of concrete for the footing.
- 10.0504 Calculate the required amount of concrete for the foundation walls.
- 10.0505 Combine the sub-totals into a total figure for the job to 5 percent accuracy.

PERFORMANCE STANDARDS:

- Using foundation detail drawings, make the necessary calculations for concrete for footings and foundation walls.
- The total for the concrete needed should be within +/- 5 percent of the instructor's calculations.

SUGGESTED INSTRUCTION TIME: 6 Hours

UNIT	10.0	FOOTING AND FOUNDATIONS
TASK	10.06	CLEAN AND REPAIR FORMS

PERFORMANCE OBJECTIVE:

Given used concrete forms, a helper, and instructions; clean and repair the forms by plugging all holes, replacing damaged parts and resetting loose nails. Eighty percent or more of the used forms must be acceptable for reuse.

PERFORMANCE ACTIONS:

- 10.0601 Replace damaged boards or sections.
- 10.0602 Replace damaged studs, plates, braces. Square the forms.
- 10.0603 Reset nails and renaill loose boards or sections.
- 10.0604 Plug all holes larger than 1/4 inch in diameter.
- 10.0605 Check form for dimensions and squareness.
- 10.0606 Apply treatment to preserve forms and prevent sticking of concrete.

PERFORMANCE STANDARDS:

- Given foundation forms, repair them so 80 percent of the forms are reusable.

SUGGESTED INSTRUCTION TIME: 3 Hours

UNIT	10.0	FOOTING AND FOUNDATIONS
TASK	10.07 (OPTIONAL)	CONSTRUCT CONCRETE STEP AND STAIR FORMS

PERFORMANCE OBJECTIVE:

Given detail plans for a typical two- or three-step concrete stair, a helper, lumber, tools and equipment; construct and install the concrete step/stair forms complete and ready to receive mixed concrete.

PERFORMANCE ACTIONS:

- 10.0701 Refer to plans for details.
- 10.0702 Determine height and width of sidewall.
- 10.0703 Build panels for sides.
- 10.0704 Locate and plumb sidewalls.
- 10.0705 Brace sidewalls.
- 10.0706 Layout treads and rises on sidewalls.
- 10.0707 Install riser boards outside or layout line and check for plumb and level.
- 10.0708 Brace center of risers to prevent spreading.
- 10.0709 Install position and hold down braces.
- 10.0710 Check for accuracy of forms locations and installation.

(EXTENSION TASK: Calculate concrete needed.)

PERFORMANCE STANDARDS:

- Construct concrete step/stair forms following detail plans and instructions.

SUGGESTED INSTRUCTION TIME: 6 Hours (Optional)

UNIT	10.0	FOOTING AND FOUNDATIONS
TASK	10.08 (OPTIONAL)	CONSTRUCT SINGLE WALL FOUNDATION FORMS

PERFORMANCE OBJECTIVE:

Given the necessary tools, a helper, detailed plans, and required materials; construct a single wall foundation form. The foundation wall form must be without gaps, be fastened together with appropriate fasteners, be positioned at 24 inch intervals, and the tongue edge of all boards must be in an up position.

PERFORMANCE ACTIONS:

- 10.0801 Refer to blueprints and building specifications.
- 10.0802 Layout tools and materials.
- 10.0803 Select form plates and cut to length.
- 10.0804 Lay off plates for studs (usually 2 feet - 0 inches O.C.).
- 10.0805 Select stud material and cut to length (usually 3 1/2 inches less than finished wall).
- 10.0806 Nail studs between plates.
- 10.0807 Plumb and brace on the outside of the form.
- 10.0808 Nail 1 inch stock to the inside face of the studs and allow stock to extend 16 inches beyond end of wall sections for outside corners.
- 10.0809 Omit end studs on inside form walls and allow longer form to butt against shorter form. This will make form remove more easily.
- 10.0810 Locate form sections in place and plumb.
- 10.0811 Fasten forms together and nail cleats in corners.
- 10.0812 Insert openings.
- 10.0813 Check forms for accuracy.

UNIT	10.0	FOOTING AND FOUNDATIONS
TASK	10.08 (OPTIONAL)	CONSTRUCT SINGLE WALL FOUNDATION FORMS (Con't.)

PERFORMANCE STANDARDS:

- Construct a single wall form from given tools, materials, equipment, and specifications.

SUGGESTED INSTRUCTION TIME: 6 Hours (Optional)

UNIT	10.0	FOOTING AND FOUNDATIONS
TASK	10.09 (OPTIONAL)	BUILD SIDE FORMS*

PERFORMANCE OBJECTIVE:

Given form lumber, previously erected batter boards, appropriate tools, a helper and foundation detail plans, make and set a building side form. The inside line of form wall will coincide with building line. All stakes will be secure, spreaders will be used to ensure uniform footing width. Form ties will be securely fastened to form boards. Distance between stakes will be that distance twice the width of the footing. Bracing will be sufficient to prevent movement of forms.

PERFORMANCE ACTIONS:

- 10.0901 Determine from plans top and bottom elevation.
- 10.0902 Determine from plans sizes and lengths of footing form.
- 10.0903 Establish location for footer with stakes driven in the ground.
- 10.0904 Determine grade of footer from datum points.
- 10.0905 Place grades stakes for outside form boards.
- 10.0906 Nail outside boards to grade stakes.
- 10.0907 Use spreaders and locate the inside footer wall.
- 10.0908 Follow step 5-7 for building inside footer form wall.

PERFORMANCE STANDARDS:

- Construct square type footing form from given material, tools, and equipment.
- Inside line of form wall must coincide with building line and all stakes must be secure.
- Spreader must be used to ensure uniform footing width and form ties must be securely fastened to form boards.
- Distance between stakes will be that distance twice the width of the footing.
- Bracing will be sufficient to prevent movement of forms.

SUGGESTED INSTRUCTION TIME: 6 Hours (Optional)

*Typically commercial building.

TRUE/FALSE

1. In the Southern U.S., large, deep footings are required. _____
2. The footing can be a trench if the soil composition is firm. _____
3. Both the footing and the floor cannot be poured at the same time. _____
4. Plywood and tongue-and-groove or shiplap sheathing are used to construct forms. Frames are made using 2 x 4's. _____
5. Concrete is made up from lime, alumina, and iron oxide. _____
6. The purpose of the key in the top of the footing is to keep the wall from shifting laterally on the footing. _____
7. A footing for a small structure on average soil should be three times as wide as the foundation wall. _____
8. Concrete should be poured into the forms with a delay of no longer than 45 minutes. _____
9. The rate of pour can increase or decrease the pressure on the forms. _____
10. Foundation walls support the beams and joists. _____
11. A brace is a piece of wood or other material used to resist weight or pressure. _____
12. The foundation is an enlarged area at the base of a which distributes weight evenly. _____
13. In a monolithic pour, the slab and foundation are poured as a solid unit. _____
14. The footing is the portion of the wall on which the building rests. _____
15. A groove in the top of the footing which ties it together with the foundation is a keyway. _____
16. The 3, 4, 5 method (6, 8, 10) for squaring a right angle is frequently used while forming a slab. _____
17. Diagonals of a square or rectangle will be equal in length. _____

Carpentry Mathematics

1. How much concrete will be needed to pour a slab 4" thick, 9' wide, and 27' long?

PRACTICAL TEST

Given a foundation (for a concrete slab) plan, and a bench mark correctly erect forms to pour the foundation/slab.

I. Tools

A. Tools

1. Sledge Hammer
2. Claw hammer
3. Hand saw and portable circular saw
4. Builder's level
5. 4' spirit level
6. Cord

B. Materials

1. Lumber
2. Nails

II. Procedures

- A. Cut stakes and form boards
- B. Locate approximate building lines
- C. Erect batter boards
- D. Locate building lines at correct slab elevation
- E. Drive form stakes to elevation
- F. Install forms on stakes
- G. Remove cords

UNIT 11.0

FLOOR AND SILL FRAMING

Upon satisfactory completion of this unit, the graduate will be able to use floor and sill framing terms, identify floor and sill framing members, name the styles of framing, and describe the purpose of a sill sealer and termite shield. The graduate will be able to demonstrate the primary methods of fastening the sill to the foundation, the construction of a box sill, how to lay off and install the floor joist, selecting and applying the various types of subflooring, and using power tools safely and correctly.

SUGGESTED MINIMUM TERMINOLOGY

FRAMING

Beam	Large timber or other material used to support concentrated loads at particular points along its length.
Bridging	Stock or steel pieces, normally used in pairs, between the bottom of one joist to the top of the adjacent joist and crossed to stiffen the support and help distribute the floor load.
Foundation	Supporting portion of a structure below first floor construction including the footings.
Joist Header	Framing member into which the common joints are fitted forming the box sill or member to support the free end of joists over openings such as stairs, chimneys, and other openings.
Joists	One of a series of parallel framing members used to support floor and ceiling loads, and in turn supported by larger beams, girders, or load bearing walls.
Sill	Lowest members of frame of a structure generally horizontally placed on the foundation and supporting the upright of the frame.
Sill Sealer	Resilient waterproof material used under the sills to seal against air, dirt, and insects.
Subfloor	Boards or panels laid directly on the floor joists over which a finished floor is laid.
Termite Shield	A shield, typically sheet metal, placed in or on a foundation wall or around pipes to prevent passages of termites into the structure.

Definitions adopted from textbook, Modern Carpentry.

UNIT	11.0	FLOOR, WALL, AND ROOF FRAMING
TASK	11.00 (Optional)	CONSTRUCT MODELS TO ILLUSTRATE SCALED FLOOR, WALL, AND ROOF FRAMING

PERFORMANCE OBJECTIVE:

(NOTE: This is an "optional task" for Floor, Wall, and Roof Framing units (Units 11, 12, 13). The task may be used for any of the framing units or all of them to introduce the student to the concept of framing.)

Given plans, specifications, stock, carpentry tools, equipment, and a scale to use; cut framing members to given sizes according to scale and construct models to illustrate floor, wall, and roof framing techniques. All framing should be within specifications required by the instructor.

PERFORMANCE ACTIONS:

- 11.0001 Review framing terminology (floor, wall, roof).
- 11.0002 Review plans and specifications.
- 11.0003 Prepare (cut) stock according to scale and framing requirements.
- 11.0004 Cut framing members to scale (according to drawings).
- 11.0005 Construct floor framing.
- 11.0006 Construct wall framing.
- 11.0007 Construct roof framing.
- 11.0008 Evaluate framing of model. Determine if specifications are met satisfactorily or not.

PERFORMANCE STANDARDS:

- For given specifications, plans, and scale; cut framing members to scale and construct a model to illustrate the proper (required) framing of a floor, wall partitions, and roof.
- The framing must meet the standards of the instructor.

SUGGESTED INSTRUCTION TIME: Optional (possibly 45 hours)

200

SUGGESTIONS FOR BUILDING STRUCTURAL MODELS

1. PURPOSE:

The main purpose of constructing a model is to gain experience in framing a house and building a roof. Exterior details are not essential unless desired.

2. HOUSE PLAN:

Use a modern set of house plans with framing details.

3. SCALE:

A scale of 1 1/2 inch to 1 foot is recommended for consideration. This scale allows use of the "architect's scale" and allows a scale of 1/8 full size. Using the 1/8 size scale, a 24 x 40 foot house becomes 3 x 5 feet. A 2 x 4 inch stock measures 1/4 x 1/2 inch and a 2 x 6 inch stock measures 1/4 x 3/4 inch.

4. FASTENERS:

Nails and fasteners should be in proportion. House framing may use 1/2 inch, 19-20 gauge wire nails. Joint, headers, and similar large members might be nailed together with 5/8 or 3/4 inch nails. Shingles may be attached using 1/2 inch staples or nails.

5. MODEL BASE:

If desired, a model base may be made of 3/4 inch plywood or particle board cut to lot size. A lot size base would allow landscaping touches to show a completed house appearance. Flocking, masking tape, wire, and foam rubber and paint can be used to create landscaping.

6. FOUNDATION:

A foundation wall can be build using rigid plastic form, molding plaster, or spackling compound. Or, the foundation can be made of wood scaled to the correct thickness and height above grade. The termite shield may be made of thin aluminum or copper foil. A concrete slab may be represented by a 1/4 inch piece of plywood. The foundation should be to scale.

7. FLOOR AND WALL FRAMING:

Studs should be cut to 1/4 x 1/2 inch.

(NOTE: Actual scale would call for a 2 x 4 inch which is actually 1 1/2 x 3 1/2 inch to be 3/16 x 7/16 inch, a difficult size to cut. Cutting studs to 1/4 x 1/4 inch is more practical. The only result will be floors, walls, and roof slightly thicker than perfect scale.)

A. FLOOR FRAMING:

If the model is to have a basement, install a beam to support floor framing (beam might be made of several layers of thin wood glued and nailed together and painted to represent a "steel" beam if applicable). Next, build sill plate, floor joists, and box sill to complete floor framing. Cover framing with thin veneer subfloor. Install bridging between floor joists if desired in scale.

B. WALL FRAMING:

Construct each wall section according to plan.

(NOTE: Use of a jig may help with spacing of studs and locating and framing of window and door openings.)

*Nail first top plate solidly to studding, Second top plate should be nailed to ceiling joists or roof trusses. Exterior sheathing can cover the crack between the top plates.

*(NOTE: This method of framing allows the entire roof section to be removed so that the interior of the home can be easily seen.)

8. ROOF FRAMING:

Build the roof by starting with a second top plate, adding ceiling joists, then adding roof framing members or trusses. If these are fastened together as a unit, the roof may be removed for full viewing of the interior.

9. EXTERIOR WALL:

The main purpose of the model is to gain experience and knowledge in framing a house. It is not necessary to add many exterior materials. It is recommended that the front (or one side) of the model be completed by adding the exterior wall, consisting of sheathing, building paper, and exterior wall covering. Sheathing may be represented by heavy construction paper, the building paper may be illustrated by thin black paper, and wall material may be made from balsa sheets.

10. ROOFING:

Thin veneer may be used for roof sheathing. Shingles may be cut from sandpaper.

(NOTE: Only a small portion of the roof should be completed.)

11. CHIMNEYS:

Chimneys or other brick or cement work may be made using molding plaster.

12. MILLWORK:

Windows may be constructed using clear plastic with framing painted on. Doors may be constructed from plywood. Windows and doors, of course, may be omitted.

13. INTERIOR FINISHING:

Drywall may be simulated to illustrate how interior finishing would appear in a section of the model house.

14. EXTENSION OF THIS TASK:

A natural extension of this task would be to move from framing and building the structural model to framing and building a small scale structure such as a mock-up or backyard utility building.

References: Carpentry and Building Construction, by Feirer and Hutchings, and Woodworking for Industry, by Feirer.

UNIT	11.0	FLOOR AND SILL FRAMING
TASK	11.01	LAYOUT A FLOOR FRAME

PERFORMANCE OBJECTIVE:

Given working drawings and specifications for a floor frame, woodstock and lumber, and the necessary layout tools and materials, layout a floor frame. All materials must be marked accurately for cutting and installing the floor according to specifications +/- 1/8 inch. Materials must be marked to indicate maximum use of wood stock and dimensioned lumber.

PERFORMANCE ACTIONS:

11.0101 Identify:

- | | |
|---------------------------------|---------------------|
| a. Sill plate | h. Floor joist |
| b. Anchor bolt | i. Toenail |
| c. Sill sealer or vapor barrier | j. Crown |
| d. Built-up girder | k. Cross bridging |
| e. Column | l. Subfloor |
| f. Bearing plate | m. Platform framing |
| g. Joist header | n. O.C. |

11.0102 Read working drawings and determine style of framing.

11.0103 Select tools and materials to layout floor frame.

11.0104 Layout floor frame.

PERFORMANCE STANDARDS:

- Layout floor frame according to specifications +/- 1/8 inch marking all materials accurately to indicate maximum use of wood stock and dimensioned lumber.

SUGGESTED INSTRUCTION TIME: 6 Hours

UNIT	11.0	FLOOR AND SILL FRAMING
TASK	11.02 (OPTIONAL)	CUT AND INSTALL SILL PLATES TO FOUNDATION WALL

PERFORMANCE OBJECTIVE:

Given working drawings and specifications for a floor frame, wood stock and dimensioned lumber, a foundation wall or slab ready to receive sill plates, necessary tools and equipment, and sufficient materials; cut and install a sill plate to the top of a foundation wall. The following standards apply:

- Joints in the sill must not be over an opening in the foundation wall.
- Sills must be cut square so they butt together closely at the corners of the foundation or slab. (Square +/- 2 degrees)
- All members will be level and straight (+/- 1/8 inch) and must be anchored according to Southern Building specification.

PERFORMANCE ACTIONS:

(NOTE: Some actions applicable only to slab construction.)

- 11.0201 Anchor bolts should be installed in foundation walls during construction.
- 11.0202 Place the sill plates along the top of the four walls in approximately their permanent position. Place sill so no joints occur over openings in walls, and square the butt joint.
- 11.0203 Lay sill plate against the inside of the anchor bolts. The ends of the sills may be left projecting over the ends of the wall.
- 11.0204 Square lines from each anchor bolts across the sill plate.
- 11.0205 Measure the correct distance along each line from the outside edge of the sill to locate the holes for the anchor bolts.
- 11.0206 Make these holes and bore or drill the holes with a bit 3/8 inch the diameter of the bolt.
- 11.0207 Place the sill over the anchor bolts.
- 11.0208 Cut the sill plates at the corners of the building so they butt together closely.

UNIT	11.0	FLOOR AND SILL FRAMING
TASK	11.02 (OPTIONAL)	CUT AND INSTALL SILL PLATES TO FOUNDATION WALL (Con't.)

PERFORMANCE ACTIONS (Con't.):

- 11.0209 Place washers and nuts on the anchor bolts and draw the nuts down to bring the sill plates down temporarily to the masonry wall.
- 11.0210 Square the plate at the corner and brace the sill in position.
- 11.0211 If the foundation wall is not level and true, level and straighten the sill over the bearing walls by using a straightedge and level.
- 11.0212 After the sill plate is level and straight, tighten the nuts on the anchor bolts.

PERFORMANCE STANDARDS:

- Cut and install sill plates to the top of a foundation wall so that no joint in the sill is over an opening in the foundation wall, so the sills are cut square and butt together closely at the corners of the foundation wall or slab, so all sill members are level and straight to +/- 1/8 inch and are anchored according to specifications (FHA if not otherwise).

SUGGESTED INSTRUCTION TIME: (Depends on availability of actual residential construction situation.) Typically, demonstrated or simulated in mode.

UNIT	11.0	FLOOR AND SILL FRAMING
TASK	11.03 (OPTIONAL)	FRAME AND INSTALL A BUILT-UP T-TYPE SILL

PERFORMANCE OBJECTIVE:

Given working drawings and specifications for a floor frame, wood stock and dimensioned lumber, a foundation wall or slab with sill plate installed, and the necessary tools, equipment, and materials; frame and install a built-up T-type sill. Floor joists must have a minimum of 4 inches bearing seat on the sill plate. The sill header must be centered on the sill plate $\pm 1/8$ inch, cut to specified length $\pm 1/8$ inch, and square at the ends.

PERFORMANCE STANDARDS:

- Frame and install a built-up T-type sill.
- so that floor joists have a minimum of 4 inches bearing seat on the sill plate and the sill header is centered on the sill plate $\pm 1/8$ inch, cut to specified length $\pm 1/8$ inch, and square at the ends.

SUGGESTED INSTRUCTION TIME: See Task 11.02

UNIT	11.0	FLOOR AND SILL FRAMING
TASK	11.04 (OPTIONAL)	FRAME AND INSTALL A BOX SILL

PERFORMANCE OBJECTIVE:

Given working drawings and specifications for a floor frame, wood stock and dimensioned lumber, a foundation sill or slab with sill plate installed, and the necessary tools, equipment, and materials; frame and install a box sill. The sill header must be flush with the outside edge of the plate, cut specified length +/- 1/8 inch, and square at the ends.

PERFORMANCE ACTIONS:

- 11.0401 Identify fastening pattern for installing a box sill.
- 11.0402 Identify size and type of lumber used for box sill.
- 11.0403 Demonstrate the procedure for framing and installing a box sill.

PERFORMANCE STANDARDS:

- Frame and install a box sill that is flush with the outside edge of the plate, cut to specified length +/- 1/8 inch, and square at the ends.
- Meet specifications of the Southern Standard Building Code concerning box sills.

SUGGESTED INSTRUCTION TIME: 12 Hours

RELATED TECHNICAL INFORMATION:

- Appropriate safety precautions.
- Southern Standard Building Code concerning box sills.

UNIT	11.0	FLOOR AND SILL FRAMING
TASK	11.05 (OPTIONAL)	INSTALL POSTS AND COLUMNS

PERFORMANCE OBJECTIVE:

Given working drawings and specifications for a floor, frame, a foundation sill installed and footings for posts or columns, steel or wood columns, of the correct size and shape, and the necessary tools, equipment, and materials, install the posts or columns. The posts or columns must be installed to Southern Building specifications and positioned to receive bearing members.

PERFORMANCE ACTIONS:

- 11.0501 Identify types of posts and columns by size, type of material, and required fasteners.
- 11.0502 Demonstrate the procedure for installing posts and columns.

PERFORMANCE STANDARDS:

- Install posts and columns to Southern Building specifications and positioned to receive bearing members.

SUGGESTED INSTRUCTION TIME: See Task 11.02

RELATED TECHNICAL INFORMATION:

- Southern Building Standard Code regarding posts and columns.

UNIT	11.0	FLOOR AND SILL FRAMING
TASK	11.06 (OPTIONAL)	FRAME AND INSTALL A BUILT-UP GIRDER

PERFORMANCE OBJECTIVE:

Given working drawings and specifications for a floor frame, a foundation wall with sill, columns, and beam installed, dimensioned lumber for a built-up girder, and the necessary tools, equipment, materials and a helper if required; set and align girder to columns and foundation wall.

The following specifications apply:

- Girder will be cut to specified length +/- 1/8 inch.
- Ends of girder will be cut square.
- Girder will be secured to foundation wall and columns as specified.
- Bearing plate will be two inches wider than girder on each side of girder.
- Installed girder will be level.

PERFORMANCE ACTIONS:

- 11.0601 Check plans and specifications.
- 11.0602 Check pockets in foundation wall and columns.
- 11.0603 Measure for length of girder.
- 11.0604 Cut off ends of girder to measurements. (If slight crown is desired consider it at this time.)
- 11.0605 Cut columns to correct length and place in position on column footings. Brace columns in plumb position.
- 11.0606 Slide girder from sidewall into position on bearing plates. (Use staging if needed.)
- 11.0607 Check to see air space exists around girder. End of the girder should not touch foundation wall.
- 11.0608 Align and plumb girder as needed.
- 11.0609 Secure girder to foundation wall and column as specified.
- 11.0610 Secure brace columns.

PERFORMANCE STANDARDS:

- Take girder and install to foundation wall and columns as specified.

UNIT	11.0	FLOOR AND SILL FRAMING
TASK	11.06 (OPTIONAL)	FRAME AND INSTALL A BUILT-UP GIRDER

PERFORMANCE STANDARDS (Con't.):

- Girder will be cut to specified length 1/8 inch. Ends of girder to be cut square and girder will be secured to foundation wall and columns as specified.
- Bearing plate will be two inches wider than girder on each side of girder. Installed girder will be level.

SUGGESTED INSTRUCTION TIME: See Task 11.02

UNIT	11.0	FLOOR AND SILL FRAMING
TASK	11.07	INSTALL FLOOR JOISTS

PERFORMANCE OBJECTIVE:

Given working drawings and specifications for a floor frame, a foundation wall or slab with support members installed, dimensioned lumber, and the necessary tools, equipment, and materials; cut and install floor joists as specified. The joists must be cut to $\pm 1/8$ inch of length specifications, positioned 16 or 24 inches O.C., and fastened to specifications with crowns facing upward.

PERFORMANCE ACTIONS:

- 11.0701 Check specifications and plans for required joists.
- 11.0702 Determine size needed.
- 11.0703 Layout sill plate according to specifications (distance between).
- 11.0704 Check to see that crown is turned up.
- 11.0705 Place joist in proper position according to layout marks on the sill. (Check spacing again of layout).
- 11.0706 Toenail joists in place.
- 11.0707 Nail on sill header. (Check crowns.)
- 11.0708 Straighten joists before installing bridging.

PERFORMANCE STANDARDS:

- Layout, cut, and install floor joists according to given specifications and meet the following standards:
 - Cut joists to length $\pm 1/8$ inch.
 - Position joists at 16 inches on center $\pm 1/8$ inch.
 - Crowns of joists will be in an up position.
 - Joists will be properly nailed.

SUGGESTED INSTRUCTION TIME: 24 Hours (on model)

UNIT	11.0	FLOOR AND SILL FRAMING
TASK	11.08	INSTALL BRIDGING BETWEEN JOISTS

PERFORMANCE OBJECTIVE:

Given working drawings and specifications for a floor frame, a frame with installed, wood stock or dimensioned lumber suited for bridging and the necessary tools, equipment, and materials; cut and install the joist bridging. The type of bridging must correspond to the requirements of the working drawings. All bridging must be cut to length specifications and installed straight and plumb +/- 1/8 inch. Cross bridging must be cut to specified angles +/- 2 degrees.

PERFORMANCE ACTIONS:

11.0801 According to specifications, install bridging.

PERFORMANCE STANDARDS:

- Layout, cut, and install bridging according to plans and Southern Standard Building Code specifications so that the following standards are met.
- Bridging will be properly cut with respect to length (+/- 1/8 inch) and angle of cut (+/- 2 degrees).
- Bridging will be nailed to joists according to Southern Building Standard Code specifications.
- Floor joists will be straight and plumb after bridging has been installed (+/- 1/8 inch).
- Bridging will be located in accordance with plans and Southern Standard Building Code specifications.

SUGGESTED INSTRUCTION TIME: 6 Hours

UNIT	11.0	FLOOR AND STILL FRAMING
TASK	11.09 *	FRAME FLOOR OPENINGS

PERFORMANCE OBJECTIVE:

Given working drawings and specifications for a floor frame, frame with full joists installed, dimensioned lumber, and the necessary tools, equipment, and materials; frame floor openings for a basement of fireplace. The opening must be square and within size specifications +/- 1/8 inch and installed straight and plumb with the required fastening.

*May be orientation or performance training.

PERFORMANCE STANDARDS:

- Frame openings in floor according to drawings and specifications.
- The following standards apply:
 - Opening will be proper size according to plan.
 - Opening will be square.
 - Framing will meet requirements of the Southern Standard Building Code.
 - Spacing as specified will be maintained between regular and tail joists.

*May be orientation task or performance task.

SUGGESTED INSTRUCTION TIME: 6 Hours

213

UNIT	11.0	FLOOR AND SILL FRAMING
TASK	11.10	INSTALL A SUBFLOOR

PERFORMANCE OBJECTIVE:

Given working drawings and specifications for a floor frame, a frame with all joists and openings installed, subfloor material (plywood, particle-board, tongue-and-groove stock), and the necessary tools, equipment, and materials, install a subfloor. The subfloor must be installed to specifications +/- 1/8 inch with the required fastening pattern. Floor openings must be allowed, and joints must be staggered. Waste of material must be maintained at 10 percent or less.

PERFORMANCE ACTIONS:

- See plans and specifications, local building code, and Southern Building standards.

PERFORMANCE STANDARDS:

- Install a subfloor to specifications +/- 1/8 inch with the required fastening pattern. Floor openings must be allowed, and joints must be staggered. Waste of material must be maintained at 10 percent or less.
- Meet specifications of the Southern Standard Building Code.

SUGGESTED INSTRUCTION TIME: 6 Hours

FLOOR AND SILL FRAMING

After completion of this unit, the student should be able to define floor and sill framing terms, identify floor and sill framing members, name the styles of framing, and write the purpose of a sill sealer and termite shield. He should also be able to name the methods of fastening sills on top of floor the sill to the foundation, construct a box sill, lay off and install the floor joist, list and apply the various types of subflooring, and use the power tools safely and correctly. This knowledge will be evidenced by demonstration and by scoring 80 percent of the unit test.

1. Match terms associated with floor and sill framing to a list of definitions.
2. Name two styles of framing.
3. Identify eight framing members that make up the floor and sill.
4. Write the purpose of a sill sealer.
5. Write the purpose of a termite shield.
6. Name two methods of fastening sills to foundation walls.
7. Write the purpose of bridging.
8. Write the purpose of beams or girders.
9. List two types of subflooring.
10. Match the appropriate nails to their use in assembling the subfloor, sill, and joists.
11. Estimate the amount of material needed to frame a floor and sill.
12. Estimate the amount of material needed to lay a subfloor.
13. Demonstrate the ability to:
 - a. Lay the sill and install the floor joist on 16 and 24 inch centers.
 - b. Install bridging.
 - c. Lay subflooring.
 - (1) Lumber
 - (2) Plywood

TRUE-FALSE

1. The chief characteristic of balloon framing is the use of continuous studs. _____
2. Lumber shrinks across the grain of a board. _____
3. Another name for balloon framing is platform framing. _____
4. Platform framing uses two inch thick material. _____
5. Bridging is used to brace the joists at the sill. _____
6. The short dimension of a sheet of plywood used for subflooring should run parallel to the joists. _____
7. Before nailing in any floor joists, the carpenter should make sure the crown is down. _____
8. The minimum recommended space between the floor joists and the soil in a crawl space is 18 inches. _____
9. At least 4 inches of floor joists should always rest on the sill plate. _____
10. Plywood that is 5/8 inch is considered strong enough for a subfloor. _____

COMPLETION

1. A framing member that carries the weight from various areas of the floor to the sills and girders is called a _____.
2. The main purpose of the _____ is to add rigidity to the structure and provide a base for the application of finished flooring materials. _____
3. The usual distance allowed between joists is _____ inches O.C. _____
4. Sills are anchored to the foundation with _____.
5. The purpose of _____ is to transfer the load from one joist to adjacent joists. _____

MULTIPLE-CHOICE

1. The framing member into which the common joists are fitted forming the box sill or a member used to support the free end of joists over openings such as stairs, chimneys, and other openings are known as the:
 - a. header
 - b. sill
 - c. beam
 - d. joist header

2. Solid lumber or small wooden or steel pieces fitted in pairs from the bottom of one joist to the top of the adjacent joist and crossed to stiffen and help distribute the load are called:
 - a. bridging
 - b. joists
 - c. framing anchors
 - d. headers

3. A system of framing a building where the floor joists of each story rest on the top plates of the story below and the bearing walls and partitions rest on the sub-floor of each story is called:
 - a. balloon
 - b. platform
 - c. common
 - d. English

4. What is a girder?
 - a. vertical beam that supports windows
 - b. large beam that supports smaller beams or joists
 - c. the floor joist of a house
 - d. what the stud is nailed to

5. How are wood sills fastened to masonry walls?
 - a. nails
 - b. 2 1/2" bolts 3" washers
 - c. 1/2" bolts 2" washers
 - d. dowels

6. What is the subflooring set upon or nailed to?
 - a. floor joist
 - b. concrete blocks
 - c. studs
 - d. ceiling joist

CARPENTRY MATH-FLOOR FRAMING

1. Estimate the number and length of joists and headers required to construct the floor frame for a single-story rectangular building 12 feet wide and 32 feet long. Use 2 x 8 lumber spaced 16 inches O.C.

(calculations)	Headers	=	_____
	Joists	=	_____
	Total Board feet	=	_____

2. Using tools, lumber, and nails provided, and the drawing included with these directions. Frame the floor section (full size) which is enclosed by a rectangle and marked by an asterisk (*) on the drawing.

The completed section will have dimensions which are approximately five feet long and two feet wide.

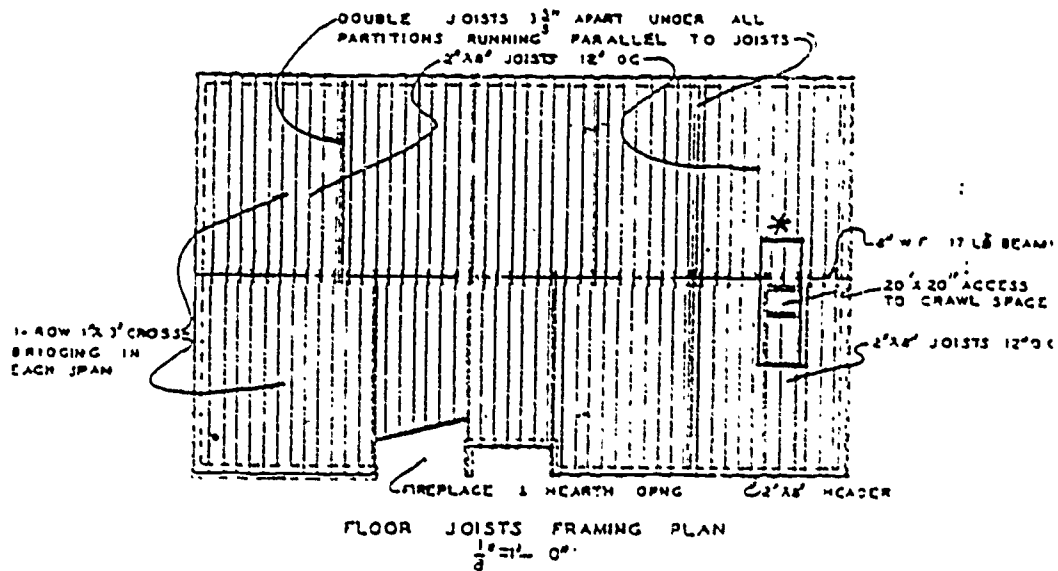

UNIT 12.0

WALL AND PARTITION FRAMING

Upon completion of this unit, the graduate should be able to use wall and partition framing terms, identify framing members, and compute the length of common members. The graduate should be able to layout, cut, and assemble a wall section, identify and apply various types of sheathing and use the power tools safely and correctly.

Emphasis is placed on platform-frame construction rather than Balloon-frame which is used infrequently in the service area.

SUGGESTED MINIMUM TERMINOLOGY

WALL AND PARTITION FRAMING

Bearing Wall	Wall support for the floors or roof directly above it in addition to its own weight.
Cripple Stud	Any part of a framing stud that is less than full size such as those found over a door or over or under a window opening.
Double Plate	Top most member of a wall section attached to the top of the studs for the purpose of stiffening the wall and for trying together splices, corners, and partitions that are at right angles to a wall.
Header	Horizontal structural member that supports the load over an opening such as a window or door. (Also; lintel)
Partition	Wall that subdivides the floor space within a structure.
Sole Plate	Lowest horizontal member of a wall or partition which rests on the rough floor to which the studding is nailed.
Stud	Main vertical framing member in walls and partitions.
Trimmer	Vertical members that form the sides of a rough opening for a door or window upon which the header or lintel rests.
Jam	The top and two sides of a door or window frame which contact the door or sash consisting of a head jamb and two side jambs.

Adopted from text, Modern Carpentry.

UNIT	12.0	WALL AND PARTITION FRAMING
TASK	12.01	LAYOUT A WALL FRAME

PERFORMANCE OBJECTIVE:

Given working drawings and specifications for an exterior or interior wall frame, wood stock and dimensioned lumber, and the necessary layout tools and materials; lay out a wall frame. All materials must be marked accurately for cutting and framing the wall frame according to specifications +/- 1/8 inch. Materials must be marked to indicate maximum use of wood stock and dimensioned lumber.

PERFORMANCE ACTIONS:

- 12.0101 Select lumber.
- 12.0102 Marking stud locations correctly.
- 12.0103 Layout wall.

PERFORMANCE STANDARDS:

- Layout a wall frame so that all materials are marked accurately for cutting and framing the wall frame according to specifications +/- 1/8 inch.
- Materials must be marked to indicate maximum use of wood stock and dimensioned lumber.
- Wall frame requirements must meet Southern Standard Building Code.

SUGGESTED INSTRUCTION TIME: 30 Hours

UNIT	12.0	WALL AND PARTITION FRAMING
TASK	12.02	CONSTRUCT CORNER POSTS AND T-POSTS

PERFORMANCE OBJECTIVE:

Given working drawings and specifications for an exterior wall frame, wood stock, dimensioned lumber, and the necessary tools, equipment, and materials; construct corner posts and T-posts. The dimensioned lumber must be straight, sound material cut to specified length $\pm 1/16$ inch. Ends must be flush for fastening to plates. Blocking must be positioned according to the drawing specifications $\pm 1/16$ inch, and members must be fastened in the required pattern. All blocks or pieces will be nailed according to Southern Standard Building Code.

PERFORMANCE ACTIONS:

- 12.0201 Select lumber.
- 12.0202 Cut and construct corner posts.

PERFORMANCE STANDARDS:

- Construct corner posts and T-posts. The posts must be uniform to the following standards:
 - Dimensioned lumber must be straight, sound material cut to specified length $\pm 1/8$ inch. Ends must be flush for fastening to plates.
 - Blocking must be positioned according to the drawing specifications $\pm 1/8$ inch, and members must be fastened in the required pattern. All blocks or pieces will be nailed according to Southern Standard Building Code.
- Ends of corner posts will be 90 degrees (± 2 degrees).

SUGGESTED INSTRUCTION TIME: 12 Hours

UNIT	12.0	WALL AND PARTITION FRAMING
◦ TASK	12.03	FRAME A WALL OPENING

PERFORMANCE OBJECTIVE:

Given working drawings and specifications, necessary tools and equipment, and sufficient materials; frame a window or door opening. The following standards will apply:

- Framing members will be flush +/- 1/16 inch.
- Members will be positioned and nailed as according to specifications. (Southern Standard Building Codes.)
- Members will be cut to exact dimensions +/- 1/8 inch.
- Installed header will be plumb and level.
- Cripple studs will be carried through an O. C. spacing.

PERFORMANCE ACTIONS:

- 12.0301 Install full studs on each side of the opening.
- 12.0302 Install built-up header.
- 12.0303 Cut and install trimmers.
(NOTE: At this point a door opening would be complete.)
- 12.0304 Cut, layout, and install the rough window sill.
- 12.0305 Install cripple studs.

PERFORMANCE STANDARDS:

- Frame a wall opening.
- The following specifications apply:
 - Framing members will be flush +/- 1/8 inch.
 - Members will be positioned and nailed according to specifications. (Southern Standard Building Code standard apply)
 - Installed header will be plumb and level.

SUGGESTED INSTRUCTION TIME: 6 Hours

UNIT 12.0

WALL AND PARTITION FRAMING

TASK 12.04

INSTALL DOOR AND WINDOW FRAMES

PERFORMANCE OBJECTIVE:

Given working drawings and specifications, an erected wall frame with door and window openings, a door, a window frame, braces, and the necessary tools, equipment, and materials; install the door and window frames. The frames must be set plumb and in alignment with the wall frame. Clearance for the door must assure that the door moves without binding.

PERFORMANCE ACTIONS:

- According to plans and specifications, Southern Building specifications, and, if stock windows or doors, to manufacturer's specifications.

PERFORMANCE STANDARDS:

- Install door and window frames so that the frame is plumb and in alignment with the wall frame.
- Clearance for the door must assure that the door moves without binding.

SUGGESTED INSTRUCTION TIME: 6 Hours

224

173

UNIT	12.0	WALL AND PARTITION FRAMING
TASK	12.05 (OPTIONAL)	BUILD BOX BEAMS

PERFORMANCE OBJECTIVE:

Given working drawings and specifications, wood stock and dimensioned lumber, and the necessary tools, equipment, and materials, frame and build a box beam in accordance with drawings, specifications and the following standards:

- Measurements must be accurate to $\pm 1/8$ inch.
- Glue bond between various members must be strong.
- Beam must not sag or webbing buckle under specified load.
- Joints must be staggered and fastened according to required patterns.

PERFORMANCE STANDARDS:

- Frame and build box beam in accordance with drawings, specifications and the following standards:
 - Measurements must be accurate to $\pm 1/8$ inch.
 - Glue bond between various members must be strong.
 - Beam must not sag or webbing buckle under specified load.
 - Joints must be staggered and fastened according to required patterns.
 - Applicable standards of the Southern Standard Building Code.

SUGGESTED INSTRUCTION TIME: (Optional)

UNIT	12.0	WALL AND PARTITION FRAMING
TASK	12.06 (OPTIONAL)	INSTALL FURRING

PERFORMANCE OBJECTIVE:

Given working drawings and specifications, necessary tools and equipment, and sufficient materials; furr masonry walls. The following standards apply:

- Furring strips will be the required length (+/- 1/8 inch).
- Furring strips will be fastened to masonry wall with appropriate fasteners.
- Furring strips will be located 16 inches on center +/- 1/16 inch.
- Furring strips will be plumb.

PERFORMANCE STANDARDS:

- Take furring strips and apply them to masonry wall so the following standards are met:
 - Furring strips are required length +/- 1/8 inch.
 - Furring strips are fastened to masonry wall with appropriate fasteners.
 - Furring strips are located 16 inches on center +/- 1/16 inch.
 - Furring strips are plumb.

SUGGESTED INSTRUCTION TIME: (Optional)

UNIT	12.0	WALL AND PARTITION FRAMING
TASK	12.07 (OPTIONAL)	INSTALL FIRESTOP*

PERFORMANCE OBJECTIVE:

Given working drawings, specifications, necessary tools, equipment, and sufficient materials; install firestops between wall studs. The following standards apply:

- Firestops will be required length +/- 1/16 inch.
- Firestops will be firmly secured in place.
- Firestops will be located as specified.

PERFORMANCE ACTIONS:

- 12.0701 Box in vital points with 1 inch boards and full boxes with incombustible materials.
- 12.0702 Cut 2 x 4 inch blocks between wall studs.
- 12.0703 Cut blocking (2 x 8 or 2 x 10 inch) between floor joists.

PERFORMANCE STANDARDS:

- Install firestops between wall studs meeting the following standards:
 - Firestops are the required length +/- 1/16 inch.
 - Firestops are firmly secured in place.
 - Firestops are located as specified.

SUGGESTED INSTRUCTION TIME: (Optional)

*May be called pertins.

UNIT	12.0	WALL AND PARTITION FRAMING
TASK	12.08	INSTALL STRUCTURAL SHEATHING

PERFORMANCE OBJECTIVE:

Given working drawings, specifications, an erected wall frame with door and window openings, wood stock (plywood, particleboard, or fiberboard), and the necessary tools, equipment, and materials; install structural sheathing. The sheathing must be installed with required patterns. Caps between sheets must not exceed 1/8 inch. Openings must be cut after the sheets are nailed.

PERFORMANCE ACTIONS:

- 12.0801 Check manufacturer's recommendations for placement of sheathing.
- 12.0802 Cut sheathing to length if required.
- 12.0803 Start first panel flush with the bottom of sill and at the end of a wall.
- 12.0804 Position sheathing and nail in place.
- 12.0805 Cut openings after sheet is nailed.

PERFORMANCE STANDARDS:

- Take sheathing material and install on exterior wall as specified by Southern Standard Building Code.
 - Joints will be centered on studs.
 - Sheathing will be properly nailed with respect to type and size of fastener and spacing as recommended by Southern Standard Building Code.
 - Joints will be tight (gap not exceeding 1/8 inch).

SUGGESTED INSTRUCTION TIME: 6 Hours

TRUE-FALSE

1. The corners of walls should be fastened with 10d nails, spaced about 12 inches apart in a staggered pattern. _____
2. Studs are fastened to plates with 10d nails. _____
3. Horizontal bracing is used on structures to prevent lateral shifting. _____
4. The standard height for a conventional door is 6' - 8" high. _____
5. A corner post must form an inside corner and an outside corner. _____
6. The double plate is the same length as the top plate. _____
7. Partition corner posts are sometimes referred to as "T" posts. _____
8. Partition walls are of two types: Bearing and non-bearing. _____
9. Top plates should be lapped at the corners and partitions. _____
10. Wall studs generally are placed 18 inches on center. _____

COMPLETION

1. The first step in estimating the number of studs required is to figure the total length of all _____.
2. Trimmer studs stiffen the sides of an opening and carry the weight of the _____.
3. In platform construction, wall-framing members include sole plates, top plates, studs, and _____.
4. On blueprints or working drawings, the view which gives window and door dimensions for layout is the _____ view.
5. The plate layout length is determined by the length of the _____.

MULTIPLE-CHOICE

1. If the window span is from 4'-6", the header has to be: _____
- a. 4 x 4
 - b. 4 x 6
 - c. 4 x 8
 - d. 4 x 10
2. Although studs are sometimes spaced 24 in. O.C. in residential structures, a spacing of _____ inches O.C. is more commonly used. _____
- a. 12
 - b. 16
 - c. 18
 - d. 20
3. If the architectural plans show the rough opening of a window to be 3'-2" x 4'-9", the height of the opening should actually measure: _____
- a. 3'-2"
 - b. 3'-3"
 - c. 4'-9"
 - d. 4'-11"
4. Headers are formed by nailing two members together with a spacer between. The spacer should be _____ inches thick. _____
- a. 1/4
 - b. 3/8
 - c. 1/2
 - d. 5/8
5. A row of bridging is required whenever the joist span _____ between supports exceeds _____ feet. _____
- a. 4
 - b. 6
 - c. 8
 - d. 10

PRACTICAL PROBLEM IN CARPENTRY MATH

1. After adding up the length of all walls and partitions a carpenter finds there is a total of 270 feet. How many lineal feet of 2 x 4 stock will be needed to build the sole and double plate? How many board feet will this equal?

(calculations)

Lineal feet = 230
Board feet = _____

IDENTIFY

1. Identify the framing members shown in this illustration.

1. _____
2. _____
3. _____
4. _____
5. _____
6. _____
7. _____
8. _____
9. _____

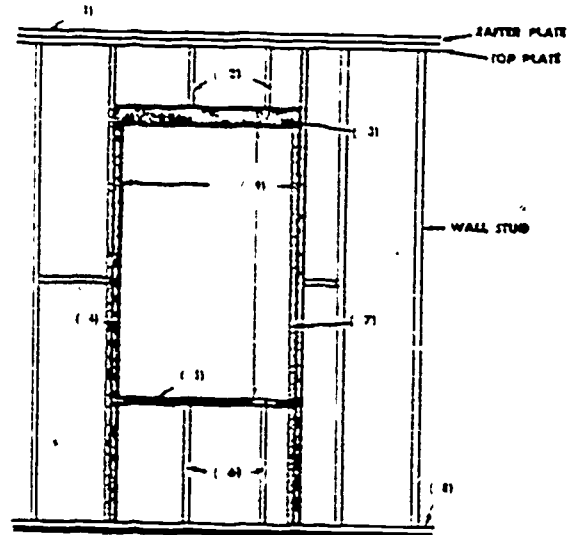

2. On the following drawing of a platform frame construction of a first-floor framing at the girder, and exterior wall, identify the marked members using the proper terminology.

1. _____
2. _____
3. _____
4. _____
5. _____

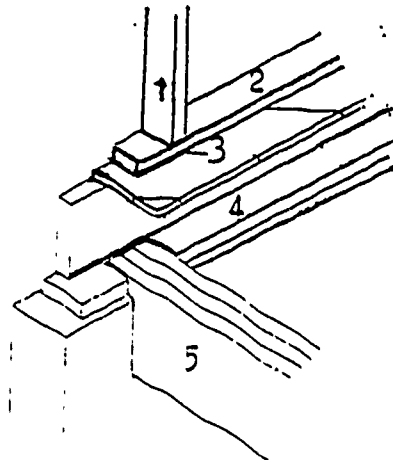

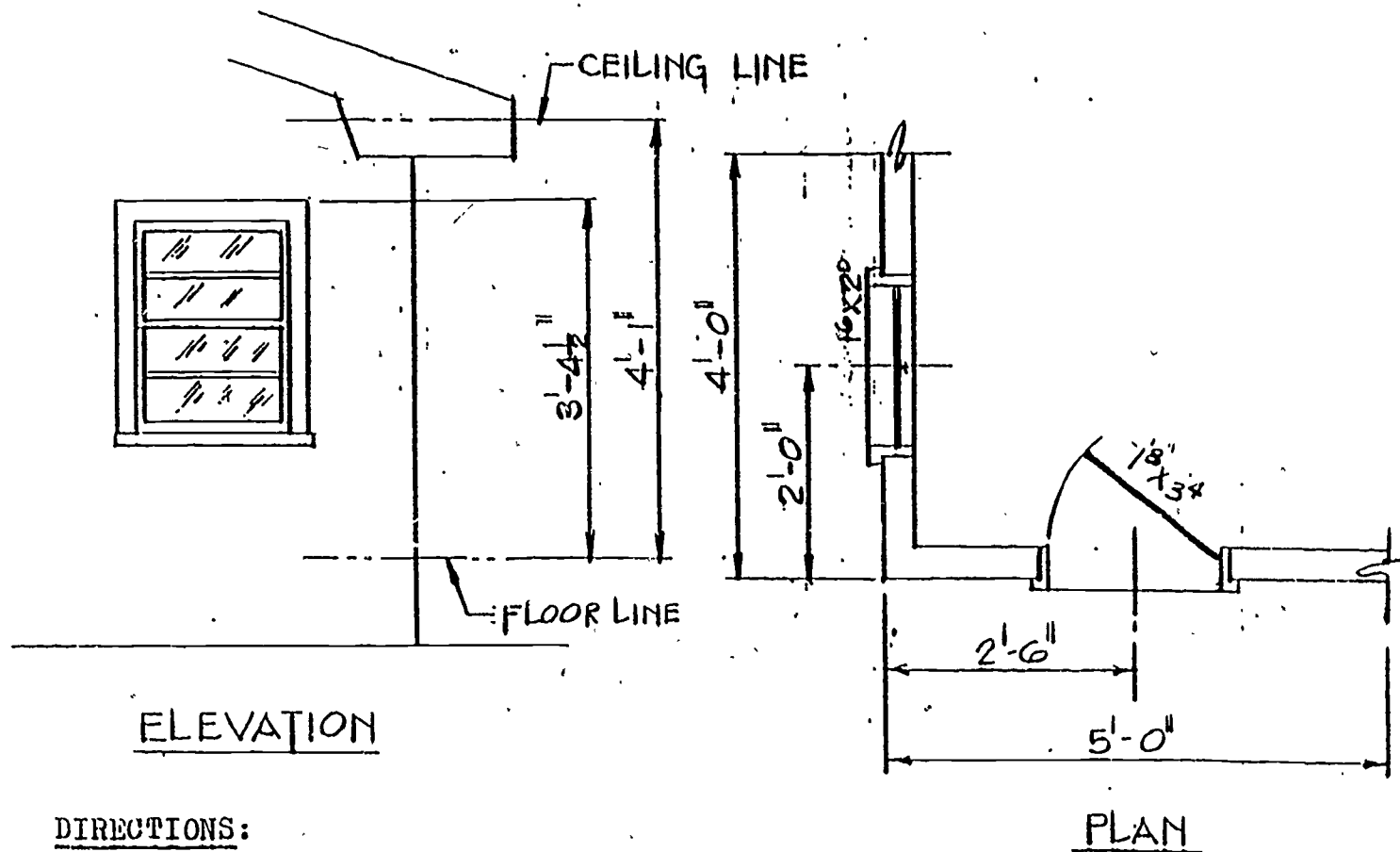
DIRECTIONS:

1. Layout plates
2. Build corner post
3. Layout R.O. for window
4. Layout R.O. for door
5. Cut framing to length
6. Frame wall
7. Square corner
8. Double plate

WALL FRAMING PROJECT

UNIT 13.0
ROOF FRAMING

Upon completion of this unit, the student should be able to identify the roofing members and roof styles, list the methods for determining rafter length, and define roof framing terms. They should be able to cut and assemble the various roof members and use the power tools safely and correctly. This knowledge will be evidenced through demonstration and scoring 80 percent on the end-of-unit test.

SUGGESTED MINIMUM TERMINOLOGY

ROOF FRAMING

Barge rafter	Exposed rafter at end of gable roof (also verge rafter).
Birdsmouth	Cutout near bottom of a rafter which fits over the double plate.
Collar beam	Horizontal tie beam connecting two opposite rafters up near the ridge to hold them together at the ridge.
Common rafter	One of a series of rafters extending from the double plate to the ridge.
Dormer	A window, vertical in a roof.
Gusset	Panel or bracket of either wood or metal attached to corners at intersections of a frame to add strength and stiffness.
Hip rafter	The rafter extending from the double plate at the corner of a building to the ridge forming the angle for a hip roof.
Jack rafter	Short rafter which fits between the plate and the hip or valley rafter or between the ridge and hip or valley rafter. (Called a cripple jack when fitted between hip and valley rafter.)
Pitch	Angle or degree of slope of a roof.
Plumb cut	Cut at right angles to the seat cut of the birdsmouth and is also the cut of the rafter at the ridge.
Purlin	Horizontal members supporting the common rafters in roof.
Ridge board	Horizontal members or timber at top of the roof to which upper end of the rafters are nailed.
Rise	Incline or pitch of a roof expressed in terms of inches per one foot of run.
Run	Horizontal distance that underlies the slope of the roof from a wall to the ridge, usually one-half of the span.

Seat cut

Cut at lower end of a rafter; the part of the birds-mouth that rest on the plate.

Truss system

A structural unit consisting of such members as beams, bars, and ties; usually arranged to form triangles. Provides rigid support over wide spans with a minimum amount of material.

Adopted from textbo. Modern Carpentry.

UNIT	13.0	ROOF FRAMING
TASK	13.01	LAYOUT, CUT, AND INSTALL COMMON RAFTERS FOR EQUAL PITCH ROOFS

PERFORMANCE OBJECTIVE:

Given working drawings (including roof layout) for a typical residential dwelling, required carpentry tools, a helper, and materials, layout, cut, and install common rafters for an equal-pitch roof.

PERFORMANCE ACTIONS:

- 13.0101 Check blueprints for specific details and instructions such as roof pitch, on-center layout for installation, etc.
- 13.0102 Calculate the total length of rafter from plate to ridge.
- 13.0103 Layout the vertical (plumb) cut on the top end of the pattern rafters.
- 13.0104 Establish a layout line and work from this line to locate the plumb cut for the birdsmouth (seat) of rafter.
- 13.0105 Determine the total amount of the overhang or tail section of the rafter. Make the corresponding layout on the tail section for the type of cornice required.
- 13.0106 Carefully check all calculations and layouts for accuracy.
- 13.0107 Layout the ridgeboard and side wall plates the designated distance on centers.
- 13.0108 Erect the rafters in pairs starting with the gable rafters (or at the apex of the first pair of hipped rafters, if it is a hipped roof).
- 13.0109 Plumb the gable rafters (or first pair of common rafters on a hipped roof). For gable roofs the end of the ridge should be flush with the outside of the rafters and corresponding wall plate.
- 13.0110 Erect the remaining rafters in pairs, first one rafters and then the opposite, nailing bottom ends of the rafters to the plate first.

UNIT	13.0	ROOF FRAMING
TASK	13.01	LAYOUT, CUT, AND INSTALL COMMON RAFTERS FOR EQUAL PITCH ROOFS (Con't.)

PERFORMANCE STANDARDS:

- Layout, cut, and install common rafters for equal pitch roofs meeting specifications and applicable standard such as the Southern Standard Building Code.

SUGGESTED INSTRUCTION TIME: 15 Hours

RELATED TECHNICAL INFORMATION:

- Blueprint reading, specifications, roof framing plan, elevations, and sections.
- Use of steel square.
- Roof framing technology.
- Carpentry (and hand) power tools.
- Fasteners.

UNIT 13.0

ROOF FRAMING

TASK 13.02

LAYOUT, CUT, AND INSTALL CEILING
JOIST

PERFORMANCE OBJECTIVE:

Given a typical residential structure with the bearing walls erected ready to receive the ceiling joists, a helper, tools, and materials; layout, cut, and install the ceiling joist.

PERFORMANCE ACTIONS:

- 13.0201 Layout top plates to receive ceiling joist.
- 13.0202 Space joist correctly O.C.
- 13.0203 Layout interior bearing walls to receive the joists.
- 13.0204 Check for crown of joist and cut away portion of the joist that extends above the rafter line.
- 13.0205 Place the required joists on top of wall plates adjacent to their nailing positions.
- 13.0206 Nail the outside ends of joists flush with outside of top plate with each joist overlapping inside bearing partition wall.
(NOTE: Install each joist with the crown up.)
- 13.0207 Brace inside center bearing wall to work from for final alignment and installation.
- 13.0208 Check that all walls are true and braced.
- 13.0209 When outside plates are aligned, nail the joist to the inside bearing wall plates.
- 13.0210 Check all outside plates for alignment and nail the overlapped joist securely.

PERFORMANCE STANDARDS:

- With the aid of a helper, layout, cut, and install the ceiling joist according to specifications and drawings.
- Measurements must be to +/- 1/8 inch.

SUGGESTED INSTRUCTION TIME: 9 Hours

UNIT 13.0

ROOF FRAMING

TASK 13.03

LAYOUT COMMON ROOF PLAN

PERFORMANCE OBJECTIVE:

Given working drawings, specifications for a gable (*or hip) roof frame (plan), wood stock and dimensioned lumber, and the necessary layout tools and materials; layout a gable (*or hip) roof frame. All materials must be marked accurately for cutting and framing the rafters, ridgeboard, gables, dormers, purlins, and collar beams according to specifications +/- 1/16 inch. Materials must be marked to indicate maximum use of wood stock and dimensioned lumber.

- *- Layout hip roof on 4/12 pitch.
- All framing members must be accurately located showing the on center (O.C.) layout.

* Optional

PERFORMANCE ACTIONS:

13.0301 Identify the following minimum roof framing terms:

- | | |
|------------------|-----------------------|
| - Common Rafter | - Birdsmouth or seat |
| - Crown | - Ridge or ridgeboard |
| - Flush | - Hip rafter |
| - Alignment | - Valley rafter |
| - Framing Square | - Jack rafter |
| - Rafter Scale | - Barge rafter |
| - Rise | - Gable |
| - Run | - Framing anchor |
| - Slope | - Pitch |
| - Plumb cut | - Span |
| - Plate cut | - Tail end |

13.0302 From specifications and drawings, identify the roof type.

13.0303 Identify the roof frame members from the working drawings.

13.0304 Select the necessary tools and materials to layout the roof frame.

13.0305 Sub-Task Objective:
DETERMINE LENGTH OF RAFTERS FROM RAFTER SCALE

Given a building plan, the pitch of the roof, and a framing square; determine the length of the rafters by using tables found on the square.

UNIT	13.0	ROOF FRAMING
TASK	13.03	LAYOUT COMMON ROOF PLAN (Con't.)

PERFORMANCE ACTIONS (Con't.):

Performance Standard:

- Determine rafter lengths for a given house.

13.0306 Sub-Task Objective:

Given the span of a building and the pitch of the roof (e.g., span = 32 feet and 6 inches, pitch = 1/3 inch); calculate the run and rise for a common roof. All calculations must be 100 percent accurate.

1. Determine (calculate) the pitch into inches rise per foot run.
2. Calculate the run of the roof frame plate to center of building (one-half the span).
3. Multiply the inches rise per foot run times the number of feet in the run of the roof to determine the total rise of the roof.

Unit Rise

$$\text{Unit Span} = \text{Pitch}$$

- 13.0307 Lay out a common roof plan that meets specifications of the Southern Standard Building Code.

PERFORMANCE STANDARDS:

- Layout a common roof plan for given specifications and working drawings.
- The roof assigned may be a gable or hip roof.
- All framing members must be accurately located showing the on center (O.C.).

SUGGESTED INSTRUCTION TIME: 12 Hours

UNIT	13.0	ROOF FRAMING
TASK	13.04 (OPTIONAL)	LAYOUT, CUT, AND INSTALL CRIPPLE JACK RAFTERS FOR HIP AND VALLEY INSTALLATIONS

PERFORMANCE OBJECTIVE:

Given hip and valley rafters installed, tools, materials, and a helper; layout, cut, and install the required cripple jack rafters. The following standards apply:

- Determined roof pitch.
- Determined cripple jack rafter run.
- Calculated length of cripple.
- Deducted one-half of 45 degrees thickness of hip or valley.
- Laid out top and bottom cuts.
- Laid out locations on hip and valley.
- Nailed cripple jack in place.
- Checked alignment, spacing, and nailing.

PERFORMANCE ACTIONS:

- 13.0401 Determine the pitch of the roof if not given in plans (rise per foot run of the common rafter).
- 13.0402 Determine the run (The run can be determined by measuring the length of the plate between the hip and valley rafters).
- 13.0403 Using the rise and run, calculate length of the cripple jack in the same manner used for common rafters.
- 13.0404 Use the rise per foot run on the tongue and 17 inch (based figure for hip, valley and jack rafters) on the blade of framing square to mark cuts.
- 13.0405 Deduct one-half of the 45 degree thickness of the hip and one-half 45 degree thickness of the valley from the overall length of jack.
- 13.0406 Layout and mark the side cuts following procedures for hip and valley jacks:
 - a. Top cheek cut layout is same as for a hip jack rafter.
 - b. Bottom cheek layout is same as for bottom cut on valley jack rafter.
- 13.0407 Layout the hip and valley rafters to receive the cripple jacks.

UNIT	13.0	ROOF FRAMING
TASK	13.04 (OPTIONAL)	LAYOUT, CUT, AND INSTALL CRIPPLE JACK RAFTERS FOR HIP AND VALLEY INSTALLATIONS (Con't.)

PERFORMANCE ACTIONS (Con't.):

- 13.0408 Nail the cripple jacks top and bottom being careful not to cause a bow in either the hip or valley.
- 13.0409 Check final installation including alignment, spacing and nailing.

PERFORMANCE STANDARDS:

- Layout, cut, and install cripple jack rafters for hip and valley installations.
- Hip jacks must extend diagonally from hip rafters and parallel to ridge +/- 1/8 inch.
- Cripple jacks must extend diagonally from valley to hip rafters +/- 1/8 inch.
- Valley jacks must extend diagonally from the ridge to valley rafters +/- 1/8 inch.
- Plumb and plate cuts must allow for a tight fit and the rafters must be installed plumb and straight +/- 1/8 inch.

SUGGESTED INSTRUCTION TIME: 12 Hours (Optional)

RELATED TECHNICAL INFORMATION:

- Southern Standard Building Code standards.
- Framing square.

UNIT	13.0	ROOF FRAMING
TASK	13.05 (OPTIONAL)	CUT AND INSTALL VALLEY RAFTERS

PERFORMANCE OBJECTIVE:

Given working drawings, specifications for a roof frame (equal or unequal pitch), a structure with an intersecting roof frame and floor, wall, and ceiling frames and ridge and common rafters installed, dimensioned lumber, and the necessary tools, equipment, and materials; cut and install valley rafters for an unequal pitch intersecting roof. The valley rafters must extend diagonally from plate to ridge. The rafter lengths, including allowances for overhand and ridgeboard must be accurate to $\pm 1/8$ inch. Plumb and plate cuts must be installed plumb and straight $\pm 1/8$ inch. (For equal pitch roofs).

PERFORMANCE ACTIONS:

- 13.0501 Calculate unit rise of roof per foot run (may be available from roof plan).
- 13.0502 Determine unit run of valley rafter (fixed at 17 inches).
- 13.0503 Calculate or determine unit length of valley rafter (diagonal distance from unit rise to unit run 17 inches/ on carpenter's square).
- 13.0504 Multiply the unit length by the total number of units run to determine the total length of the valley.
- 13.0505 Layout the plumb cut top of rafter using unit rise and unit run figures on carpenter's square.
- 13.0506 Layout the cheek cut for top of rafter.
- 13.0507 Measure the total length of rafter and deduct one-half the 45 degree thickness of ridge.
- 13.0508 Layout the plumb seat (birdsmouth) cut for the plate.
- 13.0509 Layout the tail section of the rafter for the type cornice.
- 13.0510 Make the required cuts on the rafter.
- 13.0511 Nail the rafter in place.

UNIT	13.0	ROOF FRAMING
TASK	13.05 (OPTIONAL)	CUT AND INSTALL VALLEY RAFTERS (Con't.)

PERFORMANCE ACTIONS (Con't.):

13.0512 Check the alignment and position location.

PERFORMANCE STANDARDS:

- With the assistance of a helper, layout, cut, and install the designated valley rafter.
- Valley rafters must extend diagonally from plate to ridge.
- Rafter lengths, including allowances for overhand and ridgeboard must be accurate to 1/8 inch.
- Plumb and plate cuts must allow for a tight fit, and the rafters must be installed plumb and straight 1/8 inch.

SUGGESTED INSTRUCTION TIME: 6 Hours (Optional)

RELATED TECHNICAL INFORMATION:

- Framing square.

UNIT	13.0	ROOF FRAMING
TASK	13.06 (OPTIONAL)	LAYOUT, CUT, AND INSTALL HIP RAFTERS FOR EQUAL PITCH ROOFS

PERFORMANCE OBJECTIVE:

Given working drawings, specifications for a roof frame equal or unequal pitch, a hip roof structure with floor, wall, and ceiling frames and ridgeboard installed, dimensioned lumber, and the necessary tools, equipment, and materials; cut and install hip rafters for an equal or unequal pitch roof. The hip rafters must extend diagonally from plate to ridge. The rafter lengths, including allowances for overhang and ridgeboard, must be accurate to $\pm 1/8$ inch. Plumb and plate cuts must allow for a tight fit, and the rafters must be installed plumb and straight $\pm 1/8$ inch.

PERFORMANCE ACTIONS:

- 13.0601 Calculate the rise of the common rafters per foot run.
- 13.0602 The run for a hip rafter per foot run of the roof span is fixed at 17 inches for layout. Use this figure for the horizontal base of the triangle for layout of the hip.
- 13.0603 Determine the length per foot run of the hip by measuring the diagonal distance between rise per roof run setting and the square to the run which is fixed at 17 inches.
- 13.0604 Multiply the length per foot run times the number feet of the roofs run ($1/2$ the span) to calculate the total length of the hip.
- 13.0605 Calculate the allowance for the thickness of the ridge and deduct this from the total length of the hip.
- 13.0606 Select a straight piece of full length stock and layout the hip rafter for all required cuts.
- 13.0607 Make the required cuts and use this as a pattern.
- 13.0608 Install the hip rafters in pairs nailing the seat to the plate first and then nail to the ridge.

UNIT	13.0	ROOF FRAMING
TASK	13.06 (OPTIONAL)	LAYOUT, CUT, AND INSTALL HIP RAFTERS FOR EQUAL PITCH ROOFS (Con't.)

PERFORMANCE ACTIONS (Con't.):

13.0609 Check for alignment and nailing.

PERFORMANCE STANDARDS:

- With the aid of a helper, layout, cut, and install the hip rafters for a designated roof.
- The hip rafters must extend diagonally from plate to ridge.
- The rafter lengths, including allowance for overhand and ridgeboard, must be accurate to +/- 1/8 inch.
- Plumb and plate cuts must allow for a tight fit, and the rafters must be installed plumb and straight +/- 1/8 inch.

SUGGESTED INSTRUCTION TIME: 6 Hours (Optional)

UNIT	13.0	ROOF FRAMING
TASK	13.07	CUT AND INSTALL A RIDGEBOARD

PERFORMANCE OBJECTIVE:

Given working drawings, specifications for a roof frame a structure with floor, wall, and ceiling frames installed, two sets of pre-cut common rafters, dimensioned lumber, and the necessary tools, equipment, and materials; cut and install the ridgeboard with required assistance. The ridgeboard must be marked to receive rafters, cut to specified length $\pm 1/8$ inch, and positioned plumb and level. The ridge must be installed with the required fastening pattern.

PERFORMANCE ACTIONS:

- 13.0701 Different procedures can be followed to install and align ridgeboards. The circumstances and conditions will need to be considered.
- 13.0702 Layout ridgeboard to receive rafters. Layout must coincide with wallplates layouts. (If more than one board is required, join them at the center of a pair of rafters.)
- 13.0703 Place common rafters at their respective position coinciding exactly with wall plate markings.
- 13.0704 Nail top of end common rafters flush with outside wall plate.
- 13.0705 Nail top of second rafter at opposite end of ridgeboard, if ridge is jointed, or flush with end of ridge where ridge extends to opposite wall plate.
- 13.0706 Cut uprights to temporarily assist in holding the ridgeboard in working position.
- 13.0707 Raise the ridge and the top ends of the two support rafters up to position temporarily resting on upright.
- 13.0708 Install two rafters opposite the first pair to support this section of the ridge in position.
- 13.0709 Install the remaining rafters in pairs nailing the seat of each rafter first then final nailing to ridge.

UNIT	13.0	ROOF FRAMING
TASK	13.07	CUT AND INSTALL A RIDGEBOARD (Con't.)

PERFORMANCE ACTIONS (Con't.):

- 13.0710 Check alignment of end of ridge to corresponding wall plates by plumbing down to outside edge of wall. Install one diagonal blade at each end of ridge to hold ridge and rafters in alignment position.

PERFORMANCE STANDARDS:

- With aid of a helper, install and align ridgeboard including rafters.
- The ridgeboard must be marked to receive rafters, cut to specified lengths +/- 1/8 inch, and positioned plumb and level.
- The ridge must be installed with the required fastening pattern.

SUGGESTED INSTRUCTION TIME: 3 Hours

RELATED TECHNICAL INFORMATION:

- Fasteners.
- Reading blueprints and specifications.

UNIT	13.0	ROOF FRAMING
TASK	13.08 (OPTIONAL)	FRAME ROOF OPENINGS

PERFORMANCE OBJECTIVE:

Given working drawings, specifications for a roof frame, a structure with rough frame installed, dimensioned lumber, and the necessary tools, equipment, and materials; frame roof openings for a chimney. The openings must be square and within size specifications +/- 1/8 inch. All frame members and tail rafters must be cut to required length +/- 1/8 inch and installed straight and plumb with the required fastening pattern.

PERFORMANCE ACTIONS:

- 13.0801 Determine size, location, and type of opening from plans and specifications. Applicable standards apply.
- 13.0802 Layout, cut, and frame opening after regular roof rafters have been installed.
- 13.0803 Drop a plumb line from rafter to openings already formed in the ceiling or floor frame (if framing for chimney) to mark for roof opening critical points.
- 13.0804 Layout the opening width from these points allowing for width of double headers.
- 13.0805 Nail a temporary strip across the top of the rafter or rafters to be cut, and cut the rafters.
- 13.0806 Individually install the double headers, both top and bottom.
- 13.0807 Layout the two corresponding sides on these headers.
- 13.0808 Cut and install cripple rafters to each side.
- 13.0809 Cut and install trimmer rafters beside and nailed to the outside support rafters.
- 13.0810 Check the opening for critical measurements and location.

PERFORMANCE STANDARDS:

- With aid of helper, layout, cut, and frame required roof opening for a chimney (or other opening as required).

UNIT	13.0	ROOF FRAMING
TASK	13.08 (OPTIONAL)	FRAME ROOF OPENINGS (Con't.)

PERFORMANCE STANDARDS (Con't.):

- Opening must be square and within size, specifications +/- 1/8 inch.
- All frame members and tail rafters must be cut to required length +/- 1/8 inch and installed straight and plumb with the required fastening pattern.

SUGGESTED INSTRUCTION TIME: 2 Hours (Optional)

UNIT	13.0	ROOF FRAMING
TASK	13.09 (OPTIONAL)	FRAME A DORMER

PERFORMANCE OBJECTIVE:

Given working drawings, specifications for a roof frame, a structure with rough frame and roof openings installed, dimensioned lumber, and the necessary tools, equipment, and materials; frame a dormer. The dormer must include double headers and trimmers, and all frame members must be cut to required length $\pm 1/8$ inch. Plumb and plate cuts must allow for a tight fit, and the members must be installed plumb and straight $\pm 1/8$ inch.

PERFORMANCE ACTIONS:

Gable Type

- 13.0901 Determine size and location of dormer from roof plan.
- 13.0902 Layout plate and ridgeboard for width of dormer. (Determination must be made to higher frame walls on top of double rafters or extend wall framing from the floor through roof opening.)
- 13.0903 Install common rafters on each side of dormer.
- 13.0904 Calculate height and location of dormer ridge and wall plates. Layout these critical measurements on two side rafters.
- 13.0905 Install double headers at top of dormer ridge and bottom of dormer opening.
- 13.0906 Install double trimmer rafters each side of dormer opening.
- 13.0907 Layout and cut the cripple studs and the dormer plates.
- 13.0908 Install the plates and cripple studs on top of the double side rafter.
- 13.0909 Cut and install dormer joist.
- 13.0910 Layout, cut, and install the dormer rafters and dormer ridge.

UNIT	13.0	ROOF FRAMING
TASK	13.09 (OPTIONAL)	FRAME A DORMER (Con't.)

PERFORMANCE ACTIONS (Con't.):

- 13.0911 Layout, cut, and install the two valley dormer rafters.
- 13.0912 Install additional nailers each side double rafters to carry roof sheathing.
- 13.0913 Check entire installation for plumb, level, square, measurements and adequate nailing.

PERFORMANCE STANDARDS:

- With aid of helper, frame given dormer.
- Dormer must include double headers and trimmers, and all frame members must be cut to required length +/- 1/8 inch.
- Plumb and plate cuts must allow for a tight fit, and the members must be installed plumb and straight +/- 1/8 inch.

SUGGESTED INSTRUCTION TIME: 3 Hours

UNIT	13.0	ROOF FRAMING
TASK	13.10	FRAME GABLE ENDS

PERFORMANCE OBJECTIVE:

Given working drawings, specifications for a roof frame, a structure with rafters and ridgeboard installed, dimensioned lumber, wood stock, and the necessary tools, equipment, and materials; frame the gable ends. Gable studs must be notched (if appropriate), cut to length, and installed to specifications +/- 1/8 inch. Angle cuts must allow for a tight fit of plumb, straight gable studs.

PERFORMANCE ACTIONS:

- 13.1001 Plumb down from the center of the ridge to establish center line on the plate for layout.
- 13.1002 Measure one-half of the window of louver opening size on each side of the center line and mark for the first full-length stud where openings exist.
- 13.1003 Start at each of these fixed locations and layout the shorter studs spacing 16 inches on center to the outsides of the building.
- 13.1004 Measure the two full-length studs. Layout and cut the top cuts first; then cut them to required length.
- 13.1005 Install these two studs plumb using a carpenter's level.
- 13.1006 The remaining studs can be laid out by locating each stud on its layout position. Plumb and mark the top of studs on the underside of the rafters to determine length.
- 13.1007 Cut and install these studs flush with the outside of the rafters and plates.
- 13.1008 Frame in the window sills and headers on the height of window.

PERFORMANCE STANDARDS:

- With aid of helper, layout, cut, and install the gable studs.
- Gable studs must be notched (if appropriate), cut to length, and installed to specifications +/- 1/8 inch.

UNIT 13.0

ROOF FRAMING

TASK 13.10

FRAME GABLE ENDS (Con't.)

PERFORMANCE STANDARDS (Con't.):

- Angle cuts must allow for a tight fit of plumb, straight gable studs.

SUGGESTED INSTRUCTION TIME: 3 Hours

UNIT	13.0	ROOF FRAMING
TASK	13.11 (OPTIONAL)	CUT AND INSTALL COLLAR TIES

PERFORMANCE OBJECTIVE:

Given working drawings, specifications for a roof frame, a structure with rafters and ridgeboard installed, wood stock or dimensioned lumber, and the necessary tools, equipment, and materials; cut and install the collar ties. The ties or beams must be cut to required length $\pm 1/8$ inch. End cuts must be flush with rafters.

PERFORMANCE ACTIONS:

- 13.1101 Check the plans for the location and stock specifications.
- 13.1102 Calculate the length of the collar ties. The length will be determined by the position. If attic is finished, the ties may serve as ceiling joists and should be spaced accordingly. Where no ceiling is involved, ends should tie in at approximately the midpoint of common rafters.
- 13.1103 Determine the angle for end cuts. This angle is the slope or pitch of the roof.
- 13.1104 Cut a pattern based upon calculation in step two and three.
- 13.1105 Layout and cut the required number of ties from the pattern.
- 13.1106 Locate the points where ends of collar's tie into the rafters. Snap a chalk line underneath the rafters on each side of the roof. Check across for level.
- 13.1107 Nail the ties in place on the side of the rafters at the established points.

PERFORMANCE STANDARDS:

- With assistance of helper, layout, cut, and install collar ties for the designated rafters.

UNIT	13.0	ROOF FRAMING
TASK	13.11 (OPTIONAL)	CUT AND INSTALL COLLAR TIES (Con't.)

SUGGESTED INSTRUCTION TIME: 2 Hours (Optional)

RELATED TECHNICAL INFORMATION:

- Framing square.
- Blueprint reading.

UNIT	13.0	ROOF FRAMING
TASK	13.12	LAYOUT, CONSTRUCT, AND INSTALL ROOF TRUSSES

PERFORMANCE OBJECTIVE:

Given working drawings, specifications for roof trusses, wood stock, dimensioned lumber, and the necessary tools, equipment, and materials; layout, and build roof trusses. Chord and web length must be accurate to +/- 1/8 inch. Truss members must be fastened and reinforced with trusses or plates in the required pattern.

PERFORMANCE ACTIONS:

The following performance actions are for constructing the "W" type roof truss, the most common type used to support the roof and ceiling.

- 13.1201 Check plans and drawings for details and dimensions. (If roof pitch and critical dimensions are not given, calculations must be made to determine them.)
- 13.1202 Make a full size layout of the truss on the floor. (Snap chalk lines for the three basic members, the two top rafter chords and the bottom joist chord.)
- 13.1203 Determine the plumb and plate cuts for these members.
- 13.1204 Cut the top and bottom chords and tack them in their position on the layout.
- 13.1205 Determine the length of the two tension webs.
- 13.1206 Layout, cut, and position the two tension webs. (These webs should start at the top ridge and tie into the bottom chord one-third the distance of the building span.)
- 13.1207 Layout, cut, and position the two compression webs. (These webs should run from the bottom tension webs to approximately one-half the length of each top chord.)
- 13.1208 Disassemble and use all of the pieces as patterns to cut the required number of pieces for all of the trusses.
- 13.1209 Assemble the trusses one at a time. Use the original layout or assemble one truss and use it as a pattern for assembling the remaining members.

UNIT	13.0	ROOF FRAMING
TASK	13.12	LAYOUT, CONSTRUCT, AND INSTALL ROOF TRUSSES (Con't.)

PERFORMANCE ACTIONS (Con't.):

- 13.1210 Use extra clamps on pieces that are bowed to hold them in position until plates or connections can be installed.
- 13.1211 Check each truss for alignment, glue joints where required and fasten installation before starting on additional trusses.

PERFORMANCE STANDARDS:

- With assistance of helper, layout and build roof truss.

SUGGESTED INSTRUCTION TIME: 6 Hours

TRUE/FALSE

1. Unit rise is the number of inches that a roof rises for every foot of run. _____
2. The ridge board is the horizontal piece that connects the upper ends of the rafters. _____
3. To cut a rafter without an overhang to its actual length, you must deduct one-half the thickness of the ridge board from the ridge end. _____
4. Rafters extend from the outside wall to the ridge. _____
5. Working drawings usually include a roof plan. _____
6. The type of roof which has two sloping sides is a hip roof. _____
7. A chord is the lower member of a trussed rafter. _____
8. The simplest kind of truss is the scissors truss. _____
9. Trusses are placed upside down on the walls and then swung into place. _____
10. Total span is the distance from a common rafter seat to the opposite common rafter seat. _____

COMPLETION

1. In roof construction, the vertical distance from the plate line to the ridge is called the total _____. _____
2. In roof construction, half the distance covered between the outer walls of a house generally is referred to as the _____. _____
3. The board that is placed between the upper ends of the rafters at the top of the roof structure and that serves to tie the rafters together is called the _____. _____
4. During the installation of a hip roof, the _____ rafters should be installed first. _____
5. The connector plate used on light trusses is the _____. _____

COMPLETION (Con't.)

6. The distance between rafter plates (from outside to outside) of the building is called _____.
7. The two methods that use a framing square to figure rafter length are the _____ method and the method of using the rafter table stamped on the square.
8. The studs on a dormer should be spaced at _____ inches O.C.
9. The distance between the unit rise and the unit run on a framing square is called _____.
10. The slope of a roof is expressed in terms of unit _____.

MULTIPLE CHOICE

1. What is the key on a rafter square in which the rafter is to be cut on a $5/12$?
 - a. 12.65
 - b. 13.
 - c. 13.42
 - d. 15
2. Which type of rafter is the most commonly used?
 - a. truss
 - b. valley rafter
 - c. common rafter
 - d. hip rafter
3. Trusses generally are spaced _____.
 - a. 16 inches
 - b. 24 inches
 - c. 30 inches
 - d. 36 inches
4. Total rise in a distance from _____.
 - a. sole plate to rafter plate
 - b. rafter plate to top of ridge
 - c. footing to top of foundation
 - d. none of the above

MULTIPLE CHOICE (Con't.)

5. The unit of run for all common rafters and jacks is ____.
- a. 6
 - b. 12
 - c. 16
 - d. 24

IDENTIFY

1. On the following sketch of a roof construction, identify the framing members labeled 1-5.

- 1. _____
- 2. _____
- 3. _____
- 4. _____
- 5. _____

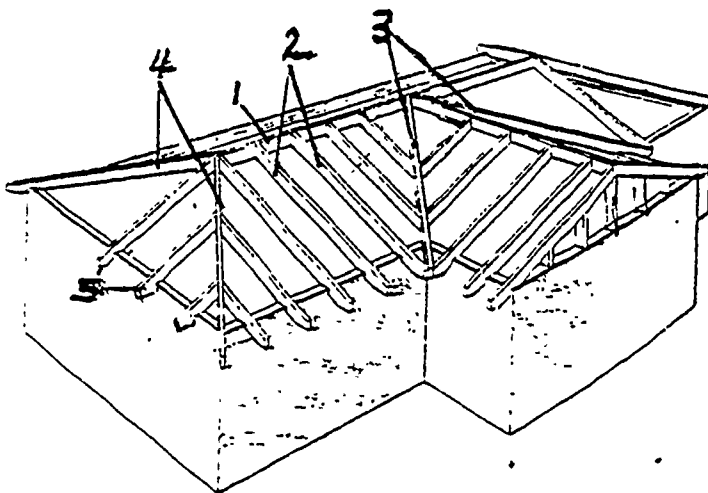

2. Identify the parts of the common rafter sketched below.

- 1. _____
- 2. _____
- 3. _____
- 4. _____

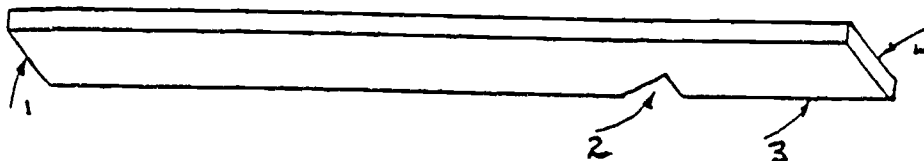

ROOF FRAMING MATHEMATICS

Complete the missing figures from the chart.

UNIT RISE	TOTAL RISE	TOTAL RUN	SPAN	PITCH
8"	<u> a </u>	<u> b </u>	30'-0"	<u> c </u>
<u> d </u>	20'-0"	20'-0"	<u> e </u>	<u> f </u>

- a. _____
 b. _____
 c. _____
 d. _____
 e. _____
 f. _____

PRACTICAL TEST

Given necessary drawings, tools, and material; students will layout, cut, and assemble conventional type ceiling joist and rafters. Also, lay out, cut, and assemble truss. When assembled, all parts will fit together (plus or minus 1/16" of an inch). Construction should be completed within time suggested by instructor for given student or student group.

Tools and Material: Pencil, Claw hammer, Hand saw, Rafter square, 2" x 4"'s, 1/4" or 3/8" Plywood, and Nails.

ALL STOCK
2x4 BOARDS

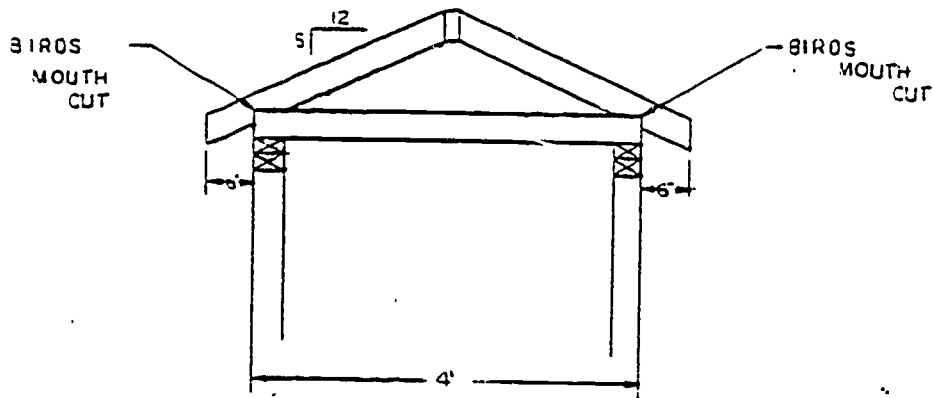

TRUSS

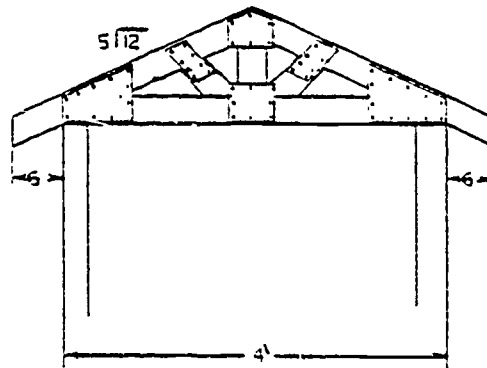

ALL STOCK
2x4 +
3/8 Plywood

UNIT 14.0

ROOFING

Upon completing the unit on roofing, the student will be able to identify the basic roof styles, determine the suitable roofing material to use with each style, estimate the cost of material for different styles of roofs or given roofs, match the correct term for parts of a roof, and match the grades of shingles to the various types.

SUGGESTED MINIMUM TERMINOLOGY

ROOFING

Building paper	Inexpensive, thick asphalt impregnated paper used to insulate a building before siding or roofing is installed.
Dormer	Vertical window in a gabled roof.
Exposure	Surface area of a shingle not covered by another shingle.
Flashing	Sheet metal or other material used around dormers, chimneys, and valleys to protect a building from seepage of water.
Hip	Line that extend from the wall plate to ridge of roof and form angle for hip roof.
Rake	Trim members that run parallel to roof slope and form finish between roof and wall at gable end.
Ridge	Horizontal line at junction of top edges of two sloping roof surfaces; rafters of both slopes are nailed to ridge board.
Rise	Incline or pitch of a roof expressed in terms of inches per one foot or run.
Roof	Covering or upper part of a building.
Roofing	Material put on a roof to protect it from wind and water.
Roof sheathing	Covering placed over exterior rafters of a structure as a base for shingles, etc. Typically plywood or lumber.
Run	Horizontal distance that underlies the slope of the roof from a wall to the ridge.
Saddle	Small gable roof place behind a chimney on a sloping roof to shed water. (Also, cricket)
Shingles	Overlapping covering, typically asphalt, of roof.
Span	Horizontal distance that underlies roof from one exterior wall to opposite exterior wall.

Square

Unit of measure consisting of 100 square feet of area.

Valley

Low place in a roof where slope of two roof surfaces meet necessitating a valley rafter at each juncture.

Adopted from textbook, Modern Carpentry.



UNIT	14.0	ROOFING
TASK	14.01	APPLY INSULATION (UNDERLAY) FOR ASPHALT SHINGLES

PERFORMANCE OBJECTIVE:

Given roofing specifications, a roof frame with decking installed, roofing felt paper (insulation and underlayment), and the necessary tools, equipment and materials; apply the roofing felt paper. The entire surface of the decking must be covered. Edges must be fastened with nails or staples 8-10 inches apart, and center sections 18-24 inches apart. Strips must be installed at lap lines or chalk snapped 2 inches from each upper edge. The felt paper must be marked and trimmed for maximum use of materials.

PERFORMANCE ACTIONS:

- 14.0101 Check plans and specifications for type of underlay required.
- 14.0102 Start at the bottom and one edge of the roof. (If the roof pitch is too steep to work from the roof, a starting scaffold must be provided.)
- 14.0103 Place the roll of felt in position to unroll along the bottom roof line and roll of the first run with the helper holding strip in position; cut the felt to length.
- 14.0104 Nail or staple the first strip to the sheathing beginning near the center and working toward each end. Nails (or staples) should be placed close enough together to hold the strip in place. (Edges 8 inches to 10 inches and center sections 18 to 24 inches apart.)
- 14.0105 If there is no lap line on the felt, shape a chalk line 2 inches from the upper edge for installation line for the bottom edge of the second strip.
- 14.0106 Install the second and additional strips following steps 2, 3, and 4 above.
- 14.0107 If shingles cannot be installed at the time underlay is applied, the roof section should be stripped. Nail thin strips of wood vertically approximately 4 feet apart.

UNIT	14.0	ROOFING
TASK	14.01	APPLY INSULATION (UNDERLAY) FOR ASPHALT SHINGLES (Con't.)

PERFORMANCE STANDARDS:

- With assistance of helper, apply insulation (underlay) to previously sheathed roof.
- If a valley roof, a strip of felt paper must be installed lengthwise down the valley before installing the horizontal strips. The entire surface of the decking must be covered.
- Edges must be fastened with nails or staples 8 to 10 inches apart, and center sections 18 to 24 inches apart.
- Strips must be installed at lap lines of chalk lines snapped 2 inches from each upper edge. The felt paper must be marked and trimmed for maximum use of materials.

SUGGESTED INSTRUCTION TIME: 3 Hours

UNIT	14.0	ROOFING
TASK	14.02	INSTALL COMPOSITION SHINGLES

PERFORMANCE OBJECTIVE:

Given roofing specifications, a roof frame with decking and felt paper installed, strip shingles in bundles, and the necessary tools, equipment, and materials; install the shingles to manufacturer's specifications. Unless superseded by manufacturer's specifications, chalk lines must be snapped to indicate vertical starting lines on the outside edge of the cornice trim. The first layer of shingles must be laid with slots upside down, and successive courses must not allow for overlapping joints or slots. The amount of exposure for each course must not exceed specifications +/- 1/8 inch. Shingles must be fastened using the required pattern and type of fasteners, and end tabs must be sealed to prevent wind damage. All runs or courses must be completed until the entire roof surface is covered. Hip and ridge cap shingles must be installed securely with the required fastening pattern and type of fasteners, and cap tab fasteners must be sealed.

PERFORMANCE ACTIONS:

(NOTE: Performance actions are for square-butt, three-tab composition strip shingles, the most widely used type.)

- 14.0201 Layout (snap) vertical starting lines from outside edge of cornice trip board for 35 inch shingles.
- 14.0202 Lay first layer with slot upside down or cut a starter strip from solid material that is the same type of color. (This is to avoid exposed joints and avoid wind breakage of tabs.) Nail along bottom edge.
- 14.0203 Start a second course over the first layer starting with a cut shingle that prevents two joints or slots coinciding.
- 14.0204 Check manufacturer's instructions to determine the amount of exposure. (Example 5 inches exposed to weather.)
- 14.0205 Measure up from top of first course the amount of exposure (example 5 inches) and snap a line for top of second course.
- 14.0206 Layout a series of horizontal lines (six or more) for the top of successive shingle runs. (This

UNIT	14.0	ROOFING
TASK	14.02	INSTALL COMPOSITION SHINGLES (Con't.)

PERFORMANCE ACTIONS (Con't.):

- allows the roofer to install four or five runs across the roof without excessive moving around.)
- 14.0207 Start every other course (holding to top of lines) with a cut shingle to avoid joints or slots falling in same position and keeping a straight line.
- 14.0208 Nail each shingle with number and type of nails specified by manufacturer. (Avoid having any nails too close to edges or low enough to be exposed after next course is installed.)
- 14.0209 Seal last tab at beginning and end of each run with sealer to prevent wind damage during storms. These end run tabs are the most susceptible to damage.
- 14.0210 Complete all runs until entire roof is covered.
- 14.0211 Install ridge cap shingles.

PERFORMANCE STANDARDS:

- With aid of a helper, install composition shingles on designated roof.
- Chalk lines must be snapped to indicate vertical starting lines on the outside edge of the cornice trim.
- The first layer of the shingles must be laid with slots upside down, and successive courses must not allow for overlapping joints or slots. The amounts of exposure for each course must not exceed specifications +/- 1/8 inch.
- Shingles must be fastened using the required pattern and type of fasteners, and end tabs must be sealed to prevent wind damage.
- Complete all runs until the entire roof surface is covered.
- Hip and ridge cap shingles must be installed securely with the required fastening pattern and type of fasteners, and cap tab fastener must be sealed.

SUGGESTED INSTRUCTION TIME: 6 Hours

UNIT	14.0	ROOFING
	14.03 (OPTIONAL)	LAYOUT FOR BONDING SHINGLES OVER DORMERS (OR OTHER ROOF APPENDAGES)

PERFORMANCE OBJECTIVE:

Given a roof with a dormer that has been prepared for shingle installation, a helper, and the necessary tools; layout the roof for bonding the shingles over the dormer.

PERFORMANCE ACTIONS:

- 14.0301 Check manufacturer's installation diagrams to determine the amount of shingle exposure (e.g., 5 inches for square butt) and the total length of a single shingle (e.g., 36 inches for square butt).
- 14.0302 Measure back from the starting edge of the roof a distance equal to one full shingle length (minus shingle overhand) and snap a chalk line from the eave to the ridge to establish the first starting line.
- 14.0303 Install the bottom run of shingles starting at one edge of roof. If the dormer is framed to the roof eave, then a measurement should be taken based upon even lengths of shingles to a layout point that is located on opposite side of the dormer.
- 14.0304 Snap a vertical chalk line from this point to a corresponding point on the ridge to use as a parallel starting line in conjunction with the basic starting line. This second starting line helps assure that shingle installation will be done on both sides of the dormer with continuity of bonding.
- 14.0305 Lay off these two starting lines into paralleling divisions that are equal to the exposure of the shingles being used.
- 14.0306 Lay off and snap chalk lines at the ends of the shingles run (both sides of the dormer) parallel to these two starting lines.
- 14.0307 Lay off these two end lines into divisions equal to the divisions of the two starting lines.
- 14.0308 Start single runs on each side of the dormer in corresponding sequences.

UNIT	14.0	ROOFING
TASK	14.03 (OPTIONAL)	LAYOUT FOR BONDING SHINGLES OVER DORMERS (OR OTHER ROOF APPENDAGES) (Con't.)

PERFORMANCE ACTIONS (Con't.):

- 14.0309 On each side of the ~~vertical~~ starting lines, count out the horizontal runs to the top of dormer (or appendages) to establish the first full run of shingles. (This is a safety check to verify correcting bonding.)
- 14.0310 If first full run of shingles (calculation) does not bond, recheck all layouts to determine where errors exist before installing the shingles on either side of the dormer (appendages).

PERFORMANCE STANDARDS:

- Layout the roof for bonding shingles over the dormer (or appendages).

SUGGESTED INSTRUCTION TIME: 3 Hours (Optional)

UNIT	14.0	ROOFING
TASK	14.04 (OPTIONAL)	INSTALL VALLEY SHINGLES

PERFORMANCE OBJECTIVE:

Given manufacturer's installation plans for the type shingles, a valley flashed and ready for shingle installation, tools, materials, and a helper; install the valley shingles.

PERFORMANCE ACTIONS:

(NOTE: When installing asphalt shingles for valley, some plans may call for the valley to be patted (overlapping). This type installation should be used only when specified. The following performance actions apply to cut shingle valleys.

- 14.0401 From plans, specifications, or local building codes, determine required open portion of the valley for the type shingles used and slope of roof.
- 14.0402 Snap a chalk line on each side of the valley water stop for required shingle clearance.
- 14.0403 As each shingle run comes into the valley, lay the last shingle in place and mark for the cut along the valley line.
- 14.0404 Taper the cut toward bottom of shingle to establish a slight overlap.
- 14.0405 Nail each valley shingle as far away from the valley as is practical.
- 14.0406 Seal each shingle with a light application of asbestos shingle cement.

PERFORMANCE STANDARDS:

- With aid of a helper, cut and install valley shingles according to specifications on a given roof.

SUGGESTED INSTRUCTION TIME: 2 Hours (Optional)

UNIT	14.0	ROOFING
TASK	14.05	FLASH CHIMNEY AND ROOF VENTS

PERFORMANCE OBJECTIVE:

Given a chimney or vent that extends through roof structure, tools and materials, flash the chimney or vent. All items on the instructor's checklist must be acceptably completed. Flashing material must be cut to specified lengths +/- 1/8 inch and installed securely with the required fastening pattern. Roof vents and chimney must be flashed with counterflashing cap strips and roofing sealer to prevent water leaks. All flashing joints must be lapped to specifications +/- 1/8 inch.

(NOTE: If chimney is 30 inches or more in width and on a sloping roof, a chimney saddle (or cricket) must be installed on the upper side.)

PERFORMANCE ACTIONS:

- 14.0501 Chisel out mortar joints that will receive counterflashing cap strips. (When saddle is not installed, flashing on upper side of chimney must extend up to at least 4 inches.)
- 14.0502 Apply flashing in two parts. Base part is secured to roof deck. Cap flashing is secured to chimney.
- 14.0503 For base flashing, use 90 lbs. mineral surfaced roofing.
- 14.0504 Cut strips that are 12 inches to 18 inches wide and install them around the chimney. Install front strips first, side strips next, and top strip last.
- 14.0505 Seal all joints with asphalt plastic cement.
- 14.0506 Use copper sheathing (or approved sheet metal) for cap flashing. Fit a piece in place for each shingle run (or no more than two runs) at the sides of the chimney. These pieces must extend up the exterior face of the chimney, be inserted between the bricks and extend under the shingle run (or runs) at least 6 inches.
- 14.0507 Counterflash at all corners.
- 14.0508 Drive nails in mortar joints, at top where flashing is imbedded to hold it in place.

UNIT	14.0	ROOFING
TASK	14.05	FLASH CHIMNEY AND ROOF VENTS (Con't.)

PERFORMANCE ACTIONS (Con't.):

- 14.0509 Fill mortar joints where flashing is imbedded with mortar (or chalk with roof cement).
- 14.0510 Check completed work for holes or cracks that might cause leaks. Fill them with roof cement, coating around edges.

PERFORMANCE STANDARDS:

- Flash given chimney or vent.
- Flashing material must be cut to specified lengths +/- 1/8 inch and installed securely with required fastening pattern.
- Roof vents and chimney must be flashed with counterflashing cap strips and roofing sealer to prevent water leaks.
- All flashing joints must be lapped to specifications +/- 1/8 inch.

SUGGESTED INSTRUCTION TIME: 3 Hours

UNIT	14.0	ROOFING
TASK	14.06 (OPTIONAL)	FLASH VALLEYS

PERFORMANCE OBJECTIVE:

Given a previously decked roof with valley, a helper, tools, and materials; flash the valley for asphalt shingle installation. Flashing material must be cut to specified lengths +/- 1/8 inch and installed securely with the required flashing pattern. Valley flashing must be at least 14 inches wide and laid on top of asphalt sealer.

PERFORMANCE ACTIONS:

(NOTE: For asphalt shingles, .019 or heavier aluminum or other material such as copper is recommended.)

14.0601 Install the first strip centered in the valley and laid with the mineral surface down. This strip should be at least 18 inches wide and nailed with roofing nails. nailing one edge first. Press the center down and nail second edge.

14.0602 Where necessary to joint either of the strips, the lapped joint must overlap a minimum of 8 inches and be sealed with asphalt cement.

14.0603 Using a chalked builder's line, snap a center line for layout. Refer to applicable specifications.

PERFORMANCE STANDARDS:

- Flash valleys for asphalt shingle installation (with the aid of a helper).

SUGGESTED INSTRUCTION TIME: 1 Hour (Optional)

COMPLETION

1. A trim board normally applied to the lower edge of a sloping roof before the application of the surface material is called the _____.
2. Roofing materials are estimated and sold by the _____ which equals an amount needed to provide 100 square feet of finished roof surface.
3. Chimney flashing consists of two parts: One is the cap of counter flashing and the other is the _____ flashing.
4. If shingles are used as a starter strip, they must be installed with the taps _____.
5. 3 in 1 shingles cannot be used if the slope of the roof is _____ or less.

MULTIPLE CHOICE

1. In installing 3 in 1 shingles on a roof, T-nails are used in each strip.
 - a. 2
 - b. 3
 - c. 4
2. When installing 3 in 1 shingles, the joints of each layer or row of shingles must be set by at least _____ inches.
 - a. 2
 - b. 3
 - c. 4
3. The waterway of a valley should diverge (grow wider) as it approaches the eaves at a rate of _____ inch per foot.
 - a. 1/8
 - b. 1/4
 - c. 1/2
4. Underlay should be applied with nails or staples approximately _____ to _____ inches apart.
 - a. 4 - 6
 - b. 6 - 8
 - c. 8 - 10

MULTIPLE CHOICE (Con't.)

5. For base flashing, such as chimney and roof vents, the recommended mineral surfaced roll roofing is _____ lb.
- a. 40
 - b. 70
 - c. 90

ROOFING MATHEMATICS

The total ground area plus overhang of a house with a gable roof (slope 5 to 12) is 1880 sq. ft. Estimate 10 percent for waste and calculate the number of squares of asphalt shingles required for roofing. Round your answer to the nearest full square.

(Calculations) Squares = _____

UNIT 15.0

EXTERIOR FINISHING

After completion of this unit, the student should be able to define terms associated with exterior wall coverings and trim. He should be able to identify the styles and parts of a cornice, identify various types of cornice molding, name the common materials used as exterior wall coverings, and identify various styles of siding.

SUGGESTED MINIMUM TERMINOLOGY

EXTERIOR FINISHING

Building Paper	(Sheathing Paper) Inexpensive, thick asphalt impregnated paper used to insulate a building prior to the installation of siding or roofing.
Dormer	Vertical window in a gabled roof.
Flashing	Sheet metal or other material used around dormers, chimneys, and valleys to protect a building from seepage of water.
Hip	Line that extend from, wall plate to ridge of roof and forms angle for hip roof.
Rake	Trim members that run parallel to roof slope and form the finish between the roof and wall at the gable end.
Ridge	Horizontal line at the junction of the top edges of two sloping roof surfaces; rafters of both slopes are nailed to ridge board.
Rise	Incline or pitch of a roof expressed in terms of inches per one foot of run.
Run	Horizontal distance that underlies the slope of the roof from a wall to the ridge.
Saddle	Small gable roof placed behind a chimney on a sloping roof to shed water (also, cricket).
Sheathing	Placed over exterior framing of a structure as a base for shingles or siding.
Span	Horizontal distance that underlies the roof from one exterior wall to the opposite exterior wall.

Adopted from text, Modern Carpentry.

UNIT	15.0	EXTERIOR FINISHING
TASK	15.01	INSTALL EXTERIOR SHEATHING (FIBERBOARD OR PLYWOOD)

PERFORMANCE OBJECTIVE:

Given working drawings, specifications for exterior walls, a structure with plywood or fiberboard structural sheathing installed, exterior sheathing material (fiberboard, plywood, or insulated sheathing), and the necessary tools, equipment, and material ; install the exterior sheathing. The sheathing must be installed with joints centered on studs +/- 1/4 inch and fastened using required patterns. Joints must be staggered and spaces between sheets must not exceed 1/8 inch. Openings must be cut after the sheathing is nailed.

PERFORMANCE ACTIONS:

- 15.0101 Layout and cut sheathing so all horizontal joints coincide with nailing surfaces.
- 15.0102 Position sheathing for tight joints, nail holding and positioning nails.
- 15.0103 Fit and nail sheathing.
- 15.0104 Cut openings to specifications.

PERFORMANCE STANDARDS:

- Install exterior sheathing according to specifications or using given materials.
- The sheathing must be installed with joints centered on studs +/- 1/4 inch and fastened using required patterns.
- Joints must be staggered and spaces between sheets must not exceed 1/8 inch.
- Openings must be cut after the sheathing is nailed.
- Meet specifications of the Southern Standard Building Code.

SUGGESTED INSTRUCTION TIME: 5 Hours

RELATED TECHNICAL INFORMATION:

- Use of sheathing paper and flashing applied before exterior sheathing.
- Importance of installing dry sheathing on dry framing.
- Types of exterior sheathing materials common to the local industry.

UNIT	15.0	EXTERIOR FINISHING
TASK	15.02	FRAME A BOXED CORNICE

PERFORMANCE OBJECTIVE:

Given working drawings, specifications for exterior trim, a residential structure with roof decking installed, wood stock and dimensioned lumber, and the necessary tools, equipment, and materials; frame the boxed cornice. Fascia boards, soffits of planciers (horizontal or sloping), lookouts, ledgers, and frieze boards must be cut and installed to specifications +/- 1/8 inch. Fascia boards must be jointed with required end and corner joints for a tight fit +/- 1/8 inch. All cornice members must be fastened using required pattern.

PERFORMANCE ACTIONS:

- 15.0201 Layout, cut, and install framing parts of ledger and lookouts in preparation for the construction of horizontal box cornice.
- 15.0202 Install horizontal covering to underside of cornice lookouts.
- 15.0203 Construct rake section at end of roof over the gable to match the cornice.
- 15.0204 Install covering to underside of rake overhang.
- 15.0205 Install frieze to intersection of exterior wall and soffit. (May be substituted by use of a molding placed at intersection of exterior siding and soffit.)

PERFORMANCE STANDARDS:

- Frame a boxed cornice to specifications +/- 1/8 inch.
- Fascia boards, soffits or planciers (horizontal or sloping), lookouts, ledgers, and frieze boards must be cut and installed to +/- 1/8 inch. Fascia boards must be jointed with required end and corner joints for a tight fit. All cornice members must be fastened using required patterns.
- Southern Standard Building Code standards apply.

SUGGESTED INSTRUCTION TIME: 10 Hours

RELATED TECHNICAL INFORMATION:

- Identify various types of cornices and rakes.
- Procedures for framing a box cornice.
- Characteristics of building materials used for exterior trim.
- Safety precautions.

UNIT	15.0	EXTERIOR FINISHING
TASK	15.03	INSTALL DOUBLE-HUNG WINDOWS

PERFORMANCE OBJECTIVE:

Given working drawings, specifications for exterior trim and windows, a framed structure, double-hung windows, wood stock and dimensioned lumber, and the necessary tools, equipment, and materials; install the double-hung windows (wood frame). The windows must be installed from the outside. Side jambs must be plumb, frames must be level, and corners must be square +/- 1/16 inch. Windows must be installed so that the sashes operate smoothly. Fasten with aluminum or galvanized casting nails approximately 16 inches O.C. Nails must penetrate well into the rough frame and must be countersunk with a nailset.

PERFORMANCE ACTIONS:

- 15.0301 Tuck paper, plastic, or aluminum around opening.
- 15.0302 Install frame.
- 15.0303 Level, center, and nail corner.
- 15.0304 Plumb jambs and nail frame securely.

PERFORMANCE STANDARDS:

- Install double-hung wood frame windows.
- Windows must be installed from the outside.
- Side jambs must be plumb, frames must be level, and corners must be square +/- 1/16 inch.
- Windows must be installed so that the sashes operate smoothly.
- Fasten with aluminum or galvanized casting nails approximately 1/16 inches O.C.
- Nails must penetrate well into the rough frame and must be countersunk with a nailset.
- Southern Standard Building Code standards apply.

SUGGESTED INSTRUCTION TIME: 8 Hours

RELATED TECHNICAL INFORMATION:

- Components of a double-hung window.
- Steps to avoid breaking or damaging windows while transporting or installing.
- Purpose of wedge blocks.
- Procedures for installing double-hung windows.
- Safety precautions.

UNIT	15.0	EXTERIOR FINISHING
TASK	15.04	INSTALL EXTERIOR DOORS

PERFORMANCE OBJECTIVE:

Given working drawings and specifications for exterior trim and doors, a framed structure, exterior doors with prefabricated frames, wood stock and dimensioned lumber, and the necessary tools, equipment, and materials; install the exterior doors. The doors must be installed with plumb jambs, level sills, and square corners +/- 1/16 inch. Hung doors must operate smoothly, and the frame must be fastened with aluminum or galvanized casting nails 16 inch O.C. The nails must penetrate well into the rough frame and must be countersunk with a nail set.

PERFORMANCE ACTIONS:

- 15.0401 Place preconstructed exterior door unit in framed opening.
- 15.0402 Shim side jambs to plumb position.
- 15.0403 Nail through side and top castings into building frame.

PERFORMANCE STANDARDS:

- Install exterior doors to specifications given.
- Doors must be installed with plumb jambs, level sills, and square corners +/- 1/16 inch.
- Hung doors must operate smoothly, and the frame must be fastened with aluminum or galvanized casting nails 16 inch O.C.
- Nails must penetrate well into the rough frame and must be countersunk with a nail set.
- Southern Standard Building Code standards apply.

SUGGESTED INSTRUCTION TIME: 10 Hours

RELATED TECHNICAL INFORMATION:

- Components of an exterior door assembly (door and door frame).
- Procedures for installing exterior doors.
- Interpret door schedule: size, type, direction of opening, and design.
- Safety precautions.

UNIT	15.0	EXTERIOR FINISHING
TASK	15.05	INSTALL PREFABRICATED STORM DOORS AND WINDOWS

PERFORMANCE OBJECTIVE:

Given working drawings, specifications for exterior trim, a door and window schedule, a framed structure with exterior doors and double-hung windows installed, storm windows and doors, and the necessary tools, equipment, and materials; install the storm doors and windows. The storm doors and windows must be installed to specifications +/- 1/16 inch. All mechanisms must operate smoothly, and the doors and windows must be installed with the required fasteners.

PERFORMANCE ACTIONS:

- 15.0501 Match given units to openings.
- 15.0502 Follow manufacturer's installation instructions.
- 15.0503 Drill pilot holes; fasten with rust proof screws.
- 15.0504 Check for proper operation (on door, install door closer).

PERFORMANCE STANDARDS:

- Install storm doors and windows.
- Installation must be given specifications, +/- 1/16 inch, all mechanisms must operate smoothly, and the doors and windows must be installed with the required fasteners.
- Manufacturer's specification apply.

SUGGESTED INSTRUCTION TIME: 8 Hours

RELATED TECHNICAL INFORMATION:

- Purposes of storm doors and windows.
- Procedures for installing storm doors and windows.
- Manufacturer's specifications regarding door installation.
- Safety precautions.

UNIT	15.0	EXTERIOR FINISHING
TASK	15.06	INSTALL EXTERIOR TRIM

PERFORMANCE OBJECTIVE:

Given working drawings, specifications, a structure with exterior doors and windows installed, exterior molding and trim material, and the necessary tools, equipment, and materials; install the exterior trim for windows, doors, and cornice. The molding or trim must be cut to required lengths +/- 1/16 inch and installed with required fasteners and tight-fitting joints.

PERFORMANCE STANDARDS:

- Install exterior trim (for windows, doors, and cornice) to specifications so that molding or trim is cut to required lengths +/- 1/16 inch and installed with required fasteners and tight joints.

SUGGESTED INSTRUCTION TIME: 20 Hours

RELATED TECHNICAL INFORMATION:

- Identify exterior trim and molding used on doors, windows, cornices.
- Procedures for cutting and installing exterior trim.
- Steps to making miter joints in molding and trim.
- Southern Standard Building Code.
- Safety precautions.

UNIT	15.0	EXTERIOR FINISHING
TASK	15.07	CUT AND INSTALL FURRING

PERFORMANCE OBJECTIVE:

Given working drawings, specifications, a room requiring installation of furring strips for ceiling panels or horizontal solid wood interior walls, wood stock or dimensioned lumber, and the necessary tools, equipment, and materials; install the furring. The furring strips must be cut to required lengths $\pm 1/8$ inch and installed level as a nailing base for the suspended ceiling or interior wall. Furring strips must be attached securely with the required fasteners.

PERFORMANCE STANDARDS:

- Cut and install furring strips to serve as a base for a suspended ceiling or interior wall.
- Furring strips must be cut to required lengths $\pm 1/8$ inch and installed level as a nailing base. Furring strips must be attached securely with the required fasteners.
- Southern Standard Building Code applies.

SUGGESTED INSTRUCTION TIME: 3 Hours

RELATED TECHNICAL INFORMATION:

- Purpose of furring strips.
- Procedure for cutting and installing furring strips.
- Fasteners and fastening patterns.
- Spacing of furring strips.
- Safety precautions.

UNIT	15.0	EXTERIOR FINISHING
TASK	15.08	CUT AND INSTALL WOOD PANELING

PERFORMANCE OBJECTIVE:

Given working drawings, specifications, a room requiring installation of solid wood paneling, installed furring strips, board-and-batten, shiplap, or tongue-and-groove paneling material, and the necessary tools, equipment, and materials; cut and install the wood paneling. The material must be cut to required lengths +/- 1/16 inch and installed securely with staggered, tight joints +/- 1/32 inch. Fasteners must be nailed in the required pattern and countersunk or blind-nailed.

PERFORMANCE STANDARDS:

- Cut and install wood paneling.
- Material must be cut to required lengths +/- 1/16 inch and installed securely with staggered, tight joints +/- 1/32 inch.
- Fasteners must be nailed in the required pattern and countersunk or blind-nailed.

SUGGESTED INSTRUCTION TIME: 8 Hours

RELATED TECHNICAL INFORMATION:

- Identify: board-and-batten, shiplap, tongue-and-groove paneling.
- Types of paneling.

UNIT	15.0	EXTERIOR FINISHING
TASK	15.09	INSTALL EXTERIOR SIDING

PERFORMANCE OBJECTIVE:

Given working drawings, specifications for exterior walls, a structure with exterior sheathing applied, exterior siding material (metal, vinyl, or wood), and the necessary tools, equipment, and materials; install exterior siding. The siding must be installed to manufacturer's standards +/- 1/16 inch with joints staggered and positioned on stud centers. The siding must be fastened using the required pattern and type of fasteners or adhesives. End, corner, and trim joints must fit tightly, and the installed material must be free of splits, dents, or chips.

PERFORMANCE STANDARDS:

- Install exterior siding to manufacturer's specifications +/- 1/16 inch with joints staggered and positioned on stud centers.
- The siding must be fastened using the required pattern and type of fasteners or adhesives.
- Ends, corner, and trim joints must fit tightly, and the installed material must be free of splits, dents, or chips.

SUGGESTED INSTRUCTION TIME: 8 Hours

RELATED TECHNICAL INFORMATION:

- Types of metal, vinyl, and wood siding typical of local construction.
- Types of fasteners, fastening patterns, and adhesives used locally.
- Procedures for installing metal, vinyl, and wood siding.
- Safety precautions.

TRUE/FALSE

1. The doors of public buildings must swing outward. _____
2. Casement windows provide 100 percent ventilation. _____
3. A single-hung window has an upper sash. _____
4. When using plywood siding over an unsheathed wall, the thickness should not be less than 1/4 inch when studs are spaced 16 inches O.C. _____
5. The most common thickness for hardboard siding material is 3/4 inch. _____

COMPLETION

1. The most widely used material for exterior finish is _____.
2. Sheathing paper must have a toplap of at least _____ inches. _____
3. An open cornice is used when the style of architecture requires the _____ to be exposed to view. _____
4. Two principle tools used to plumb a door are the _____ and _____.
5. The outer doors of homes swing _____.

MULTIPLE CHOICE

1. In residential construction the standard height of windows, measured from the bottom side of the head to the finished floor is _____.
 - a. 6'-6"
 - b. 6'-8"
 - c. 6'-10"
 - d. 7'-0"
2. Architectural drawings usually include a table (called a window schedule) that lists the manufacturer unit size and the rough opening (R.O.). If an R.O. for a given window was listed as 2'-10" x 3'-4", the actual height of the openings should be _____.
 - a. 2'-1"
 - b. 3'-0"
 - c. 3'-4"
 - d. 3'-6"

MULTIPLE CHOICE (Con't.)

3. The first step in making a window installation is to check the rough opening. Most windows require at least one-half inch clearance on each side and _____ above the head.
- a. 1/2 inch
 - b. 3/4 inch
 - c. 1 inch
 - d. 1 1/2 inch
4. Standard windows made with wooden frames are permanently secured by driving weatherproofed casing nails through the casing and into the building frame. The nails usually are spaced _____ inches O.C.
- a. 12
 - b. 16
 - c. 18
 - d. 24
5. For standard residential construction, the R.O. of an exterior door can be calculated by adding _____ inches to the door width and height.
- a. 3/4 inch
 - b. 1 inch
 - c. 1 1/4 inch
 - d. 1/2 inch
6. The flanges of blanket insulation are stapled to either the face or side of the framing members. When attaching the flange to the inside of a stud, the staple spacing should not be greater than _____.
- a. 3 inches
 - b. 12 inches
 - c. 10 inches
 - d. 16 inches
7. Filling the cores of concrete blocks with an approved insulation increases their thermal resistance. The U-value of an 8 in. light-weight block (.33) will be reduced to about _____ when filled.
- a. .17
 - b. .20
 - c. .23
 - d. .25

MULTIPLE CHOICE (Con't.)

8. Today, electricity is often used for residential heating. When heating cables are installed in the ceiling it is recommended that _____ of insulation to be used in the ceiling.
- a. 4 inches
 - b. 6 inches
 - c. 8 inches
 - d. 10 inches
9. Windows account for a large amount of the heat loss in a structure. Even with the best quality, double-glazed windows the heat losses through them will be _____ times as great as through a well insulated wall.
- a. 2 to 3
 - b. 4 to 6
 - c. 6 to 8
 - d. 8 to 10

EXTERIOR FINISHING MATHEMATICS

Estimate the number of square feet of area (walls and ceilings) to be insulated in the house plan shown below. Do not include the outside walls and ceiling of the garage. Route out any inch dimensions to a full foot. Deduct 60 square feet for the sliding glass doors in the family room, but make no other allowances. Round your answers to the next higher 10 square feet.

(Calculations):

Walls = _____
 Ceiling = _____

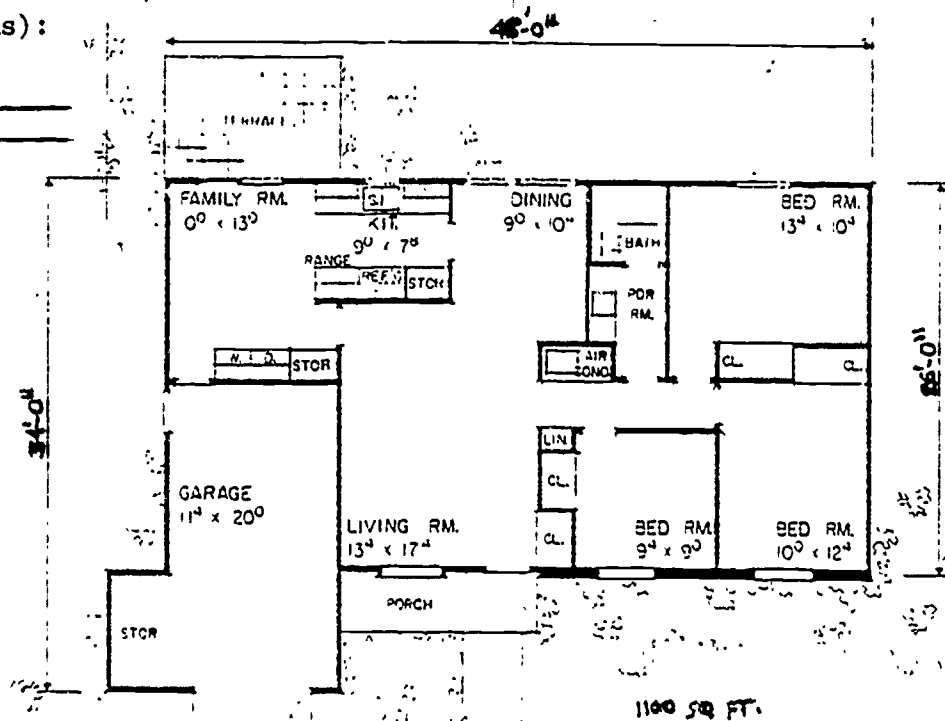

UNIT 16.0

INTERIOR FINISHING

Upon completing the unit of instruction on interior finishing, the graduate should be qualified for entry level work in the following areas of construction provided competencies have been demonstrated to the minimum suggested standards:

- a. The graduate should be able to define terminology associated with insulation, identify insulation materials, and to install insulation following manufacturer's instructions.
- b. The graduate should be able to use terminology associated with drywall construction, identify standard sizes and shapes of gypsum wallboard, estimate the amount of material needed for drywall finishing, install gypsum wallboard, and conceal joints and fasteners.
- c. The graduate should be able to identify parts of a door frame, identify types of interior door construction, identify common door sizes and, in addition, will be able to measure, cut, and install casing and trim, and hang a door.
- d. The graduate should be able to identify common trim and molding types, joints, and will demonstrate minimum suggested skill in cutting and installing coped joint miter joints in common trim material.
- e. The graduate should be able to define terms associated with paneling and to identify various styles of paneling and methods of application. The graduate should demonstrate the minimum recommended skills in the installing paneling according to specifications to be considered competent for entry level employment.

SUGGESTED MINIMUM TERMINOLOGY

INTERIOR FINISHING

Backing	Strips of wood nailed at inside angles of walls and partitions to provide solid corners for nailing wallboard.
Dimple	Impression formed in surface of wallboard when the nail is driven to the proper depth.
Drywall	Interior finish other than plaster, such as gypsum wallboard, sheetrock.
Gypsum Board	Panels from 1/2 to 5/8 inches thick, 4 by 6 feet or more in size composed of a core of gypsum sandwiched between two layers of paper.
Joint	Place where two pieces of wallboard meet.
Joint Cement	Specially prepared cement used to bond the perfa-tape to the gypsum wallboard at the joints.
Perfa-Tape	Perforated paper joint tape.
Topping	Specially prepared substance in heavy paste form used to cover the perfa-tape and fill in the joint.

UNIT	16.0	INTERIOR FINISHING
TASK	16.01	FIT AND INSTALL FLEXIBLE INSULATION

PERFORMANCE OBJECTIVE:

Given specifications, rough frame walls and ceiling ready for insulation, rolls of batts or rock wool or fiberglass insulation, staple tacker/staples, and other necessary tools and equipment; cut and install insulation according to manufacturer's instructions.

PERFORMANCE ACTIONS:

- 16.0101 Check specifications.
- 16.0102 Cut insulation to length.
- 16.0103 Fasten insulation in place.
- 16.0104 Fill all odd spaces around openings, etc., and cover with vapor barrier.

PERFORMANCE STANDARDS:

- Fit and install flexible insulation in a given structure according to specifications.
- Insulation must be cut to fit snug against framing at sides and ends.
- Vapor barrier must be toward warm side of walls and ceilings.
- Side flanges stapled to edge of framing.
- End paper extended over framing at top and bottom and stapled.
- All spaces filled with insulation and covered with vapor barrier.
- Insulation closely fitted around receptacle boxes and over wires, etc., with no torn vapor barrier.

SUGGESTED INSTRUCTION TIME: 6 Hours

RELATED TECHNICAL INFORMATION:

- Proper procedures in installing vapor barriers.
- Insulating around openings.
- Estimating material.
- Types of insulation.

SUGGESTED MINIMUM TERMINOLOGY

INSULATION

Bat Insulation	Matted organic or inorganic fiber material designed for small, easy to handle units to insulate for heat.
Blanket Insulation	Flexible lightweight blanket of loose compacted organic or inorganic fibers in rolls, strips, or panels, usually with a heavy vapor barrier.
Conduction	When heat is transmitted through a conductor.
Convection	When heat is transmitted by air or liquid across space.
Insulation	Material used to reduce heat or cold transfer from outside to inside of structure.
Loosefill Insulation	Fibrous, granular, or powdered insulation fill.
Radiation	Transmission of heat energy through space.
Vapor Barrier	Material highly resistance to passage of vapors. Metal foils, polyethylene films, and asphalt impregnated material are examples.

Adopted from text, Modern Carpentry.

UNIT	16.0	INTERIOR FINISHING
TASK	16.02	INSTALL PREFINISHED PANELING

PERFORMANCE OBJECTIVE:

Given working drawings, specifications, a framed structure requiring installation of wall paneling for one or more rooms, plywood paneling material, and the necessary tools, equipment, and materials; install the paneling.

PERFORMANCE ACTIONS:

- 16.0201 Check drawings and specifications.
- 16.0202 Set first piece of paneling in place at one corner of room.
- 16.0203 Fasten panel with nails or adhesive.
- 16.0204 Continue to set panels, fitting them in place and around openings.
- 16.0205 Fit and install ceiling molding. Fit and install base trim and shoe.

PERFORMANCE STANDARDS:

- Install given wood paneling.
- Installed panels must be installed vertically with edges centered on wall studs +/- 1/16 inch.
- Gaps between paneling joints must not exceed 1/32 inch, and the panels must be fastened in the required pattern +/- 1 inch.
- Panels must be cut accurately for wall openings and electrical outlets, and edges must be free of splinters and chips.

SUGGESTED INSTRUCTION TIME: 6 Hours

RELATED TECHNICAL INFORMATION:

- Southern Standard Building Code.
- Identify fasteners and fastening patterns.
- Identify tools and materials needed to cut and install interior paneling.
- Cutting panels for wall openings and outlets.
- Safety precautions.

UNIT	16.0	INTERIOR FINISHING
TASK	16.03	CUT AND INSTALL FURRING

PERFORMANCE OBJECTIVE:

Given working drawings, specifications, a room requiring installation of furring strips for ceiling panels or horizontal solid wood interior walls, wood stock or dimensioned lumber, and the necessary tools, equipment, and materials; install the furring.

PERFORMANCE ACTIONS:

- 16.0301 Check drawings and specifications.
- 16.0302 Measure furring strips needed, cut to length.
- 16.0303 Place first furring strip flush against wall so order tiles will be properly aligned. Nail into joists.
- 16.0304 Place second furring strip parallel to first at border width from wall. Attached remaining strips at proper intervals positioning last strip at proper distance from wall.
(NOTE: Distances should be calculated first.)
- 16.0305 Level furring strips, using wood shims to correct unevenness.

PERFORMANCE STANDARDS:

- Cut and install furring.
- Furring strips must be cut to required length +/- 1/8 inch and installed level as a nailing base for the suspended ceiling or interior wall.
- The furring strips must be attached securely with the required fasteners.
- Southern Standard Building Code applies.

SUGGESTED INSTRUCTION TIME: 3 Hours (Optional, depending on availability.)

RELATED TECHNICAL INFORMATION:

- Identifying the lengths and spacing of furring strips.
- Fasteners and patterns required for furring.
- Procedures for cutting and installing furring strips.
- Safety precautions.
- Installing furring around openings such as windows and doors.

UNIT	16.0	INTERIOR FINISHING
TASK	16.04	CUT AND INSTALL SOLID WOOD PANELING

PERFORMANCE OBJECTIVE:

Given working drawings, specifications, a room requiring installation of solid wood paneling, installed furring strips, board-and-batten, shiplap, or tongue-and-groove paneling material, and the necessary tools, equipment, and materials; cut and install the solid wood paneling.

PERFORMANCE ACTIONS:

- 16.0401 Check drawings and specifications.
- 16.0402 Snap guidelines, install furring strips or blocking for nailing base.
- 16.0403 Select panels for size and color arrangement.
- 16.0404 Set first panel in corner, plumb, and fit as necessary.
- 16.0405 Fasten panel with blind nailing.
- 16.0406 Continue to fit and install panels following above step. Fit panels surrounding openings.
- 16.0407 Fit and install base trim and ceiling trim molding.

PERFORMANCE STANDARDS:

- Cut and installed given solid wood paneling.
- Material must be cut to required lengths +/- 1/16 inch and installed securely with staggered, tight joints +/- 1/16 inch.
- Fasteners must be nailed in the required pattern and counter-sunk or blind-nailed.
- Southern Standard Building Code applies.

SUGGESTED INSTRUCTION TIME: 3 Hours (Optional)

RELATED TECHNICAL INFORMATION:

- Suitable materials for solid wood paneling.
- Board-and-batten, shiplap, and tongue-and-groove types of paneling.
- Calculating amount of solid wood paneling needed for a room.
- Procedure for cutting and installing solid wood paneling.
- Safety precautions.

300

UNIT	16.0	INTERIOR FINISHING
TASK	16.05	INSTALL PREFINISHED HARDBOARD

PERFORMANCE OBJECTIVE:

Given working drawings, specifications, a framed structure requiring installation of wall paneling in one or more rooms, hardboard paneling material, and the necessary tools, equipment, and materials; install the hardboard paneling.

PERFORMANCE ACTIONS:

- 16.0501 Check drawings and specifications.
- 16.0502 Snap guidelines, install furring strips or blocking for nailing base.
- 16.0503 Select panels for size and color arrangement.
- 16.0504 Set first panel in corner, plumb and fit as necessary.
- 16.0505 Fasten panel with blind nailing.
- 16.0506 Continue to fit and install panels following above steps. Fit panels around openings.
- 16.0507 Fit and install base trim and ceiling trim molding.

PERFORMANCE STANDARDS:

- + Install given hardboard paneling.
- Interior panels must be installed vertically with edges centered on wall studs +/- 1/8 inch.
- Caps between paneling joints must not exceed 1/32 inch.
- Fasteners must be used with the required pattern +/- 1 inch.
- Panels must be cut accurately for wall openings and electrical outlets, and edges must be free of splinters and chips.

SUGGESTED INSTRUCTION TIME: 3 hours

RELATED TECHNICAL INFORMATION:

- Tool and materials needed to cut and install hardboard paneling.
- Procedures for installing hardboard paneling.
- Cutting panels for openings and wall outlets.
- Southern Standard Building Code.
- Safety precautions.

301

UNIT	16.0	INTERIOR FINISHING
TASK	16.06 (DEMONSTRATION)	INSTALL DRYWALL BOARD (SHEETROCK) (GYPSUM WALLBOARD)

PERFORMANCE OBJECTIVE:

Given working drawings, specifications, a room requiring installation of drywall board (sheetrock), a wall and ceiling drywall material, taping and corner material, and the necessary tools, equipment, and materials; install the drywall board.

PERFORMANCE ACTIONS:

- 16.0601 Check plans and specifications.
- 16.0602 Install first panels along one wall at right angles to joists. Cut sheet to length if necessary.
- 16.0603 Fasten panels according to specifications, manufacturer's instructions, or fastening pattern.
- 16.0604 Dimple nail heads to receive joint cement.
- 16.0605 Finish joints and nailheads on gypsum board so that tape is well bedded in cement with skim coat overtop and all joints and nailheads troweled smooth ready for second coat, all excess cement is removed.

PERFORMANCE STANDARDS:

- Install drywall board (sheetrock) as required by the instructor.
- The sheets must be installed with edges centered on wall studs and ceiling joists +/- 1/16 inch.
- Gaps between joints must not exceed 1/32 inch, and the sheets must be nailed with the required pattern +/- 1/8 inch.
- Drywall sheets must be cut accurately +/- 1/8 inch for openings and electrical outlets or fixtures, and edges must be taped or covered with metal corner material.
- Southern Standard Building Code applies.

SUGGESTED INSTRUCTION TIME: 15 Hours

RELATED TECHNICAL INFORMATION:

- Drywall or sheetrock sizes.
- Care in moving, nailing, and cutting drywall.

UNIT	16.0	INTERIOR FINISHING
TASK	16.06 (DEMONSTRATION)	INSTALL DRYWALL BOARD (SHEETROCK) (GYPSUM WALLBOARD) (Con't.)

RELATED TECHNICAL INFORMATION (Con't.):

- Advantages of drywall over plaster, etc.
- Fasteners and nailing pattern used for installing drywall.
- Procedures for installing drywall on ceiling and walls, taping, and installing corners.
- Safety precautions.

UNIT	16.0	INTERIOR FINISHING
TASK	16.07	INSTALL INTERIOR DOORS

PERFORMANCE OBJECTIVE:

Given working drawings, specifications for interior trim and doors, a door schedule, a structure requiring installation of interior doors and frames, interior doors with prefabricated frames, wood stock, dimensioned lumber, and the necessary tools, equipment, and materials; install the interior doors.

(The instructor will determine the types of interior door(s): Interior door, interior folding door, interior sliding door.)

PERFORMANCE ACTIONS:

- 16.0701 Check plans and specifications.
- 16.0702 Measure door opening.
- 16.0703 Install door according to manufacturer's instructions.

PERFORMANCE STANDARDS:

- Install given interior doors in a selected structure.
- Door assemblies must be installed with plumb jambs, level sills, and square corners $\pm 1/16$ inch.
- Hung doors must operate smoothly, and the frame must be fastened with the required fasteners and pattern 16 inches O.C.
- The casing nails must penetrate well into the wall frame and must be countersunk with a nailset.
- Southern Standard Build Code applies.

SUGGESTED INSTRUCTION TIME: 6 Hours

RELATED TECHNICAL INFORMATION:

- Types of interior doors.
- Cut gains for hinges.
- Components of an interior door assembly.
- Procedures for installing interior doors.
- Safety precautions.

UNIT	16.0	INTERIOR FINISHING
TASK	16.08	INSTALL DOOR LOCK SETS

PERFORMANCE OBJECTIVE:

Given working drawings, specifications, installed interior and exterior doors requiring installation of lock sets, an assortment of door lock sets, and the necessary tools, equipment, and material; install the door lock sets.

(Related task: Install window hardware.)

PERFORMANCE ACTIONS:

16.0801 Install door and window hardware according to manufacturer's instructions or accepted practices of the trade meeting specifications and supervisor's standards.

PERFORMANCE STANDARDS:

- Install given door lock sets on doors provided.
- The holes for cylindrical lock sets (knobs), latchtails, and strike plates must be drilled to the required sizes and locations +/- 1/16 inch.
- Installed assemblies must allow for the doors to be opened, closed, locked and unlocked by turning either knob or the key.
- Southern Standard Building Code applies.
- Install door lock set as specified in manufacturer's instructions.
- The hole for lockset will be proper size and correctly located.
- No chipping will exist around hole.
- Latchtail hole will be proper size and in correct location.
- Strike plate will be in proper position, flush with surface of door jam.
- Turning either knob will unlatch door.
- Key will turn easily to lock or unlock door.
- Install window hardware according to specifications:
 - Measure and mark center of window unit.
- Install window locking devices on top, center or muntin so it will engage properly.
- Install handles in center of bottom window pail.

SUGGESTED INSTRUCTION TIME: 6 Hours

RELATED TECHNICAL INFORMATION:

- Exterior and interior lock sets.
- Tools and equipment to install door lock sets.
- Procedures for installing an interior or exterior door lock set.
- Safety precautions.

UNIT	16.0	INTERIOR FINISHING
TASK	16.09	CUT AND INSTALL FINISH FLOORING

PERFORMANCE OBJECTIVE:

Given working drawings, specifications, a room with installed subfloor and building paper or vapor barrier, strip or plank flooring material, and the necessary tools, equipment, and materials; install the finish flooring.

(Demonstrate procedure to lay and install a hardwood floor.)

PERFORMANCE ACTIONS:

- 16.0901 Check plans and specifications.
- 16.0902 Prepare subfloor. Prepare underlayment.
- 16.0903 Snap a base line.
- 16.0904 Install flooring, face nailing close to back edge and tee nail in tongue edge of strip, making sure each row is straight and parallel to base line. Joints should be well distributed. Set nails to receive filler.

PERFORMANCE STANDARDS:

- Install finish flooring in a given structure.
- Flooring must be cut to required lengths +/- 1/16 inch and installed securely with staggered, tight joints +/- 1/32 inch.
- Fasteners must be nailed in the required pattern with flooring at the right angle to floor joists.
- All fasteners must extend through the subfloor and into the joists.
- Fasteners must be face-nailed and set or blind-nailed. No visible hammer marks.
- Southern Standard Building Code applies.
- Subfloor shall be properly prepared, securely fastened, and broom clean.
- Underlayment shall be smooth and lapped +/- 2 inches sides and ends.

SUGGESTED INSTRUCTION TIME: 15 Hours

UNIT	16.0	INTERIOR FINISHING
TASK	16.09	CUT AND INSTALL FINISH FLOORING (Con't.)

RELATED TECHNICAL INFORMATION:

- Planking material.
- Procedures for cutting and installing finish flooring.
- Purpose of building paper or vapor barrier between subfloor and flooring.
- Undercut on strip flooring.
- Face-nailing and blind-nail. Importance of nailing.
- Safety precautions.

UNIT	16.0	INTERIOR FINISHING
TASK	16.10	CUT AND INSTALL BASEBOARDS, TRIM, AND MOLDING

PERFORMANCE OBJECTIVE:

Given working or detail drawings, baseboard, trim, and molding specifications, a room or rooms requiring installation of door, window, and wall trim, an assortment of baseboard, trim, and molding material, and the necessary tools, equipment, and materials; cut and install the baseboards, trim, and molding. Install molding with coped joints, on inside corners, and miter joints on outside corners.

PERFORMANCE ACTIONS:

- 16.1001 Using necessary materials, cut and install designated section of baseboard as specified.
 - Layout and miter joints.
 - Select and cut appropriate shoe.
 - Joints on the mold should have coped fit.
 - Fasten baseboard in place after flooring is layed.
- 16.1002 Install crown molding to specifications.
 - Measure wall and cut molding to length with square ends.
 - Cope next molding to fit contour of first piece installed.
 - Measure, cut, and install remaining molding.
- 16.1003 Trim according to specifications (door and window openings).
 - Install casings in place.
 - Install door stop.
 - Install window frame.
 - Install sill.
 - Case window.

PERFORMANCE STANDARDS:

- Cut and install baseboards, trim, and molding using materials provided and a given structure and specifications.
- Windows must be trimmed with picture frame or stool and apron trim.
- Doors must be trimmed with side and head casings and stops.
- Walls must be trimmed with required baseboards, moldings, and base shoe (if applicable).
- All joints must be mitered and free of gaps +/- 1/32 inch.

UNIT	16.0	INTERIOR FINISHING
TASK	16.10	CUT AND INSTALL BASEBOARDS, TRIM, AND MOLDING (Con't.)

PERFORMANCE STANDARDS (Con't.):

- Trim members must be cut to required lengths +/- 1/32 inch.
- Fasteners must be nailed in the required pattern and counter-sunk with a nailset.

SUGGESTED INSTRUCTION TIME: 1.5 Hours

RELATED TECHNICAL INFORMATION:

- Types of interior trim: Base show, quarter round, cove molding, bet molding, baseboard, door and window stops, casing, apron, stool, and picture frame molding.
- Use of miter.
- Procedures for cutting and installing interior trim for windows, doors, and walls.
- Reading detail drawings and specifications.
- Safety precautions.

UNIT	16.0	INTERIOR FINISHING
TASK	16.11 (Optional)	CUT AND INSTALL A FIREPLACE MANTEL

PERFORMANCE OBJECTIVE:

Given a detailed drawing of a fireplace, mantel specifications, dimensioned lumber, and the necessary tools, equipment, and materials; install the fireplace mantel.

PERFORMANCE ACTIONS:

- 16.1101 . Check plans and specifications.
- 16.1102 Position and align mantel.
- 16.1103 Secure to wall or masonry.

PERFORMANCE STANDARDS:

- Install a fireplace mantel using given materials and specifications.
- The mantel must be cut to required length and shaped (if a bevel or other design is specified) to specifications +/- 1/16 inch.
- The mantel must be fastened securely to the masonry and wall frame and centered over the fireplace.

SUGGESTED INSTRUCTION TIME: 6 Hours (Optional)

RELATED TECHNICAL INFORMATION:

- Shaping with a router.
- Fireplace mantel materials.
- Procedures for cutting and installing a fireplace mantel.
- Safety precautions.

UNIT	16.0	INTERIOR FINISHING
TASK	16.12	CONSTRUCT A STORAGE CLOSET

PERFORMANCE OBJECTIVE:

Given working or detailed drawings, specifications, a structure or room requiring a storage closet, cupboard, or clothes closet, wood stock and dimensioned lumber, and the necessary tools, equipment and materials; construct the closet.

(Related task: Install closet accessories.)

PERFORMANCE ACTIONS:

- 16.1201 Mark location of shelf cleats on one end of wall.
- 16.1202 Use spirit level to mark location of shelf cleats on opposite wall.
- 16.1203 Cut, fit, and fasten shelves onto cleats.

PERFORMANCE STANDARDS:

- Construct a storage closet to given drawings and specifications.
- The material must be cut to required lengths +/- 1/16 inch and installed securely with tight joints +/- 1/32 inches.
- Fasteners must be nailed in the required pattern and counter-sunk with a nailset.
- Shelves and supports must be installed level and attached securely to the closet wall.
- Rods for clothes closets must be installed level and fastened with wood screws.
- Southern Standard Building Code applies.
- No visual splintering of finished wood.
- No visual hammer marks or scarred surfaces.

SUGGESTED INSTRUCTION TIME: 6 Hours

RELATED TECHNICAL INFORMATION:

- Reading working or detail drawings and specifications.
- Locating and fastening shelf cleats or supports.
- Procedures for constructing a storage closet, etc.
- Safety precautions.

311

TRUE/FALSE

1. The interior finish work can be started as soon as the siding is put on. _____
2. Wood flooring is installed in the kitchen before the cabinets are put in. _____
3. When cutting drywall, the front side is scored with a knife. _____
4. By using an adhesive on drywall you can reduce nailing by 50 percent. _____
5. Drywall is put up after the ceiling. _____
6. The proper size nails for fastening trim and molding are 8d. _____
7. Random lengths are necessary for flooring strips so that the joints will be staggered throughout the floor. _____
8. When board paneling is put up horizontally, no furring strips are required. _____
9. To miter a corner joint, set the miter saw at 35 degrees. _____
10. Casings around doors and windows are mitered. _____
11. Baseboards are butted up to door casings. _____
12. Interior doors can be either 1 3/4 or 1 3/8 inch thick. _____
13. The inside edge of a door casing should be 3.8 inch back from the side jamb. _____
14. Tongue-and-groove joints are normally used in flooring strips. _____

COMPLETION

1. Exterior doors are generally _____ inches thick. _____
2. The rough door opening is lined with a _____. _____
3. Doors should be beveled on the _____ side. _____
4. The type of window hinged on the side and that swings outward is called a _____. _____

COMPLETION (Con't.)

5. Furring strips, when put up vertically are placed _____ inches O.C.

IDENTIFY

Name the trim parts used on the window shown below.

1. _____
2. _____
3. _____
4. _____
5. _____

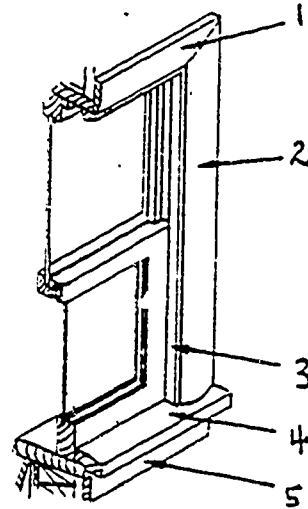

INTERIOR FINISHING MATHEMATICS

1. Calculate the amount of 1 x 6 tongue-and-groove solid wood paneling needed for one wall of a room 23 feet long with an 8 foot height. There are no openings and the boards will be applied vertically. Use the area factor of 1.17 and add 7 percent for waste. Round out your answer to the next higher full foot.

(Calculations): Board Feet = _____

2. Using information from the above problem, how many 4 x 8 sheets of plywood will be required to panel the wall described? The panels would be applied vertically, and the studs are all equally spaced 16 inches O.C.

(Calculations): No. of Panels = _____
 Sq. Ft. Plywood = _____

UNIT 17.0

STAIR CONSTRUCTION

Upon completing training on stair construction and demonstrating to minimum standards the suggested competencies, the graduate should be qualified for entry level employment in using the terminology associated with stair construction, computing the unit rise and run, calculating the number of risers and treads, as well as laying out and building a staircase.

SUGGESTED MINIMUM TERMINOLOGY

STAIR CONSTRUCTION

Total Rise	Total vertical distance the stair rises, measured vertically from finish floor to finish floor.
Unit Rise	Height of one step or riser. Distance from top of one step to top of adjacent step.
Total Number of Rises	Number of unit rises in stairway. (Also called Total Number of Risers)
Risers	Board placed between consecutive treads.
Total Run	Total horizontal distance covered by stairway.
Unit Run (Tread Run)	Width of one step measured from riser face to riser face (or back to back).
Tread	Pair of stair which is walked on.
Total Number of Treads	Number of unit runs in a given stairway. Always one less than the number of rises.
Wellhole	Space or opening in floor through which stair passes.
Headroom	Vertical distance between stair tread and ceiling.
Stringer (Carriage)	Part of stair construction which is cut out to receive risers and treads and which supports steps (inclined supports of flight of stairs).
Line of Travel (Line of Flight)	Line along which most people walk as they proceed up a stair.
Landing	Platform separating two flights of stairs, generally to change the direction of the stairway or break the run.
Flight of Stairs	Series of steps leading from one floor to another.
Stairway	Whole set of steps--One or more flights of stairs.

Source: Badzinski, Stanley Jr., Stair Layout, Alsip, IL: American Technical Publishers, Inc., pp. 11-12, 1981.

UNIT	17.0	STAIR CONSTRUCTION
TASK	17.01	CALCULATE RISER HEIGHT

PERFORMANCE OBJECTIVE:

Given working drawings and specifications, calculate riser height.

PERFORMANCE ACTIONS:

- 17.0101 Check drawings and specifications.
- 17.0102 Calculate total rise of stairs in inches.
- 17.0103 Calculate number of risers needed.
- 17.0104 Check calculations.

PERFORMANCE STANDARDS:

- Calculate riser height from given working drawings and specifications so that the minimum height of the riser will not be less than 6 1/2 inches or more than 8 1/4 inches.
- No mathematical errors will exist.
- All finished risers are to be equal.

SUGGESTED INSTRUCTION TIME: 20 Hours

UNIT	17.0	STAIR CONSTRUCTION
TASK	17.02	LAYOUT, CUT, AND INSTALL A STRAIGHT RUN STRINGER

PERFORMANCE OBJECTIVE:

Given working drawings, specifications, sufficient materials, necessary tools and equipment; frame a built-up stair stringer.

PERFORMANCE ACTIONS:

- 17.0201 Check specifications and plans (or stair location if building is in progress).
- 17.0202 Determine necessary measurements including total run, rise, clearance, tread width, and riser height. Note restrictions or limitations.
- 17.0203 Obtain required material or limitations.
- 17.0204 Layout stringer.
- 17.0205 Cut stringer.
- 17.0206 Layout triangular blocks.
- 17.0207 Cut triangular blocks.
- 17.0208 Attach blocks to stringer with appropriate fasteners.

PERFORMANCE STANDARDS:

- Frame a built-up stair stringer (horse).
- Temporary treads will be secured in place until the finished stair is installed toward the end of the job.
- Stringer will be cut to correct length, +/- 1/8 inch.
- Blocks will be securely fastened to stringer.

SUGGESTED INSTRUCTION TIME: See Task 17.01

UNIT	17.0	STAIR CONSTRUCTION
TASK	17.03	LAYOUT AND INSTALL STAIR (CARRIAGE)

PERFORMANCE OBJECTIVE:

Given a stairway ready to receive stringers, plans and specifications, finished lumber, nails, glue, tools and other necessary materials; prepare and install outside and wall stringer according to Southern Standard Building Code.

PERFORMANCE ACTIONS:

- 17.0301 Check plans and specifications for details.
- 17.0302 Determine stringer length and angle cuts.
- 17.0303 Layout and fit outside stringer to starting and landing newel posts.
- 17.0304 When stringers are neatly fitted into place, fasten securely with finish nails.
- 17.0305 Sand all work smooth and clean and set all nails to receive putty.

PERFORMANCE STANDARDS:

- Layout and install stair carriages (stringers) according to plans and specifications, meeting Southern Standard Building Code.
- Each end of wall stringer will be mitered to member with base-board.
- Outside stringer will be neatly mitered to receive mitered risers.
- All miters and joints will fit tight with no visible gaps.
- All surfaces will be sanded smooth and clean.

SUGGESTED INSTRUCTION TIME: See Task 17.01

UNIT	17.0	STAIR CONSTRUCTION
TASK	17.04 (OPTIONAL)	LAYOUT, CUT, AND INSTALL TREADS FOR OPEN RISER STAIRS

PERFORMANCE OBJECTIVE:

Given drawings, specifications, installed stringers, necessary materials, tools, and equipment; cut and install treads for open riser stairs.

PERFORMANCE ACTIONS:

- 17.0401 Check drawings and specifications.
- 17.0402 Calculate tread width in relation to stair runs so that treads not exceed 10 inches.
- 17.0403 Cut treads to specifications.
- 17.0404 Cut and fit end nosing to treads.
- 17.0405 Position and fasten treads to stringer.

PERFORMANCE STANDARDS:

- Layout, cut, and install treads for open riser stairs so that treads will be cut to specified length and width, treads will be firmly attached to stringer, and end nosing will be mitered and returned with no gap miter.

SUGGESTED INSTRUCTION TIME: (For advanced students)

UNIT	17.0	STAIR CONSTRUCTION
TASK	17.05 (OPTIONAL)	CUT, FIT, AND INSTALL BALUSTERS AND HANDRAILS

PERFORMANCE OBJECTIVE:

Given drawings, specifications, necessary materials, tools and equipment; cut, fit and install balusters and handrails.

PERFORMANCE ACTIONS:

- 17.0501 Check drawings and plans.
- 17.0502 Obtain proper handrail and balusters.
- 17.0503 Space center of baluster on tread.
- 17.0504 Center points on width of handrail.
- 17.0505 Bore holes to receive dowels of balusters.
- 17.0506 Mark and cut handrail to length.
- 17.0507 Fit baluster into tread.
- 17.0508 Make trial assembly of handrail and balusters.
- 17.0509 Glue handrail and baluster into position.
- 17.0510 Fasten handrail to newels as specified.
- 17.0511 Fasten newel posts to stairs as specified.

PERFORMANCE STANDARDS:

- Cut, fit, and install balusters and handrails so that the baluster will be accurately located, baluster will be fastened according to specifications, baluster will be plumb, handrail will be parallel to line of stair, handrail will be fastened to balusters and newels according to specifications.

SUGGESTED INSTRUCTION TIME: (For advanced students)

UNIT	17.0	STAIR CONSTRUCTION
TASK	17.06 (OPTIONAL)	FIT NEWEL POSTS IN OPEN STAIRS

PERFORMANCE OBJECTIVE:

Given stairs ready to receive newels, drawings, specifications, and necessary tools, equipment, and materials; fit and install starting and landing newels.

PERFORMANCE ACTIONS:

- 17.0601 Check drawings and specifications.
- 17.0602 Cut hole to receive starting newel.
- 17.0603 Square and cut bottom edge of post and erect it into position.
- 17.0604 Fasten post as specified.

PERFORMANCE STANDARDS:

- Fit newel posts in open stairs so that the newel posts are cut and fitted to specifications, newel posts are plumb, and securely fastened in place.

SUGGESTED INSTRUCTION TIME: (For advanced students)

UNIT	17.0	STAIR CONSTRUCTION
TASK	17.07 (OPTIONAL)	ASSEMBLE AND ERECT PREFABRICATED (MILL-BUILT) STAIRS

PERFORMANCE OBJECTIVE:

Given working drawings, specifications, a milled stairway, fasteners, and necessary tools and equipment; assemble and install mill-built stairs.

PERFORMANCE ACTIONS:

- 17.0701 Check drawings and specifications.
- 17.0702 Set stringers and fasten at top and bottom.
- 17.0703 Install temporary treads.
- 17.0704 Install string boards and skirting boards.
- 17.0705 Cut and install risers.
- 17.0706 Cut and install treads.
- 17.0707 Install nosing around well hole.
- 17.0708 Install cove molding under treads.
- 17.0709 Install balustrade.
- 17.0710 Sand and finish.

PERFORMANCE STANDARDS:

- Install mill-built stairway according to specifications so that stringers will be firmly attached in specified locations, risers will be plumb and firmly secured.

SUGGESTED INSTRUCTION TIME: . Based on availability of materials, time, or training situations.

For orientation only, students may visit construction site to observe installation of mill-built stairs.

TRUE/FALSE

1. In stair construction, the riser height can vary from tread to tread. _____
2. The thickness of the tread in stair construction must be deducted from the top of the stringer. _____
3. A total run equals the sum of all the treads. _____
4. The handrail is usually 2 feet 8 inches above the tread at the riser line. _____
5. The maximum height that is allowed for risers is 10 1/4 inches. _____

MULTIPLE CHOICE

1. The size of the rough opening for a stairwell must be known or calculated during the rough framing of a structure. Trimmers and headers around the opening should be doubled whenever they are longer than _____ feet. _____
 - a. 4
 - b. 6
 - c. 8
 - d. 10
2. Stair angle or slope is determined by the rise-run combination. The preferred angle for a standard stair is the range of _____ degrees. _____
 - a. 20-25
 - b. 25-30
 - c. 30-35
 - d. 35-40
3. The relationship of size ratio between the risers and treads is very important in stair design. One commonly accepted rule states that the sum of two risers plus one tread should equal _____. _____
 - a. 18
 - b. 20
 - c. 24
 - d. 25

MULTIPLE CHOICE (Con't.)

4. A minimum total width of 3 feet generally is recommended for a main stairway. FHA regulations permit a minimum width (clear of the handrail) of _____.
- a. 2'-6"
 - b. 2'-8"
 - c. 2'-10"
 - d. 2'-11"
5. The simplest type of stringers are formed by attaching cleats on which the treads can rest. Another method consists of cutting dados into which the treads will fit. Depth of the dados should equal _____ of the stringer thickness.
- a. 1/4
 - b. 1/3
 - c. 1/2
 - d. 5/8

COMPLETION

1. The complete grouping of balusters is known as a _____.
2. A _____ post is fastened in a vertical position at the bottom of the stairway of a landing.
3. The front edge of the tread that overhangs the riser is called the _____.
4. The easiest type of stairs to build is _____ stairs.
5. Before making the actual layout of a stair stringer, the calculated riser height is laid out and checked on a straight strip called a _____.

IDENTIFY

Identify these staircase parts. Write your answers in the blanks provided.

1. _____
2. _____
3. _____
4. _____
5. _____
6. _____
7. _____
8. _____

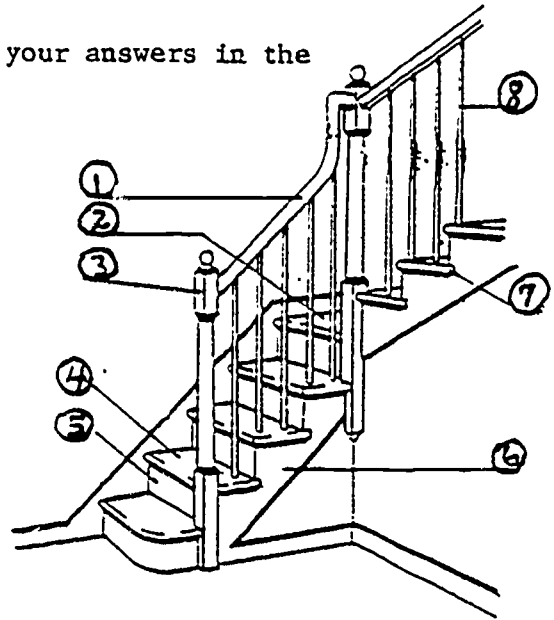

STAIR CONSTRUCTION MATHEMATICS

1. Based on the dimensions given in the following drawing calculate the riser and tread dimensions.

Riser dimensions _____
 Tread dimensions _____

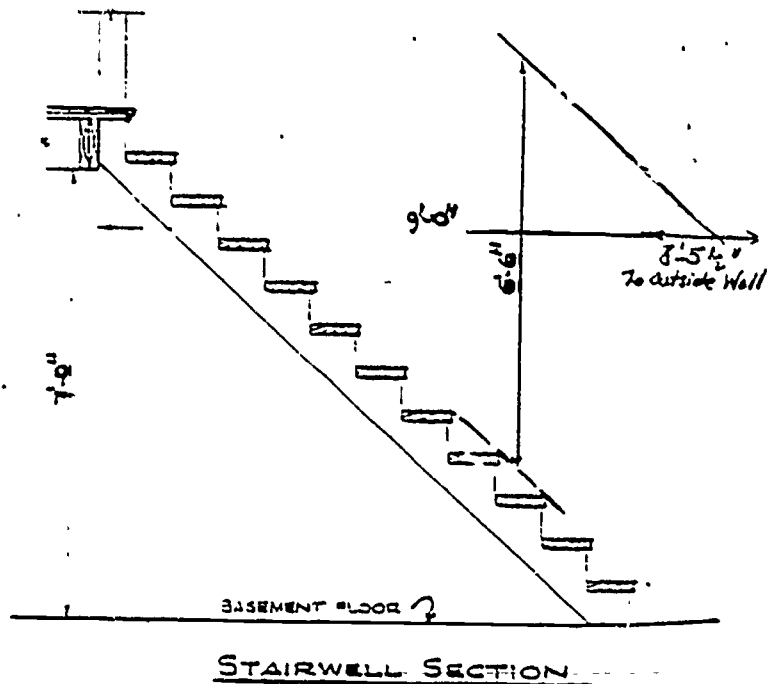

STAIR CONSTRUCTION MATHEMATICS (Con't.)

2. Calculate the number of and size of risers and tread for a main stairway (straight run) for a residential structure. The vertical distance between the finished surfaces of the two floors is 8 feet 11 inches and the riser height must not be greater than 8 1/2 inches. Use the "riser-tread" rule that the sum of two risers plus one tread should equal 25.

(Calculation):

No. of risers = _____

Riser height = _____

No. of treads = _____

Tread width = _____

UNIT 18.0

CABINETS AND BUILT-INS

Upon completing this unit, the carpentry student will be able to define cabinet building terms, identify the major parts of a cabinet, list common hardwoods (species) used in cabinet construction, and name types and grades of hardwood plywood. The student will be able to identify styles of cabinet doors, hardware items, fastening devices, joints, and counter topping as well as be able to cut out and assemble a section of cabinet using power tools safely and correctly.

Safety in cabinetmaking will emphasize stationary and portable power tools. The operation of power equipment may be fully covered in the units on portable or stationary power tools or may expand from that unit. Task emphasis is on the basic construction of typical residential cabinets and built-ins and the installation of mill-finish cabinet work.

Unit 18, Cabinets and Built-ins, is designed to introduce the carpentry student to typical cabinet work that may be required in kitchens, baths, and built-ins in dens or bedrooms.

Advanced training in cabinets and built-ins may be allotted as much as 6 weeks depending on student or potential employer (program) needs and the availability of shop facilities and materials. Advanced training typically will become an extension of Unit 18 and a possible course of training is outlined in Optional Unit 19.

UNIT	18.0	CABINETS AND BUILT-INS
TASK	18.01	INSTALL BUILT-IN SHELVING AND CABINETS

PERFORMANCE OBJECTIVE:

Given plans and specifications, a supply of materials and hardware, necessary tools and equipment; layout and install cabinets and shelving according to details and specifications at the wall or space provided.

PERFORMANCE ACTIONS:

- 18.0101 Check detail drawings and specifications.
- 18.0102 Select material for and prepare upright end panel dividers.
- 18.0103 Layout end panels and uprights and cut shelf dados.
- 18.0104 Cut shelves to length.
- 18.0105 Layout and plow grooves for adjustable shelf striping.
- 18.0106 Assemble uprights and fixed shelves.
- 18.0107 Plumb level and align assembly and fasten to wall.
- 18.0708 Prepare material and construct doors or drawers as specified for cabinet sections.
- 18.0709 Fit and install moldings and trim as required.
- 18.0710 Cut and fit adjustable shelves.
- 18.0711 Install adjustable shelf strips.
- 18.0812 Install cabinet hardware as shown.
- 18.0813 Set nails, fill and sand all edges and surfaces and clean.

PERFORMANCE STANDARDS:

- Layout and install cabinets and shelving according to details and specifications at wall or space provided.
- Layout shall be accurate to +/- 1/16 inch.

UNIT 18.0

CABINETS AND BUILT-INS

TASK 18.01

INSTALL BUILT-IN SHELVING AND CABI-
NETS (Con't.)

PERFORMANCE STANDARDS (Con't.):

- Shelves and cabinets shall be level and plumb and square.
- All joints tight fitting and neat.
- Adjustable shelf brackets neatly recessed as required.
- Cabinet doors and/or drawers shall be carefully constructed; properly fitted and installed, operating free and easy.
- Nail shall be set, and work sanded smooth and clean with edges slightly broken.

SUGGESTED INSTRUCTION TIME: 9 Hours

UNIT	18.0	CABINETS AND BUILT-INS
TASK	18.02	ASSEMBLE CABINET FRAME

PERFORMANCE OBJECTIVE:

Given pictorial exploded detail drawing, assembly specifications, necessary tools, equipment, fasteners, adhesive and cabinet frame; assemble cabinet frame to specifications.

PERFORMANCE ACTIONS:

- 18.0201 Check drawings and specifications.
- 18.0202 Complete a trial assembly of component parts (bottom, ends, top, back, and division panels).
- 18.0203 Square and align component parts and check to see if sub-assemblies fit (drawer, frame, face frame, and drawers).
- 18.0204 Disassemble parts.
- 18.0205 Assemble and glue component parts.
- 18.0206 Check for accuracy.

PERFORMANCE STANDARDS:

- Assemble cabinet members to specifications.
- All members must be securely fastened together.
- All exposed and semi-exposed joints will be tight and true.
- All exposed joints will be securely glued.

SUGGESTED INSTRUCTION TIME: 15 Hours

UNIT	18.0	CABINETS AND BUILT-INS
TASK	18.03	INSTALL PREFABRICATED CABINETS

PERFORMANCE OBJECTIVE:

Given mill built cabinets, working drawings and specifications, areas in which cabinets are to be installed, and necessary tools and equipment; install cabinets to specifications.

PERFORMANCE ACTIONS:

18.0301 For Bottom Cabinet:

- Check plans and specifications.
- Remove end stiles.
- Set bottom cabinet, level and plumb cabinet.
- Equalize clearance at both ends of unit face.
- Fasten cabinet to floor and wall.
- Layout, cut, and install stiles to cabinets.

18.0302 For Upper Cabinets:

- Remove loose end stiles.
- Cut spaces to fit between upper and lower cabinets.
- Set upper cabinet in position and block against soffit with spaces.
- Level cabinet.
- Scribe top rail to fit ceiling, rip rail to scribed line.
- Reset cabinet tight to ceiling and secure to wall.
- Scribe and install end stiles.

PERFORMANCE STANDARDS:

- Install prefabricated cabinet to specifications.
- Position and level cabinets.
- Attach to wall with appropriate fasteners.

SUGGESTED INSTRUCTION TIME: 6 Hours

TRUE/FALSE

1. The recommended (typical) accuracy for dimensions in cabinets and built-ins is +/- 1/32 inch. _____
2. Drawer pulls often are located slightly below the center line of the drawer front. _____
3. Plastic laminates commonly used for the surface of cabinet counters and tops is 1/32 inch thick. _____
4. Shelves and cabinets should be level, square, and plumb. _____
5. Prior to beginning work on cabinets and built-ins, the carpenter should complete a trial assembly of component parts. _____

MULTIPLE CHOICE

1. When cabinets are built on the job, the selection of the kind and sizes of joints is usually the responsibility of the _____.
 - a. architect
 - b. owner
 - c. contractor
 - d. carpenter_____
2. In some drawer arrangements it may be necessary to install a strip or strips somewhere over the drawer to prevent it from tilting downward when it is open. A strip of unit that serves this specific function is referred to as a _____.
 - a. kicker
 - b. guider
 - c. leveler
 - d. grounder_____
3. Several different kinds of joints are used to assemble the various parts that make up a cabinet drawer. Because of the extra strain usually encountered, the strongest joints should be used to assemble the _____.
 - a. front and bottom
 - b. bottom and sides
 - c. sides and back
 - d. front and sides_____

MULTIPLE CHOICE (Con't.)

4. Standard shelving that is $\frac{3}{4}$ inch thick should be carried on supports that are spaced not more than _____ inches apart.
- a. 32
 - b. 36
 - c. 40
 - d. 42
5. When wood or metal pins are used to support adjustable shelves it is recommended that the holes for the pins be drilled _____ the basic cabinet is assembled.
- a. before
 - b. after

COMPLETION

1. In building construction, the term cabinet work refers to such items as kitchen cabinets, bathroom cabinets, and wardrobes. When the unit is located within or attached to the structure, it is referred to as a _____.
2. A full-sized drawing (usually a section view) prepared by the carpenter, which shows the location of drawers, shelves, doors, and framing details, generally is referred to as a _____.
3. Facing strips are applied to the front of the basic cabinet frame. The vertical members are called _____.
4. The most common handsaw used in cabinetmaking is the _____ saw.
5. When shaping on the radial arm saw, a _____ cut should be made first.

PERFORMANCE TEST

Given a pictorial detail drawing, specifications, necessary tools, equipment, fasteners, adhesive, and material; cut out and assemble cabinets to specifications.

All cabinet members must be securely fastened together. All exposed and semi-exposed joints must be tight and true. All exposed joints must be securely glued and nailed.

1. Check drawings and specifications.
2. Complete a trial assembly of component parts. (Bottom, ends, top, back, and division panel).
3. Square and align component parts and check to see if sub-assemblies fit. (Drawer frame, face frame, and drawers).
4. Assemble and fasten component parts.
5. Check for accuracy.

The finished product must meet the standards of the instructor.

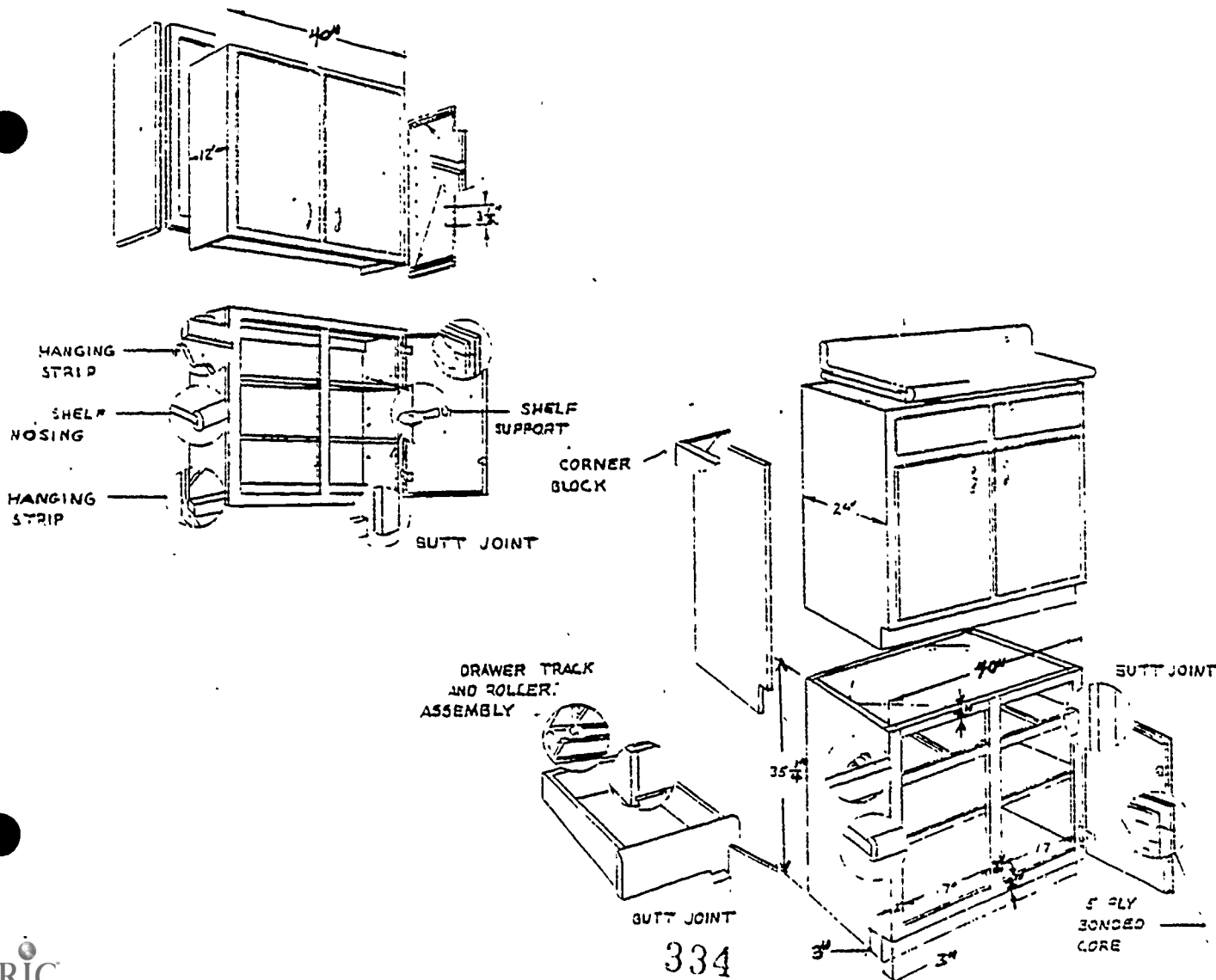

NOTE

UNITS 19, 20, 21, 22, and 23

THE FORMAT OF THE FOLLOWING UNITS HAS BEEN MODIFIED TO SHOW ONLY THE OBJECTIVES OF THE UNITS OF INSTRUCTION.

THE OPTIONAL UNITS AND TASKS MAY BE SELECTED BASED ON THE NEEDS OF THE STUDENTS AND POTENTIAL EMPLOYERS, THE EQUIPMENT AND DESIGN OF THE CARPENTRY SHOP, OR THE INSTRUCTOR'S ORIENTATION TO CARPENTRY INSTRUCTION.

UNIT 19.0

CABINETMAKING, AND FINISHING SPECIALIZATION

(OPTIONAL)

For students who wish to specialization in the fabrication or installation of cabinets and built-ins or finished carpentry, these specialized optional tasks may be utilized to provide the students with minimum skills and knowledges to prepare the student for employment.

Emphasis will be on finished carpentry work using cabinetmaking tasks. This training is not designed to change Building Construction (Carpentry) into Cabinetmaking. It is designed to provide specialized training for advanced students to become qualified for finished carpentry work, work in fabrication or cabinetmaking industries, or for entry in cabinet and built-in installation work.

These specialized tasks are grouped into two areas; (a) cutting and shaping casework components and (b) assembling and installing casework components.

UNIT	19.0	PART A	CABINETMAKING
TASK	(OPTIONAL)		CUT AND SHAPE CASEWORK COMPONENTS

TASK PERFORMANCE OBJECTIVES:

- 19.01A CUT FACE FRAME STILES AND RAILS
 Given a radial arm saw, drill press, working drawing, specifications, wood stock, and necessary tools, equipment, and materials; cut face frame stiles and rails. Stock must be cut to specified dimensions +/- 1/32 inch* with no splinters or chips.
- 19.02A CUT END AND TOP AND BOTTOM PANELS
 Given a table saw, radial arm saw, jointer, working drawing, specifications, wood stock, and necessary tools and materials; cut end and top and bottom panels. Stock must be cut to specified dimensions +/- 1/32 inch with no splinters or chips.
- 19.03A CUT PARTITIONS AND SLEEPERS
 Given a table saw, radial arm saw, jointer, working drawing, specifications, wood stock, and the necessary tools and materials; cut partitions and sleepers. Stock must be cut to specified dimensions +/- 1/32 inch with no splinters or chips.
- 19.04A CUT SHELF PANELS
 Given radial arm saw, working drawing, specifications, wood stock, and necessary tools, equipment, and materials; cut shelf panels. Stock must be cut to specified dimensions +/- 1/32 inch with no splinters or chips.
- 19.05A CUT SKELETON FRAME STILES AND RAILS
 Given table saw, radial arm saw, shaper, working drawing, specifications, wood stock, and necessary tools and materials, cut skeleton stiles and rails. Stock must be cut to specified dimensions +/- 1/32 inch with no splinters or chips.
- 19.06A CUT TOE BOARD AND BACK PANEL
 Given a radial arm saw, table saw, working drawing, specifications, wood stock, and necessary tools, equipment, and materials; cut a toe board and back panel. Toe board and back panel must be cut to specified dimensions +/- 1/32 inch with no splinters or chips.
- 19.07A CUT CASEWORK TOP OR COUNTERTOP AND BACKSPLASH
 Given a radial arm saw, sabre saw, belt sander, working drawing, specifications, wood stock, and necessary tools and materials; cut a casework top or countertop and backsplash. Casework top or

UNIT	19.0	PART A	CABINETMAKING
TASK	(OPTIONAL)		CUT AND SHAPE CASEWORK COMPONENTS (Con't.)

TASK PERFORMANCE OBJECTIVES (Con't.):

countertop and backsplash must be cut to specified dimensions $\pm 1/32$ inch with no splinters or chips.

- 19.08A CUT DRAWER FRONT, SIDES, BACK, AND BOTTOM
Given a table saw, radial arm saw, jointer, planer, detailed drawing, specifications, wood stock, casework with face frame, and necessary tools, equipment, and materials; cut drawer front, sides, back, and bottom. Stock must be cut to specified dimensions $\pm 1/32$ inch, with no splinters or scarred surfaces on exposed drawer front or sides.
- 19.09A CUT WOOD DRAWER GUIDES
Given a radial arm saw, table saw, jointer, planer, detailed drawing, specifications, wood stock, casework with face frame, and necessary tools and materials; cut wood drawer guides. Stock must be cut to specified dimensions $\pm 1/32$ inch with no splinters or chips.
- 19.10A CUT SOLID DOORS
Given a table or radial arm saw, jointer, shaper, working drawing, specifications, wood stock, and the necessary tools and materials; cut solid doors. Stock must be cut square to specified dimensions $\pm 1/32$ inch with no splinters, chips, or chatter marks.
- 19.11A ROUT OR SHAPE CASEWORK COMPONENTS
Given a router or shaper with attachments, working or detailed drawing, specifications, solid doors, drawer fronts, and necessary tools, equipment, and materials; route or shape casework components. Doors and drawer fronts must be routed or shaped to specified design and dimensions $\pm 1/32$ inch and must be free of burn marks, splinters, and chips.
- 19.12A CUT, TRIM, MOLDING, AND EDGE BANDING
Given a radial arm saw or miter box, working or detailed drawings, specifications, casework, panel or solid doors, drawer fronts, trim, molding, edge banding, and necessary tools, equipment, and materials; cut trim, molding, and edge banding. Edges must cut evenly with no splintering at 45 or 90 degree angles and to specified dimensions $\pm 1/64$ inch.

UNIT	19.0	PART A	CABINETMAKING
TASK	(OPTIONAL)		CUT AND SHAPE CASEWORK COMPONENTS (Con't.)

TASK PERFORMANCE OBJECTIVES (Con't.):

19.13A CUT SINK OPENING IN COUNTERTOP
Given a sabre saw or circular saw, electric drill, working drawing, specifications, base cabinet with countertop sink, necessary tools, and materials; cut a sink opening in countertop. Opening must be cut to specified dimensions $\pm 1/8$ inch and free of chips or gouges.

*NOTE: Standard for cuts is $\pm 1/32$ inch and should be maintained since this training unit emphasizes finish carpentry skills.

TASK (OPTIONAL)

ASSEMBLE AND INSTALL CASEWORK COMPONENTS

TASK PERFORMANCE OBJECTIVES:

- 19.01B ASSEMBLE FACE FRAME, PANELS, TOE BOARD, AND SKELETON FRAME
Given a detailed drawing, specifications, clamps, glue, pre-cut casework, components, and necessary tools, equipment, and materials; assemble face frame, panels, toe board, and skeleton frame. All casework components must be in specified location with joints tight, square, and free of excess glue. Components must be fastened according to drawing specifications with no visual openings or gaps between stock. Overall dimensions must be within +/- 1/16 inch.
- 19.02B FASTEN TOP OR COUNTERTOP AND BACKSPLASH TO CASEWORK
Given a working drawing, specifications, casework top or countertop and backsplash, and necessary tools, equipment, and materials; fasten top or countertop and backsplash to casework. The top must be fastened squarely and securely and be level and flush with the wall. No damage will be caused to the top or countertop and backsplash or casework and fasteners will be in specified locations.
- 19.03B ASSEMBLE DRAWERS
Given a detailed drawing, specifications, and necessary tools, equipment, and materials; assemble drawers. Drawer fronts must be assembled to specified dimensions +/- 1/16 inch. Joints must be secured and free of visual openings or gaps between stock. Sides and end must be square and parallel.
- 19.04B INSTALL DRAWER GUIDES
Given specifications and a detailed drawing, a framed cabinet, drawer guides, and the necessary tools, equipment, and material; install drawer guides to specified dimensions +/- 1/16 inch. The guides must form a 90 degree angle with the face frame, be fastened securely, and be level to allow the drawer to move without bending.
- 19.05B HANG CASEWORK DOORS
Given a working drawing, specifications, assemble solid or paneled doors, casework with the face frame attached and the necessary tools, equipment, and

UNIT	19.0	PART B	CABINETMAKING
TASK	(OPTIONAL)		ASSEMBLE AND INSTALL CASEWORK COMPONENTS (Con't.)

TASK PERFORMANCE OBJECTIVES (Con't.):

materials; hang casework doors. The doors must be plumb with the casework and mounted securely in specified locations $\pm 1/16$ inch. Doors hinges must be installed with correct number and type fasteners.

19.06B INSTALL SHELVING

Given a working drawing, specifications, casework, pre-cut shelving, and the necessary tools, equipment, and materials; install shelving. The shelves must fit securely in specified locations $\pm 1/16$ inch and be level.

19.07B ATTACH TRIM, MOLDING, AND EDGE BANDING

Given a working drawing, specifications, assembled casework, doors and the necessary tools and materials; attach trim, molding, and edge banding. The trim, molding, and banding must be in the specified locations $\pm 1/16$ inch.

19.08B INSTALL CASEWORK HARDWARE

Given a working or detailed drawing, specifications, assembled casework, and the necessary tools, equipment, and materials; install casework hardware. Hinges, pulls, latches, tracks, and sides must be installed in specified locations $\pm 1/16$ inch and must allow for smooth opening and closing of casework doors and drawers.

UNIT 20.0

MECHANICALS AND MASONRY

ROUGH-IN, FINISHING, AND COMPLETION

(OPTIONAL UNITS)

This optional unit concerning rough-in, finishing, and completion tasks may be used to introduce the carpentry student to related building construction duties in interior and exterior finishing; electrical, plumbing, and heating and cooling mechanical areas; as well as to basic masonry tasks.

The representative tasks of this optional unit have been chosen based on the probability that the carpenter could be required to perform them in a remodeling job or in completing new construction.

These tasks may be expanded, through individualized learning experiences, for a student who wishes to acquire specialized skills and knowledges in a carpentry related field. Upon mutual agreement between participating instructors, the student, and others as necessary, the carpentry student may participate in individualized training experiences in electrical, masonry, or other related programs. (Individualized training should be coordinated through the vocational center guidance counselor.)

Given a rough framed structure, tools, equipment, and materials needed, the carpentry student should be able to complete selected interior and exterior finishes; perform carpentry related task in electrical, plumbing, heating and cooling mechanicals; and limited masonry tasks. Upon completion, all work will be checked for accuracy or proper functioning. As applicable, codes inspections will be obtained, final hook-ups ordered, and the structure prepared for turn over to the owner

NOTE: Only tasks (objectives) are included in this unit. The appropriate training tasks may be presented by the carpentry instructor or by participating instructors, usually with input from the student. The description of the training should be specified in the student's record as either performance or orientation training.

UNIT	20.0	PART A	ROUGH-IN, FINISHING, AND COMPLETION
TASK	(OPTIONAL)		ELECTRICAL - MECHANICAL

TASK PERFORMANCE OBJECTIVES:

- 20.01A Develop complete materials list for all electrical rough-in needs.
- 20.02A Locate and install the main distribution panel housing the disconnect as specified by electrical code.
- 20.03A Locate and install wall and ceiling outlet boxes for lighting circuits.
- 20.04A Locate and install wall outlet boxes for special circuits (appliances).
- 20.05A Locate and install outlet boxes for single individual permanent appliances.
- 20.06A Locate and install recessed wall and ceiling electrical units (fans, etc.)
- 20.07A Install thin-wall conduit according to code.
- 20.08A Bore holes for wire path and rough-in all branch circuit conductors. Label each distribution panel.
- 20.09A Locate and rough-in low voltage circuit conductors for doorbell and heating and cooling system controls.
- 20.10A Locate low voltage transformer for doorbell circuits.
- 20.11A Locate and rough-in conduit or conductors for television, telephone, and intercommunications systems.
- 20.12A Install electrical cable, in a conduit, if required, threading the cable through the conduit, or run or fatten the cable according to specifications.

(NOTE: An alternate task is to replace electrical cables in an old conduit or run new wiring beside old wiring runs.)
- 20.13A Upon approval of the local electrical inspector as applicable, request the utility company to connect the electrical service to the residential structure.

UNIT	20.0	PART B	ROUGH-IN, FINISHING, AND COM- PLETION
TASK	(OPTIONAL)		HEATING AND COOLING - MECHANICAL

TASK PERFORMANCE OBJECTIVES:

- 20.01B Layout and cut holes for register boots in each room.
- 20.02B Install boots in each opening and attach in place temporarily.
- 20.03B Extend venting system for heating unit through the roof if a combustible fuel is used to heat the structure.
- 20.04B Place warm air diffusers over register boots in each room and fasten in position at the intersection of the floor and wall.
- (NOTE: Warm air floor diffusers drop into the register boot without any additional fastening needed.)
- 20.05B Secure room return air grills in positions using screws supplied. Position grills so observer cannot see directly into opening behind grills.
- 20.06B Provide ducts and roof/wall jacks for all appliance fans that exhaust air to the exterior of the structure. Generally, these may include: clothes dryers, cooking ranges, and ceiling or wall mounted exhaust fans.

UNIT	20.0	PART C	ROUGH-IN, FINISHING, AND COM- PLETION
TASK	(OPTIONAL)		PLUMBING - MECHANICAL

TASK PERFORMANCE OBJECTIVES:

- 20.01C Layout location of all fixtures requiring soil or waste connections.
- 20.02C Layout location of all vents are required by local codes.
- 20.03C Cut or bore and frame the necessary openings in walls, floors, ceiling, and roof for soil, waste, and vent pipe installations. Ascertain opening sizes and hold diameters from drainage pipe measurements.
- 20.04C Install bath tub or combination shower and bath tub unit according to instructions furnished with unit.
- 20.05C Vent each plumbing fixture through the roof as specified by local codes. Vent and drain lines must be properly graded and installed according to layout plans. All pipes must be correctly aligned and all lines must be adequately supported.
- 20.06C Extend vent through roof or connect to furnace vent if a combustible fuel is to be used for the water heater.
- 20.07C Test all water, waste, and gas connections for leaks and operate each consuming device to confirm proper working order.

UNIT	20.0	PART D	ROUGH-IN, FINISHING, AND COMPLETION
TASK	(OPTIONAL)		MASONRY

TASK PERFORMANCE OBJECTIVES:

- 20.01D Layout exterior wall in preparation for installation of brick by establishing head joint location and allowance for mortar joints by stringing out (placing) first course of brick with-out mortar. Adjust for minimum cutting by varying width of head joints.
- 20.02D Layout vertical position of all brick courses and mortar joints on a story pole. Anticipate slight vertical adjustments in thickness or mortar joint to compensate for door and window still placement.
- 20.03D Measure and mix mortar ingredients until the mortar is uniform, cohesive and of a consistency that makes it usable.
- 20.04D Add coloring to mortar as per specifications.
- 20.05D Load a masonry trowel and spread mortar on bricks until the fundamental steps have been acquired.
- (Extension of above task) Build a lead about six courses high at each corner to establish proper height and provides a place to attach the mason's line.
- 20.06D Tool vertical and horizontal mortar joint when the mortar has become "thumb print hard" or when the mortar is compacted.
- 20.07D Layout and cut line brick to specified length with a tolerance of +/- 1/8 inch.
- 20.08D Lay stretcher bricks from leads to center using a taut line as a guide.
- 20.09D Place metal ties in mortar joints and affix to frame of structure.
- 20.10D Strike off excess concrete from freshly poured concrete so that the concrete pour is level, high points are removed, and low points are filled in. All excess concrete must be removed from pour.
- 20.11D Given cement in bag form, neatly stack the cement in a storage area that is well ventilated and dry.

UNIT	20.0	PART E	FINISHING AND COMPLETION
TASK	(OPTIONAL)		THERMAL INSULATION

TASK PERFORMANCE OBJECTIVES:

- 20.01E Install flexible batt type insulation in outside walls and ceilings over heated spaces.*
- 20.01E Install loose fill insulation to exterior walls and ceilings after interior wall coverings have been applied by blowing into place using appropriate mechanical devices.*
- 20.03E Install 2 or 4 mil polyethylene film to inside of exterior walls and ceilings to prevent moisture movement from interior to exterior.*

(NOTE: Floor insulation must be delayed until all mechanical installations are complete.)

*Orientation tasks so that student will be familiar with related building construction work.

UNIT	20.0	PART F	FINISHING AND COMPLETION
TASK	(OPTIONAL)		INTERIOR FINISHING

TASK PERFORMANCE OBJECTIVES:

- 20.01F Final sand trim to be stained using 150 grit garnet paper if surface does not feel smooth to the fingertips.
- 20.02F Clean dirt, pencil marks, and dust from trim and doors to be stained using a commercial solvent.
- 20.03F Apply oil stain with a brush or sponge, allowing a few minutes for penetration, and wipe away surplus with a clean cloth in the direction of the grain and allow to dry for 24 hours.
- 20.04F Fill pores of open-grained trim by applying a commercial paste wood filler. Apply and remove excess according to manufacturer's instructions. Allow to dry 24 hours.
- 20.05F Apply a sealer coat of "thinned top coat material" 24 hours following the paste wood filler application.
- 20.06F Apply two varnish or synthetic top coats and allow adequate time for drying between coats. Smooth between coats using 220 grit abrasive paper to ensure a smooth surface.
- 20.07F Prepare new wood for painting. When first coat of paint is applied there should be no high or low places. There should be no discoloration showing through the paint.
- 20.08F Given a color to match, match the color by adding pigment to paint. When patch or spot painting, there can be no distinct line or separation between the two areas.
- 20.09F Mix paint by hand so that the paint will have a smooth even texture with no lumps.
- 20.10F Apply second coat of paint to ceiling, (unless texture) walls, and trim (if not stained). Apply final coat of paint.
- 20.11F Clean paint brushes using prescribed solvent and wrapping brushes to preserve their shape.

UNIT	20.0	PART F	FINISHING AND COMPLETION
TASK	(OPTIONAL)		INTERIOR FINISHING (Con't.)

TASK PERFORMANCE OBJECTIVES (Con't.):

- 20.12F Prepare surface for wallpaper. When finished area is wiped with a clean cloth, there can be no soiled area of discoloration. The cloth must pass smoothly over the surface without hanging up. When the wall is prepared, there can be no high or low places or other distortions.
- 20.13F Hang wallpaper so that all wallpaper patterns are uniform throughout and that there is no overlapping of patterns.
- 20.14F Join wallpaper seams by lapping method. All seams and lines in wallpaper must be perpendicular with floor with no wrinkles, laps, or bubbles.

UNIT	20.0	PART G	FINISHING AND COMPLETION
TASK	(OPTIONAL)		EXTERIOR FINISHING

。 TASK PERFORMANCE OBJECTIVES:

- 20.01G Apply a primer coat of paint by brushing to the trim and siding of a residential structure.
- 20.02G Apply a second finish coat of paint by brushing to the trim and siding of a residential structure.
- 20.03G Chalk around all exterior openings using a chalking gun and a high grade caulking material.
- 20.04G Clean paint brushes and materials with the prescribed solvent and wrap brushes to preserve their shape.

350

TRUE/FALSE

1. In bricklaying, the proper time to tool vertical and horizontal mortar joints is when the mortar has become "thumb print hard" or when the mortar is compacted. _____
2. In bricklaying, brick are usually cut within a tolerance of +/- 1/4 inch. _____
3. In exterior finishing, guttering sections generally are installed to fascia using hangers or spike and ferrule system of attachment. _____
4. Contrary to many manufacturer's suggestions, location of heating and cooling system thermostats should be at a height of 1 1/2 to 4 feet above the floor. _____
5. In electrical rough-ins, the local/national building code specifies the minimum number of outlets per wall. _____
6. Electrical meter sockets at the service entrance are generally provided by the contractor. _____
7. Flexible batt type insulation is the most commonly used insulation in outside walls and ceilings over heated spaced. _____
8. Floor insulation must be installed prior to mechanical installations. _____
9. Custom kitchen cabinets are generally installed by a custom cabinet maker while factory purchased unit cabinets are generally installed by the carpenter. _____
10. The installation of flooring sheet materials is a simple procedure that the carpenter completes with other finishing jobs. _____
11. Asphalt and vinyl asphalt tile do not need to be rolled. _____
12. When applying oil stain, the typical drying time is 24 hours. _____
13. Much decorative trim is done with the use of white pine species that does not require a paste wood filler application. _____
14. When cutting according to layout lines on lumber, in framing, a reliable general guide is to leave the penciled line. _____

TRUE/FALSE (Con't.)

15. In finishing, many products prime painted during the manufacturing process do not need a primer coat application. _____
16. Lead-oakum waste disposal system joints are growing in favor because they are simpler and more rapidly installed than other soil disposal piping. _____
17. In electrical installations, ground-interrputers should be installed for all garage and exterior outlets. _____
18. Gypsum wallboard is also called sheetrock. _____
19. If oil based paints are applied to a cold surface, the paint may blister. _____
20. The wooden floor of a porch should be located at least 12 inches above the soil. _____

SUGGESTED PERFORMANCE TESTS

A. Electrical:

1. Given necessary drawings and specifications, tools, equipment, materials, and supplies, and helper if required; connect and install given ceiling and wall light fixtures as specified and to meet local electrical code requirements. Upon completion, after testing the circuits to ensure proper functioning, request the instructor to inspect the installation.
2. Given necessary drawings and specifications, tools, equipment, materials, and supplies, and helper if required; connect given electrical convenience outlets and switches and secure in electrical outlet boxes previously placed as specified on drawings or by code requirements. Affix wall cover plates to openings where applicable. Upon completion, after testing the circuits to ensure proper functioning, request the instructor inspect the installation.

B. Mechanical:

1. Given necessary drawings and specifications, tools, equipment, materials, and supplies, and helper if required; place warm air diffusers over register boots in each room and fasten in position at the intersection of the floor and wall. Warm air floor diffusers may drop into the register boot without any additional fastening needed. Upon completion, check your work, and call the instructor to inspect the completed job.
2. Given necessary drawings, specifications, or instructions, tools, equipment, materials, and supplies, and helper if required; provide ducts and roof wall jacks for all appliances and fans that exhaust air to the exterior of the structure (such as cooking ranges, ceiling or wall mounted exhaust fans, clothes dryers). Upon completion, check your work, and call the instructor for an inspection.

C. Plumbing:

1. Given the necessary drawings, specifications, or instructions, tools, equipment, materials, and supplies, and helper if required; test all water, waste, and gas connections for leaks and operate each consuming device to confirm proper working order of plumbing system. Upon completion, minor adjustments or repairs should be made so system is operative and repairs beyond the training and expertise of the student should be reported to the instructor. Request the instructor inspect the work and any work done to the existing system.

2. Given the necessary drawings, specifications, or instructions, tools, equipment, materials, and supplies, and helper if required; for a given situation, connect copper pipes and connect plastic pipes so that the joints are properly joined and do not leak. The finished job must pass the instructor's inspection and standards.
(NOTE: This may be simulated exercise to conserve materials.)

D. Masonry:

1. Given the necessary drawings, specifications, or instructions, tools, equipment, materials, and supplies, and helper if required; construct a form as necessary, mix and pour concrete as specified, and finish the poured concrete as required. The finished job must meet the instructor's standards. (SUGGESTION: A team test may be used to complete improvements at the vocational center such as improved or repaired walks, steps, drains, or building structure.
2. (Bricklaying) Given necessary drawings, specifications, and instructions, tools, equipment, materials, and supplies, and helper(s) if required; lay out, square, and build a return corner with 4" walls in common bond, racked, 7 courses high, in two hours.

The return corner will be constructed as a lead, in advance of the wall. The 4" corner will be used as a veneer, properly anchored to the framing or other wall backing. The corner should make a 90-degree angle.

PROCEDURE

1. Assemble all the tools required for the job.
2. Lay out the job dry and square with steel square, using the plumb rule as an extension leg with the square.
3. Bed up in mortar brick #1-2-3, before disturbing the other brick. Level all three and run line from #1 to #2. Run out the line and repeat #1 to #3.
4. Continue to lay up the corner brick and last possible brick on the tail end of the course. Always level from the corner brick. Lay up the remainder of the course.
5. Lay up the remainder of the lead, racking back 1/2 brick on each course, until 7 courses have been laid.
6. Keep plumbing and leveling each course as laid.
7. Use safety precautions mentioned in previous jobs.
8. Tailings should "line up" with a plumb rule.

Drawing for Task 20.0 test.

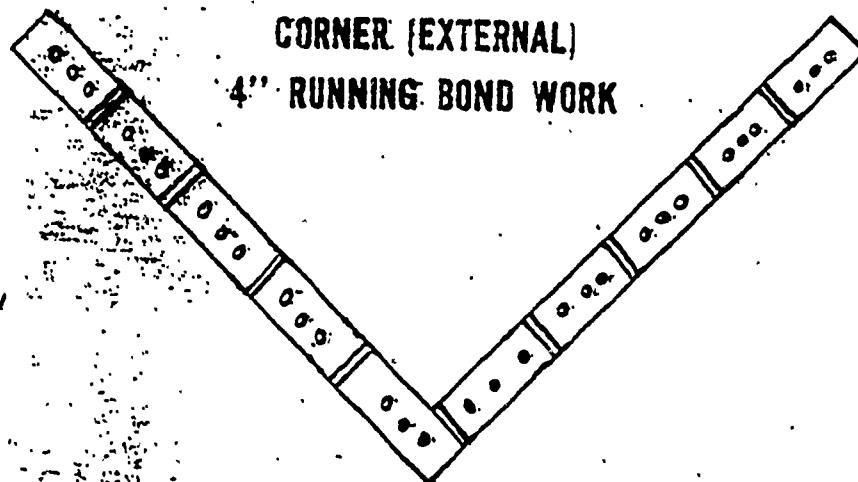

CORNER (EXTERNAL)
4" RUNNING BOND WORK

1ST COURSE PLAN

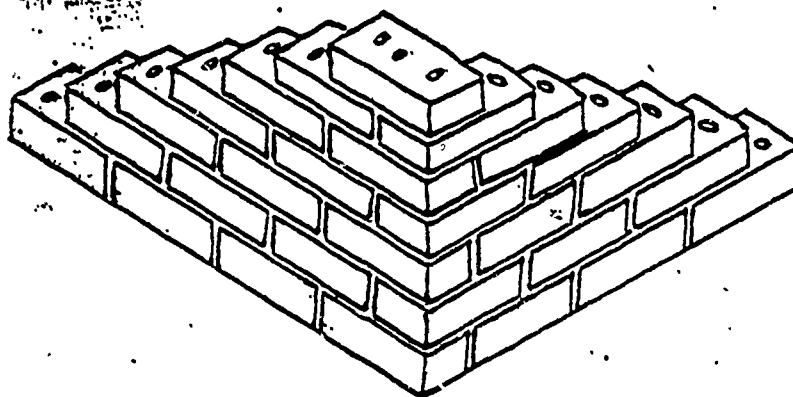

ELEVATION

E. Thermal Insulation:

1. Given necessary drawings, specifications, instructions, tools, equipment, materials and supplies, and helper(s) as required; install 2 or 4 mil polyethylene film to inside of exterior of walls and ceilings to prevent moisture movement from interior to exterior. Finished work must meet the standards of the instructor and pass the instructor's inspection.
2. Given necessary drawings, specifications, instructions, tools and equipment, materials and supplies, and helper(s) as required; install flexible batt type insulation to outside walls and ceilings over heated spaces. The finished job must meet industry standards and pass the instructor's inspection.

F. Interior Finishing:

1. Given necessary specifications, instructions, tools and equipment, materials and supplies, and helper(s) as required; prime the ceilings and wall surfaces with one coat of a primer paint as specified or as recommended by a local paint store. The completed job must pass the inspection of the instructor and be to industry standards.
2. For a given assignment, given necessary specifications and instruction, tools and equipment, materials and supplies, and helper(s) as required; apply two varnish or synthetic top coats and allow adequate time for drying between coats. Smooth between coats using 220 grit abrasive paper to ensure a smooth surface. The finished job must meet the instructor's standards and inspection.

G. Exterior Finishing:

1. Given specifications and instructions, tools and equipment, materials and supplies, and helper(s) as required, apply a primer coat of paint by brushing to the trim and siding of a given structure. Apply a second finish coat of paint by brushing. The finished job must meet the instructor's standards and inspection. No paint should be dropped on the ground.
2. Clean paint brushes and materials with the prescribed solvent and wrap brushes to preserve their shape.

UNIT 21.0

FINISH CARPENTRY TASKS

(OPTIONAL TASK)

This unit on Furniture Refinishing and Fabrication may be included in carpentry training depending on available materials, the needs of students and recommendations of the curriculum committee, for special projects, or as an extension of the unit on cabinetmaking.

Upon completing training in furniture refinishing and fabrication tasks, the student should be able to identify needed furniture repairs and estimate general costs; remove old finish including stripping, washing, and sanding; repair old finish including removing old glue, replacing broken dowels and parts, and patching veneers; and finishing furniture including filling, staining, toning, shading, coating, rubbing, and polishing.

UNIT	21.0	FINISH CARPENTRY TASKS
TASK	(OPTIONAL)	FINISH CARPENTRY

TASK PERFORMANCE OBJECTIVES:

- 21.01 REMOVE OLD FINISH
Given furniture needing r 'nishing or repair, necessary tools, equipment, and supplies; remove old finish by stripping, washing, or sanding or other appropriate methods.
- 21.02 CLEAN WOOD SURFACES
Given furniture or wood stock ready for finishing and the necessary cleaning tools, equipment, and materials; clean the wood surfaces so that all surfaces are free of loose particles, foreign material, lint, fingerprints, grease, and smudges.
- 21.03 SWELL A SOFT WOOD DENT
Given soft wood furniture with a surface dent that can be repaired, steaming equipment (household steam iron and damp pad), and necessary tools and materials; swell the dent. No warpage or water marks should be caused by wetting procedures. No glazing, discoloration, or burning of the wood surface should result from heating. The dent should be raised to the surface and sanded to match the adjacent areas.
- 21.04 REPAIR FURNITURE
Given furniture to repair, necessary tools, equipment, and materials; remove old glue, replace broken dowels and parts, and patch veneers. Repaired furniture should match original design and finish.
- 21.05 FINISH STOCK
Given unfinished furniture or stock to finish, necessary tools, equipment, and materials; finish the furniture by filling, staining, toning, shading, coating, rubbing, and polishing as necessary to make the finished stock match in appearance.
- 21.06 PAINT CASEWORK
Given paint, casework needing painting, specification, and the necessary tools and materials, apply the paint. The paint must be mixed according to specifications and applied for a uniform finish and color. The finished surfaces must be free of scratches, bubbles, and sanding marks.

UNIT	21.0	FINISH CARPENTRY TASKS
TASK	(OPTIONAL)	FINISH CARPENTRY

TASK PERFORMANCE OBJECTIVES (Con't.):

- 21.07 FABRICATE FURNITURE
Given specifications or drawings, necessary stock, tools, equipment, and materials; fabricate simple furniture such as cabinets, tables, etc. This task may be undertaken at the discretion of the instructor to provide furniture for the school district or student needs and as a training exercise to expand skills in cabinetmaking and carpentry tool use.

UNIT 22.0

ESTIMATING MATERIALS AND COSTS

Upon completion of this unit, on Estimating Materials and Costs, the student should be able to estimate building construction materials needed for a carpentry job, select appropriate materials, estimate costs, and make (and place) an order for construction materials. In addition, the student may be introduced to estimating labor costs.

Recommended: "Estimating sheets or forms" designed by the instructor or obtained from local Savings and Loan companies or builder supply businesses should be used to familiarize the student with estimating.

These tasks on estimating may be introduced as a part of carpentry math or as a separate unit.

TASK PERFORMANCE OBJECTIVES:

(NOTE: These tasks are designed for estimating materials and costs for residential structures, mock-ups, or cabinet work (built-ins).

22.01 INTERPRET BLUEPRINTS

Given a blueprint that includes all dimensions and information necessary to construct an object or structure; interpret the lines, symbols, and notations on the blueprint. A detail description of the object or structure must be provided including: (1) overall dimensions, (2) notations, (3) symbols, and (4) abbreviations.

22.02 DRAW A SET OF SHOP PLANS

Given a set of plans for a structure, room, or wood casework, the necessary drafting tools and equipment; draw a working set of shop plans. All information necessary to construct the items must be provided without dimensional error, including: (1) necessary dimensions, (2) views, (3) details, and (4) designated scale.

22.03 (FOR CASEWORK) MAKE A ROD LAYOUT

Given rod stock, a set of working drawings, and necessary tools, equipment, and materials; make a rod layout. The rod layout must be full size for each part of the casework within a tolerance of +/- 1/16 inch.

22.04 DRAW A DETAILED PLAN

Given a scale drawing and the necessary drafting tools, equipment, and materials; draw a detailed plan that includes all dimensions and information necessary to construct the structure or casework. The detailed plan must be drawn to 1 1/4 inch scale or larger, and all dimensions must be located on the drawing to 100 percent accuracy.

22.05 ESTIMATE MATERIALS FROM A BLUEPRINT OR LAYOUT

Given dimensioned blueprint or layout for a structure or a type of casework, specifications and other essential information, and a bill of materials form, estimate materials from the blueprint or layout. All materials necessary to construct the casework must be provided, including: (1) the quantity of pieces, needed, (2) the size and footage of each piece, and (3) the type

TASK PERFORMANCE OBJECTIVES (Con't.):

of material to be used. The quantity and footage figures must be within +/- 5 percent of predetermined calculations and the total must include allowances for waste material.

22.06 ESTIMATE MATERIALS COSTS

Given a detailed drawing of a structure or casework, a materials list, cost per unit information, and estimated cost per linear foot, estimate materials costs to within +/- 5 percent of predetermined calculations. (Materials 40 percent, labor 60 percent)

22.07 ESTIMATE LABOR COSTS

Given a detailed drawing of a structure of casework, a materials list, and materials costs, estimate labor costs to within +/- 5 percent of predetermined calculations. (Materials 40 percent, labor 60 percent)

(NOTE: Estimating materials and labor costs may be combined as one task.)

22.08 (EXTENSION OF ESTIMATING)

Given an estimated list of needed materials, (a) select lumber (stock) for framing, (b) select lumber (stock) for finishing, and (c) stack the lumber or stock and store building materials.

SAMPLE ESTIMATORS CHECK LIST

The following form is a sample check list which can be used to estimate the cost of building a house.

ESTIMATORS CHECK LIST

AJAX BUILDERS SUPPLIES, INC. ESTIMATE BY _____
 JOB NAME _____ DATE ESTIMATE MADE _____
 JOB NO. _____ PLAN NO. _____ DATE STARTED _____
 LOCATION _____ DATE COMPLETED _____

PHASE 1, PREPARATION, SITE WORK, FOUNDATION, MASONRY

1. Engineering, Estimating Cost, Plans, Survey _____
2. Building permits _____
3. Utility deposits _____
4. Sewer tap _____
5. Water tap _____
6. Site clearance _____
7. Strip and store top soil _____
8. General grading _____
9. Temporary power pole _____
10. Temporary power _____
11. Temporary toilet _____
12. Builder's risk insurance _____
13. Batter boards and layout _____
14. Excavation of footings _____
15. Concrete for footings _____
16. Footing reinforcement _____
17. Cement block for foundations @
 - (A) 4x8x16 _____
 - (B) 6x8x16 _____
 - (C) 8x8x16 _____
 - (D) 12x8x16 _____
 - (E) Lintel blocks _____
 - (F) Cap blocks _____

(G) Pilaster blocks

(H) Dur-o-wall

18. Brick, foundation and veneer

(A) Face brick

(B) Common brick

(C) Fire brick

(D) Flu liner

(E) Flu thimble

(F) Cleanout door

(G) Damper

(H) Ash Dump

(I) Chimney flashing & pitch

(J) Angle iron for fireplace

(K) Mantel material

19. Mortar mix

20. Sand

21. Wall ties

22. Screened foundation vents, 8x16 w/closers

23. Anchor bolts & washers

24. L-irons

25. Steel-I-Beams

26. Door and window bucks

27. Wall reinforcing

28. Termite shields or chemical treatment

29. Basement sash, steel or aluminum

30. Steel door frames

31. Steel basement posts

32. Backfill allowance

33. Period cleanup

PHASE 2, DRY-IN STAGE, MECHANICS ROUGH-IN

1. Outside sills

2. Inside beams or girders
3. Floor joists plus doubles
4. 2x4 nailers
5. 1x4 bridging
6. 1x6 s4s or ½" 5-ply plywood sub-floor
7. 2x4 sole & plates
8. 2x4 wall purlines
9. 2x4x8 fir studs
10. 2x4x12 wall bracing
11. 2x6 window and door headers
12. 2x6 interior door headers
13. 2x6 ceiling joists
14. 2x6 rafters, king rafters & valley rafters, ridge plate
15. 2x6 partition caps
16. Ceiling joist bridging
17. 4x9 asphalt impregnated fiber board sheathing
18. Roof bracing, collar beams
19. 1x6 T&G roofers or ½" 5-ply plywood roof decking
20. Roof vents
21. 15 # felt
22. Asphalt shingles
23. Foundation, window and door flashing
24. Flash plates
25. Carport and porch plate material
26. Carport ceiling joists, rafters, truss material not included elsewhere
27. Screened porch material
28. Deck material
29. Outdoor cooker material
30. Window units
31. Window screens
32. Window stool
33. Window trim
34. Door trim
35. Window locks
36. Window lifts
37. Door blocking 5/8" 4x8 AD plywood
38. Exterior door frames
39. Exterior doors
40. Exterior locks keyed alike
41. Exterior butts, 4x4

42. Patio door, thermopane or plain

43. Garage door

44. Rough hardware

(A) 16d cc nails

(B) 8d cc nails

(C) roofing nails

(D) finish nails

(E) box nails

(F) floor cletes

(G) drywall nails

(H) chalk

45. Electrical work

46. Plumbing work

47. Heating and/or air conditioning work

48. Temporary heat

49. Period cleanup

PHASE 3. FINISH CARPENTRY: FINISH WORK, APPLIANCES & SUNDRY

1. Exterior wall paneling (boards & battens, aluminum, asbestos, etc.)

2. Boxing — lookouts & ledging

3. Exterior plywood, 3/8 soffit

4. Facier boards

5. Freiz boards

6. Screen wire or soffit vents

7. Crown moulding

8. Shingle moulding

9. Brick moulding

10. Drip cap

11. Carport stripping, facier boards, boxing, crown moulding not listed elsewhere

12. Carport ceiling, 1/4" ext. plywood

13. Carport ceiling lattice strip

14. Polyethelene vapor barrier for oak floors

15. Oak flooring

16. 5/8 particle board or plywood underlayment

17. 1x4 #2 stripping material

18. Sheetrock

19. Water resistant tile backerboard

20. Prefinished paneling

21. Drywall cornerbead

22. Floor insulation

23. Ceiling insulation

24. Exterior & stairwall wall insulation

25. Interior door jambs

- 26. Interior doors

- 27. Door stop material

- 28. Interior door locks

- 29. Interior door butts

- 30. Disappearing stairway unit

- 31. Interior stairway material

- 32. Birch, pine or fir baseboard

- 33. Birch, pine or oak shoemould

- 34. Interior crown mould

- 35. Special moulding

- 36. Cabinets: Kitchen base
 - Kitchen wall

 - Bath vanities

 - Bookcases

 - Desks

- 37. Medicine cabinets

- 38. Vanity mirrors

- 39. Attic flooring

- 40. Screen doors

- 41. Screen door hardware

- 42. Aluminum Storm Screen Doors

- 43. Weatherstripping

- 44. Thresholds

- 45. Door bumpers, straight & hinged

- 46. 1x12 closet shelving

- 47. 3/4" galv. or wood closet rod

- 48. Carport fill soil & compaction, fine grade

- 49. Basement fill soil & Compaction, fine grade

- 50. Patio fill soil & compaction, fine grade

- 51. Polyethelene slab vapor barrier

- 52. Reinforcing wire or steel

- 53. Edge forms

- 54. Expansion joint

- 55. Concrete for slabs

- 56. Concrete finish work

- 57. Cure & protection

- 58. Appliances:
 - (A) Drop-in range, gas or electric

 - (B) Surface units, gas or electric

 - (C) Wall Oven, gas or electric

 - (D) Hood & fan

 - (E) Roof cap

- (F) Exhaust pipe
- (G) Plastic cement
- (H) Attic fan
- (I) Bath exhaust fan
- (J) Dishwasher
- (K) Disposal
- (L) Washing Machine
- (M) Dryer
- (N) Rotary antenna system
- (O) Intercom system
- (P) Food center appliances
- (Q) Window air conditioners
- (R) Bar-be-cue surface unit
- (S) Refrigerator

- 59. Tub enclosure or rod
- 60. Shower door or rod
- 61. Light fixture allowance (including chime equipment)
- 62. Light bulbs and tubes allowance
- 63. Gutters & Down spouts
- 64. Access door material
- 65. Period cleanup

PHASE 4, INTERIOR, AND EXTERIOR DECORATION, FINAL FINISH WORK

- 1. Tape & finish sheetrock
 - (A) Rolls of tape
 - (B) Pounds of gyp cement
- 2. Plaster
- 3. Paint interior walls & trim
 - Paint thinner
- 4. Textured ceiling allowance (sand, spray, crowfoot)
- 5. Wall paper installation
- 6. Paint windows
- 7. Clean windows
- 8. Finish doors (plain & louvered)
- 9. Paint or stain inside cabinets
- 10. Stain paneling trim, putty paneling nail holes
- 11. Sand, fill 2 coats finish OAK floors & stairway finished
- 12. Carpeting
- 13. Seamless floor covering
- 14. Inlaid floor covering
- 15. Ceramic tile
 - (A) On sheetrock

(B) On cement

16. Chrome bath accessories

17. Stone floors or quarry tile

18. Epoxy painted floors

19. Clean-up and wax

20. Period cleanup

21. Caulking compound

22. SWP Undercoater

23. SWP Exterior paint

24. Pcrch & floor enamel

25. Galvite primer

26. Paint thinner

27. Fence material

28. Stepping stones

29. Cement walkways

30. Splash blocks

31. Storm sewer material

32. Foundation waterproofing

(A) Cement parget

(B) Pitch

(C) Drain tile, gravel fill

33. Carport & porch columns

34. Wrought iron railings

35. Ornamental shutters

36. Clothes line material

37. Cupola

38. Yard rough grading

39. Yard finish grading, seeding

40. Shrubbery

41. Driveway

42. Final cleanup

43. Call back

44. Supervision

COMPLETION

1. When _____ joists are estimated, they are figured separately. _____
2. Most drywall construction is based on the number of _____ yards found in the wall. _____
3. When estimating paint needed for a structure, the amount of square footage to be painted is divided by _____ to give the number of gallons needed. _____
4. Insulation _____ are obtained in packages that vary from 50 square feet to 100 square feet. _____
5. A cubic yard contains _____ cubic feet. _____

CALCULATE THE FOLLOWING BOARD FEET

1. 3'-2" x 4" x 12' = _____ Board feet
2. 1'-1" x 4" x 10' = _____ Board feet
3. 15'-2" x 10" x 20' = _____ Board feet
4. 6'-4" x 4" x 10' = _____ Board feet
5. 7'-10" x 12" x 20' = _____ Board feet

UNIT 23.0

PRACTICAL APPLICATION PROJECT

Secondary Carpentry Task Force Committee instructors agree that they generally have students perform a practical application project either during their junior or senior year. Sometimes the project, restricted to second year students, is called a "senior project" by the instructor. A student project, however, may involve time during both the junior and senior year of a student.

The purposes of the practical application projects include:

- (a) Providing individualized training in basic carpentry that the student might otherwise not receive.
- (b) Providing learning opportunities for the student according to the student's special abilities, career interests, or to meet potential needs of employers at a particular time.
- (c) Provide opportunities for the instructor to test the student's knowledge and practical skills in realistic situations ("hands-on" examination).
- (d) A practical application project may be utilized by the instructor as a method of conducting a final examination of student carpentry skills.
- (e) Provide opportunities for a student to specialize in a specific type of carpentry work such as finished carpentry, cabinetmaking, or even related carpentry work such as painting or roofing. Activities may be for advanced skills or expanded skill development.

Recommended: Individualized learning situations should be accompanied by a written plan indicating the objective, major steps or student actions necessary to reach the objective, minimum standards expected of the student, and how the student will be evaluated. This individualized learning plan should be developed mutually by the instructor; other participating instructors, if applicable; the student; and others directly involve

Today, secondary level vocational programs including the building trades are being taught in a more realistic manner and setting. Where student interest is high, introductory study in carpentry may be followed up by practical carpentry work in the field, such as construction of a storage shed, garage, house addition, or a renovation.

A building construction field project may involve only carpentry students or the carpentry students may have an opportunity to work with vocational students from related programs such as masonry, electricity, tile setting, air conditioning and refrigeration (heating), plumbing, sheet metal, or even accounting and recordkeeping.

Carpentry field training projects (jobs) always are chosen so that there will be no direct competition with local businesses. The improvement of low-income family dwellings and the improvement of life in the community is given high priority in the selection of the carpentry field project.

Typically, the production of the carpentry students in the training project will be low and slow because the primary aim is teaching. Emphasis in field jobs is placed on developing skills for the building trade. A job not done right may have to be done over by the student. Carpentry field training projects provide a unique opportunity for students to encounter, in a controlled setting, day-to-day construction problems that never would occur in the classroom.

Through field construction projects, some exceptional instructional opportunities are available. Carpentry instructors from two vocational centers can combine their students at one construction site. In addition to increasing student manpower, joint training would provide students with a situation where they should benefit from the diversified trade experience of two instructors instead of one.

Practical application projects, however, require more instructor planning. Careful scheduling is necessary to ensure that students can reach the job site, learn, practice skills, and return to their home schools within given times. In addition, activities must be arranged in the proper sequence so that students are not bunched up on the job and so that construction develops properly.

A side benefit that results from field construction projects is that the students tend to develop good work habits and attitudes in addition to increasing their knowledges and skills in building construction.

Some typical applications of field projects include the renovations of portable classrooms used by the school district and renovations and new construction at nearby school facilities. These projects provide realistic training for students and, at the same time, result in a

UNIT 23.0

PRACTICAL APPLICATION PROJECT

NARRATIVE

RESIDENTIAL FIELD CONSTRUCTION
(Con't.)

savings to taxpayers. Typically, for field jobs for private individuals, the carpentry program receives a small fee to cover the costs of materials and expendibles and to return to the carpentry program a small fund to help support optimum training in building construction.

For residential field construction projects, a detailed plan outlining objectives, actions necessary to obtain objectives, standards of performance and production, and the criteria for evaluation should be developed and followed daily.

UNIT	23.0	PRACTICAL APPLICATION PROJECT
TASK	(OPTIONAL)	RESIDENTIAL FIELD CONSTRUCTION

TASK PERFORMANCE OBJECTIVES:

23.01 PLAN PRACTICAL APPLICATION PROJECT WITH INSTRUCTOR OR OTHERS
Given identified student or program (potential employer) needs for a practical application project, the student should participate in planning the training project so that the student can explain the purpose, the student's role, and the potential benefits from the project with 100 percent accuracy.

(NOTE: It is recommended that a written plan clarify the; (a) objective of the training project, (b) major student actions (steps) to obtain the objective, (c) minimum acceptable standards of performance for competency, and (d) how the student's competency will be measured. The student should agree to the plan of training.)

23.02 PARTICIPATE IN PRACTICAL APPLICATION PROJECT
Given a written plan for a special application project, the student should participate in the training program in an agreed upon manner, meeting minimum standards of performance as outlined.

23.03 SUCCESSFULLY PASS KNOWLEDGE OR WRITTEN TESTS ON PROJECT
Given a written plan for a special application project, mutually agreed upon minimum standards, and a process for testing knowledge or performance skills in the special training program, the student should meet the necessary minimum standards to indicate competency in the desired carpentry skills and knowledges required by the practical application project.

23.04 PARTICIPATE IN PRACTICAL TRAINING SITUATIONS
Given a practical training situation such as participating in remodeling, new construction, etc.; perform the required carpentry or carpentry related duties identified by the instructor, to the instructor's satisfaction.

FIELD TRIPS

TRAINING ORIENTATION

Where it is feasible, secondary carpentry training may include: field trips within a vocational center, to another vocational center, Greenville Technical College, a building site, or to a local business or industry for the purpose of observing carpentry or related trade work.

Possible trade activities that might be visited include: masonry, electricity, tile setting, plumbing, and air conditioning and refrigeration, vocational instruction; the construction of residential or commercial structure; cabinetmaking, truss and prefab construction product industries; and local building material suppliers.

Typically, the purpose of field trips will be for orientation and not for skill development.

Recommended: Field trips should be described in the lesson plan the primary objective of the field trip, how to accomplish the objective, and how the objective will be evaluated should be clarified to students prior to departure.

UNIT 24.0
JOB LEADERSHIP

376

UNIT	24.0	JOB LEADERSHIP
TASK	24.01	DEVELOPING LEADERSHIP CHARACTERISTICS

PERFORMANCE OBJECTIVE:

Given instruction, identify at least five important characteristics of good leadership and demonstrate positive leadership characteristics in working with other students to accomplish assigned carpentry jobs. A student self-rating checklist may be used in evaluation and evaluation may include ratings by other students as well as by the instructor.

PERFORMANCE ACTIONS:

- 24.0101 Define the process of leadership.
- 24.0102 Identify a minimum of five positive characteristics of a good leader. (Based on instruction.)
- 24.0103 Demonstrate the desired characteristics of a good leader in classroom assignment situations which calls for service as a team leader and a team member.
- 24.0104
 - a. Complete a self-rating scale of leadership skills.
 - b. Review leadership rating-scale by instructor or fellow team members or students.

PERFORMANCE STANDARDS:

- Identify at least five important characteristics of good leadership and demonstrate positive leadership characteristics in working with other students to accomplish assigned carpentry jobs.
- Rating checklists or scales may be used to evaluate performance.

SUGGESTED INSTRUCTION TIME: 3 Hours

LEADERSHIP RATING SCALE

DIRECTIONS: Check the appropriate parenthesis to indicate your impression of the leadership characteristics being rated.

	Not Observed	Needs Improvement	Observed
1. Exerts positive leadership.	()	()	()
2. Thoughtful of feelings of others.	()	()	()
3. Enthusiasm is sincere and contagious.	()	()	()
4. Perserves until job is completed.	()	()	()
5. Cheerful disposition.	()	()	()
6. Gets along well with team members.	()	()	()
7. Gets along well with instructor (supervisor)	()	()	()
8. Reacts constructively to criticism.	()	()	()
9. Punctual and gets job assignment done on time.	()	()	()
10. Free from prejudice.	()	()	()
11. Enjoys being a part of a group.	()	()	()
12. Reliable.	()	()	()
13. Adaptive to most situations.	()	()	()
14. Not easily discouraged.	()	()	()
15. Applies self to problems of job assignment.	()	()	()
16. Admits mistakes when made.	()	()	()
17. Tries to understand the other fellow's point of view.	()	()	()
18. Makes decisions quickly and accurately.	()	()	()
19. Seeks advise of others when appropriate.	()	()	()
20. Looks for opportunities to make improvements in job or work assignments.	()	()	()

END OF
TRAINING TASK

CAREER OPPORTUNITIES

IDENTIFYING POST-SECONDARY CAREER
DEVELOPMENT OPPORTUNITIES

PERFORMANCE OBJECTIVE:

Given an orientation to similar post-secondary vocational education programs, primarily the Carpentry program at Greenville Technical College and evening development programs for the building construction trade, a report of skill competencies developed during secondary training, and information as necessary; identify post-secondary career development opportunities.

PERFORMANCE ACTIONS:

1. Identify:
 - a. Need for additional training at the post-secondary level.
 - b. Benefits from additional training.
2.
 - a. Identify post-secondary training programs available at GTC.
 - b. Identify how post-secondary (GTC) training differs from secondary training in carpentry.
3. Visit GTC programs of possible interest. Talk with instructor, department head, or admissions counselor at GTC.
4. Determine with secondary and post-secondary assistance if exemption of post-secondary level training is recommended.
5. Accomplish the required steps to apply or test for exemptions. (Optional)

PERFORMANCE STANDARDS:

- Identify post-secondary training opportunities in carpentry or a related area at GTC.

SUGGESTED INSTRUCTION TIME: Typically, integrated throughout entire program.

ANSWER SHEET

Unit 1.0 - Introduction to Building Construction

True/False			Completion	
	1.	T	1.	finished
	2.	F	2.	50%
	3.	F	3.	residential
	4.	T	4.	survey
	5.	F	5.	electricity

Unit 2.0 - Construction Safety

True/False			Multiply Choice		
	1.	T	1.	c	9. b
	2.	T	2.	c	10. d
	3.	F	3.	a	11. d
	4.	T	4.	b	12. d
	5.	T	5.	b	13. c
	6.	T	6.	c	14. d
	7.	T	7.	d	15. a
	8.	F	8.	a	16. d
	9.	F			
	10.	T			

Unit 3.0 - Carpentry Math

I.	1.	4.
	2.	5.
II.	1.	IV. 1.
	2.	2.
	3.	V. 1.
	4.	2.
III.	1.	3.
	2.	4.
	3.	5.

Unit 3.0 - Carpentry Math (Con't.)

- | | | Multiple Choice | |
|-------|----|-----------------|-------|
| VI. | 1. | | 1. a |
| | 2. | | 2. c |
| | 3. | | 3. d |
| | 4. | a. | 4. d |
| | | b. | 5. a |
| VII. | 1. | 19/35 | 6. c |
| | 2. | 5/18 | 7. b |
| VIII. | 1. | 31/63 | 8. a |
| | 2. | 1/18 | 9. d |
| | 3. | 19/40 | 10. b |
| XI. | 1. | 2 2/3 | |
| | 2. | 1/10 | |
| | 3. | 9/14 | |
| X. | 1. | 11/12 | |
| | 2. | 8/9 | |

Unit 4.0 - Blueprints

Multiple Choice

- | | |
|------|-------|
| 1. c | 6. a |
| 2. a | 7. d |
| 3. d | 8. b |
| 4. b | 9. c |
| 5. c | 10. a |

Task 4.01

- a. 1/8
b. 1/4
- a. window
b. door
- 4
- section

Unit 4.0 - Blueprints

Task 4.02

- | | | | | |
|----|----|----------------------------------|-----|------------------------|
| 1. | 1. | sliding doors | 6. | door |
| | 2. | range | 7. | double-hung window |
| | 3. | fireplace | 8. | single sink (lavatory) |
| | 4. | built-in | 9. | bifold doors |
| | 5. | two units of double-hung windows | 10. | double sink |
| 2. | 1. | object | 4. | section |
| | 2. | cutting plane | 5. | hidden |
| | 3. | center | | |

Task 4.03

- | | | | |
|----|---|----|-----------|
| 1. | b | 4. | 1 5/8 |
| 2. | d | 5. | 6'-6 1/2" |
| 3. | a | | |

Unit 5.0 - Carpentry Hand Tools

Multiple Choice

- | | | | |
|----|---|-----|---|
| 1. | b | 9. | d |
| 2. | d | 10. | b |
| 3. | a | 11. | b |
| 4. | c | 12. | c |
| 5. | d | 13. | d |
| 6. | c | 14. | b |
| 7. | a | 15. | d |
| 8. | d | | |

Unit 5.0 - Carpentry Hand Tools (Con't.)

Reading an inch scale

- | | | | | |
|----|----|----------|-----|---------|
| 1. | 1. | 5/8" | 6. | 3 3/16" |
| | 2. | 2 1/4" | 7. | 2 1/8" |
| | 3. | 5 3/4" | 8. | 1 3/8" |
| | 4. | 4 15/16" | 9. | 9/16" |
| | 5. | 3 7/8" | 10. | 1/8" |
| 2. | 1. | 4 1/16" | 3. | 1 1/4" |
| | 2. | 2 3/8" | 4. | 1/2" |

Task 5.01

- | | | | |
|----|---|----|---|
| 1. | c | 4. | q |
| 2. | h | 5. | f |
| 3. | l | | |

Unit 6.0 - Fasteners, Finishing, and Hardware

True-False

- | | | | |
|----|---|-----|---|
| 1. | T | 9. | F |
| 2. | T | 10. | T |
| 3. | T | 11. | T |
| 4. | F | 12. | T |
| 5. | F | 13. | T |
| 6. | T | 14. | T |
| 7. | T | 15. | T |
| 8. | T | 16. | T |

Unit 7.0 - Portable Power Tools

Multiple Choice

- | | |
|------|-------|
| 1. d | 6. d |
| 2. d | 7. a |
| 3. a | 8. a |
| 4. c | 9. c |
| 5. c | 10. a |

Matching

- | | |
|------|------|
| 1. c | 4. a |
| 2. h | 5. f |
| 3. d | |

Unit 8.0 - Stationary Power Tools

Multiple Choice

- | | |
|------|------|
| 1. b | 4. a |
| 2. a | 5. c |
| 3. c | |

True-False

- | | |
|------|-------|
| 1. F | 9. T |
| 2. T | 10. T |
| 3. F | 11. F |
| 4. F | 12. T |
| 5. T | 13. F |
| 6. T | 14. T |
| 7. F | 15. F |
| 8. T | |

Unit 8.0 - Stationary Power Tools (Con't.)

Matching

- | | |
|------|------|
| 1. b | 5. j |
| 2. e | 6. c |
| 3. g | 7. a |
| 4. h | |

Matching

- | | |
|-------------------|---------------|
| a. a, 4, 6, 9 | f. 12 |
| b. 3, 5, 7 | g. 10, 11 |
| c. 3, 5, 7 | h. 10, 11 |
| d. 2 | i. 1, 4, 8, 9 |
| e. 1, 4, 8, 9, 10 | |

Unit 9.0 - Site Layout

Matching

- | | |
|------|------|
| a. 3 | d. 2 |
| b. 6 | e. 4 |
| c. 1 | |

Task 9.02

- | | |
|----------------------|------------------------|
| 1. 1. Focusing screw | 2. 1. $62^{\circ}-30'$ |
| 2. Bubble tube | 2. $11^{\circ}-50'$ |
| 3. Horizontal circle | 3. 90° |
| 4. Leveling screw | |
| 5. Tripod | |

Ans. 6

Unit 10.0 - Footing and Foundations

- True-False
- | | |
|------|-------|
| 1. F | 10. T |
| 2. T | 11. T |
| 3. F | 12. F |
| 4. T | 13. T |
| 5. F | 14. F |
| 6. T | 15. T |
| 7. F | 16. T |
| 8. T | 17. T |
| 9. T | |

Carpentry Mathematics

1. 3 yards

Unit 11.0 - Floor and Sill Framing

- True-False
- | | |
|------|-------|
| 1. T | 6. T |
| 2. T | 7. F |
| 3. F | 8. T |
| 4. T | 9. T |
| 5. T | 10. T |

Completion

- | | |
|-------------|-------------|
| 1. joist | 4. bolts |
| 2. subfloor | 5. bridging |
| 3. 16 | |

Multiple Choice

- | | |
|------|------|
| 1. d | 4. b |
| 2. b | 5. c |
| 3. b | 6. a |

Ans. 7

Unit 11.0 - Floor and Sill Framing (Con't.)

Carpentry Math-Floor Framing

- | | | |
|------------------|---|-----------------|
| 1. Headers | = | 4 - 1 x 8 x 16 |
| Joists | = | 25 - 1 x 8 x 12 |
| Total board feet | = | 242 2/3 |

Unit 12.0 - Framing - Wall and Partition

- | | | |
|------------|------|-------|
| True-False | 1. T | 6. F |
| | 2. F | 7. T |
| | 3. F | 8. T |
| | 4. T | 9. T |
| | 5. T | 10. F |

- | | | |
|------------|------------|--------------|
| Completion | 1. walls | 4. elevation |
| | 2. header | 5. floor |
| | 3. headers | |

Multiple Choice

- | | |
|------|------|
| 1. b | 4. c |
| 2. b | 5. c |
| 3. c | |

Practicle Problem in Carpentry Math

1. Lineal feet = 981
Board feet = 594

Unit 12.0 - Framing - Wall and Partition

- Identify
- | | | | |
|----|-------------------------|----|----------------|
| 1. | 1. double top plate | 2. | 1. stud |
| | 2. cripple (jack) studs | | 2. plate |
| | 3. header | | 3. subflooring |
| | 4. trimmer | | 4. sill |
| | 5. subsill | | 5. girder |
| | 6. cripple jack | | |
| | 7. trimmer | | |
| | 8. sole plate | | |
| | 9. rough opening | | |

Unit 13.0 - Roof Framing

- True/False
- | | | | |
|----|-------|-----|-------|
| 1. | True | 6. | False |
| 2. | True | 7. | True |
| 3. | True | 8. | False |
| 4. | True | 9. | True |
| 5. | False | 10. | True |

- Completion
- | | | | |
|----|--------|-----|----------|
| 1. | rise | 6. | span |
| 2. | run | 7. | step off |
| 3. | ridge | 8. | 16 |
| 4. | common | 9. | length |
| 5. | gusset | 10. | rise |

Multiple Choice

- | | | | |
|----|---|----|---|
| 1. | b | 4. | a |
| 2. | c | 5. | b |
| 3. | b | | |

Unit 13.0 - Roof Framing (Con't.)

- Identify
- | | | | | |
|----|----|----------------|----|---------------|
| 1. | 1. | ridge | 4. | hip rafters |
| | 2. | common rafters | 5. | tails |
| | 3. | valley rafters | | |
| 2. | 1. | plumb cut | 3. | Tail/overhand |
| | 2. | Bird's Mouth | 4. | Tail cut |

Roof Framing Mathematics

UNIT RISE	TOTAL RISE	TOTAL RUN	SPAN	PITCH
8"	a	b	30'-0"	c
d	20'-0"	20'-0"	e	f
a.	10'-0"		d.	12"
b.	15		e.	40'-0"
c.	1/3		f.	1/2

Unit 14.0 - Roofing

Completion

- | | | | |
|----|--------|----|------|
| 1. | fascia | 4. | up |
| 2. | square | 5. | 4/12 |
| 3. | base | | |

Multiple Choice

- | | | | |
|----|---|----|---|
| 1. | c | 4. | c |
| 2. | c | 5. | c |
| 3. | a | | |

Roofing Mathematics

Squares = 23

Unit 15.0 - Exterior Finishing

- True-False
1. True
 2. True
 3. True
 4. False (3/8)
 5. False (1/2)
- Completion
1. plywood
 2. 4
 3. rafters
 4. straightedge
 5. inward
- Multiple Choice
1. b
 2. c
 3. b
 4. c
 5. d
 6. b
 7. a
 8. c
 9. c

Exterior Finishing Mathematics

Walls = 840
Ceiling = 1100

Unit 16.0 - Interior Finishing

- True-False
1. False
 2. True
 3. True
 4. False
 5. True
 6. False
 7. True
 8. True
 9. False
 10. True
 11. True
 12. True
 13. False
 14. True
- Completion
1. 1 3/4
 2. door jamb
 3. lock
 4. casement
 5. 16
- Identify
1. top casing
 2. side casing
 3. stop
 4. stool
 5. apron

Interior Finishing Mathematics

1. 232
2. No. of Panels = 6
Sq. Ft. Plywood = 192

Unit 17.0 - Stair Construction

- True-False
- | | |
|----------|------------------|
| 1. False | 4. True |
| 2. True | 5. False (8 1/4) |
| 3. True | |

Multiple Choice

- | | |
|------|------|
| 1. a | 4. b |
| 2. c | 5. b |
| 3. d | |

- Completion
- | | |
|---------------|-----------------|
| 1. balustrade | 4. straight-run |
| 2. newel | 5. story pole |
| 3. nosing | |

- Identify
- | | |
|------------------------|------------------|
| 1. handrail | 5. riser |
| 2. landing | 6. open stringer |
| 3. starting newel post | 7. end nosing |
| 4. tread | 8. baluster |

Stair Construction Mathematics

- Riser dimensions = $7 \frac{7}{8}$ inches +/-
Tread dimensions = 9 inches
- No. of risers = 15
Riser height = $7 \frac{1}{8}$
No. of treads = 14
Tread width = $10 \frac{3}{4}$

Unit 18.0 and 19.0 - Cabinets and Built-ins

- True-False
- | | |
|----------|---|
| 1. True | 4. True |
| 2. False | 5. False
(check drawings and specs.) |
| 3. False | |

Unit 18.0 and 19.0 - Cabinets and Built-ins (Con't.)

Multiple Choice

- | | |
|------|------|
| 1. d | 4. d |
| 2. a | 5. a |
| 3. d | |

Completion

- | | |
|------------------|-------------|
| 1. built-in | 4. crosscut |
| 2. master layout | 5. trial |
| 3. rails | |

Unit 20.0 - Rough-ins

True-False

- | | |
|----------------|----------------|
| 1. True | 11. True |
| 2. False (1/8) | 12. True |
| 3. True | 13. True |
| 4. True | 14. True |
| 5. True | 15. True |
| 6. False | 16. False |
| 7. True | 17. True |
| 8. False | 18. True |
| 9. True | 19. True |
| 10. False | 20. False (18) |

Unit 22.0 - Estimating

Completion

- | | |
|-----------|----------|
| 1. header | 4. batts |
| 2. square | 5. 27 |
| 3. 600 | |

Calculate the following board feet

- | | |
|--------|----------|
| 1. 24 | 4. 80 |
| 2. 3.3 | 5. 1,400 |
| 3. 500 | |

392

PROFICIENCY REPORT

PROFICIENCY EVALUATION AID

This descriptive aid is designed, to possibly assist the carpentry instructor in standardizing the proficiency evaluation of students.

PROFICIENCY Description	LEVEL 0	LEVEL 1	LEVEL 2	LEVEL 3	LEVEL 4
	No skill level demonstrated or proficiency training not given in the skill.	Individual's skill level is not that generally expected for entry-level employee.	Individual's skill level probably is that expected for entry-level employment, but the individual probably will need close on-the-job supervision for a while longer.	Individual's skill level is that generally expected for entry-level employment.	Individual's skill level is equal to that of a worker with some on-the-job experience.
PLANNING PROJECTS					
Procedure	"	Did not work from a plan.	Some steps wrong or missing.	A few minor changes needed.	Plan completed; no changes needed.
Working Drawing	"	Incorrectly drawn, poor dimensioning.	Able to use with some changes.	Minor needed dimensions omitted.	Able to use; no changes needed.
Design and usefulness of project/product	"	Not usable for intended purpose.	Able to use with some changes.	No changes made; could be redesigned, improved.	Well designed for purpose intended.
Problem-solving ability	"	Solved no problems.	Solved only easy problems.	Solved nearly all problems.	Solved all problems.
CONSTRUCTION PROJECTS					
Appearance	"	Assembled poorly; not cleaned up.	Not very neatly assembled.	A few final touches needed.	Clean, neat, and commercial in appearance.
Method of building	"	Used own method; "cut and try."	Made poor use of methods shown.	Followed correct methods most of the time.	Use the demonstrated methods.
Tools	"	Careless with tools.	Used tools correctly most of the time.	Correctly used tools at all times.	Correctly use and cared for tools at time.
Materials	"	Wasteful and careless with materials.	Wasteful with materials at times.	Usually careful of materials.	Conserves materials at all times.
Accuracy of work	"	Failed to meet specifications.	Work is approximately correct.	A few measurements are off.	Meets all specifications.
Working time	"	Little or no effort made to use time wisely.	Time used fairly well.	Wasted small amount of time.	Used time to best advantage.

Adapted from: Feirer, John L., *Woodworking for Industry, Technology and Practice*, Teacher's Guide, Peoria, Ill.: Bennett Publishing Co., p. 14, 1979.

PROFICIENCY REPORT

for

Vocational Course

Student: _____

High School: _____

Vocational Center: _____

Date Training Initiated: _____

First Year Completed: _____

Second Year Initiated: _____

Second Year Completed: _____

Instructor: _____

DIRECTIONS: The purpose of the proficiency report is to communicate to the student, other instructors, or potential employers the abilities that a student has demonstrated to the instructor in vocational training. Mark each task as soon as possible after instruction or skills demonstration. If instruction is not aimed as task proficiency, or if only an orientation or introduction to the task was provided, DO NOT mark a proficiency level or mark Level 0. Levels 1-4 indicate that instruction was given and the proficiency may be interpreted as follows:

- Level 0 No skill level demonstrated or proficiency training not given in the skill.
- Level 1 Individual's skill level is not that generally expected for entry level employment.
- Level 2 Individual's skill level probably is that generally expected for entry level employment, but the individual probably will need close on-the-job supervision for a while longer.
- Level 3 Individual's skill level is that generally expected for entry level employment.
- Level 4 Individual's skill level is equal to that of a worker with some on-the-job experience.

For further description of the levels of proficiency, see the "Credentialing Process and Proficiency Report" section of the Policies and Procedures Guide for Articulation Between The School District of Greenville County and Greenville Technical College.

Student: _____

PROFICIENCY REPORT

CARPENTRY

		Proficiency								
		Level 0	Level 1	Level 2	Level 3	Level 4	Instructor's	Initials	Date	Completed
UNIT	1.0	INTRODUCTION TO BUILDING CONSTRUCTION								
	1.01	Review School Policies and Procedures								
	1.02	Orientation to Shop								
	1.03	Review Course Objectives and Standards								
	1.04	Identify Typical Building Construction Career Opportunities								
	1.05	Job Performance								
	1.06	Work Attitudes								
UNIT	2.0	CARPENTRY SAFETY								
	2.01	Classroom Safety								
	2.02	Use Personal Protective Equipment								
	2.03	Practice Safety in Using Power Tools (and machinery)								
	2.04	Ladder and Scaffolding Safety								
UNIT	3.0	BUILDING CONSTRUCTION I								
	3.01	Carpentry Math								
	3.02	Carpentry Math - Fractions								
	3.03	Carpentry Math - Decimals								
	3.04	Carpentry Math - Volumes								
	3.05	Carpentry Math - Areas								
	3.06	Carpentry Math - Angular Measurement								
UNIT	4.0	BLUEPRINT READING								
	4.01	Identify Working Drawings and Blueprints and Read Specifications								
	4.02	Interpret Common Blueprint Symbols Used in Residential Construction								
	4.03	Interpret Dimensions from Blueprints								
	4.04	Read Blueprint and Specifications and Estimate Lumber Materials								
UNIT	5.0	CARPENTRY HAND TOOLS								
	5.01	Identify and Demonstrate Proper Use of Carpentry Hand Tools								
	5.02	Read and Measure With Rules and Squares								
	5.03	Check Whether a Surface is Level or Plumb								
UNIT	6.0	FASTENERS, FINISHING, AND HARDWARE								
	6.01	Fasten Stock Using Glue, Nails, Staples, Screws, and Bolts								
	6.02	Install Wood Plugs in Prepared Holes								
	6.03	Fill and Finish Nail and Screw Holes								
	6.04	Sand Surfaces for Finishing								
UNIT	7.0	PORTABLE POWER TOOLS								
	7.01	Drill or Bore Holes With Portable Electric Hand Drill								
	7.02	Cut Stock With Portable Electric Saws () Circular, () Sabre, () Reciprocating								
	7.03	Rout Irregular Edges With Portable Router								
	7.04	Plane Stock With Portable Electric Plane								
	7.05	Sand Surfaces and Edges With Belt Sander and Finishing Sander								
UNIT	8.0	STATIONARY POWER TOOLS								
	8.01	Demonstrate Use of Table Saw								
	8.02	Demonstrate Use of Radial-Arm Saw								
	8.03	Demonstrate Use of Drill/Drill Press								
	8.04	Demonstrate Use of Jointer								
	8.05	Demonstrate Use of Planer								
	8.06	Demonstrate Use of Band Saw								
	8.07	Demonstrate Use of Router and Shaper								
	8.08	Demonstrate Use of The Belt Sander								
UNIT	9.0	SITE LAYOUT (SITE PLANNING)								
	9.01	Establish Site Property Lines								
	9.02	Demonstrate Use of Leveling Instrument								
	9.03	Locate Building Site in Relation to Property Line								
	9.04	Locate and Square Building Corners Using Builder's Level								
	9.05	Locate and Mark Excavation Lines								
	9.06	Supervise Site Preparation								
UNIT	10.0	FOOTINGS AND FOUNDATIONS								
	10.01	Install Batter Boards for Rough Excavation and Footings								
	10.02	Set Grade Stakes at Proper Elevations								

		Proficiency								
		Level 0	Level 1	Level 2	Level 3	Level 4	Instructor's	Initials	Date	Completed
	10.03	Align Form Walls								
	10.04	Brace Foundation Wall Forms								
	10.05	Calculate Concrete for Footings and Foundation walls								
	10.06	Clean and Repair Forms								
	10.07	Construct Concrete Step and Stair Forms								
	10.08	Construct Single Wall Foundation Forms								
	10.09	Build Side Forms								
UNIT	11.0	FLOOR AND SILL FRAMING								
	11.00	Construct Models to Illustrate Scaled Floor, Wall, and Roof Framing								
	11.01	Layout a Floor Frame								
	11.02	Cut and Install Sill Plates to Foundation Wall								
	11.03	Frame and Install a Builtup T-Type Sill								
	11.04	Frame and Install a Box Sill								
	11.05	Install Posts and Columns								
	11.06	Frame and Install a Builtup Girder								
	11.07	Install Floor Joists								
	11.08	Install Bridging Between Joists								
	11.09	Frame Floor Openings								
	11.10	Install a Subfloor								
UNIT	12.0	WALL AND PARTITION FRAMING								
	12.01	Layout a Wall Frame								
	12.02	Construct Corner Posts and T-Posts								
	12.03	Frame a Wall Opening								
	12.04	Install Door and Window Frames								
	12.05	Build Box Beams								
	12.06	Install Furring								
	12.07	Install Firestop								
	12.08	Install Structural Sheathing								
UNIT	13.0	ROOF FRAMING								
	13.01	Layout, Cut, and Install Common Rafters for Equal Pitch Roofs								
	13.02	Layout, Cut, and Install Ceiling Joist								
	13.03	Layout Common Roof Plan								
	13.04	Layout, Cut, and Install Cripple Jack Rafters for Hip and Valley Installations								
	13.05	Cut and Install Valley Rafters								
	13.06	Layout, Cut, and Install Hip Rafters for Equal Pitch Roofs								
	13.07	Cut and Install a Ridgeboard								
	13.08	Frame Roof Openings								
	13.09	Frame a Dormer								
	13.10	Frame Gable Ends								
	13.11	Cut and Install Collar Ties								
	13.12	Layout, Construct, and Install Roof Trusses								
UNIT	14.0	ROOFING								
	14.01	Apply Insulation (Underlay) for Asphalt Shingles								
	14.02	Install Composition Shingles								
	14.03	Layout for Bonding Shingles Over Dormers (or Other Roof Appendages)								
	14.04	Install Valley Shingles								
	14.05	Flash Chimney and Roof Vents								
	14.06	Flash Valleys								
UNIT	15.0	EXTERIOR FINISHING								
	15.01	Install Exterior Sheathing (Floorboard or Plywood)								
	15.02	Frame a Boxed Cornice								
	15.03	Install Double-hung Windows								
	15.04	Install Exterior Doors								
	15.05	Install Prefabricated Storm Doors and Windows								
	15.06	Install Exterior Trim								
	15.07	Cut and Install Furring								
	15.08	Cut and Install Wood Paneling								
	15.09	Install Exterior Siding								
UNIT	16.0	INTERIOR FINISHING								
	16.01	Fit and Install Flexible Insulation								
	16.02	Install Prefinished Paneling								

		Proficiency								
		Level 0	Level 1	Level 2	Level 3	Level 4	Instructor's	Initials	Date	Completed
	16.03	Cut and Install Furring								
	16.04	Cut and Install Solid Wood Paneling								
	16.05	Install Prefinished Hardboard								
	16.06	Install Drywall Board (Sheetrock) (Gypsum Wallboard)								
	16.07	Install Interior Doors								
	16.08	Install Door Lock Sets								
	16.09	Cut and Install Finish flooring								
	16.10	Cut and Install Baseboards, Trim, and Molding								
	16.11	Cut and Install a Fireplace Mantel								
	16.12	Construct a Storage Closet								
UNIT	17.0	STAIR CONSTRUCTION								
	17.01	Calculate Riser Height								
	17.02	Layout, Cut, and Install a Straight Run Stringer								
	17.03	Layout and Install Stair (Carriage)								
	17.04	Layout, Cut, and Install Treads for Open Riser Stairs								
	17.05	Cut, Fit, and Install Balusters and Handrails								
	17.06	Fit Newel Posts in Open Stairs								
	17.07	Assemble and Erect Prefabricated (Mill-Built) Stairs								
UNIT	18.0	CABINETS AND BUILT-INS								
	18.01	Install Built-in Shelving and Cabinets								
	18.02	Assemble Cabinet Frame								
	18.03	Install Prefabricated Cabinets								
UNIT	19.0A	CABINETMAKING								
	19.01	Cut Face Frame Stiles and Rails								
	19.02	Cut End and Top and Bottom Panels								
	19.03	Cut Partitions and Sleepers								
	19.04	Cut Shelf Panels								
	19.05	Cut Skelton Frame Stiles and Rails								
	19.06	Cut Toe Board and Back Panel								
	19.07	Cut Casework Top or Countertop and Backsplash								
	19.08	Cut Drawer Front, Sides, Back, and Bottom								
	19.09	Cut Wood Drawer Guides								
	19.10	Cut Solid Doors								
	19.11	Rout or Shape Casework Components								
	19.12	Cut, Trim, Molding, and Edge Banding								
	19.13	Cut Sink Opening in Countertop								
UNIT	19.0B	CABINETMAKING								
	19.01	Assemble Face Frame, Panels, Toe Board and Skeleton Frame								
	19.02	Fasten Top or Countertop and Backsplash to Casework								
	19.03	Assemble Drawers								
	19.04	Install Drawer Guides								
	19.05	Hang Casework Doors								
	19.06	Install Shelving								
	19.07	Attach Trim, Molding, and Edge Banding								
	19.08	Install Casework Hardware								
UNIT	20.0	MECHANICALS AND MASONRY ROUGH-IN, FINISHING, AND COMPLETION								
	20.0A	Electrical - Mechanical								
	20.0B	Heating and Cooling - Mechanical								
	20.0C	Plumbing - Mechanical								
	20.0D	Masonry								
	20.0E	Thermal Insulation								
	20.0F	Interior Finishing								
	20.0G	Exterior Finishing								
UNIT	21.0	FINISH CARPENTRY TASKS								
	21.01	Remove old Finish								
	21.02	Clean Wood Surfaces								
	21.03	Swell a Soft wood Dent								
	21.04	Repair Furniture								
	21.05	Finish Stock								
	21.06	Paint Casework								
	21.07	Fabricate Furniture								

UNIT			Proficiency				Instructor's	Initials	Date	Completed
			Level 0	Level 1	Level 2	Level 3				
UNIT 22.0	ESTIMATING									
22.01	Interpret Blueprints									
22.02	Draw a Set of Shop Plans									
22.03	(For Casework) Make a Rod Layout									
22.04	Draw a Detailed Plan									
22.05	Estimate Materials From a Blueprint or Layout									
22.06	Estimate Materials Costs									
22.07	Estimate Labor Costs									
22.08	(Extension of Estimating)									
UNIT 23.0	PRACTICAL APPLICATION PROJECT									

Instructor Describe Project Activities:

Comments:

Instructor: _____

(NOTE: This form must be accompanied by appropriate cover sheet.)

REFERENCES

Articulation Agreement, "Construction Management," Greenwood, SC: Piedmont Technical College, 1980.

Badzinski, Stanley Jr., Stair Layout, Alsip, IL: American Technical Publishers, Inc., 1971.

Building Trades 1, Course Outline, Phoenix, AZ: Department of Education, Division of Vocational Education, 1973.

Curriculum Standards for Cabinetmaking, Montgomery, AL: State Department of Education (Post-Secondary Education Services), 1982, (Draft).

Curriculum Standards for Carpentry, Montgomery, AL: State Department of Education, 1982.

Dillion, William D., and Harrington, Fred W., Building Repairer, Charleston, WV: West Virginia State Department of Education, Bureau of Vocational, Technical, and Adult Education.

Purbahn, Walter E., and Putman, Robert E., Fundamentals of Carpentry, 5th ed., Chicago, IL: American Technical Society, 1977.

Durhahn, Walter E., and Sundberg, Elmer W., Fundamentals of Carpentry Practical Construction, (& answer key), 5th ed., Chicago, IL: American Technical Society, 1977.

Feirer, John L., Woodworking for Industry Technology and Practice, 3rd. Ed., Peoria, IL: Chas. A. Bennett Co., Inc., 1979.

Feirer, John L., Woodworking for Industry Technology and Practice Teacher's Guide, Peoria, IL: Chas. A. Bennett Co., Inc., 1979.

Feirer, John L., and Hutchings, Gilbert R., Carpentry and Building Construction Revised, Peoria, IL: Chas. A. Bennett Co., Inc., 1981.

Framing, Sheathing and Insulation, Albany, NY: Delmar Publishers, 1973.

Grimes, L. A. Jr., Cabinetmaker Coordinator's Guide, Austin, TX: The University of Texas at Austin, Instructional Materials Center, 1974.

Grimes, L. A. Jr., Cabinetmaker Student's Manual, Austin, TX: The University of Texas at Austin, Instructional Materials Center, Division of Continuing Education, 1974.

Grimes, L. A. Jr., Carpenter Coordinator's Guide, Austin, TX: The University of Texas at Austin, Instructional Materials Center, 1975.

- Grimes, L. A. Jr, Carpenter Student's Manual, Austin, TX: The University of Texas at Austin, Instructional Materials Center, Division of Continuing Education, 1975.
- Grimes, L. A. Jr., Carpenter Volume 2 Coordinator's Guide, Austin, TX: The University of Texas at Austin, Center of Occupational Curriculum Development, Division of Continuing Education, 1980.
- Grimes, L. A. Jr., Carpenter Volume 2, Student's Manual, Austin, TX: The University of Texas at Austin, Center for Occupational Curriculum Development, Division of Continuing Education, 1980.
- Grimes, L. A. Jr., Tools for Woodworking Trades, Austin, TX: The University of Texas at Austin, Instructional Materials Center, Division of Continuing Education, 1972.
- Harris, Robert W., Drywall, Chicago, IL: American Technical Society, 1979.
- Math, Blueprint Reading, Measuring Tools, Stillwater, OK: State Department of Vocational and Technical Education, 1971.
- McDonnell, Leo P., Hand Woodworking Tools, Albany, NY: Delmar Publishers, 1962.
- McDonnell, Leo F., Portable Power Tools, Albany, NY: Delmar Publishers, 1962.
- Measurable Objectives for Carpentry, Montgomery, AL: State Department of Education (Vocational-Technical and Higher Education), 1973, (Draft).
- Nelms, Howard F., Competency-based Preservice Construction Trade Curriculum, Springfield, IL: Illinois State Office of Education, 1978.
- Penner, Wayman R., Residential Carpentry, Stillwater, OK: State Department of Vocational and Technical Education, 1973.
- Plumbing, Clemson, SC: Clemson University, Vocational Education Media Center, 1977.
- Putman, Robert, Basic Blueprint Reading Residential, (& answer key), Chicago, IL: American Technical Publishers, Inc., 1980.
- Putman, Robert E., Instructor's Guide for Fundamentals of Carpentry, 5th ed., American Technical Society, 1977.
- Putman, Robert E., Student Guide for Fundamentals of Carpentry Tools Materials Practices, 5th ed., Alsip, IL: American Technical Publishers, Inc., 1977.
- Reband, P., Related Mathematics for Carpenters, (& answer key), Alsip, IL: American Technical Publishers, Inc., 1973.

Thomas, John C., Carpenter, Lexington, KY: University of Kentucky, 1977.

Townsend, Gilbert, Steel Square, Alsip, IL: American Technical Publishers, Inc., 1981.

Vittone, Ronald, Student Guide for Fundamentals of Carpentry Practical Construction, Chicago, IL: American Technical Publishers, Inc., 1977.

Wagner, Willis H., Modern Carpentry, South Holland, IL: The Goodheart-Willcox Co., Inc., 1979.

Wagner, Willis H., Modern Carpentry Instructor's Guide, (& answer key), South Holland; IL: The Goodheart-Willcox Co., Inc., 1979.

Wagner, Willis H., Modern Carpentry Workbook, South Holland, IL: The Goodheart-Willcox Co., Inc., 1979.

APPENDIXES

- A Joint Articulation Agreement
- B Instructor's Signed Agreement to Articulate
- C Philosophy of Articulation Guide Design
- D Purposes of Articulation Guide
- E Definitions of Terms
- F Directions for Tests
- G Responsibility Sheet
- H Binder Design

THE SCHOOL DISTRICT
OF GREENVILLE COUNTY

GREENVILLE TECHNICAL COLLEGE

TO: All Administrators, Staffs and Faculties, The School District of
Greenville County and Greenville Technical College

SUBJECT: Application and Implementation of the Policies and Procedures for
the Articulation of Similar Vocational Training Programs of
Instruction

Since 1976, The School District of Greenville County and Greenville Technical College have been working toward making the articulation of vocational education programs a viable and valid reality. Through joint efforts in the Occupational Education Articulation Program, The School District of Greenville County and Greenville Technical College fully support the concept of articulation and agree upon the purposes of the articulation program.

This Policies and Procedures Guide has been developed as a joint effort of The School District of Greenville County and Greenville Technical College with the assistance of individuals representing the institutional administrative units, involved faculty, and the local business and industrial community. The Policies and Procedures Guide is designed to assist the articulation of very similar programs of vocational training between the secondary and post-secondary, public, vocational training institutions in Greenville County.

Appreciation is expressed to participants at both institutions for the joint effort of this endeavor.

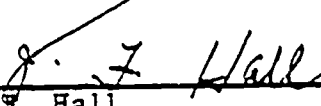

J. F. Hall
Superintendent
The School District of
Greenville County

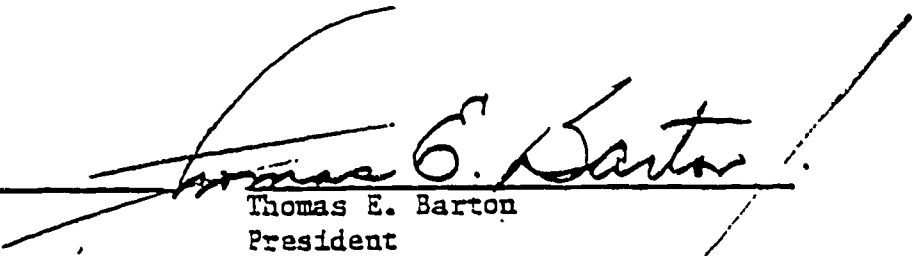

Thomas E. Barton
President
Greenville Technical College

TASK FORCE COMMITTEE
AGREEMENT TO ARTICULATE
VOCATIONAL EDUCATION

Articulation provides a system whereby secondary and post-secondary instructors can cooperate effectively in providing a continuous occupational development program where the level and type of vocational training that leads to entry-level employment skills will be clear to instructors, other educators, students, and potential employers.

The concept of articulation and the articulation program are supported fully by The School District of Greenville County and Greenville Technical College which have agreed upon a statement of purpose for the articulation of similar vocational education programs in Greenville County.

The articulation program in Greenville County is a joint effort of The School District of Greenville County and Greenville Technical College to develop a continuous program of vocational training so that students may continue their career preparation without loss of time or waste of effort in repeating tasks which have been learned previously and demonstrated. Articulation program activities are designed to help remove unnecessary gaps or overlap in student learning which may occur when a student completes a secondary vocational program and continues career development at the post-secondary level in a similar occupational field.

To implement articulation, instructor representatives from the participating institutions have met as a task force committee to develop this articulated, performance-based instruction guide which describes the secondary vocational program and which provides the parameters for vertical articulation.

Vertical articulation shall include recognition of the occupational competencies demonstrated by secondary graduates of articulated vocational programs.

It is agreed that...

The task force committee instructor representatives from The School District of Greenville County and Greenville Technical College mutually recognize the value of occupational education provided by each institution.

The task force committee instructor representatives will take the necessary actions, approved by their administrations, to ensure that this agreement to articulate is fulfilled including interpreting the program to students.

It is understood that periodic review of the articulated task objectives, performance actions, minimum standards, and outcome-referenced measures will be necessary to ensure that a valid training program is serving the needs of the community and the students.

Each task force committee participant hereby agrees to notify the others of any changes which modify the articulated, performance-based vocational program described in this guide so that each articulation guide, and where appropriate the articulation program, may be revised mutually so that articulated occupational training in Greenville County will conform to the minimum standards outlined in this guide.

This agreement to articulate establishes the necessary framework for lateral as well as vertical articulation.

AGREED UPON BY THE TASK FORCE COMMITTEE PARTICIPANTS ON THIS DAY,

April 20, 1983
date

Name	Institution/School
Therese H. Giles	Foothills
James E. Christie	Donaldson
K. F. Kirkland	GOLDEN STAIR VOC CENTER
W. C. Smith	Enoree Voc Center
James E. Bower	Greenville Tech

PHILOSOPHY OF ARTICULATED, PERFORMANCE-BASED INSTRUCTION GUIDE DESIGN

The design of the articulated, performance-based instruction guides and the articulation program is based on a philosophy that the vocational education curriculum should be for career training with few fringe or non-related subjects. The student should be given the basis to do useful skilled work upon graduation and employment. The vocational program graduate should have a background which will allow him/her to learn and advance as rapidly as possible on the job, but it should not include subject matter which will not be applicable to his/her work for years. When subject matter is introduced that will not be applicable to the graduate's work for years, it may put the graduate out of perspective. The result might be that the graduate may try to force applications which do not exist, simply because the information is in his/her repertoire. Thus, the purpose of vocational training by the articulated, performance-based instruction guides is to prepare graduates for successful entry into a skilled trade.

To ensure that the design of the articulated, performance-based instruction guides is conforming to the philosophies of both the secondary and post-secondary institutional participants, a periodic review of the guide design and philosophy is recommended.

PURPOSES OF THE ARTICULATED INSTRUCTION GUIDE

The articulated instruction objectives guide are is expected to serve the following purposes:

1. The guide serves as the primary vehicle for the articulation of subject matter in similar vocational training programs between the vocational education centers, high schools, and Greenville Technical College through use by instructors at both levels as a reference in preparing instruction.
2. The guide provides a listing of the minimum tasks that a student or worker is expected to perform in the conduct of a specific level job in the area of vocational training or work of concern.
3. The guides identify the primary detailed instruction objectives, performance objectives which are based upon the task listings. The tasks are listed in the sequence of complexity, with the least complex task being listed first, except where a task must be performed as a prerequisite to performance of another task.
4. The guides identify the tasks performed (actions, steps, sets of skills) and related technical information which must be taught and learned to accomplish each major instruction objective. The tasks performed represent the minimum skills and related information required for adequate occupational proficiency in the performance objectives.
5. The guides designate the instructional contact hours necessary to provide the required instruction, as required by appropriate educational agencies or offices and as estimated by the instructor-participants on the Vocational Articulation Project Task Forces, and based on the time required to teach the average learner to perform the task. The time estimated is based on having the essential equipment, facilities and instructional aids required to provide the instruction, whenever the class size is limited to an acceptable number.
6. The guides identify the performance standards to be met for occupational proficiency in the task. Performance standards used are those considered to be minimum business or industry standards. The ability to meet the listed standards of performance will be considered as qualification for advanced instruction in the vocational program.
7. The guides provide direction in the conduct of sequential vocational competency instruction by modules or job tasks, resulting in qualification by the learner to perform limited skill specialist jobs of

progressively higher skills until the program objective is reached (i.e., file clerk to executive secretary, etc.). As the student becomes proficient in the performance of tasks in successively more complex modules, more marketable competencies are gained and may be identified as the lower job qualifications of a specialist.

Through this procedure, even the slower student is provided an opportunity to eventually gain sufficient skills to perform adequately as a specialist at some level in the vocational field, even if the student is unable to complete the total program of training.

The standardized sequence of activities of the vocational instruction modules will facilitate lateral articulation between vocational education centers in the School District and will simplify vertical articulation when training is continued at Greenville Technical College articulating to employers.

8. The guides provide a descriptive listing of equipment required to conduct the program of vocational training. The equipment listed is considered to be the type and quantity essential for the conduct of instruction to prepare students for entry-level employment in the vocational field. It may be necessary to delay teaching some tasks involving special equipment, if that equipment is not available at all instructional sites, or to move students and equipment together as necessary to teach skills.
9. The guide provides information about requirements or limitations that typically are involved in the performance of the task, environmental conditions and physical demands, and able to perform the task.
10. The guides provide a list of standardized performance test items/ and outcome-referenced measures to be used in the determination of vocational proficiency. As long as the specifics are not provided, the test items listed cannot be compromised easily and could serve as study guides.
11. The tasks listed in the guide are the minimum requirements for job qualification under average circumstances in a regional market. It is understood that there may be unlisted tasks that some employers may require the worker to do in the occupation, when in their employment. In addition, there may be unlisted tasks, such as mental process tasks, that are not stated but that may occur and that should be considered in instructional planning or testing.

Instructors may teach skills and related technical information other than what is shown in the guides. Provision of additional information should be limited to the students who have completed the requirements for the tasks emphasized in the instructional guides. The change of tasks in the guides should be based on task force committee agreement to ensure lateral and vertical articulation.

12. It is expected that there will be updating and correction of items in the articulated instruction guide. Participants are to be sure that the contents are valid and consistent with business and industry requirements. Recommendations should be submitted to the Vocational Articulation Program office which will assemble and present them to the appropriate committee for review and possible adoption.
13. Typically, the teacher/instructor should not plan to conduct instruction in a given articulated module unless the capability exists to conduct all of the instruction to meet the instructional objectives, with the result that the successful student is qualified to perform the tasks identified within the module.
14. An underlying philosophy in vocational training is that it is better to prepare the student to be fully qualified to perform all of the tasks in a limited group of modules in a vocational field and be qualified at a lower job level rather than to be only familiar with a large number of task descriptions or duties and qualified to perform none of them fully. For higher levels of job qualification beyond the secondary level, the student or worker is encouraged to enroll at Greenville Technical College.
15. Generally, vocational programs will include certain basic modules or courses of instruction without which the student would not be considered vocationally qualified at any level. Basic modules typically will be identified and taught early in the program sequence.
16. The instruction guides provides information essential to help the vocational student who completes training at the secondary level and continues career development training at the post-secondary level in a similar program receive appropriate credit for the articulated vocational training that has been mastered at the secondary level.

DEFINITIONS OF TERMS

The following definitions of terms are applicable to the articulated, performance-based instruction guides developed as products of the Occupational Education Articulation Program.

- Behavior: The actions of a person (specifically, job or job training actions). Behavioral actions include both overt, those that can be observed, and covert, those not observable outwardly. Performance may be interchanged with behavior in the project. (See also Performance Actions).
- Concept: A group of ideas that may be classed together or that are similar.
- Criteria: A standard by which performance may be measured, usually considered the minimum standard.
- Domain: A cluster of related jobs.
- Duty: One of the distinct major activities involved in the work performed and comprising related tasks.
- Evaluation: When comparison is made between a measurement and a standard and judgment is passed on the comparison.
- Item: A single stimulus or stimulus pattern that calls for a single response or set of responses. It is one sample of behavior or performance. The response may be simple or complex.
- Job: The duties or tasks actually performed by a specified individual.
- Knowledge: In this project, knowledge refers to acquired covert behavior which facilitates skills and performance, such as the theoretical information of what should be done under given circumstances, and in what order of sequence performance should occur to accomplish the objective.
- Measurement: The process of determining the extent some characteristic is associated with the student.
- Module: Modules in the pilot Drafting and Business and Office Education curriculum modifications in the Occupational Education Articulation Program have been designed to

coincide secondary level training with post-secondary level similar areas of training.

Another method of developing modules might be for modules to represent an identifiable, complicated task or job area involving a number of sub-tasks such as "Electrical Systems" in Automotive Mechanics.

Norm-referenced Evaluation: In norm-referenced evaluation, measures are dependent on a relative standard. Measures compare the capabilities of one student to those of other students.

Objective: (See Performance Objective) A stated desired outcome of training or the end result of the job, task, or performance actions. Objectives referred to in this project will be terminal objectives, generally representing a specific job function.

Occupational Education: An organized sequence of learning experiences consisting of vocational theory, practice, and skills taught to students on a regular or systematic basis.*

*Reference: Standards of the Delegate Assembly (Atlanta: Southern Association of Colleges and Schools, Commission on Occupational Education, December, 1972) p. 12.

Outcome-referenced Evaluation: Outcome-referenced, or criterion-referenced, measurement provides a standard of achievement for the individual as compared with specific behavioral objectives and therefore provides information about the degree of competence attained by the student.

The outcome-referenced measure is a performance or other measure based upon a performance objective, the accomplishment of which measures attainment of that objective.

Performance: Performance is used in this project to refer to a job or task which results from a set of sequential actions or steps.

Performance Actions: A series of steps, generally arranged in a sequence ordinarily followed, which when completed may result in the accomplishment of a performance objective (performance of a task).

Performance actions may be referred to as a set or sets of skills, functions, or steps. V-TEC (Vocational-Technical Education Consortium of States) catalogs generally describe performance actions in the "performance guide" of their format.

Articulated, Performance-based Instruction Guide: A comprehensive collection of performance objectives, performance actions to obtain those objectives, suggested hours for instruction (for planning purposes), performance standards, related technical

information, and outcome-referenced measures, as well as general secondary level and post-secondary level descriptions of similar courses for the purposes of aiding lateral and vertical articulation concerning the subject area.

Performance-based Instruction: Performance-based (competence-based) instruction is based on the competencies or tasks performed by on-the-job workers. Everything in a performance-based instruction system is made public beforehand. There are no surprises for student, teacher, counselor, or employer. When the student begins a program, information is available to tell the student exactly what competencies are expected to be developed as a result of the instructional program, how and against what standards or/criteria the student will be evaluated, and how the student's competencies will be communicated to the student, instructors, and to employers.. A performance-based instructional system tells the student exactly what the student must learn, teaches the student that skill or knowledge, and then tests on mastery of that specific competence.

Performance Objective: A statement in precise, measurable terms of a particular behavior to be exhibited by a learner under specified conditions. It possesses each of the elements or characteristics specified below:

Conditions under which the performance is to take place.

Behavior Desired or expected of the student (things to be done, the performance desired).

Standards to determine how well the performance is to be done (criteria).

Performance Test: A performance test requires the student to demonstrate (master) the desired behavior of the objective (accomplish a job-like task) under controlled conditions and according to predetermined standards. The controlled conditions allow the student to demonstrate the desired behavior and the conditions remain consistent from student to student.

Skill: Primarily, skill refers to overt, observable performance, however, it is recognized that there are covert skills required in some performances.

Step: Step is used to refer to a task or action, generally as a sequence of steps involved in the accomplishment of a performance objective or job.

Systems Approach: The systems approach to instruction emphasizes the specification of instructional objectives, precisely controlled learning experiences to achieve the objectives, criteria for performance, and evaluative information.

Task: A task is a set of skills (set or sets of functions, actions, or steps) the student must perform to accomplish the job (training). A task may be described as a logically related set of actions necessary or required to complete the job objective. Several tasks could be referred to as a duty.

Task Analysis: Task analysis is breaking down a learning task (objective) into component tasks each of which must be mastered as a prerequisite to mastery of the total job.

Task List: A listing of tasks (performance objectives) performed by incumbent workers (students in training) within a domain of interest (course of study).

Test: An event during which the student is asked to demonstrate some aspect of knowledge or skill is a test. It can be a single test item, but usually it consists of several items.

INSTRUCTIONS FOR ANSWERING OUTCOME-REFERENCED TEST ITEMS

Typically, eleven (11) different types of outcome-referenced test items may be used in the competency test.

1. True-False
2. Completion (Fill-in Blanks)
3. A Combination of True-False and Completion
4. Multiple-Choice
5. Matching
6. Identification
7. Short Answer
8. Long Answer
9. Program Product of Performance Test
10. Simulated Performance Test
11. Actual Performance Test

An example of each type of test item is included. Carefully study the illustration test item and the directions for answering the question. These directions will not be given again. Your test questions may vary slightly in the format, however, the instruction should be applicable. Where necessary, the instructor will supplement these instructions for answering outcome-referenced test items.

Do not guess. Guessing does not add to your knowledge, even if you happen to guess right. If you do not know the answer skip the test item and go to the next question. Remember: Enter your answers in the blanks provided on the separate answer sheet, if used.

1. TRUE-FALSE

Directions: Read the statement carefully. Decide whether it is true or false. Answer by marking T or F in the blank provided to the right (or, if answer sheet requires, mark "X" in the appropriate (T) or (F) parenthesis, or "circle" T or F).

Example: Lumber shrinks across the grain of the board. (T) (F)

2. COMPLETION (Fill-in Blanks)

Directions: Complete the statement by printing on the blank line the word or words which make a complete and correct statement.

Example: Proper edge spacing will restrict
 ? and ensure good weld
 penetration. distortion

3. COMBINATION OF TRUE-FALSE/COMPLETION

Directions: If the statement is correct, in the parenthesis mark (T) or answer true, as required. If the statement is incorrect, mark (F) in the parenthesis and fill in the blank provided with the appropriate word or term which, if substituted for the underlined word, would make the statement correct.

Example: A pantry chef usually is the head chef's first assistant. (T) (F)
sous

4. MULTIPLE-CHOICE

a. Directions: You are given three or four choices from which to make a complete and correct statement. In the blank answer space provided, write in the "letter" indicate the best choice.

Example: The head chef's first assistant is a ?.

- a. junior chef
- b. sous chef
- c. pantry cook

b. Negative Answer Multiple-Choice

Directions: If the multiple-choice question includes the word EXCEPT, you should look for the choice that does not fit the question. Read the entire question carefully before you choose your answer.

Example: All of these could cause high starter current draw EXCEPT:

- a. work starter bushing
- b. bad starter relay
- c. grounded field coils
- d. grounded armature

5. MATCHING:

Directions: For each given item in the left hand column, match it with the appropriate item from the right hand column. Write the letters of the correct or best answer in the appropriate blanks.

Example: Match these metric terms on the left with their proper equivalents.

<u>b</u>	deca	a.	thousands
<u>e</u>	meter	b.	tens
<u>a</u>	kilo	c.	units of length measurement

6. IDENTIFICATION

Directions: Identify each labeled part of the illustration below and write the name next to the appropriate letter in the blank provided.

Example:

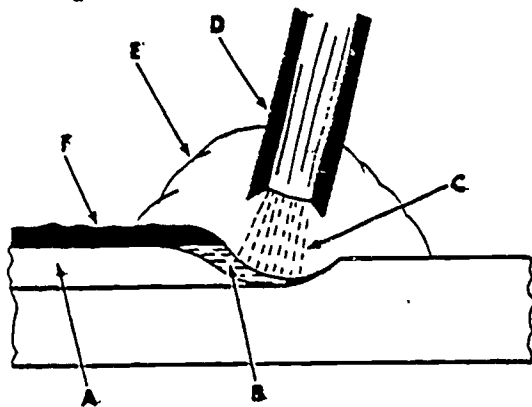

a.	<u>base metal</u>
b.	<u>molten metal</u>
c.	<u>arc</u>
d.	<u>electrode</u>
e.	<u>gas shield</u>
f.	<u>slag</u>

7. SHORT ANSWER

Directions: Write the correct answer in the blank provided.

Example: What type of electrode is best for vertical and overhead welding? fast-freeze

8. LONG ANSWER

Directions: Using as few words as possible, write the answer to the question in the blank provided.

Example: What should be done if the electrode welds fast to the work?

"Electrode should be broken loose by twisting or bending the holder."

9. PROGRAM PRODUCT OR PERFORMANCE TEST

Definition: Concrete project or production accomplishments during training are used to test knowledge or skill. Typically, test pressures are missing and the student may have had help in completing the task.

Directions: Instructor will observe student during training and by checklist or rating scale will rate student's performance or knowledge.

Example: Given an oven for baking, food items, and necessary implements and equipment; load the oven with foods to be baked. All items on a checklist used to rate performance must receive an acceptable rating. The task must be accomplished within 15 minutes.

CHECKLIST

(Load Oven Racks)

ACTIVITY	RATING	
	Acceptable	Unacceptable
1. Gathered needed supplies.		
2. Used needed supplies.		
3. Pulled oven rack partially out while loading.		
4. Stacked oven shelves 8 inches apart for baking.		
5. Placed food on rack so that heat circulated adequately.		
6. Followed appropriate safety precautions.		

10. SIMULATED PERFORMANCE

Definition: Contrived situation, resembling tasks the graduate will be required to do on the job. This form of test is useful for evaluating transferable skills such as reasoning, attitudes, and psychomotor skills necessary for occupational success.

11. ACTUAL PERFORMANCE TEST

Definition: Exhibits the advantage of realism, but may be too late to help either the student or the vocational program correct failures.

Example: Given an automobile with a leaking pinion seal, access to proper tools and equipment, replacement parts, and service manual; replace the pinion seal according to manufacturer's recommended procedures. The job should be completed within 2 hours. The manufacturer's specifications must be met and the completed job must meet the instructor's standards.

THIS DOCUMENT AND BINDER ARE THE PROPERTY OF THE SCHOOL DISTRICT
OF GREENVILLE COUNTY OR GREENVILLE TECHNICAL COLLEGE

The production of this curriculum guide and binder by the Occupational Education Articulation Program was funded through the South Carolina Appalachian Council of Governments. This guide and binder are the property of The School District of Greenville County or Greenville Technical College.

Except for document and binder copies that have been placed in libraries or shared with educational organizations, the documents and binders are issued on an accountability basis.

Documents and binders issued to instructor participants remain the property of the issuing institution. Should a vocational instructor leave the employment of The School District of Greenville County or Greenville Technical College, the document and binder must be returned to the principal, vocational center director, or department head so the instruction guide may be used by replacement personnel.

Corrections, modifications, and notes may be made on the pages of the documents for the purpose of modifying the field trial edition or to improve the instructional value of the document. Please share any corrections, modifications, and recommendations concerning this document with the Occupational Education Articulation Program.

Illegible or blank document page replacements may be requested at no cost through the Occupational Education Articulation Program. For replacement pages, please indicate:

Document Title
Module Number
Task Number or Page Number

Replacement costs for this document and binder are:

1" Binder - \$2.80
2" Binder - \$5.00
Document - .05¢ per page (1982)

Who to contact:

Occupational Education Articulation Program
The School District of Greenville County
c/o Donaldson Vocational Center
Donaldson Center
Greenville, SC 29605
(or)

Consultant, Vocational Education
The School District of Greenville County
(or)

Associate Vice President for Education
Greenville Technical College

BINDER DESIGN

(Occupational Education Articulation Program)

The binder design is simple and straightforward.

Two triangular figures, in balance, represent the two institutions participating in articulation.

Two levels of training are represented by the placement of the triangular figures and the identification of the two institutions.

Horizontal and vertical lines represent lateral and vertical articulation.

The diagonal across the design represents the progressive movement in career development for successful job performance.

The two figures are not closed when they face, but allow for interaction and are linked by the document title: Articulated, Performance-based Instruction Guide.