

DOCUMENT RESUME

ED 230 819

CE 036 367.

AUTHOR Henderson, William Edward, Jr.  
 TITLE Articulated, Performance-Based Instruction Guide for Drafting II. Final Document. Revised.  
 INSTITUTION Greenville County School District, Greenville, S.C.; Greenville Technical Coll., S.C.  
 SPONS AGENCY South Carolina Appalachian Council of Governments, Greenville.  
 PUB DATE May 83  
 CONTRACT ARC-211-B  
 NOTE 216p.; For related documents, see ED 220 579-585, CE 036 366-368, and CE 036 370-372.  
 PUB TYPE Guides - Classroom Use - Guides (For Teachers) (052) -- Tests/Evaluation Instruments (160)  
 EDRS PRICE MF01/PC09 Plus Postage.  
 DESCRIPTORS \*Architectural Drafting; Articulation (Education); Behavioral Objectives; Competency Based Education; Criterion Referenced Tests; Curriculum Guides; \*Engineering-Drawing; High Schools; Industrial Arts; Secondary Education; \*Trade and Industrial Education  
 IDENTIFIERS \*Structural Drafting

ABSTRACT

Developed during a project designed to provide continuous, performance-based vocational training at the secondary and postsecondary levels, this instructional guide is intended to help teachers implement a laterally and vertically articulated secondary level drafting II program. Introductory materials include a description of Drafting II, suggestions for optimum success in Drafting II, Drafting II options, minimum performance standards for Drafting II, discussion of sample tests provided in the guide, and suggested instructional time. Four units are provided. The first is an introduction to Drafting II and to the three Drafting II options. The next three units cover these three options/specializations: (1) architectural drafting, (2) mechanical drafting, and (3) structural drafting. Suggested instructional time and task listings begin each unit. For each task in a unit, some or all of the following are provided: performance objectives, performance actions, performance standards, recommended sources, related technical information, and other information the teacher might need. Suggested outcome-referenced tests are included. Appendixes include supplemental topics and optional tasks for Drafting II, articulation agreements, and test directions. (YLB)

\*\*\*\*\*  
 \* Reproductions supplied by EDRS are the best that can be made \*  
 \* from the original document. \*  
 \*\*\*\*\*

FINAL DOCUMENT  
FOR ARTICULATION OF DRAFTING II

ED230819

Project No. 82-1361  
Contract No. ARC 211-B

Wm. Edward Henderson, Jr.  
Coordinator, Occupational Education Articulation Program  
The School District of Greenville County  
P. O. Box 2848 - 301 Camperdown Way  
Greenville, South Carolina 29602

ARTICULATED, PERFORMANCE-BASED  
INSTRUCTION GUIDE FOR DRAFTING II

U.S. DEPARTMENT OF EDUCATION  
NATIONAL INSTITUTE OF EDUCATION  
EDUCATIONAL RESOURCES INFORMATION  
CENTER (ERIC)

This document has been reproduced as  
received from the person or organization  
originating it

Minor changes have been made to improve  
reproduction quality

Points of view or opinions stated in this docu-  
ment do not necessarily represent official NIE  
position or policy

May, 1983

"PERMISSION TO REPRODUCE THIS  
MATERIAL HAS BEEN GRANTED BY

*W. E. Henderson*

TO THE EDUCATIONAL RESOURCES  
INFORMATION CENTER (ERIC)"

Occupational Education Articulation Program  
of The School District of Greenville County  
and Greenville Technical College  
Funded in part by  
South Carolina Appalachian Council of Governments

CE036 36.7

ARTICULATED, PERFORMANCE-BASED CURRICULUM GUIDE

THE SCHOOL DISTRICT OF GREENVILLE COUNTY

DR. J. FLOYD HALL  
SUPERINTENDENT

DR. NORMAN MULLINS  
ASSOCIATE SUPERINTENDENT FOR EDUCATIONAL DEVELOPMENT

MRS. DORIS CLANTON  
DIRECTOR, INSTRUCTIONAL SERVICES

MR. O. RICHARD COTHRAN, JR.  
CONSULTANT, VOCATIONAL EDUCATION

ARTICULATION GUIDE

THE SCHOOL DISTRICT  
OF GREENVILLE COUNTY

AND

GREENVILLE  
TECHNICAL COLLEGE

THE SCHOOL DISTRICT OF GREENVILLE COUNTY  
GREENVILLE, SOUTH CAROLINA

REVISED 1983

CE 36367

DISCRIMINATION PROHIBITED - Title VI of the Civil Rights Act of 1964 states: "No person in the United States, shall, on the grounds of race, color, or national origin, be excluded from participation in, be denied the benefit of or be subjected to discrimination under any program or activity receiving federal financial assistance." Therefore, the Occupational Education Articulation Program, like all other programs or activities receiving financial assistance from the Appalachian Council of Governments must be operated in compliance with this law.

The opinions expressed herein do not necessarily reflect the position or policy of the Appalachian Council of Governments and no official endorsement by that agency should be inferred.

## BIAS STATEMENT

This articulated, performance-based instruction guide has been developed based upon the tasks (objectives) and task actions (enabling objectives) important to the success of entry level workers in the vocation. The objectives were derived from task analysis and available tasks lists such as V-TEC Catalogs. The standards of performances are those expected by local businesses and industries for job success. Test samples are included to represent valid and reliable measures of the mastery of objectives.

This articulated, performance-based instruction guide has been designed to comply with the requirements of PL 94-482 Educational Amendments of 1976, Title II, which is intended to "...ensure that...curricula do not reflect stereotypes based upon sex, race, or national origin..."

## COPYRIGHTED DISCLOSURE STATEMENT

Every effort has been made to appropriately document any copyrighted material used in this articulated, performance-based instruction guide.

The objectives and task actions in this guide were developed or contributed by task force committee (instructor) participants based on their expertise and on task lists from resources such as V-TEC Catalogs. Standards included in this guide are those identified by local businesses and industries as important to the success of entry level workers. Sample knowledge and performance tests are included for the purpose of representing valid and reliable test items that may be used to measure mastery of objectives. Test samples taken from texts or workbooks are typically of those being used locally and appropriate documentation has been included.

Wm. Edward Henderson, Jr., Coordinator  
Occupational Education Articulation Program  
The School District of Greenville County  
1982

Henderson, Wm. Edward, Jr., ed. Articulated, Performance-based Instruction Guide for Drafting II, Greenville, SC: The School District of Greenville County (Occupational Education Articulation Program funded by the South Carolina Appalachian Council of Governments), 1983.

#### ACKNOWLEDGEMENT

This Articulated, Performance-based Instruction Guide for Drafting II is the product of the work of the following Drafting instructors representing the secondary level program of The School District of Greenville County:

Buford C. Garrett  
Al Waters  
Jerry Sparks  
Richard Davis

Golden Strip Vocational Center  
Donaldson Vocational Center  
Enoree Vocational Center  
Foothills Vocational Center

The cooperation of these instructors and others representing The School District of Greenville County and Greenville Technical College is appreciated.

## ABSTRACT

Title of Project: Occupational Education Articulation Program  
Project Coordinator: Wm. Edward Henderson, Jr.  
Contracting Agency: The School District of Greenville County  
301 Camperdown Way  
P. O. Box 2848  
Greenville, South Carolina 29602  
Project Period: March 1, 1982 through February 28, 1983

PURPOSE: To develop a continuous program of vocational training in drafting so that students may continue their education the secondary and post-secondary levels without loss of time or waste of effort in repeating tasks that have been mastered previously.

To remove unnecessary gaps or overlap in student learning when the student completes a secondary level program and continues career development at the post-secondary technical education level.

To provide a system whereby teachers can cooperate effectively in providing a continuous occupational development program where the levels and types of training that lead to entry-level employment skills will be clear to students, educators, and potential employers.

METHOD: Drafting instructors from the vocational education centers of the secondary level program of The School District of Greenville County and drafting instructors from the post-secondary level program of Greenville Technical College were brought together in Task Force Committee meetings and workshops to survey similar drafting training programs and to identify possible overlap or gaps which might be encountered by students as they continue drafting training from the secondary level to the post-secondary level. The performance-based instructional objectives guide developed by the Committee served as the main vehicle for articulation. The Task Force Committee on Drafting, by the task analysis process, identified drafting competencies for Drafting I essential for the student desiring to continue drafting training, or for initial entry into the labor market in drafting. Performance identified were placed in an appropriate sequential order and assigned instructional time and performance standards according to their importance. Finally, sample outcome-referenced measures of those competencies were developed for use as a guide in articulation.

RESULTS:

As a result of this project, the product, Articulated Instruction Objectives Guide for Drafting, was developed. The Guide, however, is not an end-product since it must be field trial tested and revised. Modification and improvement to the Guide are expected since the process of education must be continually reviewed to ensure objectives are valid and are being met as best they can be met.

In addition, a Policies and Procedures Manual was developed to assist in continuing and future articulation efforts. Two sub-products, workshop guides, were assembled to assist workshop leaders/coordinators and participants in the process of writing objectives, performance actions, standards, and outcome-referenced measures in the development of performance-based curriculum material.



## PREFACE TO DRAFTING II

The time allocated during Phase One, (March, 1981, to February, 1982) of the Occupational Education Articulation Program did not permit the development of a performance-based description of Drafting II. The Drafting Task Force Committee met from May to December, 1981, and completed the Articulated, Performance-based Instruction Guide for Drafting I. The Phase One document articulated the first year of secondary drafting training with the Engineering Graphics Technology Courses 111, 121, and 131 at Greenville Technical College. During Phase One, an introduction to Drafting II was written and included as an appendix in the Phase One document.

During Phase Two (March, 1982, to February, 1983), the performance-based description for Drafting II was developed. Drafting II includes Architectural Drafting and Mechanical Drafting Options which represent the primary training offered during the second year, secondary level program.

The Articulated, Performance-based Instruction Guide for Drafting II encompasses the following:

- a. The guide summarizes the typical second year of drafting training at the secondary vocational center level, The School District of Greenville County.
- b. Drafting II options currently include (1) Architectural, (2) Mechanical, and (3) Structural.
- c. Included are supplemental tasks (competency-objectives) for electrical, etc., drafting suitable for students at an advanced level of training.
- d. It represents agreement among the four secondary vocational center instructors concerning the objectives, major actions to reach the objectives, standards, and outcome-referenced tests that will guide Drafting II instruction.
- e. The skills and knowledge needed by graduates for entry level employment are clarified.
- f. At best, it is an initial description of Drafting II which will be field trial evaluated and modified to improve validity.

While there is general agreement concerning the description of Drafting II, secondary instructors suggest that many students might benefit from partial instruction in architectural and mechanical drafting during the second year, and students with exceptional abilities or interests may benefit more from individualized performance-based instruction designed for their skills and interests.

## CONTENTS

Drafting II - Secondary . . . . .	2
Suggestions For Optimum Success in Drafting II . . . . .	4
Drafting II Options . . . . .	5
Minimum Performance Standards for Drafting II . . . . .	6
Sample Outcome-Referenced Tests . . . . .	7
Suggested Instruction Time . . . . .	8
Drafting II - Unit 6.0. . . . .	11
Suggested Instruction Time . . . . .	12
Task Listings . . . . .	13
Drafting II . . . . .	14
Introduction to Drafting II Options . . . . .	14
Upgrade Technical Drawing Skills . . . . .	15
Option Specialization: Familiarization and Selection . . . . .	16
Architectural Drafting Option - Unit 7.0 . . . . .	A-1
Recommended Tasks for Architectural Drafting . . . . .	A-4
Suggested Instruction Time . . . . .	A-5
Task Listings . . . . .	A-7
Fundamentals of Architectural Drafting . . . . .	A-10
Introduction to Architectural Drafting . . . . .	A-10
Architectural Lettering . . . . .	A-11
Architectural Symbols . . . . .	A-12
Interpret Basic Surveying of Site; Search and Verify Title and Deed . . . . .	A-13
Residential Site Planning Considerations . . . . .	A-14
Draw Plot Plans . . . . .	A-16
Draw Floor Plans . . . . .	A-18
Draw Foundation Plans . . . . .	A-20
Draw Basement Plans . . . . .	A-21
Draw Piers, Columns, and Pilasters . . . . .	A-22
Sketch and Draw Exterior Elevations . . . . .	A-23
Draw Interior Elevations and Details . . . . .	A-24
Draw Framing Plans . . . . .	A-25
Draw Typical Wall Sections . . . . .	A-26
Draw Roof Sections . . . . .	A-27
Draw Stair Sections . . . . .	A-28

Draw Fireplace/Chimney Sections . . . . .	A-30
Design and Draw Door and Window Schedules . . . . .	A-31
Draw Schedules . . . . .	A-32
Check Drawings, Plans, and Specifications . . . . .	A-33
Build Presentation Models . . . . .	A-35
Draw New Residential Construction Working Drawings . . . . .	A-36
Identify Key Parts of Contractual Specifications . . . . .	A-37
Proficiency Report . . . . .	A-39
References . . . . .	A-42
Mechanical Drafting Option - Unit 8.0 . . . . .	M-1
Standards for Mechanical Drafting Option . . . . .	M-4
Suggested Instruction Time . . . . .	M-5
Task Listings . . . . .	M-6
Mechanical Drafting . . . . .	M-8
Introduction to Mechanical Drafting as a Speciality . . . . .	M-8
Cams (Motion Transfer) . . . . .	M-9
Gears (Motion Transfer) . . . . .	M-10
Fluid Power Mechanics . . . . .	M-11
Shop Processes . . . . .	M-12
Hardware Classification and Certification . . . . .	M-13
Developments and Intersections . . . . .	M-15
Draw Electrical Power Systems and Schematics . . . . .	M-16
Shop Processes - Welding . . . . .	M-18
Design and Draw Working Drawings . . . . .	M-20
Proficiency Report . . . . .	M-21
References . . . . .	M-24
Structural Drafting - Unit 9.0 . . . . .	S-1
Structural Drafting (Option) . . . . .	S-2
Suggested Instruction Time . . . . .	S-3
Task Listings . . . . .	S-4
Structural Drafting . . . . .	S-6
Draw and Analyze Construction Applications of Wood . . . . .	S-6
Draw and Analyze Construction Applications of Concrete . . . . .	S-7
Draw The Top, Front, and End Views of Given Steel Shapes Showing Rivets, Welds, and Bolts . . . . .	S-8
Draw and Analyze Construction Applications of Structural Steel . . . . .	S-10
Layout Foundation Plan . . . . .	S-11
Layout Supported Floor Plan . . . . .	S-12

Draw and Interpret Prints of Three Types of Framing. . . . .	S-13
Detail Reinforcing Steel on Foundations, Walls, Columns, Stairs and Floor Slabs . . . . .	S-14
Describe and Draw Structural Systems Common to Commercial Construction. . . . .	S-16
Proficiency Report . . . . .	S-18
End of Training Task. . . . .	18

APPENDIXES

DRAFTING - II

Appendix A	ANSI Standards Publications
Appendix B	Supplementary Topics for Drafting II
Appendix C	Optional Tasks
Appendix D	Joint Articulation Agreement
Appendix E	Instructor's Signed Agreement to Articulate
Appendix F	Philosophy of Articulation Guide Design
Appendix G	Purposes of Articulation Guide
Appendix H	Definitions of Terms
Appendix I	Directions for Tests
Appendix J	Responsibility Sheet
Appendix K	Binder Design

COMPETENCY-BASED INSTRUCTION GUIDE

For

DRAFTING II

PROJECT PERIOD

March, 1982 - February, 1983

PREPARED BY  
OCCUPATIONAL EDUCATION ARTICULATION PROGRAM  
TASK FORCE COMMITTEE ON DRAFTING  
REPRESENTING  
THE SCHOOL DISTRICT OF GREENVILLE COUNTY  
AND  
GREENVILLE TECHNICAL COLLEGE  
GREENVILLE, SOUTH CAROLINA

OCCUPATIONAL EDUCATION ARTICULATION PROGRAM  
FUNDED BY  
SOUTH CAROLINA APPALACHIAN COUNCIL OF GOVERNMENTS

FEBRUARY, 1983

## DRAFTING II.

LEVEL: Secondary

TITLE: Drafting II

DESIGNATION: Drafting II      COMPUTER NUMBER: 754

DESCRIPTION: Drafting II is described by the South Carolina State Department of Education in the Outline of High School Credit Courses publication as a course that reviews, expands, and applies principles learned in Drafting I.

Drafting II typically includes introductory instruction in such option areas as architectural, mechanical, structural or electrical drafting depending upon the instructor's background and qualifications, the needs of potential employers, and the interests of students. A minimum of two options are recommended.

### OBJECTIVES:

The draftsman trained translates the ideas, rough sketches, specifications, and calculations of engineers, architects, and designers, into working plans which are used by skilled craftsmen in making a product. Drafting equipment and instruments are used to prepare clear, complete, and accurate working plans of buildings and structures, mechanical, components or equipment.

Upon completing Drafting II, the student will possess a base of knowledge and skills necessary for:

- A. Initial entry level employment in the general field of drafting or continuation of study at the post-secondary level of training.
- B. Initial entry level employment assignments in specialized areas of drafting such as architectural, mechanical, or other option specialization areas.

### PREREQUISITES:

Drafting I  
Suggested Grade Level: 12

REQUIRED/SUGGESTED INSTRUCTION HOURS:

SYSTEM	YEAR		
	CLASS	LAB	TOTAL
Credits	3		3
Hours	540		540

PERFORMANCE EVALUATION:

Evaluation will be by outcome-referenced (criterion-referenced) testing. Given basic drafting tools and equipment, the student will demonstrate mastery of drafting instruments and equipment to produce clear, complete, and accurate working plans from given ideas, rough sketches, specifications and designs in a graphic form usable by skilled craftsmen in making a product.

Advanced standing at the post-secondary level generally will be based on the student's portfolio of agreed upon drawing acceptable to the Engineering Graphics or other departments at Greenville TEC.

JOB QUALIFICATIONS:

Drafting II represents the second year of a two year block of training at the secondary level. Mastering Drafting II skills and knowledge will qualify the student for entry level employment as an apprentice draftsman, possibly with one or two years of experience. For those students continuing their vocational training at the post-secondary level, Drafting II will increase the student's probability for academic success and may help qualify the student to exempt Engineering Graphics Technology courses EGT 111, EGT 121, and EGT 131 at Greenville Technical College (possibly other courses determined by exemption testing).

WORKING CONDITIONS:

Work typically is in a well-lighted and ventilated drafting room. The student should see well, either naturally or with correction. The drafter must stand or sit for long periods doing tedious work. Work is not strenuous and is suited for physically handicapped persons whose disability does not limit use of small tools with hands or fingers.

SIMILAR POST-SECONDARY TRAINING:

Post-secondary level training similar to Drafting II has not been identified at the writing of this competency-based course description. The mastery of Drafting II tasks, however, should better qualify the student to enter post-secondary training with advanced standing.

OPTION SKILLS CONSIDERATION:

The competency of the student in the chosen option of Drafting II should be communicated, by "proficiency report," to the post-secondary institution or employer if the student's skills may qualify the student for possible advanced or specialized placement.



## SUGGESTIONS FOR OPTIMUM SUCCESS IN DRAFTING II

The following suggestions for drafting students were developed by guidance counselors, The School District of Greenville County.

The drafting student should like:

- To work independently in office environments.
- Activities which involve machines, processes and methods.
- Doing precise, neat, and very accurate work.
- Activities of a scientific or technical nature.
- Drawing with scales, protractors, and compasses.

The drafting student should be able to:

- Understand and apply technical knowledge and theoretical principle.
- Solve arithmetic problems involving fractions and decimals.
- Practice various exercises many times without frustration.
- Turn in consistently neat work that is within precise limits or standards of accuracy.
- Concentrate for long periods of time on detailed work.
- Follow instructions exactly.
- Work under pressure.

The following math skills will contribute to optimum success in Drafting II:

- Ability to accurately make linear measurements using various scales (e.g., Engineer's and Architect's Scales).
- Able to compute fractions.
- Able to work with angles.
- Able to understand geometric shapes and terms.

Helpful courses to the drafting student include:

- General Mathematics
- Geometry
- Algebra I and II

For optimum success, the drafting student should possess the following verbal skills:

- Comprehend and write technical notes.
- Follow written, diagrammatic, and verbal instructions.
- Read and comprehend on grade level.

DRAFTING II OPTIONS

The 1970 Drafting Curriculum Guide of the South Carolina Department of Education recommends that the second year of secondary level drafting consist of "the opportunity to choose the area of specialization the student desires to pursue." Specialization in one of the following optional areas of drafting training is recommended.

<u>OPTION</u>	<u>MODULE</u>
Architectural Drafting . . . . .	7.0
Mechanical Drafting . . . . .	8.0
Structural Drafting . . . . .	9.0

The options which a secondary level vocational education center might offer to students will depend on several factors.\*

\*The choice of which options should be offered should:

- (a) be reached jointly by the instructor and local Drafting Advisory Committee,
- (b) meet local employment needs (based on the availability of job opportunities),
- (c) consider the local regional trend in the drafting profession, and
- (d) consider what the instructor will be comfortable teaching.

A school may be able to offer only one option or it might offer two or even more options. The suggested options may be modified or expanded, depending upon employment needs of the local drafting market (Electrical Drafting, for example, might be included if there is sufficient need to justify it being offered).

## MINIMUM PERFORMANCE STANDARDS FOR DRAFTING II

All standards applicable to Drafting I apply to Drafting II training (See pages D-8 - D-10, Articulated, Performance-based Instruction Guide for Drafting I).

Minimum performance standards are those recommended for entry level job success. Performance standards encourage lateral and vertical articulation.

In addition to standards listed in Drafting I, minimum standards are included in ANSI Manuals and applicable AIA references, as well as other sources of technical data and standards.

Typically, Drafting II performance objectives actions will omit descriptions of preliminary steps of setting up drawings as well as terminating steps of checking drawings, etc., for brevity.

Given materials (conditions) typically will omit mention of necessary drafting instruments and supplies to demonstrate skills and knowledge.

Drawings must communicate the intended information to the user (The user must be able to successfully answer a set of randomly drawn questions concerning the intended content of the drawing.)

Drawings must be executed within time limits considered acceptable for initial employment.

SAMPLE  
OUTCOME-REFERENCED TESTS

DRAFTING

This articulated, performance-based instruction guide is designed to answer three critical questions necessary for quality instruction.

First, what should be taught?

The objectives of the articulated, performance-based education vocational education program are based on extensive task analysis and validation.

The task objectives represent what employers in business and industry say is important for entry level job success.

Second, how should it be taught?

It should be taught using the latest "state-of-the-art" instructional technology incorporated into each unit.

Students are taught the knowledges, skills, and attitudes needed for successful and productive employment.

Third, how should students be evaluated?

Students are evaluated using a validated competency-based approach to determine student proficiency in vocational knowledges and skills.

The minimum standards are those required for successful entry in the next high level of training or for successful employment.

The sample tests are included to illustrate how the student's competency in vocational skills and knowledges may be measured with validity and reliability. In addition, the test samples are included to promote standardization in the evaluation of vocational students in similar programs.

Test items have been constructed solely from the objectives of the vocational program. The statement of the objectives indicate the level of knowledge or skill to be tested. Task force committee participants have attempted to write tests that agree with objectives in the behavior requested, the given conditions, and the desired standards of performance.

NOTE: Unless the test page is marked "Revised" or "R," the test should be considered a field trial edition currently under review and revision.

SUMMARY  
DRAFTING II  
SUGGESTED INSTRUCTION TIME

<u>DRAFTING II</u> <u>UNIT/TASK</u>	SUGGESTED HOURS
Unit 6.0	
6.01 Introduction to Drafting II Options	6
6.02 Upgrade Technical Drawing Skills	15
6.03 Option Specialization: Familiarization and Selection	45-66
TOTAL HOURS	66 (min.) - 87
Unit 7.0	
7.01 Introduction to Architectural Drafting	3
7.02 Architectural Lettering	3
7.03 Architectural Symbols	10
7.04 Interpret Basic Surveying of Site; Search and Verify Title and Deed	9
7.05 Residential Site Planning Considerations	5
7.06 Draw Plot Plans	9
7.07 Draw Floor Plans	60
7.08 Draw Foundation Plans	30
7.09 Draw Basement Plans	*
7.10 Draw Piers, Columns, and Pilasters	*
7.11 Sketch and Draw Exterior Elevations	15
7.12 Draw Interior Elevations and Details	6
7.13 Draw Framing Plans	6
7.14 Draw Typical Wall Sections	6
7.15 Draw Roof Sections	3
7.16 Draw Stair Sections	9

7.17	Draw Fireplace/Chimney Sections	6
7.18	Design and Draw Door and Window Schedules	6
7.19	Draw Schedules	15
7.20	Check Drawings, Plans, and Specifications	3
7.21	Build Presentation Models	-
7.22	Design New Residential Construction Working Drawings	-
7.23	Identify Key Parts of Contractual Specifications	-
	TOTAL HOURS	<u>204</u>

Unit 8.0

8.01	Introduction to Mechanical Drafting as a Speciality	6
8.02	Cams (Motion Transfer)	10
8.03	Gears (Motion Transfer)	10
8.04	Fluid Power Mechanics	15
8.05	Shop Processes	6
8.06	Hardware Classification and Certification	6
8.07	Developments and Intersections	45
8.08	Draw Electrical Power Systems and Schematics	30
8.09	Shop Processes - Welding	6
8.10	Design and Draw Working Drawings	136
	TOTAL HOURS	<u>270</u> (See Note)

Unit 9.0

9.01	Draw and Analyze Construction Applications of Wood	6
9.02	Draw and Analyze Construction Applications of Concrete	6
9.03	Draw and Analyze Construction Applications of Structural Steel	6
9.04	Layout Foundation Plan	*
9.05	Layout Supported Floor Plan	*

9.06	Interpret Prints of and Draw Three Types of Framing	15
9.07	Detail Reinforcing Steel on Foundations, Walls, Columns, Stairs, and Floor Slabs	75
9.08	Draw The Top, Front, and End Views of Given Steel Shapes Showing Rivets, Welds, and Bolts	12
9.09	Describe and Draw Structural Systems Common to Commercial Construction	15
	TOTAL HOURS	<u>135</u>

UNIT 6.0  
DRAFTING II





SUMMARY  
DRAFTING II  
SUGGESTED INSTRUCTION TIME

<u>DRAFTING II</u> <u>UNIT/TASK</u>	<u>SUGGESTED</u> <u>HOURS</u>
Unit 6.0	
6.01 Introduction to Drafting II Options	6
6.02 Upgrade Technical Drawing Skills	15
6.03 Option Specialization: Familiarization and Selection	45-66
TOTAL	66 (min.) -87

## TASK LISTING

(UNIT 6.0, DRAFTING II)

UNIT/TASK	DESCRIPTION
6.01	(Introduction to Drafting II Options) After a review of Drafting I Standards, safety instructions, and acquired skills and after an introduction to the overall objectives of Drafting II; define the objectives of Drafting II, general standards, and safety rules.
6.02	(Upgrade Technical Drawing Skills) Given a general review of Drafting I, drafting equipment and supplies, and drafting assignments related to architectural or mechanical drafting; upgrade technical drawing skills to a level of proficiency to satisfactorily participate in architectural, mechanical, or structural Drafting II options.
6.03	(Option Specialization: Familiarization and Selection) Given an introduction to Drafting II options, possibly including field trips to businesses representing the options, select one Drafting II option for continued training.

UNIT 6.0

DRAFTING II

TASK 6.01

INTRODUCTION TO DRAFTING II OPTIONS

---

PERFORMANCE OBJECTIVES:

After a review of Drafting I standards, safety instructions, and acquired skills and after an introduction to the overall objectives of Drafting II; define the objectives of Drafting II, general standards, and safety rules.

PERFORMANCE ACTIONS:

- 6.0101 Demonstrate skills from Drafting I as requested by the instructor to a proficiency level required by the instructor.
- 6.0102 Identify drafting safety rules.
- 6.0103 Identify Drafting II standards.
- 6.0104 Define the basic objectives for Drafting II with 75 percent accuracy.

PERFORMANCE STANDARDS:

- Demonstrate Drafting I skills as required by the instructor, to a required level of proficiency.
- Identify class standards and safety rules to the instructor's standards.
- Define the basic objectives of Drafting II with 75 percent accuracy.

SUGGESTED INSTRUCTION TIME: 6 Hours

RELATED TECHNICAL INFORMATION:

- Basic objectives for Drafting I.
- Introductory description to Drafting II.
- Options of Drafting II.
- Safety rules, Drafting I.
- Standards for Drafting I and II.
- Other standards that may be required by the instructor or school.
- Additional safety rules that may be required by the instructor or school.

UNIT 6.0

DRAFTING II  
INTRODUCTION

TASK 6.02

UPGRADE TECHNICAL DRAWING SKILLS

---

---

PERFORMANCE OBJECTIVE:

Given a general review of Drafting I, drafting equipment and supplies, and drafting assignments related to architectural or mechanical drafting; upgrade technical drawing skills to a level of proficiency to satisfactorily participate in architectural, mechanical, and structural Drafting II options.

PERFORMANCE ACTIONS:

- 6.0201 Draw objects using orthographic drawing techniques.
- 6.0202 Draw objects using axonometric system techniques.
- 6.0203 Draw objects using perspective drawing techniques.
- 6.0204 Demonstrate technical drawing skills to standards of the instructor.

PERFORMANCE STANDARDS:

- Meet instructor's standards for upgraded skills.
- Demonstrate ability to use correctly the orthographic, axonometric, and perspective drawing techniques.
- Lettering and drawing skills demonstrated show neatness, accuracy, consistency, proper placement, and character.
- Perform required tasks within time limits considered to be acceptable for initial employment job qualification.
- Demonstrate ability to locate and identify symbols and conventions in reference materials and draw them with at least 80 percent accuracy.

SUGGESTED INSTRUCTION TIME: 15 Hours

RELATED TECHNICAL INFORMATION:

- All Drafting I skills and knowledges.
- Dimensioning.

UNIT - 6.0

DRAFTING II

TASK 6.03

OPTION SPECIALIZATION:  
FAMILIARIZATION AND SELECTION

---

**PERFORMANCE OBJECTIVE:**

Given an introduction to Drafting II options, possibly including field trips to businesses representing the options, select one Drafting II option for continued training.

**PERFORMANCE ACTIONS:**

- 6.0301 Describe the option choices at the individual vocational center, for the year of training (option choices may vary from year to year).
- 6.0302 Identify important facets of drafting work in the various options offered during selected field trips, etc. (An observation guide or checklist of what to look for during orientation is recommended.)
- 6.0303 Compare the various options offered with regard to the student's skills and vocational interests. Possibly...
  - a. Consult with instructor to define the student's skills, strengths, and weaknesses.
  - b. Obtain the instructor's recommendations concerning option choices.
  - c. Consult with counselors, drafting professionals, or others concerning the option choices.
- 6.0304 Select an option choice.
- 6.0305 Select an option choice alternative, if applicable.

**SUGGESTED INSTRUCTION TIME:** 45-66 Hours

**PERFORMANCE STANDARDS:**

- Student will select an option in Drafting II in which it appears (to student and instructor) that the student can succeed and in which the student has interest.

UNIT 6.0

DRAFTING II

TASK 6.03

OPTION SPECIALIZATION:  
FAMILIARIZATION AND SELECTION  
(Con't.)

---

---

RELATED TECHNICAL INFORMATION:

- Orientation to Drafting II options:
  - Architectural Drafting.
  - Mechanical Drafting.
  - Structural Drafting.
  - Others supplemental tasks that may be offered by the individual vocational center.

UNIT 7.0  
DRAFTING II  
ARCHITECTURAL DRAFTING OPTION

ARCHITECTURAL DRAFTING OPTION  
DRAFTING II

INTRODUCTION:

The Architectural Drafting Option, Drafting II, represents agreement (lateral articulation) among the four secondary vocational center drafting instructors, The School District of Greenville County, concerning the objectives, content, and standards of the program.

While the basic program is similar at the four vocational centers, some variation may be expected due to the training and experience of the instructors in architectural drafting, the specific needs of potential employers, or the interests and abilities of students.

The Architectural Drafting Option includes: Concurrent instruction to upgrade lettering techniques, drafting skills, and the application of industry standards; architectural materials and methods of construction such as identifying building materials, using reference materials, drawing conventions, and symbols used in construction drafting; considering applicable codes, safety, and environmental protection regulations in planning and drawing; conducting site planning and layout including surveying, drawing contours, title searching, interpreting property lines from legal descriptions, planning foundations; calculating cut and fill requirements, and drawing site profiles; and correctly drafting new residential construction working drawings or rehabilitation drawing for older buildings.

The content of the Architectural Drafting Option is determined by task analysis of the needs of local prospective employers and by the recommendations of the 1980 South Carolina revision of the V-TEC Catalog, Architectural Drafter. The tasks included in the Architectural Drafting Option represent those considered minimum for the student to be successful in entry level employment in the architectural drafting field.

The Architectural Drafting description follows the AIA suggestion of emphasizing residential construction drafting for initial skill development and possibly light commercial construction for additional architectural drafting study.

PERFORMANCE  
EVALUATION:

Evaluation will be by outcome-referenced (criterion-referenced) testing. Minimum performance standards should represent recommended entry-level competency levels for job success.



STANDARDS:

Appropriate handbooks, codes, AIA Manuals, etc., which contain the necessary technical data/standards should be consulted.

Drawings of architectural systems should meet AIA or other industry standards.

Drawings must be prepared within job qualification time limits.

Orthographics, axonometric, and perspective drawing techniques must be correct and to entry-level employment performance. Lettering must be appropriate for architectural work, and drawings must be neat, accurate, and consistent with proper placement and character.

JOB  
QUALIFICATION:

Architectural Drafting by itself may not provide a specific job qualification; however, graduates who have proven competency in architectural drafting at the secondary level may qualify for entry-level employment as an Architectural Drafting Technician in residential or light commercial design or as a Building Trades Drafter.

The Architectural Drafting Option has not been articulated with a specific course at Greenville TEC; however, the skills and knowledge developed from this second year option course may help the graduate qualify for exemption of the post-secondary level courses described in Drafting I.

RECOMMENDED TASKS FOR ARCHITECTURAL DRAFTING  
(1979-1980)

From V-TEC Catalog, Architectural Drafting

Vocational education (secondary) instructors in South Carolina reviewed the V-TEC Catalog, Architectural Drafter, developed by Maryland State Department of Education in 1979, and revised it for use in South Carolina's secondary level drafting training in the architectural option.

Architectural drafting tasks more appropriate for post-secondary training were identified and remaining tasks in the V-TEC Catalog were listed as representing a foundation to architectural drafting training at the secondary level.

The recommended tasks for secondary drafting instruction include:

1. Sketch preliminary site layout.
2. Sketch preliminary site plan layouts.
3. Sketch preliminary site elevations.
4. Sketch preliminary site section.
5. Draw plot plans.
6. Check site and plot plans.
7. Draw floor plan.
8. Reproduce common plan features.
9. Draw basement plan.
10. Draw foundation plan.
11. Draw framing plan.
12. Check plan dimensions.
13. Draw foundation sections.
14. Draw floor sections.
15. Draw typical wall sections.
16. Draw attic sections.
17. Draw stair sections.
18. Dimensions section drawings.
19. Check section drawing.
20. Draw exterior elevations.
21. Draw interior elevations.
22. Check elevation drawings.
23. Dimension plans.
24. Add title block information to drawings.
25. Indicate on plans the location of section views.
26. Draw door and window schedules.
27. Draw finish schedule.
28. Draw architectural plans.

This recommended list of architectural drafting tasks has been included in the development of Module 7.0, Architectural Drafting, Performance-based Instruction Guide for Drafting II.

DRAFTING II  
ARCHITECTURAL DRAFTING  
SUGGESTED INSTRUCTION TIME

<u>DRAFTING II</u> <u>UNIT/TASK</u>	<u>SUGGESTED</u> <u>HOURS</u>
Unit 7.0	
7.01 Introduction to Architectural Drafting	3
7.02 Architectural Lettering	3
7.03 Architectural Symbols	10
7.04 Interpret Basic Surveying of Site; Search and Verify Title and Deed	9
7.05 Residential Site Planning Consideration	5
7.06 Draw Plot Plans	9
7.07 Draw Floor Plans	60
7.08 Draw Foundation Plans	30
7.09 Draw Basement Plans	*
7.10 Draw Piers, Columns, and Pilasters	*
7.11 Sketch and Draw Exterior Elevations	15
7.12 Draw Interior Elevations and Details	6
7.13 Draw Framing Plans	6
7.14 Draw Typical Wall Sections	6
7.15 Draw Roof Sections	3
7.16 Draw Stair Sections	9
7.17 Draw Fireplace/Chimney Sections	6
7.18 Design and Draw Door and Window Schedules	6
7.19 Draw Schedules	15
7.20 Check Drawings, Plans, and Specifications	<u>3</u>

- 7.21 Build Presentation Models
- 7.22 Draw New Residential Construction Working Drawings
- 7.23 Identify Key Parts of Contractual Specifications

SUGGESTED TOTAL HOURS 270  
(Balance of second year available for additional option study.)

\*Time combined with related task.

\*\*Optional

TASK LISTINGS  
DRAFTING II

UNIT/TASK

DESCRIPTION

Unit 7.0

- 7.01 (Introduction to Architectural Drafting) Given an introduction to architectural drafting, describe the job of the architectural draftsman to the standards of the instructor. State the importance of the work of the architectural draftsman to the satisfactory completion of residential or light commercial building.
- 7.02 (Architectural Lettering) Given introduction in lettering for architectural drafting, perform architectural lettering to the quality expected of an entry level draftsman in an architect's office.
- 7.03 (Architectural Symbols) Given an introduction to architectural symbols, appropriate references, and practical assignment, read and properly draw commonly used symbols, and use architectural symbols to abbreviate properly in drawings to the instructor's standards.
- 7.04 (Interpret Basic Surveying of Site; Search and Verify Title and Deed) Given instructions concerning basic surveying, method of searching title and deed, surveying equipment and instrument, additional helper for surveying; search and verify title and deed and interpret survey of site, surveying site as needed.
- 7.05 (Residential Site Planning Considerations) Given an introduction to residential site layout, plot planning, and considerations that influence the location of a given residential structure on an existing site; using an existing site plan, survey drawing, or written legal description--sketch the layout of the site to the instructor's standards applying the rules of good architectural drafting.
- 7.06 (Draw Plot Plans) Given a survey drawing, a written legal description, drafting equipment; draw a plot plan.
- 7.07 (Draw Floor Plans) Given architectural design data, preliminary plan layouts, and architectural drafting equipment; draw floor plans for a given residential structure. The floor plan must communicate the intended information to a user.  
(ALTERNATE) Given a problem situation, solve floor plan design problems.

- 7.08 (Draw Foundation Plans) Given architectural/engineering design data, floor plan, sketches, drafting equipment; draw foundation plan. The plan must communicate the intended information to the user.
- 7.09 (Draw Basement Plans) Given architectural/engineering design data, floor plan, sketches, architectural drafting equipment; draw a basement plan for a residential structure.
- 7.10 (Draw Piers, Columns, and Pilasters) Upon completion of instructions, given drafting instruments and a typical architectural drafting assignment, draw correctly piers, columns, and pilasters, to the standards of the instructor and meet required specifications or standards.
- 7.11 (Sketch and Draw Exterior Elevations) Given a plot plan, floor plan, specifications, foundation plans, basic exterior design, wall section, sketch of preliminary elevations, and drafting equipment; draw exterior elevations.
- 7.12 (Draw Interior Elevations and Details) Given a floor plan, list of materials, specifications, supply catalogs, and architectural drafting equipment; draw the interior elevations, and details.
- 7.13 (Draw Framing Plans) Given working drawings, engineering design data sketches, and drafting equipment; draw a framing plan.
- 7.14 (Draw Typical Wall Sections) Given a plan and specifications, and architectural drafting equipment; draw a typical wall section.
- 7.15 (Draw Roof Sections) Given a plan and specifications and drafting equipment; draw an attic section.
- 7.16 (Draw Stair Sections) Given a plan and specifications, and drafting equipment; draw a stair section.
- 7.17 (Draw Fireplace/Chimney Sections) Given a plan and specifications; draw a fireplace and chimney.
- 7.18 (Design and Draw Door and Window Schedules) Given specific programs requirements concerning doors and windows and drafting equipment; draw door and window schedules.
- 7.19 (Draw Schedules) Given a set of architectural plans, interior elevations, and specifications and program requirements, and architectural drafting equipment; draw required schedules.
- 7.20 (Check Drawings, Plans, and Specifications) Given site and plot plan, list of specifications, list of specific requirements, and features, and a copy of local building codes; check site and plot plan, correcting all errors and omissions.

Given plans, specifications, and check prints of exterior and interior elevations; check elevations for line quality, symbolizing, dimensions, neatness, and equipment of special features called for in specifications.

Given architectural/engineering notes, sketches, design data and client requirements; check plans and specifications.

- 7.21 (Build Presentation Models) Given preliminary design drawings, specific instruction, necessary drafting equipment including scale, cutting tool, metal straightedge, adhesive, and matboard; build a presentation model.
- 7.22 (Draw New Residential Construction Working Drawings) Given existing information and showings for a particular residence, decide whether or not it provides appropriate information for the builder. Obtain and provide any necessary additional information.
- 7.23 (Identify Key Parts of Contractual Specifications) Given instructions; demonstrate the ability to differentiate between codes, specifications, and contract documents; state their purposes, provisions, general format, parts, administration, and responsible agencies for enforcement with at least 70 percent accuracy.

UNIT 7.0 FUNDAMENTALS OF ARCHITECTURAL  
DRAFTING, DRAFTING II, (Option)

TASK 7.01 INTRODUCTION TO ARCHITECTURAL  
DRAFTING

---

PERFORMANCE OBJECTIVE:

Given an introduction to architectural drafting, describe the job of the architectural draftsman to the standards of the instructor. State the importance of the work of the architectural draftsman to the satisfactory completion of residential or light commercial buildings.

PERFORMANCE ACTIONS:

- 7.0101 Identify similarities and differences between architectural drafting and basic drafting techniques.
- 7.0102 Describe the role of the architectural draftsman in the drafting team. Indicate how the architectural draftsman's role differs from the architects, mechanical engineers, etc.
- 7.0103 State the typical duties of the architectural draftsman.
- 7.0104 Identify architectural drafting as a career choice.

PERFORMANCE STANDARDS:

- Describe or identify the job of the architectural draftsman to the standards of the instructor, obtaining a minimum of 90 percent accuracy on knowledge tests.

SUGGESTED INSTRUCTION TIME: 3 Hours

RELATED TECHNICAL INFORMATION:

- Duties of the architect in residential construction or light commercial construction.
- Duties of the mechanical engineer in residential or light commercial construction.
- Duties of the electrical engineer and others in residential or light commercial construction.



UNIT 7.0

FUNDAMENTALS OF ARCHITECTURAL  
DRAFTING, DRAFTING II, (Option)

TASK 7.02

ARCHITECTURAL LETTERING

---

PERFORMANCE OBJECTIVE:

Given introduction in lettering for architectural drafting, perform architectural lettering to the quality expected of an entry level draftsman in an architect's office.

PERFORMANCE ACTIONS:

- 7.0201 Describe importance of lettering in architectural drafting.
- 7.0202 Identify basic types of lettering styles typical in architectural drafting and demonstrate mastery of those styles.
- 7.0203 Indicate the similarities and differences between engineering lettering and architectural lettering.
- 7.0204 Develop and demonstrate lettering techniques suitable for qualification for employment in architectural drafting.

PERFORMANCE STANDARDS:

- Able to use typical architectural lettering techniques to a competency level expected for entry level employment in the typical architect's office, as interpreted by the instructor.

SUGGESTED INSTRUCTION TIME: 3 Hours.

RELATED TECHNICAL INFORMATION:

- Mechanical drafting lettering techniques.
- Architectural letter styles.
- Pressure sensitive lettering and letter devices.
- Spacing.

UNIT 7.0

FUNDAMENTALS OF ARCHITECTURAL  
DRAFTING, DRAFTING II, (Option)

TASK 7.03

ARCHITECTURAL SYMBOLS

PERFORMANCE OBJECTIVE:

Given an introduction to architectural symbols, appropriate references, and practical assignment, read and properly draw commonly used symbols, and use architectural symbols to abbreviate properly in drawings to the instructor's standards.

PERFORMANCE ACTIONS:

- 7.0301 State the purpose and necessity for architectural symbols.
- 7.0302 Describe why standardization of symbols and abbreviations is necessary.
- 7.0303 Identify the standard symbols and abbreviation for architectural drafting.
- 7.0304 Correctly draw symbols and apply abbreviations. Use symbols for:
- |                       |               |
|-----------------------|---------------|
| a. Building materials | e. Plumbing   |
| b. Walls              | f. Kitchen    |
| c. Floors             | g. Heating    |
| d. Electrical         | h. Elevations |

PERFORMANCE STANDARDS:

- Able to apply symbols and abbreviations typical to architectural drafting to practical exercises with 100 percent accuracy and meeting instructor's standards. Minimum of 90 percent accuracy knowledge tests.

SUGGESTED INSTRUCTION TIME: 10 Hours

RELATED TECHNICAL INFORMATION:

- Construction terminology.
- Building material terminology and product identification.

UNIT 7.0

FUNDAMENTALS OF ARCHITECTURAL  
DRAFTING, DRAFTING II, (Option)

TASK 7.04

INTERPRET BASIC SURVEYING OF SITE;  
SEARCH AND VERIFY TITLE AND DEED

---

---

PERFORMANCE OBJECTIVE:

Given instructions concerning basic surveying, method of searching title and deed, surveying equipment and instrument, additional helper for surveying; search and verify title and deed and interpret survey of site, surveying site as needed.

PERFORMANCE ACTIONS:

- 7.0401 Define and interpret survey terms.
- 7.0402 Identify surveyor's duties.
- 7.0403 Use surveying equipment to measure distance and angles.
- 7.0404 Perform a land survey of the construction site.
- 7.0405 Draw property lines from legal descriptions.
- 7.0406 Perform user maintenance and care of surveying equipment.
- 7.0407 Search and verify site deed.

PERFORMANCE STANDARDS:

- Perform survey tasks within accepted error limits for entry level drafter in architectural office.
- Uses and maintains equipment properly.
- Performs deed and title search as prescribed.
- Calculations 80 percent accurate.
- Demonstrates ability to use terms, definitions, and symbols with 80 percent accuracy.
- Executes drawings neatly and accurately in a professional manner.

SUGGESTED INSTRUCTION TIME: 9 Hours

RELATED TECHNICAL INFORMATION:

- Reading evaluations.

SUGGESTED: Field trip to Block Book Room, County Court House.

UNIT	7.0	FUNDAMENTALS OF ARCHITECTURAL DRAFTING, DRAFTING II, (Option)
TASK	7.05	RESIDENTIAL SITE PLANNING CONSIDERATIONS

PERFORMANCE OBJECTIVE:

Given an introduction to residential site layout, plot planning, and consideration that influence the location of a given residential structure on an existing site; using an existing site plan, survey drawing, or written legal description--sketch the layout of the site to the instructor's standards applying the rules of good architectural drafting.

PERFORMANCE ACTIONS:

- 7.0501 Use terms associated with site selection.
- 7.0502 Review neighborhood factors:
  - a. Facilities
  - b. Physical features
  - c. Local ordinances
  - d. Restrictions
- 7.0503 Research community considerations:
  - a. Zoning restrictions which influence the election of a building site
  - b. Review protective covenants
- 7.0504 Sketch the layout of the site.
- 7.0505 Review design data, note site and house relationship.
- 7.0506 Scale and block-out boundaries and site features.
- 7.0507 Layout structure on site.
- 7.0508 Note natural and physical limitations.
- 7.0509 Indicate modifications of any existing site elevations.
- 7.0510 Indicate desired landscaping.

PERFORMANCE STANDARDS:

- Mastery will be evidenced by scoring a minimum of 85 percent on knowledge tests of terminology and considerations that influence site selection. The site layout sketch must be drawn

UNIT 7.0

FUNDAMENTALS OF ARCHITECTURAL  
DRAFTING, DRAFTING II, (Option)

TASK 7.05

RESIDENTIAL SITE PLANNING  
CONSIDERATIONS (Con't.)

---

---

PERFORMANCE STANDARDS (Con't.):

applying the rules of good architectural drafting and must indicate to the instructor a competency level as expected for entry level into architectural drafting office.

SUGGESTED INSTRUCTION TIME: 5 Hours

RELATED TECHNICAL INFORMATION:

- Sources of data concerning neighborhoods and communities.
- Zoning codes and regulations.
- Ordinances and restrictions.
- Searching title and deed.

UNIT 7.0

FUNDAMENTALS OF ARCHITECTURAL  
DRAFTING, DRAFTING II (Option)

TASK 7.06

DRAW PLOT PLANS

---

PERFORMANCE OBJECTIVE:

Given a survey drawing, a written legal description, drafting equipment; draw a plot plan.

PERFORMANCE ACTIONS:

- 7.0601 Continue previous tasks as applicable.
- 7.0602 Select the most advantageous location and position for the structure.
- 7.0603 Place the structure on the site.
- 7.0604 Draw supplementary construction extending beyond the exterior walls of the structure.
- 7.0605 Indicate recreational areas.
- 7.0606 Determine and indicate locations of exterior circulatory features.
- 7.0607
  - a. Draw existing and proposed contour lines and indicate grade elevations.
  - b. Calculate cut and fill requirements and draw profile of site.
- 7.0608 Indicate water drainage and storage systems.
- 7.0609 Locate existing and proposed utilities.
- 7.0610 Note existing natural features.
- 7.0611 Indicate modifications of any existing site elements.
- 7.0612 Dimension boundaries of site and give bearing.
- 7.0613 Dimension exterior limits of structure and supplementary construction.
- 7.0614 Indicate construction materials.
- 7.0615 Locate and dimension easements and establish setbacks.

UNIT 7.0

FUNDAMENTALS OF ARCHITECTURAL  
DRAFTING, DRAFTING II, (Option)

TASK 7.06

DRAW PLOT PLANS (Con't.)

---

PERFORMANCE ACTIONS (Con't.):

- 7.0616 Indicate existing and proposed landscape features.
- 7.0617 Indicate north arrow.
- 7.0618 Add border lines and title block information.
- 7.0619 Check plans.

PERFORMANCE STANDARDS:

- Executes drawings neatly and accurately in a professional manner.
- Demonstrates ability to correctly use terminology and symbols with 80 percent accuracy.

SUGGESTED INSTRUCTION TIME: 9 Hours

RELATED TECHNICAL INFORMATION:

- Prepare plans to compensate for problems that surface during site evaluation and other subsequent actions that are site related.

UNIT 7.0

FUNDAMENTALS OF ARCHITECTURAL  
DRAFTING, DRAFTING II, (Option)

TASK 7.07

DRAW FLOOR PLANS

---

PERFORMANCE OBJECTIVE:

Given architectural design data, preliminary plan layouts, and architectural drafting equipment; draw floor plan for a given residential structure. The floor plan must communicate the intended information to a user. (ALTERNATE) Given a problem situation, solve floor plan design problems.

PERFORMANCE ACTIONS:

- 7.0701 Review preliminary sketches and notes.
- 7.0702 Layout exterior limits of the structure.
- 7.0703 Layout rooms and interior walls.
- 7.0704 Indicate interior circulatory features.
- 7.0705 Draw kitchen and bathroom features.
- 7.0706 Locate openings in exterior and interior walls.
- 7.0707 Indicate supplementary constructions extending beyond the exterior walls of the structure.
- 7.0708 Determine water drainage and storage systems.
- 7.0709 Indicate utilities.
- 7.0710 Add dimensions, notes, and references.
- 7.0711 \*Indicate section lines.
- 7.0712 Draw material symbols.
- 7.0713 Check drawing.

ALTERNATE--In a given floor plan design problem, consider:

- 7.0701 Traffic circulation.
- 7.0702 Orientation for solar, wind, view, etc., considerations.
- 7.0703 Privacy in living area.



UNIT	7.0	FUNDAMENTALS OF ARCHITECTURAL DRAFTING, DRAFTING II, (Option)
TASK	7.07	DRAW FLOOR PLANS (Con't.)

---

---

PERFORMANCE ACTIONS (Con't.)

- 7.0704 Arrangement of room furnishings.
- 7.0705 Flexibility for expansion.
- 7.0706 Openings: Door, window, etc.

PERFORMANCE STANDARDS:

- Based on given data, solve problems of design using rules of good architectural design. Eighty-five percent mastery of knowledge tests.
- Drawings must meet instructor's criteria for entry level competency in an architectural office.
- Able to justify, to instructor's satisfaction, design or redesign of floor plan.

SUGGESTED INSTRUCTION TIME: 60 Hours

RELATED TECHNICAL INFORMATION:

- Solor, wind, view, etc., considerations.

UNIT	7.0	FUNDAMENTALS OF ARCHITECTURAL DRAFTING, DRAFTING II, (Option)
TASK	7.08	DRAW FOUNDATION PLANS

---

---

PERFORMANCE OBJECTIVE:

Given architectural/engineering design data, floor plan, sketches, drafting equipment; draw foundation plan. The plan must communicate the intended information to the user.

PERFORMANCE ACTIONS:

- 7.0801 Review the floor plan, sketches, and notes.
- 7.0802 Trace common features from floor plan.
- 7.0803 Locate and draw structural supports.
- 7.0804 Draw foundation details and sections.
- 7.0805 Outline foundation construction extending beyond the exterior walls.
- 7.0806 Add dimensions.
- 7.0807 Indicate labels, notes, and symbols.
- 7.0808 Check drawing.

PERFORMANCE STANDARDS:

- Drawings must be to standards required by the instructor, apply rules of good architectural drafting, with correct details, and correct dimensioning.

SUGGESTED INSTRUCTION TIME: 30 Hours (Total for basements and foundations)

RELATED TECHNICAL INFORMATION:

- Identify frost line information for the area.
- Interpret concrete specifications.

UNIT 7.0

FUNDAMENTALS OF ARCHITECTURAL  
DRAFTING, DRAFTING II, (Option)

TASK 7.09

DRAW BASEMENT PLANS

---

PERFORMANCE OBJECTIVE:

Given architectural/engineering design data, floor plan, sketches, architectural drafting equipment; draw a basement plan for a residential structure.

PERFORMANCE ACTIONS:

- 7.0901 Review the floor plan, preliminary sketches, and notes.
- 7.0902 Trace common features from the floor plan.
- 7.0903 Locate and draw structural supports.
- 7.0904 Draw interior walls.
- 7.0905 Locate openings in exterior walls.
- 7.0906 Locate openings in interior walls.
- 7.0907 Indicate utilities.
- 7.0908 Determine water drainage and storage systems.
- 7.0909 Add labels, notes and dimensions.
- 7.0910 Indicate material symbols.
- 7.0911 Check drawing.

PERFORMANCE STANDARDS:

- Drawing must exhibit rules of good architectural drafting, with correct dimensioning.

SUGGESTED INSTRUCTION TIME: \*See Foundations

RELATED TECHNICAL INFORMATION:

- Identify basement waterproofing techniques.
- Describe methods used to combat termites.
- Describe typical methods of correcting basement water leaking due to faults in structure or percolation.

UNIT 7.0

FUNDAMENTALS OF ARCHITECTURAL  
DRAFTING, DRAFTING II, (Option)

TASK 7.10

DRAW PIERS, COLUMNS, AND PILASTERS

---

PERFORMANCE OBJECTIVE:

Upon completion of instruction, given drafting instruments and a typical architectural drafting assignment, draw correctly piers, columns, and pilasters, to the standards of the instructor and meet required specifications or standards.

PERFORMANCE ACTIONS:

- 7.1001 Distinguish between piers and columns.
- 7.1002 Discuss pier design.
- 7.1003 Discuss the use of pilasters:  
High or long wall use.
- 7.1004 Draw piers, indicating actual sizes and spacing for project.
- 7.1005 Draw columns.
- 7.1006 Draw pilasters and indicate the dimensions of a pilaster of poured concrete.

PERFORMANCE STANDARDS:

- Drawing must exhibit rules of good architectural drafting, with correct dimensioning.

SUGGESTED INSTRUCTION TIME: \*See Foundations

RELATED TECHNICAL INFORMATION:

- Foundations.
- Pier materials.
- Curtain walls.
- Poured concrete specifications.

UNIT 7.0

FUNDAMENTALS OF ARCHITECTURAL  
DRAFTING, DRAFTING II, (Option)

TASK 7.11

SKETCH AND DRAW EXTERIOR ELEVATIONS

---

PERFORMANCE OBJECTIVE:

Given a plot plan, floor plan, specifications, foundation plans, basic exterior design, wall section, sketch of preliminary elevations, and drafting equipment; draw exterior elevations.

PERFORMANCE ACTIONS:

- 7.1101 Review design data and layouts.
- 7.1102 Indicate footings.
- 7.1103 Indicate foundations walls.
- 7.1104 Show grade line.
- 7.1105 Indicate finished floor line.
- 7.1106 Indicate ceiling and window level.
- 7.1107 Indicate supplementary structural penetrations.
- 7.1108 Sketch and draw exterior elevations.

PERFORMANCE STANDARDS:

- Drawings must be to the instructor's standards.
- Rules of good architectural practices apply.

SUGGESTED INSTRUCTION TIME: 15 Hours

RELATED TECHNICAL INFORMATION:

- Building materials.
- Construction process.
- Architectural style.

UNIT 7.0 FUNDAMENTALS OF ARCHITECTURAL  
DRAFTING, DRAFTING II, (Option)

TASK 7.12 DRAW INTERIOR ELEVATIONS AND DETAILS

---

---

PERFORMANCE OBJECTIVE:

Given a floor plan, list of materials, specifications, supply catalogs, and architectural drafting equipment; draw the interior elevations, and details.

PERFORMANCE ACTIONS:

- 7.1201 Review design data and layouts.
- 7.1202 Indicate true width of walls.
- 7.1203 Indicate all openings in interior or exterior walls.
- 7.1204 Indicate true height or width of openings.
- 7.1205 Indicate typical elevations of millwork.
- 7.1206 Call out wall materials.
- 7.1207 Indicate air circulatory systems.
- 7.1208 Indicate utilities.
- 7.1209 Indicate trim and molding.
- 7.1210 Show typical building section and other details as required.

PERFORMANCE STANDARDS:

- Use good architectural practices in drawing interior elevations.
- Instructor's standards.

SUGGESTED INSTRUCTION TIME: 6 Hours

RELATED TECHNICAL INFORMATION:

- Specifications.
- Building construction materials.
- Supply catalogs.
- Floor plans.

UNIT

7.0

FUNDAMENTALS OF ARCHITECTURAL  
DRAFTING, DRAFTING II, (Option)

TASK

7.13

DRAW FRAMING PLANS

---

PERFORMANCE OBJECTIVE:

Given working drawings, engineering design data sketches, and drafting equipment, draw a framing plan.

PERFORMANCE ACTIONS:

- 7.1301 Review working drawings, sketches, notes, and engineering data.
- 7.1302 Trace major exterior bearing walls.
- 7.1303 Locate and draw structural supports.
- 7.1304 Draw joists and headers.
- 7.1305 Locate and draw ridge boards.
- 7.1306 Locate and draw rafters and trusses.
- 7.1307 Locate and draw double headers and trimmers.
- 7.1308 Indicate location of blocking/bridging.

PERFORMANCE STANDARDS:

- Frame drawings must be to acceptable building standards.
- Drawings must be acceptable to instructor.

SUGGESTED INSTRUCTION TIME: 6 Hours

RELATED TECHNICAL INFORMATION:

- Building codes.
- Material specification.

UNIT 7.0

FUNDAMENTALS OF ARCHITECTURAL  
DRAFTING, DRAFTING II, (Option)

TASK 7.14

DRAW TYPICAL WALL SECTIONS

---

PERFORMANCE OBJECTIVE:

Given a plan and specifications, and architectural drafting equipment, draw a typical wall section.

PERFORMANCE ACTIONS:

- 7.1401 Review design data, layouts, select scale.
- 7.1402 Confirm the size and type of exterior wall openings.
- 7.1403 Indicate the size and type of floor materials.
- 7.1404 Show proper coursing of wall materials.
- 7.1405 Indicate elevations.
- 7.1406 Draw the waterproofing and flashing above and below wall openings.
- 7.1407 Indicate method of insulating the wall.
- 7.1408 Indicate termite shield.
- 7.1409 Call out wall finish.
- 7.1410 Indicate cutting plane lines on the plan view.
- 7.1411 Add dimensions and notes.

PERFORMANCE STANDARDS:

- Instructor's standards.

SUGGESTED INSTRUCTION TIME: 6 Hours



UNIT	7.0	FUNDAMENTALS OF ARCHITECTURAL DRAFTING, DRAFTING II, (Option)
TASK	7.15	DRAW ROOF SECTIONS

---

---

PERFORMANCE OBJECTIVE:

Given a plan and specifications and drafting equipment, draw an attic section.

PERFORMANCE ACTIONS:

- 7.1501 Review design data and select scale.
- 7.1502 Confirm the size of major elements and the slope of the roof.
- 7.1503 Show the method of securing the ceiling joists and roof rafters to the supporting wall.
- 7.1504 Draw the type and show the placement of bridging between joists.
- 7.1505 Show the insulation at the proper thickness, type, and placement.
- 7.1506 Show the roof construction, the over hang, gutter location, and the method of ventilation.
- 7.1507 Indicate cutting plane lines on the plan view.
- 7.1508 Add dimensions and notes.
- 7.1509 Check drawing.

PERFORMANCE STANDARDS:

- Instructor's standards.

SUGGESTED INSTRUCTION TIME: 3 Hours

UNIT 7.0

FUNDAMENTALS OF ARCHITECTURAL  
DRAFTING, DRAFTING II, (Option)

TASK 7.16

DRAW STAIR SECTIONS.

---

---

PERFORMANCE OBJECTIVE:

Given a plan and specifications, and drafting equipment; draw a stair section.

PERFORMANCE ACTIONS:

- 7.1601 Review plan and select scale.
- 7.1602 Confirm the floor-to-floor heights.
- 7.1603 Draw floor and ceiling lines.
- 7.1604 Calculate and layout risers, treads, and landings.
- 7.1605 Draw carriage and stringer.
- 7.1606 Indicate framing around stairs.
- 7.1607 Call out materials used to construct stairs.
- 7.1608 Indicate safety features.
- 7.1609 Indicate trim features.
- 7.1610 Indicate total run and rise.
- 7.1611 Call out stairwell opening.
- 7.1612 Show line of flight and indicate headroom clearance.
- 7.1613 Indicate width of stairs.
- 7.1614 Indicate structural reinforcements.
- 7.1615 Ensure consideration of requirements for the handi-capped (if non-residential).
- 7.1616 Add notes and dimensions.
- 7.1617 Indicate cutting plane line on the plan view.
- 7.1618 Check drawing.

UNIT 7.0

FUNDAMENTALS OF ARCHITECTURAL  
DRAFTING, DRAFTING II, (Option)

TASK ~~7.16~~ 7.16

DRAW STAIR SECTIONS (Con't.)

---

PERFORMANCE STANDARDS:

- Tread risers and slopes must be reasonably within standards.
- To instructor's standards.

SUGGESTED INSTRUCTION TIME: 9 Hours

UNIT 7.0

FUNDAMENTALS OF ARCHITECTURAL  
DRAFTING, DRAFTING II, (Option)

TASK 7.17

DRAW FIREPLACE/CHIMNEY/SECTIONS

---

---

PERFORMANCE OBJECTIVE:

Given a plan and specifications; draw a fireplace and chimney.

PERFORMANCE ACTIONS:

- 7.1701 Review design data and select scale.
- 7.1702 Confirm the type, size, and location of the fireplace and chimney.
- 7.1703 Show the proper material and extension of the hearth.
- 7.1704 Indicate firebrick.
- 7.1705 Determine chimney and lining size.
- 7.1706 Show mantel, ductwork, cleanout, and damper.
- 7.1707 Show finished trim.
- 7.1708 Indicate cutting plane line on the plan view.
- 7.1709 Add notes and dimensions.
- 7.1710 Check drawing.

PERFORMANCE STANDARDS:

- Instructor's standards.
- Good architectural practices.

SUGGESTED INSTRUCTION TIME: 6 Hours

RELATED TECHNICAL INFORMATION:

- SUGGESTED: Field trip to masonry class in vocational center or technical college for the purpose of observing actual construction of fireplaces (fireplaces possibly designed by drafting students).

UNIT 7.0

FUNDAMENTALS OF ARCHITECTURAL  
DRAFTING, DRAFTING II, (Option)

TASK 7.18

DESIGN AND DRAW DOOR AND WINDOW  
SCHEDULES

---

---

PERFORMANCE OBJECTIVE:

Given specific program requirements concerning doors and windows and drafting equipment; draw door and window schedules.

PERFORMANCE ACTIONS:

- 7.1801 Collect notes and symbols pertaining to the schedules.
- 7.1802 Make headings for window schedule.
- 7.1803 Make headings for door schedule.
- 7.1804 Layout schedules for the available space.
- 7.1805 Layout lettering guidelines.
- 7.1806 Letter schedules.
- 7.1807 Check for accuracy.

PERFORMANCE STANDARDS:

- Schedules will appear on the same pages(s) in parallel columns.
- To instructor's standards.

SUGGESTED INSTRUCTION TIME: 6 Hours

UNIT 7.0

FUNDAMENTALS OF ARCHITECTURAL  
DRAFTING, DRAFTING II, (Option)

TASK 7.19

DRAW SCHEDULES

---

PERFORMANCE OBJECTIVE:

Given a set of architectural plans, interior elevations, and specifications and program requirements, and architectural drafting equipment; draw required schedules.

PERFORMANCE ACTIONS:

- 7.1901 Collect information from plans, elevations and specifications for plumbing, electrical, hardware and finish schedules.
- 7.1902 Make a set of headings for each schedule.
- 7.1903 Layout schedule to fit the given location.
- 7.1904 Provide key for abbreviation explanation.
- 7.1905 Check for accuracy.

PERFORMANCE STANDARDS:

- Instructor's standards.

SUGGESTED INSTRUCTION TIME: 15 Hours

RELATED TECHNICAL INFORMATION:

- Sweet's Catalog.
- Vendor Publications.

UNIT 7.0

FUNDAMENTALS OF ARCHITECTURAL  
DRAFTING,  
DRAFTING II, (Optional)

TASK 7.20

CHECK DRAWINGS, PLANS, AND  
SPECIFICATIONS

---

PERFORMANCE OBJECTIVES:

Given site and plot plan, list of specifications, list of specific requirements and features, and a copy of local building codes; check site and plot plan, correcting all errors and omissions.

Given plans, specifications, and check prints of exterior and interior elevations; check elevations for line quality, symbolizing, dimensions, neatness, and equipment of special features called for in specifications.

Given architectural/engineering notes, sketches, design data and client requirements; check plans and specifications.

PERFORMANCE ACTIONS:

7.2001

Check site and plot plans:

- a. Review design data, local codes, and regulations.
- b. Check boundaries and site features.
- c. Check location of structures on site.
- d. Check layout of recreational areas.
- e. Check contour lines and elevations.
- f. Check water drainage and storage systems.
- g. Check natural and physical limitations.
- h. Check circulatory features.
- i. Check modifications of existing site elements.
- j. Check utilities.
- k. Check legal description of property.
- l. Check labels, notes, and dimensions.

7.2002

Check elevation drawings:

- a. Check dimensions, labels, and notes.
- b. Check grade, floor, and ceiling lines.
- c. Check schedules.
- d. Check footing and foundation lines.
- e. Check roof slope, symbol and call out of material.
- f. Check cutting plane lines and detail identifications.

NOTE: For additional performance actions see the V-TEC catalog, Architectural Draftsman.

UNIT	7.0	FUNDAMENTALS OF ARCHITECTURAL DRAFTING, DRAFTING II, (Optional)
TASK	7.20	CHECK DRAWINGS, PLANS, AND SPECIFICATIONS

---

---

PERFORMANCE ACTIONS (Con't.):

- 7.2003 Check architectural plans and specifications:
- a. Compare plan with notes, sketches, design, and specifications (requirements) architect's/engineer's or given data.
  - b. Check and verify dimensions.
  - c. Check and verify notes, lettering, and references.
  - d. Check architectural conventions and symbols.
  - e. Check and verify title block information.
  - f. Check plan for line quality and reproducibility.

PERFORMANCE STANDARDS:

- The findings of the checker (student) must concur with the findings of the instructor.

SUGGESTED INSTRUCTION TIME: 3 Hours



UNIT 7.0

FUNDAMENTALS OF ARCHITECTURAL  
DRAFTING, DRAFTING II, (Option)

TASK 7.21 (Optional)

BUILD PRESENTATION MODELS

---

PERFORMANCE OBJECTIVE:

Given preliminary design drawings, specific instruction, necessary drafting equipment including scale, cutting tool, metal straightedge, adhesive, and matboard; build a presentation model.

PERFORMANCE ACTIONS:

- 7.2101 Review model specifications and requirements.
- 7.2102 Layout boards to be used at large work station.
- 7.2103 Cut a large, solid section of material to be used as the base.
- 7.2104 Draw the plan of the building on the top of the base.
- 7.2105 Layout the shape of the walls, roof, and floor surfaces of the proposed project onto the boards.
- 7.2106 Cut out the shapes from the boards.
- 7.2107 Cut out any wall openings on the individual shapes.
- 7.2108 Assemble model elements.
- 7.2109 Add surface materials.
- 7.2110 Add title, north arrow, and graphic scale.
- 7.2111 Add periphery embellishments.

PERFORMANCE STANDARDS:

- Instructor's standards.
- To given scale.

SUGGESTED INSTRUCTION TIME: Optional

UNIT 7.0

FUNDAMENTALS OF ARCHITECTURAL  
DRAFTING, DRAFTING II, (Option)

TASK 7.22 (Optional)  
(ACCELERATED STUDENTS)

DRAW NEW RESIDENTIAL CONSTRUCTION  
WORKING DRAWINGS

PERFORMANCE OBJECTIVE:

Given existing information and showings for a particular residence, decide whether or not it provides appropriate information for the builder. Obtain and provide any necessary additional information.

PERFORMANCE ACTIONS:

- 7.2201 Describe the purpose and order of working drawings.
- 7.2202 Select correct sheet size for working drawings.
- 7.2203 Layout working drawings.
- 7.2204 Identify points of emphasis of working drawings.
- 7.2205 Use correctly symbols and conventions for construction materials and construction views shown in detail drawings, by referring to Sweets Catalogs, AIA Manuals, and/or other technical references for information.
- 7.2206 Prepare final working drawings for:
- |                    |  |
|--------------------|--|
| a. Floor plans     | g. Plumbing plan                       |
| b. Elevations      | h. Foundations plan                    |
| c. Sections        | i. Schedules and miscellaneous details |
| d. Details         |  |
| e. Mechanical plan | j. Site plan and title sheet           |
| f. Electrical plan |  |

PERFORMANCE STANDARDS:

- Task performed within time limits considered to be acceptable for initial employment job qualification.
- Meets instructor's standards.
- Lettering and drafting skills should show neatness, accuracy, consistency, proper placement, and character.
- Draws working drawings correctly, meeting entry level employment requirements for an architectural drafting office.

SUGGESTED INSTRUCTION TIME: Optional

UNIT 7.0

FUNDAMENTALS OF ARCHITECTURAL  
DRAFTING, DRAFTING II, (Option)

TASK 7.23 (Optional)

IDENTIFY KEY PARTS OF CONTRACTUAL  
SPECIFICATIONS

---

PERFORMANCE OBJECTIVE:

Given instructions, a set of specifications for a residential construction; demonstrate the ability to differentiate between codes, specifications, and contract documents; state their purposes, provisions, general format, parts, administration, and responsible agencies for enforcement with at least 70 percent accuracy.

NOTE: This is an orientation task.

PERFORMANCE ACTIONS:

- 7.2301 Identify CONTRACTUAL DIVISION of specification:
- a. Provisions and procedures for contract advertisement.
  - b. Provisions for instruction to bidders.
  - c. Provisions for contract proposal procedures.
  - d. Provisions for general conditions.
  - e. Provisions for amendments to general conditions.
  - f. Provisions for contract supplementary general conditions and definition procedures for general requirements of the project.
- 7.2302 State types of contract documents to include:
- a. Contract agreements.
  - b. Performance bonds.
  - c. Insurance policies.
- 7.2303 Identify purpose and content of specifications:
- a. General contract specifications.
  - b. Format and outline for specifications.
  - c. Outlines of typical specifications.
- 7.2304 List or match the parts of contract specifications to include:
- a. Title page.
  - b. Table of contents.
  - c. Contractual or bidding requirements.
  - d. General contract.
  - e. Mechanical specifications (plumbing, heating, and refrigeration).
  - f. Electrical contracts.
  - g. Special separate contracts (special equipment, sewage disposal, water system, site utilities, etc.).
  - h. Addendum (purpose and format).

UNIT 7.0

FUNDAMENTALS OF ARCHITECTURAL  
DRAFTING, DRAFTING II, (Option)

TASK 7.23 (Optional)

IDENTIFY KEY PARTS OF CONTRACTUAL  
SPECIFICATIONS (Con't.)

---

---

PERFORMANCE ACTIONS (Con't.):

- 7.2305 Identify the agencies responsible for building code enforcement to include:
- a. Local.
  - b. State.
  - c. Federal.
  - d. Zoning.
  - e. Building inspector, health department, etc.

PERFORMANCE STANDARDS:

- Demonstrate the ability to differentiate between codes, specifications, and contract documents; state the purpose, provisions, general format, parts, administration and responsible agencies for enforcement with at least 70 percent accuracy.

SUGGESTED INSTRUCTION TIME: Optional

RELATED TECHNICAL INFORMATION:

- Building codes.
- Zoning.
- Contracts.

PROFICIENCY REPORT

PROFICIENCY REPORT  
FOR

\_\_\_\_\_  
Vocational Course

Student: \_\_\_\_\_

High School: \_\_\_\_\_

Vocational Course: \_\_\_\_\_

Date Training Initiated: \_\_\_\_\_

First Year Completed: \_\_\_\_\_

Second Year Initiated: \_\_\_\_\_

Second Year Completed: \_\_\_\_\_

Instructor: \_\_\_\_\_

**DIRECTIONS:** The purpose of the proficiency report is to communicate to the student, other instructors, or potential employers the abilities that a student has demonstrated to the instructor in vocational training. Mark each task as soon as possible after instruction or skills demonstration. If instruction is not aimed as task proficiency, or if only an orientation or introduction to the task was provided, DO NOT mark a proficiency level or mark Level 0. Levels 1-4 indicate that instruction was given and the proficiency may be interpreted as follows:

- Level 0 No skill level demonstrated or proficiency training not given in the skill.
- Level 1 Individual's skill level is not that generally expected for entry level employment.
- Level 2 Individual's skill level probably is that generally expected for entry level employment, but the individual probably will need close on-the-job supervision for a while longer.
- Level 3 Individual's skill level is that generally expected for entry level employment.
- Level 4 Individual's skill level is equal to that of a worker with some on-the-job experience.

For further description of the levels of proficiency, see the "Credentialing Process and Proficiency Report" section of the Policies and Procedures Guide for Articulation Between The School District of Greenville County and Greenville Technical College."

Student: \_\_\_\_\_

PROFICIENCY REPORT

DRAFTING II

TASK	Proficiency					Instructor's Initials	Date	Completed
	Level 0	Level 1	Level 2	Level 3	Level 3			
UNIT 7.0 ARCHITECTURAL DRAFTING (OPTION)								
7.01 Introduction to Architectural Drafting								
7.02 Architectural Lettering								
7.03 Architectural Symbols								
7.04 Interpret Basic Surveying of Site; Search and Verify Title and Deed								
7.05 Residential Site Planning Considerations								
7.06 Draw Plot Plans								
7.07 Draw Floor Plans								
7.08 Draw Foundation Plans								
7.09 Draw Basement Plans								
7.10 Draw Piers, Columns, and Pilasters								
7.11 Sketch and Draw Exterior Elevations								
7.12 Draw Interior Elevations and Details								
7.13 Draw Framing Plans								
7.14 Draw Typical Wall Sections								
7.15 Draw Roof Sections								
7.16 Draw Stair Sections								
7.17 Draw Firelace/Chimney Sections								
7.18 Design and Draw Door and Window Schedules								
7.19 Draw Schedules								
7.20 Check Drawings, Plans, and Specifications								
7.21 Build Presentation Models								
7.22 Draw New Residential Construction Working Drawings								
7.23 Identify Key Parts of Contractual Specifications								
DRAFTING II PORTFOLIO OF 2nd YEAR DRAWINGS COMPLETED ( ) Yes ( ) No								

Comments:

Instructor's Signature: \_\_\_\_\_

UNIT 7.0 - ARCHITECTURAL DRAFTING

OUTCOME-REFERENCED TESTS

Task 7.01

1. Explain the difference between an architect and an architectural draftsman.

---

---

---

2. State five different opportunities (fields of employment) in your community for the architectural draftsman.

1. 1 \_\_\_\_\_
2. \_\_\_\_\_
3. \_\_\_\_\_
4. \_\_\_\_\_
5. \_\_\_\_\_



UNIT 7.0 - ARCHITECTURAL DRAFTING

OUTCOME-REFERENCED TESTS

Task 7.02

TRUE-FALSE

1.  The gothic lettering group uses block-type lettering.
2.  The purpose of guidelines is to guide the heights of letters.
3.  Most people call text letters script letters.
4.  In lettering, each number in a fraction should be about two-thirds the size of the width of the whole number.
5.  Uppercase test letters are not normally used because they are almost impossible to read.

# ARCHITECTURAL LETTERING SHEET NO. 3

7.02 (Practical Exercise)

## DIRECTIONS

- 1 Trace carefully over the first line of lettering as given.
- 2 Letter the same line between the guide lines directly below.
- 3 Complete the entire sheet in the same manner by first tracing over each line of lettering and then repeating it between the guide lines below.

MEMORIZE BASIC LETTER CONSTRUCTION—THE LETTERING YOU ARE NOW DOING IS ONE  
OF THE SIMPLER STYLES COMMONLY USED BY ARCHITECTS—FOR THAT REASON IT IS ESPE  
CIALLY SUITED FOR THE BEGINNER—AFTER YOU HAVE MASTERED IT BY REPEATING THE  
SHEETS AS MANY TIMES AS IS NECESSARY, YOU WILL BE IN A POSITION TO DEVELOP  
A DISTINCTIVE STYLE OF YOUR OWN—IT SHOULD BE REMEMBERED HOWEVER THAT ANY  
DISTINCTIVE STYLE ADOPTED, MUST BE CHARACTERIZED BY SPEED OF EXECUTION, LEGIB  
ILITY, NEATNESS AND CONFORMANCE TO BASIC LETTER CONSTRUCTION AND PRO  
PORTION—THE RULE OF FULL AND HALF SQUARE LETTERS SHOULD ALWAYS BE OBEYED—

IDENT \_\_\_\_\_

GROUP \_\_\_\_\_

DATE \_\_\_\_\_











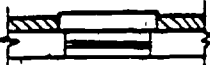

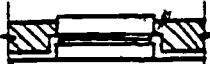







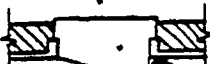

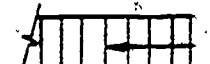

RATING \_\_\_\_\_

UNIT 7.0 - ARCHITECTURAL DRAFTING

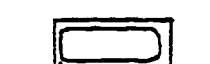
OUTCOME-REFERENCED TESTS

Task 7.03

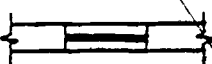
1. Without use of the text book or other references, identify the following architectural symbols by writing the name of each symbol on the line provided.

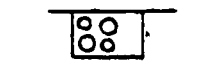
	a. _____		o. _____
	b. _____		p. _____
	c. _____		q. _____
	d. _____		r. _____
	e. _____		s. _____
	f. _____		t. _____
	g. _____		u. _____
	h. _____		v. _____
	i. _____		w. _____
	j. _____		x. _____
	k. _____		y. _____
	l. _____		z. _____
	m. _____		aa. _____
	n. _____		bb. _____

Unit 7.0 - Architectural Drafting (Con't.)

Task 7.03

2. From given AIA architectural symbols selected by the instructor, identify the standard symbols with 90 percent accuracy.
3. Given an assignment by the instructor, correctly draw architectural symbols and apply abbreviations as required by the instructor with 100 percent accuracy.

## UNIT 7.0 - ARCHITECTURAL DRAFTING

### OUTCOME-REFERENCED TESTS

#### Task 7.04

1. Given an assignment by the instructor, the necessary surveying equipment and helper are required; measure required distances and angles to within acceptable error limits for entry level drafter in architectural office (to the instructor's standards).
2. Given an assignment by the instructor, the necessary surveying equipment, helper(s) as needed, and necessary information; survey a given site with 80 percent accuracy in calculations and measurements.
3. Outline the basic steps necessary to search and verify a site deed in Greenville County, SC. The steps outlined must be 100 percent correct and must meet the instructor's standards.

UNIT 7.0 ARCHITECTURAL DRAFTING

OUTCOME-REFERENCED TESTS

Task 7.05

1. List ten (10) factors which should be considered when planning a residential structure to the size and arrangement of rooms.

1. \_\_\_\_\_
2. \_\_\_\_\_
3. \_\_\_\_\_
4. \_\_\_\_\_
5. \_\_\_\_\_
6. \_\_\_\_\_
7. \_\_\_\_\_
8. \_\_\_\_\_
9. \_\_\_\_\_
10. \_\_\_\_\_

2. A document which lists any legal claims against the property is a \_\_\_\_\_.

3. The document which shows any restrictions or easements attached to the property is the \_\_\_\_\_.

4. List four (4) features which are found on a topographical drawing of the site.

1. \_\_\_\_\_
2. \_\_\_\_\_
3. \_\_\_\_\_
4. \_\_\_\_\_

5. List the seven (7) drawings which originally are included in a set of residential house plans.

1. \_\_\_\_\_
2. \_\_\_\_\_
3. \_\_\_\_\_
4. \_\_\_\_\_
5. \_\_\_\_\_
6. \_\_\_\_\_
7. \_\_\_\_\_

UNIT 7.0 - ARCHITECTURAL DRAFTING

OUTCOME-REFERENCED TESTS

Task 7.06

1. Identify six (6) important items to be found on the plot plan.

1. \_\_\_\_\_

2. \_\_\_\_\_

3. \_\_\_\_\_

4. \_\_\_\_\_

5. \_\_\_\_\_

6. \_\_\_\_\_

2. Given the necessary information, tools and equipment; draw a typical residential plot plan. Place the structure on the site, indicate recreational areas, draw existing and proposed contour lines, and indicate grade, indicate water drainage and storage systems, locate existing and proposed utilities, note existing natural features, dimension boundaries of site and give bearings, dimension exterior limits of structure and supplementary construction, locate and dimension easements and established setbacks, indicate north arrow, add border lines, and title block information as a minimum. Execute the drawing neatly and accurately, correctly using terminology and symbols with 80 percent accuracy.
3. Draw a typical residential plot plan.

79

UNIT 7.0 - ARCHITECTURAL DRAFTING

OUTCOME-REFERENCED TESTS

Task 7.07

1. Give architectural design data such as square footage and specifications, preliminary plan layouts, and architectural drafting equipment; draw the floor plan of the residential structure. The double line floor plan drawings should locate windows and doors and be dimensioned as appropriate. The drawings must communicate the intended information to a user. The rules of good architectural design must be used. Drawings must meet the instructor's criteria.

DOOR SCHEDULE

NO.	TYPE	SIZE	REMARKS
A	PANEL	3'-0" x 6'-0"	4-PTS. SPRINGS, RING
B	ACCORDED	2'-8" x 6'-0"	3-LTS. NNB
C	PANEL	2'-8" x 6'-0"	4-LTS. 3-PANES RING
D	FLUSH	2'-6" x 6'-8"	BIRCH
E	FLUSH	2'-6" x 6'-8"	BIRCH
F	FLUSH	2'-6" x 6'-8"	SUNNING BIRCH
G	FLUSH	1'-6" x 6'-8"	BIRCH
H	FLUSH	1'-4" x 6'-8"	BIRCH
I	FLUSH	2'-8" x 6'-8"	METAL CLAD - BIRCH
J	FLUSH	1'-8" x 6'-8"	BIRCH

WINDOW SCHEDULE

NO.	TYPE	SIZE	REMARKS
1	B.M.	3'-8" x 4'-2"	4 HORIZ. LTS.
2	B.M.	2'-4" x 3'-10"	4 HORIZ. LTS.
3	B.M.	3'-4" x 3'-10"	4 HORIZ. LTS.
4	B.M.	3'-0" x 3'-2"	4 HORIZ. LTS.
5	B.M.	2'-6" x 4'-2"	4 HORIZ. LTS.
6	B.M.	3'-0" x 5'-0"	4 HORIZ. LTS.
7	SCOTCHMAN	6'-0" x 5'-10"	PLATE GLASS

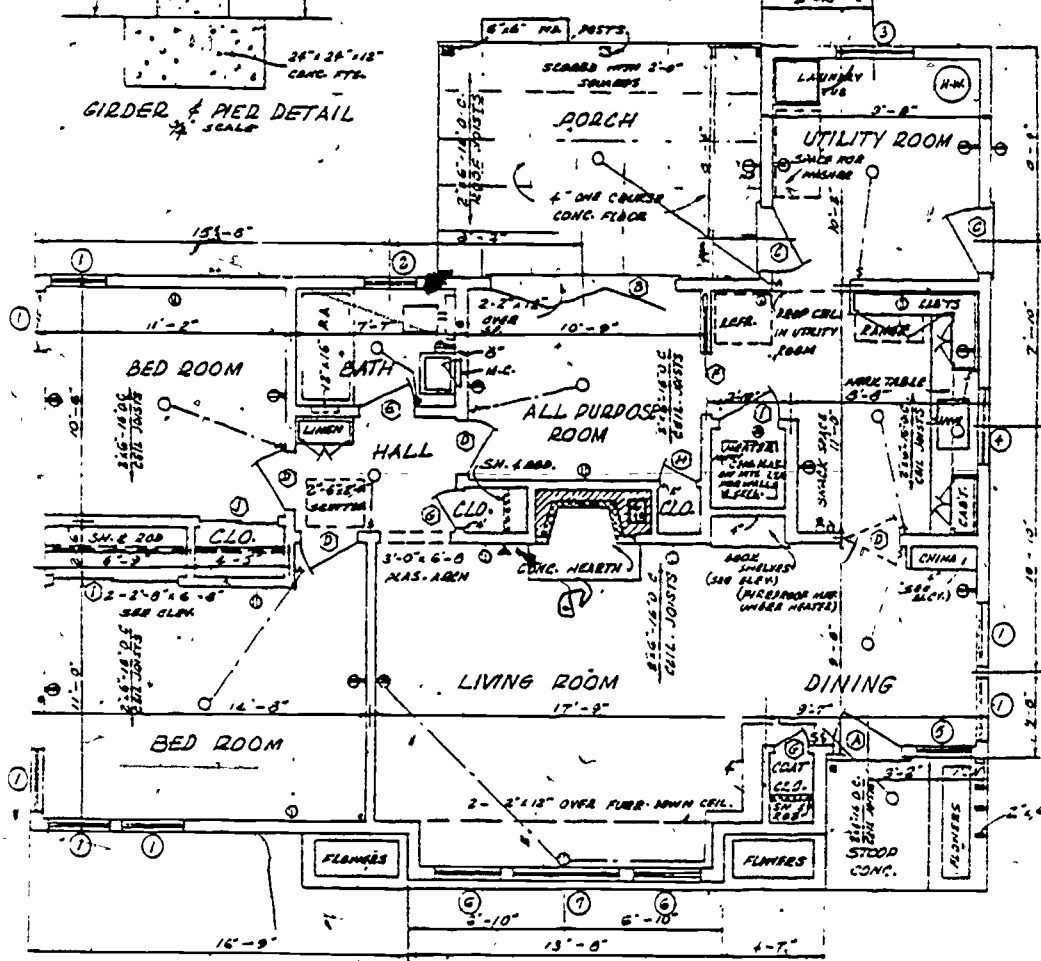
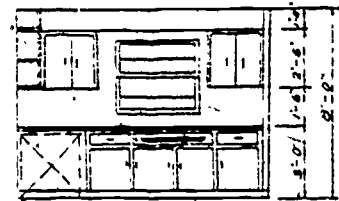
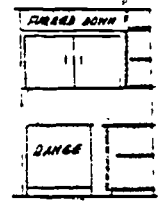
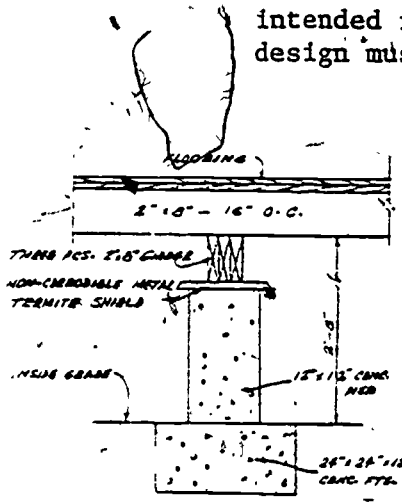

FLOOR PLAN SCALE





# UNIT 7.0 - ARCHITECTURAL DRAFTING

## OUTCOME-REFERENCED TESTS

### Task 7.08

1. Given architectural/engineering design data, floor plan, sketches, and necessary drafting equipment; draw the foundation plans. The plan must communicate the intended information to a user. Drawing must be standards required by the instructor and must apply the rules of good architectural drafting, with correct details and dimensioning.

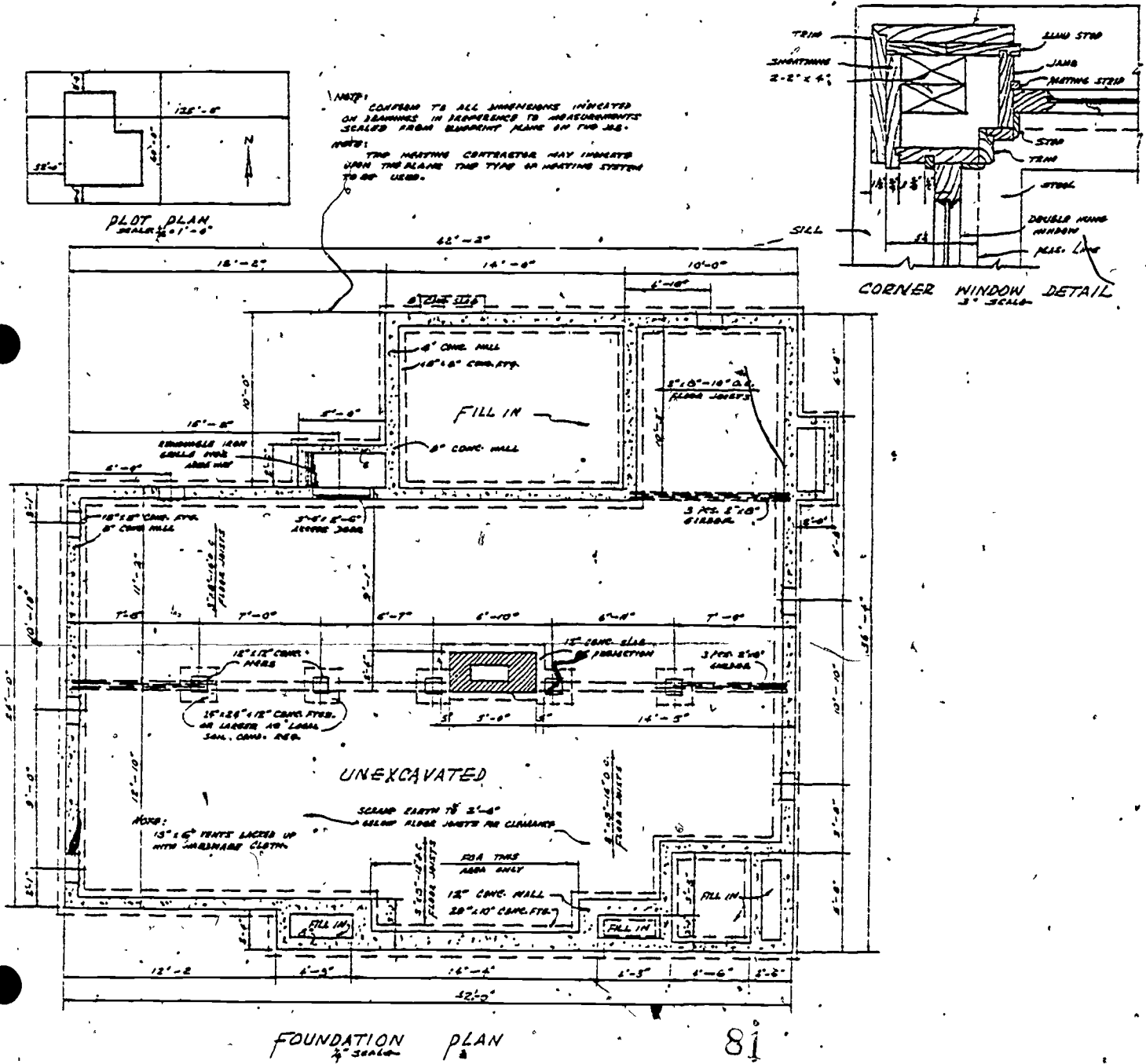

UNIT 7.0 - ARCHITECTURAL DRAFTING

OUTCOME-REFERENCED TESTS

Task 7.09

1. Residential foundation plans usually are drawn at \_\_\_\_\_ scale.
2. List eight features which usually are shown on a foundation plan.
  1. \_\_\_\_\_
  2. \_\_\_\_\_
  3. \_\_\_\_\_
  4. \_\_\_\_\_
  5. \_\_\_\_\_
  6. \_\_\_\_\_
  7. \_\_\_\_\_
  8. \_\_\_\_\_
3. The foundation plan is prepared primarily for the \_\_\_\_\_ plan, \_\_\_\_\_ plan, and \_\_\_\_\_.
4. The foundation plan is drawn from information presented on the \_\_\_\_\_ plan, \_\_\_\_\_ plan, and \_\_\_\_\_.
5. A brick ledge is at least \_\_\_\_\_ inches wide.
6. The following considerations should be checked to help determine the height of foundation walls and size of footings:
  1. \_\_\_\_\_
  2. \_\_\_\_\_
  3. \_\_\_\_\_
7. The symbol for a supporting beam is \_\_\_\_\_.
8. The purpose of a section is \_\_\_\_\_.
9. The foundation wall should be shaped to \_\_\_\_\_.
10. Explain how a basement plan differs from a foundation plan.  
\_\_\_\_\_  
\_\_\_\_\_

Task 7.09 (Con't.)

11. Given architectural/engineering design data, floor plan, sketches, architectural drafting equipment; draw a basement plan for a residential structure. The finished drawing must exhibit the rules of good architectural drafting, with correct dimensioning.

UNIT 7.0 - ARCHITECTURAL DRAFTING

OUTCOME-REFERENCED TESTS

Task 7.10

1. Given the following drawings of different types of pier from pier form the column (a-e) with the numbered (1-5) drawings.

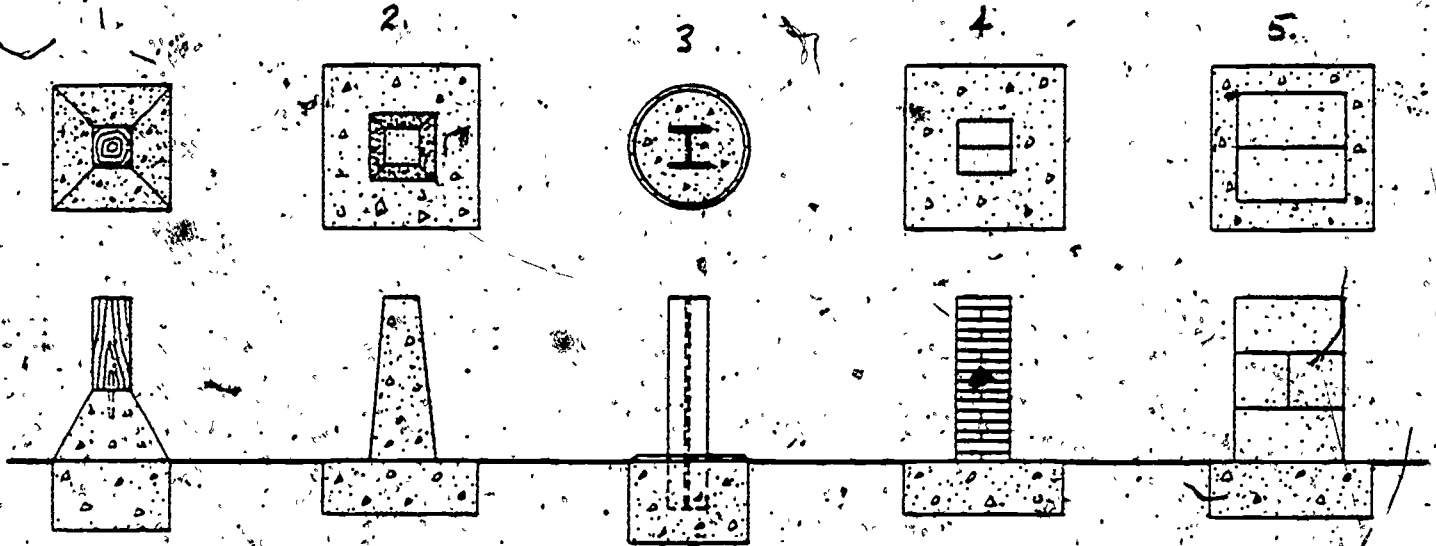

- |          |                             |
|----------|-----------------------------|
| 1. _____ | a. Concrete and I Beam Pier |
| 2. _____ | b. Concrete and Brick Pier  |
| 3. _____ | c. Two-piece Concrete Pier  |
| 4. _____ | d. Concrete and Block Pier  |
| 5. _____ | e. Concrete and Wood Pier   |

54

UNIT 7.0 - ARCHITECTURAL DRAFTING

OUTCOME-REFERENCED TESTS

Task 7.11

1. Given a plot plan, floor plan, specifications, foundation plans, basic exterior design, well section, sketch of preliminary elevations and drafting equipment; draw exterior elevations for a residential structure selected by the instructor. Drawings must apply the rules of good architectural practices and drawings must meet the instructor's standards.

(Instructor to supply given information.)

TRUE-FALSE

2.  Three (3) elevations are used to show the exterior of the average house.
3.  The side elevation usually is drawn first.
4.  The roof of an elevation view is blacked in by locating the ridge and cornices.
5.  Doors and windows are located on the elevation view by their centerlines.
6.  Symbols are used on elevation views to illustrate the types of windows to be used.

UNIT 7.0 - ARCHITECTURAL DRAFTING

OUTCOME-REFERENCED TESTS

Task 7.12

1. Given a floor plan, list of materials, specifications, supply catalogs, and architectural drafting equipment; draw interior elevations and details as required by instructor for a selected residential structure. Indicate: True width of walls, all openings in interior and exterior walls, true heights or width of openings, typical elevations of millwork, air circulatory systems, utilities, trim and molding and other details as required. Finished drawings must meet instructor's standards.

(Instructor to supply given information.)

TRUE-FALSE

- 
2.  A detail is any part that is drawn to show sections.
  3.  A detail of a stairway is unnecessary when the stairway is a manufactured, stock stair.
  4.  A horizontal section, vertical section, and front elevation usually are needed when detailing a fireplace.
  5.  Bathroom lavatory cabinets and built-ins in bedrooms usually do not need details.
  6.  The dimensions required on the typical stair detail are the rise, tread and riser sizes, headroom clearance, and the sizes of the balusters and the newel posts if they are used.

UNIT 7.0 - ARCHITECTURAL DRAFTING

OUTCOME-REFERENCED TESTS

Task 7.13

1. Given working drawings, engineering design data sketches, and drafting equipment; draw a framing plan. Show exterior bearing wall, structural supports, joists and headers, ridge boards, rafters and trusses, double headers and timbers and indicate location of bridging. The finished drawing must be to acceptable building standards, and must be acceptable to the instructor.

(Instructor to supply given items.)

TRUE-FALSE

2.  When selecting a proper joist size, the total load, type of material, and distance the joist must span must be considered.
3.  Roof pitch influences the span of the rafters.
4.  If the design load for a joist exceeds the normal figures for residences, maximum spans should be doubled to prevent over-stressing.
5.  A rafter must be able to carry the normal live loads imposed upon it, as well as the dead load of its own weight.
6.  A collar is installed between two truss members that are held together with bolts.

UNIT 7.0 - ARCHITECTURAL DRAFTING

OUTCOME-REFERENCED TESTS

Task 7.14

1. Given a plan and specifications, and architectural drafting equipment; draw a typical wall section to instructor's standards. Indicate size and type of floor material, show proper coursing of wall materials, indicate elevations, draw waterproofing and flashing above and below wall opening, indicate method of insulating wall, indicate termite shield, indicate plan lines on the plan view, and add dimensions and notes. Finished drawing must meet instructor's standards.

TRUE-FALSE

2.  Floor joists typically are bolted to the sill.
3.  The sill is typically fastened to the foundation by nailing on either side.
4.  Exterior wall studs usually are placed 12 inches on center.
5.  Wall studs are doubled around any opening in a bearing partition.
6.  When an interior partition meets an exterior wall, there is no nailing space provided for lath or drywall sheets, so an extra stud is added to the exterior wall.
7.  Sheathing strengthens the wall by resisting lateral movement.
8.  Bridging on a house consist of rows of small, diagonal braces, nailed between the studs.
9.  Bridging distributes the load on the floor over a wider area, stiffens the floor, and helps prevent warping.
10.  A header is used to support cut joists when an opening has been cut.
11.  Wood siding must be nailed through the sheathing into the studs.



UNIT 7.0 - ARCHITECTURAL DRAFTING

OUTCOME-REFERENCED TESTS

Task 7.15

1. Given a plan and specifications and drafting equipment; draw an attic section to the instructor's standards. Show the method of securing the ceiling joists and roof rafters to the support wall; draw the type and show the placement of bridging between joists; show the insulation; show the roof construction including overhand, gutter locations, and ventilation; indicate cutting plane lines on the plan view; and add dimensions and notes.

TRUE-FALSE

2.  The span of a rafter is the clear distance from the center of the roof to the point supporting the rafter.
3.  Roof pitch is the angle of the roof from the ridge pole to the plate.
4.  Slope is the ratio between rise and run.
5.  The main purpose of a roof and plot plan is to locate the house on the lot.
6.  Lending institutions insist that the locations of wells, septic tanks, or sewer lines (if existing) be recorded on the roof and plot plan.

UNIT 7.0 - ARCHITECTURAL DRAFTING

OUTCOME-REFERENCED TESTS

Task 7.16

1. Given a plan and specifications, necessary drafting equipment, and supplies; draw a required stair section. The tread riser and slopes must be within standards and the finished drawing must be to instructor's standards.
2. Identify the labeled parts of the stairway drawing.

1. \_\_\_\_\_
2. \_\_\_\_\_
3. \_\_\_\_\_
4. \_\_\_\_\_
5. \_\_\_\_\_
6. \_\_\_\_\_
7. \_\_\_\_\_
8. \_\_\_\_\_

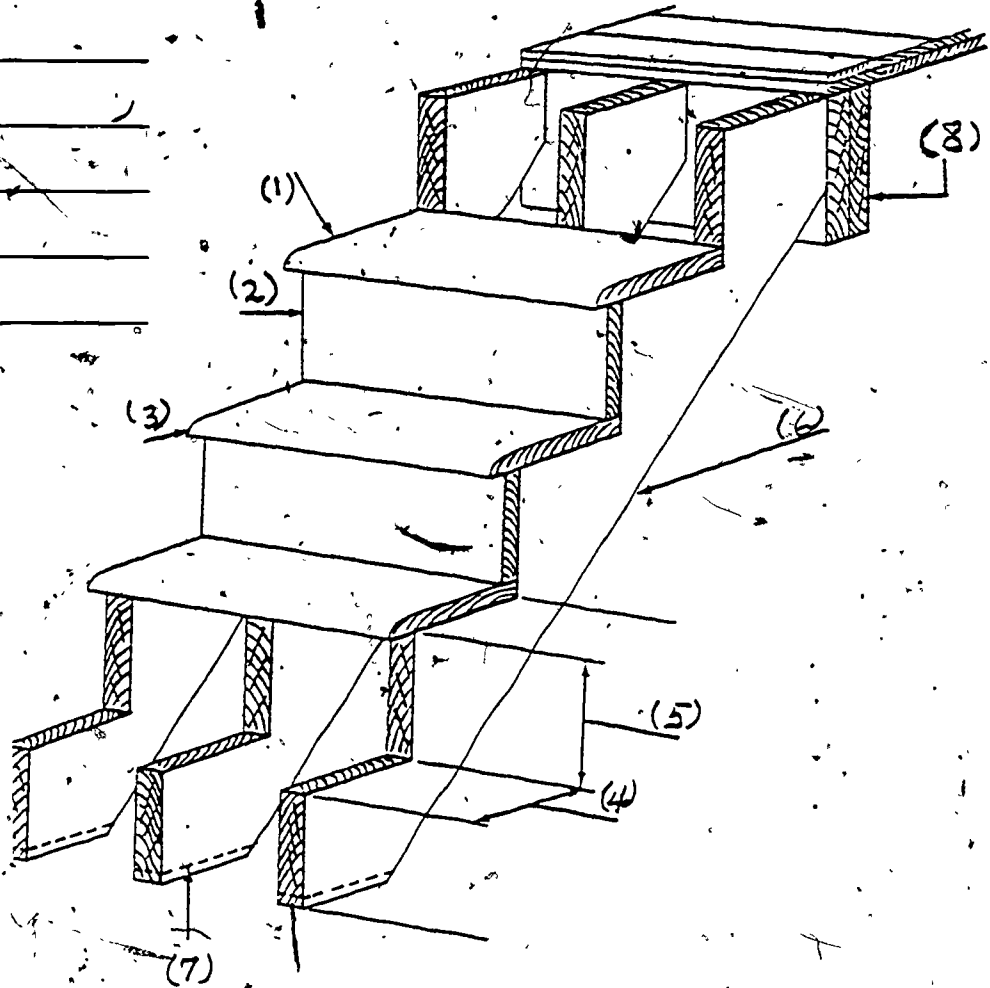

Task 7.16' (Con't.)

3. Using the following given information and drawing, calculate the rise and run of the stairs.

Rise = \_\_\_\_\_  
Run = \_\_\_\_\_

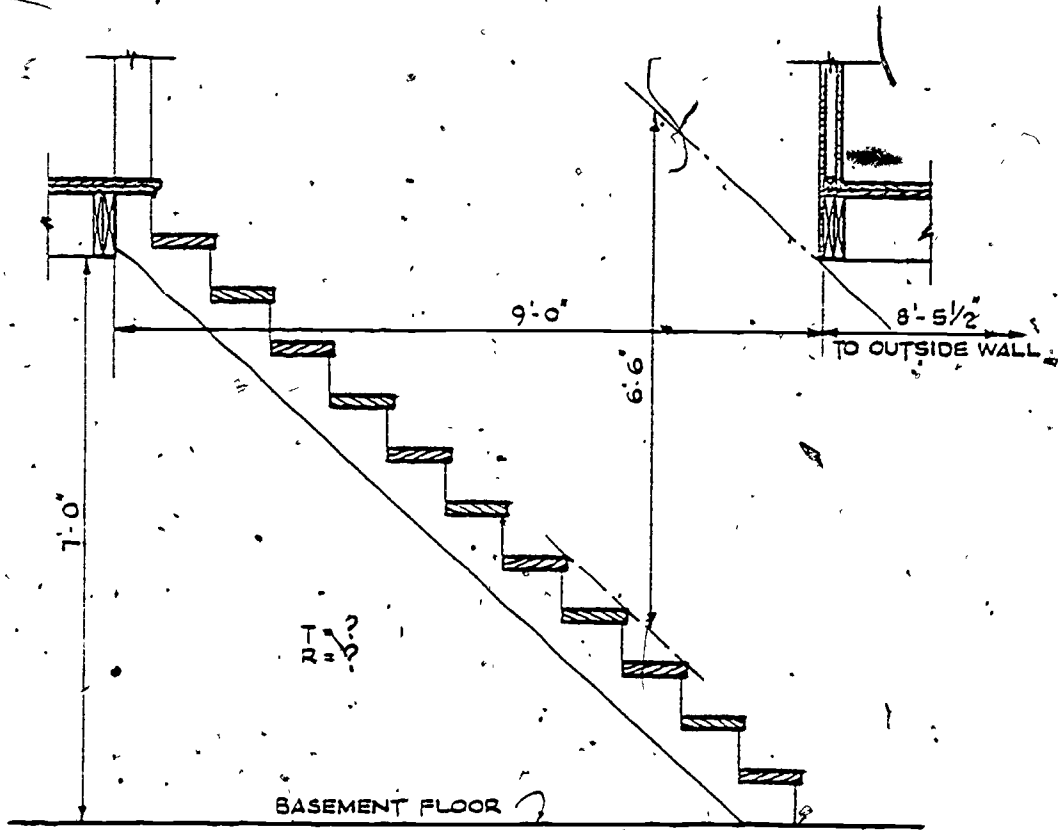

UNIT 7.0 - ARCHITECTURAL DRAFTING

OUTCOME-REFERENCED TESTS.

Task 7.17.

1. Given a plan and specifications, draw a fireplace and chimney. Show proper material and extension of the hearth; indicate fire-brick; show chimney and lining size; show mantel, ductwork, clean-out and damper; show finished trim; indicate cutting plan line of plan view, and notes and dimensions. The completed drawing must reflect good architectural practices and meet instructor's standards.

TRUE-FALSE

2.  A chimney wall should be at least 4 inches thick.
3.  An air space of 6 inches should be allowed between the chimney wall and framing members of a building.
4.  A chimney should project 24 inches above the ridge of the roof.
5.  The entire fireplace hearth is supported by the chimney footings and foundation.
6.  A fireplace hearth should be at least 12 inches in front of the fireplace opening and at least 4 inches on each side of the opening.

UNIT 7.0 - ARCHITECTURAL DRAFTING

OUTCOME-REFERENCED TESTS

Task 7.18

1. Given specific requirements concerning doors and windows and necessary drafting equipment; draw door and window schedules. Finished schedules must appear on same page(s) in parallel columns, must be accurate, properly lettered to meet minimum requirements of good architectural drafting practices, and must meet instructor's standards.

UNIT 7.0 - ARCHITECTURAL DRAFTING

OUTCOME-REFERENCED TESTS

Task 7.19

1. Given a set of architectural plans, interior elevations, and specifications and program requirements, and architectural drafting equipment; draw required schedules. Make a heading for each schedule, layout schedule to fit the given location, provide a key for abbreviation explanation. Finished schedule must meet instructor's standards.

UNIT 7.0 - ARCHITECTURAL DRAFTING

OUTCOME-REFERENCED TESTS

Task 7.20 - 7.23

TRUE-FALSE

1.  Specifications are written to describe items that cannot be clearly shown on the drawings.
2.  To make a bid on a house, a contractor must have a complete set of detailed specifications.
3.  The first part of the specifications is called "General Conditions."
4.  The first division of a set of specifications deals with schedules.
5.  Typically, specifications states that masonry joints should be 3/8 inches wide.
6.  Specifications should state that the excavation must be kept free from water and that water should not be conducted onto private property.

Unit 7.0 - Architectural Drafting

Answer Sheet

Task 7.01

1. (Possible answer)

"The architectural draftsman typically works for and under the supervision of an architect and primarily draws pictorial and working plans for structures such as houses.

The draftsman may be responsible for copying details from other drawings and with more experience for detailed planning such as the size of structural parts and methods of joining them.

The architectural draftsman should have a minimum of two years of training in a high school drafting program but completion of a two-year technical education training program will better qualify the draftsman.

2. (Short answer)

Task 7.02

1. true

2. true

3. false (Old English)

4. true

5. true

Task 7.03

1. a.
- b.
- c.
- d.
- e.
- f.
- g.
- h.



Unit 7.0 - Architectural Drafting (Con't.)

Task 7.03 (Con't.)

i  
j.  
k.  
i  
j.  
k.  
l.  
m.  
n.  
o.  
p.  
q.  
r.  
s.  
t.  
u.  
v.  
w.  
x.  
y.  
z.  
aa.  
bb.

2. Performance test

3. Performance test

Task 7.04

1. Performance test

2. Performance test

3. Performance test

Unit 7.0 - Architectural Drafting (Con't.)

Task 7.05

1. 1.
- 2.
- 3.
- 4.
- 5.
- 6.
- 7.
- 8.
- 9.
- 10.

2.

3.

4. 1.
- 2.
- 3.
- 4.

5. 1.
- 2.
- 3.
- 4.
- 5.
- 6.
- 7.

Task 7.06

1. 1. sidewalk
  2. building lines
  3. building
  4. underground utilities
  5. landscaping
  6. structural identification (sewer and water lines)
2. Performance test.

Unit 7.0 - Architectural Drafting

Task 7.06 (Con't.)

3.

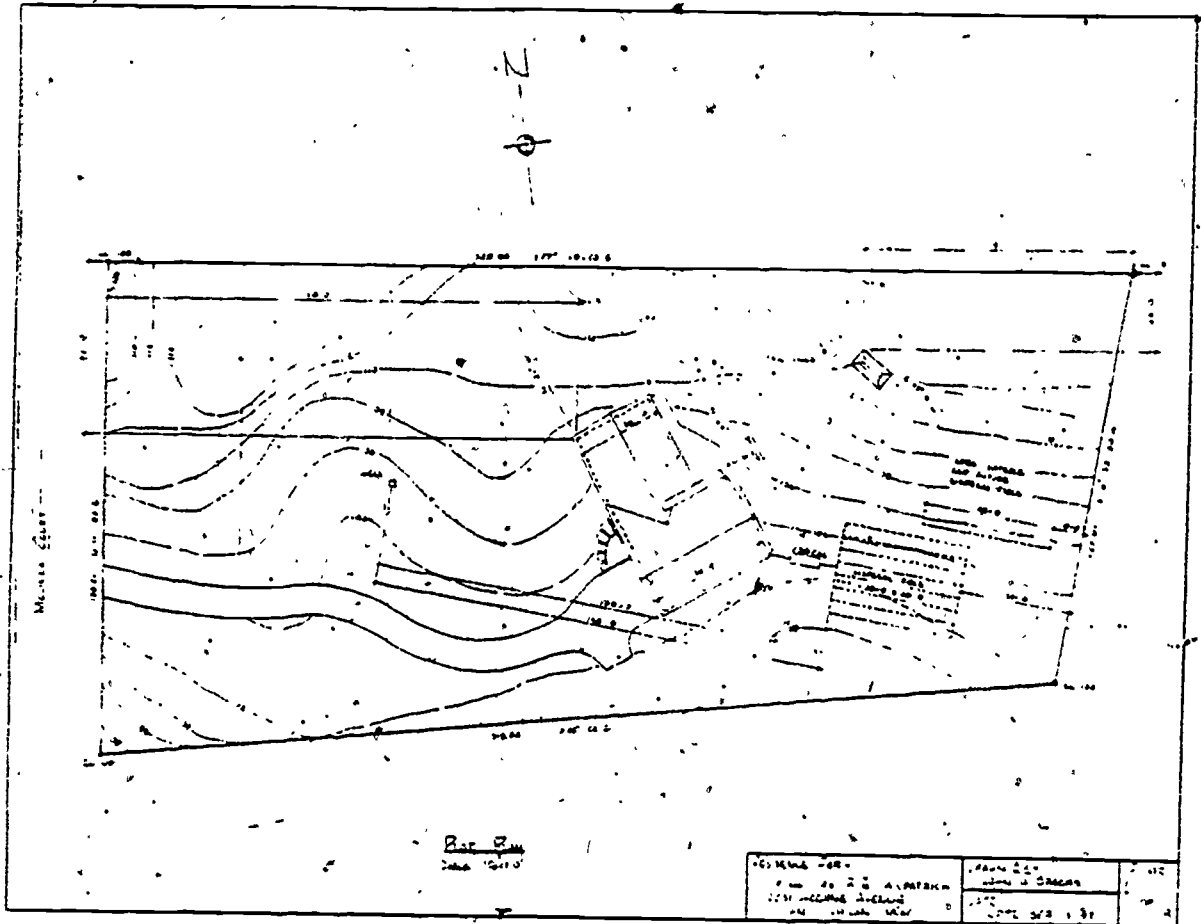

Task 7.07

1. Performance test

Task 7.08

1. Performance test

Task 7.09

- 1.
2.
  - 1.
  - 2.
  - 3.

Unit 7.0 - Architectural Drafting

Task 7.09 (Con't.)

- 4.
- 5.
- 6.
- 7.
- 8.
3.
  - 1.
  - 2.
  - 3.
4.
  - 1.
  - 2.
  - 3.
- 5.
6.
  - 1.
  - 2.
  - 3.
- 7.
- 8.
- 9.
10. (Short answer)
11. (See following sheet for sample answer)

Task 7.10

1.
  1. e
  2. c
  3. a
  4. b
  5. d

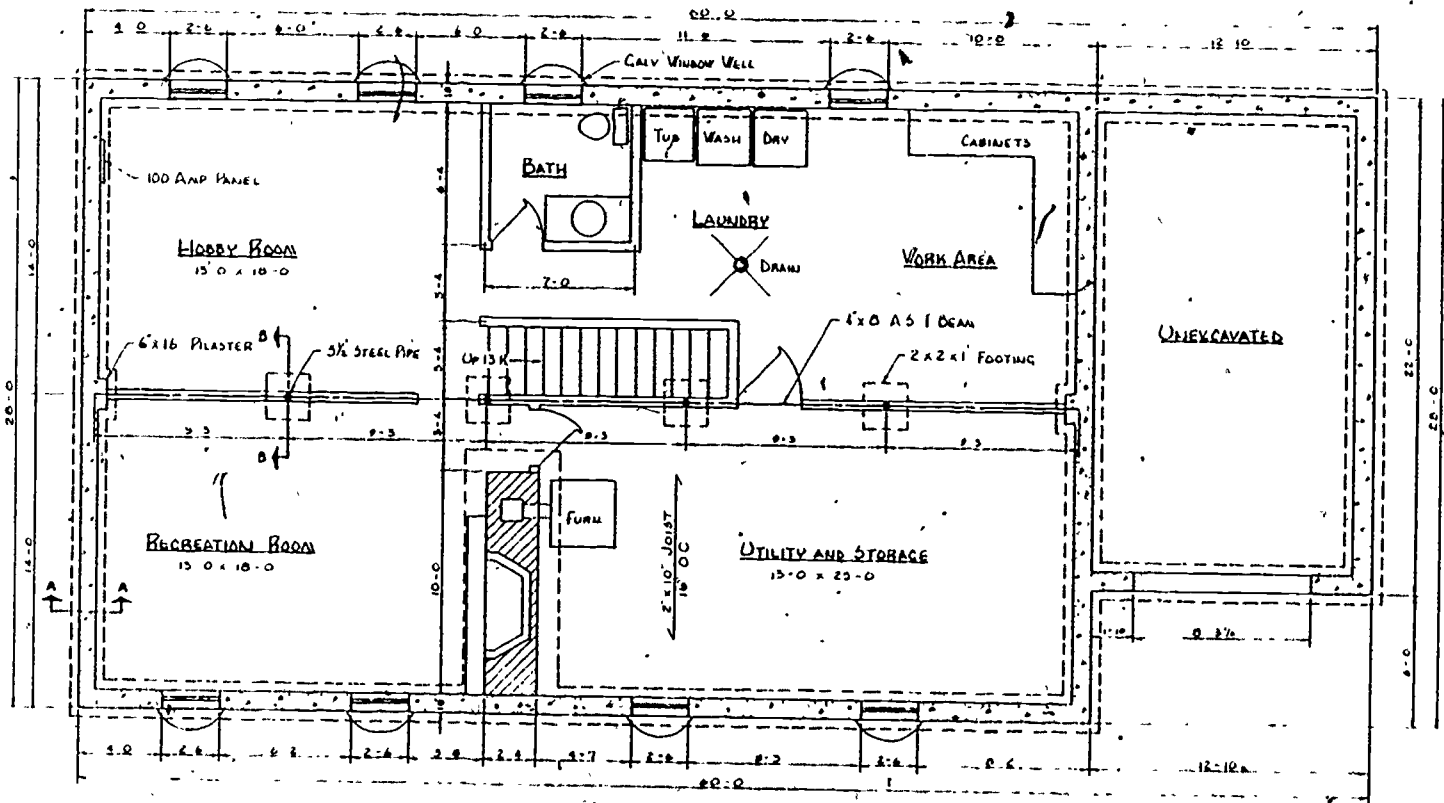

Basement plan with foundation walls of poured concrete and a frame structure.

SCALE 1/4" = 1'-0"

Sample answer for Task 7.09

Unit 7.0 - Architectural Drafting (Con't.)

Task 7.11

1. Performance test
2. false (4)
3. false (front)
4. true
5. true
6. true

Task 7.12

1. Performance test
2. false (drawn to larger scale)
3. true
4. true
5. false
6. true

Task 7.13

1. Performance test (This practical test may be combined with other tests.)
2. true
3. true
4. false (reduced)
5. true
6. false (split ring)

Task 7.14

1. Performance test
2. false (toenailed)
3. false (bolted)

Unit 7.0 - Architectural Drafting (Con't.)

Task 7.14 (Con't.)

4. false (16)
5. true
6. true
7. true
8. false (joists)
9. true
10. true
11. true

Task 7.15

1. Performance test
2. false (span point-to-point)
3. true
4. true
5. true
6. true

Task 7.16

1. Performance test
2.
  1. tread
  2. riser
  3. nosing
  4. unit run
  5. unit rise
  6. cut out stringer
  7. finished floor line
  8. stair well header
3. Rise =  $7 \frac{7}{8}$ "  
Run = 9" (tread)

Unit 7.0 - Architectural Drafting (Con't.)

Task 7.17

1. Performance test (sample answer)

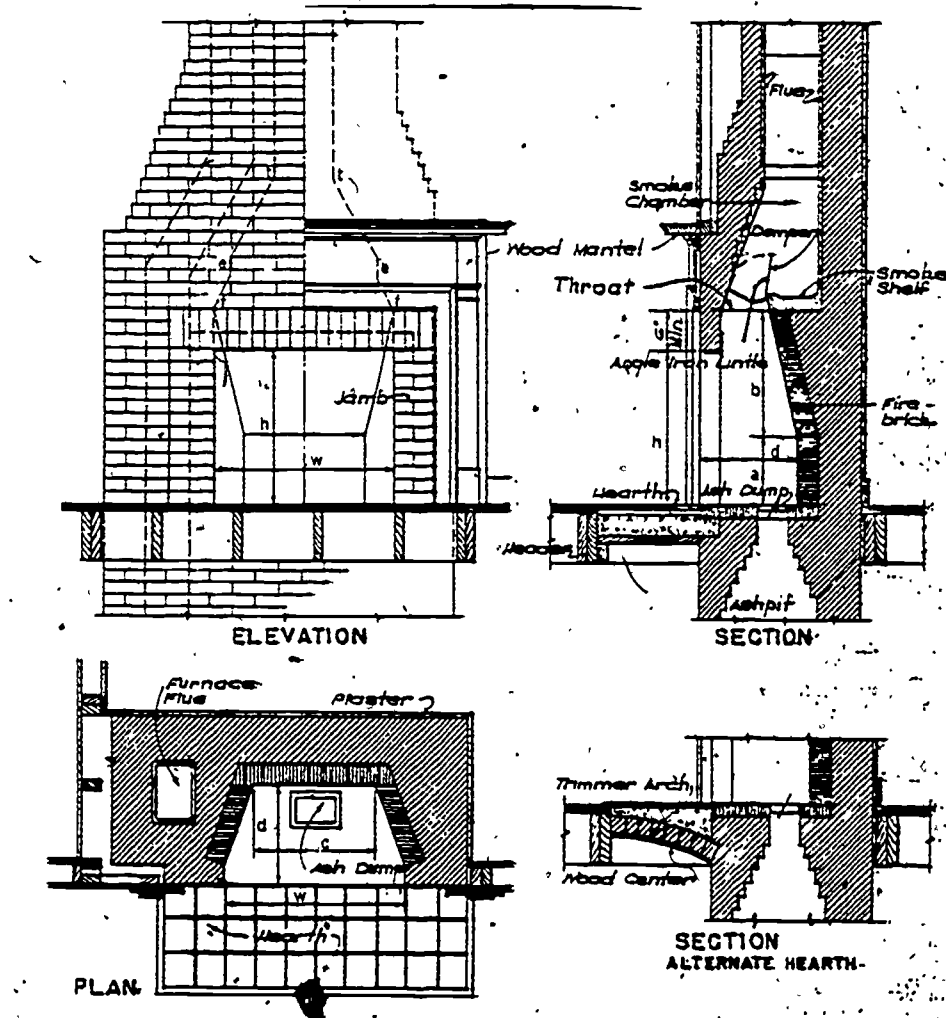

Recommended Dimensions For Fireplaces And Size of Flue Lining Required

Size of fireplace opening			Minimum width of back wall c Inches	Height of vertical back wall a Inches	Height of inclined back wall b Inches	Size of flue lining required	
Width w Inches	Height h Inches	Depth d Inches				Standard rectangular (outside dimensions) Inches	Standard round (inside diameter) Inches
24	24	16-18	14	14	16	8½ x 8½	10
28	24	16-18	14	14	16	8½ x 8½	10
30	28-30	16-18	16	14	18	8½ x 13	10
36	28-30	16-18	22	14	18	8½ x 13	12
42	28-32	16-18	28	14	18	13 x 13	12
48	32	18-20	32	14	24	13 x 13	15
54	36	18-20	36	14	28	13 x 18	15
60	36	18-20	44	14	28	13 x 18	15
54	40	20-22	36	17	29	13 x 18	15
60	40	20-22	42	17	30	18 x 18	18
66	40	20-22	44	17	30	18 x 18	18
72	40	22-28	51	17	30	18 x 18	18



Unit 7.0 - Architectural Drafting (Con't.)

Task 7.17 (Con't.)

2. true
3. false (2 inches)
4. true
5. true
6. false (16 inches, 8 inches)

Task 7.18

1. Performance test

Task 7.19

1. Performance test

Task 7.20 - 7.23

1. true
2. false (and complete set of working drawings)
3. true
4. false (excavating, filling, and grading)
5. true
6. true

REFERENCES

## ARCHITECTURAL REFERENCES

AIA, Architectural Standards, (American Institute of Architects), Somerset, NJ: John Wiley & Sons, 1982.

Davis, Ronald and Yancey, Bruce, Architectural Drafting, Stillwater, OK: Mid-American Vocational Curriculum MAVCC Consortium, 1982.

Drafting as a Career, Bartlesville, OK: American Institute for Design and Drafting.

Grimes, L. A. Jr., Architectural Draftsman Coordinator's Guide, Austin, TX: The University of Texas at Austin, Instructional Materials Center, 1976.

Grimes, L. A. Jr., Architectural Draftsman Student's Guide, Austin, TX: The University of Texas at Austin, Instructional Materials Center, 1976.

Kicklighter, Clois E., Architecture Residential Drawings and Design, South Holland, IL: Goodheart-Wilcox Company, 1976.

Muller, Edward J., Architectural Drawing and Light Construction, Englewood Cliffs, NJ: Prentiss-Hall, 1976.

Notgrass, Troy, Safety Handbook for ICT, Austin, TX: The University of Texas at Austin, Center for Occupational Curriculum Development, 1978.

Ramsey, Charles G. and Sleeper, Harold R., Architectural Graphic Standards, 7th ed. (The American Institute of Architects), Somerset, NJ: John Wiley & Sons, 1982.

Spence, William P., Architecture, 2nd ed., Bloomington, IL: McKnight Publishing Co., 1972.

Spencer/Dygon, Basic Technical Drawing, New York: Macmillan, 1980.

Wyatt, William E., General Architectural Drafting, Peoria, IL: Charles A. Bennett & Inc.

UNIT 8.0

DRAFTING II

MECHANICAL DRAFTING OPTION

108

M-1

MECHANICAL DRAFTING OPTION  
DRAFTING II

(Unit 8.0)

**INTRODUCTION:** The Mechanical Drafting Option description of Drafting II represents agreement (lateral articulation) among the secondary level drafting instructors in The School District of Greenville County, concerning the objectives, content, and standards of the Mechanical Drafting Option, Drafting II.

The theory of the Mechanical Drafting Option is that program graduates should receive an orientation to the mechanical drafting skills and knowledge areas needed by new and expanding industries in the Greenville area.

The Mechanical Drafting Option may vary slightly in focus and emphasis in each of the four vocational education center programs depending upon the individual instructor's training and experience, the needs of potential employers as determined by tasks analysis, and the career interests and drafting abilities of the students.

**GENERAL  
OBJECTIVES:**

The Mechanical Drafting Option, Drafting II, is designed to provide job qualification competencies required to perform detailed entry-level working drawings (industrial drafting) of machinery and mechanical devices, including; dimensioning and notes, tolerances, shop processes, fasteners, intersections and developments, cams and gears (motion transfer), castings, and joining requirements. The graduate will draft multiple-view assembly and sub-assembly drawings as required for manufacture and repair of mechanisms.

Mechanical Drafting may include problem solving procedures, layout and design sketching skills, and model making. It will be possible for individual student or class projects to encompass all tasks in the Mechanical Drafting Option. Use of handbooks, tables, ANSI and related manuals as references will be stressed.

The Mechanical Drafting Option will provide the graduate with knowledge of basic terminology and concepts of mechanisms. Graduates will develop the skills necessary for drafting room and mathematical solutions of problems involving the principles of machine elements.

**PERFORMANCE  
EVALUATION:**

Evaluation will be by competency-based (performance-based) testing directed to determine that the program graduate is job qualified to perform successfully at the entry-level in mechanical (industrial) drafting.

Performance standards are the minimum necessary for success in initial employment.

**JOB QUALIFICATION:** The Mechanical Drafting Option does not provide a specific industrial job qualification. It, however, is designed to prepare the secondary level vocational program graduate for entry-level employment as a Mechanical (Industrial) Drafter.

Mechanical Drafting reviews and uses most of the skills and techniques acquired in the basic first year, secondary level, training program, Drafting I.

## STANDARDS FOR MECHANICAL DRAFTING OPTION

1. All applicable standards of Drafting I apply to Drafting II.
2. Execute drawings within time limits considered acceptable for initial employment.
3. Perform required mechanical drafting tasks in the proper sequence.
4. When applicable, freehand sketching and drawing, and layout (composition) techniques must be properly applied.
5. Use appropriate reference technical manuals, tables, and catalogs correctly.
6. Drawings must conform to applicable standards as contained in ANSI Manuals and other appropriate technical manuals and tables.
7. Demonstrate knowledge of related technical information, application of theories and procedures, symbols and conventions, and terminology with a minimum of 80 percent accuracy.
8. Models, if built, must be well executed and must portray objects accurately.

DRAFTING II  
MECHANICAL DRAFTING  
SUGGESTED INSTRUCTION TIME

<u>DRAFTING II</u> <u>UNIT/TASK</u>	<u>SUGGESTED</u> <u>HOURS</u>
Unit 8.0	
8.01 Introduction to Mechanical Drafting as a Speciality	6
8.02 Cams (Motion Transfer)	10
8.03 Gears (Motion Transfer)	10
8.04 Fluid Power Mechanics	15
8.05 Shop Processes	6
8.06 Hardware Classification and Certification	6
8.07 Developments and Intersections	45
8.08 Draw Electrical Power Systems and Schematics	30
8.09 Shop Processes - Welding	6
8.10 Design and Draw Working Drawings	<u>136</u>
<u>SUGGESTED TOTAL HOURS</u> (Additional hours are available for options.)	270



TASK LISTINGS  
DRAFTING II  
MECHANICAL DRAFTING

UNIT/TASK

DESCRIPTION

Unit 8.0

- 8.01 (Introduction to Mechanical Drafting as a Speciality) Given an introduction to mechanical drafting as a speciality, describe the representative types of jobs common to the mechanical drafting field to the standards of the instructor. State the importance of the work of the mechanical draftsmen in typical local industrial settings to the satisfaction of the instructor.
- 8.02 (Cams [Motion Transfer]) Given a teacher or text assigned problem, and design data, draw cams with uniform harmonic and accelerated motion from given specifications.
- 8.03 (Gears [Motion Transfer]) Given specifications and assigned problem, prepare spur gear drawings.
- 8.04 (Fluid Power Mechanics) Given prior instruction in fundamentals and devices in Fluid Power circuits, necessary drafting instruments, standard drafting room environment, an assignment with appropriate instruction; draw diagrams of hydraulic fluid power circuit and pneumatic fluid power circuits to the standards of the instructor.
- 8.05 (Shop Processes) After proper instruction and demonstration, identify selected types of manufacturing process used to make machine parts and draw parts to be manufactured by given processes.
- 8.06 (Hardware Classification and Certification) Upon completion of instruction, given samples of hardware, identify classification of mechanical fasteners by their marking and tell how fasteners are certified.
- 8.07 (Developments and Intersections) Describe views and parts used in radial and parallel line developments and make allowances for seams and folds. Draw developments and intersections for given projects.
- 8.08 (Draw Electrical Power Systems and Schematics) Given proper instruction, drafting equipment, and a project assignment; draw electrical power systems and schematics of electrical or simple electronic systems or components that are typical of the mechanical engineering field such as power control devices (switches, circuit breakers, relays, etc.) or electrical loads (motors, heaters, etc.).

- 8.09 (Shop Processes - Welding) Given a table of welding symbols, draw, dimension, and label a welding drawing according to instructions and data given by the instructor to the standards of the instructor.
- 8.10 (Design and Draw Working Drawings) Given a mechanical drafting project, proper instruction, and drafting equipment; design and draw the required machine or machine element with each unit incorporated into it.

UNIT	8.0	DRAFTING II MECHANICAL DRAFTING (Option)
TASK	8.01	INTRODUCTION TO MECHANICAL DRAFTING AS A SPECIALITY

---

---

PERFORMANCE OBJECTIVE:

Given an introduction to mechanical drafting as a speciality, describe the representative types of jobs common to the mechanical drafting field to the standards of the instructor. State the importance of the work of the mechanical draftsmen in typical local industrial settings to the satisfaction of the instructor.

PERFORMANCE ACTIONS:

- 8.0101 Identify similarities between mechanical drafting as a speciality and basic drafting techniques learned in Drafting I.
- 8.0102 Describe the role of the mechanical drafting specialist in representative types of industries.
- 8.0103 Identify typical drafting assignments (drawings) that the mechanical drafting specialist typically might be required to perform in local industries.

PERFORMANCE STANDARDS:

- Identify typical functions of a mechanical drafting specialist in representative local industries to the satisfaction of the instructor.

SUGGESTED INSTRUCTION TIME: 6 Hours

RELATED TECHNICAL INFORMATION:

- Duties of mechanical drafting specialist in local industries.
- Typical functions (drawings) of mechanical drafting specialists.

UNIT	8.0	DRAFTING II MECHANICAL DRAFTING (Option)
TASK	8.02	CAMS (Motion Transfer)

---

PERFORMANCE OBJECTIVE:

Given a teacher or text assigned problem, and design data, draw cams with uniform harmonic and accelerated motion from given specifications.

PERFORMANCE ACTIONS:

- 8.0201 Determine necessary space allocations.
- 8.0202 Make the required cam motion diagram from given specifications.
- 8.0203 Draw the required cam curve outline.
- 8.0204 Add necessary dimensions.
- 8.0205 Check drawing for completeness and accuracy.

PERFORMANCE STANDARDS:

- Draw cam motion diagram and cam curve outline from assigned problems.
- To instructor's standards based on entry-level competence requirements of the drafting field.

SUGGESTED INSTRUCTION TIME: 10 Hours

RELATED TECHNICAL INFORMATION:

- Cam terminology.
- Radial cams.
- Cylindrical cams.
- Yoke cams.
- Cam motion diagrams.
- Uniform motion cams.
- Harmonic motion cams.
- Accelerated motion cams.
- Cam curve outlines.

OUTCOME-REFERENCED MEASURE:

- Figure 19-9, page 347, Mechanical Drawing, by French.

UNIT	8.0	DRAFTING II MECHANICAL DRAFTING (Option)
TASK	8.03	GEARS (Motion Transfer)

---

PERFORMANCE OBJECTIVE:

Given specifications and assigned problems, draw gear trains.

PERFORMANCE ACTIONS:

- 8.0301 Determine necessary space allocations.
- 8.0302 Make the required gear train drawing.
- 8.0303 Add necessary dimensions.
- 8.0304 Add necessary lettering.
- 8.0305 Check drawing for completeness and accuracy.

PERFORMANCE STANDARDS:

- Prepare gear train drawings from given specifications and assignment.
- To instructor's standards based on entry-level competence requirements of the drafting field.

SUGGESTED INSTRUCTION TIME: 10 Hours

RELATED TECHNICAL INFORMATION:

- Metric systems (Including European DIN)
- Gear terminology.
- Gear formulae.
- Gear tooth curves.
- Dimensioning gears.
- Drawing - spur gear.
- Drawing - rack.
- Drawing - bevel gear.
- Precision Instrument Reading, Quality Control (possible optional task)

ADDITIONAL RELATED TOPICS: (AS INTEREST AND TIME ALLOW)

- Identify worm gear terminology and components, calculate and draw worms and worm gears.
- Identify standard types of gear trains.
- Identify and draw standard pulleys and belts.
- Identify and draw standard chain and sprocket drives.

UNIT 8.0

DRAFTING II  
MECHANICAL DRAFTING (Option)

TASK 8.04

FLUID POWER MECHANICS

---

PERFORMANCE OBJECTIVE:

Given prior instruction in fundamentals and devices in Fluid Power circuits, necessary drafting instruments, standard drafting room environment, an assignment with appropriate instruction; draw diagrams of hydraulic fluid power circuit and pneumatic fluid power circuits to the standards of the instructor.

PERFORMANCE ACTIONS:

- 8.0401 Identify and draw fluid power symbols properly.
- 8.0402 Demonstrate understanding of pneumatic and hydraulic fluid power systems and devices on written knowledge tests.
- 8.0403 Identify or describe various types of fluid power cylinders, valves, and other components.
- 8.0404 Combine fluid power symbols and lines to form a given fluid power circuit.

PERFORMANCE STANDARDS:

- Answer written questions to 75 percent accuracy.
- Draw schematic of fluid power diagrams to instructor's standards.

SUGGESTED INSTRUCTION TIME: 15 Hours

RELATED TECHNICAL INFORMATION:

- Vendors' catalog for fluid power devices.
- Tables of fluid power symbols from ANSI 32.10 "Symbols for Fluid Power Diagram".
- ANSI 14.17 "Fluid Power Diagrams".
- Fluid Power:
  - cylinders
  - filters
  - reservoir
  - gauges

UNIT 8.0

DRAFTING II  
MECHANICAL DRAFTING (Option)

TASK 8.05

SHOP PROCESSES

---

PERFORMANCE OBJECTIVE:

After proper instruction and demonstration, identify selected types of manufacturing process used to make machine parts and draw parts to be manufactured by given processes.

PERFORMANCE ACTIONS:

- 8.0501 . Observe part being made by sand casting.
- 8.0502 Draw a part and indicate sand casting process.
- 8.0503 Observe part being made by forging.
- 8.0504 Draw a part indicating forging required.
- 8.0505 Observe a heat treating process.
- 8.0506 Draw a part indicating heat treating required.
- 8.0507 Observe part being formed by extruding process.
- 8.0508 Draw an extruding die.

PERFORMANCE STANDARDS:

- Draw parts to be manufactured by given process.
- Measurements and notes to instructor's standards.

SUGGESTED INSTRUCTION TIME: 6 Hours

RELATED TECHNICAL INFORMATION:

- Use and care of drawing instruments.
- Proper lettering.

ADDITIONAL TOPICS IF RELEVANT:

- Capabilities and limitations of common machine shop machines; flow charts, terms, notes, and symbols on working drawings to indicate machining symbols, machine shop terms and basic operations, drilling and boring of holes-notes, and miscellaneous machine shop operations.

UNIT	8.0	DRAFTING II MECHANICAL DRAFTING (Option)
TASK	8.06	HARDWARE CLASSIFICATION AND CERTIFICATION

---

PERFORMANCE OBJECTIVE:

Upon completion of instruction, given samples of hardware, identify classification of mechanical fasteners by their marking, tell how fasteners are certified, and draw and specify hardware in a mechanical assembly.

PERFORMANCE ACTIONS:

- 8.0601 Identify types of hardware, washers, nuts, bolts, rivets, etc.
- 8.0602 Identify nuts and bolts by markings.
- 8.0603 Describe the hardware certification process.
- 8.0604 Draw and specify hardware in a mechanical assembly (note certification if required).

PERFORMANCE STANDARDS:

- Draw and specify hardware in a mechanical assembly and note certification if required.
- ANSI standards.
- Instructor's standards.

SUGGESTED INSTRUCTION TIME: 6 Hours

RELATED TECHNICAL INFORMATION:

- Metric DIN system of classifying metric hardware ANSI Y14.5 and 14.5M.
- Appropriate reference catalogs.

ADDITIONAL TOPICS IF RELEVANT:

- Select, specify, and draw proper fastener(s) for project requirement.
- Identify, select, and draw proper screw thread(s) for project requirements.
- Describe screw thread development from beginning through standardizations.



UNIT	8.0	DRAFTING II MECHANICAL DRAFTING (Option)
TASK	8.06	HARDWARE CLASSIFICATION AND CERTIFICATION

---

---

ADDITIONAL TOPICS IF RELEVANT (Con't.):

- Identify, use, and draw various terms and symbols pertaining to threads to include: thread form, series, class of fit, multiplicity, direction of turn and length.
- Draw threads as required: acme, square, regular square bolts and nuts, hex-head bolts and nuts.
- Use thread tables.
- Identify, use, specify, and draw standard keys, keyways, rivets, and springs.

UNIT 8.0

DRAFTING II  
MECHANICAL DRAFTING (Option)

TASK 8.07

DEVELOPMENTS AND INTERSECTIONS

---

PERFORMANCE OBJECTIVE:

Describe views and parts used in radial and parallel line developments and make allowances for seams and folds. Draw developments and intersections for given projects.

PERFORMANCE ACTIONS:

- 8.0701 Draw stretch-out view of assigned project.  
(Pyramid, Bends)
- 8.0702 Make templates to check for accuracy.
- 8.0703 Identify different sheet metal edges and seams.
- 8.0704 Draw different elbows.
- 8.0705 Explain and draw transitions.

PERFORMANCE STANDARDS:

- Draw developments, neatly and accurately, standards set by instructor.

SUGGESTED INSTRUCTION TIME: 45 Hours

RELATED TECHNICAL INFORMATION:

- Parallel line development (prisms and cylinders).
- Radial line development (pyramids and cones).
- Terms related to development.
- Developments:
  - pipes, ducts
  - pans
  - hoppers
  - bins
  - buckets
  - cartons

UNIT 8.0

DRAFTING II  
MECHANICAL DRAFTING (Option)

TASK 8.08

DRAW ELECTRICAL POWER SYSTEMS AND  
SCHEMATICS

---

---

PERFORMANCE OBJECTIVE:

Given proper instruction, drafting equipment; and a project assignment; draw electrical power systems and schematics of electrical or simple electronic systems or components that are typical of the mechanical engineering field such as power control devices (switches, circuit breakers, relays, etc.) or electrical loads (motors, heaters, etc.).

PERFORMANCE ACTIONS:

- 8.0801 Interpret electrical/electronic terminology as required.
- 8.0802 Identify types and uses of electrical/electronic components:
- a. Electrical power control devices and monitoring devices
  - b. Electrical loads
- 8.0803 Refer to reference material and select proper electrical/electronic device symbols for drawing.
- 8.0804 Use electrical/electronic terminology and demonstrate a basic ability to identify various types of electrical/ electronic components.
- 8.0805 Apply requirements as contained in the National Electrical Code or ANSI Standards, as applicable.
- 8.0806 Given a project and freehand sketch, draw electrical systems or electrical/electronic schematics with 90 percent accuracy, referring to appropriate references as needed.
- 8.0807 Check for completeness and accuracy.

PERFORMANCE STANDARDS:

- Draw electrical systems or electrical/electronic schematics for a given project with 90 percent accuracy properly using symbols and meeting appropriate craft standards.
- Drawing must be neat, consistent, and properly placed, meeting instructor's standards.

UNIT	8.0	DRAFTING II MECHANICAL DRAFTING (Option)
TASK	8.08	DRAW ELECTRICAL POWER SYSTEMS AND SCHEMATICS (Con't.)

---

---

PERFORMANCE STANDARDS (Con't.):

- Drawing must be completed within time limits considered to be acceptable for initial employment job qualifications.

SUGGESTED INSTRUCTION TIME: 30 Hours

RELATED TECHNICAL INFORMATION:

- Electrical/electronic symbols.
- National Electrical Code, Local Codes.
- ANSI Standards: Y32.2 and Y32.9.
- Electrical/electronic abbreviations.
- Reference designations (such as component values).

UNIT	8.0	DRAFTING II MECHANICAL DRAFTING (Option)
TASK	8.09	SHOP PROCESSES - WELDING

---

PERFORMANCE OBJECTIVE:

Given a table of welding symbols, draw, dimension, and label a welding drawing according to instructions and data given by the instructor to the standards of the instructor.

PERFORMANCE ACTIONS:

- 8.0901 Identify the basic welding processes.
- 8.0902 Identify the basic types of welded joints.
- 8.0903 Discriminate between the fundamental welds.  
Identify the appropriate symbols for basic welds.
  - a. Arc and Gas weld symbols.
  - b. Resistance weld symbols.
- 8.0904 Identify the parts of the complete welding symbol (ideograph) to the instructor's standards.
  - a. Reference line.
  - b. Arrow.
  - c. Basic weld symbols.
  - d. Dimensions and other data.
  - e. Supplementary symbols.
  - f. Finish symbols.
  - g. Tail.
  - h. Specification process or other references.
- 8.0805 Draw welding symbols for a given diagram of typical welded joints (section views).
- 8.0806 Given a set of specifications and an assignment by the instructor, develop working drawings to indicate the desired welding operation and include the appropriate specifications or information with the symbols.

SUGGESTED INSTRUCTION TIME: 6 Hours

PERFORMANCE STANDARDS:

- Complete knowledge test with a minimum of 75 percent accuracy and performance test to the standards of the instructor.
- Identify how and where to find welding symbols, the standard location of the elements of the symbols and symbol meaning in drafting standards.

UNIT 8.0

DRAFTING II  
MECHANICAL DRAFTING (Option)

TASK 8.09

SHOP PROCESSES - WELDING (Con't.)

---

---

RELATED TECHNICAL INFORMATION:

- American Standards Association Z32.2.1, Graphical Symbols for Welding.
- American Welding Society-Standard Welding Symbols.

UNIT	8.0	DRAFTING II MECHANICAL DRAFTING (Option)
TASK	8.10	DESIGN AND DRAW WORKING DRAWINGS

---

PERFORMANCE OBJECTIVE:

Given a mechanical drafting project, proper instruction, and drafting equipment; design and draw the required machine or machine element with each unit incorporated into it.

PERFORMANCE ACTIONS:

- 8.1001 Assemble necessary data; engineer's sketches and calculations, design layout, general specifications, etc.
- 8.1002 Perform detail drawings showing notes and specifications (including: finishes, heat treatments, tolerances, stock sizes, titles and revisions, etc.).
- 8.1003 Perform assembly drawings as required, by the instructor (Multiview, exploded, etc.).
- 8.1004 Develop complete set of drawings.
- 8.1005 Develop bill of materials, if required.

PERFORMANCE STANDARDS:

- Design and draw mechanical project from given data incorporating motion transfer, fluid power, electrical, welding, foundry and other processes as required to produce assembly drawings that meet standards of craft and specifications.
- Must be to instructor's standards.
- Must be completed within time limit acceptable for initial employment in mechanical drafting.

SUGGESTED INSTRUCTION TIME: 136 Hours

RELATED TECHNICAL INFORMATION:

- Orthographic theory.
- Purpose of working drawings.
- Measuring and dimensioning.
- Conventions.
- ANSI Standards.

PROFICIENCY REPORT



PROFICIENCY REPORT  
FOR

\_\_\_\_\_  
Vocational Course

Student: \_\_\_\_\_

High School: \_\_\_\_\_

Vocational Course: \_\_\_\_\_

Date Training Initiated: \_\_\_\_\_

First Year Completed: \_\_\_\_\_

Second Year Initiated: \_\_\_\_\_

Second Year Completed: \_\_\_\_\_

Instructor: \_\_\_\_\_

**DIRECTIONS:** The purpose of the proficiency report is to communicate to the student, other instructors, or potential employers the abilities that a student has demonstrated to the instructor in vocational training. Mark each task as soon as possible after instruction or skills demonstration. If instruction is not aimed as task proficiency, or if only an orientation or introduction to the task was provided, DO NOT mark a proficiency level or mark Level 0. Levels 1-4 indicate that instruction was given and the proficiency may be interpreted as follows:

- Level 0 No skill level demonstrated or proficiency training not given in the skill.
- Level 1 Individual's skill level is not that generally expected for entry level employment.
- Level 2 Individual's skill level probably is that generally expected for entry level employment, but the individual probably will need close on-the-job supervision for a while longer.
- Level 3 Individual's skill level is that generally expected for entry level employment.
- Level 4 Individual's skill level is equal to that of a worker with some on-the-job experience.

For further description of the levels of proficiency, see the "Credentialing Process and Proficiency Report" section of the Policies and Procedures Guide for Articulation Between The School District of Greenville County and Greenville Technical College.

Student: \_\_\_\_\_

PROFICIENCY REPORT

DRAFTING II

TASK		Proficiency					Instructor's Initials	Date	Completed
		Level 0	Level 1	Level 2	Level 3	Level 4			
UNIT 8.0	MECHANICAL DRAFTING OPTION								
8.01	Introduction to Mechanical Drafting as a Specialty								
8.02	Cams (Motion Transfer)								
8.03	Gears (Motion Transfer)								
8.04	Fluid Power Mechanics								
8.05	Shop Processes								
8.06	Hardware Classifications and Certification								
8.07	Developments and Intersections								
8.08	Draw Electrical Power Systems and Schematics								
8.09	Shop Processes - Welding								
8.10	Design and Draw Working Drawings								
DRAFTING II PORTFOLIO OF 2nd YEAR DRAWINGS COMPLETED							( ) Yes	( ) No	

Comments:

Instructor's Signature: \_\_\_\_\_

UNIT 8.0 - MECHANICAL DRAFTING

OUTCOME-REFERENCED TESTS

Task 8.02 & 8.03

1. Explain what is a cam? \_\_\_\_\_  
\_\_\_\_\_
- 2: Explain what is a cam follower? \_\_\_\_\_  
\_\_\_\_\_
3. What is a displacement diagram for a given cam? \_\_\_\_\_  
\_\_\_\_\_
4. Identify two types of motion for which a cam may be designed.
  1. \_\_\_\_\_
  2. \_\_\_\_\_
5. In the drawing accompanying this sheet (provided by the instructor) what is the smaller of the two gears at the left side of the picture called? What is the larger of the two gears called?  
Smaller: \_\_\_\_\_  
Larger: \_\_\_\_\_
6. For a spur gear, explain what is meant by the following terms:
  - a. Outside diameter: \_\_\_\_\_  
\_\_\_\_\_
  - b. Pitch diameter: \_\_\_\_\_  
\_\_\_\_\_
  - c. Root diameter: \_\_\_\_\_  
\_\_\_\_\_
7. What is the circular pitch of a spur gear? \_\_\_\_\_  
\_\_\_\_\_
8. State what is the most widely used gear tooth form in use today?  
\_\_\_\_\_  
\_\_\_\_\_
9. Describe what is a spur gear? \_\_\_\_\_  
\_\_\_\_\_

Unit 8.0 - Mechanical Drafting (Con't.)

Task 8.02 & 8.03 (Con't.)

10. On a working drawing, how are the teeth of a spur gear shown and why?

---

---

---

IDENTIFY THE FOLLOWING SYMBOLS AS USED ON FLUID POWER SCHEMATICS:  
 WRITE ANSWER BESIDE EACH SYMBOL. SHOW N.O. OR N.C. WHERE APPLICABLE.

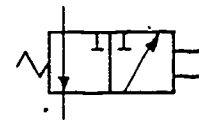
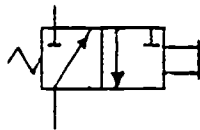
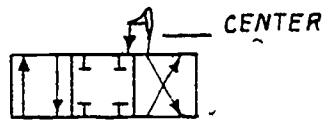
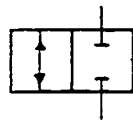
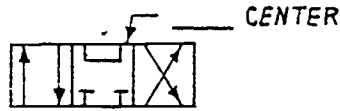
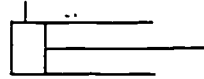
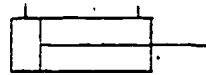

IN A FLUID POWER SYSTEM WHAT IS THE RESERVOIR ?

WHAT ARE THE TWO BASIC KINDS OF FLUID POWER SYSTEMS BASED ON THE FLUID USED IN EACH ?

HOW MUCH FORCE WILL A 2IN. DIA. PISTON EXERT WHEN SUBJECTED TO 2000 PSI FLUID PRESSURE ?

PLANT AIR

8.04 Instructions: Using drafting instruments, draw this engineer's sketch correctly to the size specified by the instructor, with standard border and title block. Finished drawing must meet instructor's standards.

ALL VALVES:

4 WAY

2 POSITION

SOL ACTUATED

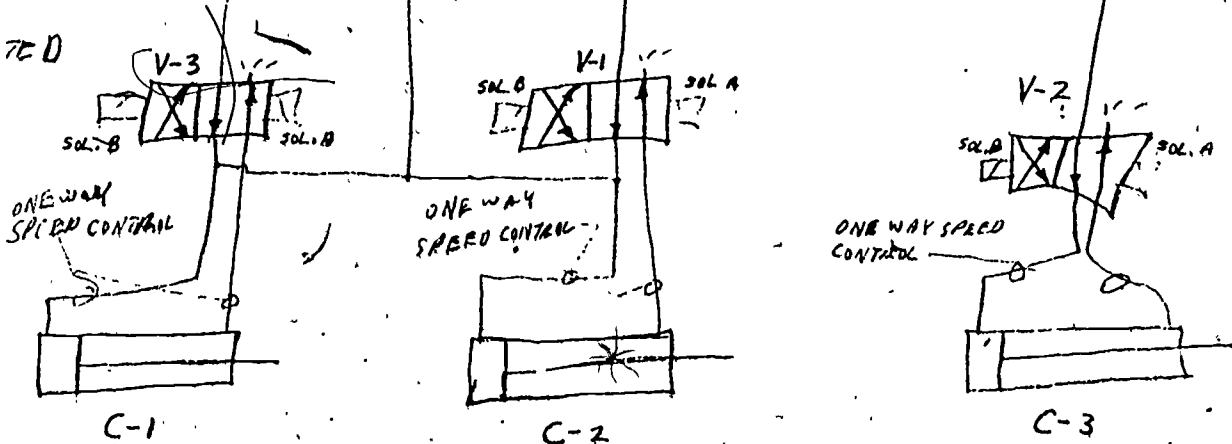

SEQUENCE (8.04 & 8.08)

1. Knob feed extends
2. Stud feed extends and begins retracting
3. Press extends and stud feed completes retraction
4. Press retracts, stud feed retracts
5. Step 1 (Knob feed extends) is repeated

KNOB FEED

STUD FEED

PRESS

PNEUMATIC VERSION OF FLUID POWER SYST FOR STUD INSTALLER

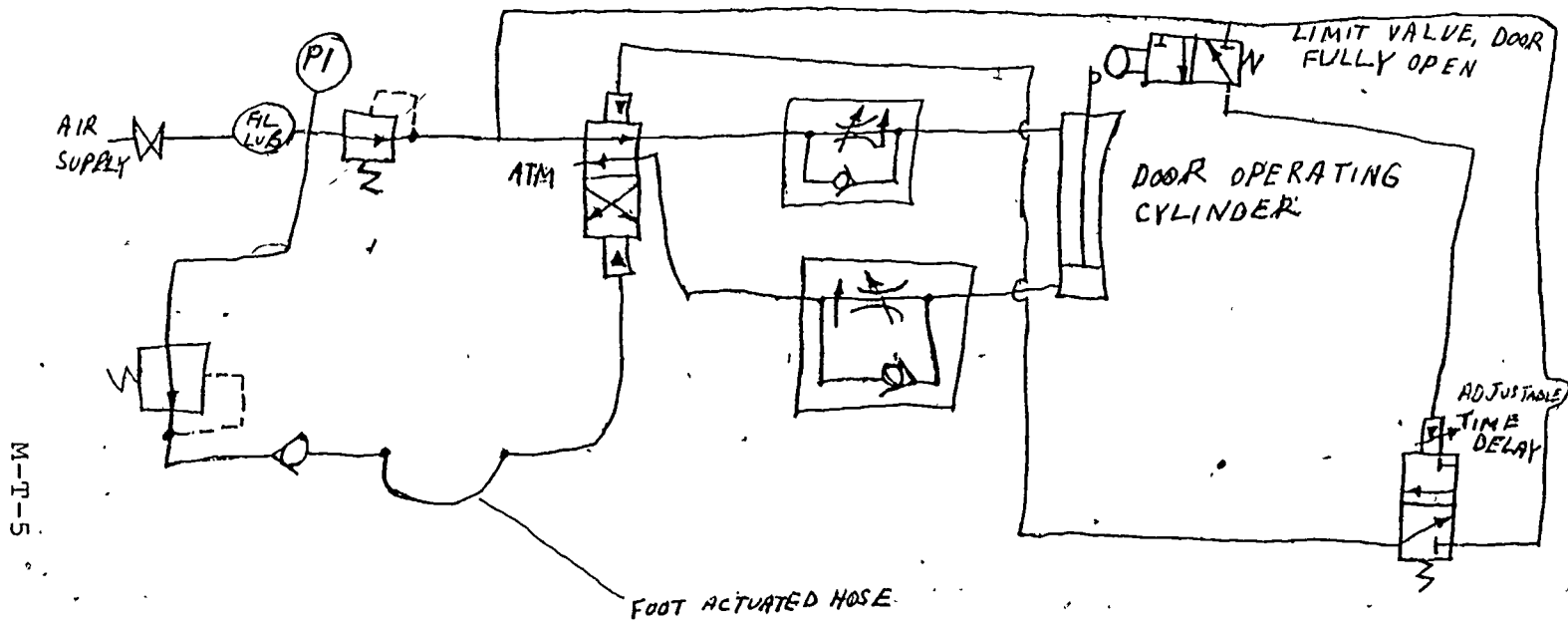

M-1-5

DOOR OPERATOR

8.04 FLUID POWER WORKSHEET A

Instructions: Using drafting instruments, draw the above engineer's sketch correctly on an 11 x 17 inch sheet, with standard border and title block. The finished drawing must be to the instructor's standards.

UNIT 8.0 - MECHANICAL DRAFTING

OUTCOME-REFERENCED TESTS

Task 8.07

1. Referring to Fig. 17-22, page 355, of the textbook, Basic Technical Drawing by Spencer/Dygdon, 1st Edition, draw all the bend lines in the development for a small round to large rectangular transition piece. Label all points when found. Using piece of aluminum wire to simulate flexible curve, draw in the curved side of the development. Drawing is to be accomplished without supervision and without exchanging information with others. Completed drawings must meet the instructor's standards.

(See drawings 1, 2, and 3)



DEVELOPMENTS. TRANSITION, SMALL ROUND TO LARGE RECTANGULAR

1.

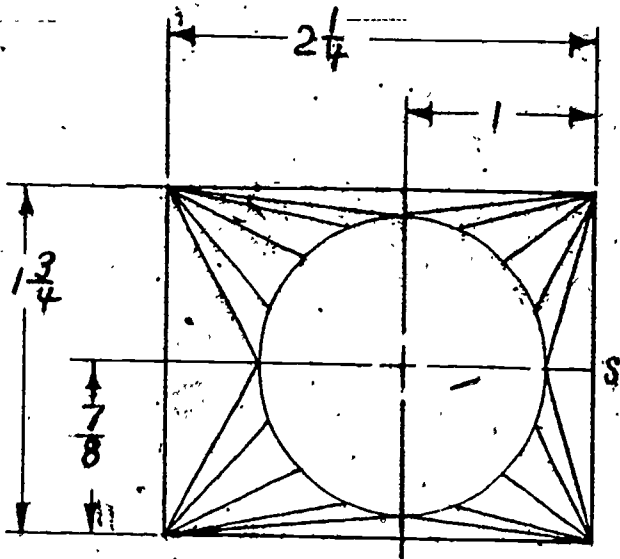

2.

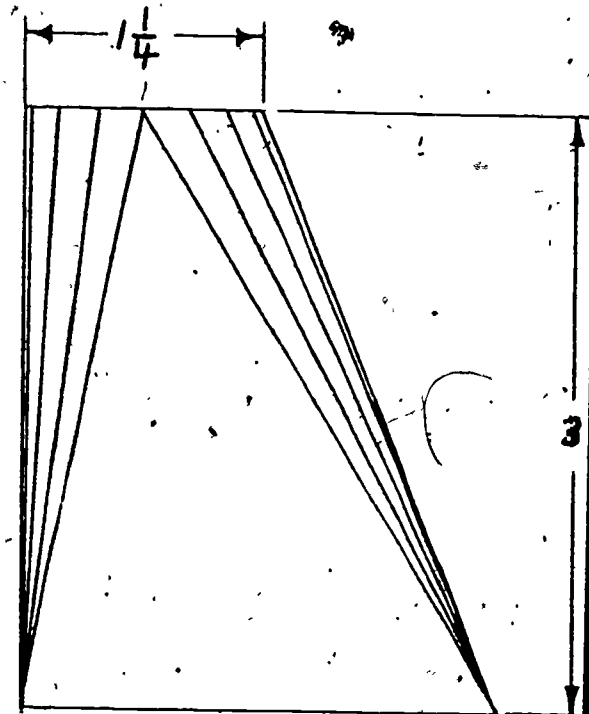
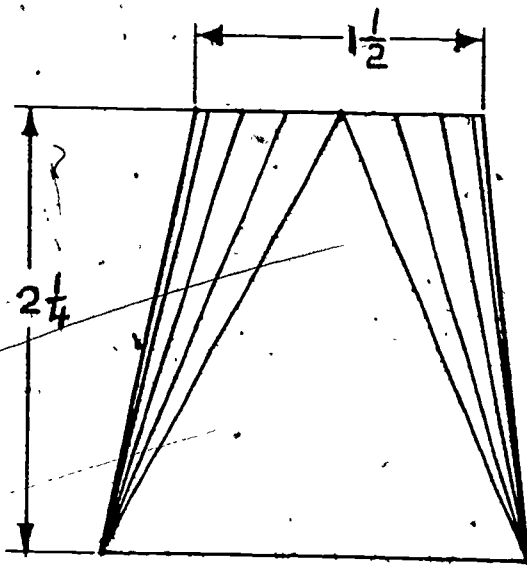
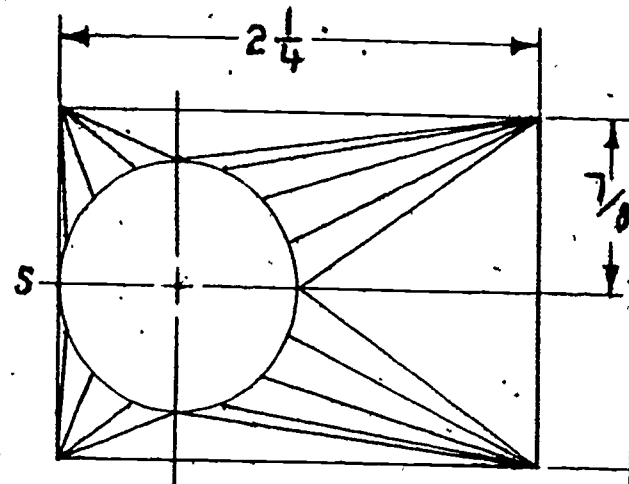

NO. \_\_\_\_\_

# DEVELOPMENTS. TRANSITION, SMALL ROUND TO LG. RECT.

31

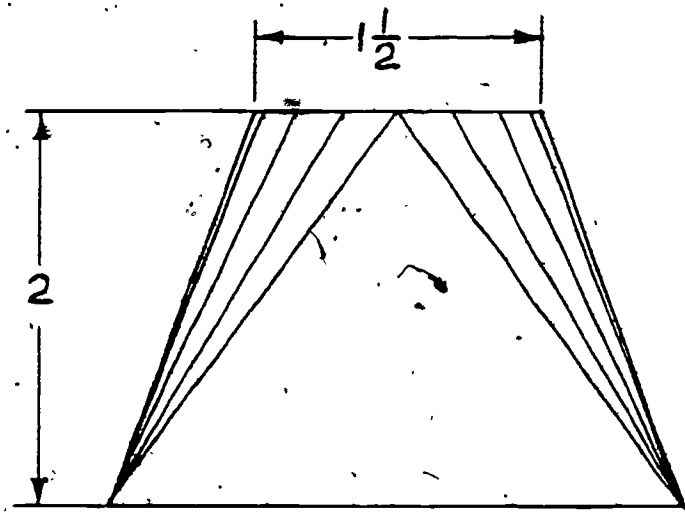
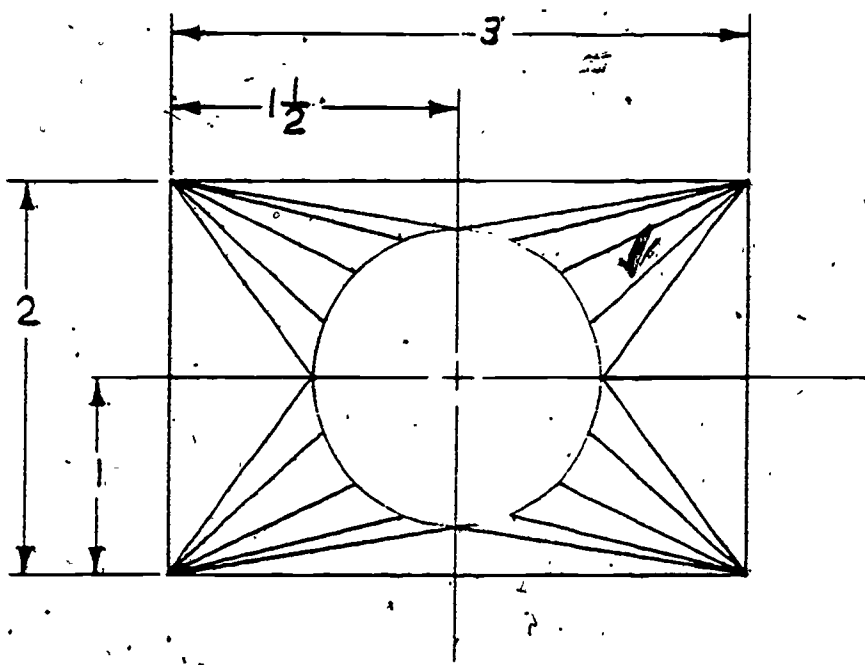

140

UNIT 8.0 - MECHANICAL DRAFTING

OUTCOME-REFERENCED TESTS

Task 8.08

1. Given the attached engineer's sketch of an electrical circuit, correctly draw the circuit using proper symbols and abbreviations. The drawing must be 100 percent accurate and must meet the instructor's standards.

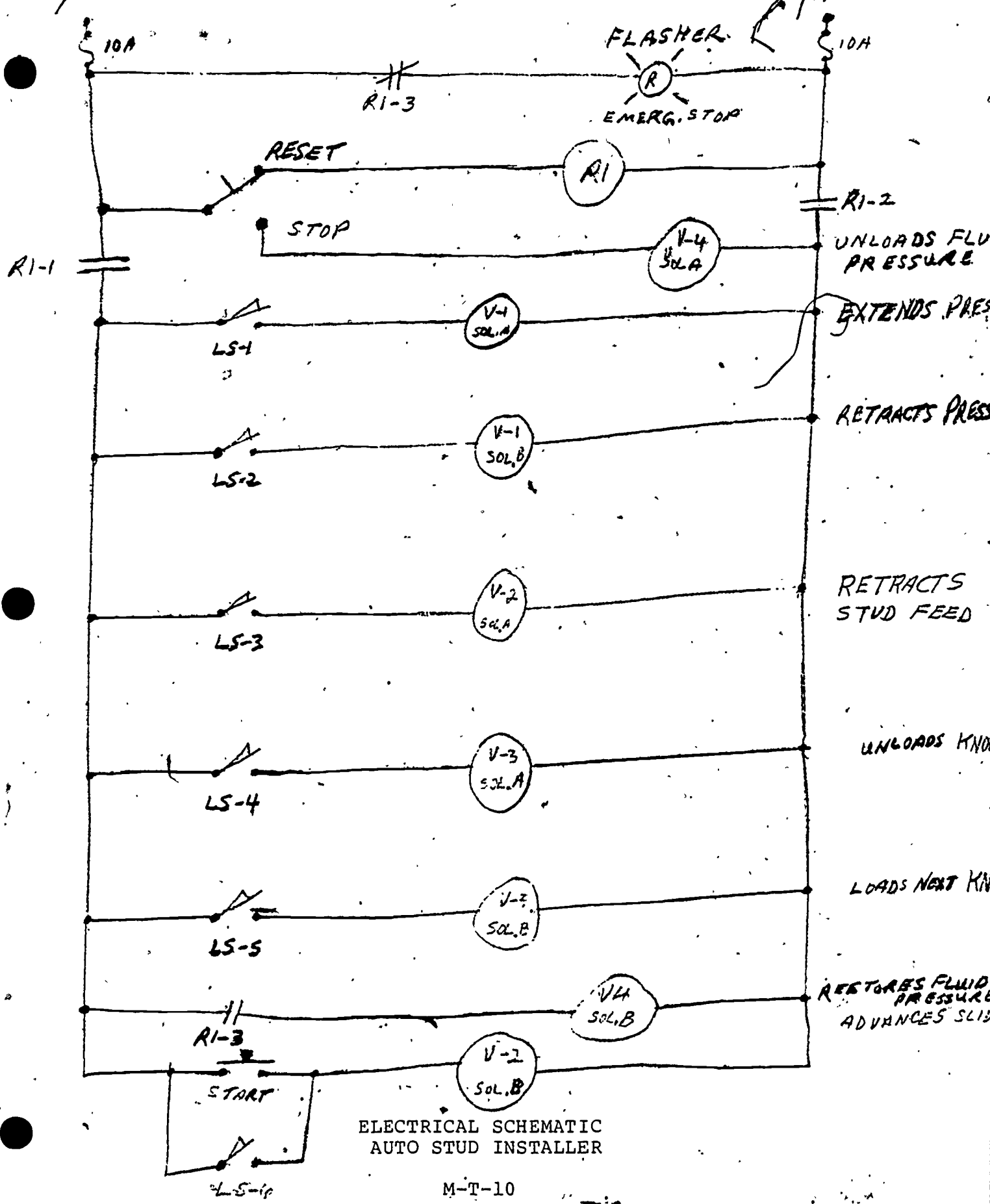

ELECTRICAL SCHEMATIC  
AUTO STUD INSTALLER

M-T-10



Unit 8.0 - Mechanical Drafting

Answer Sheet

Task 8.02 & 8.03

1. Short answer

2. Short answer

3. Short answer

4. Short answer

5. Short answer

6. Short answer

7. Short answer

8. Short answer

9. Short answer

10. Short answer

Task 8.04

1. Performance test

# FLUID POWER SYMBOLS

## VALVES:

FLOW PATHS INTERNALLY OPEN

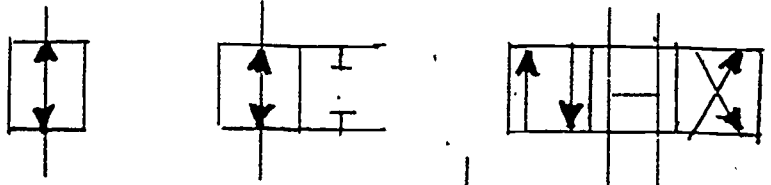

TWO WAY VALVE  
2 POSITION

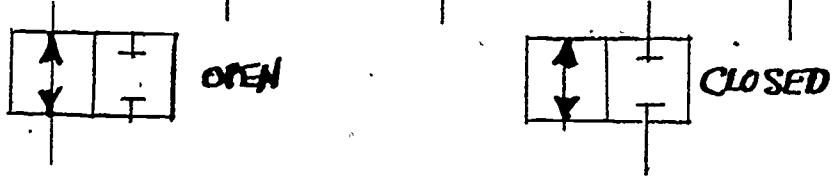

THREE WAY  
2 POSITION  
MANUALLY  
OPERATED

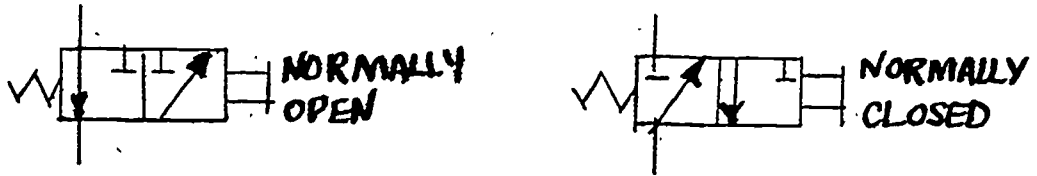

FOUR WAY  
2 POSITION



FOUR WAY  
3 POSITION

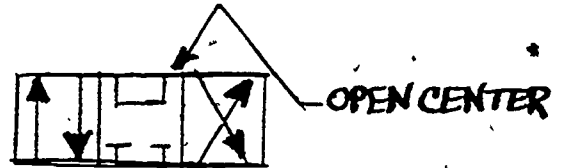

## CYLINDERS:

SINGLE  
ACTING



DOUBLE  
ACTING

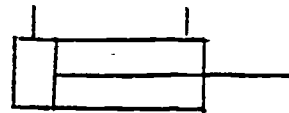

## METHODS AND DEVICES USED TO OPERATE VALVES

LEVER



PILOT PRESSURE



PUSHBUTTON



DETENT



MANUAL



SOLENOID CONTROLLED  
PILOT PRESS OPERATED



MECHANICAL



SPRING



PEDAL OR TREADLE



PRESSURE COMPENSATOR



SOLENOID



SERVO



# PNEUMATIC, AUTOMATIC CYCLING

II

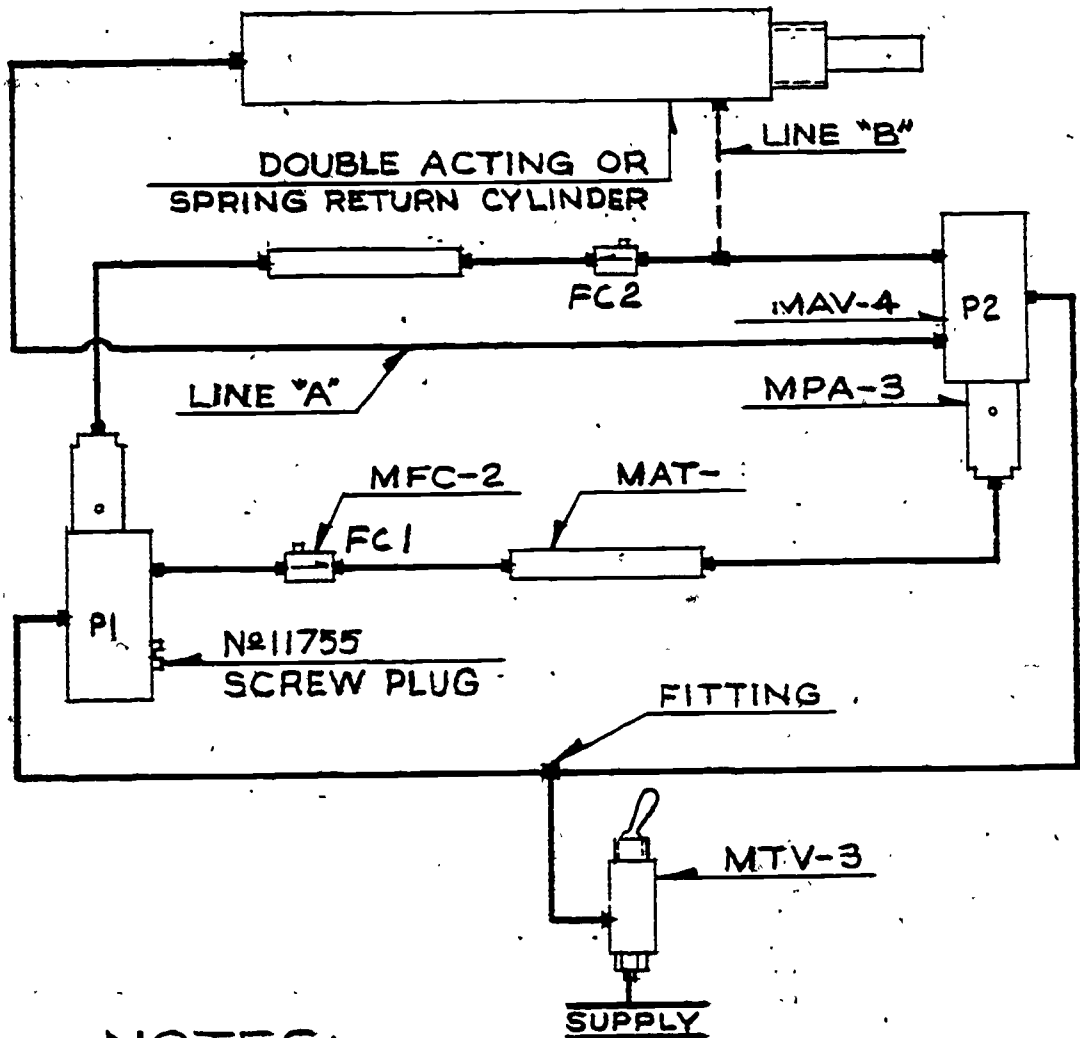

### NOTES:

- 1.) ADJUSTING FLOW CONTROLS VARIES DWELL AT EACH END
- 2.) "A" LINE ONLY — SINGLE ACTING CYLINDER  
"A" & "B" LINE — DOUBLE ACTING CYLINDER
- 3.) FLOW CONTROLS CAN BE REVERSED FOR VARIABLE ACTION ON CYLINDERS
- 4.) VOLUMES CAN BE VARIED TO LENGTHEN DWELL TIME AND CIRCUIT SPEED
- 5.) SELECTION OF THE DIFFERENT TYPES OF CLIPPARD'S MINIATURE FITTINGS AND STOCKED AIR LINES MUST BE MADE IN REGARDS TO ONES OWN DESIGNS AND NEEDS

### CLIPPARD MINIMATICS

Nº REQ	MODEL Nº	TYPE
2	MAV-4	4-WAY VAL.
1	MTV-3	TOGGLE
2	MFC-2	FLOW CON.
2	MAT-	AIR TANK
2	MPA-3	ACTUATOR
SEE NOTE # 5		FITTING

M-1-14

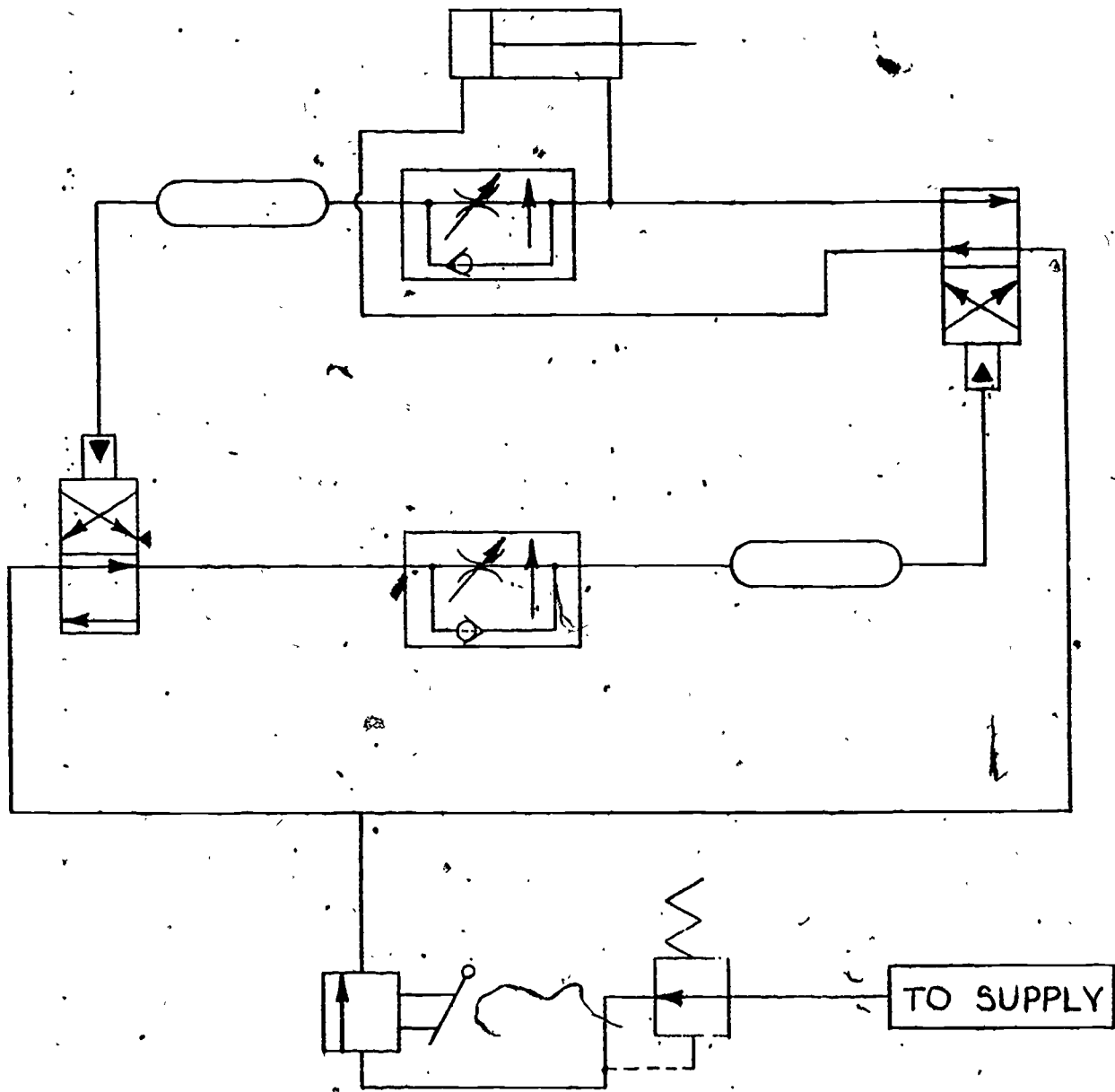

ERIC  
GSVC  
DR. BY: ANDY POTTEAT

AUTOMATIC CYCLING  
SCALE: NONE  
DATE: 2-17-82

CLASS  
DRAFTING

SEAT  
17

DR. NO.  
147



M-T-15

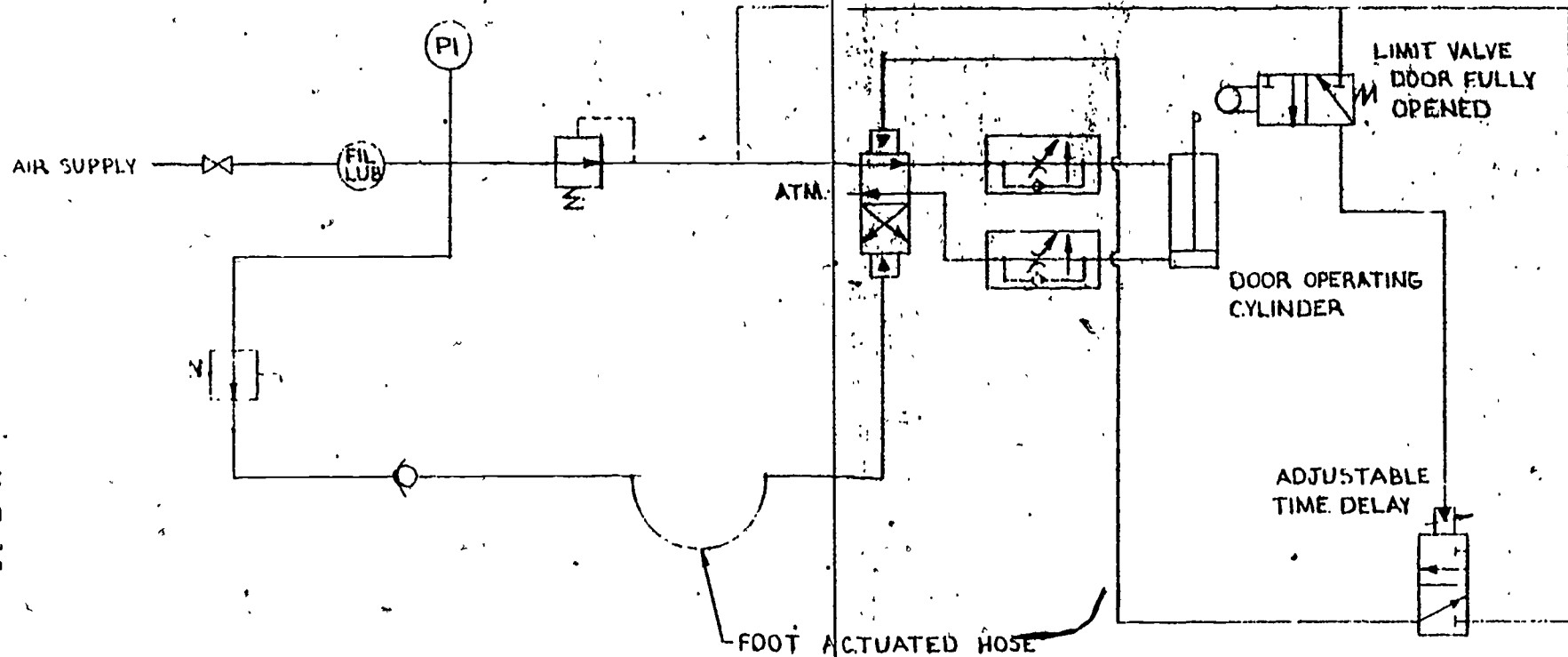

SOLUTION TO: 8.0401  
 8.0402  
 8.0403  
 8.0404

ESVC DR. BY ANLY P	DOOR OPERATOR SCALE: NONE	DATE: 2-8 82	CLASS DRAFTING	SEAT 17	DR. NO. 1
-----------------------	------------------------------	--------------	-------------------	------------	--------------

REFERENCES

TECHNICAL REFERENCES

MECHANICAL DRAFTING OPTION

Electrical and Electronics Diagrams, USAS Y14.15-1966, New York, NY: American Society of Mechanical Engineers (345 East 47th St., 10017).

Fluid Power Educational Kit, (Kit), Cincinnati, OH: Clippard Laboratory, Inc., (7390 Coleman Road., 45239).

Graphic Symbols for Electrical and Electronics Diagrams, ANSI Y32.2-1975, New York, NY: The Institute of Electrical and Electronic Engineers (345 East 47th St., 10017).

Grimes, L. A. Jr., Mechanical Drafter Student's Manual, Austin, TX: The University of Texas at Austin, Instructional Materials Center, Division of Continuing Education, 1965.

Grimes, L. A. Jr., Mechanical Draftsman Coordinator's Guide, Austin, Tx: The University of Texas at Austin, Instructional Materials Center; Division of Continuing Education, 1965.

Hodges, Charles S., Industrial Fluid Power, Vols. I, II, & III, Dallas TX: Womack Educational Publications, (2110 Shea Road., 75235).

Interconnection Diagrams, ANSI Y14.15a-1971, New York, NY: McGraw-Hill Book Company.

Oster, Jan, Basic Applied Fluid Power: Hydraulics, New York, NY: McGraw-Hill Book Company.

Vickers Industrial Hydraulics Manual 735100-A, Troy, MI: Sperry Rand Corporation, (48084).

To initiate a program in Mechanical Drafting, the following publication is recommended.

McClain, Gerald R., Mechanical Drafting, Stillwater, OK: Mid-American Vocational Curriculum Consortium, Inc., 1982. (ZIP 74074, 973 pages, CBVE Curriculum/Resource Guide featuring layouts and working drawings, dimensioning and tolerancing, fasteners and hardware, presentation drawings, materials and specifications, manufacturing processes, sheet metal developments, and power transmission).

(NOTE: This publication is available through the Articulation Program Library.)

UNIT 9.0

DRAFTING II  
STRUCTURAL DRAFTING

## DRAFTING II

### STRUCTURAL DRAFTING (OPTION)

This Structural Drafting option is designed to provide and enhance job qualification competencies required to perform Architectural Drafting tasks involving the analysis and drawing of structural systems applications of steel, wood, and concrete. Structural Drafting may be considered a specialized continuation of the Architectural Drafting option.

Emphasis in Structural Drafting will be on detailing, performing basic structural calculations, and the design of fasteners and connectors.

Currently, Structural Drafting only is offered at one vocational education center in The School District of Greenville County.

DRAFTING II  
STRUCTURAL DRAFTING  
SUGGESTED INSTRUCTION TIME

<u>DRAFTING II</u> <u>UNIT/TASK</u>	<u>SUGGESTED</u> <u>HOURS</u>
Unit 9.0	
9.01 Draw and Analyze Construction Applications of Wood	6
9.02 Draw and Analyze Construction Applications of Concrete	6
9.03 Draw the Top, Front, and End Views of Given Steel Shapes Showing Rivets, Welds, and Bolts	12
9.04 Draw and Analyze Construction Applications of Structural Steel	6
9.05 Layout Foundation Plan	*
9.06 Layout Supported Floor Plan	*
9.07 Draw and Interpret Prints of Three Types of Framing	15
9.08 Detail Reinforcing Steel on Foundations, Walls, Columns, Stairs, and Floor Slabs	75
9.09 Describe and Draw Structural Systems Common to Commercial Construction	<u>15</u>
	135

\*Intergrated with other Unit 9.0 tasks.

TASK LISTINGS  
DRAFTING II  
STRUCTURAL DRAFTING

UNIT/TASK	DESCRIPTION
Unit 9.0	
9.01	(Draw and Analyze Construction Applications of Wood) Given instruction, architectural drafting tools, equipment, and references, and a structural drafting assignment; draw and analyze construction applications of wood. The instructor's standards apply.
9.02	(Draw and Analyze Construction Applications of Concrete) Given instruction, architectural drafting tools, equipment, and references, and a structural drafting assignment; draw and analyze construction applications of concrete. The instructor's standards apply.
9.03	(Draw The Top, Front, and End Views of Given Steel Shapes Showing Rivets, Welds, and Bolts) Given instruction, architectural tools and references, and a selected structural drafting assignment; draw the top, front, and end views of given steel shapes showing rivets, welds, and bolts. The performance standards is that required by the architectural industry or entry level workers and the instructor's standards.
9.04	(Draw and Analyze Construction Applications of Structural Steel) Given instruction, architectural drafting tools, equipment, and references, and a structural drafting assignment; draw and analyze construction applications of structural steel. The instructor's standards apply.
9.05	(Lay Out Foundation Plan) After proper instruction, given appropriate drafting tools and references, and given a structural drafting assignment; layout a foundation plan with wall footings, column footings, schedules, sections, and details to standards acceptable by the architectural industry for entry level workers and to the instructor's standards.
9.06	(Lay Out Supported Floor Plan) Given instruction, a structural drafting assignment, and necessary tools and references; lay out supported floor plan with sections, show beam elevations, and schedules of reinforcing steel for beams and slabs. Performance is to be the standards expected of entry level workers in the architectural field and to the instructor's standards.
9.07	(Draw and Interpret Prints of Three Types of Framing) Given instruction, architectural tools and equipment, and a structural drafting assignment; draw three types of framing and practice reading given prints of the three types of drawings. Instructor's standards apply.

- 9.08 (Detail Reinforcing Steel on Foundations, Walls, Columns, Stairs and Floor Slabs) Given instruction, architectural tools and references, a structural drafting assignment; detail reinforcing steel on foundations, walls, columns, stairs and floor slabs. The instructor's standards as well as standards of the architectural industry for entry level performance must be met.
- 9.09 (Describe and Draw Structural Systems Common to Commercial Construction) Given proper instructions, describe and draw structural systems, given by the instructor and common to commercial construction.

*h*



UNIT	9.0	DRAFTING II STRUCTURAL DRAFTING
TASK	9.01	DRAW AND ANALYZE CONSTRUCTION APPLICATIONS OF WOOD

---

---

PERFORMANCE OBJECTIVE:

Given instruction, architectural drafting tools, equipment, and references, and a structural drafting assignment; draw and analyze construction applications of wood. The instructor's standards apply.

PERFORMANCE ACTIONS:

- 9.0101 Describe characteristics and applications and draw heavy timber construction.
- 9.0102 Describe characteristics and draw applications of wood in light construction.
- 9.0103 List considerations to be applied in applications of wood in construction.
- 9.0104 Identify types, characteristics, and how to draw applications of laminated wood in construction.
- 9.0105 Identify characteristics, types, applications, and draw wood connections.
- 9.0106 Explain wood applications fabrication procedures.
- 9.0107 Describe wood applications erection procedures.

PERFORMANCE STANDARDS:

- Eighty percent accuracy on written knowledge tests.
- Executes drawings accurately, neatly, with professional styles within an acceptable time for entry-level employment.

SUGGESTED INSTRUCTION TIME: 6 Hours

UNIT 9.0

DRAFTING II  
STRUCTURAL DRAFTING

TASK 9.02

DRAW AND ANALYZE CONSTRUCTION  
APPLICATIONS OF CONCRETE

---

---

PERFORMANCE OBJECTIVE:

Given instruction, architectural drafting tools, equipment, and references, and a structural drafting assignment; draw and analyze construction applications of concrete. The instructor's standards apply.

PERFORMANCE ACTIONS:

- 9.0201 Identify types, characteristics, and how to draw applications of concrete structural systems.
- 9.0202 List considerations to be applied in applications of concrete structural systems.
- 9.0203 Describe types, characteristics, applications, and draw connections used in concrete structural systems.
- 9.0204 Describe methods of fabrication of concrete structural systems.
- 9.0205 Explain concrete structural systems erection procedures.

PERFORMANCE STANDARDS:

- Eighty percent accuracy on written knowledge tests.
- Executes drawings accurately, neatly, with professional style within an acceptable time for entry-level employment.

SUGGESTED INSTRUCTION TIME: 6 Hours

UNIT 9.0

DRAFTING II  
STRUCTURAL DRAFTING

TASK 9.03

DRAW THE TOP, FRONT, AND END  
VIEWS OF GIVEN STEEL SHAPES  
SHOWING RIVETS, WELDS, AND  
BOLTS

---

---

PERFORMANCE OBJECTIVE:

Given instruction, architectural tools and references, and a selected structural drafting assignment; draw the top, front, and end views of given steel shapes showing rivets, welds, and bolts. Performance standards required by the architectural industry for entry level workers and the instructor's standards apply.

PERFORMANCE ACTIONS:

- 9.0301 Identify various shapes.
- 9.0302 Identify Fabricating Practices:
  - a. Material handling and cutting
  - b. Templates
  - c. Layouts
  - d. Punching and drilling
  - e. Bolting
  - f. Riveting
  - g. Welding
  - h. Finishing, cleaning, and painting
  - i. Inspection
- 9.0303 Show Method of Representation:
  - a. Structural shapes
  - b. Bolts (Unfinished & High strength)
    - (1) Shop bolts
    - (2) Field bolts
    - (3) Spacing
  - c. Welding
    - (1) Shop welds
    - (2) Field welds
  - d. Shop rivets
- 9.0304 Identify Gages.
- 9.0305 Develop a Bill of Material.
- 9.0306 Show Methods of Connecting:
  - a. Welding
  - b. Riveting
  - c. Bolting

UNIT 9.0

DRAFTING II  
STRUCTURAL DRAFTING

TASK 9.03

DRAW THE TOP, FRONT, AND END  
VIEWS OF GIVEN STEEL SHAPES  
SHOWING RIVETS, WELDS, AND  
BOLTS (Con't.)

---

---

PERFORMANCE ACTIONS (Con't.):

9.0307 Include beam and connection design.

9.0308 Indicate tolerances.

9.0309 Show beam and column marking.

PERFORMANCE STANDARDS:

- For a given structural drafting assignment, draw the top, front, and end views of given steel shapes showing rivets, welds, and bolts.

SUGGESTED INSTRUCTION TIME: 12 Hours

UNIT 9.0

DRAFTING II  
STRUCTURAL DRAFTING

TASK 9.04

DRAW AND ANALYZE CONSTRUCTION  
APPLICATIONS OF STRUCTURAL STEEL

---

---

PERFORMANCE OBJECTIVE:

Given instruction, architectural drafting tools, equipment, and references, and a structural drafting assignment; draw and analyze construction applications of structural steel. The instructor's standards apply.

PERFORMANCE ACTIONS:

- 9.0401 Identify and draw conventional structural steel shapes.
- 9.0402 List considerations in applications of structural steel.
- 9.0403 Describe and draw common types of structural steel connections.
- 9.0404 Identification structural steel fabrication procedures.

PERFORMANCE STANDARDS:

- Eighty percent accuracy on written knowledge tests.
- Executes drawings accurately, neatly, with professional style within an acceptable time for entry-level employment.

SUGGESTED INSTRUCTION TIME: 6 Hours

UNIT 9.0

DRAFTING II  
STRUCTURAL DRAFTING

TASK 9.05

LAYOUT FOUNDATION PLAN

PERFORMANCE OBJECTIVE:

After proper instruction, given appropriate drafting tools and references, and given a structural drafting assignment; layout a foundation plan with wall footings, column footings, schedules, sections, and details to standards acceptable by the architectural industry for entry level workers and to the instructor's standards.

PERFORMANCE ACTIONS:

- 9.0501 Draw column footings.
- 9.0502 Draw piers.
- 9.0503 Draw wall footings.
- 9.0504 Draw walls.
- 9.0505 Draw grade beams.
- 9.0506 Draw typical sections.

PERFORMANCE STANDARDS:

- For a given structural drafting assignment, layout a foundation plan with wall footings; column footings, schedules, sections, and details to standards acceptable by the architectural industry for entry level workers and to the instructor's standards.

SUGGESTED INSTRUCTION TIME: Integrated with other Unit 9.0 tasks

RELATED TECHNICAL INFORMATION:

- Sweets Catalogs and other appropriate references.

UNIT 9.0

DRAFTING II  
STRUCTURAL DRAFTING

TASK 9.06

LAYOUT SUPPORTED FLOOR PLAN

---

---

PERFORMANCE OBJECTIVE:

Given instruction, a structural drafting assignment, and necessary tools and references; lay out supported floor plan with sections, show beam elevations, and schedules of reinforcing steel for beams and slabs. Performance is to be to the standards expected of entry level workers in the architectural field and to the instructor's standards.

PERFORMANCE ACTIONS:

- 9.0601 Identify various bar sizes.
- 9.0602 Identify the scales most commonly used in drafting reinforced concrete buildings.
- 9.0603 Show methods of Dimensioning.
- 9.0604 Draw Columns.
- 9.0605 Draw Beams and Girders.
- 9.0606 Draw Slabs:
  - a. Joist slab
  - b. Flat slab
  - c. Two-way slab
  - d. Waffle slab
- 9.0607 Detail Stairs.
- 9.0608 Show Schedules.

PERFORMANCE STANDARDS:

- Layout supported floor plan with sections, show beam elevations, and schedules of reinforcing steel for beams and slabs.
- Performance is to be to the standards expected of entry level workers in the architectural field and to the instructor's standards.

SUGGESTED INSTRUCTION TIME: Integrated with other Unit 9.0 tasks

UNIT 9.0

DRAFTING II  
STRUCTURAL DRAFTING

TASK 9.07

DRAW AND INTERPRET PRINTS OF THREE  
TYPES OF FRAMING

---

---

PERFORMANCE OBJECTIVE:

Given instruction, architectural tools and equipment, and a structural drafting assignment; draw three types of framing and practice reading given prints of the three types of drawings. Instructor's standards apply.

PERFORMANCE ACTIONS:

- 9.0701 Draw Columns.
- 9.0702 Interpret and draw the three types of framing:
  - a. Beams and girders
  - b. Bar joints
  - c. Trusses
- 9.0703 Draw a Framing Plan.\*
- 9.0704 Draw Sections and miscellaneous details.\*
- 9.0705 Include Schedules.
- 9.0706 Identify riveting, welding, and bolting and the advantages of each.

PERFORMANCE STANDARDS:

- Draw and interpret prints of three types of framing.
- The instructor's standards must be met.

SUGGESTED INSTRUCTION TIME: 15 Hours

\*Emphasis of training.



UNIT 9.0

DRAFTING II  
STRUCTURAL DRAFTING

TASK 9.08

DETAIL REINFORCING STEEL ON  
FOUNDATIONS, WALLS, COLUMNS,  
STAIRS AND FLOOR SLABS

---

---

PERFORMANCE OBJECTIVE:

Given instruction, architectural tools and references, a structural drafting assignment; detail reinforcing steel on foundations, walls, columns, stairs and floor slabs. The instructor's standards as well as standards of the architectural industry for entry level performance must be met.

PERFORMANCE ACTIONS:

- 9.0801 Identify the scales most commonly used in detail drawing.
- 9.0802 Identify building marks.
- 9.0803 Show schedules.
- 9.0804 Show typical bar bends.
- 9.0805 Show clearance required.
- 9.0806 Detail reinforcing steel on:
  - a. Foundations and Footings
  - b. Grade beams
  - c. Walls
  - d. Columns
  - e. Slabs
    - (1) Joist slab
    - (2) Flat slab
    - (3) Two-Way slab
    - (4) Waffle flat slab
    - (5) Beam and girder floor
  - f. Stair details
  - g. Bar supports
- 9.0807 Show Fabricating Practices:
  - a. Bending
  - b. Hooks
  - c. Radius bends
  - d. Slants on truss bars
- 9.0808 Show Splices.

UNIT 9.0

DRAFTING II  
STRUCTURAL DRAFTING

TASK 9.08

DETAIL REINFORCING STEEL ON  
FOUNDATIONS, WALLS, COLUMNS,  
STAIRS AND FLOOR SLABS (Con't.)

---

PERFORMANCE ACTIONS (Con't.):

9.0809 Show Bar Lists.

9.0810 Identify Wire Fabric.

PERFORMANCE STANDARDS:

- For a given structural drafting assignment, detail reinforcing steel on foundations, walls, columns, stairs, and floor slabs.
- Performance must be to standards acceptable to the architectural industry for entry level workers and to the standards of the instructor.

SUGGESTED INSTRUCTION TIME: 75 Hours

UNIT 9.0

DRAFTING II  
STRUCTURAL DRAFTING

TASK 9.09

DESCRIBE AND DRAW STRUCTURAL SYSTEMS  
COMMON TO COMMERCIAL CONSTRUCTION

---

---

PERFORMANCE OBJECTIVE:

Given proper instructions, describe and draw structural systems, given by the instructor, common to commercial construction.

PERFORMANCE ACTIONS:

- 9.0901 Describe applications of poured and precast concrete and pan systems.
- 9.0902 Draw applications of poured and precast concrete, and pan systems.
- 9.0903 Identify characteristics of structural steel to include connections (riveted, bolted, welded, and columns) and bar joints.
- 9.0904 Draw various applications of structural steel.
- 9.0905 Describe types and characteristics of roof structures and the application of thin shell concrete.
- 9.0906 Draw various types of roof structures used in commercial buildings.
- 9.0907 Identify types, characteristics, and applications of wall sections and the details.
- 9.0908 Draw various types of wall sections and applications.
- 9.0909 Identify types, characteristics, and applications of the details of minor structural features to include steel stairs, steel trusses, bearing wall details and open weld joists.
- 9.0910 Draw various types and applications of details of minor structural features.

PERFORMANCE STANDARDS:

- Demonstrate ability to use related technical information, use of Sweets Catalogs, AIA and other technical reference material with 80 percent accuracy.

UNIT 9.0

DRAFTING II  
STRUCTURAL DRAFTING

TASK 9.09

DESCRIBE AND DRAW STRUCTURAL SYSTEMS  
COMMON TO COMMERCIAL CONSTRUCTION  
(Con't.)

---

---

PERFORMANCE STANDARDS (Con't.):

- Produce neat, accurate, and complete drawings, professional in appearance and layout.
- Draw symbols and conventions accurately and correctly.
- Perform required drawings within the time limits considered appropriate for initial employment job qualification.
- Lettering and drafting skills demonstrated must show neatness, accuracy, consistency, proper placement, and character.

SUGGESTED INSTRUCTION TIME: 15 Hours

RELATED TECHNICAL INFORMATION:

- Sweets Catalogs.
- AIA and other references.

PROFICIENCY REPORT

PROFICIENCY REPORT  
FOR

\_\_\_\_\_  
Vocational Course

Student: \_\_\_\_\_

High School: \_\_\_\_\_

Vocational Course: \_\_\_\_\_

Date Training Initiated: \_\_\_\_\_

First Year Completed: \_\_\_\_\_

Second Year Initiated: \_\_\_\_\_

Second Year Completed: \_\_\_\_\_

Instructor: \_\_\_\_\_

**DIRECTIONS:** The purpose of the proficiency report is to communicate to the student, other instructors, or potential employers the abilities that a student has demonstrated to the instructor in vocational training. Mark each task as soon as possible after instruction or skills demonstration. If instruction is not aimed as task proficiency, or if only an orientation or introduction to the task was provided, DO NOT mark a proficiency level or mark Level 0. Levels 1-4 indicate that instruction was given and the proficiency may be interpreted as follows:

- Level 0 No skill level demonstrated or proficiency training not given in the skill.
- Level 1 Individual's skill level is not that generally expected for entry level employment.
- Level 2 Individual's skill level probably is that generally expected for entry level employment, but the individual probably will need close on-the-job supervision for a while longer.
- Level 3 Individual's skill level is that generally expected for entry level employment.
- Level 4 Individual's skill level is equal to that of a worker with some on-the-job experience.

For further description of the levels of proficiency, see the "Credentialing Process and Proficiency Report" section of the Policies and Procedures Guide for Articulation Between The School District of Greenville County and Greenville Technical College.

Student: \_\_\_\_\_

PROFICIENCY REPORT

DRAFTING II

TASK	Proficiency					Instructor's Initials	Date	Completed
	Level 0	Level 1	Level 2	Level 3	Level 4			
UNIT 9.0 STRUCTURAL DRAFTING								
9.01 Draw and Analyze Construction Applications of Wood								
9.02 Draw and Analyze Construction Applications of Concrete								
9.03 Draw the Top, Front, and End Views of Given Steel Shapes Showing Rivets, Welds, and Bolts								
9.04 Draw and Analyze Construction Applications of Structural Steel								
9.05 Layout Foundation Plan								
9.06 Layout Supported Floor Plan								
9.07 Draw and Interpret Prints of Three Types of Framing								
9.08 Detail Reinforcing Steel on Foundations, Walls, Columns, Stairs, and Floor Slabs								
9.09 Describe and Draw Structural Systems Common to Commercial Construction								
DRAFTING II PORTFOLIO OF 2nd YEAR DRAWINGS COMPLETED								( ) Yes ( ) No

Comments:

Instructor's Signature: \_\_\_\_\_

## UNIT 9.0 - STRUCTURAL DRAFTING

### OUTCOME-REFERENCED TESTS

#### TRUE-FALSE

1.  In concrete structural systems, precast beams and girders usually are cast in an I, or rectangular shape.
2.  A precast, prestressed beam requires a depth of only one-fourth to one-half that of ordinary concrete construction.
3.  The two basic design considerations for precast floor and roof systems are span and height.
4.  The only way to overcome the tendency of an ordinary beam to crack is to increase its size.
5.  A monolithic reinforced concrete structure is one in which the concrete structural systems is strengthened with steel reinforcing rods.
6.  The structural steel, steel members typically are jointed by riveting, bolting, or welding.
7.  The open-web joist provides greater beam strength than the solid-web joists in structural steel systems.
8.  Structural steel trusses must be designed to withstand tension and, compression stresses.
9.  In structural steel, a chord is one of the principle members that is braced by web members.
10.  the steel framing drawing shows the location of beams, columns, and other steel members.
11.  In laminated-wood structural systems, arches are connected to purlins, which support the roof decking.
12.  In laminated-wood structural systems, the horizontal thrust of foundation arches is contained by foundation piers, with or without tie rods below the floor.
13.  In laminated-wood structural systems to support the roof decking, arches are connected to the foundation.
14.  Bowstring trusses, in laminated-wood structural systems, are designed to provide a high degree of fire safety and freedom from dimensional changes.
15.  Precast-concrete panels are reinforced with welded, galvanized wire mesh.



Unit 9.0 - Structural Drafting (Con't.)

16. Describe the duties of various drafting room employees in a structural steel fabrication shop with 70 percent accuracy according to the instructor's standards.

- a. Drawing checker: \_\_\_\_\_  
\_\_\_\_\_  
\_\_\_\_\_
- b. Detailer: \_\_\_\_\_  
\_\_\_\_\_  
\_\_\_\_\_
- c. Chief draftsman: \_\_\_\_\_  
\_\_\_\_\_  
\_\_\_\_\_
- d. Billing and Weights Clerk: \_\_\_\_\_  
\_\_\_\_\_  
\_\_\_\_\_

UNIT 9.0 - STRUCTURAL DRAFTING

OUTCOME-REFERENCED TESTS

Task 9.03 & 9.04

1. Match the various structural steel shapes with their correct symbols with a minimum of 70 percent accuracy.

<u>Description</u>	<u>Ans.</u>	<u>Symbol</u>
1. Wide flange tee	—	
2. Structural tee (standard)	—	WF or WF
3. Miscellaneous tee	—	S
4. Miscellaneous beam	—	C or I
5. Angle iron	—	M
6. Wide flange beam	—	WT
7. Standard beam	—	ST
8. Round bars	—	MT
9. Plate steel	—	PL
10. Channel iron	—	#
11. Square bars	—	Ø
12. Tube steel (rectangular and round)	—	TS

2. Detail a steel beam having a uniform load with 100 percent accuracy. The drawing details shall include the following:

- Uniform load of beams in kips.
- Uniform load on each connection.
- Size of clip angles (connecting angles.)
- Size of clip angle "A" weld.
- Size of clip angle "B" weld if used.
- Size and number of bolts used in the B- connection.
- Determine length and depth of "cope" if required.
- Determine the "minus" dimensions on each end of beam as required.

# STRUCTURAL STEEL

## DIMENSIONS FOR DETAILING

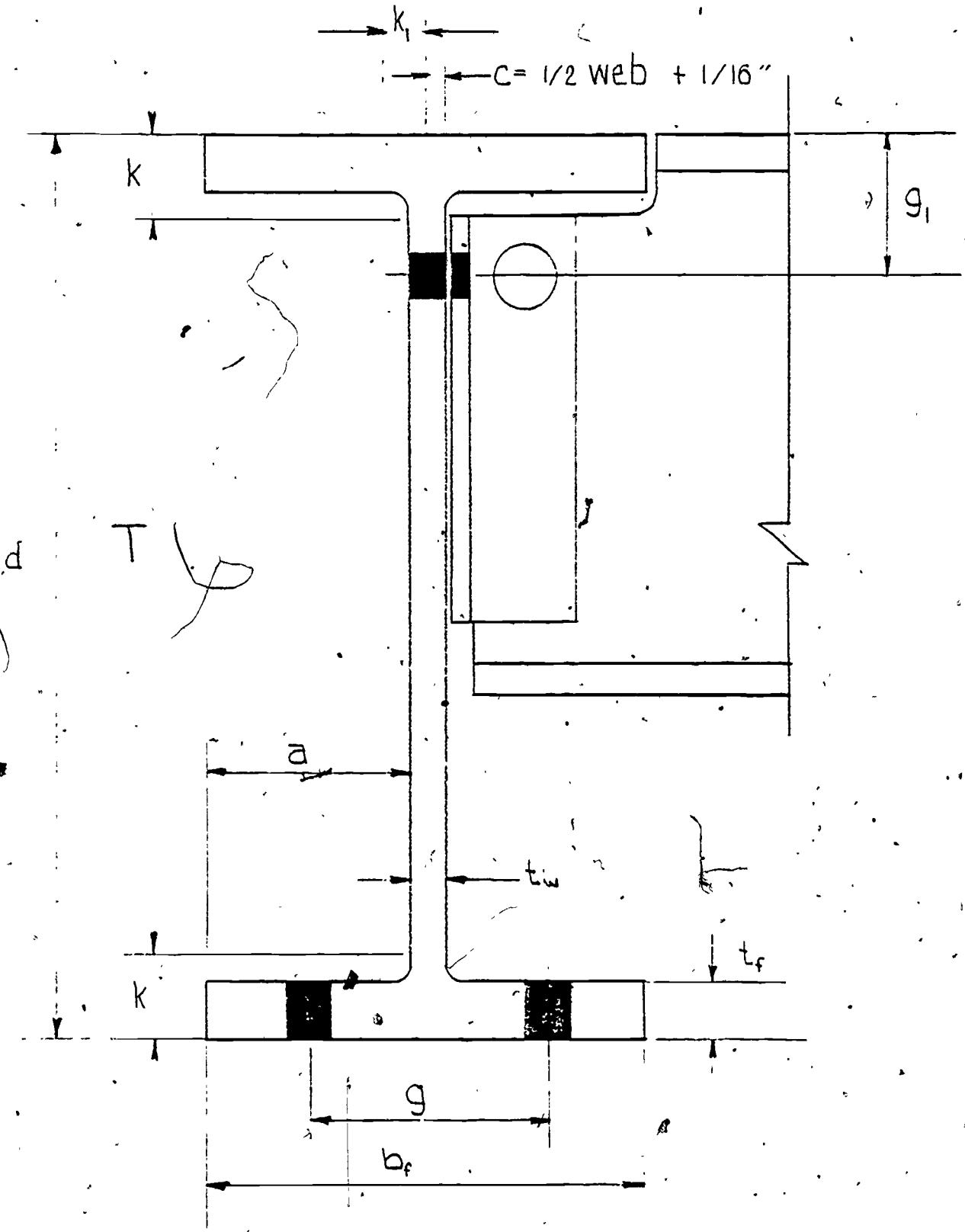

NO SCALE 175

Unit 9.0 - Structural Drafting

Task 9.03 & 9.04 (Con't.)

3. Given an engineer's sketch showing column locations, and sizes of columns, girders, and filler beams; draw a structural steel layout with 90 percent accuracy.

UNIT 9.0 - STRUCTURAL DRAFTING

OUTCOME-REFERENCED TESTS

Task 9.03

For a given structural drafting assignment, draw the top, front, and end views of a given steel shape showing rivets, welds, and bolts as required. The finished drawings must be to the instructor's standards and meet the standards expected of entry level workers in the architectural industry.

"Drawing illustrations are included to represent the level of drafting skills and knowledges that might be tested in this option specialization. The tests will be developed or selected by the instructor depending on the tasks that have been emphasized in structural drafting."

Drawing illustration:

NOTE: Flange view eliminated. Instructions, including necessary dimensions, for cutting the flanges at the right hand end are covered by a note on the web view. Transverse distance between gauge lines on the flanges is covered by the note "Ga=3 1/2." Symmetry about the center line of the beam web is understood. Notes must be explicit in showing what work, if any, is required on each flange.

SAMPLE A

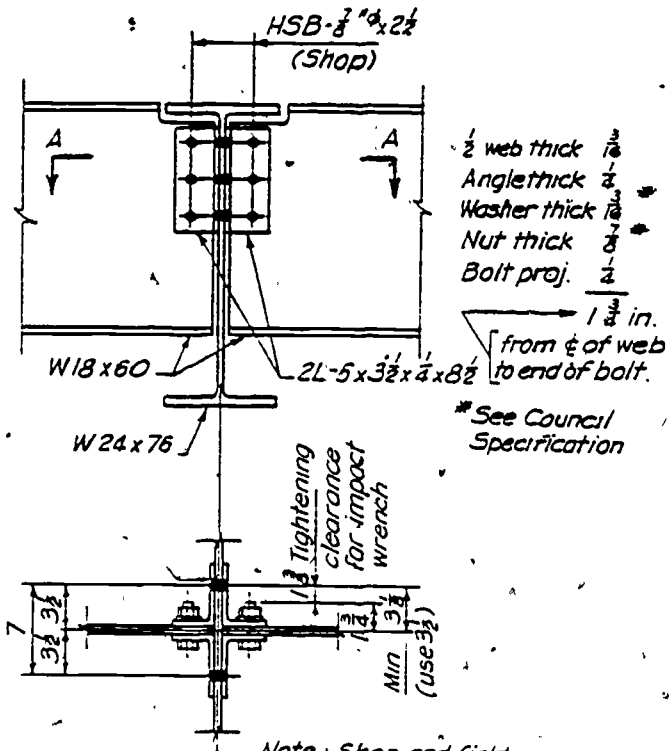
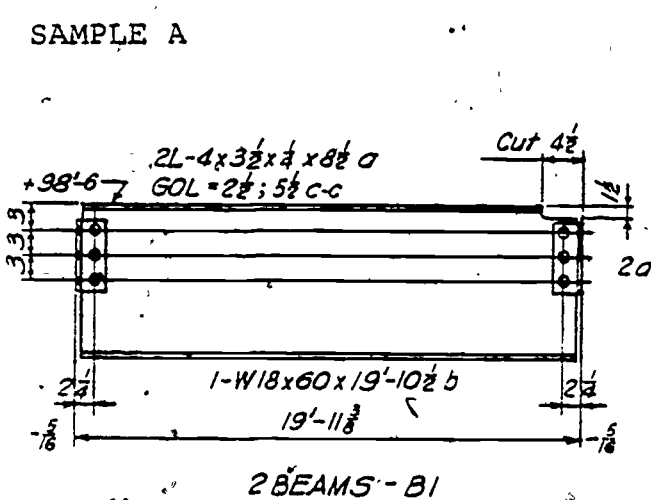

Gen. Notes  
 Spec: AISC - latest edition  
 Matl: ASTM A36  
 Open holes: 1 1/2" φ  
 Rivets: 3/4" φ A 502-1  
 Paint: One coat red lead

Note: Shop and field fasteners, 3/4" φ A325 bolts

SECT. A-A

SAMPLE B

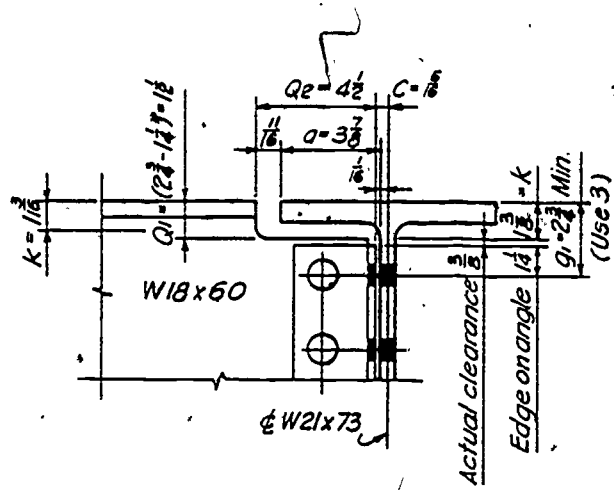

Illustration 1

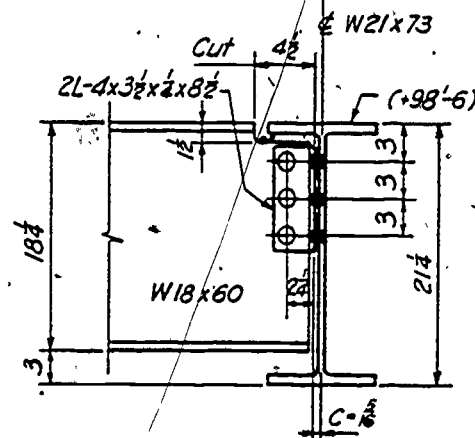

Illustration 2

SAMPLE C

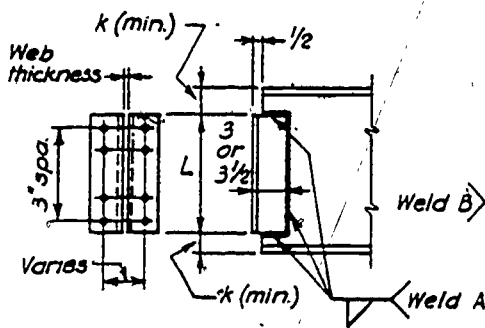

Illustration 1

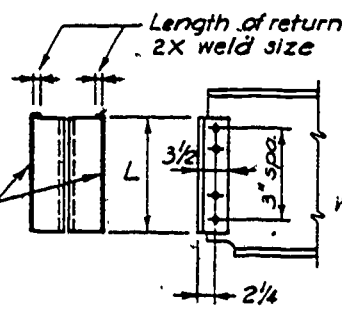

Illustration 2

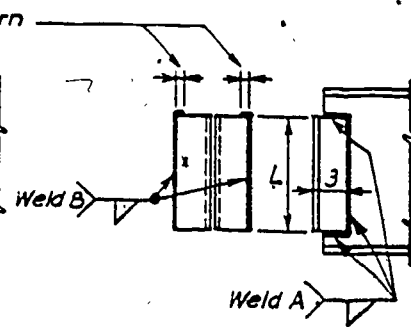

Illustration 3

UNIT 9.0 - STRUCTURAL DRAFTING

OUTCOME-REFERENCED TESTS

Task 9.04

1. Draw and analyze construction applications of structural steel. All necessary information will be provided by the instructor. The drawing must be executed accurately, neatly, with professional style, within an acceptable time for entry level employment. The instructor's standards must be met.

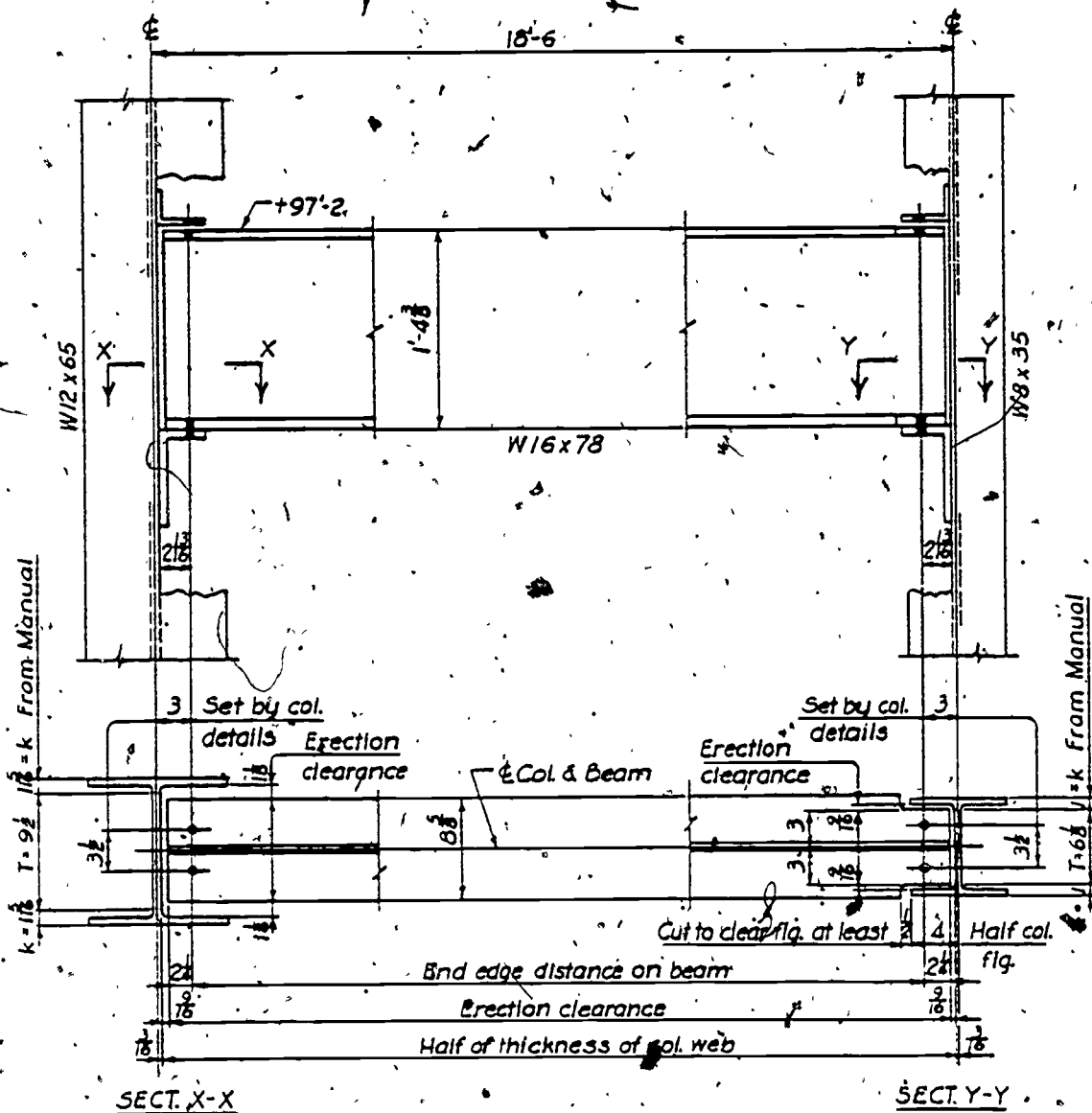

UNIT 9.0 - STRUCTURAL DRAFTING

OUTCOME-REFERENCED TESTS

Task 9.06

1. Layout supported floor plan with sections, showing beam elevations, and schedules of reinforcing steel for beams and slabs. Performance is to be the standards expected of entry level workers in the architectural field and to the instructor's standards.

Illustration drawing

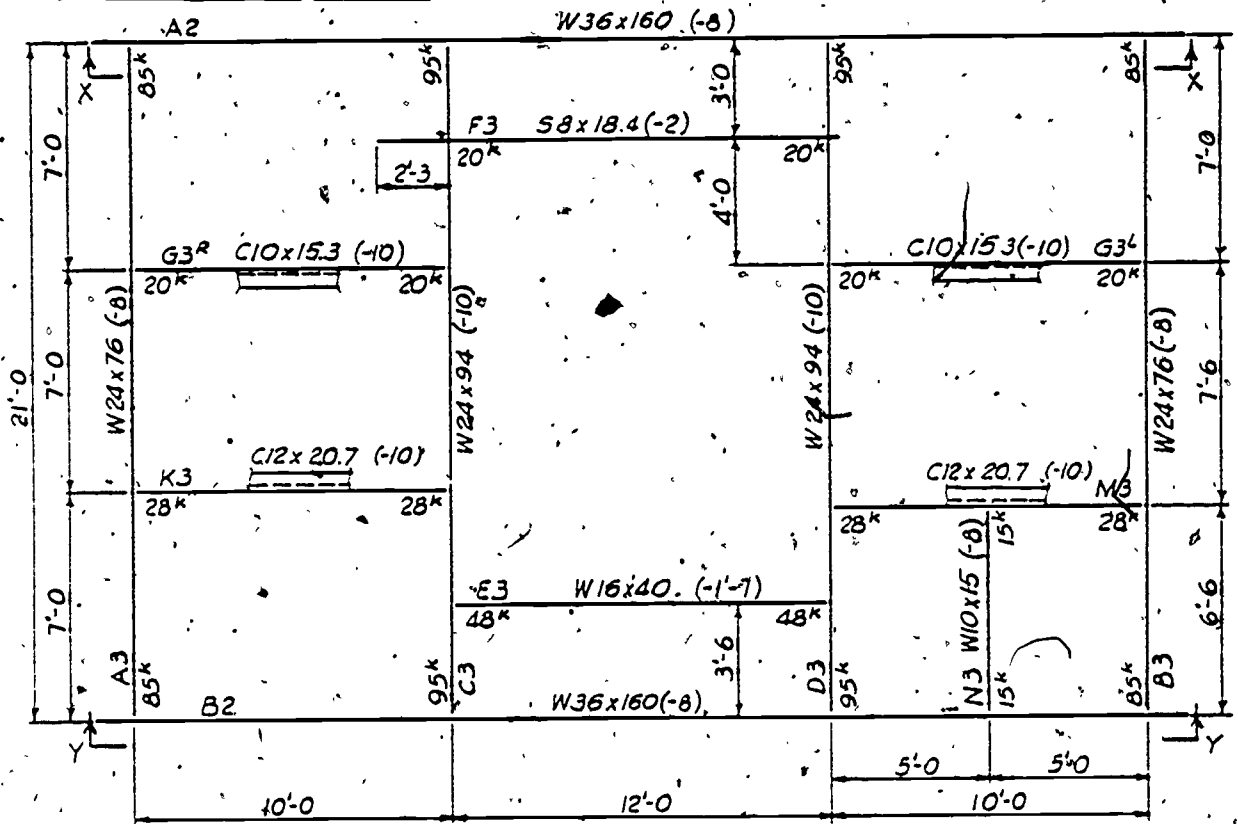

PLAN

Top of finished floor at elevation +100'-0  
 Top of steel below finished floor noted thus: (-8)  
 For General Notes, see Fig. 7-1

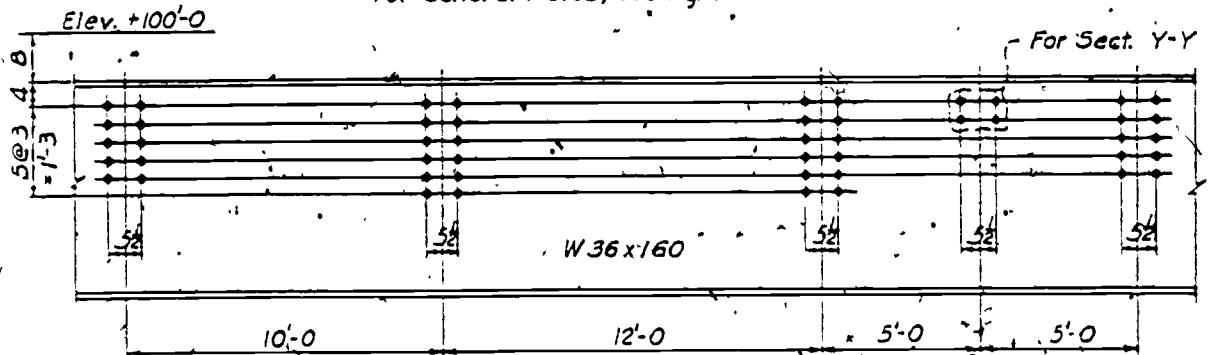

SECTIONS X-X & Y-Y



Unit 9.0 - Structural Drafting

Answer Sheet

Unit 9.0

1. true
2. false (1/2 to 2/3)
3. false (span and load)
4. true
5. true
6. true
7. false (reverse statement)
8. true
9. true
10. true
11. true
12. true
13. false (purlins)
14. true
15. true
16. a. short answer  
b. short answer  
c. short answer  
d. short answer

END OF  
TRAINING TASK

CAREER OPPORTUNITIES

IDENTIFY POST-SECONDARY CAREER  
DEVELOPMENT OPPORTUNITIES

---

---

PERFORMANCE OBJECTIVE:

Given an orientation to similar post-secondary vocational education programs, primarily the Drafting program at Greenville Technical College and evening development programs for the drafting trade, a report of skill competencies development during secondary training and information as necessary; identify post-secondary career development opportunities.

PERFORMANCE ACTIONS:

1. Identify:
  - a. Need for additional training at the post-secondary level.
  - b. Benefits from additional training.
2.
  - a. Identify post-secondary training programs available at GTC.
  - b. Identify how post-secondary (GTC) training differs from secondary training in drafting.
3. Visit GTC programs of possible interest. Talk with instructor, department head, or admissions counselor at GTC.
4. Determine with secondary and post-secondary assistance if exemption of post-secondary level training is recommended.
5. Accomplish the required steps to apply or test for exemption. (Optional)

PERFORMANCE STANDARDS:

- Identify post-secondary training opportunities in drafting or a related area at GTC.

SUGGESTED INSTRUCTION TIME: Typically, integrated throughout entire program.

APPENDIXES

DRAFTING II

Appendix A	ANSI Standards Publications
Appendix B	Supplementary Topics for Drafting II
Appendix C	Optional Tasks
Appendix D	Joint Articulation Agreement
Appendix E	Instructor's Signed Agreement to Articulate
Appendix F	Philosophy of Articulation Guide Design
Appendix G	Purposes of Articulation Guide
Appendix H	Definitions of Terms
Appendix I	Directions for Tests
Appendix J	Responsibility Sheet
Appendix K	Binder Design

## ANSI STANDARDS PUBLICATIONS

ANSI standards referred to in the Articulated, Performance-based Instruction Guide for Drafting (Drafting I and II) may be found in the following publications.

These publications are available from:

ASME  
PO Box 3199, Grand Central Station  
New York, NY 10163

"Abbreviations For Use On Drawings And In Text" ANSI Y1.1972, J00003

"Drawing Sheet Size And Format" ANSI Y14.1-1975, N00001

"Line Conventions And Lettering" ANSI Y14.2M-1979, N00002

"Multi And Sectional View Drawings" ANSI Y14.3-1975 (R 1980), N00003

"Pictorial Drawing" ANSI Y14.4-1957, N00004

"Dimensioning And Tolerancing" ANSI Y14.5-1973, N00005

"Screw Thread Representation" ANSI Y14.6-1978, N00006

"Electrical And Electronic Diagrams (with 1971 Supplement)" ANSI Y14.15-1966 (R 1973), NX0015

"Interconnection Diagrams" ANSI Y14.15a-1971, N00060

"Information Sheet On ANSI Y14.15-1966 (R 1973)" ANSI Y14.15b-1973, N00016

"Fluid Power Diagrams" ANSI Y14.17-1966 (R 1974), N00017

"Surface Texture Symbols" ANSI Y14.36-1978, N00080.

"Graphic Symbols For Electrical And Electronic Diagrams" ANSI Y32.2-1975, K00041

"Graphic Symbols For Fluid Power Diagrams" ANSI Y32.10-1967 (R 1974), N00022

"Graphical Symbols For Process Flow Diagrams In Petroleum And Chemical Industries" ANSI Y32.11-1961, K00040

## SUPPLEMENTARY TOPICS

FOR

## DRAFTING II

Given available training time, student interest, and potential employer need, the second year of drafting training (Drafting II) might include all or part of the following supplemental instruction:

- I. Electrical Drafting
- II. Electronic Drafting
- III. Piping Drafting
- IV. Welding Drafting

Although designated as supplementary training topics for the second year of drafting, these topics could be employed at the end of the first year of training.

APPENDIX C

DRAFTING II  
 OPTIONAL  
SUGGESTED INSTRUCTION TIME

<u>DRAFTING II</u> <u>OPTIONAL</u>	SUGGESTED HOURS
Pipe Drawing	6
Welding Drafting	*
Draw Electronic Pictorials and Schematics	15
Draw Electrical Power and Lighting Systems	*
Topographics and Map Drawing	15

\*Optional

TASK LISTINGS  
DRAFTING II

## OPTIONAL TASKS

## DESCRIPTION

(Pipe Drawing) Given instruction and an exercise from the teacher or text, scale layout (double line) and diagrammatic (single line) schematic pipe drawings to the satisfaction of the instructor.

(Welding Drafting) Given an exercise including specifications and a rough sketch, draw a blueprint that can be interpreted by a welder to fabricate the necessary end product. The drawing must include the correct symbols, be dimensioned appropriately, and the correct letter designations must be used. The task must be completed with time limits considered to be acceptable for initial employment job qualification and must meet the instructor's standards.

(Draw Electronic Pictorials and Schematics) Given proper instruction concerning drawing electronic pictorials and schematics, electronic templates, picture or actual orientation to electronic components, including solid state devices; draw pictorials and schematics of electronic systems or parts.

(Draw Electrical Power and Lighting Systems) Given proper instructions and orientation to electrical power and lighting system drafting, draw electrical power and lighting systems.

(Topographic and Map Drawing) Given appropriate drafting instruments and equipment and instructions, prepare topological maps and profiles according to instructor or text assignment to the satisfaction of the instructor.

OPTIONAL

DRAFTING II

ADVANCED SPECIALITY

PIPE DRAWING

---

**PERFORMANCE OBJECTIVE:**

Given instruction and an exercise from the teacher or text, prepare scale layout (double line) and diagrammatic (single line) schematic pipe drawings to the satisfaction of the instructor.

**PERFORMANCE ACTIONS:**

1. Select pencils for layout lines, finished object lines, and lettering. Sharpen pencils.
2. Tape paper to board.
3. Make measurements.
4. Layout borders. Draw guidelines for title block. Letter required information.
5. Determine space allocation.
6. Make one isometric drawing showing the following pipe fittings:
  - a. Screw
  - b. Butt welded
  - c. Flanged
  - d. Sweated
7. Draw symbols and schematics of piping.
8. Draw required pipe drawing. Orthographic projection of piping system.
9. Add necessary dimensions. Add necessary lettering.
10. Check drawing for completeness and accuracy.

**SUGGESTED INSTRUCTION TIME:** 6 Hours (minimum)**PERFORMANCE STANDARDS:**

- Prepare scale layout (double line) and diagrammatic (single line) pipe drawings according to given information and to the instructor's satisfaction.



OPTIONAL

DRAFTING II

ADVANCED SPECIALITY

PIPE DRAWING (Con't.)

---

## RELATED TECHNICAL INFORMATION:

- Pipe terminology.
- Pipe sizes.
- Pipe fittings.
- Piping symbols.
- Single line pipe drawings.
- Double line pipe drawings.
- Use of handbooks.
- ASA Bulletins.
- Pipe catalogs.

OPTIONAL

DRAFTING II

ADVANCED SPECIALITY

WELDING DRAFTING

## PERFORMANCE OBJECTIVE:

Given an exercise including specifications and a rough sketch, draw a blueprint that can be interpreted by a welder to fabricate the necessary end product. The drawing must include the correct symbols, be dimensioned appropriately, and the correct letter designations must be used. The task must be completed with time limits considered to be acceptable for initial employment job qualification and must meet the instructor's standards.

## PERFORMANCE ACTIONS:

1. Preliminary to welding drafting, review or demonstrate ability to use:
  - a. Views to show the shape of an object for fabrication purposes.
  - b. Lines to show various views of an object.
  - c. Cross sectioning for materials symbols:
    - (1) Cast iron and (general material)
    - (2) Steel
    - (3) Copper, bronze, brass
    - (4) Zinc, lead, and alloys
    - (5) Aluminum, aluminum alloys, and manesium
    - (6) Rubber, plastic, and electrical insulation
  - Dimensioning.
  - Thread fasteners.
  - f. Fabrication prints.
2. Interpret basic welding terms.
3. Describe typically used welding processes:
  - a. Gas.
  - b. Arc.
  - c. GMAW (Mig).
  - d. GRAW (Tig).
4. Identify welding symbols:
  - a. Base of a weld symbol.
  - b. Basic welding symbols and their location significance:
    - (1) Fillet
    - (2) Plug or slot
    - (3) Spot or projection
    - (4) Seam
    - (5) Back or backing
    - (6) Surfacing

OPTIONAL

DRAFTING II

ADVANCED SPECIALITY

WELDING DRAFTING (Con't)

## PERFORMANCE ACTIONS (Con't.):

- (7) Flange:
  - (a) edge
  - (b) corner
- c. Basic welding symbols and their location significance:
  - (1) Square
  - (2) V
  - (3) Bevel
  - (4) U
  - (5) J
  - (6) Flair-V
  - (7) Flair-bevel
- 5. In given drawing assignments or situations, specify weld sizes:
  - a. Show how size of fillet welds are indicated.
  - b. Show how length of fillet welds are indicated.
  - c. Show how length and pitch of intermittent filler welds are indicated.
  - d. Show how dimensions apply to plug welds.
  - e. Dimension slot welds.
  - f. Dimension arc-spot welds.
  - g. Dimension seam welds:
    - (1) Show size, length, and pitch of resistance seam weld
    - (2) Show extent of Gas Tungsten-Arc Seam Weld
  - h. Dimension groove bevel depth and effective throat size.
  - i. Show how root opening and included angle are shown for groove welds. (AWS)
  - j. Show application of break in arrow to show member to be bevelled.
- 6. Illustrate how tail is used when some special data is needed.
- 7. Locate reference for designation of welded and applied processes by letters. (See Symbols for Welding and Nondestructive Testing, American Welding Society or any good reference source).

OPTIONAL

DRAFTING II.

ADVANCED SPECIALITY

WELDING DRAFTING (Con't)

---

**PERFORMANCE ACTIONS (Con't.):**

8. Draw symbols to show how bead contour finish is indicated.
9. Given an exercise including specifications and a rough sketch, draw a blueprint that can be interpreted by a welder to fabricate the necessary end product. Use correct symbols, dimension appropriately, and apply correct letter designations.

**PERFORMANCE STANDARDS:**

- Drawing must be accurately dimensioned; use correct letter designations, and correct symbols for the welding processes.
- The task must be performed within time limits considered to be acceptable for initial employment job qualification.
- Lettering and drafting skills demonstrated must reflect neatness, accuracy, consistency, proper placement, and character.
- Must meet instructor's standards for advanced speciality drawing.

**SUGGESTED INSTRUCTION TIME:** Optional**RELATED TECHNICAL INFORMATION:**

- American Welding Society standards.
- Structural steel or metal fabrication terminology (as appropriate).

OPTIONAL

DRAFTING II  
- SUPPLEMENTARY TOPIC:- ELECTRONIC  
DRAFTING

ADVANCED SPECIALITY

DRAW ELECTRONIC PICTORIALS AND  
SCHEMATICS

---

---

**PERFORMANCE OBJECTIVE:**

Given proper instruction concerning drawing electronic pictorials and schematics, electronic templates, picture or actual orientation to electronic components, including solid state devices; draw pictures and schematics of electronic systems or parts.

**PERFORMANCE ACTIONS:**

1. Interpret electronic terminology.
2. Identify electronic component symbols and use templates to draw component symbols.
3. From given rough sketches of electronic diagrams, draw electronic schematics with 90 percent accuracy in proper identification of components.
4. Letter as appropriate, components and drawing.
5. From given sketches or drawing of electronic schematics, using references as needed, draw pictorials of electronic diagrams or drawings. Pictorials must be representative of components.
6. Check drawing for completeness and accuracy.

**PERFORMANCE STANDARDS:**

- Draw electronic drawings of circuits in schematic or pictorials with 90 percent accuracy in component identification, completing the drawing within time limits considered to be acceptable for initial employment job qualifications.
- Lettering must be neat, accurate, consistent, and properly placed.

SUGGESTED INSTRUCTION TIME: 15 Hours

193

OPTIONAL

DRAFTING II  
SUPPLEMENTARY TOPIC: ELECTRONIC  
DRAFTING

ADVANCED SPECIALITY

DRAW ELECTRONIC PICTORIALS AND  
SCHEMATICS (Con't.)

---

---

RELATED TECHNICAL INFORMATION:

- Symbols for electronic drawings.
- Electronic abbreviations.
- Reference designation (such as component values.)
- Interconnection diagrams.

NOTE: Training may be expanded to include chassis fabrication, various connector diagrams, terminals, switches and relays, etc.

OPTIONAL

DRAFTING II  
ELECTRICAL DRAFTING

ADVANCED SPECIALITY

DRAW ELECTRICAL POWER AND  
LIGHTING SYSTEMS

## PERFORMANCE OBJECTIVE:

Given proper instructions and orientation to electrical power and lighting system drafting, draw electrical power and lighting systems.

NOTE: This task may be classified as Architectural Environmental Systems.

## PERFORMANCE ACTIONS:

1. Identify types and uses of transformers.
2. From performance material, select required types of service-entrance switch and metering equipment.
3. Identify types of control devices for particular use.
4. Identify classifications and uses of switches, circuit breakers, and fuses.
5. Identify types and uses of electrical receptacles.
6. Identify general groups and classifications of electrical loads (motors, lights, heaters, etc.).
7. Explain basic terminology, design consideration, and distribution system for electrical lighting, plus standard drawing symbols.
8. Describe purpose and types of lighting protection.
9. Define electrical requirements as contained in the National Electrical Code (or AIA Code).
10. Draw electrical power and lighting system installation layouts.

## PERFORMANCE STANDARDS:

- State related technical information (equipment types and use, principles for determining light requirements, etc., applicable codes, etc.) with 80 percent accuracy.

OPTIONAL

DRAFTING II  
ELECTRICAL DRAFTING

ADVANCED SPECIALITY

DRAW ELECTRICAL POWER AND  
LIGHTING SYSTEMS (Con't.)

---

**PERFORMANCE STANDARDS (Con't.):**

- Draw electrical systems according to AIA and other industry standards.
- Neatness and accuracy apply where appropriate.
- Drawings are prepared with job qualification time limits.

**SUGGESTED INSTRUCTION TIME:** Optional**RELATED TECHNICAL INFORMATION:**

- Appropriate handbooks.
- Codes.
- AIA manuals.



OPTIONAL

DRAFTING II - CIVIL (Option)

ADVANCED SPECIALITY

TOPOGRAPHIC AND MAP DRAWING

---

**PERFORMANCE OBJECTIVE:**

Given appropriate drafting instruments and equipment and instructions, prepare topographical maps and profiles according to instructor or text assignment to the satisfaction of the instructor.

**PERFORMANCE ACTIONS:**

1. Select pencils for layout lines, finished object lines, and lettering. Sharpen pencils.
2. Tape paper to board.
3. Make measurements.
4. Layout borders. Draw guidelines for title strip. Letter in required information.
5. Determine space allocations.
6. Make required drawing.
7. Add necessary lettering.
8. Check drawing for accuracy and completeness.

**PERFORMANCE STANDARDS:**

- Prepare topographical maps and profiles for given project according to instructor's standards.

**SUGGESTED INSTRUCTION TIME: 15 Hours****RELATED TECHNICAL INFORMATION:**

- Map classifications.
- Topographic symbols.
- Plans of surveys.
- Coordinate system.
- Contour lines.

OPTIONAL

DRAFTING - CIVIL (Option)

ADVANCED SPECIALITY

TOPOGRAPHIC AND MAP DRAWING

---

---

RELATED TECHNICAL INFORMATION (Con't.):

- Profiles.
- Retaining walls.
- Tunnels.
- Overhead power lines.

THE SCHOOL DISTRICT  
OF GREENVILLE COUNTY

GREENVILLE TECHNICAL COLLEGE

TO: All Administrators, Staffs and Faculties, The School District of  
Greenville County and Greenville Technical College

SUBJECT: Application and Implementation of the Policies and Procedures for  
the Articulation of Similar Vocational Training Programs of  
Instruction

Since 1976, The School District of Greenville County and Greenville  
Technical College have been working toward making the articulation of  
vocational education programs a viable and valid reality. Through joint  
efforts in the Occupational Education Articulation Program, The School  
District of Greenville County and Greenville Technical College fully  
support the concept of articulation and agree upon the purposes of the  
articulation program.

This Policies and Procedures Guide has been developed as a joint effort  
of The School District of Greenville County and Greenville Technical  
College with the assistance of individuals representing the institutional  
administrative units, involved faculty, and the local business and  
industrial community. The Policies and Procedures Guide is designed to  
assist the articulation of very similar programs of vocational training  
between the secondary and post-secondary, public, vocational training  
institutions in Greenville County.

Appreciation is expressed to participants at both institutions for the  
joint effort of this endeavor.

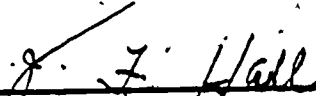
  
\_\_\_\_\_  
J. F. Hall  
Superintendent  
The School District of  
Greenville County

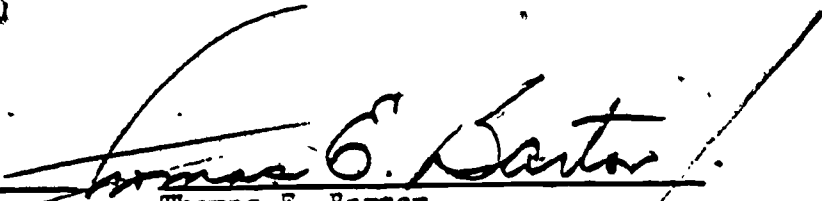
  
\_\_\_\_\_  
Thomas E. Barton  
President  
Greenville Technical College

TASK FORCE COMMITTEE  
AGREEMENT TO ARTICULATE  
VOCATIONAL EDUCATION

Articulation provides a system whereby secondary and post-secondary instructors can cooperate effectively in providing a continuous occupational development program where the level and type of vocational training that leads to entry-level employment skills will be clear to instructors, other educators, students, and potential employers.

The concept of articulation and the articulation program are supported fully by The School District of Greenville County and Greenville Technical College which have agreed upon a statement of purpose for the articulation of similar vocational education programs in Greenville County.

The articulation program in Greenville County is a joint effort of The School District of Greenville County and Greenville Technical College to develop a continuous program of vocational training so that students may continue their career preparation without loss of time or waste of effort in repeating tasks which have been learned previously and demonstrated. Articulation program activities are designed to help remove unnecessary gaps or overlap in student learning which may occur when a student completes a secondary vocational program and continues career development at the post-secondary level in a similar occupational field.

To implement articulation, instructor representatives from the participating institutions have met as a task force committee to develop this articulated, performance-based instruction guide which describes the secondary vocational program and which provides the parameters for vertical articulation.

Vertical articulation shall include recognition of the occupational competencies demonstrated by secondary graduates of articulated vocational programs.

It is agreed that...

The task force committee instructor representatives from The School District of Greenville County and Greenville Technical College mutually recognize the value of occupational education provided by each institution.

The task force committee instructor representatives will take the necessary actions, approved by their administrations, to ensure that this agreement to articulate is fulfilled including interpreting the program to students.

It is understood that periodic review of the articulated task objectives, performance actions, minimum standards, and outcome-referenced measures will be necessary to ensure that a valid training program is serving the needs of the community and the students.

Each task force committee participant hereby agrees to notify the others of any changes which modify the articulated, performance-based vocational program described in this guide so that each articulation guide, and where appropriate the articulation program, may be revised mutually so that articulated occupational training in Greenville County will conform to the minimum standards outlined in this guide.

This agreement to articulate establishes the necessary framework for lateral as well as vertical articulation.

AGREED UPON BY THE TASK FORCE COMMITTEE PARTICIPANTS ON THIS DAY,

April 20, 1983  
date

Name	Institution/School
Barbara C. Harvitt	Walter S. Trust Vocational Center
Al Watson	Donaldson Voc. Center
Ginn W. S. Smith	Emory Vocational Center
Ruth D. ...	Footbridge Vocational Center
Walter H. ...	GREENVILLE TECHNICAL COLLEGE



## PHILOSOPHY OF ARTICULATED, PERFORMANCE-BASED INSTRUCTION GUIDE DESIGN

The design of the articulated, performance-based instruction guides and the articulation program is based on a philosophy that the vocational education curriculum should be for career training with few fringe or non-related subjects. The student should be given the basis to do useful skilled work upon graduation and employment. The vocational program graduate should have a background which will allow him/her to learn and advance as rapidly as possible on the job, but it should not include subject matter which will not be applicable to his/her work for years. When subject matter is introduced that will not be applicable to the graduate's work for years, it may put the graduate out of perspective. The result might be that the graduate may try to force applications which do not exist, simply because the information is in his/her repertoire. Thus, the purpose of vocational training by the articulated, performance-based instruction guides is to prepare graduates for successful entry into a skilled trade. |

To ensure that the design of the articulated, performance-based instruction guides is conforming to the philosophies of both the secondary and post-secondary institutional participants, a periodic review of the guide design and philosophy is recommended.

PURPOSES OF THE ARTICULATED INSTRUCTION GUIDE

The articulated instruction objectives guide are is expected to serve the following purposes:

1. The guide serves as the primary vehicle for the articulation of subject matter in similar vocational training programs between the vocational education centers, high schools, and Greenville Technical College through use by instructors at both levels as a reference in preparing instruction.
2. The guide provides a listing of the minimum tasks that a student or worker is expected to perform in the conduct of a specific level job in the area of vocational training or work of concern.
3. The guides identify the primary detailed instruction objectives, performance objectives which are based upon the task listings. The tasks are listed in the sequence of complexity, with the least complex task being listed first, except where a task must be performed as a prerequisite to performance of another task.
4. The guides identify the tasks performed (actions, steps, sets of skills) and related technical information which must be taught and learned to accomplish each major instruction objective. The tasks performed represent the minimum skills and related information required for adequate occupational proficiency in the performance objectives.
5. The guides designate the instructional contact hours necessary to provide the required instruction, as required by appropriate educational agencies or offices and as estimated by the instructor-participants on the Vocational Articulation Project Task Forces, and based on the time required to teach the average learner to perform the task. The time estimated is based on having the essential equipment, facilities and instructional aids required to provide the instruction, whenever the class size is limited to an acceptable number.
6. The guides identify the performance standards to be met for occupational proficiency in the task. Performance standards used are those considered to be minimum business or industry standards. The ability to meet the listed standards of performance will be considered as qualification for advanced instruction in the vocational program.
7. The guides provide direction in the conduct of sequential vocational competency instruction by modules or job tasks, resulting in qualification by the learner to perform limited skill specialist jobs of

progressively higher skills until the program objective is reached (i.e., file clerk to executive secretary, etc.). As the student becomes proficient in the performance of tasks in successively more complex modules, more marketable competencies are gained and may be identified as the lower job qualifications of a specialist.

Through this procedure, even the slower student is provided an opportunity to eventually gain sufficient skills to perform adequately as a specialist at some level in the vocational field, even if the student is unable to complete the total program of training.

The standardized sequence of activities of the vocational instruction modules will facilitate lateral articulation between vocational education centers in the School District and will simplify vertical articulation when training is continued at Greenville Technical College articulating to employers.

8. The guides provide a descriptive listing of equipment required to conduct the program of vocational training. The equipment listed is considered to be the type and quantity essential for the conduct of instruction to prepare students for entry-level employment in the vocational field. It may be necessary to delay teaching some tasks involving special equipment, if that equipment is not available at all instructional sites, or to move students and equipment together as necessary to teach skills.
9. The guide provides information about requirements or limitations that typically are involved in the performance of the task, environmental conditions and physical demands, and able to perform the task.
10. The guides provide a list of standardized performance test items/ and outcome-referenced measures to be used in the determination of vocational proficiency. As long as the specifics are not provided, the test items listed cannot be compromised easily and could serve as study guides.
11. The tasks listed in the guide are the minimum requirements for job qualification under average circumstances in a regional market. It is understood that there may be unlisted tasks that some employers may require the worker to do in the occupation, when in their employment. In addition, there may be unlisted tasks, such as mental process tasks, that are not stated but that may occur and that should be considered in instructional planning or testing.

Instructors may teach skills and related technical information other than what is shown in the guides. Provision of additional information should be limited to the students who have completed the requirements for the tasks emphasized in the instructional guides. The change of tasks in the guides should be based on task force committee agreement to ensure lateral and vertical articulation.



12. It is expected that there will be updating and correction of items in the articulated instruction guide. Participants are to be sure that the contents are valid and consistent with business and industry requirements. Recommendations should be submitted to the Vocational Articulation Program office which will assemble and present them to the appropriate committee for review and possible adoption.
13. Typically, the teacher/instructor should not plan to conduct instruction in a given articulated module unless the capability exists to conduct all of the instruction to meet the instructional objectives, with the result that the successful student is qualified to perform the tasks identified within the module.
14. An underlying philosophy in vocational training is that it is better to prepare the student to be fully qualified to perform all of the tasks in a limited group of modules in a vocational field and be qualified at a lower job level rather than be only familiar with a large number of task descriptions or duties and qualified to perform none of them fully. For higher levels of job qualification beyond the secondary level, the student or worker is encouraged to enroll at Greenville Technical College.
15. Generally, vocational programs will include certain basic modules or courses of instruction without which the student would not be considered vocationally qualified at any level. Basic modules typically will be identified and taught early in the program sequence.
16. The instruction guides provides information essential to help the vocational student who completes training at the secondary level and continues career development training at the post-secondary level in a similar program receive appropriate credit for the articulated vocational training that has been mastered at the secondary level.

DEFINITIONS OF TERMS

The following definitions of terms are applicable to the articulated, performance-based instruction guides developed as products of the Occupational Education Articulation Program.

- Behavior: The actions of a person (specifically, job or job training actions). Behavioral actions include both overt, those that can be observed, and covert, those not observable outwardly. Performance may be interchanged with behavior in the project. (See also Performance Actions).
- Concept: A group of ideas that may be classed together or that are similar.
- Criteria: A standard by which performance may be measured, usually considered the minimum standard.
- Domain: A cluster of related jobs.
- Duty: One of the distinct major activities involved in the work performed and comprising related tasks.
- Evaluation: When comparison is made between a measurement and a standard and judgment is passed on the comparison.
- Item: A single stimulus or stimulus pattern that calls for a single response or set of responses. It is one sample of behavior or performance. The response may be simple or complex.
- Job: The duties or tasks actually performed by a specified individual.
- Knowledge: In this project, knowledge refers to acquired covert behavior which facilitates skills and performance, such as the theoretical information of what should be done under given circumstances, and in what order of sequence performance should occur to accomplish the objective.
- Measurement: The process of determining the extent some characteristic is associated with the student.
- Module: Modules in the pilot Drafting and Business and Office Education curriculum modifications in the Occupational Education Articulation Program have been designed to

coincide secondary level training with post-secondary level similar areas of training.

Another method of developing modules might be for modules to represent an identifiable, complicated task or job area involving a number of sub-tasks such as "Electrical Systems" in Automotive Mechanics.

Norm-referenced Evaluation: In norm-referenced evaluation, measures are dependent on a relative standard. Measures compare the capabilities of one student to those of other students.

Objective: (See Performance Objective) A stated desired outcome of training or the end result of the job, task, or performance actions. Objectives referred to in this project will be terminal objectives, generally representing a specific job function.

Occupational Education: An organized sequence of learning experiences consisting of vocational theory, practice, and skills taught to students on a regular or systematic basis.\*

\*Reference: Standards of the Delegate Assembly (Atlanta: Southern Association of Colleges and Schools, Commission on Occupational Education, December, 1972) p. 12.

Outcome-referenced Evaluation: Outcome-referenced, or criterion-referenced, measurement provides a standard of achievement for the individual as compared with specific behavioral objectives and therefore provides information about the degree of competence attained by the student.

The outcome-referenced measure is a performance or other measure based upon a performance objective, the accomplishment of which measures attainment of that objective.

Performance: Performance is used in this project to refer to a job or task which results from a set of sequential actions or steps.

Performance Actions: A series of steps, generally arranged in a sequence ordinarily followed, which when completed may result in the accomplishment of a performance objective (performance of a task).

Performance actions may be referred to as a set or sets of skills, functions, or steps. V-TEC (Vocational-Technical Education Consortium of States) catalogs generally describe performance actions in the "performance guide" of their format.

Articulated, Performance-based Instruction Guide: A comprehensive collection of performance objectives, performance actions to obtain those objectives, suggested hours for instruction (for planning purposes), performance standards, related technical

information, and outcome-referenced measures, as well as general secondary level and post-secondary level descriptions of similar courses for the purposes of aiding lateral and vertical articulation concerning the subject area.

Performance-based Instruction: Performance-based (competence-based) instruction is based on the competencies or tasks performed by on-the-job workers. Everything in a performance-based instruction system is made public beforehand. There are no surprises for student, teacher, counselor, or employer. When the student begins a program, information is available to tell the student exactly what competencies are expected to be developed as a result of the instructional program, how and against what standards or criteria the student will be evaluated, and how the student's competencies will be communicated to the student, instructors, and to employers. A performance-based instructional system tells the student exactly what the student must learn, teaches the student that skill or knowledge, and then tests on mastery of that specific competence.

Performance Objective: A statement in precise, measurable terms of a particular behavior to be exhibited by a learner under specified conditions. It possesses each of the elements or characteristics specified below:

Conditions under which the performance is to take place.

Behavior Desired or expected of the student (things to be done, the performance desired).

Standards to determine how well the performance is to be done (criteria).

Performance Test: A performance test requires the student to demonstrate (master) the desired behavior of the objective (accomplish a job-like task) under controlled conditions and according to predetermined standards. The controlled conditions allow the student to demonstrate the desired behavior and the conditions remain consistent from student to student.

Skill: Primarily, skill refers to overt, observable performance, however, it is recognized that there are covert skills required in some performances.

Step: Step is used to refer to a task or action, generally as a sequence of steps involved in the accomplishment of a performance objective or job.

Systems Approach: The systems approach to instruction emphasizes the specification of instructional objectives, precisely controlled learning experiences to achieve the objectives, criteria for performance, and evaluative information.

Task: A task is a set of skills (set or sets of functions, actions, or steps) the student must perform to accomplish the job (training). A task may be described as a logically related set of actions necessary or required to complete the job objective. Several tasks could be referred to as a duty.

Task Analysis: Task analysis is breaking down a learning task (objective) into component tasks each of which must be mastered as a prerequisite to mastery of the total job.

Task List: A listing of tasks (performance objectives) performed by incumbent workers (students in training) within a domain of interest (course of study).

Test: An event during which the student is asked to demonstrate some aspect of knowledge or skill is a test. It can be a single test item, but usually it consists of several items.

INSTRUCTIONS FOR ANSWERING OUTCOME-REFERENCED TEST ITEMS

Typically, eleven (11) different types of outcome-referenced test items may be used in the competency test.

1. True-False
2. Completion (Fill-in Blanks)
3. A Combination of True-False and Completion
4. Multiple-Choice
5. Matching
6. Identification
7. Short Answer
8. Long Answer
9. Program Product of Performance Test
10. Simulated Performance Test
11. Actual Performance Test

An example of each type of test item is included. Carefully study the illustration test item and the directions for answering the question. These directions will not be given again. Your test questions may vary slightly in the format, however, the instruction should be applicable. Where necessary, the instructor will supplement these instructions for answering outcome-referenced test items.

Do not guess. Guessing does not add to your knowledge, even if you happen to guess right. If you do not know the answer skip the test item and go to the next question. Remember: Enter your answers in the blanks provided on the separate answer sheet, if used.

1. TRUE-FALSE

Directions: Read the statement carefully. Decide whether it is true or false. Answer by marking T or F in the blank provided to the right (or, if answer sheet requires, mark "X" in the appropriate (T) or (F) parenthesis, or "circle" T or F).

Example: Lumber shrinks across the grain of the board. (T) (F)

2. COMPLETION (Fill-in Blanks)

Directions: Complete the statement by printing on the blank line the word or words which make a complete and correct statement.

Example: Proper edge spacing will restrict \_\_\_\_\_ and ensure good weld penetration. distortion



5. MATCHING:

Directions: For each given item in the left hand column, match it with the appropriate item from the right hand column. Write the letters of the correct or best answer in the appropriate blanks.

Example: Match these metric terms on the left with their proper equivalents.

<u>b</u>	deca	a.	thousands
<u>e</u>	meter	b.	tens
<u>a</u>	kilo	c.	units of length measurement

6. IDENTIFICATION

Directions: Identify each labeled part of the illustration below and write the name next to the appropriate letter in the blank provided.

Example:

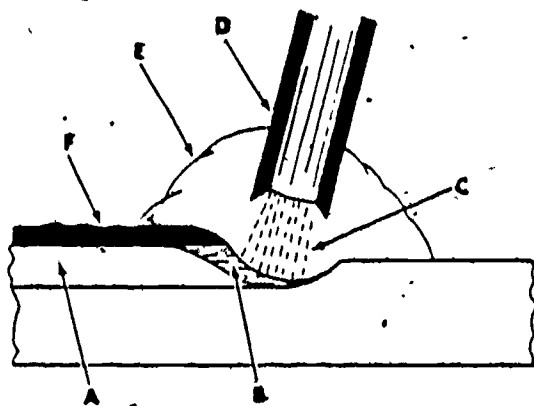

a.	<u>base metal</u>
b.	<u>molten metal</u>
c.	<u>arc</u>
d.	<u>electrode</u>
e.	<u>gas shield</u>
f.	<u>slag</u>

7. SHORT ANSWER

Directions: Write the correct answer in the blank provided.

Example: What type of electrode is best for vertical and overhead welding? fast-freeze



8. LONG ANSWER

Directions: Using as few words as possible, write the answer to the question in the blank provided.

Example: What should be done if the electrode welds fast to the work?

"Electrode should be broken loose by twisting or bending the holder."

9. PROGRAM PRODUCT OR PERFORMANCE TEST

Definition: Concrete project or production accomplishments during training are used to test knowledge or skill. Typically, test pressures are missing and the student may have had help in completing the task.

Directions: Instructor will observe student during training and by checklist or rating scale will rate student's performance or knowledge.

Example: Given an oven for baking, food items, and necessary implements and equipment; load the oven with foods to be baked. All items on a checklist used to rate performance must receive an acceptable rating. The task must be accomplished within 15 minutes.

CHECKLIST

(Load Oven Racks)

ACTIVITY	RATING	
	Acceptable	Unacceptable
1. Gathered needed supplies.		
2. Used needed supplies.		
3. Pulled oven rack partially out while loading.		
4. Stacked oven shelves 8 inches apart for baking.		
5. Placed food on rack so that heat circulated adequately.		
6. Followed appropriate safety precautions.		

## 10. SIMULATED PERFORMANCE

**Definition:** Contrived situation, resembling tasks the graduate will be required to do on the job. This form of test is useful for evaluating transferable skills such as reasoning, attitudes, and psychomotor skills necessary for occupational success.

## 11. ACTUAL PERFORMANCE TEST

**Definition:** Exhibits the advantage of realism, but may be too late to help either the student or the vocational program correct failures.

**Example:** Given an automobile with a leaking pinion seal, access to proper tools and equipment, replacement parts, and service manual; replace the pinion seal according to manufacturer's recommended procedures. The job should be completed within 2 hours. The manufacturer's specifications must be met and the completed job must meet the instructor's standards.

THIS DOCUMENT AND BINDER ARE THE PROPERTY OF THE SCHOOL DISTRICT  
OF GREENVILLE COUNTY OR GREENVILLE TECHNICAL COLLEGE

The production of this curriculum guide and binder by the Occupational Education Articulation Program was funded through the South Carolina Appalachian Council of Governments. This guide and binder are the property of The School District of Greenville County or Greenville Technical College.

Except for document and binder copies that have been placed in libraries or shared with educational organizations, the documents and binders are issued on an accountability basis.

Documents and binders issued to instructor participants remain the property of the issuing institution. Should a vocational instructor leave the employment of The School District of Greenville County or Greenville Technical College, the document and binder must be returned to the principal, vocational center director, or department head so the instruction guide may be used by replacement personnel.

Corrections, modifications, and notes may be made on the pages of the documents for the purpose of modifying the field trial edition or to improve the instructional value of the document. Please share any corrections, modifications, and recommendations concerning this document with the Occupational Education Articulation Program.

Illegible or blank document page replacements may be requested at no cost through the Occupational Education Articulation Program. For replacement pages, please indicate:

Document Title  
Module Number  
Task Number or Page Number

Replacement costs for this document and binder are:

1" Binder - \$2.80  
2" Binder - \$5.00  
Document - .05¢ per page (1982)

Who to contact:

Occupational Education Articulation Program  
The School District of Greenville County  
c/o Donaldson Vocational Center  
Donaldson Center  
Greenville, SC 29605

(or)

Consultant, Vocational Education  
The School District of Greenville County,

(or)

Associate Vice President for Education  
Greenville Technical College

BINDER DESIGN

(Occupational Education Articulation Program)

The binder design is simple and straightforward.

Two triangular figures, in balance, represent the two institutions participating in articulation.

Two levels of training are represented by the placement of the triangular figures and the identification of the two institutions.

Horizontal and vertical lines represent lateral and vertical articulation.

The diagonal across the design represents the progressive movement in career development for successful job performance.

The two figures are not closed when they face, but allow for interaction and are linked by the document title: Articulated, Performance-based Instruction Guide.