

DOCUMENT RESUME

ED 226 713

IR 010 594

AUTHOR Ricard, G. L., Ed.; And Others  
 TITLE Workshop on Instructional Features and Instructor/Operator Station Design for Training Systems.  
 INSTITUTION Naval Training Equipment Center, Orlando, Fla. Human Factors Lab.  
 REPORT NO NAVTRAEQUIPCEN-IH-341  
 PUB DATE Oct 82  
 NOTE 182p.  
 PUB TYPE Collected Works - Conference Proceedings (021) -- Guides - Non-Classroom Use (055)

EDRS PRICE MF01/PC08 Plus Postage.  
 DESCRIPTORS Classroom Design; Computer Oriented Programs; Facility Guidelines; \*Human Factors Engineering; \*Man Machine Systems; \*Military Training; Postsecondary Education; \*Simulation; Systems Development; Teacher Role; \*Training Methods; Work Environment  
 IDENTIFIERS \*Computer Simulation; Interactive Systems

ABSTRACT

These 19 papers review current research and development work related to the operation of the instructor's station of training systems, with emphasis on developing functional station specifications applicable to a variety of simulation-based training situations. Topics include (1) instructional features; (2) instructor/operator station research and development; (3) operational problems in instructor operation station designs; (4) instructional support features in flying training simulators; (5) the instructor as a user in automated training systems; (6) instructor roles and optimization of the instructor station interface; (7) front-end analysis leading to VTX instructor operating stations functional specifications; (8) conceptual design of an instructional support system for fighter and trainer aircraft flight simulators; (9) the OAS/CMC PTT instructor station; (10) training effectiveness evaluations of simulator instructional support systems; (11) computer-aided design systems in workstation design; (12) instructor/operator station design concepts; (13) modular control of simulators; (14) simplified control of the simulator instructional system; (15) the instructional subsystem; (16) procedures monitoring and scoring in a simulator; (17) student self-training capability in flight simulators; (18) generic simulator instructor training; and (19) application of artificial intelligence and voice recognition/synthesis to naval training. (LMM)

\*\*\*\*\*  
 \* Reproductions supplied by EDRS are the best that can be made \*  
 \* from the original document. \*  
 \*\*\*\*\*

ED226713

U.S. DEPARTMENT OF EDUCATION  
NATIONAL INSTITUTE OF EDUCATION  
EDUCATIONAL RESOURCES INFORMATION  
CENTER (ERIC)

This document has been reproduced as  
received from the person or organization  
originating it

Minor changes have been made to improve  
reproduction quality

Points of view or opinions stated in this docu-  
ment do not necessarily represent official NIE  
position or policy

WORKSHOP ON INSTRUCTIONAL FEATURES AND  
INSTRUCTOR/OPERATOR STATION DESIGN FOR  
TRAINING SYSTEMS

edited  
by

G.L. Ricard

T.N. Crosby

E.Y. Lambert

Naval Training Equipment Center  
Orlando, Florida 32813

October 1982

Technical Report: NAVTRAEQUIPCEN IH-341

IR010594

## PREFACE

On the 10th and 11th of August 1982, the Naval Training Equipment Center was the host organization for a Workshop on Instructional Features and Instructor/Operator Station Design for Training Systems sponsored by the Chief of Naval Research. The goal of the workshop was to review current research and development work related to the operation of the instructor's station of training systems particularly with an eye for developing functional specifications for these stations. Historically much of the research and development work has been sponsored by the Naval Air Systems Command and the Air Force; but we feel that many of the developments are applicable to a variety of simulation-based training situations.

Several people deserve thanks for their help in making the workshop possible. CDR P. M. Curran of the Office of Naval Technology cheerfully encouraged us and provided support, and locally at the Human Factors Laboratory of the Naval Training Equipment Center, Catherine Bottelman and Hilda Worsham both performed the many chores necessary during the workshop and later edited the papers and prepared the report for printing. We thank them all.

The Editors

## TABLE OF CONTENTS

	PAGE
COMMENTS ON INSTRUCTIONAL FEATURES Dr. Gilbert L. Ricard .....	5
INSTRUCTOR/OPERATOR STATION RESEARCH AND DEVELOPMENT AT AFHRL/OT Dr. Harold D. Warner .....	9
OPERATIONAL PROBLEMS IN INSTRUCTOR OPERATION STATION DESIGNS Dr. John P. Charles .....	13
THE REAL WORLD AND INSTRUCTIONAL SUPPORT FEATURES IN FLYING TRAINING SIMULATORS Mr. Clarence P. Semple and Mr. Barton K. Cross II .....	23
THEY CAN MAKE OR BREAK YOU: CONSIDERING THE INSTRUCTOR AS A USER IN AUTOMATED TRAINING SYSTEMS Dr. Robert Halley .....	33
INSTRUCTOR ROLES: OPTIMIZATION OF THE INSTRUCTOR STATION INTERFACE Dr. B. E. Mulligan and LT Thomas N. Crosby .....	39
FRONT-END ANALYSIS LEADING TO VTX INSTRUCTOR OPERATING STATIONS FUNCTIONAL SPECIFICATIONS Mr. Jeffrey N. Panches .....	53
CONCEPTUAL DESIGN OF AN INSTRUCTIONAL SUPPORT SYSTEM FOR FIGHTER AND TRAINER AIRCRAFT FLIGHT SIMULATORS Mr. Vernon E. Carter .....	61
A DESIGN WITH THE INSTRUCTOR IN MIND; THE OAS/CMC PTT INSTRUCTOR STATION Major Joseph C. Stein and Captain Michael E. Shannon .....	79
TRAINING EFFECTIVENESS EVALUATIONS OF SIMULATOR INSTRUCTIONAL SUPPORT SYSTEMS Dr. Steve R. Osborne and Dr. George W. Menzer .....	91
USE OF COMPUTER-AIDED DESIGN SYSTEMS IN WORKSTATION DESIGN Dr. Gerhard Eichweber .....	95
INSTRUCTOR/OPERATOR STATION DESIGN CONCEPTS Dr. William M. Hinton and Mr. Walter M. Komanski .....	99
MODULAR CONTROL OF SIMULATORS Mr. Steve Seidensticker and Ms. Catherine Meyn .....	107
SIMPLIFIED CONTROL OF THE SIMULATOR INSTRUCTIONAL SYSTEM Mr. Robert A. Gamache .....	115
THE INSTRUCTIONAL SUBSYSTEM, A MAJOR COMPONENT OF THE TRAINING DEVICE Dr. Thomas J. Hammeil .....	127
PROCEDURES MONITORING AND SCORING IN A SIMULATOR Mr. Steve Seidensticker and Mr. Terry Kryway .....	149
THE CASE FOR A STUDENT SELF-TRAINING CAPABILITY IN FLIGHT SIMULATORS Mr. Joseph L. Dickman .....	155
GENERIC SIMULATOR INSTRUCTOR TRAINING Dr. George W. Menzer and Dr. Steve R. Osborne .....	165
APPLICATION OF ARTIFICIAL INTELLIGENCE AND VOICE RECOGNITION/SYNTHESIS TO NAVAL TRAINING Mr. John A. Modrick, Mr. Jan D. Wald and Mr. John Brock .....	169

## COMMENTS ON INSTRUCTIONAL FEATURES

GILBERT L. RICARD  
Naval Training Equipment Center

During the past decade we have seen dramatic changes of the role instructors play in device-based training and of the training tasks to which simulation has been applied. The main change we have seen has been the extension of synthetic training to tasks which simulation previously could not support. Much of this has been due to the development of software and hardware to create visual displays, the application of new means of interacting with computer-based trainers, and the proliferation of small computer systems with large amounts of memory. Of course, some of this change has been the result of an increased reliance on simulation for training--both by military training commands and civilian organizations--but most has resulted from the greatly increased capabilities of the devices themselves. All change seems to have its good and bad aspects, and while the extension of simulator-based training to complex tasks is most welcome, our notions of how instructional personnel should interact with these new trainers have not kept pace with hardware development. Three trends have contributed to this problem:

1. Device-based flight training has developed from the simulations of takeoff and landing of a decade ago to almost all aspects of the tactical use of aircraft. Largely, this result has come from the development of simulations of sensors--radar, sonar, forward-looking infrared, low-light level TV, and computer-generated visual scenes--which allow all members of a crew to interact in the same training scenario. Thus, individual procedural training has expanded to tactical team training where more than one trainee's actions must be monitored by instructional personnel. As the number of trainees participating in a training event increases, so also does the number of instructors needed. The resulting requirement for the design of training equipment has been to reduce the workload and support the communication of these instructors. Partly this is to make their jobs easier (both to do and to learn), and partly this is to enable them to act more effectively as instructors.

2. The instructor/operator station is the interface instructional personnel have to a training device and the services it provides. The past decade has seen a good deal of change in these consoles. The repeater instruments and knobs and dials once common have been replaced by cathode ray tubes, alphanumeric and multifunction keyboards, joysticks, and the like. Today training tasks are selected by entering data in response to

choices presented in menu form on programmable displays and light pens are used to select many of the options. On the horizon, we see flat panels with touch sensitive surfaces replacing much of the input/output hardware in current use. Such systems present in successive displays the information and choices that previously were spread over console surfaces. These systems pose the design problem of recasting the rules of the spatial grouping of information and choices into successive temporal groupings. In the future we expect that a single surface will serve to present information and record inputs, and system designers shall have to be both selective and efficient in their choice of what to display at a given time and what information to require from instructors. Rules, or at least guidelines, will have to be developed for moving about in menu-driven displays, for recovering from incorrect inputs, and for keeping track of choices that have been made. This problem of engineering the flow of events which present information to instructors and allow them to exert control over a device seems to be at the heart of deficiencies in today's complex trainers. In future systems, probably nowhere will the conflicting requirements of allowing for flexible usage and of providing for standardized instruction need to be more delicately balanced than at the operator's interface to the device.

3. The past decade has seen great increases of the processing power and storage capability of computer systems--all at ever falling prices. It has become common to see training devices with several minicomputers networked to process an appropriately parsed problem, and we expect that the future will only see more of this as microcomputers are devoted to smaller and smaller elements of the information processing and display tasks. This is true now for many of the calculations involved in a simulation and will be true also for the services a device offers its users. From an instructional point of view, these developments allow possibilities previously considered impracticable--where the computer system of a trainer not only supports the simulation of a training task but also stores and manipulates data useful for instructional control. Today's computers are not only data processors but machines to store and operate upon data bases as well as engines that can manipulate symbolic relations and make inferences. These new capabilities, emerging as software with supporting hardware, will allow training systems undreamed of a decade ago. The problem for design then is to define how such services should operate and how to fit

them into operational training devices.

These three trends have resulted in the requirement to define better the instructional role a training device's computer capability should fulfill and to define functionally the services a training device should support. Research and development efforts have stressed the observation that devices should provide not only a simulation of a task but should also be equipment to support the training of that task. Much of the research work has examined instructional features that have been incorporated into current devices or has suggested new features. Presently instructional features fall into two classes: those designed to support real-time instruction using a device and those designed to provide off-line services for instructional or administrative personnel. Many of the real-time training features are old friends such as the ability to freeze a task, set environmental conditions, move vehicles and the like. Research efforts have produced others such as models to determine the actions of targets or the output of voice synthesizers, computer measurement of a trainee's progress, and schemes to automate feedback for training. Features designed for off-line support tend to be relatively new because the storage required for them has only recently become available. Here we have seen developments in the keeping of students' records, in providing briefing and debriefing information, in the incorporation of software to tutor instructors on the use of a device, and in programs to define and create new training exercises. While neither of these lists is inclusive, they do provide a flavor of the developments we expect to see in the training devices of the future.

Every so often it is prudent to review the ways we do things and the technology we employ to do them. From problems uncovered in trainers currently operational, it is clear that now is the time to examine the functional design of the instructor/operator stations of training equipment. We need to be able to take advantage of new technology by knowing how to design it well so that it can support training easily. The goal of this workshop then is to provide information for the development of new systems as well as to present an overview of the knowledge currently available.

Large and growing literature exists on many of the topics related to the design of instructor/operator stations. These include topics such as instructional systems development, workplace design, and the utilization of training devices as well as discussions of the design of man-computer dialogues and descriptions of display and control equipment for man-machine interfaces. Only a small portion of this writing is devoted to the design and operation of training equipment, and for the most part it exists as a technical literature

which may not be widely distributed. Because of this, a bibliography follows that lists many of the reports discussing instructional features and console operation particularly for training applications.

#### BIBLIOGRAPHY

- Boff, K. R., and E. A. Martin, Aircrew Information Requirements in Simulator Display Design: The Integrated Cuing Requirement Study. In Proceedings of the 2nd Interservice/Industry Training Equipment Conference and Exhibition, November 1980, pp. 355-359.
- Bell, J. D., Closed-Loop Training Systems Through the Application of Instructional Features. In Proceedings of the 2nd Interservice/Industry Training Equipment Conference and Exhibition, November 1980, pp. 180-188.
- Charles, J. P., Instructor Pilot's Role in Simulator Training (Phase II). Technical Report NAVTRAEQUIPCEN 76-C-0034-1, August 1977.
- Charles, J. P., Instructor Pilot's Role in Simulator Training (Phase III). Technical Report NAVTRAEQUIPCEN 76-C-0034-2, June 1978.
- Charles, J. P., Device 2F119 (EA-6B WST) Instructor Console Review. Technical Report NAVTRAEQUIPCEN 81-M-1083-1, In Press.
- Charles, J. P., Device 2F112 (F-14A WST) Instructor Console Review. Technical Report NAVTRAEQUIPCEN 81-M-1121-1, In Press.
- Charles, J. P., G. Willard, and G. Healey, Instructor Pilot's Role in Simulator Training. Technical Report NAVTRAEQUIPCEN 75-C-0093-1, March 1975.
- Cotton, J. C., and M. E. McCauley, Voice Technology Design Guides for Navy Training Systems. Technical Report NAVTRAEQUIPCEN 80-C-0057-1, In Press.
- Dickman, J. L., A Comparative Analysis of Three Approaches to the Man-Machine Interface Problem at the Flight Simulator Instructor/Operator Station. In Proceedings of the 3rd Interservice/Industry Training Equipment Conference and Exhibition, November 1981, pp. 158-174.
- Elworth, C., Instructor/Operator Display Evaluation Methods. Technical Report AFHRL-TR-79-41, March 1981.

- Gregory, R. L., The Display Problem of Flight Simulation. In 3rd Flight Simulation Symposium (Theory and Practice in Flight Simulation), April 1976.
- Hammell, T. J., and J. N. Crosby, Development of SMARTTS Training Technology. In Proceedings of the 2nd Interservice/Industry Training Equipment Conference and Exhibition, November 1980, pp. 269-276.
- Hinton, Jr., W. M., and W. M. Komanski, Instructor/Operator Station Design Study. Technical Report NAVTRAEQUIPCEN 80-D-0009-1, April 1982.
- Hughes, R. G., Enabling Features Versus Instructional Features in Flying Training Simulation. In Proceedings of the 11th NTEC/Industry Conference. Technical Report NAVTRAEQUIPCEN IH-306, November 1978, pp. 137-144.
- Hughes, R. G., Advanced Training Features: Bridging the Gap Between In-Flight and Simulator-Based Models of Flying Training. Technical Report AFHRL-TR-78-96, March 1979.
- Hughes, R. G., S. T. Hannan, and W. E. Jones, Application of Flight Simulator Record/Replay Feature. Technical Report AFHRL-TR-79-52, 1979.
- Hughes, R. G., G. Lintern, D. C. Wightman, R. B. Brooks, and J. Singleton, Application of Simulator Freeze to Carrier Glideslope Tracking Instruction. Technical Report NAVTRAEQUIPCEN 78-C-0060-9/AFHRL-TR-82-3, July 1982.
- Isley, R. N., and E. J. Miller, The Role of Automated Training in Future Army Flight Simulators. Technical Report PM TRADE FR-ED-76-27, October 1976.
- Mitchell, D. R., Trainee Monitoring, Performance Measuring, Briefing, and De-Briefing. In Proceedings of the 1st Interservice/Industry Training Equipment Conference. Technical Report NAVTRAEQUIPCEN IH-316, November 1979, pp. 117-122.
- Murphy, G. L. Advancements in Instructor Station Design. In Naval Training Device Center 25th Anniversary Commemorative Technical Journal, Naval Training Equipment Center, Orlando, Florida, November 1971, pp. 175-182.
- Pohlman, L. D., R. N. Isley, and P. W. Caro, A Mechanism for Communicating Simulator Instructional Feature Requirements. In Proceedings of the 1st Interservice/Industry Training Equipment Conference. Technical Report NAVTRAEQUIPCEN IH-316, November 1979, pp. 133-144.
- Semple, C. A., J. C. Cotton, and D. J. Sullivan, Aircrew Training Devices: Instructional Support Features. Technical Report AFHRL-TR-80-58, January 1981.
- Semple, C. A., D. Vreuls, J. C. Cotton, D. R. Durfee, T. Hooks, and E. A. Butler, Functional Design of an Automated Support System for Operational Flight Trainers. Technical Report NAVTRAEQUIPCEN 76-C-0096-1, January 1979.
- Smode, A. F., Human Factors Inputs to the Training Device Design Process. Technical Report NAVTRADEVCEEN 69-C-0298-1, September 1971.
- Smode, A. F., Training Device Design: Human Factors Requirements in the Technical Approach. Technical Report NAVTRAEQUIPCEN 71-C-0013-1, August 1973.
- Smode, A. F., Recent Developments in Instructor Station Design and Utilization for Flight Simulators. Human Factors, 1974, 16, 1-18.

## INSTRUCTOR/OPERATOR STATION RESEARCH AND DEVELOPMENT AT AFHRL/OT

Dr. Harold D. Warner  
University of Dayton Research Institute

### INTRODUCTION

The Operations Training Division of the Air Force Human Resources Laboratory (AFHRL/OT) has as its mission the improvement of Air Force combat effectiveness through training related science and technology. Located at Williams Air Force Base, Arizona, AFHRL/OT performs this mission through two primary functions: behavioral R&D to solve flying training problems through improved technology; and, engineering R&D to develop training devices as vehicles for training R&D. The personnel who support these two areas form a diverse, multidisciplinary team of specialists ranging from research psychologists, research instructor pilots, and human factors specialists to aerospace engineers, mathematicians, and computer programmers. AFHRL/OT operates and maintains two of the nation's most advanced simulation facilities for training and R&D, the Advanced Simulator for Pilot Training (ASPT) at Williams Air Force Base, and the Simulator for Air-to-Air Combat (SAAC) at Luke Air Force Base. At present, the ASPT is configured with an F-16 and an A-10 cockpit, and the SAAC provides two F-4 cockpits for simulated air-to-air combat.

AFHRL/OT R&D efforts have been accomplished in a variety of areas including simulator training effectiveness, training methods, pilot performance measurement, and pilot perception and cognition. In the area of simulator training effectiveness, efforts have been directed toward the development and assessment of visual display systems and display generation techniques including helmet-mounted visual displays and computer generated imagery; the evaluation of alternative motion cueing systems such as the G-seat, G-suit, and cockpit motion platform; and, the determination of visual display requirements including field-of-view, color, resolution, aerial perspective, and terrain cues. As for the area of training methods, efforts have addressed, for example, whole vs. part-task training using full-mission flight simulators and desk-top, special-function trainers. The area of pilot performance measurement has also been strongly supported and includes experiments on measures of basic flying and combat skills, pilot workload, and stress. In the area of pilot perception and cognition, a variety of pilot factors have been examined

such as decision making, tactical planning, and visual cue utilization.

Because the efficacy of aircrew training is dependent not only on the training capabilities of flight simulators but also on the quality of flight instruction, AFHRL/OT has applied considerable resources to the design and evaluation of instructor/operator station (IOS) controls, displays, and workstation layouts as well as the evaluation of various IOS configurations. The specific efforts that were accomplished by AFHRL/OT, and the activities in progress, are as follows.

### AFHRL/OT IOS R&D ACCOMPLISHMENTS

1. A-10 Flight Simulator IOS. An IOS was designed for the Air Force A-10 Operational Flight Trainer. This effort involved a determination of the IOS controls and displays required for instructing simulated A-10 flight and the design of an A-10 IOS consistent with these requirements. In this R&D effort, a group of A-10 instructor pilots (IPs) was observed during the conduct of flight simulator training in the Advanced Simulator for Pilot Training (ASPT) and each IP was administered a questionnaire when the training was concluded. The questionnaire was designed to assess what controls and displays were used to instruct the student pilots and what should be added to the IOS to facilitate flight instruction. Both the observational and questionnaire data were analyzed to determine the control and display requirements for an A-10 simulator IOS. An IOS was subsequently designed which incorporated these controls and displays. In general, the IOS consists of seven Cathode Ray Tubes (CRTs), A-10 repeater instruments, a variety of controls and indicators, and a CRT hardcopy unit. Two of the CRTs are video monitors which would be used to display the student pilot's out-the-window visual scene, and one CRT is a closed circuit television monitor that would enable the IP to monitor the in-cockpit activities of the student pilot. The remaining CRTs would provide informational feedback about the student's flight performance. A variety of displays were developed for these CRTs and the function and operation of each display were determined. The IOS also included A-10 repeater instruments which were arranged the same as they are in the actual aircraft. Additionally, a number of controls were



incorporated in the IOS for the executive and administrative control of the training process. The specific configuration of these controls was provided and the function, operation, and layout of the controls were specified. This IOS design effort was fully described by Gray, Chun, Warner, and Eubanks (1981).

## 2. A-10 Training Features Evaluation.

The utility of various instructional features of the ASPT IOS were evaluated in the context of A-10 flight training. Six of the features available on the ASPT IOS were evaluated. They were: problem and parameter freeze, rapid initialization, automatic demonstration, automated performance feedback, self-confrontation, and task difficulty. In the study, IPs were required to rate the utility of each instructional feature and a systematic observational procedure was used to determine the frequency with which each feature was used by the IPs. The data analysis indicated that performance feedback and initialization were rated highest and were used most frequently. Problem and parameter freeze was also used regularly. Many of the features, such as automated performance feedback, task difficulty, preprogrammed demonstrations, and self-confrontation, were rarely used. Some of the features, such as freeze and initialization, were not used in an instructional manner, but more for training management purposes. That is, they tended to be used to terminate a training exercise and to provide a transition to the next exercise, rather than for providing opportunities to give the student pilots performance feedback and the appropriate remediation. This study is documented in the report by Gray, Chun, Warner, and Eubanks (1981).

## 3. F-15 Simulator IOS Operational Test and Evaluation.

An operational test and evaluation of an F-15 flight trainer, IOS was conducted. Measurements of the IOS controls and displays, workstation dimensions, and workplace environment were compared with the published military standards for equipment design. These measurements included CRT display character size, pushbutton control size, lighting levels, ambient temperature, noise levels, writing surface depth and height, and reach distances. In addition, a number of F-15 IOS users were interviewed to determine operational deficiencies and recommendations were provided for correcting these deficiencies. This evaluation was accomplished in 1977 for the Air Force Tactical Air Warfare Command (TAWC).

## 4. F-5E Instrument Flight Simulator Operational Test and Evaluation. AFHRL/OT

supported an operational test and evaluation of the F-5E Instrument Flight Simulator. This effort involved the development of the test procedures and data collection materials as well as assistance in the collection and analysis of the test data. The data collection materials consisted of rating forms which were administered to F-5E IPs to determine the fidelity and training capability of the simulator cockpit and the operability and instructional capability of the IOS. The data collection effort involved: (1) briefing the pilots and IPs on the missions to be performed; (2) distributing the rating forms; (3) monitoring the activities of the IPs at the IOS and the pilots in the cockpit; and (4) recording their comments concerning the simulator. The evaluation was managed by the Air Force Test and Evaluation Center (AFTEC).

## 5. A-10 Operational Flight Trainer Operational Test and Evaluation.

The operational test and evaluation of the A-10 Operational Flight Trainer was also supported by AFHRL/OT. The support involved assistance in the development of data collection materials and collection of test data. The data collection materials consisted of rating forms that were administered to the test IPs to assess the fidelity and training capabilities of the A-10 simulator cockpit and the instructional capability of the A-10 IOS. This evaluation was also managed by AFTEC.

## 6. SAAC IOS Control Panel Design.

The control/indicator panel for the Aerial Combat Engagement Display (ACED) of the Simulator for Air-to-Air Combat (SAAC) was redesigned. The ACED is essentially a CRT which is capable of displaying several pages. These pages present a view of the gaming area and the various aircraft in the area, a pilot's view from inside the cockpit of the visual scene, and performance scoring data. Controls and indicators are used to display different pages and to change range scales. In the modified panel design, the ACED controls/indicators that were originally contained in two separate panels were consolidated into a single panel. The controls/indicators were arranged in functional groups. The panel design has been implemented on the SAAC.

## AFHRL/OT IOS R&D IN PROGRESS

### 1. IOS Design Guide.

A guide for flight simulator IOS design is currently under development by AFHRL/OT. The guide will be made up of three sections, or volumes. The first volume will include detailed descriptions of advanced flight simulator IOS configurations. The second

will contain a compilation of the appropriate human engineering design criteria. The third will provide an IOS design for fighter/attack flight simulators based on the data in the first two volumes. At present, several simulation training facilities have been visited and descriptions of the IOSs have been prepared. The facilities that were visited include: (1) F-15 Instrument Flight Simulator; (2) A-10 Operational Flight Trainer; (3) F-14 Weapons System Trainer; (4) Tactical Aircrew Combat Training System (TACTS); and (5) EA-6B Weapons System Trainer. During these visits the operation of several other simulation systems was observed, namely, the F-14 Operational Flight Trainer, F-14 Mission Trainer, TA-7J Operational Flight Trainer, A-6E Weapons System Trainer, and A-6E Night Carrier Landing Trainer. Tactics information will not be included in the report because of its classified nature. Descriptions of the IOS for the F-16, F-18, and F-4 trainers will also be incorporated in the report. The second volume will contain relevant human engineering design criteria, standards, and specifications obtained from a compilation of existing data and from studies conducted at AFHRL/OT. Examples of the areas that will be addressed in the IOS design guide include control/display design and layout, workstation configuration, workplace environment, anthropometry, and operator seating. Volume three will provide a conceptual IOS design specifically for fighter/attack simulator applications. It will contain detailed design specifications and the function and operation of the IOS controls and displays will be explained. When the three-volume report is completed, a sequel will be prepared for tanker/transport/bomber simulators.

2. IOS Interactive CRT Controls Evaluation. R&D has been initiated in which alternative control devices for IOS interactive CRT displays will be evaluated. The controls are: (1) touch panel, (2) light pen, (3) numeric keyboard, and (4) voice actuation. These controls will be compared in relation to three different CRT presented performance tasks. In one task, the subjects will be asked to load various weapons from a menu onto the pylons of a stylized aircraft. The procedure is to select an appropriate pylon number with the controls, then select and enter the weapon number identifier. For the second task, the subjects will be required to move a cursor from a specific location to another location using the controls, which is analogous to initializing a simulated aircraft at a new location on a CRT presented IOS navigation map. The third task will require the

subjects to enter numeric data to establish the simulator parameters such as altitude, airspeed, heading, radio frequencies, latitude, longitude, and glide slope. The subject sample will consist of IPs who will be tested in a repeated measures experimental design. Both response times and errors will be recorded to provide the measures of task performance. To date, the CRT displays (performance tasks) are nearly complete and the controls are operational. The test will be conducted on a special-function, part-task trainer which is comprised of a Chromatics video display terminal and a North Star minicomputer.

3. ASPT IOS Energy Maneuverability Displays: Energy Maneuverability Displays (EMDs) were developed for the IOS of the Advanced Simulator for Pilot Training (ASPT), one for use in conjunction with F-16 flight training and the other for A-10 training. These displays are presented on an IOS vector graphics CRT, and they show the current energy state of the simulated aircraft. Since aircraft maneuverability is a function of available energy, these displays will enable the simulator IP to monitor the maneuvering capability of the aircraft. With this information, the IPs can instruct their student pilots on how to increase energy to maximize aircraft performance without exceeding the structural limits of the aircraft. An experiment will be conducted to assess the utility of these displays for flight instruction at the ASPT IOS. A group of F-16 and A-10 IPs will be asked to monitor the corresponding F-16 or A-10 EMD during a series of preprogrammed flight maneuvers in the ASPT. Following the demonstration, the IPs will be asked to rate the instructional utility of the EMD and their comments will be solicited via a questionnaire. The EMDs implemented in the proposed study were adapted from the EMDs used on the Navy's Tactical Aircrew Combat Training System (TACTS) which were originally developed by Pruitt (1979).

4. IOS Tactics Display Development. R&D has been initiated to develop an IOS display for air-to-surface tactical training. A conceptual model of the display has been designed which will be implemented and evaluated on the ASPT. The display provides the essential aircraft flight parameters and tactical information such as altitude, airspeed, and G-load as well as an overhead view of the tactical area with fixed range rings to show the range and bearing of ground radar and surface-to-air missile launches. The simulated aircraft is positioned in the center of the display and the terrain moves in accordance with the speed and heading of the aircraft. In

the evaluation, a group of IPs will be asked to monitor the display during a series of preprogrammed tactical missions in which radar will lock on and missiles will be fired. The IPs will be surveyed to determine the utility of the display for instructing/monitoring pilots in simulated tactical training scenarios.

5. IOS Integrated Visual Display Development. An experimental effort is underway to develop an IOS integrated visual display for use by IPs during basic (T-37) simulator flight training. The purpose of the display is to provide all the critical flight instrument data on a single CRT, similar in form to a head-up display (HUD). In this effort, a questionnaire was developed and administered to 25 T-37 IPs to determine the display requirements for instructing/monitoring basic training missions including contact flight, aerobatics, formation flight, instrument flight, and navigation. The questionnaire data are currently being analyzed to identify the specific flight information required for each of the missions. The appropriate display symbology will be selected to depict this information and a display will be designed containing the symbology.

6. IOS Instructional Features Requirements. A survey was recently initiated to identify the utility of advanced instructional features in aircrew training devices. The survey will be administered to IPs at various flight simulation facilities. The IPs will be asked to rate how frequently the IOS advanced instructional features are used in flight training, how easy is it to use each feature, and the training value and training potential of the features. A total of 17 features will be examined including Freeze, Record/Playback, Reset, Demonstration, Crash Override, Automated Performance Feedback, and Automated Adaptive Training. The survey will be conducted at A-10, F-15, and F-4 simulator training sites. The results of the survey will be used as a guide for specifying the required instructional features in future flight simulator IOS designs.

## CONCLUSIONS

AFHRL/OT has provided scientific and engineering support to a variety of flight simulator IOS design and evaluation efforts. Many of these efforts have been in support of outside Air Force agencies which have involved the assessment of IOS instructional utility, and the development of generalized guidelines for IOS design. Other efforts have been accomplished strictly in house to solve specific IOS design problems. It is anticipated that AFHRL/OT will provide continued, if not expanded, IOS R&D support. Greater emphasis will be placed on the use of desk-top, special functions trainers in the conduct of future IOS design studies. These devices will be used to investigate IOS control and display designs as building blocks for the development of full-mission flight trainers.

## REFERENCES

Gray, T.H., Chun, E.K., Warner, H.D., and Eubanks, J.L. Advanced Flight Simulator: Utilization in A-10 Conversion and Air-to-Surface Attack Training. AFHRL-TR-80-20, AD A094 608. Williams AFB, AZ: Operations Training Division, Air Force Human Resources Laboratory, January 1981.

Pruitt, V.R. Energy Management Training Aid for the Navy's Air Combat Maneuvering Range (ACMR). Report No. N00123-78-C-1371. St. Louis, MO: McDonnell Aircraft Company, McDonnell Douglas Corporation, April 1979.

# OPERATIONAL PROBLEMS IN INSTRUCTOR, OPERATOR STATION DESIGNS

DR. JOHN P. CHARLES  
Icon, Incorporated

## INTRODUCTION

In the past, training devices, as with many other systems, were all too often "provided" to the user and left for him to use as best he could. The user neither had been involved in the specification nor in the design of the device. As a result, the operator interface or instructor operating station (IOS) was generally designed as a simulation control unit rather than as a training control unit. Fortunately, the early devices simulated relatively simple systems and were seldom used for full system or crew training. Thus, the instructor with the help of a technician, could generally "operate" the device.

Two factors have significantly changed this picture. First, the application of advanced digital technology to training devices has expanded their capabilities enormously. Existing weapon system trainers (WST) can provide multiple targets in an electronic and missile warfare environment with visual and motion simulation. Freeze, dynamic replay, reset and demonstration functions are generally available. Graphics displays provide the instructor with "pilot view" displays and plots. Hundreds of pages of alphanumeric data on simulation options are provided.

The second factor was the increased emphasis on the use of simulation for training which occurred in the 1970s. Rising costs of weapon system ownership and operation led to a renewed application of simulation to crew training.

Thus, with the requirement for expanded use of simulation and with the technology available to implement the requirement, a wide variety of trainers were developed and installed. Each major weapon system training site now has at least a WST, and in addition, most have part task trainers (PTT) to support crew position training.

Unfortunately, research and development effort in IOS design did not

follow the pace set by simulation technology. Relatively simple consoles designed primarily to control the simulation, had proven acceptable for the early devices, even though not optimum. In the absence of any more refined requirements, the consoles for the new sophisticated trainers have followed much the same approach. Unfortunately, the consequences have produced serious operability problems as well as sub-optimum training support. While the devices can come close to duplicating the weapon system characteristics, they cannot necessarily be operated to train effectively using that capability.

The Naval Training Equipment Center undertook a series of studies in the 1970s to look at instructor console problems. One of these studies (Charles, 1975) looked at the role of the instructor pilot (IP) in simulator training. The study which surveyed all of the aviation readiness training squadrons and the related simulator installations found that several changes had occurred in the operation and use of the devices. Of more importance was the expressed concern that the next generation of trainers which were then in design, and development, would prove inoperable by instructor personnel if the simulation control orientation of the IOS design continued. The extensive use of cathode ray tube (CRT) displays would compound the problem.

## IOS PROBLEM AREAS

When operability problems did arise in some of the newer WSTs, the NAVTRAEQUIPCEN undertook a review of the IOSS with the goal of identifying both the causal factors and feasible solutions. Two WST IOSS have been reviewed, the EA-6B WST Device 2F119 and the F-14A WST Device 2F112. In general, the problems which were identified are similar in both devices. They reflect two basic development problems, the lack of human factors engineering effort during design and

development and the failure to define the operational environment and requirement for the device in sufficient detail.

While the human engineering problems are significant and interact with the operational problems to compound the operability problem, the operational problems are of prime importance. The best human engineered IOS cannot solve the user or operational problems which exist. However conversely, the most user responsive system will also be ineffective if inoperable.

Although steps have been and are being taken to solve some of the operability problems, the training or utilization problems in general remain. These problems are centered about three areas:

- a. definition of the user
- b. definition of the use
- c. definition of the training functions
- d. definition of the operators

While the three are clearly interrelated, each has a unique impact on IOS design requirements since they identify the simulation requirements, the trainer and training functional requirements and the operator/instructor interface requirements.

#### USER DEFINITION

The user refers to the units which actually utilize the trainer in their training program. In the U.S. Navy, the user and the custodian and maintainer are not the same activity. Most of the WSTs are supported by the Fleet Aviation Specialized Operational Training Group (FASOTRAGRU detachments. The trainers are maintained and readied for training as scheduled by FASOTRAGRU personnel. They also provided technical support to the operation of the device. The primary users are the Fleet Readiness Squadrons (FRS) and the fleet squadrons. Their requirements, although similar in terms of the weapon system and its operation, differ in terms of the training program content and implementation.

The FRSs conduct several levels of a syllabi designed to familiarize the replacement aircrew with the weapon system and its operational missions. The majority of replacement aircrew are recent graduates of the Naval Air Training Command and are designated Naval Aviators and Naval Flight Officers. They can be considered as the bachelors degree of the aviation community and have the basic professional qualifications. The FRS training programs are designed to produce aircrews who are qualified to operate a specific weapon system and to join a fleet squadron for additional training prior to deploying. Although many of the training programs have been task analyzed and behavioral and training objectives identified, the thrust of the typical FRS training program is not criterion based, nor is training to proficiency the primary objective. The FRS has been likened to a graduate school. As in academic graduate schools, while grades are utilized, they are considered more for information than for a pass-fail function. The replacement aircrew are qualified aviators and NFOs, and they are considered to be capable of transitioning to the new system in the allotted training time. When unsatisfactory performance does occur, it is initially handled with the usual options of counseling, extra time and tutoring.

In summary, the FRS training program, given the limited training time, limited flight time, and limited simulator time, is organized to give the replacement aircrew the maximum training and experience possible while closely monitoring performance for safety and correct operating procedures.

Fleet squadron training is similarly conceived and except for NATOPS and instrument checks which have associated performance criteria, the rest of the training is aimed at imparting as much experience and knowledge across the mission requirements as possible prior to deployment. Readiness criteria have been developed but are, in general, more experience oriented rather than performance oriented.

These training programs depart from the classic training approach

which is organized around a highly structured syllabus, testing and fixed criteria.

In summary, the discussion of the user programs has emphasized the instructor oriented nature of the program since it serves to frame some of the operational problems in existing IOS design.

#### USE DEFINITION

The FRS use of the WST varies as a function of the phase of training. The FRS syllabus begins with systems familiarization and progresses through basic flight characteristics to weapon system mission and tactics training. Procedures and position training are conducted on PTTs if they are available. If not, the WST is used to support all phases of training includ-

- system familiarization
- basic flight
- operation and basic tactics
- advanced tactics
- special events

Procedures and basic flight training, when conducted on the WST, generally utilize a manual training mode in which the instructor can control the initial conditions and the evolution of the subsequent events. The instructors consider it essential to control the onset and removal of malfunctions and emergencies. They also find it easier and more realistic to simulate the various controller functions in a manual mode.

Systems operations and basic tactics training is generally conducted in a semi-manual mode if possible. Pre-programmed initial condition sets are used for establishing the target(s) and environment as well as the flight starting point. The instructor then assumes control and adjusts the scenario to meet aircrew performance and training needs.

Advanced tactics and battle problem training events are more fully programmed because of the almost impossible task of trying to control manually the targets and the many

variables involved. Some instructor interaction is, however, required to reorganize or reorient the problem based on aircrew actions.

Special events such as spin, high angle of attack and missile defense training are generally conducted in the manual mode since they involve "free flight" by the student.

Finally, although not yet implemented, programmed and standard mission events are needed to permit crew and unit evaluations. Simulation provides a feasible means of accomplishing such operations since realistic targets and weapons (and weapons effects) are generally unavailable for "shoot-offs".

Fleet squadron use is similar to FRS use except that familiarization training (procedures and basic flight) is not part of the training program. Detailed training event guides and grade sheets are generally not utilized.

In summary, the use of the WSTs in FRS and fleet squadron training includes:

- manual modes for familiarization training (if conducted on the device) as well as for special "experiential" events such as spins and missile defense.
- semi-manual modes for systems and basic tactics training
- programmed or formulated modes for advanced tactics and battle or war problems

#### TRAINING FUNCTIONS DEFINITION

Effective training requires a series of tasks ranging from instructor preparation for the event to record keeping. The set of tasks used to analyze the IOS designs included the following:

- a. Prepare - review event, aircrew files, simulator status; get forms, guides, manuals
- b. Brief - review event, objectives and procedures with aircrew and instructor staff

- c. Initialize - configure consoles and cockpit; select and implement initial conditions or programmed mission
- d. Train - instruct; control simulation; monitor performance
- e. Evaluate - evaluate aircrew proficiency; diagnose performance problems
- f. Debrief - review event results with aircrew and instructors
- g. Manage data - update aircrew, staff and simulator files
- h. Develop events - create/program/modify events, displays, missions, simulation data
- i. Train instructor - train in simulator operation and use

The training device should provide support to each of the functions, especially the brief, initialize, train, evaluate, debrief and develop functions.

#### DEFINITION OF OPERATORS

The traditional operators of training devices have consisted of the technician simulator operator (SO) provided by the FASOTRAGRU Detachment, and the instructors provided by the squadrons. The SO is typically a technician who is learning console operation prior to being assigned to a maintenance crew. Thus, in general, the SO is not an expert in simulator operation although such assistance is generally available on-call. The SO is available to assist the instructors in "button smashing".

The instructors from the FRS will have completed the instructor training syllabus which generally includes a short course on simulator use and some on-the-job experience. Of more importance is the fact that the instructor will also be instructing on other trainers as well as in-flight. Therefore, with rare exception, he is not dedicated to WST instructing. During his tour of duty, he will also be assigned other squadron duties and his ground instructing time will taper off as a function of time and duties in the squadron.

The fleet squadron instructors

are not trained in simulator operation (except for any prior FRS experience) and cannot be expected to become qualified in operating the trainer.

#### SUMMARY

The user data which should constrain the IOS design involves the specification of the:

- a. user - primarily FRS and fleet squadrons
- b. use - primarily system operation and tactics (except when supporting familiarization training)
- c. functions - all training tasks
- d. operator - the technician operator and the squadron instructors. The operator is generally new to the device, the FRS instructor has limited training in operating the device, and the fleet squadron instructor will have no training in operating the device.

#### OPERATIONAL PROBLEMS

A variety of problems occur in operating typical WSTs, many of which seriously impact training effectiveness. Some of these problems, which result from failure to consider the operational environment in terms of the user, the use, the training function support and the operators are outlined below. The problems will be grouped in terms of IOS configuration and layout problems, display and control problems, operating problems and training function problems.

#### IOS LAYOUT PROBLEMS

From the review of IOS installations, it is clear that insufficient attention is given to console location and layout. In general, it appeared that the typical IOS is located in a main traffic flow pattern, and becomes a meeting place for personnel in the area. While observation of ongoing training can contribute to learning, a ready room environment is not conducive to either the training or to beneficial observation. Figure 1 depicts the location and layout of the 2F119 IOS. All traffic to and

from the cockpit must pass through the area. In addition to the congestion problem, the aircrew can generally get a glimpse of the upcoming simulation being initialized. Light spills onto the displays when doors are opened. Noise interferes with inter-instructor communications.

#### ARRANGEMENT PROBLEMS

Most IOS consoles provide a station for each of the instructors as foreseen by the specification and the design. This rarely reflects the use and user needs. One of the major problems occurs in the battle or war problem event, especially for the fleet squadrons. As can be seen in Figure 1, only three instructor stations exist (and none for the SO!) The battle problem instructor who is responsible for the overall evolution of the event and for evaluation and critiquing of crew performance, has no effective station from which to operate. The IP mans the flight station; the ECMO instructor, the tactics station. In practice, the battle problem instructor mans the ECMO 1 station where he is forced to share the displays of the other stations, manipulate the station control between the flight and tactics modes of operation, and perform the ECMO 1 instructor functions. The problems are similar for the 2F112 as can be seen in Figure 2. Here, the battle problem instructor is forced to sit behind the instructor stations and function with a clipboard and whatever display he can read from this position.

#### DISPLAY PROBLEMS

The CRT display provided the designers the opportunity for displaying literally any simulation data available. In many of the WSTs, the opportunity was utilized. The volume of pages required the use of index pages. Table 1 summarizes the display options available on the 2F119 WST flight station displays.

The quantity of data far exceeds the capacity of any IP to access and utilize effectively during training and still be able to monitor and evaluate replacement pilot performance. The options cannot be accessed by an instructor who is not trained and proficient or experienced in the flight station operation. A similar set of displays exists at the tactics station.

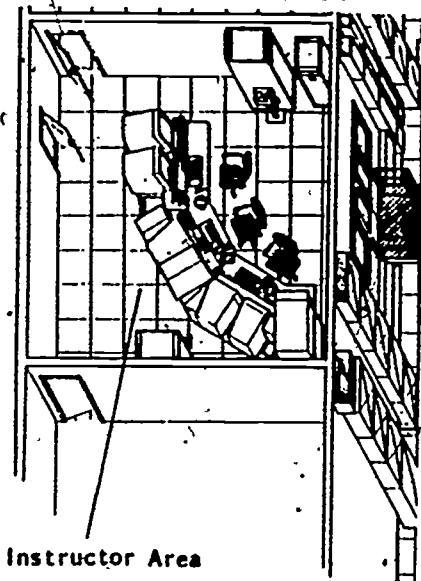

Instructor Area

Figure 1. Device 2F119 IOS Arrangement

TABLE 1. 2F119 FLIGHT DISPLAY OPTIONS

Title	Pages
Display Index	1
Initial Conditions Index	1
Initial Conditions	10
Pilot Instrument Monitor	1
Pilot Console Monitor	1
ECMO 1 Monitor	1
Procedures Monitor Index	2
Procedures Monitor	99
Malfunctions Index	1
Malfunctions	13
Input Codes	2
Function	10
Parameter Recording	1
Cross Country	1
Hostile Environment	1
Terminal Area	1
ACLS	1
GCA/CCA	1
CEM Index	1
CEM (Alphanumeric)	variable
CEM (Graphics)	1
CEM Summary	1
Demo Index	1
Demos	10
DRED	1
Visual Status Monitor	3
Graphics Test Display	2
Memory Monitor	3
System Time	5
TOTAL	167



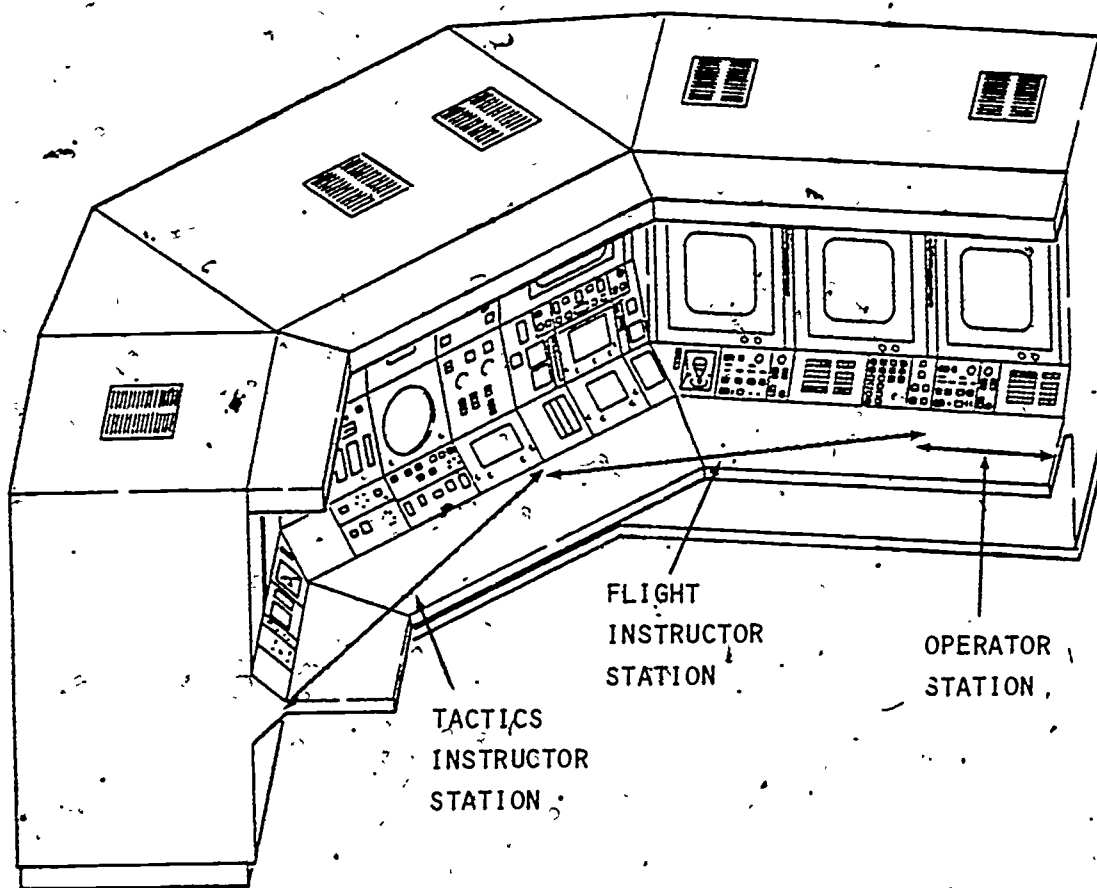

Figure 2. Device 2F112 IOS Arrangement

A similar display approach was implemented on the 2F112.

CRT cockpit monitor displays on the typical console pose serious problems since the data is not displayed in a manner readily interpreted by the instructor who is also training in flight. The displays do not typically parallel either the arrangement or the format used in the aircraft. Figure 3 depicts a typical page used in WSTs and is from the 2F119. As can be seen, the instructor cannot glance at the display and ascertain switch settings without first locating the control by reading the list and then reading the control setting.

#### CONTROL PROBLEMS

The typical instructor station has two CRT displays along with some cockpit repeater displays. The CRTs are operated by selecting the CRT (and

sometimes the specific area on the CRT) to be utilized, then selecting the display mode to be accessed and finally paging to the data required. The sequence of steps which involves both switch and light pen operations, for example, is time consuming and requires the instructors concentrated attentions. Errors, which often occur, typically require repeating the entire sequence of steps.

Light pens are widely used for simulator control. Although light pens are becoming more reliable, they are still unacceptable for time sensitive inputs such as malfunction insertion, weapons launches and training control functions. In the past, poor light pen reliability has severely handicapped console operations.

The typical joystick display-control dynamics involves a step function which renders it unusable for CRT

STALL WARNING		ADFGUAR	
REFUELING		OFF	
BOOST PUMP TEST		OFF	
TANK PRESS		NORM	
LING DROP TANK PRESS		NORM	
LING		NORM	
FUS		NORM	
FUEL SAGE		MAIN	
BLEED AIR			
MUJ			
L ENG			
R ENG			
ASSIST SPIN RECOVERY			
EMER FLAP		OFF	
APC			
AIR TEMP			
FLAPERON POP-UP			
ANTI-SKID		ON	
HOOK BYPASS		TOUCH GO	
SPD BRAKES TEST		OFF	
EXTERIOR LIGHTS MASTER		ON	
COLLISION LIGHT		ON	
TAIL LIGHT		BRT	
TAXI/PROBE LIGHT		ON	
LING LIGHTS		BRT	
FORMATION LIGHT		BRT	
PYLON		OFF	
SLEW			
RADAR ENTER			
OXYGEN			
SEL STORES JETT		SAFE	
CABIN DUMP			
IFF ANT			
TACAN ANT		FUD	
ADF			
RADAR BEACON PUR		PUR	
MODE		ACLS	
AIR COND CKBT			
AIR COND MSTR			
MAN RAM AIR			
AUTO TEMP			
EQUIP COOL MSTR			
TEST/NORM (AJ)		ACLS	
DATA LINK		NORM	
FREQ		ON	
		0.8	
CHANNEL		ARA-63	
POWER		7	
BIT			
VERT REF		DISPLAYS	
ACLS			
PACK 1		CHAFF	
PACK2		8	
EMIT		8	
RUDD/MAN		DECN	
		-OFF	
		AFT	
POWER		TEST	
L GBN		R GBN	
L BNG		R ENG	
AUTOPILOT		OFF	
ALT HOLD		OFF	
MACH HOLD		OFF	
ACLS		NORM	
STAB AUG		STAB AUG	
UHF		PRESET	
FREQ		MAIN	
		(8)	
MASTER		IFF-SIF	
CODE			
RAD TEST			
MODE 1			
MODE 2			
MODE 3			
MODE C			
MODE 4			
IDENT			
UHF 1			
UHF 2			
HF			
TAC/IFF			
COM/JX			
LARN			
TJS			
ICS			
ICS			
AMPL SEL		NORMEN	
MIC SEL		COLD	
ENG ANTI-ICE		OFF	
DEFOG			
WINDSHIELD			
PITOT HEAT		AUTO	
WINGFOLD		LOCKUN	
UHF		PRESET	
FREQ		MAIN	
		(8)	
COMP			
LAT			

Figure 3. Typical CRT Monitor Display

operations. Manual control or flying of targets using the joysticks has proven equally impossible because of the lack of sufficient flight information and because of joystick control axes coupling.

Cockpit configuration and initial condition control mismatches generally require extensive manipulation of IC procedures to resolve the problem.

Communication options controls on most WST IOSs have proven so time consuming to use and so error producing that the options are not utilized. The control panel is left in "override".

OPERATING PROBLEMS

Manual modes of trainer operation have generally proven difficult to utilize even though required for many events. The exception is the IC which involves starting with the cockpit pre-flight procedure at the take-off end of the runway. However, even for this IC, the instructor, unless he accesses relevant data pages is unsure as to fuel state, stores configuration, weather, etc. The major problem is one of knowing on what page and in which display mode the relevant data is available, and when accessed, how to edit and what the impact will be on inter-related parameters. The task is beyond the "novice" user.

Programming or formulating methods requires extensive training and recent experience to utilize. This requirement cannot be met by the typical instructor. The procedures on most WSTs do not provide an "interface" between the instructor and the mission programmer.

Target creation is normally accomplished in simulation parameters rather than in user terminology. Thus, targets are created in terms of "small fighter" with an "IR" missile and a spot jammer, for example, rather than in terms of a Badger or Backfire or Muffcob. The result is that the instructor does not generally know what the displayed target represents or how to evaluate the aircrews tactics relative to the target.

TRAINING FUNCTION PROBLEMS

Ideally, a training device should be able to support each of the train-

ing tasks involved in the training mission. Few do. To the extent that they do not, additional workload is placed on the instructor or SO and additional training may be required. Table 2 is a summary of three WSTs support to the training functions outlined earlier.

TABLE 2. TRAINING FUNCTION SUPPORT

Function	WST		
	2F111	2F112	2F119
Prepare	none	none	none
Brief	none	none	none
Initialize	yes	yes	yes
Train	yes	yes	yes
Evaluate	none	none	some
Debrief	none	none	none
Manage Data	none	none	none
Develop events	yes	yes	yes
Train instruc.	none	none	none

As can be seen, the typical WSTs are not designed to support training functions. As has been discussed in the previous sections, even those tasks in Table 2, which are recorded as "yes", present marginal support to the function. Yet, each of the devices has data stored within the system which would be useful for the instructor in:

- reviewing the scenario and options prior to briefing the student
- reviewing the weapon system operating procedures and simulation options.
- briefing the aircrew on event procedures, scenario and objectives
- briefing the instructor staff on the scenario and training procedures
- debriefing the aircrew on the results of the training
- debriefing the instructors on the problems and changes required
- updating training records

Communications simulation is performed manually in most trainer and can require up to two instructors full time for some battle problems.



Simulation of controllers and providing relevant background communications, especially for sequential battle problems, is almost impossible.

None of the WSTs reviewed provide the capability of either briefing or debriefing the aircrew (or instructor staff) without utilizing training time and the instructor console. None of the WSTs provide the additional displays and controls required or the interface required.

Hard copy output on most WSTs is typically so slow and involved that it is not used. Yet, all instructors agree, that hard copy is desirable, especially if no debriefing displays are available.

Malfunction options far exceed a usable set on most WSTs (typically in the hundreds). In addition, information on the simulation characteristics of the malfunction is not provided. As a result, the instructor has no information on the different cockpit indications and relevant procedures, for example, for different engine fires of flight control system failures.

#### SUMMARY

Recent reviews of the IOSs of several WSTs have documented a variety of operational problems. In general, they result from both the failure to consider user requirements or to design the IOS to basic human factors engineering criteria.

#### REFERENCES

1. Charles, John P. "Instructor Pilot's Role in Simulation Training (phase II)." NAVTRAEQUIPCEN 76-C-0034-1. Naval Training Equipment Center, Orlando, FL, August 1977.
2. Charles John P. "Device 2F119 (EA-6B WST) Instructor Console Review". NAVTRAEQUIPCEN 81-M-1083-1; Naval Training Equipment Center, Orlando, FL, (in printing).

THE REAL WORLD AND INSTRUCTIONAL SUPPORT  
FEATURES IN FLYING TRAINING SIMULATORS

Clarence A. Semple and Barton K. Cross, II  
Canyon Research Group, Inc.  
741 Lakefield Rd., Suite B  
Westlake Village, CA 91361

ABSTRACT

The real world is defined as the operational training environment. Instructional support features (ISF) are simulator hardware and software capabilities that allow instructors to manipulate, supplement and otherwise control the student's learning experiences with the intent of promoting the rate at which skills are learned and maximizing the levels of skills achieved. This paper summarizes research findings, observations and experiences dealing with the design and use of the following ISFs: automated demonstrations; record and replay; programmable and manual malfunction control; automated cueing and coaching; automated controllers; computer controlled adversaries; and quantitative performance measurement. Definitions of the features are given, followed by comments on their design and use. A final section deals with persistent needs for improved instructor training in the use of simulation in general and in ISFs in particular.

BACKGROUND

The increasing complexity of modern weapon systems, combined with their ever increasing performance capabilities, have created a situation in which the performance capabilities of crewmembers are becoming commensurately more critical. As crew performance capabilities become more critical, the training of those capabilities becomes an increasingly difficult problem in that less performance variance can be tolerated.

Training using operational equipment is becoming increasingly difficult. Acquisition, operation and maintenance costs are all high. Skilled maintenance and instructional personnel often are scarce. Finally, environmental constraints constantly encroach upon real world training areas and impact on how they can be used.

The use of aircrew training devices (ATDs), while not as glamorous as inflight training, has several inherent advantages. ATDs still are relatively inexpensive to procure, operate and maintain, at least in comparison with actual equipment. Consequences of operator error or inability to appropriately respond to normal and emergency requirements are significantly less in a simulator. Control over training events is vastly superior to that available in the air. Simulators can be used to create low probability conditions at will for training purposes, training events easily can be repeated until necessary operator skill levels are achieved, and their utilization rates are significantly greater than actual equipment.

The question now has become how to maximize the training utility of ATDs rather than whether to use them in training. With the proper design, application and use of instructional support features (ISFs) in training devices, the utility and advantages of training devices over actual equipment can become even greater. The training simulator can become an even more integral part of the real-world operational training environment.

INSTRUCTIONAL SUPPORT FEATURES

ISFs are features of training simulators that are specifically designed to facilitate the instructional process. ISFs are the hardware and software capabilities that allow instructors to manipulate, supplement and otherwise control the student's learning experiences with the intent of promoting the rate at which skills are learned and maximizing the levels of skills achieved. They are designed to allow control of instructionally related variables such as rate of content presentation, amount of content presented in a single block, amount and distribution of practice, types of tasks practiced, knowledge of results, and measures of performance. ISFs are the capabilities that transform a simulator from simply a practice device into a flexible element of the total training system. Common instructional support features include freeze, record and replay, and programmable initializing conditions.

Early ISF implementation efforts were frequently viewed as compromising the hard won fidelity of simulators. While it certainly is possible to implement ISFs in ways that will compromise the fidelity of simulation, lower levels of fidelity are not the necessary consequence of introducing ISFs into a training simulator. The features can be implemented in ways that will leave the fidelity of the simulator intact and at the same time enhance the training effectiveness and utility of the device. The commonly assumed justification for high levels of fidelity is to enhance training effectiveness. Instructional support features are capable of still further enhancing training effectiveness and efficiency. Thus, instructional support features can be regarded as "fidelity plus." This statement assumes that the implementation of the support features is accomplished in a professional manner that does not compromise the fidelity of the simulation itself (e.g., video display terminals used for instructional feedback are not placed in middle of an otherwise accurate instrument panel).

This paper does not attempt a discussion of each ISF available with current technology. Rather, several were selected on the basis of difficulties that seem to persist in their design and use. The content of this paper is based in part upon the rather meager experimental research data that exist on instructional support features, and in part upon observations of training and research applications of various instructional features. The following are addressed:

- Automated demonstrations;
- Record and replay;
- Programmable and manual malfunction control;
- Automated cueing and coaching;
- Automated controllers;
- Computer controlled adversaries; and
- Quantitative performance measurement.

Definitions of the features are given, followed by comments on their design and use. A final section deals with persistent needs for improved instructor training in the use of simulation in general and ISFs in particular.

#### Automated Demonstrations

Automated demonstrations (auto-demo) permit the standardized presentation of a mission segment or entire simulated flight. All simulator systems, including the visual scene (if present), motion system, primary flight controls and displays, crew communications, and sensor displays respond as though skilled aircrews were at the controls.

Auto-demo requires substantial two-way communication between ATD controlling software and hardware, and crew station controls and displays. Given this requirement, auto-demo is found only in more sophisticated computer controlled ATDs. Technically, auto-demo can be constructed for any segment of flight (e.g., takeoff, fly straight and level, perform aerobatic or air combat maneuvers, deliver weapons, fly a standard approach, and land) without the student or instructor operating any primary controls.

Two instructional values commonly are assumed for auto-demo. First, the feature provides a performance model that the student can observe, analyze, pattern his own behavior pattern after, and use as a reference for self-evaluation in subsequent trials. The student's workload is considerably reduced during auto-demo, providing him with a better opportunity to observe relationships among cues and system responses. Similarly, instructor workload is considerably reduced, allowing a better opportunity for instructional interaction with the student.

A second value is that automated demonstrations may be the only way to show the student what is expected of him in ATDs that exactly reproduce crewstation physical configuration. When the crewstation is either single seat (e.g., F-15) or incorporates controls and displays necessary to execute manual demonstrations at only one crew position (e.g., F-4), there is no opportunity for an instructor to enter the crewstation and do a hands-on demonstration. Therefore, the only remaining avenue for a demonstration is by means of auto-demo.

In an examination of auto-demo utilization, Semple, Cotton and Sullivan (1981) concluded: "The training value of an automated demonstration will be greatest when the cues, responses and task performance requirements being demonstrated are new to the student (i.e., they are not highly familiar to him)."

Navy research with the A-7 Night Carrier Landing Trainer (NCLT) has shown that auto-demo has a "significant" instructional value (Bricton and Burger, 1976). However, there were no data quantifying the specific contribution that the feature made to overall training effectiveness or efficiency. This application does represent a case, however, where an instructor-flown demonstration was not possible because the ATD is a single seat configuration. No other method for demonstration was possible.

The only known experimental study to address the auto-demonstration capability

was reported by Hughes, Hannan and Jones (1979). This study attempted to address the instructional impact of both the auto-demo and record and replay instructional features. Subjects were divided into three groups with each group receiving the same basic instruction followed by either extra practice, recorded replays in lieu of one practice trial in each block of trials, or an auto-demo in lieu of one practice trial in each block of trials. The results indicated that extra practice was most instructionally beneficial, followed by record and replay and auto-demo in that order. The generalizability of these conclusions must be questioned, however, in that the basic instruction for all three groups incorporated auto-demo, and automated instruction was used in lieu of instructors. Given a real-world instructional setting, these results might not hold-up.

There are two basic methods for creating auto-demos. One is to use an ATD's record and replay capability. This method requires that a proficient aircrew member fly the necessary profiles in the desired manner using desired techniques. This method has the advantage that highly proficient crewmembers usually are available and the disadvantage that it is difficult, even for highly proficient aircrew members, to fly profiles with the perfection often judged necessary for a performance model for the student. Also, the lack of well defined criteria for the largest percentage of flying tasks makes it difficult for instructors to agree on what constitutes an acceptable demonstration.

The second method for creating an auto-demo is to develop customized software for each demonstration. This approach has the advantage that mathematically perfect demonstrations can be created. It has the distinct disadvantage, however, of requiring computer software specialists to create new demonstrations or to modify initial demonstrations. Both manufacturer and user personnel view the direct software approach as the more time consuming and costly of the two methods available.

The need for "perfect" demonstrations must be questioned for either method of development. Demonstration of "typical" performance may be more appropriate in that no one flies "perfect" maneuvers in the real world. Appropriate tactics, techniques and perhaps even typical errors and performance problems should be emphasized, rather than precise flight path control.

#### Record and Replay.

Record and replay is the capability of simulators to record relevant system

parameters and then use these data to recreate student's performance. Typically, the last five continuous minutes of performance are recorded. After freezing the ATD, the instructor selects the point in time during the last five consecutive minutes that he wants replay to be initiated. All events of consequence are reproduced during replay, including the visual scene (if present), motion system operation, primary flight control and display movements, and appropriate sensor display content. The ATD performs as though the student was again flying the replayed segment exactly as it had been flown before.

Experience has shown that record and replay is used more often in the training of tasks that are new to the student and are relatively complex (for him). In general, the use of record and replay has centered on undergraduate pilot training and on the training of new (to the pilot) and relatively complex advanced flying skills, including night carrier landing and air combat maneuvering.

The primary instructional benefit attributed to record and replay is that it provides both students and instructors with an objective recreation of the student's performance that can be examined for problems, errors and their causes. In short, the student is provided with objective knowledge of results and the instructor with concrete evidence from which to suggest areas or techniques for the improvement of the student's performance. Replay seems to be most useful when the student is not aware that he had made an error or is uncertain of the precise cause of his error and resulting performance problem. This situation is most apt to arise when complex tasks are being initially learned. Following interviews with instructor pilots throughout the military, Semple et al. (1981) concluded: "The training value of record and replay will be greatest when the cues, responses and task performance requirements being learned are new to the student."

Record and replay is currently used almost exclusively for pilot and/or copilot training. Replay could be used, however, in a crew training environment as a means to evaluate and improve crew interaction. Voice replay also would be required in this application since some of the better indicators of crew interaction are crew communications. This potential value for replay depends heavily on how well individual crewmember responsibilities are defined.

The record and replay feature requires substantial two-way communication between ATD controlling software and hardware, and

crew station displays and controls. Thus, the feature is found only in more sophisticated, computer controlled ATDs. ATD hardware and software must be configured to induce changes in the operation of simulated subsystems without intervention by the student or the instructor.

Several factors should be considered when implementing a record and replay feature. For replay, a total of five minutes appears to be more than adequate. In most uses, 1.5 to 2.0 minutes probably would be sufficient. The amount of replay time to be incorporated into an ATD should be determined on a case by case basis. An alternative to specific time increments also should be given consideration. A reasonable alternative would be to provide the instructor with a cueing control. Replay then could be started at a determined time prior to when the cueing control was activated (e.g., 20 seconds; or whatever would be reasonable for the particular training application). This would allow instructors to relate replay to training events rather than clock time. Voice replay should receive serious consideration for training tasks where voice communication is a significant element of total task performance. Finally, there may be training and user acceptance values in being able to deactivate replay part way through, thereby allowing the student to assume manual control using a "fly out" capability.

#### Malfunction Control

Procedures trainers, part task trainers, operational flight trainers and full mission simulators generally include capabilities to simulate a variety of malfunctions. It is widely accepted that ATDs provide a safe and controlled environment for training responses to malfunctions and emergencies. In such settings, responses to single and multiple malfunctions can be trained and practiced either in isolation or in mission contexts. The number of malfunctions that instructors can present to a student typically ranges from 60 to several hundred. The number typically used ranges from 20 to 50.

The most common method of inserting and removing simulated malfunctions is manual operation of controls by the instructor. Types of controls now in use include dedicated pushbuttons, programmable pushbuttons, alphanumeric keyboards, and touch panels.

Another alternative is automated malfunction insertion. One assumed value of automatic malfunction insertion and removal is that it unburdens the instructor from more routine tasks, freeing his attention and time for more important instructional

activities. A second value involves student self practice. Some training managements encourage students to practice whenever ATD time is available, even if instructors cannot be present. In these cases, automatic malfunction insertion could be used to structure training sessions.

Little creative thought has been applied to meaningful methods for automatically inserting malfunctions. Time into the mission is the most common method and has proved unworkable because mission time often does not correlate with mission events. For example, ATD clock time into a mission typically does not take freeze into account. If the ATD is frozen so the instructor can work with the student, the malfunction clock keeps running. As a result, a new malfunction can be inserted at a very inappropriate time in the mission. The acceptability of this circumstance is low, both instructionally and in terms of user acceptance.

Semple, Vreuls, Cotton, Durfee, Hooks and Butler (1979) developed a functional specification for a simulator instructor's console which, among other things, incorporated automated malfunction insertion and removal. In the initial concept, the instructor could select a malfunction and select from a list of initiating conditions for that malfunction. The malfunction would be inserted when the initiating conditions were met and would be removed following the completion of correct student responses. In an experimental prototype of the system, automatic malfunction insertion and removal were incorporated, but instructors did not have a choice of initiating conditions. During a preliminary test of the system, instructors did not respond favorably to the automated malfunction scheme (Semple, 1982). Their strongest complaint was lack of flexibility. However, instructor training in system utilization was minimal, and it is not known whether their comments would hold if instructor training in the feature had been more rigorous.

There are four general issues which should be considered when implementing malfunction insertion options in an ATD. One is the amount of malfunction cue recognition which should be trained in versus out of the ATD. Using valuable training devices to train content, which would be equally appropriate for other media, is inefficient training design. Ease and convenience of use by instructors and operators is equally important. If a feature is difficult or troublesome in use, experience shows that it is likely to go unused (Semple, et al.; 1981). Memory aids should be designed into the system to remind instructors which malfunctions are engaged and which are available.



Finally, with automated malfunction insertion, programming must allow for meaningful failures relative to the mission rather than to an arbitrary time-line and instructors must be able to override automated insertions and removals.

### Automated Cueing and Coaching

Cueing messages alert students, e.g. "check altitude." Coaching messages instruct, e.g. "return to flight level 150." Automated cueing and coaching are not common in present ATDs. Their assumed instructional values center on the promptness and accuracy of guidance and feedback information provided to the student, and the unburdening of instructors through automation. Such systems also can provide feedback and guidance to students when a qualified instructor may not be present, as in "extra time" practice. They require good automated performance measurement to determine what messages should be given to the student and the timing of their delivery. Automated cueing and coaching systems can be disruptive if messages occur too frequently, which suggests the need to be able to deactivate the system, and further suggests the desirability of decision logics designed to keep the frequency of cueing and coaching messages within acceptable bounds in relation to student skill levels.

A programmed mission scenario typically is required so that desired performance is defined clearly. A quantitative performance measurement (QPM) system and additional decision logics also are required for determining message content and timing. A QPM capability is needed to sense when student performance is less than what is required for the task he is practicing. When differences are found, system logics are needed to identify the appropriate message content. Typically, a cueing message would be transmitted first and performance monitoring would continue. If the performance deficiency was not corrected, the appropriate coaching message would be transmitted. If the deficiency continued, either coaching messages could be continued or the instructor alerted so that he could intervene.

Three technologies are available for creating the messages to be transmitted to the student: audio tapes; digitally stored speech; and computer generated speech. Computer generated speech is relatively new but is readily understandable. Digitally stored speech is even more "human." Taped messages often involve prolonged search times and mechanical unreliabilities. Digitally stored or computer generated speech technologies are well suited to automated cueing and coaching message delivery because the messages

involved usually are brief, and computer memory requirements are well within reason. Also, changes in message content are easily accomplished.

The issue of which messages should be built into an automated cueing and coaching system must be addressed on a case by case basis. The analysis should begin by identifying typical performance problems that go unattended by the student. Commonalities among the performance problems (and association cueing and coaching messages) then should be identified so that the smallest possible set of cueing and coaching messages can be identified. Draft messages then should be developed and reviewed for clarity and brevity. Finally, the automated cueing and coaching system should be tried out in a representative target operational training setting before its design is finalized.

Present applications of automated cueing and coaching center on basic flight and navigation task training. In the future, it may be possible to incorporate these capabilities into procedures task training. In one application, use of the feature varied considerably from instructor to instructor, which was to be expected because of lack of instructor training on potential values and limits. Some instructors indicated that the feature was used "quite often" by students who came in to practice on their own, but they could not quantify the amount of use.

It is likely that the use of looser performance tolerances is desirable early in training to trigger cueing or coaching messages. This could serve to reduce the number of messages transmitted to the student during early training when his abilities to perform may be significantly less than at the conclusion of training, and when distractions may be of negative training value. However, there presently are no guidelines for determining these tolerances. Further research is needed.

### Automated Controllers

Control means to regulate or direct. Instructors often play the roles of air traffic controllers, tactical controllers, or they control the actions of simulated airborne threats. The automated controller instructional support feature is designed to assist ATD instructors in providing the controller function.

Automated controller systems incorporate models of the specific operational situations that they control and require automated performance measurement capabilities to relate actual student performance to desired

performance. Controller messages are then appropriate to both the original incoming message and the operational situation. The combination of automated speech understanding, situation recognition and computer generated speech are becoming powerful instructional tools for automated controller appreciations. A typical example involving both speech understanding and speech synthesis might be:

Incoming communication:  
From Pilot

"Approach Control - X RAY 1  
turning to final"

Situation:

Aircraft X RAY 1 is turning  
onto the final ILS approach  
at the correct altitude.  
Environmental conditions are  
those selected for the exercise.

Outgoing Communication:  
From Automated Controller

"X RAY 1 you are cleared to  
land. Wind now 150 at 20  
gusting 27"

Synthetic voice-based controllers are expected to be used increasingly for many ATD voice applications with highly structured vocabularies.

Potential training benefits stemming from automated controllers lie in four areas: 1) unburdening instructors and/or ATD operators from playing controller roles; 2) increasing the timeliness and correctness of controller messages and feedback; 3) unburdening instructors from the measurement of verbal task performance (and associated record keeping); and 4) providing a new medium through which students and ATDs can interact in a highly natural manner. As examples of the fourth point, it is technically possible for the student to ask the ATD, "How did I do on that bomb run?" If the system has the necessary performance models and performance measurement capabilities, it could respond: "Very well," and provide a detailed performance diagnosis if desired. Automated voice technology also opens opportunities for very precise, automated student coaching and cueing.

Current training systems which incorporate computer speech understanding are limited to individual word recognition (IWR) technology to interpret individual words or very short phrases. This technology requires very precise, stylized speech by the human and requires each student to repeat

each phrase or word up to 10 times to "train" the computer to understand what was said. In a recent prototype training system evaluation, recognition rates 50 to 97% were found with an average of 85% (McCaughey and Semple, 1980). This is far below the 95 to 99% recognition rates possible under ideal conditions (Lea, 1980). Connected speech recognition technology has recently surfaced, allowing people to speak more naturally, without the stylization constraints required by IWR. Also, connected speech systems seem to be easier to "train."

With respect to computer generated speech, present technology is quite adequate for creating words and sentences that can be understood by the human. Work continues on ways to make the computer generated speech sound more natural. Finally, much of the technology needed to create the mathematical models and performance assessment capabilities required by automated controllers also exists. However, it still is the case that all such models require experimental testing and fine tuning.

The design of automated controller models involves two principal considerations. First, the technology of computer speech understanding is improving very rapidly. Computer speech technology developments in the last seven years have emphasized "applications" rather than the development of basic principles of speech understanding and synthesis. This has resulted in certain system inadequacies at this time, but dramatic improvements are currently under development and will become available in the near future (Cotton and McCaughey, 1982).

A second and important consideration is the design of the operational performance model that drives the controller. Early controller models, for example, were derived from "text book" procedures for performing the maneuvers that were being controlled. In the operational world, pilots seldom fly profiles strictly according to procedures. Human controllers are aware of this and respond accordingly. For example, a pilot may choose to turn to intercept his final approach course at a distance from touchdown and at an altitude that an automated controller has not been programmed to recognize as the initial point for a final approach to landing. Two things can result. One is that the controller model may issue spurious commands because it has not correctly recognized initial conditions for the start of the approach. Second, the automated performance measurement system that provides information to the controller model also may be "fooled" because of a departure from the procedure it has been programmed to accept as baseline performance. This can provide

the controller model with inaccurate information and can result in a poorer score on the approach than actually was earned.

An automated, ground controlled approach (GCA) controller has been successfully applied to an F-4E simulation as an integral part of the Automatic Flight Training System (AFTS) (Swink, Smith, Butler, Futas and Langford, 1975). This instructional application of automated speech technology marked the beginning of a new era of automated controllers for ATDs. While the F-4E AFTS GCA controller required a resident general purpose computer and a disk memory system to provide a limited repertoire of GCA oriented words and phrases, modern microelectronics technology now offers similar capability on 2 to 4 chips with repertoires of up to 200 words. The AFTS technology was, however, found sufficient for its purpose and subsequently employed in A7 Air National Guard and Greek Air Force training.

There are many prototype systems either under development or in testing which incorporate automated controllers including the Navy's F-14A operational flight trainer (Semple et al., 1979), the Precision Approach Radar Training System (PARTS) (McCaughey and Semple, 1980) and an Air Intercept Controller (AIC) training system (McCaughey, Root and Muckler, 1982).

The use of controller models in aircrew training is relatively new. The technology and the "lessons learned" data bases require expansion. It is strongly recommended, therefore, that all automated controller models be evaluated and refined during the development process to ensure that the models function accurately before their design is frozen.

### Computer Controlled Adversaries

Computer controlled adversaries frequently are referred to as "iron pilots." They are computer models that control the actions of simulated adversary aircraft. Iron pilots have been used in visually equipped air combat simulators such as the Air Force SAAC, Northrop Corporation's LAS/WAVS, and NASA's Differential Maneuvering Simulators. Properly designed, they can provide realistic adversary maneuvering while unburdening the instructor from controlling the adversary. When combined with an automated performance measurement capability, summary information can be generated describing engagement final outcome, offensive/defensive times for each aircraft, time in the gun envelope, time in missile envelopes and similar performance information.

Three primary instructional values are associated with computer controlled adversaries. One is the repeatability of the behavior of the adversary, which is consistent and predictable (by instructors) during training and provides a more consistent baseline against which to evaluate student performance and diagnose learning problems. A second value is the unburdening of the instructor during training so he can concentrate on student performance and provide more meaningful and timely guidance and feedback. A third value is the lessening of specialized instructor skills that must be developed to continuously control a simulated adversary aircraft from a remote console.

Iron pilots with selectable levels of pilot skill hold considerable potential for air combat training. Easier adversaries could be used earlier in training. As the student's skill levels increase, more difficult adversary reactions could be selected. The progressive approach to adversary capabilities could hasten the learning process. This was the rationale behind the "normal" and "difficult" autopilot adversaries developed for the Northrop LAS/WAVS simulation. Instructors in LAS/WAVS used both difficulty levels for the training of transitioning students (Spring, 1976; Payne, et al., 1976).

Experience gained with iron pilots in the SAAC device and the Northrop LAS/WAVS suggests three relevant design considerations. The first is that adversary actions controlled by iron pilot models must be realistic. Original iron pilots were "too good" and consequently were unrealistic. They operated on perfect information, and their decisions were made almost instantly. This made them virtually unbeatable. They had little training values as a result. When iron pilots are designed to provide realistic maneuvering, they are well received by instructors and are used extensively. The second consideration is that iron pilots with selectable "skill levels" should be developed so that adversary responses can coincide with student pilot skill levels during training. The third consideration is to incorporate fundamental or basic adversary maneuvering capabilities (such as simple turning maneuvers) for use early in basic air combat training.

### Quantitative Performance Measurement

Quantitative performance measurement (QPM) for training is the computer-based monitoring, recording, processing and displaying of objective, quantitative information for describing and diagnosing student performance. QPM systems have been fairly

common in research simulators for over ten years, but research systems are not well suited for operational training. They have been tailored for research use and frequently produce voluminous performance data that require subsequent statistical processing. A QPM system designed for use in training must perform all statistical and other processing of performance data in real or near-real time so that students and instructors are provided with useful, concise and timely performance feedback information.

Practically all quantitative measurement capabilities in existing ATDs or ATDs soon to be delivered are best described as performance monitoring and data recording capabilities. They allow instructors to select tolerance bands (e.g., +/- 100 feet) around various performance parameters (e.g., altitude). The system then monitors for cases that exceed tolerance band values, and records and/or reports out of tolerance conditions. Such limited performance monitoring capabilities have been applied effectively to drive automated cueing and coaching systems where individual parameter variations have been assumed to have instructional meaning. However, such capabilities have found little acceptance for performance evaluation and learning problem diagnosis in day-to-day training. In other words, such systems are not used by instructors. The volume of data produced by such systems often is overwhelming and is difficult to integrate and interpret. Also, instructors almost never are trained to use individual parameter variation data meaningfully for training.

APM research has shown that some measures contribute more to the total description of student performance than do others. Research also has shown that individual measures may not be useful for discriminating between "good" and "poor" performance, but properly weighted and combined are quite useful for discriminating performance differences (Waag, Eddowes, Fuller and Fuller, 1975). The extent to which various measures must be weighted and/or combined remains a research issue, but the need to do so has been demonstrated for basic instrument flight maneuver training (Vreuls, Wooldridge, Obermayer, Johnson, and Goldstein, 1976) and air combat maneuvering training (Kelly, Wooldridge, Hennessy, Vreuls, Barnebey and Cotton, 1979).

Quantitative measurement of performance of procedural sequences is a relatively new technology. A number of newly acquired ATDs will incorporate procedure monitoring capabilities (e.g., F-16, A-10, F-5, B-52 and C-130). These systems will display the sequences in which procedures are performed. It will be the instructor's responsibility

to determine whether or not the performance is acceptable.

Under Navy sponsorship, blends of "manual" and "quantitative/automated" performance measurement capabilities were incorporated into a recent experimental prototype instructional support system (Semple et al., 1979). Among other factors, procedural performance was displayed on a video display terminal. An ideal sequence of procedural steps was displayed, irrelevant procedures were separately displayed as they occurred, and the clock times at which all procedures actually were performed were displayed beside the steps. In a rather limited initial trial use, instructor pilots found this display valuable, although actual event times were not considered necessary (Semple, 1982).

In the same system, procedural performance scores were derived and displayed. The scores were based on algorithms developed by a group of highly qualified instructor pilots, and following much heated debate. In practice, the weighted scores were judged invalid by instructor pilots. The lesson seems to be that valid quantitative performance measures (individually) and scores (collections of weighted measures) must be derived through statistical analyses, at least for flying training.

Taken together, flying training QPM capabilities which emphasize either quantities of individual measures or analytically-derived weightings of several measures will be of little practical value until both instructor training and measurement methodologies improve with respect to quantitative measure indices.

Guidelines for the design of practical, valid and acceptable QPM systems are not yet at hand. Human performance is complex, and one human's evaluation of another human's performance is more complex. Computer-based systems for assessing and diagnosing human performance are beginning to evolve, but operational applications of true QPM systems basically are non-existent in flying training. Further research is required.

#### INSTRUCTOR TRAINING

Virtually all instructors who train other pilots using aircrew training devices, other than basic procedures trainers, are rated airmen. Typically they are motivated and dedicated personnel who are highly competent at performing the tasks they are teaching others to do. They may have been assigned their instructional duties, or they may have volunteered for the job.

Instruction (in ATDs and/or aircraft) may be their primary job assignment, or it may be an assignment dominated by collateral duties. Specific training for their instructional assignment may have been systematic and rigorous, but more likely it was not.

The best of training equipment, by itself, will not produce operationally ready aircrews. The equipment must be used effectively and efficiently to achieve this goal. Obviously, instructor training should be central to the effective and efficient use of ATDs. This comment continues to have considerable face validity even though there is no empirical evidence indicating that rated personnel are required for flight-oriented training, or that instructor training in instructional principles, ATD use, or instructional feature utilization actually has any benefit (Caro, Shelnuttt and Spears, 1982). The fact of the matter is, these issues never have been systematically examined.

It seems self evident that ATD instructors are central to the proper use of training devices. Part of the instructor's job is knowing how to operate ATDs. A second part is knowing how to use such devices and their capabilities effectively. Achieving the second goal requires knowledge of device capabilities along with principles of instruction. Present, typical military instructor training provides neither with certainty.

There are exceptions. However, typical military pilot instructor training programs focus on how to perform the tasks to be trained, safety, and training-related administrative matters. On average, only about three hours of formal instruction deals with how to be a teacher. The operation and use of ATDs typically is left to informal on-the-job training. Overall, there is little instructional quality control, except for standardization and evaluation functions, which may or may not focus on instructional processes and products.

There is no question that the military pilot training system, including simulation training, works. The issue really is one of efficiency and effectiveness: could more be done and could it be done with more efficient use of resources. Simulation plays an important role in pilot training, and this role likely will grow. As it grows, instructor selection and training will be keys to enhance productivity. Perhaps it is time that the principles of instructional system development are applied to the tasks of managing and conducting training, as well as to the tasks to be trained.

## REFERENCES

- Bricton, C.A. and Burger, W.J. Transfer of Training Effectiveness: A7E Night Carrier Landing Trainer (NCLT) Device 2F103. Technical Report NAVTRAEQUIPCEN 74-C-0079-1. Naval Training Equipment Center, Orlando FL, August 1976.
- Caro, P.W., Shelnuttt, J.B. and Spears, W.D. Aircrew Training Devices: Utilization. Technical Report AFHRL-TR-80-35. Air Force Human Resources Laboratory, Logistics and Technical Training Division, Wright-Patterson AFB, OH, January 1981.
- Cotton, J.C. and McCauley, M.E. Voice Technology Design Guides for Navy Training Systems. Technical Report NAVTRAEQUIPCEN 80-C-0057-1. Naval Training Equipment Center, Orlando, FL, 1982 (Draft Report).
- Hughes, R.G., Hannan, S.T. and Jones, W.E. Application of Flight Simulator Record/Replay Feature. Technical Report AFHRL-TR-79-52. Air Force Human Resources Laboratory, Flying Training Division, Williams AFB, AZ, 1979.
- Kelly, M., Wooldridge, L., Hennessy, R., Vreuls, D., Barnebey, S. and Cotton, J. Air Combat Maneuvering Performance Measurement. Technical Report AFHRL-TR-79-3. Air Force Human Resources Laboratory, Flying Training Division, Williams AFB, AZ, 1979.
- Lea, W.A. (Editor) Trends in Speech Recognition. Englewood Cliffs: Prentice-Hall, 1980.
- McCauley, M.E. and Semple, C.A. Precision Approach Radar Training System (PARTS) Training Effectiveness Evaluation. Technical Report NAVTRAEQUIPCEN 79-C-0042-1. Naval Training Equipment Center, Orlando, FL, August 1980.
- McCauley, M.E., Root, R.W. and Muckler, F.A. Training System Evaluation of the Prototype Air Controller Training System for Air Intercept Controllers (PACTS AIC). Technical Report NAVTRAEQUIPCEN 81-C-0055-1. Naval Training Equipment Center, Orlando, FL, 1982 (Draft Report).
- Payne, T.A., Hirsch, F.L., Semple, C.A., Farmer, J.R., Spring, W.G., Sanders, M.S., Wimer, C.A., Carter, V.E. and Hu, A. Experiments to Evaluate Advanced Flight Simulation in Air Combat Pilot Training: Volume 1. Transfer of Learning Experiment. Northrop Corporation, Hawthorne, CA, March 1976.

Semple, C.A. Instructor Pilot Evaluation of the Automated Instruction Support Station (ISS). Technical Report NAVTRAEQUIPCEN 81-C-0084-1. Naval Training Equipment Center, Orlando, FL, March 1982.

Semple, C.A., Cotton, J.C. and Sullivan, D.J. Aircrew Training Devices: Instructional Support Features. Technical Report AFHRL-TR-80-58. Air Force Human Resources Laboratory, Logistics and Technical Training Division, Wright-Patterson AFB, OH, January 1981.

Semple, C.A., Vreuls, D., Cotton, J.C., Durfee, D.R., Hooks, J.T. and Butler, E.A. Functional Design of an Automated Instructional Support System for Operational Flight Trainers. Technical Report NAVTRAEQUIPCEN 76-C-0096-1. Naval Training Equipment Center, Orlando, FL, January, 1979.

Spring, W.G. Experiments to Evaluate Advanced Flight Simulation in Air Combat Pilot Training. Volume 4. Simulation Development and Preparation. Technical Report NOR 76-52. Northrop Corporation, Aircraft Division, Hawthorne, CA, March, 1976.

Swink, J., Smith, J., Butler, E., Futas, G. and Langford, H. Enhancement of Automated Adaptive Flight Training System (AFTS) for F-4E Weapon Training Set (WSTS): Training Specification. Technical Report NAVTRAEQUIPCEN 75-C-0017-1. Naval Training Equipment Center, Orlando, FL, September 1975.

Vreuls, D., Wooldridge, A.L., Obermayer, R.W., Johnson, R.M., Goldstein, I. and Norman, D.A. Development and Evaluation of Trainee Performance Measures in an Automated Instrument Flight Maneuvers Trainer. Technical Report NAVTRAEQUIPCEN 74-C-0063-1. Naval Training Equipment Center, Orlando, FL, May 1976.

Waag, W.L., Eddowes, E.E., Fuller, J.H. and Fuller, R.R. ASUPT Automated Objective Performance Measurement System. Technical Report AFHRL-TR-75-3. Air Force Human Resources Laboratory, Flying Training Division, Williams AFB, AZ, 1975.

THEY CAN MAKE OR BREAK YOU: CONSIDERING THE INSTRUCTOR  
AS A USER IN AUTOMATED TRAINING SYSTEMS

Dr. Robert Halley  
Logicon, Inc.

Military systems are becoming more advanced and complex. This results in a requirement for increased training time by users. Concurrently, the growing manpower shortage is causing a decrease in the number of experienced people available to provide instruction and training on any new system. Thus, the military is facing a need to provide more training using less instructor resources.

One solution has been the development of automated training systems to help shoulder the training burdens. These training systems, more than just simulators or part-task trainers, present design problems which operational systems don't have. Designers have to produce systems which will train the required operational skills and also provide training related functions for the students and instructors. These include such capabilities as on-system instruction, performance measurement, preprogrammed scenarios, automated feedback, and training management functions.

Training system design is a fairly young art and the design artists are slowly learning how to do what they intend. In the past, the system designers have tended to concentrate primarily on hardware and software considerations. More recently, there has been an increasing realization that courseware considerations (e.g., what is being trained, who is being trained, etc.) should also be a driving force in training system design. The latest revelation in system design is "peopleware", attention to the people factors in the interface between man and machine.

Unfortunately, for many designers the term "users" only means students. Training systems have many other sets of users. The users include instructors, operators, administrators, and maintenance personnel. Each of these sets of people will use the system and their needs should be considered in the system design. Of this additional set of users, instructors have the most influence on system implementation and success. As a result, it is very important to design the system to be instructor friendly.

There are a large number of factors to consider in making automated training

systems instructor friendly. It is important to note that instructors, often for good reason, tend to resist a change from their traditional approaches to computer-based training. First, they see that they will have to learn a new job, when they already know the old one very well. Second, they often perceive this change as a demotion from an important instructional position to an assignment as a computer system lackey. Third, there is a common popular fear about having to deal with things computerish. Computers are typically regarded as being mysterious, expensive, and very breakable. This keeps people from just stepping in and using them. Fourth, the instructors have real concerns about whether the new system will be a training improvement. They are often concerned about both instructional effectiveness and possible dehumanization of the training environment.

This instructor resistance can be expressed in a variety of ways, anywhere from an outright refusal to use the system to a subtle lack of faith in the system which gets transmitted to the student. All these types of resistance can lead to the same outcome. No matter how good a system is, if the instructors don't like and trust it, they can completely destroy its effectiveness. A personal example dates back to college, when a new videotape-based curriculum was being used to replace normal lecturing in an oral communications course. The instructor wasn't convinced about the new approach and introduced the materials by saying "All right, you guys'll have to watch these dumb tapes. Then we'll get to the important stuff." Not many people watched the tapes very carefully.

Implementing instructor friendliness in a system means anticipating the instructors' needs and making them as easy as practical to accomplish. It is not enough to put together a system which can do many and magic things and not also make it easy to use. For example, many systems have extensive error checking to help identify when problems occur, but the system reports them as a "TM error 106" or a "100 413.218 error" leaving the user to first go look up in an error table precisely what happened and then to figure out what caused the error. A more user friendly approach would be to have the system report something like "That statement is incorrectly formatted. Please

correct the statement and re-enter it."

Practically, you need to get the instructors involved as early in the system design process as you can. Instructors can provide important input in identifying which tasks they will use the system to accomplish and what ways those tasks can be done simply and effectively. This information can be used in designing the system-instructor interface and in preparing the instructor training materials. In one Logicon system design, instructor pilots were utilized in designing the system's information-presentation approach. The result was a very concise set of CRT displays which have been well received as comprehensive and easy to use.

Instructional design is typically accomplished by contractors or military curriculum designers working outside the actual instructional context. They often fail to recognize that the instructors have important things to contribute concerning the curriculum and about the instructional approaches and methodologies that are feasible and practical for the student population. It is valuable to get instructor input and then make sure you point out their contribution in the system materials. This will add credibility to the system and give subsequent instructors some pride of ownership.

Training systems are often implemented at user commands with only a minimum of accompanying documentation. The documentation is sometimes supplemented by a minimum of user training and then the instructors are left on their own to figure out the rest. The typical result is that the system is exercised in only the simplest modes.

It is important to integrate instructor training into the system for both initial and continuing use. This important tool can affect the instructor's willingness to use the system. It is important to ensure the instructors' knowledge and attitudes about the system. Important training topics include (1) the continuing importance of the instructor's roles in system success, (2) the reasons that the system is being used to replace the old methodologies (3) how the system is used in this instructional situation, and how to use the system to maximum instructional advantage. Using the system to provide this training can also show the instructors that the system can train effectively.

This training must provide the rationale for the development of the system and present the system's approach to the instructional task. The system should also detail the important decision-making roles that the instructor will be asked to fill and also explain the breadth of the system's capabilities for instructor options. Practice should be provided in utilizing all the options and capabilities.

The initial instructor training can be provided through a thorough instructor tutorial which covers all the topics listed above in an instructional package. This should be supported by a system HELP capacity which provides access to individual topics from within the tutorial. This would allow a presentation of any area in which the instructor needs a review.

A pragmatic example of applying these design principles is the Logicon developed Instructor Support System (ISS). Designed specifically as a tool to assist instructors with trainer associated tasks, in its initial application, ISS has been attached to an existing flight simulator. ISS is being used to replace an instructor station that is so difficult to use that the instructor must spend most of his energy interacting with the instructor station, leaving very little time or energy for the task of instructing.

The ISS provides many functions to support the instructors' tasks. For example, the instructors can choose from three different ISS training modes: specialized task training (STT), instructor select (ISEL), and canned. Each of these training modes allows the instructor to hand tailor the students' simulator experience during each exercise. The ISS training curriculum is comprised of a set of training modules such as "afterburner take-off" or "Miramar TACAN 1 approach" or "left engine fire." Each module is separate and includes software identifying what behaviors are to be measured, how success is to be graded, what checklists and procedures are involved, and what marks the beginning and end of the task. In each training mode these modules are utilized differently.

STT mode allows the instructor to schedule one or more training modules which feature practice on a specific skill. This allows repeated executions of a task such as landings without having to practice take-offs and other tasks associated with a normal mission. Thus, if the instructor



felt the student needed work on landings, several landings in a row could be scheduled. After each landing the computer would automatically set up the next one until the session was finished.

ISEL mode requires the instructor to assemble a complete "chocks-to-chocks" mission. In either ISEL or SIT the instructor can choose malfunctions to be inserted into the practice.

The canned mode provides a predesigned practice session. In this mode the training modules have already been selected and sequenced and the instructor need only select the overall package. Since canned mode practice sessions are generally designed to follow the training syllabus, the canned mode helps to ease the instructors' training burden. Canned mode exercises are also used in check rides and "graduation" exercises to provide a consistent measurement environment.

In addition to assisting the instructor with his task by providing practice exercise control, ISS provides other instructor support features. These include student monitoring, performance measurement, grading, instructional records keeping, and student performance debriefing. The student monitoring function allows the instructor to watch a display of what the student is doing while it is being done. Important

display information including aircraft configurations (e.g., flaps up, hook down), aircraft parameters (e.g., speed, altitude), a geographic plot and historic trail of aircraft position, and diagnostic message as problems occur are clearly presented on two display devices, rather than spread over a ten-foot long instructor console.

The diagnostic messages are a very important feature which appear, thus far, to be unique to ISS. Although some training systems have diagnostic messages which are displayed at the end of a practice session, ISS provides a real-time diagnostics display at a very detailed level. This allows the instructor to know immediately the precise cause of a student problem. Figure 1 below shows an example of ISS diagnostics.

The performance measurement function keeps track of student behaviors and compares them to expected behaviors. The grading function uses these performance measures to provide a suggested grade for the student practice session on any of a number of skills. Since there is often some instructor resistance to having the grading function taken over by a computer, ISS has been carefully designed so as to easily let the instructor review all the scoring criteria and how the student's grade has been derived. Figure 2 on the following page shows a sample of the ISS "grade sheet." The instructor can review the

---



---

### DIAGNOSTICS

---

POOR NAV CONTROL --- FEEGA = 068 RAD 26 DME  
 NAV AID IMPROPERLY SET --- UHF FREQUENCY = 281.8  
 POOR ALTITUDE CONTROL -- CROSS FEEGA AT 16000 FT

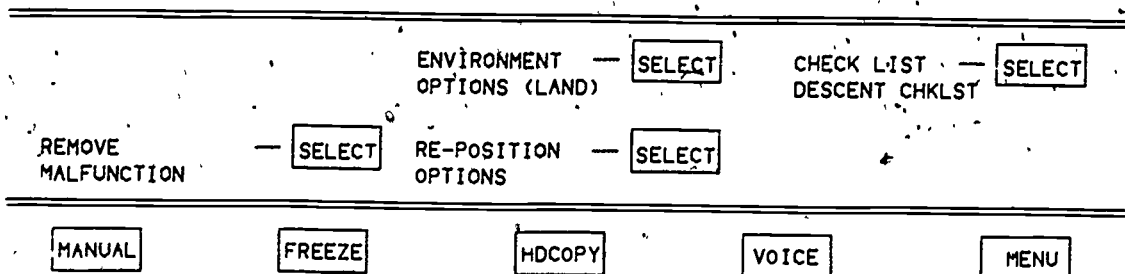

FIGURE 1. ISS DIAGNOSTICS DISPLAY

# GRADE CRITERIA

TASK MODULE = 'GCA

FINAL GRADE = 32

MEASURE	NOMINAL	4.0	3.5	3.0	2.5	VALUE	GRADE	WT
/ ON GLIDESLOPE	0	100.01	80.	70	55	44.73	2.5	10
	0	80	70	55	40			
/ SLIGHTLY OFF GLIDESLOPE	1	15	20	30	40	27.63	3.0	10
	1	0	15.01	20.01	30.01			
/ WELL OFF GLIDESLOPE	2	5	10	15	20	27.63	2.0	10
	2	0	5.01	10.01	15.01			
/ ON CENTERLINE	0	100.01	80	70	55	91.66	4.0	10
	0	80	70	55	40			
/ SLIGHTLY OFF CENTERLINE	1	15	20	30	40	0	4.0	10
	1	0	15.01	20.01	30.01			
/ WELL OFF CENTERLINE	2	5	10	15	20	10.52	3.0	10
	2	0	5.01	10.01	15.01			
-AOA DEVIATIONS (RMS)	15	.6	1.2	1.8	2.4	2.47	2.0	10
	15	0	.6	1.2	1.8			
GLIDE SLOPE SNAP SHOT	0	30	50	75	125	8	4.0	10
	0	0	30.01	50.01	75.01			
CTR LINE SNAP SHOT	0	100.01	150	200	300	7	4.0	10
	0	0	100.01	151.01	200.01			
ANGLE OF ATTACK SNAPSHOT	15	15.6	16.1	16.6	17.6	15.09	4.0	10
	15	14.4	13.9	13.4	12.9			

FIGURE 2. ISS GRADE SHEET DISPLAY

session and quickly and simply change any of the grades. The scoring criteria have also been designed so that they can be easily revised if the standards are incorrect or are changed.

The ISS instructional records keeping function stores the performance measurements, results, and grading for immediate CRT access and as well as for printing hard copy records. The student debriefing function is an extension of the records keeping capability. The student's last entire practice session is recorded and the individual tasks can be played back at either normal or fast (4 times normal) speeds or can be frozen at any point for the student and instructor to review. All of the aircraft data and student performance data are replicated during the debrief playback.

ISS playback is different than that found in most similar systems. In newer training systems, for example, the playback mode recreates the cockpit activities such as moving the stick and the pedals. This information is not very valuable instructionally. In ISS the diagnostics

messages, aircraft parameter displays, and a historic radar and communications trail are provided for review.

The ISS provides multiple functions to assist the instructor with his job. Because of careful use of instructor input and a continuing consideration of the instructor as user during the design process, the ISS provides a very instructor friendly interface. The instructions for system use are defined in terminology normally associated with the aviation environment. A series of decision menus are readily accessible through touch pad controls on the lower display. In contrast to many new systems (e.g., 2F112, 2F119) where scenario generation is very difficult, these menus provide the instructor with complete exercise authoring and practice control capabilities through a simple series of screen touch interactions.

The ISS encompasses an extensive instructor tutorial introducing the system and the system's functions as well as giving the instructor an extensive series of practice exercises. The tutorial has been subdivided into a set of minitutorials

which are accessible at all times through a HELP function.

There are at least two more lessons to be learned from the ISS experience. First, it is not enough to have the ISS features. The features must be implemented well or they can even make the system less usable. For example, most new systems provide information on CRTs and provide system control through light pens or function keys. The concept is good, but the tendency is to provide the system access and system information without much thought to human factors. Thus, the screens are crowded and hard to read and the menus hard to use.

Second, the ISS is not yet all happiness and light. It, too, still has some problems in the area of user friendliness. Design of good practice sessions requires that the instructors have done some prior planning and know what they are going to use the session to accomplish. Otherwise the training session can turn out somewhat haphazard and not meet its training objectives. These requirements for planning and forethought can make the ISS a little scary to the user. Requiring this pre-planning may, in the end, be beneficial to the process, but it is not entirely user friendly. An improvement on this approach might be to have the system be "smart" enough to help the instructor develop the process by having guidelines and rules built in.

Any good training system design will attempt to design the training system to be sufficiently capable and flexible to ensure that the machines serve the users rather than the other way around. The users should not have to accommodate the hardware and software by learning little tricks and changing their behaviors to meet the machine's needs. However, the choice of any approach will constrain the ultimate flexibility of the design and its ability to meet all of the users' needs. If, for example, you put the "ON" key on the left, people who are used to having the "ON" key on the right or who have never had to turn anything "on" will have to learn to adapt to the machine. Money, personnel, and time constraints tend to conspire to make your design choices for you, but it is important to remember to build in as much user consideration as you can and to learn from your mistakes. ISS, in its next incarnations, is going to provide a mode where it acts just like the instructor console it is replacing. This way the instructors will have to learn fewer new skills, but will still have the power of the ISS at their disposal when they want it.

It is crucial to remember that instructors are a vital instructional resource. Instructors can help a training system provide effective and efficient training or they can severely limit the system's usefulness simply by how they respond to the system. Instructor friendliness, then, becomes a major consideration in training system design. Two important initial steps in building an instructor friendly system are getting to know the instructors' needs and getting the instructors involved in the development process. A third very important step is using the training system to train and convince the instructors about the system's usefulness. A fourth important design consideration is building the system to serve the user, rather than vice versa. Lastly, one must remember the "user friendly" includes all the users, not just the students.

# INSTRUCTOR ROLES: OPTIMIZATION OF THE INSTRUCTOR STATION INTERFACE

DR. B. E. MULLIGAN  
University of Georgia

and

LT. THOMAS N. CROSBY  
Naval Air Systems Command

## INTRODUCTION

Use of the computer in its various manifestations as a medium for instruction has contributed much to our understanding of the instructional process. Impact of this powerful medium on instructor roles, however, has received little theoretical attention. It is the purpose of this paper to examine the impact of computer-based instruction on traditional instructor roles and functions in order to achieve a better understanding of the possibilities it creates for enhanced instructor-machine interfacing.

Use of instructional media of any kind tends to alter in some ways instructors' roles, at least how they are performed. Some media may alter the functions performed by instructors to such an extent that qualitative changes in roles results. It is our contention that such changes occur wherever the computer is employed as the primary medium for instruction. Wherever it is used in whatever mix with other media, it seems that the computer uniquely alters instructor functions.

The type of computer application we shall consider consists of a network of terminals tied to a central processing unit (CPU). In its simplest form the system may consist of a single terminal devoted entirely to student use. In more elaborate form the system may contain several terminals, at least one of which would serve as the instructor's console.

In even the simplest form of the system, there would exist two-way communication between terminal and CPU. In its more elaborate form, there also may exist the capability for communication among terminals directly and via the CPU. Theoretically, the inputs to and outputs from such a network may include virtually any response a human is capable of

making so long as it can be transduced at the terminal, and any pattern of energy change a human is capable of perceiving if it can be displayed with fidelity to the human's senses at the terminal. As futuristic as this conception may appear, such networks already form the core of multi-terminal training systems. Indeed, simplified versions may be found in your child's toy box. This is not to say that limitations on transduction, processing, and displays are not real, but rather these limitations are currently technological as opposed to conceptual. The basic idea seems clear, but its ramifications for instruction do not. It is to achieve a better understanding of this that we shall attempt to explore the conception more closely, especially as it applies to the instructor.

How much of the human instructor's traditional roles may be taken over by computer-based instructional systems? What functions will remain or newly emerge for human instructors to perform? These are questions especially pertinent to the design of instructor stations.

For purposes of this paper "instructor station" is defined as one member of a network of computer terminals driven by a CPU programmed for interactive instructional delivery and two-way communication between the instructor's terminal and each student's terminal. Clearly, the role of an instructor operating such a station would differ significantly from his role in the traditional classroom even if the instructional subject matter remained the same.

Before changes in instructor roles and functions due to use of the computer as an instructional medium can be assessed, it seems necessary to first arrive at some categorization of them as they have been traditionally practiced, and to further

examine the major classes of factors which determine their selection.

### TRADITIONAL ROLES

Five instructor roles may be distinguished as a minimum number of categories needed to describe the major domains of instructor activity within traditional settings. These are:

1. Lecturer
2. Leader
3. Supervisor
4. Tutor
5. Aide

Instructor roles are here distinguished in terms of the emphasis each gives to the performance of seven categories of instructor functions.

### TRADITIONAL FUNCTIONS

The major categories of instructor functions in traditional instructional contexts may be divided into seven categories. These are:

1. Information development
2. Information delivery
3. Student supervision
4. Student guidance
5. Student evaluation
6. Data management
7. Course management

It will be apparent in the following definitions of traditional instructor functions that all categories are not mutually exclusive of one another. Even though various of these functions are interdependent and overlap somewhat, they nevertheless represent different channels into which instructional energy is directed. Function definitions are:

1. Information development: The gathering, synthesizing, and organizing of subject matter (facts, concepts, principles, procedures, etc.) pertinent to course objectives into formats appropriate for presentation in particular instructional situations. In many industrial and armed services situations, more formal approaches to instructional systems development (ISD) would be taken, beginning with task analysis.

2. Information delivery: The presentation of subject matter necessary to achieve course objectives by

whatever means that are available, effective, and consistent with the instructor's role and situation.

3. Student supervision: The direction of student learning activities toward timely realization of course objectives through mandate, directive advice, personal example, assignment of study materials, stipulation of practice techniques, performance evaluation, praise, criticism, etc.

4. Student guidance: The assistance of students in discovering, orienting toward, and developing feasible approaches to realization of future goals through counseling, interpretative evaluation of aptitudes, providing information pertinent to formulation and realization of long-term objectives, etc.

5. Student evaluation: Assessments of relative performance, subject matter and/or skills mastery, and any other dimension of behavior correlated with success in an area of activity (attitudes, motivation, emotional stability, etc.) on the basis of test scores, proficiency scores, subjective ratings, physiological indices, etc.

6. Data management: The recording, categorizing and filing of individual performance data; calculations of norms, trends, statistics, etc.; documentation of instruction-related student activities (attendance, promptness, awards, demerits, etc.); collation of summary data for, and preparation of, student progress reports; etc.

7. Course management: Controlling the conduct of a course of instruction including all decisions regarding subject matter, examples, demonstrations, etc., to be presented, the study materials and practice exercises to be required, the instructional media to be used, the tests and other evaluative instruments to be used, the sequencing and time allotments for instructional segments, the updating and revisions of course objectives, syllabi, and instructional materials, etc., the allocation of instructional resources (funds, supplies, etc.) and facilities, etc.

## ROLES AND FUNCTIONS

Roles are not sharply delineated in terms of the traditional instructor functions, but rather in terms of the ways the functions are performed and the level of responsibility each role assumes for the execution of a given function. Not all of the traditional functions are present in every instructor role, e.g., aides are usually not responsible for information development and lecturers are minimally, if at all, responsible for student guidance. Even where two roles are responsible for the same type of function, they would rarely carry them out in the same manner, e.g., the delivery of instructional information by lecturers and supervisors is entirely different.

Both the level of responsibility for, and the manner of performing each of the traditional instructor functions may be viewed as outcomes of a deterministic process.

## DETERMINANTS OF FUNCTIONS

There appear to be four immediate determinants of instructor functions. These are:

1. Instructional objectives
2. Instructional media
3. Delivery situations
4. Instructor/student ratios

Usually, the above conditions are established by a more remote group of determinants, including:

1. Instructional goals
2. Entry-level requirements
3. Through-put requirements
4. Exit-proficiency requirements
5. Resources and facilities
6. Time/Cost constraints

While the above by no means exhausts the realm of potential determinants, immediate or remote, they seem to be the ones that are most influential in most instructional settings. Consider the following examples:

Example 1. Assume that the instructional goal of a university's department of philosophy is to offer instruction in philosophy of science at a level which could be taken by graduate students in all areas of science. Entry-level requirements in this case would be quite general,

limited to students with graduate status, but stipulating no specific prerequisites. University and departmental policies would determine the through-put requirements; a minimum and maximum acceptable number of students per academic term. Exit-proficiency requirements could be set by a committee of experts, consistent with the instructional goal, but usually this would be done by the instructor(s). Resources and facilities would include instructional manpower, library holdings, media, rooms, etc.

In order to satisfy the instructional goal, a high level of expertise would be required of the instructor, usually, a Ph.D. with a specialty in the philosophy of science. Few universities would have more than one such individual available and it is unlikely that the university could afford to bring in additional instructors. The bottom line would be that this course of instruction would be offered by one instructor and that the delivery situation would be a classroom with media support restricted to that on hand (slide projector, blackboard, textbooks, mimeographed handouts, etc.). This would not be a serious handicap since, in this case, the instructional objectives would be conceptual rather than skilled. At this point all major aspects of the instructor's functions have been determined.

The cost constraint has limited the number of instructors to one and the through-put requirements, together with the available delivery situation, has set the acceptable number of students at, say, between 15 and 30. The resulting small instructor/student ratio combined with a single instructor delivering abstract conceptual material in a classroom situation with only rudimentary media support would mean the following:

a) The instructor's responsibility for information development would be nearly total and probably it would have to be carried out personally, the result depending heavily on the level of specialized expertise of which the instructor is capable;

b) The instructor would bear total responsibility for delivery of subject matter information in the

classroom, and, due to the limited support media at his disposal and the number of students he must reach, the only mode available for information delivery would be that of the lecture;

c) The very conditions that dictate the lecture form of information delivery would pre-empt one-to-one student interaction (unless it occurred outside of class) and, therefore, would render negligible any presumption of responsibility by the instructor for the functions of student supervision or student guidance;

d) Unless the instructor were assigned an assistant to evaluate assignments, grade tests, and keep track of attendance, etc., the instructor's responsibility for the functions of student evaluation and data management would be total. In the case that an assistant were available for these duties, the instructor's responsibilities could be reduced to a minimum depending upon the competence of the assistant;

e) The instructor would assume complete responsibility for developing the course, syllabus, determining when and how much time will be devoted to each instructional section of the course, the nature and number of assignments and tests to be given, selection of textbooks and other reading materials, and all other decisions affecting the conduct of the course.

It is apparent that the job description which emerges from the above enumeration of functions could only be that of a lecturer. The roles of leader and tutor would entail similar levels of responsibility for information development and delivery, as well as for student evaluation and the management functions, but the levels of responsibility assumed by leaders and tutors for student supervision and guidance would be considerably greater than that afforded by the determinants.

In the example under consideration, the instructor could be a (discussion) leader if the instructor/student ratio were reduced thus enabling a more informal mode of informational delivery. In order for the instructor to serve as a tutor (permitting a highly interactive, one-on-one mode of information delivery)

the university's through-put requirements, resources and restraint allocations, perhaps even its instructional goals, would have been quite different. Certainly, requirements for student supervision and guidance in association with this course of instruction would have been far more compelling than they were. The point is that, given the assumptions in this example, the only role that is feasible within this traditional instructional context is that of lecturer.

It should be noted here that a distinction can be made between two kinds of instructional leaders. The first kind is that mentioned in the example above, i.e., the discussion leader. The second kind is what we shall call the field (or team) leader. Both provide instruction for relatively small groups of students and the levels of responsibility assumed for each of the seven instructor functions is approximately the same. (Incidentally, the ranges of levels of responsibility assumed by leaders for the various functions appears to be more variable than in the case of any other instructor role.) The chief differences between field and discussion leaders are that the latter serves within classroom-like situations and the former relies heavily on personal example, usually with some authority beyond that of instruction.

Example 2. Assume that the instructional goal of a major airline is to train technicians in the maintenance of a particular kind of jet engine. The entry-level requirements for students to be admitted to this program include previous training in basic electricity theory, circuits design and construction, blueprint reading, transformers and motors, electro mechanical devices, micro-processor controls and operations, etc. The through-put requirements call for six students to be trained in an 11-week apprenticeship-type training program. Exit-proficiency requirements stipulate that each student must be capable of performing all normal maintenance functions, trouble shooting electrical circuits, carrying out performance tests and measurements, making minor repairs, etc. Physical resources and facilities are available at a centralized company maintenance school. The

information delivery situation will be a skills laboratory with such media as engine mock-ups, engine circuit mock-ups with programmable malfunctions, testing instrumentation, individual student study-carrels equipped with audio-visual devices, student notebooks containing job-aides, etc.

Although the cost for skills laboratory and media are considerable, they are made feasible by concentrating the training into one well-equipped centralized facility. This also reduces the number of instructors needed to one. The instructor's qualifications include several years experience in aircraft maintenance plus successful completion of an extensive instructor training program conducted by the manufacturer of the engine in question. It may be assumed that the company's maintenance training program is a somewhat streamlined version of the manufacturer's instructor training program. The instructional objectives would consist almost entirely of concept applications and hands-on skills.

The instructor's responsibilities for information development in this case would be negligible, but he would be almost totally responsible for information delivery, student supervision, student guidance, student evaluation, and data management. The instructor's level of responsibility for course management would be moderate since all decisions regarding sequencing of instructional units, testing, evaluation, etc. would have been made at the time of training program development. Given this array of function responsibilities and their determining conditions, the role of this instructor could only be that of a supervisor.

Although this instructor may, from time to time, carry on group discussions with his students, his role could not be that of a discussion leader because the instructional objectives dictate that he personally supervise hands-on exercises in a skills laboratory. Neither could this instructor be regarded as a tutor because he has no responsibility for information development, is minimally concerned with general theoretical knowledge, and he is required to demonstrate and oversee the acquisition of skills by more

than one student. Superficially, the supervisor's role appears most like that of the aide in that the latter might well work with the same number of students under much the same conditions. However, in this example, an aide would have little responsibility for information delivery and moderate to low responsibility for student supervision, guidance, and evaluation. In this situation an aide's responsibility for data management could range between high and low, and relatively little responsibility would exist for course management. Thus the configuration of responsibilities assumed for instructor functions in this example clearly limits the choice of roles to that of a supervisor.

The relationships between determinants, functions, and instructor roles are both interesting and complex, involving considerations other than just those mentioned in the above examples. One such consideration is the level and type of expertise that is generally required for each role. Since expertise is usually inversely correlated with supply in the market place, within limits expertise can be translated into dollar cost. However, when instructor costs are added to the total costs of instructional delivery and the cost per student is calculated, the cost of instructor expertise in some roles may be markedly diminished. While a highly qualified lecturer may be expensive relative to a supervisor, the cost per student for the lecture-type instruction usually would be less due to the larger number of students and the absence of any need for expensive media. Even so, the matter of instructor expertise seems to be more a problem of supply than cost. In fact it appears that, the higher the level of required expertise is, the shorter the supply of qualified instructors.

Instructor availability is one factor that is directly impacted by modern instructional technology, especially computer-based instruction. If the supply of instructors in any given field is reduced or even limited by the time it takes to train, or educate, those instructors, then any approach to instruction which can replace at least some instructor functions with automated functions should decrease the time required to produce the needed



supply. This is not to say that the number of months or years it takes to train effective instructors is the only factor affecting their supply at any point in time. Monetary and career incentives, job satisfaction, aptitude and previous education are among the major factors which control the number of individuals who are motivated and competent to receive instructor training in the first place. In this area also, computer-based systems should improve supply through incentives and job satisfaction. Time savings in training, and increased motivation, of instructors are two factors which should prove especially important to instructional systems that experience high rates of instructor turnover, such as those in the armed services.

It is not the purpose of the present paper to examine the ways in which computer-based instructional systems provide motivational incentives and increased job satisfaction for the instructors that operate them, but some of these ways will become apparent later on in this paper. Suffice it to say that the possibilities for instructor motivation inherent in the network-type computer-based system is an exciting and important frontier for future development. It is the other avenue of impact that the computer-based system has on instructor supply (indeed, instructor effectiveness also) with which we are concerned here, i.e., the alteration of instructor functions.

Which of the traditional functions will be altered? Each of the functions will be altered in some ways, and several may be virtually eliminated. However, one further aspect of traditional instruction needs some mention before proceeding to an examination of automated instructor functions. That is, the relationship between traditional instructional delivery situations and instructor roles.

#### TRADITIONAL SITUATIONS

The physical situations in which instruction is traditionally delivered constrains instructor functions and thus narrows the choice of roles appropriate to be performed in them. Five major classes of instructional delivery situations may be distinguished. These are:

1. Classroom
2. Skills laboratory
3. Individualized study-station
4. Simulated operational environment
5. Actual operational environment

It is probably unnecessary to enumerate the distinguishing characteristics of each of these situations since they are generally familiar. Certainly, this classification scheme could be expanded if finer distinctions were made. The scheme offered here is the minimal number of categories of situations in which instruction is traditionally delivered, and which permits the distinctions we wish to make.

The degree and kind of interactions between students and instructors differ in these situations, i.e., the emphasis on functions and the way they are carried out change as do instructor roles. Instructors simply do not lecture in situations 3, 4, and 5. Only rarely would a lecture occur in situation 2. It seems that the lecture form of instructional delivery is largely confined to situation 1. Thus it goes without saying that the lecturer is at-home only in the classroom. Likewise, the discussion leader also finds his primary place there. The role of field leader, on the other hand, seems to occur with greatest frequency in actual operational environments, but this role would not be uncommon in simulated environments. Of course, the supervisor is most at home in the skills laboratory but he may be found in situations 4 and 5. Tutors, which appear to be decreasing in their frequency of appearance, probably due to their high cost per student, carry out their functions only in individualized-stations. By contrast, aides appear to be the most ubiquitous of instructors, occurring in all situations except the classroom.

The changes in roles with situations reflect changes in other traditional determinants as well. Instructional media, objectives, delivery techniques, and instructor/student ratios also change with situations. The covariance of these immediate determinants of instructor functions is attributable to the combined influences of the conditions referred to in the last section as

remote determinants. The flow of influence between remote and immediate determinants, however, is not always unidirectional, i.e., from remote to immediate to functions and ultimately to roles. Rather, the flow of influence occasionally is two-way, in both the vertical and horizontal directions. For example, if the situation we have is a one-room schoolhouse, just money enough for one instructor who must meet state qualification standards, a blackboard, a couple boxes of chalk, a closet full of dog-eared books, and 30 or so right-handed chairs, then the instructional goals and other remote determinants have to be modified to suit the more immediate ones, if they are considered at all. It is inescapable that, in this situation, the instructor is going to be a lecturer regardless of what behaviors are to be trained (taught).

If there is any truth to the assertion that the behaviors which can be trained in any situation depend on the behaviors which can be brought to occur there, then it must also be true that instructional delivery situations substantially influence training effectiveness since they certainly limit (if not induce) much of the behavior that does occur in them. Unfortunately, too much of what appears to occur in the schoolroom today, seems to be learned, the surprise being that anything else (e.g., academics) could be. An answer to this problem that one so often hears calls for "more discipline." It would seem that this sentiment is, if nothing else, at least in the right direction for it implies control of behavior. We suggest that it is the interactions with subject matter that needs most to be controlled. It is just this kind of control that automated systems can be effective in providing.

#### AUTOMATED FUNCTIONS

In this section we summarize what, in general, a computer-based instructional system can provide in the place of each of the traditional instructional functions. The lists of automated functions presented here are state-of-the-art. As exciting as current capabilities are for instructional application, it should be kept in mind that considerable progress remains to be achieved in all areas of this man-machine interface (response transduction, intelligent

programs, information displays). Although some of the automated functions listed below can be performed by relatively small systems, the type system we are considering consists of a network of sophisticated terminals (both student and instructor) driven by an imaginatively programmed large-capacity CPU.

1. Development of instructional information: (a) serves as a guide to instructional development by means of programs (menus with prompts and messages) based on algorithms for each successive stage of course design; (b) facilitates writing, editing, and drawing of instructional materials through programs for word processing and graphics production; (c) permits convenient filing, cross-referencing, and combining of instructional information through programs for information management.

2. Delivery of instructional information: (a) presents course subject matter ranging from abstract concepts to factual itemizations in self-paced, mastery-based formats displayed in written, spoken, and/or graphic forms; (b) delineates relevance and applicability of subject matter by presenting contextual information and sample problem solutions, problem-solving exercises, etc.; (c) provides instructions for proceeding through programmed lessons, performing skills, correcting mistakes, or obtaining remedial information for review; (d) produces or controls simulated representations of operational devices, field or job situations, abstract processes, performance procedures, job aides, etc., enabling demonstrations, practice, rehearsal, etc., of concepts, rules, skills, procedures, attitudes, roles, team exercises, "what if" explorations, etc.; (e) delivers individual and/or group response-contingent feedback designed to aide self-diagnosis of learning progress; information may consist of prompts, questions, encouraging messages, scores, etc., in a variety of display formats that may include special auditory or visual effects; (f) provides summary feedback at the end of each instructional unit or major exercise consisting of scores, outcome statements, evaluations of relative performance, recommendations for improvement, overall course performance profiles, course grades, etc.

3. Student supervision: (a) guides students along instructional paths adjusted for level of achievement and rate of progress; (b) optimizes individualized instructional paths through frequent performance checks, variable path branching, and review sequences; (c) provides supervisory instructions and feedback (written, spoken, and/or visual; graphical or simulated visual demonstrations of "do this") contingent upon individual or group actions with possible instructor intervention;

4. Student guidance: (a) provides recommendations for future courses of action (remedial study, more in-depth study, information sources, job possibilities, etc.) based upon performance profiles; (b) response to student questions about their performance profiles with interpretive answers and comparative data; (c) provides job descriptions (requirements, work conditions, salary data, etc.) in areas related to course of instruction.

5. Student evaluation: (a) determines correctness of choices, problem solutions, or actions on an item-by-item basis; (b) tests performance proficiency relative to instructional objectives, group norms, and standards; (c) diagnoses learning progress, detects learning difficulties early, prescribes remedial work, and adjusts difficulty levels/rates to match students' abilities; (d) provides overall performance profiles, course grades, percentile ranks, etc.

6. Data management: (a) accepts as inputs any properly computer-interfaced responses by students and instructors; (b) automatically records in central memory input data from all system terminals, pools group data, forms generic data bases and carries out statistical or other processing while preserving individual student records; (c) displays selected data files, analysis results, or interpretative messages automatically, or on command to designated terminal in written, spoken, and/or graphical formats.

7. Course management: (a) describes syllabus-controlled sequencing of, and time allocations for, successive instructional units and the timely execution of tests, evaluations, and student feedback; (b)

tracks individual and group progress relative to established course milestones, performance standards, and through-put rates; (c) carries out course evaluations and recommendations for revision based on data analysis and success in attaining instructional objectives; (d) enables monitoring of individual or group performance by instructor who may selectively intervene or interact with individuals or group; (e) provides prompts and messages to instructors to insure timely occurrence of non-computer instructor functions.

The above lists of automated functions include no mention of how they are, or might be, effected. Even though this question is certainly beyond the scope of this paper, there are at least three good reasons why it is worthwhile to consider automated functions independently of the technological means by which they can, or might be, achieved; (a) applications of technology must be justified in terms of the functions it can perform, and those functions must stand on their own merits; (b) the same functions may be accomplished in different ways depending on the requirements of particular applications, and (c) new applications of the same functions and new techniques for effecting them may be developed. It is also the case that new technologies result in the emergence of previously unanticipated functions and applications. As we shall show, applications of computer technology in instruction modifies instructor roles not only by assuming and improving upon traditional instructor functions, but also by laying the foundation for emergence of new instructor functions. But first, let us compare automated and traditional instructor functions.

#### FUNCTION DIFFERENCES

Perhaps the appropriate question at this point would be, what instructor functions can, and must, humans perform that computerized machines cannot? In answer, we must admit to ignorance. It is the word "must" in the question that renders its answer obscure, at least to us. Even if we could enumerate every possible human activity that might be construed to be an instructor function, we could not say on the basis of scientific evidence which of them were essential

to the learning process. Perhaps none are.

It would seem safe to conclude from the last half-century's research on the learning process that the minimum necessary conditions for learning are (a) the presentation of energy-borne information to the senses of a living organism, and (b) the consequent occurrence of some sensory effect within the organism that may be overtly manifested in its behavior. While these two conditions are necessary, even if they are met the occurrence of learning is not assured. Information enhancement, repetition of its presentation, response-feedback, etc., also may be required in certain circumstances to increase the probability that learning will occur, that it will occur rapidly, and that it will endure. Whether or not such conditions are essential to the learning process in some fundamental theoretical sense (if, indeed, there is just one learning process), it seems they must be considered practically indispensable in circumstances appropriate for the accomplishment of instruction. Since instructor functions traditionally have been the means through which production and manipulation of these conditions for learning, has been effected, it seems reasonable to assume that any instructor function which a computerized machine cannot be programmed to simulate effectively should be considered a "must" for the human instructor. Some insight into what these "must" functions should be may be gained by examining the differences between instructor and automated functions. Function differences are summarized below using the same numbering of categories as before.

1. Computer-based systems can facilitate the development of instructional information, but they cannot recognize instructional needs, originate program goals, or conceive of the means by which to attain them. Humans must assume virtually all responsibility for gathering and synthesizing information, evaluating what would be important and interesting, creating stimulating conceptualizations, examples, etc., of the information, and finally, originating innovative computer programs to achieve effective information delivery to, and interaction with, students. However, these indispensable

instructor functions do not have to be carried out by the individuals who serve as instructors with computer-based systems. In fact, it would probably be more cost-effective for information development functions to be exclusively the jurisdiction of professional scientists, scholars, computer programmers, instructional designers, etc. The salience of this specialist approach to information development is ramified in the rapidly emerging areas of computer-based imagery, animation, simulation gaming, etc. If the possibilities for computer-based instruction are to be exploited to the fullest in the years to come, it is apparent that we shall have to rely more upon the specialist (better still, teams of specialists).

2. It is in the performance of information delivery functions that the computer-based instructional system proves its worth. The degree to which such a system can carry out the automated functions listed previously depends on the fidelity of its man-machine interfacing (sensors and manipulanda; visual, auditory, etc., display devices), its CPU capacity, and the sophistication of its software. If we wish to think very far ahead, display functions might be expanded to include computer-driven machine movements (robotics).

It is apparent that we can expect dramatic advances in all areas of computer technology in the relatively near future. However, even current capabilities permit the execution of nearly all information delivery functions for which human instructors are responsible, including some functions unachievable by any means other than the computer (e.g., interactive video displays). This is not to say that computerized machines duplicate human actions in carrying out the same functions, or that such duplication is always desirable even when it is possible. For example, it may be that some information can be transmitted to a student more effectively in a written, visual display than in a spoken, auditory display, where the latter might be the format traditionally used by human instructors. Conversely, if it were beneficial to transmit the information in a simulated human form, a speech synthesizer could be employed. Thus, in order to duplicate human functions, it may not be necessary to simulate human actions.

A review of the capabilities listed under automated functions indicates a high order of individualized and interactive information delivery by computer-based instructional systems. The question is, are there any additional delivery functions that must be performed by a human instructor-operator whose station is a terminal tied into a network of student stations? It is implicit in this question that the instructor's communication with students is limited to just those channels available in his station. These may be of two types: (a) extra-CPU, and (b) intra-CPU. By means of the extra-CPU channels, the instructor may deliver non-computer-based information (e.g., speech and other acoustic signals, visual signals and displays, etc.). These displays may be presented either independently of, or in synchrony with, CPU-produced information. Also, the instructor may selectively open channels to one or more student stations, enabling two-way video and/or audio communication. By means of the intra-CPU channels the instructor may interact in ways and at times permitted by the program (e.g., as a team leader, as a competitor in a gaming situation, as a prompter, etc.) or he may override the program and initiate appropriate pre-program directives, messages, data listings, etc.

These are some of the delivery functions an instructor may perform from within a network station. Due to this system's large capability for performing automated functions, probably none of the possible human instructor information delivery functions can be considered a priori to be indispensable. Depending on specific training program requirements, both extra- and intra-CPU instructor functions may be considered desirable features and incorporated as part of the whole delivery system. Since none of the automated functions need be sacrificed in order to accomplish this, it seems highly likely that instructor functions of the sort indicated above would be included wherever possible. In addition to monitoring students, inclusion of these functions would enable the instructor to interact with his students on an individual or group basis, competing with or leading them, correcting or encouraging them, directing or questioning them, etc. The motivational influences of these

kinds of interactions on both instructors should magnify the effectiveness of the entire learning experience in this situation.

The instructor's responsibilities for delivery information outside of the network station probably should be regarded as essential. They would include familiarization of students with training systems operating procedures, demonstrating system operation, orienting students to training objectives and performance expectations, carrying on post-training session discussions with students, etc. These functions would probably require that the instructor serve in several traditional roles: as lecturer during initial familiarization; as supervisor during demonstration of system operations; and as discussion leader during pre- and post-training sessions. By contrast, during system training sessions the instructor's role would be characterized by a mixture of elements from the traditional roles of field (team) leader, supervisor, and tutor. An additional set of elements of a non-traditional nature may also be included, i.e., those of a competitor. The compound of these elements results in the emergence of a new role for the instructor station. For want of a better name for this role, we shall call it "coach".

3. Student supervision is a category of functions which ultimately depend on the delivery of information from instructor to student. Although this information is instructional, the knowledge components of it are generally limited to system, or machine, operations conveyed through demonstrations of the skills involved in performing the operations. Supervisory information also consists of evaluative feedback from the instructor regarding both the actions made in skills performance and the outcomes or products of those actions. Characteristic of supervisory information is a strong directive component which is intended to control both actions and outcomes. As the instructor's responsibility for supervisory functions depends on how closely the students' actions are to be controlled. As indicated in the list of automated supervisory functions, the computer-based system enables a high order of student direction on a response-by-response basis. The instructor is thus

relieved of much of the drudgery of student supervision, this being replaced by finely attuned immediate response-contingent feedback to the student. Supervisory functions remaining for instructors to perform, as in the case of information delivery functions, must be divided into station and non-station functions, the former being broken down into extra- and intra-CPU functions.

While operating from his network station, the instructor's supervisory responsibilities would require monitoring of student performance via both computer and non-computer displays. Instructor supervision via intra-CPU channels might consist of program overrides, re-initializing some portion of the program, interacting with students in ways permitted by the program (e.g., entering instructions, calling up visual displays, manipulating pointers and such on visual displays; etc.), activating pre-programmed directives, etc. By means of extra-CPU channels, the instructor might issue commands, instructions, corrections, etc., at any point independently of CPU-controlled actions. Whether or not, and the degree to which, any of these activities were considered necessary would depend on particular program requirements. The instructor's supervisory duties outside of his network station, and after initial familiarization and demonstrations, probably would be negligible consisting mainly of informal advice and encouragement. Thus none of the instructor's supervisory functions can be considered a priori indispensable, though certainly they would be desirable in most cases, especially those involving skill performance.

It is interesting to observe that, even if the instructor's supervisory functions are strong, in this type of automated instructional situation his role would not be that of the traditional supervisor. Rather, it would be that of a coach as indicated earlier. On the other hand, if supervisory responsibilities were negligible, the instructor's role would tend toward that of the tutor (if he supplied knowledge information interactively) or that of the competitor (in a gaming simulation).

4. The advisory and counseling responsibilities usually subsumed under student guidance probably would

be largely peripheral to the instructor's network station functions. The instructor's responsibility for student guidance, outside of the network station, however, would include both formal and informal discussions regarding student career goals, relevance of the current training to attainment of those goals, job availability and requirements (some of this may be available at the student's network terminal), etc. Furthermore, specific advisory or counseling sessions probably would be scheduled to correspond with major course milestones. At such times students may be faced with decisions involving changes in job aspirations. The instructor's counseling responsibilities probably should be limited to providing recommendations for alternative courses of action for students to pursue depending on their success in the present course of instruction. Formal counseling by instructors might be carried out in conjunction with, or referred entirely to, a professional counselor knowledgeable in the area of instruction. Thus, the computer-based system of instruction under consideration would seem to permit a large range of instructor commitment to student guidance and, consequently, this may not be regarded as an indispensable area of instructor functions. At least some modest level of informal counseling, however, would appear to be beneficial.

5. As indicated in the list of automated student evaluation of functions, the computer-based system requires little additional instructor input in this area, if any at all. However, if the instructor's supervisory responsibilities within his network station constitute a significant element in the training program the instructor's responsibility for some forms of evaluative feedback to students would be greater. Such feedback would be in the form of corrections, reprimands, indications of performance deficiencies, etc. Likewise, because the system can be programmed to provide the student with virtually any form of evaluative performance index, diagnoses of learning progress, overall performance profiles, etc., the instructor's responsibility for student evaluation outside of his network station would consist largely of interpretation and explanation. Of course, need for the latter would depend on the ease with

which students could read and interpret their machine-generated evaluations. In this, as in any other area of computer-based instruction, programming inadequacies devolve into instructor responsibilities. In summary, the network system instructor's student evaluation functions are negligible except where supervisory responsibilities are high. In that case, the two areas of instructor functions are parallel and, to some extent, indistinguishable.

6. In the area of data management, instructor functions are eliminated. Instructors may enter their comments, evaluative scores, etc., into student records, but the instructors bear no responsibility for filing, updating, or other processing of performance data.

7. The mechanics for course management are all pre-set in the training program. Instructor responsibilities in this area consist mainly of keeping the prearranged program on schedule, ensuring smooth integration of non-program activities with the schedule. Thus, insofar as course management is concerned, the instructor's role is essentially that of an aide. He must service and otherwise work to ensure the uninterrupted continuance of the program. In a sense, the program manages itself. This is to say that all management decisions regarding scheduling, resource allocations, program requirements, contingency plans (including provisions for instructor intervention), etc., are made prior to implementation.

#### INSTRUCTOR STATIONS

The kernel of our analysis is that, if computer-based automated instructor functions are utilized to their fullest potential, no human instructor functions may be considered a priori as indispensable. The machine is much more than an extraordinary medium for the delivery of instructional information. It is also a capable instructor.

The question becomes, then, what human instructor functions may be considered desirable? A cursory enumeration of these functions was given in the preceding section. They were divided into two situational classes; functions to be performed in the instructor's network station, and

functions to be performed outside of the station. Within-station functions were further divided into extra-CPU channels and intra-CPU channels. The question now that we have to address is what characteristics of network instructor stations are necessary to permit the performance of human instructor functions?

The model of the computer-based instructional system (trainer) that we are considering consists of a network of terminals tied to each other through a CPU and through direct circuits. The CPU assumes the lion's share of responsibility for presenting information, collecting performance data, data management, interactive processing of inputs and outputs, sequencing, etc., depending on the ways it is programmed, the CPU may call for instructor actions, decisions, feedback to students, etc., thus structuring and integrating instructor functions into the complex flow of events. If the program involves a gaming simulation, the instructor may interact with students on a competitive basis as an opponent or as a team leader. Furthermore, through the CPU the instructor's station may be tied into a network of instructor stations thereby placing at the instructor's disposal a generic data base built up through common experience with the system or originally designed for instructor training.

It should be clear that the core of this system is the CPU, not the instructor. Its programming, capacity, and speed determine what it can process (the inputs it can accept, the decisions it can make, and the displays it can present). The instructor station, as well as student stations, are the peripheral input and output interfaces with the CPU. Excluding direct links between stations, the specifications for station input sensors and output displays must conform to CPU capabilities. At present CPU technology appears to be more advanced than sensing and display technology. With some temerity we suggest, therefore, that anything which can be sensed in analog and converted to digital, and vice versa, is within the capabilities of existing CPU technology and thus can be incorporated into student and instructor stations. Ignoring technological limitations due to such problems as digital conversion of

analog inputs and outputs, etc., let us examine some desirable input and display characteristics of instructor stations.

Interface features of the instructor station may be organized into a two-by-two contingency table. The columns of this table designate channel type and the rows designate interface type. The two channels are, as before, intra-CPU and extra-CPU. The two rows are controls and displays. Thus we have controls and displays for each channel, resulting in four categories of instructor station features.

1. Intra-CPU displays: there are two classes of displays within this category: (a) monitors and (b) read-outs. The intra-CPU monitor displays provide the instructor with duplicates of the CPU outputs to student stations. These would include both visual displays (CRT) and auditory displays (headphones). The student station being monitored would be selectable from the instructor station, as would the type display. Since these displays duplicate those in student stations, they could be used by the instructor while participating in game simulations. The read-out displays would provide the instructor with private CPU outputs thereby enabling him to receive information from the computer independently of that available at student stations. Status reports on all stations, data files, prompts and messages, etc., would be delivered at these displays.

2. Extra-CPU displays: these displays permit two-way communication between students and instructor. They may be audio (headphone) and/or video (television) displays. In addition to communication between students and instructor, these displays could also be used as extra-CPU monitors. In either case, student stations would be selectable by the instructor, as would open channel communication with all stations (audio only). By means of one of these displays (probably audio), students would be able to initiate communication with the instructor.

3. Intra-CPU controls: These instructor response interfaces are of two types: (a) operator and (b) master. The operator controls duplicate those present in each student station.

They permit the instructor to engage the system as a participant (competitor or leader) in game simulations, etc. The master controls enable the instructor to address the CPU independently of student stations. By means of the master control terminal, non-automated instructor functions provided for in the computer program could be carried out.

4. Extra-CPU controls: these controls include all switches, knobs, levers, etc., necessary to activate, select, operate, etc., any non-CPU devices or displays. Instructor controls for extra-CPU displays would be included in this category.

Of course, specific design features of instructor stations would be determined by the same sorts of determinants that were shown to influence traditional instruction. Indeed, the entire network system would be impacted by these factors. There is, however, an additional element which must be taken into account in designing the instructor station. It is the CPU; the sophistication of its programming, the capacity of its memory, and the speed of its operation.

The technology exists to provide advanced CPU hardware as it does for controls and to a lesser extent for displays, but the program software has to be created for each application of this technology. We suggest that system design and software development should be parallel efforts, both directed toward the same end, an integrated instructional system. If the contributions of instructional, software, and hardware designers are weighted equally throughout the planning and development stages of computer-based instructional systems, then the instructor station concept may be fully realized. At that point we will see the new instructor roles emerge; the coach, the competitor, the team leader, etc. Whatever kind of animal we build, let us design it so that its appendages and its brain form an integrated whole. In that the instructor will be but one functioning organ.



# FRONT-END ANALYSIS LEADING TO VTX INSTRUCTOR OPERATING STATIONS FUNCTIONAL SPECIFICATIONS

Jeffrey N. Punches  
Vice President  
MATHETICS, INC.  
P.O. Box 26655  
San Diego, CA 92126

## INTRODUCTION

The emerging Navy Undergraduate Pilot (VTX) training system, designed under the guidelines of OMB Circular A-109, is a training system composed of a number of integrated elements. These elements are the aircraft, simulators, training management system, academic system, and an integrated logistics system. In the McDonnell-Douglas/British Aerospace VTX system, the simulators are in reality a family of training devices which provide a systematic, hierarchical method of training hands-on learning objectives. The purpose of this paper is to present the front-end analysis procedures which were used during design of the instructor stations for the family of VTX training devices.

## PRELIMINARY ANALYSIS

The VTX training system (VTXTS) development effort centered around a cost-effective method to meet the training requirements of Navy jet pilots through the year 2010. The VTXTS is based upon the requirement to train to criterion 87 Navy-provided objectives and any developed during the ensuing ISD analysis. Each of the contractors involved in the VTX procurement was required to use Instructional Systems Development (ISD) principles and methodology in the design of the system. The ISD analysis also provided answers to problems in areas of design-to-cost and life cycle cost and resource requirements. Through the use of ISD, a usable, integrated system was created into which the family of training devices were fully interfaced. This paper describes the "down-in-the-trenches" procedures that were used by the team of analysts who developed the functional specifications for the VTXTS simulator Instructor Operating Station. Figure 1 depicts the Mathetics analytical process which lead to the functional specifications for the VTXTS Instructor Stations. The right hand blocks depict the groups or personnel who provided data to or received data from the study. The left hand blocks are the analytical steps used during the effort.

Within the ISD process, considerable work was performed as part of the process of developing functional specifications for the

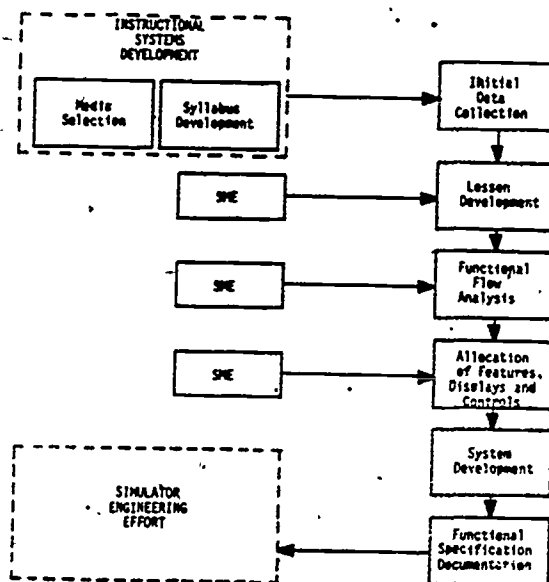

Figure 1  
VTXTS Simulator Front-End Analysis

family of simulators. The ISD steps involved were:

- Navy Jet Pilot Warfare Specialty Job Analysis
- Navy Jet Pilot Task Analysis
- Objective Hierarchy Development
- Media Selection
- Syllabus Specification
- Course Map Development

Of the above steps in the ISD process, the media selection and syllabus development inputs formed the base on which the analysis began. The media selection models suggested three types of devices, an Instrument Flight Trainer (IFT), an Operational Flight Trainer (OFT), and an Aerial Situation Trainer (AST). These devices and their associated capabilities support a hierarchical acquisition (simple progressing to complex) of flight skills. Table 1 lists the types of training devices, the key capabilities and the associated pilot training stages.

TABLE 1

Device	Capabilities	Training Stages
IFT	<ul style="list-style-type: none"> <li>• No visual</li> <li>• Platform Motion</li> <li>• Flight &amp; Ground Modes</li> <li>• Auxiliary IOS</li> <li>• CPT mode</li> </ul>	<ul style="list-style-type: none"> <li>• Flight Support</li> <li>• FAM</li> <li>• BI</li> <li>• RI</li> <li>• ANAV</li> </ul>
OFT	<ul style="list-style-type: none"> <li>• Large field-of-view</li> <li>• G-suit, G-seat</li> <li>• Interactive Target</li> <li>• CGI Visual</li> </ul>	<ul style="list-style-type: none"> <li>• FAM</li> <li>• BI</li> <li>• RI</li> <li>• ANAV</li> <li>• FORM</li> <li>• NFORM</li> <li>• GUNS</li> <li>• WEPS</li> <li>• TACNAV</li> <li>• CQ</li> </ul>
AST	<ul style="list-style-type: none"> <li>• Dynamic Visual</li> <li>• Dome Visual</li> <li>• G-seat/G-suit buffet systems</li> <li>• Interactive Target</li> <li>• Auxiliary IOS</li> </ul>	<ul style="list-style-type: none"> <li>• FORM</li> <li>• NFORM</li> <li>• TACF</li> <li>• GUNS</li> <li>• WEPS</li> <li>• ACM</li> </ul>

Building on the data produced during the ISD development process, Mathetics, Inc. performed an analysis which led to a functional specification for the instructor operating stations for these devices. The design was to be specifically oriented toward making the instructor a teacher rather than an operator.

#### CONSIDERATIONS

Initially MATHETICS' study team reviewed the literature on prior simulator design and applicable human factors considerations. Although many studies and authors contributed to the data base for this study, two works were particularly valuable. The first, "The Instructor Pilot's Role in Simulation Training" by Dr. John P. Charles (1978), formed the basis on which the design algorithms were formed. The second, "Training Device Design: Human Factor's Requirements in the Technical Approach", by Dr. Alfred F. Smode (1972), provided a wealth of information pertaining to design considerations and presents many pertinent examples of human factors considerations for design of simulators.

This concept of a generic instructor station for all of the training devices was a desirable goal for the VTXTS for several reasons, including cost and risk reduction, commonality of hardware and software, and a

reduction in instructor training requirements. The instructor consoles, although generally common, would have some differences due to the varying capabilities of the devices and therefore, the magnitude of the requirement for instructor monitoring and instructional activities.

The study of all factors to be considered in designing a generic IOS revealed that the instructor console should have a number of computer-assistance features designed to aid the instructor. These features were:

- Standardization of Training  
Preprogrammed lessons which would provide a series of standardized exercises graduated in difficulty with some capability for instructor intervention in prescribed ways to control the training process. This concept includes the possible manual override of defined mission events to accommodate students who perform below expectation for a given exercise and for insertion of additional related events in an exercise to challenge student who exceed scenario requirements. These additions and deletions of training events are only allowed if the preprogrammed mission scenario software allows manual intervention.

- Computer Assisted Measurement System  
Automated evaluation and scoring with objective criteria adjusted to the stage of instruction and level of difficulty for each student. The system would provide error indications and information which are displayed at the instructor console.
- Automated Monitor and Control Capability  
Computer driven multi-format, interactive CRT displays at the IOS which present performance/error and syllabus status information in all relevant modes and in variable formats (both alphanumeric and graphic).
- Records of Student Performance  
Software recording of student performance for debrief. Student performance information (syllabus event would be error, and summary information) available on demand for use during and after a training exercise (for both debrief and for record-keeping purposes).

The first of these computer assisted features became a driving factor in the IOS design. The nature of the Navy Jet Training Command requires that specific prerequisite knowledges and/or skills must be acquired prior to the follow-on event. Therefore, the training problem in the Undergraduate Pilot Training (UPT) context is best placed under software control where the instructor can only minimally alter the training scenario. This allows for training syllabus configuration control across the entire Jet Training Command, in that the learning objectives, conditions and standards assigned to a particular lesson cannot be modified by the instructor who thinks he has "a better way". These preprogrammed lessons are designed in such a way as to specify the applicable instructional features, controls, and strategies which may be employed to teach certain objectives maneuvers, or flight elements. One might contend that such an approach would take the instructor "out of the loop" however, it is believed that such an approach would actually enhance the instructor's capability to teach rather than operate the device.

Heavy programming of lessons is also necessary where automated performance measurement is to be utilized. One cannot alter the training scenario and/or lesson methodology without impacting the results from the performance measurement system. Preprogrammed lessons also create a predictably capable pilot with the skills necessary for entry into the weapons system oriented aircraft located at the various Fleet Readiness Squadrons (FRS). Therefore, a conscious

effort has been made, in concert with ISD methodology, to design out the flexibility of past simulators. Designing out flexibility means designing in standardization. It is believed that designing out flexibility would also reduce cost and increase operating simplicity. The MATHETICS study team held that it is possible to design an IOS which has no training controls other than interactive CRTs which were controlled by a package of training software designed specifically to enhance the instructor's capability to train.

The last consideration of note was the concept of separating the simulation system software (aero model, motion model, etc.) from the package of training software (syllabus, scenario control, etc.) in terms of configuration control and management. Detailed unique training software programs can be created for each lesson containing the initial conditions for each segment, allowable instructional features and strategies, and performance measurement routines. These packages of training software would act as executive routines for the entire training device computational system, prioritizing programs, routines and features in terms of training requirements. The training software would be under the control of a Training Support Center and would be easily updatable as part of the training system quality control effort. Instructional personnel would create the training methodologies which would then be implemented in software. This concept would allow for training implementation of the syllabus by flight instructors trained to instruct in the visual/motor skills of flying high performance jet aircraft.

#### ANALYSIS PROCEDURES

Based upon the results of the initial data collection, the MATHETICS study team selected the Operational Flight Trainer (OFT) as the first trainer for analysis. This was done primarily because the OFT syllabus encompassed every training module within the VTXTS curriculum and varied in complexity from simple hands-on system familiarization to weapons delivery. The functional specification for the OFT could then be later adapted for use in the Instrument Flight Trainer (IFT) and the Aerial Situation Trainer (AST). The MATHETICS study team selected sixteen lessons from the OFT syllabus for full development and analysis. The lessons were written from the existing lesson specifications developed in previous project work. The sixteen lessons were selected for their instructional content, the nature and intensity of instructor involvement; and the possibility for use of training features or strategies.

Each of these sixteen lessons was then fully analyzed in order to determine the sequence and validity of the learning objectives, detail instructor and student activities, and estimate the scope, possible application of simulator learning strategies and the use of instructional features. After full lesson development the analysts looked at each of the lessons for a number of attributes and selected six of the original sixteen lesson scenarios for further analysis. The scope of the general training requirements included:

- Basic Instrument Procedures
- Procedural Demonstration Requirements
- Modulized Lessons
- Emergency Procedures
- Verbally Described Demonstrations
- Self-Training Requirements
- High Density Student/Instructor/System Interactions
- Visual Task Training
- Replay requirements
- Performance Measurement System Requirements
- Backward Chaining Requirements
- Intense Instructional Activity
- Subjective Instructor Evaluation

The second portion of the analysis utilized a functional flow analysis procedure adapted from the work of both Smode and Charles. The functional flow analysis involved the development of "training algorithms" aided by Subject Matter Experts (SME). The SMEs were asked to examine each of the lessons and describe how they, as flight instructors, would best teach each of the lessons. This process yielded a set of eleven training algorithms which were entitled:

- Pre-Briefing
- Lesson Modification
- Briefing
- Initialization
- Start
- Demonstration
- Single Task Segment
- Multiple Repetition Segment (loop segment)
- Post-Mission
- Debrief
- Post-Debrief

The analysts then created strings of these algorithms which corresponded to the lessons as written in the earlier development effort. The instructional methods and instructional flow for each of the six lessons was then validated by SMEs. These strings of algorithms became the functional flow diagram for each lesson. This step in the

process really involves developing an overview of the instructor's role in the training system in order to consolidate thinking about design philosophy and aid in the further definition of design requirements for the instructor station.

The next step, the allocation of features, displays, and controls, began with a review of the literature to determine the types of Instructor Station capabilities which were currently being utilized in existing and near term simulators. These capabilities fell into seven categories:

- Instructional Features
- Displays
- Controls
- Console Type
- Instructor Activity Type
- Controlling System/Software
- Subsystem Involvement

A "relative time-line" allocation of simulation system capabilities was then performed, again utilizing heavy SME inputs. The "relative time-line" analysis allowed specification of activities, instructional features, controls, displays, etc. for each activity on the functional flow diagram. An alphabetical character was assigned to each of the above listed instructor/system capabilities. Each subactivity was assigned a numerical identifier. The alphanumeric identifiers were placed under each functional flow diagram in "relative time-line" fashion. This data format can be seen in Figure 2 which depicts a portion of a functional flow diagram containing a single task algorithm. This format was utilized to determine the instructional requirements for each lesson and to provide a qualitative indication of frequency of use and an indication of criticality. Additionally, the functional flow analysis permitted the analysts to "visualize" the desired sequence of instructional activities and options available to the instructor while actually involved in a training evolution.

#### SPECIFICATION OF INSTRUCTIONAL FEATURES AND STRATEGIES

Based upon the data that was generated during the preceding analyses, a set of instructional strategies and features for the simulator was developed. Instructional strategies are defined as simulator capabilities which are utilized as methods of presenting simulator training materials. The instructional strategies applicable to the VTXTS OFT are DEMONSTRATION, REPLAY, PREPROGRAMMED LESSONS, MANEUVER/SEGMENT RERUN, BACKWARD CHAINING and FREE FLIGHT. These strategies are defined below.

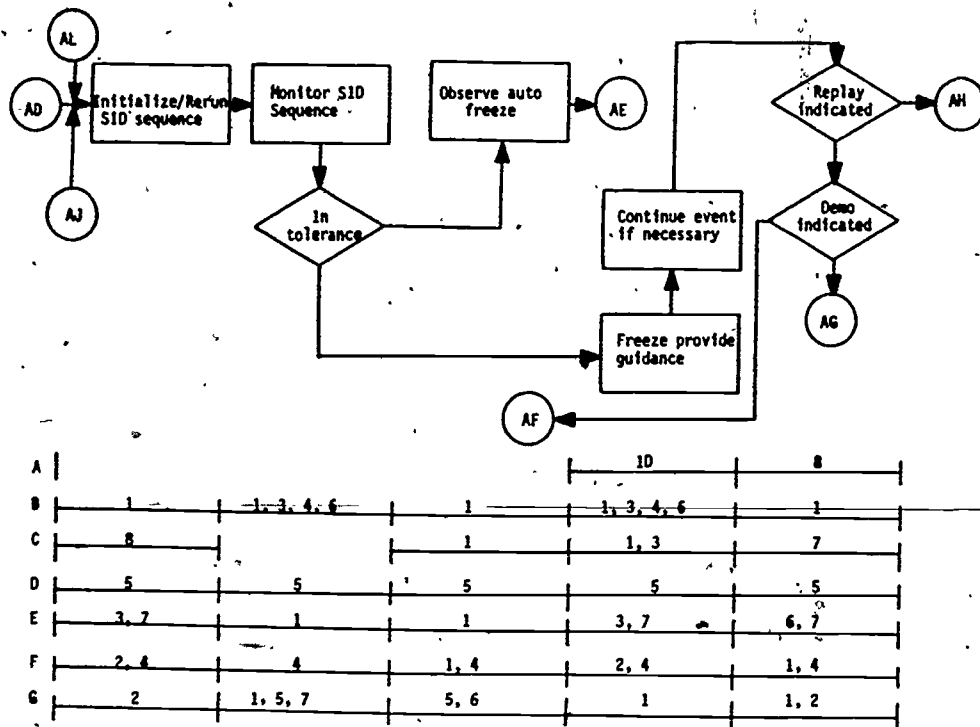

Figure 2  
Functional Flow Diagram

DEMONSTRATION is an OFT instructional strategy that consists of a prerecorded aircraft maneuver, or series of maneuvers, that provides a model of desired performance for a flight event. REPLAY enables the instructor to replay the student's performance during any portion or all of the most recent five minutes of simulated flight. PREPROGRAMMED LESSONS comprise 98% of all training events and consist of a pre-defined sequence of maneuvers, segments of flight, instructional events and allowable instructional features and strategies which reside in the OFT training software. MANEUVER/SEGMENT RERUN is an instructional strategy which permits the instructor to return to the flight conditions which existed at the beginning of a maneuver, either by flight segment designation or by entering any mission time within the five minute replay recording. BACKWARD CHAINING is a strategy which presents a set of prerecorded points (initial conditions) which allow a student to learn the last response (last portion) in a response or maneuver chain first. Learning then proceeds "backward" up the chain until all members of that chain are acquired. FREE FLIGHT lessons, comprising approximately 2% of the scenarios, enable the instructor to construct his own flight scenario from a menu of initial conditions, malfunctions, flight segments, and instructional modules.

Instructional features are defined as simulator capabilities which enhance the training of a student by modifying the instructional scenario or strategies. The

features applicable to the OFT were determined to be SELECTABLE DIFFICULTY LEVELS (SDL), DIGITAL SPEECH GENERATION, and PARAMETER FREEZE. SELECTABLE DIFFICULTY LEVELS is an OFT instructional feature that consists of a simultaneous programming of three levels of difficulty for any scenario and which is utilized to either challenge or unload a student whose performance is above or below the UPT student average respectively. SDL is in reality a simple "poor man's" adaptive training capability. DIGITAL SPEECH GENERATION unloads the instructor of the requirement to act as a manned interactive system (GCA controller, ATIS, clearance delivery ACLS messages, LSO control, etc.) by means of speech synthesis. PARAMETER FREEZE allows the instructor to selectively freeze a certain flight parameter (airspeed, angle-of-attack, etc.) or a portion of a flight path (glideslope, centerline, etc.) to within acceptable performance measurement parameters.

It is felt by many simulation industry observers that information about the intended use to be made of a simulator's instructional features, if made available during the design process, could be used to design a more effective vehicle for training. The needed information must convey to the designer the prospective simulator user's concept of how the various instructional features are to be employed during simulator instruction. It was decided by the study personnel that the use of Instructional Feature Design Guides, adopted from Pohlman, Isley and Caro (1978),

would best accomplish this purpose. The VTX Instructional Feature Design Guides accounted for learner characteristics and teaching methodologies appropriate to Undergraduate Pilot Training. Each of the instructional strategies and features was written up in an individual design guide which described the feature and how it would be employed by the simulator instructor to perform coaching, demonstration, feedback and instructional functions for relatively unskilled pilots.

A six-element format was utilized for the instructional feature design guides and included the following items:

- Feature name
- Definition
- Purpose and Intended Use
- Function Description
- Concurrent Events
- Feature Diagram

Figure 3 is an example of a Feature Diagram.

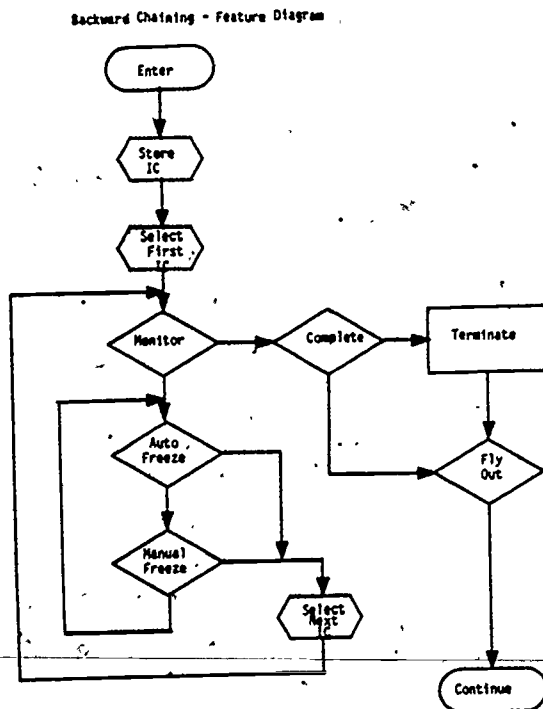

Figure 3  
Example of a Feature Diagram

#### SYSTEM DEVELOPMENT

A survey of existing and emerging simulator technology was conducted in order to incorporate ideas and technology which would improve the instructor's capability to teach. The two devices which most dramatically influenced the IOS design process were the F-14 Instructor Support Station and the F-18 OFT, Device 2F132. These two devices

incorporate a number of features that were deemed appropriate as a result of the previously discussed analyses. These capabilities of interest are as follows:

- F-14 Instructor Support Station (ISS)
  - Interactive CRT Touchpanels
  - Preprogrammed Lesson
  - Digital Speech Generation
  - Performance Measurement System
- F-18 OFT
  - Display System
  - Interactive CRT
  - Procedures Monitor
  - Preprogrammed Missions

Of particular interest is the simplicity of the F-18 OFT IOS. In fact, the VTX family of training devices all include an IOS which is very much similar in hardware configuration to the 2F132. However, they are markedly different in software design, operational capability and syllabus implementation from the F-18 OFT.

The analyses indicated that it would be desirable to include two additional subsystems into the simulator design to further enhance its capability to meet challenges the training system. These subsystems were an Automatic Performance Measurement System (APMS) and a Remote Briefing and Debriefing Station. The APMS would provide a computer system that would score a student's performance automatically and package those scores in a manner which would be useable to the instructor in real time and during the subsequent debrief. The APMS programs will compare the student's performance with a definitive criterion, normalize these scores in order to provide peer ratings, determine student errors, and suggest remedial strategies. The APM system is designed in such a way that performance on one leg or segment does not affect scoring on subsequent legs except that the possible use of the SDL feature may be continued.

The Remote Briefing and Debriefing Console consists of an isolated station interfaced to both the simulators and the Training Management System. This console can be utilized for Simulator lesson preparation, pre-mission briefing, post-mission debriefing, student data management and training management functions. The intent of the Remote Briefing and Debriefing Capability is two fold; one, to allow briefs and debriefs to be held in an area more compatible to the instructional activities involved in pre- and post-mission training than the simulator itself, and two, to increase the available OFT training time by freeing the device from the briefing and debriefing activities.

The analyst team then used the functional flow diagrams to validate the IOS design, ensuring that the six lessons could be taught as envisioned. This validation process was iterative in nature as the IOS design and the functional flow diagrams were continually changed and updated until a working design was completed. This analytical step is similar to design "mock-up" review and ensures that the instructor can instruct from the instructor station. The final step was documentation of the actual functional specifications.

#### LESSONS LEARNED

The front-end analysis leading to the VTXTS IOS functional specifications was not without pitfalls. As the analysis proceeded, it was necessary to work around a number of problems. The following paragraphs describe the most important lessons learned from the Mathematics study effort.

1. Simulation engineers are hardware specification oriented. It was difficult to communicate training requirements to the engineers due to the lack of hardware definition. Feature design guides describing in detail the use of instructional features to meet the UPT training requirements largely obviated this problem.
2. The ISD base on which the IOS front-end analysis is anchored must be complete. Considerable effort must be expended on the development of learning objectives, conditions and standards prior to media selection and lesson specification. Improper media selection and/or poor lesson specifications could lead to functional specifications which do not address actual training requirements.
3. Subject Matter Expert (SME) participation is essential during lesson development and the functional flow analysis. Without user inputs the analytical effort may end up in left field. SME input injects reality into the front-end efforts.
4. Functional flow analyses are labor intensive and must be iterative in nature. The functional flow analysis is not the area to skimp on manpower. The work must be iterative in nature and previously developed algorithms updated as the diagrams are created.
5. The analytical "mock-up" is necessary to validate the functional flows. Performing a "mock-up" review with SMEs identifies weak points and allows for improvement of the specification. Without this step, the functional flow

diagrams, and feature allocations will never communicate the instructional requirements.

6. Front-end analysis can yield significant improvement in user/manufacturer cooperation. SME inputs before the development of the functional specification, if properly implemented, will reduce the adverse impact of Fleet Project teams later.
7. Without front-end analysis "gold plating" may result. This front-end analysis showed that existing or near-term technology was adequate for the VTXTS simulators and incorporation of exotic features and capabilities was not necessary.

#### FINAL COMMENTS

A number of conferences have addressed the value of front-end analysis in simulator instructor station design in theoretical terms. This paper has presented an example of one approach to performing a front-end analysis leading to functional specifications that has been tried. The methodology utilized in this study is not original but is adapted from previously published work. This front-end analysis achieved a much better collaboration with project engineers than ordinarily occurs during simulator IOS design efforts and thus greatly enhanced their understanding of the UPT training requirements and how a typical scenario would be taught on the device. The Mathematics study team sees the actual development of working specifications for a simulator IOS as an iterative process which continues throughout the simulator procurement cycle. The functional specifications generated as a result of this front-end analysis was an initial training input to that iterative process. The training team must remain involved throughout the engineering design, construction, and user acceptance processes in order to ensure incorporation and proper implementation of key training recommendations. Without training requirements inputs and analysis, there is a risk of user dissatisfaction with the device when placed in the actual training situation.

#### REFERENCES

Charles, John P. "Instructor's Role in Simulation Training" Technical Reports NAVTRAEQUIPCEN 75-C-0093-C, 76-C-0034-1, and 76-C-0034-2, Naval Training Equipment Center, Orlando, Florida; June, 1978.

Mackie, R.R.; Kelley, G.R.; Moe, G.L.; Mencherikoff, M.; "Factors Leading to the acceptance or Rejection of Training Devices", Technical Report NAVTRAEQUIPCEN 70-C-0276-1, Naval Training Equipment Center, Orlando, Florida, 1972.

Pohlman, Lawrence D.; Isley, Robert N.; Carb, Paul W.; "A Mechanism for Communicating Simulators Instructional Feature Requirements", Proceedings, Naval Training Equipment Center Industry Conference, 1978.

Smode, Alfred F. "Training Device Design: Human Factors Requirements in the Technical Approach", Technical Report NAVTRAEQUIPCEN 71-C-0013-1. Naval Training Equipment Center, Orlando, Florida, August 1972.



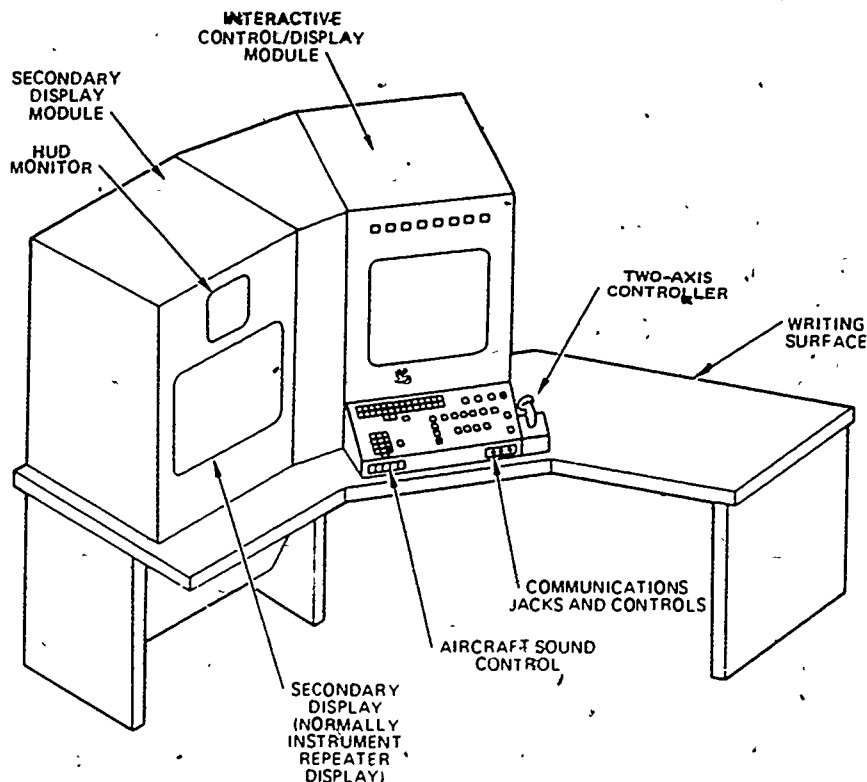

FIGURE 1. GENERAL CONFIGURATION OF VTXTS SIMULATOR INSTRUCTOR CONSOLE (USED ON IFT, OFT, ACMT)

is located in back of and to the left of the student's seat, and at right angles to the instrument panel. An instructor seated at the console can thus see the student and his instrument panel and/or the simulated outside visual scene by looking over his right shoulder. For an ACMT, a full console is located outside the simulator, and a miniconsole consisting of an interactive display module is located in front of a jumpseat next to the cockpit.

The configuration of the interactive module is presented in Figure 2. The switches on the interactive module consist of dedicated special function switches and the CRT touch screen, which is used in conjunction with various types of menu displays presented on the CRT. The selection of membrane-type off-screen touch panels over mechanical switches and of the transparent membrane-type touch screen over infrared and sonar-type touch screens was made on the basis of a detailed comparison of the ease-of-use, initial cost, reliability and maintainability of these alternatives. A caution in making these kinds of control hardware comparisons is that the cost of the decoding and interface equipment required for different types of switches and switch panels is often much greater than the cost of the switches or panels themselves, and thus must be broken out separately.

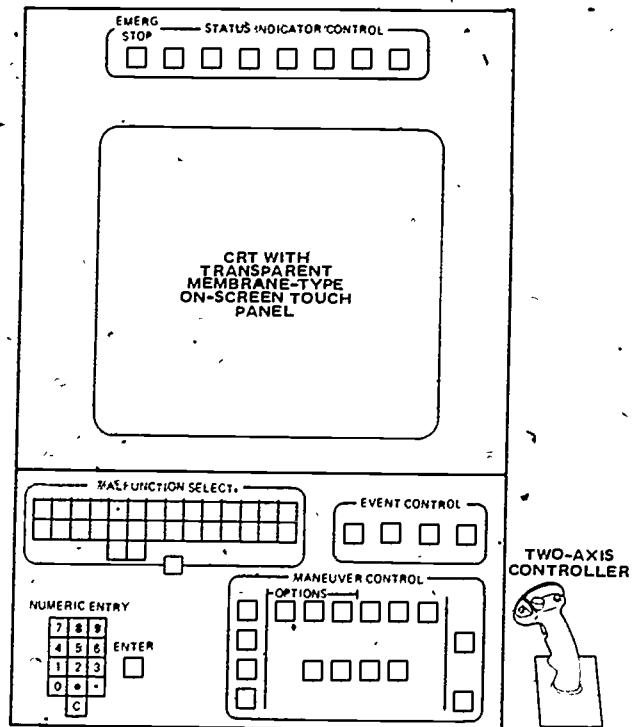

FIGURE 2. INTERACTIVE CONTROL/DISPLAY MODULE

## Functional Design

The functional design of the instructor console consists of several major features which appear capable of dramatically simplifying procedures and improving training. These features are as follows:

1. An extension of the task module concept developed by Logicon and the Canyon Research Group for the F-14 OFT ISS. (Semple, et. al., 1979)
2. The use of "event" modules in addition to task modules.
3. The inclusion of explicit provisions for conducting three basic types of simulator training: routine; partially specialized; and fully specialized.
4. The inclusion of explicit provisions for controlling four basic types of simulator learning events: IP demonstration; autopilot or canned demonstration; live run; and replay.
5. A special, minimal set of dedicated function switches and switch logic designed to interact with event modules, task modules and special purpose displays in a way that permits highly efficient control of each type of training and each type of learning event.
6. Low-density pictorial and tabular special-purpose displays designed to provide the instructor with the essential information at each point in the training process.

The following sections describe the nature, use, and projected advantages of each of the above instructor console design features.

**Task Modules.** As originally conceived by Logicon and the Canyon Research Group for the F-14 OFT ISS, a task module is a detailed pre-specification of the initial conditions, performance conditions, and automated performance measurement algorithms appropriate to a given maneuver or task, which is stored in computer memory. One of the primary functions of such modules is to automate maneuver set-up. Using this approach an instructor can set up a simulator to train any given maneuver by simply identifying the name of the maneuver to the computer. The computer then sets up the simulator automatically according to the specifications in the task module. Task modules thus greatly reduce instructor workload by eliminating the need to remember or look up and then manually enter all of the information which must be specified to set up a simulator to train a specific maneuver.

The proposed approach expands the original task module concept in two ways. First, the task module specification is expanded to include additional information such as 1) the

method to be used to control the second aircraft in ACM and formation training; 2) the standard and optional instructor console displays to be shown to the instructor in each part of each maneuver; and 3) the displays to be recorded on videotape for later use in debriefing. Second, "auxiliary" task modules are created which enable the instructor to quickly set up standard variations on basic maneuvers in order to tailor training to the needs of individual students - i.e., to conduct partially specialized training as discussed below. This is done with a minimum impact on computer memory requirements or software development costs by using auxiliary modules to specify only those parameter values which are different from those in the "core" module for the basic maneuver. Standard variations on a given maneuver can then be set up by selecting a desired maneuver variation from a menu of standard variations. In addition to greatly reducing instructor workload, core and auxiliary task modules will increase training standardization to a level not possible with current consoles, in that all maneuvers and maneuver variations will be set up, displayed to the instructor, evaluated, and recorded in the same way for each student and instructor.

The procedures for fully specialized training are simplified by requiring the instructor to manually input only those parameter values which are different from those in the core or auxiliary task module under consideration, as discussed below.

**Event Modules.** Event modules are an extension of the canned mission mode defined for the F-14 OFT ISS. As defined here, an event module is a detailed pre-specification of the lesson plan for a given training event which is stored in computer memory. An event module is created for each simulator event in the flight syllabus. The event module for a given event specifies the specific maneuvers to be trained in the event, as well as the sequence in which they will be trained. It also specifies the type and number of demonstrations to be used in the training of each maneuver, as well as the minimum, standard, and maximum number of student practice trials to be flown. The use of a pre-specified minimum, standard, and maximum number of trials will be further discussed below under controls and displays. In general the event module will automatically set up the simulator to fly each run of each maneuver in the sequence called for by the lesson plan for that event. It will do this by calling up appropriate task modules. For example, at the start of a training session the event module will automatically set up the simulator for the first run of the first maneuver. This might be, e.g., an automated demonstration of a lazy 8. After he finishes talking to the student and verifies that the student is ready, the instructor starts the run by pushing the START switch. The run will

# CONCEPTUAL DESIGN OF AN INSTRUCTIONAL SUPPORT SYSTEM FOR FIGHTER AND TRAINER AIRCRAFT FLIGHT SIMULATORS

VERNON E. CARTER  
Northrop Corporation

## ABSTRACT

A conceptual design for a comprehensive instructional support system (ISS) for fighter and trainer aircraft flight simulators was developed as part of an independent research project to develop and evaluate advanced pilot training techniques. The major elements of this ISS are:

1. A low-workload flight simulator instructor console based in part on the task module approach developed by Logicon and the Canyon Research Group for the F-14 Operational Flight Trainer ISS;

2. A comprehensive automated performance monitoring system based on techniques developed by Northrop, Vought, and Systems Technology, Inc. (STI)

3. A set of automated and nonautomated simulator instructional features selected on the basis of a review of the literature and recent field experience

4. A low-cost, low-workload brief/debrief console designed to minimize the time spent in the simulator on tasks other than active instruction.

These elements are designed to work together to reduce instructor workload and increase the effectiveness and efficiency of simulator training. Although the design is oriented towards large, highly-structured training systems, many of its features appear applicable to other training environments.

## INTRODUCTION

A conceptual design for a comprehensive instructional support system (ISS) for fighter and trainer aircraft flight simulators was developed as part of an independent research and development project to develop and evaluate advanced pilot training techniques. The major elements of the ISS are 1) a low-workload instructor console based in part on the task module approach developed by Logicon and the Canyon Research Group for the F-14 operational flight trainer ISS; 2) a comprehensive automated performance monitoring system based on techniques developed by Northrop for evaluating student performance in introductory air-to-air tactics, by Vought for evaluating student performance in carrier landing and by STI for examining pilot control techniques in a variety of tasks; 3) a set of nonautomated and automated simulator instructional features selected on the basis of a review of the recent

literature on instructional features, supplemented by interviews with research and user personnel; 4) a low-cost, low-workload brief/debrief console designed to reduce time spent in the simulator on tasks other than active instruction.

Working together these elements appear capable of dramatically reducing instructor workload and significantly increasing the effectiveness and efficiency of simulator training. In general, it appears that the proposed approach should

1. reduce the instructors perceptual and procedural workload far below that of current simulators;

2. reduce the time required to achieve a given level of student performance;

3. permit a much higher level of training standardization and control than is possible with current simulators;

4. provide a full capability for tailoring training to the needs of individual students;

5. reduce instructor training requirements; and

6. minimize the need to refer to user's manuals.

## DESIGN GUIDELINES

Two basic design guidelines were established for this development. The first, a point often stressed by Mr. William Harris of the Analysis and Design Branch at NTEC, is that the design of all equipment to be used by military flight instructors should reflect the fact that they are typically undermanned and already working long hours. Their time, as well as their energy and patience, should therefore be treated as a scarce, essential resource to be conserved wherever possible. It should be recognized for example that instructors do not have time to stop in the middle of a training session to try to remember a complex procedure or a set of parameter values in order to set up a given maneuver. They have even less time to look up the correct procedure or information in a user's manual. Instructor consoles and other equipment to be used by instructors should thus be as simple, self-explanatory, and easy to use as possible. Achieving such simplicity not only reduces the time normally spent in remembering, looking up and performing procedures, but also reduces

set-up errors which are time consuming and frustrating in themselves. Finally, equipment that is simple to operate should significantly reduce instructor training requirements, or at least allow more time to be spent on teaching instructors how to instruct rather than how to operate the equipment.

The problem with all this is that making operating procedures simple and self-evident for something as complex as a flight simulator typically requires the development of fairly complex software to partially automate the procedures. The development of such software is both time-consuming and expensive. Although it seems clear that simpler procedures can contribute to reduced life cycle costs in several ways, there is simply not enough data at this point to prove that the projected savings will be enough to offset the cost of developing and maintaining the additional software. A second and very important guideline established for the study was thus the working assumption that the cost of developing and maintaining the software required to simplify operator procedures will be offset in the long run by savings in investment and operating costs resulting from such benefits as reduced instructor training requirements and more effective and efficient student training. For example, the proposed instructor console design appears capable of reducing the time now spent in deciding what maneuvers to train, in obtaining needed information, and in setting up the maneuvers. These savings should translate into reduced time in the simulator for each student. This in turn should result in a reduction in the total number of simulators required, and/or a reduction in the operating and maintenance costs per simulator.

An example of the problems caused by not simplifying operator procedures is provided by some current military instructor consoles that are reported to require the instructor to perform as many as 40 procedural steps to set up a single maneuver for training. Obviously such a design will waste a great deal of student time, instructor time, and device time in each of thousands of training sessions throughout its life cycle. Lengthy set-up procedures lower simulator training efficiency by reducing the ratio of productive training time to total simulator time. They further lower efficiency and effectiveness by introducing continual delays in training which have an unavoidable effect on student and instructor concentration and motivation.

## INSTRUCTOR CONSOLE

### Design Approach

A high level of partial automation is used to achieve a very low level of workload for the most frequent case of routine or standardized training. A moderate level of automation

is used to achieve a relatively low level of workload for the less frequent case of partially specialized training. A low level of automation is used for the relatively rare case of fully specialized training, resulting in a level of workload for this type of training which approaches that found on current consoles.

The application of automation to the simplification of console procedures is thus in accordance with a frequency-of-use approach in that the size of the development effort to simplify procedures is proportional to how often the procedures are used. This results in a console that is "managed by exception" in that the instructor has to do very little unless he wishes to deviate from the standard "default" condition. From a different standpoint, the console design makes use of the principle of least effort in a way that should result in a much higher level of training standardization than is realized with current simulators. For example, the console design makes it easiest of all for the instructor to conduct the standard training specified in the syllabus and lesson plan; harder but still relatively convenient to conduct partially specialized training; and least convenient of all to conduct fully specialized training. Thus, the more the instructor deviates from the syllabus or lesson plan, the harder he has to work. In this way the design strongly encourages standardized training but makes it possible for the instructor to introduce specialized training whenever he decides that it is necessary.

### Physical Configuration

The general physical configuration of the instructor console consists of an interactive control/display module, a secondary display module, and a two-axis controller, as shown in Figure 1. The interactive module consists of a 21" calligraphic CRT with a transparent membrane-type on-screen touch panel or "touch screen", and several off-screen membrane-type illuminated touch switches, where individual switches are created from a continuous matrix of switches by making cutouts where desired in a thick, e.g., 1/8", plastic overlay. The secondary display module consists of a second 21" calligraphic CRT plus a smaller CRT included primarily for the purpose of presenting the instructor with the view seen on and through the students HUD.

The configuration shown in Figure 1 was designed for use with an instrument flight trainer (IFT), operational flight trainer (OFT), or air combat maneuvering trainer (ACMT). The interactive display module by itself can be used as the instructor console for a cockpit procedures trainer (CPT), where it can be swiveled to face the student for self-instruction. For an IFT or OFT, the console



stop when the instructor pushes the STOP switch or when the run time reaches some pre-specified maximum stored in the task module for that maneuver. When the run stops, the event module will start setting the simulator for the next run to be flown, typically a student practice run ("live run") for the same maneuver. After the standard number of student practice runs have been flown for the first maneuver, the event module will start setting up the simulator to fly the first run of the second maneuver. This procedure is repeated until all maneuvers have been flown. Unless he wants to deviate from the standard lesson plan, the only inputs the instructor has to make are to push POSITION SIM to initialize each run, START to start each run, and NEXT MANEUVER to proceed to the next maneuver.

Although it may appear at first that the event modules are too restrictive, a variety of ways are provided to permit the instructor to deviate from the standard lesson plan to tailor training to the needs of the individual student. As with task modules, the difficulty of deviating from the standard lesson plan for an event is inversely proportional to the estimated frequency of the need for such deviation. Thus, modifying the number of trials within the prespecified minimum and maximum number of trials is very easy. Modifying the lesson plan to provide training on a maneuver which is not even in the lesson plan is relatively complex, although still fairly straightforward.

On the surface it may seem desirable to let a student practice each maneuver or task until he reaches the specified or customary level of performance for that point in training, regardless of the number of trials called for in the syllabus or lesson plan. In practice, however, most large-scale training programs permit only slight deviations from the planned number of trials for each maneuver. This is due to the fact that large deviations have a chain reaction effect on subsequent syllabus events. For example, excessive time spent on one maneuver will usually result in insufficient practice on one or more of the other maneuvers scheduled for the same event. The student is then faced with the problem of going to the next regularly scheduled simulator or aircraft training event without being able to perform these other maneuvers at the expected level. This is yet another example of how individualized progression, although desirable from a theoretical standpoint, creates serious problems in large scale training systems. Recent advancements in dynamic scheduling techniques may someday provide an answer to this dilemma.

Provisions for Routine vs Specialized Training. The proposed design makes explicit provisions for three types of training: routine training; partially specialized training; and fully-specialized training.

In the context of individual maneuver training, routine training consists of training the student to perform one of the standard versions of the maneuver called for in the flight syllabus. Partially specialized training in this context refers to tailoring training to the needs of the student by having the student fly a relatively common variation of one of the standard versions of the maneuver, e.g., under different visibility conditions or with a different c.g. Fully specialized training refers to training the student to fly uncommon variations on one of the standard versions of the maneuver, e.g., in turbulence with one engine out, etc.

In the context of the training of an entire event, routine training refers to conducting the training exactly as specified in a pre-established lesson plan, in terms of the maneuvers trained, the sequence of maneuvers trained, the type of runs or "learning events" used to train each maneuver and the number of runs of each type flown. Partially specialized training here refers to making relatively slight variations in the lesson plan, e.g., varying the number of student practice runs for a particular maneuver within pre-established minimum and maximum limits. Fully specialized training here refers to making major changes in the lesson plan such as exceeding the maximum number of runs specified for a given maneuver or introducing a maneuver which is not in the lesson plan.

As discussed above, the console is designed so that routine training, which should be completely adequate most of the time, requires an absolute minimum of instructor inputs. Partially specialized training, needed occasionally, requires a moderate number of instructor inputs. Fully specialized training, needed only on rare occasions, requires a relatively high number of manual inputs. In comparison with current consoles instructor workload should thus be very low for routine training, higher but still relatively low for partially specialized training, and approach that of current consoles only for the relatively infrequent case of fully specialized training.

Provisions are also made to record the number and nature of each partially or fully specialized maneuver or task used by the instructor to identify: 1) standard variations of maneuvers and tasks which are used frequently enough that they should be added to the syllabus to become part of standardized training; and 2) nonstandard variations of maneuvers and tasks which are used frequently enough that they should be added to the menus of standard variations available to the instructor for conducting partially specialized training.

Provisions for Different Run Types. The proposed console design also makes explicit provisions for four basic types of runs or "learning events" which are used in simulator training: IP demonstration runs; automated demonstration runs; student practice runs; and replay runs.

In IP demonstration runs the instructor pilot flies the simulator from the instructor console using the inside-out and outside-in graphic displays and the two-axis controller. This feature was included to permit the instructor to actively fly the simulated aircraft in order to illustrate facets of performance that are not adequately illustrated by any of the automated demonstrations. Automated demonstration runs are runs flown by an interactive autopilot or by a "canned" tape. Student practice runs ("live runs") and replay runs are self-explanatory. The use of the instructor console to set up and control each of these types of runs is described in the following sections.

Controls. Figure 2, above illustrates the three basic types of controls provided on the instructor control/display module. These are:

1. A transparent CRT touch screen used to select items from alphanumeric or pictorial menus displayed on the CRT.

2. Dedicated function switches located both above and below the CRT. These are grouped into five subpanels corresponding to five basic functions performed by the instructor: simulator status monitoring; event control; maneuver or task control; number entry; and malfunction insertion. The switches used to perform each of these functions are discussed below.

3. A two-axis controller located to the right of the control switch slant panel. (For use with an IFT, OFI or ACMT. Not required for a CPT.) The two-axis controller can be used by the instructor a) to fly the student's aircraft during manual demonstrations of correct maneuver performance ("IP demos"); b) to manually control the simulated enemy aircraft during ACM and gunnery training; and c) to fly one of the friendly aircraft during close formation or traffic pattern training.

Five types of dedicated function indicator switches were defined for the console: 1)

those used to control and monitor the status of the simulator itself; 2) those used to identify and modify the event to be trained; 3) those used to monitor and control the training of individual maneuvers and tasks; 4) those used to enter numbers into the computer (e.g. to change the value of parameters defining initial conditions, etc.); and 5) those used to insert, monitor, and remove malfunctions in the simulated aircraft. The subpanels containing each of these types of switches are shown below in Figures 3 and 4.

The Simulator Status Panel, the Numeric Entry Panel, and the Malfunction Select Panel are self-explanatory. The functions associated with the Event Control Panel and the Maneuver Control Panel are described below.

Event Control Panel. The Event Control Panel is used as follows. Pressing the STAGE switch causes a menu of the different stages of training to appear on the CRT display, e.g., Instruments, Formation, ACM, etc. Indicating a specific stage with the touch screen calls up a menu of the different training events (simulator sorties) which must be flown during that stage. Indicating a specific event on this menu causes the detailed lesson plan for that event to be displayed, showing the sequence of maneuvers and tasks to be trained, and the minimum, standard, and maximum number of trials for each maneuver or task. If the lesson plan is more than one page long, pressing a point on the bottom right (or left) corner of the touch screen will cycle forward (or backward) through the pages in the menu. Indicating a specific event also causes the event module for that event to be loaded into main memory. Pressing the START EVENT switch then calls up the task module for the first maneuver or task to be trained and starts setting up the simulator for the first trial of the first maneuver or task. (Where desirable, this could be mechanized so that an instructor could start an event from somewhere other than the beginning by simply touching the screen to indicate the first maneuver or task to be trained before pressing the START EVENT switch.)

The LESSON PLAN switch shown in Figure 4 can be used to call up the lesson plan for review at any time during the event. The lesson plan can also be used as a menu to conduct specialized training by introducing maneuvers and tasks out of sequence, e.g., to skip a

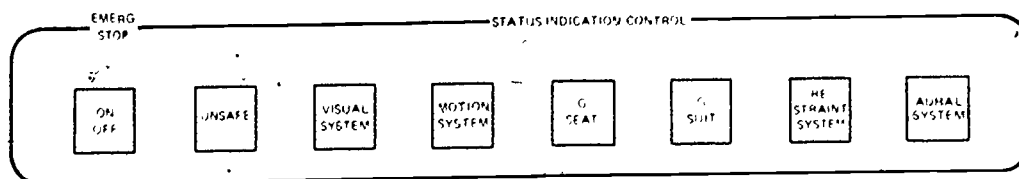
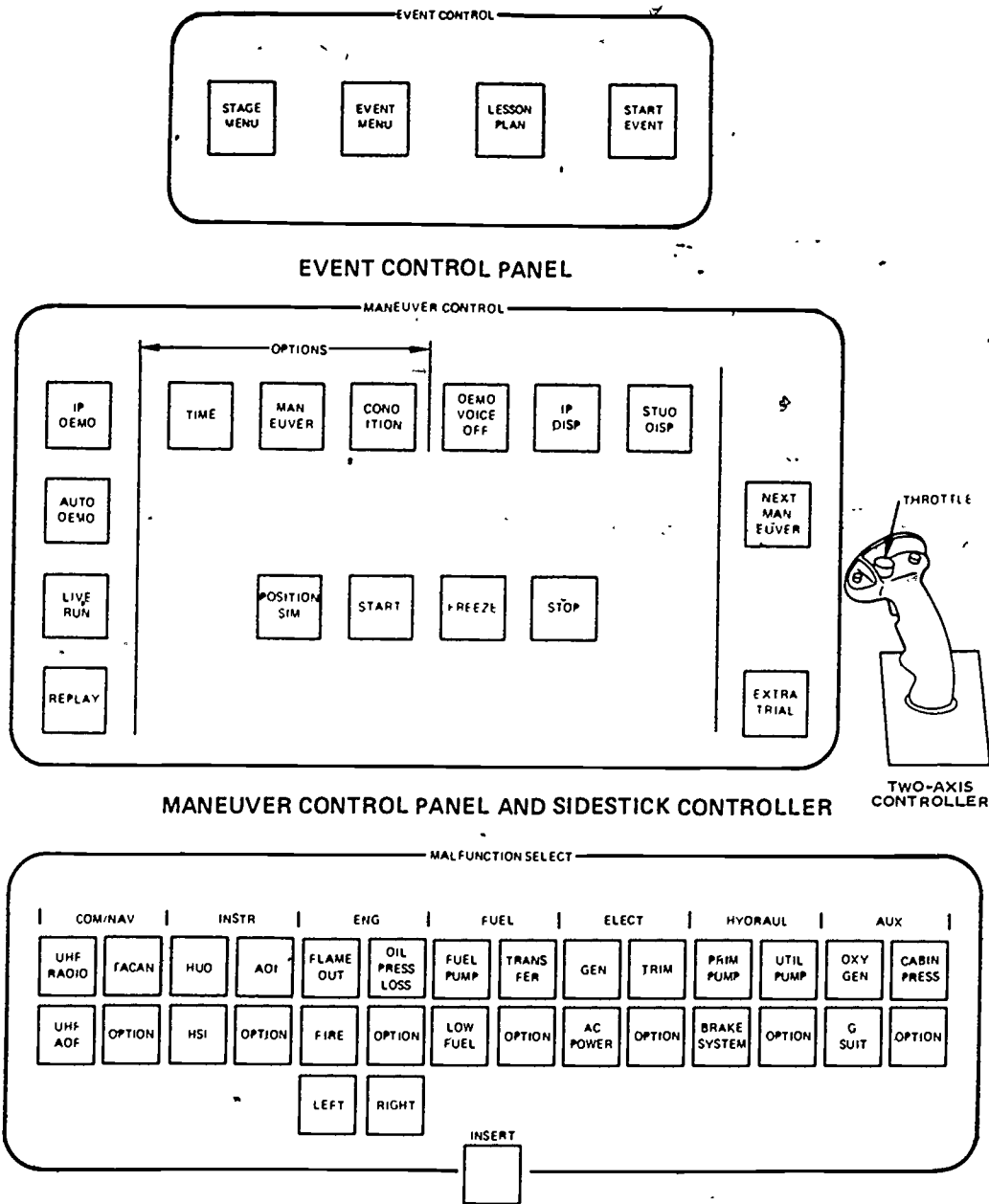

FIGURE 3. SIMULATOR STATUS PANEL



MANEUVER CONTROL PANEL AND SIDESTICK CONTROLLER

REPRESENTATIVE MALFUNCTION CONTROL PANEL

FIGURE 4. LOWER SUBPANELS

section of the plan, or to return to a maneuver already completed. Similarly, event menus and stage menus can be used to introduce maneuvers normally practiced only in other events or even maneuvers normally practiced only in other stages. Again, the more radical the departure from the standardized training pre-specified for the event, the greater the number of procedural steps required.

**Maneuver Control Panel.** The Maneuver Control Panel is used as follows. The POSITION SIM, START, FREEZE, and STOP switches were carefully selected as a minimal, necessary and sufficient set of simulator run controls on

the basis of our experience in conducting simulator training experiments over the past several years. The function of these switches is described below in Figure 9 which presents a detailed sequential description of instructor control inputs and display indications for a standard prerecorded maneuver demonstration. These controls function in exactly the same way for an instructor flown demonstration (IP DEMO), autopilot or prerecorded demonstration (AUTO DEMO), student practice run (LIVE RUN), or replay. The functions of the NEXT MANEUVER and EXTRA TRIAL switches are described below in the discussion of the Quantitative Performance Display.

Displays. Dynamic "inside-out," and "outside-in" pictorial representations of the student's aircraft and its relation to other aircraft or ground features are now relatively common, at least for certain maneuvers. For example, many current instructor consoles can show dynamic two-dimensional pictorial representations of aircraft glideslope and localizer error. Similarly, dynamic three-dimensional perspective outside-in and inside-out pictorial representations of ACM engagement like those developed by Cubic for the Tactical Air Combat Training System/Air Combat Maneuvering Range (TACTS/ACMR) have been developed for ACM simulator instructor consoles by Northrop and other companies. (Spring, 1976) In the proposed design, dynamic inside-out and outside-in views of the maneuver being flown are combined with a number of special purpose displays to provide the instructor with the essential information required at each point in training. Figure 5 shows an outside-in display of an ACM engagement. The numbers in Figure 5 show the relative position of attacker and bogey at four different times during the engagement.

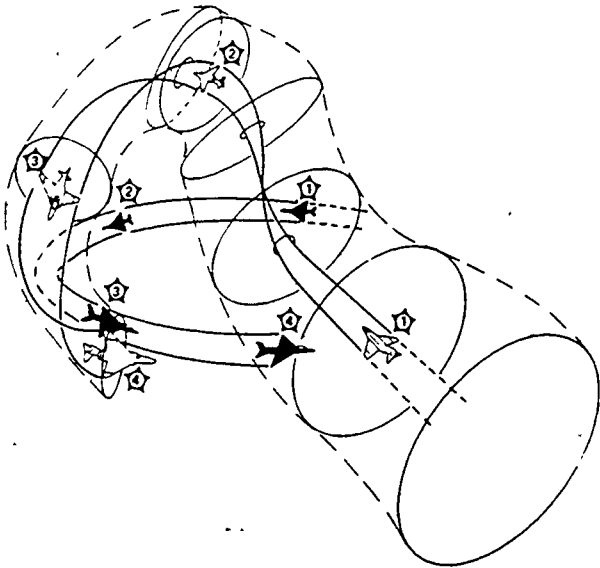

FIGURE 5. OUTSIDE-IN DISPLAY OF ACM ENGAGEMENT

As noted previously, the generalized (all except CPT) configuration of the instructor console has three CRT displays. These are:

1. A small CRT at the top of the left-hand or "secondary display" module. This is normally used as a repeater display to show the instructor the view through the HUD and the HUD symbology being seen by the student.
2. A 21" CRT on the secondary display module. During a run this is normally used to present a dynamic outside-in pictorial representation of the student's aircraft and its relation to other aircraft or features on the ground.

3. A 21" CRT on the interactive control/display module. During a run this is normally used to present a dynamic inside-out pictorial representation of the view through the wind-screen of the student's aircraft. Between runs this CRT is used to present special-purpose displays which provide the instructor with a variety of additional information required to set up, conduct, monitor, and evaluate training.

A description of the primary special-purpose displays developed during the design study is presented in the following sections.

Maneuver Description Display. A sample Maneuver Description Display is shown in Figure 6. This display is automatically presented to the instructor at the beginning of a training for each new maneuver or task. The display shows:

1. The type and number of demonstrations to be flown; and the minimum, standard and maximum number of student practice or "live" runs to be flown following the demonstrations.
2. The standard or "desired" time of occurrence of critical points or "windows" which normally occur during the maneuver, on a time scale appropriate to the maneuver.
3. A detailed description of the performance standards, initial conditions, and performance conditions for the maneuver to be flown.

The purpose of the maneuver description display is to refresh the instructor's memory as to a) the way in which the maneuver should be flown and b) the specific criteria which should be used to evaluate student performance.

Quantitative Performance Display. A typical Summary Quantitative Performance Display is shown in Figure 7. This display is automatically presented to the instructor at the end of each trial. The display shows:

1. An indication of the training status for the maneuver. This part of the display is unchanged from that shown in the Maneuver Description Display except that the number of the trial just completed is brightened to show the instructor the number of trials completed and the number yet to be trained.
2. Both the actual and desired (standard) time of occurrence of each critical point or "window" for the maneuver. This display was added because of analytical studies which suggest that the times of occurrence of critical points in a maneuver are sensitive indicators of overall maneuver performance.
3. A description of the most important out-of-tolerance conditions detected at each



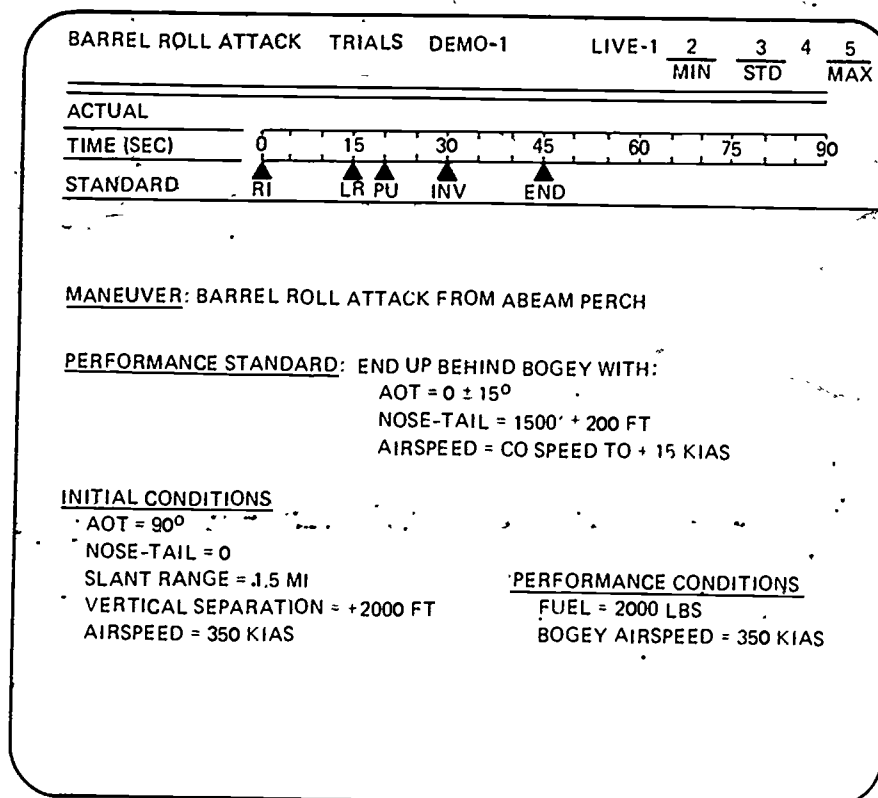

FIGURE 6. MANEUVER DESCRIPTION DISPLAY

window or in the segment or "corridor" immediately following that window. The out-of-tolerance conditions for windows and corridors are detected by the automated performance monitoring system discussed in the following section.

As illustrated in Figure 7, the Summary Quantitative Performance Display shows out-of-tolerance conditions detected for each window and succeeding segment. Each out-of-tolerance condition is indicated by a very brief English-language description of the out-of-tolerance condition, followed by the observed value of the parameter and the standard or desired value in parentheses. For example, Figure 7 shows that the pull-up occurred very late, that it was initiated when the attacker was 1/2 miles from the bogey, and that it should have been initiated when the attacker was approximately 7/8 of a mile from the bogey. The values in parentheses serve to continually remind the instructor of the qualitative performance standards established for the maneuver.

It would of course be possible to present this same display to the student by projecting it on the simulator's image presentation system or by displaying it on the student's multifunction display in the cockpit. This feature could be used as a tool to assist the instructor in providing feedback to the student. With appropriate controls added to the cockpit this could also be used to provide the

simulator with a capability for self-instruction, which can be highly efficient when alternated with conventional instruction.

It should be noted that the display presents only the two or three most important out-of-tolerance conditions detected for each window and accompanying segment. This is done to prevent overloading the instructor with too much information. It is done by means of a table look-up system which identifies the most important errors by consulting a table containing the prespecified rank order of importance of each of the known errors for each window and segment for the maneuver. This table is part of the automated performance monitoring algorithm which is in turn part of the task module for the maneuver. If desired, the instructor can obtain information on additional performance information for any window and segment by simply touching the name of the window. This causes a Detailed Quantitative Performance Display of all the out-of-tolerance conditions detected for that window and segment to be displayed. This detailed display for a given window and segment would probably group out-of-tolerance conditions by parameter type to make it easier for the instructor to read, e.g., under headings such as "Energy Parameters," and "Relative Geometry Parameters."<sup>4</sup>

The time scale at the top of the display has a second, possibly very useful function.

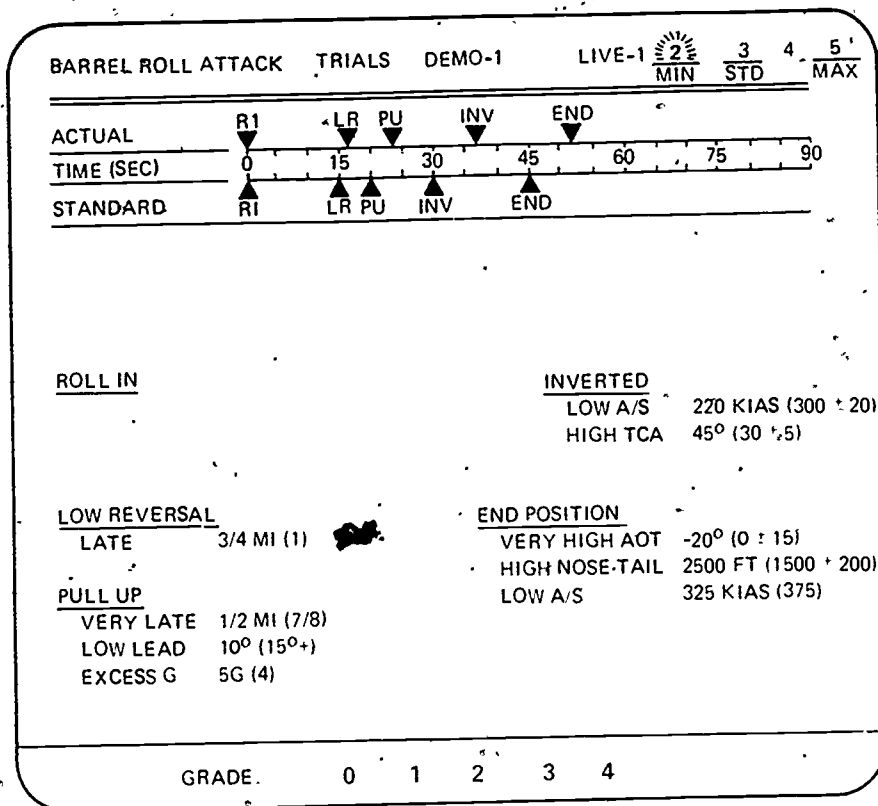

FIGURE 7. SUMMARY QUANTITATIVE PERFORMANCE DISPLAY

By pressing any two points on the scale the instructor can preset the starting and stopping points of any automated maneuver demonstration or replay. This might be done to save time or to highlight some aspect of maneuver performance. Thus, in the example shown in Figure 7, the instructor could use this technique to quickly set up the simulator to replay a just completed live run from a point just before the low reversal to a point just after the inverted position, in order to illustrate some detail of correct or incorrect performance in that part of the maneuver.

A similar capability can be provided for live runs by developing additional software to enable the computer to pick off nonstandard initial conditions, etc. from intermediate points in a canned demonstration of the maneuver. The ability to set up arbitrary start and stop points for live runs provides an inherent capability for backward chaining and similar instructional techniques as discussed below in the section on instructional features.

In addition to enabling the instructor to keep track of where he is in the training for each maneuver the part of the display showing the trials completed and trials remaining are used by the instructor in connection with the NEXT MANEUVER and EXTRA TRIAL switches shown above in Figure 4.

Normally, as soon as the standard number of student practice trials ("live runs") have been completed for a given maneuver, the instructor will debrief the student and then press the NEXT MANEUVER switch. This will cause the simulator computer to call up the task module for the next maneuver specified in the event module and start setting up the simulator for the first trial of the next maneuver, typically a demonstration. If the standard number of practice runs have not been completed but the instructor decides that no further practice is necessary, and if the number of trials completed is equal to or greater than the minimum shown on the display, the instructor can move directly to the next maneuver to by pressing the NEXT MANEUVER switch. Similarly, if the standard number of practice runs have been completed but the instructor decides the student needs more practice, and if the number of trials flown is less than the maximum shown on the display, the instructor can set up an extra trial on the same maneuver simply by pressing the EXTRA TRIAL switch. In this way the instructor can easily vary the number of trials flown within prespecified limits to tailor training to the student's needs. He cannot exceed these limits without going through a more complex procedure. This feature is designed to make it difficult to reduce the number of trials to the extent that a student receives little or no practice on a maneuver, or to increase the number of trials to the extent that insufficient time is left

for training on remaining maneuvers. Here, again, the actual number of trials flown on each maneuver could be recorded to provide an empirical basis for modifying the minimum, standard, and maximum number of trials specified in the event module.

**Other Displays.** Several other displays were developed to reduce instructor workload for various tasks. For example two-dimensional tabular menus were developed to enable the instructor to quickly set up the desired mode of controlling each aircraft in a three ship formation, or in two-on-one or one-on-two ACM engagements. This type of display is illustrated in Figure 8.

ATTACKER	AUTO	STUDENT	IP	OTHER SIM
WINGMAN	AUTO	STUDENT	IP	OTHER SIM
BOGEY	AUTO	STUDENT	IP	OTHER SIM

FIGURE 8. MENU DISPLAY FOR SELECTING METHOD OF CONTROLLING EACH AIRCRAFT FOR ACM

**Detailed Functions Analyses.** Detailed functions analyses have been developed showing exactly how the Event Control Panel, Maneuver Control Panel, Maneuver Description Display, and Summary Quantitative Performance display would be used to carry out each of the following instructional functions and subfunctions:

Identify event to be trained

Conduct standardized training

- demonstrate maneuver
- instruct live run
- replay live run

Conduct partially standardized training

- modify start-stop points
- modify number of trials per maneuver
  - normal transition
  - skip to next maneuver
  - give extra trials on current maneuver
- introduce standard variation of maneuver

Conduct fully specialized training

- introduce nonstandard variation of maneuver
- introduce maneuver out-of-sequence
- introduce maneuver not contained in event module

Insert and remove malfunction

Specify method of controlling each aircraft for ACM and Formation Flights.

A sample functions analysis for demonstrating a maneuver is shown in Figure 9. This type of analysis is an important first step in developing instructor console software in that it can fairly easily be translated into a computer flow diagram.

#### Automated Performance Monitoring (APM) System

As discussed in the previous section, the automated performance monitoring (APM) system generates a quantitative performance display at the end of a maneuver which is a summary of the most important out-of-tolerance conditions detected during the maneuver. An example of a quantitative performance display is shown above in Figure 7. This information is presented to the instructor as an aid for evaluating and diagnosing student performance on the maneuver.

The APM system is based primarily on techniques developed by Northrop, Vought, and Systems Technology, Inc. (Carter 1976; Carter 1977; Sepp 1977; Heffley et al. 1982). It also uses APM concepts developed by Appli-Mation, Inc., the Canyon Research group, and Vreuls Research, Inc. (Semple, et al. 1979; Vreuls, et al. 1975)

The system is designed to detect three types of errors: flight path errors, control technique errors, and procedural (switch sequence) errors. In all cases, errors or out-of-tolerance conditions are detected by comparing the observed value of a parameter for a specific point or segment in a maneuver or task with the standard value and tolerance limits stored in computer memory. Flight path errors, e.g., "excessive airspeed at roll in," are currently being measured in this way by the Vought A-7 NCLT APM system now in operational use at NAS Lemoore. Control technique errors, e.g., "controlling attitude instead of Nz" can be measured in this way by pilot behavior identification techniques like those developed by STI, which were used in Northrop simulation studies to evaluate the effectiveness of alternate training aircraft configurations for carrier landing. Procedural errors, e.g., "arming switch thrown out of sequence" are now being detected in this manner by the EA-3 Low-Cost CPT developed by Appli-Mation, Inc., and several other systems.

The potential impact of APM techniques on the effectiveness and efficiency of simulator training has been demonstrated by studies on the inter- and intra-observer reliability of instructor judgments. (Carter, 1976; Knoop & Welde, 1973) These studies show that instructor judgments of overall maneuver performance are fairly reliable, but that instructor judg-

## CONDUCT STANDARDIZED TRAINING

Following the identification of the event to be trained, the instructor conducts a standardized training event by using the Maneuver Control Panel and the special purpose displays as follows:

1. Demonstrates Maneuver (AUTO DEMO)
  - a. Presses "POSITION SIM" switch which causes the "POSITION SIM" light to start blinking and the computer to start setting up the simulator for the prerecorded demonstration specified for this maneuver in the task module.
  - b. ("POSITION SIM" switch comes on steady and first frame of HUD, flight path, and instrument repeater dynamic displays are displayed on instructor console CRTs, indicating that simulator is ready to fly.)
  - c. Comments on the demonstration to be flown and verifies that the student is ready.
  - d. Presses "START" switch to start the prerecorded demonstration.
  - e. Makes comments during the demonstration.
  - f. Presses "FREEZE" switch to freeze demonstration in mid-air. (This freezes the visual scene, motion platform, g-seat, g-suit, instruments, etc, in the position existing at time of freeze.)
  - g. Presses "START" switch to restart prerecorded demonstration from frozen position.
  - h. Instructor presses "STOP" switch/demonstration reaches auto stop point.
    - (1) Turns off visual scene and returns motion platform, g-seat, g-suit, instruments, etc, to a neutral position.
    - (2) Freezes last frame of HUD and flight path displays.
    - (3) Causes Summary Quantitative Performance Display and Grading Scale Display to appear on the interactive CRT.

FIGURE 9. SAMPLE FUNCTIONS ANALYSIS

ments relating to the acceptability of specific parameters at specific points or over specific segments during the maneuver are highly unreliable. Since these judgments are the basis for the instructor's diagnosis of the causes of substandard maneuver performance, it follows that much of the feedback currently given to students is in error. The effect of this on the effectiveness and efficiency of training can be understood by considering the effect of telling a student he pulled up late when he actually pulled up early, which is precisely what the data indicate is happening.

The proposed APM system is designed to correct this problem by providing instructors with objective data which can be used to give students more accurate feedback. This same data can be recorded to provide an objective data base for improved management of student progress, improved student selection, and more accurate evaluation of total system performance.

Although the benefits of the proposed APM system are extensive, the cost of developing and perfecting an APM algorithm for a single complex maneuver can be quite high. For large-scale training systems a phased APM development may be required to spread these costs over time. In this approach algorithms are first developed only for selected, skill-sensitive maneuvers. Algorithms for additional maneuvers can then be developed as part of an ongoing ISD effort.

## INSTRUCTIONAL FEATURES

A review of current literature on instructional features served as a starting point for the identification and evaluation of candidate instructional features. (e.g., Bailey & Hughes, 1980; Caro et al. 1979, 1980; Hughes, 1978, 1979; Lintern & Gopher, 1977; Lintern 1978; Semple, et al. 1980; Shaw 1979; and Weller, 1979) Candidate instructional

features were classified into two broad types: nonautomated and automated.

Nonautomated Features. Figure 10 illustrates the results of an analysis performed to evaluate a variety of nonautomated instructional features identified as candidates for simulator training. In general, the features shown as rejected were rejected because of a total lack of empirical data on their training effectiveness.

Backward chaining has been found to be a highly effective simulator training technique in an experimental setting. (Hughes, 1979) It is therefore recommended for IFT, OFT, and ACMT training pending further investigations of its cost-effectiveness in military pilot training programs. The instructor console feature used to set up arbitrary start and stop points for live runs provides a basic capability for backward chaining and similar instructional techniques, as discussed above in the section on instructor console displays.

Fast time has been found to be very effective simulator training technique at NASA-Ames for preparing NASA test pilots for the severe time-compression effect encountered in actual test flights. Fast time is a technique whereby the program integration interval is greater than the elapsed real-time interval, causing frequencies and velocities to increase, i.e., things happen more quickly than in real flight. Fast time is thus a form of overtraining which could conceivably increase the training effectiveness of IFT and OFT training by better preparing students for the increased stress and workload associated with aircraft flights. Like other types of overtraining it could also result in excessive simulator training time. While current simulator computers have an inherent capability for fast time, the cost of upgrading image generation computers, motion system servos, and other hardware to achieve the required frequency response would be very high. This

FEATURE	REJECTED	SELECTED
1. PARAMETER FREEZE (CAPABILITY FOR FREEZING ONE OR MORE SELECTED PARAMETERS, E.G. RANGE TO TARGET)	X	
2. BACKWARD CHAINING (CAPABILITY FOR TRAINING LAST SEGMENT IN A MANEUVER FIRST PROGRESSIVELY ADDING EARLIER SEGMENTS)		IFT, OFT AND ACMT (SEE DISCUSSION)
3. FAST TIME (CAPABILITY FOR FLYING SIMULATOR AT FASTER THAN REAL TIME)	X	
4. SLOW TIME (CAPABILITY FOR FLYING SIMULATOR AT SLOWER THAN REAL TIME)	X	
5. NON INTERACTIVE DYNAMIC VISUAL SCENE FOR CPT (DISPLAY ENABLING STUDENT TO CORRELATE PROCEDURES WITH THE SIGHT PICTURE, E.G., FOR LEARNING TRAFFIC PATTERN PROCEDURE)	X	
6. INSTRUMENT BLANKING (CAPABILITY FOR BLANKING OUT SELECTED INSTRUMENTS FOR SCAN TRAINING)	X	
7. EYE-TRACK DISPLAY (DYNAMIC DISPLAY SHOWING INSTRUCTOR WHERE STUDENT IS LOOKING AT EACH MOMENT)	X	
8. MANUAL REPOSITIONING (CAPABILITY FOR INSTRUCTOR TO CHANGE ATTITUDE AND ALTITUDE OF STUDENTS AIRCRAFT DURING FREEZE TO ILLUSTRATE CHANGE IN THE SIGHT PICTURE (A TYPE OF PARAMETER FREEZE))	X	
9. AUGMENTED VISUAL CUES/PREDICTOR DISPLAYS TO BE DISPLAYED ON HUD		OFT, ACMT

FIGURE 10. EVALUATION OF NON-AUTOMATED INSTRUCTIONAL FEATURES

technique is therefore not recommended pending a more direct demonstration of its effectiveness for military flight training.

Landing-point predictor displays and augmented visual cues such as the "pole track" display are recommended as selectable OFT HUD displays for field and carrier landing training. The "pole track" is a display of successively shorter "poles" on each side of the glideslope showing the correct glideslope and providing an external indication of aircraft velocity. The effectiveness of such displays for simulator training in field and carrier landings has been demonstrated in the studies by Lintern (1978) and Weller (1979).

Electronic tracer bullets and funnel displays like those on the G.E. HUD are recommended as selectable ACMT HUD displays for air-to-air gunnery training. These displays have been shown to be extremely effective for

teaching a student the effect of aircraft control inputs on the dynamics of the bullet stream. A continuously computed impact point, velocity vector, and bomb fall line are recommended as selectable OFT HUD displays for air-to-ground weapon delivery training. It is assumed that these HUD displays would duplicate those in the aircraft.

Automated Features. Figure 11 illustrates the results of an analysis performed to evaluate automated instructional features which were identified as candidates for an ACMT.

The capability for preprogrammed initial conditions and preprogrammed malfunctions is inherent in the task module concept. Techniques for using normal and emergency procedure task modules in conjunction with other types of task modules are described in Semple, et. al. (1980).

FEATURE	REJECTED	SELECTED
PREPROGRAMMED INITIAL CONDITIONS		CPT, IFT, OFT, ACMT (TASK MODULE)
PREPROGRAMMED MALFUNCTIONS		CPT, IFT, OFT, ACMT (TASK MODULE)
AUTOMATED GROUND CONTROLLER		IFT, OFT
PRERECORDED BOGIES AND FRIENDLY A/C		OFT, ACMT
MANEUVER-SPECIFIC AUTOPILOT BOGIES AND FRIENDLY AIRCRAFT		OFT, ACMT
GENERALIZED AUTOPILOT BOGEY		ACMT (ADVANCED TRAINING ONLY)
AUTOMATED PERFORMANCE MONITORING		CPT, IFT, OFT, ACMT
AUTOMATED AUDIO ALERTS DURING MANEUVER (TO INSTRUCTOR)		CPT, IFT, OFT, ACMT
AUTOMATED GRADING (AT THE INSTRUCTORS CONSOLE)		OFT ONLY (RECOMMENDED FOR FIELD AND CARRIER LANDING)
AUTOMATED FEEDBACK AFTER MANEUVER (TO STUDENT)		CPT ONLY
AUTOMATED INSTRUCTION		CPT ONLY
ADAPTIVE TRAINING (USE OF HUD SYMBOLOGY)		OFT ONLY
AUTOMATED COACHING DURING MANEUVER (TO STUDENT)	X	

FIGURE 11. EVALUATION OF AUTOMATED INSTRUCTIONAL FEATURES

An automated ground controller similar to that developed for the F-14 OFT Instructional Support System is recommended for IFTs and OFTs for simulating the ground controller's voice instructions in ground-controlled approaches and carrier-controlled approaches. Instructor pilots consulted agreed that instructor pilots cannot accurately simulate ground controller voice instructions due to the specialized training and practice required. This feature should thus increase the training effectiveness of IFTs and OFTs while reducing instructor workload.

Maneuver-specific "autopilot bogies" are recommended for controlling the simulated bogey and wing-man in introductory ACM training and for controlling the lead aircraft, second aircraft, or third aircraft in close-and tactical-formation training. This approach was used with success in ACM simulator training experiments performed by Northrop for NADC in 1976. (Spring, 1976; Carter, 1976) The autopilot bogey is used for introductory training in classic maneuvers. Typically, it is a relatively simple algorithm which causes the bogey or friendly aircraft to react to a

change in student aircraft position in the same way that the instructor would react at this stage of training. For example, a barrel roll attack bogey is programmed to tighten its turn as the student reduces angle-off-tail and nose-to-tail, and to reverse when the student overshoots. Autopilot bogies increase OFT and ACMT training effectiveness in two ways: 1) they provide much more realistic training than is possible with noninteractive prerecorded bogies; and 2) they significantly reduce the need for the simulator instructor to fly the bogey aircraft in ACM and formation training, thus permitting the instructor to concentrate on observing and coaching student performance.

The term "generalized autopilot bogey" is used here to refer to an autopilot bogey which is capable of flying an entire ACM engagement against a human pilot. This type of bogey is used in the Northrop Large Amplitude Simulator (LAS), the Simulator for Air-to-Air Combat (SAAC) at Luke AFB, and the 2E6 ACM simulator at NAS Oceana. A generalized autopilot bogey is recommended for ACMTs to be used in advanced training but would probably not be cost-effective for undergraduate ACM training.

As shown in Figure 11, an automated performance monitoring system is recommended for all four types of simulators. As described in the previous section, the APM system detects out-of-tolerance conditions during each trial of each maneuver or task, and displays this information to the instructor at the end of the trial. By providing more detailed and more accurate data on student performance, the APM system performs three essential functions. First, it increases the effectiveness of active instruction by providing the instructor with objective information which can be used as an aid in evaluating and diagnosing individual trials. Second, it puts the management of student progress through the syllabus on a more objective basis by providing instructors with more complete and accurate data on which to base grades. Finally, it provides a greatly increased system evaluation capability by providing operational ISD personnel with objective data on the effects of variations in training content, sequence, techniques, and equipment.

Automated audio alerts are recommended for all four types of simulators to alert the instructor to certain critical student errors which might otherwise be missed. This enables the instructor to correct errors as soon as they occur to prevent formation of unsafe habits, such as pulling too many Gs. This is done by means of audio tones and/or digitally recorded voice messages.

Automated verbal coaching and cueing of the student during a maneuver is not recommended because of research evidence that such coaching is at best distracting, and at worst constitutes an irrelevant cue to correct maneuver performance which can be used consciously or unconsciously to "beat the system."

Automated grading is recommended for field and carrier landing training in OFTs because of the demonstrated agreement between A-7 NCLT Landing Signal Officer (LSO) grades and the grades assigned by the A-7 NCLT automated grading system developed by Vought.

A capability for fully automated Computer-Assisted Instruction (CAI) is recommended only for CPTs. At the completion of each procedure this system provides automatic feedback to the student by displaying the errors and the correct procedures on the instructor/student console CRT display. The system then instructs the student to reset all switches to their normal positions. Depending on performance to that point, it then instructs the student to perform the previous procedure again or to start training on a new procedure.

Adaptive training is recommended for OFTs in conjunction with an A-7 NCLT-type grading system to vary the difficulty of field or carrier landing as a function of student perfor-

mance. Task difficulty is decreased by displaying a predictor display and augmented visual cues such as a "pole track" display on the student's HUD. Task difficulty is increased by removing these displays. While it is possible for the instructor to insert and delete these displays manually, the training effectiveness of these displays is greatest if they are inserted and deleted according to an optimized adaptive training algorithm. (Lintern, 1978)

Adaptive training in which task difficulty is varied by varying system dynamics, (e.g., changing the stability of the simulated aircraft) has been shown to be ineffective and is not recommended. (Shaw, 1979).

### BRIEF/DEBRIEF CONSOLE

The brief/debrief console for the proposed ISS is essentially a CAI terminal interfaced to a videodisc system, which has an added video cassette playback capability for debriefing. It is assumed that the brief/debrief console would be interfaced to a computerized scheduling and records keeping system.

### Physical Configuration

The physical configuration of the console consists of a 21" CRT display with a transparent membrane-type touch screen and a set of dedicated function switches located on an off-screen membrane-type touch panel, where individual switches are located and grouped by means of cutouts in a thick plastic overlay. Ideally, the brief/debrief console would be identical to the CAI/videodisc terminals used for academic training, with the exception of the video cassette unit and additional function switches used only for debriefing. A detachable alphanumeric keyboard is required to permit the IP to enter nonstandard comments in the students computer file.

### Functional Design

The console is designed to be used for both simulator and aircraft flights. It supports five major instructional functions, as follows:

1. Event Planning. The console is used by instructors to determine student status; to review the student's performance in past events; to request schedule changes if necessary; and to identify minor changes in the standard lesson plan which could benefit the student.

2. CAI Briefing and Test. The console is used to give students a CAI review and test on academic and flight support materials relevant to the flight to be flown.

3. IP Briefing. The console can provide a hard copy of the CAI test results to be used by the IP as a starting point for the IP briefing which follows the CAI briefing. (A hard copy printer could be time shared by several brief/debrief consoles.)

4. Debriefing. The console can be used for debriefing both simulator and aircraft flights, assuming that the aircraft has an onboard video recorder.

5. Data Entry. The console is used by the IP to enter grades and comments on the flight in the student's computer file.

#### Debriefing Displays

For simulator debriefings, a multiplexing scan converter is used to make a two-channel videotape record of what was shown during and after each maneuver on any two of the instructor console CRT displays. Thus one videotape channel will typically show a dynamic "inside-out" presentation of the pilot's view through the windshield during the maneuver, including continuously changing digital readouts of key parameters on the edges of the display. This is followed by the Summary Quantitative Performance Display shown to the instructor at the end of the maneuver, plus any detailed quantitative performance displays requested at that time. The second channel will typically show a dynamic "outside-in" presentation of an outside observer's view of the maneuver, also including digital readouts. This is followed by a static graphic display of the desired and actual flight path flown. The instructor can switch back and forth between these displays as required during debriefing.

#### Debrief Procedure

For debriefing, the brief/debrief console is used by the IP and the student to review the videotape record of the aircraft or simulator flight to be debriefed. For both aircraft and simulator debriefings it is expected that only selected segments of the tape would be reviewed, since reviewing the entire tape would require as much time as the original flight. To make this process as efficient as possible, three different methods are provided to enable the IP to quickly get to a point of interest on the tape. First, he can slew directly to any electronic flags which he inserted on the tape during the event. Second, he can slew to a specific trial of a specific maneuver, using a display of the lesson plan as a menu. (This approach will be most effective for simulator debriefings, due to frequent changes in lesson plans which are dictated by events and conditions in the air.) Third, he can use fast-forward and rewind controls to slew to an approximate time in the flight, where the approximate flight time at each point on the tape will be continuously

displayed on the screen. Once the approximate point is located by one of these three methods, the precise segment of the tape to be replayed will be controlled by conventional tape playback controls (fast-forward, rewind, stop, pause, and play.) Detailed functions analyses have been developed which describe the procedures used for slewing to a desired point on the tape with each method.

#### Data Entry Procedure

The instructor grades each event using the console touch screen and an event-specific grading form displayed on the CRT. The grading form consists of a matrix of grading categories listed vertically down the left side of the display and a grading scale displayed horizontally across the top. To grade a specific category, the instructor simply presses the touch screen across from the category in the column corresponding to the desired grade. Standard comments on the student's performance are entered by pressing the touch screen next to one or more appropriate comments in a menu of standard comments. Nonstandard comments are typed in with the alphanumeric keyboard. It is assumed that all grades and comments entered by the instructor at the console would be automatically entered into a centralized computer file containing a record of the student's performance in each event.

#### CURRENT STATUS AND FUTURE PLANS

An independent research and development project is now in progress to develop a working model of the Summary Quantitative Performance Display. Current plans are to follow up this effort by developing working models of the other instructor console features described above.

#### ACKNOWLEDGEMENTS

Special thanks are due to William G. Spring of Paradise Research, Inc., for assistance in developing and verifying the feasibility of many of the design features of the proposed ISS.

#### REFERENCES/RELATED REPORTS

- Bailey, J.S., and Hughes, R.G. Applied Behavior Analysis in Flying Training Research. AFHRL TR 79-38. Air Force Human Resources Laboratory, January 1980.
- Caro, P.W., Pohlman, L.D., and Isley, R.N. Development of Simulator Instructional Feature Design Guides. Seville TR 79-12. Seville Research Corporation, October 1979.



Caro, P.W., Shellnut, J.B., and Spears, W.D. Utilization of Aircrew Training Devices. Seville TR 80-01. Seville Research Corporation, February 1980. (Final report on STRES contract performed for Air Force Human Resources Laboratory.)

Carter, V.E. "Development of Automated Performance Measures," Volume 2 of Experiments to Evaluate Advanced Flight Simulation in Air Combat Pilot Training. NOR 76-52. Northrop Corporation, March 1976. (NADC Contract N62269-74-C-0314)

Carter, V.E. "Development of Automated Performance Measures for Introductory Air Combat Maneuvers." In Proceedings of the 21st Annual Meeting of the Human Factors Society, San Francisco, CA, October 1977.

Charles, J.P., Johnson, R.M., and Swink, J.R. Automated Flight Training (AFT) Instrument Flight Maneuvers. NAVTRAEQUIPCEN 71-C-0205-1. Naval Training Equipment Center, Orlando, FL, February, 1973.

Heffley, R.K., Clement, W.F., and Jewell, W.F. "Overview of Work in Progress on Nonintrusive Assessment of Pilot Workload and Pilot Dynamics." In Proceedings of the AIAA Workshop on Flight Testing to Identify Pilot Workload and Pilot Dynamics, Air Force Flight Test Center, Edwards AFB, CA, January, 1982. (STI Paper No. 311, System Technology, Inc.)

Hughes, R.G. "Enabling Features Versus Instructional Features in Flying Training Simulation." In 11th NTEC/Industry Conference Proceedings. Naval Training Equipment Center, Orlando, FL, November, 1978.

Hughes, R.G. Advanced Training Features: Bridging the Gap Between In-Flight and Simulator Based Models of Flying Training. AFHRL-TR-78-96. Air Force Human Resources Laboratory, Flying Training Division, Williams AFB, AZ, March, 1979.

Knoop, P.A. and Welde, W.L. Automated Pilot Performance Assessment in the T-37: A Feasibility Study. AFHRL-TR-72-6. Air Force Human Resources Laboratory, WPAFB, Ohio, April, 1973.

Lintern, G. and Gopher, D. Adaptive Training of Perceptual Motor Skills: Issues, Results, and Future Directions. TR ARL-75-5/AFOSR-77-5. Aviation Research Laboratory, University of Illinois at Urbana-Champaign, January, 1977.

Lintern, G. Transfer of Landing Skill After Training with Supplementary Visual Cues. TR Eng. Psy. 78-3/AFOSR-78-2. Engineering Psychology Department, University of Illinois at Urbana-Champaign, July, 1978.

Semple, C.A., Vreuls, D., Cotton, J.C., Durfee, D.R., Hooks, J.T., and Butler, E.A. Functional Design of an Automated Instructional Support System for Operational Flight Trainers. NAVTRAEQUIPCEN 76-C-0096-1. U.S. Naval Training Equipment Center, Orlando, FL, January, 1979.

Semple, C.A., Cotton, J.C. and Sullivan, D.J. Aircrew Training Device Instructional Support Features. CRG-TR-3041C. Canyon Research Group, Inc., July, 1980. (Final report on STRES contract performed for Air Force Human Resources Laboratory.)

Sepp, G.D. Computer-Assisted Pilot Grading and Prediction System - Phase 3 Final Report: Data Analysis and Training Aid Development. Vought Report No. 2-54202/7R-51460. Vought Corporation, 1 September 1977. (NASC Contract No. N00019-73A-0010)

Spring, W.G. "Simulation Development and Preparation," Volume 4 of Experiments to Evaluate Advanced Flight Simulation in Air Combat Pilot Training. NOR 76-52. Northrop Corporation, March, 1976. (NADC Contract N62269-74-C-0314)

Shaw, A.W. "Adaptive Training and In-Flight Simulation." Briefing presented at Northrop Corporation. Vought Corporation, Dallas, TX, October, 1979 (Unpublished)

Vreuls, D., Obermayer, R., Goldstein, I., and Norman, D. Trainee Performance Measurement in Four Instrument Flight Maneuvers. NAVTRAEQUIPCEN 74-C-0063-1. Naval Training Equipment Center, Orlando, FL, 1975.

Weller, D.R. "Predictor Displays in Carrier Landing Training." NAVTRAEQUIPCEN IH-311. Naval Training Equipment Center, Orlando, FL, April, 1979.

A DESIGN WITH THE INSTRUCTOR IN MIND;  
THE OAS/CMC PTT INSTRUCTOR STATION

MAJOR JOSEPH C. STEIN AND CAPTAIN MICHAEL E. SHANNON  
OAS/CRUISE MISSILE TRAINING MANAGERS  
4235 STRATEGIC TRAINING SQUADRON  
Carswell Air Force Base, Texas 76127

INTRODUCTION

The Offensive Avionics System (OAS) PPT (See Figure 2) includes two user interfaces, one for the crewmembers and one for the instructor. The instructor can interact with the CPT in three operational modes: Pre-Run, Run, and Post-Run. The interface has been designed to facilitate moving back and forth among any of the three modes (See Figure 1). The Pre-Run mode occurs prior to the training (simulation) session and allows the instructor to select and edit a scenario for training and complete setup and initialization procedures. The Run mode is the actual training period during which the instructor monitors the crewmembers' actions and injects changes into the session. The Post-Run mode occurs after the training session in which the instructor can initiate a limited review and analysis. All sessions must go through some minimum initialization via the Pre-Run mode of the user interface. Depending on the desired degree of interaction, initialization can vary widely. After the appropriate initialization, the instructor will enter the Run mode to begin the training session. He will be provided with commands that allow him to abort the session and return to the Pre-Run mode or interrupt for a time period and then resume within the Run mode itself. Once the run is complete, the instructor enters the Post-Run mode in which he may conduct limited review and analysis or he may return to the Pre-Run mode to initiate another training session.

Separate areas or windows will be set aside for various types of information.

The largest area at the top of the console is reserved for two major functions. In the Pre-Run mode this area is used for displaying tables of values describing flight path characteristics of a selected scenario. During the Run mode, this area shall be dedicated to the real-time display and update of a set of variables denoted as real-time parameters. During Post-Run mode, this area shall also be used to reflect real-time parameter updates, but shall reference only a subset of those parameters used during the Run mode.

The Command Menu area, at the bottom left, will be used in all three modes to display the commands, in menu form, available to the instructor for selection. As the instructor transits from one menu to another, this area will display the new menu.

The area located to the right and top of the menu consists of two lines displaying faults and pilot-controlled status information. This area will be active only during Run mode and will be empty during both Pre-Run and Post-Run modes. The first line of the area, the Faults Injected line, will indicate any malfunctions or faults currently in effect. The second line shall display the current status of both the Pilot Steering mode (manual/auto) and Terrain Avoidance mode (on/off).

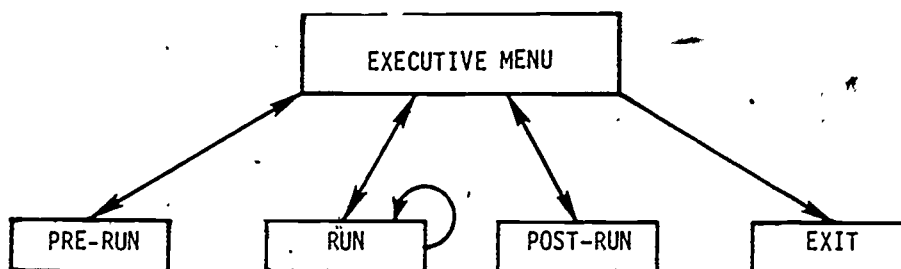

Figure 1  
Instructor Interface

COMMANDS AND DISPLAY LAYOUT

Within any given mode, the instructor has a set of commands available for carrying out his responsibilities. The command menus and other information will be presented on an alphanumeric CRT laid out as in Figure 3.

In all three modes, prompts to the instructor for input and notification of errors will appear in the Prompts and Error Messages area. If the instructor inadvertently enters any form of unacceptable input, he will be notified, told the nature of the mistake, and requested to reenter the

Figure 2

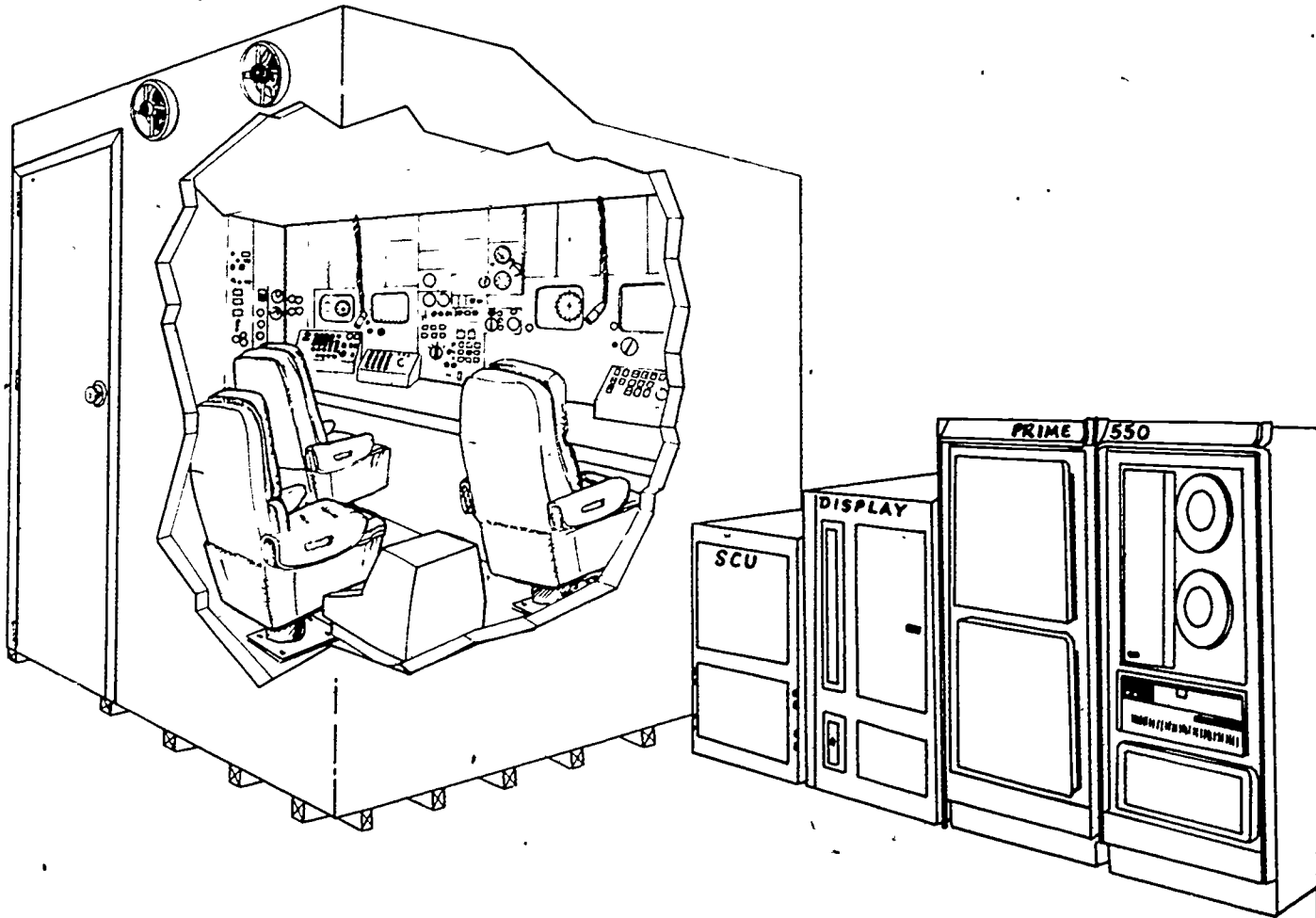

## B-52G/H OAS/CMC PART TASK TRAINER

75



EXECUTIVE menu to change modes any time during a training run. From this menu, the instructor may choose to enter any of the three modes or exit the training program entirely. In the event the instructor activates the Run or Post-Run modes without having specified a working scenario, a default value will be assumed and scenario #1 will be loaded into the system as the current working scenario. Once the instructor selects any of the modes, the terminal displays the master menu for that mode. Using the commands in these master menus, the instructor can move to other subsets of commands that allow him to carry out any of the tasks required in the selected mode. At any time, the instructor can activate the RETURN TO EXECUTIVE command available in each of the master menus and return to EXECUTIVE menu to select a new mode.

```

-----
EXECUTIVE MENU
1) PRE-RUN
2) RUN
3) POST-RUN
4) EXIT
-----

```

Figure 4  
The Executive Menu

#### OPERATIONAL MODES AND FORMAT OF COMMANDS

The instructor will be provided with a set of seven pre-canned scenarios and material describing each of these, including navigational charts. The seven scenarios will be permanently numbered 1 through 7 and will be available at any time for the instructor's use. There is additional space for three more scenarios, numbered 8 through 10, which can be generated by the instructor through modification of any of the available scenarios and stored in these last three slots. Thus, there are a total of ten possible scenarios, seven permanent ones (numbers 1 through 7) and three replaceable ones (numbers 8 through 10).

Upon entering the Pre-Run mode, one of the first requirements of the instructor is to select a scenario by recalling one of the ten that are stored. Once recalled, all of the initialization values stored under that scenario's number will be loaded into the mainframe. This scenario now becomes the "working" scenario and can be used for the training session as is or edited to create a new, modified working scenario. Note that if a working scenario is not explicitly

selected, the default working scenario will be scenario #1.

The canned scenarios can be modified by the Instructor. Modifications to the working scenario are divided into two categories: (1) direct alteration of specific flight leg characteristics (such as aircraft speed, altitude, wind velocity, etc.), and (2) scenario reduction. The first editing capability is accomplished by identifying specific flight legs of the working scenario, and replacing current flight plan values with different values. Scenario reduction is achieved by specifying a contiguous set of flight legs that exist in the working scenario. This set becomes the new "reduced" scenario, and retains all flight characteristics as defined for the corresponding legs of the original working scenario. All editing functions which create a new scenario description cause the original working file to be replaced by the new scenario which then becomes the current working scenario. Only the working scenario stored in the mainframe is changed by the editing functions; the scenario stored on the disk remains unchanged. When the instructor has completed editing a scenario, he may choose to save a copy of the working scenario for future retrieval. If the copy is not saved, all modification and initialization which has occurred during Pre-Run will be lost when the CPT program is exited. If no editing has occurred, it is not necessary to save the working scenario since it is merely a copy of one of the scenarios already stored.

#### PRE-RUN COMMANDS

The four commands which are available for selection during Pre-Run mode are listed in menu form in Figure 5. When activated, each command will either produce a new menu of sub-commands, or will cause a request for additional information in the form of a prompt. In the following sections each command will be addressed in detail with the corresponding display changes and required inputs clearly outlined.

```

-----
PRE-RUN MENU
1) SELECT SCENARIO
2) EDIT/PREVIEW SCENARIO
3) SAVE SCENARIO
4) RETURN TO EXECUTIVE
-----

```

Figure 5  
Pre-Run Menu

Activation of the SELECT SCENARIO command is required before any manipulation of any scenario other than scenario #1 may be accomplished. When the SELECT SCENARIO command has been activated (by having the instructor type 1 CR ), the command menu will remain on the screen, but a prompt will appear requesting a scenario file number. The instructor must then input a number from 1 to 10 (representing the ten scenario files) followed by a CR . This will define the scenario file which will become the current working scenario. Any previous working scenario will be replaced by this selection. Should the instructor decide not to define a (new) working scenario, he may enter a CR by itself. This will be accepted as a negation to the original command and control will resume at the command menu level. Any illegal input will be flagged as such in the error and prompt area of the console and the instructor will be requested for new input.

By entering 2 CR , the instructor activates the EDIT/PREVIEW SCENARIO command which causes a new command menu to be displayed (see Figure 6). Each command in the menu is related to the display of particular data tables or values providing information describing certain attributes of the working scenario. These tables or values can be requested for purposes of preview by the instructor, or can be edited for production of a new scenario.

```
-----  
EDIT/PREVIEW SCENARIO  
1) FLIGHT PLAN  
2) SRAM TARGET TABLE  
3) DESTINATION TABLE  
4) FIX-POINT TABLE  
5) MISSILE STATUS  
6) RETURN TO PRE-RUN  
-----
```

Figure 6  
Edit/Preview Scenario Menu

The first command on the menu is the FLIGHT PLAN command (see Figure 6). Entering a 1 CR will cause the first page (11 lines) of the Flight Plan table to appear in the scenario display area (upper window), and the FLIGHT PLAN menu to appear in the Command Menu area. The Flight Plan table lists the destination points and flight characteristics associated with each flight leg in the working scenario. The FLIGHT PLAN menu contains a set of commands allowing editing

and scrolling of the flight plan. The editing commands will explicitly call out only those columns in the flight plan which may be edited. Whenever the instructor decides to change one entry in the table, all other entries which are affected by that change will be automatically replaced and updated on the display.

The second command available in the EDIT/PREVIEW SCENARIO menu is SRAM TARGET TABLE (see Figure 6). Activated by a 2 CR keystroke input, the SRAM Target Table is displayed in the scenario display area, and the SRAM TARGET TABLE menu appears in the command menu area. All targets in the scenario are listed in the table by target number, with the flight leg destination number and target characteristics such as latitude, longitude, and elevation displayed in the corresponding row. The only two columns which are available for editing by the instructor are SAIR (Safe And In Range) ENTRY and SAIR EXIT.

The Destination Table (see Figure 6) is called up by selecting 3 CR from the EDIT/PREVIEW SCENARIO menu and presents the working scenario flight plan by listing each destination point, type of destination point, latitude, longitude, elevation, and planned time of arrival. The DESTINATION TABLE menu will also be displayed in the command menu area. No editing of specific values in the Destination Table is possible, but the instructor may create a new scenario by reducing the current working scenario by selecting a contiguous sub-portion of it. This sub-portion will then become the new working scenario.

The Fix-Point Table (4 CR) is only available for presentation; no editing may occur. This table will list all fix points which may be accessed within the limits of the working scenario. The points will be listed sequentially by number with the corresponding latitude, longitude, and elevation of each point displayed as well. This table will usually exceed display capacity in size and will require a paging capability.

By entering a 5 CR , the instructor can change Missile Status. This parameter is set to either 1 (Fully Aligned) or 2 (Power Off) in the scenario. The Fully Aligned status will cause the elimination of the required warm-up time of missiles and weapons within a scenario. It will initialize the scenario with missiles fully targeted (powered, armed, and in "GO" status) and MIUs fully powered. The Power Off status assumes no warm-up of missiles or weapons has occurred. Upon entering the command, no change in the menu occurs and nothing is displayed in the

scenario area. Rather, a message appears in the prompt and error area indicating the current value of the missile status parameter and requesting a new value. Entering anything other than 1 CR or 2 CR will cause an error message to appear and a request for new input. Entering CR only will negate the command giving control to the EDIT/PREVIEW SCENARIO menu.

When the instructor selects the RETURN TO PRE-RUN (6 CR), the EDIT/PREVIEW SCENARIO command menu will clear from the display area and control will return to the PRE-RUN master command menu (see Figure 6).

If the instructor wishes to save the current working scenario and its corresponding parameters for later retrieval/usage, he must activate the SAVE SCENARIO command by entering 3 CR in the PRE-RUN master menu (See Figure 5). A prompt will appear requesting a scenario file number for 8 to 10 (representing the three replaceable files available for storage). Once selected, the old contents of the file will be destroyed and replaced by the current working scenario. If the instructor decides

not to save the working scenario, he may enter a CR by itself. This will negate the command activation, and control will return to the PRE-RUN master command menu. All illegal inputs will be flagged as such to the instructor and he will be requested for new input.

Activation of this command will clear the PRE-RUN master command menu from the display and control will return to the EXECUTIVE command menu (See Figure 5).

RUN MODE

The instructor activates the Run mode by entering 2 CR from the EXECUTIVE menu. Upon entering this command, the training session (simulation) starts.

Throughout the training session, a set of real-time parameters reflecting aircraft, navigational, and command information are displayed in the upper window of the console and updated every 5 sec (see Figure 7). The simulated time is displayed at the top, right-side. Below that is the aircraft data

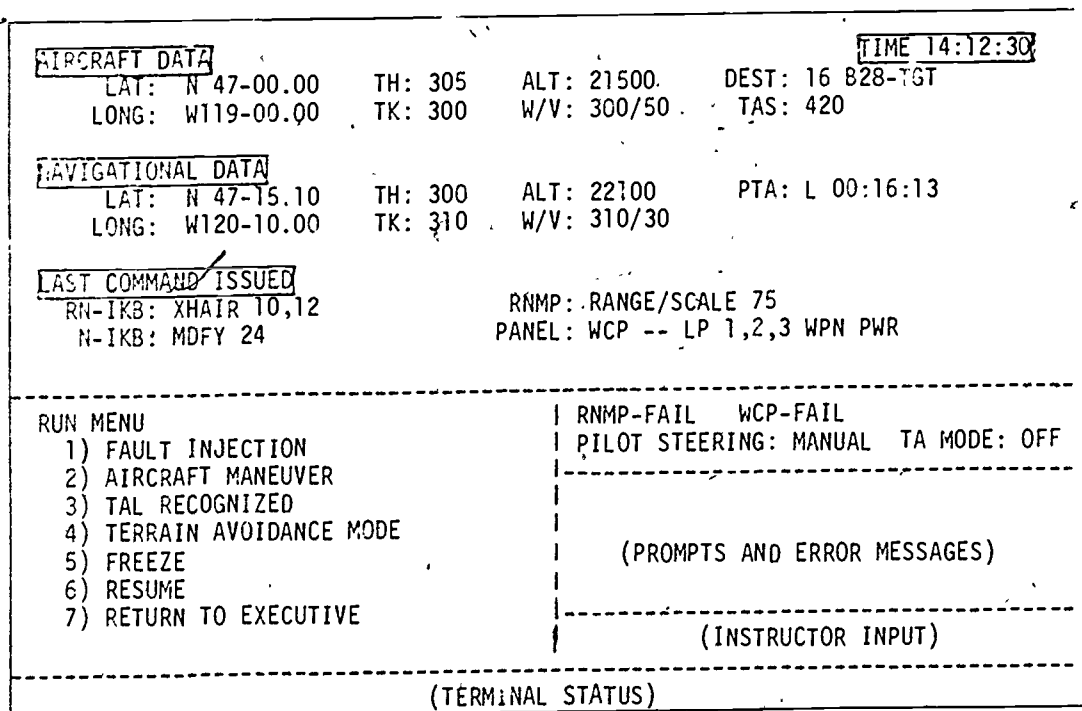

Figure 7  
Run Display

consisting of: latitude and longitude, true heading and ground track, altitude and wind/velocity, current destination point, and true air speed. Next is the navigational data reflecting values for the prime navigational system. These parameters are: latitude and longitude, true heading and ground track, altitude and wind/velocity, and the planned time of arrival error (early or late). Navigational errors can be determined from these parameters by subtracting corresponding values of the aircraft and navigational data.

The bottom portion of the window displays the last command issued by the crewmembers -- separately for the three major panels: RN-IKB, N-IKB, and RNMP. The last command issued for the remaining set of panels is designated by a panel label followed by the command given.

This display of real-time parameters allows the instructor to have immediate, completely updated information as to the aircraft state and crewmember actions.

In addition to the real-time parameter display, entering the Run mode causes the RUN menu to be displayed in the command menu area. There are seven commands associated with the Run menu and the following sections will explain each of these in detail.

#### RUN MODE COMMANDS

The instructor has the capacity to inject malfunctions, or faults, at any time during Run mode (see Figure 7). This allows him to cause failures to occur at critical times corresponding with crewmember activity. The fault specified will occur at the moment of selection. He also has the ability to terminate a given malfunction that is currently in progress.

Upon entering a 1 CR, the FAULT INJECTION menu will appear in the command menu area (see Figure 8). The menu provides four fault commands and a RETURN TO RUN command.

FAULT INJECTION	
1)	RN MANAGEMENT PANEL
2)	WEAPONS CONTROL PANEL
3)	DOPPLER RADAR
4)	OAS BUS FAILURE
5)	RETURN TO RUN

Figure 8  
Fault Injection Menu

Selection of the RN Management Panel command (1 CR) will cause the current status of the RN Management Panel (RNMP) to be indicated in the prompt and error area [1(FUNCTIONING), 2 (FAILED)] along with a request for input. If the current status is FUNCTIONING and the instructor enters a 2 CR, the RNMP will immediately cease to function, and the message RNMP-FAIL will appear on the Faults Injected line of the instructor's console. If the current status is FAILED and a 1 CR is entered, the RNMP will begin to function again and the RNMP-FAIL message will be erased. If a CR is input by itself, the command will negate and the fault status will remain unchanged. An input of any value other than 1 or 2 will cause an error message and a request for new input.

Validation checking will occur by the system prior to activating any fault. Since no other fault can occur simultaneously with an OAS bus failure, the system will check the OAS bus status before initiating other failures. If the OAS bus status is FAILED and the instructor attempts to inject an RNMP failure, an error message will appear in the prompt and error area and RNMP status will remain FUNCTIONING.

Weapon Control Panel failure (see Figure 8) is activated by entering 2 CR. It operates exactly as the RN MANAGEMENT PANEL command except that the message WCP-FAIL appears in the Faults Injected area of the console.

The Doppler Radar failure (see Figure 8) is activated by entering 3 CR. It operates exactly as the RN MANAGEMENT PANEL command except that the message DOPPLER-FAIL appears in the Faults Injected area of the console.

The OAS Bus Failure (see Figure 8) differs from the other fault commands in that once this fault is injected, it must remain FAILED for the rest of the training session. Thus, there is no need to prompt for an input value for the command.

When 4. CR is entered, the system will check the status of the other three panels. If any of them are currently FAILED, an error message will appear and the command will be ignored. If all three of the other panels are currently FUNCTIONING, the system then checks the OAS Bus status. If it is currently FAILED, another error message will appear and the command will be ignored. Finally, if all three panels and the OAS Bus status are currently FUNCTIONING when the command is activated, the system changes the OAS bus status to FAILED and the message OAS BUS-FAIL appears in the Faults Injected area



of the console. Once the instructor has injected this failure, he will have no further need to return to the Fault Injection menu throughout the remainder of the training session.

Entering 5 CR (see Figure 8) will clear the FAULT INJECTION menu from the display area and control will return to the RUN menu (see Figure 7).

During the progression of the training session, the instructor has the capability of acting as a simulated pilot in taking the aircraft through changes in speed, altitude, heading, and steering mode. He can also change the wind/velocity (direction and magnitude) and the alternate navigational heading error.

Upon entering 2 CR, the AIRCRAFT MANEUVER menu will be displayed in the command menu area (see Figure 9). This menu consists of seven commands for maneuvering the aircraft, changing conditions, or returning to the RUN menu.

- ```
AIRCRAFT MANEUVER
1) TAS
2) ALTITUDE
3) HEADING
4) PILOT STEERING MODE
5) W/V
6) ALTER NAV HEADING ERROR
7) RETURN TO RUN
```

Figure 9  
Aircraft Maneuver Menu

When TAS is selected by the instructor with a (1 CR), a prompt will be issued for input of a new air speed value. The current air speed value is displayed continually and updated in the real-time parameter display window.

Once a new value has been successfully input, the aircraft will begin a constant acceleration/deceleration until it reaches the desired velocity. The real-time parameter will reflect this change.

As with the aircraft velocity, when the ALTITUDE command (see Figure 9) is activated by entering 2 CR, a prompt will be issued for input of a new altitude. The current altitude is another real-time parameter that is displayed in the upper window.

Once a new altitude has been successfully

input, the aircraft will begin a constant 2000 ft/min climb or descent until it reaches the desired altitude. The real-time ALT parameter will reflect the updated altitude.

After a new altitude has been input by the instructor, the aircraft remains at that new altitude until further input from the instructor.

The instructor has the capability to input a new heading by selecting a 3 CR command (see figure 9). Before changing the heading, the system will check the Pilot Steering Mode. In order for the pilot (instructor) to manually change the heading, the Pilot Steering Mode must be MANUAL. If the Pilot Steering Mode is AUTO, no change in heading can be initiated by the instructor, an error message will appear, and the command will be ignored. If the Pilot Steering Mode is MANUAL, the HEADING Command will be initiated.

After successfully entering a new heading, the aircraft will begin a turn of constant radius until the new heading is reached. Once attained, if this heading does not take the aircraft to the expected destination point, it will remain in effect until a new heading value is issued.

The Pilot Steering Mode can be changed (see Figure 9) by entering 4 CR. The current value of the mode [1(AUTO), 2 (MANUAL)] will be displayed in the prompt and error area along with a prompt to enter a new value. Entering a value other than 1 or 2 will cause an error message to appear and a prompt for a new input. The current setting of the Pilot Steering Mode is also displayed on the console below the Faults Injected line. At the start of the training session, the Pilot Steering Mode will default to AUTO.

Entering 5 CR allows the instructor to update the wind/velocity (direction and magnitude). A prompt for a new value of wind/velocity will appear. The new value of W/V entered by the instructor will remain in effect until the next turn point in the scenario is reached. After the turn point the next wind will be obtained from the (scenario) flight plan. All changes to wind/velocity will be reflected in the real-time W/V parameter value.

The instructor can change the Alternate Navigation Heading Error (see Figure 9) by entering 6 CR. A prompt for a new value, not to exceed +5, will appear. Any illegal input by the instructor will be flagged with an error message and a prompt for a new input will appear.

If the Alternate Navigation system is the

prime navigational model, the instructor can determine the current alternate navigation heading error by subtracting the real-time TH values for aircraft and navigational data. Upon entering a new acceptable value for the alternate navigation heading error, the alternate navigation system will replace the old error with this new value and update the TH parameter to reflect the new error. Any other navigation parameters affected by the change (such as TK) will also be updated.

If the alternate navigation system is not the prime navigational model, the instructor cannot determine the current alternate navigation heading error. He can still enter a value within the +5 limit and this new error will be stored in the alternate navigation system replacing the old value. However, the aircraft and the current prime navigational model will not act upon this new value until the alternate navigation system is selected as the prime navigational model.

Entering 7 CR will replace the AIRCRAFT MANEUVER menu with the RUN menu (see Figure 7) and pass control on to it.

When missiles and weapons are powering up and reach the Transfer Alignment (TAL) mode (see Figure 7), a TAL REQD message will appear on the crewmember's display. In order to complete transfer alignment, the instructor must issue a TAL RECOGNIZED command. This is done by entering 3 CR from the RUN menu. Once entered, TAL is completed and the missiles enter Fine Alignment (FA) mode. If the TAL RECOGNIZED command is entered before either the TAL mode is reached or the TAL REQD message appears, it will be ignored and have no effect on the system.

The Terrain Avoidance (TA) mode affects the width of the sector that appears in the radar video display. There are two values for the mode: 1 (OFF) and 2 (ON). Upon entering 4 CR, (see Figure 7) the current value of TA will be displayed along with a prompt for a new value. Entering a value other than 1 or 2 will result in an error message and prompt for new input.

The current TA mode is also displayed on the console below the Fault Injection line following the Pilot Steering Mode display. Any change in the TA mode will be reflected on this display. At the start of the training session, the TA mode will default to OFF.

The FREEZE command (see Figure 7) allows the instructor to halt the training session at any point without destroying the validity and consistency of the simulation. The complete session can be frozen at an instant

in time, allowing the instructor to go to the crewmembers and point out a sequence of operations or recent commands that were in error or inadequate.

The instructor "freezes" the session by entering 5 CR. At that instant, all training and simulation procedures for crewmember activity will halt. The instructor may interact verbally with the crewmembers and advise them of any problems they may be experiencing.

Once the instructor has finished his verbal instruction during the "freeze", he can then resume the simulation at precisely the point at which it was stopped, and the training session can continue as planned from that point.

To continue a "frozen" session, the instructor enters 6 CR (see Figure 7). The training session resumes from the exact point at which it was frozen.

#### POST RUN MODE

The major purpose of the Post-Run Mode (see Figure 4) is to provide a limited review of the currently defined working scenario. The instructor may specify an arbitrary point in the scenario as a start time for review. Once selected, he may begin a review of the scenario by activating the RESUME command.

When the review is in progress, the instructor may stop the review at any time. This will enable him to make any notes of the scenario without missing critical material or allow him to define a new starting point. Thus, when used in conjunction with defining start points and resuming the review process, a particular sequence can be replayed many times.

#### POST RUN COMMANDS

Four commands are available during the Post-Run mode and are presented in menu form in Figure 10. Only the DEFINE START POINT command requests additional input from the instructor, and none of the commands invoke a second level of command menu.

```
-----  
POST-RUN MENU  
1) DEFINE START POINT  
2) FREEZE  
3) RESUME  
4) RETURN TO EXECUTIVE  
-----
```

Figure 10  
Post-Run Master Menu

Activated by a 1 CR, the system will display the current start time (which defaults to the beginning of the flight plan). The instructor will then be prompted for a new start time and must enter a value that is between the start and end of the flight scenario. If he enters an illegal value, an error will be flagged, and he will be requested for new input. Once a new start time is successfully entered, it will become the point at which the review process will start when the RESUME command is activated.

The FREEZE command is only meaningful during the review process. Activated by a keystroke sequence of 2 CR, this command will stop the reviewing process.

When RESUME command is activated, the reviewing process will be started or restarted. The scenario will begin at the currently defined start point, or freeze point if the session was frozen, and will

continue along as though the aircraft was following the flight path perfectly. Radar video will correspond to the exact flight path with MFD formats available for inspection. No on-line interaction of crewmember commands will be available except for radar video presentation format. Once the post-run review is completed, the instructor can return to the executive menu by inputting a 4 CR command. Activation of this command will clear the POST-RUN master command menu from the display and control will return to the EXECUTIVE command menu.

#### HARDWARE

The PTT has been designed in modules to facilitate modifications as the OAS itself changes and as additional OAS trainer capabilities are identified. The five modules -- independent subsystems -- of the hardware configuration are depicted in Figure 4 and described below. They illustrate the

## MAINFRAME PROCESSING SUBSYSTEM BLOCK DIAGRAM

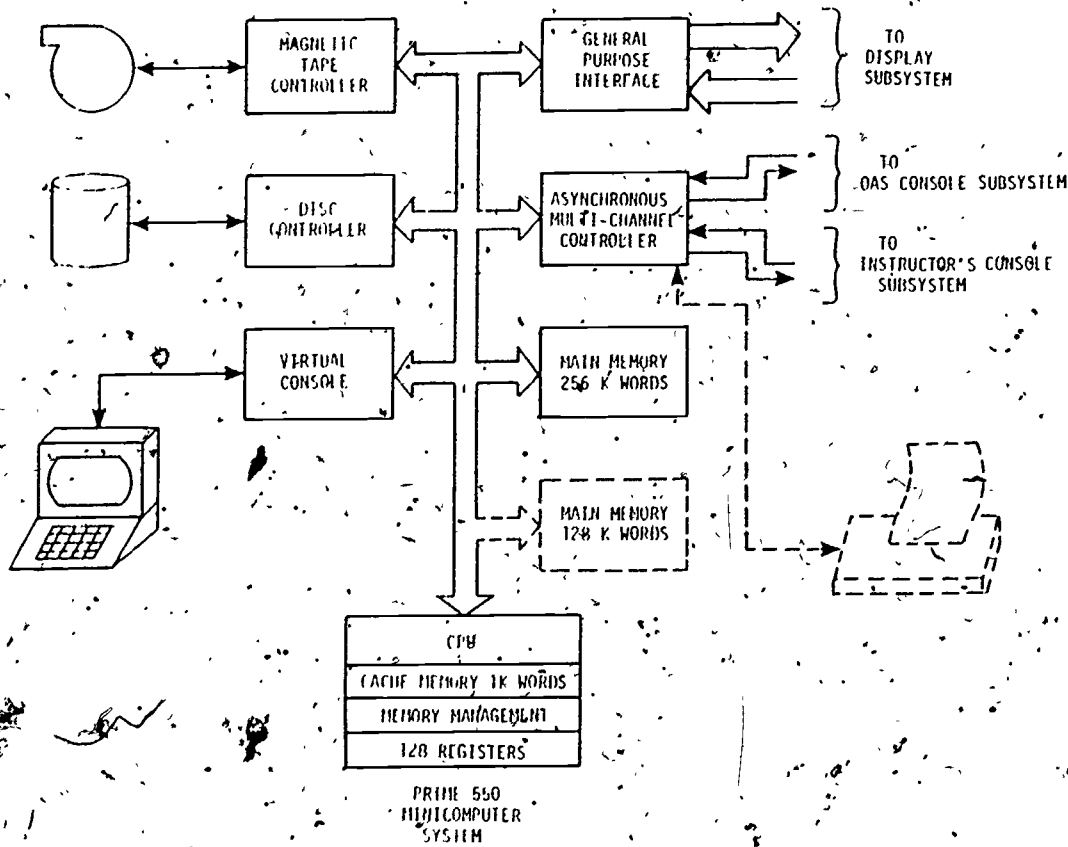

Figure 11

use of off the shelf equipment.

The Mainframe Processing Subsystem (MPS) consists of a minicomputer with disk drive, magnetic tape drive, and system console (see Figure 11). The disk is used for real-time storage and retrieval of radar imagery data; the magnetic tape is used for transfer of software and updates of terrain data.

The MPS is the central processor for the PTT. It is responsible for logical and numerical processing plus control of all other subsystems. The PTT Software runs on the MPS.

The virtual console is a CRT required for the PRIMOS Operating System. The disk drive is required for the operating system, for software and data file storage, and for real-time access to display files for synthetic radar imagery updates. The magnetic tape drive is required for loading terrain files and software updates on the operational systems in the field. All peripherals are standard PRIME equipment.

All peripheral devices on the PRIME 550 CPU (disk drive, magnetic tape drive, and virtual console) have standard interfaces supported by PRIME hardware and software.

The mainframe processing subsystem capabilities are listed below for the PRIME 550 CPU.

#### PRIME 550 CPU

32 Bit CPU Architecture  
128 Registers  
512 K Byte Error Correcting Code Main

Memory (expandable to 2 M Byte)

1 K Word Cache  
Single/Double Precision Floating Point

#### INSTRUCTOR'S CONSOLE SUBSYSTEM (ICS).

The Instructor's Console Subsystem (ICS) serves as a system monitor and control interface for the instructor. It provides for interchange of textual data with the Part Task Trainer control programs executing in the MPS. The following data are displayed at the Instructor's Console on an alphanumeric CRT display:

Flight Parameters  
Mission Data  
Status of OAS-Emulated Subsystems  
Operational Faults  
-Alphanumeric data and control codes are input through a keyboard.

Functions which can be exercised are:

Trainer Session Control  
Alteration of Flight Parameters  
Modification of OAS-Emulated Subsystems  
Status  
Fault Seeding  
Recovery from Operational Faults

The ICS is a SOROC IQ 140 CRT terminal (See Figure 12).

#### GROWTH POTENTIAL

We realized that if we did not build a growth capability into the basic PTT design, we would start at square one again if future considerations required an expansion of PTT capabilities. Therefore, growth potential was a high priority consideration throughout the entire program. This requirement for growth potential spilled over into the design of the instructor station as well.

First, the instructor station EXECUTIVE software was designed with this growth capability in mind. For example, we realized that we would eventually have to include more malfunctions in the PTT. Therefore, the instructor software had to be able to handle these additional malfunction requirements as well. Therefore, the EXECUTIVE software design included a group of unused input/output flags. Thus, when an addition is made to the PTT software, the EXECUTIVE routines will not have to change. This will greatly reduce the time and cost of software development.

The system hardware also lends itself to expansion. A 30% growth capability was designed into the PTT mainframe computer. If expansion requires more than the planned pad, we can add a 50% memory capability by purchasing a \$12,000 memory board.

The SOROC IQ 140 terminal (see Figure 12) also provides us with tremendous growth potential. We have not even begun to take advantage of the special functions available on the SOROC.

Finally, the instructor's command formats and displays are ideally suited to expansion. The single keystroke command format can easily handle doubledigit or even triple-digit commands. In addition, the instructor's displays can be easily changed to meet growth requirements. For example, if we were to add more faults than could fit on the Fault Injection Menu (Figure 8), we could simply scroll this menu just as the destination tables are already scrolled in the present configuration.

SUMMARY

The B-52 Offensive Avionics System (OAS) Part Task Trainer (PTT) is a trainer that is designed to focus on procedures training; specifically those procedures unique in operation of the new B-52 Offensive Avionics System. With emphasis on procedures training, the instructor plays a major role in the training of the students. The OAS PTT was a two-user interface, one for the crewmembers and one for the instructor. The instructor's interface is designed to free the instructor to interact with the students at all times. Specification requirements of the instructor station included; ease of operation, rapid scenario setup, access to students, easy student and system monitoring, the growth capability. With these requirements in mind, an instructor station and interface was designed to make the instructor's job simple and effective.



Figure 12  
Soroc IQ 140 Instructor Console

## TRAINING EFFECTIVENESS EVALUATIONS OF SIMULATOR INSTRUCTIONAL SUPPORT SYSTEMS

DR. STEVE R. OSBORNE AND DR. GEORGE W. MENZER  
Allen Corporation of America

Substantial increases in simulator technology have dramatically increased the scope and potential of simulator training. Ultimate simulator training effectiveness, however, is not only a function of a device's capability to simulate training tasks accurately, but also of its ability to operate as an effective instructional tool. Its effectiveness as an instructional tool depends upon Instructor/Operator Station (IOS) factors such as instructor/operator workload, performance monitoring and evaluation capabilities, and training task/mission set-up. Effective design and proper utilization of the IOS can affect the potential and achieved effectiveness of simulator training.

Advances in simulator technology, and attempts to incorporate state-of-the-art instructional technology, have resulted in increasingly complex and sophisticated instructor/operator stations. Unfortunately, this application of new technology has not always led to advances in instructional effectiveness or efficiency. This shortcoming, and the potential importance of effective IOS functioning, highlight the importance of evaluating IOS design and innovations in simulator instructional support systems. However, accurately assessing the effectiveness of simulator instructional support systems poses a set of problems that often are not solved by traditional approaches to evaluating simulator training effectiveness.

This paper discusses some of the problems encountered in attempting to evaluate the effectiveness of simulator instructional support systems and provides some potential solutions to these problems. Three areas are addressed: selection of a suitable evaluation model and sensitivity of performance measures; evaluation objectives; and instructor training.

### Evaluation Models

Additions or modifications to training systems usually must be justified by showing that they either increase training effectiveness and/or that they somehow reduce training costs while maintaining some given level of effectiveness. This is especially true if the addition or modification represents a prototype or proof-of-concept training device or instructional aid.

In general, evaluation models used to assess training effectiveness can be grouped

into one of two categories: analytical models and experimental models. Analytical models span a broad variety of procedures ranging from simple questionnaires and opinion surveys to well-developed, highly structured rating scale evaluations.

Analytical models usually do not involve direct measures of student or instructor performance. Instead, they rely upon estimates, judgements, or opinions that are based on direct observation or experience. Experimental models rely on direct measurement of performance. They normally involve comparing the performance of one group of students trained with the addition/modification to the performance of another group of students who are trained without the addition or modification. Under this model, differences in performance can be attributed to the influence of the instructional addition or modification provided that other factors that influence performance are held constant for both groups of students.

A transfer of training evaluation is representative of the experimental model in which the amount of training required to attain proficiency with the actual equipment is related to the amount of previous (simulator) training. Transfer of training studies allow simulator training effectiveness to be expressed as the amount of actual equipment training that can be saved by simulator training. Such studies also allow calculation of potential cost savings that can be achieved through simulator training.

Experimental comparisons, such as transfer of training studies, have become the standard for assessing simulator training effectiveness. There has been a natural tendency, therefore, to apply these same experimental models to assess the effectiveness of simulator instructional support systems such as instructor/operator stations, special instructional features, and simulator instructional capabilities. From a methodological standpoint, experimental models represent the preferred approach to assessing training effectiveness. However, there are at least two factors that limit the adequacy of this approach for evaluating simulator instructional support systems.

The first factor concerns the expected contribution of the instructional system addition/modification to training compared to the contribution made by the overall

training system. If the relative increment in training effectiveness is small, then it may not be detected on the overall system level, i.e., in terms of student performance. For example, student performance typically is affected by multiple components of the training system such as academic, classroom, simulator, and actual equipment training. In most cases, the instructional support system of a simulator, compared to the overall training system, represents a modest influence on student performance. Such small effects require very sensitive performance measures and a level of experimental control and rigor that usually is not available for evaluations conducted in operational settings.

The second factor concerns using instructor-assigned grades as a measure of student performance. Although instructor grades frequently are used in training effectiveness evaluations, they normally are not very sensitive to actual differences in student performance. Instructor grades are used more to manage student progress through the training program than they are to measure performance. Instructor grades also tend to be norm-referenced, i.e., they are assigned relative to the average performance of other students of comparable training and experience. Although grades serve their intended purpose, they alone usually are not sufficient to detect differences in performance, especially if those differences are small.

The solution of the first problem requires that the evaluation be conducted at a level commensurate with the expected increment in training effectiveness. If the change or addition to training represents a major impact on training, then it may be sufficient to assess that change at a molar level, such as by measuring differences in student performance. On the other hand, if the change or modification represents a small impact then it will be necessary to assess that change at a more molecular level. This may require a change in the way training effectiveness evaluations are conducted. Experimental comparisons of student performance may need to be replaced or supplemented with more analytical comparisons. For example, changes in the instructional features of a simulator, which represent a small change in the overall training system, could be evaluated by establishing a list of behavioral objectives that the new instructional capability should achieve. The evaluation would then assess the extent to which those objectives were met. Such objectives should be a natural part of the design process itself and they should reflect the original purpose for developing or modifying a particular instructional feature or capability. Establishing a list

of behavioral objectives would allow a clear and specific statement to be made about the expected results of a particular simulator feature and also would provide a clear basis for assessing the extent to which those results were achieved. This information could be used to evaluate the merits of a given simulator feature, regardless of how small a component that feature was, relative to the overall training system. An assessment of behavioral objectives also could be viewed within the context of a broader scale evaluation of student performance.

The second problem, i.e., sensitivity of instructor grades can be addressed in a number of ways. First, a set of objective measures of student performance could be developed. However, the time and cost requirements to develop good performance measures often exceeds the resources available for training effectiveness evaluations. Second, instructors could be asked to record actual deviations in performance for a selected set of parameters judged to be especially critical to successful performance of the task being graded. This would provide some additional performance information for the purpose of the evaluation. It also would allow subsequent instructor ratings to be based, in part, on selected aspects of student performance. Third, the standard four-point grading scale used by instructors could be expanded to a seven-point scale by inserting intermediate points between each original scale point. This would increase the potential sensitivity of the middle part of the scale which is most frequently used, but it would not significantly alter the basic format of the scale. Therefore, instructors still would have a scale they are familiar with, but one that has greater sensitivity. Finally, automated performance capabilities of simulators should be utilized if they are available.

#### Evaluation Objectives

Related to the topic of evaluation models is the issue of evaluation objectives. Although the overall goal of an evaluation may be to assess the training effectiveness, or efficiency of a simulator instructional support system, more specific evaluation objectives should be formulated. Specific evaluation objectives are especially important for evaluating instructional support systems because the specific procedures for evaluating such systems, including dependent variables, are not as well defined as they are for evaluations of total simulator systems. Specific evaluation objectives can provide a conceptual framework for the development of specific evaluation procedures. Clearly stated, specific evaluation objectives also can be helpful in selecting an evaluation model and for guiding the development of measures of

instructional effectiveness. )

The development of evaluation objectives can take many forms, however, some criteria that objectives should satisfy are as follows. First, objectives should be based on the overall purpose of the evaluation. Objectives, therefore, should be stated so that their fulfillment will provide answers to the questions that originally generated the evaluation. Second, objectives should be operationally meaningful in the sense that their fulfillment will provide useful information. Third, objectives should be stated clearly. Finally, objectives should be testable within the operational context in which the evaluation will be conducted.

#### Instructor Training

Another important factor in conducting an accurate evaluation of any instructional support system involves instructor/operator training. A device must be used correctly, and with sufficient knowledge of its limitations and capabilities, to achieve an accurate assessment of its true effectiveness. Instructor training also plays a key role in user acceptance of new training systems. Unfortunately, many evaluations begin without adequate instructor/operator training.

The solution to the problem of instructor training is straightforward. Training effectiveness evaluations of simulators and their instructional support systems should not be started until the instructors/operators who are going to use them are adequately trained. The nature of such training should be threefold. First, instructor/operators need to know how to operate the simulator. Second, they need to be trained in how to effectively utilize the instructional capabilities of the simulator. Third, they need to be trained with the procedures that are going to be used during the evaluation.

Theoretically, instructor training should be a simple task to complete. However, it often poses a number of problems, including the time required to train all of the instructors, scheduling instructor training around the existing training schedule, and rotation of instructors in and out of the training command. Many of these problems could be solved by selecting a set of instructors who are not expected to transfer away from the training squadron until after the evaluation is completed. Having a smaller group of instructors participate in the evaluation would simplify the instructor training task and would perhaps allow enough time to provide them with some individualized on-the-job tutorials. Alternatively, using a subset of available instructors will

reduce the number of students that can be followed at any given time and, hence, will increase the duration of the evaluation. It also may cause some problems for scheduling simulator training events.

#### Summary

Conducting training effectiveness evaluations of simulator instructional support systems involves all of the problems generally associated with assessing simulator effectiveness and poses some special problems as well. This paper addressed some of these problems and discussed some potential solutions.

Listed below are some guidelines that may help in designing and conducting training effectiveness evaluations of instructional support systems. These guidelines incorporate some of the problem solutions discussed above as well as some recommendations not discussed.

- Ensure that the system to be evaluated is sufficiently developed and debugged before the evaluation begins.
- Develop specific evaluation objectives that can be addressed with the resources available to conduct the evaluation.
- Select or develop an evaluation model that will allow evaluation objectives to be satisfied.
- Ensure that the evaluation model is appropriate for the size of the training effect expected to be detected by the evaluation.
- Select or develop a set of measures that together will allow all evaluation objectives to be addressed.
- Ensure that measures of performance are sensitive enough to detect differences attributable to using the instructional system being evaluated.
- Develop a conceptual plan for relating measures of performance to evaluation objectives (this is especially important for evaluations that use analytical models).
- Ensure that instructors/operators are adequately trained to operate the simulator, and to utilize the capability of the instructional system being evaluated. Instructors/operators also should be trained with the evaluation procedures to be followed.
- Monitor daily the conduct of the evaluation and data collection procedures.



Following these guidelines will not guarantee a successful evaluation and they do not address all of the issues associated with conducting a training effectiveness evaluation. However, they may provide some assistance in designing and planning an evaluation and they may help minimize some of the problems encountered by previous evaluations of instructional support systems.

# USE OF COMPUTER-AIDED DESIGN SYSTEMS IN WORKSTATION DESIGN

GERHARD EICHWEBER  
Kurt Eichweber Präzisionsgeratewerk  
Hamburg, West Germany

## ABSTRACT

The increasing technical complexity of modern systems require the application of new techniques in the design of the man-machine interface. Stress caused by information overload and "underload" will not be relieved by increased training or better personnel selection. Rethinking the man-machine dialogue is required. Advances in modeling methodologies offer promising possibilities for the future; 3-D Computer-Aided Design (CAD) systems offer solutions that are available today. Application of one such system, the Enhanced Interactive Design System (EIDS), is discussed with reference to its use in actual weapons system design.

## INTRODUCTION

Ever more complex technological demands for ever more accurate weapons systems have made these systems so complex that the operating personnel are being pushed toward their operational performance limits. Neither prolonged training nor increased personnel selectivity can ensure the right solutions to these pressing problems. The use of human engineering principles to define the man-machine dialogue and the man-machine interface has long been stressed as the solution to the need for shorter training times and lower qualification profiles, with better operating results. However, appropriate human engineering principles have yet to be adequately applied.

Human factors engineering considers a large area that includes not only anthropometrics, mechanical, and chemical (chemo-physical) stress factors but also the whole range of man-machine interactions. These factors impact the man-machine dialogue through indicators, controls, and visual and auditory information from the environment and also include other sensory data and information that are not directly related to the operator's task, such as movement, especially accelerations and vibrations, sound, noise, temperature, and the whole microclimate. Another factor in the man-machine dialogue is the proprioceptive information, i.e., the information regarding the localization of the body and its extremities in space, its movement, etc.

In today's human engineering community, our efforts must no longer be primarily ori-

ented toward further increases in the rate of data output. The way toward higher efficiency is increasingly dependent on how well we succeed in reducing stress. Man has become the weakest link in the chain. This is mostly because engineers and system designers have always tried to solve the technical problems first. Because of their mechanistic blinders, they have hardly ever confronted man-related problems unless forced to. Those human factors that were recognized and respected were the most primitive and easiest to capture, e.g., anthropometrics (at least I have no other explanation why, for a lot of people, ergonomics is still understood as a synonym for anthropometrics). Man is much more complex than simply a set of measurements. A lot of physiological and psychological knowledge has been collected during the past 50 years, but little of this has been directly applied to workstation design. Actually, having approached the limits of man's capabilities, we largely lack the methods for applying this knowledge to the engineering of a modern workstation.

## STRESS AND INFORMATION LOAD

One of the major tasks for human factors specialists is stress reduction. In order to achieve optimum results in stress reduction, we have to work with both the chemo-physical stress factors and the proprioceptive information. Only a coordinated effort on all areas can assure good results, since otherwise isolated "peaks" of stress can affect the results of all the efforts. (It is often noted that an isolated disturbance in an otherwise undis-

turbed environment will generally be much more noted and have more effect than if surrounded by a higher level of other disturbances.)

In order to achieve a better, more effective, and more operational interface by structuring the man-machine dialogue, we must have as a goal the reduction of stress. Stress itself is in some respects linked to information. There can be all kinds of information, not only those regarding the task itself. Stress, from this point of view, can be caused by both under-information and over-information. If one gets too little information, one instinctively starts to worry and tries to fill the gap, searching for more information. This applies not only to information needed consciously for the task, but as well to subconsciously needed information regarding the environment and oneself, e.g., proprioceptive information. Over-information as well can provoke stress and thus hinder the proper accomplishment of a task. We must therefore strive to suppress all unnecessary and superfluous information. Stress reduction by structuring the man-machine dialogue goes beyond the anthropometrical positioning of controls based on the criteria of reach and operability and beyond positioning of indicators, in order to read them better and more quickly. Structuring the man-machine interface is a very complex process, which, under given time-cost constraints, and manpower constraints, requires new, more effective tools and methods.

### THE ROLE OF MODELS IN SYSTEM DESIGN

Many different tools have been developed that attempt to handle the complexity of parameter interdependence in the anthropometrical field. Man-models have been developed and successfully applied in many different areas. Techniques include bidimensional approaches, the simplest being the Dreyfuss scale, the Bosch drawing aids developed by Dr. Jenik of Darmstadt University, and other very special application-oriented approaches, like the computer-based design for car driver's workstations by Volkswagen, the Reach model for astronauts used by NASA, and more complex man-models such as SAMMIE, BOEMAN, CAR (Edwards, et al., 1976), CAPE (Bittner, 1975), COMBIMAN (Evans, 1972; Kroemer, 1973; Dillhoff, Evans, and Krause, 1974), and HOS (Strieb, 1974; Lane, Wherry, Strieb, 1977). It is tempting to consider developing even more complex computer-based man models, where many more parameters, like comfort and maximum limits of movement and joints, forces, reaction time, manipulative precision, resonance frequencies of organs, etc., would be considered. The data from these models could be stored and automatically studied in relationship to postures within the working environment.

Such models are feasible and given the increasing power of modern computer systems will be developed as man reaches toward more perfectionistic levels of elaboration of such man models. However, because of economic considerations and pending the development of such elaborate models, we must be satisfied with less perfectionistic approaches and make optimum use of available low-cost computer-aided design systems, available specialized manpower, and last but not least common sense.

### COMPUTER-AIDED DESIGN SYSTEMS

Today three-dimensional computer-aided design systems (3-D CAD systems) are available that, for a reasonable price, can run on the medium-sized computers already available in many institutions and companies. The Enhanced Interactive Design Systems (EIDS), a CAD software package that we use for engineering, architectural design, and human engineering of man-machine interfaces, can run even on small 16 bit computers such as an HP1000. With such a CAD system, we have a tool at hand which can be used in developing interesting alternative approaches to workstation layout.

A tool is, of course, only worthwhile if it is both helpful and cost effective. Although initially expensive, the cost effectiveness, i.e., the return on investment, of a 3-D CAD system is favorable if you take into account that through its use we are really multiplying the output achievable from the rather limited human factors manpower available in the system design field. The rate of return on investment is very much dependent on the use one makes of the data base once it is developed. In our engineering designs, we make repeated use of the data in designing (and redesigning) the man-machine interface. Once we have established the linkages between the data, the engineers can continually redesign the "black boxes" and their contents to optimize the system's functionality.

State-of-the-art CAD systems allow a total three-dimensional description of objects and structures. For most workstation design situations, only a true 3-D solid modeling CAD system will suffice. So-called 2½-D systems are not of much help nor are wire-frame 3-D systems that lack the hidden line and hidden surface capabilities of solid modeling systems. The data structures of a 3-D solid modeling system are such that the topological description of the real object is stored in the computer. All imaginable views, planes, isometric, or perspective, as well as cutaways are just "aspects" (in the Latin sense of the word). The computer does not "think" of the objects as planimetric projections. But any desired view can be obtained by choosing a

viewpoint, a direction of view and the type of view, and striking a few keys on the computer terminal's keyboard.

A further important feature is the ability to remove or suppress hidden lines and hidden surfaces. Only with such features can we evaluate visibility and parallax problems and obtain views of the objects that adequately reflect the real product or structure being designed. With such a system, we can design every item of our workstation and assemble these items and structures in many different ways, trying out alternatives and testing for reach and legibility for representative populations. Since the system is a 3-D system and since the computer's internal description is an entirely three-dimensional topological one, we are able to try different inclinations of parts, examine parallax problems from different viewpoints, etc. (Eichweber, 1981)

But besides enabling us to control every detail of the layout and enabling us to examine different anthropometric conditions and postures for representative populations, EIDS aids us in the process of organizing the man-machine dialogue by enabling us to try out different arrangements of indicators and controls. We can design and test symbols and scales and develop new integrated solutions for the man-machine dialogue. We can determine the best organization for readability. If the indicators move, we can test different positions and combinations of the respective symbols, even in their extremes. We can "build" our workstations and examine them from any viewpoint, test and discuss them with others. The tedious time-consuming and costly process of building mock-ups can in many cases be almost totally omitted. We can ensure that in most of our man-machine interfaces, little or nothing will have to be changed as the result of trials even if we go directly to prototype construction.

For different workstations involving similar tasks, we can design functional modules, which, once they are stored in the data base, can be reused for different applications. For standard engineering analyses, we can use the geometric data in finite element stress analysis programs and for the numerical control of parts machining equipment.

Three-dimensional data bases can also be used for simulation processes. Indicator systems can, for example, be represented on display screens, linked to simulators of the respective workstation or weapons system, and then be used together with appropriate controls to simulate the response of the system to the actions of the operators. This can be helpful for instance in the layout and immediate testing of crew stations for airplanes, fire control systems, traffic controllers, etc.

Finally, we can use the data base to obtain the documentation drawings needed for training handbooks, service manuals, and illustrated parts lists. Perspective drawings and exploded views are readily-available by-products of the same data base. If one considers the extensive amount of manpower and time it costs to obtain these with traditional drafting techniques, it is obvious that the repeated use of the same 3-D data base multiplies its cost-effectiveness.

At Eichweber, for instance, we have used EIDS for the engineering design of the newest generation of our Tactical Laser Illuminating Shot Simulators (TALISSI) systems for directly aimed weapons. All mechanical parts in the system were entered into the data base. Moving parts are simulated in their various operational positions. Perspective and exploded view drawings for documentation are also prepared with EIDS.

### SUMMARY

In our work, we have found 3-D CAD systems to be a vital tool in the proper human engineering of a modern weapons system. Nevertheless, a tool is only worthwhile if it is applied well. Human engineering can only be done well if all available knowledge and criteria are applied adequately.

To achieve this goal, we use interdisciplinary teams and what we call the Value Design method (Eichweber, 1981). This method is based on Value Engineering and helps to get close to the optimum in both function and cost. (By the word "design" we mean to indicate that man and man-related functional considerations are inherent in the conceptual design.) This approach helps us to easily integrate specialists into an interdisciplinary, goal-oriented working team, with the rules of Value Engineering and Value Analysis serving as the "rules of the game."

### REFERENCES

- Bittner, A.C., "Computerized Accommodated Percentage Evaluation (CAPE) Model for Cockpit Analysis and Other Exclusion Studies," TP-75-49, TIP-03, Pacific Missile Test Center, Point Mugu CA, December 1975.
- Dillhoff, K.J., Evans, S.M., Krause, H.E., "Incorporation of Reach, Dynamic and Operational Capabilities in an Improved COMBIMAN Man-model," UDRI-TR-74-50, University of Dayton Research Institute, Dayton OH, 1974.
- Edwards, R.E., Osgood, A.G., Renshaw, K.S., Chen, H.H., "Crewstation Assessment of Reach: User's Manual," Boeing Aerospace Company,

Seattle WA, April 1976.

Eichweber, G., "Chance fuer Mittelstandische Unternehmen," der Arbeitgeber, Koeln, April 1981.

Evans, S.M., "Cockpit Design and Evaluation Using Interactive Graphics," Proceedings of NASA Conference on Applications of Graphics in Engineering, October 1972.

Kroemer, K.H.E., "COMBIMAN, COMputerized BIO-mechanical MAN-model," AMRL-TR-72-16, Wright-Patterson Air Force Base OH, 1973.

Lane, N.E., Wherry, R.J., Strieb, M.I., "The Human Operator Simulator: Estimation of Workload Reserve Using a Simulated Secondary Task," NATO Agard Conference #216, Neuilly sur Seine, 1977.

Rohmert, W., "Determination of Stress and Strain of Air Traffic Control Officers," NATO Agard Conference #216, Neuilly sur Seine, 1977.

Strieb, M.I., "The Human Operator Simulator: HOS Study Guide Overview," TR-1181, Analytics, Inc., Willow Grove PA, 1981.

# INSTRUCTOR/OPERATOR STATION DESIGN CONCEPTS

DR. WILLIAM M. HINTON

and

MR. WALTER M. KOMANSKI  
SPECTRUM OF AMERICA, INC.

## INTRODUCTION

The ever-increasing sophistication and complexity of weapon systems and the attendant rise in costs are parallel trends in the devices being procured to support weapon systems training. Compounding the situation is the explosion in simulation technology which has led to development of sophisticated training devices. Often the devices have resulted from the technology because it is available and not as a result of an analysis defining the specific training requirement.

In the development of a training device, the first step is an analysis of the training requirements which the device will satisfy. Over the years these analyses have been non-existent or when conducted have taken various forms with differing levels of accuracy and thoroughness. All too often the analyses have been a cursory assessment of the existing or projected training requirements. As a result the design and development of the devices have been left in the hands of engineering, computer, and software specialists. Their primary orientation and interest is the development of training hardware which operates in accordance with the approved specification. This does not, however, necessarily mean that the device satisfies the training requirements.

The emphasis on the engineering development of a training device has developed by default (i.e., the lack of an analysis of the training requirements). The lack of participation by human factors and training analysis personnel in providing the necessary input related to the training requirements, the instructor role, ease of operation, and in particular the design of the Instructor/Operator Station (IOS), has been a major contributor to the situation.

As a result training devices have been delivered with IOSs which are complex and difficult to operate. For example, many IOSs have multiple data entry methods such as switches, light pens, numeric keyboards,

alpha-numeric keyboards, multi-function switches, pages and pages of CRT information which must be called up before the specific item can be located, etc. Extensive formal training is required for the instructor/operator to become proficient. Daily use is required to remain familiar with the operation of the IOS. In the "real world" situation the instructor/operator may or may not have had formal training. More likely he has received an abbreviated on-the-job training program and does not use the device daily. Many instructors are, therefore, not qualified to administer training in the device. The result is that training quality, quantity, standardization, and efficiency suffer.

IOS design is not just the physical layout of a work place. It also encompasses consideration of instructional features, information management, software capabilities, and many other varied factors. To properly incorporate the many factors into an efficient training-effective design requires a systematic analysis process. It is apparent that many IOSs currently in use have not evolved through such an analysis and design process.

The purpose of this paper is to summarize the problem areas which have resulted from analysis and design shortcomings and to present design principles and concepts to overcome these deficiencies. The focus is on operational flight trainers (OFT). Many of the problems and recommendations, however, are applicable to a wide range of training devices.

## PROBLEM AREAS

There are significant differences in the design features of existing simulator IOSs. Some work better than others; some have sophisticated features, but do not work very well; others are simple and work quite well. Collectively, however, there are weaknesses which characterize OFT IOSs. These weaknesses are as follows:

- Layout, labelling, coding, etc. do not optimize device operation and minimize instructor workload.
- Steps required to access many CRT displays are time consuming and inefficient.
- Delays in display access cause inefficiencies in training problem control and monitoring.
- Data entry methods are confusing, redundant, and inefficient.
- Many features and capabilities are not needed, not used, or difficult to use.
- Instructor training does not adequately prepare instructors for their roles and responsibilities in using simulators.
- Instructor roles and responsibilities are not completely defined and implemented.
- Student training syllabi are poorly developed and used. Standardization, organization, efficiency, and quality of instruction are, therefore, impaired.
- Simulator capabilities are not keyed to the training requirements (i.e., objectives) of the training system in which it will be used. The simulators are, therefore, not properly integrated into the training system as an efficient element which fills a clearly-defined need.
- Instructor handbooks are not properly organized and formatted to provide instructor assistance in operating the device in a training situation. They are massive informational volumes, not training tools.

When taken together, the clear impression is conveyed that the total concept of design for the instructor is very "loose" (i.e., the systematic principles of man-machine interface, human factors, and training technology have not been properly applied). The net result is that planning and design for operation of the device are secondary components of the total simulator development process. Actual operation of the device

and training using the device, therefore, suffer.

In many cases it is evident that a number of the features and capabilities were included, not because they were clearly required to accomplish the desired level of training, but because no one really knew whether or not they should be there; so they were put in. This tendency toward overkill has resulted from two primary causes: (1) failure to perform the proper training analysis efforts leading up to device design and (2) the explosion in potential device capabilities resulting from technological advances in the state-of-the-art. The former can be characterized as follows: "We're not completely sure what we need to teach in the device or how we should teach it, so we'll stick these characteristics in just to be sure." The latter could go something like this: "We do not know just how we'll use these instructional features, but we'll put them in anyway. They're neat." The overkill increases the requirements for software and/or hardware and escalates cost.

The easy way is to allow simulator technology to dictate and include everything that it permits and hope every contingency is included. The rationale sometimes expressed "we may need it someday" or "it's nice to have" or "it doesn't cost anymore". This approach is the development of a substitute aircraft and not a training vehicle, with the result that due to the complexity of the IOS, the instructor pilot has neither the skill, the time nor the inclination to utilize the capabilities of the simulator. Thus training capabilities of the simulator are degraded.

While the capabilities and features may be very desirable on paper, they tremendously complicate device operations and increase costs. Complications result from the amount of information which must be handled, the variety of data presented to the instructor, the complexity of the simulator control, the amount of training required for instruction, and human limitations.

#### ASSUMPTIONS

The data on IOS problem areas lead to a set of assumptions which provide guidelines and a framework for the design principles and concepts. The assumptions are as follows:

- A specific simulator training

syllabus will be developed as part of the overall planning, design, and fabrication of a device. The syllabus will result from a systematic front end analysis in which the simulator is treated as a component of an integrated training system. It will be approved by the user and will form the basis for implementation of training on the completed device. Admittedly this assumption does not always embody the way things are usually done. Rather it embodies the way simulator acquisitions should work and is a direction in which acquisition policies and procedures are moving. A well-designed syllabus is an important prerequisite to good simulator design.

- Training system and human engineering personnel will participate in the design of the IOS. It is further assumed that these personnel will have the skills required to develop and validate the training tasks and syllabus to convert the validated data into an efficient IOS station. The emphasis is that the IOS will be keyed to the training requirements and situation, not to technology, excess capabilities, and designer whims.

- Instructor pilots (IPs) will continue as simulator training instructors for the foreseeable future. This assumption has both positive and negative aspects. Positively, it means that tactically and with respect to flight skills, the instructors will be highly qualified. They will possess the ability to closely identify with student problems. Negatively, they may not be highly motivated and trained to perform the roles and responsibilities of simulator instructors. IOS design must, therefore, encompass instructor aid features which minimize instructor shortcomings and which maximize their strengths.

- Training of IPs will not improve in the future. As noted previously, most instructor training is insufficient to properly prepare them for their role in administering, monitoring, and evaluating training exercises. IOS hardware and software must, therefore, be easily interpreted and used, and must provide support to offset the effect of insufficient training.

- Simulator technology will continue to advance in rapid strides. It will, therefore, be increasingly important for analysts and designers to stay abreast of technological developments and to closely evaluate their applications to individual simulator acquisitions.

- Simulators will be used as training vehicles and not as substitutes for the aircraft. They will, therefore, contain only those attributes which contribute to training. The attributes will be determined through a systematic analysis of the training requirements and the training system.

#### DESIGN PRINCIPLES

The flight simulator design and operation weaknesses, and the assumptions form the basis for the IOS design principles. The design principles serve two primary purposes; (1) to provide a summary of what should be done to correct the weaknesses discussed previously and to implement the assumptions and (2) to provide a set of guidelines which will direct the development of IOS design recommendations. The design principles are as follows:

- Reduce the instructor/operator requirements for formal training by providing an instructor/operator instructional aid system at or near the IOS. This feature will not only provide training in the operation of the device but will actively assist the IP throughout the training exercise.
- Emphasize the use of automated training as the normal mode of training.
- Reduce the instructor/operator workload by automating the ancillary tasks.
- Reduce the number and type of data entry methods at the IOS.
- Use "touch" panels on CRTs and electronic "touch pads" on the IOS console as the primary data entry methods.
- Design IOS layouts to enhance operation, interpretation, sequences of actions, etc.
- Eliminate the use of multi-function controls/switches.
- Standardize the nomenclature used on controls to reflect IP terminology.
- Investigate the use of color on CRT displays to highlight important points.



As discussed above, display location is standard. There is, therefore, no concern with where a given display will appear. Also displays which are candidates to replace a given display which is being presented on a CRT are selectable using the touch pads on the CRT face. In most cases changing displays will require a one-step touch. In most other cases software design should minimize the number of decision points (i.e., steps) the instructor must handle.

- Minimum steps to manipulate training exercises. Minimum steps to manipulate is closely related to minimum steps to change displays. In this case, however, rather than changing displays for monitoring purposes only, the instructor is locating the display from which he will affect training problem control (e.g., locate and select a specific emergency, locate and activate a specific navigational beacon, etc.).

- Large selection of programmed exercises. One of the strengths of the proposed approach to IOS design and operation is a high-quality front-end analysis. Among other things, the analysis yields a realistic training device syllabus which is keyed to the training requirements and training situation. The programmed exercises designed from the syllabus are, therefore, essential parts of the total training system and should be administered to each student. The large selection allows consideration of student skills and progress, a variety of equally difficult exercises for different students, standardized training, programmed exercise capability for all training phases, and elimination of time-consuming set-up required in conventional free flight exercises.

- Large selection of initial conditions. Setting up initial conditions in the free flight mode on many simulators is time-consuming and may be non-standard. A large set of initial conditions gives instructors the flexibility they desire and improves use of time and standardization. Selection of a given set of initial conditions would key other responses from the IOS. For example, selecting initial conditions for an aircraft on the parking ramp may activate display of the normal cockpit checklist, or selecting initial conditions for an aircraft in marshall may activate the carrier approach display.

- IAS teaching and prompting. The IAS has two primary roles. The first is to

teach instructors how to use the simulator. In this role it is a CAI terminal used to present information on the operation of the IOS and on the procedures for conducting training exercises. The second role is to prompt instructors during set-up and execution of training exercises. In this role the IAS is a job aid which improves instructor efficiency and standardization of instruction.

#### CONCLUSION

A quote from the 2F114 (A-6 WST) instructor handbook is as follows: "This volume is designed to give the instructor the flexibility necessary to provide each student with the complex and repetitive training he requires." This emphasis on flexibility has led to IOS designs which are needlessly complex and which actually hinder training.

This is not to say that flexibility should be eliminated: certainly not. Degrees of flexibility are necessary to meet the variety of needs in a typical FRS training situation. A major thesis of this paper, however, is that too much flexibility is a hindrance. To balance flexibility with ability to meet realistic training requirements, the IOS should be accurately programmed based on the results of a thorough front-end analysis. The software concepts presented above provide the guidelines for this programming. The more structured approach embodied in the analyses and resulting software will help ensure that simulator training is standardized yet sufficiently flexible to meet training needs, readily manageable, and is easy for instructors to learn to administer.

- Upgrade student and instructor training and operating materials.
- Improve reliability and maintainability by use of touch controls, eliminating light pens, etc.
- Reduce cost by limiting IOS capabilities to training requirements.

Each of the IOS design principles is discussed in the following paragraphs.

**INSTRUCTIONAL AID SYSTEM.** To implement the principle to reduce the need for formal training of IPs, it is proposed that a computer aided instructional (CAI) system be incorporated as an integral part of the IOS. This Instructional Aid System (IAS) will have the capability of presenting instructional programs to the IP for operation of the device; provide the necessary instructions to the IP in the set-up, operation, and conduct of instructional exercises for a selected mode of operation; and cue the IP as necessary during a training exercise.

As a pure instructional tool it will be programmed to present instruction on basic operations of the device to include topics such as control locations and operations, display formats and interpretation, exercise control, and use of related training material (e.g., instructor guides and checklists). During set-up and conduct of exercises it will aid the instructors via prompts which guide them through the required operational steps. For example, set-up on most devices requires the instructor to make a sequence of decisions which establish the characteristics of the exercise. The IAS would step instructors through this process, thus reducing instructor training requirements and reducing error rates. During exercises the IAS would provide cues and instructions to enhance instructor performance, decision making etc., as he monitors, controls, and evaluates.

**AUTOMATED OPERATIONS.** The most sophisticated simulator, which will be efficient to use in achieving the training objectives and which will simplify the instructor workload, allowing him to concentrate on instruction versus operation, is the trainer which incorporates automated (programmed) training exercises. The apprehension that automating training will be highly structured and thus rigid can be eliminated by astute planning in the development of a simulator training syllabus

and the specific training exercises. By using the analytical approach, the planning will consider all the variables and contingencies required for achieving the training objectives and, therefore provide all the required flexibility in simulator training.

Use of an automated simulator instructional system, by its very nature, will promote standardization. The training exercises are the same for each trainee. The information presented to the trainee is consistent and in the correct format and the performance measurement parameters and scoring procedures are the same for each trainee. Evaluation of the trainee performance is more objective and, therefore, more valid. Due to simplicity of the design of the IOS, Instructor Pilot activity at the IOS is greatly reduced, allowing him to concentrate on his instructional role.

The use of automated instruction will require a reorientation in the concept of simulator training. This requires the recognition that the simulator is a training vehicle and not a poor substitute for the airplane. As a training vehicle it should be responsive only to the determined training requirements as defined by specific training syllabi.

The use of automated training exercises, specifically designed to provide training in achieving designated training objectives, will eliminate excessive trainer set-up time required in a "free flight" mode. In the "free flight" mode of operations in many devices, the instructor must determine, select and insert every parameter such as initial conditions, aircraft location, fly-to points, ground communications facilities, geographic displays, environmental factors, and others. A manual set-up time of 15-30 minutes is not unusual; this situation not only is non-productive time for the trainee but deprives him of scheduled training.

It is recommended that automation go one step further. There would be no "free flight" mode as currently defined. Free flight would be a cross between current free flight and automation (i.e., certain operations would be automated, and instructor prompting would be provided). For example, the instructor could not enter initial conditions on-line. Rather, he would always select from the programmed set of initial conditions. To accommodate this feature the set of initial conditions would be large and would be systematic.

cally derived from an analysis of the training requirements.

Selection of initial conditions to begin an exercise would automatically branch the IOS to pre-determined displays and instructions for instructor actions. This basic philosophy of pre-selecting those displays and actions which can be predicted ahead of time, based on the syllabus and type of training to be conducted, would be carried throughout the free flight mode.

**IOS LAYOUT.** At first sight the IOS for a sophisticated aircrew simulator may be overwhelming in its size and complexity. The numbers of switches, displays, keyboards, and other assorted input/output features may be ominous to the potential simulator instructor. Even after the instructor has become familiar with operation of the device, there may still be a feeling of being overwhelmed.

The IAS and emphasis on automation are features which will reduce the complexity of the IOS. Even with these features, however, there will still be requirements for enough controls and displays to present a confusing operating situation. In order to reduce confusion and increase the efficiency of operation, the IOS design must be developed through a systematic human factors analysis. The analysis is not just to meet the requirements of MIL-STD 1472C (Human Engineering Design Criteria for Military Systems, Equipment, Facilities). It is intended to yield the most efficient training/operating environment possible for the instructors. Principles such as placement based on frequency, criticality, and sequence of use, must be used.

Characteristics of the CRT displays must be closely considered. Many of the displays used in existing devices are cluttered and difficult to interpret. One salient point is the possibility of using color to highlight selected portions of displays.

**DATA ENTRY.** Data entry in many devices is needlessly complicated. For example, in some devices combinations of light pens, fixed function keys, and variable function keys are required interchangeably throughout an exercise. This mixing of modes increases the time required to gain proficiency and the probability of error and confusion.

To remedy this weakness it is recommend-

ed that data entry modes be limited to a set of fixed function electronic touch pads on the IOS console and touch panels on the IOS CRTs. The touch pads available on each CRT display would be a function of the training situation as reflected on the CRT and would vary from display to display. Basically the fixed function keys would provide simulator control. The CRT touch pads would provide training exercise control.

**STANDARDIZED NOMENCLATURE.** Operating inefficiencies may be caused by unclear, confusing, ambiguous, or unfamiliar terminology. To help remedy the problem, it is recommended that standardized terms be adopted and used. Since IPs are the primary operators of the simulators, the terms used should be in "pilotesse". Abbreviations should be avoided when feasible. Coding should be minimized and when used should be used in a clearly interpretable, easily remembered scheme.

**SUPPORTING MATERIALS.** Although the student and instructor materials are not directly involved in IOS design, they do play an indirect role in that they will be used in conjunction with the IOS to carry out training exercises. They should, therefore, be designed to prepare the students and instructors to carry out their roles during training exercises.

The IAS is intended to take over some of the functions served by the instructor training and operating materials. Adjunct written materials, however, will still be required. These materials include the instructor handbook, exercise guides, and checklists. As noted previously, the quality of these materials for existing simulators is generally inadequate. Their shortcomings contribute to simulator utilization problems. For emerging systems they must be upgraded.

**RELIABILITY AND MAINTAINABILITY.** Reliability and maintainability will be enhanced by the application of the design principles, stated above, to the IOS which in turn will be reflected in the total simulator. The elimination and/or reduction of switches and replacement with touch controls; elimination of complex keyboards and light pens will make the IOS more reliable and require less maintenance.

**COST.** Reduction in cost for the IOS/simulator is a primary goal in the application of the design principles. Eliminating the overkill capabilities inherent in current

simulators will result in lower procurement, operating, and maintenance costs.

#### DESIGN CONCEPT

The design concept is based upon consideration of four data sources:

- Instructor tasks: the roles and responsibilities of IPs in administering training exercises. For example, brief student, select mode of operation, initialize exercise, monitor trainee, evaluate performance, etc.

- Training tasks: tasks the trainee will practice in the device. These are the tasks from a typical Instructional Systems Development task listing which are selected for simulator training.

- Design principles discussed in the previous section.

- Technology resulting from an assessment of current and projected state-of-the-art.

The design concept consists of two components: hardware and software. The components interact and are dependent one upon the other. A major issue in any design involving both hardware and software is establishing the proper functional balance between the two. In pointing out the distinction between hardware and software, there is an emphasis that IOS design is much more than using good human factors principles in determining what the IOS should look like. It is a systematic process of determining the information storage, retrieval, display, and manipulation requirements and implementing these requirements in a combination of hardware and software which optimizes instructor performance. Major design concepts are discussed in the following paragraphs.

**HARDWARE.** The IOS hardware must be reliable, maintainable and easy to operate and yet must contain the components required for control, monitoring, and evaluation. Major hardware components of the proposed IOS design concept are as follows:

- The main console. The main console is compact and is designed for a single instructor/operator. All layout is consistent with good human factors design principles. Particular emphasis is on ease of use of controls, orientation of CRTs for ease of

display interpretation, and a functional work surface which accommodates instructor guides, checklists, etc.

- Instructor Aid Station (IAS). The IAS is a separate small system with associated controls. It is an integral part of the IOS and serves two functions: (1) present instruction on basic trainer operation and (2) prompt and guide instructors during the course of training exercises. It may also be used to display selected cockpit instruments (e.g., multi-function display, horizontal situation indicator, etc.).

- Instructor's control panel. The instructor's control panel is the major "hard-wired" part of the IOS dedicated to simulator control. It consists primarily of fixed-function electronic touch pads.

**SOFTWARE.** In order to combine simplicity of hardware with complexity of weapons systems and training problems, it is essential that software be designed to enhance instructor performance. The software must be simple to manipulate, present information in easily used formats, and facilitate problem control and monitoring. Major features of the proposed software design concept to meet these goals are as follows:

- Display continuity. A given display is always presented on the same CRT. There is no switching of displays between CRTs at the instructor's discretion. When a display is selected or is called up automatically by the software, it always appears in the same place.

- Standardized displays. Each type of display has a distinct, precisely prescribed format which is always used for that type of display. Formats are developed to enhance interpretation and use of the information presented. Display highlights are emphasized by spacing, graphics, bold alphanumeric, etc. It is also recommended that color be used to highlight portions of the displays.

- Automatic presentation of displays. Maximum use is made of software selection of displays, so that minimum instructor intervention is required. During pre-programmed modes all displays are software selected. During free flight the amount of instructor display selection is minimized through keying displays to trainee tasks.

- Minimize steps to change displays.

As discussed above, display location is standard. There is, therefore, no concern with where a given display will appear. Also displays which are candidates to replace a given display which is being presented on a CRT are selectable using the touch pads on the CRT face. In most cases changing displays will require a one-step touch. In most other cases software design should minimize the number of decision points (i.e., steps) the instructor must handle.

- Minimum steps to manipulate training exercises. Minimum steps to manipulate is closely related to minimum steps to change displays. In this case, however, rather than changing displays for monitoring purposes only, the instructor is locating the display from which he will affect training problem control (e.g., locate and select a specific emergency, locate and activate a specific navigational beacon, etc.).

- Large selection of programmed exercises. One of the strengths of the proposed approach to IOS design and operation is a high-quality front-end analysis. Among other things, the analysis yields a realistic training device syllabus which is keyed to the training requirements and training situation. The programmed exercises designed from the syllabus are, therefore, essential parts of the total training system and should be administered to each student. The large selection allows consideration of student skills and progress, a variety of equally difficult exercises for different students, standardized training, programmed exercise capability for all training phases, and elimination of time-consuming set-up required in conventional free flight exercises.

- Large selection of initial conditions. Setting up initial conditions in the free flight mode on many simulators is time-consuming and may be non-standard. A large set of initial conditions gives instructors the flexibility they desire and improves use of time and standardization. Selection of a given set of initial conditions would key other responses from the IOS. For example, selecting initial conditions for an aircraft on the parking ramp may activate display of the normal cockpit checklist, or selecting initial conditions for an aircraft in marshall may activate the carrier approach display.

- IAS teaching and prompting. The IAS has two primary roles. The first is to

teach instructors how to use the simulator. In this role it is a CAI terminal used to present information on the operation of the IOS and on the procedures for conducting training exercises. The second role is to prompt instructors during set-up and execution of training exercises. In this role the IAS is a job aid which improves instructor efficiency and standardization of instruction.

#### CONCLUSION

A quote from the 2F114 (A-6 WST) instructor handbook is as follows: "This volume is designed to give the instructor the flexibility necessary to provide each student with the complex and repetitive training he requires." This emphasis on flexibility has led to IOS designs which are needlessly complex and which actually hinder training.

This is not to say that flexibility should be eliminated: certainly not. Degrees of flexibility are necessary to meet the variety of needs in a typical FRS training situation. A major thesis of this paper, however, is that too much flexibility is a hinderance. To balance flexibility with ability to meet realistic training requirements, the IOS should be accurately programmed based on the results of a thorough front-end analysis. The software concepts presented above provide the guidelines for this programming. The more structured approach embodied in the analyses and resulting software will help ensure that simulator training is standardized yet sufficiently flexible to meet training needs, readily manageable, and is easy for instructors to learn to administer.

## MODULAR CONTROL OF SIMULATORS

Steve Seidensticker  
Catherine Meyn

Tactical and Training Systems Division  
Logicon, Inc.  
San Diego, CA

### ABSTRACT

One of the issues facing the designer of sophisticated simulators today is how to control their operation. The traditional approach has been to supply the instructor/operator with a series of hardware devices (push buttons, keys, switches, etc.) with which to command the machine. A recent trend has moved the functions to a CRT where commands are activated via an associated light pen, special function keys, or, in some cases by touching the CRT screen. Although the methods of entering commands to a simulator are changing, the commands themselves are not.

This paper explores a concept, in which series of lower level events or commands are grouped into a larger entity called, for the sake of this discussion, a "task module". Manipulation of these task modules permits simpler operation of a simulator and the task modules themselves provide natural vehicles for performance measurement, scenario generation, briefing/debriefing, replay, and other associated functions. In the future this concept can provide the framework for modeling intelligent adversaries or supporting organizations in multi-unit simulators.

### BACKGROUND

#### General

Simulators for flight training purposes have been in use for many years. As material and energy costs climb, the need for inexpensive effective training has correspondingly grown. The simulator is a natural tool for this kind of training. The typical simulator of today is a highly mechanized collection of dials, gauges and displays, connected to a computer, relying on limited numerical inputs by a skilled technician to drive a mockup of the equipment being simulated. A typical example is the 2F95 F-14 Operational Flight Trainer (OFT).

#### Typical Cockpit Simulator Characteristics/Operation

The F-14 Tomcat is a U.S. Navy high performance aircraft. To fulfill its role, the aircraft contains very sophisticated and complex avionics and weapon systems.

The 2F95 OFT is a relatively modern device consisting of a simulated F-14A cockpit (pilot only) mounted on a motion platform capable of providing pitch, roll, heave, and lateral displacement about the related axes. Visual scene simulation is provided by a single channel, narrow field of view

VITAL III-S display that provides night/dusk scenes for both land and carrier-based operations.

The 2F95 incorporates a single XEROX Sigma 5 computer system for all simulation and interaction with the student and instructor. Operation is controlled from a remote instructor/operator station located away from, but in sight of, the simulated cockpit.

The instructor controls operation in two ways, one sets up an exercise, and one controls operation during the training session.

The set up operation of the OFT is done by "programming" an Alphanumeric Data Display (ADD) system. This system consists of a CRT terminal and a ten key numeric keypad. The ADD system has a total of 22 informational displays, nine of which deal with the parameters of flight (that is, carrier site, sea state, wind state and so forth). To create an exercise, the information on these displays must be updated to reflect the intent of the current training session. By editing the information on the parameter pages, the instructor programs the malfunctions and reposition options to be encountered in the training exercise.

The second method of controlling the exercise is via a special control panel, which contains hardware switches, dials, and indicators that allow direct manipulation of the simulator (fig. 1). From this panel the instructor can reposition the aircraft, insert malfunctions, adjust air turbulence and sea state and control the motion platform.

Now the plane is on the runway.

4. To program the malfunction, a new page number must be entered to put up the malfunction display.

5. An engine fire, represented by another code number must be added to the

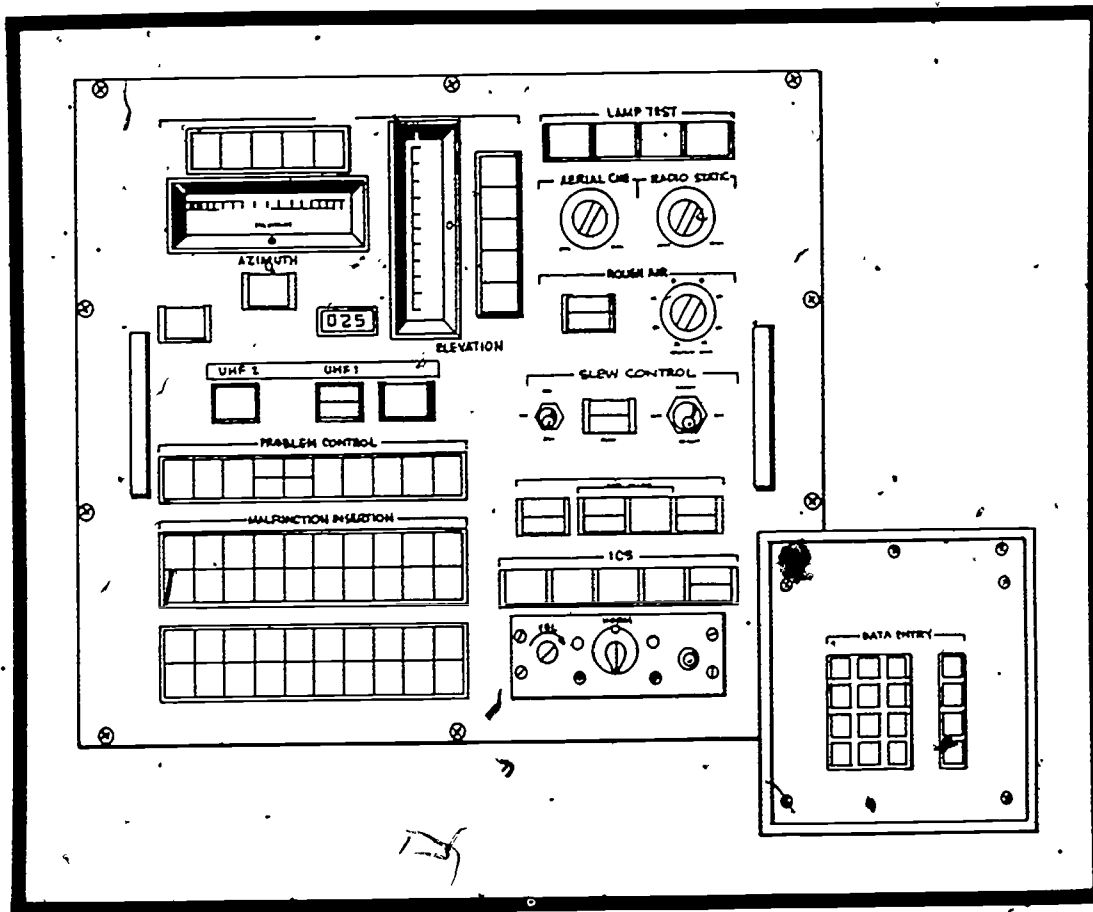

Figure 1. OFT Control Panel

Unfortunately, this method of control results in the instructor spending more time playing with numbers than with doing the primary job, instructing a student. For example, to give a student experience in dealing with an engine fire on takeoff, the following inputs must occur.

1. First, the plane must be on the end of the runway to start takeoff. To do this, one must enter the ADD page number of the reposition display on the keypad mentioned previously.

2. Next, a code number representing the desired position is entered.

3. Then a reset button is pressed.

list of available malfunctions. Another number, associating this malfunction with a malfunction insertion push button on the control panel, must be entered.

6. When the student starts takeoff, the instructor monitors the airspeed indicator and inserts the malfunction by pushing the malfunction button at precisely the right time.

7. A fire light goes on in the cockpit.

At no time during this button pushing exercise has the instructor accomplished anything that has a direct impact on teaching the student. In the worst case, the entire instructional function can be lost in the mechanics of controlling the simulator.

## Instructor Support System

To alleviate this situation and other problems associated with simulator training, the U.S. Navy through NAVTRAEQUIPCEN sponsored the development of an Instructor Support System (ISS). The purpose of this system is to take the mechanized aspects out of the training program and replace them with intelligible user interfaces that describe an exercise functionally and in terms familiar and acceptable to any trained flight instructor.

The ISS completely replaces the 2F95 IOS with a new station consisting of two graphic CRT displays, placed one above the other, with a touch sensitive device overlaid on the lower display. All information needed to conduct a training session is presented dynamically on these displays and all control of the problem and the simulator itself is via the selection of menu choices with the touch panel.

The subject of this paper is but one aspect of the ISS. Other important ones are dealt with in other papers presented at this workshop.

### TASK MODULE CONCEPT

In a system as complex as the F-14 OFT a valid training structure is imperative. To facilitate such a structure, logic suggests the breakdown of the student pilot's tasks into functional groups. For the sake of this discussion these groups are called "task modules". A task module is a logically related series of external events and pilot actions that should result in the meeting of predefined criteria. Examples might be the takeoff from a particular airfield, a pre-start checklist, or a wing sweep malfunction. Task modules as conceived here have certain important characteristics and qualities. A brief identification follows, more detailed discussion is provided later.

1. They can be "run" or executed. That is, they have beginnings and endings in time. They can run in parallel, that is, two or more task modules can run at the same time independent of each other.

2. They can be easily identified and manipulated. This forms the basis of high level simulator control, exercise definition, replay, and the like.

3. They provide the vehicle for associated training functions, such as performance evaluation and record keeping.

### TASK MODULE TYPES

In the development of this concept task modules have quite naturally fallen

into three types or groups. They are normal, flight and malfunction. Normal task modules include pre- and post-flight checkouts and checklists during flight. Flight task modules encompass those tasks related to flying skills, procedures and navigation. Malfunction task modules relate to system failures:

#### Normal

These are non-emergency procedures such as engine starts, checklists, etc. An example of this type is the takeoff checklist. In this case, the task module is activated by an instructor request at the touch panel. At this time, the checklist appears on the instructor's display containing the items to be accomplished (fig. 2). Additionally, the training system may monitor these procedures. The student pilot will perform such actions as are required, and when through, indicates completion verbally. To end this task module, the instructor pushes another button. The checklist disappears, and data concerning performance is recorded for later replay, review, or analysis.

#### Flight

Flight task modules are those concerned with the student's ability to carry out the mission, be it navigation, landing practice, or the like. This can be exemplified by the TACAN II approach to Miramar Naval Air Station. The pilot flies a tear drop pattern from an initial approach fix to a final approach fix (fig. 3). In this situation, the events beginning and ending the task module are entirely automatic. The instructor can devote all energy to monitoring the student's performance. The task module starts when the pilot is going in a specific direction at a specified speed and altitude. When the student has started the approach, and by inference, the approach task module, monitoring begins again. This time, however, the events being monitored are those specifically related to the approach task. The student flies at certain speeds, headings, and altitudes to follow the proper approach patterns. When the student completes the approach, based on speed, altitude and heading, the task module also ends.

#### Malfunction

Malfunctions are activated by instructor request, again through the use of a push button. In this case, however, the button is on a touch panel, and is labeled with the name of the malfunction to be inserted, for example, ENGINE FIRE. Once the instructor has pressed the button, an indicator light appears in the student cockpit and a malfunction checklist appears on the instructor's display (fig. 4). As the student follows procedures,



- TAKE OFF CHECK LIST -

|                               |                   |                     |
|-------------------------------|-------------------|---------------------|
| 1                             | BRAKES            | CHECK               |
|                               |                   | ACCLN PRESS UP      |
| - CHECK TAPES 6200/6600 MAX - |                   |                     |
| 2                             | FUEL              | NORM FEED/AUTO TRAN |
|                               |                   | DUMP OFF            |
| 3                             | CANOPY            | CLOSED              |
| 4                             | SEAT              | ARMED               |
| 5                             | SAS               | ALL ON              |
| 6                             | TRIM              | ALL ZERO            |
| 7                             | WING              | 20 AUTO             |
| 8                             | FLAPS/SLATS/SPLRS | DVN/DVN/UP          |
| 9                             | CONTROLS          | FREE/MYO 3000       |
| 10                            | CIR BRAKERS       | ALL IN              |
| 11                            | MASTER TEST       | OFF                 |
| 12                            | BI DI PUMP        | NORMAL              |
| 13                            | COMP/STB ORYO     | ALIGNED             |
| 14                            | HARNES            | LOCKED              |
| 15                            | CAUT/ADV LTS      | ALL OUT             |

- PILOT S VERBAL RESPONSE -

SAT --       UNSAT --

---

DIAGNOSTICS

---

|                              |                                          |                               |                                          |                               |                                          |
|------------------------------|------------------------------------------|-------------------------------|------------------------------------------|-------------------------------|------------------------------------------|
| ACTIVATE NEXT<br>MALFUNCTION | -- <input type="button" value="SELECT"/> | ENVIRONMENT<br>OPTIONS (LAND) | -- <input type="button" value="SELECT"/> | CHECK LIST<br>TAKEOFF CHKLIST | -- <input type="button" value="SELECT"/> |
|                              |                                          | RE-POSITION<br>OPTIONS        | -- <input type="button" value="SELECT"/> |                               |                                          |

---

Figure 2. Takeoff Checklist

HI TACAN 2

|                                                                                                              |                                                                                                                                               |
|--------------------------------------------------------------------------------------------------------------|-----------------------------------------------------------------------------------------------------------------------------------------------|
| <p>COM/NAV (TAC 33 /NKK)</p> <p>ARA/63 20      RAD 041</p> <p>USP      260 3      RNG 9 7</p> <p>CONTROL</p> | <p>A/C PARAMETERS</p> <p>ALT 15687    VSI -485</p> <p>SPD 242      MACH 486</p> <p>HOG 040      AOA 8 35</p> <p>G      822      FUEL 6 83</p> |
|--------------------------------------------------------------------------------------------------------------|-----------------------------------------------------------------------------------------------------------------------------------------------|

|                                                 |                                                                                                                                                                                                                          |
|-------------------------------------------------|--------------------------------------------------------------------------------------------------------------------------------------------------------------------------------------------------------------------------|
| <p>A/C MALFUNCTIONS</p> <p>UNSCHE WINGSWEEP</p> | <p>A/C CONFIGURATION</p> <p>GEAR UP    RAMP LA/RA</p> <p>FLPS UP    APLT OFF</p> <p>SPD/BK PAR ROLL ON</p> <p>WING 52/M PITCH ON</p> <p>HOOK DN    YAW ON</p> <p>DLC OFF    THROT BOOST</p> <p>SPLR/BK OFF RPM 70 70</p> |
|-------------------------------------------------|--------------------------------------------------------------------------------------------------------------------------------------------------------------------------------------------------------------------------|

Figure 3. Tacan 2 Approach Checklist

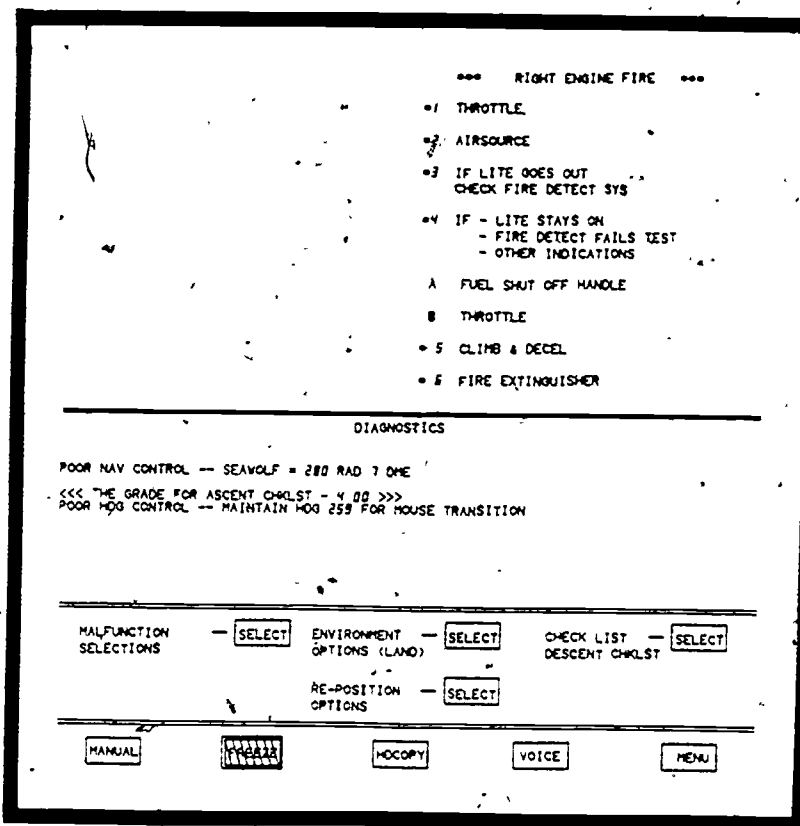

Figure 4. Malfunction Display

updates appear on the checklist indicating activity in the cockpit as it occurs. If a student completes all procedures correctly, the malfunction is removed automatically, or, if the instructor has requested it, may stay in until the instructor chooses to remove it manually with another button press.

#### APPLICATION OF THE CONCEPT

##### Simulator Operation

In the examples above the relationship between task modules and simulator operation is implied. The key is the linking of the larger units of the training operation to the simulator directly. In the ISS this is done via touch selections of dynamic menu items put on the display. That is, the instructor is now allowed to manipulate the problem using tools that are natural to the application, not those tied to the simulator hardware. In a sense then, the task module structure becomes a kind of high order language, where pilot-relevant expressions replace numerical code commands.

In contrast the procedure outlined earlier for inducing an engine fire on takeoff, a single menu selection marked ENGINE FIRE ON TAKEOFF will accomplish the same thing.

##### Exercise Definition

Exercise building is much simplified. Here the task modules can be likened to building blocks. A complete training session can be developed quickly and conveniently from a list of task modules. In the exercise set up facility of the ISS, groups of available task modules which are related in function are presented to the instructor in logical sequence (fig. 5). The instructor then simply selects the task modules which are appropriate for the exercise. All such building can be performed at the start of an exercise, and thus the instructor does not have to work "on the fly" to make sure all exercise components are covered.

##### Performance Measurement

Performance measurement and monitoring is also simplified. Grading parameters and performance criteria may be associated with specific task modules. The computer is therefore free to monitor only those events which have direct bearing on the task module procedures being graded. Without such a mechanism to limit the processing requirements, the system designer is faced with the prospect of having to watch everything all the time. This can be an overwhelming requirement.

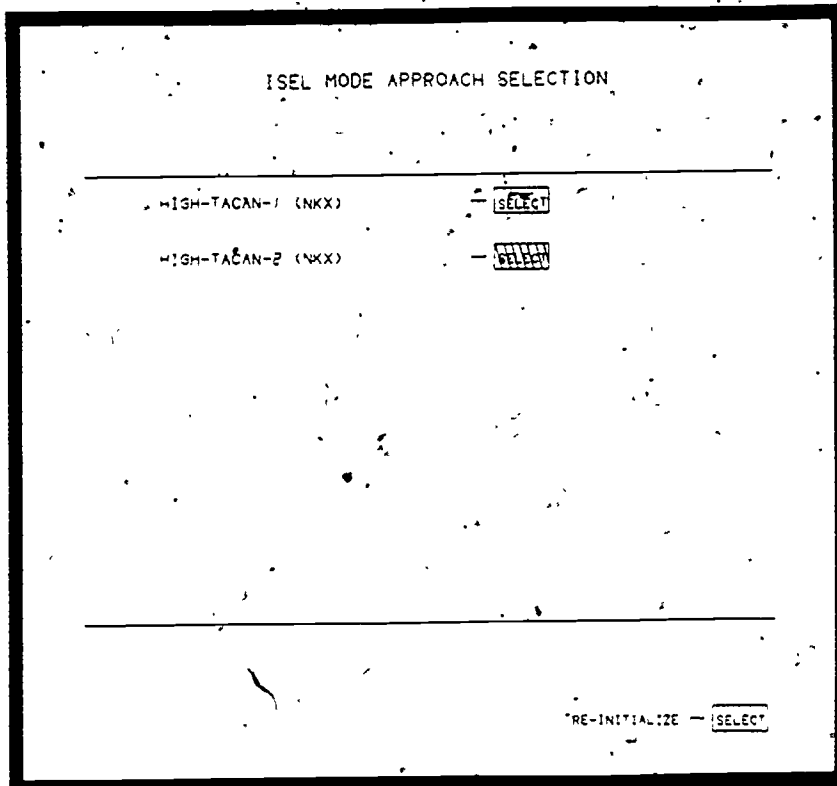

Figure 5. Exercise Definition Selection Page

A related benefit in this area is the self limiting nature of the performance data generated. Diagnostic messages and grades are only displayed for task modules associated with that training session. This simplifies and reduces the amount of data the instructor needs to examine to make valid decisions regarding the student's performance and abilities.

#### Modeling Outside Agencies

Another area in which task modules can improve a training session is handling mathematical models of outside agencies. Usually the actions of FAA controllers and other individuals who interact with the pilot can be linked to a single task module. For example, all the activity of a GCA controller can be linked to a final approach task module. Thus, a specific function can be tied to a specific task module. This contributes to a simplification of software design. If a function changes, the related task module can be altered without interfering with programs or other task modules. Modularity is a natural part of the system.

An extension of this concept, which has not been incorporated into the ISS, is that task modules could be built to provide

intelligent adversaries or supporting entities in multi-role simulators. For example, the skill or aggressiveness of an enemy pilot in an intercept trainer could be easily manipulated using the task module concept. In another application the imaginary crew of an ASW aircraft could be commanded to perform some complex maneuvers in support of a shipboard ASW simulator via a simple menu choice.

#### Debrief/Replay/Record Keeping

Debriefing the student is much enhanced by the use of task modules. The student can be shown a specific task during a replay without extraneous information unrelated to the learning experience. Since grading is linked to a task module, record keeping becomes more viable and more clear to student and instructor alike. Any task module may be replayed in any order, saving time and enhancing the student's understanding by emphasizing the specific areas that need work. This is in sharp contrast to the problems that ensue when replay is time related and the action of interest must be searched for, or worse, when no replay is available.

## STANDARDIZATION AND FLEXIBILITY

The concept of handling operation via high level task modules also has some secondary benefits.

Generally, the task module also provides standardization, which allows student performance to be evaluated more consistently. A task module will always start at the same time under the same conditions. The same procedures must be followed and nothing will be overlooked.

At first glance it may appear that this approach may reduce general flexibility in simulator operation. This could be a problem if only a small number of task modules are maintained. However, to support a full syllabus such as that associated with F-14 replacement training, a large number (150 in the ISS) is required. This, plus the fact that the task modules can be linked in a variety of ways, assures adequate flexibility.

### SOME CAUTIONS

In order for this concept to work effectively the task modules must be constructed very carefully. Less than a very thorough analysis of start/stop events can cause task modules to run or stop running unexpectedly.

Haphazard definition of scoring criteria can have very detrimental effect of user acceptance of the system.

The greatest problem faced by the developers of the ISS was an underestimation of the resources required to define the training tasks from which the task modules were derived and the time and effort required to create and checkout the task modules. A means has been identified to ease the latter burden by automating some of the task module creation functions. This will enable members of the user's community to create and modify task modules interactively at a computer terminal. This will not require programming skills nor a knowledge of the simulator itself, but it will require a thorough and very detailed understanding of the learning process, not a trivial task.

### ABOUT THE AUTHORS

Steve Seidensticker is the Technical Contract Manager for the ISS development project at Logicon. He has been involved in the project from its early stages in 1978. He holds a master's degree in System's Management from the University of Southern California.

Catherine Meyn is a computer scientist for Logicon. She has worked extensively with the ISS project. Previously she worked with the Navy Personnel Research and Development Center designing and implementing adaptive testing and counseling programs. She holds a bachelor's degree in Computer Science and Psychology from San Diego State University.

# SIMPLIFIED CONTROL OF THE SIMULATOR INSTRUCTIONAL SYSTEM,

ROBERT A. GAMACHE.  
The Singer Company  
Link Flight Simulation Division

## INTRODUCTION.

Recent advances in information processing and display capabilities have permitted significant increases in both the number and the complexity of training features found in today's simulator instructional systems. These advances reflect a combination of more detailed user requirements as well as the rapidly increasing complexities of the systems and vehicles being simulated.

These overall advances in capabilities have produced a corresponding and steady increase in system operating and control requirements. Efforts to advance the state of the art have focused primarily on system capabilities and fidelity rather than instructional value, often short-changing the role and the needs of the simulator instructor. These and other factors have contributed to increasing task loading up to and in some cases beyond acceptable levels. This need not be the case; instructional system control and operation can

be made simple and straight-forward. Task loading can be dramatically reduced and instructional effectiveness increased through careful front-end activities combined with the systematic application of appropriate design principles. These principles concern the recognition of the goals of the training program and the unique capabilities and requirements of the simulator instructor in meeting these goals.

The simulator instructor, like the flight instructor, performs several key functions in the instructional process. Some of these functions can be automated while some can be facilitated through the provision and formatting of training-relevant information. In addition, information and control capabilities can be made available with minimum instructor intervention. The instructor's workload can be minimized and, equally significant, the instructor can be given ready access to the instructional capabilities he requires.

## THE INSTRUCTIONAL SYSTEM.

The function of the simulator instructional system is to support the goals of the instructional program and to support the instructor as he performs the tasks required in facilitating instruction. The instructional system can be optimized through the application of two key design considerations: OPERABILITY and ACCEPTABILITY. Operability is achieved when an instructional system is as easy to use as is practical, while acceptability is achieved when the system makes optimum use of the instructor's unique talents and of the simulator's unique capabilities. While these are somewhat simplified and generic definitions of criteria which touch on virtually every aspect of system design, they do address the main concerns. For this reason they are the primary guidelines for the system design approach to be developed here.

Except for the aircraft preflight, the jobs of the simulator instructor and the flight instructor are closely analogous. They perform highly similar functions, including the arrangement of training conditions, briefing, demonstration, performance monitoring and diagnosis, modification of preplanned training exercises, coaching and guidance, performance evaluation and critique, and communications functions. In addition, of course, the flight instructor devotes a major part of his attention to acting as a safety pilot. The flight instructor performs these

tasks by observing the performance of the student and the aircraft, comparing these performances with the prescribed performance standards and with his own estimate of the capabilities expected of the student at a given time. In addition, he facilitates learning by prescribing practice conditions within the limits imposed by the flight environment.

The simulator has the inherent capability of providing more task-relevant information than is available to the instructor in flight. In addition, it has the inherent capacity for providing and standardizing practice conditions as they are required for effective instruction, and it has the ability to provide information in many different forms and relationships.

## AN EXAMPLE.

An example of a training exercise as it might occur in a typical simulator is used to illustrate the application of twelve basic design objectives used to achieve optimum instructional system operability and acceptability. These design objectives assume that the simulator and its instructional program have been developed in response to a set of well-defined training objectives. The definition of these objectives results in the identification of relevant practice conditions, performance measures, and performance criteria reflecting student progress in the

training exercise. The design objectives are as follows:

1. Minimize the number of individual controls and functions on the instructor console
2. Automate non-instructional tasks to the greatest extent possible
3. Minimize the instructor control actions required to perform all operating and control tasks
4. Minimize requirements for changing displays during critical instructional periods; anticipate and program displays needed in each phase of the exercise
5. Provide maximum instructor flexibility in the control of the instructional process
6. Provide continuous trainee performance feedback
7. Correlate the simulator's graphic display and performance data capabilities with trainee monitoring techniques used in the aircraft
8. Minimize requirements to enter or modify variable data through exercise pre-planning
9. Provide instructor selectable performance data recording
10. Make maximum use of relevant advanced instructional techniques to enhance feedback, control the training setting, and simplify performance data interpretation
11. Minimize use of the instructor for exercise preparation
12. Design each feature to minimize requirements for handbook reference

Many of these guidelines appear to be contradictory. How, for example, does one design an instructional system to provide maximum instructor flexibility and control while restricting the number of controls, control actions and modifications of variable data?

The answer lies in a thorough analysis of the training to be provided in the simulator. The training analysis must define the training objectives to be addressed, the optimum conditions necessary for effective training, the performance parameters to be monitored, and the criteria associated with acceptable performance and learning. In addition, the training analysis must anticipate the needs of both the student and the instructor in practicing and learning and in directing and instructing. The functional requirements in the training analysis are reflected in the approach illustrated in the following example as they indicate antici-

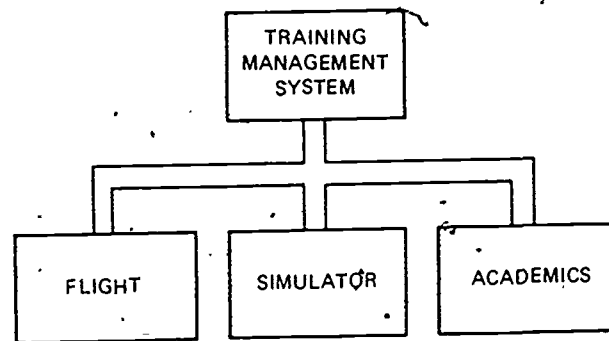

Figure 1. Training Management System Overview

pations of training events and instructor involvement.

The example used here assumes the existence of a system by which academic, simulator, and flight training are managed. Figure 1 is an overview of a typical training management system. Data used in scheduling training resources and aircraft and simulator maintenance as well as data relating to syllabus preparation and student grading are handled by the training management system. Data are entered through computer terminals in appropriate areas of the training facility.

The instructional design approach illustrated in this example is concerned with three major phases of a typical simulator training session. The first phase includes the activities of the instructor from the onset of his preparation tasks up to the point of commencing the training session. The second illustrates instructor conduct of an instructional task of moderate complexity, while the final phase covers post-exercise activities from the completion of the final training task to the completion of the debrief.

Each of these three phases begins with a discussion of instructor activities performed for a training flight in the aircraft, followed by the corresponding activities and supporting instructional system characteristics required for a simulator training session. A one-to-one correlation is used to simplify the presentation. The training tasks, task sequences, and grading methods and criteria are representative of today's instructional environment and its requirements. "Single Engine Landings" has been selected as the typical instructional task. An instructional environment relating to a mid-phase aircraft familiarization session is used to provide overall continuity.

#### TRAINING PREPARATION - AIRCRAFT.

Prior to commencing the briefing the instructor obtains a print-out of the flight grading form by way of the remote flight Training Management (TMS) terminal located in the briefing area. The form provides an up-to-date list of the required training for this flight since it is

|               |          |      |
|---------------|----------|------|
| PLUMBER, U.R  | ENS      | 1234 |
| SCREAMER, I.M | LT       | 5678 |
| FAM-S         | 08/10/82 |      |
| TIME 1:30     |          |      |

|   |                        | AA | A | BA | U |
|---|------------------------|----|---|----|---|
| P | HEADWORK               | ○  |   |    |   |
| P | PROCEDURES             |    | ○ |    |   |
| P | BASIC AIRWORK          | ○  |   |    |   |
| P | START MALFUNCTIONS     |    | ○ |    |   |
| P | TAXI MALFUNCTIONS      |    | ○ |    |   |
| I | ABORTED TAKEOFF        |    |   |    |   |
| P | NORMAL TAKEOFF         |    | ○ |    |   |
| P | CLIMBOUT/DEPARTURE     |    | ○ |    |   |
| R | BREAK TURN STALL       |    |   | ○  |   |
| I | ENGINE FIRE            |    |   | ○  |   |
| A | COMPLETE HYD FAILURE   |    |   |    |   |
| I | EMERGENCY DESCENT      |    |   |    |   |
| P | VFR RECOVERY           |    | ○ |    |   |
| P | PATTERN                |    | ○ |    |   |
| P | NORMAL LANDINGS        |    | ○ |    |   |
| I | SINGLE ENGINE LANDINGS |    |   |    |   |
| A | HYDRAULICS OFF-LANDING |    |   |    |   |
| P | SHUTDOWN               |    |   |    |   |

Figure 2. Representative Grading Form

an output of the TMS training selection process resulting from the request for data. The instructor then obtains the complete training record file which includes all previously completed and annotated flight grading forms and reviews this information to identify performance trends, weaknesses, and strengths. External factors such as weather, traffic density and restrictions, and practice landing field selection are introduced to complete the instructor's overall flight planning requirements.

The format briefing is a fairly standard instructional event and requires no special consideration here. Typically, it includes discussions and review of the flight profile or plan, sequence of events, environmental factors, performance expectations, procedural knowledge, and other trainee flight preparation requirements, and other related areas as applicable. On completion of the briefing, the instructor

and trainee proceed to the flight line, review the assigned aircraft maintenance data by way of the remote aircraft maintenance TMS terminal, and then perform the aircraft preflight concluding the preparations for flight.

### TRAINING PREPARATION - SIMULATOR.

Instructor preparations for the corresponding (mid-phase familiarization) simulator session are identical to those required for the aircraft excepting those areas that pertain solely to the actual flight (i.e., external environmental factors, air traffic instructions, aircraft preflight). The grading form is obtained by the instructor through the remote simulation TMS terminal located in the simulator briefing area. The format, identical for both flight and simulator applications, is shown in Figure 2.

As an output of the TMS the form provides the instructor with supporting information that is not available through conventional means. Note, for example, that a performance indicator (d) is identified for each of the listed training areas or tasks preceded by the letters P or R. This indicator represents a past performance average accumulated from all previous instruction. The letter P denotes tasks or performance areas primarily introduced and graded while R identifies areas of difficulty where performance has been substandard and additional (beyond the norm) review and instruction is required. Tasks preceded by the letter I are to be introduced for the first time, while A identifies areas of advance instruction to be introduced providing time and trainee performance permit.

Upon completion of the briefing, the instructor and trainee proceed to the simulator, pausing briefly at the remote simulator maintenance TMS terminal to review simulator and instructional system status. Upon arrival at the instructor console the START function is selected on the instructional system input device configured as shown in Figure 3.

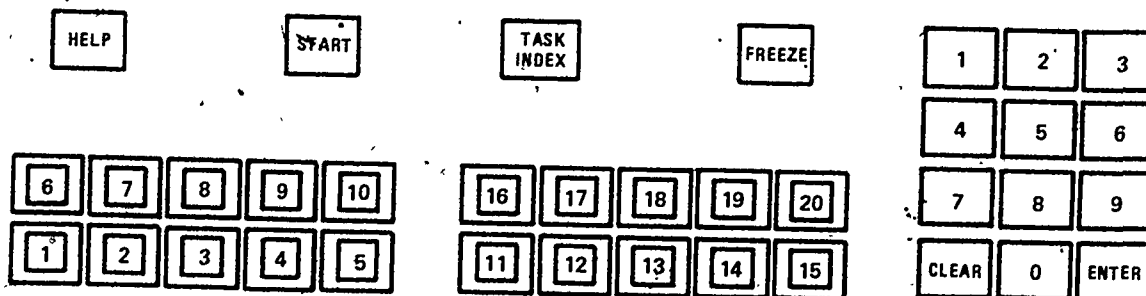

Figure 3. Instructor Input Device

This action initializes all resources of the instructional system in preparation for the activation of the training selection process. To simplify the instructor's input procedures all displays and repeaters are blanked and the following instruction is provided.

#### ENTER TRAINEE IDENTIFIER

The four digits selected on the numeric pad (Figure 3, extreme right) are repeated for verification on the CRT immediately beneath the displayed instruction. Assuming the selection is acceptable to the TMS, (incorrect or unacceptable entries are ignored and specific correction instructions provided) ENTER causes the displayed data to be cleared and the following data and instruction presented:

- |   |                 |
|---|-----------------|
| 1 | FAMILIARIZATION |
| 2 | INSTRUMENTS     |
| 3 | NAVIGATION      |
| 4 | FORMATION       |
| 5 | TACTICS         |
| 6 | CARRIER QUAL    |

#### SELECT PHASE

The phase is identified through selection of the corresponding enclosed numeric, in this case 1, for the familiarization phase in the instructor's input device (Figure 3, lower left). Selection again causes all display data to be cleared, and through direct interface with TMS, initiates the training selection process. After a short pause (during which an IN-PROGRESS message is provided), the following instruction and corresponding control function are displayed:

#### 1 INITIALIZE FOR TRAINING

Selection causes a complete training initialization to occur by positioning and configuring the simulated aircraft, selecting and depicting the appropriate visual scene content to both the instructor and trainee, and displaying the applicable monitoring and control data for the initial task at the instructor console. Upon completion of these processes, the simulator is placed in freeze and a READY message is displayed to the instructor.

In review, the simulator preparation procedures have included:

1. Selection of the START function to perform a complete instructional system reset.
2. ENTERING the trainee four-digit identifier.
3. Selecting the desired instructional phase.
4. Activating the training initialization process.

These procedures differ significantly from those used with systems that employ extensive and time-consuming selection and modification of instructional data in the special exercise

preparation or planning mode. Many of these systems extend simulator turnaround times beyond acceptable limits and often require extensive instructor knowledge of complex and cumbersome data manipulation procedures.

#### INSTRUCTIONAL TASK-AIRCRAFT

The flight has logically and sequentially progressed on through to the pattern entry, and the practice of previously introduced normal landings has been concluded. As an introduction to the next maneuver the instructor takes control of the aircraft and demonstrates a single-engine downwind and approach to a touch-and-go landing (simulated by retarding of throttle to idle). Extensive verbal commentary is provided on cockpit procedures and aircraft handling techniques including the shut-down procedures for simulated engine fire on downwind. In addition, the instructor must initiate and respond to required voice communications with the tower and monitor the traffic pattern to insure safe aircraft separation at all times.

Upon completion of the demonstration the instructor returns the aircraft to its normal two-engine pattern configuration, and once re-established on downwind, control is returned to the trainee.

The instructor then introduces the maneuver by announcing a simulated engine fire and begins to monitor the trainee's procedural response and control of the aircraft, coaching and guiding as necessary. In this capacity the instructor's sequence of monitoring activities might typically include:

1. Procedural response to the simulated engine fire as related verbally by the trainee; the trainee reduces the throttle to idle at the appropriate time to simulate the engine shutdown
2. Response of the trainee to the aircraft flight requirements (e.g., the addition of power on the remaining engine to maintain altitude and airspeed, maintaining balanced flight, smooth basic airwork, etc.)
3. Establishing the proper downwind path for the existing wind condition and arriving at an optimum single engine abeam distance
4. Simulated transmission to the tower requesting emergency clearance
5. Completion of landing checks and transmission to the tower requesting landing clearance insures gear check is verified and landing clearance is received and acknowledged
6. Basic aircraft control during the approach, focusing on angle of bank, rate of descent, angle of attack, power setting, verifies parameters at key checkpoints



7. Final approach for proper distance at roll-out, smooth basic airwork, proper alignment, minor corrective adjustments
8. Touchdown in first third of the runway on center line at the optimum rate of descent and angle of attack
9. Acceleration on the runway for aircraft control on center line, and smooth power application
10. Optimum pitch angle at lift-off; stable lateral control, smooth acceleration to single-engine climb speed, and a positive rate of climb throughout to pattern altitude
11. Proper angle of bank during downwind turn to establish an optimum distance from the runway

In addition, and throughout the maneuver, instruction is provided, the traffic pattern is monitored for safe separation, all transmissions on the selected frequency are monitored, and trainee performance is noted for post-flight analysis, debriefing, and grading. The maneuver is repeated as required to achieve the desired level of skills development for this flight.

#### INSTRUCTIONAL TASK-SIMULATOR.

The corresponding simulator training session has also logically and sequentially progressed on through all the pattern entry, and the practice of previously introduced normal landings has been concluded. Upon instructor request, the instructional system is advanced to the

next task area (SINGLE-ENGINE LANDINGS) as the trainee completes the crosswind turn to the downwind leg. Through this simple request (discussed later) the required instructional system features (visual repeater, CRT displays, and supporting programs) are selected and configured to monitor and control this specific training event as it evolves (in addition to a view of the visual scene of interest, the instructor is provided with two CRT displays configured as shown in Figure 4).

The primary display (on the left) provides a graphic depiction and tabular performance listing in the main areas, with supporting data and controls to the right. The secondary CRT display (on the right) provides the instructor with a view of the applicable cockpit instruments and indicators with supporting problem and task controls depicted to the right. The arrangement of the instruments and indicators corresponds to the rear aircraft cockpit configuration to support the normal in-flight scan patterns of the instructor.

Figure 4 also identifies the applicable control functions from the instructor input device (Figure 3) used to interact with each display type. Since the functional arrangements are dedicated, the requirement to assign controls to a CRT and the accompanying input errors that often result from such an arrangement have been eliminated.

Continuing with the task, the instructor takes control of the simulated aircraft by activating freeze (Figure 3, upper right) and alerts the trainee to an impending initialization. As an introduction to the maneuver the instructor

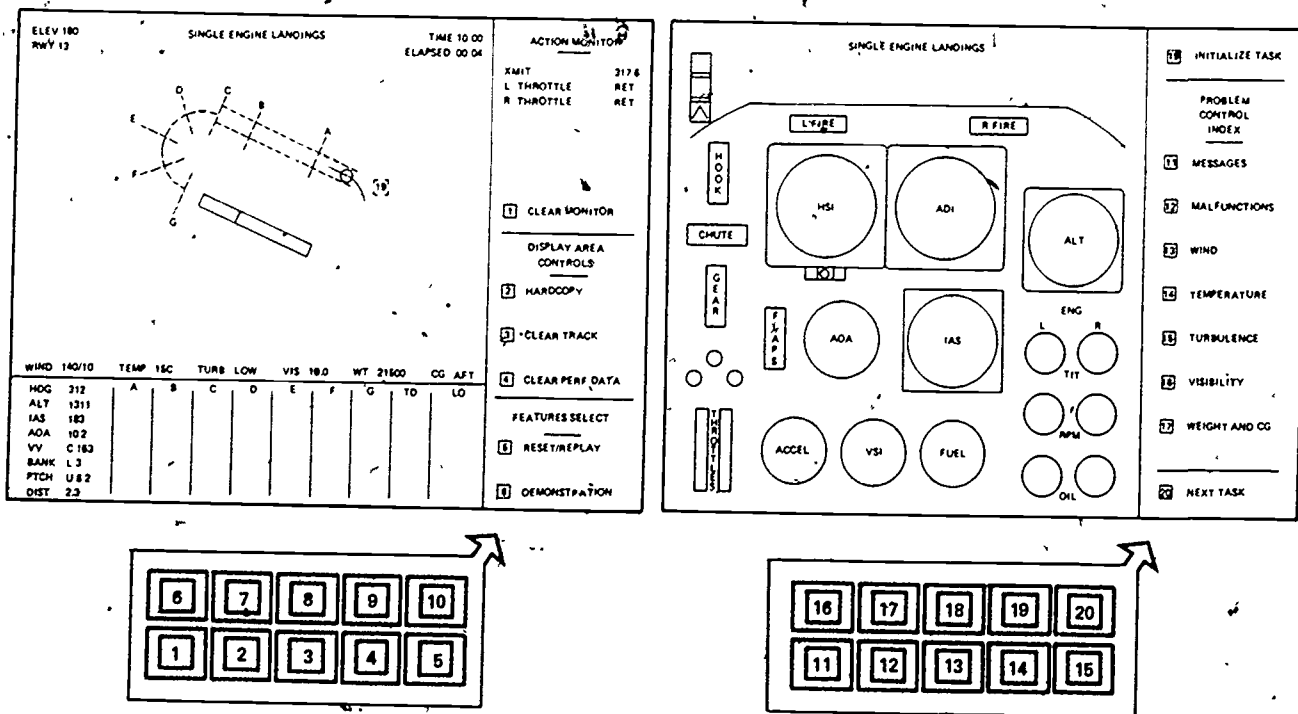

Figure 4. Task Display Configuration

selects function 6 by way of the input device (Figure 4) to access the prerecorded demonstration. When selected, the supporting data area of the primary display is updated as shown in Figure 5. Function 1 is selected, causing the simulated aircraft to INITIALIZE for the start of the demonstration. Upon completion, a READY indication is provided (lower area) with the system awaiting the release of freeze to initiate the playback. Function 2 is selected to activate the accompanying prerecorded verbal commentary.

Upon freeze release, the instructional system takes control of the simulated aircraft and demonstrates a prerecorded single-engine downwind approach to a touch-and-go landing (also simulated by retarding the throttle to idle). The simulated single-engine configuration is again used to maintain continuity with the previously described aircraft training flight maneuvers. Extensive prerecorded verbal commentary is provided on cockpit procedures and aircraft handling techniques, including the shutdown procedures for a single-engine fire on downwind. Communications with the tower are included in the commentary.

As the simulated aircraft passes the 90-degree position in the approach, the instructor momentarily deactivates the verbal commentary to provide additional remarks that are applicable to this specific trainee based on past performance trends. At touchdown the commentary is reactivated.

Throughout the demonstrated maneuver, the CRT displays and visual repeater provide all normal

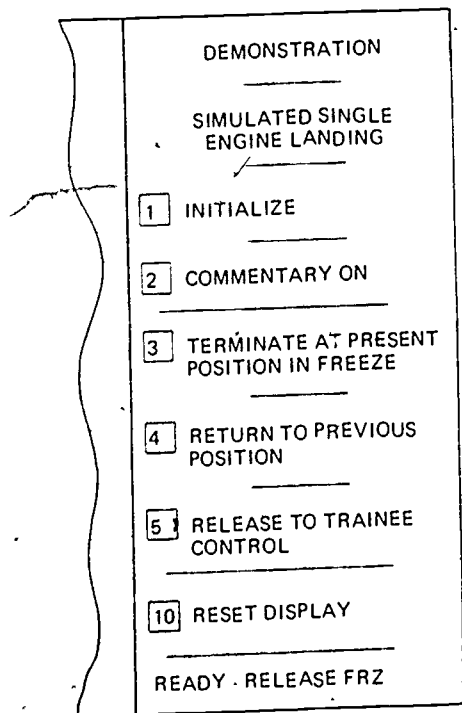

Figure 5. Demonstration Control

feedback to the instructor, including the performance data (discussed later) depicted in the lower main area of the primary display (Figure 4).

Once the simulated aircraft returns to the downwind leg and while still under demonstration control, a normal flight configuration is restored and the primary display is cleared of all accumulated track and performance history. At this point, the instructor alerts the trainee and returns control of the simulated aircraft to him (Figure 5 - Function 5) and then resets the supporting data area to its original data configuration (Function 6). Once assured that the trainee is in comfortable control of the situation, the instructor introduces the maneuver by announcing a simulated engine fire and begins to monitor the trainee's procedural response and control of the simulated aircraft, coaching and guiding as necessary. In this capacity, the instructor's sequence of monitoring activities and supporting system control inputs might typically include:

1. Procedural response to simulated engine fire as related verbally by the trainee through the simulator communications system. The instructor verifies, the the correct throttle is reduced to idle at the appropriate time by way of the ACTION MONITOR feature (primary display) or the THROTTLE position status (secondary display). No control or selection inputs are required.
2. Response of the trainee to the immediate aircraft flight requirements (e.g., the addition of power on the remaining engine to maintain altitude and airspeed, maintaining balanced flight, smooth basic airwork, etc.) by scanning the cockpit instruments and indicators by way of the secondary display in the forward view scene of interest in the visual repeater. No control or selection inputs are required.
3. Establishing the proper downwind for the existing wind conditions and arriving at an optimum single-engine abeam position by observing the aircraft symbol and track history depicted relative to the optimum downwind corridor (primary display, upper area) and abeam position (key checkpoint B) and by scanning the abeam view area of interest on the visual repeater. No controller selection inputs are required.
4. Simulated trainee transmissions to tower requesting emergency clearance with the simulated communications system. Frequency is verified on the ACTION MONITOR feature (primary display) and the instructor responds to the transmission or selects a pre-recorded message. Available messages are accessed on the PROBLEM CONTROL INDEX (secondary display, Function 11). The desired message (Figure 6) is activated

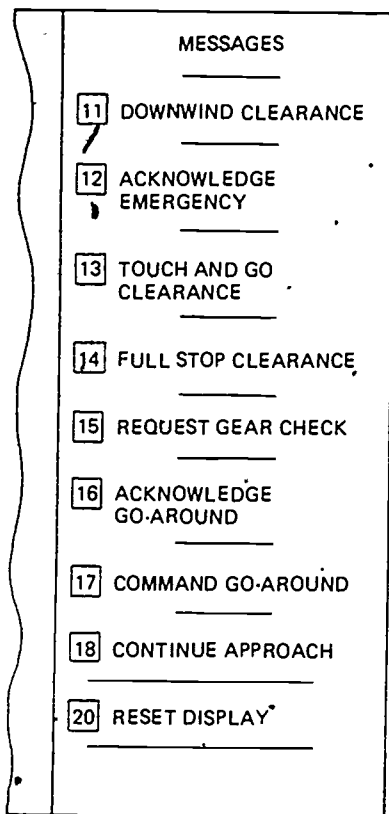

Figure 6. Message Control

- upon selection of the appropriate function -- in this case, 12.
- Completion of landing checks by observing the ACTION MONITOR feature and the cockpit instruments and indicators display. Transmission to the tower requesting landing clearance is monitored in the simulator communications system and the instructor transmits or activates landing clearance (Figure 6) and monitors for acknowledgment and gear check verification from the trainee.
  - Basic aircraft control during the approach focusing on angle of bank, rate of descent, angle of attack, and power setting as provided by the cockpit instruments and indicators (secondary display); verifies parameters at key checkpoints by observing the aircraft track history and performance data areas of the primary display reinforced by the varying scene-of-interest view from the visual repeater. No control or selection inputs are required.
  - Final approach for proper distance and runway alignment at roll-out by observing the aircraft symbol relative to the ideal distance (checkpoint G) and the optimum path reinforced by the visual scene of interest. Basic airwork and minor corrective techniques are observed in the cockpit instruments and indicators display and are also reinforced by the view of the visual

scene of interest; no control or selection inputs are required.

- Touchdown on the first third of the runway as indicated on the runway depiction (primary display) on center line as viewed from the visual scene of interest and at the optimum attitude rate of descent, etc. as depicted in the performance area of the primary display (checkpoint TD), no control or selection inputs are required.
- Acceleration on the runway for center-line control as monitored in the visual scene of interest and smooth power application depicted in the THROTTLES status area of the secondary display; no control or selection inputs are required.
- Optimum lift-off attitude (performance data area, checkpoint LO), smooth acceleration to single-engine climb speed, and a positive rate of climb to level off at pattern altitude as observed on the cockpit instruments and reinforced in the visual scene of interest. The instructor transmits the downwind clearance or activates the applicable pre-recorded message.
- Adjustments to angle of bank during the downwind turn to arrive at an optimum distance abeam the runway as depicted by the aircraft track history on the primary display, supported by the cockpit instruments and the visual scene of interest for basic aircraft control and airwork. No control or selection inputs are required.

Upon completion the primary data display provides the instructor with a concise, graphic and alphanumeric performance history of the maneuver. When combined with occasional notes on basic airwork and general performance trends recorded as required by the instructor, a comprehensive base of information is made available for post-training analysis debrief and performance reassessment. A sample primary data display depicting a completed touch-and-go is shown in Figure 7. (Some of the depicted data is applicable to additional instructional capabilities to be addressed shortly.)

The HARDCOPY feature (Figure 4, Function 2) provides a printed copy of the entire display as it appears on the CRT and is commanded by the instructor at the conclusion of each maneuver. The print-out (which does not affect the operability of the system) occurs when selected, thus avoiding storage problems and the delays often encountered when processing large amounts of accumulated data at the conclusion of training. Once a print-out has been commanded, the track history and performance data may be cleared (Figure 4, Functions 3 and 4) at the instructor's option in preparation for the next maneuver:

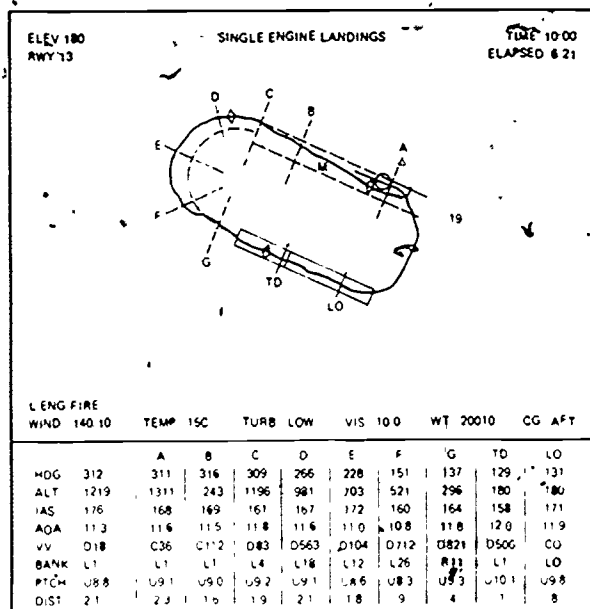

Figure 7. Sample Primary Display Data

Note that a number of additional simulation capabilities are provided to the instructor; these offer training assistance and task control not available during aircraft instruction. The supporting data area of the secondary display provides access to a variety of these maneuver-applicable control features (Figure 4, PROBLEM CONTROL INDEX). In addition to the prerecorded messages discussed previously, environmental controls and engine failures are also available for selection.

The index includes control of environmental conditions and parameters that are required in providing the flexibility for complete instruction. Changing the wind component, for example, requires the trainee to alter his approach path over the ground, while varying the temperature affects engine performance and resultant power requirements. Increasing the turbulence level makes smooth basic airwork more difficult, while limiting visibility effects judgments which depend on the pilot's perception of the flight area. Varying aircraft weight and center of gravity can totally change handling characteristics requiring altogether different approach techniques. Since the simulator provides the only safe environment for the development of proficiency in single-engine landings, the index also provides access to selected failures to realistically create the required conditions.

All selection and control functions are accomplished in the supporting data area allowing the cockpit instruments and indicators to be continuously displayed for performance in status monitoring. All control actions (e.g., selection of desired malfunction, wind component, aircraft weight, etc.) are accomplished through use of the enclosed numeric functions (Reference 7, Message Activation). The selected

conditions are displayed and the lower graphic area of the primary display as shown in Figure 7. Active malfunction titles are depicted in the lower left and the letter M is displayed in the graphic maneuver area at the point of activation. This information provides the instructor with a continuous display of simulator status during training and also facilitates post-training maneuver reconstruction and debriefing.

The INITIALIZED function, also found in the supporting data area immediately above the PROBLEM CONTROL INDEX, resets the simulated aircraft to an optimum position from which the task may be commenced. As a visual aid to the instructor, the position is identified in a graphic area (Figure 7) by depicting the corresponding function. Control and system checks are performed upon selection and appropriate cuing messages provided to insure the simulated aircraft is compatible with the demanded configuration prior to release of control to the trainee.

The ACTION MONITOR system depicted in the supporting data area of the primary display (Figure 4) is a continuously active procedure monitoring display feature that lists all trainee actions that are detectable by the computational system. The CLEAR MONITOR function provides the instructor with a means of erasing all displayed actions in preparing to monitor a specific procedure or sequence. As a part of the primary display, ACTION MONITOR data is included in all HARDCOPY print-out selections.

Interaction with the final instructional system feature assigned for use with this task and to be addressed here is also accomplished with the primary display. Selection of the depicted function (Figure 4) reconfigures the supporting data area with typical RESET and REPLAY control features as shown in Figure 8. As a visual aid to the instructor in selecting the optimum time increment, positions corresponding to the available reset points are depicted in the graphic area of the primary display on the simulated aircraft track history (Figure 7, Diamond Symbols).

These basic and straightforward control and monitoring features offer the instructor all of the flexibility required to successfully complete the prescribed instruction with minimum distraction and maximum commonality with aircraft training procedures.

Obviously, the simulator provides much greater capability for the control of training in many significant respects than the aircraft. By the same token, however, these capabilities must be implemented in the simulator and in the instructional system with operability and acceptability as primary guidelines. These are reflected in the example used here as unique simulator capabilities are organized to support the methods

|                |             |      |
|----------------|-------------|------|
| PLUMBER, U.R   | ENS         | 1234 |
| SCREAMER, I.M. | LT          | 5678 |
| FAM SESSION 4  | 08/10/82    |      |
| PLANNED 1 30   | ACTUAL 1 28 |      |

|                           | AA | A | BA | U |
|---------------------------|----|---|----|---|
| P HEADWORK                |    |   |    |   |
| P PROCEDURES              |    |   |    |   |
| P BASIC AIRWORK           |    |   |    |   |
| P START MALFUNCTIONS      |    | X |    |   |
| P TAXI MALFUNCTIONS       |    |   | X  |   |
| I ABORTED TAKEOFF         |    | X |    |   |
| P NORMAL TAKEOFF          |    | X |    |   |
| P CLIMBOUT/DEPARTURE      |    | X |    |   |
| R BREAK TURN STALL        |    | X |    |   |
| I ENGINE FIRE             | X  |   |    |   |
| A COMPLETE HYD FAILURE    |    | X |    |   |
| I EMERGENCY DESCENT       |    | X |    |   |
| P VFR RECOVERY            |    | X |    |   |
| P PATTERN                 |    |   |    |   |
| P NORMAL LANDINGS         | X  |   |    |   |
| I SINGLE ENGINE LANDINGS  |    | X |    |   |
| A HYDRAULICS OFF LANDINGS |    |   |    |   |
| P SHUTDOWN                |    | X |    |   |

Figure 9. Representative Grading Form

simulator TMS terminal and integrated with the existing data in the trainee history file. The training selection process is initiated and the grading form for the next simulator familiarization training session is printed out. Its contents and corresponding preparation requirements are briefly reviewed with the trainee (who retains the form for subsequent reference). The instructional event is concluded by placing the completed grading form in the trainee's folder.

#### DRAWING THE CONCLUSIONS.

Although brief and limited to somewhat confined areas, the information presented should provide a sufficient basis to allow the main issues identified at the onset to be re-addressed.

Have the two key design considerations of operability and acceptability been satisfied? Would the design approach promote ease of use? Is it one to which instructors could relate? There is a third and equally important consideration as well: Is it realistically achievable?

How well did the design approach conform to the twelve objectives and guidelines stated at the onset? Specifically:

1. Were the number of individual controls and functions minimized?
2. Where required instructor control actions minimized?
3. Did the design minimize requirements to enter or modify variable data?
4. Were non-instructional tasks automated to the greatest extent possible?
5. Were display switching requirements minimized?

6. Was maximum instructor flexibility and control of the problem provided?
7. Did the system provide continuous feedback of trainee performance?
8. Was performance data recording instructor selectable?
9. Did graphic and performance data correlate with aircraft monitoring techniques and procedures?
10. Were applicable advanced instructional features made available?
11. Did exercise preparation minimize the use of the simulator?
12. Would it be possible for new instructors to operate this system totally without referencing a handbook?

One remaining issue needs to be resolved before any valid conclusion can be drawn. How were these guidelines and objectives selected, and do they accurately identify the critical design areas to be addressed? Since they have all (and for some, repeatedly) appeared in military procurement specifications in the recent past, it is fairly safe to assume that they do.

#### SOME FINAL THOUGHTS.

Effective and efficient simulator instructional systems can be designed and produced today, but a few significant trends must be altered. First is the specification that calls for minimum instructor task loading, but then demands maximum system capability combined with complete and continuously available instructor control of all system variables and training features. Minimum task loading is normally stated as a design goal and maximum control as a requirement. Since the two are essentially incompatible when specified in this manner, the requirement must obviously take precedence, often resulting in systems that are characterized by unnecessary and burdensome operations. This situation is further compounded by the erroneous tendency to measure capability and training effectiveness by the amount of instructor control provided. These and other similar trends serve only to mask system capabilities and discourage effective utilization.

The answer, therefore, will not necessarily be found in more systems and more technology, but more likely from a willingness on the part of both users and designers to make the true distinction between want and need when identifying the trainee, instructor and the system requirements. This is a matter of analytical procedure tempered by self-discipline -- a process that must be totally oriented toward the specific learning objectives of each system.

#### THE WRITER'S CONCLUSION.

This paper has explored and expanded on some very basic design concepts emphasizing practical application and common sense. It has offered no really new or innovative technology, but simply

|                |             |      |
|----------------|-------------|------|
| PLUMBER, U.R   | ENS         | 1234 |
| SCREAMER, I.M. | LT          | 5678 |
| FAM SESSION 4  | 08/10/82    |      |
| PLANNED 1 30   | ACTUAL 1 28 |      |

|                           | AA | A | BA | U |
|---------------------------|----|---|----|---|
| P HEADWORK                |    |   |    |   |
| P PROCEDURES              |    |   |    |   |
| P BASIC AIRWORK           |    |   |    |   |
| P START MALFUNCTIONS      |    | X |    |   |
| P TAXI MALFUNCTIONS       |    |   | X  |   |
| I ABORTED TAKEOFF         |    | X |    |   |
| P NORMAL TAKEOFF          |    | X |    |   |
| P CLIMBOUT/DEPARTURE      |    | X |    |   |
| R BREAK TURN STALL        |    | X |    |   |
| I ENGINE FIRE             | X  |   |    |   |
| A COMPLETE HYD FAILURE    |    | X |    |   |
| I EMERGENCY DESCENT       |    | X |    |   |
| P VFR RECOVERY            |    | X |    |   |
| P PATTERN                 |    |   |    |   |
| P NORMAL LANDINGS         | X  |   |    |   |
| I SINGLE ENGINE LANDINGS  |    | X |    |   |
| A HYDRAULICS OFF LANDINGS |    |   |    |   |
| P SHUTDOWN                |    | X |    |   |

Figure 9. Representative Grading Form

simulator TMS terminal and integrated with the existing data in the trainee history file. The training selection process is initiated and the grading form for the next simulator familiarization training session is printed out. Its contents and corresponding preparation requirements are briefly reviewed with the trainee (who retains the form for subsequent reference). The instructional event is concluded by placing the completed grading form in the trainee's folder.

#### DRAWING THE CONCLUSIONS.

Although brief and limited to somewhat confined areas, the information presented should provide a sufficient basis to allow the main issues identified at the onset to be re-addressed.

Have the two key design considerations of operability and acceptability been satisfied? Would the design approach promote ease of use? Is it one to which instructors could relate? There is a third and equally important consideration as well: Is it realistically achievable?

How well did the design approach conform to the twelve objectives and guidelines stated at the onset? Specifically:

1. Were the number of individual controls and functions minimized?
2. Where required instructor control actions minimized?
3. Did the design minimize requirements to enter or modify variable data?
4. Were non-instructional tasks automated to the greatest extent possible?
5. Were display switching requirements minimized?

6. Was maximum instructor flexibility and control of the problem provided?
7. Did the system provide continuous feedback of trainee performance?
8. Was performance data recording instructor selectable?
9. Did graphic and performance data correlate with aircraft monitoring techniques and procedures?
10. Were applicable advanced instructional features made available?
11. Did exercise preparation minimize the use of the simulator?
12. Would it be possible for new instructors to operate this system totally without referencing a handbook?

One remaining issue needs to be resolved before any valid conclusion can be drawn. How were these guidelines and objectives selected, and do they accurately identify the critical design areas to be addressed? Since they have all (and for some, repeatedly) appeared in military procurement specifications in the recent past, it is fairly safe to assume that they do.

#### SOME FINAL THOUGHTS.

Effective and efficient simulator instructional systems can be designed and produced today, but a few significant trends must be altered. First is the specification that calls for minimum instructor task loading, but then demands maximum system capability combined with complete and continuously available instructor control of all system variables and training features. Minimum task loading is normally stated as a design goal and maximum control as a requirement. Since the two are essentially incompatible when specified in this manner, the requirement must obviously take precedence, often resulting in systems that are characterized by unnecessary and burdensome operations. This situation is further compounded by the erroneous tendency to measure capability and training effectiveness by the amount of instructor control provided. These and other similar trends serve only to mask system capabilities and discourage effective utilization.

The answer, therefore, will not necessarily be found in more systems and more technology, but more likely from a willingness on the part of both users and designers to make the true distinction between want and need when identifying the trainee, instructor and the system requirements. This is a matter of analytical procedure tempered by self-discipline -- a process that must be totally oriented toward the specific learning objectives of each system.

#### THE WRITER'S CONCLUSION.

This paper has explored and expanded on some very basic design concepts emphasizing practical application and common sense. It has offered no really new or innovative technology, but simply

proposed some logical and straightforward approaches in helping to resolve some rather old, frustrating, and costly problems. It is not the answer, but if your response to some

or even just a few of the areas addressed was positive, then perhaps it is a step in the right direction and merits further consideration.

# THE INSTRUCTIONAL SUBSYSTEM, A MAJOR COMPONENT OF THE TRAINING DEVICE

Dr. Thomas J. Hammell  
Eclectech Associates, Incorporated  
North Stonington Professional Center  
North Stonington, Connecticut 06359

## ABSTRACT:

The instructional subsystem has traditionally been a part of every simulator/training device. However, it has often been a misnomer consisting of little more than an operator's station for the controlling of the sophisticated simulator. The necessary technology currently exists, both in the form of hardware/software capabilities and training/instructional techniques, for the development and application of potentially high cost effective instructional tools to enhance the instructional process. Thus, a "bonafide" instructional subsystem should be a part of every training device. This paper addresses the methodology for developing the instructional subsystem, suggests several capabilities of that subsystem, and presents an applied example of an instructional subsystem in the form of SMARTTS.

## INTRODUCTION

The General Accounting Office, in their report to Congress concerning "How to Improve the Effectiveness of U.S. Forces Through Improved Weapon System Design" (1981), focused on the importance of the operator to the overall effective functioning of the weapon system, and the current situation of insufficient early planning to provide an adequate operator interface. They estimated that human errors account for at least 50 percent of the failures of major weapon systems. They further subdivided these failures into operator skill level and proficiency limitations, amongst other factors. Their findings attribute these problems to the increasing complexity of modern day systems. Two important issues are evident from this recent investigation. The most obvious is the need for improved training, as one means of improving operator proficiency and reducing operator error. This points to the need for more effective training systems, of which the instructional subsystem is one contributing aspect, albeit a major aspect. Second, the complexity of training systems is increasing in parallel with that of the

operational systems, requiring better human factors design of the training system itself (i.e., instructor and trainee interfaces). Both of these issues point to the need for effective human factors design of the training system from an instructional process standpoint.

This problem of developing a more effective training system is not really new, since the training community has always been concerned with effective instruction. The predominant emphasis in the design of training systems in recent years, however, has been placed on the engineering aspects, such as concern over adequate simulation fidelity and the technology to achieve that fidelity. Although cost-effective fidelity should be a major issue, proportionate emphasis should be given to the other training-related aspects of the training device and system. In an investigation of the training effectiveness differences attributable to differing levels of fidelity of major simulation characteristics (e.g., 120 degrees versus 240 degrees visual scene horizontal field of view, for a shiphandling/shipbridge simulator), instructor differences were found to have several times the impact on the effectiveness of training in comparison with any of the simulation characteristics investigated (Hammell, Gynther, Grasso, and Gaffney, 1981). The relative importance of the instructor was not unexpected (e.g., Caro, 1973), although its strength was surprising in the presence of simulation characteristics selected for their potential impact on training effectiveness. The importance of this finding is that the instructor typically embodies most of those non-simulation characteristics of the training device and training system (e.g., exercise design, monitoring of student performance, student feedback). The instructor is that "catch-all" that magically transforms the simulator into a training device. This, of course, should not be the case. The training device should be more than just a simulator, it should have capabilities specifically designed to augment the training process.

The training device is rapidly becoming a most important element of the training system, and is often the centerpiece of



that training system. This paper focuses on the simulator-based training system, wherein the simulator/training device is a major element of that system. Other elements include the training objectives, the training syllabus and other training media (e.g., at-sea training). The training device, as it has often been traditionally known, is nothing more than a simulator. It merely seeks to imitate aspects of the real world, such as providing a radar display showing information similar to that which would be seen on the actual ship. The simulator is, of course, limited in that which it can reproduce faithfully. Those aspects that are simulated are presumably those deemed necessary to the conduct of an effective training process, while many others are simply not addressed by the simulator.

"The training device is more than a simulator" (Hammell, 1981). Whereas the simulator simply has a simulation system, the training device has both simulation and training subsystems. The simulation subsystem is that noted above. The training subsystem, on the other hand, should consist of capabilities that are designed specifically to enhance the training process via aiding the instructor, providing information to the students, and so on. The instructional subsystem (i.e., training subsystem) has traditionally been a part of every simulator/training device. However, it has often been a misnomer consisting of little more than an operator station for the controlling of the sophisticated simulator; it has seldom really provided capabilities to support the training process. The necessary technology currently exists, both in the form of hardware/software capabilities and training/instructional techniques, for the development and application of potentially high cost effective instructional features to enhance the instructional process. Thus, a "bonafide" instructional subsystem should be a part of every training device.

The instructional subsystem should be tailored based on the many considerations surrounding the particular training application and the training device. Training assistance capabilities should be provided to support the instructor, the trainee(s), and training system management (see Figure 1). The instructor support capabilities should provide tools and information for (1) development of training exercises and support materials, (2) monitoring and control of the training process, and (3) assisting in achievement of an effective training process interface with the trainee(s). The trainee support capabilities are often coincident with "(3)". Management support capabilities

should deal with inter and intra site coordination, the continual improvement in training cost/effectiveness, and so on. Although management support capabilities are a part of the instructional subsystem since they directly impact the effectiveness of training, they will be only cursorily addressed herein.

The availability of sophisticated computer-display technology and its traditional incorporation in virtually all sophisticated simulator-based training systems enables a wide variety of training assistance technology to be readily integrated into the simulator-based training device. The issue, then, is twofold: (1) instructional technology should be incorporated as a major part of every training device, and (2) the extent to which the instructional technology should be incorporated depends upon the particular training objectives, the capabilities feasibly available on the training device, and the many other issues and constraints surrounding the particular training situation.

### Third Generation Training System

The issues currently faced in the development and integration of instructional support capabilities represent the start of the third generation training device. The first generation training device, which is typified by early efforts at simulation (e.g., Link Trainer) had as the primary concern simulation fidelity. The problem at that time could be viewed as one of simulation fidelity at almost any cost. It was simply necessary to achieve a sufficient amount of fidelity in the early simulators so as to achieve what was considered as meaningful training. The primary requisite methodologies and research information at that time concerned engineering-related issues; that is, engineering design and simulation techniques. These issues, of course, still remain and will continue as relevant issues for the development of simulators.

As adequate simulation capabilities were achieved in several areas, the second generation of training devices emerged. This generation was no longer concerned with achieving adequate simulation at any cost, since the engineering capabilities were often available. Rather, the second generation training device had as its primary issue cost effectiveness -- the cost of design with regard to the effectiveness of resultant training. Rather than maximizing simulation fidelity at any cost, the major considerations focused on the minimal level of simulation

fidelity necessary to achieve requisite training effectiveness (i.e., identification of the essential features of the simulator, and their respective levels of fidelity, required to meet specific training objectives and performance standards). The variety of methodologies developed to address this issue focused on a systematic approach to the design of the training system and/or the training device. Examples include the Training Situation Analysis (TSA) and the Instructional Systems Development approach (ISD). These methodologies typically identified the specific behavioral tasks (i.e., including skills, knowledge, and training objectives) of the trainee, and then sought to identify the minimum necessary simulator/training device characteristics for their achievement. As was the case with the first generation training device issues, the second generation issue (i.e., cost effectiveness) remains today, and will continue to remain pertinent.

The training industry is currently embarking on the third generation training device. As the second generation was a further refinement of the first, so the third generation training device and issues represent a further refinement of the second and first generations. Whereas the second generation's emphasis was on identifying the minimally acceptable level of simulation fidelity and thus minimizing the cost while maintaining effectiveness, the third generation will focus on providing training enhancement features to greatly improve the effectiveness of training at relatively small additional cost. This further evolution of the training device will augment the earlier generations in substantially improving the cost effectiveness of training, by specifically designing in instructional support capabilities.

Recognition of the importance of the instructional support capabilities has been a fundamental problem, but one that is being steadily overcome in both the training and operational communities. The major technological problem is twofold: (1) the development of appropriate methodologies and resulting research information pertaining to the design of the instructional subsystem, and (2) utilization of these methodologies and information to actually design the instructional subsystem. The third generation training device does not, as yet, have appropriate methodologies adequately developed, much less an empirical information base from which to draw, to guide the design of the instructional support subsystem. This is a

substantial problem currently facing the training device industry.

Methodologies for design of the instructional subsystem have not been formalized. Hence, the instructional subsystem has traditionally not been included as a part of the training device. Instructional subsystems, of course, have been developed and implemented on certain devices, although to an extremely limited extent. The instructional subsystem should consist of (1) instructor support capabilities, (2) trainee interface capabilities, and (3) training system management capabilities. The remainder of this paper will identify aspects of these capabilities, and issues to be considered in their development. Since one of the most effective means of instructing is that of presenting examples to the students, this paper presents an example of an instructional subsystem known as SMARTTS (Submarine Advanced Reactive Tactical Training System), which has been recently implemented on a Submarine Combat System Trainer (SCST).

#### INSTRUCTIONAL SUBSYSTEM CHARACTERISTICS AND ISSUES

The instructional subsystem, as noted above, should address the instructor, the trainee, and system management (Figure 1). Each of these are considered as important elements of the instructional subsystem (Hammell and Crosby, 1980; Hammell, 1981). This paper, focuses particularly on capabilities to support the instructor and trainee.

The Submarine Advanced Reactive Tactical Training System (SMARTTS) (Hammell and Crosby, 1980) is a pioneering effort in the development of instructional support capabilities, in that it is currently integrating a sophisticated instructional support subsystem with an existing submarine combat systems trainer. This project developed a substantial body of information regarding the design and application of the instructional subsystem, and may be used as a departure point for directly addressing many relevant issues. The SMARTTS project has, for example, (1) developed and applied some of the potentially useful techniques for the generation of information to design instructional support characteristics, (2) has designed a variety of instructional support characteristics which are currently being implemented, and (3) is planning to embark on a test and evaluation of the instructional support subsystem and its particular set of characteristics. The problems identified, the experiences, and

the techniques developed during the SMARTTS project provide considerable insight into many specific issues relevant to the instructional subsystem.

The instructional subsystem is addressed below in terms of (1) design methodology, which discusses the overall approach to the design of the instructional subsystem; and (2) training assistance technology, the specific capabilities of the instructional support subsystem. Several issues are addressed under each of these, with examples drawn from SMARTTS as appropriate. Also, concepts for future development are introduced.

### Design Methodology

Highly structured methodologies are available for the selection and design of training media (e.g., Training Situation Analysis (TSA), Chenzoff, 1965; Instructional System Development (ISD), NAVEDTRA 106A). These methods, which have been demonstrated as effective, are primarily intended to address the student/trainee interface with the training media. For example, a major use of the ISD approach is to determine simulator/training device fidelity characteristics (e.g., level of visual scene fidelity). These systematic approaches relate the training device/training system characteristics to specific trainee operational tasks. This of course is necessary. However, such an approach does not directly address those training device/training systems capabilities that can directly augment the training process but are not directly linked to the operational tasks (e.g., external feedback). These other training-related characteristics do not derive from the operational tasks, but rather derive from the base of generic training research and methodologies. There is obviously a need to design the training system with regard to both operational tasks and generic training methodologies. In practice, both are addressed, although the latter is not done so formally.

INSTRUCTOR INTERFACE ANALYSIS. The available methods have not adequately addressed the instructor interface (i.e., including various forms of instructor aids) to the training device/training system. Relatively little emphasis has typically been placed on the design characteristics of the training device/training system to directly assist the instructor in conducting the training process. Needed is a structured approach for the design of the instructional subsystem. The analysis should be quite similar to that of ISD,

although not focusing on operational tasks, but rather focusing on instructor tasks and training methodological principles. This type of analysis has been employed in the past, although to a very limited extent (e.g., the SMARTTS example presented later; also, Charles, 1978). Several elements of an ISD process for the instructional subsystem might include the following elements:

- Instructor task analysis -- a detailed analysis of the functions and tasks to be performed by the instructor on all aspects associated with his training role. This analysis should form the basis for the design of training system/training device characteristics to support the instructor in conducting an effective training process.
- Analysis of instructor loading -- an estimate should be made of the load placed on the instructor in the performance of his functions and tasks. This load should address for each task the difficulty, time to perform, frequency, available resources, accuracy of performance required, and so on. The intention is to develop an accurate profile of the loading placed on the instructor across his functions and tasks, and his expected performance level on the basis of the training system design.
- Identification of critical instructor functions and tasks -- based on the above two elements, those instructor functions and tasks that would benefit substantially from other assistance should be identified. For example, data recording is a task that a good instructor would perform frequently, so as to have good postexercise feedback information. Data recording can be extremely cumbersome and time consuming; furthermore, it is a task that can often be readily performed by the computer/training device, thus off loading the instructor to devote more of his time to those tasks that only he can adequately perform (e.g., monitoring student communication).
- Determine instructor support capabilities -- specific instructor support capabilities should be determined via a cost/effective trade-off analysis based on the above elements, alternative design approaches for providing support capabilities, and their expected

effectiveness in assisting the instructor and enhancing the effectiveness of the training process. A media selection approach to support the instructor functions and tasks should be performed, similar to that accomplished under ISD for the trainee.

This type of front-end analysis is devoted to the instructor, and should result in the generation of cost/effective training device/training system characteristics. Although aimed at specifically supporting the instructor, their usefulness is based on enhancing the training process with regard to cost/effective considerations. Many of these characteristics will also directly impact the trainee interface as well, since many of the instructor tasks deal with the trainee interface.

TRAINING METHODOLOGY AIDS ANALYSIS. A similar analysis should be conducted to determine support capabilities with regard to generic training methodologies (e.g., importance of specific external feedback). This type of analysis, which would impact instructor and trainee interfaces, would have a similar series of elements, as follows:

- Training methodology characteristics -- identification of those specific training process characteristics that are relevant to the particular training situations supported by the training device/training system (e.g., immediate graphical feedback of tactical parameters). This would be similar to a task analysis, but conducted to identify the specific training methodology characteristics. The intention is to identify all those characteristics of the generic training methodologies that may be important for this particular training process.
- Prioritization of training methodology characteristics -- each of the training methodology characteristics should be evaluated with regard to its potential effectiveness during the training process, for the particular training device/training system under consideration. The result would be a prioritization of those characteristics on the basis of their likely training effectiveness impact.
- System/device capability analysis -- the capability of the training device/training system to support each of the training methodology

characteristics should be determined. This should be done with regard to the specific aspects of the training situation and methodology characteristics desired to achieve an effective training process. For example, if a complex tactical problem is being trained, delayed feedback regarding detailed tactical and performance parameters may be desired to enable detailed analytical investigation of parameter interrelationships; the ability of the training system/training device to provide the detailed feedback information in an appropriate form (e.g., on a large screen graphical display) should be evaluated.

- Identify instructional support capabilities -- based on the above elements and a cost/effectiveness trade-off analysis, specific support capabilities would be identified. The results could identify deficient capabilities on the existing training device/training system, or could identify/select capabilities to be developed in a new training device.

The above elements represent an outline of steps, similar to that of the ISD process, for the design of the instructional subsystem characteristics. Obviously, all of the steps have not been detailed, nor have their specific procedures been adequately developed. Rather, they are intended to indicate that a structured process similar to that of ISD should be accomplished for each of the major aspects of the instructional support subsystem. Furthermore, the instructional support subsystem includes several major parts of the training device/training system, each of which requires a distinct analysis. It is important to note that the above analyses should be adequately developed, but done so quickly with a minimum of frills. The analysis should be tailored to the available information, the sophistication of the training device/training system, and the available resources. Many of the characteristics could be evaluated from the standpoint of a shopping list of potentially useful characteristics; and the final set selected from the list.

This approach is appropriate for the design of a new training device/training system, as well as that of improving an existing one. SMARTTS is an example of the latter case. The methodologies are likely to be slightly different for each case, but basically the same.

SMARTTS DESIGN. The SMARTTS instructional support subsystem design was the result of several analyses similar to the above, over a period of years. The initial concepts of SMARTTS stems from an investigation of submarine tactics training (Hammell, Sroka, and Allen, 1971; Hammell, Gasteyer, and Pesch, 1973). Of the variety of recommendations that were developed regarding basic and advanced submarine officer training systems, many addressed the need for appropriate instructional support capabilities. Figure 2, taken from the latter report, lays out the fundamental instructional support capabilities that were later to be developed under SMARTTS. The concepts developed in these earlier investigations were later fully developed in specific detail on the basis of a front end analysis conducted under the SMARTTS project. This later analysis included several of the above-recommended steps, focusing on both the instructor tasks and generic training methodologies. This analysis also selected which of the capabilities recommended in the earlier studies were to be developed in the initial preprototype SMARTTS, and which will be developed in subsequent developmental versions of SMARTTS.

An overview of the instructor function and task analysis conducted for SMARTTS is presented below.

Instructor Function and Task Analysis. An overview of the analysis of instructor functions and tasks is presented in Figures 3, 4, 5, and 6. This analysis identified the major functions conducted by the submarine tactics instructor, the specific tasks he performs with regard to each function, and estimated the time loading and difficulty associated with performance of those tasks. The major instructor functions were determined as follows:

- exercise development
- monitor and control of the training process
- briefing (pre, freeze, post)
- training system management

Monitor and control of the training process is the instructor function given the greatest recognition by training device builders (Figure 4). When a training device is employed, the instructor must set-up the exercise, control the device during the exercise (e.g., maneuvering targets), monitor the trainees' activities, and provide some amount of training during the exercise (e.g., guidance and feedback to the trainees). Capabilities, in one form or another, are provided on most training devices to enable set up and

control of the exercise. Some capabilities are often provided to permit monitoring of trainee activities, and often some recording. Occasionally, capabilities are available for providing some training assistance, such as feedback. However, all too often the monitoring and control capabilities installed on a training device are designed from an engineering-control standpoint, rather than from an instructional process control viewpoint. Specific instructor tasks, A-L, are included in Figure 4, along with generic training issues and considerations under each task. Also, the multiplicity of branching paths between tasks is also indicated to some extent by the (A) and (B) symbols. The information contained in Figure 4 is a summary of the type of analysis information upon which the SMARTTS characteristics were based. For example, the instructor has a task to monitor the scenario (i.e., Task C). A consideration under that task, particularly in a complex system, is providing cues to the instructor regarding current and upcoming scenario events. Capabilities were developed in SMARTTS to provide cues and alerts to the instructor regarding various tactical actions on the part of the target, as well as when various performance indicators (e.g., probability of ownship counterdetection) went beyond preset standards. These capabilities, which are easily provided by the computer-controlled training device, reduce the instructor's scenario monitoring load, enabling him to devote a greater proportion of time to monitoring the trainees (i.e., Task H). Other examples are given later under Training Assistance Technology.

Briefing of the trainees (Figure 5), in its various forms, is probably the most important function performed by the instructor. In this function the instructor has a direct interface with the trainees, and provides them with specific information to reinforce and/or modify their behavior. In a simulator-based training system briefings may be given prior to, during a pause in, and following completion of the session on the simulator (i.e., pre, freeze, and post briefings respectively). Although essential to the effectiveness of the training process, the emphasis placed on briefings varies considerably across training establishments. Furthermore, the capabilities provided as part of the training device/training system to assist in conducting effective briefings are often quite limited. Examples of capabilities to support briefing tasks will be provided later below under Training Assistance Technology.

TRAINING SYSTEM

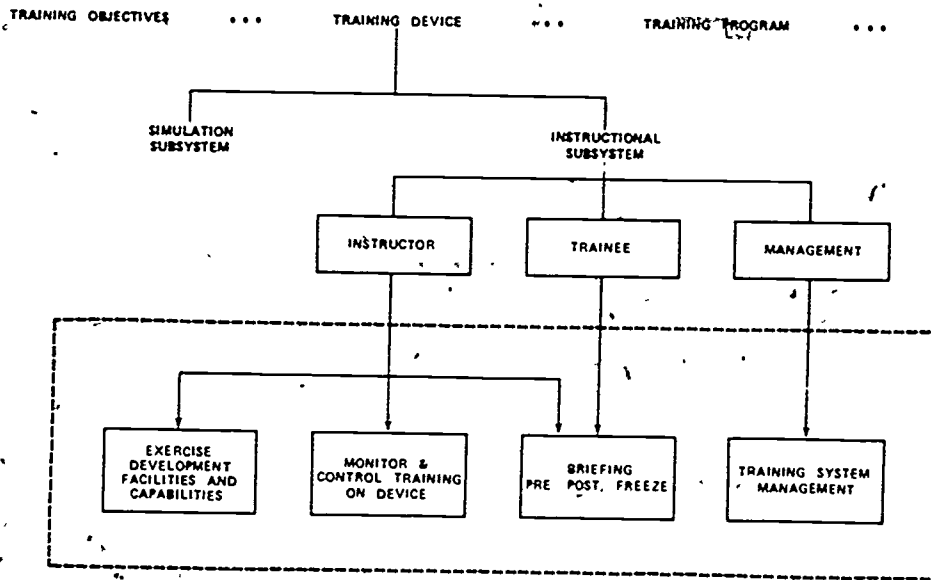

Figure 1. Focus of Instructional Subsystem

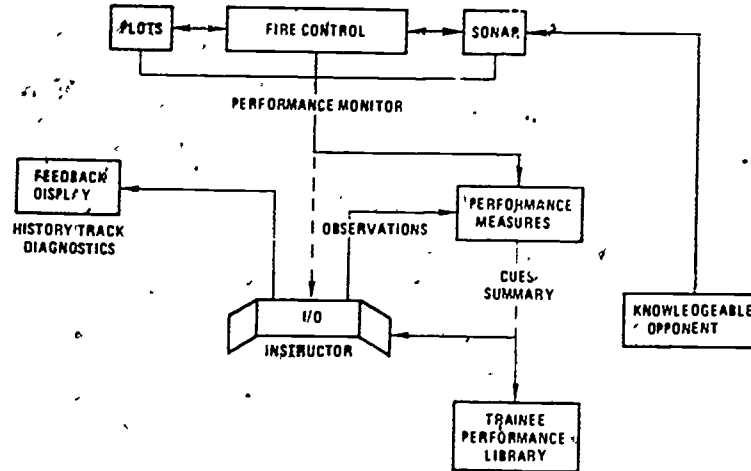

Figure 2. Instructional Support Capability Requirements for the 21A Series Submarine Combat System Trainers (from Hammell, Gasteyer and Pesch, 1973).

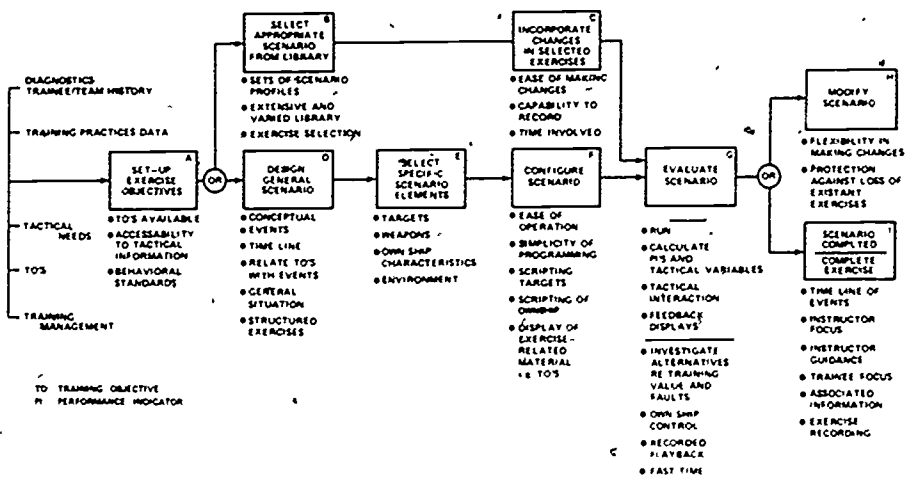

Figure 3. Exercise Development

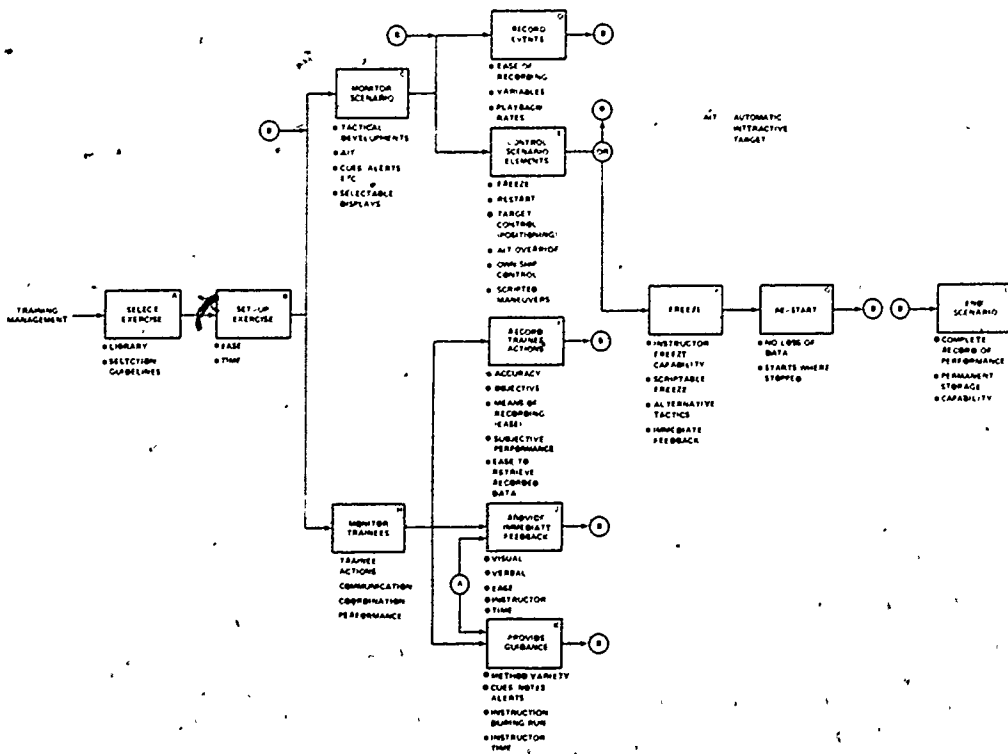

Figure 4. Monitor and Control Training

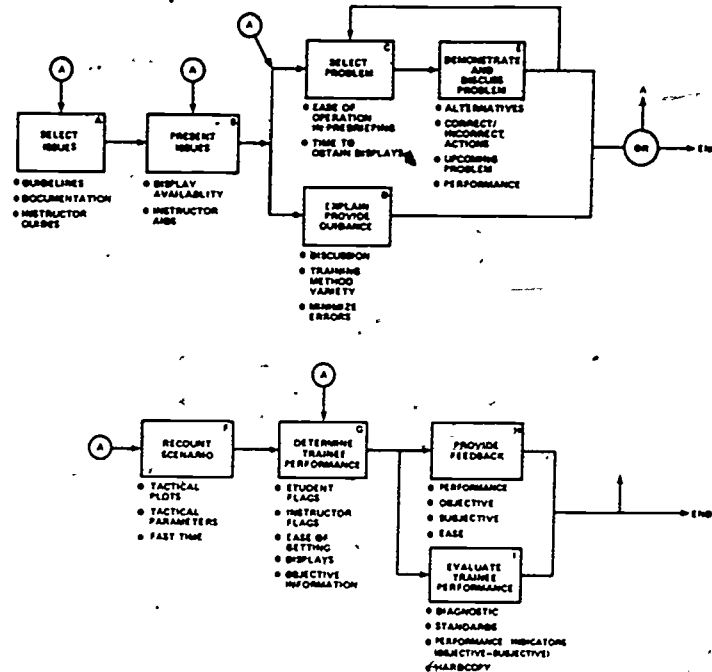

Figure 5. Briefing (Pre, Freeze, Post)

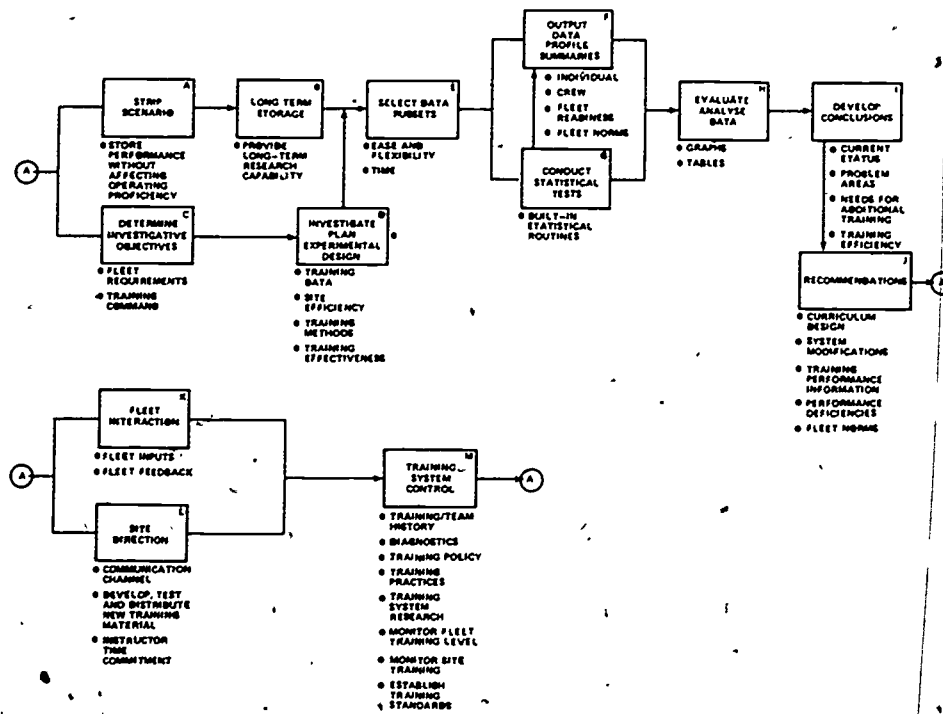

Figure 6. Training System Management



Exercise development (Figure 3), which proceeds the conduct of training sessions, consumes a substantial portion of an instructor's time. This is a complex function wherein the instructor actually develops the training program and its supporting materials. It is complex in that it often requires the creative design of the course and its training exercises, with the instructor drawing upon the state-of-the-art in training methodology to achieve an effective training process. Whereas some capabilities, although usually quite limited, are often provided on the training device/training system to support exercise monitoring, control and briefing, usually little if any capabilities are provided to support exercise development. It is the exercise development function, interestingly, that determines how the training device will be employed within the training system. Examples of system capabilities to support exercise development are presented later under Training Assistance Technology.

Training system management, similar to exercise development, is typically an overlooked function of the instructor, and one with which he spends substantial time. A wide variety of tasks, issues, and considerations may be associated with training system management. Furthermore, each of these may depend on the particular training establishment under which the training device/training system operates. Nevertheless, several training system management tasks are common across training establishments, as indicated in Figure 6. Perhaps the most important common set of tasks involves monitoring the effectiveness of training over time. For example, it is highly desirable to identify those training objectives (i.e., with associated exercises) that the typical trainees can readily perform upon entering the training program; and likewise to identify those training objectives (and exercises) that the trainees typically have substantial difficulty with, even near the end of the training program. Ideally, reduced emphasis would be placed on the former while increased emphasis would be placed on the latter training objectives in subsequent training programs. For another example, alternative training methods and training materials should be periodically evaluated to continually upgrade their quality and the effectiveness of the training process. These are major management tasks directly impacting the cost/effectiveness of training, and subsequently the operational readiness and effectiveness of weapon systems.

Each time a training exercise is run on the simulator valuable training performance

data is generated. These data could be collected over time and used as the basis for the above evaluations, and other training system development activities. These data would be extremely useful to most levels of management for evaluation and planning purposes. Relatively little of these data are recorded and used today with regard to most training device/training systems. This is one example of a set of training device/training system capabilities that could substantially augment training system management.

The instructor function and task analysis conducted on SMARTTS was integrated with the generic training methodology analysis as indicated in Figures 3 through 6. This analysis resulted in the identification of issues and constraints deemed important to the conduct of an effective training process for submarine officer tactics training. These form the basis for the subsequent design of the SMARTTS preprototype system (i.e., the instructional support subsystem capabilities which make up SMARTTS). A similar process should be conducted as part of the design for each training device/training system.

The next step of the design process is the trade-off analysis to identify and design the specific capabilities to be included in the particular instructional support subsystem for the particular training device/training system. This trade-off analysis should be conducted similar to that of other cost/effective analyses done under the ISD process. The results of the analysis conducted for SMARTTS, although not the analysis itself, will be summarized later in this paper under Training Assistance Technology.

Other Design Issues. The above recommended analysis has as its objective the development of the characteristics of the instructional subsystem from the standpoints of the instructor functions and application/enhancement of effective training methodologies. Several other issues should also be considered during the design of this subsystem. Of primary importance is the flexibility of the instructional subsystem with regard to future upgrading. That is, the subsystem should be designed with evolution in mind. As the training device/training system is used, and as information is generated regarding the effectiveness of its various characteristics, the instructional subsystem should be continually improved. More effective training methodologies should be incorporated, new performance indicators and feedback displays developed, and so on. As the instructors continually

increase their experience in training and with the device/system, as the operational systems continually change, and as the trainees continually improve their performance the training device/training system should likewise change to refocus training emphasis and to continually improve the effectiveness of training. The flexibility to permit evolution in this regard must be designed-in at the onset, with a conscious effort made to continually upgrade training. The engineering characteristics of the system should be such that the major training-related characteristics can be readily modified, and new characteristics added. This impacts the design of the hardware components and the software architecture. For example, new performance indicators and feedback displays will always be required. Hence, the software architecture should be designed to permit easily adding new performance indicator algorithms, which may require access to a wide variety of scenario parameters; generic display formats should be set up which enable the construction of new displays drawing upon the variety of parameters generated and recorded, and a variety of graphical formats. Although details of system design flexibility are not discussed in this paper, they have been incorporated into the SMARTTS system. It is anticipated that as SMARTTS is used demand for new capabilities will continually exist. The SMARTTS software architecture is designed to readily accommodate such modifications and additions as relatively minor software changes. Some of the capabilities identified under the SMARTTS front-end analysis that would further enhance this evolution/modification process have not been included in the preprototype, but are obviously considered for the further developmental units.

It is apparent, as indicated above, that the training process conducted using a particular training device/training system will change over time. Furthermore, in a similar vein, at any given point in time the complex simulator-based training system is likely to be used for a wide range of training levels and training needs. Hence, system flexibility should also address the ready tailoring of the instructional support capabilities to a particular training situation. That is, different types of support capability characteristics are required for the different levels of training likely to be encountered. Many of these can be determined in advanced, while others must be tailored close to the time of initiating the training exercise. The training device/training system, and its instructional support subsystem should be flexibly designed to permit on the spot

tailoring of the training exercise, performance indicators used, feedback displays and their formats, and so on. For example, it may be necessary to generate/modify the next training exercise specifically on the basis of performance in the previous training exercise. Also, the performance standard on which a cue is presented to the instructor may likewise have to be modified shortly prior to running the exercise. The system architecture should be flexible to enable this type of tailoring with relatively little effort.

As noted in the introductory paragraph to this paper, human factoring of the instructor and trainee interfaces is as important in the training device/training system as it is in the operational weapons system. Too often this aspect of design is overlooked. Many of the instructional support capabilities provided to the instructor could simply be included under the category of "good human factors design", since their main purpose is to facilitate the instructor/system interface and improve the effectiveness of his performance. This includes, for example, the specific human computer/training device interface for exercise set up, control and monitoring. An effort should be made to minimize the amount of training necessary for the instructor to be able to operate the training device. On SMARTTS, for example, the traditional alphanumeric/function-key input device was replaced with a touch-sensitive plasma display device. The plasma input device has many advantages beyond those which have been incorporated into the preprototype SMARTTS; nevertheless, those plasma-related input features incorporated into SMARTTS should provide a substantial increase in the effectiveness with which the instructor can communicate with the training device. The instructor does not have to learn, for example, a large number of input codes for effecting control of the training device; he does not have to remember the options available to him, and look up the appropriate codes, or coordinate the options from the CRT to the alphanumeric input keyboard; he does not have to input a sequence of alphanumeric commands on the keyboard. Rather, the complete set of input commands are logically layed out in a tree structure, and only those commands available to him at any point in time are displayed on the plasma entry device. These available commands are displayed in English. To enter a command, he simply points with his finger to the appropriate command. This type of interface is user friendly, and to a large extent self-teaching through use of the device itself. Careful consideration should be given to the many other aspects

of the instructor and trainee interfaces with the training device (e.g., location of instructor information, location of trainee feedback displays).

### Training Assistance Technology

The remainder of this paper identifies aspects of training assistance technology that are important elements of the instructional support subsystem. These are presented with regard to each of the four major instructor functions identified above. Specific examples of characteristics are given pertaining to the SMARTTS system, where applicable.

EXERCISE DEVELOPMENT CAPABILITIES. (Figure 3). Exercise development may include the development of the training objectives, the course syllabus, and so on. Although these capabilities can be supported by parts of the instructional subsystem, under this function and under the training system management function, they are not directly addressed herein. Rather, those capabilities more directly related to the training device activities itself (i.e., conduct of scenario exercises) are specifically addressed herein, and summarized in Figure 3.

Instructional Support Material. A variety of material should be available to the instructor as his primary resource for developing the training device exercise scenario. Most of this material would likely be in the form of handbooks, although some could be available in a computer data base. This information should include (1) a complete set of tactical and behavioral training objectives, cross-referenced to exercises and operational situations; (2) a complete set of tactical reference information, such as Naval Weapons Publication (NWP) series documents; (3) a set of guidelines regarding training methodologies, training device operations, and training exercise development; and (4) trainee input characteristics information, including previous trainee/team performance information, and training/tactical needs. The information related to trainee input characteristics could be available on a large information base assembled from previous training exercises of that particular individual or team, together with comparative data on the population of similar trainees, and so on. The necessary data would be collected under the training system management function of the instructor.

The SMARTTS system, to support this exercise development function, has developed documents to aid the instructor in the design of exercises. SMARTTS has developed not only the standard system operating handbook, but also an instructor's handbook which addresses how to design exercises, alternative training methods that can be employed, how to conduct a training exercise, and so on. Additionally, a comprehensive set of training objectives have been developed along with a set of training exercises cross-referenced to these objectives. A training structure has been developed across multiple levels of trainee proficiency, with diagnostic information supplied to evaluate the trainee/team input characteristics; remedial training activities have also been included to help assure that all trainees meet the minimum entry level standards. Furthermore, training materials for the initial tactical course, including exercises, have been developed utilizing the SMARTTS capabilities. This approach not only has provided the structure and guidelines with which instructors can develop subsequent training courses and exercises, but has also provided an example in the form of the initial such course.

Exercise Development Simulation. A flexible high speed simulation capability is necessary to enable the instructor to review existing exercises in the library, modify an exercise, or create a new exercise. This fast time simulation capability is necessary in support of tasks "B" through "I" under the exercise development function (Figure 3). Review, modification, or development of an exercise can be an extremely cumbersome and time consuming process. This is particularly the case where calculation of the developing time line scenario interaction is necessary to assure appropriate scenario events in support of the exercise objectives. Furthermore, it is well recognized that scenarios often turn out substantially different when run on the device than as they appeared on the desk top plot sheet of the developer. The fast time simulation should provide capability for the instructor to:

- (1) call up an existing exercise and run it in fast time to any desired point, retrace steps, and so on;
- (2) investigate alternative actions from any desired time to any other desired time;
- (3) generate and display relevant performance indicators and situation

parameters (e.g., target range) at the various times of the actual scenario and the alternatives under investigation;

- (4) modify any of the scenario parameters, enabling comparison of the tactical parameters and performance indicators at any subsequent point in time;
- (5) enter new performance indicator algorithms to be recorded and displayed during or subsequent to the exercise;
- (6) insert instructor cues to be automatically keyed at times during the exercise based on various aspects of the scenario parameters and/or time;
- (7) configure new feedback display formats for trainee briefings based on the training objectives, issues to be focused on, or parameters generated during the scenario, and so on;
- (8) develop new subjective performance monitoring input categories for observation entry by the instructor during the actual exercise;
- (9) set up all necessary scenario parameters for running the scenario on the training device;
- (10) permanently record the exercise in the exercise library for later review via this fast time simulation capability, or for actual running during a training exercise on the training device.

Additional capabilities could also be listed; but these present a good overview of the type of capabilities that should be available to the instructor in an off-line mode of the training device to enable him to review and configure scenarios. A library of all available training exercise scenarios should obviously be accessible to the instructor for this development process. This fast-time simulation capability should be available at an off-line location to the training device, permitting access and fast time simulation in parallel with the actual running of the training device. The terminal should have appropriate graphical displays and an entry device to facilitate instructor interaction and evaluation.

SMARTTS has identified the need for a fast time simulation capability to assist the instructor in developing exercises. This

full capability would require the fast-time simulation capability as well as other elements of the exercise development function. In the preprototype SMARTTS this capability was given secondary importance to the monitoring, control, and briefing capabilities. Nevertheless, a fast-time simulation capability at a remote terminal was provided on SMARTTS, partly due to a particular design of the system which has two parallel complete operating systems with associated simulation models and two complete instructor consoles (i.e., one in a classroom and the other in an attack center). The SMARTTS system permits the fast-time running (i.e., at a rate up to 16X) of any exercise scenario in the library. All of the tactically relevant variables and performance indicators can be evaluated on either of the instructor consoles. Modifications of any of the tactical parameters can be effected from these consoles, with the modified exercises permanently stored for later training use. This SMARTTS capability, during the limited time in which it has been given operational use, has been found to greatly assist the instructors in preparing and evaluating scenario exercises. Requirements had been earlier identified to more fully develop this capability in the later developmental versions of SMARTTS; initial indications to date are that these planned additions should be carried out.

Instructor Interface Language. The typical instructor in military training systems has a good operational background (e.g., submarine operating experience for a submarine tactical instructor), although a limited instructional and computer background, particularly with regard to operating particular training devices. Hence, it is desired to have a computer language developed to facilitate the instructor's interface with the training device. This interface language should permit the instructor to interact using somewhat standardized operational terminology, instructional terminology, and/or near-English terminology. It should be designed to accommodate those activities normally performed by the instructor when interfacing to the training device. With regard to exercise development, for example, this language should accept descriptive commands by the instructor in the form of the normal operational parameters (e.g., whereas the computer manipulates targets on an X, Y, Z grid, operational personnel often view the geographic situation in terms of range, bearing, and depth/evaluation). Furthermore, the interface language should be structured to contain a large set of macro functions that readily translate the

instructor's needs into exercise, performance indicator, cue, feedback display, etc., modifications. For example, the capability should be provided to enable the instructor to readily tailor feedback displays to particular exercises. This macro function should enable the instructor to rapidly provide the information necessary to configure the display in terms as close as possible to those operationally used, and then enable the computer to automatically configure the display. This might be accomplished using a digital interface drawing tablet, with appropriate parameter data readily accessible, and with standardized manipulation algorithms available.

SMARTTS, although not possessing capabilities to this extent, does permit instructor flexibility in setting-up and tailoring trainee information displays. SMARTTS, for example, provides several generic plot formats of X versus Y with which the instructor can display any parameter (i.e., performance indicators and tactical variables) as a function of any other parameter. The instructor simply has to indicate which variables he wishes to plot and they would be automatically plotted. The instructor can also set-up several groups of parameters to be called-up for display simultaneously by requesting the group(s) rather than each individual parameter. These capabilities are not only useful during the exercise generation function but are also intended for the briefing function. SMARTTS has identified the need for an instructor interface language for exercise development, but has not formally developed such a language as part of the preprototype system, although some capabilities of this type are included in the preprototype.

MONITOR AND CONTROL TRAINING. The instructional support subsystem should provide a predominance of its capabilities for the monitoring and control of training, and for the briefing function which is addressed later. Suggested monitoring and control capabilities are presented below, in reference to Figure 4.

Exercise set up. At the point when the scenario exercise will be run on the training device during actual training, it should have undergone prior development and evaluation. Hence, typically, exercise set up would be a matter of simply selecting the appropriate exercise from the library and initiating the problem on the training device. Some minor modification may also be desired at this time. An exercise library, therefore, should be available to

the instructor from which he can select the appropriate exercise. Actual set up on the device should be as automated as possible, so as to free the instructor to perform other duties, and to enable quick turn around time between training exercises if desired. The exercise set-up procedure on today's training devices, even after the exercises have been fully developed, is often cumbersome and time consuming; manual entry of all the set up parameters is often necessary at the time of initiating the exercise (e.g., in some instances this may take up to 45 minutes). This laborious entry process should be unnecessary for standard exercises; on a sophisticated training device the exercise parameters can simply be stored on a disk for automatic entry. A capability should be provided to enable the instructor to modify any of the parameters at the time of initiation, if he so desires.

SMARTTS provides an instructor's console immediately adjacent to the fire control system consoles from which the instructor can select an exercise from the exercise library and have it automatically entered upon command. He can also investigate and manipulate many of the relevant tactical variables at this time to modify the exercise. Furthermore, if the instructor so desires, a modified copy of the exercise can be automatically stored in the exercise library as a new exercise for later use. This type of capability substantially reduces the low level time consuming task of set-up.

Exercise Monitor. The instructor must monitor both the scenario and the trainee activities. Relevant monitoring information should be generated by the training device, with much of the information selectable by the instructor in real-time when he requires it. It should be provided to him in a timely manner and in a clearly understood and meaningful format. Cues should be provided as appropriate to off-load an appropriate part of his monitoring function. This information should be provided to the instructor in a convenient location which enables him to perform his other duties with a minimum of travel. Both alphanumeric and graphical information should be provided, depending on the purpose of the information and the precision the instructor requires.

SMARTTS provides an instructor's console in the attack center, immediately adjacent to the fire control party and the MK117 fire control system. An identical instructor's console is located in the classroom for briefing purposes. SMARTTS automatically records a wide variety of tactical

variables and performance indicators. This information is available to the instructor upon request at the instructor's console. Both graphical and alphanumeric formats are provided, depending upon the information and the instructor's desires. The display is automatically up dated over time to provide the most recent information, as well as to provide historical information from the beginning of the exercise or other designated times. Cues are provided to the instructor regarding (1) performance indicator values or tactical parameter values that have gone beyond predetermined limits (e.g., probability of counterdetection going beyond 50 percent); and (2) pending action by the automatic interactive target (AIT) (see below regarding control capabilities). The display formats used to provide information to the instructor were developed with regard to the requirements of the training situation and the type of information submarine officers normally deal with (e.g., line-of-sight diagram). Hence, the instructor need not return to the program operator consoles to monitor exercise progress. Rather, he can stay with the fire control party to monitor the trainees' actions, and still have the normal scenario monitoring information available. Furthermore, SMARTTS provides the instructor with a variety of additional information concerning trainee performance and the problem status.

Data Recording. The analysis of instructor functions and tasks revealed that typical instructors spend a relatively large amount of time recording exercise data, if they provide this type of feedback to the trainees after the exercise. Furthermore, the better postscenario briefing sessions are those in which the instructor has substantial information available for presentation and discussion with the trainees regarding various aspects of the problem. Much of the information recorded by the instructor is normally generated by the training device (e.g., tactical parameters and events). The typical computer-based training device has the capability to record these data for later accessing by the instructor during the postscenario briefing. In addition, a considerable part of the instructor's tasks is to monitor and record actions of the trainee that could not be automatically recorded by the system (e.g., communication between team members, coordination). These types of subjective performance indicators would be relatively difficult to achieve via automated means in many training situations. Hence, the instructor should focus a substantial portion of his time monitoring and recording these types of performance indicators for later feedback.

The training device could assist the instructor by facilitating his recording of this information via a standardized interface with the training device.

The SMARTTS system records a wide variety of tactical variables that occur during the exercise scenario. Additionally, a set of objective performance indicators are generated and also automatically recorded during the exercise scenario. Finally, a capability is provided for the instructor to enter a variety of subjective observations into the training device/computer storage facility. For example, if the instructor observes highly proficient communication between the fire control coordinator and the plot coordinator during a particular time of the scenario regarding a particular aspect of the scenario, he can easily enter this observation into the computer by designating the appropriate observation. All of the above data are readily accessible to the instructor during the exercise, and also following the exercise for discussion in the briefing session. This set of capabilities not only reduces the instructor's load, but also provides tools to the instructor for training that he here-to-fore did not have. For example, the instructor typically was unable to monitor changes in the fire control system solution accuracy over the course of the exercise as a function of ownship's maneuvering; this information is now automatically recorded and can be accessed by the instructor at any time, including during the postscenario briefing session.

Scenario/Exercise Control. The instructor should be provided with a wide range of control capabilities to enable him to readily control all aspects of the scenario, and also control presentation of pertinent information to the trainees as necessary. The control capabilities should be provided in a convenient location, similar to that for the monitoring information, preferably near the trainees such that the instructor can continually monitor the trainees and the problem while entering necessary control commands. Ideally, the instructor would spend a minimum of time controlling the exercise, devoting most of his resources to other training-related activities. In this regard, scripted scenarios should be available wherein the target has predetermine actions. Additionally, other types of control for the target and other aspects of the problem would be desirable if they freed the instructor from these tasks. It should be noted, however, that the instructor should be allowed to control any of the aspects he so desires. In addition

to the scenario control capabilities, the information presentation capabilities should likewise be located for appropriate viewing by the trainees, and so that the instructor can control the information presentation via convenient and effective media. The location of this information presentation (e.g., feedback) would normally be, either in the operational simulator environment (e.g., attack center) and/or in a briefing room. In either case, the instructor should have complete control over the information presented, enabling him rapid configuration of the desired displays.

The instructor's console in the SMARTTS system is located near the fire control party in the attack center. The instructor is presented with monitoring information on a color graphic CRT as well as the plasma display entry device. The instructor can control many of the relevant tactical problem variables (e.g., maneuver targets) from this console, as well as control a wide variety of information to be presented to the trainees. The information presentation to the trainees is achieved in the attack center via two overhead-mounted color CRT displays. A variety of display formats can be put up independently on each of these CRTs via command from the instructor's console. The similar instructor's console located in the adjacent classroom controls the information to be displayed on a large screen display during briefing sessions.

SMARTTS has the normal scripted scenario capability, along with an automatic interactive target (AIT). The AIT capability provides a computer-controlled model of an enemy target platform. This model is based on the best available intelligence information for the particular platform. The model automatically controls the target in response to the evolving situation events in real-time. Cues are provided to the instructor prior to any action on the part of the AIT, enabling the instructor to (1) allow the AIT to carry out its planned action, (2) override the AIT's planned action by having it continue doing its current activity, (3) enter a different target course of action, or (4) take over manual control of the target. The AIT capability is intended to reduce the instructor's load in controlling the principle target, which has been observed to be considerable. The AIT, furthermore, brings in the best available intelligence information to probabilistically control the target in a realistic fashion. This capability will assist in off-setting experience differences and biases between instructors.

Information Presentation. Information presentation to the trainees, in the form of a preproblem briefing or postproblem feedback, is an essential part of an effective training process. Appropriate information must be generated by the training system, and presented to the trainees in an effective way to assist their assimilation. A wide variety of media is available for presenting information to the trainees. The most common is that of verbal presentation by the instructor. Unfortunately, verbal presentation is limited with regard to handling complex relationships. The use of augmenting graphical information (i.e., pictures) and examples has been shown to substantially increase the effectiveness of training (Lesgold, Pellegrino, Fokkema, and Glaser, 1978). Hence, a visual information display capability should be made available in the instructional subsystem, particularly for complex training situations. A variety of capabilities may be associated with that information display, such as a fast time model to explore alternative actions in a given problem. Also, a variety of information should be available in the training device regarding the recently completed exercise scenario for presentation to the trainees. Ready access to, and flexible control over, this information and these capabilities should be provided to the instructor at an appropriate location. Obviously, the monitor, record, and control capabilities act together with the information display capabilities to provide appropriate information to the trainees. The information presentation capabilities are further discussed below under the briefing function which overlaps considerably with this monitor and control function.

The monitor and control capabilities of the instructional subsystem are quite extensive on SMARTTS, as part of the submarine combat system trainer. These capabilities are generic, although their specific characteristics have been tailored to the submarine tactics training problem. The above discussion presents a very general summary overview of the particular characteristics incorporated in SMARTTS for this instructor function, and its associated tasks, issues and considerations.

BRIEFING. The briefing of trainees is a major training process function of the instructor. It obviously overlaps with the monitor and control tasks as noted above, and also overlaps with the trainee interface requirements of the instructional subsystem. It is the opinion of this author that many of the trainee interface

characteristics of the instructional subsystem are the same as those required for the briefing function. The briefing function of the instructor deals with providing external information to the trainees to correlate with their actual or desired actions. This information is a primary means by which training actually occurs. For example, this information provides feedback informing the trainee of how successful his particular actions were with regard to the operational objectives. Since a major objective of training is to develop an awareness on the part of the trainee of the relationship between available information, alternative actions that can be taken, and the resultant likely situation outcomes, external information presented to the trainee is extremely important. Hence, the effectiveness with which information can be presented to and assimilated by the trainee will have a direct bearing on the effectiveness of the training process. Information presented to the trainee attempts to achieve the following:

- (1) explain a particular evolving situation (e.g., events that occur during a tactical encounter),
- (2) identify possible alternative situations and actions (e.g., the types of targets likely to be encountered in this area, each target's likely set of tactics, and appropriate defenses),
- (3) the outcome of the trainee's particular actions during the problem (e.g., the trainee teams tactical approach on a target),
- (4) the relationships between tactical variables that were relevant in the problem (e.g., the relationship between ownship speed and probability of counterdetection), and
- (5) the likely impact of various alternative trainee actions on the situation outcome (e.g., the impact of different ownship speeds on achieving a successful target approach). These categories of information might be differentially brought up prior to a real-time training exercise, during a freeze pause in that exercise, or following the exercise.

The information categories fall into two general classes. The first is to provide information regarding a particular problem. This is typically in the form of feedback after the problem occurred. It may involve dissecting the problem to

investigate the trainee's actions, why he took those actions, what options were available to him, and so on. The second class of information is somewhat independent of the particular actions on the part of the trainee. Rather, it deals with the general set of possible problems, investigating relevant issues surrounding a particular set of problems. This would normally occur in a briefing session prior to the real-time exercise on the device. It may also evolve during the postproblem briefing session. Whereas the former class of information presentation class relies on the data generated and collected during the training exercise, this latter relies on a fast time modeling capability to generate the various alternative actions, tactical parameters, and performance indicators. This briefing capability should be located where most convenient to the trainees, and conducive to the types of activities occurring during the training process.

Information displays in the SMARTTS system have been provided both in the attack center and in the classroom. These two locations recognize the different activities that may take place in both. The classroom can operate in conjunction with the attack center (e.g., monitoring the ongoing exercise in the attack center), or both can operate independently on separate problems. A variety of performance indicators are available for display to provide the trainees with information concerning the various aspects of their performance. The intention in SMARTTS has been not to develop performance indicators pertaining to good or bad performance, but rather to generate information that can be meaningful from the standpoint of informing the trainee about the scenario and his performance. Often, performance indicators change in an opposing fashion, necessitating trade-offs between them when selecting the appropriate tactical action. From a training process standpoint, the important consideration is not how well the trainee did, but rather that the trainee understand the impact of his actions and the other actions available to him. SMARTTS provides the instructor with a wide range of capabilities to access the various information that was recorded during the training problem. A variety of information display formats are available for presenting and discussing this information, as well as a range of flexibility to dissect the information and focus on particular aspects of the problem. The instructor's subjective observations, which were entered during the exercise, are also available for a reference during the postproblem briefing session. Also, time-flag units are available at several trainee locations to



enable the trainees to place a time-tagged indication in the scenario recording at a point when they were concerned with a particular issue and unable to bring it to the attention of the instructor. These trainee-instituted time-tags can be accessed during the postproblem briefing session for investigation.

The fast-time simulation capability, discussed above several times, is also available in SMARTTS to generate problems for presentation and discussion. The fast-time capability may be used in a preexercise briefing wherein the trainees can be given a preview of the particular exercise they will encounter, or other relevant exercises. Various performance indicators and tactical parameters can be investigated at this prebriefing time to focus on the aspects of importance during the problem. Alternative sets of ownership and/or target actions can also be addressed at this time to explore their impact on the various tactical parameters and performance indicators. This capability is also available during a problem freeze and during the postproblem briefing session. During the latter session, alternative sets of actions may be explored for the particular problem just completed in the attack center. It is important to note that models are provided in SMARTTS to generate information that would normally be generated by the trainee team (e.g., target motion analysis solution). This information, generated in fast time, is useful for comparison with the actual values generated by the trainee team with regard to the alternative actions being investigated for comparative purposes.

It is important that an adequate human factors design be implemented for the instructor/computer interface with regard to the briefing capabilities. At this time, the instructor is standing on-stage and has to perform in a timely fashion. These briefing capabilities provide the instructor with a substantial amount of information to access and present to the trainees. However, it must be facilitated in such a way that it can be brought up flexibly and quickly, with relative ease on the part of the instructor. It must also be presented clearly to the trainees. The design of the SMARTTS instructor's console (e.g., a color graphic CRT and a plasma display entry device), as noted above, has been designed to facilitate this interface.

#### Training System Management

A variety of capabilities are desirable for training system management. The most important capability that the device

automation can assist is the recording and storage of data generated during exercise scenario runs and the statistical analysis routines to enable investigation of these data at a later time. As noted earlier, important training system-related data are generated each time the training device is used. These data can be extremely useful in evaluating and upgrading a variety of aspects of the training process (e.g., development of exercises as noted above). The SMARTTS front-end analysis has identified the need for many of these capabilities. The preprototype SMARTTS system has the capability to record and long-term store exercise data for later analysis. Additional analysis capabilities should become a part of the later SMARTTS developmental units.

#### SUMMARY

The training device is more than a simulator. It has both simulation and instructional subsystems, each specifically designed for a vastly different purpose. The instructional subsystem encompasses capabilities that directly support the training process. These capabilities focus on the instructor, the trainee, and training system management. Their incorporation in modern training devices/training systems is essential to achieve the high levels of training cost/effectiveness requisite for adequate operational effectiveness of modern weapon systems.

Although many training support capabilities should be automated, such as the computer driven automatic interactive target and others discussed in this paper, many additional capabilities that are part of the instructional subsystem can be effectively accomplished via traditional manual means (e.g., instructor guidelines for exercise development). The training device/training system should provide a range of capabilities in the instructional subsystem selected on the basis of their cost/effectiveness impact on the training process. These capabilities, furthermore, should be flexibly tailored to each specific training situation. The training device/training system can greatly assist the instructor in enabling him access to here-to-fore unavailable complex information directly impacting trainee performance (e.g., probability of counterdetection). Presentation of this complex information can also be enhanced via presentation on highly effective media (e.g., large screen graphical display). A variety of data manipulation capabilities can enable dissecting various operational problems, investigation of alternative

actions, illustration of a range of examples, and so on (e.g., via fast-time computer modeling). These and many other computer-based and manual capabilities make up essential elements of the instructional subsystem.

The instructional subsystem encompasses elements beyond those discussed in this paper, such as a variety of manual media typically used in the training process. The instructor himself, for example, is probably the single most important element of the instructional subsystem and the training system (Gardenier and Hammell, 1981). Empirical research has shown that the instructor can have a substantial impact on the effectiveness of simulator-based training. The capabilities discussed in this paper provide tools for the instructor to enable him to achieve a more effective training process. Nevertheless, the fundamental characteristics of the instructor himself, independent of these tools, may have a substantial impact on the effectiveness of any training situation.

As discussed early in this paper, we are now emerging on the third generation training device, emphasizing the importance of the instructional subsystem and built-in training technology capabilities to enhance the training process. Although the emphasis given to the instructional subsystem in the past has been relatively minor, its importance is becoming recognized, with increasing emphasis given to these capabilities in the design of today's training devices/training systems. SMARTTS is one example, and a forerunner of that trend. Another example is a set of guidelines for deck officer training systems (Gynther, Hammell, Grasso, and Pittsley, 1982) which address the use and design of the shiphandling/ship bridge simulator for training senior commercial ship deck officers. This report recognizes and places emphasis on "three major elements of the training system - the simulator design, the training program structure, and the instructor qualifications" (page i). This document, which is intended to provide training system design guidance to the potential users of shiphandling/ship bridge simulator-based training devices, addresses and recommends many of the training assistance characteristics discussed in this paper, and embodied in the SMARTTS preprototype.

The instructional subsystem has been presented in this paper as one of two major parts of the training device. As such the training-related capabilities were strongly emphasized, while the fundamental

engineering aspects of this subsystem were played down. In the past, along with the lack of adequate instructional capabilities, most training devices received inadequate attention and scrutiny of their training-related capabilities. Following from the effective procedures established to monitor the design and development of the hardware and software aspects of the training device, a similar procedural policy should be established by training device procurement activities to monitor and evaluate the potential training effectiveness of the training device. These procedures should evaluate the training device from its initial conceptual design stages on through development, factory acceptance testing, and site acceptance testing. The focus of these additional evaluations should not be on the specific hardware and software engineering aspects, but rather on the potential impact of the trainers and their development characteristics on training effectiveness. The evaluation of the potential training device's characteristics should not end with the initial conceptual design; rather, it should continue to monitor the specific details of the implementation of those initial concepts. For example, a detailed human factors review of the various characteristics of the instructor interface should be accomplished at appropriate stages during the development process to verify effective design details. SMARTTS developed a training system evaluation test (TSET) to be conducted at the time of the Factory Acceptance Test for the hardware and software. The TSET addressed specific characteristics of the design as they were expected to impact the effectiveness of the training process. This type of evaluation should take place at all stages from initial conceptual design through the production run of a particular device, and continue after the device is operational to constantly evolve its capabilities and hence improve its training effectiveness.

This paper focused heavily on training system aids for assisting the instructor, and providing an effective interface with the trainee. It did address, although to a limited extent, the importance of the training methodologies employed for achievement of an effective training process. The instructor, the training device and its tools are mechanisms for implementing an effective training process. The methods they use in implementing this process are extremely important for achieving maximally cost/effective training. The training methods are, obviously, an extremely important part of the instructional subsystem. They represent the strategy that is employed to achieve the training

objectives. As training system capabilities improve, the breath and potential effectiveness of available training methodologies also increase. For example, learning by example has been shown to be an effective training method (Lesgold et al, 1978). This can be accomplished in the modern training system in a variety of ways, including several facilitated by capabilities discussed in this paper (e.g., fast-time modeling in the classroom to investigate alternative tactics). By providing appropriate instructional support capabilities on the training device, effective training methods that could not be used due to the problem complexity or other situation limitations are now available.

The training expert must also be careful not to overlook other training methodology principles which are available but might be overshadowed by the automated capabilities provided on sophisticated training devices. For example, overlearning is a potentially effective approach for the training of individuals to perform under high stress conditions; to take advantage of the benefits of overlearning in such situations does not require any particular instructional subsystem capabilities (Fitts, 1965). As always, the most cost/effective training process will be achieved by taking into account all of the relevant elements that impact that process, including the simulation characteristics of the training device, the training methods employed, and the capabilities of the instructional subsystem.

#### REFERENCES

Lesgold, A.M., J.W. Pelligrino, S.D. Fokkema, and R. Glaser. "Cognitive Psychology and Instruction" in Proceedings of Data International Conference held at the Free University of Amsterdam, June 13-17, 1977 sponsored by the NATO Special Program Panel on Human Factors. New York, Plenum Press, 1978.

Chenzoff, A.P. et al. "Guidelines For Training Situation Analysis (TSA)." Applied Science Associates, Incorporated, Valencia, Pennsylvania, July 1965.

Comptroller General. Report to the Congress of the United States; "Effectiveness Of U.S. Forces Can Be Increased Through Improved Weapon System Design." U.S. General Accounting Office, PSAD-81-17, January 29, 1981.

Krahenbuhl, G.S., P.W. Darst, J.R. Maret, L.C. Reuther, and S.H. Constable.

"Undergraduate Pilot Training: Instructor Pilot Behavior And Student Stress And Performance, Level II." Department of Health and Physical Education, Tempe, Arizona, July 1980.

Charles, J.P. "Instructor Pilot's Role In Simulator Training (Phase III)." U.S. Naval Training Equipment Report, NAVTRAEQUIPCEN 76-C-0034-2, June 1978.

Gardenier, J.S. and T.J. Hammell. "Shiphandling Simulator Standards and Training Technology." U.S. Coast Guard, Washington, D.C. and CAORF/Ship Analytics, North Stonington, Connecticut. Paper presented at the Second International Maritime Simulation Conference, Kings Point, New York, June 1981.

Gynther, J.W., T.J. Hammell, J.A. Grasso, and V.M. Pittsley. "Simulators For Mariner Training And Licensing: Guidelines For Deck Officer Training System." National Maritime Research Center, Kings Point, New York, January 1982.

NAVEDTRA 106A. "Interservice Procedures For Instructional Systems Development." Center for Education Technology, Florida State University and U.S. Army Combat Arms Training Board, Ft. Benning, Georgia, 1975.

Fitts, P.M. "Factors In Complex Skill Training" in R. Glaser (Ed.) "Training Research and Education." Wiley, New York, 1965.

Hammell, T.J. "The Training Device Is More Than A Simulator." Ship Analytics, Incorporated, North Stonington, Connecticut. Paper presented at the Second International Maritime Simulation Conference, Kings Point, New York, June 1981.

Hammell, T.J., J.W. Gynther, J.A. Grasso and M.E. Gaffney. "Simulators For Mariner Training and Licensing Phase 2: Investigation Of Simulator Characteristics For Training Senior Mariners." National Maritime Research Center, Kings Point, New York, January 1981.

Hammell, T.J. and T.N. Crosby. "Development of SMARTTS Training Technology." Eclectech Associates, North Stonington, Connecticut and Naval Training Equipment Center, Orlando, Florida. Paper presented at the Second Interservice Industry Training Equipment Conference, Salt Lake City, November 1980.

Caro, P.W. "Aircraft Simulators and Pilot Training" in Human Factors, 1973.

Hammell, T.J., F.P. Sroka, and F.L. Allen.  
"Volume I of II, Study of Training Device  
Needs for Meeting Basic Officer Tactics  
Training Requirements." Naval Training  
Device Center, Orlando, Florida, 1971.

Hammell, T.J., C.E. Gasteyer and A.J.  
Pesch. "Volume I of II, Advanced Officer  
Tactics Training Device Needs and  
Performance Measurement Technique."  
General Dynamics/Electric Boat Division,  
Groton, Connecticut, November 1973.

# PROCEDURES MONITORING AND SCORING IN A SIMULATOR

Steve Seidensticker  
Terry Kryway

Tactical and Training Systems Division  
Logicon, Inc.  
San Diego, CA

## ABSTRACT

As the quality of cockpit simulation increases and as economic pressures force more training into simulators, the number and type of training tasks handled in the simulator are also expanding. Many of these new tasks are procedures oriented. This is particularly evident in pilot replacement training in high performance aircraft. In such situations the simulator is used to expose the student to emergencies and other situations where judgement and the ability to follow certain procedures accurately and quickly are vital. To do this rational techniques are needed to detect and assign meaning to the procedural events. This paper will relate in some depth the efforts to incorporate a comprehensive procedures monitoring and scoring facility in an Operational Flight Trainer.

## BACKGROUND

The quality of flight and weapons systems simulation in military simulators has advanced rapidly with the application of digital computers. This is particularly visible in the areas of visual scene and weapons system simulations. Transitional (from one aircraft to another) training curricula have taken advantage of these recent advancements and flight trainers are now being used in scenarios where more than just flying skills and the rote responses to emergencies are being taught. Instructors are now subjecting the student to situations where pre-planning, headwork and a thorough knowledge of the aircraft and its systems are required.

### General Problem

The quality of training received from these expensive systems depends a great deal on the instructor's ability to operate these trainers and of his ability to keep up with activities in the cockpit. Often the existence of such ability is an exception rather than the rule. This is not because instructors are incapable of the tasks, but because the complexities of operation require substantial training and experience in order for the instructors to become proficient. And operation of the trainer is only one of the many responsibilities of the flight instructor.

An example of such a situation stems from a recent improvement to the Navy's F-14 Operational Flight Trainer (OFT), device 2F95. The visual system has been enhanced to simulate carrier operations including catapult launches. The training syllabus has taken advantage of this and now single engine failures are being practiced during the catapult shots. A timing problem exists

in the insertion of the engine failure after the catapult stroke has started. If it is not inserted at precisely the correct moment, the simulation is not accomplished correctly and the training value is lost. Therefore the instructor spends most of his attention in the operation of the trainer and not to the student's reaction to the emergency. If the student crashes, the instructor obviously notices the result, but does not know what, if anything, the student was doing prior to getting wet.

Recent emphasis has been placed on simulator design to help the instructor with scenario generation and problem control. One of the important aspects of problem control is that of procedures monitoring and performance measurement. Though simulators in the past have attempted to provide the instructor with this type of information, in most cases these enhancements are the first to be ignored by the instructor.

### Early Attempts

An example of recent performance measurement capabilities are on the existing F-14 OFT. This trainer has the capability of monitoring the performance of a trainee and issuing a hard-copy printout whenever performance limits are exceeded. The instructor may select five of ten flight parameters and set a low and high limit on these values. He may also segment the exercise by time. Then by paging into an alphanumeric display, he may observe the trainee performance with respect to these flight parameters.

Some of the problems voiced by instructors with respect to this particular mechanism are:

The performance monitoring is restricted to flight parameters only.

The high and low limits are not standardized and the values are often meaningless because they usually must be related to the scenario.

Indexing by time into the training session is not effective in that instructors do not keep track of a training session by time, but by training task. Time references may be meaningful if used within a particular training task but not if used with respect to the entire training session (e.g. two minutes after commencing an approach is meaningful, however, 17 minutes after commencing the exercise is not).

Setting up the performance measurement is a laborious process. The instructor must use a keyboard and paging functions for data entry.

The data generated is not readily available nor is it in a format easy to interpret and apply to the evaluation of the student's progress.

Another performance measurement feature in a recently delivered flight simulator is an overview of the cockpit activity where the trainee's 20 most recent actions are listed on a CRT.

Interviews with and observations of users of this device indicate that the time event monitor is not very effective for monitoring specific procedures in the cockpit because:

Not all of the 20 most recent actions may be applicable to the task the instructor is monitoring and the page tends to become cluttered with inappropriate information.

Certain procedures applicable to the task may not be represented on this page and must be followed on another area of the Instructor/Operator Station (IOS).

When the student becomes very busy in the cockpit, these action messages appear and disappear more quickly than they can be read.

#### ISS APPROACH

Rational techniques are needed to detect and assign meaning to the procedural events and performance measurements in a trainer. This information must be made readily available and must be presented in an easy to understand format to the user. While this may not seem to be a difficult task on the surface it has not been built into any trainer successfully.

The remainder of this paper describes efforts by Logicon personnel to incorporate a comprehensive procedures monitoring and scoring facility in the Instructor Support System (ISS). The ISS is the product of a general effort to improve IOSs sponsored by the U.S. Naval Training Equipment Center.

#### Problem Management

In approaching this effort one of the first technical issues that arose was the sheer size of the problem and computer processing power required to handle it. The F-14 OPT has approximately 350 switches and other pilot adjustable mechanisms in the cockpit. If one attempted to monitor all of them all the time and condense, evaluate, and present derived information to the instructor, one would require more processing power than is available with any computer and more software than a small army of talented programmers could produce.

The only reasonable solution appeared to be the creation of a mechanism whereby only the subset of activity in the cockpit that was appropriate at the moment would be monitored and processed. This resulted in the establishment of "task modules".\*

These are operationally logical training segments such as takeoff, departure, or hydraulic malfunction. A training session/scenario is composed of a group of these task modules. Part of each task module are detectable "events". The ISS can follow the scenario by watching for these events. For example, a combination of events such as gear transition to up, flaps transition to up, speed increasing through 200 knots, heading increasing and passing 275 degrees, "starts" a task module representing a particular departure from NAS Miramar. When this task module is started, only those flight parameters and procedures applicable to this training task are monitored and processed.

Task modules may also be "forced" to run by direct action of the instructor. More than one task module can run at the same time, if the activities associated with them overlap. This quality was also used to monitor vital safety functions at all times the aircraft was off the ground. A task module was defined whose start condition was "weight off wheels" and stop condition

\* A companion paper, also prepared for this workshop, entitled MODULAR CONTROL OF SIMULATORS explains the concept of task modules in depth. Although this paper indicates how task modules fit into procedures monitoring and scoring, the reader is encouraged to refer to the other paper for additional information.

was "weight on wheels". Among other items it monitored the accelerometer and informed the instructor of any aircraft overstresses. It was nicknamed the "umbrella" and kept the ISS from looking stupid by not informing the instructor if some disaster occurred. The maximum number of concurrently running task modules in the ISS is four. This constraint was due to processing power limitations, but it did not hamper operations.

#### Task Module Structure

In order to understand in more detail how the ISS monitors procedures and performance measurement, one must examine the ISS software and task module structure. The system is driven by a data base consisting of task module data files. Each task module is defined by a set of data files which are unique to that individual task.

One of the files within a task module set defines detectable events (or actions) that are directly, functionally, and physically related to the training task. Directly related actions are those that are depicted in the NATOPS manual as part of the procedure (e.g. switch A - off, switch B - stby, lever C - up, etc.). Functionally related actions are any actions which are similar in function but are not part of the procedure. (e.g. in a particular hydraulic failure a secondary hydraulic isolate switch is part of the hydraulic system of the aircraft, but does not play a part in the particular procedure.) By identifying this switch, a diagnostic message can be created informing the instructor if this switch is mistakenly thrown. Physically related actions are those linked to switches that are in close proximity to the appropriate switch and may look the same (e.g. if the wrong circuit breaker was pulled in a procedure, this identification would produce a diagnostic message).

In the definition of these events the following considerations are made:

Relationship of the cockpit device value to a reference value (greater than, less than, etc.).

Stable time (to avoid triggering on transient changes).

Whether the event is external, something happening in the trainer, or internal, a combination of external events.

Whether the event is a verification of a value or a change in its state.

Whether the event has the "dropout" property (whether it is considered to be another occurrence when the reverse of the initial happens).

#### Procedures Monitoring

A program dedicated to monitoring these events is notified when a task module becomes active and opens a file defining the appropriate events for that task module. In this way, only a select group of switches are monitored at any one time.

Whenever any of these events have been detected, this event monitoring program informs another program, dedicated to the procedures monitoring function. Like the event monitor, this program is also informed when a particular task module becomes active. It opens a file which has defined the relationship of the events.

This program evaluates actions with respect to relationships and contingencies and causes a variety of actions to be taken by the system. That is, it can evaluate a sequence of events such as the case where switches A B C must be thrown in sequence, and C D E must be thrown after the first three but not necessarily in sequence. An example of this is the engagement of nose wheel steering during an F-14 takeoff. The steering is optional prior to 15 knots, a requirement between 15 and 80 knots, and must be disengaged prior to 100 knots.

With respect to contingencies, not only must the specific action be identified, but also the circumstances under which it is to take place must be defined. That is, when an event occurs, alternate actions may be specified depending on other circumstances or contingencies. For example, during takeoff if the aircraft heading drifts off the runway heading by a specified amount while the plane is still on the runway, an illegal action has occurred and a diagnostic message is generated. However, heading changes after the wheels are off the runway are normal and no action is taken by the system.

#### Performance Measurement

One of the actions that may be taken by the system as the result of the occurrence of an event is taking measurements of flight parameters. For example, when the aircraft reaches a certain altitude the system may start measuring the pilot's ability to maintain that level altitude. Or it may take a single measurement at a specific point. For example, when the aircraft reaches Ground Controlled Approach (GCA) minimums, it may measure the distance from the centerline of the runway. A performance measurement program is dedicated to taking measurements associated with a task module while it is active and when completed, calculates a score for the task. It, like the other programs, is informed when a particular task module is active.

The measurements are each defined in one of the task module files. They fall into several general categories:

**Continuous.** A measurement with predefined start and stop conditions. The parameter is sampled 1 to 20 times per second.

**Monitor.** A continuous measurement wherein a limit is defined. The parameter is sampled during the time that it is outside the limit.

**Snap Shot.** A single parameter is sampled once.

### Procedures Evaluation

Performance measurement for normal and emergency procedures, because of their nature, is handled quite differently than flight parameters. The following factors, or subset of them, are considered:

**Critical errors.** Those actions which, by their omission or commission, will produce catastrophe.

**Recognition reaction time.** This measures student response to certain cockpit stimuli in the case of aircraft system degradation and/or failures.

**Total procedure time.** This measures the total time required to complete the procedure.

**Percent of mandatory actions taken.** These are actions that are depicted in the F-14 NATOPS manual.

**Percent of optional actions.** These are actions that are not mandatory but demonstrate that the student is well prepared and well in command of the situation.

### Scoring

The performance measurement program is informed when the task module is completed and calculates a score. It does so by comparing both the flight parameters measured and the procedures evaluated with criteria unique to the task module.

Scoring of performance by a computer is a controversial issue and is one of the first to be questioned by students and instructors alike. Developers of the ISS have attempted to defuse this problem by putting the grading criteria under control of the user's community and by making visible to the instructor (at his request) the measurements and calculations used to derive the score.

The key to this is a scoring template in which are placed all measurement definitions

and scoring formulas. This template is one of the files making up the task module definition and is easily established or modified using a text editor. After a task module has been executed the system displays the template in a format similar to that in which it was created but with the addition of the actual measurements taken and all the figures used in deriving the final score.

Figure 1 is a template for a task module which defines the SAN PEDRO DEPARTURE from NAS Miramar. The first column under "MEASURE" are measurements that the student is graded on in performing this departure.

DME SNAPSHOT is the distance from a particular fix the student is to fly over. This is a single measurement.

RADIAL DEVIATION is the ability to fly a specific radial. This is a continuous measurement. RMS indicates that "root mean squared" is the basic transform used in processing the data.

AIRSPEED DEVIATION is ability to maintain a specific airspeed. This is a continuous measurement and the RMS transform is used.

The second column under "NOMINAL" is the reference value of the particular measurement. This can also be used to differentiate between measurements with the same name. In this example the first radial measured is the 280 degree radial and the second is the 300 degree radial. Likewise the 1, 2, 3, next to the DME SNAPSHOT measurements indicate the first second and third fixes in the departure.

The "4.0, 3.5, 3.0, 2.5" columns are the scores on the Navy's 4.0 scale. The grade for a particular step in a task module is derived by comparing the measured value with the range of values below these columns. For example, the first measurement listed on figure 1 is the distance at closest point of approach from the first fix the student was to fly over. The actual value measured was .79 miles recorded under the "VALUE" column. By looking across the template opposite the first DME measurement we see that the measured value, .79, falls between 0 and 2.5 which is under the 4.0 column. Therefore the student is assigned a 4.0 for that measurement. This is recorded under the "GRADE" column. The last column "WT" is the weight factor given to that particular measurement. In this case it was worth 10 percent of the total grade. After all of the steps have been calculated in the method described above, they are summed to form the final grade, which in this example is 2.7.

This example does not show any procedures scoring. If it did, REACTION TIME, % MANDATORY STEPS, or the like would appear as additional measurements. That is, procedures are scored



| GRADING CRITERIA        |         |     |        |                  |        |        |          |
|-------------------------|---------|-----|--------|------------------|--------|--------|----------|
| SAN PEDRO DEPT          |         |     |        | FINAL GRADE = 27 |        |        |          |
| MEASURE                 | NOMINAL | 4 0 | 3 5    | 3 0              | 2 5    | VALUE  | GRADE VT |
| DME SNAPSHOT            | 1       | 2 5 | 2 75   | 3                | 3 5    | 79     | 4 0 10   |
|                         | 1       | 0   | 2 51   | 2 76             | 3 01   |        |          |
| RADIAL DEVIATION(RMS)   | 200     | 2   | 3      | 5                | 10     | 69     | 4 0 10   |
|                         | 200     | 0   | 2 01   | 3 01             | 5 01   |        |          |
| ALTITUDE DEVIATION(RMS) | 2000    | 100 | 200    | 300              | 500    | 206 96 | 3 0 10   |
|                         | 2000    | 0   | 100 01 | 200 01           | 300 01 |        |          |
| AIRSPEED DEVIATION(RMS) | 325     | 10  | 25     | 50               | 100    | 68 06  | 2 5 10   |
|                         | 325     | 0   | 10 01  | 25 01            | 50 01  |        |          |
| DME SNAPSHOT            | 2       | 1   | 1 5    | 2                | 3      | 55     | 4 0 10   |
|                         | 2       | 0   | 1 01   | 1 51             | 2 01   |        |          |
| RADIAL DEVIATION(RMS)   | 300     | 2   | 3      | 5                | 10     | 13 96  | 2 0 20   |
|                         | 300     | 0   | 2 01   | 3 01             | 5 01   |        |          |
| ALTITUDE DEVIATION(RMS) | 26000   | 100 | 200    | 300              | 500    | 535 34 | 2 0 20   |
|                         | 26000   | 0   | 100 01 | 200 01           | 300 01 |        |          |
| DME SNAPSHOT            | 3       | 1   | 2      | 3                | 5      | 5 13   | 2 0 10   |
|                         | 3       | 0   | 1 01   | 2 01             | 3 01   |        |          |

Figure 1. Scoring Template

in the same manner as flight parameters. An exception is the CRITICAL ERROR. If one of these occurs, the task module is assigned the lowest possible grade regardless of other measurements.

#### Information Presentation

Although it may not seem to have direct application to procedure monitoring, the manner in which the information is presented to the user is very important to the successful application of these features. The ISS approach again centers around task modules. As part of each task module's definition, pictures are defined in the task module data files. As task modules become active and are completed, appropriate pictures are added to and removed from the user's displays. Task modules covering procedures (e.g. check lists, malfunctions) are composed of text identical to the procedures as depicted in the aircraft NATOPS manual. As each step in the procedure is accomplished, the action is noted next to the appropriate step.

Figure 2 shows two concurrently running task modules on the upper half of the display, a normal checklist on the left and a malfunction on the right. Both are procedure oriented and indicate that the steps are in progress. The section below, labeled "diagnostics", contains messages generated by the procedures monitor program. These appear at the bottom of that section and move up either when displaced by a new diagnostic message or when 30 seconds

have passed. All messages eventually disappear from the top of that section. The small rectangles represent menu selections that can be picked by the user via a touch mechanism associated with the display. This is the input/control mechanism of the ISS.

#### SUMMARY

This paper has described a software/hardware system that is able to monitor procedures, and score individually, and concurrently, the many training tasks in a complex training scenario. This system has approached the problems from the instructor's viewpoint and is intended to give him understandable and appropriate information on an uncluttered instructor/operator station. Using this he will be able to better evaluate the student's performance and provide the instruction needed to improve it.

The ISS, of which this procedure monitoring and scoring mechanism is a key part, has been under development for several years and is now undergoing operational evaluation at NAS Miramar. The concepts developed in this prototype promise improved training in existing flight trainers and can serve as the basis for instructor/operator stations on new simulators.

#### ABOUT THE AUTHORS

Steve Seidensticker is the Technical Contract Manager for the ISS development

|                      |            |                                       |                                   |
|----------------------|------------|---------------------------------------|-----------------------------------|
| -LANDING CHECK LIST- |            | ** UNSCHEDULED WINGSVEEP **           |                                   |
| 1 WING SWEEP MODE SV | 20 AUTO    | 01 EMERG WING SWEEP                   |                                   |
| 2 WHEELS             | 3 DOWN     | HDL POS AND HOLD                      |                                   |
| 3 FLAPS              |            | 02 GT & INN FULL AFT                  |                                   |
| 4 DLC                | AS DESIRED | 03 LT & INN FULL FWD                  | FULL FORWARD                      |
| 5 HOOK               | AS DESIRED | 04 DECEL BELOW 6 IMN                  | BELOW 6 IMN                       |
| 6 HARNESS            | LOCKED     | 05 C/B LE1 & LE2 FULL                 |                                   |
| 7 SPEED BRAKES       |            | 06 REMAIN IN EMERG WINGSVEEP POSITION | AND COMPLY WITH EMERG VS SCHEDULE |
| 8 BRAKES             | CHECK      | 07 LAND AS SOON AS PRACTICABLE        |                                   |
| 9 FUEL               | CHECK      |                                       |                                   |

- PILOT'S VERBAL RESPONSE -

SAT  UNSAT

---

DIAGNOSTICS

SPEED BRAKES NOT EXTENDED  
FLAPS NOT FULL DOWN

JWF NOT SET ON APPROACH CONTROL - 281 #

---

|                        |                                       |                            |                                       |            |                                       |
|------------------------|---------------------------------------|----------------------------|---------------------------------------|------------|---------------------------------------|
| MALFUNCTION SELECTIONS | <input type="button" value="SELECT"/> | ENVIRONMENT OPTIONS (LAND) | <input type="button" value="SELECT"/> | CHECK LIST | <input type="button" value="SELECT"/> |
|                        |                                       | RE-POSITION OPTIONS        | <input type="button" value="SELECT"/> |            |                                       |

---

|                                       |                                       |                                       |                                      |                                     |
|---------------------------------------|---------------------------------------|---------------------------------------|--------------------------------------|-------------------------------------|
| <input type="button" value="MANUAL"/> | <input type="button" value="FREEZE"/> | <input type="button" value="HDCOPY"/> | <input type="button" value="VOICE"/> | <input type="button" value="MENU"/> |
|---------------------------------------|---------------------------------------|---------------------------------------|--------------------------------------|-------------------------------------|

Figure 2. Running Task Modules

project at Logicon. He has been involved in the project from its early stages in 1978. He holds a master's degree in System's Management from the University of Southern California.

Terry Kryway is a training system analyst at Logicon and has been responsible for the

operational design of the ISS. He previously served two tours as a flight instructor in Navy Fleet Readiness Squadrons. Mr. Kryway holds a bachelor's degree in Naval Science from the Naval Postgraduate School at Monterey, California.

# THE CASE FOR A STUDENT SELF-TRAINING CAPABILITY IN FLIGHT SIMULATORS

JOSEPH L. DICKMAN  
Sperry Systems Management - SECOR  
Fairfax, Virginia

## ABSTRACT

The conventional use of instructor pilots at flight simulators contains a number of problems--a continuous training program is required because of instructor rotation to the assignments, pilots are often not interested in being simulator instructors, and they frequently require assistance from device operators. Furthermore, to obtain maximum utilization of a simulator a large number of instructors are required. The use of student self-training programs, enabling a simulator to be operated without an instructor when required, would solve many of these problems. This paper presents the advantages of such a capability and discusses the related design considerations. It describes the required instructional programs and offers several solutions to the problem of locating simulator controls in the cockpit. In addition, it discusses the subjects of safety and realism and concludes with recommendations applicable to future specifications.

## INTRODUCTION

Conventionally, flight simulators have been equipped with more or less elaborate instructor stations, located either on-board (in the cabin behind the pilot's or co-pilot's seat) or remotely (entirely removed from the cockpit). With the on-board instructor station the instructor is able directly to observe the crew members and evaluate their performance; with the remote instructor station the instructor observes the crew performance through repeater instruments and CRT displays.

In either case, the trend has been to strengthen and emphasize the role of the instructor. Instructor stations have been designed to enable the instructor to take maximum advantage of the simulator's instructional capabilities, to provide him with extensive information regarding the progress of the student's training, and at the same time to reduce his (the instructor's) workload.

Yet there are many problems inherent in this arrangement. Instructors require training--the more sophisticated the simulator the more extensive is this requirement. Then, after a certain amount of utilization, most instructors rotate to other assignments and never return to instructing on the simulator. Or, if they go to sea duty or other forms of lengthy TDY (temporary duty), they need retraining when they return.

Many pilots do not want to be simulator instructors. If the simulator is complex, pilots find that learning and keeping

current on its operating procedures detract from their concentration on keeping current on the aircraft. These procedures are perhaps not difficult to learn but apparently are impossible to retain without frequent practice. The problem is exacerbated by the fact that many instructor stations are equipped with a confusing array of switches and other controls, often poorly labeled, and offer a bewildering variety of instructional features, many rarely used. Furthermore, most pilots never accept having to operate an alphanumeric keyboard with lengthy formats for data entry.

It is possible to design instructor station controls, displays, and programs so as to reduce the demands on instructors. The instructor station for Device 2F132, the F/A-18 Operational Flight Trainer, is an example of such an effort.<sup>(1)</sup> However, the ultimate solution to this requirement has not yet been demonstrated.

The use of device operators is a way to solve these problems. Device operators who do not have other, conflicting duties can keep current on all of the instructor station features and procedures and can assist instructors in many ways, from serving as operator of the alphanumeric keyboard to handling all of the complex instructional features. However, device operators are usually not provided at on-board instructor stations, probably in order to minimize the number of persons in the cabin and to conserve on the size of the instructor station. Furthermore, if device operators are always required, in addition to instructors, the manpower

requirements for operating the simulator become significantly increased.

Another approach is to hire former pilots--retired military or naval personnel--to be simulator instructors. Since they will presumably have no other function, they can keep as proficient on the simulator as device operators can. However, there are issues involved in this approach--the instructors' credibility with the students, the cost of the additional personnel, and the availability of qualified individuals--that may militate against widespread adoption.

Regardless of the source of the instructors, the requirement to have the simulator manned by someone other than the students is a limitation on its utilization. A modern simulator is capable of operating at least 16 hours per day. To continually provide an instructor for this level of operation for five days per week requires a force of at least six instructors if they are not active duty pilots, or approximately twice that number if they are.

A different solution to all of these problems is to develop a concept of student self-training--not to eliminate all instructors, of course, but to provide users with the capability to conduct some training without the presence of an instructor being required.

#### CONCEPT

In a simulator with a student self-training capability the student should be able to conduct a complete training exercise using controls entirely in the cockpit. To this end he should be able to initialize at a desired geographical location, fly a pre-planned flight profile; introduce and remove malfunctions, operate simulator control functions such as freeze and crash override, and operate instructional features such as demonstrations and performance measuring.

The exercise should be part of an overall training syllabus that would include both aircraft missions and simulator exercises. The number of self-training exercises with an instructor being present should be planned in advance and scheduled in the syllabus. Self-training should never be an "ad lib" use of the simulator, resorted to only when an instructor is absent.

The optimum ratio between self-training and instructor-monitored exercises in a syllabus would depend on a variety of condi-

tions. The availability of trained instructors would be a major factor. If the number of available instructors is small and the number of students is large, self-training exercises would comprise a substantial part of the syllabus. The qualifications of the students would be another factor. A pilot who needs only refresher training could use more self-training exercises than a recent flying school graduate. In general, if instructors are used primarily for initial indoctrination and/or checkrides, the ratio of self-training exercises to instructor-monitored exercises could be in the order of four or five to one.

#### DESIGN CONSIDERATIONS

Providing a student self-training capability will have a significant impact on simulator design--on the instructional system software and, to a lesser extent, on the student station hardware (i.e., the cockpit).

#### Controls

Controls in the student station will have to be considerably more elaborate than for a conventional simulator, which may have only a Freeze switch located very inconspicuously. How elaborate will depend on the number of functions provided for the student--to the same degree that the complexity of an instructor station depends on the functions provided for the instructor. If cost considerations dictate an austere approach, student station controls can be kept to a minimum--only sufficient for initialization, freeze, motion control and emergency off. Additional capabilities can be provided at increased cost, although the fact that these capabilities must be in the cockpit, not at an instructor station, will have a distinctly limiting effect.

Student station controls must have certain required characteristics. The first of these requirements is that the controls--and the instructional features that they relate to--must be understandable and easily operated by untrained individuals. In this case, "untrained" means not having attended an operator's course and having been required to read only minimum instructions on the simulator's operations. Simplicity and consistency in the design of simulator controls will be required to a degree far greater than heretofore.

A second requirement is that student station simulator controls be easily accessible. Since the student will be devoting his full attention to flying the

simulator, it is imperative that the distraction of locating and operating non-aircraft related controls be kept to a minimum.

A third requirement, which is not easily reconciled with the previous one, is that controls be located as inconspicuously as possible. On the premise that student acceptance of a simulator depends on how closely its cockpit, sound effects, and "feel" resemble the actual aircraft, it is apparent that panels, switches, and indicators that are foreign to the aircraft would be an irritant to the student. Obtrusive simulator controls in the cockpit would be as distracting as those that are hard to find.

Two simulators built by Sperry Systems Management - SECOR contain controls for operation from the cockpit, although how much they will be used for aircrew self-training has apparently not been determined. The two approaches have both similarities and differences, with respect to scope of capabilities and concept of operation.

One design, the CH-53 Operational Flight Trainer, the first unit of which is scheduled to be delivered to the U.S. Marine Corps in late summer 1982, contains a small control panel on each side of the cockpit, above and in front of the two side windows (see Figure 1). The panels are identical, each

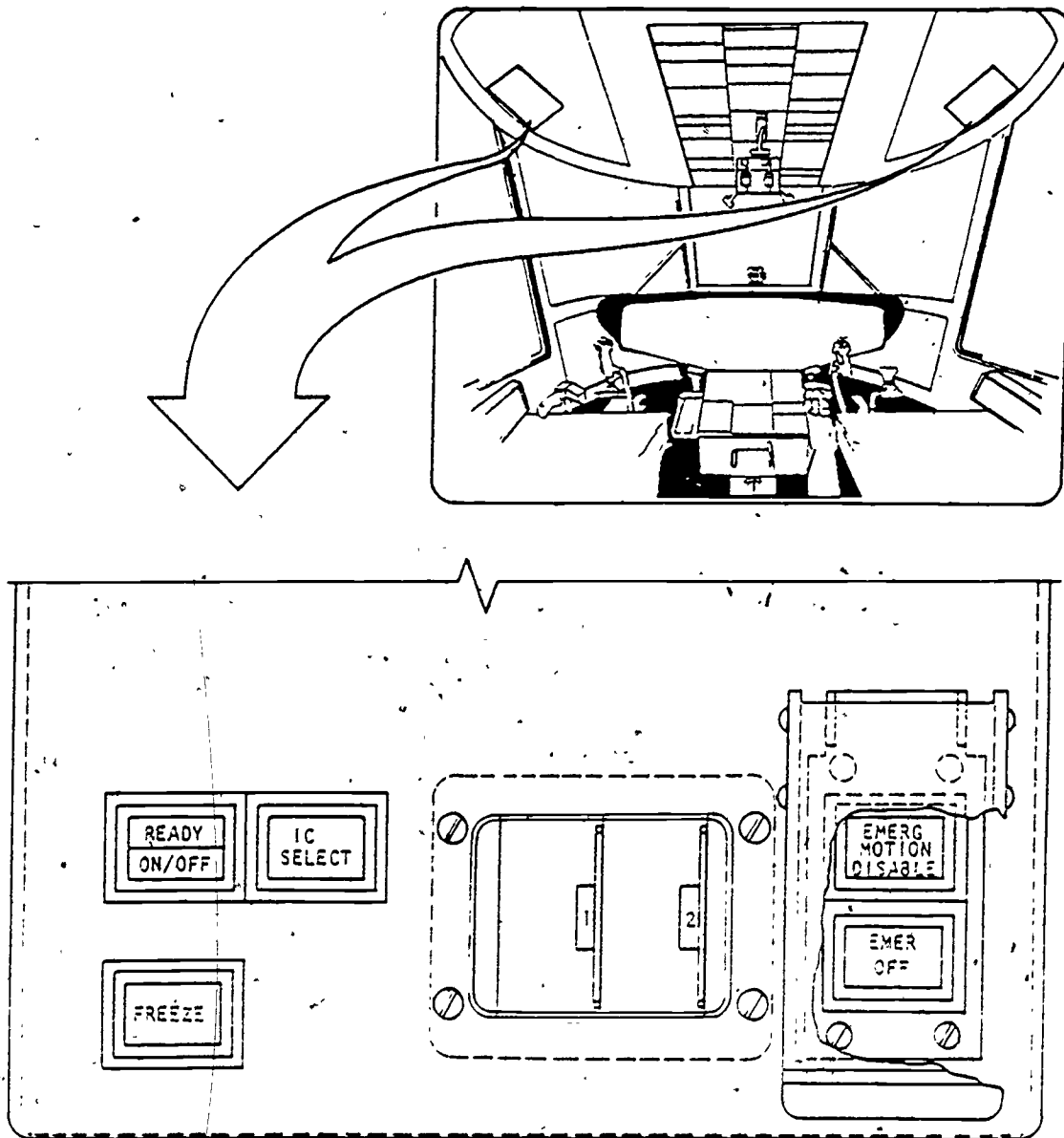

Figure 1. CH-53 OFT Remote Control Panels

having push-button switches for Initial Conditions Select, Freeze, Motion Ready/On, Emergency Off, and Motion Emergency Disable. Two thumbwheel controls on each panel enable the students to select a set of initial conditions from twenty available. The control panels are not covered or otherwise concealed but are located above the pilots and copilot's normal forward field of view.

The other approach is found in the HU-25A and HH-65A Flight Training Systems currently being built for the U.S. Coast Guard for delivery in early 1984. A 20-key keypad, provided primarily for the instructor station, which is located in the cabin, is installed with a cable that enables it to be placed on the pedestal or the floor between the pilot's and copilot's seats. The keys include Freeze, Override (for crash), Store (for flight conditions), Reset, Enter, Clear, Remove (for malfunctions), ten digits, two punctuation marks, and backspace (see Figure 2).

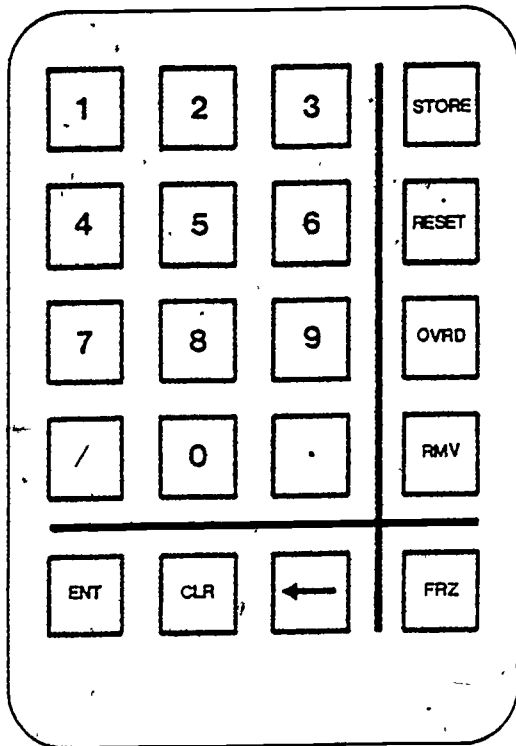

Figure 2. HU-25A/HH-65A FTS Keypad

In both the CH-53 and the Coast Guard trainers the students will be able to use the instructor station controls to accomplish functions that are not possible via the cockpit simulator controls. Conducting demonstrations would be an example of such a function. Also, if necessary one of the students will be able to call up displays on

the instructor station CRTs and use them for self-training purposes. For example, the students will be able to inspect the aircraft track depicted on an approach display, after making an approach.

The self-training capabilities of these simulators are facilitated by the fact that they have on-board instructor stations and two-man crews. The copilot can readily go to the instructor station and use the simulator controls as he desires without interfering with what the pilot is doing. If the simulator had a single-place cockpit and a remote instructor station, the student station controls for self-training would have to be more self-sufficient.

#### Formats

The design of the controls will be influenced considerably by whether the data entry formats are page-dependent or not. For a "worst case" situation, in which the student will have no access to the display system, the formats will have to be non-page dependent, utilizing input codes for entering and clearing malfunctions, modifying flight parameters such as fuel load and armament, and modifying environmental parameters such as ceiling and visibility.

Since an alphanumeric keyboard in the cockpit is out of the question, all input codes will have to be useable on a keypad. This requirement suggests that the codes should be numeric, but to help the student remember at least the most-used ones the keys on the keypad could be labeled both alphabetically and numerically, like a telephone, and the codes could be alphabetical.

If alphabetical codes are used, and other alphabetical inputs such as N, E, S, and W for latitude and longitude are required, the student will need a shift key to select one of the three letters on a key and to differentiate between letters and numerals. This approach tends to complicate the operation of the keypad but the alternative, the use of all-numeric codes, is less desirable.

There is another alternative to the use of shift keys, i.e. a two-digit code, used in the FAA's Voice Response System for telephonic weather briefings, that identifies each letter on a key. For example, the letter "A" is selected by entering "2,1" (referring to the 2 key and the first letter on it). Similarly, "B" is "2,2". This method, however, will increase the time spent in entering all formats, and is con-

sidered to be acceptable only if the input codes can be kept to one or two letters in length.

The number of input codes required will depend on how much capability is provided to the student. It is likely, however, that the number will exceed what can be remembered by the student, particularly if he is not using the simulator frequently. Therefore, a list of input codes will be needed to be kept in the cockpit. This list could be part of an abbreviated checklist, similar to the Pocket Checklist used in aircraft, and could cover all of the operating procedures that the student would need to be reminded of.

### Functions

In a self-training mode the student could forego many functions that are available at the instructor station in a conventional simulator. Also, many functions that are usually accomplished with controls could be performed via alphanumeric entries to the computer. These principles will have to be imaginatively applied to the design of the student station in order to keep the number of controls to a minimum. A minimum-sized control unit, whether it is a panel like the CH-53 OBT or a keypad like the Coast Guard simulators, is essential to meeting the three required design characteristics discussed previously.

The following discusses a broad range of functions typically exercised at an instructor station and describes how they could be best performed with controls in the cockpit.

Turn-On Procedures. Turn-on procedures can be considered to include powering-up the system, initializing the computer and peripheral equipment, turning on the visual system if there is one, and performing a readiness test. None of these procedures requires special consideration for the self-training concept; they can all be accomplished by maintenance personnel, who presumably will always be present.

Initialization. In conventional simulators, initialization is accomplished in a variety of ways: thumbwheel controls, pushbutton switches, and alphanumeric keyboard or keypad entries are used, sometimes in combinations, to select the set desired and enter it into the computer. Keyboard entries and pushbutton switches are used to display the available sets on a CRT at the instructor station. If the instructor wishes, he can modify the parameters by

making keyboard entries.

For the self-training concept, keypad entries should be used exclusively, in order to minimize the need for hardware controls. In the absence of a CRT in the cockpit, the available sets can be included in the abbreviated checklist mentioned previously.

The question arises whether the student should be allowed to make on-line modifications to an initial conditions set before it is entered, and if he is allowed to make modifications, how he will be able to record them. The simplest approach is to allow no pre-entry modifications. In this case, if the student is not satisfied with the initial conditions he can make parameter changes after the set is entered. The student will then observe the results directly on the aircraft instruments.

Motion. Because of safety considerations, the motion system presents a special problem for the self-training concept. With a six-post system, the operator, before activating the system, must have a positive indication that access ladders are stowed and maintenance platforms around the cockpit are cleared. Even smaller systems have safety problems.

One approach, for the self-training concept, would be to make the maintenance personnel responsible for operating the motion system--they could use an intercom system to communicate with the student when necessary. On the other hand, it would be almost mandatory to provide a "disable" capability in the cockpit. If a switch is provided for that purpose, it could be designed to indicate a "motion ready" condition and to provide both an "enable" and "disable" capability for the student (in some types of installation, this may not be feasible; an additional switch may be required). Additionally, the student could be required to obtain a verbal clearance with the maintenance personnel, over the intercom, before activating the system.

Normal Operating Functions. There are a number of routine operating capabilities, usually performed with push-button switches at a conventional instructor station, that must be provided in the cockpit, in a way that conserves hardware controls as much as possible. The most basic of these is Freeze; dedicating a push-button switch for this function appears to be mandatory. Emergency Off is a similar requirement, although the switch should be guarded in a way that guarantees against inadvertent actuation. Crash Override can be accomplished

with a keypad entry, if it is assumed that the student will not need to activate it as an immediate response to difficulty. Slewing, which in a conventional simulator usually requires a joystick control and a pushbutton switch; can be omitted in the self-training mode. If the student wants to change the geographical position of the simulated aircraft he can enter a new latitude and longitude with a keypad entry (or, with a more sophisticated program, a radial and DME from a NAVAID). Or he can reinitialize. Although possibly not essential, Store IC's and Reset are very useful functions; they enable the instructor to store the existing flight conditions at any time and then to reset the simulated aircraft there when desired later. If these functions are provided for the self-training concept, two pushbutton switches would be needed. Finally, an intercom capability with maintenance personnel must be provided. A switch is not needed, however, if the student's microphone is continually "hot".

Instructional Features. The major instructional features found in most current simulators are demonstrations, checkrides (also known as programmed missions), playback, parameter record, and event print. Probably the one most applicable to the self-training concept is demonstrations; the possibilities for learning by observation and emulation, through this method, are almost limitless. All of the actions required to select, activate, and terminate a demonstration can be taken with keypad entries (plus use of the Freeze switch to start after the pre-demonstration initial conditions have been attained).

Checkrides are also very applicable to the self-training concept, although they will pose a problem with respect to the monitoring function. In a conventional simulator, the instructor uses the CRT displays to monitor the progress of the mission; if the student makes a gross error sufficient to confuse the computer and induce it to score a leg that is different from the one that the student is flying, the instructor can correct the situation with a Manual Advance switch. In the self-training mode it is not feasible to provide the student with this capability or to expect him to monitor the mission leg by leg. It is essential that the missions be very carefully designed so as to reduce to a minimum the need for instructor intervention; if the mission cannot be completed as intended, it will have to be aborted.

Playback (Dynamic Replay) will be of lesser usefulness without an instructor

present to contribute comments. The student will know generally what his errors were; redoing the maneuver or procedure correctly will be his primary concern. If desired, however, Playback can be operated with keypad entries, assisted by the Freeze switch.

A variation of Playback called Minute Replay, or sometimes Instant Replay, enables the instructor to store a number of segments of flight history, usually of one-minute duration each, and to replay them during the critique period after the mission. This capability is not considered to be important in the self-training mode. To provide it, however, a switch will be needed to enable the student to quickly select the segment to be stored.

Parameter Record is a little-used data-gathering capability. To operate Parameter Record the instructor must select individual parameters to be monitored, specify the reference value and tolerances, and start and stop the recording. These are time-consuming functions that are not at all suitable for a student to perform.

Similarly, Event Print is not appropriate for the self-training concept: This feature prints, either on the Parameter Record printout or independently, the time of occurrence of a number of events that the instructor selects in advance. To be useful this capability must be part of a very detailed analysis and critique of the mission which only an instructor can conduct.

Malfunction Control. As in conventional simulators, malfunctions can be entered and cleared in the self-training mode by using keypad entries. The list of programmable malfunctions can total several hundred items depending on the type of aircraft and amount of attention to this subject desired by the user. A shorter list can be devised for the self-training mode and included in the student's abbreviated checklist. A Malfunction Override control, if desired, will require a pushbutton switch.

Critics of self-training could say that considerable training value is lost, due to the absence of surprise, if the student enters the malfunction himself. However, all training value is not lost, particularly with respect to practicing the steps in emergency procedures. Furthermore, it would be possible to enable the student to program a series of malfunctions to occur, randomly during a mission, thereby assuring that he would at least not have foreknowledge of when a malfunction would occur. Also, programmed malfunction "packages", with



different types of malfunctions and levels of difficulty depending on the mission and student qualifications, could be entered by the maintenance personnel.

Miscellaneous. Additional functions found in conventional simulators can be accommodated in the self-training mode with keypad entries or omitted entirely in the interest of simplicity. A volume control for sound effects, for example, can be omitted (if considered necessary this function can be accomplished with a keypad entry). Controls for the voice recorder, if one is provided, can be omitted--separate control is not needed in the self-training mode. The catapult-hold and -fire functions, for a carrier-based aircraft, can be accomplished with keypad entries. Alternatively, catapult fire can be programmed to occur a few seconds after the pilot gives the "ready" signal by turning on his exterior lights, or in another way, after he lowers the hand-grip. Similarly, chocks, external power, starting air, rough air, and arresting gear can be provided via keypad entries. A warning horn for a malfunction of the simulated oxygen system, provided at the instructor station in conventional simulators for safety reasons, can also be installed at the student station (if, in fact, it is truly needed).

#### Optimum Design

In summary, it is concluded that the most desirable functions for the self-training concept could be accomplished with a keypad containing 20 keys. The following functions are considered to be the most useful: Motion Ready, Motion On, Emergency Off, Freeze, Malfunction Override, Store ICs, Reset, ten digits, Enter, Clear, punctuation, and backspace.

The 20 keys could be accommodated in a unit similar to the hand-held terminal manufactured by the Termiflex Corporation. Various models of the Termiflex have the capability of displaying one or two lines of alphanumeric text, each 10 to 12 characters in length. This feature would be essential for the self-training concept, to enable the student to verify his input codes and values before entering them into the computer. Three shift keys would provide access to the letters and punctuation. An example of a self-training terminal is shown in Figure 3.

The terminal should have some features not found in the current models of the Termiflex. The keys should be backlighted, to enable reading when the cockpit is

darkened for simulated night operation. Further, certain function keys (Freeze, Motion Ready/On, and Malfunction Override) should be brightened when selected, to provide a status indication to the student. Also, the Emergency Off key should be guarded, preferably with a cover that would have to be lifted before the key is actuated.

A hand-held terminal eliminates the problem of finding a blank panel in the cockpit behind which to conceal the switches. The terminal could be hung behind the seat or stowed under it, seat design permitting, and could be removed entirely for instructor-monitored missions if it had a plug-in capability similar to the Termiflex.

#### Displays

In the foregoing discussion of simulator functions and the options available for accomplishing them, it has been assumed that the CRT displays normally found at an instructor station would not be available in the cockpit. However, it is possible to display both graphic and alphanumeric data to the student via the visual system. This approach has been used modestly in the A-6E Night Carrier Landing Trainer (NCLT), Device 2F122; one display, depicting a plot of certain parameters (vertical velocity, bank, pitch, rpm, glide slope, and centerline) recorded during an approach, can be shown on the two visual display CRT's in front of the pilot and B/N.

In the NCLT the alphanumeric/graphic display replaces the visual scene; an alternative method is used in the A-4M OFT, Device 2F108/2B34F--a line of weapon scoring data is superimposed across the bottom of the visual scene. The parameters include a hit or miss evaluation, bearing and range of the input, airspeed at release, and others. This information is available only on the instructor station visual monitor, but it could be easily displayed to the pilot if desired.

The possibility of using the visual system for alphanumeric/graphic displays provides almost unlimited opportunities for enhancing self-training. If a side-viewing visual CRT is provided in the cockpit, it could be used, as frequently as desired by the student, for any of the displays available at the instructor station. A front-viewing visual CRT could also be used, but in a more restricted way.

Of predictable interest to the student would be the procedure monitoring displays of normal and emergency procedures showing

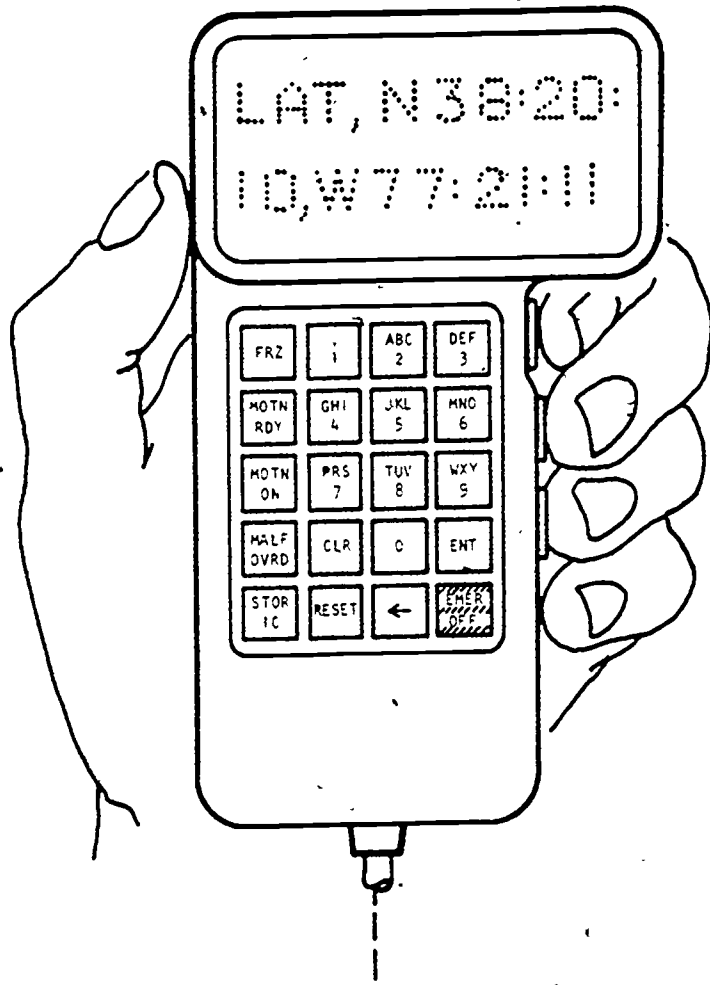

Figure 3. Student Self-Training Terminal

the results of the student's attempts, the approach displays showing the various published approaches and a record of the aircraft track, and GCA/CCA/ILS displays with both horizontal and vertical projections of the aircraft track. Static data such as the list of input codes and the contents of the initial conditions sets, which would be available as instructor station displays, could also be presented in the cockpit, rather than in a Pocket Checklist as suggested previously. Special displays providing checklist instructions for operating the simulator could be included.

If displays are available to the student, it is possible that he will want to print the most significant ones for post-mission analysis. Checkride summary data would be particularly useful. In any event, the display printout function could be operated by a keypad entry.

### Safety

In any discussion of students operating a simulator without an instructor, concern is usually expressed regarding safety. There are a number of potential sources of danger around a simulator--high voltage electricity, high pressure hydraulics, the motion system, and possibly others. However, most of these should be of concern only to maintenance personnel. There should be no reason for students to be exposed to high voltage, for example. In any event, maintenance personnel will always be present during self-training periods and can be made responsible for enforcing restrictions on access to hazardous areas.

The only source of danger of importance to the self-training concept is the motion system. The danger, of course, is to personnel working outside and in the vicinity of the student station. As discussed previously, the best solution to this problem is to have motion system turn-on procedures involving both the students and the maintenance personnel. Communication between the two is a necessary element of these procedures.

### CONCLUSIONS

Excluding the basic flight training period, most training in flying is conducted without the immediate presence of an instructor. This statement is made on the premise that flying to maintain proficiency is essentially training. Throughout his career a pilot receives instrument checks, annual proficiency checks, upgrade training, and refresher training, during all of which

an instructor or supervisor is very much in evidence; but in most of his flying he is expected to train himself--to assimilate guidance and instructions on the ground and to apply them in the aircraft. Especially in practicing takeoffs and landings, in instrument flying, and in weapon delivery, he learns primarily by self-correction and repetition. In brief, he is training by acquiring experience.

It follows that a pilot can learn in a simulator also by these methods. What makes self-training effective in an aircraft is the pilot's conscientiousness and professionalism; the same characteristics in the student can make self-training effective in a simulator. There is a difference in the two situations, of course. The penalty for lack of motivation or a lapse in concentration is sometimes fatally severe in an aircraft; in a simulator there is no penalty other than wasted time and a relatively small amount of money.

A controversial aspect of self-training is the effect of the loss of realism caused by the student's frequent interacting with the simulator. From time to time during a self-training exercise, the student will take such actions as reinitializing the simulator, entering and clearing malfunctions, storing flight conditions and resetting to the stored conditions, and adding fuel and armament. In addition he may display emergency procedures via the CRT system and review them before entering malfunctions, freeze the trainer and study the pertinent approach plates, and interrupt the flight and call up a demonstration. All of these actions would be foreign to his procedures as a pilot. The question is, would they reduce the transfer of training expected from the simulated control responses, instrument readings, and visual scenes that he is also perceiving?

It is believed that the answer to that question is negative. Again, professionalism and conscientiousness will enable the student to bridge the gap between managing his own training and receiving effective training experiences. One ingredient is necessary: the management task must not become too engrossing.

A related concern is whether the design of the student station--and the associated software--is sufficiently simple. It would be possible to overwhelm the student by attempting to provide all the capabilities of an instructor station. Designers will have to keep in mind the three required characteristics for student station controls

cited previously--simplicity, accessibility, and inconspicuousness--and the necessity to be conservative in providing instructional features. The need for disciplined and responsive human factors engineering will be possibly greater than for any other area of development of a simulator.

In conclusion, it is recommended that specifications for flight simulators (cockpit procedures trainers, operational flight trainers, weapon system trainers, team tactics trainers, and similar training devices) include provisions for a student self-training capability, in addition to a conventional instructor station. The users will gain tremendous flexibility in simulator utilization. In the final analysis, they will be able to schedule simulators like aircraft--simply, some flights can be solo and some dual.

#### REFERENCES

1. Dickman, J. L. A Comparative Analysis of Three Approaches to the Man-Machine Interface Problem at the Flight Simulator Instructor/Operator Station. Proceedings of 3rd Interservice/Industry Training Equipment Conference, Orlando, FL, November 1981.

## GENERIC SIMULATOR INSTRUCTOR TRAINING

DR. GEORGE W. MENZER AND DR. STEVE R. OSBORNE  
Allen Corporation of America

Flight simulation has been extensively used in both military and commercial aviation training for the past several decades. Every year the complexity and versatility of flight simulators grow. However, the full training potential of these devices is not often realized. There are, of course, a variety of reasons why this situation persists. Lack of transfer of training due to procedural or configurational similarities between the simulator and parent aircraft, lack of adequate out-the-window visual displays, and the completeness of the mission relevant aspects of the simulations are but a few. However, the point of this paper is that the training potential of flight simulators could be enhanced by improving the knowledge and understanding of the operating principles of the devices, by understanding instructional arrangements and by utilizing instructional skills.

Lack of realization of the full training potential of many simulators varies a great deal from one simulator to another. This variance is created by the complexity of the mission being simulated, the age and sophistication of the simulator, the instructor/operator station design, and the availability of instructional aids.

In this paper, a solution to the problem is explored--the development of generic instructor training packages for flight simulators. In the following sections of the paper, the several general topical areas relating to generic instructor training are presented. These include the advantages of simulator training, the principles of effective instruction related to simulator instructional features, and possible implementation and delivery strategies.

### Advantages of Simulator Training

Ground-based flight simulators play an important role in the overall training scheme of most civilian and nearly all military aviation training programs. The advantages of simulator training are clear. It offers a means to provide cost effective and instructionally effective training in a safe environment. Cost savings are realized in both the obvious and some not so obvious training parameters. Obviously, fuel and maintenance costs associated with actual flight are conserved. Not so obviously, tremendous savings in time are realized in simulator training. These savings are observed in both student and instructor time requirements. Students get more relevant training per hour of "flight" because they can concentrate on

the goals of a particular mission while instructors may supervise much more relevant training per hour of their commitment. Simulators also allow a safe training environment. In the area of safety, the advantages are clear and obvious--simulators allow practice in flight activities where the only negative consequences are learning with some embarrassment and where realistic responses to emergency or compound emergency situations may be practiced. Last, but from the point of view of this paper, by no means least, simulators provide a necessary hands-on instructional format for flight operations. With simulators as a part of the overall flight training regimen, the opportunity is presented to allow hands-on and associated cognitive learning experiences of the proper training density in proximity to the preceding academic events and to the subsequent inflight events. These simulator events are particularly valuable because they provide practice with appropriate feedback for the learning objectives of interest, as well as allow repeated exposures to particularly difficult and important segments of a mission.

Needless to say, a component of any instructor training course related to flight simulation should be a thorough discussion of these and other advantages of simulation.

### Instructional Principles and Instructional Features

A generic simulator instructor training program should amplify a few basic principles of effective instruction particularly as they relate to the usual set of instructional features found on most in-service flight simulators. The following is a list of such principles with their relationship to some commonly available instructional features.

1. Student Preparation Leads to Effective Learning. It is a well established, even intuitively obvious, fact that the better prepared the student is when he comes to a simulator exercise, the more he will profit from it. A generic simulator instructor training program should be designed to emphasize this point as well as to key the instructor to use some commonly available student preparation aids. These aids would include the formal simulator exercise guides and prompts/briefing aids. Formal simulator exercise guides are universally available in all Navy training squadrons. Some are squadron developed while others are the result of contractor

supported ISD development activities. The generic training should emphasize that through the use of these guides both the instructor and the student will be prepared for the content and flow of the activities in the exercise. Also, depending on the sophistication of the documents, the student may have an excellent feeling for the level of proficiency he is expected to demonstrate. At least one simulator program, the F-14 OFT program at NAS Miramar, has been supported by a very sophisticated device, the Instructor Support System, which allows CRT displayed briefing aids. Aids of this type could become part of a device-resident generic instructor course or any course in support of a new IOS design that is sufficiently complex to contain it.

2. Accurate and Timely Feedback Leads to Improvements in Performance. Another well known principle of effective instruction is that accurate and timely feedback leads to improvements in performance. A properly designed simulator instructor training course would emphasize this point and relate it to the several instructional features which are commonly available on most simulators that allow accurate and timely feedback. These instructional features include freeze record/replay, automated performance measures, graphics displays and hardcopy printouts. The freeze function allows immediate feedback for the development of fine motor control as well as directional control. It is particularly useful because it can be employed in, both real time or during a performance replay session. Record/replay has an obvious application and, in fact, provides the basis of many of the other instructional features. Automated performance measures provide an excellent opportunity for lessening the workload of the instructor while providing a more accurate and complete record of performance than even the most diligent instructor is capable of providing. However, while the value of automated performance measures should be emphasized in a generic simulator instructor training program, it must be noted that the value of this instructional feature depends on the amount of instructor inputs to the variables, the weights of the measures and the accuracy of the computations. While automated performance measurement systems are not generally available for most current simulators, it is clear that they will be available in future systems or in outboard support systems. Graphics displays, particularly those which display approach, weapons delivery, and pattern information, are an excellent means to provide post-session performance feedback. These displays are fairly common on many current simulators, although some are fairly unsophisticated. However, future simulator instructor stations and support systems for current simulators

will include these displays. A clear emphasis should be placed on the value and use of these displays in a generic instructor course. Hardcopy performance printouts are almost universally available on all complex simulators. However, they are almost universally unused as an instructional feature. A generic instructor training course would emphasize the potential value of these printouts as well as provide suggestions about how they could be summarized to be a more useful resource. Here again, the value and acceptance of these printouts depends on the legitimacy of the measures expressed.

3. Practice Improves Performance. Another well established principle of effective instruction is that practice, particularly practice combined with accurate and timely feedback, improves performance. As a matter of fact, it has been conclusively demonstrated that practice beyond the point of proficiency is effective in consolidating learning and making it less likely that deterioration in future performance will occur. Opportunities for practice are provided by both supporting materials and instructional features. That is, within the supporting materials designed for specific training goals, the training objectives have been arranged to provide practice that is related to the difficulty, criticality, and frequency of the psychomotor response in question. From the point of view of instructional features, the reset function is a key feature that allows repeated practice for difficult or problem maneuvers. Reset is a commonly available feature which allows the instructor to reinitiate a training routine repeatedly with constant or variable flight conditions until satisfactory performance is observed. Malfunction insertion is another practice-relevant instructional feature. With this commonly available feature, the instructor can manually or automatically insert aircraft malfunctions at any stage in a mission. These malfunctions may be presented once, or repeatedly, at the instructor's option. This feature allows excellent practice in dealing with emergency situations.

A generic simulator instructor training program would emphasize the importance or use of these practice-relevant features. The course would include clear direction relating to the use and adherence to the supporting materials. Several problem analytic studies have shown that departure from the training routines specified in supporting materials is a problem in many Navy training squadrons. The course would also include direction relating to the proper use of the reset and malfunction insertion features. This direction should emphasize that resetting is an excellent and

timely method to provide repeated practice for problem maneuvers. Emphasis would be placed on the proper use of the malfunction insertion features. Here the theme would center on adherence to required malfunction insertions specified on supporting materials and the proper use of random malfunction insertion. The generic course would make it clear that intentionally overloading the student with compound emergencies is unrealistic and may lead to confusion and restricted skill advancement in the areas of primary interest.

4. Guidance and Motivation Improves Performance. A final generally accepted principle of effective instruction related to simulator training is that proper guidance and motivation improves performance. Surely, one of the most important jobs of the simulator instructor is to provide proper guidance and direction to the student. The generic course would emphasize that this guidance must be organized, mission relevant, and provided in an instructional mode. That is, it must be provided in a cooperative setting characterized by joint achievement student/instructor goals. Several instructional features relate to the organization of student guidance in the simulator setting. These include use of the trainer supporting materials and use of the prompts/briefing aids. These features provide a vehicle for guidance. However, the key vehicle for guidance is a sensitive student/instructor relationship. A generic course should emphasize that point. Instructor provided motivation is another key feature in the student/instructor relationship. A generic course should emphasize the need for motivational comments, rewards, and open communication. In addition, the course should emphasize the use of some commonly available instructional features which may aid student motivation. These would include the demonstration feature, the freeze feature and all the features that provide feedback about performance. A generic course should emphasize that demonstrations can be motivationally effective if they are not overused or if they are used as a feedback mechanism to provide direction on the proper procedures. The freeze feature can also have a profound motivational effect when it is used to intercept poor performance or to indicate a "terminal" condition such as striking the ground or being hit by a weapon. The course would point out clearly that the instructor is responsible for providing motivation through the thoughtful use of all of the performance feedback features. These would include automated performance measures, record/replay, graphics displays, and hardcopy printout. The emphasis here should be on the proper and sensitive use of these data sources to improve performance.

#### Implementation of Generic Training

There are several potential advantages for a generic simulator training program. The program would undoubtedly improve the effectiveness of the instructor cadre for every simulator where it might be implemented. This improved effectiveness should lead to a more professional approach to the overall use of simulator training, or a part of flight training in general, and to potential improvement in student performance. In addition, the course should lead to improvements in student management from both the interpersonal and administrative points-of-view. Interpersonal improvements could result from the course content in the areas of guidance, motivation, and performance feedback. Administrative improvements could result from the generally improved organization of simulator training and from the use of automated management aids that might be part of a device-resident training course.

A disadvantage of the proposed concept is that each instructor training course associated with a particular simulator would have to be tailored to reflect the particular instructional features and the nature of the supporting materials of that device. This requirement admittedly diminishes the generic value of the concept but, hopefully, only a small amount of tailoring would be required to address most simulators. The training course could be implemented in two distinctly different formats--device-resident or device-independent. In the device-resident format, the course could be contained in the software of the simulator computer and presented on a CRT associated with the IOS, or a supporting system. With this format, the course would be continuously available, obviously convenient, and might even be made contingent for instructor utilization of the device. In the device-independent format, the course could be presented in a stand alone media, such as a workbook or slide/tape, and could be presented in an individualized study atmosphere in a learning center or training support center. This format would allow instructor access in a self-paced, individualized arrangement which is consistent with the manning demands of most training squadrons. In either format, the course would demand a minimum of intrusion into training squadron activities during its development while providing a maximum of benefit for instructor training.

APPLICATION OF ARTIFICIAL INTELLIGENCE AND VOICE RECOGNITION/SYNTHESIS  
TO NAVAL TRAINING

JOHN A. MODRICK, JAN D. WALD AND JOHN BROCK

HONEYWELL, INC.  
SYSTEMS AND RESEARCH CENTER  
MINNEAPOLIS, MN 55440

INTRODUCTION

The objective of the research reported here is to evaluate the feasibility and usefulness of applying two emerging technologies to naval training. These technologies are artificial intelligence and voice recognition and synthesis.

Artificial intelligence (AI) is a body of concepts and techniques which have been developed to permit computers/machines to do some of the complex, cognitive activities that have been regarded traditionally as the unique province of human beings, in some instances exceptionally talented human beings. Representative cognitive activities are problem formulation, searching for problem solutions, diagnosis, and decisionmaking. These activities require representation of knowledge and inferential reasoning about that knowledge.

If these concepts can be combined with voice recognition and synthesis, then an interactive, oral dialogue can take place; the verbal exchanges can be flexible, meaningful, and appropriate to the context of the on-going events. Applied to training and education, computer-aided instruction moves a major step in the direction of a realistic journeyman-apprentice relationship. The journeyman can be designed to be not only a technical expert but an expert tutor as well.

The organization of this paper consists of four parts:

Review and Evaluation of the Component Technologies and Principal Concepts in Artificial Intelligence

Review of Naval Training Needs Suitable for a Prototype Course Using AI and Voice Recognition/Synthesis

Recommended Guidelines for Instructor Support

Discussion of Implications and Issues

This research has been funded through two sources. One source is an on-going, multi-year project under Honeywell's program of Independent Research and Development. The second source is a contract with the Naval Training Equipment Center (NTEC 81-C-0093-13) entitled "Use of Voice Technology as the Instructor's Assistant."

It is assumed that the demographic predictions of unavailability of future military manpower are accurate. Therefore, it will be necessary to develop more efficient training systems and instructional methodology that are more effective in amount of competence produced per hour of instruction. The proposed approach is feasible and will provide a training capability to meet the need. The cost, versus benefit is more difficult to assess, however. We can assume that software costs will continue to accelerate and that all technology is expensive to develop. Intelligent systems of this type are software intensive. Further, the technological development needed is undetermined but certainly not trivial.

Artificial intelligence and voice technology may no longer be embryonic but they are far from mature for most applications.

REVIEW AND EVALUATION OF THE COMPONENT TECHNOLOGIES AND PRINCIPAL CONCEPTS IN ARTIFICIAL INTELLIGENCE

The needs of the Navy in instructional capability were examined briefly for the purpose of guiding the survey of technology. The results of that survey were that the Navy needs instructor support, friendly and forgiving interfaces between the training devices and both the instructor and student, and automated performance measurement. The functions and tasks for which instructor support is needed are:

Subject Matter Expertise  
Performance Evaluation  
Problem Selection  
Delivering Feedback  
Progress Management  
Documentation  
Role Playing

The review of AI technology was organized into the following topical categories:

Knowledge Representation  
Learning Theory  
The Nature of; Expertise  
Intelligence Computer Aided Instruction  
Software Architecture for Artificial Intelligence  
Natural Language Understanding  
Interactive Speech

The major conclusions will be summarized briefly.



The area of Knowledge Representation is known as Domain Knowledge. There are two relevant domains for a training system: the knowledge content of the technical specialty being taught and the instructional knowledge of methods, strategies, and procedures. They present no unresolvable problems for knowledge representation. The content of the domains will become manifest as the training materials are developed. However, not all of the necessary knowledge has been explicitly articulated or well-defined.

An important area of instructional knowledge is the evaluation of student performance. The level of effectiveness of a training system is dependent on the availability of two kinds of evaluative data:

Assessment of the level of performance in terms of level of competence and one's standing in the subject matter.

Diagnosis of errors committed in terms of specific deficiencies in knowledge or skill and necessary corrective action.

Existing techniques of knowledge representation are adequate for constructing an intelligent, interactive training device to support an instructor. These techniques consist of representing things and events in templates, frames, and scripts and the relationships among them in control rules and production rules. These rules also govern additions to knowledge derived internally by inference.

The contribution of Learning Theory is primarily in providing a structure and methodology for preparing training materials. One's first expectation might be that learning theory would provide models of the learning process; however, it performs that function only indirectly. Learning theory will provide a generic, transportable framework and methods for developing courseware and rules and techniques for performing task analysis. These methods and techniques entail specification of stimuli, acceptable and unacceptable responses, feedback, sequencing, branching, display formats and so on; they are in turn a function of the domain content, training objectives, instructional strategy, media, rules for performance assessment, and specific instructional techniques. All of this is dependent on the learning process. However, that knowledge must be encoded into the rules for instructional expertise and it will be transparent in the application.

Our interest in the nature of expertise is how the knowledge of competent practitioners should be used in the training system. Examination of the representation of that knowledge revealed that the form of representation varies with domain. Domains

differ in structure encompassing the gamut from production rules to hierarchical organization; multiple conceptualizations for the same phenomena are available in some domains; multiple levels of abstraction are characteristic of some domains.

Problem solving methods also varied across domains. Different methods are available for different tasks. A given problem solving method is also adapted to the requirements and constraints of specific task conditions.

Therefore, it seems unlikely that expertise can be captured in a few, simple, generic algorithms or procedures that are generalizable across knowledge domains or even within a domain. The interaction between the nature of expertise and knowledge representation is perhaps the most critical element in developing an intelligent training system. Knowledge structures and control rules that can represent the complex contingencies will have to be developed. The subject matter to be learned at novice levels will probably be relatively simple and without much of the troublesome complexity. This problem must be faced, though, when the training moves into more sophisticated or intermediate level topics.

One perspective on the purpose for developing these intelligent systems is to shorten the transition time from novice to expert. We want to produce higher levels of competence in shorter periods of instruction and with lower support costs. Ideally, this transubstantiation will be accomplished on trainees who are naive with respect to the technical area and of no more than average intelligence (general intellectual ability). An instructional system that will accomplish this feat will heed a model of the sequences of developmental stages from novice to expert, states within those stages, and the pedagogical techniques for transformation between states or stages. At the present state of our technology such a model must be derived within the context of a specific domain.

The Software Architecture for Artificial Intelligence was viewed as consisting of two parts: the hardware necessary to execute the program and the software. The hardware was found to be specific to the training program and thus no generalizations can be made. It was concluded that LISP is the software system that should be used for development and operation of such training systems. Knowledge representation techniques exist in LISP as well as an assortment of supporting tools and facilities. Further, there is a history of experience with this language which provides both a body of knowledge and experience AI practitioners to draw upon.

Interactive Speech and Natural Language Understanding present no obstacle in principle

although deriving and organizing the detailed dialogue requirements can be a challenging management task. Spoken messages can be synthesized at the current state-of-the-art. Generation of the messages in the context of on-going events and conditions and in an adequate approximation to real time is uncertain and must be determined in the specific applications.

Current and near future voice recognition systems can recognize utterances of only a few words in length; recognition and understanding of unconstrained, connected speech is not feasible and may not be practical for some time. This character of voice technology imposes a requirement that the natural language dialogue consist of short statements. Short statements may be characteristic of speech in task-oriented situations and thus this constraint may not be a practical limitation.

#### REVIEW OF NAVAL TRAINING NEEDS SUITABLE FOR A PROTOTYPE COURSE

Four training areas were reviewed for suitability. They are:

- Electronic Maintenance
- Air Intercept Control
- Naval Flight Officer Course
- Anti-Submarine Warfare Team Training

In addition, training equipment in team training and air traffic control was analyzed. The team trainers analyzed were TACDEW, 14A2 ASW, and 14A12; the air traffic control trainers were PARTS (McCauley and Semple, 1980) and the AIC Trainer (Halley, King, and Regelson, 1978).

The criteria used to evaluate the trainers were cost-benefit, availability/shortfall of instructors, appropriateness of content to AI and voice, impact on readiness, and stability of the subject matter. The cost-benefit criterion was broken down into three parts. First, the developmental cost of the prototype was treated in terms of the availability of appropriate information, data, and on-going training. Second, operating cost was treated as cost of instructors as the major factor differentiating among courses. The third part was a payback component in terms of readiness of trained personnel and reduction in personnel replacement.

Appropriateness of the subject matter for the use of artificial intelligence and interactive voice is an important methodological consideration. The prototype application must be able to reflect an advantage from utilizing the new technologies. Artificial intelligence will be beneficial in domains that have a significant cognitive component; voice technology is useful in areas of high workload

which can be reduced by using hearing and speech as media of interaction, rather than vision and manual responses.

ASW team training was chosen out of the four training areas as the best candidate for a prototype application. Electronic maintenance was rejected because it does not have a significant voice potential and developmental costs could be high. Maintenance skills are poorly understood and significant costs and delay could be incurred in getting necessary information. Air intercept control and the naval flight officers course were rejected because the subject matter is not stable.

#### RECOMMENDED GUIDELINES FOR INSTRUCTOR SUPPORT

Analysis of the instruction yielded needs for the following modules for instructor support:

- Record Keeping
- Scenario Set Up
- Subject Matter Expert
- Subject Matter Tutor
- Speech Generation
- Speech Recognition
- Ability to Understand Errors
- Omniscient Instructor

The major components of an Automated Training System are:

- Instructor Work Station
- Student Work Station
- Domain Expert
- Instructional Expert
- Performance Measurement

The Instructor Work Station was examined in more detail to identify the capability it should have. The Instructor Work Station should have the following functions:

- Explanation of Decisions and Actions
- Record Keeping and Scheduling
- Scenario Design and Debug
- Communications Control
- Problem Status

An important capability of the system is to recognize and cope with errors committed by the trainee. This capability entails several requirements in knowledge and use of the knowledge to make inferences about the trainee's behavior. The system must know the constraints reflected in the rules for correct behavior. Since the application is ASW team training, the system must also know how the trainee deals with other team members. Each player must know the roles of the other players at a minimal level of their nominal, expected behaviors in relation to one's own role.

Therefore, the system must know not only the role structure of the team but also each trainee's beliefs about knowledge and competence of other players. It must be able to follow a trainee's reasoning about the knowledge of other players and know whether he attributes erroneous or unexpected behavior from another player to a lack of knowledge, misinformation, or faulty, missing, or inappropriate procedures. The inferences the trainee makes and how he responds to the other player's behavior are relevant; he may fill in missing information, correct the other player; request verification, or adjust his own behavior to compensate for the perceived deficiencies in the other player's behavior.

These capabilities have been clustered into four sets which represent increasing levels capability and related to three stages in developing an intelligent, automated instructor or instructor's assistant, based on Crowe et al., (1981). We have modified the model of Crowe et al. by adding a fourth stage consisting of the ability to provide feedback and performance evaluation to team behaviors. The cross-correlation of these classifications is depicted in Table 1.

The correspondence between the major components of an Automated Training System and the AI technological areas on which they depend is summarized in Table 2.

#### DISCUSSION OF IMPLICATIONS AND ISSUES

Our intent in this section is to be explicit about some issues and concerns that were recurrent during our analyses and set aside for the purpose of attaining the immediate goal of developing some guidelines for how to proceed in developing an simulated, intelligent, talking instructor's assistant. They should at least be stated openly because they may represent potential problems or obstacles to developing, fielding, and effectiveness of this type of system. The intrepid innovator can then beware and take appropriate cautionary or preemptive actions.

These issues and implications are:

- Impact on the Instructor
- Reduction of Personal Contact between the Student and Instructor
- The Achievable Level of Naturalness
- Effect of Complexity on Friendliness and Support
- Importance of Message Generation Versus Voice Synthesis in the User-System Interface
- Compressibility of the "Novice-To-Expert" Curve

There are several possible effects on the instructor and his role which can have a negative impact on system effectiveness. The content of instructor training will necessarily be changed and perhaps increased in length and difficulty. Our intuition tells us that the instructor will need a better understanding of the instructional process than he presently has. At the same time his automated assistant will permit him to handle more trainees and attain higher levels of proficiency; his productivity should undergo a marked enhancement. However, without an instructionally sophisticated supervisor the automated instructor's assistance can run amok like the sorcerer's apprentice.

The instructor's morale, involvement, and sense of using his own talents will be affected. These factors will be enhanced if the instructor perceives his automated assistant as a tool which helps him in doing his job, as something to which he delegates tasks and which increases his effectiveness and permits him to do a better job. If in contrast he sees the "iron monster" as something which he must labor to support and dominates his activities, then his morale, motivation, and involvement will decline.

Reduction of personal contact between the instructor and trainee can compromise the effectiveness of social reinforcers and attenuate an important source of feedback and diagnostic information which every good instructor learns to use. It will also minimize the opportunity to use a mentor relationship to model behaviors and facilitate the instructional process. The voice of the simulated assistant may take on a personality and a reality as an individual and thus be able to satisfy some of these social functions. Realizing them may be a function of the creativity in preparation of the dialogues, the types interactions embedded in them, and the naturalness of the interaction as perceived by the trainee. The personality of the automated assistant may be another domain of expertise needed to develop and deploy these systems.

The achievable level of naturalness is unknown at this time as is the required level of naturalness. Naturalness and friendliness are concepts that are not well defined, and have a large subjective, intuitive component as the terms are used. Specifications are difficult to state and satisfy under such conditions. These terms need to be differentiated and made more precise.

The impact of naturalness and the complexity of the interactions on system support and maintenance is a very serious issue. The transparency of natural, friendly, simple dialogues is achieved by putting the complexity and processing behind the interfacing

| Technology                                 | Tutor | Stages of System Development |               |                       |
|--------------------------------------------|-------|------------------------------|---------------|-----------------------|
|                                            |       | Limited Role Play            | Student Model | Omniscient Instructor |
| Expert System Explanation                  | X     |                              |               |                       |
| Simulation (With Errors) Speech Generation |       | X                            |               |                       |
| Speech Recognition                         |       |                              | X             |                       |
| Understanding Misconceptions & Intent      |       |                              |               | X                     |
| Learning Model & Feedback                  |       |                              |               |                       |

TABLE 1. CORRESPONDENCE BETWEEN STAGES OF DEVELOPMENT OF AN AUTOMATED INSTRUCTOR'S ASSISTANCE AND AI CAPABILITIES

| Key Trainer Components            |  | Knowledge Representation | Natural Language Understanding | Interactive Speech Technology | Learning Theory | Cognitive Science | ICAI | AI Architecture |
|-----------------------------------|--|--------------------------|--------------------------------|-------------------------------|-----------------|-------------------|------|-----------------|
| Instructor workstation            |  |                          | +                              | +                             |                 |                   | +    |                 |
| Student workstation               |  |                          | +                              | +                             |                 |                   | +    |                 |
| Domain expert subsystem           |  | +                        |                                |                               |                 | +                 | +    | +               |
| Instructional expert subsystem    |  | +                        |                                |                               | +               |                   | +    | +               |
| Simulation subsystem              |  |                          | +                              | +                             |                 |                   | +    | +               |
| Performance measurement subsystem |  |                          |                                |                               |                 |                   | +    |                 |

TABLE 2. AI TECHNOLOGIES

console and into the software. Experience tells us that maintenance and support increase as software and hardware become more complex; Murphy's Law is imperative.

Voice synthesis with some degree of natural sounding speech is relatively easy to achieve in the current state of the art. However, the appropriateness of the message in the context of on-going events and the speech community of the listener are more difficult to accomplish. These features are the problem of message generation. It is dependent on a lot of information processing involving knowledge representation, inference, and domain knowledge. This area is critical to the effective use of voice technology.

Compressibility of the curve for transforming a novice into some level of expert is an ultimate instructional issue. There are many differences between novice and expert in amount of knowledge, its organization, techniques for formulating and solving problems, and the use of heuristics derived from experience and the accumulated lore of the discipline. A subset of these things must be chosen in terms of their utility on the job for a given level of proficiency, the ease of learning them, and the progression of states of knowledge and skill in the growth of proficiency. There is a multitude of empirical questions inherent in this issue; they must be unscrambled and addressed if we are to have an effective technology for automation of instructional systems.

#### CONCLUDING REMARKS

Application of artificial intelligence and voice technology to training systems in the form of an automated instructor's assistant is feasible and can provide significant increases in the cost-effectiveness of training. Artificial intelligence provides several concepts and techniques which are useful in structuring and implementing the design and use of such a system. This paper is a brief summary of an on-going investigation of the feasibility, utility, and approach to developing an automated instructor's assistant for use in training Navy personnel. ASW team training was chosen as the vehicle for a prototype application of the automated instructor's assistant.

#### REFERENCES

Crowe, W., Hicklin, M., Kelly, M., Obermayer, R., and Satzer, W. Team Training Through Communications Control, Report NAVTRAEQUIPCEN 80-C-0095-2, 1981. Naval Training Equipment Center, Orlando, Florida 32813.

McCauley, M.E., Semple, C.A. Precision approach radar training systems (PARTS) training effectiveness evaluation. NAVTRAEQUIPCEN 79-C-0042-1. 1979 Naval Training Equipment Center, Orlando, Florida.

Halley, R., King, M.R., Regelson, E.C. Functional requirement for air intercept controller prototype training system. NAVTRAEQUIPCEN 78-C-0182-4. 1978 Naval Training Equipment Center, Orlando, Florida.

## NAVTRAEQUIPCEN IH-341

## DISTRIBUTION LIST

|                                                                                                                                             |     |                                                                                                                       |   |
|---------------------------------------------------------------------------------------------------------------------------------------------|-----|-----------------------------------------------------------------------------------------------------------------------|---|
| Naval Training Equipment Center<br>Orlando, FL 32813                                                                                        | 100 | OUSDR&E (R&AT) (E&LS)<br>CAPT Paul R. Chatelier<br>Room 3D129, The Pentagon<br>Washington, DC 20301                   | 1 |
| Technical Library<br>Naval Training Equipment Center<br>Orlando, FL 32813                                                                   | 1   | OASD (MRA & L)/Training<br>Room 3B922, The Pentagon<br>Washington, DC 20301                                           | 2 |
| Commanding Officer<br>Navy Submarine Base New London<br>ATTN: Psychology Section, Box 600<br>Groton, CT 06340                               | 1   | Chief, Research Office<br>Office Deputy Chief of Staff<br>for Personnel<br>Department of Army<br>Washington, DC 20310 | 1 |
| Dr. Donald W. Connolly<br>Research Psychologist<br>Federal Aviation Administration<br>FAA NAFEC ANA-230, Bldg. 3<br>Atlantic City, NJ 08405 | 1   | National Defense University<br>Research Directorate<br>Ft. McNair, DC 20319                                           | 1 |
| National Aviation Facilities<br>Experimental Center<br>Library<br>Atlantic City, NJ 08405                                                   | 1   | HQAFSC/DLS<br>Andrews AFB, DC 20334                                                                                   | 1 |
| CDR Joseph Funaro<br>Code 602<br>Human Factors Engineering Div.<br>Naval Air Development Center<br>Warminster, PA 18974                     | 1   | AFOSR/NL (Dr. A. R. Fregley)<br>Bolling AFB<br>Washington, DC 20332                                                   | 1 |
| Commander<br>Naval Air Development Center<br>ATTN: Technical Library<br>Warminster, PA 18974                                                | 1   | Dr. Genevieve Haddad<br>AFOSR/NL<br>Bolling AFB, DC 20332                                                             | 1 |
| Technical Library<br>OUSDR&E<br>Room 30122<br>Washington, DC 20301                                                                          | 1   | Chief of Naval Operations<br>OP-115D<br>LCDR Jim Lawhorn<br>Washington, DC 20350                                      | 1 |
| Director<br>Defense Research and Engineering<br>Washington, DC 20301                                                                        | 1   | Assistant Secretary of the Navy<br>Research, Engineering & Systems<br>Washington, DC 20350                            | 1 |
| Commanding Officer<br>Air Force Office of Scientific<br>- Research<br>Technical Library<br>Washington, DC 20301                             | 1   | Chief of Naval Operations<br>OP-115<br>Research, Development & Studies<br>Room 6836<br>Washington, DC 20350           | 1 |
|                                                                                                                                             |     | Office of Deputy Chief of Naval<br>Operations<br>Manpower, Personnel & Training<br>(OP-01)<br>Washington, DC 20350    | 1 |

1-0617

100

NAVTRAEQUIPCEN IH-341

DISTRIBUTION LIST (cont'd)

|                                                                                                 |   |                                                                                                                     |   |
|-------------------------------------------------------------------------------------------------|---|---------------------------------------------------------------------------------------------------------------------|---|
| Chief of Naval Operations<br>OP-593B<br>Washington, DC 20350                                    | 1 | Commander<br>Naval Sea Systems Command<br>Code 61R2 (Mr. P. J. Andrews)<br>Washington, DC 20362                     | 1 |
| Chief of Naval Operations<br>OP-987H<br>ATTN: Dr. R. G. Smith<br>Washington, DC 20350           | 1 | Director, Personnel & Training<br>Analysis Office<br>Building 200-3<br>Washington Navy Yard<br>Washington, DC 20374 | 1 |
| Chief of Naval Operations<br>OP-596C<br>Washington, DC 20350                                    | 1 | Naval Research Laboratory<br>ATTN: Library<br>Washington, DC 20375                                                  | 1 |
| Chief of Naval Material<br>MAT 031M<br>Washington, DC 20360                                     | 1 | Commander<br>Naval Supply Systems Command<br>Code 03<br>Washington, DC 20376                                        | 1 |
| Commander<br>Naval Electronic Systems Cmd<br>Code 03<br>Washington, DC 20360                    | 1 | HQ, Marine Corps<br>Code APC<br>ATTN: LTC J. W. Biermas<br>Washington, DC 20380                                     | 1 |
| CDR Dick Gibson<br>Naval Air Systems Command<br>Code 413<br>Washington, DC 20361                | 1 | Scientific Advisor<br>HQ, US Marine Corps<br>Washington, DC 20380                                                   | 1 |
| CDR Tom Jones<br>Naval Air Systems Command<br>Code 334A<br>Washington, DC 20361                 | 1 | Commandant of Marine Corps<br>Code OTTF-31<br>Washington, DC 20380                                                  | 1 |
| Commander<br>Naval Air Systems Command<br>AIR 340F<br>Washington, DC 20361                      | 1 | Library<br>Division of Public Documents<br>Government Printing Office<br>Washington, DC 20402                       | 1 |
| Commander<br>Naval Air Systems Command<br>Technical Library<br>AIR-950D<br>Washington, DC 20361 | 1 | Scientific Technical Information<br>Office<br>NASA<br>Washington, DC 20546                                          | 1 |
| LT Thomas N. Crosby<br>Naval Air Systems Command<br>Code 5313X<br>Washington, DC 20361          | 2 | Federal Aviation Administration<br>Technical Library<br>Bureau Research & Development<br>Washington, DC 20590       | 1 |
| Commander<br>Naval Air Systems Command<br>AIR 413F<br>Washington, DC 20361                      | 1 | US Coast Guard (G-P-1/62)<br>400 Seventh Street, SW<br>Washington, DC 20590                                         | 1 |



## NAVTRAEQUIPMENT IH-341

## DISTRIBUTION LIST (cont'd)

|                                                                                                                                                              |    |                                                                                                                                             |    |
|--------------------------------------------------------------------------------------------------------------------------------------------------------------|----|---------------------------------------------------------------------------------------------------------------------------------------------|----|
| Dr. Sam Schiflett<br>Naval Air Test Center<br>SY 721<br>Patuxent River, MD 20670                                                                             | 1  | Dr. Henry M. Halff<br>Office of Naval Research<br>Code 442<br>Arlington, VA 22217                                                           | 1  |
| Commander<br>Naval Air Test Center<br>CT 176<br>Patuxent River, Maryland 20670                                                                               | 1  | Marshall Farr<br>Personnel & Training Research<br>Group<br>Code 442<br>Office of Naval Research<br>800 N. Quincy St.<br>Arlington, VA 22217 | 1  |
| Karl Feintuch<br>Arinc Research Corporation<br>2551 Riva Rd.<br>Annapolis, MD 21401                                                                          | 1  | Center for Naval Analyses<br>ATTN: Dr. R. F. Lockman<br>2000 N. Beauregard St.<br>Alexandria, VA 22311                                      | 1  |
| Director Educational Development<br>Academic Computing Center<br>US Naval Academy<br>Annapolis, MD 21402                                                     | 1  | Defense Technical Information<br>Center<br>Cameron Station<br>Alexandria, VA 22314                                                          | 12 |
| Dr. Jesse Orlandy<br>Institute for Defense Analyses<br>Science & Technology Div.<br>400 Army-Navy Drive<br>Arlington, VA 22202                               | 1  | PERI-OU<br>US Army Research Institute for<br>the Behavioral & Social<br>Sciences<br>5001 Eisenhower Ave.<br>Alexandria, VA 22333            | 1  |
| Dr. Martin Tolcott<br>Office of Naval Research<br>800 N. Quincy St.<br>Arlington, VA 22217                                                                   | 1  | US Army Research Institute for<br>the Behavioral & Social Sciences<br>ATTN: Russell Kirton<br>5001 Eisenhower Ave.<br>Alexandria, VA 22333  | 1  |
| CDR P. M. Curran<br>Office of Naval Research<br>800 N. Quincy St.<br>Arlington, VA 22217                                                                     | 12 |                                                                                                                                             |    |
| Personnel & Training Research<br>Programs<br>Office of Naval Research<br>Code 458<br>Psychological Sciences Div.<br>800 N. Quincy St.<br>Arlington, VA 22217 | 3  | Commanding Officer<br>Fleet Combat Training Center<br>Atlantic<br>ATTN: Mr. Hartz, Code 02A<br>Dam Neck<br>Virginia Beach, VA 23461         | 1  |
| Chief of Naval Research<br>Code 455<br>800 N. Quincy St.<br>Arlington, VA 22217                                                                              | 1  | Robert Goodwin<br>Commander Naval Air Force, US<br>Atlantic Fleet<br>Norfolk, VA 23511                                                      | 1  |
| Chief of Naval Research<br>Code 442 PT<br>800 N. Quincy St.<br>Arlington, VA 22217                                                                           |    | Army Training Support Center<br>ATTSC-DS<br>Ft. Eustis, VA 23604                                                                            | 1  |

## DISTRIBUTION LIST (cont'd)

|                                                                                                                                  |   |                                                                                                                                                                     |   |
|----------------------------------------------------------------------------------------------------------------------------------|---|---------------------------------------------------------------------------------------------------------------------------------------------------------------------|---|
| Commander<br>HQ, TRADOC<br>ATTN: ATTNG-PA<br>Ft. Monroe, VA 23651                                                                | 1 | Mr. Harold A. Kottmann<br>ASD/YWE<br>Wright Patterson AFB, OH 45433                                                                                                 | 1 |
| Chief<br>ARI Field Unit<br>P. O. Box 2086<br>ATTN: Librarian<br>Ft. Benning, GA 31905                                            | 1 | Mr. Steven P. Gunzburger<br>ASD/ENETC<br>Wright Patterson AFB, OH                                                                                                   | 1 |
| LT Frank C. Petho, MSC, USN<br>Chief Naval Education & Training<br>Code 433<br>NAS Pensacola, FL 32508                           | 1 | Mr. Craig McLean<br>USAF, ASD/YWE<br>Wright Patterson AFB, OH 45433                                                                                                 | 2 |
| Commanding Officer<br>Naval Education Training Program &<br>Development Center<br>ATTN: Technical Library<br>Pensacola, FL 32509 | 1 | Air Force Human Resources<br>Laboratory<br>AFHRL/LR<br>Logistics Research Div.<br>Wright Patterson AFB, OH 45433                                                    | 1 |
| Commanding Officer<br>Naval Aerospace Medical Rsch.<br>Laboratory<br>Code L5<br>Department of Psychology<br>Pensacola, FL 32512  | 1 | Mr. John Schreiber<br>Naval Air Systems Command<br>Code 4131<br>Washington, DC 20301                                                                                | 1 |
| TAWC/TN<br>Eglin AFB, FL 32542                                                                                                   | 1 | Dr. Kenneth Boff<br>ARAMRL/HEA<br>Wright Patterson AFB, OH 45433                                                                                                    | 1 |
| USAHEL/USAAVNC<br>ATTN: DRXHE-PR (Dr. Hofmann)<br>P. O. Box 476<br>Ft. Rucker, AL 36362                                          | 1 | Mr. Jim Loomis<br>ASD/ENETV<br>Wright Patterson AFB, OH 45433                                                                                                       | 1 |
| Dr. Will Bickley<br>USARI Field Unit<br>P. O. Box 476<br>Ft. Rucker, AL 36362                                                    | 1 | Mr. R. G. Cameron<br>ASD/ENETC<br>Wright Patterson AFB, OH 45433                                                                                                    | 1 |
| Chief<br>ARI Field Unit<br>P. O. Box 476<br>Ft. Rucker, AL 36362                                                                 | 1 | Dr. Ralph R. Canter<br>US Army Research Institute<br>Field Unit<br>P. O. Box 16T17<br>Ft. Harrison, IN 46216                                                        | 1 |
| Chief of Naval Technical Tng.<br>Code 0161<br>NAS Memphis (75)<br>Millington, TN 38054                                           | 1 | Headquarters 34 Tactical Airlift<br>Training Group/TTDI<br>Little Rock AFB, AK 72076                                                                                | 1 |
|                                                                                                                                  |   | Chief, Methodology & Standards<br>Staff<br>Federal Aviation Administration<br>Academy<br>Aeronautical Center, AAC-914<br>P. O. Box 25082<br>Oklahoma City, OK 73125 | 1 |

## DISTRIBUTION LIST (cont'd)

|                                                                                                                                         |   |                                                                                                                                           |   |
|-----------------------------------------------------------------------------------------------------------------------------------------|---|-------------------------------------------------------------------------------------------------------------------------------------------|---|
| Commandant<br>US Army Field Artillery School<br>Counterfire Department<br>ATTN: Mr. Eugene C. Rogers<br>Ft. Sill, OK 73503              | 1 | Mr. Harold D. Warner<br>AFHRL/OT (UDRI)<br>Williams AFB, AZ 85224                                                                         | 3 |
| Commandant<br>US Army Field Artillery School<br>ATSF-TD-TS<br>Mr. Inman<br>Ft. Sill, OK 73503                                           | 1 | Chief of Naval Education & Training<br>Liaison Office<br>Human Resources Laboratory<br>Flying Training Division<br>Williams AFB, AZ 85224 | 1 |
| CAPT Michael E. Shannon<br>4235 STS/XPX USAF<br>Carswell AFB, TX 76127                                                                  | 1 | US Air Force Human Resources Lab<br>AFHRL-OT<br>Operational Training Div.<br>Williams AFB, AZ 85224                                       | 1 |
| Headquarters<br>Air Training Command, XPTI<br>ATTN: Mr. Goldman<br>Randolph AFB, TX 78148                                               | 1 | AFHRL/OTO<br>Luke AFB, AZ 85309                                                                                                           | 1 |
| US Air Force Human Resources Lab<br>AFHRL-MPM<br>Manpower & Personnel Div.<br>Manpower & Force Mgm. Systems Br.<br>Brooks AFB, TX 78235 | 1 | Commanding Officer<br>Naval Education & Training Support<br>Center, Pacific<br>Code N5B (Mr. Rothenberg)<br>San Diego, CA 92132           | 1 |
| US Air Force Human Resources<br>Laboratory<br>TSZ<br>Brooks AFB, TX 78235                                                               | 1 | Commander<br>Naval Air Force<br>US Pacific Fleet (Mr. Bolwerk/Code 316)<br>NAS North Island<br>San Diego, CA 92135                        | 1 |
| AFHRL/PE<br>Brooks AFB, TX 78235                                                                                                        | 1 | Commanding Officer<br>Fleet Training Center<br>ATTN: Training Department<br>Naval Station<br>San Diego, CA 92136                          | 1 |
| Chief of Naval Air Training<br>ATTN: Code 333<br>NAS<br>Corpus Christi, TX 78419                                                        | 1 | Commander<br>Training Command<br>ATTN: Educational Advisor<br>US Pacific Fleet<br>San Diego, CA 92147                                     | 1 |
| US Air Force Human Resources Lab<br>AFHRL-UT (Dr. Rockway)<br>Williams AFB, AZ 85224                                                    | 1 | Commanding Officer<br>Fleet Combat Training Center,<br>Pacific<br>Code 09A<br>San Diego, CA 92147                                         | 1 |
| Dr. Thomas Longridge<br>AFHRL/OTR<br>Williams AFB, AZ 85224                                                                             | 1 | Commanding Officer<br>Fleet Anti-Submarine Warfare<br>Training Center, Pacific<br>ATTN: Code 001<br>San Diego, CA 92147                   | 1 |
| Commanding Officer<br>Human Resources Laboratory<br>Operational Training Div.<br>Williams AFB, AZ 85224                                 | 1 |                                                                                                                                           |   |

## DISTRIBUTION LIST (cont'd)

|                                                                                                                               |   |                                                                                                                                         |   |
|-------------------------------------------------------------------------------------------------------------------------------|---|-----------------------------------------------------------------------------------------------------------------------------------------|---|
| Navy Personnel Research &<br>Development Center<br>ATTN: M. McDowell<br>Library, Code P201L<br>San Diego, CA 92152            | 1 | Dr. David C. Nagel<br>LM-239-3<br>NASA Ames Research Center<br>Moffett Field, CA 94035                                                  | 1 |
| LT Wayne R. Helm<br>Human Factors, Engineering<br>Code 1226<br>Point Mugu, CA 93042                                           | 1 | Dr. J. Huddleston<br>Head of Personnel Psychology<br>Army Personnel Research<br>Establishment<br>C/o RAE, Farnborough<br>Hants, ENGLAND | 1 |
| Commander<br>Pacific Missile Test Center<br>Point Mugu, CA 93042                                                              | 1 | Mr. David A. Citrin<br>General Electric Ordnance Systems<br>Rm 2372<br>100 Plastics Avenue<br>Pittsfield, MA 01201                      | 1 |
| Frank Fowler<br>3306 TES (ATC)<br>STOP 223<br>Edwards AFB, CA 93523                                                           | 3 | Mr. Ron Handy<br>Pacer Systems<br>87 2nd Avenue<br>Burlington, MA 01803                                                                 | 1 |
| LTC J. E. Singhton<br>3306 TES<br>Edwards AFB, CA 93523                                                                       | 1 | Corporate-Tech Planning Inc.<br>ATTN: Katherine E. Blythe<br>275 Wyman St.<br>Waltham, MA 02154                                         | 1 |
| Commander<br>Naval Weapons Center<br>Code 3154<br>ATTN: Mr. Bob Curtis<br>China Lake, CA 93555                                | 1 | Mr. Albert Stevens<br>Bolt Beranek & Newman, Inc.<br>10 Moulton St.<br>Cambridge, MA 02238                                              | 1 |
| Commander<br>Naval Weapons Center<br>Human Factors Branch (Code 3194)<br>ATTN: Mr. Ronald A. Erickson<br>China Lake, CA 93555 | 1 | Mr. Harvey F. Silverman<br>Professor of Engineering<br>Brown University<br>Providence, RI 02912                                         | 1 |
| Dr. Wayne D. Gray<br>ARI Field Unit<br>P. O. Box 5787<br>Presidio of Monterey, CA 93940                                       | 1 | Director<br>G/G-Training Dynamics<br>90 National Drive<br>Glastonbury, CT 06033                                                         | 1 |
| AFHRL Technology Office<br>ATTN: MAJ Duncan L. Dieterly<br>NASA-Ames Research Cen., MS 239-2<br>Moffett Field, CA 94035       | 1 | Analysis & Technology, Inc.<br>New London Office<br>P. O. Box 769<br>ATTN: Frederick M. Ball<br>New London, CT 06320                    | 1 |
| Mr. Robert Wright<br>Aeromechanics Lab. (USAAVRADCOM)<br>Ames Research Ctr., MS 239-2<br>Moffett Field, CA 94035              | 1 | Mysteeh Associates, Inc.<br>P. O. Box 220<br>Mystic, CT 06355                                                                           | 1 |

## DISTRIBUTION LIST (cont'd)

|                                                                                                                                                |   |                                                                                                 |   |
|------------------------------------------------------------------------------------------------------------------------------------------------|---|-------------------------------------------------------------------------------------------------|---|
| Eclectech Associates<br>North Stonington Professional<br>Center<br>P. O. Box 178<br>North Stonington, CT 06359                                 | 1 | Rowland & Co.<br>P. O. Box 61<br>Haddonfield, NJ 08033                                          | 1 |
| Dr. Thomas J. Hammell<br>Eclectech Associates<br>P. O. Box 178<br>North Stonington, CT 06333                                                   | 3 | Techplan Corp.<br>1000 Maplewood Dr.<br>Maple Shade, NJ 08052                                   | 1 |
| Mr. W. Bertsche<br>Eclectech Associates<br>P. O. Box 178<br>North Stonington, CT 06359                                                         | 1 | Geoffrey M. Heddon<br>Computer Sciences Corp.<br>P. O. Box H<br>Morrestown, NJ 08057            | 1 |
| Analysis & Technology, Inc.<br>ATTN: Bonnie E. Jennings<br>Technology Park<br>Route 2, P. O. Box 220<br>North Stonington, CT 06359             | 1 | John D. Gould<br>IBM Research Center<br>Yorktown Heights, NY 10598                              | 1 |
| Sonalysts, Inc.<br>215 Parkway North<br>Waterford, CT 06385                                                                                    | 1 | Grumman Aerospace Corp.<br>Plant 36, C02-04<br>ATTN: Mr. Sam Campbell<br>Bethpage, LI, NY 11714 | 1 |
| Dunlap & Associates, Inc.<br>One Parkland Drive<br>ATTN: J. T. Fucigna, Executive VP<br>Darien, CT 06820                                       | 1 | Martin Plawsky<br>Grumman Aerospace Corp.<br>C21-05<br>Bethpage, NY 11714                       | 1 |
| E. P. Washchilla<br>Talley Industries, Research<br>Center<br>58 Progress Drive<br>P. O. Box 1456<br>Stanford, CT 06902                         | 1 | Glynn R. Ramsay<br>Gould, Inc.<br>Simulation Systems Div.<br>Melville, NY 11747                 | 1 |
| Rockwell International<br>Autonetics Marine Systems Div.<br>New England Operations<br>1028 Poquonnock Rd.<br>Groton, CT 06340                  | 1 | Martin Morganlander<br>Gould SSD<br>50 Marcus Drive<br>Melville, NY 11747                       | 1 |
| Lockheed Electronics Co., Inc.<br>ATTN: Support Engineering Dept.<br>Mail Station 1100<br>1501 US Highway 22, C. S. #1<br>Plainfield, NJ 07061 | 1 | Howard Jaslow<br>Gould Simulation Systems<br>50 Marcus Dr.<br>Melville, NY 11747                | 1 |
| Systems Engineering Assocs. Corp.<br>P. O. Box 2030<br>19 Cherry Hill Industrial Park<br>Perina Blvd.<br>Cherry Hill, NJ 08003                 | 1 | Harris Corp.<br>PRD Electronics Div.<br>6801 Jerico Turnpike<br>Syosset, NY 11791               | 1 |
|                                                                                                                                                |   | Eric/IR<br>Syracuse University<br>School of Education<br>Syracuse, NY 13210                     | 1 |

## DISTRIBUTION LIST (cont'd)

|                                                                                                                                                    |   |                                                                                                                                             |   |
|----------------------------------------------------------------------------------------------------------------------------------------------------|---|---------------------------------------------------------------------------------------------------------------------------------------------|---|
| Drs. Cohen and Stark<br>Link Division<br>The Singer Company<br>Binghamton, NY 13902                                                                | 2 | American Institute for Research<br>in the Behavioral Sciences<br>1055 Thomas Jefferson St., NW<br>Washington, DC 20007                      | 1 |
| Bob Gamache<br>Singer-Link FSD<br>Colesville Rd.<br>Binghamton, NY 13902                                                                           | 2 | Robert F. Archer<br>American Institutes for Research<br>in the Behavioral Sciences<br>1055 Thomas Jefferson St., NW<br>Washington, DC 20007 | 1 |
| Alexandra B. Taylor<br>Singer-Link FSD<br>Binghamton, NY 13902                                                                                     | 1 | American Psychological Assoc.<br>Psychological Abstracts<br>1200 17th St., NW<br>Washington, DC 20036                                       | 1 |
| SCIPAR, Inc.<br>ATTN: Leslie A. Duffy<br>P. O. Box 185<br>Buffalo, NY 14221                                                                        | 1 | Robert T. Hennessy<br>Committee on Human Factors<br>National Research Council<br>2101 Constitution Ave., NW<br>Washington, DC 20418         | 1 |
| Falcon Research & Development Co.<br>ATTN: Patricia D. Pfohl<br>One American Drive<br>Buffalo, NY 14225                                            | 1 | TRACOR, Inc.<br>ATTN: Training Section Head<br>Two Pine Hill Center<br>P. O. Box 600<br>Lexington Park, MD 20653                            | 1 |
| Calspan Corporation<br>4455 Genesee St.<br>Buffalo, NY 14225                                                                                       | 1 | GP Technology Corp.<br>5615 Landover Rd.<br>Landover Hills, MD 20784                                                                        | 1 |
| George R. Purifoy, Jr.<br>Applied Science Assocs., Inc.<br>Box 158<br>Valencia, PA 16059                                                           | 1 | B-K Dynamics, Inc.<br>ATTN: Barbara Schardt<br>MIS Division<br>15825 Shady Grove Rd.<br>Rockville, MD 20850                                 | 1 |
| Dr. M. M. Reddi<br>Vice President, Engineering Dept.<br>Franklin Research Center<br>20th St. & Benjamin Franklin Parkway<br>Philadelphia, PA 19103 | 1 | E. Scott Baudhuin<br>Singer-Link<br>11800 Tech. Rd.<br>Silver Spring, MD 20904                                                              | 2 |
| James J. Perriello<br>Deputy Div. Mgr., Arlington Div.<br>Systems Consultants, Inc.<br>2828 Pennsylvania Ave.<br>Washington, DC 20007              | 1 | Richard Kause<br>Singer-Link<br>Link Simulation Sys. Div.<br>11800 Tech. Rd.<br>Silver Spring, MD 20904                                     | 1 |
| Charles B. Colton, P. E.<br>Marketing Director<br>Systems Consultants, Inc.<br>2828 Pennsylvania Ave.<br>Washington, DC 20007                      | 2 | ORI, Inc.<br>1400 Spring St.<br>Silver Spring, MD 20910                                                                                     | 1 |

## DISTRIBUTION LIST (cont'd)

|                                                                                                                                               |                                                                                                                                    |    |
|-----------------------------------------------------------------------------------------------------------------------------------------------|------------------------------------------------------------------------------------------------------------------------------------|----|
| Vitro Laboratories Div.<br>ATTN: MO<br>Automation Industries, Inc.<br>14000 Georgia Ave.<br>Silver Spring, MD 20910                           | 1 Bert Alton<br>Sperry Systems Management<br>12010 Sunrise Valley Drive<br>Reston, VA 22091                                        | 1  |
| Westinghouse Electric Corp.<br>Defense Group, ILS Div.<br>ATTN: Carole W. Forsythe<br>MS 7740<br>1111 Schilling Road<br>Hunt Valley, MD 21030 | 1 Joseph L. Dickman<br>Sperry Systems Management-SECOR<br>12010 Sunrise Valley Dr.<br>Reston, VA 22091                             | 10 |
| Technical Information Center<br>General Physics Corp.<br>1000 Century Plaza<br>Columbia, MD 21044                                             | 1 Library, Tactical Operations<br>Analysis Div.<br>Science Applications, Inc.<br>8400 Westpark Drive<br>McLean, VA 22102           | 1  |
| Joyce F. Peacock, Librarian<br>AAI Corp.<br>Technical Library<br>P. O. Box 6767<br>Baltimore, MD 21204                                        | 1 Behavioral Sciences Department<br>ATTN: R. J. Ely<br>The BDM Corporation<br>7915 Jones Branch Drive<br>McLean, VA 22102          | 1  |
| CADCOM<br>ATTN: Mr. James W. Foust<br>107 Ridgely Ave.<br>Annapolis, MD 21401                                                                 | 1 PRO Technical Applications, Inc.<br>ATTN: Karen B. Burklow<br>7600 Old Springhouse Road<br>McLean, VA 22102                      | 1  |
| Ruth Ehrensberger<br>ARINC Research Corp.<br>2551 Riva Rd.<br>Annapolis, MD 21401                                                             | 1 Dr. Edward N. Hobson<br>The BDM Corporation<br>7915 Jones Branch Drive<br>McLean, VA 22102                                       | 1  |
| American Communications Corp.<br>Mail Station-B<br>7617 Little River Turnpike<br>Annadale, VA 22003                                           | 1 General Research Corporation<br>ATTN: Mr. Robert Watt<br>7655 Old Springhouse Road<br>Westgate Research Park<br>McLean, VA 22102 | 1  |
| Synectics Corp.<br>ATTN: Mr. E. M. Jaehne<br>10400 Eaton Place<br>Fairfax, VA 22030                                                           | 1 Advanced Technology, Inc.<br>ATTN: Debbie Burns<br>Suite 500<br>7923 Jones Branch Drive<br>McLean, VA 22102                      | 1  |
| Institute of Human Performance<br>Circle-Towers Plaza Level<br>9411-R Lee Highway<br>Fairfax, VA 22031                                        | 1 Alan G. Hundt, PhD<br>SAI Comsystems Corporation<br>7921 Jones Branch Drive<br>McLean, VA 22102                                  | 1  |
| Biotechnology, Inc.<br>ATTN: Alma Collie<br>3027 Rosemary Lane<br>Falls Church, VA 22042                                                      | 1 Human Sciences Research, Inc.<br>Westgate Research Park<br>7710 Old Springhouse Road<br>McLean, VA 22102                         | 1  |

## DISTRIBUTION LIST (cont'd)

|                                                                                                                                                |   |                                                                                                                                             |   |
|------------------------------------------------------------------------------------------------------------------------------------------------|---|---------------------------------------------------------------------------------------------------------------------------------------------|---|
| Engineering Research Associates<br>ATTN: Erik Thamm<br>1517 Westbranch Drive<br>McLean, VA 22102                                               | 1 | Rockwell International<br>ATTN: D. B. Lafferman<br>1745 Jefferson Davis Highway<br>Suite 1107<br>Arlington, VA 22202                        | 1 |
| Jean Hillman<br>Advanced Technology, Inc.<br>7923 Jones Branch Drive<br>Suite 500<br>McLean, VA 22102                                          | 1 | Mantech International<br>Century Building<br>2341 Jefferson Davis Highway<br>Arlington, VA 22202                                            | 1 |
| George H. Datesman, Jr.<br>Program Manager<br>Applied Science Associates, Inc.<br>P. O. Box 975<br>Middleburg, VA 22117                        | 1 | W. Kessler<br>Data-Design Laboratories<br>Suite 307<br>1755 South Jefferson Davis Highway<br>Arlington, VA 22202                            | 1 |
| XMCO, Inc.<br>ATTN: Director of Training<br>Developments<br>6501 Loisdale Court, Suite 606<br>Springfield, VA 22150                            | 1 | SRI International<br>1611 North Kent St.<br>Arlington, VA 22209                                                                             | 1 |
| Litton Mellonics<br>ATTN: Ms. Sue Tepper, Libn.<br>P. O. Box 1286<br>Springfield, VA 22151                                                     | 1 | Don R. Lyon<br>Editor-in-Chief<br>News & Notes<br>Personnel & Training Research<br>Group<br>Office of Naval Research<br>Arlington, VA 22217 | 1 |
| Performance Measurement Assocs.,<br>Inc.<br>131 Park St., NE<br>Vienna, VA 22180                                                               | 1 | Control Data Corporation<br>ATTN: Mr. W. W. Doescher<br>1800 North Beauregard St.<br>Alexandria, VA 22311                                   | 1 |
| Delex Systems, Inc.<br>ATTN: J. Golden<br>Suite 700, 8150 Leesburg Pike<br>Vienna, VA 22180                                                    | 1 | Dr. Edgar L. Shriver, President<br>Kinton Incorporated<br>Suite 205<br>1500 North Beauregard St.<br>Alexandria, VA 22311                    | 1 |
| Raymond G. Fox<br>Society for Applied Learning<br>Technology<br>50 Culpeper St.<br>Warrenton, VA 22186                                         | 1 | Director<br>Human Resources Research<br>Organization<br>300 N. Washington St.<br>Alexandria, VA 22314                                       | 1 |
| Analysis & Technology, Inc.<br>ATTN: Bradley Keyes<br>Taylor Building (NC-3 - Pentouse)<br>2531 Jefferson Davis Highway<br>Arlington, VA 22202 | 1 | Allen Corp. of America<br>ATTN: W. M. Rugemer, Jr.<br>401 Mythe St.<br>Alexandria, VA 22314                                                 | 1 |
| Potomac Research, Inc.<br>1600 North Beauregard St.<br>Alexandria, VA 22311                                                                    | 1 |                                                                                                                                             |   |



## DISTRIBUTION LIST (cont'd)

|                                                                                                                                          |   |                                                                                                                         |   |
|------------------------------------------------------------------------------------------------------------------------------------------|---|-------------------------------------------------------------------------------------------------------------------------|---|
| Essex Corporation<br>ATTN: Dr. Thomas B. Malone<br>333 N. Fairfax St.<br>Alexandria, VA 22314                                            | 1 | Georgia Institute of Technology<br>Computer Science & Tech. Lab.<br>Engineering Experiment Station<br>Atlanta, GA 30332 | 1 |
| Dr. Saul Lavisky, Executive Officer<br>HumRRO<br>300 N. Washington St.<br>Alexandria, VA 22314                                           | 1 | B. E. Mulligan<br>University of Georgia<br>Dept of Psychology<br>Athens, GA 30602                                       | 1 |
| Q. E. D. Systems, Inc.<br>ATTN: Special Projects<br>4646 Witchduck Rd.<br>Virginia Beach, VA 23455                                       | 1 | Paul W. Caro<br>Seville Research Corp.<br>400 Plaza Bldg.<br>Pensacola, FL 32505                                        | 3 |
| Comptek Research, Inc.<br>#5 Kroger Executive Center, Suite 127<br>Norfolk, VA 23502                                                     | 1 | Seville Research Corporation<br>Pace Blvd. at Fairfield<br>Pensacola, FL 32505                                          | 1 |
| Janet L. Winner<br>4208 Colonial Ave.<br>Norfolk, VA 23508                                                                               | 1 | John T. McShera, Jr.<br>2112 Lewis Turner Blvd.<br>Ft. Walton Beach, FL 32548                                           | 1 |
| Dr. Robert C. Williges<br>Industrial Eng. & Operations Rsch.<br>Virginia Polytechnic Inst. & State<br>University<br>Blacksburg, VA 24061 | 1 | G. H. Balz<br>Balz Enterprises, Inc.<br>2524 Chinook Trail<br>Maitland, FL 32751                                        | 1 |
| R. L. Parker<br>Lockheed Georgia Co.<br>Customer Eng. Dept.<br>86 S. Cobb Dr.<br>Marietta, GA 30063                                      | 1 | Mr. A. E. Plogstedt M/S 100<br>McDonnell Douglas Astronautics Co.<br>P. O. Box 600<br>Titusville, FL 32780              | 1 |
| Dr. Ross Gagliano<br>Head, Operations Research Branch<br>Georgia Tech. Eng. Experiment Station<br>326 Baker Bldg.<br>Atlanta, GA 30332   | 1 | R. Fagan<br>250 W. Lake Sue Ave.<br>Winter Park, FL 32798                                                               | 1 |
| David M. Eakin<br>Bell Aerospace Textron<br>Naval Coastal Systems Center<br>Bldg. 319<br>Panama City, FL 32407                           | 1 | John P. Quinn<br>NSI<br>1315 S. Semoran Blvd.<br>Winter Park, FL 32792                                                  | 1 |
| B. L. Nissley<br>Bell Aerospace Textron<br>Naval Coastal Systems Center<br>Panama City, FL 32407                                         | 1 | Grace P. Waldrop<br>McDonald & Associates, Inc.<br>988 Woodcock Rd.<br>Suite 136<br>Orlando, FL 32803                   | 1 |
|                                                                                                                                          |   | Bruce McDonald<br>McDonald & Associates<br>988 Woodcock Rd.<br>Orlando, FL 32803                                        | 1 |

## DISTRIBUTION LIST (cont'd)

|                                                                                                     |   |                                                                                                                  |   |
|-----------------------------------------------------------------------------------------------------|---|------------------------------------------------------------------------------------------------------------------|---|
| Appli-Mation, Inc.<br>31291 Maguire Blvd.<br>Suite 244<br>Orlando, FL 32803                         | 1 | Walter M. Komanski<br>Spectrum of America<br>1040 Woodcock Rd.<br>Suite 214<br>Orlando, FL 32803                 | 2 |
| Michael Skurzewski<br>Veda, Inc.<br>3203 Lawton Rd.<br>Suite 233<br>Orlando, FL 32803               | 1 | Northrop Services, Inc.<br>ATTN: G. F. Stackpole<br>3203 Lawton Road<br>Suite 201<br>Orlando, FL 32803           | 1 |
| Jim Hazzard<br>Veda, Inc.<br>3203 Lawton Rd.<br>Suite 233<br>Orlando, FL 32803                      | 1 | Harold Rosenblum<br>1310 Webster St.<br>Orlando, FL 32804                                                        | 1 |
| John Keegan<br>Allen Corporation of America<br>3751 Maguire Bldg.<br>Suite 270<br>Orlando, FL 32803 | 2 | Martin A. Traub<br>Appli-Mation, Inc.<br>6955 Hanging Moss Road<br>Orlando, FL 32807                             | 1 |
| Bob Baker<br>Allen Corporation of America<br>999 Woodcock Rd.<br>Suite 308<br>Orlando, FL 32803     | 1 | Dave Daly<br>Rowland & Co.<br>6961 Hanging Moss Rd.<br>Orlando, FL 32807                                         | 1 |
| Science Applications, Inc.<br>3655 Maguire Blvd.<br>Suite 150<br>Orlando, FL 32803                  | 1 | Diana Barry<br>Rowland & Co.<br>6961 Hanging Moss Rd.<br>Orlando, FL 32807                                       | 1 |
| Diana Z. Bryan<br>Eagle Technology<br>3165 McCrory Pl., STE. 235<br>Orlando, FL 32803               | 1 | Patricia Kilgore<br>Rowland & Co.<br>6961 Hanging Moss Rd.<br>Orlando, FL 32807                                  | 1 |
| Deborah Bush<br>E-Tech, Inc.<br>3165 McCrory Pl.<br>Orlando, FL 32803                               | 1 | Dr. Angelo P. Verdi<br>Rowland & Co.<br>6961 Hanging Moss Rd.<br>Orlando, FL 32807                               | 1 |
| William Hinton<br>Spectrum of America<br>1040 Woodcock Rd.<br>Suite 214<br>Orlando, FL 32803        | 1 | R. W. Schultheis, Jr.<br>Computer Systems Division<br>Perkin-Elmer<br>7200 Lake Ellenor Dr.<br>Orlando, FL 32809 | 1 |
| Moses Aronson<br>Aronson Industries<br>3705 Wilder Lane<br>Orlando, FL 32804                        | 2 | Jeffery L. Maxey<br>3165 McCrory Pl.<br>Orlando, FL 32813                                                        | 1 |
|                                                                                                     |   | Ergonomics Associates, Inc.<br>P. O. Box 20987<br>Orlando, FL 32814                                              | 1 |

## DISTRIBUTION LIST (cont'd)

|                                                                                                                                                  |   |                                                                                                                                      |   |
|--------------------------------------------------------------------------------------------------------------------------------------------------|---|--------------------------------------------------------------------------------------------------------------------------------------|---|
| DBA Systems, Inc.<br>ATTN: Advanced Programs<br>P. O. Drawer 550<br>Melbourne, FL 32901                                                          | 1 | John M. Howard<br>Staff Scientist<br>Human Factors Div.<br>SSS Consulting<br>2600 Far Hills<br>Dayton, OH 45419                      | 1 |
| T. F. McCrea<br>Chrysler Defense<br>2423 Auburn Dr.<br>Cocoa, FL 32922                                                                           | 2 | Carmine Vaccarino<br>SRL, Inc.<br>2800 Indian Ripple Rd.<br>Dayton, OH 45440                                                         | 1 |
| DEACO International, Inc.<br>Intercontinental Bank Bldg.<br>3899 N. W. 7th St., Suite 211<br>Miami, FL 33126                                     | 1 | Systems Research Lab. Inc.<br>ATTN: George A. Whiteside<br>2800 Indian Ripple Rd.<br>Dayton, OH 45440                                | 1 |
| Thomas P. Ross, Jr.<br>Science Applications, Inc.<br>2109 W. Clinton Ave.<br>Suite 800<br>Huntsville, AL 35805                                   | 1 | James R. Bridges<br>Program Mgr. Tng. Equipment<br>General Dynamics<br>Land Systems Div.<br>P. O. Box 1901<br>Warren, Michigan 48090 | 3 |
| Rudolf K. Walter<br>International Aerospace Technologies,<br>Inc.<br>Executive Plaza, Suite 103<br>4717 University Drive<br>Huntsville, AL 35805 | 1 | Bjorksten Research Laboratories,<br>Inc.<br>P. O. Box 9444<br>ATTN: Mr. Michael J. Maloney<br>Madison, WS 53715                      | 1 |
| Dr. Richard S. Jensen<br>Aviation Psychology Lab.<br>Dept. of Aviation<br>The Ohio State University<br>Box 3022<br>Columbus, OH 43210            | 1 | John F. Brock<br>Systems & Research Center<br>Honeywell, Inc.<br>2600 Ridgeway Parkway<br>Minneapolis, MN 55413                      | 2 |
| Joseph R. Gleydura<br>Goodyear Aerospace Corp.<br>1210 Massillon Rd.<br>Akron, OH 44315                                                          | 3 | Tony Modrick<br>Honeywell Systems & Research Center<br>P. O. Box 312<br>Minneapolis, MN 55440                                        | 1 |
| George E. Palar<br>Goodyear Aerospace Corp.<br>1210 Massillon Rd.<br>Akron, OH 44315                                                             | 1 | J. L. Runquist<br>Market Analyst<br>Sperry Univac<br>Univac Park<br>P. O. Box 3525<br>St. Paul, MN 55165                             | 1 |
| Donald K. Oldham<br>Goodyear Aerospace<br>1210 Massillon Rd.<br>Akron, OH 44315                                                                  | 1 | McDonnell Douglas Astronautics Co.<br>ATTN: E. J. Reilly<br>Dept. E080, Bldg 106, Level 2<br>P. O. Box 516<br>St. Louis, MO 63166    | 1 |
| Simulation Technology, Inc.<br>ATTN: R. B. Penwell<br>4124 Linden Ave., Suite 200<br>Dayton, OH 45432                                            | 1 |                                                                                                                                      |   |

## DISTRIBUTION LIST (cont'd)

|                                                                                                                                        |   |                                                                                                                               |   |
|----------------------------------------------------------------------------------------------------------------------------------------|---|-------------------------------------------------------------------------------------------------------------------------------|---|
| John W. Robbins<br>McDonnell Douglas Astronautics Co.<br>Dept. E502, Bldg 81, Level 2, Post E10<br>Box 516<br>St. Louis, MO 63166      | 1 | Pete Chism<br>Bell Aerospace Textron<br>6800 Plaza Dr.<br>New Orleans, LA 70127                                               | 1 |
| J. Germeroth<br>McDonnell Douglas Electronics Co.<br>2600 N. Third St.<br>St. Charles, MO 63301                                        | 1 | John Priest<br>1651 Rockwood Trail<br>Fayetteville, AR 72701                                                                  | 1 |
| Ross E. Ailslieger<br>Crew Systems Technology - M.S. K36-40<br>Boeing Military Airplane Co.<br>3801 S. Oliver St.<br>Wichita, KS 67210 | 1 | Lynn R. Whisman<br>Burtek, Inc.<br>P. O. Box 1677<br>Tulsa, OK 74101                                                          | 1 |
| Robert B. Grow<br>Simuflite Tng. Intl.<br>7610 Stemmons<br>Suite 300<br>Dallas, TX 75247                                               | 2 | R. L. Sands<br>General Dynamics, Fort Worth<br>P. O. Box 748, MZ 2637<br>Fort Worth, TX 76101                                 | 1 |
| V. S. Perkins, Jr.<br>Vaught Corporation<br>P. O. Box 225907<br>M. S. 31-02<br>Dallas, TX 75265                                        | 1 | Mr. Frank J. Roy<br>General Dynamics, Fort Worth<br>P. O. Box 746, MZ 2219<br>Fort Worth, TX 76101                            | 1 |
| Dr. Ronald R. Calkins<br>Vaught Corporation<br>Bldg. 31<br>P. O. Box 225907<br>Dallas, TX 75265                                        | 1 | Joseph C. Stein<br>4235 Strategic Training Sq.<br>4235 STS/XPX<br>Carswell AFB, TX 76126                                      | 2 |
| General Dynamics/Fort Worth<br>ATTN: J. A. Davis<br>P. O. Box 746, MZ 2865<br>Fort Worth, TX 76101                                     | 1 | Ford Aerospace & Communications<br>Corporation<br>Space Information Systems Operation<br>P. O. Box 58487<br>Houston, TX 77058 | 1 |
| Terry Nagle<br>Bell Aerospace Textron<br>6800 Plaza Dr.<br>New Orleans, LA 70127                                                       | 1 | Richard L. Strong<br>Singer Co.<br>2222 Bay Area Blvd.<br>Houston, TX 77058                                                   | 2 |
| Robert Tucker<br>Bell Aerospace Textron<br>6800 Plaza Dr.<br>New Orleans, LA 70127                                                     | 1 | Technology, Inc.<br>Life Sciences Div.<br>P. O. Box 32644<br>San Antonio, TX 78216                                            | 1 |
| Jerry Wages<br>Bell Aerospace Textron<br>6800 Plaza Drive<br>New Orleans, LA 70127                                                     | 5 | Texas Tech University<br>Psychology Department<br>Box 4100<br>ATTN: Dr. Charles G. Halcomb<br>Lubbock, TX 79409               | 1 |
|                                                                                                                                        |   | Applied Science Associates, Inc.<br>Box 6057<br>Ft. Bliss, TX 79916                                                           | 1 |

NAVTRAEQUIPCEN IH-341

DISTRIBUTION LIST (cont'd)

|                                                                                                                          |   |                                                                                                                               |    |
|--------------------------------------------------------------------------------------------------------------------------|---|-------------------------------------------------------------------------------------------------------------------------------|----|
| H. Rudy Ramsey<br>Science Applications, Inc.<br>7935 E. Prentice Ave.<br>Englewood, CO 80110                             | 1 | Human Factors Society<br>ATTN: Bulletin Editor<br>P. O. Box 1369<br>Santa Monica, CA 90406                                    | 2  |
| Christopher Lin<br>United Airlines Flight Tng. Cen.<br>Stapleton International Airport<br>Denver, CO 80207               | 1 | Dr. James E. Roberts<br>Medical Systems Technical Services,<br>Inc.<br>23824 Hawthorne Blvd., Suite 200<br>Torrance, CA 90505 | 1  |
| University of Denver<br>ATTN: Ralph E Williams, Associate<br>Head<br>University Park<br>Denver, Colorado 80208           | 1 | William E. Haulman<br>Mail Code 35-93<br>Douglas Aircraft Co.<br>3855 Lakewood Blvd.<br>Long Beach, CA 90846                  | 1  |
| Hughes Aircraft Co.<br>Corporate Marketing/RFP Control<br>P. O. Box 92996<br>Los Angeles, CA 90009                       | 1 | Stanley M. Aronberg<br>Mail Code 35-93<br>Douglas Aircraft Co.<br>3855 Lakewood Blvd.<br>Long Beach, CA 90846                 | 1  |
| D. W. Linder<br>Orgn, 2170/84<br>Northrop Corp.<br>One Northrop Ave.<br>Hawthorne, CA 90250                              | 1 | XYZYX Information Corp.<br>ATTN: Frank Fuchs, Project Mgr.<br>P. O. Box 193<br>Canoga Park, CA 91305                          | 1  |
| C. W. Meshier<br>Northrop Corp.<br>One Hawthorne Ave., MS 91<br>Hawthorne, CA 90250                                      | 1 | Clarence Semple<br>Canyon Research Group, Inc.<br>741 Lakefield Rd., Suite B<br>Westlake Village, CA 91361                    | 10 |
| Vernon E. Carter<br>Northrop Corp.<br>Human Factors<br>3901 W. Broadway<br>Hawthorne, CA 90250                           | 1 | Ms. Sarah A. S. Goldberg<br>Perceptronics, Inc.<br>6271 Variel Ave.<br>Woodland Hills, CA 91367                               | 1  |
| John Westland<br>205 Avenue I, Suite 15<br>Redondo Beach, CA 90277                                                       | 1 | Ms. Betty Huls<br>Lockheed-California Co.<br>P. O. Box 551<br>Burbank, CA 91520                                               | 1  |
| Edward C. Taylor<br>TRW Defense Systems Group<br>#1 TRW Circle<br>Redondo Beach, CA 90277                                | 1 | John P. Charles<br>ICON, Inc.<br>3401 Pangor Fl.<br>San Diego, CA 92106                                                       | 2  |
| Barten & Associates<br>225 Santa Monica Blvd.<br>Santa Monica, CA 940401                                                 | 1 | Instructional Science &<br>Development, Inc.<br>5059 Newport Ave., Suite 303<br>San Diego, CA 92107                           | 1  |
| William S. Meisel<br>Technology Service Corporation<br>Computer Sciences Div.<br>2950 31st St.<br>Santa Monica, CA 90405 | 1 |                                                                                                                               |    |

## DISTRIBUTION LIST (cont'd)

|                                                                                                                                             |   |                                                                                                      |   |
|---------------------------------------------------------------------------------------------------------------------------------------------|---|------------------------------------------------------------------------------------------------------|---|
| Miss Nancy Marcue<br>Veda, Inc.<br>7851 Mission Center Court<br>Suite 320<br>San Diego, CA 92108                                            | 1 | Mr. R. Dupree<br>Cubic Corporation<br>Defense Systems Div<br>9333 Balboa Ave.<br>San Diego, CA 92123 | 1 |
| Pace Systems, Inc.<br>3737 Camino Del Rio South<br>Suite 411<br>San Diego, CA 92108                                                         | 1 | Mr. David A. Miller<br>Cubic Defense Systems Div<br>9333 Balboa Ave.<br>San Diego, CA 92123          | 1 |
| TRACOR, Inc.<br>3420 Kenyon St., Suite 209<br>San Diego, CA 92110                                                                           | 1 | Mr. D. C. Snyder<br>Cubic Corp.<br>Defense Systems Div.<br>9333 Balboa Ave.<br>San Diego, CA 92123   | 1 |
| Advanced Technology, Inc.<br>2120 San Diego Ave.<br>Suite 105<br>San Diego, CA 92110                                                        | 1 | Dr. Robert C. Feuge<br>Mathetics, Inc.<br>P. O. Box 26655<br>San Diego, CA 92126                     | 1 |
| Mr. Raymond E. Marshall<br>Educational Technologist<br>Essex Corporation<br>San Diego Facility<br>3211 Jefferson St.<br>San Diego, CA 92110 | 1 | Mr. Jeff Panches<br>Mathetics, Inc.<br>P. O. Box 26655<br>San Diego, CA 92126                        | 2 |
| Mantech International Corporation<br>ATTN: Mr. Robert L. McCauley<br>8352 Clairemont Mesa Blvd.<br>San Diego, CA 92111                      | 1 | SAI Comsystems Corp.<br>P. O. Box A-81126<br>San Diego, CA 92138                                     | 1 |
| Mr. Steve Osborne<br>Allen Corporation<br>8361 Vickers St.<br>Suite 307<br>San Diego, CA 92111                                              | 1 | Mr. Robbin Halley<br>LOGICON<br>P. O. Box 80158<br>San Diego, CA 92138                               | 2 |
| Systems Exploration, Inc.<br>ATTN: Mr. M. Reilly, Senior<br>Systems Engineer<br>4010 Morena Boulevard<br>San Diego, CA 92117                | 1 | Mr. Steve Seidensticker<br>LOGICON<br>4010 Sorento Valley Blvd.<br>San Diego, CA 92138               | 3 |
| Dr. H. Harvey Cohen<br>Program Director<br>Safety Sciences<br>Division of WSA, Inc.<br>7586 Trade St.<br>San Diego, CA 92121                | 1 | Mr. L. D. Egan<br>LOGICON, Inc.<br>P. O. Box 80158<br>San Diego, CA 92138                            | 2 |
| Dr. Gerhard Eichweber<br>Kurt Eichweber PRAZISIONSGERATEWERK<br>Schuetzenstr 75-85<br>2000 Hamburg 50<br>W. GERMANY                         | 1 | Mr. Terry Kryway<br>LOGICON, Inc.<br>P. O. Box 80138<br>San Diego, CA 92138                          | 1 |

## DISTRIBUTION LIST (cont'd)

|                                                                                                                                           |   |                                                                                                                                                            |   |
|-------------------------------------------------------------------------------------------------------------------------------------------|---|------------------------------------------------------------------------------------------------------------------------------------------------------------|---|
| Dr. Steven K. Null<br>Hughes Aircraft<br>Ground System Group<br>P. O. Box 3310, MS 688/4104<br>Fullerton, CA 92634                        | 2 | Ms. Katie M. Dent<br>Lockheed Missiles & Space Co.<br>Organization 6653<br>Bldg. 573<br>Sunnyvale, CA 94086                                                | 4 |
| John J. McMullen Assocs., Inc.<br>ATTN: Mr. R. S. Downey<br>2021 Sperry Ave., Suite 30<br>Ventura, CA 93003                               | 1 | Sperry Support Services<br>West Coast Operations<br>Bldg. 92<br>Benicia Industrial Park<br>Benicia, CA 94510                                               | 1 |
| Human Factors Research, Inc.<br>ATTN: Dr. R. Mackie<br>5775 Dawson Ave.<br>Goleta, CA 93017                                               | 1 | Mr. John B. Sinacori<br>P. O. Box 1043<br>Hollister, CA 95023                                                                                              | 1 |
| AMETEK<br>Offshore Research & Engineering Div.<br>ATTN: Mrs. Marjorie A. Burnight<br>1224 Coast Village Circle<br>Santa Barbara, CA 93108 | 1 | FMC Corporation<br>ATTN: Mr. Carl W. Sullinger<br>Mail Drop 770<br>1105 Coleman Ave., Box 1201<br>San Jose, CA 95108                                       | 1 |
| Mr. C. Dennis Wylie<br>Human Factors Research<br>5775 Dawson Ave.<br>Goleta, CA 93117                                                     | 1 | Ms. Winnie Lee<br>Crew Systems & Simulation Technology<br>The Boeing Aerospace Co.<br>P. O. Box 3999, M.S. 82-87<br>Seattle, WA 98124                      | 1 |
| HumRRO/Western Div., Carmel Ofc.<br>27857 Berwick Drive<br>Carmel, CA 93923                                                               | 1 | Mr. Wolf J. Habenstein<br>Crew Systems & Simulation Technology<br>The Boeing Aerospace Co.<br>P. O. Box 3999, M.S. 82-87<br>Seattle, WA 98124              | 1 |
| Pulsepower Systems, Inc.<br>ATTN: Ms. Patricia M. Snowden,<br>Librarian<br>815 American St.<br>San Carlos, CA 94070                       | 1 | Dr. D. G. Pearce<br>Behavioral Sciences Div.<br>Defense & Civil Institute of<br>Environmental Medicine<br>P. O. Box 2000<br>Downsview, Ontario M3M, CANADA | 1 |
| Mr. D. P. Germeraad, Mgr.<br>Dept. 57-70, Bldg. 568<br>Lockheed Missiles & Space Co., Inc.<br>P. O. Box 504<br>Sunnyvale, CA 94086        | 1 | Colonel M. D. Calnan (DODC)<br>National Defense Headquarters<br>Ottawa, Ontario, CANADA KIA 0K2                                                            | 1 |
| Mr. Bill Hefley<br>Lockheed Missiles & Space Co.<br>Organ. 60-95<br>Bldg. 156A<br>P. O. Box 564<br>Sunnyvale, CA 94088                    | 1 | Dr. Eldad Gal-Ezer<br>Israel Aircraft Industries Ltd.<br>Electronics Div./MBT Weapons Systems<br>P.O.B.: 105<br>TAHUD 56000<br>ISRAEL                      | 1 |
| Mr. Henry T. Manning<br>1293 Shelby Drive<br>Fairfield, CA 94533                                                                          | 1 |                                                                                                                                                            |   |