

DOCUMENT RESUME

ED 224 913

CE 034 649

TITLE Resource Book for Slipcover Construction.
 INSTITUTION Madison Area Technical Coll., Wis.; Wisconsin State Board of Vocational, Technical, and Adult Education, Madison.
 PUB DATE 82
 NOTE 79p.; For related documents see CE 034 642-648.
 PUB TYPE Guides - Classroom Use - Guides (For Teachers) (052)
 EDRS PRICE MF01/PC04 Plus Postage.
 DESCRIPTORS Adult Programs; *Adult Vocational Education; *Furniture; *Home Furnishings; Learning Activities; *Occupational Home Economics; *Resource Materials; *Sewing Instruction
 IDENTIFIERS *Upholsterers

ABSTRACT

This resource book for slipcover construction is one of four resource books developed for use in Code 30 or adult vocational programs in the home furnishings service area. Representative, illustrative, and informative materials contained in the resource book are Safety and Machine Instructions, Estimates for Slipcover Yardage, Prepare Furniture for Slipcovering, Three Types of Pinning, Make Slipcover Sections for Chair Arms, Block Out the Material, Make Paper Patterns of Flat-Shaped Section, Sewing a Corded-Boxed Cushion Cover, The Skirt, Applying Slipcover to the Chair, and The Completed Chair. (YLB)

 * Reproductions supplied by EDRS are the best that can be made *
 * from the original document. *

FORWARD

This publication contains illustrative and informative materials for teaching Slipcover Construction.

Reference is made to these resources in the Suggested Curriculum Guide for Slipcover Construction. In the guide, the word RESOURCE is identified in capital letters and the pages from the Resource Book are listed.

These materials may be reprinted for classroom use.

1982

ACKNOWLEDGEMENTS

Special appreciation is extended to the following coordinators, consultants and post-secondary instructors for their efforts, in the development of this curriculum for the home furnishings service programs.

PROJECT DIRECTOR

Carol Swiggum
Instructor
Madison Area Technical College
Madison, Wisconsin

CONSULTANT AND COORDINATOR

Helen Scheve
Home Economics Consultant
Wisc. Board of Vocational,
Technical & Adult Education
Madison, Wisconsin

Phyllis Schwebke
Home Economics Chairperson
Madison Area Technical College
Madison, Wisconsin

CURRICULUM WRITERS

FURNITURE RENOVATION (REFINISHING AND REUPHOLSTERING)

Diane Barton
Home Economics Coordinator
Southwest Wisc. Technical Institute
Fennimore, Wisconsin

Jay Robinson
Instructor
Southwest Wisc. Technical Institute
Fennimore, Wisconsin

SLIPCOVER CONSTRUCTION

Alice Iverson
Instructor
Waukesha County Technical Institute
Pewaukee, Wisconsin

ENTREPRENEURSHIP

Mary Schmolesky
Instructor
Madison Area Technical College
Madison, Wisconsin

ROD INSTALLATION

Gladys Olson
Home Economics Chairperson
Blackhawk Vocational-Technical Institute
Beloit, Wisconsin

WINDOW TREATMENTS

Carol Swiggum
Instructor
Madison Area Technical College
Madison, Wisconsin

RESOURCE PERSONS

Jean Carlson
Home Economics Consultant
Wisc. Board of Vocational, Technical & Adult Education
Madison, Wisconsin

Robert Martin
Div. Supervisor Home and Consumer Sciences
Fox Valley Technical Institute
Appleton, Wisconsin

Materials received from the following schools were used in the development of the curriculum and resource book.

Blackhawk Technical Institute
Gateway Technical Institute
Madison Area Technical College
Southwest Wisconsin Technical Institute
Waukesha County Technical Institute

Special thanks to the typists Anne Zimmerman, Luanne Storley, and Mary Jane Zummo.

TABLE OF CONTENTS

	Page
FORWARD	i
ACKNOWLEDGEMENTS	ii
SAFETY AND MACHINE INSTRUCTIONS	0
ESTIMATES FOR SLIPCOVER YARDAGE	1
PREPARE FURNITURE FOR SLIPCOVERING	1A
SLIPCOVERS - CORDING	2
A CONTINUOUS BIAS	6
THREE TYPES OF PINNING	8
MAKE SLIPCOVER SECTIONS FOR CHAIR ARMS	8A
HAND AND THUMB - JOINT MEASUREMENTS	9
BLOCK OUT THE MATERIAL	10
MAKE PAPER PATTERNS OF FLAT SHAPED SECTIONS	15A
SEWING A CORDED BOXED CUSHION COVER - METHOD A	16
SEWING A CORDED BOXED CUSHION COVER - METHOD B	17
KISSING CORNERS PILLOW	18
TURKISH CORNER PILLOW	19
ZIPPER CLOSING - BOXED CUSHION - METHOD 1	20
ZIPPER CLOSING - BOXED CUSHION - METHOD 2	24
JOINING THE CORDING	30
SQUARE, CORDED CUSHION CORNER	36
ROUNDED, CORDED CUSHION CORNER	37
THE SKIRT	38
APPLYING SLIPCOVER TO THE CHAIR	39
THE COMPLETED CHAIR	48

FORWARD

This publication contains illustrative and informative materials for teaching Window Treatments and Rod Installation.

Reference is made to these resources in the Suggested Curriculum Guide for Window Treatments and Rod Installation. In the guide, the word RESOURCE is identified in capital letters and the pages from the Resource Book are listed.

These materials may be reprinted for classroom use.

ACKNOWLEDGEMENTS

Special appreciation is extended to the following coordinators, consultants and post-secondary instructors for their efforts in the development of this curriculum for the home furnishings service programs.

PROJECT DIRECTOR

Carol Swiggum
Instructor
Madison Area Technical College
Madison, Wisconsin

CONSULTANT AND COORDINATOR

Helen Scheve
Home Economics Consultant
Wisc. Board of Vocational,
Technical & Adult Education
Madison, Wisconsin

Phyllis Schwebke
Home Economics Chairperson
Madison Area Technical College
Madison, Wisconsin

CURRICULUM WRITERS

FURNITURE RENOVATION (REFINISHING AND REUPHOLSTERING)

Diane Barton
Home Economics Coordinator
Southwest Wisc. Technical Institute
Fennimore, Wisconsin

Jay Robinson
Instructor
Southwest Wisc. Technical Institute
Fennimore, Wisconsin

SLIPCOVER CONSTRUCTION

Alice Iverson
Instructor
Waukesha County Technical Institute
Pewaukee, Wisconsin

ENTREPRENEURSHIP

Mary Schmolesky
Instructor
Madison Area Technical College
Madison, Wisconsin

ROD INSTALLATION

Gladys Olson
Home Economics Chairperson
Blackhawk Vocational-Technical Institute
Beloit, Wisconsin

WINDOW TREATMENTS

Carol Swiggum
Instructor
Madison Area Technical College
Madison, Wisconsin

RESOURCE PERSON

Jean Carlson
Home Economics Consultant
Wisc. Board of Vocational, Technical & Adult Education
Madison, Wisconsin

Robert Martin
Div. Supervisor Home and Consumer Sciences
Fox Valley Technical Institute
Appleton, Wisconsin

Materials received from the following schools were used in the development of the curriculum and resource book.

Blackhawk Technical Institute
Gateway Technical Institute
Madison Area Technical College
Southwest Wisconsin Technical Institute
Waukesha County Technical Institute

Special thanks to the typists Anne Zimmerman, Luanne Storley, and Mary Jane Zummo.

TABLE OF CONTENTS

	Page
FORWARD.....	i
ACKNOWLEDGEMENTS	ii
SAFETY AND MACHINE INSTRUCTIONS	0
ESTIMATES FOR SLIPCOVER YARDAGE	1
PREPARE FURNITURE FOR SLIPCOVERING	1A
SLIPCOVERS - CORDING	2
A CONTINUOUS BIAS	6
THREE TYPES OF PINNING	8
MAKE SLIPCOVER SECTIONS FOR CHAIR ARMS	8A
HAND AND THUMB-JOINT MEASUREMENTS,	9
BLOCK OUT THE MATERIAL	10
MAKE PAPER PATTERNS OF FLAT SHAPED ECTIONS	15A
SEWING A CORDED BOXED CUSHION COVER - METHOD A	16
SEWING A CORDED BOXED CUSHION COVER - METHOD B	17
KISSING CORNERS PILLOW	18
TURKISH CORNER PILLOW	19
ZIPPER CLOSING - BOXED CUSHION - METHOD 1	20
ZIPPER CLOSING - BOXED CUSHION - METHOD 2	24
JOINING THE CORDING	30
SQUARE, CORDED CUSHION CORNER	36
ROUNDED, CORDED CUSHION CORNER	37
THE SKIRT	38
APPLYING SLIPCOVER TO THE CHAIR	39
THE COMPLETED CHAIR	48

SAFETY AND MACHINE INSTRUCTIONS

Name _____

Instructor _____

DO:

-Know how to thread the power sewing machines properly!

- ____ 1. Make sure thread holder faces in the right direction.
- ____ 2. Put thread only through one tension hole, not all three holes.
- ____ 3. Make sure the thread goes through the tension properly.
- ____ 4. Demonstrate knowledge of winding a bobbin properly.
- ____ 5. Make sure bobbin is "locked in."
- ____ 6. Bring bobbin thread up through center hole in foot.
- ____ 7. Demonstrate use of re-adjustment button.
- ____ 8. Demonstrate how you would start to sew once machine is threaded...
(with needle down in fabric and presser foot down on fabric.)

-Ask to be shown how to use the machine in a correct manner. Each machine works a little bit differently so ASK if you really aren't sure about how to thread it.

-Pull out all pins before sewing over fabric. These are not domestic machines... if you sew over pins with a power sewing machine the needle will break.

-Be sure to let instructor know if a machine has broken down. This way we might be able to make a minor adjustment before the machine is used by another person and jams even further.

-Be sure to ask for help when lifting anything heavy that you think you cannot handle...especially if you will be bringing a piece of furniture down from up high.

-Be sure to wear protective goggles when using the band saw, spring clipper, or the bolt cutter...it's for your own protection. For any other procedure that you are unsure of, wear goggles. Goggles may be purchased at WCTI bookstore or you may borrow a pair belonging to the Department. Please ask Instructor to borrow.

WE REQUEST THAT YOU REPORT ALL ACCIDENTS, HOWEVER MINOR, TO YOUR INSTRUCTOR IMMEDIATELY. THIS MEANS AT THE TIME THE ACCIDENT OCCURS.

DON'T:

Don't leave thread in needle while winding a bobbin unless you are actually sewing something. Again, the needle will break or the thread will get caught underneath the plate causing a terrific jam.





























































Don't leave the thread in the machine for any reason. Always take your thread out when you are finished sewing and remove the bobbin from its case.

Don't help others thread a machine...let the instructor demonstrate...that is what he or she is there for.

Don't try to adjust the tension! If you think the machine needs an adjustment ask the instructor...chances are that it is not the tension that needs adjustment!

Don't sew at the same time you use the knee pedal. The needle might break and the thread will clog up in the machine.

ESTIMATES FOR SLIPCOVER YARDAGE

									
1 10 yds	2 10 yds	3 10 yds	4 10 yds	5 10 yds	6 10 yds	7 10 yds	8 10 yds	9 12 yds	10 12 yds
									
11 10 1/2 yds	12 6 yds	13 10 yds	14 7 yds	15 10 yds	16 9 yds	17 10 yds	18 11 1/2 yds	19 10 1/2 yds	20 4 1/2 yds
									
21 7 yds	22 7 1/2 yds	23 6 yds	24 9 yds	25 6 yds	26 5 1/2 yds	27 5 yds	28 3 yds	29 2 1/2 yds	30 2 1/2 yds
									
31 4 yds	32 5 yds	33 6 yds	34 6 yds	35 6 yds	36 5 yds	37 5 yds	38 5 yds	39 5 yds	40 5 yds
									
41 5 1/2 yds	42 5 yds	43 6 1/2 yds	44 5 yds	45 6 yds	46 6 yds	47 6 yds	48 6 yds	49 5 1/2 yds	50 5 1/2 yds
									
51 4 1/2 yds	52 3 1/2 yds	53 4 yds	54 4 yds	55 4 1/2 yds	56 5 yds	57 6 yds	58 5 1/2 yds	59 4 yds	60 5 yds

plus 1 yard for cording

plus 1 yard for patterned fabric

1. Fill unnecessary indentations with padding.

2. Sew with twine.

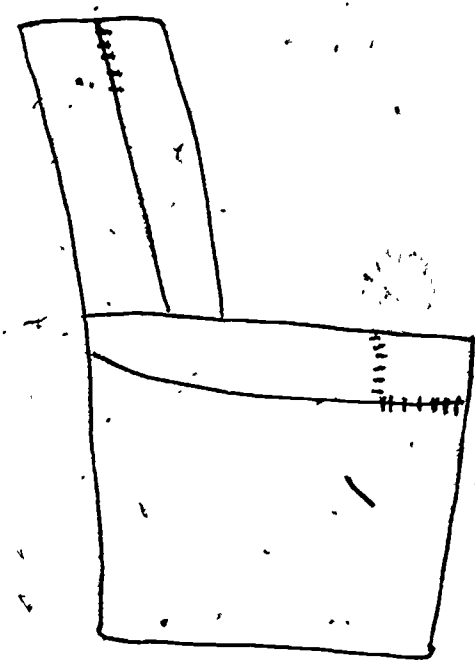
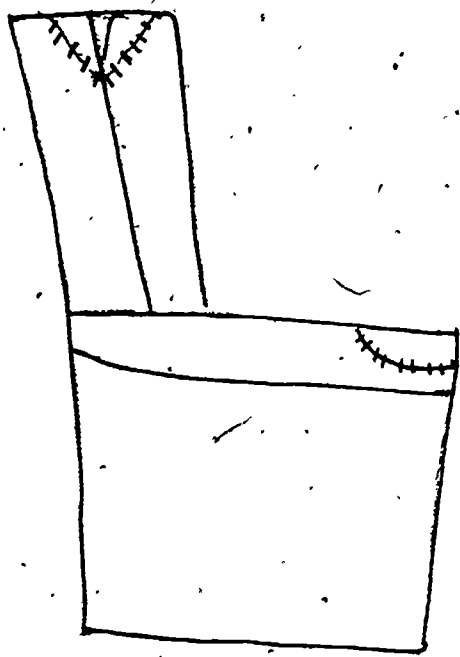
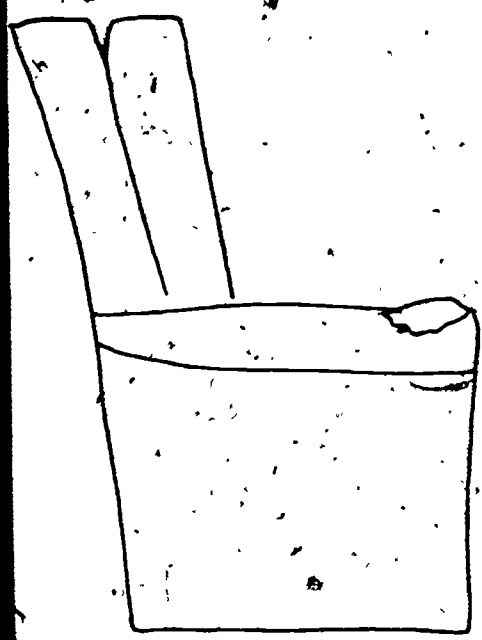

PREPARE FURNITURE FOR SLIPCOVERING IF NECESSARY

- SLIP COVERS -
CORDING

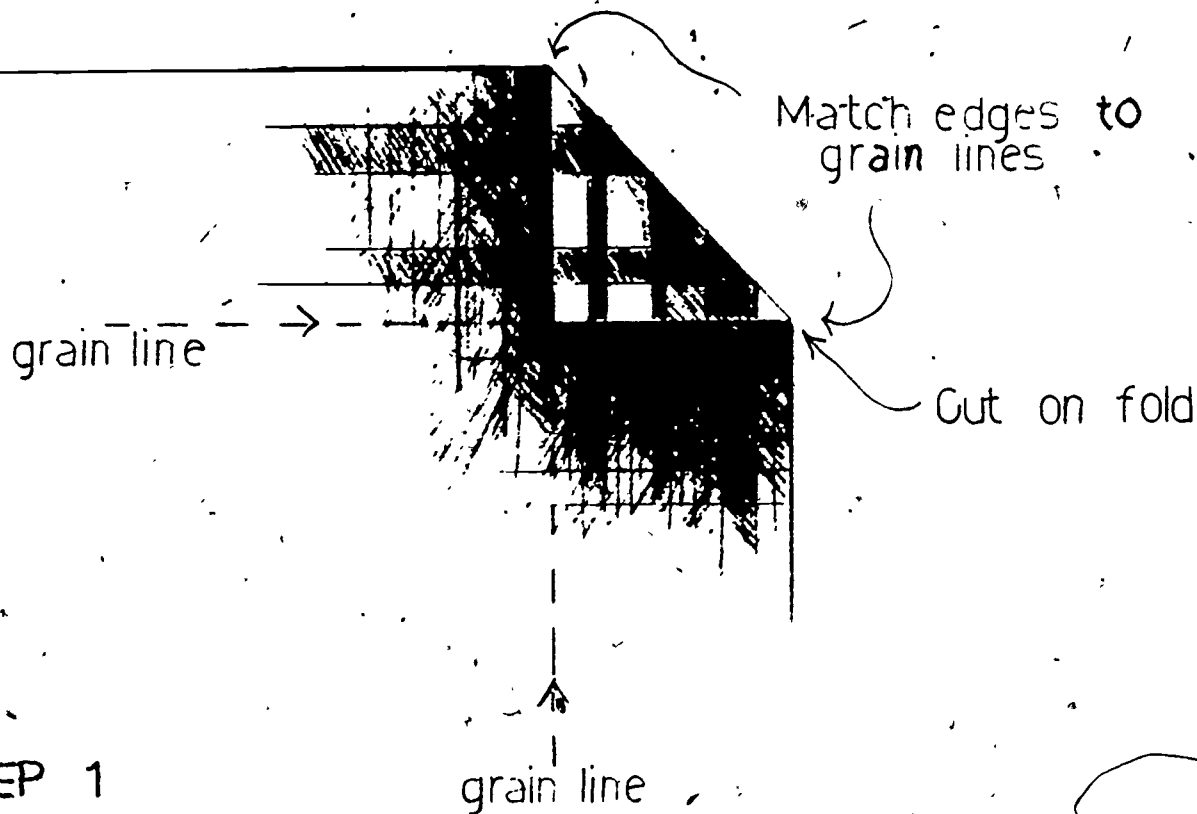

Finding the bias.

-SLIPCOVERS-
CORDING

Mark edge with pencil

STEP 2

5/8"

STEP 3

Width of bias strip
to be cut

Measuring to find the width for bias cord covering

same width
as in
STEP 3

STEP 4

Cut all bias strips the
same width

—SLIPCOVERS—
CORDING

060 17

—SLIP COVERS—
CORDING

STEP 5

Joining cording

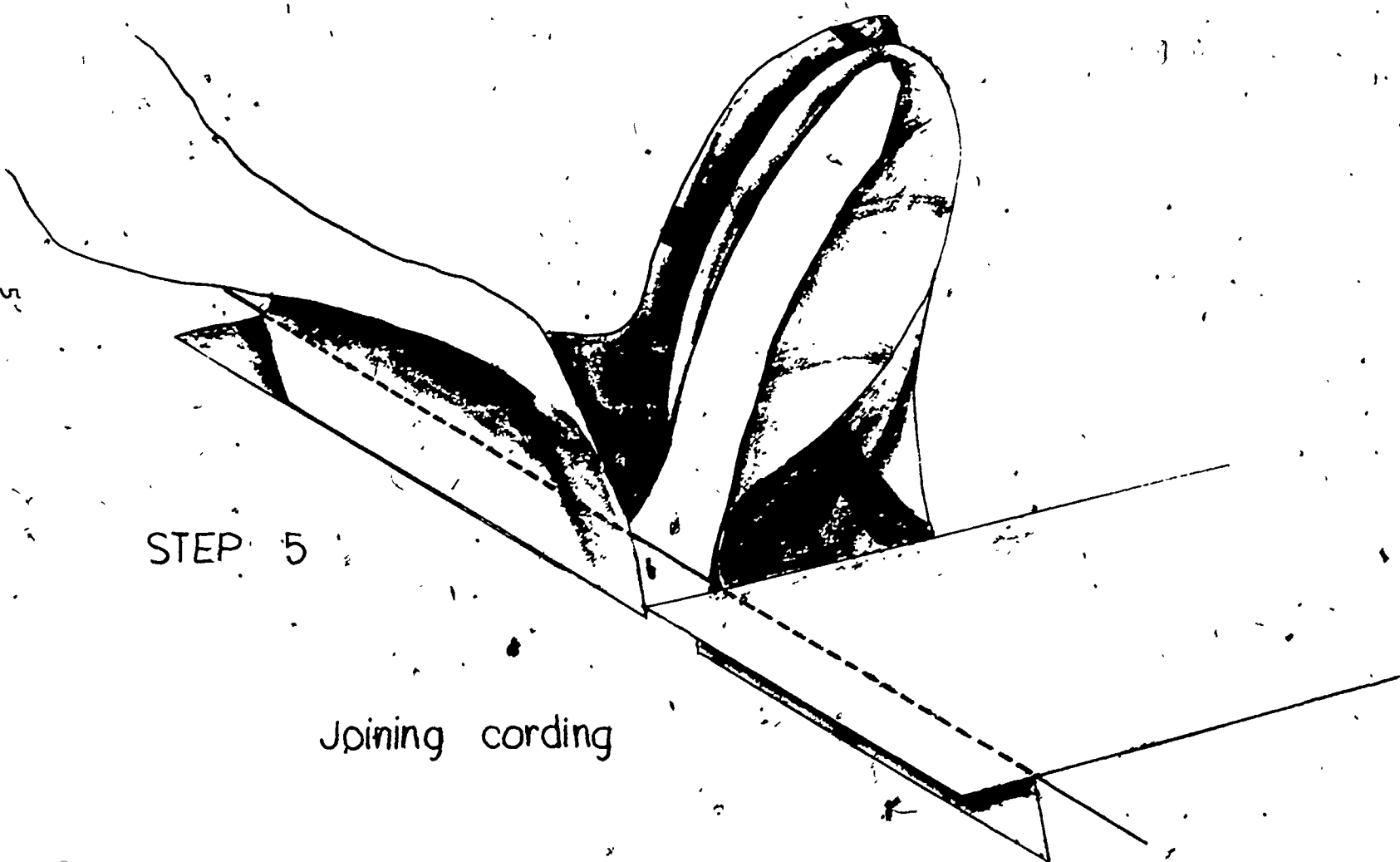

A CONTINUOUS BIAS

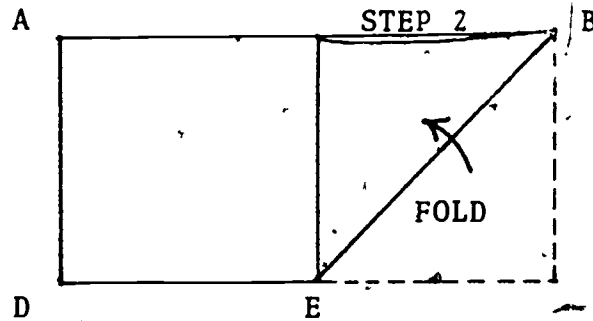

1. START WITH ANY SQUARE OR RECTANGULAR PIECE OF FABRIC, CUT STRAIGHT WITH LENGTHWISE AND CROSSWISE THREADS.
2. FOLD UP CORNER "C" TO GET BIAS EDGE "BE".

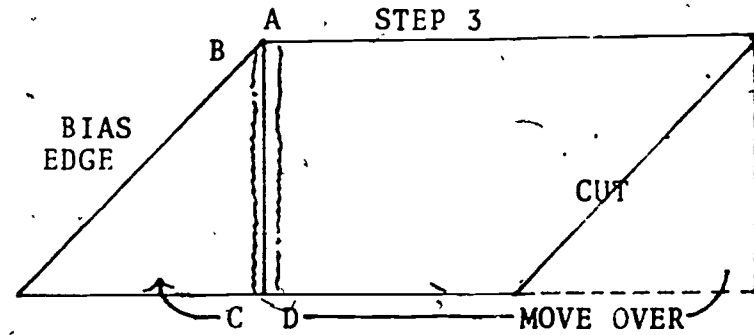

3. CUT THROUGH FOLD "BE". JOIN STRAIGHT EDGES "BC" AND "AD". PRESS SEAM OPEN.

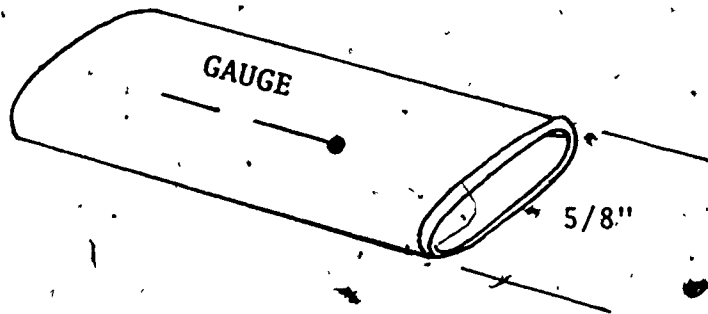

4. MAKE A 5/8" GAUGE. FOLD A PIECE OF PAPER ABOUT 2 INCHES LONG TO A 5/8 INCH WIDTH. PIN IN PLACE.

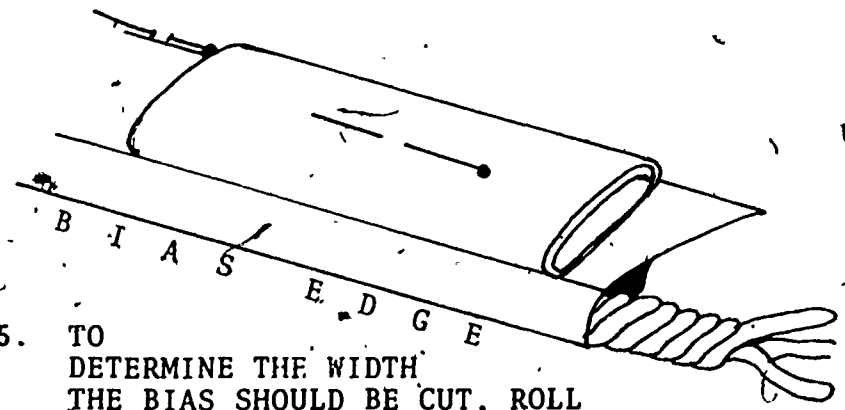

5. TO DETERMINE THE WIDTH THE BIAS SHOULD BE CUT, ROLL BIAS EDGE OF FABRIC OVER CORD. USING GAUGE, ALLOW 5/8 INCH FOR SEAM. MARK WITH PINS FOR SEVERAL INCHES. NOW MEASURE WIDTH YOU WILL NEED TO CUT BIAS.....FROM PINS TO BIAS EDGE. THIS WILL BE A LITTLE MORE OR LESS THAN 2".

A CONTINUOUS BIAS

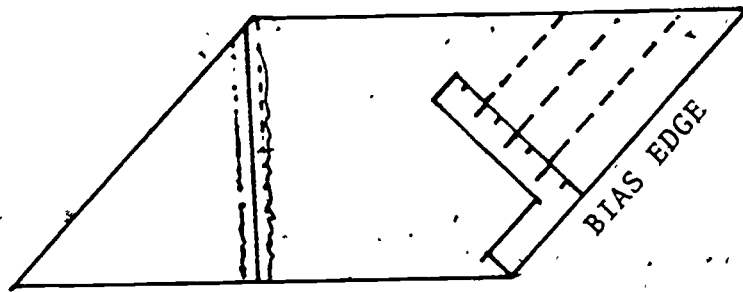

6. TURN FABRIC WRONG SIDE UP. LAY ONE EDGE OF SQUARE ON BIAS EDGE OF FABRIC. NOW MARK ENTIRE PIECE THE WIDTH BIAS SHOULD BE CUT.

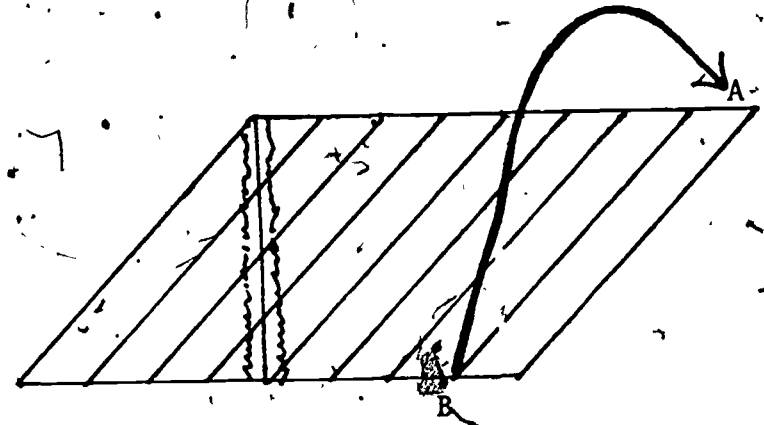

7. WITH RULER AND TAILOR'S CHALK, DRAW LINES CONNECTING MARKS YOU HAVE JUST MADE. NOW JOIN THE TWO STRAIGHT EDGES. BEGIN BY BRINGING "B" TO POINT "A". THIS ALLOWS A WIDTH OF THE BIAS TO EXTEND ON BOTH SIDES OF A CYLINDER PIECE.

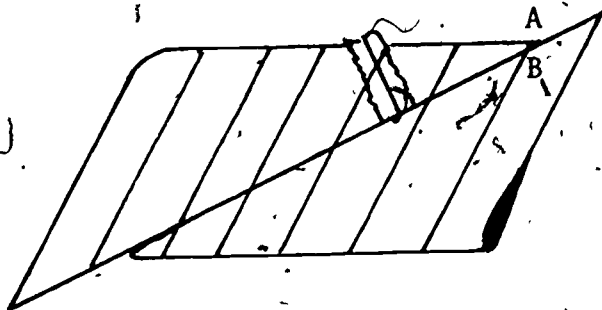

8. STITCH AND PRESS SEAM OPEN, BEGINNING AT POINT "BA", CUT THE CONTINUOUS BIAS, FOLLOWING THE CHALK LINES YOU HAVE DRAWN.

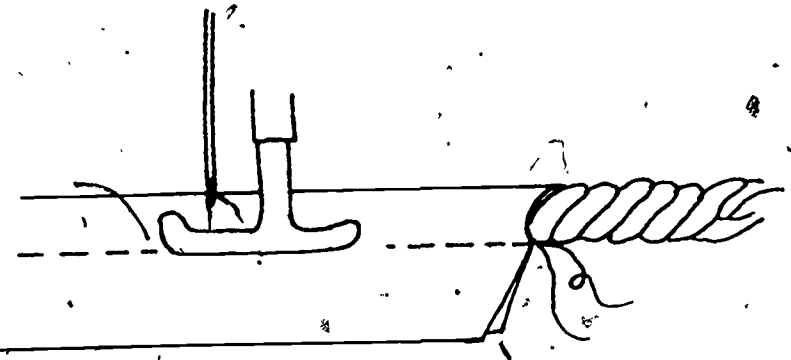

9. PLACE CORD IN FOLD OF BIAS STRIP. USING CORDING FOOT ATTACHMENT, STITCH CLOSE TO CORD WITH A LONG MACHINE STITCH. USE THREAD THE SAME COLOR AS FABRIC FOR STITCHING. THIS STITCHING LINE IS THE LINE ON WHICH ALL FITTING OF THE SLIP COVER IS DONE. THE SEAM ALLOWANCE ON THE CORD SHOULD BE 5/8 INCH.

THREE TYPES OF PINNING

1. Anchor pinning. Each piece of material is held in place on the chair with large T or wig pins. Lengthwise threads of material, are always perpendicular to floor or chair seat. Crosswise threads of material are always parallel to floor or chair-seat. Anchor each piece up and down, and across to hold lengthwise and crosswise threads in place. Anchor each piece to the chair as it is used. The material should be anchored as snugly to the chair as you wish the slip cover to fit when finished.

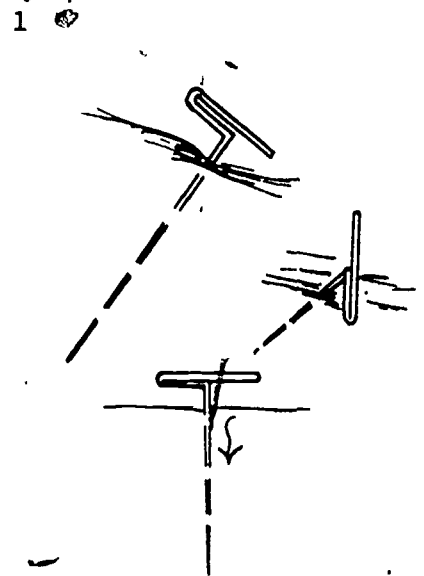

Pins are pushed directly into the chair for anchor pinning

2. Perpendicular pinning on stitching line of cord. When applying cord, insert T pins on stitching line of cord perpendicular to the chair, or at right angles into the upholstery.

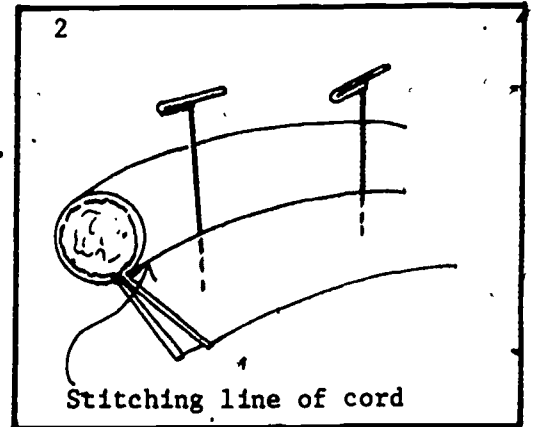

3. Folded-edge pinning. This occurs in the final fitting process as applying the outside-back. About every 1 inch apart, insert pins on very edge of fold, through stitching line on cord and perpendicular to the chair.

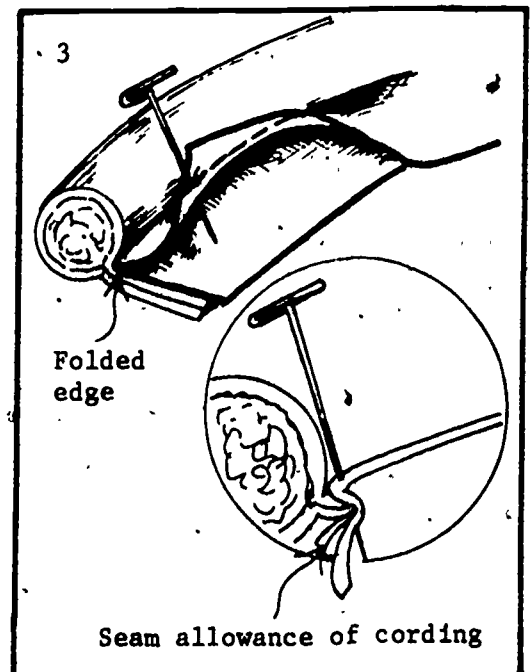

MAKE SLIPCOVER SECTIONS FOR CHAIR ARMS

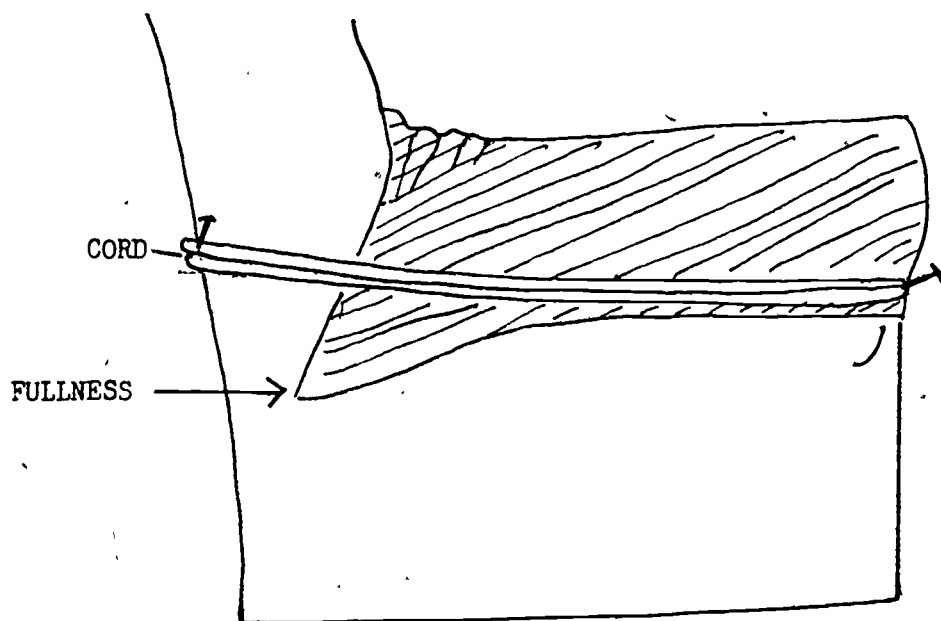

EASE FULLNESS OUT UNDER CORD

MAKE SLIPCOVER SECTIONS FOR CHAIR ARMS

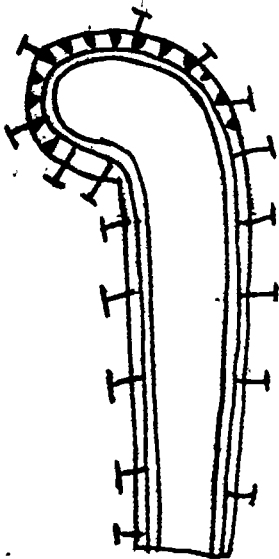

PIN FRONT SHAPED PIECE
TO CHAIR ARM

8 B

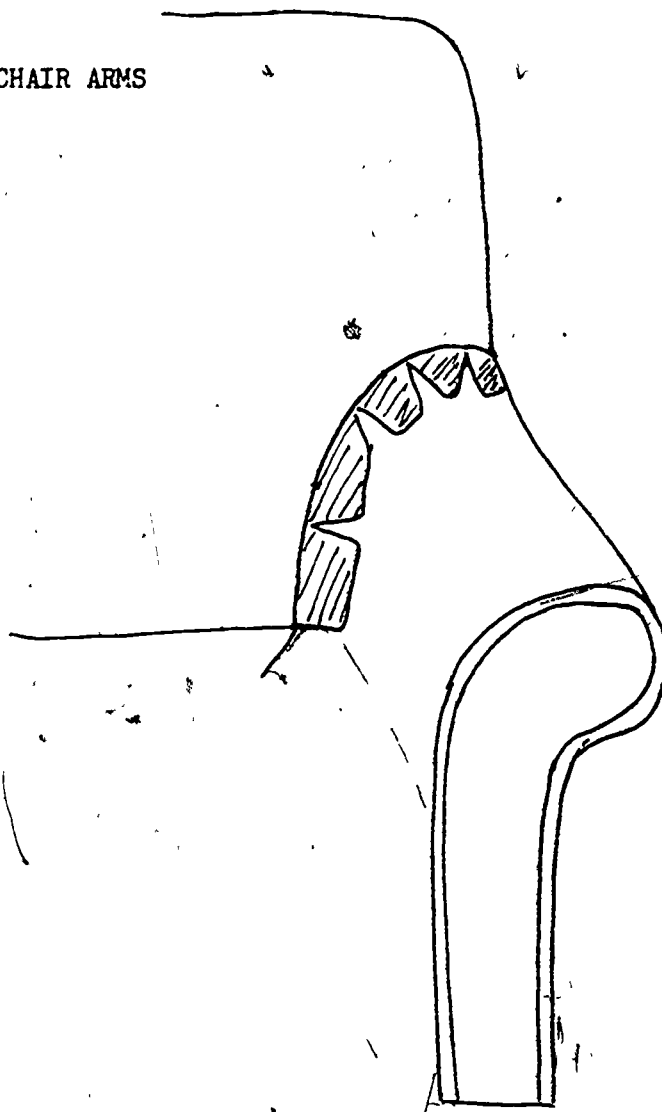

CLIP TO EASE TENSION
WHERE ARM MEETS BACK

8 C

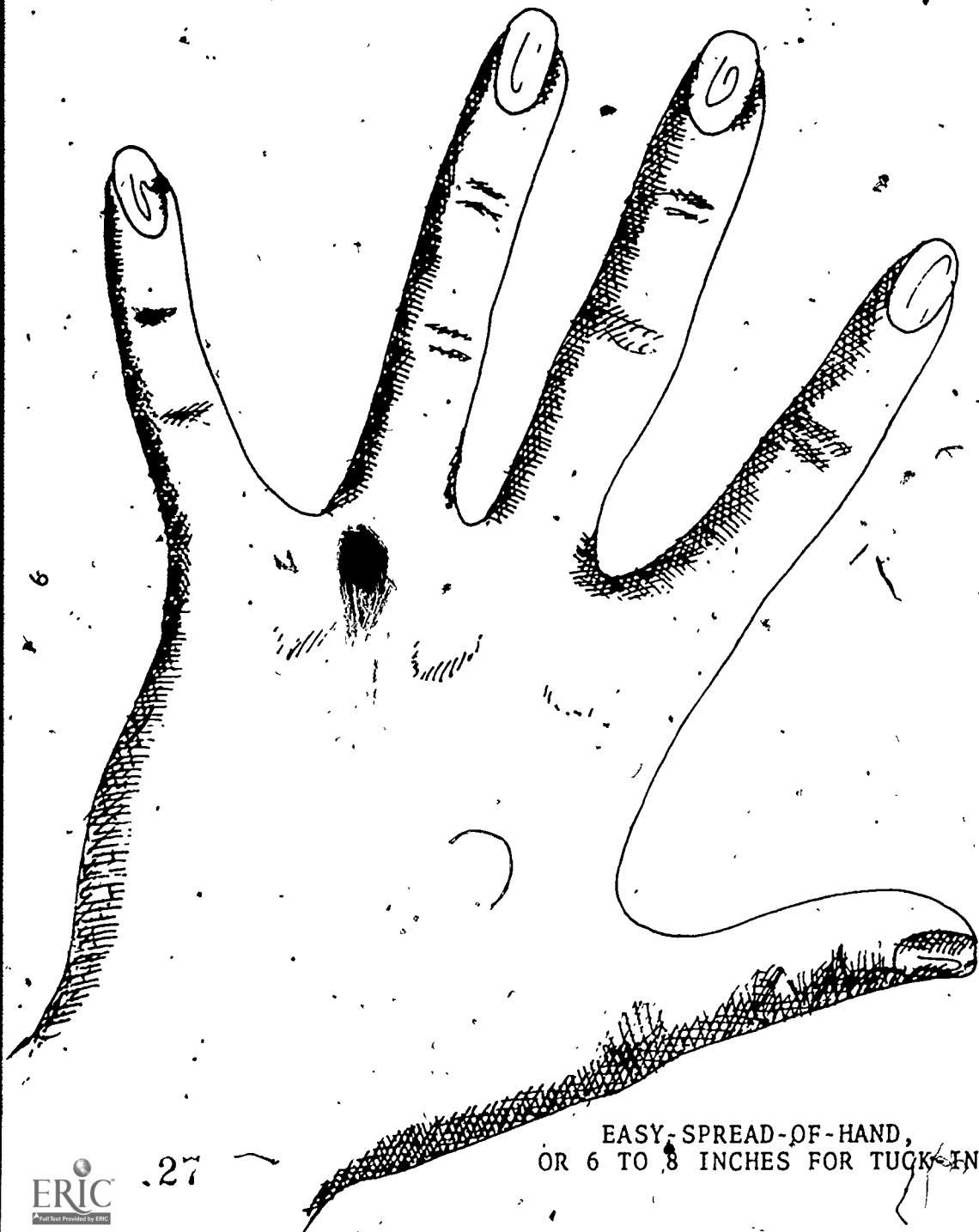

EASY-SPREAD-OF-HAND,
OR 6 TO 8 INCHES FOR TUCK-IN.

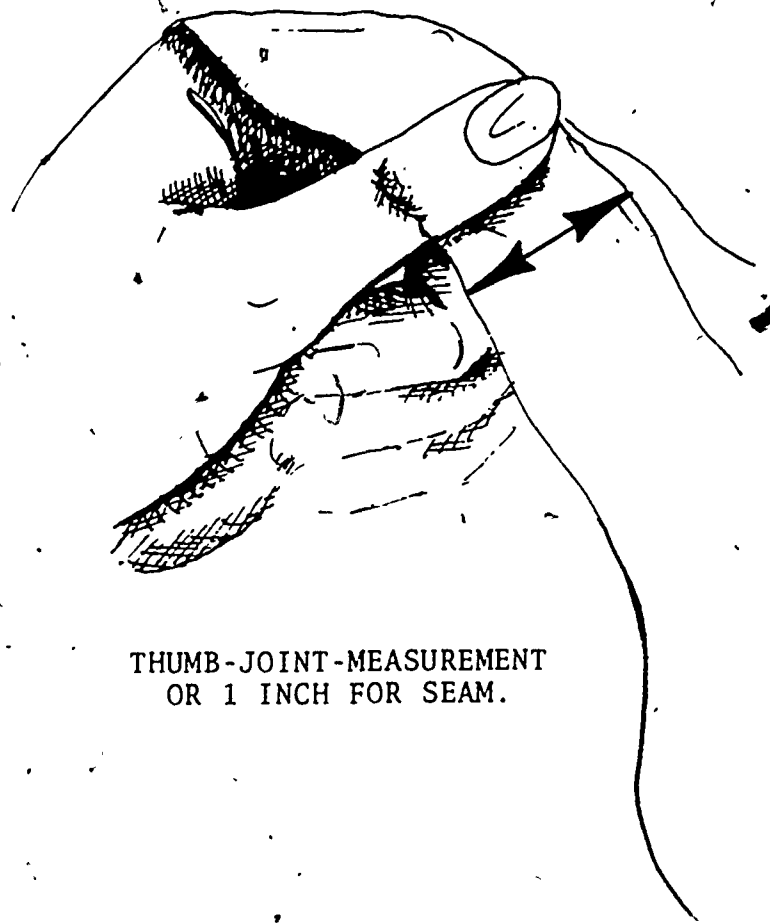

THUMB-JOINT-MEASUREMENT
OR 1 INCH FOR SEAM.

BLOCK CUT THE MATERIAL

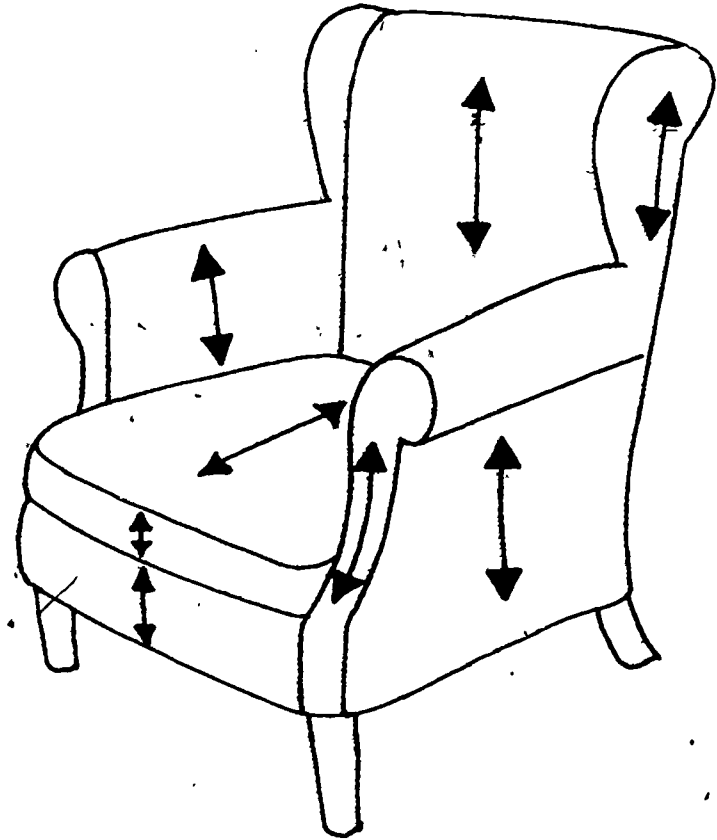
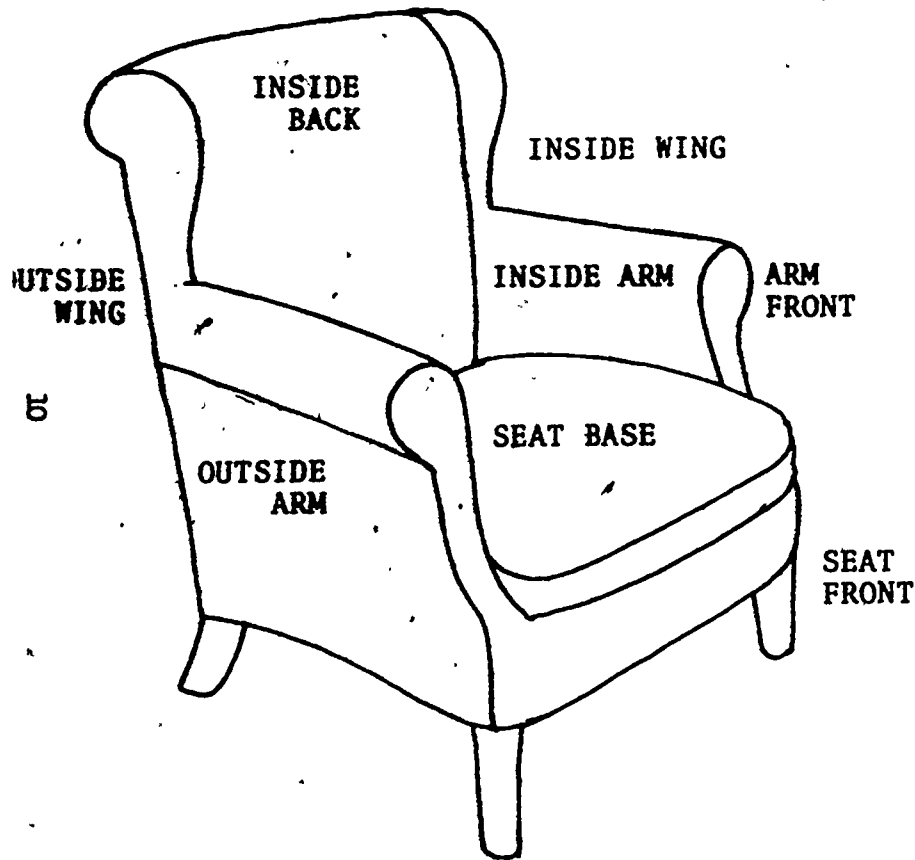

1. Become familiar with NAME of each section.
2. Observe LENGTHWISE threads of fabric for each section.
3. Study any design in the material to determine how it looks best on the chair. Try it several ways -----then decide.
4. USE ENTIRE WIDTH OF MATERIAL FOR ALL BLOCK CUTTING. Never cut away from the width of any piece until after the fitting is complete.
5. Examine material. Draw a thread at top end, cut straight across or tear. Remove chair cushion.

SLIP COVERS

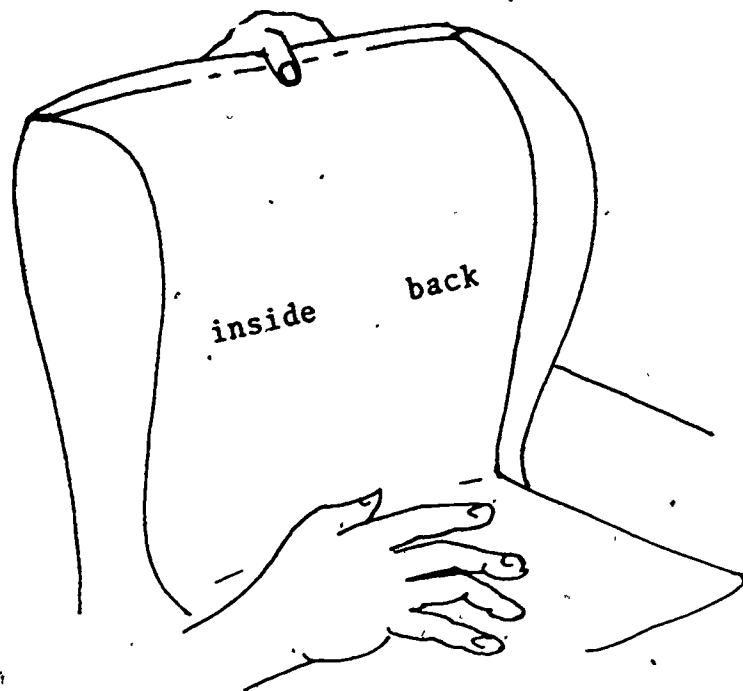

Step 1

INSIDE-BACK. Place material on highest point of chair inside-back. At top allow 1 inch, (First thumb-joint measurement,) for seam. At chair seat allow 6 inches to 8 inches, (Easy-spread-of-hand,) for tuck-in. Snip cloth and cut on thread, from center to selvage each way--or tear.

31

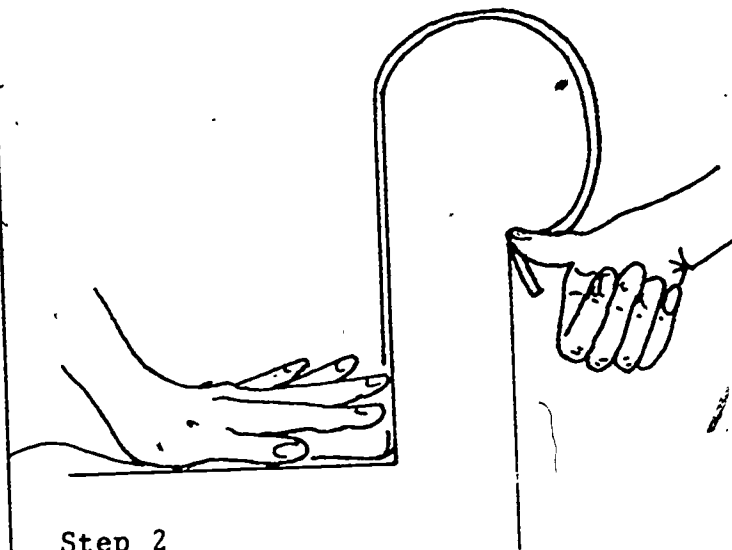

Step 2

INSIDE-ARM. Place material on inside-arm, bring to point where inside-arm joins outside-arm. Allow 1 inch. At chair seat, allow 6-8 inches. Snip cloth and cut both ways--or tear. Cut a piece for each arm.

32

SLIP COVERS

Step 3

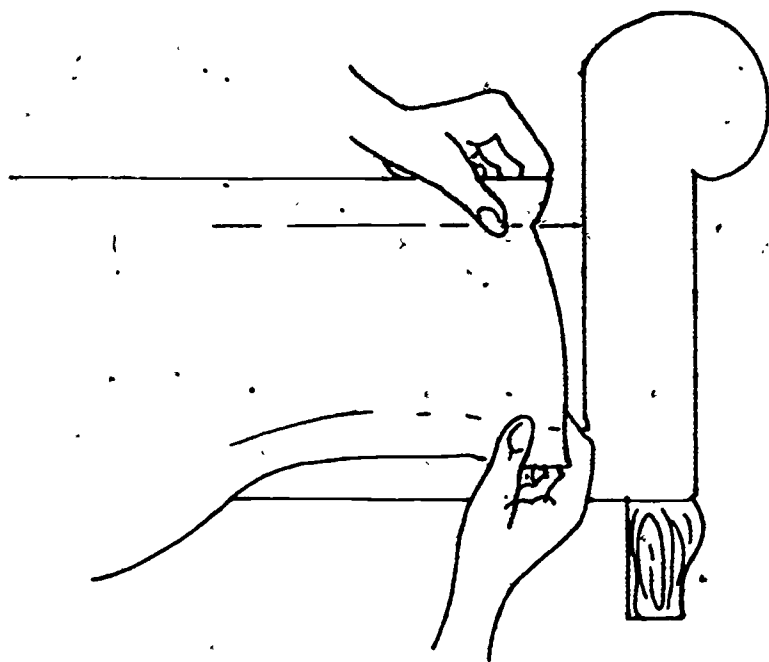

FOR CHAIR WITH SEPARATE CUSHION. Bring material to line where original cover joins seat lining. Allow 1 inch. Smooth material over front edge of chair to cord line. Allow 1 inch. Snip cloth and cut both ways--or tear.

33 FOR CHAIR WITH NO SEPARATE CUSHION. Bring material to back of seat where tuck-in begins. Allow 6-8 inches. Smooth material over seat and front edge of chair to cord line. Allow 1 inch. Snip cloth and cut both ways--or tear.

Step 4

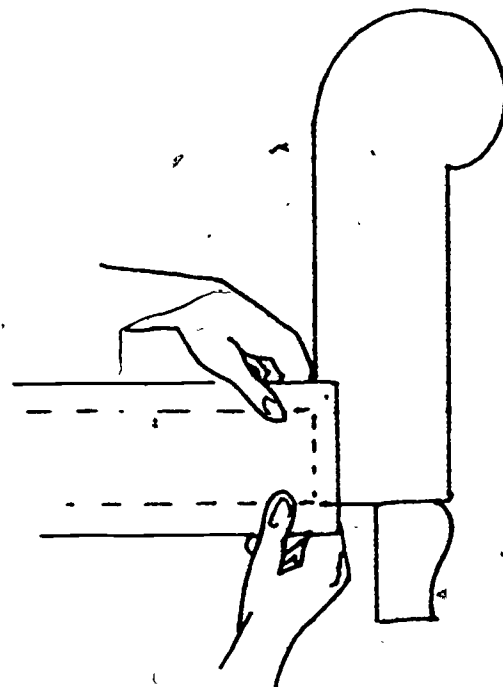

SEAT FRONT. Bring material to cord line on seat-front. Allow 1 inch. Take material to bottom of chair. Allow 2 inches, (Two thumb-joint-measurements,) to turn under chair. Snip cloth and cut both ways--or tear.

SLIP COVERS

Step 5

CUSHION. Starting at back, place material on cushion. Allow 1 inch. Smooth material to front. Allow 1 inch. Snip and cut--or tear. If material is 48 inches or 54 inches wide, cut only one length. If material is 36 inches wide, cut two lengths.

BOXING. Cut front boxing strip the width of boxing on cushion, plus $\frac{5}{8}$ inch on each side for seams. A piece of good design is needed for front boxing. Other boxing pieces may be cut from scraps.

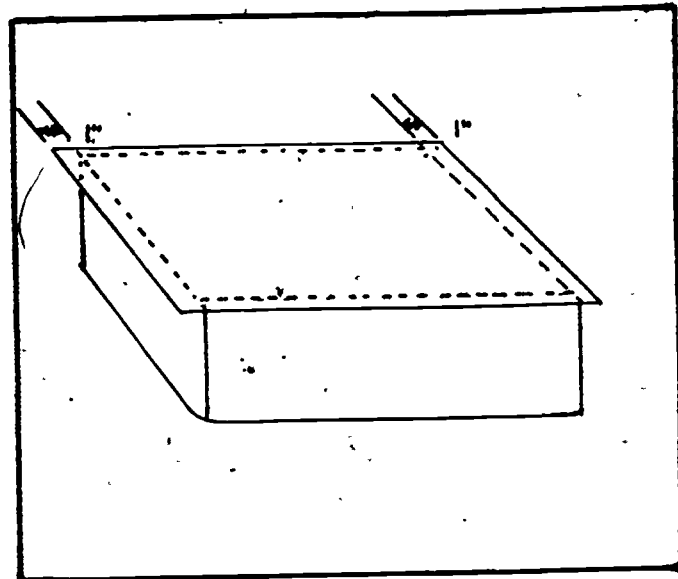

STEP 6

INSIDE-WING. Bring material to top back corner of inside-wing. Allow 1 inch. Smooth material down to point where inside-wing joins inside-arm. Allow 2 inches. Snip and cut--or tear. If wing is narrow, one length may be enough for both inside-wing pieces. If wing is wide, cut two lengths.

OUTSIDE-WING. Place material on highest point of outside-wing. At top, allow 1 inch. Bring material down to point where outside-wing meets outside-arm. Allow 2 inches. Snip and cut--or tear. If wing is narrow, outside-wing may be cut from outside-back piece after fitting is done on outside-back. It may also be cut from inside wing pieces after fitting is done on inside-wing.

SLIP COVERS

STEP 7

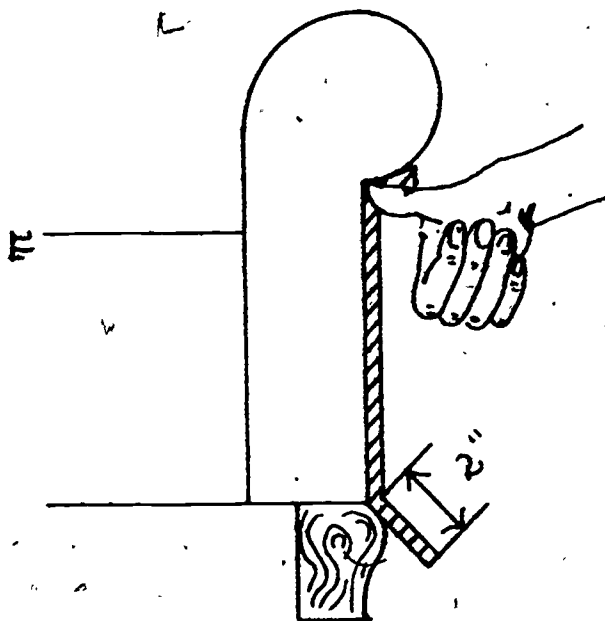

30 **OUTSIDE-ARM.** Place material on outside-arm. At under arm seam, allow 1 inch. At bottom, allow 2 inches to turn under chair. Snip cloth and cut both ways--or tear. Cut a piece for each arm.

STEP 8

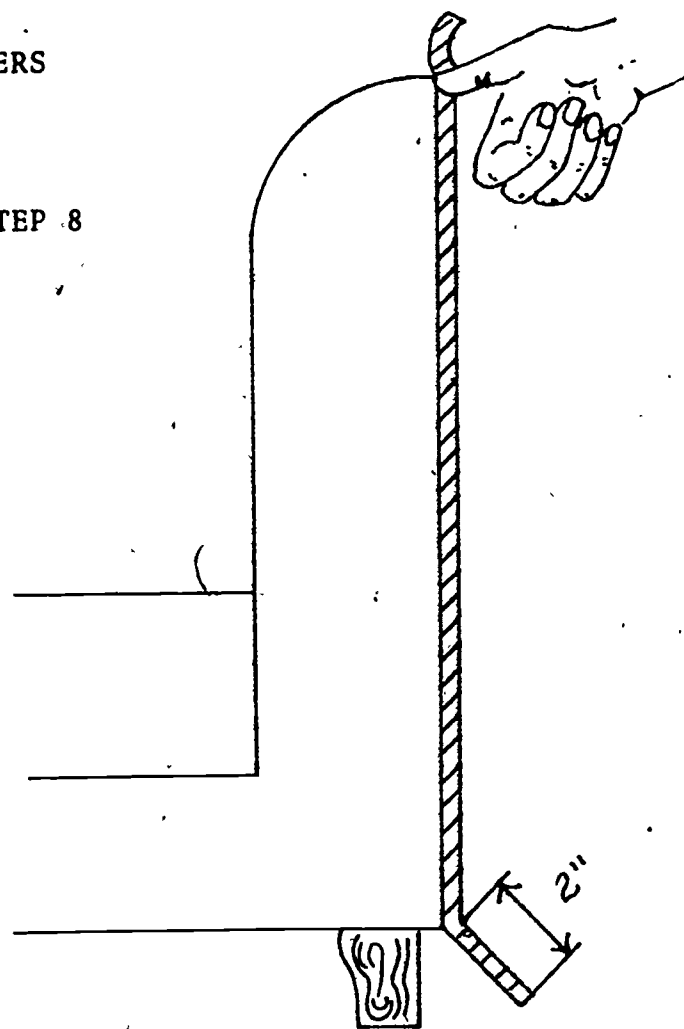

OUTSIDE-BACK. Place material on highest point of outside back. At top, allow 1 inch. At bottom, allow 2 inches to turn under chair. Snip cloth and cut as before--or tear.

3

SLIP COVERS

STEP 9

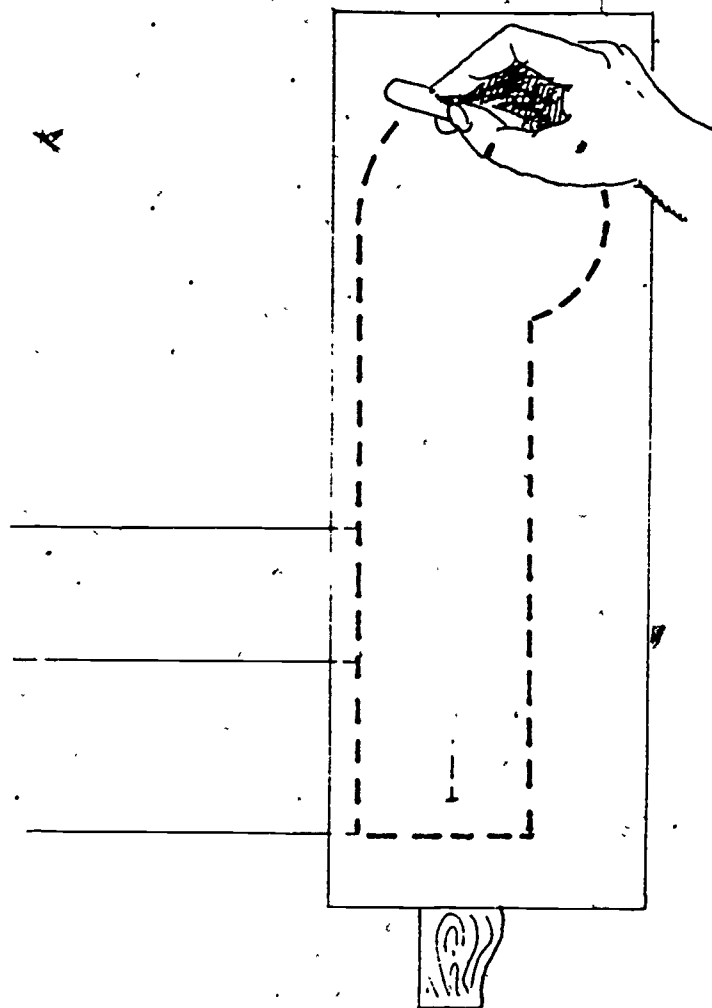

ARM-FRONT. Make a pattern for arm-front. Anchor a piece of wrapping paper on arm-front of chair. With crayola, mark outer edge of arm-front (9a). Hold crayola at 45° angle, (9b). Cut on crayola line. Check pattern for accuracy.

MAKE PAPER PATTERNS FOR FLAT SHAPED SECTIONS OF FURNITURE



ARM FRONTS



SIDE BACKS



WING SIDES

61 4J

SEWING A CORDED BOXED CUSHION COVER

METHOD A

1. Make covered cording with an exact $1\frac{1}{2}$ cm seam allowance. If the cording is made on the bias, it will handle more easily.

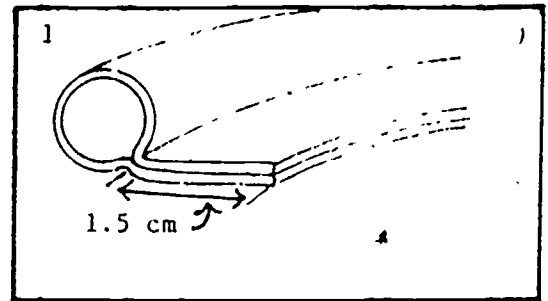

2. Make a pattern for the cushion top and bottom. The top and bottom are usually the same size.

If the cushion is in good condition, lay the new fabric on the old cushion, warp threads running straight from front to back. Center the design if there is any. Hold the fabric in place by pushing T pins straight down into the cushion.

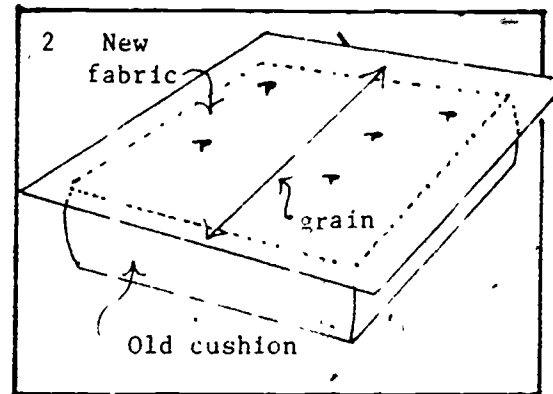

3. Anchor pin the covered cording on the cushion, new cord just inside and next to the old cord, seam allowance toward the outside.

Machine stitch cording to cushion bottom.

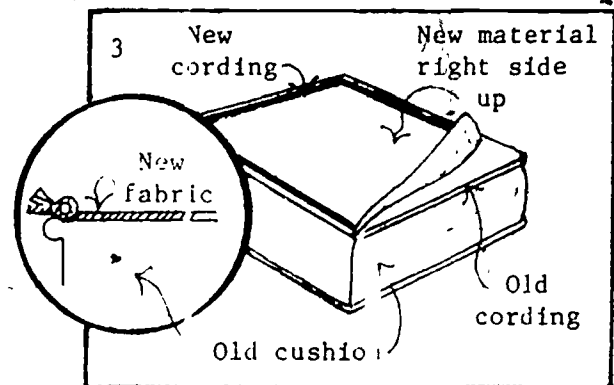

4. Clip the seam allowance to its stitching at the corners. Fit by pushing T pins perpendicular into the cushion.

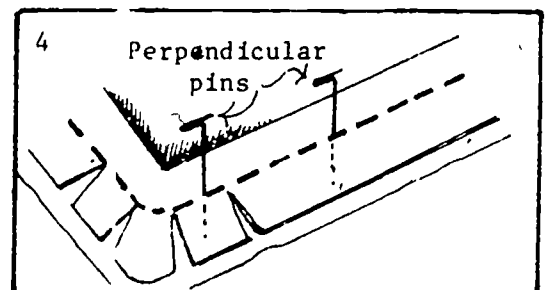

5. Remove pins and adjust perpendicular pins for machine sewing. Sew. Trim excess material to the exact width of cording seam allowance. Close the cording.

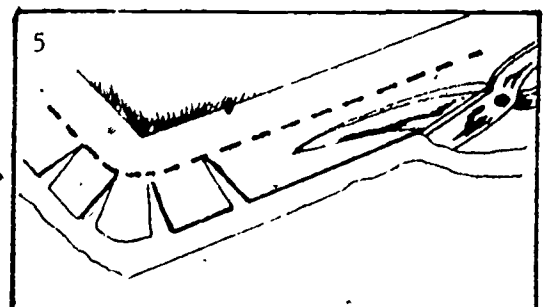

SEWING A CORDED BOXED CUSHION COVER
Method B

1. If the cushion is slightly lopsided or crooked, make a paper pattern just inside the old corded line.

Fold the pattern in half, from front to back. Trim until both halves are the same size. It is better to have a new cover slightly smaller rather than slightly larger than the old cushion.

Pin the pattern on the new fabric, warp threads running from front to back, the design on the fabric centered.

Add a 1½ cm seam allowance to all sides of the cushion. Mark it on the new fabric. Cut out the top and bottom of the new cushion.

2. Sew the cording to the new cushion top and bottom.

3. Measure the depth of the boxing on all sides of the old cushion. Sides may differ. Use a figure that is an average of the side measurements. Add to the figure 3 cm or two 1½ cm seam allowances.

4. Matching seam allowances, sew the cushion boxing to the corded top. Close at the back. Match design on fabric if there is one.

5. Pin the bottom of the cushion to the bottom of the boxing matching seam allowances.
 - a. Pin corners first making sure that the grain line of the boxing runs straight from the top corner to the bottom corner.
 - b. Pin centers next, easing out the fullness if there is any.
 - c. Matching seam allowances, sew.
 - d. Insert cushion and hand sew the closing.

NOTE: If a zipper is used, make the zippered section of the boxing first using either method. The zippered section of the boxing should be the same depth as the other pieces when com-

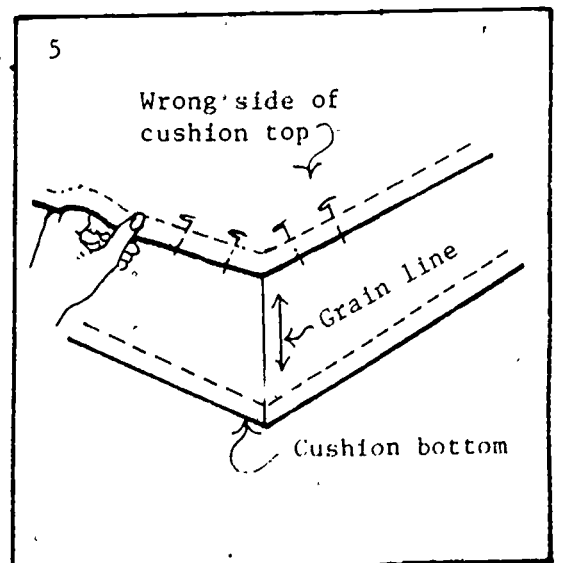
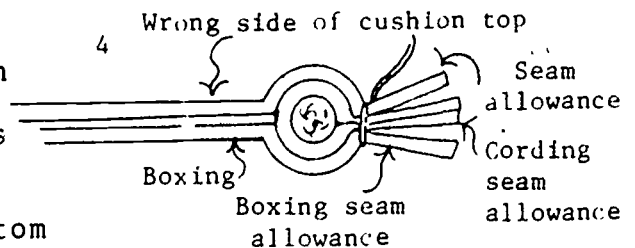
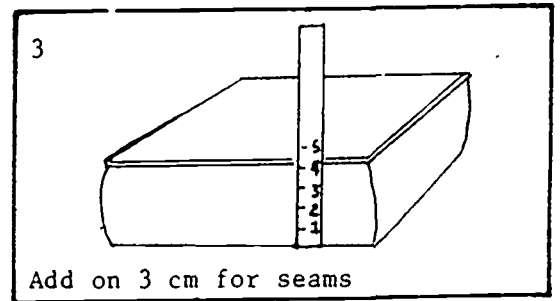
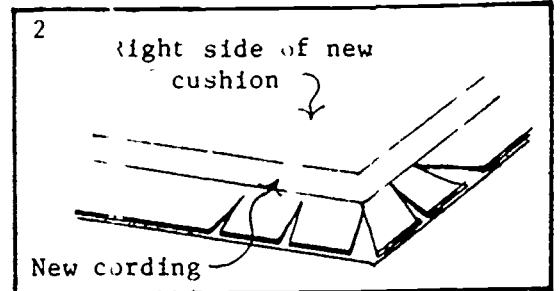
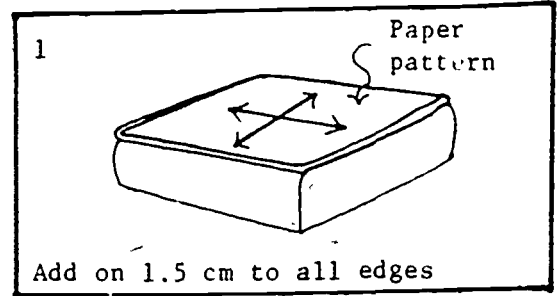

KISSING CORNERS PILLOW

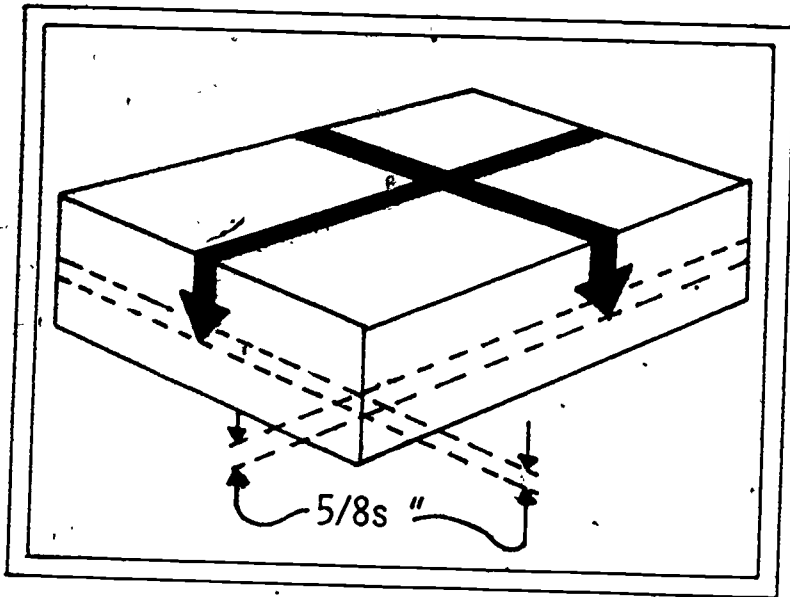

1. MEASURE TO THE CENTER,
ADD $5/8s$ " SEAM
ALLOWANCE.

2. STITCH ON SEAM ALLOWANCE
3. TIE CORNERS.
4. TURN AND STUFF.

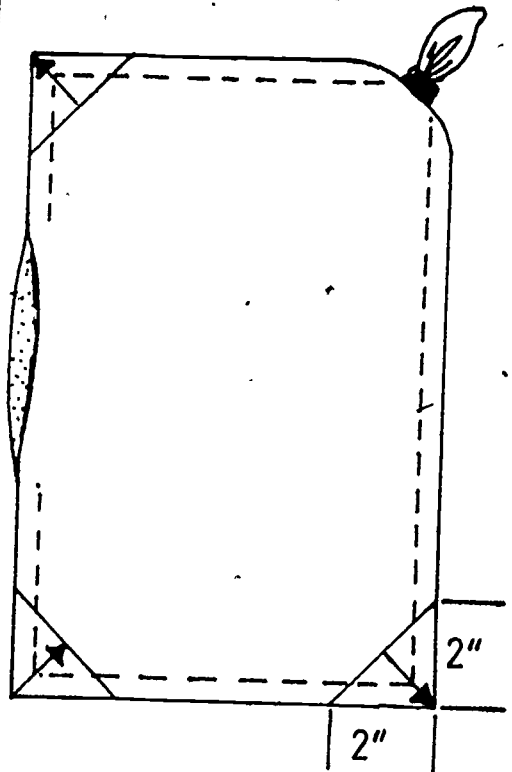

THE
COMPLETED PILLOW

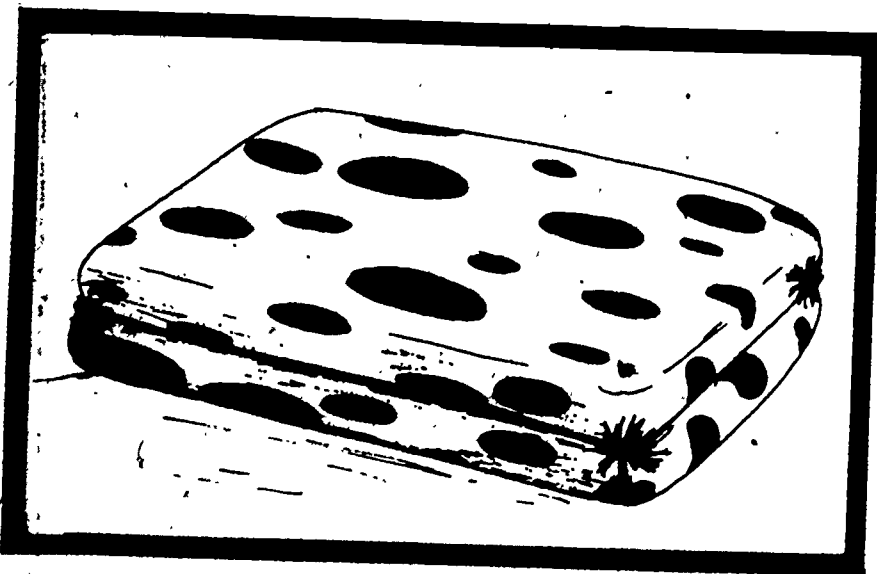

TURKISH CORNER PILLOW

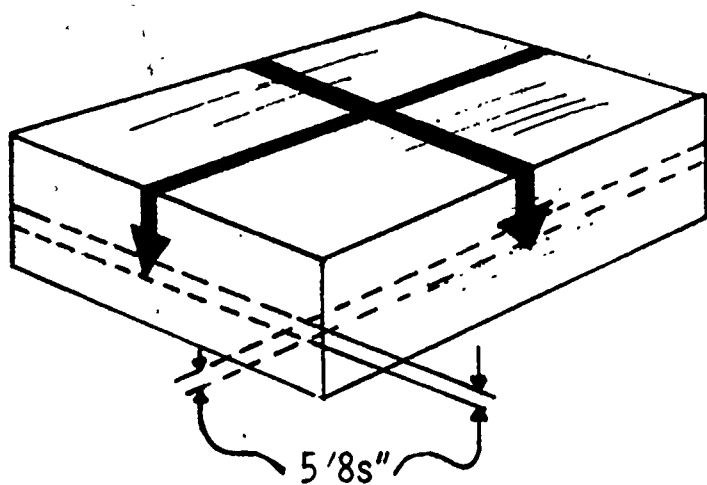

1. MEASURE TO THE CENTER,
ADD 5/8s " SEAM
ALLOWANCE.

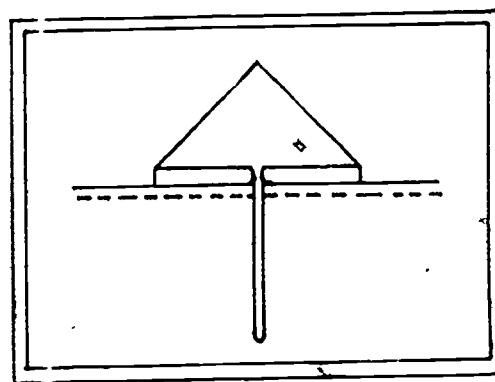
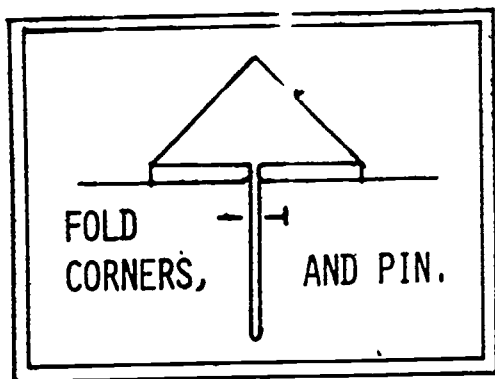

MACHINE BASTE PINNED FOLD.

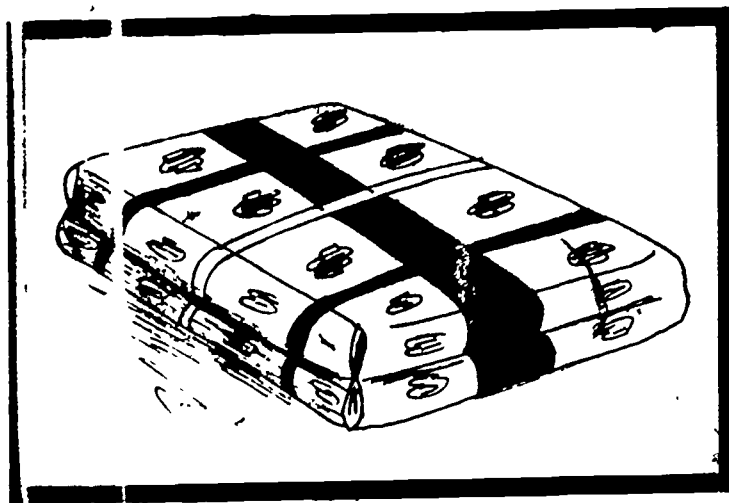
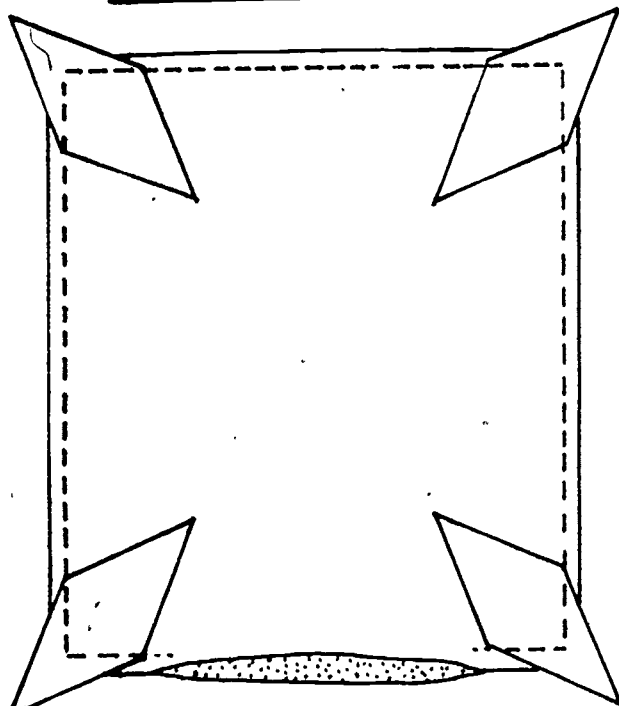

THE COMPLETED PILLOW.

STITCH ON SEAM ALLOWANCE

SLIP COVERS

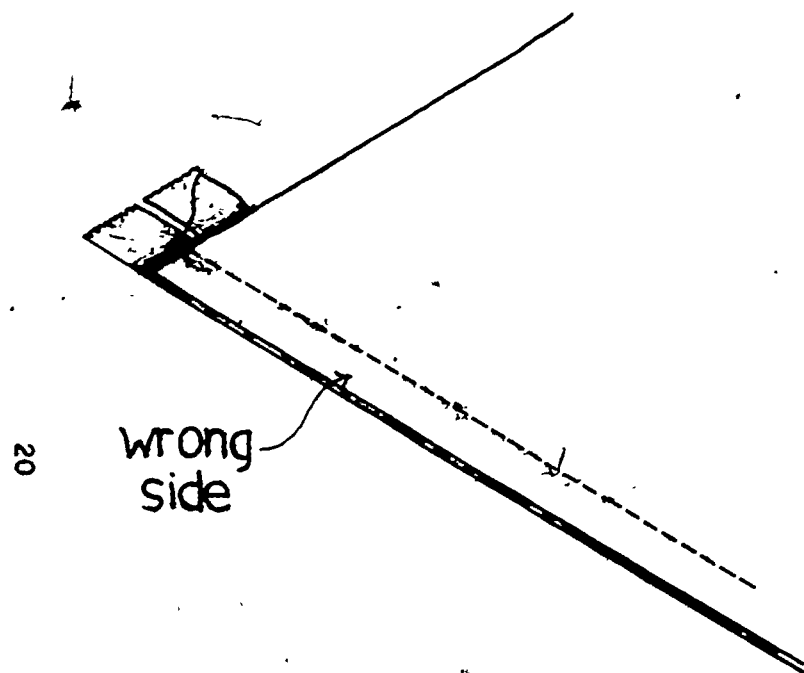

STEP 1

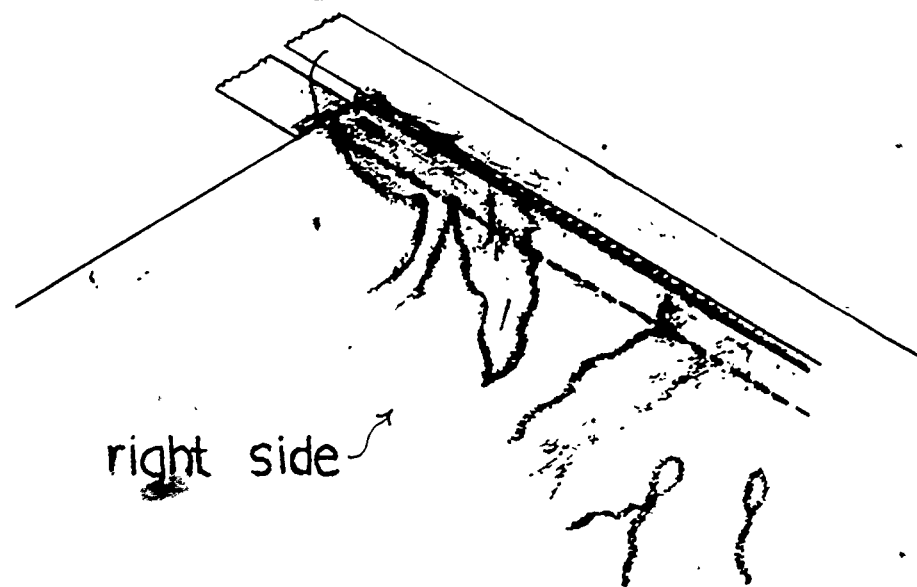

STEP 2

Zipper closing for the back of a boxed cushion.

METHOD 1

SLIP COVERS

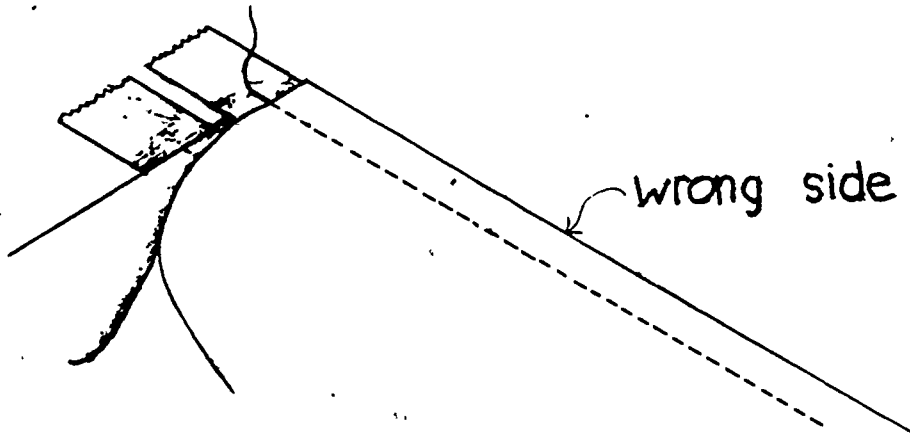

STEP 3

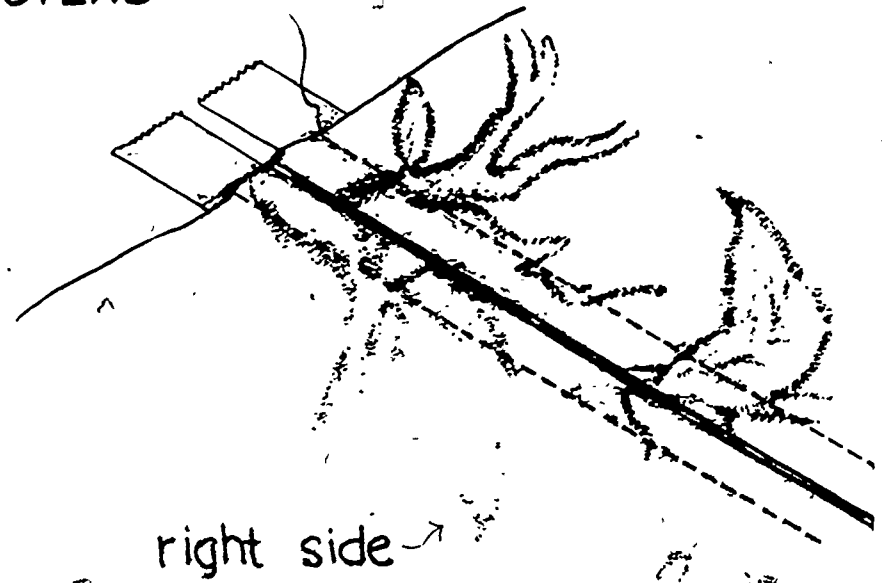

STEP 4

Zipper closing for the back of a
boxed cushion.

METHOD 1

SLIP COVERS

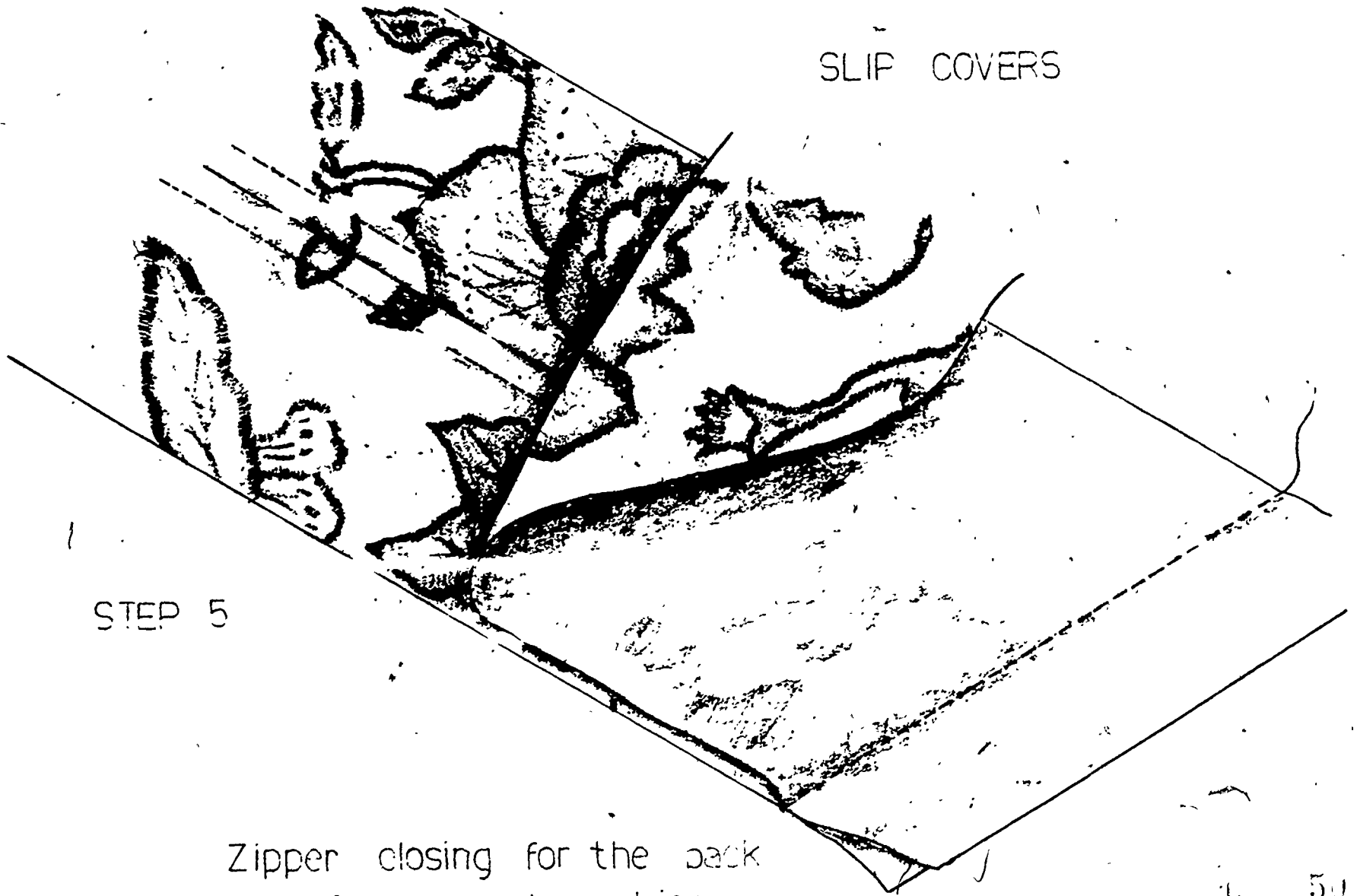

STEP 5

Zipper closing for the back
of a boxed cushion.

METHOD 1

SLIP COVERS

Construct a flap to cover the zipper tab.

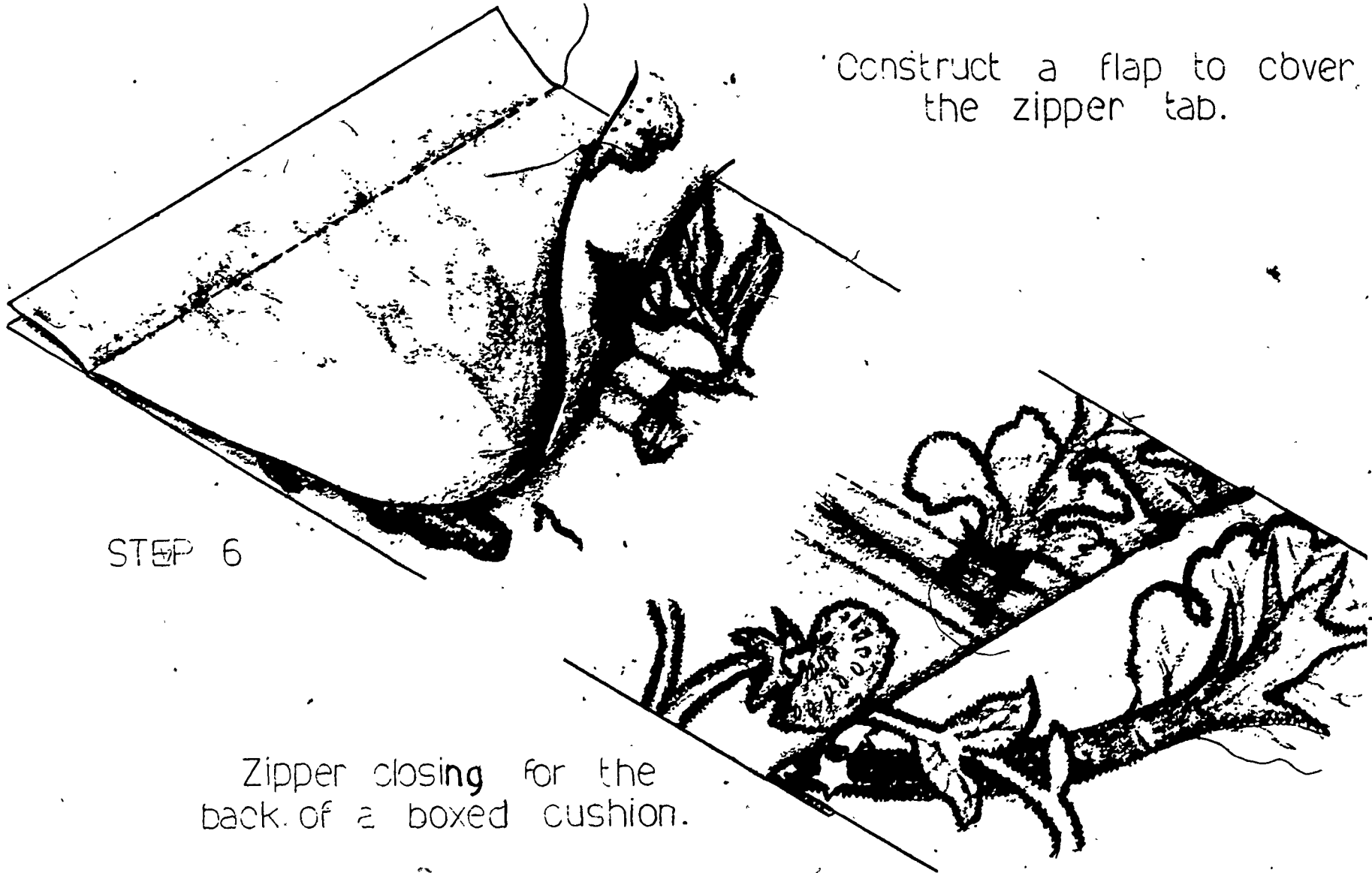

STEP 6

Zipper closing for the back of a boxed cushion.

23

51

METHOD 1

52

SLIP COVERS

Flap covers the zipper tab

STEP 7

Zipper closing for the back of a boxed cushion.

METHOD 1

50

-SLIPCOVERS-

ZIPPER CLOSING FOR
THE BACK OF A
BOXED
CUSHION.

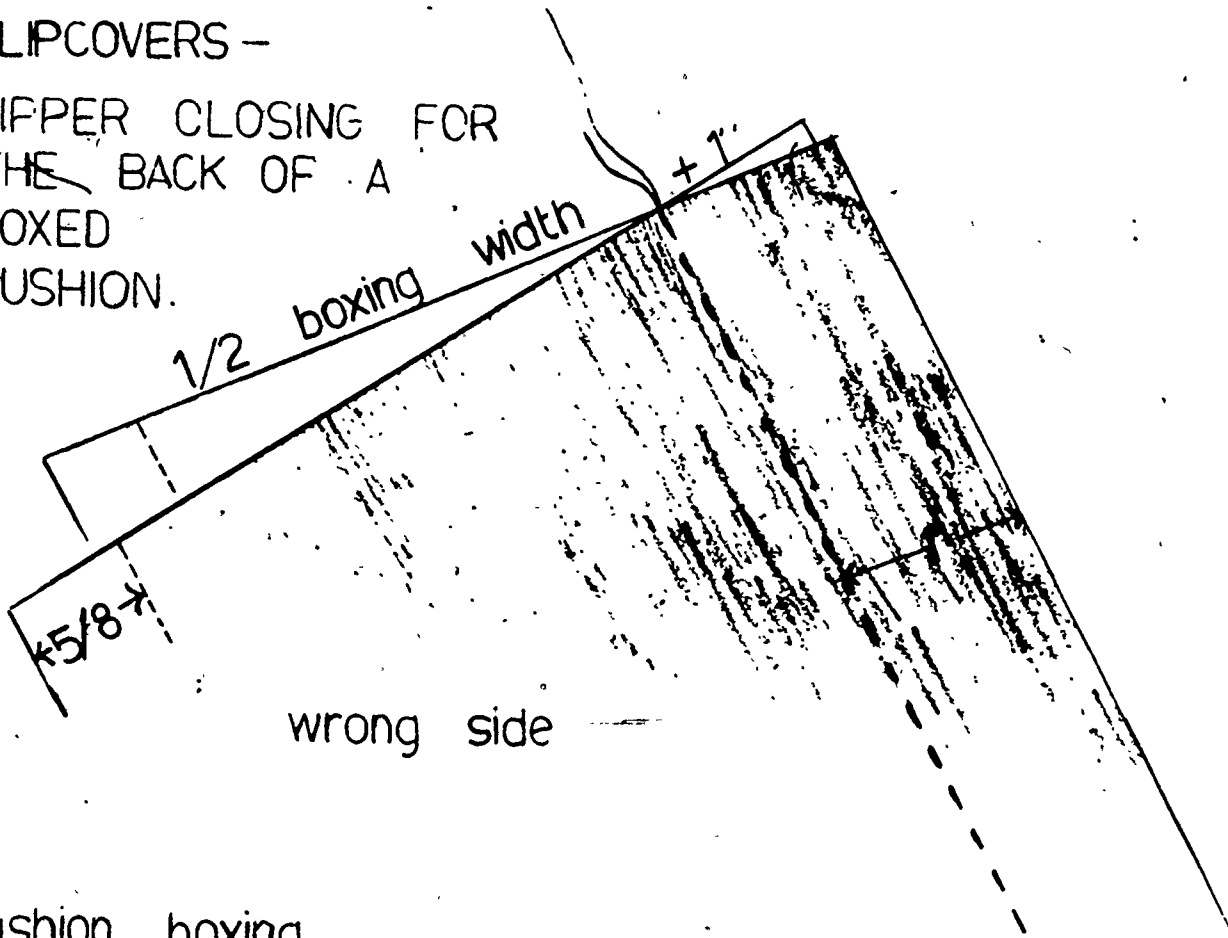

cushion boxing
Zipper type A

STEP 1

-SLIPCOVERS-

ZIPPER CLOSING FOR
THE BACK OF A
BOXED CUSHION

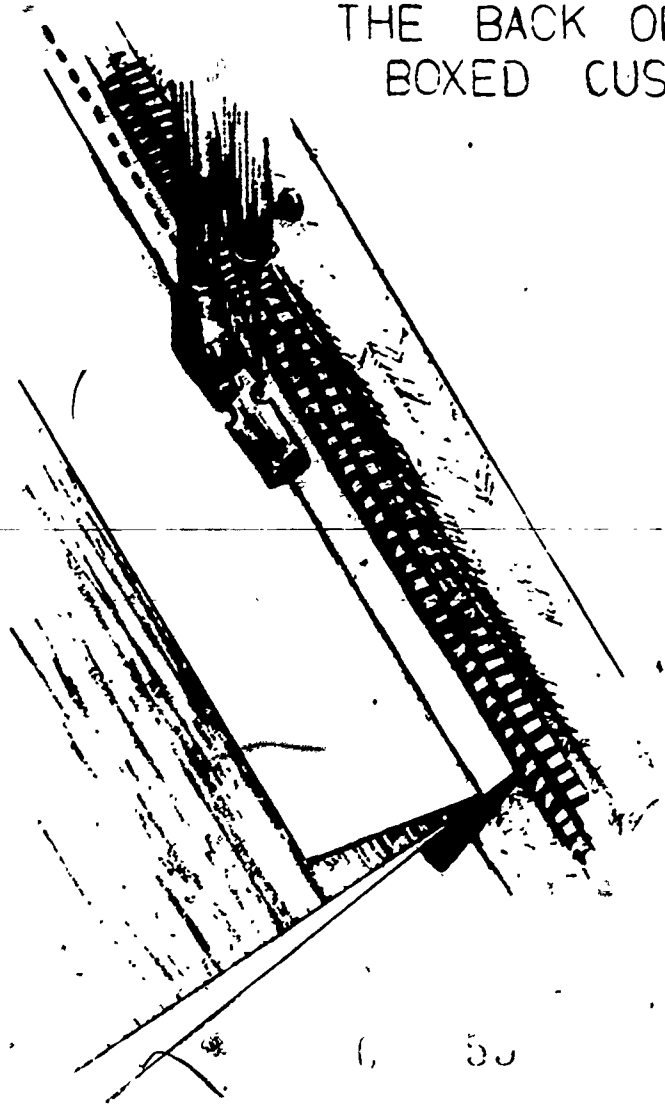

wrong side

Cushion boxing
Zipper type A

STEP 3

✓

-SLIPCOVERS-

ZIPPER CLOSING FOR
THE BACK OF A
BOXED CUSHION

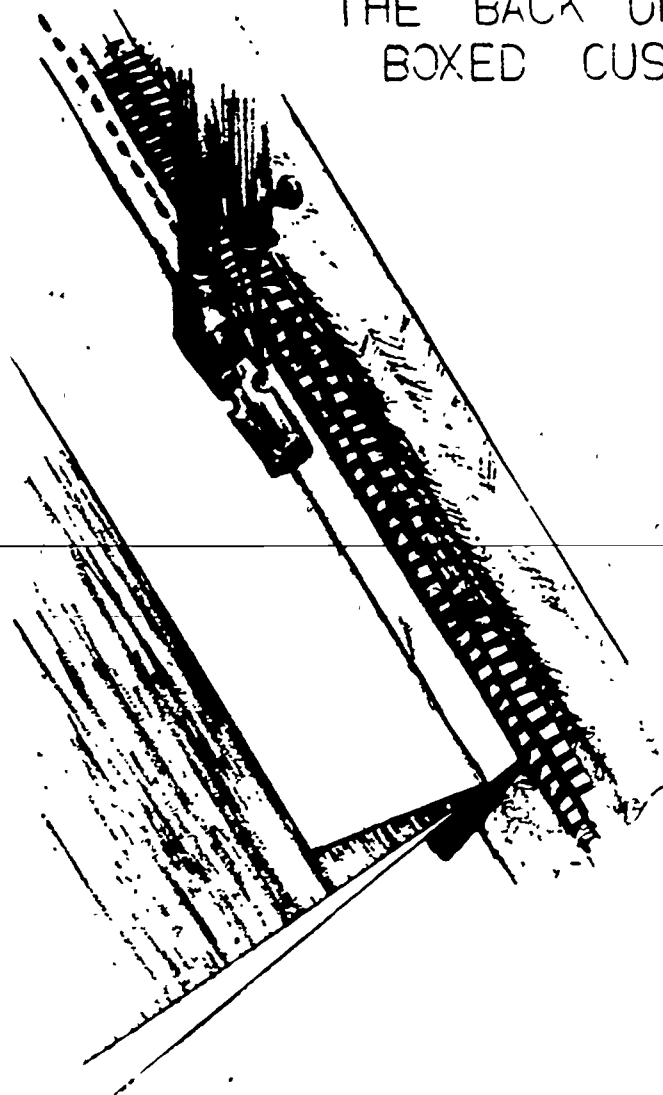

Cushion boxing
Zipper type A

wrong side

STEP 3

— SLIPCOVERS —

ZIPPER CLOSING FOR THE BACK
OF A BOXED CUSHION

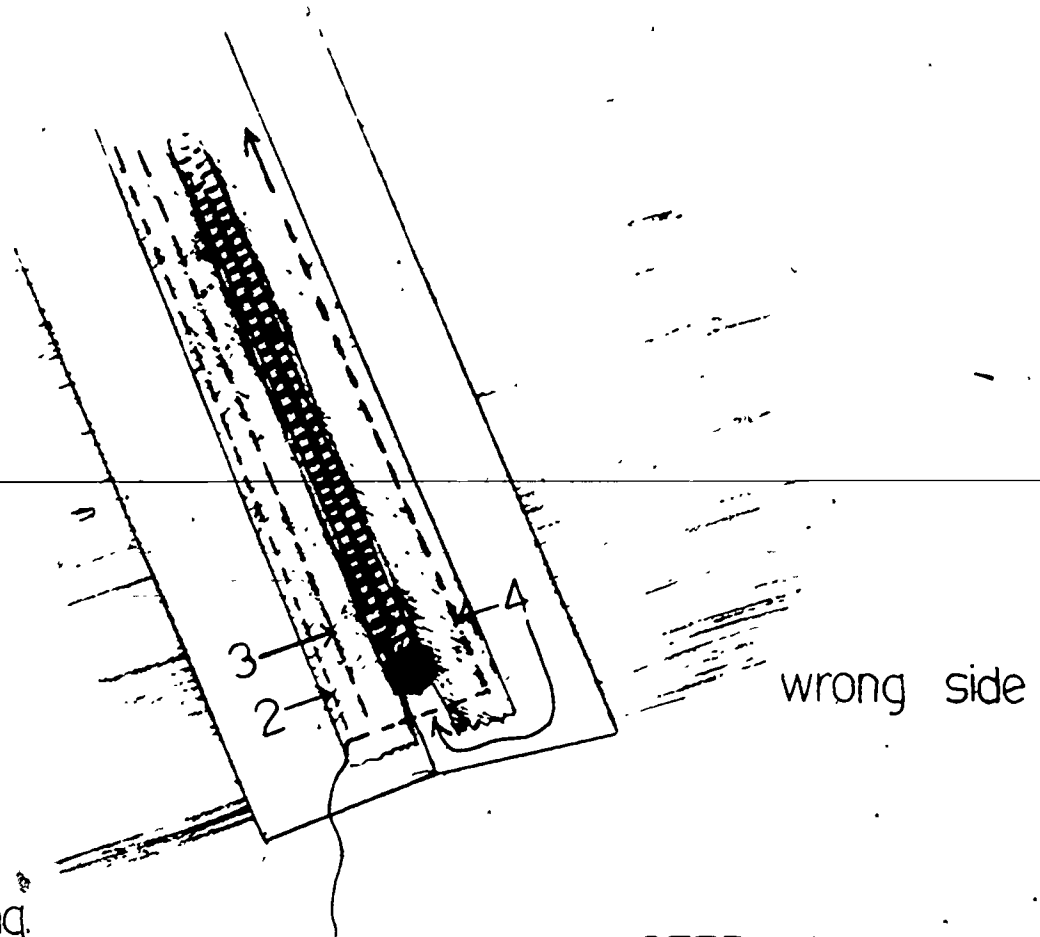

Cushion boxing.
Zipper type A

STEP 4

SLIPCOVERS

ZIPPER CLOSING FOR THE BACK OF A BOXED CUSHION



right side

Cushion boxing
Zipper type A

STEP 5

JOINING THE CORDING AT
THE BACK OF A CUSHION

30

STEP 1

60

50

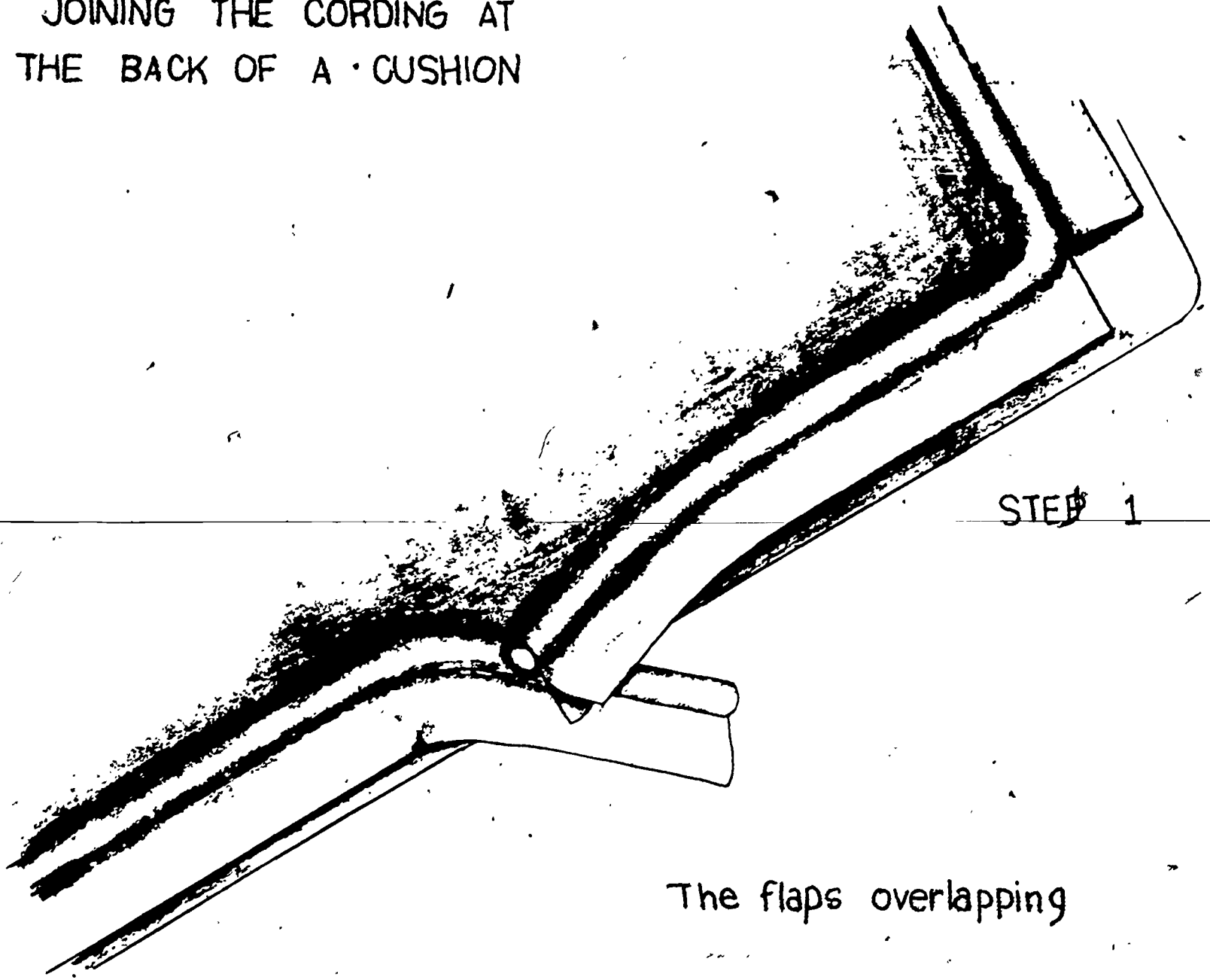

The flaps overlapping

JOINING THE CORDING AT
THE BACK OF A CUSHION

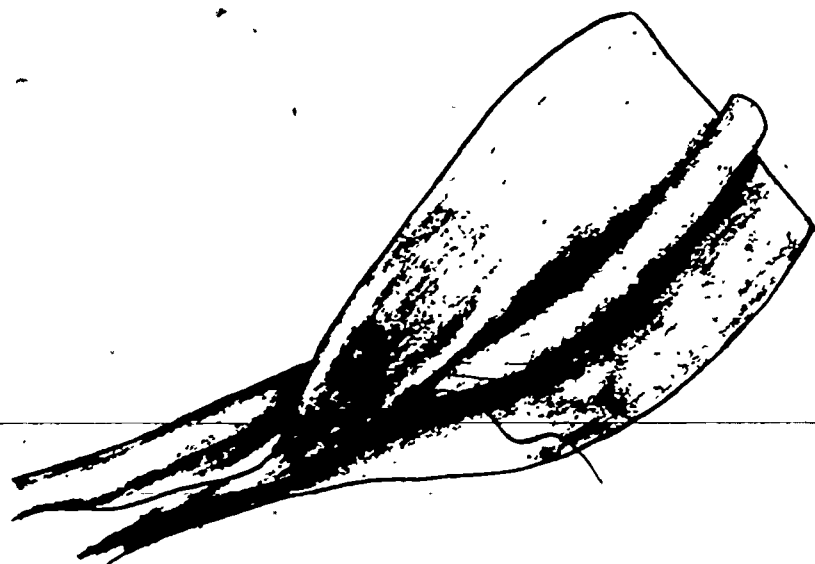

STEP 2

Open both casings at the
ends

JOINING THE CORDING AT
THE BACK OF A CUSHION

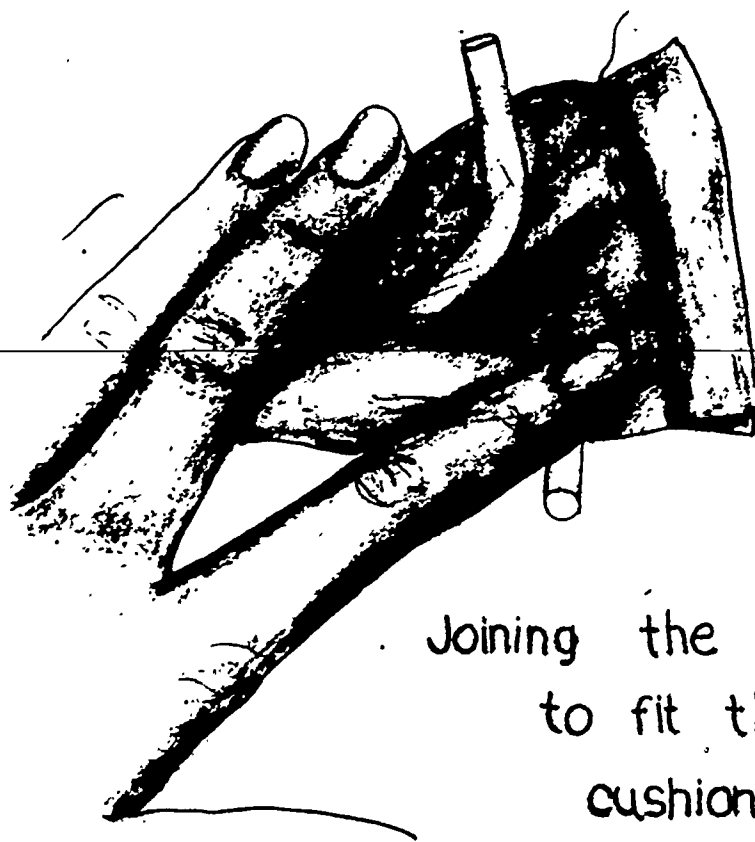

STEP 3

Joining the casing
to fit the
cushion.

JOINING THE CORDING AT
THE BACK OF A CUSHION

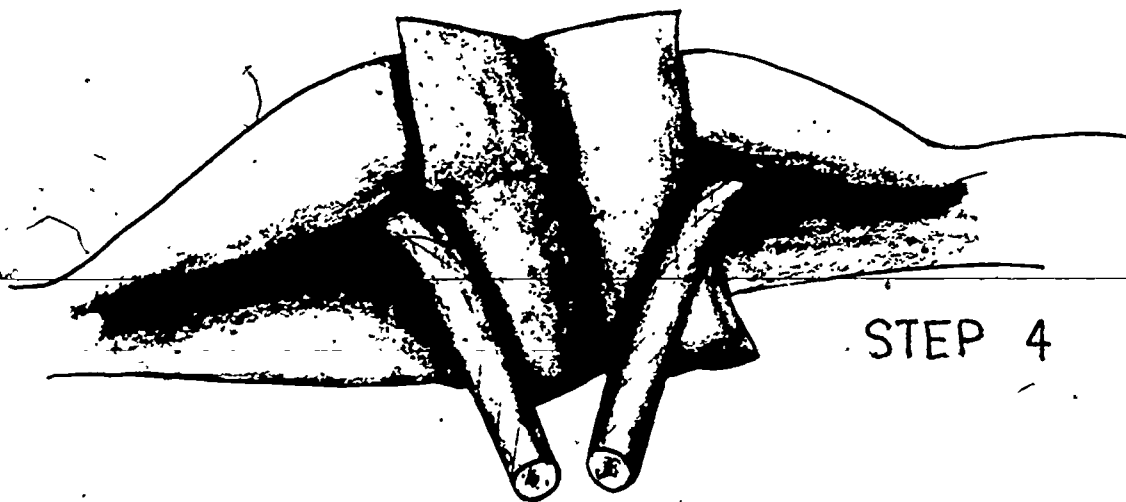

STEP 4

The casing joined

JOINING THE CORDING AT
THE BACK OF A CUSHION

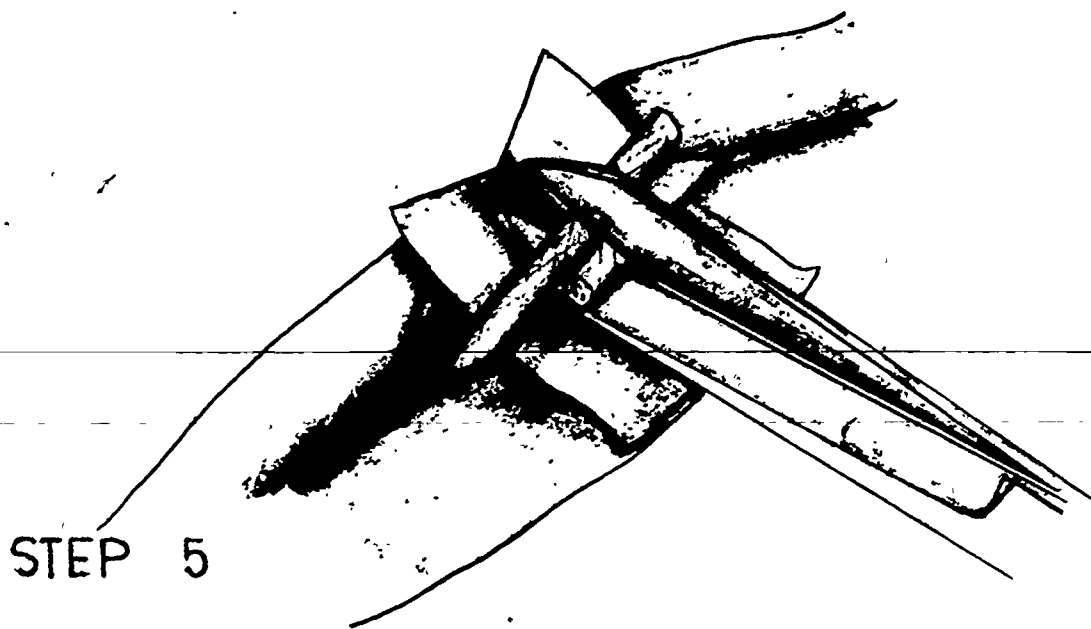

STEP 5

Clip the cords evenly

JOINING THE CORDING AT
THE BACK OF A CUSHION

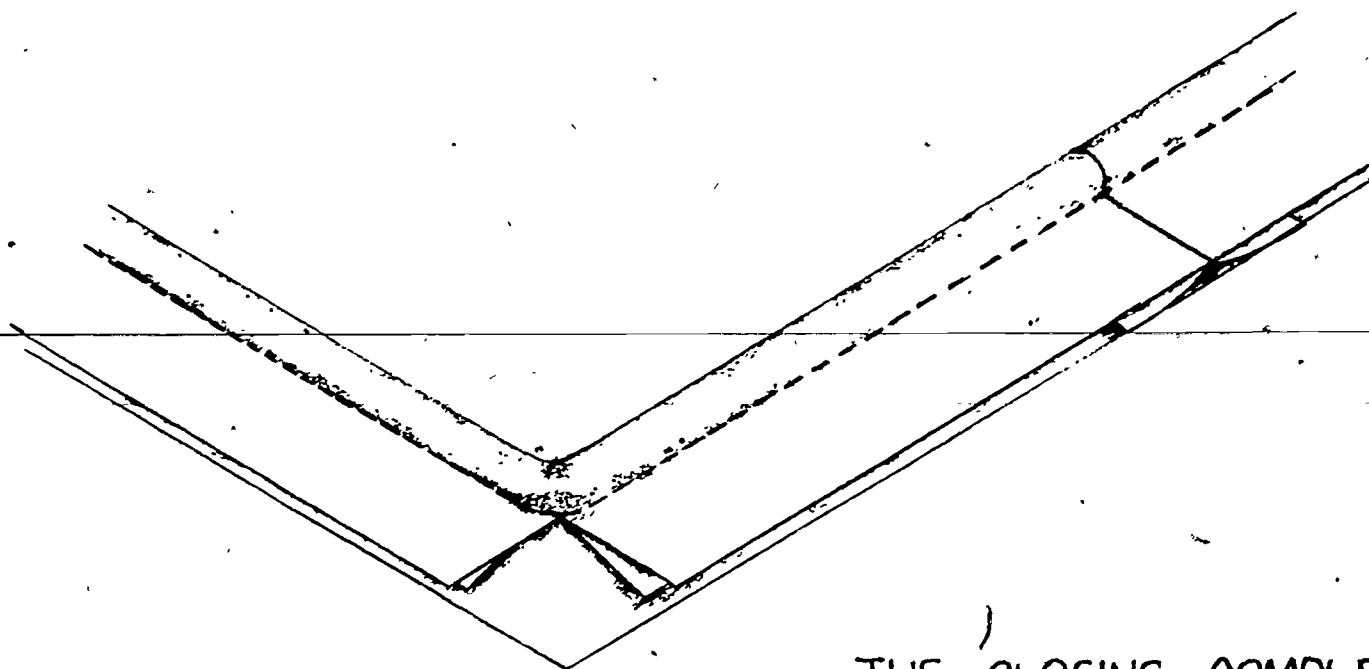

THE CLOSING COMPLETED

-SLIPCOVERS-
CUSHIONS

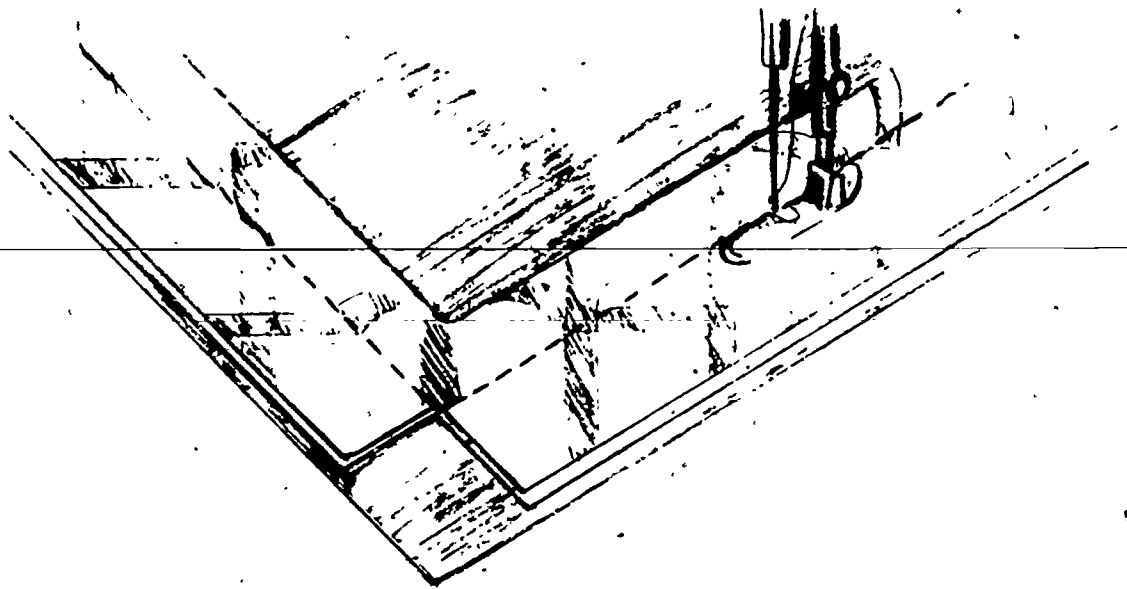

A square, corded, cushion corner

-SLIPCOVERS-
CUSHIONS

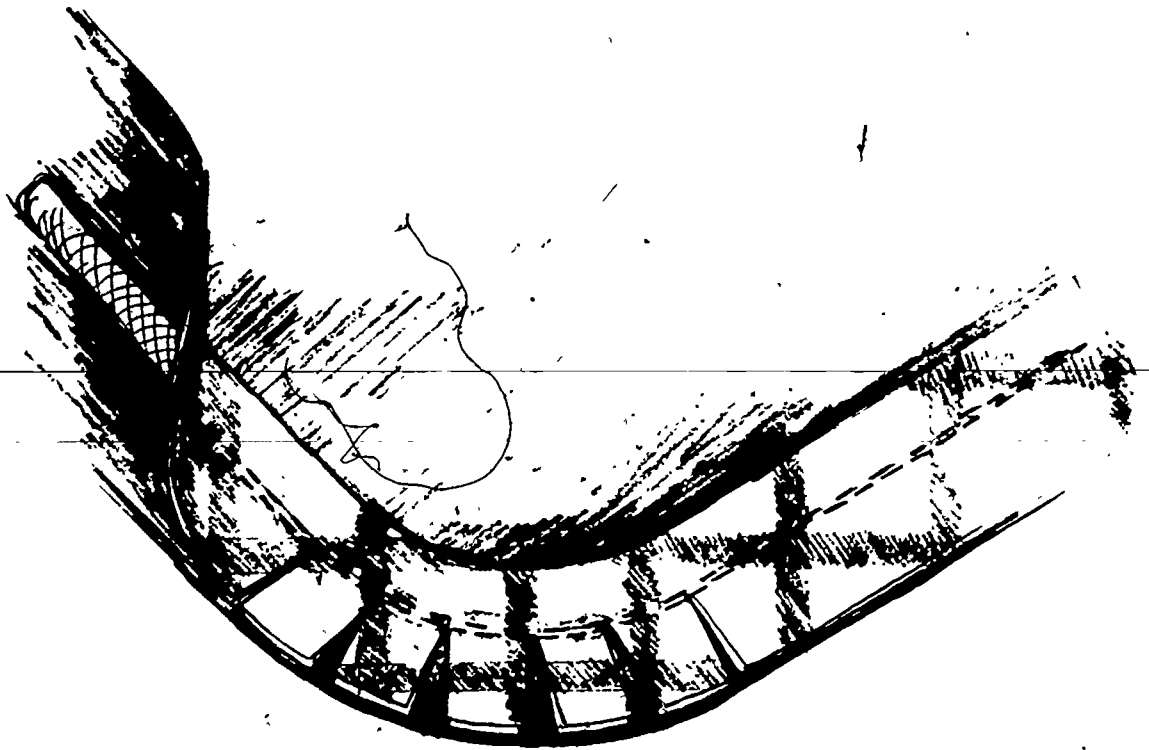

A rounded, corded, cushion corner

THE SKIRT.

1. Mark position of skirt and block-cut. Before beginning to block-cut material, put a chalk line around chair indicating depth of skirt. For depth of skirt on most chairs, measure from bottom of seat-front to floor. Changes in block-cutting will be made only on outside-back and outside-arm. In each case, bring material to chalk mark rather than to bottom of chair, and allow 1 inch.

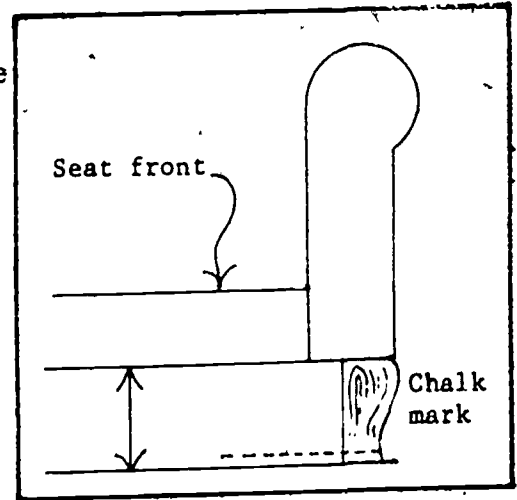

Measuring the length of the skirt

2. Cut skirt lengths. Bring material up to chalk line, allow 1 inch. Take material to floor, allow 1 inch. Cut 4 pieces, one for each side of the chair. If skirt is gathered or pleated all around, cut 8 pieces of 36 inch material, and 6 pieces of 48 inch or 54 inch material.

For box pleats at corners only, allow 10 extra inches,

If you have a shag rug, make the skirt somewhat shorter, depending on the depth of the shag.

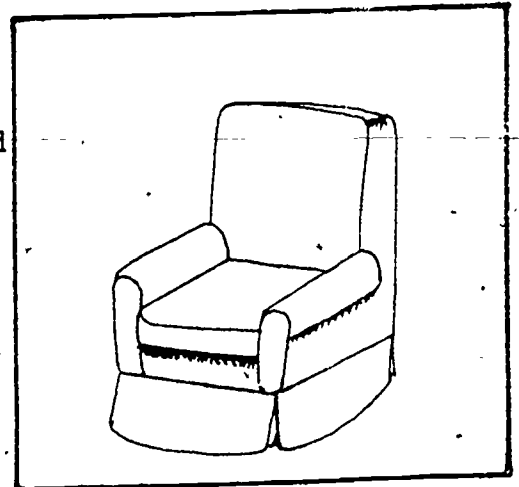

Box pleats at corners

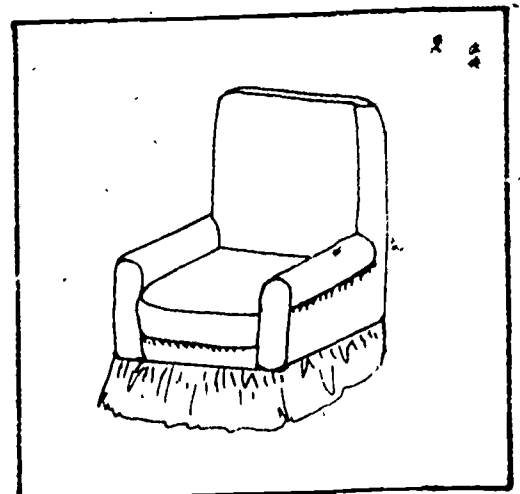

Gathered skirt

SLIP COVERS

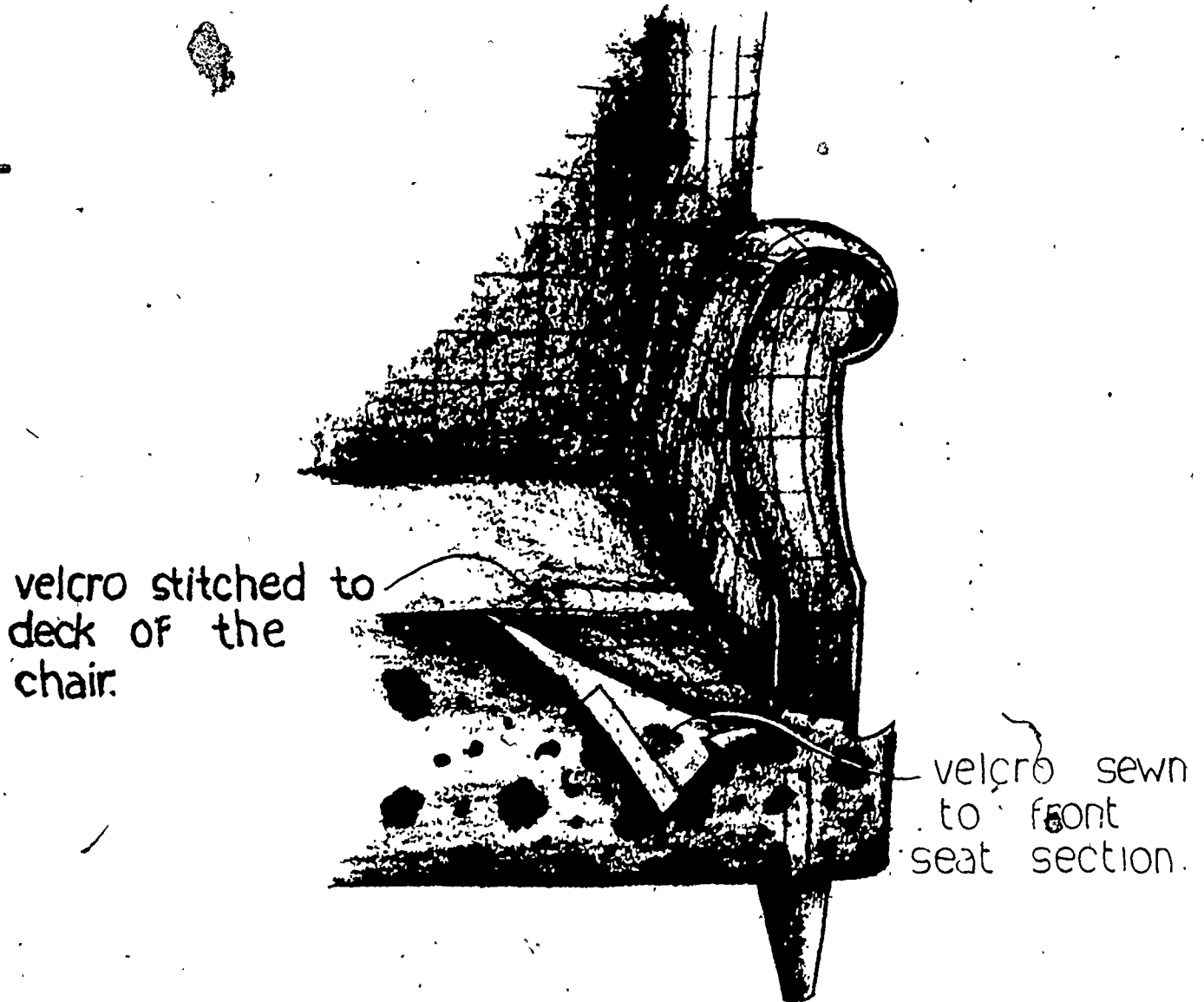

APPLYING THE FRONT SECTION

STEP 1

SLIP COVERS

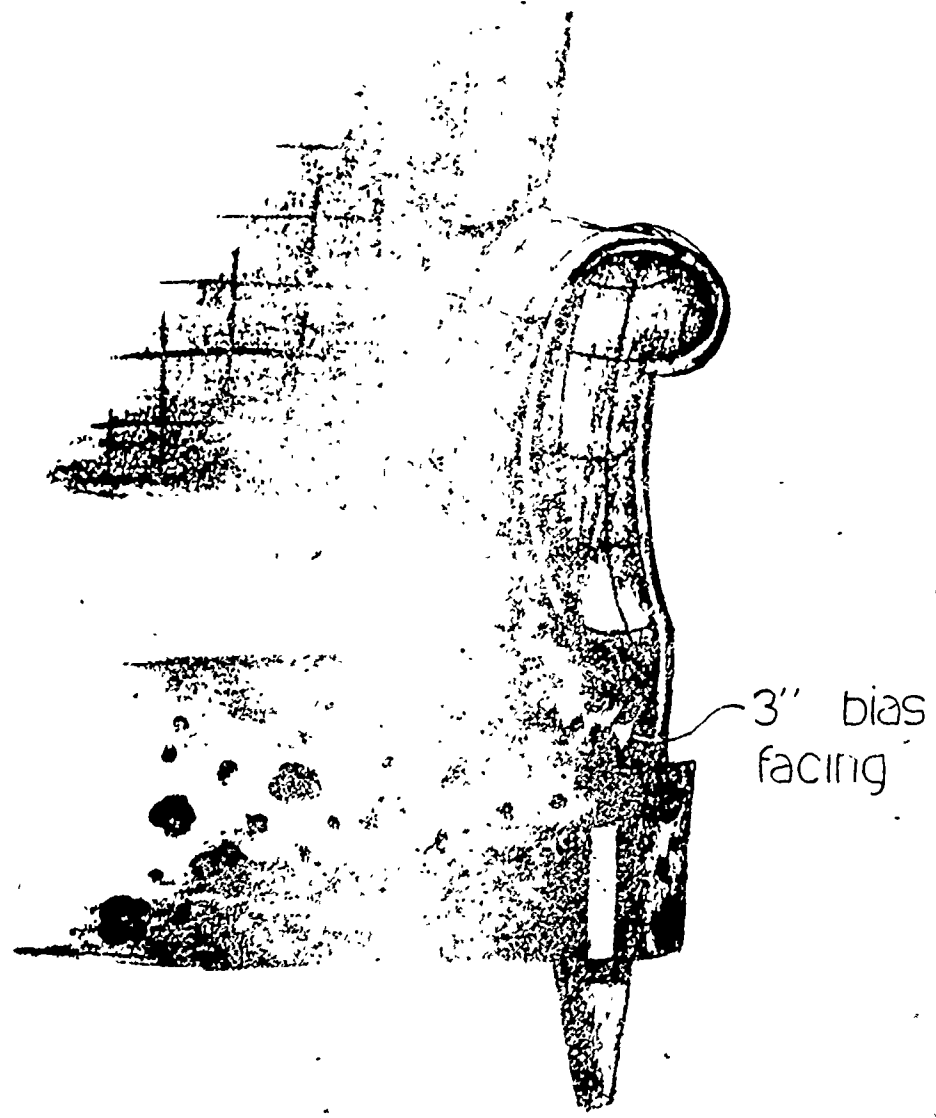

APPLYING THE FRONT SECTION

STEP 1

70

SLIP COVERS

3" wide bias
facing at the base
of the wing.
Tucks in at
the inside arm

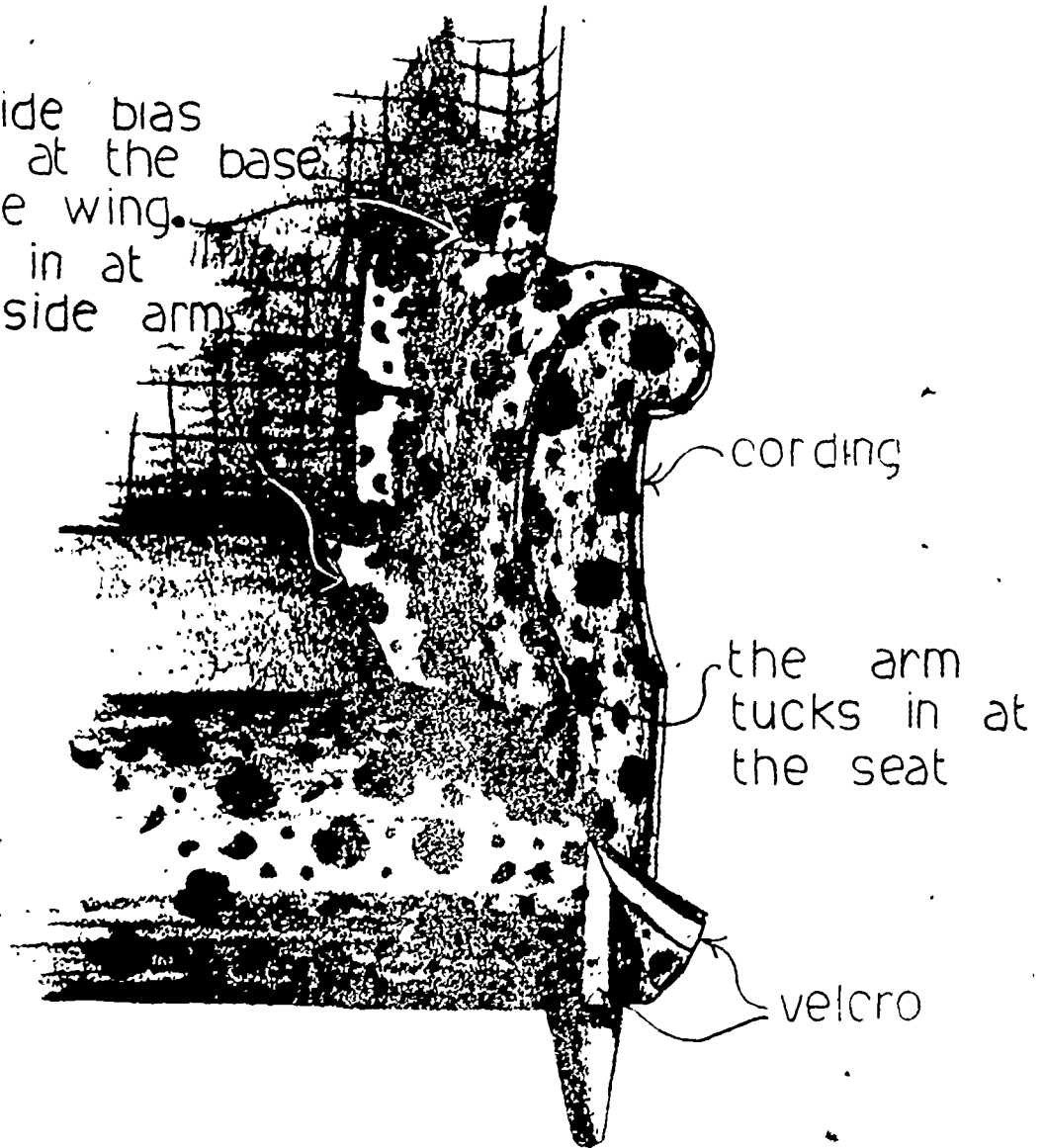

THE ARM ATTACHMENT TO THE FRONT
SECTION WITH VELCRO

ST 2

SLIP COVERS

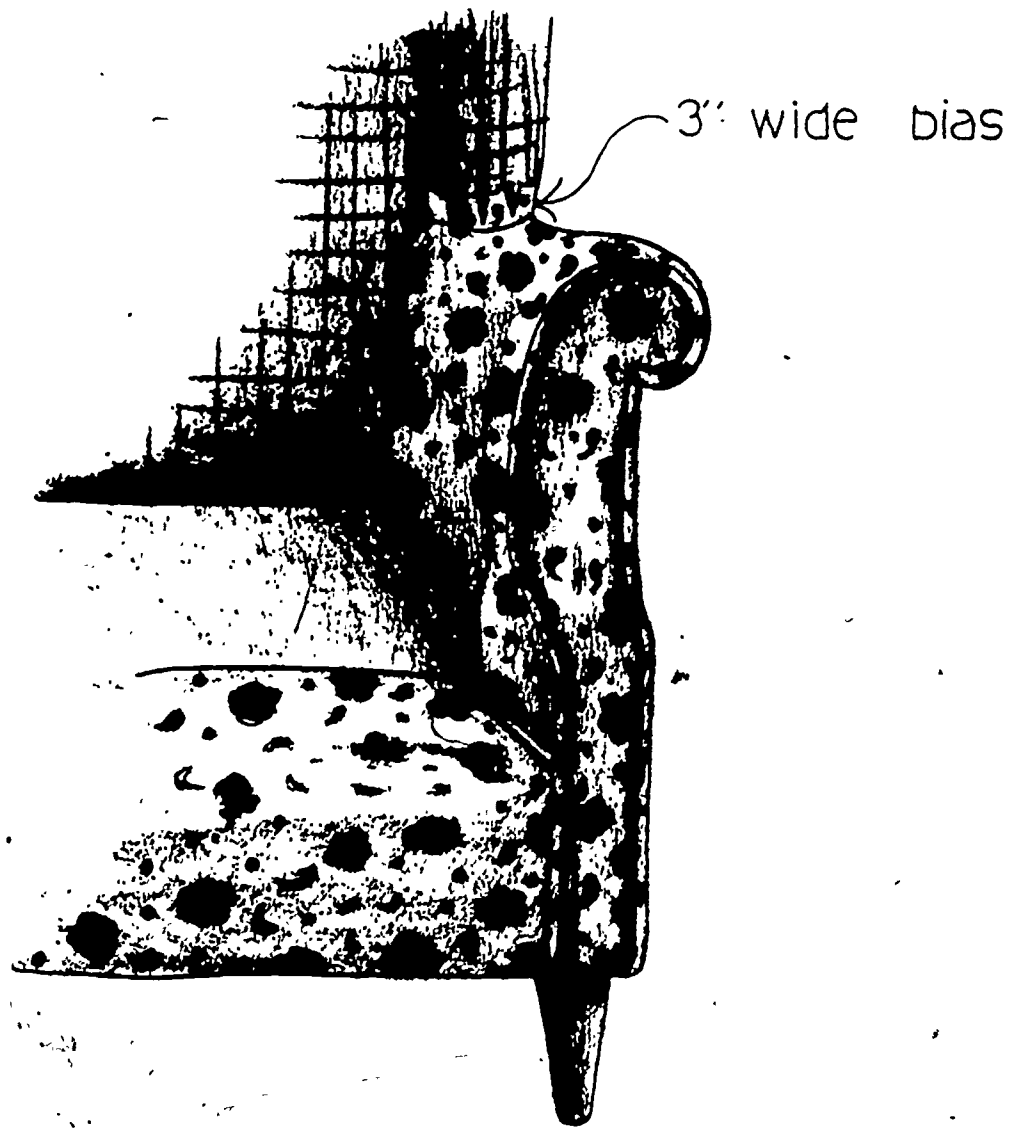

THE COMPLETED ARM AND FRONT
SEAT SECTION.

STEP 4

72

SLIP COVERS

a 3" wide bias
is turned under
the cording

a 3" wide
bias is turned
under here

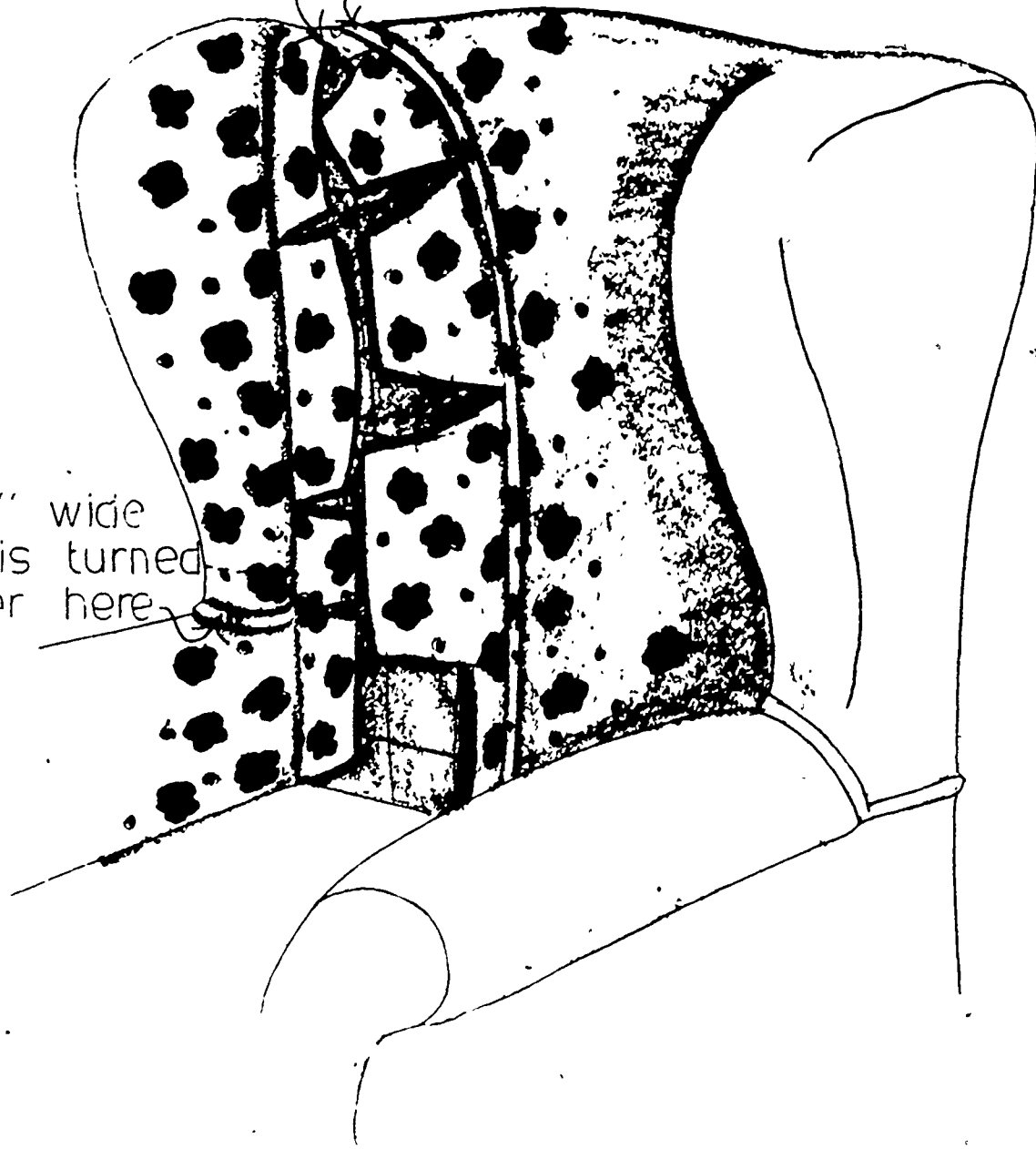

THE INSIDE IS NOT STITCHED TO THE WING,
IT IS HELD IN PLACE WITH TABS.

STEP 5
13 73

SLIP COVERS

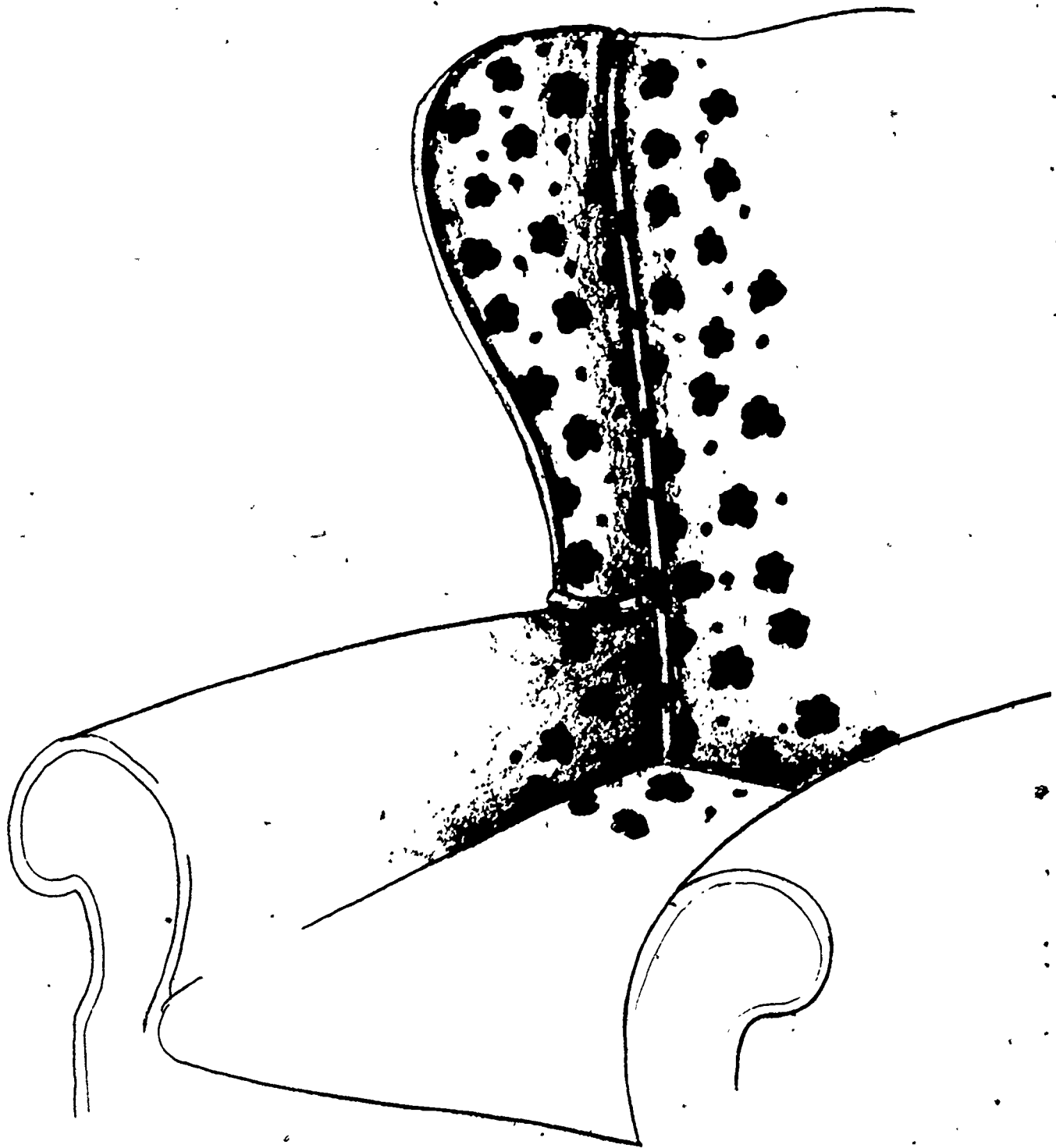

CORDING FINISHES THE INSIDE BACK

STEP 6

SLIP COVERS

this velcro matches
tabs stapled to base
of the chair

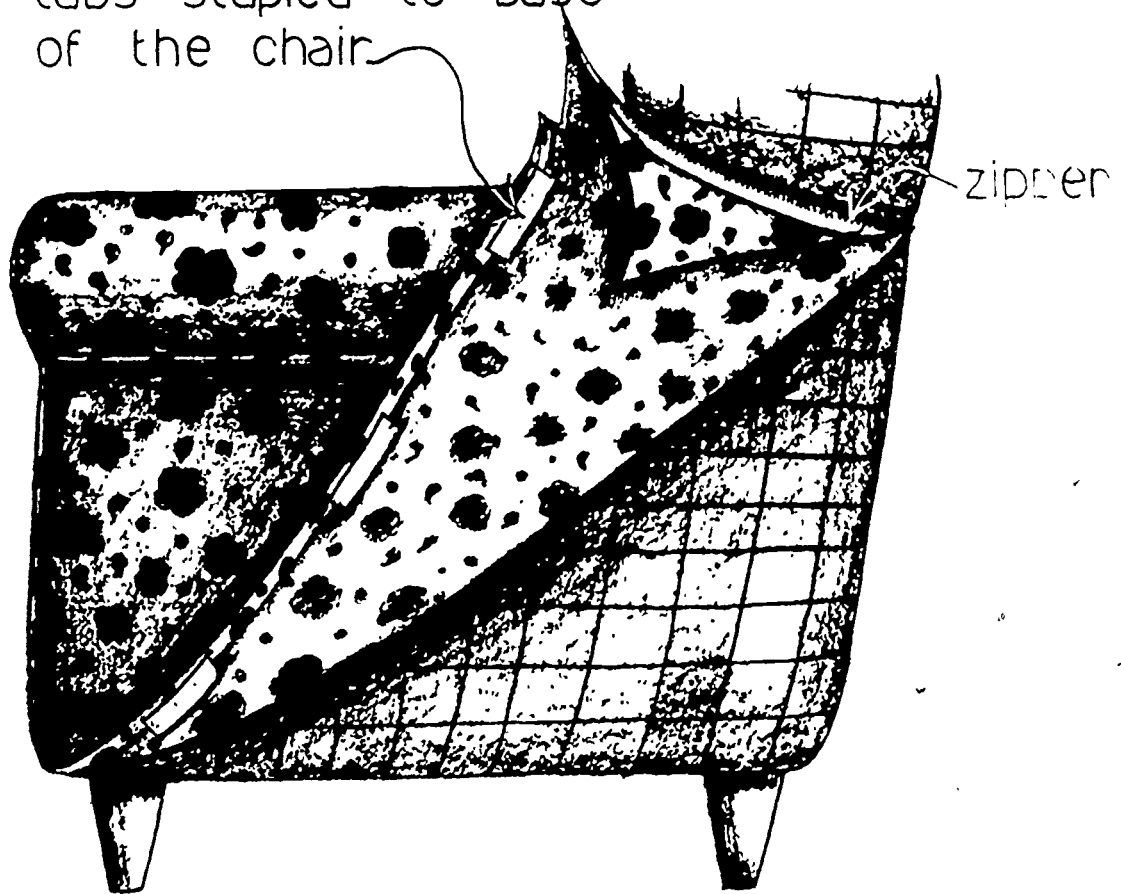

OUTSIDE OF THE ARM ATTACHES TO
THE BASE OF THE CHAIR WITH VELCRO

STEP 7

SLIP COVERS

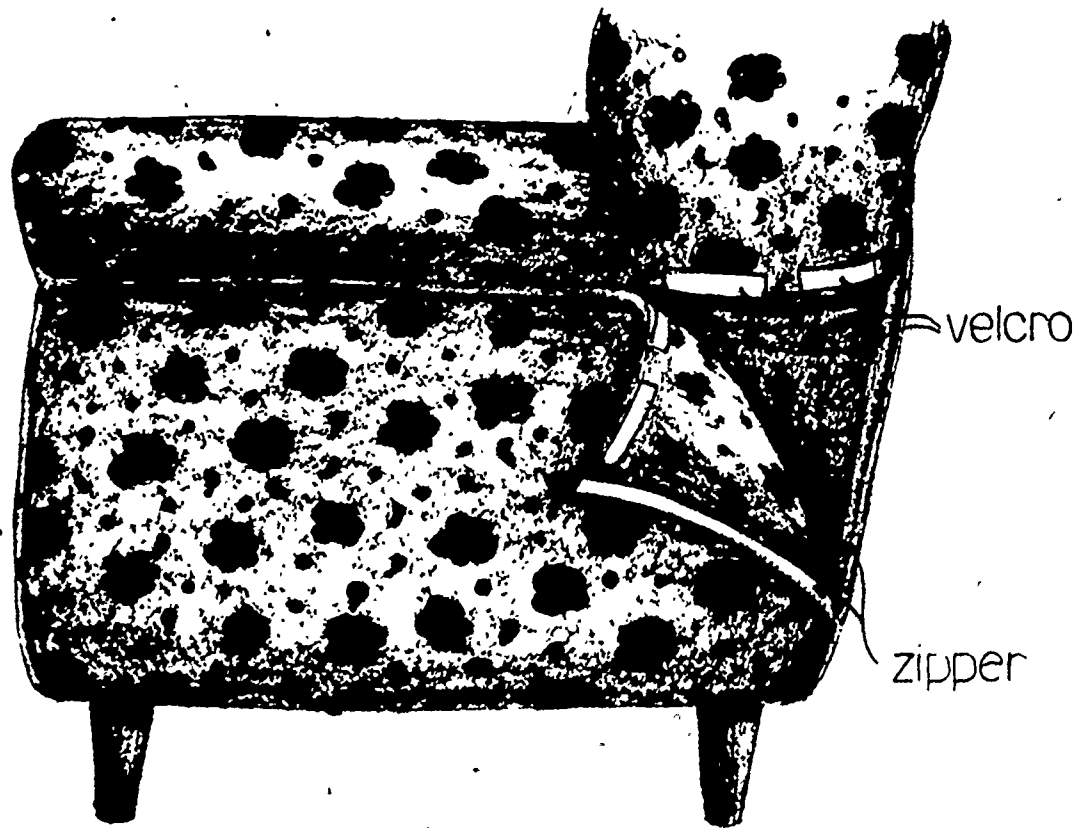

THE OUTSIDE ARM ATTACHES TO THE WING WITH VELCRO, AND TO THE 'BACK WITH A ZIPPER

STEP 8

70

SLIP COVERS

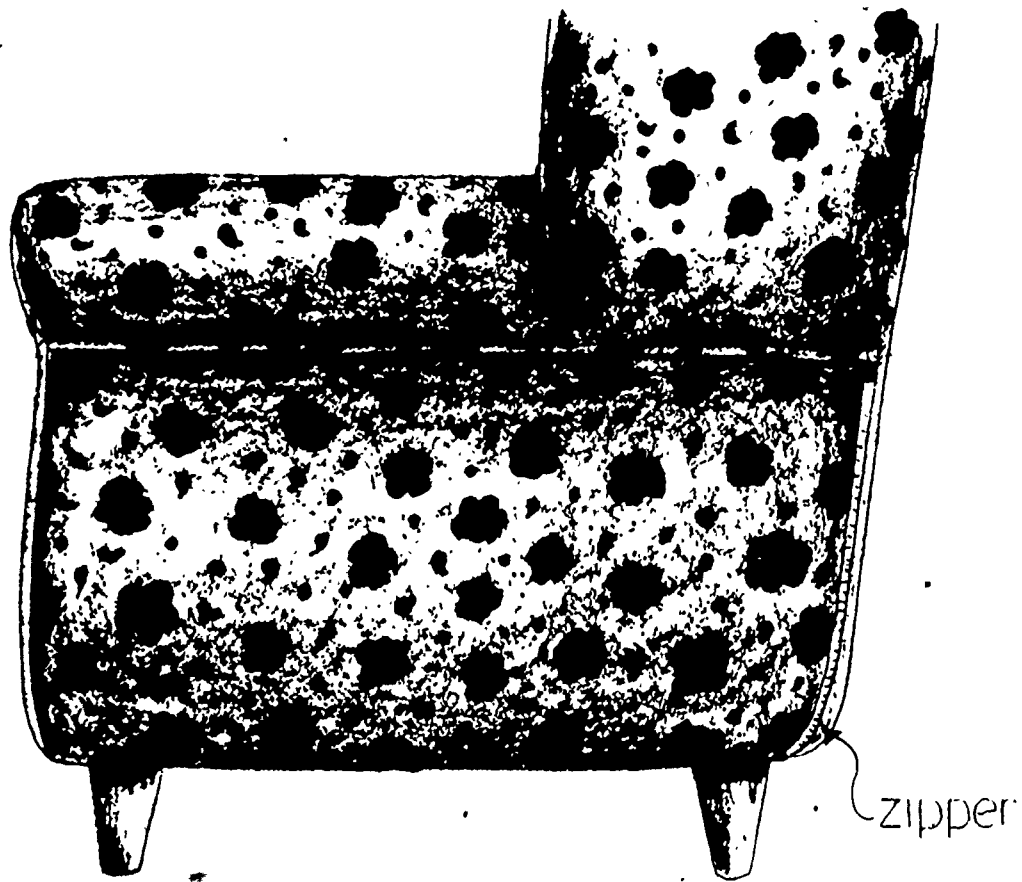

THE OUTSIDE ARM WITH THE ZIPPER CLOSED

STEP 9

SLIP COVERS

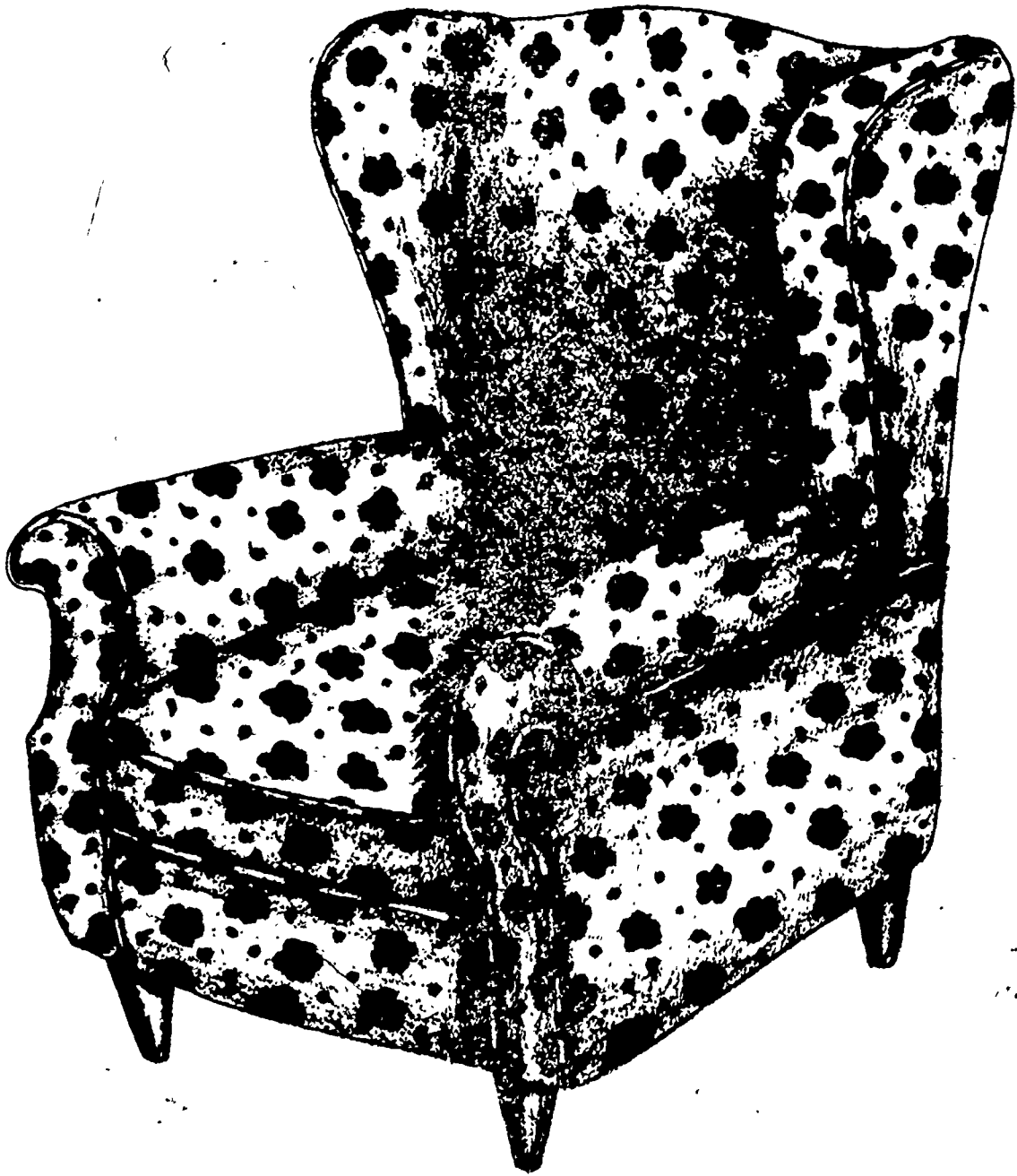

THE COMPLETED CHAIR

We would appreciate any comments on the content, the format and the usefulness of this material.

Please send any suggestions and comments to:

Mrs. Phyllis W. Schwebke, Home Economics Chairperson
Madison Area Technical College
211 N. Carroll Street
Madison, Wisconsin 53703
608-266-5077