

DOCUMENT RESUME

ED 224 906

CE 034 642

**AUTHOR** Olson, Gladys; Swiggum, Carol  
**TITLE** Resource Book for Window Treatment Construction [and] Rod Installation.  
**INSTITUTION** Madison Area Technical Coll., Wis.; Wisconsin State Board of Vocational, Technical, and Adult Education, Madison.  
**PUB DATE** 82  
**NOTE** 116p.; For related documents see CE 034 643-649.  
**PUB TYPE** Guides - Classroom Use - Guides (For Teachers) (052)

**EDRS PRICE** MF01/PC05 Plus Postage.  
**DESCRIPTORS** Adult Programs; \*Adult Vocational Education; Check Lists; Glossaries; \*Home Furnishings; Learning Activities; \*Occupational Home Economics; \*Resource Materials; \*Sewing Instruction; \*Windows  
**IDENTIFIERS** \*Drapery Makers

**ABSTRACT**

This resource book for window treatment construction and rod installation is one of four resource books developed for use in Code 30 or adult vocational programs in the home furnishings service area. Representative, illustrative, and informative materials contained in the resource book are Window Treatments Glossary, Window Treatments, Parts of a Window, Types of Windows, Window Measurements, Worksheet to Determine Yardage Required, Width Conversion Chart, Sample Work Order, Work Order Information, Work Tables, Power Sewing Equipment, The Sewing Machine, Safety Procedures, Safety Check List, Types of Pleats, Worksheet for Calculating Pleats and Spaces, Drapery Hooks, Evaluation Pinch-Pleated Draperies, Window Headings, Window Shade Measurements, Construction of Roman Shades, Austrian Shades, Window Treatment Hardware, Traverse Rods, Curtain Rods, Rod Identification, Mounting Methods for Draperies and Curtains, Assemble Traverse Rods, Installation Tools, Installation Tips, Installation Procedures, and Achievement Test. (YLB)

\*\*\*\*\*  
 \* Reproductions supplied by EDRS are the best that can be made \*  
 \* from the original document. \*  
 \*\*\*\*\*

## FORWARD

This publication contains illustrative and informative materials for teaching Window Treatments and Rod Installation.

Reference is made to these resources in the Suggested Curriculum Guide for Window Treatments and Rod Installation. In the guide, the word RESOURCE is identified in capital letters and the pages from the Resource Book are listed.

These materials may be reprinted for classroom use.

1982

## ACKNOWLEDGEMENTS

Special appreciation is extended to the following coordinators; consultants and post-secondary instructors for their efforts in the development of this curriculum for the home furnishings service programs.

### PROJECT DIRECTOR

Carol Swiggum  
Instructor  
Madison Area Technical College  
Madison, Wisconsin

### CONSULTANT AND COORDINATOR

Helen Scheve  
Home Economics Consultant  
Wisc. Board of Vocational,  
Technical & Adult Education  
Madison, Wisconsin

Phyllis Schwebke  
Home Economics Chairperson  
Madison Area Technical College  
Madison, Wisconsin

### CURRICULUM WRITERS

#### FURNITURE RENOVATION (REFINISHING AND REUPHOLSTERING)

Diane Barton  
Home Economics Coordinator  
Southwest Wisc. Technical Institute  
Fennimore, Wisconsin

Jay Robinson  
Instructor  
Southwest Wisc. Technical Institute  
Fennimore, Wisconsin

#### SLIPCOVER CONSTRUCTION

Alice Iverson  
Instructor  
Waukesha County Technical Institute  
Pewaukee, Wisconsin

#### ENTREPRENEURSHIP

Mary Schmolesky  
Instructor  
Madison Area Technical College  
Madison, Wisconsin

## ROD INSTALLATION

Gladys Olson  
Home Economics Chairperson  
Blackhawk Vocational-Technical Institute  
Beloit, Wisconsin

## WINDOW TREATMENTS.

Carol Swiggum  
Instructor  
Madison Area Technical College  
Madison, Wisconsin

## RESOURCE PERSONS

Jean Carlson  
Home Economics Consultant  
Wisc. Board of Vocational, Technical & Adult Education  
Madison, Wisconsin

Robert Martin  
Div. Supervisor Home and Consumer Sciences  
Fox Valley Technical Institute  
Appleton, Wisconsin

Materials received from the following schools were used in the development of the curriculum and resource book.

Blackhawk Technical Institute  
Gateway Technical Institute  
Madison Area Technical College  
Southwest Wisconsin Technical Institute.  
Waukesha County Technical Institute

Special thanks to the typists Anne Zimmermann, Luanne Storley, and Mary Jane Zummo.

# TABLE OF CONTENTS

	Page
FORWARD . . . . .	i
ACKNOWLEDGEMENTS . . . . .	ii
WINDOW TREATMENTS GLOSSARY . . . . .	1
WINDOW TREATMENTS . . . . .	8
PARTS OF A WINDOW . . . . .	18
TYPES OF WINDOWS . . . . .	19
WINDOW TREATMENTS FOR PROBLEM WINDOWS . . . . .	23
CHOOSE APPROPRIATE FABRIC . . . . .	25
WINDOW MEASUREMENTS . . . . .	26
MEASURING FOR TRAVERSE DRAPERIES . . . . .	27
WORKSHEET TO DETERMINE YARDAGE REQUIRED . . . . .	29
WIDTH CONVERSION CHART . . . . .	31
ALTERNATE METHOD - CALCULATE YARDAGE . . . . .	32
SAMPLE WORK ORDER . . . . .	33
WORK ORDER INFORMATION . . . . .	34
WORK TABLES . . . . .	35
BAR TACK MACHINE . . . . .	37
POWER SEWING EQUIPMENT . . . . .	38
THE SEWING MACHINE . . . . .	41
SAFETY PROCEDURES . . . . .	42
SAFETY CHECK LIST . . . . .	43
WORK ORDER - PINCH PLEATED DRAPERY . . . . .	45
CUTTING DRAPERY AND LINING LENGTHS . . . . .	46
SEAMING DRAPERY AND LINING LENGTHS . . . . .	47
HEM PRESSING GAUGE . . . . .	50

	Page
DRAPERY SIDE AND BOTTOM HEMS . . . . .	51
APPLYING THE CRINOLINE TO THE DRAPERY . . . . .	53
TYPES OF PLEATS . . . . .	54
HOW TO CALCULATE PLEATS FOR TRAVERSE DRAPERY . . . . .	55
CONVERSION CHART . . . . .	56
WORKSHEET FOR CALCULATING PLEATS AND SPACES . . . . .	57
ALTERNATE METHOD - PLEAT CALCULATION . . . . .	58
GAUGE FOR PLEAT AND SPACE SIZE . . . . .	59
PIN-OFF DRAPERY PLEATS . . . . .	60
STACKING AND BANDING DRAPERY PANELS . . . . .	62
STITCHING, FORMING AND TACKING DRAPERY PLEATS . . . . .	64
DRAPERY HOOKS . . . . .	65
EVALUATION - PINCH PLEATED DRAPERY . . . . .	67
THE CARTRIDGE PLEAT . . . . .	68
THE BOX PLEAT . . . . .	69
SHIRRED CURTAIN . . . . .	70
WINDOW HEADINGS . . . . .	72
WINDOW SHADE MEASUREMENTS . . . . .	73
CONSTRUCTION OF ROMAN SHADES . . . . .	74
LAMINATED ROLLER SHADES . . . . .	77
AUSTRIAN SHADES . . . . .	79
IMPORTANT DECISIONS - CONSTRUCTION OF WINDOW TREATMENTS . . . . .	82
WINDOW TREATMENT HARDWARE . . . . .	83

	Page
TRAVERSE RODS . . . . .	84
CUSTOM - CUT TRAVERSE RODS . . . . .	85
PARTS OF A TRAVERSE ROD . . . . .	86
CURTAIN RODS . . . . .	87
ROD IDENTIFICATION . . . . .	89
MOUNTING METHODS FOR DRAPERIES AND CURTAINS . . . . .	91
ASSEMBLE TRAVERSE ROD . . . . .	93
INSTALLATION TOOLS . . . . .	95
BRACKETS . . . . .	96
INSTALLATION TIPS . . . . .	97
INSTALLATION PROCEDURES . . . . .	99
ACHIEVEMENT TEST . . . . .	100
REFERENCES . . . . .	101

## WINDOW TREATMENTS GLOSSARY

angle iron	L-shaped brace used in the installation of cornice and valance boards.
apron	The flat wood trim below the window sill.
arched window	A window with a curved top.
Austrian shade	A window treatment made of shirred fabric that gives the effect of vertical rows of swags and ends in a row of scallops; raised and lowered by a pulley cord.
balloon shade	A fabric shade with deep inverted pleats that create a billowing or balloon effect when the shade is raised by means of cords running through rings attached to back of shade.
bay window	Three or more windows set at an angle to each other and projecting from the wall.
box pleat	A single pleat, flattened to the drape.
bracket	End support holding the drapery rod.
cafe curtains	Panels which hang on cafe rods with plain, scalloped or pleated headings; hung singly or in tiers.
canopy	A valance treatment creating an awning effect.
casement fabric	A loosely woven or open weave fabric commonly used in family rooms or modern settings.
casement window	A window that opens outward; operated by a crank or by hand.
casing	The frame around a door or window. A pocket made at the top edge of a curtain for holding a rod.
cathedral window	A large window with an angled top which follows the line of a slanting roof.
close left or close right	Refers to the side which a one-way drapery stacks.  The side on which the return is located.



conventional roll

Roller shade is mounted with blade end to left. Roller shade is wound toward the window fitting close to the glass.

corner window

Windows that join at the corner of a room.

cornice

A painted, stained, papered or fabric covered wooden frame mounted horizontally above a window to cover the drapery heading. Lower edge may be plain or scalloped to a specific design.

crinoline

A type of stiff interfacing that is attached to the underside of the heading and gives strength to hold the pleats in place.

criss-cross curtains  
(priscilla curtains)

Extra-wide, ruffled, sheer panels hung so that one overlaps the other; suitable for use in double-hung, bay and picture windows.

curtains (sheers)

Fabric gathered onto a rod by means of a rod pocket at the top or at the top and bottom; can be stationary or adjustable. Informal look.

custom-made draperies

Draperies made from very accurate measurements in custom sewing rooms from an unlimited choice of fabrics and linings; the most expensive type of drapery available from retail stores or designers; usually professionally installed.

cut-length

The length of fabric which must be cut from the yard goods to allow enough fabric for the finished length plus heading and hem.

decorative rod

A metal or wooden curtain or traverse rod which has rings and finials.

dormer window

A small window set in an alcove-like extension of the roof.

double-hung window  
(sash window)

A window with two sashes, one or both of which slide up and down.

draperies

Window treatment that has a pleated heading and provides a formal look.

drapery hook

A metal pin used to fasten the drapery heading to the glides on a traverse rod.

draw drapery	A drapery that is pulled along a rod by means of a traverse arrangement of cords and pulleys.
extender plate	A device fastened to the window frame to allow the extended mounting of a drapery rod (or bracket) without making a hole in the wall.
fabric width	Width of fabric from one selvage to other. Usually 45, 48, 54, 118.
finial	A decorative terminating piece; an ornamental end on a decorative rod.
finished length	The exact length of the finished drapery after sewing the heading and hem.
flaw	A defect in fabric weave or dyeing.
frame or casing	The wood framing around a window.
French doors	Narrow doors that come in pairs and have glass insets; usually open onto a porch or patio or from one room to another in older homes and apartments.
French pleat (pinch pleat)	A common finish for drapery headings which consists of a three-fold pleat; made by hand or with the use of commercially available tape.
fullness	A term used to describe the amount of fabric (number of panels) required for pleating draperies.
fusible webbing	Synthetic fiber that is placed between layers of fabric; it melts and bonds the layers together when heat and steam are applied.
gathering	One or two rows of stitching pulled up to create fullness in a fabric.
glides	Plastic carriers that hold the drapery hooks on a traverse rod.
hand	The way a fabric drapes and hangs. The "feel" of the fabric.
hardware	All decorative and utilitarian objects used to attach window treatments to walls and woodwork.

heading	The top part of the drapery where the pleats are formed. The top of a rod-pocket curtain that extends above the rod.
hollow wall construction	Wall construction of plaster, composition board, plywood, sheet rock, or any thin, easily crumbled or cracked material.
hourglass curtain	Stationary curtain with rod-pocket top and bottom tied back in the center to give an hour-glass appearance.
inside hang or mount	A window treatment installed inside the window frame on the jamb.
jalousie window	A window that contains narrow, horizontal strips of glass that can be cranked open to the desired angle.
jamb	Vertical side piece of a window frame.
made-to-measure draperies (semi-custom draperies)	Draperies made in a factory to custom measurements from pre-selected fabrics; moderate in price.
master slide	The overlapping arms of a traverse rod to which the cord is locked to allow the traverse cord to operate the carrier.
memory stitch	Stitching along the back of bottom hem to prevent flaring out.
molly bolt	A screw anchor used to attach drapery hardware to hollow walls.
one-way draw	A traverse drapery that draws to one side; suitable for windows with no wall space on one side, sections of bay windows, corner windows, and sliding glass doors.
outside hang or mount	A window treatment installed outside the window proper on the frame or wall.
overlap	The portion of the drapery affixed to the master carrier of a traverse rod; the overlap occurs when the two panels meet in the center of the rod.
pair	Two drapery panels for a given window.
panel	One-half of a pair of draperies or a single sheer or glass curtain; consists of one or more widths of fabric.

pattern repeat

The distance between a point in a pattern and the point where that exact part of the pattern repeats; important in calculating the amount of yardage required for draperies and curtains, as additional yardage will be needed to match the pattern.

picture window

A window which has a large fixed pane of glass.

plaster plug

An insert used to hold screws more securely in plaster or dry walls.

projection

The distance from the wall to the front of the drapery rod or valance board.

railroading

The turning of fabric at right angles to its normal hang. Used with 118" sheers to avoid seaming.

ranch (strip) window

A wide window high off the floor found commonly in modern homes.

ready-made draperies

Draperies made in a factory in standard sizes; the least expensive draperies to buy.

return

The portion of the drapery which extends around the corner of the rod to the wall; the standard return is 3 inches.

reverse roll

Roller shade is mounted with blade end to the right. Shade is wound away from the window, allowing more space between glass and shade and permitting more light at sides than a conventional roll.

ring-shirr tape

A purchased ring tape with two enclosed cords that when pulled, shirr the fabric to which the tape has been sewn. Used for Austrian shades.

ring tape

A purchased fabric strip with rings attached at regular intervals; used for Roman and balloon shades.

rod pocket

The casing stitched in the curtain fabric through which the curtain rod is fed, resulting in a gathered or shirred effect.

roller shade

A common, mass-produced shade hung from a round, semi-sprung bar at the inside head of a window frame; can be raised and lowered by a pull.

Roman shade

A shade made of fabric or woven woods; pleats are formed or disappear as it is raised or lowered.

sash	The framing in which the glass pane or panes are set in a window.
sash (glass) curtains	Panels which cover only the glass portion of a window; shirred at the top and bottom on close-fitting rods; suitable for in-swinging casement windows and for windows in doors.
self-lined	In drapery fabric where the back of the fabric using resistant materials in the weave is woven into a special lining.
selvage	The finished edge that runs the length of a piece of fabric; more firmly woven than the rest of the fabric.
shaped valance	Valance with lower edge scalloped. The pleating is usually more widely spaced than for the regular drapes.
shirring	The gathering of material in tight folds, either at the top or at both top and bottom, along two or more parallel lines of stitching through which a securing rod can be run.
sill	The flat ledge at the bottom of the window frame.
sliding glass door	The modern counterpart of French doors; often set into a wall or used as a part of a glass wall with the center panel sliding.
slubs	Heavier fabric threads showing up through the face of a drapery fabric.
stackback	The space taken up by a completely "opened" drapery.
stationary draperies	Draperies which cannot be opened or closed; form side panels in elaborate treatments.
swags and jabots	Top treatments in which fabrics are draped in sections and fastened to a valance board.
tension pulley	A spring tension device, installed on the floor moulding, sill, etc. to take up the slack in the traverse rod cord.
tieback	Piece of fabric, chain or cord by which curtains or draperies are tied back at the sides.
thermal lining	A coating sprayed on the back of ready-made draperies that acts as a substitute for a separate cloth lining; promotes insulation and reduces light transmission.

toggle bolt	An anchor for attaching hardware to hollow walls; used with heavier draperies.
top treatment	An arrangement of fabric and/or wood which covers the drapery heading and hardware in a decorative way.
translucent	Permits light to filter through.
traverse rod	A drapery rod that is backed with a track for guides on which the drapery is hung. The guides are attached to cords which are pulled to open and close the draperies.
two-way pull	Draperies that open from the center and draw toward the outer edges of a window; suitable for double-hung, picture, bay, and jalousie windows.
valance	A straight-across top treatment made of fabric which is pleated or shirred.
Venetian blinds	A window covering of horizontal metal slats through which cords are threaded which raise, lower, and tilt the slats for maximum light and air control.
work order	A form used for customer and order information.
weights	Small pieces of metal, usually lead, sewn in the bottom hem of a drapery to provide additional weight and make the drapery hang better.
width of fabric	Total width of the goods measured in inches as it comes from the bolt; usually 36, 45, or 54 inches.
window wall	A group of basic window units fitted together to form a glass wall.
woven wood shades	Wooden slats woven together with string or yarn in a decorative manner; available in both roller and Roman shades.

## WINDOW TREATMENTS

### CURTAINS

Glass curtains are usually sheer and hang straight next to the glass to give privacy and to diffuse the light. The fabric used for glass curtains may be Dacron, nylon, dotted swiss, fiberglass, or other sheers (see Figure 23).

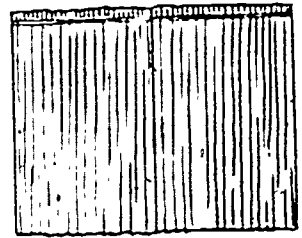

Figure 23.

Ruffled curtains are used in many ways. They are approximately 2-3 times the width of the window in fullness. They may be highly and richly decorated and of varying lengths. Two different types of ruffled curtains are the criss-cross or Priscilla and the tieback. The main difference between the two is that the criss-cross curtains are extra wide panels which are overlapped at the top as they are hung (see Figure 24).

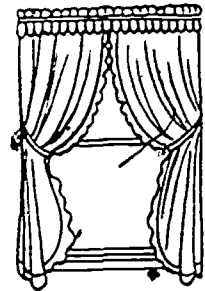

Figure 24.

Cafe curtains can be used in so many different ways that they provide an opportunity to use one's creative ability and produce any of a variety of original effects. They lend themselves to almost any decorating period as well as any fabric. Although they are usually rather informal, they may be adapted to more formal treatments with the use of over-draperies (see Figure 25).

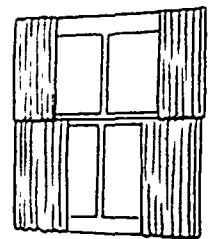

Figure 25.

### DRAPERIES

Draperies may be lined or unlined. They are used widely with many decorating periods and are made from a wide variety of fabrics. Draperies may be formal or informal, and they may be combined with curtains. Unlined draperies are less formal, and it is necessary to keep the appearance from the outside of the home in mind when making the fabric selection. Colored or floral prints in the window can detract from the outside appearance of the house. Unlined draperies, however, give more opportunity for the light to filter through than lined draperies.

## BLINDS

Venetian Blinds are functional in their use and serve as an effective means of regulating light. A pulley is used to raise or lower the blind, and thus, control the amount of light which enters the room. They may be used alone or with curtains, draperies, valances, or cornices. They may be used with a variety of window types and are available in wood, aluminum, or steel. Bamboo is another type of blind that is often used on porches, dens, or in informal settings. Blinds may be vertical or horizontal, wide or narrow, in colorful or neutral tones, and textured or smooth (see Figure 26).

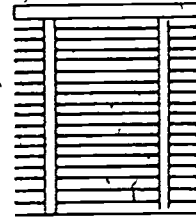

Figure 26.

## SHADES

Austrian shades are made of sheer or semi-sheer fabrics, such as pongee, nylon, silk, and blends. A braided cord is attached to the lower edge of each row of tape and drawn up through rings to the top and across to one side for raising and lowering the shade (see Figure 27).

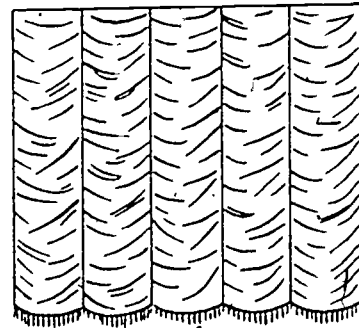

Figure 27.

Roller shades have been a stand-by for many years. Imagination in the use of fabrics and trims can result in shades which are decorative as well as functional (see Figure 28).

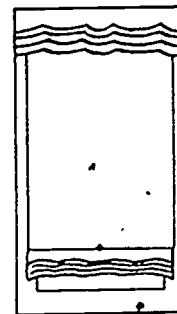

Figure 28.



## SHUTTERS

Louvered shutters can be draped, stained, or painted to give a variety of effects. They may be used with valances, cornices, cafe curtains, or draperies. The louvers can be adjusted to direct the light as preferred (see Figure 29).

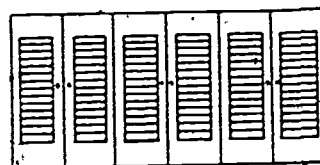

Figure 29.

## VALANCES AND CORNICES

A valance is a decorative piece at the top of the window used to unify two or more windows, to change the proportions of a window, or to conceal the drapery hardware. Valances include swags, cascades, canopies and short pleated drapes. An example of a swag is shown in Figure 30 and a cascade in Figure 31.

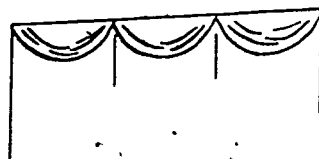

Figure 30.

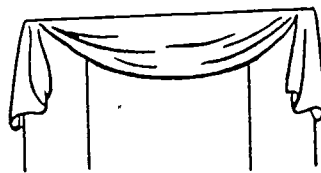

Figure 31.

The term cornice is often used interchangeably with valance by designers. A cornice is distinguished by some designers as being made of wood, plastic, or hard material backing and covered with fabric, while a valance is a soft, tailored, or shaped drapery across the top of the window (see Figure 32).

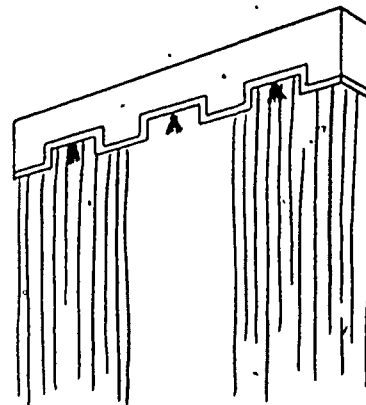

Figure 32.

Reprinted from Home Furnishings Aide  
Curriculum Guide, Lubbock, Texas

## ENERGY SAVING WINDOW TREATMENTS

Windows are one of the biggest winter heat wasters. Twenty to fifty percent of the annual heat could be lost through the window area.

To conserve energy:

1. Caulk and weatherstrip
2. Add additional glazings
3. Improve existing window treatments
4. Install insulated window treatments

### Improve existing window treatments

Various window treatments help conserve energy; some are more efficient than others.

Insulation values are measured as "R-values." (This refers to resistance to heat flow. The higher the number, the better the insulation value.)

- I. Draperies can act as an insulation if they trap air between room and window. To be effective there must be a seal at sides and at bottom or top. This prevents the formation of convection currents that could carry warm air along windows, cool it, and release it into the room.

Sides can be sealed by using a tape to connect drape to frame. If drapery rod projects out from wall, drapery should fit around corner of rod and to wall.

To seal bottom, drapery could stop at sill, floor or a constructed window/box shelf. Bottom of drapery should be 4" above baseboard heating and 8-10" above heat registers unless a curved or angled heat deflector is used to direct heat into room.

A cornice at top of windows or a drape to ceiling can seal off top of window treatment.

If all three (top, bottom and sides) were sealed, a vapor barrier is needed to prevent condensation.

- II. Draperies can prevent infiltration of cold air around the window frame.

1. Select a closely woven, heavy or bulky fabric to stop drafts. If light can be seen through it, it is not closely woven.
2. Use a lined as opposed to unlined drapery. Use a thermal or insulated lining.
3. Construct separate liner to be attached behind existing drape on the same hooks.
4. Extend drapery over frame of window on both sides and at top at least 4" to keep air from seeping in along frame.
5. Draperies should overlap 3" at center. Squeeze together hooks on overlaps allowing drapes to fit closer.

#### 1(f). Utilize the sun's energy

1. Draperies that stack off window give full advantage to save energy on a sunny day.
2. Valances positioned above window do not cut off warm bright light that comes directly from the sun.
3. Keep in mind window's exposure

- Southern and western windows admit the most sunlight during the day

Western exposure also admits light at sunset

Eastern has direct sun in morning

Northern only admits indirect light and is coldest due to northern winds

A combination of shades and drapes can better utilize the sun at various times of the day.

#### Install insulated window treatments

An effective insulated window treatment performs three functions:

1. Reduces heat loss
2. Provides tight seal
3. Has vapor barrier

The insulated Roman shade performs the above three functions. It is composed of four layers.

1. Outer decorator fabric (firmly woven cotton-polyester blend)
2. Vapor barrier (polyethylene)
3. Fiberfill (thinsulate, sontique)
4. Inner lining (cotton-polyester blend)

# WINDOW TREATMENT

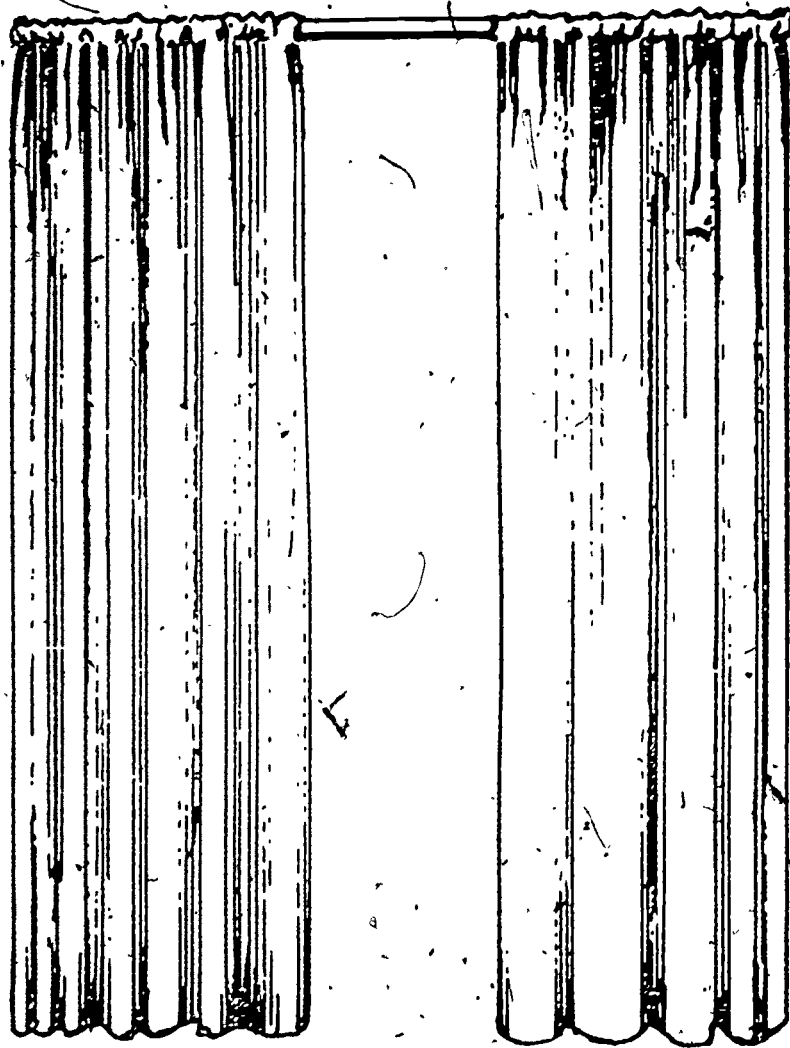

**SHIRRED DRAPERIES**

# WINDOW TREATMENT

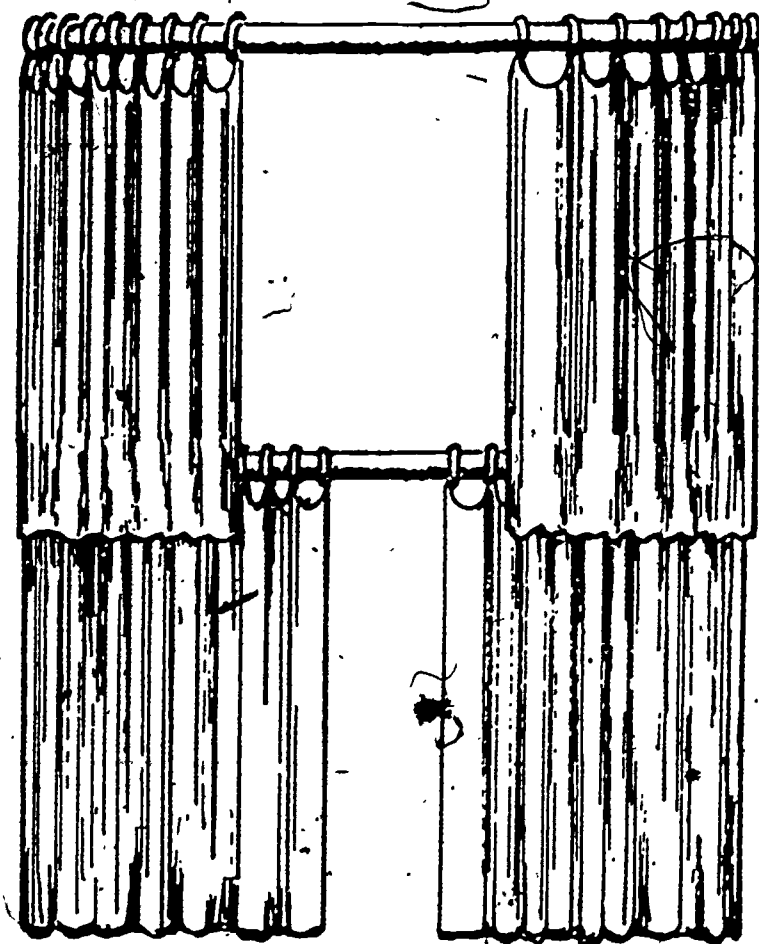

66 22  
**CAFE CURTAINS**

# WINDOW TREATMENT

15

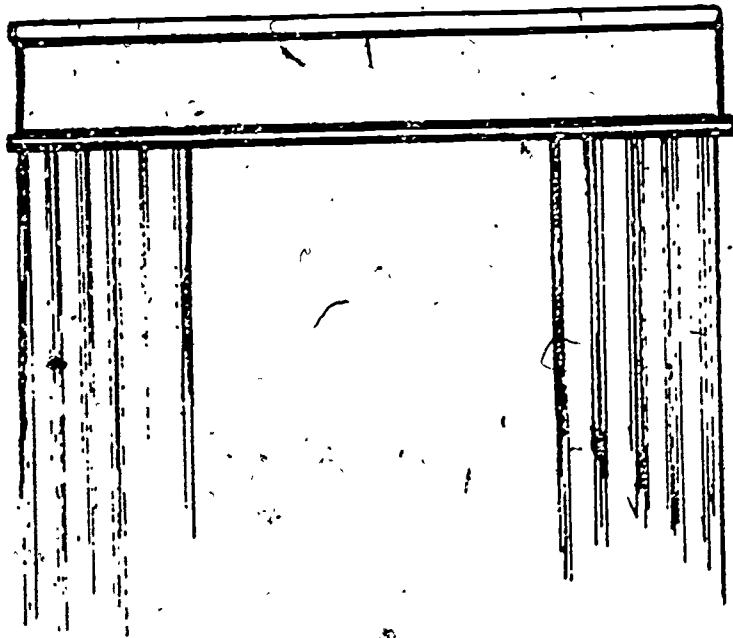

**CORNICE**

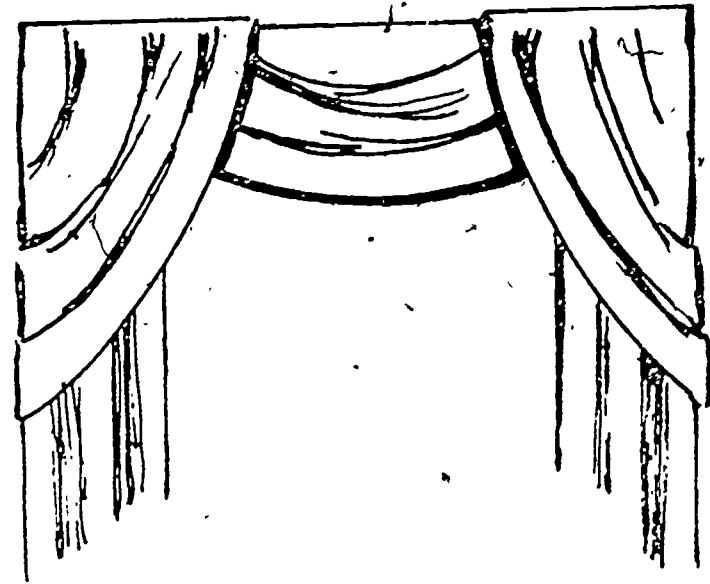

**VALANCE**

# WINDOW TREATMENT

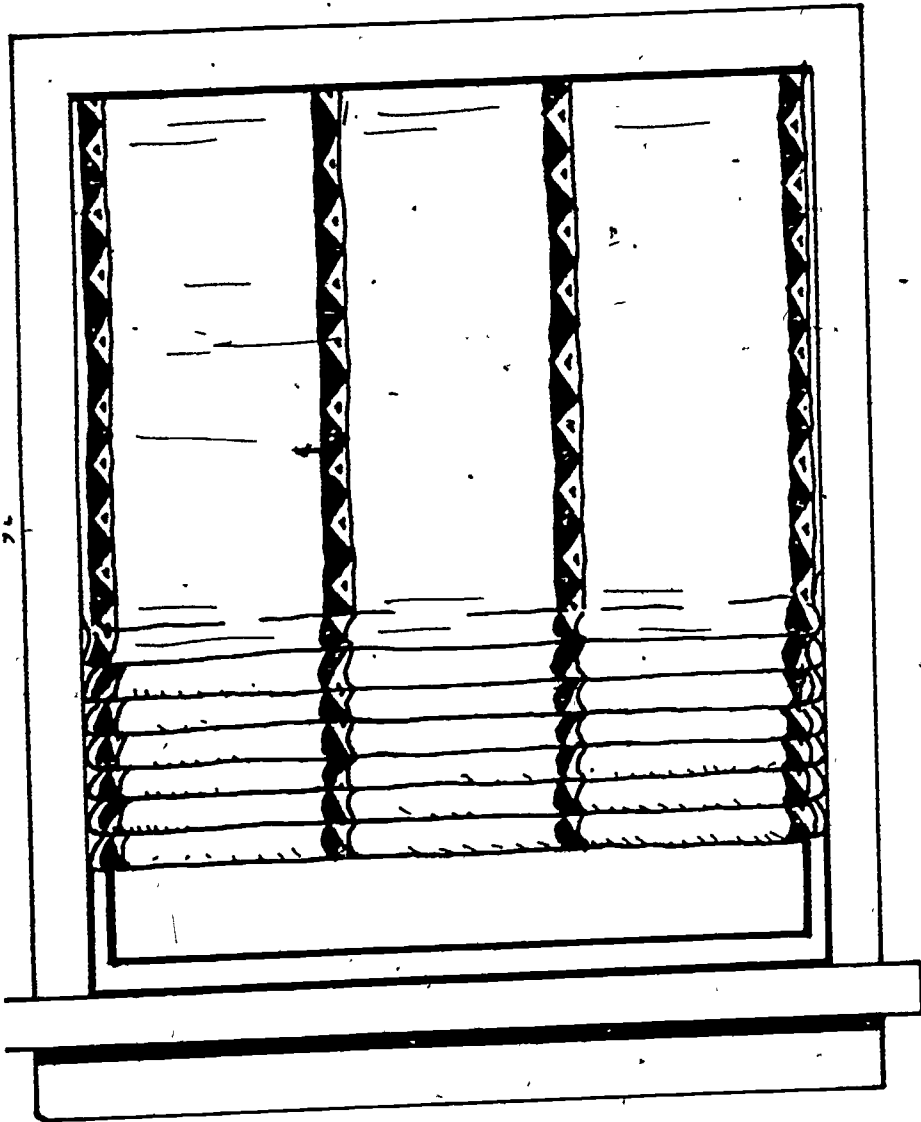

**ROMAN SHADE**

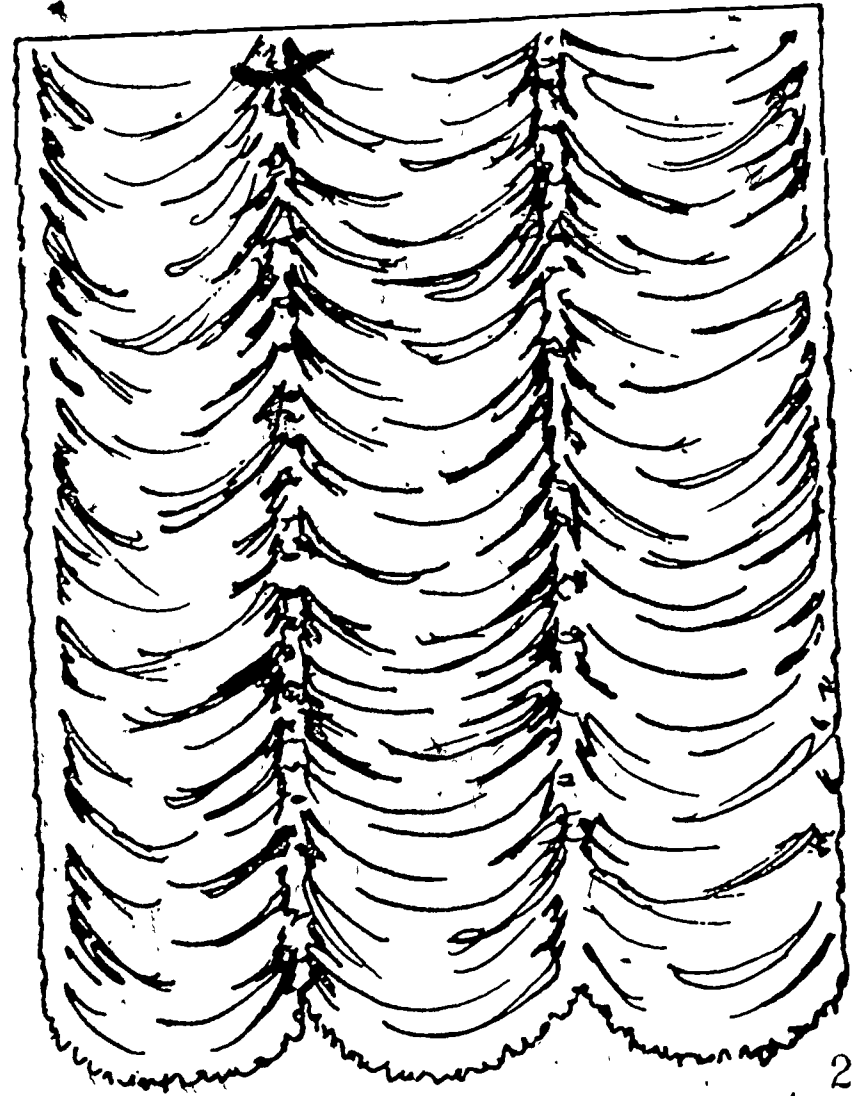

**AUSTRIAN SHADES**

# WINDOW TREATMENT

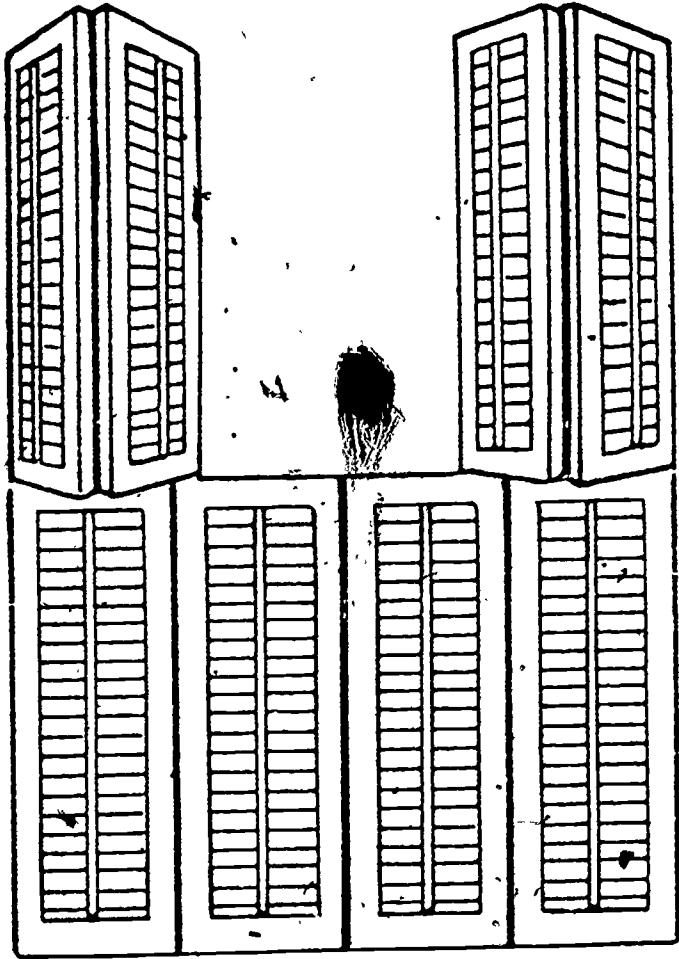

**SHUTTERS**

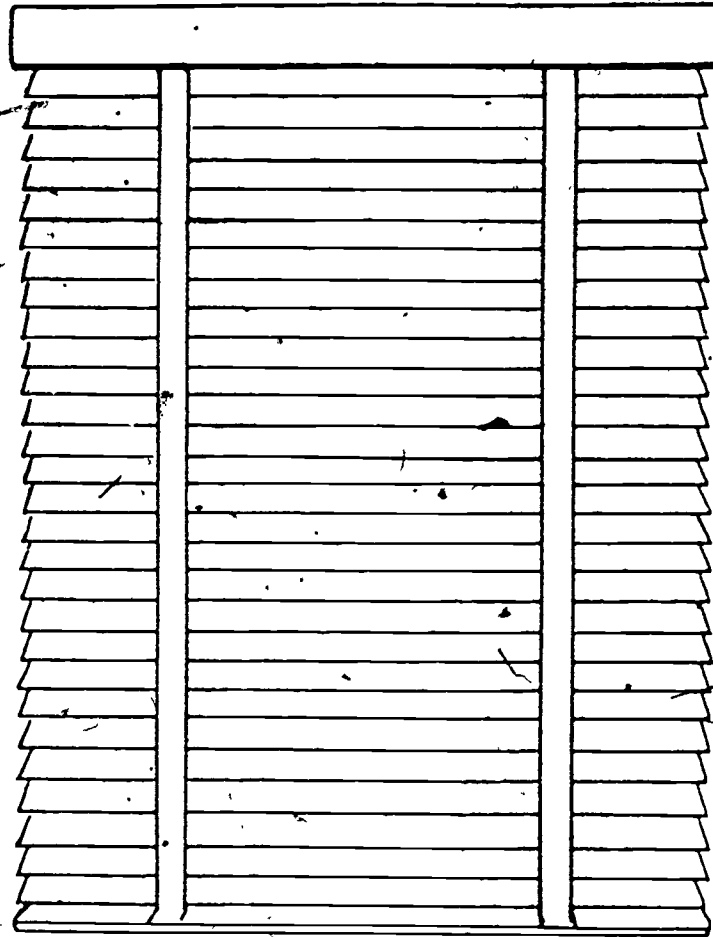

**BLINDS**



# PARTS OF A WINDOW

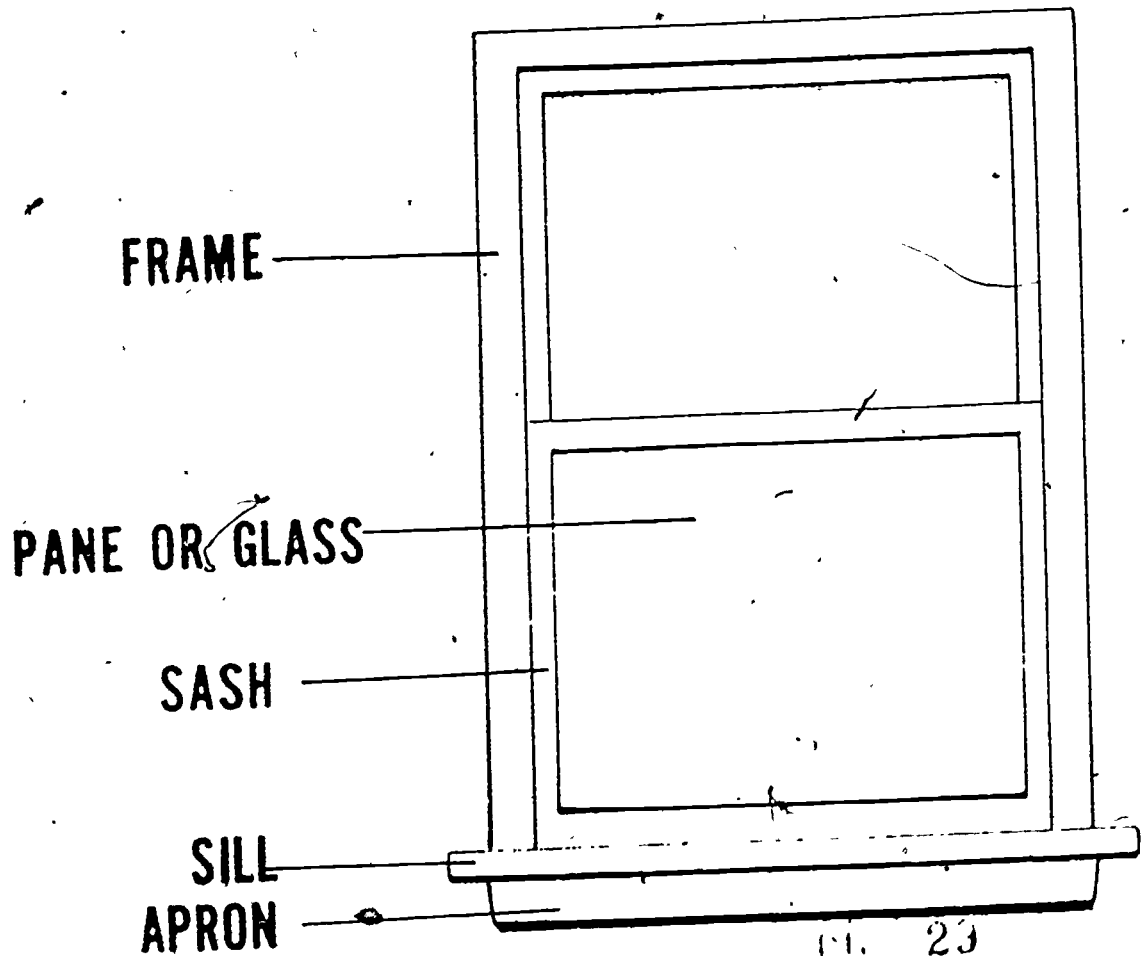

Pl. 23

TYPES OF WINDOWS

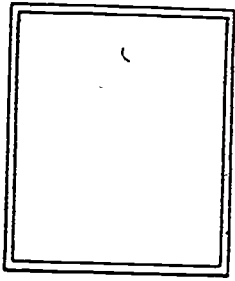

FIXED

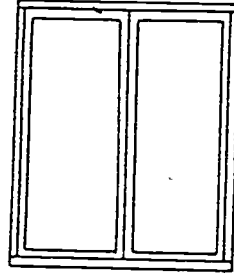
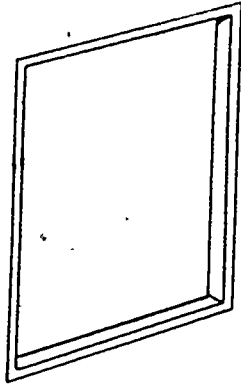

CASEMENT

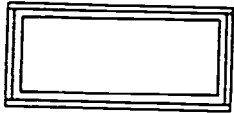
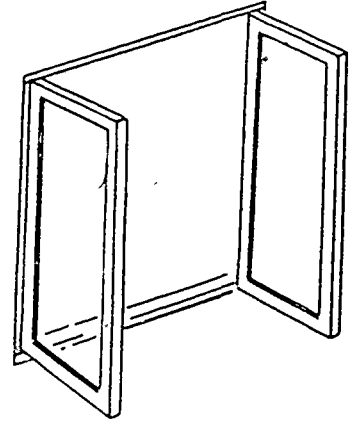

AWNING

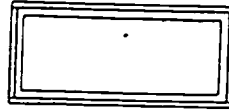
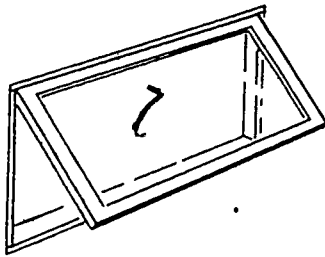

HOPPER

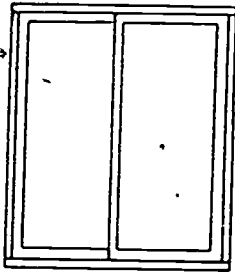
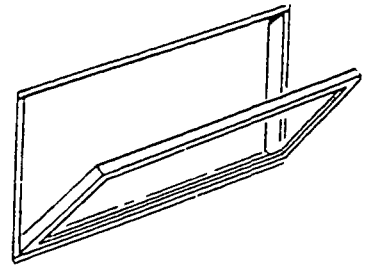

SLIDING

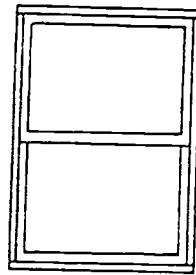
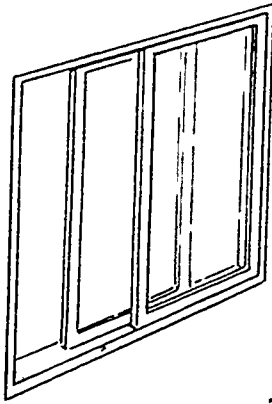

DOUBLE-HUNG

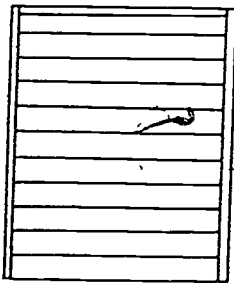
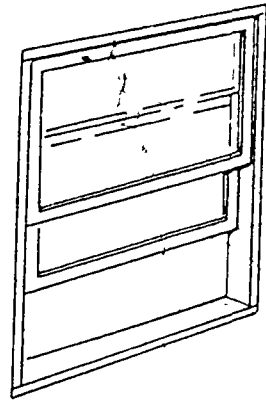

JALOUSIE

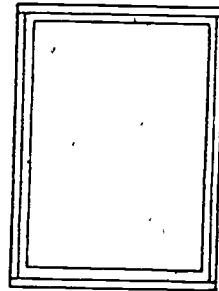
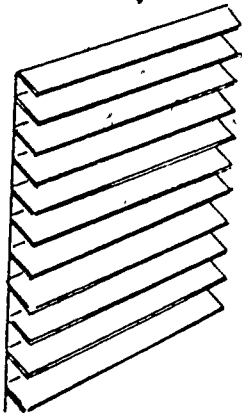

PIVOTING

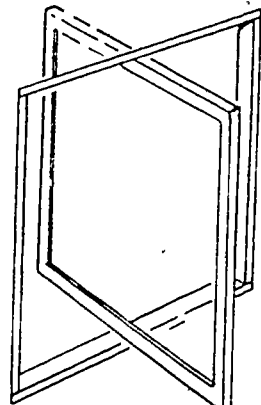

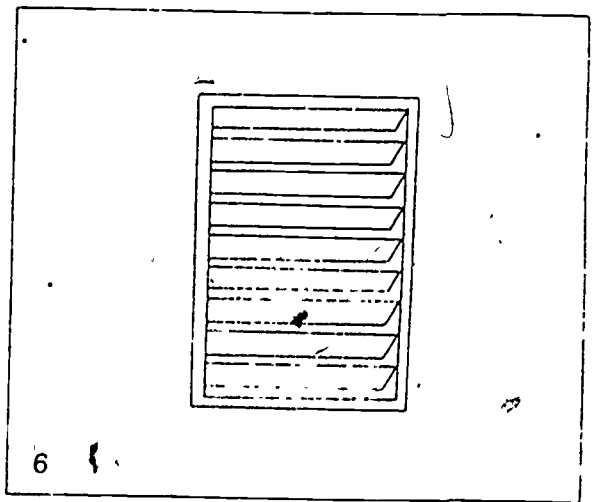
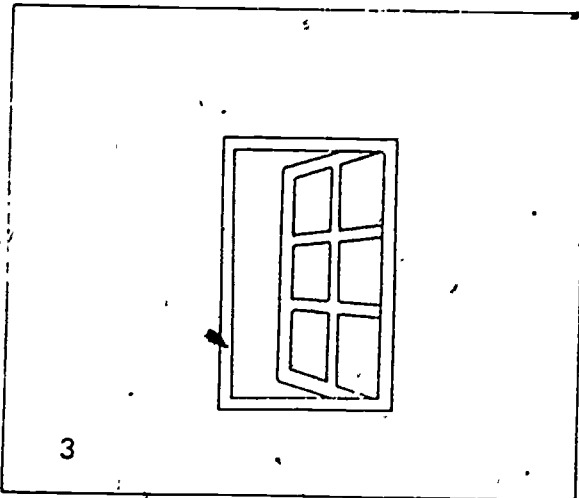
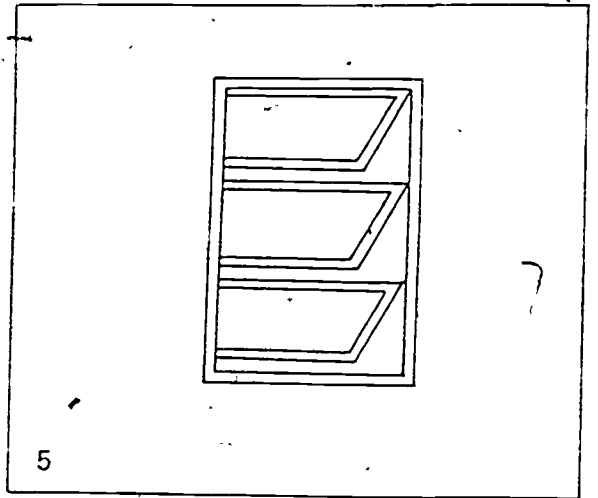
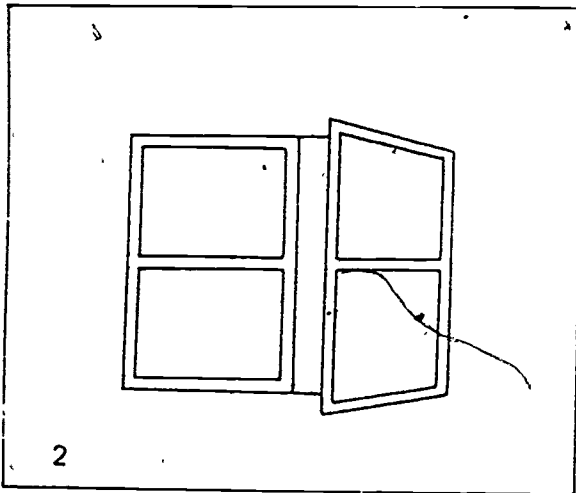
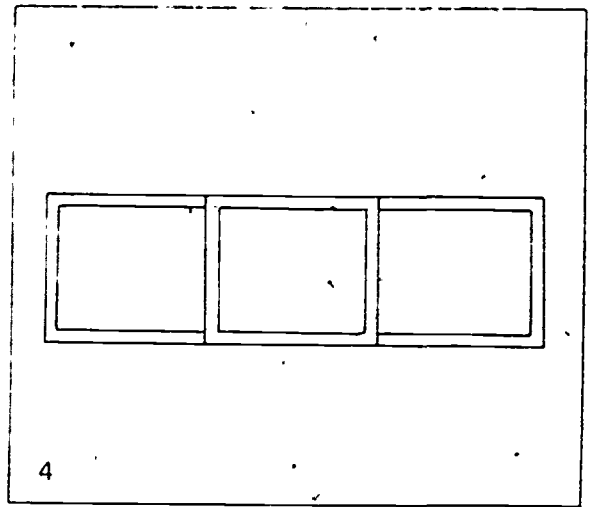
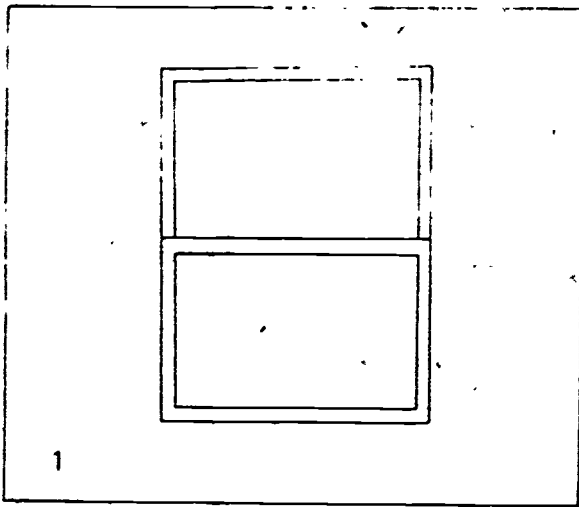

1. double hung (standard)
2. double casement
3. casement (outward)

4. ranch or strip
5. awning
6. jalousie (louvered)

3i

17

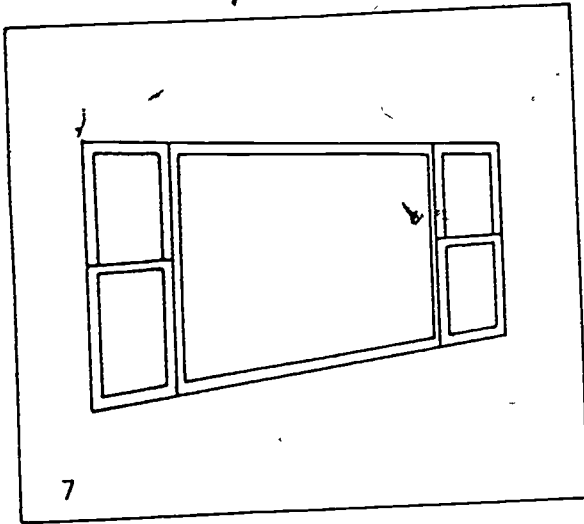

7

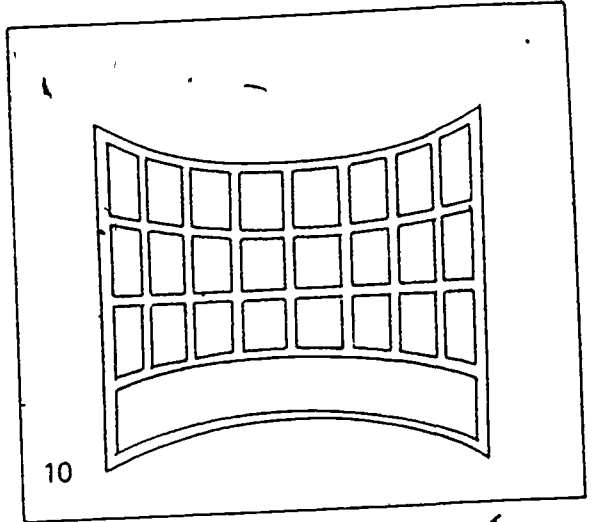

10

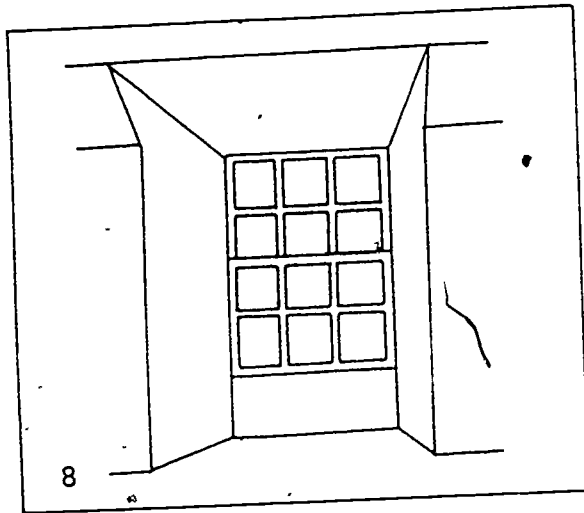

8

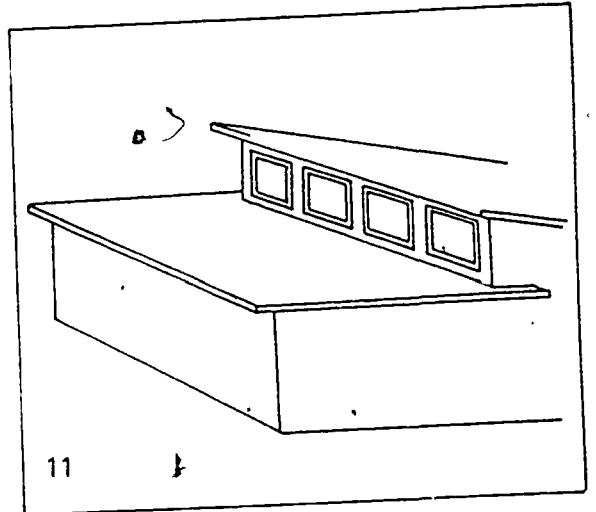

11

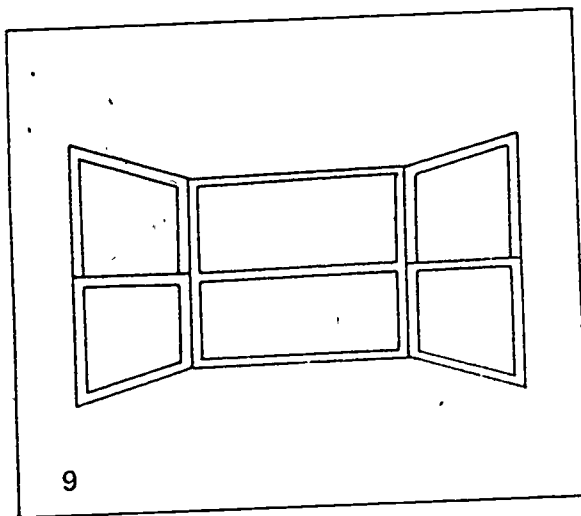

9

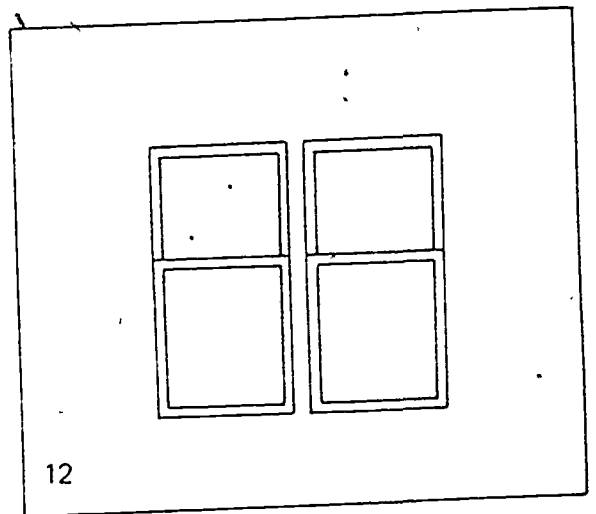

12

- 7. picture
- 8. dormer
- 9. bay

- 10. bow
- 11. clerestory
- 12. double

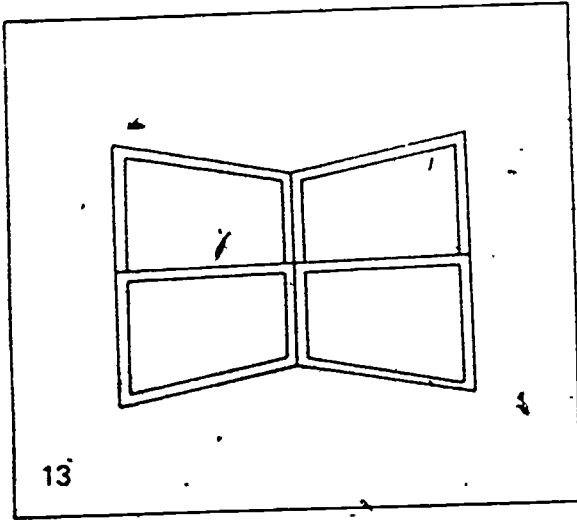

13

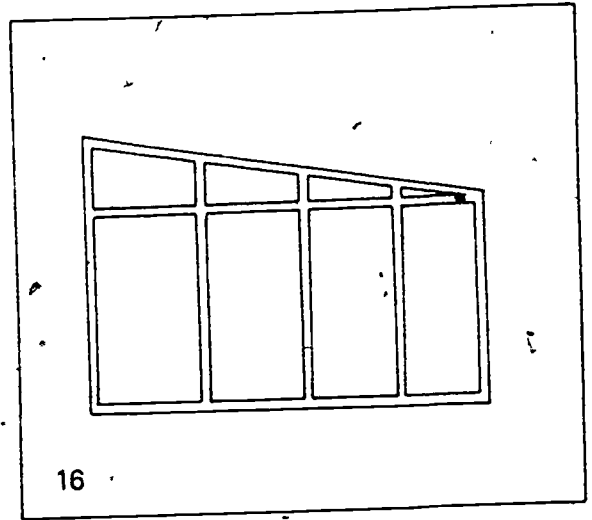

16

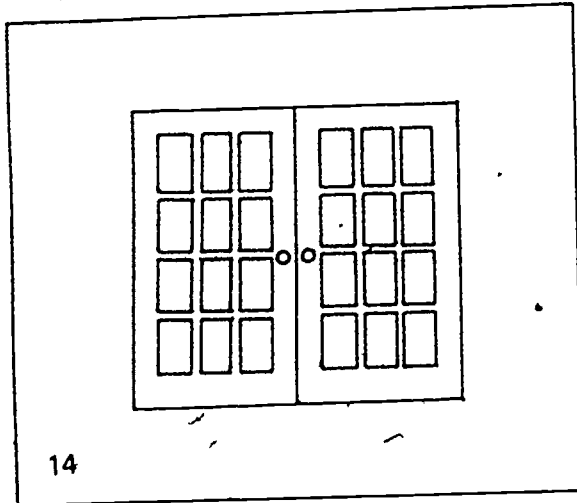

14

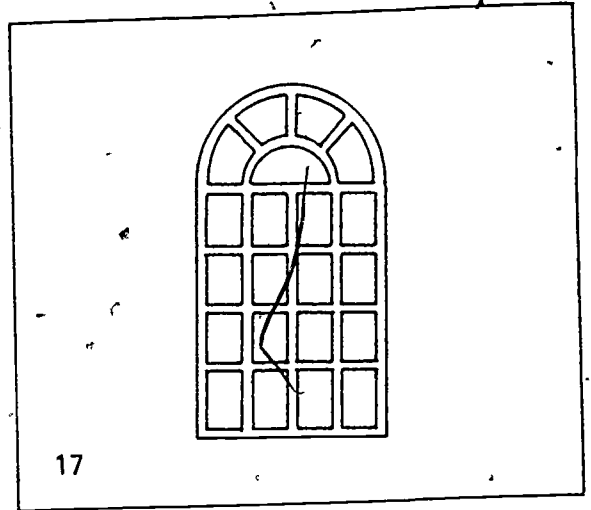

17

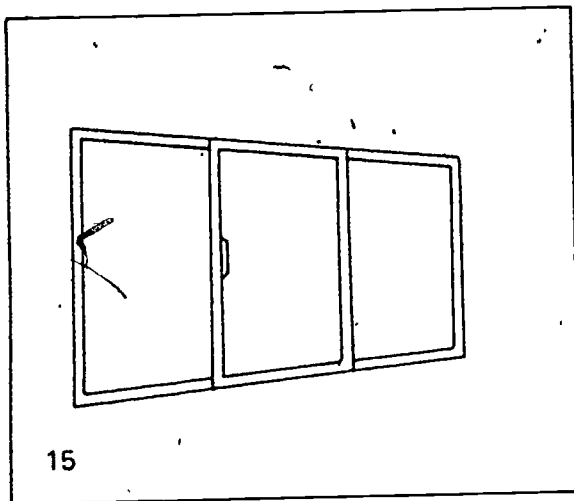

15

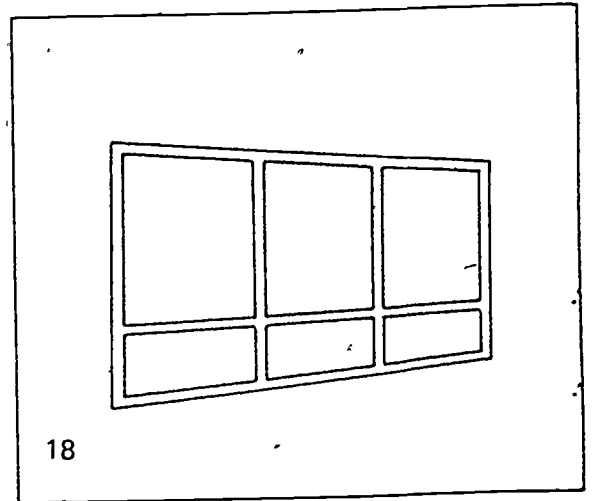

18

- 13. corner
- 14. French
- 15. sliding

33

- 16. slanted window wall
- 17. arched
- 18. window wall

# WINDOW TREATMENT FOR PROBLEM WINDOWS

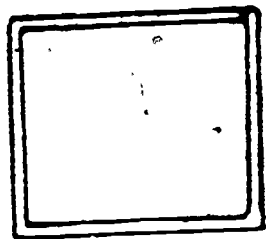

**CLOSE TO CEILING**

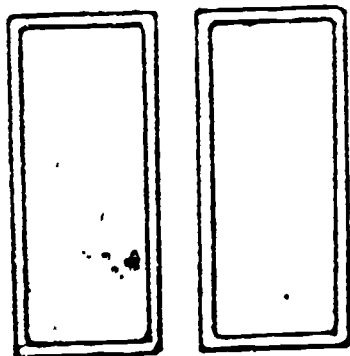
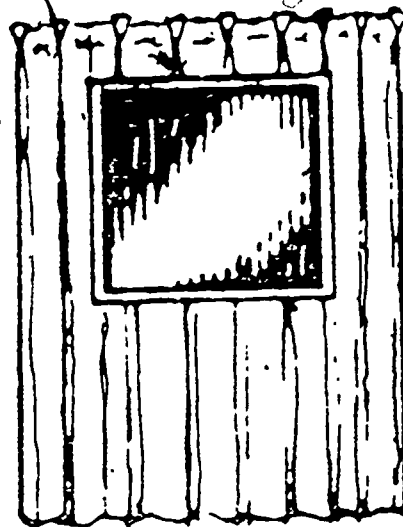

**TWO OR MORE**



# WINDOW TREATMENT FOR PROBLEM WINDOWS

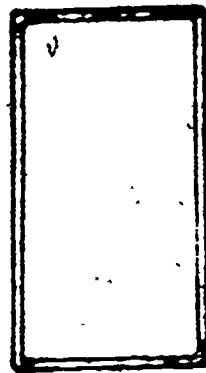

**LONG, THIN**

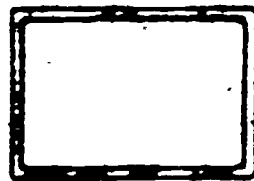
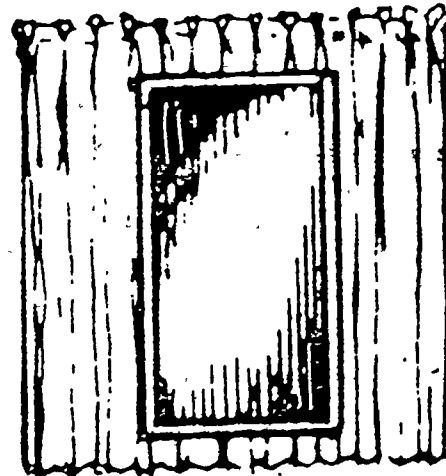

**SMALL,  
LARGE WALL AREA**

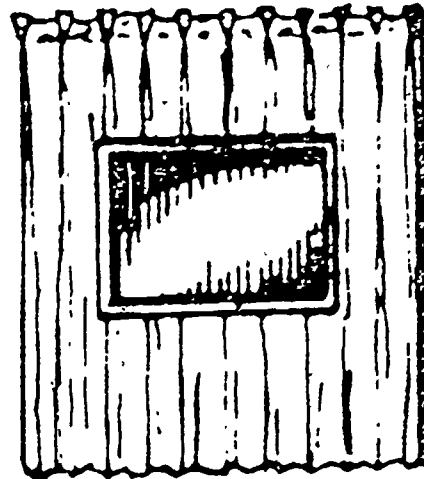

## CHOOSE APPROPRIATE FABRIC

Consider:

1. Appropriate weight (dropeability)
2. Fiber content (sun rot, fading, abrasion resistance)
3. Fabric construction and characteristics (type, closeness of weaves, construction of fiber and yarn, fabric grain, fabric width, printed or dyed)
4. Finishes (wrinkle resistant, stain resistant, moth proof, flame retardant)
5. Recommended care (washable, dry clean only)
6. Aesthetic appearance - color, texture, design
7. Cost
8. Performs intended function (energy, light control, privacy)
9. Difficulty of sewing on fabric

Additional considerations when printed pattern.

1. Examine design
  - Good proportion for intended use
  - Content of design appropriate
2. Printed "on grain"
3. Check if lengths will match if seamed together
4. Check if it is a "drop match"
5. Check length of pattern repeat
6. Readjust cut length
7. Add length of 1 repeat length or 1/2 yard to total yardage. This accommodates variances in repeat length and for proper placement of design on finished product.



# WINDOW MEASUREMENTS

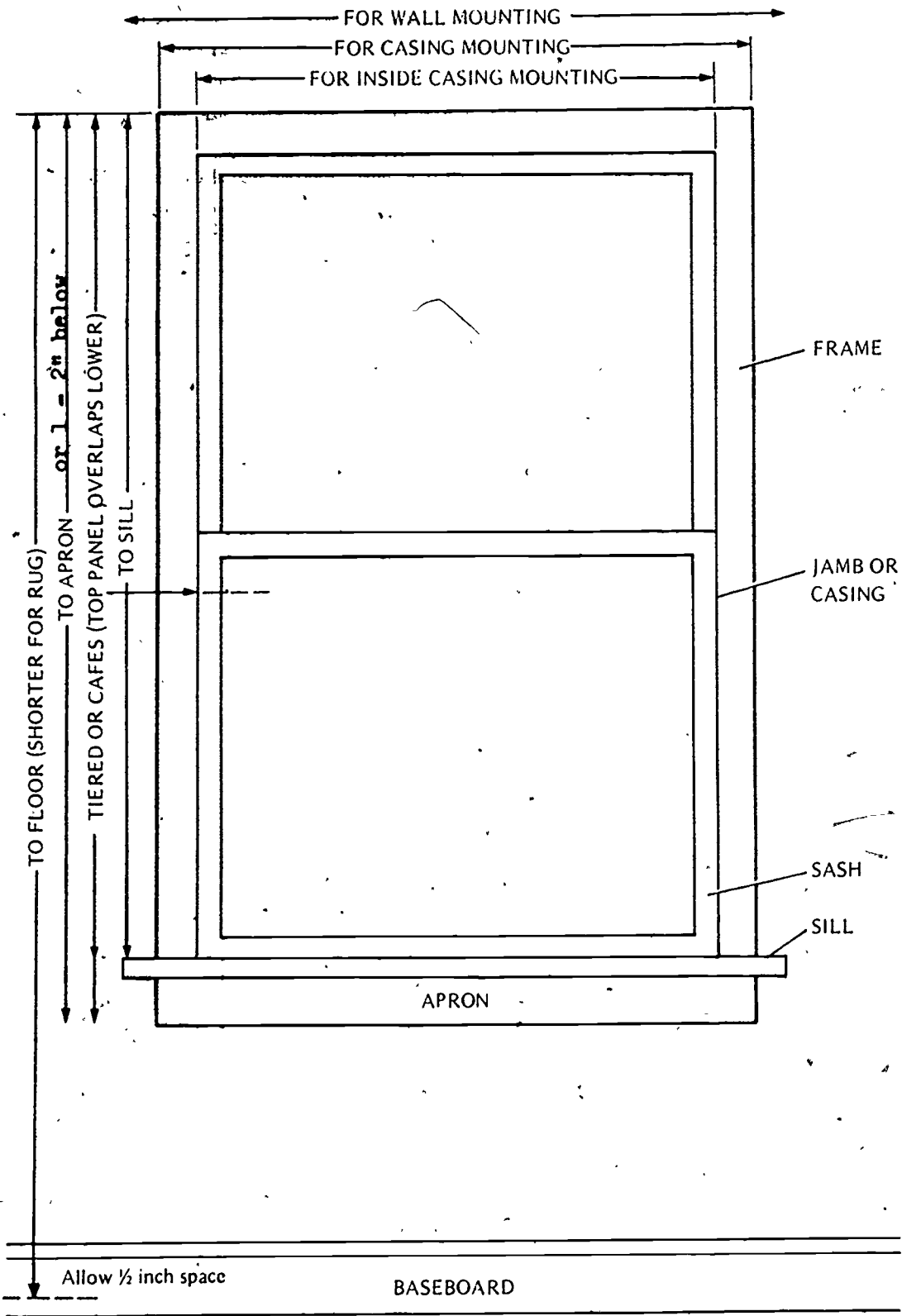

## MEASURING FOR TRAVERSE DRAPERIES

### I. Window Measurements

- A. When measuring windows, use a steel tape.
- B. Make the following decisions before measuring:
  1. The style or type of window treatment.
  2. The finished length of your drapery
    - a. sill length
    - b. floor length
    - c. apron length (1-2" below the apron)
    - d. length to the top of the baseboard
    - e. ceiling to floor length (1/2-1" off floor)
    - f. length when including an extension above the window
  3. The finished width of the window treatment (Rod width - face of rod)
    - a. just inside the window frame
    - b. just covering the window frame
    - c. extending beyond the window frame (stackback)
- C. Traverse rods should be installed before measuring, to insure accuracy.
- D. Measure each window or group of windows from the top of the rod (standard traverse) to the desired drapery length. For decorator traverse, measure from below ring.

### II. To Determine Yardage Required

- A. Length
  1. Measure the desired finished length and add 15-16" to each length for hems and heading. This is a cut length.
  2. For sheers, add another 4" for a double wrap of the crinoline (19-20").
- B. Width
  1. The fullness is determined by the weight of the fabric and the amount of fullness desired.
  2. Allow 2-1/2 times the window width for fullness with most fabrics; 2-1/2 to 3 times for sheer fabrics.
  3. Measure the space to cover and multiply by 2-1/2. To determine how many widths of fabric you will need to get the necessary fullness, divide the number of inches required by the width of the fabric. If in between, nearly always go to the greater number.
- C. If there is no pattern or an allover pattern with no matching problem, multiply cut length by number of widths required. Divide by 36 to convert to yards.

### III. Patterned Fabrics

#### A. Consider repeats when selecting patterned fabric

1. Select repeat whose length divides into cut-length with minimum waste.
2. A long repeat, carefully chosen, need not be a fabric waster.
3. Extra fabric lost in matching can sometimes be utilized by making a valance or pillows, etc.

#### B. Plan where the design is to appear

1. Design must be placed in identically the same position on all lengths used.
2. In putting lengths together, they must be matched.
3. If it is not possible to have a complete design at both the top and bottom of a drapery length, it is best to break the design at the top.

#### C. Figuring yardage for repeat patterns

1. To allow for matching of repeat, determine length of one repeat and see how many you need to cover a cut length.
2. Cut length in example below requires two full repeats. Three inches between each cut are lost in matching.

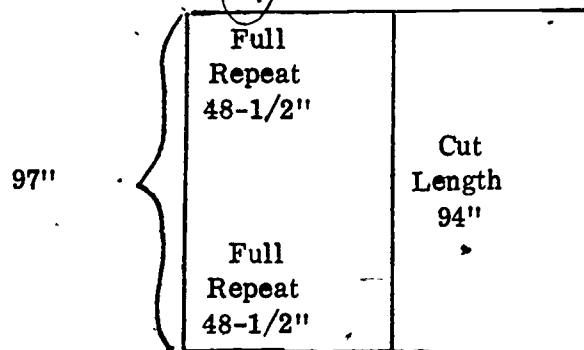

3. Multiply length of necessary repeats (in this case 97") by the number of cut lengths required. Divide by 36 to convert to yards.

### IV. Lining

- A. Use the same width fabric as you have chosen for draperies whenever possible.
- B. Multiply the finished drapery length plus 2 or 4" by the number of widths required for the draperies. Divide by 36 to convert to yards.

## WORKSHEET TO DETERMINE YARDAGE FOR TRAVERSE DRAPERIES

	Sample	Your Measurements
1. Measure the ROD WIDTH or face of rod	<u>66"</u>	_____
2. To determine FULLNESS, multiply $2\frac{1}{2}$ x for medium weight fabrics and 3 x for sheer fabric	<u><math>\times 2\frac{1}{2}</math></u>	_____
3. Answer is the desired amount of FULLNESS or total cut width of drapery	<u>= 165"</u>	_____
To figure the number of fabric widths needed for entire drapery:		
4. WIDTH OF DRAPERY FABRIC being used	<u>48"</u>	_____
5. Divide the FULLNESS (total cut) needed by the FABRIC WIDTH (no. 3 $\div$ no. 4)	<u><math>165 \div 48</math></u>	_____
6. The answer will be the NUMBER OF CUT LENGTHS needed. (This must be a whole no. unless the other partial can be used on another window).	<u>4</u>	_____
7. Measure the FINISHED LENGTH	<u>84"</u>	_____
8. Add 15-16" for heading allowance (5"), hem allowance (8") and 2-3" for raveling, patterned fabrics, etc.	<u>+ 15"</u>	_____
Add 19-20" for sheer fabric (double wrapping of crinoline)		
9. Answer is total CUT LENGTH (If patterned fabric refer to #12)	<u>= 99"</u>	_____
To figure the yardage of fabric required for the entire window:		
10. Multiply the NO. OF CUT LENGTHS x the CUT LENGTH measurement. This = TOTAL NO. OF INCHES. (no. 9 x no. 6)	<u><math>99 \times 4 = 396"</math></u>	_____
11. Divide the answer above by 36" per yard to find YARDAGE OF FABRIC REQUIRED	<u><math>396 \div 36 = 11 \text{ yds.}</math></u>	_____

Patterned Fabric

Sample                      Your  
Measurements

If drapery fabric has a pattern repeat, the CUT LENGTH may require adjustment. One needs to cut in multiples of the repeat.

12. Measure the LENGTH OF THE REPEAT (Example: a pattern repeat 15" in length)

15"                      \_\_\_\_\_

13. Divide the CUT LENGTH by the REPEAT LENGTH (no. 9 ÷ no. 12)

99 ÷ 15                      \_\_\_\_\_

14. This = number of repeats needed for each cut length. It must be a whole number.

7 repeats                      \_\_\_\_\_

15. Multiply the LENGTH OF THE PATTERN REPEAT x the NO. OF REPEATS (no. 12 x no. 14)

15 x 7                      \_\_\_\_\_

16. The answer is the READJUSTED CUT LENGTH

= 105"                      \_\_\_\_\_

17. Multiply READJUSTED CUT LENGTH x NO. OF CUT LENGTHS (no. 16 x no. 6)

105 x 4                      \_\_\_\_\_

18. Answer = subtotal no. of INCHES

420"                      \_\_\_\_\_

19. Plus one repeat length

+ 15"                      \_\_\_\_\_

20. Answer = TOTAL NO. OF INCHES

435"                      \_\_\_\_\_

21. Divide the TOTAL NO. OF INCHES by 36 to find REQUIRED YARDAGE OF PATTERNED FABRIC

435" ÷ 36 = 12 1/4 yds.                      \_\_\_\_\_

Width Conversion Chart - Draperies

If Width of Fabric is:

	36"	40"	45"	48"	50"	54"	81"
1	36	40	45	48	50	54	81
2	72	80	90	96	100	108	162
3	108	120	135	144	150	162	243
4	144	160	180	192	200	216	324
5	180	200	225	240	250	270	405
6	216	240	270	288	300	324	486
7	252	280	315	336	350	378	567
8	288	320	360	384	400	432	648
9	324	360	305	432	450	486	729
10	360	400	450	480	500	540	810
11	396	440	495	528	550	594	891
12	432	480	540	576	600	648	972
13	468	520	585	624	650	702	1053
14	504	560	630	672	700	756	1134
15	540	600	675	720	750	810	1215
16	576	640	720	768	800	864	1296
17	612	680	765	816	850	918	1377
18	648	720	810	864	900	972	1458
19	684	760	855	912	950	1026	1539
20	720	800	900	960	1000	1080	1620

Number of drapery lengths

Amount of fullness in inches

## ALTERNATE METHOD - CALCULATE YARDAGE

- |  |  |
|--|--|
| 1. Measure ROD WIDTH   | <u>66"</u>   |
| 2. Add size of overlap (3");<br>2(3") returns; and 1" ease   | <u>+ 10"</u>   |
| 3. Finished width of pleated drapery   | <u>= 76"</u>   |
| 4. To determine no. of panels, consider<br>the following:<br>48" fabric pleats down to<br>15" for 200% fullness or (3x)<br>18" for 150% fullness or (2½x)<br>21" for 100% fullness or (2-2½)<br>If 150% fullness is desired, divide<br>the finished pleated width by 18".<br>If fraction is more than 1/3, use<br>one more cut length. | <br><br><br><br><br><br><br><br><br><br><u>76 ÷ 18 = 4 1/6</u> |
| 5. Answer is no. of CUT LENGTHS  | <u>4</u>   |
| 6. FINISHED LENGTH   | <u>85"</u>   |
| 7. Plus 15"-20" (hems, etc.)   | <u>+ 15"</u>   |
| 8. Answer is CUT LENGTH<br>Readjust cut length if patterned fabric   | <u>= 100"</u>  |
| 9. Multiply CUT LENGTH x NO. OF CUT LENGTHS<br>Answer is Total no. of inches   | <u>100 x 4</u><br><u>= 400"</u>                                |
| 10. Divide answer by 36"/yd. to find YARDAGE<br>OF FABRIC REQUIRED   | <u>400 ÷ 36 = 11 1/3 yds.</u>                                  |

## THE WORK ORDER

DOT'S DRAPERY SHOP  
123 4th - Street  
Townsville, Texas

### WORK ORDER

Name _____	Date sold _____
Address _____	Date promised _____
City _____	Sold by _____
Phone _____	Room _____
	(use separate sheet for each room)

### FABRICS

Name	Color	No. Yds.	Price/Yd.	Total	Sample
A.					
B.					
Lining					
C.					
D.					

### DRAPERY SPECIFICATIONS

Type of Drapery	Quantity Pairs/Panels	No. of Widths	Finished Width	Finished Length	Re-turn	Lined
A.						
B.						
C.						
D.						

Special Instructions:

### ROD SPECIFICATIONS

Style No.	Bracket to Bracket	Type Draw R/L/C	Re-turn	Cord Rt/Left	Type Wall	Type Bracket	No. of Support
A.							
B.							
C.							
D.							

Special Instructions:



## WORK ORDER INFORMATION

Information that could be included on work order:

1. Data on customer (name, address, telephone no.)
2. Date sold
3. Date promised
4. Fabric description (name, color, manufacturer, yardage)
5. Lining description (name, color, yardage)
6. Room for which drapery is being made
7. Description of style (lined-unlined, pleated, shirred, two-way draw, one-way draw, stationery panel)
8. No. of pairs or panels and no. of width in each pair or panel
9. Rod width
10. Finished length
11. Rod return (return size)
12. Specifications of rod (type, placement)
13. Amount of fullness allowed (100-150-200)
14. Misc. facts that you, the customer or decorator, deem pertinent

## WORK TABLES

Large, flat surfaces are necessary for the construction of draperies so the panels can be spread out. Work tables are used to meet this need in drapery workrooms. The work tables usually measure 48" by 96" and are at a height convenient for handstitching or pressing while standing.

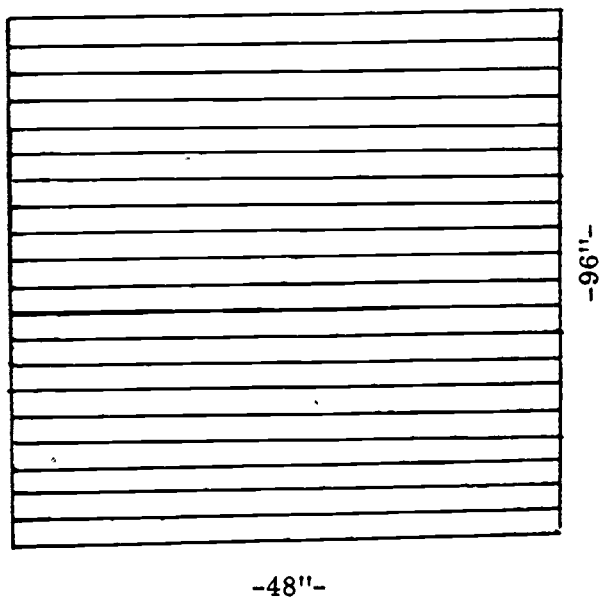

Tables can be padded with inexpensive blankets to provide 1/2" thickness. Staple blanket to table underside. Cover with canvas that is pulled taut and stapled to table underside.

On the work table illustrated above, the solid horizontal lines represent inch divisions and are numerically labeled.

Hems can be pressed evenly and accurately with use of table. Bottom and sides are placed along the ruled lines. The hems are then turned up along these penciled lines which serve as a guide for measuring hem depth. This reduces the time spent and increases the accuracy of the process, especially for sheer fabrics.

To assure a consistent finished length, hemmed panels are placed on work table, hemline at finished length lines. Fabric can be pressed over crinoline at zero line, assuring a consistent length.

Large surface also is used for applying lining.

Usually at one end of a table, space is allowed for the placement of sewing equipment. Pins, needles, hem gauges, and shears are kept here to increase the efficiency of the drapery seamstress. If these items are checked daily and kept in place, the seamstress will not have to look for an item when she needs it. A steam iron is usually placed on each table, also.

In most drapery workrooms, a cutting table is provided. It may be a table with a canvas top, as used in the tabling process, or a specially designed table for cutting as illustrated below

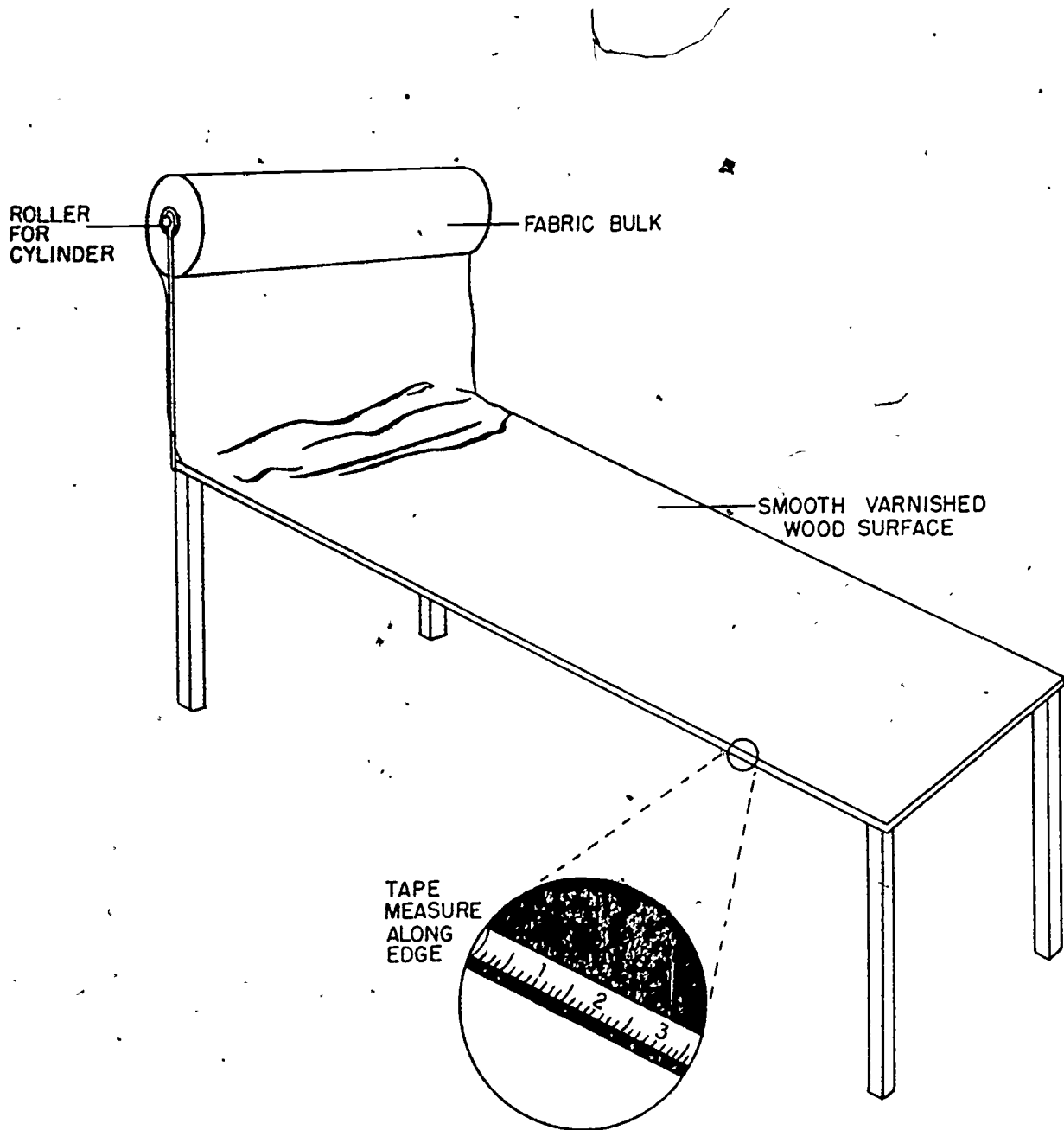

Reprinted from Home Furnishings  
Aide Curriculum Guide, Lubbock,  
Texas

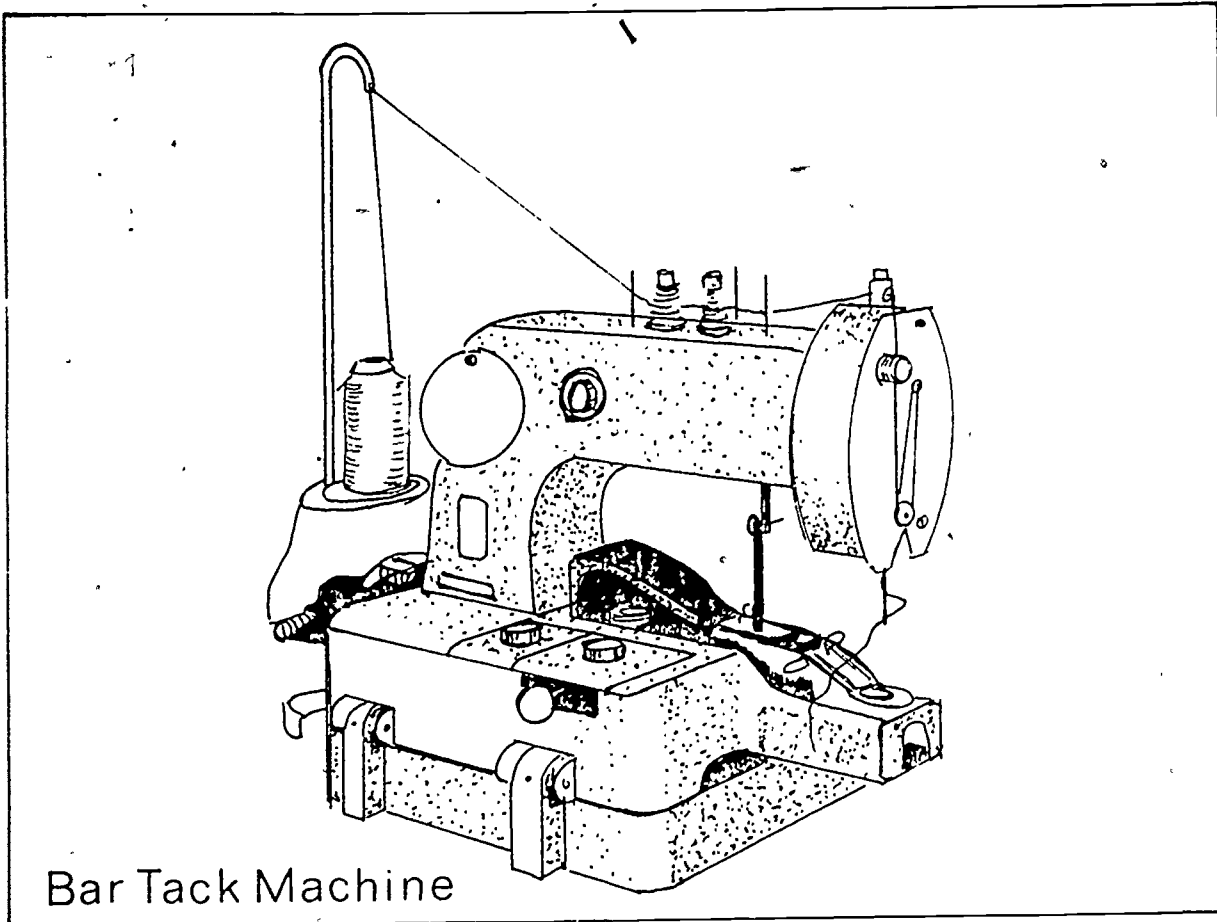

Bar Tack Machine

#### BAR TACK MACHINE

The bar tack machine is used to tack pinch pleats or French pleats on drapery headings at the lower edge of the crinoline. With special attachments, it can be used to stitch rings to curtains or to attach buttons and snaps. The tack made by the machine is 1/4-inch wide and consists of several rows of straight stitching back and forth over the same spot.

It is important to remember that regardless of the length or width of the tack, the area to be sewn must be placed in the center of the stitching area on the machine.

Reprinted from Home Furnishings  
Services Curriculum Guide,  
Lubbock, Texas

SUBJECT: Power Sewing Equipment

TASK: Operates power sewing equipment

OBJECTIVES: Be able to (1) identify function, describe operation, and identify safety precautions to observe for the following:

- (a) commercial sewing machine
- (b) serging machine
- (c) blindstitch machine
- (d) tacking machine

(2) evaluate own safety habits when using power sewing machines

Several types of sewing machines may be used in a drapery workroom. The most common ones are the commercial sewing machine, serging machine, blindstitch machine, and the tacking machine. At your training station, additional power sewing equipment may be available or only one or two of the previously mentioned machines may be used.

#### COMMERCIAL SEWING MACHINE

The commercial sewing machine is similar to the sewing machine used in the home or in the homemaking department. It is heavier and sturdier and operates at a higher rate of speed because it is used daily for production sewing. This machine is operated in much the same way as the machines you may have used, but it is recommended that the manufacturer's operation handbook be studied before using the machine.

The commercial sewing machine is used in the drapery workroom to make lines of straight stitching, such as sewing panel lengths together, attaching crinoline, and sewing some types of hems.

#### SERGING MACHINE

The serging machine is used to sew panel lengths together and to attach the crinoline to some sheer drapery fabrics. The serger trims the edges of the seam as it stitches the fabric together. At the same time, the machine finishes the edges of the seam with a cable stitch as shown in Figure 35.

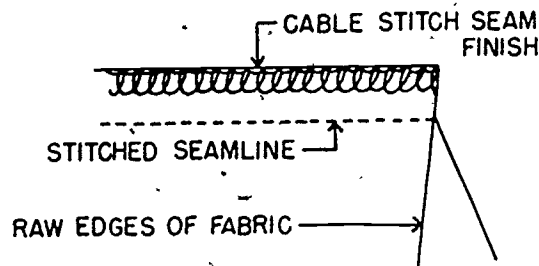

Figure 35.

The serger is not used to stitch lengths of velvet or sheer fabric together because the resulting line of stitching would be puckered. The commercial sewing machine is recommended for these fabrics in order to have a smooth line of stitching.

Serging machines are not difficult to operate, but they do require a skilled operator because of their high speed. Always refer to the manufacturer's operation handbook for instructions.

#### BLINDSTITCH MACHINE

In some drapery workrooms, a blindstitch machine may be available for hemming drapery panels and attaching the lining to drapery panels. When used properly, the stitches from a blindstitch machine do not show on the right side of the fabric.

The needle goes through the fabric as shown in Figure 36. Note that it goes only partly through the fabric to which the hem is being attached. Since the thickness of fabrics varies, the machine must be adjusted for fabrics of different weights. This adjustment is made by changing the position of the ridge over which the fabric passes.

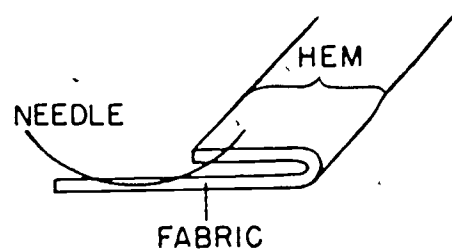

Figure 36.

Figure 37 shows what happens when the ridge is set too low. The needle does not catch the fabric and the hem is not sewn down. In Figure 38, the ridge is set too high and the needle goes through the fabric, allowing the stitches to show on the right side.

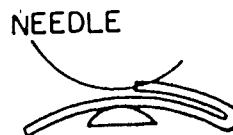

Figure 37.

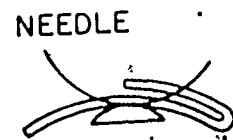

Figure 38.

It is important that the machine not only be adjusted properly for different weights of fabric, but also that the fabric be accurately fed into the machine. A distance as small as 1/16 inch may mean that the edge of the hem is missed and the garment is not hemmed.

Figure 39 shows the fabric too far to the right with the result that the hem is not caught. In Figure 40, the hem is caught in the center instead of at the edge because the fabric is being fed too far to the left.

The number of stitches per inch can also be changed according to the fabric being hemmed. In general, stitches on heavier fabrics are farther apart than on lightweight fabrics.

NEEDLE



Figure 39.

NEEDLE



Figure 40.

#### TACKING MACHINE

The tacking machine is used to tack the pleats on drapery headings and, with the addition of a special attachment, can also be used to stitch rings to curtains. The tack made by the machine is 1/4 inch in width and consists of several rows of straight stitching back and forth over the same spot.

It is important to remember that regardless of the length or width of the tack, the area to be sewn must be placed in the center of the stitching area on the machine (see Figure 41).

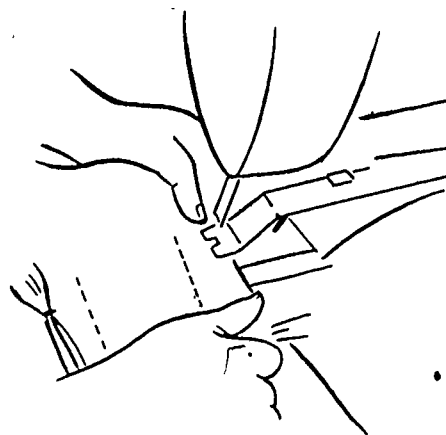

Figure 41.

Name \_\_\_\_\_

### THE SEWING MACHINE

Directions: Without the aid of books or notes, name each part of the sewing machine provided in your classroom. Especially note the purpose of each part and orally explain the function of each part to your supervisor. As you name each part and explain its function, point to that part on the machine. Demonstrate threading the machine and filling the bobbin. Explain and demonstrate how to adjust the size of the stitches and the type of stitch.

PARTS TO IDENTIFY AND EXPLAIN THEIR FUNCTION INCLUDE:

TENSION DIAL

TENSION DISCS

BOBBIN WINDER TENSION DISCS

TAKE UP LEVER

PRESSURE DIAL

FACE PLATE

THREAD CUTTER

PRESSER FOOT

FEED DOGS

THROAT PLATE

SPOOL PIN

BOBBIN WINDER LATCH AND SPINDLE

BOBBIN WINDER THREAD POST

HAND WHEEL

POWER AND LIGHT SWITCHES

NEEDLE POSITION LEVER

STITCH WIDTH CONTROL

NEEDLE CLAMP

SLIDE PLATE

PRESSER FOOT LIFTER

BOBBIN

BOBBIN CASE TENSION SCREW

BOBBIN CASE

KNEE OR FOOT SPEED CONTROL

HAND WHEEL KNOB

HEAD

SEWING LIGHT

REVERSE STITCH LEVER

STITCH LENGTH CONTROL

OTHERS: (please list)



## SAFETY PROCEDURES

1. HAVE FULL CONCENTRATION UPON YOUR WORK.
2. KEEP EQUIPMENT IN PROPER WORKING CONDITION.
3. CLEAN MACHINE AS RECOMMENDED IN OPERATOR'S MANUAL.
4. NEVER ATTEMPT TO SEW ON AN UNFAMILIAR MACHINE WITHOUT FIRST STUDYING THE MANUFACTURER'S OPERATION HANDBOOK.
5. OBSERVE RULES ISSUED BY THE MANUFACTURERS OF THE EQUIPMENT YOU ARE USING IN REGARD TO OPERATION AND SAFETY OF THE MACHINE.
6. TURN MACHINE OFF WHEN CHANGING A NEEDLE OR REPLACING MACHINE PARTS.
7. REPLACE BURNED OUT BULBS PROMPTLY AND PROPERLY.
8. REPORT ALL ACCIDENTS WHETHER MINOR OR MAJOR.
9. REFRAIN FROM PLACING SHARP OBJECTS ON OR NEAR YOUR WORK.
10. PLACE NEEDLES OR PINS IN THEIR PROPER PLACE, NEVER IN YOUR MOUTH.
11. STORE ALL SUPPLIES AND EQUIPMENT AS CLOSE TO THE AREA YOU ARE WORKING IN AS POSSIBLE.
12. DRESS APPROPRIATELY. (HAVE COMFORTABLE CLOTHES AND SHOES AS WELL AS CLOTHES THAT WILL NOT INTERFERE WITH YOUR WORK.)
13. MAINTAIN PROPER POSTURE HABITS AND YOU WILL LESSEN FATIGUE.

## SAFETY CHECK LIST

Check the column under the heading that best describes the way you observe safety practices on your job.

A-~~always~~  
 S-sometimes  
 N-never  
 O-no opportunity

DO I

1. put pins and needles in pin cushions?
2. pass sharp objects to others with the handle first?
3. store scissors and other sharp objects in holders or in a secure place?
4. observe safety precautions as recommended by the operator's manual when using power sewing equipment?
5. use slow speed on power sewing machine while learning to operate it?
6. keep hands away from the hot area of the iron while pressing?
7. use non-flammable or treated ironing board cover?
8. arrange cord so there is no danger of stumbling over it while appliance is connected?
9. disconnect cord at the wall outlet before removing from appliance?
10. grasp plug rather than cord when removing from wall outlet?
11. replace electrical cords when noticeably worn?
12. keep any objects out of traffic lanes over which people are likely to trip or stumble?

A	S	N	O
	9		

- 13. store equipment and supplies as close to work areas as possible to avoid unnecessary carrying of heavy articles?
- 14. have step ladder or safe stepstool handy for reaching high places?
- 15. have shelves sufficiently strong to hold materials without sagging or collapsing?
- 16. keep storage areas free of flammable fluids, paper, rags?
- 17. pay attention to the job at hand?
- 18. lift heavy objects by grasping article firmly; keeping back as straight as possible; stooping first, then lifting with leg and thigh muscles?
- 19. wear safe, comfortable, and sensible clothing and shoes at work?
- 20. pick up broken glass, broken china, or other sharp objects with a broom and pan?
- 21. never put hands into wastebasket when emptying?
- 22. report all unsafe conditions to the supervisor immediately?
- 23. report all accidents to the supervisor immediately?
- 24. consult the supervisor if in doubt about how to perform a job or how to do the work safely?

A	S	N	O

Reprinted from Home Furnishings Aide Curriculum Guide, Lubbock, Texas

## WORK ORDER - PINCH PLEATED DRAPERY

Custom drapery method using the machine - the lining is attached in the side hems.

1. Seam the drapery panels. (Half panels are on the far ends - not at center of a two-way draw)
2. Press double 4" bottom hem on drapery. Place and stitch weights at seams.
3. Stitch bottom hem - use machine or hand blindstitch.
4. Press side hems on drapery - double 1" hem.
5. Lining (if used)
  - a. Seam panels together.
  - b. Hem - Press double 1 or 2" bottom hem. Straight stitch bottom hem by machine (8-10 st. per inch).
  - c. Place drapery panel on work table wrong side up, hemline at desired finished length line on canvas and side hem at edge of table.
  - d. Unfold drapery side hem.
  - e. Start at drapery side hem and place wrong side of lining to wrong side of drapery.
  - f. Trim selvage from side edge of lining.
  - g. Place lining in position. Lining side edge should come to first fold of drapery side hem and bottom edge of lining 1-2" above bottom of drapery hem. Work from bottom up and across width of table. Press if needed. Place pins parallel to side hem to hold lining and drapery fabric together.
6. Apply crinoline to top edge of drapery. At this point, the extra drapery fabric length is trimmed and the drapery is finished to the EXACT FINISHED LENGTH. Lining should extend to top edge of drapery or slightly longer. The drapery wrapping the crinoline is not covered by lining.
7. If drapery panel is wider than table width, move drapery panel over and repeat 5g and 6. At other side edge, lining should come to first fold of drapery side hem; excess lining is trimmed off.
8. Calculate pleats and pin-off on drapery panel. Mark center of pleat at hemline.
9. Stack and band the drapery panel.
10. Stitch pleats.
11. Form pleats.
12. Tack pleats.
13. Place hooks in pleats and on ends.

## CUTTING DRAPERY AND LINING LENGTHS

### I. Cutting Drapery Lengths

A. Each length must be cut square. This is done in one of two ways depending upon the fabric.

Study the fabric and decide whether one should:

1. Pull a thread

- a) Fabric that has a woven design (plaid) must be done this way
- b) Plain fabric that is "on grain" is cut this way (Antique satin, sheers)

2. Cut the fabric square with the use of a square and yardstick

- a) Plain fabrics that are "off grain" and have permanent finishes; thus cannot be straightened. (lining)
- b) Printed fabrics must be cut with the pattern but square with the selvages. If a fabric is printed "off grain" it may not be a good choice.

B. Measuring and cutting each panel or length

1. Lay the fabric out flat, right side up.

If patterned:

a. Bring the selvages together and check

- 1) Does it match?
- 2) Is it a straight or drop match?

b. Check length of repeat. Calculate cut length.

c. Determine the top of the design.

2. Measure one cut length from the squared top edge. Mark with a pin. If patterned, check placement of design on finished drapery length.

3. Continue until all lengths have been measured and marked with a pin. Check for flaws in fabric as you are measuring.

4. Cut each length carefully, remembering to pull a thread or to cut each panel square with the selvages.

Pin a slip of paper on the top right sides of each panel. State the cut and finished length on the paper. Panels could be marked with cross pins on top right side of each cut length.

5. Fold drapery lengths so top markings show on each cut.

6. When using an odd number of widths for a pair of draperies, one width must be split in half lengthwise. Fold panel in half lengthwise (selvage to selvage), press and cut on creased line. Mark each half of split panel for top and right side.

### II. Cutting Lining Lengths

A. Cut each length the finished drapery length plus 2 or 4 inches, depending upon size of lining hem (dbl 1" or 2" hem).

B. If the lining width is the same as the drapery width, cut the same number of panels as you did drapery panels.

C. If the width is not the same, (drapery is wider than lining) you will need to cut one more panel of lining.

D. Cut the lining panels square with the selvages. Do not pull a thread.

E. Cut lining panels in half lengthwise if necessary.

## SEAMING DRAPERY AND LINING LENGTHS

Uneven feeding of fabric can be a problem when seaming drapery lengths. If the underneath layer of fabric is not held firmly at the sewing machine, it will pull over the machine feed dog faster than the upper layer of fabric, causing the upper layer to be longer. (Figure A) The hang and appearance of the finished drapery is affected. Figure B shows the correct holding of the underneath layer to avoid creeping.

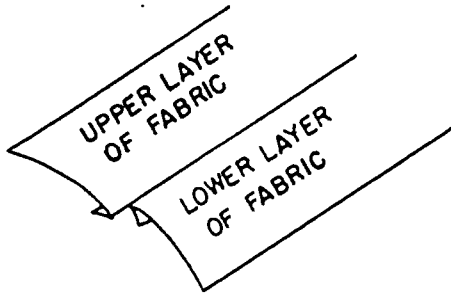

Figure A

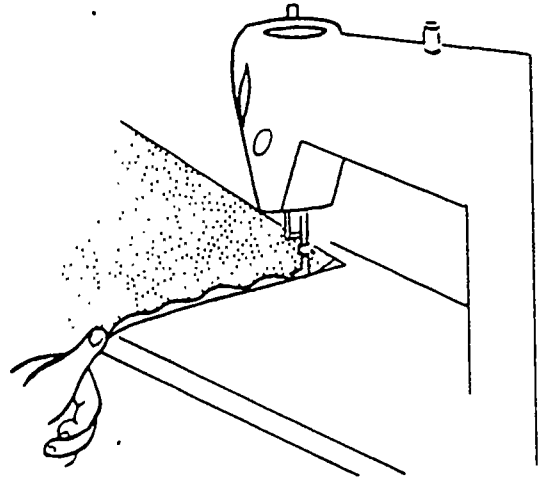

Figure B Holding the under layer firmly.

The following is a chart of the machine needle sizes and stitches per inch most commonly used for drapery fabrics:

FABRIC WEIGHT	MACHINE NEEDLE SIZE	MACHINE STITCHES/ INCH
Light	Fine #9 - 11	12 - 14
Medium	Medium # 11 - 14	10 - 14
Heavy	Medium coarse #14 - 18	8 - 12

## SEAMING DRAPERY AND LINING LENGTHS

### I. Follow these basic rules for each seam method.

1. A more experienced drapery seamstress may be able to sew the panel lengths together without pinning, but an inexperienced or beginning seamstress should pin as described.
2. Place top to top, selvage to selvage and fabric right side to fabric right side. This will produce a right and left panel for each pair of draperies. Especially important when pair has odd number of widths (3, 5, 7, etc.) and one width has to be split.
3. Stitch all seams from bottom hemline to top.
4. Hold underneath fabric length firmly as it tends to be pulled over the machine dog feed faster than the upper length of fabric. Do not let upper length creep.
5. Seam width is  $1/2$ " or width determined by pattern in fabric.

### II. When seaming two or more lengths of fabric, the design of the print should be matched absolutely. Seams should be made wide enough to include the entire selvage. In order to match a seam, one may take varying seam allowances when seaming two lengths together.

To accurately match a pattern, use one or more of the following:

1. Accurately pin the two lengths together. Place pins perpendicular to the stitching line and on the stitching line.
2. Use an even feed foot on sewing machine when stitching the seam.
3. Fuse the seam together.
  - a. Turn under the selvage width on side of one fabric length. Press sharply.
  - b. Working on the right side, place the pressed edge on top of the selvage of the second fabric length matching the pattern.
  - c. Lift top length up and place  $1/4$ " width fusible web under the fold. Use steam iron to fuse in place. Always test fabric as to heat temperature and use of steam.
  - d. Turn to wrong side, pin. Machine stitch in the folded crease.

III. Choose one of the following methods:

Method #1 (Suggested use: Antique satin, cotton or cotton blend of medium weight)

1. Clip selvage every 6 to 8 inches or trim entire selvage off and overcast raw edge.
2. Place right sides together and pin.
3. Stitch 1/2" seam. Stitch length 10-12 st/inch.
4. Press seam open.

Method #2 (Suggested use: Printed fabrics that have been matched using fusible web, casements, or unlined window treatments)

1. Place right sides together, pin, and stitch seam. (As done in Method #2)
2. Using the zig zag stitch, stitch 1/4" from first line of stitching; stitching the two seam allowances together.
3. Trim excess seam allowances.
4. Press seam allowances to one side.

OR DO THE ABOVE METHOD BY USING AN INDUSTRIAL SERGER MACHINE.

When stitching a casement with the serger, place pins parallel and  $\perp$  to the selvages.

Method #3 (Suggested use: Sheers, unlined window treatments)

1. Trim selvages from edges to be seamed.
2. Place right sides together, one raw edge extending 1/4" beyond other raw edge.
3. Turn extended edge over other raw edge, encasing it. Press.
4. Turn over once again. Press. Pin.
5. Stitch on inner folded edge.

IV. Seam lining by Method #1 or Method #2.



# HEM PRESSING GAUGE

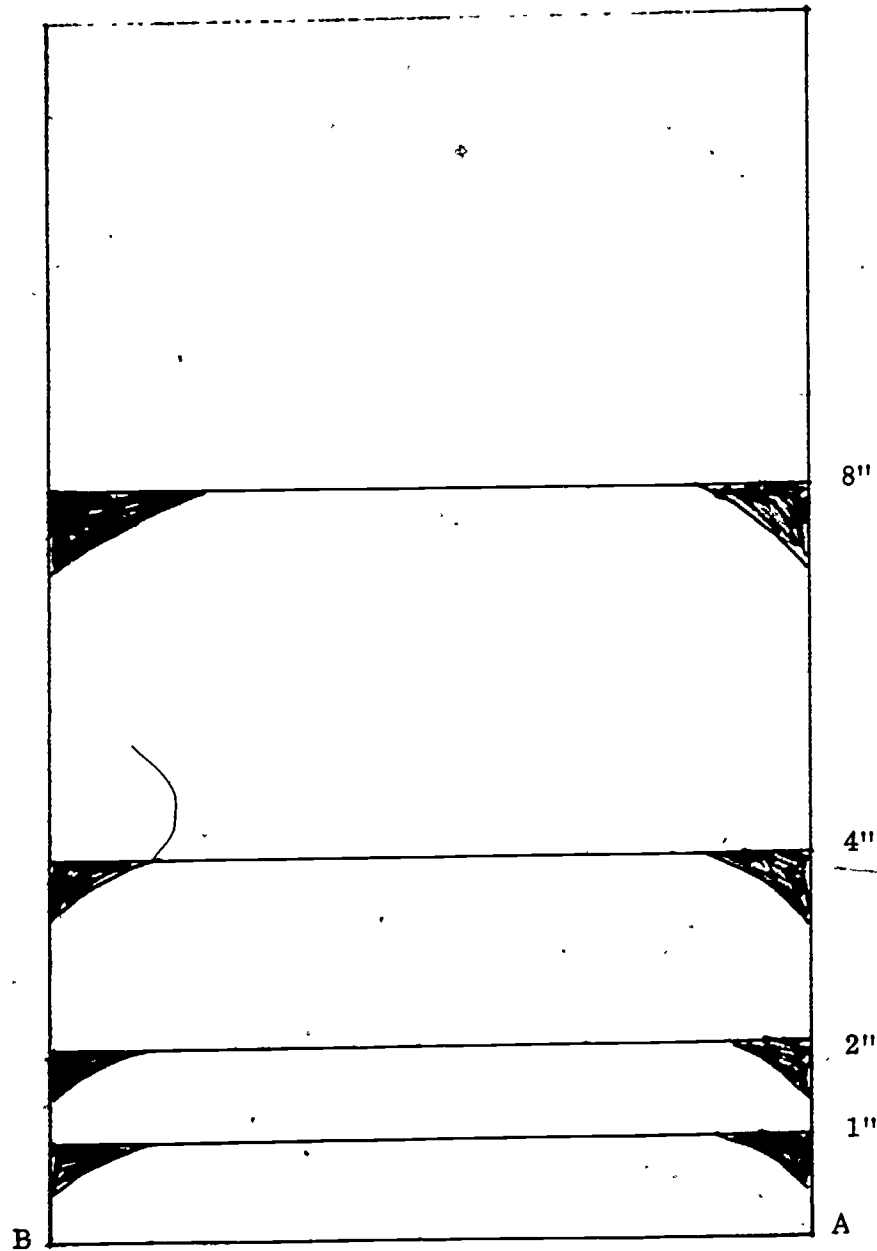

1. To make hem pressing gauge use 1/4 of a manila folder or lightweight cardboard. Use square and ruler to measure off a rectangle, approximate size 4" x 12". Cut out.
2. From A, measure up 1, 2, 4 and 8". From B, do the same.
3. With pencil, draw lines across gauge. Trim out shaded areas. Press fabric over the gauge for an even hem width.

63

## DRAPERY SIDE AND BOTTOM HEMS

### I. General principles

1. Press by lifting and lowering the iron to avoid stretching the fabric.
2. Press on sample piece to TEST the effects of heat, moisture and pressure on the fabric. **HEAT CAN BE AN ENEMY.**
3. Selvages can be clipped at 6-8 inch intervals unless the selvaige is too tight and causes side to draw up. Trim selvaige off in this case.
4. Use metal or cardboard hem pressing guage to measure consistent width.
5. Side hems may be double or single depending on method of construction. Widths of hem may be 1 - 1 1/2".
6. Bottom hems are usually double. A full length drapery would have a double 4". A shorter window treatment such as a 13" valance may have a double 2 or 3" bottom hem.
7. Hand stitches can give a window treatment the extra touch of quality. Use single thread, find needle and keep stitches uniform, spacing them about 1/2" apart.
8. The method of pinning hem will depend on method of stitching and individual preferences. Two methods are shown below.

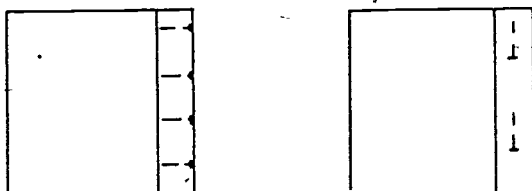

Important to avoid creeping. Seams of hem and drape should match. Hem width should remain consistent.

### II. Side Hems

1. Turn in 2" along side edge. Press. This represents finished side hem line.
2. Open hem up.
3. Fold selvaige or cut edge to crease made in step 1. Press this fold. Turn again, repressing first crease. (Double 1" side hem).
4. Blind stitch the hem using 1/2" hand stitches or the blindhemmer. Leave 6" from top of drapery open.

#### Bottom Hem

1. Turn up 8" and press. This represents the finished line.
2. Open hem up.
3. Fold selvaige or cut edge to crease made in step 1. Press the fold. Turn again, repressing first crease. (Double 4" bottom hem).
4. Blind stitch the hem using 1/2" hand stitches or the blindhemmer.

## DRAPERY SIDE BOTTOM HEMS

Hems are stitched by hand, home sewing machine or industrial blindhemmer.

### HAND SEWING

Stitches are worked right to left.

Fasten thread, bringing needle and thread out through fold of hem. Use single thread.

Opposite, in the drapery, take a small stitch, catching only a few yarns.

Opposite that stitch, insert needle in the hem edge and slip needle through fold for  $\frac{1}{2}$ ".

Continue alternating stitches.

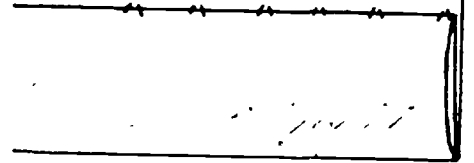

### HOME SEWING MACHINE

#### MACHINE STRAIGHT STITCH

Press hem.

Straight stitch close to inner fold.

Use 10 - 12 st. / inch.

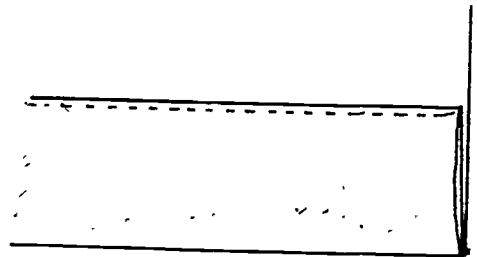

#### MACHINE BLINDSTITCH

Press hem. Figure A

Fold entire hem back against right side of drapery panel as shown. (Figure B)

Hem edge extends out  $\frac{1}{4}$ " beyond the fold.

Refer to machine manual for stitch length and width.

Stitch on  $\frac{1}{4}$ " extension beyond fold, catching in drapery panel with the zigzag.

Use machine blindhemmer foot.

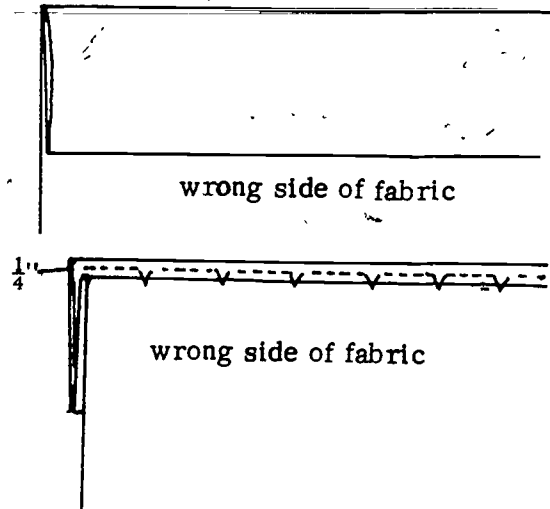

#### INDUSTRIAL BLINDHEMMER

If a blindstitch machine is used properly, stitches do not show on the right side of the fabric.

The curved needle goes through the fabric and then into the hem. There is only a top thread.

Nylon thread is many times used to avoid rethreading the machine for various colors.

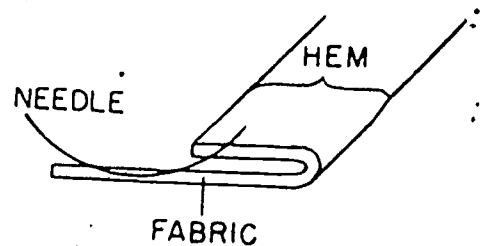

## APPLYING THE CRINOLINE TO THE DRAPERY

### PURCHASING THE CRINOLINE

Use 4" for drapery; use 3" for shorter valances

Buy a good quality, permanent woven crinoline

Amount to buy - Fabric width x no. of panels PLUS

4" (double 1" side hem) or 8" (single 1" side hem) per window on two-way draw

2" (double 1" side hem) or 4" (single 1" side hem) per window on one-way draw

Crinoline is inserted into headings to give them extra strength for holding pleats.

The crinoline is cut 6 inches longer than the finished enclosed drapery. This provides 3" reinforcement at each side hem.

### APPLYING THE STIFFENING

The top 6 inches of the drapery is not hemmed on the sides.

More would need to be left open if the cut length was adjusted for pattern repeat.

- I. Pin hemmed drapery, wrong side up, to desired length line on canvas. This is the finished length measurement. Check the canvas with your measurement tool. ~~The final finished length is determined at this time.~~
- II. Smooth out fabric to top of drapery. Press if needed.
- III. Place stiffening on fabric zero canvas line, and at top press drapery over the stiffening. Drapery fabric should extend 1 inch below lower edge of crinoline. Trim excess drapery fabric. Fold 1 inch under crinoline. Press. Pin.
- IV. Unfold the drapery fabric covering the crinoline. Fold the 3 inch end of crinoline at a 1/8 - 1/4" slant to make a slightly mitered corner. Trim the upper edge of the crinoline. See diagram below. Repeat at other side hem of drapery.

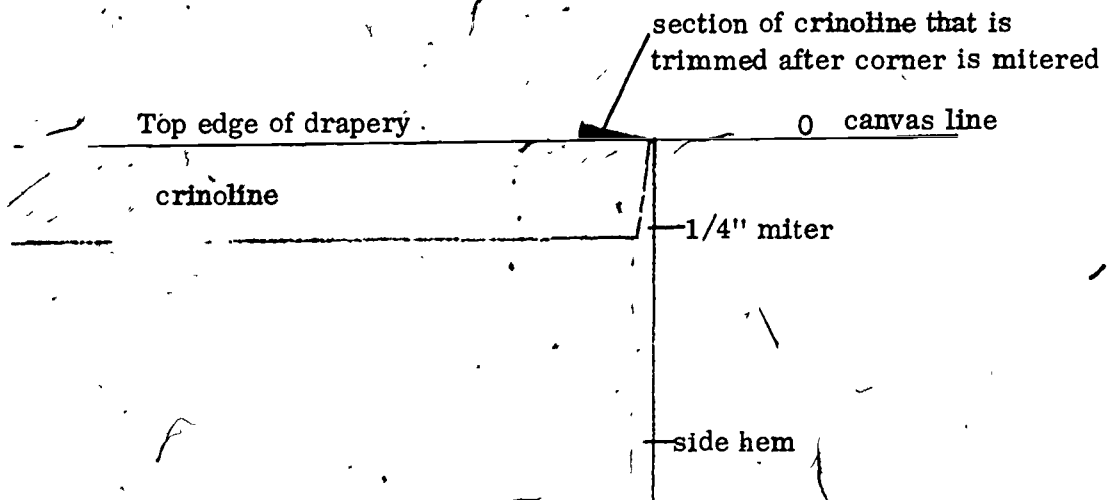

- V. Repress the drapery side hem to follow the crinoline where the miter has been made. The crinoline is under the side hem.
- VI. Stitch with a long machine stitch at the bottom edge through two thicknesses of fabric and the crinoline. The stitching does not show in outside of drapery.
- VII. Turn the stiffening to the inside of the drapery and securely hand slipstitch the mitered ends or machine stitch.

## TYPES OF PLEATS

French or pinch pleats, box pleats, and cartridge pleats are commonly placed in drapery headings. They are all spaced and stitched alike. The final treatment of the pleat determines which of the three types of pleats are constructed. The final treatment of the pleats is illustrated and described below.

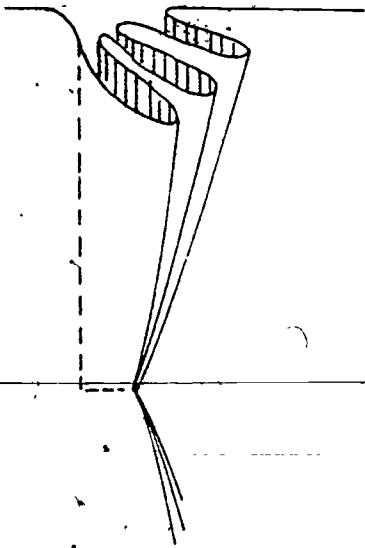

French or pinch pleats: Each large fold is divided or pinched into three small folds and tacked by hand at the top and with a bar tack at the bottom of the heading.

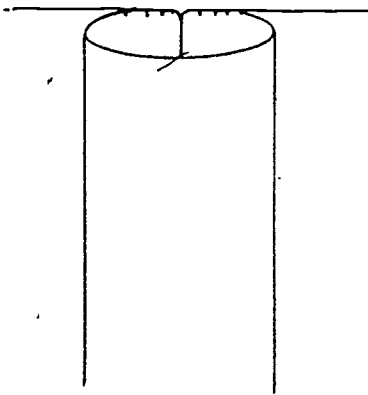

Box pleat: Material is distributed evenly on each side of the machine stitching and pressed flat. The pleat is blind-stitched across the top and may be tacked at the bottom of the crinoline.

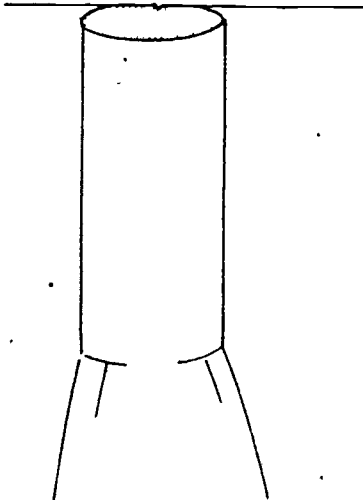

Cartridge pleats: Each pleat is rounded out by stuffing it with cotton, a roll of cardboard, or interfacing. A smaller pleat (2 1/2 inches) is more attractive if this treatment is used.

Reprinted from Home Furnishings Services  
Curriculum Guide, Lubbock, Texas

## HOW TO CALCULATE PLEATS IN A TRAVERSE DRAPERY

The size of the pleats and the spaces between pleats depend on amount of fullness allowed. Each window requires figuring the number of inches that each pleat will absorb and what the size of the spaces between pleats will be. Below are formulas for figuring in which you may substitute your own window and fabric measurements. Install rods before measuring; measure with a steel tape. Do your calculations in decimals and carry them to .00 place. Use conversion chart to convert fractions to decimals and visa versa.

### The Window's Measurements:

Rod width (face of rod) . . . . .	.50"
Overlap . . . . .	3"
Ease (1" for traverse) . . . . .	1"
Returns (variable figure) one return 3.25; 2 returns . . . . .	6.50"
<u>Total</u> space to cover . . . . .	<u>60.50"</u>

Divide total space to cover by 2 to find how much each half of drapery must cover if two-way draw. Do not divide in half if one-way draw.

$$60.5" \div 2 = 30.25" (30\frac{1}{4}") \text{ (space to cover for one-half of the total drapery)}$$

This is measurement drapery heading should measure after pleating.

### Spaces:

- (1) Space to cover for 1/2 of total drapery or total . . . . . 30.25"  
space to cover (one way draw)
- (2) Subtract each end space + 1/2" (.5) . . . . . -7.25"  
overlap + .5 + return + .5 = 7.25  
3 + .5 + 3.25 + .5 = 7.25
- (3) Material that goes into remaining spaces . . . . . 23.00"  
(spaces between pleats)
- (4) Divide by four to get approximate no. of spaces  
 $23 \div 4 = 5.75$  or 6 (no. of spaces)  
(If working with even no. of lengths in the drapery panel, it is usually desirable to have even no. of spaces.)
- (5) Then divide material for remaining spaces by no. of spaces. This equals  
size of each space.  $23 \div 6 = 3.83"$

### Pleats:

- (6) Measurement across top of one enclosed hemmed drapery . . . . . 69"
- (7) Subtract space to cover . . . . . -30.25"
- (8) Material that must go into pleats . . . . . 38.75"
- (9) There will be one more pleat than space between pleats  
No. of pleats . . . . . 7 pleats
- (10) Divide material for pleats by no. of pleats  
Answer is size of each pleat  $38.75" \div 7 = 5.54"$
- (11) Calculate 1/2 of pleat ( $1/2 \times 5.54 = 2.77$ )
- (12) Calculate 1 pleat(10) + 1 space (5) =  $5.54 + 3.83 = 9.37$

## CONVERSION CHART

Use the following to transfer your decimal calculations into fractions when reading your tape measure.

.0625	1/16
.125	1/8 - 2/16
.1875	3/16
.25	1/4
.3125	5/16
.375	3/8 - 6/16
.4375	7/16
.50	1/2 - 8/16
.5625	9/16
.625	5/8
.6875	11/16
.75	6/8 - 12/16
.8125	13/16
.875	7/8
.9375	15/16
1.000	1.00

# WORKSHEET FOR CALCULATING PLEATS AND SPACES IN A TRAVERSE DRAPERY

Refer to sheet, How to Calculate Pleats, to aid you in completing the following for your drapery.

The \* measurements are measurements that must be specific for your drapery and window.

The window's measurements: (the whole window)

\*Rod width (face of rod) \_\_\_\_\_

\*Overlap (usually 3") \_\_\_\_\_

Ease (always 1" for traverse) \_\_\_\_\_

\*Returns one return \_\_\_\_\_ 2 returns \_\_\_\_\_

Total space to cover \_\_\_\_\_

Divide total space to cover by 2 (if two-way draw) to find how much each half of drapery must cover. (Do not divide in half for one-way draw).

Space to cover for one-half of the total drapery = \_\_\_\_\_

Work with this figure from here on. This is measurement drapery should measure after pleating.

## SPACES

(1) Space to cover for 1/2 of drapery . . . . . \_\_\_\_\_

(2) Subtract each end space plus 1/2" (.5)  
(1 overlap plus .5 plus 1 return plus .5 . . . . . \_\_\_\_\_  
\_\_\_\_\_ + \_\_\_\_\_ + \_\_\_\_\_ + \_\_\_\_\_

(3) Material that goes into remaining spaces . . . . . \_\_\_\_\_  
(spaces between pleats)

(4) Divide by 4 to get approximate no. of spaces \_\_\_\_\_

(5) Then divide material for remaining spaces by number of spaces. This = size of each space between pleat. Size of each space . . . . . \_\_\_\_\_

## PLEATS

\* (6) Measurement across top of one enclosed hemmed drapery \_\_\_\_\_

(7) Subtract space to cover (1). . . . . \_\_\_\_\_

(8) Material that must go into pleats . . . . . \_\_\_\_\_

(9) No. of pleats (one more than no. of spaces). . . . . \_\_\_\_\_

(10) Divide material for pleats by no. of pleats (no. 8 ÷ no. 9)  
Size of each pleat . . . . . \_\_\_\_\_

(11) Calculate 1/2 of pleat (1/2 x no. 10) . . . . . \_\_\_\_\_

(12) Calculate 1 pleat + 1 space (no. 5 + no. 10) . . . . . \_\_\_\_\_



## ALTERNATE METHOD

### Example Measurement

1. Measure width of unpleated drapery panel . . . . . 138"
2. Measure installed drapery rod width . . . . . 108"
3. Measure return size x 2 (3" x 2) . . . . . 6"
4. Measure overlap size . . . . . 3"
5. Add 1" ease . . . . . 1"
6. Total of 2, 3, 4 and 5 . . . . . 118"
7. One drapery panel will cover 1/2 of the window or 1/2 x 118 . . . . . 59"
8. To determine no. of inches for pleats, subtract panel width needed to cover 1/2 of window (59") from the measured width of the unpleated drapery panel (138")  $138 - 59 =$  . . . . . 79"
9. Decide on number of pleats wanted in each drapery panel. Rule to follow is 5 pleats for each width of fabric; 2 pleats for each 1/2 width. Thus, for a 3 width drapery panel, 15 pleats would be required.
10. To find size of pleat, divide no. of inches for pleats (79") by no. of pleats (15)  $79 \div 15 =$  . . . . . 5.26
11. End spaces will be size of overlap +  $\frac{1}{2}$ " and return +  $\frac{1}{2}$ " ( $3 + \frac{1}{2} + 3 + \frac{1}{2}$ ). This equals 7". To find inches for spaces between pleats, subtract 7 from 59.  $59 - 7 =$  . . . . . 52"
12. Rule: One less space than number of pleats. Thus subtract 1 from total number of pleats.  $15 - 1 =$  . . . . . 14 spaces
13. To find size of each space, divide no. of inches for spaces between pleats (52") by no. of spaces. (14).  $52 \div 14 =$  . . . . . 3.71"

7

## PIN-OFF DRAPERY PLEATS

Pinning off is the process of marking with pins the location of pleats and spaces. Pleat center and stitching line is marked. The experienced draper maker will mark only the center of the pleat.

1. Fold drapery panel in half at crinoline area. Right side out and side hems brought together. Determine if the panel being pleated is the right or left panel.
2. Mark with pins the size of the end spaces (return + .5 and overlap + .5) at appropriate amounts. Refer to #2 on worksheet. This pin indicates the beginning of the first pleat.
3. Place these two pins one on top of other, refolding drapery (if necessary).
4. Mark centers of pleats only and check.

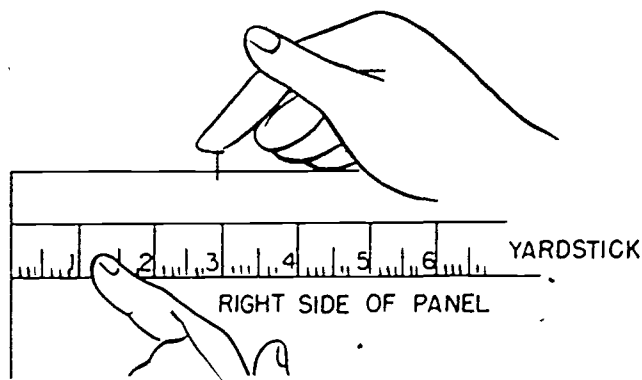

1. Using guage, place a pin the distance of  $\frac{1}{2}$  pleat width from end space pin marker. (#11 on worksheet)
2. Next, place remaining pins on top layer of crinoline only the distance of one pleat plus one space from the previous pin (#12 on worksheet). These pins are placed at center of pleat. Continue until top half has been pinned-off. If uneven number of pleats, the last center pin marking falls on the fold, Diagram B. If even number of pleats, the distance from last center marking to fold is one half of 1 pleat + 1 space. Fold guage in half to check this. Diagram A. If it measures out accurately as explained above, continue on. If not, check accuracy of measurements and guage.
3. Check placement of seams. If drapery seam falls in center of a space or pleat, do one or two procedures:
  - a. Recalculate using one more or less space and pleat. Changing the number of spaces and pleats repositions the seam.
  - b. Rearrange the pleats and spaces. Make some pleats larger; some pleats smaller. Retain size of space.
4. Pin lower layer identical to top layer. Mark center of pleat with two pins. Pin-off the distance of  $\frac{1}{2}$  pleat on each side of the center of pleat. Use single pin for this.

DIAGRAM A - Shows EVEN Number of Pleats

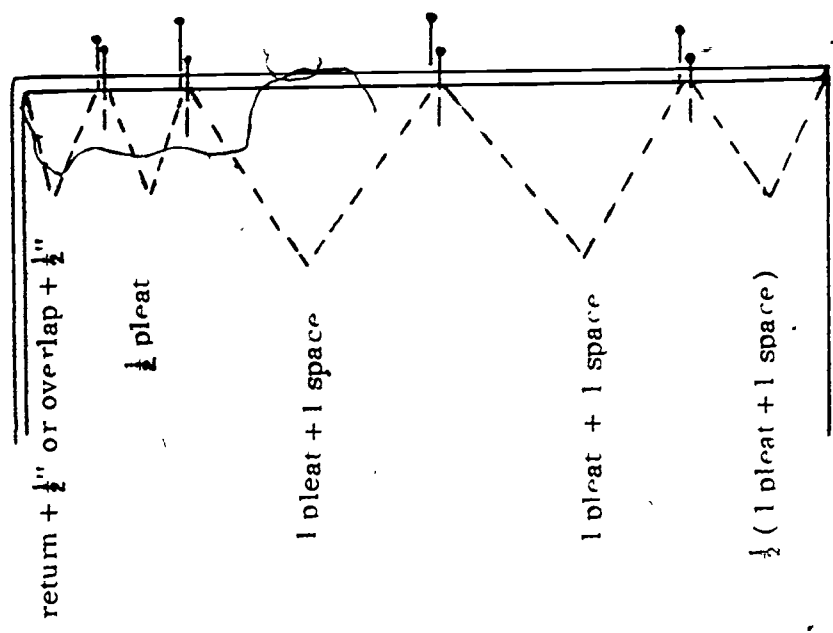
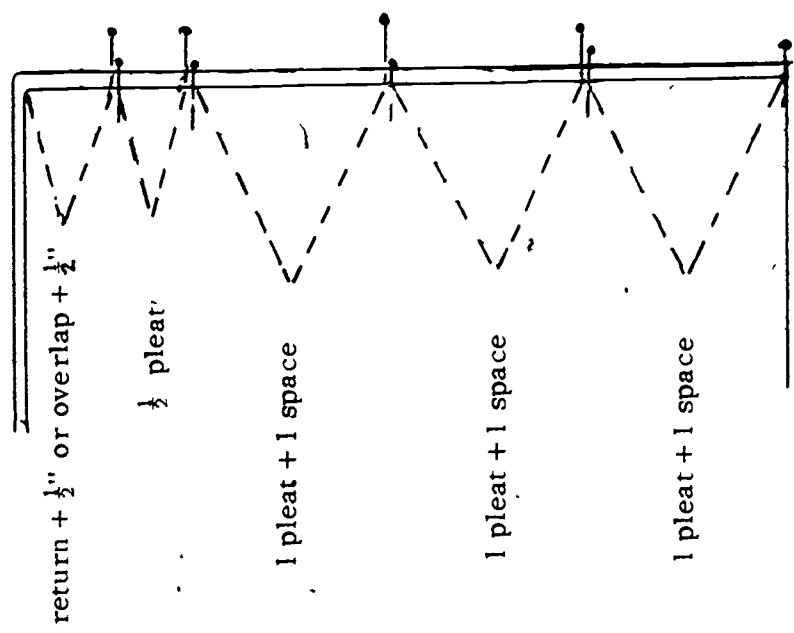

DIAGRAM B - Shows UNEVEN Number of Pleats



73

## GAUGE FOR PLEAT AND SPACE SIZE

To make a gauge for pinning-off pleat and space size, use a one inch strip of crinoline approximately 10" long. Refer to illustration below for marking gauge as the following explains.

1. Start at left end (Point A). Measure distance of 1/2 pleat (Point B). Refer to #11 on calculation sheet - 2.77
2. From Point B, measure distance of 1 space (Point C). Refer to #5 on calculation sheet - 3.83
3. From Point C, measure distance of 1/2 pleat (Point D). Refer to #11 on calculation sheet - 2.77
4. To double check, measure distance from Point A to Point D. This should be measurement of 1 pleat + 1 space. Refer to #12 on calculation sheet - 9.37
5. Label gauge as shown below.

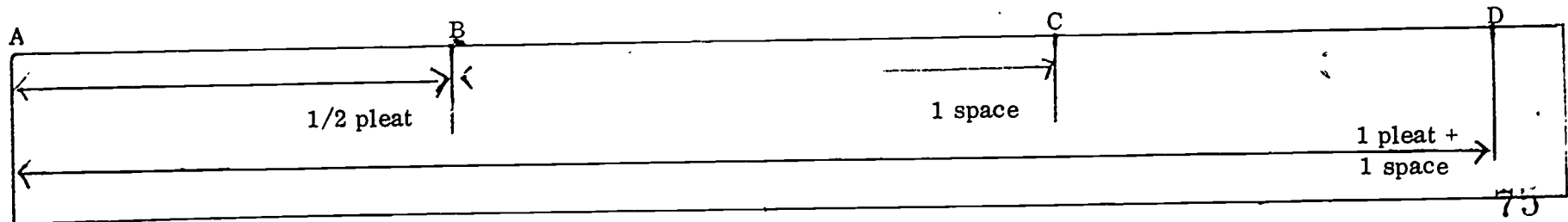

## STITCHING, FORMING AND TACKING DRAPERY PLEATS

1. Place a piece of masking tape on machine bed. Edge of tape to needle = distance of  $1/2$  pleat.
2. Bring marking for pleats together making a tuck on right side of drapery heading.
3. Stitch the pleat using following guidelines:
  - a. Use a sturdy needle (14-16)
  - b. Use stitch length of 8-10 st/inch
  - c. Check to be certain top edges and fold are even.
  - d. Place top of pleat under machine needle. Lower needle through the two layers of crinoline and fabric  $1/2$ " from top edge. Lower pressure foot. Backstitch to top edge.
  - e. Stitch to  $1/2$ " below crinoline and backstitch (lined). Stitch to bottom edge of crinoline and backstitch (unlined).
  - f. Use edge of masking tape as guide to stitch straight.
  - g. Hold lower layer taut to avoid puckering.
4. After stitching two pleats, check space between two pleats with guage.
5. Stitch all pleats.
6. Measure top edge of drapery. It should measure space it is to cover. (Refer to no. 1 of Worksheet for Pleat and Space Calculations.)
7. Finger press the stitched tuck to flatten the line of stitching.
8. To form a French pleat, take hold of the creased center of the pleat with your thumb and forefinger and push down to the stitched line as illustrated below. Rock back and forth to form three pleats of equal depth.

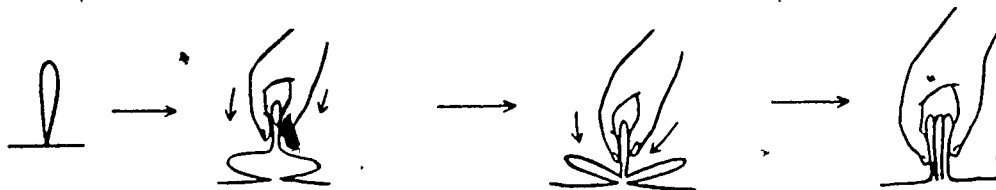

9. Pin and tuck the tuck by one of following methods.
  - a. Stitch by hand across lower edge of pleat just below the heading.
  - b. Tack by machine. Bar tack is placed  $1/4$ " from edge of fold and  $1/2$ " up from lower edge of crinoline.

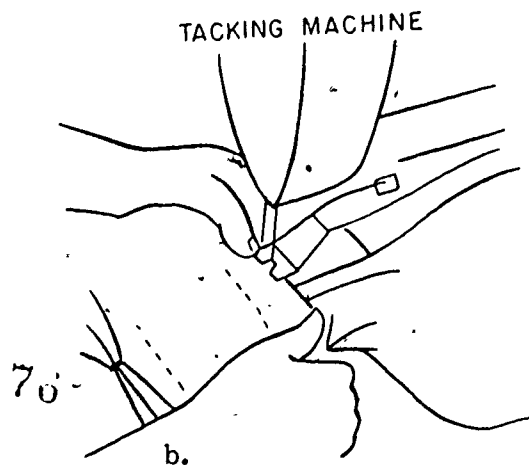
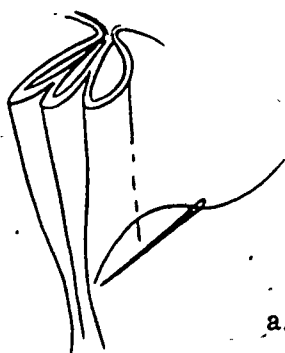

## STACKING AND BANDING DRAPERY PANELS

1. Correct folding is one of the secrets of evenly hanging draperies. On long lengths it is necessary for one person at heading and one person at hem.
2. Place panel on table and fold in direction as shown.

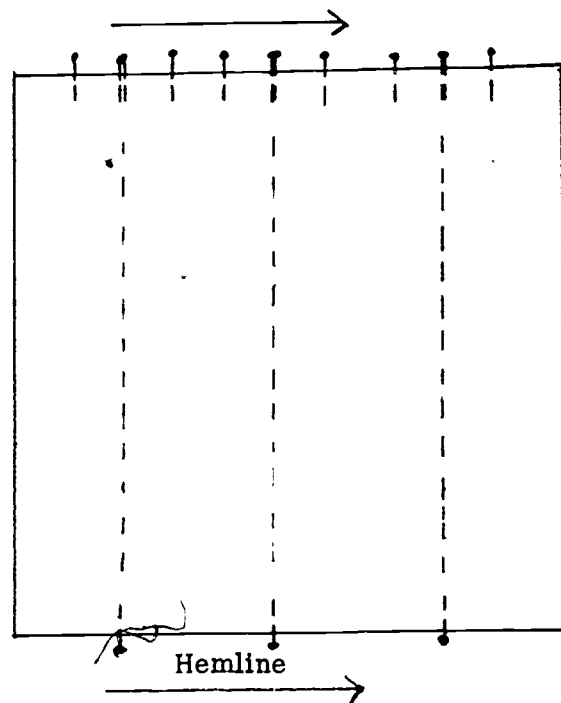

3. Crease heading at double pin (center of pleat). Fold at hemline at pin (marking center of pleat). Hold taut between the 2 ends making certain lining is also taut. Smooth center of pleat the entire length of the panel. Dash line indicates position of crease in heading and fold in hemline.

4. To make second fold, crease heading at next double pin (center of pleat). Fold at hemline at pin (marking center of pleat). Hold taut and place on top of first pleat. Also crease center of space. Continue until entire panel is stacked. Keep top edges of pleat even. Keep pleat width even.

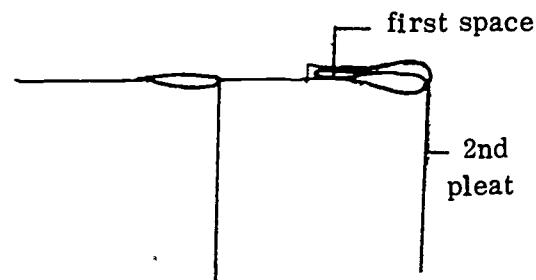

5. After all pleats have been folded, the end spaces (return and overlap) are folded around to back.

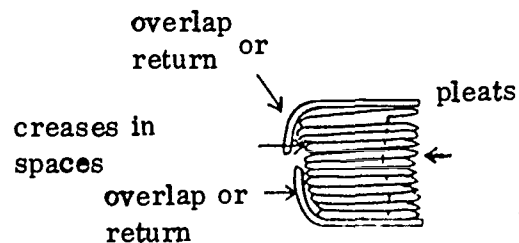

6. After a drapery panel is stacked, it is banded to hold the folds in place. Usually bands of paper or cloth, approximately 1 - 1½" wide and 12" long are used.

7. Being careful to hold stacked panels in place, place band under panel near heading.

Bring ends to top and tie or tape.

Place bands every 12-18".

Write length and width of panel on one of the bands.

Allow the banded panels to lie flat for 48 hours to aid in setting the folds.

8. Remove top 1 or 2 bandings and work with heading only to stitch, form and tack pleats. Band heading after hooks have been inserted.

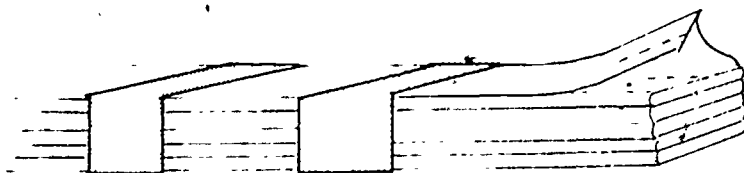
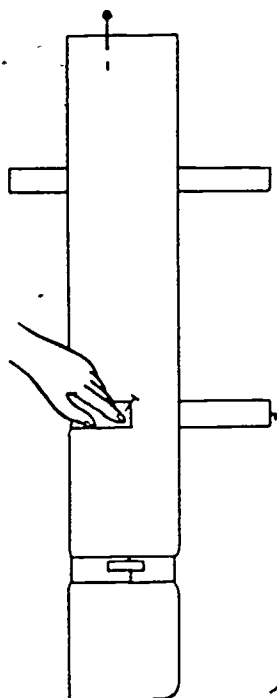

## DRAPERY HOOKS

### I. DEFINITION

Hooks are an accessory used for hanging draperies on slide carriers; also used directly over rod for stationary panels and valances.

### II. TYPES OF HOOKS

A. The pin-on hooks come in various sizes and shapes. The following are commonly used.



#### "U" - Shaped

- . Fits over rod
- . Used on valance or curtain rod
- . Small size illus. at left is used for sheer draperies
- . Larger size used for med. - heavy wt. draperies



#### Semi-Pointed

- . Used on traverse rods
- . Small size, illus. at left used for sheer draperies
- . Larger size used for med. - heavy wt. drap.

B. Selection of proper hook is determined by:

1. Type of rod
2. The weight of the drapery - light weight (sheer) or medium weight (antique satin)

### III. PIN SETTING

A. The point of inserting the hook from top of drapery is determined by:

1. Size of hook - small (1") or larger (1 3/8 - 1 1/2")
2. Type of rod (standard traverse, decorator or valance)

B. FOR STANDARD TRAVERSE ROD

Add the following together to determine point of hook insertion

1. Measure from top of drapery rod to bottom of hole in slide.

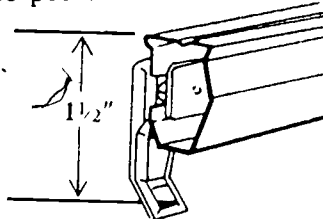

2. Measure length of pin

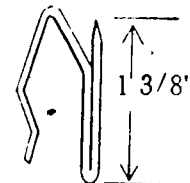

3. Add 1/4" more if desire drapery to hang 1/4" above top of rod.

Example:  $1\frac{1}{2} + 1\frac{3}{8} + \frac{1}{4} = 3\frac{1}{8}$ " Hook would be inserted  $3\frac{1}{8}$ " from top of drapery.

This will vary from  $2\frac{1}{2}$  -  $3\frac{1}{4}$  inches.



### C. FOR DECORATOR ROD

Add  $\frac{1}{2}$ " to length of the pin being used.

Larger hook usually placed  $1\frac{3}{4}$ " from top edge.

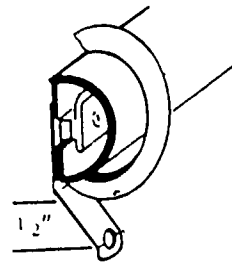

### D. FOR VALANCE ROD

Add  $\frac{1}{4}$  -  $\frac{1}{2}$ " to length of pin being used. Large hook usually placed  $1\frac{1}{2}$ " from top edge.

### E. PROCEDURES TO FOLLOW

1. Hooks are placed at back of each drapery pleat and at each side edge of panel. (approx.  $\frac{1}{2}$  - 1" from finished edge.)
2. Using measurement found in B, C, or D, mark back of drapery heading or use a marked guide to place all pins at the same distance from top edge.

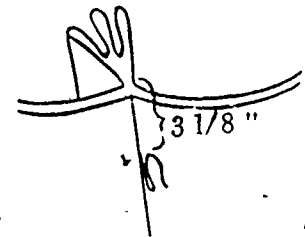
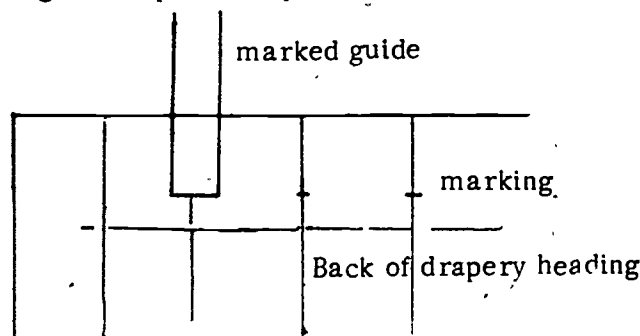

3. To put hook into heading, place finger down in pleat. Bring hook down in and have it come out again.
4. When hung on a standard traverse rod, the top of the heading should be level with top of rod or slightly above. When the draperies are closed, the rod is completely concealed behind the heading.
5. When hung on a decorator traverse rod, the top of the heading should come to the bottom of the ring, exposing the rod.
6. After draperies are hung, compress the hook on the overlap to avoid its catching in the other panel when opened and closed.
7. The space section on the drapery panel must be retrained (cracked) when hung on a standard traverse rod. Bring the center of the space forward and re crease it.

Name \_\_\_\_\_

### DRAPERY EVALUATION - PINCH PLEATED DRAPERY

Evaluate drapery sample for each item listed below. Number of possible points is given in column 1. Student is to fill in column 2, instructor will complete column 3.

	Column 1	Column 2	Column 3
HEMS Bottom hem Correct width; even width, on grain. Well-pressed, not overpressed Stitching (neat, proper tension correctly done)	15		
Side hems Same as for bottom hems Weights placed correctly	15		
CRINOLINE Method done correctly Corner mitered properly Handstitching on ends neat & secure	15		
DRAPERY MEASUREMENT      Length _____ Width _____  Length even and correct Width correct to within 1/4" End spaces correct amount	15		
LINING Hem, correct width, even width Stitching, neat and secure Applied correctly	10		
PLEATS Evenly placed Stitching straight, correct stitch length, backtacking Pinch pleat-evenly divided in 3 parts, lining in correct position Tacking Secure and correctly done	15		
DRAPERY STACKED AND TIED CORRECTLY	5		
INSERTION OF HOOKS	5		
OVERALL FINISHED APPEARANCE Corners square, straight across top, neat	5		
TOTAL POINTS			

LETTER GRADE \_\_\_\_\_

## The Cartridge Pleat

- I. This pleat gives a more formal appearance, and is suitable for a traverse drapery.
- II. Pleats may range from pencil size to pipe organ size.
- III. With pins, mark the exact size of each space and pleat at the top edge of the drapery. If necessary, rearrange pleats to keep from having a seam in the center of a pleat or space. Be sure to keep spaces all the same size.
- IV. To make the tuck:
  - A. Bring markings for pleats together, making a tuck on the right side of the material allowed for pleats.
  - B. Pin and stitch tuck from the top edge to 1/2" below the heading as in illustration (a). Backstitch at each end to fasten threads securely.
- V. Finger press the stitched tuck, as in illustration (b).
- VI. This is a round pleat. Stuff with cotton, a roll of buckram, or pellen to retain its shape, as in illustration (c).
- VII. The pipe-organ pleat is a variation of the cartridge pleat. It is much larger and used on high, tall windows, such as theatres, etc.

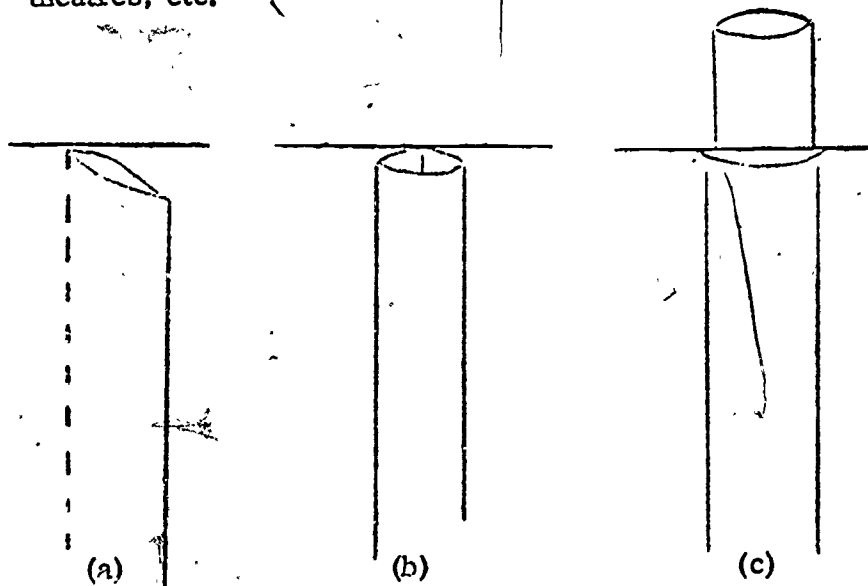

### The Box Pleat

- I. The box pleat is a more tailored finish. Use only on valance or side draperies - not for traverse draperies.
- II. Box pleats should be at least 2" wide, taking up 4" fullness.
- III. Try for uniformity; that is, the space between pleats should be the same as the size of the pleat.
- IV. With pins, mark the exact size of each space and pleat at the top edge of the drapery. If necessary, rearrange pleats to keep from having a seam in the center of a pleat or space.
- V. To make the tuck:
  - A. Bring markings for pleats together, making a tuck on the right side of the material allowed for pleats.
  - B. Pin and stitch tuck from the top edge to 1/2" below the heading as in illustration (a). Backstitch at each end to fasten threads securely.
- VI. Finger press the stitched tuck.
- VII. Spread the large tuck an equal distance on both sides of the stitching line and press flat as in illustration (b).
- VIII. Secure pleat by stitching across lower edge, or tack in place at top and bottom.

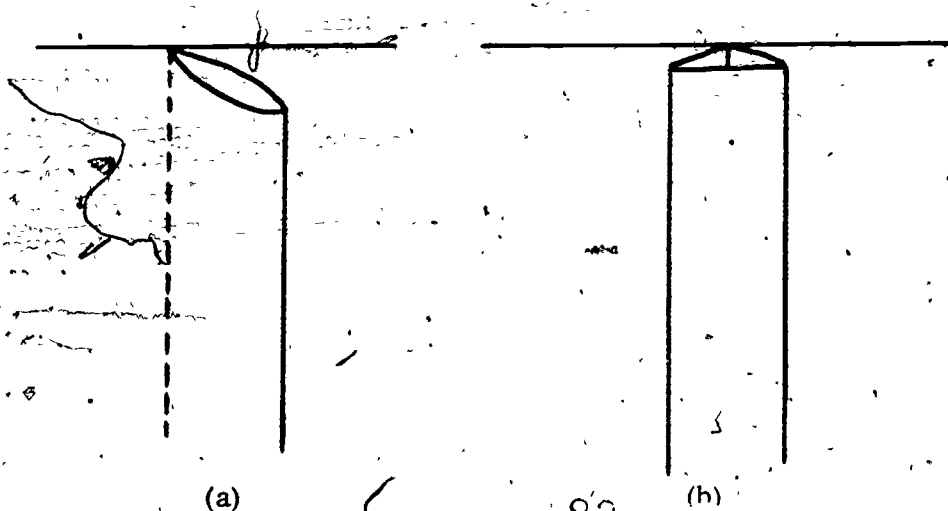

## Shirred Curtain

A casing made at the top of the curtain is used to shir the curtain on the rod. It is a quick, simple window treatment.

The casing can be plain or it can have a heading that extends above the rod.

### Calculate fabric amount

#### Fullness

Measure width of area to be covered. Allow 2-3 times this width for fullness. To figure the number of panels needed, divide the fullness by the fabric width being used.

#### Length

To determine cut length, add the following together (A plus B plus C)

\_\_\_\_\_ A. Finished length. Measure from top of rod to desired length plus depth of heading that will extend above rod. (heading is optional)

\_\_\_\_\_ B. Bottom hem. Allow 8 inches for a double 4" hem at bottom

\_\_\_\_\_ C. Top hem. \_\_\_\_\_ 1) 1/2" for turn under of raw edge.

\_\_\_\_\_ 2) width of casing. Width of casing is 1/2 of the rod diameter plus 1/4-1/2" ease allowance.

\_\_\_\_\_ 3) depth of heading (heading is optional).

\_\_\_\_\_ TOTAL allowance for top hem.

NOTE: If a patterned fabric is used, the cut length must be readjusted so that fabric is cut in multiples of the repeat.

### CONSTRUCTION

1. Trim or cut off fabric selvages to avoid puckering.
2. Seam panels together.
3. Press and stitch a double 1" hem on each side (hand or machine).

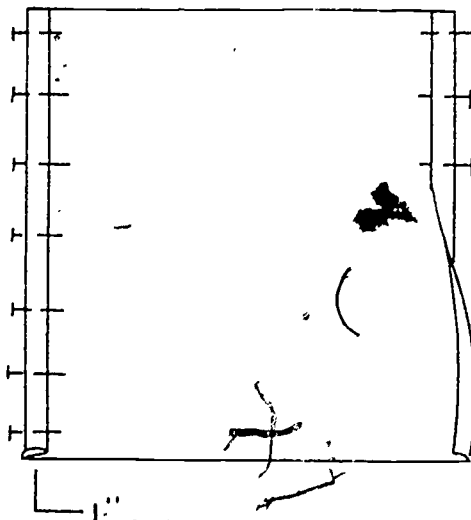

4. Press and stitch a double 4" hem on bottom (hand or machine).

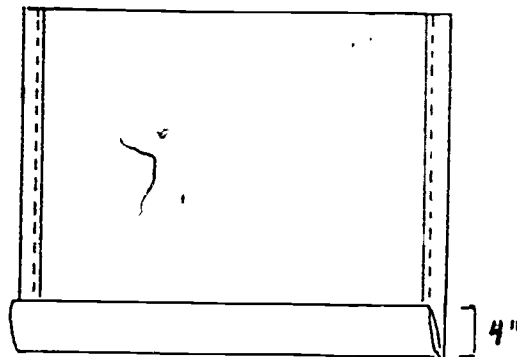

5. Place curtain on cutting tables, wrong side up, having bottom hem on finished length. At zero line, fold fabric to wrong side and press along top fold. The amount you have turned under at the top should equal the amount calculated in C above. Trim additional off.

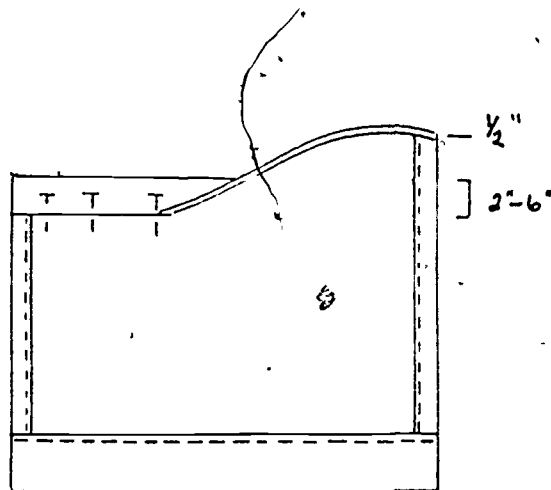

6. At top cut edge, turn under 1/2" and press. Repress along the top fold. Stitch close to the lower fold. Straight stitch using 9-10 st. per inch. Reinforce each end by backstitching.

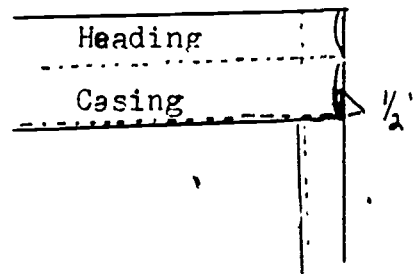

7. The width of the casing is 1/2 of the rod diameter plus 1/4-1/2" ease allowance. Measure and mark a line from the stitching line done in the previous step. The distance between the two lines is the width of the casing. Standard casing width is 1 1/2". Reinforce ends of stitching when stitching this second line. If no heading is desired, This step is skipped.

## WINDOW HEADINGS

### What is a Valance?

**Definition** - Any short drapery or treatment hung at the top of the window. They are decorative toppings and can be made from draped fabric, which may be the same as drapery, may be a contrasting material, and may be quilted or trimmed.

### What is a Cornice?

**Definition** - A treatment at the top of the window used to conceal rods and pulley cords. They are more permanent and are usually made of wood, metal, plastic, cork, leather, mirrors, etc.

### Purpose or function of the Valance

1. Decorative
2. It covers the operating machinery of draperies
3. May unify a group of windows
4. May fill in any awkward space
5. It can make windows look larger and add height
6. Make ceilings seem higher
7. Can camouflage a window not perfect in proportion

### Types of Valances

1. Plain gathered - two rows of stitching below a heading depth  
Curtain rod is inserted between the stitching
2. Shirred valance - more than two rows of stitching below the heading
3. Box pleated
4. Pinch pleated
5. Cartridge pleated
6. Straight - usually hung from a valance board, with the use of buckram
7. Shaped valance - see mimeographed sheet on the shaped valance

### Depth of Valances

1. A tall window should have a deep valance, while a low window should have a narrow valance
2. There is no set rule, but usually the valance is between 1/6 and 1/8 of the full length of the drapery

## WINDOW SHADE MEASUREMENTS

Shades (Roman, roller and Austrian) may be mounted inside the window frame, on the window frame or entirely off the window frame. The following gives some guidelines as to placement of brackets and measurement of width and length.

### WIDTH

- \_\_\_\_\_ (A) Outside brackets would be placed on the window frame. They can cover the entire window frame but should at least extend 1 1/2 to 2 inches from the glass.
- \_\_\_\_\_ (B) Inside brackets are placed inside. Measure from one inside surface of window frame to opposite inside surface.
- \_\_\_\_\_ (C) Brackets or mounting board ~~could~~ be placed above the window frame.

### LENGTH

Measure the full height of the window opening.

Do this by measuring from the brackets or mounting board to where you want the shade to extend. This could be the sill (D), the bottom of the apron (E), or to the floor (F).

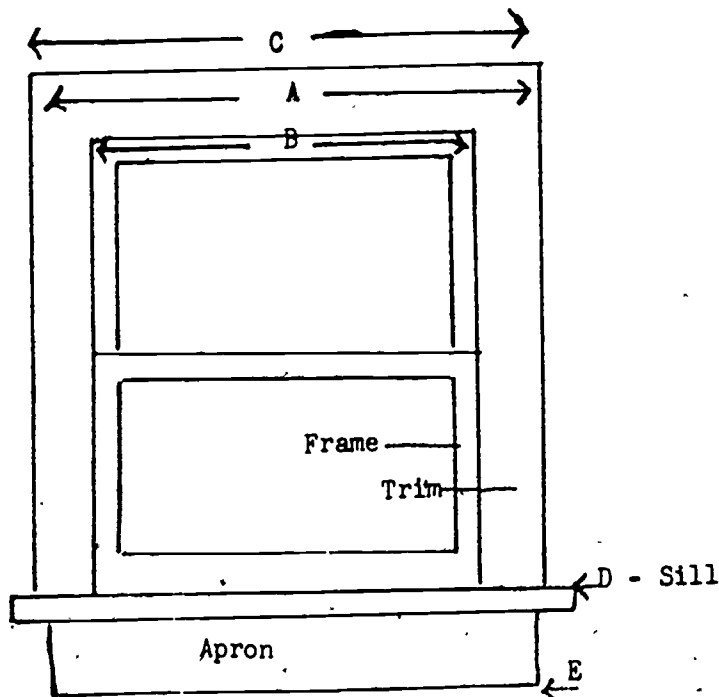



## CONSTRUCTION OF ROMAN SHADES

### I. Measure for fabric:

- A. Width - width to be covered plus 3" for side hems.
- B. Length - length to be covered plus 3" at the top and 3" at the bottom for hems if the shade is to be plain. Add an additional 3-6" at bottom if using scallops, etc.

### II. Cut fabric square

### III. Side hems:

- A. Turn  $1\frac{1}{2}$ " side hems to wrong side. Press.

### IV. Lining - is used

- A. Cut lining square  
Width - width to be covered plus 2 inches  
Length - Same length as shade fabric
- B. Place right side of lining to right side of shade fabric, side cut edges together. It will not lie flat in middle.
- C. Stitch a 1 inch seam width.
- D. Turn shade right side out. Press. Seam will go toward lining.

\*If finishing lower edge at this point, turn shade wrong side out and stitch lower edge seam. Lower edge could be straight, scalloped, etc. Again turn shade right side out and press.

### V. Attach outside rows of tape.

- A. Using  $\frac{1}{2}$ " twill tape, sew outside rows of tape in place.
  1. Stitch  $1\frac{1}{2}$ " from each side, catching side hems.
  2. Sew bottom up.
  3. Use a wide zigzag, multiple zigzag or 2 rows of straight stitching.

### VI. Sew on remaining tape.

- A. Measure distance between two rows of tape already stitched on shade.
- B. Divide into equal size sections anywhere from 6" to 12" apart
- C. With a ruler and pencil, mark rows lightly on lining side.
- D. Stitch tapes on these lines.

### VII. Pocket for slat:

- A. Press 3" to wrong side at lower edge.
- B. Press under 1 inch on cut edge - forming a 2 inch pocket.
- C. Stitch on this folded edge through all thicknesses.
- D. Insert slat or dowel.

\*If lower edge has been finished, determine area of slat pocket and stitch a  $1\frac{1}{2}$ " tuck for the slat. EX. Measure and press a fold 5" from lower edge. Stitch tuck.

VIII. Stiffening at top.

- A. Place on ruled matt, lining side up. Fold upper edge to wrong side determining finished length. There should be at least 3 inches. If more than 3", trim excess off. Press fold at top edge.
- B. Using 4" width crinoline, fold it in half to give a 2" width. Place crinoline in top fold.
- C. Press lower 1" of shade fabric under crinoline.
- D. Stitch lower edge through all thicknesses.

IX. Placement of rings (refer to drawing)

- A. Use  $\frac{3}{8}$ " bone or plastic rings and attach to tape.
- B. Rings should start 3" from slat area and then be spaced equal distances apart of approximately 6". Last row of rings is placed directly below crinoline.
- C. AT upper corner on side from which shade will be pulled, 3 metal rings are to be attached.

X. Cords:

- A. Refer to drawing for details on stringing cords through rings.
- B. Adjust cords for even pull. Make overhand knot to outside of rings.
- C. Braid cords together to desired length, tie knot and cut.

XI. Awning cleat - attached to window to wrap cords around when shade is pulled up.

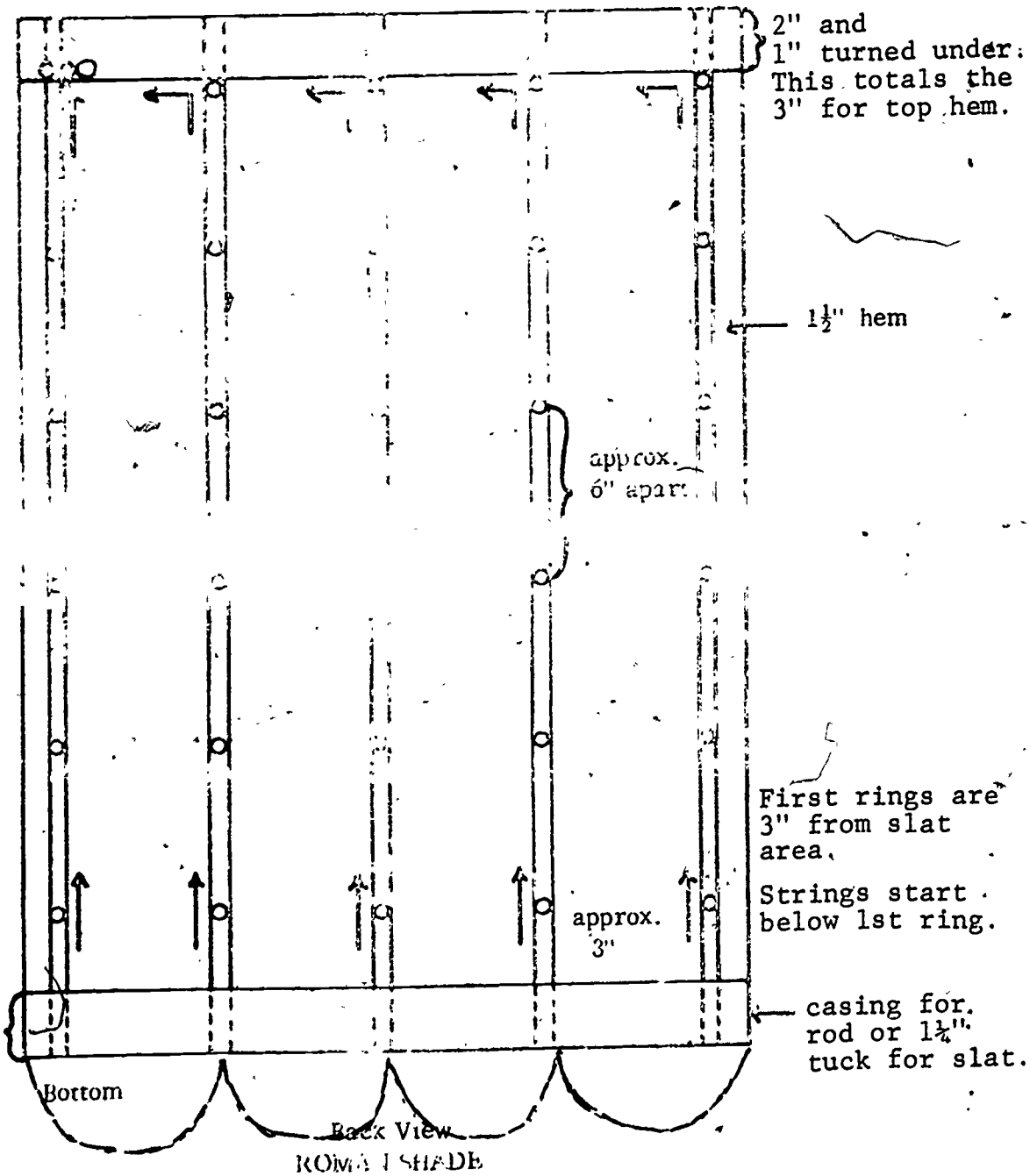

30

## LAMINATED ROLLER SHADES

### Equip Equipment and Supplies Needed:

fabric - Lightweight, closely-woven fabrics (linens, cottons) are best.

Note: Flocked fabrics and fabrics with special finishes such as Scotchguard do not laminate well. Allow enough fabric for matching patterns if more than one shade is to be made for a room.

yardstick  
square  
empty shade roller  
shade backing  
glue and water mixture  
decorator fabric

shears  
sewing machine and thread, if stitched  
slat pocket  
staple gun or masking tape  
wood slat for pocket  
trim, if desired  
decorative pull

### Construction:

1. Measure width and length of window.
2. Cut roller to correct size according to measurements of window.
3. Prepare and cut decorator fabric
  - Preshrink, if fabric is washable
  - Determine placement of pattern
  - Determine cut size 1" wider than roller  
10-15" longer than window length
  - Square both ends
  - Remove fuzz, etc.
  - Mark center at top with pencil
4. Prepare and cut shade backing
  - Determine cut size 2" wider than roller  
13-18" longer than window length
  - Square both ends
  - Mark center at top with pencil
5. Place shade backing on pressing table, laminated side up.  
Measure down 3 inches from the top.  
Draw a line across the width. Do NOT cut on this line. The backing above this line will be used for attaching the shade to the roller. Mark center on this line.
6. Place decorator fabric on top of shade backing, right side up. Top edge of fabric to penciled line. Match center markings.

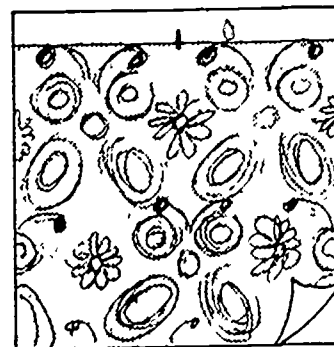
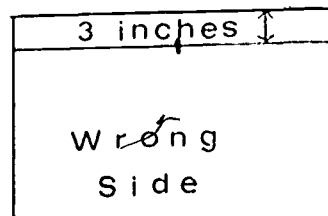

7. Adhere fabric to shade backing
  - Work on flat surface
  - Start at top center and work to sides
  - Check iron temperature setting and usage of steam on sample of fabric. May need to use paper for press cloth.
  - Adhere with cooler iron first to place design straight with edges. Then go over with warmer iron and possibly steam for a better bonding.
  - Adhere on fabric side and backing side.
  - Press using short, smooth strokes from the center out to the edges, applying downward pressure as needed.
  - Let shade cool before moving.

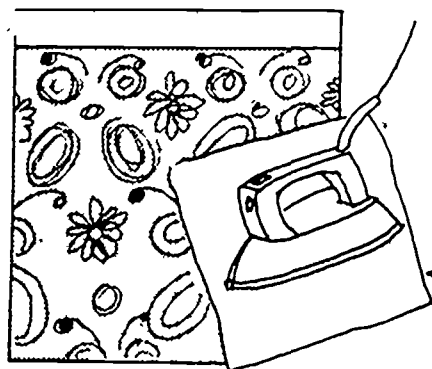

8. Trim shade to fit roller
  - Mark center of roller
  - Match centers of roller and shade
  - Mark side cutting line at top and bottom. Shade should be 1/8 narrower than roller on each side.
  - Lightly pencil side cutting line
  - Trim excess off.
  - Re-square top and bottom edge, if necessary.

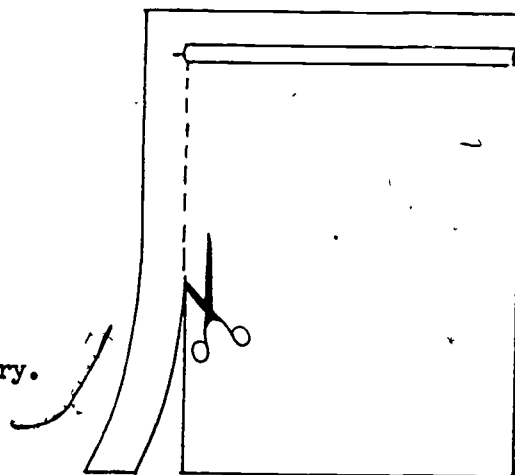

9. Form slat pocket
  - Press 2" to wrong side at bottom edge. Stitch or fuse in place
  - OR
  - Form a 1 1/2" pocket 3-5" from bottom edge. Stitch.
  - Bottom edge could be shaped and trimmed by glueing braid or fringe to the edge.

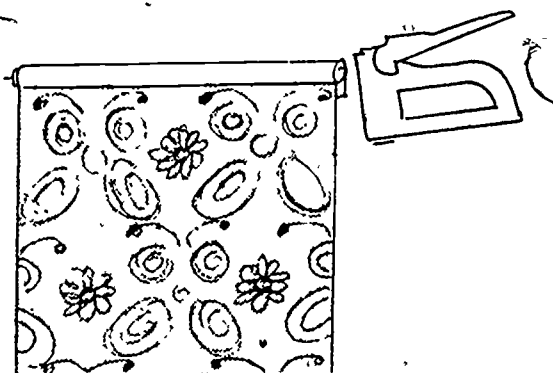

10. Attach the 3 inches of backing at top of shade to the roller. Use staple gun or masking tape.

11. To hold the cut edges in place better, apply a glue mixture of 3/4 glue and 1/4 water to edges with finger tips or small artist's brush.

12. Insert slat into hem or pocket.

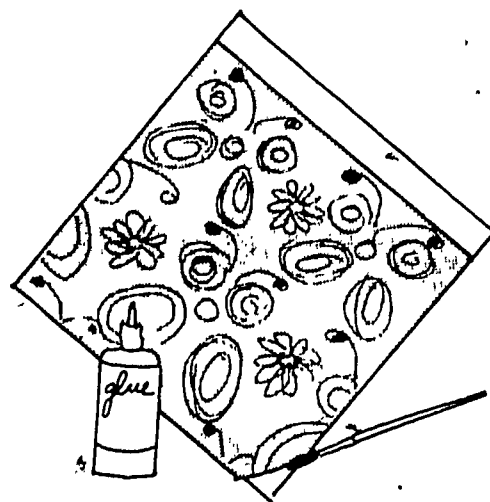

92

## AUSTRIAN SHADES

### Equipment and Supplies Needed:

fabric  
shirring tape for Austrian shades (This tape has cords for shirring the shade and rings for the pull cords.)  
window board with screw eyes  
(cut to fit window frame)

traverse rod  
thread  
sewing machine  
decorative fringe  
snap tape or nylon fastening tape  
metal rod  
cleat

### Instructions:

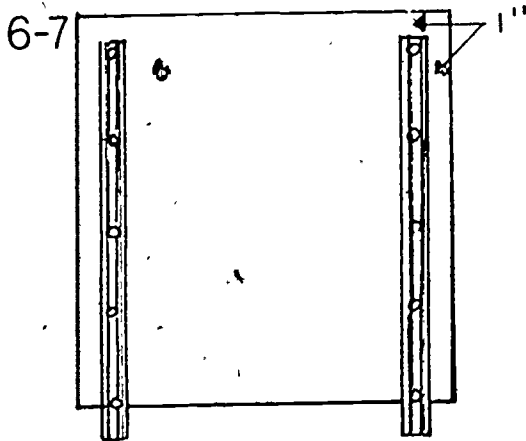
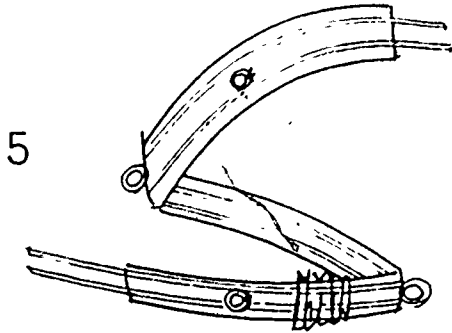
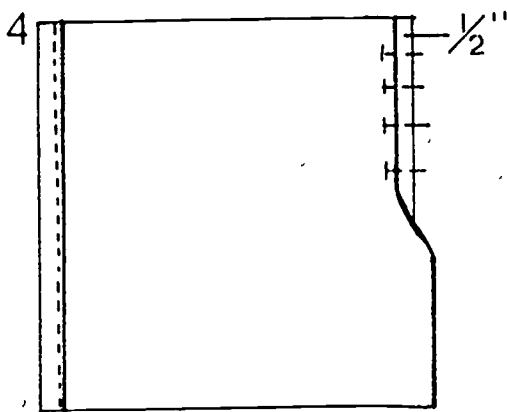

1. Measure the length and width desired for the finished shade.
2. Cut the fabric 2 to 3 times the length of the finished shade plus 1 inch for the bottom hem and 1/2 inch for the top hem. The more fabric used, the fuller the draping of the shade will be.
3. Cut the fabric 3 inches wider for a 1 1/2-inch hem at each side, plus 2 to 4 inches wider for each shirred section. The more shirring used, the deeper each scallop will be.
4. Turn under 1/2 inch on both side edges and press. Then turn under another 1-inch on each side, and press. Machine stitch these side hems.
5. Cut the shirring tape 1 inch longer than the fabric for the shade. Cut one more length of tape than the number of scallops.
6. On the wrong side of the fabric, pin a strip of tape 1 inch from the finished edge of each side and 1 inch below the top edge. Be sure the rings of each tape strip are directly in line with the rings of the strip on the other side edge.
7. Stitch down each side of the tape to within 1 inch of the bottom of the shade.
8. Divide the width of the shade by the desired number of scallops to find where the rest of the shirring tape strips should be placed.

11  
12

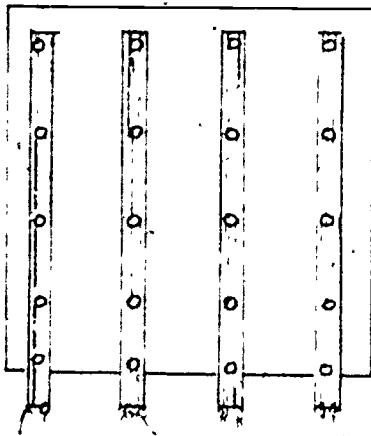

13  
14

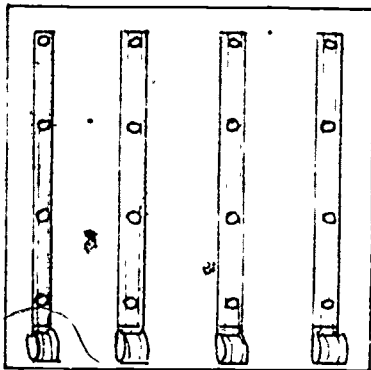

15-16

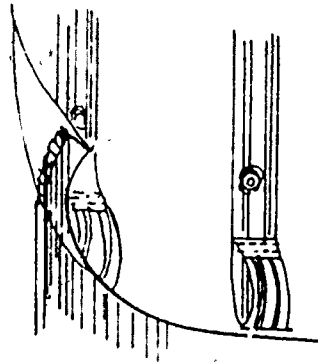

17  
18

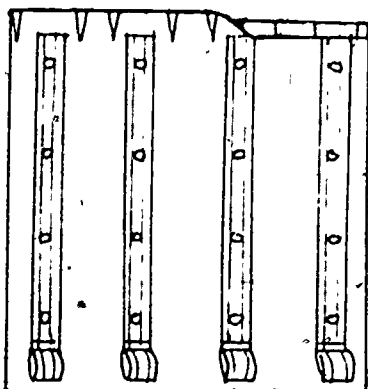

6. Scallops of an Austrian shade can be from 10 to 15 inches apart. Most scallops are placed 12 inches apart.
10. Mark the position for the scallops so that they are evenly spaced across the shade.
11. Pin each tape in position 1 inch below the top of the shade, and stitch along each side of the tape to 1 inch from the bottom of the shade. Be sure the rings of each tape strip are directly in line with the rings of every other tape strip across the shade.
12. Loosely knot the ends of the shirring cords at each end of each strip of tape.
13. At the bottom of the shade, turn up the end of each tape strip 1/4 inch, and press.
14. Turn up the bottom tape 3/4 inch, and stitch the ends in place to form loops through which the bottom rod will be slipped.
15. Finish the bottom edge of the shade by turning 1/4 inch of fabric toward the right side of the shade. Press. Turn up another 1/2 inch to the right side and press.
16. Pin decorative fringe over the hem. Place the top of the fringe just above the top fold of the hem. Stitch the fringe and hem in place.
17. To finish the top edge, place 1 1/2-inch pleats at either side of each shirring tape strip so that the shade measures exactly the desired finished width.
18. At the top of the shade, turn a 1/2-inch hem to the wrong side of the fabric. Stitch the hem, stitching in the pleats at the same time.

19

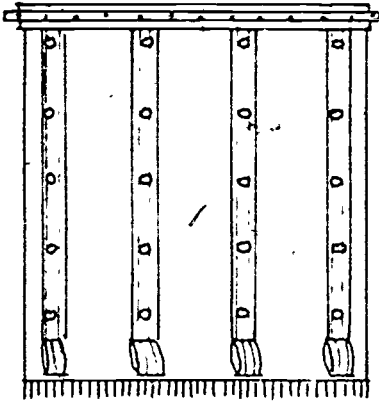
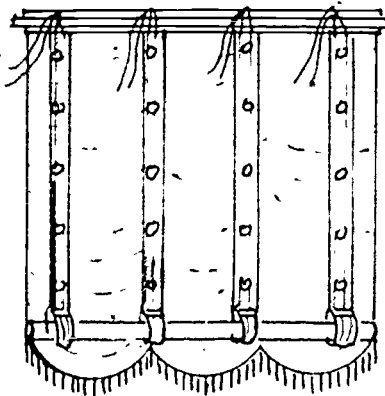
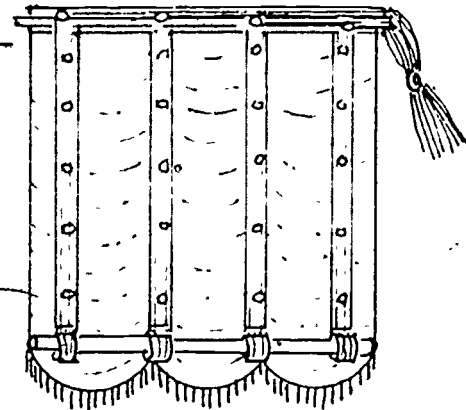
21-  
2425-  
28

19. Sew snap tape or nylon fastening tape on the wrong side of the shade directly over the top hem. The other side of the tape will be attached to the window board.
20. Cover a metal rod with a fabric casing. The rod should be 1 inch shorter than the width of the shade so that the rod will not show.
21. Put the fabric-covered rod through the loops formed by the shirring tapes at the bottom of the shade.
22. Pull up the two cords in each strip of shirring tape until the shade is the desired length.
23. Be sure that each tape is shirred to the same length and that the rings on each tape strip are in line with the rings of every other tape strip across the shade.
24. Knot the cords of each strip together at the top of the shade. Do not cut the cords, so that they can be released and the shade can be unshirred for cleaning.
25. Cut a length of traverse cord for each strip of shirring tape. The cord should be long enough to go up the shade, across the top, and back down the side of the shade.
26. Tie each cord to the covered rod at the bottom. Then thread the cord through the rings of the shirring tape.
27. Fasten the shade to the window board, and string the traverse cord through the screw eyes on the underside of the board.
28. Thread the cords through the screw eyes, and gather them at one side of the shade.
29. Lower the shade to its full length and knot the traverse cords together under the last screw eye.
30. Cut all the cords, but one, just under the knot. The remaining cord will be used to raise and lower the shade.
31. Attach a cleat to the window frame for wrapping the cord around when the shade is raised.



## IMPORTANT DECISIONS IN THE CONSTRUCTION OF A WINDOW TREATMENT

- A. Choose appropriate fabric for intended use
- B. Estimate yardage
1. Establish finished size
  2. Add for seams, hems, top and bottom finishes. Fullness (varies).  
To length allow for:  
top and bottom finish  
fullness (lengthwise) (Austrian shade)  
seams or added construction features (Roman shade tucks)  
To width allow for:  
fullness (2 - 2 1/2 or 3 x for fullness)  
seams (to seam panels together)  
side hems
  3. Determine  
cut length  
cut width and how many fabrics width to achieve cut width
  4. Determine direction to cut from fabric width  
lengthwise (most used)  
crosswise (railroading such as seamless sheers)  
bias (swag)
  5. Determine total yardage
- C. Choose special techniques in construction to establish a quality end product

WINDOW HARDWARE VOCABULARY

1. Single extension rod
2. Double extension rod
3. Curved extension rod
4. Cafe Rod
5. Decorative swinging rod
6. Traverse rod
7. Cafe rings
8. Pleater rings
9. Pleater hooks
10. Pin on hooks
11. Weights
12. Bracket adapter and supports
13. Toggle Bolt
14. Molly bolt
15. Hook and screw anchor
16. Pleater tape
17. Shirring tape
18. Austrian shade tape
19. Roman shade tape
20. Transverse rigged
21. Tension pulley
22. Master slides
23. Carriers

## TRAVERSE RODS

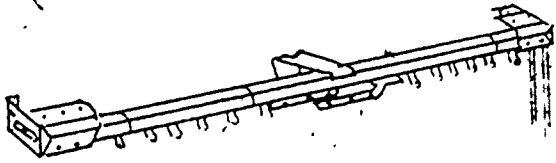

Adjustable Two-Way-Draw Traverse Rod  
Use: for draperies or pleated curtains that open from the center.

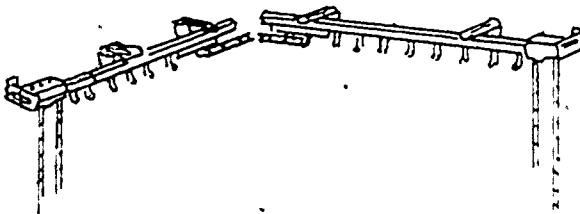

One-Way Traverse Rod  
Use: for pairs that meet in a corner (one left-hand draw, one right-hand draw)

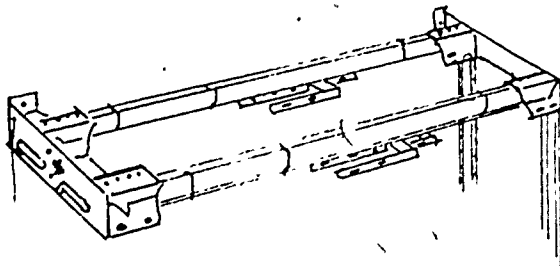

Double Traverse Rod  
Use: for pairs of draperies such as sheer or medium weight draperies with over-draperies (can draw to the center or all to one side)

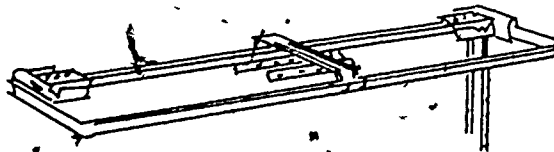

Combination Traverse and Valance Rod  
Use: for draperies and valance

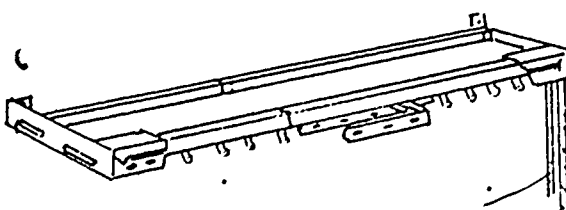

Combination Curtain and Traverse Rod  
Use: for shirred curtains and pleated draperies

Reprinted from Home Furnishings Services Curr.

CUSTOM-CUT TRAVERSE RODS

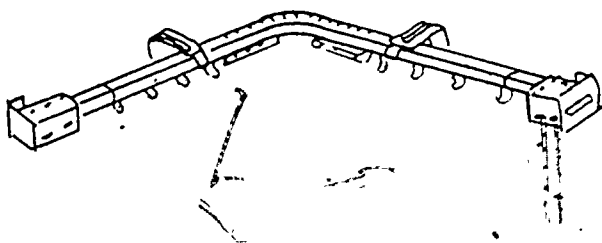

Corner Window Curved Rod Set

Use: for two windows which meet in a corner with no wall space between them

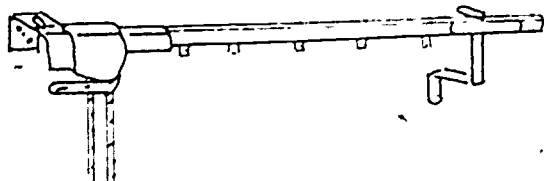

Swinging Door Custom Cut Rod

Use: for single or double doors and in-swinging casement windows

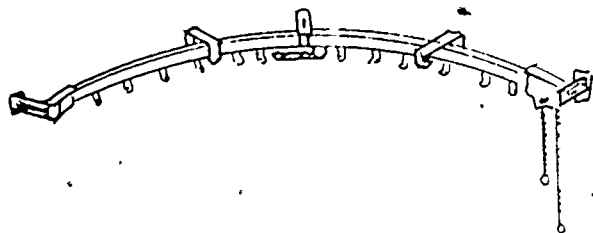

Curved Bay Window Rod

Use: for curved bay window

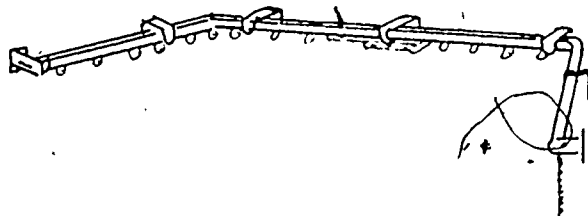

Angled Bay Window Rod

Use: for angled bay window

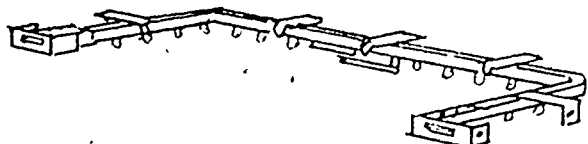

Rectangular Bay Window Rod

Use: for rectangular bay window

Reprinted from Home Furnishings Services Curric.

PARTS OF A TRAVERSE ROD

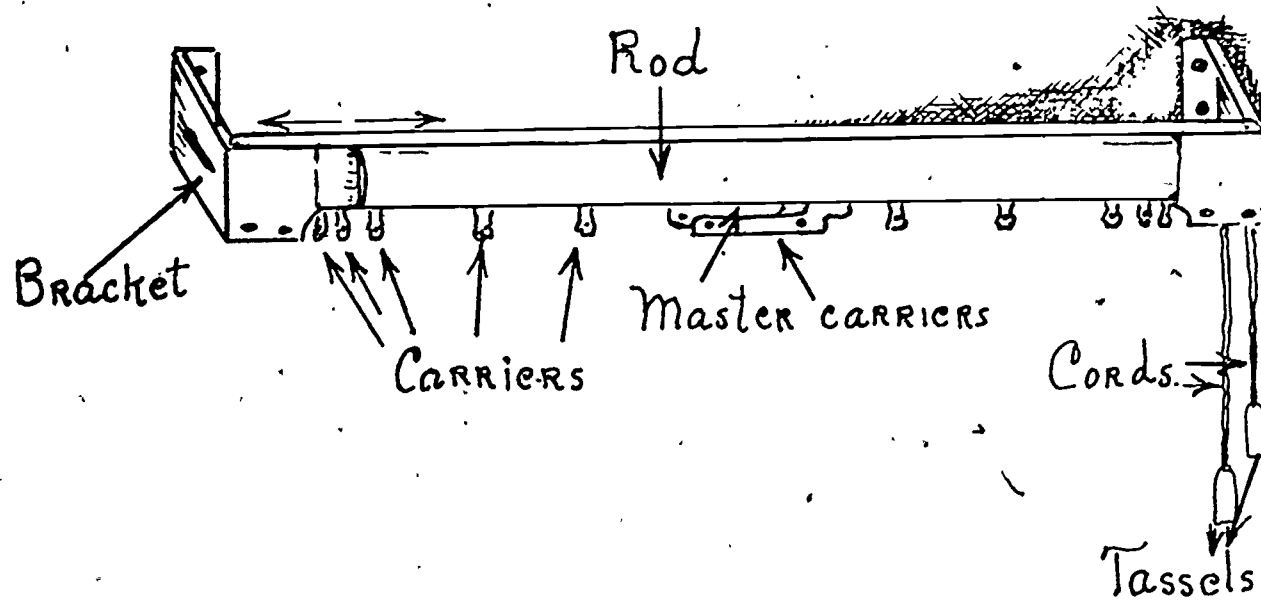

98

100

Reprinted from Drapery Making Curriculum

101

CURTAIN RODS

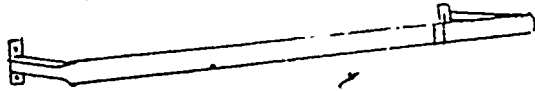

Single Curtain Rod

Use: for curtains and stationary draperies

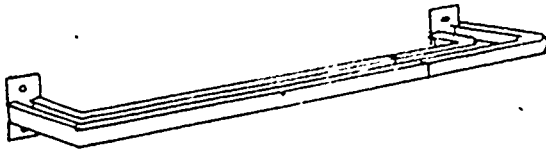

Double Extension Curtain Rod

Use: for curtain and valance or crisscross curtains

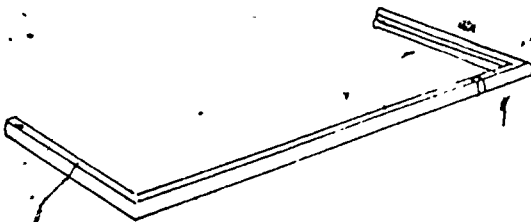

Extension Canopy Curtain Rod

Use: for canopy or valance (placed inside the bottom hem of canopy or valance to hold curtain taut)

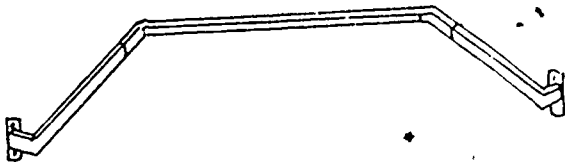

Single Bay Window Curtain Rod

Use: for bay window curtains

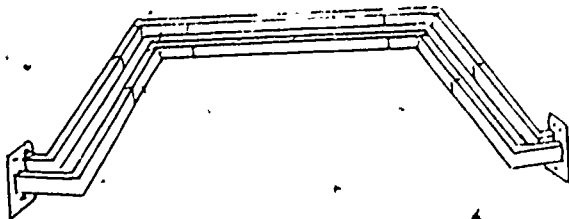

Double Bay Window Curtain Rod

Use: for curtains and valance for bay windows

Reprinted From Home Furnishings Services Curric.

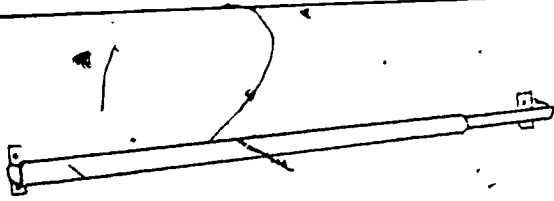

Sash and Door Curtain Rod

Use: for shirred curtains on doors or windows (rods placed in both top and bottom of curtains)

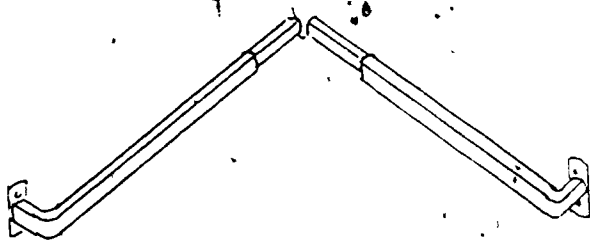

Corner Window Curtain Rod

Use: for stationary curtain or drapery for corner windows



Curved Curtain Rod

Use: for extending curtains into the room for a bowed effect



Spring Pressure Curtain Rod

Use: for shirred or cafe curtains (rod placed inside casings of curtains)

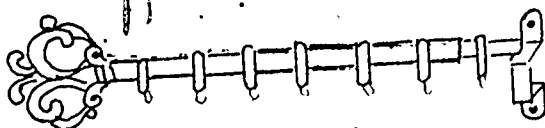

Swinging Crane Curtain Rod

Use: for curtains for in-swinging French doors or casement windows

ROD IDENTIFICATION

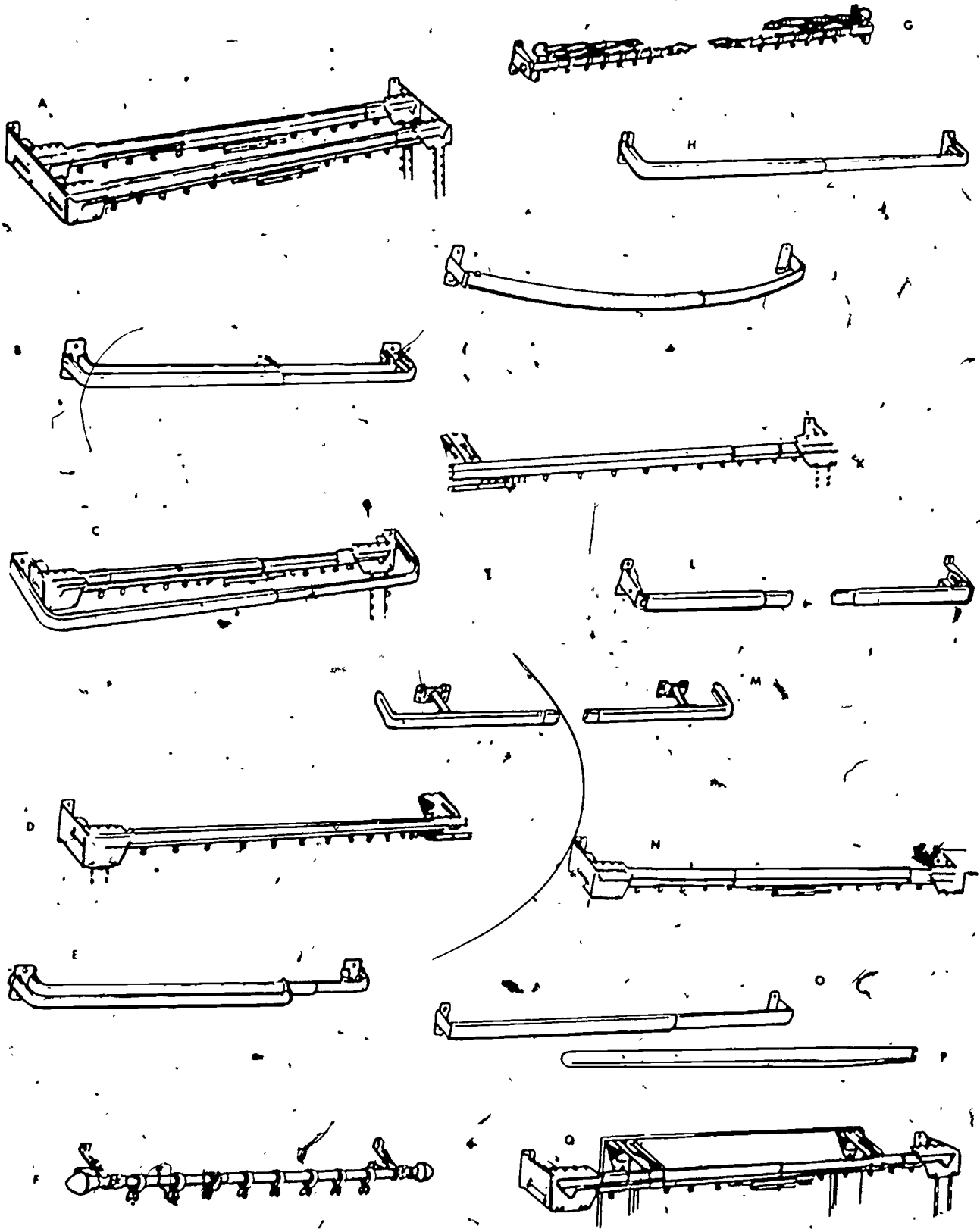



# Key to Identification

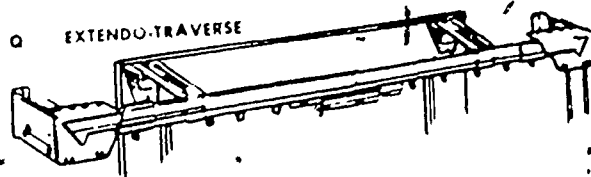
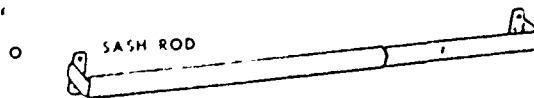
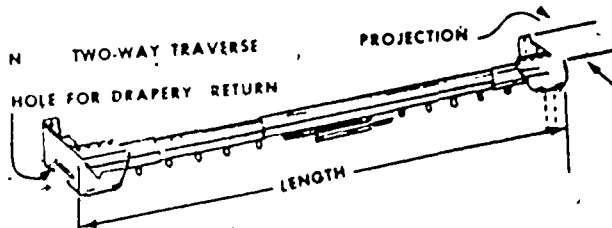
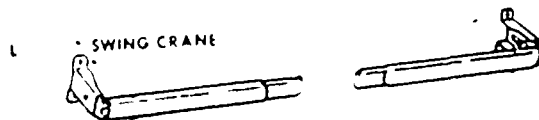
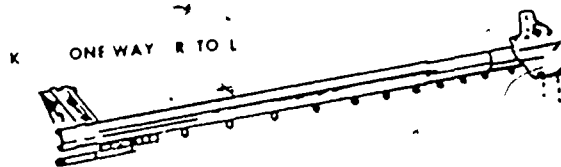
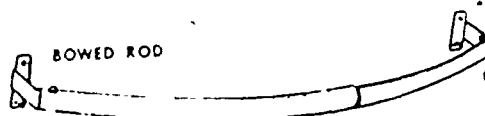
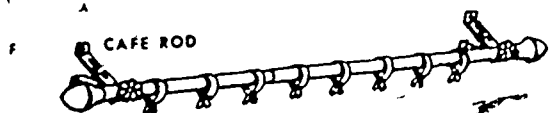
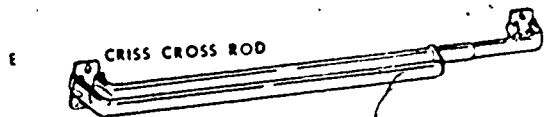
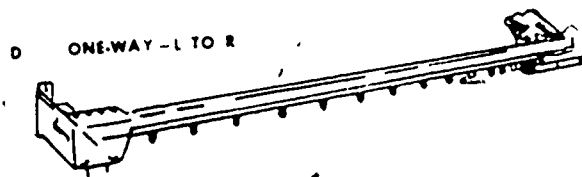
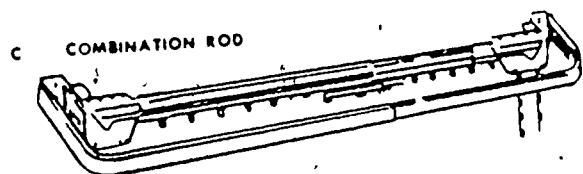
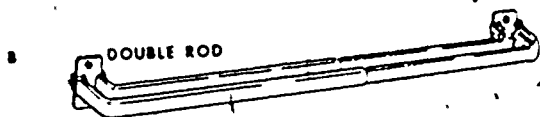
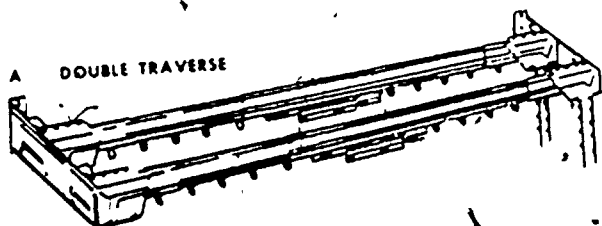

Reprinted from Publication 654, Mississippi  
Co-operative Extension Service

## MOUNTING METHODS FOR DRAPERIES AND CURTAINS

The style of draperies, type of window, and the method of mounting determine the type of drapery hardware to be used. The sketches below show the most common mounting methods.

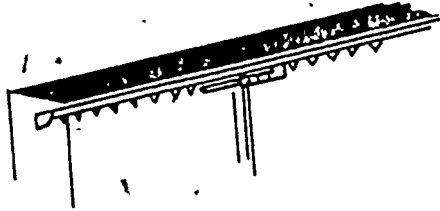

### Inside Casing Mounting

This type of mounting is used for any treatment in which the fabric is hung close to the glass. When traverse rods are used, special inside casing brackets are used.

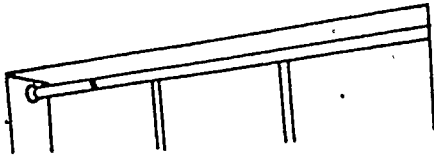

### Spring Tension Mounting

When spring tension rods are used, no brackets are necessary.

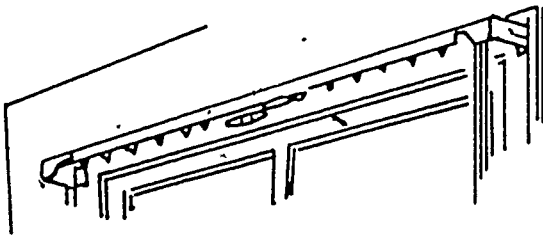

### Casing Mounting

This is the most conventional type of mounting if the windows are wide enough for the drapery treatment.

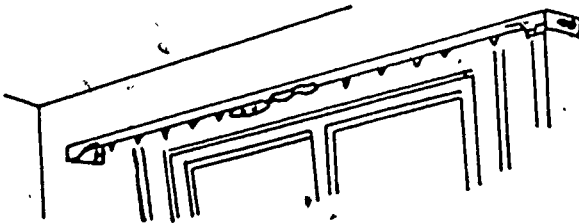

### Wall Mounting

The rod is extended beyond the casing and mounted on the wall to make the window appear wider.

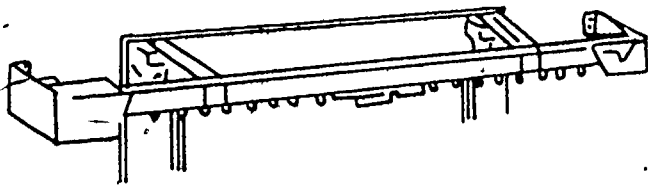

#### Extended Mounting

The brackets are mounted on the casing, but the rod has extensions on each end to make the window look wider. The end brackets do not touch the wall, but simply accommodate the drapery wall returns.

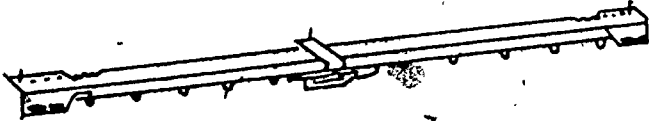

#### Ceiling Mounting

The rod is mounted directly to the ceiling by screws inserted through the tops of brackets and supports. Ceiling track sets are sometimes used. These mount directly to the ceiling, and no brackets are needed.

---

Reprinted from Home Furnishings Services  
Curriculum Guide, Lubbock, Texas

107

## ASSEMBLE TRAVERSE ROD

- When mounting the brackets, be sure both sides are at exactly the same level. Be sure all extra supports are even with the brackets.

Drapery rods usually come in kits with an information sheet for assembling the pieces. The instructions packed with each kit should be studied carefully. Although the rods, master slides, and carriers vary in shape for each drapery hardware company, the assembling method is similar.

To assemble the parts for a two-way draw set:

1. Insert the master slides through end pulley gates on the back of the rod (see Figure 62). Some types may snap onto the back of the rod.
2. Insert the carriers in the same manner as for the master slide. Allow one carrier for each pleat in addition to the pleats for the master slide and the corner of each panel.

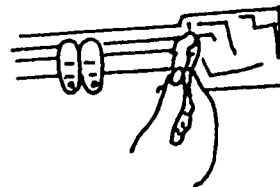

Figure 62.

3. Insert a pulley set at each end of the rod.

- To lace the cord for a two-way draw set with a tension pulley (see Figure 63):

1. Starting with cord knotted at master slide "A," thread the cord through the pulleys at one end.

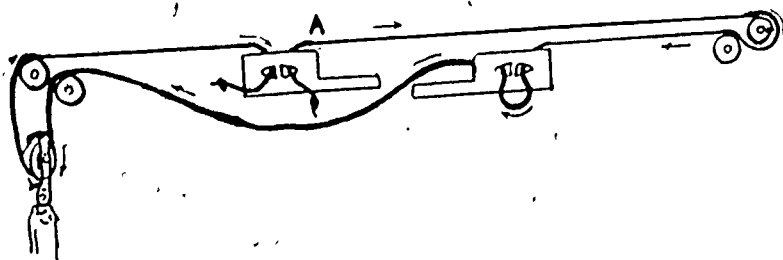

Figure 63.

2. Thread behind carriers under the down-facing hook (see Figure 64).
3. Thread back through the bridge of the other master slide.
4. Thread through the pulleys at the draw end.
5. Thread through the yoke and around the wheel of the tension pulley.
6. Thread back over the outside pulley wheels at the draw end.
7. Adjust the cord for proper tension (the tension pulley spring should be partially extended for best results).
8. Knot the cord end behind the master slide.

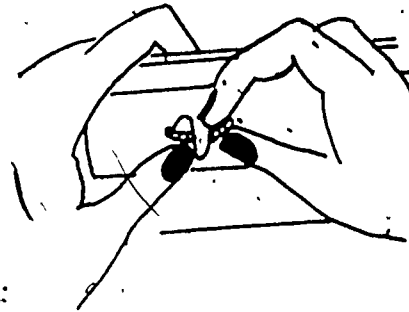

Figure 64.

To lace the cord for a one-way draw set with a tension pulley; refer to Figure 65. The steps are the same as for a two-way draw except there is only one master slide and only one end with two pulleys.

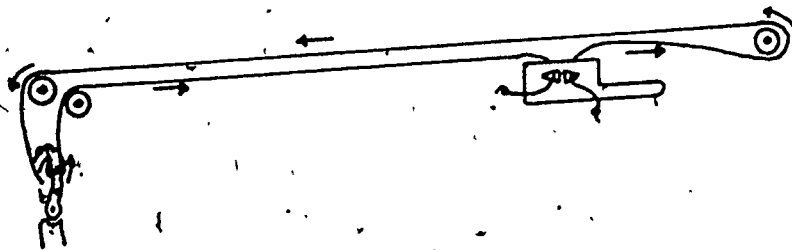

Figure 65.

Insert the hooks into the carriers and pull the cord to make sure the draperies draw. If they do not draw, check to see if the cord has slipped from under the down-facing hook on the back of each carrier. If the error is not here, re-check the entire threading process. Make sure the draperies draw correctly before leaving. Also, make sure the heading is even. The hook pins may have to be adjusted to correct any unevenness.

Reprinted from Home Furnishings Aide,  
Lubbock, Texas

## INSTALLATION TOOLS

The proper installation of drapery hardware is as important as the construction of the draperies. Two simple rules are to be followed:

1. Take measurements carefully. Use either a steel tape,
2. Determine the best screw, plug, or bolt for the hardware according to the type of wall, casing, or ceiling.

In some instances, electric drills are needed, but generally only a few simple tools are needed for installing. These are illustrated below.

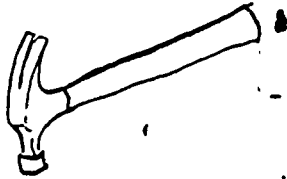

Hammer

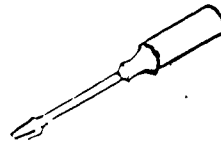

Screw driver



Awl (or ice pick)

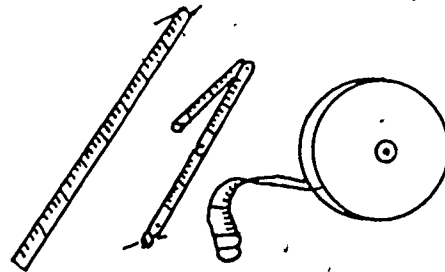

Steel tape, folding ruler,  
or yardstick

Many types of screws, bolts, and plugs are available. The selection of the type to be used will depend upon the type of wall, the weight of the draperies, and/or the type of drapery hardware. Following is a chart giving some installation tips for attaching the hardware.

Reprinted from Home Furnishings Services  
Curriculum Guide, Lubbock, Texas

## BRACKETS

A bracket is a fixture for mounting drapery rods to the wall, casing, or ceiling. One end of the bracket attaches to the wall. The drapery or curtain rod slips in and locks to the other end. Several types of brackets are shown in the following illustrations.

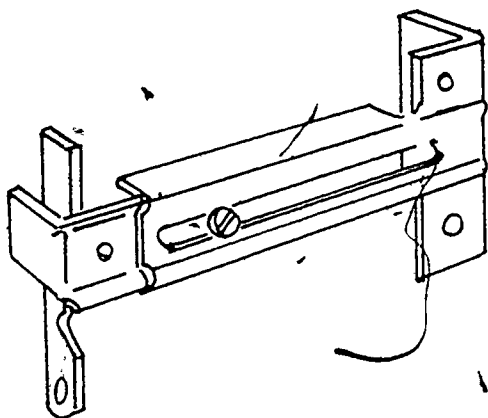

Traverse Bracket  
Used with a regular traverse rod.

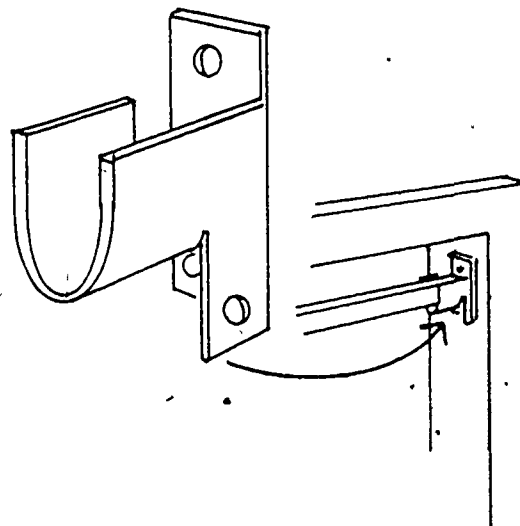

Inside Bracket  
Mounts inside window casing or door frame to hold curtains.

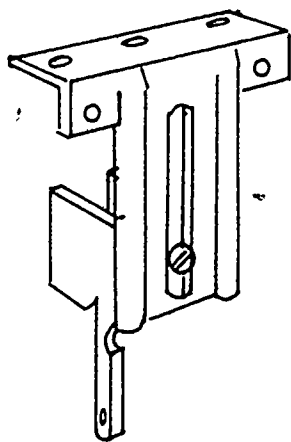

Ceiling Bracket  
Mounts on the ceiling to hold traverse rods.

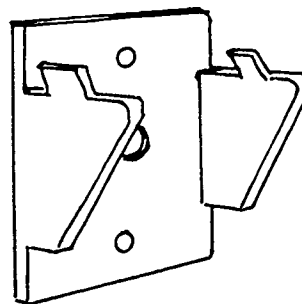



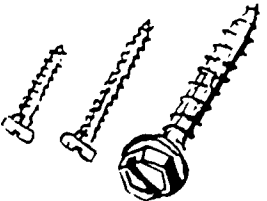
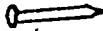
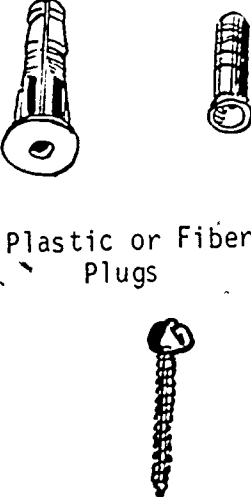

Double Bracket  
Used with layered window-treatments to hold flat curtain rods or traverse rods.

Reprinted from Home Furnishings Services  
Curriculum Guide, Lubbock, Texas

## INSTALLATION TIPS

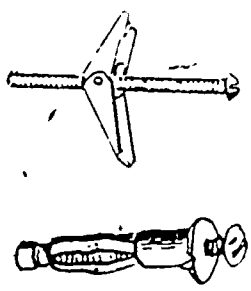
TYPE OF WALL	TYPE OF SCREW	PROCEDURES FOR INSTALLING
Wood	 <p style="text-align: center;">Wood Screws</p>	<p>Soft wood--Use an awl to make starter holes for screws</p> <p>Hard wood--Drill holes of proper size</p> <p>Do not fasten into the mitered joint of window casing.</p> <p>The heavier the draperies, the longer the screw.</p>
	 <p style="text-align: center;">Nails</p>	<p>Use only for putting up lightweight curtain rods</p>
<p>Hollow Wall</p> <p>Dry Wall</p>	<p style="text-align: center;">Combination of</p>  <p style="text-align: center;">Plastic or Fiber Plugs</p> <p style="text-align: center;">and Screws</p>	<p>Use an awl to make starter holes.</p> <p>Insert plug, then insert screw in plug.</p>



TYPE OF WALL	TYPE OF SCREW	PROCEDURES FOR INSTALLING
	 <p data-bbox="595 725 784 828">Toggle Bolts or Molly Bolts</p>	<p data-bbox="972 404 1379 704">Use as anchors for heavy draperies. Use in a hollow wall where there is a separation between outer and inner walls. Arms open inside wall as shown.</p>  <p data-bbox="972 725 1379 890">Use 3/8-inch drill for holes. (Used when screws will not hold.)</p>
Plaster	<p data-bbox="595 1305 784 1346">Molly Bolts</p> <p data-bbox="595 1367 878 1471">Toggle Bolts (As shown for dry wall installation)</p>	<p data-bbox="972 953 1426 1284">Use an awl or drill to make starter holes. Wet the bit of the drill as well as the screw or bolt to insure smoother, cleaner job. To prevent bits of plaster from falling, place a piece of transparent tape over the point on the wall where the hole will be made.</p> <p data-bbox="972 1367 1364 1450">Use as anchors for heavy draperies.</p>
Masonry	 <p data-bbox="595 1667 925 1740">Plugs (Fastener and Anchor)</p>	<p data-bbox="972 1533 1332 1636">Mark location of holes accurately. Drill necessary holes.</p>
Steel	 <p data-bbox="595 1885 893 1926">Sheet Metal Screws</p>	<p data-bbox="972 1781 1426 1885">Use with standard steel casement windows which have holes punched for screws.</p>

Reprinted from Home Furnishings Services, Curriculum Guide

## INSTALLATION PROCEDURES

Use check list to complete installation procedures.

1. Determine the best screw, plug or bolt to use for installing rods.
2. Install both brackets the same height.
3. Mount extra supports needed. This depends upon the length of the rod and weight of window treatment.
4. Remove or add extra slide on rods as needed.
5. Place the rod on the brackets and supports.
6. Adjust the cord in the rods.
7. Place the drapery pins in the slides on the rods starting from the center.
8. Close the drapery. Check if the heading is even. If not, adjust the hook pins to correct any unevenness in the heading.
9. Open the drapery. Retrain the spaces between the pleats if drapery is hung on a standard traverse rod.

If it does not operate correctly:

- a) check to see if the cord has slipped from under the down-facing hook on the back of the master-carriers.
  - b) if the problem is not located, recheck the entire threading process.
10. Use a steam presser to reset pleat folds or remove wrinkles.

## ACHIEVEMENT TEST

Fill in the blanks:

1. Traverse rods are used with \_\_\_\_\_ draperies.
2. Rods can be mounted on the \_\_\_\_\_ the \_\_\_\_\_ or on the \_\_\_\_\_.
3. Place hooks  $1\frac{1}{2}$ " from the top of the drapery when the rods are mounted on the \_\_\_\_\_.
4. When the rods are on the ceiling place hooks \_\_\_\_\_ from the top of drape.
5. \_\_\_\_\_ rods add beauty to a room.
6. Decorative rods should match the \_\_\_\_\_ or \_\_\_\_\_ of the room.
7. Plain round rods can be \_\_\_\_\_ or \_\_\_\_\_.
8. \_\_\_\_\_ rods are flat rods with returns.
9. Curtain rods are cheaper than \_\_\_\_\_ rods.
10. They are \_\_\_\_\_ to install.
11. A criss-cross rod is used for \_\_\_\_\_ - \_\_\_\_\_ curtains.
12. \_\_\_\_\_ means a stretching out.

115

## REFERENCES

1. Home Furnishings Aide, Home Economics Instructional Materials Center, Texas Tech. University, Box 4067, Lubbock, Texas 79409, 1976, Teacher copy - \$17.50, Student copy - \$12.00.
2. Home Furnishings Service, Jacqueline McLeoy, Home Economics Instructional Materials Center, Texas Tech. University, Box 4067, Lubbock, Texas 79409, 1975, \$15.00
3. Home Decoration and Furnishings Occupations Curriculum Guide, California State Department of Education, Bureau of Publications, 721 Capitol Mall, Sacramento, California 95814, 1979, \$2.75
4. Drapery Making - 2, Catherine Kane, Vocational-Tech. Curriculum Laboratory, Rutgers - The State University, Building 4103, Kilmer Campus, New Brunswick, New Jersey, 1970, \$2.50.
5. VTECS PUBLICATION refers to Instructor's Guide, Home and Home Furnishings Module # 9. Written by DPI, Office of Voc, Ed. , Home Economics Educ. Section, Columbia, South Carolina in co-operation with Voc. Education Curriculum Development Section. Available at Vocational Studies Center, Univ. of Wisconsin - Madison, 265 Educ. Science Bldg.; 1025 W. Johnson St., Madison, Wisc. 53706