

DOCUMENT RESUME

ED 224 879

CE 034 458

TITLE Present Information with Overhead and Opaque Materials. Second Edition. Module C-23 of Category C--Instructional Execution. Professional Teacher Education Module Series.

INSTITUTION American Association for Vocational Instructional Materials, Athens, Ga.; Ohio State Univ., Columbus. National Center for Research in Vocational Education.

REPORT NO ISBN-0-89606-092-6

PUB DATE 82

NOTE 55p.; For related documents, see CE 034 263, CE 034 459, and ED 220 674.

AVAILABLE FROM American Association for Vocational Instructional Materials, 120 Driftmier Engineering Center, University of Georgia, Athens, GA 30602.

PUB TYPE Guides - Classroom Use - Materials (For Learner) (051)

EDRS PRICE MF01/PC03 Plus Postage.

DESCRIPTORS *Audiovisual Aids; Behavioral Objectives; *Competency Based Teacher Education; Educational Equipment; Equipment Utilization; Higher Education; Individualized Instruction; Job Skills; Learning Activities; Learning Modules; Media Selection; Opaque Projectors; Overhead Projectors; Postsecondary Education; Secondary Education; *Teaching Methods; *Teaching Skills; Transparencies; *Visual Aids; Vocational Education; *Vocational Education Teachers

ABSTRACT

This module for vocational teachers, one in a series of performance-based teacher education learning packages, focuses on skills dealing with methods and strategies for delivering instruction. The purpose for the module is to help educators become competent in operating overhead and opaque projection equipment, using overhead and opaque materials to present information in the classroom or lab, and determining when it is appropriate to use projectors. Introductory material provides terminal and enabling objectives, prerequisites, necessary resources, and general information. The main portion of the module includes five learning experiences based on the enabling objectives. Each of the first four learning experiences includes educational activities with information sheets, worksheets, and a self-evaluation form. Completion of the first four experiences is intended to lead to achievement of the terminal objective in the fourth and final learning experience that includes a teacher-performance assessment form to be completed by a resource person. (YLB)

 * Reproductions supplied by EDRS are the best that can be made *
 * from the original document. *

MODULE
C-23

**Present Information with
Overhead and Opaque Materials**

Second Edition

Module C-23 of Category C--Instructional Execution
PROFESSIONAL TEACHER EDUCATION MODULE SERIES

The National Center for Research in Vocational Education
The Ohio State University

Key Program Staff:

- James B. Hamilton, Program Director
- Robert E. Norton, Associate Program Director
- Glen E. Fardig, Specialist
- Lois G. Harrington, Program Associate
- Karen M. Quinn, Program Associate

Second Edition. Copyright © 1982 by The National Center for Research in Vocational Education,
The Ohio State University, 1960 Kenny Road, Columbus, Ohio 43210.

Copyright is claimed until full term. Thereafter all portions of this work covered by this copyright will be in the public domain.

This work was developed under a contract with the Department of Education. However, the content does not necessarily reflect the position or policy of that Agency, and no official endorsement of these materials should be inferred.

1982

ISBN 0-89606-092-6

Published and distributed by the American Association for Vocational Instructional Materials (AAVIM), 120 Driftmier Engineering Center, University of Georgia, Athens, Georgia 30602, (404) 542-2586.

U.S. DEPARTMENT OF EDUCATION
NATIONAL INSTITUTE OF EDUCATION
EDUCATIONAL RESOURCES INFORMATION
CENTER (ERIC)

✓ This document has been reproduced as received from the person or organization originating it.
Minor changes have been made to improve reproduction quality.

- Points of view or opinions stated in this document do not necessarily represent official NIE position or policy.

"PERMISSION TO REPRODUCE THIS MATERIAL HAS BEEN GRANTED BY



TO THE EDUCATIONAL RESOURCES INFORMATION CENTER (ERIC)."

ED224879

034458

INTRODUCTION

Audiovisual equipment and materials are versatile tools that can be used in a variety of ways and that can help ensure that your lessons will be more effective and interesting. Overhead and opaque projectors are two audiovisual devices that are especially valuable to vocational educators since vocational curriculum changes in response to the real world of work. Texts, because they take so long to write and publish, cannot always be kept up to date. With teacher-made materials prepared for overhead and opaque projectors, the teacher has a constantly updated "text" always available.

There are a number of advantages to using these projectors: (1) they permit the teacher to remain at the front of the room facing the class; (2) creative projection materials can help the teacher present complicated concepts or processes in a simple, clear way; (3) visuals allow students to see, as well as hear about, the material being covered; and (4) students can be involved in the classroom activities by preparing materials or operating the equipment. The opaque and overhead projectors can be used at any point in the lesson (introduction, body, summary) and they can be very effectively used in combination with other types of media.

This module is designed to help you become competent in operating overhead and opaque projection equipment, and in using overhead and opaque materials to present information in the classroom or laboratory. It will also help you gain skill in determining when it is appropriate to use the overhead or opaque projector for a particular lesson.

It should be noted that the overhead projector is particularly suited to lessons or presentations given to large groups. This device has considerably less use in individualized, self-paced instructional programs, where the teacher gives fewer, if any, formal lessons or lectures.

Many vocational programs no longer use the opaque projector. If you and your resource person decide that the opaque projector can make a valuable contribution to your instructional effectiveness, you will want to complete those sections of the module dealing with the use of the opaque projector. Otherwise, you may choose to complete only those experiences dealing with the overhead projector.

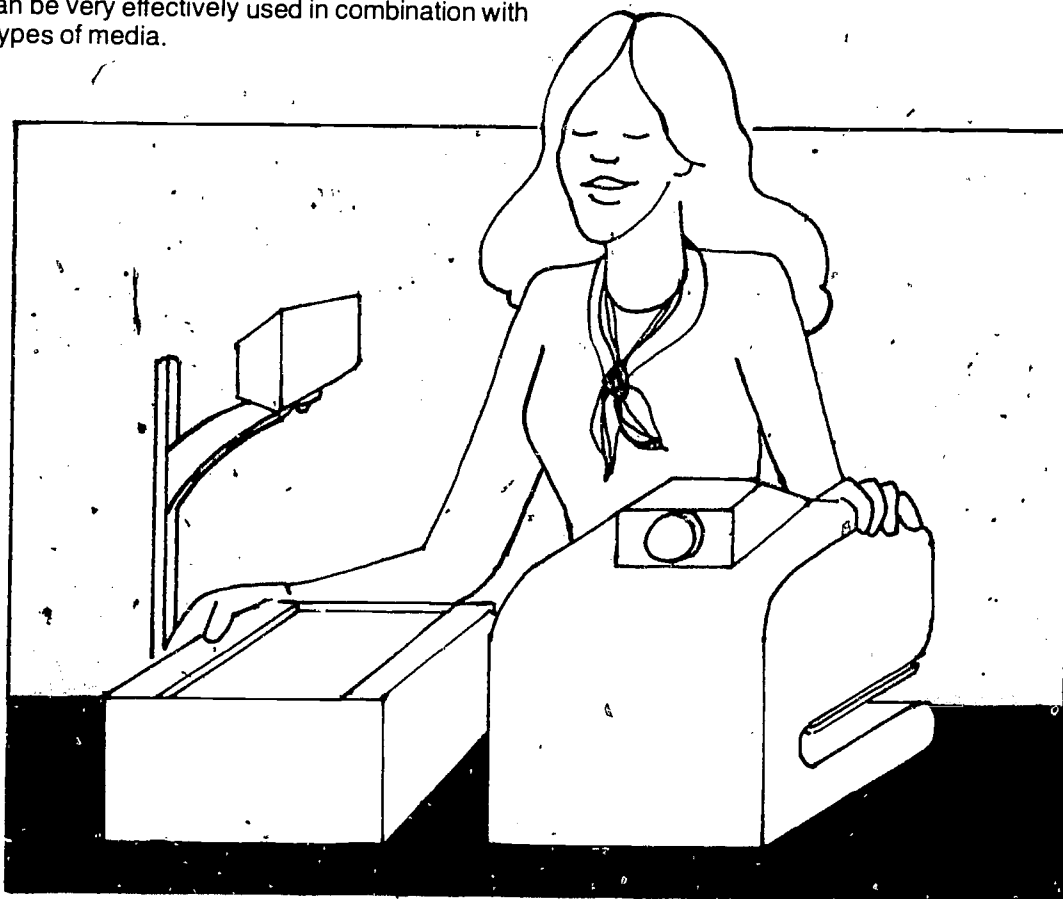

ABOUT THIS MODULE

Objectives

Terminal Objective: In an actual teaching situation, present information with overhead and/or opaque materials. Your performance will be assessed by your resource person, using the Teacher Performance Assessment Form, pp. 51 - 52.

Enabling Objectives:

1. After completing the required reading, set up and operate overhead equipment (*Learning Experience I*).
2. After completing the required reading, present information with overhead materials and equipment in a practice situation (*Learning Experience II*).
3. After completing the required reading, set up and operate opaque equipment (*Learning Experience III*).
4. After completing the required reading, present information with opaque materials and equipment in a practice situation (*Learning Experience IV*).

Prerequisites

To complete this module, you must have competency in developing a lesson plan and in selecting student instructional materials. If you do not already have these competencies, meet with your resource person to determine what method you will use to gain these skills. One option is to complete the information and practice activities in the following modules:

- *Develop a Lesson Plan*, Module B-4
- *Select Student Instructional Materials*, Module B-5

Resources

A list of the outside resources that supplement those contained within the module follows. Check with your resource person (1) to determine the availability and the location of these resources, (2) to locate additional references in your occupational specialty, and (3) to get assistance in setting up activities with peers or observations of skilled teachers, if necessary. Your resource person may also be contacted if you have any difficulty with directions or in assessing your progress at any time.

Learning Experience I

Required

- An overhead projector* to set up and operate.
- A projection screen* to use with the projector.
- Materials* (e.g., transparencies, a pointer) for use in setting up and operating the projector.
- A measuring device* (e.g., ruler, yardstick, tape measure) for use in setting up the projector.

Optional

- An audiovisual expert* with whom you can discuss the uses and operation of overhead projectors.
- An audiovisual equipment dealer* whom you can visit or write to concerning current overhead projector equipment and supplies.

Learning Experience II

Required

- An overhead projector* to use during a lesson.
- A projection screen* to use with the projector.
- Materials* (e.g., transparencies, a pointer) with which to present information in a lesson.
- A resource person* to role-play a student to whom you are presenting a lesson and to evaluate your performance in using overhead materials to present information.

Optional

- A resource person* to review the adequacy of your lesson plan.
- A teacher* skilled in presenting information using overhead materials whom you can observe.

Learning Experience III

Required

- An opaque projector* to set up and operate.
- A projection screen* to use with the projector.
- Materials* (e.g., book pages, pictures, coins, diagrams) for use in setting up and operating the projector.

A measuring device (e.g., ruler, yardstick, tape measure) for use in setting up the projector.

Optional

An audiovisual expert with whom you can discuss the uses and operation of opaque projectors.

An audiovisual equipment dealer whom you can visit or write to concerning current opaque projector equipment and supplies.

Learning Experience IV

Required

An opaque projector to use during a lesson.

A projection screen to use with the projector.

Materials (e.g., book pages, pictures, coins, diagrams) with which to present information in a lesson.

A resource person to role-play a student to whom you are presenting a lesson and to evaluate your performance in using opaque materials to present information.

Optional

A resource person to review the adequacy of your lesson plan.

A teacher skilled in presenting information with opaque materials whom you can observe.

Learning Experience V

Required

An actual teaching situation in which you can present information with overhead and/or opaque materials.

A resource person to assess your competency in presenting information with overhead and/or opaque materials.

General Information

For information about the general organization of each performance-based teacher education (PBTE) module, general procedures for its use, and terminology that is common to all the modules, see About Using the National Center's PBTE Modules on the inside back cover. For more in-depth information on how to use the modules in teacher/trainer education programs, you may wish to refer to three related documents:

The *Student Guide to Using Performance-Based Teacher Education Materials* is designed to help orient preservice and inservice teachers and occupational trainers to PBTE in general and to the PBTE materials.

The *Resource Person Guide to Using Performance-Based Teacher Education Materials* can help prospective resource persons to guide and assist preservice and inservice teachers and occupational trainers in the development of professional teaching competencies through use of the PBTE modules. It also includes lists of all the module competencies, as well as a listing of the supplementary resources and the addresses where they can be obtained.

The *Guide to the Implementation of Performance-Based Teacher Education* is designed to help those who will administer the PBTE program. It contains answers to implementation questions, possible solutions to problems, and alternative courses of action.

NOTES

Lined area for taking notes, consisting of approximately 25 horizontal lines.



Learning Experience I

OVERVIEW



After completing the required reading, set up and operate overhead equipment.



You will be reading the information sheet, Operating the Overhead Projector, pp. 8-11.

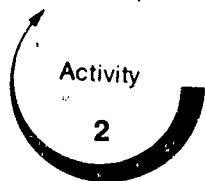

You will be setting up and operating an overhead projector by completing the exercises specified in the Overhead Projector Worksheet, pp. 13-16.

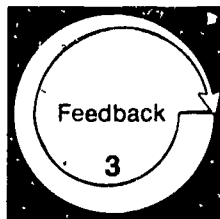

You will be evaluating your competency in setting up and operating the overhead projector, using the Overhead Projector Operation Checklist, p. 17.

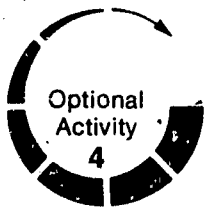

You may wish to locate and meet with a person with expertise in the area of audiovisuals for the purpose of discussing further the uses and operation of the overhead projector.

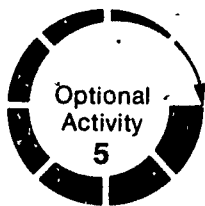

You may wish either to visit an audiovisual equipment dealer or to write to a dealer for catalogs describing the latest types of equipment and supplies available.

FIGURE 1

OVERHEAD EQUIPMENT

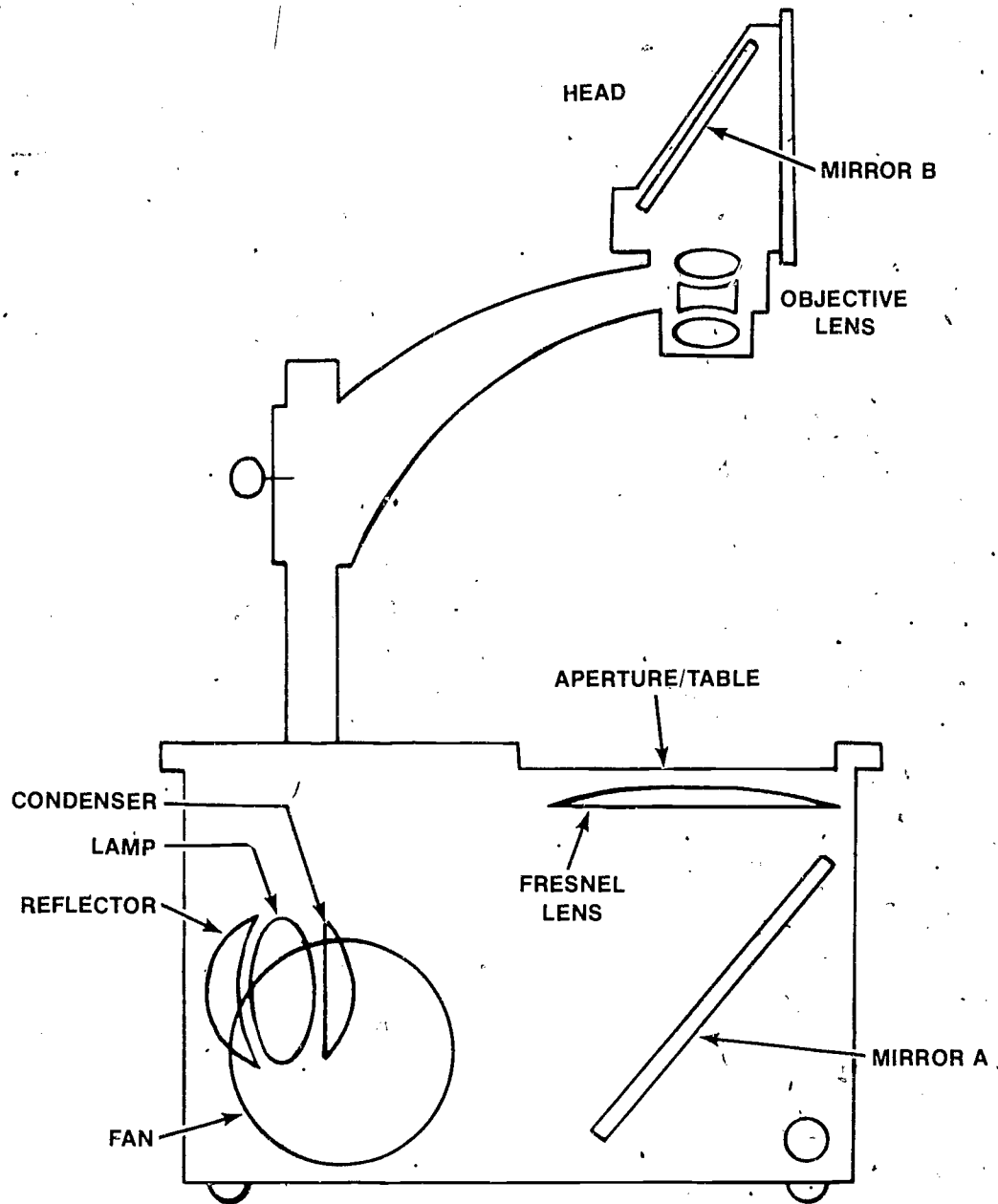

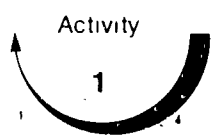

The overhead projector is basically a simple piece of equipment that, once learned, takes little time or trouble for the teacher to use. To learn how to set up the overhead projector in a classroom and how to operate and maintain the equipment so it will provide clear, sharp pictures, read the following information sheet.

OPERATING THE OVERHEAD PROJECTOR

Projection Principles

The typical overhead projector, as shown in figure 1, uses an **indirect projection system**. This simply means that the light is not traveling in a straight line from the bulb to the screen, but instead is redirected by mirrors before reaching the screen. The lamp is the light source, and this light is redirected by **mirror A** so that it passes straight up through the **table**. The transparent material to be projected is placed on that table, so that light passes through it, also. The projected image travels straight up to the projector head, where it is again redirected by **mirror B**, so that it travels to the screen. The light is so intense that the overhead projector can be used in a normally lighted classroom.

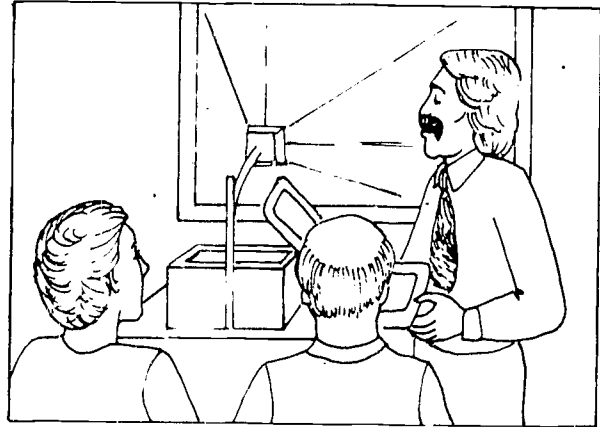

Projector Placement

Because the projector has a short focus lens, you can project a large image on a screen from a short distance. For example, at a distance from screen to projector of 12 feet, you can get a picture size of 8 feet by 8 feet. Thus, the projector should be placed at the **front** of the room. Some authorities recommend that the teacher be seated next to the projector so that he/she (1) does not block the students' view of the screen, (2) can change transparencies easily, (3) can point to items of importance, or (4) can write on the transparency. In this case, you need a low table or stand on which to place the projector.

Others, who use the overhead projector regularly, suggest that, when the overhead is being used to present part of the material for the lesson, the teacher needs to be mobile, not in a stationary position. In this case, a higher stand would be needed, one that allows you to write on the transparency and read the transparency comfortably while standing.

Projection Materials

The materials that can be projected by the overhead projector include any materials that are transparent (i.e., materials through which the light will pass). The most common type of material used is the 10" by 10" acetate transparency. Transparencies can be machine-produced through the use of a variety of duplication processes, hand-produced through the use of grease pencils or special audiovisual felt-tip pens, or commercially produced.¹

Transparencies are simply placed on the projection table so that the image appears right side up to the teacher who is facing the class. Usually, transparencies are mounted on cardboard frames to make them easier to handle. Mounting the transparency on a cardboard frame is especially desirable when the transparencies will be used repeatedly. The frame also provides space for jotting down thought-stimulating notes or key points that are to be made during the presentation.

1. To gain skill in producing transparencies, you may wish to refer to Module B-6, *Prepare Teacher-Made Instructional Materials*.

Acetate can also be purchased in 25' to 50' rolls. The roll is placed on the machine via a special attachment, providing the teacher with a continuous writing surface. Writing on this acetate requires the use of a china marking pencil (grease pencil) or felt-tip pens made especially for this purpose. The marks left on the acetate by these writing instruments can be readily removed by using a soft cloth moistened with carbon tetrachloride (cleaning fluid).

Operation Procedures

The overhead projector is a simple machine to operate. Usually, there is just a single switch that can be placed in one of two or three positions. In older machines the positions are off, fan, and lamp; in newer machines the positions are off and on.

The bulb in an overhead projector is very powerful and, thus, gets very hot. When the switch is positioned at **fan**, **lamp**, or **on**, the fan is on, keeping the machine cooled. On the newer machines, when the projector is turned to **off**, the fan continues to operate and then turns itself off automatically when the bulb cools down. On older machines, **never** turn the projector completely off immediately after using it. Always turn it first to **fan** and allow the fan to run a few minutes in order to cool the lamp down.

Picture-size adjustment is also simple. To enlarge the image on the screen, move the projector away from the screen. To reduce the image on the screen, move the projector closer to the screen. To raise or lower the position of the image on the screen, either adjust the extendable legs at the front of the machine, or adjust the tilt of the mirror in the lens head.

To focus the screen image, simply raise or lower the lens head. Obviously, these are **general** operating procedures. Before attempting to operate any **specific** model of overhead projector, it is a good idea to check the operating manual for that model.

Projection Screen

Ideally, the screen used with the overhead projector should be 70" by 70", assuming you have a standard-sized classroom. There are three basic types of screens: matte, glass beaded, and lenticular. A **matte** screen looks like a dull white cloth and will provide a good, bright picture over a wide viewing angle. In other words, persons seated at the center of the room and at either side of the room will see the same bright picture. A **glass beaded** screen has a surface covered with tiny glass beads. It gives a much brighter picture than the matte screen, but only to persons seated along the line of projection. The **lenticular** screen has tiny ridges molded into the surface. It gives a bright image to viewers from all angles. The lenticular

screen is probably the best screen to use with the overhead projector (if you have a choice) since it provides a bright image suitable for viewing in a normally lighted room.

Whichever screen you use, students need to be seated so that all have a good view of a clear picture. It is usually recommended that, if possible, you mount the screen on the wall in the corner of the front of the room nearest the windows. Since the windows are then behind the screen, glare is reduced.

The bottom of the screen should be at least as high off the floor as the level of the heads of the seated members of the audience so that the teacher and the projector do not block the audience's view. Preferably, the top of the screen should be tilted out from the wall to prevent distortion. This distortion, called the keystone effect, occurs when the screen surface is not perpendicular to the line of projection. The result is a distorted image in which the top of the image appears larger than the bottom because the top part of the image is farther away from the projector.

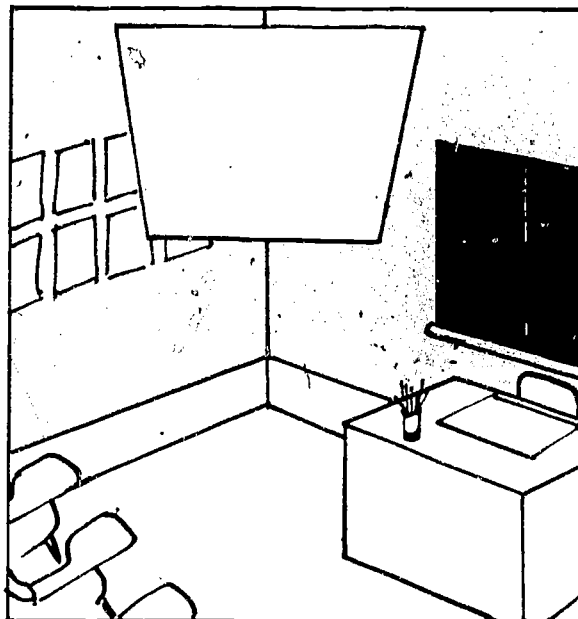

Machine Maintenance

The most important step in keeping the overhead projector in good operating condition has already been mentioned: make sure you allow the fan to cool the bulb before turning the projector off and putting it away. The bulb has a life expectancy of approximately 75 hours, but if it is bumped or jarred while it is hot, the filaments may fuse together. If this happens, the bulb will probably burn out the next time the machine is turned on.

Whenever you use the overhead projector, make sure you have a spare bulb available. It is very frustrating to have prepared or selected transparencies that illustrate your lesson perfectly, only to have the bulb (your only bulb) burn out halfway through your presentation.

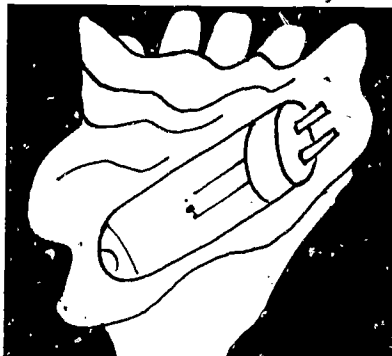

To change the bulb, unplug the machine, and wait until it is cool. In some projectors, the bulb can be reached by opening a side panel in the body of the projector. In others, you simply tip back the head and projection table assembly to gain access to the bulb and mirrors. Pull the bulb up out of its spring-loaded

socket. Use a cloth to handle the new bulb during replacement since fingerprints or other foreign substances on the bulb cause light to be reflected back into the bulb. This increases the heat and shortens the bulb's projection life.

Some late-model projectors have a second bulb built right into the equipment. If a bulb does burn out, all you have to do is turn a lever on the control panel and a new bulb moves into place.

Your only other maintenance concern is keeping the glass parts of the machine (table and lens head) clean. You can prevent the table from getting dirty by protecting it with a sheet of clear plastic before projecting real objects. If the lens or table gets dirty, it may be cleaned with a soft, lint-free cloth that has been dampened with lukewarm water containing a mild detergent. You may find it even more convenient to have a spray can of commercial glass and mirror cleaner handy for this purpose.

NOTES



The following worksheet is designed to help you become competent in operating the overhead projector. No one need see this worksheet unless you choose to show it to someone, so do not be reluctant to record what actually happens, right or wrong. The sheet is not intended to show proof that you did everything perfectly the first time; it is intended to help you to organize your knowledge about the operation of overhead equipment, to point out to you where you have gaps in your knowledge, and to help you determine how to fill those gaps. Completed thoughtfully and thoroughly, this sheet should make an excellent reference for you in the future. Read the directions carefully and then complete each of the 21 exercises.

OVERHEAD PROJECTOR WORKSHEET

Directions: Locate an overhead projector, a screen to use with the projector, a sheet of clear acetate, an audiovisual felt-tip pen, a teacher-made or commercially produced transparency; and a measuring device (e.g., ruler, yardstick, tape measure). Arrange for this equipment and material to be placed in the room in which you will be working with them. Complete each of the following exercises using the actual equipment and materials. Each exercise requires a short response. Please respond fully, but briefly, and make sure you respond to all parts of each item. Do **not** answer simply YES or NO; explain your responses. Should you have any difficulty with an exercise, make a note of that problem.

1. What is the make and model of the overhead projector with which you are working?
2. Is there an operating manual? Does it contain any information that is different from, or was not covered in, the information sheet? If so, briefly describe that information.
3. What type of table is being used to hold the projector (portability, height, etc.)?
4. Describe the overhead materials that you are using.
5. What type or brand of felt-tip pen are you using? What color ink does it have?

6. Describe the type of screen with which you are working (matte, beaded, or lenticular; how is it mounted; what size is it; etc.?).

7. Set up the screen for use. Briefly describe any special procedures involved (e.g., "There is a release button that must be pushed."). If the screen is portable, where have you placed it and why?

8. What type of lighting are you using in the room? Is this type of lighting appropriate for using the overhead projector? Why or why not?

9. Locate the projection lamp. Remove it from the projector, and then replace it. Describe the lamp's location and the procedure for removing it.

15

10. Locate the on/off control on the projector. How many positions does it have, and what are they (e.g., fan, lamp)? What type of control is it (e.g., switch, knob)?
11. Plug in the machine, and turn it on. At which positions of the on/off control does the fan operate?
12. What is the maximum size of material (transparency, acetate) that the projection table will hold?
13. Does the projector have an attachment for mounting a roll of acetate onto the machine? If so, describe how to place the attachment onto the projector and how it operates once it is in place.
14. Place your transparency on the projection table properly, and turn on the machine. Focus the image on the screen. Describe the procedure for focusing.
15. Draw a rough sketch of how the material should be placed on the projection table so that the image is projected properly (right side up, etc.) onto the screen.

16. Raise and/or lower the screen image so that it is centered on the screen. Describe the method(s) for elevating and lowering the image.
17. Move the projector gradually closer to the screen, refocusing as you get closer. How close to the screen can you get **before** either (1) you can no longer get the picture in focus or (2) the material is too small to see?
18. Move the projector gradually away from the screen, refocusing as you get farther away. How far away from the screen can you get **before** either (1) you can no longer get the picture in focus or (2) the image is too large for the screen?
19. At what distance (from screen to projector) do you get the best screen image?
20. Are you using the type and size of screen recommended for use with the overhead projector according to this module? If not, is this affecting your ability to project a high-quality image? How is the quality affected?
21. Assume you have a class of 20 students. Arrange the seating, the screen, and the projector as you would if you were using the projector to present information to that group of 20. Turn on the projector. Place the blank acetate on the projection table, and write or draw some material on the acetate. Make any necessary adjustments to the focus, etc.

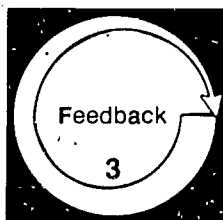

After you have completed each of the activities on the worksheet, use the Overhead Projector Operation Checklist, p. 17, to evaluate your work.

17

OVERHEAD PROJECTOR OPERATION CHECKLIST

Name

Date

Directions: Place an X in the YES or NO box to indicate whether each item was performed successfully or not.

Resource Person

Yes No

When you were locating parts on the overhead projector, you remembered to:

- | | | |
|--|--------------------------|--------------------------|
| 1. handle the projection lamp with a soft cloth | <input type="checkbox"/> | <input type="checkbox"/> |
| 2. be careful not to jar the machine (and lamp) while the lamp was hot | <input type="checkbox"/> | <input type="checkbox"/> |
| 3. treat the glass parts of the machine carefully | <input type="checkbox"/> | <input type="checkbox"/> |

The overhead projector, screen, and room are arranged for the group of 20 so that:

- | | | |
|--|-------------------------------------|--------------------------|
| 4. the projector is at the front of the room | <input type="checkbox"/> | <input type="checkbox"/> |
| 5. you will be facing the class when using it | <input type="checkbox"/> | <input type="checkbox"/> |
| 6. the projector and the projectionist will not block the view of anyone in the class | <input type="checkbox"/> | <input type="checkbox"/> |
| 7. the projected image is large enough for all viewers to see it | <input checked="" type="checkbox"/> | <input type="checkbox"/> |
| 8. the projected image is well centered on the screen | <input type="checkbox"/> | <input type="checkbox"/> |
| 9. the table on which the projector is placed is high enough or low enough for you to work comfortably | <input type="checkbox"/> | <input type="checkbox"/> |
| 10. there is no keystone effect produced | <input type="checkbox"/> | <input type="checkbox"/> |
| 11. there is no glare from the window on the screen | <input type="checkbox"/> | <input type="checkbox"/> |

The projected image is:

- | | | |
|----------------------------------|--------------------------|--------------------------|
| 12. clear and sharp | <input type="checkbox"/> | <input type="checkbox"/> |
| 13. bright | <input type="checkbox"/> | <input type="checkbox"/> |
| 14. well focused | <input type="checkbox"/> | <input type="checkbox"/> |
| 15. free of spots or marks | <input type="checkbox"/> | <input type="checkbox"/> |

Level of Performance: All items should receive YES responses. If any item receives a NO response, correct that condition using the actual equipment and materials. If you have trouble correcting the condition, check with your resource person or someone with expertise in the area of audiovisuals.



You may wish to contact your resource person, or someone else you or your resource person may know of with expertise in the area of audio-visuals. This person could discuss with you special techniques or helpful hints that can be of use to you when you work with the overhead projector.

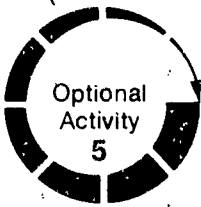

You may wish to check into the latest advancements in overhead projectors and supplies. If there is an audiovisual equipment dealership in your vicinity, you may wish to visit there and look over the equipment, or to arrange to have one of the salespersons talk to you. If you cannot make such a visit, you could write to one or more of the major manufacturers of overhead equipment, asking for catalogs.

Learning Experience II

OVERVIEW



After completing the required reading, present information with overhead materials and equipment in a practice situation.



You will be reading the information sheet, *Using the Overhead Projector as an Instructional Device*, pp. 21-24.

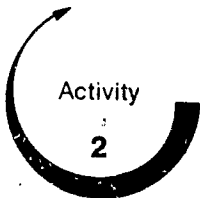

You will be selecting an objective in your occupational specialty that lends itself to the use of overhead materials.



You will be selecting, modifying, or developing a lesson plan designed to achieve that objective using overhead materials.

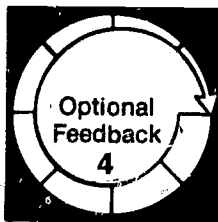

You may wish to have your resource person review the adequacy of your plan.

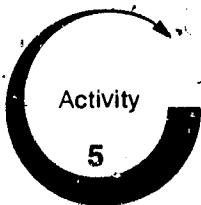

You will be obtaining or preparing the necessary materials, and making arrangements to secure the necessary equipment.

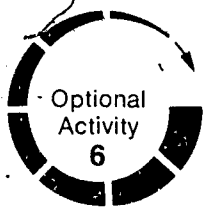

You may wish to arrange through your resource person to visit a classroom in which a teacher experienced in the use of overhead materials is presenting information using overhead materials and equipment.



You will be presenting your lesson to your resource person.

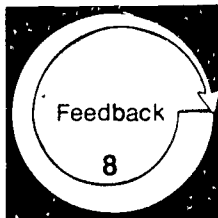

Your competency in presenting information with overhead materials and equipment will be evaluated by your resource person, using the Presentation Checklist: Overhead Materials, pp. 27-28.



In recent years, the overhead projector has become a familiar sight in vocational classrooms. This information sheet tells you why teachers have found it so useful. To learn how to use the overhead projector as an instructional tool, as well as how to create some especially interesting effects with the overhead projector, read the following information sheet.

USING THE OVERHEAD PROJECTOR AS AN INSTRUCTIONAL DEVICE

Though most of us are probably accustomed to seeing the overhead projector used only to present simple transparencies, it is actually a far more versatile machine with a wide range of possible applications. To make **maximum** use of this projector, you should know what it can and cannot do. To make **effective** use of the overhead projector—whether in projecting simple transparencies or projecting motion—you should know certain basic procedures and techniques. Although these techniques will be covered here one at a time, they are most effective when used creatively in combination.

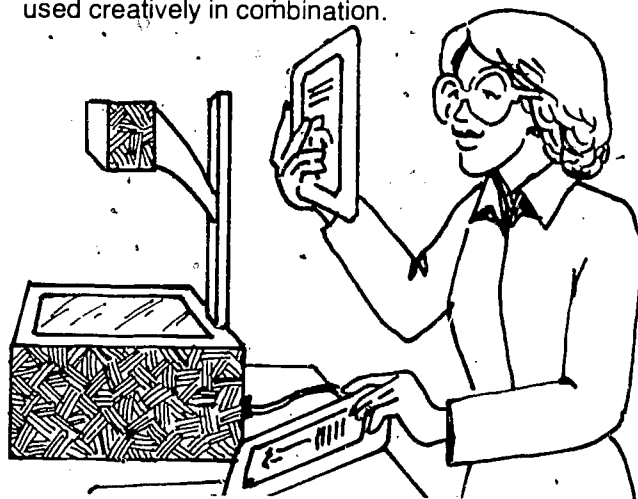

Advantages

There are many advantages to using the overhead projector. For example, its use allows you to teach from the front of the room, facing the students. Thus, you can maintain eye contact with the students, and teacher-student interaction is possible. In addition, the overhead projector can be used in a normally lighted classroom. Therefore, (1) it can be used in almost any classroom or laboratory, (2) students can take notes if they desire or if necessary, and (3) ventilation is not impaired by closed blinds. Since the overhead projector is generally lightweight (approximately 20 pounds), portable, and simple to operate, it can be used almost anywhere. It also can be used by almost anyone.

The materials for the overhead can be acquired and prepared ahead of time. You, therefore, can

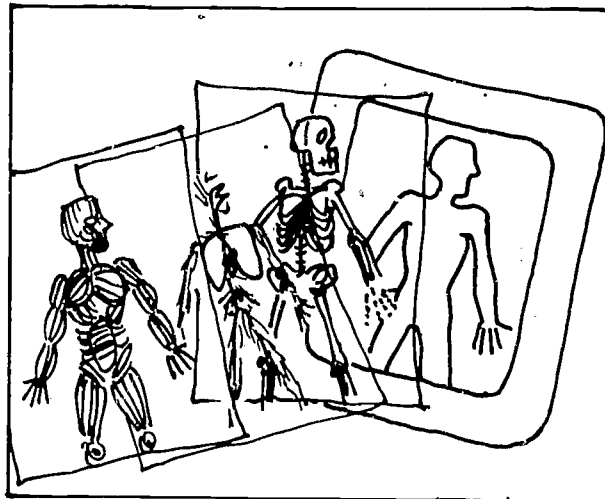

save class time by not having to write everything on the board as the lesson progresses. Furthermore, once acquired or prepared, projection materials can be easily stored and reused. Transparencies that have been mounted on cardboard are especially easy to store, but even unframed transparencies can be stored safely if each transparency is placed in a folder or between two sheets of paper for protection.

Two additional advantages of using the overhead projector should also be mentioned. First, by using overlays or by attaching masks to transparencies, complex concepts can be presented in simple parts. This makes it easier for students to master the concepts. Second, real objects that are transparent can be projected, and real objects that are opaque can be seen as silhouettes on the screen.

Disadvantages

The overhead projector cannot project students' papers or pages from books or magazines directly. Before such material can be projected, it first must be reproduced on a transparency.

The fact that the overhead can show motion in only a limited way is another disadvantage. If motion is an essential element in the concept being presented, a film would probably be more effective.

General Classroom Procedures

The procedures you follow in using the overhead projector start with the thorough planning and preparation activities that precede the actual showing of the overhead materials. You should **first** develop a unit of instruction² and a lesson plan. **Then**, you should select instructional materials that help meet the objectives of the unit and lesson, and meet the needs and interests of students.³ Thus, in order for the overhead projector to be used effectively, its use must fit the needs of the lesson, and the materials projected should meet the following criteria:

- Meet the lesson objectives
- Fit students' needs, interests, and abilities
- Provide concrete experiences
- Motivate or arouse interest
- Develop continuity of thought
- Clarify meaning and new vocabulary
- Provide variety in learning
- Save instructional time
- Provide experience not as easily obtained by some other instructional device
- Be up to date
- Be presented in logical order
- Be clear, logical, concise, error free, legible, and attractive
- Be simple (i.e., ten or less lines of type per transparency, six to seven words or less per line)
- Not be overused (i.e., to make the most impact, you should use a **few** transparencies that highlight, explain, or illustrate the key points of your presentation)

Furthermore, before using the projector in the classroom, you should have (1) arranged the physical setting of the room so that all students will be able to see the projected image clearly, (2) prechecked and prefocused the projector, and (3) made sure you had a spare bulb available.

During the presentation, two techniques can be used to direct and control student attention. The first involves the use of the projector on-off switch to **control** student attention. When the projector is on and an image is projected on the screen, student attention will tend to be directed to that image. Therefore, when you are through with a particular transparency and wish the students' attention to be directed back to you, remove the transparency from the pro-

2. To gain skill in developing a unit of instruction, you may wish to refer to Module B-3, *Develop a Unit of Instruction*.

3. To gain skill in determining the needs and interests of students, you may wish to refer to Module B-1, *Determine Needs and Interests of Students*.

JOB APPLICATION

Name _____

Address _____

Phone _____ Age _____

Social Security No. _____

Position desired _____

jection table. Unless other transparencies are to be used immediately, it is also a good idea to go one step further and turn off the machine (just the lamp, not the fan) since the light projecting on the screen can also distract students' attention:

The second technique involves the use of a pointer to **direct** student attention to specific items being projected. For example, if you are projecting a transparency of a job application form while explaining to the class what information is required on such a form, it is helpful to point out each item as you discuss it. Any opaque (nontransparent) item can be used as a pointer, even a pen or pencil. When you point at an item on a transparency, the pointer projects on the screen as a solid black object. A colored pointer can be made by attaching a triangular piece of colored plastic to the end of a stick.

Remember that one of the important advantages of the overhead projector is that you can face the class when using it. Don't make the mistake of turning your back to the class and talking to the screen. This, too, can cause students' attention to drift.

Chalkboard Technique

By placing a sheet of clear acetate on the projection table or mounting a roll of acetate on the projector, the overhead projector can be used much like a chalkboard. Instead of writing or drawing on the board with chalk, you can write on the acetate with a grease pencil or special audiovisual felt-tip pen. It is important to use good handwriting or lettering techniques when writing directly on the acetate. Irregular or sloppy writing will be magnified on the screen.

There are a number of advantages to using this technique with the overhead rather than using the chalkboard itself. You are able to write in a normal position using normal-sized script because the overhead enlarges the material so that all students can see. If the written material needs to be saved—to be used another day, to allow students to review, or to allow absent students to see what was covered—it is

far more simple to remove and save a sheet of acetate than it is to make sure the chalkboard does not get erased. If the chalkboard is full and cannot be erased, you have no space on which to write when the next class walks into the room. With the overhead, you can simply remove the full sheet, and replace it with a fresh sheet of acetate.

Another advantage of using the overhead projector instead of the chalkboard (or in addition to the chalkboard) concerns the use of grids, outlines, and curves. If you want the grid drawn in advance so you can plot one or more graphs during class, it is fairly simple to draw the grid in pencil and then prepare a number of transparencies from the pencil drawing using an infrared copier. During class, you have only to put the prelined transparency on the projection table and you have a grid on which to plot data.

The data can be plotted on the transparency and then removed when no longer needed. Therefore, the grid can be reused, or the completed graph can be saved if desired. A grid drawn with chalk on the chalkboard, on the other hand, is more difficult to work with. The grid can be erased too easily, and once used, it is difficult to erase the plotted data without erasing the grid at the same time.

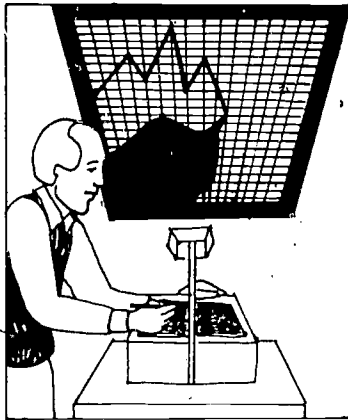

Revelation Technique

The revelation technique allows you to reveal a part of the transparency while masking other parts, thus directing students' attention to the point being discussed and preventing their attention from being distracted. For example, you could prepare a single transparency, half of which shows a four-cycle engine and half of which shows a two-cycle engine. Each engine can be discussed individually while the other is masked, and then both can be revealed at once and compared.

Any opaque material (e.g., a sheet of paper) can be used as a mask. A separate sheet of paper can be simply moved down the transparency to reveal parts



in sequence. Or, pieces of paper, each cut to the shape of the material to be covered, can be hinged with masking or cellophane tape to the sides of the transparency frame. The hinged paper is then just lifted when the material is to be revealed, and/or dropped back into the proper place when the material is to be masked. Colored plastic film can be used in place of the paper to create interesting and dramatic effects.

Overlay Technique

The use of overlays is another way to reveal material a bit at a time. With overlays, one prepares a series of transparencies, each containing a portion of the whole. The material on any one transparency is, in itself, very simple. Placed one over the other, they show the whole system, and the relation of the individual parts to the whole system. The sequential steps involved in setting a table properly for dinner can be illustrated by overlays. Each step is clearly visible and the final product, the properly set table, is clearly illustrated when all the overlays are in place.

Projecting Transparent Objects

Any real object that is transparent (e.g., a plastic ruler or plastic protractor) can be projected. If you wish to present a lesson on how to convert measurements from the English system to the metric system, for example, you could illustrate the lesson effectively by projecting a standard ruler and a metric ruler simultaneously. Be sure to experiment with these kinds of objects before presenting the lesson to the class. Some objects that appear transparent actually project as opaque.

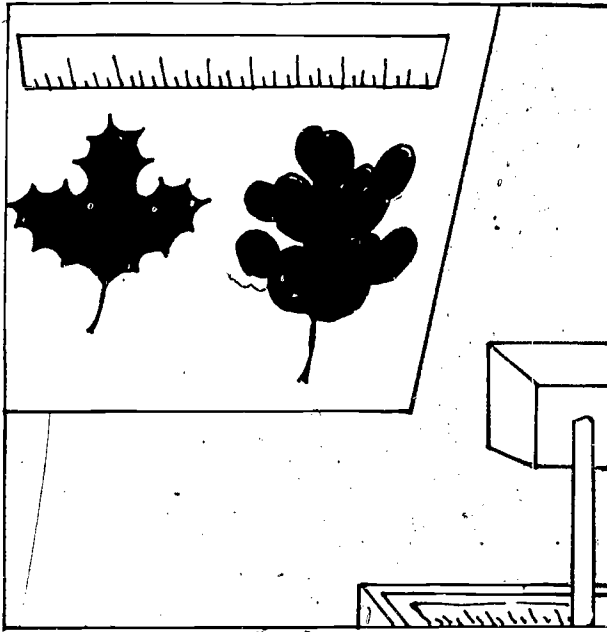

Silhouette Projection

Opaque objects can be projected, but will appear on the screen only as silhouettes. A horticulture teacher teaching how to identify plants by the shape of their leaves could place the actual leaves on the projection table to illustrate the key points being made in the lesson. Since a projected item is enlarged, students are not seeing actual size. If size is important, a transparent ruler can be projected with the item to indicate scale. To project well, the objects should be relatively thin and should lie flat on the projection table.

Using Color

Adding color to a transparency does more than just produce a more attractive visual; it can increase the effectiveness of the visual as well. Obviously, for certain concepts, color is an essential element. For example, color is an important element in a presentation of the effect of furnishings done in warm vs. cool colors. Even where color is not a natural part of the concept, it can be used to differentiate or highlight elements. A transparency illustrating a side of beef subdivided into its various cuts of meat can be more effective if each cut is a different color.

Colored transparencies are available commercially, and a copy machine that produces color transparencies from colored originals is now available, although it is quite expensive. The simplest method for adding color is to use color adhesive film. The film comes in sheets in a variety of colors. One simply cuts off a piece that is slightly larger than the area to be colored, positions the film in place, firmly presses down, and removes any excess with a sharp blade. Small areas of color can be produced by using felt-tip pens available for this purpose, but large areas produced in this way may appear streaky and blotchy on the screen.

Using Motion

On a simple level, motion can be shown by the overhead projector with "animated" or "operable" devices. For example, if you wished to illustrate the interaction of gears in a car's transmission, this could be done by manipulating transparent models of those gears on the projection table. Elaborate (and costly) transparent models of common mechanisms are available from commercial sources.



Select a student performance objective in your occupational specialty that could be achieved, at least partially, using visuals. (In a real-world situation, you start with an objective and then select the most appropriate materials and/or teaching methods. In this practice situation, however, you need to select an objective that lends itself to using overhead materials.)



Prepare a detailed lesson plan that includes the use of overhead materials. In your plan, outline what overhead materials will be needed, how they will be used, and when. Instead of developing a lesson plan, you may select a lesson plan that you have developed previously, and adapt that plan so that it includes the use of overhead materials.

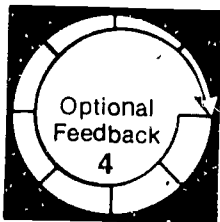

You may wish to have your resource person review the adequacy of your plan. He/she could use the Teacher Performance Assessment Form in Module B-4, *Develop a Lesson Plan*, as a guide.



Based on your lesson plan, select, obtain, or prepare the materials you will need to make your presentation. Also, arrange to have an overhead projector and a screen available when you make your presentation.

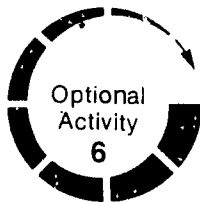

Before presenting your lesson, you may wish to arrange through your resource person to observe a lesson involving the use of overhead materials that is being presented by a vocational teacher in your service area who is experienced in using this technique.



In a simulated classroom situation, present your lesson to your resource person. Your resource person will serve two functions: (1) he/she will role-play a student to whom you are presenting the lesson, and (2) he/she will evaluate your performance.

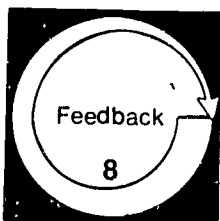

Your competency in presenting information with overhead materials and equipment will be evaluated by your resource person, using the Presentation Checklist: Overhead Materials, pp. 27 - 28. Give your resource person the checklist before making your presentation in order to ensure that he/she knows what to look for in your lesson.

PRESENTATION CHECKLIST: OVERHEAD MATERIALS

Directions: Place an X in the NO, PARTIAL; or FULL box to indicate that each of the following performance components was not accomplished, partially accomplished, or fully accomplished. If, because of special circumstances, a performance component was not applicable, or impossible to execute, place an X in the N/A box.

Name _____

Date _____

Resource Person _____

LEVEL OF PERFORMANCE

The teacher:

| | N/A | No | Partial | Full |
|---|--------------------------|--------------------------|--------------------------|--------------------------|
| 1. arranged the physical setting in advance in a way that would ensure that all students could both see and hear the presentation clearly | <input type="checkbox"/> | <input type="checkbox"/> | <input type="checkbox"/> | <input type="checkbox"/> |
| 2. had equipment and materials assembled in advance | <input type="checkbox"/> | <input type="checkbox"/> | <input type="checkbox"/> | <input type="checkbox"/> |
| 3. set up the equipment according to manufacturer's recommendations | <input type="checkbox"/> | <input type="checkbox"/> | <input type="checkbox"/> | <input type="checkbox"/> |
| 4. prechecked and prefocused the equipment | <input type="checkbox"/> | <input type="checkbox"/> | <input type="checkbox"/> | <input type="checkbox"/> |
| 5. had a spare bulb available | <input type="checkbox"/> | <input type="checkbox"/> | <input type="checkbox"/> | <input type="checkbox"/> |
| 6. projected the image on the screen clearly and accurately so that it met the following criteria: | | | | |
| a. no keystone effect | <input type="checkbox"/> | <input type="checkbox"/> | <input type="checkbox"/> | <input type="checkbox"/> |
| b. no glare from the window | <input type="checkbox"/> | <input type="checkbox"/> | <input type="checkbox"/> | <input type="checkbox"/> |
| c. well focused | <input type="checkbox"/> | <input type="checkbox"/> | <input type="checkbox"/> | <input type="checkbox"/> |
| d. well centered on the screen | <input type="checkbox"/> | <input type="checkbox"/> | <input type="checkbox"/> | <input type="checkbox"/> |
| e. readable | <input type="checkbox"/> | <input type="checkbox"/> | <input type="checkbox"/> | <input type="checkbox"/> |
| 7. used visuals that met the following criteria: | | | | |
| a. content of each visual was simple | <input type="checkbox"/> | <input type="checkbox"/> | <input type="checkbox"/> | <input type="checkbox"/> |
| b. content was at students' comprehension level | <input type="checkbox"/> | <input type="checkbox"/> | <input type="checkbox"/> | <input type="checkbox"/> |
| c. content of each visual was of good quality in terms of artwork, printing, etc. | <input type="checkbox"/> | <input type="checkbox"/> | <input type="checkbox"/> | <input type="checkbox"/> |
| d. visuals aided in meeting the objective of the lesson | <input type="checkbox"/> | <input type="checkbox"/> | <input type="checkbox"/> | <input type="checkbox"/> |
| 8. presented visuals in a logical sequence | <input type="checkbox"/> | <input type="checkbox"/> | <input type="checkbox"/> | <input type="checkbox"/> |
| 9. clearly emphasized points being presented visually | <input type="checkbox"/> | <input type="checkbox"/> | <input type="checkbox"/> | <input type="checkbox"/> |

| | N/A | No | Partial | Full |
|---|--------------------------|--------------------------|--------------------------|--------------------------|
| 10. maintained adequate eye contact with students | <input type="checkbox"/> | <input type="checkbox"/> | <input type="checkbox"/> | <input type="checkbox"/> |
| 11. used the on/off switch to control attention | <input type="checkbox"/> | <input type="checkbox"/> | <input type="checkbox"/> | <input type="checkbox"/> |
| 12. used a pointer to direct attention | <input type="checkbox"/> | <input type="checkbox"/> | <input type="checkbox"/> | <input type="checkbox"/> |

Level of Performance: All items must receive FULL or N/A responses. If any item receives a NO or PARTIAL response, the teacher and resource person should meet to determine what additional activities the teacher needs to complete in order to reach competency in the weak area(s).

Learning Experience III

OVERVIEW



After completing the required reading, set up and operate opaque equipment.

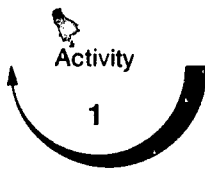

You will be reading the information sheet, Operating the Opaque Projector, pp. 30-32.

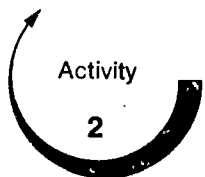

You will be setting up and operating an opaque projector by completing the exercises specified in the Opaque Projector Worksheet, pp. 33-37.

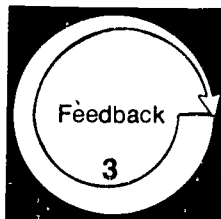

You will be evaluating your competency in setting up and operating the opaque projector, using the Opaque Projector Operation Checklist, p. 39.



You may wish to locate and meet with a person with expertise in the area of audiovisuals for the purpose of discussing further the uses and operation of the opaque projector.

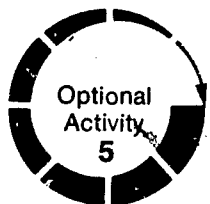

You may wish either to visit an audiovisual equipment dealer or to write to a dealer for catalogs describing the latest types of equipment and supplies available.

FIGURE 2

OPAQUE EQUIPMENT

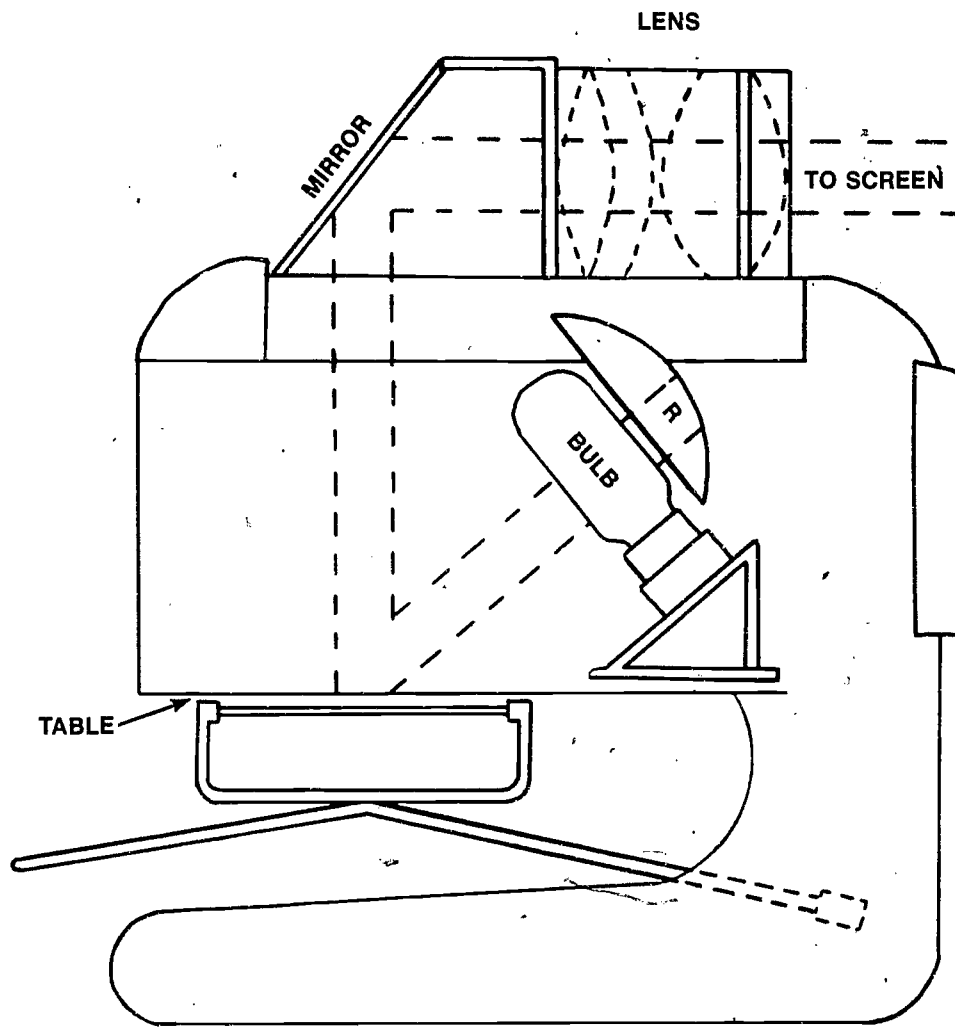

31

Although the use of the opaque projector has been decreasing, it is sometimes the best piece of equipment for the job to be done. To learn how to set up the opaque projector in the classroom and how to operate and maintain the equipment so it will provide clear, sharp pictures, read the following information sheet.

OPERATING THE OPAQUE PROJECTOR

Projection Principles

Like the overhead projector, the opaque projector, as shown in figure 2, uses an **indirect projection system**. In other words, the light is redirected rather than traveling along a straight line from the bulb to the screen. The **bulb** is the light source, and this light is aimed at the **projection table (platen or stage)**. The opaque object to be projected is placed on that table, and the light is reflected by the opaque material up toward the **mirror**, which redirects the projected image through the **lens** to the **screen**.

Because the opaque projector depends on light **reflected** from opaque copy rather than transmitted light, the image that appears on the screen is relatively dim. To get the brightest possible screen image, it is necessary to use the projector in a darkened room.

Projector Placement

Another way to increase the brightness of the screen image is to place the projector close to the screen. It is preferable to have a small bright screen image rather than a large dim one. Therefore, the projector needs to be placed near the front of the room in line with, and perpendicular to, the center of the screen. The table or stand used with the opaque projector needs to be high enough that you can feed the materials into the machine comfortably.

Projection Materials

The opaque projector will project almost any non-transparent (opaque) material that is 10" by 10" or smaller, and 2½" thick or less. Pages from books or magazines can be projected without removing them from the book. Written assignments completed by students, flat pictures, postcards, blueprints, diagrams, coins, flat stones, small tools, and other actual objects can all be projected using the opaque projector.

When working with flat materials such as pictures, papers, and charts, it is usually easier to handle

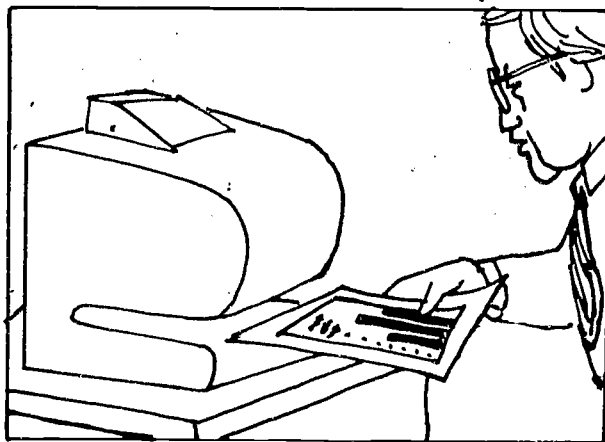

these materials and position them in the projector (and easier to store and save them) if they are first mounted on cardboard or heavy construction paper by glue, paste, tape, photographic mounting tissue, or staples. This gives you a margin to grip, and prevents the "flutter" that can be caused by air currents from the cooling fan and rising air heated by the projection lamp.

Once selected and prepared, materials are placed in the opaque projector. Whereas materials are simply laid on the projection table of the overhead projector, with the opaque projector, you must first lower the projection table. You then insert and position your material, and raise the projection table so that your material is pressing up against the glass pressure plate located above the projection table. All materials are positioned with the bottom of the page or item toward the screen.

Because a considerable amount of heat is produced by the projection bulb, papers (especially valuable books) should not be left in the projector more than a minute or two or they may be severely damaged. Glossy photographs, in particular, are susceptible to heat damage.

Operation Procedures

The opaque projector is nearly as simple to operate as the overhead projector. Usually, there is just a single-switch that can be placed in one of two positions: **on** or **off**. The cooling fan on older machines operates only when the machine is turned on. Therefore, to turn off the lamp, you must turn off the machine, so the lamp cools slowly to room temperature without any assistance from a fan. This is quite hard on the lamp. On newer projectors, the fan continues to operate when the machine is turned off. It then shuts itself off automatically when the bulb cools down. If the machine is equipped for it, it is always best to allow the fan to cool the bulb after the machine is turned off.

To adjust picture size, move the projector closer to the screen to reduce the image, and farther away from the screen to enlarge the image. To raise or lower the position of the image on the screen, elevate or lower the front of the projector using the elevator lock screws. To focus the screen image, adjust the lens by simply turning the knob located at the side of the projector. Again, these are **general** operating procedures. When you prepare to use a **specific** model of opaque projector, check the operating manual for that projector first.

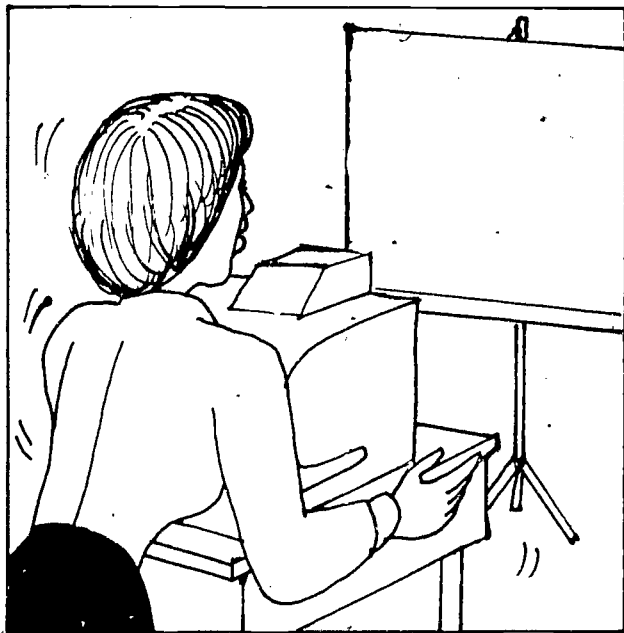

Projection Screen

In a normal-sized classroom, it is best to use a 70" by 70" screen with the opaque projector. Since the opaque projector is used in a darkened room, the type of screen you use—matte, glass beaded, or lenticular—will depend on how your students will be placed. For information on these different types of screens, on screen placement, and on the keystone effect, refer to p. 10.

Machine Maintenance

Maintenance of the opaque projector is simple because there are only a few moving parts: the cooling fan motor, the projection table, the optical pointer, and the focusing mechanism. The most important concerns of the teacher in maintaining the projector are to (1) allow the fan to cool the projection bulb before turning the projector off and putting it away, (2) avoid jarring or bumping bulbs, especially while they are hot, and (3) keep a spare projection bulb and pointer bulb on hand.

The projection bulb is located behind a door in the side of the projector; the pointer bulb is located under the pointer cover. Before changing either of these bulbs, make sure that you allow the bulbs to cool, and that you unplug the projector first. Use a cloth to handle the new bulbs since fingerprints can shorten their projection life.

You should also make sure that the projector is kept clean. The optical mirrors and the projection lens can be cleaned with a lens tissue and alcohol or lens fluid. The curved reflector can be cleaned with a damp cloth after the projection lamp has been removed. The projection table and the glass pressure plate above it can be cleaned with a damp cloth.



Your only other maintenance concern is oiling the cooling fan motor periodically according to the manufacturer's recommendations.



The following worksheet is designed to help you become competent in operating the opaque projector. No one need see this worksheet unless you choose to show it to someone, so do not be reluctant to record what actually happens, right or wrong. The sheet is not intended to show proof that you did everything perfectly the first time. It is intended to help you to organize your knowledge about the operation of opaque equipment, to help you apply that knowledge to actual equipment, to point out to you where you have gaps in your knowledge, and to help you determine how to fill those gaps. Completed thoughtfully and thoroughly, this sheet should make an excellent reference for you in the future. Read the directions carefully and then complete each of the 25 exercises.

OPAQUE PROJECTOR WORKSHEET

Directions: Locate an opaque projector, a screen to use with the projector, and the following materials: a typewritten sheet of paper, a hardback book, a magazine with colored illustrations, and a measuring device (e.g., ruler, yardstick, tape measure). Arrange for this equipment and material to be placed in the room in which you will be working with them. Each exercise requires a short response. Please respond fully, but briefly, and make sure you respond to all parts of each item. Do not answer simply YES or NO; explain your responses. Should you have any difficulty with an exercise, make a note of that problem.

1. What is the make and model of the opaque projector with which you are working?

2. Is there an operating manual? Does it contain any information that is different from, or was not covered in, the information sheet? If so, briefly describe that information.

3. What type of table is being used to hold the projector (portability, height, etc.)?

4. Describe the opaque materials that you are using (sizes, shapes, thickness).

5. Describe the type of screen with which you are working (matte, beaded, or lenticular; how is it mounted; what size is it, etc.?).

6. Set up the screen for use. Briefly describe any special procedures involved (e.g., "There is a release button that must be pushed."). If the screen is portable, where have you placed it and why?

7. What type of lighting are you using in the room? Is this type of lighting appropriate for using the opaque projector? Why or why not? What type of shades or other window light controls are built into the room? Do they darken the room satisfactorily?

8. Locate the projection lamp. **Do not** attempt to change it. Describe the lamp's location.
9. Locate the on/off control on the projector. How many positions does it have, and what are they (e.g., fan, lamp)? What type of control is it (e.g., switch, knob)?
10. Plug in the machine, and turn it on. At which positions of the on/off control does the fan operate?
11. Does the machine have an optical pointer? If so, describe its location and how it is operated.
12. What is the maximum size and thickness of material that the projection table will accommodate?
13. Lower the projection table, and place the typewritten sheet on the table. Draw a rough sketch of how the material should be placed on the projection table so that the image is projected properly (right side up, etc.) onto the screen.

14. With the typewritten sheet still on the table, raise the table so that the sheet is pressed up against the pressure plate. Focus the image on the screen. Describe the procedure for focusing.

15. Raise and/or lower the screen image so that it is centered on the screen. Describe the method for elevating and lowering the image.

16. Move the projector gradually closer to the screen, refocusing as you get closer. How close to the screen can you get **before** either (1) you can no longer get the picture in focus or (2) the material is too small to see?

17. Move the projector gradually away from the screen, refocusing as you get farther away. How far away from the screen can you get **before** (1) you can no longer get the picture in focus, (2) the image is too large for the screen, or (3) the image is too dim?

18. In terms of using the opaque projector to enlarge items, how large is the print on the original typewritten sheet? What is the smallest print size you can project clearly?

19. At what distance (from screen to projector) do you get the best screen image?

20. Describe the quality of the projected image of the typewritten sheet (readability of the words, distance from which sheet can be read, etc.).

21. Remove the typewritten sheet and replace it with the book, opened to a page you have selected. Refocus if necessary. Describe the quality of the projected image.

22. Remove the book and replace it with some coins and/or dollar bills. Refocus if necessary. Describe the quality of the projected image.

23. Remove the coins and replace them with the magazine, opened to a page containing a colored illustration. Refocus if necessary. Describe the quality of the projected image.

24. Are you using the type and size of screen recommended for use with the opaque projector according to this module? If not, is this affecting your ability to project a high-quality image? How is the quality affected?

25. Assume you have a class of 20 students. Arrange the seating, the screen, and the projector as you would if you were using the projector to present information to that group of 20. Turn on the projector, and project the magazine illustration. Make any necessary adjustments to the focus, etc.

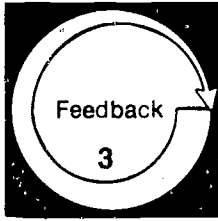

After you have completed each of the activities on the worksheet, use the Opaque Projector Operation Checklist, p. 39, to evaluate your work.

39

38

OPAQUE PROJECTOR OPERATION CHECKLIST

Name _____

Date _____

Directions: Place an X in the YES or NO box to indicate whether each item was performed successfully or not.

Resource Person _____

Yes No

When you were locating parts on the opaque projector, you remembered to:

- 1. be careful not to jar the machine (and lamp) while the lamp was hot.....
- 2. treat the glass parts of the machine carefully (e.g., protected the table somehow against scratching when you projected the coins)

The opaque projector, screen, and room are arranged for the group of 20 so that:

- 3. the projector is near the front of the room
- 4. the projector and the projectionist will not block the view of anyone in the class .
- 5. the projected image is large enough for all viewers to see it
- 6. the projected image is well centered on the screen
- 7. the table on which the projector is placed is low enough for you to work comfortably
- 8. there is no keystone effect produced
- 9. the room is adequately darkened

The projected image is:

- 10. clear and sharp
- 11. bright
- 12. well focused

Level of Performance: All items should receive YES responses. If any item receives a NO response, correct that condition using the actual equipment and materials. If you have trouble correcting the condition, check with your resource person or someone with expertise in the area of audiovisuals.



You may wish to contact your resource person, or someone else you or your resource person may know of with expertise in the area of audio-visuals. This person could discuss with you special techniques or helpful hints that can be of use to you when you work with the opaque projector.

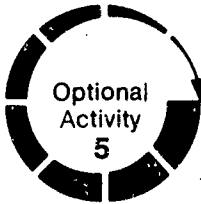

You may wish to check into the latest advancements in opaque projectors and supplies. If there is an audiovisual equipment dealership in your vicinity, you may wish to visit there and look over the equipment, or to arrange to have one of the salespersons talk to you. If you cannot make such a visit, you could write to one or more of the major manufacturers of opaque equipment, asking for catalogs.

Learning Experience IV

OVERVIEW



After completing the required reading, present information with opaque materials and equipment in a practice situation.



You will be reading the information sheet, *Using the Opaque Projector as an Instructional Device*, pp. 43-45.

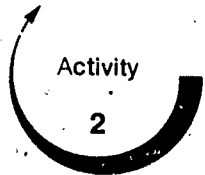

You will be selecting an objective in your occupational specialty that lends itself to the use of opaque materials.



You will be selecting, modifying, or developing a lesson plan designed to achieve the objective using opaque materials.

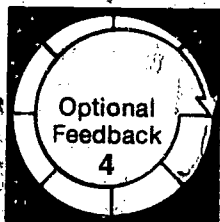

You may wish to have your resource person review the adequacy of your plan.



You will be obtaining or preparing the necessary materials, and making arrangements to secure the necessary equipment.



You may wish to arrange through your resource person to visit a classroom in which a teacher experienced in the use of opaque materials is presenting information using opaque materials and equipment.



You will be presenting your lesson to your resource person.

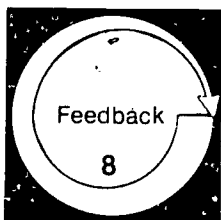

Your competency in presenting information with opaque materials and equipment will be evaluated by your resource person, using the Presentation Checklist: Opaque Materials, pp. 47-48.

The opaque projector may not be the most sophisticated piece of equipment in the classroom, but it does have some unique capabilities. For information describing the general and specific uses of opaque materials and equipment in presenting information, and explaining the procedures for their classroom use, read the following information sheet.

USING THE OPAQUE PROJECTOR AS AN INSTRUCTIONAL DEVICE

At one time, the opaque projector was a key aid in lesson presentations. With the advent of the overhead projector, a more portable machine that could project materials in a lighted room, use of the opaque projector decreased. Now that duplication machines and special acetate sheets make possible the preparation of transparencies from almost any printed material, the opaque projector is generally used for only a few special purposes. The unique advantages and disadvantages of the opaque projector determine, for the most part, how it is used in the classroom today.

Advantages

The opaque projector can project opaque materials directly, without their having to be reproduced as transparencies first. This means that, if a student brings in a paper or a picture, it can be shared immediately with the entire class by using the opaque projector. This assumes, of course, that you have access to an opaque projector at all times. In addition, there are certain illustrations in books or magazines that do not reproduce well, usually because of a lack of contrast. It would be difficult to prepare a transparency from these illustrations. However, the opaque projector can project them directly. A teacher of architectural drawing, for example, could project a portion of a blueprint for the whole class to study.

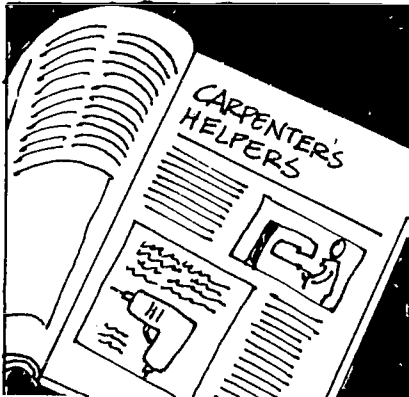

With the opaque projector, colors and textures reproduce well. A home economics teacher could place a piece of fabric on the projection table and project it for the whole class to see easily.

Since any opaque material of an appropriate size can be projected by the opaque projector, it is inex-

pensive and simple to have an abundance of materials to use with this machine. The opaque projector can also be used to enlarge pictures, drawings, maps, and so on, so that they can be traced on the chalkboard or on a flip chart.

Disadvantages

The opaque projector is awkward, bulky, and fairly heavy (approximately 33 pounds); thus, it is less portable than the overhead projector.

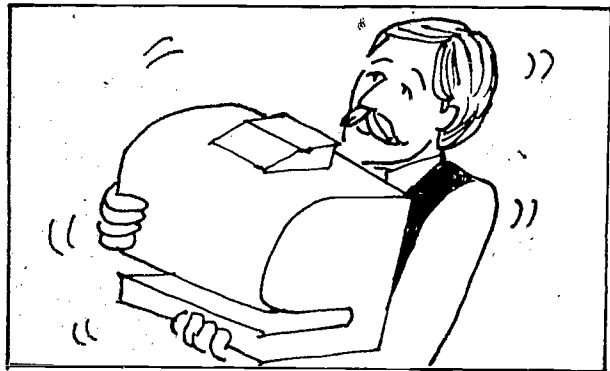

Since the opaque projector relies on reflected light, it has a very powerful bulb that gets very hot. Consequently, the opaque projector has a cooling fan to keep down the heat level. This fan may be somewhat noisy. Even with the fan, the light gets so hot that materials can be damaged by the heat. In addition, the light from this powerful lamp flashes into the darkened room each time the projection table is lowered to insert new material, which can be very annoying and distracting to the viewers.

Another disadvantage resulting from the opaque projector's reliance on reflected light is that the projector needs to be operated in a room that is very dark. It is possible to use it in a lighted room if you are working with a very small group that can be seated close to the screen. However, to use it with a class, it is necessary to have the room nearly or totally dark. Many times, the ordinary classroom cannot be made dark enough, and the teacher has to move the class to a special room in order to use the projector.

In a darkened room, you have no eye contact with students, and students cannot take notes. Furthermore, in a presentation in which the projector is used periodically throughout the presentation, the classroom lights must be turned off and on each time the projector is used. This means students and teacher alike are going to be adjusting their eyes to these changes in light a great deal.

Although books and magazines can be put directly on the projection table, unless they lie completely flat, it is often difficult to get all parts of the page in focus.

General Classroom Procedures

As with the overhead projector, in order for the opaque projector to be used effectively, its use must fit the needs of the lesson, and the materials projected must meet the criteria for high-quality materials (see p. 22). Materials need to be simple. A page of printed material from an ordinary book will probably not be readable when projected unless the viewers are seated very close to the screen.

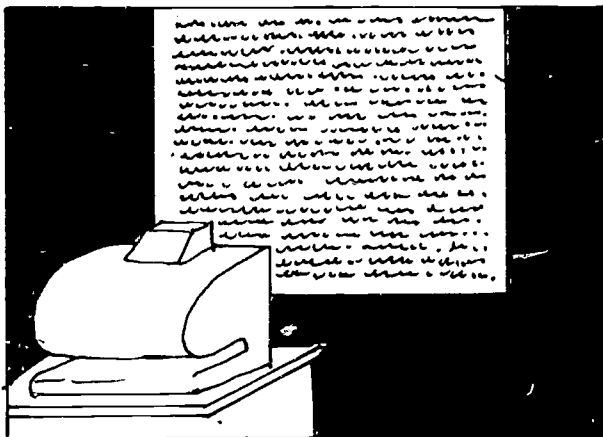

Again, as with the overhead projector, before using the projector in the classroom, you should (1) arrange the physical setting of the room so that all students will be able to see the projected image clearly, (2) precheck and prefocus the projector, and (3) make sure you have spare bulbs available. In addition, during the presentation, you should use the on/off switch to control attention.

With the opaque projector, you can use a pointer to direct student attention. Most opaque projectors have built-in pointers, or lighted arrows, as part of the projector equipment. This pointer can be manipulated by a control near the focusing knob. Another method of directing attention to key points on the material is by underlining, boxing in, or shading those points.

Roll Mounting Technique

If you have a sequence of materials to present via the opaque projector, these can be mounted, in the proper order, on a roll of paper 11" wide or less. The roll can then be handled like a scroll—unrolled at one end, and rolled up at the other—as it is fed through the opaque projector.

A roll feed attachment (a nylon belt that rotates around the projection table like a conveyor belt) is available for the opaque projector. Once this is attached, the continuous projection of flat materials is possible. With a roll of material being fed through continuously in this way, you do not need to raise or lower the projection table for each new projection. Therefore, the bright light is not flashing into the room, and the material does not need to be centered each time. If materials a full 2 1/2" thick are to be projected, the attachment must be removed.

Folded Card Technique

Another way of sequencing the material you wish to present is by mounting each item on a 10" by 11" piece of cardboard, sequencing the items, and taping the pieces of cardboard together with cloth tape. The materials can then be folded accordion style. Material mounted in this way is particularly easy to store.

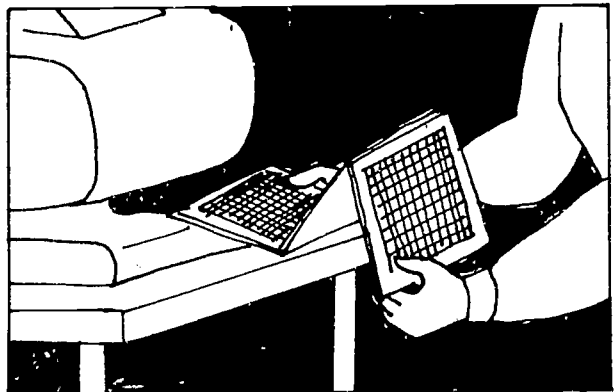

Projecting Students' Work

The opaque projector can be used to project work that students have completed so that you and the class members can discuss and evaluate the work. For example, if a student turns in a particularly good landscape design, this could be shared with the class via the opaque projector. By pointing out what makes the design a good one, the teacher can help other class members improve their work. Likewise, a design that contains mistakes common to many members of the class could be projected while the teacher points out the mistakes, or while students in the class

try to locate the mistakes. This, too, can aid students in improving.

It is best to present these materials without indicating the name of the student whose work it is. In that way, the student is not embarrassed or put in a position where he/she is set apart from other class members.

Enlarging Materials

Because of the opaque projector's ability to enlarge materials, it can be used in several ways other than to simply project materials during a presentation. The teacher who wishes to draw a large, detailed drawing of some complicated part of a car's engine, but who cannot draw well, can project a small picture of that part onto the chalkboard or a flip chart. The teacher can then trace the projected lines. If that teacher wished to present the picture a section at a time, the projected picture could be traced lightly in pencil ahead of time. It then could be drawn, a part at a time, in bright chalk or crayon during the presentation. The opaque projector is especially useful in enlarging letters. When you or your students need to



do lettering for a poster or some other such project, letters of uniform size can be cut from magazines, assembled in the right order, pasted onto a card, projected to the desired size, and traced.

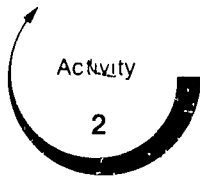

Select a student performance objective in your occupational specialty that could be achieved, at least partially, using visuals. (In a real world situation, you start with an objective and then select the most appropriate materials and/or teaching methods. In this practice situation, however, you need to select an objective that lends itself to using opaque materials.)



Prepare a detailed lesson plan that includes the use of opaque materials. In your plan, outline what opaque materials will be needed, how they will be used, and when. Instead of developing a lesson plan, you may select a lesson plan that you have developed previously, and adapt that plan so that it includes the use of opaque materials.

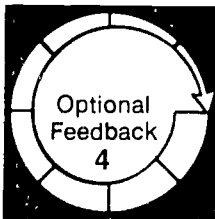

You may wish to have your resource person review the adequacy of your plan. He/she could use the Teacher Performance Assessment Form in Module B-4, *Develop a Lesson Plan*, as a guide.



Based on your lesson plan, select, obtain, or prepare the materials you will need to make your presentation. Also, arrange to have an opaque projector and a screen available to you at the time when you will make your presentation.



Before presenting your lesson, you may wish to arrange through your resource person to observe a lesson involving the use of opaque materials that is being presented by a vocational teacher in your service area who is experienced in using this technique.

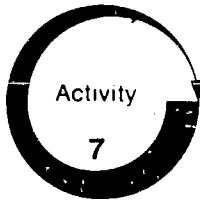

In a simulated classroom situation, present your lesson to your resource person. Your resource person will serve two functions: (1) he/she will role-play a student to whom you are presenting the lesson, and (2) he/she will evaluate your performance.

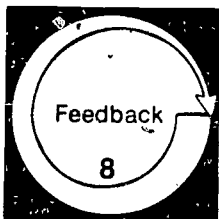

Your competency in presenting information with opaque materials and equipment will be evaluated by your resource person, using the Presentation Checklist: Opaque Materials, pp. 47 - 48. Give your resource person the checklist before making your presentation in order to ensure that he/she knows what to look for in your lesson.

47

PRESENTATION CHECKLIST: OPAQUE MATERIALS

Directions: Place an X in the NO, PARTIAL, or FULL box to indicate that each of the following performance components was not accomplished, partially accomplished, or fully accomplished. If, because of special circumstances, a performance component was not applicable, or impossible to execute, place an X in the N/A box.

Name _____
 Date _____
 Resource Person _____

LEVEL OF PERFORMANCE

N/A No Partial Full

The teacher:

- | | | | | | | | | | | | | | | | | | | | | | | | | | | | | | | | | | | | | | | | | | | | | | | | | | | | | | | | | | | | | | | | | | | | | | | | | | | | | | | | | | | | | | | | | | |
|--|---|--------------------------|--------------------------|--------------------------|--------------------------|--------------------------|--------------------------|--------------------------|--------------------------|--------------------------|--------------------------|--------------------------|--------------------------|--------------------------|--------------------------|--------------------------|--------------------------|--------------------------|--------------------------|--------------------------|--------------------------|--------------------------|--------------------------|--------------------------|--------------------------|--------------------------|--------------------------|--------------------------|--------------------------|--------------------------|--------------------------|--------------------------|--------------------------|--------------------------|--------------------------|--------------------------|--------------------------|--------------------------|--------------------------|--------------------------|--------------------------|--------------------------|--------------------------|--------------------------|--------------------------|--------------------------|--------------------------|--------------------------|--------------------------|--------------------------|--------------------------|--------------------------|--------------------------|--------------------------|--------------------------|--------------------------|--------------------------|--------------------------|--------------------------|--------------------------|--------------------------|--------------------------|--------------------------|--------------------------|--------------------------|--------------------------|--------------------------|--------------------------|--------------------------|--------------------------|--------------------------|--------------------------|--------------------------|--------------------------|--------------------------|--------------------------|--------------------------|--------------------------|--------------------------|--------------------------|--------------------------|--------------------------|--------------------------|--------------------------|--------------------------|--------------------------|--------------------------|--------------------------|--------------------------|
| <ol style="list-style-type: none"> 1. arranged the physical setting in advance in a way that would ensure that all students could both see and hear the presentation clearly 2. had equipment and materials assembled in advance 3. set up the equipment according to manufacturer's recommendations 4. prechecked and prefocused the equipment 5. had a spare bulb available 6. projected the image on the screen clearly and accurately so that it met the following criteria: <ol style="list-style-type: none"> a. no keystone effect b. the room was adequately darkened c. well focused d. well centered on the screen e. readable 7. used visuals that met the following criteria: <ol style="list-style-type: none"> a. content of each visual was simple b. content was at student's comprehension level c. content of each visual was of good quality in terms of artwork, printing, etc. d. visuals aided in meeting the objective of the lesson 8. presented visuals in a logical sequence 9. clearly emphasized points being presented visually 10. turned projector off and room lights on whenever the presentation did not require the use of the projector 11. used a pointer to direct attention | <table border="0"> <tr> <td><input type="checkbox"/></td> <td><input type="checkbox"/></td> <td><input type="checkbox"/></td> <td><input type="checkbox"/></td> </tr> <tr> <td><input type="checkbox"/></td> <td><input type="checkbox"/></td> <td><input type="checkbox"/></td> <td><input type="checkbox"/></td> </tr> <tr> <td><input type="checkbox"/></td> <td><input type="checkbox"/></td> <td><input type="checkbox"/></td> <td><input type="checkbox"/></td> </tr> <tr> <td><input type="checkbox"/></td> <td><input type="checkbox"/></td> <td><input type="checkbox"/></td> <td><input type="checkbox"/></td> </tr> <tr> <td><input type="checkbox"/></td> <td><input type="checkbox"/></td> <td><input type="checkbox"/></td> <td><input type="checkbox"/></td> </tr> <tr> <td><input type="checkbox"/></td> <td><input type="checkbox"/></td> <td><input type="checkbox"/></td> <td><input type="checkbox"/></td> </tr> <tr> <td><input type="checkbox"/></td> <td><input type="checkbox"/></td> <td><input type="checkbox"/></td> <td><input type="checkbox"/></td> </tr> <tr> <td><input type="checkbox"/></td> <td><input type="checkbox"/></td> <td><input type="checkbox"/></td> <td><input type="checkbox"/></td> </tr> <tr> <td><input type="checkbox"/></td> <td><input type="checkbox"/></td> <td><input type="checkbox"/></td> <td><input type="checkbox"/></td> </tr> <tr> <td><input type="checkbox"/></td> <td><input type="checkbox"/></td> <td><input type="checkbox"/></td> <td><input type="checkbox"/></td> </tr> <tr> <td><input type="checkbox"/></td> <td><input type="checkbox"/></td> <td><input type="checkbox"/></td> <td><input type="checkbox"/></td> </tr> <tr> <td><input type="checkbox"/></td> <td><input type="checkbox"/></td> <td><input type="checkbox"/></td> <td><input type="checkbox"/></td> </tr> <tr> <td><input type="checkbox"/></td> <td><input type="checkbox"/></td> <td><input type="checkbox"/></td> <td><input type="checkbox"/></td> </tr> <tr> <td><input type="checkbox"/></td> <td><input type="checkbox"/></td> <td><input type="checkbox"/></td> <td><input type="checkbox"/></td> </tr> <tr> <td><input type="checkbox"/></td> <td><input type="checkbox"/></td> <td><input type="checkbox"/></td> <td><input type="checkbox"/></td> </tr> <tr> <td><input type="checkbox"/></td> <td><input type="checkbox"/></td> <td><input type="checkbox"/></td> <td><input type="checkbox"/></td> </tr> <tr> <td><input type="checkbox"/></td> <td><input type="checkbox"/></td> <td><input type="checkbox"/></td> <td><input type="checkbox"/></td> </tr> <tr> <td><input type="checkbox"/></td> <td><input type="checkbox"/></td> <td><input type="checkbox"/></td> <td><input type="checkbox"/></td> </tr> <tr> <td><input type="checkbox"/></td> <td><input type="checkbox"/></td> <td><input type="checkbox"/></td> <td><input type="checkbox"/></td> </tr> <tr> <td><input type="checkbox"/></td> <td><input type="checkbox"/></td> <td><input type="checkbox"/></td> <td><input type="checkbox"/></td> </tr> <tr> <td><input type="checkbox"/></td> <td><input type="checkbox"/></td> <td><input type="checkbox"/></td> <td><input type="checkbox"/></td> </tr> <tr> <td><input type="checkbox"/></td> <td><input type="checkbox"/></td> <td><input type="checkbox"/></td> <td><input type="checkbox"/></td> </tr> </table> | <input type="checkbox"/> | <input type="checkbox"/> | <input type="checkbox"/> | <input type="checkbox"/> | <input type="checkbox"/> | <input type="checkbox"/> | <input type="checkbox"/> | <input type="checkbox"/> | <input type="checkbox"/> | <input type="checkbox"/> | <input type="checkbox"/> | <input type="checkbox"/> | <input type="checkbox"/> | <input type="checkbox"/> | <input type="checkbox"/> | <input type="checkbox"/> | <input type="checkbox"/> | <input type="checkbox"/> | <input type="checkbox"/> | <input type="checkbox"/> | <input type="checkbox"/> | <input type="checkbox"/> | <input type="checkbox"/> | <input type="checkbox"/> | <input type="checkbox"/> | <input type="checkbox"/> | <input type="checkbox"/> | <input type="checkbox"/> | <input type="checkbox"/> | <input type="checkbox"/> | <input type="checkbox"/> | <input type="checkbox"/> | <input type="checkbox"/> | <input type="checkbox"/> | <input type="checkbox"/> | <input type="checkbox"/> | <input type="checkbox"/> | <input type="checkbox"/> | <input type="checkbox"/> | <input type="checkbox"/> | <input type="checkbox"/> | <input type="checkbox"/> | <input type="checkbox"/> | <input type="checkbox"/> | <input type="checkbox"/> | <input type="checkbox"/> | <input type="checkbox"/> | <input type="checkbox"/> | <input type="checkbox"/> | <input type="checkbox"/> | <input type="checkbox"/> | <input type="checkbox"/> | <input type="checkbox"/> | <input type="checkbox"/> | <input type="checkbox"/> | <input type="checkbox"/> | <input type="checkbox"/> | <input type="checkbox"/> | <input type="checkbox"/> | <input type="checkbox"/> | <input type="checkbox"/> | <input type="checkbox"/> | <input type="checkbox"/> | <input type="checkbox"/> | <input type="checkbox"/> | <input type="checkbox"/> | <input type="checkbox"/> | <input type="checkbox"/> | <input type="checkbox"/> | <input type="checkbox"/> | <input type="checkbox"/> | <input type="checkbox"/> | <input type="checkbox"/> | <input type="checkbox"/> | <input type="checkbox"/> | <input type="checkbox"/> | <input type="checkbox"/> | <input type="checkbox"/> | <input type="checkbox"/> | <input type="checkbox"/> | <input type="checkbox"/> | <input type="checkbox"/> | <input type="checkbox"/> | <input type="checkbox"/> | <input type="checkbox"/> | <input type="checkbox"/> | <input type="checkbox"/> | <input type="checkbox"/> |
| <input type="checkbox"/> | <input type="checkbox"/> | <input type="checkbox"/> | <input type="checkbox"/> | | | | | | | | | | | | | | | | | | | | | | | | | | | | | | | | | | | | | | | | | | | | | | | | | | | | | | | | | | | | | | | | | | | | | | | | | | | | | | | | | | | | | | |
| <input type="checkbox"/> | <input type="checkbox"/> | <input type="checkbox"/> | <input type="checkbox"/> | | | | | | | | | | | | | | | | | | | | | | | | | | | | | | | | | | | | | | | | | | | | | | | | | | | | | | | | | | | | | | | | | | | | | | | | | | | | | | | | | | | | | | |
| <input type="checkbox"/> | <input type="checkbox"/> | <input type="checkbox"/> | <input type="checkbox"/> | | | | | | | | | | | | | | | | | | | | | | | | | | | | | | | | | | | | | | | | | | | | | | | | | | | | | | | | | | | | | | | | | | | | | | | | | | | | | | | | | | | | | | |
| <input type="checkbox"/> | <input type="checkbox"/> | <input type="checkbox"/> | <input type="checkbox"/> | | | | | | | | | | | | | | | | | | | | | | | | | | | | | | | | | | | | | | | | | | | | | | | | | | | | | | | | | | | | | | | | | | | | | | | | | | | | | | | | | | | | | | |
| <input type="checkbox"/> | <input type="checkbox"/> | <input type="checkbox"/> | <input type="checkbox"/> | | | | | | | | | | | | | | | | | | | | | | | | | | | | | | | | | | | | | | | | | | | | | | | | | | | | | | | | | | | | | | | | | | | | | | | | | | | | | | | | | | | | | | |
| <input type="checkbox"/> | <input type="checkbox"/> | <input type="checkbox"/> | <input type="checkbox"/> | | | | | | | | | | | | | | | | | | | | | | | | | | | | | | | | | | | | | | | | | | | | | | | | | | | | | | | | | | | | | | | | | | | | | | | | | | | | | | | | | | | | | | |
| <input type="checkbox"/> | <input type="checkbox"/> | <input type="checkbox"/> | <input type="checkbox"/> | | | | | | | | | | | | | | | | | | | | | | | | | | | | | | | | | | | | | | | | | | | | | | | | | | | | | | | | | | | | | | | | | | | | | | | | | | | | | | | | | | | | | | |
| <input type="checkbox"/> | <input type="checkbox"/> | <input type="checkbox"/> | <input type="checkbox"/> | | | | | | | | | | | | | | | | | | | | | | | | | | | | | | | | | | | | | | | | | | | | | | | | | | | | | | | | | | | | | | | | | | | | | | | | | | | | | | | | | | | | | | |
| <input type="checkbox"/> | <input type="checkbox"/> | <input type="checkbox"/> | <input type="checkbox"/> | | | | | | | | | | | | | | | | | | | | | | | | | | | | | | | | | | | | | | | | | | | | | | | | | | | | | | | | | | | | | | | | | | | | | | | | | | | | | | | | | | | | | | |
| <input type="checkbox"/> | <input type="checkbox"/> | <input type="checkbox"/> | <input type="checkbox"/> | | | | | | | | | | | | | | | | | | | | | | | | | | | | | | | | | | | | | | | | | | | | | | | | | | | | | | | | | | | | | | | | | | | | | | | | | | | | | | | | | | | | | | |
| <input type="checkbox"/> | <input type="checkbox"/> | <input type="checkbox"/> | <input type="checkbox"/> | | | | | | | | | | | | | | | | | | | | | | | | | | | | | | | | | | | | | | | | | | | | | | | | | | | | | | | | | | | | | | | | | | | | | | | | | | | | | | | | | | | | | | |
| <input type="checkbox"/> | <input type="checkbox"/> | <input type="checkbox"/> | <input type="checkbox"/> | | | | | | | | | | | | | | | | | | | | | | | | | | | | | | | | | | | | | | | | | | | | | | | | | | | | | | | | | | | | | | | | | | | | | | | | | | | | | | | | | | | | | | |
| <input type="checkbox"/> | <input type="checkbox"/> | <input type="checkbox"/> | <input type="checkbox"/> | | | | | | | | | | | | | | | | | | | | | | | | | | | | | | | | | | | | | | | | | | | | | | | | | | | | | | | | | | | | | | | | | | | | | | | | | | | | | | | | | | | | | | |
| <input type="checkbox"/> | <input type="checkbox"/> | <input type="checkbox"/> | <input type="checkbox"/> | | | | | | | | | | | | | | | | | | | | | | | | | | | | | | | | | | | | | | | | | | | | | | | | | | | | | | | | | | | | | | | | | | | | | | | | | | | | | | | | | | | | | | |
| <input type="checkbox"/> | <input type="checkbox"/> | <input type="checkbox"/> | <input type="checkbox"/> | | | | | | | | | | | | | | | | | | | | | | | | | | | | | | | | | | | | | | | | | | | | | | | | | | | | | | | | | | | | | | | | | | | | | | | | | | | | | | | | | | | | | | |
| <input type="checkbox"/> | <input type="checkbox"/> | <input type="checkbox"/> | <input type="checkbox"/> | | | | | | | | | | | | | | | | | | | | | | | | | | | | | | | | | | | | | | | | | | | | | | | | | | | | | | | | | | | | | | | | | | | | | | | | | | | | | | | | | | | | | | |
| <input type="checkbox"/> | <input type="checkbox"/> | <input type="checkbox"/> | <input type="checkbox"/> | | | | | | | | | | | | | | | | | | | | | | | | | | | | | | | | | | | | | | | | | | | | | | | | | | | | | | | | | | | | | | | | | | | | | | | | | | | | | | | | | | | | | | |
| <input type="checkbox"/> | <input type="checkbox"/> | <input type="checkbox"/> | <input type="checkbox"/> | | | | | | | | | | | | | | | | | | | | | | | | | | | | | | | | | | | | | | | | | | | | | | | | | | | | | | | | | | | | | | | | | | | | | | | | | | | | | | | | | | | | | | |
| <input type="checkbox"/> | <input type="checkbox"/> | <input type="checkbox"/> | <input type="checkbox"/> | | | | | | | | | | | | | | | | | | | | | | | | | | | | | | | | | | | | | | | | | | | | | | | | | | | | | | | | | | | | | | | | | | | | | | | | | | | | | | | | | | | | | | |
| <input type="checkbox"/> | <input type="checkbox"/> | <input type="checkbox"/> | <input type="checkbox"/> | | | | | | | | | | | | | | | | | | | | | | | | | | | | | | | | | | | | | | | | | | | | | | | | | | | | | | | | | | | | | | | | | | | | | | | | | | | | | | | | | | | | | | |
| <input type="checkbox"/> | <input type="checkbox"/> | <input type="checkbox"/> | <input type="checkbox"/> | | | | | | | | | | | | | | | | | | | | | | | | | | | | | | | | | | | | | | | | | | | | | | | | | | | | | | | | | | | | | | | | | | | | | | | | | | | | | | | | | | | | | | |
| <input type="checkbox"/> | <input type="checkbox"/> | <input type="checkbox"/> | <input type="checkbox"/> | | | | | | | | | | | | | | | | | | | | | | | | | | | | | | | | | | | | | | | | | | | | | | | | | | | | | | | | | | | | | | | | | | | | | | | | | | | | | | | | | | | | | | |

Level of Performance: All items must receive FULL or N/A responses. If any item receives a NO or PARTIAL response, the teacher and resource person should meet to determine what additional activities the teacher needs to complete in order to reach competency in the weak area(s).

49

Learning Experience V

FINAL EXPERIENCE



In an **actual teaching situation**,* present information with overhead and/or opaque materials.

As you plan your lessons, decide when overhead and/or opaque materials could be used effectively to aid in meeting the lesson objectives. Based on those decisions, present information with overhead and/or opaque materials. This will include—



- deciding if you wish to teach a lesson using only **one** of the techniques, or if you wish to teach one or two lessons using **both** techniques
- selecting, modifying, or developing the necessary lesson plans that include use of these techniques
- selecting, obtaining, or preparing the necessary materials
- securing the necessary equipment
- presenting the lesson(s) to the class

NOTE: Your resource person may want you to submit your written lesson plan(s) to him/her for evaluation before you present your lesson(s). It may be helpful for your resource person to use the TPAF from Module B-4, *Develop a Lesson Plan*, to guide his/her evaluation.

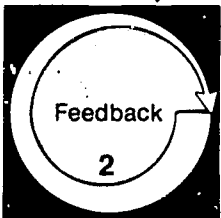

Arrange in advance to have your resource person observe your lesson presentation(s).

Your total competency will be assessed by your resource person, using the Teacher Performance Assessment Form, pp. 51–52.

Based upon the criteria specified in this assessment instrument, your resource person will determine whether you are competent in presenting information with overhead and opaque materials.

*For a definition of "actual teaching situation," see the inside back cover

NOTES

TEACHER PERFORMANCE ASSESSMENT FORM

Present Information with Overhead and Opaque Materials (C-23)

Name _____
 Date _____
 Resource Person _____

Directions: Indicate the level of the teacher's accomplishment by placing an X in the appropriate box under the LEVEL OF PERFORMANCE heading. If, because of special circumstances, a performance component was not applicable, or impossible to execute, place an X in the N/A box.

LEVEL OF PERFORMANCE

Overhead

The teacher:

| | N/A | None | Poor | Fair | Good | Excellent |
|---|--------------------------|--------------------------|--------------------------|--------------------------|--------------------------|--------------------------|
| 1. arranged the physical setting in advance in a way that would ensure that all students could both see and hear the presentation clearly | <input type="checkbox"/> | <input type="checkbox"/> | <input type="checkbox"/> | <input type="checkbox"/> | <input type="checkbox"/> | <input type="checkbox"/> |
| 2. had equipment and materials assembled | <input type="checkbox"/> | <input type="checkbox"/> | <input type="checkbox"/> | <input type="checkbox"/> | <input type="checkbox"/> | <input type="checkbox"/> |
| 3. set up the equipment according to manufacturer's recommendations | <input type="checkbox"/> | <input type="checkbox"/> | <input type="checkbox"/> | <input type="checkbox"/> | <input type="checkbox"/> | <input type="checkbox"/> |
| 4. prechecked and prefocused the equipment | <input type="checkbox"/> | <input type="checkbox"/> | <input type="checkbox"/> | <input type="checkbox"/> | <input type="checkbox"/> | <input type="checkbox"/> |
| 5. had a spare bulb available | <input type="checkbox"/> | <input type="checkbox"/> | <input type="checkbox"/> | <input type="checkbox"/> | <input type="checkbox"/> | <input type="checkbox"/> |
| 6. projected the image on the screen clearly and accurately so that it met the following criteria: | | | | | | |
| a. no keystone effect | <input type="checkbox"/> | <input type="checkbox"/> | <input type="checkbox"/> | <input type="checkbox"/> | <input type="checkbox"/> | <input type="checkbox"/> |
| b. no glare from the window | <input type="checkbox"/> | <input type="checkbox"/> | <input type="checkbox"/> | <input type="checkbox"/> | <input type="checkbox"/> | <input type="checkbox"/> |
| c. well focused | <input type="checkbox"/> | <input type="checkbox"/> | <input type="checkbox"/> | <input type="checkbox"/> | <input type="checkbox"/> | <input type="checkbox"/> |
| d. well centered on the screen | <input type="checkbox"/> | <input type="checkbox"/> | <input type="checkbox"/> | <input type="checkbox"/> | <input type="checkbox"/> | <input type="checkbox"/> |
| e. readable | <input type="checkbox"/> | <input type="checkbox"/> | <input type="checkbox"/> | <input type="checkbox"/> | <input type="checkbox"/> | <input type="checkbox"/> |
| 7. used visuals that met the following criteria: | | | | | | |
| a. content of each visual was simple | <input type="checkbox"/> | <input type="checkbox"/> | <input type="checkbox"/> | <input type="checkbox"/> | <input type="checkbox"/> | <input type="checkbox"/> |
| b. content was at students' comprehension level | <input type="checkbox"/> | <input type="checkbox"/> | <input type="checkbox"/> | <input type="checkbox"/> | <input type="checkbox"/> | <input type="checkbox"/> |
| c. content of each visual was of good quality in terms of artwork, printing, etc. | <input type="checkbox"/> | <input type="checkbox"/> | <input type="checkbox"/> | <input type="checkbox"/> | <input type="checkbox"/> | <input type="checkbox"/> |
| d. visuals aided in meeting the objective of the lesson | <input type="checkbox"/> | <input type="checkbox"/> | <input type="checkbox"/> | <input type="checkbox"/> | <input type="checkbox"/> | <input type="checkbox"/> |
| 8. presented visuals in a logical sequence | <input type="checkbox"/> | <input type="checkbox"/> | <input type="checkbox"/> | <input type="checkbox"/> | <input type="checkbox"/> | <input type="checkbox"/> |
| 9. clearly emphasized points being presented visually | <input type="checkbox"/> | <input type="checkbox"/> | <input type="checkbox"/> | <input type="checkbox"/> | <input type="checkbox"/> | <input type="checkbox"/> |
| 10. maintained adequate eye contact with students | <input type="checkbox"/> | <input type="checkbox"/> | <input type="checkbox"/> | <input type="checkbox"/> | <input type="checkbox"/> | <input type="checkbox"/> |
| 11. used the on/off switch to control attention | <input type="checkbox"/> | <input type="checkbox"/> | <input type="checkbox"/> | <input type="checkbox"/> | <input type="checkbox"/> | <input type="checkbox"/> |

| | N/A | None | Poor | Fair | Good | Excellent |
|--|--------------------------|--------------------------|--------------------------|--------------------------|--------------------------|--------------------------|
| 12. used a pointer to direct attention. | <input type="checkbox"/> | <input type="checkbox"/> | <input type="checkbox"/> | <input type="checkbox"/> | <input type="checkbox"/> | <input type="checkbox"/> |

Opaque

The teacher:

| | | | | | | |
|--|--------------------------|--------------------------|--------------------------|--------------------------|--------------------------|--------------------------|
| 13. arranged the physical setting in advance in a way that would ensure that all students could both see and hear the presentation clearly | <input type="checkbox"/> | <input type="checkbox"/> | <input type="checkbox"/> | <input type="checkbox"/> | <input type="checkbox"/> | <input type="checkbox"/> |
| 14. had equipment and materials assembled in advance .. | <input type="checkbox"/> | <input type="checkbox"/> | <input type="checkbox"/> | <input type="checkbox"/> | <input type="checkbox"/> | <input type="checkbox"/> |
| 15. set up the equipment according to manufacturer's recommendations | <input type="checkbox"/> | <input type="checkbox"/> | <input type="checkbox"/> | <input type="checkbox"/> | <input type="checkbox"/> | <input type="checkbox"/> |
| 16. prechecked and prefocused the equipment | <input type="checkbox"/> | <input type="checkbox"/> | <input type="checkbox"/> | <input type="checkbox"/> | <input type="checkbox"/> | <input type="checkbox"/> |
| 17. had a spare bulb available | <input type="checkbox"/> | <input type="checkbox"/> | <input type="checkbox"/> | <input type="checkbox"/> | <input type="checkbox"/> | <input type="checkbox"/> |
| 18. projected the image on the screen clearly and accurately so that it met the following criteria: | | | | | | |
| a. no keystone effect | <input type="checkbox"/> | <input type="checkbox"/> | <input type="checkbox"/> | <input type="checkbox"/> | <input type="checkbox"/> | <input type="checkbox"/> |
| b. the room was adequately darkened | <input type="checkbox"/> | <input type="checkbox"/> | <input type="checkbox"/> | <input type="checkbox"/> | <input type="checkbox"/> | <input type="checkbox"/> |
| c. well focused | <input type="checkbox"/> | <input type="checkbox"/> | <input type="checkbox"/> | <input type="checkbox"/> | <input type="checkbox"/> | <input type="checkbox"/> |
| d. well centered on the screen | <input type="checkbox"/> | <input type="checkbox"/> | <input type="checkbox"/> | <input type="checkbox"/> | <input type="checkbox"/> | <input type="checkbox"/> |
| e. readable | <input type="checkbox"/> | <input type="checkbox"/> | <input type="checkbox"/> | <input type="checkbox"/> | <input type="checkbox"/> | <input type="checkbox"/> |
| 19. used visuals that met the following criteria: | | | | | | |
| a. content of each visual was simple | <input type="checkbox"/> | <input type="checkbox"/> | <input type="checkbox"/> | <input type="checkbox"/> | <input type="checkbox"/> | <input type="checkbox"/> |
| b. content was at students' comprehension level | <input type="checkbox"/> | <input type="checkbox"/> | <input type="checkbox"/> | <input type="checkbox"/> | <input type="checkbox"/> | <input type="checkbox"/> |
| c. content of each visual was of good quality in terms of artwork, printing, etc. | <input type="checkbox"/> | <input type="checkbox"/> | <input type="checkbox"/> | <input type="checkbox"/> | <input type="checkbox"/> | <input type="checkbox"/> |
| d. visuals aided in meeting the objective of the lesson | <input type="checkbox"/> | <input type="checkbox"/> | <input type="checkbox"/> | <input type="checkbox"/> | <input type="checkbox"/> | <input type="checkbox"/> |
| 20. presented visuals in a logical sequence | <input type="checkbox"/> | <input type="checkbox"/> | <input type="checkbox"/> | <input type="checkbox"/> | <input type="checkbox"/> | <input type="checkbox"/> |
| 21. clearly emphasized points being presented visually ... | <input type="checkbox"/> | <input type="checkbox"/> | <input type="checkbox"/> | <input type="checkbox"/> | <input type="checkbox"/> | <input type="checkbox"/> |
| 22. turned projector off and room lights on whenever the presentation did not require the use of the projector .. | <input type="checkbox"/> | <input type="checkbox"/> | <input type="checkbox"/> | <input type="checkbox"/> | <input type="checkbox"/> | <input type="checkbox"/> |
| 23. used a pointer to direct attention | <input type="checkbox"/> | <input type="checkbox"/> | <input type="checkbox"/> | <input type="checkbox"/> | <input type="checkbox"/> | <input type="checkbox"/> |

Level of Performance: All items must receive N/A, GOOD, or EXCELLENT responses. If any item receives a NONE, POOR, or FAIR response, the teacher and resource person should meet to determine what additional activities the teacher needs to complete in order to reach competency in the weak area(s).



ABOUT USING THE NATIONAL CENTER'S PBTE MODULES

Organization

Each module is designed to help you gain competency in a particular skill area considered important to teaching success. A module is made up of a series of learning experiences, some providing background information, some providing practice experiences, and others combining these two functions. Completing these experiences should enable you to achieve the terminal objective in the final learning experience. The final experience in each module always requires you to demonstrate the skill in an actual teaching situation when you are an intern, a student teacher, an inservice teacher, or occupational trainer.

Procedures

Modules are designed to allow you to individualize your teacher education program. You need to take only those modules covering skills that you do not already possess. Similarly, you need not complete any learning experience within a module if you already have the skill needed to complete it. Therefore, before taking any module, you should carefully review (1) the introduction, (2) the objectives listed on p. 4, (3) the overviews preceding each learning experience, and (4) the final experience. After comparing your present needs and competencies with the information you have read in these sections, you should be ready to make one of the following decisions:

- That you do not have the competencies indicated and should complete the entire module
- That you are competent in one or more of the enabling objectives leading to the final learning experience and, thus, can omit those learning experiences
- That you are already competent in this area and are ready to complete the final learning experience in order to "test out"
- That the module is inappropriate to your needs at this time

When you are ready to complete the final learning experience and have access to an actual teaching situation, make the necessary arrangements with your resource person. If you do not complete the final experience successfully, meet with your resource person and arrange to (1) repeat the experience or (2) complete (or review) previous sections of the module or other related activities suggested by your resource person before attempting to repeat the final experience.

Options for recycling are also available in each of the learning experiences preceding the final experience. Any time you do not meet the minimum level of performance required to meet an objective, you and your resource person may meet to select activities to help you reach competency. This could involve (1) completing parts of the module previously skipped, (2) repeating activities, (3) reading supplementary resources or completing additional activities suggested by the resource person, (4) designing your own learning experience, or (5) completing some other activity suggested by you or your resource person.

Terminology

Actual Teaching Situation: A situation in which you are actually working with and responsible for teaching secondary or postsecondary vocational students or other occupational trainees. An intern, a student teacher, an inservice teacher, or other occupational trainer would be functioning in an actual teaching situation. If you do not have access to an actual teaching situation when you are taking the module, you can complete the module up to the final learning experience. You would then complete the final learning experience later (i.e., when you have access to an actual teaching situation).

Alternate Activity or Feedback: An item that may substitute for required items that, due to special circumstances, you are unable to complete.

Occupational Specialty: A specific area of preparation within a vocational service area (e.g., the service area, Trade and Industrial Education includes occupational specialties such as automobile mechanics, welding and electricity).

Optional Activity or Feedback: An item that is not required but that is designed to supplement and enrich the required items in a learning experience.

Resource Person: The person in charge of your educational program (e.g., the professor, instructor, administrator, instructional supervisor, cooperating/supervising/classroom teacher, or training supervisor who is guiding you in completing this module).

Student: The person who is receiving occupational instruction in a secondary, postsecondary, or other training program.

Vocational Service Area: A major vocational field: agricultural education, business and office education, marketing and distributive education, health occupations education, home economics education, industrial arts education, technical education, or trade and industrial education.

You or the Teacher/Instructor: The person who is completing the module.

Levels of Performance for Final Assessment

N/A: The criterion was not met because it was not applicable to the situation.

None: No attempt was made to meet the criterion, although it was relevant.

Poor: The teacher is unable to perform this skill or has only very limited ability to perform it.

Fair: The teacher is unable to perform this skill in an acceptable manner but has some ability to perform it.

Good: The teacher is able to perform this skill in an effective manner.

Excellent: The teacher is able to perform this skill in a very effective manner.

Titles of the National Center's Performance-Based Teacher Education Modules

Category A: Program Planning, Development, and Evaluation

- A-1 Prepare for a Community Survey
- A-2 Conduct a Community Survey
- A-3 Report the Findings of a Community Survey
- A-4 Organize an Occupational Advisory Committee
- A-5 Maintain an Occupational Advisory Committee
- A-6 Develop Program Goals and Objectives
- A-7 Conduct an Occupational Analysis
- A-8 Develop a Course of Study
- A-9 Develop Long-Range Program Plans
- A-10 Conduct a Student Follow-Up Study
- A-11 Evaluate Your Vocational Program

Category B: Instructional Planning

- B-1 Determine Needs and Interests of Students
- B-2 Develop Student Performance Objectives
- B-3 Develop a Unit of Instruction
- B-4 Develop a Lesson Plan
- B-5 Select Student Instructional Materials
- B-6 Prepare Teacher-made Instructional Materials

Category C: Instructional Execution

- C-1 Direct Field Trips
- C-2 Conduct Group Discussions, Panel Discussions, and Symposiums
- C-3 Employ Brainstorming, Buzz Group, and Question Box Techniques
- C-4 Direct Students in Instructing Other Students
- C-5 Employ Simulation Techniques
- C-6 Guide Student Study
- C-7 Direct Student Laboratory Experience
- C-8 Direct Students in Applying Problem-Solving Techniques
- C-9 Employ the Project Method
- C-10 Introduce a Lesson
- C-11 Summarize a Lesson
- C-12 Employ Oral Questioning Techniques
- C-13 Employ Reinforcement Techniques
- C-14 Provide Instruction for Slower and More Capable Learners
- C-15 Present an Illustrated Talk
- C-16 Demonstrate a Manipulative Skill
- C-17 Demonstrate a Concept or Principle
- C-18 Individualize Instruction
- C-19 Employ the Team Teaching Approach
- C-20 Use Subject Matter Experts to Present Information
- C-21 Prepare Bulletin Boards and Exhibits
- C-22 Present Information with Models, Real Objects, and Flannel Boards
- C-23 Present Information with Overhead and Opaque Materials
- C-24 Present Information with Filmstrips and Slides
- C-25 Present Information with Films
- C-26 Present Information with Audio Recordings
- C-27 Present Information with Televised and Videotaped Materials
- C-28 Employ Programmed Instruction
- C-29 Present Information with the Chalkboard and Flip Chart
- C-30 Provide for Students' Learning Styles

Category D: Instructional Evaluation

- D-1 Establish Student Performance Criteria
- D-2 Assess Student Performance: Knowledge
- D-3 Assess Student Performance: Attitudes
- D-4 Assess Student Performance: Skills
- D-5 Determine Student Grades
- D-6 Evaluate Your Instructional Effectiveness

Category E: Instructional Management

- E-1 Project Instructional Resource Needs
- E-2 Manage Your Budgeting and Reporting Responsibilities
- E-3 Arrange for Improvement of Your Vocational Facilities
- E-4 Maintain a Filing System
- E-5 Provide for Student Safety
- E-6 Provide for the First Aid Needs of Students
- E-7 Assist Students in Developing Self-Discipline
- E-8 Organize the Vocational Laboratory
- E-9 Manage the Vocational Laboratory
- E-10 Combat Problems of Student Chemical Use

Category F: Guidance

- F-1 Gather Student Data Using Formal Data-Collection Techniques
- F-2 Gather Student Data Through Personal Contacts
- F-3 Use Conferences to Help Meet Student Needs
- F-4 Provide Information on Educational and Career Opportunities
- F-5 Assist Students in Applying for Employment or Further Education

Category G: School-Community Relations

- G-1 Develop a School-Community Relations Plan for Your Vocational Program
- G-2 Give Presentations to Promote Your Vocational Program
- G-3 Develop Brochures to Promote Your Vocational Program
- G-4 Prepare Displays to Promote Your Vocational Program
- G-5 Prepare News Releases and Articles Concerning Your Vocational Program
- G-6 Arrange for Television and Radio Presentations Concerning Your Vocational Program
- G-7 Conduct an Open House
- G-8 Work with Members of the Community
- G-9 Work with State and Local Educators
- G-10 Obtain Feedback about Your Vocational Program

Category H: Vocational Student Organization

- H-1 Develop a Personal Philosophy Concerning Vocational Student Organizations
- H-2 Establish a Vocational Student Organization
- H-3 Prepare Vocational Student Organization Members for Leadership Roles
- H-4 Assist Vocational Student Organization Members in Developing and Financing a Yearly Program of Activities
- H-5 Supervise Activities of the Vocational Student Organization
- H-6 Guide Participation in Vocational Student Organization Contests

Category I: Professional Role and Development

- I-1 Keep Up to Date Professionally
- I-2 Serve Your Teaching Profession
- I-3 Develop an Active Personal Philosophy of Education
- I-4 Serve the School and Community
- I-5 Obtain a Suitable Teaching Position
- I-6 Provide Laboratory Experiences for Prospective Teachers
- I-7 Plan the Student Teaching Experience
- I-8 Supervise Student Teachers

Category J: Coordination of Cooperative Education

- J-1 Establish Guidelines for Your Cooperative Vocational Program
- J-2 Manage the Attendance, Transfers, and Terminations of Co-Op Students
- J-3 Enroll Students in Your Co-Op Program
- J-4 Secure Training Stations for Your Co-Op Program
- J-5 Place Co-Op Students on the Job
- J-6 Develop the Training Ability of On-the-Job Instructors
- J-7 Coordinate On-the-Job Instruction
- J-8 Evaluate Co-Op Students' On-the-Job Performance
- J-9 Prepare for Students' Related Instruction
- J-10 Supervise an Employer-Employee Appreciation Event

Category K: Implementing Competency-Based Education (CBE)

- K-1 Prepare Yourself for CBE
- K-2 Organize the Content for a CBE Program
- K-3 Organize Your Class and Lab to Install CBE
- K-4 Provide Instructional Materials for CBE
- K-5 Manage the Daily Routines of Your CBE Program
- K-6 Guide Your Students Through the CBE Program

Category L: Serving Students with Special/Exceptional Needs

- L-1 Prepare Yourself to Serve Exceptional Students
- L-2 Identify and Diagnose Exceptional Students
- L-3 Plan Instruction for Exceptional Students
- L-4 Provide Appropriate Instructional Materials for Exceptional Students
- L-5 Modify the Learning Environment for Exceptional Students
- L-6 Promote Peer Acceptance of Exceptional Students
- L-7 Use Instructional Techniques to Meet the Needs of Exceptional Students
- L-8 Improve Your Communication Skills
- L-9 Assess the Progress of Exceptional Students
- L-10 Counsel Exceptional Students with Personal-Social Problems
- L-11 Assist Exceptional Students in Developing Career Planning Skills
- L-12 Prepare Exceptional Students for Employability
- L-13 Promote Your Vocational Program with Exceptional Students

Category M: Assisting Students in Improving Their Basic Skills

- M-1 Assist Students in Achieving Basic Reading Skills
- M-2 Assist Students in Developing Technical Reading Skills
- M-3 Assist Students in Improving Their Writing Skills
- M-4 Assist Students in Improving Their Oral Communication Skills
- M-5 Assist Students in Improving Their Math Skills
- M-6 Assist Students in Improving Their Survival Skills

RELATED PUBLICATIONS

- Student Guide to Using Performance-Based Teacher Education Materials
- Resource Person Guide to Using Performance-Based Teacher Education Materials
- Guide to the Implementation of Performance-Based Teacher Education
- Performance-Based Teacher Education: The State of the Art, General Education and Vocational Education

For information regarding availability and prices of these materials contact—AAVIM, American Association for Vocational Instructional Materials, 120 Driftmier Engineering Center, University of Georgia, Athens, Georgia 30602, (404) 542-2586