

DOCUMENT RESUME

ED 221 343

SE 035 013

AUTHOR Kerr, Donald R., Jr.; And Others
 TITLE Measurement. Mathematics-Methods Program Unit.
 INSTITUTION Indiana Univ., Bloomington. Mathematics Education
 Development Center.
 SPONS AGENCY National Science Foundation, Washington, D.C.
 REPORT NO ISBN-0-201-14620-7
 PUB DATE 76
 GRANT NSF-GY-9293
 NOTE 137p.; For related documents, see SE 035 006-018.

EDRS PRICE MF01 Plus Postage. PC Not Available from EDRS.
 DESCRIPTORS College Mathematics; Elementary Education;
 *Elementary School Mathematics; Elementary School
 Teachers; *Geometric Concepts; Higher Education;
 *Instructional Materials; Learning Activities;
 Mathematical Concepts; Mathematics Instruction;
 *Measurement; Metric System; *Preservice Teacher
 Education; Problem Solving; Supplementary Reading
 Materials; Textbooks; Workbooks
 IDENTIFIERS *Mathematics Methods Program

ABSTRACT This unit is 1 of 12 developed for the university
 classroom portion of the Mathematics-Methods Program (MMP), created
 by the Indiana University Mathematics Education Development Center
 (MEDC) as an innovative program for the mathematics training of
 prospective elementary school teachers (PSTs). Each unit is written
 in an activity format that involves the PST in doing mathematics with
 an eye toward application of that mathematics in the elementary
 school. This document is one of four units that are devoted to
 geometry instruction in the elementary school. In addition to an
 introduction to the unit and an overview of measurement in the
 elementary school, the text has sections on the measurement process,
 certain common measurements, and child learning of measurement.
 (MP)

 * Reproductions supplied by EDRS are the best that can be made *
 * from the original document. *

MEASUREMENT

ED221343

U.S. DEPARTMENT OF EDUCATION
NATIONAL INSTITUTE OF EDUCATION
EDUCATIONAL RESOURCES INFORMATION
CENTER (ERIC)

- ✓ This document has been reproduced as received from the person or organization originating it.
- Minor changes have been made to improve reproduction quality.
- Points of view or opinions stated in this document do not necessarily represent official NIE position or policy.



"PERMISSION TO REPRODUCE THIS MATERIAL IN MICROFICHE ONLY HAS BEEN GRANTED BY

NATIONAL SCIENCE FOUNDATION
ADDISON-WESLEY

TO THE EDUCATIONAL RESOURCES INFORMATION CENTER (ERIC)."

Mathematics-Methods Program
units written under the direction of

John F. LeBlanc or Donald R. Kerr, Jr. or
Maynard Thompson

035 013
ERIC
Full Text Provided by ERIC

MATHEMATICS EDUCATION DEVELOPMENT CENTER

INDIANA UNIVERSITY

John F. LeBlanc, *Director*
Donald R. Kerr, Jr., *Assistant Director*

The following is a list of faculty and project associates who have contributed to the development of the Mathematics-Methods Program.

Mathematics Education Faculty

Frank K. Lester, Jr.
Sally H. Thomas
Paul R. Trafton
Ronald C. Welch

Project Associates — Mathematics Education

Gertrude R. Croke
Carol A. Dodd-Thomton
Nancy C. Fisher
Fadia F. Harik
Kathleen M. Hart
Tom S. Hudson
Calvin J. Irons
Graham A. Jones
Charles E. Lamb
Richard A. Lesh
Barbara E. Moses
Geraldine N. Rossi
Thomas L. Schroeder
Carol L. Wadsworth
Barbara E. Weller
Larry E. Wheeler

Mathematics Faculty

George Springer,
*Co-principal
Investigator*
Billy E. Rhoades
Maynard Thompson

Project Associates — Mathematics

Glenn M. Carver
A. Carroll Delaney
Alfred L. LaTendresse
Bernice K. O'Brien
Robert F. Olin
Susan M. Sanders
Barbara D. Sehr
Karen R. Thelen
Richard D. Troxel
Karen S. Wade
Carter S. Warfield
Lynnette O. Womble

Resource Teacher

Marilyn Hall Jacobson

Continued on inside back cover

MEASUREMENT

DONALD R. KERR, JR.

Substantial contributors

JOHN F. LEBLANC

Carol A. Dodd-Thornton

Kathleen M. Hart

Calvin J. Irons



ADDISON-WESLEY PUBLISHING COMPANY

Reading, Massachusetts • Menlo Park, California
London • Amsterdam • Don Mills, Ontario • Sydney

This book is in the
ADDISON-WESLEY SERIES IN MATHEMATICS

The preparation of this book was supported by National Science Foundation Grant #GY-9293. However, the opinions, findings, conclusions or recommendations expressed herein are those of the authors and do not necessarily reflect the views of the National Science Foundation. Except for the rights to material reserved by others, the publisher and copyright owner will grant permission without charge for use of this work and related material in the English language after December 31, 1981. For conditions of use and permission to use materials contained herein for foreign publications in other than the English language, apply to either the publisher or the copyright owner. Publication pursuant to such permission shall contain the statement: "Some (all) of the materials incorporated in this work were developed with the financial support of the National Science Foundation. Any opinions, findings, conclusions or recommendations expressed herein do not necessarily reflect the views of the National Science Foundation."

Reproduced by Addison-Wesley from camera-ready copy supplied by the authors.

Copyright © 1976 by Indiana University Foundation. Philippines
copyright 1976 by Indiana University Foundation.

All rights reserved. No part of this publication may be reproduced, stored in a retrieval system, or transmitted, in any form or by any means, electronic, mechanical, photocopying, recording, or otherwise, without the prior written permission of the copyright owner or the publisher. Printed in the United States of America. Published simultaneously in Canada.

ISBN 0-201-14020-7
ABCOEFGHIJAL 700765

PREFACE

The Mathematics-Methods Program (MMP) has been developed by the Indiana University Mathematics Education Development Center (MEDC) during the years 1971-75. The development of the MMP was funded by the UPSTEP program of the National Science Foundation, with the goal of producing an innovative program for the mathematics training of prospective elementary school teachers (PSTs).

The primary features of the MMP are:

- It combines the mathematics training and the methods training of PSTs.
- It promotes a hands-on, laboratory approach to teaching in which PSTs learn mathematics and methods by doing rather than by listening, taking notes or memorizing.
- It involves the PST in using techniques and materials that are appropriate for use with children.
- It focuses on the real-world mathematical concerns of children and the real-world mathematical and pedagogical concerns of PSTs.

The MMP, as developed at the MEDC, involves a university classroom component and a related public school teaching component. The university classroom component combines the mathematics content courses and methods courses normally taken by PSTs, while the public school teaching component provides the PST with a chance to gain experience with children and insight into their mathematical thinking.

A model has been developed for the implementation of the public school teaching component of the MMP. Materials have been developed for the university classroom portion of the MMP. These include 12 instructional units with the following titles:

Numeration

Addition and Subtraction

Multiplication and Division

Rational Numbers with Integers and Reals

Awareness Geometry

Transformational Geometry

Analysis of Shapes

Measurement

Number Theory

Probability and Statistics

Graphs: the Picturing of Information

Experiences in Problem Solving

These units are written in an activity format that involves the PST in doing mathematics with an eye toward the application of that mathematics in the elementary school. The units are almost entirely independent of one another, and any selection of them can be done, in any order. It is worth noting that the first four units listed pertain to the basic number work in the elementary school; the second four to the geometry of the elementary school; and the final four to mathematical topics for the elementary teacher.

For purposes of formative evaluation and dissemination, the MMP has been field-tested at over 40 colleges and universities. The field implementation formats have varied widely. They include the following:

- Use in mathematics department as the mathematics content program, or as a portion of that program;
- Use in the education school as the methods program, or as a portion of that program,
- Combined mathematics content and methods program taught in

- either the mathematics department, or the education school, or jointly;
- Any of the above, with or without the public school teaching experience.

Common to most of the field implementations was a small-group format for the university classroom experience and an emphasis on the use of concrete materials. The various centers that have implemented all or part of the MMP have made a number of suggestions for change, many of which are reflected in the final form of the program. It is fair to say that there has been a general feeling of satisfaction with, and enthusiasm for, MMP from those who have been involved in field-testing.

A list of the field-test centers of the MMP is as follows:

ALVIN JUNIOR COLLEGE
Alvin, Texas

GRAMBLING STATE UNIVERSITY
Grambling, Louisiana

BLUE MOUNTAIN COMMUNITY COLLEGE
Pendleton, Oregon

ILLINOIS STATE UNIVERSITY
Normal, Illinois

BOISE STATE UNIVERSITY
Boise, Idaho

INDIANA STATE UNIVERSITY
EVANSVILLE

BRIDGEWATER COLLEGE
Bridgewater, Virginia

INDIANA STATE UNIVERSITY
Terre Haute, Indiana

CALIFORNIA STATE UNIVERSITY,
CHICO

INDIANA UNIVERSITY
Bloomington, Indiana

CALIFORNIA STATE UNIVERSITY,
NORTHRIDGE

INDIANA UNIVERSITY NORTHWEST
Gary, Indiana

CLARKE COLLEGE
Dubuque, Iowa

MACALESTER COLLEGE
St. Paul, Minnesota

UNIVERSITY OF COLORADO
Boulder, Colorado

UNIVERSITY OF MAINE AT FARMINGTON

UNIVERSITY OF COLORADO AT
DENVER

UNIVERSITY OF MAINE AT PORTLAND-
GORHAM

CONCORDIA TEACHERS COLLEGE
River Forest, Illinois

THE UNIVERSITY OF MANITOBA
Winnipeg, Manitoba, CANADA

MICHIGAN STATE UNIVERSITY
East Lansing, Michigan

UNIVERSITY OF NORTHERN IOWA
Cedar Falls, Iowa

NORTHERN MICHIGAN UNIVERSITY
Marquette, Michigan

NORTHWEST MISSOURI STATE
UNIVERSITY
Maryville, Missouri

NORTHWESTERN UNIVERSITY
Evanston, Illinois

OAKLAND CITY COLLEGE
Oakland City, Indiana

UNIVERSITY OF OREGON
Eugene, Oregon

RHODE ISLAND COLLEGE
Providence, Rhode Island

SAINT XAVIER COLLEGE
Chicago, Illinois

SAN DIEGO STATE UNIVERSITY
San Diego, California

SAN FRANCISCO STATE UNIVERSITY
San Francisco, California

SHELBY STATE COMMUNITY COLLEGE
Memphis, Tennessee

UNIVERSITY OF SOUTHERN MISSISSIPPI
Hattiesburg, Mississippi

SYRACUSE UNIVERSITY
Syracuse, New York

TEXAS SOUTHERN UNIVERSITY
Houston, Texas

WALTERS STATE COMMUNITY COLLEGE
Morristown, Tennessee

WARTBURG COLLEGE
Waverly, Iowa

WESTERN MICHIGAN UNIVERSITY
Kalamazoo, Michigan

WHITTIER COLLEGE
Whittier, California

UNIVERSITY OF WISCONSIN--RIVER
FALLS

UNIVERSITY OF WISCONSIN/STEVENS
POINT

THE UNIVERSITY OF WYOMING
Laramie, Wyoming

CONTENTS

INTRODUCTION TO THE GEOMETRY UNITS OF THE MATHEMATICS-METHODS PROGRAM	1
INTRODUCTION TO THE MEASUREMENT UNIT	5
OVERVIEW	9
Overview of Measurement in the Elementary School	10
<u>SECTION I THE MEASUREMENT PROCESS</u>	<u>15</u>
Activity 1 Identifying and Comparing Attributes	17
Activity 2 Nonstandard Units	19
Activity 3 Metrics Are Coming	23
<u>SECTION II CERTAIN COMMON MEASUREMENTS</u>	<u>31</u>
Activity 4 Area	33
Activity 5 Geoboards	52
Activity 6 Familiar Formulas for Area	63
Activity 7 π and Circles	67
Activity 8 Volume Measurements	72
Activity 9 More About Measurement	80
Activity 10 Measuring Minds	84
Activity 11 Measurement Versus the Real World	87

<u>SECTION III CHILD LEARNING OF MEASUREMENT</u>	93
Activity 12 Child Readiness for Measurement	95
Activity 13 Child Problems with Measurement	103
Activity 14 Doing and Analyzing Measurement Activities	108
Activity 15 Writing Measurement Activities	113
Activity 16 Building on Textbooks	122
Activity 17 Seminar on Child Measurement	124
REQUIRED MATERIALS	125

INTRODUCTION TO THE GEOMETRY UNITS OF THE MATHEMATICS-METHODS PROGRAM

Geometry to most people just means proving theorems about angles opposite equal sides, squares of hypotenuses, and such. This is natural since most people have their only exposure to geometry in high school where the traditional course has been built around such proofs. Geometry has been gradually working its way into the elementary school. Today's new textbooks contain a considerable amount of geometry.* Much of this material is being ignored or badly taught since many teachers see little relevance of this geometry to their own lives, to other aspects of the elementary school curriculum, or to the lives of their pupils. Moreover, some of the topics that are currently contained in textbooks were not taught when the teacher went to school and, therefore, are not fully understood by the teacher.

The geometry units of the Mathematics-Methods Program attempt to present geometry from a point of view that will bring out the potential for geometry with children. Geometry is presented as the study of space experiences. This point of view is not only consistent with the historical development of geometry, but it also keeps the focus on the relationship between geometry and the objects and shapes in our environment.

*Paul R. Trafton and John F. LeBlanc, "Informal Geometry in Grades K-6," in The 36th Yearbook of the National Council of Teachers of Mathematics, 1973: Geometry in the Mathematics Curriculum.

The study of space experiences addresses itself mainly to shapes. Shapes are abstractions from the environment. They can be informally investigated and analyzed. One can also study the changes (or transformations) that shapes undergo.

To effect this study of space experiences, four units have been developed.

- The Awareness Geometry unit is designed to orient the prospective teacher to the informal study of geometry. In this unit one looks carefully at the environment, experiments with shapes that are observed there, and informally analyzes certain shapes. At the end of the unit, one is given experience with planning for geometry lessons with children.

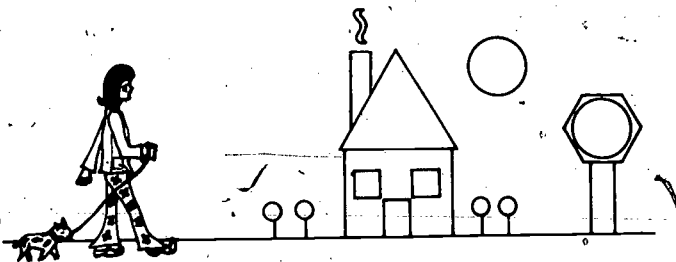

- The Transformational Geometry unit studies changes that shapes can undergo. The unit is organized into the study of rigid transformations, projective transformations, and topological transformations. The presentation is informal and the focus is on concrete real-world examples of the concepts.

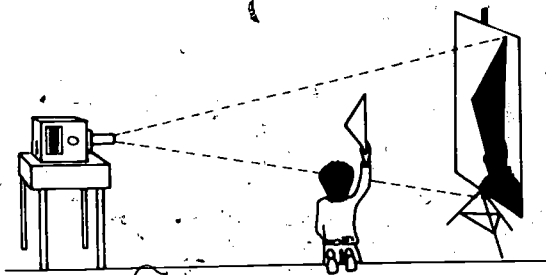

- The Analysis of Shapes unit studies straight lines, triangles and circles. The real-world occurrences and importance of each shape are investigated; each shape is informally analyzed to determine some of its important properties; and then the fruits of these analyses are applied to real-world problems. Many of the traditional topics of Euclidean geometry, including coordinate geometry, are considered here from a nontraditional point of view. There is also a section which deals with problems of verification and places into perspective the informal methods of elementary school geometry and the formal approach to high school geometry.

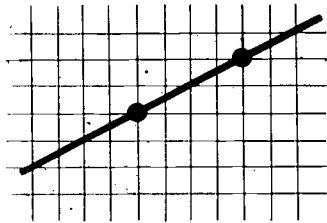

$$\frac{\text{up}}{\text{out}} = \frac{2}{4} = \frac{1}{2}$$

- The Measurement unit provides experiences with identifying attributes, choosing unit quantities of attributes, and determining numbers through comparisons. The emphasis is on informal, concrete, conceptual activities. There is a separate section which is devoted to child readiness and the planning of measurement activities for children. Metric units are used throughout. While measurement could have been included in the Analysis of Shapes unit, it has been placed in a separate unit because of its importance in the elementary school curriculum and in order to provide flexibility in the use of the units.

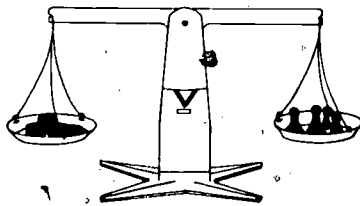

The four geometry units of the Mathematics-Methods Program are independent of one another. Any number of them can be used in any order. They can be used in a separate geometry course; they can be interspersed among other units of the Mathematics-Methods Program; or they can be used in conjunction with other materials.

These geometry units, like the other units of the Mathematics-Methods Program, involve one as an adult learner in activities which have implications for teaching children. One works with concepts that children might learn, with materials that children might use, and on activities that might be modified for use with children. The objective is to provide growth in understanding and enjoyment of geometry along with increased ability and desire to teach geometry to children.

INTRODUCTION TO THE MEASUREMENT UNIT

Measurement is an important human activity. It is an everyday skill. It is an essential tool of science, and it provides a useful link between the real world and mathematics. Measurements are as diverse as the length of a straight line, the I.Q. of a human being, and the speed of light. Measurement skills include simple dexterity, the techniques of calculus, and the ability to construct models of human thought and behavior. This unit concentrates on those aspects of measurement that are relevant to the elementary school.

From one point of view, measuring involves the following steps:

- Identifying an attribute;
- Choosing a unit quantity of the attribute;
- Comparing a quantity of the attribute with the unit quantity in order to arrive at a number.

For example, if one wishes to measure the attribute length of a pencil, one might choose the centimeter as a unit of length and then compare the length of the pencil with the centimeter to arrive at a number, say 15. So the introduction of measurement concepts to children must involve the recognition of attributes, comparison of quantities of attributes, familiarization with the systems of units

quantities of attributes that are in common use, and experiences with measurements involving these standard units.

There are many approaches that one could take in introducing children to attributes, comparisons, and units. Section I of this unit is organized around an instructional sequence that involves the various aspects of the measurement process and takes into account the elementary child's lack of experience with attributes, with comparisons, and with units. The three steps of the instructional sequence are:

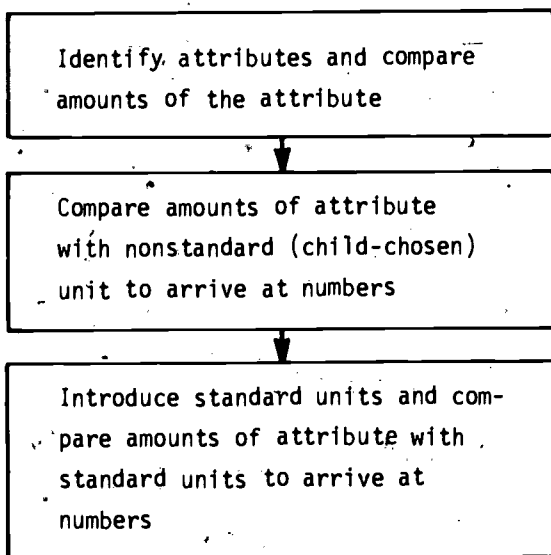

The activities in Section I are presented at an adult level, but they follow this instructional sequence in order to provide you experience with and insight into the sequence.

In the elementary school a wide variety of measurement topics is introduced. Children measure length, area, volume, weight, time, angle, temperature, etc. You have had considerable experience with these measurements and certainly do not need a complete treatment in each of them. Section II develops certain aspects of some of these measurements that are important in the elementary school and that seem to be challenging for adult learners. Again, the presentation is made with an eye toward the teaching of children.

Section III is concerned with some of the measurement problems that children face. Measurement requires the recognition of attributes that may not yet have become conscious parts of a child's experience. This frequently involves the introduction of new words in the child's vocabulary. It demands that the child grasp certain physical principles. Dexterity is also required to manipulate measurement instruments. Consequently, children seem to require both experience and maturity to grasp measurement skills and concepts. In Section III you will be given an opportunity to take advantage of any insights that you have gained in preparing some measurement lessons for children.

Before you start with Section I of this unit, you will be presented with an overview of measurement in adult life and in the elementary school. This overview is designed to orient you to the goals and content of this unit.

Throughout this unit, you will find several boxed-in puzzles and anecdotes entitled "Teacher Teasers" and "Historical Highlights." These are designed to provide you with interesting background and enrichment in measurement and its history. The Teacher Teasers are meant to challenge you. You should try to do them when you get a chance. (Many kids love to be challenged with problems.) The Historical Highlights are meant to be read for interest and background.

Since a great deal of attention is currently being given to the adoption of the metric system in the U.S.A., metric units are used widely throughout the unit, and there are frequent boxed-in "Metrics in Life" measurements to help increase your familiarity with the metric system.

OVERVIEW

MEASUREMENT IN THE ELEMENTARY SCHOOL

FOCUS:

This overview is intended to provide you with an orientation to this unit. To this end it provides perspective on:

- The history of measurement,
- Current measurement practices,
- Methods of teaching measurement in the schools,
- Child problems with learning measurement, and
- The move toward metrication in the U.S.A.

Each of these topics will be treated in greater depth in the rest of the unit.

MATERIALS:

(Optional) The Mathematics-Methods Program slide-tape overview entitled "Measurement in the Elementary School."

DIRECTIONS:

Read the questions below before reading the essay entitled "Measurement in the Elementary School" (or watching the slide-tape cited above). Then engage in a class discussion based on the questions.

1. How many different kinds of measurements can you name? Use your imagination. How many measuring instruments can you name?
2. Can you think of reasons why measurement would be a particularly appropriate and appealing mathematical topic for children?
3. Take a simple measurement task, such as finding the length of a table, and try to determine the skills and concepts that a child needs in order to accomplish and comprehend this measurement.

MEASUREMENT IN THE ELEMENTARY SCHOOL

For thousands of years measurement has been an important human activity, and as society becomes more technically sophisticated, humans will be faced with greater demands for skill and precision in measurements. This essay will give a brief glimpse of the history of measurement, and will indicate some of the practices and problems of preparing children to be adequate measurers.

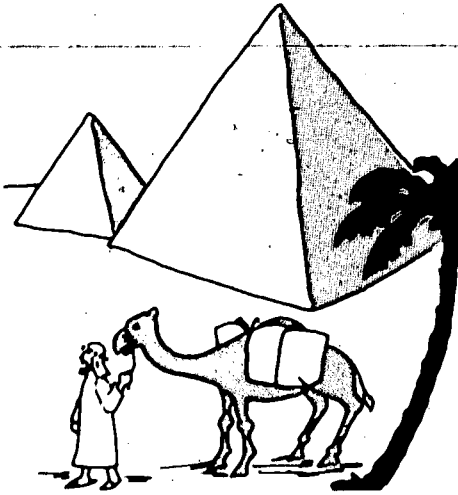

The planets and the stars seem to have always held a fascination for humans. For example, the pyramids of Egypt, many of the Greek temples and the calendars of various early civilizations reflect a surprising amount of knowledge of the heavens. This knowledge was acquired through careful observations and measurements. By today's standards the measuring instruments used before the birth of Christ were not very

sophisticated. But it seems that the more precise measurements become, the more sophisticated our knowledge of the universe becomes; and the more sophisticated that knowledge becomes, the greater our demand for precision in measuring. This cycle has given rise to modern measuring instruments that can determine the size, weight, composition, and distance of heavenly bodies with amazing accuracy.

The passage of time is another attribute that has been measured with increasing accuracy. For most early civilizations time, both daily and yearly, was measured using the sun. The sundial was an early, crude but fairly effective

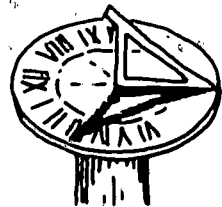

clock. Today, citizens wear watches that are accurate to within a very small fraction of a second per day.

Surveying is a form of measurement that has been preserved since ancient Egypt. As you can imagine, surveying practices have become more precise; such aids as aerial photographs have added new dimensions to civilization's ability to measure and describe portions of land. Describing and predicting the weather requires many different measurements. Today, cities measure noise pollution, smog content, and pollen density. In a typical family auto there are instruments for measuring speed, gasoline volume, water temperature, oil pressure, and electrical charge. Attitude, aptitude, and achievement tests measure human abilities and traits. These measurements are used in psychological research as well as in decision-making about individuals. The list goes on and on. It includes the activities of the homemaker in the kitchen as well as the chemist in the lab. One has no choice but to agree that measurement is an important skill for every citizen.

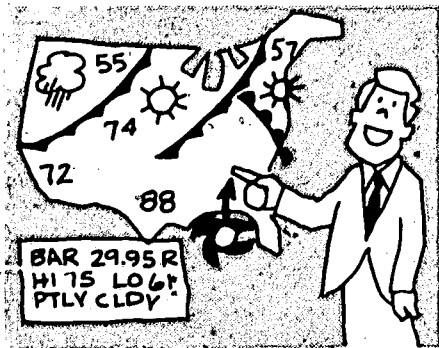

The increased measurement demands on citizens have resulted in increased concern for the instruction of children in measurement. At times in the past, the schools have been content to give children a few simple measurement drills with a ruler, a few conversions between measurement units, and a few basic formulas. There is, among educators, a growing feeling that measurement concepts should be acquired

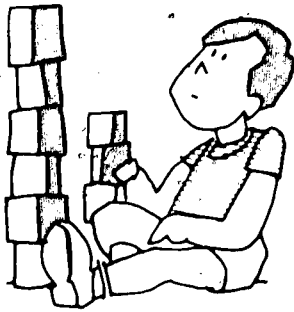

by a child through carefully developed activities. If a child is to learn to measure length, he or she is first given informal experiences comparing actual objects to see which is longer. Then the child compares the lengths of objects with a fixed object to determine relative length. It is only after the concepts of length and of comparison of lengths have been firmly established

that length measurements are made with respect to nonstandard and finally to standard units of measure.

Even such a careful development as the one just described can run into serious snags. Research into child learning of measurement has established that young children lack some very important prerequisite understandings for measurement. For example, a child may fail to understand that changing the position of an object does not change its length. If you think about it for a moment, you will see that a child who lacks this basic understanding may not see much sense in the use of a ruler for measuring. One need not despair of teaching measurement, but one must be most careful. In teaching a child to measure an attribute, one accepted procedure is to:



- Teach the child to identify the attribute;
- Give the child experience with comparing quantities of the attribute;
- Give the child experience with comparing the quantity of the attribute with a nonstandard unit quantity of the attribute; and
- Give the child experience with comparing the quantity of the attribute with a standard unit quantity of the attribute.

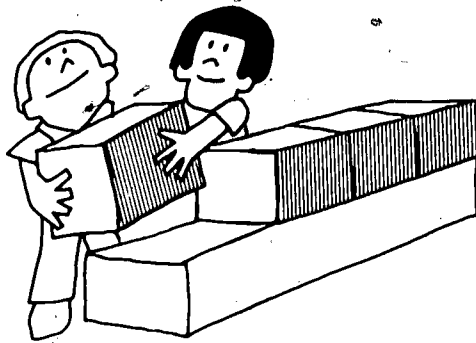

At each of these stages, care must be taken to see that the child has the prerequisite understandings to give meaning to the stage.

Among the attributes that are measured in the elementary school are:

- Length
- Area
- Volume
- Time
- Temperature
- Angle
- Weight

Currently, there is a special concern for measurement instruction in the U.S.A. We are one of the last of the countries in the world to shift to the use of metric units of measure. So for future generations of measurers, centimeters, decimeters, and meters will replace inches, feet, and yards as the standard units of length measurement. Similar changes will come in the measurement of area, volume, capacity, and weight. One reason for the change to the metric system from the English system can be inferred from the table below.

1 kilometer = 1000 meters

1 foot = 12 inches

1 meter = 100 centimeters

1 yard = 3 feet

Each of the conversions within the metric system can be effected by using some power of 10, while each conversion within the English system has a different conversion factor.

Because of the change in systems of standard units, there will be a period of transition and confusion. It seems that during this period it will be most important for teachers to have a clear understanding of the measurement process, in order to provide proper perspective and instruction. So you, as a prospective teacher, are faced with the challenge of teaching measurement, a topic of historic and continuing importance to children. These children must learn many prerequisite skills and have certain prerequisite understandings. This unit is designed to help you gain the skills and insights required to meet the challenge.



Section I

THE MEASUREMENT PROCESS

As was indicated in the Introduction, measurement involves an attribute, a unit, the comparison of a quantity of the attribute with the unit, and the assignment of a number to the quantity of the attribute. The design of measurement experiences for children must take each of these aspects into consideration.

In this section the intent is for you to learn about the measurement process. However, this process will be presented to you in a development that parallels a reasonable approach to child instruction. Therefore, the section will follow the instructional sequence presented in the Introduction.

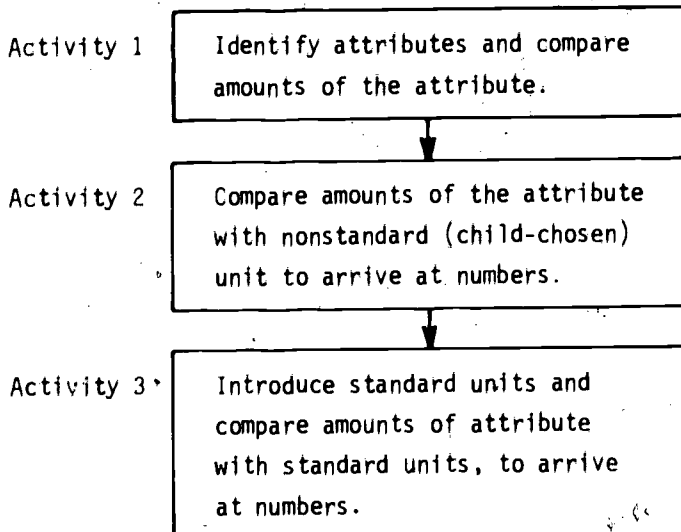

In Activity 1 you will be asked to identify and compare attributes. Because of your familiarity with the usual attributes that are measured in the elementary school, you will be asked to come up with some unusual attributes. Rather than jumping directly into standard units, Activity 2 provides experience with nonstandard, personally chosen, units. It also leads you to see some of the problems that such units present, thus setting the stage for standard units.

Since there is considerable current emphasis on the introduction of the metric system into the U.S.A., Activity 3 focuses on the standard units of the metric system. Some of the units are presented; you are given experiences with these units, designed to increase your familiarity with them; and you are given experiences with making measurements using metric units.

Throughout Section I you will be making different kinds of measurements and not focusing in depth on any kind such as length, weight, volume, time, etc. Section II will provide in-depth experiences with certain kinds of measurements.

MAJOR QUESTIONS

1. Identify modern uses of nonstandard units and discuss the advantages and disadvantages of the use of nonstandard units in measurement.
2. Discuss the following issues regarding the adoption of the metric system in the U.S.A.:
 - The current extent of the adoption;
 - The rationale for the adoption;
 - The procedures being used in effecting the adoption;
 - The implications of the adoption for individuals, for business, and for the schools.

ACTIVITY 1
IDENTIFYING AND COMPARING ATTRIBUTES

FOCUS:

This activity focuses on the first of the three steps in our measurement instructional sequence, that of identifying attributes and comparing quantities of attributes. This is an important step for children, since many children are not familiar with even such common attributes as length, area, volume, and weight. Because of your familiarity with common attributes, you will be asked to work here with uncommon ones.

DIRECTIONS:

As you work through this activity, try to imagine that common attributes may be as nebulous and difficult for a child as less common attributes are for you.

1. Each group of students in class should secretly decide on a human attribute and on what it means for a human to possess more or less of that attribute. The group should then decide which of its members possesses the most, which the next most, and so on. When all groups are ready, each group should present its ordering to the rest of the class so that they can try to guess what attribute was used. (To be in the spirit of this activity, you should try to choose an attribute that is clever or unusual, but not impossible to guess.)

2. Color
Volume
Pain
Intelligence
Value

are all attributes that one might want to measure. Determine (individually, in a small group, or as a class):

- a) How you would describe each attribute to someone who was not familiar with it;
 - b) Some experiences you might give an individual to make him or her better able to identify each attribute;
 - c) A procedure for each attribute to determine which of two objects possesses more of the attribute.
3. Suppose that you asked a child, "Which is heavier, a brick or a pillow?" and the child responded, "The pillow."
- a) What attribute might the child have focused on?
 - b) Describe some experiences that you could provide that would help a child grasp the concept of weight.
4. Instructors are sometimes asked to compare students on the basis of their work in a class.
- a) Identify various attributes that are used in such comparisons.
 - b) What techniques are used in effecting comparisons with each of these attributes?

TEACHER TEASER



When asked the distance from the house to the church, different people in different situations would answer with different units. Can you guess anything about the people who gave the following answers?

- a. Four minutes
- b. A 25¢ bus ride
- c. A good half-hour's walk
- d. About 150 chains
- e. Far, far
- f. What time do you intend to go?
- g. It depends on the current.

ACTIVITY 2

NONSTANDARD UNITS

FOCUS:

Having learned to identify an attribute and to compare different quantities of that attribute, one wants to be able to determine how much of the attribute is present and to communicate that information to others. In this activity, you will work with the second step in our instructional sequence, that of comparing quantities of attributes with a nonstandard unit quantity in order to arrive at a number, and you will explore the effectiveness of nonstandard units for communicating "how much."

DISCUSSION:

A unit is a quantity of an attribute which is to be used as a basis for comparison in measurement. Once one has chosen a unit, one makes a comparison with an object to determine a number. The number reflects the amount of the attribute possessed by the object as compared with the unit.

For example, you are quite familiar with the minute, which is a unit of duration. If you wished to determine how long a time period was, you might compare the time period with the minute, and determine a number which represented the number of minutes in the time period.

It seems reasonable to believe that the base 10 numeration system reflects the fact that we have 10 fingers and 10 toes. In a similar way, man's early attempts at measurement employed bodily references. The length of an arm, a foot, a finger joint, or a stride were all used as units of length for measurement. Units such as these, which may vary from one measurer to another, are called non-standard units.

Introducing the concept of unit to children through nonstandard units may make the development of measurement concepts and skills more personal and more natural. If a child sees that units can be chosen in many different ways and that the standard units that are widely used were chosen for reasons of history, convenience, and communication, then the child may not be unduly mystified by the introduction of a new unit into his or her life. This understanding of the arbitrariness of standard units may be of particular importance in the United States at this time. The country is adopting a new system of standard units, namely, the metric system. So children are being brought up in a transitional period when both the metric system and the traditional English system are in use. It seems reasonable that, in this situation, a clear understanding of the nature and role of units in the measurement process would be most helpful.

DIRECTIONS:

1. Each member of your group should determine the length of the room in strides.
 - a) Certainly the room did not change in length. Why do different people get different lengths for the measure of the room?
 - b) What does this exercise say about the use of strides for ordering a certain length of a product through the Sears catalog?
 - c) Despite the above problem, can you see advantages that the stride has over a meter stick and a tape measure for introducing length measurement to children?
 - d) What are the standard units that are most commonly used to make a measurement of this kind? Can you see that the use of these standard units would enhance communication?
2. Repeat the procedures and questions in (1), using the hand as a unit of area for measuring your table.

3. Repeat the procedures and questions in (1), using a nonstandard unit of your choice to measure some object near at hand. (Choose some attribute other than length and area.)
4. The following are some reasons for introducing nonstandard units to children. Choose the reasons that you feel are most valid, and justify your choices.
 - a) Historically, man used nonstandard units before establishing standard ones.
 - b) Nonstandard units are easier to use.
 - c) A child's involvement is greater when he or she chooses a unit than when a unit is imposed upon him or her.
 - d) Materials for nonstandard unit measurement are easier to obtain.
 - e) Using nonstandard units shows a child that one can measure anything with some object that one possesses.
 - f) Just as we use bases other than 10 in numeration, it is good to give a child experience with unfamiliar systems of measurement.
 - g) Nonstandard units do not have to be used as accurately as standard ones.

A standard is a physical embodiment of a unit. For example, the National Bureau of Standards keeps a small cylinder of platinum-iridium alloy as a standard of mass for the United States. The standard of length in the U.S. was formerly a platinum-iridium base. Now the standard of length is the wavelength of the orange-red light of Krypton 86.

HISTORICAL HIGHLIGHT

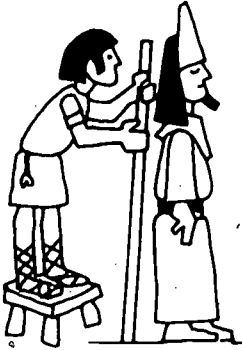

Standard Measures in Ancient Egypt*

Crude ways of measuring, good enough for their forefathers, were not good enough for these builders of great temples and pyramids. The farmer who set out to build a stone or wooden hut with his own hands could say: "My hut will be six paces long and four paces wide, the roof will be a hand-span higher than the crown of my head." The temple ar-

chitect could not give building instructions in paces and spans. Every workman under him might have a different pace and span.

For large-scale building there thus had to be measures that were always the same, no matter who did the measuring. In the beginning they were commonly based on the proportions of one man's body, possibly a king's. These standard measures were marked on rules of wood or metal.

*Taken from Lancelot Hogben, The Wonderful World of Mathematics, (Garden City, N.Y.: Doubleday and Co., 1968), p. 17.

ACTIVITY 3 METRICS ARE COMING

FOCUS:

In Activity 2 you found some difficulty in communicating measurements made with nonstandard units. In this activity you will be introduced to standard units. Since you are most familiar with the English system of standard units (e.g., inch, pound, quart) and since the United States is changing to the metric system of standard units (e.g., centimeter, kilogram, and liter), this activity emphasizes the metric system. You will note that this activity represents the third step in our instructional sequence, which started with identifying attributes and comparing quantities of attributes, and then went to comparing quantities of attributes with nonstandard units to arrive at a number.

MATERIALS:

Metric measuring instruments, including meter sticks, balance scales, and liter containers; an assortment of objects to be measured.

DISCUSSION:

The English system of units has been used in this country since colonial times. The metric system of units has spread throughout the world since its birth in France in 1840. The United States and Great Britain have been slow to abandon their traditional English units, but both countries are now moving to adopt the metric system. In fact the next generation of Americans will be brought up communicating measurements in terms of meters and liters instead of in yards and quarts. In not too many years, the English system will be of little more than historical interest.

In the first part of this activity, you will gain experience with estimating in the metric system. After all, many of the measurements

that are communicated are estimations such as, "He is about 6 feet tall." So you will want some skill with such estimations.

In the second part of this activity, you will learn certain features of the metric system and will have an opportunity to compare the merits of the English and metric systems.

Finally, you will be asked to consider some of the implications of the switch to the metric system in the United States. In order to further build your awareness, familiarity, and skill with the metric system, brief exercises and comments concerning metrics have been inserted throughout the remainder of the unit.

HISTORICAL HIGHLIGHT



In his first message in 1790, President Washington reminded Congress that it was time to establish our own standards of weights and measures. The matter was referred to Secretary of State Thomas Jefferson who quickly proposed two plans.

His first was to use the pendulum as a standard to "define and render uniform and stable" the weights and measures of the English system. From this standard, the units for area, volume, weight, force, and other measurements would follow.

The second plan was to establish a new system of weights and measures based on decimal ratios, which the U.S. had just adopted for coins. He felt the size should be as close as possible to the old units and thus suggested that his new "foot" be nearly as long as the old foot but divided into ten "inches."

The report was accepted by Congress and discussed for the next six years. Neither plan, however, was accepted.

DIRECTIONS:

1. In order to get an idea of the magnitude of certain of the most common metric units, do the following:
 - a) Inspect the metric measuring instruments that are available to you.
 - b) Use each instrument to quickly measure some object that is convenient and easy to measure. (Pay attention to the results that you get, so that you will start to build up your skill at estimating metric measurements.)
2. In order to further develop your skills with estimating in metric units, do the following tasks:
 - a) Select from the classroom an object which you think:
 - Weighs one gram;
 - Weighs one kilogram;
 - Holds one liter;
 - Is one centimeter long;
 - Is one meter long.

Then measure each object that you have chosen to see how close you were. You may want to repeat the selection and measuring process to improve your skill.
 - b) Estimate and then measure your own weight in kilograms and your height in meters and centimeters.
 - c) About how many kilometers did you travel to school today?
3. The table on the following page contains pairs of measurements to be estimated and then actually carried out.
 - a) Estimate the first measurement in the pair.
 - b) Actually make the measurement.
 - c) Compute the error, i.e., how far off your estimate was.

d) Repeat this procedure with the second measurement in the pair, trying to reduce the error in your estimation.

	Metric Estimate	Metric Measurement	Error
The length of your foot			5
The length of a book			
The length of the room The width of the room			
The capacity of a coffee cup The capacity of a drinking glass			
The weight of a 25¢ coin The weight of a door key			
The area of a sheet of paper The area of a dollar bill			

.....

DISCUSSION:

If the United States is going to the trouble of changing to the metric system, there must be some reasons. In order to help you judge these reasons, you will be provided with some facts about the English and metric systems.

LENGTH UNITS

12 inches = 1 foot
3 feet = 1 yard
1760 yards = 1 mile

10 millimeters = 1 centimeter
10 centimeters = 1 decimeter
10 decimeters = 1 meter
10 meters = 1 decameter
10 decameters = 1 hectometer
10 hectometers = 1 kilometer

METRIC LANGUAGE

Length

millimeter centimeter decimeter METER Decameter Hectometer Kilometer

Weight (Mass)

milligram centigram decigram GRAM Decagram Hectogram Kilogram

Capacity (Volume)

milliliter centiliter deciliter LITER Decaliter Hectoliter Kiloliter

.....

DID YOU KNOW?

A cubic decimeter (1000 cubic centimeters) occupies the same amount of space as a liter. The mass* of the water that will fill the decimeter cube is 1 kilogram (to an accuracy of 28 parts in 1 million). Thus the metric measurement of the attributes of length, volume and mass are conveniently linked.

* We use "mass" instead of "weight" in order to comply with the International System of Units (S.I. units). Weight varies according to the gravitational pull in various places. Mass, however, does not vary. For example, a mass of 1 kg. of sand would not change on a lunar journey even though the weight would change according to the gravitational effect at the moment of measurement. The kilogram is a recognized unit of mass. On the surface of the earth, where the gravitational effect is fairly constant, one does not usually need to worry about the distinction between weight and mass.

4. a) Convert each of the following to the indicated units in the metric system.

- 81 centimeters = _____ decameters
375 meters = _____ hectometers
271.5 hectometers = _____ centimeters
1.31 kilometers = _____ decameters
440 meters = _____ millimeters

b) Convert each of the following to the indicated units in the English system.

- 81 feet = _____ yards
375 yards = _____ miles
271.5 miles = _____ feet
1.31 miles = _____ yards
440 yards = _____ inches

5. Compare the English and the metric systems of units according to the following criteria. Feel free to introduce additional criteria that you feel are important.

- Ease of conversion within the system
- Ease of conversion into the other system
- Convenience of size of units
- Ease with which relationships between units are remembered
- Ease of precise definition of the units
- Ease of remembering unit name (Don't forget, a young child does not know the names in either system.)
- Compatibility of unit interrelationships with our base 10 numeration system
- Popular familiarity with units

6. A change in the standard system of units may have more implications than you would guess at first. Tools, machines, and habits need to be changed, not to mention measuring instruments. Congress recently rejected a metric conversion bill, reportedly because this bill would have forced the U.S. Government to pay many of the costs of the change to the metric system.

a) Discuss the impact of the change to the metric system on the people in each of the following categories.

- store clerk
- auto mechanic
- housewife
- manufacturer
- farmer
- school teacher

b) What do you suppose will become of the standard weight, volume, or dimensions of each of the following products?

- sheet of paper
- carton of milk
- basketball
- package of bacon
- large bottle of coke

c) New content in the school curriculum is a source of frustration to many parents. It is important for the teacher to foster a positive attitude in the parents of pupils. Discuss how you would respond to a parent who made the following statement during a parent-teacher conference:

"The school's got me and my first child completely confused with the new math. Now you're at it again with my younger child with this new metric math."

d) Measurement provides one of the major applications of fractions. What impact do you expect the change to the metric system to have on the teaching of fractions?

.....

The International Organization for Standardization (also called the International Standards Organization or ISO) has set up recommended standards for the size of various products. The organization is a nongovernmental body supported primarily by industrial trade groups in the member countries. Some of the standards of this body apply to the fabrication of screws, bricks, softwood lumber, hardwood, glass, pipe and tubing, paper, and envelopes. Care has been taken in formulating these standards. For example, the envelopes were expressly designed to work with certain sizes of paper or to enclose other envelopes.

.....

HISTORICAL HIGHLIGHT

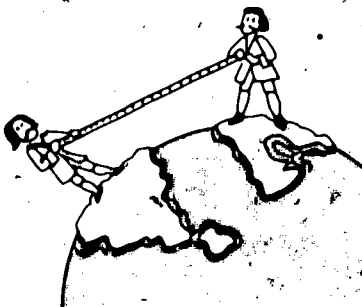

In 1790, Talleyrand received approval to formulate a new system of weights and measures. The Paris Academy constructed the system based on the most scientific principles of the day. The meter was the keystone for the entire system which has become known as the metric system, and was defined as a certain fraction of the earth's circumference.

Originally, every type of measurement possible was related to the metric system, but the system was not an unqualified success in all cases. Some units did not survive the test. The decimal watch, the ten-month calendar, and the ten-day week are some of the forgotten units.

In 1837, France officially passed a law which made the metric system compulsory throughout the country by January 1, 1840. After that, it spread internationally at a rapid pace. By 1900, over 40 countries had officially adopted this new system.

Section II

CERTAIN COMMON MEASUREMENTS

As an adult you have had considerable experience with measuring. In particular, you have used a ruler or a tape measure to measure the length of many different objects. So we have chosen in this section to present you with a selection of measurement topics which omits length and weight measurements and several other important topics. The topics chosen, however, are important in the elementary school and might be beneficial for you to investigate.

Activity 4 introduces you to the concept of area, from two different points of view. Activities 5 and 6 extend Activity 4, introducing you to geoboards and to the use of geoboards in developing certain formulas for area. In Activity 7 that famous number π , is introduced in the context of its role in the formula for the area and circumference of circles. In Activity 8 the topic of measuring volumes is presented, as was area, from two different points of view. In Activity 9, measurement is reviewed in its entirety and some additional measurement topics are briefly considered. Activity 10 departs from usual measurement topics and considers the problems involved in measuring human attributes and abilities. Finally, in Activity 11, the nature and sources of error in measurement are considered.

Throughout the section the focus is on your learning measurement in a way that is as much as possible analogous to a way that you might use with children.

MAJOR QUESTIONS

1. Compare and contrast two approaches to measuring area. Be sure to indicate the circumstances in which each is appropriate.
2. Do as in (1) for volume. How do the approaches to volume and area compare?
3. Discuss how you would relate π to children's work with rational and irrational numbers.
4. Apply the error analysis procedure introduced in Activity 11 to analyze the sources of error in approximating the area of an irregular shape as introduced in Activity 4.

HISTORICAL HIGHLIGHT

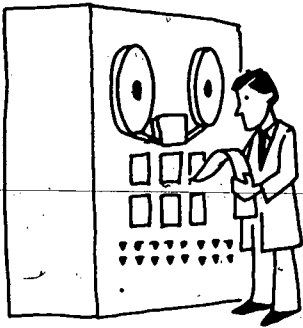

Even before the time of Newton, π had been computed to more decimal places of accuracy than would ever be needed in any computation problem. With the advent of the high-speed computers, the computation of π continued. The following is the track record on computing π , using computers:

<u>Year</u>	<u>Number of Decimal Places</u>
1949	2,037
1954-55	3,089
1957	7,480
1959	16,167
1961	100,000
1966	250,000
1967	500,000
1972	1,000,000

ACTIVITY 4

AREA

FOCUS:

The development of the measurement of area is approached in three different ways:

- Precisely covering a region with a certain number of unit regions;
- Approximating the area of a region by determining numbers of unit regions that are contained in it and completely cover it;
- Using a formula to compute the area of a region in terms of certain linear measurements.

In this activity you will have experience with the first two of these approaches.

MATERIALS:

Scissors and paper.

DISCUSSION:

You recall the instructional sequence for measurement introduced in Section I:

- Identify and compare amounts of the attribute;
- Compare amounts of attributes with nonstandard units to arrive at numbers;
- Introduce standard units and compare amounts of attributes with standard units to arrive at numbers.

Since Section II is designed to attend to your measurement learning rather than that of children, the steps in this sequence will be slighted. You should notice, though, that you are engaging in each

of the steps involved in measuring:

- Identifying an attribute;
- Choosing a unit quantity of the attribute;
- Comparing a quantity of the attribute with the unit quantity, in order to arrive at a number.

One particular concept that you should note here is approximation. As you will discover in Activity 11, every measurement is an approximation and is subject to error from several sources. But approximation will be more prominent and more important in the measurement of areas of irregular shapes than in almost any other common measurement activity.

DIRECTIONS:

1. The different members of your group should describe the attribute area to each other. How would you decide which of two objects possesses more of the attribute?
2. The names of the standard units for area measurement have been a part of your vocabulary for years. "Square inches," "square feet," and "square yards" are commonly used terms. "Square centimeters" and "square meters" are going to become much more common. There are a few specialized terms such as "acre" and "section," but most units for area measurement are called square such-and-so's. To gain some insights into why, consider these three shapes as candidates for units of area.

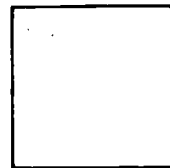
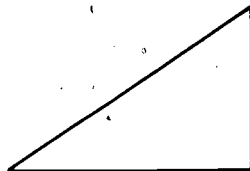
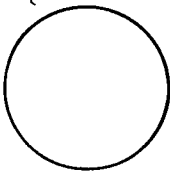

Choose your favorite, taking the following three questions into account:

- Does it cover well? That is, how well do copies of it fit together?
- Is it common and easy to draw?
- Is it easy to count how many copies have been used to cover a shape?

You may want to experiment with a few copies of each shape.

3. For a number of reasons, some historical, some practical and some unknown, squares are the most common units used for area measurement. Most procedures for measuring area are designed to determine how many squares of a certain size will cover a shape. Determine how many square glops* like this one:

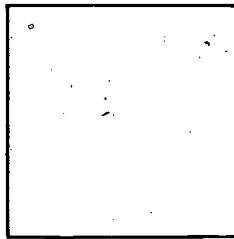

are required to cover each of the shapes below. Do not use formulas. Use copies of this square glop to cover the shapes. Put your answers in the table which follows the shapes.

Shape #1

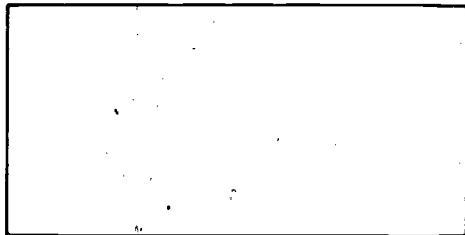

* We use the nonstandard unit "square glops" to avoid your overreliance on your previous experience with measurement.

If you have the time you might enjoy conjecturing on the use of the "lizard" as a unit of measure.

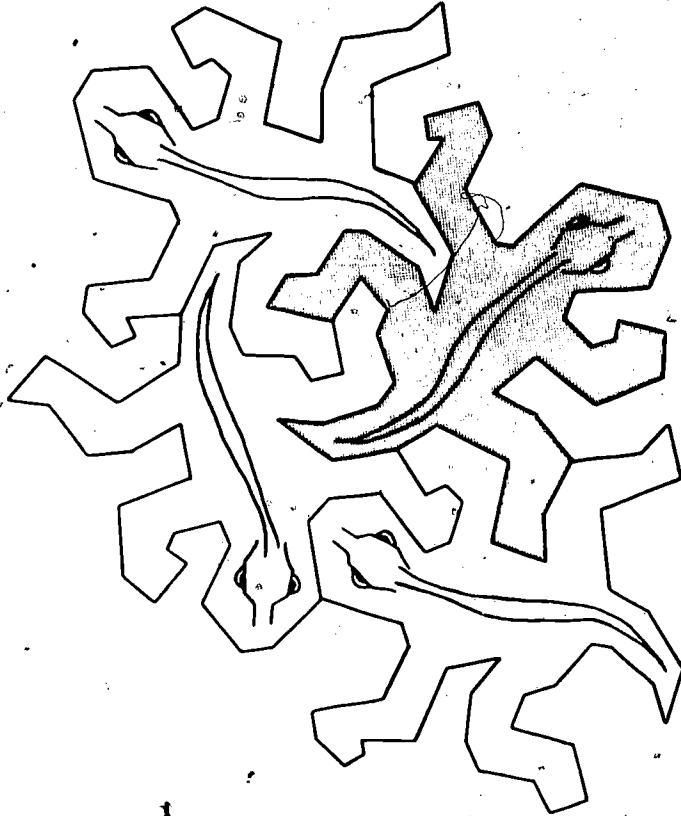

In addition to this lizard design, the late Dutch graphic artist M. C. Escher designed birds, salamanders and even a man on horseback that would qualify as units for area measurement.

Shape #2

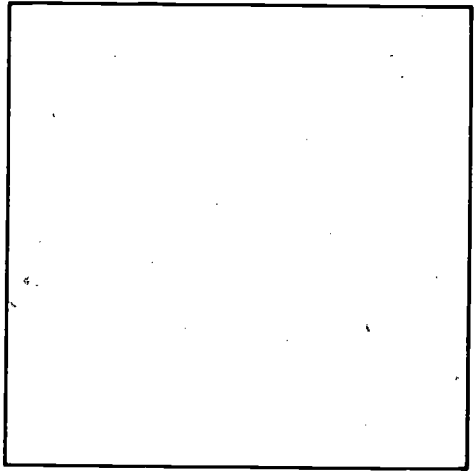

Shape #3

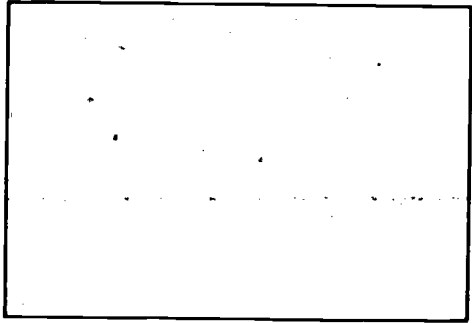

Shape #4

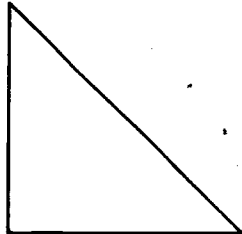

Shape #5

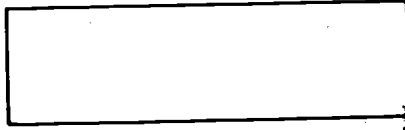

Shape #6

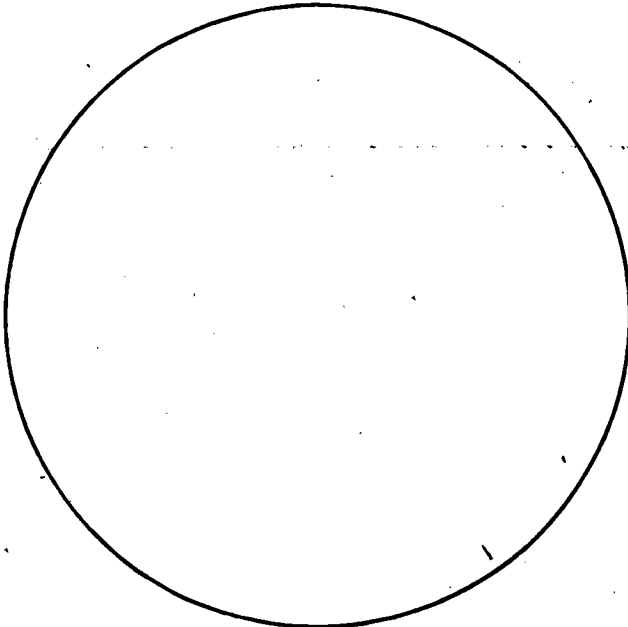

48

Shape #7

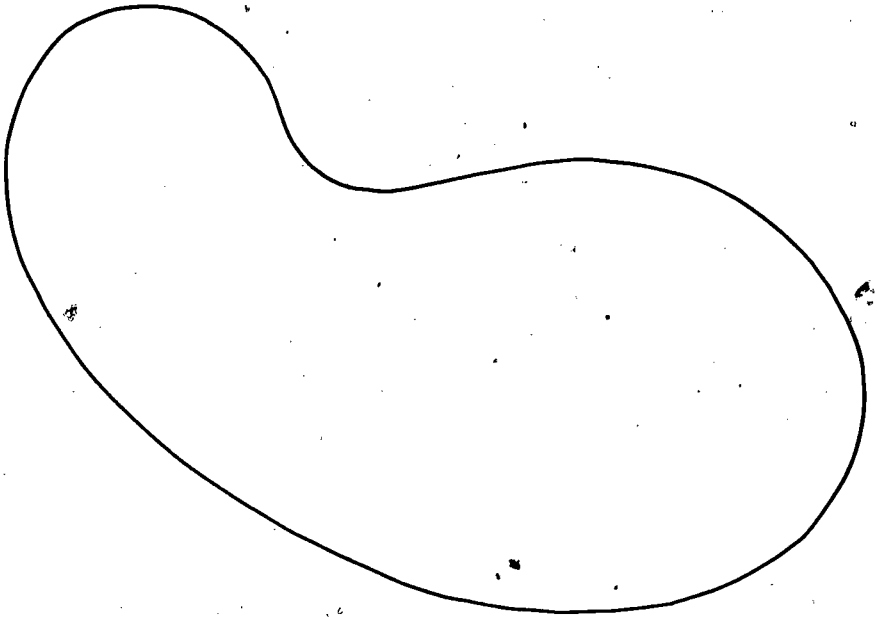

	Number of Square Glops
Shape #1	
Shape #2	
Shape #3	
Shape #4	
Shape #5	
Shape #6	
Shape #7	

Did you find yourself doing more approximating toward the end? As you will see, such approximations are a very important part of area measurement.

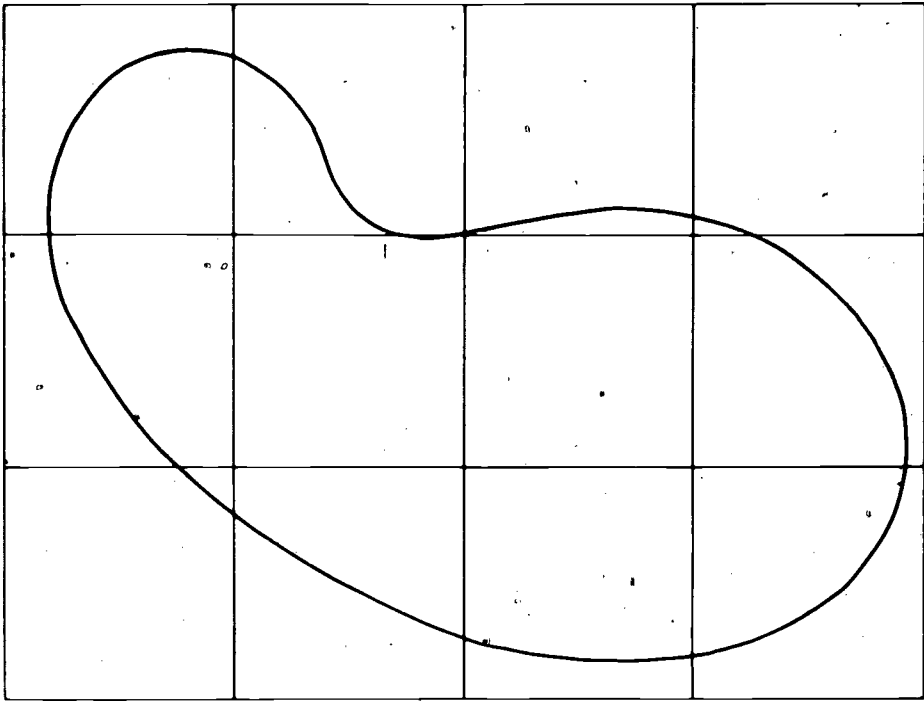

DISCUSSION:

Let's focus for a moment on shape #7 and on the notion of approximating. Look at the illustration above and convince yourself that the following statement is true.

$$2 \text{ square glops} < \text{Area of shape \#7} < 12 \text{ square glops}$$

That is, the area of shape #7 lies somewhere between 2 and 12 glops. So we can choose a number between 2 and 12 as our estimate to the area of shape #7, in square glops. Suppose we choose 7 (it's halfway between). We don't know how close we are to the exact area except that we do know that we can't be off by more than 10 square glops. Do you see why? Clearly this is not very helpful information. But other grids than the square glop grid on this page may help us get better estimates.

On the pages following this activity you will find copies of additional grids. The next question will help you determine the properties of those grids before you go on to use the grids in approximating the area of shape #7.

METRICS Estimate the volume of a coke
IN LIFE! can in milliliters.

4. a) Each square on grid #1 is what fraction of a square glop?
50 of these squares is how many square glops?
 - b) Each square on grid #2 is what fraction of a square glop?
18 of these squares is how many square glops?
 - c) Each square on grid #3 is what fraction of a square glop?
155 of these squares is how many glops?
5. Now use grids 1, 2, and 3 to answer the following questions:
- a) The area of shape #7 is between _____ and _____ of the squares on grid #1. So the area of shape #7 is between _____ and _____ square glops.
 - b) The area of shape #7 is between _____ and _____ of the squares on grid #2. So the area of shape #7 is between _____ and _____ square glops.
 - c) The area of shape #7 is between _____ and _____ of the squares on grid #3. So the area of shape #7 is between _____ and _____ square glops.
6. a) Summarize your findings from (5) in the first two columns of the following table.

AREA ESTIMATES FOR SHAPE #7

	Lower Area Estimate (square glops)	Upper Area Estimate (square glops)	In-between Estimate (square glops)	Maximum Possible Error (square glops)
Grid #1				
Grid #2				
Grid #3				

- b) For grid #1, choose a number as your estimate of the area of shape #7; place that in-between estimate in column 3. Do the same for grids #2 and #3.
- c) On the basis of your lower and upper area estimates, using grid #1 determine the maximum possible error in your in-between estimate. Put it in the fourth column. Do the same for grids #2 and #3.
- d) Look over the completed table. Can you explain why your maximum possible error gets smaller as your grid gets finer? Do you think that you could make the grid fine enough so that the maximum possible error would be zero?

.....

METRICS Estimate the weight of a tennis
IN LIFE! shoe in grams.

.....

7. Fill in the following table for the circles on page 45. If you find the counting with the finer grid to be too tedious, try to find a system for counting which will make it easier.

AREA ESTIMATES FOR CIRCLES
(in one-inch square units)

		Lower Area Estimate	Upper Area Estimate	In-between Estimate	Maximum Possible Error
Large Circle	Grid #1				
	Grid #2				
	Grid #3				
Small Circle	Grid #1				
	Grid #2				
	Grid #3				

SUMMARY COMMENTS

You can now guess that, with most shapes that one encounters, one can use finer and finer grids in order to obtain increasingly accurate approximations to the area of the shape. Is there no relief? Is one doomed to a life of counting tiny squares? In many practical cases, such as in the measurement of irregular land area, one is unlikely to get relief. But then, in those cases the accuracy required may not demand too fine a grid. In some cases, such as with rectangles, triangles, and circles, one does get relief in the form of formulas for computing area in terms of linear dimensions. These will be discussed in Activities 7 and 8.

You may have heard of calculus. One of the applications of that branch of mathematics is to compute areas of regions in a way that is similar to taking finer and finer grids. Calculus provides a technique for finding a number that the upper and lower estimates approach as the grids get finer. This number is defined to be the area.

8. Suppose that you own the plot of land which is shaded in the drawing below.

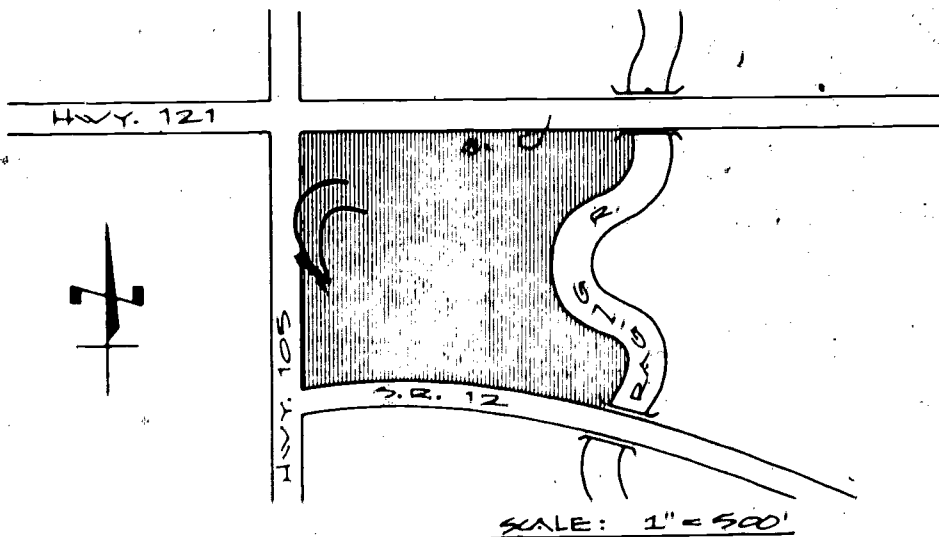

You are anxious to sell your lot, so you contact a realtor.

- How much land do you own? (Use grid #3.) Just in case the realtor asks you, figure out by how much you might be off in your estimate of the area of the lot.
- The realtor finds a buyer for you who says that he will purchase the lot if you can give him an estimate of the area of the lot that is within 1% of being correct. How fine a grid would you need? Or, at least, how would you proceed to provide the potential buyer with a sufficiently accurate estimate?

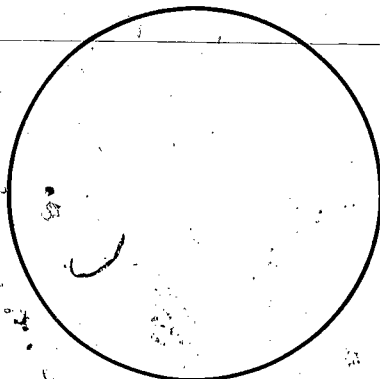
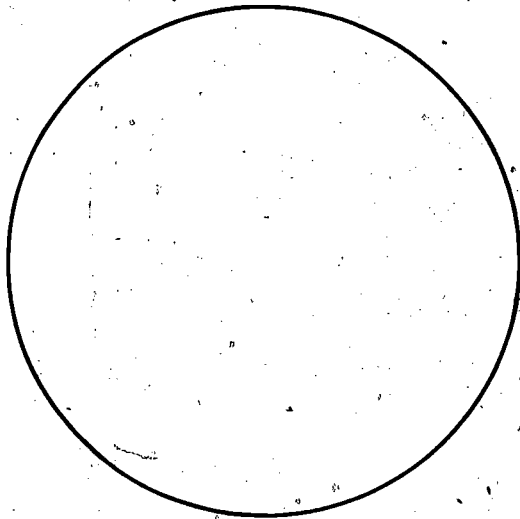

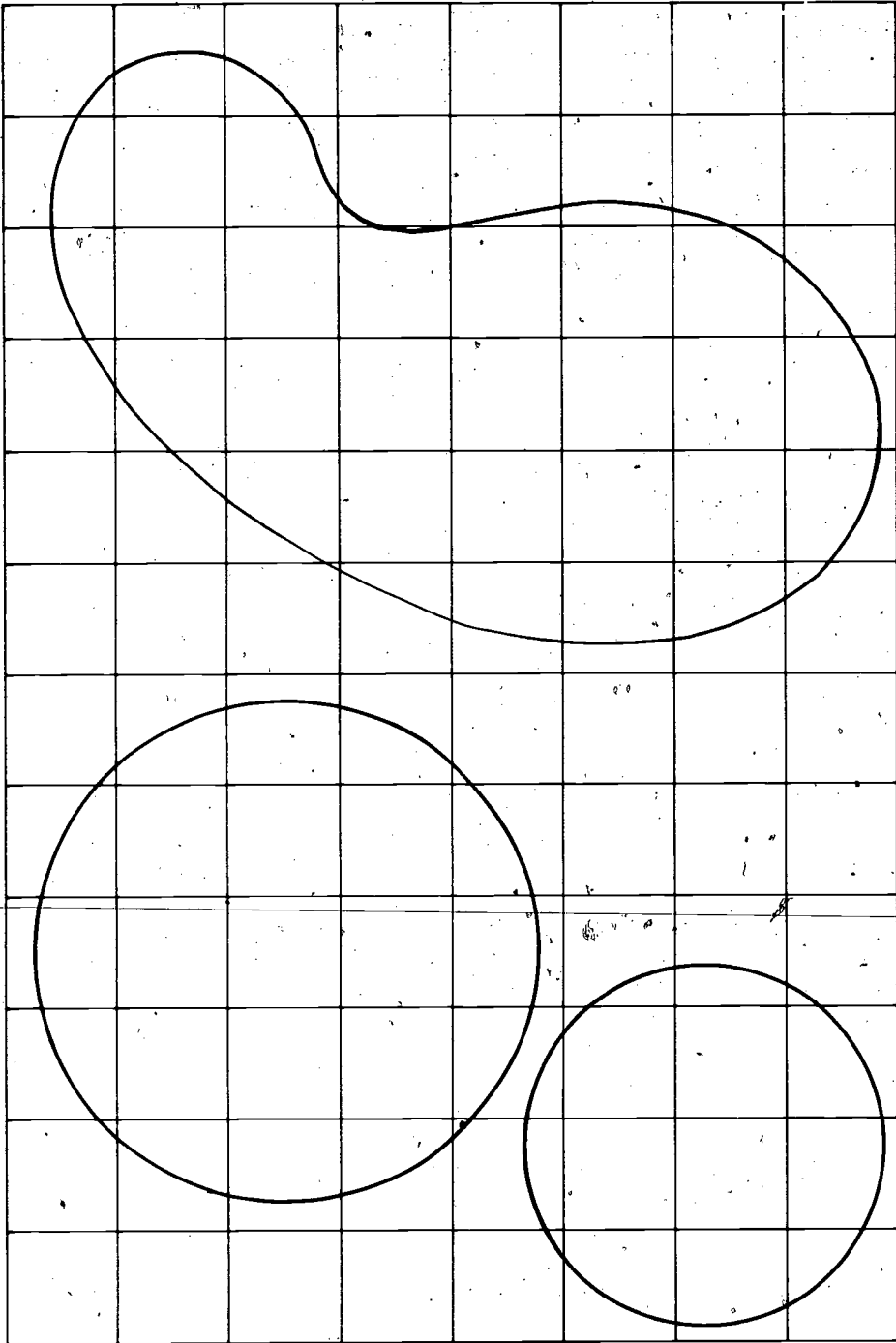

Grid #1

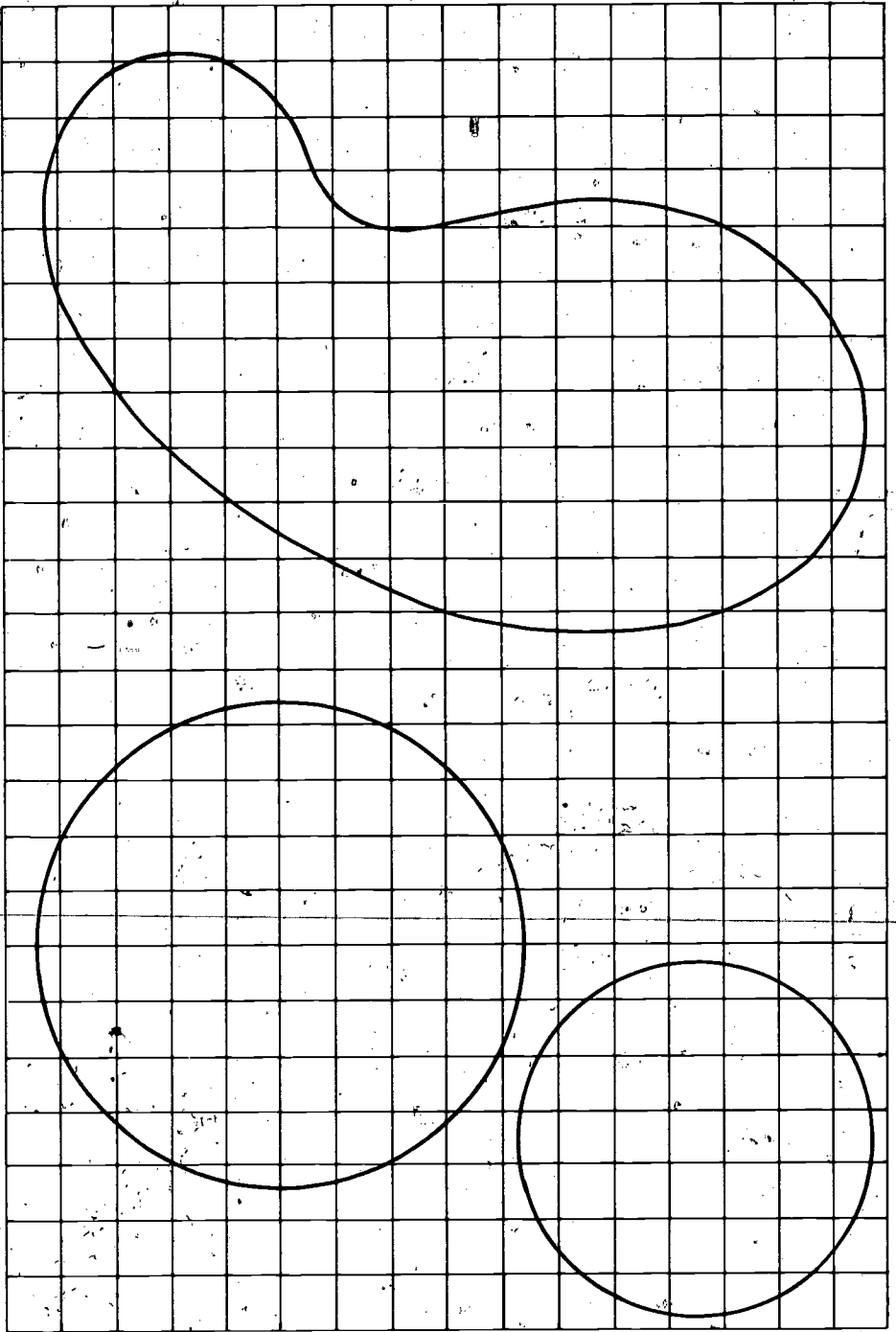

Grid #2

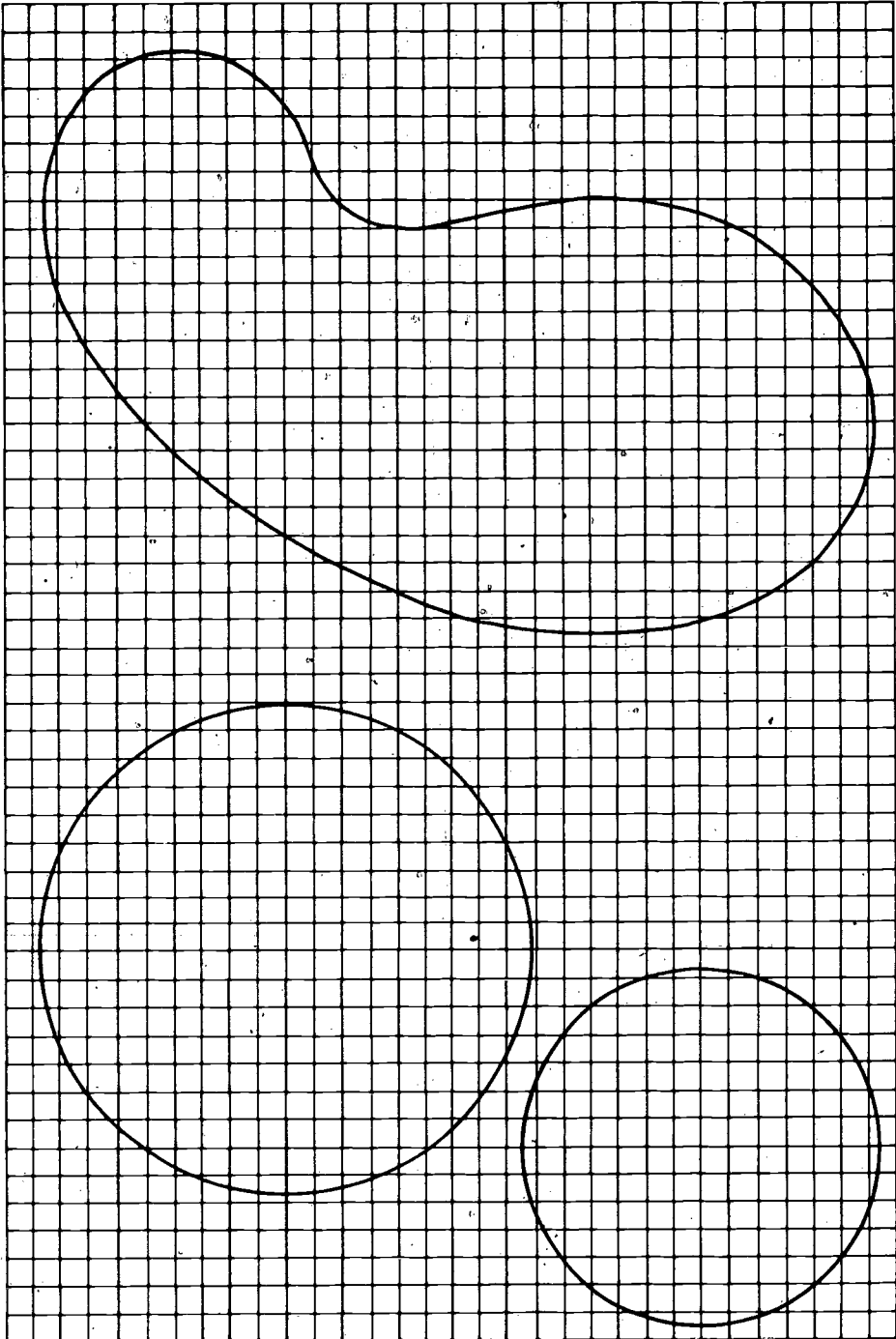

Grid #3

Grid #1

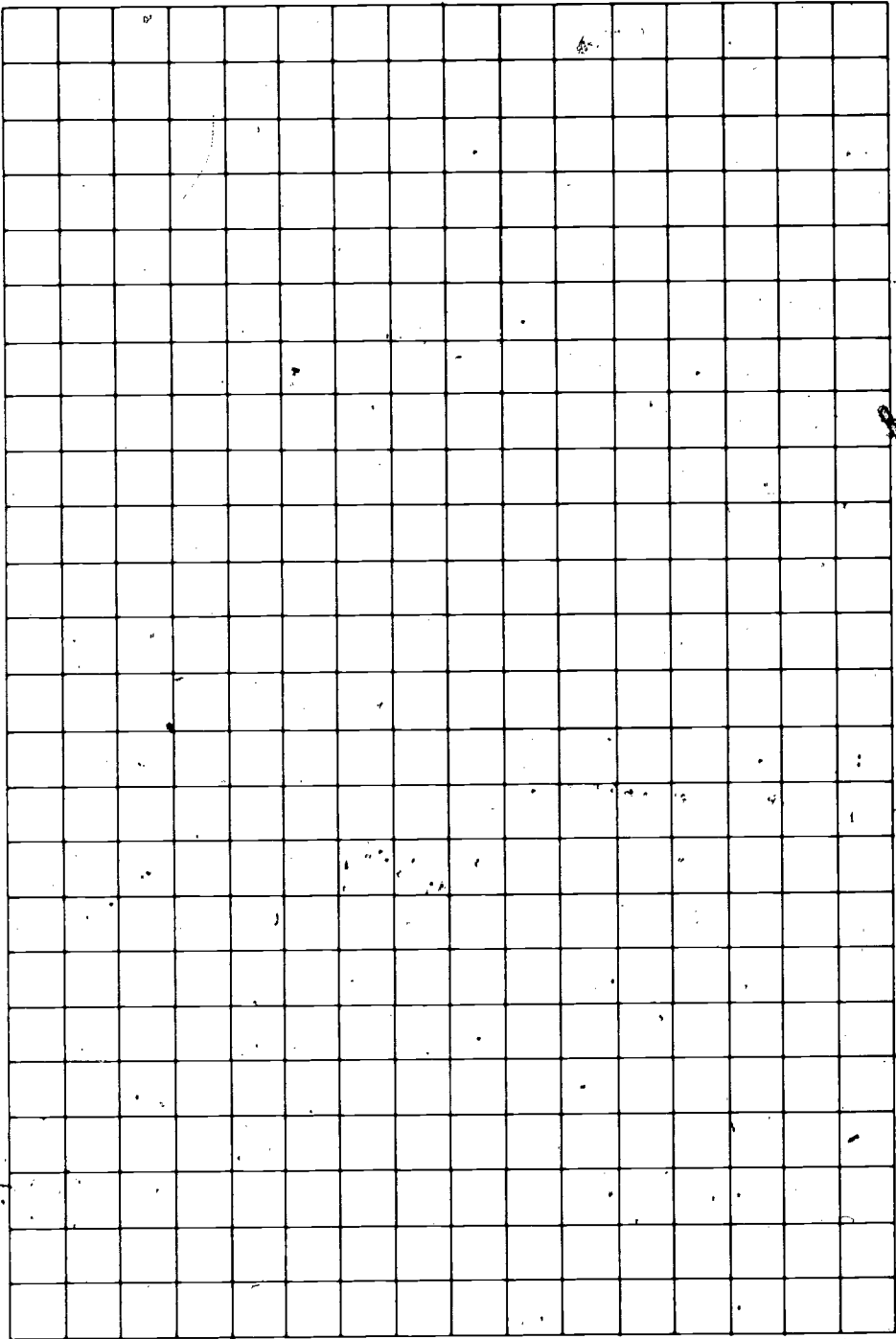

Grid #2

50

60

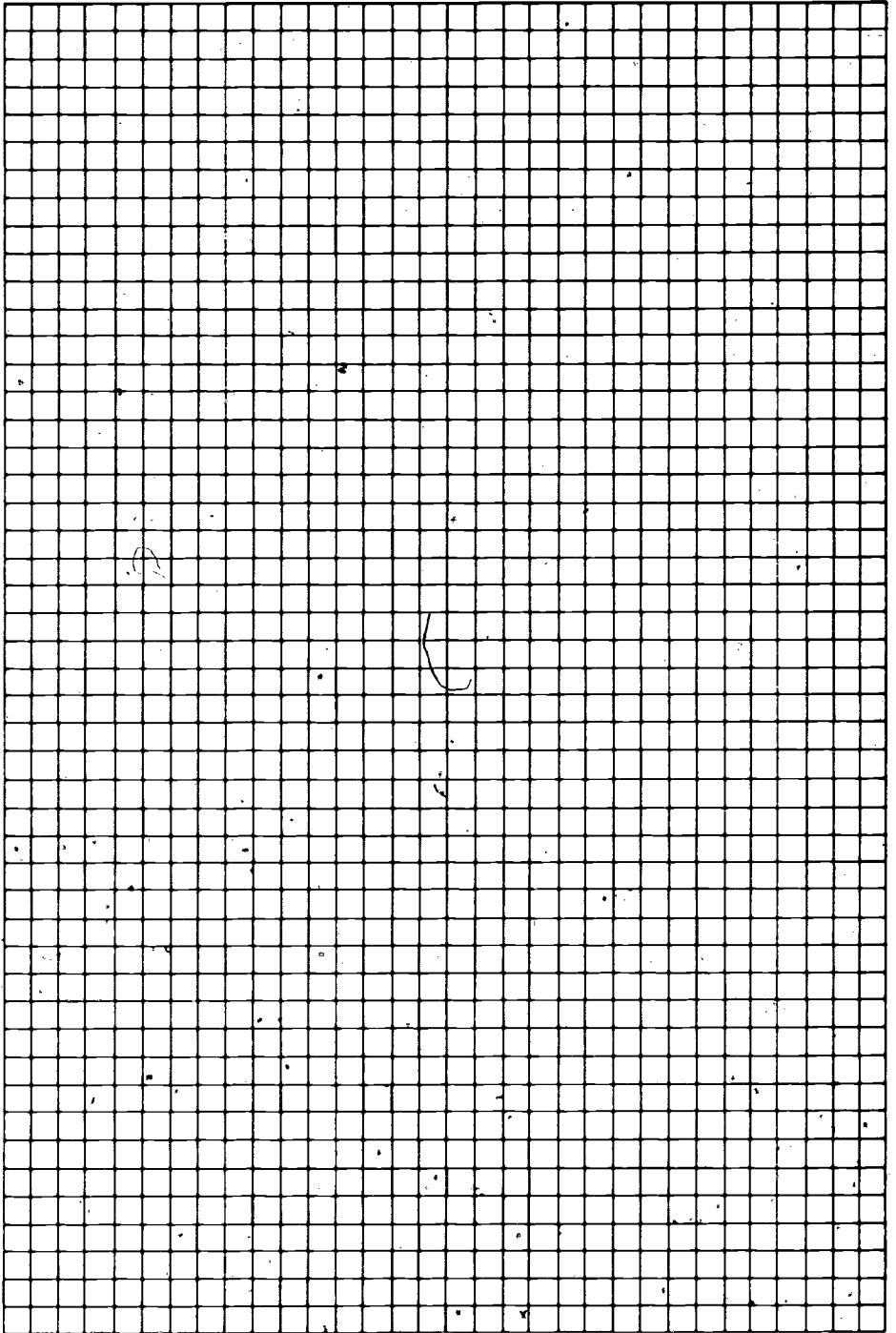

Grid #3

51

61

ACTIVITY 5

GEOBOARDS

FOCUS:

There are thousands of instructional aids that have been devised to help motivate, illustrate, or embody mathematical concepts. Certain of these have become popular and are available commercially. Cuisenaire rods and Dienes blocks are widely used for work in numeration and early work with the basic operations. Geoboards have become a popular aid in measurement instruction, especially in area work. This activity will give you some problem-solving experiences with geoboards, and will attempt to raise some issues concerning their value and appropriate use.

MATERIALS:

Geoboards and/or dot paper, rubber bands.

DIRECTIONS:

The standard geoboard looks like this.

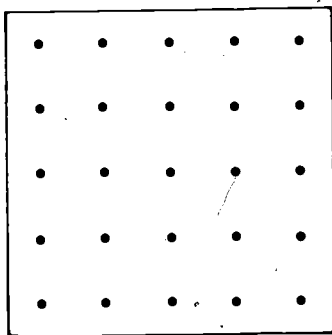

There are variants, but most consist of a plywood square with a square array of 25 nails around which rubber bands can be placed. Teachers and children have found geoboards fun to work with and not too difficult to make.

You should note that in most of your work with the geoboard you will be working with "ideal" regions. That is, you will be assuming that your regions are perfect squares, rectangles, triangles, etc., and you will be determining the exact area of the ideal region (not necessarily of the actual region on the geoboard).

- Suppose that we define the unit of area to be the smallest square on the geoboard whose vertices are at nails.



Can you find squares with areas 1, 2, 3, and 4 on your geoboard?

- Using the smallest square as unit, find the area of the four figures that follow. (You could form each figure on the geoboard, and use extra rubber bands to decompose the figure into unit squares. Then you could count squares--or half squares--to find the area. In some cases, you may find it easier to enclose a figure in a larger one whose area you know and then subtract any excess area.)

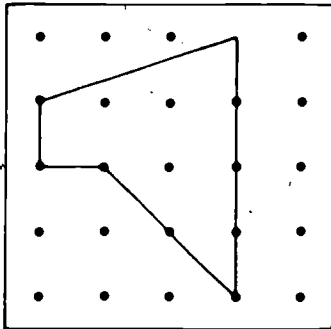

Area of above pentagon
= _____ units of area

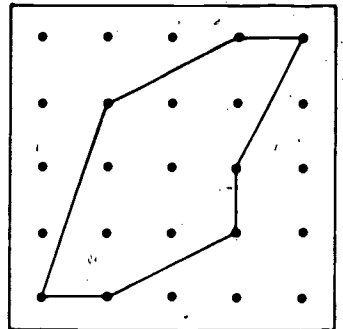

Area of above polygon (heptagon)
= _____ units of area

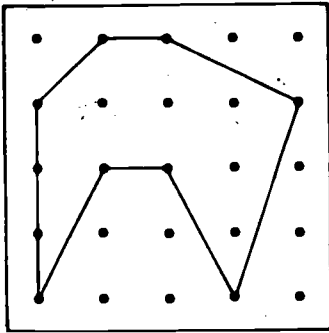

Area of above octagon
= _____ units of area

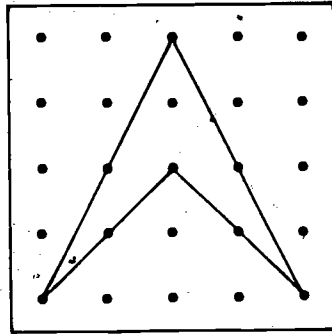

Area of above quadrilateral
= _____ units of area

3. Can the following rectangles be formed? Place a check (✓) in the last column beside each rectangle that you can construct on your geoboard, and actually draw the rectangle on the dot paper provided you after page 59.

Area (Units of area) of Rectangle	Perimeter (Units of length) of Rectangle	Check (✓) those that can be formed
a) 1	4	_____
b) 3	8	_____
c) 4	8	_____
d) 4	10	_____

4. Construct the following figures, if possible, on your geoboard. Place a check (✓) on the line beside any you were able to form, and draw the figure on dot paper.

- _____ a) A triangle--area 3 units
 _____ b) A parallelogram--area 4 units
 _____ c) A trapezoid--area 5 units

- d) A pentagon--area 8 units
- e) A hexagon--area 8 units
- f) An octagon--area 8 units

5. Form the octagon shown below on your geoboard. What is the largest possible square that can be constructed inside the octagon? (The square may touch the boundary, but may not go outside the octagon.) When you have found the square, draw it in below, and calculate its area. (Note that similar problems can be posed using figures other than an octagon.)

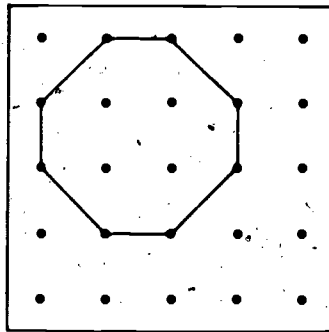

Area of "largest possible square"
is _____ units.





6. One variation in area problems is to use different shapes and sizes for the unit of area. A simple unit, for example, might be the triangle, enclosed by placing a rubber band around three adjacent nails or pegs:

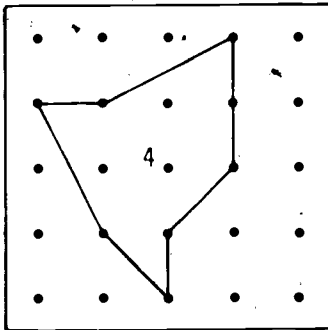
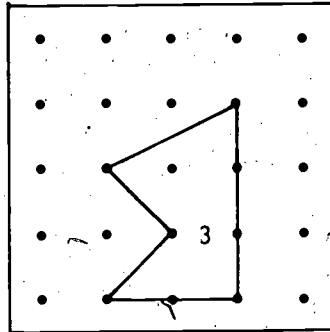
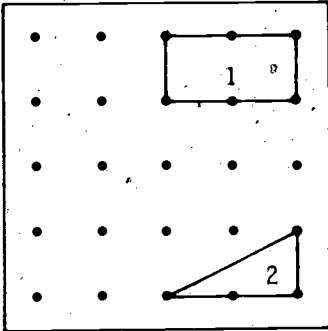

If we adopt this as our unit of measure (for this problem only), then:

a) What is the area of the figures below, in triangle units of area?



Area of: 1 =  units
 2 =  units
 3 =  units
 4 =  units

b) Is it possible to construct a pentagon with an area of 11 triangle units? (If so, draw it on the grid to the right.)

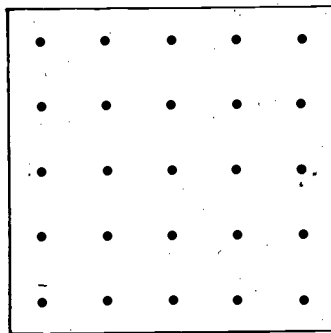

7. Two figures are congruent if they have the same size and shape.



ARE congruent

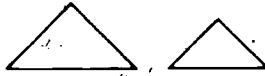

ARE NOT congruent

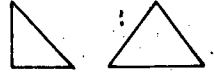

ARE NOT congruent

- a) Do congruent figures always have the same area?
b) Are figures with the same area always congruent?

Record on dot paper any figures that you formed in arriving at your answer.

8. You may want to explore with your geoboard or on dot paper in order to answer the following questions:

- a) Do two polygonal figures with the same area always have the same perimeter?
b) Do two polygonal figures with the same perimeter always have the same area?
c) If you answered "no" to either question above, sketch figures on dot paper to prove your point.

9. Here is a challenging problem which is solved by discovering a pattern with the help of a geoboard.

HOW CAN THE NUMBER OF NAILS ENCLOSED BY A RUBBER BAND BE RELATED TO THE AREA OF THE FIGURE THAT IS FORMED?

You may want to make a table like the following one. As you gather more data, can you derive a formula which expresses this relationship? There is such a formula, and it is called Pick's formula.

Number of Nails on Perimeter	Number of Nails in Interior of Figure	Area of Figure
8	0	3 units
10	2	6 units
6	0	2 units
12	2	7 units

Area (A) = _____ (Pick's Formula)

10. OPTIONAL: On dot paper...

a) Is it possible to have a shape with five boundary dots and an area of 7?

b) Can you represent $\frac{1}{5}$ using  as 1? (This is a tough one. You can make shapes whose vertices are not at dots; see (11) below.)

c) What is the largest area of a triangle that can be constructed with two interior dots? (These vertices do not have to be at dots either.)

11. Can you find the area of the square region below? This problem is a challenging one and will require you to use techniques that you have not needed to this point.

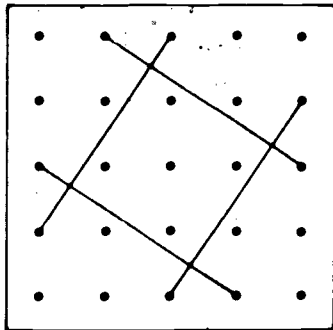

12. You have now had an opportunity to gain some familiarity with geoboards. You have probably seen some potential in them for involving children in profitable and enjoyable activities. Geoboards can be helpful and fun; but, as with any aid, they should be used with planning and caution. Some educators feel that geoboards are inappropriate for introductory area work because they do not focus on the covering aspect of area. Some educators have found that geoboards can be used in a myriad of situations, including the multiplication of fractions.

There follows a list of statements about geoboards that might be made. Discuss each one to determine to what extent you do or do not agree with it.

- With a geoboard the focus is on perimeter rather than area.
- Geoboards are limiting. Can you form a circle on a geoboard?
- Kids love geoboards. They should be used at every opportunity.
- Geoboards are not worth the rubber band fights that they generate.
- Geoboards are good because they force a kid to distinguish between 1 and $\sqrt{2}$.
- Every child should make his own geoboard and should have it readily available.
- The geoboard promotes the notion that every shape is a polygon.
- The geoboard can become a crutch--a replacement for learning graphic skills and using one's imagination.
- The transition to areas on the geoboard should be effected through covering shapes on dot paper with cut-out squares.

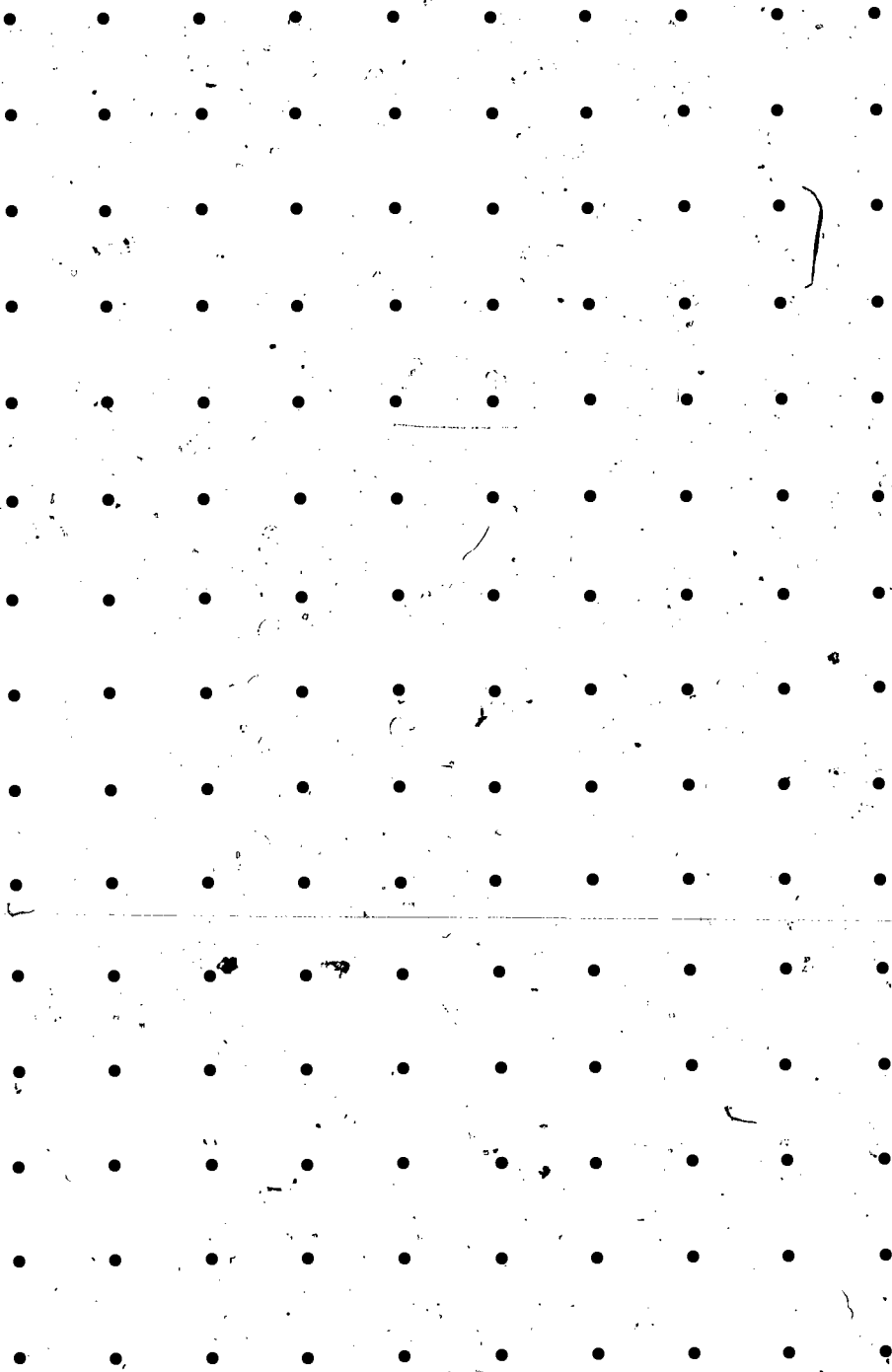



ACTIVITY 6

FAMILIAR FORMULAS FOR AREA

FOCUS:

Once the concept of area in terms of covering has been firmly established, and once it is recognized that the area of a rectangle is equal to its length times its width, the formulas for the areas of other shapes can be derived. In this activity the geoboard is used as a vehicle for the discovery of the formulas for the areas of parallelograms and triangles in terms of their linear dimensions. There is also an opportunity to develop a strategy for helping children discover these formulas.

MATERIALS:

Geoboards, rubber bands, construction paper, and scissors.

DISCUSSION:

It is most important that students first visualize area in terms of covering a region with copies of a unit area. We emphasize this since there is a tendency for children to latch onto formulas and to ignore the meaning of the numbers generated by the formulas. However, once the covering concept is established one can start to do the actual computation of area by formulas. The first step in developing formulas for children is usually to establish that if A is the number of square units of area in a rectangle, then $A = \ell \times w$ (where the length ℓ and the width w are given in the same units). This formula can be derived by giving children experiences counting w rows of unit squares, each of which contains ℓ squares, and then by helping children see that the counting process can be expedited by using this formula.

$$\ell = 10$$

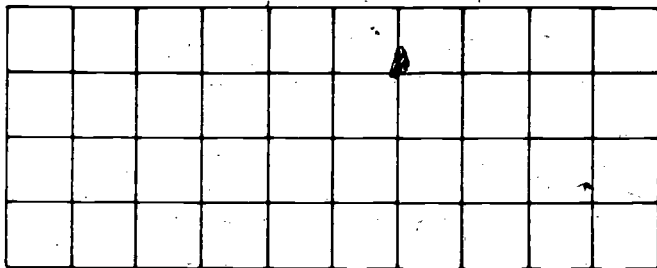

$$w = 4$$

$$A = \ell \times w = 40$$

Then one can discover formulas for the areas of parallelograms and triangles using this formula for the area of a rectangle.

The geoboard is one convenient tool for work with area formulas. However, since on a geoboard the vertices and edges of a figure are more prominent than its interior, a teacher has to be sure that children are focusing on area. This drawback is probably outweighed by the ease of experimentation with the geoboard.

METRICS
IN LIFE! Estimate the weight of a nickel in grams.

DIRECTIONS:

1.



The picture above suggests how any parallelogram can be transformed into a rectangle with the same area.

- Practice making this transformation on your geoboard or on dot paper.
- Use this transformation and the formula for the area of a rectangle to derive a formula for the area of a parallelogram.

2.

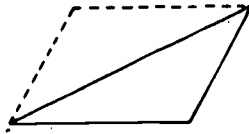

The above picture suggests how any triangle can be made a part of a parallelogram.

- a) Practice making this transformation on a geoboard or on dot paper.
 - b) Use this transformation and a formula for the area of a parallelogram to derive a formula for the area of a triangle.
3. Answer the following questions in order to check your understanding and to provide you with some ideas for teaching.
- a) Find the area of each of the following parallelograms by determining how many unit squares are contained in each. Explain your findings in terms of the formula for the area of the parallelogram.

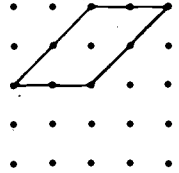
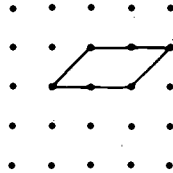

- b) Proceed as in (a) for these triangles.

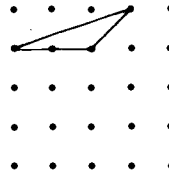
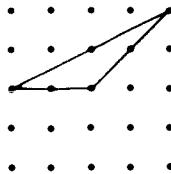
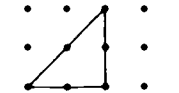

- c) Determine the area of these two regions. Can you see how a child might think that they have the same area? What could you do to help such a child see the error?

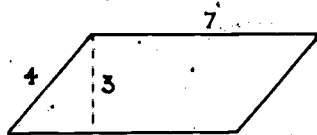
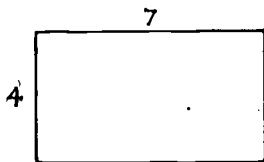

4. Assuming that you had convinced your fifth-grade class of the formula for the area of a rectangle, devise a sequence of questions that you would ask in order to help them discover on geoboards the formulas for the areas of parallelograms and triangles.
5. In some ways paper cutouts of regions provide a better embodiment of the area concept than geoboards.
- Do (1a) using paper cutouts rather than a geoboard or dot paper.
 - Discuss relative advantages and disadvantages of paper cutouts and geoboards for work on area.
 - How would you change your questions in (3) if you were going to have children work with paper cutouts?
6. Explain how you have been using the following formula in much of your work with area.

$$a(A \cup B) = a(A) + a(B) \text{ if } A \cap B = \emptyset.$$

Here $a(A)$ stands for the area of the region A , and $A \cap B = \emptyset$ means that the regions A and B do not overlap.

.....

METRICS - Estimate the length of a
IN LIFE! cigarette in centimeters.

.....

ACTIVITY 7
 π AND CIRCLES

FOCUS:

Circles are very easy to draw. They have aesthetic and structural merit. They have been valued by civilization since the first time that the wheel was invented. π , on the other hand, is a Greek letter that stands for a very unusual and important number. Mathematicians have unearthed π in the solution of many different problems. In this activity you will do some experiments that will provide insights into the formulas that relate the circumference and area of a circle and π .

MATERIALS:

Grids from Activity 4, several circular objects, string, rulers.

DIRECTIONS:

1. Find several circles in your environment. Measure the circumference (distance around) and the diameter (distance across) of each circle and fill out this table and the graph on page 68.

Circle	Circumference (C)	Diameter (D)	C/D
1			
2			
3			
4			
5			
6			

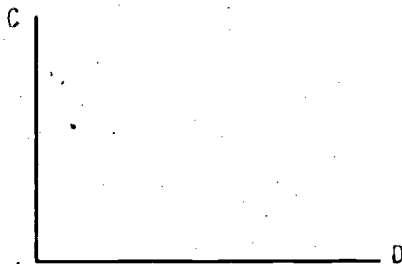

2. Analyze the data that you have collected in (1). Is there any pattern? What can you say about C/D ? Compute C/D for some more circles if you feel the need.
3. Now let's compute the areas of some circles. Use the areas of the circles that you computed in Activity 4 and some more computed in this activity (use grid #3) to complete the table below and the graph on page 69. (Since counting the squares in grid #3 can be tedious, different members of the class may want to do different circles.)

Circle	Radius (R)*	R^2	Area (A)*	A/R^2
1				
2				
3				
4				
5				
6				
7				

* Be careful; some attention will need to be given to computing R in units which are the length of one side of a square glop. The grid paper can also be used for this purpose.

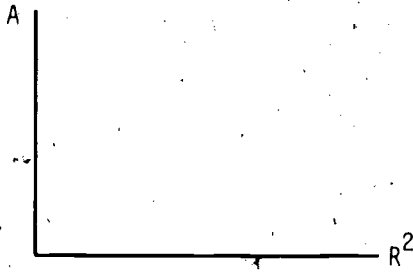

4. What seems to be true about A/R^2 ? Is there a pattern? How does it compare with C/D ?
5. What can you say about the slopes of the graphs in (1) and (3) above?

HISTORICAL HIGHLIGHT



Archimedes (ca. 287-212 B.C.), by using inscribed and circumscribed polygons of 96 sides, nested π between 3.14084 and 3.142858. He accomplished these calculations without the benefit of trigonometry, decimal (or any other positional) notation, and without computers.

DISCUSSION:

You may have guessed that A/R^2 and C/D have the same value for all circles. Your experiments have probably suggested this fact, but they have not proved it. One needs to be willing to devote some time to the study of integration in elementary calculus in order to understand a proof.

Since A/R^2 and C/D do actually have the same value, we can give that value a single name. The name that is commonly given is " π ." Hence we have:

$$A/R^2 = \pi$$

and

$$C/D = \pi$$

You may be used to seeing these written in the form:

$$A = \pi R^2,$$

and

$$C = \pi D \text{ or } C = 2\pi R.$$

Do you see how to get from the first pair of equations to the second pair?

6. "O.K.," you say, "you have given the name ' π ' to C/D and A/R^2 . What does that accomplish? What is π ?" Look back at your tables and graphs in (1) and (3) to make an estimate of π . Can you get any idea of how accurate your estimate might be, by looking at your tables in Activity 4?

π is an irrational number. This means that π cannot be expressed as a fraction. That is, $\pi \neq \frac{a}{b}$ no matter which integers a and b you choose. It also means that π is not equal to any finite decimal. π has, however, been computed to 1,000,000 decimal places using a high-speed computer. An approximation that you can use in this activity is:

$$3.1415 < \pi < 3.1416$$

7. a) Compute the areas of circles with diameters $2\frac{1}{4}$ cm and 0.75 m.

b) If you were told that the radius of a circle was within .01 cm of 2 cm and if you used 3.14 as an approximation for π , what could you say about the maximum possible error in your computation of the area of the circle using the formula $A = \pi R^2$?

8. Because of the inconvenience of working with such numbers as 3.1416 and for other less clear reasons, there have been attempts to declare that $\pi = \frac{22}{7}$ or some other convenient number. Explain what is wrong with such a declaration. What would happen if an entire civilization adopted the convention $\pi = \frac{22}{7}$?

TEACHER TEASER

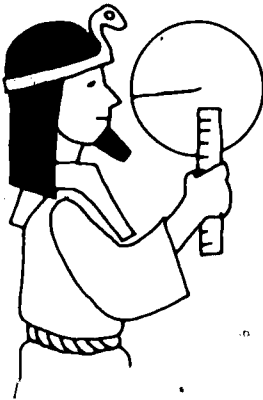

The Egyptians computed the area of a circle by diminishing the diameter by $\frac{1}{9}$ of its length and then squaring.

- What value were they inadvertently giving to π ?
- How much were the Egyptians off in their inadvertent estimate of π ? How much would you be off if you used $\frac{22}{7}$ for π ?

METRICS IN LIFE!

Estimate the weight of a newborn baby in kilograms.

ACTIVITY 8

VOLUME MEASUREMENTS

FOCUS:

In this activity you are introduced to two approaches to measuring volume. For each approach you are given experiences that might be useful in helping upper elementary children understand the concept of volume.

MATERIALS:

A quantity of cubes, such as the units from Dienes blocks or Cuisenaire rods; cans or jars; assorted transparent containers; a pourable substance such as water, sand, rice, or beans; rectangular containers.

DISCUSSION:

Have you ever been confused by volume measurements? At the grocery store you purchase liquids by the gallon, quart, pint, cup or ounce. Yet if you are measuring volumes in a scientific setting, or if you are using any of the many volume formulas such as $l \times w \times h$ (rectangular solid), $\frac{4}{3}\pi r^3$ (sphere), or area of base times altitude (cylinder), your answer will be in cubic units such as cubic inches, cubic feet, and cubic yards. The differences in the two sets of units reflect two different approaches to measuring volume, each of which is more convenient than the other in certain situations. The cubic units reflect an interpretation of volume that is like the interpretations of area in Activity 4. That is, the volume of a solid is the number of unit cubes that the solid contains.

If you count the cubic units in the figure on page 73, you will see that the rectangular solid has a volume of 24 cubic units. Just as with area, if a solid has an irregular shape, you can get better estimates for its volume by using successively smaller cubes.

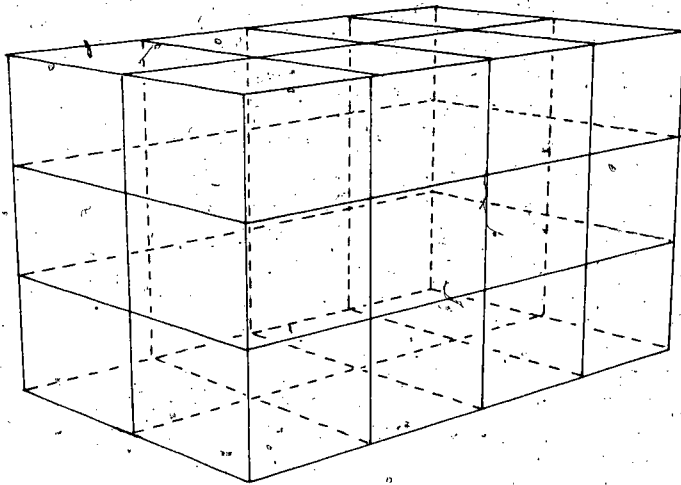

In many measurement situations, a different approach to volume is more convenient. If one wants to measure the volume of a substance that can be poured, e.g., a liquid, one can pour the substance into a container and determine what portion of the container it fills. In that case the total capacity of the container can be used as the unit of volume.* This is, for example, the role of a measuring cup. The cup's capacity is the unit of volume. The $\frac{1}{2}$ -unit line is determined by finding an amount which, if poured in twice, would give the whole unit, and so on.

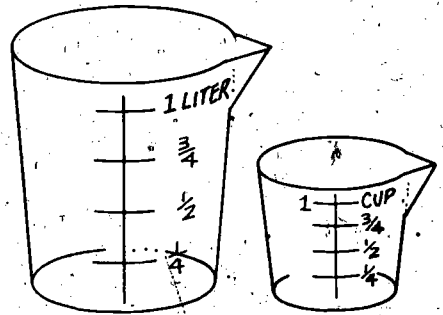

The two approaches mentioned here are compatible in the sense that one can express measurements from one in terms of the other. For example, one cup is approximately 16.8 cubic inches, and one liter is 1000 cubic centimeters.

* Volume measured in this way is sometimes referred to as capacity.

The remainder of this activity is designed to give you experiences with the two approaches to volume measurement described above. Since metrics are coming, and since you will probably be able to profit from further experiences with the metric system, most of the questions will be phrased in terms of cubic centimeters, cubic meters, liters, and milliliters, instead of cubic inches, cubic yards, quarts, and fluid ounces.

DIRECTIONS:

1. Use the cubic centimeter as the unit of volume here.

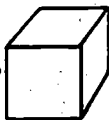

Count the number of cubic centimeters in the following solid shapes. Try to resist using any formulas that you know. Try to find systematic ways of counting. If you have some cubes to work with, determine the answer by building these shapes out of them.

a)

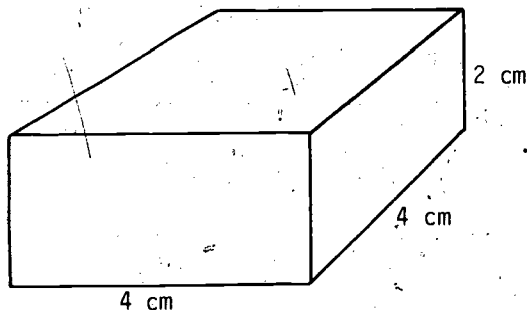

b)

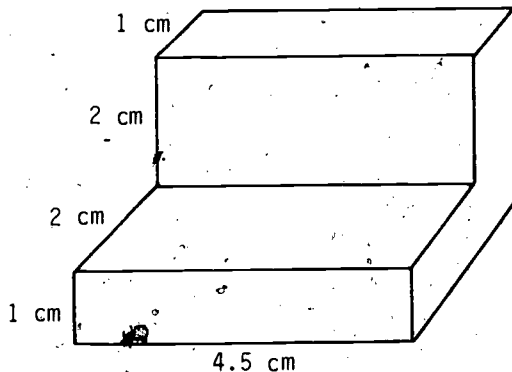

- c) Using cubes such as the units from Cuisenaire rods or Dienes blocks, estimate the volume of a can or jar. (As you can see, this kind of estimation is much more difficult for volume than for area.)
-

DISCUSSION:

In order to give context to the work on volume, we will relate back for a moment to our earlier work on area.

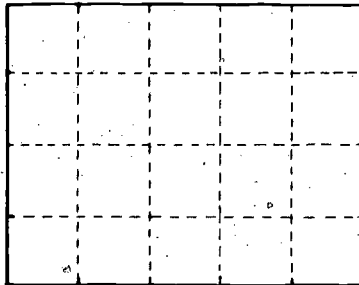

In finding the area of this rectangle, one can directly count the number of squares and determine that the area is 20 square centimeters. Or one can note that each row has 5 squares and that there are 4 rows so that there are 4×5 squares. Also, one can see that the length of the rectangle is 5 cm and the width is 4 cm. From this one can conclude that there will be 4 rows of 5 squares where each square has one-centimeter sides; that is, there are 4×5 squares. Most people abbreviate this last approach by saying that the area of a rectangle equals the width times the length, or by saying that the formula for area is $A = w \times \ell$ (more commonly $A = \ell \times w$). They mean:

If one measures the length (ℓ) and the width (w) of a rectangle in the same linear unit, the area (A) is given by $\ell \times w$ square units, where the square units are squares whose sides are the length of the linear unit.

Now back to working with volumes.

**METRICS
IN LIFE!**

Estimate the volume of a
bottle cap in milliliters.

2. Go through a discussion analogous to the above in order to establish a formula for the volume of a rectangular solid in terms of its length, width, and height. Apply your formula to several examples of your own choosing.
3. Suppose that you gave a sixth-grade class a rectangular solid and told them its length, width, and height were 10 cm, 3 in., and 2 cm. What answer do you suppose that most of the children would come up with for the volume? Is the answer wrong? How might you attempt to determine if the children understand what they are doing?
4. Turning to the capacity model for measuring volume:
 - a) Take any transparent container and designate its capacity as your unit of volume. Then using any other unmarked container and a pourable substance such as water, sand, rice, or beans, determine and mark on the side of your unit container $\frac{3}{4}$ unit, $\frac{1}{2}$ unit, and $\frac{1}{4}$ unit.
 - b) Use any rectangular container such as the lower section of a milk carton to determine how many cubic centimeters your unit of volume in (a) is. Mark the centimeter equivalents on your unit container.
 - c) Given that the liter is 1000 cubic centimeters, determine the number of liters in your unit of volume.
5. What about the volumes of various irregular shapes that one meets? Fortunately, one can almost always get a fairly good estimate.



- a) Devise a strategy for finding the capacity of any container in liters.
- b) Devise a strategy for determining the volume of any quantity of liquid in cubic meters. (Think of several strategies, if you can, that would be useful for different kinds and amounts of liquid stored in different ways.)
- c) Devise a strategy for finding the volume in any unit of any (manageably small) solid object. (Archimedes is credited with a discovery in this direction when he was taking a bath.)
6. There are some shapes other than rectangular solids for which there are formulas that give volume in terms of linear measurements. For example, the volume of a sphere whose radius is R units long is $\frac{4}{3}\pi R^3$ cubic units. Unfortunately, it is hard to establish this formula at an elementary level. There are a few activities that one can do with children to make such formulas seem reasonable.
- a) Devise an activity analogous to the area activity for circles in Activity 4 that might help to convince sixth-graders of the validity of the formula $V = \frac{4}{3}\pi R^3$ for spheres.
- b) A city council decided that its city should have at least 115 000 cubic meters of drinking water in storage at all times. The local construction company said that the only type of storage tower that they build is spherical with radius no greater than 12 meters. How many storage tanks will they have to build in order to meet the council's specifications?
7. You are probably used to using the term "cylinder" to describe the shape of the typical tin can. You may also be familiar with the fact that a formula for the volume of such a cylinder is:



$$\text{Volume} = (\text{Area of base}) \times (\text{Height})$$

There are many other shapes that can be called cylinders. For example,

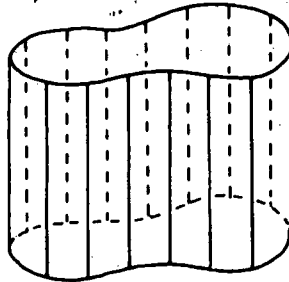
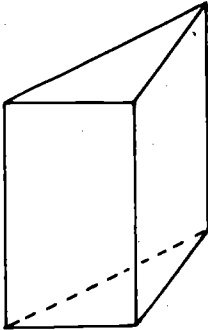
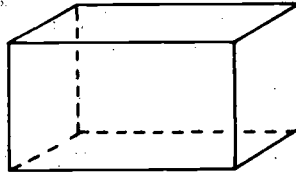
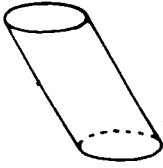

What makes each of these a cylinder is their parallel sides and the fact that if you "slice" a figure parallel to the base you get the same plane shape no matter where you slice. For example, no matter where you slice this cylinder you get a triangle that is congruent to the base triangle. The formula for the volume of any cylinder is

$$\text{Volume} = (\text{Area of base}) \times (\text{Height})$$

where the height is measured perpendicular to the base.

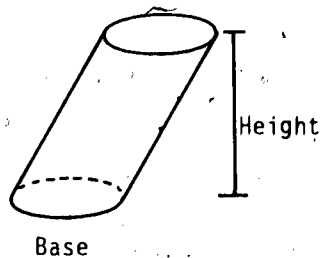
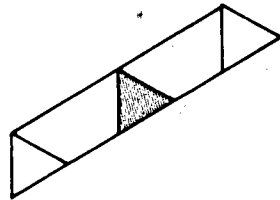

- a) Rectangular solids are cylinders. Explain how the formula on the preceding page is consistent with the one that you already know for the volume of a rectangular solid.
- b) Devise an activity using stacks of coins, decks of cards, etc., to help convince sixth-graders of the formula for the volume of a cylinder.
- c) You are planning to build an addition to your home, and you know two things:
- The ceiling must be 3.1 meters high to match the rest of your house;
 - Your furnace is adequate to heat only another 200 cubic meters of space.

What can the floor space of your new room be? (Assume that the walls are at least parallel if not vertical.) What assumptions have you made about the shape of the floor? Did you need to make these assumptions?

- d) In the stairwell pictured below, each step is 0.3 meters high and 0.3 meters deep and one meter wide, and the doorways are 3 meters high. What is the volume of the stairwell?

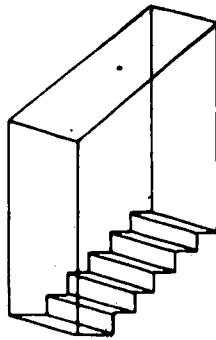

ACTIVITY 9

MORE ABOUT MEASUREMENT

FOCUS:

The measurement activities of this section are put in the context of the entire subject of measurement, and a few questions are asked concerning several measurement topics that are important in the elementary school but have not yet been considered in this section.

DISCUSSION:

In this section you have worked mostly with area and volume measurement with a little attention to linear measurement (circumference of circles). Area and volume measures are examples of a family of measures that can be called geometric measures. The geometric measures include linear measures, angle measures, area measures, and volume measures. Another category of measures is the common physical measures, which include temperature, time, weight, and velocity. Other measures, including some of the less common physical measures, include atmospheric pressure, I.Q., and economic growth. Even money is sometimes considered a part of measurement.

<u>Geometric Measures</u>	<u>Common Physical Measures</u>	<u>Other Measures</u>
Length	Temperature	Money
Angle	Time	Atmospheric pressure
Area	Weight	Economic growth
Volume	Velocity	I.Q.

In this activity we will provide you--through a few questions about each--with a glimpse of some of these additional measurement topics. The ones that we have chosen are among those that are important for the elementary classroom. In the next activity we will consider a

family of measures that are not commonly dealt with by children, but which are relevant to an elementary teacher.

**METRICS
IN LIFE!** Estimate the circumference of
your neck in centimeters.

DIRECTIONS:

Discuss answers to the questions raised about each measurement topic. One or several activities could be built around each topic if time permits.

1. Linear measures

- a) What is meant by length? How are length and distance related?
- b) Suppose that this curve represents a driveway.



- i) Describe how you could measure its length using a long rope; then a short rope.
- ii) Describe how you could measure its length using a board.
- iii) Suppose you wanted greater accuracy in your measurement than you got with your board in (ii). How could you modify the board to improve your accuracy? Do you see an analogy between your approach here and the approach used in Activity 4 to approximate the area of irregular shapes?

2. Angle measures

- a) What is an angle? When we say that the measure of an angle is 30° , what does that mean? That is, what attribute is being measured when you measure an angle?

b) What is the rationale for choosing each of the following as a unit for angle measurement?

- degree
- radian
- "whole turn"

Which of these would you use first with children, and why?

c) Can you see why a child would have difficulty understanding that the two angles represented below have the same measure?

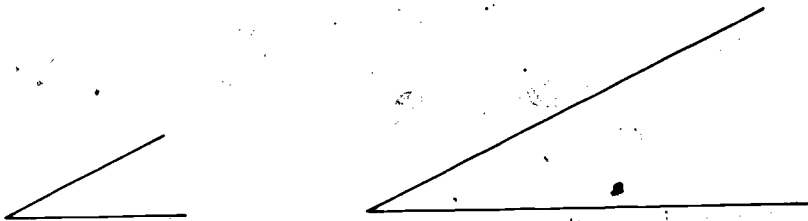

What experiences would you give a child who was having difficulties with this concept?

3. Money measures

- What is the relationship between money and measurement? Is money a unit of measure, a measurement instrument, or what?
- How can work with money be used to enhance learning in various parts of the school curriculum?

4. Time measures

- How would you explain to a child what a clock measures?
- Could we change our time measurement units to a base 10 system like the metric system? Which time units are natural and which are arbitrary?
- Brainstorm a number of different ways to measure time that could be explored by children.

5. Speed measures

- a) Describe several ways in which speed can be measured. In particular, discuss the relationship between distance, time and speed.
- b) What is the difference between velocity and speed?
- c) Can you think of some interesting activities that would get children involved with measuring speed?

6. Temperature measures

- a) Can you guess how thermometers are made? What physical principle is fundamental to the operation of standard glass tube thermometers?
- b) Which system seems most natural and why: Fahrenheit or Centigrade?

7. Weight measures

- a) What is weight? What is the difference between weight and mass? What instrument do you need to measure each?
- b) What is the relationship between weight, volume and density? If a child wants to throw a rock a long way, describe how weight and density should enter into his choice of a rock.
- c) Describe common ways to measure weight. Which are best for what purposes? Which also measure mass?

ACTIVITY 10
MEASURING MINDS

Everything that exists exists to some degree and can be measured.

-- Ashley Horace Thorndike
(1871-1933)

We are shocked by the callow empiricism which confers honorary validity on whatever measurement techniques it has managed to devise, and confers honorary nonexistence on all aspects of the human psyche that have not yet been explained to an IBM punching machine.

-- The Report of the Cambridge
Conference on School
Mathematics, 1963

FOCUS:

There is a whole aspect of measurement, namely, the measurement of human abilities and performance, that is frequently not thought of as measurement. This activity has the limited objective of bringing this aspect of measurement to your attention and of evoking some thought concerning the possible sources and magnitudes of error in these measurements. All of these measurements fall in the category of "other measures" discussed in the previous activity.

DISCUSSION:

The two quotations preceding this activity were chosen to reflect the existence of a strong difference of opinion between educators concerning the methods, the importance, and the usefulness of measuring human ability and achievement. As a teacher you will administer tests, and you will make a number of decisions concerning the lives of students. In some cases these decisions may, in part, be based on the outcome of tests. This activity is designed to raise questions,

not to answer them. Courses or books entitled "Tests and Measurement" are potential sources of further information concerning the measurement of human capacity and performance.

**METRICS
IN LIFE!** Estimate the weight of the world's weight-lifting record in kilograms.

DIRECTIONS:

The questions raised here are intended to be used as the basis for small-group or whole-class discussion.

1. Below is a list of measurements that are common in our society and a list of questions. Answer the questions for each of the measurements.

MEASUREMENTS

- a) I.Q.
- b) School grades
- c) Attitude score
- d) Vocational preference score
- e) Standardized arithmetic test score
- f) S.A.T. score
- g) Nielsen rating
- h) Gallup Poll outcome

DISCUSSION QUESTIONS

- What attribute(s) is being measured?
- Do the instruments used adequately measure that attribute?
- What seem to be potential dangers in applying the results of the measurement to an individual? To a group?

2. List some other measurements of human ability and performance that seem to be less difficult and less subject to error than those above. Can you characterize the difference? That is, can you determine what kind of human attributes tend to be easier to measure?
3. Choose an attribute that is difficult to measure and spend a few minutes discussing how you would go about measuring the attribute.

TEACHER TEASER



Find the measurement of a rectangle which is such that, when folded in half, a similar (same ratio of length and width) rectangle results. The newspapers in some countries have the appropriate dimensions. Does your newspaper?

ACTIVITY 11

MEASUREMENT VERSUS THE REAL WORLD

FOCUS:

We conclude this section with the consideration of the relationship between the number that arises in the measurement process and the actual quantity of the attribute being measured. You have already seen that the number is not exact. Here you will discuss sources of inexactness. For example, if you measure a table to be three feet wide, is it actually three feet wide? If Joe's I.Q. is 10 points higher than Jim's, is Joe actually smarter than Jim?

MATERIALS:

A variety of linear measuring instruments.

DISCUSSION:

This activity is intended for you. You would be unlikely to teach much of this content directly to children, but an understanding of this content may provide you with useful insights for teaching measurement to children.

Each measurement begins with the identification of an attribute. Following that are four steps, each of which may introduce error into the measurement. These steps are:

- I. The choice of a model
- II. The choice of a measuring instrument
- III. The application of the measuring instrument
- IV. The performance of computations

For example, in determining the area of a basketball court in order to purchase varnish to refinish it, one would probably go through steps like the following:

- I. Assume that the court is flat and rectangular.
- II. Choose a tape measure.
- III. Measure the lengths of two sides of the court, in terms of the same unit.
- IV. Multiply the numbers of length units of the two sides to determine the area of the court.

In each step there is a potential for error.

- I. The court may be neither perfectly flat nor exactly rectangular.
- II. The tape measure will not be exactly constructed; its markings are not perfectly fine, nor are they dense on the tape, so that estimates will have to be made.
- III. The tape will be imperfectly applied to the sides of the court; the markings may be read inaccurately; error is inevitable in estimating.
- IV. Round-off error may result from computations; human arithmetic errors may be made.

In this activity you will have an opportunity to analyze a few measurement situations to determine the four steps described above. Then some extra attention will be given to the estimation of error due to step II. In Activity 12, a source of step III error will be investigated.

DIRECTIONS:

1. a) Measure the length of a wall in your classroom as carefully and accurately as you can.
- b) Compare the result of your measurement with that of a classmate.
- c) Discuss with your classmate what you did for each of the four steps (model, instrument, use of instrument, computation) in measuring the length of the wall.

- d) Discuss why your measurements differ if they do. Discuss what you feel to be the major source of error in your measurements.
2. Choose at least one of the following attributes, devise a strategy for measuring it, indicate which steps in your strategy correspond to each of the four steps outlined above, and indicate the possible sources of error in each step.
- a) The volume of water in a glass.
 - b) The weight of one grain of sand.
 - c) The likelihood of drawing a pair of kings in a hand of five cards.
 - d) The ability of a child to learn new information (I.Q. tests are sometimes used for this purpose).
 - e) The speed of a car that you are driving.

.....

<p>METRICS IN LIFE!</p>	<p>Estimate the height of the world's pole-vault record in meters.</p>
------------------------------------	--

.....

DISCUSSION:

As you can see, measurement is a fairly complex human activity, which is doomed to inaccuracy. Fortunately, in real situations one does not need exact measurements. One needs only measurements that are accurate within certain tolerances. For example, a stopwatch for timing a track meet need only measure time intervals as short as $\frac{1}{10}$ of a second, while a quartz-crystal oscillator is capable of measuring to within one microsecond per day. (A microsecond is a millionth of a second.) One can, in certain measurement situations, estimate the greatest possible error due to the measuring instrument, i.e., step II error.

EXAMPLE

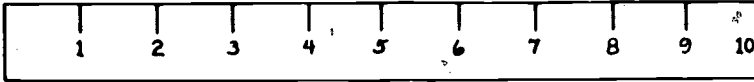
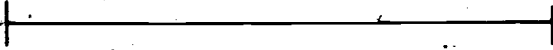

Centimeter Ruler

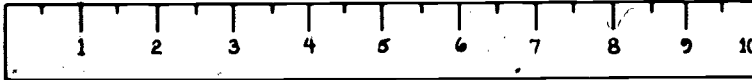

Half-Centimeter Ruler

If one follows the rule of "rounding off" to the nearest mark, one's maximum error in measuring the line with the centimeter ruler would be $\frac{1}{2}$ centimeter. For the half-centimeter ruler it would be $\frac{1}{4}$ centimeter. Can you see why? So in measuring this line with either of these rulers one can predict the largest possible error introduced by the instrument. We have not accounted here for possible inaccuracies in the construction of the rulers. Moreover, we have only discussed the error due to the instrument, i.e., step II error. If the line is not exactly straight, the model will introduce additional step I error. If the ruler is not used carefully in step III, additional human error will be introduced. In this case there is not a step IV computation.

3. Estimate the maximum possible error introduced by the measuring instrument (i.e., step II error) in each of the following situations:
 - a) Measuring a straight line with a ruler that has ten marks per centimeter.

- b) Measuring the area of a table, with the ruler from (a) above. (Be careful, you have to consider step IV to make your estimate.)
- c) Measuring a volume of liquid with a measuring cup that has two marks per fluid ounce.
- d) Measuring a one-hour time interval with a clock whose dial is marked in seconds and which loses one minute per day.
4. In the light of your experiences with this activity discuss the statement: Every measurement is an approximation. Can you think of a measurement which is exact?
5. In the light of your experiences with this activity and of any experiences that you have had with children, discuss:
- a) Which aspects of accuracy in measurement you would introduce to third-graders; to sixth-graders.
- b) How much emphasis you would be inclined to put on accuracy in measurement with third-graders; sixth-graders.
- c) Any situations that would motivate children to analyze the error in certain measurements.
- d) Any situations where inaccuracy in measurement might confuse young children and interfere with their learning of another concept.

Section III

CHILD LEARNING OF MEASUREMENT

In Sections I and II the emphasis was on your learning about measurement. There was, of course, a constant eye on the elementary child; but the primary objective was adult measurement learning. In Section III you will focus directly on child learning. You will still be involved and you will still be the learner, but you will be learning about activities, techniques, and problems associated with child learning of measurement.

In Activity 12 some issues are raised concerning child readiness for measurement activities. You will see that certain concepts that seem very obvious and natural to you are neither obvious nor natural to children at early stages in their development.

In Activity 13 you will analyze certain anecdotes related to child measurement, in order to gain further insights into the problems that children encounter when measuring.

Activity 14 should provide you with some useful ideas for doing measurement work with children. Through your own experience with measurement activities, you will become aware of the great potential for measurement in the elementary school and of some of the problems that children will encounter in measuring.

In Activity 15 you will be asked to do some long-range and some short-range planning for measurement work. Most importantly, you will be asked to write some actual measurement activities for children.

Activity 16 is designed to relate your experiences with the entire unit to standard elementary mathematics curricula. In this activity you will analyze what is done in elementary texts, and you will plan how you would take advantage of your experiences with this unit to build on the measurement material in the texts.

Activity 17 is a summary seminar, in which the entire class can consider selected measurement topics from the points of view of developing the topic with children and analyzing problems that children may encounter in the development.

MAJOR QUESTIONS

1. Choose a specific measurement objective for a child, such as learning to measure time. Describe a short sequence of activities that would help the child achieve the objective. Describe one of the activities in detail, indicating what knowledge and skill a child should bring to the activity, what demands the activity might make on the child's grasp of conservation, and what difficulties seem most likely with the activity.
2. Compare your perception of the goals and procedures of measurement instruction before and after your experience with this unit.

ACTIVITY 12

CHILD READINESS FOR MEASUREMENT

FOCUS:

An interesting phenomenon that one observes when teaching young children is that they understand many measurement tasks in a much different way than adults do. This activity focuses on some very important problems that children have with the concept of the conservation of the quantity of an attribute during certain measuring processes. It is also brought out that there are many situations where adults have trouble determining if conservation occurs.

DISCUSSION:

You may have difficulty conceiving of yourself on the older end of a generation gap. This is, however, a real danger in measurement work with children. Not only are certain words that you use meaningless or vague to children, but also certain assumptions that seem obvious to you may either not occur to children or may seem false to them.

The Swiss psychologist Jean Piaget has spent over forty years talking with children and listening to them. His keen insight into children's thinking has provided a basis for his theory on how children grow in their ability to learn and to handle new information and new situations. In particular, Piaget has placed warning flags over certain aspects of the measurement process.

In every measurement situation there comes a moment when you actually perform the measurement. Frequently, this involves doing something to the object being measured. For example, you may move the object; you may change its container, or you may shine a light on it. Usually, you assume that this change does not affect the quantity of the attribute present. Otherwise, you are not measuring what you set out to measure. Piaget refers to this assumption by saying that the attribute is conserved. He has found that many young children do not share our assumption of conservation in some very basic measurement situations.

Here you will have a brief opportunity to explore the concept of conservation both for children and for adults.

DIRECTIONS:

1. Read the following interview between a teacher and a child named Billy. Then answer the questions which are posed at the end of the interview. It should be noted that this interview is typical of many that have been reported by Piaget.

Billy had been having some trouble with measurement activities in his first-grade class, so his teacher decided to try a little experiment with him. She placed two glasses of water in front of him. The glasses were identical, and they were filled to the same level.





QUESTIONS

- What is Billy's problem?
- What sense would the use of a measuring cup make to Billy?
- Could you rephrase the question to Billy so that you might be reasonably sure that his answers reflected the intended idea of "more"?
- According to Piaget's definition, Billy does not conserve volume. Explain what this means in the light of the above interview.
- Suppose you had shown two identical balls of clay to Billy and then flattened one of them. Do you think that Billy would agree that the flattened ball contained the same amount of clay as the nonflattened one? If not, would he say that it contained more or less?
- A child may answer that the lower rod is longer when two rods are changed from this configuration:

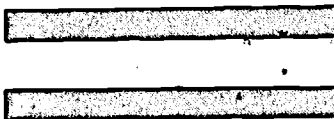

to this one.



What are the implications of this misunderstanding of conservation for measurement learning?

g) On the adult level:

- Why do you suppose that bottles of liquor that have different volumes have different shapes?
- Why might a storekeeper sell, as a special offer, 100 sheets of paper at 25¢ when his regular line of 500 sheets is usually \$1.00?
- Why, when knitting a sweater on circular needles, is one surprised at how heavy it is?

2. If you have an opportunity, perform the above experiment with a young child, e.g., age 4, or 5. (Ages 6, 7, and 8 are O.K., too; but you are somewhat less likely to get responses like Billy's.) Be very careful only to ask questions. Most of us have a strong urge to lead a child (or an adult for that matter) to say what we want said. You may want to get some help from your instructor in preparing for this.

.....
• **METRICS** Estimate the weight of a basket-
• **IN LIFE!** ball in grams.
.....

DISCUSSION:

Piaget has found that many preschool children fail, as Billy did, to understand the conservation of volume or substance. In the early

grades (1, 2, and 3), a teacher is likely to encounter some children who still lack this understanding. Clearly, one can expect these children to have some problems with measuring volume.

Research literature is not conclusive as to whether a child can be taught conservation of volume, or whether he or she will just come to it. A teacher would probably do best to give Billy exploratory activities involving relative volumes. The most important message to you is to be sensitive to this and other possible gaps in a child's understanding.

In your teaching, you should be making frequent informal checks to determine the level of readiness of children. If a child lacks certain prerequisite understandings, you may or may not want him to engage in a certain activity. But you should definitely be forewarned against expecting the child to master the concepts involved.

If you are interested in reading further about child readiness for measurement, you are encouraged to look at any of the following references that are available to you.

Copeland, Richard W. How Children Learn Mathematics. New York: Macmillan, 1970.

Harrison, D.-B. "Piagetian Studies and Mathematical Learning." In Studies in Mathematics, Vol. 18, pp. 93-127. Stanford, Calif.: School Mathematics Study Group, 1969.

Wadsworth, Barry. Piaget's Theory of Cognitive Development: An Introduction for Students of Psychology and Education. New York: McKay, 1971.

Checking Up, I and II, (Nuffield Mathematics Project), New York: John Wiley & Sons, Inc., 1970 and 1972.

.....

3. For the moment think of measurement as a game played with attributes that are possessed by objects, unit quantities of the attributes, and measurement instruments. One of the rules of the game is that you can make any change in an object that does not change that quantity of the relevant attribute possessed by the

object. For example, if the relevant attribute of a glass of water is volume, you can pour the water into a measuring cup, but you cannot freeze it (it expands by 10%). On page 101 is a table listing objects, attributes, and changes in the objects. With your group, you are to decide whether the change indicated is a legal one in the "game" of measurement.

4. Discuss your answers in (3). In particular discuss the following points:

- a) Was your personal experience important in your choice of answers?
- b) Did you learn the answers in school?
- c) Would a six-year-old child have been able to answer them all correctly?
- d) What effect would it have on one's ability to measure the attribute in question if one did not know whether or not the change was "legal"?

5. Is an individual's ability to answer questions on an I.Q. test the same under testing conditions as it is under everyday conditions? Is any behavior attribute in a classroom the same with an observer in the room as it is when only the teacher is present? These are important conservation questions that have no simple answers. Yet one makes an assumption about the answer to these questions when one interprets an I.Q. score or the results of a classroom observation.

- a) Discuss other situations where we make conservation assumptions that may or may not be warranted.
- b) Discuss where in the four steps of measurement presented in Activity 11, the error resulting from such conservation assumptions falls.

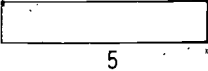
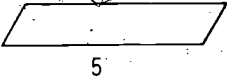
OBJECT	RELEVANT ATTRIBUTE	CHANGE	LEGAL YES OR NO	COMMENTS
Quantity of liquid in a glass	Volume	Pour into measuring cup	Yes	Volume conserved with any change of container
1 	Area	1 		
Rectangle	Area	Cut into 2 triangles		
A \$5 bill	Monetary value	Exchange for 5 \$1 bills		
A \$5 bill	Weight	Exchange for 5 \$1 bills		
Slum dweller	Self-concept	Give him a job		
Ingredients for a cake	Weight	Bake		
Ingredients for a cake	Volume	Mix		
Two sticks	Relative length	Change relative position		

OBJECT	RELEVANT ATTRIBUTE	CHANGE	LEGAL YES OR NO	COMMENTS
Quantity of liquid	Temperature	Turn on intense light		
A space ship	Duration of time	Set ship into motion at speed near speed of light		

ACTIVITY 13

CHILD PROBLEMS WITH MEASUREMENT

FOCUS:

In the previous activity you considered the problem of child readiness for measurement. In particular, you considered the problem of conservation. There are many other problems that children run into in measurement situations. Some of them have to do with dexterity; some have to do with misinterpretation of words. This activity presents you with several anecdotes about child problems with measurement, which you will be asked to analyze.

1. In order to focus your attention on some of the problems that a child might have with measurement, you should discuss the questions that accompany the following measurement anecdotes, situations, and examples:

ANECDOTES

- a) An illustration in a book:



Which is heavier?

What would you expect a child to answer?

Is that answer necessarily correct?

How could you make a child aware of the problem with the question as it is posed?

How would you pose the question to avoid ambiguity?

2. John sorts several objects into small and large objects.

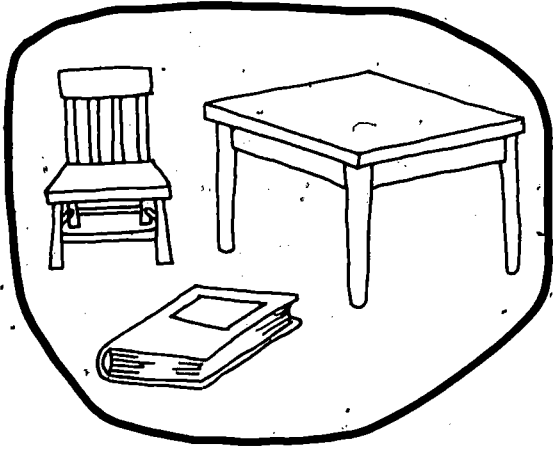
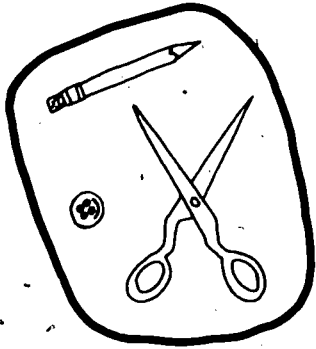

Mary sorts the same objects into small and large objects.

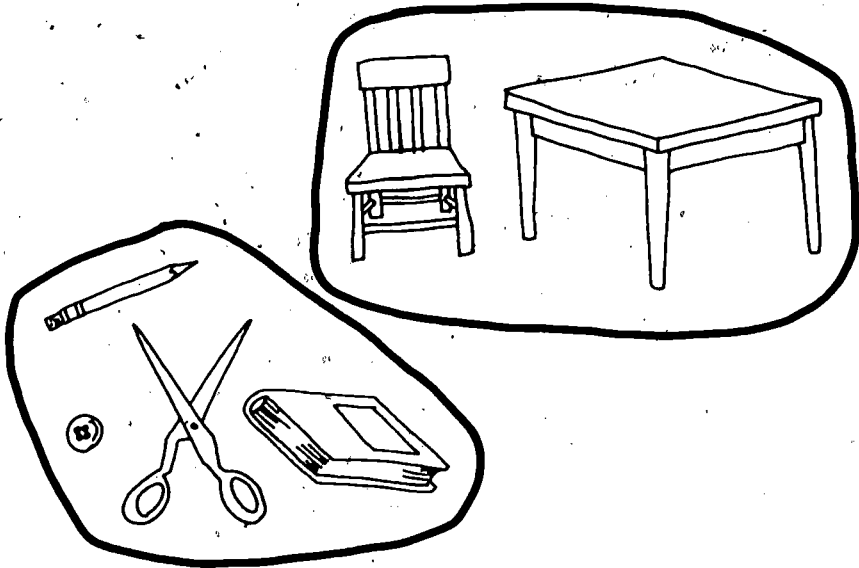

Why do they get different results?

3. A fourth-grader's answer to a question:

"I cannot tell you whether the table is longer than the bookcase; I don't have a ruler."

What kind of experiences seem to be lacking in the child's background? What would you do if a child said that to you?

4. Man to shop owner:

"My wife has left me a note that the yard is 120 paces long and 40 paces wide. How much fence do I need to enclose the yard?"

What would you say if you were the shop owner? Is there any way that the man and the shop owner could decide how much fencing is needed?

5. Teacher: Can you give me the area of figures A and B?

Pupil: The area of A is $2 \times 3 = 6$, but I don't have any formula for the area of B.

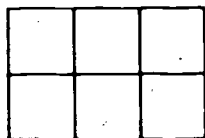

(A)

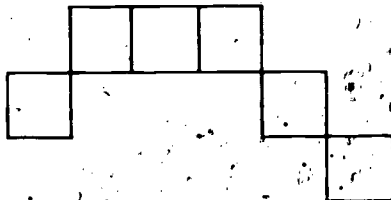

(B)

What is missing in the pupil's concept of area? What experiences would you provide to help? Have you ever fallen into such an overreliance on formulas?

6. Child to teacher:

"Why did they make sundials? Why didn't they just look at their watches to tell the time?"

Is it important for a child to have an historical perspective? Why?

7. First-grade child measuring the length of a table with a ruler:

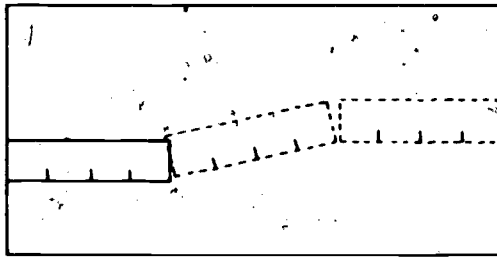

Are there any problems, other than conceptual ones, which enter into measurement? What kind of measurement readiness might this child lack?

8. Child in dismay:

"These two pieces of ribbon are both marked $12\frac{1}{2}$ inches, but they are not the same length."

Is it possible that the markings and the child are both correct?

- What might you have the child do in order to give insight into the situation?

9. "The only ruler that we have is 6 inches. I don't have time to measure the perimeter of the back yard."

Can you help this person out? How would you promote measurement flexibility in children?

10. "If I can pour water into a measuring cup without changing its volume, why can't I use the same formula for the area of this parallelogram and this rectangle?"

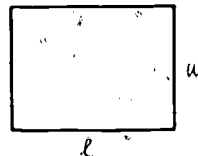
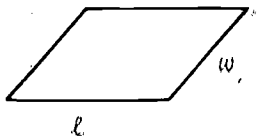

What do you say to that? Do you see any justification for the doubt in the child's mind?

11. Summarize the discussions that you have had concerning anecdotes 1 through 10. Are there any generalizations that you can make concerning the kinds of problems that children might have with measurement?

**METRICS
IN LIFE!**

Estimate the length of a new pencil in centimeters.

In 1960 the General Conference on Weights and Measures adopted the symbol SI (Système Internationale d'Unités) to designate the system of units involving the meter, kilogram, second, and related units. The SI system is currently based on the following seven base-units*:

Base-quantity	Base-unit
Length.....	Meter
Mass.....	Kilogram
Time.....	Second
Electric current.....	Ampere
Temperature.....	Kelvin
Luminous intensity.....	Candela
Amount of substance.....	Mole

*Chester H. Page and Paul Vigoureux (ed.), The International System of Units (SI), National Bureau of Standards Special Publication 330 (Washington, D.C.: U.S. Government Printing Office, 1974), p. 6.

ACTIVITY 14

DOING AND ANALYZING MEASUREMENT ACTIVITIES

FOCUS:

A child's life and environment are full of opportunities to measure. The concrete nature of many measurement activities makes them particularly appropriate for primary children. However, as you have seen, the sophisticated nature of certain measurement concepts necessitates that caution be exercised in assigning measurement tasks and in defining expectations. In this activity you will have an opportunity to take part in several measurement activities. These activities are chosen to provide you with a repertoire of measurement activities for use with children, and to make you aware of some of the problems that you and children might have with measurement.

MATERIALS:

A central supply table of equipment including: scissors, square-centimeter graph paper, large sheets of plain paper, a supply of water and of sand, liter cubes, metric tape measures, metric bathroom scales, masking tape, string, balance with metric weights, postal scale, kitchen scale, plastic beakers, colored chalk. In addition, each of the measurement experiments requires certain equipment that is listed in parentheses below the experiment.

DISCUSSION:

In this activity you will be assigned measurement experiments to do. The purpose of the experiments is to provide you with practical experiences with measurement that are analogous to appropriate experiences for children. Each experiment presents you with a task. You will need to devise a strategy for completing the task. Different groups are likely to devise different strategies for the same task, so it will be interesting to share your experiences with other groups that have done the same task. Also, different groups are likely to

do different tasks, so you may want to share your experiences with the entire class. In reporting your experiences to the class, make note of any difficulty that you encountered or that you feel a child might encounter in doing the same experiment. You should draw on any insights gained in the previous two activities.

Your work with this activity is summarized in the following diagram.

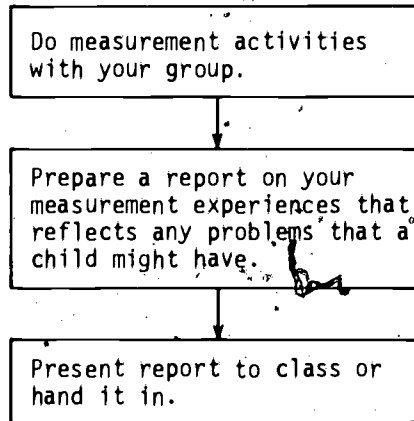

DIRECTIONS:

1. Proceed on the following experiments as directed by your instructor.

EXPERIMENTS

A. Place the 8 bottles in order of capacity.
Guess first.

(Eight bottles labeled A through H in random order; supply of water or sand)

B. Drop a ball from different heights and measure the height of the bounce. What is the relationship, if any, between these two heights? Does the relationship vary with the ball? Repeat the task with a ball of different size or elasticity.

(Tape measure)

C. This bag of scraps is what is left from making a suit from 3 yards of material that is 60 inches wide. How much does the suit weigh (discounting buttons, zippers, and lining)?

(Heavy material such as wool cloth)

D. What is the effect on the volume of a cube if you double the length of the sides? How about if you triple the length of each side? What is the effect on the volume of a sphere if you double or triple its radius?

(Could use blocks or water and clay)

E. Using only the quantity of string provided you, determine the longest, next longest, and shortest of the curves A, B, and C.

(Sheets of cardboard with string configurations glued on)

F. Find 10 measures that might answer the question, "How big are you?" Collect the data for each measure from the members of your group. Do any two measures seem to correlate (i.e., a person who has a large measurement in one measure tends to have a large measurement in the other)? Plot the data for two correlated measures on graph paper. (You might want to get these measures from other members of the class in order to have more data.) Does your graph have an interesting shape?

G. Make a cylinder and a cone that have the same vertical height and the same circular base. What is the relationship between the volume of the cylinder and the volume of the cone? Check your answer by constructing another cylinder-cone pair. Do you know a formula for the volume of a cylinder? If so, what would be the formula for the volume of a cone?

(Heavy paper and sand)

H. Find the surface area of the tennis ball.

(Chalk and paper)

I. Find the volume and weight of water wasted in 24 hours by a dripping tap.

(Water tap)

J. Determine the dimensions of the rectangle of perimeter 36 cm that has the greatest area. Use your string and graph paper to experiment. If you are not restricted to rectangles, what shape of perimeter 36 cm would you say has the greatest area?

K. Find the volume of each ball. Do the balls have the same surface area? Do the balls have the same weight? Do all objects with the same surface area have the same volume?
(Measuring jar, water, two balls)

- L. Find the sailing distance from
- i) New York to Saigon via the Cape of Good Hope
 - ii) New York to Saigon via the Suez Canal (assuming the Canal is open)
 - iii) San Francisco to Saigon via the Pacific Ocean.

Assume that the shortest route from New York to New Orleans is 1000 miles long.

3. You have done some measuring, and you have discussed some problems which adults or children might have in measurement situations. Now prepare a report (in a form specified by your instructor). This report should describe your measurement experiences, including any difficulties that you encountered and any difficulties that you feel that a child might encounter in making similar measurements.

ACTIVITY 15

WRITING MEASUREMENT ACTIVITIES

FOCUS:

The first section of this unit was designed to provide you with some measurement concepts and skills. Activity 12 raised the issue of child readiness for certain measurement concepts. Activity 13 raised some additional child measurement problems, and Activity 14 gave you some idea of the kinds of measurement activities that can be done with children. This activity and the next two will help you learn to take advantage of these experiences with measurement in planning measurement activities for children. In this activity you will have an opportunity to plan for a child's long-term (six-year) experience with a measurement topic, e.g., length, area, volume, or time. You will also have an opportunity to write detailed activities for a short-term sequence of activities.

MATERIALS:

Elementary school mathematics textbook series.

DISCUSSION:

It is important when you plan instruction for children on any topic that you have a picture of how that instruction fits into the child's long-term experience with the topic. It is also important in planning instruction that you plan each lesson as part of a short-term sequence that accomplishes certain objectives. In order to help prepare you for planning instruction, we present you with an example of a "six-year" outline of a child's experience with the topic of length. We also present you with specific activities for an introduction to length using standard units. You will be asked to analyze these, and then to prepare an outline and activities of your own on a different topic.

A DEVELOPMENT OF "LENGTH" THROUGHOUT THE ELEMENTARY SCHOOL

- The attribute, length; vocabulary; conservation; units (nonstandard)
- Standard units in the English or metric system (not both); connections between the units in that system (not conversion from one system to the other)
- Measuring length in centimeters to nearest 0.5 centimeter, including perimeter and circumference
- Experiences with larger distances (miles or kilometers)
- Recording measurements in decimal notation
- Length connected with scale drawings; e.g., representing a meter by a centimeter; graphs and maps
- Length connected with time and speed; the meaning of "constant rate"
- Length on a sphere; distances on a globe; longitude and latitude
- Conversion between English and metric systems of measure

SAMPLE SEQUENCE OF INTRODUCTORY ACTIVITIES ON LENGTH

Note: The child who is ready for the introduction of standard units (e.g., the meter) may be able to do the first few cards easily. If the child has difficulty with cards 1 through 5, he or she should be provided with more activities at this level before proceeding to the use of the meter stick. For each card, the teacher would provide the child with the indicated materials. They are listed for your convenience. The child would not be given the list of materials.

.....
• **METRICS** Estimate the distance record for
• **IN LIFE!** a Frisbee throw in meters.
•
.....

3 pieces of ribbon, red, blue, yellow, in that order of size.

CARD 1

Is the red ribbon longer than the blue ribbon ?

Is the blue ribbon longer than the yellow ribbon ?

Is the red ribbon longer than the yellow ribbon ?

Which ribbon is shorter than the blue ribbon ?

How many ribbons are shorter than the yellow ribbon ?

Which ribbons are they ?

3 pieces of ribbon, blue, red, green, in that order in size.

CARD 2

Is the blue ribbon longer than the red ribbon ?

Is the red ribbon longer than the green ribbon ?

Is the blue ribbon longer than the green ribbon ?

Which ribbon is the longest ?

Which ribbon is the shortest ?

A feather which is shorter but wider than a pencil, a piece of string longer than the pencil, a can which has a perimeter longer than the string.

CARD 3

Is the feather longer than or shorter than the pencil ?

Is the piece of string longer than or shorter than the pencil ?

Is the distance around the can longer than the length of the feather ?

Table, chair, and book.

CARD 4 GUESS FIRST - THEN MEASURE

How many handspans in width is the table ?

How many handspans in width is the chair ?

How many handspans in width is the book ?

How many thumbwidths is the book ?

How many thumbwidths is the chair ?

How many thumbwidths in a handspan ?

How many thumbwidths in the length of the table ?

A pencil, a Cuisenaire rod or similar wood or plastic "brick" (about 5 cm long), collection of objects with straight edges (e.g., books of different sizes), desk, pieces of card, ribbon, drinking straw.

CARD 5

Measure the length of each of the objects, using the pencil and also the brick (Make a guess first.)

RECORD YOUR RESULTS LIKE THIS.

Object	Guess	Length	Error
Book	3 pencils	2 pencils	1 pencil
	5 bricks	3 bricks	2 bricks

Why do you have different results when you measure?

CARD 6

How many paces in length is this room?

How many of your friend's paces in length is this room?

Why do you have different answers?

How many paces in length is the corridor?

Would you expect your friend's answer to be more or less than yours?

A stick, unmarked and about 80 cm long.

CARD 7

Take the stick. In each question, guess what your answer should be before you measure.

How many stick lengths are there in the length of the room ?

How many stick lengths are there in the length of the corridor ?

How much longer is the corridor than the room ?

Measure four things with the stick. Guess first. Was your guess correct ?

Meter stick, not marked in centimeters.

CARD 8

Take the meter stick.
(Make a guess first.)

How many meters long is the classroom ?

How many meters long is the corridor ?

What is the difference in length of the room and the corridor ?

What do you buy in meters ?

Measure 5 things in meters. Make a guess first. What was your error ?

Meter trundle wheel.

CARD 9 Take the trundle wheel.

What is the distance all around the trundle wheel ?

Place the "click" on the wheel so that it is just about to click. Now turn the pointer until it reaches the wooden block again. How far has the pointer travelled ?

How many "clicks" do you hear when you wheel along the line on the floor ? (Start with the pointer and wooden block together.)

How long is the line ?

Measure the room with the wheel.

DIRECTIONS:

1. Read through "A Development of Length Throughout the Elementary School," and discuss the following with your group.
 - a) Can you see a "logic" to the sequence?
 - Progressively greater sophistication?
 - Attribute → comparison → nonstandard units → standard units → mathematics?
 - Progressively greater dexterity required?
 - b) Can you see a good reason for introducing metric units first and not engaging in conversions to English units until much later?

c) The "Development" is not exhaustive. What other length topics might you include?

d) Can you brainstorm one or two activities that you might do at each stage in the development?

2. Read through "Sample Sequence of Introductory Activities on Length," and discuss the following with your group.

a) Do you see the development of the concept of length in these lessons?

b) Why not start with Card 4?

c) Can you see advantages to writing activities on separate cards?

- Flexibility? You can insert extra cards for a struggling child, or you can omit some cards for an advanced child.
- Freedom? You, as teacher, can give cards to small groups of children, and you can focus on helping the children rather than talking to the entire class.

d) Is there enough on each card to keep a first- or second-grader interested for a few minutes? Is there sufficiently little to do on each card that the child will maintain a sense of progress?

e) What are the objectives of each card?

f) What would you do differently and why?

g) Judging from your experiences in the previous activity, do you anticipate that children will have serious problems with any of the cards?

3. As a group choose a measurement topic, such as area, volume, or time, that is dealt with in the elementary school.
- a) Using any references or help that you need, brainstorm an outline of a "Development" of that topic for the elementary school experience of a child. You may want to look at some elementary mathematics texts. Be sure that there is a "logic" or rationale to your development, so that you could tell someone why you did things the way you did.
- b) Choose a stage in your "Development" and write a "Sequence" of activities for that stage. Be sure to:
- Specify the knowledge prerequisite.
 - State the objectives of each activity.
 - Make each activity intelligible for children at the specified stage of development.
 - Make each activity of an appropriate length and scope.

A good strategy for (b) is for your group to decide on the sequence of activities. Have each member of the group write a couple of activity cards. Then exchange cards in order to criticize and refine.

4. As your instructor prescribes, hand in or present to your class your "Development" and your "Sequence."

.....
: **METRICS** Estimate the volume of a basket-
: **IN LIFE!** ball in cubic centimeters.
:
.....

ACTIVITY 16
BUILDING ON TEXTBOOKS

FOCUS:

You have gained some experience planning your own measurement activities. However, as a teacher, you are likely to use a commercially published textbook as the basis for your mathematics instruction. In this activity, you will consider how to use the information and skills gained in previous activities to enhance your use of a textbook.

MATERIALS:

Several sets of popular, current elementary mathematics text series.

DIRECTIONS:

1. Each group should choose a measurement topic. The topic should be selected so that each one is chosen by at least two groups.
2. Your group should select a textbook series. Each member of your group should select a text from the series, carefully read the pages related to the chosen topic, and engage in a discussion of the following questions.
 - a) Do you see a "logic" to the "Development" of the topic over the different grade levels? Are there any gaps, redundancies, or incongruities?
 - b) Is each individual lesson going to communicate with children? Is there a need for accompanying experiences? Will some children need additional experiences to keep up with the class?
 - c) Is there adequate real-world experience built into the lessons?
 - d) Is there any stress on estimation?
 - e) Will the child gain the everyday measurement skills that are needed?

3. Choose a sequence of lessons from a text. Plan how you would introduce, motivate, and enrich the lessons, in the light of your experience in this unit.
4. Engage in a class discussion on how to plan measurement experiences for elementary school children.

**METRICS
IN LIFE!**

Estimate the diameter of a Frisbee in centimeters.

HISTORICAL HIGHLIGHT



The 1875 Treaty of the Meter was signed by about 20 countries, including the United States. It created a permanent body (the General Conference on Weights and Measures) to pass upon matters involving international weights and measures. The treaty also provided for the construction of new and improved standards for metric weights and measures. The General Conference is headquartered at Sèvres, France, near Paris.

ACTIVITY 17

SEMINAR ON CHILD MEASUREMENT

FOCUS:

You have considered measurement activities that children can do, and you have considered problems that they may encounter in doing them. This activity provides for a class discussion on measurement which should serve to synthesize and summarize the insights gained in this unit.

DIRECTIONS:

Engage in a class discussion on questions chosen from the following list.

- How are the concepts and skills of length measurement developed in children, and what are the key problems that children are likely to encounter in this development?
- How are the concepts and skills of area measurement developed in children, and what are the key problems that children are likely to encounter in this development?
- How are the concepts and skills of volume measurement developed in children, and what are the key problems that children are likely to encounter in this development?
- How are the concepts and skills of angle measurement developed in children, and what are the key problems that children are likely to encounter in this development?
- How are the concepts and skills of time measurement developed in children, and what are the key problems that children are likely to encounter in this development?
- How are the concepts and skills of weight measurement developed in children, and what are the key problems that children are likely to encounter in this development?

REQUIRED MATERIALS

ACTIVITY-	MANIPULATIVE AIDS	SUPPLIES	AUDIO-VISUAL AND OTHER
Overview			Slide-tape, "Measurement in the Elementary School," cassette recorder, projector. (Optional)
3	Metric measuring instruments, including meter sticks, balance scales, and liter containers; an assortment of objects to be measured.		
4		Scissors, paper.	
5	Geoboards and/or dot paper.	Rubber bands.	
6	Geoboards and/or dot paper.	Rubber bands, construction paper, scissors.	
7	Several circular objects.	String, rulers.	

ACTIVITY	MANIPULATIVE AIDS	SUPPLIES	AUDIO-VISUAL AND OTHER
8	A quantity of 1 cm. cubes (such as the units from Dienes blocks or Cuisenaire rods), cans or jars, assorted transparent containers, rectangular containers.	A pourable substance such as water, sand, rice or beans.	
11	A variety of linear measuring instruments.		
14	Liter cubes, metric tape measures, metric bathroom scales, balance with metric weights, postal scale, kitchen scale, plastic beakers. (See Instructor's Manual for additional required materials.)	Scissors, square centimeter graph paper, large sheets of plain paper, a supply of water and of sand, masking tape, string, colored chalk. (See Instructor's Manual for additional required materials.)	
15			Elementary school mathematics textbook series.
16			Several sets of popular, current elementary textbook series.

Continued from inside front cover

**Project Associates —
Audio-Visual**

Stephen B. Walter,
Design Coordinator
Wallace S. Goya
John W. Hiner
Deane W. Hutton
Jean A. Leschler
Carrie Hendron Lester
James L. McKittrick
Alexander C. Millar
Kyu-Sun Rhee
Vicki J. Semler
Donna J. Toler
Anne S. Walker

Staff

Susan E. Cote,
Administrative Assistant
Susan J. Bakshi
Joyce A. Ford
Jane Kaho
Linda A. Svrcek

The contributions of other individuals who have helped the project in various ways are also gratefully acknowledged. These individuals include Roger J. Chilewski, Robert M. French, Carole E. Greenes, Nathan B. Habegger, John E. Hall, Larry L. Hatfield, Donald W. Hazekamp, Howard C. Johnson, Richard O. Kratzer, Michael L. Mahaffey, Golam Mannan, Janet P. Morris, Michael E. J. Orme, Bernadette Perham, James R. Sanders, James E. Schultz, Richard L. Turner, Charles S. Weaver, Thomas A. Whitehurst, Lawrence Woodard, Lauren G. Woodby,

.....

The units of the Mathematics-Methods Program were developed by the Mathematics Education Development Center under a grant from the UPSTEP program of the National Science Foundation. The writing of each unit was supervised by Professors LeBlanc, Kerr, or Thompson. Suggestions for and reactions to each unit were received from several members of the Center as well as from consultants. The list of authors for each unit represents those individuals whose contributions were substantial. LeBlanc and Kerr refined and edited each unit.

This unit integrates the content and methods components of the mathematical training of prospective elementary school teachers. It focuses on an area of mathematics content and on the methods of teaching that content to children. The format of the unit promotes a small-group, activity approach to learning. The titles of other units are *Numeration, Addition and Subtraction, Multiplication and Division, Rational Numbers with Integers and Reals, Awareness Geometry, Transformational Geometry, Analysis of Shapes, Graphs: The Picturing of Information, Number Theory, Probability and Statistics, and Experiences in Problem Solving.*



ADDISON-WESLEY PUBLISHING COMPANY
Reading, Massachusetts · Menlo Park, California
London · Amsterdam · Don Mills, Ontario · Sydney