

DOCUMENT RESUME

ED 220 619

CE 033 477

TITLE Military Curriculum Materials for Vocational and Technical Education. Arc Welding-Pipe, 3-25.

INSTITUTION Naval Construction Training Center, Port Hueneme, Calif.; Ohio State Univ., Columbus. National Center for Research in Vocational Education.

SPONS AGENCY Department of Education, Washington, DC.

PUB. DATE [82]

NOTE 109p.

EDRS PRICE MF01/PC05 Plus Postage.

DESCRIPTORS Behavioral Objectives; Course Descriptions; Curriculum Guides; Learning Activities; \*Metal Working; Postsecondary Education; \*Safety; Secondary Education; Textbooks; \*Trade and Industrial Education; \*Welding

IDENTIFIERS Military Curriculum Project

ABSTRACT

This instructor guide and text for a secondary-postsecondary level course in arc welding-pipe comprise one of a number of military-developed curriculum packages selected for adaptation to vocational instruction and curriculum development in a civilian setting. Purpose of the course is to teach students to weld 5-inch mild steel schedule 80 pipe, with backing rings, in the vertical and horizontal fixed position while using Mil E 7018 5/32" diameter electrodes. Some experience in arc welding is required. The course contains two units: Introduction and Safety (1 hour of classroom time) and Arc Welding, Pipe, Vertical and Horizontal Fixed Positions (1 hour of classroom instruction and 82 hours of shop instruction). The instructor guide contains an introduction to the course; outline of instruction; outline of training objectives; lists of texts, references, tools, equipment, materials, training aids, and training aids equipment; and the master schedule. Student job sheets and information sheets are included. The required text from a Navy manual, Introduction to Welding, is provided. Three additional commercial references are suggested. (YLB)

\*\*\*\*\*  
 \* Reproductions supplied by EDRS are the best that can be made \*  
 \* from the original document. \*  
 \*\*\*\*\*

## MILITARY CURRICULUM MATERIALS

The military-developed curriculum materials in this course package were selected by the National Center for Research in Vocational Education Military Curriculum Project for dissemination to the six regional Curriculum Coordination Centers and other instructional materials agencies. The purpose of disseminating these courses was to make curriculum materials developed by the military more accessible to vocational educators in the civilian setting.

The course materials were acquired, evaluated by project staff and practitioners in the field, and prepared for dissemination. Materials which were specific to the military were deleted, copyrighted materials were either omitted or approval for their use was obtained. These course packages contain curriculum resource materials which can be adapted to support vocational instruction and curriculum development.

# The National Center Mission Statement

The National Center for Research in Vocational Education's mission is to increase the ability of diverse agencies, institutions, and organizations to solve educational problems relating to individual career planning, preparation, and progression. The National Center fulfills its mission by:

- Generating knowledge through research
- Developing educational programs and products
- Evaluating individual program needs and outcomes
- Installing educational programs and products
- Operating information systems and services
- Conducting leadership development and training programs

## FOR FURTHER INFORMATION ABOUT Military Curriculum Materials

### WRITE OR CALL

Program Information Office  
The National Center for Research in Vocational  
Education  
The Ohio State University  
1960 Kenny Road, Columbus, Ohio 43210  
Telephone: 614/486-3655 or Toll Free 800/  
848-4815 within the continental U.S.  
(except Ohio)

  
THE NATIONAL CENTER  
FOR RESEARCH IN VOCATIONAL EDUCATION  
The Ohio State University • 1960 Kenny Road • Columbus, Ohio 43210  
Tel. (614) 486-3655  
Cable: CTRVOCEDUS/COLUMBUS, OHIO

# Military Curriculum Materials for Vocational and Technical Education

Information and Field  
Services Division

The National Center for Research  
in Vocational Education

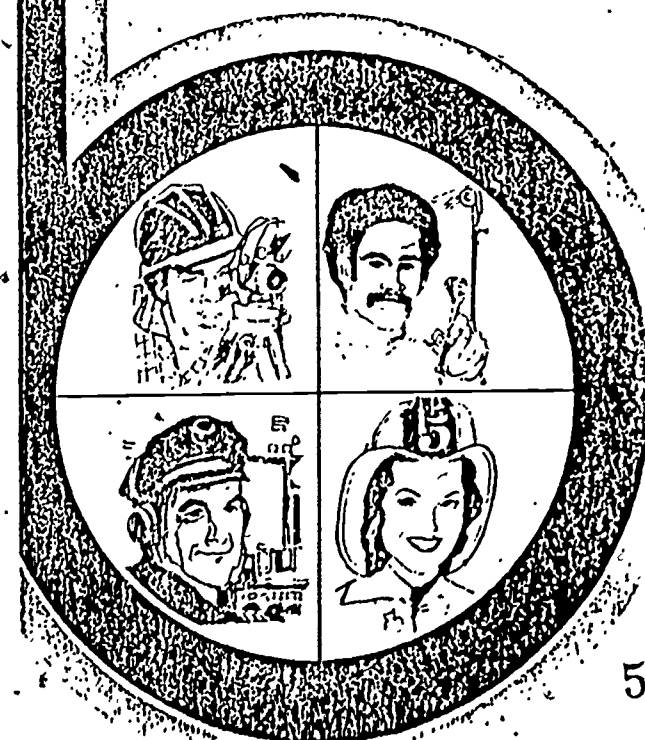

## Military Curriculum Materials Dissemination Is . . .

an activity to increase the accessibility of military-developed curriculum materials to vocational and technical educators.

This project, funded by the U.S. Office of Education, includes the identification and acquisition of curriculum materials in print form from the Coast Guard, Air Force, Army, Marine Corps and Navy.

Access to military curriculum materials is provided through a "Joint Memorandum of Understanding" between the U.S. Office of Education and the Department of Defense.

The acquired materials are reviewed by staff and subject matter specialists, and courses deemed applicable to vocational and technical education are selected for dissemination.

The National Center for Research in Vocational Education is the U.S. Office of Education's designated representative to acquire the materials and conduct the project activities.

### Project Staff:

Wesley E. Budke, Ph.D., Director  
National Center Clearinghouse

Shirley A. Chase, Ph.D.  
Project Director

## What Materials Are Available?

One hundred twenty courses on microfiche (thirteen in paper form) and descriptions of each have been provided to the vocational Curriculum Coordination Centers and other instructional materials agencies for dissemination.

Course materials include programmed instruction, curriculum outlines, instructor guides, student workbooks and technical manuals.

The 120 courses represent the following sixteen vocational subject areas:

|                         |                                       |
|-------------------------|---------------------------------------|
| Agriculture             | Food Service                          |
| Aviation                | Health                                |
| Building & Construction | Heating & Air Conditioning            |
| Trades                  | Machine Shop Management & Supervision |
| Clerical Occupations    | Meteorology & Navigation              |
| Communications          | Photography                           |
| Drafting                | Public Service                        |
| Electronics             |                                       |
| Engine Mechanics        |                                       |

The number of courses and the subject areas represented will expand as additional materials with application to vocational and technical education are identified and selected for dissemination.

## How Can These Materials Be Obtained?

Contact the Curriculum Coordination Center in your region for information on obtaining materials (e.g., availability and cost). They will respond to your request directly or refer you to an instructional materials agency closer to you.

### CURRICULUM COORDINATION CENTERS

**EAST CENTRAL**  
Rebecca S. Douglass  
Director

100 North First Street  
Springfield, IL 62777  
217/782-0759

**MIDWEST**  
Robert Patton  
Director

1515 West Sixth Ave.  
Stillwater, OK 74704  
405/377-2000

**NORTHEAST**  
Joseph F. Kelly, Ph.D.  
Director

225 West State Street  
Trenton, NJ 08625  
609/292-6562

**NORTHWEST**  
William Daniels  
Director

Building 17  
Airdustrial Park  
Olympia, WA 98504  
206/753-0879

**SOUTHEAST**  
James F. Shill, Ph.D.  
Director

Mississippi State University  
Drawer DX  
Mississippi State, MS 39762  
601/325-2510

**WESTERN**  
Lawrence F. H. Zane, Ph.D.  
Director

1776 University Ave.  
Honolulu, HI 96822  
808/948-7834

STEELWORKER SCHOOL, ARC WELDING, PIPE

Table of Contents

|  |         |
|--|---------|
| Course Description   | Page 1  |
| <u>Steelworker School 612.1 Arc Welding, Pipe -</u><br>Instructor Guides and Supporting Material | Page 3  |
| <u>Steelworker 3&amp;2</u><br>Chapter 7 - Introduction to Welding                                | Page 44 |

Developed by:

United States Navy

Development and Review Dates

March 1975

D.O.T. No.:

600.280

Occupational Area:

Building and Construction

Target Audiences:

Grades 10-adult

Print Pages:

76

Cost:

\$2.00

Availability:

Military Curriculum Project, The Center for Vocational Education, 1960 Kenny Rd., Columbus, OH 43210

Contents:

Unit 1.1 - Introduction and Safety Precautions

Unit 1.2 - Arc Welding, Pipe, Vertical and Horizontal Fixed Positions

Type of Materials:

| Lesson Plans: | Programmed Text: | Student Workbook: | Handouts: | Text Materials: | Audio-Visuals: |
|---------------|------------------|-------------------|-----------|-----------------|----------------|
| •             |                  |                   | •         |                 |                |
| •             |                  |                   | •         | •               |                |
|               |                  |                   |           |                 |                |
|               |                  |                   |           |                 |                |
|               |                  |                   |           |                 |                |
|               |                  |                   |           |                 |                |
|               |                  |                   |           |                 |                |
|               |                  |                   |           |                 |                |
|               |                  |                   |           |                 |                |
|               |                  |                   |           |                 |                |
|               |                  |                   |           |                 |                |
|               |                  |                   |           |                 |                |
|               |                  |                   |           |                 |                |
|               |                  |                   |           |                 |                |
|               |                  |                   |           |                 |                |
|               |                  |                   |           |                 |                |

Instructional Design:

| Performance Objectives: | Tests: | Review Exercises: | Additional Materials Required: |
|-------------------------|--------|-------------------|--------------------------------|
| •                       | •      |                   |                                |
| •                       | •      |                   | *                              |
|                         |        |                   |                                |
|                         |        |                   |                                |
|                         |        |                   |                                |
|                         |        |                   |                                |
|                         |        |                   |                                |
|                         |        |                   |                                |
|                         |        |                   |                                |
|                         |        |                   |                                |
|                         |        |                   |                                |
|                         |        |                   |                                |
|                         |        |                   |                                |
|                         |        |                   |                                |
|                         |        |                   |                                |
|                         |        |                   |                                |
|                         |        |                   |                                |

Type of Instruction:

| Group Instruction: | Individualized: |
|--------------------|-----------------|
| •                  |                 |
| •                  | •               |
|                    |                 |
|                    |                 |
|                    |                 |
|                    |                 |
|                    |                 |
|                    |                 |
|                    |                 |
|                    |                 |
|                    |                 |
|                    |                 |
|                    |                 |
|                    |                 |
|                    |                 |
|                    |                 |

\* Materials are recommended but not provided.

---

Course Description

Students completing this short course will be able to weld 5-inch mild steel schedule 80 pipe, with backing rings, in the vertical and horizontal fixed positions while using Mil E 7018 5/32" diameter electrodes. Some experience in arc welding is required for this course.

The course consists of two unit lessons. Part of Unit 1.1—Introduction and Safety deals with military organization and is deleted. The entire unit involves one hour of classroom time. Unit 1.2—Arc Welding, Pipe, Vertical and Horizontal Fixed Positions is suitable for vocational education. It consists of one hour of classroom instruction and 82 hours of shop instruction.

The course contains both teacher and student materials. An instructor guide contains an introduction to the course, outline of instruction, outline of training objectives, and lists of texts, references, tools, equipment, materials, training aids, training aids equipment, and the master schedule. Student job sheets and information sheets are also provided.

The text used is a Navy manual, *Steelworker 3 & 2, NAVPERS 10653-E*. The required chapter is provided. Three additional commercial references are suggested. No audio-visual materials are suggested.



3-25

# SPECIAL CONSTRUCTION BATTALION TRAINING

## STEELWORKER SCHOOL 612.1 ARC WELDING, PIPE

March 1975





TITLE PAGE

TITLE: SPECIAL CONSTRUCTION BATTALION TRAINING COURSE  
ARC WELDING, PIPE

COURSE NUMBER: SCBT 612.1

COURSE LENGTH: 84 Hours

CONTACT TIME: 84

TAUGHT AT: Naval Construction Training Center,  
Port Hueneme, California 93043

CLASS CAPACITY: Maximum - 10  
Minimum - 5

INSTRUCTOR REQUIREMENTS PER CLASS: 1 Instructor per 10 students.

COURSE CURRICULUM MODEL MANAGER: Naval Construction Training Center  
Port Hueneme, California 93043

CURRICULUM CONTROL: Chief of Naval Technical Training

QUOTA MANAGEMENT AUTHORITY: School at which taught.

QUOTA CONTROL: School at which taught.

APPROVAL/IMPLEMENTATION DATA: Chief of Naval Technical Training Letter  
N335-hh 1500 Ser 33/308 of 5 March 1975

TABLE OF CONTENTS

5

|   | <u>PAGE</u> |
|---|-------------|
| COPY OF APPROVED LETTER . . . . .               | 1           |
| RECORD OF CHANGE PAGE . . . . .                 | 11          |
| TITLE PAGE . . . . .                            | 111         |
| HOW TO USE INSTRUCTOR GUIDES . . . . .          | v           |
| COURSE DATA PAGE . . . . .                      | 1           |
| OUTLINE OF INSTRUCTION . . . . .                | 2           |
| OUTLINE OF TRAINING OBJECTIVES . . . . .        | 3           |
| ANNEX I TEXTS . . . . .                         | A-I-1       |
| ANNEX II REFERENCES . . . . .                   | A-II-1      |
| ANNEX III TOOLS, EQUIPMENT, MATERIALS . . . . . | A-III-1     |
| ANNEX IV TRAINING AIDS . . . . .                | A-IV-1      |
| ANNEX V TRAINING AIDS EQUIPMENT . . . . .       | A-V-1       |
| ANNEX VI MASTER SCHEDULE . . . . .              | A-VI-1      |

## HOW TO USE THE INSTRUCTOR GUIDE

Instructor guides are provided for each topic and include supporting instructional materials and aids identified by the topic number and preceded by a letter code designation. The letter code key is as follows:

|                        |   |
|------------------------|---|
| AS - Assignment Sheet  | TR - Transparencies                     |
| JS - Job Sheet         | DS - Diagram Sheet                      |
| IS - Information Sheet | PS - Problem Sheet                      |
| CN - Class Notes       | PT - Pretest                            |
| OS - Operation Sheet   | PE - Performance Evaluation             |
| T - Test               | WS - Work Sheet                         |
| FT - Final Test        | G - General (give a definition of item) |

A complete listing of all supporting materials and aids is documented with full descriptive titles in Annex.

The instructor guides are intended to be used as master lesson plans subject to personalization by the individual instructor. In all cases, it is expected that the instructor will study the references in preparation for annotating the guide. It is also expected that each instructor will develop an appropriate introduction for each topic that will (1) create interest, (2) show the value of the topic to the student, (3) relate the topic to previous and future topics in the course, and (4) communicate the learning objectives to the student. Well prepared introductions will then provide the important motivational conditioning to establish readiness and effect for learning appropriate to each topic.

The first page of each instructor guide contains the following functional information:

1. Topic of lesson
2. Time in periods
3. References
4. Instructional Aids
5. Instruction Aids
6. Objectives
7. Topic criterion test (as applicable)
8. Homework assignment (when applicable)
9. Tools and materials

The pages following Page 1 of each instructor guide provide in a three-column format the teaching/learning procedures for conducting the lesson. The left hand column includes the outline of instructional content required by the objectives; the center column includes recommended instructor activities or methodology; the right hand column contains recommended student learning activities.

While the methodology and student learning activities documented in each instructor guide have been tested and proven to be effective for the lead school, those schools implementing this curriculum are encouraged to exercise creativity in designing learning exercises and conceiving methods and techniques to meet course objectives.

8

COURSE DATA PAGE

COURSE MISSION: To train selected Steelworkers in the knowledge and skill factors defined by the Personnel Readiness and Capability Program for Steelworker skills.

PERSONNEL AND RATINGS ELIGIBLE: E-3 through E-6

OBLIGATED SERVICE: None

NEC EARNED: N/A

PHYSICAL REQUIREMENTS: No special requirements.

SECURITY CLEARANCE REQUIRED: None.

PREREQUISITE TRAINING AND/OR BASIC BATTERY TEST SCORE REQUIRED:  
Arc Welding Structural I-610.1 and Arc Welding Structural II-610.2

RELATED TRAINING: None.

FOLLOW-UP TRAINING: None.

EVALUATION: Performance will be evaluated on a Go/No Go Basis.

OUTLINE OF INSTRUCTION

| TOPIC | Unit 1.1   | CLASS    | PRACT     | TOTAL     |
|-------|--|----------|-----------|-----------|
|       | Introduction and Safety Precautions                        |          |           |           |
| 1.1.1 | Introduction and Safety Precautions                        | <u>1</u> | <u>0</u>  | <u>1</u>  |
|       |  | 1        | 0         | 1         |
|       | Unit 1.2   |          |           |           |
| 1.2.1 | Arc Welding, Pipe, Vertical and Horizontal Fixed Positions | <u>1</u> | <u>82</u> | <u>83</u> |
|       |  | 1        | 82        | 83        |

Total periods classrooms: 2  
 Total periods practical: 82  
 Total periods for course: 84  
 Total weeks for course: 3

OUTLINE OF TRAINING OBJECTIVES

Unit 1.1 INTRODUCTION

Contact Hours: 1

Terminal Objective: Upon completion of this unit the student will have reported to the Steelworker School, received text books, complied with NAVCONSTRACEN and CBC regulations governing the reporting and fighting of fires and shop safety procedures which pertained to him as a student.

Topic 1.1.1 INTRODUCTION AND SAFETY

Contact Hours: 1

Enabling Objectives: Upon completion of this topic the student will be able to answer orally specific questions pertaining to the mission, regulations and organization of the command, and the method of reporting/fighting a fire and the precautions to be observed to ensure personal safety as established by NAVCONSTRACEN and CBC regulations.

Unit 1.2 ARC WELDING, PIPE, VERTICAL AND HORIZONTAL  
FIXED POSITIONS

Contact Hours: 83

Terminal Objective: Upon completion of this unit the student will have welded 5" mild steel schedule 80 pipe, with backing rings, in the vertical and horizontal fixed positions while using Mil E 7018 5/32" diameter electrodes. The finished welds will meet the standards set forth in SCBT 612.1-SW-IS-1.2.1.1.

Topic 1.2.1 ARC WELDING, PIPE, VERTICAL AND HORIZONTAL  
FIXED POSITIONS

Contact Hours: 83

Enabling Objectives: Upon completion of this topic the student will be able to weld mild steel pipe in all positions. In the performance of this task he will select proper electrodes, use correct machine settings and use proper welding procedures. He will properly prepare the pipe for welding by utilizing the Mapp-Oxygen Pipe Cutting/Beveling Machine. All welding will be accomplished with 5/32" diameter Mil E 7018 electrodes.

ANNEX I

TEXTS

1. Steelworker 3 and 2 NAVPERS 10653-E.





ANNEX II

REFERENCES

1. American Welding Society, Standard For Qualifications of Welding Procedures and Welders For Piping and Tubing, AWS D10.9-69.
2. Operator's Manual Welding Theory and Applications TM9-237.
3. The Welding Encyclopedia, 16th Edition.

ANNEX III

TOOLS, EQUIPMENT, MATERIALS

TOOLS:

|     |                      |                                    |        |       |        |
|-----|----------------------|------------------------------------|--------|-------|--------|
| 1.  | 9QG 7920-00-269-1269 | Brush, wire stn stl 14 LG          | 10 Ea. | .98   | 9.80   |
| 2.  | 9QV 5120-00-555-7829 | Hammer, handwelders                | 10 Ea. | 1.65  | 16.50  |
| 3.  | 9QG 5110-00-186-7107 | Chisel Cold 1/2                    | 10 Ea. | .46   | 4.60   |
| 4.  | 9QG 5120-00-061-8542 | Hammer Hand Mch 12 Oz.             | 10 Ea. | 2.63  | 26.30  |
| 5.  | 9QG 5120-00-223-7397 | Pliers Slp Jt. 8"                  | 10 Ea. | .93   | 9.30   |
| 6.  | 9DD 8415-00-268-7860 | Gloves Leather Gauntlet            | 10 Pr. | 4.16  | 41.60  |
| 7.  | 9GD 4240-00-540-0623 | Helmet Welders                     | 10 Ea. | 8.00  | 80.00  |
| 8.  | 9DD 8415-00-261-6437 | Sleeves Weld MD                    | 10 Ea. | 19.10 | 191.00 |
| 9.  | 9DD 8415-00-268-8264 | Jacket Welders 42                  | 10 Ea. | 21.70 | 217.00 |
| 10. | 9GD 4240-00-269-9460 | Spectacles Industrial Lens Shade 2 | 10 Ea. | 2.72  | 27.00  |

EQUIPMENT:

|    |                      |                                      |        |        |         |
|----|----------------------|--------------------------------------|--------|--------|---------|
| 1. | 2CD 3431-00-165-4144 | Welder, Arc 300 Amp DC Rectifier     | 10 Ea. | 800.00 | 8000.00 |
| 2. | 3416-00-204-0035     | Grinder, Pedestal                    | 2 Ea.  | 526.00 | 1052.00 |
| 3. | NSN-N/A              | Pipe Beveling Machine                | 1 Ea.  | 500.00 | 500.00  |
| 4. | 9GD 3433-00-076-3261 | Torch Outfit Gas Cutting and Welding | 2 Ea.  | 345.00 | 690.00  |

14

TOOLS, EQUIPMENT, MATERIALS (Cont'd)

MATERIALS:

|     |                               |  |         |      |         |
|-----|-------------------------------|--|---------|------|---------|
| 1.  | 9GL 6830-00-935-1125          | Gas Mapp                               | 70 Lb.  | .30  | 21.00   |
| 2.  | 9GL 6830-00-169-0805          | Gas Oxygen                             | 1000 CF | .01  | 10.00   |
| 3.  | 9QG 7530-00-285-3083          | Pad, Ruled 8 x 10 1/2 white            | 1 Dz.   | 5.50 | 5.50    |
| 4.  | 9GD 4240-00-276-8940          | Lens Helmet Filter Shade 10            | 10 Ea.  | .45  | 4.50    |
| 5.  | 9GD 4240-00-276-8941          | Lens Helmet Filter Shade 12            | 10 Ea.  | .45  | 4.50    |
| 6.  | 5345 L00 8204 (Local Stock #) | Disk Grinding Hi Spd.<br>7 x 1/4 x 7/8 | 6 Ea.   | 2.16 | 12.96   |
| 7.  | 1HL 3439-00-465-1917          | Electrodes 5/32" M11 E 7018            | 300 Lb. | .32  | 96.00   |
| 8.  | 9C 471-00-277-8681            | Pipe Steel Schedule 80 5"<br>Diameter  | 360 Ft. | 4.00 | 1440.00 |
| 9.  | Local Purchase                | Backing Ring Steel w/spacers           | 360 Ea. | .50  | 180.00  |
| 10. | 9QG 7510-00-281-5234          | Pencil Lead No. 2                      | 1 Dz.   | .29  | .29     |

A-III-2

ANNEX IV

TRAINING AIDS:

1. Instructor Prepared Materials (Local)
  - a. Introduction SCBT 612.1-SW-IS-1.1.1.1
  - b. Safety Precautions SCBT 612.1-SW-IS-1.2.1.1
  - c. Information Sheet, Arc Welding, Pipe SCBT 612.1-SW-IS-1.2.1.1.
  - d. Sample of pipe beveled and tack welded together with back-up  
ring in place and showing weld bead placement.

ANNEX V

TRAINING AIDS EQUIPMENT:

None

17

ANNEX VI

MASTER SCHEDULE

FIRST WEEK

| <u>TOPIC NO.</u> | <u>TYPE</u> | <u>PERIOD</u> | <u>TITLE</u> | <u>RATIO</u> |
|------------------|-------------|---------------|--------------|--------------|
|------------------|-------------|---------------|--------------|--------------|

FIRST DAY

|       |   |   |   |      |
|-------|---|---|---|------|
| 1.1.1 | C | 1 | Introduction and Safety Precautions               | 10/1 |
| 1.2.1 | C | 2 | Arc Welding, Pipe Vertical & Horizontal Positions | 10/1 |
|       | P | 3 | Arc Welding Vertical Position                     | 10/2 |
|       |   | 4 |   |      |
|       |   | 5 |   |      |
|       |   | 6 |   |      |
|       |   | 7 |   |      |

SECOND DAY

|       |   |    |                               |      |
|-------|---|----|-------------------------------|------|
| 1.2.1 | P | 8  | Arc Welding Vertical Position | 10/1 |
|       |   | 9  |                               |      |
|       |   | 10 |                               |      |
|       |   | 11 |                               |      |
|       |   | 12 |                               |      |
|       |   | 13 |                               |      |
|       |   | 14 |                               |      |

THIRD DAY

|       |   |    |                               |      |
|-------|---|----|-------------------------------|------|
| 1.2.1 | P | 15 | Arc Welding Vertical Position | 10/1 |
|       |   | 16 |                               |      |
|       |   | 17 |                               |      |
|       |   | 18 |                               |      |
|       |   | 19 |                               |      |
|       |   | 20 |                               |      |
|       |   | 21 |                               |      |

FOURTH DAY

|       |   |    |                               |      |
|-------|---|----|-------------------------------|------|
| 1.2.1 | P | 22 | Arc Welding Vertical Position | 10/1 |
|       |   | 23 |                               |      |
|       |   | 24 |                               |      |
|       |   | 25 |                               |      |
|       |   | 26 |                               |      |
|       |   | 27 |                               |      |
|       |   | 28 |                               |      |

18

SECOND WEEK

| <u>TOPIC NO.</u> | <u>TYPE</u> | <u>PERIOD</u> | <u>TITLE</u> | <u>RATIO</u> |
|------------------|-------------|---------------|--------------|--------------|
|------------------|-------------|---------------|--------------|--------------|

FIRST DAY

|       |   |   |                               |      |
|-------|---|---|-------------------------------|------|
| 1.2.1 | P | 1 | Arc Welding Vertical Position | 10/1 |
|       |   | 2 |                               |      |
|       |   | 3 |                               |      |
|       |   | 4 |                               |      |
|       |   | 5 |                               |      |
|       |   | 6 |                               |      |
|       |   | 7 |                               |      |

SECOND DAY

|       |   |    |                               |      |
|-------|---|----|-------------------------------|------|
| 1.2.1 | P | 8  | Arc Welding Vertical Position | 10/1 |
|       |   | 9  |                               |      |
|       |   | 10 |                               |      |
|       |   | 11 | Criterion Test                |      |
|       |   | 12 |                               |      |
|       |   | 13 |                               |      |
|       |   | 14 |                               |      |

THIRD DAY

|       |   |    |                                 |      |
|-------|---|----|---------------------------------|------|
| 1.2.1 | P | 15 | Arc Welding Horizontal Position | 10/1 |
|       |   | 16 |                                 |      |
|       |   | 17 |                                 |      |
|       |   | 18 |                                 |      |
|       |   | 19 |                                 |      |
|       |   | 20 |                                 |      |
|       |   | 21 |                                 |      |

FOURTH DAY

|       |   |    |                                  |      |
|-------|---|----|----------------------------------|------|
| 1.2.1 | P | 22 | Arc Welding Horizontal Position. | 10/1 |
|       |   | 23 |                                  |      |
|       |   | 24 |                                  |      |
|       |   | 25 |                                  |      |
|       |   | 26 |                                  |      |
|       |   | 27 |                                  |      |
|       |   | 28 |                                  |      |

A-VI-2



19  
1

THIRD WEEK

| <u>TOPIC NO.</u> | <u>TYPE</u> | <u>PERIOD</u> | <u>TITLE</u>                    | <u>RATIO</u> |
|------------------|-------------|---------------|---------------------------------|--------------|
| <u>FIRST DAY</u> |             |               |                                 |              |
| 1.2.1            | P           | 1             | Arc Welding Horizontal Position | 10/1         |
|                  |             | 2             |                                 |              |
|                  |             | 3             |                                 |              |
|                  |             | 4             |                                 |              |
|                  |             | 5             |                                 |              |
|                  |             | 6             |                                 |              |
|                  |             | 7             |                                 |              |

SECOND DAY

|       |   |    |                                 |      |
|-------|---|----|---------------------------------|------|
| 1.2.1 | P | 8  | Arc Welding Horizontal Position | 10/1 |
|       |   | 9  |                                 |      |
|       |   | 10 |                                 |      |
|       |   | 11 |                                 |      |
|       |   | 12 |                                 |      |
|       |   | 13 |                                 |      |
|       |   | 14 |                                 |      |

THIRD DAY

|       |   |    |                                 |      |
|-------|---|----|---------------------------------|------|
| 1.2.1 | P | 15 | Arc Welding Horizontal Position | 10/1 |
|       |   | 16 |                                 |      |
|       |   | 17 |                                 |      |
|       |   | 18 |                                 |      |
|       |   | 19 |                                 |      |
|       |   | 20 |                                 |      |
|       |   | 21 |                                 |      |

FOURTH DAY

|       |   |    |                                 |      |
|-------|---|----|---------------------------------|------|
| 1.2.1 | P | 22 | Arc Welding Horizontal Position | 10/1 |
|       |   | 23 |                                 |      |
|       |   | 24 |                                 |      |
|       |   | 25 | Criterion Test                  |      |
|       |   | 26 |                                 |      |
|       |   | 27 |                                 |      |
|       |   | 28 |                                 |      |



NAVAL CONSTRUCTION TRAINING CENTER  
PORT HUENEME, CALIFORNIA 93043  
SPECIAL CONSTRUCTION BATTALION TRAINING (SCBT) 612.1

Classification: Unclassified

Topic: Introduction and Safety Precautions

Average Time: 1 Period (Class)

Instructional Materials:

A. Texts.

- 1. None.

B. References:

- 1. NAVCONSTRACEN INST. 5400.4 (Current Series) Organizational Manual of NAVCONSTRACEN
- 2. "Safety Practices For Shore Activities", NAVMAT P-5100 (Jan '73), Chapter 5

C. Training Aids and Devices.

- 1. Instructor Prepared Materials (Local):
  - a. Introduction SCBT 612.1-IS-1.1.1.1
  - b. Safety Precautions SCBT 612.1-IS-1.1.1.2

Terminal Objective: Upon completion of this unit the student will have reported to the steelworkers school, received textbooks, com with NAVCONSTRACEN and CBC regulations governing the reporting and fighting of fires and shop safety procedures which pertained to his student.

Enabling Objective: Upon completion of this topic the student will be able to answer oral specific questions pertaining to the mission regulations and organization of the Command, the method of reporting/fighting a fire and the precautions to be observed to ensure personal safety as established by NAVCONSTRACEN and CBC regulations.

Criterion Tests: The student will answer oral specific questions pertaining to the mission regulations and organization of the Command, the method of reporting/fighting a fire and the precautions to be observed to ensure personal safety as established by NAVCONSTRACEN and CBC regulations.

Homework: None

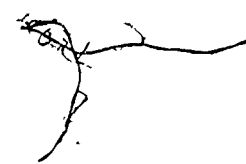

OUTLINE OF INSTRUCTION

INSTRUCTOR ACTIVITY

STUDENT ACTIVITY

I. Introduction to the lesson

I. Introduce self and topic.

A. Establish contact.

1. Name:

2. Topic: Introduction and Safety Precautions

B. Establish readiness

I.B. Motivate student.

1. Purpose

2. Assignment

C. Establish effect

I.C. Bring out need and value of material being presented.

1. Value

a. Pass course.

b. Perform better on the job.

c. Get advanced.

d. Be a better steelworker.

D. Overview:

I.D. State learning objectives.

1. Introduction

I.D.1 State information and materials necessary to guide student.

2. Safety Precautions

I.D.2. Notes may be taken.

I.D.3. Classroom conduct

I.D.4. Shop area conduct

I.D.5. Questions

OUTLINE OF INSTRUCTION

INSTRUCTOR ACTIVITY

STUDENT ACTIVITY

II. Presentation

A. Introduction

1. Mission

- a. Special training courses
- b. Higher state of readiness
- c. Compliance with COMCBPAC Instructions

II.A.1.b. Stress

2. Organization and chain of command

- a. Commanding Officer
  - b. Executive Officer
  - c. Training Officer
  - d. School Department Officer
  - e. Division Director
  - f. Senior Instructor
  - g. Primary Course Instructor
  - h. Class Petty Officer
  - i. Class Safety Petty Officer
3. Regulations and policies:

II.A.2. Give names as appropriate.

II.A.2.a. Issue I.S. 1.1.1.1 and I.S. 1.1.1.2.

a. Schedule

b. Break procedures

OUTLINE OF INSTRUCTIONINSTRUCTOR ACTIVITYSTUDENT ACTIVITY

## c. Uniform regulations

(1) Working uniform of the day.

(a) Must be clean and neat.

II.A.3.c. Maintain a military appearance at all times.

## d. Absenteeism

(1) Must be kept to a minimum.

(2) Medical or dental sick call.

(3) Permission to be absent.

II.A.3.d.(2). Stress

## e. Parking

(1) Where

(2) When

(3) How

## f. Visitors and phone calls

(1) Emergencies only

(2) Phone numbers

(a) School number

## g. Lost or damaged material

(1) Text books

(2) Publications

(3) Tools

(4 of 9)

OUTLINE OF INSTRUCTIONINSTRUCTOR ACTIVITYSTUDENT ACTIVITY

- (4) Materials
- (5) Statement of charges
- h. Off-limits areas
  - (1) Restricted
  - (2) Hard hat
- i. Clean-up procedures
- j. Problems
  - (1) Scholastic
  - (2) Personal
  - (3) Counseling assistance
- 4. Standards of student performance
  - a. Go-No Go Performance Test.
  - b. Homework assignments
  - c. Practical application
- 5. Course outline
  - a. Mission of course
  - b. Course objectives
  - c. Reading assignments
  - d. Class Schedule

OUTLINE OF INSTRUCTION

INSTRUCTOR ACTIVITY

STUDENT ACTIVITY

- 6. Grading system
  - a. Homework
  - b. Practical application
  - c. Final examination
- B. Safety Precautions
  - 1. Personal safety
    - a. Tripping hazards
      - (1) Tools and equipment
        - (a) Hand tools
        - (b) Jacks
        - (c) Extension cords
        - (d) Welding leads
        - (e) Foreign objects
    - b. Slippage hazards
      - (1) Oil and grease
      - (2) Water
      - (3) Paper
    - c. Eye hazards

II.A.6. Trainee achievement will be evaluated by practical performance evaluations.

II.A.6.c. Students must meet all learning objectives in order to pass.

II.B.1.a. Relate personal experience if applicable.

II.B.1.a.(1).(b). Stress

OUTLINE OF INSTRUCTION

INSTRUCTOR ACTIVITY

STUDENT ACTIVITY

- (1) Face mask, goggles
- (2) Hammering, chiseling
- (3) Welding
- (4) Grinding

d. Compressed air hazard

- (1) Eye and face
- (2) Skin penetration

e. Reporting accidents

- (1) Class safety man
- (2) Instructor
- (3) School Director
- (4) First aid when appropriate

II.B.1.e.(1) Introduce class safety man.

2. Fire safety

a. Avoiding and preventing fires

- (1) Good housekeeping
- (2) Proper storage of materials
- (3) Smoking

II.B.2.a.(1) Stress

b. Know evacuation routes.

II.B.2.b. Explain in detail evacuation routes.



OUTLINE OF INSTRUCTION

INSTRUCTOR ACTIVITY

STUDENT ACTIVITY

(1) Classroom

(2) Shop area

c. Reporting fires

(1) Location of fire alarm switch.

(2) Report to class safety man.

d. Fighting fire

(1) Location of extinguishers

III. Application

A. Oral Questions

IV. Summary.

A. Introduction

1. Mission

2. Organization

3. Regulations

4. Standards of student performance

5. Course outline

6. Grading system

B. Safety

1. Personal safety



OUTLINE OF INSTRUCTION

INSTRUCTOR ACTIVITY

STUDENT ACTIVITY

2. Fire safety

V. Test.

A. None

VI. Homework

A. None

NAVAL CONSTRUCTION TRAINING CENTER  
PORT HUENEME, CALIFORNIA 93043  
SPECIAL CONSTRUCTION BATTALION TRAINING (SCBT) 612.1

Classification: Unclassified

Topic: Arc Welding, Pipe, Vertical and Horizontal  
Fixed Position

Average Time: 1 Period (Class) Practical (82 Periods)

Instructional Materials:

A. Text.

- 1. Steelworker 3 & 2 NAVPERS 10653-E Ch. 7, pages 145-154 and 243-246.

B. References.

- 1. American Welding Society, Standard For Qualifications of Welding Procedures and Welders for Piping and Tubing. AWS D10-9-69.
- 2. Operator's Manual Welding Theory and Application, TM9-237
- 3. The Welding Encyclopedia, 16th Edition

C. Training aids and Devices.

- 1. Instructor Prepared Materials (Local)
  - a. Arc Welding, Pipe SCBT 612.1-SW-IS-1.2.1.1
  - b. Samples of Pipes Beveled, Spaced and Tacked (Locally Prepared)

Terminal Objective: Upon completion of this unit the student will have welded 5" mild steel schedule 80 pipe, with backing rings, in the vertical and horizontal fixed positions while using Mil E 7018 5/32" diameter electrodes. The finished welds will meet the standards set forth in SCBT 612.1-SW-IS-1.2.1.1.

Enabling Objective: Upon completion of this topic the student will be able to weld mild steel pipe in all positions. In the performance of this task he will select proper electrodes, use correct machine setting, and use proper welding procedures. He will properly prepare the pipe for welding by utilizing the Mapp-Oxygen Pipe Cutting/Beveling Machine. All welding will be accomplished with 5/32" diameter Mil E 7018 Electrodes.

Criterion Test: The student will weld two pieces of 5" mild steel schedule 80 pipe, each 6" long, into one homogeneous section. This will be accomplished once for the vertical position and once for the horizontal position. Evaluation of welded area will be by the visual acceptance requirements stated in SCBT 612.1-SW-IS-1.2.1.1.

Homework: None.

- c. Samples of pipes showing bead placement,  
(Locally prepared).
- d. X-Rays showing defects in welds and good welds,  
(Locally prepared).

**D. Tools:**

- 1. Chipping hammer
- 2. Chisel
- 3. Hammer, ball peen
- 4. Pliers, 8"
- 5. Gloves
- 6. Hood, arc
- 7. Sleeves
- 8. Jacket
- 9. Spats
- 10. Flash goggles

**E. Equipment:**

- 1. Oxy-mapp cutting and welding unit.
- 2. Electric arc welding unit!
- 3. Portable sander
- 4. Bench grinder

5. Pipe beveling machine.

F. Materials.

1. Pipe, mild steel 5" schedule 80
2. Oxygen
3. Mapp gas
4. Sanding disc
5. Backing rings w/spacers

OUTLINE OF INSTRUCTION

INSTRUCTOR ACTIVITY

STUDENT ACTIVITY

- I. Introduction to the lesson
  - A. Establish contact.
    - 1. Name:
    - 2. Topic: Arc Welding Pipe, Vertical and Horizontal Fixed Position
  - B. Establish readiness
    - 1. Purpose
    - 2. Assignment
  - C. Establish effect
    - 1. Value
      - a. Pass course.
      - b. Perform better on the job.
      - c. Get advanced.
      - d. Be a better Steelworker.
  - D. Overview:
    - 1. Arc weld a V-butt joint in the vertical and horizontal fixed position.

- I. Introduce self and topic.
  - I.B. Motivate student.
  - I.C. Bring out need and value of material being presented.
  - I.D. State learning objectives.
    - I.D.1. State information and materials necessary to guide student.
    - I.D.2. Notes may be taken.
    - I.D.3. Questions.
    - I.D.4. Classroom Conduct.
    - I.D.5. Shop area conduct.



OUTLINE OF INSTRUCTIONINSTRUCTOR ACTIVITYSTUDENT ACTIVITY

## II. Presentation

## A. Techniques of Pipe Welding (Vertical and Horizontal Fixed Position)

## 1. Machine setting

## a. Amperage

## (1) Determined by

(a) Size of electrode

(b) Thickness of metal

(c) Position

## b. Polarity

## (1) Reverse

## (2) Straight

## 2. Length of Arc

## 3. Speed of travel

## 4. Correct electrode selection

## 5. Angle of electrode

II.A.1. Explain to students correct machine setting. II.A.1. Take notes.

II.A.1.b. Explain polarity.

II.A.2. Stress the importance of the length of arc.

II.A.3. Illustrate speed of travel.

II.A.4. Explain the difference between E7018 and E6011 electrodes.

II.A.5. Demonstrate the effects on the contour of the bead by the angle of electrode.

OUTLINE OF INSTRUCTION

INSTRUCTOR ACTIVITY

STUDENT ACTIVITY

B. Stress-relieving and cleaning of pipe

- 1. Peening to relieve stress
- 2. Degree of cleaning

II.B. Stress the importance of removing all slag.

C. Preparation of pipe prior to welding

- 1. Beveling
  - a. By manufacture
    - (1) Premachined by manufacture
  - b. In the field
    - (1) Beveled by pipe beveling machine
    - (2) Beveled by hand torch

2. Cleaning

- a. Clean off all mill scale and slag

3. Aligning

- a. Very important because one bevel will not melt evenly with the other.

4. Spacing

- a. Predetermined by spacing stubs on backing rings.

5. Tacking

- a. Size and number

II.C.5. Stress the importance of proper tacking of pipe.

OUTLINE OF INSTRUCTION

INSTRUCTOR ACTIVITY

STUDENT ACTIVITY

(1) Small tacks

(2) Four tacks

NOTE: DO NOT PLACE TACKS WHERE YOU PLAN TO START OR STOP WELDING.

D. Faults in arc welding.

1. Porosity

2. Undercut

3. Overlap

4. Poor fusion

5. Incomplete penetration

6. Spatter

7. Warpage

III. Application

A. Practice welding in the shop.

IV. Summary

A. Techniques of pipe-welding (vertical & horizontal).

B. Stress relieving and cleaning pipe

C. Preparation of pipe prior to welding

D. Faults in arc welding

II.D. Explain reasons for faults in welding.

II.D.a. Stress the importance of neatness.

II.D.b. For testing, a completed test piece can only be evaluated.

II.D.c. Have test pipe cut, beveled and letter stamped prior to practical test time.

II.D.d. Stress that pipe will not be turned for welding during test.

III.A. Observe students during welding to help overcome difficulties.

II.D. Make single V-butt vertical and horizontal fixed pipe welds for evaluation.

III.A. Practice under supervision



36

SCBT 612.1-SW-IG-1.2.1

OUTLINE OF INSTRUCTION

INSTRUCTOR ACTIVITY

STUDENT ACTIVITY

V. Test

A. Criterion test will be based on the students ability to pass the visual standards as set forth in SCBT 612.1-SW-IS-1.2.1.1

VI. Assignment: Read Pages 145-154 and 243-246  
Steelworker 3 & 2 NAVPERS 10653-E.

<

31

SPECIAL CONSTRUCTION BATTALION TRAINING  
NAVAL CONSTRUCTION TRAINING CENTER  
PORT HUENEME, CALIFORNIA 93043

INFORMATION SHEET

INTRODUCTION

1. Organization and Chain of Command

- a. Commanding Officer \_\_\_\_\_
- b. Executive Officer \_\_\_\_\_
- c. Training Officer \_\_\_\_\_
- d. School Department Officer \_\_\_\_\_
- e. Division Director \_\_\_\_\_
- f. Senior Instructor \_\_\_\_\_
- g. Primary Course Instructor \_\_\_\_\_
- h. Class Petty Officer \_\_\_\_\_
- i. Class Safety Petty Officer \_\_\_\_\_

2. Schedule

- a. Classes will convene at 0730 and continue until 1600.
- b. Five-minute breaks between each class and one hour for lunch.

3. Uniform regulations

- a. Working uniform of the day
- b. Must be clean and neat.

4. Absenteeism

- a. Must be kept to a minimum.
  - (1) One complete day is grounds for dismissal.



5. Parking
  - a. As directed by the instructor.
6. Visitors and phone calls
  - a. Emergencies only
    - (1) School ext. \_\_\_\_\_
7. Lost or damaged material
  - a. Students will be accountable for all books, tools and special equipment when issued to them.
8. Off-limits areas
  - a. Set by the instructor.
9. Clean-up procedures
  - a. Daily clean-up every evening.
    - (1) Areas designated by the instructor.
    - (2) Senior Class Petty Officer is responsible.
  - b. Field day held on Fridays.
    - (1) Area designated by the instructor.
    - (2) Senior Class Petty Officer is responsible.
10. Problems
  - a. Chain of Command will be utilized
  - b. Major problems will be referred to the student's command.
11. Grading system
  - a. Emphasis will be placed on the practical application rather than knowledge.

(2 of 2)

SPECIAL CONSTRUCTION BATTALION TRAINING  
NAVAL CONSTRUCTION TRAINING CENTER  
PORT HUENEME, CALIFORNIA 93043

INFORMATION SHEET

SAFETY PRECAUTIONS

INTRODUCTION: This information sheet is designed to provide information on safety precautions and proper actions in case of fire.

SUBJECT MATTER:

1. Alcoholic liquors or narcotics shall not be transported to the school or working area, and no man shall go to work while under the influence of liquor or narcotics.
2. Fighting, wrestling, or throwing of objects and hoseplay is positively prohibited.
3. Strict attention to duty is the first requirement of safety. You are warned against permitting your attention to be distracted from your work as this is the cause of many injuries. "Keep your mind on your work and safety on your mind."
4. Do not talk to or distract the attention of machine and equipment operators while the machines or equipment is in operation.
5. Obey warning signs and tags. Their purpose is to point out hazards. To disregard them is to deliberately invite injury.
6. No one is permitted to ride on fenders, running boards, or bus steps; nor to ride standing on truck bodies.
7. Employees riding on trucks or other vehicles must keep arms and legs inside the body of the vehicle at all times. Sitting on side boards is prohibited.
8. No one is permitted to get on or off a moving vehicle.
9. Never try to operate any equipment unless you are familiar with its operation and have been authorized to do so.
10. Report to your supervisor any defects in equipment or any other condition which might cause an accident.
11. Remember that at all times some of your co-workers on the job are inexperienced and may not know where danger exists. Warn any man when danger is near. He may know all about it; if so no harm is done.
12. Be constantly aware and stay clear of moving equipment and material

13. You are in danger when you are in a position between a moving piece of equipment or load of material and a stationary object.
14. Do not use a box, chair, barrel, or other makeshift in place of a ladder.
15. Leaning tools or materials against walls, columns, or machines is an unsafe practice.
16. Cleaning, oiling, repairing, or adjusting machinery or equipment while it is in motion may cause serious injury and is prohibited.
17. Always use all safeguards provided. See that all guards or other protective devices are in place before beginning work.
18. Any extension lamp, power tool, welding cable, etc. with frayed insulation, loose connection, or damaged plug should be repaired or replaced immediately.
19. Do not touch, handle or tamper with any electrical equipment, air, water, gas, oil, or steam line, or machinery which does not come within your regular duties unless you have received permission and instructions from your supervisor.
20. Do not throw any switch, turn any air, water, steam or oil valve, or start any machine without first making certain that everything is in the clear and that no worker will be injured by such action.
21. In doing work entailing possible eye injury, protect the eyes by wearing the proper type of safety goggles provided for this purpose.
22. Every precaution must be taken to prevent fires. Extinguish all lighted matches, cigarettes or cigars before throwing them away.
23. Throw waste paper, oily rags, and other refuse in containers provided for that purpose.
24. Keep aisles, stairways, exits, and fire equipment clear of obstruction at all times.
25. In case of fire turn in the alarm and return to the scene of the fire to help in extinguishing it.
26. The following are rules to be observed while in the welding shop area.  
YOU WILL:
  - a. observe all safety rules.
  - b. at all times wear flash goggles in the arc shop.

(2 of 3)

- c. Wear cutting goggles when using cutting torches.
- d. Wear face shields while grinding.
- e. Wear gloves when welding or cutting.
- f. Wear welding leathers at all times in arc shop.
- g. Use pliers to pick up hot metal.
- h. Keep curtains closed on welding booths.
- i. Make complete use of welding electrode.
- j. Use only materials designated by the instructor.
- k. Clean your welding booth and area.
- l. Replace oxy-acetylene bottles when found empty.
- m. Take breaks on east end of building.

YOU WILL NOT:

- n. Use grinders or buffers unless directed to by instructor.
- o. Waste materials.
- p. Weld on face of plates.
- q. Throw electrode stubs on the deck.
- r. Pick up hot metal with gloves.
- s. Use flash goggles when cutting.
- t. Weld anything other than that designated by instructor.
- u. Play or fool in shops or with another man's tools and equipment.
- v. Enter toolroom unless directed to do so by instructor.
- w. Bring any type food or beverages into the shops.
- x. Go to the exchange gedunk truck.
- y. Leave the area without instructors approval.

NAVAL CONSTRUCTION TRAINING CENTER  
PORT HUENEME, CALIFORNIA 93043

ARC WELDING, PIPE  
INFORMATION SHEET

INTRODUCTION:

The purpose of this information sheet is to list the acceptance requirements for welding pipe in the vertical and horizontal fixed positions.

TOOLS:

1. Brush, wire hard
2. Hammer, hand welders
3. Chisel cold 1/2"
4. Hammer Hand Mch 1202
5. Pliers Slip Jt. 8"
6. Gloves leather gauntlet
7. Helmet welders
8. Sleeves weld Md
9. Jacker Welders
10. Spectacles Industrial

EQUIPMENT:

1. Welder, Arc 300 AMP DC Rectifier
2. Grinder, Pedestal
3. Pipe Beveling Machine
4. Torch Outfit Gas Cutting and Welding

MATERIALS:

1. Electrodes Mil E 7018 5/32" diameter
2. Mapp Gas
3. Oxygen
4. Pipe, 5" mild steel schedule 80
5. Backing rings 5" w/spacers

ACCEPTANCE REQUIREMENTS:

1. Appearance: The ripples formed by the deposited weld metal shall present a uniform appearance at all points of the weld.
2. Build-up: The face of the weld shall be at least flush with the outside surface of the pipe and the weld shall merge smoothly with the base metal. Weld build-up shall not exceed 3/16" in height from surface of the pipe.



INFORMATION SHEET (Cont'd)

- 3. Weld Width: The width of the finished weld shall not exceed 15/16".
- 4. Undercut: The weld shall not have more than 1" total length of undercut and no undercut shall exceed 1/16" in depth.
- 5. Overlap: The weld shall not have more than 1" total length of overlap.
- 6. Cracks: There shall be no cracks in the welded joint.





44

3-25

# CHAPTER 7 INTRODUCTION TO WELDING

While various methods are used for joining metals, welding is one of the most convenient and rapid methods available. In the naval service, as well as in private industry, welding and its allied processes are widely used by metal workers in the fabrication, maintenance, and repair of parts and structures ranging from chair legs to atomic reactors.

Welding, the same as any of the skilled trades, is broad in scope. You cannot become a welder simply by reading a book. You will need practice and experience, as well as patience. There is a lot to be gained, however, through study. For instance, by learning the correct method or procedure for doing a job from a book you may eliminate many unnecessary errors which otherwise would occur through trial and error.

As an introduction to the subject of welding, this discussion is designed to equip you with a background of basic information applicable to welding in general. Various topics covered include types of welded joints, welding positions, welding sequences, methods of controlling expansion and contraction in metal during welding, welded joint design, and welding difficulties likely to be encountered by the inexperienced welder. Special attention also is given to safety, the purpose being to brief you on protective clothing and other devices, such as welding goggles and helmets, designed for your personal protection. Throughout the discussion various technical terms peculiar to the welding trade are used, and care has been taken to explain the meaning of terms that might be new to the beginner.

## WELDING PROCESSES AND MATERIALS

The term WELDING PROCESS refers to a metal-joining process wherein coalescence is produced by heating to suitable temperatures,

with or without the application of pressure or by the application of pressure alone, and with or without the use of filler metal. COALESCENCE means the growing together, or growth into one body, of the base metal parts. A master chart of welding processes is shown in figure 7-1.

Welding processes obviously have differences which distinguish one from another. However, all welding processes are based upon the principle of applying or generating HEAT at the joint and bringing the surfaces into INTIMATE CONTACT so that the joining surfaces will coalesce. Although coalescence of the joining surfaces is the goal of all welding processes, this goal is achieved in different ways.

With respect to HEAT, the welding processes differ as to the source of heat, the manner in which heat is applied or generated, and the intensity of the heat. The source of heat may be the combustion of a fuel gas such as acetylene in combination with oxygen; and electric arc; an electric, gas, or oil furnace; the resistance of metal to the flow of electric current; or a chemical reaction between a metal oxide and finely divided aluminum.

The welding processes most commonly used by Navy Steelworkers involve the combustion of a fuel gas, as in oxyacetylene welding and torch brazing; and the use of an electric arc, as in metal-arc welding.

The intensity of heat applied or generated at the joint varies according to the metals being joined and according to the welding process being used. All welding processes except brazing utilize temperatures high enough to melt the base metal; brazing is the ONLY welding process in which the melting of the base metal is not necessary for coalescence to occur. Brazing is, therefore, similar to soldering (not considered a welding process), except that higher temperatures are used for brazing.



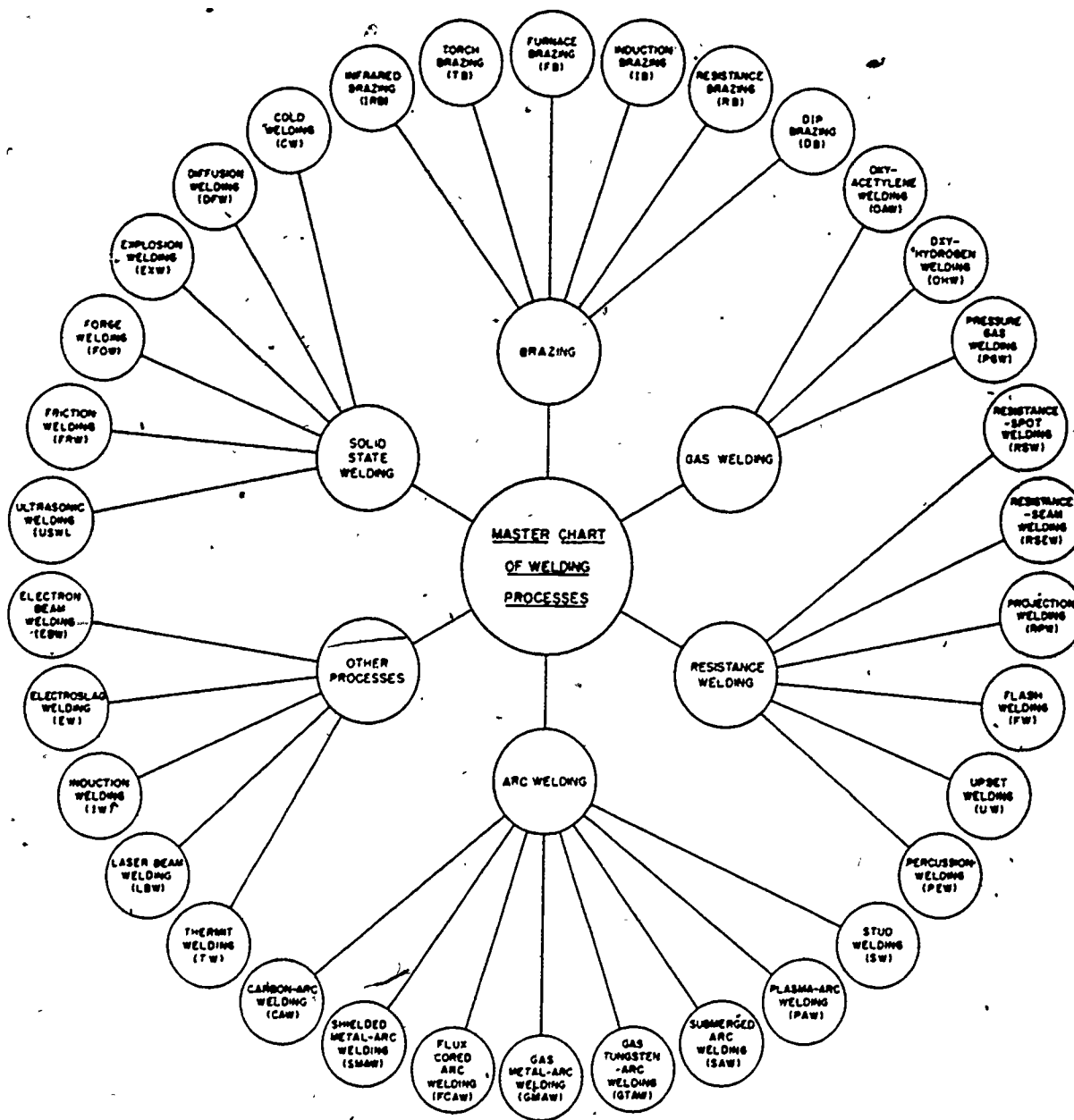

R11.34X  
Figure 7-1. — Master chart of welding processes.

The term BRAZING refers to a group of welding processes wherein coalescence is produced by heating to a suitable temperature and by using a filler metal having a liquidus above 800° F (427° C) and below the solidus of the base metals. The filler metal is distributed between

the closely fitted surfaces of the joint by capillary attraction.

For clarity note that LIQUIDUS means the lowest temperature at which a metal or an alloy is completely liquid; and SOLIDUS means

the highest temperature at which a metal or alloy is completely solid.

The term SOLDERING refers to a group of joining processes wherein coalescence is produced by heating to a suitable temperature and by using a filler metal having a liquidus not exceeding 800° F (427° C) and below the solidus of the base metals.

### OXYACETYLENE AND ELECTRIC-ARC WELDING

Since oxyacetylene and electric-arc welding are the processes you will be concerned with primarily at your present level, let us note a few of the similarities and differences in the two processes.

A main difference between the two processes is in the source of heat used. In the oxyacetylene process, heat is produced by burning acetylene gas mixed with oxygen, discharged under pressure from a torch designed for that purpose.

The heat source for electric-arc welding is provided by motor-generated sets, transformers, or rectifiers. This process employs carbon or metal electrodes. The carbon arc is sometimes used for metal cutting.

The two processes are similar in that the intimacy of contact required for coalescence is attained without pressure. The joint in either process is made by melting the edges of the base metal with a suitable degree of heat and introducing a filler metal into the molten puddle. They are similar also in the phases leading up to the actual joining operation such as cleaning, joint design, selection of filler metal, preheating, the control of expansion, contraction, and internal stresses, and determining the sequence of filler metal deposition. They are dissimilar in that the temperature developed by the electric arc is considerably higher than that produced by the oxyacetylene flame.

In electric-arc welding, the heat is concentrated over a relatively small area, while the heat of the oxyacetylene flame spreads over a large area. Heat concentration is a distinct advantage for many applications because less heat spread reduces buckling or warping, increases the depth of heat penetration, and speeds up the welding operation.

### FLUXES

The welding or brazing of most metals requires the use of a flux to produce a sound joint. The term FLUX refers to material used

to dissolve, prevent, or facilitate the removal of oxides and other undesirable substances in welding. Fluxes serve to bring the filler metal into intimate contact with the metals being joined. Fluxes act as cleaning agents in that they dissolve oxides, release trapped gases and slag, and cleanse metals for welding, soldering and brazing.

Fluxes are available in paste, powdered, and liquid form. Powders can be sprinkled on the base metal, or the filler rod can be heated and dipped into the powder. Liquid and paste fluxes may be applied to the filler rod and to the base metal with a brush.

In electric-arc welding the flux is on the electrode in the form of a cellulose or mineral encasement around a wire core.

In the welding of alloyed metals, the use of a flux is necessary. This is because the oxides of most alloys have higher melting points than the metals themselves, and remain solid when the filler metal has become fluid. As solids, they interfere with the proper disposal of the molten filler metal.

No single flux is satisfactory for universal use. The composition of the flux depends chiefly upon the base metal and the filler metal. In welding cast iron, for example, a flux composed of equal parts of carbonate of soda and bicarbonate of soda is frequently used.

The essential characteristics of a good flux are as follows:

- Is fluid and active at the melting point of the filler metal.
- Remains stable and does not change to a vapor rapidly within the temperature range of the welding procedure.
- Dissolves all oxides and removes them from the joint surfaces.
- Adheres to the metal surfaces while they are being heated and does not ball up or blow away.
- Does not cause a glare which makes it difficult to see the progress of welding or brazing.
- Is easy to remove after the joint is welded.
- Is available in an easily applied form.

You may think of fluxes as cleaning agents, and in a sense they are; however, the purpose

of fluxed will be defeated unless the base metal is cleaned physically prior to their use. Then, too, the flux must not be overheated, or it will fail to serve its purpose. In addition, fluxes will deteriorate if kept at brazing temperatures for too long a time.

Nearly all fluxes give off fumes which may be toxic; they should always be used in well-ventilated spaces. It is well to remember that ANY welding operation requires adequate ventilation, whether a flux is used or not.

#### FILLER METALS

The metals that are added during the welding process are known as filler metals or filler materials. In welding processes in which a space is left between the parts to be joined, filler metals provide the intimacy of contact necessary for coalescence. Two types of filler metals used in welding processes are welding rods and electrodes.

The term WELDING ROD refers to a form of filler metal used for welding (or brazing) wherein the filler metal does not conduct the electrical current. The only purpose of a welding rod is to supply filler metal to the joint.

The term ELECTRODE applies, in arc welding, to a component of the welding circuit through which current is conducted between the electrode holder and the arc. Some electrodes are a source of filler metal supply, but others are not.

#### WELDING TERMINOLOGY

It is essential that you have a good command of the technical vocabulary related to your work. A technical vocabulary makes it possible for weldors to convey information to one another and exchange ideas accurately without misunderstandings. In the discussion thus far, you have learned the meaning of a number of technical terms. In the following sections you will be introduced to additional terms you should know; these terms relate to types of welded joints, types and parts of welds, joint parts, welding positions, welding procedures and deposition sequences, and weld and welding symbols.

#### TYPES OF WELDED JOINTS

The term WELDED JOINT means a union of two or more members, the union being produced by the application of a welding process.

There are five fundamental types of welded joints known as the butt, edge, tee, corner, and lap. Each type is illustrated in figure 7-2; the joint area of each type is indicated by the shaded portion of the drawing. While there are many variations, every joint you weld will be one of these basic types.

A BUTT joint is used to join two members lying approximately in the same plane. Here the joint area is between the edges of the members. The butt joint is frequently used in plate, sheet metal, and pipe work.

EDGE joints also may be used to join parallel members lying in the same plane, but in most cases, one of the members is flanged. The edge joint shown in figure 7-2 indicates that the members need not be in the same plane as in the case of a butt joint. With edge joints, the joint area is between the contracting surfaces of the members. While this type of joint has some applications in plate work, it is more frequently employed in sheet metal work. Occasionally, the edge joint is used to join reinforcing plates to

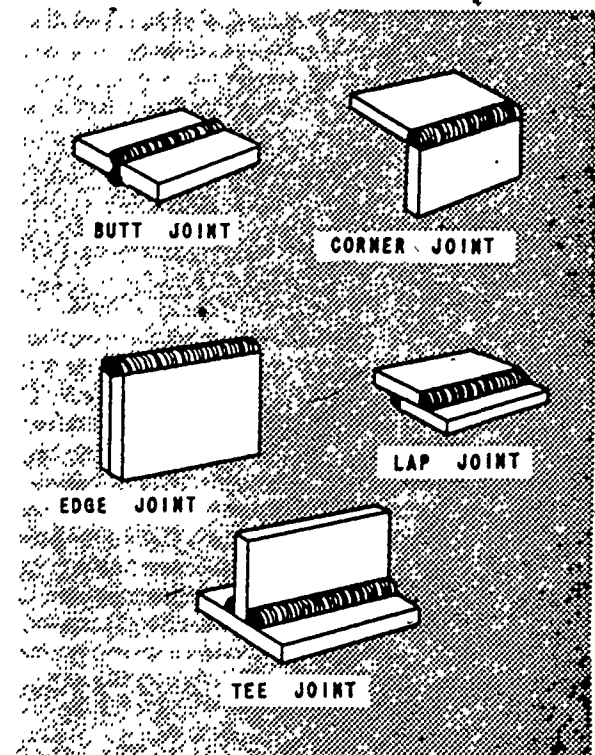

11.35A  
Figure 7-2.— Types of welded joints.

48

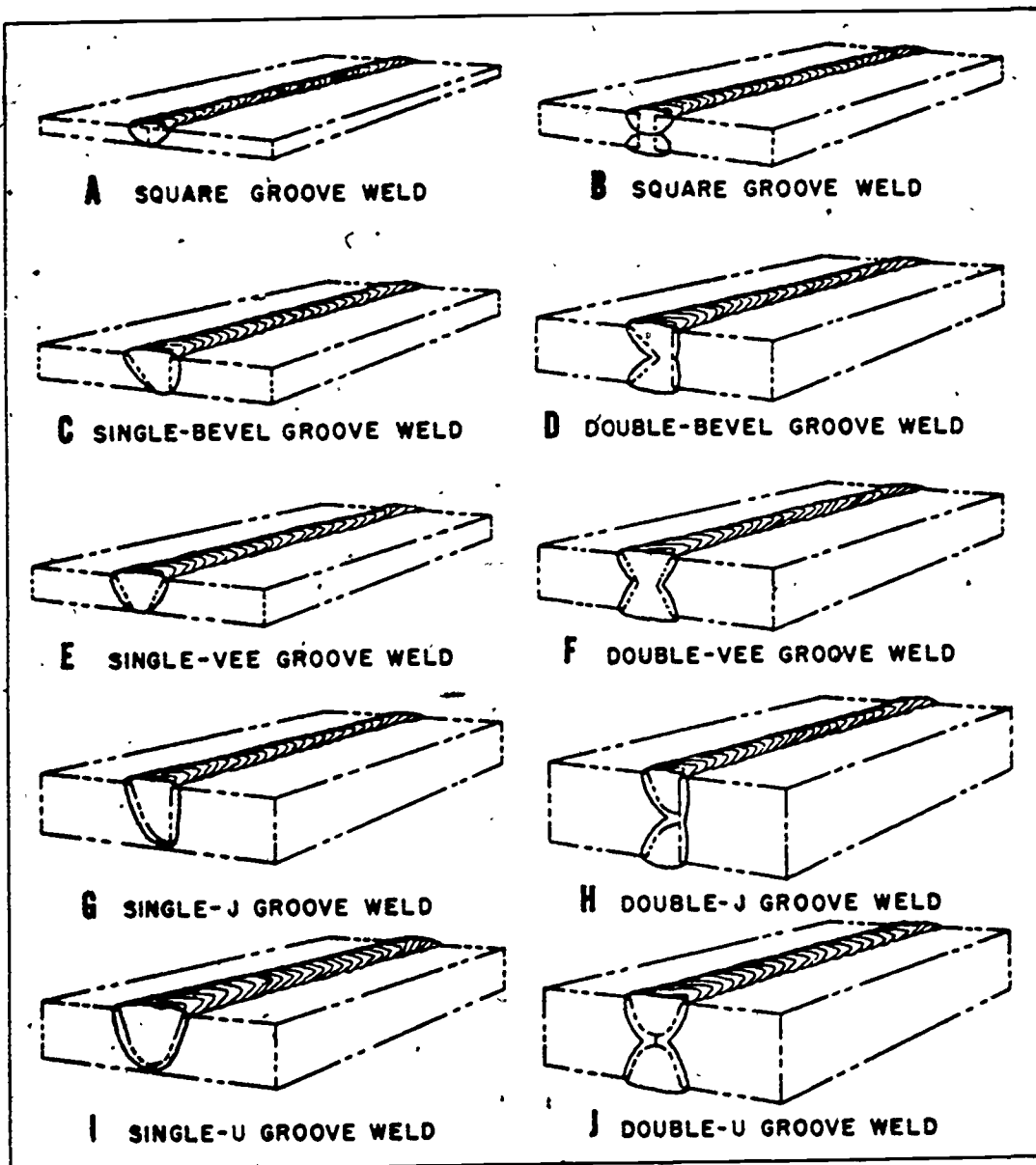

11.37  
Figure 7-3. —Standard groove welds.

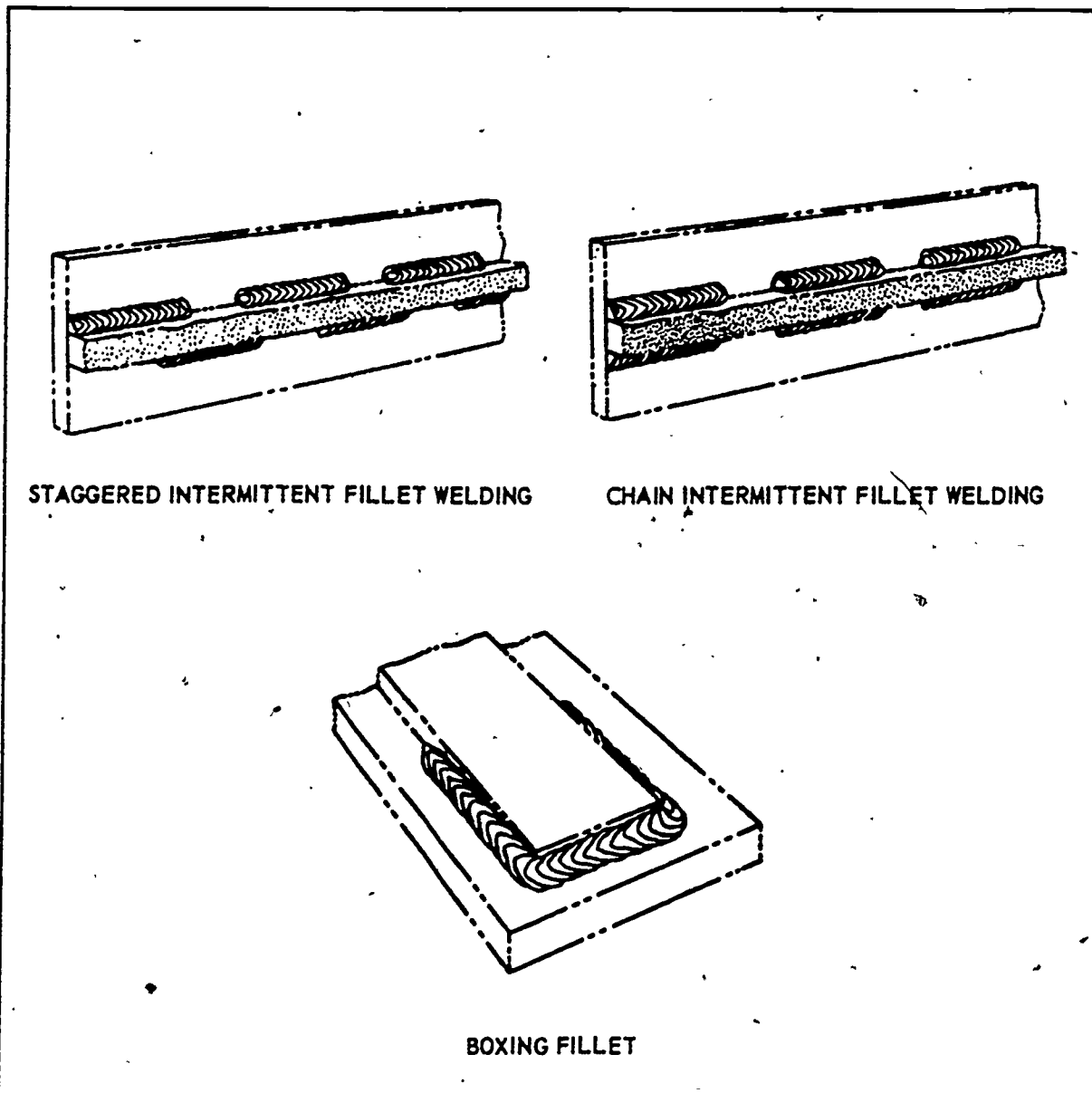

11.36

Figure 7-4. — Fillet welds.

the flanges of I-beams and the edges of angles. In many cases, no filler metal is used in joining edge joints by the gas welding process. The edges are fused together and the base metal supplies the weld filler metal.

TEE joints and CORNER joints are used to join two members located at approximately right

angles to each other. The joint area in both cases is between the end of one member and the side or edge of another. Where the corner joint forms an L-shape, the tee joint has the shape of the letter T. Corner joints are used in making tanks, boxes, box frames, and similar objects. These joints are used only in very low

pressure tanks since the root of the weld is in tension under load. Tee joints have uses in many types of metal structures.

The LAP JOINT is used to join overlapping members of a structure. The joint area of a lap joint is between the parallel surfaces of the members. Lap joints are used frequently in torch brazing processes where capillary action draws filler metal into the space between the hot surfaces. Lap joints are also used in many resistance welding processes, especially in sheet metal structures fabricated with spot welds.

TYPES OF WELDS

There are many types of welds. Some of the common types which will concern you in your work are: groove, fillet, surfacing, tack, plug, slot, spot, and seam. Incidentally, you may often hear welding operators use the term "seal weld." This term does not actually refer to any one type of weld; rather, a seal weld is any weld that is designed primarily to provide a specific degree of tightness against leakage. Seal welds are frequently used to seal threaded pipe connections and to prevent corrosive element from entering the ends of lap joints.

GROOVE WELDS are made in a specially prepared groove between two members to be joined. Figure 7-3 illustrates a number of variations of the groove weld. Note in particular the square, single bevel, and single-V types because you will use these grooves frequently in welding operations.

Choice of groove welds depends largely upon the accessibility and the design of the part being fabricated, and upon the degree of joint penetration that will be possible. If the square groove weld is suitable to the job, select it for reasons of economy, since it requires no chamfering; which means there is no edge preparation.

While the edge of a vertical plate of a tee joint is sometimes beveled for welding, grooves are most frequently used for butt joints in plate and pipe work. Groove welds are designed to provide the strength required, with a minimum amount of filler metal. Plate edges may be prepared for groove welding by flame cutting, shearing, machining, chipping, or grinding.

A FILLET WELD is approximately triangular in cross section. It joins two surfaces that are at approximately right angles to each other. Fillets are used to weld lap, tee, and corner joints. As shown in figure 7-4, some variations of the fillet weld are chain intermittent, staggered intermittent, and boxing.

A SURFACING WELD is a type of weld composed of one or more stringer or weave beads deposited on an unbroken surface to obtain desired properties or dimensions. A bead, however, may be made without externally added filler metal by forming a molten puddle in the base metal with a heat source (oxyacetylene torch) and then moving the heat source steadily in one direction. (See fig. 7-5) Surfacing welds are used principally on butt-type joints, and to build up a surface. The cross section of a single surfacing weld usually has an oval shape. Incidentally, you may frequently hear this weld referred to as a "bead weld," but "surfacing weld" is the preferred term.

A TACK WELD is a weld made to hold parts of a weldment in proper alignment until the final welds are made.

The sizes of tack welds usually are not specified; generally they are one-half of an inch to three-quarters of an inch in length. They should never be more than 1 inch in length.

Tack welds should be made small so that they will be consistent with the size of electrode being used. Tack welds are usually incorporated into the finished weld. Cracked or broken tacks

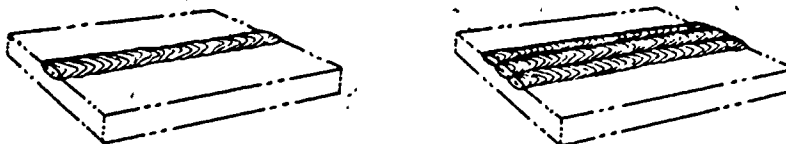

11.36.1

Figure 7-5.— Surfacing welds.

must be chipped out before the joint is finally welded.

Plug and slot welds are used to join overlapping plates not otherwise accessible for welding. They may be used to join face-hardened plate from the back or soft side, to install liner metals inside tanks, or to fill up a hole in a plate.

A **PLUG WELD** is a circular weld made through a hole in one member of a lap or tee joint to join that member to the other. The walls of the hole may or may not be parallel and the hole may be filled completely or only partially with weld metal. (See fig. 7-6.) Note that a fillet-welded hole or a slot weld should not be considered as conforming to this definition. Plug welds are normally not used except to fill a hole.

A **SLOT WELD** is a weld made in an elongated hole in one member of a lap or tee joint joining that member to that portion of the surface of the other member which is exposed through the hole. The hole may be open at one end. Then, too,

the hole may be partially or completely filled with weld metal, by either the oxyacetylene or the electric-arc process. (See fig. 7-6.) Slot welds permit development of required strength where fillets or butts are not economical or good designs, as in fastening a plate to the surface of another plate. A joint that is made with a fillet weld at the intersection of the edge of the slot and the exposed surface of the second member is considered a fillet weld, NOT a slot weld.

Spot welds and seam welds (fig. 7-7) are common types of resistance welds. In resistance welding coalescence is produced by the heat obtained from resistance of the work to electric current in a circuit of which the work is a part, and by the application of pressure.

A **SPOT WELD** is a weld made between or upon overlapping members wherein coalescence may start and occur on the faying surfaces or may have proceeded from the surface of one member. (See fig. 7-7.) The weld cross section (plan view) is approximately circular.

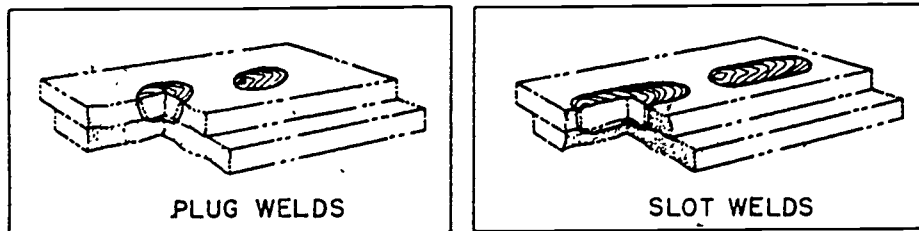

127.11  
Figure 7-6.— Plug and slot welds.

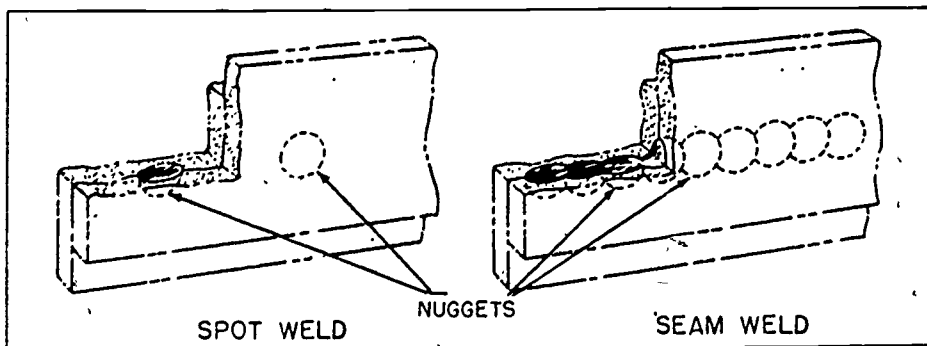

11.38  
Figure 7-7.— Spot weld and seam weld (resistance welds).



A SEAM WELD is a continuous weld made between or upon overlapping members, wherein coalescence may start and occur on the faying surfaces, or may have proceeded from the surface of one member. The continuous weld may consist of a single weld bead. Or, it may consist of a series of overlapping spot welds, like the seam weld shown in figure 7-7. Note that the welds in figure 7-7 have been labeled to show the location of nuggets. The term NUGGET refers to the weld metal joining the parts in spot, seam, or projection welds. The NUGGET SIZE is determined by the diameter or width of the nugget measured in the plane of the interface between the pieces joined, as illustrated in figure 7-8.

PARTS OF WELDS

You should be familiar with the terms used to describe the parts of welds. Figure 7-9 illustrates the face and the toe on groove and fillet welds. The FACE is the exposed surface, on the side from which the weld was made, of a weld made by a gas or arc welding process. The TOE is the junction between the face of the weld and the base metal.

The ROOT of a weld includes the points at which the back of the weld intersects the base metal surfaces, as seen in cross section. Figure 7-10 illustrates weld roots.

The legs and throat of a fillet weld are shown in figure 7-11. When we look at a triangular cross section of a fillet weld, the LEG is the portion of the weld from the toe to the root. The THROAT is the distance from the root to a point on the face of the weld along a line which would form a 90° angle with the weld face, as shown in figure 7-11. Theoretically, the face is considered to form a straight line between the toes. If the face of the weld is convex or concave, it will not form a straight line between the toes. In that case, the actual face will be larger than the theoretical face, and the actual throat will be either larger or smaller

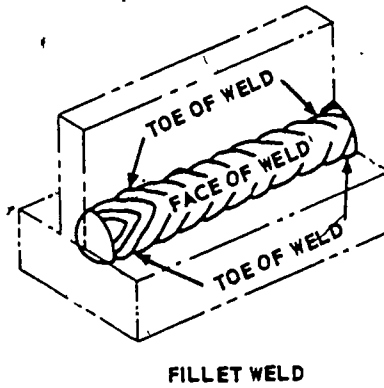
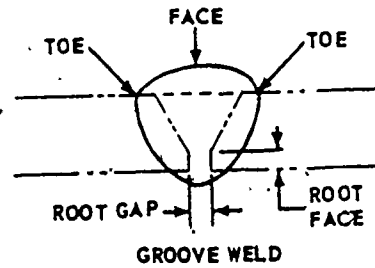

11.39  
Figure 7-9.— Face and toe of groove and fillet welds.

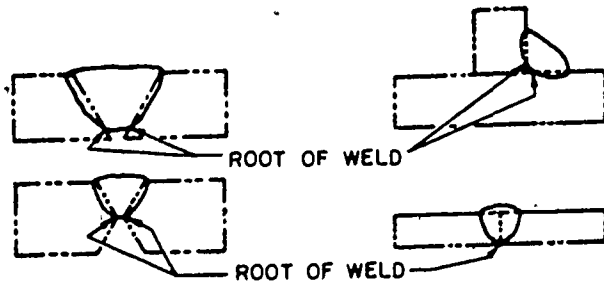

11.40  
Figure 7-10.— Weld roots.

than the theoretical throat. It should be noted that the terms "leg" and "throat" apply only to fillet welds.

Several other terms are used to describe areas or zones of welds. Figure 7-12 illustrates the use of some of these terms. The BOND LINE is the junction of the weld metal and the base metal or, if weld metal is not used, the junction of the base metal parts. FUSION is the melting

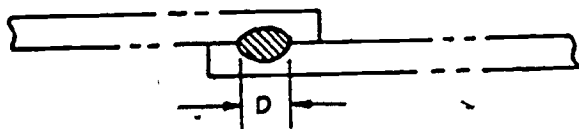

R127.152X  
Figure 7-8.— Nugget size.

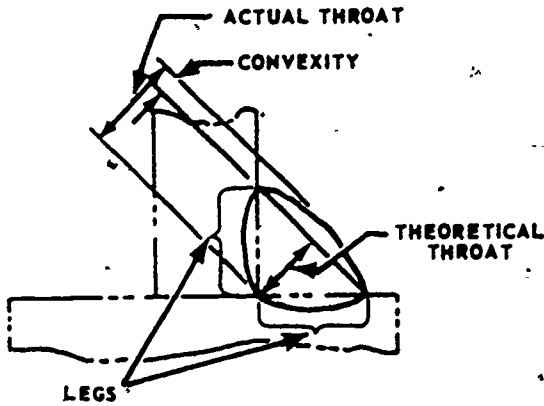

11.41

Figure 7-11.—Legs and throat of fillet weld.

together of base and filler metal, or the melting of base metal only, that results in coalescence. The FUSION ZONE is the region of the base metal that is actually melted. The DEPTH OF FUSION is the distance that fusion extends into the base metal or previous pass from the surface melted during welding.

Another zone of interest to the weldor is the HEAT-AFFECTED ZONE (See fig. 7-12.). This zone includes that portion of the base metal which has not been melted, but whose mechanical properties or microstructure have been altered by the heat of welding, brazing, soldering or cutting. The extent of this zone varies with the thermal conductivity of the metal. The changes that occur within the area are related to the kind of metal being welded, the

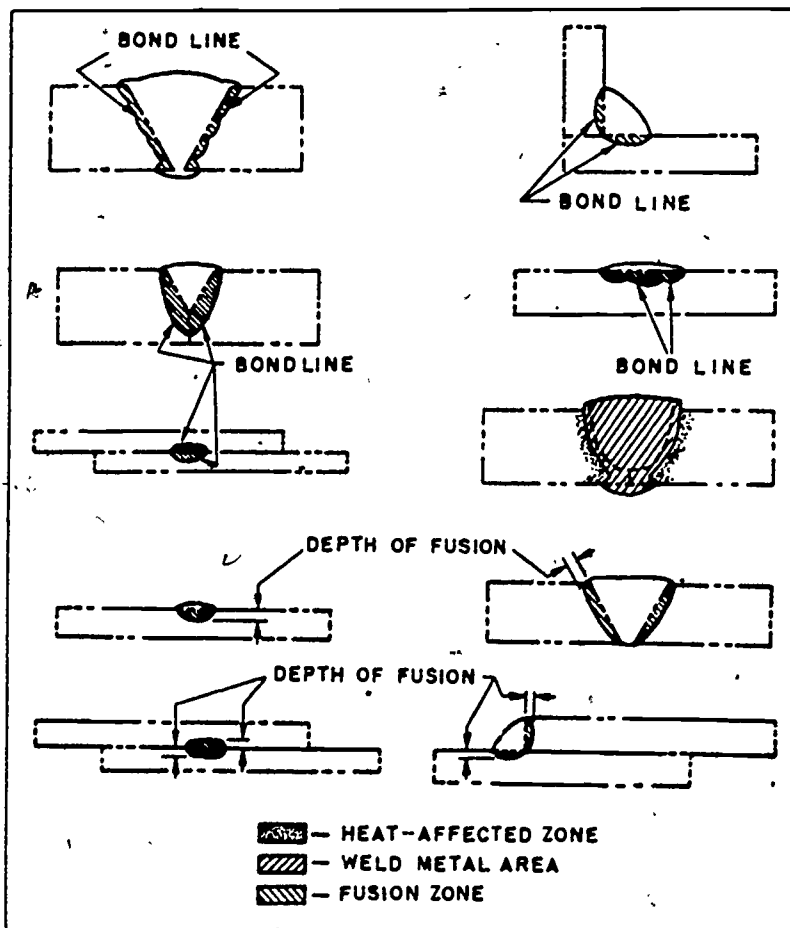

11.42

Figure 7-12.—Fusion zone, depth of fusion, heat-affected zone, and bond line of weld.

intensity and duration of heat, and the control embodied in the welding procedure.

PARTS OF JOINTS

In order to follow the specifications for any welding job, you must have a very clear knowledge of the terms used to describe welds and joints. In some cases, the similarity between terms used to describe parts of welds and those used to describe parts of joints may lead to confusion. For example, the root of a weld is NOT precisely the same as the root of a joint. In other cases, it may be somewhat difficult to decide whether a term usually refers to a part of a weld or to a part of a joint. In all cases, it is essential that you know EXACTLY what part, zone, or measurement is being referred to.

While there are many groove designs, the various parts of the joint are described by

standard terms. The ROOT of a joint is that portion of the joint to be welded where the members approach closest to each other. It may be a point, a line, or an area, when viewed in cross section. (See fig. 7-13.) A GROOVE is an opening provided between the edges of the metal parts to be welded. The GROOVE FACE is that surface of a member included in the groove, as indicated in view A, figure 7-14. A given joint design may have a root face or it may have a root edge. The ROOT FACE, also indicated in view A, is that portion of the groove face adjacent to the root of the joint. The ROOT EDGE is a root face of zero width, as shown in view C. As indicated in parts B and D of the illustration, the groove face and the root face are the same metal surfaces in some joint designs.

Details of joint design involve the size of the groove and the space existing between the members of the joint. Specifications for joint

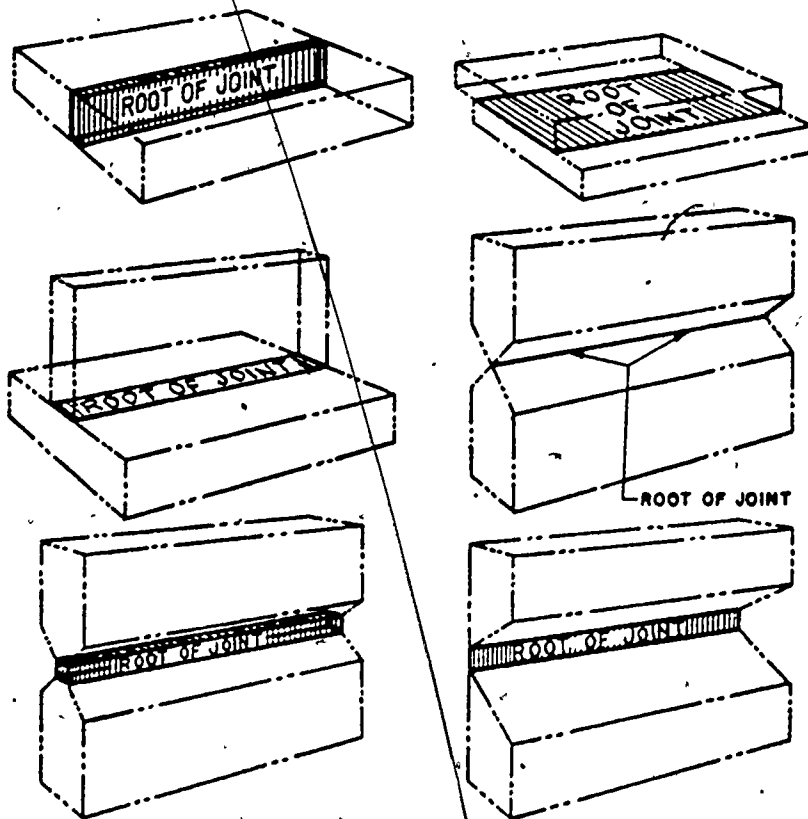

R127.153X  
Figure 7-13.—Root of joint.

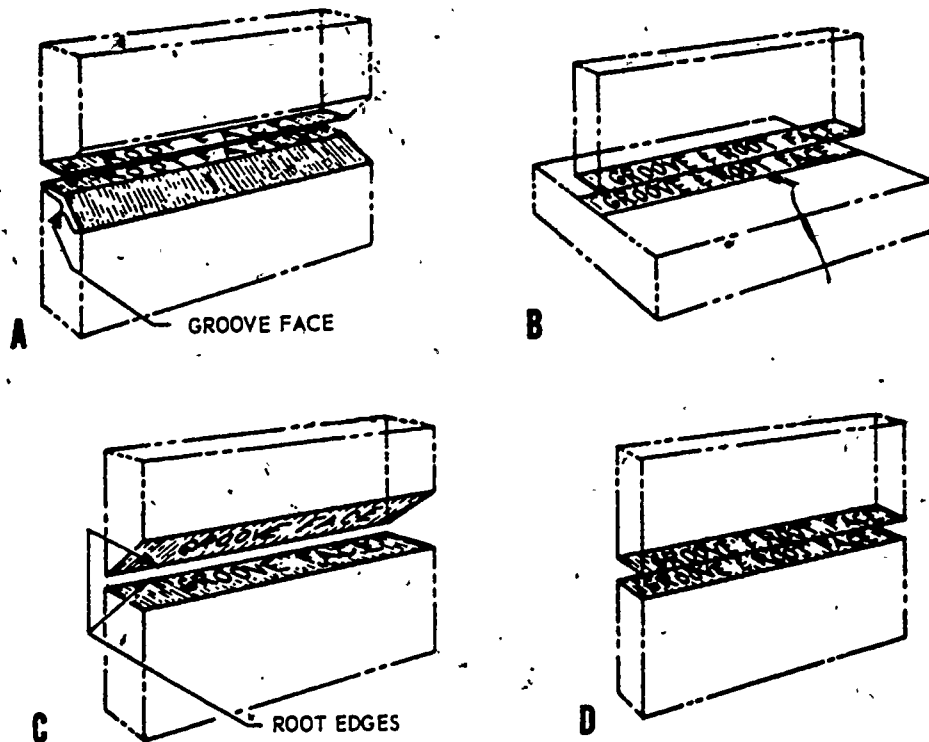

11.43

Figure 7-14.—The groove face, root face, and root edge of joints for welding.

designs are expressed in terms of bevel angle, groove angle, groove radius, and root opening. Here is a brief description of these terms, and each is illustrated in figure 7-15.

The **BEVEL ANGLE** is the angle formed between the prepared edge of a member and a plane perpendicular to the surface of the member.

The **GROOVE ANGLE** is the total included angle of the groove between the parts to be joined. For example, if the edge of each of two plates to be joined were beveled to an angle of  $30^\circ$ , the groove angle would be  $60^\circ$ .

The **GROOVE RADIUS** is the radius of a J- or U-groove. It exists only in special groove joint designs.

The **ROOT OPENING** refers to the separation between the members to be joined, at the root of the joint.

To determine the bevel angle, groove angle, and root opening for a joint you must consider the thickness of material to be welded, the kind of joint to be made, and the welding process to be employed. (As a rule, gas welding requires

a larger groove angle than manual metal arc welding.)

Root opening is usually governed by the diameter of the filler material which, in turn, depends on the thickness of the base metal and the position of welding.

Root penetration and joint penetration in groove welds are illustrated in figure 7-16. **ROOT PENETRATION** refers to the depth that a groove weld extends into the root of the joint. Root penetration is measured on the centerline of the root cross section. **JOINT PENETRATION** refers to the minimum depth that a groove (or a flange) weld extends from its face into a joint, exclusive of reinforcement. (Incidentally, this brings up another term, **REINFORCEMENT OF WELD**, which means weld metal in excess of the metal necessary for the specified weld size. (See fig. 7-17.)

As may be seen from figure 7-16, the terms "root penetration" and "joint penetration" often refer to the same dimension. This is the case in parts A, C, and E of the illustration. Part B, however, shows how a difference may exist

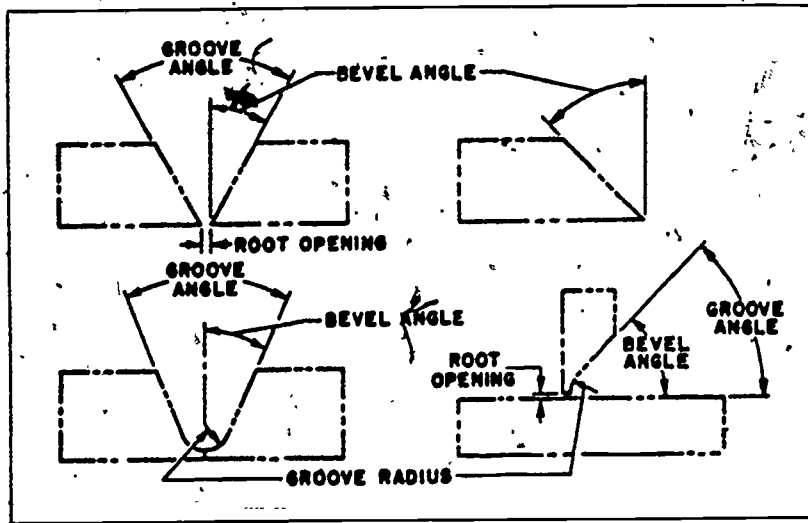

11.44  
 Figure 7-15.—The bevel angle, groove angle, groove radius, and root opening of joints for welding.

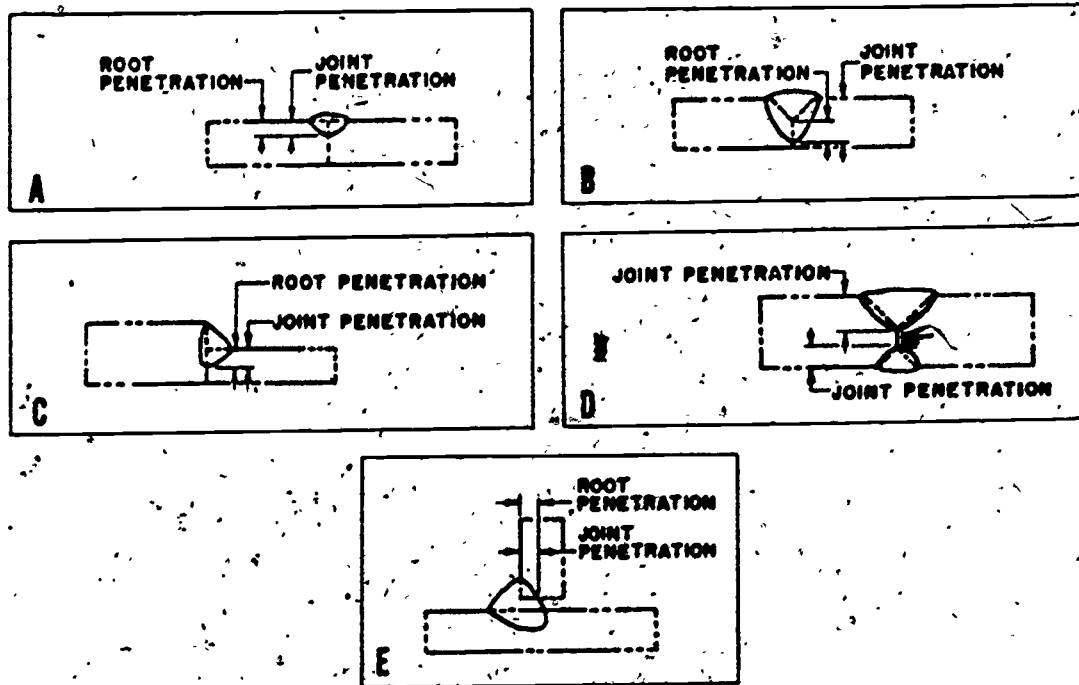

11.45  
 Figure 7-16:—Root penetration and joint penetration of groove welds.

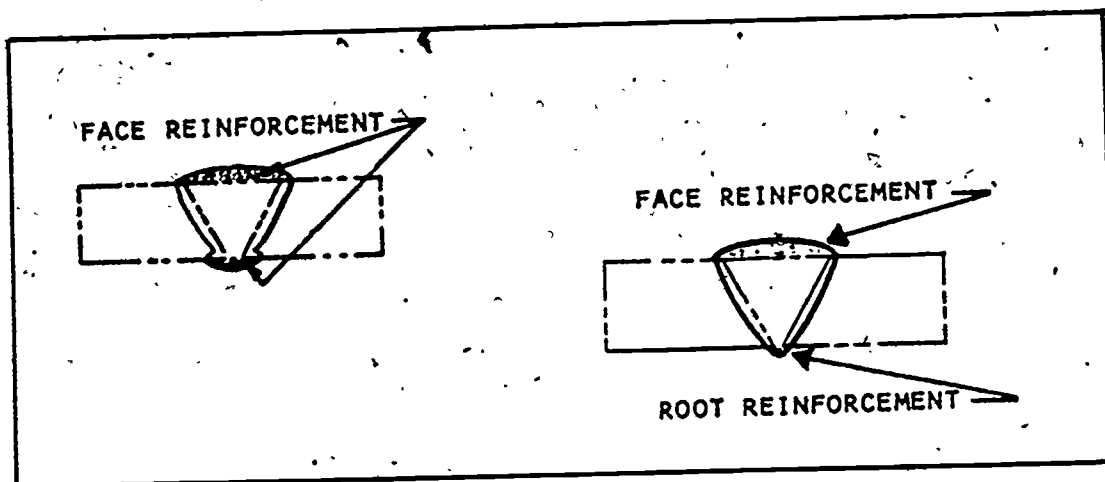

R127.154X

Figure 7-17.—Reinforcement of weld.

between root penetration and joint penetration. Part D shows joint penetration only.

#### WELDING POSITIONS

Welding is performed in different positions. In plate work, positions of welding are flat, horizontal, vertical, and overhead. Fillet or groove welds may be made in all of these positions.

In the **FLAT POSITION**, welding is performed from the upper side of the joint and the face of the weld is approximately horizontal. This is the case in the flat position of welding for both groove and fillet welds, as you note in figures 7-18 and 7-19. You may hear this position referred to as the "downhand position;" the preferred term, however, is "flat position."

When a **GROOVE WELD** is made in the **HORIZONTAL POSITION**, the axis of the weld lies in an approximately horizontal plane and the face of the weld lies in an approximately vertical plane (see fig. 7-18). Incidentally, the **AXIS OF A WELD** in the **HORIZONTAL POSITION** involves depositing filler metal on the upper side of an approximately horizontal surface and against an approximately vertical surface (see fig. 7-19). The face of a fillet weld lies in a plane approximately 45° to the surfaces of the parts joined.

When welding is performed in the **VERTICAL POSITION**, the axis of the weld is approximately vertical (see figs. 7-18 and 7-19). In the vertical position, weld metal is usually deposited in an upward direction.

In the **OVERHEAD POSITION**, welding is performed from the underside of the joint (see figs. 7-18 and 7-19). The axis of the weld is in a horizontal plane, as is the axis of a flat position weld; however, the overhead weld is, you might say, upside down if compared to the flat position weld.

The terms "flat," "horizontal," "vertical," and "overhead" adequately describe the positions in which plate is welded. This terminology, however, does not describe the position for welding pipe. In pipe welding, three positions are used; they are horizontal rolled position, horizontal fixed position, and vertical position. These terms refer to the position of the pipe, not to the weld.

In **HORIZONTAL ROLLED POSITION** welds, the axis of the pipe is approximately horizontal. The joint is made by welding in the flat position, at the same time rotating the pipe at a rate equal to the speed of filler metal deposition. Pipe welded in the horizontal rolled position is first carefully aligned and tack welded. Then it is placed in a jig which facilitates rotation of the pipe. In figure 7-20, note that all welding should be accomplished between points A and C.

The pipe axis in a **HORIZONTAL FIXED POSITION** weld is the same as in the horizontal rolled position weld. In this position, however, the pipe is not rotated during welding. As a consequence, welding must be accomplished by progression through the overhead, vertical, and flat welding positions. When welding in the horizontal fixed position (fig. 7-21), the weld is started at the bottom and progresses upward

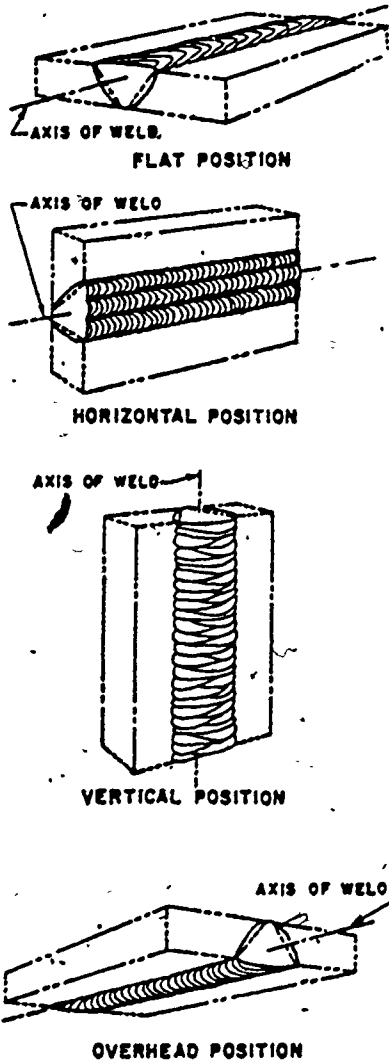

R127.155X  
Figure 7-18. — Positions of welding for groove welds.

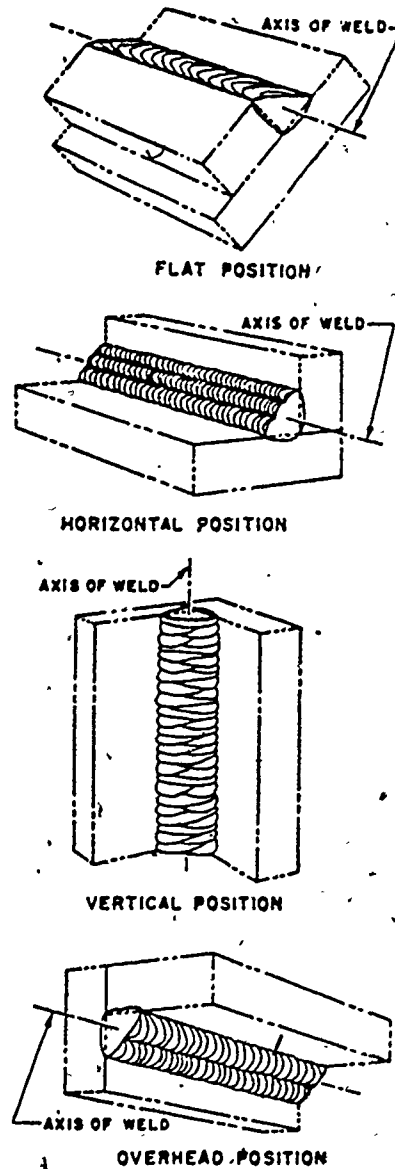

R127.156X  
Figure 7-19. — Positions of welding for fillet welds.

to the top of the pipe—first on one side, then on the other side.

In the VERTICAL POSITION, the pipe axis is vertical and the pipe may or may not be rotated. The weld itself is made in the horizontal welding position. (See fig. 7-22.)

**WELDING PROCEDURES AND DEPOSITION SEQUENCES**

Whether large or small, simple or complex, the manufacture of any object requires careful

planning. This is especially true when welding is employed to join parts into an integrated whole. One of the first decisions to be made regarding welding is the WELDING PROCESS to be used—that is, which of the processes is most applicable. But this is only the beginning. There are many details. Each must be worked out in such a way that the completed job serves the purpose

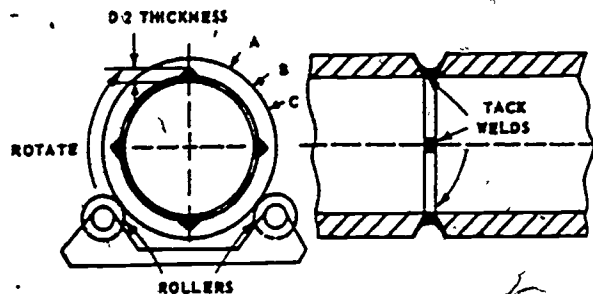

11.47.1  
Figure 7-20.—Horizontal rolled position.

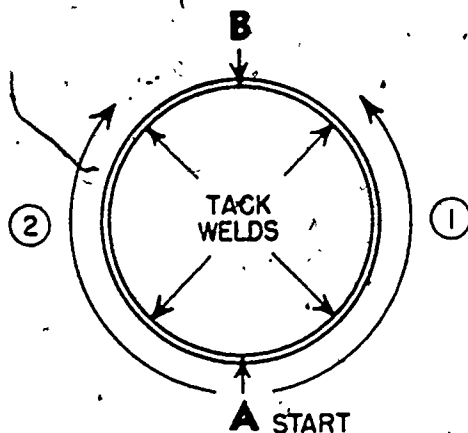

11.131  
Figure 7-21.—Horizontal fixed position.

for which it is intended. You, as a third class, are not expected to work out these details except for relatively simple jobs. While you are not responsible for planning, you are responsible for understanding the terms in which the plans are expressed. These terms are presented, insofar as possible, from the top down; that is, from the broad, inclusive terms to the less inclusive but more specific terms.

A single part of a structure consisting of several parts is called a **COMPONENT**. When a structure is made up of several components joined by welding, the structure is called a **WELDMENT**. Typical examples of weldments are storage and pressure tanks, frames, and fabricated pipe fittings (like crosses, tees, and elbows).

The detailed methods and practices including all joint welding procedures involved in the production of a weldment are known as the **WELDING**

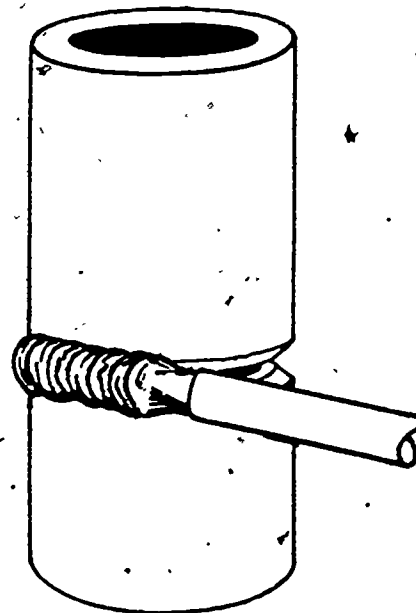

127.17.2  
Figure 7-22.—Vertical position.

**PROCEDURE.** The welding procedure includes the kinds of welding materials, joint design, pre-heat and postheat temperatures, the chronological order and manner in which a series of joints are to be welded, and the way individual welds in the series are to be made. The chronological order of making the various welds in the weldment is called the **WELDING SEQUENCE**. Thus, the welding procedure spells out all the details for producing a given weldment with a predetermined welding process.

An important part of the welding procedure is the **JOINT WELDING PROCEDURE**. This term refers to the details pertaining to the materials, methods, and practices used to make a particular joint in the weldment. Included in the joint welding procedure is **DEPOSITION SEQUENCE**, which applies to the order in which the weld metal in a given joint is to be deposited.

The deposition sequence may call for an intermittent weld or a continuous weld. There are two types of **INTERMITTENT WELDS**—chain intermittent and staggered intermittent. Both are fillet welds in which weld continuity is broken by recurring unwelded spaces. Both types are illustrated in figure 7-23. In chain intermittent fillet welding, the increments or parts of the weld are approximately opposite each other. In staggered intermittent fillet welding,



60

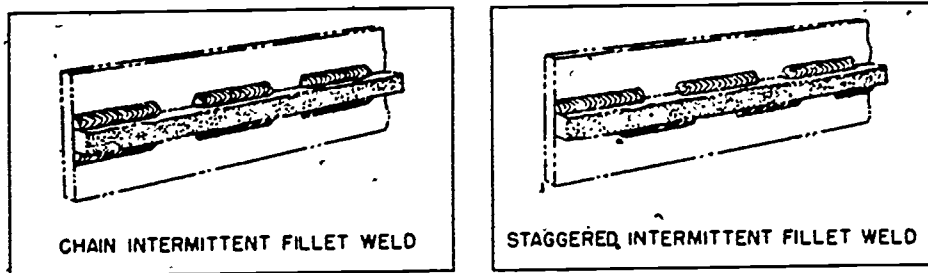

11.36.2  
Figure 7-23.—Intermittent fillet welds.

the weld increments are staggered with respect to each other on opposite sides of a tee joint.

A CONTINUOUS WELD is a weld which extends continuously from one end of a joint to the other. In other words, there are no unwelded portions in the joint as in an intermittent weld. Where the joint is essentially circular, it extends completely around the joint. Three sequences which are commonly used to produce a continuous weld are: the continuous sequence, the backstep sequence, and the wandering sequence. These are longitudinal sequences and involve only a single pass or weld bead. To avoid confusion, we should explain that LONGITUDINAL SEQUENCE specifies the order in which the various increments of the continuous weld are to be made with respect to the entire length of the joint. We might add, too, that a PASS is a single

longitudinal progression of a welding operation along a joint or weld deposit; the result of a pass is a weld bead.

You will probably find the CONTINUOUS SEQUENCE less difficult than the backstep or wandering sequence for producing a continuous weld. In a continuous sequence, welding begins at one end of the joint and proceeds continuously to the other.

The BACKSTEP SEQUENCE (illustrated in view A, fig. 7-24) is a longitudinal sequence which is used to prevent the accumulation of stresses and distortion. In this sequence the weld does not begin at the end of the joint. The weld is broken into short increments, which are deposited in a direction opposite to that in which the entire joint is made.

Usually the length of the increment is specified; if not, you can determine the proper weld

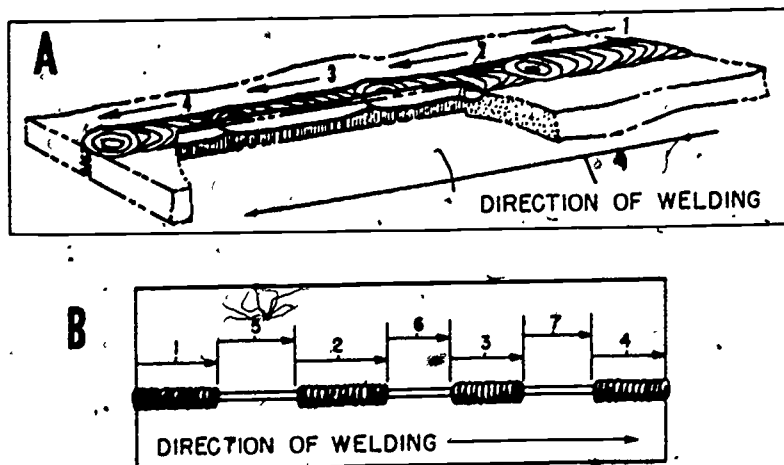

11.48  
Figure 7-24.—(A) Backstep sequence. (B) Wandering sequence.

length in this method for electric-arc welding. Select an electrode of the proper type and diameter, then using the same method to be used in welding the joint, run a practice bead on a piece of scrap metal the length of the electrode.

The length of the practice bead will be the length of the increment. For example, if your practice bead is 8 inches long you would start your first increment 8 inches from the edge of the plate; successive increments would start 8 inches away from the previous weld increment.

In oxyacetylene welding one of the ways you can use this sequence is to mark the increment lengths with a piece of soapstone or a few light center punch marks. For example, if you had a joint 80 inches long and you were going to weld 8-inch increments, you would measure off every 8 inches and mark it and weld the increments in the manner illustrated in figure 7-24, view A. Occasionally you will hear the backstep sequence referred to as the "stepback sequence;" note that the preferred term is "backstep sequence."

The WANDERING SEQUENCE combines some of the features of both the continuous and the backstep sequences (see view B, fig. 7-24). Weld increments are deposited in the same direction as the weld joint proper, as in a continuous sequence, but the order in which the weld increments are deposited is not progressive along the joint. Instead, gaps equal in length to that of the increment itself are left along the joint. Once the length of the joint has been welded in this manner, the weldor fills the gaps, thus producing a continuous weld. The order in which the parts of the weld are made may differ from that indicated in B of figure 7-24. Another order, such as 6-7-5-3-1-4-2, might be equally satisfactory. Thus, you can understand why the wandering sequence is often called the RANDOM or SKIP sequence. No matter which order is selected, the pattern must be predetermined. Increment length is determined in the manner described

for the backstep sequence. It is a good idea to lay out the joint increment lengths and number each portion according to the chronological order in which it is to be welded.

Thus far in our discussion of longitudinal sequences for making a continuous weld, we have considered only sequences in which a single pass or weld bead is concerned. The sequences we will consider next often consist of many passes and layers. It is important, therefore, that you understand the difference between a single-pass and a multiple-pass weld, and what makes up a layer.

A bead resulting from a single pass may be relatively narrow or relatively wide, depending upon the amount of transverse oscillation (backward and forward movement at approximately a right angle to the axis of the weld) used by the weldor. If there is a great deal of oscillation, the bead will be wide; if there is little or no oscillation, the bead will be narrow.

A LAYER is a stratum or horizontal portion of weld metal consisting of two or more beads. A groove weld may be made with multiple-pass layers, as illustrated in figure 7-25. As a rule, in manual operations, a multiple-pass layer is made with string beads (minimum oscillation). When a layer is made with multiple passes the weld itself consists of several layers, the number depending chiefly on the thickness of the metal in which the weld is made.

Figure 7-26 illustrates block sequence, build-up sequence, and cascade sequence. Note all of these sequences involve longitudinal sequence and multiple passes and layers.

A BLOCK SEQUENCE is a combined longitudinal and build-up sequence for a continuous multiple-pass weld wherein separated lengths are completely or partially built up in cross section before intervening lengths are deposited. (See view A, fig. 7-26.)

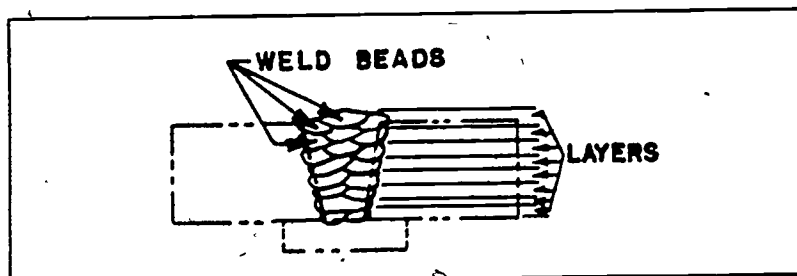

11.49  
Figure 7-25.—Multiple-pass layers.

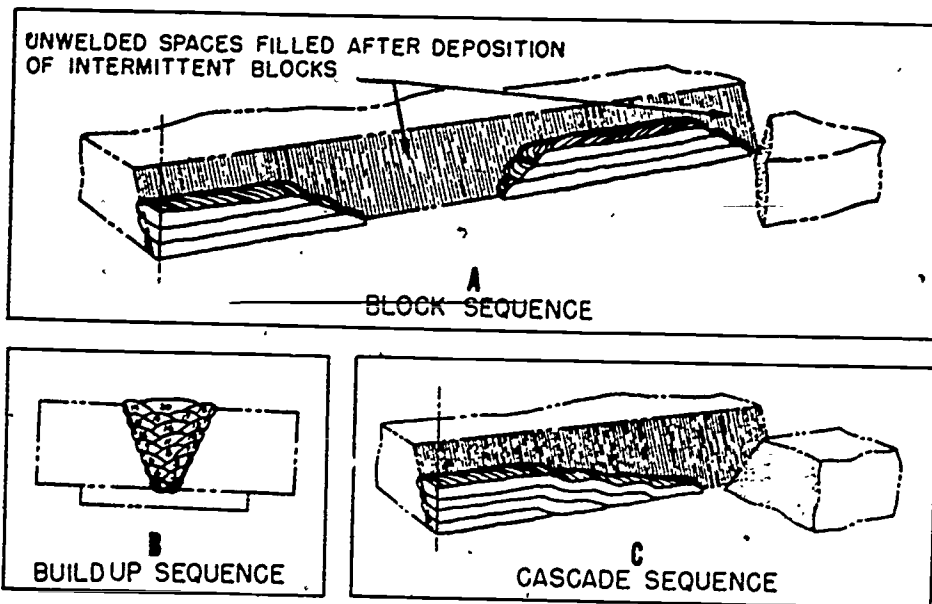

11.50  
Figure 7-26.—Block, build-up, and cascade sequences.

The meaning of the term **BUILD-UP SEQUENCE** is graphically illustrated in view B, figure 7-26. It refers to the order in which the weld beads of a multiple-pass weld are deposited with respect to the cross section of the joint. Thus, a build-up sequence is a part of any joint which requires layers of filler metal deposits to make the weld. Frequently, the instructions outlined in the welding procedure specify the interpass temperature; that is, the temperature of the previously deposited weld metal before the next pass is started.

A **CASCADE SEQUENCE** is a combined longitudinal and build-up sequence wherein weld beads are deposited in overlapping layers. (See view C, fig. 7-26.)

There are several variations of the block sequence. One variation is known as the **PROGRESSIVE BLOCK SEQUENCE**. Here, successive individual blocks of the continuous weld are completed progressively along the joint either from one end to the other or from the center of the joint toward either end.

Another variation is the **WANDERING BLOCK SEQUENCE**, in which successive blocks are completed at random after several starting blocks have been finished. There is also a variation called the **SELECTIVE BLOCK SEQUENCE**. In this sequence, successive blocks are completed

in a certain order so that a predetermined stress pattern is created within the joint.

#### WELD SYMBOLS AND WELDING SYMBOLS

Special symbols are used on drawings to show the kinds of welds to be used. These symbols have been standardized by the American Welding Society and the Department of Defense. The basic reference in this field for Navy welders is the Joint Army-Navy Standard for Welding Symbols, JAN-STD-19. Although there is no need for you to memorize all the welding symbols given in JAN-STD-19, you should be familiar with the basic weld symbols and with the standard location of all elements of a welding symbol.

The distinction between a weld symbol and a welding symbol should be noted. A **WELD SYMBOL** is a basic symbol used to indicate the type of weld. Thus, the basic symbols shown in figures 7-27 and 7-28 are weld symbols. The supplementary symbols shown in figure 7-29 are used when necessary in connection with the basic weld symbols.

An assembled **WELDING SYMBOL** consists of the following eight elements (or as many

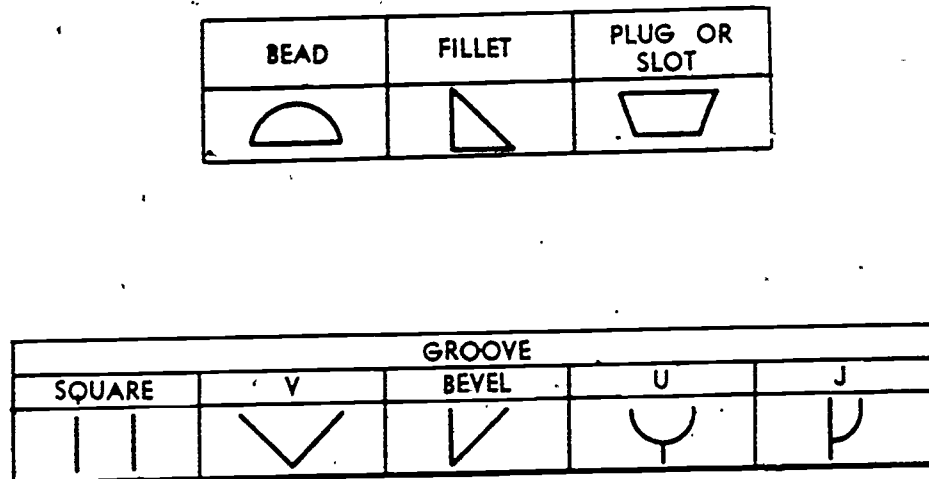

11.54

Figure 7-27.—Basic arc and gas weld symbols.

of these elements as are required): (1) reference line, (2) arrow, (3) basic weld symbols, (4) dimensions and other data, (5) supplementary symbols, (6) finish symbols, (7) tail, and (8) specification, process, or other reference. The finish symbols indicate the METHOD of finish, not the degree of finish; C is used to indicate finish by chipping, M indicates machining, and G indicates grinding.

The elements of a welding symbol have standard locations with respect to each other, as shown in figure 7-30.

### EXPANSION AND CONTRACTION

When a metal is heated, it expands appreciably in all its dimensions. On cooling, the metal decreases in size—or contracts.

The steel rails in a railroad track provide a familiar example of the effect of changes in temperature upon metal. In hot weather, for instance, a high temperature causes the rails to expand until the ends of all sections of the

rails are in contact. In cold weather, a low temperature causes the rails to contract until there is a sizeable gap between the ends.

The factors of expansion and contraction are always problems in welding. This is especially true when metals having different coefficients of expansion are joined. Unless the proper procedures are employed, the joint may crack immediately or it may subsequently fail in service because of the severe stresses developed during the uneven expansion and contraction of the dissimilar materials.

Incidentally, the term COEFFICIENT OF EXPANSION refers to the amount that a unit length of metal will increase in length if the temperature is raised 1° F.

Even when the weld joins identical metals, expansion and contraction may not be uniform throughout all parts of the metal. This non-uniformity leads to internal stresses, distortion, and warpage. Unless metal parts are free to move when heat is applied or withdrawn, expansion-contraction sets up high stresses which may cause difficulty in the weld itself or in the adjacent base metal.

STEELWORKER 3 & 2

| TYPE Q&E WELD |            |      |                |
|---------------|------------|------|----------------|
| SPOT          | PROJECTION | SEAM | FLASH OR UPSET |
| ✱             | X          | XXX  |                |

11.55  
Figure 7-28.— Basic resistance weld symbols.

| WELD ALL AROUND | FIELD WELD | CONTOUR |        |
|-----------------|------------|---------|--------|
|                 |            | FLUSH   | CONVEX |
| ○               | ●          | —       | ⤿      |

11.56  
Figure 7-29.— Supplementary weld symbols.

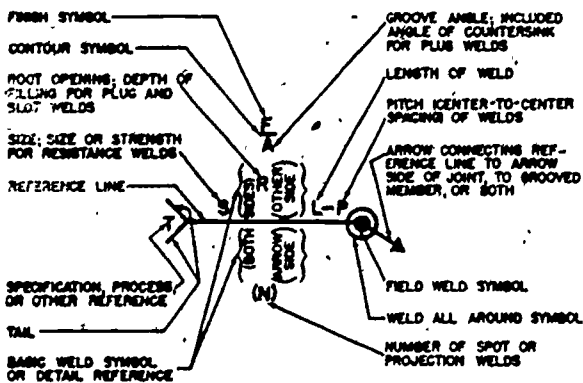

Figure 7-30.— Standard location of elements on a welding symbol. 11.57

In light gage metals, uneven expansion and contraction may cause the metal to warp. In heavy material, the stresses set up may exceed the ultimate strength of the metal and cause cracking in the weld or in the metal adjacent to the weld.

Thus, to make some metals weldable, the overall welding procedure must include, among other things, careful control of expansion and contraction, and the relief of residual stress.

Preheating can control to some extent the expansion and contraction in gray-iron castings. Both preheating and postheating are important in relieving internal stresses. Before welding small gray-iron castings, preheat them to a dull-red heat, visible in a darkened room. After they have been welded, reheating and slow cooling should serve to relieve stresses and

ensure the proper structure. Local preheating of the part next to the weld may be all that is required. For large castings, however, it may be necessary to construct a furnace of firebrick, covered with asbestos. The same method can be used on steel castings, or on castings to be bronze-welded, except that you will need less preheat.

Tack-welding sheet metal joints at short intervals is a good method of preventing distortion under welding. The joints can be aligned and then secured with angle irons or C-clamps; if necessary, special clamps and jigs can be made for a job.

The backstep sequence of welding is a method that is particularly useful in welding long joints. You may recall that the backstep sequence already has been discussed in this chapter and is illustrated in figure 7-24. In using this sequence, remember that the joint is welded one section at a time, and the direction of the individual welds is opposite to the general direction of the welding. In this way, the heat is directed onto the weld, and away from the open end of the joint. Each section is cleaned as you get ready to weld it.

Another method of preventing the metal from warping under the welding process is by using the wandering sequence of welding. This sequence also was discussed earlier and is illustrated in figure 7-24. In regard to this sequence, remember that instead of running a continuous bead from one end of the joint to the other, you weld separate sections, and then go back and fill in the gaps.

### WELDED JOINT DESIGN

You may recall that earlier in this chapter we discussed the five fundamental types of welded joint—butt, edge, tee, corner, and lap. It was also noted that, while there are many variations, every joint you weld will be one of these basic types. Now let us consider joint efficiency and some of the different designs for welded joints.

Before proceeding, note that in many joints the edges of the members are grooved. The purpose of grooving is to give the joint the required strength with the use of a minimum amount of filler metal. Standard groove designs include the square groove, bevel groove, V-groove, and U-groove. Depending upon the thickness of the material to be welded, the joint is single grooved (grooved on one side only)

or double grooved (grooved on both sides). Most materials up to 3/16 inch in thickness may be welded without grooving.

### JOINT EFFICIENCY

Joint efficiency is a term used to indicate the strength of a welded joint as compared with the strength of the unwelded base metal. If the welded joint is as strong as the unwelded base metal, the joint efficiency is 100 percent. If the welded joint is only half as strong as the unwelded base metal, the joint efficiency is 50 percent. Joint efficiencies are specified on the basis of the service for which the welded structure is intended, taking into account such factors as the type of loading that will occur and the nature of the stresses that may develop.

If the members of a joint have different strengths, the calculation of joint efficiency is based on the strength of the weaker member. In full-penetration welds where the weld metal matches the base metal in physical and chemical properties, joint efficiency is considered as 100 percent. If the properties of the weld metal are not the same as the properties of the base metal, the joint efficiency is based on the proportionate strength of the weld metal to the base metal. Joints welded from one side only, without backing strips, are rated as being not more than 80 percent efficient.

You will find charts useful in calculating the efficiencies of single- and double-fillet weld joints. Figure 7-31 shows such an efficiency chart for medium steel, for continuous double-fillet welded tee joints made with certain specified electrodes.

Study figure 7-31 and see how to use it. What information can you get from it? First of all, knowing the size of the steel to be welded, you can find out the size of the fillet weld that must be made IN THESE STEELS, WITH THE SPECIFIED ELECTRODES, in order to obtain a joint with the required efficiency.

Let's take an example. Suppose you are going to weld on medium steel that is 1/2 inch thick (20.4 pounds per square foot per indicated thickness). The job calls for a joint efficiency of 90 percent. Locate the vertical line that represents 90-percent efficiency and follow it up until it crosses the line representing the 1/2-inch, 20.4-pound plate. This intersection falls in a cross-hatched area that is bounded by two curved lines. For all intersections falling within this area, the weld size is indicated as

66

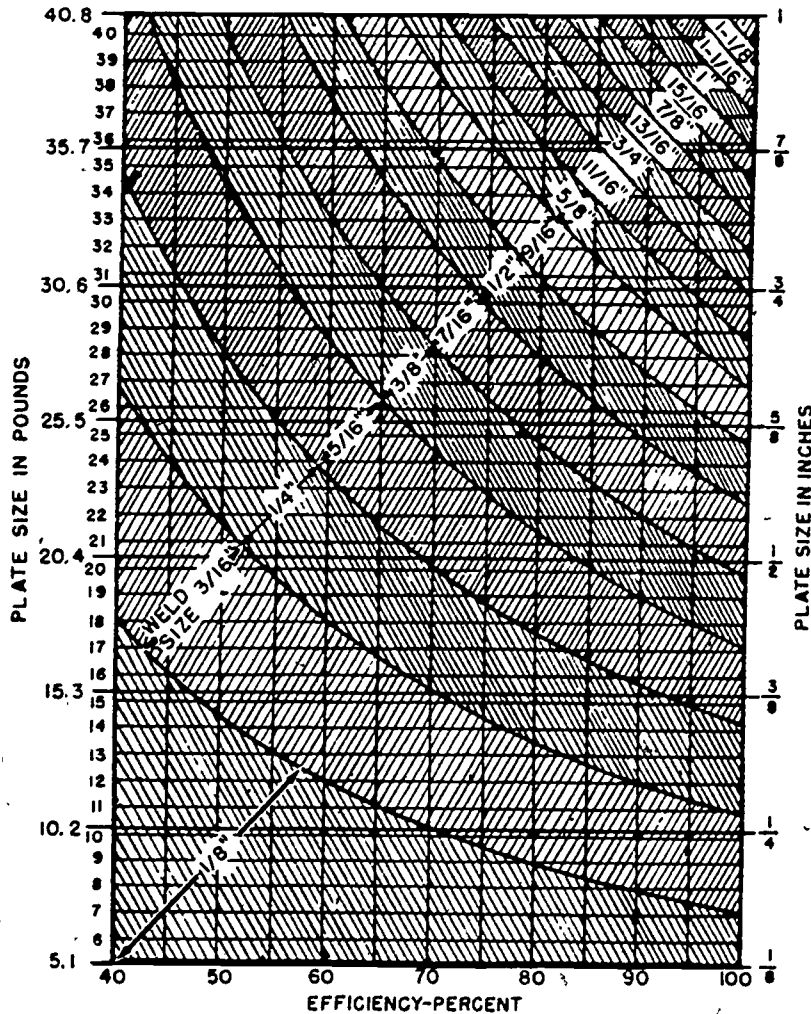

98.42

Figure 7-31.— Efficiency chart for continuous double-fillet tee joints welded with electrodes conforming to Specifications MIL-E-15599 and MIL-E-16715.

3/8 inch. Therefore, a weld of 3/8 inch is required in this particular case to obtain a double-fillet tee joint of 90-percent efficiency. For the same size medium steel, the weld size would have to be 7/16 inch thick to obtain a joint efficiency of 100 percent. If only 60-percent joint efficiency were required, the weld would only have to be 1/4 inch thick.

This chart is useful in another way, too. It shows you what joint efficiency is possible with a double-fillet weld of a certain size on plate of varying thickness. For example, look at the cross-hatched area in which the weld size is

given as 5/16 inch. By checking to see what intersections fall in this area, you can find that a double-fillet weld of 5/16 inch has 40-percent efficiency on 40-pound plate, 50-percent efficiency on 30-pound plate, 75-percent efficiency on 20-pound plate, and 100-percent efficiency on 15-pound plate.

#### STANDARD JOINT DESIGNS

The basic guide for the selection of welded joint designs is the Military Standard Welded-Joint Designs, MIL-STD-22A. This publication

covers joint design for manual and semiautomatic arc and gas welding processes. Structural joints, piping joints, and pressure vessel connections are included. Pressures, temperatures, and services are specified for piping and pressure vessel joint designs.

Many modifications of the basic types of welded joints are used in the production of weldments. MIL-STD-22A gives details for a number of butt joint designs, corner joint designs, lap joint designs, edge joint designs, and tee joint designs for structural work, piping, and pressure vessels.

As a rule, you will use only a few of the joint designs illustrated in MIL-STD-22A. Many of the designs are intended for metal thicknesses greater than those normally welded by shop personnel. However, you should be somewhat familiar with the joints described in this standard.

In studying MIL-STD-22A, note that certain joint designs may not be used when the root of the weld is subject to bending tension. Also, some designs are restricted to certain welding positions, while others may be used in all positions.

The following sections describe some of the more commonly used designs for welded joints. Further information on these and other joint designs may be obtained through study of MIL-STD-22A.

Note that standard weld and welding symbols are used on the drawings of welded joint designs. The identification of joint designs by letter and number (as B-1, C-19, etc.) is that established by MIL-STD-22A.

### Butt Joint Designs

In the structural butt joint designs shown in figure 7-32 the dimension T refers to metal thickness and the dimension Y refers to the MINIMUM size of root opening required.

Design B-1 may be used on metal thicknesses up to a maximum of 1/16 inch. No root opening is required in this design. The amount of weld reinforcement should be between 1/32 and 1/8 inch. This design must not be used when the root of the weld is subject to bending tension.

Designs B-2 and B-5 are welded from both sides. The two designs are the same except for dimension Y. Design B-2 requires no minimum root opening, but design B-5 requires a minimum root opening of one-half the thickness of the material. Design B-2 may be used for materials up to a maximum of 1/8 inch; design

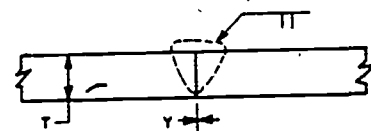

B-1 WELDED ONE SIDE

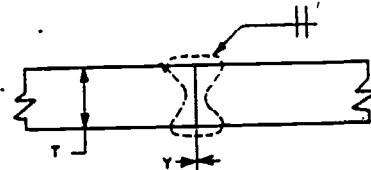

B-2, B-5 WELDED BOTH SIDES

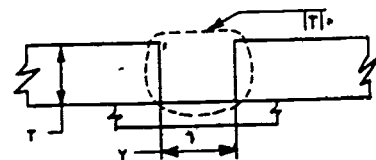

B-3 WELDED ON BACKING

98.43

Figure 7-32.—Butt joint designs B-1, B-2, B-3, and B-5.

B-5 may be used for materials up to a maximum of 3/16 inch.

Design B-3 incorporates a permanent backing strap. This design may be used for materials up to a maximum of 3/16 inch. The minimum root opening required for this design is T—that is, the thickness of the metal being joined.

Figure 7-33 shows the design of the backing strap used with joint design B-3. This backing strap design is also used with other single-grooved butt joint designs. Notice that the width of the strap is centered so that one-half the width is on each side of the centerline of the weld. The size (S) of the fillet weld is one-half the thickness of the thinner member, or 3/8 inch, whichever is less. The thickness of the backing strap and the width of the backing strap depend upon the thickness of the metal being welded. Minimum thicknesses and widths of backing straps for various sizes of plate are shown in table 7-1.

Some single-V butt joint designs are shown in figure 7-34. Design B-14 is welded from both sides. This design is suitable for all welding positions. It requires a minimum groove angle (X) of 60° and a minimum root opening (Y) of 1/8 inch.



STEELWORKER 3 & 2

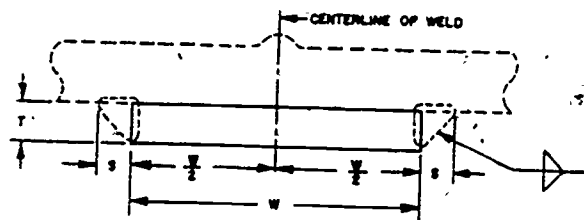

98.44

Figure 7-33.—Design of a permanent backing strap for use with single-grooved butt joints.

135.53

Table 7-1.—Minimum Thicknesses and Widths of Backing Straps for Various Sizes of Plate, Single-Grooved Butt Joints

| Plate Thickness (inch) | Minimum Thickness of Backing Strap (inch) | Minimum Width of Backing Strap (inches) |
|------------------------|---|---|
| 1/8                    | 1/8                                       | 1/2                                     |
| 3/16 thru 5/16         | 3/16                                      | 1                                       |
| 3/8 and over           | 1/4                                       | 1 1/2                                   |

Designs B-10, B-11, B-41, and B-46 are welded on backing. Design B-10 is suitable only for plate up to a maximum of 3/8 inch. Information on minimum groove angles (X), minimum root openings (Y), and suitable welding positions for these joint designs is given in table 7-2.

Designs B-31, shown in figure 7-35, is a double-V butt joint design that is suitable for all positions of welding. The groove angle (X) must be at least 1/8 inch. The root edge or root face may be from 0 to 1/16 inch.

The designs shown in figure 7-36 are for single-bevel butt joints. Designs B-17 is welded from both sides; designs B-15, B-18, and B-21 are welded on backing. The minimum groove angles, minimum root openings, and suitable welding positions for these joint designs are given in table 7-3.

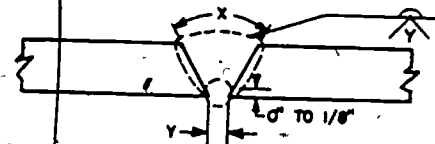

B-14 WELDED BOTH SIDES

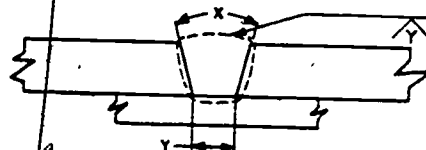

B-10, B-11, B-41, B-46 WELDED ON BACKING

98.45

Figure 7-34.—Single-V butt joint designs B-14, B-10, B-11, B-41, and B-46.

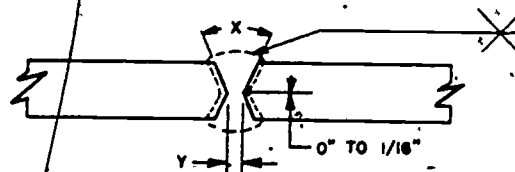

B-31 WELDED BOTH SIDES

98.46

Figure 7-35.—Double-V butt joint design B-31.

Design B-32, shown in figure 7-37, is a double-bevel butt joint design that is suitable for all welding positions. This design requires a minimum groove angle of 45° and a minimum root opening of 1/8 inch.

Corner Joint Designs

The corner joints that you are likely to use most frequently are described here. Other corner joint designs are given in MIL-STD-22A.

Two simple corner joints that require no edge preparation are shown in figure 7-38. Design C-1 may be used on metal thicknesses up to a maximum of 1/8 inch. The root opening must be at least as wide as the thickness of the thinner member. This joint must not be used when the root of the weld is subject to bending tension. Design C-2 may be used where the thickness of the thinner member does not exceed 3/16 inch. For this design, the root opening

135.54

Table 7-2.— Minimum Groove Angles (X), Minimum Root Openings (Y), and Suitable Welding Positions for Joint Designs B-10, B-11, B-41, and B-46

| Joint | Minimum Groove Angle, X (°) | Minimum Root Opening, Y (inch) | Suitable Welding Positions |
|-------|-----------------------------|--------------------------------|----------------------------|
| B-10  | 60                          | 1/8                            | All                        |
| B-11  | 45                          | 1/4                            | All                        |
| B-41  | 20                          | 1/2                            | Flat, vertical, overhead   |
| B-46  | 12                          | 1/2                            | Flat                       |

135.55

Table 7-3.— Minimum Groove Angles (X), Minimum Root Openings (Y), and Suitable Welding Positions for Joint Designs B-17, B-15, B-18, and B-21

| Joint | Minimum Groove Angle, X (°) | Minimum Root Opening, Y (inch) | Suitable Welding Positions |
|-------|-----------------------------|--------------------------------|----------------------------|
| B-17  | 45                          | 1/8                            | All                        |
| B-15  | 45                          | 1/4                            | All                        |
| B-21  | 35                          | 3/8                            | All                        |
| B-18  | 25                          | 3/8                            | Flat, vertical, overhead   |

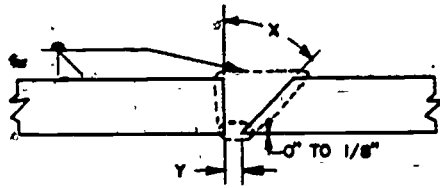

B-17 WELDED BOTH SIDES

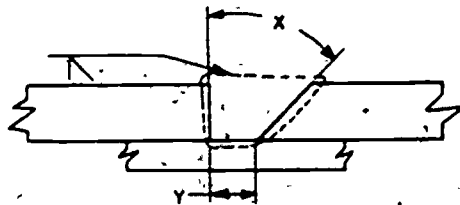

B-15, B-18, B-21 WELDED ON BACKING

Figure 7-36.— Single-bevel butt joint designs B-17, B-15, B-18, and B-21. 98.47

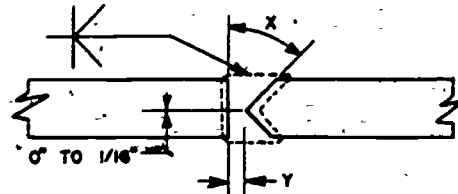

B-32 WELDED BOTH SIDES

Figure 7-37.— Double-bevel butt joint design B-32. 98.48

must be at least one-half the thickness of the thinner member. The size of the fillet (S) is governed by the joint efficiency requirements.

Figure 7-39 shows two other corner joints that do not require edge preparation. Design C-20 for an outside single-fillet welded corner joint, must not be used when the root of the weld is subject to bending tension. Design C-21 is a

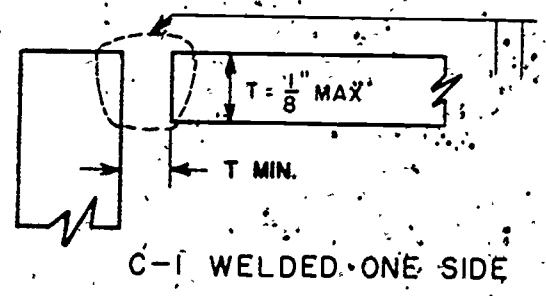

C-1 WELDED ONE SIDE

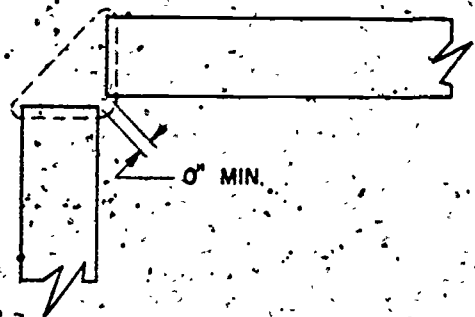

C-20 OUTSIDE SINGLE FILLET

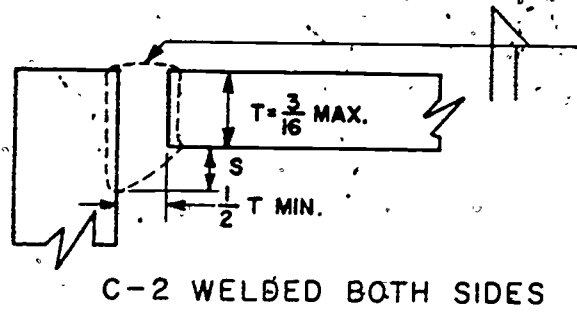

C-2 WELDED BOTH SIDES

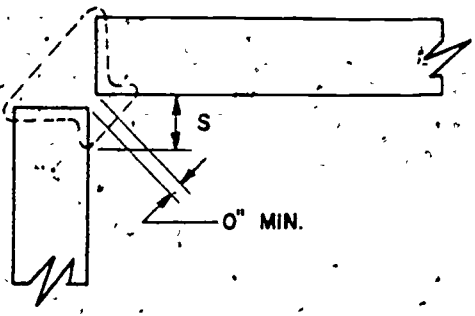

C-21 DOUBLE FILLET

98.49

Figure 7-38. — Designs C-1 and C-2 for open square corner joints.

98.50

Figure 7-39. — Fillet welded corner joint designs C-20 and C-21.

double-fillet welded corner joint. In both designs, the size of the fillet weld is determined by the requirements of joint efficiency.

The fillet reinforced, outside single-bevel corner joints C-15 and C-15A, shown in figure 7-40, differ with respect to which member of the joint is beveled. In both designs, the groove angle must be at least 45° and the root opening must be at least 1/8 inch. For joint C-15, the horizontal member is beveled; this design may have a root edge or root face of from 0 to 1/8 inch. Design C-15A is used when the vertical member is thicker than the horizontal member; in this design, at least 3/16 inch of the original plate thickness must remain after the edge has been beveled.

When the location of the joint is a bottom corner, the inside single-bevel joint illustrated in figure 7-41 is used. This design, C-19, has a reinforcing fillet on the inside. Minimum groove angle for this design is 45°, and minimum root opening is 1/8 inch.

Designs C-11 and C-12, shown in figure 7-42, are signal-V corner joint designs. Design C-11 is welded only from the outside; design C-12 has an additional inside fillet reinforcement. For both designs, the minimum groove angle is 60°

and the minimum root opening is 1/8 inch. Both designs require a minimum of 3/16 inch of the original plate thickness to be left after the vertical member is beveled. Design C-11 must not be used when the root of the weld is subject to bending tension.

Design C-32, shown in figure 7-43, is frequently used for corner joints when the thickness of the material is greater than 3/4 inch. For material thicknesses of more than 1 1/2 inches, a double-U edge preparation is necessary.

Tee Joint Designs

Designs T-1, T-2, and T-3, shown in figure 7-44, are tee joint designs that require no edge preparation.

Design T-1 requires no space between the edge of one member and the surface of the other (dimension A, in fig. 7-44). However, a space up to 1/8 inch may be used when both surfaces are straight and a space up to 3/16 inch may be



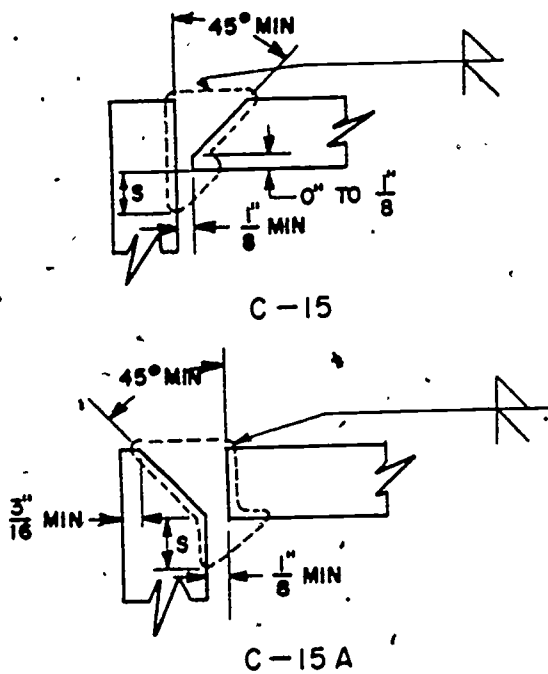

C-15

C-15A

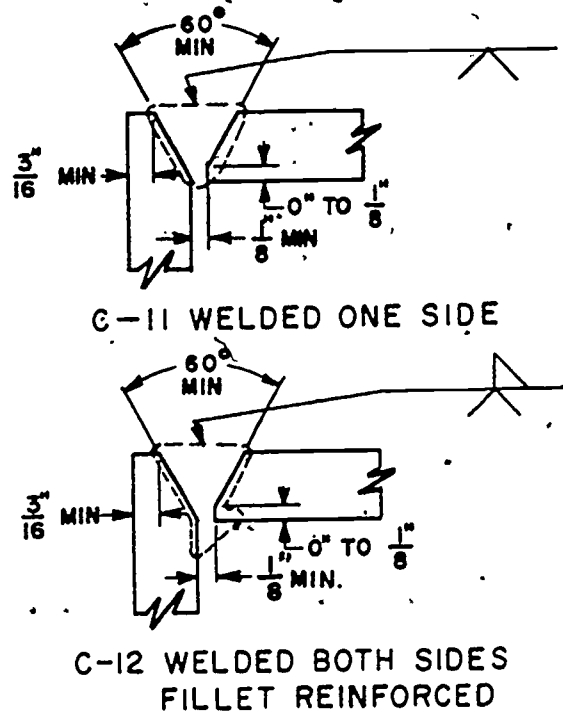

C-11 WELDED ONE SIDE

C-12 WELDED BOTH SIDES  
FILLET REINFORCED

98.51  
Figure 7-40.—Designs C-15 and C-15A for fillet reinforced, outside single-bevel corner joints.

98.53  
Figure 7-42.—Designs C-11 and C-12 for single-V corner joints.

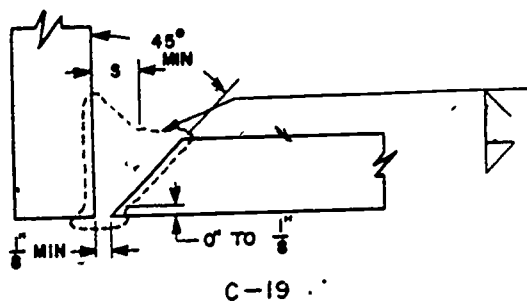

C-19

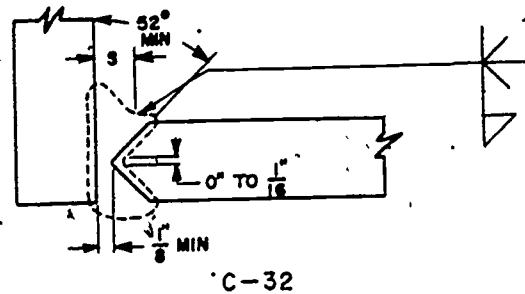

C-32

98.52  
Figure 7-41.—Design C-19 for fillet reinforced, inside single-bevel corner joint (welded both sides).

98.54  
Figure 7-43.—Design C-32 for fillet reinforced double-bevel corner joint.

used when one of the surfaces is curved. Where A is greater than 1/16 inch, S will equal the size governed by design requirements plus A.

Let's take an example to illustrate this point. Suppose you are required to weld a tee joint in 1/2-inch (20.4-pound) medium steel plate. One of the surfaces is curved. The specifications

require the joint to be 100 percent efficient. You are going to use an electrode conforming to MIL-E-15599, type 6011, class 1. Dimension A is specified as 1/8 inch. Taking all this information into account, what size fillet weld will be required?

To find the size of fillet required, you must go back to the efficiency chart shown in figure

STEELWORKER 3 & 2

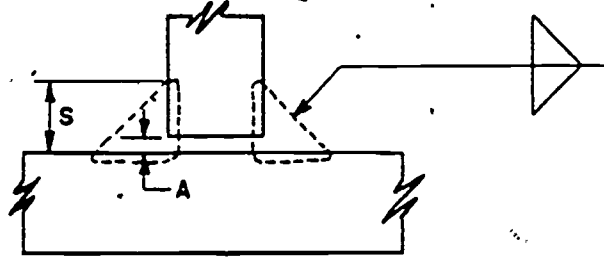

A=0" TO 1/8" FOR STRAIGHT SURFACES AND 0" TO 3/16" FOR CURVED SURFACES.

T-1 DOUBLE FILLET

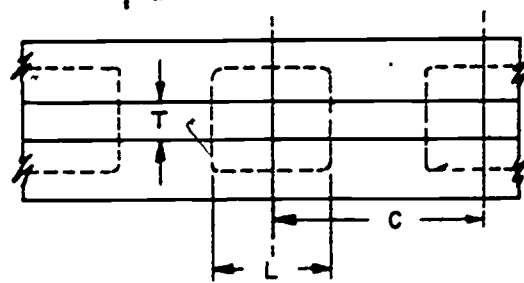

S = T MAX.

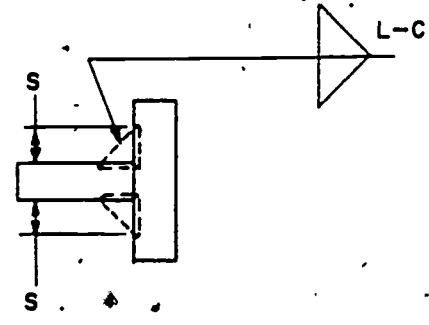

T-2 CHAIN INTERMITTENT

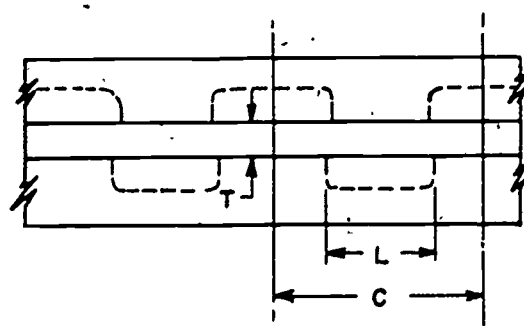

S = T MAX.

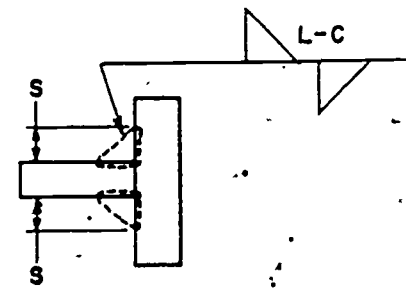

T-3 STAGGERED INTERMITTENT

Figure 7-44.— Tee joint designs requiring no edge preparation (T-1, T-2, and T-3). 98.55



7-31. This chart gives joint efficiencies of various sizes of continuous double-fillet welded tee joints, when the welding is done with electrodes conforming to Specifications MIL-E-15599 and MIL-E-16715. Looking at this chart, you will find that a 7/16-inch fillet is necessary to obtain a joint efficiency of 100 percent. In this particular example, however, dimension A is greater than 1/16 inch. Consequently, the value of A must be added to S to obtain the final size of the fillet. In this example, then, fillet size is 7/16 PLUS 1/8, or 9/16 inch.

Chain intermittent joint T-2 and staggered intermittent joint T-3 are modifications of design T-1. As may be seen in figure 7-44, the size of the fillet weld (S) is equal to the maximum thickness (T) of the plate. The length (L) of the fillet is specified in terms of minimum and maximum length. The minimum length must be 8 times S, but in no case less than 1-1/2 inches; the maximum length is 16 times the thickness (T) of the thinner member, but in no case more than 6 inches. The maximum spacing from center to center of the intermittent increment (C) is 16 times the thickness of the thinner member, but in no case more than 12 inches.

A single-bevel tee joint design, T-14, is illustrated in figure 7-45. As may be seen, this joint is welded from both sides and has a reinforcing fillet. The design calls for a minimum groove angle of 45° and a minimum root opening of 1/8 inch. The root edge or root face may be from 0 to 1/8 inch.

Figure 7-46 shows a double-bevel tee joint design, T-32, that is used for metal thicknesses of more than 3/4 inch. The design requires a minimum bevel angle of 52° and a minimum root opening of 1/8 inch.

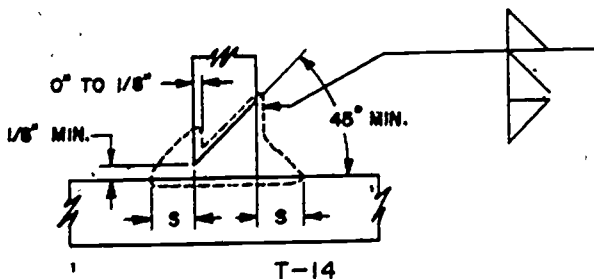

98.56

Figure 7-45.—Design T-14 for single-bevel tee joint.

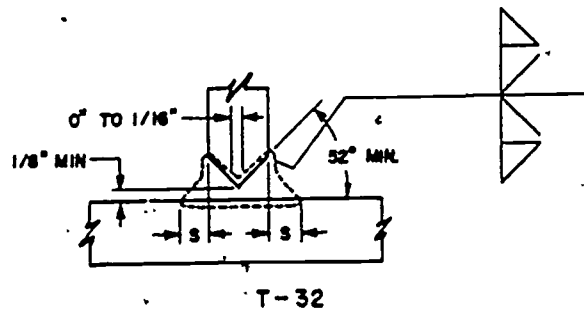

98.57

Figure 7-46.—Design T-32 for double-bevel tee joint.

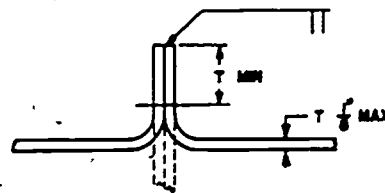

E-1 SQUARE GROOVE

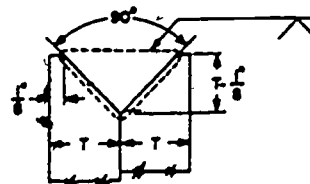

E-11 SINGLE-V

98.58

Figure 7-47.—Designs E-1 and E-11 for edge joints.

#### Edge Joint Designs

Edge joint designs are seldom used in plate work but are used extensively in sheet metal work. Two edge joint designs are illustrated in figure 7-47. The square-grooved edge joint, design E-1; may be used for metal thicknesses up to a maximum of 1/8 inch. For material over 1/8 inch thick, the single-V edge joint, design E-11, is often used. Design E-11 requires a groove angle of 90°. Note that the depth of the V is related to the thickness of the material. If metal thickness (T) is 1/2 inch, then the depth of the V is 3/8 inch—in other words, the depth of the V is always T minus 1/8 inch.

STEELWORKER 3 & 2

Edge joints are not used when the root of the weld is subject to bending tension.

Lap Joint Designs

Three variations of the double-fillet welded lap joint are shown in figure 7-48. Design L-1 is a plain lap joint; designs L-2 and L-3 are offset lap joints. These designs are identical except for the differences arising from the variations of the plates with respect to an axial plane.

The designs shown in figure 7-48 are not used when the root of the weld is subject to bending tension. It is not necessary for the two members to be of the same thickness. In all three designs, the amount of overlap must be at least five times the thickness of the thinner member.

Designs for plug welded and slot welded lap joints are shown in figure 7-49. Design L-11 requires a minimum groove angle of 45°. The diameter of the plug varies with the thickness of the material. When the thickness (T) is 1/8 inch or less, the diameter of the plug must be

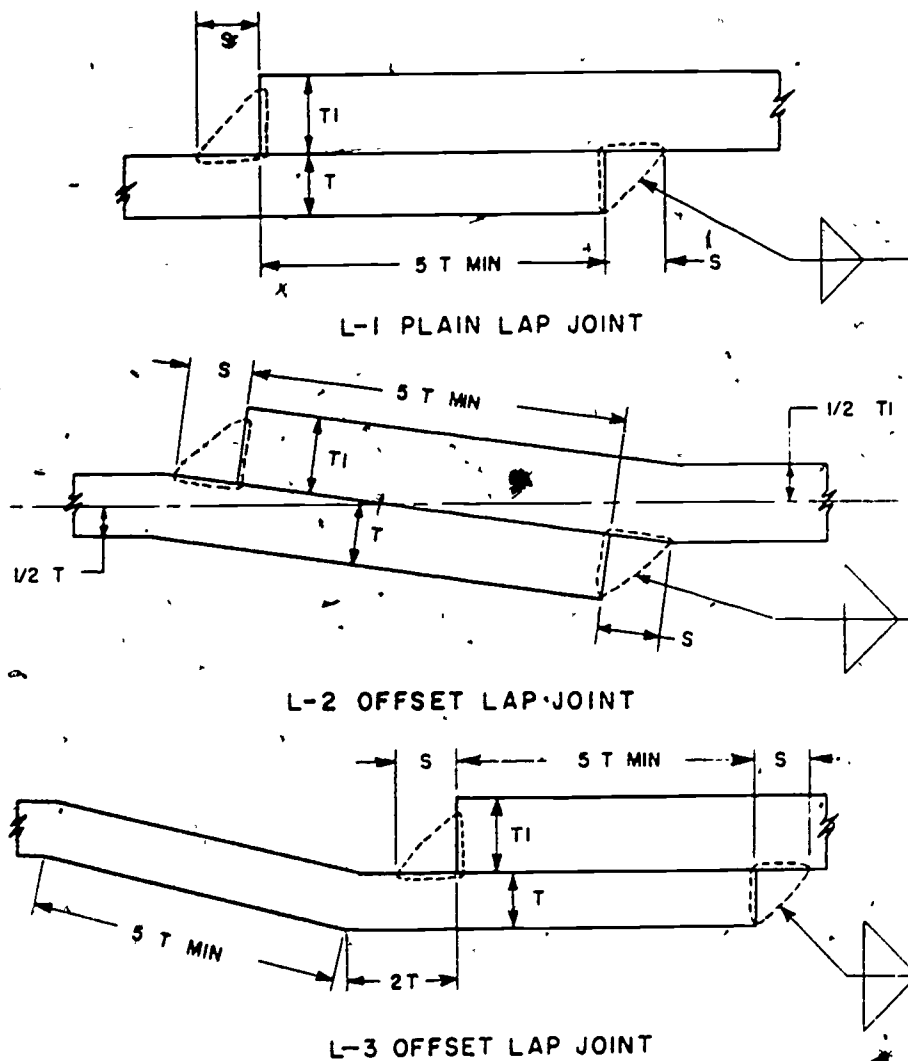

98.59

Figure 7-48.— Designs L-1, L-2, and L-3 for double-fillet welded lap joints.

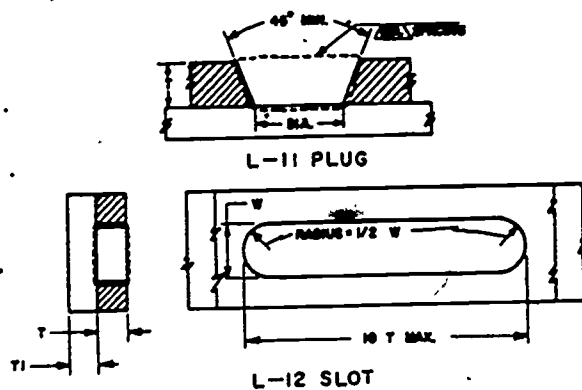

98.60

Figure 7-49.— Plug welded lap joint (L-11) and slot welded lap joint (L-12).

at least 1/4 inch. When  $T$  is 1/8 to 1/2 inch, the diameter of the plug must be at least twice the thickness of the material. For plate over 1/2 inch thick, the diameter of the plug must be equal to the thickness of the plate PLUS 1/2 inch. For example, if the plate thickness is 3/4 inch, the plug diameter would be 1-1/4 inches.

For relatively thick materials, slot welded lap joint designs are generally used instead of plug welded lap joint designs. In design L-12, shown in figure 7-49, the slot is entirely filled with filler metal. Other slot welded lap joint designs (not shown) include L-13, in which the slot is fillet welded, and L-14, in which the slot is beveled to a 45° included angle and entirely filled with weld metal. In all of these slot welded lap joint designs, the length of the slot is at least 10 times the thickness of the metal in which the slot is made. The width of the slot ( $W$ ) depends upon the thickness of the metal; the slot radius is in all cases one-half the slot width.

Lap joint designs—whether fillet welded, plug welded, or slot welded—must not be used in any case where a standard butt joint design could be used instead.

#### Pipe Joint Designs

The selection of a joint design for welded piping involves consideration of several factors, including the size of the piping, the operating pressure of the system, the operating temperature of the system, and the nature of the fluid carried by the system.

Note that the designation  $P$  for a pipe joint design (as  $P-1$ ,  $P-43$ , etc.) refers to the JOINT DESIGN, not to the piping system. There is no relationship between the designation of these pipe joint designs and the  $P-1$ ,  $P-2$ , and  $P-3$  piping system designations.

The pipe joint designs discussed here are the more or less basic designs for pipe work. Many other designs are given in MIL-STD-22A.

Figure 7-50 illustrates several typical designs for welded joints in piping. The simplest design is  $P-1$ , a square butt joint design. This design is suitable for any size of pipe in which the pressure is 50 psi or less and the temperature 212° F or less. It may be used for all services, including salt water and other corrosive fluids, provided the inside of the pipe is inspected and complete weld penetration is ensured.

Design  $P-2$ , a fillet welded slip-on butt joint design, is suitable for all services except salt water or other corrosive fluids. The pressure is limited to 150 psi for pipe sizes of more than 2 inches; for pipe sizes of 2 inches and less, there is no pressure limitation. Temperature is limited to 212° F in pipe sizes of more than 2 inches. There is no temperature limitation for pipe sizes of 2 inches or less.

The design details of a  $P-2$  joint are keyed to the size of the pipe. Sleeve thickness is from 1-1/4 to 1-1/2 times the wall thickness of the pipe. Sleeve length ( $L$ ) depends upon the pipe diameter. As indicated in figure 7-50, the cross section of the fillet welds is equal to the thickness of the pipe wall on the leg adjacent to the sleeve and to twice the thickness of the pipe wall on the leg adjacent to the pipe surface.

The V-groove butt joint design,  $P-3$ , is suitable for pressures of 150 psi and below and for temperatures of 212° F and below. It may be used for all services, including salt water and other corrosive fluids, when the inside of the pipe is inspected and complete weld penetration is ensured. Wall thickness must be at least 5/32 inch for this design.

Design  $P-4$  is a V-groove butt joint welded on a plain backing ring. This joint design may be used in all types of systems, at any pressure and any temperature. The size of the root opening varies according to the pipe size. A root opening of at least 1/4 inch is required on root sizes of more than 3 inches; on pipe sizes of 3 inches or less, the minimum root opening is 3/16 inch. Backing rings are available in all



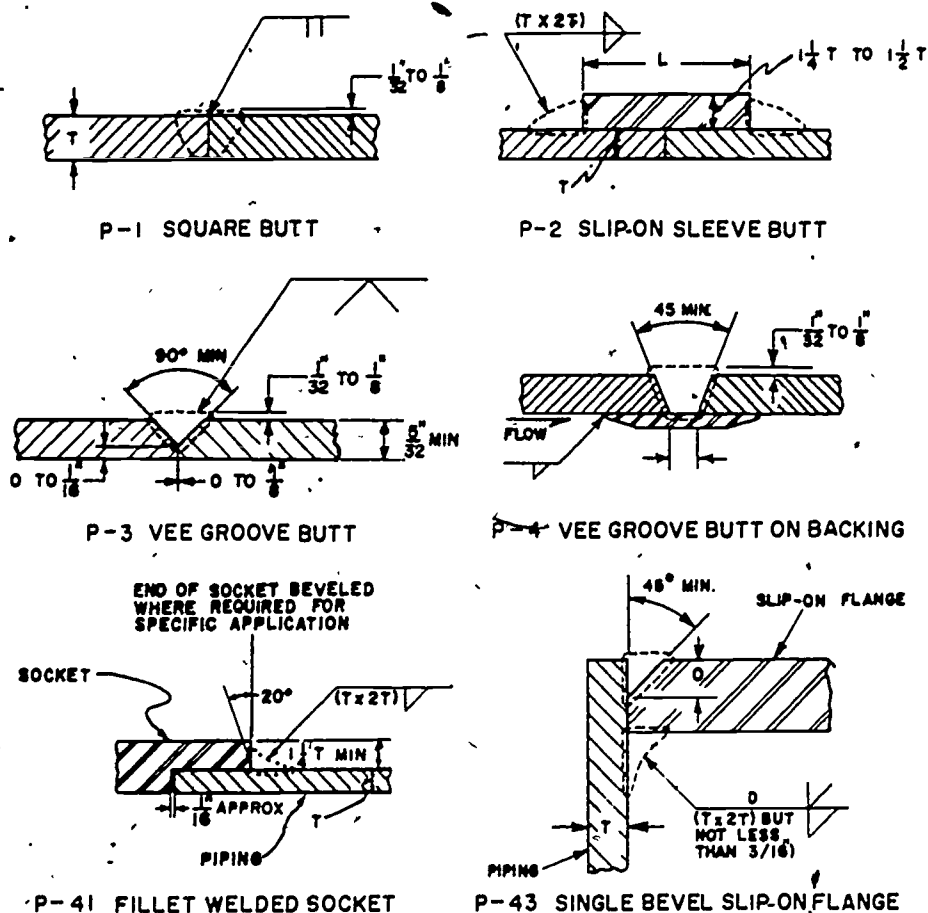

98.61

Figure 7-50.— Typical welded joint designs for piping.

nominal pipe sizes. If it is necessary to manufacture a backing ring, the design of the ring must be in accordance with MIL-STD-22A.

Design P-41 is a fillet welded socket joint that may be used in all services except salt water or other corrosive fluids. For pipe sizes over 2 inches, the pressure may not exceed 150 psi where this design is used; for pipe sizes of 2 inches and smaller, there is no pressure limitation. Temperature limitations for this design are rather complicated. For pipe sizes over 2 inches, the maximum temperature is 212° F. For pipe sizes of 2 inches and less, there is no general temperature limitation; however, if the temperature exceeds 875° F, or if austenitic stainless steels are used, the joint design must not be used for pipe sizes of more than 1 inch.

Design P-43 is for a single-bevel, fillet reinforced, welded slip-on flange. This design has a number of applications in systems operating at 150 psi or less and 650° F or less. The bevel on the flange is always at least 45° in this design. Dimension D varies with the pipe size and with the weight of the flange material. Detailed information on dimensions is given in MIL-STD-22A.

A single-bevel, fillet reinforced design for a root connection is shown in figure 7-51. This design, P-62, is not used on pipe less than 5/32 inch in wall thickness. This design is suitable for pressures of 150 psi and below and for temperatures of 212° F and below. It may be used for all services, including salt water and other corrosive fluids, providing the inside of the pipe

77

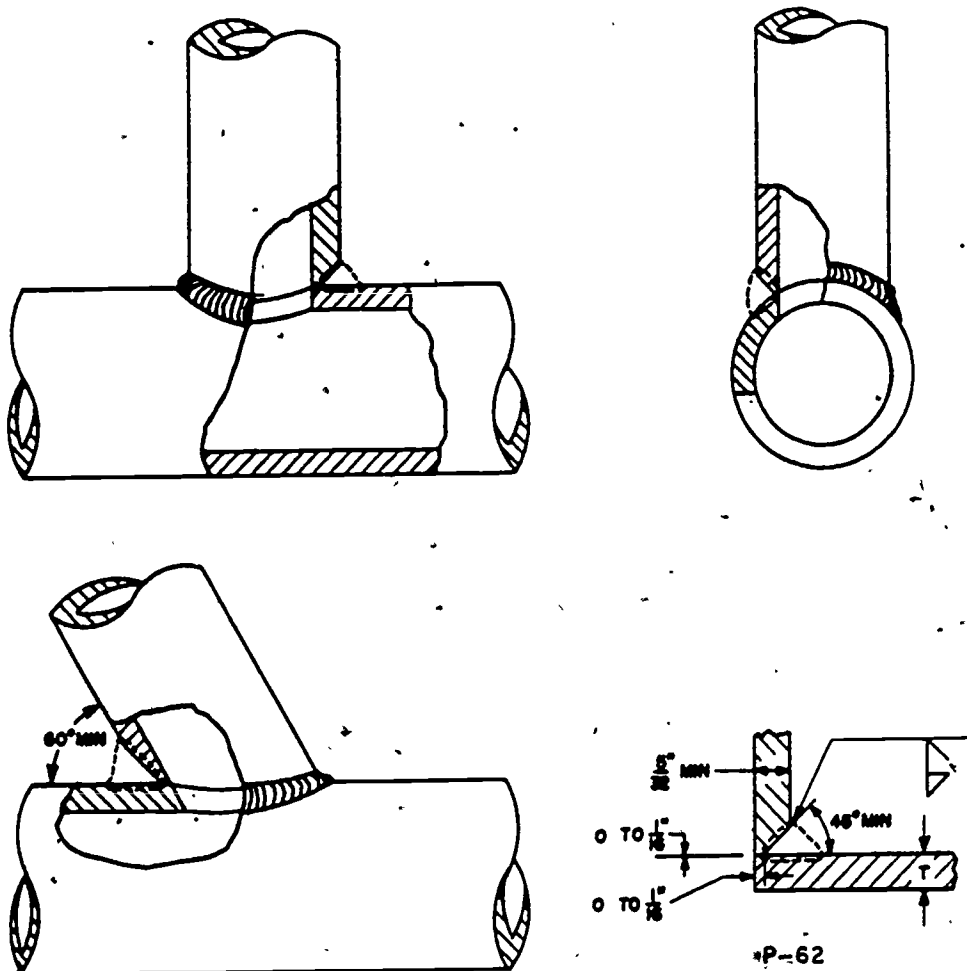

Figure 7-51.—Single-bevel, fillet reinforced root connection, welded on one side (design P-62.) 98.62

is inspected and complete weld penetration is ensured.

**Pressure Vessel Joint Designs**

The term **PRESSURE VESSELS** is used to include all drums, turbine casings, tanks, or closed receptacles subjected to internal pressure at normal or at elevated temperatures and all feed tanks and lubricating oil storage tanks not subjected to any pressure or vacuum other than the static head of the contained liquid. Pressure vessels are classified as being **FIRE**D or **UNFIRE**D, and are further divided into several classes on the basis of operating pressure, operating temperature, and the nature of the contained fluid.

Welded joints for pressure vessels must have joint efficiency of 100 percent. All joints must be designed either to permit welding from both sides or to include the use of backing rings, so that complete weld penetration can be ensured. For pressure vessels containing flammable or lethal substances, welded joints involving tightness must be made with multiple layers of weld metal. Various designs for pressure vessels are given in MIL-STD-22A.

**WELDING DIFFICULTIES**

This section will brief you on some of the common welding troubles that the inexperienced

welder may encounter. Defects discussed include spatter, undercut, overlap, cracks, incomplete fusion, incomplete penetration, gas pockets, porosity, and brittle welds.

**SPATTER** is the term used to describe metal particles or globules that are expelled during welding and that do not form part of the weld. When spatter occurs, small balls of metal are stuck to the surface of the base metal along the line of weld. (See fig. 7-52.)

An **UNDERCUT** is a groove melted into the base metal adjacent to the toe or root of the weld and left unfilled by weld metal. (See fig. 7-53.) In electric-arc welding, this condition is caused by excessive welding current or improper manipulation of the electrode. It also can be caused by attempting to weld in a position for which the electrode is not designed.

In gas welding, undercutting is caused by too much torch oscillation, not enough filler metal added to the molten puddle, or a tip size that is too large.

To avoid undercutting, use proper welding techniques, correct size electrode, correct tip size, and filler material.

An **OVERLAP**—a first cousin of the undercut—is a protrusion of weld metal beyond the toe or root of the weld (Fig. 7-53). This condition

is caused by a set of circumstances the opposite of those mentioned as the cause of undercutting. It can be avoided by employing a larger tip size, a smaller rod, or faster welding speed. Both defects (undercutting and overlapping) are usually accompanied by weld deposits that have varying widths and reinforcement crowns.

A welded joint may be defective because it has any one of several kinds of cracks. Conditions which lead to cracked welds, to mention a few, include: (1) welds too small for the parts being joined; (2) rigid joints; (3) wrong filler material; and (4) poor welding techniques.

One of the more common kinds of crack is the **CRATER CRACK**; that is, a crack in the crater of a weld bead. We might add that, in arc welding, a **CRATER** is a depression at the termination of a weld bead or in the weld pool beneath the electrode. A good way to avoid a crater crack is not to leave any crater. When you are terminating a weld, no crater will be left if you weld back over the crater to fill it up.

A **TOE CRACK**, as illustrated in figure 7-54, is a crack in the base metal occurring at the toe of the weld. A similar defect is the **ROOT CRACK**. Here the crack may be in the weld or on the heat-affected zone. In either case, the crack occurs at the root of the weld. Root, toe, and crater cracks are readily detected by

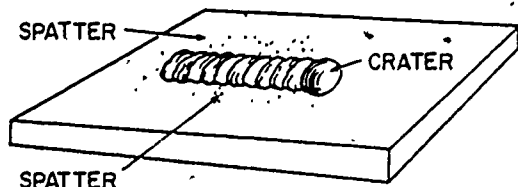

11.52  
Figure 7-52.—Spatter.

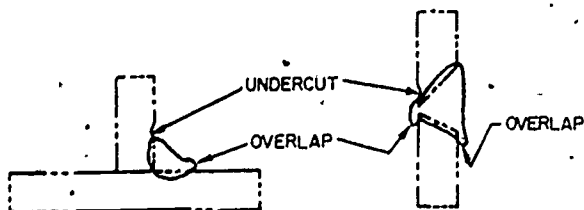

127.12  
Figure 7-53.—Undercut and overlap defects.

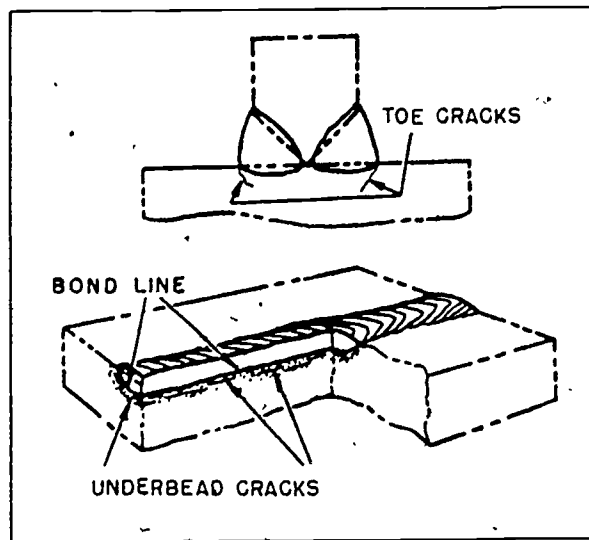

11.53  
Figure 7-54.—Typical crack defects.

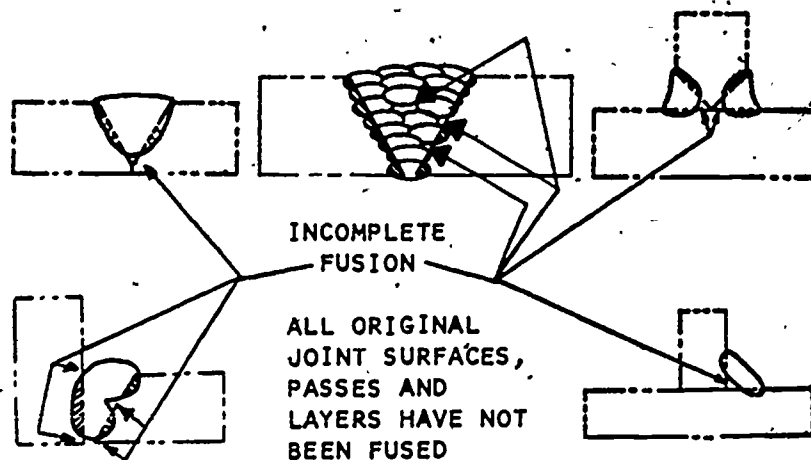

R127.157X

Figure 7-55.— Examples of incomplete fusion.

magnetic particle inspection since the defect extends to the surface.

An UNDERBEAD CRACK, on the other hand, is difficult to detect. This crack occurs in the heat-affected zone and generally does not extend to the surface of the base metal (see fig. 7-53). As a rule, this defect is detectable only by destructive testing, although X-ray may pick it up.

The solution to cracked welds lies largely in depositing a bead of the correct size, by employing the proper joint design, and filler rod, and by using proper technique. Whenever you have a cracked weld, it must be chipped, ground, or gouged out, and the joint rewelded.

INCOMPLETE FUSION is fusion which is less than complete. To explain further, it is a condition in which the base metal and weld metal or adjacent layers of weld metal fail to fuse together into one homogeneous mass. Incomplete fusion occurs when a low welding current is used and improper weaving procedure is employed. Welds such as those shown in figure 7-55 would be classified as defective because of incomplete fusion. Eliminate problems of incomplete fusion by properly preparing joints for welding, using sufficient heat, and employing suitable manipulation techniques. In arc welding, use an electrode small enough to reach the bottom of narrow vees, sufficient current to penetrate into plates, and a weave motion wide enough to melt the sides of the joint. In gas welding, incomplete fusion is caused by dropping the filler material into the joint instead of melt-

ing the filler rod in the puddle. The deposited metal should fuse into the plates and not tend to curl away from them.

INCOMPLETE PENETRATION occurs when the base metal and the deposited filler metal are not integrally fused at the root of the weld (see fig. 7-56). The most frequent cause of this condition is the melting of areas of the base metal before the root reaches the welding temperature. As a result, the filler metal bridges the joint. This usually occurs when the electrode diameter or filler rod is too large or the joint is improperly prepared. It may also arise from

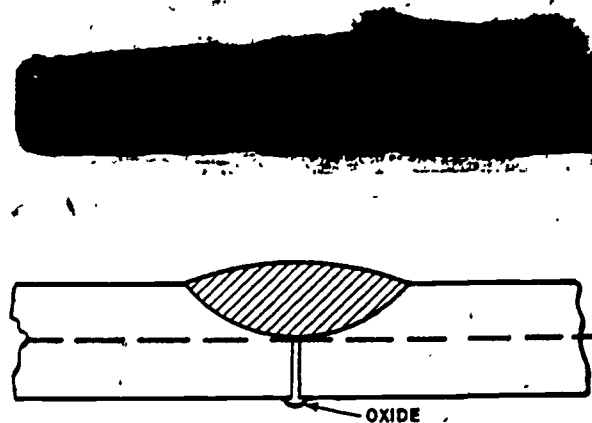

127.13X

Figure 7-56.— Incomplete penetration.

insufficient heat (welding current) or too fast a welding speed. Using joint designs having adequate root openings and small diameter electrodes or filler rods for the first or root pass go a long way toward ensuring good penetration. The right type electrode or right size filler rod, sufficient current, and proper speed of travel are also essential. If possible use a back-up strip and chip or cut out the back of the joint and deposit a bead.

Gas pockets within the weld metal are another common type of defect. A GAS POCKET is a cavity in the weld metal caused by entrapped gas. (This defect is also known as a blowhole, but the preferred term is gas pocket.) The term POROSITY is used when there are a number of gas pockets or voids in the metal. In both instances, the defect arises from the trapping of gas which is expelled by the metal upon cooling. As a rule, excessive heat and poor manipulation are circumstances leading to porosity. While poor base metal or filler material contributes to porosity, insufficient puddling to allow gases to escape and, in arc welding, holding too short an arc are the usual causes. Since puddling keeps the metal molten longer, permitting gases to escape, layers made by weaving rather than a series of string beads ensure sounder welds. Welds made with a series of string beads are more likely to contain minute pinholes.

BRITTLE WELDS are caused by unsatisfactory welding electrodes, excessive heat input, or improper flame adjustment. Failure to take into consideration the presence of a high percentage of carbon or other alloying materials in the base metal will also cause brittle welds. Brittleness in welds can be avoided by using the proper electrode, correct tip size and flame adjustment, and by taking advantage of preheating and postheating procedures.

#### WELDING PUBLICATIONS

All personnel engaged in welding should be familiar with a number of basic references in the field. Some of these publications have already been mentioned in this chapter. In the field of welding, as in so many other fields, official publications are constantly under revision; therefore, it is important to make an effort to keep up with the latest changes as they are issued.

The following military standards are of particular importance to Navy weldors:

- MIL-STD-20, Welding Terms and Definitions
- MIL-STD-22A, Welded-Joint Designs
- MIL-STD-248A (NAVY), Qualification Tests for Weldors (Other Than Aircraft Weldments)

A great many military specifications have been developed to cover welding equipment, welding procedures, and procedures for inspecting welds. Although by no means a complete list of the military specifications pertaining to welding, the following examples give some indication of the range of these specifications:

- MIL-R-908, Rods, Welding, Steel and Cast Iron (for Gas Welding)
- MIL-E-15599, Electrodes, Welding, Covered, Low- and Medium-Carbon Steel
- MIL-E-15716, Electrodes, Welding, Covered, Molybdenum Alloy Steel Application
- MIL-E-18038, Electrodes, Welding, Mineral Covered, Low Hydrogen, Medium and High Tensile Steel as Welded or Stress-Relieved Weld Application
- MIL-W-21157 (NOrd), Weldment, Steel, Carbon and Low Alloy

#### SAFETY

Accidents frequently occur in welding operations, and in many instances they result in serious injury to the weldor or others working in the immediate area. What many weldors fail to realize is that accidents often occur NOT because of a lack of protective equipment, but because of carelessness, lack of knowledge and misuse of available equipment. Precautions that apply to specific welding equipment are pointed out in the following chapters on welding. In this discussion we are particularly interested in such topics as protective clothing, eye protection devices, and safe practices applicable to the personal safety of the operator and other persons who may be working nearby.

Proper eye protection is of utmost importance, not only for the welding operator, but also other personnel—such as helpers, chippers or inspectors—in the vicinity of welding and cutting operations. Eye protection is necessary because of hazards posed by stray flashes, reflected glare, and flying sparks and globules of molten metal.

Devices used for eye protection include helmets, hand shields, and welding goggles. A point to note is that, in addition to providing eye protection, helmets and hand shields also provide a shield for the entire face and neck. Figure 7-57 shows you several types of eye protection devices in common use.

There are two general types of welding goggles in common use. One is a SPECTACLE type, often referred to as FLASH GOGGLES, which is furnished with metal side shields (see fig. 7-57A). This type may have either a rigid, nonadjustable or an adjustable metallic bridge.

The other type of welding goggles is an EYECUP or COVER type having flexibly connected lens containers shaped to conform to the configuration of the face (see fig. 7-57B). This type is designed for those who wear glasses.

For welding or cutting operations near or above eye level, only the eyecup or cover type of welding goggles should be used. The spectacle type (side-shielded) or the eyecup or cover type should be worn during all gas welding or cutting operations. The spectacle type with suitable filter lenses is permitted for use with gas-welding operations on light work and for inspection.

For electric-arc welding and cutting operations, a helmet or hand shield having a suitable filter lens is necessary. Figure 7-57C shows a helmet which has an opening, sometimes called a window, for a filter lens 2" x 4-1/4" in size. Figure 7-57D shows another type of helmet which has an opening (window) to accommodate a 4-1/2" x 5-1/4" filter lens. The wider opening affords the weldor a wider view and is especially useful when working in a confined place

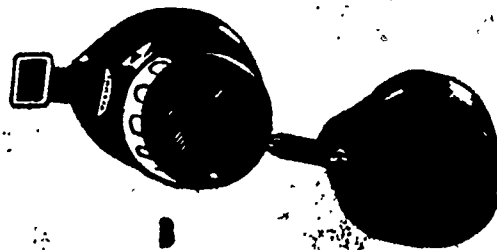
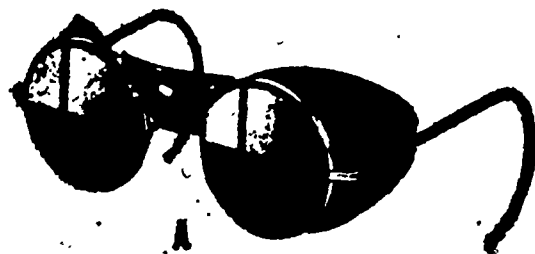

29.200  
Figure 7-57. — Eye protection devices.

STEELWORKER 3 & 2

where movement of the head and body is restricted. When welding operations are performed in locations where other weldors are working, such as in an assembly welding shop, the weldor should wear flash goggles beneath the helmet to provide protection from flashes from other weldors' arcs. These flash goggles will help prevent slag getting into the eyes when chipping slag from a previous weld deposit.

Helmets, hand shields, and welding goggles used for eye protection are made from a non-flammable, insulating material that can be sterilized. They are fitted with a protective color filter and a clear cover glass, mounted so that they can easily be replaced without tools. The purpose of the clear cover glass is to protect the filter lens against pitting caused by sparks and hot metal spatter. The clear glass should be replaced when it impairs vision.

Filter lenses are furnished in a variety of shades, which are designated by number. The lower the number the lighter the shade; the higher the number the darker the shade. Table 7-4 shows you the recommended filter lens shade for various welding operations. The filter lens shade number selected depends on the purpose for which eye protection is required, and

somewhat on the preference of the user. Remember, though, that a filter lens serves two purposes: (1) to diminish the intensity of the visible light to a point where there is no glare so that the welding area can be distinctly seen; and (2) to eliminate harmful infrared and ultra-violet radiations from the arc or flame. Consequently, the filter lens shade number you select should not vary more than two shades from the numbers recommended in table 7-4.

A variety of special weldor's clothing is used to protect parts of the body other than the eye during welding operations. The clothing selected will vary with the size, location, and nature of the work to be performed. During any welding or cutting operation, you should wear flame-proof gauntlets at all times. For gas welding and cutting, a five-finger glove like that shown at A, figure 7-58 should be used. For electric-arc welding, the two-finger type mitt shown at B, figure 7-58 is recommended.

Both types of gauntlets protect the hands from heat and metal spatter. The two-finger mitt has an advantage over the five-finger glove in that it reduces the danger of weld spatter and sparks lodging between the fingers. It also reduces chafing of fingers, which sometimes occurs when five-finger gloves are used for electric-arc welding.

Many light gas-welding and torch-brazing jobs require no special protective clothing other

127.158

Table 7-4.—Recommended Filter Lenses for Various Welding Operations

| Shade No.         | Operation   |
|-------------------|---|
| Up to 4 . . . . . | Light electric spot welding or for protection from stray light from nearby welding. |
| 5 . . . . .       | Light gas cutting and welding.  |
| 6 . . . . .       | Gas cutting, medium gas welding, and arc welding up to 30 amperes.                  |
| 8 . . . . .       | Heavy gas welding and arc welding and cutting, 30-75 amperes.                       |
| 10 . . . . .      | Arc welding and cutting, 76-200 amperes.  |
| 12 . . . . .      | Arc welding and cutting, 201-400 amperes.   |
| 14 . . . . .      | Arc welding and cutting exceeding 400 amperes.                                      |

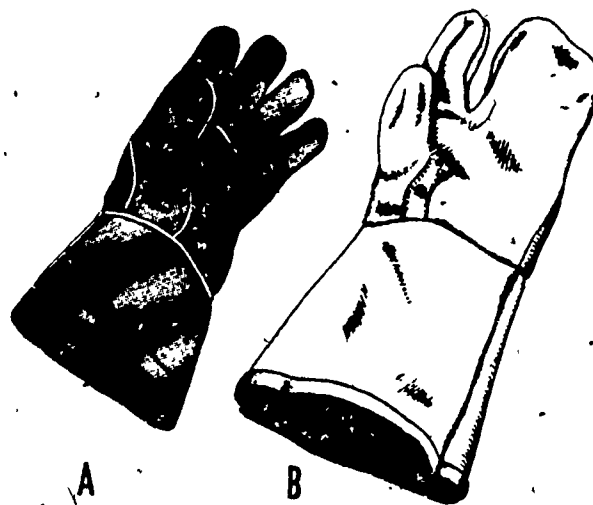

29.201  
Figure 7-58.—Gas and electric-arc welding gauntlet gloves and mitts.

than gauntlets and goggles. Here, though, it is essential that your work clothes be worn properly. Sparks are very likely to lodge in rolled up sleeves, pockets of clothing, or cuffs of trousers or overalls. Sleeves should be rolled down and the cuffs buttoned. The shirt collar also should be buttoned. Trousers should not be turned up on the outside, and pockets not protected by button-down flaps should be eliminated from the front of overalls and aprons. All outer clothing must be free of oil and grease. Wear high top or safety shoes; low cut shoes are hazards for sparks and molten metal, especially if you are sitting down.

In medium- and heavy-gas welding, all electric welding, and any welding job in the overhead position, specially designed flameproof clothing made of leather, asbestos, or other suitable material may be required to protect you against radiated heat, splashes of hot metal, or sparks. The clothing consists of aprons, sleeves, combination sleeves and bib, jackets and overalls, which afford a choice of protection depending upon the specific nature of the particular welding or cutting job. Sleeves provide satisfactory protection for welding operations at floor or bench level.

Cape and sleeves are particularly suited for overhead welding, because the cape protects the back of the neck, top of the shoulders, and upper part of the back and chest. Use of the bib in combination with the cape and sleeves gives added protection to the chest and abdomen in cases where protection to the lower part of the back is not required. The jacket should be worn only when there is necessity for complete all-around protection to the upper part of the body, such as is required when several weldors are working in proximity to one another. Aprons and overalls provide protection to the legs and therefore are suited for welding operations on the floor.

Sleeves are of two types. Type A consists solely of sleeves extending over the top of the shoulder and having leather thongs attached to the upper parts by means of which they can be secured in position. The cuff is provided with glove-type snap buttons for size adjustment. Type B consists of a combination cape and sleeves, to which a bib is attached with snap fasteners. (See fig. 7-59.) The bib is removable so that the cape and sleeves can be used independently of the bib, if conditions warrant such an arrangement.

Aprons are two types: Type A, plain, and Type B, split leg. In the Type B garment, provision



127.14

Figure 7-59.—Weldor's protective clothing.

has been made for securing the lower part of the apron to the thighs (see fig. 7-59) with leather thongs which tie at the back of the leg.

The jacket shown in figure 7-59 is a complete assembly designed to cover the entire body above the waistline. Overalls of conventional pattern—including pockets, bib, and shoulder straps—also are available. During overhead welding operations, leather caps should be worn under helmets to prevent head burns. Where the weldor is exposed to sharp objects, hard hats or head protectors, attached to form a part of the arc welding helmet, should be used. For very heavy work, fire-resistant leggings or high boots should be worn. Shoes or boots having exposed nail heads or rivets should NOT be worn. Oilskins or plastic clothing must NOT be worn in any welding operation.



If leather protective clothing is not available, then woolen clothing is preferable to cotton. Woolen clothing is not as readily ignited as cotton and helps protect the operator from changes in temperature. Cotton clothing, if used, should be chemically treated to reduce its flammability.

Some of your welding assignments may require that the equipment be taken to the job and the work done in place. In such instances, bear in mind that welding and cutting operations should be conducted in locations that have been specifically designated for the purpose. Other locations may be used if they have been freed of fire hazards by removal or protection of combustible or explosive materials, liquids, or vapors, and if suitable precautions have been taken against the accumulation of such materials. When welding or cutting is to be done in any location other than one specifically designated for such purposes, make sure before starting operations that you check with the petty officer in charge or other person authorized to approve (or disapprove) the work request.

Now let us consider some of the important safety precautions that apply to welding and cutting operations on hollow metal articles, whether the work is performed in or out of the welding shop. Before welding, cutting, or applying heat, any hollow metal article (barrels, used drums, tanks, or jacketed containers) must be cleaned and safeguarded by adequate ventilation if it has ever held a flammable substance. A check with an explosion meter should be made prior to welding. Even though a hollow metal article has never contained a flammable substance, it must be adequately vented before heat is applied. Any metal part which is suspiciously light should be drilled to vent it before heating. After welding is completed, the drill hole may be tapped and a plug inserted to restore its original condition.

It is not difficult to see that the presence of even a trace of flammable substance in a drum

or tank constitutes a hazard. The hazard from a closed container that has not held such a substance may be less obvious. Remember, though, that air contained in a hollow will expand greatly when heated. This expansion creates an internal pressure which may be sufficient to cause the part to act like a bomb. Adequate venting eliminates the possibility of building up internal pressure when heat is applied.

A container which has held a flammable substance may be cleaned with steam if the substance is easily vaporized. For heavy oils, a strong solution of caustic soda or similar chemical followed by rinsing is necessary. Even though the container has been thoroughly cleaned, it should be filled with water, carbon dioxide, or nitrogen for added protection. The reason for this is that an apparently clean container may still have traces of oil or grease under the seams. If you are cutting the top of a container, such as a 50 gallon drum, with a cutting torch you will hear little pops that may have a tendency to scare you. The heat of the welding or cutting operation may cause the oil or grease to give off flammable vapors to such an extent that an explosive mixture may be formed inside the container.

If it becomes necessary for a welding operator to enter a confined space through a manhole or other small opening, proper means must be provided for removing him quickly in the event of an emergency. Safety belts and lifelines used for this purpose should be so attached to the operator's body that the body cannot be jammed in a small exit opening. Adequate ventilation is mandatory for any person working in a confined space.

When operations are necessary in spaces with only small openings, heavy equipment (such as gas cylinders and welding generators) should be left on the outside. Also, a watch should be stationed outside to observe the operation and operator at all times. The watch should fully understand what action to take in case of an emergency.