

DOCUMENT RESUME

ED 220 579

CE 032 524

**AUTHOR** Henderson, Wm. Edward, Jr.  
**TITLE** Articulated Instruction Objectives Guide for Drafting. Final Document for Articulation of Drafting.  
**INSTITUTION** Greenville County School District, Greenville, S.C.; Greenville Technical Coll., S.C.  
**SPONS AGENCY** South Carolina Appalachian Council of Governments, Greenville.  
**PUB DATE** 28 Feb 82  
**CONTRACT** ARC-211-B  
**NOTE** 237p.; For related documents see CE 032 525-530. Figures may not reproduce clearly.

**EDRS PRICE** MF01/PC10 Plus Postage.  
**DESCRIPTORS** \*Articulation (Education); Competence; Curriculum Development; \*Drafting; Educational Planning; \*Engineering Graphics; Guidelines; Instructional Materials; Learning Modules; Mathematics; Postsecondary Education; Program Development; School Safety; Secondary Education; Technical Education; Technical Illustration; Technical Occupations; Vocational Education

**ABSTRACT**

Intended for use in competency-based and criterion-referenced vocational programs, this articulated, performance-based instruction objectives guide for Drafting I is designed for reference use in the articulation of drafting programs at the secondary and postsecondary levels. It consists of a description of the development of the guide, 14 sections pertaining to development of an articulated instructional program in drafting, five learning modules, textbook references, and other references. Following a description of secondary drafting and postsecondary engineering graphics course content, various topics are covered, including project scope, similar areas of training, module designations, standards applicable to drafting, student-teacher agreement, students' drafting portfolios, suggested instructional time, task listings, equipment lists, outcome-referenced measures, and proficiency reports. Addressed in the modules are classroom safety, basic math, principles and techniques of drafting, and working drawings. The modules include some or all of the following: performance objectives, performance actions, suggested instructional time, performance standards, related technical information, and suggestions to the teacher. (MN)

\*\*\*\*\*  
 \* Reproductions supplied by EDRS are the best that can be made \*  
 \* from the original document. \*  
 \*\*\*\*\*

ED220579

FINAL DOCUMENT  
FOR ARTICULATION OF DRAFTING

Project No. 81-1708  
Contract No. ARC 211-B

Wm. Edward Henderson Jr.  
Coordinator, Occupational Education Articulation Program  
The School District of Greenville County  
P.O. Box 2848 - 301 Camperdown Way  
Greenville, South Carolina 29602

ARTICULATED INSTRUCTION OBJECTIVES GUIDE FOR DRAFTING

February 28, 1982

Occupational Education Articulation Program  
Funded by  
SOUTH CAROLINA APPALACHIAN COUNCIL OF GOVERNMENTS

"PERMISSION TO REPRODUCE THIS  
MATERIAL HAS BEEN GRANTED BY

W. E. Henderson

TO THE EDUCATIONAL RESOURCES  
INFORMATION CENTER (ERIC)."

U.S. DEPARTMENT OF EDUCATION  
NATIONAL INSTITUTE OF EDUCATION  
EDUCATIONAL RESOURCES INFORMATION  
CENTER (ERIC)

✓ This document has been reproduced as  
received from the person or organization  
originating it  
Minor changes have been made to improve  
reproduction quality

• Points of view or opinions stated in this docu-  
ment do not necessarily represent official NIE  
position or policy

CE03a524

DISCRIMINATION PROHIBITED - Title VI of the Civil Rights Acts of 1964 states: "No person in the United States, shall, on the grounds of race, color, or national origin, be excluded from participation in, be denied the benefit of or be subjected to discrimination under any program or activity receiving federal financial assistance." Therefore, the Occupational Education Articulation Program, like all other programs or activities receiving financial assistance from the Appalachian Council of Governments must be operated in compliance with this law.

The opinions expressed herein do not necessarily reflect the position or policy of the Appalachian Council of Governments and no official endorsement by that agency should be inferred.

## ABSTRACT

**Title of Project:** Occupational Education Articulation Program

**Project Coordinator:** Wm. Edward Henderson, Jr.

**Contracting Agency:** The School District of Greenville County  
301 Camperdown Way  
P. O. Box 2848  
Greenville, South Carolina 29602

**Project Period:** March 1, 1981 through February 28, 1982

**PURPOSE:** To develop a continuous program of vocational training in drafting so that students may continue their education at the secondary and post-secondary levels without loss of time or waste of effort in repeating tasks that have been mastered previously.

To remove unnecessary gaps or overlap in student learning when the student completes a secondary level program and continues career development at the post-secondary technical education level.

To provide a system whereby teachers can cooperate effectively in providing a continuous occupational development program where the levels and types of training that lead to entry-level employment skills will be clear to students, educators, and potential employers.

**METHOD:** Drafting instructors from the vocational education centers of the secondary level program of The School District of Greenville County and drafting instructors from the post-secondary level program of Greenville Technical College were brought together in Task Force Committee meetings and workshops to survey similar drafting training programs and to identify possible overlap or gaps which might be encountered by students as they continue drafting training from the secondary level to the post-secondary level. The performance-based instructional objectives guide developed by the Committee served as the main vehicle for articulation. The Task Force Committee on Drafting, by the task analysis process, identified drafting competencies for Drafting, I essential for the student desiring to continue drafting training or for initial entry into the labor market in drafting. Performances identified were placed in an appropriate sequential order and assigned instructional time and performance

standards according to their importance. Finally, sample outcome-referenced measures of those competencies were developed for use as a guide in articulation.

**RESULTS:** As a result of this project, the product, Articulated Instruction Objectives Guide for Drafting, was developed. The Guide, however, is not an end product since it must be field trial tested and revised. Modification and improvement to the Guide are expected since the process of education must be continually reviewed to ensure objectives are valid and are being met as best they can be met.

In addition, a Policies and Procedures Manual was developed to assist in continuing and future articulation efforts. Two sub-products, workshop guides, were assembled to assist workshop leaders/coordinators and participants in the process of writing objectives, performance actions, standards, and outcome-referenced measures in the development of performance-based curriculum material.

## PREFACE

The Articulated, Performance-based Instruction Objectives Guide for Drafting I is designed for reference use in the articulation of very similar vocational training programs at the secondary level, The School District of Greenville County, and at the post-secondary level, Greenville Technical College, and to encourage performance-based (competence-based) instruction and outcome-referenced (criterion-referenced) evaluation in vocational training.

The writing of this Guide was compacted into a nine months period due to the project beginning at a date later than originally planned and due to the possibility that 1982-83 federal funding cutbacks might effect the program. The compacting of the development time emphasized the need to limit the initial scope of the project to Drafting I, that area of drafting where very similar vocational training was occurring and where there was tentative agreement that students continuing their training beyond the secondary level could exempt post-secondary training if they demonstrated competency in the performance of articulated skills taught at the secondary level.

The Articulated, Performance-based Instruction Objectives Guide is based on the concept that similar vocational training programs which start at the same point in the total occupational program often result in a duplication of instruction. To address this problem articulation, through the vehicle of performance-based instruction, is designed to reduce the need for post-secondary level students to repeat vocational training successfully completed at the secondary level, if the similar training at the postsecondary level is continued within a specified time. Currently, Greenville Technical College does not conduct "Open Program" instruction and students who qualify, upon entry, for advanced vocational training at TEC require individual counseling and instructional attention.

The articulation of vocational training between the secondary and post-secondary levels is based on several concepts:

1. Similar vocational training courses at the secondary and post-secondary levels must be standardized in content so as to be identifiable.
2. In addition to standardized performance objectives, both levels of training must require the same standards of job performance in tasks.
3. Finally, to foster validity and reliability in the articulation process, it is necessary to standardize test items and procedures in evaluating student job performance.

The standardization of performance objectives (course content) is based on the actual tasks necessary for employment success in the local or regional labor market. The performance standards are determined by the level of performance emphasized by employers for initial job entry level qualification. Performance standards exceeding the minimum recommendations for articulation are encouraged, especially for the better student. Outcome-reference measures and evaluation of performance should reflect agreement at both levels of instruction.

Traditionally, educators have tended to generate instructional objectives from content, working forward to an output. Trainers in industry, the military and, more recently, in the vocational education field, have stressed instructional objectives for a specific job, working from performance to curriculum development. The latter approach is preferred to ensure the validity of curriculum objectives and content in performance-based vocational training.

Participants in performance-based articulation or instruction should be committed to a systems approach of occupational training which starts with a definition of the purposes of the training. This definition (objectives statement) remains the criteria for evaluation throughout the course and achievement against the stated goals is the measure of success.

Performance actions to reach the objectives represent detailed job functions or activities which typically may be required of the draftsman at the entry level. It is understood that a given employer may require different tasks of an employee depending upon the particular situation. The selection of performance actions represents an agreement by secondary level instructors and concurrence by the post-secondary level instructors that the actions are typical to those required on the job.

The performance-based instruction guide for drafting is designed to provide a framework for lateral and vertical articulation for training purposes and for articulation to employers.

CONTENTS

Abstract . . . . .	11
Preface . . . . .	iv
Introduction . . . . .	1
Articulation . . . . .	2
The Articulation Program . . . . .	2
Articulation Coordinator . . . . .	3
Initial Program Objectives . . . . .	3
Putting Articulation into Action . . . . .	3
Articulation is not without Work . . . . .	4
A System for Instruction . . . . .	5
Benefits from Articulation . . . . .	6
A Progressive Step Ahead . . . . .	6
Purpose of the Articulated Instruction Guide . . . . .	7
Definition of Terms . . . . .	10
Executive Committee . . . . .	15
Advisory Committee . . . . .	15
Executive Committee Membership . . . . .	16
Advisory Committee Membership . . . . .	19
Drafting Task Force Committee . . . . .	21
Task Force Committee Membership . . . . .	22
Schedule of Activities, 1981-82 . . . . .	24
Summary of Participation: Task Force Committee . . . . .	25



Final Document

Project No. 81-1708  
Contract No. ARC 211-B

Title of Document

ARTICULATED INSTRUCTION OBJECTIVES GUIDE  
FOR DRAFTING

Wm. Edward Henderson, Jr.  
Coordinator  
Occupational Education Articulation Program  
The School District of Greenville County  
301 Camperdown Way  
P. O. Box 2848  
Greenville, South Carolina 29602

February, 1982

Funded by

South Carolina Appalachian Council of Governments

INTRODUCTION

## OCCUPATIONAL EDUCATION ARTICULATION PROGRAM

### INTRODUCTION

#### ARTICULATION

Articulation is the joining or interrelating of two or more levels of education, secondary and post-secondary or vocational and technical, in order that very similar programs form a continuous progression of sequential, unduplicated training.

Articulation provides a system whereby teachers can cooperate effectively in providing instruction to meet the needs of individual students in other that there will be no unnecessary gaps or overlap in student learning, and where the levels and types of training lead directly to entry-level employment skills.

Vocational articulation, in short, is a clear expression and joining of two similar levels of career training into a continuous sequence to the benefit students, educators, employers, and the taxpayers.

#### THE ARTICULATION PROGRAM

Articulation of secondary and post-secondary vocational training programs has been discussed in educational circles for many years. In recent years, articulation has become the subject of nationwide concern as well as positive effort. In South Carolina, secondary and post-secondary level vocational administrators have taken a supportive position for articulation since the mid-1970s. Vocational articulation programs now are underway in several locations in South Carolina.

The concept of articulation and the articulation program are supported fully by The School District of Greenville County and Greenville Technical College which agreed upon a statement of purpose for articulating the various vocational programs in Greenville County. Since 1976, they have been working toward this goal. Thus, this articulation program is a joint effort of The School District of Greenville County and Greenville Technical College with the purpose of developing a continuous program of vocational training so that students may continue their education without loss of time or waste of effort in repeating tasks which have been learned previously. This articulation program will help to remove unnecessary gaps or overlap in student learning which sometimes occur when the student completes a secondary level program and continues career development at the technical education level.

Articulation provides a system whereby teachers and instructors can cooperate effectively in providing a continuous occupational development

program where the level and type of training that leads to entry-level employment skills will be clear to teachers and instructors, other educators, students, and potential employers.

In addition to the educational benefits resulting from an articulated vocational training program in Greenville County, taxpayers will benefit through a reduction in the cost that is required to train students for entry-level employment.

#### ARTICULATION COORDINATOR

The articulation coordinator and the articulation program are funded largely through a federal grant to The School District of Greenville County through the South Carolina Appalachian Council of Governments. The coordinator reports to the School District's Consultant for Vocational Education.

The articulation coordinator is responsible for the overall planning and sequential implementation of articulation efforts between The School District of Greenville County and Greenville Technical College. The sequential implementation is structured so that designated programs which are very similar in nature are "articulated" and evaluated, the articulation process is modified (if necessary), and other programs are brought into the articulation process.

To facilitate articulation, the coordinator works cooperatively with administrators, teachers and instructors, counselors, and job placement coordinators on both the secondary and post-secondary levels as well as with business, industry, and the general public.

The coordinator is assigned the tasks of providing leadership in planning curriculum development, articulation agreements, resource development, and evaluation of articulation.

#### INITIAL PROGRAM OBJECTIVES

Objective 1. Drafting and Business and Office Education courses at the secondary level and similar training at the post-secondary level were modified into performance-based modules.

Objective 2. Performance tests over each Business and Office Education and Drafting module were developed. The outcome-referenced test may include a written examination on the theory and knowledge of the area of instruction and a proficiency test of application of knowledge obtained.

Objective 3. The predictive validity of the tests over the Business and Office Education and Drafting modules is being determined in order that meaningful and accurate scores reflecting competency in the areas tested can be determined.

#### PUTTING ARTICULATION INTO ACTION

For initial implementation of the articulation program, Drafting and Business and Office Education were chosen as pilot programs. Drafting

course articulation involves courses at four vocational education centers within the school district as well as at Greenville TEC. Business and Office Education involves courses at two vocational education centers, fifteen high schools, and Greenville TEC.

To bridge any gaps that might exist between secondary and post-secondary vocational training and to strengthen the sequence of occupational training available to students, there must be (1) contact, (2) communications, (3) coordination, (4) cooperation, (5) consolidation and, of course, (6) articulation between instructional participants at both levels of training.

Among program participants, there must be: (1) agreement on purpose, (2) trust, (3) respect, (4) a willingness to take risks, and (5) a willingness to experiment. The articulation process began with statements of support from top management of The School District of Greenville County and Greenville Technical College. Implementation of the articulation program is under way and the final step will be the evaluation of program effectiveness.

Those things which were accomplished during the initial stage include:

1. Existing curriculum content in Business and Office Education and Drafting was revised into performance-based modules.
2. Scope and sequence of module instruction were established.
3. Cognitive and proficiency tests were developed.
4. "Tryout" testing of cognitive and performance tests was initiated.

Those things which can be accomplished after the initial year include: (1) pilot implementation of performance-based modules, and (2) full validation of cognitive and performance tests.

#### ARTICULATION IS NOT WITHOUT WORK

Articulation cannot take place without the implementation of performance-based instruction.

Performance-based instruction requires each student to master the vocational curriculum material at a level of proficiency necessary for success in entry level employment in the local labor market.

Everything in a performance-based instruction system is made public before instruction. There are no surprises for students, teachers, administrators, or employers. When the student begins a program, information is available to tell the student exactly what competencies are expected to be developed as a result of the instructional program, how the student will be evaluated and against what standards or criteria, and how the student's competencies will be communicated to the student, to other instructors, and to future employers.

Developing performance-based instruction guides take time and work. Program goals must be identified. Vocational training must be made more relevant to actual job tasks. The training or job environment, the equipment needed and factors acting upon the student must be spelled out. Furthermore, outcome-referenced measures must be developed to demonstrate the student's mastery in knowledge and skill performance.

A SYSTEM FOR INSTRUCTION

A performance-based instruction system tells a student exactly what the student must learn, instructs the student in that skill or knowledge, and then tests on mastery of that specific competence.

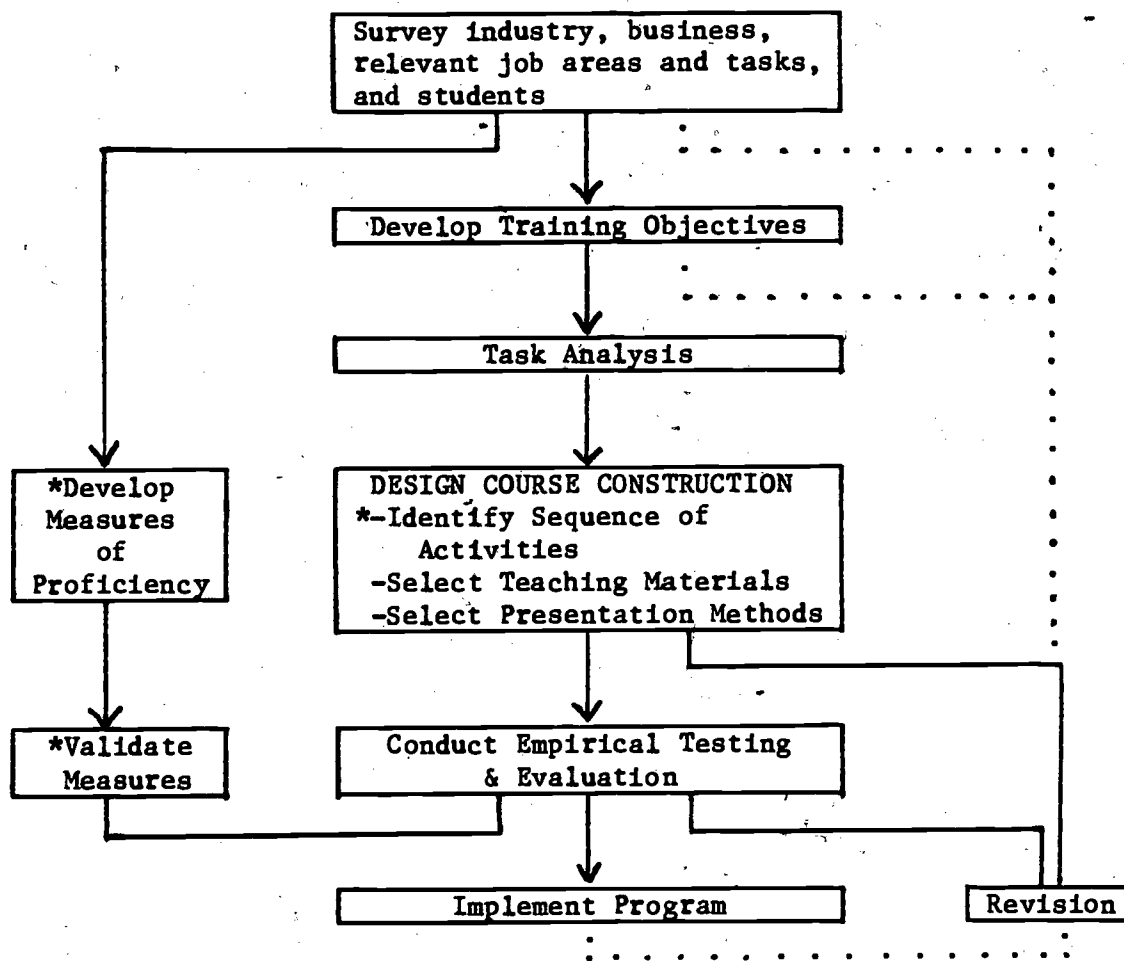

Schematic of the Systems Approach to Instruction. Articulation will help clarify those areas marked with an asterisk (\*). The actual system may vary with the program, institution, or individual instructor.

## BENEFITS FROM ARTICULATION

Articulation will enable the secondary school graduate to enter a very similar vocational training program at the technical college level and pick up with the next logical step in career development. Articulation will enable the student to continue his training beyond the knowledge and skills level already mastered so there will be a minimum of duplication in time and cost and maximum benefits in terms of knowledge and proficiencies gained from the instructional program.

Articulation should result in a more sequential vocational training opportunity. Training at the secondary and post-secondary levels should become more responsive to the needs of a rapidly changing technological community. Articulation should help improve retention of students who continue their vocational training beyond high school. Moreover, the motivation for learning and performance should be improved among these students.

The articulation process will require teachers and administrators from different schools to work closely together, will encourage cooperation between instructors, and will result in a more uniform curriculum program.

For vocational students, career and educational alternatives will be increased while training time and costs should be decreased. Vocational students should gain mastery of the competencies of their chosen occupational field and will be encouraged to continue their career education as a life-long process. Articulation will facilitate the progression of the student through training and into the work force.

As a by-product of articulation, vocational training should become more relevant to actual job tasks. Graduates should be more productive employees due to their training.

As articulation is thoroughly developed, the taxpayers of Greenville County will gain through the savings of tax dollars that result from more efficient vocational and technical training.

## A PROGRESSIVE STEP AHEAD

Typical barriers to articulation such as individual education system divisions, each with its own philosophy, administrative "logistics" or the magnitude of the task of curriculum revision, have not delayed The School District of Greenville County and Greenville Technical College from recognizing the common need to work together at the instructional level as well as at the institutional level. The District and TEC are committed to developing a management system for articulation between similar secondary and post-secondary vocational training programs.

The School District of Greenville County and Greenville Technical College are committed to doing their best to meet the expanding need in Greenville County for workers proficient in vocational skills and knowledge.

## PURPOSES OF THE ARTICULATED INSTRUCTION GUIDE

The articulated instruction objectives guide for Drafting is expected to serve the following purposes:

1. The guide serves as the primary vehicle for the articulation of drafting subject matter in similar vocational training programs between the vocational education centers and Greenville Technical College through use by instructors at both levels as a reference in preparing instruction.
2. The guide provides a listing of the minimum tasks that a student or worker is expected to perform in the conduct of a specific level job in the area of vocational training or work of concern.
3. The guide identifies the primary, detailed instruction objectives (performance objectives) which are based upon the task listings. The tasks generally are listed in the sequence of complexity with the least complex task being listed first, except where a task must be performed as a prerequisite to performance of another task.
4. The guide identifies the actions performed (actions, steps, or sets of skills) and related technical information which must be taught and learned to accomplish each major instruction objective. The tasks performed represent the minimum skills and related information required for adequate occupational proficiency in the performance objectives.
5. The guide designates the instruction contact hours necessary to provide the required instruction, as required by appropriate educational agencies or offices, as estimated by the instructor-participants on the Occupational Education Articulation Program Drafting Task Force Committee, and based on the time required to teach the average learner to perform the task. The time estimated is based on having the essential equipment, facilities and instructional aids required to provide the instruction whenever the class size is limited to an acceptable number.
6. The guide identifies the performance standards to be met for occupational proficiency in the task. Performance standards used are those considered to be minimum business or industry entry level standards. The ability to meet the listed standards of performance will be considered as qualification for advanced instruction in the vocational program.



7. The guide provides direction in the conduct of sequential vocational competency instruction by modules or job tasks, resulting in qualification by the learner to perform limited skill specialist jobs of progressively higher skills until the program objective is reached (i.e., apprentice to draftsman, etc.). As the student becomes proficient in the performance of tasks in successively more complex modules, more marketable competencies are gained and may be identified as the lower job qualifications of a specialist. Through this procedure, even the slower student is provided an opportunity to eventually gain sufficient skills to perform adequately as a specialist at some level in the vocational field, even if the student is unable to complete the total program of training.

The standardized sequence of activities of the vocational instruction modules will facilitate lateral articulation between vocational education centers in The School District of Greenville County and will simplify vertical articulation when training is continued at Greenville Technical College and when communicating to employers.

8. The guide provides a descriptive listing of equipment required to conduct the program of vocational training. The equipment listed is considered to be the type and quantity essential for the conduct of instruction to prepare students for entry-level employment in the vocation field. It may be necessary to delay teaching some tasks involving special equipment, if that equipment is not available at all instructional sites, or to move students and equipment together as necessary to teach skills.
9. The guide provides information about requirements or limitations that typically are involved in the performance of the task, environmental conditions and physical demands that affect performance of the task.
10. The guide provides a list of standardized performance test items/ and outcome-referenced measures to be used in the determination of vocational proficiency. As long as the specifics are not provided to students, the test items listed cannot be compromised easily and could serve as study guides.
11. The tasks listed in the guide are the minimum requirements for job qualification under average circumstances in a regional market. It is understood that there may be unlisted tasks that some employers may require the worker to do in the occupation, when in their employment. In addition, there may be unlisted tasks, such as mental process tasks, that are not stated but that may occur and that should be considered in instructional planning or testing.

Instructors may teach skills and related technical information other than what is shown in the guide. Provision of additional information should be limited to the students who have completed the requirements for the tasks emphasized in the instructional guide. The change of tasks in the guide should be based on task force committee agreement, to ensure lateral and vertical articulation.

12. It is expected that there will be updating and correction of items in the articulated instruction guide. Participants are to be sure that the contents are valid and consistent with business and industry requirements. Recommendations should be submitted to the Occupational Education Articulation Program office which will assemble and present them to the appropriate committee for review and possible adoption.
13. Typically, the teacher/instructor should not plan to conduct instruction in a given articulated module unless the capability exists to conduct all of the instruction to meet the instructional objectives, with the result that the successful student is qualified to perform the tasks identified within the module.
14. An underlying philosophy in vocational training is that it is better to prepare the student to be fully qualified to perform all of the tasks in a limited group of modules in a vocational field and be qualified at a lower job level rather than to be only familiar with a large number of task descriptions or duties and qualified to perform none of them fully. For higher levels of job qualification, beyond the secondary level of vocational training, the student or worker is encouraged to enroll at Greenville Technical College.
15. Generally, vocational programs will include certain basic modules or courses of instruction without which the student would not be considered vocationally qualified at any level. Basic modules typically will be identified and taught early in the program sequence.
16. The articulated instruction guide provides information essential to help the vocational student, who completes training at the secondary level and continues career development training at the post-secondary level in a similar program, receive appropriate credit for the articulated vocational training that has been mastered at the secondary level.

## DEFINITIONS OF TERMS

The following definitions of terms are applicable to the articulated, performance-based instruction guides developed as products of the Articulated, Performance-Based Instruction Guide.

- Behavior: The actions of a person (specifically, job or job training actions). Behavioral actions include both overt, those that can be observed, and covert, those not observable outwardly. Performance may be interchanged with behavior in the project. (See also Performance Actions).
- Concept: A group of ideas that may be classed together or that are similar.
- Criteria: A standard by which performance may be measured, usually considered the minimum standard.
- Domain: A cluster of related jobs.
- Duty: One of the distinct major activities involved in the work performed and comprising related tasks.
- Evaluation: When a comparison is made between a measurement and a standard and judgment is passed on the comparison.
- Item: A single stimulus or stimulus pattern that calls for a single response or set of responses. It is one sample of behavior or performance. The response may be simple or complex.
- Job: The duties or tasks actually performed by a specified individual.
- Knowledge: In this project, knowledge refers to acquired covert behavior which facilitates skills and performance, such as the theoretical information of what should be done under given circumstances, and in what order of sequence performance should occur to accomplish the objective.
- Measurement: The process of determining the extent some characteristic is associated with the student.
- Module: Modules in the pilot Drafting and Business and Office Education curriculum modifications in the Occupational Education Articulation Program have been designed to

coincide secondary level training with post-secondary level similar areas of training.

Another method of developing modules might be for modules to represent an identifiable, complicated task or job area involving a number of sub-tasks such as "Electrical Systems" in Automotive Mechanics.

Norm-referenced Evaluation: In norm-referenced evaluation, measures are dependent on a relative standard. Measures compare the capabilities of one student to those of other students.

Objective: (See Performance Objective) A stated desired outcome of training or the end result of the job, task, or performance actions. Objectives referred to in this project will be terminal objectives, generally representing a specific job function.

Occupational Education: An organized sequence of learning experiences consisting of vocational theory, practice, and skills taught to students on a regular or systematic basis.\*

\*Reference: Standards of the Delegate Assembly (Atlanta: Southern Association of Colleges and Schools, Commission on Occupational Education, December, 1972) p. 12.

Outcome-referenced Evaluation: Outcome-referenced, or criterion-referenced, measurement provides a standard of achievement for the individual as compared with specific behavioral objectives and therefore provides information about the degree of competence attained by the student.

The outcome-referenced measure is a performance or other measure based upon a performance objective, the accomplishment of which measures attainment of that objective.

Performance: Performance is used in this project to refer to a job or task which results from a set of sequential actions or steps.

Performance Actions: A series of steps, generally arranged in a sequence ordinarily followed, which when completed may result in the accomplishment of a performance objective (performance of a task).

Performance actions may be referred to as a set or sets of skills, functions, or steps. V-TEC (Vocational-Technical Education Consortium of States) catalogs generally describe performance actions in the "performance guide" of their format.

Articulated, Performance-based Instruction Guide: A comprehensive collection of performance objectives, performance actions to obtain those objectives, suggested hours for instruction (for planning purposes), performance standards, related technical

information, and outcome-referenced measures, as well as general secondary level and post-secondary level descriptions of similar courses for the purposes of aiding lateral and vertical articulation concerning the subject area.

Performance-based Instruction: Performance-based (competence-based) instruction is based on the competencies or tasks performed by on-the-job workers. Everything in a performance-based instruction system is made public beforehand. There are no surprises for student, teacher, counselor, or employer. When the student begins a program, information is available to tell the student exactly what competencies are expected to be developed as a result of the instructional program, how and against what standards or criteria the student will be evaluated, and how the student's competencies will be communicated to the student, instructors, and to employers. A performance-based instructional system tells the student exactly what the student must learn, teaches the student that skill or knowledge, and then tests on mastery of that specific competence.

Performance Objective: A statement in precise, measurable terms of a particular behavior to be exhibited by a learner under specified conditions. It possesses each of the elements or characteristics specified below:

Conditions under which the performance is to take place.

Behavior Desired or expected of the student (things to be done, the performance desired).

Standards to determine how well the performance is to be done (criteria).

Performance Test: A performance test requires the student to demonstrate (master) the desired behavior of the objective (accomplish a job-like task) under controlled conditions and according to predetermined standards. The controlled conditions allow the student to demonstrate the desired behavior and the conditions remain consistent from student to student.

Skill: Primarily, skill refers to overt, observable performance, however, it is recognized that there are covert skills required in some performances.

Step: Step is used to refer to a task or action, generally as a sequence of steps involved in the accomplishment of a performance objective or job.

Systems Approach: The systems approach to instruction emphasizes the specification of instructional objectives, precisely controlled learning experiences to achieve the objectives, criteria for performance, and evaluative information.

Task:

A task is a set of skills (set or sets of functions, actions, or steps) the student must perform to accomplish the job (training). A task may be described as a logically related set of actions necessary or required to complete the job objective. Several tasks could be referred to as a duty.

Task Analysis: Task analysis is breaking down a learning task (objective) into component tasks each of which must be mastered as a prerequisite to mastery of the total job.

Task List:

A listing of tasks (performance objectives) performed by incumbent workers (students in training) within a domain of interest (course of study).

Test:

An event during which the student is asked to demonstrate some aspect of knowledge or skill is a test. It can be a single test item, but usually it consists of several items.

ORGANIZATION



OCCUPATIONAL EDUCATION ARTICULATION PROGRAM  
EXECUTIVE COMMITTEE

Because the Occupational Education Articulation Program involved important joint decisions between The School District of Greenville County and Greenville Technical College, such as advanced credit or placement and methods of communications, it was crucial that a governing board be established to provide the necessary structure for coordinating the program through the two institutions. Consequently, an Executive Committee was established during the summer of 1980.

The Executive Committee met at regular intervals to review and discuss the Occupational Education Articulation Program activities and products and to plan the direction of future articulation activities.

OCCUPATIONAL EDUCATION ARTICULATION PROGRAM  
ADVISORY COMMITTEE

An Advisory Committee was established so that representatives from the participating institutions and industry might participate in the formulation of the program. The Advisory Committee primarily functioned as a sounding board to determine completion requirements for job entry skill training and to provide current data about industry manpower needs, new techniques, and equipment trends.

In addition to project outlined responsibilities, the Advisory Committee, because of its unique membership composition, was called upon for recommendations concerning the credentialing of students at the secondary level, communicating competencies between institutions or to employers, post-secondary handling of graduates of secondary articulated programs that may qualify for advanced placement, and a procedure for meaningful feedback from the post-secondary institution to the secondary institution concerning the competencies of advanced placement students.

The Executive Committee and Advisory Committee membership for the 1981-82 period is listed on the following pages.



EXECUTIVE COMMITTEE

Occupational Education Articulation Program

Greenville County School District

Dr. J. Floyd Hall  
Superintendent of Schools  
The School District of Greenville County  
P.O. Box 2848  
Greenville, SC 29602  
242-6450

Dr. Norman Mullins  
Associate Superintendent for Educational Development  
The School District of Greenville County  
P.O. Box 2848  
Greenville, SC 29602  
242-6450

Mr. Thomas E. Kerns  
Associate Superintendent for Personnel Services  
The School District of Greenville County  
P.O. Box 2848  
Greenville, SC 29602  
242-6450

O. Richard Cothran  
Consultant for Vocational Education  
The School District of Greenville County  
P.O. Box 2848  
Greenville, SC 29602  
242-6450

Eddie Jones Jr., Director  
Donaldson Vocational Center  
Donaldson Center  
Greenville, SC 29605  
277-3656

Bill Jordan, Director  
Enoree Vocational Center  
108 Scaleybark Road  
Greenville, SC 29609  
246-7250

Dr. John Baucum, Director  
Foothills Vocational Center  
Rt. 1, St. Marks Road  
Taylors, SC 29687  
244-9585

W. H. Chastain, Director (Committee Chairman)  
Golden Strip Vocational Center  
Rt. 10, East Butler Road  
Greenville, SC 29607  
288-1842

Mr. Wm. Edward Henderson, Jr., Coordinator  
Occupational Education Articulation Program  
The School District of Greenville County  
Donaldson Center  
Greenville, SC 29605  
277-3656

Greenville Technical College

Dr. Thomas E. Barton, President  
Greenville Technical College  
P.O. Box 5616  
Greenville, SC 29606  
242-3170

Dr. Lester Reed  
Vice President for Education  
Greenville Technical College  
P.O. Box 5616  
Greenville, SC 29606  
242-3170

Dr. Kay Grastie  
Dean of Instruction  
Greenville Technical College  
P.O. Box 5616  
Greenville, SC 29606  
242-3170

Appalachian Council of Governments

Sam Cargill  
Educational Planner  
South Carolina Appalachian Council of Governments  
P.O. Drawer 6668  
Greenville, SC 29606  
242-9733

Ad hoc (Corresponding Members)

Dr. Cecil Walters  
Coordinator of Vocational Articulation  
Division of Educational Services  
SC State Board for Technical and Comprehensive Education  
Robinson Building - Lexington Avenue  
West Columbia, SC 29169  
758-7830

Dr. Robert T. Benson  
Chief Supervisor, Curriculum Development  
Office of Vocational Education  
SC State Department of Education  
1107 Barringer Building  
1338 Main Street  
Columbia, SC 29201  
758-5971

Mr. Wm. Edward Henderson, Jr., Coordinator  
Occupational Education Articulation Program  
The School District of Greenville County  
Donaldson Vocational Center  
Donaldson Center  
Greenville, S.C. 29605  
277-3656

OCCUPATIONAL EDUCATION ARTICULATION PROGRAM  
ADVISORY COMMITTEE

Mrs. Hazel Hall  
Vice President for Student Affairs  
Greenville Technical College  
P. O. Box 5616  
Greenville, South Carolina 29606  
Telephone: 242-3170 (316)

Mrs. Sharon Shook  
Business Counselor  
Business Technical College  
P. O. Box 5616  
Greenville, South Carolina 29606  
Telephone: 242-3170

Mr. Walter Rice, Chairman  
Engineering Graphics Department  
Greenville Technical College  
P. O. Box 5616  
Greenville, South Carolina 29606  
Telephone: 242-3170

Mr. Rudolph G. Gordon  
Assistant Superintendent, Southwest Area  
The School District of Greenville County  
37 Tindal Avenue  
Greenville, South Carolina 29605  
Telephone: 233-1652

Mr. Lloyd E. Kelly, Principal  
Woodmont High School  
Route 4, Box 402  
Piedmont, South Carolina 29673  
Telephone: 277-1618

Mr. Eddie Jones, Director  
Donaldson Vocational Center  
Donaldson Center  
Greenville, South Carolina 29605  
Telephone: 277-3656

Mr. Steven A. McMeekin  
Job Placement Coordinator  
Enoree Vocational Center  
108 Scalybark Road  
Greenville, South Carolina 29609  
Telephone: 246-7250

Mrs. Barbara A. Haney, Counselor  
Southside High School  
100 Blassingame Road  
Greenville, South Carolina 29605  
Telephone: 277-6135

Program Staff

Mr. Wm. Edward Henderson, Jr., Coordinator  
Occupational Education Articulation Program  
The School District of Greenville County  
Donaldson Center  
Greenville, SC 29605  
277-3656

OCCUPATIONAL EDUCATION ARTICULATION PROJECT  
TASK FORCE COMMITTEE  
DRAFTING

Research and situational analysis indicated that the primary group involved in curriculum development efforts should be the local vocational and technical education instructors.

The vocational and technical education instructors probably are some of the best informed persons at the local level to identify present and future training needs in the drafting career field, define objectives which will have to be realized, outline a syllabus of instruction, determine the order of tasks or topics, suggest an appropriate instructional time, and describe the resources involved to accomplish the overall job.

Occupational Education Articulation program development activities were organized around a nucleus Task Force Committee on Drafting composed of teachers representing drafting programs at the secondary level vocational education centers of The School District of Greenville County and at the post-secondary level at Greenville Technical College's Engineering Graphics Technology program in the Engineering Technology Division.

One purpose of the Drafting Task Force Committee was to revise the drafting curriculum into a sequential, performance-based program. A second purpose was to develop outcome-reference tests to be administered to students at the completion of their secondary level of training so they would objectively demonstrate levels of achievement. A third purpose of the Task Force Committee was to contribute to the development of a policy and procedures manual to guide continued implementation of vocational articulation and assist with further articulation activities.

The Task Force Committee included four drafting program teachers from the vocational education centers of The School District of Greenville County and the Graphics Engineering Technology Department Chairman and other drafting instructors from Greenville Technical College.

DRAFTING  
TASK FORCE COMMITTEE

SECONDARY LEVEL: Drafting I

Golden Strip Vocational Center	Buford Garrett
Foothills Vocational Center	Richard T. Davis
Enoree Vocational Center	Jerry D. Sparks
Donaldson Vocational Center	Albert L. Waters

POST-SECONDARY LEVEL: Engineering Graphics Technology

Greenville Technical College Engineering Graphics Technology Engineering Technology Division	Walter Rice, Department Chairman
--	-------------------------------------

John Terry  
Lester Caraway  
Jim Henderson  
George Failor

SUMMARY OF  
ACTIVITIES AND PARTICIPATION



1981-82 PRODUCTION SCHEDULE (ACTUAL)

(DRAFTING TASK FORCE COMMITTEE)

	Program Description	Task Listing (Objectives)	Performance Actions	Performance Standards	Outcome-Referenced Measurement
MAY	Workshop #1 Committee began Writing Descriptions	Workshop #1 Began Writing Objectives	Workshop #1 Began Writing Actions	Workshop #1 Began Writing Standards	
JUNE	Committee Reviewed Drafts	Committee outlined Major Objectives (Task Listing)	Task action Writing Continued	Continued Writing	
JULY	Completed	Draft Revisions	Actions completed for each objective	Developed jointly with Performance Actions	
AUGUST		Completed	Revisions	Revisions	
SEPTEMBER	Progress report to Executive Committee				
24 OCTOBER		Began review and revisions	Began review and revisions	Began review and revisions	Workshop #2 Began writing sample test items
NOVEMBER		Completed review	Completed review	Completed review	Completed review test items Credentialing Instrument Developed
DECEMBER	Reviewed by Executive Committee	Reviewed by Executive Committee	Reviewed by Executive Committee	Reviewed by Executive Committee	Reviewed by Executive Committee
JANUARY 1982	Final Revisions and Reproduction Approved by Executive Committee	Final Revisions and Reproduction	Final Revisions and Reproduction	Final Revisions and Reproduction	Final Revisions and Reproduction
FEBRUARY	Print & Distribute -----	Print & Distribute -----	Print & Distribute -----	Print & Distribute -----	Print & Distribute -----

DRAFTING TASK FORCE COMMITTEE  
SUMMARY OF PARTICIPATION

Secondary  
Drafting  
Instructor

Secondary  
Vocational  
Center

		May	June	July	August	September	October	November	December	January	February	Committee Hours
Al Waters	Donaldson	x	x	x	x	*	x	x	*			36
Richard Davis	Foothills	-	-	-	-	*	x	x	*			12
Jerry Sparks	Enoree	x	x	-	-	*	x	½	*			21
Buford Garrett	Golden Strip	x	x	-	-	*	x	x	*			24

CODE:

\* = No meeting  
- = No Participation  
x = Participation  
½ = ½ day

The post-secondary drafting participants, met regularly to develop materials. Walter Rice, Chairman of the Engineering Graphics Department, Greenville Technical College, participated regularly as his schedule and responsibilities permitted. When Mr. Rice was unable to attend a committee meeting, material was shared prior to and after the meeting for information and to gain input. The cooperative interest that Mr. Rice and his instructional staff took in the project made personal visits, telephone and mail exchanges of information, and input feasible.

The summary of participation by committee members does not reflect mail, telephone and office visits, and exchanges in information regarding the outside work that the individual participants gave to the writing of the articulated, secondary level instruction guide.

The estimated total hours for the development of Drafting I by the Task Force Committee, including the TEC representative but not including the Program Coordinator, is 99 hours (calculated release time from classroom/supervisory responsibilities for development of instruction guide).

Two one-hour (approximate) workshops were conducted during the production time allotted for the development of the Articulated, Performance-based Instruction Guide for Drafting I and involved approximately 8 total hours of the participants' time. This resulted in approximately 91 hours total writing time for the Task Force Committee to draft the articulated instruction guide for Drafting I.

ARTICULATED INSTRUCTION OBJECTIVES GUIDE

For

DRAFTING I

PROJECT PERIOD

March, 1981 - February, 1982

(Pilot Model)

PREPARED BY  
OCCUPATIONAL EDUCATION ARTICULATION PROGRAM  
TASK FORCE COMMITTEE ON DRAFTING  
REPRESENTING  
THE SCHOOL DISTRICT OF GREENVILLE COUNTY  
AND  
GREENVILLE TECHNICAL COLLEGE  
GREENVILLE, SOUTH CAROLINA

FEBRUARY, 1982

EDITION I

OCCUPATIONAL EDUCATION ARTICULATION PROJECT  
FUNDED BY  
SOUTH CAROLINA APPALACHIAN COUNCIL OF GOVERNMENTS

#### ACKNOWLEDGEMENT

This articulated, performance-based instruction objectives guide is the product of the work of the Drafting Task Force Committee which consisted of Buford Garrett, Richard T. Davis, Jerry D. Sparks, and Albert L. Waters, vocational education center drafting instructors, The School District of Greenville County, and Mr. Walter Rice, Department Head, Engineering Graphics Technology, Greenville Technical College. Appreciation is extended to the instructors of the Engineering Graphics Technology department at TEC for their contribution to this document.

The professional interest of Mr. Michael Cox of The School District of Greenville County in editing this guide is appreciated.

ARTICULATED INSTRUCTION OBJECTIVE GUIDE

CONTENTS

Articulated Instruction Guide, Drafting I . . . . .	D-1
Secondary Description, Drafting I . . . . .	D-1
Post-secondary Description, Engineering Graphics I, II, and III . . . . .	D-2
Scope of Project . . . . .	D-4
Similar Areas of Training . . . . .	D-5
Module Designations . . . . .	D-6
Standards Applicable to Drafting . . . . .	D-8
Student-Teacher Agreement . . . . .	D-11
Student's Drafting Portfolio . . . . .	D-12
Summary, Suggested Instruction Time, Drafting I . . . . .	D-14
Task Listing, Drafting I . . . . .	D-17
Module 1.0, Classroom Safety . . . . .	D-23
Module 2.0, Basic Math Review . . . . .	D-27
Fractions . . . . .	D-28
Decimals . . . . .	D-29
Volumes . . . . .	D-30
Areas . . . . .	D-31
Metrics . . . . .	D-32
Angular Measurement . . . . .	D-34
Module 3.0 . . . . .	D-35
Introduction to Drafting . . . . .	D-36
Use and Care of Instruments . . . . .	D-37
Clean Drafting Instruments/Equipment . . . . .	D-39
Applying the Alphabet of Lines . . . . .	D-40
Lettering . . . . .	D-41
Lettering with Mechanical Devices . . . . .	D-42
Use of the Drafting Machine . . . . .	D-43
Geometrical Constructions . . . . .	D-44
Sketching and Shape Description . . . . .	D-46
Multiview (Orthographic) Projections . . . . .	D-48
Principles of Diazo Reproduction Process . . . . .	D-49
Make Diazo (Oxalid) Copies of Original Drawings . . . . .	D-50

Dimensioning . . . . .	D-51
Shop Processes - Machining . . . . .	D-53
Applying Tolerances . . . . .	D-54
 Module 4.0 . . . . .	 D-55
Section Views . . . . .	D-56
Auxiliary Views . . . . .	D-57
Revolutions . . . . .	D-58
Threads and Fasteners . . . . .	D-59
Axonometric Pictorial Drawings . . . . .	D-60
Oblique Pictorial Drawings . . . . .	D-61
Perspective Pictorial Drawings . . . . .	D-62
Parallel Line Development . . . . .	D-64
Radial Line Developments . . . . .	D-65
Intersections . . . . .	D-66
 Module 5.0 . . . . .	 D-67
Working Drawings . . . . .	D-68
Equipment List . . . . .	D-71
Outcome-Referenced Measures . . . . .	D-72
Proficiency Report . . . . .	D-116
Textbook References . . . . .	D-120
References . . . . .	D-121

## APPENDIXES

- Appendix 1      Engineering Graphics Technicology  
                         Articulation, 1976
- Appendix 2      Engineering Graphics I, Course Syllabus
- Appendix 3      Engineering Graphics II, Course Syllabus
- Appendix 4      Engineering Graphics III, Course Syllabus
- Appendix 5      "Do's and Don'ts of Dimensioning"
- Appendix 6      Optional Tasks: Cams, Gears, Pipe Drawing, Inking,  
                         Welding, and Shop Processes
- Appendix 7      Status Report on Drafting II
- Appendix 8      Drafting II: Introductory Description to Incomplete  
                         Articulated Instruction Guide
- Appendix 9      Copy of Drafting II Instruction Guide Curriculum Guide,  
                         1970, South Carolina State Department of Education
- Appendix 9-A    Architectural Drafting, Secondary Level, Drafting II
- Appendix 9-B    Machine Drafting, Secondary Level, Drafting II
- Appendix 9-C    Structural Drafting, Secondary Level, Drafting II
- Appendix 9-D    Supplementary Topics, Secondary Level, Drafting II;  
                         Electrical/Electronic, Piping, and Welding Drafting

## DRAFTING

**LEVEL:** Secondary

**TITLE:** Drafting I

**DESIGNATION:** Drafting I                      **COMPUTER NUMBER:** 753

**SECONDARY DESCRIPTION:** Drafting I trains the student to interpret the notes and sketches of engineers and to develop plans which bring the engineer's design into reality. Graduates of the program are prepared to enter industry as apprentice draftsmen or graphic technicians.

**OBJECTIVES:** The draftsman trainee translates the ideas, rough sketches, specifications, and calculations of engineers, architects, and designers into working plans which are used by skilled craftsmen in making a product. The draftsman uses such instruments as compasses, dividers, protractors, and triangles to prepare clear, complete, and accurate working plans of buildings and structures as well as electrical, mechanical, and aeronautical components or equipment.

Upon completing Drafting I, the student will possess a base of knowledge and skills necessary for:

- A. Initial entry level employment in the general field of drafting.
- B. Entry into advanced study at the secondary level in Drafting II, a second year of training with specialized study in such areas as mechanical, architectural, or structural drafting.
- C. Entry into Engineering Graphics Technology at Greenville Technical College with possible advanced standing credit awarded for Engineering Graphics Technology courses 111, 121, and 131, based on demonstrated acceptable knowledge and performance standards.

**PREREQUISITES:** The student should possess a mechanical aptitude, the ability to visualize space relations or visualize in three dimensions, and should have ability in mathematics. Free-hand drawing ability and knowledge of basic geometry are helpful.



**REQUIRED/SUGGESTED INSTRUCTION HOURS:**

Level		Secondary	
System		Year	
Division	Class	Lab	Total
Credits	3		3
Hours	540		540

**PERFORMANCE  
EVALUATION:**

Given basic drafting tools and equipment, the student will demonstrate mastery of drafting instruments to produce clear, complete, and accurate working plans from given ideas, rough sketches, specifications, and designs in a graphic form useable by skilled craftsmen in making a product. The student will demonstrate, through outcome-referenced measures, the knowledge and skill level necessary to successfully pursue Drafting II, a second year of study; to qualify for advance standing at the post-secondary level in Engineering Graphics Technology with credit for EGT 111, 121, or 131; or to qualify for entry level employment as a drafting trainee or apprentice.

**JOB  
QUALIFI-  
CATIONS:**

Drafting I is part of a two-year block of training at the secondary level. Mastery of Drafting I skills and knowledge will qualify the student to pursue Drafting II with a high probability of success and may qualify the student to exempt Engineering Graphic Technology courses EGT 111, 121, and 131, at Greenville Technical College if the student continues career development training at the institution in Engineering Graphics Technology. Basic skills and knowledge of Drafting I prepares the student for entry level employment as an apprentice draftsman with one year of experience.

**WORKING  
CONDITIONS:**

Usually, work is in a well lighted and ventilated drafting room. The drafter must stand or sit for long periods doing tedious work. Work is not strenuous and is suited for physically handicapped persons whose disability does not limit use of hands or fingers.

**LEVEL:**

Post-secondary

**TITLES:**

Engineering Graphics I, II, and III

**DESIGNATIONS:**

EGT 111, EGT 121, and EGT 131

**POST-SECONDARY  
DESCRIPTION:**

Engineering Graphics Technology is a two-year Associate Degree program of Greenville Technical College. It is the art and science of representing three-dimensional objects upon a two-dimensional surface. This representation is done according to mathematical rules of projection and the engineering design process in a manner and form necessary to define precisely their shape, size, material, and manufacturing specifications. Instruction is given in drafting fundamentals including manufacturing drawings; methods and processes; assemblies and layouts; and speciality drafting such as machine, electrical, mechanical, piping, structural, civil, and architectural. The student is trained to enter the field as a drafter apprentice.

**COURSE  
OVERVIEW:**

**EGT 111, Engineering Graphics I**

This is an introductory course for students majoring in Engineering Graphics and related engineering technology programs. Students will learn basic skills, including instruments use, lettering, sketching, geometric construction, orthographics, and dimensions.

**EGT 121, Engineering Graphics II**

A continuation of Engineering Graphics I, students learn to draft pictorials, auxiliaries, sections, intersections, developments, and fasteners.  
(Prerequisite: EGT 111)

**EGT 131, Engineering Graphics III**

This course is a continuation of Engineering Graphics II and introduces the student to the different types of working drawings, including their use and purpose. Students also learn notes, limits, tolerances, and precision. (Prerequisite: EGT 121)

**REQUIRED/SUGGESTED INSTRUCTION HOURS:**

Level		Post-Secondary			
Course	Class	Lab	Hrs./Wk.	Qtr./Hrs.	Credits
EGT 111	3	3	6	60	4
EGT 121	1	9	10	110	4
EGT 131	1	9	10	110	4
<b>TOTAL QUARTER HOURS:</b>				<b>280</b>	

**PERFORMANCE  
EVALUATION:**

Evaluation of student performance is accomplished through objective measures of knowledge and performance and by instructor rating of performance. (See appendixes for further information.)

SCOPE OF PROJECT  
DRAFTING  
(Similar Training)

Secondary Level  
(Year or 9-months system)

Post-Secondary Level  
(Quarter system)

DRAFTING

Drafting I

EGT 111 Engineering Graphics I  
EGT 121 Engineering Graphics II  
EGT 131 Engineering Graphics III

Drafting II\*

No specific equivalent identified

Unless otherwise specified, secondary level courses are based on the 180 day school year system and post-secondary level courses are based on the quarter system.

The post-secondary level courses are those of the Engineering Graphics Technology Department of Greenville Technical College.

\*As yet, an articulated, performance-based instruction guide has not been completed for Drafting II.

POST-SECONDARY DRAFTING TOPICS  
SIMILAR TO SECONDARY LEVEL DRAFTING I

1st Quarter (Engineering Graphics I EGT 111)

1. Instrument Drawing (one view)
2. Lettering
3. Geometric Construction
4. Sketching and Shape Description
5. Dimensioning
6. Reproduction and Control of Drawing
7. Multiview (Orthographic) Projections

2nd Quarter (Engineering Graphics II, EGT 121)

8. Section Views
9. Auxiliary Views
10. Revolutions
11. Screw, Threads, and Fasteners
12. Isometric Drawings
13. Oblique Drawings
14. Intersections and Developments

3rd Quarter (Engineering Graphics III, EGT 131)

15. Shop Processes
16. Working Drawings

This information was taken from "Articulated Course Description", produced by Greenville TEC (1976), a copy which may be found in the appendixes. In addition, 1981 revised course syllabus forms from the post-secondary courses EGT 111, EGT 121, EGT 131 are included in the appendixes.

Consult the "Summary, Suggested Instruction Time, Drafting I", of this guide for a listing of the secondary level Drafting I topics.

## MODULE DESIGNATIONS

### DRAFTING

The following are the module designations for the secondary level Drafting program courses included in the articulated, instruction objectives guide.

#### Drafting I

- |            |  |
|------------|--|
| Module 1.0 | Classroom Safety   |
| Module 2.0 | Basic Math   |
| Module 3.0 | (Untitled Similar to Post-secondary course, EGT 111, Engineering Graphics I)   |
| Module 4.0 | (Untitled Similar to Post-secondary course, EGT 121, Engineering Graphics II)  |
| Module 5.0 | (Untitled Similar to Post-secondary course, EGT 131, Engineering Graphics III) |

#### Drafting II

Module 6.0 begins Drafting II at the secondary level.

STANDARDS FOR DRAFTING

## STANDARDS APPLICABLE TO DRAFTING

### CLASSROOM STANDARDS:

To provide an instructional vehicle, every effort will be made to organize the classroom and conduct instruction, class administration, and supervision in a way that portrays an Engineering Office atmosphere. Such action will provide the opportunity for concurrent instruction in "office practices or procedures."

### RECURRING PERFORMANCE ACTIONS:

The following recurring performance action will be applicable to many performance objectives and, because they are recurring, they may not be stated with each task. These recurring performance actions will be expected meet to acceptable standards\* for each performance objective unless inappropriate.

- Select pencils for layout lines, finish object lines, and lettering.
- Sharpen pencils.
- Fasten paper to board or table.
- Make measurements.
- Lay out border.
- Draw guidelines for title strip.
- Letter in required information.
- Determine necessary space allocations for necessary views and developments.
- Add necessary lettering.
- Check entire drawing for completeness and accuracy.

\*Standards are to the instructor's satisfaction or are the minimum standards for entry level job performance.

### RECURRING RELATED TECHNICAL KNOWLEDGE:

- Use of instruments.
- Selection of paper.
- Alphabet of Lines, Lettering.
- Proper type of lettering.
- Read specifications and instructions.
- Select appropriate instruments for measurements.

## RECURRING PERFORMANCE STANDARDS:

The minimum basic performance standards outlined below will apply to Drafting unless specified differently in individual modules, task sheets, or by the instructor/student will:

- Appropriate care for and use of drafting instruments.
- Use proper type of lettering
- Meet neatness, accuracy of drawing, and sketch execution criteria.
- Execute drawings and sketches within the time limits considered acceptable for initial employment performance.
- Apply the most appropriate techniques and use the proper equipment and materials for the execution drawings.
- Demonstrate knowledge of related technical information, application of theories and procedures, symbols and conventions, and terminology with at least 80 percent accuracy.
- Demonstrate knowledge and ability to correctly use the appropriate technical manuals, manuals of standards, tables, and catalogs.
- Execute drawings which conform to standards that apply as contained in American National Standards Institute (ANSI) publications and other appropriate technical references.
- Apply prescribed inking techniques.
- Read blueprints with at least 80 percent accuracy.
- Use correct templates as prescribed when appropriate.



## THE AMERICAN NATIONAL STANDARDS INSTITUTE

Reference to ANSI standards will occur in this articulated, performance-based instruction objectives guide. ANSI is the American National Standards Institute. The Institute is a private nonprofit organization operating in the public interest. ANSI coordinates the national standards activities for large and small companies and hundreds of technical, professional, labor, and consumer organizations.

In its activities, ANSI coordinates voluntary development of national standards, establishes national consensus standards, and represents U.S. interests in international standardization carried out by such non-treaty organizations as the International Organization for Standardization (ISO).

ANSI does not develop standards but provides a means for determining the need for them and ensures that organizations competent to fill these needs undertake the standards development work.

Users of American National Standards include producers, distributors, retailers, utilities, architects, builders, governments, schools, testing laboratories, and many more. American National Standards provide a common language that can be used confidently by industry and its suppliers and customers.

The use of American National Standards is voluntary and become mandatory only when adopted or referenced by government.

Further information about ANSI may be obtained by writing to:

American National Standards Institute  
1430 Broadway  
New York, New York 10018

This information about ANSI was excerpted from Q & A American National Standards Institute, PR 18d-April 1979-A2M481, by the Institute.

**STUDENT-TEACHER AGREEMENT  
FOR  
PERFORMANCE-BASED LEARNING**

---

---

**DIRECTIONS:** The student, after reviewing the objectives and standards for the course either individually or as a member of the class, will check the appropriate course title block, sign his/her name at the bottom of the page, and indicate the school and date. The student and instructor, by signing the agreement indicate that they will abide by the stated objectives and standards of the course.

**THIS STATEMENT CERTIFIES THAT I HAVE READ THE OBJECTIVES AND STANDARDS FOR:**

**DRAFTING I**

**DRAFTING II**

**AND THAT I FULLY UNDERSTAND THE CONTENT OF THE OBJECTIVES, COURSE REQUIREMENTS, AND GRADING PROCEDURES.**

**STUDENT'S SIGNATURE** \_\_\_\_\_

**SCHOOL** \_\_\_\_\_

**DATE** \_\_\_\_\_

**INSTRUCTOR'S SIGNATURE** \_\_\_\_\_

RECOMMENDED  
STUDENT'S DRAFTING PORTFOLIO

The secondary level drafting student should be informed at an early stage in his or her training program of the importance of developing a "Drafting Portfolio" of examples of corrected or non-corrected drawings to illustrate competency in the areas articulated between the secondary and post-secondary levels. This is particularly important if the student chooses to continue vocational training at the post-secondary level and possibly desires to apply for advanced placement in a TEC drafting program.

The drawings the student should include in the portfolio as suggested by Greenville Technical College include, but are not limited to, the following list.

Recommended for Advanced Standing Application (EGT 111)

- ( ) Alphabet of Lines
- ( ) Lettering
- ( ) Geometric Construction
- ( ) Sketching and Shape Description
- ( ) Multiview (Orthographic) Projections
- ( ) Dimensioning
- ( ) Shop Processes - Machining
- ( ) Tolerancing

Recommended for Advanced Standing Application (EGT 121)

- ( ) Section Views
- ( ) Auxiliary Views
- ( ) Revolutions
- ( ) Threads and Fasteners
- ( ) Pictorial Drawings:
  - Oblique
  - Axonometric
  - Perspective
- ( ) Developments
- ( ) Intersections

Recommended for Advanced Standing Application (EGT 131)

- ( ) Working Drawings
- ( ) Ink Drawing, if applicable
- ( ) Drawings of Cams and Gears as applicable
- ( ) Option Area Drawings: Architectural, Mechanical, Structural, or other option areas of specialization

Other drawings not included in the above list but representing the student's skill development should be included. For example, a student with drawing experience and skill in architectural drafting may wish to include a special section of architectural drawings in the portfolio.

The student should consult with the secondary drafting instructor periodically concerning the development of the drafting portfolio and should include drawings that the instructor may suggest.

SUGGESTED  
INSTRUCTION TIME

SUMMARY  
DRAFTING I  
SUGGESTED INSTRUCTION TIME

<u>DRAFTING I</u> <u>MODULE/TASK</u>	<u>SUGGESTED</u> <u>HOURS</u>
MODULE 1.0	
1.01 Classroom Safety	1
MODULE 2.0	
2.01 Basic Math - Fractions	1
2.02 Basic Math - Decimals	1
2.03 Basic Math - Volumes	1
2.04 Basic Math - Areas	1
2.05 Basic Math - Metrics	1
2.06 Basic Math - Angular Measurements	1
MODULE 3.0	
3.01 Introduction to Drafting	2
3.02 Use and Care of Instruments	2
3.03 Clean Drafting Instruments/Equipment	1
3.04 Applying the Alphabet of Line	2
3.05 Lettering	2
3.06 Lettering with Mechanical Devices	2
3.07 Use of the Drafting Machine	2
3.08 Geometrical Construction	20

MODULE 3.0 (Continued)

	SUGGESTED HOURS	
3.09	Sketching and Shape Description	30
3.10	Multiview (Orthographic) Projections	30
3.11	Principles of Diazo Reproduction Process	½
3.12	Make Diazo (OZALID) Copies of Original Drawings	½
3.13	Dimensioning	60
3.14	Shop Process and Machining	10
3.15	Tolerances	10

MODULE 4.0

4.01	Section Views	60
4.02	Auxiliary Views	40
4.03	Revolutions	*
4.04	Threads and Fasteners	30
4.05	Axonometric Pictorial Drawing	53
4.06	Oblique Pictorial Drawing	10
4.07	Perspective Pictorial Drawing	20
4.08	Parallel Line Development	8
4.09	Radial Development	8
4.10	Intersections	10

MODULE 5.0

5.01	Working Drawings	120
------	------------------	-----

---

TOTAL HOURS FOR DRAFTING I 540

\*Task 4.02 and 4.03, Auxiliary Views and Revolutions, are treated as separate objectives; however, they generally are covered during the same time period of instruction and, therefore, are combined for time planning.

NOTE: Drafting II begins with Module 6.0

TASK LISTING SUMMARY

TASK LISTINGS  
DRAFTING I

MODULE/TASK	DESCRIPTION
Module 1.0	
1.0	(Classroom Safety) Given a typical drafting classroom or office working situation, the student will exhibit an awareness of safety practices, safe work habits and a positive attitude concerning drafting room safety and accident prevention, and meeting standards established by the instructor.
Module 2.0	
	Module 2.0 features a basic math review of fractions, decimals, volumes, areas, angular measurement, the four basic math processes, and the metric system. Objectives in Module 2.0 basically are at the eighth grade level. The purpose of Module 2.0 is to assist the instructor in evaluating the approximate math skills level of students entering Drafting I and to review basic math as needed. The instructor is encouraged to refer to the <u>Curriculum Guide for High School General Mathematics</u> , Greenville, SC: The School District of Greenville, County, 1979, for additional information. The Math Guide should be available to the drafting instructor in each vocational center.
2.01	(Basic Math Review - Fractions) Given a pretest or examples by the instructor, conduct required fraction operations.
2.02	(Basic Math Review - Decimals) Given a pretest or examples by the instructor, perform required decimal math operations.
2.03	(Basic Math Review Volumes) Given a pretest or examples by the instructor, find the volume of any rectangular prism or cube.
2.04	(Basic Math Review - Areas) Given a pretest or examples by the instructor, find the area of given figures.
2.05	(The Metric System) Given basic instruction in the metric system and conversion United States Customary units to metric, read and convert dual dimensions on drawings and specifications and convert dimensions from one system into the other system on teacher or text assigned problems with 100 percent accuracy.



- 2.06 (Basic Math - Angular Measurements) Given a pretest or examples by the instructor which involve the four basic math processes in angular measurement, perform the math operations changing degrees, minutes, and seconds to whichever one of the three units will expedite the mathematical processes involved.

### Module 3.0

- 3.01 (Introduction to Drafting) Given an introductory study of Drafting I; information from the guidance and placement offices and drafting instructor at the vocational education center; the guidance offices at the high school and post-secondary levels; statistics and data provided by the South Carolina Employment Securities Commission as well as the South Carolina and United States Departments of Labor; the student will be able to describe the general history of drafting and will be able to state essential occupational and career information related to the field of drafting.
- 3.02 (Use and Care of Instruments) Given drafting equipment to include a drafting table, parallel bar, appropriate basic drafting instruments, and lettering sheets, demonstrate correct use of basic drafting equipment, maintenance of equipment, reading of scales, and attaching paper to drafting table.
- 3.03 (Clean Drafting Instruments/Equipment) Given a drafting board/machine, parallel straightedge, triangles, lettering devices, and electric eraser; clean drafting instruments/equipment.
- 3.04 (Applying the Alphabet of Lines) Given practical exercises by the instructor or from a text, apply the Alphabet of Lines to given drawings according to given specifications.
- 3.05 (Lettering) Given a single-stroke lettering guide or referring to an assigned style of lettering from a text, letter freehand in a style that is perfectly legible, uniform, and capable of rapid execution, compatible to the guide in shapes and proportions. Using a 4-H pencil to draw guidelines based on given specifications and using an H or 2-H pencil to complete the lettering.
- 3.06 (Lettering with Mechanical Devices) Given a lettering job with a requirement to use a common mechanical lettering device, demonstrate the ability to select and use the correct mechanical lettering items for the job and produce in a reasonable time limit, lettering that is correctly spelled, properly spaced, and neat.
- 3.07 (Use of the Drafting Machine) Given the arm or track of drafting machine, identify how the drafting machine replaces the straightedge, triangle, scale, and protractor and how the machine reduces drafting time. Demonstrate the basic operations of the two types of drafting machines to the instructor's satisfaction.

- 3.08 (Geometrical Construction) Given step-by-step procedures, drawing instruments, accessories, and geometric definitions, construct geometrical figures and polygons common to the drafting field by completing a given exercise with 90 percent accuracy.
- 3.09 (Sketching and Shape Description) Given a requirement to neatly sketch and draw freehand, to instructor's satisfaction in a reasonable time, draw an object using orthographic projections and pictorials.
- 3.10 (Multiview (Orthographic) Projections) Given an object with a requirement to draw the object using orthographic projections, draw three necessary views showing complete views in correct positions.
- 3.11 (Principles of Diazo Reproduction Process) Given instruction, manufacturer's manual on Diazo machine, and safety consideration, describe the operational principles of the Diazo reproduction process.
- 3.12 (Make Diazo (OZALID) Copies of Original Drawing) Given a Diazo copier, copy paper, and an original drawing; produce a clear, readable Diazo print of an original drawing with consistent line quality in terms of contrasting background.
- 3.13 (Dimensioning) Given problem simulations by the instructor, demonstrate knowledge of the universal rules and procedures for showing shapes and sizes pictured, by illustrating how and where dimensions are placed on drawings to the satisfaction of the instructor.
- 3.14 (Shop Processes - Machining) Given an introduction to shop processes in machining, identify and describe common machining processes, machine tools, and complete working drawings of given exercises to the satisfaction of the instructor.
- 3.15 (Applying Tolerances) Given access to relevant charts, symbols, and problems, demonstrate the ability to apply tolerances to given drawing with specifications or to instructor provided drawing of objects with measurements made by the student.

#### MODULE 4.0

- 4.01 (Section Views) After instruction and demonstrations by the instructor, complete a minimum of two exercises to describe the internal features of three-dimensional objects by using various types of sectional views, drawing figures to meet specifications concerning: (1) the correct type of sectional view, (2) correct placement of cutting plane line, and (3) correct placement of section lines.
- 4.02 (Auxiliary Views) After instruction and demonstrations explaining the theory of auxiliary views, given exercises by the instructor,

draw the true shape of inclined and oblique planes and draw a minimum of two assigned figures using auxiliary planes to describe the true size and shape of faces which are not parallel to the regular planes of projection.

- 4.03 (Revolutions) Given a three-dimensional object, with an inclined plane in the front or right side view, develop a primary revolution by showing the true size and shape of the inclined plane in the right side or front side views respectively.
- 4.04 (Threads and Fasteners) Given problems by the instructor, select or identify and draw the proper threads and fasteners for project requirements using appropriate tables or references to demonstrate job qualification level competencies in the drawing of threads and fasteners.
- 4.05 (Axonometric Pictorial Drawing) Given an object to be drawn using the axonometric system, draw the object using one of the following procedures: (1) Draw the object in isometric. (2) Draw the object in dimetric. (3) Draw the object in trimetric. (4) Draw axonometric sections.
- 4.06 (Oblique Pictorial Drawings) Given an object to be drawn in the oblique, draw in the oblique using three of the following: (1) Top emphasis. (2) Cavalier. (3) Right side emphasis. (4) Reverse axis. (5) Cabinet. (6) Foreshortened.
- 4.07 (Perspective Pictorial Drawings) Given an object to be drawn, draw the object in one point and two point perspective with the following elements applied and identified so that drawing parts appear progressively smaller as they are further away: (1) Variables of Perspective-Station points. (2) Angles of View: a. Horizontal b. Vertical (3) Distance from the Object: Cone of Vision (4) Group Line (5) Picture Plane (6) Horizon Line (7) Vanishing Point: a. Lines parallel to picture plane b. Horizontal lines not parallel to picture plane c. All other lines (8) Vertical Measurements (9) Horizontal Measurements: a. Sighting b. Measuring.
- 4.08 (Parallel Line Development) Given an assignment by the instructor or from the text, create the rectangular patterns of the prism and the cylinder.
- 4.09 (Radial Line Developments) Given teacher or text problems, create pie shaped patterns of the pyramid and the cone.
- 4.10 (Intersections) Given teacher or text problems, create required patterns of two intersecting solids.

#### MODULE 5.0

- 5.01 (Working Drawings) Given problems and the appropriate tools and supplies, prepare preliminary working drawings to demonstrate a detailed part drawing including all information necessary to

properly fabricate the parts to the satisfaction of the instructor. Also prepare assembly drawings with bill of materials utilizing the detailed drawings.

**NOTE:**

The completion of Modules 1.0 - 5.0, Drafting I at the secondary level, basically is equivalent to the post-secondary Engineering Graphics courses; EGT 111, EGT 121, and EGT 131, at Greenville Technical College.

Drafting II at the secondary level begins with Module 6.0



MODULE 1.0

DRAFTING I

MODULE 1.0 DRAFTING I  
TASK 1.01 CLASSROOM SAFETY

---

---

**PERFORMANCE OBJECTIVE:**

Given a typical drafting classroom or office working situation, the student will exhibit an awareness of safety practices, safe work habits, and a positive attitude concerning drafting room safety and accident prevention and meeting standards established by the instructor.

**PERFORMANCE ACTIONS:**

- 1.0101 Develop an awareness of hazards and become more safety conscious.
- 1.0102 Develop a serious attitude toward the use of safety procedures.
- 1.0103 Prepare for safety before entering the work area.
- 1.0104 Prepare for safety on entering the work area.
- 1.0105 Prepare for safety at the work station.
- 1.0106 Demonstrate knowledge of color coding.
- 1.0107 Practice safe procedures.
- 1.0108 Prepare for safety on leaving the work environment.

**SUGGESTED INSTRUCTION TIME:** 1 Hour

**PERFORMANCE STANDARDS:**

- "Zero-Level" accident record.
- Standards acceptable to the instructor based on recommended resources.

**RECOMMENDED RESOURCES:**

Jacobs, Clinton O., and Howard J. Turner, Developing Shop Safety Skills, Athens, GA: American Association for Vocational Instructional Materials. Approximately 80 pages of brief, visually clear suggestions concerning a variety of shop safety situations. Good student or resource manual.

Safety Handbook, A Guide for Trade and Industrial Programs, Clemson University, SC: Vocational Education Media Center, 1968. (No 13/2/70, \$2.25; Accompanying 31 Transparencies, No. 9/8/68. \$5.75.) Available from Trades and Industries District Supervisors, Office of Vocational Education, South Carolina State Department of Education or from the Vocational Education Media Center, Clemson University, SC.

MODULE 1.0

DRAFTING I

TASK 1.01

CLASSROOM SAFETY

---

---

**RECOMMENDED RESOURCES: (continued)**

Planning for Emergencies, Occupational Safety and Health Short Course  
Number Seven, Columbia, SC: SC State Board for Technical and  
Comprehensive Education.

Notgrass, Troy. Safety Handbook for ICT, The University of Texas  
at Austin: Center for Occupational Curriculum Development, Division  
of Continuing Education, 1978.

**RELATED TECHNICAL INFORMATION:**

- Regulations of individual school or classroom
- Regulations of The School District of Greenville County
- Codes, laws, and ordinances
- Materials and equipment handbooks and manuals
- OSHA Regulations
- E.P.A. Regulations

**DRAFTING ROOM SAFETY RECOMMENDATIONS:** Attached (Courtesy of Mr. Al  
Waters, Donaldson Vocational Center, Source unknown.) Possible use:  
Handout for students.

DRAFTING ROOM SAFETY

A most important factor in safety in the drafting room is the attitude of the worker or student. By developing safe work habits and an awareness of safety practices, accidents may be avoided. Although no set of rules and good practices can cover all cases, the following will help the drafting worker or student enjoy a safer working environment.

1. Keep adequate clearance around drafting tables according to safety and fire regulations.
2. Keep stools and chairs out of aisles. Place them under tables and desks when they are not in use.
3. Stools must be used so they rest on all four legs. A "tilted stool" may cause a serious fall or accident.
4. In adjusting drafting tables with the instructor's supervision, keep fingers clear of the top and hinged area.
5. Drafting machine arms, T-square blades, and other equipment must not block aisles.
6. Use dividers, compass, ruling pen, and pencils carefully so they will not be a source of puncture wounds.
7. Pencils, erasers, and other small articles should be picked up from the floor to prevent them from becoming the cause of a serious fall.
8. Pencils, thumbtacks, and other small articles should not be placed in the mouth. (These could be swallowed or cause injury and infection).
9. Chemicals must be kept away from the eyes, nose, and throat; they should be used only in an area where adequate ventilation can be provided.
10. Always keep hands and fingers clear of the paper-cutter blade.
11. The blade of the paper-cutter must be kept in the "down" position when not in use.
12. Hands must be kept clear of the light tube and belt feeding mechanism of the reproduction machine (white-printer) in order to avoid crushed fingers.
13. Playing or scuffling, often referred to as "horseplay", is extremely dangerous and is not permitted. A playful push could cause a bad cut or bruise from contact with the sharp edge of a piece of furniture or equipment.



14. Articles and materials should be properly stored: Avoid stacking items that could fall from the top of lockers or shelves.
15. Any injury, no matter how slight, is to be reported to the instructor immediately. Infection can result from minor cuts and scratches left unattended.

Courtesy of Al Waters, Donaldson Vocational Center, Source is unknown.

MODULE 2.0

DRAFTING I

MODULE 2.0

DRAFTING I

TASK 2.01

BASIC MATH REVIEW - FRACTIONS

---

---

**PERFORMANCE OBJECTIVE:**

Given a pretest or examples by the instructor, conduct the following operations with fractions:

1. Change any fraction to a decimal number, and any terminating decimal number to a fraction.
2. Arrange in order...unit and simple nonunit fractions.
3. Write equivalent fractions in higher, lower, and lowest terms.
4. Write improper fractions as whole or mixed numbers, and mixed numbers as improper fractions.
5. Multiply fractions and mixed numbers, expressing answers in simplest form.
6. Divide fractions and mixed numbers, expressing answers in simplest form.
7. Add and subtract unlike fractions, expressing answers in simplest form.
8. Add and subtract mixed numbers with unlike fractions, expressing answers in simplest form.
9. Use rational numbers to solve simple word problems.

**PERFORMANCE ACTIONS:**

Consult: Curriculum Guide for High School General Mathematics, Greenville, SC: The School District of Greenville County, 1979.

**SUGGESTED INSTRUCTION TIME:** 1 Hour (Actual hours of instruction will be determined by student's math skill as indicated by pretest. Remedial instruction may be at initiation of Drafting I or as the actual skill is required.)

**PERFORMANCE STANDARDS:**

- Student should be able to complete pretest in Math Curriculum Guide with 90 percent accuracy.
- Consult the Math Curriculum Guide for pretests, suggested exercises, and references.

**NOTE:** The level of this math skill is eighth grade, General Math I.

MODULE 2.0

DRAFTING I

TASK 2.02

BASIC MATH REVIEW - DECIMALS

---

**PERFORMANCE OBJECTIVE:**

Given a pretest or examples by the instructor, conduct the following decimal math operations:

1. Name the place value of digits in decimal numbers of up to nine digits before the decimal and six digits after the decimal.
2. Compare decimal numbers and arrange them in order.
3. Write the numeral for any decimal number of up to four decimal places.
4. Round decimal numbers to any designated place value up to thousandths.
5. Add and subtract decimal numbers of up to six digits.
6. Multiply decimal numbers by whole numbers or decimal numbers.
7. Divide a number by a three digit decimal number.
8. Multiply and divide decimal numbers by powers of ten, by inspection.

**PERFORMANCE ACTIONS:**

Consult: Curriculum Guide for High School General Mathematics, Greenville, SC: The School District of Greenville County, 1979.

**SUGGESTED INSTRUCTION TIME:** 1 Hour (Actual hours of instruction will be determined by the student's math skill as indicated by pretest. Remedial instruction may be at initiation of Drafting I or as the actual skill is required.)

**PERFORMANCE STANDARDS:**

- Student should be able to complete pretest in Math Curriculum Guide with 90 percent accuracy.
- Consult: Curriculum Guide for High School General Mathematics, 1979, for pretests, suggested exercises, and references.

**NOTE:** The level of this math skill is eighth grade, General Math I.

MODULE 2.0

DRAFTING I

TASK 2.03

BASIC MATH REVIEW - VOLUMES

---

---

**PERFORMANCE OBJECTIVE:**

Given a pretest or examples by the instructor, find the volume of any rectangular prism or cube.

**PERFORMANCE ACTIONS:**

Consult: Curriculum Guide for High School General Mathematics, Greenville, SC: The School District of Greenville County, 1979.

**SUGGESTED INSTRUCTION TIME:** 1 Hour (Actual hours of instruction will be determined by the student's math skill as indicated by pretest. Remedial instruction may be at initiation of Drafting I or as the actual skill is required.)

**PERFORMANCE STANDARDS:**

- Student should be able to complete present in Math Curriculum Guide with 90 percent accuracy.
- Consult: Math Curriculum Guide for pretests, suggested exercises, and references.

**NOTE:** The level of this math skill is eighth grade, General Math I.

MODULE 2.0

DRAFTING I

TASK 2.04

BASIC MATH REVIEW - AREAS

---

**PERFORMANCE OBJECTIVE:**

Given a pretest or examples by the instructor, find the area of the following types of figures:

- a. Rectangle, square, and parallelogram
- b. Triangle and trapezoid
- c. Circle
- d. Surface area of any rectangular prism, cube or cylinder

**PERFORMANCE ACTIONS:**

Consult: Curriculum Guide for High School General Mathematics, Greenville, SC: The School District of Greenville County, 1979.

**SUGGESTED INSTRUCTION TIME:** 1 Hour (Actual hours of instruction will be determined by the student's math skill as indicated by pretest. Remedial instruction may be at initiation of Drafting I or as the actual skill is required.)

**PERFORMANCE STANDARDS:**

- Student should be able to complete pretest in Math Curriculum Guide with 90 percent accuracy.
- Consult the Math Curriculum Guide for pretests, suggested exercises, and references.

**NOTE:** The level of this math skill is eighth grade, General Math I.

MODULE 2.0

DRAFTING I

TASK 2.05

THE METRIC SYSTEM

---

PERFORMANCE OBJECTIVE:

Given basic instruction in the metric system and conversion from United States Customary units to metric, read and convert dual dimensions on drawings and specifications and convert dimensions from one system into the other system on teacher or text assigned problems with 100 percent accuracy.

PERFORMANCE ACTION:

- 2.0501 Demonstrate ability to read and use U.S. Customary measurements, especially length measurements.
- 2.0502 Describe the development of the Metric System (SI).
- 2.0503 Identify basic SI units and their symbols.

Unit	Name	Symbol
Length	Meter	m
Mass	Kilogram	kg
Time	Second	s
Electric Current	Ampere	A
Temperature	Kelvin	K
Luminous	Candela	cd

- 2.0504 Identify basic Metric prefixes:

Prefix	Amount	Fraction	Decimal
Milli	One-thousandth	1/1000	0.001
Centi	One-hundredth	1/100	0.01
Deci	One-tenth	1/10	0.1
Deka	Ten	10	10.0
Hecto	Hundred	100	100.0
Kilo	Thousand	1000	1000.0

- 2.0505 Convert Inches to Millimeters  
Inches x 25.4 = Millimeters
- 2.0506 Convert Millimeters to Inches  
Millimeters x 0.0394 = Inches
- 2.0507 Round off to three decimal places - given odd numbers
- 2.0508 Indicate acceptable methods of Dual Dimensioning

$28.58 \pm 0.1$  Millimeters  
 $1.125 \pm .004$  29.58  $\pm 0.1$  / 1.125  $\pm .004$   
Inches

SUGGESTED INSTRUCTION TIME: 1 Hour

MODULE 2.0  
TASK 2.05

DRAFTING I  
THE METRIC SYSTEM

---

---

**PERFORMANCE STANDARDS:**

- Accuracy of 100 percent in conversion of length from one system to the other system.
- ANSI Standards

**RELATED TECHNICAL INFORMATION:**

- ANSI Standards
- System International d'United (SI) ((Metric System))
- U.S. Customary Measurements System



MODULE 2.0

DRAFTING I

TASK 2.06

BASIC MATH - ANGULAR MEASUREMENT

---

**PERFORMANCE OBJECTIVE:**

Given a pretest or examples by the instructor which involve the four basic math processes in angular measurement, perform the math operations changing degrees, minutes, and seconds to whichever one of the three units will expedite the mathematical processes involved.

**PERFORMANCE ACTIONS:**

- 2.0601 Identify the parts of an angle.
- 2.0602 State or identify rules for:
  - a. Changing degrees to minutes.
  - b. Changing minutes to seconds.
  - c. Changing an angle expressed in degrees and minutes to seconds.
  - d. Changing minutes to degrees.
  - e. Measuring length of an arc (circular length).
- 2.0603 Determine the degrees in various parts of a circle.
- 2.0604 For given problems, determine equivalent values of angles: Degrees to parts of a circle, angular measurement to degrees, minutes, or seconds.
- 2.0605 Compute circular and angular measurements arriving at the appropriate combination of measurements required for the process involved.
- 2.0606 Measure angles by the direct method and by computation.

**SUGGESTED INSTRUCTION TIME:** 1 Hour (As needed)

**PERFORMANCE STANDARDS:**

- 90 percent accuracy in basic angular measurements necessary for the completion of tasks in Drafting I.

**SUGGESTED REFERENCES:**

- Curriculum Guide for High School General Mathematics, Greenville, SC: The School District of Greenville County, 1979.
- Olivo, S. Thomas, and Olivo, Thomas P., Basic Mathematics Simplified, 3rd edition, Albany, NY: Delmar Publishers, 1972.

\*Four basic math processes: Addition, Subtraction, Multiplication, Division.

MODULE 3.0

DRAFTING I

MODULE 3.0

DRAFTING I

TASK 3.01

INTRODUCTION TO DRAFTING

---

---

**PERFORMANCE OBJECTIVE:**

Given an introductory study of Drafting I; information from the guidance and placement offices and drafting instructor at the vocational education center; the guidance offices at the high school and post-secondary levels; statistics and data provided by the South Carolina Employment Security Commission as well as from the South Carolina and United States Departments of Labor, the student will be able to describe the general history of drafting and will be able to state essential occupational and career information related to the field of drafting.

**PERFORMANCE ACTIONS:**

- 3.0101 Describe the general history or development of drafting, such as the various materials used in drawing.
- 3.0102 List specialized fields in drafting.
- 3.0103 Describe the application of drawings as used in industry.
- 3.0104 List career opportunities for the two-year secondary level drafting program graduate, on a regional and local scale in a representative selection of industries, indicating job requirements for each position, job functions, and career ladders.
- 3.0105 Outline salary and fringe benefits in the field of drafting, given local statistical and other data concerning the labor market and employment trends.
- 3.0106 Define employment opportunities in drafting, based on the student mastering Drafting I, Drafting II, and possibly continuing drafting training at Greenville TEC and based on local labor market trends.
- 3.0107 State the environmental and working conditions in the field of drafting.
- 3.0108 Outline the techniques of getting and holding a job and advancing in the field of drafting.
- 3.0109 Define terms used in drafting.

**SUGGESTED INSTRUCTION TIME:** 2 Hours

**PERFORMANCE STANDARDS:**

- The student must satisfactorily complete an outcome-reference test on knowledge of the performance actions with a minimum of 75 percent accuracy.

MODULE 3.0

DRAFTING I

TASK 3.02

USE AND CARE OF INSTRUMENTS

---

**PERFORMANCE OBJECTIVE:**

Given drafting equipment, to include a drafting table, parallel bar, appropriate basic drafting instruments, and lettering sheets, demonstrate correct use of basic drafting equipment, maintenance of equipment, reading of scales, and attaching paper to drafting table.

**PERFORMANCE ACTIONS:**

- 3.0201 Given a basic drafting table and parallel bar, steady the drafting table and square the parallel bar.
- 3.0202 Given the draftman's pencil sharpener, sandpaper and/or pencil pointer, and drafting pencils or lead, sharpen drawing lead to conical and chisel points suitable for fine line drawing.
- 3.0203 Demonstrate how to rotate and position pencil when drawing to a standard acceptable by the instructor.
- 3.0204 Demonstrate the use of the T-square, triangle, pencil leads, paper, erasers, and erasing shields as instructed in class or textbook.
- 3.0205 Given T-square and triangles, paper and tape, and other supplies, draw lines from horizontal to vertical angle in increments of 15° to within 1° accuracy.
- 3.0206 Draw parallel and perpendicular lines, using the T-square and triangles with 100 percent accuracy.
- 3.0207 Given different types of drafting scales, references for given scales, and dimensions required, student will identify each scale, and state the differences with 100 percent accuracy, read and record distances using selected scales with 100 percent accuracy, read and record distances using selected scales with 100 percent accuracy, and lay out and draw different lengths of lines with 90 percent accuracy.
- 3.0208 Given paper, tape, and drawing board or table, attach paper to drawing board in an acceptable sequence so that it is smooth, secure, and square on the board.
- 3.0209 Using 30-60° or 45° triangles, student will check T-square for proper alignment (squareness) with 90 percent accuracy.

**SUGGESTED INSTRUCTION TIME:** 2 Hours

MODULE	3.0	DRAFTING I
TASK	3.02	USE AND CARE OF INSTRUMENTS

---

---

**PERFORMANCE STANDARDS:**

- Student will demonstrate to the accuracy required in the performance actions or to the standards required by the instructor by practical exercises and by written knowledge measures. The instructor may use the performance actions description as a checklist as appropriate.

**RELATED TECHNICAL INFORMATION:**

- Paper sizes and types of paper and their uses
- Different grades and use of each grade of drawing lead
- Recognize differences between architectural, civil engineer, and mechanical engineer scales and the units of measurements available

MODULE 3.0

DRAFTING I

TASK 3.03

CLEAN DRAFTING INSTRUMENTS/EQUIPMENT

---

**PERFORMANCE OBJECTIVE:**

Given a drafting board/machine, parallel straightedge, triangles, lettering devices, and electric eraser; clean drafting instruments/equipment.

**PERFORMANCE ACTIONS:**

- 3.0301 Select the best cleaning agent.
- 3.0302 Review the manufacturer's instructions for care and cleaning.
- 3.0303 Identify and assemble instruments and equipment to be cleaned.
- 3.0304 Establish routine.
- 3.0305 Apply appropriate techniques.
- 3.0306 Make note of damage or need for adjustments.
- 3.0307 Ensure that regularly scheduled servicing is performed on drafting equipment and instruments.
- 3.0308 Return equipment to normal storage/operating position.

**SUGGESTED INSTRUCTION TIME:** 1 Hour

**PERFORMANCE STANDARDS:**

- Student will demonstrate proper knowledge of instrument, and equipment cleaning by knowledge and performance measures to the satisfaction of the instructor using the performance actions as a checklist.
- Use of the instruments/equipment will not be impaired due to lack of cleaning.

**RELATED TECHNICAL INFORMATION:**

- Manufacturer's manuals
- Cleaning agent directions
- Supply catalogs

MODULE 3.0

DRAFTING I

TASK 3.04

APPLYING THE ALPHABET OF LINES

---

**PERFORMANCE OBJECTIVE:**

Given practical exercises by the instructor or from a text, apply the Alphabet of Lines to given drawings according to given specifications.

**PERFORMANCE ACTIONS:**

- 3.0401 State the ASA recommended use of thick, medium, and thin widths of lines.
- 3.0402 Given access to the Alphabet of Lines, apply them by drawing given drawings with all lines comparable to the guide in thickness and character with 95 percent accuracy.
- 3.0403 By laying out borders, demonstrate the method and correct line weights of border lines when necessary according to the type of drawing.

**SUGGESTED INSTRUCTION TIME:** 2 hours

**PERFORMANCE STANDARDS:**

- 95 percent accuracy in thickness and character of drawings to given guides.
- Neatness applies.

**RELATED TECHNICAL INFORMATION:**

- Know identification and purpose of each type of line used in drafting
- Know Alphabet of Line weights

MODULE 3.0

DRAFTING I

TASK 3.05

LETTERING

---

**PERFORMANCE OBJECTIVE:**

Given an single-stroke lettering guide or referring to an assigned style of lettering from a text, letter freehand in a style that is perfectly legible, uniform, and capable of rapid execution, compatible to the guide in shapes and proportions use a 4-H pencil to draw guidelines based on given specifications and using an H or 2H pencil to complete the lettering.

**PERFORMANCE ACTIONS:**

- 3.0501 Letter single-stroke vertical upper case letters, numerals, and fractions.
- 3.0502 Practice spacing.
- 3.0503 Practice composition of lettering.
- 3.0504 Use drawn (built-up) lettering using Roman letters.

**SUGGESTED INSTRUCTION TIME:** 2 Hours

**PERFORMANCE STANDARDS:**

- Acceptable to instructor.
- Letter compatible to the guide used in shapes and proportions.
- Lettering style must be acceptable to the type of drafting (i.e., a fancy lettering style appropriate to architectural drafting may not be appropriate to mechanical drafting).
- Identify, with 80 percent accuracy, different freehand lettering techniques, most commonly used types and styles, and when used.
- Demonstrate ability to letter freehand most common types and styles of letters, accurately, with proper letter proportions and neatness considerations applied.

**RELATED TECHNICAL INFORMATION:**

- Types of materials used in lettering
- Style charts and letter types
- Identify appropriate styles of lettering for general, mechanical drafting.



MODULE 3.0

DRAFTING I

TASK 3.06

LETTERING WITH MECHANICAL DEVICES

---

**PERFORMANCE OBJECTIVE:**

Given a lettering job with a requirement to use a common mechanical lettering device, demonstrate the ability to select and use the correct mechanical lettering items for the job and produce in a reasonable time limit, lettering that is correctly spelled, properly spaced, and neat.

**PERFORMANCE ACTIONS:**

- 3.0601 Use Ames Lettering instruments
- 3.0602 Use Leroy type lettering devices.
- 3.0603 Use of grid back-up sheets.

**SUGGESTED INSTRUCTION TIME:** 2 Hours

**PERFORMANCE STANDARDS:**

- Demonstrate ability to correctly and neatly use Ames type lettering device to produce lettering for specific jobs.
- Proper word spacing.
- 100 percent correct spelling.
- Letter correctly and neatly (90 percent).
- Lettering type, style, size, etc., appropriate for job.

**RELATED TECHNICAL INFORMATION:**

- Supply catalogs
- Manufacturer's manuals

**NOTE:** Leroy type lettering device may be introduced at this time, but generally it is not taught until the secondary year of drafting training.

MODULE 3.0

DRAFTING I

TASK 3.07

USE OF THE DRAFTING MACHINE

---

**PERFORMANCE OBJECTIVE:**

Given the arm or track type of drafting machine, identify how the drafting machine replaces the straightedge, triangle, scale, and protractor and how the machine reduces drafting time. Demonstrate the basic operations of the two types of drafting machine to the instructor's satisfaction.\*

**NOTE:** \*Performance actions may vary depending upon the number of drafting machines available to the student. Some drafting classrooms have demonstration drafting machines while other drafting classrooms may be fully equipped with drafting machines. The minimum objectives is familiarization with the two types of drafting machines.

**PERFORMANCE ACTIONS:**

- 3.0701 Demonstrate the basic mechanical operations of the arm drafting machine. (Similar, appropriate performance actions apply to track drafting machine.)
- a. Mounting, anchor adjustment
  - b. Protractor Head operation
  - c. Inserting scales
  - d. Setting scales:
    - (1) Using thumblock on anchor, line up lower scale with top or bottom edge of drawing board.
    - (2) Draw reference line along lower scale, near center of board. Adjust scale as required.
    - (3) Swing protractor head to minus 90° and align upper scale with reference line. Adjust scale as required.
    - (4) Adjust to an established baseline.
  - e. Square the scales.
  - f. Park the drafting machine.
- 3.0702 Using the arm or track type of drafting machine, draw given exercises to demonstrate ability to use the machine.

**SUGGESTED INSTRUCTION TIME:** 2 Hours

**PERFORMANCE STANDARDS:**

- Student will demonstrate the basic operation of the two types of drafting machines in practical exercises of drafting, given assignments by the instructor.

MODULE 3.0

DRAFTING I

TASK 3.08

GEOMETRICAL CONSTRUCTIONS

---

---

**PERFORMANCE OBJECTIVE:**

Given step-by-step procedures, drawing instruments, accessories, and geometric definitions, construct geometrical figures and polygons common to the drafting field by completing a given exercise with 90 percent accuracy.

**PERFORMANCE ACTIONS:**

- 3.0801 Construct geometric figures using compasses, protractors, French curve, and dividers.
- 3.0802 Bisect straight lines, arc, and angles.
- 3.0803 Draw parallel and perpendicular lines.
- 3.0804 Divide a line into equal parts
- 3.0805 Construct the following triangles:
- a. Isosceles
  - b. Equilateral
  - c. Scalene
  - d. Right
- 3.0806 Construct the following regular polygons:
- a. Square
  - b. Pentagon
  - c. Hexagon
  - d. Octagon
- 3.0807 Construct the following tangency problems:
- a. Draw a circle tangent to a line at a given point
  - b. Draw a tangent to a circle through a point
  - c. Draw tangent to two circles
  - d. Draw an arc tangent to line or arc and through a point
  - e. Draw a tangent arc to two lines at right angles
  - f. Draw a tangent arc to two lines at acute or obtuse angles
  - g. Draw a tangent arc to an arc and a straight line
  - h. Draw an arc tangent to two arcs
  - i. Draw an arc tangent to two arcs and enclosing one or both
  - j. Draw a series of tangent arcs conforming to a curve
  - k. Draw an ogee curve
  - l. Draw a curve tangent to three intersecting lines
  - m. Construct an ellipse by three of the following methods:
    - (1) Foci
    - (2) Axis and foci
    - (3) Pin and string
    - (4) Trammel

MODULE 3.0 DRAFTING I  
TASK 3.08 GEOMETRICAL CONSTRUCTIONS (continued)

---

---

- (5) Concentric circles
- (6) Oblique circles
- (7) Parallelogram
- (8) Approximate method
- (9) Template
- (10) Isometric

3.0808 Find geometric figure centers.

SUGGESTED INSTRUCTION TIME: 20 Hours

PERFORMANCE STANDARDS:

- Appropriate elements of American Standards Association conventions and practices apply.
- 90 percent accuracy in constructing assigned geometric figures and polygons common to the drafting field.

MODULE 3.0

DRAFTING I

TASK 3.09

SKETCHING AND SHAPE DESCRIPTION

---

**PERFORMANCE OBJECTIVE:**

Given a requirement to neatly sketch and draw freehand, to instructor's satisfaction in a reasonable time, draw an object using orthographic projections and pictorials.

**PERFORMANCE ACTIONS:**

- 3.0901 Given a situation which will require an object to be presented by freehand sketch drawing, accurately state (a) the applications and (b) advantages of freehand sketching and drawing.
- 3.0902 Given a requirement to communicate shape and composition of an object by freehand sketching and drawing, apply the following techniques to perform the task:
- a. Sketch lines (line definitions)
  - b. Sketch shapes
  - c. Sketch from subject (observation)
  - d. Sketch from written or verbal instruction
- STANDARD: Items a-d acceptable to instructor with recognizable object, neat work, and in a reasonable time limit.
- 3.0903 Make three-view drawings and label on each view the length, width, and depth as appropriate to illustrate the three principal dimensions. 100 percent accuracy applies.
- 3.0904 Convert an isometric picture drawing on grid paper to three-view sketches on grid paper to scale in their proper position, given problems from the text or instructor.
- 3.0905 Add to view problems assigned by the instructor missing lines to complete the description of the objects with all lines added to complete the project.
- 3.0906 Given a problem with two views, draw the third view to fully describe the object. The third view must be shown in its proper position to scale with all necessary lines.

**SUGGESTED INSTRUCTION TIME:** 30 Hours

MODULE 3.0 DRAFTING I  
TASK 3.09 SKETCHING AND SHAPE DESCRIPTION (continued)

---

PERFORMANCE STANDARDS:

- Sketch accurately, employing stated techniques to communicate a specific or imaginary object.
- Neatness applies.
- Performance to instructor's satisfaction.
- Accurately state the applications and advantages of freehand drawing and sketching.

NOTE: Sketching stages:

1. Sketching of straight lines and arcs; sketching simple geometric figures and solids.
2. Sketching simple solids (multiviews) to develop the sense of proportion and the ability to select and align views, and recognize precedence of lines.

MODULE 3.0

DRAFTING I

TASK 3.10

MULTIVIEW (ORTHOGRAPHIC) PROJECTIONS

---

---

**PERFORMANCE OBJECTIVE:**

Given an object with a requirement to draw the object using orthographic projections, draw three necessary views showing complete views in correct positions.

**PERFORMANCE ACTIONS:**

- 3.1001 Illustrate, on an exercise given by the instructor, the theory of orthographic projection in describing the shape of three-dimensional objects. Supply the following information graphically:
- a. Correct choice of views
  - b. Correct number of views
  - c. Correct placement of views
  - d. All visible, hidden, and center lines
- 3.1002 Given access to a variety of three-dimensional models, sketch the views necessary to describe each object.
- 3.1003 Given access to pictorial drawings, graphically describe the shape of three-dimensional objects with normal planes, inclined planes, and oblique planes.
- 3.1004 Given access to relevant problems, draw the views necessary to illustrate the following conventional practices of orthographic projection:
- a. Fillets and rounds
  - b. Conventional edges
  - c. Machined holes
- 3.1005 Illustrate the six principal views used in describing the shape of an object graphically on paper with 100 percent accuracy, given drafting instruments, supplies, and instructor assigned problems.

**SUGGESTED INSTRUCTION TIME:** 30 Hours

**RELATED TECHNICAL INFORMATION:**

- Know history and origin of orthographic drawings.
- Know relationship of six principal views according to third-angle projection.

**PERFORMANCE STANDARDS:**

- Visualize within the orthographic drawing system.
- Draw three necessary views showing complete views in correct positions.

MODULE 3.0

DRAFTING II

TASK 3.11

PRINCIPLES OF DIAZO REPRODUCTION  
PROCESS

---

---

**PERFORMANCE OBJECTIVE:**

Given instruction, manufacturer's manual on Diazo machine, and safety considerations, describe the operational principles of the Diazo reproduction process.

**PERFORMANCE ACTIONS:**

- 3.1101 Identify primary components of the Diazo machine.
- 3.1102 Describe the functions of the Diazo machine.
- 3.1103 List the Diazo Machine capabilities.
- 3.1104 Differentiate the different types of Diazo process equipment.

**SUGGESTED INSTRUCTION TIME:** ½ Hour

**PERFORMANCE STANDARDS:**

- Identify accurately the operating components of the Diazo Machine with 100 percent accuracy.
- Demonstrate knowledge of the Diazo process.
- Demonstrate knowledge of the safety requirements for the Diazo process.

**RELATED TECHNICAL INFORMATION:**

- Trade terminology
- Machine operating manual (manufacturer's manual)
- Trade catalogs, supply catalogs
- Safety considerations
- Types of papers and dyes used in Diazo process
- Uses of various types of reproductions



MODULE 3.0

DRAFTING II

TASK 3.12

MAKE DIAZO (OZALID) COPIES OF  
ORIGINAL DRAWINGS

---

**PERFORMANCE OBJECTIVE:**

Given a Diazo copier, copy paper, and an original drawing; produce a clear, readable Diazo print of an original drawing with consistent line quality in terms of contrasting background.

**PERFORMANCE ACTIONS:**

- 3.1201 Turn on ventilation fan in the vicinity of the Diazo copier.
- 3.1202 Turn on machine, light, and fluid.
- 3.1203 Adjust duration of light exposure.
- 3.1204 Simultaneously feed copy paper and original drawing into the exposure portion of the copy machine.
- 3.1205 Remove original drawing.
- 3.1206 Feed exposed Diazo paper into the development portion of the copy machine.
- 3.1207 For further copies, adjust the duration of the light exposure in accordance with the quality of linework obtained in the first copy.
- 3.1208 Trim prints, if required.

**SUGGESTED INSTRUCTION TIME:** ½ Hour (For planning only.)

**PERFORMANCE STANDARDS:**

- Demonstrate ability to operate Diazo equipment according to manufacturer's instructions.
- Demonstrate knowledge and ability of proper storage of Diazo media.
- Select proper media for a given job.
- Observes correct safety procedures.

**RELATED TECHNICAL INFORMATION:**

- Manufacturer's operating manual
- Types of reproductions
- Paper classifications
- Safety requirements
- Diazo supply requirements

MODULE 3.0

DRAFTING I

TASK 3.13

DIMENSIONING

---

---

**PERFORMANCE OBJECTIVE:**

Given problem simulations by the instructor, demonstrate knowledge of the universal rules and procedures for showing shapes and sizes pictured, by illustrating how and where dimensions are placed on drawing to the satisfaction of the instructor.

**PERFORMANCE ACTIONS:**

- 3.1301 Describe significance of dimensions and notes placed on working drawings.
- 3.1302 Identify, define, and illustrate proper use and draw dimensioning symbols, lines, and notations.
- 3.1303 Illustrate appropriate methods of dimensioning different parts of a drawing.
- 3.1304 Use the dimensioning practices described in ANSI Y14.5.
- 3.1305 Determine limit dimensions, tolerances, clearances, etc., by the proper use of ANSI B4.1 Limit Tables.
- 3.1306 Apply special dimensioning practices as required by the instructor.
- 3.1307 Given a set of problems which show undimensioned views of a part, measure the shape and sizes and place the dimensions on the view to the satisfaction of the instructor to demonstrate an understanding of how and where shape and size dimensions are placed on a drawing.

**SUGGESTED INSTRUCTION TIME:** 60 Hours

**PERFORMANCE STANDARDS:**

- Emphasis will be placed on linework, lettering, proper placement of dimensions, and choice of optimum method of dimensioning.
- Apply the following ASA dimensioning rules:
  - a. Aligned and unidirectional system
  - b. Notes
  - c. Shop processes
  - d. Size dimension for the following geometrical shapes:
    - (1) Prisms
    - (2) Cylinders
    - (3) Holes
    - (4) Miscellaneous shapes
    - (5) Contour dimensions
  - e. Location dimensions
  - f. Rounded and shapes
  - g. Dimensions on and off views

MODULE	3.0	DRAFTING I
TASK	3.13	DIMENSIONING (continued)

---

---

- h. Angles, arcs, and curves
- i. Staggered numerals
- j. Superfluous dimensions
- k. Mating dimensions

RELATED TECHNICAL INFORMATION:

- (Measuring) Given a variety of machine parts, measure, draw and dimension each part with the aid of the following measuring devices
- Outside spring caliper
- Inside spring caliper
- Vernier Caliper
- Micrometer
- Fixed gauges
- Combination square
- American Machinist's Handbook (dimensions and specifications in - standard threads, fasteners, twist drills, etc.)

MODULE 3.0

DRAFTING I

TASK 3.14

SHOP PROCESSES - MACHINING

---

**PERFORMANCE OBJECTIVE:**

Given an introduction to shop processes in machining, identify and describe common machining processes, machine tools, and complete working drawings of given exercises to the satisfaction of the instructor.

**PERFORMANCE ACTIONS:**

- 3.1401 Participate in introductory field trips to vocational training and industrial business machine shops to acquire the ability to identify and describe common machining processes and machine tools.
- 3.1402 Correctly draw and apply surface finish symbols for text or instructor supplies exercises.

**SUGGESTED INSTRUCTION TIME:** 10 Hours

**PERFORMANCE STANDARDS:**

- Student is to successfully complete a test on terminology related to shop processes, machine tools, and manufacturing processes.
- Working drawings must be to the satisfaction of the instructor based on entry level competence required by the local drafting industry.

**RELATED TECHNICAL INFORMATION:**

- Possible Machine Processes:
  - a. Drilling
  - b. Boring
  - c. Reaming
  - d. Breaching
  - e. Counterboring
  - f. Countersinking
  - h. Spotfacing

MODULE 3.0

DRAFTING I

TASK 3.15

APPLYING TOLERANCES

---

---

**PERFORMANCE OBJECTIVE:**

Given access to relevant charts, symbols, and problems, demonstrate the ability to apply tolerances to given drawing with specifications or to instructor provided drawings of objects with measurements made by the student.

**PERFORMANCE ACTIONS:**

- 3.1501 Define related terminology.
- 3.1502 Describe the following types of fits and tolerancing systems:
  - a. Basic hole system
  - b. Basic shaft system
  - c. Clearance fits
  - d. Interference fits
  - e. Transition fits
  - f. Running and sliding fits
  - g. Force fits
  - h. Location fits

**SUGGESTED INSTRUCTION TIME:** 10 Hours

**PERFORMANCE STANDARDS:**

- 90 percent accuracy in decimal-inch measurements on given drawing or instructor provided object.

**RELATED TECHNICAL INFORMATION:**

- Limits and Fits: ANSI B4.1-1967
- Surface Texture: ANSI B46.1-1962
- Dimensioning and Tolerancing for Engineering Drawings (terms, datum, identifying symbols): ANSI Y14.5-1966
- Machinist's Handbook

MODULE 4.0

DRAFTING I

95

D-55

MODULE 4.0

DRAFTING I

TASK 4.01

SECTION VIEWS

---

---

**PERFORMANCE OBJECTIVE:**

After instruction and demonstrations by the instructor, complete a minimum of two exercises to describe the internal features of three-dimensional objects by using various types of sectional views, drawing figures to meet specifications concerning: (1) the correct type of sectional view, (2) correct placement of cutting plane lines, and (3) correct placement of section lines.

**PERFORMANCE ACTIONS:**

- 4.0101 Given access to the Alphabet of Lines, draw examples of cutting plane and section lines comparable in thickness and character to standards set by USASI.
- 4.0102 Given access to relevant problems, choose the type of sectional view needed to describe the internal features of an object.
- 4.0103 Given examples of sectional problems, identify the types of section indicated in each drawing.
- 4.0104 Given access to examples of sectional problems, correctly locate the apply section lines and cutting plane lines.
- 4.0105 Given access to relevant problems, draw at least one of each of the following types of sections:
  - a. Full section
  - b. Half section
  - c. Broken-out section
  - d. Revolved section
  - e. Removed section
  - f. Offset section
  - g. Ribs and spokes in section
  - h. Aligned section
  - i. Conventional breaks

**SUGGESTED INSTRUCTION TIME:** 60 Hours

**PERFORMANCE STANDARDS:**

- Drawings to the instructor's satisfaction.

**RELATED TECHNICAL INFORMATION:**

- Correct terminology related to sectional view

MODULE 4.0

DRAFTING I

TASK 4.02

AUXILIARY VIEWS

---

**PERFORMANCE OBJECTIVE:**

After instruction and demonstrations explaining the theory of auxiliary views, given exercises by the instructor, draw the true shape of inclined and oblique planes and draw a minimum of two assigned figures using auxiliary planes to describe the true size and shape of faces which are not parallel to the regular planes of projection.

**PERFORMANCE ACTIONS:**

- 4.0201 Given access to three-dimensional objects, with inclined planes, use the reference plane method and draw the required auxiliary views.
- 4.0202 Given relevant problems, draw the following types of auxiliary views:
  - a. Depth auxiliary
  - b. Height auxiliary
  - c. Width auxiliary
- 4.0203 Construct primary auxiliary view of objects with symmetrical planes from problems showing orthographic views of objects. Drawings are to be to instructor's satisfaction.
- 4.0204 Construction auxiliary view of objects that have asymmetrical planes; given textbook or handout problems from the instructor who will judge when the project is satisfactorily completed.
- 4.0205 Construct auxiliary views of objects with curved surfaces from problems given by the instructor. Drawings are to be to instructor's satisfaction.

**SUGGESTED INSTRUCTION TIME:** 40 Hours (Task 4.03, Revolutions, taught during the same time frame as Auxiliary Views. See comment in Task 4.03.)

**PERFORMANCE STANDARDS:**

- Construct auxiliary views of objects with symmetrical planes, asymmetrical planes, and curved surfaces to the instructor's satisfaction (using entry level job competence as the standard).

**RELATED TECHNICAL INFORMATION:**

- Proficiency in use of correct terminology related to auxiliary views



MODULE 4.0

DRAFTING I

TASK 4.03

REVOLUTIONS

---

**PERFORMANCE OBJECTIVE:**

Given a three-dimensional object, with an inclined plane in the front or right side view, develop a primary revolution by showing the true size and shape of the inclined plane in the right side or front side views respectively.

**PERFORMANCE ACTIONS:**

- 4.0301 State purpose, principles, types, and uses of revolutions and significance in technical drafting.
- 4.0302 Draw standard representations.
- 4.0303 Accurately decipher the relationship of lines, planes, angles, points when part of a revolved axis.
- 4.0304 Describe and use the conventional drafting practices for describing objects.
- 4.0305 Given access to a step-by-step procedures, apply the theory of revolutions to describe the true size and shape of inclined and oblique planes by performing the following exercises:
  - a. Given access to a three-dimensional object with an inclined plane in the front view, develop a primary revolution by showing the true size and shape of the inclined plane in the right side view.
  - b. Given access to a three-dimensional object with an inclined plane in the right side view, develop a primary revolution by showing the true size and shape of the inclined plane in the front view.
  - c. Given access to a suitable drawing, draw the primary revolutions needed to describe the true size and shape of inclined planes and lines.

**SUGGESTED INSTRUCTION TIME:** Revolutions taught in the same time frame as, Task 4.02, Auxiliary Views. (See note.)

**PERFORMANCE STANDARDS:**

- Develop a primary revolution by showing the true size and shape of the inclined plane in the right side or front side view respectively, given an instructor or text assigned exercise.
- 100 percent correct projection methods.
- Done to standards acceptable to the instructor (using entry level job competence as standard).

**NOTE:** Revolutions, while treated as a separate objective, is taught during the same time frame as Auxiliary Views, Task 4.02.

MODULE 4.0

DRAFTING I

TASK 4.04

THREADS AND FASTENERS

---

**PERFORMANCE OBJECTIVE:**

Given problems by the instructor, select or identify and draw the proper threads and fasteners for project requirements using appropriate tables or references to demonstrate job qualification level competencies in the drawing of threads and fasteners.

**PERFORMANCE ACTIONS:**

- 4.0401 Identify and describe the use of various common fasteners used in mechanical devices and locate specifics in appropriate reference catalog(s). To be included are: screws, bolts, nuts, threads, and fasteners.
- 4.0402 Select, specify, and draw proper fasteners for project requirements given by the instructor.
- 4.0403 Identify, select, and draw proper screw threads for project requirements given by the instructor. Use notes and dimensions.
- 4.0404 Identify, describe the meaning of, draw, and use the various terms and symbols pertaining to threads to include: thread form, series, class of fit, multiplicity, direction of turn and length.
- 4.0405 Draw threads as required:
  - a. Acme - using semi-conventional or detailed representation method.
  - b. Square - using semi-conventional or detailed representation.
  - c. Profiles of simplified and schematic threads.
  - d. Regular square bolts and nuts.
  - e. Hex-head bolts and nuts.
- 4.0406 Use thread tables.
- 4.0407 Identify, know use of, specify and draw standard keys, keyways and rivets.

**SUGGESTED INSTRUCTION TIME:** 30 Hours

**PERFORMANCE STANDARDS:**

- To instructor's satisfaction (using entry level job competence as standard).
- Select or identify and draw the proper threads and fasteners for project requirements, given problems by the instructor, using appropriate tables of references to demonstrate job qualification level competencies in the drawing of threads and fasteners.

MODULE 4.0

DRAFTING I

TASK 4.05

AXONOMETRIC PICTORIAL DRAWINGS

---

---

**PERFORMANCE OBJECTIVE:**

Given an object to be drawn using the axonometric system, draw the object using one of the following procedures:

1. Draw the object in isometric.
2. Draw the object in dimetric.
3. Draw the object in trimetric.
4. Draw axonometric sections.

**PERFORMANCE ACTIONS:**

- 4.0501 Determine proper layout for drawing. Construct enclosing box, with full length, height, and width of object.
- 4.0502 Establish all detail measurements of object with enclosing box.
- 4.0503 Draw all necessary lines connecting measurements within enclosing box. Dimension at required places.
- 4.0504 Show angles correctly in isometric.

**SUGGESTED INSTRUCTION TIME:** 53 Hours

**PERFORMANCE STANDARDS:**

- Measurements and services to satisfaction of instructor.

**RELATED TECHNICAL INFORMATION:**

- Know history and origin of axonometric system, State uses of axonometric drawings
- Identify differences between projected and constructed axonometric drawings
- Use and care of instruments
- Proper lettering
- Geometric construction

MODULE 4.0

DRAFTING I

TASK 4.06

OBLIQUE PICTORIAL DRAWINGS

---

---

**PERFORMANCE OBJECTIVE:**

Given an object to be drawn in the oblique, draw in the oblique using three of the following:

1. Top emphasis
2. Cavalier
3. Right side emphasis
4. Reverse axis
5. Cabinet
6. Foreshortened

**PERFORMANCE ACTIONS:**

- 4.0601 Determine proper layout arrangement for drawing. Construct enclosing box, with full length, height, and width or part. Establish all detail measurements of part within enclosing box.
- 4.0602 Draw all necessary lines connecting measurements within enclosing box. Dimension at required places.

**SUGGESTED INSTRUCTION TIME:** 10 Hours

**PERFORMANCE STANDARDS:**

- Follow procedures and present correct view for obliques selected. Neatness applies.

**RELATED TECHNICAL INFORMATION:**

- Know history, origin, and uses of oblique drawings
- Use and care of instruments
- Proper type of lettering
- Geometric construction

MODULE 4.0

DRAFTING I

TASK 4.07

PERSPECTIVE PICTORIAL DRAWINGS

---

---

**PERFORMANCE OBJECTIVE:**

Given an object to be drawn, draw the object in one point and two point perspective with the following elements applied and identified so that drawing parts appear progressively smaller as they are further away.

1. Variables of perspective - Station point
2. Angles of View:
  - a. Horizontal angle
  - b. Vertical angle
3. Distance from the Object  
- Cone of vision
4. Ground Line
5. Picture Plane
6. Horizon Line
7. Vanishing Point
  - a. Lines parallel to picture plane
  - b. Horizontal lines not parallel to picture plane
  - c. All other lines
8. Vertical Measurements
9. Horizontal Measurements
  - a. Sighting
  - b. Measuring

**PERFORMANCE ACTIONS:**

- 4.0701 Determine proper layout arrangements for drawing.
- 4.0702 Draw views of object. Draw top and side views in positions. Locate vanishing points. Locate true heights. Draw visual rays.
- 4.0703 Complete drawing, lettering, and check entire drawing for completeness and accuracy.

**SUGGESTED INSTRUCTION TIME: 20 Hours**

**PERFORMANCE STANDARDS:**

- Draw object in one point and two point perspective with accuracy and neatness.

MODULE 4.0  
TASK 4.07

DRAFTING I  
PERSPECTIVE PICTORIAL DRAWINGS (Continued)

---

---

RELATED TECHNICAL INFORMATION:

- Know history and origin of perspective drawing, Know use of perspective drawing
- Use and care of instruments
- Proper lettering
- Geometric construction
- Orthographic construction

MODULE 4.0

DRAFTING I

TASK 4.08

PARALLEL LINE DEVELOPMENT

---

---

**PERFORMANCE OBJECTIVE:**

Given an assignment by the instructor or from the text, create the rectangular patterns of the prism and the cylinder.

**PERFORMANCE ACTIONS:**

- 4.0801 Determine necessary space allocations for necessary views of object and development.
- 4.0802 Draw necessary views of object.
- 4.0803 Dimension views where necessary.
- 4.0804 Establish all elements in views.
- 4.0805 Complete all drawing of elements in views.
- 4.0806 Letter and/or number elements in views.
- 4.0807 Draw development or developments, transferring dimensions and elements from views.

**SUGGESTED INSTRUCTION TIME: 8 Hours**

**PERFORMANCE STANDARDS:**

- Create the rectangular patterns of the prism and the cylinder, given an assignment by the instructor or from the text.
- Draw to instructor's standards (based on entry level job competence requirements).

**RELATED TECHNICAL INFORMATION:**

- Read information (directions and specifications)
- Geometric construction

MODULE 4.0

DRAFTING I

TASK 4.09

RADIAL LINE DEVELOPMENTS

---

**PERFORMANCE OBJECTIVE:**

Given teacher or text problems, create pie shaped patterns of the pyramid and the cone.

**PERFORMANCE ACTIONS:**

- 4.0901 Determine required space allocations for necessary views of object and development.
- 4.0902 Draw necessary views of object.
- 4.0903 Dimension views where necessary.
- 4.0904 Establish all elements in views.
- 4.0905 Complete all drawing of elements in views.
- 4.0906 Letter and/or number elements in views.
- 4.0907 Draw the true length layout.
- 4.0908 Draw developments, transfer dimensions, elements and true lengths from views.

**SUGGESTED INSTRUCTION TIME:** 8 Hours

**PERFORMANCE STANDARDS:**

- Stretchout view should show inside of object.
- Make right section where needed, show total length, show bend lines when necessary, lay out in proper sequence.
- Draw and develop transitional pieces.
- Draw to instructor's standards based on entry level competence requirements of drafting field.

**RELATED TECHNICAL INFORMATION:**

- Geometric construction
- Read information

**SUGGESTION:**

- Students may benefit from making a model, such as a cardboard cutout, of the drawing or figure.



MODULE 4.0

DRAFTING I

TASK 4.10

INTERSECTIONS

---

---

**PERFORMANCE OBJECTIVE:**

Given teacher or text problems, create required patterns of two intersecting solids.

**PERFORMANCE ACTIONS:**

- 4.1001 Locate, show point of intersection and show visibility for the following:
  - a. Cutting plane
  - b. Cutting spear
  - c. Parallel cylinder
  - d. Edge view
  - e. Piercing point
- 4.1002 Draw intersections of:
  - a. Line and plane
  - b. Plane and plane
  - c. Solid and plane
  - d. Solid and solid
- 4.1003 Draw intersections of ducts and bends of similar surfaces.
- 4.1004 Draw development of surfaces involved.

**SUGGESTED INSTRUCTION TIME:** 10 Hours

**PERFORMANCE STANDARDS:**

- Draw intersections of ducts and bends of similar surfaces acceptable to instructor based on entry level competence requirements for the drafting field.

MODULE 5.0

DRAFTING I

D-67

107

MODULE 5.0

DRAFTING I

TASK 5.01

WORKING DRAWINGS

---

**PERFORMANCE OBJECTIVE:**

Given problems and the appropriate tools and supplies, prepare preliminary working drawings to demonstrate a detailed part drawing including all information necessary to properly fabricate the parts to the satisfaction of the instructor. Also, prepare assembly drawings with bill of materials utilizing the detailed drawings.

**PERFORMANCE ACTIONS:**

- 5.0101 Apply principles of third angle orthographic projection as practiced in the U.S. and Canada.
- 5.0102 Apply recommendations of USA Standards Institute pertaining to Drafting Practices (Y14.1-Y14.17) and Graphic Symbols (Y32 Series).
- 5.0103 Use drafting templates and drafting machines.
- 5.0104 Use appropriate catalogs, industrial standards, company standards, and handbooks.
- 5.0105 Determine information relevant to design.
- 5.0106 Make selection of standard parts.
- 5.0107 Select standard parts which can be altered to meet design requirements.
- 5.0108 Complete assembly and installation drawings.
- 5.0109 Given a problem with exploded pictorial drawings with dimensions and materials noted or cross sectioned assembly drawings with design parameters defined, draw assembly drawings illustrating the relationship that detail and assembly drawings have to each other.

**NOTE:** Students must determine which part requires detailed part drawings, and prepare drawings to include all information necessary to properly fabricate the parts to the satisfaction of the instructor. Prepare all necessary sub-assembly and assembly drawings which include a listing of parts in family-tree order.

**SUGGESTED INSTRUCTION TIME:** 120 Hours

**PERFORMANCE STANDARDS:**

- Neatness and accuracy apply.
- Drawings conform to ANSI Manuals where appropriate.

MODULE	5.0	DRAFTING I
TASK	5.01	WORKING DRAWINGS

---

---

PERFORMANCE STANDARDS (Continued)

- Problem-solving, freehand sketching and drawing, and composition (layout) techniques properly applied. Reports are clear, concise, and to the point. Model is well executed and portrays object accurately.
- Execute drawings within time limits considered acceptable for initial employment.
- Demonstrate knowledge of related technical information, application of theories and symbols and conventions, and terminology with at least 80 percent accuracy.
- Perform tasks required in this duty area in proper sequence and conducts the necessary coordination.
- Use appropriate reference technical manuals, tables, and catalogs correctly.

RELATED TECHNICAL INFORMATION: (Suggested Time: 1-3 Hours)

- Optional Supplementary Performance:  
(File Original Working Drawings) Given an unassembled set of working drawings and a file; file the original working drawings. The drawings will be filed so that they can be retrieved upon demand.

Performance Actions:

1. Confirm project titles/numbers assigned to each drawing.
2. Arrange and group drawings under headings.
3. File drawings.
4. Check for accuracy.

SUMMARY NOTE

THE COMPLETION OF MODULES 1.0 - 5.0, DRAFTING I AT THE SECONDARY LEVEL, THE SCHOOL DISTRICT OF GREENVILLE COUNTY, BASICALLY IS EQUIVALENT TO THE POST-SECONDARY ENGINEERING GRAPHICS COURSES; EGT 111, EGT 121, AND EGT-131, AT GREENVILLE TECHNICAL COLLEGE.

NOTE: Module 6.0 will begin Drafting II, the second year of the secondary level program of vocational training.

DRAFTING I  
(Secondary Level)

EQUIPMENT LIST

The following minimum equipment is recommended for students of Drafting I.

Drawing Instrument Set  
Vinyl Drawing Top Covers  
T-Square or Straight Edge  
Triangle, 30° x 60°, plastic, 10"  
Triangle, 45°, plastic, 10"  
Adjustable Triangle  
Architect's Triangular Scale  
Mechanical Engineer's Scale  
Civil Engineer's Scale  
Metric Scale  
Irregular Curve  
Roll of 3/4" Drafting Tape  
Lead Holder  
Eraser  
Sandpaper Pad Pencil Pointer  
Lettering Chart  
H-Leads  
2-H Leads  
4-H Leads

The following equipment is recommended for the drafting classroom and is based on a hypothetical class size of 18 students.

Bench Dusters	18
Drafting Machines	1 of each type, 3 preferred minimum
Proportional Dividers	1
Compass Beam	1
Compass, Drop Bow Pen and Pencil	1
Caliper, Inside	1
Diazo Machine	1
Paper Cutter (36" Blade Minimum)	1
Shears, Trimming, 12"	1
Pencil Sharpeners	2
Drafting Tables with Stools	18
Light Table	1

The actual equipment for students or classroom may exceed the above suggested minimums and will vary with program funding, instructor preference, etc. The recommendation is for Drafting I conducted at the secondary level.

OUTCOME-REFERENCED MEASURES

## OUTCOME-REFERENCED MEASURES

### DRAFTING I

Outcome-referenced measures provide a means for evaluation standardization and help ensure that measures are valid and reliable with regard to on-the-job requirements.

The sample test items in the Outcome-referenced Measures are selected to articulate to teachers and students how student performance can be evaluated with validity and reliability. The test items have been constructed from the objectives of the training program.

The sample test items may be used in the actual testing situations or may serve only as guides, allowing for specific test items to be developed at the individual instructional level. The test items, in fact, could serve as a study guide for the student since students should understand that job qualification will be determined by evaluation of job-task competencies.

Technical training in Drafting I begins with Module 3.0 and continues through Module 5.0

Module 1.0, Safety, has been omitted from the measures section of the instruction guide.

Module 2.0, Math Review, refers the instructor to measures that have been identified in the Curriculum Guide for High School General Mathematics published by The School District of Greenville County; therefore, specific samples of math review measures are omitted in the Articulated, Performance-based Instruction Guide for Drafting I.

Test items for Modules 3.0 - 5.0 have been constructed from the objectives of Drafting I which indicate the level of knowledge and skill to be attained.

NOTE: The sources of the sample drawings in the outcome-referenced measures have been identified clearly. The sample drawings from textbooks are those being used currently by instructors who use the textbooks in their classrooms. The drawings have been reproduced for reference at the suggestion of the instructors to improve lateral and vertical articulation. In practice, the instructors will use the actual textbooks.



MODULE 3.0

TASK 3.0101 In the history of drafting, list two materials on which drawings were made prior to the invention of paper.

3.0102 List four specialized (career) fields in drafting.

3.0103 Describe the primary purpose of technical drawings in industry based on information given by the text-book or instructor.

3.0106 Define regional employment opportunities in drafting based on the student mastering Drafting I and II and possibly continuing drafting training at Greenville TEC, considering local market trends.

Sample Ans. The approximately 2,560 drafters employed in SC during 1980 is expected to increase by around 2,750 by 1982. It is estimated that there will be an average of 120 openings each year with around 95 due to growth and 25 due to replacement needs. Best prospects will be for graduates with associate degrees in drafting.

3.0107 State the environmental and working conditions in the field of drafting.

Sample Ans. Drafters may work alone or as members of a drafting team under the direction of supervision of a more experienced drafter, chief drafter, project drafter, engineer, or architect.

Drafters either sit or stand at drafting tables in well-lighted rooms. They may sometimes work at construction sites, in machine shops or at other places where their drawings are required.

Drafters generally work a 5-day, 35-40 hour week. Overtime may be necessary to meet deadlines.

TASK 3.02 Given drafting equipment to include a drafting table, appropriate basic drafting instruments, and lettering sheets, demonstrate in a practical exercise correct use of basic drafting equipment, maintenance of equipment, reading of scales, and attaching paper to drafting table.

The instructor may use the performance actions description as a checklist and correct procedures with the students prior to observing them.

TASK 3.0204

(Use of Instruments: T-Square) Given a T-square, triangle, pencil leads, paper, erasers, and erasing shields, and an assignment to draw the irregular polygon in Figure 3-82, p. 66, French et al., Mechanical Drawing, draw the exercise as instructed in class or the textbook to the satisfaction of the instructor.

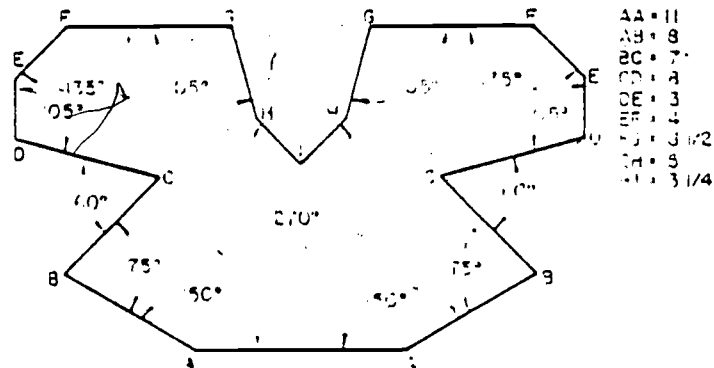

Fig. 3-82 Irregular polygon. Construct the irregular polygon as shown. Use a scale of  $\frac{1}{2}'' = 1''$ . Begin by drawing line AA near the bottom of the sheet and centered horizontally. The length of each line is given at the right of the figure above. All angles may be drawn with the T-square and a combination of triangles.

3.0205 Given T-square and triangles, paper and tape, and other supplies, draw lines from horizontal to vertical angle in increments of  $15^\circ$  to  $1^\circ$  accuracy.

3.0207 (Same exercise as 3.0204) Given different types of drafting scales, references for given scales, and dimensions required, students will identify each scale, and state the difference with 100 percent accuracy, and lay out and draw different lengths of lines with 90 percent accuracy.

Instructor may employ: "Handout on Drafting Scales" (3 pages follow).

DETERMINE THE READINGS INDICATED ON EACH SHOP SCALE AND PRINT THE ANSWERS IN THE SPACES PROVIDED.

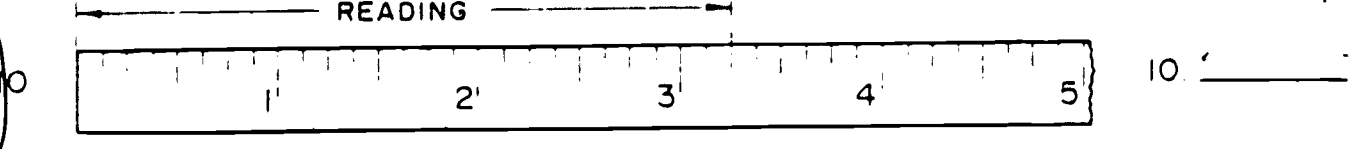
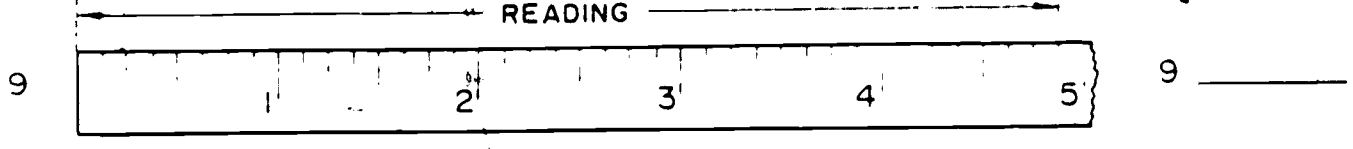
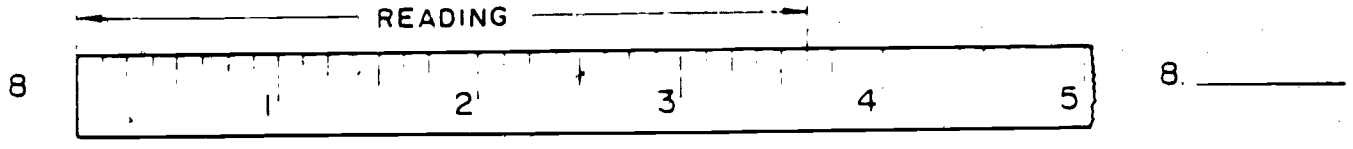
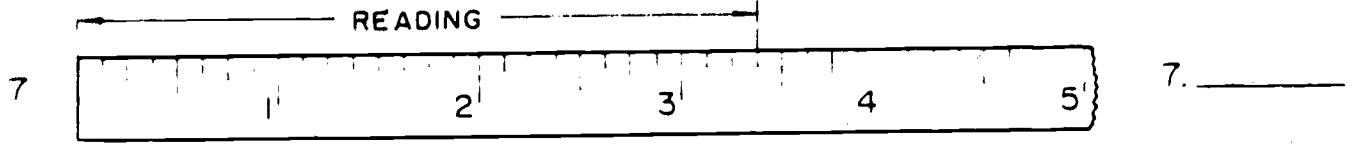
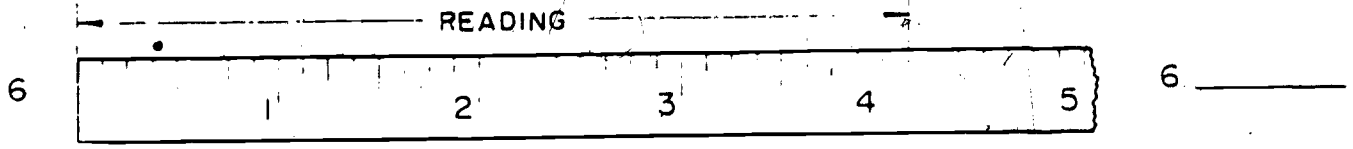
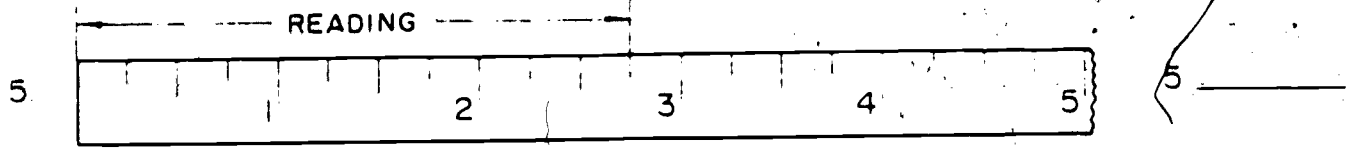
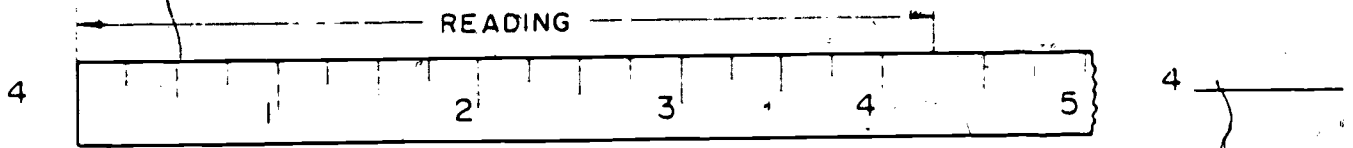
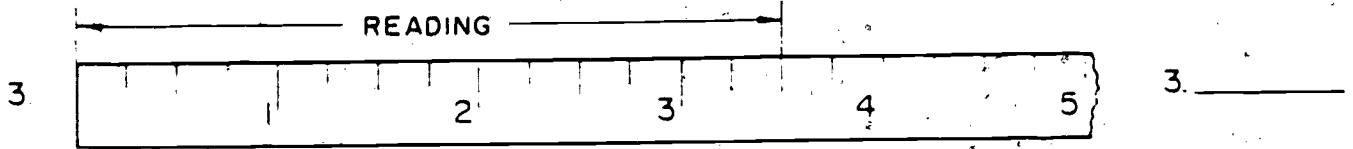
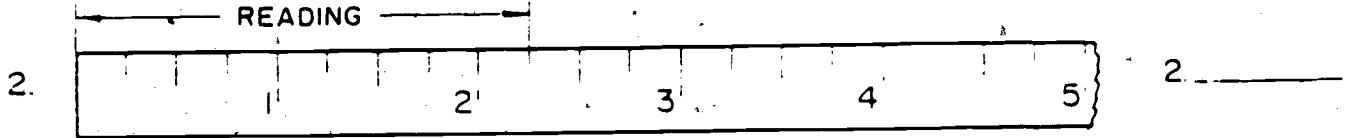
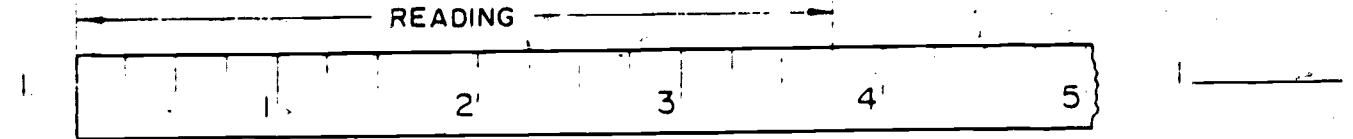

TASK 3.0207

SCALE READINGS #1

DETERMINE THE READINGS INDICATED ON EACH SHOP SCALE AND PRINT THE ANSWERS IN THE SPACES PROVIDED.

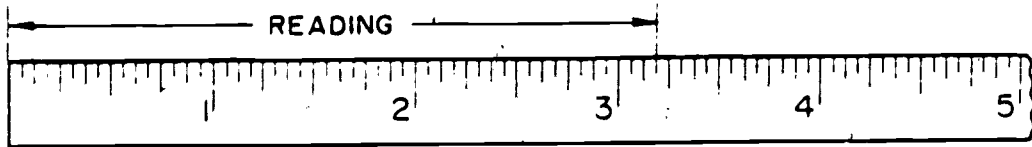

1. \_\_\_\_\_

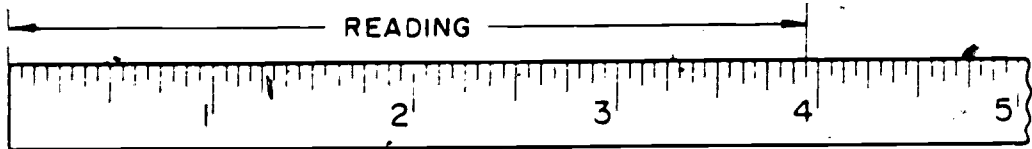

2. \_\_\_\_\_

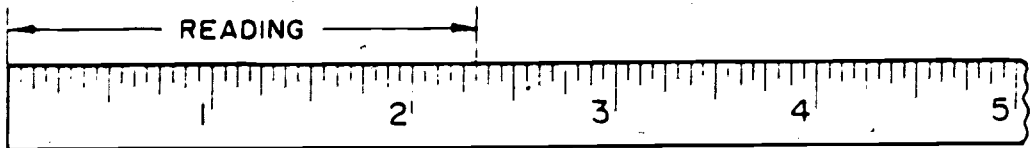

3. \_\_\_\_\_

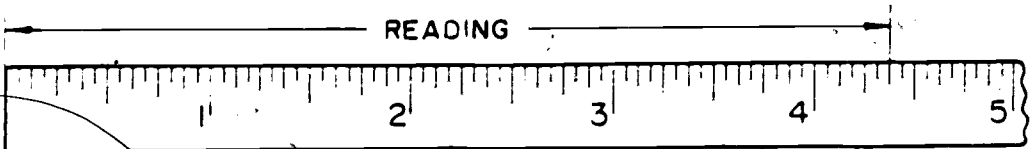

4. \_\_\_\_\_

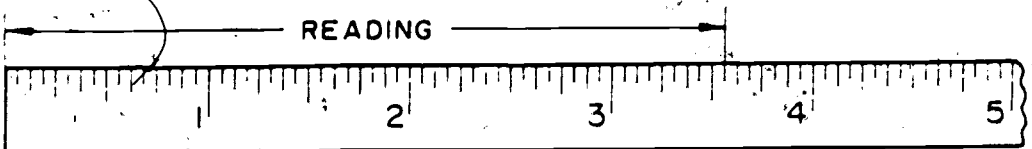

5. \_\_\_\_\_

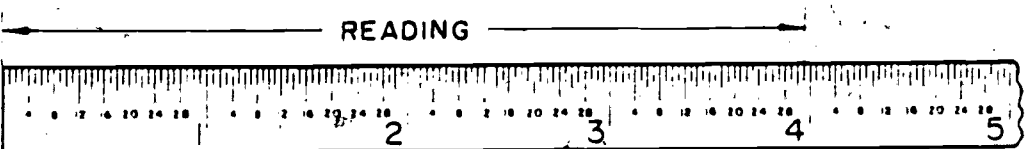

6. \_\_\_\_\_

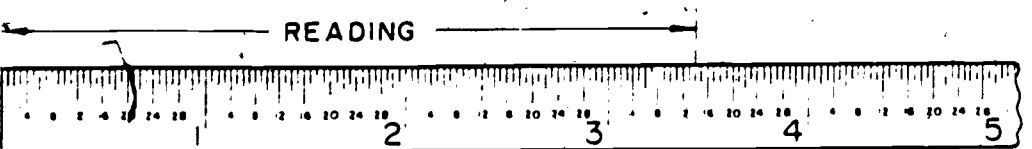

7. \_\_\_\_\_

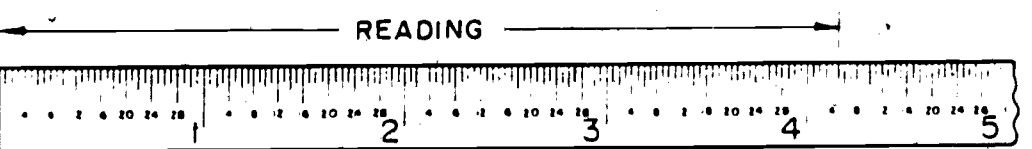

8. \_\_\_\_\_

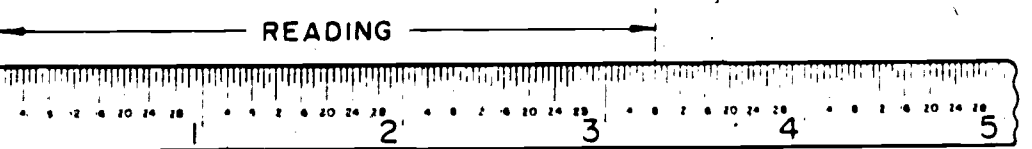

9. \_\_\_\_\_

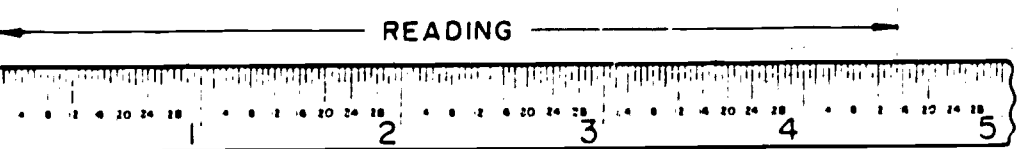

10. \_\_\_\_\_

TASK 3.0207

#2

117

DETERMINE THE READINGS INDICATED ON THE ARCHITECT'S SCALES AND PRINT THE ANSWERS IN THE SPACES PROVIDED.

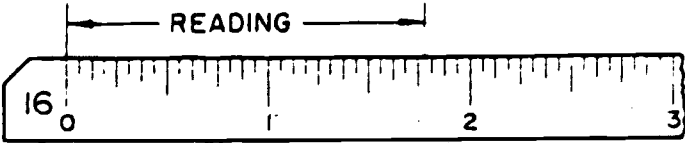
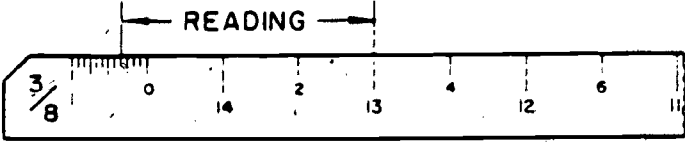
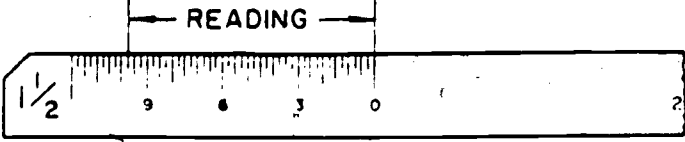
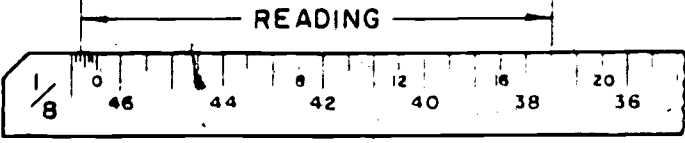
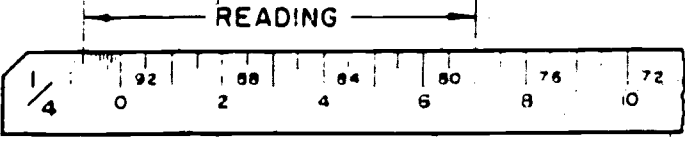
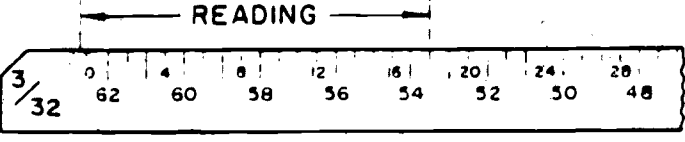
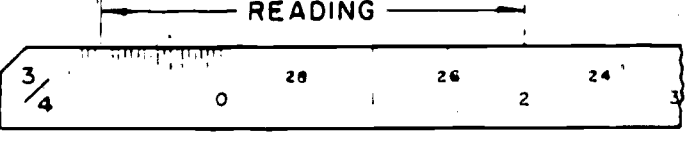
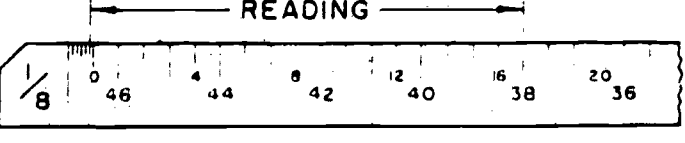
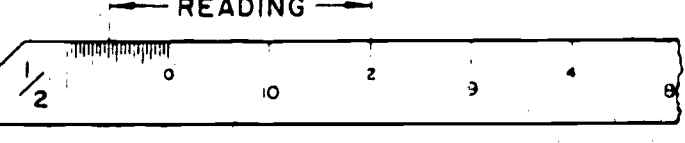
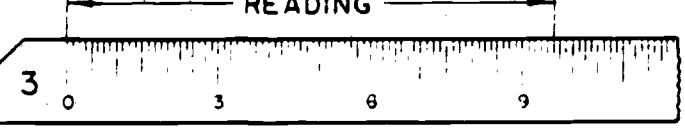
1.		1. _____
2.		2. _____
3.		3. _____
4.		4. _____
5.		5. _____
6.		6. _____
7.		7. _____
8.		8. _____
9.		9. _____
10.		10. _____

TASK

3.03

Given drafting instruments and equipment, clean the items based on performance actions which will be reviewed by the instructor and used by the instructor as a checklist for evaluation.

3.04

Alphabet of Lines--OUTCOME-REFERENCE MEASURE (3.04)  
Given practical exercises by the instructor or from a text, draw the Alphabet of Lines to given drawings to given specifications such as 95 percent accuracy in thickness and character of drawings to given guides, with neatness.

The following sample guide from Figure 3-11, Alphabet of Lines p.26, Spence et al., Basic Technical Drawings applies.

PENCIL LINES

APPLICATIONS

INK LINES

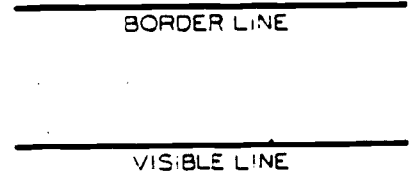
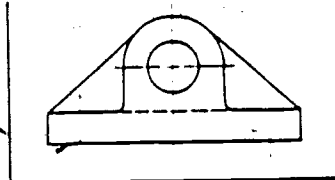
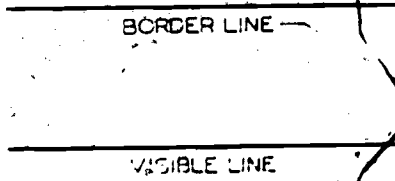

CONSTRUCTION LINE

Construction lines are never drawn in ink.

SECTION LINE

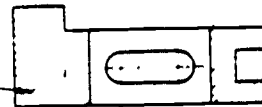

SECTION LINE

$\frac{3}{32}$  APPROX  $\frac{1}{8}$  APPROX  
HIDDEN LINE

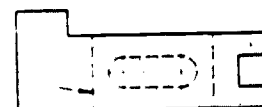

HIDDEN LINE

$\frac{3}{8}$  APPROX  $\frac{3}{8}$  APPROX  $\frac{3}{8}$  APPROX  
CENTER LINE (CL)

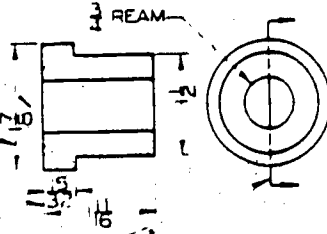

CENTER LINE (CL)

DIMENSION LINE  
EXTENSION LINE

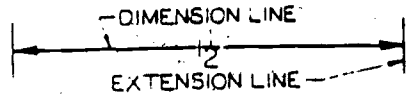

$\frac{3}{32}$  APPROX  $\frac{3}{8}$  APPROX  $\frac{3}{8}$  APPROX  
CUTTING-PLANE LINE

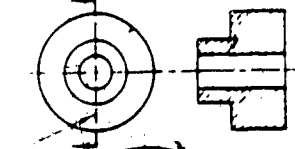

CUTTING-PLANE LINE

$\frac{1}{8}$  APPROX  $\frac{1}{4}$  APPROX  
CUTTING-PLANE LINE

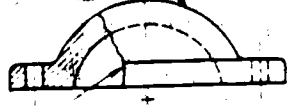

CUTTING-PLANE LINE

(freehand)  
SHORT-BREAK LINE



SHORT-BREAK LINE

$\frac{3}{4}$  to  $\frac{1}{2}$  APPROX (freehand)  
LONG-BREAK LINE

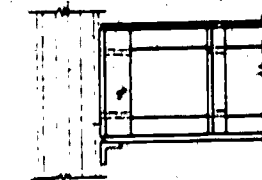





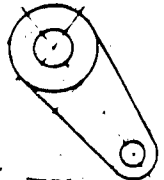

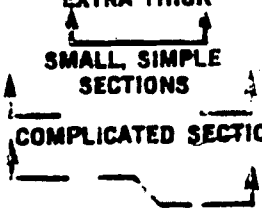
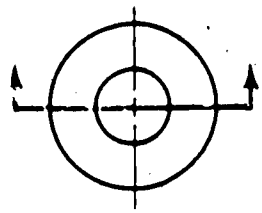

LONG-BREAK LINE

$\frac{1}{8}$  APPROX  $\frac{3}{8}$  APPROX  $\frac{3}{4}$  to  $\frac{1}{2}$  APPROX  
PHANTOM LINE

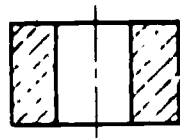

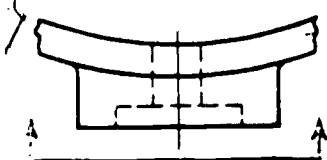

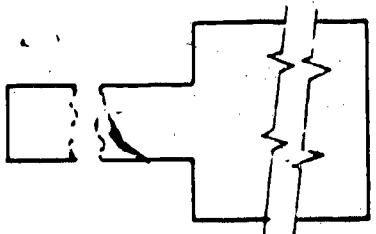

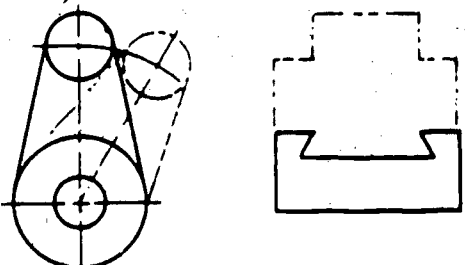
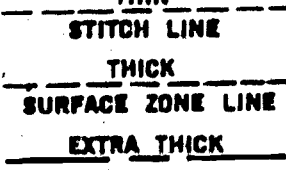
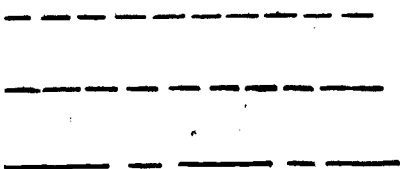

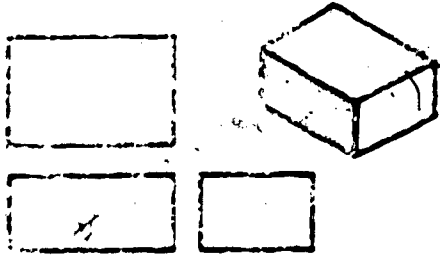

PHANTOM LINE

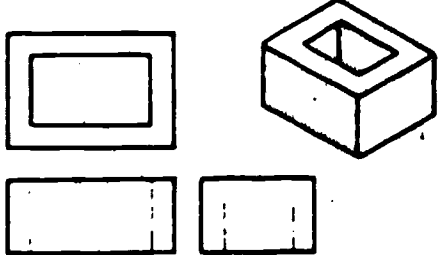
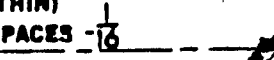
Fig. 3-11. Alphabet of Lines.

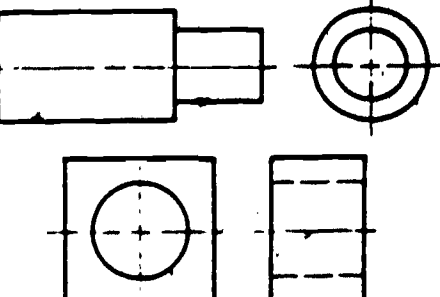
TYPE OF LINE	DESCRIPTION AND APPLICATION	EXAMPLES
<p><b>CUTTING PLANE —</b>  <b>EXTRA THICK</b></p>  <p><b>SMALL, SIMPLE SECTIONS</b></p> <p><b>COMPLICATED SECTIONS</b></p> <p><b>OFFSET SECTIONS</b></p>	<p>The cutting-plane line is used in a section view to designate where an imaginary cutting took place.</p>	
<p><b>SECTION LINES</b></p>  <p><b>THIN</b></p>	<p>Section lining is used to indicate the surface in the section view imagined to have been cut along the cutting plane line. Sometimes called "hatching lines", their construction and spacing may be used to indicate symbolically the material from which the part was made.</p>	
<p><b>VIEWING PLANE LINE</b></p>  <p><b>EXTRA THICK</b></p>	<p>The view plane line is used to indicate direction and height of partial view.</p>	
<p><b>BREAK LINES</b></p>  <p><b>THIN</b>  <b>LONG BREAK</b></p> <p><b>THICK</b>  <b>SHORT BREAK (FREEHAND)</b></p>	<p>Break lines are used when it is desirable to shorten the view of a long part when this part has a uniform shape for all, or part of, its length.</p>	
<p><b>PHANTOM LINES</b></p>  <p><b>THIN</b></p> <p><b>BROKEN LINE OF ONE LONG AND TWO SHORT DASHES</b></p>	<p>Phantom lines are used to indicate the alternate position of a part or to show the position of a part that is adjacent to, or fits with, the part being drawn, or the portion to be removed.</p>	
<p><b>MISC. LINES</b></p>  <p><b>THIN</b>  <b>STITCH LINE</b></p> <p><b>THICK</b>  <b>SURFACE ZONE LINE</b></p> <p><b>EXTRA THICK</b>  <b>PATH OF CABLE LINE</b></p>	<p>Stitch-line used to indicate seams in leather, plastic and textiles.</p>	

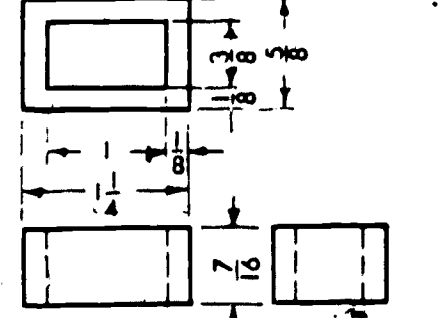

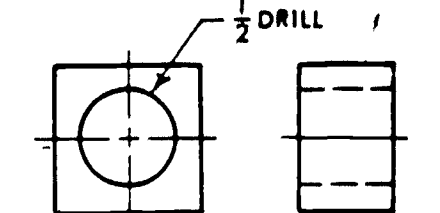
TYPE OF LINE	DESCRIPTION AND APPLICATION	EXAMPLES
<p><b>OBJECT OR VISIBLE OUTLINE</b></p>  <p><b>THICK</b></p>	<p>The object line is used to indicate the visible edges and corners of an object. Object lines should stand out clearly in contrast to other lines so that the general shape of the object is apparent to the eye.</p>	
<p><b>HIDDEN FEATURE LINE</b></p>  <p>(MEDIUM)</p> <p>DASHES APPROX. <math>\frac{1}{8}</math> LONG SPACES APPROX. <math>\frac{1}{2}</math> LONG</p>	<p>The hidden feature line is used to show those surfaces, edges, or corners of an object that are hidden from view.</p>	
<p><b>CENTRE LINE</b> (THIN)</p>  <p>SPACES - <math>\frac{1}{16}</math></p> <p>DASHES LONG - <math>\frac{3}{4}</math> TO <math>1\frac{1}{2}</math> SHORT - <math>\frac{1}{8}</math></p> <p><b>ALTERNATIVE</b> <b>SOLID THIN LINE</b></p> 	<p>Centre lines are used to designate the axes of round and symmetrically shaped holes and solids, two lines, perpendicular to each other, as used in the view when the shape is symmetrical about both axes. Also used for path lines, pitch circles, and axes of symmetry.</p>	
<p><b>EXTENSION AND DIMENSION LINES</b> (THIN)</p>  <p><b>ALTERNATIVE</b></p> 	<p>Extension lines extend from object lines to receive the dimension line. They should almost touch the line which they are extending and should extend approximately <math>\frac{1}{8}</math> past the dimension line. Arrowheads are placed at each end of the dimension line and touch the extension line. The dimension is placed approximately at the halfway point in the dimension line, either in an opening in the dimension line or above the line.</p>	
<p><b>LEADER</b> (THIN)</p> 	<p>The leader is used to indicate the part of the drawing to which a note refers. When used to indicate a hole, it is aimed at the centre of the hole, usually at an angle of 60°, 45°, or 30°. The arrowhead touches the circumference of the circle, while the large dot rests on the surface.</p>	 <p><math>\frac{1}{2}</math> DRILL</p>

TASK

3.05

Given an instructor or text provided exercise, a single-stroke lettering guide or four references to an assigned style of lettering form from a text, letter in upper case letters, numbers, and fractions, freehand in a style that is perfectly legible, uniform, and capable of rapid execution, comparable to the guide in shapes and proportions. Use a 4-H pencil to draw guidelines based on given specifications and using an H or 2H pencil to complete the lettering.

3.06

On a lettering exercise, demonstrate in a reasonable time limit the ability to select, if required, the correct mechanical lettering items for the job or use the Ames type lettering device to produce lettering that is correctly spelled, neat, and with proper word spacing.

3.07

Given a drafting machine, an exercise from the instructor or a text, demonstrate the basic operations of the drafting machine.

The exercise used in Task 3.0204 may be used for 3.07 (fig. 3-82, p. 66, French's Mechanical Drawing, 8th ed.).

3.08

Given step-by-step procedures, drawing instruments, accessories, geometrical definitions, and a set of exercises, construct geometrical figures and polygons common to the drafting field by completing a given exercise with 90 percent accuracy.

Refer to exercises 4-76, 4-78, and 4-79, page 124, of Technical Drawing, by Giesecke.

3.0904

Given a requirement to neatly sketch and draw freehand and one or more exercises from the instructor or a text, draw objects using orthographic projections and pictorials to the instructor's satisfaction in a reasonable time.

For sample exercises, see Figures 6.27 and 6.28, pages 98-99, Basic Technical Drawing, Spencer.

For the purposes of articulation, Figures 6.27 and 6.28 are reproduced on the following pages.

3.0905

Continuation of 3.09: Missing Line exercise. For sample problems, see Figure 6.29, page 101, Basic Technical Drawing, Spencer.

For purposes of articulation, Figure 6.29 is reproduced on the following pages.

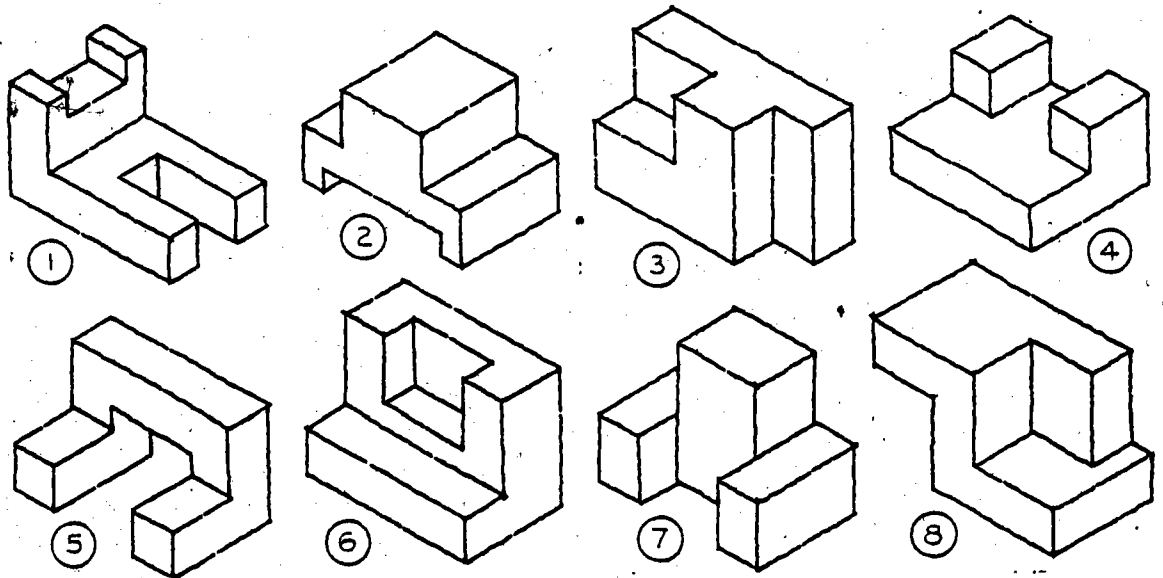

Fig. 6.27, Page 98

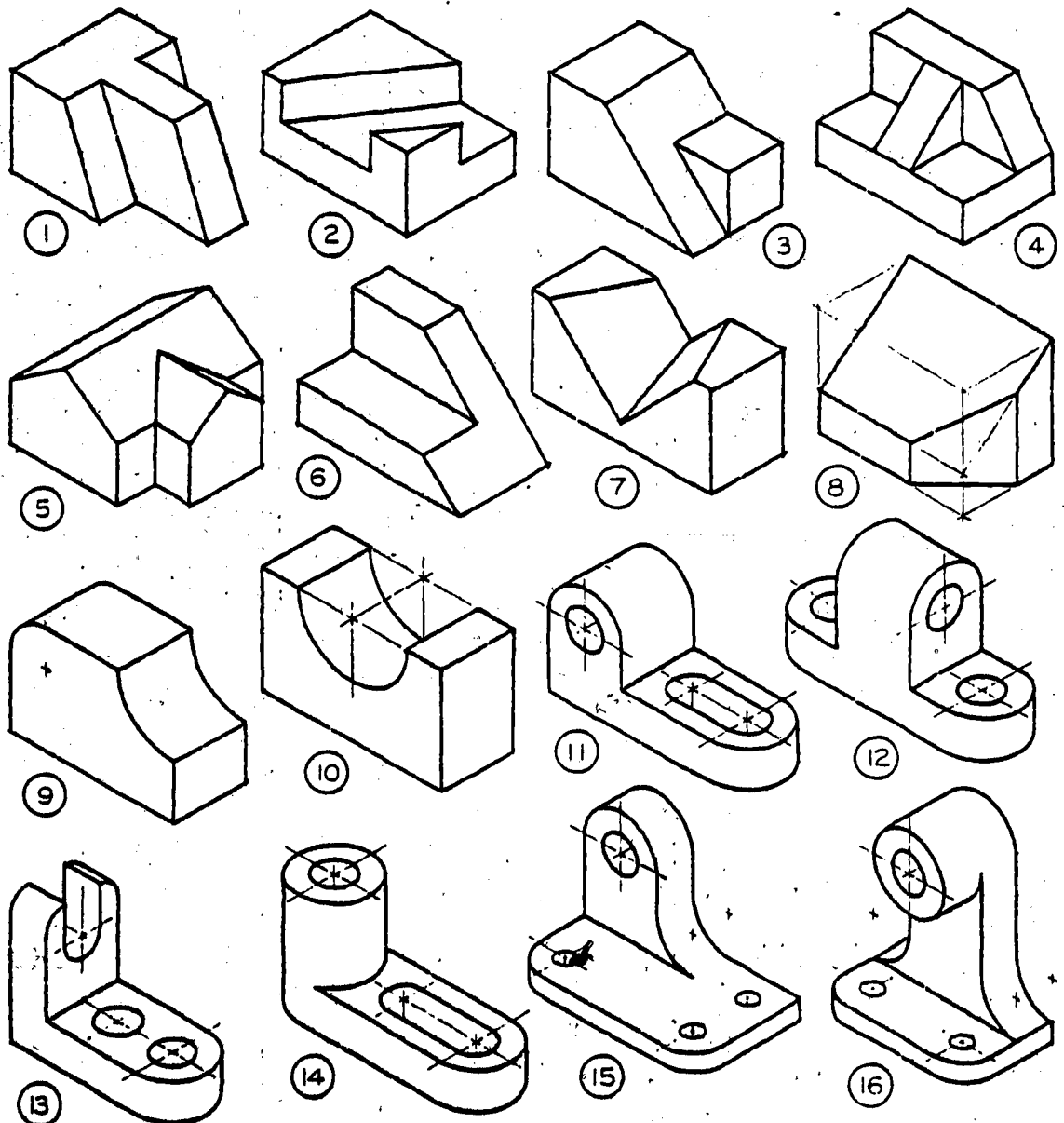

Fig. 2-27, Page 99

Task 3.0905

Sample exercise from Basic Technical Drawing, by Spencer, p. 100.

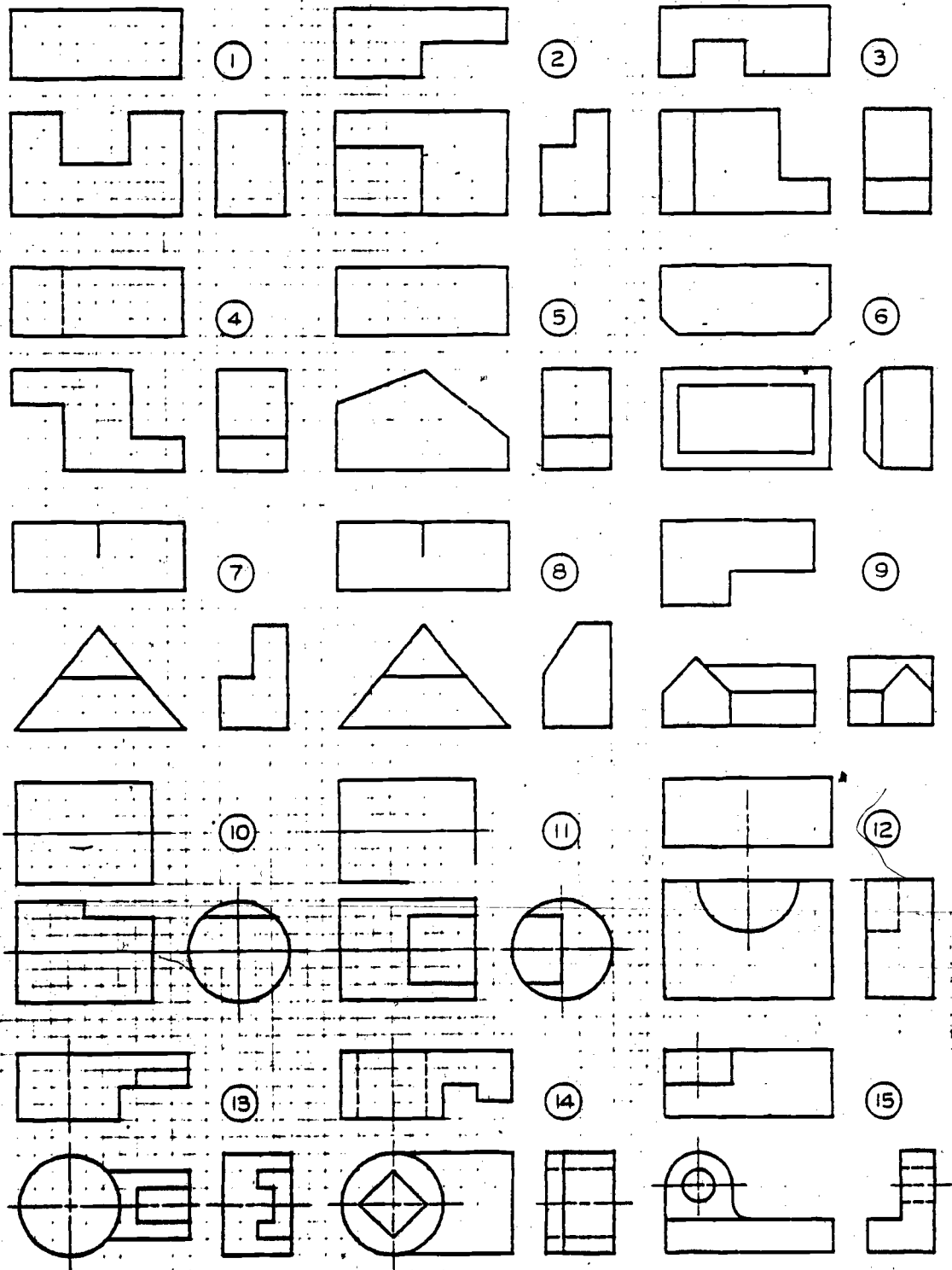

Fig. 6-29. Missing-Line Problems. Sketch the views of assigned problems, adding all missing lines. Each grid space = 1/4". In most cases, spacing between views can be improved by spacing views farther apart.

Task 3.0906 Continuation of 3.09: Missing View exercises. For sample problems, see Figure 6.28, page 101, Basic Technical Drawing, Spencer.

Sample pages reproduced on following pages.

Task 3.0906

Sample exercises from Basic Technical Drawing, by Spencer, p. 101.

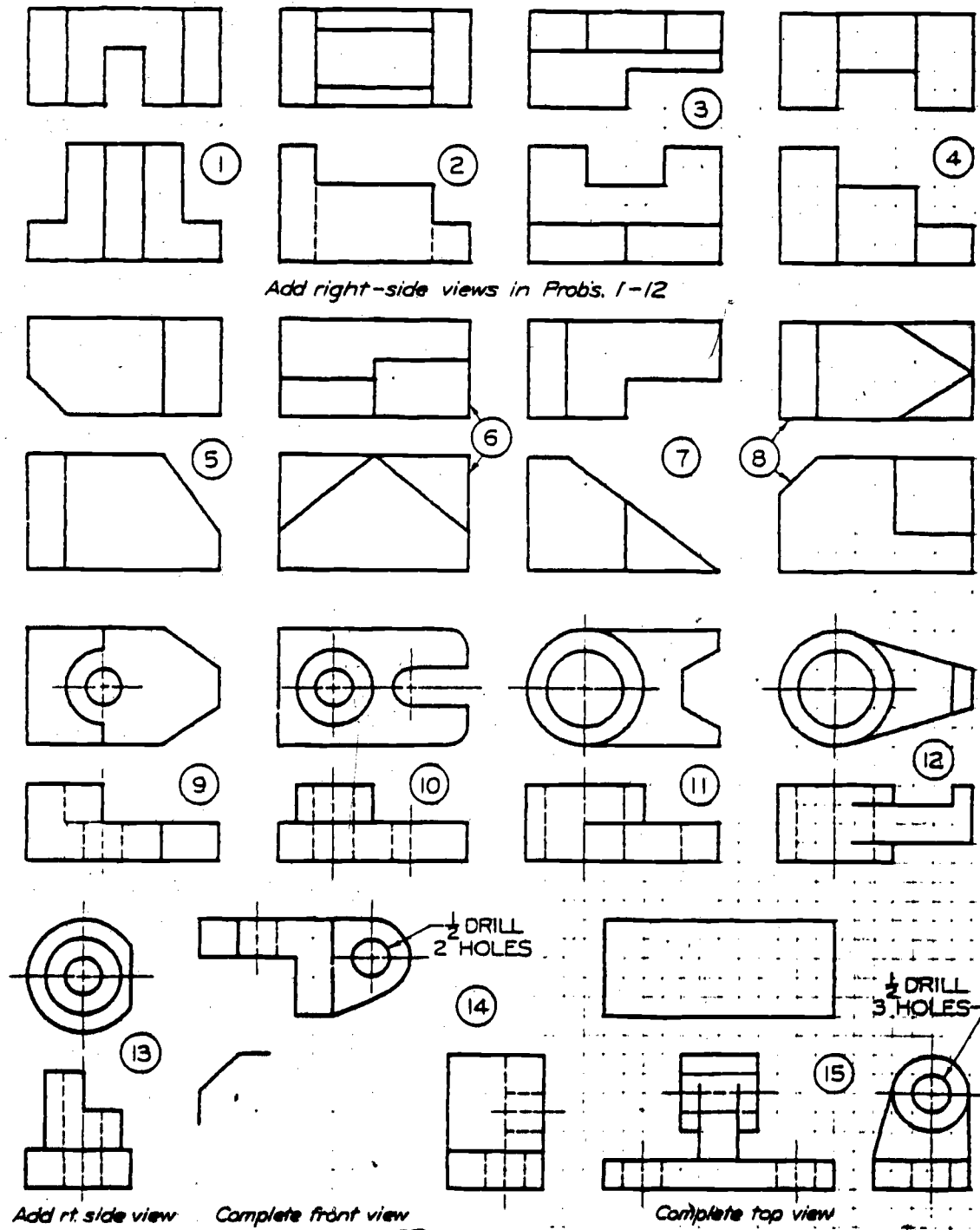

Fig. 6-28. Missing-View Problems. Sketch the given views, and then add the third view in each problem. Use cross-section paper or plain paper, as assigned. In most cases, spacing between views can be improved by spacing views farther apart than shown here. Each grid space = 1/4".

Task 3.10

Given an object with a requirement to draw the object using orthographic projections, draw three necessary views showing complete views in correct positions.

For sample exercises, see pages 120-121, Basic Technical Drawing, by Spencer.

For articulation purposes, a sample page is reproduced.

Fig. 7-30. Working Drawing Problems. Make mechanical drawings as assigned. Omit dimensions unless assigned. Omit pictorial drawings. Move titles to title strip.

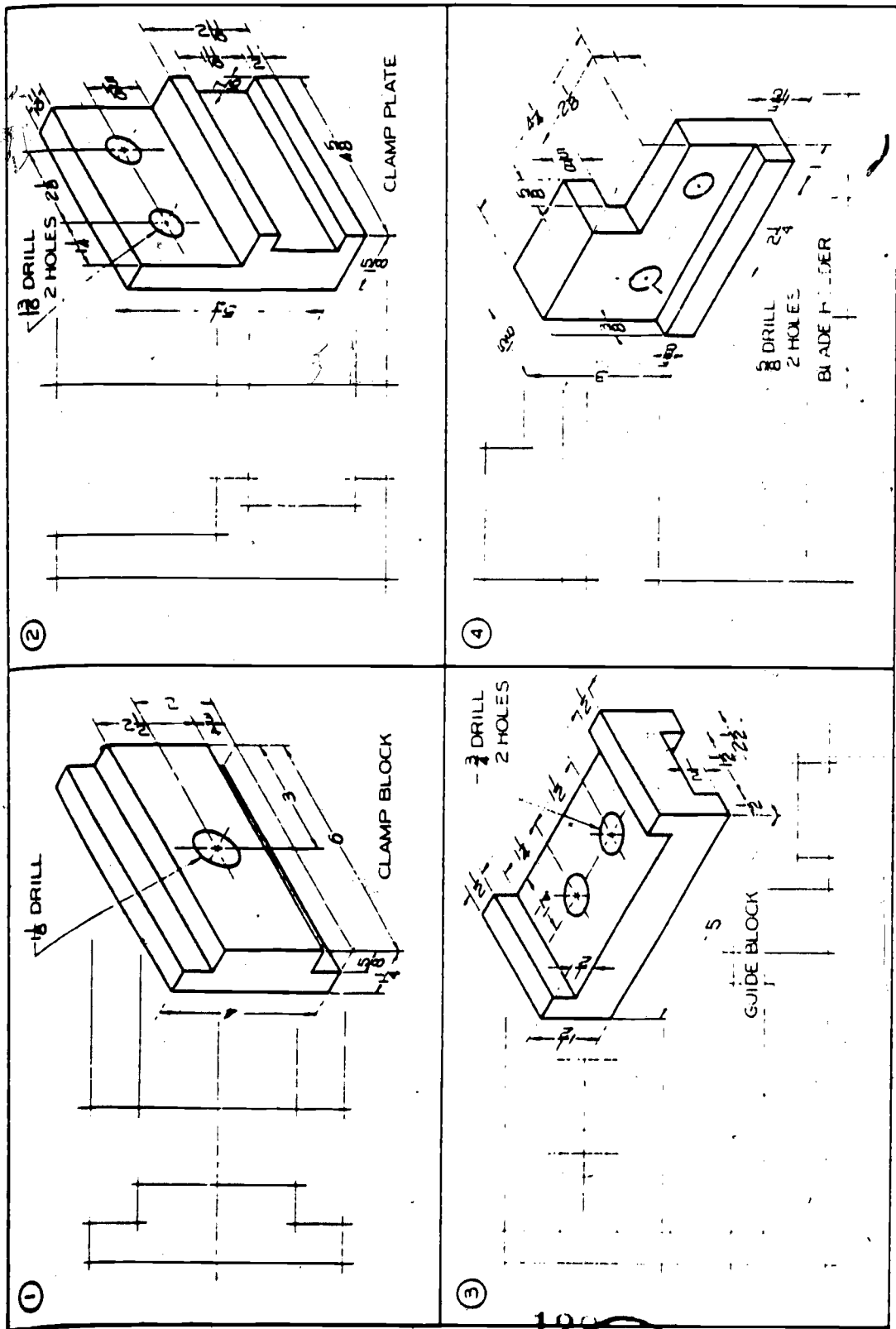

TASK

- 3.11 Given exercises by the instructor, demonstrate knowledge of the universal rules and procedures for showing shapes and sizes pictured, by illustrating how and where dimensions are placed on drawings to the satisfaction of the instructor.

(See attached sample test.)

- 3.1103 Illustrate appropriate methods of dimensioning parts of a drawing.

(See Figures 9-37 - 9-41, pages 165-167, Basic Technical Drawing, by Spencer.

For examples of tests, see: Drawing #2 and #4, Figures 9-39, page 165; Drawing #2 and #3, Figure 7-30, page 121; Figure 9-40, page 166; and Figure 9-41, page 167; Basic Technical Drawing, by Spencer.

For purpose of articulation, sample drawings are attached.

- 3.1105 (True Dimensional Tolerancing) Determine limit dimensions, tolerances, clearances, etc., by proper use of ANSI B4.1. Limit Tables or by information given by the instructor.

For sample test item, see Figure 15-39, page 294, Basic Technical Drawing, by Spencer.

"Run a print of the Drawing 15-39 and mark on it carefully in freehand. Use a pencil so that it can be erased. Use True Dimensional Tolerancing Symbols to indicate the following: (1) C-bored Holes located within 0.10 at maximum material condition. (2) Datum for tapped holes and lower counter-bored hole is bottom of part and centerline of part. Bottom of part is Datum A and centerline of part is Datum B. (3) The slot running lengthwise on the back of the part must be symmetric about Datum B within .002 inch regardless of material condition. (4) The 5/8" wide projection on the back must be perpendicular to B within .0015. (5) The 1/2" slot across the front must be located with .001 at the maximum material condition, and perpendicular to B within .0001.

- 3.12 Given relevant charts, symbols, and problems, demonstrate the ability to apply tolerances to given drawings with specifications or to instructor provided drawings of objects with measurements made by the student.

For sample test drawings, see Figure 12.26, page 353, Technical Drawing, by Giesecke.



Task 3.1103

Dimensioning Problems. Redraw with instruments. Add missing lines and dimension fully.

Fig. 9-39, p. 165, Dimensioning

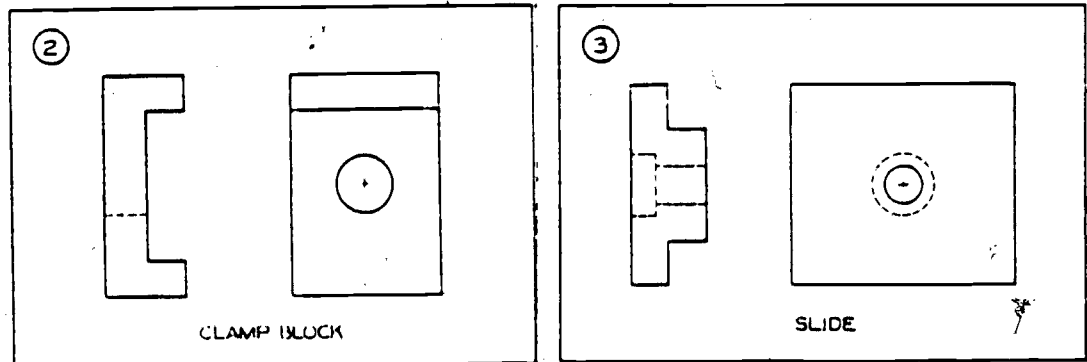

Fig. 9-40, p. 166, Dimensioning

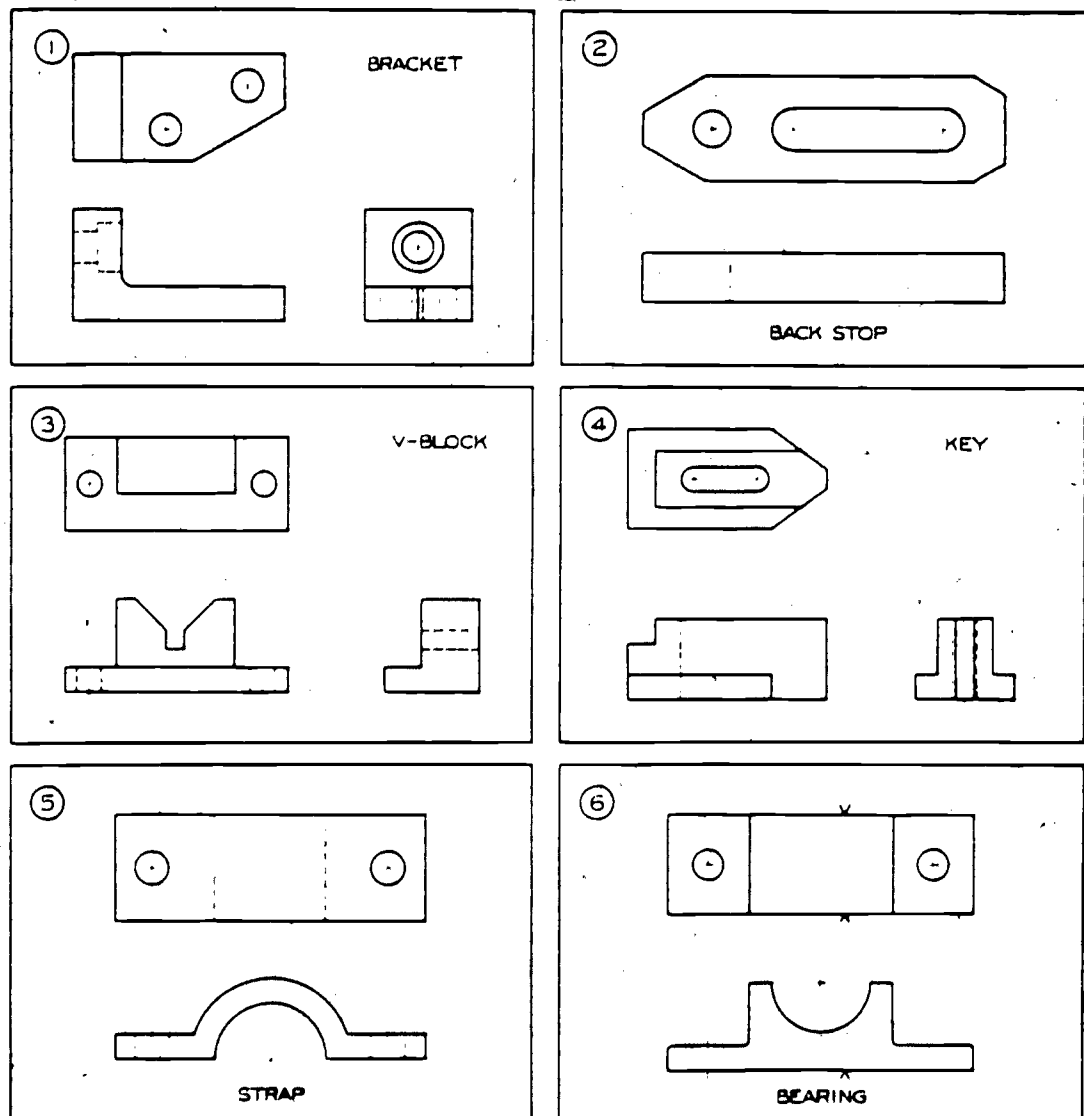

Fig. 9-40, p. 166, Dimensioning (con't.)

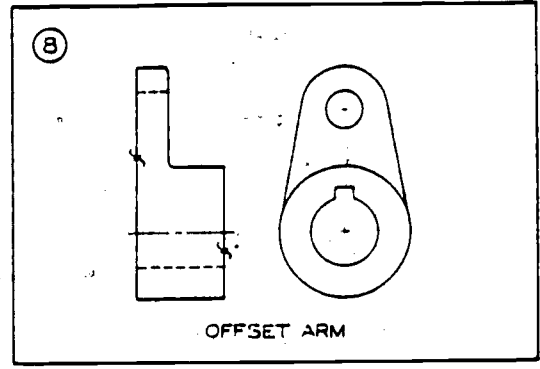
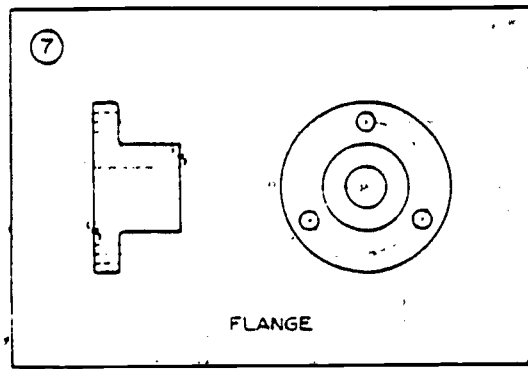
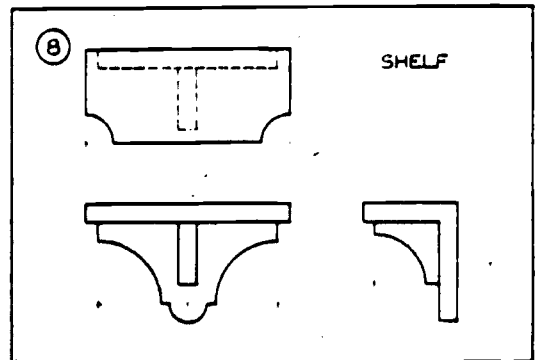
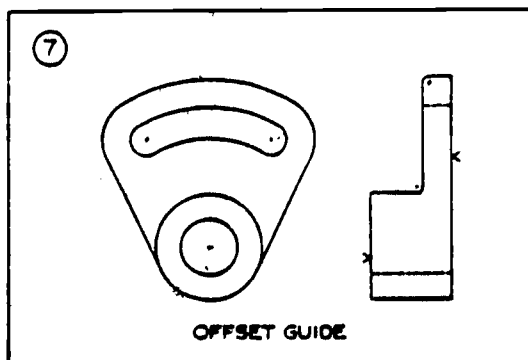
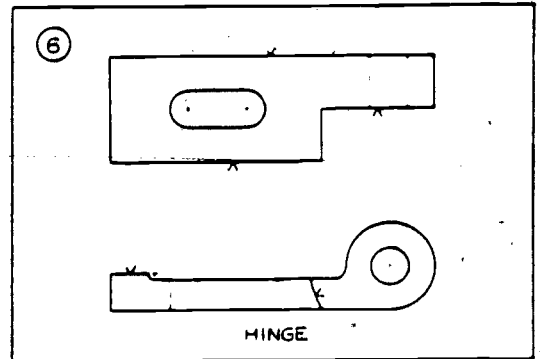
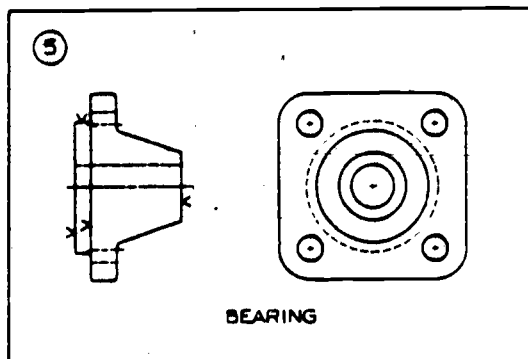
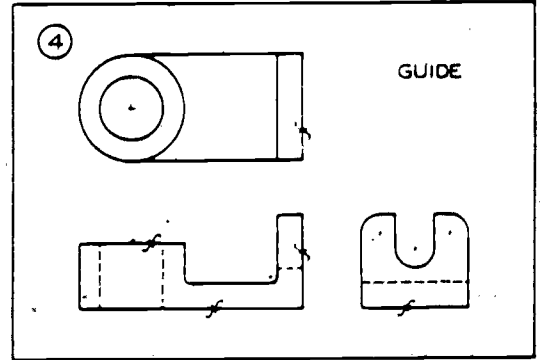
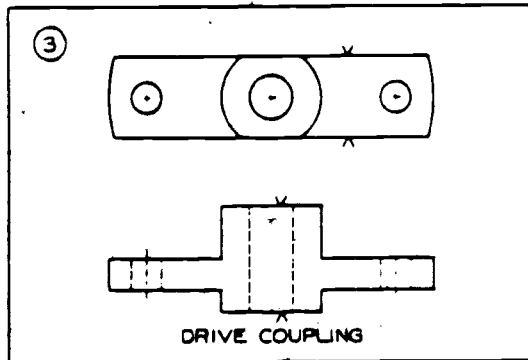
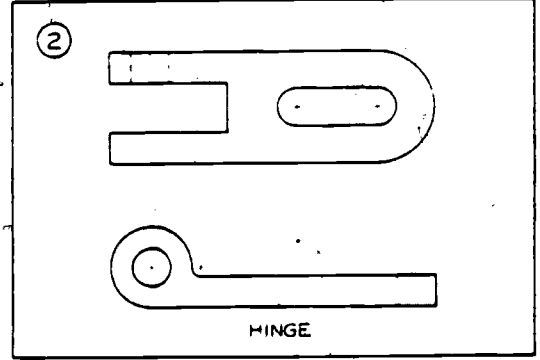
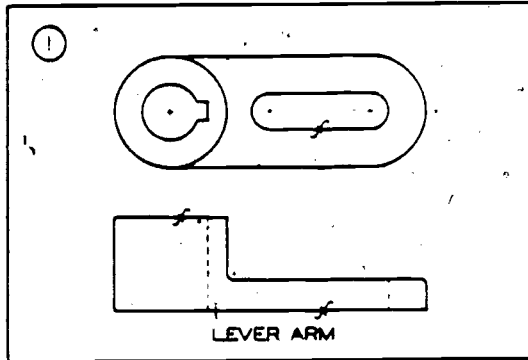

Fig. 9-41, p. 167, Dimensioning



3.1105, 3.1106, 3.1108: Sample Test

TOLERANCES

1.

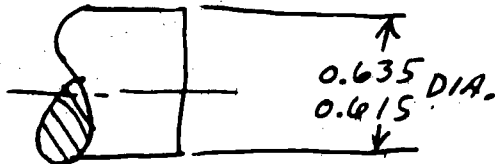

- A. The tolerance on this diameter is \_\_\_\_\_
- B. The basic diameter, in decimal form is \_\_\_\_\_
- C. The basic diameter in fraction form is \_\_\_\_\_
- D. The lower limit is \_\_\_\_\_
- E. The upper limit is \_\_\_\_\_

2.

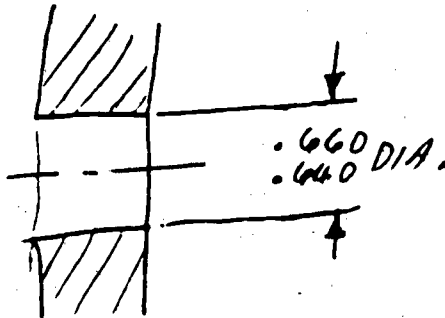

The shaft shown in item 1 above is to fit into the hole shown at left.

- A. What is the minimum clearance?  
\_\_\_\_\_
- B. What is the maximum clearance?  
\_\_\_\_\_

3.

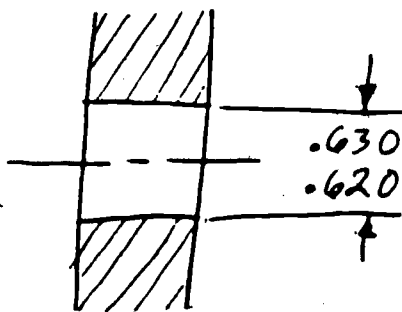

The shaft in item 1 above will be inserted into the hole at the left.

- A. What is the maximum clearance?  
\_\_\_\_\_
- B. What is the maximum interference?  
\_\_\_\_\_

4. What is the normal size of a 3/4" pipe? \_\_\_\_\_

5. Using ANSI B4.1 Tables and given a 1/2" nominal size shaft, what are the (A) maximum and (B) minimum shaft sizes and (C) maximum and (D) minimum hole sizes for a Class RC 3 fit?

- A. \_\_\_\_\_ B. \_\_\_\_\_ C. \_\_\_\_\_ D. \_\_\_\_\_

TOLERANCES, PART II

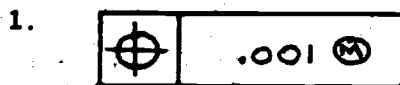

Write what each part of the symbol means.



What does this symbol mean?

3. What is a reference point?

4. What is a maximum material condition for:

- a. A hole?
- b. A slot?
- c. A shaft?

5. What is meant by "perpendicularity"?

6. What is meant by "runout"?

7.

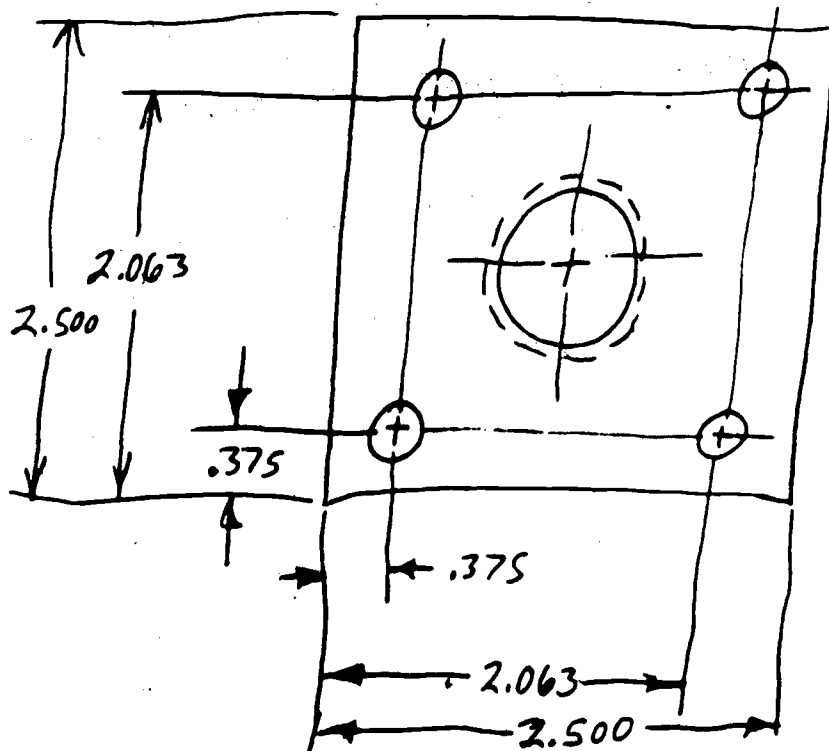

For the drawing on the left, all holes are  $9/32$ " diameter, except the center, threaded  $7/8-5$  Acme. All holes are True Position within .001.

Label datums and show true position tolerance symbols. Show proper hole and thread notes (freehand).

MODULE 4.0

4.01

Complete a minimum of two exercises to describe the internal features of three-dimensional objects by using various types of sectional views, drawing figures to meet specifications concerning: (1) the correct type of sectional view, (2) correct placement of cutting plane line, and (3) correct placement of section lines.

For sample test drawings, see Figure 11-24, page 204; Figure 11-25, page 205; and pages 206-210 for representative exercises for performance actions 4.0105 (a-1): Basic Technical Drawing, by Spencer.

Samples attached for articulation.

Also, see Figure 7.56, page 225 and Figure 6.67, page 227, Technical Drawing, by Giesecke.

4.02

Draw the true shape of inclined and oblique planes and draw a minimum of two assigned figures using auxiliary planes to describe the true size and shape of faces which are not parallel to the regular planes of projection.

See Figure 8.41, page 248, Technical Drawing, by Giesecke.

Sample 4.01

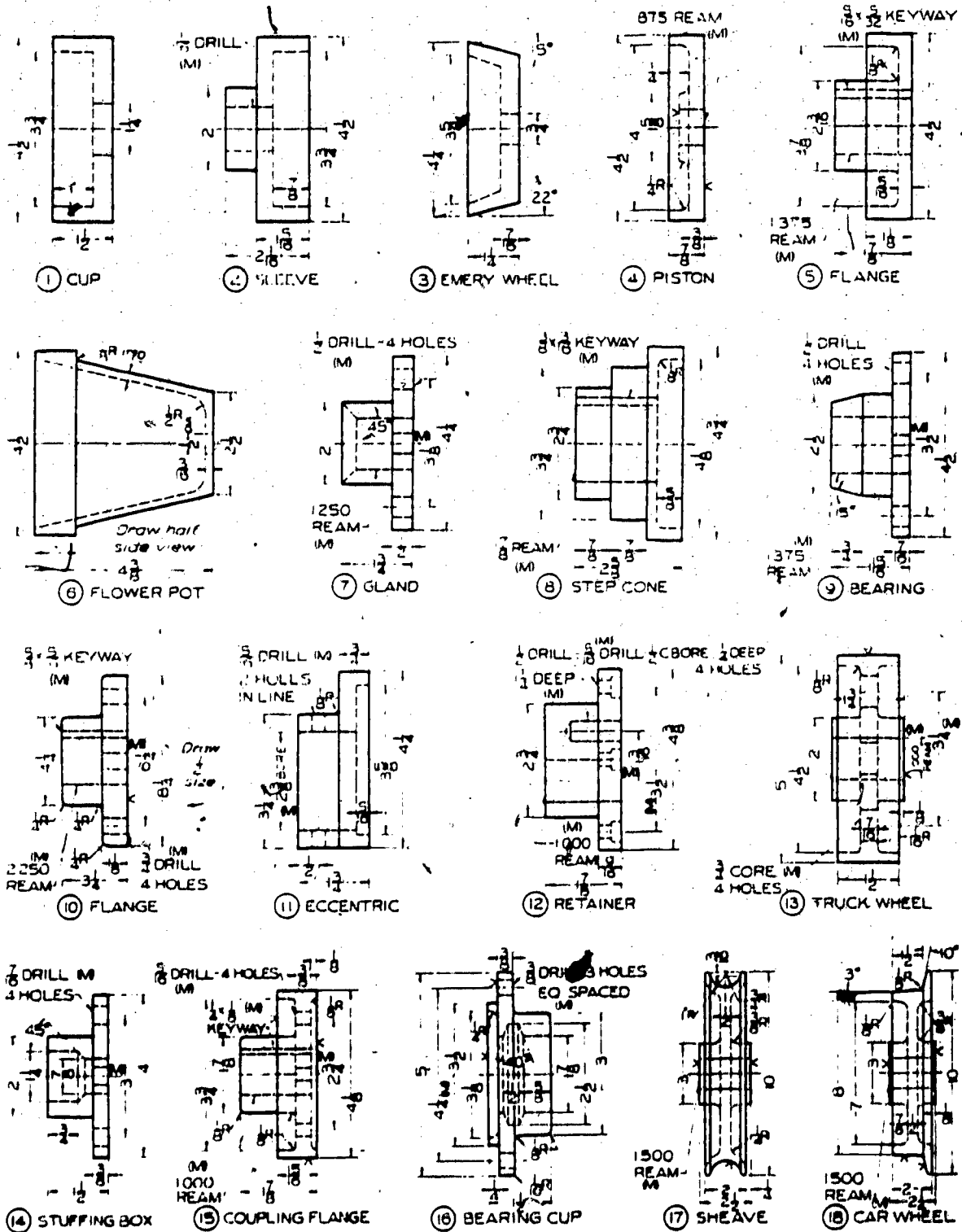

Fig. 11-24. Sectioning Problems. Page 204, Spencer. Make sketch or mechanical drawing of problem assigned from above. In each case draw a circular view and a full or half section as assigned. Vertical dimensions are diameters. Dimensions marked (M) should be moved to circular view. Holes are equally spaced. Give part names in title strips.

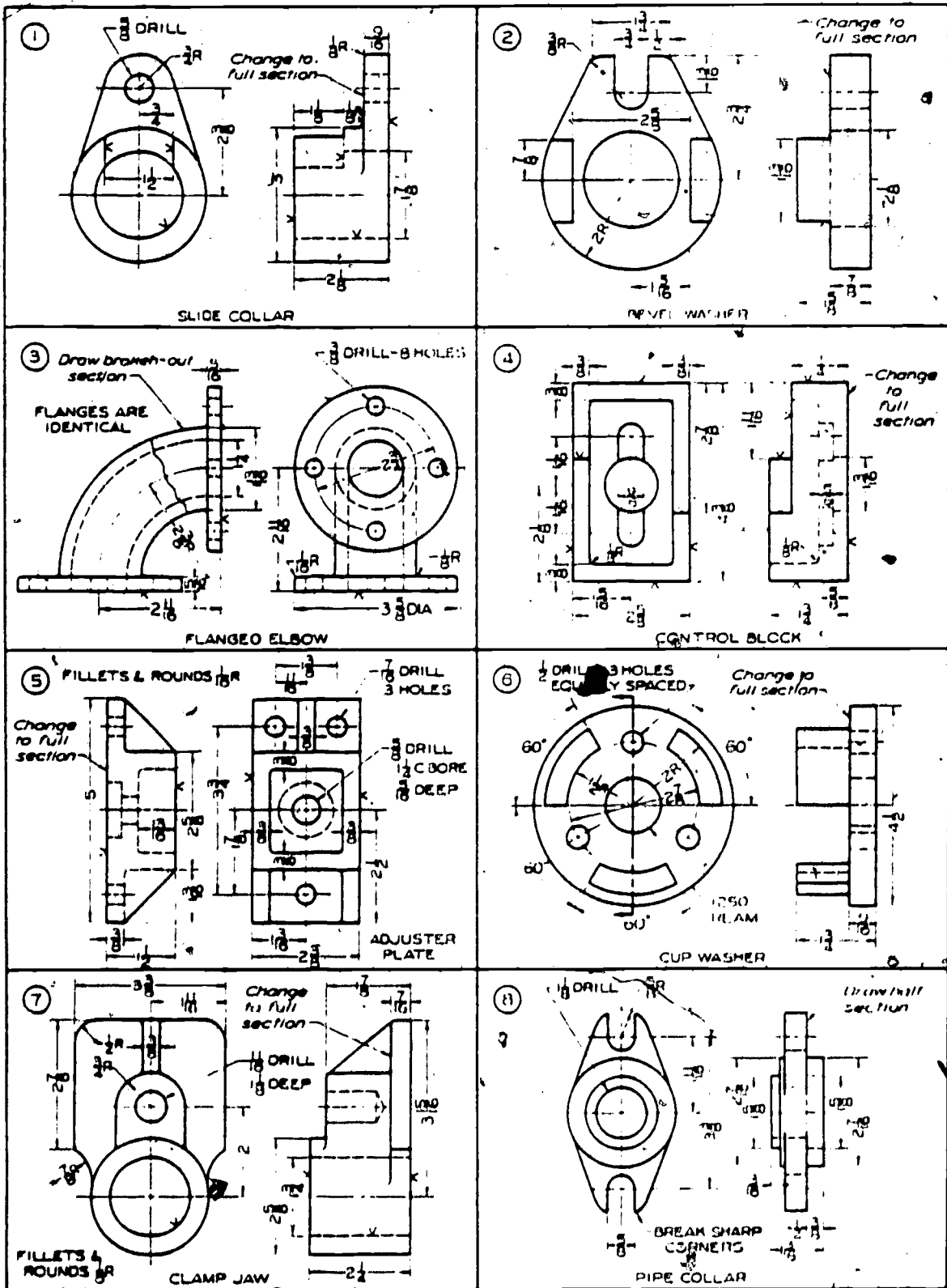
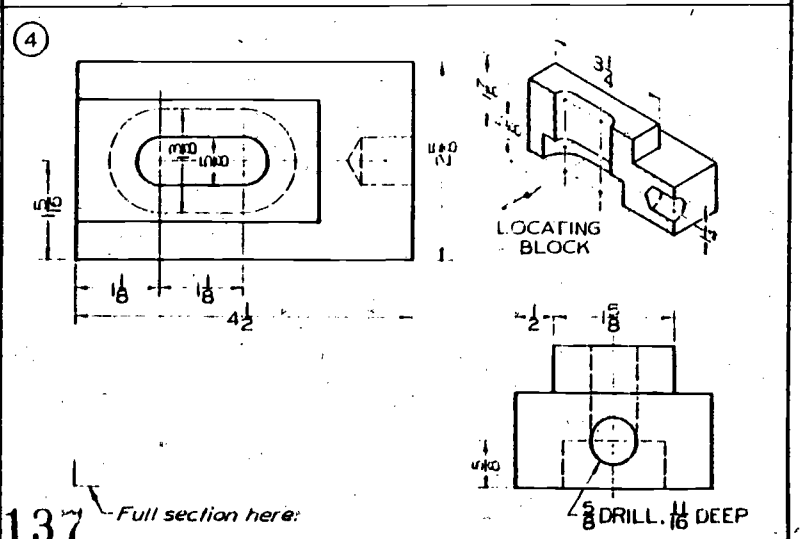
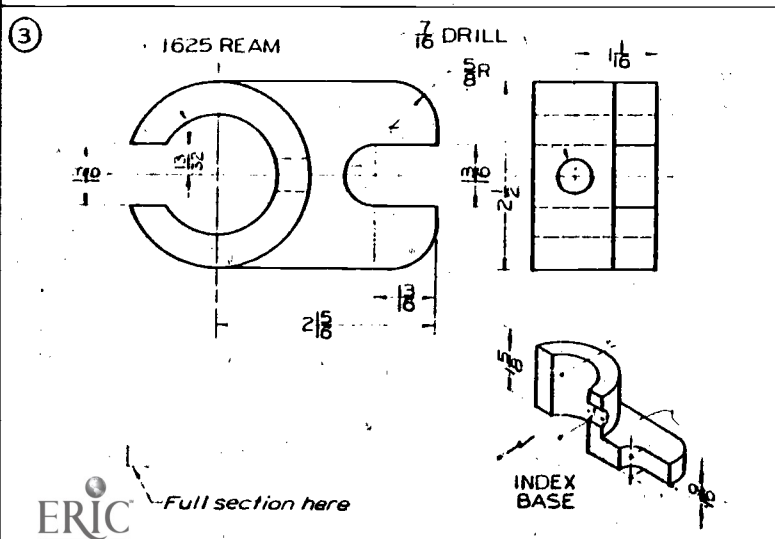
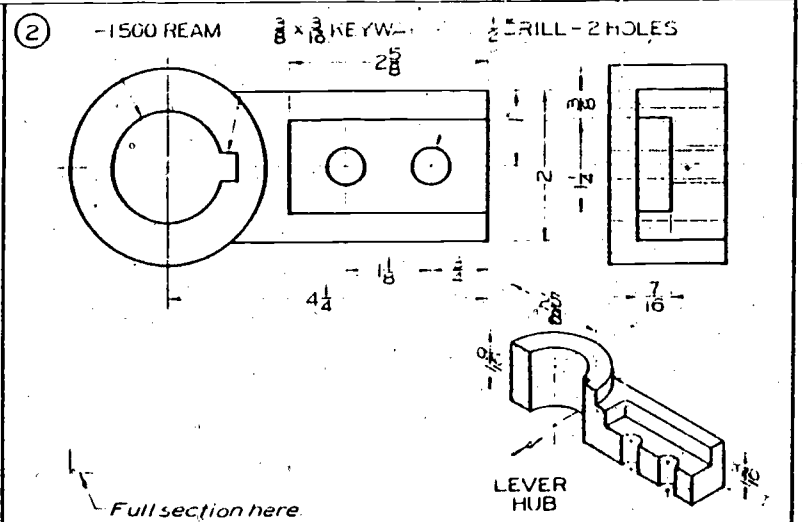
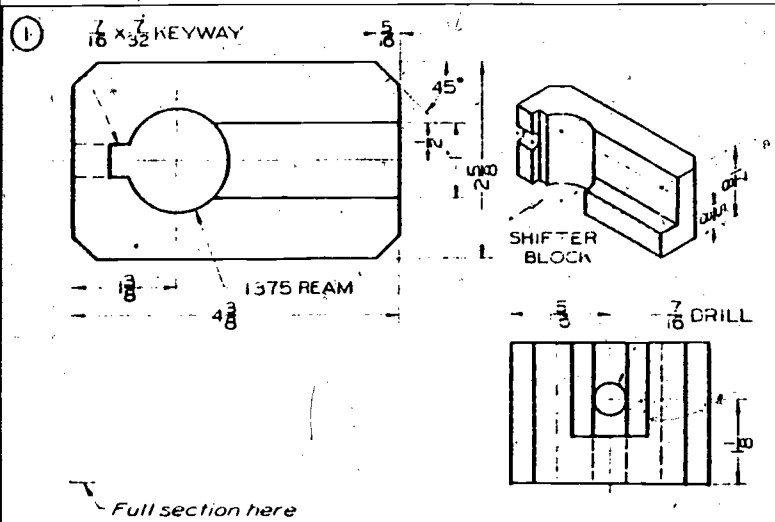

Fig. 11-25, Sectioning Problems. Page 205, Spencer. Make sketch or mechanical drawing. Section as indicated. Omit instructional notes. Give part names in title strips.

Sample 4.0105

Sectioning Problems. Page 206, Spencer. Make sketch or mechanical drawing of assigned problem showing the given views plus a section as indicated. Omit pictorial drawings and instructional notes. Move dimensions from pictorial drawings to the sectional views. Give part names in title strips.





Sample 4.0105

Sectioning Problems. Page 206, Spencer. Make sketch or mechanical drawing of assigned problem, showing the given views plus a section as indicated. Omit pictorial drawings and instructional notes. Move dimensions from pictorial drawings to the sectional views. Give part names in title strips.

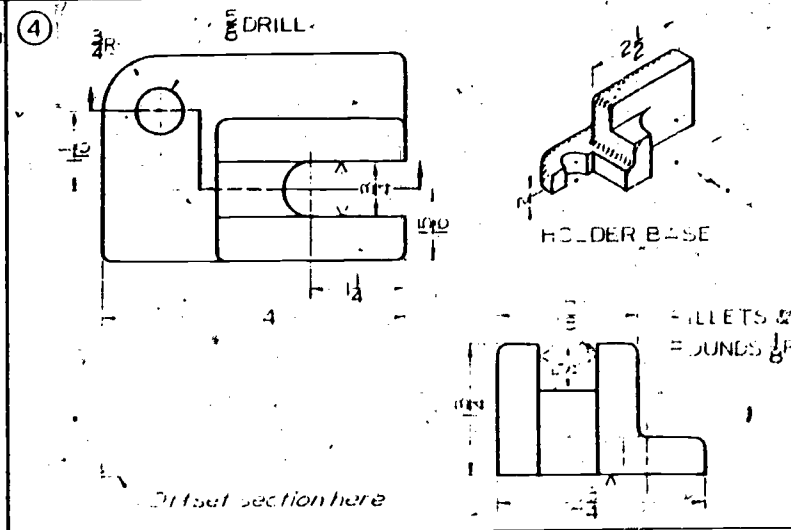
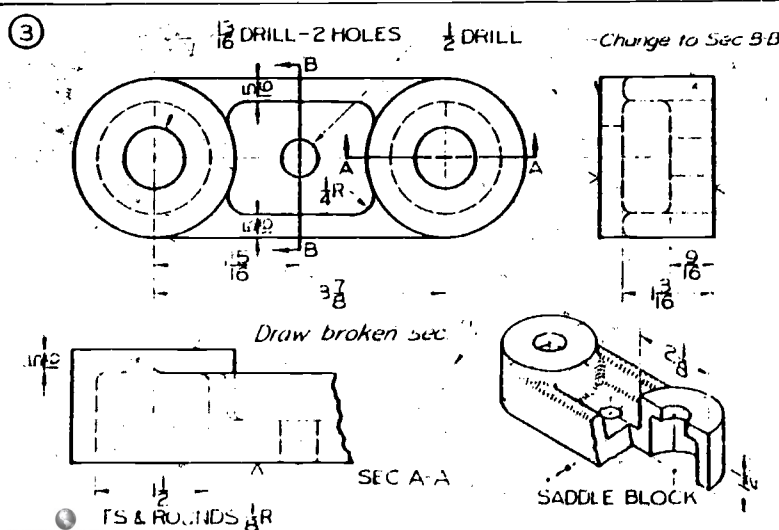
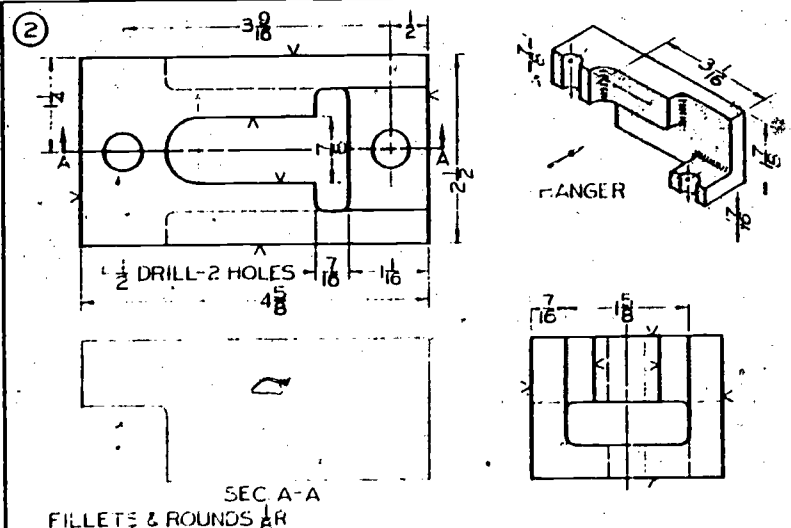
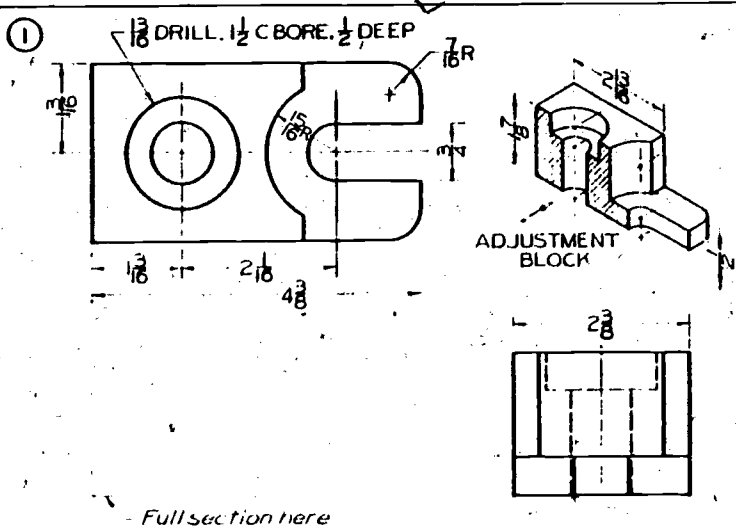

Sample 4.0105

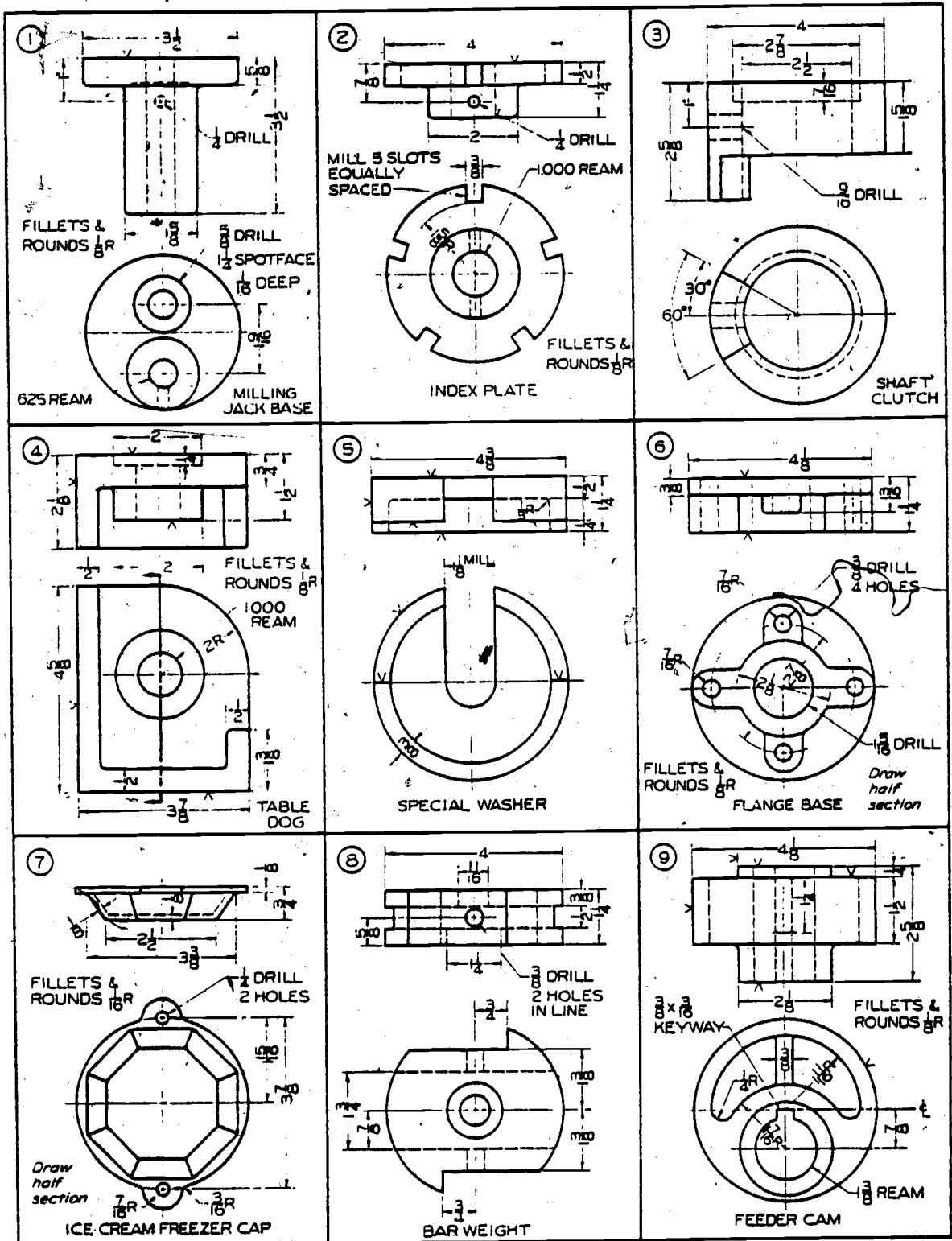

Sectioning Problems. Page 203, Spencer. Make sketch or mechanical drawing. Omit given top view, draw front view as shown, and draw side view in full section, except in Problems 6 and 7, which require half sections. Omit instructional notes. Given part names in title strips. Move dimensions to new locations as necessary.

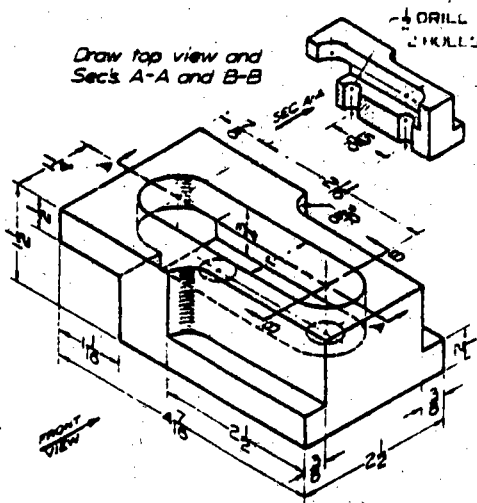

Guard Block

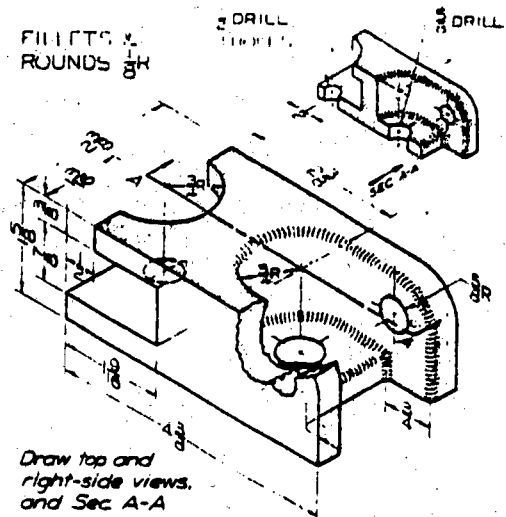

Pivot Base

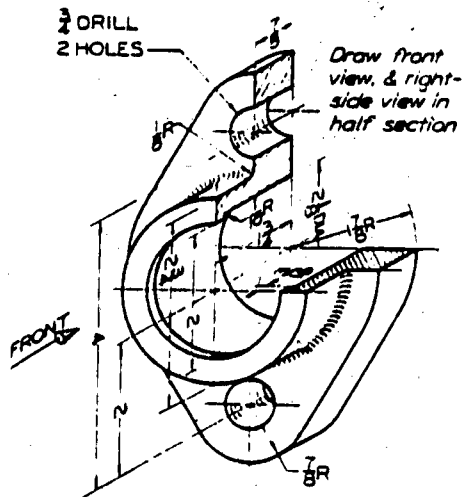

Packing Gland

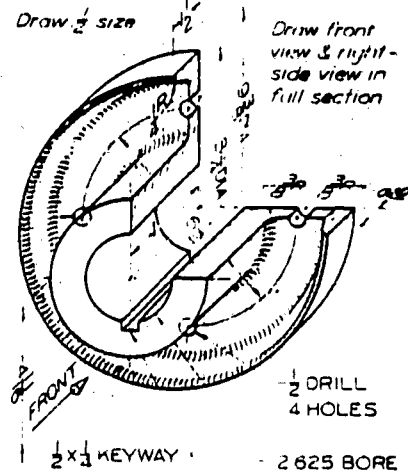

Flange

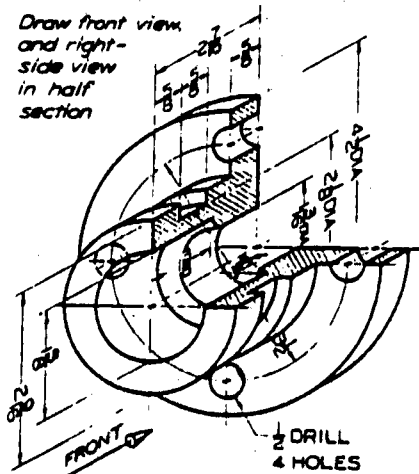

Stuffing Box

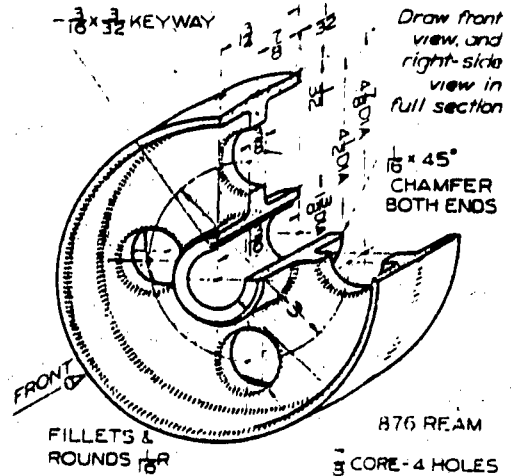

Pulley

Task 4.0403 See Fig. 10-48, p. 210, Mechanical Drawing, French.

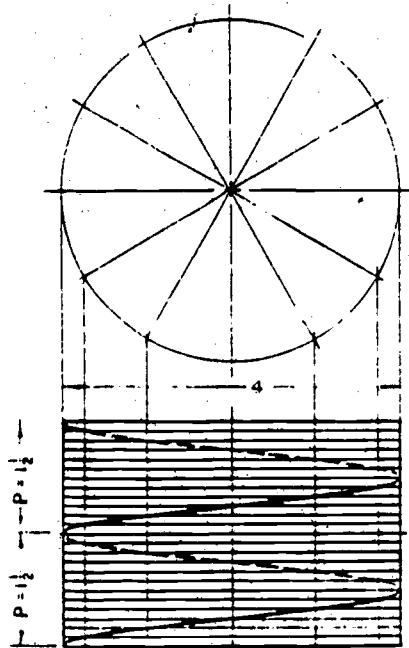

Fig. 10-44 Draw two complete turns of a right-hand helix as shown above. Use dimensions indicated and work full size. Number all points to avoid errors.

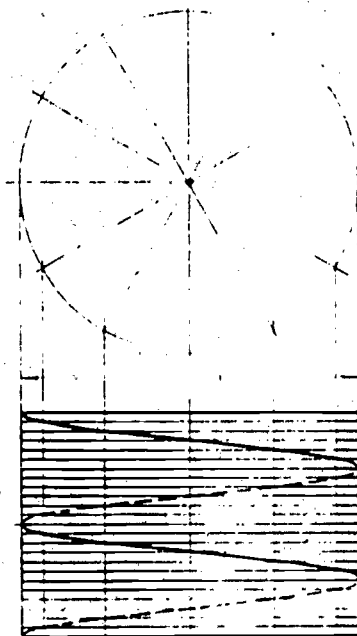

Fig. 10-45 Draw two complete turns of a left-hand helix as shown above. Use dimensions indicated and work full size. Number all points to avoid errors.

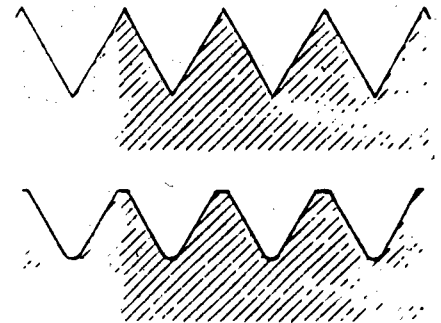

Fig. 10-46 Draw the profiles of the sharp "V" and the American National Unified thread. Letter the name of each under it. Pitch = 1".

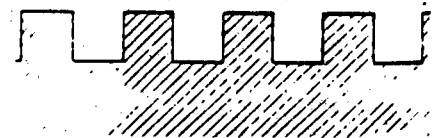

Fig. 10-47 Draw the profile of the square thread. Letter the name under it. Pitch = 1".

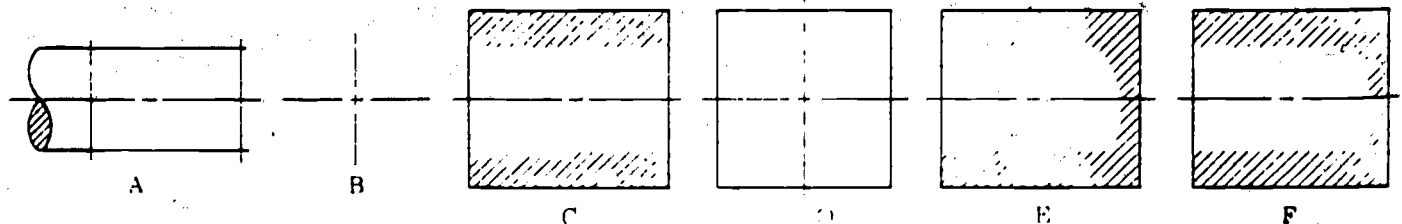

Fig. 10-48 Schematic representation of screw threads. Take dimensions from the printed scale at the bottom of the page, using dividers. Draw the views as shown and complete each as follows: A = schematic representation showing 1"-8UNC-2A threads; B = end view of A; C = schematic representation of

section through 1"-8UNC-2B (internal) threads; D = right-side view of C; E = schematic representation of section through  $\frac{7}{8}$ " drill  $\times 1\frac{1}{2}$ " deep; F = schematic representation of section through  $\frac{7}{8}$ " drill  $\times 1\frac{1}{2}$ " deep, 1"-8UNC-2B  $\times 1\frac{1}{2}$ " deep.

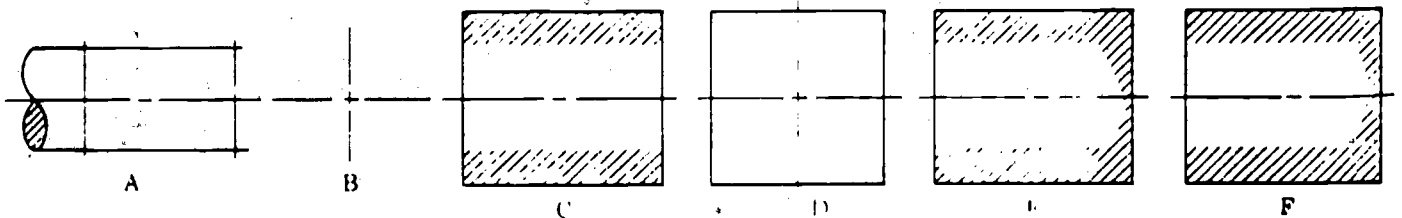
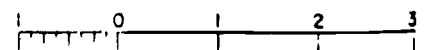

Fig. 10-49 Simplified representation of screw threads. Take dimensions from the printed scale at the bottom of the page, using dividers. Draw the views as shown and complete each as follows: A = simplified representation showing 1"-8UNC-2A threads; B = end view of A; C = simplified representation of

section through 1"-8UNC-2B (internal) threads; D = right-side view of C; E = simplified representation of section through  $\frac{7}{8}$ " drill  $\times 1\frac{1}{2}$ " deep; F = simplified representation of section through  $\frac{7}{8}$ " drill  $\times 1\frac{1}{2}$ " deep, 1"-8UNC-2B  $\times 1\frac{1}{2}$ " deep.



Task 4.0403 See Fig. 14-39, p. 263, Spencer.

Detailed Threads. Draw problems assigned. Omit all inclined lettering. Transfer titles to title strip.

① AMERICAN STANDARD THREADS

2 1/2 - 4 UNC - 3A

45° x THD DEPTH CHAMFER

2

7 1/2

1/4

2

Complete threads here

Draw internal threads here in section

Alternate Problems (1) Draw 2 1/2 - 4 UNC - 2A, LH Triple threads (2) Draw 2 1/2 - 4 1/2 UNC - 3A thds but with nut in elevation

② AMERICAN STANDARD THREADS

Complete the views

1 1/2 - 5 UNC - 2A

1 1/2

1 1/2

1 1/2

1/8

2 1/2 SQ

1 1/2

Threaded

End view of shaft

Sectional view of nut

End view of nut

Alternate Problems (1) Draw 1 1/2 - 5 UNC 2A LH TRIPLE threads (2) Draw 1 1/2 - 6 UNC - 2A threads

③ SQUARE AND ACME THREADS

2 1/2 - 2 SQUARE

3/8 DRILL

2 1/2 - 2 ACME, L11

3 (Threaded)

1

3 (Threaded)

1 1/2

8

Alternate Problem Draw double threads

④

2 1/2 - 2 SQUARE

3

1

3

1 1/2

8 1/2

SQUARE THREADS

Alternate Problems (1) Draw 2 1/2 - 2 ACME thds (2) Draw 2 1/2 - 2 ACME or SQUARE, DOUBLE, L11 or R11

Task 4.0405

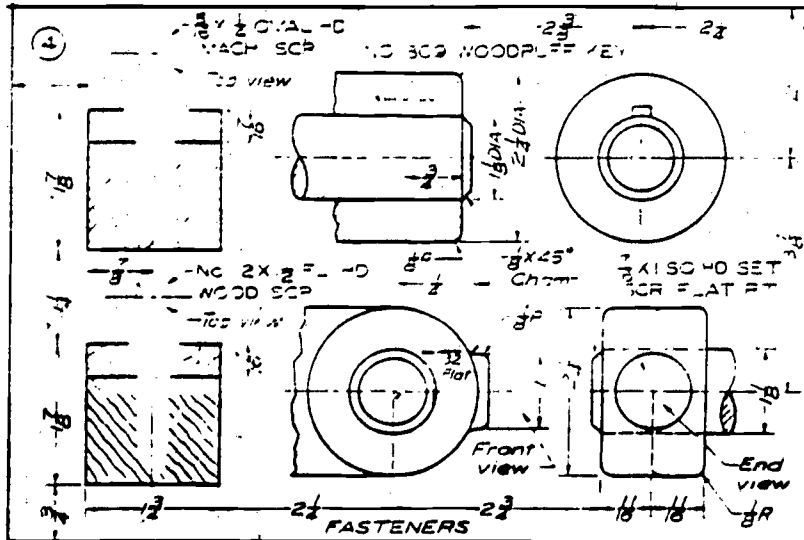

Fig 14-40, (Exercise 4), page 264, Basic Technical Drawing, Spencer. Symbolic Threads and Fasteners. Draw problem assigned. Omit all inclined lettering. Transfer titles to title strip.

Task 4.05 See Fig. 16-46, p. 332, Basic Technical Drawing, Spencer.

See Fig. 16-49, p. 334, (Examples 3 and 8 for given degree angles in isometrics), Basic Technical Drawings, Spencer.

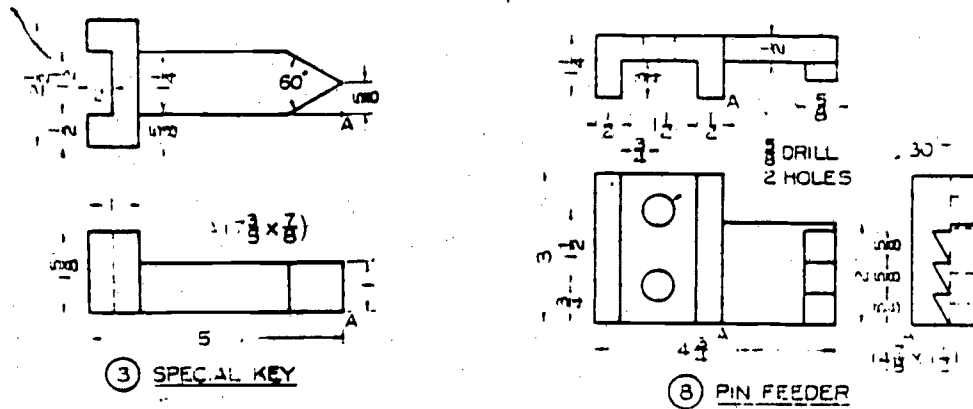

Fig 16-49. Isometric Problems. Locate starting corners A. Move titles to titles strip and omit dimensions unless assigned.

Task 4.06

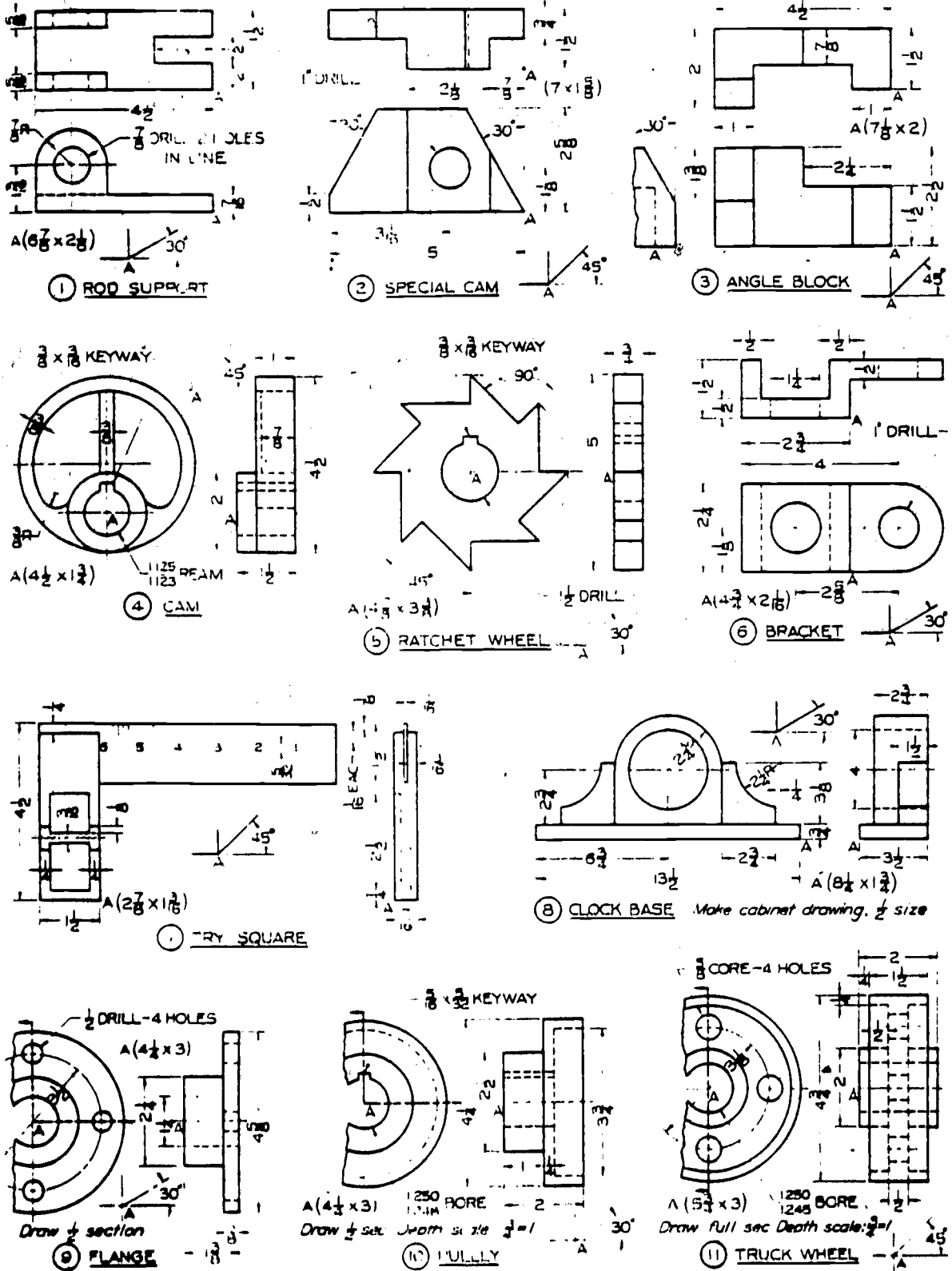

Fig. 16-53, p. 337, Basic Technical Drawing, Spencer. Oblique Problems. Locate starting corners A. Move titles to title strip and omit dimensions unless assigned.



Task 4.07

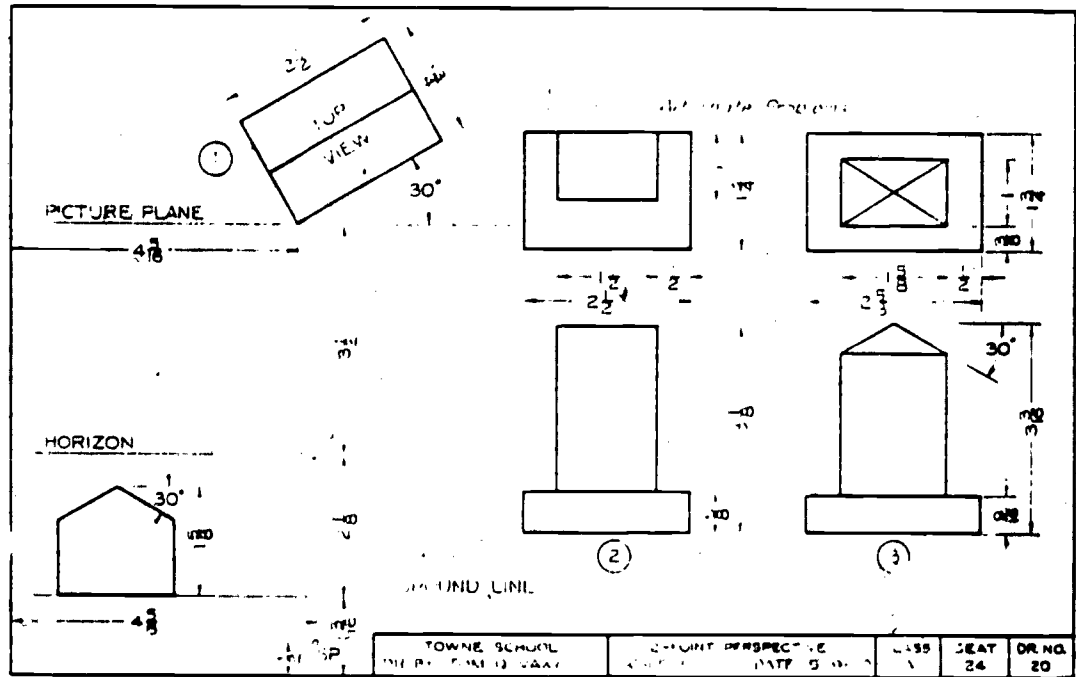

Fig. 16-54, p. 338, **Basic Technical Drawing**, Spencer. Two-Point Perspective Problems. Omit all dimensions. Letter VPL, SP, etc.

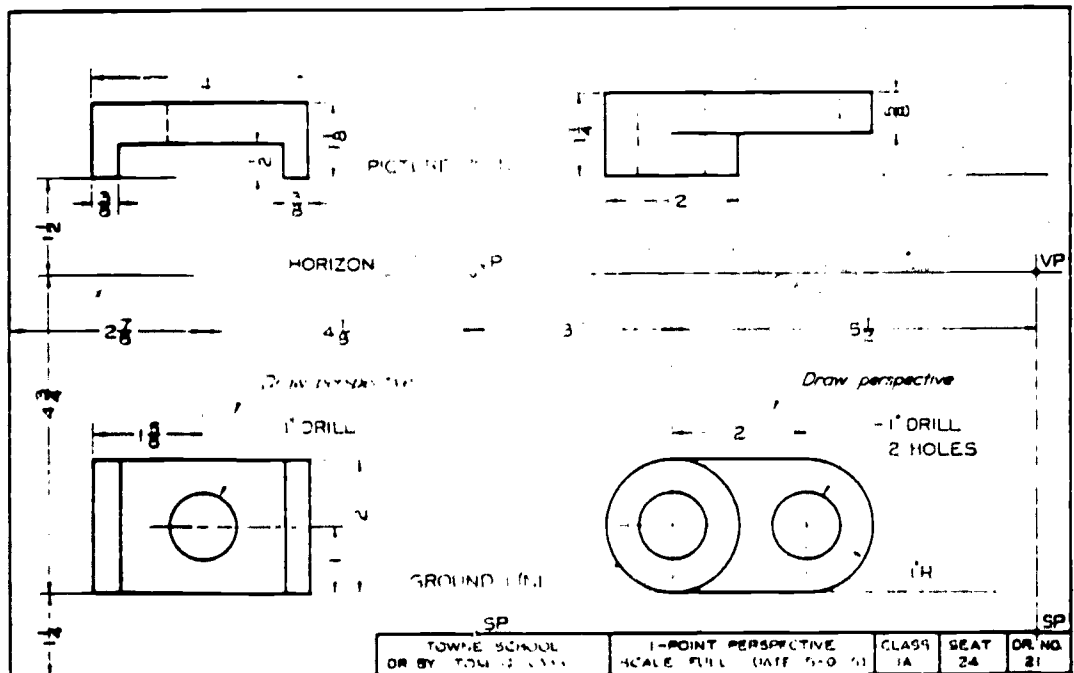

Fig. 16-55, p. 339, **Basic Technical Drawing**, Spencer. One-Point Perspective Problems. Omit all dimensions. Letter VPL, SP, etc.

See Fig. 18-54, **Technical Drawing**, 6th ed., Giesecke.

**Task 4.08**

Fig. 18-53 Developments. Scale: full size. Problems A through L are planned to fit on an 11" x 17" or 12" x 18" drawing sheet. Draw the front and top views of the problem assigned. Develop the stretchout (pattern) as shown in the example at the right. For problems A through F, add the top in the position it would be drawn for fabrication. Include dimensions and numbers if instructed to do so. Patterns may be cut out and assembled.

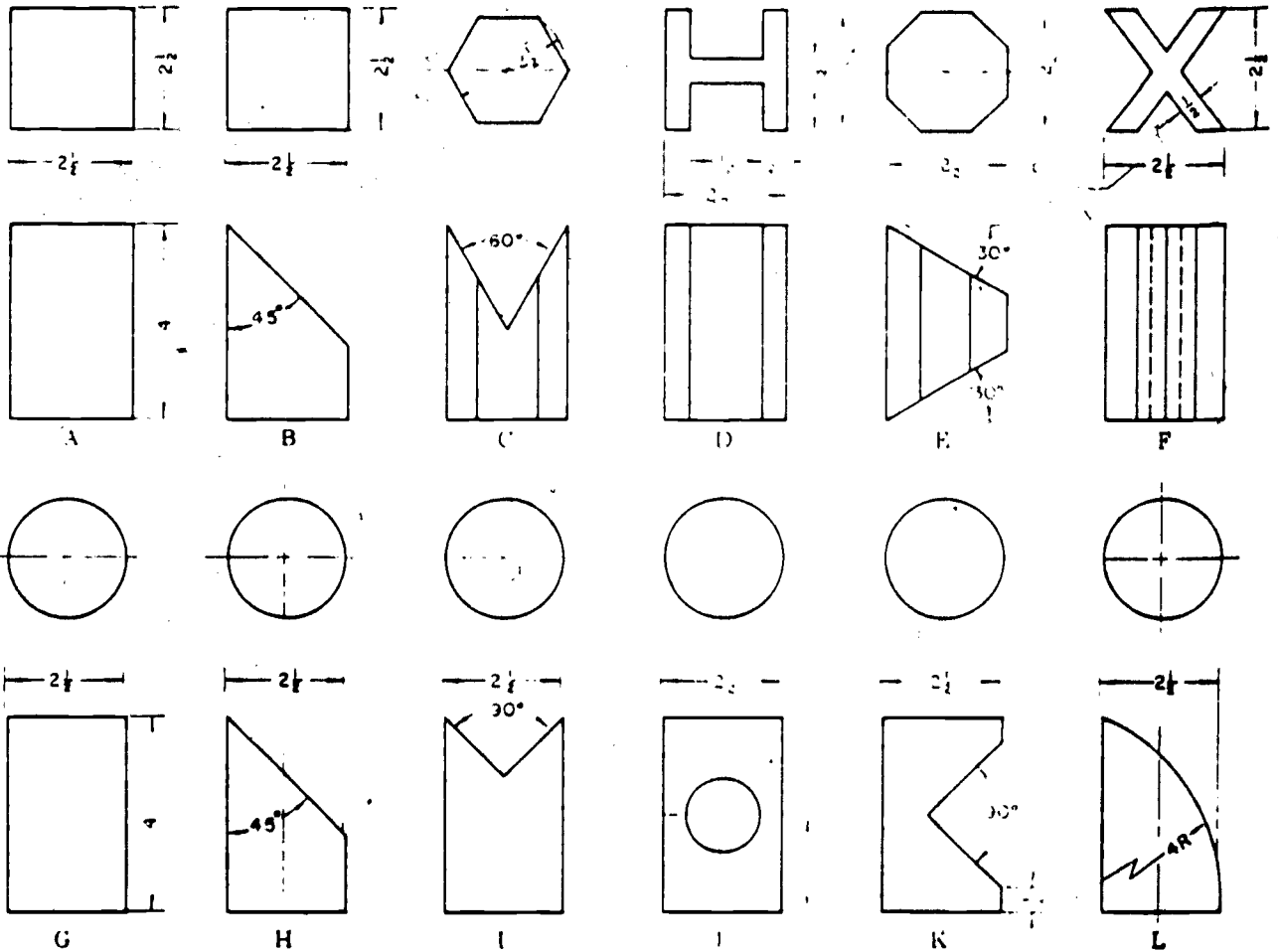
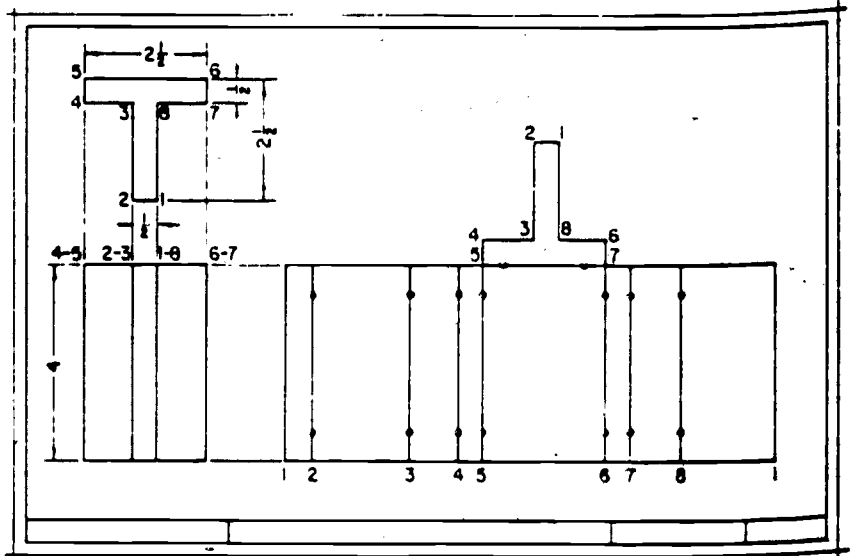

Fig. 18-53, p. 340, and 18-54, p. 341, Mechanical Drawing, French.

Fig. 17-32, p. 362, Basic Technical Drawing, Spencer.

Task 4.08

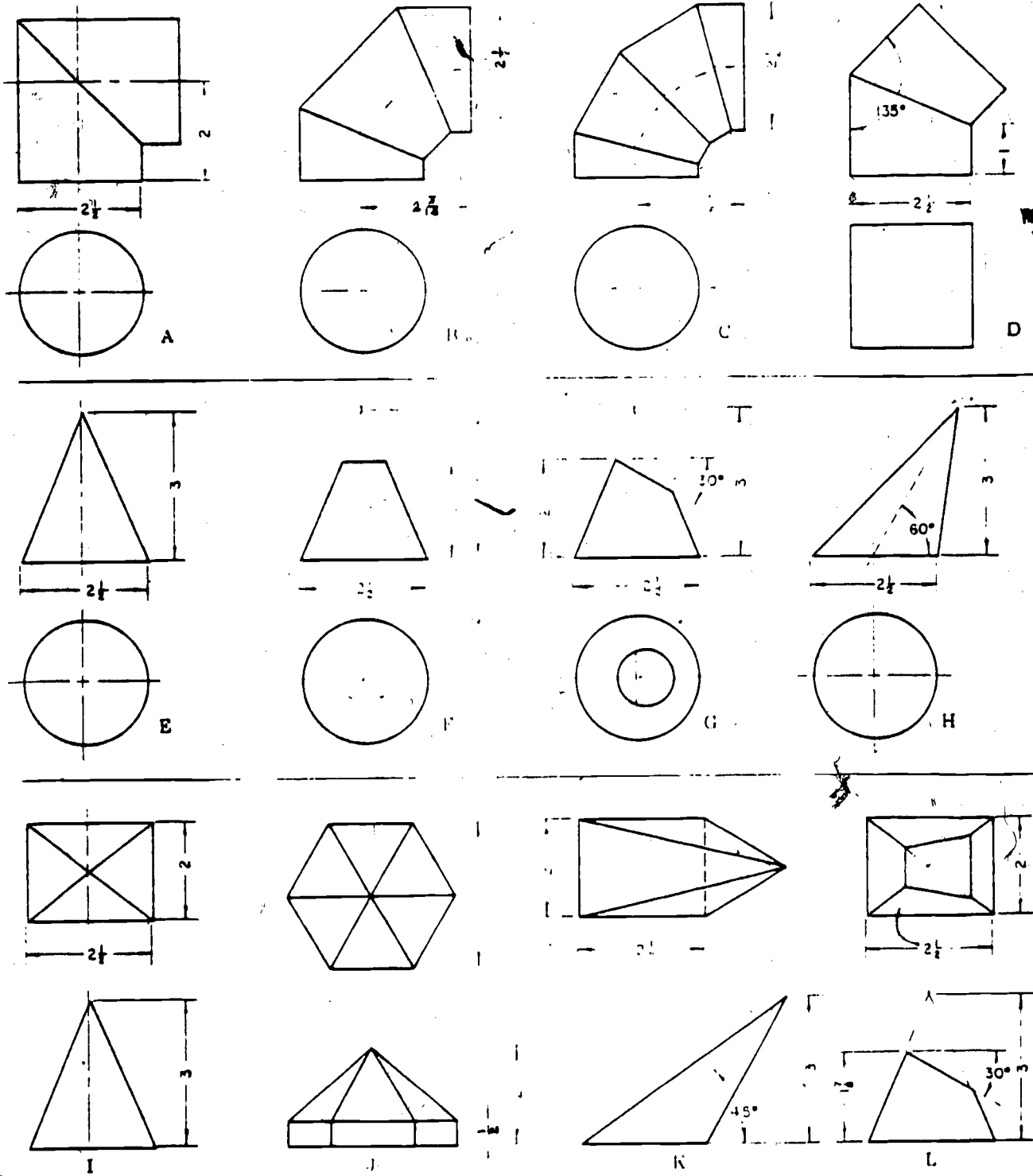

Fig. 18-54 Make two views of the problem assigned and develop the pattern. Scale: full size.

Page 341, French.

Task 4.08

**I**

	1	2	3	4	5	6	7	8
A	$3\frac{1}{2}$	$3\frac{7}{8}$	$3\frac{3}{8}$	$3\frac{1}{8}$	$3\frac{1}{2}$	$3\frac{3}{4}$	$3\frac{7}{8}$	$3\frac{5}{8}$
B	$2\frac{1}{2}$	$2\frac{3}{8}$	$2\frac{5}{8}$	$2\frac{1}{2}$	$2\frac{1}{8}$	$2\frac{3}{8}$	$2\frac{5}{8}$	$2\frac{3}{4}$
C	$1\frac{1}{8}$	$1\frac{1}{2}$	$1\frac{3}{8}$	$1\frac{1}{2}$	$1\frac{7}{8}$	$1\frac{1}{2}$	$1\frac{1}{8}$	$1\frac{3}{8}$
D	$45^\circ$	$30^\circ$	$45^\circ$	$48^\circ$	$40^\circ$	$45^\circ$	$30^\circ$	$38^\circ$

Include ends in pattern

**II**

Omit ends in pattern

From Fig 12-18 select problem and draw two given views in position shown here, then draw pattern. Omit ends from pattern. Letter all points.

**III**

	1	2	3	4	5	6	7	8
A	$2\frac{1}{2}$	$2\frac{3}{8}$	$2\frac{5}{8}$	$2\frac{1}{8}$	$2\frac{3}{4}$	$2\frac{1}{2}$	$2\frac{7}{8}$	$2\frac{5}{8}$
B	$3\frac{1}{2}$	$3\frac{3}{8}$	$3\frac{5}{8}$	$3\frac{1}{8}$	$3\frac{1}{2}$	$3\frac{3}{4}$	$3\frac{7}{8}$	$3\frac{5}{8}$

Omit ends in pattern

**IV**

	1	2	3	4	5	6	7	8
A	$2\frac{1}{2}$	$2\frac{3}{8}$	$2\frac{5}{8}$	$2\frac{1}{8}$	$2\frac{3}{4}$	$2\frac{1}{2}$	$2\frac{7}{8}$	$2\frac{5}{8}$
B	$3\frac{1}{2}$	$3\frac{3}{8}$	$3\frac{5}{8}$	$3\frac{1}{8}$	$3\frac{1}{2}$	$3\frac{3}{4}$	$3\frac{7}{8}$	$3\frac{5}{8}$
C	$3\frac{1}{2}$	$3\frac{3}{8}$	$3\frac{5}{8}$	$3\frac{1}{8}$	$3\frac{1}{2}$	$3\frac{3}{4}$	$3\frac{7}{8}$	$3\frac{5}{8}$

Omit ends in pattern

Fig. 17-32, p. 362, Spencer. Parallel-Line Development Problems. Draw given views and pattern of problem assigned by instructor. Omit table and all spacing, dimensions, and instructional notes.

TASK 4.09

See Fig. 17-34 and Fig. 17-35, p. 364, Basic Technical Drawing, Spencer.

Also see Fig. 18-54, p. 341, Mechanical Drawing, French.

**Task 4.10**

See Exercises E and F, Fig. 18-55, p. 342, Mechanical Drawing, French.

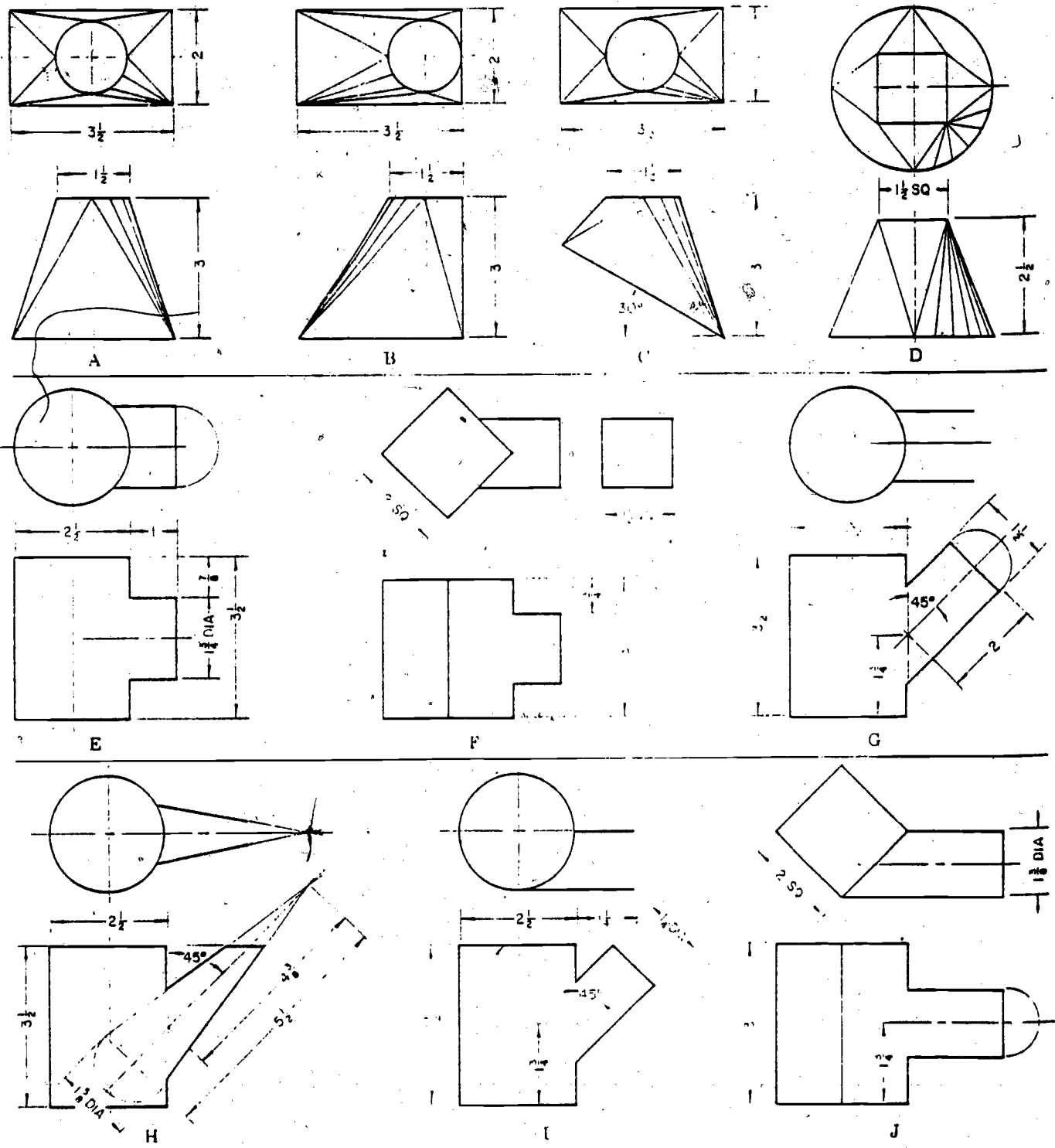

**Fig. 18-55** Make two views of the problem assigned. In problems A through D, complete the top view and develop the pattern. In problems E through J, complete views where necessary by developing the line of intersection and completing the top view in G, H, and I. Develop patterns for both parts in problems E through J.







Sample Test 5.0401

Student's Name \_\_\_\_\_

Date \_\_\_\_\_

QUIZ ON FIELD TRIP  
SHOP PROCESSES

Field trip to: NORFAB (local industry)

1. List at least three machine tools you observed during the field trip.
2. In which direction does the flat horizontal table, on which many of the machine tools are mounted, move?
3. If a round part, such as a shaft, were to be made, which machine tool normally would be used to machine the part?
4. What is the smooth flat granite table used for in the machine shop?
5. What is the use of the Optical Comparator?
6. Why are some metal parts pellet blasted?
7. Summarize the Shop Foreman's statement concerning showing dimensions on drawings?

Sample Test 5.0401

SHOP PROCESSES

WORKSHEET A

NAME: \_\_\_\_\_

1. List two ways of rough forming machine parts.
2. Identify where finishing work usually is done on machine parts.
3. Describe how castings are made.
4. Define forging.
5. Sketch and identify eight different forms (or shapes) in which metals can be purchased.
6. Define welding.
7. Describe a lathe.
8. Identify the tool used to form a counterbored hole.
9. Identify the tool used to countersink a hole.
10. Describe a milling machine.

PROFICIENCY REPORT

PROFICIENCY REPORT  
for

Vocational Course

Student: \_\_\_\_\_

High School: \_\_\_\_\_

Vocational Center: \_\_\_\_\_

Date Training Initiated: \_\_\_\_\_

First Year Completed: \_\_\_\_\_

Second Year Initiated: \_\_\_\_\_

Second Year Completed: \_\_\_\_\_

Instructor: \_\_\_\_\_

**DIRECTIONS:** The purpose of the proficiency report is to communicate to the student, other instructors, or potential employers the abilities that a student has demonstrated to the instructor in vocational training. Mark each task as soon as possible after instruction or skills demonstration. If instruction is not aimed at task proficiency, or if only an orientation or introduction to the task was provided, DO NOT mark a proficiency level or mark Level 0. Levels 1-4 indicate that instruction was given and the proficiency may be interpreted as follows:

- Level 0 No skill level demonstrated; proficiency training not given in the skill.
- Level 1 Individual's skill level is not what is generally expected for entry level employment.
- Level 2 Individual's skill level probably is what is generally expected for entry level employment, but the individual probably will need close on-the-job supervision for a while longer.
- Level 3 Individual's skill level is what is generally expected for entry level employment.
- Level 4 Individual's skill level is equal to that of a worker with some on-the-job experience.

For further description of the levels of proficiency, see the "Proficiency Report" section of the Policies and Procedures Guide for Articulation Between The School District of Greenville County and Greenville Technical College.

Student: \_\_\_\_\_

**PROFICIENCY REPORT**

**DRAFTING I**

		Proficiency	Level 0	Level 1	Level 2	Level 3	Level 4	Date	Completed	Instructor's Initials
MODULE 1.0	CLASSROOM SAFETY									
MODULE 2.0	BASIC MATH REVIEW									
2.01	Fractions									
2.02	Decimals									
2.03	Volumes									
2.04	Areas									
2.05	Metric System									
2.06	Angular Measurement									
MODULE 3.0	DRAFTING I									
3.01	Introduction to Drafting									
3.02	Use and Care of Instruments									
3.0207	Reads and Uses Different Drafting Scales									
3.03	Clean Drafting Instruments/Equipment									
3.04	Applying the Alphabet of Lines									
3.05	Lettering, Freehand									
3.06	Lettering with Mechanical Devices									
3.07	Use of Drafting Machine									
3.08	Geometrical Constructions									
3.09	Sketching and Shape Description									
3.10	Multiview (Orthographic) Projections									
3.11	Principles of Diazo Reproduction Process									
3.12	Make Diazo Copies of Original Drawings									
3.13	Dimensioning									
3.14	Shop Processes - Machining									
3.15	Applying Tolerances									
MODULE 4.0	DRAFTING I									
4.01	Section Views									
4.02	Auxiliary Views									
4.03	Revolutions									
4.04	Threads and Fasteners									
4.05	Axonometric Pictorial Drawings									
4.06	Oblique Pictorial Drawings									
4.07	Perspective Pictorial Drawings									
4.08	Parallel Line Development									
4.09	Radial Line Development									
4.10	Intersections									
MODULE 5.0	DRAFTING I									
5.01	Working Drawings									
DRAFTING I	PORTFOLIO OF DRAWINGS (SEE RECOMMENDATIONS)									
OPTIONAL TASK	Cams									
OPTIONAL TASK	Gears									
OPTIONAL TASK	Pipe Drawing									
OPTIONAL TASK	Render Design Using Ink									

For vertical articulation, emphasis should begin with Task 3.04

Comments:

150

Instructor's Signature: \_\_\_\_\_

REFERENCES

## TEXTBOOK REFERENCES

### SECONDARY LEVEL

French, Thomas E., Svensen, Carl L.; Helsel, Jay D.; and Urbanick, Byron. Mechanical Drawing, 8th edition, New York: McGraw-Hill Company, 1974.

French, Thomas E., and Svensen, Carl L. Mechanical Drawing, 7th edition, New York: McGraw-Hill Company, 1966.

Giesecke, Fredick E.; Mitchell, Alva; Spencer, Henry Cecil; and Hill, Ivan Leroy. Technical Drawing, 6th edition, New York: MacMillan Publishing Co., Inc., 1974.

Jensen, C. H. Engineering Drawing and Design, New York: McGraw-Hill Company Canada Limited, 1968. (Reference for drawing)

Spencer, Henry Cecil, and Dygdon, John Thomas. Basic Technical Drawing, New York: MacMillan Publishing Co., Inc., 1974 and 1980 editions.

## REFERENCES

- A State Articulated Instructional Objectives Guide for Occupational Education Programs (State Pilot Model): Drafting (Graphic Communications), Kenansville, NC: James Sprunt Institute (Joint research project sponsored by North Carolina State Department of Public Instruction and the North Carolina State Department of Community Colleges), 1978.
- Articulation Agreement for Drafting/Engineering Graphics Technology, Bennettsville, South Carolina: Marlboro Vocational School/Chesterfield-Marlboro Technical College, 1979.
- Curriculum Articulation: Engineering Graphics Technology, Florence, SC: Florence-Darlington Technical College, 1980.
- Curriculum Guide for Drafting, Baltimore, MD: Baltimore City Public Schools (Vocational Education Area), 1975.
- Curriculum Guide for High School General Mathematics, Greenville, SC: The School District of Greenville County, 1979.
- Curriculum Guide for Trades and Industries Drafting and Design Technology Programs, Columbia, SC: Office of Vocational Education, South Carolina State Department of Education, 1970.
- Dictionary of Occupational Titles, 4th edition, Washington, DC: U.S. Government Printing Office, 1977.
- Engineering Graphics Technology Articulation; Greenville, SC: Greenville Technical College, 1978.
- Engineering Technology Division, 1978-1980, (Catalog), Greenville, SC: Greenville Technical College, 1978.
- High School Credit Courses for The School District of Greenville County, Greenville, SC: Instructional Services, The School District of Greenville County, 1980.
- Outline of High School Credit Courses, Accreditation and Educational Improvement Section of the South Carolina State Department of Education, Columbia, SC: South Carolina State Department of Education, 1980.
- Schurter, William J.; Geary, James M.; Seger, Craig A.; and Veverka, Paul A. Architectural Drafter; A catalog of performance objectives, performance guides, tools and equipment, College Park, MD: University of Maryland, Department of Industrial Education, 1979.



## RECENTLY ACQUIRED SOURCES

The following references have been recently acquired and are available from the Articulation Coordinator. They will be available in The School District of Greenville County Professional Library at the end of the articulation project.

Mechanical Drafter is relevant to Drafting I as well as to the Mechanical Drafting option of Drafting II, secondary level. In addition, the materials contain math review instruction, suggestions, and sample measures.

Grimes, L. A., Jr. Architectural Draftsman, Student's Guide, Austin, TX: Instructional Materials Center, Division of Continuing Education, The University of Texas at Austin, 1975.

Grimes, L. A., Jr. Architectural Draftsman, Coordinator's Guide, Austin, TX: Instructional Materials Center, Division of Continuing Education, The University of Texas at Austin, 1975.

Grimes, L. A., Jr. Assignment Tests for Students and Worksheets for Coordinating Job Experience and Related Instruction Using Architectural Draftsman, Austin, TX: Instructional Materials Center, Division of Continuing Education, The University of Texas at Austin, 1975.

Grimes, L. A., Jr. Mechanical Drafter, Student's Guide, Austin, TX: Instructional Materials Center, Division of Continuing Education, The University of Texas at Austin, 1975. (Good reference information for Drafting I as well as for the Mechanical option in Drafting II)

Grimes, L. A., Jr. Mechanical Drafter, Coordinator's Guide, Austin, TX: Instructional Materials Center, Division of Continuing Education, The University of Texas at Austin, 1975.

Grimes, L. A., Jr. Assignment Tests for Students and Worksheets for Coordinating Job Experience and Related Instruction Using Mechanical Drafter, Austin, TX: Instructional Materials Center, Division of Continuing Education, The University of Texas at Austin, 1975.

APPENDIXES

# ENGINEERING GRAPHICS TECHNOLOGY ARTICULATION

**Greenville Technical College** GREENVILLE, SOUTH CAROLINA 29606

The work upon which this publication is based was performed pursuant to Grant G00-75-00453 with the U. S. Office of Education, Department of Health, Education, and Welfare.

The project presented or reported herein was performed pursuant to a Grant from the U. S. Office of Education, Department of Health, Education, and Welfare. However, the opinions expressed herein do not necessarily reflect the position or policy of the U. S. Office of Education and no official endorsement by the U. S. Office of Education should be inferred.

**TABLE OF CONTENTS**

<b>OVERVIEW. . . . .</b>	<b>1, 2</b>
<b>FLOW CHART. . . . .</b>	<b>3</b>
<b>ARTICULATION EVALUATION PROCEDURE . . . . .</b>	<b>4</b>
<b>EMPLOYABILITY PROFILE . . . . .</b>	<b>5 - 9</b>
<b>TUITION SCHOLARSHIPS. . . . .</b>	<b>10</b>
<b>GUIDANCE INFORMATION FORM . . . . .</b>	<b>11, 12</b>
<b>ARTICULATED DRAFTING UNITS. . . . .</b>	<b>13</b>
<b>COURSE CONCEPT SHEETS . . . . .</b>	<b>14 - 26</b>

**ENGINEERING GRAPHICS TECHNOLOGY**

**ARTICULATION GRANT**

**GREENVILLE TECHNICAL COLLEGE**

**JUNE, 1976**

## OVERVIEW

In order for the graduates of the vocational high school drafting programs to enter the Engineering Graphics Technology program at Greenville Technical College at an advanced level, course objectives, an Employability Profile, and articulation procedures have been developed.

The concept sheets have been developed jointly by the instructors in the vocational high schools of Greenville County and the department head, division chairman and members of the Educational Development Team at Greenville Technical College. Their purpose is to help insure uniformity of objectives to be covered at either school or college.

The Student's Employability Profile shows the major mechanical drafting units plus a further breakdown of competencies that can be used by an instructor to keep a running account of a student's progress. The completed form supplied by the vocational school instructor will be used along with other data to help determine at what level the student may enter the Engineering Graphics Department at Greenville Technical College. The same form will be used at Greenville Technical College and the additional tasks and competencies will be checked as they are reached.

When the student leaves GTEC, the completed form may be used by an employer as a guide with reference to his technical skills accomplishments and also as an indication of his attitudes, behavior, and work habits.

The major units and competencies listed in the Employability Profile cover many specialized fields of drafting so that it is highly unlikely that any one student will cover them all even though he completes two years at a vocational school and two years at Greenville Technical College.

The following courses will be considered for exemption:

Course Title

Course Number

Engineering Graphics I  
Engineering Graphics II  
Engineering Graphics III

EGT 111  
EGT 121  
EGT 131

**Related Drafting Courses**

Engineering Drawing I  
Engineering Drawing II

EGT 112  
EGT 122

FLOW CHART OF ARTICULATION STUDENTS - EGT

VOCATIONAL CENTER

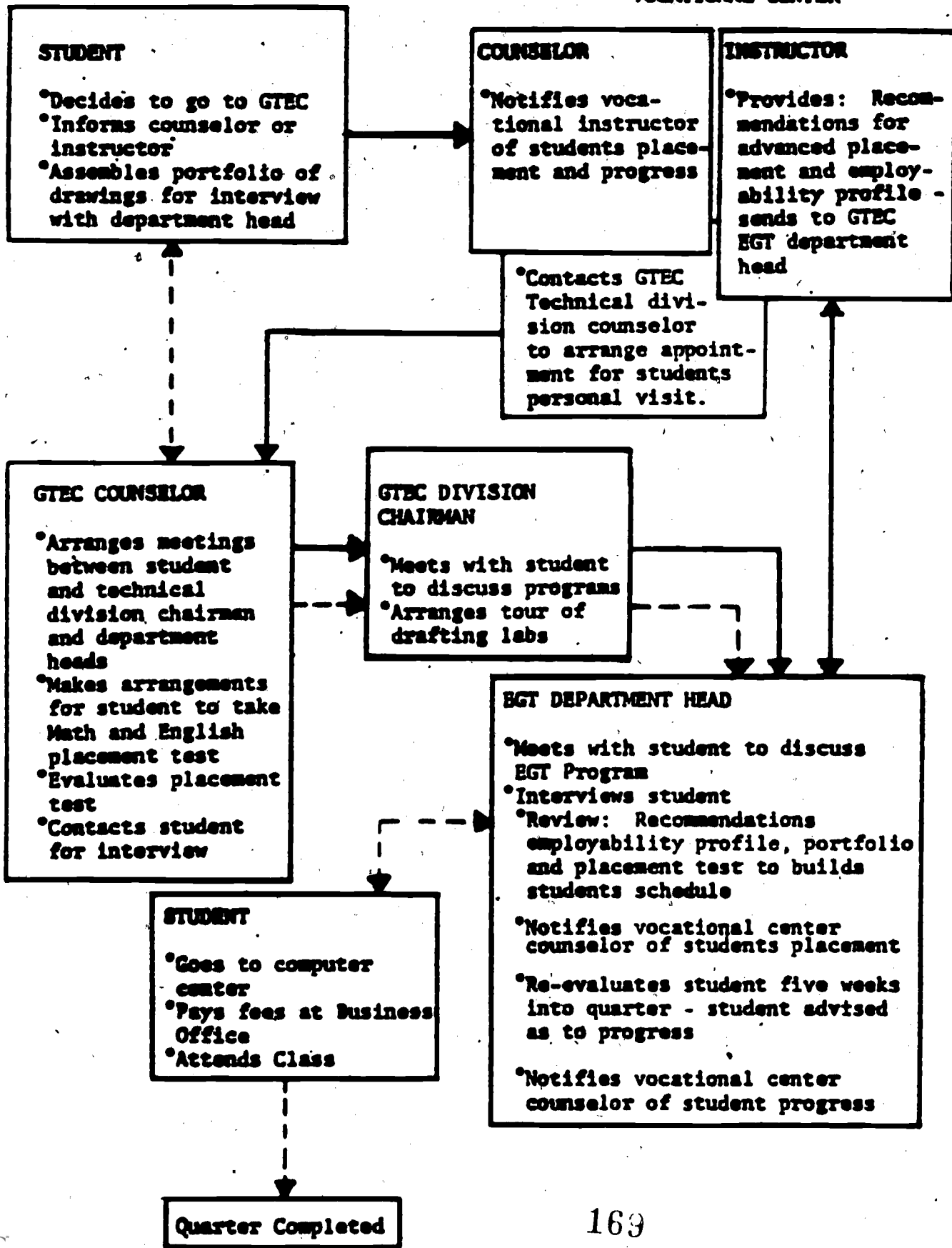



## ARTICULATION EVALUATION PROCEDURE

Students who graduate from any Greenville area vocational centers' drafting program may be permitted to exempt one, two, or three quarters of engineering graphics from the Engineering Graphics curriculum or one quarter of engineering drawing from the Architectural Engineering Technology curriculum at Greenville Technical College.

The following steps should be taken by vocational school students who plan to apply for exemption from engineering graphics or engineering drawing courses.

1. By the middle of your senior year ask your instructor or counselor to contact the Technical Division counselor at GTEC and set up an appointment for you to make a personal visit.
2. Arrangements will be made by the GTEC counselor for you to meet the Technical Division chairman, the department heads and to visit the drafting labs while classes are in session.
3. Your counselor can make arrangements for you to take the placement test administered by GTEC either at your school or at GTEC.
4. The GTEC technical division counselor will evaluate your test and contact you to arrange for an interview.
5. Providing that you have met the general entrance requirements you will need a recommendation from your instructor for advanced placement. (This will be sent directly to the department head).
6. You will need an Employability Profile. (This will be sent directly to the department head by your instructor).
7. You will need a portfolio of your drawings either originals or prints. (Bring this with you when you are called for an interview with the GTEC department head).

GREENVILLE TECHNICAL COLLEGE  
 ENGINEERING GRAPHICS DEPT.  
 P. O. BOX 5616 STA. "B"  
 GREENVILLE, S. C. 29606  
 TELEPHONE, 242-3170 EXT. 253

EMPLOYABILITY PROFILE

Occupation: Drafting

SKILLS PROFICIENCY RATING

NAME \_\_\_\_\_

                    Last                    First

ADDRESS \_\_\_\_\_ PHONE \_\_\_\_\_

TOWN, STATE, ZIP \_\_\_\_\_

EVALUATOR \_\_\_\_\_ TITLE \_\_\_\_\_ DATE \_\_\_\_\_

RATING LEVELS:

- |                             |                 |
|-----------------------------|-----------------|
| 1. Instruction Not Received | 3. Satisfactory |
| 2. Needs More Instruction   | 4. Outstanding  |

	1	2	3	4
<b>BASIC TECHNIQUES</b>				
Use & care of instruments & materials				
Alphabet of lines				
Lettering				
Use of scales				
<b>GEOMETRIC CONSTRUCTIONS</b>				
Basic constructions				
Basic applications				
<b>MULTIVIEW DRAWINGS</b>				
Orthographic projection				
Major views				
Selection of scales, sheet size, views				
<b>DIMENSIONING</b>				
Methods				
Rules				
<b>PRECISION DIMENSIONING</b>				
Standard fits and limits				
Tolerances				
Surface finishes				
<b>SPECIAL VIEWS</b>				
Full and half section, other sections				
Primary and double auxiliary views				

	1	2	3	4
<b>FASTENERS</b>				
Specification and representation				
Kinds and classifications of threads				
Springs				
<b>WELDING</b>				
Standards and symbols				
Application				
<b>PRODUCTION DRAWING</b>				
Assembly and detail				
Layout and design				
Bills of Materials, standard notes				
Revisions and related forms				
Detailed assembly				
<b>DETAILED DRAWING - SPECIALIZED</b>				
Casting and pattern				
Machine				
Stamping				
Welding				
Exploded view				
<b>PICTORIAL DRAWING</b>				
Isometric				
Oblique Projection				
Perspective				
<b>TECHNIQUES IN INK</b>				
Line work				
Lettering				
<b>SKETCHING REPRODUCTION</b>				
Prints				
Sepia				
Other				
<b>RELATED INFORMATION</b>				
Time cards and clock				
Time sheets				
Drawing no. and part no. system				
<b>REFERENCES</b>				
Machinery's Handbook				
Architectural Handbook				
Industrial catalogs				

	1	2	3	3
<b>BASIC MATH INCLUDING METRIC SYSTEM</b>				
Fractions and decimals				
Volumes and areas				
Weights				
Basic slide rule				
<b>SPECIAL PROJECTS (LIVE WORK)</b>				
Mechanical				
Electrical				
Construction				
Architectural				
Graphs & charts				
<b>GEARS AND CAMS</b>				
Nomenclature and profiles				
Introduction to formulae ratios				
Bearings				
<b>OTHER DRAFTING AREAS</b>				
Architectural				
Structural				
Plumbing, heating and air conditioning				
Electrical and electronic				
Map and topographical				
<b>PRECISION DIMENSIONING</b>				
Positional and form tolerances (true position)				
Maximum Material Condition				
Numerical control				
<b>APPLYING FOR A JOB</b>				
Appearance				
Attitude and feeling				
Filling out applications				
Resume				
What not to do				
References				
Interview Know-How				

**COMMENTS**

## ATTITUDES, BEHAVIOR, AND WORK TRAITS

**EVALUATION:** Please draw circle around numbers that are most appropriate.

### RELATIONSHIP WITH OTHERS

1. Unable to determine at this time
2. Has difficulty with others
3. Gets along satisfactorily
4. Exceptionally well accepted

### COOPERATION

1. Unable to determine at this time
2. Generally not cooperative
3. Generally cooperative
4. Exceptionally cooperative

### COURTESY

1. Unable to determine at this time
2. Poor attitudes, needs improvement
3. Generally courteous
4. Exceptionally courteous and considerate

### DEPENDABILITY

1. Unable to determine at this time
2. Needs constant follow-up
3. Generally accepts responsibility
4. Exceptionally reliable

### INITIATIVE

1. Unable to determine at this time
2. Never initiates action
3. Seldom needs prodding
4. Exceptionally good "self starter"

### JUDGMENT

1. Unable to determine at this time
2. Often uses poor judgment
3. Usually makes the right decision
4. Above average in making decisions

### SELF CONTROL

1. Unable to determine at this time
2. Tends to be excitable
3. Well balanced
4. Exceptionally well balanced

### CONCENTRATION

1. Unable to apply self to job at hand
2. Concentration fluctuates
3. Satisfactory concentration level
4. Highly satisfactory

### ADAPTABILITY TO NEW JOB TASKS

1. Cannot adjust to new assignment
2. Has difficulty adjusting
3. Adjusts adequately
4. Adjusts well to new assignments

### MOTIVATION IN OCCUPATIONAL AREA

1. Unable to determine at this time
2. Lacks motivation
3. Average interest and application
4. Highly motivated

### ADAPTABILITY

1. Unable to determine at this time
2. Has difficulty in adapting
3. Usually accepts change
4. Self reliant, imaginative

### DEXTERITY REQUIREMENTS FOR THE OCCUPATION

1. Unable to determine at this time
2. Prognosis for success is poor
3. Is well suited. Shows potential
4. Highly suited to needs of occupation

### CRAFTSMANSHIP AND SKILLS

1. Unable to determine at this time
2. Substandard work
3. Average performance
4. High standards of performance

### EFFICIENCY AND PRODUCTION

1. Unable to determine at this time
2. Often wastes time and effort
3. Makes effort to work effectively
4. A steady and productive worker

### SAFETY

1. Unable to determine at this time
2. Lacks genuine concern for safety
3. Satisfactory practice of safety
4. High regard for safety requirements

### WRITTEN PERFORMANCE

1. Unable to determine at this time
2. Work is self-form good
3. Work is generally good
4. Work is consistently good

### TOLERANCE

1. Cannot tolerate many obstacles
2. Has difficulty with obstacles
3. Generally sticks to job
4. Sticks to job in face of obstacles

### CONSISTENCY OF WORK BEHAVIOR

1. Very unstable work behavior
2. Generally more erratic than not
3. Showed moderately steady work behavior
4. Showed steady work behavior

## TUITION SCHOLARSHIP

Greenville Technical College is proud to offer tuition scholarships in each of the Articulation Grant programs: Machine Tool Technology, Industrial Electricity, and Engineering Graphics Technology. These scholarships were suggested at an Articulation Grant Advisory Committee meeting and hardily approved by the Greenville Technical College administration. It is hoped their inception will stimulate interest in continuing quality education and training in these fields.

The Donaldson, Enoree, and Foothills Vocational Centers will each select their most outstanding and/or worthy student in their drafting, electricity, and machine shop programs. Wade Hampton High School will select a student from their electricity program. The three scholarship students from each center will receive one quarter of tuition free study at Greenville Technical College. After their first quarter, each student may receive an extension for another quarter based upon review and approval by his or her instructors and department head.

After the selection of the students by their instructors, the director or principal of each school should send a copy of all the names to the heads of the Industrial and Technical Divisions, Mr. J.D. Warren and Mr. Les Caraway. This is necessary to insure the tuition waiver be available when the student begins.

**GUIDANCE INFORMATION FORM**

This form was designed to supply feedback to guidance counselors, instructors, and administrators. It will be sent by the Greenville Technical College department involved to the vocational center each time there is a horizontal line of asterisks. The information on the form will supply data to evaluate our effectiveness and suggest continuation or change in our procedures.

\*\*\*\*\*

IT IS EXTREMELY IMPORTANT THAT THE STUDENT OR HIS/HER PARENT IF THE STUDENT IS UNDER 18 SIGNS THE PERMISSION BLANK ON THE SIDE OF THE FORM. IT WOULD BE ILLEGAL TO DISSEMINATE THIS INFORMATION FROM GREENVILLE TECHNICAL COLLEGE WITHOUT THE PROPER SIGNATURE.



ENGINEERING GRAPHICS  
ARTICULATION STUDENT'S PROGRESS

Your student, \_\_\_\_\_, from \_\_\_\_\_  
Vocational Center has exempted EGT \_\_\_\_\_, \_\_\_\_\_, \_\_\_\_\_, and may  
(conditionally, unconditionally) enroll in EGT \_\_\_\_\_ (quarter \_\_\_\_\_).

This placement was based on  
\_\_\_\_\_ portfolio  
\_\_\_\_\_ employability profile filled out by \_\_\_\_\_  
\_\_\_\_\_ vocational instructor's recommendation

Date of evaluation \_\_\_\_\_

\*\*\*\*\*  
The student at mid-term has been re-evaluated and is  
\_\_\_\_\_ progressing satisfactorily  
\_\_\_\_\_ moved back to level of competence (may be able to finish  
quarter's work, may have to take Incomplete)

\_\_\_\_\_  
Student's signature

\_\_\_\_\_  
Instructor's signature

Date \_\_\_\_\_

\*\*\*\*\*  
The student at the end of the first quarter of work  
\_\_\_\_\_ successfully completed EGT \_\_\_\_\_ (grade \_\_\_\_\_) on \_\_\_\_\_ (date).  
\_\_\_\_\_ received an incomplete  
\_\_\_\_\_ dropped out before the end of the quarter  
because of \_\_\_\_\_

\*\*\*\*\*  
Student's status at the end of the first year of work - \_\_\_\_\_  
\_\_\_\_\_  
\_\_\_\_\_

I GIVE MY PERMISSION FOR THE INFORMATION ON THIS SHEET TO BE RELEASED TO GREENVILLE COUNTY SCHOOL SYSTEM  
DATE \_\_\_\_\_ LEGAL SIGNATURE \_\_\_\_\_ SIGNATURE OF PARENT IF UNDER 18 \_\_\_\_\_

## ARTICULATED DRAFTING UNITS

### FIRST QUARTER

1. Instrument Drawing (One View)
2. Lettering
3. Geometric Construction
4. Sketching and Shape Description
5. Dimensioning
6. Reproduction and Control of Drawing
7. Multiview Projection

### SECOND QUARTER

8. Section Views
9. Auxiliary Views
10. Revolutions
11. Screw Threads and Fasteners
12. Isometric Drawings
13. Oblique Drawings
14. Intersections and Developments

### THIRD QUARTER

15. Shop Processes
16. Working Drawings

CONCEPT/PERFORMANCE	CONDITIONS	CRITERIA
1.0 Instrument Drawing (One View)		
1.1 Demonstrate the use of drafting instruments	Given a drafting assignment to do on the drafting board where instruments and other basic drafting equipment is necessary	To the instructors' satisfaction
1.2 Do the assigned one view drafting problems	Drawings will be drawn to scale using the proper pencils on the assigned sheet size and title block layout. Drawing will be centered on the sheet.	ANSI Standards will be used to the instructors' satisfaction
1.3 Letter the necessary notes on the drawing and in the title block	Use the proper pencil to get dark, sharp lettering	It must be dark enough to make a good readable reproduction
2.0 Lettering		
2.1 Perform legible lettering exercises (letters, numbers, fractions symbols)	Drafting standards and handout examples will be followed. Proper number of strokes and direction of stroke must be used.	Lettering must be easy to read, reproducible and not more than a 5 variation away from verticle. Spacing between letters must have equal area within a 5% variation. Spacing between sentences must be uniform using two letter heights as the optimum.
2.2 Perform lettering exercises of words, sentences, and paragraphs.		

CONCEPT/PERFORMANCE	CONDITIONS	CRITERIA
3.0 Geometric Construction		
3.1 Bisect lines, angles and construct figures.	Use drafting instruments as required to do the problems on the handout sheet or as assigned by instructor.	Bisected lines must measure within a tolerance of 1/64". Angles must be within 1/2 constructed figures must be to instructors' satisfaction.
3.2 Draw regular polygons.	Same as above.	To instructors' satisfaction.
3.3 Draw tangents to arcs, lines and circles.	Same as above.	Arcs and lines must be tangents to the instructors' satisfaction.
3.4 Make drawings that show the above techniques applied.	Complete one view drawings with points of tangency indicated.	To instructors' satisfaction.

## CONCEPT/PERFORMANCE

## CONDITIONS

## CRITERIA

## 4.0 Sketching and Shape Description

4.1 Illustrate the six principle views used in describing the shape of an object graphically.

On paper using drafting instruments

100%

4.2 Illustrate the three principles dimensions.

Make 3 view drawings and label on each view length, width and/or depth as appropriate.

100%

4.3 Convert an isometric picture drawing on grid paper to three view sketches on grid paper.

Use the problems assigned in the text and do them on the grid paper provided.

All three views must be shown to scale in their proper positions.

4.4 Sketch 3 views of assigned objects on grid paper.

Problems assigned in text shows 2 views on grid paper, the third one is to be added.

The 2 views as shown plus the 3rd view must be shown in its proper position to scale with all necessary lines.

4.5 Add missing lines to complete the shape description of objects.

3 view problems are given with missing lines.

All lines must be added before assignment is complete.

CONCEPT/PERFORMANCE	CONDITIONS	CRITERIA
<p>5.0 Dimensioning</p> <p>5.1 Demonstrate an understanding of how and where shape dimensions are placed on a drawing.</p> <p>5.2 Demonstrate an understanding of how and where size dimensions are placed on a drawing.</p> <p>5.3 Demonstrate ability to completely define a part by selecting the views necessary to completely and correctly dimension it.</p>	<p>Problems will be given which show undimensioned views of a part. The student will measure the shape and place the dimensions on the view.</p> <p>Same as above, except that some additional information may be partially given i.e., thread class.</p> <p>Both textbook problems and layout drawings will be used. The student must prepare the drawings and dimension them using drafting instruments.</p>	<p>To the satisfaction of the instructor.</p> <p>The same as above.</p> <p>To the satisfaction of the instructor; ANSI Y14 will serve as a standard for dimensioning practices. (Emphasis will be placed on linework, lettering, proper placement of dimensions, and choice of optimum method of dimensioning.)</p>
<p>6.0 Reproduction and Control of Drawing</p> <p>6.1 Demonstrate an understanding of a drawing identification system.</p> <p>6.2 Demonstrate the ability to make a diazo print from a tracing.</p> <p>6.3 Demonstrate an understanding of the preparation and use of brownline drawings.</p>	<p>He will provide drawing and/or part number identification for a set of detail and assy drawings (See Para 5.2 &amp; 5.3).</p> <p>Given a tracing, he will properly and safely operate a diazo print machine.</p> <p>He will prepare a brownline of a tracing using similar technique as 6.2 above.</p>	<p>Drawing numbers must be chosen so as to avoid duplication, to the satisfaction of the instructor.</p> <p>To instructor's satisfaction using both vellum and polyester base drawings</p> <p>Ditto</p>

CONCEPT/PERFORMANCE	CONDITIONS	CRITERIA
<p>7.0 Multiview Projections</p> <p>7.1 Make 3 view sketches.</p> <p>7.2 Do the assigned Missing View Problems.</p> <p>7.3 Do the assigned Missing Line Problems.</p>	<p>To be made on 8 1/2 X 11 cross section paper from Isometric Sketching Problems on handouts or the ones in the textbook.</p> <p>Given: 2 orthographic views to copy on cross section paper and the third view.</p> <p>Given: 3 orthographic views with lines missing--Lines to be sketched in. May be either on a handout sheet or problems in the textbook.</p>	<p>All three principal views must be in their proper positions and sketching must be to the instructors' satisfaction</p> <p>Same as above.</p> <p>All lines must be shown.</p>

## CONCEPT/PERFORMANCE

## CONDITIONS

## CRITERIA

## 8.0 Section Views

8.1 Demonstrate a proficiency in the correct terminology relating to section views.

8.2 Make section drawings of cylindrical shaped objects.

8.3 Make section drawings of irregular shaped objects.

8.4 Make section drawings showing revolved sections and broken-out sections.

Written

Apply good standard sectioning principles to simple cylindrical shaped objects. Drawings will consist of one circular view and a full or half section as assigned by instructor.

Same conditions as above.

Problems will be assigned from textbook or handouts.

Pass as a written test.

Problems will be drawn until they show clearly to the instructor's satisfaction that the principles of sectioning are being applied in a neat and orderly manner.

Problems will be assigned until they are done to instructor's satisfaction.

To instructor's satisfaction.



COURSE

CONCEPT/PERFORMANCE	CONDITIONS	CRITERIA
9.0 Auxiliary Views		
9.1 Demonstrate a proficiency in the use of correct terminology relating to auxiliary views.	Written	Make a passing grade on a written test.
9.2 Construct primary auxiliary view of objects with symmetrical planes	Problems showing orthographic views of objects will be given from which the auxiliary view will be drawn.	To the instructor's satisfaction.
9.3 Construct auxiliary view of objects that have asymmetrical planes.	Textbook problems or handout sheets will be provided.	To the instructor's satisfaction.
9.4 Construct auxiliary views of objects with curved surfaces.	Problems to be assigned.	Same as above.

CONCEPT/PERFORMANCE	CONDITIONS	CRITERIA
10.0 Revolutions		
10.1 Construct a three view drawing of an object with a revolution of the given front view about an axis perpendicular to the frontal plane.	Given a 3-view drawing and direction and/or degree of revolution.	100% correct projection methods I.01 accuracy answers line quality.
10.2 Same as above except revolve the right view about an axis perpendicular to profile plane.	"	"
10.3 Same as above with top view revolved about axis perpendicular to horizontal plane.	"	"
10.4 Successive revolution	"	"
10.5 Revolve a point about a normal axis.	Given axis, point and degrees of revolution.	<ol style="list-style-type: none"> <li>1. To I.01 accuracy</li> <li>2. Answers, line quality</li> <li>3. And example</li> </ol>
10.6 Revolve a point about an inclined axis.	"	"
10.7 Revolve a point about an oblique axis.	"	"
10.8 Revolve a line about as normal, inclined or oblique axis.	Given axis, line and degrees or position criteria for revolved line	<ol style="list-style-type: none"> <li>1. To I.01 accuracy</li> <li>2. To answer standard of line.</li> <li>3. By example</li> <li>4. Using revolution &amp; auxiliary view methods as required.</li> </ol>

CONCEPT/PERFORMANCE	CONDITIONS	CRITERIA
<p>11.0 Screw Threads &amp; Fasteners</p> <p>11.1 Demonstrate knowledge concerning terminology used with screws, bolts, nuts, threads, and fasteners.</p> <p>11.2 Make drawings that show simplified, Schematic and detailed threads complete with notes and dimensions.</p> <p>11.3 Make drawings that show square head and hex head bolts and nuts assembled. Complete with notes, and dimensions.</p>	<p>Written</p> <p>Problems as assigned by instructor.</p> <p>Problems assigned by instructor.</p>	<p>Make a passing grade on a written and/or performance test.</p> <p>To instructor's satisfaction.</p> <p>To instructor's satisfaction.</p>

## COURSE

CONCEPT/PERFORMANCE	CONDITIONS	CRITERIA
12.0 Isometric Drawing		
12.1 Draw an isometric drawing of a cube.	Given cube size and instruction to use principles of isometric construction.	To instructor line quality and accuracy standards ansi lines and $\pm .01$ accuracy to isometric form,
12.2 Draw ellipse in face of cube using template.	Given cube size and circle size.	"
12.3 Draw ellipse in each face of cube using approximate four-center ellipse method.	Given cube size and circle size.	"
12.4 Draw an isometric view of object that has inclined planes and angles.	Given object in 3-view, oblique or physically.	"
12.5 Draw an isometric of an object that has an irregular curved surface.	Given object, 3-view drawing or pictorial.	"
12.6 Draw and dimension completely an isometric view of an object having angles and circles.	Given object or pictorial of object.	"

## CONCEPT/PERFORMANCE

## CONDITIONS

## CRITERIA

## 13.0 Oblique Drawing

13.1 Draw an oblique view of a cube using oblique pictorial method.

Given size of cube and angle of sight, percent of depth reduction and viewing direction (cabinet, cavalier, etc.)

Ansi line quality  $\pm .01$  accuracy to oblique form.

13.2 Draw oblique view of object having angles and inclined surfaces.

Given object, 3-view of object or pictorial of object.

"

13.3 Draw oblique view of object having circular planes or features.

"

"

## 14.0 Intersection and Developments

14.1 Construct prisms and cylinders by parallel line development.

Assigned problems to be done on the drafting board using standard drafting techniques.

To the instructors' satisfaction

14.2 Construct pyramids and cones by radial line developments.

Assigned problems to be done on the drafting board using standard drafting techniques.

When cut out and folded or rolled they must form into the intended shape.

14.3 Construct transition pieces by triangulation.

Same as above.

Pieces must join together to form the intended shape when cut out, rolled, folded and stuck together.

## CONCEPT/PERFORMANCE

## CONDITIONS

## CRITERIA

## 15.0 Shop Processes

15.1 Make working drawings of machine parts

Parts are to be machined from castings. Correct terminology must be shown in the notes and specifications.

To the instructors' satisfaction

15.2 Make working drawings of fabricated parts

Parts are to be shown assembled by welding.

To the instructors' satisfaction

15.3 Take a test on terminology relating to shop processes

Written test to cover terms, notes, machine tools, manufacturing processes, dimensioning, techniques and applications, etc.

85%

CONCEPT/PERFORMANCE	CONDITIONS	CRITERIA
16.0 Working Drawings		
16.1 Demonstrates an understanding of a detail part drawing	The student will prepare part drawings from problems assigned by the instructor.	Each drawing must include all information necessary to properly fabricate the parts to the satisfaction of the instructor.
16.2 Demonstrate an understanding of assembly drawings and the relationship that detail and assembly drawings have to each other.	Problems will be given in either of two formats: a) Exploded pictorial drawings with dimensions and materials noted b) Cross sectioned assembly layout drawings with design parameters defined.	The student must determine which part require detail part drawings, and the must prepare these drawings as noted above. He then must prepare all necessary sub-assembly and assembly drawings which will include a listing of parts in family-tree order.
16.3 Advanced student work: Demonstrate an understanding of the responsibilities of a layout draftsman.	The advanced students will be appointed as job leaders and will be assigned one or more detail draftsmen. The job captain will prepare a layout of a more complicated device from a problem assigned by the instructor. When the layout is complete, he will assign detail drawings to the draftsmen and supervise their work.	The layout will be completed to the satisfaction of the instructor, and will include a sequenced assembly procedure. The responsibility for handing in a complete drawing package will be on the job leader. (The job leader will check all detail and assembly drawings for completeness and correctness.

## ACCOMPLISHMENTS

The overall accomplishment of the Occupational Education Program Articulation Project was the development of comprehensive articulation policies and procedures in three instructional areas common to Greenville Technical College and the Greenville County School System. The areas were Machine Tool Technology-Machine Shop, Engineering Graphics Technology-Drafting, and Industrial Electricity-Electricity.

The attainment of the articulation policies and procedures was facilitated by the following:

Statement of compatible and sequential behavioral objectives by both secondary and post-secondary instructors

Adjustment of classroom evaluation techniques to conform to a competency-based placement program

Broadening of counselor information and skills in the implementation of articulation procedures

The Articulation Project was funded for FY-76 and a three month extension (July 1-September 30, 1976).

The status of the grant activities is explained in the following narrative.

Specific performance objectives were developed for three occupational training programs to replace credit and clock-hour requirements. (Included in the appendices of this report are Program Articulation Booklets which contain copies of performance objectives.) The objectives for the Machine Tool Technology program were specified through the South Carolina State Department of Education Career Cluster Project.



The Career Cluster Project provides objectives, materials, and evaluation methods whose usage is required of the area vocational centers. Vocational center and Greenville TEC instructors specified performance objectives for the Industrial Electricity and Engineering Graphics Technology Programs.

Procedures were adopted to allow advanced placement of vocational center students in post-secondary programs. Following the specification of program objectives, instruments to rate student skills were constructed. The Engineering Graphics Technology program will be using a "Skills Proficiency Rating Form" and the Machine Tool Technology Program will use a "Machine Shop Transcript Evaluation Form." Each of the three programs uses a placement exam. (The Industrial Electricity Program uses a competency exam exclusively to determine advanced placement.)

Effective advanced placement is a bilateral decision. The institution must determine a student's competencies and prescribe appropriate instruction. The student must also feel confident of his abilities and of the placement. Students have the option of requesting lower program placement. Counselors encourage students, however, not to choose an entry level lower than the one prescribed.

The vocational centers and Greenville TEC programs utilize advisory committees to ensure instructional compatibility with industrial reality. These committees advise on the specification of curricula, selection of equipment and instruction of new methodologies. The committees also make certain that training practices are commensurate to industrial needs.

Special Articulation Project Committees were established early in the project funding period. Committee membership was composed of counselors, instructors, program administrators, community representatives, and project staff. The varied membership

provided effective constructive criticism of project activities and commitment to the implementation of the project.

Program Completion Requirements were based on graduation standards established by the State Board for Comprehensive and Technical Education and skills levels demanded by employers. The principal goal of the technical college and the vocational centers is to provide opportunities for individuals to enter the labor market with maximum skills.

An integral function of the articulation process was the regularly scheduled meetings of technical college and vocational school instructors. Instructors were able to discuss common goals and frustrations, share teaching methodologies, and become generally more informed about each other's programs.

#### MAJOR ACTIVITIES AND EVENTS

The major activities and events of the project are described below.

Tuition Scholarships—Greenville TEC established a tuition scholarship for the three departments of each vocational center involved in the project. The ten scholarships are awarded each June and provide one quarter of free tuition. The scholarships are renewable for one quarter after the student's work is satisfactorily reviewed by his college department faculty.

Guidance Information Form—This form was developed to provide feedback to the College and vocational center counselors on the progress of articulated students.

Teacher Visitations—Instructors in the drafting and engineering graphics programs exchanged teaching positions for one day. This exchange facilitated understanding

of the particular instructional needs of each program level.

Counselor's Workshop--Project Staff coordinated a September workshop for Greenville TEC and vocational center counselors. The workshop allowed counselor to "walk through" the program. Program administrators presented synopses of the articulation process as it applied to their instructional areas. Vocational center instructors were given information and materials to use in advising their students.

### PROBLEMS

The project was not completed within the fiscal year for which it was funded. At the end of June, four activities remained unfinished. These activities were the validation of the Industrial Electricity Articulation Test, the completion of the counselor training program, the establishment of a testing center to handle placement exams, and the dissemination of developed materials.

The Industrial Electricity Articulation exam was validated during the late summer. Test items were matched with program objectives and difficulty and discrimination indices calculated for each item. A college testing center has not been established. The lack of these facilities, however, has not inhibited the program. The counselor training workshop and procedures for dissemination of materials are explained elsewhere in this report.

Fall 1976, was the first quarter the articulation process had been used to place students in instructional programs. Although comprehensive evaluation of the program is premature, the program does appear to have the necessary mechanisms to support efficient placement of students. The program needs to become more widely accepted, but this acceptance will be a function of time as the participants become more

comfortable with the process.

#### PUBLICITY ACTIVITIES

Included in the appendices are four articles which were published by the Greenville TEC "in-house" newspaper, "Tectonics". The "Tectonics" circulation includes all full and part-time instructors and administrators and officials of forty other institutions throughout the country. Two newspaper articles were published to promote the program. These articles, also included in the appendices, were announcements of scholarship awards.

#### DISSEMINATION ACTIVITIES

Copies of the final report and the program articulation booklets will be sent to the ERIC Clearinghouse for Junior Colleges, the Center for Vocational Education (Ohio State University), the sixteen technical colleges of South Carolina, each vocational center in Greenville County, and the offices of the Greenville County School System. Additional copies will be printed and made available to any institution requesting materials.

#### PROGRESS ON DATA COLLECTION AND EVALUATION PLANS AND PROCEDURES

The Articulation Project was funded for one year only. The year was spent in the activities of initiating the project. The grant did not provide for a formal evaluation process, however, as the program is fully implemented it will be evaluated through the institutional research and program auditing function of the College.

This evaluation will be examining such program aspects as:

Are the levels of advanced placement appropriate for the student?

What is the effect of the articulation program on retention/attrition rates?

What is the effect of the program on length of study of vocational center graduates?

How do vocational center students compare with non-vocational center students on characteristics as academic success, job placement, and wage levels?

What are the attitudes of vocational center and college faculty toward the articulation process?

Greenville TEC hopes to answer these questions when the program enters its second and third years. The grant funded seed activities only and therefore, the College deems it more valuable to assess the effectiveness of the total program rather than the initiating activities.

#### OTHER ACTIVITIES

(not applicable)

#### STAFF EMPLOYMENT AND UTILIZATION

(not applicable)

# Greenville Technical College

## COURSE SYLLABUS

**COURSE NUMBER** EGT 111

**COURSE TITLE** ENGINEERING GRAPHICS I

**LECTURE HOURS PER WEEK** 3      **LAB/SHOP/CLINIC HOURS PER WEEK** 3      **QUARTER CREDIT HOURS** 4

**PREREQUISITES** NONE      **SEMESTER HOURS** \_\_\_\_\_

### CATALOG COURSE DESCRIPTION

This course is the introductory course for students majoring in Engineering Graphics and related engineering technologies. Students will learn basic drafting skills, including instruments and their use, lettering, sketching, geometric construction, orthographics, and dimensioning.

### PURPOSE OF THE COURSE

The purpose of this course is to provide the student with basic "know-how" and develop drafting skills to the point where the student can make good detailed drawing showing all the views, notes, lettering, and dimensions necessary for a complete shape and size description of an object.

### REQUIRED TEXTS AND OTHER MATERIALS

Text: Technical Drawing, Giesecke et. al.

Materials: Drafting Kit  
8½ x 11 drafting paper - pad

**DEVELOPED BY** W. L. Caraway      **DATE** 6/16/81

**APPROVED BY** \_\_\_\_\_      **DATE** \_\_\_\_\_

## ENGINEERING GRAPHICS TECHNOLOGY

### Drafting Kits

EGT Kit (for EGT Div. students)

6" Bow Compass  
Triangular scale - architectural  
45° triaggles  
30° - 60° triangle  
Eraser  
Erasing shield  
1 - Lead holder  
1 - tube each F, 4H leads  
Drafting tape 3/4" wide  
Drafting brush  
Sandpaper pad  
Lettering instrument  
Circle template  
Fineline lead holder .3 dia. lead  
Fineline lead holder .5 dia. lead  
6" Flat scale

Small Kit (for all other tech. div. students)

6" Bow compass  
Triangular scale - architectural  
45° triaggle  
30° - 60° triangle  
Eraser  
Erasing shield  
1 pencil each H, 2H, 4H  
Drafting tape 3/4"  
Drafting brush  
Sandpaper pad  
Circle template

Edge of the paper

Edge of the paper

7 1/4

Edge of the paper

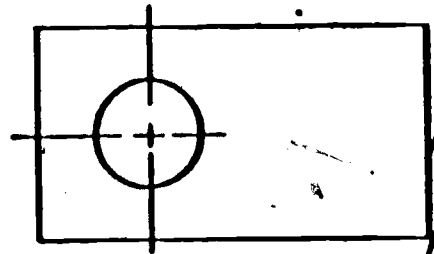

Visible Lines  
.025 to .032 wide

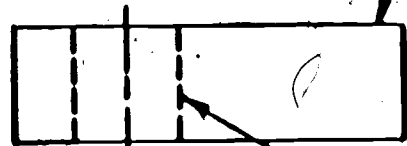

Hidden Lines  
.020 to .025 wide

Centerlines (also Extension,  
Dimension and Section Lines)  
.015 to .020

Border Lines  
(darkest line on the dwg.)  
.030 to .040 wide

Scale, see textbook

Date

Title of dwg.  
from textbook

Student's  
Name

Fig. No.  
from  
textbook

Lettering Guide-  
lines too light to  
print

Edge of the paper

1" 1" 1"



ENGINEERING GRAPHICS TECHNOLOGY

Assignment Outline

EGT 111

FIRST WEEK

6 HOURS

DATE COMPLETED

Introduction

- A. Introduction to Chapter 1

Instrument Drawings

- a. Study - Chapter 2
- b. Introduction to Instrument Drawings
- c. Draw Fig. 1 and Fig. 2 from Handout  
EGT 111 - 1A

---

---

---

---

Lettering

- a. Study - Chapter 3
- b. Introduction to Lettering
- c. Begin Lettering Practice Sheet

---

---

---

SECOND WEEK

6 HOURS

Dimensioning

- a. Study - Chapter 11, pages 296 to 307
- b. Introduction to Dimensioning

---

---

Instrument Drawings

- a. Draw Fig. 3 and Dimension from Handout  
EGT 111 - 1B
- b. Draw Fig. 4 from Handout EGT 111-1B
- c. Draw Fig. 5 and Dimension from Handout  
EGT 111 - 1C

---

---

---

THIRD WEEK

6 HOURS

Instrument Drawings Con't.

- a. Draw Fig. 6 from Handout EGT 111 - 1C
- b. Draw Fig. 2.89 and Dimension
- c. Test Problem

---

---

FOURTH WEEK

6 HOURS

DATE COMPLETED

Geometric Construction

- a. Study Chapter 4
- b. Complete Handout EGT 111 - 2
- c. Draw Fig. 4.70
- d. Draw Fig. 4.69 and Dimension

---



---



---



---

FIFTH WEEK

6 HOURS

Geometric Construction

- a. Draw Fig. 4.68
- b. Test Problem

---



---

Isometric Sketching (Homework)

- a. Study Chapter 5 and 16
- b. Introduction to Isometrics
- c. For Homework - Make Isometric Sketches on Grid paper provided, of:

Fig. 5.51-2  
 10  
 13  
 17  
 23

Fig. 5.52-4  
 8  
 11  
 15  
 18

---



---



---



---

SIXTH WEEK

6 HOURS

Three View Drawings (Homework)

- a. Introduction to Three View Drawings
- b. For Homework - Make Three View Sketches on paper provided, of:

Fig. 5.51-2    -13  
 -5    -17  
 -8    -21  
 -10    -23

Fig. 5.52 -5    -18  
 -9    -20  
 -12    -21  
 -15    -23

---



---



---



---

Multiview Projections, Introduction To Dimensioning (CLASSWORK)

- a. Study Chapter 6
- b. Study Chapter 11, pages 269-307
- c. Draw Fig. 6.53 and Dimension

---



---



---

SEVENTH WEEK

6 HOURS

DATE COMPLETED

Introduction to Shop Processes

- a. Study Chapter 10, pages 267 to 295
- b. Draw Fig. 6.54
- c. Draw Fig. 6.55 and Dimension
- d. Test Problem

---

---

---

EIGHTH WEEK

6 HOURS

- a. Draw Fig. 6.62
- b. Draw Fig. 6.76 and Dimension

---

---

NINTH WEEK

6 HOURS

- a. Complete Missing Line Handout  
EGT 111-4
- b. Complete Missing View Handout  
EGT 111-5

---

---

TENTH WEEK

6 HOURS

- a. Con't. assignment from ninth week

---

ELEVENTH WEEK

FINAL EXAM

# Greenville Technical College

## COURSE SYLLABUS

**COURSE NUMBER** EGT 121

**COURSE TITLE** Engineering Graphics II

**LECTURE HOURS PER WEEK** 1      **LAB/SHOP/CLINIC HOURS PER WEEK** 9      **QUARTER CREDIT HOURS** 4

**PREREQUISITES** EGT 111      **SEMESTER HOURS** \_\_\_\_\_

### CATALOG COURSE DESCRIPTION

A continuation of Engineering Graphics I. Students will learn to make section views, auxiliary views and draw threads and fasteners to meet industry standards. The students will also learn the use and purpose of working drawings and how to draw them.

### PURPOSE OF THE COURSE

The purpose of this course is to enhance the students drafting skills acquired in EGT 111 through application and practice while learning to draw sectional and auxiliary views, screw threads, fasteners and working drawings.

### REQUIRED TEXTS AND OTHER MATERIALS

Text: Technical Drawing - Giesecke et. all.

Materials: Drafting Kit  
 8½ x 11 drafting paper - pad  
 11 x 17 drafting paper - pad

**DEVELOPED BY** W. L. Caraway      **DATE** 8/10/81

**APPROVED BY** \_\_\_\_\_ **DATE** \_\_\_\_\_

# ENGINEERING GRAPHICS TECHNOLOGY

## Assignment Outline

EGT 121

### First Week                      10 Hours

#### A. Introduction to sectional views Chapter 7

##### Instrument Drawings

- (a) Study Chapter 7
- (b) See film "Sections and Conventions"
- (c) See slides "Sections" No. 8
- (d) Complete handout No. EGT 111-6 and review with instructor before continuing.
- (e) Do assigned problems from text Fig. 7.40 thru Fig. 7.45 (3 reqd.) use decimal-inch and metric dimensional problems.

### Second Week                      10 Hours

Sectional problems continued

##### Instrument Drawings

- (a) Draw Fig. 7.47 with dimensions.
- (b) Draw Fig. 7.49 with dimensions.

### Third Week                      10 Hours

Sectional problems continued

- (a) Do Fig. 7.56 with dimensions
- (b) Do Fig. 7.57 with dimensions

### Fourth Week                      10 Hours

Sectional problems Continued

- (a) Draw Fig. 7.58 with dimensions and finish marks
- (b) Draw Fig. 7.59 with dimensions and finish marks

### Fifth Week                      10 Hours

Sectional problems continued

- (a) Draw Fig. 7.67 with dimensions and finish marks
- (b) Do quiz problem as assigned by instructor

### Sixth Week                      10 Hours

#### A. Introduction to auxiliary views

- (a) Read and study Chapter 8
- (b) See film "Single Auxiliary Views"
- (c) See slides "Single Auxiliary Views" No. 18
- (d) Complete handout EGT-121-1 drawing a complete auxiliary view of each problem. Review with instructor before continuing with next problem assignment.

Seventh Week

10 Hours

Auxiliary views problems continued

- (a) Draw a complete working drawing of the following problems from handout sheet:
- (a) push off plate
  - (b) brush holder
  - (c) off-set base
  - (d) angle bracket

After completing each problem, review with instructor.

Eighth Week

10 Hours

Auxiliary view problems continued

Draw a complete working drawing of the following problems:

- (a) Fig. 8.30 with dimensions
- (b) Fig. 8.35 with dimensions

Ninth Week

10 Hours

Auxiliary view problems continued

Draw a complete working drawing of the following problems:

- (a) Fig. 8.38 with dimensions
- (b) Fig. 8.50-1 with dimensions
- (c) Fig. 8.50-3 with dimensions

Tenth Week

10 Hours

Auxiliary view problems continued

- (a) Do quiz drawing as assigned by instructor
- (b) Introduction to Treads, Fasteners, and Springs
  - (a) Study Chapter 13
  - (b) See slides "Screw Thread Drawing and Specifications" No. 20
  - (c) See slides "Threaded Fasteners" No. 21
  - (d) Complete handout on screw threads and fasteners, EGT 121-2 and review with instructor

Eleventh Week

10 Hours

- (a) Complete any unfinished problems
- (b) Final exam as assigned by instructor

# Engineering Graphics Technology

## EGT 121

### Grading

Grades for EGT 121 will be based on drawing, quizzes and an exam.

Drawing & Handouts	40%
Quizzes	20%
Exam	40%

Drawings will be graded on line quality, neatness, lettering, accuracy and dimensioning. All drawings, quizzes, handouts will be available to students to review and return to Instructor for filing.

Students work will be reviewed daily by instructor for the purpose of making comments, corrections, additions, etc. as deemed appropriate for continued progress.

### Classroom Appearance

Student will clean his or her working area daily. Brush off drawing board, reference table top and shelves.

Student will wash drawing board and reference table top every week or as necessary.

All trash will be disposed of properly.

The Engineering Graphics III Course Syllabus has not been received at the time this instruction guide is reproduced.



DO'S AND DON'TS OF DIMENSIONING

The following Do's and Don'ts of Dimensioning are taken from:

Giesecke, Frederick E.; Mitchell, Alva; Spencer, Henry Cecil; and Hill, Ivan Leroy. Technical Drawing, 6th ed., NY: Macmillan Publishing Co., Inc., 1974, pages 329-331.

They are reproduced at the suggestion of the Task Force Committee on Drafting.

1. Each dimension should be given clearly, so that it can be interpreted in only one way.
2. Dimensions should not be duplicated or the same information be given in two different ways, and no dimensions should be given except those needed to produce or inspect the part.
3. Dimensions should be given between points or surfaces that have a functional relation to each other or that control the location of mating parts.
4. Dimensions should be given to finished surfaces or important center lines in preference to rough surfaces wherever possible.
5. Dimensions should be so given that it will not be necessary for the machinist to calculate, scale, or assume any dimension.
6. Dimensions should be attached to the view where the shape is best shown (contour rule).
7. Dimensions should be placed in the views where the features dimensioned are shown true shape.
8. Avoid dimensioning to hidden lines wherever possible.
9. Dimensions should not be placed upon a view unless clearness is promoted and long extension lines are avoided.
10. Dimensions applying to two adjacent views should be placed between views, unless clearness is promoted by placing them outside.
11. The longer dimensions should be placed outside all intermediate dimensions, so that dimension lines will not cross extension lines.
12. In machine drawing, omit all inch marks, except when necessary for clearness; for example, 1" VALVE.

13. Do not expect the workman to assume a feature is centered (as a hole on a plate); he should be given a location dimension from one side. However, if a hole is to be centered on a symmetrical rough casting, mark the center line  $\text{C}$  and omit the locating dimension from the center line.
14. A dimension should be attached to only one view (extension lines not connecting two views).
15. Detail dimensions should "line up" in chain fashion.
16. Avoid a complete chain of detail dimensions; better omit one, otherwise add REF (reference) to one detail dimension or the over-all dimension.
17. A dimension line should never be drawn through a dimension figure. A figure should never be lettered over any line of the drawing.
18. Dimension lines should be spaced uniformly throughout the drawing. They should be at least  $3/8$ " from the object outline and  $1/4$ " apart.
19. No line of the drawing should be used as a dimension line or coincide with a dimension line.
20. A dimension line should never be joined end-to-end (chain fashion) with any line of the drawing.
21. Dimension lines should not cross, if avoidable.
22. Dimension lines and extension lines should not cross, if avoidable (extension lines may cross each other).
23. When extension lines cross extension lines or visible lines, no break in either line should be made.
24. A center line may be extended and used as an extension line, in which case it is still drawn like a center line.
25. Center lines should generally not extend from view to view.
26. Leaders for notes should be straight, not curved, and pointing to the circular views of holes wherever possible.
27. Leaders should slope at  $45^\circ$ ,  $30^\circ$ , or  $60^\circ$  with horizontal but may be made at any odd angle except vertical or horizontal.
28. Leaders should extend from the beginning or end of a note, the horizontal "shoulder" extending from the mid-height of the lettering.
29. Dimension figures should be approximately centered between the arrowheads, except that in a "stack" of dimensions, the figures should be "staggered."

30. Dimension figures should be about  $1/8$ " high for whole numbers and  $1/4$ " high for fractions.
31. Dimension figures should never be crowded or in any way made difficult to read.
32. Dimension figures should not be lettered over lines or sectioned areas unless necessary, in which case a clear space should be left for the dimension figures.
33. Dimension figures for angles should generally be lettered horizontally.
34. Fraction bars should never be inclined except in confined areas, such as in tables.
35. The numerator and denominator of a fraction should never touch the fraction bar.
36. Notes should always be lettered horizontally on the sheet.
37. Notes should be brief and clear, and the wording should be standard in form.
38. Finish marks should be placed on the edge views of all finished surfaces, including hidden edges and the contour and circular views of cylindrical surfaces.
39. Finish marks should be omitted on holes or other features where a note specifies a machining operation.
40. Finish marks should be omitted on parts made from rolled stock.
41. If a part is finished all over, omit all finish marks, and use the general note: FINISH ALL OVER, or FAO, not "f"AO or "f" ALL OVER,
42. A cylinder is dimensioned by giving both its diameter and length in the rectangular view, except when notes are used for holes. A diagonal diameter in the circular view may be used in cases where clearness is gained thereby.
43. Holes to be bored, drilled, reamed, etc., are size-dimensioned by notes in which the leaders preferably point toward the circular views of the holes. Indications of shop processes may be omitted from notes.
44. Drill sizes are preferably expressed in decimals. Particularly for drills designated by number or letter, the decimal size must also be given.
45. In general, a circle is dimensioned by its diameter, an arc by its radius.
46. Avoid diagonal diameters, except for very large holes and for circles of centers. They may be used on positive cylinders when clearness is gained thereby.

47. A diameter dimension figure should be followed by DIA except when it is obviously a diameter.
48. The letter R should always follow a radius dimension figure. The radial dimension line should have only one arrowhead, and it should touch the arc.
49. Cylinders should be located by their center lines.
50. Cylinders should be located in the circular views, if possible.
51. Cylinders should be located by coordinate dimensions in preference to angular dimensions where accuracy is important.
52. When there are several rough noncritical features obviously the same size (fillets, rounds, ribs, etc.), it is necessary to give only typical dimensions, or to use a note.
53. When a dimension is not to scale, it should be underscored with a wavy line or marked NTS or NOT TO SCALE.
54. Mating dimensions should be given correspondingly on drawings of mating parts.
55. Pattern dimensions should be given in two-place decimals or in common whole numbers and fractions to the nearest 1/16".
56. Decimal dimensions should be used when accuracy greater than 1/64" is required on a machine dimension.
57. Avoid cumulative tolerances, especially in limit dimensioning.

OPTIONAL TASKS

Optional tasks typically will be reserved for the second year of drafting training at the secondary level or for advanced students. At the discretion of the instructor, optional tasks may be taught during the first or second year of secondary level training.

OPTIONAL

DRAFTING

TASK

CAMS

---

---

**PERFORMANCE OBJECTIVE:**

Given a teacher or text assigned problem, design and draw cams with uniform harmonic and accelerated motion from given specifications.

**PERFORMANCE ACTIONS:**

1. Determine necessary space allocations.
2. Make the required cam motion diagram from given specifications.
3. Draw the required cam curve outline.
4. Add necessary dimensions.
5. Check drawing for completeness and accuracy.

**SUGGESTED INSTRUCTION TIME:** 10 Hours

**PERFORMANCE STANDARDS:**

- Draw cam motion diagram and cam curve outline from assigned problems.
- To instructor's satisfaction based on entry-level competence requirements of the drafting field.

**RELATED TECHNICAL INFORMATION:**

- Cam terminology
- Radial cams
- Cylindrical cams
- Yoke cams
- Cam motion diagrams
- Uniform motion cams
- Harmonic motion cams
- Accelerate motion cams
- Cam curve outlines

**OUTCOME-REFERENCED MEASURE:**

- Figure 19-9, page 347, Mechanical Drawing, by French.

OPTIONAL

DRAFTING

TASK

GEARS

---

---

**PERFORMANCE OBJECTIVE:**

Given specifications and assigned problems, prepare spur gear drawings.

**PERFORMANCE ACTIONS:**

1. Determine necessary space allocations.
2. Make the required spur gear drawing.
3. Add necessary dimensions.
4. Add necessary lettering.
5. Check drawing for completeness and accuracy.

**SUGGESTED INSTRUCTION TIME:** 10 Hours

**PERFORMANCE STANDARDS:**

- Prepare spur gear drawings from given specifications and assignment.
- To instructor's satisfaction based on entry-level competence requirements of the drafting field.

**RELATED TECHNICAL INFORMATION:**

- Gear terminology
- Gear formulae
- Gear tooth curves
- Dimensioning gears
- Drawing - spur gear
- Drawing - rack
- Drawing - bevel gear
- Gear ratios

OPTIONAL

DRAFTING

TASK

PIPE DRAWING

---

---

PERFORMANCE OBJECTIVE:

Given instruction and an exercise from the teacher or text, prepare scale layout (double line) and diagrammatic (single line) schematic pipe drawings to the satisfaction of the instructor.

PERFORMANCE ACTIONS:

1. Select pencils for layout lines, finished object lines, and lettering. Sharpen pencils.
2. Tape paper to board.
3. Make measurements.
4. Layout borders. Draw guidelines for title block. Letter required information.
5. Determine space allocation.
6. Draw required pipe drawing. Orthographic projection of piping system.
7. Add necessary dimensions. Add necessary lettering.
8. Check drawing for completeness and accuracy.

SUGGESTED INSTRUCTION TIME: N/A

PERFORMANCE STANDARDS:

- Prepare scale layout (double line) and diagrammatic (single line) pipe drawings according to given information and to the instructor's satisfaction.

RELATED TECHNICAL INFORMATION:

- Pipe terminology
- Pipe sizes
- Pipe fittings
- Piping symbols
- Single line pipe drawings
- Double line pipe drawings
- Use of handbooks
- ASA Bulletins
- Pipe catalogs



OPTIONAL

DRAFTING

TASK

RENDER DESIGN USING INK

---

---

**PERFORMANCE OBJECTIVE:**

Given preliminary presentation layouts, presentation sheets, straightedge, scale, pencil and pen set, render the design in ink to communicate the intended information to the user so that the user can answer successfully a set of randomly drawn questions concerning the intended content of the rendering.

**PERFORMANCE ACTIONS:**

1. Review design data and layouts.
2. Align and affix presentation drawing to board.
3. Lightly draw outline of object on sheet.
4. Render outline plus major elements of drawing.
5. Add notes and labels.
6. Check drawing.

**SUGGESTED INSTRUCTION TIME:** N/A

**PERFORMANCE STANDARDS:**

- Neatness applies.
- Using given materials and assignment, render drawings in ink as specified so the user can answer successfully a set of randomly drawn questions concerning the intended content of the rendering.

**RELATED TECHNICAL INFORMATION:**

- Inking instruments
- Media
- Leroy set

**PERFORMANCE OBJECTIVE:**

Given a table of welding symbols, draw, dimension, and label a welding drawing according to instructions and data given by the instructor to the satisfaction of the instructor.

**PERFORMANCE ACTIONS:**

1. Describe the value of welding to industry today.
2. Identify the basic welding processes.
3. Identify the basic types of welded joints.
4. Discriminate between the fundamental welds. Identify the appropriate symbols for basic welds.
  - a. Arc and Gas weld symbols
  - b. Resistance weld symbols
5. Identify the complete welding symbols (ideograph) parts to the instructor's satisfaction.
  - a. Reference line
  - b. Arrow
  - c. Basic weld symbols
  - d. Dimensions and other data
  - e. Supplementary symbols
  - f. Finish symbols
  - g. Tail
  - h. Specification process or other references
6. Draw welding symbols for a given diagram of typical welded joints (section views).
7. Given a set of specifications and an assignment by the instructor, develop working drawings to indicate the desired welding operation and include the appropriate specifications or information with the symbols.

**SUGGESTED INSTRUCTION TIME:** 4 Hours

**PERFORMANCE STANDARDS:**

- Complete knowledge test with a minimum of 75 percent accuracy and performance test to the satisfaction of the instructor.

**RELATED TECHNICAL INFORMATION:**

- American Standards Association Z32.2.1, Graphical Symbols for Welding
- American Welding Society-Standard Welding Symbols

ARTICULATED, PERFORMANCE-BASED  
INSTRUCTION GUIDE  
FOR DRAFTING II  
(SECONDARY LEVEL)

## DRAFTING II

The availability of Drafting Task Force Committee participants during the summer of 1981 (June, July, and August) and the time allocated for the project did not permit the writing of a Drafting II instruction guide during the initial year of the project. Drafting I was completed and an introduction to Drafting II was initiated.

The introduction to Drafting II, a general description of the training, is complete. It was identified that Drafting II should consist of several options in specialized drafting training at each vocational center. Suggested options include: Architectural, Mechanical, and Structural Drafting. These are the specialized areas of drafting training that now are being taught at the secondary level to some degree.

There is not full agreement concerning offering a student the option to select a full year of specialized training during the student's second year of secondary drafting training. Some instructors suggest that students could benefit from partial instruction in architectural and partial instruction in mechanical drafting during the second year. It is clear that the articulation meetings resulted in a sharing of information and thoughts concerning what should constitute Drafting II and that Drafting II will be more standard in the four vocational centers as a result of the articulation process.

Drafting II should be articulated. While that is no apparent similar areas of training in Engineering Graphics at Greenville Technical College, there may be other areas of training where there is similarity, such as TEC's Architectural Drafting program. In addition, an articulated Drafting II training program could be interpreted clearly to potential employers.

The articulation of Drafting II at the secondary level will involve describing at least three areas of drafting training; architectural, mechanical, and structural. The four instructors involved in secondary training have suggested that they would prefer to work in teams of at least two persons in the writing of instructional objectives for Drafting II. Release time will be essential to obtaining instructor participation since all or most of the instructors have secondary jobs or responsibilities that limit after hours or summer participation.

One possibility is to have a late or early summer workshop for several days consecutively to develop an instructional guide for Drafting II.

In the mean time, a 1970 instructional outline developed by the SC State Department of Education exists for Drafting II and is being shared with the four vocational center instructors.

THIS DOCUMENT AND BINDER ARE THE PROPERTY OF THE SCHOOL DISTRICT  
OF GREENVILLE COUNTY OR GREENVILLE TECHNICAL COLLEGE

The production of this curriculum guide and binder by the Occupational Education Articulation Program was funded through the South Carolina Appalachian Council of Governments. This guide and binder are the property of The School District of Greenville County or Greenville Technical College.

Except for document and binder copies that have been placed in libraries or shared with educational organizations, the documents and binders are issued on an accountability basis.

Documents and binders issued to instructor participants remain the property of the issuing institution. Should a vocational instructor leave the employment of The School District of Greenville County or Greenville Technical College, the document and binder must be returned to the principal, vocational center director, or department head so the instruction guide may be used by replacement personnel.

Corrections, modifications, and notes may be made on the pages of the documents for the purpose of modifying the field trial edition or to improve the instructional value of the document. Please share any corrections, modifications, and recommendations concerning this document with the Occupational Education Articulation Program.

Illegible or blank document page replacements may be requested at no cost through the Occupational Education Articulation Program. For replacement pages, please indicate:

Document Title  
Module Number  
Task Number or Page Number

Replacement costs for this document and binder are:

1" Binder - \$2.80  
2" Binder - \$5.00  
Document - .05¢ per page (1982)

Who to contact:

Occupational Education Articulation Program  
The School District of Greenville County  
c/o Donaldson Vocational Center  
Donaldson Center  
Greenville, SC 29605  
(or)

Consultant, Vocational Education  
The School District of Greenville County  
(or)

Associate Vice President for Education  
Greenville Technical College

## BINDER DESIGN

(Occupational Education Articulation Program)

The binder design is simple and straightforward.

Two triangular figures, in balance, represent the two institutions participating in articulation.

Two levels of training are represented by the placement of the triangles and the identification of the two institutions.

Horizontal and vertical lines represent lateral and vertical articulation.

The diagonal across the design represents the progressive movement in career development for successful job performance.

The two figures are not closed when they face, but allow for interaction and are linked by the document titles: "Articulation Policies and Procedures Guide" and "Articulated, Performance-based Instruction Guide."

Binder covers by the Graphics Arts program  
Donaldson Vocational Center  
The School District of Greenville County