

DOCUMENT RESUME

ED 219 598

CE 033 317

AUTHOR Seitz, Thomas E.  
 TITLE Construction Mechanic 1 & C.  
 INSTITUTION Naval Education and Training Program Development Center, Pensacola, Fla.  
 REPORT NO NAVEDTRA-10645-F  
 PUB DATE 82  
 NOTE 361p.; For a related document see ED 170 540.

EDRS PRICE MF01/PC15 Plus Postage.  
 DESCRIPTORS Administrative Principles; Auto Mechanics; Aviation Mechanics; Behavioral Objectives; Diesel Engines; Electric Motors; Independent Study; Learning Modules; \*Mechanical Skills; \*Mechanics (Process); \*Military Training; Postsecondary Education; \*Power Technology; \*Programed Instructional Materials; \*Supervision; Supervisory Methods; Units of Study  
 IDENTIFIERS Construction Equipment Mechanics; \*Navy

ABSTRACT

This Rate Training Manual and Nonresident Career Course (RTM/NRCC) form a self-study package that will enable Naval Construction Mechanics First and Chief to fulfill the requirements of their rating. (Persons holding these ratings direct and coordinate efforts of individuals and crews in maintaining, repairing, and overhauling automotive, material-handling, and construction equipment, including automatic transmissions; maintain records, prepare reports, conduct training, supervise safety, and coordinate tasks assigned.) Designed for individual study and not formal classroom instruction, the RTM provides subject matter that relates directly to the occupational standards of the construction mechanic. It is organized into nine chapters which cover the following topics: administration, supervision, public works transportation shops supervisor, battalion equipment company shops supervisor, engine overhaul, electrical systems and equipment, diesel fuel systems, vehicle inspections, and power trains/automatic transmissions. The NRCC contains assignments and perforated answer sheets corresponding to the chapters in the RTM textbook. Assignments in the NRCC include learning objectives, supporting items designed to lead the student through the RTM, and self-test items. (KC)

\*\*\*\*\*  
 \* Reproductions supplied by EDRS are the best that can be made \*  
 \* from the original document. \*  
 \*\*\*\*\*

ED219598

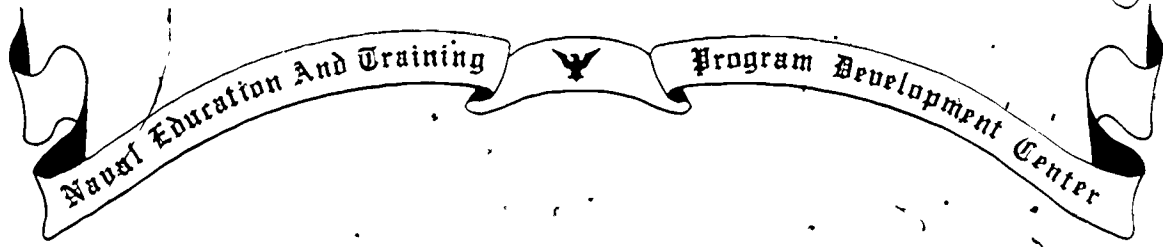

# CONSTRUCTION MECHANIC 1 & C

NAVEDTRA 10645-F

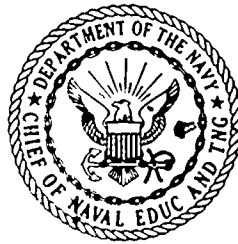

1982 Edition Prepared by  
CMCS Thomas E. Seitz

U.S. DEPARTMENT OF EDUCATION  
NATIONAL INSTITUTE OF EDUCATION  
EDUCATIONAL RESOURCES INFORMATION  
CENTER (ERIC)

This document has been reproduced as  
received from the person or organization  
originating it.  
Minor changes have been made to improve  
reproduction quality.

• Points of view or opinions stated in this docu-  
ment do not necessarily represent those of  
ERIC or the Department of Education.

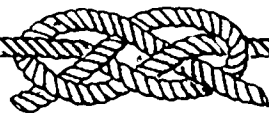

J  
E O.B. 317

Although the words "he," "him," and "his" are used sparingly in this manual to enhance communication, they are not intended to be gender driven nor to affront or discriminate against anyone reading *Construction Mechanic 1 & C*, NAVEDTRA 10645-F.

## PREFACE

The ultimate purpose of training Naval personnel is to produce a combatant Navy which can insure victory at sea. A consequence of the quality of training given them is their superior state of readiness. Its result is a victorious Navy.

This Rate Training Manual and Nonresident Career Course (RTM/NRCC) form a self-study package that will enable Construction Mechanics First and Chief to help themselves fulfill the requirements of their rating. They direct and coordinate efforts of individuals and crews in maintaining, repairing, and overhauling automotive, material-handling and construction equipment, including automatic transmissions; maintain records, prepare reports, conduct training, supervise safety; and coordinate tasks assigned.

Designed for individual study and not formal classroom instruction, the RTM provides subject matter that relates directly to the occupational standards of the Construction Mechanic. The NRCC provides a way of satisfying the requirements for completing the RTM. Assignments in the NRCC include learning objectives and supporting items designed to lead the student through the RTM.

This RTM/NRCC was prepared by the Naval Education and Training Program Development Center, Pensacola, Florida, for the Chief of Naval Education and Training. Technical assistance was provided by the Naval Facilities Engineering Command, Alexandria, Virginia; the Naval Construction Training Center, Port Hueneeme, California; the Naval Construction Training Center, Gulfport, Mississippi; and the Civil Engineering Support Office, Port Hueneeme, California.

Revised 1982

Stock Ordering No.  
0502-LP-053-2265

Published by  
NAVAL EDUCATION AND TRAINING PROGRAM  
DEVELOPMENT CENTER

UNITED STATES  
GOVERNMENT PRINTING OFFICE  
WASHINGTON, D.C.: 1982

# **THE UNITED STATES NAVY**

## **GUARDIAN OF OUR COUNTRY**

The United States Navy is responsible for maintaining control of the sea and is a ready force on watch at home and overseas, capable of strong action to preserve the peace or of instant offensive action to win in war.

It is upon the maintenance of this control that our country's glorious future depends; the United States Navy exists to make it so.

## **WE SERVE WITH HONOR**

Tradition, valor, and victory are the Navy's heritage from the past. To these may be added dedication, discipline, and vigilance as the watchwords of the present and the future.

At home or on distant stations we serve with pride, confident in the respect of our country, our shipmates, and our families.

Our responsibilities sober us; our adversities strengthen us.

Service to God and Country is our special privilege. We serve with honor.

## **THE FUTURE OF THE NAVY**

The Navy will always employ new weapons, new techniques, and greater power to protect and defend the United States on the sea, under the sea, and in the air.

Now and in the future, control of the sea gives the United States her greatest advantage for the maintenance of peace and for victory in war.

Mobility, surprise, dispersal, and offensive power are the keynotes of the new Navy. The roots of the Navy lie in a strong belief in the future, in continued dedication to our tasks, and in reflection on our heritage from the past.

Never have our opportunities and our responsibilities been greater.

# CONTENTS

CHAPTER	Page
1. Administration .....	1-1
2. Supervision .....	2-1
3. PW Transportation Shops Supervisor .....	3-1
4. Battalion Equipment Company Shops Supervisor .....	4-1
5. Engine Overhaul .....	5-1
6. Electrical Systems and Equipment .....	6-1
7. Diesel Fuel Systems .....	7-1
8. Vehicle Inspections .....	8-1
9. Power Trains/Automatic Transmissions .....	9-1
INDEX .....	I-1

Nonresident Career Course follows Index

## CREDITS

The materials listed below are included in this edition of *Construction Mechanic 1 & C* through the courtesy of the designated sources. Permission to reproduce illustrations and other materials in this publication must be obtained from the source.

<u>Source</u>	<u>Material</u>
Allison Division, General Motors Corporation	Figure 9-40, 9-41, 9-42, 9-43, and Table 9-4.
Black and Decker Manufacturing Company	5-29
Caterpillar Tractor Company	7-2, 7-7, 7-8, 7-9, 7-11
Clayton Manufacturing Company	5-1
Cummins Engine Company	7-29
Delco-Remy Company	6-3, 6-4, 6-5
Detroit Diesel Engine Division	5-40
Fairbanks, Morse and Company	5-41
General Motors Corporation	5-24, 9-25, 9-26, 9-27, 9-28, 9-29
International Harvester Company	7-21
Sun Electric Corporation	6-8

## CHAPTER 1

# ADMINISTRATION

As a CMI or CMC, you will have many responsibilities added to those which you had as a second class petty officer. You have acquired a lot of valuable knowledge and now it is your turn to pass on the technical know-how of your job to others. In addition to supervising and training lower rated personnel, you must be able to perform various administrative duties, such as preparing official correspondence, maintaining company records and reports, and administering a company accident prevention program.

The type of activity to which you are assigned will determine just how you carry out your administrative responsibilities. But, the ability to plan and organize your work, to apply effective techniques of supervision, and to get along with people will help you succeed in the Navy no matter to what activity you are assigned.

### THE PERSONNEL READINESS CAPABILITY PROGRAM

The Personnel Readiness Capability Program (PRCP) is a management tool now used throughout the active and reserve Naval Construction Force (NCF). Its purpose is to provide managers at all levels of the NCF with timely personnel information which will increase their capabilities in planning, decision making, and control.

Before PRCP was developed, personnel information was kept on an "as required" basis by various members of the unit in personal notebooks, files, and records. This information was collected as management required it to determine military and construction capabilities, training requirements, logistics support, etc. The collection of this information was usually a

time-consuming, laborious task that required a piecemeal inventory of the command's capabilities or requirements. Another way of getting this information was through the use of rough estimates. Neither way, however, produced the accuracy or rapid response desired. PRCP has helped to do so by establishing standard procedures for identifying, collecting, processing, and utilizing this information.

The Personnel Readiness Capability Program requires each participating command to gather and continuously update information on each member of the unit. Most of this information concerns skills acquired through actual job experience or through some type of training program. Other information, such as expiration of enlistment or rotation date, is required for accurate planning. The gathering of this other information is called a SKILL INVENTORY.

### SKILL INVENTORY

An accurate and current skill inventory is the backbone of PRCP. Without it, the reliability of any planning based on information stored in the PRCP DATA BANK is questionable. Presently, all PRCP skills and other data are based on requirements established by COMCBPAC and COMCBLANT and promulgated in their joint instruction of the 1500.20 series. Additionally, these skills have been conveniently classified into five major categories:

(1) Individual General Skills. These are essentially nonmanipulative skills (knowledge) related to two or more ratings, such as material liaison office operation, instructions, and safety inspections.



(2) Individual Rating Skills. These are primarily manipulative skills associated with one of the seven Occupational Field 13 (Construction) Ratings. Some examples are: light frame construction for Builder, cable splicing for Construction Electrician, and shore-based boiler operation for Utilitiesman.

(3) Individual Special Skills. These are technical skills performed by several ratings, including those other than Occupational Field 13's; for example, forklift operation, ham radio operation, or typing.

(4) Military Skills. These are further classified into two subcategories: General Military Requirements and SEABEE Combat Readiness. Examples are disaster recovery training and mines and booby traps.

(5) Crew Experience Skills. These are gained by working with others on specific projects. Most of these projects are related to advanced base construction, such as steel tank erection, pile driving, and Short Airfield for Tactical Support (SATS) installation.

A skill inventory has three principal steps. First, each skill is closely defined so that each person will give it the same meaning. Second, a standard procedure for obtaining the information is developed. This procedure helps to insure that the information, regardless of where it is collected or by whom, will meet certain standards of acceptability. The third and last step is the actual collection of the skill data and includes the procedures for submitting the data to the data bank.

### Skill Definitions

A manual, PRCP NAVFAC P-458, Volume I Skill Definitions, contains a definition for every PRCP skill identified in the Personnel Readiness Capability Program. Each definition has been jointly approved by COMCBLANT, COMCBPAC, and COMRNCF (Commander Reserve Naval Construction Force) and applies to the entire Naval Construction Force.

### PRCP Standards and Guides

The skill definitions alone do not contain sufficiently detailed information to accurately classify people, nor do they provide any classification procedures. Recognizing this, the Civil Engineer Support Office (CESO) conducted special SEABEE workshops where NAVFAC P-458 Volume II-PRCP *Standards and Guides* were developed under the guidance of CESO. This volume consists of seven separate manuals—one for each SEABEE rating. The PRCP *Standards and Guides* are the principal tools used in collecting and updating skill data. By following the interviewing procedures in the *Standards and Guides*, a trained interviewer is able to classify people to a predetermined skill level within an acceptable degree of uniformity. Also, by having a thorough knowledge of the tasks required of each skill, anyone so authorized can classify others to an appropriate skill level by actually observing them perform the tasks, either in training or on the job.

Skill information obtained from interviewing or observing is submitted to the Facilities Systems Office (FACSO), Port Hueneme, California on a special form known as a PRCP SKILL UPDATE RECORD (fig. 1-1). It is only necessary to mark the appropriate skill levels attained, then send a copy to FACSO—where the data bank is maintained—and retain a designated copy at the unit level. Complete instructions and information for using the PRCP reports, as well as other PRCP data processing information, can be obtained from the training officer of the units participating in the program.

As a crew/squad leader, you are directly responsible for using the PRCP *Standards and Guides* to interview your personnel (or others) and to provide the initial information for the PRCP data bank. Subsequent UPDATING of this initial information for each person is based on either performance on the job (which you observe) or performance at a school. New personnel, however, and others returning from long periods of certain types of shore duty, may require interviewing.

NMCB 3

UIC 55103

DET SR

COMPANY B

570-49-4561 CHUA FRANK SIMMS

BU3 PNEC 0000

SNEC 0000

TNEC 0000

SKILL CATEGORY	SKILL TITLE	SKILL CODE	SKILL LEVEL	SKILL YEAR
GENERAL BUILDER	GENERAL MATHEMATICS	000	1	79
	WOODWORKING AND MILLWORKING	110	1	80
	FORMING AND REINFORCING	130	1	79
	MIXING PLACING & FINISHING CONCRETE	132	2	80
	MASONRY UNIT CONSTRUCTION	140	2	79
	LIGHT FRAME CONSTRUCTION	150	2	80
	ROOFING	162	1	79
	FINISH CARPENTRY	164	2	80
	PLASTERING	166	1	81
	HEAVY CONSTRUCTION	170	1	81
	PAINTING AND PRESERVATION	190	1	81
	GLAZING	198	1	81
SPECIAL MILITARY	DRIVERS LICENSE	801	1	81
	BASIC MILITARY	940	1	79
	M16 RIFLE	953	1	81
	COMBAT COMMUNICATIONS	964	1	79
	DISASTER RECOVERY NBC TEAM	980	1	81
	DISASTER RECOVERY CNTRL COMMNCTN	981	1	81
CREW SKILLS	TENT CAMP CANTONMENT	1000	1	81
	PRE-ENGINEERED METAL STRUCTURES	1001	1	81

COMPANY CHANGE	
----------------	--

DET TEAM CHANGE		
-----------------	--	--

SKILL ADD CHANGE DELETE			
SKILL CODE	SKILL LEVEL	SKILL CODE	SKILL LEVEL

**INSTRUCTIONS:**

1. DET TEAM CHANGE - VALID ENTRY IS TWO POSITION ALPHANUMERIC
2. ADD CHANGE SKILL - ENTER SKILL CODE AND SKILL LEVEL 1, 2, or 3.
3. DELETE SKILL - ENTER SKILL CODE. LEAVE SKILL LEVEL BLANK
4. FORWARD CHANGES TO CBC PORHUE, CODE 18112

REFER to NAVFAC P. 458 (STANDARD & GUIDES) FOR SKILL CODES  
SKILL YEAR IS COMPUTER GENERATED AND IDENTIFIES YEAR SKILL LEVEL ASSIGNED.  
SHELF LIFE WILL BE COMPUTED FROM SKILL YEAR

Chapter 1-ADMINISTRATION

Figure 1-1.--PRCP Skill Update Record. 2.537



**PRCP INTERVIEWS**

There are two types of PRCP interviews. The first, and most important is the **INDIVIDUAL RATING SKILL INTERVIEW**. The second type is simply called **OTHER INTERVIEWS**. Both types require the use of the *PRCP Standards and Guides*.

**Rating Skill Interviews**

In conducting an individual rating skill interview, the interviewer uses a discussion technique to classify other SEABEES in the skill levels of the various individual rating skills. This technique requires a thorough understanding of the skills and tasks defined in the *Standards and Guides*. Since few individuals possess the talent required to interview in all the skills of a rating, the interviewers must be mature enough to recognize their own limitations and be willing to seek assistance from others in their ratings.

**Other Interviews**

Other interviews are used to classify people into the individual general and special skills, military skills, and crew experience. With only a few exceptions, these skills do not require an experienced interviewer; and in many cases, skill levels can be assigned to individuals on the basis of their service or training record. This should be done whenever possible to cut down on interviewing time. Then, when the person is in for interviewing, it will be just a matter of verification or of updating.

**USING THE STANDARDS AND GUIDES FOR INDIVIDUAL RATING SKILLS**

When assigned as an interviewer, you must obtain, read, understand, and use the *PRCP Standards and Guides*. The format is standard. After the **SKILL TITLE**, you find the contents, **SKILL DEFINITIONS** and the **TASKS** which are broken down into **TASK ELEMENTS**. (See figs. 1-2 through 1-4.)

**Skill Title and Contents**

The title identifies the skill. For example, figure 1-2 identifies the Individual Construction Mechanic Skill of 325, Engine Overhaul. The number 325 is a numerical code for this skill. The **CONTENTS** can be used to insure that there are no missing pages. The skill definition will always be listed first and directly under it will be .1 Skill Level 1. The tasks are listed under each skill level. You must interview each candidate to see if he or she is qualified for that level.

**Skill Definitions**

Figure 1-3 illustrates an individual rating skill definition. This definition of engine overhaul is a statement of tasks to be performed at each skill level.

There are one, two, or three skill levels, depending upon the complexity and number of the tasks. Each level within a given skill is more difficult to attain than the previous one.

The purpose of the skill definition in the *Standards and Guides* is to introduce the skill material to the interviewees. In fact, you begin your interview by reading the skill definition. If the interviewees say they can do the related work, you may continue with the interview for the skill level; however, if they say they can NOT do the work, it is obvious that you should go on to some other skill.

**Task and Task Elements**

A **TASK** is a specific portion of the overall skill level. Some tasks cover relatively broad areas; others are quite specific and brief. Each task is further broken down into several smaller jobs called task elements.

A task element is a basic part of each task. When interviewing, you will use the task elements and their related **ACTION STATEMENTS** to determine the interviewee's qualifications.

Action statements tell you the type of information you should get from the person being interviewed. Each action statement is

LIST OF  
STANDARDS AND GUIDES  
FOR  
INDIVIDUAL CONSTRUCTION MECHANIC SKILLS

<u>Skill Number</u>	<u>Skill Title</u>	<u>Page</u>
325	Engine Overhaul . . . . .	3-22
332	Engine Tune-up (Gasoline) . . . . .	3-30
334	Engine Tune-up (Diesel) . . . . .	3-42
345	Equipment Electrical . . . . .	3-58
355	Equipment Power Train . . . . .	3-70
365	Equipment Chassis . . . . .	3-82
375	Cost Control (Automotive and Construction Equipment) . . . . .	3-99
385	Repair Parts Storeman . . . . .	3-101
395	Stationary Diesel Engine Mechanic . . . . .	3-104
396	Radiator Repair . . . . .	3-104
325	- Engine Overhaul	

CONTENTS

- 325 Skill Definition
  - .1 Skill Level 1
    - .01 Remove and replace external engine components
    - .02 Disassemble, inspect, repair, and assemble external engine components
  - .2 Skill Level 2
    - .01 Disassemble, inspect, repair, and reassemble the basic engine
    - .02 Disassemble, inspect, repair, and reassemble external engine components
    - .03 Operate engine rebuild shop equipment

Figure 1-2.—Example of Standards and Guides and Contents.

SKILL DEFINITION

NOTE: Skill Levels include automotive, weight handling, materials handling, construction and stationary equipment.

Skill Level 1: Individual must perform engine repairs to the extent of removing and replacing cylinder heads, intake, exhaust, and water manifolds, water pumps, thermostats, cooling fans, blowers, turbochargers, oil coolers, precombustion chambers, clutch housing, and engine mounting brackets; disassemble, inspect, repair, and assemble valve mechanisms and their associated components; and recondition valves, valve seats, and valve guides using test and reconditioning equipment.

Skill Level 2: Skill Level 1 plus completely disassemble and clean engine block and its component parts, visually inspect for damage; measure all wear and friction surfaces for wear using measuring instruments; hone cylinders; counterbore for and install valve seat inserts, rebuild water and oil pumps; align connecting rods; fit piston pins, pistons, piston rings, and bearings, replace all defective or worn parts and assemblies; assemble engine insuring correct tolerances and adjustments; and test run.

Skill Level 3: Not applicable

2.538

Figure 1-3.—Skill definition.

identified in the *Standards and Guides* by a capital letter (A, B, C, etc.). The number of statements varies from task to task. A matrix is used to show how the statements relate to the task elements.

To illustrate the matrix, refer to Task Element .01 (See fig. 1-4.) "Remove and replace the following: Extend a line to the right and note the matrix. You will find an X under columns H and I, indicating that action statements H and I are to be applied to these task elements.

**STEPS FOR INTERVIEWING**

When interviewing, you should first try to put the interviewees at ease. A good way of doing this is to explain the purpose of the interview. For example, the interview will:

a. Let the interviewees know what they are actually expected to know and to do.

b. Determine what the interviewees can actually do so they can be assigned to the right job.

c. Determine the interviewees' deficiencies, so that they can be programmed to receive proper training.

Next, explain to the interviewees that they should discuss what they know of the skill honestly and that they should NOT be embarrassed if they do not know every item covered in the Guides.

Tell the interviewees what skill and skill level they are being interviewed for. Read the skill definition, as suggested previously, to see if the interviewees know the subject.

**Task Interviewing**

Begin interviewing by reading the skill definition again. This helps interviewees to

325.1.01 TASK: Remove and replace external engine components.

Apply these ACTION STATEMENTS to the TASK ELEMENTS listed below:

- A. Describe the sequence of steps of this procedure and explain the reasons for each.
- B. List significant tools/equipment used in this procedure.
- C. Describe principal materials used in this procedure.
- D. Discuss the parameters of this procedure.
- E. Describe indications that would be observed during this procedure.
- F. Describe assistance required while performing this procedure.
- G. Explain results if this procedure is not performed properly or if it is neglected.
- H. Discuss safety precautions to be observed.
- I. Perform the steps of this procedure when practical.

TASK ELEMENTS:

	<u>A</u>	<u>B</u>	<u>C</u>	<u>D</u>	<u>E</u>	<u>F</u>	<u>G</u>	<u>H</u>	<u>I</u>
.01 Remove and replace the following:								X	X
a. Cylinder heads.	X	X	X	X	X	X			
b. Manifolds.									
1. Intake.	X	X	X	X	X	X	X		
2. Exhaust.	X		X		X	X	X		
3. Water.	X		X		X	X	X		
c. Water pump and fan.	X		X		X	X	X		
d. Engine mounting brackets.	X				X	X	X		
e. Turbochargers.	X	X	X	X	X	X	X		
f. Blowers.	X	X	X	X	X	X	X		
g. Oil coolers.	X		X		X	X	X		
h. Clutch housing.	X	X	X	X	X	X	X		

Figure 1-4.—Example of Task and Task Elements.

concentrate. The task should be rephrased: "The first thing we will discuss in Engine Overhaul is the setup, use, and care of items in the NMCB mechanics shop and toolkits." Then read the first TASK ELEMENT, (.01 Remove and replace the following:). When applied to action statement H (Discuss safety precautions to be observed), it goes something like this:

"Describe the safety precautions you should follow when removing and replacing the cylinder head."

As you can see this is not a question. It is a statement directing interviewees to tell what they know about the safety precautions used in preparing to remove or replace the cylinder head. There are no questions in the PRCP *Standards and Guides*; therefore, no answers are provided. The *Standards and Guides* point out the areas to be discussed (in terms of task elements and action statements), and the interviewees' replies are evaluated by the interviewer on the basis of personal experience, knowledge, and judgment.

It should be obvious now why all rating skill interviewers MUST be experienced in all skills for which they will interview. The only way you can determine whether an interviewee knows the task element is to know it thoroughly yourself. If you are unfamiliar with, or "rusty in," any tasks in the *Standards and Guides*, study them thoroughly before attempting to interview anyone. Also, if you do not understand how a particular action statement is used with a task element, find out before interviewing. Discuss the problem with others who are familiar with the skill.

Discuss only the task element with the action statements indicated in the columns of the matrix. For example, in figure 1-4 only action statements H and I are used with task element .01 and, task element .01 g., only action statements A, C, E, F, and G.

As an expert in the skill, you will probably have a desire to "ask questions" in tasks not covered by the *Standards and Guides*. This must be avoided as then there will be no standard. If you feel strongly that the *Standards and Guides* can be improved, discuss your recommendation with the PRCP coordinator.

### Scoring Interviews

If interviewees have an NEC in the skill for which they are being interviewed, they are automatically assigned to that skill level without being interviewed for any of the lower skill levels. When interviewing, use a positive approach. The interviewees either do or do NOT know the skill. The decision is left up to the interviewer. All TASKS must be accomplished for each skill level. The results of the interview are then introduced into the PRCP system.

### ADMINISTERING A COMPANY ACCIDENT PREVENTION PROGRAM

Each command is required to establish a safety organization to develop, organize, and direct a comprehensive accident prevention program and to provide for the promulgation and enforcement of safety precautions and safe construction techniques. The safety program is usually under the direction of a SAFETY OFFICER, designated by the commanding officer. The safety officer has the authority to take immediate steps to stop any operation where there is impending danger of injury to personnel or damage to equipment or material.

The safety officer lays out the safety program after conducting job analyses and consultations with the supervisors in charge of the various phases of construction.

Under the direction of the safety officer, and with the assistance of the safety chief, each company is required to administer an accident prevention program. As a CMI or CMC, you may be appointed to administer ALFA Company's accident prevention program.

### SUPERVISION AND SAFETY

Safety and production go hand in hand. Supervisors should consider the safety, health, and physical welfare of their personnel as one of their chief responsibilities.

In teaching a new job or operation, always emphasize the safety measures that apply. In

planning your jobs, make sure you keep safety in mind; do not wait until after an accident to teach safety. Remember that a lost-time injury means a nonproducer, and a high-accident rate certainly will not reflect favorably upon your ability to supervise. To show concern over the health and physical welfare of your crewmembers not only will pay off in production, but also will enable you to earn their respect.

Some pointers that will be useful in preventing accidents are outlined below:

A. Size up the job.

1. Analyze the shop and spot the hazards.
2. Review the previous accident experience in the shop.
3. Get help, if needed, from your company officer.

B. Plan to control the hazards.

1. Weigh means for controlling the hazards.
2. Select the right methods and the right personnel for the job.
3. Decide on the proper tools and equipment.
4. Check for protective equipment needs.

C. Work your plan.

1. Make specific work assignments and give instructions.
2. Check to see that everyone understands what is expected of them and that they do it.
3. Remove hazards or protect the crew against them.
4. Insist on safe practices.

D. Check results.

1. Was the plan followed?
2. How could the plan have been improved?
3. What hazardous conditions or work practices, if any, need further attention?

## SAFEGUARDS AND SAFETY EDUCATION

Many supervisors feel that it is only necessary to provide safeguards; then safety will take care of itself. Provision of safeguards is a move in the right direction, but it alone will not get good results. To maintain a good safety record, you, as the supervisor, need to employ a combination of safety devices and safety training. If all your crewmembers have had sound safety training, they will be able to guard against even those hazards where safety devices are impracticable. You must, however, train them in the use of safeguards, explaining why, as well as how, they should be used. How many times have you seen a crewmember shut off the power on a machine and then walk away from it before it has stopped turning? Such a person misuses a safeguard, but does not know why. By providing the necessary training, you, as an alert supervisor, must make sure that such careless uses of safeguards do NOT happen again.

Standup safety meetings should be held in the shop once every week. The meetings should be held at or near the work area. Instead of a routine safety lecture, it is much better to hold a group discussion on specific accidents that are to be guarded against or that may have happened in the unit. Crewmembers should be encouraged to express their ideas. A group conclusion about how specific accidents can be prevented should be reached.

In another type of safety meeting, you present a safety problem that has developed because of new work or new equipment. Again, crewmembers should be invited to express their ideas.

In a third type of safety meeting, actual demonstrations and practices by the group are carried out. You might demonstrate how to lift, and then have the crew practice lifting. Also, to make the reason for lifting in this manner more realistic, a little lesson on the classes of tools and a little problem in ratio and proportion should prove interesting.

If you are demonstrating how to use a forklift—bring in a forklift and use it—do not just talk about how to use it. Then, again, let the crew practice.



Making these meetings interesting is of the utmost importance. You should not complain or scold, and the meetings should be limited in time. The subject matter should be thought out carefully in advance, and it should be timely. Considerable ingenuity is required to keep these meetings from degenerating into dull, routine affairs. Some supervisors have the crewmembers themselves rotate as leaders of the safety meetings—an excellent way to maintain interest. Hundreds of good motion pictures and other visual aids are available on safety subjects. Use them!

As company safety administrator, you are required to submit safety meeting reports periodically to the safety chief. You must keep a record of all meetings conducted within the company. Information required for this report will include the topics discussed, the number of personnel attending, and the length of the meeting.

### SAFETY INSPECTIONS

To do your part in the administration of the safety program, you must know the safety precautions which apply to the various types and phases of construction involving personnel and equipment. Furthermore, you must carry out the recommendations of the safety officer, which usually include the following:

1. Promulgate and enforce all safety regulations.
  - a. Safety shoes must be worn in the shops.
  - b. Eye protection is essential when you are grinding or welding.
2. Instruct and drill your crewmembers in safe practices.
3. Caution your crew with regard to occupational hazards.
4. Inspect work areas regularly.
5. Assign crewmembers to jobs that are not beyond their technical and physical capabilities.
6. Report accidents, analyze them, and recommend appropriate action to prevent recurrence.

### ACCIDENT REPORTING

As the shop or company safety representative, you will assist in obtaining information in cases of bodily injury and motor vehicle accidents. The information provided here will familiarize you with procedures and forms. The safety officer will have access to the complete manuals. An accident report is required when an injury or a fatality occurs or damage exceeds three hundred dollars.

#### Bodily Injury

When an accident occurs in your shop, office, or within your crew, you must fill out an OPNAV Form 5102/1 Accidental Injury/Death Report (figs. 1-5 through 1-8). This form provides a method of recording the essential facts concerning an accident, from which data for use in accident prevention can be compiled. Item 33—(shown in figure 1-6) “Corrective action taken/recommend”—is the most important part of this report. Your response to this item provides a clue to your attitude toward safety. Too many supervisors respond with, “The crewmember was warned to be more careful.” Such a response is useless since it does not tie in with the rest of the report. If an unsafe working condition is the cause of the accident, you will NOT correct it by warning the crewmember to be more careful. Study the report; analyze it; then take corrective action. When properly used, this report is one of your best accident prevention tools. In many cases, the difference between a minor accident and a major one is a matter of luck. Do not ignore accidents that result in small cuts and bruises; investigate the reason for them and correct the cause. If you do this, you will have a safe and efficient shop or office.

#### Motor Vehicles Accidents

For the purpose of accident reporting, a vehicle is considered to be any mechanically or electrically powered device by which any person or property may be transported. The load carried on a motor vehicle is considered a part of the vehicle.

# Chapter 1—ADMINISTRATION

<b>ACCIDENTAL INJURY/DEATH REPORT</b> OPNAV 5102/1 (5-76) S/N 0107 LF 051 0205		FOR OFFICIAL USE ONLY	REPORT SYMBOL OPNAV 5102-1 Page 1 of 4 Pages
TO COMMANDER NAVALSAFETY CENTER NAVAL AIR STATION NORFOLK VA 23511			
A Complete instructions for filling out this form are contained in OPNAVINST 5102/1 B The entire form may be hand printed. Legibility is important. C Where blocks are provided for the individual characters of the data follow these rules: (1) If the entry is letters place the first letter in the left hand block. (2) If the entry is a number place it so that the last digit is in the right hand block.		<b>CAUTION</b> Ensure compliance with the requirements of the Privacy Act of 1974 prior to recording personnel data (See para 204b of this instruction)	
THIS SPACE FOR NAVSAFECEN USE ONLY			
YR MO DAY LOG LINE VEHICLE PERSONNEL FILE			
EVENT DATE: 01 02 03 04 05 06 07 08 09 10 11 12 13 14 15 16 17 18			
SECTION A - GENERAL			
1 REPORTING ACTIVITY (omit USS and USS)		2 SHIP TYPE HULL NO. 2 UIC. 23 24 25 26 27	
3 INJURY DATE		4 REPORT SERIAL	
5 INJURY DATE		6 LIGHT CONDITION A ADEQUATE B INADEQUATE Explain in item 18 C UNKNOWN	
7 PARENT TYCOM SYSCOM or BUREAU OF PERSON'S PERMANENT DUTY STATION		8 LOCATION ABOARD ACTIVITY where injury occurred (Main Engine Room, Main Deck, etc.) If not aboard reporting activity give place name.	
9 SHIP STATUS A UNDERWAY B ANCHORED C MOORED D SUBMERGED E DRY DOCK F OTHER (Specify)		10 EVOLUTION AT TIME OF INJURY (LYREP, VLF, etc.) If multiple injuries involved give number. BE NO repeating last digit and initial serial.	
SECTION B - INJURY KILLED PERSON If multiple injuries are involved see OPNAVINST 5102/1			
11 NO REPORTABLE INJURIES DEATHS THIS ACCIDENT		12 NAME (Last, initial)	
13 SOCIAL SECURITY NUMBER		14 AGE	
15 SEX		16 RANK RAT. NGOR GRADE AND JOB TITLE	
17 YEARS EXPERIENCE MIL in present regularly assigned duties CIV in present occupation		18 JOB OR ACTIVITY ACTUALLY ENGAGED IN AT TIME OF INJURY (Driving forklift, loading aircraft, etc.)	
19 MONTHS EXPERIENCE IN JOB OR ACTIVITY SHOWN IN ITEM 18		20 EMPLOYMENT STATUS A USN B USNR C FOREIGN NATIONAL D NAVY FEDERAL CIVILIAN E NAVY NON APPROPRIATED FUND CIVILIAN F OTHER (Specify)	
21 DUTY STATUS A ON DUTY B OFF DUTY		22 MEDICAL STATUS A DEAD B MISSING C HOSPITALIZED D A ANOC E NONE OF THESE	
23 JOB DISPOSITION AFTER INJURY A RETURN TO DUTY B TEMPORARY TRANS TO NEW JOB C PERMANENT TRANS TO NEW JOB D EMPLOYMENT TERMINATED DUE TO INJURY E OTHER (Specify)		24 NO OF LOST WORKDAYS A AWAY FROM WORK B RESTRICTED ACTIVITY	
25 SOURCE OF INJURY (Cut by saw, overcome by flames, etc.)		26 PERMANENT DUTY STATION OF INJURED PERSON IF NOT REPORTING ACTIVITY	
27A MEDICAL DIAGNOSIS FROM MEDICAL DEPARTMENT (include body part)		27B DISABILITY Check most probable: <input type="checkbox"/> PERMANENT TOTAL <input type="checkbox"/> PERMANENT PARTIAL <input type="checkbox"/> NONE	
Chemical/Toxic Exposure - Provide as much of the following information as is known: (1) Manufacturer name of product, manufacturer's stock number, manufacturer's part number, NSN, MILSPEC. (2) Type of exposure (inhaled, contact, etc.). (3) Length of exposure. Electric Shock/Electrocution - If portable equipment is involved specify if grounded/ungrounded.			
FOR OFFICIAL USE ONLY			

192.92.1

Figure 1-5.—Accidental Injury/Death Report, OPNAV Form 5102/1. (Page 1 of 4.)

# CONSTRUCTION MECHANIC 1 & C

<b>ACCIDENTAL INJURY/DEATH REPORT (Continued)</b> OPNAV 5102/1 (5-76) S/N 0107 LF-081-0208		REPORT SYMBOL OPNAV 5102.1 Page 2 of 4 Pages
FOR OFFICIAL USE ONLY		
SECTION C - PERSONAL PROTECTIVE EQUIPMENT		NOT APPLICABLE <input type="checkbox"/>
28. EQUIPMENT (Name, MK/Mod, Model, etc.) (Include L/C if available)		
29. INVOLVED IN INJURY A. NOT A FACTOR B. REDUCED INJURY C. INCREASED INJURY	30. NEED AND AVAILABILITY A. NOT NEEDED B. AVAILABLE USED C. AVAILABLE NOT USED D. NOT AVAILABLE NEEDED	31. EQUIPMENT ADEQUACY A. ADEQUATE B. INADEQUATE C. MISUSED D. FAILED
76	76	77
SECTION O - NARRATIVE		
32. DESCRIBE THE CHAIN OF EVENTS LEADING UP TO AND THROUGH THE INJURY TO AID IN THE ANALYSIS OF WHAT HAPPENED, HOW IT HAPPENED AND WHY IT HAPPENED. DETAILED INFORMATION GIVEN ELSEWHERE IN THE REPORT NEED NOT BE REPEATED UNLESS IT IS REQUIRED FOR CLARITY.		
33. COMMANDING OFFICER (or Authorized Deputy) REVIEW AND COMMENTS. INCLUDE CORRECTIVE ACTION TAKEN LOCALLY AND OR CORRECTIVE ACTION RECOMMENDED TO HIGHER AUTHORITY.		
34. NAME, TITLE, TELEPHONE NO. (if applicable) OF THE PERSON PREPARING THIS REPORT	DATE SIGNED	COMMANDING OFFICER (or Authorized Deputy) (Printed name and rank)  (Signature)
ENCLOSURES		
<input type="checkbox"/> OPNAV 5102/2 <input type="checkbox"/> OPNAV 5102/2E	<input type="checkbox"/> PHOTOGRAPHS <input type="checkbox"/>	<input type="checkbox"/> <input type="checkbox"/>
FOR OFFICIAL USE ONLY		

Figure 1-6.—Accidental/Death Report, OPNAV Form 5102/1. (Page 2 of 4.)

192.92.2

# Chapter 1—ADMINISTRATION

**ACCIDENTAL INJURY/DEATH REPORT (Continued)**  
 OPNAV 5102/1 (5-78)  
 SN 0107 LF 051-0205

REPORT SYMBOL OPNAV 5102-4  
 Page 3 of 4 Pages

FOR OFFICIAL USE ONLY

**SECTION E - CAUSE FACTORS**

In assigning cause factors the bare details of the injury and the determination of specific circumstances represent nothing more than a point of departure for further detailed analysis. It is not enough to conclude that an injury was caused by "poor judgment", "human error" or an "Act of God". The validity of conclusions about an investigation must be based upon the "why" of the injury. The reason for the sometimes obvious, sometimes obscure errors which may initiate or contribute to a mishap. Without this knowledge, projections from the immediate injury to other possibly similar situations cannot be made and injury prevention efforts will be degraded. Answers to the "why" of injuries only become available if the proper questions are asked. This section provides these questions.

**35 PERSONNEL CAUSE FACTORS**

NOT A CAUSE FACTOR

**INSTRUCTIONS**

- A WHO?** Enter the number from LIST A which best describes WHO was a cause factor. Make your choice based on what the person was doing and not on his job title.  
**B WHAT?** Enter the number from LIST B which best describes WHAT the person in Item A did not do which was a cause factor in this injury.  
**C WHY?** Enter the number(s) (up to 4) from LIST C which best describe WHY the person in Item A did not do the action in Item B.

**35-1 PERSON NUMBER 1 - THE INJURED PERSON HIMSELF IF HE WAS A CAUSE FACTOR**

A WHO?	B WHAT?	C WHY? (up to 4)	D (Not applicable)	E (Not applicable)
23 24	25 26	27 28 29 30 31 32 33 34		
F (Not applicable)			G HOURS SINCE LAST SIGNIFICANT SLEEP	H ADDITIONAL COMMENTS
			38 39	

**35-2 PERSON NUMBER 2 - ANOTHER PERSON WHO WAS A CAUSE FACTOR**

A WHO?	B WHAT?	C WHY? (up to 4)	D JOB OR ACTIVITY ACTUALLY ENGAGED IN AT THE TIME OF THE INJURY	E MONTHS EXPERIENCE AT JOB or ACTIVITY SHOWN IN ITEM D
40 41	42 43	44 45 46 47 48 49 50 51		52 53 54
F RANK/RATING OR GRADE AND JOB TITLE			G HOURS SINCE LAST SIGNIFICANT SLEEP	H ADDITIONAL COMMENTS
			56 57	

**35-3 PERSON NUMBER 3 - ANOTHER PERSON WHO WAS A CAUSE FACTOR**

A WHO?	B WHAT?	C WHY? (Up to 4)	D JOB OR ACTIVITY ACTUALLY ENGAGED IN AT THE TIME OF THE INJURY	E MONTHS EXPERIENCE AT JOB or ACTIVITY SHOWN IN ITEM D
57 58	59 60	61 62 63 64 65 66 67 68		69 70 71
F RANK/RATING OR GRADE AND JOB TITLE			G HOURS SINCE LAST SIGNIFICANT SLEEP	H ADDITIONAL COMMENTS
			72 73	

**LIST A - WHO WAS A CAUSE FACTOR?**

- |  |  |
|--|--|
| 11 Supervisor/Foreman                  | 15 Watchstander                                      |
| 12 Operator                            | 16 Off-duty military (use for all off-duty injuries) |
| 13 Maintenance worker                  | 99 Other (specify)                                   |
| 14 Quality Assurance/Control Inspector |  |

**LIST B - WHAT DID HE FAIL TO DO?**

- |  |                                   |
|--|-----------------------------------|
| 21 Correctly operate controls/monitor displays           | 28 Plan adequately                |
| 22 Perform PMS/maintenance properly/completely           | 29 Match task to man's ability    |
| 23 Recognize hazardous situation                         | 30 Coordinate tasks               |
| 24 Use proper caution for known risk                     | 31 Provide proper work/rest cycle |
| 25 Use protective equipment (Complete Section C)         | 32 Supervise progress of work     |
| 26 Use proper tool/equipment for job (specify in Item H) | 33 Inspect completed work         |
| 27 Take corrective action (time was available)           | 99 Other (specify in Item H)      |

**LIST C - WHY DID HE FAIL TO DO IT?**

- |   |                                 |   |
|---|---------------------------------|---|
| <b>Behavioral Factors</b>                     | <b>Medical Factors</b>          | <b>Design Factors</b>   |
| 41 Not convenient/comfortable                 | 61 Fatigue                      | 73 Failure to detect warning signal/indicator                 |
| 42 Lack of concern/interest                   | 62 Alcohol/hangover             | 81 Restricted vision  |
| 43 Distracted/inattentive                     | 63 Drug use (Note 1)            | 82 Inadequate work space                                      |
| 44 Hate                                       | 64 Drug abuse (Note 1)          | 83 Personal equipment interference (explain in Item H)        |
| 45 Habit                                      | 65 Illness (Note 2)             | 84 Inadequate/unavailable tools/equipment (specify in Item H) |
| 46 Overconfidence                             | 66 Physical Handicap/impairment | 85 Poor design/location of controls/displays                  |
| 47 Excessive Motivation                       | <b>Communication Factors</b>    | 99 Other (explain in Item H)                                  |
| 48 Emotionally aroused (angry, worried, etc.) | 71 Disrupted communications     |   |
| <b>Training/Experience Factors</b>            | 72 Misunderstanding             |   |
| 51 Inadequate knowledge of men/equipment      |                                 |   |
| 52 Insufficient experience/skill/training     |                                 |   |

**NOTE 1** Drug use, (1) Prescribed drugs/medicine used as prescribed or (2) Non-prescription drugs/medicine used as directed - any other use of drugs/medicine is drug abuse.

**NOTE 2** If the illness is a result of present or past employment give details in narrative.

FOR OFFICIAL USE ONLY

Figure 1-7.—Accidental Injury/Death Report, OPNAV Form 5102/1. (Page 3 of 4.)

# CONSTRUCTION MECHANIC I. & C

<b>ACCIDENTAL INJURY/DEATH REPORT (Continued)</b> OPNAV 5102/1 (5-76) S/N D107 LF-061-0206		REPORT-SYMBOL OPNAV 5102-1 Page 4 of 4 Pages				
FOR OFFICIAL USE ONLY						
<b>36. MATERIAL CAUSE FACTORS</b>		NOT A CAUSE FACTOR <input type="checkbox"/>				
NOTE: This item may not be applicable if OPNAV 5102/2E (Explosive Mishap Supplement) is submitted - see Chapter 7 OPNAVIST 5102.1. List all items of material/equipment including components if applicable which caused or contributed to the injury.						
<b>A. NAME, MK/MOO, MODEL ETC OF MATERIAL/EQUIPMENT AND/OR COMPONENTS</b>	<b>B. EIC (if available) / TEC (if available) / NATIONAL STOCK NO (Indicate which is used)</b>	<b>C. EXPLAIN HOW IT CONTRIBUTED TO THE INJURY AND IF APPLICABLE THE NATURE AND CAUSE OF THE FAILURE/MALFUNCTION</b>				
<b>37. PROCEDURE/PRECAUTION CAUSE FACTORS</b>		NOT A CAUSE FACTOR <input type="checkbox"/>				
<b>A. WHAT PROCEDURE/PRECAUTION CONTRIBUTED TO THE INJURY?</b> <input type="checkbox"/> A. OPERATING PROCEDURES <input checked="" type="checkbox"/> B. SAFETY PRECAUTION <input type="checkbox"/> C. TEST PROCEDURES <input type="checkbox"/> D. MAINTENANCE PROCEDURE <input type="checkbox"/> E. OTHER (Specify)	<b>C. SPECIFICALLY WHAT IS WRONG WITH IT? (Give title and identify source of procedure/precaution)</b>					
<b>B. WHAT IS WRONG WITH IT?</b> <input type="checkbox"/> A. INADEQUATE <input checked="" type="checkbox"/> B. INCOMPLETE <input type="checkbox"/> C. INCORRECT <input type="checkbox"/> D. NON-EXISTENT <input type="checkbox"/> E. NOT POSTED <input type="checkbox"/> F. OTHER (Specify)						
<b>38. ENVIRONMENTAL CAUSE FACTORS</b>		NOT A CAUSE FACTOR <input type="checkbox"/>				
<b>A. WHAT ENVIRONMENTAL CONDITIONS CONTRIBUTED TO THE INJURY? (Enter up to 4)</b>  A. WIND                      N. TEMPERATURE B. SEAS                      J. VISIBILITY C. SWELL                     K. S. M. RADIATION D. CURRENT                 L. NOISE LEVEL E. TIDES                      M. VIBRATION F. HUMIDITY                 N. VENTILATION G. LIGHTING                Z. OTHER (Specify)	<b>B. WHAT WERE THE SPECIFIC CONDITIONS AND THEIR EFFECT? (Indicate if the conditions were normal/abnormal or expected/unexpected)</b>					
<table border="1" style="width: 100%; border-collapse: collapse; text-align: center;"> <tr> <td style="width: 25px;">76</td> <td style="width: 25px;">77</td> <td style="width: 25px;">78</td> <td style="width: 25px;">79</td> </tr> </table>	76	77	78	79		
76	77	78	79			
<b>39. REMARKS.</b> Use this space to expand or explain the cause factors as required.						
FOR OFFICIAL USE ONLY						

Figure 1-8.—Accidental Injury/Death Report, OPNAV Form 5102/1. (Page 4 of 4.)

192.92.4

3. Unsafe act. Was the crewmember operating a machine without proper authorization or working at an unsafe speed, that is, too fast or too slow? Was a safety device made inoperative, that is, blocked out or removed? Was a load made unsafe or were tools or equipment put in an unsafe place where they would fall? Did someone fail to wipe oil, water, grease, paint, etc., from working surfaces? Did the injured crewmember take an unsafe position of posture, or lift with a bent back or while in an awkward position, or lift jerkily, or ride in an unsafe position on a vehicle, or use improper means of ascending or descending? Was the injury caused by failure to wear the provided safe attire or personal protective devices, such as goggles, gloves, masks, aprons, or safety shoes? 4. Unsafe personal factor. Was the person absentminded or inattentive, unaware of safe practices, unpracticed, or unskilled or unable to recognize or appreciate the hazards? Did the person fail to understand instructions, regulations, or safety rules, willfully disregard instructions or safety rules, have a bodily defect, such as poor eyesight, defective hearing, or a hernia? 5. Type of injury. Was the injury sustained a cut, sprain, strain, hernia, or fracture? 6. Part of body affected. Did the injury involve an arm, leg, ribs, feet, fingers, head, etc.?

These categories suggest some of the things (not all) you must investigate and report when accidents occur.

Remember there are some questions in these categories that request medical information which can only be obtained from a doctor. Each accident is different, and each should be investigated and judged on its own merits. Do not jump to conclusions. Start each investigation with an open mind and as soon as possible insure factual information is obtained. The most important reason for any accident investigation is the prevention of a similar accident.

OFFICIAL CORRESPONDENCE

On occasion, you may be expected to compose official correspondence, perhaps only

2. Type of accident. Did an object strike the person? Did the person fall at the same level or a different level or get caught between objects or slip (not fall)?

1. Unsafe conditions. Was the equipment improperly guarded, unguarded, or inadequately guarded? Was the equipment or material rough, slippery, sharp-edged, decayed, worn, or cracked? Was there a hazardous arrangement, such as congested work space, lack of proper lifting equipment, or unsafe planning? Was the proper safety apparel being worn? Were the proper respirator, goggles, gloves, etc., provided?

Before filling out an Accidental Injury/Death Report, OPNAV Form 5102/1, you must conduct an accident investigation to get answers to questions, such as those in the six categories below.

ACCIDENT INVESTIGATION

Accidents involving the use of equipment such as cranes, shovels, and related equipment shall be considered motor vehicle accidents. These incidents are reported by the operator on a Standard Form 91 and handled separately by the safety office.

The safety office is responsible for completing the OPNAV Form 5102/3, figures 1-11 through 1-14, for accidents involving fatality, injury, or total damage in excess of three hundred dollars involving government-owned or leased equipment.

Accidents of a cost exceeding three hundred dollars including damage to property are to be reported on Standard Form 91, figures 1-9 and 1-10, by the operator. Slight scratches or damage to bumpers occurring over a period of time as normal wear and tear are not reportable. Operators are responsible for their vehicles as soon as they assume the driver's seat. The operator should thoroughly inspect the vehicle and note damage on the Operator's Inspection Guide and Trouble Report, NAVFAC 9-11240/13.

91-1

**THIS FORM TO BE FILLED OUT BY THE GOVERNMENT OPERATOR AT THE TIME AND AT THE SCENE OF THE ACCIDENT, INsofar AS POSSIBLE.**

### OPERATOR'S REPORT OF MOTOR-VEHICLE ACCIDENT

DEPARTMENT OR AGENCY \_\_\_\_\_

NAME AND LOCATION OF ORGANIZATION TO WHICH YOU ARE ASSIGNED \_\_\_\_\_

**I OPERATOR**

PLEASE PRINT FULL NAME (Last, First, Middle Initial) \_\_\_\_\_ AGE \_\_\_\_\_ NAME, BIRTH, OR TITLE \_\_\_\_\_

SERVICE NUMBER OR SOCIAL SECURITY NUMBER \_\_\_\_\_ OPERATOR'S GOV. PERMIT NUMBER \_\_\_\_\_

HOME ADDRESS (Street, city, State, ZIP Code) \_\_\_\_\_ TELEPHONE (Area) \_\_\_\_\_

**II TIME AND PLACE**

DATE AND DAY OF WEEK OF ACCIDENT \_\_\_\_\_ TIME \_\_\_\_\_ HOURS OR DUTY HOURS TO ACCIDENT \_\_\_\_\_

PLACE OF ACCIDENT (If accident on city, town, city, street and number and State if outside city limits, indicate mileage or nearest city or other landmark) \_\_\_\_\_

FROM WHAT PLACE TO WHAT PLACE WERE YOU BOUND \_\_\_\_\_

FOR WHAT PURPOSE \_\_\_\_\_

**III IN YOUR VEHICLE**

MAKE \_\_\_\_\_ TYPE \_\_\_\_\_ REGISTRATION NUMBER OR OTHER IDENTIFICATION \_\_\_\_\_

PARTS OF VEHICLE DAMAGED (Describe) \_\_\_\_\_

IF THIS IS A BACKING ACCIDENT WAS GUIDE AVAILABLE?  YES  NO

IF AVAILABLE, WAS GUIDE USED?  YES  NO

**IV OTHER VEHICLE AND PROPERTY**  
(If an additional vehicle, see page 2)

OPERATOR'S STATE PERMIT NUMBER \_\_\_\_\_ VEHICLE LICENSE NUMBER AND STATE \_\_\_\_\_

OPERATED BY (Name) \_\_\_\_\_ VEHICLE OWNED BY \_\_\_\_\_

OPERATOR'S HOME ADDRESS (Street, city, State) \_\_\_\_\_ OTHER'S ADDRESS (Street, city, State) \_\_\_\_\_

PARTS OF VEHICLE DAMAGED (Describe) \_\_\_\_\_

OTHER VEHICLE OR PROPERTY DAMAGED (Describe) \_\_\_\_\_

Standard Form 91 (9-1-60) 0100 200,7200 (9-1-60) BUREAU OF THE BUDGET (Circular A-5 (Rev.)

**V PERSONS INJURED**

NAME	HOME ADDRESS

**VI OCCUPANTS IN YOUR VEHICLE**

**VII OCCUPANTS IN OTHER VEHICLE**

**VIII WITNESSES AND POLICE**

POLICE OFFICER \_\_\_\_\_ BADGE NO. \_\_\_\_\_ PRECINCT OR HSE. \_\_\_\_\_

**IX THE ACCIDENT**

YOUR VEHICLE	OTHER VEHICLE
DIRECTION OF TRAVEL _____	DIRECTION OF TRAVEL _____
SIDE OF STREET OR HIGHWAY _____	SIDE OF STREET OR HIGHWAY _____
APPROXIMATE SPEED (Miles per hour) _____	APPROXIMATE SPEED (Miles per hour) _____
CONDITION OF ROADWAY (Hot or dry, icy, etc.) _____	
WEATHER (Clear, foggy, rain, snow, etc.) _____	
TYPE OF ROADWAY (Concrete, asphalt, etc.) _____	
OTHER INFORMATION (Indicate stop signs, traffic lights, observations, etc.) _____	

2

CONSTRUCTION MECHANIC I & C







25

192.96.1

Figure 1-9.—Accident Report, Standard Form 91. (Front.)



I EVENTS AFTER ACCIDENT	IF MEDICAL AID RENDERED STATE BY WHOM		WHERE WAS INJURED TAKEN
	CONDITION OF OTHER DRIVER		
	IF OTHER DRIVER OR PERSON INJURED MADE STATEMENTS AS TO CAUSE OF ACCIDENT AND EXTENT OF PERSONAL OR PROPERTY DAMAGE. RELATE CONVERSATION AND NAME AND ADDRESS OF OTHERS HEARING SUCH STATEMENTS		
II OTHER VEHICLE AND PROPERTY (Use only if more than one vehicle involved)	MAKE	TYPE	YEAR
	OPERATOR'S STATE PERMIT NUMBER	VEHICLE LICENSE NUMBER	
	OPERATED BY	OWNED BY	
	ADDRESS (Home)	OWNER'S ADDRESS (Business)	
	PARTS OF VEHICLE DAMAGED (Describe)		
OTHER PROPERTY DAMAGED (Describe)			

XI. INDICATE BY DIAGRAM BELOW WHAT HAPPENED:  
 1. Number Federal vehicle as 1—other vehicle as 2—additional vehicle as 3, and show direction of travel by arrow  
 (Example: )  
 2. Use solid line to show path before accident   
 Dashed line after accident   
 3. Show pedestrian by   
 4. Show railroad by   
 5. Give names or numbers of streets or highways  
 6. Indicate north by arrow in this circle 

TELL IN YOUR OWN WAY HOW ACCIDENT HAPPENED

XIII  
 OPERATOR'S STATEMENT OF ACCIDENT AND USE OF SAFETY EQUIPMENT

WAS VEHICLE EQUIPPED WITH SEAT BELT?  YES  NO  
 IF YES, WERE THEY IN USE AT TIME OF ACCIDENT?  YES  NO  
 SIGNATURE OF OPERATOR \_\_\_\_\_ DATE \_\_\_\_\_

HAVE YOU ANSWERED ALL QUESTIONS AS COMPLETELY AS POSSIBLE?

Figure 1-10.—Accident Report, Standard Form 91. (Reverse.)





# CONSTRUCTION MECHANICS I & C

MOTOR VEHICLE ACCIDENT REPORT										REPORT SYMBOL OPNAV 5102-4 <i>Page 1 of 4 Pages</i>																			
OPNAV 5102/3 (5-78) CORRECTED COPY 6/77 S/N 0107 LF-061-0220										FOR OFFICIAL USE ONLY																			
TO: COMMANDER, NAVAL SAFETY CENTER, NAVAL AIR STATION, NORFOLK, VA 23511										CAUTION: Ensure compliance with the requirements of the Privacy Act of 1974 prior to recording personal data. (See para 204b of this instruction.)																			
A. Complete instructions for filling out this form are contained in OPNAVINST 5102.1 B. The entire form may be hand printed. Legibility is important. C. Where blocks are provided for the individual characters of the data follow these rules: (1) If the entry is letters place the first letter in the left-hand block. (2) If the entry is a number place it so that the last digit is in the right-hand block.																													
THIS SPACE FOR NAVSAFEEN USE ONLY																													
EVENT DATE: YR MO DAY LOG LINE VEHICLE TRANSACTION [01][02][03][04][05][06][07][08][09][10][11] [A][80]																													
SECTION A - GENERAL																													
1. REPORTING ACTIVITY (Omit U.S. and USS)										2. SHIP TYPE/HULL NO.					3. UIC					4. REPORT SERIAL									
SECTION B - ACCIDENT LOCATION																													
5. TYPE ACCIDENT					6. STREET/HIGHWAY					7. CITY/COUNTY					8. ON BASE		9. ACCIDENT DATE (mo/day/yr)					10. TIME							
11. DAY					12. INTERSECTION ACCIDENT					13. AT INTERSECTION WITH (street/highway)					14. LOCATION (not intersection)					15. FROM (land mark)									
16. KIND OF LOCALITY					18. LIGHT CONDITION					17. WEATHER CONDITION																			
SECTION C - VEHICLE/ROAD DATA																													
18. VEHICLE NO.					19. MAKE (Ford, Buick, etc.)					YEAR		20. MODEL (Pinto, Dart, etc.)																	
21. STYLE (2 dr sedan, etc.)					22. VEHICLE CATEGORY					23. VEHICLE LICENSE NUMBER					24. TRAFFIC CONTROL														
25. ROAD CHARACTER					26. ROAD CLASSIFICATION					27. ROAD DEFECTS					28. ROAD SURFACE CONDITION					29. VEHICLE DEFECTS					30. PRE-ACCIDENT ACTION				
SECTION D - OPERATOR DATA																													
31. VEHICLE NO.					32. NAME (Last, first, initials)										33. SOCIAL SECURITY NUMBER					34. AGE		35. SEX							
36. RANK/RATING OR CIVIL SERVICE GRADE					37. DESIGNATOR/NEC/CSC OCCUPATION CODE					38. EMPLOYMENT STATUS					39. DUTY STATUS					40. DUTY STATION OR ADDRESS									
41. UIC					42. PARENT TYCOM, SYSCOM, OR BUREAU OF DUTY STATION					43. PROPERLY LICENSED					44. OPERATOR LICENSE NO.					STATE									
45. YEARS DRIVING EXPERIENCE					46. OPERATOR FACTOR					47. VISION OBSCURED					48. BEHAVIORAL FACTOR					49. TRAINING/EXPERIENCE FACTOR									
50. MEDICAL FACTOR					51. COMMUNICATION FACTOR					52. INJURY					53. SEAT					54. RESTRAINT SYSTEM									
55. LOST WORKDAYS					56. JOB DISPOSITION (After injury)					57A. MEDICAL DIAGNOSIS FROM MEDICAL DEPARTMENT (Include body part)																			
57B. DISABILITY (Check most probable) <input type="checkbox"/> PERMANENT TOTAL <input type="checkbox"/> PERMANENT PARTIAL <input type="checkbox"/> NONE																													
FOR OFFICIAL USE ONLY																													

Figure 1-11.—Motor Vehicle Accident Report, OPNAV Form 5102/3. (Page 1 of 4.)

2.536.1

# Chapter 1—ADMINISTRATION

MOTOR VEHICLE ACCIDENT REPORT (Continued)												REPORT SYMBOL OPNAV 5102-4											
OPNAV 5102/3 (8-78) CORRECTED COPY 4/77												Page 2 of 4 Pages											
I/N 0107 LP-081-0220												FOR OFFICIAL USE ONLY											
SECTION E - OTHER PERSONS INJURED/KILLED												NOT APPLICABLE <input type="checkbox"/>											
PERSON 1																							
68. VEHICLE NO			69. SEQUENCE NO			70. NAME (Last, first, initial)						81. SOCIAL SECURITY NUMBER											
62. AGE			63. SEX			64. RANK/RATING OR CIVIL SERVICE GRADE						65. DESIGNATION/NEC/CS OCCUPATION CODE											
66. DUTY STATION OR ADDRESS			69. IUC			70. PARENT TYCOM SYS/COM OR BUREAU OF DUTY STATION						71. DRINKING			72. INJURY								
73. SEAT			74. RESTRAINT SYSTEM						75. LOST WORKDAYS						76. JOB DISPOSITION (after injury)								
77A. MEDICAL DIAGNOSIS FROM MEDICAL DEPARTMENT (include body parts)												77B. DISABILITY (Check most probable)											
												<input type="checkbox"/> PERMANENT TOTAL <input type="checkbox"/> PERMANENT PARTIAL <input type="checkbox"/> NONE											
PERSON 2																							
88. VEHICLE NO			89. SEQUENCE NO			90. NAME (Last, first, initial)						91. SOCIAL SECURITY NUMBER											
82. AGE			83. SEX			84. RANK/RATING OR CIVIL SERVICE GRADE						85. DESIGNATION/NEC/CS OCCUPATION CODE											
86. DUTY STATION OR ADDRESS			89. IUC			90. PARENT TYCOM SYS/COM OR BUREAU OF DUTY STATION						91. DRINKING			92. INJURY								
93. SEAT			94. RESTRAINT SYSTEM						95. LOST WORKDAYS						96. JOB DISPOSITION (after injury)								
97A. MEDICAL DIAGNOSIS FROM MEDICAL DEPARTMENT (include body parts)												97B. DISABILITY (Check most probable)											
												<input type="checkbox"/> PERMANENT TOTAL <input type="checkbox"/> PERMANENT PARTIAL <input type="checkbox"/> NONE											
SECTION F - MOTORCYCLE DATA												NOT APPLICABLE <input type="checkbox"/>											
78. VEHICLE NO			79. WINDSHIELD			80. HELMET			81. GOGGLES			82. FACESHIELD											
83. GLOVES			84. JACKET			85. BOOTS			86. REFLECTIVE MATERIAL			D ON MOTORCYCLE											
E NONE																							
SECTION G - PEDESTRIAN DATA												NOT APPLICABLE <input type="checkbox"/>											
87. VEHICLE NO			88. SEQUENCE NO			89. ACTION			90. CLOTHING			91. BEHAVIORAL FACTOR											
92. MEDICAL FACTOR			93. COMMUNICATION FACTOR																				
SECTION H - GROUND SUPPORT & MATERIAL HANDLING EQUIPMENT DATA												NOT APPLICABLE <input type="checkbox"/>											
94. VEHICLE NO			95. TEC/MUC/EC			96. MATERIAL FAILURE (WUC/EC) AND CAUSE OF FAILURE																	
SECTION I - PROPERTY DAMAGE												NOT APPLICABLE <input type="checkbox"/>											
97. GOVERNMENT PROPERTY DESCRIPTION (other than vehicle)												98. COST TO REPAIR/REPLACE											
99. OTHER PROPERTY DESCRIPTION (other than vehicle)												100. COST TO REPAIR/REPLACE											
												100. COST TO REPAIR/REPLACE NON-DOO PROPERTY DAMAGE COSTS											

Figure 1-12.—Motor Vehicle Accident Report, OPNAV Form 5102/3. (Page 2 of 4.)

2.536.2

# CONSTRUCTION MECHANIC 1 & C

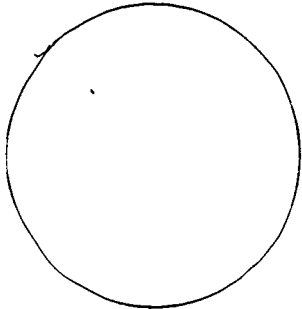
<b>MOTOR VEHICLE ACCIDENT REPORT (Continued)</b>		REPORT SYMBOL OPNAV 5102-4 <small>Page 3 of 4 Pages</small>																					
OPNAV 5102/3 (5-78) CORRECTED COPY 6/77		FOR OFFICIAL USE ONLY																					
<b>SECTION J - ACCIDENT DESCRIPTION</b>																							
101 ACCIDENT DIAGRAM Draw the scene of the accident and indicate what probably happened by locating impact points and paths of vehicles prior to and after impact. Refer to the vehicles by number. Use supplemental sheet if additional space is necessary. Indicate the direction of North.																							
																							
WITNESSES																							
102 VEHICLE NO	103 LAWFUL SPEED	104 ESTIMATED SPEED	106 VEHICLE DAMAGE DIAGRAM																				
<table border="1" style="width: 100%; border-collapse: collapse;"> <tr><td style="width: 25%; height: 20px;"> </td><td style="width: 25%;"> </td><td style="width: 25%;"> </td><td style="width: 25%;"> </td></tr> </table>					<table border="1" style="width: 100%; border-collapse: collapse;"> <tr><td style="width: 25%; height: 20px;"> </td><td style="width: 25%;"> </td><td style="width: 25%;"> </td><td style="width: 25%;"> </td></tr> </table>					<table border="1" style="width: 100%; border-collapse: collapse;"> <tr><td style="width: 25%; height: 20px;"> </td><td style="width: 25%;"> </td><td style="width: 25%;"> </td><td style="width: 25%;"> </td></tr> </table>					<table border="1" style="width: 100%; border-collapse: collapse;"> <tr> <td style="width: 25%; padding: 5px;">108 COST TO REPAIR VEHICLE</td> <td style="width: 25%; padding: 5px;">DOD PROPERTY DAMAGE \$</td> <td style="width: 25%; padding: 5px;">NON-DOD PROPERTY DAMAGE \$</td> <td style="width: 25%; padding: 5px;">ALL OTHER COSTS \$</td> </tr> <tr> <td style="padding: 5px;">DOD MAINTENANCE (MIL/DCV)</td> <td style="padding: 5px;"> </td> <td style="padding: 5px;"> </td> <td style="padding: 5px;"> </td> </tr> </table>	108 COST TO REPAIR VEHICLE	DOD PROPERTY DAMAGE \$	NON-DOD PROPERTY DAMAGE \$	ALL OTHER COSTS \$	DOD MAINTENANCE (MIL/DCV)			
108 COST TO REPAIR VEHICLE	DOD PROPERTY DAMAGE \$	NON-DOD PROPERTY DAMAGE \$	ALL OTHER COSTS \$																				
DOD MAINTENANCE (MIL/DCV)																							
107 ACCIDENT DESCRIPTION DESCRIBE THE ACCIDENT REFER TO THE VEHICLES BY NUMBER. (Use supplemental sheet if additional space is required.)																							
108 COMMANDING OFFICER (or authorized deputy) REVIEW AND COMMENTS INCLUDE CORRECTIVE ACTION TAKEN LOCALLY AND/OR CORRECTIVE ACTION RECOMMENDED TO HIGHER AUTHORITY																							
109 NAME, TITLE, TELEPHONE NO (if applicable) OF THE PERSON PREPARING THIS REPORT	DATE SIGNED	COMMANDING OFFICER (or Authorized deputy) (Printed name and rank)																					
		(Signature)																					
ENCLOSURE																							
<input type="checkbox"/> PHOTOGRAPHS	<input type="checkbox"/>																						
<input type="checkbox"/> CIVIL POLICY INVESTIGATION REPORT	<input checked="" type="checkbox"/>																						
<input type="checkbox"/> ALCOHOL INFLUENCE REPORT DO FORM 1920	<input type="checkbox"/>																						
FOR OFFICIAL USE ONLY																							

2.536.3

Figure 1-13.—Motor Vehicle Accident Report, OPNAV Form 5102/3. (Page 3 of 4.)

# Chapter 1—ADMINISTRATION

**MOTOR VEHICLE ACCIDENT REPORT (Continued)**  
OPNAV 5102/3 (E-78) CORRECTED COPY 8/77  
SNW 0187 LF-0514220

REPORT SYMBOL OPNAV 5102-4  
Page 4 of 4 Pages

CODE LIST

**5 TYPE OF ACCIDENT**

A Collision with Pedestrian  
B Motorcycle/Motorcoaster  
C Automobile  
D Truck  
E Train  
F Bicycle  
G Animal  
H Flared Object

Non-collision  
J Ran off road only  
K Overturned  
L Submersed  
M Fire  
Z Other (specify)

**11 DAY**

A Sun  
B Mon  
C Tue  
D Wed  
E Thu  
F Fri  
G Sat

**24 TRAFFIC CONTROL**

A None  
B Traffic signal  
C Stop sign  
D Flashing light  
E Yield sign  
F No passing zone  
G R/R crossing sign  
H R/R crossing light  
J R/R crossing gates  
K Other (specify)

**25 ROAD CHARACTER**

A Straight, level  
B Straight, upgrade  
D Straight, downgrade  
E Curved, level  
F Curved, upgrade  
G Curved, hillcrest  
H Curved, downgrade

**26 ROAD CLASSIFICATION**

A Interstate  
B U.S. highway  
C State Highway  
D County road  
E Local street  
F Service road  
G Toll road/tunnel  
H Private roadway  
J Beach road  
K Parking lot  
L Off-road  
M Competition  
Z Other (specify)

**27 ROAD DEFECTS**

A None apparent  
B Construction/repair  
C Soft/defective shoulder  
D Obstructions  
E Changing width  
F Holes/ruts/bumps  
Z Other (specify)

**28 ROAD SURFACE CONDITIONS**

A Dry  
B Wet  
C Snow/ice  
D Oil  
E Loose material  
Z Other (specify)

**29 VEHICLE DEFECTS**

A None

Defective  
B Exhaust system  
C Wheel assembly  
D Brakes  
E Headlights  
F Tail lights  
G Brake lights  
H Turn signals  
J Steering  
K Windshield wipers  
L Front end

Other  
M Puncture/blowout  
N Worn/missing tire  
P Improper tire tires  
Q Improper lights or reflectors on trailer  
Z Other (specify)

**30 PRE-ACCIDENT ACTION**

A Going straight ahead  
B Rounding curve  
C Making left turn  
D Making right turn  
E Making U-turn  
F Parallel  
G Parked  
H Unparking  
J Starting in traffic  
K Slowing/stopping  
L Stopped in traffic  
M Avoiding object in road  
N Sliding  
P Changing lanes  
Q Overtaking  
R Merging  
S Backing  
Z Other (specify)

**38 EMPLOYMENT STATUS**

A USN  
B USNR  
C Foreign National  
D Navy Federal Civilian  
E Navy Non-appropriated Fund Civilian  
F Other civilian  
Z Other military

**39 DUTY STATUS**

A On duty  
B PCS Travel  
C Leave (not PCS)  
D TAD  
E Duesary  
F Unauthorized absence  
G Liberty  
Y Not applicable  
Z Other (specify)

**45 YEARS DRIVING EXPERIENCE - less than 1 year**

AA No experience  
BB 1 month  
CC 2-3 months  
DD 4-11 months

**46 OPERATOR FACTOR**

A Illegal speed  
B Unsafe speed  
C Hit and run  
D Failed to yield right-of-way  
E Lost control  
F Failed to signal  
G Disregard traffic control  
H Following too close  
J Going wrong way  
K On wrong side of road  
L Improper turn  
M Improper start from parked  
N Improper backing  
P Improper passing  
Q Stopped in roadway  
R No proper driving  
Z Other (specify)

**47 VISION OBSCURED**

A Not obscured  
B Windows not clear  
C Cracked windshield  
D Tires/traps/etc  
E Parked vehicle  
F Sun glare  
G Headlights  
H Snow/fog/dust  
J Load on vehicle  
Z Other (specify)

**48 BEHAVIORAL FACTOR**

41 Uncomfortable/unconvenient  
42 Lack of concern/interest  
43 Distracted/inattentive  
44 Haste  
45 Habit  
46 Overconfidence  
47 Excessive Motivation  
48 Emotionally aroused (angry, worried, etc.)  
99 Other (specify)

**49 EXPERIENCE/TRAINING FACTOR**

51 Inadequate knowledge of vehicle  
52 Inefficient experience/skill/training  
99 Other (specify)

**50 MEDICAL FACTOR**

61 Fatigue/sleepy  
62 Alcohol/drug/gas  
63 Drug use (1) Prescribed drug/medicine used as prescribed or (2) Non-prescription drug/medicine used as directed - any other use of drug/medicine is drug abuse  
64 Drug abuse Any use of drug/medicine except as in 6.3 above  
65 Illness  
66 Physical Handicap/impairment  
99 Other (specify)

**51 COMMUNICATION FACTOR**

71 Inadequate/misused/unfunctioning signal/signs  
72 Misunderstanding of signal/signs  
73 Failure to detect signal/signs  
99 Other (specify)

**52 INJURY**

A Fatal  
B Visible signs of serious injury (bleeding wounds, fractured member, etc.)  
C Other visible injury (bruises, abrasions, lacerations, etc.)  
D No visible injury but momentarily unconsciousness or complaint of pain  
E No indication of injury

**53 SEAT**

C	D	A
H	E	B
J	F	C

K Not in passenger compartment (passenger)  
L Unknown  
M Pedestrian  
N Pedestrian  
Z Other (specify)

**54 RESTRAINT SYSTEM**

A Installed in vehicle  
A Not applicable  
B None installed  
C Seat belt only  
D Seat belt and shoulder harness  
E Positive restraint (air bags, etc.)  
F Positive restraint and seat belt  
Z Other combinations

B Used by occupant  
A Not applicable  
B Used  
C Used - failed  
D Not used  
Z Unknown

C Ejected from vehicle  
A Not ejected  
B Partially ejected  
C Completely ejected  
Z Unknown

**56 JOB DISPOSITION**

A Return to normal job  
B Temporary transfer to new job  
C Permanent transfer to new job  
D Employment terminated due to injury  
Z Other (specify)

**66 EMPLOYMENT STATUS** Same as Item 38.  
**67 DUTY STATUS** Same as Item 39  
**72 INJURY** Same as Item 52  
**73 SEAT** Same as Item 53  
**74 RESTRAINT SYSTEM** Same as Item 54  
**76 JOB DISPOSITION** Same as Item 56  
**89 ACTION**

A Not applicable  
B Crossing - with signal  
C Crossing - against signal  
D Crossing - no signal, marked crosswalk  
E Crossing - no signal, no crosswalk  
F Walking with traffic  
G Walking against traffic  
H Emerging from in front of or behind parked vehicle  
I Getting on/off vehicle  
K Pushing/working on vehicle  
L Working on roadway (work zone traffic director, etc.)  
M Playing in roadway  
N Walking on sidewalk  
O Hitchhiking  
O At safety zone  
Z Other (specify)

**90 CLOTHING**

A Blue uniform  
B White uniform  
C Khaki uniform  
D Fatigue/engineer uniform  
E Light colored civilian clothing  
F Dark colored civilian clothing  
Z Other (specify)

**91 BEHAVIORAL FACTOR** Same as Item 48  
**92 MEDICAL FACTOR** Same as Item 50  
**93 COMMUNICATION FACTOR** Same as Item 51

Figure 1-14.—Motor Vehicle Accident Report, OPNAV Form 5102/3. (Page 4 of 4.)

2.536.4

from brief notes or oral instructions. Official correspondence in its true sense encompasses all recorded communications, including messages.

In general, official outgoing correspondence is prepared only in the rough at the department level and is "chopped" to the executive officer or the administrative assistant for approval and preparation in the smooth for the commanding officer's signature.

### STANDARD NAVAL LETTERS

Figures 1-15 and 1-16 illustrate the standard naval letter in finished form. When preparing correspondence in the rough, always double space the text to allow for corrections or insertions by reviewing officers. Before starting the letter, find out from the drafting officer (you may physically prepare the draft, but the officer is responsible for the finished product) whether it is to be classified. If so, the classification must appear near the top and bottom of each page. Note the identification and indentation of paragraphs and subparagraphs. The drafting officer will have to determine who the "via" and "copy to" addressees (if any) are to be. There are two important rules of thumb: (1) references shown in the heading of the letter should be mentioned (in chronological order) within the text at least once, and (2) unless they are very closely related, do not cover two subjects in one letter. The latter practice can result in administrative confusion when replies are required.

When preparing correspondence, bear in mind that the usual purpose of Navy mail is to provide the reader with concisely stated information. If you turn out a confused, rambling, repetitious, or needlessly lengthy masterpiece of semantic purity, you only create an editing chore for the drafting officer—and you may wind up doing the whole thing over.

Before starting the letter, be sure you understand exactly what the letter is to accomplish. Then, its organization becomes essentially simple. The first paragraph should state the purpose of the letter; the following paragraphs explain circumstances and state the action (give orders, make request, give consent, or refuse permission).

When the letter is in answer to or closely related to another letter, the first sentence should refer to that letter. For example: "1. Reference (a) requested information about the allowance lists for the next 3 fiscal years. Reference (b) pointed out that such information is available for only 2 years in advance. . ."

The usual causes of confusion and rambling in a letter are:

1. Failure to follow the basic pattern (purpose, circumstances, action).
2. Inclusion of more than a single idea in a sentence, more than one central thought in a paragraph, or more than a single subject in the letter.
3. Failure to consider the readers (Can the letter be misinterpreted?).

In letters of average length, each significant unit may be one paragraph, although there is no rule about this; explaining the reasons why something should be done may take more than one paragraph, while other letters are so simple that a single paragraph makes up the entire body. The important thing for the writer is to (1) arrange the units in what seems the most satisfactory order, (2) complete each unit before moving on to the next, and (3) maintain continuity by providing transition from one unit to another.

When you prepare the first draft, do not worry too much about the finished product. Get something on paper. You can go over it later for errors, clarity, and good order. If possible, let the first draft cool for a while and occupy your mind with other matters before going over it again. This practice tends to make you more objective—you will find flaws not apparent to you earlier. Delete unneeded words, cut down the big ones, take out the intensives (very much, extremely), eliminate unnecessary introductory phrases such as "it is to be noted" and "we call your attention to the fact that," and avoid repetition.

### MEMORANDUMS

Although there are variations of the form of naval correspondence called a memorandum,

Chapter 1—ADMINISTRATION



DEPARTMENT OF THE NAVY  
HEADQUARTERS NAVAL MATERIAL COMMAND  
WASHINGTON, D.C. 20360

\*IN REPLY REFER TO  
PSX:ABC:PLM  
\*5216  
5 Jan 19—

\*AIRMAIL

\*From: Chief of Naval Material  
To: Commander, Portsmouth Naval Shipyard  
\*Via: Commander, Naval Ships System Command

Subj: Correspondence practices; recommendations of NAVMAT team concerning

\*Ref: (a) NAVMAT ltr PSX:ABC:PLM of 1 Jan 19— to COMONE  
(b) FONECON between Mr. Dial, NAVMAT, and Mr. Davis, Portsmouth, 3 Jan 19—

\*Encl: (1) NAVMAT survey team report of Portsmouth Naval Shipyard  
(2) (SC) Department of the Navy Correspondence Manual (2 copies)

1. In response to reference (a), the findings of the Headquarters, Naval Material Command survey team are provided in detail in enclosure (1). The information on correspondence practices in this letter and in the accompanying material are submitted at the request of the Administrative Officer of the Portsmouth Naval Shipyard.

2. The copies of the Department of the Navy Correspondence Manual (enclosure (2)), which are forwarded under separate cover, may be retained for your use.

3. This letter is specifically designed to be used as a guide to the procedures contained in the NAVMAT team report, and in accordance with reference (b). Few letters will contain as many parts as this one; however, the general arrangement is the same, regardless of the number of elements in a letter or its length.

a. The identification symbols, and, if any, the postal instructions, the classification, and the "from" line, are fixed in their relative positions.

b. The positions of the other headings depend on the number of lines required for each entry:

(1) Between the "from" line and the "to" line, and the "to" line and the "via" line, if any, there is no blank line.

\*INDICATES ITEMS THAT MAY NOT BE REQUIRED.

Figure 1-15.—Standard naval letter.

95.17

FBX:ABC:PLM  
\*5216  
\*5 Jan 19-

\*Subj: Correspondence practices; recommendations of NAVMAT team  
concerning

(2) Between all other heading entries, and between the last  
heading entry and the body of the letter, there is a blank line.

4. The month may be abbreviated or spelled in full. The date may  
be either typed or stamped.

PETER L. MURPHY  
\*By direction

\*Copy to:  
CNO  
COMONR

\*Blind copy to:  
(List of information addressees not shown on the original)  
(Appears on copies retained in department or headquarters only)

Prepared by:  
(Drafter's name and organization, \*room number, and telephone  
extension, and date of typing)  
(Appears on file copies only)

\*INDICATES ITEMS THAT MAY NOT BE REQUIRED.

95.17

Figure 1-16.—Standard naval letter—Continued.

the one most frequently utilized is the simple "From-To" type between subordinates within the same activity.

A preprinted Department of the Navy Memorandum (short or long) form is available, or you may use a plain or letterhead (when the memorandum is addressed outside the organization) sheet of paper. When using other than the preprinted form, type "MEMORANDUM" in capital letters at the left margin. Two spaces below that type "From:" and proceed as you would for a naval letter. For very informal communications, memorandums may be handwritten.

Variations of the "From-To" style include the "Memorandum For" and "2-Way Letter-Memo" types. The former is used between high-level officials within the Department of Defense. The "2-way" incorporates the efficiencies of a preprinted format and preinserted carbon; it is employed only for communications that require a reply.

### SPEEDLETTERS

A speedletter is used for an urgent communication that does not require electrical transmission. It is prepared on a standard, preprinted form prominently marked across the top with NAVAL SPEEDLETTER in large letters. Unlike other types of correspondence, an extra copy is provided the addressee so that they may reply on the speedletter (copy) itself.

The main purpose of the speedletter format is to call attention to the communication so that it will be given priority handling by the addressee. To this end, a special speedletter envelope is available to insure that mail handlers give the speedletter immediate attention. If a regular envelope must be used, it should be conspicuously marked with the word "SPEEDLETTER" in capital letters.

With some variations, a speedletter is prepared in much the same way as a naval letter (except that if time is critical, the speedletter may be handwritten). Identifying blocks take care of most of the information normally placed

at the top of a standard letter down through the "To" line. Therefore, unless the "Subj" and "Ref" lines are used, the writer places nothing in the textual portion of the speedletter form except the text itself, the signature, a list of enclosures, if any, and, if needed, downgrading and classification data.

### MESSAGES

A message is a written thought or idea, expressed briefly and to the point, and prepared for transmission by the most suitable means of telecommunication.

The originator of a message is the command by whose authority the message is sent. The drafter—usually the communications officer or a department head—is the person who actually composes the message for release. The releasing officer authorizes transmission of the message for and in the name of the originator. Usually the commanding officer is releasing officer, but may delegate the releasing authority.

### Basic Message Format

With a few exceptions, military messages sent by electrical telecommunications are arranged in a basic naval message format. (See fig. 1-17.)

Communications requiring expeditious delivery are prepared for transmission as brief, concise messages with a message heading and a message text.

### Heading

Figure 1-17 shows which parts of the heading must be completed. Although you do not fill in the date/time group block, you need to understand how to read this information.

The date/time group is expressed as six digits with a zone suffix, plus an abbreviated month and a two-digit year. The first pair of digits (080005Z AUG 81) denotes the date of the month, the second pair (080005Z AUG 81) the hours, and the third pair (080005Z AUG 81) the minutes, followed by a capitalized letter which



CONSTRUCTION MECHANIC 1 & C

JOINT MESSAGEFORM						SECURITY CLASSIFICATION	
						UNCLASSIFIED	
PAGE	RELATION OF MESSAGE PAGE	PRECEDENCE ACT	INFO	IMP	CLASS	FOR MESSAGE CENTER/COMMUNICATIONS CENTER ONLY	
3	of 3	RR			IIIIIIII	DATE	TIME
MESSAGE HANDLING INSTRUCTIONS							
<p>FROM: CNO</p> <p>TO: CINCLANTFLT</p> <p>UNCLAS //NO 52LL//</p> <p>MESSAGE FORMAT</p> <p>A. SECNAVINST 5211.1B</p> <p>1. &lt;TEXT&gt;</p> <p>2. &lt;TEXT&gt;</p> <p>3. &lt;TEXT&gt;</p>							
<p>6</p> <p>5</p> <p>4</p> <p>3</p> <p>2</p> <p>1</p> <p>0</p>							
<p>DATE:</p> <p>ACTION . . . 11</p> <p>00 . . . 01 . . . 03 . . . CVO</p>							
<p>DRAFTER (TYPED NAME, TITLE, OFFICE SYMBOL, PHONE AND DATE)</p> <p>H. B. JONES, LT, 43C, 55999 1 FEB</p>						<p>SPECIAL INSTRUCTIONS</p>	
<p>RELEASES</p> <p>TYPED NAME, TITLE, OFFICE SYMBOL AND PHONE</p> <p>M. K. SMITH, CAPT, 43 57995</p> <p>SIGNATURE</p>						<p>SECURITY CLASSIFICATION</p> <p>UNCLASSIFIED</p>	
<p>DD FORM 173</p>							

Figure 1-17.—Format for naval message.

31.47

indicates the time zone. For standardization, all naval communications use Greenwich (Z) time. Duplicate date/time groups should not be used by the same originator during any one 24-hour period. Normally, the time included in the date/time group is the time at which the originator delivered the message to the communications center for transmission. All

numerals in abbreviated titles used in naval messages are spelled out.

**Text**

The text of a naval message is prepared as shown in figure 1-17. Notice that the message paragraphs are numbered, except for short,

one-paragraph messages. Subparagraphs are indented and lettered or numbered as appropriate. If the message is classified, it is marked with the proper downgrading/declassification markings. The number of characters and spaces on a line is sixty-nine.

Short titles or abbreviations are not used in the text if the message is addressed to a Member of Congress, a commercial concern, or a nonmilitary address.

The following punctuation marks or symbols may be used to enhance clarity within the message text:

- Hyphen (-)
- Question mark (?)
- Colon (:)
- Apostrophe (')
- Ampersand (&)
- Parentheses (left and right) ( )
- Period (.)
- Comma (,)
- Virgule (or slant) (/)
- Quotation mark (")
- Number symbol (#)

Symbols that may NOT be used in a naval message are:

- “At” sign (@)
- Percent (%)
- Fractions (1/2, 1/4, et cetera)
- Asterisk (\*)
- Underscore ( \_ )
- Cent sign (¢)

### TRAINING AND DEVELOPMENT OF SUBORDINATES

Each training program is formulated to provide personnel with the skills needed to accomplish the current and mobilization missions. The program is developed in accordance with the pattern, priorities, and tempo established by the commanding officer. It covers many phases from orientation courses to special technical courses. The success of a training program depends upon operational

commitments, policies, and directives from higher authorities; experience and previous training of the personnel, and training facilities available. Although much of the construction training will be provided by Class A, and C-1 Advanced Schools, as well as Special Construction Battalion Training (SCBT) courses, additional skill and experience must be acquired.

### TRAINING ORGANIZATION

Navy regulations state that the NMCB executive officer will supervise and coordinate the work, exercises, training and education of personnel of the command. (See fig. 1-18.) The executive officer will supervise the training of officers, coordinate the planning and execution of the training program and, when necessary, act to correct deficiencies in the program. The executive officer does this in the capacity as chief staff officer (CSO). The executive officer's principal assistant is the plans and training officer (S-2).

Company commanders are directly responsible for the training of their company personnel and for fulfilling training goals established by the commanding officer. The company commanders will help formulate training programs; supervise training of subordinate officers; and direct technical military and general training of their companies. The battalion service department heads are responsible for the individual training of personnel in the departments. They conduct training for advancement and administer the OPNAV-sponsored general training. Platoon leaders observe closely the training progress of personnel in their platoons. They directly supervise on-the-job construction and military training. All petty officers assume the responsibility for training their members and must be able to conduct effective training courses utilizing lectures, discussions, project work, and so on.

The plans and training officer is generally assisted by a permanently assigned staff of three or four petty officers and by additional personnel on a part-time basis as necessitated by

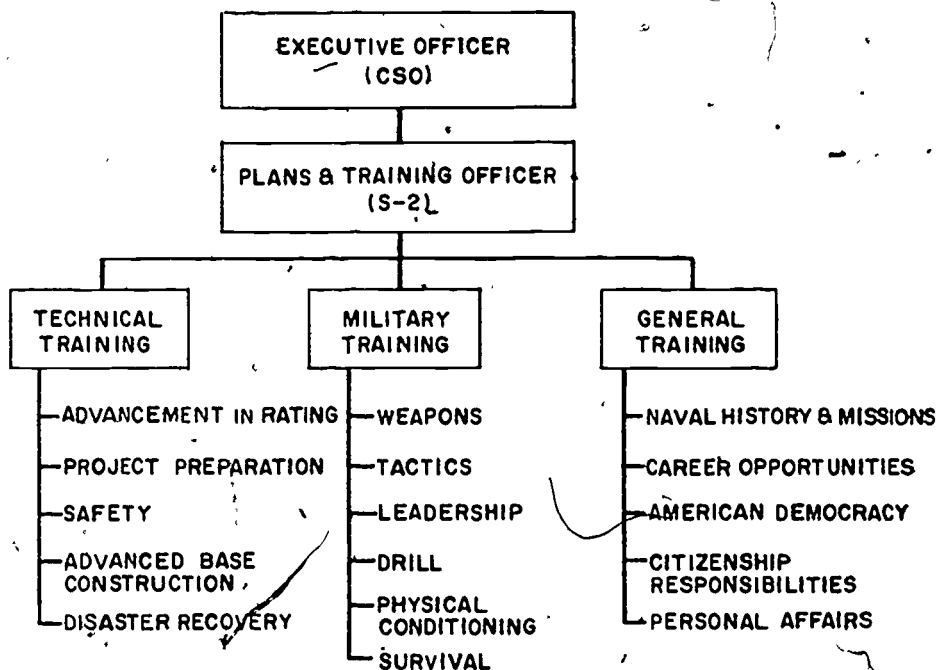

143.133

Figure 1-18.—Training organization chart.

the formal training workload. This group is generally headed by a chief petty officer, and its members often function as training instructors. Although responsible for the entire training program, this group is primarily concerned with the formulation and administration of the formal military training program and that part of the technical training program which includes advanced base construction and disaster recovery. The other aspects of the technical training and general training programs are formulated and administered within each company, but should correspond to the general guidelines established by the plans and training officer.

In the Amphibious Construction Battalion (PHIBCB), the training officer may serve as assistant to the operations officer. The training officer arranges and schedules all formal training of officers and enlisted personnel, performing essentially the same duties as the

plans and training officer of the Naval Mobile Construction Battalion (NMCB). However, the training program planned by the training officer of an PHIBCB is tailored to meet the specialized mission of the PHIBCB. It provides the knowledge that operational teams and crews apply in carrying out all phases of their primary missions. Included are seamanship, the installation and operation of causeway piers, fuel systems, and beach salvage techniques.

In general, training for both the NMCB and the PHIBCB should be closely integrated and coordinated with daily operations of the battalion. The adopted training plan and organization must not interfere with essential construction functions. Nevertheless, the construction schedule should be flexible so training opportunities that will expedite the construction schedule are not neglected. Every opportunity should be taken to derive training benefits from routine operations.

## TRAINING NEEDS

Training for advancement is a continuous concern of all personnel within a battalion, whether at the company or platoon level.

In homeport, training programs become the primary mission. The NMCB is expected to spend about 75 percent of the available man-days in formalized technical, military, and general training. In addition, the planning and estimating group may be considered to be involved with on-the-job training. Shortly before an NMCB returns to homeport, it sends an advance party to the homeport regiment to prepare the training schedule for the battalion's homeport stay. Although this advance party performs other than training functions necessary for the battalion's arrival, it prepares for instructors, sets up material support, and obtains quotas for schools. All personnel are trained in the areas of technical, military, and general topics. However, the program may be tailored to meet the specialized mission of the battalion's next deployment. If one of the projects scheduled is the construction of an airstrip, there will undoubtedly be a great deal of site preparation going on. You will need to see how many qualified Construction Mechanics are available; you might need to train more personnel to maintain and repair specific equipment. Whenever an uncommon work item of sufficient magnitude is encountered during a forthcoming deployment, it should allow the majority of your personnel to gain experience and training in the operation.

Take inventory of the skills the members in your crew possess, whether through actual job experience or through some type of training program. After you have made this study, you can easily see whether the required skills for a particular job match the available skills. When they do not match, you have a good indication that training is needed to bring the crew up to the desired level of proficiency. In some cases, you will need to conduct refresher training; in other cases, you will have to give instructions on new techniques.

As a supervisor, you may also check your personnel's service records, conduct a PRCP interview with each person and select those best suited for training given at a C-1 Advance

School or Special Construction Battalion Training Courses.

## ON-THE-JOB TRAINING

There are many forms of on-the-job training (OJT). It may be in the form of an especially tailored, well-organized program, such as one designed to help welders acquire advanced skills in welding. Then again, OJT may be in the form of simple instruction, like explaining and showing a person how to tie a certain kind of knot. In other words, when one person helps others learn to do a job and makes sure they learn the right way, it is a form of OJT.

You may not have realized it, but in the SEABEES, on-the-job training goes on about all the time. For instance, two CM strikers were assigned the job of reconditioning a cylinder head. Although they had performed many comparable jobs, they had not done that particular one. Their supervisor assigned an experienced crewmember to guide them. This person explained the exact procedure for disassembling the component parts, how they were to be cleaned and inspected, and why particular angles were used. The CM strikers understood and easily proceeded with the job.

There are as many examples of OJT as there are contacts between personnel in the SEABEES. Its importance becomes readily apparent in an organization, such as the SEABEES, where changes in equipment, personnel, and improvements call continuously for new and better methods of doing things.

In the SEABEES, as well as in private industry, the term on-the-job training has come to mean "helping an individual acquire the necessary knowledge, skill, and habits to perform a specific job." This definition implies that the job training applies not only to the Constructionman or new personnel in an organization, but also to any other person who is assigned a new job. It indicates that job training is a continuous function in the SEABEES. No person should be regarded as completely trained. One's performance can always be improved by keeping interest high and by passing on directions, suggestions, and information which will increase proficiency of the trainee.

Bear in mind, however, that OJT is an active process and requires active supervisors who are aware of the needs of the trainees and who can motivate them to learn. Use methods which will add meaningful experiences to the trainees' storehouse of knowledge.

A supervisor who does a good job of training personnel stands to benefit in many ways. For one thing, well-trained crewmembers brag about their supervisor, especially to their buddies in other crews. A remark they might make proudly is "I sure do enjoy working for Chief Murray because I learn so much." As you can see, this will multiply your effectiveness on the crew. If you have a skill, knowledge, or attitude of value to the Navy and can impart that skill, knowledge, or attitude to 10 others—you have multiplied your effectiveness 10 times.

### Setting Up An On-The-Job Training Program

In setting up an OJT program, one of the first things you will want to do is to make an administrative analysis to determine the type of training required.

One of the requirements may be for advancement in rate for your personnel. There is nothing that can make you feel any prouder than to see the CM's that you have helped make their first crow, with the wrench and nut on it, that of a third class Construction Mechanic. Do you know what their thoughts are? They are not, as commonly believed, "Oh boy, no more mess cooking." The real thought of that person is "I cannot wait until I can sew on the next one."

In preparing your program, keep in mind the broad knowledge you have about the objectives and how you can best utilize your experience. You will have to determine, of course, the subjects to be taught. It may be that you are going to teach CM strikers how to put a clutch disk in a 1/2-ton pickup. Or perhaps you are going to teach them how to rebuild a starter.

You will have to break your subjects down into lessons, taking into consideration the length of time to be devoted to each subject and

whether you are going to teach your subjects in a classroom, field, or shop. You may have to establish lesson sequence, determine lesson objectives, analyze reference materials, prepare lesson plans, and so on. Remember that in any type of training program, the objective should be to help the trainee learn the most and in the shortest time possible.

### Implementing An On-The-Job Training Program

You should consider various courses of action in implementing an OJT program. To the supervisor or trainer, some of the most important are:

1. Survey unit assignments and insure that each assignment is in the best possible accord with the individual's classification and specific skills background.

2. Determine the exact need for training. To determine this need, establish two things: (A) the specific job requirements, and (B) the individual skills of the trainee. When A and B are known, the on-the-job training required can be stated in a simple formula:

$$A - B = \text{on-the-job training required.}$$

3. Determine the method or methods of training which will be most effective. Number of people, time available, facilities required, nature of training, and individual capabilities are factors which will affect your decision.

4. Select the personnel who will actually conduct the training, remembering that the end product will be no better than those who conduct the training program.

5. Procure all available materials which may help supplement the program.

6. Followup. You should continuously monitor the program to see that it does not lag, that training records are kept current, and that newly developed skills are properly applied.

This is truly a large order. But now, more than ever, our Navy depends upon quality training. It is an important job, and it is one that never ends.

### Methods of On-The-Job Training

In OJT, you must be prepared to use a combination of training methods, depending upon the nature of the subject, time available, and the capabilities of the trainee. The following methods of training are basic to any well-planned unit training program.

No other method of training is as effective as intelligent, interested **COACH-PUPIL INSTRUCTION**. In addition to being a quick way of fitting a new worker into the operation of a unit, it serves as one of the best methods of training. Without specific directions and guidance in learning to perform the necessary duties, a worker is likely to waste time and material and form bad work habits.

It happens that many organizations in industry have apprenticeship courses which are designed to train workers in a trade or skill. Their training consists of coach-pupil supervision under skilled workers with periodic group instruction when it is advantageous.

**SELF-STUDY** should be encouraged. Skilled and semiskilled jobs require a considerable amount of job knowledge and judgment ability. Even in simple jobs there is much basic information that the worker must acquire. The more complicated technical jobs involve both basic and highly specialized technical knowledges and related skills which must be taught.

**GROUP INSTRUCTION** is a practical adjunct to direct supervision and self-study. It is a timesaver when several workers are to be instructed in the same job knowledge or procedures. The supervisor or trainer can check training progress and clarify matters which are difficult for the trainees to understand. Group instruction, if intelligently used, can expedite production. For example, suppose you have six trainees learning the same job. Four of the trainees are having trouble with a certain job element, while the other two have it "knocked." The four people having trouble can be brought over to the other two, and in a short time the difficulty will probably be solved. In OJT, this is

called group instruction; and, as you can see, group instruction is not the same as classroom or so-called "academic-type" instruction.

Another type of OJT is **PIECEMEAL INSTRUCTION**. For instance, a crewmember asks you for information and you supply it. That is piecemeal instruction. A supervisor's orders are, in a sense, a piecemeal method of instruction because they let others know what, when, where, and perhaps, how and why. Other examples of piecemeal instruction are: explaining regulations, procedures, and orders; holding special meetings; indoctrinating a new person; and conducting organized or unorganized meetings.

### Developmental On-The-Job Training

In any type of effective training in which one individual is working directly under the supervision of another, the trainers and trainees must understand the objectives of the training. Factors deserving careful consideration include determining the training needs of the trainees, defining the purpose of training, and explaining or discussing different points concerning training with the trainees.

In determining training needs, it is often a good idea to interview the trainees. A summary of previously acquired skills and knowledges relative to the job they are to do can be learned by proper questioning. Compare jobs the trainees know how to do with those they will be doing. Determine training needs (required knowledges and skills minus knowledges and skills already possessed). Training needs should be determined for each job pertaining to the trainee's position assignment. Analyze the job to be done and have all necessary equipment and materials available prior to each job training situation.

In defining the purpose of training, the trainers should clearly explain the purpose of the job, duty, or task to be performed by the trainees. Point out to the trainees their place on the team and explain to them how they assist in getting the unit mission accomplished. Stress the advantages of doing the job well, and how the training benefits themselves, their organization, and the SEABEES.

The trainers should also explain facts about the job to be done, principles that are proved and workable, and directions on how to accomplish the job safely, easily, and economically. The trainers should explain, too, the techniques that will improve the skill of the trainees. The importance of each operation in a job should be stressed. The technical terms relating to the job should also be explained.

The trainers and trainees should discuss the problems that arise in doing a job, and endeavor to clear up any questions of the trainees concerning the job. Point out to the trainees any similarity of different operations of the job wherein transfer of knowledge or training may be utilized. The relationship of procedures in a particular job to things with which the trainees are acquainted, should also be discussed. This allows the trainees to learn through association with past experiences. It also is important to discuss the progress of the trainees.

Developmental training in any situation is a process which aids an individual in progressing from what one KNOWS to what one NEEDS TO KNOW—from the KNOWN to the UNKNOWN.

The end product of peacetime military operations is TRAINED PERSONNEL. Regardless of your unit mission, you must have trained personnel to carry it out. IT IS THE RESPONSIBILITY OF EVERY PETTY OFFICER IN THE NAVY TO TRAIN THE PERSONNEL UNDER THEIR IMMEDIATE SUPERVISION.

### Systematic Training

Effective training requires a great deal of planning and directed effort, organization of materials into a logical sequence to prevent a haphazard approach to the job of training, and accurate measuring methods for evaluation results. There must be some results if any learning takes place. If you push as hard as you can on an object and there is no result—if you fail to move it—no work has been done regardless of the energy expended. If no learning takes place, you have NOT trained. Three steps

that may help you in planning and carrying out your training programs are:

1. Insure learning by use of correct training methods;
2. Measure achievement at regular intervals to assure that learning is taking place; and,
3. Record results where interested parties can check progress; records in the open can create competition which often is a great motivating factor.

**EVALUATION.**—Generally, the most valid trainer evaluation can be obtained by testing the trainees to see how much they have achieved under your guidance. If they have learned to perform in a highly satisfactory manner, you are doing a good job of training. The effectiveness of the training is determined by how much training has taken place and the value of that training. The personnel must be trained correctly. Improper training, in many cases, is worse than no training at all.

**PERFORMANCE TESTING.**—Performance testing helps you do a better job of conducting an on-the-job program. You can use performance tests to find how well your trainees are performing their jobs. However, it is difficult to find a test that does its job well.

Performance tests should enable you to evaluate the work of subordinates accurately enough to accomplish the following objectives:

1. To help determine when trainees can actually perform the tasks that they are being trained to do;
2. To aid you in evaluating the improvement of persons in on-the-job training;
3. To help locate strengths and weaknesses in OJT programs;
4. To determine the qualifications of personnel entering OJT programs; and
5. To help assign new people to particular jobs.

Since it is a practical check on a work project, the performance test must be a sample work situation in which the trainee performs some active piece of work that can be examined. The test is not designed to measure what a person knows about the job (a written or oral test may fill that need for you). Instead, it is intended to help you evaluate that person's ability to actually do the job. Do the best you can in organizing and administering the performance test. There will always be room for improvement in most of the testing that you do.

### FACILITIES PLANNING GUIDE

You should consult the *Facilities Planning Guide* (NAVFAC P-437) when tasked to assist in planning the construction of an advanced base. This document identifies the structures and supporting utilities of the Navy Advanced Base Functional Component (ABFC) System. It was developed to make preengineered facility designs and corresponding material lists available to planners at all levels. While these designs relate primarily to expected needs at advanced bases and to the Navy ABFC System, they can be used to satisfy peacetime requirements as well. Facilities, logistic, and construction planners will each find the information required to select and document the material necessary to construct facilities.

NAVFAC P-437 consists of two volumes. Volume I contains reproducible engineering drawings organized as follows: Part 1, Component Site Plans, indexed by component and ABFC designation; Part 2, Facility Drawings, indexed by facility number and DOD category code; Part 3, Assembly Drawings, containing assembly information and indexed by assembly number. Each drawing is a detailed construction drawing that describes and quantifies the facilities, assemblies, or line items required to complete it. A summation of logistic, construction, and cost data is provided for each component, facility, and assembly of the ABFC System. A component is defined as a grouping of personnel and material that has a specific function or mission at an advanced base. Whether located overseas or in CONUS, a component is supported by facilities and assemblies.

Volume II of NAVFAC P-437 contains the detailed data display for each component, facility, and assembly. Also arranged in three parts, Part 1 quantifies and describes by DOD category code the facilities requirement for each component. Part 2 quantifies and describes by assembly number the assembly requirement for each facility. Part 3 quantifies line-item requirements by National Stock Number (NSN) for each assembly. Except for earthwork, material lists in Volume II are complete bills of material.

The P-437 also contains other useful information for planners. For example, crew-sizes, man-hours by skill, land areas and amounts of fuel necessary to make a component, facility, or assembly operational, as well as predesigned facilities and assemblies that are not directly related to components shown in the table of the ABFC System (OPNAV 41P3). These facilities and assemblies give the planner alternatives for satisfying contingency requirements when callout of a complete component is not desired. To make the P-437 compatible with other DOD planning guides, NAVFAC P-72 (Category Codes for Classifying Real Property of the Navy) is a related publication that establishes the category codes, nomenclature, and required units of measure for identifying, classifying, and quantifying real property. The cardinal category codes are as follows:

- 100 Operational and Training
- 200 Maintenance and Production
- 300 Research, Development and Evaluation
- 400 Supply
- 500 Hospital and Medical
- 600 Administrative
- 700 Housing and Community Support
- 800 Utilities and Ground Improvement
- 900 Real Estate



## CONSTRUCTION MECHANIC 1 & C

If a facility is required for enlisted personnel quarters, for example, it will be found in the 700 series, "Housing and Community Support." The assemblies contained within each facility will consist of a grouping of line items at the National Stock Number Level which when assembled will perform a specific function in support of the facility. An assembly is functionally grouped so that the assembly number relates to the Occupational Field 13 skill required to install it. The groupings are numbered as follows:

DESCRIPTION	NUMBER	SEQUENCE
	START	STOP
Builder oriented (BU)	10,000	19,999
Utilitiesman oriented (UT)	20,000	29,999
Construction Electrician oriented (CE)	30,000	39,999
Steelworker oriented (SW)	40,000	49,999
Equipment Operator oriented (EO)	50,000	54,999
Water Front Equipment	55,000	57,999
Underwater Const and Diving Equip	58,000	59,999
Operational Supplies	60,000	62,499
Operating Consumables	62,500	64,999
NBC Warfare	65,000	67,499
Personnel Related Supplies	67,500	69,999
Unassigned at present	70,000	Series
Shop Equip including Maintenance Tools	80,000	80,999
Unique ABFC Tool Kits	81,000	81,999
NCF TOA Const Tools & Kits (power tools)	82,000	82,099
NCF TOA Const. Tools & Kits (elec.)	82,500	82,599
NCF TOA Const Tools & Kits (misc)	83,000	83,199
NCF TOA Const Tools & Kits (rigging)	84,000	84,099
Shop Equipment (ABFC Unique)	85,000	87,499

### TAILORING COMPONENTS AND FACILITIES

It is important to realize, when you are considering tailoring, that the ABFC System contents are based on a set of assumptions. This makes it possible to develop modular elements which can serve similar functions in various locations. The exact requirements for a specific base cannot be defined, economically designed, nor supported within the general system. However, the base development planner knows the specific location, mission, unit composition, and availability of other assets. The planner can then select from the ABFC System components or facilities that satisfy requirements. Tailoring is then applied to the preplanned ABFC assets to come up with what is needed.

Components or facilities can be tailored by

- (1) deleting or adding facilities or assemblies and
- (2) specifying requirements for tropical or

northern temperate zones. Assemblies required in tropical installations only are coded with the letter "T" in the zone column to the right of the assembly description. Assemblies required in northern temperate installations only are coded with the letter "N." Uncoded assemblies are common to both zones.

### USE AND APPLICATION OF THE FACILITIES PLANNING GUIDE

Although a listing in the P-437 may help you order individual items in general supply, it does NOT replace Stock Lists of System Commands or Bureaus, Offices, Single Managers, or Inventory Control Points. Stock numbers and descriptions can be verified through appropriate Stock Lists. However, you do this automatically in ordering a component, facility, or assembly.

A representative sample of the types of components displayed in Volume II is presented to show the structure and kind of information provided. Figure 1-19 depicts a P-25 component, Naval Mobile Construction Battalion. You can see that a component contains a list of facilities by category code. From this list select a facility, such as Diesel Storage and Dispensing Facility, 200,000-gallon, facility 123-10F. Locate this facility in Part 2 of Volume II. Figure 1-20 shows this facility. Note that within the facility, the necessary assemblies required to perform the defined function are identified. Figure 1-21 depicts an assembly within facility 123-10F. Within assembly 20002, titled 50,000-gallon pillow fuel tank, line items by NSN required to make the assembly operative are displayed. Certain installed equipment and collateral equipment, furniture, and fixtures contributed by others are not furnished with the facilities or the assemblies listed in P-437. They must be requested separately instead. The assembly listings indicate what installed or NAVFAC collateral equipment is provided.

### ADVANCED BASE FUNCTIONAL COMPONENTS

Advanced Base Functional Components are normally complete entities. However, housing,

## Chapter 1—ADMINISTRATION

COMPONENT P25 NAVAL MOBILE CONSTRUCTION BATTALION									
PROVIDES PERSONNEL, ADMINISTRATION, HOUSING, SUBSISTANCE AND EQUIPMENT REQUIRED FOR THE MOBILIZATION OF ONE MOBILE CONSTRUCTION BATTALION.									
SITE PLAN 60D350									
FACILITY	DESCRIPTION	FACILITY CAPACITY	QTY	COMPONENT CAPACITY	WEIGHT SHORT TON	CUBE MEAS TON	DOLLAR VALUE	CONST EFFORT MANHOURS	
111 208	HELICOPTER LANDING PAD SMALL	1000 SF	1	1000 SF	10.8	33.9	29,291	244	
123 10A	MORGAS STOR-DEFRSG FACIL 20000 GAL	20000 GL	1	20000 GL	5.5	22.6	21,258	111	
123 10B	DIESEL STOR-DEFRSG FACIL 20000 GAL	20000 GL	1	20000 GL	21.7	83.6	78,820	231	
131 15A	COMMUNICATION CENTER	240 SF	1	240 SF	18.4	18.3	9,131	558	
141 75C	ARMORY	310 SF	2	420 SF	15.4	145.2	14,940	74	
213 41D	CENTRAL TOOL ROOM-SUPPLY ROOM	4008 SF	1	4000 SF	3.1	9.9	15,108	74	
214 20M	A CO AUTO VEHICLE SHOP	4800 SF	1	4000 SF	7.9	10.2	18,552	126	
218 20A	A COMPANY CONSTRUCTION EQUIP SHOP	4000 SF	1	4000 SF	2.4	7.1	13,552	84	
219 10D	B, C AND D COMPANY SHOP	7744 SF	1	7744 SF	5.7	17.6	26,207	212	
421 35A	READY MAGAZINE	160 SF	1	160 SF	1.6	32.0	4,770	0	
441 10G	GENERAL WAREHOUSE REPAIR PARTS	4000 SF	2	8000 SF	6.2	19.8	30,217	148	
441 10H	GENERAL WAREHOUSE W/O	4000 SF	2	8000 SF	6.2	19.8	30,217	148	
441 10J	GENERAL WAREHOUSE GALLEY	936 SF	2	1872 SF	2.4	8.0	7,856	54	
441 10K	GENERAL WAREHOUSE SUPPLY	4000 SF	2	8000 SF	6.2	19.8	30,217	148	
510 77A	MEDICAL STORAGE	160 SF	1	160 SF	1.6	32.0	4,770	0	
540 102	DENTAL CLINIC	250 SF	1	250 SF	10.5	87.4	52,940	0	
550 10C	DISPENSARY	936 SF	2	1872 SF	2.4	8.2	6,605	66	
610 10N	ADMINISTRATIVE OFFICE	936 SF	10	9360 SF	8.0	24.0	27,024	300	
610 73A	COMPANY HEADQUARTERS (C AND D CO)	936 SF	1	936 SF	.7	2.4	2,328	24	
610 73B	A COMPANY OFFICE/DISPATCHER	936 SF	1	936 SF	.7	2.4	2,328	24	
723 10R	GALLEY MESS	8936 SF	1	8936 SF	58.1	262.6	119,882	737	
723 20J	LATRINE	336 SF	1	336 SF	2.0	3.1	403	112	
723 20K	HEAD/WASHROOM 6 FT X 8 FT	48 SF	3	144 SF	2.7	6.6	4,276	37	
723 30G	LAUNDRY	936 SF	2	1872 SF	11.6	67.1	38,017	17	
725 10E	TROOP MSG ENBRG OFF/CPO W/SH-WR	40 MM	2	60 MM	23.2	78.0	43,431	1,448	
725 10F	TROOP MSG ENBRG W/SHOWER-WASHROOM	130 MM	6	780 MM	98.0	252.6	180,995	6,192	
730 30B	BAKERY PLANT FIELD PORTABLE	936 SF	1	936 SF	4.3	27.4	20,569	41	
740 02A	EXCHANGE-BARBER SHOP	936 SF	1	936 SF	1.9	24.0	5,697	24	
740 33E	SPECIAL SERVICES/POST OFFICE	936 SF	1	936 SF	.7	2.4	2,328	24	
740 54B	RECREATION FACILITY	936 SF	3	2808 SF	2.1	7.2	6,985	72	
740 63A	CLUB ENLISTED MENS	4000 SF	1	4000 SF	10.7	52.1	27,260	204	
750 20A	PLAYING FIELD	1 EA	1	1 EA	.0	.0	0	0	
750 50A	OUTDOOR THEATER	800 SE	1	800 SE	.0	.0	0	0	
811 10AU	ELECTRIC PWR PLANT 2-200KW GEN SETS	500 KV	2	1000 KV	23.6	35.4	92,691	172	
812 30CX	ELECTRICAL DISTR LIMBS-UGND 17000LF	17000 LF	1	17000 LF	58.2	94.5	324,396	1,128	
817 40A	PERIMETER LIGHTING 1100 LF	1100 LF	8	8800 LF	4.8	12.7	6,885	1,384	
841 30A	LEACH FIELD	1 EA	3	3 EA	2.4	8.1	456	216	
833 40A	GARBAGE HOUSE	936 SF	1	936 SF	.7	3.3	1,944	14	
841 10H	WATER TREATMENT FACILITY 1500 GPM	30 PG	3	90 PG	16.5	27.0	31,334	78	
841 40B	WATER STORAGE POTABLE 30000 GAL	30000 GA	3	90000 GA	14.4	31.8	36,782	168	
842 10J	WATER DISTRIBUTION LINE POTABLE	7640 LF	1	7640 LF	14.9	27.0	20,452	324	
851 10A	ROAD WITH DRAINAGE 1 MI	14000 SY	2	28000 SY	70.4	142.4	16,047	5,268	
852 10A	PARKING	200 SY	4	800 SY	8.4	15.6	825	784	
872 10E	SECURITY FENCING 1980FT	1980 LF	5	9900 LF	73.0	228.0	75,418	3,325	
872 20B	GUARD/WATCH TOWER	4 MM	4	16 MM	72.0	31.2	13,796	1,440	
872 20C	BUNKER FIGHTING 7FX7FX7F	2 MM	40	80 MM	128.0	168.0	20,556	4,560	
872 20D	BUNKER COMMAND POST	10 MM	6	60 MM	53.4	76.8	15,183	3,348	
872 20F	BLIT TRENCH	36	36	36	.0	.0	0	0	
890 27A	ICEHAKING PLANT	1 TM	1	1 TM	1.5	4.7	6,871	4	
TOTAL NORTH					886.6	2,283.9	1,542,603	34,235	
TOTAL TROPICAL					856.9	2,201.5	1,391,535	33,301	
COMPONENT P25									
CONST STD	LAPSED DAYS	LAND ACRE	POWER CONNECTED	KVA DEMAND	WATER GPD	SEWER GPD	FUEL GAL/30DAYS HEATING	NOGAS	PWR GEN DSE
INIT	21	18.5	458	323	305,134	8	61,056	83,778	0
SKILLED MANHOURS - EA			BU	UF	CE	SW	EO	UNSKILLED CH	
0			7,653	6,093	3,657	1,767	5,428	9,627	

143.298

Figure 1-19.—Component.

messing, medical facilities, maintenance facilities, defensive ordnance, communication equipment, and utilities may not be supplied with each component and are themselves service components or facilities to be integrated into an overall base development or augmentation plan. ABFC's are assigned descriptive names to

indicate their functions and alphanumeric designators to facilitate reference. A detailed Advanced Base Initial Outfitting List (ABIOL) is an itemized line item printout of the material in each ABFC. Each System Command or Bureau is responsible for maintaining a detailed listing of that part of the ABIOL assigned to it.

## CONSTRUCTION MECHANIC 1 & C

FACILITY 123 108		JCS PLANNING FACTOR								
DIESEL STORAGE AND DISPENSING FACILITY										
200000 GALLON										
THIS FACILITY PROVIDES 200000 GALLON OF DIESEL OIL STORAGE AND RECEIVING-DISPENSING CAPABILITY.										
NAVFAC DRAWING NUMBER 6002621										
ASSEMBLY	DESCRIPTION	ZONE	QTY.	WEIGHT POUNDS	CUBIC FEET	DOLLAR VALUE	CONST EFFORT MANHOURS			
20002	TANK FUEL PILLON 50000 GAL		1	7,610.8	688.4	26,805.76	112			
20124	HOSE HAMP P/20000 GAL TANK ARR		1	564.2	60.4	1,491.61	2			
20204	FUEL TRANSFER ASSEMBLY 150 GPM		1	3,985.9	487.5	7,872.64	48			
20385	FUEL DISPENSING ASSEY PORTABLE		1	1,615.3	52.9	2,519.73	3			
20506	FUEL FILTER AND METER ASSY 600 GPM		1	3,329.4	276.1	1,625.71	22			
20508	HEATER FUEL HOT OIL 150 GPM		1	25,092.5	1,751.9	10,859.07	24			
28703	TANK FUEL 275 GAL W/PIPING		2	758.2	91.9	1,729.44	16			
29782	EXTINGUISHER FIRE W/BRKT PKP 20 LB		3	540.0	18.9	125.14	3			
TOTAL NORTH		SHORT TON	HEAS TON	43,456.9	3,348.0	78,819.51	231			
TOTAL TROPICAL		9.2	39.8	18,364.4	1,592.1	41,966.44	267			
FACILITY 123 108		PRIMARY	200,000 GL	SECONDARY	0					
CONST. STD.	LAPSED DAYS	LAND ACRES	POWER KVA CONNECTED DEMAND	VOLTS PHASES	WATER TOT. GPD	WATER PEAK GPM	SEWER GPD	RECOV. CODE		
INIT	0	1.28	17	8	208	3	0	0		
FUEL (GAL/30DAYS)		HEATING		SKILLS MANHOURS		UNSKILLED		CONST EFFORT		
DSL	MOGAS	PWR GEN	DSL	EA	SU	UT	CE	SM	EO	CM
0	490	0	0	0	8	119	0	6	21	21

Figure 1-20.—Facility.

143.299

ASSEMBLY 20002		TANK FUEL PILLON 50000 GAL									
THIS ASSEMBLY PROVIDES 50000 GALLON OF FUEL STORAGE											
NAVFAC DRAWING NUMBER 6002614											
COG STOCK NUMBER	DESCRIPTION	UI	QTY	WEIGHT POUNDS	CUBIC FEET	DOLLAR VALUE					
9C 4710-00-639-9445	PIPE STL BLK 2	PT	20	75.00	7800	9.80					
9C 4710-00-773-1041	PIPE CULVT WREST 12M ALUM	EA	4	26.40	3,1600	21.52					
9C 4720-00-778-8867	HOSE ASSY BRB 4X10 EUCT	EA	3	171.00	7,5000	246.00					
9C 4730-00-088-9284	COUPLING HLP QCPLR 4 FX4P	EA	2	16.00	.4000	34.80					
9C 4730-00-194-2079	NIPPLE PP SMRT 4X4	EA	1	3.15	.0600	1.20					
9C 4820-00-289-2474	VALVE GATE QUICK 2NPT	EA	1	11.00	.2000	27.70					
9C 5330-00-499-4509	WASHER BRB 4 HSE CPLG	EA	3	.15	.0030	.42					
2C 5430-00-992-3739	TANK FAB COL 50000GL	EA	1	1,600.00	150.0000	4,860.00					
ASSEMBLY 20002				TOTAL	1,902.70	161.1030	5,201.44				
FUEL (GAL/30DAYS)		HEATING		SKILLS MANHOURS		UNSKILLED		CONST EFFORT			
DSL	MOGAS	DSL	EA	SU	UT	CE	SM	EO	CM	MANHOURS	
8	0	0	0	8	2	0	0	22	4	28	
NOTE - CREW SIZE: 1 EO, 1 UT, 2 CM											

Figure 1-21.—Assembly.

143.300

## CHAPTER 2

# SUPERVISION

As a First Class or Chief Petty Officer, you will have many responsibilities added to those you have now. The higher your pay grade, the more likely it will be that your main duties will consist of supervising rather than doing. To become an effective supervisor, you must be able to meet the requirements of your rate as well as other requirements. You must know how to handle your crews to get the most out of them; be able to plan projects, make estimates, and set up programs to train your personnel; be able to foresee difficulties and devise methods for overcoming them; and be able to maintain records and reports. Also, you must be safety conscious by insuring that your personnel observe all safety precautions in their jobs.

### THE SUPERVISOR

Supervision involves working with people, and a major responsibility of a supervisor is production. A good supervisor knows how to get a job done by getting the most out of personnel. As a word of caution, however, the drive for production must be tempered by consideration for the human element. People are not machines. The supervisor who treats them as such will find that no amount of pressure will permanently increase the production rate. While striving for a high level of production, a supervisor wants people to produce willingly and to show an interest in their work. If you have had only a small amount of supervisory experience, you are no doubt aware that the job of a supervisor is not as easy as it sometimes appears. The following discussion will give you an idea of some of the major factors involving a supervisory position.

### EARNING RESPECT

Respect must be earned. You can not win it by flattery, apple-polishing, throwing your weight around, avoiding issues, or striving for popularity. In supervising your crews, create an atmosphere of courteous and helpful direction. The less noise you make, the better will be the results. There is no room for the "Do as I say, not as I do" approach. In today's technical and ever-changing Navy, the need is for personnel who lead with intelligence, by know-how, and by good example. Good supervision produces a smooth-running organization; poor supervision creates confusion, dissatisfaction, and dismay.

### COMMON MISTAKES

Your first days as a new supervisor are mighty important. Your crew will be watching to see how you react to the new responsibility. Your superiors will be observing you, too. This is the time to avoid some of the common mistakes made by supervisors. Learning what NOT to do is often as important as learning what to do.

"New broom" tactics are out! It is not unusual for an inexperienced supervisor to go into a new job with the idea that "things are going to be different around here." Try not to make a big showing, or let it be known that you did not like the way the last supervisor operated. If so, you have overlooked a psychological factor called "resistance to change." Some people fear and resent change. Better to let your crew know that change can wait right now. After getting your feet on the ground, you can make changes gradually.

Do not promise to gain your crew's friendship and support. Even a hinted or implied promise can sometimes be dynamite. For example, "if you do this job right, you may get a little time off or other compensation." You could be overruled by higher authority.

Avoid dictatorial practices; they are fiercely resented. An overshadowing of authority during your first days on the job will be particularly noticed.

Playing favorites, being partial to former friends, ignoring the more timid of your crewmembers, and assigning the best jobs to a chosen few will rapidly break down the morale of your crew.

Careless remarks, which would go unnoticed if they came from one of the crew, take on new significance when they come from a supervisor. You must carefully weigh your remarks when members of your crew are listening.

Failure to delegate work and fearing to trust subordinates are common failings of a new supervisor, and the result is that soon you become so stacked up with work that you bottleneck the whole unit.

When you make a promise to have a vehicle ready to go at a certain time and you are unable to keep that promise, accept the blame yourself. There may be a good reason for your inability to keep your promise or the fault may lie with one of your subordinates, but the important thing is that you accept the responsibility and do not pass the buck. Passing the buck when something goes wrong is a sure way to lose the respect of your crew. And above all, do not lose your temper in front of your crewmembers. You must be master of yourself before you can control others.

### THE FINE LINE

As supervisor, you must draw a fine line in your relationship with your crew. Do not assume a false dignity; but at the same time, the old "buddy-buddy" relationships that you used to enjoy are no longer appropriate. Drawing this

fine line is one of the most difficult parts of the job of a new supervisor, but it must be drawn. As a First Class Petty Officer who is the shop supervisor or crew leader, you have a difficult job in drawing this fine line, especially when on battalion duty. You wear the same uniform, and in many cases eat and sleep with your subordinates. You also attend the same clubs, but you must insure that your subordinates understand that your general conversation in the relaxed atmosphere of the club and your comments on the job carry different weights and have different values. This does not mean that as a supervisor you have free rein to act 180° opposite of the way you act in the shop, but it does allow you to relax some. To maintain balance, ask your crew for advice and help rather than give the impression that you know it all. Let the crewmembers know that you have confidence in them; maintain a friendly but conservative attitude; treat them alike; be consistent; and set a good example yourself.

### SUPERVISORY DUTIES AND RESPONSIBILITIES

Specific duties and responsibilities can be listed for a specific position only. However, here are some that are typical:

1. Getting the right person on the job at the right time.
2. Using and placing materials economically.
3. Preventing accidents and controlling hazards.
4. Keeping morale high.
5. Maintaining quality and quantity of work.
6. Keeping records and reports.
7. Maintaining discipline.
8. Planning and scheduling work.
9. Training your crewmembers.

10. Procuring the tools and equipment to do the work.
11. Inspecting, caring for, and preserving tools and equipment.
12. Giving orders and directions.
13. Maintaining liaison with other units.
14. Checking and inspecting jobs and crewmembers.
15. Promoting teamwork.
16. Maintaining good housekeeping on the job.
17. Keeping operations running smoothly and efficiently.

This list of typical duties and responsibilities shows that the following factors are common to all supervisory positions:

1. Production.
2. Safety, health, and physical welfare of the crew.
3. Development of cooperation.
4. Development of morale.
5. Training and development of subordinates.
6. Records and reports.
7. Balanced supervision.

### PRINCIPLES OF LEADERSHIP

Supervision or leadership is an art. It requires the ability to organize, delegate, and coordinate which you, the supervisor, should apply daily on the job. You can learn to organize, delegate, and coordinate in the same way you learn any other art. Developing this art is a continuing process.

Military leadership is NOT inborn; it becomes a matter of understanding and applying sound leadership principles and techniques, as given below.

1. Be technically and tactically proficient.
2. Know yourself, and seek self-improvement.
3. Know your personnel, and look out for their welfare.
4. Keep your personnel informed.
5. Set an example.
6. Insure that the task is understood, supervised, and accomplished.
7. Train your personnel as a team.
8. Make sound and timely decisions.
9. Develop a sense of responsibility in your subordinates.
10. Employ your crews in accordance with their capabilities.
11. Seek responsibility, and take responsibility for your actions.

### ORGANIZE

As a supervisor, you must be able to organize. This means that you should be able to analyze the requirements of a job and plan the sequence of events that will bring about desired results.

You should be able to look at a job and estimate how many man-hours are required to complete it; you will probably have been given a time by which the work is to be completed. Next (or perhaps even before making your estimate of man-hours), plan the sequence of repairs. Make sure that you also know the answers to the following questions. What is the size of the repair? Are the parts on hand? What tools are available, and what is their condition?

Before assigning work, carefully consider the qualifications of your personnel. Are they experienced, or do they need training? Are any scheduled for leave? Will you need to request outside support? After getting answers to these questions, you should be able to assign your crews and set up tentative schedules. If work shifts are necessary, arrange for the smooth transition from one shift to another with a minimum of work interruption. How well you do so is directly related to your ability to organize.

### **DELEGATE**

A supervisor must know how to delegate. As stated earlier, failure to delegate is common in a new supervisor. It is only natural to want to carry out the details of a job yourself, particularly when you know that you can do them better than any of your subordinates. Trying to do too much, however, is one of the quickest ways to get bogged down in details and to slow down a large operation. As a shop supervisor, you may have crews working in several different places. Obviously, you cannot be in two places at the same time. There will be times when a crewmember needs help or instruction on some problem. If the crew has to wait until you are available, then time will be lost. It is important, therefore, to delegate crew leader authority to one of your crewmembers to make decisions in certain matters. Here, knowledge of your personnel is important. Some people can handle responsibility well; others cannot. You must know who can make sound decisions in your absence and who cannot. But remember, although you are allowed to delegate authority, you are still responsible for the complete repair job.

### **COORDINATE**

A supervisor must be able to coordinate. When several repairs are in progress, plan them so one can follow another without delay. It also helps to work closely with your sister companies.

Coordination is not limited to projects only. You would not want to approve a leave chit for one of your crewmembers then remember a

school during the same time period, nor would you want to schedule a crewmember for the rifle range only to find that the range coaches will not be available at that time.

### **SUPERVISORY RESPONSIBILITIES**

An effective supervisor has direct contact with and direct control over the individuals who produce the work. In this regard, the major duties and responsibilities of the supervisor include production; safety, health, and physical welfare of subordinates; development of cooperation; development of morale; and training of subordinates.

### **PRODUCTION**

The primary responsibility of every supervisor is PRODUCTION. You can produce best by (1) planning and organizing the work to get maximum production with minimum effort and confusion, (2) delegating as much authority as possible, but remaining responsible for the final product, and (3) continuously supervising and controlling to insure that the work is done properly.

### **SAFETY, HEALTH, AND PHYSICAL WELFARE OF SUBORDINATES**

Safety and production go hand in hand, since the only efficient way to do anything is the safe way. When your personnel are absent because of injury, your shop equipment is down because of damage, or completed work is destroyed by accident, production is sure to fall. Therefore, you must teach safety constantly and set examples by always observing safety precautions. Teach safety as part of each training unit, and plan each job with safety in mind.

Showing concern for the health and physical welfare of your subordinates will also help increase production. Remember that a healthy worker is more efficient than one who is not. Besides, your concern for these matters is bound to increase the respect your subordinates have for you and should motivate them to produce more.

## DEVELOPMENT OF COOPERATION

You can best get the members of your crew to cooperate by willingly telling them the whats and whys of their work. It also helps to develop cooperation among the crewmembers by training them to prepare for increased responsibilities and teaching them new skills.

It is essential that you cooperate with your seniors on the project and in the battalion. You can do so by continually informing them of circumstances which (1) require their decisions or other actions, and (2) what would be unknown to them unless you passed the word. It is often the case that what you, and perhaps your crews as well, imagine to be the indifference of your seniors is actually a result of your NOT keeping them informed.

## DEVELOPMENT OF MORALE

Morale may be defined as an individual's, a team's, or a unit's state of mind. It depends upon their attitude toward everything that affects them—their fellow SEABEES, their leaders, Navy life in general, and other things which seem important to them.

Morale is closely related to satisfying a person's basic human needs. If the training, administration, and everyday routine of a unit is conducted to assist in satisfying the crewmember's basic needs, a favorable attitude will be developed. High morale is a positive state of mind which gives individuals a feeling of confidence and well-being that enables them to face hardship with courage, endurance, and determination.

Morale does NOT remain the same; rather, it is constantly changing. Morale of your crew is an index to the effectiveness of your leadership abilities. You can measure morale by closely observing crewmembers in their daily activities, by inspections, by formal and informal interviews, and by evaluating reports. Specific things to watch for include appearance, personal hygiene, military courtesy, personal conduct, use of recreational facilities, excessive quarreling, harmful or irresponsible rumors,

condition of mess and quarters, care of equipment, response to orders and directives, job proficiency, and motivation during training.

When properly evaluated, administration reports concerning the status of personnel aid in measuring morale. Particularly valuable are reports which concern the following: military or civil arrest, damage to or loss of equipment through carelessness, family problems, indebtedness, malingerers, absence without leave and desertion, requests for transfer, self-inflicted wounds, sick call rate, stragglers, and reenlistment rates.

## TRAINING OF SUBORDINATES

The training program of each battalion is formed to provide the personnel with the skills needed to accomplish the battalion's current and mobilization mission. The program covers many phases—from orientation courses to special technical courses. Extent of the training depends on operational commitments; policies and directives from higher authority; experience and previous training of the personnel; training facilities available; and other factors. Although much of the construction training will be provided by class A or C-1 schools, as well as special SEABEE training courses, additional skills and experiences must be acquired in the battalion.

As a supervisor, you must emphasize training of your personnel. At the same time, impress upon them the need to use correct terminology or technical language common to the Construction Mechanic rating. In so doing, they should learn more readily and also retain a more detailed picture of the functions and operations of their jobs.

## HINTS ON PLANNING

In planning, you determine requirements and devise or develop methods and schemes of action for constructing a project. In addition to day-to-day planning, consider the following primary matters in construction: work element estimates, material estimates, equipment



estimates, manpower estimates, plant layout, material delivery and storage, work schedules, and progress control. They depend more or less upon each other and all are part of any well-planned project. The success of any project depends to a great extent upon the amount of detail and the care taken in planning it.

Proper planning saves time and money, makes the work easier and more pleasant for your crews, and expedites the work. It can eliminate friction, jealousy, and confusion. It can free you from many of the details of the work, thus giving you time to carry out other important duties. Also, it eliminates "bottlenecking," (remember that the neck of the bottle is always at its top).

As the petty officer in charge of a crew, you are responsible for the time of your crewmembers as well as your own. You must plan so that they will be kept busy doing constructive work. Remember to PLAN AHEAD. Having the crewmembers stand around idle each morning while you plan obviously would be a waste of manpower. At the close of each day, you should confirm planning for the next workday. In doing so, you may need answers to questions that bear on the availability and use of manpower, equipment, and supplies.

1. Manpower. Who is to do what? How is it to be done? When is it to be finished? Knowing that idleness may breed discontent, have you arranged to have another job ready for starting as soon as the first one is finished? Is every crewmember fully utilized?

2. Equipment. Are all necessary tools and equipment on hand to do the job? Is safety equipment on hand?

3. Supplies. Are all necessary supplies on hand to start the job? If not, who should take action?

Have a definite work schedule and inspection plan. Set up goals or quotas for the day. Have a definite plan for personally checking at intervals to see that the work is being done and that the goals are going to be met. Spot check for

accuracy, workmanship, and the need for training.

CM's must be trained to do a variety of jobs by means of the rotation method, on-the-job training, or classroom work. Allow time for the training in planning for a job.

Allow time too for handling personnel problems and military duties, and time for records, reports, and other paperwork necessary for the control of personnel and materials under your charge.

### DAILY WORK ASSIGNMENTS

How to assign work. On a rush job, you may have to assign the best qualified person available to insure meeting the deadline. When time and workload permit, rotate work assignments so that each crewmember can acquire skills and experience in different phases of the mechanic's job. Also, the work becomes more interesting for the crewmember. Another good reason for rotating work assignments is to prevent one person from doing all the work of a certain type. What would you do if that person is transferred or hospitalized or goes on leave for a long time?

Give special consideration to strikers in job assignments. Bring them along gradually before assigning them to a hard or complicated job. Use them as assistants first. Do not expect them to fully understand the different phases of the job until they have worked on the basic tasks.

Be sure to give a worker all the information it takes to do the job. An experienced worker may need only a general statement concerning the finished product. A less experienced worker is likely to require more detail.

Sometimes, you may want to put more workers on a project than it normally takes. Do so only when it will speed completion of the project. Remember, there is a limit to the number of workers you can put on the job at a given time. Having too many workers can slow down the project instead of speeding it up.

## SITE DEPLOYMENT OF MATERIALS AND EQUIPMENT

When moving into a new location, you will have to locate material and equipment in and around the shop. Although design of the shop was determined in advance of the move, exact locations of shop equipment are left up to you.

### STOWAGE OF MATERIALS

Material required to operate an efficient maintenance organization should be located where it is convenient to most of its users. Its frequency of use, security, and bulk must be known before you can set up new locations. Are materials that go together stored together? Have you considered safety?

#### Repair Parts

When an NMCB deploys, its repair parts are in prepackaged mount-out boxes. The parts are already inventoried and the boxes kept in numerical sequence. Your main concern is to store them efficiently. It stands to reason that the most often used items (Modifier 97), should be kept near the issue area. For mount-out purposes, when possible, organic and augment repair parts should be separated.

Be sure to retain and preserve the mount-out boxes and lids. Avoid cutting the retaining bands. Replacing lost boxes or lids and bands is expensive and time consuming in case a complete unit mounts out or moves.

#### Paints and Lubricants

Paints and lubricants are inventoried by the supply department. However, you are responsible for storing those in use or drawn in large quantities. Storing lubricants properly includes taking steps to prevent fire or contamination by water. Paints should be stored away from flames. Provide a fire-resistant area for paints stored inside a building. A well-constructed metal CONEX box is generally suitable for small quantities. Good housekeeping practices can help avoid accidents or fires.

## STOWAGE OF TOOLS AND EQUIPMENT

Tools not permanently mounted as shop equipment should be kept in the shop's central toolroom to allow for an accurate inventory, proper cleaning, repairs, and stowage. When not in use, jacks, safety stands, and creepers should be removed from the working areas to reduce accidental damage to tools and injury to personnel.

Toolkit mount-out boxes should be retained and maintained by inventory for re-use during mountouts. Tool inventories are normally conducted on a biweekly basis. They include shop equipment and complete kits in the custody of the mechanics or the toolroom. Other tools are available to the mechanics through the battalion central toolroom and from kits not normally assigned to "A" company. Civil Engineer Support Office (CESO) has established a National Stock Number breakdown in NSN sequence of Sets, Kits, and Outfits (SKO) to aid the supervisor in identifying, inventorying, and ordering individual items within kits.

Safety and preventive maintenance inspections of power tools are conducted through the unit's central toolroom and are the responsibility of the support section supervisor. Maintenance of shop tools is scheduled as prescribed by the manufacturer. Daily maintenance is conducted by assigned shop personnel. Weekly, monthly, and quarterly services are performed by support shops personnel.

### HANDLING GASES

Gases normally used by Construction Mechanics include oxygen, acetylene, MAPP-gas, helium, and butane. Oil and grease must NOT be allowed to come in contact with gases; if so, they will explode or burn out of control.

Compressed gas containers will be segregated, stowed in the manner prescribed, at specific distances from each other, and working areas. *Safety Precautions for Shore Activities*, NAVMAT P-5100 provides the guidelines for stowing and handling compressed gases.

## HANDLING FUELS

Fuels may be stored in underground tanks, fuel bladders, or properly equipped fuel tankers. The method of disbursing fuels depends on whether the site is temporary or not. At a temporary site, drummed fuels may be used. When selecting a fueling site, consider the accessibility of vehicles requiring fuel. Tracklaying equipment and automotive equipment are usually fueled in separate areas to avoid congestion.

## HANDLING TIRES

Ready-to-issue tires are drawn from supply and stored in the repair area. Do you know how many to get? That depends on several factors, including the number, size, and type of tires on the ground; the type of operations underway; and operating conditions. Keep ready for issue enough tires of each type to prevent long delays at the tire shop. The fewer kept, the easier it makes your inventory of unmounted tires.

When removed from active vehicles in a tactical unit, spare tires are identified and maintained so they can be remounted during mountout. They are NOT part of the ready-to-issue stock. Where possible, store unmounted tires in a covered rack to prevent them from collecting water, oil, and other foreign matter. Or put them on pallets (according to size) and cover with canvas to prevent dry rot and weathering. Either way, they can be maintained at low cost and inventoried quickly and accurately.

Not all personnel assigned to work at the tire shop are mechanics. Nor are they experienced in tire repairing and stowage since rotation into other assignments are frequent. In any shop where this is the case, supervise the workers closely and make sure they work safely to avoid injury.

## AIR POLLUTION CONTROL

As a Construction Mechanic, you work in or around many things that contribute to air

pollution; for example, vehicle exhaust gases, paint booths, parts washers, and spray cans. As a result, you are in a position to play an important part in controlling air pollution.

## FUEL COMBUSTION

Unburned gases and biproducts of burning fuels are emitted from the exhaust systems of automotive vehicles. The amounts omitted are less in properly maintained and tuned vehicles that are equipped with emission control systems. As supervisor or inspector, you must make sure that these systems work properly. Also, you are responsible for removal of exhaust fumes from the working areas. Heavy fumes can be removed by cross ventilation or properly placed pedestal fans. The preferred means of removing exhaust gases is through a suction-ducting system that filters and cleanses the harmful products. Look in the *Air Pollution Engineering Manual, AP-40* for information on containing and cleansing shop emissions. Your local environmental pollution agency can assist you in maintaining standards.

## SPRAYS AND GASES

Paint spray contains heavier contaminants than exhaust gases and is controlled differently. Paint is sprayed in a well-ventilated area designed for painting, or in spray paint booths, where additional hazards are introduced unless filters and exhaust systems work properly. The painters must wear the right kind of filters or masks to protect themselves against the effects of spray painting. Since the enclosed work areas increase the potential of an explosion, all electrical connections and switches must be explosion proof.

Gases that force paint out of spray cans also pollute the air. When many cans of spray paint are used, a hood or device that sucks paint fumes into the ventilation system is needed.

Hoods and exhaust fans should be installed at the parts washers. Fans combined with cross ventilation will help protect the workers. However, fumes must NOT be exhausted into other work spaces.

## FUEL SPILLAGE

When spilled in the shop, fuels are hazardous. They cause fires and accidental falls and they contaminate air and water. Small spills can be cleaned with sorbents that must be properly disposed of. Good housekeeping means fewer accidents.

### BULK FUEL SPILLS

Controlling fuel spills that occur on and near water means having to clean the contaminated beaches usually with sorbents. Sometimes, parts of a beach must be removed. But that depends on the kind of fuel spilled and the extent of contamination.

If in charge of the cleanup, you will provide the sorbents and the personnel to clean up the spill. Sorbents may be natural or modified natural products, such as straw and clays. Or they may be made of synthetic material, such as polymer, resin, or rubber. Sheets or pads of polyurethane foams are the most effective. Foams are more expensive to manufacture. However, they are reusable after treatment in most cases.

The amount of oil absorbed will vary with the nature of the oil. Straw, for example, is most effective with bunker fuel oil and least effective with gasoline or JP-4 type fuel. After use, sorbents are picked up and hauled to disposal sites.

For more on containing and controlling fuel spills, refer to *Oil Spill Control for Inland Waters and Harbors*, NAVFAC P-908 or your local environmental pollution agency.

## STATION FUEL SPILLS

Spills at fueling stations are normally smaller than bulk fuel spills. They may be absorbed with sand or oil dry-type sorbents. These sorbents must be properly disposed of also.

Fueling spills spells fire! Hosing the affected area with water will dilute the fuel to a degree, but also spread the fuel over a larger area. Fuels may contaminate water systems as well as sewer systems. Should a large quantity of volatile fuel enter a sewer system, notify proper authorities.

Oil drums at fueling stations used by the Equipment Operators must have a catch trough for spillage. Oil caught in this way is placed in a container for waste oil. Waste oil from service stations, shops, and lubrication areas are disposed of by re-refining when possible.

Using waste oil as a dust or weed control agent is prohibited, because this oil often washes into water systems during heavy rains. Burning of waste oil contributes to air pollution and is a no-no. Re-using or burning waste oils is allowed in large power plants which can separate contaminants or blend the waste with fuel properly.

### FIELD REPAIR SPILLS

Field repair personnel are responsible for collecting oils and fuels drained during repair operations. Spilled lubricants penetrate the soil and could reach the ground water table. Contaminating the ground water table may harm local drinking water. Immobilize a ground spill by adding dry soil which soaks up the spill. To prevent contamination of the water table, collect the waste lubricants and return them to a collection point for disposal.

## CHAPTER 3

# PW TRANSPORTATION SHOPS SUPERVISOR

A good supervisor must possess a large amount of TACT and DIPLOMACY. Directing shop activities requires that you contact all types of people; i.e., the mechanics who work for you, the personnel (military and/or civilian) who operate the equipment, and the officers (or civilian) to whom you are responsible. You must be very careful not to let prejudices interfere with your good judgment.

A good transportation maintenance shop supervisor will need all of his past experience. Experience shows up in diagnosing mechanical troubles accurately, scheduling and planning repair work skillfully, using all kinds of repair equipment, and directing the many activities in maintaining transportation and earthmoving equipment.

At sometime during your career in the Navy, you may be assigned as a foreman in a Public Works (PW) Transportation Maintenance Shop. You may also have to serve as supervisor of a Construction Battalion Equipment Maintenance Shop. Because of the variation in the two different types of duty, the responsibilities of a foreman in a PW transportation maintenance shop will be discussed in this chapter and the battalion equipment company shops supervisor's responsibilities will be discussed in the following chapter. Although many of the positions have the same basic duties, the methods of doing the work may differ considerably. Certain areas of cost control vary a great deal. Duty in a transportation maintenance shop includes work of a continuing nature. Therefore, to provide continuity, civil service personnel are also employed.

## PW TRANSPORTATION DEPARTMENT ORGANIZATION

A PW transportation department of a naval shore facility is generally stationary. As a supervisor in the PW maintenance branch, you would probably not have to plan and construct a new transportation shop, but would supervise the repair of equipment. However, if you are involved in the establishment of a new base, you will probably be consulted about the location and layout of the maintenance shops. Detailed information on the physical layout of the buildings can be obtained by referring to *Naval Facilities Planning Guide*, P-437. The location of tools and shop equipment will depend on the amount and type of equipment to be maintained.

The PW transportation organization discussed in this chapter will be typical of the type usually found within a public works activity. The titles and organization may vary from activity to activity. To learn more about these organizations, you should obtain and study current NAVFAC instructions and publications which pertain to the public work centers and public work departments. By referring to figure 3-1, you can see that the Transportation Division is broken down into two branches—Operations Branch and Equipment Maintenance Branch. Note that both come under the control of the transportation division director who reports through a chain of command to the Public Works Officer (PWO).

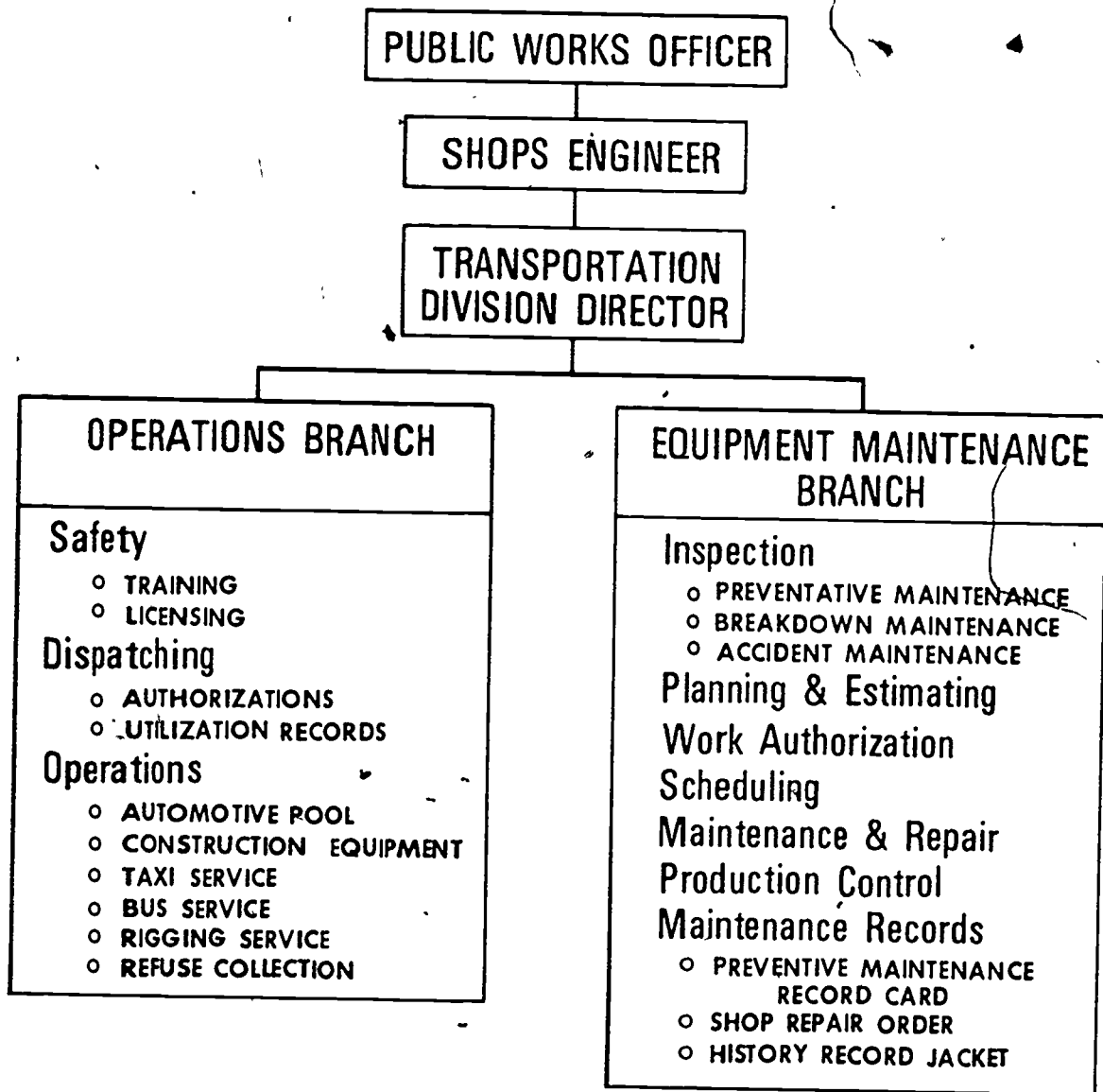

Figure 3-1.—Functional organization for transportation management.

**DUTIES AND RESPONSIBILITIES OF SUPERVISORY PERSONNEL**

This phase of our discussion deals with the duties and responsibilities of various supervisory personnel within the maintenance branch. Remember that these duties and responsibilities will vary from activity to activity. The individual assignments will depend upon the needs of the

activity and the skill and experience of personnel available. The Public Works Officer makes the final decision.

**TRANSPORTATION DIVISION DIRECTOR**

As head of the Transportation Division, the transportation director exercises full technical,

managerial, and administrative responsibility for organizing, directing, and controlling the work of the division. The director also functions as the technical advisor within and outside the activity in planning and procuring vehicle/equipment requirements for the activity and other supported customers.

The transportation director exercises complete managerial responsibilities for the efficient, economical, and timely administration of the divisions; directs operations assignments; manages scheduled preventive maintenance as well as repair/overhaul; and is charged with the requisition and disposition of automotive vehicles, construction, materials-weight handling, and miscellaneous specialized equipment.

#### **MANAGER OF THE EQUIPMENT MAINTENANCE BRANCH**

The manager of the maintenance branch is responsible for planning, work direction, administration, and acts as, and assumes the duties of, the transportation director in case of absence. The maintenance branch's responsibilities include:

1. Timely preparation and submission of the maintenance division fiscal financial budget.
2. Scheduling of work for subordinate supervisors and planning for the efficient use of materials and equipment.
3. Organizing, coordinating, and directing the work activities of personnel and units supervised.
4. Maintaining a balanced workload for subordinate work units by shifting personnel effectively among the units.
5. Coordinating the work in areas of responsibilities with other activities and department/division supervisory personnel to maintain a balanced scheduled workflow.
6. Reviewing and analyzing production, cost, and personnel utilization records to evaluate the progress of work and to control or reduce costs.

7. Reviewing completed work records (Shop Repair Order, NAVFAC Form 9-11200/3A, in figure 3-2) and other computer reports to assure that production and quality standards are met.

8. Inspecting the shop areas periodically, and checking safety conditions, cleanliness, security, requirements for materials, and shop equipment.

9. Acting on any personnel matter concerning subordinates and assisting in the resolution of grievances referred by subordinate supervisors.

10. Promoting safety programs within the immediate organization, and reviewing the safety performance of the supervisors, and initiating corrective action as required.

11. Seeing that progress, production, cost, and other records are prepared, maintained, and consolidated.

12. Developing training programs for employees and subordinate supervisors.

#### **PRODUCTION CONTROL SUPERVISOR**

The production control supervisor is responsible for receiving, inspecting, and classifying, within applicable Navy codes, all new and used equipment, preparation of reports on equipment received; scheduling equipment into the shop for its first servicing; and arranging for its inclusion into the preventive maintenance program. Additionally, the production control supervisor determines parts and tools required to support equipment during its life cycle; directs the inspection of vehicles coming into the shop to find the nature and extent of repair or preventive maintenance service required; and determines the most economical means and methods of repairs. The production control supervisor applies standard hours and cost estimates on individual equipment jobs; initiates shop repair orders; and schedules work into the various work centers/shops for orderly accomplishment. Finally, the production control supervisor directs the inspection of the mechanics' work while in progress; insures a quality inspection upon completion of this work; and directs the

# CONSTRUCTION MECHANIC 1 & C

SHOP REPAIR ORDER										PAGE	OF	111. 500 NUMBER	112	112. JOB ORDER NUMBER	113. USER NUMBER				
3. EQUIPMENT DESCRIPTION <b>PANEL TRK</b>										10. MAKE <b>GHEV</b>		11. MODEL <b>C 1404</b>		12. YEAR <b>66</b>		13. EQUIP CODE <b>0313</b>		14. DOD ALPHA <b>G</b>	
4. ACTIVITY <b>ELEC SHOP</b>										15. PHONE NUMBER <b>6342</b>		16. LAST A TIME PM <b>11, 110</b>		17. LAST B TIME PM <b>13, 270</b>		18. LAST C TIME PM <b>8, 890</b>		19. ACCU MILES NOS <b>2, 340</b>	
TO BE COMPLETED UPON EQUIPMENT AVAILABILITY FOR MAINTENANCE REPAIR										15. IN TIME DUE <b>50</b>		16. IN DATE DUE <b>C 1/24</b>		17. OUT TIME <b>15, 610</b>		18. PRESENT METER READING <b>15, 610</b>		BLOCK (14) REPRESENTS ACCU MILES/HRS SINCE LAST PM	
19. WORK GENERAL (Check applicable box) <input checked="" type="checkbox"/> 1. SCHEDULED <input type="checkbox"/> 2. INTERIM <input type="checkbox"/> 3. BREAKDOWN <input type="checkbox"/> 4. ACCIDENT <input type="checkbox"/> 5. OTHER										20. WORK PERFORMANCE <input checked="" type="checkbox"/> 1. OWN M/T EQUIP <input type="checkbox"/> 2. COST EBU <input type="checkbox"/> 3. OTHER GOVT SHOP <input type="checkbox"/> 4. OWN CONT		21. REPAIRED BY							
MATERIAL RECORD										120. WORK DESCRIPTION		121. WEEK							
22. QTY	23. DESCRIPTION	24. MPG PART NO	25. AMOUNT	26. WAGE CTD	27. LCC	28. STD	29. ACT	30. WORK DESCRIPTION		31. WEEK									
1	SET POINTS	1954457	1.12	60	10	0.6		LUBE CHASSIS SERVICE AIR CLEANER AND BATTERY		GA									
1	CONDENSOR	1928111	.42	60	10	0.5		CHANGE MOTOR OIL AND FILTER CARTRIDGE		GA									
	FSN 9N-5910-644-6204							REPLACE BATTERY (CLEAN TERMINAL AND BOX)		GA									
6	SPARK PLUGS	AC-47	2.22	60	10	0.5		ADJUST BRAKES & CHECK FLUID LEVEL		GA									
1	OIL FILTER	5578052	.63					TOTAL ACTUAL { R/R IGN POINTS & CONDENSOR R/R SPARK PLUGS ADJ-DWELL, TIMING, CHOKE & IDLE R/R TWO WIPER BLADES		GA									
1	AIR CLEANER REPL CART	5648136	3.06	60	10	1.5				GA									
1	HEADLIGHT ASSY	5954670	6.75							GA									
2	WIPER BLADES	AC-12"	1.44	60	10	0.2				GA									
							3.3	3.4											
1	TIRE	650x16-48R	25.89	60	35	0.5	0.4	R/R L REAR TIRE		NM									
	FSN 2G10-720-2244																		
				62	19	4.8	7.8	REPLACE DAMAGED HEADLIGHT ASSY AND REPAIR LEFT FRONT FENDER & PAINT		GA									
32. PERSONNEL (Regn. Numbers)										33. TOTAL AMOUNT \$		34. TOTAL HRS		35. TOTAL COST					
										41.53		8.6		11.6					
36. WORK A. 100-210 Inspector's Signature: <b>E. G. McLoe</b>										37. DATE <b>1/24/7-</b>		38. CONTRACTING FIRM		39. LABOR (MAINT) HRS + \$		40. LABOR (OPER) HRS + \$			
36. WORK B. 100-210 Supervisor's Signature: <b>E. H. Barnes</b>										37. DATE <b>1/24/7-</b>		SIGNATURE		41. MATERIAL \$		42. OTHER \$			
														43. TOTAL COST \$					

Figure 3-2.—Shop Repair Order, NAVFAC Form 9-11200/3A.

2.466

maintenance of PM records, shop backlog records, and vehicle history files.

## MAINTENANCE AND REPAIR FOREMAN

The foreman of Maintenance and Repair Shop supervises subcenters, such as the body and paint shop, battery shop, tire shop, toolroom, and lubrication shop. Responsibilities of the foreman include:

1. Establishing priorities and sequences in which scheduled workloads will be accomplished, primarily on a day-to-day/job-by-job basis.

2. Analyzing and interpreting shop repair orders, work requests, and other work documentation and specifications to determine work requirements.

3. Assigning work among subordinates and providing specific material requirements.

4. Consulting with higher authority and staff personnel to make sure that appropriate tools, materials, and equipment are available as needed.

5. Requesting and coordinating the services and work of other shops when required.

6. Assigning work by written or oral orders.



7. Assisting in the training of subordinates in work methods, procedures, and the operation of tools and equipment, both new and already in use.

8. Certifying that the work is efficient and economical and that the work is performed safely.

9. Anticipating operational problems and acting to overcome delays.

10. Directing and recommending changes in shop layout to improve efficiency.

11. Insuring that subordinates houseclean.

12. Issuing and enforcing safety practices and fire regulations.

13. Checking attendance and leave of subordinates and other personnel matters.

### **CONSTRUCTION AND SPECIALIZED EQUIPMENT SHOP FOREMAN**

The foreman of the Construction and Specialized Equipment Shop supervises the machine shop as a subcenter. The responsibilities are basically the same as those given under maintenance and repair foreman, except for the technical supervision. This shop is responsible for the maintenance, repair, and major overhaul (mechanical and electrical) of specialized equipment, such as tractors, graders, ditchdiggers, bulldozers, road rollers, asphalt machines, farm tractors, jet starters, auxiliary power units, emergency generators and pumps, and aircraft tow-tractors.

The machine shop bores cylinders; rebuilds all types of gasoline and diesel engines, automatic transmissions, and differentials; and performs other related repairs.

### **PREVENTIVE MAINTENANCE**

The most important phase of the maintenance system is scheduled, periodic preventive, maintenance (PM). PM is the

systematic inspection, detection, and correction of potential equipment failures before they develop into major defects. The purpose of PM is to keep equipment in safe and reliable condition, with maximum equipment availability and minimum cost of maintenance.

Operators are the first line of defense against equipment wear, failure, and damage. Equipment must be inspected by the operator daily—before, during, and after operations so that defects or malfunctions can be detected before they result in serious damage, failure, or accident.

It is your responsibility, as a CM1 or CMC, to see that the operators are performing their duties. You should work with the operations branch in making recommendations regarding operators' PM. Changes may be necessary in the operators' PM to cope with certain operating conditions. You may need to set up classes of instruction for the operators so that they will become familiar with the right way to maintain their equipment, especially when new equipment is received in the activity. If you do set up classes, be sure to coordinate your training periods with the foreman in charge of the equipment operations branch so that you do not interfere with the foreman's equipment operating schedules. Also, try to have the equipment on hand so you can point out maintenance services that need attention. It is better to hold the instructions with small groups and to keep them as informal as possible. Do not forget to stress operator maintenance on the overall operating efficiency of the equipment.

### **SERVICE STATION PREVENTIVE MAINTENANCE**

Service station PM is what you would expect from any first-rate filling station when you purchase fuel; namely, washing the windshield, checking the oil, battery and radiator water, fan belt, tire conditions, etc. Unfortunately, shortages of personnel have sometimes curtailed this type of maintenance. Service station PM is a "visible" area of public works, but is not intended to relieve the operator of his responsibility.

## SAFETY INSPECTIONS

Vehicles will be inspected periodically by qualified automotive inspection personnel for safety as follows:

Each motor vehicle will be inspected for safety at intervals not to exceed 6 months or 6,000 miles, whichever occurs first. To avoid unnecessary downtime, the safety inspection will be performed at the time of the scheduled serviceability inspection in accordance with the manufacturer's recommendation. This safety inspection will include all the items listed below. All deficiencies uncovered during the safety inspection that affect the safe operation of the vehicle will be corrected before the vehicle becomes operational again.

### 1. Brakes

a. Test to see if brakes are in good working order.

b. Check brake pedal free travel as required.

c. Remove front and rear brakedrums; inspect lining for wear or cracking; inspect lining for excessive wear; and check wheel cylinders for leaks and deterioration.

d. Check fluid level and all hydraulic brake lines for leaks.

e. On airbrake systems, inspect airbrake accessories, all air lines, and air tanks for leaks and deterioration; check airbrake instrument controls, air valves, trailer hose, and glad hands.

### 2. Lights

a. Check all lights, signals, and reflectors.

b. Check condition of trailer jumper cable.

c. Check headlights for proper alignment.

### 3. Instruments, Controls, and Warning Devices

a. Check all instruments, gages, mirrors, switches, controls, horns, and warning devices for function and damage.

### 4. Exhaust System

a. Check muffler, exhaust, and tailpipe connections for leaks.

### 5. Steering System

a. Check all steering devices and linkage for wear and damage.

### 6. Seat Belts

a. Check all safety belts for wear and correct mounting.

### 7. Fifth Wheel and Trailer

a. Check fifth wheel mounting bolts or clamps, and the operation of the safety lock.

b. Check trailer kingpin for wear or damage.

c. Check towbars, tongue sockets, and safety chains.

### 8. Tires

a. Check all tires for damage and excess wear.

b. Remove and replace all tires showing 1/16 inch or less of tread.

c. Check wheel lug nuts for tightness.

### 9. Windshield Wipers, Glass, and Defrosters

a. Check wipers, glass, and defroster for operation, wear damage, and deterioration.

## UNSCHEDULED MAINTENANCE SERVICE

Unscheduled maintenance service is the correction of deficiencies reported by the vehicle operator that occur between scheduled safety or other inspection and services prescribed by the manufacturer. Unscheduled maintenance services will be limited to correcting only those items reported as deficient by the operator and confirmed by qualified inspection personnel. Unreported deficiencies observed by the inspector at an unscheduled service and, in particular, those affecting safety will be corrected prior to releasing the vehicle for service.

## COST CONTROL

The Navy's cost control system is designed to obtain complete cost data on maintenance and operation of automotive, construction, firefighting, railway, weight-handling and materials-handling equipment. Actual performance of maintenance work is compared

to hourly standards for (such work, as established and published by various manufacturers and the Naval Facilities Engineering Command (NAVFAC), to determine efficiency of maintenance operations. The Navy also uses cost control to justify the performance of repairs at its activities.

### RECORDS AND REPORTS

In the cost control system, all costs accumulated in the maintenance and operation of the equipment are recorded and charged to appropriations and allotments. These costs may be direct or indirect labor or material. They may also include services provided, such as shop stores, utilities, and even building maintenance.

To evaluate performance and to assist in effective management of transportation maintenance, a series of transportation management reports has been designed which will furnish useful information to management at all levels. These reports are prepared by the accountable fiscal office from the cost records maintained in that office, and from feeder reports prepared by the transportation office. These reports provide the facts required by supervisors to pinpoint deficient areas and should be used for corrective action.

The objectives of the transportation management reports are to provide:

1. Information on the productivity of maintenance shop personnel (actual versus standard hours).
2. Data on overhead costs.
3. Comparison between activity costs and commercial costs.
4. Comparison between actual direct labor hours expended and established maintenance input standards.
5. Comparison between actual and standard maintenance costs.

Variances indicated in reports frequently require a searching review of detailed shop records to determine the causes. The individual

Shop Repair Order, NAVFAC Form 9-11200/3A, shown in figure 3-2, and the "Shop Repair Order" (Continuation Sheet), NAVFAC 9-11200/3B, shown in figure 3-3, contain all of the basic data required for this review.

A Shop Repair Order (SRO) is the transportation equivalent of the specific job order. It is initiated by the control section inspector/estimator or other specifically authorized personnel designated by the Equipment Maintenance Branch supervisor. It is the authorizing document, estimating form, and cost control record of maintenance expenditures. Repair costs are estimated in advance to insure that costs stay within economic limitations and to provide a standard against which to measure job performance and productivity of the mechanics. Estimates for transportation repairs are taken from commercial *Flat Rate Manuals* or estimating guides. Labor costs and material costs are logged on the SRO by shop personnel, and the completed document then serves as a principal source of data for transportation reports and analysis.

### DEPTH OF MAINTENANCE, REPAIR, AND OVERHAUL

The depth of maintenance, repair, and overhaul is governed by many factors, mainly economics—that is, to provide the best service available at the least possible costs.

The geographic location of an activity bears heavily on the depth of maintenance, repair, and overhaul which a maintenance shop must perform. Maintenance costs must compare with national standards. It is easy to see that an activity near a large city, where many repair services are available at commercial shops, is limited as to the type of repairs allowed. Due to the large volume of work, many of these specialized commercial shops can perform services at a reduced cost. When the commercial shop is nearby, there are no appreciable transportation or shipping costs to be added to the cost of repairs. On the other hand, an activity located a great distance from commercial sources of repair services and



areas, warehouses, or active storage. Vehicles and equipment are complex when they are being prepared for storage. All components of the equipment must be considered, as well as the basic unit, to insure efficient operation, with a minimum amount of work after storage. The objective of preservation and storage is to provide efficient and economical protection to components and equipment from environmental and mechanical damage during handling, shipment, and storage from the time of original purchase until used. NAVFAC P-434, *Management and Operations Manual For Construction Equipment Departments*, contains the standards and guides for equipment preservation.

The three levels of preserving and packaging equipment for storage are A, B, and C.

Level A is that level of preservation that will protect adequately against corrosion, deterioration, and physical damage during shipment, handling, indeterminate storage, and worldwide redistribution.

Level B is the degree of preservation and packaging which will protect adequately against known conditions less hazardous than A. Level B should be based on firmly established knowledge of the shipment and storage conditions and a determination that money will be saved. This level requires a higher degree of protection than that afforded by level C preservation and packaging.

Level C is protected adequately against corrosion, deterioration, and physical damage during shipment from the supply source to the first receiving activity for immediate use.

The proper level of preservation depends on the availability of information on the probable handling, shipping, storing units, and conditions to which the vehicles and equipment will undergo before final issue to the command. Physical characteristics of the vehicles—and equipment must also be considered.

An approved cleaning technique is a first in preservation. Any applied preservation depends

upon the quality of surface preparation. Effectiveness of an applied preservative may be measured by the quality of the surface preparation. All corrosion and contaminants must be removed before a preservative is applied.

No single cleaning method or material is suitable for all cleaning situations. The selection of a cleaning method, or combination of methods, depends on one or more of these factors:

1. Material composition of the part.
2. Complexity of construction and assembly.
3. Nature of contaminants as well as extent.
4. Amount and age of equipment.
5. Availability of cleaning materials and equipment.

Steam cleaning is suitable for removal of greases, tar, road deposits, and other contaminants. This process is particularly adaptable to parts other than the ENGINE and GEARCASE EXTERIORS of vehicles and equipment that ordinarily would not be disassembled before preservation. Engines and gearcases should be cleaned by spraying with a degreasing solvent, by allowing for solvent penetration, and, finally, by flushing with a clean petroleum solvent or by wiping with a clean cloth.

Active storage means that complex equipment is maintained in serviceable condition by operating all components for brief periods at regularly scheduled intervals. When lubricants are redistributed, friction is reduced and deterioration is prevented or reduced to a minimum. Only unboxed automotive and construction-type equipment is included in the active storage program.

Material preserved and packaged for storage or shipment requires depreservation and servicing prior to use. Equipment must be

## CONSTRUCTION MECHANIC 1 & C

lubricated under the manufacturer's instructions. Seals and closures should be removed. Housings, casings, and other enclosures should be drained of preservatives and refilled with specified operating fluids prior to operation. Those components that were removed for storage should be reinstalled.

Upon activation, in equipment containing piston-cylinder components—such as internal combustion engines and air compressors—rotate the crankshaft slowly with the throttle closed, ignition off, and compression release lever (if so equipped) in START position.

Avoid abrasives in removing preservatives. Remove blocking, wiring or strapping from clutch levers or pedals secured in a partially disengaged position. Adjust drive belts on which tension has been released. Flush from the system any corrosion inhibitor mixed with preservative oil.

The above procedures and methods are equally applicable to the NMCB's.

### TECHNIQUES OF SCHEDULING

An effective and efficient maintenance program requires a scheduling system and sound shop control. In accordance with *Management of Transportation Equipment*, NAVFAC P-300, equipment should be scheduled for inspection and service by time, mileage, or operating hours as recommended by the manufacturer. The schedule may be set by determining (or estimated) annual use of each vehicle and dividing by the manufacturer's recommended interval to determine the number of PM's per year for each vehicle. By dividing the number of PM's required into 252 working days per year, you will obtain the number of working days between PM's or inspection (group) for each vehicle. From this figure, a schedule can be established for a quota of vehicles to be inspected daily, or a balanced workload. Safety inspection intervals of 6 months or 6,000 miles shall not be exceeded.

Establish the daily quota of vehicles that will be scheduled for PM services during the forthcoming 6 months by ascertaining the number of vehicles that will be scheduled daily

and the number of vehicles that will be serviced on intermittent days. For instance, if there were 150 vehicles in PM Group 50, the vehicles would be scheduled at the rate of three vehicles per day (150 divided by 50 equals three vehicles per day). If there were 10 vehicles in PM Group 126, the vehicles would be scheduled at the rate of approximately one vehicle every 12 1/2 days (10 divided by 126 equals the ratio of one to 12.6 or approximately one vehicle every 12 1/2 days). The following is an example of developing a schedule of a hypothetical activity.

Example: The daily quota established for a hypothetical activity with 278 vehicles in the PM Groups listed below would be as follows:

Number of Vehicles	PM Group	Established Daily Quota
50	126	$50/126 = 1 \text{ to } 2.5$ — Schedule 1 vehicle every 2 1/2 days.
83	84	$83/84 = .99$ to 1— Schedule 1 vehicle per day.
126	63	$126/63 = 2$ to 1— Schedule 2 vehicle per day.
6	50	$6/50 = 1$ to 8.3— Schedule 1 vehicle every 8 days.
13	31	$13/31 = 1$ to 2.3— Schedule 1 vehicle every 2 1/2 days.
<u>278</u>		

These 278 vehicles in the hypothetical activity would be scheduled as illustrated. It will be observed that:

(a) Vehicles in PM Group 126 and 31 are scheduled on an alternative basis of between 2 and 3 days to compensate for the ratio of one vehicle to 2 1/2 days.

(b) Scheduling for PM Groups 31 and 50 begins on the second and fourth days respectively to balance shop workloads.

(c) Irregular intervals for PM Group 50 are arranged to balance shop workloads.

## Chapter 3—PW TRANSPORTATION SHOPS SUPERVISOR

Arrange the PM Record cards in the tub file in the daily sequence in which the PM services will be performed. Divider No. 1 represents the first day, divider No. 2, the second day, and so on.

### PROGRESS CONTROL AND CHARTING PROCEDURES

Control, positive direction of shop workloads, is achieved through current

information on direct labor available in shop work centers, backlog man-hours by work center, and man-hours assigned. One means is a transportation maintenance shop workload control board (fig. 3-4) to display the workload status of the shop/work centers. The indicator on each line can be moved across the scale to show current standard hours of backlog. This board may also show the available man-hours by shop or subcenter.

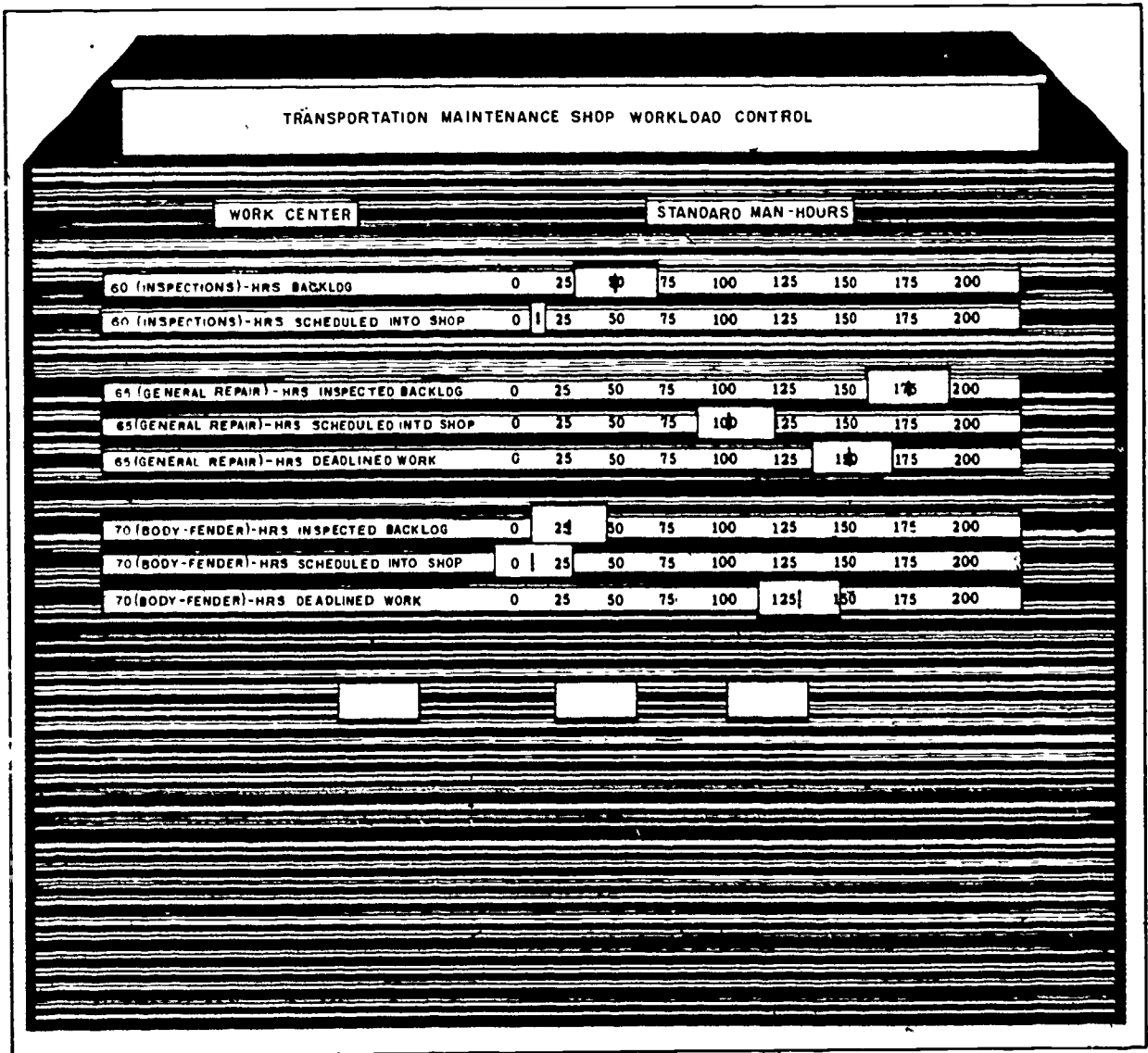

Figure 3-4.—Transportation maintenance shop workload control board.

Progress in-obtaining the most availability of safe working equipment within budget restrictions may be charted as required by local commands. Accuracy in man-hours expended and maintenance cost is essential to meaningful data. Comparison of standard hours with actual man-hours could indicate a shortage of ability, lack of training, or even shop or tool features that cause delays. When standard hours are added to induction time, you should be able to forecast an accurate completion date. Time spent obtaining repair parts may also be charted and used to determine positive or negative availability or management. Some Public Works have contracted repair parts suppliers to increase availability and reduce lead time.

### ESTIMATING PROCEDURES

The use of arrow diagrams, critical path, network analysis, and precedence diagrams will be covered in chapter 4 of this manual. Projects undertaken by a PW are recurring and fit bar chart scheduling. Bar charts are activity or time-oriented charts used to monitor and control work progress. They may indicate equipment schedules, progressing activities, and overlaps through the entire project. Since both manpower and equipment are reasonably stable in PW's, the bar chart may be used over a short or long time by management.

### EQUIPMENT ESTIMATES

The type and number of equipment required will depend upon the scope of the project. By using the manufacturer's production or standards equipment ratings and dividing into the total, you may determine the total number of loads. This figure, divided by the time available, will give you the number per time. After adjusting for distance, loading time, and unloading time, you may determine the number of units required for a project within a given time for a particular type of equipment.

Example: You have 4,000 yards of dirt to move with 5-yard-rated dumps in 20 working days. Turnaround time is 30 minutes per truck. The working day is 7 1/2 hours:

$$4,000 \text{ yards} \div 5 \text{ yards} = 800 \text{ loads}$$

$$800 \text{ loads} \div 20 \text{ days} = 40 \text{ loads/day}$$

$$7.5 \text{ hours} \div .5 \text{ hours} = 15 \text{ loads per truck/day}$$

$$40 \text{ loads} \div 15 \text{ loads} = 2 \frac{2}{3} \text{ trucks/day}$$

A minimum average of 3 trucks will be needed to move this dirt in 20 working days.

Once this figure is determined, you may adjust it as needed. Days lost due to weather might be made up with extra trucks. One truck, off the road an hour for tire repairs, would not hurt your schedule. With the bar chart to schedule vehicles, you could foresee when extra trucks could be available. Otherwise, the completion date would shift, and any other place these units are scheduled would also require adjustment. For example, the removal of dirt may affect other aspects of the project. These affects may be readily seen on a properly prepared bar chart.

### MANPOWER ESTIMATES

Manpower may be estimated like equipment. The standards for each task have been established and set in manuals, such as the *Flat Rate Manuals*. Though it is possible to bar chart each crew or individual all the way through a project, this detail becomes impractical because of vacations, sickness, or other emergencies. On numerous tasks, assigning more personnel will not increase productivity; on the contrary, this step may hinder and lead to mistakes. For instance, if you assign three more dump trucks, you must assign operators and, to assign four people to change one tire would cause wasted man-hours.



## CHAPTER 4

# BATTALION EQUIPMENT COMPANY SHOPS SUPERVISOR

In a Naval Mobile Construction Battalion (NMCB), the equipment maintenance branch is composed of four sections—administration, automotive repair, heavy equipment repair, and support. These sections come under the overall supervision of the maintenance supervisor who is normally a CMCS. As a CM1 or CMC, you may be assigned as an inspector or supervisor in any one of the four sections within the maintenance branch.

In your role as a supervisor or inspector, you will not only need to call upon all of your past experience, but also you will have to be constantly alert for new ideas and ways of accomplishing your mission within the time allotted. Of course, skillful predeployment planning is essential; but, deployments rarely go according to plans, especially with equipment maintenance. In addition to facing unusual maintenance problems not encountered at a public works duty station, you must be ready to pack your gear and mount out at any given moment.

This chapter will describe the duties and responsibilities you will be expected to perform when assigned to a section. It will cover the composition of the different sections as well as the duties and responsibilities you will be expected to perform when assigned to any one of the sections. Remember that these duties and responsibilities will vary from battalion to battalion; assignments are made by the maintenance supervisor.

One of the most important tasks is to stay abreast of developments in equipment maintenance. Here are some publications to

consult that will help you keep up to date: the *Naval Construction Force Manual*, NAVFAC P-315; *Naval Construction Force Equipment Management Manual*, NAVFAC P-404, *Naval Construction Force Safety Manual* (COMCBPAC/COMCBLANT Instruction 5100.1 series); COMCBPAC/COMCBLANT and NAVFAC Instructions 11200 series; Civil Engineer Support Office Maintenance Bulletins; Equipment Officer Technical Bulletins; and Modification Work Orders.

### SETTING UP A MAINTENANCE BRANCH

Due to the mobility of an NMCB, you will be required to assist the maintenance supervisor in planning for the location, construction, and layout of the maintenance branch.

Remember that the maintenance shops should be close to the transportation facilities. In addition, the site chosen should be large enough to allow for expansion and have a large area for parking various vehicles which are deadlined or awaiting PM's or repair. The number and types of vehicles to be maintained are important in laying out the shop. You can get more information on the physical arrangement of the buildings from the *Facilities Planning Guide*, NAVFAC P-437.

### TOOLS AND EQUIPMENT

The quantities and kinds of tools and equipment required for a maintenance shop will vary with each shop. In deciding what tools and what type of equipment to have on hand,

consider two factors: (1) the operational needs of the battalion and (2) cost of the work at a component overhaul facility. Of course, the needs of the service come first, but not entirely without cost justification. Base your decision concerning the second factor solely on the facts and figures given in transportation maintenance management reports.

In a maintenance shop set up for repairing all types of equipment, you will coordinate and supervise work on many different types; therefore, study carefully the layout of the shop and the placement of shop equipment. Decisions on where to put shop equipment will probably be yours. This is where experience counts. You should know where the repair equipment is needed and where it will be accessible to the operators who will use it. Without careful planning you can waste a lot of space and time in shifting equipment from one place to another. If space in the main shop is critical, special repair equipment can be put in smaller shops or rooms adjoining the main shop.

Power tools, such as drill presses and bench grinders commonly used in repairing all kinds of equipment, should be located in or near the main shop area. The locations of other power tools, such as hydraulic or electric lifts, valve grinders, and machines for alining wheels and relining brakes, depend on where the tools will be best utilized. The master switch that controls all power in the shop should be installed where it can be reached quickly in an emergency.

In placing power tools, secure the legs or bases to a level surface strong enough to support them and make sure they will not move or bounce when in use. Before connecting stationary, electrically operated power tools to power outlets, be sure that each one is positioned so that the starting and stopping switch is within easy reach of the operator. Ground-fault interruptors should be installed to prevent accidental electrical shock. When the connection is complete, test the tools to insure that the installation is safe. Also, let your mechanics operate them and consider any suggestions they may have for improvements. As always, make sure your tool and equipment

operators wear protective gear. Double check often, looking for ways to improve the efficiency, as well as the safety of the whole maintenance shop.

Welding equipment must be operated in an area apart from the rest of the shop. Post hazard warning signs in the area and equip it with firefighting equipment. Erect screens that will confine flying sparks in order to reduce the chances of starting fires or getting into somebody's eyes.

Tire repair equipment should also be in a separate section of the shop located near one of the shop entrances. With this arrangement, tire tools, tube-patching equipment, and airhoses can be used by the EO as readily as by the CM.

Before deciding where to place an air compressor, (the large shops have more than one), consider the uses you have for air and where the air outlets would be most convenient. Compressed air is needed for operating pneumatic power tools, cleaning parts, and inflating tires. By keeping compressor lines as short and free of bends as possible, you minimize drops in air pressure at the outlets. Short lines do not collect as much water as long lines and are therefore less likely to freeze in cold weather. When you have long lines, install condensation traps in them and drain the traps daily.

Battery-charging equipment must be in a well-ventilated section of the shop away from the welding area, or in a separate well-ventilated explosive-proof building. Because fumes of hydrogen produced by a charging battery are highly explosive, always install an exhaust fan near the battery charger. Make sure a water outlet is available because an approved eye wash and shower must be installed so that anyone involved in a battery shop accident can be bathed immediately to prevent severe burns. Delay in diluting or washing out sulphuric acid from a victim's eyes could result in loss of sight.

### SAFETY

Safety is everyone's responsibility. It is a never-ending job that cannot be left to an

individual or an office. Everyone must always be alert to accident prevention. You must emphasize safe working practices to the point where they are routine.

One of the basic rules of shop safety requires that everyone behaves himself. Practical jokes and horseplay cannot be tolerated. The possible consequences of such actions are too high a price to pay for the little humor derived.

You can help prevent accidents by appointing a shop safety petty officer to detect unsafe practices, bad habits, and defective tools that would otherwise go unnoticed. Also replace your shop safety petty officer periodically, thereby rotating these duties.

The number of personal injuries in a shop can be reduced through good housekeeping practices, for example, keeping the shop floor free of grease and oil spots to help prevent mechanics and others from slipping or falling. Likewise, clearing the floor of creepers, stray tools, and parts will eliminate the chances of tripping over them. Curing bad habits will also cut down on injuries. Crack down on bad habits, such as leaving jack handles sticking out into walkways and leaving vehicle doors open while mechanics work underneath.

### HEAT, LIGHT, AND VENTILATION

Heat, light, and ventilation for a large, permanent maintenance shop are included in the plan specification. However, the installation of these facilities in the small or temporary shop will depend on the maintenance supervisor.

Whether you will heat your shop depends upon its geographical location. Heaters should be arranged to provide warmth where it is most needed. Persons working at benches or in the shop store require more heat than men working in the main shop for comparatively short periods. For this reason, heaters are placed in corners convenient to work benches and away from shop doors.

For adequate lighting, most maintenance shops depend upon lights arranged in the overhead of the main shop, lights and windows

near the work benches, and extension lights that can be plugged into electrical outlets. When you are in charge of setting up a maintenance shop, make sure that enough electrical outlets are provided for extension lights and electric power tools. Only the most elaborate shops have enough windows for efficient lighting.

Removing exhaust gases becomes a big problem in every maintenance shop. Large doors in the front and rear of the shop, and windows at the work benches will normally supply all the fresh air needed, but even these are inadequate to remove excessive amounts of exhaust gases. These gases rise and are trapped in the shop overhead unless roof openings with ventilating fans are provided. Normally, it is up to the supervisor of a temporary shop to provide his own method of ventilation. A piece of flexible steel or neoprene hose, attached to the exhaust on a running engine, and carried outdoors through an opening in the building will serve the purpose. Do not allow any unnecessary operation of an engine inside the shop.

When stationary gasoline or diesel engines are used to produce power in the maintenance shop, provide exhaust outlets for them. Do not depend on natural ventilation through doors and windows.

### MAINTENANCE SUPERVISORS

Maintenance supervisors, usually CMCS's, have direct control over the administration section. They are responsible for the maintenance and repair of all automotive, construction, and material handling equipment assigned to the battalion or Naval Construction Force (NCF) unit. Specifically, their duties and responsibilities include:

1. Control and supervision of all maintenance personnel, through the shop supervisors.
2. Insuring adherence to the scheduled preventive maintenance program.
3. Insuring accurate cost control, record maintenance, and updating.

## CONSTRUCTION MECHANIC 1 & C

4. Submitting equipment reports to the ALFA Company Commander and the Commanding Officer for distribution to higher authority.

5. Maintaining the Construction Mechanics' tool allowance and insuring that biweekly tool inventories are conducted.

6. Providing technical and safety training.

7. Providing technical assistance to the supply and logistics officer with regard to repair parts.

8. Insuring quality control of the repair and maintenance work.

9. Insuring that the Battalion Equipment Evaluation Program is carried out under the latest instructions.

### SHOP INSPECTORS

One of the keys to a successful maintenance program is the shop inspectors. This assignment requires maturity and tact when dealing with shop supervisors who are often militarily senior. Each inspector is normally a seasoned mechanic who has the ability to locate underlying causes of failures and prescribe corrective action and is also capable of determining repairs or determining the type of PM necessary. The inspector determines which operator complaints receive immediate interim repairs and which may be delayed until the next scheduled PM inspection or service.

The inspector will conduct inspections of equipment in varied statuses. Deadlined or storage equipment inspections are equally as vital as PM or interim inspections. Acceptance inspections are the basis for warranty work or parts replacement of new equipment by the manufacturer. It is probable that claims against carriers or shipping companies will require a complete inspection, as well as possible causes of damage. Inspections of vehicles involved in accidents are often subject to legal actions. Thoroughness in inspection will prevent unnecessary downtime or rework and will clearly define what repairs are to be accomplished.

Before inspecting a piece of equipment, the inspector checks the file of the Operator's Inspection Guide and Trouble Report (fig. 4-1) and the Operator's Daily PM Report (fig. 4-2). As part of the inspection, the inspector performs minor adjustments, completes appropriate record forms and completes the Equipment Repair Order (ERO) (figs. 4-3, 4-4, and 4-5).

The ERO is delivered first to the cost control clerk for information on repair parts which have been received, or on order to prevent reorders. The ERO is then delivered to the maintenance supervisor for work approval and assignment. After repair or overhaul, the shop inspector

OPERATOR'S INSPECTION GUIDE AND TROUBLE REPORT	
REGISTRATION NO.	93-45513 11385
Use this form as a guide when performing routine and special inspections. Check off items that require servicing by maintenance personnel.	
1. LUBRICATION	
2. TIRE	
3. ELECTRICAL	
4. SAFETY DEVICES	
5. HOOD	
6. INSTRUMENTS	
<input checked="" type="checkbox"/> 7. WASH ENGINE	
8. CLEAN WASH ENGINE AFTER OP	
9. CARDS MOUNTED EQUIPMENT	
10. STEERING	
11. SAFETY DEVICES (Seat Belts, etc.)	
12. CRANE BELTS/PULLEYS	
<input checked="" type="checkbox"/> 13. BRAKES (Train and Traction when equipped)	
14. OTHER SPECIAL REPAIRS	
DATE	2-24-
INSPECTOR'S SIGNATURE	H. L. Baker
REMARKS	BRAKES SEEM TO GRAB WHEN APPLIED - NOT DUE TO WEATHER CONDITIONS.
NAVFAC 9-11240-13-12-69	

29.50

Figure 4-1.—Operator's Inspection Guide and Trouble Report, NAVFAC 9-11240/13.



Chapter 4—BATTALION EQUIPMENT COMPANY SHOPS SUPERVISOR

<b>OPERATOR'S DAILY PM REPORT</b> NAVFAC 11260/4 (9-74) Supersedes NAVDOCKS 2664 S/N 0105-LF-004-1520 Use Reverse Side for Remarks Explanatory Notes on Reverse Side.			USN NO <b>44-05178</b> <hr/> FUEL 12 <hr/> OPER MRS 3
NO	ITEM	OK	SERVICES PERFORMED
1	RADIATOR SOLUTION	✓	
2	SER. & FAN BELT	✓	Adjusted
3	ENGINE OIL LEVEL	✓	
4	AIR CLEANER	✓	
5	PRECLEANER	✓	
6	BATTERY	✓	Added water
7	HYD. OIL LEVEL	✓	
8	LUBRICATION	✓	
9	TIRE CONDITION	✓	
10	SAFETY EQUIP.	✓	
11	GENERAL COND.	✓	
12	FUEL LEVEL	✓	Added 12gal
13	INSTRUMENTS	✓	
14	SHUTDOWN PRECAUTIONS	✓	
15	OTHER	✓	
DATE		OPERATOR'S SIGNATURE	
1/14/		R. R. Ryan	

- OPERATOR'S DAILY SERVICES**
- 1 Fill radiator to proper level. Remove debris from core
  - 2 Inspect belts for proper tension, alignments and condition.
  - 3 Fill to proper level, inspect for leaks.
  - 4 Inspect and clean oil bath and dry type as required.
  - 5 Clean filter jar as often as conditions warrant
  - 6 Visually inspect for condition. Fill to proper level.
  - 7 Fill to proper oil levels and inspect for leaks.
  - 8 Perform daily lubrication services as designated by the Transportation Division.
  - 9 Check tire pressure with gage. Inflate as necessary to recommended pressure. Remove glass, stones, nails, etc
  - 10 Inspect for condition, safety guards, boom stops, radius indicators, warning devices, ladders, fire extinguishers, etc.
  - 11 Inspect unit for general condition. Correct or report any deficiencies requiring mechanical attention.
  - 12 Fill fuel tank as necessary.
  - 13 Check all gages and meters for proper operation
  - 14 Perform prescribed shutdown services such as securing machines, draining air tanks, cover exhaust stacks, close hoods, etc.
  - 15 List any deficiencies noted during operation
- REMARKS

FRONT

BACK

81.323

Figure 4-2.—Operator's Daily PM Report, Construction and Allied Equipment, NAVFAC 11260/4.

performs a final inspection. After a satisfactory final inspection, the shop inspector recommends to the shop supervisor that the equipment be released to full service. The ERO is returned to cost control for final closing.

**AUTOMOTIVE REPAIR SUPERVISORS**

Automotive shop supervisors, who are usually CMC's, have direct control over the automotive repair section and normally work

directly for the maintenance supervisor. Among the duties are:

1. Control and supervision of all maintenance personnel assigned to the shop.
2. Insuring that preventive maintenance is performed under current instructions.
3. Submitting accurate maintenance records to the cost control section.
4. Maintaining the mechanics' toolkits and conducting required inventories.

# CONSTRUCTION MECHANIC 1 & C

EQUIPMENT REPAIR ORDER (ERO)  
NAVFAC 11200/41 (Rev 10 75) 1 4 0 1 0 1 0 1 2 0 2 0

480087		485001		NS5000		PHG1		CB400		02		2617		AAB0001	
ESTIMATED HOURS		ACTUAL HOURS		ESTIMATED COST		ACTUAL COST		TIME		JULIAN DATE		A EMP AVAILABLE		B INSPECTION START	
1.2 = 2		1.0 = 0		1.88		1.88		1,1,0,0		7,8,3,0,8		1,1,0,0		7,8,3,0,8	
1.2 = 2		1.0 = 0		1.88		1.88		1,4,1,5		7,8,3,0,8		1,4,1,5		7,8,3,0,8	
1.0 = 0		1.0 = 0		1.0 = 0		1.0 = 0		0,9,3,0		7,8,3,1,0		0,9,3,0		7,8,3,1,0	
1.0 = 0		1.0 = 0		1.0 = 0		1.0 = 0		1,0,0,0		7,8,3,2,1		1,0,0,0		7,8,3,2,1	
1.0 = 0		1.0 = 0		1.0 = 0		1.0 = 0		0,8,3,0		7,8,3,2,2		0,8,3,0		7,8,3,2,2	
7 2		8 5 6 7 8		IHC		TD20 R									
TRACTOR CRAWLER															
W/C	FUNCTION CODE	WORK DESCRIPTION	MECH	MECH	MECH	MECH	MECH	MECH	MECH	MECH	MECH	MECH	MECH	MECH	MECH
	1.2 X	Steam Clean													
	2.3 X	Change Oil and Filters													
	0.1 X	Lube Complete													
	0.4 X	Change Fuel Filters													
	1.1 X	Clean and Service Batteries													
	1.0 X	Service Air Cleaners													
		Replace Rain Cap													on order
	F. 5.5	Replace #6 Fuel Injector													
	N. 9.4	Adjust R/H Steering Brake													
SUB TOTALS											12.2				
RECEIPT OF ABOVE ORDER AND EQUIPMENT IS HEREBY ACKNOWLEDGED															
PERMISSION TO EXCEED WORK ON ERO MUST BE AUTHORIZED BY REQUESTING ACTIVITY															

2.469A

Figure 4-3.—Equipment Repair Order (ERO), NAVFAC 11200/41.

5. Providing necessary technical and safety instruction and leadership.
6. Insuring all work listed on ERO's is performed and that any additional work is recorded and performed and authorized.
7. Insuring that only top quality work is performed in the shop.

### HEAVY EQUIPMENT REPAIR SUPERVISORS

Heavy equipment repair supervisors, who are usually CMC's, have direct control over the

heavy equipment repair section and work directly for the maintenance supervisor. In addition to the duties of the automotive repair supervisor just listed, the heavy equipment repair supervisor is responsible for the assignment and supervision of the field maintenance crew and injector shop if one is established.

### Field Maintenance

The importance of field maintenance and field repairs cannot be overemphasized. The success or failure of the deployment from an



# Chapter 4—BATTALION EQUIPMENT COMPANY SHOPS SUPERVISOR

TYPE REPAIR (BLOCK 6)	BRAKES	HYDRAULIC	SAFETY EQUIPMENT
01 A CM	809 Linings/Disks/Plates/Pads	H60 Pump	P06 Hoses/Lines/Pipes/Fittings
02 B CM	810 Drums/Rotors	H61 Pressure Control Valves	P07 Controls
03 CM	811 Backing Plate/Cones/Callipers	H62 Operating Valves	P08 Receivers/Oilers
04 Interim Repair	812 Hoses/Lines/Pipes/Fittings	H63 Cylinders	P09 Other
05 Overhaul	813 Master/Wheel Cylinder	H64 Motors	
06 Breakdown (Field Repair)	814 Chambers/Diaphragms	H65 Hoses/Lines/Pipes/Fittings	T11 Fire Extinguisher
07 Acceptance	815 Hydrovac/Vacuum Pump	H66 Accumulators/Tanks	T12 Mirrors/Reflectors
08 Repair for Stock	816 Valves, Governors, Tank	H67 Other	T13 Windshield Wipers
09 Preservation and Storage Maintenance	817 Parking/Hand Brake		T14 Mud Flaps/Guards/Shields
10 Warranty	818 Other	<b>ELECTRICAL</b>	T15 Glass/Windshield
11 Rework		J69 Replace Battery	T16 Horn
12 Accident	<b>SUSPENSION</b>	J70 Replace Speedometer/Hourmeter	T17 Other
13 Shipping Inspection (CEN)	C20 Springs	J71 Charging System	
14 Surveillance Inspection (CEN)	C21 Shock Absorbers	J72 Cranking System	<b>PRODUCT TRANSFER</b>
15 Operational Test (EC)	C22 Pins/Rods	J73 Lighting/Wiring System	T19 Asphalt Pump
	C23 Other	J74 Electrical Control Oil/Panel	T20 Water/Mud Pump
		J75 Ignition System	T21 Refueling Pump
		J76 Instruments/Gages	T22 Concrete Pump
		J77 Generators, Power/Welding	T23 Conveyor Belt/Bucket/Screw
		J78 Electric Drive Motors	T24 Other
		J79 Electronic Circuits	
		J80 Other	<b>HEATER/VENTILATING SYSTEM</b>
	<b>DRIVE TRAIN</b>		V26 Asphalt/Tank Heater
	D25 Clutch, Main Drive	<b>BODY AND FRAME</b>	V27 Water Heater/Defroster
	D26 Clutch, Control/Drum	K82 Cab/Sheet Metal	V28 Aggregate Heater
	D27 Manual Transmission	K83 Body/Bed	V29 Sceded Heater
	D28 Auto/Power Shift Transmission	K84 Cushions/Seats/Canvas/Mounts/Sideracks	V30 Air Conditioning
	D29 Auxiliary Transmission	K85 Painting/Marking	V31 Other
	D30 Transfer Cases/Power Dividers	K86 Frame/Mast	
	D31 Drive Shafts/Jooints	K87 Humpers/Guard/Lifting Device	<b>WHEELS/TRACKS</b>
	D32 Differentials	K88 Fifth Wheel/Winch Hitch/Towing Hook	W32 Wheels/Tires
	D33 Drive Axles	K89 Sutrigger/Landing Gear	W34 Tires/Tubes
	D34 Final Drive/Planetaries	K90 Other	W35 Bearings/Seals/Packings
	D35 Power Take-Off		W36 Hub Assy/Studs/Nuts
	D36 Drive Belts/Chains	<b>STEERING SYSTEM</b>	W37 Rollers/Idlers/Sprockets
	D37 Torque Converter	S92 Adjustments/Wheel/Alignment	W38 Track Frame/Guards
	D38 Other	S93 Steering Wheel/Box	W39 Rails/Pins/Crossers
		S94 Steering Knives/Clutches	W40 Track Ad Juster/Accumulator
	<b>ENGINE</b>	S95 Linkages/Tie Rods/Etc.	W41 Other
	E40 Engine Assy, Gas	S96 Ball Joints/King Pins	
	E41 Engine Assy, Diesel	S97 Power Steering Pump/Belt	<b>PRODUCTION EQUIPMENT</b>
	E42 Engine Assy, Aux	S98 Steering Cylinder/Hoses	P43 Jaws/Hammer Mills
	E43 Air Intake System	S99 Other	P44 Rolls/Liners/Concaves
	E44 Blowers/Supercharges/Turbochargers		P45 Screens
	E45 Exhaust System	<b>PNEUMATIC</b>	P46 Sizers
	E46 Emission Control System	P01 Cylinders	P47 Dryers
	E49 Cooling System	P02 Compressors	P48 Sceded
	E50 Other	P03 Separator/Filter	P49 Scales/Meters
		P04 Dryifiers	P50 Colletor
	<b>FUEL</b>	P05 Motors	P51 Other
	F52 Fuel System		
	F53 Fuel Transfer Pump		
	F54 Fuel Injection Pump		
	F55 Injectors/Nozzels		
	F56 Carburetor		
	F57 Gov/Throttle Controls		
	F58 Other		

Figure 4-4.—Equipment Repair Order (ERO), NAVFAC 11200/41 (back).

2.469B

equipment maintenance standpoint, and in some cases from the project standpoint, can be traced to the unavailability of equipment due to poor field maintenance or inability to perform adequate and timely repairs in the field. Experienced field mechanics are worth their weight in gold, and the heavy equipment repair supervisor must be careful in the selection of the field mechanics, even to the point of shortchanging himself in the shop. In the long run, good field maintenance will reduce the shop workload and improve the operator's concern for the equipment. Remember, it is the responsibility of the heavy equipment repair

supervisor to provide the tools and equipment required by the field mechanics.

### Injector Shop

When an area or shop has been established to repair injectors and injection pumps, it will normally be under the supervision of the heavy equipment repair supervisor. In addition to the necessary testing equipment, an injector repair area requires a method of controlling the temperature and cleanliness.





to work together on joint projects. The MR's are capable of manufacturing or repairing equipment parts, tools, and machine parts.

### **Chassis, Body, Fender, and Radiator Shop**

In most battalions, Steelworkers (SW's) and Hull Technicians (HT's) form the nucleus of this shop. Their work includes repairing or rebuilding chassis components, fenders, and other body parts, repairing, rebuilding, and testing radiators; bulldozer blades, and other steel components; and welding and brazing.

### **Electrical Shop**

Manned by Construction Mechanics, the electrical shop repairs, rebuilds, cleans, adjusts, and tests all automotive electrical parts and accessories, such as generators, starters, and voltage regulators. In many battalions, Construction Electricians (CE's) are assigned to conduct load test and make electrical repairs to lightplants, generators, and welders.

### **Battery Shop**

Men assigned to the battery shop maintain and recharge wet cell batteries, mix electrolyte, and keep a supply of fully charged, spare batteries for equipment used by the battalion.

The battery shop should be well separated from any open flames. It must be well ventilated to prevent accumulation of explosive hydrogen gas fumes given off during battery charging. Adequate safety equipment located within the battery shop includes rubber aprons and gloves, face shields, eye wash, and treadle shower. Electrical light fixtures and plug-in connections should be of explosive-proof design.

### **Tire Shop**

The Construction Mechanics assigned to the tire shop repair and replace the pneumatic tires in the battalion.

Normally, the tire shop is located in an area accessible to all types of equipment, utilizing

rubber tires which require removal, repair, or replacement from time to time. This shop should be equipped with tire-mounting sets, tools, air compressors, and other support equipment necessary to complete tire repairs in a reasonable time so that the equipment can be returned to the jobsite with little or no lost time.

### **Lube Shop**

The mechanics assigned to the lubrication racks maintain adequate stocks of all lubricants required by the battalion, and lubricate automotive and construction equipment as required under the Preventive Maintenance Program.

Although you will have skid-mounted lubricators and lubricating teams for servicing equipment in the field, most of your scheduled PM's will be accomplished in the maintenance shop area. Outdoor locations for lubrication stalls are satisfactory in temperate climates and during favorable weather, but efficiency is increased by providing suitable shelter. PM racks should include provisions for storage of greases and oils, preferably at a distance from your other shop areas, as a precaution against fire. In addition to facilitating lubrication services, these racks should provide for easier inspection and cleaning of under parts and surfaces of equipment.

There is sometimes a tendency to overlook another important type of servicing—operator servicing. Anything that affects your specific area of responsibility automatically becomes a collateral duty. You, as a supervisor, should tactfully initiate action to prevent this collateral area from hindering you in the accomplishment of your principal duties. It may be necessary to institute operator servicing classes, or, in some cases, operator training classes on troublesome pieces of equipment. Remember, tact is the key when you leave your specific area of responsibility to get a job done.

### **COST CONTROL SUPERVISORS**

CMI's might be assigned as cost control supervisors to work directly for the maintenance

## CONSTRUCTION MECHANIC 1 & C

supervisor. The duties include monitoring the PM clerk, cost control clerk, and the direct turn over (DTO) clerk. When necessary, they keep the vehicle status boards current, review and purify history jackets, and act as liaison to detachments. The cost control supervisors may also be responsible for updating the equipment computer program for vehicle maintenance.

### PM Clerk

The PM clerk is responsible for completing the basic information on the ERO, maintaining

the ERO log (fig. 4-6), and PM Record Cards (figs. 4-7 and 4-8). The yearly PM Schedule (fig. 4-9) and Equipment Repair Order Worksheet (fig. 4-10) are also prepared by the PM clerk. Notifying the dispatcher in advance of equipment due for PM and keeping status boards current as to the units in-shop are also tasks usually assigned to the PM clerk.

### Cost Control Clerk

The cost control in a battalion consists basically of accurate reporting of all repair costs,

ERO NUMBER	CODE	USN NUMBER	TYPE ERO				DATE IN	DATE OUT	REMARKS
			INT	A	B	C			
AA00 0001	252021	25-01286	X				11/2/8	11/8/8	
AA00 0002	030701	97-23465		X			11/2/8	11/2/8	
---	---	---	--	--	--	--	---	---	--
---	---	---	--	--	--	--	---	---	--
---	---	---	--	--	--	--	---	---	--
AA00 0013	485011	48-00123	X		X		11/28/8	12/12/8	D/L 12/1/8

ERO NUMBER - Eight-digit number. The first four digits of the ERO number will be two Alpha characters and two numeric such as AA00. The second group will be all numeric and will run continuously from 0001 through 9999 with no regard to end of fiscal year.

CODE - Self-explanatory. (Six Digit)

USN NUMBER - Self explanatory.

TYPE ERO - Type maintenance performed: interim repair, A, B, or C-PM.

DATE IN (SHOP) - Date ERO forwarded to inspector.

DATE OUT (SHOP) - Date ERO returned. Work completed.

REMARKS - Date deadlined etc.

Figure 4-6.—Equipment Repair Order Log Sheet.

2.470

Chapter 4—BATTALION EQUIPMENT COMPANY SHOPS SUPERVISOR

ASSIGNED TO NMCB		PHONE	COLOR RLD	TYPE OF ASSIGNMENT	EQUIP. CODE 821001	JOB ORDER NO.	PM GROUP 13			
NAME THEW		NO. TC.	MC 32-M	TYPE	YEAR 66	EST. ANNUAL MILEAGE	USN REG. NO. 82-03317			
TYPE PM	DATE	CUMULATIVE MILEAGE OR HRS. OPN	MILES (OR HRS.) SINCE LAST PM	MILES (OR HRS.) REPORTED FOR 6 MO. PERIOD	TYPE PM	DATE	CUMULATIVE MILEAGE OR HRS. OPN	MILES (OR HRS.) SINCE LAST PM	MILES (OR HRS.) REPORTED FOR 6 MO. PERIOD	
LAST A	2-4-78	1945	ENTRIES TRANSFERRED FROM PM1 R REL. RE	[Hatched Box]						
LAST B	6-5-78	2259								
LAST C	4-1-78	2060								
A	8-7-7	2371	C/O							
B	10-1-7	2480	C/O, C/F							

VEHICLE/CONSTRUCTION EQUIPMENT PM RECORD NAVFAC 11240/6 (2-75) Supercedes NAVDOCKS 1949  
S/N 0108-LF 003 8530

2.468A

Figure 4-7.—PM Record Card, NAVFAC 11240/6.

downtime, and other data that relates to NCF automotive, construction, weight-handling, and material-handling equipment. The individual assigned this task must be thoroughly familiar with NAVFAC P-404, COMCBPAC/COMCB-LANT 11200, and local procedures. The cost control clerk insures that all charges are accurately recorded on the ERO worksheet and checks the back of the ERO for completeness. Additionally, this individual maintains the file of parts received for each USN (fig. 4-11).

**DTO Clerk**

The person assigned as DTO clerk will maintain the DTO log (fig. 4-12) for all parts placed on order. This task includes receiving direct turn over parts, storing them by USN in PM groups, and notifying the cost control clerk of parts received. Liaison with repair parts issue, supply office, and receiving are factors to be

considered when assigning this individual. Attendance in repair parts procedure school should be considered.

**TECHNICAL LIBRARIAN**

The mechanic assigned as technical librarian is accountable to the maintenance supervisor for the inventory and control of the prepackaged library.

**REPAIR PARTS**

Normally, a mechanic is assigned to supply to aid in identifying parts and to work the issue counter. This individual serves as an interface between supply and the maintenance supervisor. This individual should have attended repair parts procedure training.



## CONSTRUCTION MECHANIC 1 & C

TYPE PM	DATE	CUMULATIVE MILEAGE OR HRS. OPN	MILES (OR HRS) SINCE LAST PM	MILES (OR HRS) REPORTED FOR 6 MO PERIOD	TYPE PM	DATE	CUMULATIVE MILEAGE OR HRS. OPN	MILES (OR HRS) SINCE LAST PM	MILES (OR HRS) REPORTED FOR 6 MO PERIOD
					A14000		FAIRLEAD	1	32-FL-0004
					AO4000		BOOM TIP	1	32-BT-0004
					AO3500		BOOM IIB	1	32-BU-0003
					AO2500		BOOM BUTT	1	32-BB-0004
					A11500		CRANE HOOK	1	32-CH-0005
					AO 3000		BOOM EXT	3	32-BE-0013
					A23500		TAGLINE	1	32-BE-0014
									32-BE-0015
									32-TL-0006

NAVFAC 11240/6 (2 75) BACK

Figure 4-8.—PM Record Card, NAVFAC 11240/6 (back).

2.468B

### BATTALION MAINTENANCE PROGRAM

The purpose of the maintenance program of a battalion is to keep its automotive and heavy equipment operating and to prevent minor mechanical problems from becoming major ones. The Civil Engineer Support Equipment (CESE) maintenance system of the NCF consists of two levels of maintenance—organizational and intermediate.

#### ORGANIZATIONAL MAINTENANCE

The first, or organizational, level of maintenance is divided into two categories—operator maintenance and preventive maintenance (PM). Operator maintenance is that which every operator is required to perform to maintain the equipment in a clean, safe, and serviceable condition. It includes the daily inspections, lubrications, and adjustments

necessary to insure early detection of malfunctions of equipment. Figures 4-1 and 4-2 show the preventive maintenance forms which the operator can use as guides for a daily prestart inspection, and as a trouble report in case of any defect or unsafe conditions which need be reported to the dispatcher immediately. Preventive maintenance goes beyond the inspections, lubrications, and adjustments in operator maintenance. The prime objective of PM is insuring availability and minimizing unnecessary repair costs. Operators should participate in PM unless specifically directed otherwise.

#### INTERMEDIATE MAINTENANCE

The maintenance shop whether mobile, semimobile, permanent, or semipermanent has the responsibility of the intermediate level of maintenance. A higher degree of skill is required

Chapter 4—BATTALION EQUIPMENT COMPANY SHOPS SUPERVISOR

ACTIVITY \_\_\_\_\_

YEAR \_\_\_\_\_

PM SCHEDULE GROUP	MONTH AND DAY SCHEDULE											
	JAN	FEB	MAR	APR	MAY	JUN	JUL	AUG	SEP	OCT	NOV	DEC
1	21		19		14		11		6		1	
2	22		20		15		12		9		4	
3	23		21		16		15		10		5	
4	24		22		17		16		11		6	
5	25		25		20		17		12		7	
6	28		26		21		18		13		8	
7	29		27		22		19		16		12	
8	30		28		23		22		17		13	
9	31		29		24		23		18		14	
10		1		1	27		24		19		15	
11		4		2	28		25		20		18	
12		5		3	29		26		23		20	
13		6		4	31		29		24		21	
14		7		5		3	30		25		22	
15		8		8		4	31		26		25	
16		11		9		5		1	27		26	
17		12		10		6		2	30		27	
18		13		11		7		5		1	29	
19		14		12		10		6		2		2
20		15		15		11		7		3		3
21		18		16		12		8		4		4
22		19		17		13		9		7		5
23		20		18		14		12		8		6
24		21		19		17		13		9		9
25		25		22		18		14		10		10
26		26		23		19		15		11		11
27		27		24		20		16		14		12
28	2	28		25		21		19		15		13
29	3		1	26		24		20		16		16
30	4		4	29		25		21		17		17
31	7		5	30		26		23		18		18
32	8		6		1	27		26		21		19
33	9		7		2	28		27		22		20
34	10		8		3		1	28		23		21
35	11		11		6		2	29		24		24
36	14		12		7		3	30		25		26
37	15		13		8		5			28		27
38	16		14		9		8		3	29		30
39	17		15		10		9		4	30		31
40	18		18		13		10		5	31		

2.467

Figure 4-9.—PM Schedule.

**CONSTRUCTION MECHANIC 1 & C**

EQUIPMENT REPAIR ORDER (ERO) WORKSHEET									PAGE 1 of 2	
1. UEMO NUMBER 4813087	2. EQPT. COST CODE 485001	3. ACTIVITY UIC	4. JOB ORDER NUMBER	5. LOCATION/ALLOWANCE	6. TYPE REPAIR	7. HR. METER READING	8. MILE METER READING	9. LNO NUMBER AA000001		
10. CUSTOMER		11. WORK CENTER	12. DESCRIPTION		13. YEAR	14. MAKE	15. MODEL	16. APL NUMBER 95000518		
17. ENGINE MANUFACTURER			18. ENGINE MODEL		19. ENGINE SERIAL NUMBER		20. CHASSIS SERIAL NUMBER			
21. NSN	22. FSCM	23. MANUFACTURER PART NUMBER	24. DESCRIPTION			25. QTY	26. U.I.	27. UNIT COST	28. DOCUMENT NUMBER PART NUMBER	29. ACVD
2910-00-555-1234	31007	165437R91	Injector Line #6			1	FA	8.50		
30. APPROVED BY (SIGNATURE) A B Sea CMI									31. DATE 12/5/79	

Figure 4-10.—Equipment Repair Order Worksheet, NAVFAC 11200-41B.

2.469D

to accomplish this type of maintenance since it includes removal, replacement, repair, alteration, calibration, modification, rebuild, and overhaul of individual assemblies, subassemblies, and components.

**SCHEDULING MAINTENANCE**

The standard interval between PM service inspections for NCF equipment is 40-working days, 2,000 miles, or 120 hours, whichever occurs first. This interval is established initially by grouping all assigned equipment into 40 separate PM groups. The equipment is

distributed evenly among the PM groups so that the minimum number of similar items are out of service at any one time.

It is the responsibility of the maintenance supervisor to determine whether the PM interval for any item of equipment should be reduced. The maintenance supervisor can shorten the interval by assigning specific items of equipment to more than one group or reducing the total number of groups. The maintenance supervisor cannot, however, extend the standard interval between PM service inspections. To establish a deployment schedule of PM due dates, the maintenance supervisor records the workdays of

Chapter 4—BATTALION EQUIPMENT COMPANY SHOPS SUPERVISOR

CODE 485001 USN 48-00123						
DATE	DEPT. NO.	PRI.	REQ. NO.	NOMENCLATURE	FOLLOW-UP	REC'D
79018	0009	B	2021-2211	GASKET SET	1/31	2/28
79189	0161	A	2230-2713	INJECTOR	8/28 9/15 10/2	10/11
79346	0218	C		RAINCAP		

CODE	- Self-explanatory.
USN	- Self-explanatory.
DATE	- When the 1250 was submitted to Supply for ordering.
DEPT. NO.	- Four digit number in numerical sequence starting with number 0001 for each 1250 you submitted to Supply.
PRI	- See COMCBPAC or COMCBLANT 4614.1 Series Instruction.
REQ. NO.	- Supply's voucher number found in Block G of the 1250. Enter after red 1250 is returned from Supply.
NOMENCLATURE	- Self-explanatory.
FOLLOW-UP	- When did you request status from Supply.
REC'D	- Self-explanatory.

2.472A

Figure 4-11.—Repair Parts Summary Sheet.

Dept. No.	Julian Date	PMG.	USN	NSN	Desc	Qty	PRI	Req. No.	Rec'd
0001	4003	01	48-00123	2815-739-6098	VALVE	1	C	4010-2111	
0002	4003	01	48-00123	2815-962-5622	SPRING	1	C	4010-2112	
0003	4010	06	96-11031	2810-950-8385	INJECTOR	6	B		

Figure 4-12.—Direct Turn Over (DTO) Log.

the month consecutively beside the PM group numbers. See the sample schedule (fig. 4-9).

A Preventive Maintenance Record Card (fig. 4-7) is maintained for each item of assigned equipment to help the PM clerk prepare the ERO. The following information is taken from

the completed ERO and entered on a record card:

Type of PM Service performed.

Date performed.

Cumulative mileage/hours.

Whether oil or filter was changed (shown by the abbreviation O/C or F/C).

PM Record Cards are maintained by PM group in a tickler file which the maintenance supervisor reviews at least once a month. When a vehicle is transferred, its PM Record Cards are placed in the equipment history jacket.

The Preventive Maintenance Record Card (back) (fig. 4-8) is convenient for listing attachments for each USN. This will aid the inspector in locating the proper attachments for PM.

The types of PM inspection are defined and given as follows:

#### Type A Inspections

They are given at intervals of 40-working days, using appropriate PM Service and Inspection Guide. They are performed on scheduled PM due dates. After two type A PM's, the vehicle qualifies for a type B inspection.

#### Type B Inspections

They are given at intervals of 2,000 miles, 120 hours, or after two consecutive type A inspections, using the appropriate PM Service and Inspection Guide. The interval between engine oil changes on internal combustion engines shall not be less than 4,000 miles, 240 hours or 80-working days (whichever occurs first).

#### Type C Inspections

They are given as determined necessary by the maintenance supervisor, using the appropriate PM Service and Inspection Guide. They may be performed to increase the life of the equipment that is not scheduled for replacement.

**CAUTION:** Cost and availability of repair parts as well as resources and working conditions must be considered along with equipment commitments and conditions.

### EQUIPMENT REPAIR ORDER AND CONTINUATION SHEET

The Equipment Repair Order (ERO) (figs. 4-3 and 4-4) and the continuation sheet (fig. 4-5) are used in the Naval Construction Force (NCF) to record costs of repairs, hours required for repairs, and total time that equipment is out of service. The data will help the NCF in budget planning, determining life expectancies of equipment, and predicting future equipment and training requirements. The Naval Facilities Engineering Command Systems Office (FACSO), Port Hueneme, California, also uses the data to compile cost and utilization figures on each piece of USN-numbered equipment. Therefore, the data must be complete, accurate, and neatly recorded in accordance with NAVFAC P-404 and COMCBPAC/COMCB-LANT Instruction 11200 series.

The Equipment Repair Order Worksheet (fig. 4-10) is used solely to list repair parts used. It may be used by the mechanic and shop supervisor to insure that all supply documents are attached to the ERO. The cost control supervisor and the maintenance supervisor may use this form to properly record parts cost.

The ERO is the sole authority to perform work on equipment regardless of whether the work is performed in the field or in the shop. An ERO is required each time labor time exceeds 1.0 hour or materials are expended on scheduled PM, interim repairs, modernization or alteration of equipment, or deadline cycling or preservation of equipment. The ERO Log Sheet (fig. 4-6) is one means for keeping track of the status of the ERO's.

### REPAIR PARTS

NAVFAC-funded initial outfitting repair parts allowances required by the Naval Construction Force (NCF) for support of its assigned equipment are listed in Consolidated SEABEE Allowance Lists (COSAL's). The COSAL establishes the support for assigned organic and augment equipment based on USN-numbered listings. COSAL's are published



under the authority contained in the NAVFAC/NAVSUP Program support agreement by Navy Ships Parts Control Center (SPCC), Mechanicsburg. COSAL's are both technical and supply documents. They are technical documents in that equipment nomenclature, operating characteristics, technical manuals, etc., are described in Allowance Parts Lists. They are supply documents in that they list all parts by manufacturer's code and part number, national stock number, unit of issue, and price and quantity authorized by NAVFAC maintenance policy. Repair parts allowances are designed to provide a 90 percent effectiveness for 1,800-construction hours or 90-days support. This 90-day period is defined as a 3-month utilization period for vehicles or equipment in new or like new condition. Selection of parts included in the COSAL is made after identification; usage and insurance items are coded by maintenance capability in accordance with NAVFAC lead Allowance Parts Lists. Maintenance codes are used to control the allowed item range for each of the various organizational maintenance capabilities. The definition and application of maintenance codes are contained in Appendix C of the COSAL introduction. There are two basic categories of repair parts; parts peculiar—NAVSUP modifier code 98 and parts common—NAVSUP modifier code 97. These are published in two separate COSAL's. Parts peculiar are applicable only to specific makes or models of equipment. Parts common are general repair-type items, (Appendix G of the COSAL introduction) and are not referenced to any specific equipment. Military and commercial operators' manuals, parts manuals, and maintenance manuals are listed in the parts peculiar to COSAL. A descriptive account showing the method of entry and how to use the COSAL is contained in Appendix F of the COSAL instruction.

A third category of repair parts has been added to the Battalion's Allowance. The NAVSUP modifier 96 is a minimodifier 97 for use with the air detachment or, an extended detachment, without jeopardizing the main body:

## SUPPLY AIDS

To assist personnel in the repair parts program, the following supply aids have been developed and are distributed with each COSAL:

NAVSUP Form 1114 (fig. 4-13)—Printed stock record cards

Add Item Listing—Repair parts provided by a Naval Construction Battalion Center (NCBC) to support new equipment not previously supported.

Delete Item Listing—Repair parts provided by a previous COSAL that are no longer required.

DD Form 1348-1 (fig. 4-14)—Single Line Item Release/Receipt Document.

Transfer Item Listing—A list showing previous COSAL items which must be transferred to other locations due to equipment transfer.

Summary Item List—A composite list of all items required by the old COSAL.

Stock Number Changes—Two listings: old-to-new National Stock Number (NSN) and new-to-old (NSN) which show changes in the stock number listed in the old COSAL and updated by the new COSAL.

## PREPACKAGED LIBRARY

An effective equipment management program needs technical data and guides for each item of equipment. Within the NCF, operator manuals, lubrication charts, parts manuals, and shop repair manuals are included in each parts-peculiar COSAL.

Shop manuals should be centrally located. Inventory control of technical manuals (TM's) must be maintained through periodic inventories and checkout procedures. Replacement manuals for older equipment are normally expensive and hard to obtain. Civil Engineer Support Office

# CONSTRUCTION MECHANIC I & C

COE PN		STOCK NO AND DESCRIPTION	U/I	UNIT PRICE	ALLOWANCE PARTS LIST	LOCATION	HIGH LIMIT	LOW LIMIT		
971		5340-582-2741 PADLOCK	EA	1.09	58602901	C 103A	16	9		
REQ'S/ISSUES OUTSTANDING		ALL FILL QTY AT	YSHC	EL	INC.	INCLUSIVE DATES OF REMARK	REMARKS BY FWD	FREQ BY FWD	M.L. ESSENT	
DATE	DOCUMENT NO	QTY	TITLE	DATE/DOCUMENT NO	ISSUES	OR HAND	DATE/DOCUMENT NO	RECEIPTS	ISSUES	OR HAND
		12	1				* 7/1/9 12/3/9	11	4	
				12/13/69	BF					
				2/13/70	107-4					
				3/25/70	211-4					
0048	0120			3/30/70	4120	7				
				5/9/70	INV	LB1				
				10/2/70	371-4	3				
COE PN		STOCK NO AND DESCRIPTION	U/I	UNIT PRICE	ALLOWANCE PARTS LIST	LOCATION	HIGH LIMIT	LOW LIMIT		
971		5340-582-2741 PADLOCK	EA	1.09	58602901	C 103A	16	9		

Figure 4-13.—Stock Record Card Afloat, NAVSUP Form 1114.

66.19

STOCK OR PART NUMBER		DOCUMENT NUMBER		SUPPLIER'S ADDRESS		FUNDING SYMBOL		UNIT PRICE		QUANTITY	
SHIPPED FROM		SHIP TO		MARK FOR PROJECT		DOLLARS					
WAREHOUSE LOCATION		TYPE OF UNIT		UNIT WEIGHT		UFC		NMFC		FREIGHT RATE	
S		G		H		K		L		M	
ITEM NOMENCLATURE		FREIGHT CLASSIFICATION		NOMENCLATURE							
SELECTED BY AND DATE		TOTAL WEIGHT		RECEIVED BY AND DATE		INSPECTED BY AND DATE					
PACKED BY AND DATE		TOTAL CUBE		WAREHOUSED BY AND DATE		WAREHOUSE LOCATION					
REMARKS											
FIRST DESTINATION ADDRESS		DATE SHIPPED									
TRANSPORTATION CHARGEABLE TO		LOADING AND/OR RECEIVER'S SIGNATURE AND DATE		RECEIVER'S DOCUMENT NUMBER							

Figure 4-14.—Single-Line Item Release/Receipt Document, DD Form 1348-1.

2.471

Chapter 4—BATTALION EQUIPMENT COMPANY SHOPS SUPERVISOR

(CESO) administers the technical manual support program. Inadequate or deficient TM's are reported to CESO.

The mechanic assigned to the technical library generally does research of parts numbers and prepares the requests for parts.

**PROCEDURES FOR REQUESTING REPAIR PARTS**

The NAVSUP Form 1250 shown in figure 4-15 is used as authorization for drawing or ordering repair parts. Preparation of the 1250 must be in accordance with NAVSUP P-485 Section 6207 and is the responsibility of the appropriate shop supervisor. Pay particular attention to the source code, Block 18, when parts are obtained through other methods.

When ordering repair parts that are in stock, indicate the required part by its nomenclature as given in the applicable maintenance manual and by other information required by the local command. After being authorized by the shop supervisor or higher authority, the NAVSUP 1250 and the ERO are presented to the storekeeper at the repair parts section. The

storekeeper determines and records all applicable information and takes other appropriate action as directed by the supply officer. After the required part is obtained, the yellow copy of the 1250 is attached to the ERO.

When ordering repair parts not in stock, follow the same procedure outlined above except that, when it is determined that the required part is not available immediately, the NAVSUP 1250 (fig. 4-16) is annotated (marked) with data concerning like items on order but not received and also marked NIS (Not In Stock) or NC (Not Carried) and returned to the mechanic. The maintenance supervisor or higher authority assigns a priority and authorizes the part to be ordered. The cost control clerk assigns a department order number for each part ordered, starting with number 0001. Pull the yellow copy and forward the other copies of the 1250 to supply. Supply will complete the ordering action and return the pink copy of the 1250 with a requisition number to the cost control clerk. If the pink copy is not received within seven days, request supply to furnish you with a status of your order.

The following information is provided as a guide in determining the number of days it

1 REQ DATE 6003	2 DEPT NO	3 URGY	4 ROD	5 LOCATION	6 SW	7 ISSUE DATE 6.0.03	A REQN QTY	B REQN NO
8 NOUN NAME OR REF SYM CONTACT		9 FPR	10 APL/AEL/CID 9.5009.3.89.000		11 INV QTY	12 NIS <input type="checkbox"/> N/C <input type="checkbox"/>	C OBLT AMT	D POSTED
13 JOB CONTROL NUMBER				14 WC	15 JSN	16 EIC	17 EQUIP COSAL SUPPLY	E URG <input type="checkbox"/> MART <input type="checkbox"/>
18 SC COG MCC 21 FSC 22 STOCK NUMBER 19N 5930008521548				23 SMC	24 U/I	25 QUANTITY EA0001	26 UNIT PRICE 345	27 EXTENDED PRICE 345
28 REMARKS USN-94-88647							29 APPROVED BY SHOP SUPERVISOR	
							30 RECEIVED BY	

Figure 4-15.—Single-Line Item Consumption/Management Document (Manual), NAVSUP Form 1250.



CONSTRUCTION MECHANIC 1 & C

1 REQ DATE 6003A1011	2 DEPT NO B	3 URGY	4 ADD	5 LOCATION	6 BIN <input type="checkbox"/> BIN <input type="checkbox"/> NON-BIN	7 ISSUE DATE	A REON QTY	B REON NO
8 NOUN NAME OR REFSYM C.A.R.B.U.R.E.T	9 FPR <input type="checkbox"/>	10 APL/AEUCID 9,5,0,0,6,3,8,9,0,0,0	11 INV DIT <input checked="" type="checkbox"/> NIS <input type="checkbox"/> M/C	12	C OBL AMT		D POSTED	
13 JOB CONTROL NUMBER N 5 5 4 4 4 A A * *			14 WC		15 JSN	16 EIC		17 EQUIP COSAL SUPPT D YES <input checked="" type="checkbox"/> NO <input type="checkbox"/>
18 SC 9C			19 COG 2,9,1,0,0,0,0,2,4,2,2,2,7		20 STOCK NUMBER E, A, 0, 0, 0, 1		21 UNIT PRICE 1,250	22 EXTENDED PRICE 1250
23 REMARKS USN-94-88647						24 APPROVED BY MAINTENANCE SUPERVISOR		
25 RECEIVED BY						26		

17.84B

Figure 4-16.—NAVSUP Form 1250, NIS Ordered DTO.

usually takes to receive repair parts, or a status report on the requisition for repair parts.

REQUISITION PRIORITY	CONUS TIME (DAYS)	OVERSEAS TIME (DAYS)
A	5	7
B	8	15
C	20	45

To maintain an accountability and status of your requisitioned repair parts, the following procedure is given:

1. For Parts Pending Action: The cost control clerk maintains one Repair Parts Summary Sheet (fig. 4-11) for each item of equipment assigned. This sheet is filed by PM group. The cost control clerk enters the data from the yellow copy of the 1250 on the appropriate Repair Parts Summary Sheet, then files the yellow ERO and yellow 1250 with the sheet. Upon receipt of the pink 1250, the requisition number is entered on the sheet and the pink 1250 is filed in place of the yellow 1250.

2. For Deadline Parts Action: The procedure outlined above is followed, except that the Repair Parts Summary Sheet is filed with the complete ERO in the deadline file.

3. Upon Receipt of Parts: On receiving an ordered repair part, supply will forward a copy of the DD Form 1348-1 (fig. 4-13) to the cost control clerk. The cost control clerk tags the repair part with the correct USN number, PM group, and the pink 1250 copy, insuring that the DTO Log and Summary Sheet show the date the part was received. The part is then stored in the DTO bin, and the 1348-1 is filed with the appropriate Summary Sheet. Each time an ERO is issued, the cost control clerk checks the Repair Parts Summary Sheets to determine whether parts are stored in the DTO bin for the equipment concerned. If they are stored, the shop supervisor is alerted by attaching the 1348-1 to the ERO. The shop supervisor will insure that the parts are either used or returned to the unit supply. If the received part is for a deadlined piece of equipment, the maintenance supervisor is notified to determine if enough parts are available to restart work on the equipment.

**BATTALION EQUIPMENT EVALUATION PROGRAM**

The reliability of equipment is one of the main factors in the ability of an NMCB to

perform its assigned mission. The Battalion Equipment Evaluation Program is a vital link in maintaining the degree of equipment readiness required of a battalion. Before you take a look at this program from the maintenance viewpoint, you should familiarize yourself with current COMCBPAC/COMCBLANT Instructions, 11200 series. These instructions are established as uniform procedures which occur during a battalion's onsite relief and equipment turnover.

### RESPONSIBILITIES OF THE RELIEVING BATTALION

Prior to arriving on the site, the incoming battalion is responsible for the following:

1. Notify COMCBPAC Equipment Office, Port Hueneme, CA; COMCBLANT Detachment, Gulfport, MS; and the battalion being relieved of the commencement date of the BEEP, at least 30 days prior to commencement date.
2. Insure that personnel required for the BEEP are assigned to the advance party.
3. Insure that required documents and supplies accompany the advance party.

### RESPONSIBILITIES OF THE BATTALION BEING RELIEVED

Prior to, and during the BEEP, the battalion being relieved is responsible for the following:

1. Coordinate the BEEP commencement date with the incoming battalion.
2. Assign counterparts to personnel arriving with the incoming battalion, and insure that these personnel remain onsite until completion of the BEEP.
3. Make available all necessary tools and shop equipment with which to evaluate and repair the equipment.
4. Clean and make available all equipment for evaluation and repair.

5. Coordinate the scheduling of equipment for inspection with the incoming battalion.

NOTE: The recommended procedure is to schedule the equipment by PM group, using the appropriate number of PM groups to enable the BEEP to be completed within 10-working days.

6. Insure that an ERO is prepared for each item of equipment with a copy of the Equipment Evaluation Inspection Guide (figs. 4-17 and 4-18), along with a copy of the Attachment Evaluation Inspection Guide (fig. 4-19), when appropriate.

### JOINT RESPONSIBILITIES

The following tasks are accomplished jointly by the battalions during the BEEP.

1. An inspection of all maintenance records, noting accuracy and deficiencies and updating as required.
2. A review and accountability of all maintenance correspondence which is pending final action.
3. An inventory and inspection of all permanent ALFA Company shop equipment, noting condition and deficiencies. Submit a list to the COMCBLANT or Commander, 31st Naval Construction Regiment (NCR) representative, noting the condition and deficiencies.
4. A preventive maintenance inspection of each nonpreserved item of USN-numbered equipment assigned, using the Equipment Evaluation Inspection Guide. Accomplish all repairs possible, dependent upon the work force, space, and repair parts available as determined jointly by both maintenance supervisors.

NOTE: Interval between engine oil changes on internal combustion engines shall not be less than 4,000 miles, 240 hours or 80-working days (whichever occurs first).

# CONSTRUCTION MECHANIC 1 & C

				DATE	
CODE	USE NO.	MILEAGE	HOURS	ENGINE SERIAL NO.	
PRESTART INSPECTION	INSPECTORS	INITIALS	NMCB	INITIALS	NMCB
	COOLING SYSTEM	LEVEL	LEAKS	CONDITION	
	LUBRICATION SYSTEM	LEVEL	LEAKS	CONDITION	
	CHARGING SYSTEM	BATTERY LEVEL	BELTS	CABLES	CONNECTIONS
	LIGHTING SYSTEM	HEADLIGHTS	TAIL LIGHTS	BLACK OUT	INSTRUMENTS
		CLEARANCE	REFLECTORS	REMARKS	
	FUEL SYSTEM	LEVEL	LEAKS	CONDITION	
	TIRES	SIZE	TAPE TREAD	CONDITION	INFLATION
		MOUNTED SPARE SIZE		CONDITION	INFLATION
	TRACKS	RAILS	PINS	SHOES	SPROCKETS
		IDLERS	REMARKS		
	MISCELLANEOUS	AUTO TRANS FLUID		MIRRORS	BOLT NUTS
CONTROLS		CABLES	DOORS	GLASS	
UPHOLSTERY		BODY CONDITION			
REMARKS					
ENGINE RUNNING	INSPECTORS	INITIALS	NMCB	INITIALS	NMCB
	ACCESSORIES	INSTRUMENTS	WARNING DEVICES		HORN
		W/S WIPERS	BRAKES	CLUTCH	HAND BRAKE
	LEAKS	ENGINE	TRANSMISSION		TRANSFER CASE
		DIFFERENTIALS	BRAKES	STEERING	WINCH
	ENGINE PERFORMANCE	STARTING	IDLING	FULL LOAD	
		PARTIAL LOAD			REMARKS
	VEHICLE PERFORMANCE	STEERING	BRAKES	CLUTCH	TRANSMISSION
		DIFFERENTIALS	TRANSFER CASE	PTO	WINCH
		HYD SYSTEM	DRIVE SHAFTS	UNUSUAL NOISE MOTION	
	REMARKS				

Figure 4-17.—Equipment Evaluation Inspection Guide.

2.473

Chapter 4—BATTALION EQUIPMENT COMPANY SHOPS SUPERVISOR

INVENTORY	INSPECTORS	INITIALS	NMCB	INITIALS	NMCB
	COLLATERAL EQUIPMENT INVENTORY	DISCREPANCY - SHORTAGES			
	OPERATIONS SUPERVISORS	INITIALS	NMCB	RECOMMENDED CONDITION CODE	
INITIALS		NMCB	RECOMMENDED CONDITION CODE		
REMARKS					
SHOP INSPECTION AND REPAIR	INSPECTORS	INITIALS	NMCB	INITIALS	NMCB
	MOUNTING BOLTS	ENGINE	TRANSMISSION	AXLES	TRANSFER CASE
		SPRINGS	BODY	CAP	FENDERS
		AIR TANKS	REMARKS		
	MISCELLANEOUS	EXHAUST SYSTEM	SPRINGS	SHOCKS	THR RODS
		DRAG LINK	DRIVER ARM	CONTROL LINKAGE	
	AIR INTAKE SYSTEM	CLEANER COND	PIPING/CONNECT	TURBOCHARGER	BLOWER
	FRONT WHEELS	BRAKE LINING	BEARING ASSEMBLYS		SEALS
		BOOTS	DRUMS	CYLINDERS	BACKING PLATE
		SHOE MOUNT	ADJUST MECH	REMARKS	
	REAR WHEELS	BRAKE LINING	BEARING ASSEMBLYS		SEALS
		BOOTS	DRUMS	CYLINDERS	BACKING PLATE
		SHOE MOUNT	ADJUST MECH	REMARKS	
	SHOP SUPERVISOR	MAKE MINOR REPAIRS ORDER PARTS (initials)			
FINAL INSPECTION (Initials)					
OVERALL CONDITION					
	N - NEW			1 - EXCELLENT	
	F - USED-RECONDITION			2 - GOOD	
	O - USED-USABLE WITHOUT REPAIRS			3 - FAIR	
	R - USED-REPAIRS REQUIRED			4 - POOR	
	X - NO FURTHER VALUE FOR USE AS ORIGINALLY INTENDED				
ABOVE CONDITION AGREED TO BY MAINTENANCE SUPERVISORS FROM BOTH BATTALIONS					
NMCB (SIGNATURE)			NMCB (SIGNATURE)		

Figure 4-18.—Equipment Evaluation Inspection Guide—Continued.

## CONSTRUCTION MECHANIC I & C

				DATE
I. D. NUMBER	DESCRIPTION	LOCATION		
ASSIGNED TO CODE	USN NO.	MOUNTED/UNMOUNTED	NAVFAC 6-11200/15	
INSPECTORS	INITIALS	NMCB	INITIALS	NMCB
PRESTART INSPECTION	FRAME	MOUNTINGS	MOUNTING HARDWARE	
	CONTROLS	CABLES/SHEAVES		BUSHINGS/BEARINGS
	HOSES	HYD SYSTEM	CUTTING EDGE/TEETH	
REMARKS				
INSPECTORS	INITIALS	NMCB	INITIALS	NMCB
OPERATIONAL INSPECTION	PARTIAL LOAD		FULL LOAD	
	REMARKS			
OPERATIONS SUPERVISORS	INITIALS	NMCB	RECOMMENDED CONDITION CODE	
	INITIALS	NMCB	RECOMMENDED CONDITION CODE	
REMARKS				
SHOP SUPERVISOR	MAKE MINOR REPAIRS /ORDER PARTS (Initials)			
	FINAL INSPECTION (Initials)			
OVERALL CONDITION				
	N - NEW		1 - EXCELLENT	
	E - USED-RECONDITION		2 - GOOD	
	O - USED-USABLE WITHOUT REPAIRS		3 - FAIR	
	R - USED-REPAIRS REQUIRED		4 - POOR	
	X - NO FURTHER VALUE FOR USE AS ORIGINALLY INTENDED			
ABOVE CONDITION AGREED TO BY MAINTENANCE SUPERVISORS FROM BOTH BATTALIONS				
NMCB (SIGNATURE)			NMCB (SIGNATURE)	

Figure 4-19.—Attachment Evaluation Inspection Guide.

2.474



## Chapter 4—BATTALION EQUIPMENT COMPANY SHOPS SUPERVISOR

5. A preventive maintenance inspection of all equipment attachments, using an Attachment Evaluation Inspection Guide. Accomplish all repairs possible, dependent upon the work force, space, and repair parts available as determined jointly by both maintenance supervisors.

6. A visual inspection of each preserved item of assigned USN-numbered equipment, using an Equipment Evaluation Inspection Guide. The equipment is not de-preserved for testing unless visual inspection shows major discrepancies.

The Equipment Condition Codes as defined below are used in completing the parts of figures 4-18 and 4-19 that describe the overall condition of the equipment being BEEPed.

### ALPHABETICAL CODING

N—New, unused.

E—Used, but reconditioned (overhauled); not used since overhaul.

O—Used; fully operational, without repairs.

R—Deadlined: Repairs required before this item can perform its intended mission.

X—No further value for use as originally intended.

### NUMERICAL CODING

1—Excellent Condition. (Repairs would cost no more than 10 percent of replacement cost to upgrade to O-1.)

2—Good Condition. Does not qualify for excellent; slightly shop worn, but with considerable use left before any important repairs would be required. (Repairs would cost from 11 percent to 25 percent to upgrade to O-1.)

3—Fair Condition. Worn, rusted, or deteriorated to the extent where some parts or portions should be replaced. (Repairs would cost from 26 percent to 40 percent to upgrade to O-1.)

4—Poor Condition. Badly worn, rusted, deteriorated, and would still be in doubtful state of dependability and uneconomical in use, if repaired at location. (Repairs would cost from 41 percent to 65 percent of replacement cost to upgrade to O-1.)

NOTE: Repair costs by percentage of replacement as set forth in numerical coding will pertain to deadlined equipment only.

### REPAIR PARTS (BEEP)

The repair parts portion of the BEEP will be accomplished in accordance with COMCBPAC/COMCBLANT Instruction 4040.1 series.

### EMBARKATION

As indicated in Mobile Construction Battalions, mobility is a major portion of the unit's tasking. The battalion maintains a staff that preplans for given situations. They work with the air detachment, air echelon, and sea echelon scheduling for ships or planes. The embarkation staff determines and adjusts load requirements to fit the type of units doing the transporting. As a CM1 or CMC, your tasking will be to communicate with the embark staff through your chain of command. This communication will include changes in types of equipment available, deadlined units designated as air detachment or air echelon, and parts requirements changes.

### SCHEDULING

Scheduling of equipment through the shop during embarkation will depend on which equipment is to be embarked, number of mechanics available, and time allowed. All equipment must be thoroughly cleaned and time must be allotted for this operation. Air detachment equipment will receive top priority. As a shop supervisor, your input and knowledge of the mechanic's capabilities will be vitally important.

## INSPECTING

Equipment to be embarked should have minor repairs accomplished prior to embarkation. These units must be capable of operating for sometime without breakdown. Deadlined units on the sea echelon may be repaired underway. Equipment to be transported aboard aircraft will be delayed if fuel, oil, and water leaks are not detected during your inspection and corrected while in the shop.

## PREPARING

Coordinated preplanned efforts between the mechanics, wash rack personnel, collateral equipment, and Equipment Operators are essential for a successful embark. All collateral equipment must accompany the unit for which it was intended; spare tires must be mounted. Depending on the method of transporting, dump truck headache boards need to be removed and secured in the bed, tops removed, windshields down and taped, and exhaust stacks loosened. Front-end loaders often require that the buckets and counterweights be removed. Detailed data for each unit will be coordinated between the embark staff and the transporting unit.

## STAGING

After the equipment has completed the shop requirements, it might have the requirement to be loaded with designated equipment. All air-transported units must be weighed and the center of balance marked in the configuration in which it is to be loaded. After this has been accomplished, it may be staged for convoy or movement in a place that is not congested and does not interfere with continued progress of equipment in process.

## TRANSPORTING

Often a convoy movement is required to reach the transporting unit. This operation may be used to arrange equipment in load-number order if it was not done during the staging phase. Loading and tiedown are normally under the directions of the aircraft loadmaster or the ship's boatswain.

## CONSTRUCTION SCHEDULE DRAWINGS

In construction, schedules play a large part in keeping production flowing smoothly. Before, during, and after construction, the schedule serves as a guide for all managerial and supervisory personnel. Without a schedule, coordination and teamwork would be difficult to achieve. As you advance to CM1 or CMC, your knowledge of management tools increases, regarding manpower and equipment utilization. The methods discussed in this section include the arrow diagram, the critical path, the network analysis, and the precedence diagram.

### ARROW DIAGRAM

The arrow diagram is drawn in graphic form to identify work, service, or task items (referred to as **ACTIVITIES**). Arrow diagrams also reflect how each activity depends upon others during the work sequence.

In arrow diagrams, both circles and arrows are used to describe the work sequence (fig. 4-20). A circle represents an **EVENT** or starting point of the **ACTIVITY**, represented by an arrow. An event occurs only when all the activities preceding it (which means all the arrows leading to the circle) have been completed. In figure 4-21, event 4, which starts activity F, cannot occur until both C and D are completed. Broken arrows in an arrow diagram represent a constraint or unknown element and are called **DUMMIES**. Arrow diagramming makes up about 80 percent of the planning phase. By adding the time elements (fig. 4-22), the critical path can be determined.

### CRITICAL PATH

The critical path (fig. 4-23) consists of a sequence of time dependent, directly following activities and is defined as the longest path in terms of time through the project. Each activity within the critical path must be completed on time to finish a project within the scheduled time frame.

SYMBOLS		DEFINITIONS	
		<b>EVENT</b>	A progress step A state of or conditions of progress Does not consume time
		<b>ACTIVITY</b>	A separately described assignable task A distinct portion of the planned work A work package any time predictable element Stated in terms of the time needed
		<b>DUMMY</b>	A performance constraint A dependence illustrator may represent an unpredictable time element such as weather review approval delivery etc. It is also a network logic sustainer differentiator
		<b>ELAPSED TIME</b>	The best time estimate Obtained from the most knowledgeable person currently responsible for actual performance of the activity Not obtained from actual historical data (Past errors are not intended to be repeated)
		<b>CRITICAL ACTIVITY</b>	Each activity on the Critical Path (longest path) in terms of time from the project start event to the project completion event

Figure 4-20.—Symbols and definitions of arrow diagraming.



117.308

Figure 4-21.—Activities and events.

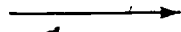
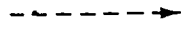
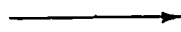
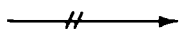
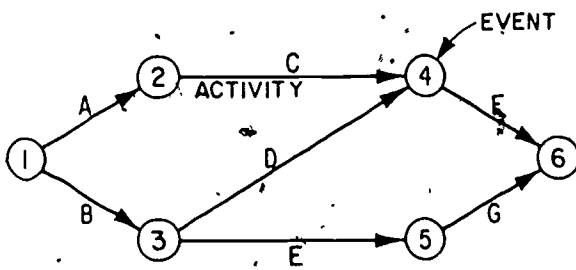
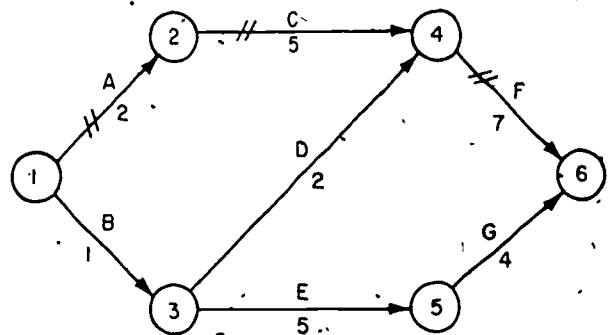

Figure 4-23.—Critical path indicated for activities and events.

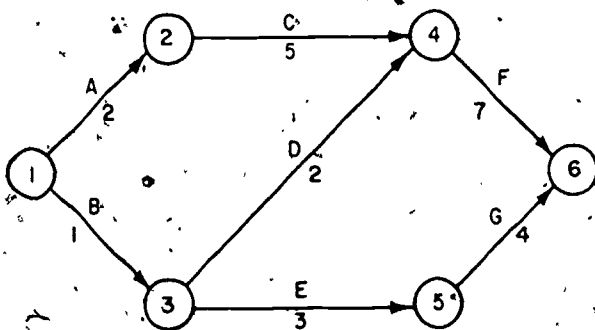

Figure 4-22.—Time elements added to activities and events.

### NETWORK ANALYSIS

The object of network analysis is to combine all the information relevant to the planning and scheduling of project functions into a single master plan—a plan that coordinates efforts, shows interrelationships, shows which efforts are critical, and promotes efficient use of equipment and manpower.

Because everything that happens in a network, analysis is activity dependent (fig.

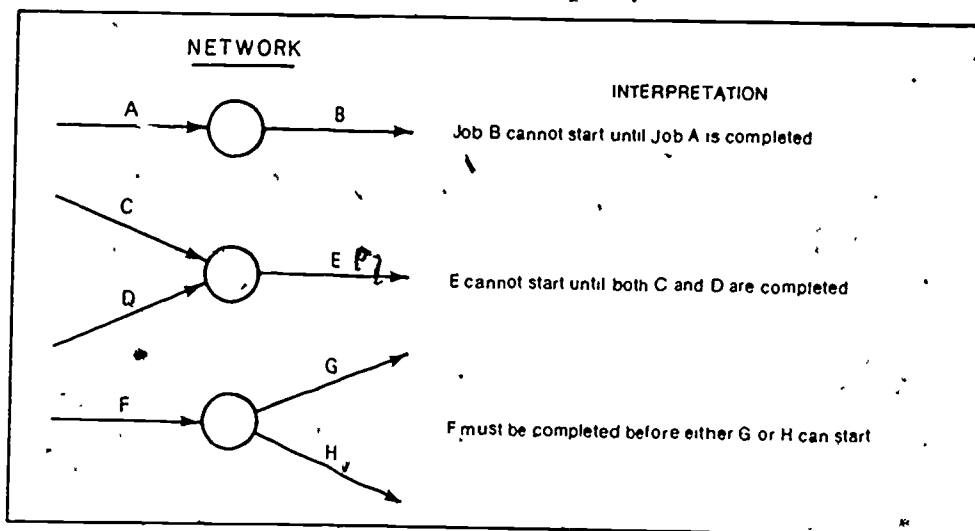

Figure 4-24.—Elements of network diagramming.

4-24), the arrow diagram must be a meaningful description of the project. If not, less than satisfactory results will be obtained from the network analysis. In almost every case of difficulty or dissatisfaction with network analysis, the cause can be traced to a faulty or unrealistic arrow diagram. Since everything in an arrow diagram is significant, the basic principles must be understood and applied completely.

After a project has been planned on an arrow diagram, the next phase is to schedule the project—that is, place it on a working timetable.

The development of a schedule is governed by four principles which remain fixed even though the type of schedule is changed.

Scheduled operations cannot exceed the CAPABILITY to accomplish the work. For example, if only five bulldozers are available, the maximum possible which can be scheduled at any given time is five.

Scheduled operation must follow the SEQUENCE of work required for the particular job. For instance, the finished surface of a road cannot be applied before the base course is

constructed, nor can a roof be put on a building before the foundation and walls are up.

These two principles may appear so obvious as to merit little attention, yet the most common errors in scheduling involve violations of both. If a schedule is made which does NOT violate either of these principles, it will be a workable schedule, but it will NOT necessarily be a good schedule. Two other principles must be observed to develop a good schedule.

CRITICAL items must be scheduled as soon as possible. Maximum speed of completion of a project is most frequently the aim in advanced base construction. This is usually achieved by scheduling those items which take the longest time, or upon which many other operations are based to begin as early as possible.

SCHEDULING must insure continuity of work effort. Maximum efficiency in accomplishing a particular work item is best achieved if the time for accomplishing that item is as continuous as possible. For example, a grader on a road job should not be required to change, during short periods, from fine grading to sloping ditches or to some other type of work. This reduces production and requires more supervisory personnel. These last two principles are often in opposition to one another and a balance must be made between them to obtain

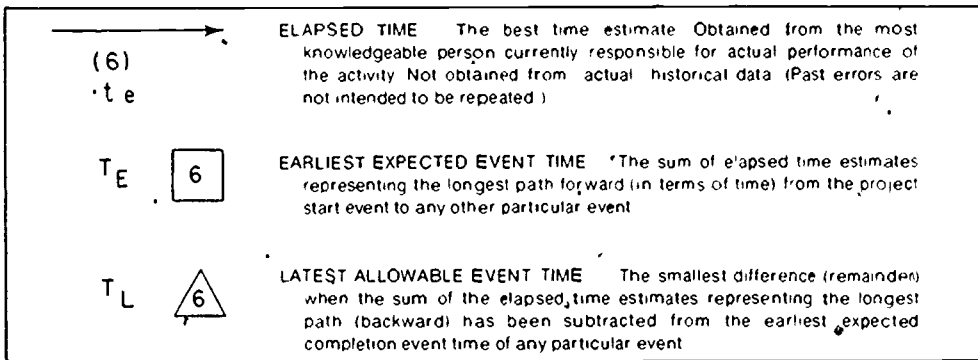

Figure 4-25.—Symbols and definitions of network diagraming.

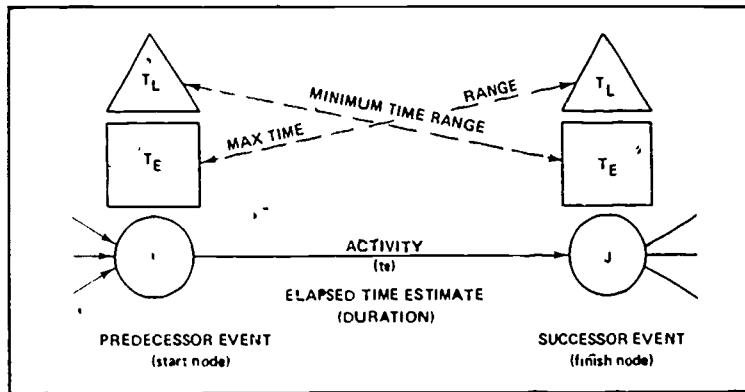

Figure 4-26.—Network symbols in perspective.

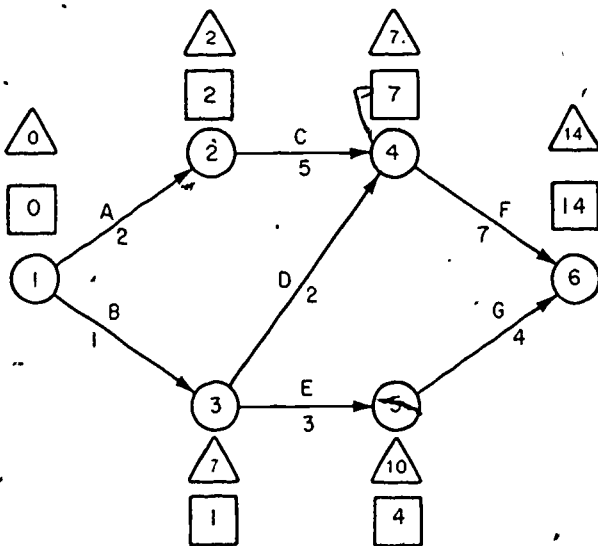

Figure 4-27.—Example of a network diagram.

the best schedule. The steps taken in this phase determine whether or not network analysis will be used successfully.

Network analysis differs from arrow diagraming in that additional symbols (fig. 4-25) are utilized to accumulate progressive days. Events are referred to as the "i" node (start) and the "j" node (end) (fig. 4-26). Using the same project as in arrow diagraming (fig. 4-21) and adding the network symbols (fig. 4-27), it can be determined that this project will be complete in fourteen units of time. Slack (flexibility) may be total slack, free slack, or shared slack. The following formulas using the symbols in figures 4-25 and 4-26 are used to determine the slack.

$$T_L - T_E - t_e = \text{Total slack}$$

$$T_E - T_L - t_e = \text{Free slack}$$

$$\text{Total slack} - \text{Free slack} = \text{Shared slack}$$

**PRECEDENCE DIAGRAM**

While arrow diagramming is most often used in the NCF, precedence diagramming does not require dummy activities and is adaptable to computer programming. Activities in precedence diagrams are represented by a rectangular box (fig. 4-28) and are identified by the activity number. The left side of the box (fig.

4-29) represents the start, and the right side represents completion. Lines linking the boxes are called "connectors."

The rule governing the drawing of a network is that the start of an activity must be linked to the ends of all completed activities before the start may take place. Activities taking place at the same time are not linked in any way. In figure 4-30, both activity 2 and activity 3 start as

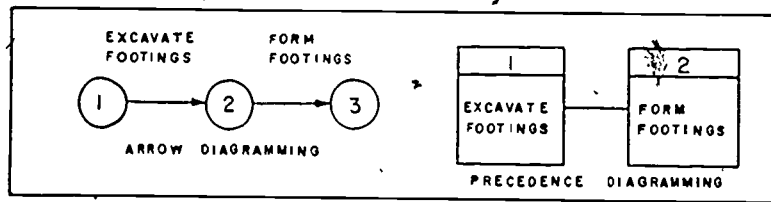

Figure 4-28.—Comparison representation of arrow and precedence diagrams.

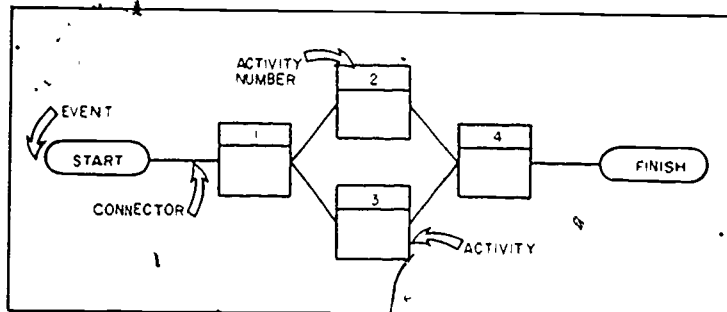

Figure 4-29.—Precedence diagram.

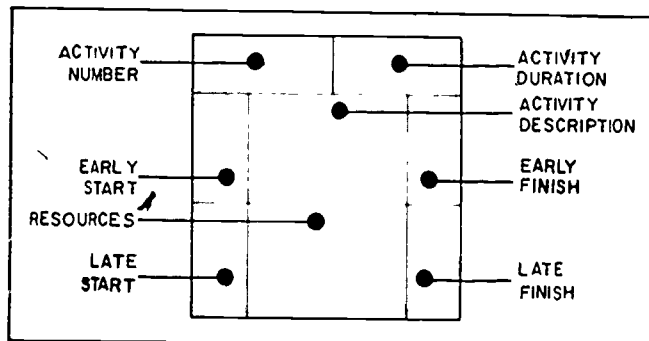

Figure 4-30.—Information for a precedence activity.

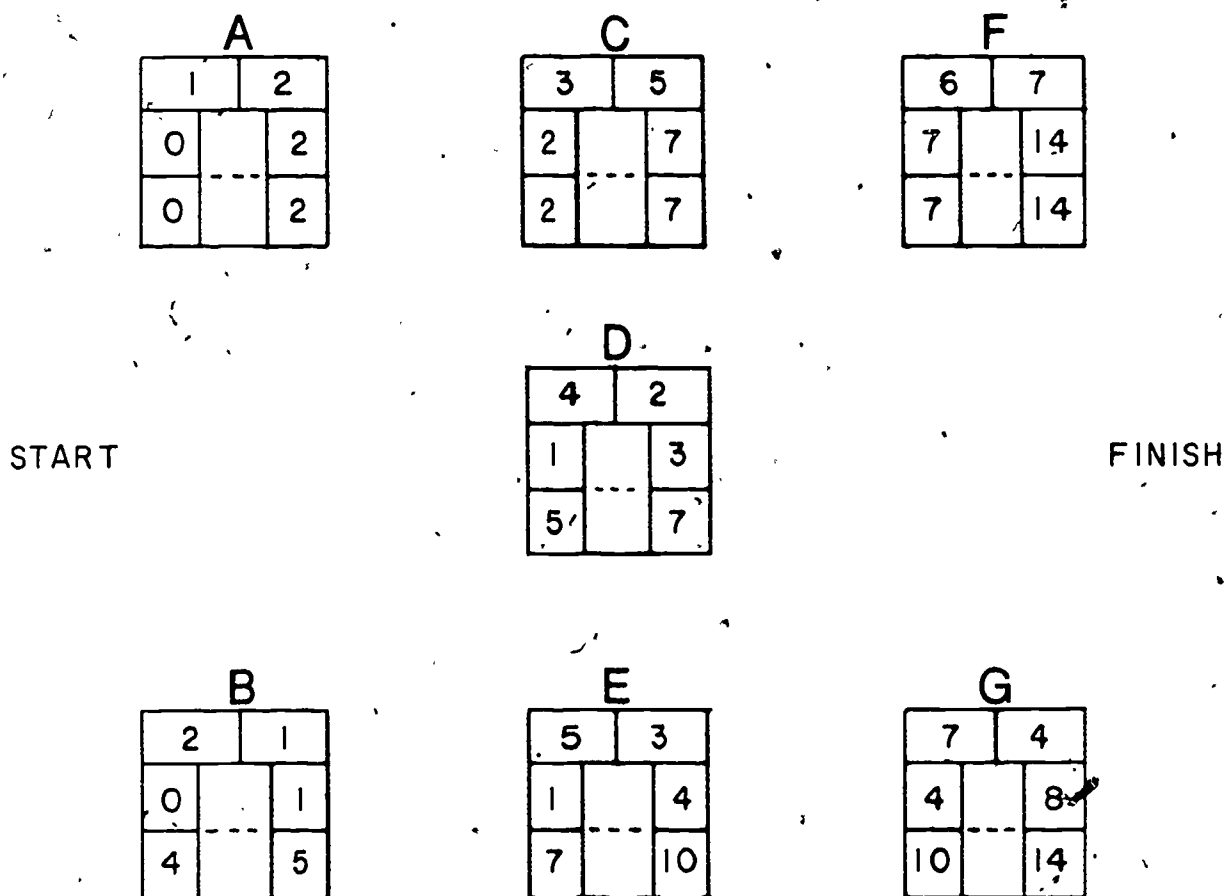

Figure 4-31.—Example of a precedence drawing layout.

soon as activity 1 is complete. Activity 4 requires the completion of both activities 2 and 3 before it can start.

Precedence networks are easily drawn by placing all activities on small cards and manipulating them into a logical manner. Connectors which are drawn to each of the activities show the relationship between the activities.

The information provided in figure 4-29 is the same basic data used in network analysis of the arrow diagrams. Figure 4-31 is the same project used in arrow diagram figure 4-21 and is completed in 14 days.

While most mechanics do not work from arrow diagrams, critical paths, network analysis, or precedence diagrams daily, by applying the terms to a related task, they do in fact work with similar plans.

- EVENT— progress step: example, head removed
- ACTIVITY— time to accomplish a repair procedure within the total job: example, remove head
- CRITICAL ACTIVITY— time to repair item: example, grind valves
- ELAPSED TIME— time estimate of activity: example, remove head, one hour

CONSTRUCTION MECHANIC 1 & C

---

EARLIEST EXPECTED  
EVENT TIME—

time estimate considering no delay: example, flat rate time

LATEST ALLOWABLE  
EVENT TIME—

latest time considering delays: example, head returned from  
machine shop

---

For a detailed study of arrow diagraming,  
network analysis and precedence diagraming,

refer to the *SEABEE Planner's and Estimator's  
Handbook*, NAVFAC P-405.



## CHAPTER 5

# ENGINE OVERHAUL

The engine of any piece of equipment is taken for granted as long as it runs smoothly and efficiently. But all engines lose power sooner or later from normal wear. When this happens, the mechanic must be able to determine the cause and know what is needed to correct the trouble.

Generally speaking, it is NOT the supervisor's job to perform engine repairs but, it IS the supervisor's job to see that these repairs are performed correctly and to assist and instruct those doing the work.

Since the SEABEES use many models of internal combustion engines, it is impossible to specify the detailed overhaul procedures for all the engines. However, here are several basic principles which apply to all engine overhauls:

1. Consult the detailed repair procedures given in manufacturers' instruction and maintenance manuals. Study the appropriate manuals and pamphlets before attempting any repair work. Pay particular attention to tolerances, limits, and adjustments.

2. Observe the highest degree of cleanliness in handling engine parts during overhaul.

3. Before starting repair work, be sure all required tools and replacements for known defective parts are available.

4. Keep detailed records of repairs, such as the measurements of parts, hours of use, and new parts installed. An analysis of these records will indicate the hours of operation that may be expected from the various engine parts, and help in determining when a part should be renewed to avoid a failure.

Since maintenance cards, manufacturers' technical manuals, and various instructions contain repair procedures in detail, this chapter will be limited to general information on some of the troubles encountered during overhaul, their causes, and methods of repair.

### HORSEPOWER AND HORSEPOWER RATINGS

Horsepower is a unit for measuring work per unit of time. One horsepower is equivalent to 33,000 foot-pounds of work per minute. Horsepower is determined by either measuring mechanically or computing mathematically.

Maintenance manuals should be consulted for engine performance data and specifications. These manuals will also have additional horsepower designations and the many different horsepower ratings used by manufacturers in describing the equipment. The method used in measuring power and the purpose for which it is intended account for the variety of horsepower and horsepower ratings.

### INDICATED HORSEPOWER

INDICATED HORSEPOWER is the theoretical power that an engine would deliver if all frictional losses were eliminated. It is used mainly by experimental engineers in designing new and more efficient engines. Indicated horsepower may be computed from the following formula:

$$\text{Indicated HP} = \frac{\text{PLANK}}{33,000}$$

## CONSTRUCTION MECHANIC 1 & C

Where

**P** = Mean effective pressure in pounds per square inch (This is the average pressure on the piston during the power stroke minus the average pressure during the other three strokes.)

**L** = Length of stroke in feet

**A** = Area of piston head in square inches

**N** = Working strokes per minute

**K** = Number of cylinders in the engine

33,000 = The equivalent of one horsepower in foot-pounds per minute

Of all the factors given in this formula, only cylinder pressure (**P**) and engine rpm (**N**) can be changed during the normal operation of the engine. The remaining factors are constant.

### CONVERSION TO METRIC

Converting engine displacement from the old (English) system to the new (metric) system means converting from cubic inches to liters.

The formula for engine displacement is **A** (area of a piston) times **L** (the length of stroke) times **N** (the number of cylinders). Find **A** by squaring the radius of the piston and multiplying by  $\pi$  (3.14).

To convert inches to centimeters, use a conversion factor of 2.54. Square inches may be converted to square centimeters (cm<sup>2</sup>) with the conversion factor of 6.45. To convert cubic inches to cubic centimeters, multiply by 16.39. When the bore and stroke are indicated in millimeters, simply put a decimal point one place to the left to obtain centimeters. After obtaining the total cubic centimeters within the engine, divide by 1000 or move the decimal point three places to the left to obtain liters.

For example, take Caterpillar D-342, a 6-cylinder engine whose bore is 5.75 inches and stroke is 8 inches.

	ENGLISH	METRIC
Bore	5.75 in	14.6 cm
Radius	2.875 in	7.3 cm
Area of Piston	25.97 in <sup>2</sup>	167.5 cm <sup>2</sup>
Stroke	8 in	20.3 cm
Displacement Per Cylinder	207.76 in <sup>3</sup>	3400.9 cm <sup>3</sup>
Cylinders	6	6
Total Engine Displacement	1246.5 in <sup>3</sup>	20405.2 cm <sup>3</sup>
Rated Engine Displacement	1246 in <sup>3</sup>	20.4 L

By using the conversion factor of 1.014, you can convert indicated horsepower to approximate horsepower metric. To obtain approximate horsepower metric from known specifications, use the equation:

$$\frac{P L K}{450} = \text{HP metric, where}$$

**P** = mean effective pressure in kg/cm<sup>2</sup>

**L** = liters of displacement, and

**K** = revolutions per minute

With the same equation, you can find mean effective pressure when horsepower metric is known.

$$P = (\text{HP metric}) \times 450 \div K \div L$$

As a second example, take the GMC 454 V8 with 245 indicated horsepower at 3800 rpm, stroke of

4 inches and bore of 4.25 inches. Convert units as follows:

	English Unit	Conversion Factor	Metric Unit
Stroke	4 in	2.54	10.16 cm
Area	14.18 in <sup>2</sup>	6.45	91.46 cm <sup>2</sup>
Horsepower	245 HP	1.014	248.4 HP
Displacement	453.76 in <sup>3</sup> (4 X 14.18 X 8)		7.4 L $\frac{(10.16 \times 91.46 \times 8)}{1000}$

Therefore,  $P = 248.4 \times 450 + 3800 + 7.4 = 3.98 \text{ kg/cm}^2$

Likewise,  $\frac{PLK}{450} = \frac{3.98 \times 7.4 \times 3800}{450} = 248.4 \text{ HP metric}$

**BRAKE HORSEPOWER**

**BRAKE HORSEPOWER** is the actual amount of power that an engine can deliver at a

certain speed with a wide-open throttle. The term, brake horsepower, is derived from the braking device (usually a dynamometer) which is applied to measure the horsepower an engine develops. The dynamometer consists of a resistance-creating device, such as an electric armature revolving in a magnetized field. A paddle wheel revolving in a fluid may also be used to absorb the energy.

An **ENGINE DYNAMOMETER** may be used to test an engine that has been removed from the vehicle it drives. If the engine does not develop the manufacturer's recommended horsepower and torque at specific rpms, the engine must be tuned up or repaired.

The **CHASSIS DYNAMOMETER** can give a quick report on engine conditions by measuring output at various speeds and loads. It is useful in shop testing and adjusting automatic transmissions.

On the chassis dynamometer, figure 5-1, the driving wheels of the vehicle are placed on

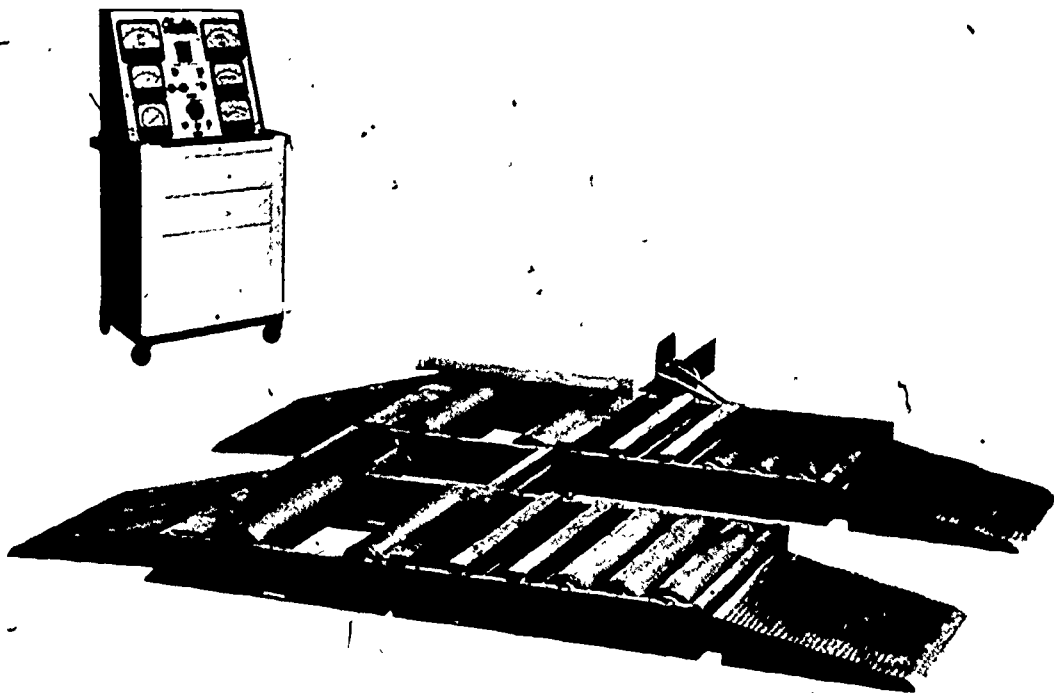

Figure 5-1.—Chassis dynamometer.

2.16X

5-3  
102

rollers. The engine drives the wheels and the wheels drive the rollers. By loading the rollers varying amounts and by running the engine at different rpms, nearly all normal driving conditions can be simulated. The tests and checks can be made without the interference of body noises, as happens when the vehicle is driven on the road.

**FRICTION HORSEPOWER**

FRICTION HORSEPOWER is the difference between indicated horsepower and brake horsepower. Actually, it is the power required to overcome friction within the engine, such as friction between engine parts, resistance in driving accessories, and, among other things, loss due to pumping action of the pistons. The latter may be compared to the effort required to raise the handle of a hand-operated tire pump. It may be difficult to properly define friction horsepower, but with proper maintenance, it can

be reduced to improve the mechanical efficiency of the engine.

**DRAWBAR AND BELT HORSEPOWER**

There are two kinds of horsepower commonly used by manufacturers in rating the power of construction vehicles—drawbar and belt horsepower.

DRAWBAR HORSEPOWER is the power that can be exerted in pulling a load. Specifications of the Caterpillar D-8 H series with a D-342 engine, for example, rate the drawbar horsepower at 180.

BELT HORSEPOWER is equivalent to the rated engine power, except in cases where the belt pulley is driven through a gear train. In this case, there is a slight loss of power caused by gear friction. Also, while there may be some belt-pulley slippage, it is considered negligible in arriving at the belt horsepower rating.

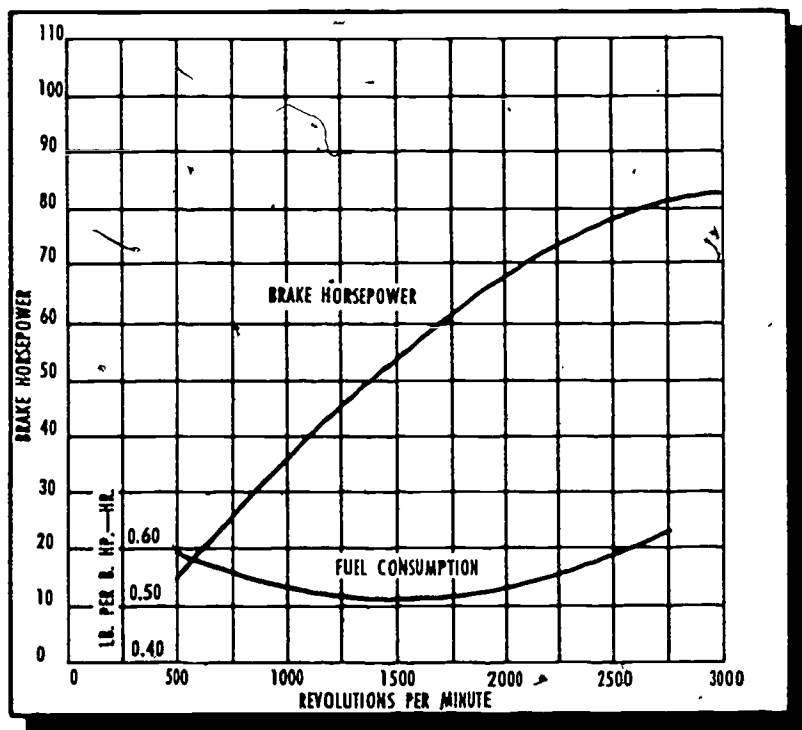

Figure 5-2.—Performance curves of a typical 6-cylinder gasoline engine.

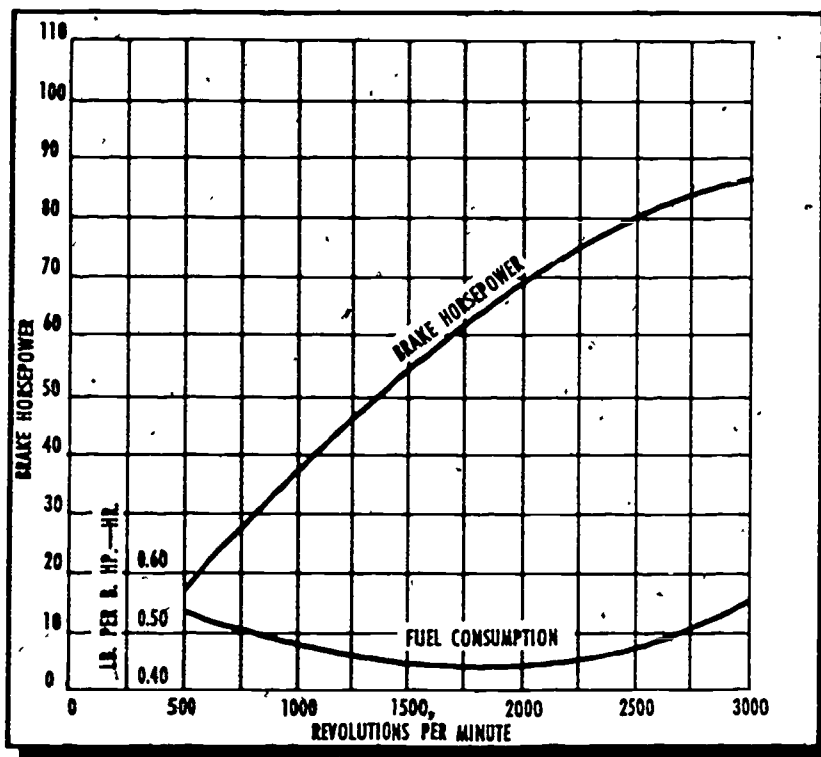

Figure 5-3.—Performance curves of a typical 6-cylinder diesel engine.

2.18

The national Automotive Chamber of Commerce has developed a simplified method of determining taxable horsepower based on the bore of the engine and the number of cylinders. This specification is listed in most manufacturers' manuals, but it does not truly represent the actual horsepower of modern high-speed, high-compression engines. It is used for licensing purposes only in some states.

### GRAPHS AND DIAGRAMS

Graphs and diagrams are abbreviated methods of recording operation and maintenance data.

Manufacturers' operation and maintenance manuals often contain graphs and diagrams. The technical bulletins, prepared chiefly for tuneup mechanics, may use a particular graph or

diagram to eliminate pages of written description that otherwise would be necessary.

### PERFORMANCE CURVES

Figures 5-2 and 5-3 are examples of graphs that describe engine performance in terms of brake horsepower and fuel consumption. Dynamometer tests provide the data used in plotting the performance curves for each engine. Figure 5-4 is another example of a graph. It shows that the amount of torque an engine produces varies with its speed. The relationship between torque and horsepower is shown in figure 5-5.

Horsepower is related to both torque and speed. When both are increasing, as they do between 1200 and 1600 rpm, then horsepower goes up sharply. As torque reaches maximum and begins to taper off, horsepower continues to

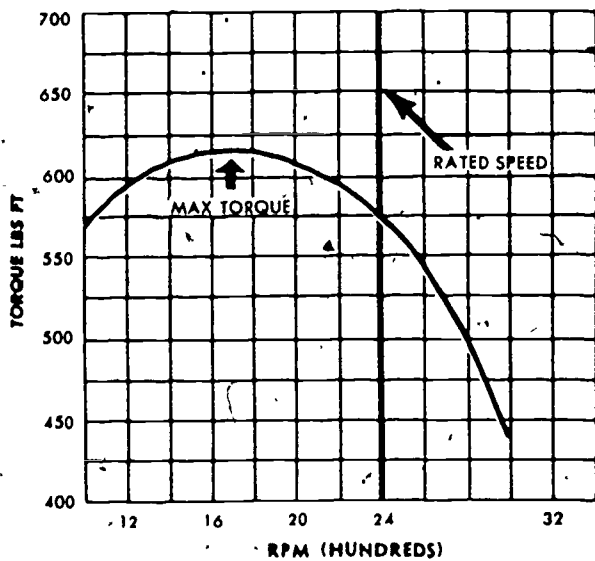

2.21

Figure 5-4.—Graph showing relationship between torque and speed.

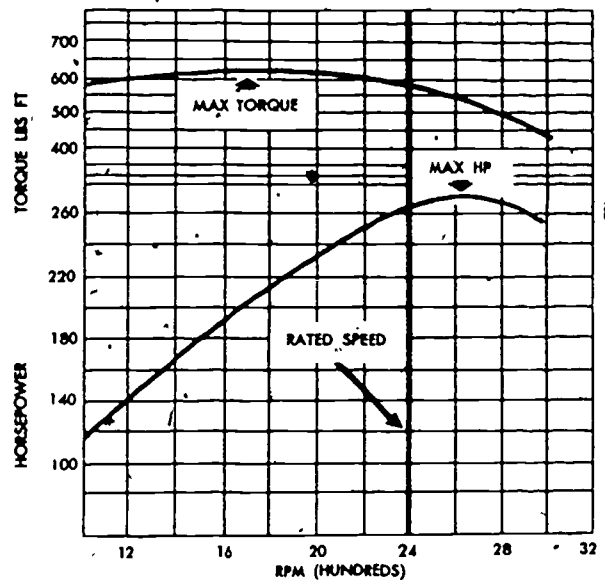

2.22

Figure 5-5.—Relationship between torque and horsepower.

rise to maximum. The horsepower starts to decline beyond rated speed where torque falls off sharply.

### TIMING DIAGRAMS

Engine timing, as described in *Construction Mechanic 3 & 2*, is largely a matter of opening and closing valves or ports, and of adjusting ignition or fuel injection, so that these events occur at the proper time in the cycle of engine operation. Timing diagrams picture these events in relation to each other and in relation to top dead center (TDC) and bottom dead center (BDC). They are useful to the CM for quick and easy reference. However, before timing diagrams can be very useful, the mechanic must recall a few facts about engine cycles.

The 4-stroke cycle engine makes two complete crankshaft revolutions in one cycle (intake, compression, power, and exhaust). The 2-stroke cycle engine completes a cycle with just one crankshaft revolution. With diesel engine cycles (2- and 4-stroke), the event of fuel injection will be shown on the timing diagram instead of spark ignition which is common to gasoline engine operating cycles.

### Four-Stroke Cycle Engine Timing

Figure 5-6 illustrates a typical timing diagram for a 4-stroke cycle diesel engine. The actual length of the strokes illustrated and the beginning of fuel injection will vary a few degrees in either direction, depending on a specific manufacturer's recommendations. Follow the events in this cycle by tracing the circular pattern around two complete revolutions in a clockwise direction.

Start TDC with the beginning of the **POWER STROKE**. Compression is at its peak, fuel injection has been completed, and combustion is taking place. Power is delivered to the crankshaft as the piston is driven downward by the expanding gases in the cylinder. Power delivery ends when the exhaust valve opens.

After the exhaust valve opens, the piston continues downward to BDC and then upward in the **EXHAUST STROKE**. The exhaust gases are pushed out of the cylinder as the piston rises to TDC, and the exhaust valve closes a few degrees after TDC to insure proper scavenging. The crankshaft has made a complete revolution during the power and exhaust strokes.

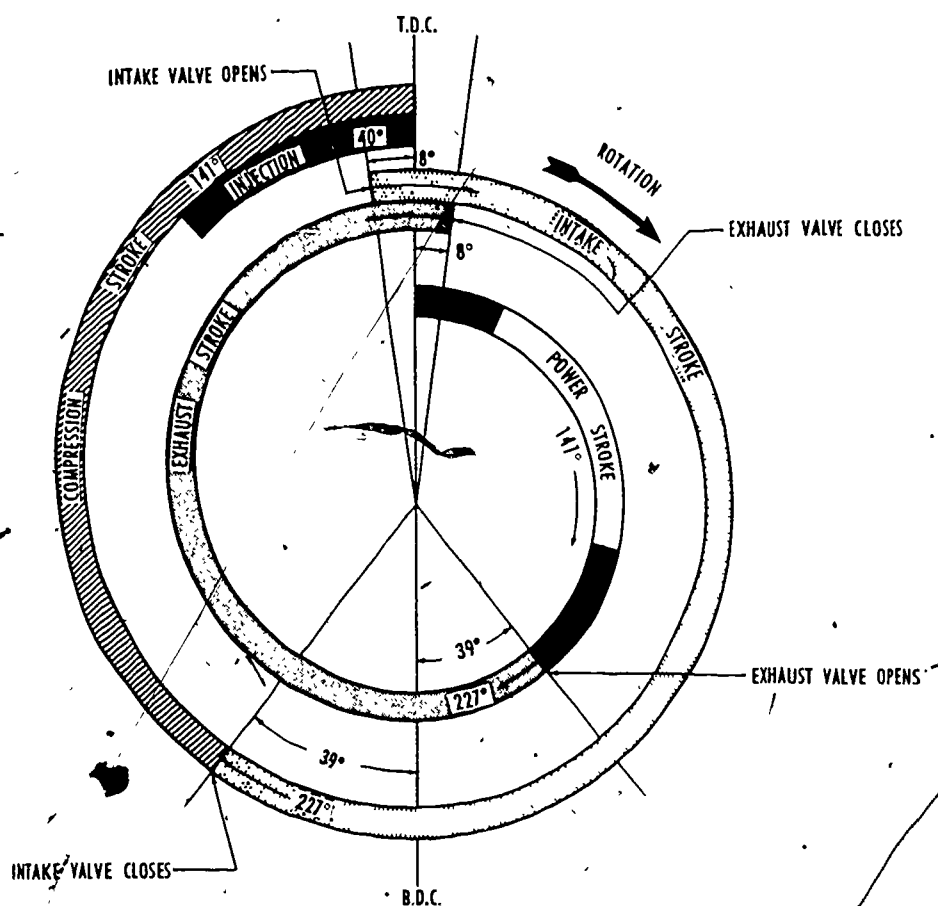

Figure 5-6.—Typical timing diagram of a 4-stroke cycle diesel engine.

2.23

To aid in scavenging the cylinder, the intake valve opens a few degrees before TDC near the end of the upward exhaust stroke. As the crankshaft continues to rotate past TDC, the INTAKE STROKE begins. The intake stroke continues for the whole downward stroke and part of the next up stroke to take advantage of the inertia of the incoming charge of fresh air.

The rest of the upward stroke is the COMPRESSION STROKE, which begins at the instant of intake valve closing and ends at TDC. FUEL INJECTION may begin as much as 40° before TDC, and continue to TDC, thus completing the power cycle and the second complete revolution of the engine.

By substituting the event of IGNITION for fuel injection, figure 5-6 could easily represent a timing diagram for a typical gasoline engine.

For additional information on diesel fuel injection system tests that can be made both in the shop and in the field, refer to the manufacturer's service manual.

### Two-Stroke Cycle Engine Timing

Figure 5-7 illustrates a timing diagram of a 2-stroke cycle diesel engine. This engine is typical of the General Motors series which uses a blower to send fresh air into the cylinder and to clear out the exhaust gases. The movement of the piston itself does practically none of the work of intake and exhaust, as it does in a 4-stroke cycle engine. This fact is important to the mechanic in detecting 2-stroke cycle diesel engine power losses.

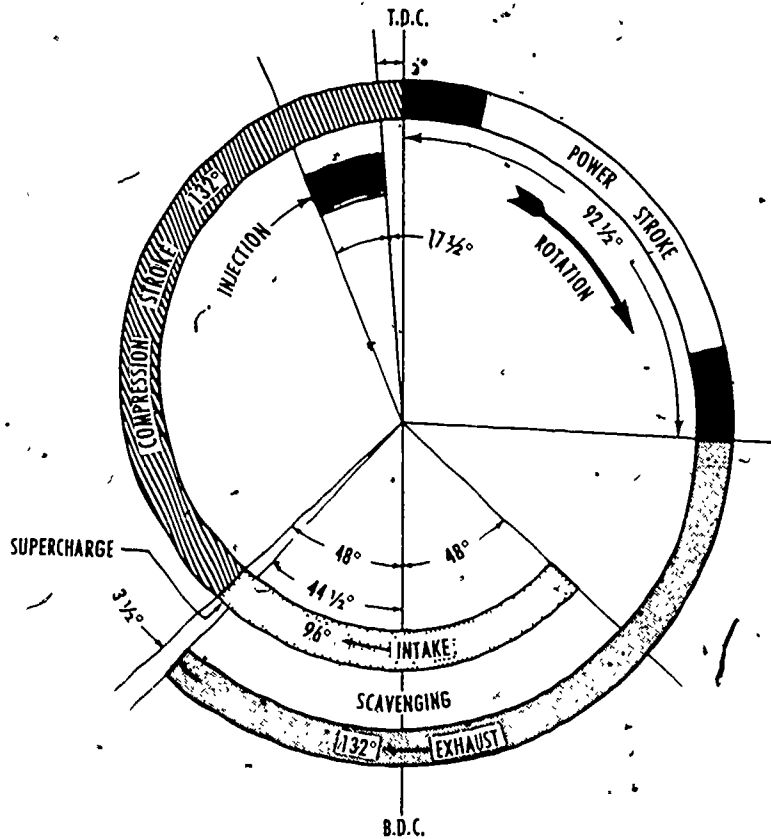

Figure 5-7.—Timing diagram of a 2-stroke diesel engine.

2.24

Beginning at TDC (fig. 5-7), the fuel has been injected, and combustion is taking place. The piston is driven down, and power is delivered to the crankshaft until the piston is just a little more than halfway down. The exhaust valves (two in each cylinder) open 92 1/2° after TDC. The exhaust gases blow out through the manifold, and the cylinder pressure drops off rapidly.

At 132° after TDC (48° before BDC), the intake ports are uncovered by the downward movement of the piston. Scavenging air under blower pressure swirls upward through the cylinder and clears the cylinder of exhaust gases. This flow of cool air also helps to cool the cylinder and the exhaust valves. Scavenging continues until the piston reaches 44 1/2° after BDC. At this point, the exhaust valves are

closed. The blower continues to send fresh air into the cylinder for just a short time (only 3 1/2° of rotation), but it is sufficient to give a slight supercharging effect.

The intake ports are closed at 48° after BDC, and compression takes place during the remainder of the upward stroke of the piston. Injection begins at about 22 1/2° before TDC and ends about 5° before TDC, depending on the engine speed and load.

The whole cycle is completed in one revolution of the crankshaft, and the piston is ready to deliver the next power stroke.

### Multiple Cylinder Engines

Theoretically, the power stroke of a piston continues for 180° of crankshaft rotation on a



4-stroke cycle engine. Best results can be obtained, however, if the exhaust valves are opened when the power stroke has completed about four-fifths of its travel. Therefore, the period that power is delivered during  $720^\circ$  of crankshaft rotation, or one 4-stroke cycle, will be  $145^\circ$  multiplied by the number of cylinders in the engine. This may vary slightly in accordance with manufacturers' specifications. If an engine has two cylinders, power will be transmitted for  $290^\circ$  of the  $720^\circ$  necessary to complete the four events of the cycle. The momentum of the fly wheel rotates the crankshaft for the remaining  $430^\circ$  of travel.

As cylinders are added to an engine, each one must complete the four steps of cycle during two revolutions of the crankshaft. The number of power impulses for each revolution also increases, producing smoother operation. If there are more than four cylinders, the power strokes overlap as shown in figure 5-8. The length of overlap increases with the number of cylinders. The diagram for the 6-cylinder engine shows a new power stroke starting each  $120^\circ$  of crankshaft rotation and lasting  $145^\circ$ . This provides an overlap of  $25^\circ$ . In the 8-cylinder engine, a power stroke starts every  $90^\circ$  and continues for  $145^\circ$ , resulting in a  $55^\circ$  overlap of power. Because the cylinders fire at regular intervals, the power overlap will be the same regardless of firing order and will apply to either in-line or V-type engines.

### POWER LOSSES AND FAILURE

Power failures can result from minor troubles, such as loose or bare wires and disconnected or damaged fuel lines. When reported by the Equipment Operator, these troubles are easy to detect without too much checking and testing. The supervisor must, however, make the mechanics aware that there probably was, in addition, an actual or contributing cause to the power failure. The supervisor must train them to look for this cause while making repairs. Unless eliminated, this may be the cause of major trouble later on.

Too often, troubles concerned with power loss occur within the engine and are not easily

found. It is these hard-to-find troubles, with little or no visual indication, that keep the CM's busy. An operator may notice a decided power loss in the equipment, and because there is excessive smoke coming from the exhaust report the trouble as improper carburetion, or, in the case of a diesel engine, as injector trouble.

An inexperienced mechanic may notice an increased engine temperature in addition to the exhaust smoke and diagnose the loss of power as improper valve action, or as trouble in the cooling system. The diagnoses are comparatively simple through visual indications. But, as a CM1 or CMC, you know that there are many causes of power loss that have little or no visual indications. Examples are incorrect ignition timing, faulty coil or condenser, defective mechanical or vacuum spark advance, worn distributor cam, or slipping clutch. Any of them can cause a power loss.

After a deficiency has been located in an engine, it is usually easy to make the necessary corrections to eliminate the conditions causing the deficiency. Careful analysis and straight thinking, however, are often needed to find the cause of engine deficiencies. With a thorough knowledge of the basic engineering and operating principles of an engine, the supervisor's job of training the mechanics will be easier and more interesting. In diagnosing engine deficiencies, the supervisor must never jump to conclusions and make a decision on the nature of repairs to be made until sure that what will be done will eliminate the trouble. The mechanics must be able to interpret the engine instrument indications, as well as use the proper testing devices. Furthermore, they must be able to road-test the equipment to determine whether repairs have been made satisfactorily and whether a unit should be adjusted or replaced. Besides, the mechanic must know when and how to make emergency adjustments for every unit on the engine.

It may seem that some of the qualifications required of a good mechanic point to the know-how of an automotive engineer. However, no one person can know all about engines and also be an expert in repairing all kinds of powered

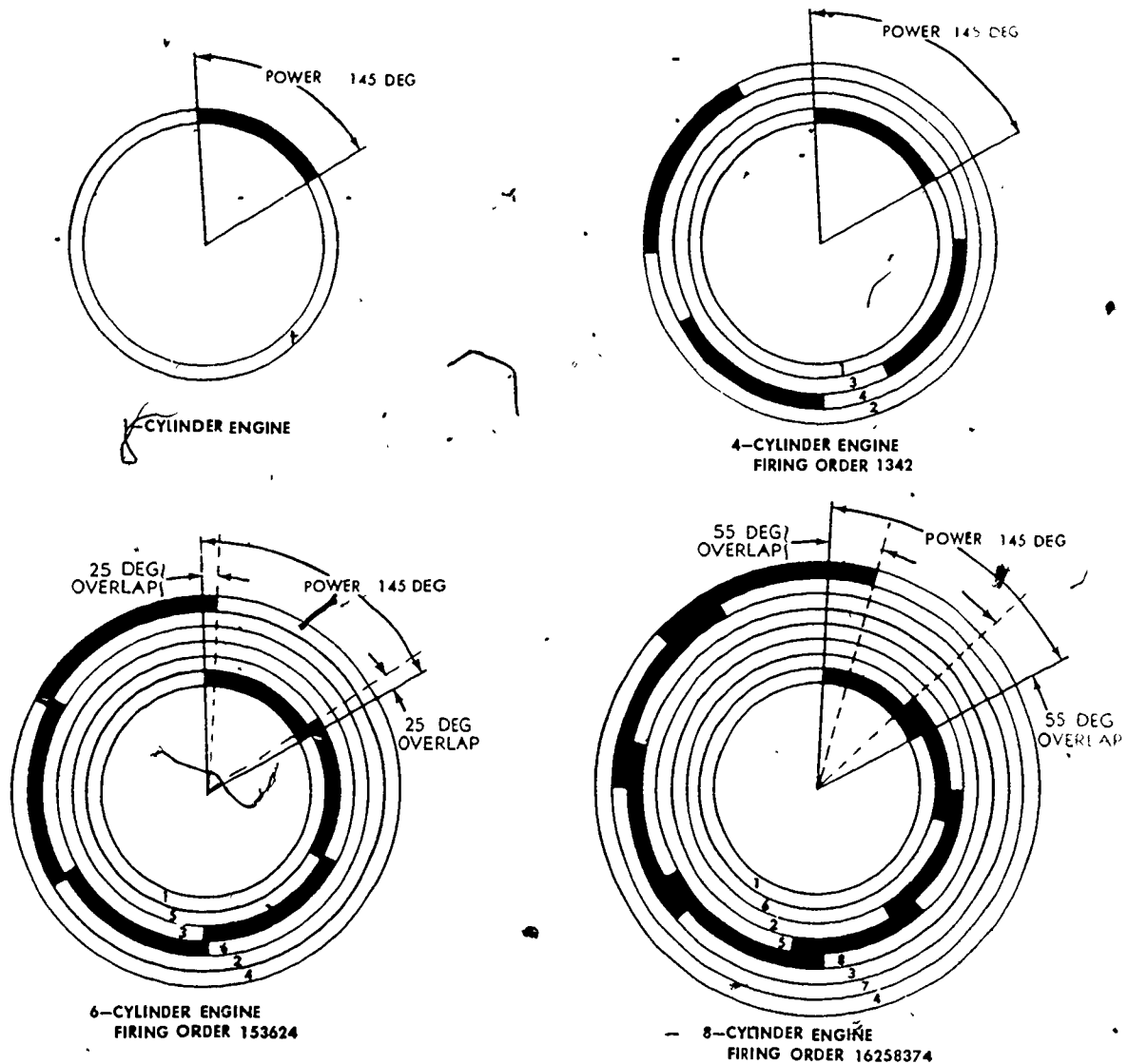

NOTE -THE CIRCLES SHOWN ABOVE REPRESENT 720 DEG NOT 360 DEG BECAUSE THE CRANKSHAFT MUST ROTATE THROUGH 720 DEG TO COMPLETE THE CYCLE ONCE FOR ALL CYLINDERS

2.25

Figure 5-8.—Power strokes in 1-, 4-, 6-, and 8-cylinder engines.

equipment used by the SEABEES. For instance, if the checks or instrument tests indicate some internal trouble in a magneto, carburetor, or fuel injection unit, the repairs should be made by mechanics who have experience or have been specially trained to use the equipment to do the particular job at hand. It is the supervisor who

will be expected to have the answers, or know where to find the answers, to all the questions asked by less experienced mechanics.

The three basic factors that affect an internal combustion engine's power are: COMPRESION, IGNITION, and CARBURETION. In

the diesel engine, fuel is injected into each cylinder, and ignition depends on the heat of compression; in the gasoline engine, ignition and carburetion are independent. In both engines, of course, proper action and timing of all three factors are necessary for the engine to produce its rated power.

It is obvious then that an engine runs and develops rated power only if all of its parts function or operate as they should. If any of these parts wear or break, requiring replacement or adjustment, the performance charts and engine specifications are "tools" that will help bring those parts back to their original relationship to each other.

There are more factors NOT directly associated with engine working parts that must be considered in correcting engine power losses.

**OPERATING CONDITIONS** can affect engine power. For example, the usable horsepower of an engine is reduced by the number of accessories it must operate. If the engine is required to provide power for lifting operations at the same time it is delivering power to wheels or tracks, the engine may be overloaded and may not be able to develop its rated rpm; consequently, the rated horsepower would NOT be reached.

The effect of **ALTITUDE** on engine power must also be considered. As a rule, 2 1/2 percent of the output of an engine is lost for every 1,000-foot increase in elevation above sea level. Overheated air entering the cylinders has the same effect on engine power as an increase in altitude. In computing horsepower output, engineers will deduct as much as 1 percent for each 10°F rise in the intake air temperature above a "normal" temperature of 70°F.

### DIAGNOSING ENGINE PROBLEMS

Diagnosing may be defined as a systematic means of identifying a problem by utilizing all available information and facts. Usually, the Equipment Operator will be able to tell the symptoms, such as the engine lacks power, uses

excessive oil, has low oil pressure, or makes certain noises.

Some internal engine problems may be found by listening for unusual noises and knocks or by examining the exhaust gases for indications of incomplete combustion. Then too, placing an artificial load on an engine can emphasize certain noises; for example, applying the brakes and partially engaging the clutch with the vehicle transmission in high gear. In this manner, the engine operating under a load can be heard without the interference of body noises.

There are other tricks of the trade that a mechanic may also use, such as feeling the oil or shorting out the spark plugs to get an idea of the source of trouble.

### EXCESSIVE OIL CONSUMPTION

Excessive oil consumption would probably first be noted by the Equipment Operator who has to add oil to maintain the proper oil level. There are two main causes of excessive oil consumption—external leakage and burning in the combustion chamber.

External oil leaks can often be detected by inspecting the seals around the oil pan, valve covers, timing gear housing, and at the oil line and oil filter connections.

The burning of oil in the combustion chamber usually produces a bluish tinge in the exhaust gas. Oil may enter the combustion chamber in three ways—through a cracked vacuum pump diaphragm when the vehicle is equipped with a combination fuel and vacuum pump, through clearances caused by wear between the intake valve guides and stems, and around the piston rings.

Excessive oil consumption caused by worn valve guides or stems may be indicated by too much carbon on the undersides of the intake valve. In this case, it is usually necessary to install valve seals, new valve guides, or new valves. If excessive oil consumption is caused by worn rings or worn cylinder walls, the supervisor will probably have the mechanics do a complete engine overhaul.

## LOW OIL PRESSURE

Low oil pressure often indicates worn engine bearings. The bearings can pass so much oil the oil pump cannot maintain oil pressure. Other causes of low oil pressure include a weak relief-valve spring, a worn oil pump, a broken or cracked oil line, or a clogged oil line. Oil dilution, foaming, sludge, insufficient oil, or oil made too thin by the engine overheating will also cause low oil pressure.

## ENGINE NOISES

A variety of engine noises may occur although some have little significance. Other noises can indicate serious engine trouble that will require prompt attention to prevent major damage to the engine.

A listening rod can be of help in locating the source of a noise. The rod acts somewhat like the stethoscope a doctor uses to listen to a patient's heartbeat or breathing. When one end is placed at the ear and the other end at some particular part of the engine, noises from that part of the engine will be carried along the rod to your ear. By determining the approximate source of the noise, you can, for example, locate a broken or noisy ring in a particular cylinder or a main bearing knock.

### Valve and Tappet Noise

Valve and tappet noise is a regular clicking sound that increases in intensity as the engine speed increases. The cause is usually excessive valve clearance. A feeler gage inserted between the valve stem and lifter or rocker arm will reduce the clearance, and the noise should decrease. If the noise does not decrease when the feeler gage is inserted, it is probably caused by weak lifter springs, worn lifter faces, lifters loose in the block, a rough adjustment-screw face, a rough cam lobe, or possibly the noise is not from the valves at all.

A noisy hydraulic valve lifter may be sticking because of dirt in the ball or disk valve. When this happens, you must disassemble the lifter and clean all the parts in a clean solvent. Then

reassemble the lifter and fill it with clean, light engine oil.

### Connecting Rod Noise

Connecting rod noise usually tends to give off a light knocking or pounding sound. The sound is more noticeable when the engine is "floating" (not accelerating or decelerating) or as the throttle is eased off with the vehicle running at medium speed. To locate a noise in the connecting rod, short out the spark plugs one at a time. The noise will be greatly reduced when the piston in the cylinder that is responsible is not delivering power.

### Piston-Pin Knock

Piston-pin knock is identified more as a metallic double-knock rather than a regular clicking sound like that heard in valve and tappet noise. In addition, it is most noticeable during idle with the spark advanced. A check can be made by idling the engine with the spark advanced and then shorting out the spark plugs. Piston-pin noise coming from a cylinder will be reduced somewhat when the spark plug for that cylinder is shorted out. Causes of this noise are a worn or loose piston-pin, a worn bushing, and a lack of oil.

### Piston-Ring Noise

Piston-ring noise is also similar to valve and tappet noise since it is identified by a clicking, snapping, or rattling sound. This noise is most noticeable on acceleration. Low-ring tension, broken or worn rings, or worn cylinder walls will produce this sound. To avoid confusing this sound with other engine noise, make the following test: remove the spark plugs and add an ounce or two of heavy engine oil to each cylinder. Crank the engine for several revolutions to work the oil down past the rings. Replace the spark plugs and start the engine. If the noise has decreased, it is probable that the rings are at fault.

### Piston Slap

Piston slap may be detected by a hollow, bell-like knock and is due to the rocking back

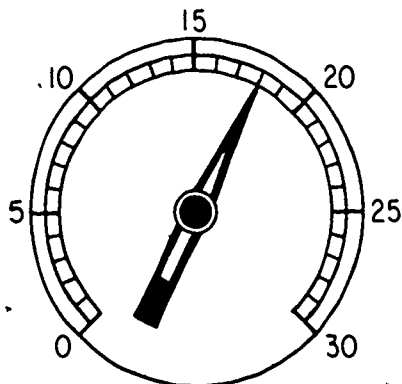

NORMAL IDLE

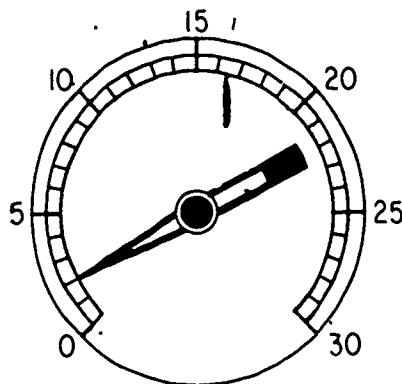

THROTTLE OPENED SUDDENLY

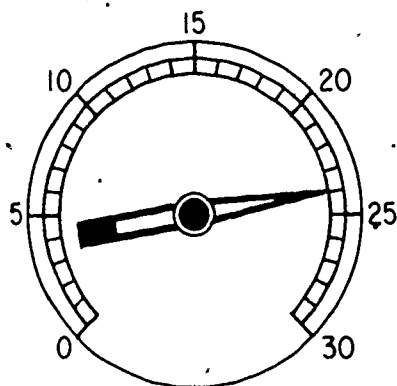

MAX READING AFTER THROTTLE IS OPENED SUDDENLY

227.8

Figure 5-10.—Approximate vacuum gage readings on a normal operating engine.

pointer to swing widely as the engine is accelerated. A loose intake manifold, or a leaking gasket between the carburetor and manifold, would show a steady low reading on the vacuum gage.

Vacuum gage tests only help to locate the trouble. They are not always conclusive, but as you gain experience in interpreting the readings, you can usually diagnose engine behavior.

### Cylinder Leakage Test

Another aid in locating compression leaks is the cylinder leakage test. The principle involved is that of simulating the compression that develops in the cylinder during operation. Compressed air is introduced into the cylinder through the spark plug or injector hole, and by listening and observing at certain key points, basic deductions can be made.

There are commercial cylinder leakage testers available, but actually the test may be conducted with materials readily available in most repair shops. In addition to the supply of compressed air, a device for attaching the source of air to the cylinder is required. For a gasoline engine, this device can be made by using an old spark plug of the correct size for the engine to be tested. By removing the insulator and welding a pneumatic valve stem to the spark plug's threaded section, you now have a device for introducing the compressed air into the cylinder.

The next step is to place the piston at TDC or "rock" position between the compression and power strokes. The compressed air may then be introduced into the cylinder. Note that the engine will tend to spin. Now, by listening at the carburetor, the exhaust pipe, and the oil filler pipe (crankcase), and by observing the coolant in the radiator, when applicable, the area of air loss can be pinpointed. A loud hissing of air at the carburetor would indicate a leaking intake valve or valves. Excessive hissing of air at the oil filler tube (crankcase) would indicate an excessive air leak past the piston rings. Bubbles observed in the coolant at the radiator would indicate a leaking head gasket.

As in vacuum testing, indications are not conclusive. For instance, the leaking head gasket may prove to be a cracked head, or the bad rings may be a scored cylinder wall. The important thing is that the source of trouble has been pinpointed to a specific area, and a fairly broad, accurate estimate of the repairs or adjustments required can be made without dismantling the engine.

In making a cylinder leakage test, all the spark plugs are removed so that each piston can be positioned without the resistance of compression of the remaining cylinders. The commercial testers, such as the one shown in figure 5-11 have a gage indicating a percentage of air loss. The gage is connected to a spring-loaded diaphragm. The source of air is connected to the instrument and counterbalances the action of the spring against the diaphragm. By adjusting the spring tension, the gage may be properly calibrated against a variety of air pressure sources within a given tolerance.

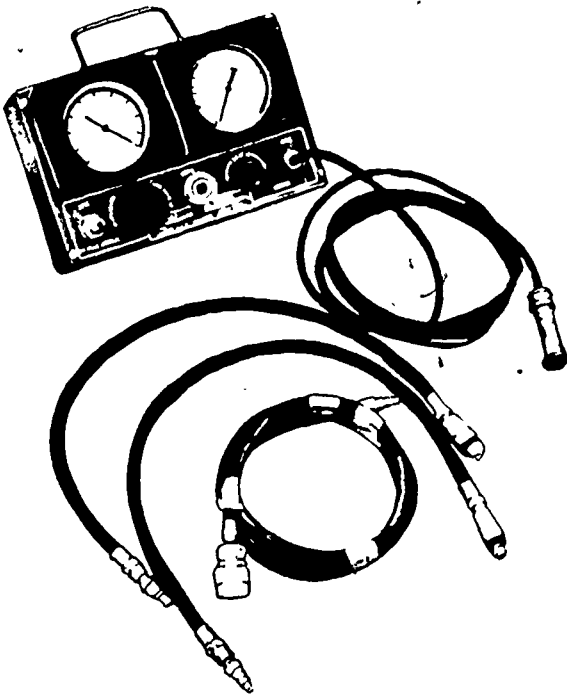

Figure 5-11.—Cylinder leakage tester.

227.6

### Tachometer

The tachometer is a speed-indicating instrument which measures the rpm's of a rotating shaft. It may be either manually or electrically operated.

A manual tachometer (fig. 5-12) is held by its tip against the end of an exposed rotating shaft. Make sure the end of the shaft is clean and there is no slippage between the tip of the tachometer and the shaft. Read the speed directly on the tachometer dial which is calibrated in revolutions per minute. No timing is necessary as variations in speed will be reflected by movement of the pointer on the dial during the test.

When using the manual tachometer on a shaft, make sure that shaft turns the same speed as the crankshaft or you will not get an accurate reading of engine rpms. In many instances, it is easy to take manual tachometer readings off a camshaft or fuel pump shaft. On 4-cycle engines, this shaft runs at one-half engine speed. Consequently, any manual tachometer reading

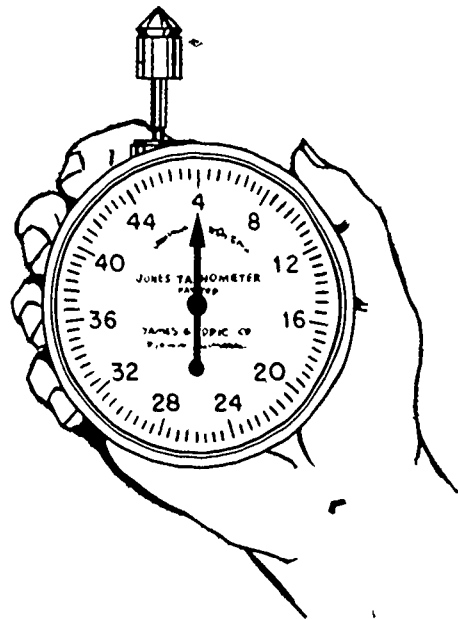

Figure 5-12.—Manually operated tachometer.

227.5

and forth of the piston in the cylinder. If the slap occurs only when the engine is cold, it is probably not serious. However, if it occurs under all operating conditions, a further examination is called for. The slap can be caused by worn cylinder walls, worn pistons, collapsed piston skirts, or misaligned connecting rods.

### Crankshaft Knock

Crankshaft knock is a heavy, dull, metallic knock that is noticeable when the engine is under load or accelerating. When the noise is regular, it can be contributed to worn main bearings. When irregular and sharp, the noise is probably due to worn thrust bearings.

### TESTING

In most shops, the Navy provides accurate and dependable testing equipment. But having the testing equipment in the shop is NOT enough. The supervisor and the crew must know how to use this equipment since proper use provides the quickest and surest means of finding out what is wrong and where the fault lies.

Four of the most widely used testing instruments are the cylinder compression tester, vacuum gage, cylinder leakage tester, and tachometer.

### Compression Test

As you have learned, engine power results from igniting a combustible mixture which has been compressed in the combustion chamber of an engine cylinder. The tighter a given volume of fuel mixture is squeezed in the cylinder before it is ignited, the greater the power developed. Unless approximately the same power is developed in each cylinder, the engine will run unevenly. The cylinder compression tester (fig. 5-9) is used to measure cylinder pressure in psi, as the piston moves to TDC on the compression stroke.

By measuring compression pressures of all cylinders with a compression gage, then comparing them with each other and with the

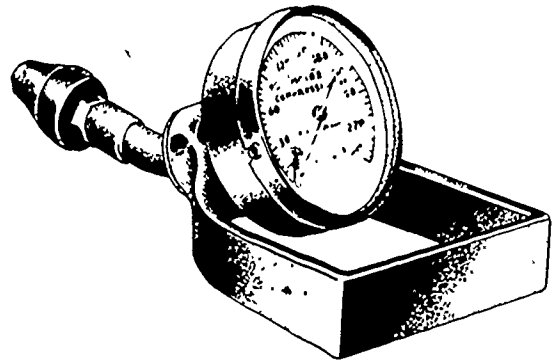

Figure 5-9—Cylinder compression tester.

81.1

manufacturer's specifications for a new engine, you get an accurate indication of engine condition.

The compression pressures in the different cylinders of an engine may vary as much as 20 pounds. The variation is caused largely by the lack of uniformity in the volume of the combustion chamber. It is nearly impossible to make all the combustion chambers in a cylinder head exactly the same size. For example, in a given engine with a 7 to 1 compression ratio with all combustion chambers the same volume, the compression pressure would be about 120 pounds in all cylinders. However, if one combustion chamber is  $\frac{1}{3}$  cubic inch too small, the pressure will be about 126 pounds, and if it is  $\frac{1}{3}$  cubic inch too large, the compression pressure would be about 114 pounds. This is a variation of 12 pounds. Note, also that a carbon deposit will raise the compression pressure at any given ratio by reducing the combustion chamber volume—the greater the deposit, the higher the pressure.

To make a compression test, first, warm up the engine. Warming up will allow all the engine parts to expand to normal operating condition and will insure a film of oil on the cylinder walls. Remember that the oil film of the walls of the cylinder helps the expanded piston rings to seal the compression within the cylinder. After the engine is warmed to operating temperature, shut it down and remove all the spark plugs.

Removing all the plugs will make the engine easier to crank while you obtain compression readings at each cylinder. The throttle and choke should be in a wide-open position when compression readings are taken. Some compression gages can be screwed into the spark plug hole. Most compression gages, however, have a tapered rubber end plug and must be held securely in the spark plug opening until the highest reading of the gage is reached.

Crank the engine with the starting motor until it makes at least four complete revolutions. Normal compression readings for gasoline engine cylinders are usually 100 psi, or slightly higher. Compression testing is faster and safer when there are two mechanics assigned to the job. Remember that the compression test must be completed before the engine cools off.

Unless the compression readings are interpreted correctly, it is useless to make the tests. Any low readings indicate a leakage past the valves, piston rings, or cylinder head gaskets. Before taking any corrective action, make another check to try to pinpoint the trouble. Pour approximately a tablespoon of heavy oil into the cylinder through the spark plug hole, and then retest the compression pressure. If the pressure increases to a more normal reading, it means the loss of compression is due to leakage past the piston rings. If adding oil does not help compression pressure, the chances are that the leakage is past the valves. Low compression between two adjacent cylinders indicates a leaking or a blown head gasket. If the compression pressure of a cylinder is low for the first few piston strokes, then increases to near normal, a sticking valve is indicated. Near normal compression readings on all cylinders indicate that the engine cylinders and valves are in fair condition. Indications of valve troubles by compression tests may be confirmed by taking vacuum gage readings.

#### Vacuum Test

When an engine has an abnormal compression reading, it is likely that the cylinder head will have to be removed to repair the trouble. Nevertheless, the mechanics should test

the vacuum of the engine with a gage. The vacuum gage provides a means of testing intake manifold vacuum, cranking vacuum, fuel pump vacuum, and booster pump vacuum. The vacuum gage does NOT replace other test equipment, but rather supplements it, and diagnoses engine trouble more conclusively.

Vacuum gage readings are taken with the engine running and must be accurate to be of any value. Therefore, the connection between the gage and intake manifold must be leakproof. Also, before the connection is made, see that the openings to the gage and intake manifold are free from dirt or other restrictions.

When a test is made at an elevation of 1,000 feet or less, an engine in good condition, idling at a speed of about 550 rpm, should give a steady reading of from 17 to 22 inches on the vacuum gage. The average reading will drop approximately 1 inch of vacuum per 1,000 feet at altitudes of 1,000 feet and higher above sea level.

Upon opening and closing the throttle suddenly, the vacuum reading should first drop to about 2 inches with the throttle open, and come back to a high of about 24 inches before settling back to a steady reading as the engine idles, as shown in figure 5-10. This is normal for an engine in good operating condition.

If the gage reading drops to around 15 inches and remains there, it would indicate compression leaks between the cylinder walls and the piston rings, or power loss caused by incorrect ignition timing. A vacuum gage pointer indicating a steady 10, for example, usually means that the valve timing of the engine is incorrect. Below normal readings that change slowly between two limits, such as 14 and 16 inches, could point to a number of troubles. Among them are improper carburetor idling adjustment, maladjusted or burned breaker points, and spark plugs with the electrodes set too closely.

A sticking valve could cause the gage pointer to bounce from a normal steady reading to a lower reading and then back to normal. A broken or weak valve spring would cause the



taken from this shaft must be doubled to get the true engine speed.

The electric tachometer is connected to the ignition primary circuit to measure the number of times per minute the primary circuit is interrupted. It then translates this information into engine speed.

The electric tachometer may have a selector switch on it that can be turned to correspond with the number of lobes on the distributor cam. The number of lobes will be the same as the number of cylinders in the engine. For the proper method of hooking up and using the electric tachometer, check the manufacturer's instructions for the tachometer you are using.

### Gage Care and Maintenance

As CM1 or CMC, you will probably be responsible for the care and maintenance of the engine testing equipment, such as cylinder compression tester, vacuum gage, cylinder leakage tester, and tachometer. The supervisor must impress upon the mechanics that these gages and testers are fragile instruments that can be damaged through improper use or rough handling. They should be kept in a safe place in the toolroom and should be returned there immediately after being used. Keeping the gages and testers clean is about all the maintenance that is required. If they are dropped, broken, or jarred out of calibration, it is generally necessary to return them to the manufacturer for repairs.

### MICROMETERS

Since a micrometer is often used in diagnosing engine problems, it is important that the mechanics understand its mechanical principles and construction and learn to use and care for it. Micrometers are used to measure distances to the nearest one-thousandth of an inch. Each measurement is usually expressed or written as a decimal. Figure 5-13 shows an outside micrometer with the various parts clearly indicated.

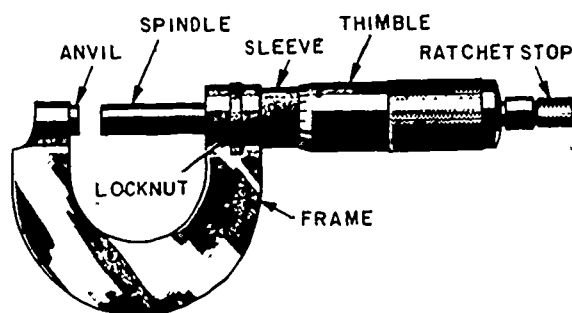

4.20.1A

Figure 5-13.—Nomenclature of an outside micrometer.

### Types

There are three types of micrometers commonly used throughout the Navy: the outside micrometer (including the screw thread micrometer), the inside micrometer, and the depth micrometer. (See fig. 5-14.) The outside micrometer is used for measuring outside dimensions, such as the diameter of a piece of round stock. The screw thread micrometer is used to determine the pitch diameter of screws. The inside micrometer is used for measuring inside dimensions, such as the bore of a cylinder or the width of a recess. The depth micrometer is used for measuring the depth of holes or recesses.

### Reading a Micrometer

The sleeve and thimble scales of the micrometer have been enlarged in figure 5-15. To understand these scales, you need to know that the threaded section on the spindle, which revolves, has 40 threads per inch. Therefore, every time the thimble completes a revolution, the spindle advances or recedes  $1/40$  (0.025) inch.

Notice that the horizontal line on the sleeve is divided into 40 equal parts per inch. Every fourth graduation is numbered 1, 2, 3, 4, etc., representing 0.100 inch, 0.200 inch, etc. When you turn the thimble so that its edge is over the first sleeve line past the "0" on the thimble scale, the spindle has opened 0.025 inch. If you

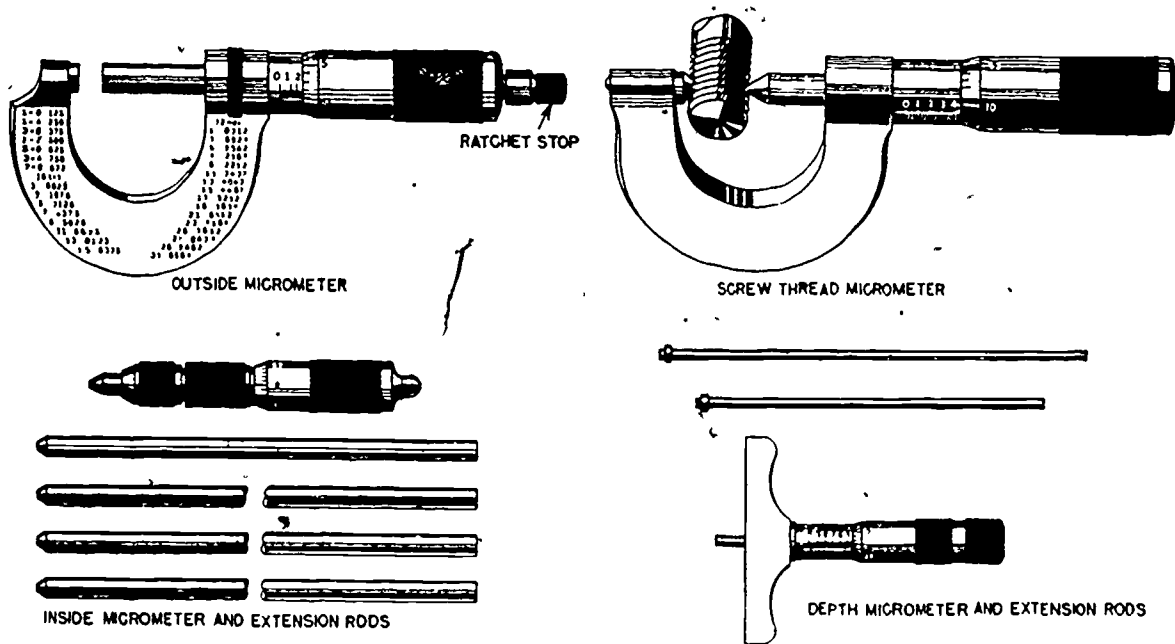
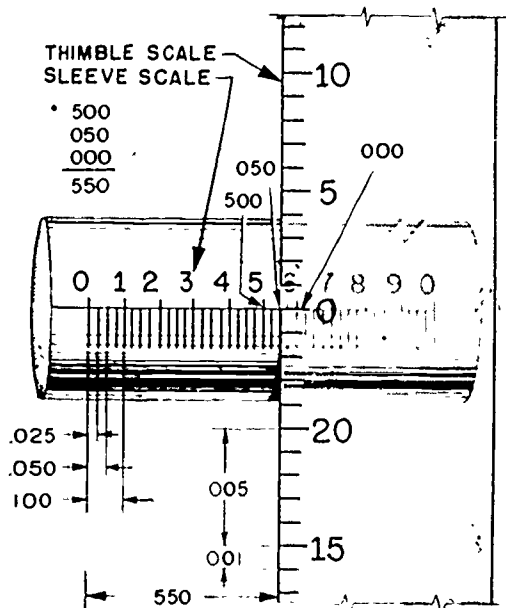

Figure 5-14.—Common types of micrometers.

4.20.1B



29.266D

Figure 5-15.—Sleeve and thimble scales of a micrometer (enlarged).

turn the spindle to the second mark, it has moved 0.025 inch plus 0.025 inch or 0.050 inch. You use the scale on the thimble to complete your reading when the edge of the thimble stops between graduated lines. This scale is divided into 25 equal parts, each part representing one twenty-fifth of a turn. And  $\frac{1}{25}$  of 0.025 inch is 0.001 inch. As you can see, every fifth line on the thimble scale is marked 5, 10, 15, etc. The thimble scale, therefore, permits you to take very accurate readings to the thousandths of an inch, and, since you can estimate between the divisions on the thimble scale, fairly accurate readings to the ten-thousandth of an inch are possible.

The closeup in figure 5-16 will help you understand how to take a complete micrometer reading. Count the units on the thimble scale, and add them to the reading on the sleeve scale. The reading in the figure shows a sleeve reading of 0.250 inch (the thimble having stopped slightly more than halfway between 2 and 3 on the sleeve) with the 10th line on the thimble scale coinciding with the horizontal sleeve line.

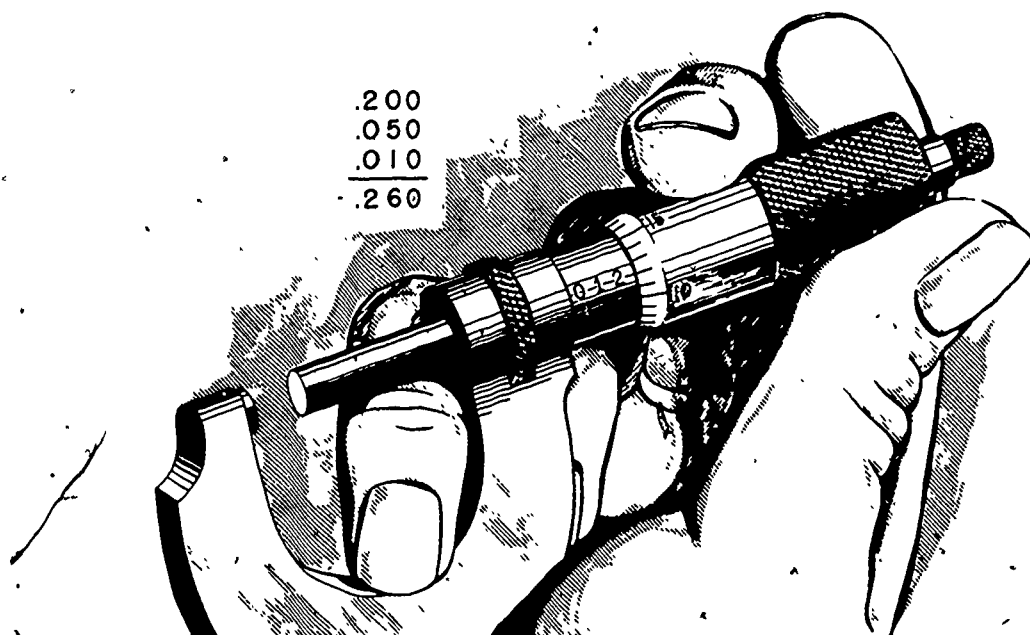

Figure 5-16.—Reading a micrometer.

4.20.2

Number 10 on this scale means that the spindle has moved away from the anvil an additional 10 x 0.001 inch or 0.010 inch. Add this amount to the 0.250 inch sleeve reading and the total distance is 0.260 inch.

Read each of the micrometer settings in figure 5-17 so that you can be sure of yourself when you begin to teach your mechanics. The correct readings are given following the figure so that you can check yourself and your mechanics.

Figure 5-18 shows a reading in, which the horizontal line falls between two graduations on the thimble scale and is closer to the 15 graduation than it is to the 14. To read this to **THREE** decimal places, refer to figure 5-18 and calculation A. To read it to **FOUR** decimal places, estimate the number of tenths of the distance between thimble-scale graduations that the horizontal line has fallen. Each tenth of this distance equals one ten-thousandth (0.0001) of an inch. Add the ten-thousandths to the reading as shown in calculation B of figure 5-18.

**Reading a Vernier Micrometer**

Many times you will be required to work to exceptionally precise dimensions. Under these

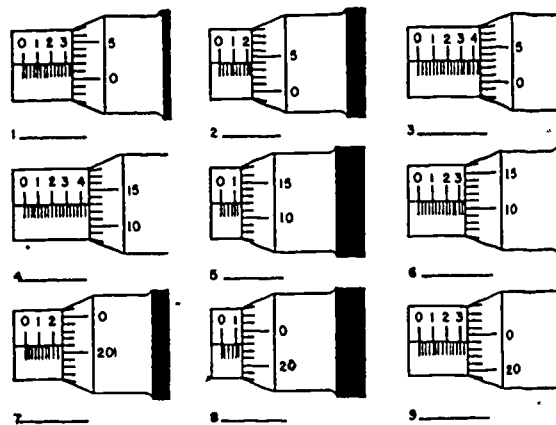

**Answers for checking—**

- |            |            |
|------------|------------|
| 1. = 0.327 | 6. = 0.336 |
| 2. = 0.229 | 7. = 0.246 |
| 3. = 0.428 | 8. = 0.148 |
| 4. = 0.438 | 9. = 0.349 |
| 5. = 0.137 |            |

Figure 5-17.—Micrometer-reading exercises.

4.20

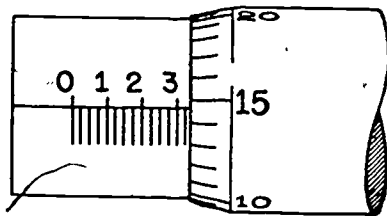

$$\begin{array}{r}
 A \left\{ \begin{array}{l} .300 \\ .025 \\ .015 \\ \hline .340 \end{array} \right. \qquad B \left\{ \begin{array}{l} .300 \\ .025 \\ .014 \\ .0007 \\ \hline .3397 \end{array} \right.
 \end{array}$$

29.266F

Figure 5-18.—Interpolating a micrometer reading.

conditions, it is better to use a micrometer that is accurate to ten-thousandths of an inch. This degree of accuracy is obtained by the addition of a vernier scale. This scale, shown in figure 5-19, furnishes the fine readings between the lines on the thimble rather than making you estimate. The 10 spaces on the vernier are equivalent to 9 spaces on the thimble. Therefore, each unit on the vernier scale is equal to 0.0009 inch and the

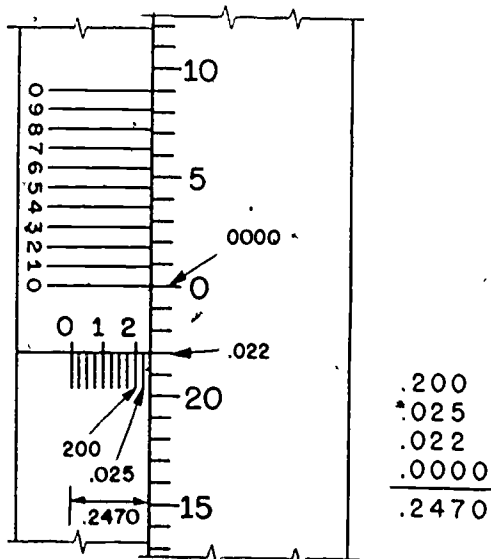

29.266G

Figure 5-19.—Vernier scale on a micrometer.

difference between the sizes of the units on each scale is 0.0001 inch.

When a line on the thimble scale does not coincide with the horizontal sleeve line, you can determine the additional space beyond the readable thimble mark by finding which vernier mark coincides with a line on the thimble scale. Add this number, as that many ten-thousandths of an inch, to the original reading. In figure 5-20, see how the second line on the vernier scale coincides with a line on the thimble scale. This means that the 0.011 mark on the thimble scale has been advanced an additional 0.0002 inch beyond the horizontal sleeve line. When you add this to the other readings, the reading will be 0.200 + 0.075 + 0.011 + 0.0002 or 0.2862 inch as shown.

### Measuring Hole Diameter with an Inside Micrometer

To measure the diameter of small holes from 0.2 inch to 1 inch in diameter, an inside micrometer caliper of the jaw type, as shown in view A, figure 5-21 may be used. Note that the figures on both the thimble and the barrel are reversed, increasing in the opposite direction from those on an outside micrometer. This is because this micrometer reads inside measurements. Thus, as you turn the thimble clockwise

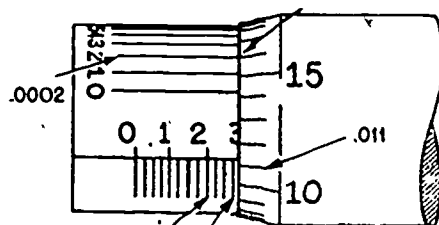

$$\begin{array}{r}
 .200 \\
 .075 \\
 .011 \\
 .0002 \\
 \hline
 .2862
 \end{array}$$

29.266H

Figure 5-20.—Reading a vernier micrometer.

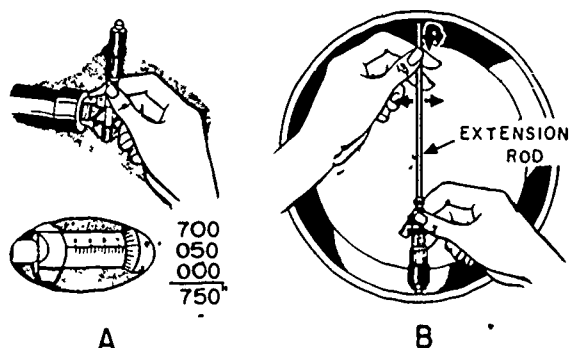

44.77

Figure 5-21.—Measuring an inside diameter with an inside micrometer.

on this micrometer, the measuring surfaces move farther apart and the reading increases. (On an outside micrometer, as you turn the thimble clockwise, the measuring surfaces move closer together and the reading decreases.)

For holes 2 inches or more in diameter, select the inside micrometer having extension rods whose range includes the required dimension. The extension rod marked "6-7" for example, when inserted into the head of the micrometer, will measure inside diameters from 6 to 7 inches. The shoulder on the rod must seat properly to insure a correct reading. View B, figure 5-21 shows that, for large measurements, both hands are used to set the micrometer for checking a diameter. Hold one end in place with one hand as you "feel" for the maximum possible setting by moving the other end from left to right, and in and out of the hole with the other hand. When no left-to-right movement is possible, and a slight drag is noticed on the in-and-out swing, take the reading.

### Care of Micrometers

Keep micrometers clean and lightly oiled. Make sure they are placed in a case or box when they are not in use. Anvil faces must be protected from damage and must NOT be cleaned with emery cloth or other abrasive.

## SERVICING VALVES, VALVE MECHANISMS, AND CYLINDER HEADS

When an engine has been properly maintained and serviced, its first major repair job will normally involve the valves. A general procedure for servicing valves is described in *Construction Mechanic 3 & 2*. Here, you will get more detail on the servicing and troubleshooting of valves, valve mechanisms, and cylinder heads.

### VALVE TROUBLES

Some of the common valve troubles that you may encounter in working with engines, and possible causes of these troubles are indicated below.

1. Sticking valves may be caused by gum or carbon deposits, worn valve guides, a warped valve stem, insufficient oil, cold engine operation, or overheating.
2. Valve burning may be caused by a valve that is sticking, insufficient valve tappet clearance, a distorted seat, overheated engine, lean fuel-air mixture, preignition, detonation, or valve seat leakage.
3. Valve breakage may occur by valve overheating, detonation, excessive tappet clearance, seat eccentric to stem, cocked spring or retainer, or scratches on the stem due to improper cleaning.
4. Valve face wear may be caused by excessive tappet clearance, dirt on the face, or distortion.
5. Valve deposits may be produced by gum in the fuel, a rich fuel mixture, poor combustion, worn valve guides, dirty oil, or the use of a wrong oil.

### VALVE ADJUSTMENTS

Proper and uniform valve adjustments are required for a smooth running engine. Unless the clearance between valve stems and rocker arms or valve lifters is adjusted in accordance

with the manufacturer's specifications, the valves will not open or close at the proper time and engine performance will be affected. Too great a clearance will cause the valves to open late. Excessive clearance may also prevent a valve from opening far enough and long enough to admit a full charge of air or fuel mixture (with either a diesel or gasoline engine), or it will prevent the escape of some exhaust gases from the cylinder. A reduced charge in the cylinder obviously results in engine power loss. Exhaust gases that remain in the cylinder take up space, and when combined with the incoming charge, they reduce the effectiveness of the mixture. Valves adjusted with too little clearance will overheat and warp. Warped valves can NOT seat properly and will permit the escaping combustion flame to burn both the valve and valve seat.

When you have reassembled an engine after reconditioning the valves, make sure the adjusting screws are backed off before rotating the engine. A valve that is too tight could strike the piston and either damage the piston or the valve, or both. Adjust the valves in accordance with the manufacturer's specifications, following recommended procedure.

On any engine where valve adjustments have been made, be sure the adjustment locks are tight, and that the valve mechanism covers and gaskets are in place and securely fastened to prevent oil leaks.

### Overhead Valves

Most overhead valves are adjusted "hot"; that is, valve clearance recommendations are given for an engine at operating temperatures. Before valve adjustments can be properly effected, the engine must be run and brought up to normal operating temperature.

To adjust a valve, remove the valve cover and measure the clearance between the valve stem and the rocker arm. Loosen the locknut and turn the adjusting screw in the rocker arm as shown in figure 5-22. On engines with steel-supported rocker arms, the adjustment is made by turning the studnut.

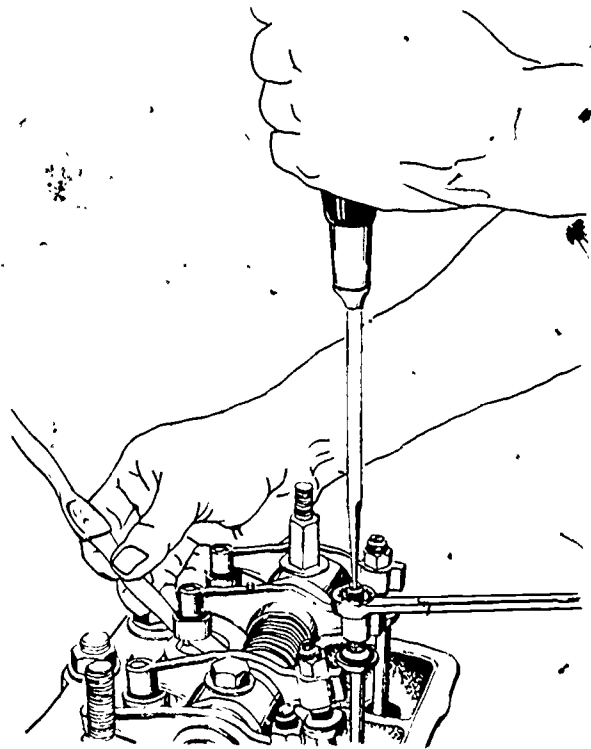
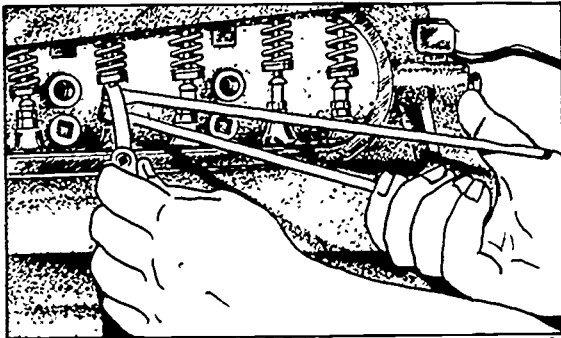

Figure 5-22.—Adjusting overhead valves.

2.475

### Valves in Block

Valves within the block are generally adjusted "cold"; that is, recommended valve clearances are given for a cold engine. These valves have mechanisms very much like overhead valves and are adjusted by removing the side plates, usually found beneath the intake manifold on the side of the engine block (fig. 5-23). Since this engine must be stopped to adjust the valves, the piston in the cylinder to be adjusted must be on TDC of the compression stroke. This can be determined by watching the valves of the piston that is paired with the one that is being set. As the cylinder that is being positioned is coming up on the compression stroke, the paired cylinder will be coming up on the exhaust stroke. Therefore, an exhaust valve will be open. Just as the exhaust valve closes and the intake valve begins to open, the cylinder that is to be set will be on TDC of the compression



2.476

Figure 5-23.—Adjusting valve in block.

stroke and the two valves can be set. Once number one cylinder is positioned, follow through according to the firing order of the engine, as this makes the job much easier and faster. This procedure may also be used when valves on overhead valve engines are being adjusted.

### Hydraulically Operated Valves

On engines equipped with hydraulic valve lifters (fig. 5-24), it is not generally necessary to adjust the valves periodically. The engine lubrication system supplies a flow of oil to the lifters at all times. These hydraulic lifters operate at zero clearance and compensate for changes in engine temperature, adapt automatically for minor wear at various points, and thus provide ideal valve timing.

The first indication of a faulty hydraulic valve lifter is "clicking" noise. In one method for locating a noisy valve lifter, you use a piece of garden hose. Place one end of the hose near the end of each intake and exhaust valve, and the other end of the hose to the ear. This localizes the sound, making it easy to determine which lifter is at fault. Another method is to place a finger on the face of the valve spring retainer. If the lifter is not functioning properly, a distinct shock will be felt when the valve returns to its seat.

Usually, where noise exists in one or more of the valve lifters, all lifter units should be removed, cleaned in a solvent, reassembled, and reinstalled in the engine. If dirt, carbon, or the

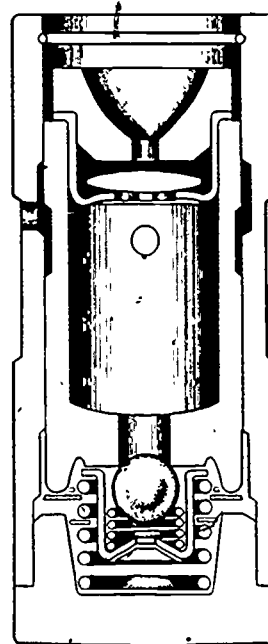

2.38

Figure 5-24.—Hydraulic valve lifter.

like, is found in one unit, it more than likely is present in all of them; and, it will only be a matter of time before the rest of the lifter units will give trouble.

### VALVE REMOVAL

For such services as valve or valve seat grinding, valve seat insert replacement, and valve guide cleaning or replacement, the cylinder head and valves must be removed from the engine. Avoid interchanging valves; each valve must be replaced in the valve port from which it was removed. A valve rack in which the valves may be placed in their proper order—along with their valve springs, retainers, and locks—is normally provided. Different tools and procedures for removal are used for different engines. Check the manufacturer's maintenance manual for your particular engine.

### GRINDING VALVES

The first step in servicing valves after they have been removed from the engine is to rid

them of carbon. The best method for doing this is cleaning with a wire buffing wheel or brush.

**CAUTION:** When using the wire buffing wheel, always wear goggles to protect your eyes from wire or carbon that may fly off the buffing wheel.

After the cleaning process, inspect each valve to determine whether it can be serviced and reused or must be replaced. The valve should be checked with a runout gage for eccentricity and inspected for worn valve stem and badly cracked, burned, or pitted valve face. Minor pits, burns, or irregularities in the valve face may be removed by grinding.

To grind valves, clamp the valve stem in the chuck of the valve-refacing machine so that the face of the valve will contact the grinding wheel. (See fig. 5-25.) Set the chuck at the proper angle to give the correct angle to the setting face. This angle must just match the valve seat angle. It is becoming common, however, in some engines to reface the valve at a slightly flatter angle than the seat, usually  $1/4^\circ$  to  $1^\circ$  to provide what is known as an "interference angle." This angle provides greater pressure at the upper edge of the valve seat which aids in cutting through any deposits that form and provides for better sealing. Some engines use the interference angle on the exhaust valve only, and others use it on both the intake and exhaust valves. Check the manufacturer's manual for the recommended angle for both valve and valve seat.

**CAUTION:** Due to the different angles between the valve and the valve seat, grinding compound can NOT be used to finish the surface.

At the start of the grinding operation, make the first cut a light one. If metal is removed from only one-third or one-half of the valve face, check to make sure you have cleaned the valve stem and grinder chuck thoroughly and centered the valve in the chuck. If the valve is properly centered, then the valve stem is bent and the valve must be replaced. Remove only the amount of metal necessary to true up the face and remove the pits. Make sure there is a proper margin of thickness as indicated in figure 5-26. If this margin cannot be retained after refacing, then the valve must be discarded.

There are many different makes and models of valve-refacing machines. Make sure that you read and understand the instructions that apply to the machine you are using.

### SERVICING VALVE GUIDES

When servicing valve guides, remember that the guides must be clean and in good condition for normal valve seating. If, after cleaning a valve guide, you find it worn, remove and install a new one. To remove old or worn valve guides and install new ones, special guide removing and replacing tools are required. One procedure for checking valve guide wear in an engine involves the use of a dial indicator (fig. 5-27). With the

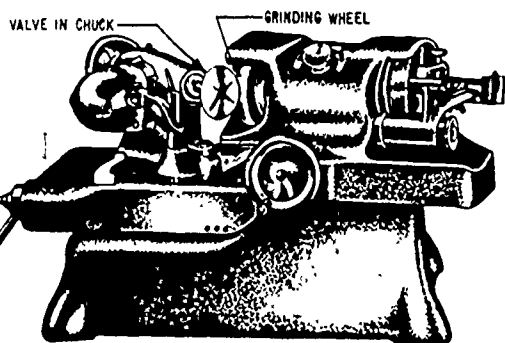

Figure 5-25.—Valve-refacing machine.

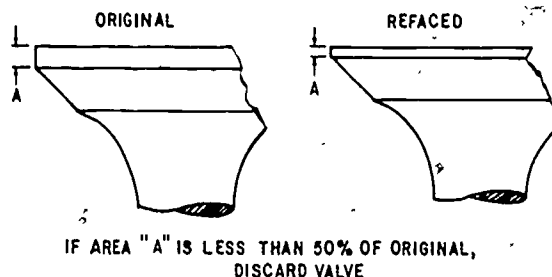
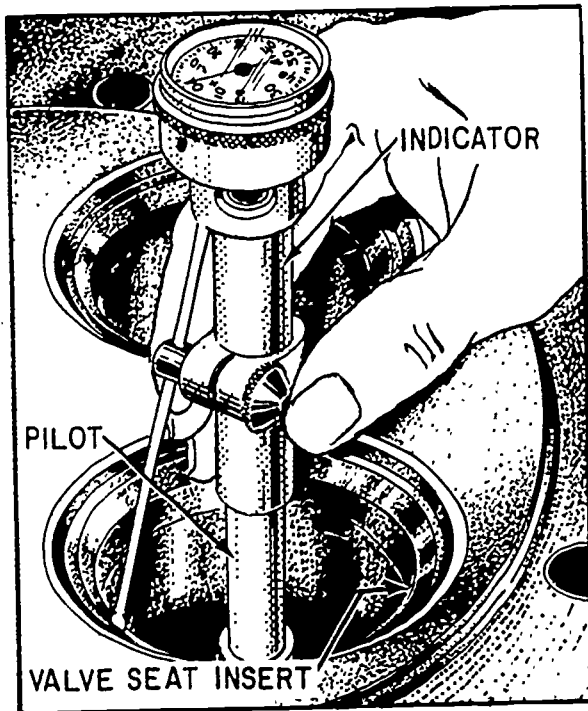

Figure 5-26.—Proper valve margin of thickness after refacing.

81.9

2.478





75.73

Figure 5-27.—Determining concentricity of the valve seat with a dial indicator.

valve in place, turn the engine over so that the valve is moved off its seat. Install the dial indicator on the block with the indicating button touching the edge of the valve head. Move the valve sideways to determine the amount of wear. Almost the same procedure may be used on an I-head engine, except that the valve must be held off its seat while the guide is checked for wear.

Another checking procedure involves the use of a small hole gage to measure the inside diameter of the guide and a micrometer to measure the valve stem; the difference in the readings will be the clearance. When the maximum clearance is exceeded, the valve guide needs further servicing before you can proceed. If of the integral type, the valve guide must be reamed to a larger size and a valve with an oversized stem installed. But if the guide is replaceable, it should be removed and another one installed.

To remove valve guides you will need a special puller. On many L-head engines the

guides may be driven down into the valve spring compartment and then removed. When guides are removed from overhead type engines, an arbor press may be used.

To replace the guides, you will use a valve guide driver or a valve guide replacer, except on overhead valve engines where an arbor press is necessary. In any case, the guides must be installed to the proper depth in either the block or head as specified by the manufacturer.

After the valve guides are serviced and the valve seats ground, check the concentricity of the two with a dial indicator. (See fig. 5-27.) Any irregularity in the seat will register on the dial.

### GRINDING VALVE SEATS

Two general types of valve seat grinders are in use. One is a concentric grinder, the other an eccentric grinder. Only the concentric grinder is discussed here because of its greater availability.

In the concentric valve seat grinder (fig. 5-28), a grinding stone of the proper shape and angle is rotated in the valve seat. The stone is kept concentric with the valve guide by means of a self-centering pilot (fig. 5-29) which is installed in the guide. Check the self-centering pilot for trueness prior to using. A damaged pilot will cause the seat position to move in relation to the valve guide. The valve guide must be kept clean and in good condition. Most of the Navy's concentric grinders automatically lift the stone off the valve seat about once every revolution to allow the stone to clean itself of dust and grit by centrifugal action.

The abrasive stone must be dressed frequently with a diamond-tipped dressing tool, such as that illustrated in figure 5-30. Dressing the stone will insure a uniform, even grinding of the valve seat.

After the seat is ground, it will be too wide. It must be narrowed by using upper and lower grinding stones to grind away the upper and lower edges of the seat. Figure 5-31 shows a typical valve seat that was ground at 45°, then narrowed at the top with a 20° grinding stone,

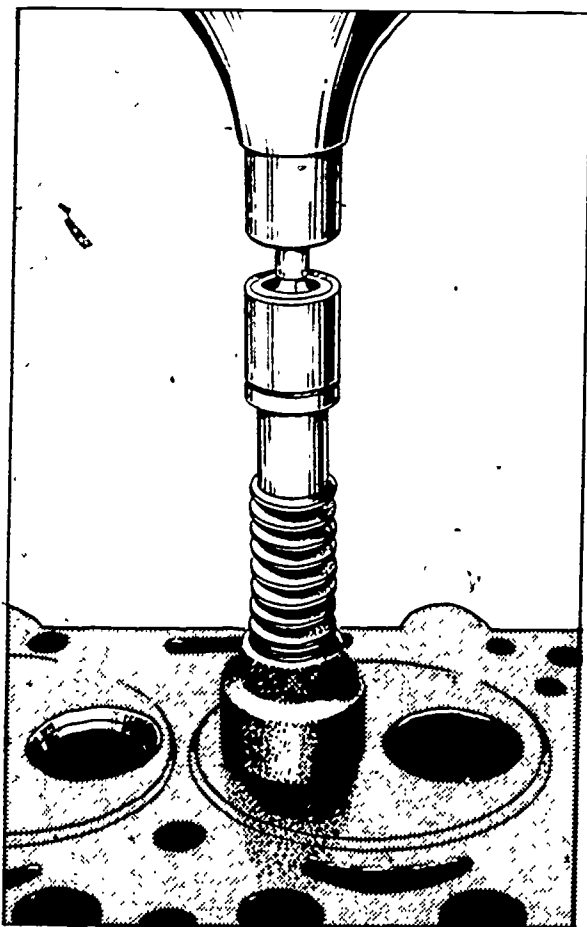

2.479

Figure 5-28.—Grinding valve seats using a concentric type of grinder.



2.29

Figure 5-29.—Self-centering pilot.

and then ground at the bottom with a 70° grinding stone to narrow and center the valve seat.

To test the contact between the valve seat and the valve, mark lines with a soft pencil

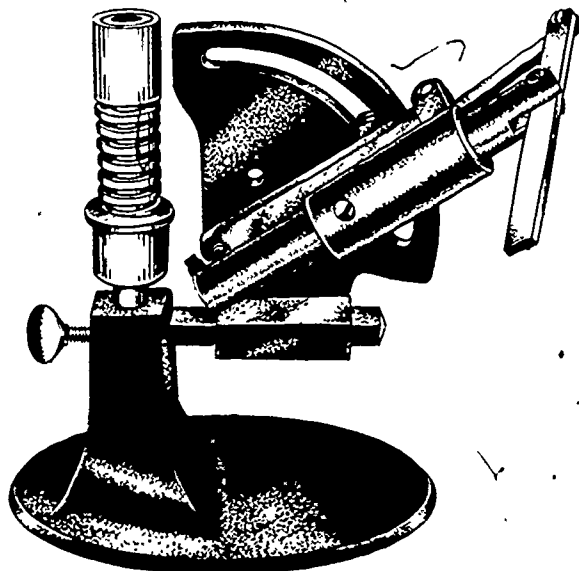

2.480

Figure 5-30.—Stone dresser.

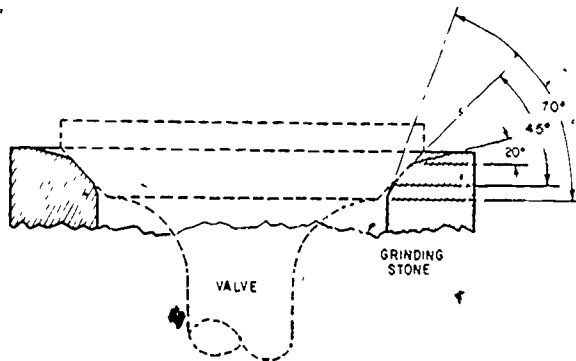

2.481

Figure 5-31.—Valve contact correction.

about one-fourth inch apart around the entire face of the valve. Next, put the valve in place and rotate, using a slight pressure, one-half turn to the right and then one-half turn to the left. If rotating removes the pencil marks, the seating is good.

In another method for checking the valve seating, the valve face is coated lightly with Prussian blue and turned about one-fourth turn

in the seat. If the Prussian blue transfers evenly to the valve seat, it is concentric with the valve guide. All the Prussian blue should be washed from the seat and valve. The valve seat should then be lightly coated with Prussian blue. If the blue again transfers evenly, this time to the valve when it is turned in the seat, the seating can be considered normal.

### REPLACING VALVE SEAT INSERTS

Some engines are equipped with valve seat inserts that may be replaced when they are badly

worn or burned, or have been ground down to where insufficient metal remains to permit another grind. The old valve seat may be removed by using a special puller such as the one shown in figure 5-32. However, if a puller is not available, you can punchmark each side of the insert and then drill almost through. After drilling, take a hammer and chisel and break the insert into halves for easy removal.

Before installing a new insert, chill it for 15 minutes in dry ice or by any other chilling method. Chilling shrinks the insert so that it will fit in place. It may then be driven in place and the seat ground.

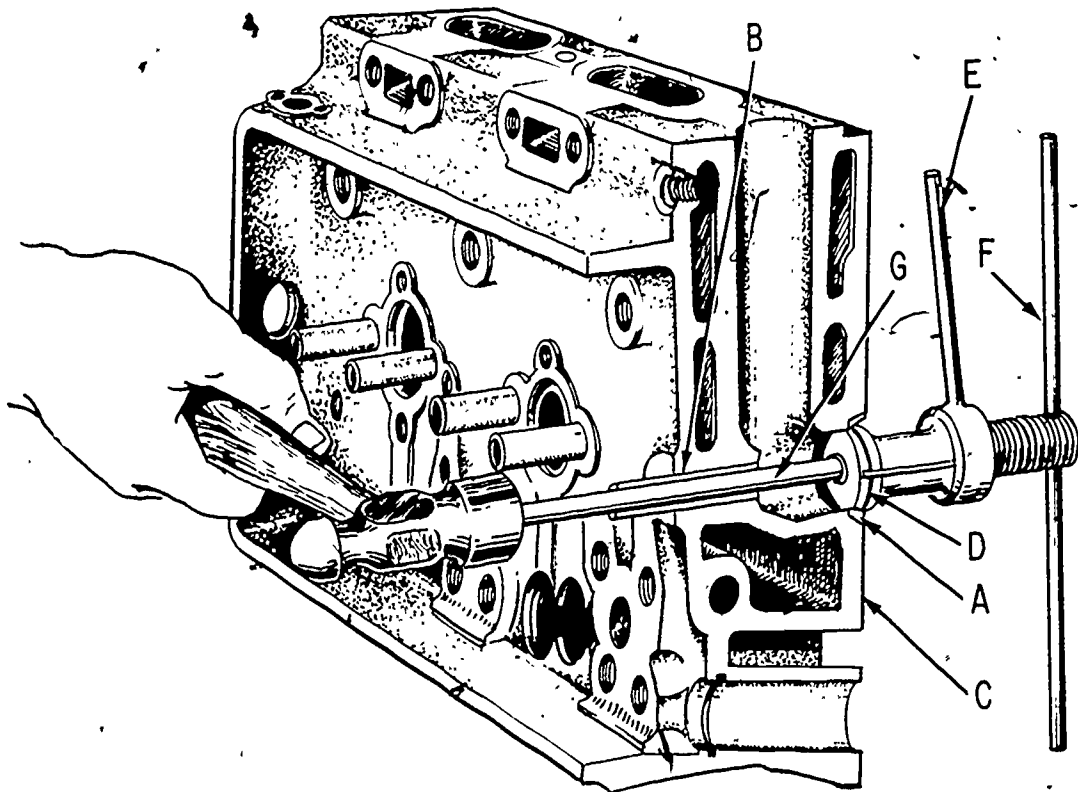

- A. Insert, Valve Seat
- B. Guide, Exhaust Valve
- C. Cylinder Head
- D. Collet

- E. Handle, Collet
- F. T Handle
- G. Bar, Drive

Figure 5-32.—Puller used in removing valve seat inserts.

## SERVICING ROCKER ARMS

After removing rocker arms, inspect them for wear or damage. Rocker arms which are equipped with bushings may be rebushed if the old bushing is only worn. As you know, the worn valve on slightly worn rocker arm ends can be ground down on a valve-refacing machine, whereas excessively worn rocker arms should be discarded.

When installing rocker arms and shafts in the cylinder head, make sure that the oil holes (in shafts so equipped) are on the underside so that they will feed oil to the rocker arms. If springs and rocker arms are suitable for continued use, they should be reinstalled in their original positions in the head.

## TESTING VALVE SPRINGS

Valve springs should be tested for uniform height and proper tension. To test for uniformity of height, place the used springs on a level surface beside a new pair of springs. Use a straightedge to determine any differences in height. Unequal or cocked valve springs may cause faulty valve and engine performance.

The preferred method of testing valve springs for proper tension is by using a valve spring tester. The pressure required to compress the spring to the proper length is measured in accordance with the manufacturer's specifications. Never use shims to compensate for a weak valve spring. Shims are used to adjust spring installed height only.

## SERVICING VALVE LIFTERS

There are two types of valve lifters—the solid type and the hydraulic type. Procedures for removing and servicing the two types are quite different.

Solid lifters are removed from the camshaft side on some engines. This requires removal of the camshaft. The lifters must be held up by clips or wires so that the camshaft can be extracted. Then the clips or wires are removed so that the lifters may be extracted. Most valve

lifters may be extracted from the pushrod or valve side of the engine block, in which case extraction of the camshaft is not necessary. Be sure to keep the lifters in the proper order so that they may be replaced in the same bores from which they were removed.

If the lifter-screw face is worn or pitted, it may be refaced on a valve-refacing machine. If the lifter bore in the block becomes worn, it may be rebored by reaming; then oversized lifters must be installed.

Hydraulic lifters on some engines are tested by the leak down rate test. In testing, insert a feeler gage between the rocker arm and the valve stem, and note the time it takes the valve lifter to leak enough oil to permit the valve to seat. As the valve seats, the feeler gage becomes loose and signals the end of the test. If the leak down rate time is too short, the lifter is defective and must be replaced. In any case, be sure to follow the manufacturer's recommended procedures for performing this test.

To remove hydraulic lifters, remove the pushrod. On engines with shaft-mounted rocker arms, the rocker arm may be moved by compressing the spring so that the pushrod can be removed. Thus, the rocker arm assembly does NOT have to be removed.

After the lifter has been removed, check the bottom or cam side to insure that it is flat. To do this, place a straightedge across the lifter bottom. If light can be seen between the straightedge and the lifter, the lifter should be discarded.

When you disassemble the lifter, be sure to clean all parts in a cleaning solvent. Reassemble and fill the lifter with clean, light engine oil. Also, make sure that all lifters are replaced in the same bore from which they were removed. Work on one lifter at a time so that parts are not mixed between lifters.

## CHECKING THE CAMSHAFT

The camshaft must be checked for bearing-journal or cam wear and alignment. In checking

alignment, place the camshaft in a set of V-blocks, and use a dial indicator to check the runout of the journals when the shaft is turned. Journals should be checked with a micrometer and the reading compared to the manufacturer's specifications. The cam wear should be measured with a micrometer; however, if wear shows across the full face of the cam, you can be almost certain that excessive wear has taken place.

### REPLACING CAMSHAFT BEARINGS

When camshaft bearings are worn or show excessive clearance, they should be replaced. Special tools are required to remove and replace cam bearings. When installing new bearings, be sure that the oil holes are aligned with those in the block. Make sure, also, that new bearings are staked in the block if the old bearings were staked. On some engines which do not use precision-insert bearings, line reaming of the bearings is required after they have been installed.

### TIMING THE VALVES

The relationship between the camshaft and crankshaft determines the valve timing. Sprockets and chains are used to open and close the valves in relation to the position of the pistons in the cylinders.

The gears or sprockets, as the case may be, of the camshaft and crankshaft are keyed in position so they cannot slip. Since they are keyed to their respective shafts, they can be replaced if they become worn or noisy.

With directly driven timing gears (fig. 5-33), one gear usually has a mark on two adjacent teeth and the other a mark on only one tooth. To time the valves properly, it is necessary to mesh the gears so that the two marked teeth of the one gear straddle the single marked tooth of the other gear.

In chain-driven sprockets, correct timing may be obtained by having a certain number of chain link teeth between the marks, or by lining up the marks with a straightedge, as shown in

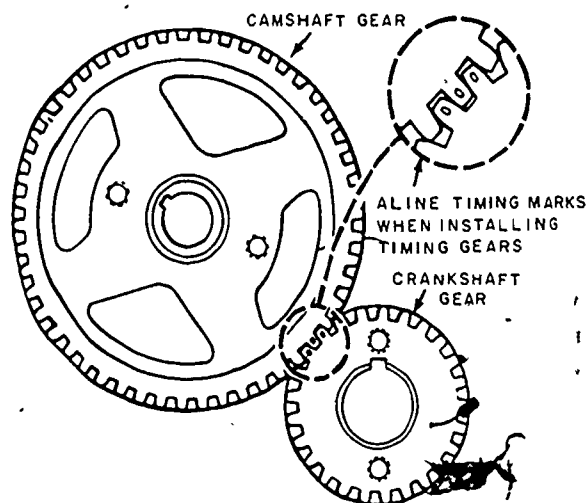

81.69

Figure 5-33.—Timing gears and their markings.

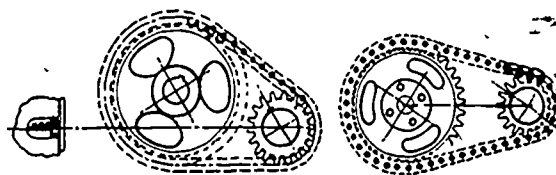

81.70

Figure 5-34.—Methods of valve timing with a chain drive.

figure 5-34. In the latter method, the position of the piston is determined by the markings on the flywheel. Some engines have timing marks on the crankshaft pulley if there is no opening provided in the flywheel housing. Always check the manufacturer's instructions when you are in doubt about the method of timing the engine you are overhauling.

### SERVICING THE CRANKSHAFT AND CYLINDERS

Most modern engines have main and connecting rod bearings of the precision-insert type, which can be replaced without removing the crankshaft. However, if oil passages are blocked, journals are tapered out of round, or

the crankshaft is bent, simply replacing the bearings will not correct the trouble.

If the bearings appear to have worn uniformly, probably the only requirements are crankshaft journal checks and bearing replacement. If bearing wear is uneven, then the safest procedure is to remove the crankshaft from the engine and check it.

**CHECKING CRANKSHAFT JOURNALS AND BEARINGS**

There are two methods of measuring crankshaft journals. One method requires the use of a bridge gage of the type shown in figure 5-35, the other method requires an outside micrometer. Regardless of the method used, take several measurements along the journal to check for taper. Also, rotate the crankshaft one-quarter or one-eighth turn at a time so additional measurements can be taken to check out of round wear. Journals that are tapered or out of round by more than 0.003 inch must be reground.

**REMOVING BEARING CAPS**

When removing bearing caps, make sure to mark them so they can be replaced on the same

journals from which removed. If the bearing caps stick, carefully work them loose to avoid distorting them. When a bearing cap puller is used, the puller bolt is screwed into the oil-coupling bore hole of the journal, allowing the cap to be removed. Another method of removing the bearing cap is to work it loose by tapping the cap lightly on one side and then the other side with a brass hammer.

**CHECKING BEARING FIT**

Bearing fit or oil clearance should always be checked when new bearings are installed. When the bearing caps are off, the journals should be measured so that wear, out of roundness, or taper can be detected.

Bearing clearance can be checked either with feeler stock or Plastigage. Plastigage is a plastic material that is flattened by pressure. The amount it flattens indicates the amount of clearance.

Before checking bearing clearance with Plastigage, wipe the journal and the bearing clean of oil. Then place a strip of the Plastigage lengthwise in the center of the bearing cap (fig. 5-36). Install the cap next and tighten into place.

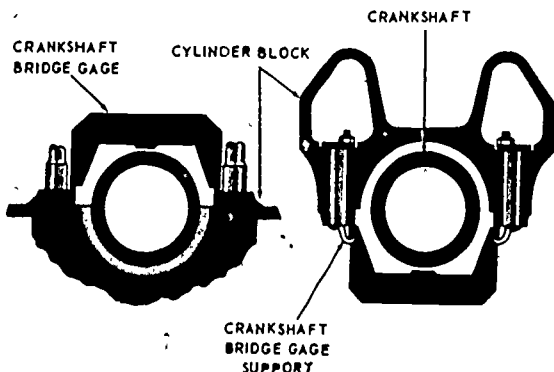

75.90  
Figure 5-35.—Crankshaft bridge gage.

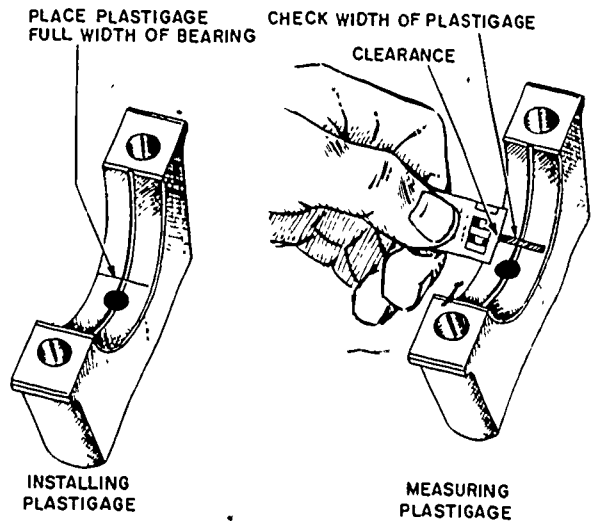

75.327  
Figure 5-36.—Checking bearing clearance with Plastigage.

When the cap is removed, the amount of flattening of the strip can be measured with a special scale (fig. 5-36). The flattened strip should NOT be removed from the cap or the journal to measure the width, but it should be measured in place, as shown in figure 5-36. Not only does the amount of flattening measure bearing clearance, but uneven flattening also indicates a tapered or worn crankshaft journal or bearing.

**CAUTION:** Do not turn the crankshaft with the Plastigage in place.

When feeler stock is used to check main bearing clearances, a piece of stock of the correct size and thickness should be placed in the bearing cap after it is removed. The feeler stock should be coated lightly with oil. The bearing cap should then be replaced and tightened. Note the ease with which the crankshaft can be turned. As a word of caution, do not completely rotate the engine, which could damage the bearing. Turn it only about an inch in one direction or the other.

If the crankshaft is locked or drags noticeably after the bearing cap has been replaced and tightened, then bearing clearance is less than the thickness of the feeler stock. If it does not tighten or drag, place an additional thickness of feeler stock on top of the first and again check the ease of crankshaft movement. Clearance normally should be about .002 inch. Be sure to check the engine manufacturer's shop manual for exact specifications.

### CHECKING CRANKSHAFT END PLAY

Crankshaft end play will become excessive if the thrust bearings are worn, producing a sharp, irregular knock. If the wear is considerable, the knock will occur each time the clutch is engaged or released; this action causes sudden endwise movement of the crankshaft. Crankshaft end play should only be a few thousandths of an inch. To measure this end play, force the crankshaft endwise as far as possible by using a pry bar and then measure the clearance between the thrust bearing and the block with a feeler gage.

### CYLINDER SERVICE

There are certain limits to which cylinders may become tapered or out of round before they require refinishing. If they are only slightly out of round or have only a slight taper (consult the manufacturer's manual for the maximum allowable out of round or taper), new standard rings can be installed. Where the walls have some taper, but not enough to warrant the extra expense of a rebore or hone job, special compression and oil-control rings should be used. Such rings are called SEVERE, or DRASTIC, because of their ability to withstand higher ring pressures and to work under more severe operating conditions or against greater taper than standard rings.

When cylinder wear goes beyond the point recommended in the engine manufacturer's specifications, even the severe or drastic rings cannot hold compression and control oil; loss of compression, high oil consumption, poor performance, and heavy carbon accumulations in the cylinder will result. In such cases, the only way to put the engine back into good operating condition is to refinish the cylinders and fit new pistons (or oversized pistons) and rings.

### CHECKING CYLINDER WALLS

As a first step in checking cylinder walls, wipe them clean and examine them carefully for scored places and spotty wear (which shows up as dark, unpolished spots on the walls). Holding a light at the opposite end of the cylinder from the eye will help in the examination. If scores or spots are found, the cylinder walls should be refinished; even drastic rings will not give satisfactory performance on such walls.

Next, measure the cylinders for taper and oval wear. This can be done with an inside micrometer, a telescope gage and an outside micrometer, or by a special dial indicator, as shown in figure 5-37. As the dial indicator is moved up and down in the cylinder and turned from one position to another, any irregularities will cause the needle to move. This will indicate how many thousandths of an inch the cylinder is out of round or tapered.

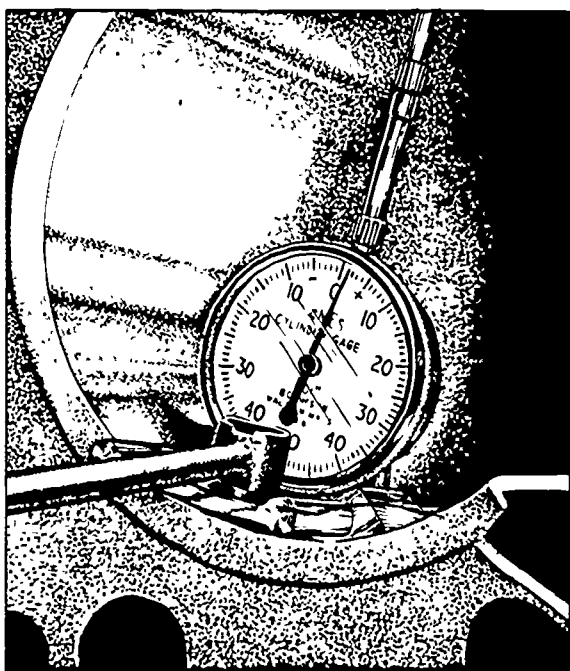

2.483

Figure 5-37.—Dial indicator for measuring cylinders.

The permissible amount of taper or out of roundness in a cylinder varies somewhat with different engines. Engine manufacturers issue recommendations based on experience with their own engine. When the recommendations are exceeded, the cylinders have to be refinished.

### REFINISHING CYLINDERS

There are two methods of refinishing cylinders—honing and boring. Cylinders are refinished by honing when wear is not too great. Otherwise, they are bored with a machine and oversized pistons and rings installed. This machine consists of a boring bar and cutting tool that revolves. The procedures for mounting the boring bar, setting the cutting tool, and operating the boring machine will vary among different makes of equipment. Consult the manufacturer's operating manual for the procedures recommended.

In honing, two sets of stones, coarse and fine, are generally used along with honing oil or

cutting fluid. If a lot of material must be removed, start with the coarse stones. You must leave sufficient material, however, so that the rough-honing marks can be removed with the fine stones. The final honed size must equal the size of the piston and rings to be installed.

Occasionally, during the final honing stage, clean the cylinder walls and check the piston size to guard against the removal of too much material or honing the cylinder oversize.

Honing is sometimes used to "break" or "crack" the glaze on cylinder walls when new rings are installed. The idea behind this is to remove the smooth glaze that has formed on the cylinder walls, thus giving the new rings a chance to set quickly.

### SERVICING PISTONS AND RINGS

When service is required on pistons and rings, they must first be removed from the engine. Where removal is to be from the top of the cylinder block, take the cylinder head off and examine the cylinder for wear. If the cylinder is worn, there will be a ridge at the upper limit of the top ring travel. Remove this ridge. If not removed, it will damage the piston and rings as they are forced out of the top of the cylinder.

To remove this ridge use a reamer of the type shown in figure 5-38. Before placing the ridge reamer in the cylinder, be sure the piston has been placed at BDC. Stuff rags into the cylinder to protect the piston and piston rings from metal shavings during the reaming operation. Be sure to adjust the cutters to the correct depth of cut. Check the manufacturer's specifications for the recommended amount of metal, take the rags from the cylinder and wipe the cylinder wall clean. Repeat the reaming operation for other cylinders where necessary.

Before the connecting rods can be detached from the crankshaft, the oil pan must be removed. With the cylinder head and oil pan off, crank the engine so that the piston of the



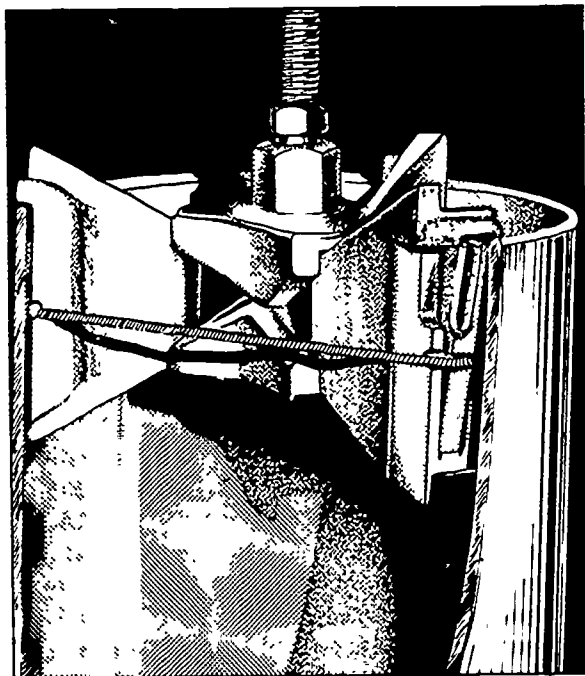

2.484

Figure 5-38.—Ridge reamer.

No. 1 cylinder is near BDC. Examine the piston rod and rod cap for identifying marks, and, if none can be seen, mark them with numbering dies to insure replacing them in the same cylinders from which removed. Remove the rod nuts and cap with a wrench, and slide the rod and piston assembly up into the cylinder away from the crankshaft. After all piston and piston rod assemblies have been detached, they may be removed from the tops of the cylinders. It will be necessary to turn the crankshaft as you go from one cylinder to the next to detach the piston rods.

### CLEANING PISTONS

After you have removed the piston rings, the piston should be cleaned inside and out. Examine the piston to determine whether it can be re-installed in the engine. Even if the old piston is in good condition, a new piston may be required if the cylinder into which the piston fits is so worn that it must be bored to a larger diameter. Oversized pistons are installed in

cylinders that are bored. When a piston is being cleaned, accumulations of carbon should be scraped from the head and from inside the piston. Do not scrape the sides or skirts of the piston, since this may scratch the finish and cause excessive cylinder wall wear. Use a ring-groove cleaner to remove built-up carbon from the ring grooves. When pulling this cleaner through the groove, remove only the carbon; do not remove any of the metal.

### FITTING PISTONS

After a piston has been cleaned, it should be measured with an outside micrometer. The measurements must be taken in various places to determine whether the piston is excessively worn or collapsed. Compare the measurements with those of the cylinder to determine if correct clearance exist. Consult the engine manufacturer's maintenance manual for details of measurements and allowable clearances, as well as for maximum allowable piston and cylinder wall taper. Most of the pistons you will encounter will be of the cam-ground type. This type is not round when cold, but slightly elliptical in shape. On this type of piston, taper is measured over the largest dimension which is perpendicular to the piston-pin holes.

The fit of the piston in the cylinder must be accurately determined. This fit can be measured with a piece of feeler stock of the proper thickness and a spring gage. The piston is inserted into the cylinder upside down with the feeler stock (lightly oiled) placed at right angles to, and 90° from, the piston-pin holes. (See fig. 5-39.) The fit is measured at the point of greatest piston size. Check the amount of force required to pull out the feeler stock on the spring gage. If the feeler stock pulls out too easily, the fit is too loose. If it pulls out too hard, the fit is too tight. Check the manufacturer's maintenance manual for the correct amount of clearance.

### FITTING PISTON PINS

If the piston-pin bushings are worn, they should be reamed or honed oversize and oversize pins installed. The pins should also be replaced if they are worn, pitted, or otherwise defective.

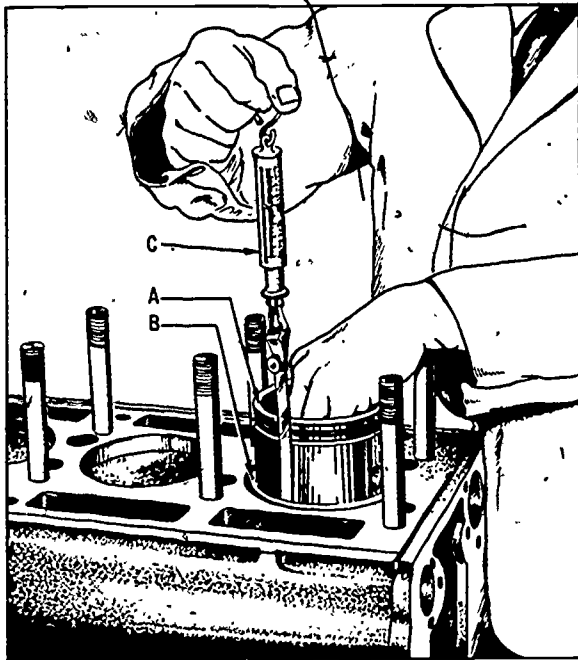

A. Piston  
B. Cylinder Sleeve  
C. Thickness Ribbon and Spring Scale

2.485

Figure 5-39.—Checking piston fit in sleeve.

Where the pin is of the type that floats, or turns in the piston-pin bushing, the fit is correct if the pin will pass through with a light thumb pressure when the piston and the pin are at room temperature. Where the pin is of the type that does NOT turn in the piston-pin bushing, the pin is forced in place under pressure. Check the manufacturer's maintenance manual for the correct pressure. If the pressure is too low, the fit is too loose and will result in noise. Excessive pressure indicates that the fit is too tight and may fracture the piston-pin bosses.

### FITTING PISTON RINGS

Piston rings must be fitted to their cylinder and to their grooves on the piston. First, check the gap or space between the ends of each ring. To do so, push a ring down into the cylinder with a piston, and measure the ring gap with a

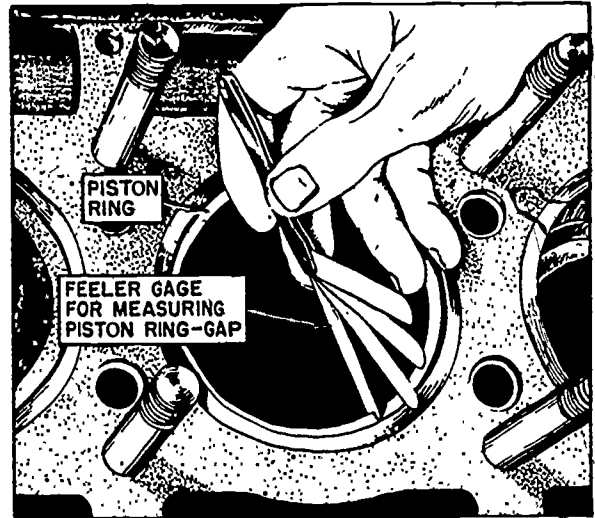

75.54

Figure 5-40.—Measuring ring gap clearance in cylinder bore.

feeler gage (fig. 5-40). If the ring gap is too small, try a slightly smaller ring, which will have a larger gap. If the cylinder is worn tapered, the diameter at the lower limit of ring travel (in the assembled engine) will be smaller than the diameter at the top: In this type of cylinder, the ring must be fitted to the diameter at the lower limit of ring travel. If fitted to the upper part of the cylinder, the ring gap will NOT be great enough as the ring is moved down to its lower

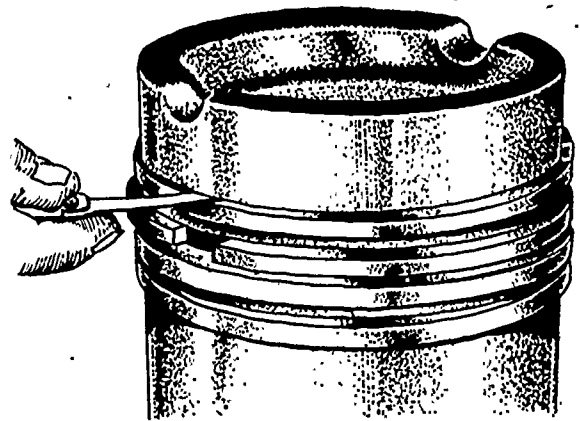

75.318

Figure 5-41.—Checking ring groove side clearance.

limit of travel. This means that the ring ends will come together and the ring will be broken or the cylinder walls scuffed. In tapered cylinders, make sure that the ring fits the cylinder at the point of minimum diameter, or at the lower limit of ring travel.

After the ring gap has been corrected, the ring should be installed in the proper ring groove on the piston and rolled around in the ring

groove to be sure that the ring has a free fit around the entire circumference of the piston. An excessively tight fit means the ring groove is dirty and should be cleaned. After the rings are installed in the ring groove, test each ring for clearance by inserting a feeler gage between the ring and the side of the ring groove, as shown in figure 5-41. Check the manufacturer's repair manual for proper clearance. If it is excessive, the piston should be replaced,

## CHAPTER 6

# ELECTRICAL SYSTEMS AND EQUIPMENT

In the early days of the automobile, only its ignition system depended on electricity for operation. In today's automobile, electricity operates the ignition, lighting, and starting systems as well as many accessories, such as heating and ventilating fans, control units on automatic transmissions and overdrives, choke controls, emission controls, radios, cigarette lighters, and air-conditioners. Even heavy construction equipment depends on electricity for operating its starting systems and accessories.

Storage batteries, generators, regulators, and other units are required to provide an adequate source of electrical current for construction and automotive equipment. The *Construction Mechanic* is responsible for maintaining the parts and units of the electrically operated systems and accessories on this equipment. Electrical repairs and adjustments, however, are special tasks that require the know-how of an expert—a person trained for this kind of work. In other words, an automotive electrician.

As a CMI or CMC, you will supervise the mechanics who perform these special tasks. In an emergency, you may have to perform them yourself. To do so in the shop or garage, you need automotive electrical testing equipment. In troubleshooting batteries and generators, for example, you will save time and reduce damage to equipment by using ammeters and voltmeters instead of hit-and-miss methods.

Another special task for the automotive electrician is maintaining the shielding components in a built-in system for reducing interference with radio reception. The sources of this interference are the ignition and battery charging circuits. However, no special handtools are required to maintain these factory-installed components.

All units in an automotive electrical system operate on the few basic principles that are described in this chapter. You can find more on automotive electricity in *Construction Mechanic 3 & 2*. Included in this chapter are the techniques of troubleshooting the charging, cranking, and ignition systems and their units.

### A.C. ELECTRICAL SYSTEMS

The output requirements of automotive electrical generators have increased considerably in recent years because of the growing popularity of current-consuming electrical accessories, such as two-way radios and radio-telephones for communications, heavy-duty heaters, and air-conditioners.

To build a conventional d.c. generator that would produce the required amount of electricity at both high- and low-speed ranges would mean an increase in size, thereby limiting application. An a.c. generator (ALTERNATOR) has been developed that can be used with a rectifier bridge to produce enough current to fulfill almost any need over a speed range that varies from idle-to-top engine speed.

### ALTERNATORS

Because of the small size of the alternator, it can be adapted to almost any application. It is mechanically constructed to withstand vibrations and top speeds met in normal service.

A review of *Construction Mechanic 3 & 2* will show that the alternator and the conventional d.c. generator operate on the same basic principles. The rotor assembly in the alternator does the same job as the field coil and pole shoe assembly in the d.c. generator. The stator assembly in an alternator has the same function

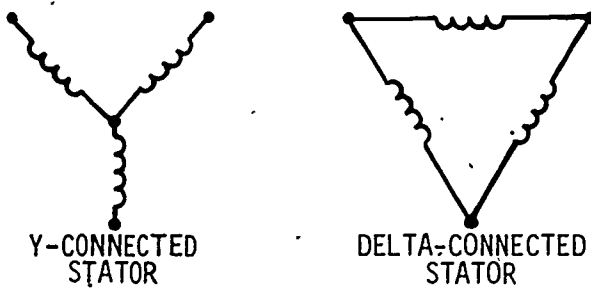

Figure 6-1.—Types of alternator internal windings.

as the armature in a d.c. generator, while in fixed position. The stator may be either "Y" or delta connected to fit the application. (See fig. 6-1.) The delta-connected alternator would normally be found where lower voltage, but higher current is required. The "Y"-connected alternator provides higher voltage and moderate current. The device for converting alternating current to direct current is the rectifier bridge. The rectifier bridge may be mounted internally within the alternator casing, or it may be mounted externally.

**RECTIFIERS**

Rectifiers of various types are manufactured for many uses. The most common type of externally mounted rectifier for automotive use is the magnesium-copper sulfide rectifier.

A rectifier mounted within the generator is the silicon-diode rectifier, such as the one shown in figure 6-2. An advantage of the silicon-diode

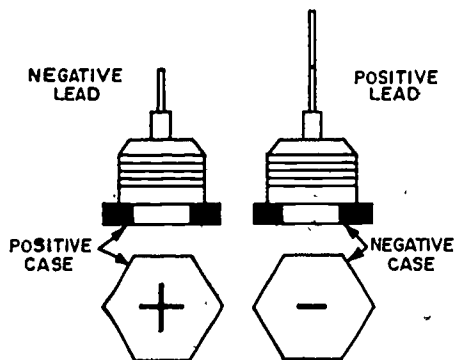

Figure 6-2.—Diodes.

20.26

rectifier is its small size, which permits it to be mounted internally within the casting of the alternator. The chemical composition of a diode enables current to flow through the diode in only one direction under normal conditions.

In the automotive-type alternator using silicon-diode rectifiers, six rectifiers are used—three positives and three negatives of the same construction, making a "full-wave bridge" rectifier.

The markings on silicon diodes vary with the alternator model and manufacturer. Some diodes are plainly marked with a (+) or (-) sign to identify their polarity (fig. 6-2). Others are marked with black or red lettering. When identifying diodes, always refer to the manufacturer's specifications.

**REGULATORS**

As with the d.c. generator, some means must be provided to regulate the electrical output of an alternator. Normally, one of the following types of regulators is used: the electromagnetic, the transistor, or the transistorized.

The electromagnetic regulator is discussed in *Construction Mechanic 3 & 2*. A short description of the transistor and transistorized regulators follows.

The transistor regulator shown in figure 6-3 is a Delco-Remy model. It has only two

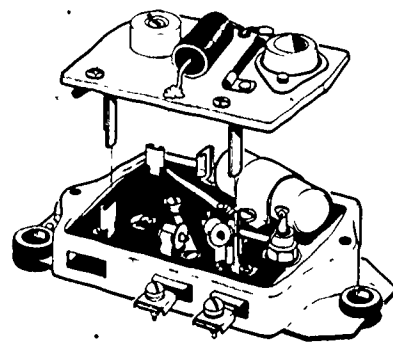

Figure 6-3.—Transistor regulator (Delco-Remy).

2.306.2X

terminals and no moving parts and limits the alternator voltage through the action of two transistors working together. It performs one function only—to control the alternator voltage to a preset value. From the wiring diagram shown in figure 6-4, the charging circuit consists of the alternator, regulator, battery, field relay, junction block, wiring, and either an ammeter or indicator light.

Voltage settings may be adjusted externally by relocating a screw in the base of the regulator

to make adjustments. The screw contacts the series of resistors and makes a connection to ground at the point of contact. Usually, voltage is adjusted internally by turning a slotted-head screw on the potentiometer which varies the connection, allowing for adjustments less than one volt.

In some transistorized regulators, a single transistor works with a conventional voltage regulator unit containing a vibrating contact point to control the alternator field current and

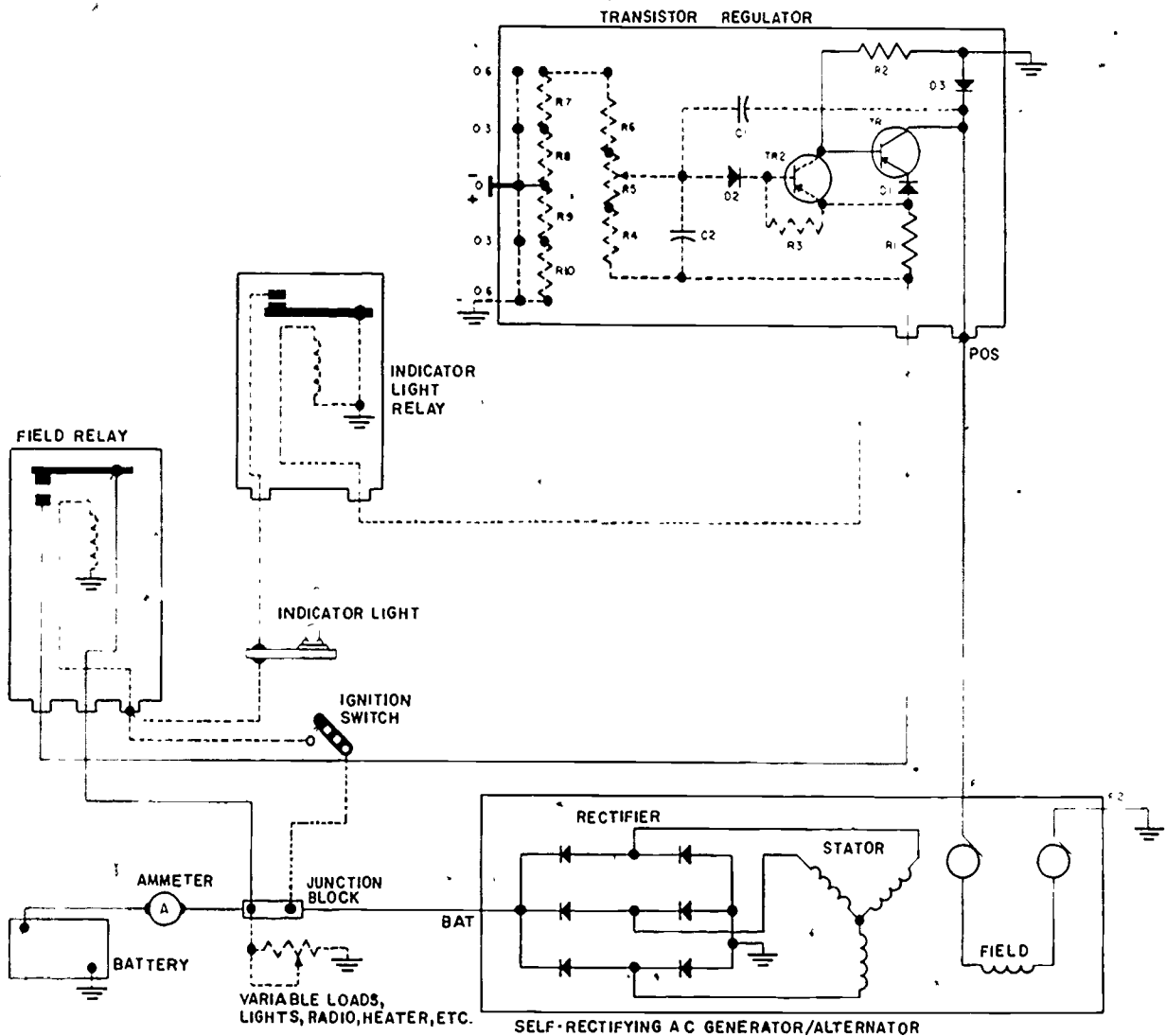
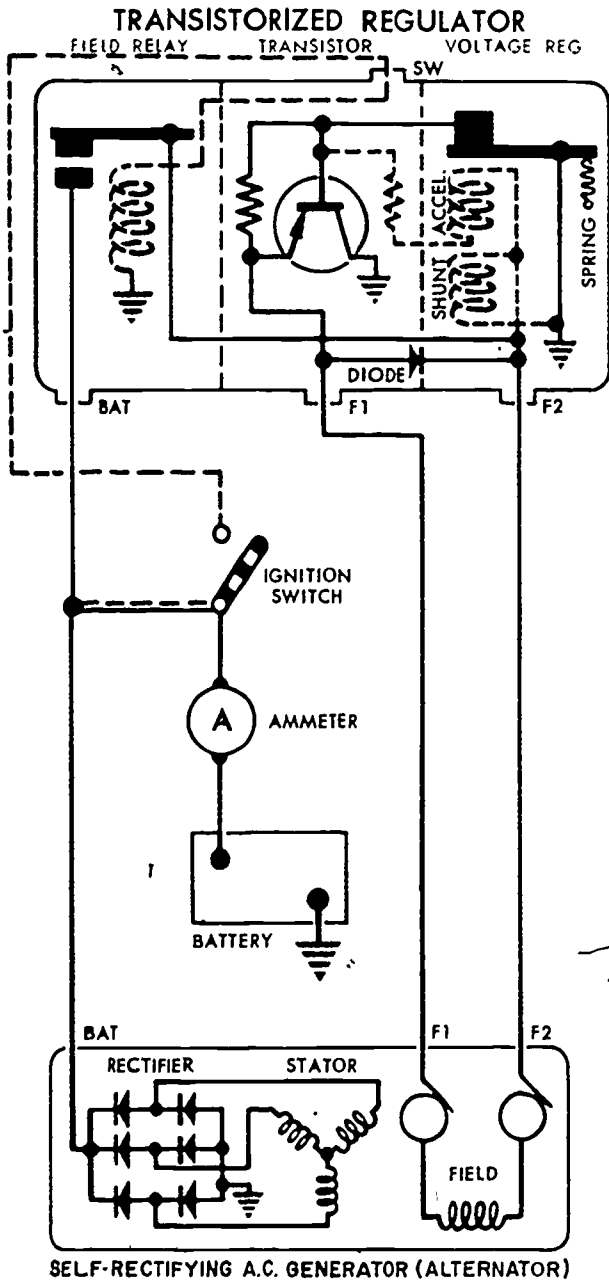

Figure 6-4.—Typical wiring diagram (transistor regulator).

2.308X

thereby limit the alternator voltage to a preset value.

The complete charging circuit, containing a four-terminal regulator consists of the alternator, regulator, battery, ignition switch, ammeter, and wiring as illustrated in figure 6-5.



2.307X

Figure 6-5.—Charging circuit (transistorized regulator).

The alternator develops a.c. voltage in the stator windings and is rectified to a d.c. voltage that appears across the generator "BAT" terminal and the ground screw in the slipping end frame.

When servicing or repairing a regulator, follow the manufacturer's service instructions for that specific make and model of regulator. Do not guess on how to repair and adjust regulators.

### TROUBLESHOOTING THE CHARGING SYSTEM WITH A VOLT-AMPERE TESTER

Two types of vehicle charging systems are in use today. One system is equipped with a d.c. generator, while the other is equipped with an a.c. generator or alternator. Both systems are tested in much the same manner.

Field circuits are commonly classified as "A" and "B" circuits. The "A" circuit or externally grounded field, as shown in figure 6-6, is connected to the armature terminal of the generator and is grounded outside the generator by the regulator contacts. In the "B" circuit, illustrated in figure 6-7, the ground is reached

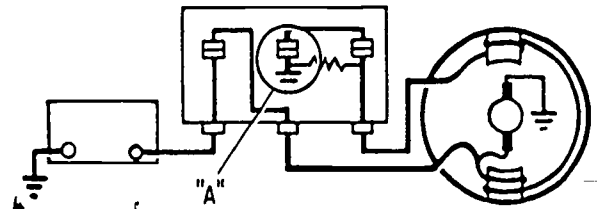

2.510

Figure 6-6.—"A" circuit.

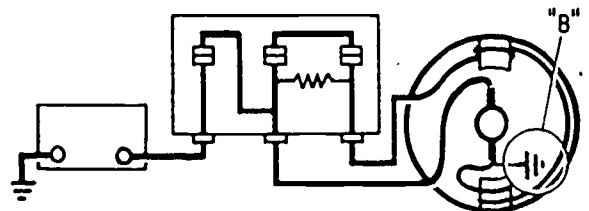

2.511

Figure 6-7.—"B" circuit.

internally, and the supply to the field is obtained via the armature circuit of the regulator. Most alternators and some d.c. generators are "B" circuits.

A d.c. generator depends upon its relatively permanent field pole piece magnetism for initial generator output. The polarity of this magnetic field determines the output polarity of the generator. A mismatched electrical system will cause early component failure. A generator with no magnetic field can produce no output. Therefore, each time a generator is repaired, installed, inoperative for a period of time, or disconnected, it must be polarized. Do so by passing an electric current through the field winding in the proper direction BEFORE THE SYSTEM IS STARTED.

To polarize an "A" CIRCUIT GENERATOR at the generator, ground the field and momentarily apply battery voltage to the armature terminal. To polarize at the regulator, momentarily apply a jumper lead from the armature terminal to the battery terminal. To polarize "B" CIRCUIT GENERATORS, you disconnect the FIELD circuit lead at the regulator and momentarily touch this lead to the regulator BATTERY terminal.

**REMEMBER:** Alternators do not require polarization.

Various instruments can be used to locate problems in the charging system. The following sections describe troubleshooting as carried out with the volt-ampere tester (fig. 6-8).

### ALTERNATOR TEST

An alternator output test is one of the first tests to be made with the volt-ampere tester. This test is made as follows: Disconnect the field wire at the alternator, and connect the tester's field lead (fig. 6-9) to the alternator's field terminal. Insure that the proper connector for the alternator being tested is used.

**CAUTION:** Do NOT allow the vehicle field wire to contact ground.

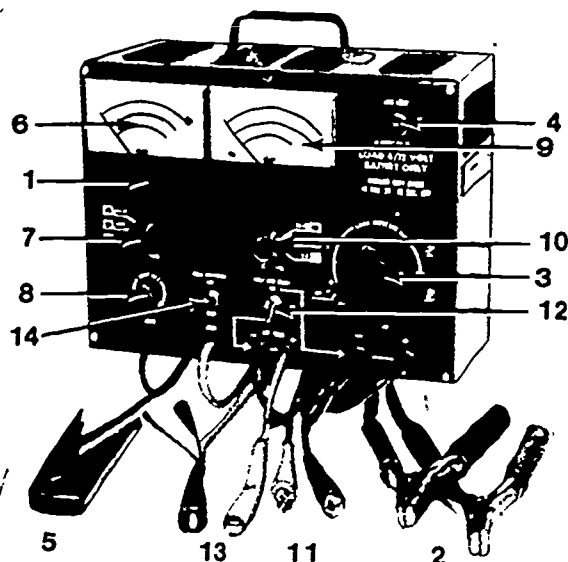

1. Zero adjustment
2. Load leads
3. Load increase knob
4. Load light
5. Clamp-on ampere pickup
6. Ammeter
7. Ampere range knob
8. Ampere zero set adjustment
9. Voltmeter
10. Volt range knob
11. External volt leads
12. Volt lead selector
13. Field leads
14. Field activation switch

2.528

Figure 6-8.—Volts-ampere tester.

Start the engine and bring the rpm's up to the manufacturer's specifications. While observing the AMMETER scale for the highest current indication, adjust the load increase knob. The field activation switch will be held in the test position during this procedure. If the ammeter indication reads at the normal output (+ or -) ten percent, the regulator must be replaced. When the ammeter indication reads at low or no output, the alternator must be repaired or replaced.



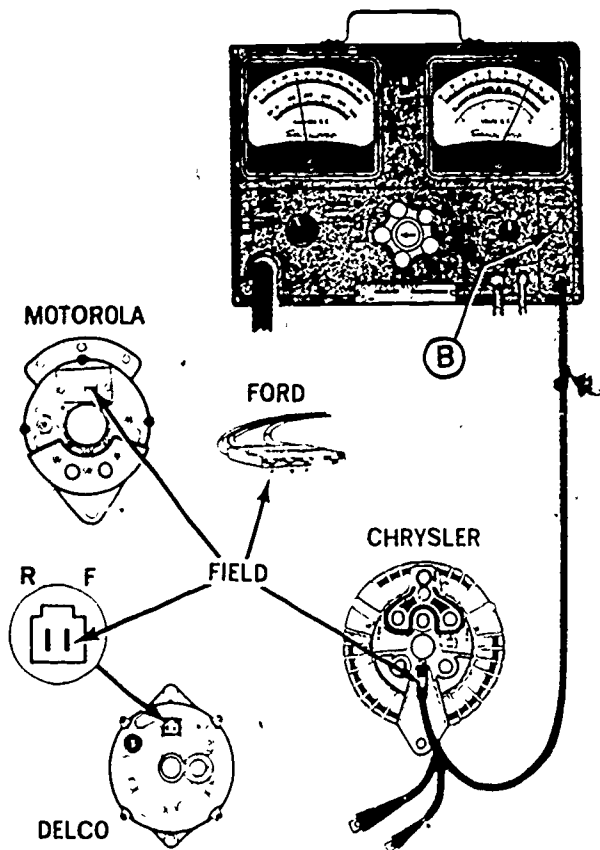

2.512

Figure 6-9.—Alternator output test.

When a vehicle is equipped with an "A"-type field circuit generator and the charging system fails, a generator test is made.

### GENERATOR TEST

A generator test is made by disconnecting the field at the generator and connecting the tester's field lead (fig. 6-10) to the generator field terminal. Do NOT allow the vehicle or tester field wires to contact ground. For the "B"-type field circuit generator, disconnect the field wire at the regulator and connect it to the armature terminal of the regulator. Start the vehicle engine and slowly increase speed as you observe the AMMETER scale for the highest ammeter reading. When the ammeter reads at the normal

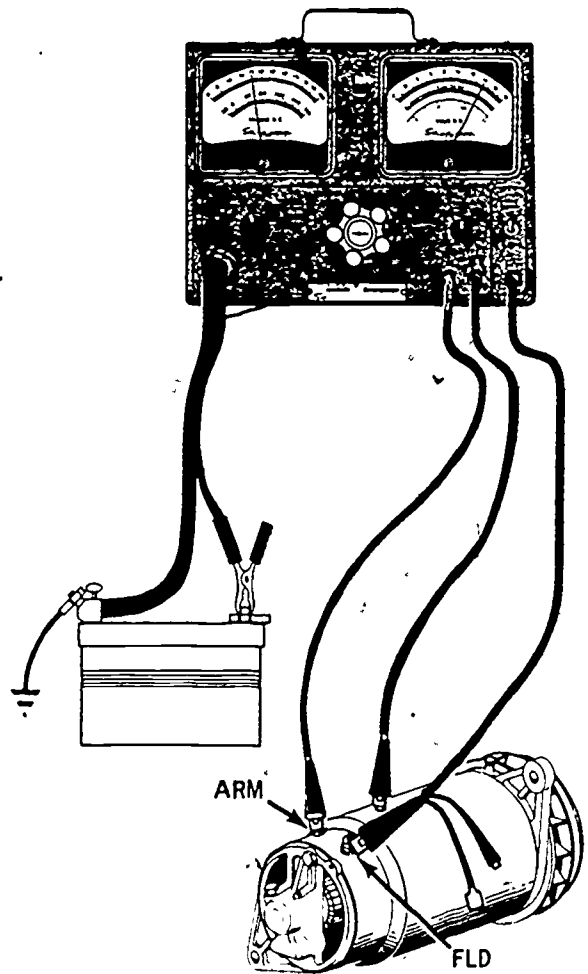

2.513

Figure 6-10.—Generator output test.

output, test the field lead of the wiring harness for an open circuit. If the field lead is okay, remove the regulator for testing, repair, or replacement, as required. When the ammeter reads at low output or normal voltage, the generator must be replaced or repaired. When the ammeter reads at no output or high voltage, and the circuit is not fused at the regulator, the regulator is removed for replacement or repair of its cutout relay. Also check the regulator ground. If the regulator is fused, bypass the fuse with a heavy jumper and observe the ammeter for output. An output at this point in your check indicates a blown fuse.

**EXCESSIVE OUTPUT TEST**

Set the volt range knob to the correct voltage range and the volt lead selector to the EXT VOLTS position. Connect the black external volts lead to the generator armature terminal, and the red external volts lead to the generator frame or a good ground. While observing the VOLTMETER scale for the highest voltmeter reading, start the engine and slowly increase its speed. If the voltmeter reads less than 16 volts (12-volt system) or 8 volts (6-volt system), the regulator's current limiter relay is the reason for the high output. If the voltmeter reads more than 16 volts (12-volt system) or 8 volts (6-volt system), remove the FIELD wire at the regulator and observe the AMMETER scale. When the ammeter reading shows no output, you have a defective regulator which should be repaired or replaced. When the ammeter reading indicates a current flow, remove the field wire at the generator and observe the ammeter. If the ammeter reading then shows no output, you have a shorted field wire. Replace the field wire and connect the generator to the regulator. On the other hand, if the ammeter shows that current is flowing, then the generator has a grounded field.

Another component of the vehicle charging system to be tested is the VOLTAGE REGULATOR. If the results of the test indicate that the voltage is too high or too low, a faulty regulator voltage limiter or a high-series resistance in the charging system could be causing the trouble. Erratic or unstable voltage indicates poor circuit electrical connections, faulty regulator contacts (burned or oxidized), or damaged regulator resistors. In any case, you should proceed with a charging system circuit resistance test.

**CHARGING SYSTEM CIRCUIT RESISTANCE TEST**

A charging system circuit resistance test is made to determine the voltage loss between the output terminal of the generator or alternator and the insulated battery post, and between the generator or alternator housing and battery ground post, respectively. These tests can be run

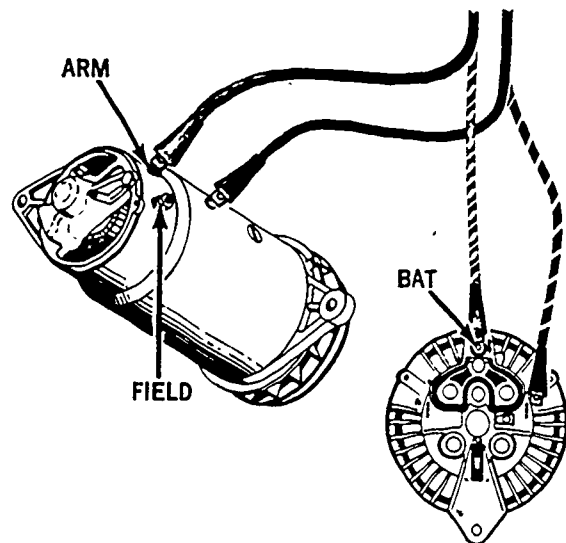

2.514

Figure 6-11.—Circuit resistance test.

with any voltmeter having a small scale i.e., 3-5 volts. Any voltage loss caused by high resistance in these circuits will reduce the overall charge rate and lead to eventual battery discharge.

The external volts lead is connected to the generator armature terminal, as indicated in figure 6-11, when a generator is tested, and to the battery terminal when an alternator is tested.

If a voltage loss exceeds the specified amount for the unit being tested, an excessive resistance is present within the charging system—that is, within the wiring harness, connections, regulator, and vehicle ammeter (if used). The excessive resistance might take the form of LOOSE or CORRODED CONNECTIONS at the output terminal of the generator or alternator, the armature terminal of the regulator, or the back of the ammeter or battery terminal of the starter solenoid battery cable connections. Excessive resistance can also be due to faulty wiring from generator to regulator, regulator to ammeter, or ammeter to starter solenoid; to burned or oxidized cutout relay contacts within the regulator; or to poor electrical connections between the generator or alternator and the engine. To isolate the point of excessive resistance, a charging system insulated circuit resistance test is made.

### CHARGING SYSTEM INSULATED CIRCUIT RESISTANCE TEST

A charging system insulated circuit resistance test is made by setting the volt range selector knob to the -0.3 to 3.0 volt scale position. When an alternator is tested, observe the polarity, and connect the external volts lead to the generator armature terminal or to the battery terminal. (See fig. 6-12.) Remember to reverse the external

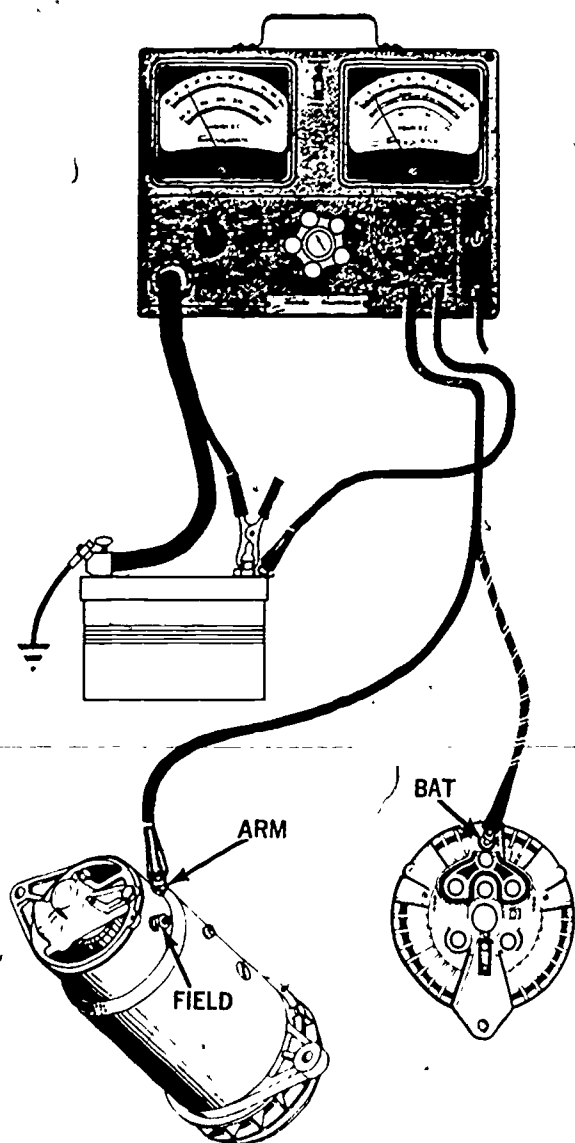

2.515

Figure 6-12.—Insulated circuit resistance test.

volts lead for positive ground systems. Start the engine and adjust its speed to approximately 2,000 rpm. Then adjust the load increase knob until the AMMETER scale indicates a current of 20 amperes for d.c. systems, or 10 amperes for a.c. systems. Also observe the voltage reading on the (3-volt) VOLTMETER scale and compare it with the specifications for proper charging system operation, as required by the vehicle manufacturer. If the reading is within specification, you should proceed with a charging system ground circuit resistance test.

### CHARGING SYSTEM GROUND CIRCUIT RESISTANCE TEST

Observing polarity, connect the external volts lead to the generator or alternator ground terminal. (See fig. 6-13.) Adjust the load increase knob until the ammeter scale indicates a current of 20 amperes for d.c. systems or 10 amperes for a.c. systems. Also, observe the voltage reading on the (3-volt) VOLTMETER scale and compare it with the specifications for proper charging system operation, as required by the vehicle manufacturer. If the reading is within specifications, you should proceed with a regulator ground circuit resistance test.

### REGULATOR GROUND CIRCUIT RESISTANCE TEST

Set the volt lead selector to the INT VOLTS position. Observing polarity, connect the external volts lead to the generator or alternator ground terminal and to the regulator ground terminal. (See fig. 6-14.) Adjust the load increase knob until the AMMETER scale indicates a current of 10 amperes. Also observe the reading on the (3-volt) VOLTMETER scale and compare it with the specifications. If the voltmeter reading exceeds 0.1 volt, excessive resistance is in the ground circuit between the regulator and the generator or alternator. Check the regulator ground system for loose mounting bolts or a damaged ground strap.

### BATTERY DRAIN TEST

This test is made to determine if there is a discharge current flowing when all accessories

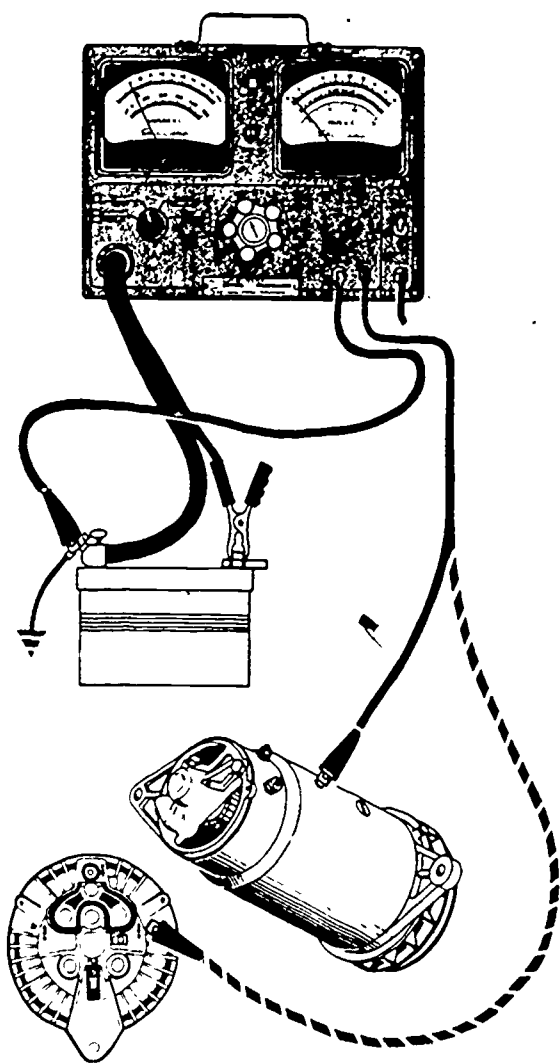
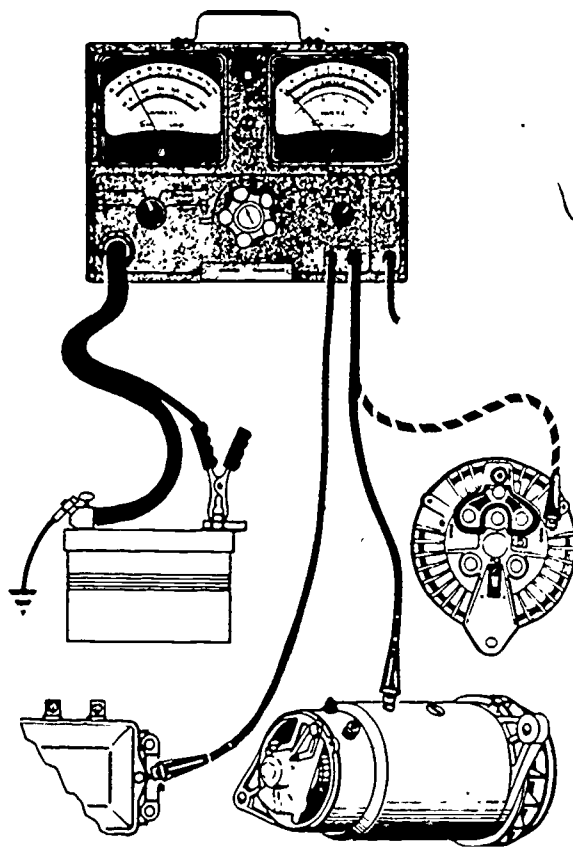

Figure 6-13.—Ground circuit resistance test.

2.516

and lights are turned off. Any discharge at this time would indicate the presence of partially shorted or grounded wires, defective switches, or accessories. This condition of discharge leads to a frequently rundown battery and starting failure complaints. Turn the vehicle ignition switch to OFF. Lights and accessories must be OFF and doors closed. Observe the AMMETER scale. If the ammeter scale reads zero, there are no short or grounded circuit paths for current, in which case the electrical system is okay and all



2.517

Figure 6-14.—Regulator ground circuit resistance test.

tests are completed. If the ammeter scale reads other than zero, an electrical short or grounded circuit exists if all the vehicle circuits are turned OFF. The short or grounded circuit may be found by isolating each circuit, one at a time, until the ammeter reads zero. The last circuit isolated, as the ammeter returned to zero, is the defective one. Many circuits can be isolated by removing the circuit fuse from the fuse panel.

NOTE: At the conclusion of tests, return the engine to idle and stop it before disconnecting test leads. Reconnect the ground cable to the ground post of the battery and make sure all vehicle wires disconnect during the tests are once again securely and properly connected.

### TROUBLESHOOTING THE ALTERNATOR USING THE ENGINE ANALYZER SCREEN

Since the engine analyzer has been added to the Table of Allowances, mechanics and others assigned to the electrical repair shop will be able to troubleshoot alternators. This chapter includes an explanation on how to use the analyzer (fig. 6-15) in testing the charging circuits of a vehicle. Patterns that appear on the

screen of the analyzer indicate the alternator output and identify faults in the diodes of the alternator. ALWAYS refer to the manufacturer's manual for the analyzer and the unit being tested before making connections.

### CHARGING CIRCUIT DIODES

When an alternator produces fully, each of its diodes conducts an equal share of the current.

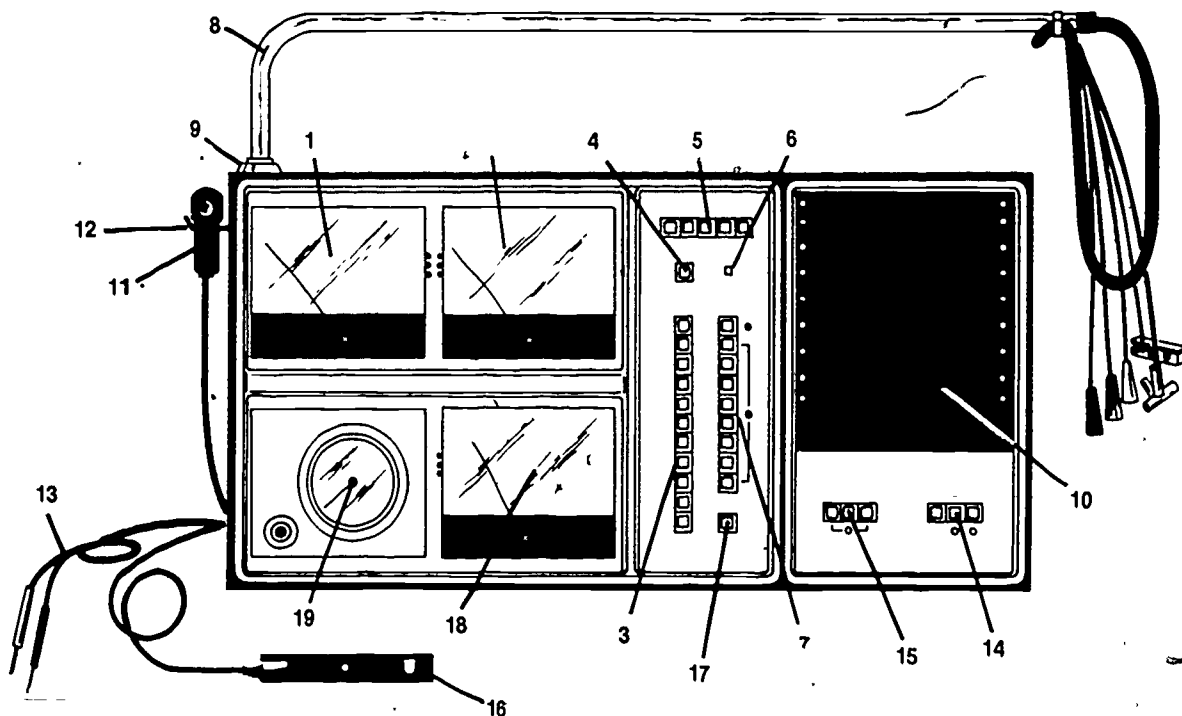

- |                                |                                |
|--------------------------------|--------------------------------|
| 1. Voltmeter-CO                | 10. Screen-viewing area        |
| 2. Tachometer-Ohm              | 11. Timing light               |
| 3. Test Selector               | 12. Hanger                     |
| 4. Special Ignition            | 13. Ohm leads and special test |
| 5. Engine Selector             | 14. Sweep selector             |
| 6. Primary load "ON" indicator | 15. Pattern selector           |
| 7. Cylinder selector and kill  | 16. Current Probe              |
| 8. Boom                        | 17. On-Off                     |
| 9. Boom collar                 | 18. Timing-Amp-Dwell           |
|                                | 19. Vacuum Gage                |

Figure 6-15.—Engine analyzer.

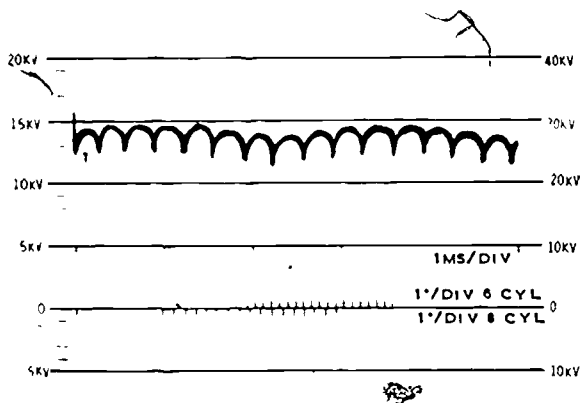

Figure 6-16.—Ripple pattern of the alternator output.

This condition is indicated by a ripple pattern that appears on the screen of the engine analyzer. (See figure 6-16.) But a single nonconducting diode places a strain on the charging circuit which causes a decrease in the output of the alternator. Whereas an ammeter or voltmeter may not detect this strain, the analyzer can do so easily. The strain brought on by an open field condition, for example, will stop the alternator output ripple entirely. See the screen display of figure 6-17.

A likely result of decreased alternator output is an undercharged battery. And without a fully charged battery, there may not be enough current available to start the engine or meet the demands of the electrical circuits. When a good battery cannot be fully charged, the fault is usually in the alternator or voltage regulator. The engine analyzer can help you determine which is at fault. However, the regulator has to

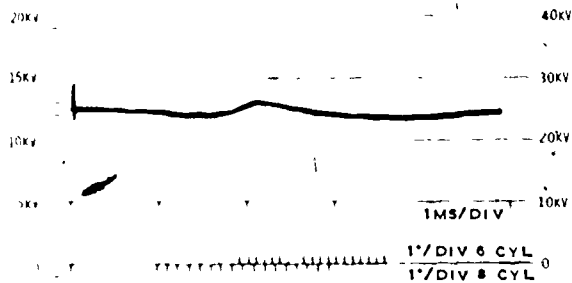

Figure 6-17.—Open field stops the ripple.

be bypassed altogether and battery voltage applied to the field terminal of the alternator. Not all alternators can be full fielded. Refer to the manufacturer's field test procedure.

### BYPASS PROCEDURE

The first step in the procedure for bypassing the voltage regulator is turning OFF the engine. Next disconnect the regulator and place a jumper wire between the positive (+) battery terminal and the field terminal of the alternator. Or you can use the bypass adapter hooked up as shown in figure 6-18. Again start the engine and slowly increase its speed until the rated alternator output is reached. **DO NOT RUN THE ENGINE FOR MORE THAN 20 SECONDS.**

If the ripple pattern now appears on the screen of the engine analyzer, the regulator is faulty. No change in the screen pattern means the alternator or output wiring is at fault. Stop the engine, disconnect the jumper wire or bypass adapter, and reconnect the voltage regulator.

### OPEN AND SHORTED DIODES

A shorted diode or shorted winding will usually burn itself open. The pattern on the screen will show a shorted diode (fig. 6-19) or open diode (fig. 6-20). Notice the similarity in the patterns. At any rate, the alternator will require service or replacement even though both output current and voltage regulation appear to be acceptable. As a general rule, a shorted diode

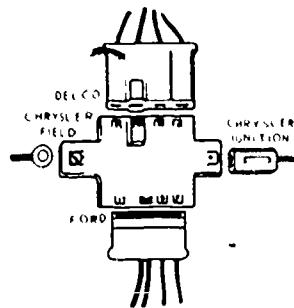

Figure 6-18.—Bypass adapter.

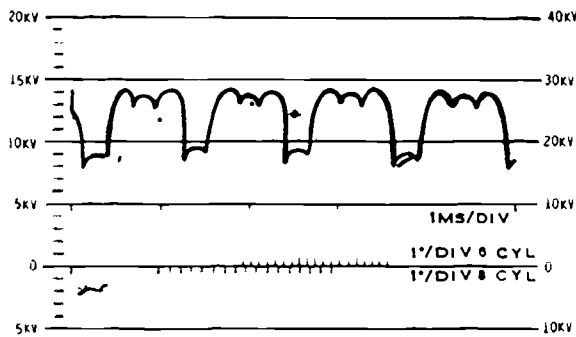

Figure 6-19.—Shorted diode pattern.

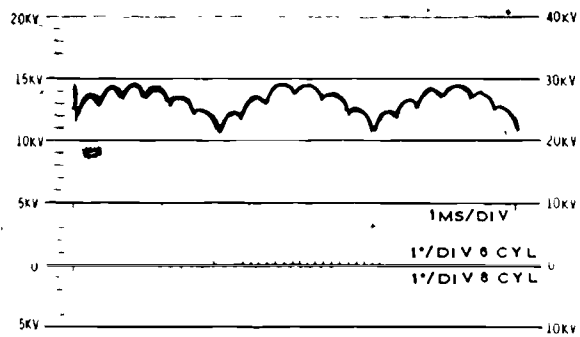

Figure 6-21.—Poor diode pattern.

### SHORTED WINDINGS

Shorted windings and shorted diodes will produce similar screen patterns since the defect is the same, depending on the location of the short. Compare figures 6-19 and 6-22. The alternator test screen patterns shown are for diagnosis only; therefore, the alternator must be removed to locate the defective internal component. Now, it is a matter of verifying the problem with simple ohmmeter tests or by replacing defective components.

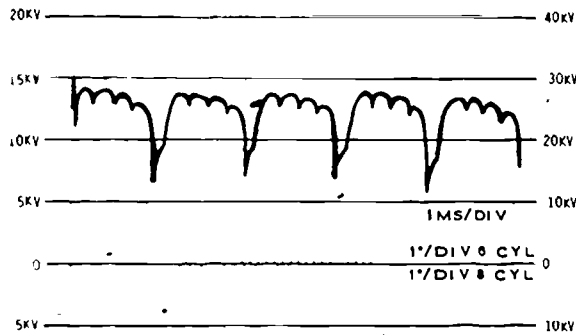

Figure 6-20.—Open diode pattern.

affects the output more than an open diode does. It not only reduces the output but also opposes the next pulse by allowing the current to flow back through the winding containing the shorted diode.

### WEAK DIODES

As you can see from the screen pattern in figure 6-21, there is no interruption in the rectification of the diodes. However, there is a high and low peak every sixth pulse, indicating that the output of one diode is low and that it may be deteriorating (high resistance). This pattern may also occur due to a shorted winding since the number of windings determines the amount of output as well as the condition (resistance) of the diodes.

### TROUBLESHOOTING THE CRANKING SYSTEM USING THE BATTERY STARTER TEST

To determine whether a battery is fit for service, cranking system tests are performed

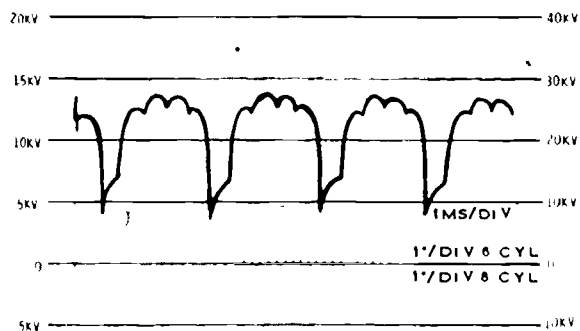

Figure 6-22.—Shorted winding pattern.

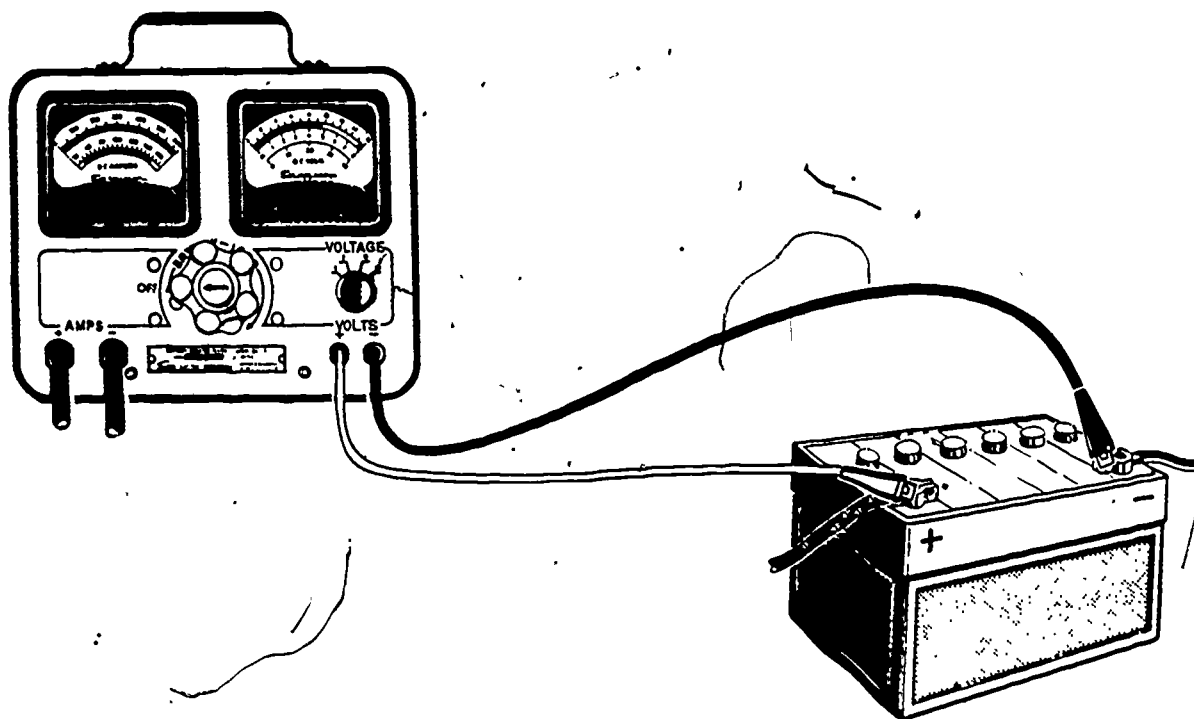

Figure 6-23.—Cranking voltage test.

2.518

with a battery starter tester, model BST, as illustrated in figure 6-23. This tester, made by Sun Electric Corporation, is designed to test only batteries and starting systems of vehicles using 6-, 12-, 24-, or 32-volt systems.

### CRANKING VOLTAGE TEST

In testing the cranking voltage in a 6-, 12-, or 24-volt series system, connect the tester's voltmeter leads as shown in figure 6-23. Observe the polarity as you make the connections. Turn the voltmeter selector switch to 8 volts for a 6-volt system, 16 volts for a 12-volt system, or 40 volts for a 24-volt system. When a vehicle is equipped with a 24-volt series parallel system, the voltmeter leads are attached to the two terminals on the starting motor. Before cranking the engine with the ignition switch ON, connect a jumper from the secondary terminal of the coil to ground to prevent the engine from starting while testing. While cranking, observe both the

voltmeter reading and cranking speed. The starter should crank the engine evenly, and at a good rate of speed, with a voltmeter reading as follows (UNLESS OTHERWISE SPECIFIED):

4.8 volts or more for a 6-volt system.

9.6 volts or more for a 12-volt system.

18 volts or more for a 24-volt system.

When the cranking voltage and cranking speed are good, it is reasonably safe to assume that the starting motor and starting circuits are in order. If the cranking voltage is lower than specified, test the battery capacity, starter circuits, and starter cranking current. However, if the cranking voltage is high, but the starter action is sluggish, check for starting circuit resistance, as outlined in the circuit resistance tests given later in this chapter.

Excessive starting motor current indicates trouble in the starting circuit, provided the



engine cranking load is normal. However, increased current is normal on new or newly overhauled engines or where the cranking load is above normal.

To check an excessive starting motor current, a starting motor current draw test of the 6-, 12-, or 24-volt series system is performed.

**STARTING MOTOR CURRENT DRAW TEST**

Turn the battery starter tester control knob to the OFF position. Then turn the voltmeter selector switch to 8 volts for a 6-volt system or 16 volts for a 12-volt system. When a vehicle is equipped with a 24-volt series system, the voltmeter selector switch is turned to 16 volts if 12-volt batteries are used or to 8 volts if 6-volt batteries are used. On a 24-volt series system, connect the voltmeter leads across one 6- or 12-volt battery ONLY. Connect the tester's VOLTMETER leads, as shown in figure 6-24.

Before cranking the engine with the ignition switch ON, connect a jumper from the secondary terminal of the coil to ground to prevent the engine from starting while testing. While cranking, note the exact reading on the voltmeter. After cranking, turn the control knob

of the battery tester clockwise until the voltmeter again reads exactly as it did during cranking. The test AMMETER should indicate the starting motor current within the normal range of the vehicle being tested, as determined from the manufacturer's specifications. However, if the test indicates normal starter current, but low cranking speed, check the resistance in the starting circuit. If high starter current is encountered during the test, starting circuit trouble is indicated. In case of low starter current—accompanied by low cranking speed—or complete failure of the engine to crank, look for resistance within the starting circuit wiring or starting motor.

**STARTER INSULATED CIRCUIT RESISTANCE TEST (CABLES AND SWITCHES)**

The starter insulated circuit resistance test of a 6-, 12-, or 24-volt series system is performed as follows. Connect the tester's VOLTMETER leads as shown in views A, B, and C of figure 6-25 for the type of current being tested, observing the polarity as you make the connections. The voltmeter will read off-scale to the right until the engine is cranked. The voltmeter lead clips must be in good contact with the battery posts and the starter terminal. Now, turn the voltmeter selector switch to the No. 4

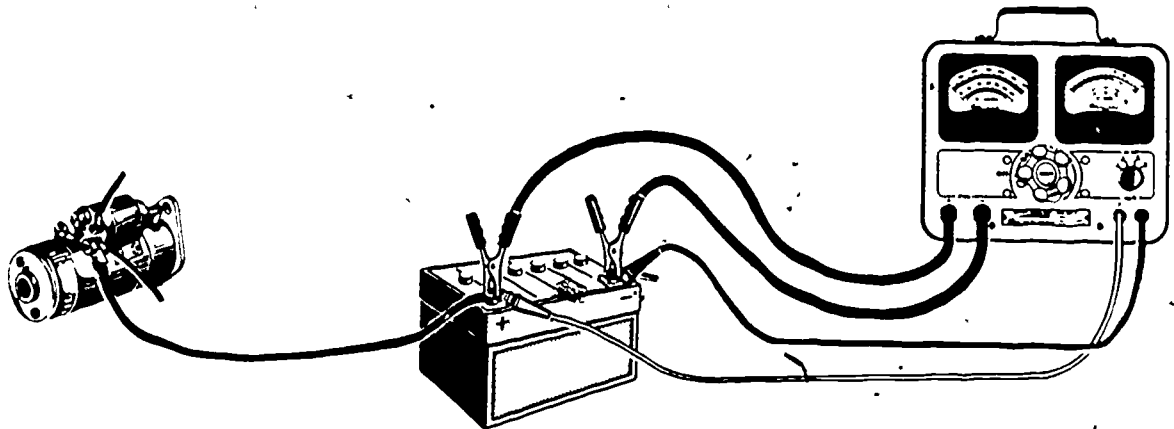

Figure 6-24.—Starting motor current draw test.

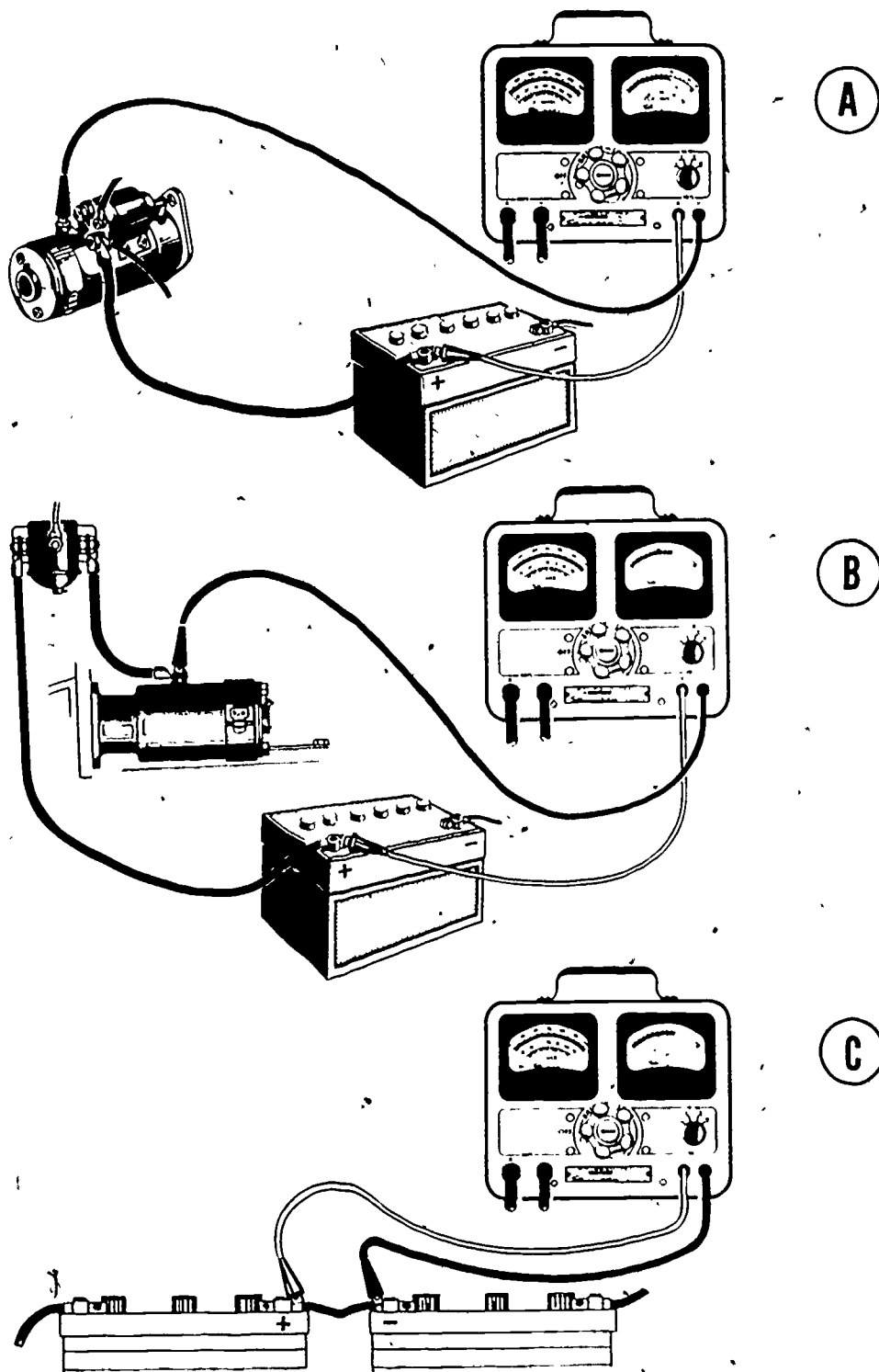

Figure 6-25.—Starter insulated circuit resistance test.

2.520

VOLT position. Before cranking the engine with the ignition switch ON, connect a jumper from the secondary terminal of the coil to ground to prevent the engine from starting while it is being tested. While cranking the engine, observe the voltmeter reading which should be within the manufacturer's specifications. Unless otherwise specified by the manufacturer, the voltage loss in each of the circuits shown in views A, B, and C should not exceed the value given.

When you are testing a 6-volt system, the completed circuit shown in view A allows a 0.2 volt loss and that of view B, allows a 0.3 volt loss. When you are testing a 12-volt system, the completed circuit shown in view A allows a 0.4 volt loss and that of view B, a 0.3 volt loss, and that of view C, a 0.1 volt loss. If testing a 24- or 32-volt system, refer to the manufacturer's specifications. If the voltmeter reading is more than specified for the type of system being tested, high resistance is indicated in the cables, switches, or connections. Repeat the test with

the voltmeter connected to each cable, switch, and connector of the circuit. The maximum readings taken across these parts should not exceed the values listed below.

	6-Volt System	12-Volt System
Each cable	0.1 volt	0.2 volt
Each switch	0.1 volt	0.1 volt
Each connector	0.0 volt	0.0 volt

### STARTER GROUND CIRCUIT RESISTANCE TEST

Excessive resistance in the ground circuit of the starting system can cause sluggish cranking action or failure to crank, and can also seriously interfere with the operation of the electrical circuits using the same ground.

The starter ground circuit resistance test of a 6-, 12-, or 24-volt series system is performed as follows: Connect the tester's VOLTMETER leads as shown in figure 6-26, observing the

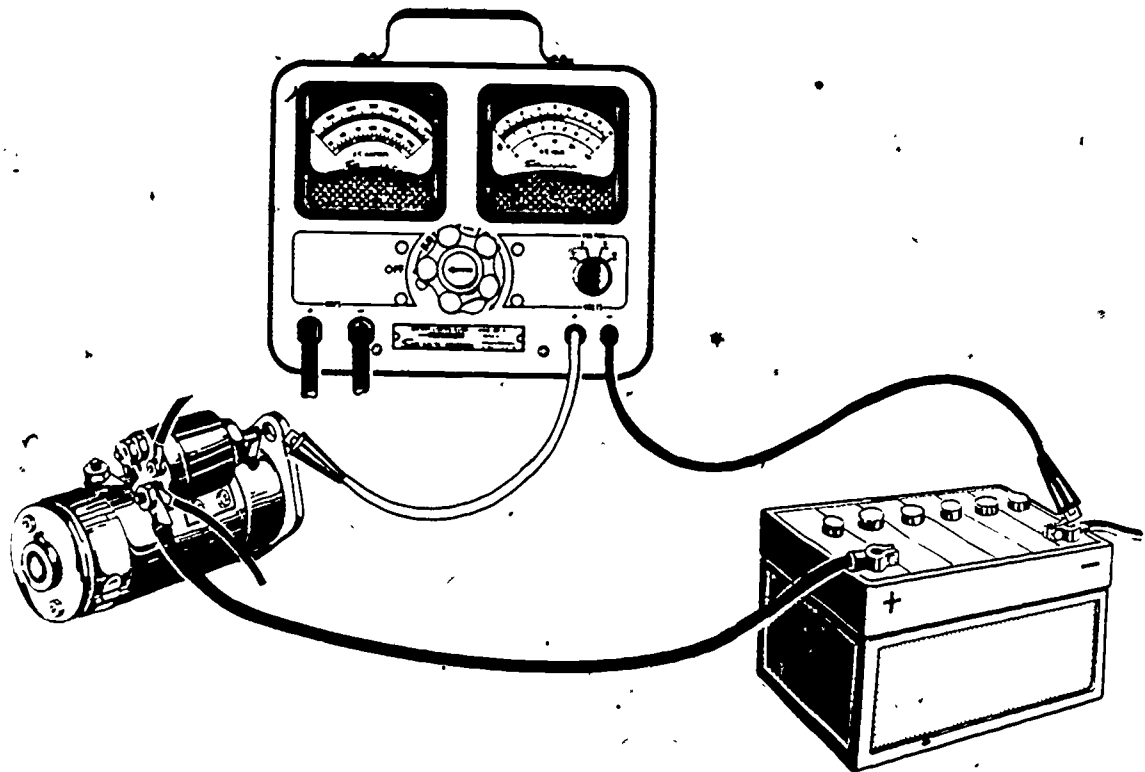

Figure 6-26.—Starter ground circuit resistance test.

polarity as you make the connections. Be sure the voltmeter lead clip at the battery contacts the battery post and not the battery cable clamp. Now, turn the voltmeter selector switch to the No. 4 VOLT position. Before cranking the engine with the ignition switch ON, connect a jumper lead from the secondary terminal of the coil to ground to prevent the engine from starting while it is being tested. While cranking the engine, observe the voltmeter reading. Unless otherwise specified by the manufacturer's specifications, this reading should not exceed a 0.2 volt loss. A reading of more than the 0.2 volt loss usually indicates a loose, dirty or corroded connection or ground cables that are too small to carry the current. To locate the point of excessive resistance, apply the voltmeter leads across each connection and cable, in turn, and take the readings with the starting motor in operation. These readings

should not exceed 0.1 volt loss on short ground cables and should be zero across each connection. Long ground cables may have slightly more than a 0.2 volt loss.

### SOLENOID SWITCH CIRCUIT RESISTANCE TEST

High resistance in the solenoid switch circuit will reduce the current flow through the solenoid windings and cause the solenoid to function improperly or not at all. Improper action of the solenoid switch will, in most cases, result in burning of the main switch contacts, thus reducing current flow in the starter motor circuit.

The solenoid switch circuit resistance test of a 6-, 12-, or 24-volt series system is performed as follows: Connect the tester's VOLTMETER leads as shown in figure 6-27, observing the

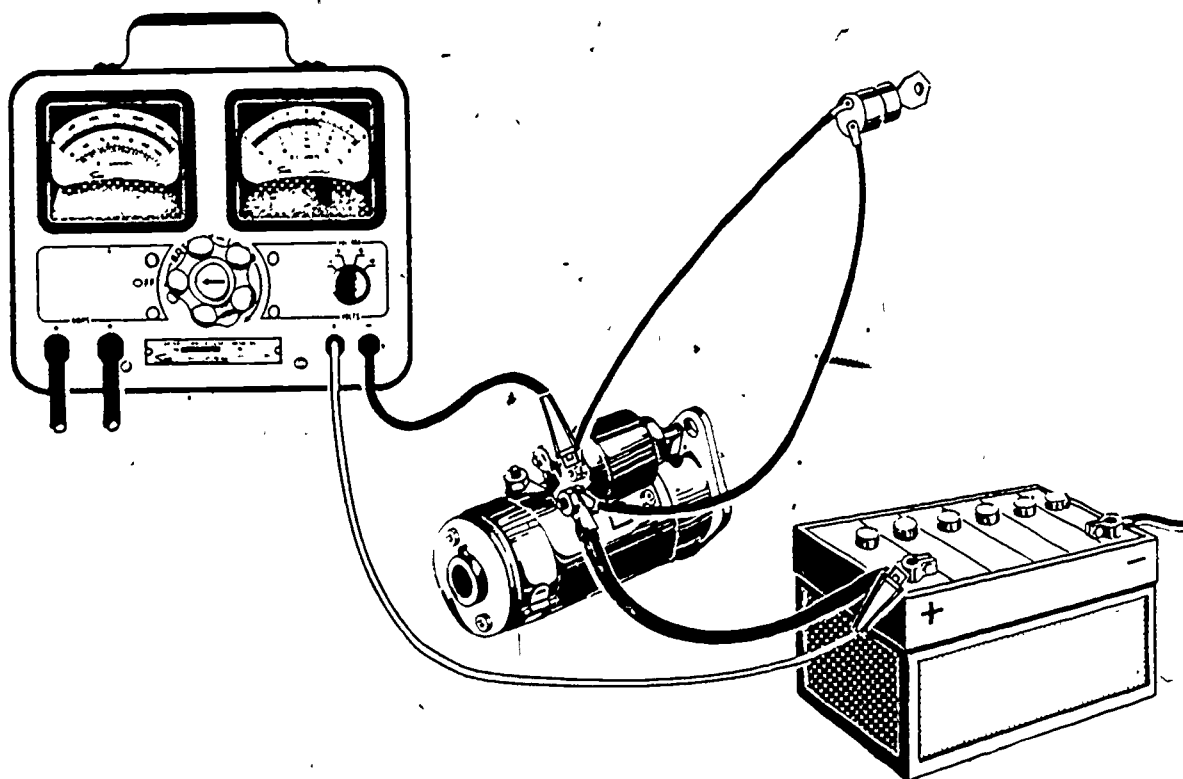

Figure 6-27.—Solenoid switch circuit resistance test.

polarity as you make the connections. Be sure the voltmeter lead clip at the solenoid contacts the switch terminal, not the solenoid wire end. Now, turn the voltmeter selector switch to the No. 4 VOLT position. Before cranking the engine with the ignition switch ON, connect a jumper lead from the secondary terminal of the coil to ground to prevent the engine from starting during the test. While cranking the engine, observe the voltmeter reading. This reading, unless otherwise specified by the manufacturer's specifications, should not exceed a 0.5 volt loss. A reading of more than a 0.5 volt loss usually indicates excessive resistance. However, on certain vehicles, experience may show that a slightly higher voltage loss is normal. To isolate the point of high resistance, apply the voltmeter leads across each part of the circuit in turn, taking readings with the starting motor in operation. A reading of more than 0.1 volt loss across any one wire or switch usually indicates trouble. If high readings are obtained across the neutral safety switch used on automatic transmission equipped vehicles, check the adjustments of the switch as outlined in the manufacturer's manual. Make sure all vehicle wires disconnected during the tests are reconnected securely and properly at the conclusion of the tests.

### IGNITION SYSTEMS

The treatment of ignition systems given in *Construction Mechanic 3 & 2*, NAVEDTRA 10644-G, deals mainly with the operating principles of a conventional automotive ignition system. The treatment here continues with the basic types of transistor ignition systems (breaker-point and magnetic-pulse), the capacitor discharge ignition system, the Chrysler electronic ignition system, and the Delco-Remy unitized ignition system.

#### TRANSISTOR IGNITION SYSTEM (BREAKER-POINT TYPE)

The breaker-point type of transistor ignition system was developed to replace the standard or conventional ignition system. To obtain the maximum power and speed that this engine can

produce, it is necessary to install an ignition system which outperforms the conventional one. Electronic-type ignition systems provide a hotter, more uniform spark at a more precise interval. This promotes more efficient burning of the air/fuel mixture in the combustion chamber, producing less exhaust emissions, resulting in better engine performance and increased mileage. The increased reliability of electronic ignition allows less frequent maintenance by increasing parts life. At high speeds, the breaker points of a conventional ignition system cannot handle the increased current flowing across them without pitting too much. Also, the dwell angle of the breaker points is too small for complete saturation of the ignition coil. The transistorized ignition system takes care of both drawbacks.

By comparing figures 6-28 and 6-29, you can see how the transistor ignition system differs from the conventional. Connecting the breaker points to the transistor, as shown in figure 6-29, nearly eliminates arcing across them, since the

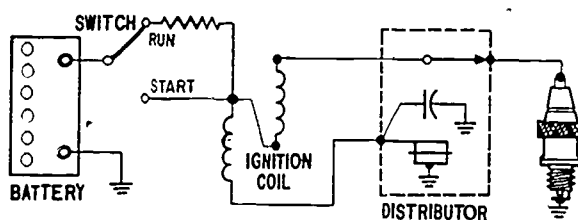

2.523

Figure 6-28.—Conventional ignition system.

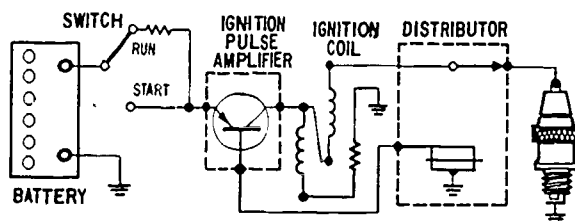

2.524

Figure 6-29.—Transistor ignition system (breaker-point type).

current flow is small (about 1/2 ampere). However, the current flow in the primary windings of the coil is about 6 amperes. This amount is enough to completely saturate the coil at high engine speeds and results in a higher output to the secondary circuit. At high engine speeds, therefore, the transistor ignition system is superior to the conventional system because there is less arcing across the breaker points and higher and steadier voltage in the secondary circuit.

### TRANSISTOR IGNITION SYSTEM (MAGNETIC-PULSE TYPE)

The drawbacks of a conventional ignition system operating at high engine speeds can also be overcome with the magnetic-pulse type of transistor ignition system (fig. 6-30). Notice that a magnetic pulse distributor, which resembles a conventional distributor, is used instead of a breaker-point type of distributor. An iron timer core in this distributor replaces the standard breaker cam. The timer core has equally spaced projections (one for each cylinder of the engine) and rotates inside a magnetic pickup assembly. This pickup assembly replaces the breaker plate assembly of the conventional distributor. Since there are no breaker points or condenser, there can be no arcing across them. Capacitors in this system are for noise suppression. This overcomes one of the drawbacks already mentioned. The other drawback is overcome by controlling the amount of current that flows through the primary windings of the ignition coil and to ground. Transistors in the ignition pulse amplifier do the controlling. Another feature of

this transistor ignition system is its coil, which has fewer and heavier primary windings and a higher turns ratio of primary to secondary windings than the conventional coil. Controlling the current flow and using a special coil produce the desired voltage in the secondary circuit at high engine speeds.

### CAPACITOR DISCHARGE IGNITION SYSTEM

The capacitor discharge (CD) ignition system is also superior to the conventional ignition system. Like the magnetic pulse transistor ignition system, the CD system has a special ignition coil, a transistorized pulse amplifier, and a magnetic pulse distributor. Unlike the magnetic pulse transistor ignition system, the CD system has a high voltage condenser connected across the primary windings of the coil. The input to the coil is constant and assures complete saturation of the coil, which results in the desired secondary voltage output at high engine speeds.

### ELECTRONIC IGNITION SYSTEM (CHRYSLER)

Like the magnetic pulse transistor ignition system, Chrysler's electronic ignition system is breakerless—that is, there are no breaker points or condenser. (See fig. 6-31.)

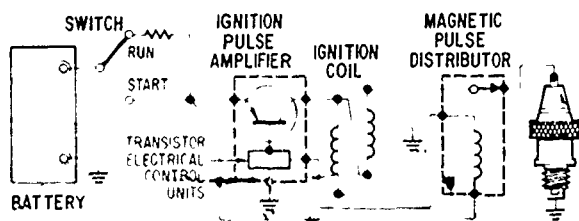

2.525

Figure 6-30.—Magnetic-pulse type transistor ignition system.

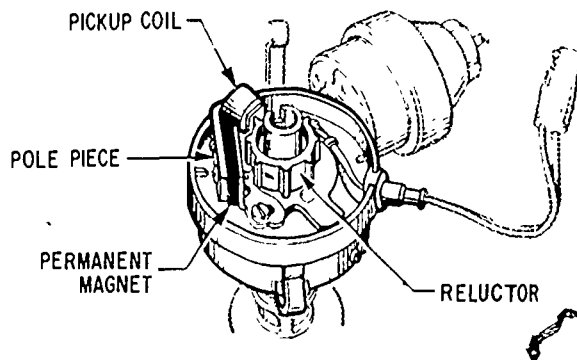

2.526

Figure 6-31.—Electronic ignition distributor components.

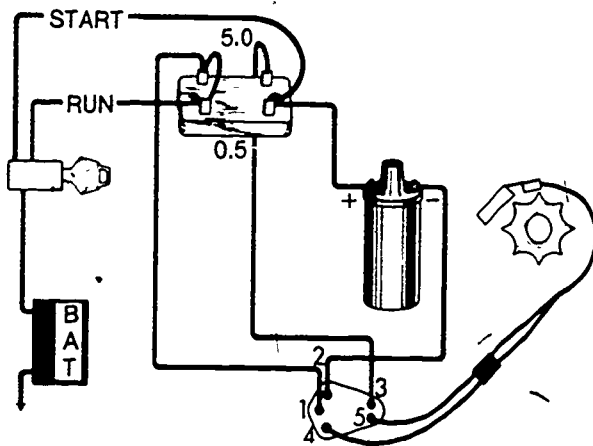

Figure 6-32.—Electronic ignition system.

2.530

The Chrysler electronic ignition system in figure 6-32 consists of a battery, an ignition switch, a dual ballast resistor, a special ignition coil, an electronic control unit, and a special pulse-sending distributor.

In place of the cam and rubbing block of the conventional ignition system, the Chrysler electronic system uses a magnetic pickup coil and a rotating reluctor (fig. 6-33). As the teeth of the reluctor pass the magnet of the pickup coil, a voltage pulse is induced in the pickup coil which is a signal for the module to "interrupt" the primary coil current. The magnetic field in the ignition coil collapses and induces a high voltage into the secondary winding which fires the spark plugs.

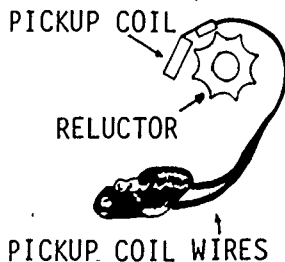

Figure 6-33.—Electronic pickup and reluctor.

The electronic module is a solid-state device that interrupts the primary coil current when signaled and self-starts the primary current after a predetermined time lapse. A compensating ballast resistor (0.5 ohms typical) is used in series with the ignition coil and battery circuit. The compensating ballast resistor maintains a constant primary current with changes in engine speed. During starting or cranking, the compensating ballast resistor is bypassed, supplying full battery voltage to the ignition coil. The auxiliary ballast resistor (5.0 ohms typical) limits the current to the electronic module.

On this system, you adjust the airgap by aligning one reluctor tooth with the pickup coil tooth. After loosening the holding screw, use a nonmagnetic feeler gage of the correct size to obtain proper airgap between the reluctor and the pickup coil. Check the setting for proper clearance at the reluctor tooth with a nonmagnetic feeler gage that is 0.002 inch larger than the manufacturer's specification.

**CAUTION:** Do not force the feeler gage into the airgap. This should be a go-no-go tolerance.

The engine analyzer may be used to check the magnetic pickup coil unless the distributor sensors depend directly on the electronic module for operation, as they do in the American Motors Breakerless Inductive Discharge System (BID). To check the coil, operate the analyzer in the self-sweep mode and disconnect the pickup from the harness. NEVER connect the analyzer to a distributor without first referring to the operator's manual for the correct procedure. Connect the red and black test probes across the pickup coil wires and crank the engine as you observe the screen display. The screen trace should oscillate above and below the zero line if the pickup is good.

### CHRYSLER ELECTRONIC LEAN BURN SYSTEM/ELECTRONIC SPARK CONTROL

Since current model engines burn a leaner fuel air mixture within the cylinders, a special means of igniting this mixture is required, for example, the electronic lean-burn system (fig. 6-34). It consists of a solid-state spark control

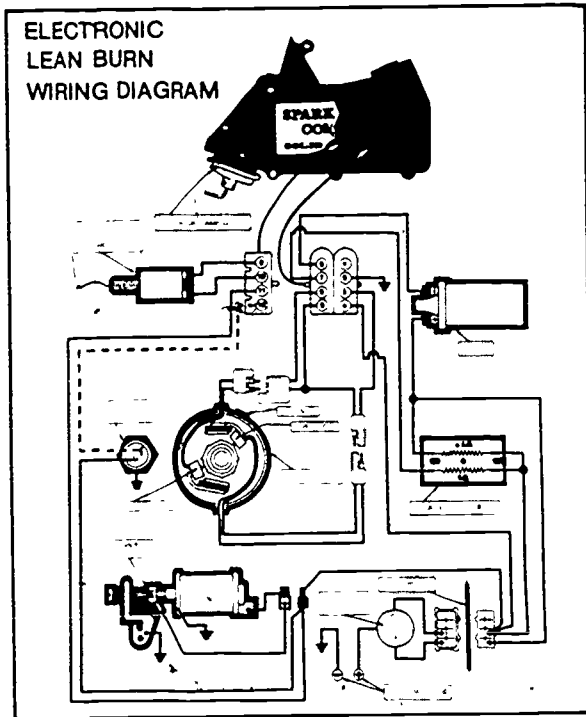

2.531

Figure 6-34.—Lean burn ignition system.

computer, various engine sensors, and a specially calibrated carburetor. Also, the distributor provides centrifugal spark advance only (no vacuum advance). Located in the distributor are two pickup coils (fig. 6-35) NOT found in 1978-1979 models. One coil operates

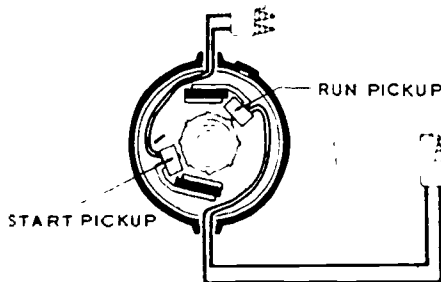

Figure 6-35.—Lean burn pickup coils.

during starting, whereas the other coil operates when the engine is running. The starting pickup is easily identified; its distributor connection is larger.

The computer selects either the start or run coil, not the ignition switch. The spark advance is controlled primarily by the spark control computer which receives its signals from the engine sensors listed below:

1. Coolant Temperature Switch (on the water pump housing) signals that the engine temperature is below 150°.

2. Air Temperature Switch (inside the computer, but not used after 1979) senses the temperature of the incoming fresh air which controls the throttle position advance.

3. Carburetor Switch (on the right side of the carburetor) tells the computer whether engine is at idle or off idle.

4. Vacuum Transducer (on the computer) signals the computer for more spark advance with higher vacuum and less spark advance with lower vacuum. The computer responds over a period of time rather than suddenly, using a timed countdown delay.

5. Throttle Position Transducer (on the carburetor but eliminated in 1980) signals the computer to advance by indicating the new throttle plate position and the rate of change.

### UNIT IGNITION SYSTEM (DELCO-REMY)

This unitized ignition system by Delco-Remy is another breakerless ignition system. It is called unitized because the entire system is built into one unit, the distributor. This distributor contains the ignition coil, the secondary wiring harness and cap, shell, rotor, vacuum advance unit, pickup coil, timer core (which replaces the cam), and electronic module. The distributor operates on an electronically amplified pulse. Vacuum spark advance and mechanical spark advance are applied in the usual way. The moving parts of this system induce a voltage



which signals the electronic module to interrupt the primary circuit. The desired voltage is then induced in the secondary windings of the ignition coil, and directed to the proper spark plug by the rotor and the secondary wiring harness and cap.

### HIGH-ENERGY IGNITION SYSTEM (DELCO-REMY)

The Delco-Remy High-Energy Ignition (HEI) System is a breakerless, pulse-triggered, transistor-controlled, inductive discharge ignition system. The HEI system and the older Unit Ignition System differ in that the HEI system is a full 12-volt system. Also, the Unit Ignition System incorporates a resistance wire to limit the voltage to the coil, except during starter motor operation.

The cam and point rubbing block of the conventional ignition system are replaced by the timer core, pickup coil, and electronic module in the HEI system (fig. 6-36). A timer core rotates inside the pickup coil pole piece (fig. 6-37). When the timer core teeth align with the pole piece, a voltage pulse is induced in the pickup winding. This pulse signals the module to activate the primary coil current, inducing high voltage in the secondary windings and ultimately

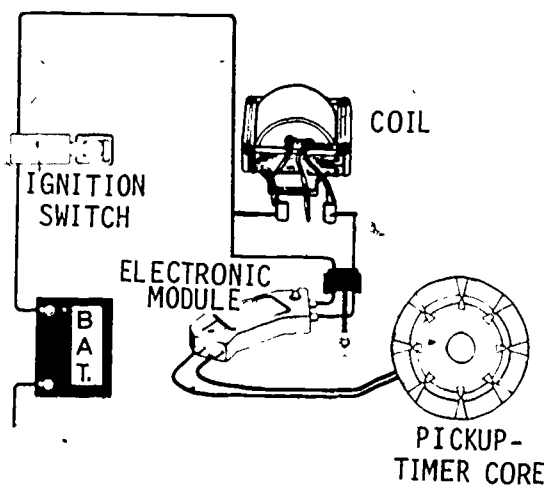

2.532

Figure 6-36.—High-energy ignition system.

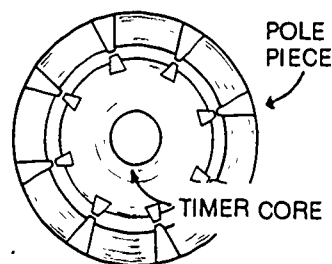

Figure 6-37.—High-energy timer and pole pieces.

firing the spark plug. The module automatically controls the dwell period, stretching it as engine speed increases. Therefore, the primary current reaches its maximum strength at high engine speeds and reduces the chances of high-speed misfire. The secondary coil energy (35,000 volts) is greater than in conventional ignition systems which allows increased spark duration. The longer spark duration of the HEI system is instrumental in firing lean and exhaust gas recirculation (EGR) diluted fuel/air mixtures. The condenser within the HEI distributor is provided for noise suppression only.

### TROUBLESHOOTING

As an automotive electrician, you will be called on to troubleshoot the conventional, transistor, and electronic ignition systems. The instruments you need to pinpoint problems in a conventional ignition system include the simple voltmeter and ohmmeter. Although an engine analyzer simplifies the troubleshooting of electronic ignition systems, you can do so with a volt/ohmmeter (0 to 20,000-volt/ohm range). Better yet is an ignition scope tester since it can test system components while the engine is running.

### CONVENTIONAL/COIL IGNITION SYSTEM

In troubleshooting a conventional ignition system, you conduct separate tests on the primary circuit (low voltage) and the secondary circuit (high voltage). The primary circuit carries

current at battery voltage, whereas the secondary voltage could be as much as 30,000 volts.

### Primary Circuit Tests

Using a simple voltmeter, you can check a 12-volt primary circuit as follows:

1. Hook up the voltmeter between the switch side of the ignition coil and a good ground. The engine must be at operating temperature, but stopped, and the distributor side of the coil grounded with a jumper wire. (See figure 6-38.)

2. With the ignition switch on, jiggle it and watch the voltmeter. The switch is defective if the meter needle fluctuates. The voltmeter should read a steady 5.5 to 7 volts with the points open on systems using a ballast resistor.

3. Crank the engine and watch the voltmeter. It should read at least 9.6 volts while the engine is being cranked.

4. Remove the jumper wire from the coil, then start the engine. The meter reading should be 5 to 8 volts on a ballast resistor system while the engine is running.

5. Stop the engine by turning off the ignition switch. Hook up the voltmeter between the distributor side of the coil and ground. Remove the high tension wire from the coil and ground it.

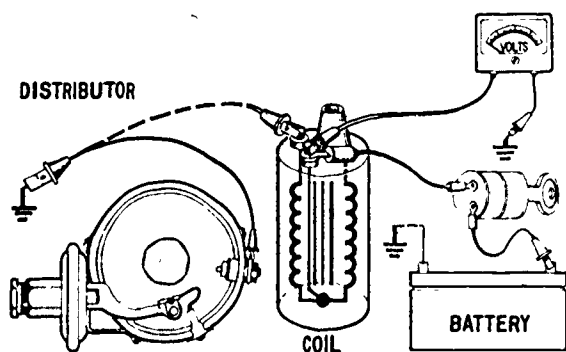

2.527

Figure 6-38.—Testing ignition primary circuit.

6. Close the ignition switch and slowly open and close the breaker points by bumping the engine. When the points make and break, the voltmeter should read between 4 and 6 volts. Normally, with the engine stopped and points opened, the reading will be 12 volts; with points closed, the reading will be near zero volts. If while the engine is cranked, the voltmeter reading stays at zero or near zero, the following three checks will have to be made to locate the source of trouble.

7. Check for current flow at the distributor. Disconnect the distributor primary wire from the top of the coil. Take a voltmeter reading from the distributor terminal of the coil. Current should flow through the circuit.

8. Check the opening and closing of the breaker points. If not adjusted properly, they may not open and close. Also look for a mechanical failure of the points or cam. Lubricate the rubbing block at this time if necessary.

9. Check grounding of the movable breaker point, the stud at the primary distributor wire terminal, or the wire of the condenser (pigtail). None of these should be grounded.

### Secondary Circuit Tests

The high voltage in the secondary circuit is produced by the ignition coil. Current flows out of the coil at the secondary terminal through a cable to the distributor cap and rotor. The rotor distributes the current through the cap and cables to the spark plugs, and then to ground. The checkpoints for the secondary circuit are the secondary terminal of the coil, the coil-to-distributor cap cable, the distributor cap, rotor, spark plug cables, and spark plugs.

The secondary circuit can be checked as follows:

1. Pull the coil high-voltage cable from the distributor cap and hold the loose end of the cable about one-fourth of an inch from a good grounding point on the engine block.

2. Crank the engine and look for a spark to bridge the gap between the loose end of the cable and the grounding point. If you see a blue spark, proceed to the next step since the coil is functioning normally. If you see a yellow spark or no spark at all, the trouble sources are in the primary circuit, the coil, and the coil-to-distributor cable.

3. Remove the spark plug cables from the spark plugs and lift off the distributor cap. Connect one ohmmeter test lead to a spark plug cable connector and the other test lead to the terminal inside the distributor cap for the spark plug cable. Measure the resistance of the other spark plug cables in turn. Cable resistance should not exceed the manufacturer's recommendations. Excessive resistance can result from cable damage, defective spark plug connector, corroded distributor cap tower, or unseated cable in the tower.

4. Inspect the distributor cap inside and out for carbon tracking and cracks; also inspect for a worn center contact button or burned spark plug cable contacts.

5. Remove the rotor and inspect it. Look for high-resistance carbon, a burned tip, or a grounded rotor.

NOTE: Due to the difference in materials and quality control used by manufacturers of distributor caps and rotors, it is desirable to use both items from the same manufacturer.

6. Remove all spark plugs from the engine and inspect each one. Look for fouled plug tips, gaps that are too wide or bridged, chipped insulators, and other conditions that can cause high resistance at the electrodes.

### Coil Resistance Tests

Using a simple ohmmeter, you can check the resistance of the ignition coil. Its primary circuit and secondary circuit are tested separately. To check the primary side, connect the ohmmeter leads across the primary terminals of the coil. Use the low ohms scale of the meter. The resistance should be about 1 ohm for coils

requiring external ballast resistors, and about 4 ohms for coils not requiring the ballast resistors. In checking the secondary side, switch to the high scale of the ohmmeter. Connect one ohmmeter lead to the distributor cap end of the coil secondary wire, and the other lead to the distributor terminal of the coil. The condition of the coil is satisfactory if the meter reading is between 4,000 and 8,000 ohms, although the resistance of some special coils may be as high as 13,000 ohms. Should the reading be a lot less than 4,000 ohms, the secondary turns of the coil are probably shorted. A reading of 40,000 ohms or more indicates an open secondary, a bad connection at the coil terminal, or a high resistance in the cable.

### TRANSISTOR IGNITION SYSTEM

The preceding techniques for troubleshooting a conventional battery/coil ignition system also apply, for the most part, to troubleshooting the basic types of transistorized ignition systems—breaker-point type and breakerless. Special techniques, however, are used in checking the electronic components of a transistorized ignition system. Prior to testing any electronic ignition system, refer to the manufacturer's manual. Not all systems may be checked for spark across a gap to ground without damaging the module. Other systems may only allow specific plug wires to be tested by sparking across the gap. Since these components are easily damaged by heat, shock, or reverse polarity, you must be extra careful in checking them. The following steps form the procedure for troubleshooting breakerless systems:

1. Pull the high-voltage cable from the distributor cap and hold the loose end of the cable about one-half of an inch from a good grounding point on the engine block.

2. With the ignition switch ON, crank the engine and look for a spark to bridge the gap between the loose end of the cable and the grounding point. If you see a blue spark, reconnect the high-voltage cable to the distributor and proceed to step 3. If you do not see a spark or see a weak spark, proceed to step 4.

3. Pull the cable from a spark plug and hold the loose end of the cable about one-half of an inch from the spark plug terminal. With the ignition switch ON, crank the engine and look for a spark to bridge the gap between the loose end of the spark plug cable and the spark plug terminal. A blue spark here indicates a normal operating condition.

4. With weak spark or no spark, test the coil. Since a special coil is used in this ignition system, you cannot test it with a conventional coil tester. Use an ohmmeter to check the continuity of the coil's primary and secondary windings. With leads disconnected from the coil, connect the ohmmeter across the primary terminals. If the meter reading is infinite, the primary winding is open. The secondary winding is checked by connecting the ohmmeter to the coil case and to the high voltage center tower. Again, an infinite reading indicates an open winding; if any reading is obtained, it indicates a shorted winding. Be sure to use the middle or high-resistance range of the ohmmeter when you check the continuity of the secondary winding.

5. Check the operation of the ignition pulse amplifier. To do so, detach the positive and negative leads from the coil and connect them in series to a 12-volt, 2-candlepower bulb.

6. Crank the engine and observe the bulb. If it flickers on and off, the amplifier is operating properly. If the bulb does not flicker on and off, check the distributor.

7. Connect a vacuum source to the distributor and an ohmmeter to the two terminals on the distributor connector. Open the vacuum source to the distributor, and observe the ohmmeter throughout the range of the vacuum source. A reading less than 550 ohms or more than 750 ohms indicates a defective pickup coil in the distributor.

8. Remove one ohmmeter lead from the distributor connector and ground it. Again, open the vacuum source to the distributor as you observe the ohmmeter. A reading less than infinite indicates a defective pickup coil.

## ELECTRONIC IGNITION SYSTEM

Should the engine analyzer not be available, you may troubleshoot the electronic ignition system to prevent unnecessary replacement of its expensive units. (See table 6-1.) You will need a volt/ohmmeter with a 20,000 volt/ohm range. Check the battery in the system being tested; battery voltage must be at least 12 volts.

**CAUTION: MAKE SURE THE IGNITION SWITCH IS OFF WHEN THE CONTROL UNIT CONNECTOR IS BEING REMOVED OR REPLACED.**

Disconnect the wiring plug from the control unit, and turn on the ignition switch. Ground the negative voltmeter lead. Connect the positive voltmeter lead to the harness cavities designated in the sequence recommended by the manufacturer. Voltage should be within one volt of battery voltage with all accessories off. If not, check that circuit through to the battery. Turn the ignition switch off after completing the voltage test. Connect the ohmmeter to the cavities designated. If resistance is not within the manufacturer's range, disconnect the dual lead connector from the distributor. Recheck resistance at the dual lead connector. With one ohmmeter lead still grounded, connect the other lead to either distributor connector. If the ohmmeter shows a reading, replace the distributor pickup coil. To test for control unit continuity, ground one ohmmeter lead and connect the other lead to the control unit pin designated. If continuity cannot be obtained after removing and remounting the control unit in an attempt to get good ground, replace the control unit. Make sure the ignition switch is OFF, and reconnect the control unit connector plug and the distributor plug. Check the airgap adjustment as described previously. After these tests or repairs, test the entire system by removing the center wire from the distributor cap. Using insulated pliers and a heavy rubber glove, hold this wire about one-half of an inch from the engine block and operate the starter. If there is no spark, replace the control unit and retest. If no spark is obtained, replace the coil.

## CONSTRUCTION MECHANIC 1 & C

Table 6-1.—Troubleshooting Chrysler Electronic Ignition

Condition	Possible Cause	Correction
ENGINE WILL NOT START (Fuel and carburetion known to be OK)	a) Dual Ballast	Check resistance of each section: Compensating resistance: .50-.60 ohms @ 70°-80°F Auxiliary Ballast: 4.75-5.75 ohms Replace if faulty. Check wire positions.
	b) Faulty Ignition Coil	Check for carbonized tower. Check primary and secondary resistances: Primary: 1.41-1.79 ohms @ 70°-80°F Secondary: 9,200-11,700 ohms @ 70°-80°F Check in coil tester.
	c) Faulty Pickup or Improper Pickup Air Gap	Check pickup coil resistance: 400-600 ohms Check pickup gap: .010" in. feeler gauge should not slip between pickup coil core and an aligned reluctor blade. No evidence of pickup core striking reluctor blades should be visible. To reset gap, tighten pickup adjustment screw with a .008 in. feeler gauge held between pickup core and an aligned reluctor blade. After resetting gap, run distributor on test stand and apply vacuum advance, making sure that the pickup core does not strike the reluctor blades.
	d) Faulty Wiring	Visually inspect wiring for brittle insulation. Inspect connectors. Molded connectors should be inspected for rubber inside female terminals.
	e) Faulty Control Unit	Replace if all of the above checks are negative. Whenever the control unit or dual ballast is replaced, make sure the dual ballast wires are correctly inserted in the keyed molded connector.

## CHAPTER 7

# DIESEL FUEL SYSTEMS

The fuel and air induction systems are the most crucial of all of the diesel engine systems. Therefore, special care must be exercised when making adjustments and repairs to these systems. The *Construction Mechanic 3 & 2*, Rate Training Manual, NAVEDTRA 10644-G edition, covered the general maintenance, removal and replacement of pumps, injectors, blowers, and turbochargers; as well as, timing, minor adjustments, and repairs to the Caterpillar, International Harvester, General Motors, and Cummins diesel fuel systems. This chapter provides information that will aid you in the disassembly, reassembly, testing, overhaul, and troubleshooting of diesel fuel and air induction systems.

### CATERPILLAR FUEL INJECTION SYSTEMS

In this section, the three types of Caterpillar fuel injection systems—the forged body, the compact, and the sleeve metering—will be discussed. While these systems serve the same purpose and use common general troubleshooting procedures, each is individual in design. These systems utilize a capsule-type injector with a precombustion chamber to atomize the fuel for effective combustion.

#### FORGED BODY FUEL SYSTEM

The main parts of the Caterpillar fuel injection system are (1) the fuel injection pump (See fig. 7-1.) which times, meters, and creates the pressure needed for fuel delivery and (2) the capsule-type injector valve (See fig. 7-2.) which injects and atomizes the fuel.

The most likely causes of faulty fuel injection performance are (1) air in the fuel, (2) low fuel supply, (3) water in the fuel, (4) dirty fuel filters, and (5) low transfer pump pressure. If, after you have checked and corrected these conditions, the engine still does not perform properly, the fuel injection components must be

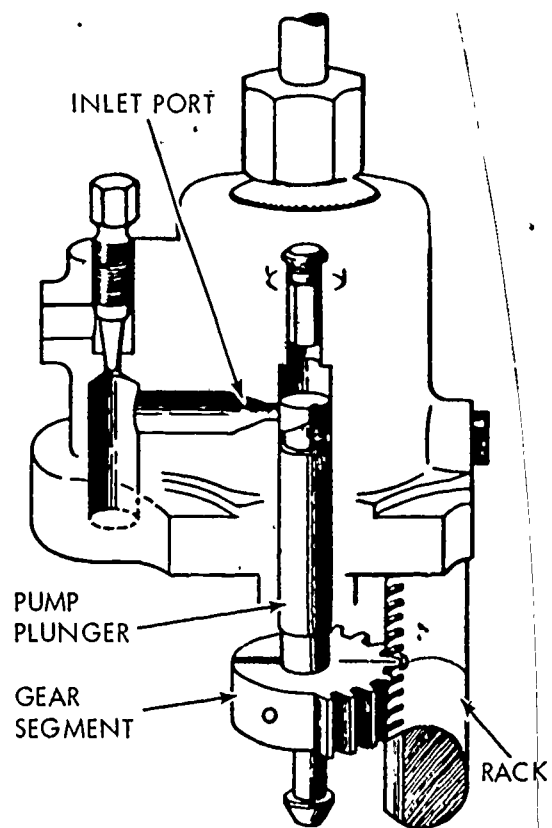
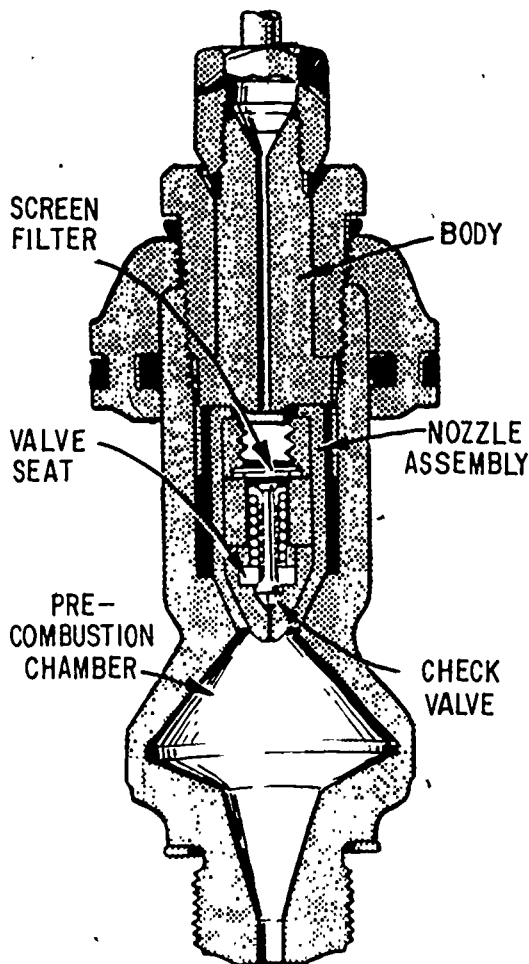

Figure 7-1.—Fuel injection pump.

2.486



81.345X

Figure 7-2.—Capsule-type fuel injection valve assembly.

checked. The guidelines for troubleshooting and general test procedures used when the injector pumps and valves are being tested are given below.

### Troubleshooting

Prior to removing either the injector pump or injector valve from an engine running erratically, make a simple test by running the engine at a speed which makes the defect most pronounced. Momentarily, loosen the fuel line nut on the injector pump far enough so that the cylinder misfires or "cuts out"; check each cylinder in the same manner. If one is found

where the loosened nut has no effect on the irregular operation of the engine or black smoke stops puffing from the exhaust, you have located the misfiring cylinder. Probably only the pump and valve for that cylinder need to be removed for additional testing.

### Testing

The Caterpillar fuel injection tester provides a means for determining the condition of the fuel injection pumps and valves. Prior to performing any test, be sure to study and follow the instructions in the manual for the type of testing equipment you are using.

**INJECTION PUMP.**—Clean the fuel pump thoroughly before installing it on the tester. Any abrasive material allowed to enter the pump may be carried into the tester's discharge collector and impair the discharge measurement accuracy. Close the fuel pump openings with the covers provided, holding the plunger in place. Clean thoroughly with clean solvent or fuel oil.

Pumps are tested at or near (within .025 inch) the full-load setting of the engine. If the fuel delivery from the pump is within the limits of the full-load setting, the pump will perform properly throughout the full range of rack travel. The governor will compensate for pump wear at any rack setting less than the full-load setting.

Caterpillar fuel injection pumps have no adjustments or replacement parts for rebuilding. If the tester reveals that the pump is no longer serviceable, discard the pump.

To test the injector pump, determine the plunger diameter by inserting the portion of the plunger under the gear into the gage supplied with the tester. Insert the portion of the pump plunger and gear segment into the gage setting of the tester's housing, as shown in figure 7-3. Determine the proper full-load rack setting by referring to the rack setting charts for the engine from which the pump was removed. After you have made the full-rack setting (usually to the nearest .025 inch), you also will be able to determine the number of discharge strokes

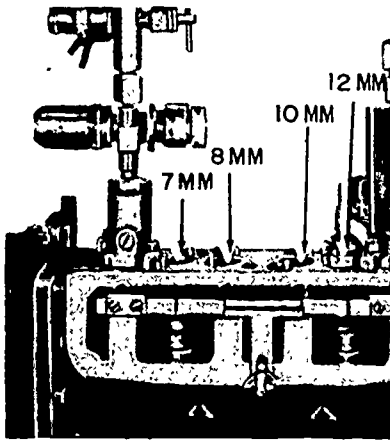

2.487  
Figure 7-3.—Test location for various size pumps.

required from the pump test chart. Now you are ready to attach the collector assembly and jar to the fuel pump, as shown in figure 7-4. Remember to bleed the air from the pump and the collector assembly before proceeding with the test. Operate the pump at least 50 strokes to do this. Remember the collector jar is loosely placed on the collector assembly during the priming. After the priming, remove the collector jar and drain. Reset the counter to zero and

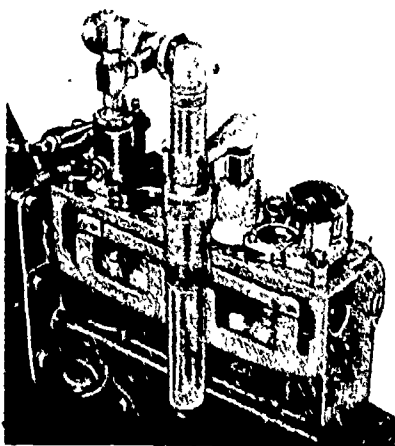

2.488  
Figure 7-4.—Collector assembly and jar.

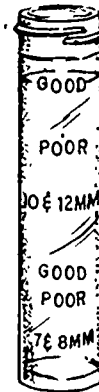

2.489  
Figure 7-5.—Correct level in collector jar.

attach the collector jar to the collector assembly. Operate the pump the prescribed number of discharge strokes. Remove the collector jar and place it on a level surface. The fuel level in the jar is to be read from the bottom as shown in figure 7-5.

The condition of the pump is indicated directly by the calibrations on the collector jar. If the fuel level is within or above the GOOD range, the pump is equivalent to a new one. A fuel level within or below the POOR range shows that the pump plunger and barrel have worn so much that the engine will be hard to start and may have less power. Such pumps should be replaced.

#### CAPSULE-TYPE INJECTOR VALVE.—

The capsule-type fuel injection valves can be tested on the fuel injection tester for spray characteristics, valve opening pressure, and leakage rate. Before testing the valve, inspect the screen filter. (See fig. 7-2.) If the screen is broken or clogged with dirt particles, discard the valve.

When cleaning the deposited carbon from the injection valve nozzle (See fig. 7-6.), use a drill from the cleaning tool group kit, furnished by Caterpillar, corresponding to the orifice size of the nozzle. The orifice size is usually stamped on the side of the valve. NEVER clean the injection valves with a wire brush. The use of a



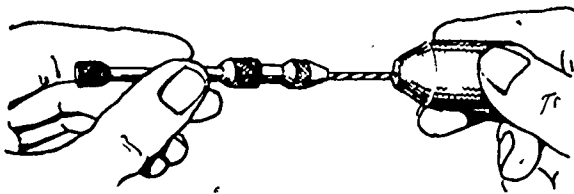

2.490

Figure 7-6.—Cleaning capsule-type nozzle.

wire brush to remove carbon from the injection valves might damage the orifice and reduce power output.

After inspecting the valve screen filter and cleaning the injector valve nozzle, test the valve for spray characteristics. A solid stream of fuel with little or no atomization may be caused either by a gummy carbon accumulation or a particle of foreign material.

If the fuel emitted is properly atomized and the cutoff is sharp with no dribble, the spray characteristics of the valve are satisfactory.

Next, test the valve for opening pressure and leakage. Valve opening pressure might range from 400 to 800 psi, as registered on the test gage. If the injection valve fails to reach a minimum of 400 psi, discard the valve. If the valve opening pressure is satisfactory, reduce the pressure to 300 psi and observe the gage to note any drop in pressure. If the pressure falls more than 100 psi in 30 seconds, discard the injection valve nozzle.

### COMPACT FUEL SYSTEM

The pressure-type compact fuel system has a separate injection pump and injection valve for each cylinder. Fuel is injected into a precombustion chamber (fig. 7-7). A transfer pump delivers filtered fuel to the manifold from which the injection pumps get their fuel. The transfer pump supplies more fuel than is required for injection. A bypass pressure relief valve limits the maximum pressure.

#### Operation

The injection pump in figure 7-8 forces fuel under high pressure to the injection valves.

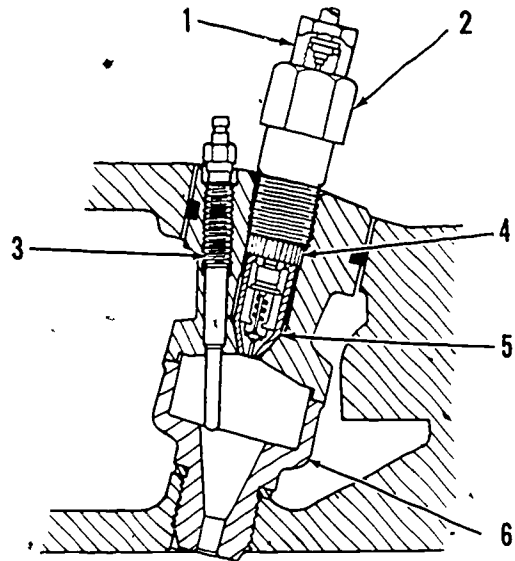

- |                        |                          |
|------------------------|--------------------------|
| 1. Fuel injection line | 4. Body                  |
| 2. Nut                 | 5. Nozzle assembly       |
| 3. Glow plug           | 6. Precombustion chamber |

Figure 7-7.—Precombustion chamber and fuel injection valve.

Injection pump plungers and lifters are actuated by lobes on the pump camshaft and always make a full stroke. The lifters are held against the pump camshaft by spring pressure, applied to the plungers.

#### Governor

The governor on the compact fuel system is hydraulically operated. Governor action controls the amount of fuel injected by turning the plunger (fig. 7-1) in the barrel through a gear segment on the bottom of the plunger. Pressurized lubrication oil enters the passage in the governor cylinder. The oil encircles the sleeve within the cylinder and is directed through a passage to operate the piston.

When the engine is started, the speed limiter plunger restricts the governor control linkage. Operating oil pressure has to react on the speed limiter before the governor control can be moved to the high-idle position. At low idle, a

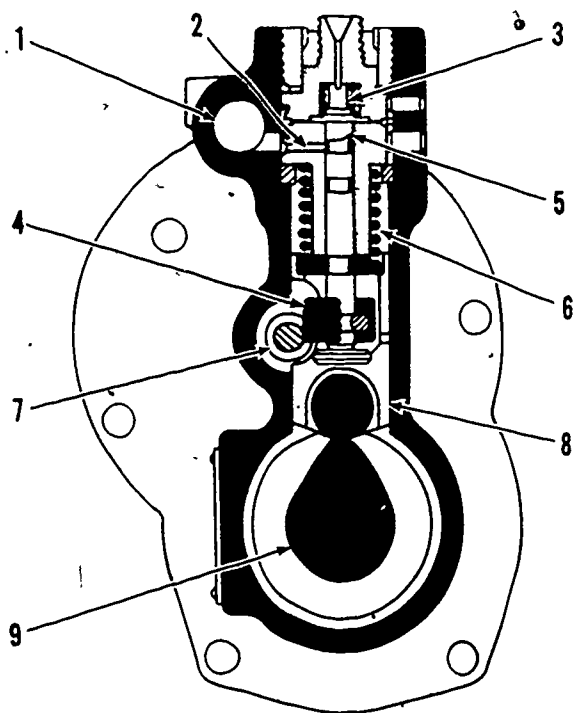

- |                  |              |
|------------------|--------------|
| 1. Fuel manifold | 6. Spring    |
| 2. Inlet port    | 7. Fuel rack |
| 3. Check valve   | 8. Lifter    |
| 4. Gear segment  | 9. Camshaft  |
| 5. Pump plunger  |              |

Figure 7-8.—Compact fuel injection pump.

spring-loaded plunger bears against the shoulder of the low-idle adjusting screw. Forcing the plunger past the shoulder on the adjusting screw stops the engine.

Lubrication oil from the governor drains into the fuel injection pump housing.

### Troubleshooting

Many times the fuel system is blamed when the fault lies elsewhere, especially when smokey exhaust is the problem. Smokey exhaust can be caused by lack of air for complete combustion, overloading, oil burning, lack of compression, as well as faulty injection valves or pumps.

The two troubles in the compact system are lack of fuel and too much fuel for proper

combustion. If the time dimension is too small, injection will begin early; and if too great, injection will be late. When checking plunger wear, check the lifter washer for wear. Replace the washers showing visible wear to avoid rapid wear of the plunger. If the plunger length is not within limits, discard the plunger.

### SLEEVE METERING SYSTEM

The sleeve metering fuel system on some models of the Caterpillar engine derives its name from the method of controlling the amount of fuel injected into the cylinder. This system has an injection pump and an injection valve for each cylinder. Most injection valves are located in the precombustion chamber, while the injection pumps are located in a common housing.

As with other diesel injection systems, the quality and cleanliness of the fuel used is paramount for proper operation. Certain applications of the sleeve metering system have a water separator to remove up to 95 percent of the water in the fuel.

### Components

The sleeve metering fuel system has three main components that are designed and operated differently from earlier Caterpillar fuel injection systems. These components are the plunger, barrel, and sleeve, which are mated sets (fig. 7-9) and must be kept together. The plunger moves up and down inside the barrel and sleeve. The barrel is stationary while the sleeve is moved up and down the plunger. Sleeve position is controlled by the action of the governor through varied loads to regulate the amount of fuel injected. Located in the inlet side of the system is a priming pump. Opening the bleed valve and operating the priming pump removes air from the injection pump housing filters and suction lines.

### Operation

The lifter and plunger are lifted through a full stroke with each revolution of the pump camshaft. Spring force on the plunger, through

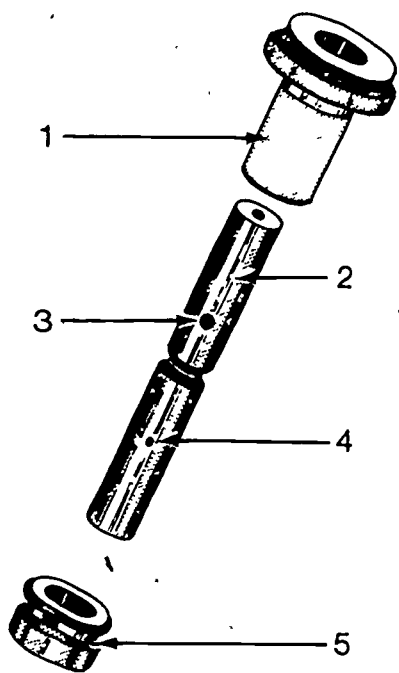

- 1. Barrel
- 2. Plunger
- 3. Fill port
- 4. Spill port
- 5. Metering sleeve

Figure 7-9.—Sleeve metering barrel and plunger assembly.

the retainer, holds the lifter against the camshaft through the full stroke cycle. The fuel in the housing supplies the injection pumps and lubricates the moving parts in the housing. Before the engine will start, the housing must be charged as shown in position 1, figure 7-10, and the sleeve must be high enough on the plunger to close the fuel outlet (spill port) during part of the stroke. The chamber fills with fuel through the fuel inlet (fill port) which is below the level of the fuel in the housing.

Injection begins when the rotation of the camshaft lifts the plunger far enough into the barrel to close the fuel inlet as shown in position 2, figure 7-10. Both the fuel inlet and outlet are now closed. Continued rotation of the camshaft, as shown in position 3, figure 7-10, lifts the plunger farther into the chamber of the barrel and increases the pressure on the trapped fuel. This pressure is felt by both the reverse flow

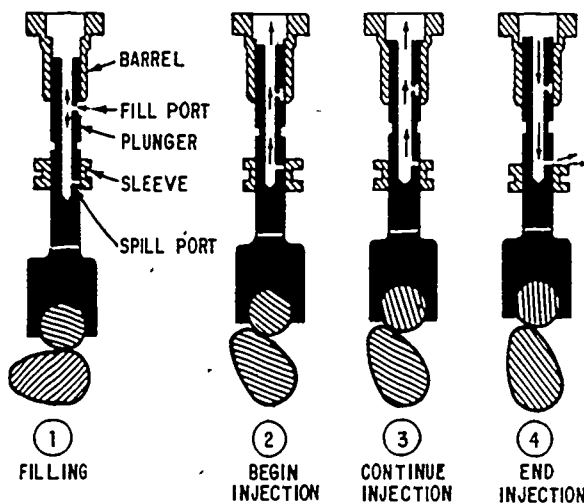

Figure 7-10.—Injection pump operating cycle.

check valve in the pump, No. 1 of figure 7-11, and the injector valve located in the nozzle assembly, No. 5 of figure 7-7. When the pressure is high enough to open the capsule, injection occurs.

Injection ends when the camshaft rotation causes the plunger to open the fuel outlet, as shown in position 4, figure 7-10. The open fuel outlet reduces the pressure on the fuel within the pumping chamber. Residual pressure in the fuel line closes the reverse flow check valve in the pump, and prevents surges on the fuel lines. No fuel flowing permits the injection valve to close, and complete injection.

The camshaft continues to lift the plunger to the top of the stroke. The fuel in the housing fills the space in the pumping chamber through the fuel outlet until the sleeve closes the outlet on the downward stroke. Spring pressure pushes the plunger farther down as the camshaft rotates allowing the fuel inlet to fill the rest of the chamber and restarting the cycle.

### Governor

The mechanical-type governor's shaft for the sleeve metering fuel system controls the position of the sleeve on the plunger to regulate the

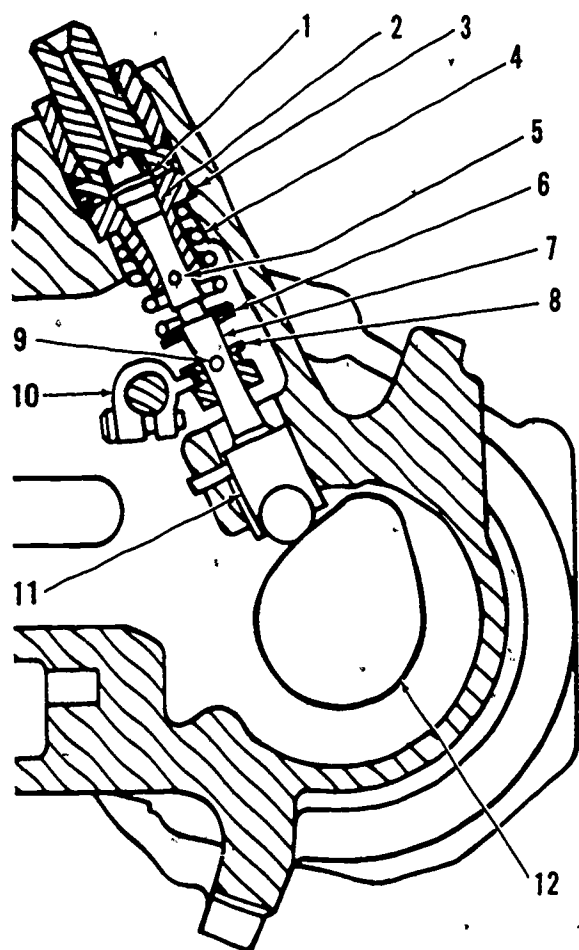

- |                             |                          |
|-----------------------------|--------------------------|
| 1. Reverse flow check valve | 7. Plunger               |
| 2. Chamber                  | 8. Sleeve                |
| 3. Barrel                   | 9. Fuel outlet           |
| 4. Spring                   | 10. Sleeve control lever |
| 5. Fuel inlet               | 11. Lifter               |
| 6. Retainer                 | 12. Camshaft             |

Figure 7-11.—Sleeve metering fuel pump.

amount of fuel injected. The volume of fuel injected is equal to the displacement of the plunger lift into the barrel between start and end of injection. The higher the sleeve position, the more fuel injected. To aid in starting, the start-up control sets the fuel injection pumps at full stroke regardless of the throttle position. Normal governor operation takes over at low-idle speed, approximately 500 rpm.

### Troubleshooting and Adjustments

Most problems in this system can be traced to lack of fuel, low-fuel pressure, dirty fuel filters, poor quality fuel, or a broken or damaged fuel line. Air enters the fuel system when there are loose connections on the suction side of the pump.

Individual fuel injection pumps for each cylinder with built-in calibration means little or no balancing or adjustment. Prior to calibrating any sleeve metering fuel system, insure that the proper tools and manuals are available.

### ROOSA MASTER FUEL INJECTION PUMP

The *Construction Mechanic 3 & 2*, NAVED-TRA 10644-G, chapter 4, covers the general construction and operation of the Roosa Master DB and DC fuel injection pumps, as well as the International Harvester engine series 817 fuel injector. Here we will cover troubleshooting, disassembly, inspection, reassembly, and testing of the basic DC fuel pump of the Roosa Master system. Prior to performing any work on an injection pump, refer to the manufacturers' maintenance and service manuals.

The troubleshooting chart, shown in table 7-1, lists some of the problems and their possible causes that you might encounter in the Roosa Master fuel system.

### TROUBLESHOOTING

A field test (Kiene) on an engine is an efficient way to pinpoint the cause of poor engine performance. This test will eliminate unnecessary fuel injection pump removal. Since this field test permits some analysis of engine condition, as well as the fuel system, you will quickly see the extent of the difficulty and the remedies required.

Since most tests are more conveniently made under no load conditions, all readings possible are determined at high idle. If the supply pressure is lower than normal, an engine can still

Table 7-1.—Troubleshooting Chart for Roosa Master Fuel System

CAUSE OF PROBLEM	PROBLEM										CORRECTIVE MEASURES	
(Numbers in "Problem" Check-Chart indicate order in which to check possible "Causes" of Problem.)	A. Fuel not reaching pump. B. Fuel delivered from transfer pump but not to nozzles. C. Fuel reaching nozzles but engine won't start. D. Engine starts hard. E. Engine starts and stops. F. Erratic engine operation, misfiring, poor governor regulation. G. Engine idles improperly. H. Engine does not develop full power. I. Engine smokes black. J. Engine smokes blue or white.											
	3											
Hand primer installed backwards.	3											Re-install properly.
One or more Connector Screws obstructed.		3		2					9			Replace.
Seizure of Distributor Rotor.	2											Check for cause of seizure. Replace hydraulic head and distributor rotor assembly.
Failure of electrical shut-off.	2				7							Remove, inspect and adjust parts. Replace parts as necessary.
Fuel supply lines clogged, restricted, wrong size or poorly located.	6	7	5	3	1	2	8	4				Blow out all fuel lines with filtered air. Replace if damaged. Remove and inspect all flexible lines.
Air leaks on suction side of system.	7			4	6	7	3	5				Trouble-shooting the system for air leaks.
Automatic advance faulty or not operating.			8	9		9	8	11	4	2		Remove, inspect, correct and reassemble.
Water in fuel.			3	6	2	5	1	13				Drain fuel system and pump housing, provide new fuel, prime system.
Return oil line or fittings restricted.				11	4	13	11	8				Remove line, blow clean with filtered air and reassemble. Replace if damaged.
Air intake restricted.				3				14	1			Check manual.

7-8

CONSTRUCTION MECHANIC I & C

Pump housing not full of fuel.					6	2				Operate engine for approximately 5 minutes until pump fills with fuel.	
Fuel lines incorrect, leaking or connected to wrong cylinders.			4		1		15			Relocate pipes for correct engine firing sequence.	
Shut-off device interfering with Governor linkage.			6	8				2		Check and adjust governor linkage dimension.	
Governor high-idle adjustment incorrect.								3		Adjust to pump specifications.	
Throttle Arm travel not sufficient.			2					1		Check installation and adjust throttle linkage.	
Transfer Pump Blades worn or broken.	5			7	9	12	5	12		Replace.	
Shut-off device at "stop" position.		1								Move to "run" position.	
Metering Valve sticking or closed.		4		8	8	10	6	10		Check for governor linkage binding, foreign matter, burrs, etc.	
Governor Spring worn or broken.		5				11	9			Remove and replace.	
Governor linkage broken.		6						10		Remove, replace and readjust per specifications.	
Tank valve closed.	1									Open valve.	
Nozzles faulty or sticking.			7	10		8	7		3	Replace or correct nozzles.	
Pump timed incorrectly to engine.			1	1		1	1	7	2	1	Correct timing.
Filters or Inlet Strainer clogged.	1			5	5	3			6		Remove and replace clogged elements. Clean strainer.

operate smoothly at approximately the correct high-idle speed. The governor opens the metering valve further to make up for the lower pressure; so, you can take successful readings at high idle.

First, disconnect the throttle linkage, then, with the engine running, hold the throttle lever all the way to the rear. Adjust the high-idle stop screw until the specified high-idle speed is obtained to test the fuel pressure at high idle. Install the gage assembly in the pressure trap of the transfer pump, as shown in figure 7-12. If the reading obtained does not fall within the prescribed range, the pump will not deliver sufficient fuel to obtain full power under load. The most common causes of low pressure are restricted fuel supply, air leaks on the suction side of the pump, worn transfer pump blades, or a malfunctioning regulator valve.

To test for excessive pressure, remove the injection fuel pump timing plate. Be sure you make a small hole in the timing plate gasket as you install the gage on the pump. (See fig. 7-13.) This hole allows pump pressure to reach the gage as you operate the engine at both low and high idle. If pressure is excessive, a restricted fuel return line is the probable cause.

To test for restricted fuel supply on the suction side of the pump, operate the engine at



2.492

Figure 7-12.—Gage installed for checking transfer pump pressure.

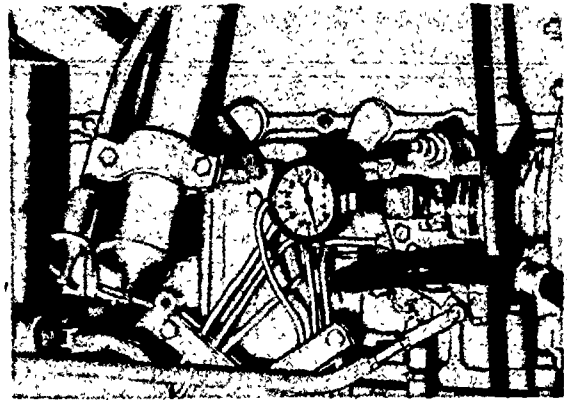

2.493

Figure 7-13.—Testing pump housing pressure.

high idle and read the vacuum developed. If the vacuum reading exceeds 10 inches mercury (Hg), check the fuel supply system for dirty filters, pinched or collapsed hoses, or a plugged vent.

## REMOVAL

If it is determined that the injection fuel pump must be removed from the engine, after field testing, be sure to remove all external grease and dirt. Keep in mind that dirt, dust, and other foreign matter are the greatest enemies of the injection fuel pump. As a precaution, keep all openings plugged during removal and disassembly.

## DISASSEMBLY

The workbench and surrounding area must be clean, as well as the tools to be used in disassembly. Have available a clean pan in which parts may be placed as you disassemble and a pan of clean diesel fuel oil in which the parts can be washed and cleaned.

After mounting the pump in a holding fixture, clamp the fixture in a vise. You are now ready for disassembly. For pump disassembly, follow the step-by-step procedure in the manual for the model pump on which you are working. Figure 7-14 illustrates the main internal working parts of the Roosa Master fuel injection pump.

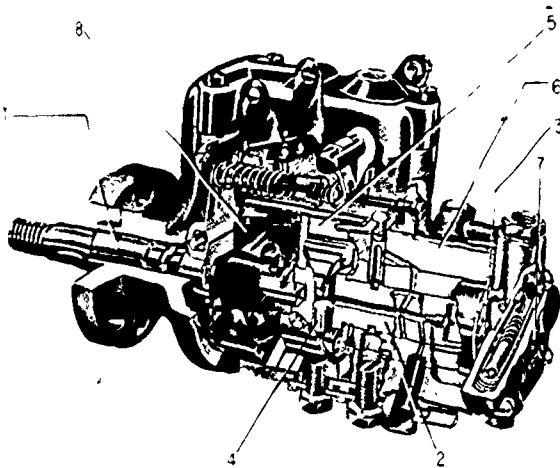

- |                      |                      |
|----------------------|----------------------|
| 1. Drive Shaft       | 5. Internal Cam Ring |
| 2. Distributor Rotor | 6. Hydraulic Head    |
| 3. Transfer Pump     | 7. End Plate         |
| 4. Pumping Plungers  | 8. Governor          |

81.349

Figure 7 14. — Roosa Master fuel injection pump.

### CLEANING AND INSPECTION

Now that you have disassembled the pump, all parts must be cleaned and inspected carefully.

Check all O-rings, seals, and gaskets for distortion, or damage, and all springs for wear, distortion, or breakage. Clean and carefully check all bores, grooves, and seal seats for damage of any kind. Replace damaged parts as necessary.

With care, inspect each part of the injection pump for excessive wear, rust, nicks, chipping, scratches, cracks, distortion, or binding. Replace any defective parts.

### REASSEMBLY

Reassemble in the manner specified by the manufacturer's maintenance and repair manual.

### AMERICAN BOSCH FUEL PUMP

The American Bosch fuel injection pump that is used on the multifuel engine both meters

and distributes fuel. It is a constant-stroke, distributing-plunger, sleeve-control type pump. As with other fuel systems, only clean fuel should be used. Good maintenance of the filtering system and reasonable care in fuel handling will give trouble-free operation. Fuels used in the multifuel engine must contain sufficient lubrication to lube the fuel pump and injectors. Due to close tolerances, extreme cleanliness and strict adherence to service instructions are required when it becomes necessary to service this pump.

In this section, we will discuss the operation and troubleshooting of the American Bosch, Model PSB pump and the Bosch nozzles that are used with the International Harvester engines.

### OPERATION

The purpose of the fuel pump (fig. 7-15) is to deliver accurately measured quantities of fuel under high pressure to the spray nozzle for injection. The positive displacement fuel supply pump (fig. 7-16) is gear driven by the pump camshaft through an engine camshaft gear, and provides fuel to the hydraulic head for injection and cooling. Fuel injection begins (fig. 7-17) when fuel flows around the fuel plunger annulus (fig. 7-18) through the open distributing slot to the injection nozzle. By continued upward movement of the fuel plunger, the spill passage passes through the plunger sleeve (fig. 7-19). This reduces pressure, allowing the fuel delivery valve to close which ends injection. This is accomplished through a single plunger, multi-outlet hydraulic head assembly. (See fig. 7-15.) The plunger is designed to operate at crankshaft speed on four-cycle engines and is actuated by a camshaft and tappet arrangement. The pump camshaft, which also includes the gearing for fuel distribution, is supported on the governor end by a bushing-type bearing and by a ball roller bearing on the driven end. An integral mechanical-centrifugal governor (fig. 7-20) driven directly from the pump camshaft without gearing, controls fuel delivery in relation to engine speed. This pump has a smoke limit cam within the governor housing to aid in controlling the exhaust smoke of various fuels. The mechanical centrifugal advance unit of this



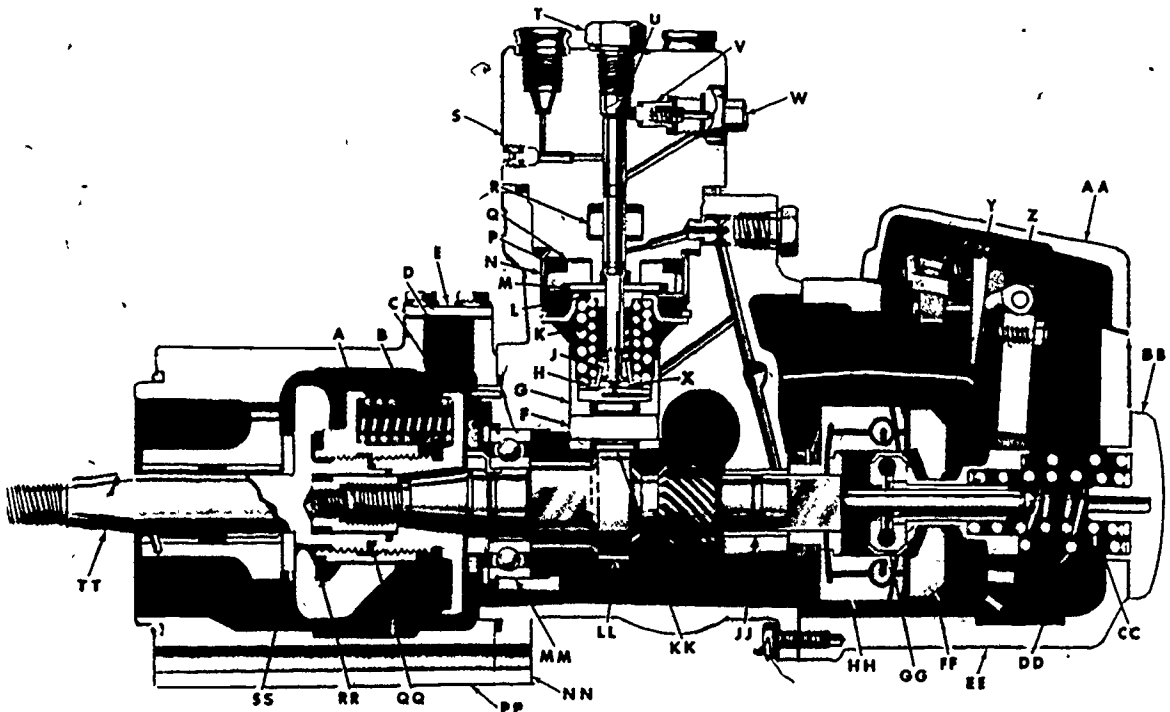

- A - Sliding gear
- B - Advance unit spring
- C - Advance unit hub
- D - Timing pointer
- E - Timing cover
- F - Tappet roller pin
- G - Tappet guide
- H - Spring lower seat
- J - Plunger lock
- K - Plunger inner spring
- L - Spring upper seat
- M - Plunger guide
- N - Drive gear retainer
- P - Plunger drive gear
- Q - Gear thrust washer
- R - Plunger sleeve
- S - Hydraulic head
- T - Plunger bore screw
- U - Fuel plunger
- V - Fuel delivery valve
- W - Delivery valve screw

- X - Plunger button
- Y - Stop plate
- Z - Smoke limit cam
- AA - Governor cover
- BB - Governor end cap
- CC - Governor inner spring
- DD - Governor outer spring
- EE - Governor housing
- FF - Governor weight
- GG - Sliding sleeve
- HH - Friction drive spider
- JJ - Camshaft bushing-type bearing
- KK - Tappet roller
- LL - Camshaft
- MM - Camshaft ball bearing
- NN - Injection pump housing
- PP - Advance unit housing
- QQ - End play spacer
- RR - Sliding gear spacer
- SS - Spider thrust plate
- TT - Spider assembly

Figure 7-15.—Metering and distributing fuel pump assembly—left sectional view.

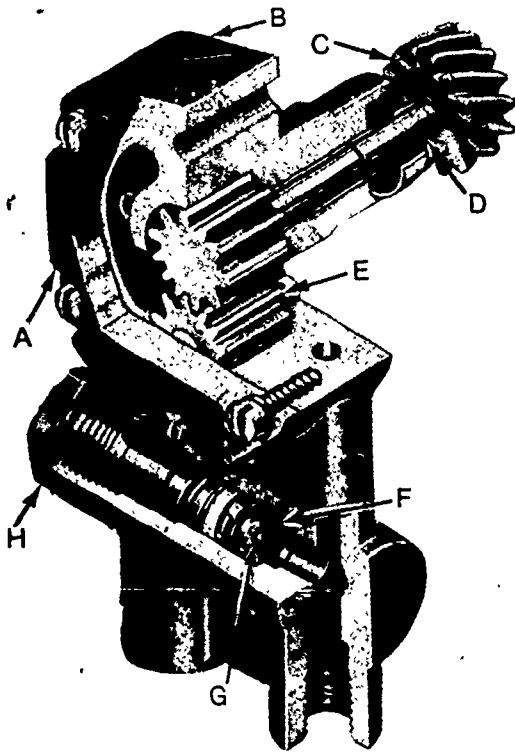

- |                          |                        |
|--------------------------|------------------------|
| A — Housing cover        | E — Idler gear         |
| B — Supply pump housing  | F — Check valve spring |
| C — Camshaft driven gear | G — Check valve        |
| D — Drive shaft          | H — Valve screw        |

2.534

Figure 7-16.—Fuel supply pump assembly—sectional view.

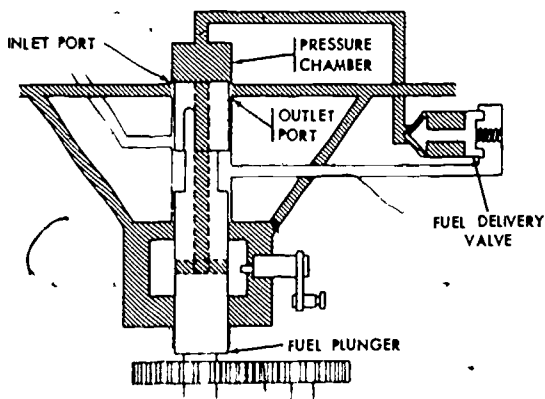

Figure 7-17. Beginning of fuel delivery flow diagram.

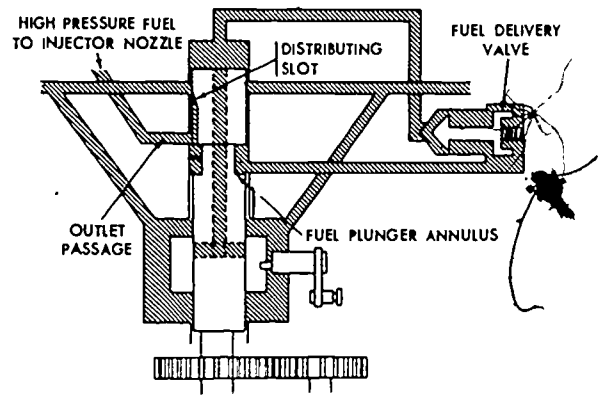

Figure 7-18.—Fuel delivery flow diagram.

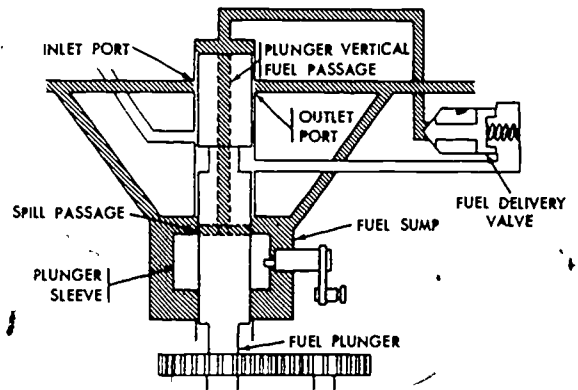

Figure 7-19.—End of fuel delivery flow diagram.

pump provides up to 9° advance timing and is driven clockwise at crankshaft speed.

## TROUBLESHOOTING

Table 7-2 lists the most common malfunctions and probable causes. Further tests, adjustments, and specifications are available through the manufacturer's manual which you should use for repairs or adjustments.

## TYPES OF NOZZLES

Bosch nozzles are inward opening with a multiple orifice and a hydraulically operated nozzle valve. There are two models of this nozzle in use—the American Bosch and the Robert

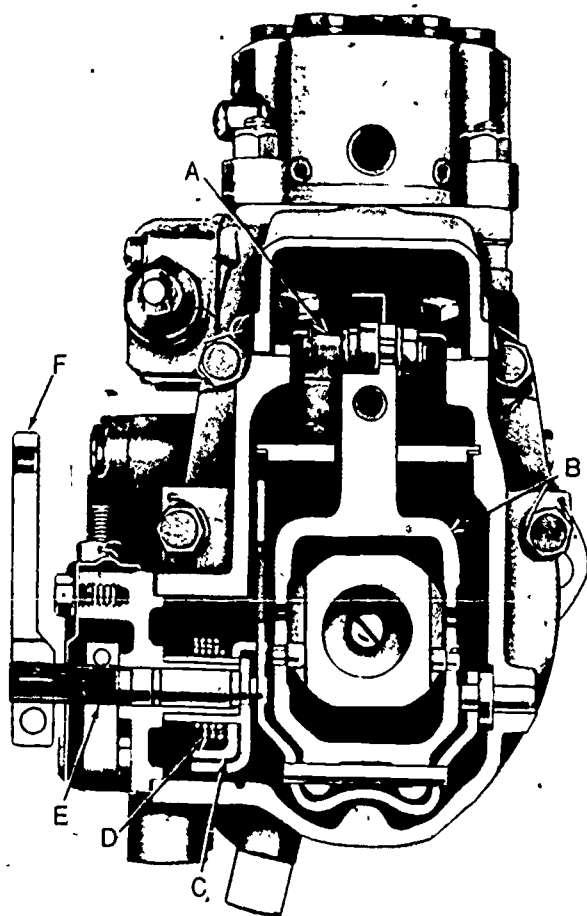

- |                        |                            |
|------------------------|----------------------------|
| A — Fuel control rod   | D — Operating shaft spring |
| B — Fulcrum lever      | E — Operating shaft        |
| C — Shaft spring plate | F — Operating lever        |

2.535

Figure 7-20.—Governor—sectional view.

Bosch. They may be easily identified by either the length of the nozzle tip holding nut or the nozzle drilling code on the smaller diameter of the nozzle valve body. The American Bosch nozzle nut is 3 inches long and the nozzle tip has a hand-printed drilling code. The Robert Bosch nozzle nut is 2 inches long and the nozzle tip has a machine-etched drilling code. Figure 7-21 shows a view of the nozzle which identifies the various component parts. Component parts, although, similar, are not interchangeable between the two nozzles.

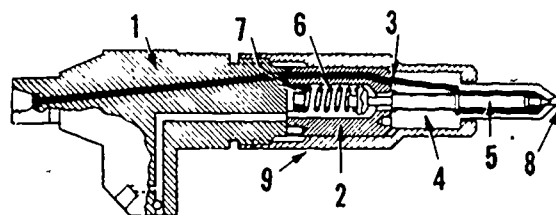

- |                      |                       |
|----------------------|-----------------------|
| 1. Nozzle Body       | 6. Nozzle Spring      |
| 2. Spring Retainer   | 7. Shims              |
| 3. Annular Groove    | 8. Orifice Holes      |
| 4. Nozzle Valve Body | 9. Nozzle Holding Nut |
| 5. Nozzle Valve      |                       |

Figure 7-21.—Bosch nozzle nomenclature.

### NOZZLE OPERATION

The pressurized fuel from the injection pump enters the top of the nozzle body and flows through a passage in the body and nozzle spring retainer. An annular groove in the top face of the nozzle valve body fills with fuel, and two passages in the nozzle valve body direct fuel around the nozzle valve. When the fuel in the pressure chamber reaches a predetermined pressure, the spring force (adjusted by shims) is overcome and injection occurs. Atomized fuel sprays from the orifice holes in the nozzle tip as the nozzle valve is opened inward by pressurized fuel. When injection ends, spring pressure snaps the valve in its seat. During each injection, a small quantity of high pressured fuel passes between the nozzle valve stem and the nozzle valve body to lubricate and to cool the nozzle valve. A manifold which connects to all of the nozzles returns this fuel to the tank.

### NOZZLE TROUBLESHOOTING

By using the field test (Kiene), you can check the condition of a nozzle prior to disassembly. Remove the nozzle from the engine, and using the test pump shown in figure 7-22, check for nozzle spray angle and pattern. There are four orifices in the nozzle tip and the spray angle should be uniform from all four. Also check the spray valve opening pressure. A pressure reading

## Chapter 7—DIESEL FUEL SYSTEMS

Table 7-2.—Troubleshooting Bosch System

Malfunction	Probable Cause
1. No fuel output	<ol style="list-style-type: none"><li>Operating shaft frozen in operating shaft bearing.</li><li>Operating shaft spring plate broken or not engaged with fulcrum lever or operating shaft.</li><li>Fuel control rod bent or broken.</li><li>Sheared plunger guide in hydraulic head assembly.</li></ol>
2. Fuel output cannot be controlled.	<ol style="list-style-type: none"><li>Incorrect idle and full speed adjustments.</li><li>Operating shaft spring not engaged with fulcrum lever or operating shaft.</li><li>Fuel control rod bent or broken.</li></ol>
3. Fuel leakage into oil lubrication system.	<ol style="list-style-type: none"><li>Hydraulic head lower ring gasket damaged.</li><li>Worn fuel plunger.</li><li>Worn supply pump housing oil seal.</li></ol>
4. Fuel leakage around the fuel control unit.	<ol style="list-style-type: none"><li>Control unit packing damaged.</li><li>Fuel control unit assembly worn.</li></ol>
5. Fuel leakage around the hydraulic head assembly.	Head upper ring gasket damaged.
6. Uneven fuel distribution.	<ol style="list-style-type: none"><li>Inner plunger spring broken.</li><li>Worn fuel plunger.</li><li>Fuel plunger sticking.</li></ol>
7. Excessive vibration.	<ol style="list-style-type: none"><li>Excessive camshaft runout.</li><li>Governor weight and spider worn or damaged.</li><li>Camshaft ball bearing worn or damaged.</li><li>Camshaft bushing-type bearing worn or damaged.</li><li>Advance unit housing bushing-type bearings worn or damaged.</li><li>Advance unit weight and spider worn or damaged.</li></ol>

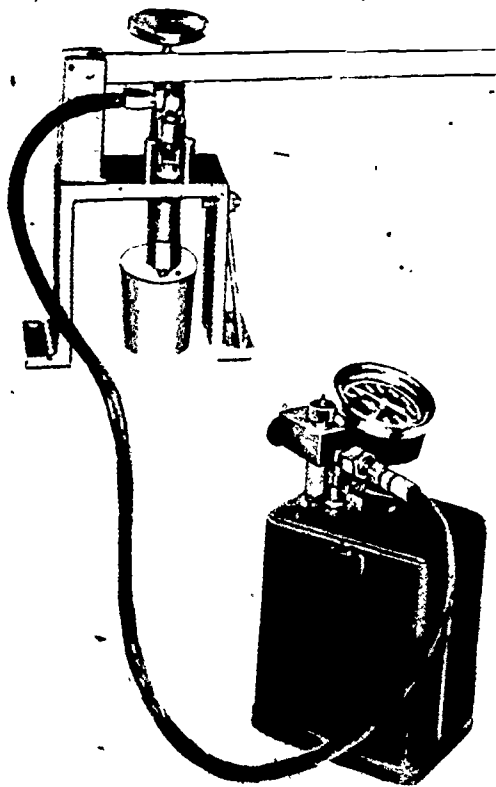

2.495

Figure 7-22.—Test pump.

that is more than 50 psi below the valve's specified opening pressure indicates a need to adjust the pressure by adding shims. Next, test the leakage past the seat and stem. If this leakage is excessive, due to wear, install a new nozzle valve.

Proceed with nozzle disassembly only after you have performed these and other tests prescribed in the test manual. While testing, record the results of the tests for each nozzle. They can help you determine the nature and extent of necessary repairs.

### NOZZLE DISASSEMBLY

Before disassembly of the nozzle, clean the external area with cleaning fluid or clean diesel fuel oil, using a brush with long bristles. Keep the disassembled nozzles separated to prevent

mixing the various components. During inspection, refer to the test results which are used as a guide to determine the extent of reconditioning necessary.

### NOZZLE CLEANING AND INSPECTION

After you have disassembled the nozzle, make sure each disassembled nozzle has been placed in a separate pan containing a cleaning solvent or clean diesel fuel oil. Soak the tips in a good carbon solvent for the length of time prescribed by the manufacturer. As a word of caution, remember NOT to mix the tips together. Each tip must be reassembled with its own group of parts.

Be careful when the spray holes of the nozzle tip are cleaned so as not to enlarge or damage them. Use a magnifying glass during your inspection for signs of scratches, corrosion, or erosion on the spring retainer, the nozzle body holder, and the valve body face. Also check the stem and the body of the valve, making sure they do not bind.

### NOZZLE REASSEMBLY

Reassemble it in the manner prescribed and specified by the manufacturer's maintenance and repair manual.

### CHECKING THE NOZZLE AFTER REASSEMBLY

Before you install the nozzle in the engine, test it for (1) spray angle and pattern, (2) valve opening pressure, and (3) leakage past the seat and stem. When test results are good, install the nozzle in the engine.

### GENERAL MOTORS FUEL SYSTEM

The General Motors fuel system includes fuel injectors, fuel pipes, fuel manifolds, fuel pump, fuel strainer, fuel filter, and fuel lines connecting the fuel tank. This system depends on the injection of the correct amount of fuel at exactly

the right time into the combustion chamber. Efficient engine operation demands that the fuel system be maintained in first-class condition at all times. Use only clean, water-free fuel. Good maintenance of the fuel filtering system and reasonable care in handling the fuel is the key to a trouble-free fuel system.

Servicing the fuel system is not a difficult task and may be performed by most mechanics. However, due to the close tolerances of the various fuel system components, extreme cleanliness and strict adherence to service instructions are required.

In this section, troubleshooting, disassembly, inspection, reassembly, and testing of the fuel pump and fuel injector are discussed. Prior to performing any work on these components, refer to the manufacturer's maintenance and service manuals.

### TROUBLESHOOTING

When a piece of equipment is brought into the shop for maintenance and servicing, the hard card or Equipment Repair Order (ERO) may show a fuel system problem. A method of pinpointing the problem is by troubleshooting the fuel system until the trouble is located.

Check the fuel lines for improper or faulty connections. If any leaks occur, tighten the connection only enough to stop the leak. Also, check the filter cover bolt for tightness. If the fuel pump fails to function satisfactorily, first check the level of the fuel tank, then make sure the fuel supply valve is open. Check for a broken pump driveshaft or drive coupling by inserting the end of a wire through one of the pump flange drain holes, then crank the engine and note if the wire vibrates. Vibration will be felt if the pump shaft is turning.

Most fuel pump failures result in no fuel or insufficient fuel being delivered to the fuel injectors. This lack of fuel will show up if the engine runs unevenly, vibrates too much, stalls at idling speeds, or loses power.

The most common failure of a fuel pump is a sticking relief valve. The relief valve, due to its

close fit in the valve bore, may stick in a full open position due to a small amount of grit or foreign material lodged between the relief valve and its bore or seat. The fuel oil circulates within the pump rather than being forced through the fuel system. Therefore, if the fuel pump is not functioning properly, remove the fuel pump from the engine. Then, remove the relief valve plug, spring, and pin, and check the movement of the valve within the valve bore. If the valve sticks, recondition it by using the fine emery cloth to remove any scuff marks. Clean the valve bore and the valve components. Then, lubricate the valve and check it for free movement throughout the entire length of its travel. If its operation is satisfactory, reassemble the valve in the pump. If not, replace it.

After the relief valve has been checked, and the fuel pump reinstalled on the engine, start the engine and check the fuel flow at some point between the restricted fitting in the fuel return manifold and the fuel tank.

If, after making the above checks, there is still a lack of power, uneven running, excessive vibration, or stalling at idle; suspect a faulty injector in one or more cylinders. Start the engine and run it at part load until it reaches normal operating temperature. Remove the valve rocker cover(s) and then let the engine run at idle speed. Hold the injector follower down with a screwdriver which prevents operation of the injector. If the cylinder has been misfiring, there will be no noticeable difference in the sound or operation of the engine. If the cylinder has been firing properly, there will be a noticeable difference in the sound and operation when the follower is held down. If that cylinder is firing properly, repeat the procedure on the other cylinders until the faulty one has been located.

Provided that the injector operating mechanism of the faulty cylinder is functioning satisfactorily, remove the fuel injector for additional testing.

### TESTING

The General Motors injector tester provides a means for determining the condition of the

injector to avoid unnecessary overhauling. An injector that passes all of the tests outlined below may be considered to be satisfactory for service without disassembly, except for the visual check of the plunger. However, an injector that fails to pass one or more of the tests is unsatisfactory. Be sure to identify each injector and record the pressure drops and fuel output during the tests. Also remember, all tests must be performed BEFORE the injector is disassembled.

To perform the INJECTOR CONTROL RACK AND PLUNGER MOVEMENT TEST, place the injector against a bench, as shown in figure 7-23, and depress the follower to the bottom of its stroke while the rack is moved back and forth. Failure of the rack to move freely indicates that the internal parts of the injector are damaged or dirty.

**CAUTION:** Always hold the injector so that fuel spray will not penetrate the skin and poison the blood.

The purpose of the VALVE OPENING PRESSURE TEST is to determine the pressure at which the valve opens and injection begins. Place the injector in the tester. (See fig. 7-24.) Operate the pump handle until all air is purged

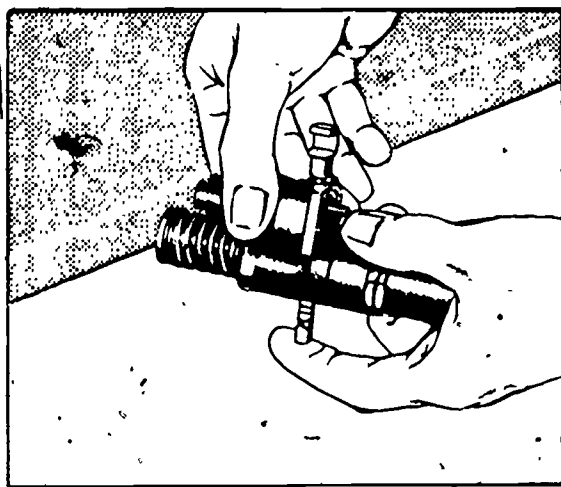

2.497

Figure 7-23.—Checking rack and plunger freeness.

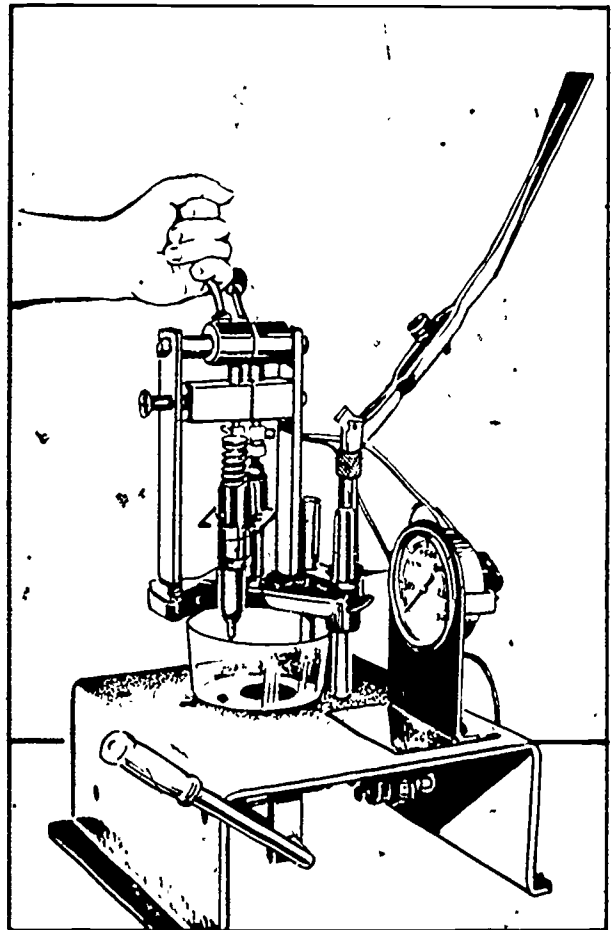

2.498

Figure 7-24.—Injector installed in tester.

from the injector tester and the injector. Then, close the outlet clamp. As a word of caution, when an injector that has just been removed from the engine is tested, the flow of fuel through the injector on the tester should be the same as it was on the engine. If required, fuel connections on the tester may be reversed to obtain the proper fuel flow.

With the injector rack in the full-fuel position, pump the handle of the injector tester with smooth even strokes (See fig. 7-25.) and record the injector valve opening pressure. The specified valve opening pressure for the crown or high valve injector is 450 to 850 psi. For the needle valve injector, the specified opening

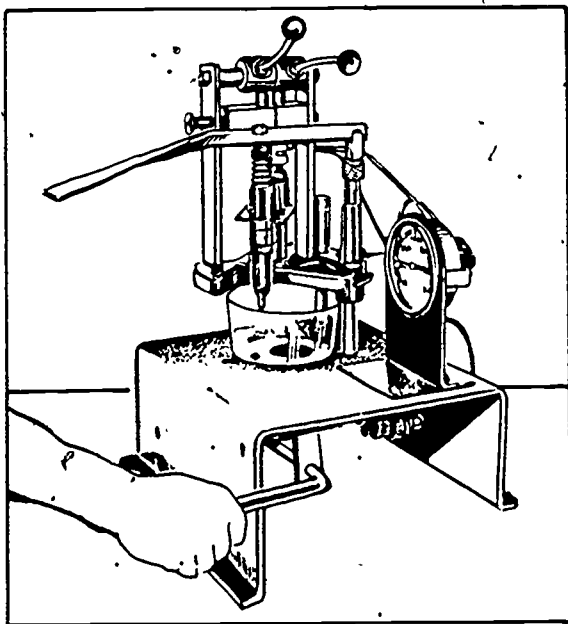

2.499

Figure 7-25.—Checking injector valve opening pressure.

pressure is 2000 to 3200 psi. If the pressure is not within limits, check the manufacturers' maintenance manuals for probable causes and corrections.

The **HOLDING PRESSURE TEST** will determine whether the various lapped surfaces in the injector are sealing properly.

By bringing the pressure up to a point just below the valve opening pressure (450 psi for crown, needle, and high valve injectors), and then closing off the fuel shut-off valve, the pressure will drop. The time for the pressure to drop from 450 psi to 250 psi must not be less than 40 seconds. If the injector pressure drops from 450 psi to 250 psi in less than 40 seconds, check the injector as follows:

1. Thoroughly dry the injector.
2. Open the injector tester fuel valve and operate the pump to maintain the test pressure.
3. Check for a leak at the injector rack opening. A leak indicates a poor bushing-to-body fit.

4. A leak around the spray tip or seal ring usually is caused by a loose injector nut, a damaged seal ring, or a burned surface on the injector nut or spray tip.

5. A leak at the filter cap indicates a loose filter cap gasket.

6. A "dribble" at the spray tip orifices indicates a leaking valve assembly due to a damaged surface or dirt. Leakage at the tip will cause preignition in the engine.

**NOTE:** A drop or two of fuel at the spray tip is only an indication of the fuel trapped in the spray tip at the beginning of the test and is not detrimental as long as the pressure drop specified is not less than 40 seconds.

The **HIGH PRESSURE TEST** is performed to discover any fuel leaks at the injector filter cap gaskets, body plugs, and nut seal ring which did not appear during the valve holding pressure test. The high pressure test also indicates whether the injector plunger and bushing clearance is satisfactory.

Place the injector rack in the **FULL-FUEL** position, and operate the pump handle (See fig. 7-26.) to build up and maintain the pressure of 1600 to 2000 psi. Then, inspect for leaks at the injector filter cap gaskets, body plugs, and injector nut seal ring.

Use the adjusting screw in the injector tester handle to depress the injector plunger just far enough to close both ports in the injector bushing. Both ports are closed if the injector spray decreases and the pressure rises. Now, you can determine the condition of the plunger and bushing. Excessive clearance between the plunger and bushing means that pressure will not rise beyond the normal valve-opening pressure. Replace the plunger and bushing.

A **SPRAY PATTERN TEST** is performed after completing the valve holding pressure test. After placing the injector in the tester, open the fuel shut-off valve, then place the injector rack in the **FULL-FUEL** position and operate the injector several times in succession by pumping



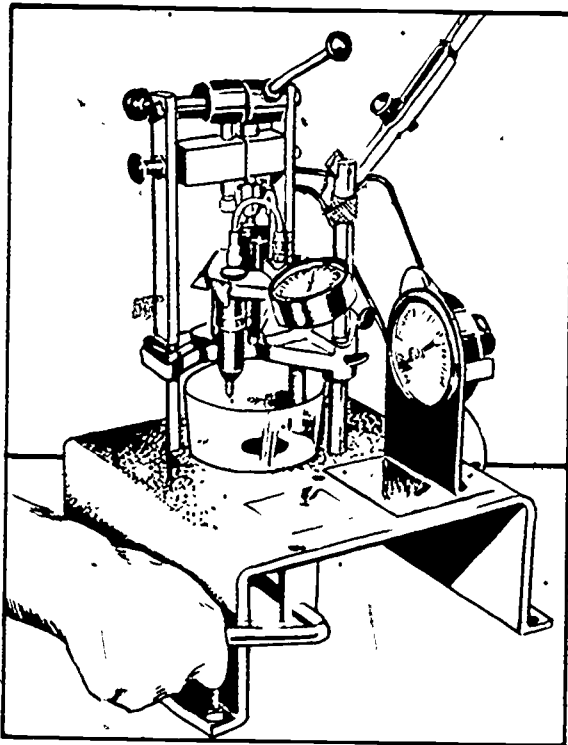

2.500

Figure 7-26.—Injector high pressure test.

the tester handle (See fig. 7-27.) at approximately 40 strokes per minute. Observe the spray pattern to see that all of the spray tip orifices are open and injecting evenly. The beginning and ending of injection should be sharp and the fuel injected should be finely atomized.

If all the spray tip orifices are not open and injecting evenly, clean the orifices in the spray tip during injector overhaul.

**CAUTION:** To prevent damage to the pressure gage, do not exceed 250 psi during this test.

A visual inspection of the injector plunger should be made even if the injector passes all of the previous tests. The plunger is visually checked under a magnifying glass for excessive wear or a possible chip on the bottom helix. There is a small area on the bottom helix and the

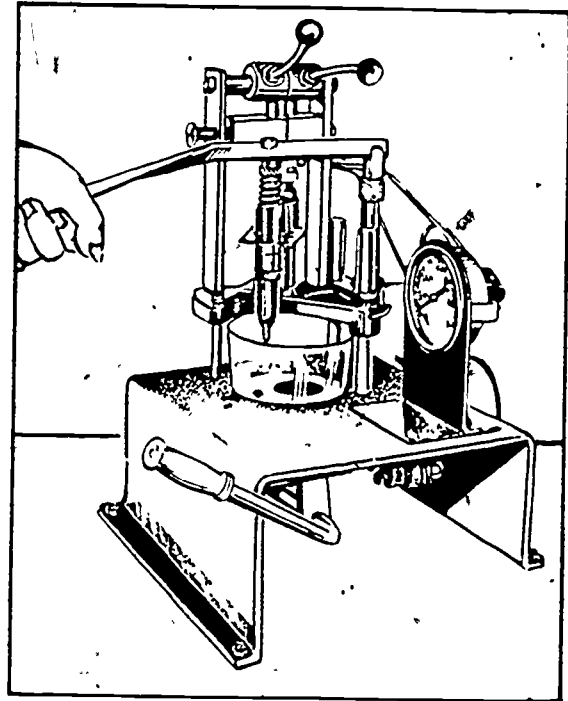

2.501

Figure 7-27.—Spray pattern test.

lower portion of the upper helix, that, if chipped, will not be indicated in any of the tests.

A FUEL OUTPUT TEST is performed to check injector fuel output. To test the injector, place it in the comparator (See fig. 7-28.), and seal the injector firmly by tightening the handwheel. Pull the injector rack out to the NO-FUEL position and start the comparator. After the comparator has started, push the injector rack to the FULL-FUEL position. Let the injector run for approximately 30 seconds to purge air in the system. After 30 seconds, press the fuel flow start button to start the flow of fuel into the vial. The comparator will automatically stop the flow of fuel after a thousand strokes. After the fuel has stopped flowing into the vial, be sure to pull the injector rack out to the NO-FUEL position. Turn the comparator off, reset the counter, and observe the reading on the vial. Refer to the chart on the comparator and see if the injector fuel output falls within its specified limits. If the quantity of fuel in the vial does not

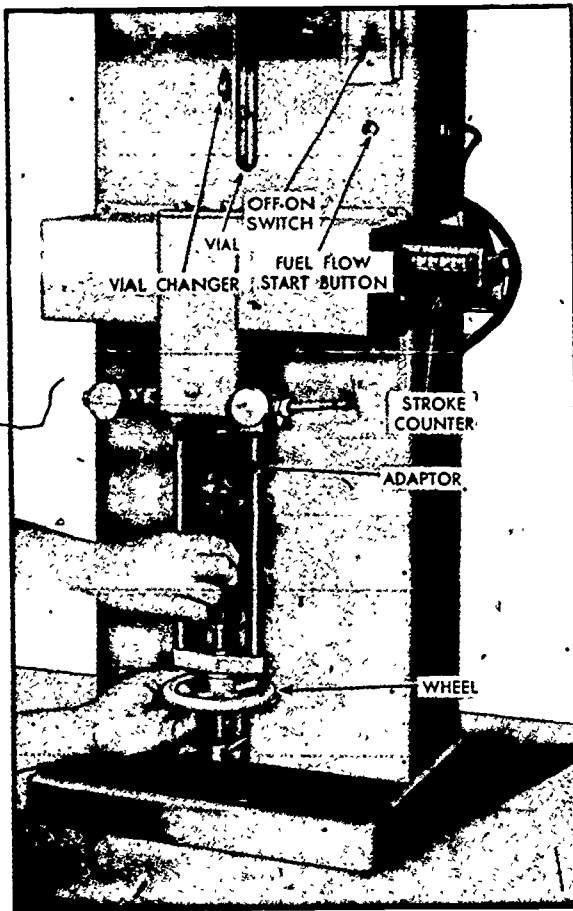

2.502

Figure 7-28.—Comparator used to check injector fuel output.

fall within the specified limits, refer to the manufacturer's manual for the cause and remedy.

Any injector which has been disassembled and rebuilt must be tested again before being placed in service.

### INJECTOR DISASSEMBLY

An injector to be disassembled is placed in the injector assembly fixture to remove filter caps, springs, filter elements, and gaskets. Be sure to discard the filter elements and gaskets and replace them with new components during reassembly.

Disassembly is completed in the manner prescribed by the manufacturer's repair and maintenance manual.

### INJECTOR CLEANING AND INSPECTION

After disassembly of the injector, be sure you keep each injector and its parts together in a separate receptacle containing a cleaning solvent or clean diesel fuel oil.

Wash all the parts and dry them. Do not use waste or rags for cleaning. Clean out all passages, drilled holes, and slots in all of the injector parts.

Injector spray tips should be soaked in a suitable solvent for approximately 15 minutes to loosen the carbon on the inside of the tip. Then, they can be reamed out by using the proper size spray tip cleaning wire.

Inspect injector parts for excessive wear, damage, defects, burrs, scratches, scoring, erosion, or chipping. Replace damaged or excessively worn parts.

Before reinstalling used valve parts in an injector, lap all of the sealing surfaces, such as the bottom of the injector body, the injector bushing, the valve seat, the valve cage, the check valve, and the spray tip.

### INJECTOR REASSEMBLY

As with the other type of injectors mentioned in the previous sections of this chapter, reassembly of the injector will be in the manner prescribed by the manufacturer's maintenance and repair manuals.

### CHECKING THE INJECTOR AFTER REASSEMBLY

Before placing a reconditioned injector in service, perform all of the tests (except the visual inspection of the plunger) previously outlined under the heading "Testing."

The injector is satisfactory if it passes these tests. Failure to pass any one of these tests indicates that defective or dirty parts have been assembled. In this case, disassemble, clean, inspect, reassemble, and test the injector again.

## CUMMINS PRESSURE TIME FUEL SYSTEM

The Cummins Pressure Time (PT) fuel system consists of the fuel pump (with governor and often an Aneroid valve), the supply and drain lines, and the injectors.

As in previous sections of the chapter, we will cover troubleshooting, disassembly, inspection, reassembly, and testing of components. Remember, before performing any service on the PT injector or pump, refer to the manufacturer's maintenance and repair manuals.

### TROUBLESHOOTING

Troubleshooting is an organized study of the problem and a planned method of procedure to investigate and correct the difficulty.

Most troubles are simple and easy to correct; examples are "excessive fuel oil consumption" caused by leaking gaskets or connections, etc. A complaint of "sticking injector plunger" is usually corrected by repairing or replacing the faulty injector, but something caused the plunger to stick. The cause may be improper injector adjustment, or, more often, water in the fuel.

In general, the complaint of "low-power" will be the most troublesome to correct because of the many variables in operation and installations, as well as the difficulty of correctly measuring power in the field. With the PT fuel system, you can often eliminate the pump as a source of trouble simply by checking to see that the manifold pressure is within specified limits. The fuel rate of the pump must not be increased to compensate for a fault in other parts of the engine; damage to the engine will result.

To check the fuel pump on the engine, remove the pipe plug from the pump shut-off valve and connect the pressure gage line. At governed speed (just before the governor cuts in) maximum manifold pressure should be obtained. If the manifold pressure is not within specified limits, adjust for maximum manifold

pressure by adding or removing shims from under the nylon fuel adjusting plunger in the bypass valve plunger. Take care not to lose the small lockwasher which fits between the fuel adjusting plunger and the plunger cap.

To check the suction side of the pump, connect the suction gage to the inlet side of the gear pump. The valve in the pump, if properly adjusted, should read 8 inches on the gage. When the inlet restriction reaches 8.5 to 9 inches, a fuel filter element change should be made or any other sources of restriction removed. The engine will lose power when the restriction is greater than 10 to 11 inches.

Always make the above checks on a warm engine and operate the engine for a minimum of 5 minutes between checks to clear the system of air.

When pump manifold and suction pressures are within specified limits and there is still a loss of power, the injectors must be checked.

Carbon in the PT injector metering orifices restricts the fuel flow to the injector cups with a resulting engine power loss. Carbon can be removed from the metering orifices by reverse flushing; it should be performed on a warm engine.

Loosen all injector adjusting screws one turn from the bottom or one and one-eighth turns from the set position. Lock with the jamnut after completing the required turns.

Start the engine and accelerate with maximum throttle from idling to high—10 to 15 times.

Readjust the injectors to their standard setting.

The engine will be difficult to start with the loose injector setting—it will smoke badly and will be sluggish. If the injector adjusting screws are loosened, the metering orifice will not be closed during injection. Extremely high injection pressure will force some of the fuel to backflow through the orifice and should remove carbon

deposits. If this method is not effective, remove the injectors for cleaning.

When working on the PT fuel system of a turbo-charged Cummins engine, you may encounter an Aneroid control device. This device creates a lag in the fuel system so that its response is equivalent to that of the turbocharger, thus controlling the engine smoke level.

It is recommended that the Aneroid not be removed, disconnected, or otherwise rendered ineffective on this engine, nor should the settings be altered. The exception, of course, is during troubleshooting of the fuel system when the Aneroid is checked according to the manufacturer's specifications, as are other components of the fuel system.

### PUMP DISASSEMBLY

If it is determined after troubleshooting that the fuel pump (See fig. 7-29.) must be removed from the engine, be sure the pump is cleaned of all dirt. Be sure the shop area is clean and use clean tools. Good cleaning practices must be used, for they are essential to good quality fuel pump repair. Special care must be taken when the PT fuel pump which is made of a lightweight aluminum alloy is disassembled. Be sure proper tools are used to prevent damage to its machined surfaces which are more easily damaged than parts made of cast iron.

Before disassembling the unit, always try to determine, if possible, which parts need replacement.

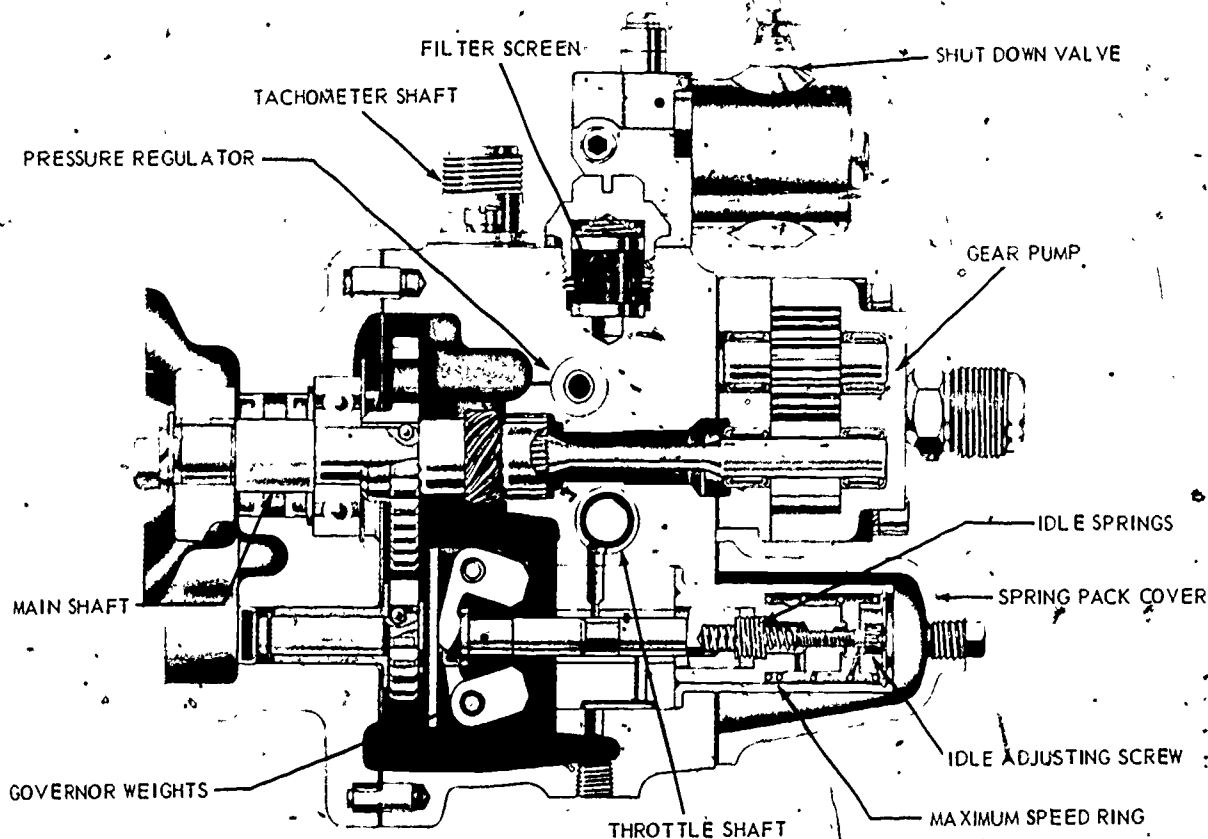

Figure 7-29.—Cummins PT fuel pump.

2.72X

After placing the fuel pump on the holding device, place the device in a vise and proceed with the disassembly of the pump. Follow the procedures given in the manufacturer's maintenance and repair manuals.

### PUMP CLEANING AND INSPECTION

Now that the pump has been disassembled, clean and inspect all parts. Parts must not be discarded until they are worn beyond reasonable replacement limits. The PT fuel pump parts will continue to function long after they show some wear. Parts that are worn beyond reasonable replacement limits must not be reused. From experience you will quickly learn the "reasonable replacement limits," and reuse all those parts that will give another complete period of service without danger of failure.

**NOTE:** Special care must be taken when aluminum alloy parts are cleaned. Some cleaning solvents will attack and corrode aluminum. Mineral spirits is a good neutralizer after using cleaning solvents.

### PUMP REASSEMBLY

After a complete cleaning and inspection of the pump and pump parts, the pump is reassembled in the manner prescribed by manufacturer's manual. In all assembly operations, be careful to remove burrs and use a good extreme pressure lubricant on the mating surfaces during all pressing operations. An extreme pressure lubricant aids in pressing and prevents scoring and galling.

Flat steel washers are used throughout; they go next to the aluminum to prevent goring by the spring steel lockwashers.

### PUMP TESTING

The PT fuel pump is mounted on a test stand as shown in figure 7-30. In the test, the pressure from the PT pump is measured and adjusted before the pump is placed on the engine.

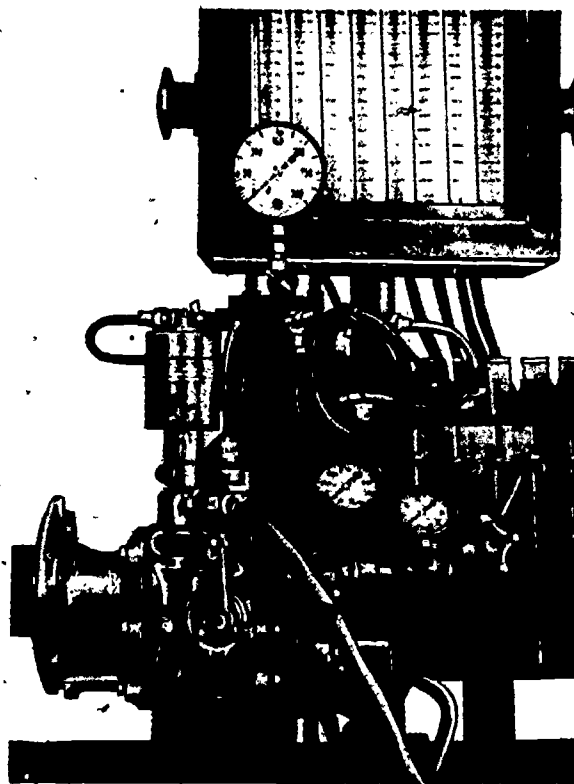

Figure 7-30.—PT pump mounted on test stand.

2.504

Pressure is developed across special orifices in the orifice block assembly and is measured on the gages provided.

All pump tests should be made with the testing fuel oil temperature between 90° and 100° F.

Open the fuel shut-off valve and manifold orifice valve. Open the stand throttle, start and run the pump at 500 rpm's until the manifold pressure gage shows the recommended pressure. If the pump does not pick up the specified pressure, check for closed valves in the suction line or for an air leak.

If the pump is newly re-built, run at 1500 rpm's for five minutes to flush the pump and allow the bearings to seat. Continue to run the pump at 1500 rpm's and turn the rear throttle stop screw in or out to find the maximum manifold pressure at full throttle.

**NOTE:** With a standard governed pump, the throttle screws will be re-adjusted later. If the pump has a variable speed governor, the throttle shaft is locked in full throttle position; do not re-adjust. On a dual or torque converter governor pump, the throttle must be locked in the shut-off position and the converter-driven governor idle-adjusting screw turned "in" until the spring is compressed. The converter-driven governor must be set on the engine.

The pump idle speed is set by closing the bypass and manifold orifice valves and opening the idle orifice valve. Set the pump throttle to idle and run at 500 rpm's. To decrease or raise the idle pressure, add or remove shims from under the idle spring. Remember not to set the idle screw until you have adjusted the throttle screws.

Once the tests and adjustments have been completed in accordance with the specifications recommended by the manufacturer, remove the pump from the test stand, making sure that the suction fitting is not removed or disturbed. Next, loosen the spring pack cover and drain the pump through the pipe plug at the bottom of the pump body. Be sure to cover all openings and bind fittings with tape until you are ready to install the pump.

### INJECTOR MAINTENANCE AND TESTING

In the PT fuel system, fuel is metered by fuel pressure against the injector's metering orifice. Any change in fuel pressure, metering orifice, or timing will affect the amount of fuel delivered to the combustion chamber.

Two things will interfere with the normal functions of injector orifices:

1. Dirt or carbon in the orifices or in the passages to and from the orifices;
2. A change in the size or shape of the orifices, particularly caused by improper cleaning of the orifices.

After soaking dirty injectors in a cleaning solvent to remove the carbon, be sure to dip the injectors into a neutral rinse, such as mineral spirits, and then dry them.

**NOTE:** Never use cleaning wires on PT fuel injector orifices.

Be sure to use a magnifying glass to inspect the injector orifices for damage. When the injector orifices are damaged, they cannot be made to function properly and must be replaced.

Check the injector for a worn plunger or injector body. Worn injectors may cause engine oil dilution from excessive plunger to body clearances. Dilution may also result from a cracked injector body or cup, or a damaged "O" ring. To check the injector for leakage, it must be assembled. Remember to plug off the injector inlet and drain connection holes, then mount it on the injector test stand.

Test the injector at a maximum of 1000 psi with the fuel flowing upward through the cup spray holes. If the counterbore at the top of the injector body fills with fuel in less than 15 seconds, the plunger clearance is excessive and may cause engine oil dilution. During this check, inspect the injector for leaks around the injector cup, body, and plugs. If the injector does not pass the test and checks, remove the damaged parts and replace with new parts.

Any time you remove an injector plunger, be sure to use the lubricant recommended by the manufacturer upon replacing the plunger in the injector body.

If the injector plunger does not seat in the injector cup, change the cup rather than trying to lap the plunger and cup together. Lapping will change the relationship between the plunger groove and metering orifice, and disturb fuel metering. Always use a new injector cup gasket when you assemble the cup to the injector body to avoid distortion of the cup. When the cup is tightened to the injector body, the gasket compresses everywhere, except under the milled slot on the end of the injector body; then, if the gasket is reused, the uncompressed areas may cause the injector cup to cock and prevent the injector plunger from seating properly.

## AIR INDUCTION SYSTEM

The purpose of an air intake system is to supply the air needed for combustion of the fuel. In addition, the air intake system of a diesel engine will have to clean the intake air, silence the intake noise, furnish air for supercharging, and supply scavenged air in two-stroke engines.

The three major components of the air induction system which increase internal combustion engine efficiency are blowers, superchargers, and turbochargers. They may be of the centrifugal or rotary type, or they may be gear driven directly from the engine, belt or chain driven, or driven by the flow of exhaust gases from the engine.

We will cover, in the following sections, certain abnormal conditions of air induction system components which sometimes interfere with satisfactory engine operation. Also, methods of determining causes of such conditions will be covered. Prior to performing any work on these components, make sure you follow the recommendations given in the manufacturer's service manual.

## BLOWERS

Scavenging blowers are used to clear the cylinders of exhaust gases to introduce a new charge of fresh air. Superchargers and turbochargers increase the power output of specific engines by forcing air into the combustion chambers so that an engine can burn more fuel and develop more horsepower than if it were naturally induced.

### Blower Inspection

The blower, as shown in figure 7-31, may be inspected for any of the following conditions without being removed from the engine. However, the air silencer or air inlet housing must be removed. A word of caution: when a blower on an engine is being inspected with the engine running; keep your fingers and your clothing away from moving parts of the blower and be sure to run the engine at low speeds only.

Dirt or chips, drawn through the blower, will make deep scratches in the rotors and housing and throw up burrs around these abrasions. If the burrs cause interference between rotors or between rotors and blower housing, the blower should be removed from the engine and the parts dressed down to eliminate this interference, or the rotors should be replaced if they are too badly scored.

Oil on the blower rotors or inside surfaces of the housing means that oil seals leak. Run the engine at low speed and focus a light into the rotor compartment at the end plates and oil seals. A thin film of oil radiating from the seal shows an oil leak.

A worn blower drive, resulting in a rattling noise inside the blower, may be detected by grasping the top rotor firmly and attempting to rotate it. The rotor may move from 3/8 inch to 5/8 inch, measured at the lobe crown. When released, the rotor should move back at least one-fourth inch. If the rotor cannot be moved this distance, or if the rotor moves too freely, the flexible blower drive coupling should be inspected and replaced, if necessary.

If a check shows the drive coupling to be worn, the blower drive assembly may be removed from the cylinder block end plate. After the blower has been removed from the engine, the drive gear hub bearing support-to-cylinder block end plate bolts are removed.

Loose rotor shafts or damaged bearings will cause rubbing and scoring between the crowns of the rotor lobes and the mating rotor roots, between rotors and end plates, or between rotors and the blower housing. Generally a combination of these conditions exists.

Excessive backlash in the blower timing gears usually results in rotor lobes rubbing throughout their length.

To correct any of the above conditions, the blower must be removed from the engine and either repaired or replaced.

The blower inlet screen should be inspected periodically for dirt accumulation which, after

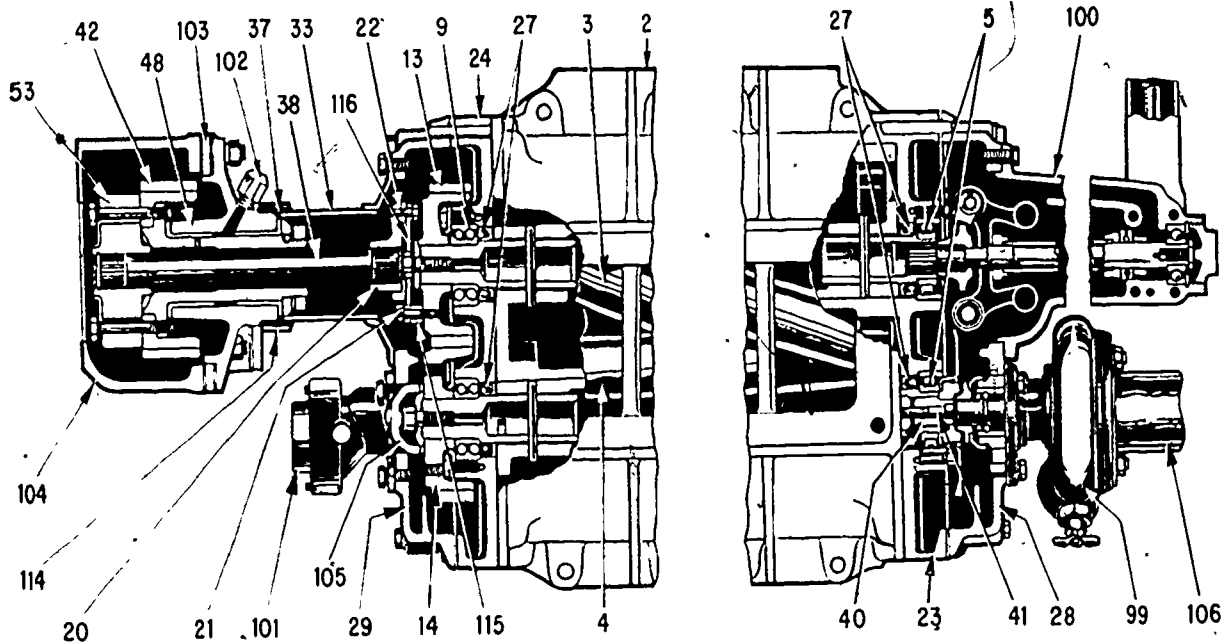

- 2. Housing
- 3. Rotor, Blower, Upper
- 4. Rotor, Blower, Lower
- 5. Bearing, Front
- 9. Bearing, Rear
- 13. Gear, Rotor, Upper
- 14. Gear, Lower, Rotor
- 20. Hub, Rotor Drive
- 21. Bolt
- 22. Bolt
- 23. End Plate, Front
- 24. End Plate, Rear
- 27. Seal, Oil, Rear
- 28. Cover, End Plate, Front
- 104. Housing, Flywheel
- 106. Cover, Water Pump Inlet
- 115. Plate, Blower Rotor Drive Hub

- 29. Cover End Plate Rear
- 33. Cover, Blower Drive Shaft
- 37. Seal, Drive Shaft Cover
- 38. Shaft, Blower Drive
- 40. Shaft Coupling
- 41. Bolt
- 42. Gear Blower Drive
- 48. Support
- 53. Coupling Assembly
- 99. Pump Fresh Water
- 100. Housing, Governor Weight
- 101. Pump, Fuel
- 102. Elbow
- 103. End Plate
- 105. Fork
- 114. Clamp, Drive Cover Seal
- 116. Spacer, Plate to Gear

2.505.

Figure 7-31.—Blower and drive assembly and accessories.

prolonged operation, may affect the airflow. Wash the screen thoroughly in clean fuel oil and clean it with a stiff brush until no dirt remains.

The air box drains should always be open. Check them regularly and make sure the passages are clean. If liquid collects on the air box floor, a drain tube may be plugged. Remove the cylinder block handhold covers. Wipe the

dirt out with rags or blow it out with filtered compressed air. Then remove the drain tubes and connectors from the cylinder block and clean them thoroughly.

#### Blower Removal and Disassembly

Having inspected the blower and determined the extent of recondition necessary, remove and



disassemble the blower. Do what the instructions say in the manufacturer's maintenance and service manuals.

After the assembly has been removed, be careful when disassembling not to damage any parts. Be sure you use the proper tools and follow recommended disassembly procedures, particularly when the blower drive, driven gears, and timing gears from the rotor shafts are removed. Pull them from the rotor shaft at the same time, or you will damage the rotors.

### Cleaning and Inspecting

After the blower has been disassembled, all parts should be washed in cleaning solvent or clean fuel oil, blown dry with filtered compressed air, and inspected before reassembly.

Wash the bearings by rotating them by hand in either cleaning solvent or fuel oil until they are free from grease and foreign matter. Clean the balls (or rollers) and races by directing air through the bearing, at the same time, rotating by hand. Do not spin the bearing with air pressure.

After cleaning thoroughly, again rotate the bearing by hand and inspect it for rough spots. The bearings should run free and show no indications of roughness. The double-row bearings are preloaded and have no end play. A new double-row bearing will seem to have considerable resistance to motion when revolved by hand.

Check oil seals in the end plates and, if necessary, replace. When the blower is being reconditioned, the installation of new seals is recommended.

Inspect blower rotor lobes for smoothness. Inspect rotor shaft serrations and bearing surfaces for wear or burrs.

Check the finished faces of the end plates to see that they are smooth and flat.

Check the finished ends of the blower housing, which receive the end plates, to see that

they are flat and free from burrs. The end plates must set flat against the blower housing.

Check blower timing gears for wear or damage. If either timing gear is worn or damaged sufficiently to require replacement, both gears must be replaced as a set.

Inspect the inside of the housing to see that the surfaces are smooth. The blower drive shaft should be straight and true. Shaft serrations should be clean and straight.

Replace all worn or excessively damaged blower parts.

### Blower Reassembly

With all blower parts cleaned and inspected, reassemble the blower as prescribed in the manufacturer's maintenance and service manuals.

### SUPERCHARGERS

A diesel engine may be equipped with a supercharger (See fig. 7-32.) which is a gear-driven air pump that employs rotors to force air into the engine cylinders when a requirement for

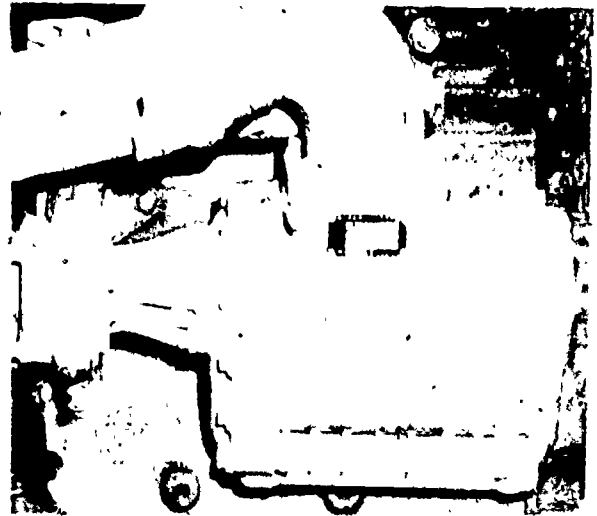

Figure 7-32.—Supercharger.

81.366

more power exist. The supercharger must be maintained periodically.

Remove the supercharger's outlet connection and visually check the ends of the rotors and case for evidence of oil leaking from the supercharger seals. Rotors will always show some oil from the vapor tube which is connected to a rocker housing cover. However, only the appearance of "wet" oil at the ends of the rotors would be cause for changing the supercharger's seals. Be sure to check the lubricating oil lines and connections for any leaks and correct if needed.

### Removal

When the supercharger has to be removed from the engine, follow the procedures given in the manufacturer's service manual.

### Disassembly

If you have to disassemble the supercharger, be careful when you remove the intake and discharge connections. Be sure to cover both openings. To prevent damage to its finished surfaces, usually made from aluminum, wash the outside of the supercharger with mineral spirits.

Use the service tool kit furnished and follow recommended disassembly procedures in the manufacturer's maintenance and service manuals.

### Cleaning and Inspection

As the supercharger parts are disassembled, clean and dry them thoroughly with filtered compressed air. Be sure to discard all used gaskets, oil seals, recessed washers, roller bearings, and ball bearings and replace with new ones.

Inspect the rotors, housing, and end plates for cracks, abrasions, wear spots, and buildup of foreign material. Smooth all worn spots found with a fine emery cloth. Discard cracked, broken, or damaged parts. Remember, rotors and shafts are not separable and must be replaced as a matched set or unit.

Inspect the drive coupling for worn pins, distorted or displaced rubber bushings, and damaged or worn internal splines. Examine the hub surface under the oil seal and replace the coupling if its surface is grooved or worn.

Check the gear fit on the rotor shafts, and the gear teeth for evidence of chatter and wear. Replace the rotors and gears if not within the required tolerances.

Inspect all dowels, oil plungers, piston ring seals, and gasket surfaces. Replace as necessary.

### Reassembly

After you have inspected, cleaned, and replaced worn or damaged parts, put the supercharger back together as prescribed in the manufacturer's maintenance and service manuals.

Upon complete reassembly, and after the supercharger is installed on the engine, add the proper quantity of, recommended engine lubricating oil to the gear end plate through the pipe plughole.

## TURBOCHARGERS

The turbocharger (See fig. 7-33.) is a unit driven by exhaust gas to force (charge) air into the diesel engine cylinders for more complete burning of fuel and to increase engine power. As with any air induction component, the turbocharger is subject to environmental situations which could result in a turbocharger failure.

The real problem lies not in fixing the failure, but in determining the cause. Replacing a failed turbocharger without first determining the cause will, more often than not, result in a repeat failure.

The things which can cause a turbocharger to fail are many and varied, but they can be grouped into the following categories:

1. Lack of lubricating oil.
2. Foreign material or dirt in the lubricating system.
3. Foreign material in either the exhaust or air induction system.
4. Material or workmanship.

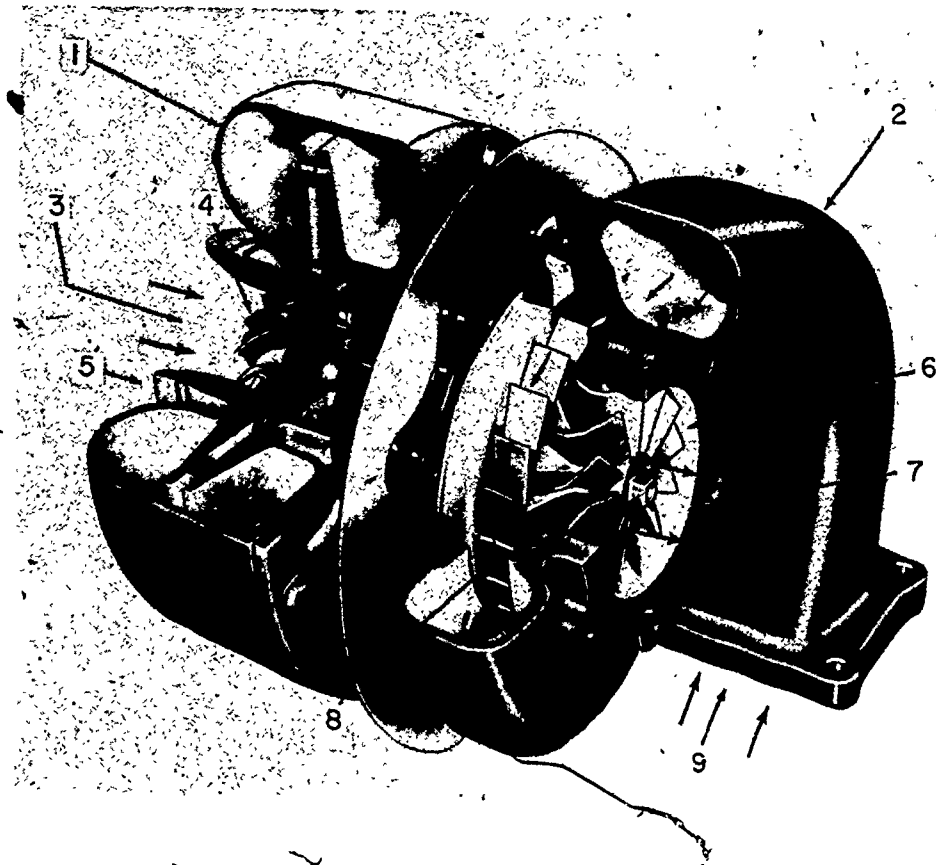

Figure 7-33.—Turbocharger (cutaway view).

81.367

A failure can occur if the lubricating oil being supplied to the turbocharger is not sufficient to (1) lubricate the thrust and journal bearings, (2) stabilize the journal bearings and shaft, and (3) cool the bearing and journal surfaces, even for periods as short as five seconds.

Operating the engine with contaminated oil, under the assumption that the oil filter will remove the contaminants before they reach the bearings of the turbocharger, can be quite costly. Actually, there are certain conditions under which the oil filter is bypassed and, if the oil is contaminated, turbocharger damage can

result. Some examples of instances where the filter will be bypassed are:

1. The turbocharger lubrication valve is open as it is in starting.
2. The oil filter is clogged and the bypass valve is open.
3. A lubrication valve or filter bypass valve malfunctions as a result of worn or binding components.

If enough contaminated oil enters the turbocharger bearings, the bearings will wear out; or, large particles may plug the internal oil passages and starve the turbocharger of oil.

Because of extremely high-top speeds of the turbine and compressor wheels (up to 100 miles per hour), any large particles which enter through the inlet or exhaust systems can mechanically damage the rotating parts of the turbocharger. This is why proper maintenance of the air cleaner is extremely important, and also why thorough cleaning of the inlet and exhaust systems is essential if there has been a previous turbocharger failure, valve failure, or other failure which could leave foreign particles in the engine.

Material or workmanship failure is self-explanatory, that is, either some component of the turbocharger was faulty or its parts were not assembled right.

### Removal

The removal of the turbocharger from the engine is not a complicated task when the procedures set forth by the manufacturer are followed.

### Disassembly and Cleaning

After removal of the turbocharger from the engine, make sure the exterior of the turbocharger is cleaned of all loose dirt before disassembly to prevent unnecessary scoring of the rotor shaft. Disassemble it in accordance with the manufacturer's maintenance and repair manuals.

The turbocharger parts accumulate hard, glazed carbon deposits difficult to remove with ordinary solvents, especially the turbine wheel and shaft, diffuser plate, and the nozzle ring and inner heat shield. The cleaner must remove these stubborn deposits without attacking the metal. All parts should be cleaned as follows:

1. Place all parts in a divided wire basket so parts will not be damaged through contact with each other. Do not pile in the basket. Avoid mutilating precision ground surfaces.

2. Immerse the parts in mineral spirits or similar solvent.

**CAUTION:** Never use a caustic solution or any type solvent that may attack aluminum or nonferrous alloys.

3. Allow the parts to soak as needed to remove the carbon. A soft bristle brush may be used, if necessary, to remove heavy deposits. Never use wire or other type brushes with stiff bristles.

4. With the oil orifice plug removed, flush out the oil passages in the main casing from the bearing end to remove dirt loosened by the soaking.

5. Remove the parts from the tank. Drain and steam clean thoroughly to remove all carbon and grease. Apply steam liberally to the oil passages in the main casing.

6. Blow off excess water and dry all parts with filtered compressed air.

7. Place parts carefully in a clean basket to avoid damage prior to inspection and reassembly.

### Parts Inspection

Inspect all turbocharger parts carefully before re-using. All parts within manufacturer's recommended specifications can be used safely for another service period. Damage to the floating bearing may require replacement of the turbocharger main casing with a new part or an exchange main casing.

Inspect the turbine casing. If you find cracks which are too wide for welding, replace the casing.

If the exhaust casing is warped or heavily damaged on the inside surface, due to contact with the turbine wheel or a foreign object, or cracked in any way, the casing is unfit for reuse.

Oil seal plates usually do not wear excessively during service and can be reused if they have not been scored by a seizure of the piston ring.

As you inspect the diffuser plates, look for contact scoring by the rotor assembly on the back of the diffuser plate or broken vanes which will make the plate unacceptable for reuse.

Inspect the inner heat shield. If distorted, replace it, too.

Dents found on the outer heat shield can usually be removed, allowing for its reuse. However, if this shield is cut or split in the bolt circle area, it must be replaced.

Inspect the nozzle rings closely for cracks. If cracked, or if the vanes are bent, damaged, or burnt thin, do not reuse.

If you see signs of wear or distortion during the inspection of the piston ring seals, discard and replace with new ring seals.

Inspect the turbocharger main casing for cracks in the oil passages, capscrew bosses, etc. Also, check the casing for bearing bore wear. If it exceeds the limits allowed by the manufacturer, the bearing bore may be reworked to permit oversize, outer diameter bearings.

Check the oil orifice plug for stripped or distorted threads. Install a new plug if necessary.

The rotor assembly, which consists of a turbine wheel and shaft, sleeve, compressor wheel, thrust washer, and locknut, is an accurately balanced assembly; therefore, if any one of the above parts is replaced as a result of your inspection, the assembly must be rebalanced in accordance with the manufacturer's specifications.

When inspecting the semifloating bearing, be sure to measure both outside and inside diameters of the bearing. If either diameter is worn beyond limits allowed by the manufacturer, the bearing must be replaced.

The front covers that are deeply scored from contact with the compressor wheel cannot be reused. Slight scratches or nicks only can be smoothed out with a fine emery cloth and the covers reused. Cracked covers, however, cannot be reused and must be replaced with new ones.

All capscrews, lockwashers, and plain washers should be cleaned and reused unless they are damaged beyond reuse.

### Reassembly

After inspection of the turbocharger component parts and replacement of parts found damaged or worn, the turbocharger can be reassembled in the manner prescribed by the manufacturer's maintenance and repair manuals.

Be sure to close off all openings in the turbocharger immediately after reassembly to keep out abrasive material prior to mounting on the engine.

### Installation

Turbochargers can be mounted on the engine in many different positions. Always locate the oil outlet at least 45° below the turbocharger horizontal centerline when the unit is in the operating position.

## CHAPTER 8

# VEHICLE INSPECTIONS

Preventive maintenance and safety inspection of a vehicle go hand-in-hand. Besides keeping a vehicle in good operating condition, preventive maintenance should help insure that a vehicle is safe to operate. Proper inspection of the devices or parts of a vehicle that make for safe operation can be carried out at the same time as regularly scheduled preventive maintenance service.

As a CM1 or CMC, you may be assigned the job of vehicle inspector. Besides making scheduled safety inspections, you should look for dangerous operating practices and for inoperative devices that make a vehicle unsafe. You will need to know the regulations pertaining to safety inspection of automotive equipment and the procedures which pertain to this area of responsibility which can be found in the *Naval Construction Force Safety Manual*, (COMC-BPAC/COMCBLANT Instruction 5100.1 series) and the *Department of the Navy Safety Precautions for Shore Activities Manual*, NAVMAT P-5100. Insure that mechanics under your supervision who perform vehicle inspections are fully aware of all facets of making a thorough inspection.

Like preventive maintenance inspections, safety inspections are very important. As you may know, the condition of an engine is seldom considered in the safety inspection. This inspection concerns items such as lights, brakes, tires, and steering mechanisms. Make sure your mechanics repair or report faults that effect the safety of a vehicle.

As an inspector, it will normally be your responsibility to insure that NO vehicle is released from the shop until it is definitely determined that the vehicle is completely safe to operate. Remind your people of the danger to

life and property from driving or riding in a hazardous vehicle.

Some of the major items to be checked during a vehicle inspection and the procedures for making these inspection checks are covered in following sections. To a limited extent, procedures for troubleshooting some of the discrepancies found during a vehicle inspection will be discussed.

### THE INSPECTOR

The mechanic assigned as inspector needs to be experienced in all aspects of the rating. You may be assigned as either a Public Works or Battalion Inspector. In addition to the safety manuals previously listed, you will have to be familiar with the manuals and instructions pertaining to your assignment. Procedures for conducting safety and preventive maintenance inspections apply to either assignment. Frequency of inspections varies with command assignments.

### PW SHOP INSPECTOR

The main publications that the inspector uses for inspections are the *Management of Transportation Equipment*, NAVFAC P-300 and the manufacturer's service manuals for the unit being inspected. As inspector, you will complete the work description section of the Shop Repair Order discussed in chapter 3. The types of inspections required will be safety, preventive maintenance, interim, and storage/shipment inspections.

## BATTALION SHOP INSPECTOR

As an inspector in the battalion vehicle maintenance shop, you will have to be totally familiar with the *Naval Construction Force Equipment Management Manual*, NAVFAC P-404, and the COMCBPAC/COMCBLANT TI200.1 Instruction series. You will complete the work description section of the Equipment Repair Order discussed in chapter 4. In addition to the types of inspections above, you will conduct preservation, embarkation, BEEP, and deadline inspections.

### INSPECTION OF LIGHTING EQUIPMENT

Many kinds of lights are on modern vehicles, each useful. Each light is subjected to periodic inspection. Besides headlights and taillights, there are parking lights, stoplights, and a number of auxiliary lights, such as instrument panel lights and spotlights. Directional signal lights, a requirement for trucks, are also required for passenger cars in most localities. Clearance and identification lights are required for large trucks, buses, and all kinds of trailers. (See fig. 8-1.) Some regulations require that reflectors be mounted on the vehicle as a dual safety precaution if the lights fail. When making a safety inspection, follow the general rules: if a light is on a vehicle, the light must work and be safe.

### ICC REGULATIONS

Lighting requirements prescribed by the Interstate Commerce Commission (ICC) change frequently. This enables ICC to put the latest developments of lighting and emergency equipment into regulations with a minimum of delay. The list below is intended to show the general type of regulations that the ICC prescribes.

#### ICC Equipment Regulations:

**HEADLAMPS**—Two minimum.

**REAR LAMPS**—Every bus or truck, every tractor, and every semitrailer or full trailer in excess of 3,000 pounds gross weight. on the rear, one red taillamp, one red or amber stoplight.

Every semitrailer or full trailer weighing 3,000 pounds gross or less: on the rear, one red taillamp, one red or amber stoplight if the semitrailer or full trailer obscures the stoplight on the towing vehicle.

Every pole trailer: on the rear, one red taillamp.

**CLEARANCE LAMPS**—On every bus or truck 80 inches or more in width and on every semitrailer or full trailer in excess of 3,000 pounds gross weight: on the front, two amber clearance lamps—one at each side; on the rear, two red clearance lamps—one at each side.

On every tractor: on the front, two amber clearance lamps—one at each side.

**SIDE MARKER LAMPS**—Every bus or truck 80 inches in width and every semitrailer or full trailer having a gross weight in excess of 3,000 pounds: on each side, one amber side marker lamp located at or near the front, one red side marker lamp located at or near the rear.

On every pole trailer: on each side, one combination marker lamp showing amber to front and red to side and rear.

(Side marker lamps may be combined with clearance lamps.)

**REFLECTORS (REAR)**—On the rear of every bus or truck, semitrailer or full trailer, two red reflectors, one at each side.

On the rear of every pole trailer, two red reflectors, one at each side, placed to indicate extreme width of the pole trailer or its load, whichever is wider.

One or both of the required red reflectors may be within the taillamp or taillamps, provided that taillamps be within the height limits specified for reflectors.

**REFLECTORS (SIDE)**—On every truck or bus 80 inches or more in width and on a semitrailer or full trailer having a gross weight in excess of 3,000 pounds: one amber reflector on each side, located at or near the front; one red reflector on each side, located at or near the rear.

Chapter 8—VEHICLE INSPECTIONS

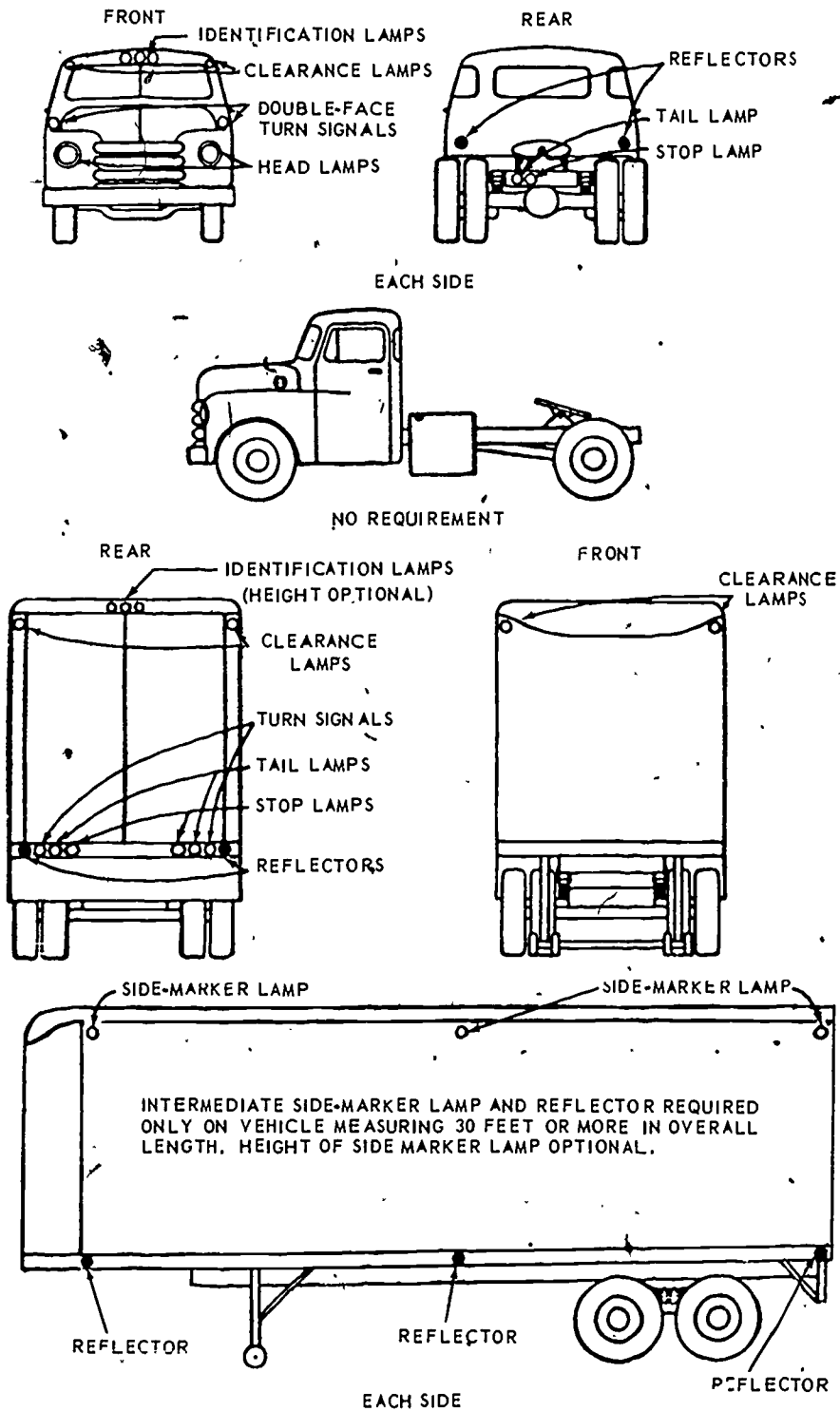

Figure 8-1.—Truck-tractor and semitrailer showing approved lighting equipment.

2.420



On every pole trailer: on each side, one red reflector.

**FLARES**—Three on every bus, truck or tractor. (The use of reflector flares in lieu of electric lanterns or flares (pot torches) permitted on all vehicles.)

**HEADLIGHTS**

Headlights are tested for intensity, focus, and aim. With the sealed-beam-lights used on present vehicles, the focus is preset when manufactured. Your main concern will be the aiming and the intensity of the headlights. Traffic laws require that headlights reveal persons and objects for a distance of at least 350 feet ahead. The minimum output established by most states is 5,000 beam candlepower for the upper beam, and 3,500 beam candlepower for the lower beam, on each headlight; for vehicles having two pairs of headlights, these requirements apply to each pair.

Your shop may have an output meter that measures the headlight intensity that can be used with a screen for aiming the lights. Or a headlight tester may be available that can be used for aiming the headlight, as well as for measuring the intensity of the light. The headlight tester is preferable, because it checks the headlight without a cumbersome screen.

Headlight testing equipment in the shop should be located so that the equipment can be moved in and out conveniently. A small board and cabinet for tools and equipment used for testing and adjusting headlights should be near the headlight testing area.

**Using a Screen for Aiming Headlights**

Although an output meter may not be available for measuring headlight intensity, you should nevertheless insure that the headlights of vehicles under your supervision are aimed correctly; a headlight that is not aimed properly may blind drivers of oncoming vehicles. A screen can be made that will enable personnel to test headlight aim.

The screen for aiming headlights (fig. 8-2) should be no less than 10 feet wide and 42 inches high. When it is mounted on a frame or easel with casters, the screen should be no more than 12 inches from the floor surface.

When making a screen, put only the headlight center level and vehicle axis lines on it. These lines can accommodate all types of vehicles. By moving the screen up and down, you can make the headlamp level conform with the measured height of any headlamp. Moving the vehicle or the screen left or right will align either with the vehicle axle line. After these basic steps, vertical lines conforming to the distance

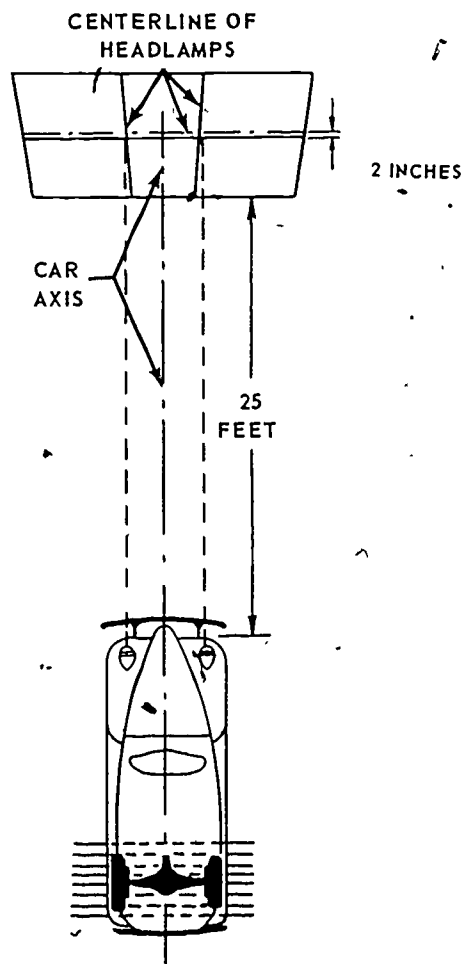

Figure 8-2.—Screen for checking aim of headlights.

2.125

between the centers of the headlamps can be added by line or tape. The vertical lines should intercept the headlamp level line at a point measured from the vehicle axis line exactly one-half the distance between the lamp centers.

To comply with regulations of most localities, the screen should be placed 25 feet ahead of the headlight. Make sure all tires on the vehicle are properly inflated. The vehicle should have a full tank of fuel (to compensate for weight) and only the operator should be in the vehicle.

Before beginning the tests or adjustments, check the regulations for your location. Most vehicle inspection regulations contain, in addition to instructions for making the tests, illustrations of proper light patterns and suggestions for inspecting parts of the headlight assembly. Points of adjustment for aiming headlights may

differ for makes of vehicles. Check the manufacturer's manual for the make and model of vehicle being inspected.

When aiming the headlights of a vehicle using the 7-inch sealed-beam light unit, remember that the pattern of the upper or driving beam will be aimed. The 7-inch lamp is designed so that when the upper beam is aimed correctly the lower or passing beam will also be aimed correctly. Cover the lamp not being aimed so that one beam will not interfere with the other.

The accepted driving beam pattern for passenger vehicles will show the high-intensity portion (hotspot) of the light rays centered on a horizontal line 2 inches below the center or horizontal reference line on the screen. (See fig. 8-3.) This means that there will be a 2-inch drop of the light beam in every 25 feet of longitudinal beam.

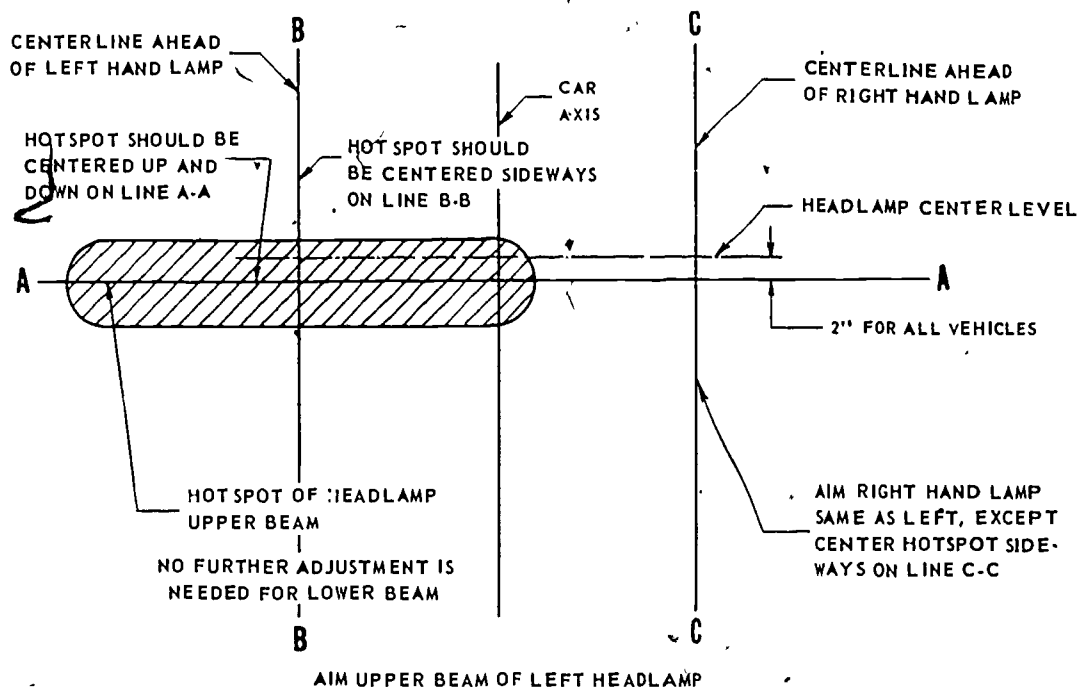

Figure 8-3.—Accepted beam pattern for aiming passenger vehicle headlights.

Headlights on trucks present a problem because of the effect of a heavy load. At the same distance of 25 feet, truck headlights should be aimed so that none of the high-intensity portion of the light will project higher than a level of 5 inches below the center of the lamp to compensate for the variations in loading. Bus headlights are similar, except that the effect of a load is usually not quite so great.

Some large equipment will have the lamp centers higher than the testing screen. In this case, place the screen 75 feet ahead of the lights and adjust the horizontal line on the screen to 42 inches; the top of the hotspot of the beam of light should not be above the horizontal line on the screen.

When a four-headlight system is used, the number two lamp will always be mounted on the outboard side of the vehicle.

When using a screen for aiming the headlights on a vehicle that uses the four-headlight system, adjust the hotspots of the number one (inboard) lamps so that they are centered on the vertical lines 2 inches below the horizontal line. (See fig. 8-4.) The low beams of the number two (outboard) lamps are aimed so that the left edge of the hotspot does not extend to the left of straight ahead or does not extend more than 6 inches to the right of straight ahead. The top of the hotspot of the number two lamp is aimed at the horizontal line, as shown in figure 8-4. When the low beams of the number two lamps are properly adjusted, the high beam will be correct.

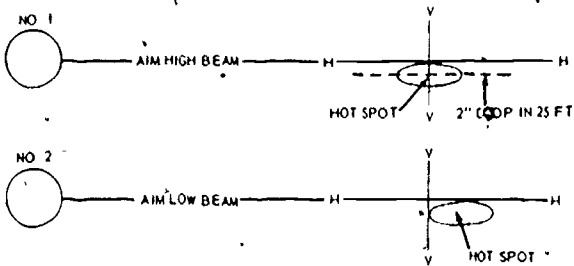

2.127

Figure 8-4.—Accepted beam pattern for 4-headlight system.

### Using a Headlight Tester for Checking Headlights

When using a headlight testing device for checking beam patterns, measuring beam candlepower, and adjusting headlamps, follow the instructions furnished by the manufacturer. Headlight testers differ considerably in design and the operation; therefore, correct instructions for using one tester will not be correct for another. Make sure that all vehicle inspectors know how to use the headlight tester assigned to your shop.

The headlight tester may be permanently mounted on a track or it may be portable. The floor where the tester is used should be reasonably level, and if there is a slope to the floor, the tester must be adjusted to this slope. Since the track-type tester will always be used in the same location, it can be adjusted to the slope of the floor when installed. On the portable-type tester, the testing unit must be set to the slope of the floor for each location where it is used.

Figure 8-5 shows a beam pattern being checked on a Bear headlight tester screen.

Figure 8-6 illustrates the same machine being used to obtain a candlepower reading of the headlamp beam. Notice the image of the

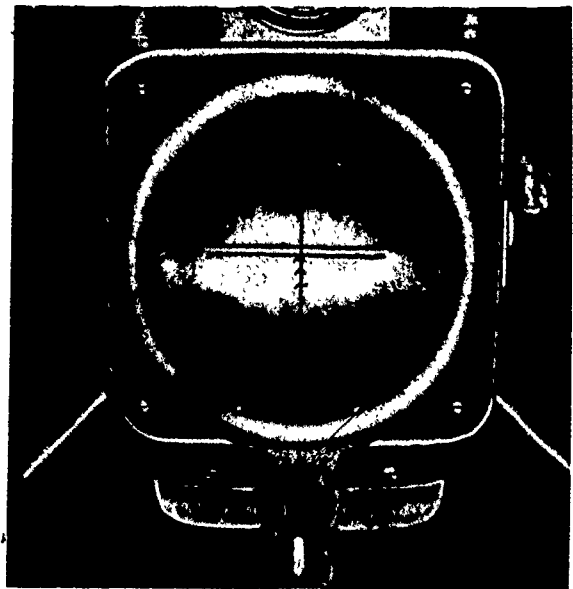

2.128

Figure 8-5.—Checking beam pattern with Bear headlight tester.

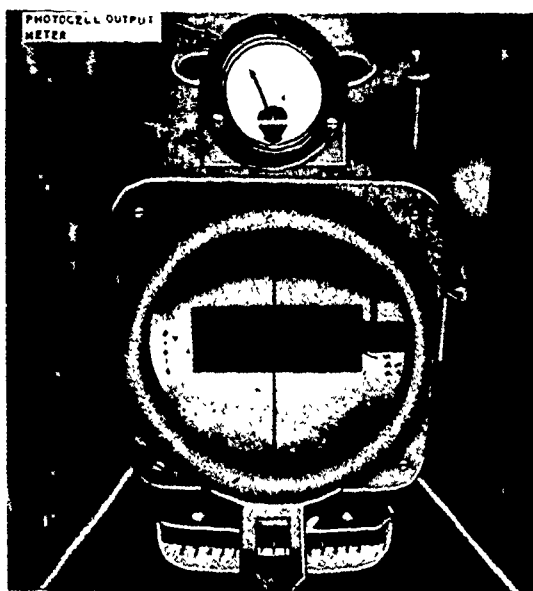

2.129

Figure 8-6.—Measuring beam candlepower with a Bear tester.

photoelectric cell on the screen and the reading on the output meter. To check candlepower in this manner, the operator simply turns the small handle mounted on top of the testing unit to the left until the photocell touches the glass holding the screen. Then raise and lower the photocell with the same handle until the highest reading is obtained on the output meter. Be sure the hotspot of the light beam is centered on the vertical line before reading candlepower.

If the beams are aimed properly but do not meet the required candlepower, check the wires and connections in the circuit. Poor light from sealed beams often results from a loose connection, a bad ground, or undersized wire. Any one of these faults increases the resistance of the circuit. If you cannot find a fault in the wiring or connections, replace the sealed-beam unit.

### TAILLIGHTS AND STOP LAMPS

All TAILLIGHTS must be approved and meet local regulations. Taillights must show red, visible at least 500 feet to the rear of the vehicle. All bulb and lens replacements for them must be of the same type as originally approved. If the vehicle was originally equipped with two rear lamps, both must be working well. If the taillight

lens is not red or contains a dot of another color, or if it is cracked, broken, or does not fit tightly, it should be replaced. The taillight should be mounted near the extreme rear of the vehicle. Dump trucks or other especially constructed vehicles may have taillamps. If mounted elsewhere, the lamp is clearly visible from the rear. Further, a red reflector should be mounted on the extreme rear of the vehicle. The taillights must not be hidden by a bolster or other part of the body or frame. They must be mounted securely to prevent vibration and to make a good electrical contact. The taillights of a vehicle must burn when the headlights are turned on to any position.

A STOP LAMP is usually combined with the taillight by using a double-contact, double-filament bulb. It may, however, be a separate light. Stop lamps must be adjusted to light up immediately when the brake pedal is depressed; that is, at the beginning of the downward action of the brake pedal. Just as with other lights, bulb and lens replacements for stop lamps must be the same as those originally approved.

### LICENSE PLATE LIGHTS

LICENSE PLATE LIGHTS must be bright enough to illuminate the entire license plate so the numbers can be read 50 feet to the rear. Most states now require that a separate white light be used to illuminate the license plate; license plates on some older vehicles may still be illuminated through a window in the taillight. License plate lights must be wired so they will turn on and off with the same switch as the taillights.

### DIRECTIONAL SIGNALS

Any vehicle or combination of vehicles requires directional signal devices when: (a) the distance from the center of the steering column to the left lateral extension of the body, or load thereon, exceeds 24 inches; or (b) the distance from the top center of the steering column to the extreme rear end of the vehicle or combination of vehicles or their loads exceeds 14 feet.

Most localities do not require directional signals on vehicles of less dimensions than described in the preceding paragraph. However, if a vehicle is equipped with directional signals, they must be approved and in good repair.

On truck tractors, a double-faced directional signal unit should be mounted on the top crown of each front fender, or if more practical, on each side of the cab or body. In either case, the lights must be visible from a distance of 100 feet in front of, and to the rear of, the vehicle.

Single-faced signal units of the dual-direction indicating type may be mounted on the rear of vehicles less than 80 inches wide, if the double-faced signals on the front of the vehicle are not clearly visible from behind the vehicle at all angles of approach.

Single-signal units are required at the extreme and opposite corners of the rear of all vehicles or combination of vehicles over 80 inches wide. To be visible at 100 feet, they should be mounted at a height of not more than 72 inches, nor less than 24 inches from the level of the ground.

On squared-front vehicles, such as buses or cab-over-engine trucks without fenders, or vehicles constructed to a width of 96 inches and over, the double-faced directionals required on the front fenders of the vehicles may be omitted and two single-faced signals mounted instead. These signals must, however, be mounted securely elsewhere on the front of the vehicle and be clearly visible 100 feet to the front of the vehicle.

### CLEARANCE LAMPS

Besides the conventional headlamps and taillamps, large trucks, buses, semitrailers, and full trailers require clearance lamps, side-marker lamps, and reflectors.

CLEARANCE LAMPS indicate the extreme width of the vehicle—not necessarily its height as the word “clearance” implies. It is the protruding unlighted front and rear corners of the vehicle subject to collision with other vehicles or persons, not the top of the vehicle. Therefore, clearance lamps should be mounted at a height best suited to this purpose, and where they can be readily seen at least 500 feet. The clearance lights on the front of the vehicle should be amber, and those facing the rear should be red.

As for clearance lamps to indicate the height of the vehicle, some state regulations require that large vehicles have “identification lights” which more or less answer this purpose. For example, Pennsylvania requires that every vehicle, trailer, semitrailer, or combination thereof in excess of 80 inches wide and over 30 feet long shall be equipped with three amber lights in front and three red lights to the rear. These lights, in addition to clearance lights, shall be spaced not less than 6 inches nor more than 12 inches apart, and placed along a horizontal line at or near the top of the vehicle.

SIDE MARKER LAMPS are similar to clearance lamps but indicate the full overall length of the vehicle. They are viewed from the side and must be visible for 500 feet. Side marker lamps mounted near the front of the vehicle, like clearance lights, must be amber and those near the rear must be red.

Some local regulations require REFLECTORS (apart from those used in the lamps) to be mounted on the rear of a vehicle. This is an additional safety precaution in case lights burn out or get broken. When mounting reflectors, make sure they are between 42 inches and 24 inches above the ground.

### AUXILIARY LIGHTS

Lights that can be turned on or off for the convenience or safety of the driver or passengers are called auxiliary lights. These lights must be wired to be turned on or off independently, and not with the headlights. Any auxiliary light mounted on a vehicle must work for the vehicle to pass a light inspection.

SPOTLIGHTS are not approved in all areas as permanent vehicle lighting equipment. Laws in some states permit the use of only one. If a spotlight is installed on a vehicle, it must meet inspection. Spotlights should never be used as a supplementary light for headlamps.

BACKUP LIGHTS are approved as accessories for many vehicles. They may be mounted singly or as a pair, one on each side. Backup light lenses must be colorless and, when

replaced, of the type originally approved. In addition, backup lights must turn off automatically when the vehicle is in a forward motion, or else be provided with a visible or audible signal to let the operator know that they are on. A backup light must be aimed to strike the road not over 25 feet from the rear of the vehicle.

**PARKING LAMPS** must have amber or white lenses showing to the front of the vehicle, and must turn on and off with the same switch as the taillights.

A vehicle may not have any light showing red to the front, except school buses, fire and police vehicles, ambulances, and wreckers, unless specifically authorized by local regulations or commands.

### INSPECTION OF BRAKE SYSTEMS

Brakes are inspected often to insure safe operation, to comply with state and local regulations, and to keep personnel and equipment safe. Defective brakes cause many accidents that might have been avoided with frequent and thorough brake inspections. These brake inspections will be more frequent when vehicles are used in sand, mud, or constant fording.

Regulations for testing and inspecting brakes are about the same all over. One requirement is that the brakes must stop the vehicle within a prescribed distance, at a given speed, with a minimum of effort, and without deviating the vehicle from a straight line.

The stopping distances for all vehicles depend on the distance the driver can see and think before he or she hits the brake pedal. Figure 8-7 illustrates some stopping distances from different speeds with good brakes. These stopping distances came from actual tests.

Brakes can be tested by machines or on the road. If a machine is used for testing brakes, a road check should also be made before inspection is finally approved.

Machine testers are suitable in permanent shops. Since these machines are somewhat

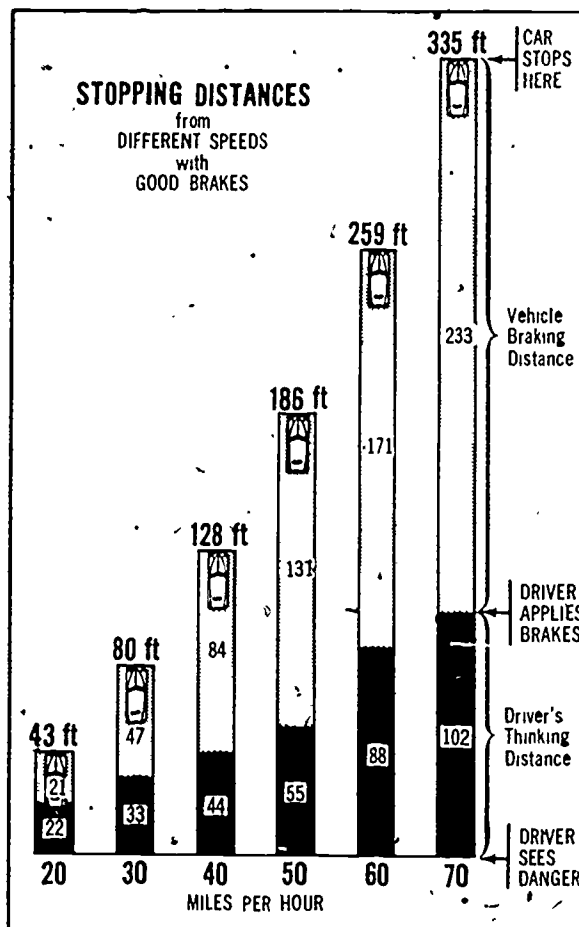

2.131  
Figure 8-7.—Stopping distances from different speeds with good brakes.

complicated and require considerable time for setting up, few of them are at advanced bases. Once the machines are set up, they indicate brake efficiency more accurately than road tests do.

As illustrated in figure 8-8, machine testers indicate through tube or dial gages whether the brakes are satisfactory in pounds of braking action at each wheel, and whether brakes need equalizing. Fifty pounds difference in friction-braking effort at each wheel is the maximum allowable variation. The amount of braking friction desirable at each wheel depends on the size of the brakes and the vehicle being tested.

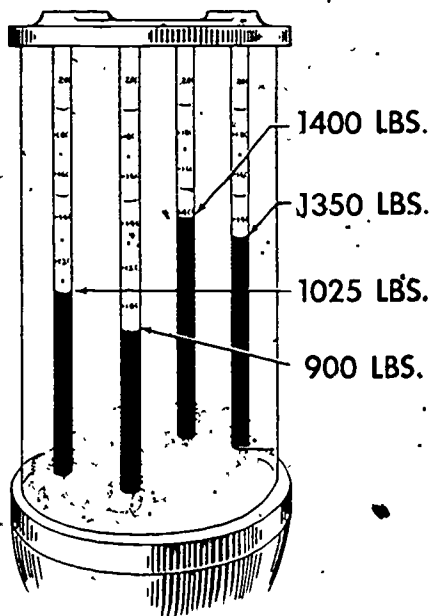

2.133

Figure 8-8.—Columns of liquid indicate 4-wheel brake friction.

Instructions for testing are provided with each machine and should be studied by the person making the brake inspections.

All road tests should be made on a dry, hard, and level surface and be free of loose material.

Road tests for brakes may be made in several ways. The method commonly used in the SEABEES is to put a line or mark on the roadway at the point the brakes are to be applied. After the vehicle is stopped, usually from a speed of 20 miles per hour, the stopping distance is measured. Be sure the measurement is made from the mark to the FRONT of the vehicle, not the REAR. Inspect the tire marks on the roadway to see if one wheel is braking more than the others. If the brakes do not stop the vehicle within the prescribed distance, are not equalized, grab, or do not hold at all, adjust or repair them and repeat the test.

All brake systems should be inspected visually from the brake pedal to the brake assembly at the wheel. Make sure that all loose, broken,

or missing parts are repaired or replaced. It is important that the movable parts of the system, which have grease fittings, be lubricated—but not overlubricated.

## HYDRAULIC

Hydraulic brakes should be inspected for the external condition of the hose and tubings; especially for leakage or seepage at the couplings. Hose or tubing worn or weakened by rubbing against other parts of the vehicle must be replaced.

**CAUTION:** Never replace steel brake tubing with copper tubing.

Test for leakage by holding the brake pedal depressed for at least 1 minute. If the pedal does not hold, there is a leak in the system. If you find a leak, repair it, even if you have to pull all wheels to examine the wheel cylinders. Then fill the master cylinder with fluid and bleed the brakes.

Naval Construction Force vehicles are to use silicone brake fluid (SBF), as detailed in CESO maintenance Bulletin #75. Silicone brake fluid will not mix with glycol brake fluid. If lightly combined accidentally, no adverse effects to rubber parts, metals or fluid properties should occur. Advantages of silicone brake fluid are that it is not damaging to painted surfaces, has excellent dielectric properties, has no deterioration from long periods of climatic exposure or system storage, and will not absorb or retain moisture.

To comply with requirements for testing and inspecting brakes, you must see that at least one of the wheels is removed to check the brake lining and drum. Some manufacturers recommend pulling two wheels—one on each side. Look for loose or broken brakeshoe retracting springs, worn clevis and cotter pins in the brake operating mechanisms, and grease or oil leaks at the wheel-bearing grease retainer. Check for leaks of hydraulic fluid at the hydraulic brakeshoe operating cylinder.

Brake linings that pass inspection for wear must be securely fastened to the brakeshoes and

free from grease and oil. Small grease or oil spots can be removed from the lining with an nonoil-base solvent. If the lining is saturated with grease or oil, it should be replaced. Be sure the cause for the grease or oil on the lining is remedied.

Badly worn or scored brakedrums should be turned smooth and true on a lathe or replaced. Cracked brakedrums should be replaced, for they may break at any time.

Brakeshoe and drum trouble not immediately evident when the wheels are pulled, yet which is detected during road tests, may be caused by the wrong kind of lining, ill-fitting brakeshoes, or brakedrums slightly out-of-round. The clue to these troubles may be chattering, spongy, or grabbing brakes.

Navy vehicles seldom have the wrong kind of brake lining. However, a careless mechanic may reverse the primary and secondary shoes on one of the wheels or interchange them between wheels so that the shoes are not exactly mated with the drums against which they expand. If you replace shoes or turn the drum on one side, do the same to the opposite side to prevent pull or loss of control.

If you pull one wheel, inspect the brake lining. If it is all right, chances are the other linings are also satisfactory. So, you do not need to pull the other wheels. If you find fault in the linings of the wheel you just pulled, then pull and inspect all the wheels.

The procedures for inspecting and checking the condition of the brake lining and drum given in the preceding paragraphs will also apply when you inspect and check other brake systems.

For other probable causes of trouble (and remedies) in a standard hydraulic brake system, refer to table 8-1.

### **VACUUM-ASSISTED HYDRAULIC BRAKES (POWER)**

The same basic inspection procedures given in the hydraulic brake section apply to the

vacuum-assisted hydraulic brake system. When checking this system for a source of trouble, refer to the chart for the standard hydraulic brake system (table 8-1). After the possible causes on this chart have been eliminated, check for causes in the troubleshooting chart of table 8-2.

**NOTE:** Make the following test before checking the cause for hard pedal. With the engine stopped, depress the brake pedal several times to eliminate all vacuum from the system. Apply the brakes, and while holding the foot pressure on the brake pedal, start the engine. If the unit is operating correctly, the brake pedal will move forward when the engine vacuum power is added to the pedal pressure. If this test shows that the power unit is not operating, check the probable causes of vacuum failure in table 8-2.

### **AIR**

When a vehicle is equipped with airbrakes, first make a visual inspection of hose lines and tubing to find leaks or near leaks from badly worn places. To make an **AIR LEAKAGE TEST**, start the engine and let it run until the air pressure gage indicates normal operating pressure. With the engine turned off, hold the airbrakes in the maximum applied position and watch the air pressure gage on the dash of the vehicle. The pressure should drop no more than 3 pounds in 1 minute after the brakes are applied and 2 pounds in 1 minute with the brakes released.

An **AIR BUILDUP TEST** should be made. With the engine stopped, drain all air from the reservoir. Then close all reservoir drain cocks, start the engine, and watch the air pressure gage to see how long it takes to build up to safe operating pressure. If longer than 10 minutes are required to bring the air pressure from 0 to 60 psi, you should have the air compressor and the pressure relief valve checked. With air pressure exhausted from the airbrake system, start the engine and press the brake pedal to applied position. Observe pressure registered by the dash gage when the stop lamps light. Stop lamps should light before the dash gage registers 10 psi.



# CONSTRUCTION MECHANIC 1 & C

**Table 8-1.—Troubleshooting Chart for Hydraulic Brakes (Standard)**

<u>MALFUNCTION</u>	<u>PROBABLE CAUSE</u>	<u>POSSIBLE REMEDY</u>
A. Low pedal or pedal goes to toe board.	<ol style="list-style-type: none"> <li>1. Excessive clearance between linings and drum.</li> <li>2. Automatic Adjusters not working.</li> <li>3. Weak brake hose.</li> <li>4. Leaking brake pipe.</li> <li>5. Leaking wheel cylinder.</li> <li>6. Leaking master cylinder.</li> <li>7. Leaking master cylinder check valve.</li> <li>8. Leaking Stop Light switch.</li> <li>9. Air in system.</li> <li>10. Plugged master cylinder filler cap.</li> <li>11. Improper brake fluid.</li> <li>12. Low fluid level.</li> </ol>	<ol style="list-style-type: none"> <li>1. Adjust brakes.</li> <li>2. Make forward and reverse stops. If pedal stays low, repair faulty adjusters.</li> <li>3. Replace hose.</li> <li>4. Repair or replace faulty parts.</li> <li>5. Clean and rebuild.</li> <li>6. Clean and rebuild.</li> <li>7. Replace valve.</li> <li>8. Replace switch.</li> <li>9. Bleed system.</li> <li>10. Clean filler cap vent holes, bleed system.</li> <li>11. Flush system and replace with correct fluid.</li> <li>12. Fill reservoir, bleed system.</li> </ol>
B. Springy, spongy Pedal.	<ol style="list-style-type: none"> <li>1. Air trapped in hydraulic system.</li> <li>2. Improper brake fluid.</li> <li>3. Anchor pin adjustment incorrect.</li> <li>4. Improper lining thickness or location.</li> <li>5. Drums worn too thin.</li> <li>6. Master cylinder filler vent clogged.</li> <li>7. Weak hose.</li> </ol>	<ol style="list-style-type: none"> <li>1. Remove air by bleeding.</li> <li>2. Flush and bleed system.</li> <li>3. Adjust anchor pin.</li> <li>4. Install specified lining or replace shoe and lining.</li> <li>5. Replace drums.</li> <li>6. Clean vent or replace cap; bleed brakes.</li> <li>7. Replace hose.</li> </ol>
C. Excessive pedal pressure required to stop car.	<ol style="list-style-type: none"> <li>1. Brake adjustment not correct.</li> <li>2. Incorrect lining.</li> <li>3. Grease or fluid soaked lining.</li> <li>4. Improper fluid.</li> <li>5. Frozen master or wheel cylinder pistons.</li> <li>6. Brake pedal binding on shaft.</li> <li>7. Linings installed on wrong shoes.</li> <li>8. Glazed linings.</li> </ol>	<ol style="list-style-type: none"> <li>1. Adjust brakes or repair self adjuster.</li> <li>2. Install specified lining.</li> <li>3. Repair grease seal, or wheel cylinder. Install new linings.</li> <li>4. Flush out system, fill with correct type fluid.</li> <li>5. Rebuild or replace.</li> <li>6. Lubricate or replace.</li> <li>7. Install primary and secondary linings correctly.</li> <li>8. Sand surface of linings.</li> </ol>
D. Light pedal pressure - Brakes too severe.	<ol style="list-style-type: none"> <li>1. Brake adjustment not correct.</li> <li>2. Loose backing plate on front axle.</li> </ol>	<ol style="list-style-type: none"> <li>1. Adjust the brakes or repair self adjusters.</li> <li>2. Tighten plates.</li> </ol>

2.507

## Chapter 8—VEHICLE INSPECTIONS

**Table 8-1.—Troubleshooting Chart for Hydraulic Brakes (Standard)—Continued**

<u>MALFUNCTION</u>	<u>PROBABLE CAUSE</u>	<u>POSSIBLE REMEDY</u>
D. Light pedal pressure—Brakes too severe (Cont.).	<ol style="list-style-type: none"> <li>3. A small amount of grease or fluid on linings.</li> <li>4. Glazed linings.</li> <li>5. Incorrect lining.</li> <li>6. Wheel bearings loose.</li> <li>7. Lining loose on shoe.</li> <li>8. Excessive dust and dirt in drums.</li> <li>9. Bad drum.</li> </ol>	<ol style="list-style-type: none"> <li>3. Replace the linings.</li> <li>4. Sand the surfaces of the linings.</li> <li>5. Install factory specified linings.</li> <li>6. Adjust wheel bearings.</li> <li>7. Replace lining or shoe and lining.</li> <li>8. Clean and sand drums and linings.</li> <li>9. Turn drums in pairs or replace.</li> </ol>
E. Brake pedal travel decreasing.	<ol style="list-style-type: none"> <li>1. Master cylinder compensating port plugged.</li> <li>2. Swollen cap in master cylinder.</li> <li>3. Master cylinder piston not returning.</li> <li>4. Weak shoe retracting springs.</li> <li>5. Wheel cylinder pistons sticking.</li> </ol>	<ol style="list-style-type: none"> <li>1. Open with compressed air or replace.</li> <li>2. Replace rubber parts, flush system.</li> <li>3. Rebuild master cylinder.</li> <li>4. Replace springs.</li> <li>5. Clean cylinder bores and parts. Replace bad parts.</li> </ol>
F. Pulsating Brake Pedal.	<ol style="list-style-type: none"> <li>1. Drums out of round.</li> <li>2. Loose brake drum on hub.</li> <li>3. Worn or loose wheel bearings.</li> <li>4. Bent rear axle.</li> </ol>	<ol style="list-style-type: none"> <li>1. Refinish drums to specifications.</li> <li>2. Tighten.</li> <li>3. Replace or adjust.</li> <li>4. Replace axle.</li> </ol>
G. *Brake Fade.	<ol style="list-style-type: none"> <li>1. Incorrect lining.</li> <li>2. Thin drum.</li> <li>3. Dragging brakes.</li> </ol>	<ol style="list-style-type: none"> <li>1. Replace lining with lining recommended by factory.</li> <li>2. Replace drums.</li> <li>3. Adjust or correct cause.</li> </ol>
H. All brakes drag when adjustment is known to be correct.	<ol style="list-style-type: none"> <li>1. Pedal does not return to stop.</li> <li>2. Improper fluid.</li> <li>3. Compensating or bypass part of master cylinder closed.</li> </ol>	<ol style="list-style-type: none"> <li>1. Lubricate the pedal.</li> <li>2. Replace rubber parts and refill.</li> <li>3. Open with compressed air or replace.</li> </ol>
I. One Wheel drags.	<ol style="list-style-type: none"> <li>1. Weak or broken shoe retracting springs.</li> </ol>	<ol style="list-style-type: none"> <li>1. Replace the defective Brake shoe springs and lubricate the brake shoe ledges.</li> </ol>

\*Fade is a temporary reduction of brake effectiveness resulting from heat.

2.507

# CONSTRUCTION MECHANIC 1 & C

Table 8-1.—Troubleshooting Chart for Hydraulic Brakes (Standard)—Continued

<u>MALFUNCTION</u>	<u>PROBABLE CAUSE</u>	<u>POSSIBLE REMEDY</u>
I. One Wheel drags. (Cont.).	2. Brake shoe to drum clearance too small or the brake shoe eccentric is not adjusted properly.	2. Adjust.
	3. Loose wheel bearings.	3. Adjust wheel bearings.
	4. Wheel cylinder piston cups swollen and distorted or the piston stuck.	4. Rebuild cylinders.
	5. Pistons sticking in wheel cylinder.	5. Clean or replace pistons; clean cylinder bore.
	6. Drum out-of-round.	6. Grind or turn front or rear drums.
	7. Obstruction in line.	7. Clean out or replace.
	8. Loose anchor pin.	8. Adjust and tighten lock nut.
	9. Distorted shoe.	9. Replace.
	10. Defective lining.	10. Replace with specified lining.
	11. Parking brake cable frozen.	11. Lubricate.
	J. Rear brakes drag.	1. Maladjustment.
2. Parking brake cables frozen.		2. Lubricate.
K. Vehicle pulls to one side.	1. Grease or fluid soaked lining.	1. Replace with new linings.
	2. Anchor pin adjustment not correct.	2. Major brake adjustment.
	3. Loose wheel bearings; loose backing plate on rear axle or front axle or loose spring bolts.	3. Adjust the wheel bearing; tighten the backing plate on the rear axles and tighten spring bolts.
	4. Linings not of specified kind or primary and secondary shoes reversed.	4. Install specified linings.
	5. Tires not properly inflated or unequal wear of tread. Different tread non-skid design.	5. Inflate the tires to recommended pressures. Rearrange the tires so that a pair of non-skid tread surfaces of similar design, and equal wear will be installed on the front wheels and another pair with the tread will be installed on the rear wheels.
	6. Linings glazed.	6. Sand the surfaces of the linings.

## Chapter 8—VEHICLE INSPECTIONS

**Table 8-1.—Troubleshooting Chart for Hydraulic Brakes (Standard)—Continued**

<u>MALFUNCTION</u>	<u>PROBABLE CAUSE</u>	<u>POSSIBLE REMEDY</u>	
K. Vehicle pulls to one side (Cont.)	7. Water, mud, etc. in brakes.	7. Remove any foreign materials from all of the brake parts and the inside of the drums. Lubricate the shoe ledges and the rear brake cable ramps.	
	8. Wheel cylinder sticking.	8. Repair or replace wheel cylinder.	
	9. Weak or broken retracting springs.	9. Check springs—replace bent, open-coiled or cracked springs.	
	10. Out-of-round drums.	10. Re-surface or replace drums in left and right hand pairs (both front and both rear).	
	11. Brake dragging.	11. Check for loose lining. Adjust.	
	12. Weak chassis springs, loose "U" bolts, loose steering gear, etc.	12. Replace spring, tighten "U" bolts, adjust steering gear, etc.	
	13. Loose steering.	13. Repair and adjust.	
	14. Unequal camber.	14. Adjust to spec.	
	15. Bad drum.	15. Refinish drums in pairs.	
	L. One Wheel locks.	1. Gummy lining.	1. Reline.
		2. Tire tread slick.	2. Match up tire tread side to side.
		3. Faulty anchor adjustment.	3. Adjust.
	M. Wet Weather, Brakes Grab or won't hold.	1. Linings sensitive to water.	1. Reline.
		2. Dirty brakes.	2. Clean out.
		3. Bent backing plate-opening.	3. Straighten or replace.
4. Scored drums.		4. Grind or turn in pairs.	
N. Brakes Squeak.	1. Backing plate bent or shoes twisted.	1. Straighten or replace damaged parts.	
	2. Metallic particles or dust embedded in lining.	2. Sand linings and drums. Remove all particles of metal in surface of linings.	
	3. Lining rivets loose or lining not held tightly against the shoe at the ends.	3. Replace rivets and/or tighten lining by reriveting.	
	4. Drums not square or distorted.	4. Turn or grind or replace drums.	
	5. Incorrect lining.	5. Replace lining per factory specs.	
	6. Shoes scraping on backing plate ledges.	6. Lube ledges. Replace with new shoe and linings, if distorted.	

2.507

## CONSTRUCTION MECHANIC 1 & C

Table 8-1.—Troubleshooting Chart for Hydraulic Brakes (Standard)—Continued

<u>MALFUNCTION</u>	<u>PROBABLE CAUSE</u>	<u>POSSIBLE REMEDY</u>
N. Brakes Squeak (Cont.).	7. Weak or broken hold down springs.	7. Replace defective parts.
	8. Loose wheel bearings.	8. Tighten to proper setting.
	9. Loose backing plate, anchor, drum wheel cylinder.	9. Tighten.
	10. Loose shoe links.	10. Tighten.
	11. Linings located wrong on shoes.	11. Install linings correctly.
O. BRAKES Chatter.	1. Incorrect lining to drum clearance.	1. Readjust to recommended clearances.
	2. Loose backing plate.	2. Tighten securely.
	3. Grease, fluid, road dust on lining.	3. Clean or reline.
	4. Weak or broken retractor spring.	4. Replace.
	5. Loose wheel bearing.	5. Readjust.
	6. Drums out-of-round.	6. Grind or turn drums in pairs.
	7. Caulked or distorted shoes.	7. Straighten or replace.
P. Grinding Noise.	1. Shoe hits drum.	1. Switch drums or grind drums.
	2. Foreign material in lining.	2. Remove or replace lining.
	3. Rivets or shoe rubbing drum.	3. Reline—refinish drums.
	4. Rough drum surface.	4. Refinish drums.

2.507

Airbrakes on trailers get an external brake inspection as part of the inspection required on a truck-tractor and trailer combination. They are also tested for holding as if the trailer were suddenly disconnected from the tractor. To make this test, first see that the air lines between tractor and trailer brakes are coupled properly. Then, after starting the engine so both tractor and trailer air reservoirs are charged, quickly and simultaneously disconnect both air line couplings. The trailer or semitrailer brakes should be automatically applied. Trailer brakes are designed to stop the trailer when it is accidentally disconnected from the towing vehicle. All states require automatic application of trailer brakes in this emergency. Some states go even further for trailers having a chassis and body weight of 1,000 pounds or over; such trailers must be equipped with adequate brakes which

will also hold the vehicle for at least 15 minutes after automatic application.

If these inspections and tests do not disclose the fault, consult the troubleshooting chart of table 8-3.

### AIR-OVER-HYDRAULIC

On vehicles equipped with air-over-hydraulic brakes, a good visual inspection should be made of the air compressor, air reservoir, air lines, brake pedal and linkage, the wheel brakes, the master cylinder, and the hydraulic line from the master cylinder to the air-hydraulic power cylinder and from the air-hydraulic power cylinder to the wheel brakes.

Operating troubles resulting from malfunction of the air-over-hydraulic power cylinder are

## Chapter 8—VEHICLE INSPECTIONS

Table 8-2.—Trouble Chart for Vacuum Assisted Hydraulic Brakes (Power)

<u>MALFUNCTION</u>	<u>PROBABLE CAUSE</u>	<u>POSSIBLE REMEDY</u>
A. *Hard Pedal.	<ol style="list-style-type: none"> <li>1. Broken or damaged hydraulic brake lines.</li> <li>2. Vacuum failure.</li> <li>3. Defective diaphragm.</li> <li>4. Restricted air filter element.</li> <li>5. Worn or badly distorted reaction disc. (tandem diaphragm).</li> <li>6. Cracked or broken power pistons or retainer.</li> <li>7. Incorrect selective reaction piston (tandem diaphragm only).</li> </ol>	<ol style="list-style-type: none"> <li>1. Inspect and replace as necessary.</li> <li>2. Check for:               <ol style="list-style-type: none"> <li>a. Faulty vacuum check valve or grommet—replace.</li> <li>b. Collapsed or damaged vacuum hose—replace.</li> <li>c. Plugged or loose vacuum fitting—repair.</li> <li>d. Faulty air valve seal or support plate seal—replace.</li> <li>e. Damaged floating control valve—replace.</li> <li>f. Bad stud welds on front or rear housing of power head—replace unless easily repaired.</li> </ol> </li> <li>3. Replace.</li> <li>4. Replace.</li> <li>5. Replace reaction disc.</li> <li>6. Replace power pistons and piston rod retainer.</li> <li>7. Gauge reaction piston and replace with correct piston.</li> </ol>
B. Grabby brakes. (Apparent off and on condition).	<ol style="list-style-type: none"> <li>1. Broken or damaged hydraulic brake lines.</li> <li>2. Insufficient fluid in master cylinder.</li> <li>3. Defective master cylinder seals.</li> <li>4. Cracked master cylinder casting.</li> <li>5. Air in hydraulic system.</li> </ol>	<ol style="list-style-type: none"> <li>1. Inspect and replace as necessary.</li> <li>2. Fill reservoirs with approved brake fluid and check for leaks.</li> <li>3. Repair or replace as necessary.</li> <li>4. Replace.</li> <li>5. Bleed system.</li> </ol>
C. Brakes FAIL to release.	<ol style="list-style-type: none"> <li>1. Blocked passage in power piston.</li> <li>2. Air valve sticking shut.</li> <li>3. Broken piston return spring.</li> <li>4. Broken air valve spring.</li> <li>5. Tight pedal linkage.</li> </ol>	<ol style="list-style-type: none"> <li>1. Inspect and replace as necessary.</li> <li>2. Check for proper lubrication of air valve "O" ring.</li> <li>3. Replace.</li> <li>4. Replace.</li> <li>5. Repair or replace as necessary.</li> </ol>

\*Hard pedal is excessive pedal pressure required to apply the brakes.

2.508

## CONSTRUCTION MECHANIC 1 & C

**Table 8-3.—Troubleshooting Chart for Air Brakes**

<u>MALFUNCTION</u>	<u>PROBABLE CAUSE</u>	<u>POSSIBLE REMEDY</u>
A. Low air pressure in system or slow air pressure build-up.	<ol style="list-style-type: none"> <li>1. Leakage in air system.</li> <li>2. Improperly adjusted compressor governor.</li> <li>3. Loose compressor drive belts.</li> <li>4. Worn compressor.</li> </ol>	<ol style="list-style-type: none"> <li>1. Check and tighten any loose connecting lines and fittings.</li> <li>2. Adjust governor.</li> <li>3. Adjust belt tension.</li> <li>4. Rebuild or replace.</li> </ol>
B. Rapid loss of air pressure when engine is stopped.	<ol style="list-style-type: none"> <li>1. Leakage in air system.</li> <li>2. Leaking compressor discharge valves.</li> </ol>	<ol style="list-style-type: none"> <li>1. Check and tighten any loose connecting lines and fittings.</li> <li>2. Rebuild or replace.</li> </ol>
C. Excessive Air Pressure.	<ol style="list-style-type: none"> <li>1. Improperly adjusted compressor governor.</li> <li>2. Sticking compressor governor plunger.</li> <li>3. Leaking compressor governor diaphragm.</li> <li>4. Restricted air line leading to governor.</li> </ol>	<ol style="list-style-type: none"> <li>1. Adjust governor.</li> <li>2. Lubricate governor.</li> <li>3. Rebuild or replace.</li> <li>4. Replace air line.</li> </ol>

2.509

hard pedal (excessive pedal pressure required to apply the brakes) and dragging brakes (power cylinder fails to return to released position when the brake pedal is released).

To test a sluggish or inoperative power cylinder, first install an air pressure gage in the control valve housing and a hydraulic gage at both the hydraulic fluid inlet line and the hydraulic brake line output port. Then, slowly depress the brake pedal and observe the gages. When the air control pressure gage shows between 1 and 5 psi, the hydraulic pressure at the hydraulic inlet should not exceed 40 psi. Excessive hydraulic pressure indicates a sticking relay piston (caused by swollen or damaged piston sealing cups or a corroded or damaged relay piston sleeve) or sticking control valve poppets (caused by corrosion of the poppets, poppet seats, or damaged poppets).

With the brake pedal fully depressed to the fully applied position, the air control pressure

gage should show 90 psi and the hydraulic output pressure gage should show full power (runout) pressure of 1,400 to 1,600 psi. Low pressure or no pressure on the air pressure gage indicates air leakage or an inoperative control valve. Low hydraulic output pressure indicates hydraulic fluid leakage, a sticking hydraulic piston, or an inoperative check valve (in the hydraulic piston) or a residual line check valve.

To test for internal and external air leakage or hydraulic leakage, first depress the brake pedal and apply soapsuds at the air control line and its connections, the double check valve (if so equipped), and at the cylinder body and end plate. Bubbles appearing at any of these points indicate external air leaks. While the pedal is depressed, check for hydraulic fluid leakage at the outlet fitting cap and around the jamnut on the slave cylinder housing. Internal air leakage is indicated by a pressure drop in excess of 2 psi in 15 seconds. The trouble is a worn or damaged

piston packing, a scored cylinder body, or leakage at the poppets in the control valve. Internal hydraulic pressure leakage can also be indicated by hydraulic pressure drop at both hydraulic pressure gages while the brake pedal is depressed.

Dragging brakes can be tested by releasing the brake pedal and observing the air pressure gage and the two hydraulic pressure gages. All gages should register zero without lagging. When pressure is noted at the air pressure gage, a sticking relay piston, damaged or corroded control valve poppet, or a ruptured control valve diaphragm exists. Pressure at the hydraulic pressure gages indicates a sticking hydraulic piston, a sticking power piston, or a weak or broken piston return spring. If the hydraulic pressure gages show a slow pressure drop, a defective check valve (in the hydraulic piston) or a defective residual line check valve is indicated.

If the tests indicate external air leakage, tighten the control line connections. Replace a damaged control line, control line gasket, or double check valve. Internal air leakage requires removal of the unit for replacement of worn or damaged power piston packing or end plate gasket, and repair or replacement of the cylinder body or end plate.

If the tests indicate hydraulic fluid leakage, an inoperative control valve, sticking power piston, relay piston, or hydraulic piston, remove the unit for disassembly and repair or replace worn or damaged parts.

### VACUUM-OVER-HYDRAULIC

To check the vacuum brake system, first shut off the engine and apply the brakes several times to bleed all vacuum from the system. Twenty or thirty applications may be needed on systems with vacuum reservoirs. Spongy or soft action of the brake pedal indicates air in the hydraulic system. If this fault occurs, the system must be bled.

With the pedal held at the normal braking pressure, start the engine. If the pedal lowers toward the floorboard when the engine starts,

the vacuum system is operating properly. If the pedal fails to move, the vacuum system is at fault. Although this usually indicates a faulty vacuum cylinder, the vacuum lines, reservoir, and connections should be checked for leaks first. The applicable instructions manual should be consulted to replace and repair the vacuum power cylinder.

### EMERGENCY

Emergency brake inspections should be made just as carefully as those for service brakes. Two types of emergency brakes are in use on modern vehicles—an external contracting drive shaft transmission brake and a mechanical linkage rear wheel brake. The parking brake is designed primarily to hold the vehicle after it is stopped. You can also use the parking brake to stop a vehicle in an emergency, but it usually is not as efficient as the emergency brake. Because emergency brakes are seldom used except for holding the vehicle when parked, some unthinking inspectors forget them. Too, in reporting brake troubles, the operator often neglects troubles in the emergency brake. (For this discussion, both types of brakes will be called emergency brakes.)

Safety regulations require that the emergency brake be adequate to stop the vehicle from a speed of 20 mph within 55 feet. This requirement may vary in different localities, depending upon state regulations. The emergency brake must hold the vehicle on any grade. This requirement covers both passenger and commercial motor vehicles equipped with either the enclosed-type emergency brake at each rear wheel, or a single emergency brake at the drive shaft.

When testing emergency brakes, do so at the same time you test the service brakes; however, make a separate run in a road test. Pay attention to the ratchet and pawl or any other automatic locking device that holds the brake in the applied position to insure that it is operating properly.

Inspect the condition of emergency brake linings and drums just as you would for service brakes. In addition, when inspecting the drive



shaft brake, examine the universal joints and splines for loose bolts and grease leaks. Loose universal joint bolts are not uncommon for vehicles having emergency brakes on the drive shaft. Although most vehicles throw a little grease from the spinning drive shaft, none of it should remain on the emergency brake lining.

## INSPECTION OF STEERING SYSTEMS

When inspecting the steering system of automotive equipment, start with the tires. Replace a tire with a cut that extends into the cord body or that is worn to the tread wear marker (if so equipped) or is worn smooth so that the cord fabric is showing. Examine how the tire treads are wearing. The condition of wear will help determine steering troubles.

Some shops have special equipment for balancing wheels and for checking wheel eccentricity and wobble. The wheels must be removed from the vehicle when some wheel balancing machines are used. There are other types of balancing equipment that can be used without taking the wheels from the vehicle.

The preliminary check for proper steering can be made during the road test for brakes. At this time, you can feel if the vehicle steers hard, or has too much play in the steering wheel. Likewise, you can tell by "feel" if the front wheels of the vehicle shimmy, wobble, or wander from a straight course.

Steering troubles, except for free play in the steering mechanism, may also result from improper tire inflation, worn tires, maladjusted brakes, or all of these faults. No steering adjustments should be made until the items just mentioned have been checked and corrected.

Under ordinary conditions, major alignment checks for front wheel camber, caster, and kingpin angle are unnecessary for safety inspections. When there is an indication of front end misalignment, such as excessive tire wear or hard steering, major alignment checks should be made. When this is necessary, special equipment must be used. Make sure the manufacturer's

instructions are followed when checks and corrections are being made to the front end alignment.

After you finish preliminary steering inspections, continue with these jobs:

1. Examine the amount of free movement at the rim of the steering wheel and follow the specifications recommended by the manufacturer. Remember that proper free movement of the steering wheel will minimize steering system wear.

2. Jack up the front wheels of the vehicle and check for loose, broken, and worn parts, such as wheel bearings, spindles, and bushings. Excessive lateral movement at the top or bottom of the tire indicates looseness. When looseness is apparent, adjust the wheel bearings and recheck the lateral movement to determine whether the wheel bearings are loose, or the kingpins or ball joints are worn. Follow the manufacturer's specifications.

3. Check for wear in the steering linkages, particularly at the tie-rod ends. Also, look for broken spring leaves, worn spring shackles, loose spring U-bolts, and worn or loose suspension bolts or bushings. At the same time, check for bad shock absorbers.

4. Finally, check for proper toe-in. You can expect to make changes in the toe-in if adjustments for wear in the steering linkages were necessary.

Many problems can develop on a vehicle which affect its steering safety. The experience of a well-qualified inspector is indispensable in quickly identifying a problem and having it corrected. Accurate and timely identification of the problems not only saves maintenance dollars but also puts the vehicle back on the road in a safe condition in a minimum of time. Experience is your best teacher.

## INSPECTION OF EXHAUST SYSTEMS

When inspecting a vehicle, examine the condition of its exhaust system. See that all parts of

the system are securely attached or supported. Gaskets or packing must not show signs of leakage. Remember that exhaust pipes, mufflers, and tailpipes rust from the inside out. Look for places rusted through or on the verge of doing so or are damaged badly enough to obstruct the flow of exhaust gases.

Any restriction or clogging in the exhaust system will cause a back pressure in the manifold. This back pressure inhibits the fuel mixture from entering the combustion chamber. A hissing noise at the tailpipe with the engine running at high speeds indicates a restricted exhaust. Using a vacuum gage will confirm the condition of the exhaust system. A slow or hesitating reading under acceleration with a lower-than-normal reading during deceleration indicates an exhaust restriction.

Look closely where a tailpipe discharges the exhaust gases. On vehicles with full bodies, such as sedans, the discharge point must be beyond the rear bumper. On a pickup truck or other short-bodied vehicle, the tailpipe must extend to the rear of the cab and beyond any saddle fuel tanks on the vehicle. Make sure that NO part of the exhaust system is where it might burn wires, fuel system components, or other combustible parts of the vehicle. Also, see that no oil or grease collects on any part of the system.

#### INSPECTION OF WINDSHIELD WIPERS, GLASS, AND DEFROSTERS

When inspecting windshield wipers, check the condition of the wiper blades. See whether hardness or dry-rot has set in. If so, replace the blades with new ones. Also check the mechanical operation of the wipers to see if they properly move across the operator's view.

Window glass in the vehicle must be checked to insure that the glass lets the operator see well through each window. Pitted or cracked glass should be replaced.

When inspecting for proper mirror installation, be sure that every bus, truck, or truck-tractor is equipped with two rear-view mirrors,

one on each side of the vehicle. Insure that the mirrors are firmly attached and located so as to give the driver a view of the road to the rear along both sides of the vehicle. On vehicles where only one outside mirror is required, it must be on the driver's side. Such a vehicle should also have an inside rear-view mirror to give the driver a view to the rear.

Vehicles that will operate under frosty, icy, or snowy conditions are usually equipped with an automatic defrosting device. Inspect this device for proper operation. Check the level of the coolant in the radiator, and the radiator and defroster hoses and connections. Make sure the defroster is free of any obstruction which limits its capacity to defrost.

#### INSPECTION OF SEAT BELTS

Seat belts are a safety requirement of all automotive vehicles and should be inspected at regular intervals. When inspecting seat belts, see that they are not frayed or worn. Insure that the anchors are secure and tight. Check each belt to make sure it does not rub against any sharp metal part of the seat or vehicle that could cut the belt upon impact. The buckle should be inspected to insure that the locking device is not worn or bent and that it works. Also check for operation of the seat belt warning device, when the vehicle is so equipped.

#### INSPECTION OF INSTRUMENTS, CONTROLS, AND WARNING DEVICES

When inspecting a vehicle, check all instruments, controls, horns, and warning devices for proper functioning and damage.

The instruments inform you of the approximate speed, engine temperature, oil pressure, rate of charge or discharge of the battery, amount of fuel in the fuel tank, distance traveled, and the operating hours. Should any of these instruments not operate properly, have them repaired or replaced.

Certain controls—throttle, choke, starter, heater, windshield wipers, and others—like the

instruments must function or perform the task for which they are provided. When they malfunction, they too must be repaired or replaced.

The horn installed on automotive equipment warns pedestrians, workmen, or other vehicles. If the horn does not sound during inspection, have it checked for proper ground and correct voltage. When these have been checked out, but the sound is weak, you can improve the tone and volume of the horn by loosening the adjusting locknut and turning the adjusting nut.

Some manufacturers prefer a warning light system rather than a gage indicator system to indicate unsafe operation. A warning light is usually controlled by a pressure switch, temperature switch, or mechanical linkage. When this light system is on a vehicle you are inspecting, check for proper operation. Have any malfunction corrected and damaged warning lights replaced.

### INSPECTION OF FIFTH WHEEL AND TRAILER

When inspecting a truck-tractor and trailer, make sure the truck fifth-wheel rocker plate and bed are in good condition, properly assembled, adequately lubricated, and securely mounted. The coupling device—kingpin lock—should operate freely and properly, lock securely, and not show excessive wear. This type of locking device should open only when the positive release lever is manually or automatically activated. Also, the trailer landing gear assembly must be in good condition, adequately lubricated, and properly mounted.

Inspect trailer springs, suspension hanger mechanisms, tension bar assemblies, and associated parts, such as U-bolts, hangers, and shackles; they must show no signs of fractures or breaks. Also see that trailer tires are properly inflated; and free of bruises, breaks, or blisters. Reject and replace any tire in which a cut or other damage extends to the tire cords, or the tread is worn smooth in the center. Be sure that the tires match on trailers equipped with dual wheels.

### INSPECTION OF PRESERVED EQUIPMENT

Equipment in preservation and live storage is inspected on a cycle determined by COMC-BPAC/COMCBLANT, according to site location. Preserved equipment has the batteries removed, preservation lubricants installed, and all openings securely sealed. These units require hand cranking the engine, transmission, and gear boxes to lubricate surfaces not submerged in oils. All wheels should be rotated by hand to limit bearing damage and to prevent the grease from becoming hard.

Live storage is similar; the gear boxes and engines do not normally have preservation lubricants installed. These units may be started, brought to temperature, and operated through all cycles.

Both the preserved and live storage equipment need an application of rust-inhibiting preservation to prevent metal and paint deterioration. All glass is to be boxed or taped as the situation demands. Engine belts should be loosened to limit pulley and belt damage.

### EMBARKATION INSPECTIONS

Clean vehicles, a critical part of embarkation inspections, not only allow for closer inspections, but also speeds up clearance of customs where vehicles must be certified free of dirt and bugs. Vehicles leaving foreign countries normally will be inspected leaving that area and again upon arrival.

In addition to safety and operational checks, vehicles being inspected for embarkation require emphasis on oil, fuel, and water seepage. An occasional drip may not adversely affect the vehicle's normal operation, but it could become hazardous while being transported. Insure that the spare tire and all collateral equipment are loaded within the vehicle, especially under tactical situations.

In the shop area, it is easy to accomplish the configuration of the vehicle for loading, to put

down the headache cages, and to remove the counterweights, etc. Itemizing these and related tasks on the Equipment Repair Order (ERO) will insure that the work will be completed and, in addition, provide a record of work required at the destination.

### “BEEP” INSPECTIONS

As discussed in chapter 4, a Battalion Equipment Evaluation Program, “BEEP”, inspection is conducted under COMCBPAC/COMCBLANT 11200 Series Instructions each time battalions relieve on site.

This inspection evaluates the condition of the equipment to establish replacement priorities and, when conducted properly, provides the maintenance supervisor a means of establishing a shop workload throughout the deployment.

At the time the “BEEP” inspection is conducted, all discrepancies, including serious rust and paint requirements are written on the ERO. The repairs needed during the BEEP varies with each situation. As a rule, all needed safety repairs will be corrected and repairs of less than 4-hours time completed if parts are available. Major repairs, component overhaul, and body work are generally deferred until the relieving unit is established.

### INSPECTION OF DEADLINE EQUIPMENT

Deadlined equipment is inspected on its scheduled PM due date, or sooner if it is determined by the maintenance supervisor that it is needed. The inspection insures that (1) openings are covered and weathertight, (2) machine surfaces are preserved, (3) disassembled components are tagged, covered, and stored, and (4) nothing has been cannibalized. Interchanging of controlled parts is not recommended or approved as a normal procedure, but the maintenance supervisor may authorize it to meet operational commitments. In each case, the maintenance supervisor makes sure that parts removed from deadlined equipment are replaced with nonserviceable parts, and replacement parts are requisitioned.

All parts cost and labor hours related to the interchange are charged against the piece of equipment on which the part failed, making the interchange necessary.

When the requisitioned replacement parts are received and installed, only the labor is charged to the piece of equipment from which the interchanged part was taken.

When possible, while it is deadlined, this equipment is cycled to prevent deterioration and preserved as necessary.

## CHAPTER 9

# POWER TRAINS AND AUTOMATIC TRANSMISSIONS

In a vehicle, the mechanism that transmits the power of the engine to the wheels and accessory equipment is called the power train. In a simple situation, a set of gears or a chain and sprocket could perform this task, but automotive vehicles are not designed for such simple operating conditions. They are designed to have pulling power as well as move at high speeds, to travel in reverse as well as forward, and to operate on rough terrain as well as on smooth roads. To meet these varying demands, a number of units have been added including clutches, transmissions, transfer cases, propeller shafts, universal joints, differentials, and live axles (fig. 9-1). The many different units that make up power trains operate on the same basic

principles. Also, the procedures for maintaining and repairing these units are similar.

This chapter provides information on the various units and the various indications of abnormal operation so that you will be able to diagnose the problems and prescribe corrective action. To obtain more detailed information on the operation and repair of these units, refer to the specific manufacturer's manuals.

## CLUTCHES

It might be well to review briefly not only the purpose of the clutch but also the various types. The purpose of the clutch is to permit the

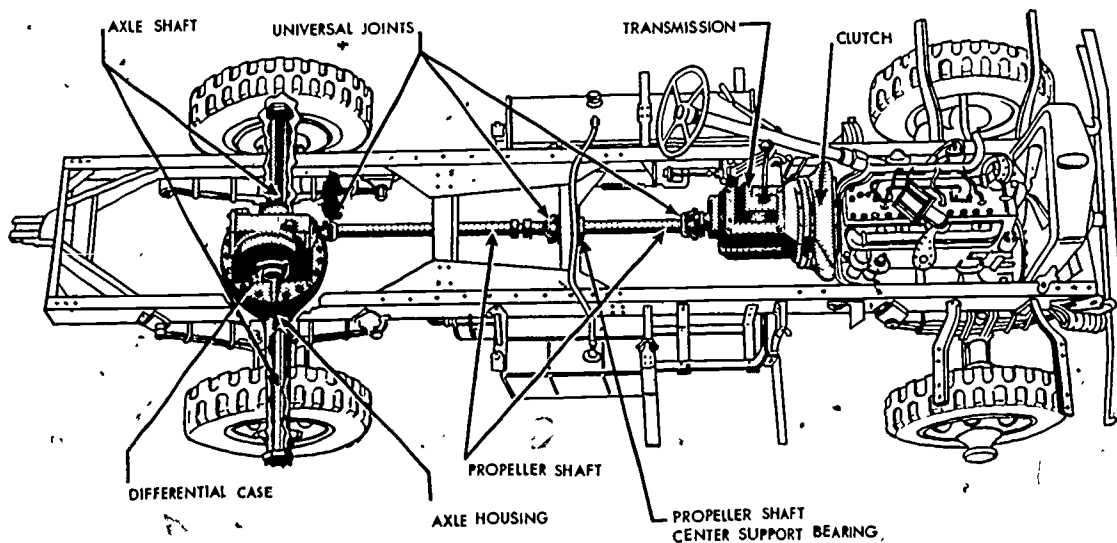

Figure 9-1.—Type of power transmission system.

81.174

operator to couple or uncouple the engine and transmission. When the clutch is in the coupling (or normal running) position, power flows through it from the engine to the transmission. If the transmission is in gear, power flows through to the vehicle wheels so that the vehicle moves. Essentially, the clutch enables the operator to uncouple the engine temporarily so that the gears can be shifted from one forward gear position to another or into reverse or neutral. The flow of power must be interrupted before the gears are shifted; otherwise, gear shifting is extremely difficult, if not impossible.

The clutch (fig. 9-2) contains a friction disk (or driven plate) about a foot in diameter. It also contains a spring arrangement and a pressure plate for pressing this disk tightly against the smooth rear face of the flywheel. The friction disk is splined to the clutch shaft. The splines consist of two sets of teeth—an internal set on the hub of the friction disk and a matching external set on the clutch shaft. They permit the friction disk to slide back and forth along the shaft but force the disk and the shaft to rotate together.

The flywheel which is attached to the end of the engine crankshaft rotates when the engine is running. When the clutch is engaged in the

coupling position, the friction disk is held tightly against the flywheel by the clutch springs so that it must rotate with the flywheel. This rotary motion is carried through the friction disk and clutch shaft to the transmission.

To disengage (or uncouple) the clutch, the clutch pedal is pushed down by the operator's foot. This causes the clutch fork to pivot so that the clutch throwout bearing is forced inward. As the throwout bearing moves inward, it operates the release levers. The release levers take up the spring pressure and lift the pressure plate away from the friction disk. The friction disk is no longer pressed against the flywheel face, and the engine can run independently of the power train. Releasing the clutch pedal permits the clutch fork to release the throwout bearing so that the springs once again cause the pressure plate to force the friction disk against the flywheel face. Again, the two revolve together.

All automotive clutches used with standard transmissions are very similar in construction and operation. There are some differences in the details of the linkages, as well as the pressure-plate assemblies.

Of the various types of clutch disks, the type shown in figure 9-2 is known as the plate clutch. The plate clutch is a simple clutch with two

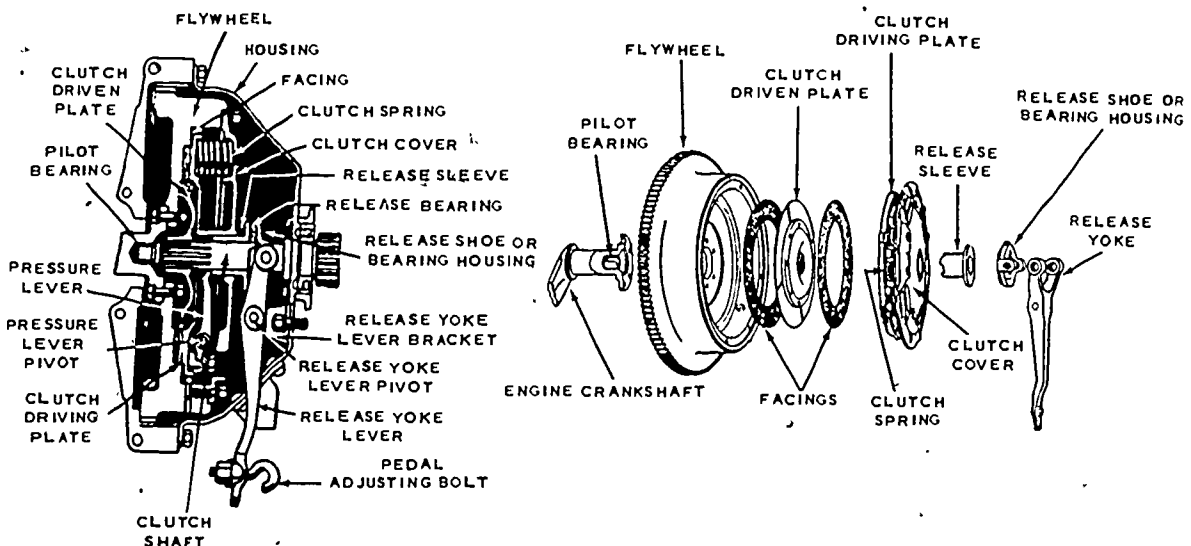

Figure 9-2.—Exploded and cross-section view of a plate clutch.

plates and one disk which is clamped between the two plates. Another type is the double-disk clutch. The driving members of the single-disk clutch consist of the flywheel and driving (pressure) plate. The driven member consists of a single disk splined to the clutch shaft and faced on both sides with friction material. When the clutch is fully engaged, the driven disk is firmly clamped between the flywheel and the driving plate by pressure of the clutch springs, forming a direct, nonslipping connection between the driving and driven members of the clutch. In this position, the driven disk rotates the clutch shaft to which it is splined. The clutch shaft is connected to the driving wheels through the transmission, propeller shaft, final drive, differential, and live axles.

The double-disk clutch is substantially the same as the single-disk clutch described in the section above, except that another driven disk and intermediate driving plate is added.

Other basic information on the elements and operation of the clutch is not included here because it is given in *Construction Mechanic 3 & 2*, NAVEDTRA 10644-G. However, information on various indications of abnormal clutch operation is given so that you will be able to diagnose and correct these troubles.

## CLUTCH TROUBLESHOOTING

The information given in this section is general and can be applied to nearly every type of clutch that you are likely to encounter. You will probably have special problems which can be solved only by referring to the manufacturer's manual.

Several types of clutch trouble may be encountered. Usually the trouble is fairly obvious. When the malfunction is explained on the Operator's Trouble Report, a quick personal check of the vehicle will generally enable you to correctly diagnose the trouble. It is your responsibility to see that the job is properly performed with a minimum of work. Clutch trouble generally falls into one of seven categories:

1. Slipping clutches
2. Chattering or grabbing when engaging
3. Spinning or dragging when disengaging
4. Clutch noises

5. Stiff clutch pedal
6. Clutch pedal pulsations
7. Rapid clutch disk wear

### Slipping Clutches

A clutch that slips when it is engaged is extremely hard on the clutch facings. The facings will wear and burn so badly that the clutch may soon become completely inoperative. Heat from a slipping clutch can soon become great enough to warp the pressure plate and to cause heat checks (small surface cracks) on both the flywheel and pressure plate.

Clutch slippage is particularly noticeable during acceleration, especially from a standing start or in low gear. You can test for clutch slippage by starting the vehicle engine, setting the handbrake, shifting the transmission into an intermediate gear, and slowly releasing the clutch pedal while accelerating the engine. If the clutch is in good condition, the engine should stall immediately when the clutch engagement is completed.

Several conditions can cause clutch slippage. For instance, the clutch linkage may not be properly adjusted. With an incorrect adjustment that reduces the pedal free travel too much, the clutch release bearing will press against the release levers even with a fully released clutch pedal. This prevents full pressure plate engagement, and there will not be enough pressure to hold the friction disk tightly enough against the flywheel. As a result, there is slippage between the surfaces. The way to correct this is to adjust the clutch linkage to give specified clutch pedal free travel.

A binding clutch release linkage may keep the clutch from returning to its fully engaged position and cause the clutch to slip. Binding can generally be eliminated by proper lubrication of all points of friction in the linkage. You may have to readjust and realine the clutch operating linkage. If readjustment, lubrication, and freeing of the clutch linkage do not work, then you may have to remove the clutch for repair. Any of the following conditions within the clutch itself could cause slippage:

1. Weak or broken pressure springs
2. Worn friction disk facings
3. Grease or oil on the disk facings

Replacing the facings or the complete disk is necessary to remedy condition No. 2 or No. 3 listed above.

Incorrectly adjusted release levers (if they are of the adjustable type) may act in the same manner as incorrectly adjusted clutch linkage or a binding clutch release linkage. In fact, they could prevent full spring pressure on the clutch plate with resulting slippage.

### Clutches That Chatter or Grab When Engaging

Several things cause a clutch to chatter or grab when it is being engaged. Loose spring shackles or U-bolts, loose transmission mounting, and worn engine mounts are among the items that must be checked. If the clutch linkage binds, it may release suddenly to throw the clutch into quick engagement, with a resulting heavy jerk. If all these items are checked and are in good condition, the trouble is inside the clutch itself, and the clutch will have to be removed from the vehicle for repairs.

In the clutch, the trouble could be oil or grease on the disk facings or glazed or loose facings. Binding of the friction disk hub on the clutch shaft could prevent smooth engagement; this condition will require cleaning the splines in the disk hub and on the clutch shaft. Broken parts in the clutch, such as broken disk facings, broken cushion springs in the disk, or a broken pressure plate could cause poor clutch action or grabbing.

### Clutches That Spin or Drag When Disengaged

The clutch friction disk may spin briefly after the clutch is disengaged. In other words, it takes a moment for the friction disk to come to rest. This normal spinning should not be confused with a dragging clutch. When the clutch drags, the friction disk continues to rotate with and to rub against the flywheel or pressure plate.

When this condition exists, first check the pedal-linkage adjustment. If there is excessive free travel of the clutch pedal, even full movement of the pedal will fail to force the release bearing in far enough against the release levers to release the clutch fully. If adjustment of the

linkage does not correct the trouble, the trouble is in the clutch, and the clutch must be removed, disassembled, and repaired.

When the trouble is in the clutch assembly, you will generally find a warped disk or pressure plate or the facing on the disk may be loose. On the type of pressure plate assembly with adjustable release levers, improper adjustment of the levers could prevent full disengagement so that the clutch would drag. A friction disk hub that is binding on the clutch shaft can also cause the clutch to drag.

### Clutch Noises

When an operator reports that a clutch is making noise, find out whether the noise is heard when the clutch is engaged or when it is disengaged. Clutch noises are usually most noticeable when the engine is idling and the clutch disengaged.

A disk hub that is loose on the clutch shaft will make a noise when the clutch is engaged, and will require replacement of the disk or clutch shaft or perhaps both, if both are worn excessively. Friction disk dampener springs that are weak or worn will also cause clutch noises. If the engine and transmission are not properly aligned, the disk hub will move back and forth on the clutch shaft. This will cause the splines of the disk hub and clutch shaft to wear; thus, a noisy clutch will soon appear. Any time excessive wear is found on the splines of the disk hub and/or the clutch shaft, always check the transmission and engine alignment.

If clutch noises are noticeable when the clutch is disengaged, the trouble will likely be in the clutch release bearing. The bearing is probably worn, binding, or has lost its lubricant. Most clutch release bearings are factory lubricated; however, on some of the larger trucks and on construction equipment, the clutch release bearing does require lubrication. As a rule, when the release bearing starts making a noise, it must be replaced. If the release levers on the pressure plate assembly are not properly adjusted, they could rub against the disk hub when the clutch is disengaged. If the pilot bearing in the crankshaft is worn or lacks lubricant, it will sometimes produce a high-pitched whine when the transmission is in gear, the clutch is



disengaged, and the vehicle is standing still. Under these conditions, the clutch shaft which is piloted in the bearing in the crankshaft is stationary, but the crankshaft and pilot bearing are turning.

### Stiff Clutch Pedal

A stiff clutch pedal or a pedal that is hard to depress is likely to result from lack of lubricant in the clutch linkage, from binding of the clutch-pedal shaft in the floorboard seal, or from misaligned linkage parts that are binding. In addition, the overcenter spring (on vehicles so equipped) may be out of adjustment. Also, the clutch pedal may be bent so that it rubs on the floorboard and is hard to operate. To correct these conditions, parts must be realigned, lubricated, or readjusted as required.

### Clutch Pedal Pulsation

A series of slight movement that can be felt on the clutch pedal or operating lever when the clutch is being disengaged is called clutch-pedal pulsation. These pulsations are noticeable when a slight pressure is applied to the clutch pedal. This is an indication of trouble that could result in serious damage if not corrected immediately. Several conditions could cause these pulsations. One is misalignment of the engine and transmission.

If the engine and transmission are not in line, detach the transmission and remove the clutch assembly. Check the clutch housing alignment with the engine and crankshaft. At the same time, the flywheel can be checked for wobble, since a bent crankshaft flange or a flywheel that is not seated on the crankshaft flange will produce clutch-pedal pulsations. If the flywheel does not seat on the crankshaft flange, remove the flywheel; after cleaning the flange and the flywheel, replace the flywheel, and make sure of a positive seat between the flywheel and crankshaft flange. If the flange is bent at the crankshaft, the crankshaft must be replaced.

Other causes of clutch-pedal pulsations include uneven release-lever adjustments, warped pressure plate, or warped clutch disk. If the pressure plate or clutch disk is warped, it should be replaced.

### Rapid Clutch Disk Wear

Rapid clutch disk wear will be caused by any condition that permits slippage between the clutch disk facings and the flywheel or pressure plate. An operator might have the habit of "riding" the clutch; this practice can cause slippage. Frequent use of the clutch or slow releasing of the clutch after disengaging will increase clutch facing wear. The remedy here is for the operator to use the clutch properly and only when necessary. Broken or weak pressure springs within the plate assembly will cause slippage. The springs must be replaced to correct this problem. Improper clutch linkage adjustment or binding of the linkage might prevent full spring pressure from being applied to the clutch disk. Any condition that keeps less than full spring pressure from being applied to the clutch disk is apt to cause slippage.

## TRANSMISSION

The transmission (fig. 9-3) is part of the power train. It is located in the rear of the engine between the clutch housing and the propeller shaft, as shown in figure 9-1. The transmission transfers engine power from the clutch shaft to the propeller shaft, and allows the driver or operator to control the power and speed of the vehicle. The transmission shown in figures 9-3 and 9-4 is a sliding gear transmission. Many late model trucks have either constant-mesh or synchromesh transmissions (explained later). However, the principles of operation and gear ratios are the same.

The Rate Training Manual *Basic Machines*, NAVPERS 10624-A, discusses gears and their mechanical advantages, and explains how to compute the speed and reduction ratio of gears in a typical automotive transmission if you are a little rusty on these points. This manual will help you to understand the transmission and power transfer mechanisms described in this chapter.

### FOUR-SPEED TRUCK TRANSMISSION

The gearshift lever positions shown in the small inset in figure 9-4 are typical of most four-speed truck transmissions. The gear shifting

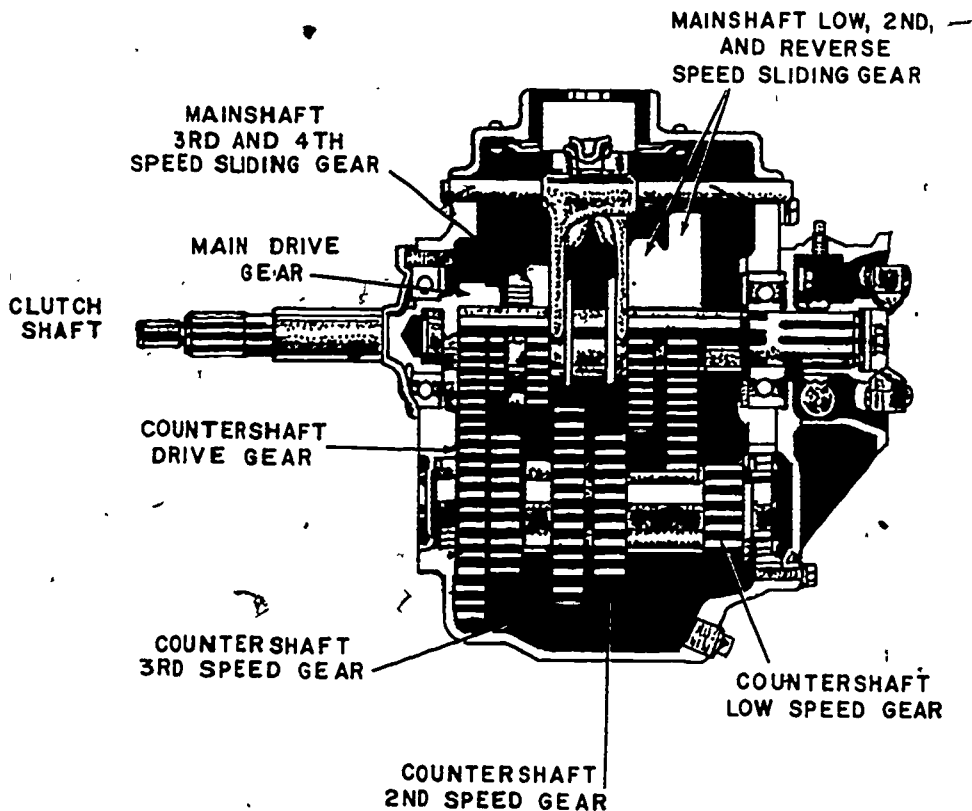

Figure 9-3.—Four-speed truck transmission.

81.181

lever, shown at A, B, C, D, and E in the illustration, moves the position of the two shifting forks which slide on separate shafts secured in the transmission case cover. Follow the separate diagrams to learn what takes place in shifting from one speed to another. For example, as you move the top of the gearshift lever toward the forward left position, the lower arm of the lever moves in the opposite direction to shift the gears. The fulcrum of this lever is in the transmission cover.

In shifting transmission gears, use the clutch pedal to disengage the clutch. Improper use of the clutch will cause the gears to clash, and may damage them by breaking the gear teeth. A broken tooth or piece of metal can wedge itself between two moving gears and ruin the entire transmission assembly.

When you shift from NEUTRAL to FIRST or LOW speed (A of fig. 9-4), the smallest countershaft gear engages with the largest sliding gear. LOW gear moves the truck at its lowest speed and maximum power. The arrow indicates the flow of power from the clutch shaft to the propeller shaft.

The SECOND-speed position is obtained by moving the gearshift lever straight back from the LOW-speed position. In B of figure 9-4, you will see that the next to the smallest countershaft gear is in mesh with the second largest sliding gear. The largest sliding gear (shift gear) has been disengaged. The flow of power has been changed as shown by the arrow. The power transmitted to the wheels in SECOND gear (speed) is less, but the truck will move at a greater speed than it will in LOW gear if the engine speed is kept the same.

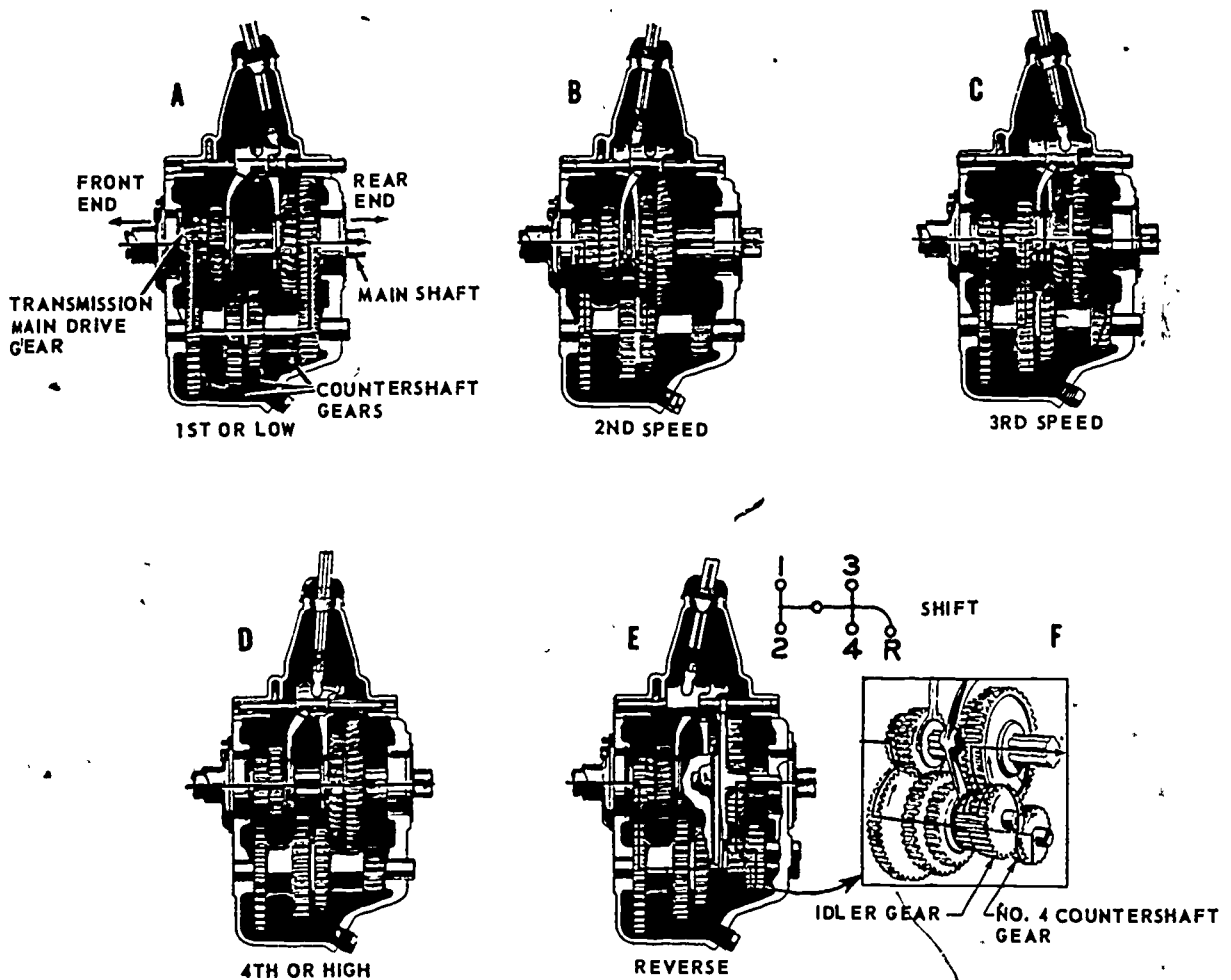

81.182

Figure 9-4.—Power flow through a four-speed transmission.

4

In shifting from the second speed to the THIRD-speed position, you move the gearshift lever through the neutral position. This is done in all selective gear transmissions. From the NEUTRAL position, the driver can select the speed position required to get the power needed. In C of figure 9-4, you will notice that the gearshift lever is in contact with the other shifting fork, and that the forward slide gear has been meshed with the second countershaft gear. The power flow through the transmission has again been changed, as indicated by the arrow, and the truck will move at an intermediate speed between SECOND and HIGH.

You shift into FOURTH- or HIGH-speed position by moving the top of the shift lever back and to the right from the NEUTRAL position. In the HIGH-speed position, the forward shift or sliding gear is engaged with the constant speed gear, as shown in D of figure 9-4. The clutch shaft and the transmission shaft are now locked together and the power flow is in a straight line. In HIGH, the truck propeller shaft revolves at the same speed as the engine crankshaft, or at a 1 to 1 ratio.

You shift to REVERSE by moving the top of the gearshift lever to the FAR right and then to the rear. Most trucks overcome spring pressure

to avoid accidental shifting into reverse. Never attempt to shift into reverse until the forward motion of the vehicle has been completely stopped.

In F of figure 9-4, you can see how the idler gear fits into the transmission gear train. Remember that an idler gear is used to reverse direction but has no effect on the gear ratio in a gear train. In E of figure 9-4, you can see what happens when you shift into reverse. An additional shifting fork is contacted by the shift lever in the far right position. When the shift to reverse is completed, this fork moves the idling gear into mesh with the small countershaft gear and the large sliding gear at the same time. The small arrows in the inset show how the engine power flows through the transmission to move the propeller shaft and the wheels in a reverse direction.

The different combination of gears in the transmission case makes it possible to change the vehicle speed while the engine speed remains the same. It is all a matter of gear ratios, having large gears drive small gears, and small gears driving large gears. If a gear with 100 teeth drives a gear with 25 teeth, the small gear will travel four times as fast as the large one. You have stepped up the speed. Now, let the small gear drive the large gear, and the large gear will make one revolution for every four of the small gear. You have reduced speed, and the ratio of gear reduction is 4 to 1.

In the truck transmission just described, the gear reduction in **LOW** gear is 7 to 1 from the engine to the propeller shaft. In **HIGH** gear the ratio is 1 to 1, and the propeller shaft turns at the same speed as the engine. This holds true for most all transmissions. The **SECOND-** and **THIRD-speed** positions provide intermediate gear reductions between **LOW** and **HIGH**. The gear ratio in **SECOND** speed is 3.48 to 1, and in **THIRD** is 1.71 to 1. The gear reduction or gear ratio in reverse is about the same as it is in **LOW** gear, and the propeller shaft makes one revolution for every seven revolutions of the engine, but in the opposite direction of rotation.

All transmissions do not have four speeds forward, and the gear reductions at the various

speeds are not necessarily the same. Passenger cars, for example, usually have only three forward speeds and one reverse speed. Their gear ratios are about 3 to 1 in both low and reverse gear combinations. You must remember that the gear reduction in the transmission is only between the engine and the propeller shaft. Another reduction gear ratio is provided in the rear axle assembly. If you have a common rear axle ratio of about 4 to 1, the gear reduction from the engine of a passenger car to the rear wheels in low gear would be approximately 12 to 1. In high gear, the ratio would be 4 to 1 as there would be no reduction of speed in the transmission.

### CONSTANT-MESH TRANSMISSION

To eliminate the usual transmission noise developed in the old-type spur-tooth gears used in the sliding gear transmission, the automotive manufacturers developed the constant-mesh transmission which contains helical gears.

In this type of transmission, certain countershaft gears are constantly in mesh with the main shaft gears. The main shaft meshing gears are arranged so that they cannot move endwise. They are supported by roller bearings so that they can rotate independently of the main shaft (figs. 9-5 and 9-6). In operation, when the shift lever is moved to **THIRD**, the **THIRD-** and **FOURTH-**shifter fork moves the clutch gear (A, fig. 9-6) toward the **THIRD-speed** gear (D, fig. 9-6). This engages the external teeth of the clutch gear with the internal teeth of the **THIRD-speed** gear. Since the **THIRD-speed** gear is rotating with the rotating countershaft gear, the clutch gear must also rotate. The clutch gear is splined to the main shaft, and therefore, the main shaft rotates with the clutch gear. This principle is carried out when the shift lever moves from one speed to the next.

Constant-mesh gears are seldom used for all speeds. Common practice is to use such gears for the higher gears, with sliding gears for **FIRST** and **REVERSE** speeds or for **REVERSE** only.

### SYNCHROMESH TRANSMISSION

-- The synchromesh transmission is a type of constant-mesh transmission that permits gears to

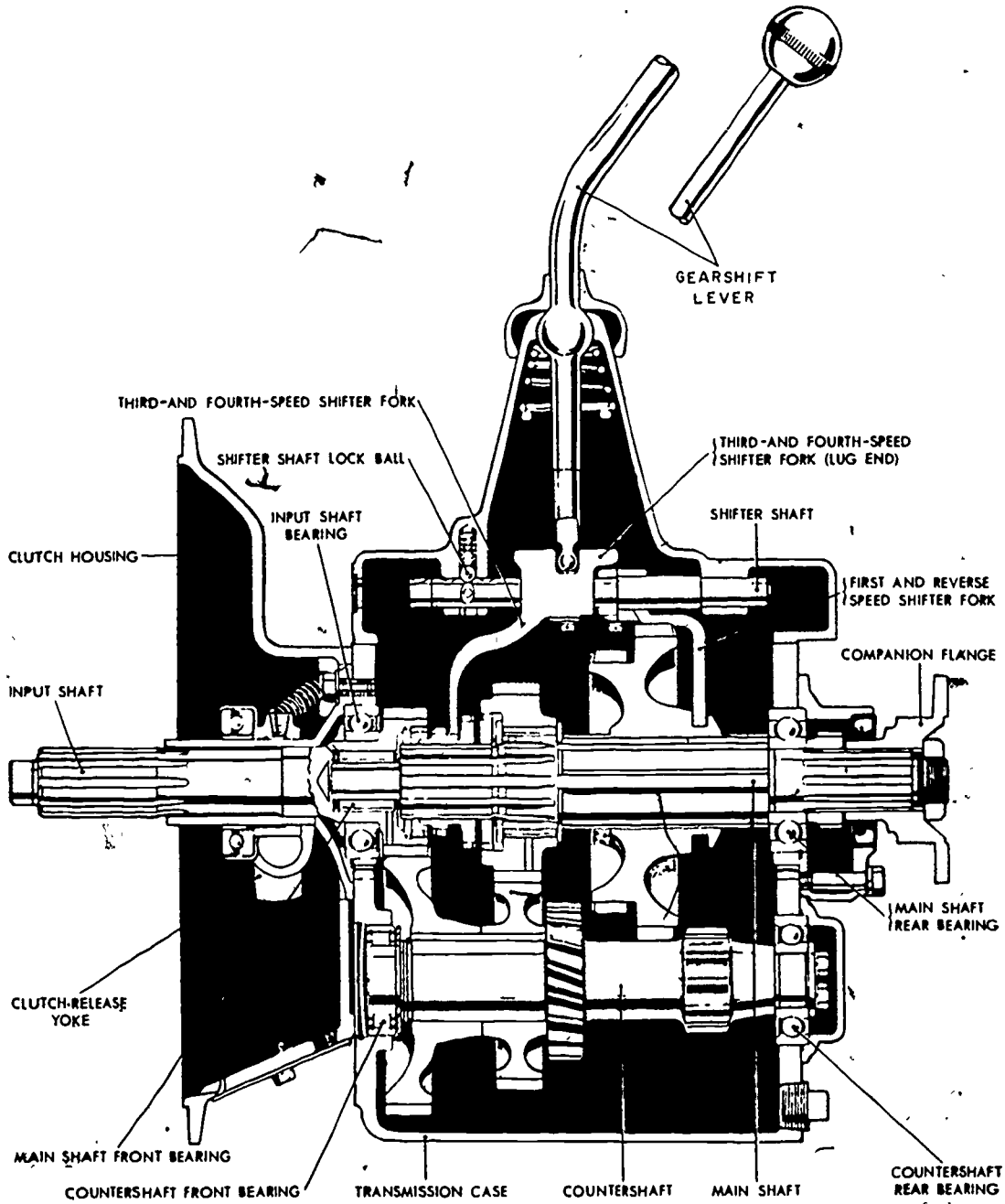

Figure 9-5.—Constant-mesh transmission assembly-sectional view.

81.183

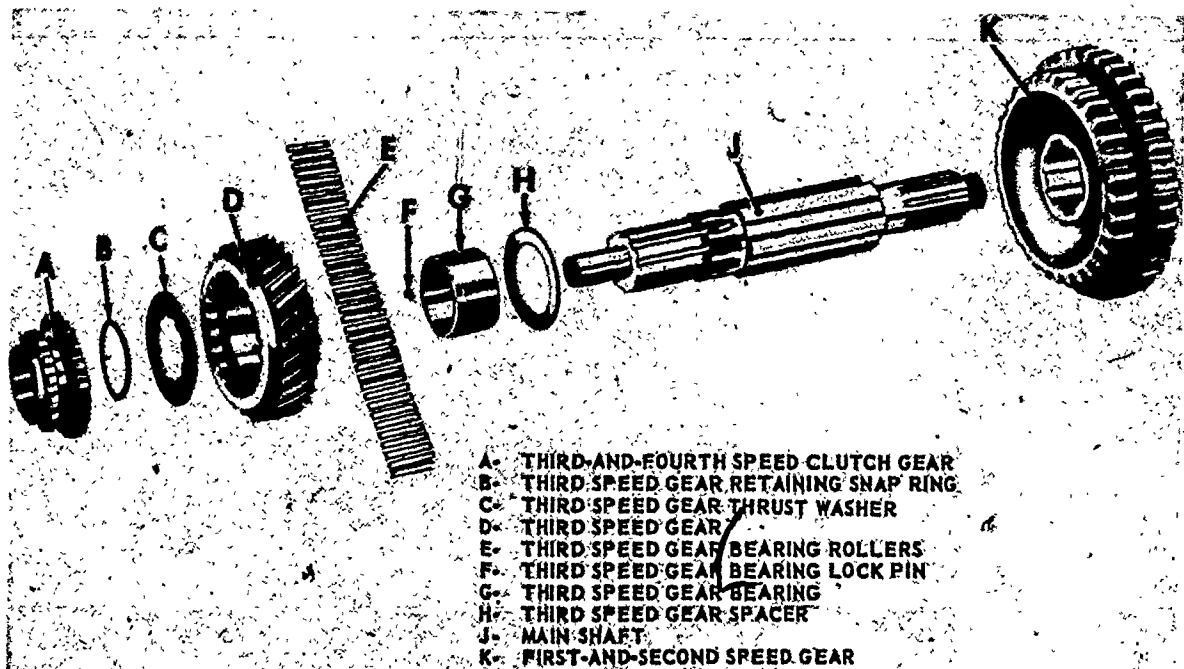

Figure 9-6.—Disassembled main shaft assembly.

81.184

be selected without clashing by synchronizing the speeds of mating parts before they engage. It employs a combination metal-to-metal friction cone clutch and a dog or gear positive clutch to engage the main drive gear and second-speed main shaft gear with the transmission main shaft. The friction-cone clutch engages first, bringing the driving and driven members to the same speed, after which the dog clutch engages easily without clashing. The operation is continuous when the driver declutches and moves the control lever in the usual manner. The construction of a synchromesh transmission varies somewhat with different manufacturers, but the principle is the same in all.

The construction of a popular synchromesh clutch is shown in figure 9-7. The driving member consists of a sliding gear splined to the transmission main shaft with bronze internal cones on each side. It is surrounded by a sliding sleeve, having internal teeth that are meshed with the external teeth of the sliding gear. The sliding sleeve is grooved around the outside to receive the shift fork. Six spring-loaded balls in

radially drilled holes in the gear fit into an internal groove in the sliding sleeve and prevent it from moving endwise relative to the gear until the latter has reached the end of its travel. The driven members are the main drive gear and second-speed main shaft gear; each has external cones and external teeth machined on its sides to engage the internal cones of the sliding gear and the internal teeth of the sliding sleeve.

The synchromesh clutch operates as follows: when the transmission control lever is moved by the driver to the third-speed or direct-drive position, the shift fork moves the sliding gear and sliding sleeve forward as a unit until the internal cone on the sliding gear engages the external cone on the main drive gear. This action brings the two gears to the same speed and stops endwise travel of the sliding gear. The sliding sleeve then slides over the balls and silently engages the external teeth on the main drive gear, locking the main drive gear and transmission main shaft together, as shown in figure 9-7. When the transmission control lever is shifted to the second-speed position, the sliding gear and

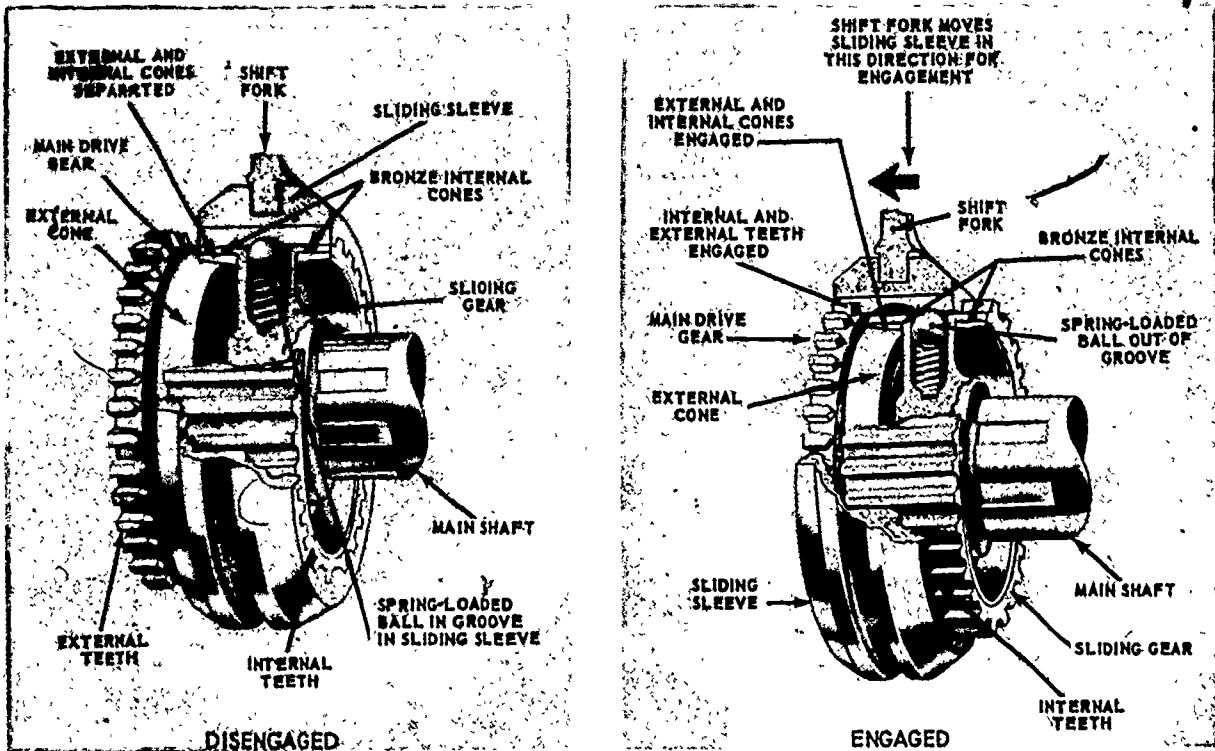

Figure 9-7.—Synchronesh clutch-disengaged and engaged.

81.185

sleeve move rearward and the same action takes place, locking the transmission main shaft to the second-speed main shaft gear. In past years, it has been the practice of the manufacturers not to use the synchronesh clutch on the first or reverse speeds. However, it is becoming common practice on many late model vehicles to use synchronesh clutches on first speed. On transmissions of the type that do not use synchronesh clutches on first and reverse speeds, the first speed is engaged by an ordinary dog clutch when constant mesh is employed, or by a sliding gear; reverse is always engaged by means of a sliding gear. Figure 9-8 shows a synchronesh transmission in cross section which uses constant-mesh helical gears for the three forward speeds and a sliding spur gear for reverse.

Some transmissions are controlled by a steering-column control lever (fig. 9-9). The positions for the various speeds are the same as

those for the vertical control lever, except that the lever is horizontal. The shifter forks are pivoted on bell cranks which are turned by a steering-column control lever through the linkage shown. The poppets shown in figure 9-8 engage notches at the inner end of each bell crank. Other types of synchronesh transmissions controlled by steering-column levers have shifter shafts and forks moved by a linkage similar to those used with a vertical control lever.

### AUXILIARY TRANSMISSION

Auxiliary transmissions are mechanisms mounted in the rear of the regular transmission to provide more gear ratios. The types most commonly used normally have only a low and a high (direct) range, incorporated into a transfer assembly. The low range provides an extremely low-gear ratio on hard pulls. At all other times,

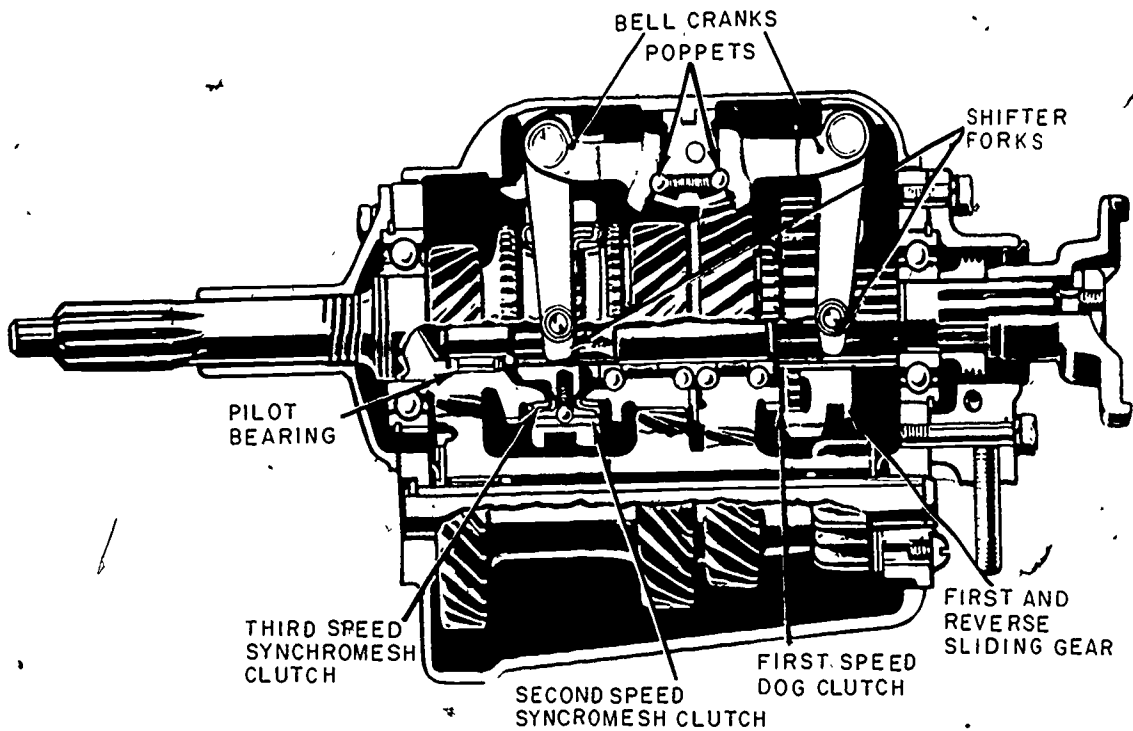

81.186

Figure 9-8.—Synchromesh transmission arranged for steering column control.

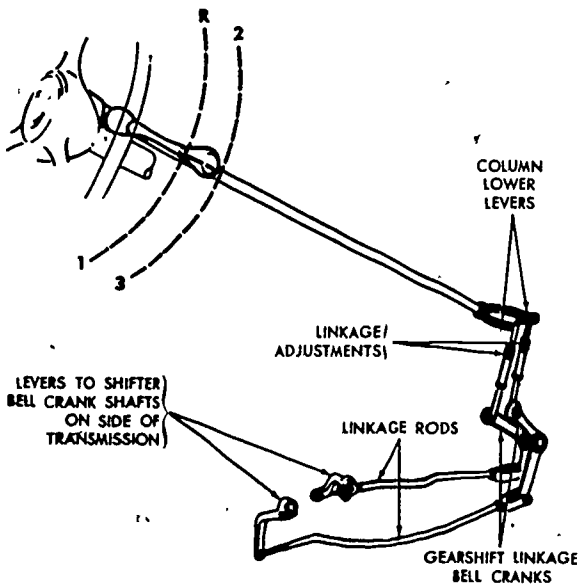

81.187

Figure 9-9.—Steering column transmission control lever and linkage.

the high range is used with the power merely passing through the main shaft. Gears are shifted by a separate gearshift lever in the driver's cab. (See fig. 9-10.)

Trucks require a greater engine-to-axle gear ratio than passenger cars, particularly when manufacturers put the same engine in both types of equipment. In a truck, the auxiliary transmission increases the mechanical advantage. It is connected to the rear of the main transmission by a short propeller shaft and universal joint. Its weight is supported on a frame cross member, as shown in figure 9-10. This illustration also shows how the shifting lever would extend into the driver's compartment near the lever operating the main transmission.

In appearance and in operation, auxiliary transmissions are similar to main transmissions, except that some may have two and some, three speeds (low, direct, and overdrive). When an auxiliary transmission, like the one shown in



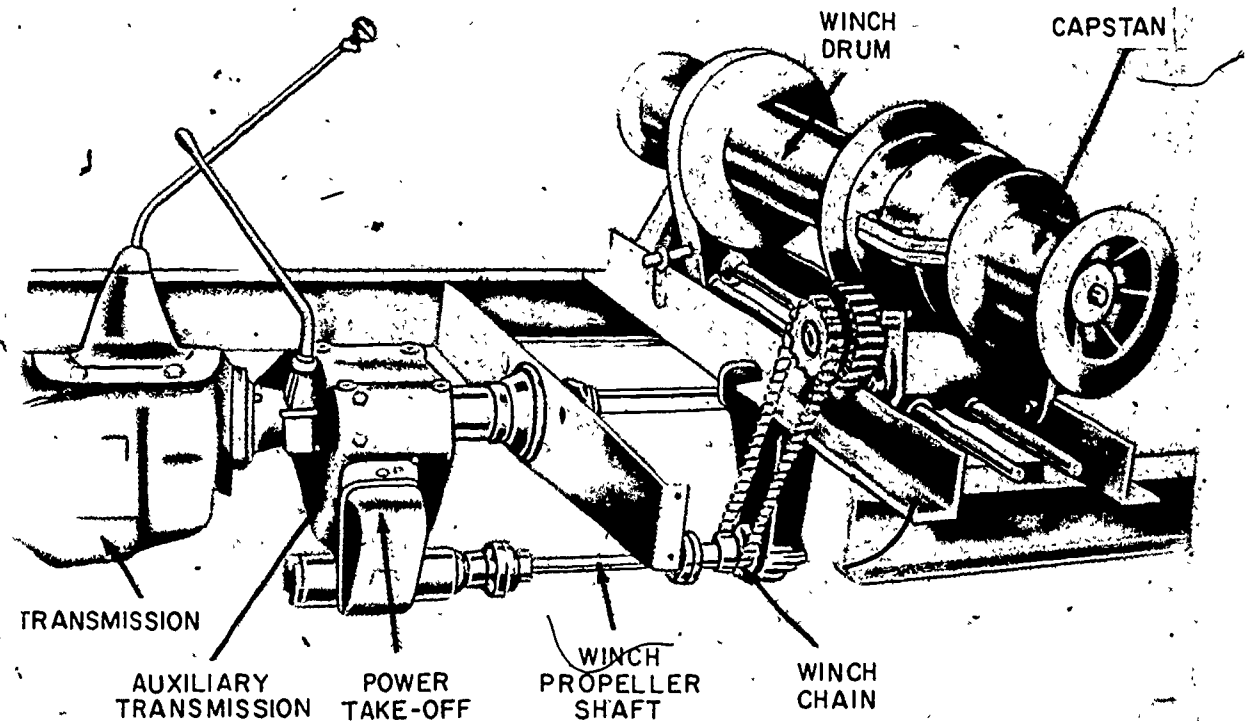

Figure 9-10.—Auxiliary transmission power take-off driving winch.

81.188

figure 9-11, is in the **DIRECT-SPEED** position, power is transmitted directly through the auxiliary transmission to the propeller shaft, and the **FORWARD** and **REVERSE** speeds on the main transmission are the same. When the auxiliary transmission is shifted into **LOW SPEED**, it reduces each speed of the main transmission. When the low speed of the auxiliary transmission is used with the lowest speed of the main transmission, it causes the engine to drive the wheels very slowly and with less engine horsepower.

The constant-mesh type of auxiliary transmission illustrated in figure 9-11 has two gear combinations. The main drive gear is part of the input shaft, and it is in constant mesh with the countershaft drive gear. A pilot bearing aligns the main shaft with the input shaft. The low-speed main shaft gear runs free on the main shaft when direct drive is being used and is in constant mesh with the countershaft low-speed gear. A gear-type dog clutch, splined to the main

shaft, slides forward or backward when you shift the auxiliary transmission into high- or low-gear position.

In **HIGH GEAR**, when direct drive from the main transmission is being used, the dog clutch is forward and makes a direct connection between the input shaft and the main shaft as shown in the illustration. When in **LOW GEAR**, the dog clutch is meshed with the low-speed main shaft gear and is disengaged from the main drive gear.

### TRANSMISSION TROUBLESHOOTING

As a first step in transmission service, diagnosis of the trouble should be made to pinpoint the malfunction in the unit. It is not always possible to determine the exact location of the trouble, and the unit must be removed from the vehicle so that it can be torn down and examined. As a first class or chief, it will be your responsibility to make the final diagnosis of the

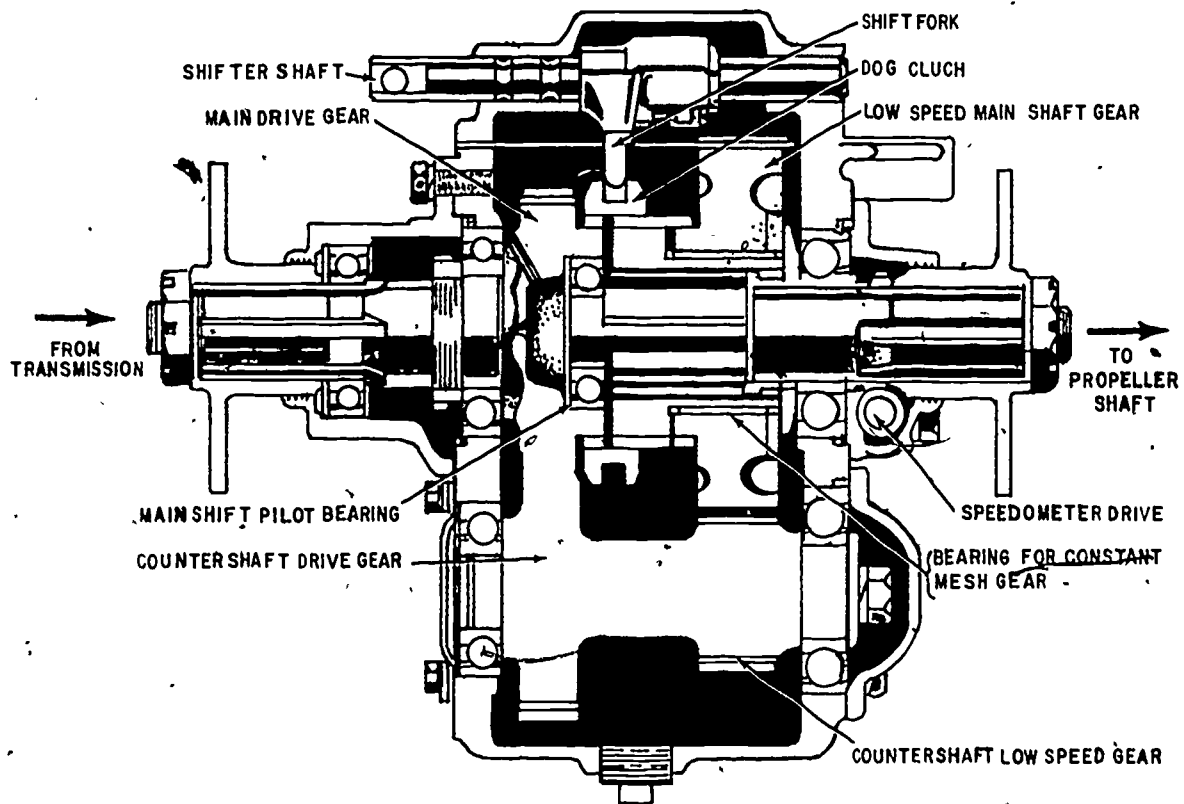

81.189

Figure 9-11.—Sectional view of auxiliary transmission showing gear arrangement.

trouble. Many times an operator will report transmission noise on the Operator's Trouble Report when, in fact, the noise may be coming from some other component of the power train.

Noises that appear to come from the transmission but actually originate at some other point are many and varied. For example, an unbalanced propeller shaft, defective wheel bearings, or damaged tires on a vehicle may cause noises which are transmitted to the transmission. These noises have no particular or characteristic sounds that would indicate their origin; therefore, they are difficult to identify.

Torsional vibration is one of the most frequent causes of noises that appear to be in the transmission, but actually originate outside of it.

Included among these possible outside torsional vibrations are:

1. Propeller shaft (drive shaft) out of balance
2. Worn universal joints
3. Drive shaft center bearings loose
4. Worn and pitted teeth on axle pinion and ring gear
5. Wheels out of balance
6. Worn spring pivot bearings
7. Loose frame or axle U-bolts
8. Engine cooling fan out of balance
9. Engine crankshaft, flywheel, and/or clutch plate out of balance
10. Tires or wheels wobbly or mismatched

This list, along with other troubles that you have encountered in your own experience, can be used as a step-by-step guide in transmission

noise troubleshooting. Make sure that all possibility of outside noise has been eliminated before you remove the transmission.

When analyzing a vehicle for transmission noise, raise the vehicle so that the driving wheels are clear of the deck. Start and operate the vehicle in all the speed ranges, including COASTING with the shift lever in neutral. Listen carefully for noises and try to determine the origin. Other procedures for checking transmission noises may be used. Any procedure that is used relies principally on the experience and good judgment of the supervisor/inspector doing the troubleshooting.

When it is determined that the noise is within the transmission, generally it is necessary to remove the transmission from the vehicle and disassemble it.

### Hard Shifting Into Gear

A low lubrication level in the transmission housing will allow gears and bearings to heat, causing hard shifting. The fluid level of the transmission should always be checked when you are diagnosing hard shifting.

Hard shifting into gear can be caused by improper linkage adjustment between the gearshift lever and the transmission. The same trouble could result when the linkage is badly in need of lubrication, rusted, or jammed at any of the pivot points.

Other causes of hard shifting are failure of the clutch to release fully, the clutch linkage out of adjustment, or a warped friction disk or pressure plate that prevents full clutch disengagement. Gear clashing will continue since the engine will still be delivering at least some power through the clutch to the transmission.

Inside the transmission, hard gear shifting could be due to a bent shifter fork, a tight sliding gear on the shaft splines, a battered sliding gear tooth, or a damaged synchronizing unit. If a bent shifter fork is making it necessary to exert greater pressure when gears are shifted, it should be either replaced or, if not too badly bent, straightened and reused. If the splines in the gears or on the shaft become gummed up or battered from excessive wear so that the gear will not move easily along the shaft spline, then the shaft and gears should be cleaned or, if worn,

replaced. When the sliding gear teeth have been battered, nothing can be done to repair the gears; new gears are required. The synchronizing unit could be tight on the shaft, or it could have loose parts, or worn or scored cones; any of these would increase the difficulty of gear meshing. To correct these and other troubles, the transmission must be removed, disassembled, parts replaced, reassembled, bench tested, and then remounted.

### Slips Out of Gear

When the transmission slips out of gear, improper adjustment of the gearshift linkage between the gearshift lever and the transmission can produce pressure on the linkage so that the gears would work out of mesh.

Worn gears or gear teeth may also increase the chances of gears coming out of mesh. Likewise, if the detent balls (or lockout mechanism in the transmission) lack sufficient spring pressure, there will be little to hold the gears in mesh and they can slip out. Worn bearings or loose gears on the shaft tend to cause excessive play or free motion either of which allows the gears to demesh.

When the transmission slips out of high gear, the trouble could be misalignment between the transmission and the engine. If this condition exists and is allowed to continue, it could soon damage not only the clutch but also transmission parts. This misalignment can often be detected by the action of the clutch pedal; it causes clutch-pedal pulsations, or nervous pedal. Check for misalignment by rotating the crankshaft slowly and measuring the amount of wobble in the flywheel with a dial indicator. This amount should not exceed 0.005 inch. Remember to check the manufacturer's specifications which vary with different types of vehicles.

### No Power to the Propeller Shaft

If the transmission is in mesh, with the clutch engaged, and no power passes through the transmission to the propeller shaft, the clutch could be slipping. If the clutch is not slipping, trouble could be in the transmission itself. Conditions inside the transmission that would

prevent power from passing through to the propeller shaft include gear teeth being stripped, a shifter fork or some other linkage part broken, a gear or shaft broken, and a driving key or spline sheared off. To find and correct these possible troubles, remove the transmission, disassemble, replace those parts that are damaged or broken, reassemble, and remount after bench testing.

### Gears Clash When Shifting

Gear clashing that accompanies shifting into either second or high gear may be failure of the synchronizing mechanism to operate properly. Clashing might well be caused by a broken synchronizer spring, incorrect synchronizer end play, or defective synchronizer cone surfaces. Also, gears could stick on the main shaft or the clutch could fail to release fully. Gear clashing can also be obtained in low or reverse on many vehicles if a sudden shift is made to either of these positions while the gears are still in motion. In some transmissions, these two gear positions do not have synchromesh devices. In these cases, to prevent gear clash when shifting into either of these positions, pause long enough to allow the gears to come to rest. If the clutch is not releasing fully, the gears will still be driven and may clash when the shift is made. Conditions that may prevent the clutch from releasing fully and the procedures for correcting these conditions were discussed in the section covering clutch troubleshooting.

### Transmission Oil Leaks

Oil leaks that are observed in the transmission could result from any of the conditions noted below.

Lubricant in the transmission case which is not the correct type recommended by the manufacturer may foam excessively. As it foams, it will completely fill the case and begin to leak out. The same thing might happen if the oil level is too high. In addition, if the gaskets are broken or missing, or if seals and slingers are damaged or missing, oil will tend to work past the shafts at both ends of the transmission.

If the drain plug is loose or if the transmission bearing retainer is not tightly bolted to the case, or if the case is cracked, oil will be lost.

The right amount of the recommended oil should be used in the transmission to prevent excessive oil leakage due to foaming. Remove and disassemble the transmission so that the defective gaskets, oil seals, and slingers can be replaced. Reassemble the transmission after making these repairs and remount on the vehicle.

### Transmission Noises

Several types of noise might be encountered in transmissions. Whining or growling, either steady or intermittent, might be due to worn, chipped, rough, or cracked gears. As the gears continue to wear, the noise might take on a grinding characteristic, particularly in the gear position that throws the greatest load on the worn gears. Bearing trouble often produces a hissing noise that will develop into a bumping or thudding sound as the bearings wear badly. Metallic rattles could be due to worn or loose shifting parts in the linkage or to gears loose on shaft splines. If the clutch friction-disk cushion springs or the engine torsional-vibration dampener are defective, the torsional vibration of the engine will sometimes carry back into the transmission. This vibration would be apparent only at certain engine speeds.

When analyzing noise in the transmission, note whether the noise is obtained in neutral with the vehicle not moving or in certain gear positions. If the noise is evident with the transmission in neutral with the vehicle not moving, disengage the clutch. If the noise does not stop, the chances are the trouble is not in the transmission at all (provided the clutch actually disengages and does not have trouble, such as stated in the section covering clutch troubleshooting). The noise is probably in the engine or the clutch. If the noise stops when the clutch is disengaged, the trouble is probably in the transmission.

Noise obtained in neutral with the clutch engaged could come from transmission misalignment with the engine, worn or dry bearings, worn gears, a worn or bent countershaft, or excessive end play of the countershaft. These are the parts that are in motion when the clutch is engaged and the transmission is in neutral.

Noise obtained in gear could result from any of the conditions described in the previous

paragraph. It could also be due to a defective friction disk in the clutch or a defective engine torsional-vibration dampener. In addition, the rear main bearing of the transmission could be worn or dry, gears could be loose on the main shaft, or gear teeth could be worn. Another cause of noise could be worn speedometer gears. Placing the transmission in the different gear positions and listening for the noise will help you pinpoint the worn parts producing the noise.

As outlined in previous sections of this chapter, worn transmission parts should be replaced after transmission removal and disassembly.

### TRANSFER CASES

Transfer cases are placed in the power trains of vehicles driven by all wheels (fig. 9-12). Their purpose is to provide the necessary offsets for additional propeller-shaft connections to drive the wheels.

Transfer cases in heavier vehicles have two-speed positions and a declutching device for disconnecting the front driving wheels. Two-speed transfer cases also serve as auxiliary transmissions.

Some transfer cases are quite complicated. When they have speed-changing gears, declutching devices, and attachments for three or more propeller shafts, they are even larger than the main transmission. A cross section of a common type of two-speed transfer case is shown in figure 9-13.

The declutching mechanism for the front wheels consists of a sliding sleeve spline clutch.

This same type of transfer case is used for a six-wheel drive vehicle. The additional propeller shaft connects the drive shaft of the transfer case to the rearmost axle assembly. It is connected to the transfer case through the transmission brakedrum.

Some transfer cases contain an overrunning sprag unit (or units) on the front output shaft. (A sprag unit is a form of overrunning clutch; power can be transmitted through it in one direction but not in the other.)

On these units the transfer case is designed to drive the front axle slightly slower than the rear axle. During normal operation, when both front

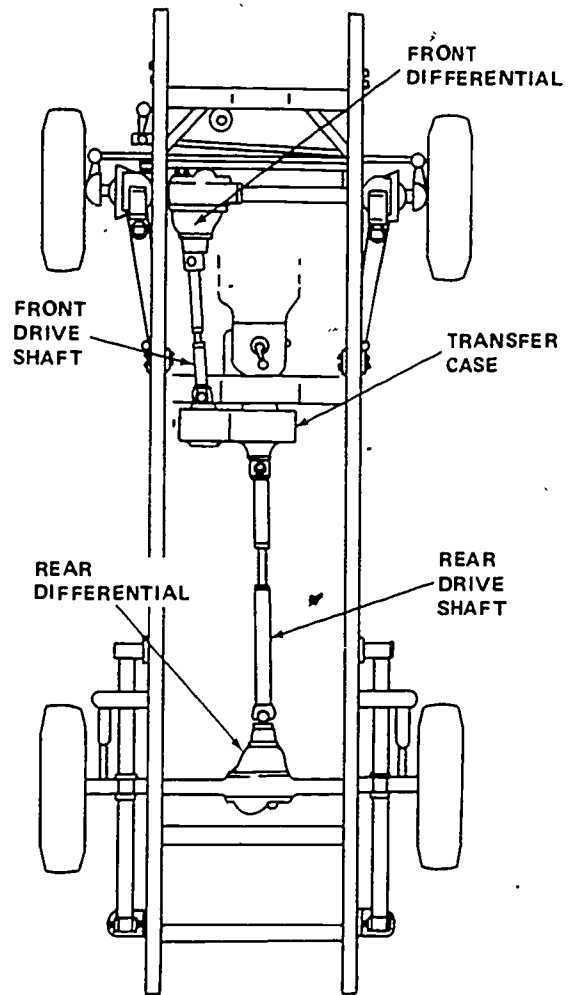

81.190

Figure 9-12.—Transfer case installed in a four-wheel drive truck.

and rear wheels turn at the same speed, only the rear wheels drive the vehicle. However, if the rear wheels should lose traction and begin to slip, they tend to turn faster than the front wheels. As this happens, the sprag unit automatically engages so that the front wheels also drive the vehicle. The sprag unit simply provides an automatic means of engaging the front wheels in drive whenever additional traction is required. There are two types of sprag-unit-equipped transfer—a single-sprag-unit transfer and a double-sprag-unit transfer. Essentially, both types work in the same manner.

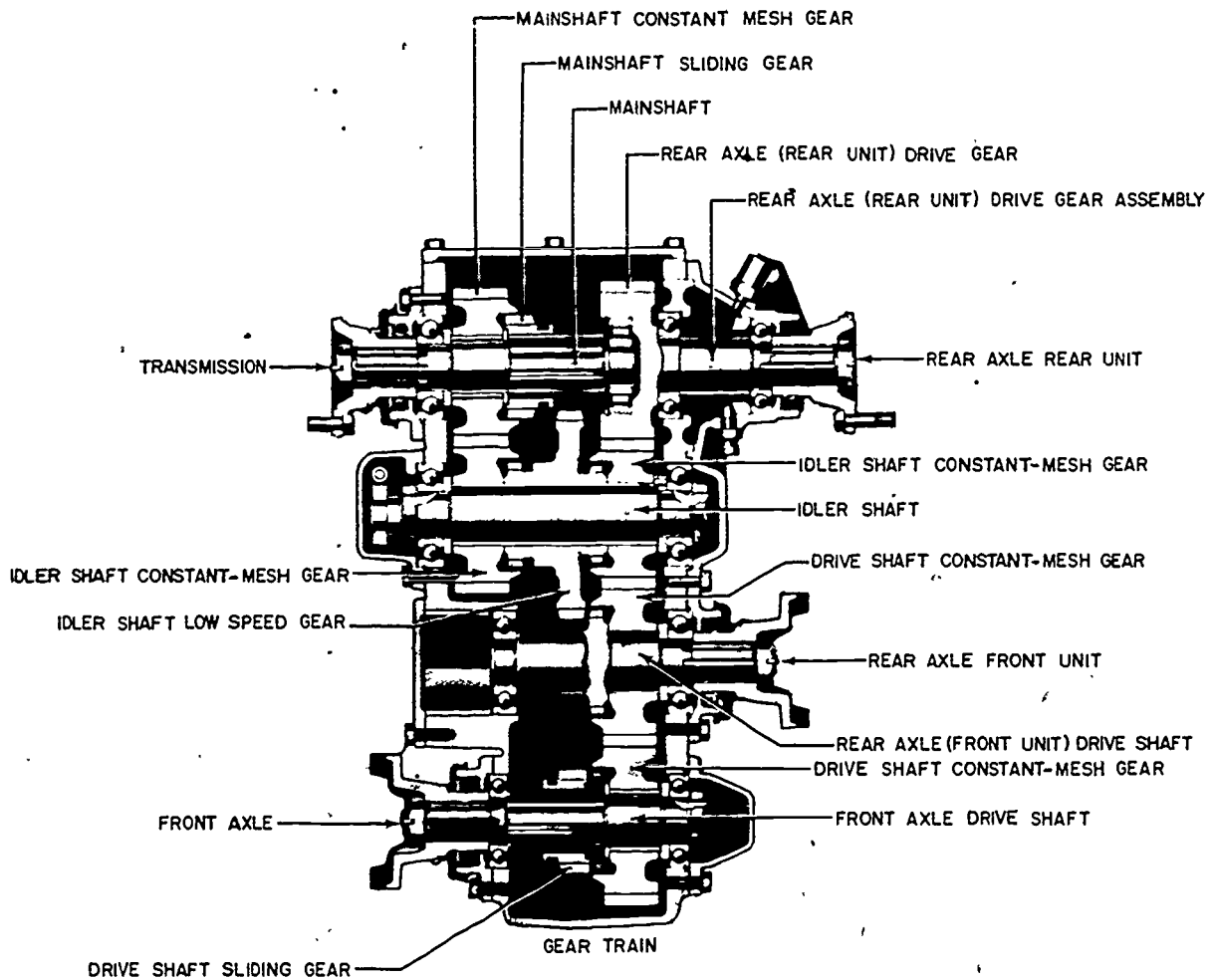

Figure 9-13.—Cross-section of a two-speed transfer case.

81.191

The first indication of trouble within a transfer case, as with other components of the power train, is usually "noisy" operation. If an operator reports trouble, make a visual inspection before removing the unit from the vehicle. Check for such things as oil level, oil leakage, and water in the oil.

Make sure the shift lever linkages are inspected. If the shift lever linkages are bent or improperly lubricated, it will be hard to shift the transfer case or, in some cases, will make shifting impossible. Make sure other possible troubles, such as clutch slippage, damaged propeller shaft, and damaged axles have been eliminated.

Worn or broken gears, worn bearings, and excessive end play in the shafts will cause noisy operation of the transfer case. When it is decided that the trouble is within the transfer case, remove the unit from the vehicle for repairs.

Make sure the transfer case is thoroughly cleaned before disassembly of the unit begins. When the unit is disassembled, clean each part with an approved cleaning solvent. Inspection of the individual parts should follow the same procedure as outlined for transmissions. Avoid waste by reusing old parts that are good.

You should check the manufacturer's repair manual for the particular make and model of

transfer case to insure that proper adjustments and assembly procedures are followed.

### POWER TAKEOFFS

Power takeoffs are attachments in the power train for power to drive auxiliary accessories. They are attached to the transmission, auxiliary transmission, or transfer case. A common type of power takeoff is the single-gear, single-speed type shown in figure 9-14. This unit is bolted to an opening provided in the side of the transmission case, as shown in figure 9-10. The sliding gear of the power takeoff will then mesh with the transmission countershaft gear. The operator can move a shifter shaft control lever to slide the gear in and out of mesh with the countershaft gear. The spring-loaded ball holds the shifter shaft in position.

On some vehicles, you will find power takeoff units with gear arrangements that will give two speeds forward and one in reverse. Several forward speeds and reverse gear arrangements are usually provided in power takeoff units which operate winches and hoists. Their operation is about the same as the single-speed units.

The troubleshooting and repair procedures for the power takeoff are similar to those for the transfer case.

### PROPELLER SHAFT ASSEMBLIES

The propeller shaft assembly consists of a propeller shaft, a slip joint, and one or more universal joints. This assembly provides a flexible connection through which power is transmitted from the transmission to the live axles. The propeller shaft may be solid or tubular. A solid shaft is somewhat stronger than a hollow or tubular shaft of the same diameter, but a hollow shaft is stronger than a solid shaft of the same weight. Solid shafts are generally used inside of a shaft housing that encloses the entire propeller shaft assembly. These are called torque tube drives. To make repairs and adjustments to the propeller shaft assembly in a torque tube, you will have to remove the tube. Hollow shafts are used in the open. (See fig. 9-15.)

A slip joint is provided at one end of the propeller shaft to take care of end play. The driving axle, being attached to the springs, is free to move up and down while the transmission is attached to the frame and cannot move. Any upward or downward movement of the axle, as the springs are flexed, shortens or lengthens the distance between the axle assembly and the transmission. To compensate for this changing distance, the slip joint is provided at one end of the propeller shaft.

The usual type of slip joint consists of a splined stub shaft welded to the propeller shaft which fits into a splined sleeve in the universal joint. A cross-sectional view of the slip joint and universal joint is shown in figure 9-16.

A universal joint is a connection between two shafts that permits one to drive the other at an angle. Passenger vehicles and trucks usually have universal joints at both ends of the propeller shaft.

Universal joints are double hinged with the pins of the hinges set at right angles. They are made in many different designs, but they all work on the same principle. The universal joint shown in figure 9-17 is used in a torque tube drive, and the entire assembly is lubricated with light grease within the bell housing which connects the torque tube to the rear end of the transmission case.

Universal joints normally do not require any maintenance other than lubrication. Some universal joints (U-joints) have grease fittings and should be lubricated when the vehicle has a preventive maintenance inspection. Others may require disassembly and lubrication periodically. When lubricating U-joints that have grease fittings, use a low-pressure grease gun to avoid damaging seals.

### DIFFERENTIALS

The purpose of the differential is easy to understand when you compare a vehicle to a company marching in mass formation. When the company makes a turn, the members in the inside file must take short steps, almost marking time, while members in the outside file must take long steps and walk a greater distance to make the turn. When a motor vehicle turns a corner, the wheels on the outside of the turn must rotate

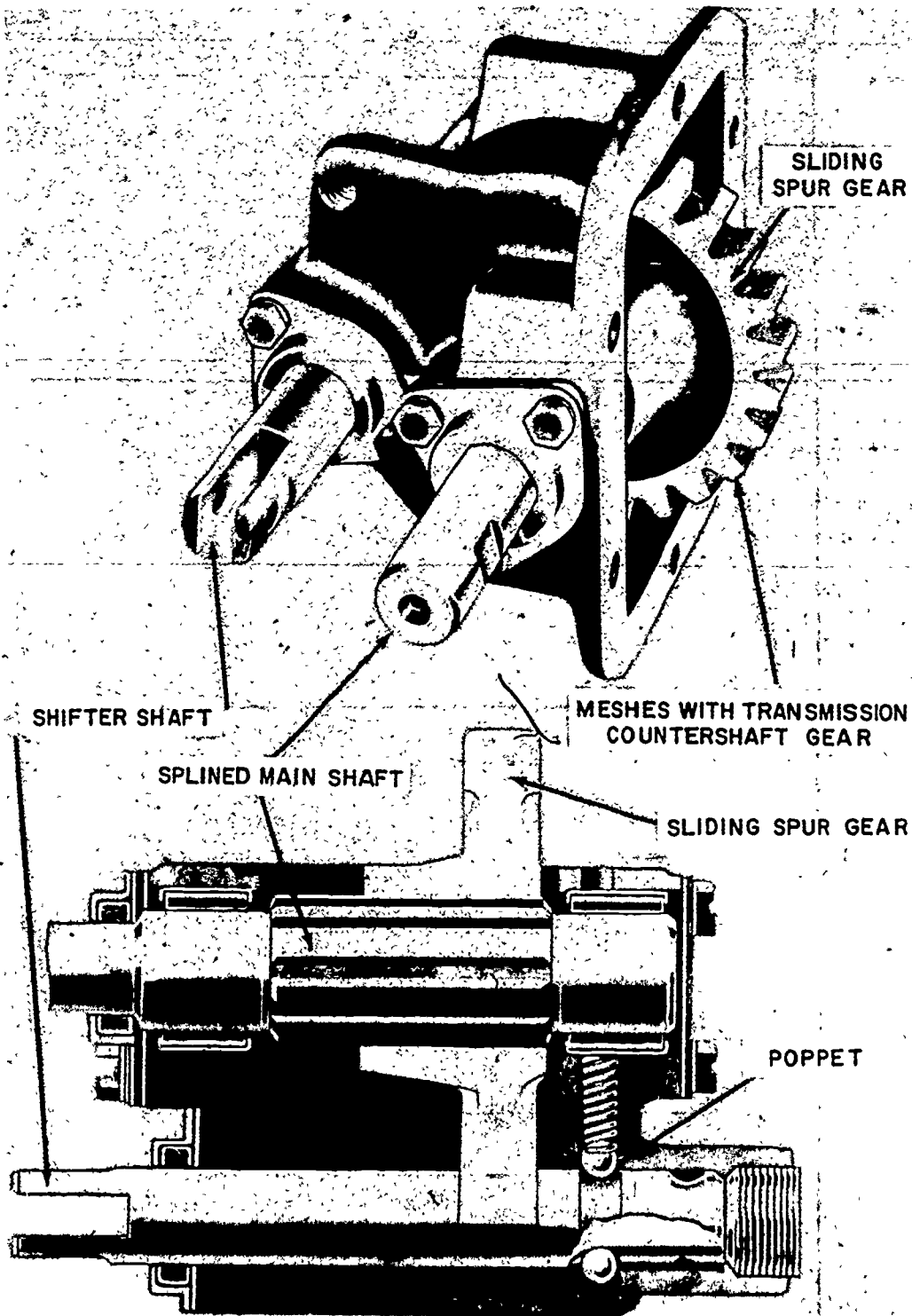

Figure 9-14.—Single speed, single gear, power takeoff.

81.192

920

237



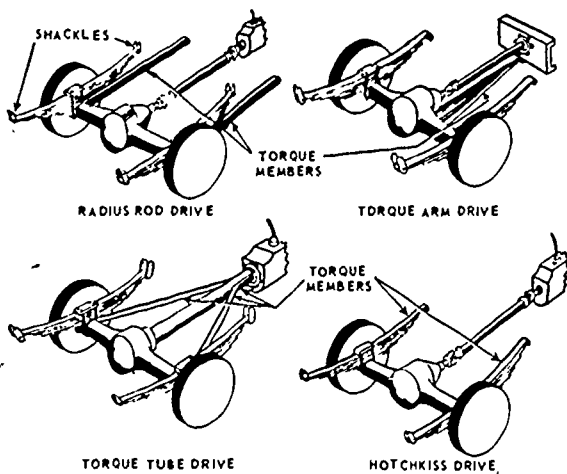

Figure 9-15.—Types of drive. 81.193

faster and travel a greater distance than the wheels on the inside. This causes no difficulty for front wheels of the usual passenger car because each wheel rotates independently. However, to drive the rear wheels at different speeds, the differential is needed. It connects the individual axle shaft for each wheel to the bevel drive gear. Therefore, each shaft can turn at a different speed and still be driven as a single unit. Refer to the illustration in figure 9-18 as you study the following discussion on differential operation.

The bevel drive pinion, connected to the propeller shaft, rotates the bevel drive gear and the differential case which is attached to it. Within the case, the differential pinions are free to turn on individual pivots called trunnions. Power is transmitted to the axle shafts through the differential pinions and the side gears. The axle shafts are splined to the side gears and keyed or bolted to the wheels.

When the resistance is equal on each rear wheel, the differential pinions, side gears, and axle shafts all rotate as ONE UNIT with the drive gear. In this case, there is no relative motion between the pinions and the side gears in the differential case. That is, the pinions do not turn on the trunnions, and their teeth will not move over the teeth of the side gears.

When the vehicle turns a corner, one wheel must turn faster than the other. The side gear driving the outside wheel will run faster than the side gear connected to the axle shaft of the inside wheel. To compensate for this difference in speed, and to remain in mesh with the two side gears, the differential pinions must then turn on the trunnions. The average speed of the two side gears, axle shafts, or wheels is always equal to the speed of the bevel drive gear.

To overcome the situation where one spinning wheel might be undesirable, some trucks are provided with a DIFFERENTIAL LOCK. This is a simple dog clutch, controlled manually or

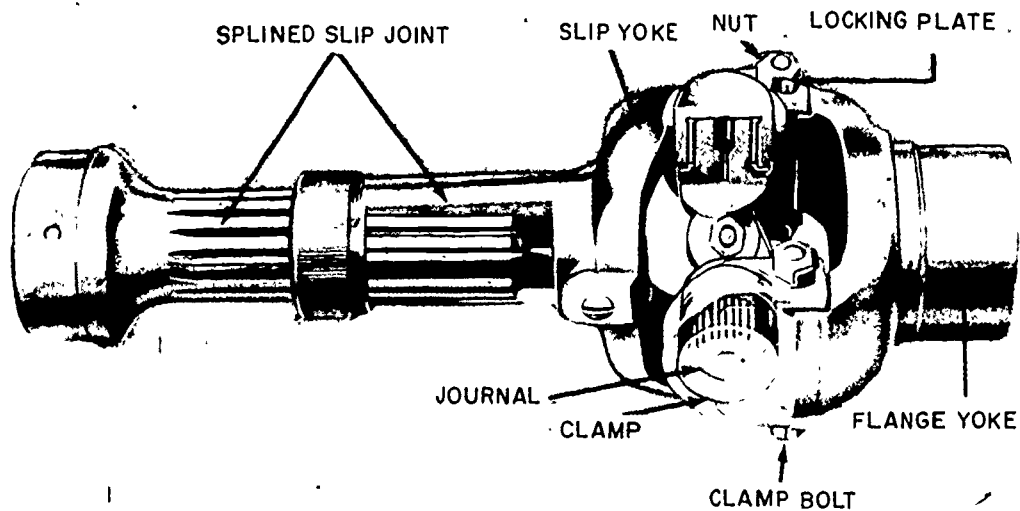
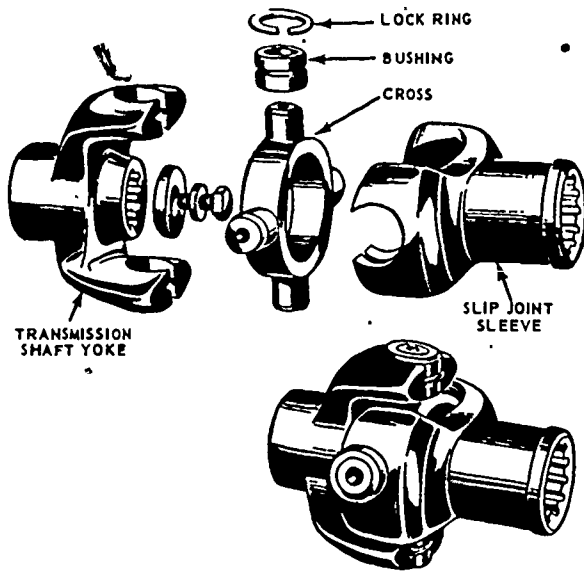

Figure 9-16.—Slip joint and common joint type of universal joints.

2.200



81.194

Figure 9-17.—Ring and trunion universal joint.

automatically, which locks one axle shaft to the differential case and bevel drive gear. Although this device forms a rigid connection between the two axle shafts and makes both wheels rotate at the same speed, it is used very little. Too often, the driver forgets to disengage the lock after using it. There are, however, automatic devices for doing almost the same thing. One of these, which is used rather extensively today, is the high-traction differential. It consists of a set of differential pinions and side gears which have fewer teeth and a different tooth form from the conventional gears. Figure 9-19 shows a comparison between these and standard gears. These differential pinions and side gears depend on a variable radius from the center of the differential pinion to the point where it comes in contact with the side gear teeth, which is, in effect, a variable lever arm. As long as there is relative motion between the pinions and side gears, the torque is unevenly divided between the two driving shafts and wheels; whereas, with the usual differential, the torque is evenly divided at all times. With the high-traction differential, the torque becomes greater on one wheel and less on the other as the pinions move around until both wheels start to rotate at the same speed. When this occurs, the relative motion between the pinion and side gears stops and the torque on each wheel is again equal. This device assists

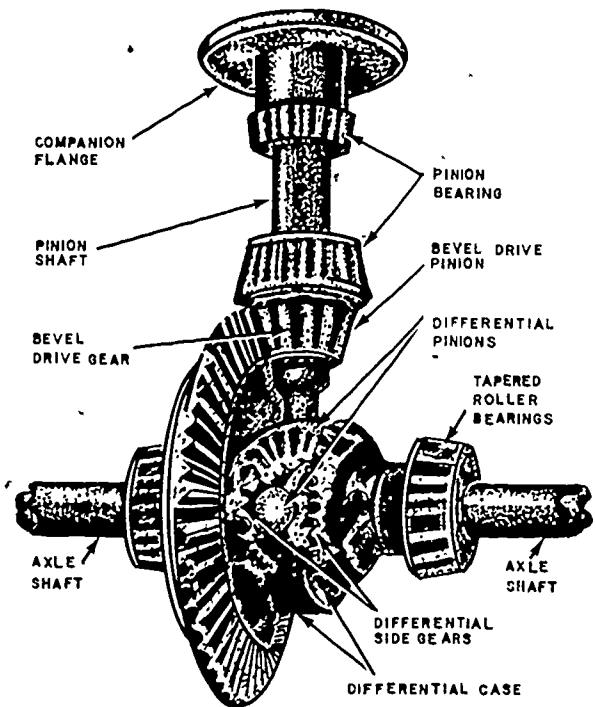

81.196

Figure 9-18.—Differential with part of case cut away.

considerably in starting the vehicle or keeping it rolling in cases where one wheel encounters a slippery spot and loses traction while the other wheel is on a firm spot and has traction. It will not work, however, when one wheel loses traction completely. In this respect, it is inferior to the differential lock.

With the no-spin differential (fig. 9-20), one wheel cannot spin because of loss of tractive effort and thereby deprive the other wheel of driving effort. For example, one wheel is on ice and the other wheel is on dry pavement. The wheel on ice is assumed to have no traction. However, the wheel on dry pavement will pull to the limit of its tractional resistance at the pavement. The wheel on ice cannot spin because wheel speed is governed by the speed of the wheel applying tractive effort.

The no-spin differential does not contain pinion gears and side gears as the conventional differential does. Instead, it consists essentially of a spider attached to the differential drive ring gear through four trunnions, plus two-driven clutch members with side teeth that are indexed by spring pressure with side teeth in the spider.

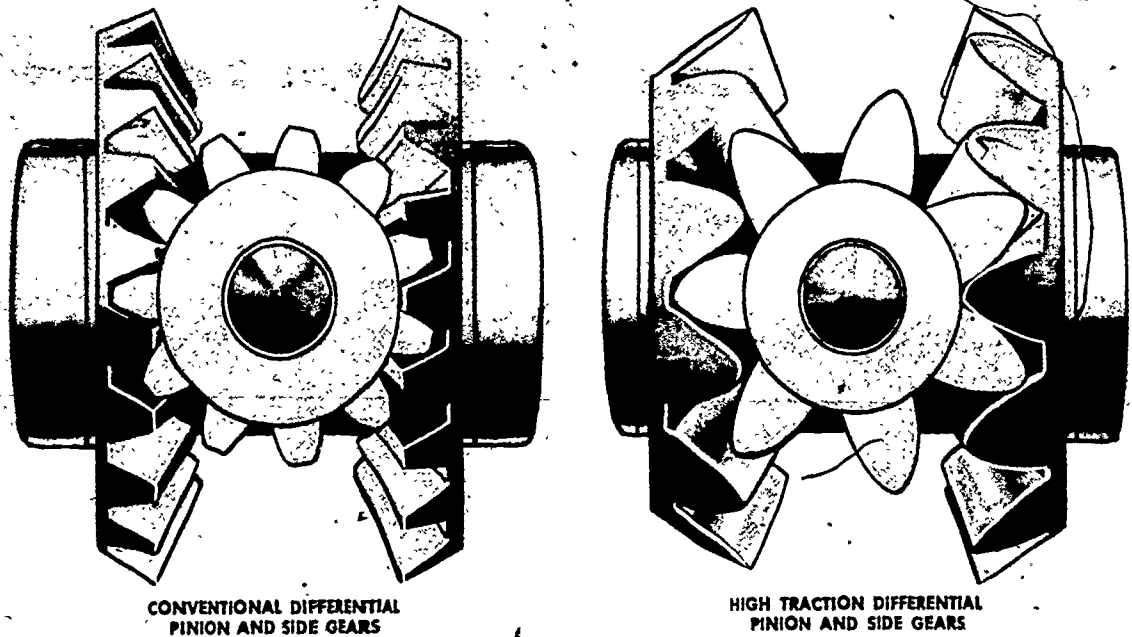

Figure 9-19.—Comparison of high-traction differential gears and standard differential gears.

81.197

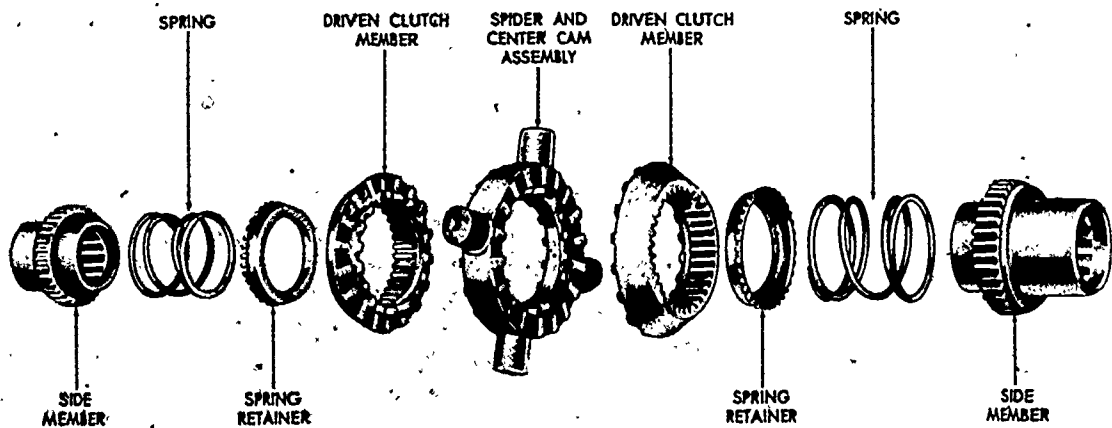

Figure 9-20.—No spin differential—exploded view.

81.198

Two side members are splined to the wheel axles and in turn are splined into the driven clutch members.

### DIFFERENTIAL TROUBLESHOOTING

The first hint of existing trouble in a differential is generally an unusual noise in the rear axle housing. To properly diagnose the trouble,

however, you must determine the source of the noise and under what operating conditions the noise is most pronounced. Defective universal joints, rough rear wheel bearings, or tire noises may be improperly diagnosed by the inexperienced mechanic as differential trouble. Some clue may be gained as to the cause of trouble by noting whether the noise is a growl, hum,

or knock; whether it is heard when the car is operating on a straight road, or on turns only; and whether the noise is most noticeable when the engine is driving the vehicle or when it is coasting with the vehicle driving the engine.

A humming noise in the differential generally means the ring gear or pinion needs an adjustment. An improperly adjusted ring gear or pinion prevents normal tooth contact between the gears and, therefore, produces rapid gear tooth wear. If the trouble is not corrected immediately, the humming noise will gradually take on growling characteristics, and the ring gear and pinion will probably have to be replaced.

It is very easy to mistake tire noise for differential noise. Tire noise will vary according to the type of pavement the vehicle is being driven on, while differential noise will not. To confirm a doubt as to whether the noise is caused by tire or differential, drive the vehicle over various types of pavement.

If a noise is present in the differential only when the vehicle is rounding a corner, the trouble is likely to be in the differential case assembly.

### AXLES, WHEELS, AND TRACKS

A live axle may support part of the weight of a vehicle and also drive the wheels connected to it. A dead axle carries part of the weight of a vehicle but does not drive the wheels. The wheels rotate on the ends of the dead axle.

Usually, the front axle of a passenger car is a dead axle, and the rear axle is a live axle. In four-wheel drive vehicles, both front and rear axles are live axles, and in six-wheel drive vehicles, all three axles are live axles. The third axle, part of a **BOGIE DRIVE**, is joined to the rearmost axle by a trunnion axle as shown in figure 9-21. The trunnion axle is attached rigidly to the frame. Its purpose is to help in distributing the load on the rear of the vehicle to the two live axles which it connects.

There are **THREE** types of live axles used in automotive and construction equipment. They are: semifloating, three-quarter floating, and full floating.

#### Semifloating Axles

The semifloating axle (fig. 9-22) that is used on most passenger cars and light trucks has its

differential case independently supported. The differential carrier relieves the axle shafts from the weight of the differential assembly and the stresses caused by its operation. For this reason, the inner ends of the axle shafts are said to be floated. The wheels are keyed or bolted to outer ends of axle shafts, and the outer bearings are between the shafts and the housing. The axle shafts, therefore, must take the stresses caused by turning or skidding of the wheels. The axle shaft in a semifloating live axle can be removed after the wheel and brakedrum have been removed.

#### Three-Quarter Floating Axles

The axle shafts in a three-quarter floating axle (fig. 9-23) may be removed with the wheels which are keyed to the tapered outer ends of the shaft. The inner ends of the shafts are carried as in a semifloating axle. The axle housing, instead of the shafts, carries the weight of the vehicle because the wheels are supported by bearings on the outer ends of the housing. However, axle shafts must take the stresses caused by the turning, or skidding of the wheels. Three-quarter floating axles are used in some trucks but in very few passenger cars.

#### Full Floating Axles

The full floating axle is used in most heavy trucks. (See fig. 9-24.) These axle shafts may be removed and replaced without removing the wheels or disturbing the differential. Each wheel is carried on the end of the axle tube on two ball bearings or roller bearings, and the axle shafts are bolted to the wheel hub. The wheels are driven through a flange on the ends of the axle shaft which is bolted to the outside of the wheel hub. The bolted connection between axle and wheel does not make this assembly a true full floating axle, but nevertheless, it is called a floating axle. A true full floating axle transmits only turning effort or torque.

#### Driving Wheels

Wheels attached to live axles are the driving wheels. The number of wheels and number of driving wheels is sometimes used to identify equipment. You, as a mechanic, may identify a

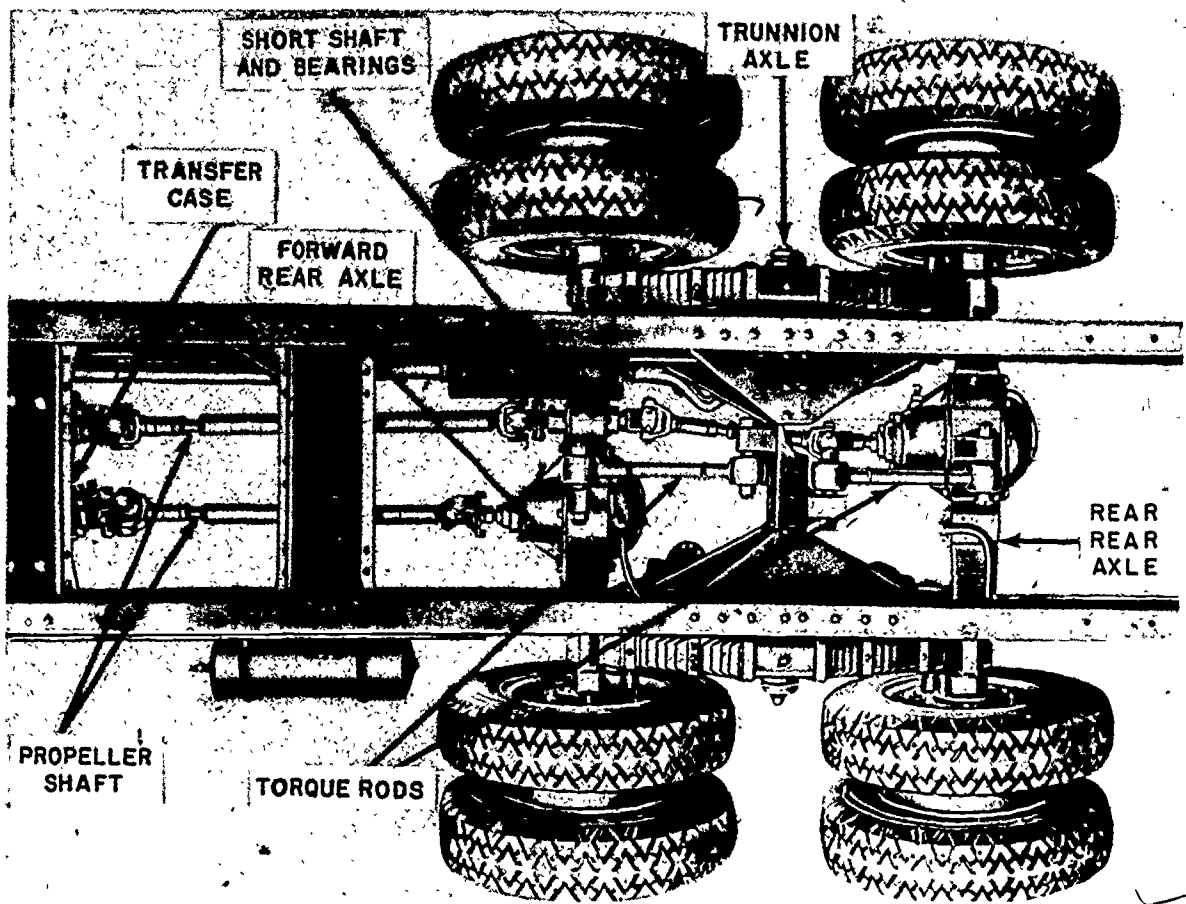

81.199

Figure 9-21.—Bogle four-wheel drive with independent propeller shafts.

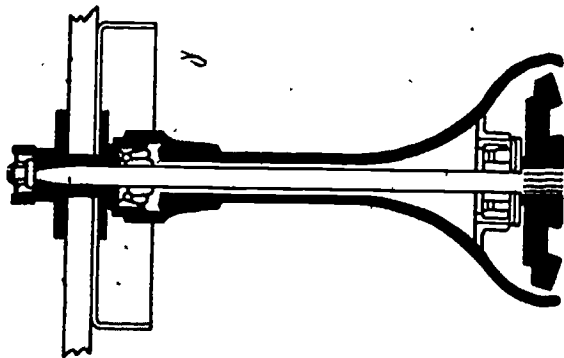

81.200

Figure 9-22.—Semifloating rear axle.

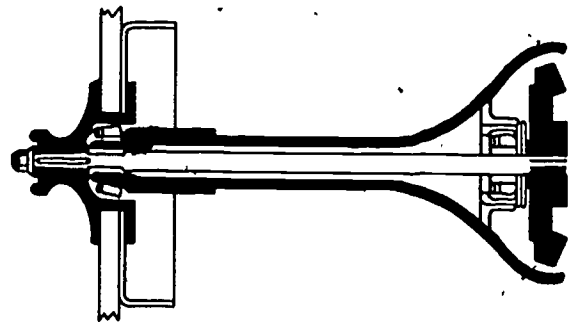

81.201

Figure 9-23.—Three-quarter floating rear axle.

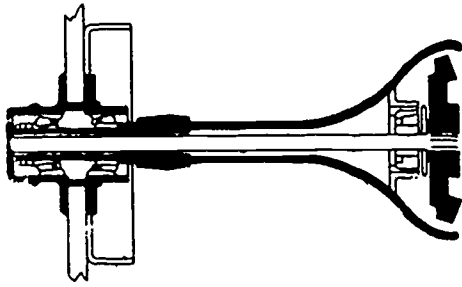

Figure 9-24.—Full floating rear axle.

truck by the gasoline or diesel engine that provides the power. Then again, you may refer to it as a bogie drive.

Wheels attached to the outside of the driving wheels make up **DUAL WHEELS**. Dual wheels give additional traction to the driving wheels and distribute the weight of the vehicle over a greater area of road surface. They are considered as single wheels in describing vehicles. For example, a 4 x 2 could be a passenger car or a truck having four wheels with two of them driving. A 4 x 4 indicates a vehicle having four wheels with all four driving. In some cases, these vehicles will have dual wheels in the rear. You would describe such a vehicle as a 4 x 4 with dual wheels.

A 6 x 4 truck, although having dual wheels in the rear, is identified by six wheels, four of them driving. Actually, the truck has ten wheels but the four wheels attached to the driving wheels could be removed without changing the identity of the truck. If the front wheels of this truck were driven by a live axle, it would be called a 6 x 6.

The tracks on tracklaying vehicles are driven in much the same manner as wheels on wheeled vehicles. Sprockets instead of wheels are driven by live axles to move the tracks on the rollers. These vehicles are identified as either full-track, half-track, or vehicles that can be converted.

### Full-Track

Full track vehicles are entirely supported, driven, and steered by two tracks which replace all wheels.

### Half-Track

Half-track vehicles are supported and steered by wheels at the front, and are driven and supported by tracks at the rear. In addition to having driving tracks, some half-track vehicles are also provided with front-driven axles.

### SERVICE AND MAINTENANCE

There are very few adjustments to be made in power trains during normal operation. Most of your duties concerned with power trains will be limited to preventive maintenance. You will be working with the disassembly, repair, and reassembly of transmissions, rear axles, and propeller shaft assemblies when they break down. You will also inspect these units for indications of major repairs needed. Major repairs can be reduced by proper lubrication and periodic inspection of gear cases, propeller shafts, and wheel bearings.

Proper lubrication depends upon the use of the right kind of lubricant which must be put in the right places in the amount specified by the **LUBRICATION CHARTS**. The charts provided with the vehicle will also show what units in the power train will require lubrication, and where they are located. These units are similar to the ones described and illustrated in this chapter.

In checking the level of the lubricant in **GEAR CASES** and before you add oil, keep these two important points in mind: first, always carefully wipe the dirt away from around the inspection plugs and then use the proper size wrench to remove and tighten them. A wrench too large will round the corners and prevent proper tightening of the plug. For the same reason, never use a pipe wrench or a pair of pliers for removing plugs. Secondly, be sure the level of the lubricant is right—usually just below or on a level with the bottom of the inspection hole. Before checking the level, allow the vehicle to stand for a while on a level surface so the oil can cool and find its own level. Oil heated and churned by revolving gears expands and forms bubbles. Although too little oil in the gear boxes is responsible for many failures of the power train, do not add too much gear lubricant. Too much oil results in extra maintenance.

Excessive oil or grease can find its way past the oil seals or gear cases. It may be forced out of a transmission into the clutch housing and result in a slipping clutch; or it may get by the rear wheel bearings from the differential housing to cause brakes to slip or grab. In either case, you will have extra work to do. Always clean differential and live axle housing vents to prevent pressure buildup (caused by heat) which can result in leaking seals.

**UNIVERSAL JOINTS** and **SLIP JOINTS** at the ends of propeller shafts are to be lubricated if fittings are provided. The same holds true for **WHEEL BEARINGS**. Some of these joints and bearings are packed with grease when assembled; others have grease fittings or small plugs with screwdriver slots that can be removed for inserting grease fittings. Do not remove these plugs until you consult the manual for instructions.

Some passenger cars and trucks have a leather boot or shoe covering the universal and slip joint. The boot prevents grease from being thrown from the joint and it also keeps dirt from mixing with the grease. A mixture of dirt and grease forms an abrasive that will wear parts in a hurry. Never use so much grease on these joints that the grease will be forced out of the boot. The extra grease will be lost and the added weight of the grease will tend to throw the propeller shaft out of balance.

When you are to give a vehicle a thorough inspection, inspect the power trains for loose gear housings and joints. Look for bent propeller shafts that are responsible for vibrations, and examine the gear housings and joints for missing screws and bolts. Check to see that the U-bolts fastening the springs to the rear axle housing are tight. A loose spring hanger can throw the rear axle assembly out of line, and place additional strain on the propeller shaft and final drive. When making these inspections, always tighten the lugs that fasten wheels to live axles.

After tightening gear housings, loose connections, and joints, and finding that no repairs are required, road test the vehicle to see if the various units in the power train are working properly. Shift the gears into all operating speeds and listen for noisy or grinding gears.

## AUTOMATIC TRANSMISSIONS

Different types and models of automatic transmissions and their components are used by the Naval Construction Force in automotive and construction equipment. They include the Turbo Hydra-matic 400, International Harvester (TD-20 series B tractor and model 250 series B loaders), hydraulic torque converter, power shift transmission, and Allison Torqmatic transmission (series 4460).

To become thoroughly familiar with automatic transmissions, you will need special training. The "C-1" advanced schools at Port Hueneme, California and Gulfport, Mississippi indoctrinate CM's in proper maintenance and repair of automatic transmissions and their components.

As a CMI or CMC, consider training an important part of your job. Get your mechanics together for instruction whenever possible. Even your best mechanics can learn more about a particular subject. Tie the work they will be doing and the training together. Those mechanics who are more skilled in the maintenance and repair of automatic transmissions can be utilized to help teach other mechanics in the shop. A good, all-around on-the-job training program will keep you, as well as your mechanics up to date on the latest changes and developments in automatic transmissions. More detailed instructions are to be found in manufacturers' service manuals.

Automatic transmissions operate on the basic mechanical principles of planetary gears controlled by hydraulic pressure. The transmission is a series of complex levers that enables an engine to move heavy loads with less effort.

Transmissions provide neutral, reverse, and forward driving ranges that increase the torque from the engine to the rear wheels, as necessary. Given a suitable number of torque multiplying ratios, it is possible to improve the performance and economy of a vehicle over its entire driving range. Changing the ratio automatically relieves the operator of the responsibility of selecting the best possible ratio for each condition and makes driving safer and easier.

**TURBO HYDRA-MATIC 400**

The model 400 Hydra-matic transmission is a fully automatic unit consisting primarily of a three-element hydraulic torque converter and a compound planetary gear set. Three multiple-disc clutches—one sprag, one roller clutch, and two bands—provide the reaction elements required to obtain the desired function of the compound planetary gear set (fig. 9-25).

The torque converter smoothly couples the engine to the planetary gears through oil and hydraulically provides additional torque multiplication when required. The torque converter consists of a driving member, driven member, and a reaction member known respectively as the pump, turbine, and stator.

The compound planetary gear set gives three forward ratios and one reverse. Changing of the gear ratios is fully automatic in relation to

vehicle speed and engine torque input. Vehicle speed and engine torque signals are constantly fed to the transmission to provide the proper gear ratio for maximum efficiency and performance at all throttle openings.

**Planetary Gears**

Planetary gears are used in the Hydra-matic 400 transmission as the basic means of multiplying the torque from the engine. Planetary gears are so named because of their physical arrangement. They are always in mesh and thus cannot "clash" like other gears that go in and out of mesh. The gears are designed so that several gear teeth are in mesh or in contact at once. This distributes the forces over several teeth for greater strength. Because the shafts generally used with planetary gear trains can be arranged on the same centerline, a very compact unit can be obtained.

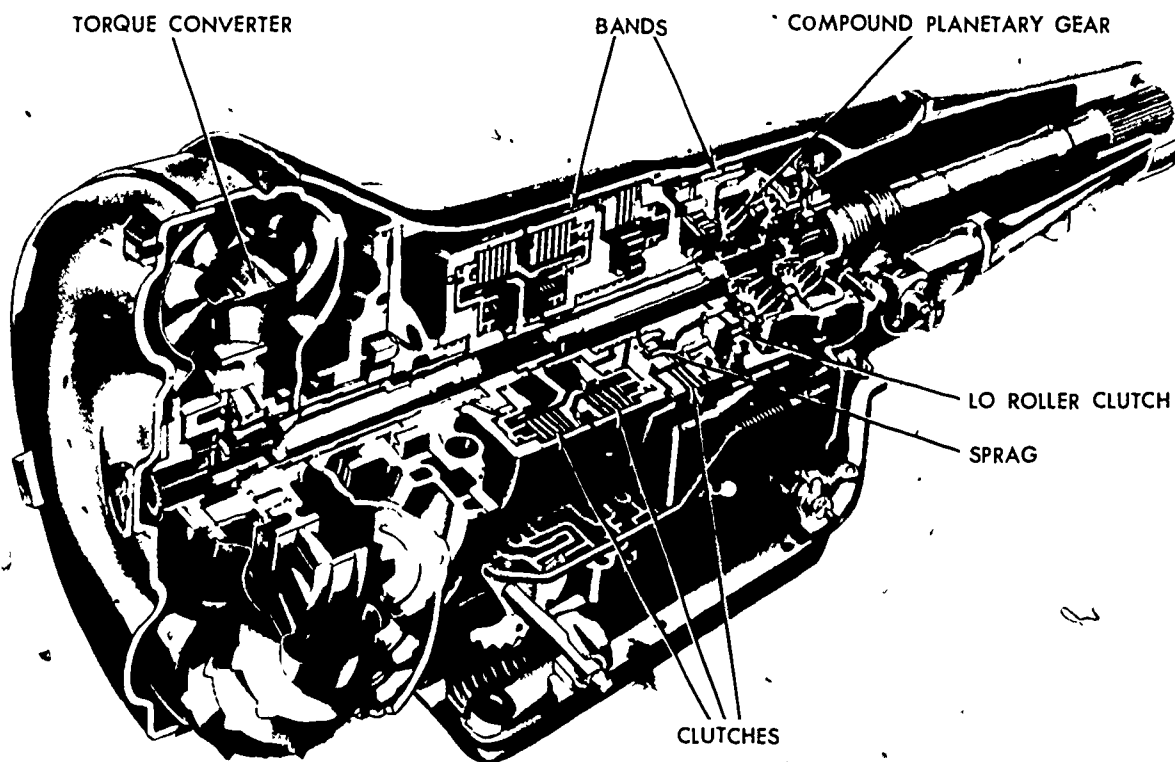

Figure 9-25.—Cut-away view of model 400 Hydra-matic transmission.

2.448.1



A planetary gear train consists of a center or sun gear, an internal gear or ring gear, and a planetary carrier assembly which includes and supports the smaller planet gears or pinions (fig. 9-26). A planetary gear train can be used to increase torque, increase speed, reverse the direction of rotation, or function as a coupling or connector for direct drive. Increasing the torque is generally known as operating in reduction because there is always a decrease in the speed of the output member which is proportional to the increase in the output torque. This means that with a constant input speed, the output torque increases as the output speed decreases.

Reduction can be obtained in several ways. In simple reduction, the sun gear is held stationary and power is applied to the internal gear in a clockwise direction. The planetary pinions rotate in a clockwise direction and "walk" around the stationary sun gear, thus rotating the carrier assembly clockwise in

reduction (fig. 9-27). When any two members of the planetary gear train rotate in the same direction at the same speed, direct drive results. This forces the third member to turn at the same speed. In this condition, the pinions do not rotate on their pins but act as wedges to lock the entire unit together as one rotating part (fig. 9-27). To get a reversal of direction, the carrier is restrained from turning free and power is applied to either the sun gear or internal gear. This causes the planet pinions to act as idlers, thus driving the output member in the opposite direction (fig. 9-28). In both cases the output member is turning in a direction opposite that of the input member.

### Torque Converter Operation

The torque converter serves two primary functions. First, it acts as a fluid coupling to smoothly connect engine power through oil to the transmission gear train. Second, it multiplies

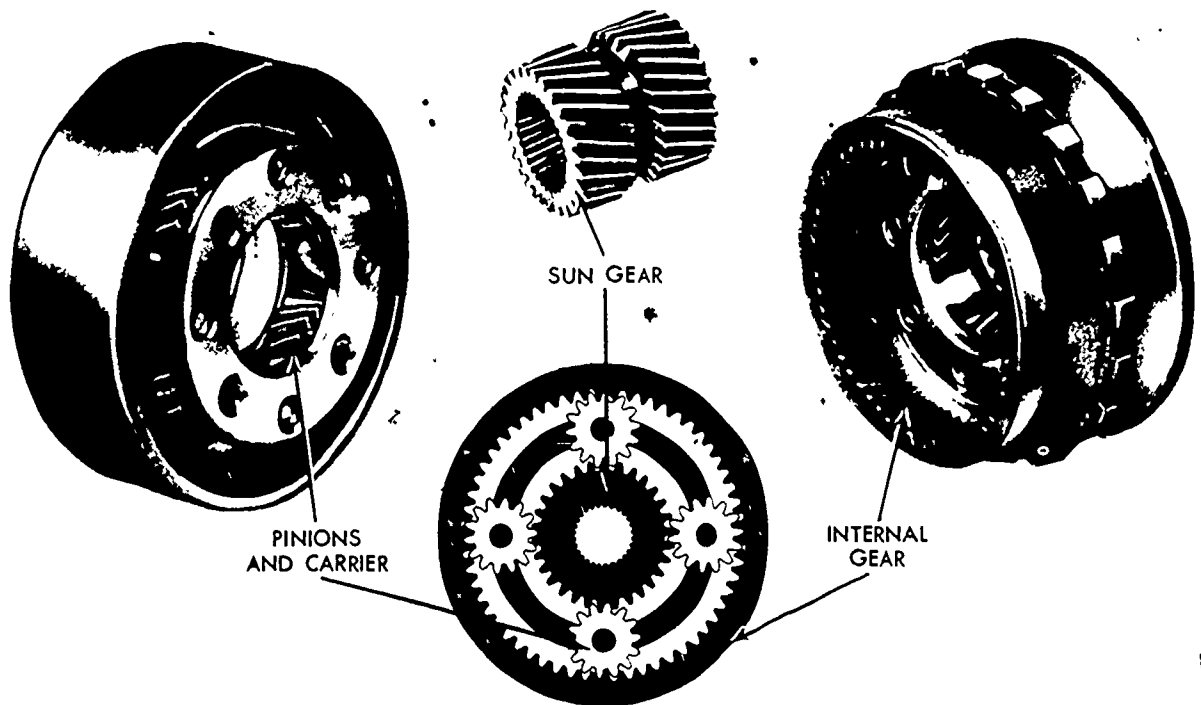

Figure 9-26.—Planetary gear set.

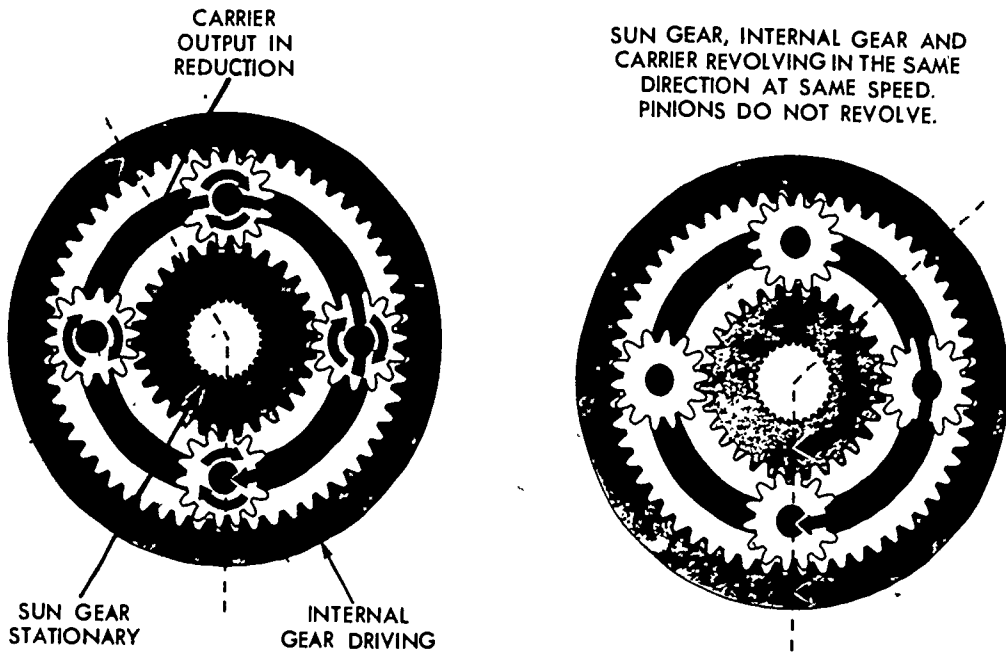

Figure 9-27.—Simple reduction-direct drive.

2.539

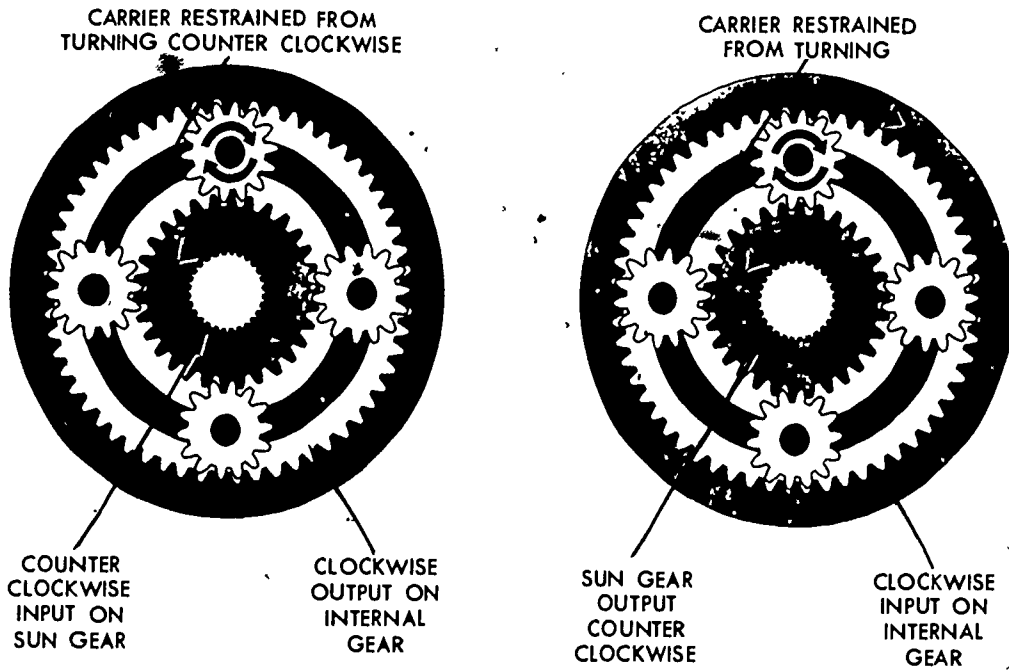

Figure 9-28.—Reversal of direction.

2.540

the torque from the engine when additional performance is desired.

The torque converter, as shown in figure 9-29, consists of the pump (driving member), the turbine (driven or output member), and the stator (reaction member). The converter cover is welded to the pump to seal all three members in an oil-filled housing. The converter cover is bolted to the engine flex-plate which is bolted directly to the engine crankshaft. The converter pump is, therefore, mechanically connected to the engine and turns at engine speed whenever the engine is operating.

When the engine is running and the converter pump is spinning, it acts as a centrifugal pump, picking up oil at its center and discharging this oil at its rim between the blades. The shape of the converter pump shells and blades causes this oil to leave the pump, spinning in a clockwise direction toward the blades of the turbine. As the oil strikes the turbine blades, it imparts a

force to the turbine causing it to turn. When the engine is idling and the converter pump is not spinning fast, the force of the oil leaving the pump is not great enough to turn the turbine with any efficiency. This allows the vehicle to stand in gear with the engine idling. As the throttle is opened and the pump speed increases, the force of the oil increases and engine power is more efficiently transmitted to the turbine member and the gear train. After the oil has imparted its force to the turbine, the oil follows the contour of the turbine shell and blades so that it leaves the center section of the turbine spinning counterclockwise.

Because the turbine member has absorbed the force required to reverse the direction of the clockwise spinning oil, it now has greater force than is being delivered by the engine. The process of multiplying engine torque through the converter has begun. If the counterclockwise spinning oil was allowed to continue to the inner section of the pump member, the oil would strike the blades of the pump in a direction that would hinder its rotation, thus canceling out any gains in torque that have been obtained. To prevent this from happening, a stator assembly is added.

The stator is located between the pump and turbine and is mounted on a one-way or roller clutch which allows it to rotate clockwise but not counterclockwise. The purpose of the stator is to redirect the oil returning from the turbine and change its direction of rotation back to that of the pump member. The energy of the oil is then used to assist the engine in turning the pump. This increases the force of the oil driving the turbine and, as a result, multiplies the torque. The force of the oil flowing from the turbine to the blades of the stator tends to rotate the stator counterclockwise, but the roller clutch prevents it from turning.

With the engine operating full throttle, transmission in gear, and the vehicle standing still, the converter is capable of multiplying engine torque by approximately 2:1. As turbine and vehicle speed increase, the direction of the oil leaving the turbine changes. The oil flows against the rear side of the stator vanes in a clockwise direction. Since the stator is now impeding the smooth flow of oil, its roller clutch automatically releases, and the stator revolves

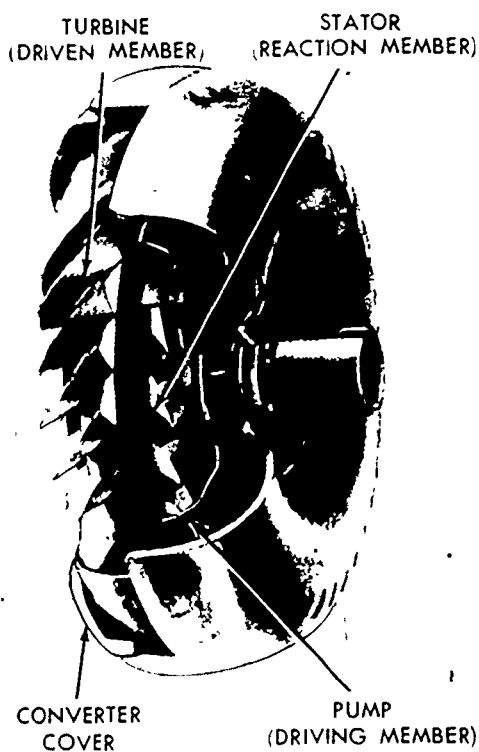

2.541

Figure 9-29.—Torque Converter Assembly.

freely on its shaft. Once the stator becomes inactive, there is no further multiplication of engine torque within the converter. At this point, the converter is merely acting as a fluid coupling as both the converter pump and the turbine are turning at the same speed or at a 1:1 ratio.

### Hydraulic Operation

A hydraulic pressure system requires a source of clean hydraulic fluid and a pump to pressurize the fluid. The Hydra-matic 400 uses an internal-external gear-type pump with its oil intake connected to a strainer assembly. The strainer intake draws oil from the transmission, bottom pan or sump. The pump drive gear is keyed to the converter pump hub and, therefore, turns whenever the engine is operating. As the drive gear turns, it also turns the driven gear, causing oil to be lifted from the sump. As the gears turn, the oil is carried past the crescent section of the pump. Beyond the crescent, the gear teeth begin to come together, causing the oil to be pressurized as it is squeezed from between the gear teeth. At this point, the oil is delivered through the pump outlet to the pressure system.

Oil pressure is controlled by the pressure regulator valve. As the pressure builds, oil is directed through an orifice to the top of the pressure regulator valve. When the desired pressure is reached, the valve moves down against the spring, thus opening a passage to feed the converter. When the converter is filled, oil returning from it is directed to the transmission cooler in the engine radiator. Oil returning from the cooler is then directed to the transmission's lubrication system. As pressure continues to increase, the pressure regulator valve moves to expose a port that directs excess oil to the suction side of the pump. The pressure regulator valve is spring balanced to regulate line pressure at approximately 70 psi at idle.

When the transmission selector lever is moved to the D position, the manual valve moves to allow line pressure to be delivered to the forward clutch. The oil enters the small area first to provide a smooth initial takeup. The larger area is then filled gradually by oil metered

through an orifice to provide the final holding force required.

With the forward clutch applied, the mechanical connection for torque transmission between the turbine shaft and main shaft has been provided. The LO roller clutch assembly becomes effective as a result of the power flow through the compound planetary gear set, and the transmission is in first gear, ready for the vehicle to start moving. As the vehicle begins to accelerate and first gear reduction is no longer required, the transmission automatically shifts to second gear. The vehicle speed signal for the shift is supplied by the transmission governor which is driven by the output shaft. The governor assembly consists of a regulating valve, a pair of primary weights, a pair of secondary weights, the secondary springs, the body, and the driven gear. The governor weights are so arranged that the secondary weights act only on the regulating valve. Because the centrifugal force varies with weight and speed, small changes in output shaft rpm at low speed result in small governor pressure changes. To give even greater change in pressure, the primary weights add force to the secondary weights. As the primary weight moves out at greater vehicle speeds, it finally reaches a stop and is no longer effective. From this point on, only the secondary weights and secondary springs are used to apply the force to the governor valve.

Drive oil pressure is fed to the governor. This in turn is regulated by the governor valve and gives a governor pressure that is proportional to vehicle speed. To initiate the shift from first to second gear, governor oil pressure is directed to the end of the 1-2 shift valve. It acts against the spring pressure holding the valve in the closed position blocking drive oil. As vehicle speed and governor pressure increase sufficiently to overcome spring force, the 1-2 valve opens, allowing drive oil to flow into the intermediate clutch passage and through an orifice to apply the intermediate clutch. This makes the intermediate sprag effective which shifts the transmission into second gear. Further increases in vehicle speed and governor pressure will cause the transmission to shift to third gear.

The operation of the 2-3 shift valve is very similar to the 1-2 shift valve operation. Springs acting on the valve tend to keep the shift valve

closed while governor pressure attempts to open the valve. When speed and governor pressure become great enough to open the 2-3 shift valve, intermediate clutch oil passes through the shift valve and enters the direct clutch passages to apply the direct clutch, thus shifting the transmission into third gear. Oil pressure to the direct clutch piston is applied only to the small inner area in third gear.

When the accelerator is released and the vehicle allowed to decelerate to a stop, the transmission automatically downshifts 3-2 and 2-1. This is accomplished by the decrease in governor pressure as the vehicle slows and the springs closing the shift valves in sequence.

In this system, shifts would always take place at the same vehicle speeds when the governor pressure overcomes the force of the springs on the shift valves. When accelerating under a heavy load or for maximum performance, it is desirable to have the shifts occur at higher vehicle speeds. To make the transmission shift at higher vehicle speeds with greater throttle opening, a variable oil pressure called modulator pressure is used. Modulator pressure is regulated by engine vacuum which is an indicator of engine torque and carburetor opening. The engine vacuum signal is provided to the transmission by the vacuum modulator which consists of an evacuated metal bellows, a diaphragm, and springs. These are so arranged that, when installed, the bellows and one spring apply a force that acts on the modulator valve to increase modulator pressure. Engine vacuum and the other spring act in the opposite direction to decrease modulator pressure; the result is low-engine vacuum which gives a high-torque signal and high-modulator pressure. High-engine vacuum gives a low-torque signal and low-modulator pressure.

Modulator pressure is directed to the 1-2 regulator valve which regulates modulator pressure to a lesser pressure that is proportional to modulator pressure. This tends to keep the 1-2 shift valve in the closed or downshift position. Modulator pressure is also directed to the 2-3 modulator valve to apply a variable force proportional to modulator pressure. This tends to hold the 2-3 shift valve in the closed or downshift position. The shifts can now be

delayed to take place at higher vehicle speeds with heavy throttle operation.

Line pressure is controlled in D (drive) range so that it will vary with torque input to the transmission. Since torque input is a product of engine torque and converter ratio, modulator pressure is directed to a pressure regulator boost valve to adjust the line pressure for changes in either engine torque or converter ratio.

To regulate modulator pressure and, in turn, line pressure with the converter torque ratio that decreases as vehicle speed increases, governor pressure is directed to the modulator valve to reduce modulator pressure with increases in vehicle speed. In this way, line pressure is regulated to vary with torque input to the transmission for smooth shifts with sufficient capacity for both heavy and light acceleration.

The 1-2 shift feel and the durability of the intermediate clutch are dependent on the apply pressure that locks the clutch pack. At minimum or light throttle operation, the engine develops a small amount of torque and as a result, the clutch requires less apply pressure to engage or lock. At heavy throttle, the engine develops a great amount of torque which requires a higher apply pressure to lock the clutch pack. If the clutch locks too quickly, the shift will be too aggressive. If it locks too slowly, it will slip excessively and burn, due to the heat created by the slippage.

### Troubleshooting

The troubleshooting guide (table 9-1) shows some of the most common operators' complaints and measures for correcting troubles in the Turbo Hydra-Matic 400 transmission. These in-vehicle measures will provide the quick answers to transmission problems. For detailed out-of-vehicle checks or tests, refer to the manufacturer's service manual.

### HYDRAULIC TORQUE CONVERTER

The International Harvester (TD-20 series B tractor and model 250 series B loaders) hydraulic torque converter automatically varies the output required at the tracks to meet the changing load requirements of the tractor. Engine power is transferred by the converter with little change in

## CONSTRUCTION MECHANIC 1 & C

**Table 9-1.—Troubleshooting Guide for Turbo Hydra-matic Transmission (Model 400)**

Complaint	Item to be Checked
No drive in D range.	<ul style="list-style-type: none"> <li>a. Oil level.</li> <li>b. Manual linkage (external).</li> <li>c. Oil pressure.</li> <li>d. Manual control disconnected internally.</li> </ul>
No drive or slips in reverse.	<ul style="list-style-type: none"> <li>a. Oil level.</li> <li>b. Manual linkage (external).</li> <li>c. Oil pressure.</li> <li>d. Modulator or lines.</li> <li>e. Clogged strainer or intake leaks.</li> <li>f. Reverse feed passage.</li> <li>g. Valve check balls.</li> <li>h. Reverse servo and accumulator.</li> <li>i. Pump regulator and boost valve.</li> </ul>
Drive in neutral.	<ul style="list-style-type: none"> <li>a. Manual linkage (external).</li> </ul>
Slips in all ranges.	<ul style="list-style-type: none"> <li>a. Oil level.</li> <li>b. Oil pressure.</li> <li>c. Modulator or lines.</li> <li>d. Clogged strainer or intake leaks.</li> <li>e. Valve or body leaks.</li> </ul>
First speed only.	<ul style="list-style-type: none"> <li>a. Governor or feedline seals.</li> <li>b. Valve or body leaks.</li> </ul>
First and second speeds only.	<ul style="list-style-type: none"> <li>a. Detent solenoid.</li> <li>b. Detent switch.</li> <li>c. Valve or body leaks.</li> </ul>
Shifts occur at too high or too low vehicle speeds	<ul style="list-style-type: none"> <li>a. Oil pressure.</li> <li>b. Governor or feedline seals.</li> <li>c. Modulator or line.</li> <li>d. Detent solenoid.</li> <li>e. Valve or body leaks.</li> <li>f. Pump regulator and boost valve.</li> </ul>

torque when the load is light. When a heavy load is encountered, the torque multiplication becomes greater, but with a resulting loss of tractor speed. It is important to note that the converter does not increase engine horsepower, but it does increase the amount of torque available at the tracks.

The converter has three basic parts—impeller, stator, and turbine. (See fig. 9-30.) The IMPELLER is bolted to the converter drive housing, and the drive housing is driven by the engine flywheel. The STATOR is splined to the stationary ground sleeve hub and contains a row of stationary blades, sometimes called guide blades or reactor blades. The TURBINE is splined to the output shaft. The three parts are contained in the converter housing. The housing is filled with fluid held at a constant pressure of 50 to 80 psi during operation to suppress vacuum pockets which form at the blades under high-fluid velocities. There is no direct mechanical connection between the impeller and turbine or stator.

The impeller draws fluid from the opening surrounding the hub and ejects it from its blades at high velocity. The turbine is positioned opposite the impeller, and its blades receive the full impact of this velocity. Fluid exits from the turbine in the opposite direction of rotation from that of the impeller. Then, the curved blades of the stator (positioned between the impeller and turbine) redirects the flow back to the impeller in the same direction as the impeller is moving, completing the cycle.

Torque multiplication is determined by the speed of the turbine in relation to the impeller. A ball thrown at a paddle will strike it with more force if the paddle is stationary rather than moving in the same direction as the ball. Similarly, when the turbine is rotating as fast as the impeller, the fluid passes easily through the turbine, applying little or no force to the blades. As the output shaft slows down, the fluid strikes the turbine blades with more force. The maximum striking force of the fluid is reached when the turbine is stopped. This occurs in the tractor when the output shaft is stalled by a heavy load.

The reservoir for the torque converter fluid is in the rear main frame. The flow from the

reservoir to the converter and from the converter back into the lubricating system is described later in this discussion.

The troubleshooting chart shown in table 9-2 will aid you in locating and correcting mechanical problems in the International Harvester (TD-20 series B tractor and model 250 series B loaders) hydraulic torque converter.

### POWER SHIFT TRANSMISSION

The International Harvester (TD-20 series B tractor and model 250 series B loaders) power shift transmission is designed to provide high-speed shifting by using hydraulic actuated clutches. (See fig. 9-31.) The transmission has two forward and two reverse speeds in low range, and two forward and two reverse speeds in high range. Shifting from one range to another is controlled by the HI-LO shifting lever mounted on the front cover of the transmission.

The transmission is coupled, by a universal joint, to the torque converter which is attached to the flywheel on the engine. Gears are mounted on four shafts: the bevel pinion shaft, the spline shaft, the forward clutch shaft, and the reverse clutch shaft.

The BEVEL PINION SHAFT consists of the high- and low-range gears which are keyed to the shaft. (See fig. 9-32.) The shaft is supported at the rear by a straight roller bearing, and at the front by a double-row taper roller bearing. The pinion gear is splined to the rear of the pinion shaft and held in place by a nut. A shim pack is provided between the front bearing cage and the transmission case front cover for setting the cone center of the pinion and bevel gear.

The SPLINE SHAFT, illustrated in figure 9-33 rotates on two straight roller bearings. The rear bearing is mounted in the transmission case, and the front bearing is in the transmission cover. The first- and second-speed driven gears are held in position on the spline shaft by snap-rings and are in constant mesh with the first- and second-speed drive gears on the clutch shafts. The HI-LO driving gear slides freely on the shaft and drives the bevel pinion shaft when brought into mesh with either the high- or low-range driven gear by the use of the HI-LO shifting lever.

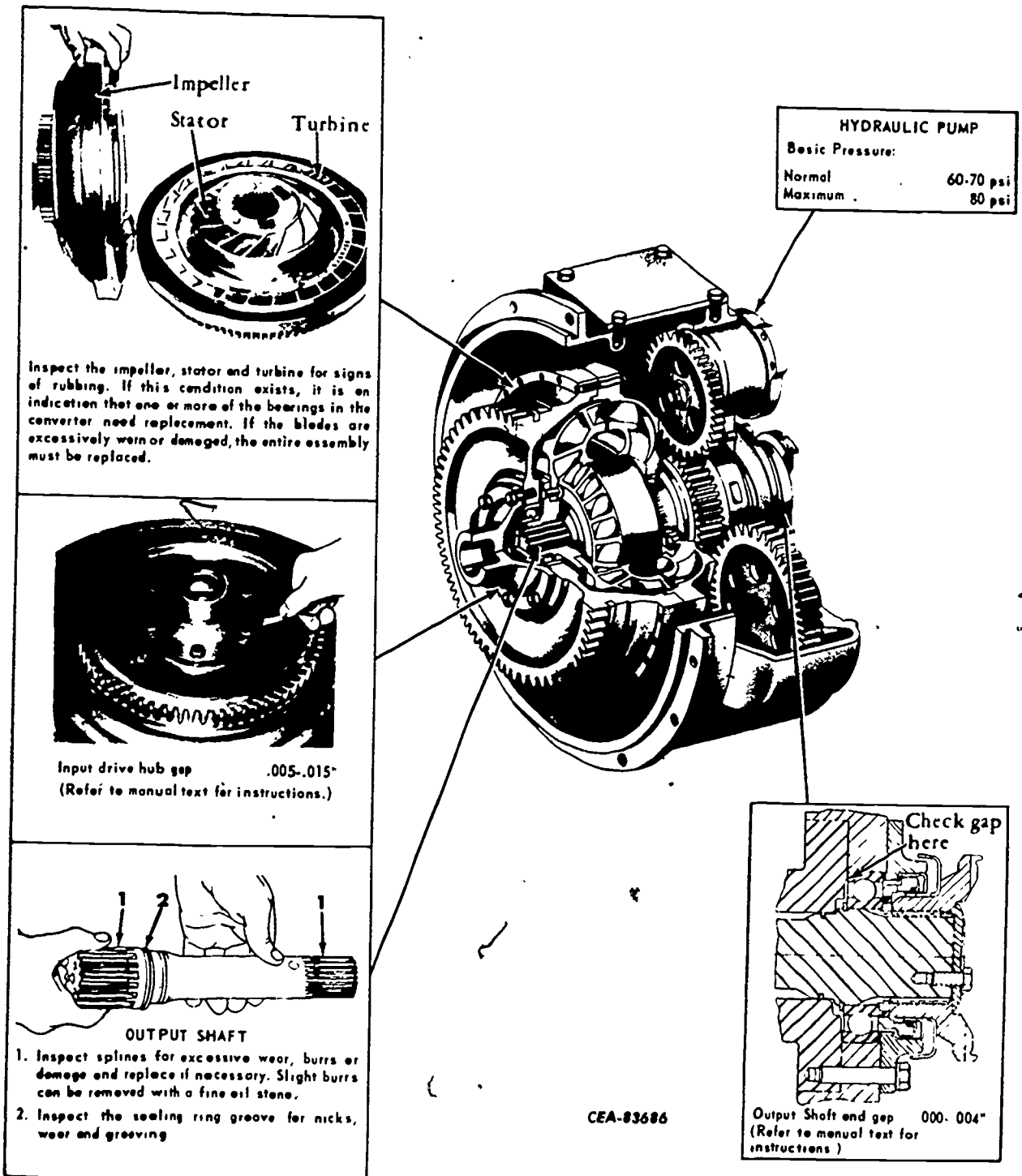

Figure 9-30.—Torque converter.

2.427



**Table 9-2.—Troubleshooting Chart for International Harvester (TD-20 Series B Tractor and Model 250 Series B Loaders) Hydraulic Torque Converter**

Trouble	Possible Causes	Corrective Measures
Loss of fluid from torque converter.	Leaking connections.	Operate the engine at part throttle and inspect all lines and connections for leaks. Tighten or replace parts as necessary.
	Leaking converter.	Check all bolts and nuts and gasket joints while the system is under pressure. Replace parts as necessary.
Torque converter overheating.	Operating too long in low efficiency ranges.	Review operating instructions in the operator's manual.
	Low basic pressure.	Check for broken lines or loose connections on the pressure side of the system. Check for excessive fluid leaking.
	Low oil level.	Check the level in the rear main frame.
	Thermo bypass valve inoperative (if equipped).	Remove and add parts to operate the hydraulic system without a thermo bypass valve.
	Converter bypass valve sticking.	Remove valve and clean. Inspect bore and spring.
Loss of power.	Low oil level.	Check the level in the rear main frame.
	Low basic pressure.	Check for broken lines or loose connections on the pressure side of the system. Check for excessive fluid leaking.
	Converter input pump inoperative.	Inspect pump for damaged parts and replace as necessary.
	Converter bypass valve sticking.	Remove valve and clean. Inspect bore and spring.
	Engine not up to rated performance.	Refer to engine service manual.
Grinding or scraping noise inside converter housing.	Bearing failure allowing the turbine or impeller blades to strike the fixed stator.	Replace bearings, turbine, or impeller as necessary.

# CONSTRUCTION MECHANIC 1 & C

### HI-LO SHIFTER LEVER SPRINGS



Free Length Inches	Test Length Inches	Test Load Pounds	No. of Coils
2	$1\frac{1}{16}$	67	$12\frac{1}{2}$

### CLUTCH SHAFT

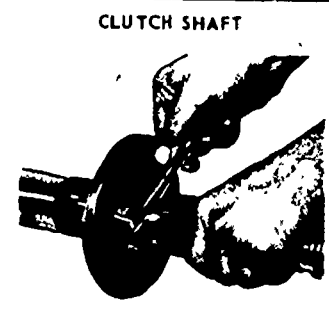

Clutch peck gear and drum assembly end play (Inch):  
 New clutch peck assy. . . . .010-.030  
 Used clutch peck assy. . . . .010-.040  
 (Refer to manual text for instructions.)

Using an oil stone, remove any burrs that might damage sealing surfaces or increase wear to close tolerance parts.

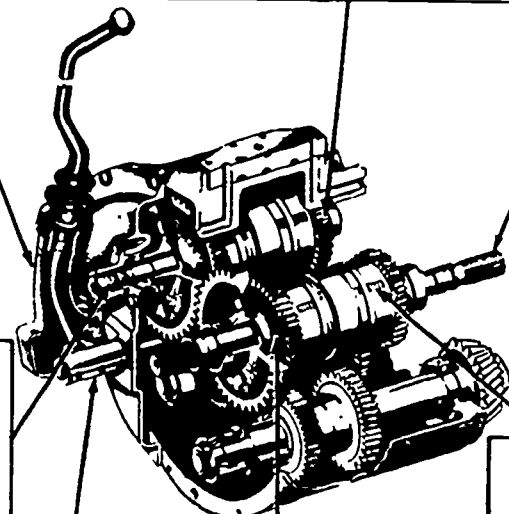



Reverse clutch shaft end play (Inch) . . .030-.040  
 (Refer to manual text for instructions.)

### CLUTCH PLATES



Inspect clutch plates for excessive wear and warpage.  
 Minimum allowable thickness for internally splined bronze clutch plates (Inch) . . .088

### HI-LO SHIFTER FORK AND DRIVING GEAR

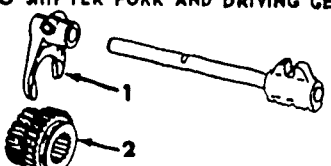

Inspect the hi-lo shifter fork fingers for misalignment or wear and the shifter fork slot in the driving gear for wear

1 Width of shifter fork fingers (Inch)	.365-.375
2 Width of slot in driving gear (Inch)	.380-.390

### FIRST AND SECOND SPEED DRIVE GEAR, BUSHING AND THRUST WASHER

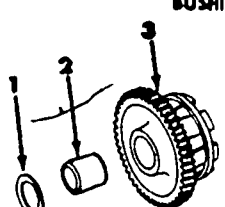

1. Inspect the first and second speed drive gear and drum assemblies for excessive wear or damage.
2. First and second speed drive gear bushing- inside diameter (assembled in gear (Inches) 2.254-2.257  
 Maximum allowable running clearance (Inch) 009
3. Thrust washer minimum allowable thickness (Inch)  
 First speed drive gear .388  
 Second speed drive gear 054

CEA-84393

Figure 9-31.—Power shift transmission.

2.428

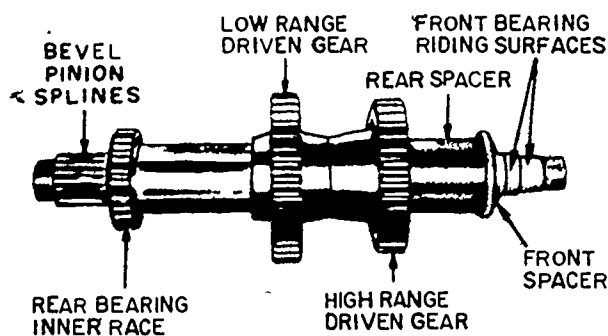

2.429

Figure 9-32.—Bevel pinion shaft.

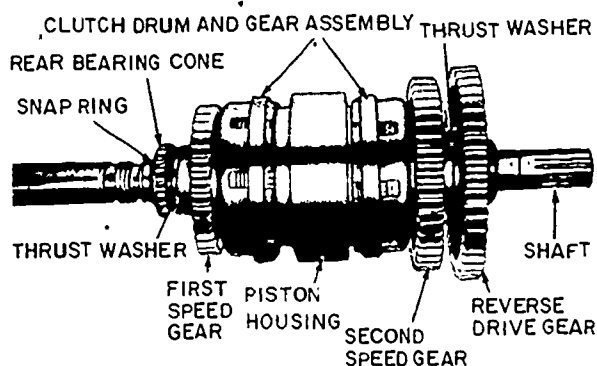

2.431

Figure 9-34.—Forward clutch shaft.

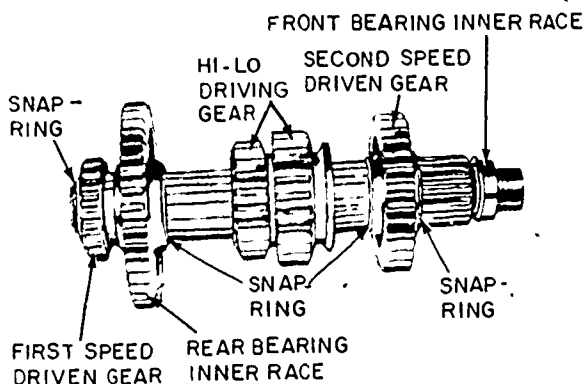

2.430

Figure 9-33.—Spline shaft.

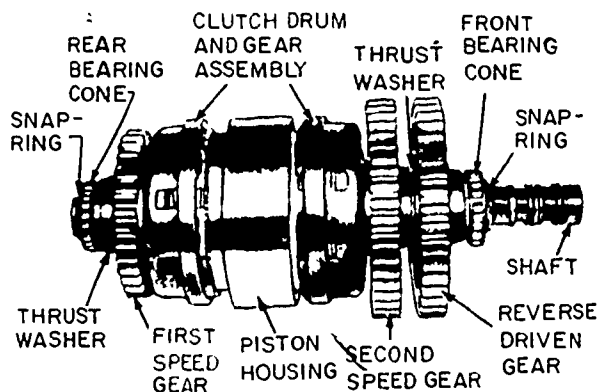

2.432

Figure 9-35.—Reverse clutch shaft.

The FORWARD CLUTCH SHAFT shown in figure 9-34 rotates on a straight roller bearing at the rear and at a ball bearing at the front.

The REVERSE CLUTCH SHAFT shown in figure 9-35 has a straight roller bearing at each end. The reverse drive gear is keyed to the front of the forward clutch shaft, and the reverse-driven gear is keyed to the front of the reverse clutch shaft. Each shaft consists of first- and second-speed drive gears which ride on bushings and are welded to the dual hydraulic clutch pack assemblies.

### Forward and Reverse Hydraulic Clutch Operation

The forward and reverse hydraulic clutch is actually two clutches on a common shaft with a

common apply force piston between them. The clutches allow the simple transfer of oil from the disengaged clutch into the cavity created by the engaging clutch. This allows a low volume of main pressure to actuate the clutch for high-speed shifting.

The heart of the clutch is contained in two pistons—the accelerator piston and the force piston. Pump oil volume is not needed to fill the applying clutch cavity, and only a relatively low volume is needed to pressurize the clutch. In neutral, all accelerator and force piston cavities are filled with oil at lube pressure (10 to 25 psi). A selector valve, located on the top of the

transmission case, directs the oil to the accelerator piston cavities and, in turn, to the force piston cavities. From this valve, oil is directed through the inside of a tube pressed in the clutch shaft and a cross-drilled shaft hole and on the outside of the tube and through a cross-drilled shaft hole to fill both clutch piston cavities. Once the pistons are filled with oil, they remain full under lube pressure. Other small cross-drilled shaft holes furnish a constant supply of lube oil to the bushing beneath the drive gear and drum assemblies and to the clutch hubs for distribution through the clutch plates.

In neutral, neither clutch is engaged; the drive gear and drum assemblies are free and no torque is transmitted through the clutch. (See fig. 9-36.)

Upon application of a clutch, main oil pressure (approximately 200-230 psi) is directed through the clutch shaft for the specific side of the clutch desired and enters the accelerator piston cavity. In figure 9-37, main oil pressure enters the accelerator piston cavity (A) through the cross-drilled hole in the clutch shaft. During this phase, main pressure also lubricates the clutch plates and the bushing under the drive gear and drum assembly on the activated side.

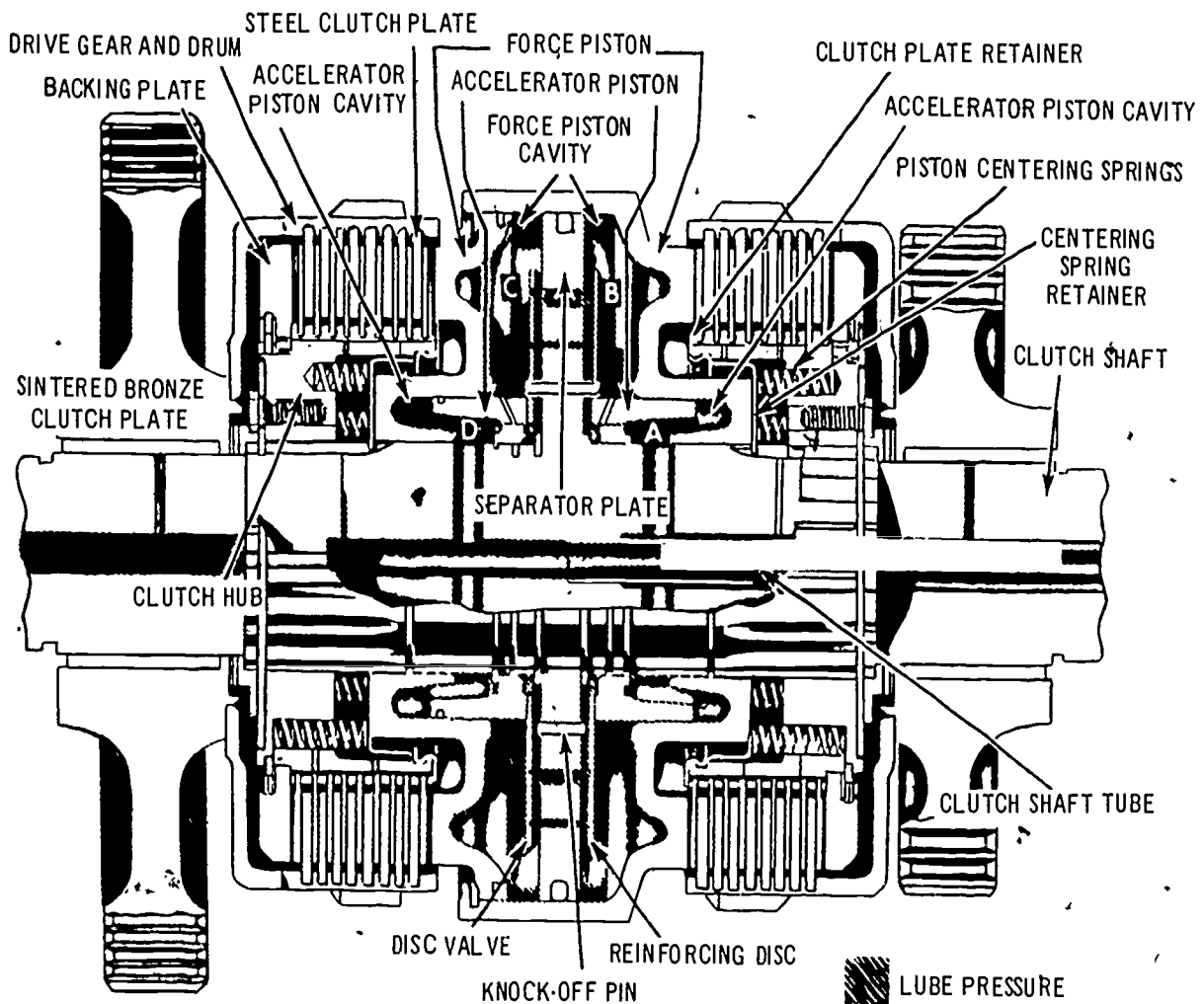
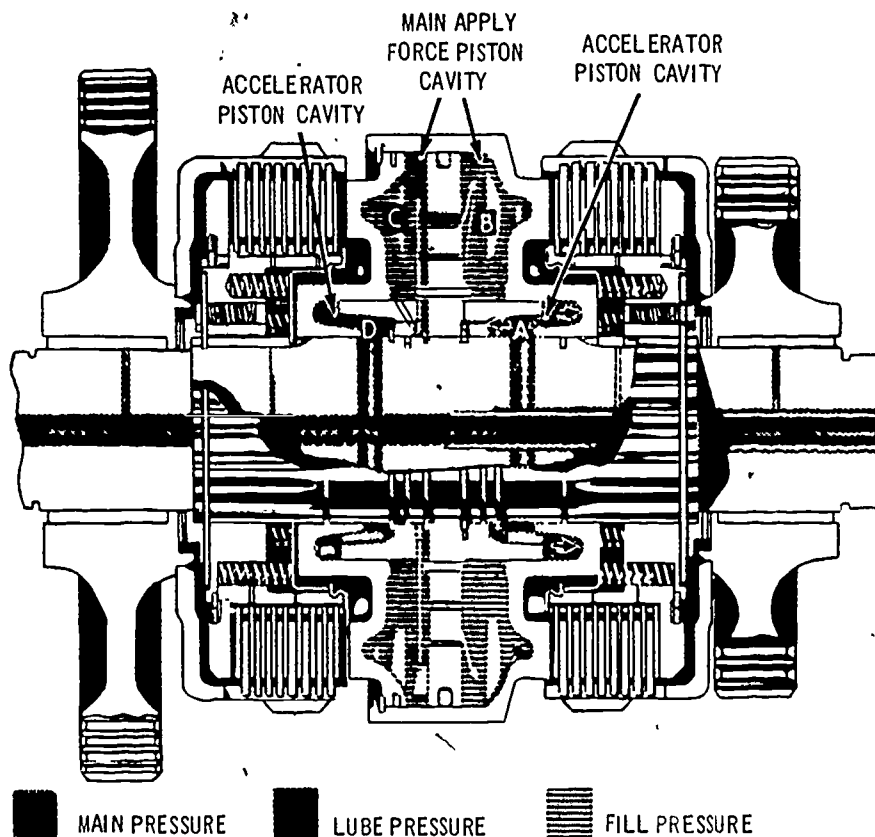

Figure 9-36.—Flow of oil through clutch in neutral position.

2.433



2.434

Figure 9-37.—Flow of oil through clutch in travel position.

NOTE: Lube oil pressure remains in the cavities (C and D) on the unapplied side and lubricates the clutch plates and bushing under the drive gear and drum assembly.

Oil entering the accelerator piston cavity (A) performs three functions: (1) forces the accelerator piston, reinforcing disk, and disk valve against the separator plate; (2) forces the accelerator piston to push the guide pins (knock-off dowel pins on clutch packs with swagged-type guide pins) against the opposite accelerator piston, positioning this piston, reinforcing disk, and disk valve away from the separator plate; and (3) starts to move the force piston to the right. As a result, the force piston cavity (B) expands, and the area in the opposite force piston cavity (C) contracts in an equal amount. At this time, oil in the nonapplied force piston cavity (C) enters the holes in the separator plate

and pushes open the disk valve and enters the applying force piston cavity (B). This fill pressure puts the clutch in its primary engagement position. Simultaneously, main oil pressure passes through the orifice in the applied accelerator piston and pressurizes the force piston cavity (B). When the force piston cavity is pressurized, the clutch is in its full engaged position. The reinforcing disk and disk valve in area B are now flat against the separator plate. (See fig. 9-38.)

When the transmission is returned to neutral, main pressure on the applied clutch is released and oil pressure in the disengaging clutch is regulated by the lube pressure system. An immediate pressure drop occurs within the disengaging accelerator piston cavity (A). Simultaneously, the compressed piston centering springs in the clutch hub return the common

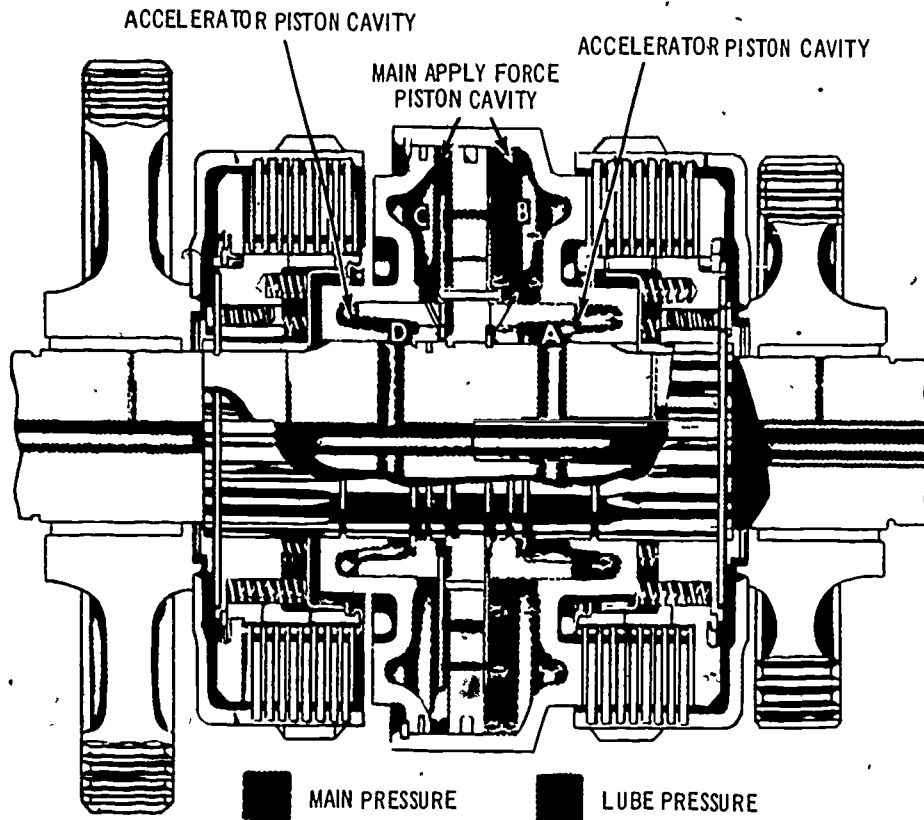

Figure 9-38.—Flow of oil through clutch in engaged position.

2.435

apply force piston to its axially centered position or neutral. Lubrication of all parts is now controlled by the lube pressure system.

If the selector valve on the transmission is positioned to direct main pressure into the left-hand clutch instead of neutral, the right-hand clutch is disengaged and the left-hand clutch is immediately applied.

**Gear Shifter Mechanism  
(Mechanically Controlled)**

The gearshift lever, located on the left-hand side of the operator, is connected through linkage to the range selector valve assembly on the top of the transmission case. Movement of the gearshift lever positions the selector valve to allow main oil pressure to engage the side of the clutch desired. (See fig. 9-39.)

The HI-LO shifting lever (on the transmission cover) is held in position by a poppet lock in the HI-LO shifter housing. To shift from one range to another, the engine must be running and the gearshift lever must be in neutral position. At this time, main oil pressure from the pump passes through a drilled hole in the selector valve and through an oil line to the shifter housing. Here, it releases the poppet lock from the HI-LO shifter poppet.

**Gear Shifter Mechanism  
(Hydraulically Controlled)**

The gearshift hand lever is directly connected to the spool of the pilot control valve located within the control tower. This valve is connected through hoses to the range selector valve assembly on the top of the transmission case.

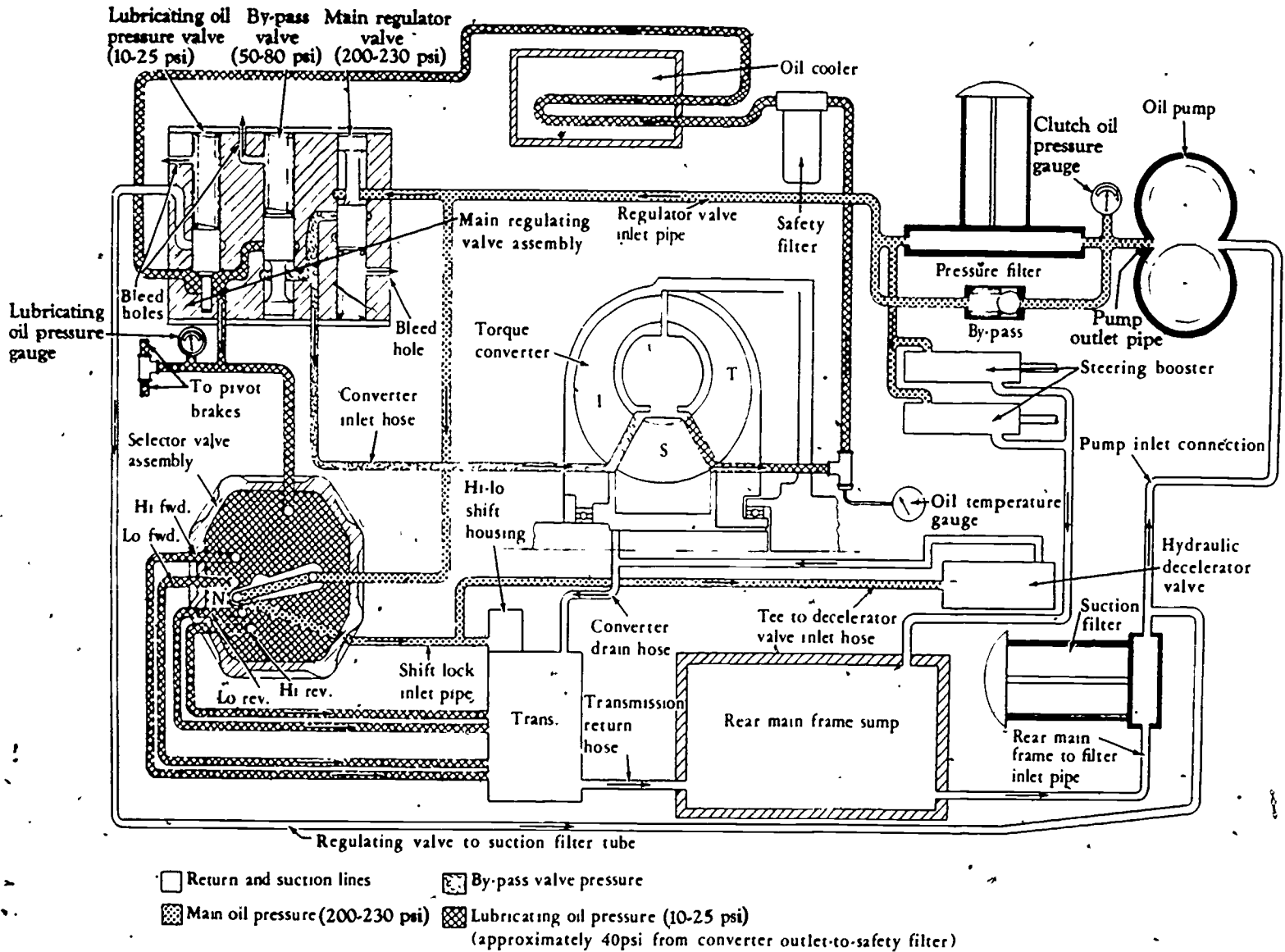

Figure 9-39.—Hydraulic oil flow diagram.

2.436

9-43

261

261

Movement of the gearshift hand lever positions the pilot control valve spool to allow main pressure oil to activate the spool in the range selector valve assembly. Main pressure oil within the range selector valve is then allowed to engage the side of the clutch pack selected.

**RANGE SELECTOR VALVE.**—The assembly consists of a lock-out spool and two range spools. The only function of the lock-out spool is to separate the lubricating pressure oil and the main pressure oil passages within the selector valve housing.

In neutral, the range spools are centered in the housing by springs and equal oil pressure. Main pressure oil cannot engage the transmission clutch packs because the range spools are centered and close the ports.

Under all conditions, lubricating oil pressure and main oil pressure are directed by hydraulic hose to the pilot control valve inside the gear shifter tower and returned to the main regulating valve.

**PILOT CONTROL VALVE ASSEMBLY.**—This valve is manually operated by the gear selector hand lever. When the gear selector lever is placed in a speed range, the pilot control valve allows main pressure oil to act upon the end of the range spool selected. This pressure, being higher than the lubricating oil pressure at the opposite end of the spool, upsets the pressure balance and the spool moves. Main pressure oil within the range selector valve housing is then directed to the clutch shaft to engage the selected clutch pack.

**Hydraulic Oil Flow**

The rear main frame sump is the source of oil supply for the transmission, torque converter, steering boosters, and pivot brakes. The oil is drawn through an oil intake pipe, located at the bottom of the rear main frame sump, by the suction developed by the pump located in the right-hand side of the torque converter. The oil leaves the pump at approximately 200-230 psi and enters the hydraulic valve spacer (not shown) on top of the transmission case. From here, the oil is directed through drilled passages to the main regulator valve in the main

regulating valve assembly, to the selector valve, and to the steering boosters.

Through drilled passages in the main regulating valve assembly, hydraulic valve spacer, and transmission case, oil at lubricating pressure (10-25 psi) fills the selector valve and transmission clutch shafts for lubrication of the transmission clutches. This pressure is maintained by the oil passing through the bypass valve in the main regulating valve housing, and also by the return oil from the oil cooler. When this pressure is over 25 psi, the lubricating valve opens and the excess oil is returned to the suction side of the oil pump. When the selector valve is in the neutral position, as shown in figure 9-39, the main oil pressure from the pump is directed through an outlet hose to the HI-LO shift lever lock and hydraulic decelerator valve. When the selection valve is moved to any other position, main oil pressure is directed to the clutch shaft to engage the clutch desired.

When the oil pump pressure at the main regulating valve exceeds 230 psi, the main regulating valve opens and allows the oil to enter the torque converter. Oil pressure in the torque converter is maintained between 50-80 psi by the bypass valve in the main regulating housing. When this pressure exceeds 80 psi, the bypass valve opens and allows the excess oil to be returned to the suction side of the pump or to be used for transmission clutch lubrication. The oil on the output side of the torque converter enters the air-cooled oil coolers and is returned to the suction side of the oil pump through the lubricating oil valve, or is directed to the selector valve for clutch lubrication if the pressure at the valve is under 25 psi.

The troubleshooting chart shown in table 9-3 will assist you in locating sources of mechanical troubles, such as transmission oil pressure problems, clutch engagement problems, and transmission gear and bearing problems in the International Harvester (TD-20 series B tractor and model 250 series B loaders) power shift transmission.

**ALLISON TORQOMATIC TRANSMISSION (SERIES 4460)**

The Allison 4460 series transmissions include a torque converter with planetary gears



## Chapter 9—POWER TRAINS AND AUTOMATIC TRANSMISSIONS

**Table 9-3.—Troubleshooting Chart for International Harvester (TD-20 Series B Tractor and Model 250 Series B Loaders)  
Power Shift Transmission**

Trouble	Possible Causes	Corrective Measures
Main oil pressure gage shows low or high pressures.	Pressure gage malfunction.	Replace gage.
	Plugged suction or pressure filter.	Clean suction filter. Replace pressure filter element.
	Air leakage at suction filter.	Tighten fittings or replace "O" rings.
	Air entry into suction line.	Replace Marmon clamp gasket. Replace "O" rings in system.
	Main regulating valve springs malfunctioning.	Remove and replace with new valve springs.
	Wrong number of washers at main regulating valve springs.	Do not use more than a total of four washers.
	Binding of lube valve, bypass valve or main pressure valve in regulator housing.	Check valves. Install new valve body gasket.
	Charging pump malfunctioning.	Replace pump.
Low oil pressure when in forward or reverse speed.	Contaminated or restricted oil lines.	Clean or replace oil lines.
	Shims or "O" ring leaking at reverse clutch shaft manifold.	Replace with new shims or "O" rings.
	Tachometer drive plug "O" ring leaking.	Replace "O" ring.
	"O" ring at clutch shaft end cover leaking.	Replace "O" ring.
	Oil leakage past cover and case gasket at reverse manifold.	Replace gasket.
	Hook type seal rings on shaft leaking.	Replace seal rings.
	Clutch piston seal ring leaking.	Replace seal ring.
Slow or erratic clutch engagement.	Low oil level.	Add oil to proper level.
	Clogged filters.	Remove and clean suction and safety filters. Replace pressure filter element.
	Faulty hydraulic oil pump.	Replace worn parts or replace pump.

## CONSTRUCTION MECHANIC 1 & C

**Table 9-3. - Troubleshooting Chart for International Harvester (TD-20 Series B Tractor and Model 250 Series B Loaders)  
Power Shift Transmission—Continued**

Trouble	Possible Causes	Corrective Measures
Slow or erratic clutch engagement—continued.	Internal oil leaks.	Check for damaged or worn sealing rings in clutch packs.
	External oil leaks.	Check all gaskets, lines and connections.
	Low main oil pressure.	Clean main regulator valve and bore; check spring tension.
	Selector hand lever improperly adjusted.	Adjust as described in service manual.
	Contaminated or restricted oil lines.	Clean or replace oil lines.
	Binding of main pressure valve in regulator housing.	Check valve. Install new valve body gasket.
	Range selector valve wiper seal leaking.	Replace seal.
Noise in transmission.	Bearings worn or broken. Worn drive gear and drum bushings.	Remove and install new parts.
	Foreign material in oil.	Drain, flush and <del>refill</del> with clean oil. Clean suction and safety filters. Replace pressure filter element.
	Gears badly worn.	Install new gears.
	Bevel gear and pinion not in proper mesh.	Adjust to proper clearance.
High oil temperature.	Clogged oil cooler.	Remove and clean.
	Improper tractor operation.	Operate in correct range.
	Improper torque converter operation.	Refer to table 10-1.
	Low or high oil level.	Add or drain to proper level.
	Oil leakage.	Check all gaskets, lines and connections and replace parts as necessary.
	Faulty thermo bypass valve (if equipped).	Discard valve assembly.
	Faulty hydraulic oil pump.	Replace worn parts or replace pump.
	Temperature gage malfunction.	Replace gage or sending unit.
Air entry into suction line.	Replace Marmon clamp gasket. Replace "O" rings in system.	

controlled by hydraulic-operated clutches. (See fig. 9-40.) The entire transmission is a single compact unit, equipped with a torque converter lockup clutch (for direct drive in any range) and a hydraulic retarder integral with the transmission.

The gear train includes the splitter planetary, low-range planetary, intermediate-range planetary, and reverse-range planetary. The splitter planetary has two clutches, and each range planetary has one clutch. High range has one clutch. This combination of clutches and

planetary gears gives six forward ranges and two reverse ranges.

### Transmission Model Designation

Transmission configurations are identified by the letters and figures in the model designation on the nameplate. The nameplate is located on the left side of the transmission housing near the rear. In addition to the model designation, a transmission part (assembly) number (A/N) and a serial number (S/N) appear

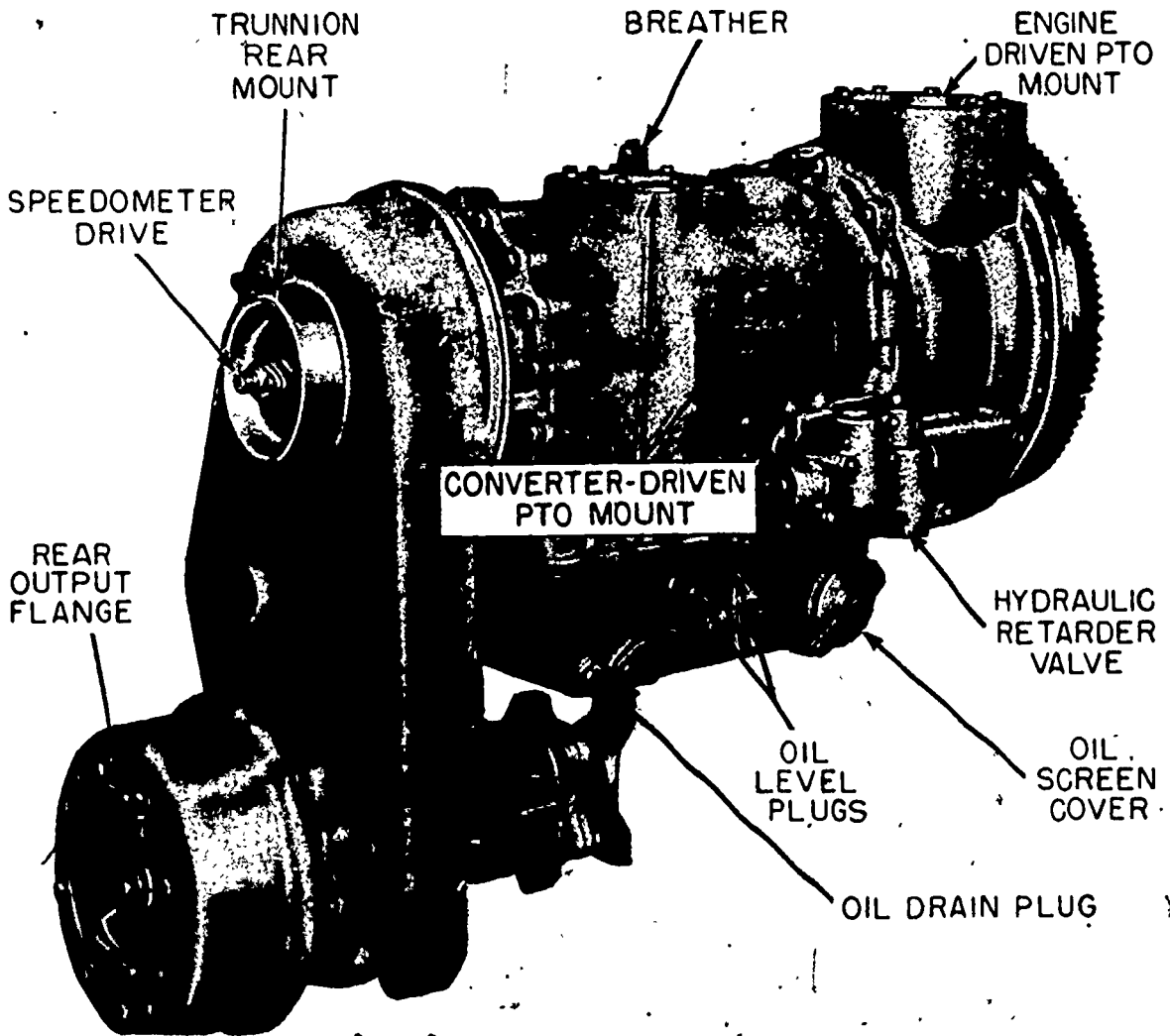

Figure 9-40.—Allison model CLBT 4460-2 torque automatic transmission with drop box—right-rear view.

2.437X

on the nameplate. The assembly number and serial number indicate the specific arrangement of the transmission and options not covered by the model number. Therefore, it is very important that both the serial number and assembly number, as well as the model number, be given in all correspondence concerning any transmission, as well as in the ordering of parts.

The letters in the model designation (CLBT 4460-1 or CLBT 4460-2) indicate the following:

- C—Torque converter
- L—Torque converter lockup clutch
- B—Hydraulic (braking) retarder
- T—Planetary transmission

The four figures following the letter designation indicate the following:

- 1st figure (4)—Basic converter, size 400
- 2nd figure (4)—Transmission capacity
- 3rd figure (6)—Number of forward speeds
- 4th figure (0)—Model change

The dash and figure following the above designations indicate the following:

- 1 — Straight-through model
- 2 — Drop box model

### Input Drive

A laminated steel flex-disk assembly connects the engine crankshaft with the flywheel assembly which is part of the transmission input drive. The inner bolt circle of the flex-disk assembly bolts to the hub assembly. This hub bolts to the engine crankshaft. The outer bolt circle of the flex-disk assembly bolts to the flywheel. The engine starter ring gear is pressed onto the front end of the flywheel's outer diameter.

When the transmission is mounted apart from the engine, a drive shaft with a universal joint on each end is used. The input shaft and drive housing are bolted to the torque converter pump (in place of the flywheel used in the direct mount). The front cover is bolted to the torque converter housing to enclose the front of the transmission and support the input drive shaft ball bearing. The bearing is lubricated externally through a grease gun-type fitting.

### Torque Converter and Lockup Clutch

The three-element torque converter is made up of a pump, turbine, and stator assembly. These elements are cast aluminum with bladed-oil passages curved so that the pump (input element) directs the oil flow through the turbine (output element) as directed by the stator (torque multiplying element) for torque multiplication. The turbine is splined to the shaft that transmits power to the splitter planetary carrier. The stator is supported by a freewheel roller race, splined to a stationary converter ground sleeve so that the stator rotates freely on rollers in the direction of pump rotation, but it locks against rotation in an opposite direction when torque multiplication is needed.

The engine-driven pump blades direct oil into the turbine blades, causing the turbine to rotate with the pump. This oil returns to the pump through the stator vanes. Under heavy loads, that slow turbine (output) rotation, the stator "locks up" on the one-way, over-running clutch and redirects the oil to increase torque. This is the key to torque multiplication. As turbine speed approaches pump speed, the stator freewheels, and the torque converter becomes a fluid coupling. The lockup clutch then locks up, making the converter a straight through, direct-drive unit.

The lockup clutch consists of a friction plate, splined to the turbine, a clutch backplate, and a hydraulic-operated piston, attached to the input drive with the friction plate between them.

When turbine speed approaches pump speed, oil pressure is directed to the piston to apply the clutch. This locks the input to the output for direct drive through the converter for economy of operation. Lockup is released briefly during shift changes to provide shock-free converter action for a smooth shift.

### Torque Converter Housing and Engine-Driven Power Takeoff

The torque converter housing assembly front fits the engine flywheel housing, and its rear is bolted to the transmission main housing. On the top is a mounting pad for an engine-driven heavy-duty, power takeoff. Inside the housing

are the torque converter elements, the input-driven pump, and the pump and power takeoff gear train.

On models equipped with an engine-driven power takeoff, which is optional equipment, a drive gear is installed on the torque converter pump hub and an idler gear on the spindle. The idler gear is positioned to mesh with the power takeoff driven gear.

### Splitter Planetary and Clutches

The splitter planetary includes the carrier, the four pinions, the sun gear in the housing, and the ring gear assembly. The four pinions rotate on rollers on spindles in the carrier. The carrier is part of the turbine output shaft. The sun gear is splined to the splitter housing and the ring gear is splined to the shaft.

The splitter planetary overdrive ratio is 1.00:1.42, in the basic transmission. This is provided by 72 teeth in the ring gear, 21 teeth in each pinion, and 30 teeth in the sun gear. An optional ratio of 1.00:1.32 is available. This is provided by 85 teeth in the ring gear, 28 teeth in each pinion, and 27 teeth in the sun gear.

There are two splitter clutches. The smaller diameter (direct-drive, low-splitter) clutch has two internal-splined clutch plates and one external-tanged plate. The larger diameter clutch (overdrive, high-splitter) has three internal-tanged plates and three external-tanged plates. The low-splitter clutch has a piston and a reaction plate. The internal-splined or tanged plates have a sintered bronze facing on steel and the external-tanged plates are steel.

For direct drive (low splitter), hydraulic pressure is directed against the piston. It compresses the clutch plates, locking the planetary carrier and sun gear together.

With any two gear members locked together, the entire planetary must rotate together as a unit for direct drive.

For overdrive (high splitter), hydraulic pressure is directed against the piston and compresses the clutch plates to hold the housing (with sun gear) stationary.

The planetary pinions rotate around the stationary sun gear and overdrive the ring gear.

### Hydraulic Retarder

The hydraulic (braking action) retarder is located between the splitter and range gearing and consists of a rotor between two stators. The rotor is a bladed member riveted to the retarder shaft and rotor assembly. The front stator consists of vanes cast into the rear face of the splitter clutch reaction plate. The rear stator is formed by vanes cast into the front face of the high-range clutch diaphragm.

When the vehicle is in motion, in any drive range, the rotor turns at splitter output shaft speed, but it functions as a retarder only when the cavity around the rotor is filled with oil. A manually operated (usually foot-pedal operated) control valve directs oil into the cavity when retarding is desired. The churning of the oil between the stators and rotor resists rotation of the rotor. Releasing the control valve stops the flow of oil into the cavity and the oil is evacuated immediately. The retarder is used to slow the vehicle in traffic, on curves, or on downgrades. The churning action heats the oil which circulates continuously through the oil cooler.

### High-Range Clutch and Converter-Driven Power Takeoff

The high-range clutch includes the housing assembly, piston assembly, four internal-splined clutch plates, three external-tanged plates, the apply plate, and 13 piston return springs. The clutch housing is splined to the splitter output shaft. The external-splined plates engage the housing. The internal-tanged plates engage splines on the intermediate-range carrier assembly. An external snapping retains the apply plate, the clutch plates, and the piston in the housing. An internal snapping and retainer retain the springs.

Hydraulic pressure is applied to the high-ring clutch piston, and the clutch plates are locked together between the piston and the apply plate. This locks the intermediate-range carrier and sun gear together. As a result of the interconnection of the low-range planetary carrier with the intermediate-range carrier, both planetaries are locked up. Rotation of the splitter output shaft is transmitted to the

low-range planetary carrier assembly and transmission output shaft.

In the basic transmission, a sleeve surrounds the high-clutch housing. With the power takeoff option, the sleeve is replaced by a PTO drive gear which will mesh with a regular-duty PTO at either of the two side mounting pads or a heavy-duty PTO at an optional top mounting pad above the gear. Tangs on the apply plate engage the slots in the gear to provide the drive.

The PTO drive gear is driven at turbine speed in neutral. As turbine speed approaches pump speed, the lockup clutch engages to drive the gear at engine speed.

### Intermediate-Range Planetary and Clutch

The intermediate-range planetary gear set consists of a carrier, six pinions, sun gear, and ring gear. The six pinions rotate on rollers on spindles in the carrier. The carrier is splined to the low-range planetary ring gear and supported at its forward end by splined engagement with the high-range clutch plates. The sun gear is splined to the splitter output shaft. The ring gear is splined into the inner circumference of the clutch plates. A welded band around the ring gear prevents end movement.

The intermediate-range clutch consists of a reaction housing, three internal-splined plates, two external-tanged plates, and an apply plate compressed by a Belleville spring and piston in the piston housing. The external-tanged plates and apply plate engage the stationary reaction housing. The internal-spline rotating plates engage the intermediate-range ring gear.

Hydraulic pressure applied to the piston compresses the Belleville return spring against the clutch apply plate, which compresses alternately the stacked clutch plates against the stationary reaction housing. This holds the ring gear stationary.

The intermediate-range sun gear rotates the pinions within the stationary ring gear. The rotation of the pinions within the ring gear drives the carrier which is splined to and drives the low-range ring gear. The low-range sun gear rotates at the same speed as the intermediate-range sun gear. The combination of the low-range sun gear and ring gear rotating at different

speeds drives the low-range carrier and transmission output shaft.

### Low-Range Planetary and Clutch

The low-range planetary gear set consists of a carrier, four pinions, sun gear, and ring gear. The pinions rotate on rollers on spindles in the carrier which is splined to the output shaft. The ring gear splines into the internal splined plates of the low-range clutch. The ring gear is splined also to the intermediate-range carrier and to the shaft of the reverse-range sun gear for compounding in intermediate and reverse ranges.

The low-range clutch includes a reaction housing, two internal-splined plates, external-tanged plate, apply plate, Belleville return spring, and piston. The piston housing serves the low-range and reverse-range clutches jointly. The clutch components and their operation is similar to that of the intermediate-range clutch.

When hydraulic pressure is direct to the clutch piston, the low-range ring gear is held stationary. The pinions, driven by the sun gear, are forced to rotate within the ring gear. The rotation of the pinions within the stationary ring gear rotates the carrier assembly and the transmission output shaft.

### Reverse-Range Planetary and Clutch

The reverse-range planetary consists of four main elements. These are the carrier, six pinions, the sun gear, and the ring gear. The pinions rotate on rollers on spindles in the carrier. The carrier splines to the transmission output shaft. The ring gear is splined to the reverse-range, internal-splined clutch plates.

The reverse-range clutch includes a reaction housing, two internal-splined plates, external-tanged plate, apply plate, Belleville return spring, and piston. The piston works in a housing, which also serves the low-range clutch. The clutch components and their operation is similar to that of the intermediate-range clutch.

When hydraulic pressure is applied to the clutch piston, the planetary ring gear is held stationary. The sun gear, driven in reverse by the action of the low-range planetary ring gear, forces the reverse pinions to rotate within the stationary, reverse-range ring gear. The pinions drive the reverse-range carrier and transmission output shaft.

### Transfer Housing (Drop Box Models)

Where front and/or rear outputs, offset from the transmission centerline are desired, a transfer housing is used instead of the output section. A cast-iron housing is fitted to the rear of the transmission housing by an adapter. (See fig. 9-40.) The adapter supports the reverse-range planetary carrier and transmission output shaft on a bearing.

### Output Disconnect Assemblies

The front output disconnect assembly includes a housing, the output shaft, the driven coupling, the drive coupling, the shifter fork, and the shifter shaft. When the drive is disconnected from the front output, the driven coupling, shifter fork, and shifter shaft will be forward so that the driven coupling and the drive coupling are out of mesh. This permits the transfer driven gear output shaft to rotate without transmitting power to the front output. When the driven coupling is rearward, it meshes with the drive coupling and the shaft is driven.

### Control Valve Bodies

The hydraulic retarder control valve assembly is located at the right side of the transmission housing near the front. The valve is a spool type which slides endwise in the body. Ports are provided in the body which permit oil to be directed from the cooler-out connection to the retarder-in connection and from the retarder-out connection to the cooler-in connection when the valve is open. When the valve is closed, oil flow to the retarder stops and the oil remaining in the retarder is exhausted to the transmission sump. The stem of the valve projects from the body toward the rear of the

transmission. The valve is normally closed (toward front). A movement of 1 inch toward the rear fully opens it. Shorter movements give partial retarder application. Linkage connects the valve to a foot-operated treadle in the vehicle cab.

The main control valve body assembly, located in the oil pan, controls main oil pressure and lockup engagement automatically. In addition, it contains the manual selector valve by which shifts are made to neutral, six forward speeds, and one reverse speed.

All except the selector valve assembly are spool-type valves. The selector valve is a tubular type with internal passages. The assembly bolts to the bottom of the transmission housing upon an oil transfer plate assembly.

The converter and lubrication pressure regulator valve assembly, mounted on the oil transfer plate in the sump which is forward of the main control valve assembly, has two functions. It regulates lubrication pressure and converter-in pressure.

### Oil Transfer Plate

The oil transfer plate is an aluminum casting with cast channels to direct oil from valves mounted upon it to various passages in the transmission housing. The assembly includes a plate, valve, and plugs. The assembly mounts on the bottom surface of the transmission housing with its channeled side against the housing bottom. The plate, when installed, retains a discharge tube in a vertical position at the right-front corner of the oil pan.

### Oil Pumps

A dual-type oil pump supplies oil pressure to both the main circuit and to the converter circuit. The oil pump drive gear is driven by the converter pump hub. This results in the oil pump being driven at engine speed. The oil pump drive gear meshes with two oil pump driven gears and delivers oil at two separate outlets. Figure 9-41 shows the location of transmission oil pressure checkpoints.

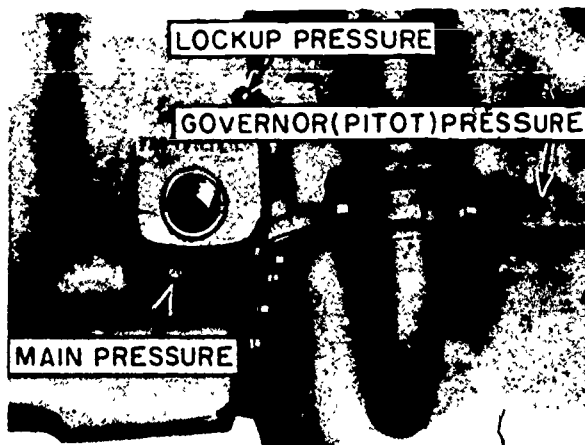

2.438X

Figure 41.—Transmission oil pressure checkpoints.

A gear-type pump scavenges both the converter housing and the transfer gear housing, if used. The scavenge pump drive gear is driven by the power takeoff drive gear which is bolted to the converter pump. The scavenge pump internal drive gear meshes with one pump-driven gear (-1 models) or two pump-driven gears (-2 models) to scavenge the converter housing only, or both converter housing and transfer gear housing.

### Oil Pan and Screen

The oil pan is the oil sump of the transmission. It also encloses the main control valve assembly and oil screen. The oil screen is a 60 x 40 mesh, cylindrical screen and is easily accessible for removal and cleaning. The same type of oil pan is bolted to the bottom of the transmission housing on both the straight through and the transfer gear models.

### Hydraulic System Operation

The hydraulic system comprises the valves, pumps, lines, clutch application components, filters, cooler, flow passages, and controls. The function of the hydraulic system is to provide the oil flow and oil pressure necessary for all hydraulic operation, cooling, and lubrication.

Located on the right-front side of the transmission is the hydraulic retarder control valve assembly. It is a spool-type valve, mounted in a horizontal position, and connected by linkage with a hand lever or foot pedal operated by the driver of the vehicle.

The retarder is applied when the valve is pulled outward from the valve body (toward the rear). A spring, located in the rear end of the valve, assures an OFF position when the retarder is released. Oil supply to the retarder comes from the converter-out circuit. The oil flow from the retarder is directed to the oil cooler.

The converter-out pressure regulator valve is located in the main transmission housing. The valve works against spring pressure and regulates oil pressure coming from the converter through the cooler. Therefore, converter pressure is regulated by this valve, plus any restriction in the cooler and converter-out oil line.

The main oil pressure in the hydraulic circuit is regulated by the movement of the main-pressure regulator valve. This is a spool-type, spring-loaded valve located in the control valve assembly which is bolted to the bottom of the transmission housing inside the oil pan. Its movement opens and closes ports through which oil may flow. The function and the movement of the valve are fully automatic.

The flow of oil to and from the lockup clutch piston cavity is controlled by the lockup shift valve. When this spool-type valve moves in its bore, it opens and closes ports which determine whether the lockup clutch is engaged or disengaged. This valve is located in the control valve assembly.

Governor pressure, acting at the upper end of the valve, pushes the valve downward to engage the lockup clutch when speed is sufficient for lockup operation. In overdrive (second, fourth, and sixth gear) operation, overdrive clutch pressure is directed to the lower end of the lockup plug. This compresses the lockup shift valve spring and raises the governor speed at which lockup occurs. This action offsets the increase in governor speed during overdrive operation.

Operating with the lockup valve is the spool-type flow valve. It is located in the control valve assembly. Its function is to override the



lockup shift valve to disengage the lockup clutch, momentarily placing the transmission in converter operation when shifts are made. The movement of the valve, which is automatic, exhausts lockup clutch apply to sump.

The converter-in pressure regulator valve is an umbrella-type valve. It is located in the converter and lubrication pressure regulator valve assembly which is bolted to the transmission housing inside the oil sump pan. Its purpose is to limit converter-in pressure so that it will not exceed lockup pressure and thus prevent the lockup clutch from engaging. Converter pressure is limited during converter operation and during lockup operation. Any pressure overages that might occur, such as during cold starts, are exhausted to the sump.

The lubrication regulator valve is a spring-loaded, spool-type valve, located in the converter and lubrication pressure regulator valve assembly inside the oil sump pan. Lubrication pressure forces the valve to move against its spring pressure, relieving the lubrication circuit to the converter-in circuit.

The main-pressure regulator valve is controlled by the pilot valve. Located in the same bore as the main-pressure regulator valve, the pilot valve regulates main pressure in the cavity between the two valves. Its purpose is to modulate main pressure and provide a pressure reduction to give two pressure schedules. Retarder-out signal pressure assists spring pressure in moving the pilot valve toward the main-pressure regulator valve, increasing main pressure for retarder operation. Thus, for retarder operation, main pressure is higher to prevent the clutches from slipping.

At the end of the pilot valve opposite the spring, two hydraulic forces act upon the valve to move it against its spring pressure and thus reduce main pressure. The two forces are forward and neutral knockdown pressure and governor pressure. Thus, during forward, neutral, or high-speed operation, main pressure is reduced.

Located in the control valve assembly inside the oil pan, the manual selector valve is a slotted-shaft type with two integral passages drilled lengthwise. It has eight positions which are manually selected by the operator, and it is connected by linkage to a control near the

operator. Its movements to each of the eight positions determine the range in which the transmission operates. Each position directs oil to clutches requiring engagement for that particular range.

Another function of the manual selector valve is to direct oil pressure to the pilot valve in neutral and all forward ranges. In reverse range, the manual selector valve cuts off oil pressure to the pilot valve. Spring-loaded detent balls accurately locate the selector valve in each shift position and restrain its movement until manually shifted.

The fluid velocity governor provides the pressure necessary to assist in the regulation of main pressure and to actuate the lockup valve to secure lockup of the torque converter. The fluid velocity governor consists of two simple parts. One part is the collector ring which is secured to the high-range clutch housing assembly and turns at splitter output speed. The other part is the pitot tube which is a stationary tube bolted to the high-range clutch diaphragm with the open end facing opposite the rotation of the governor collector ring.

When the transmission is in operation, oil is supplied to the collector ring, keeping it filled. Oil is retained in the collector ring by centrifugal force as the ring turns. The pitot tube, being in and facing the moving oil, receives the oil and directs it to the pilot valve and the lockup valve. Pressure in the pitot line is proportional to the velocity of the oil striking the open end of the pitot tube. Pitot pressure, if it exceeds main pressure, opens a check valve leading to the main oil pressure circuit. This prevents pitot pressure from appreciably exceeding main pressure.

### Hydraulic System in Action

Oil is drawn from the sump by the two-section oil pump and forced into the hydraulic system through two circuits. One circuit is the converter-in circuit; the other is the main pressure circuit. Pressure to the converter is regulated by the converter-in pressure regulator valve. Main pressure is regulated by the main-pressure regulator valve in combination with the pilot valve.

Main oil pressure to the flow valve flows around the lands at the upper end of the flow valve and on to the lockup valve where it is blocked. Main oil also flows through an orifice and through a check valve to the opposite end of the flow valve; thus main pressure is equal on each end of the valve. Because of a slightly larger area on the lower end of the valve, main pressure holds it in a closed (upward) position.

Continuing on to the manual selector valve, main oil pressure fills the plugged, lengthwise passage within the valve. Range clutch oil pressure is exhausted to the sump through the other lengthwise passage which is open at one end.

In neutral position, the manual selector valve has two outlets—the forward and the neutral knockdown circuit which leads to the pilot valve, and the splitter direct drive clutch apply passage.

In neutral, the two-section oil pump supplies oil pressure for the converter-in circuit to charge the torque converter. The converter pressure regulator valve regulates the pressure for lockup operation and for converter operation. During lockup operation, lockup pressure moves the lockup plug and reduces the valve spring pressure, causing the umbrella-type valve to open more readily, and reduce the converter-in pressure. Oil from the converter flows through the cooler to the converter-out pressure regulator. If the oil pressure from the cooler becomes excessive, the valve will open against its spring pressure and exhaust to the sump.

In neutral, there will be a pressure in the pitot (governor) line that is proportional to the speed of the pitot collector ring which is driven by the turbine. At engine idle speed, this pressure will exert only a negligible force on the pilot valve and on the lockup valve.

As turbine speed increases, the pitot collector ring rotates faster and builds up pitot pressure. The rise in pitot pressure moves the pilot valve against its spring, reducing main pressure in the cavity between the pilot valve and the main-pressure regulator valve. The reduced main pressure in this cavity, in turn, causes a reduction in the main pressure controlled by the regulator valve. Excessive pitot pressure is exhausted to main pressure through a check valve.

The transmission lockup clutch disengages automatically to place the transmission in converter operation during each range shift. Except during range shifting operation, pitot pressure controls the operation of the lockup clutch. As pitot pressure rises, it forces the lockup valve to move against its spring pressure and opens main pressure to the lockup clutch apply line. Lockup clutch apply pressure flows through the flow valve and on to the lockup clutch where the converter pump is locked to the converter turbine. During a range shift, a momentary drop in pressure at the larger end of the valve allows the flow valve to move and cut off lockup pressure; the lockup clutch apply line pressure is exhausted to the sump. To check clutches, use air pressure, as shown in figure 9-42.

In converter operation, with the lockup valve closed by its spring pressure, lubrication pressure from the main-pressure regulator valve flows to the lubrication pressure regulator valve where it is regulated to 100 psi. When the lubrication pressure regulator valve opens, oil flows into the converter-in passage, supplementing the oil flow from the charging oil

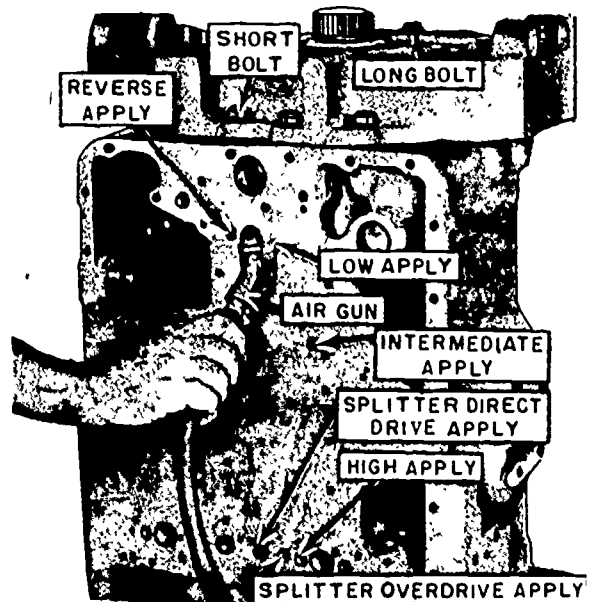

2.439X

Figure 9-42.—Checking clutch operation, with air pressure.

pump, if converter-in pressure is below 100 psi. With converter-in pressure of 100 psi, excess oil from the lubrication system is exhausted to the sump through the umbrella-type converter-in pressure regulator valve. However, when the lockup valve is opened against its spring pressure, the valve cuts off the lubrication circuit segment leading to the lubrication regulator valve. In this case, the lubrication circuit is regulated by the main-pressure regulator valve. Each of the lubrication passages which supply the clutch and gear package and which supply the speedometer drive has an orifice to restrict the flow of oil.

In first gear, hydraulic conditions are the same as described above, except as follows: the manual selector valve is in first-gear position and main oil pressure is directed to the low-range clutch apply line, the low-clutch pressure circuit leading to the lockup clutch, the splitter direct clutch apply line, and the forward and neutral knockdown line.

As in neutral, lockup will occur as turbine speed increases in EACH OF THE SIX FORWARD GEARS.

In second gear, main oil pressure is directed to the low-range clutch apply line, the splitter overdrive clutch apply line, and the forward and neutral knockdown line. In this position, the manual selector valve exhausts all other clutch apply lines.

In third gear, main pressure is directed to the intermediate-range clutch apply line, the splitter direct clutch apply line, and the forward and neutral knockdown line. In this position, the manual selector valve exhausts all other clutch apply lines.

In fourth gear, main pressure is directed to the intermediate-range clutch apply line, the splitter overdrive clutch apply line, and the forward and neutral knockdown line. In this position, the manual selector valve exhausts all other clutch apply lines.

In fifth gear, main oil pressure is directed to the high-range clutch apply line, the splitter

direct clutch apply line, and the forward and neutral knockdown line. In this position, the manual selector valve exhausts the intermediate-range clutch apply line to the sump. The splitter overdrive clutch is also exhausted to the sump through the manual selector valve.

In sixth gear, main oil pressure is directed to the high-range clutch apply line, the splitter overdrive clutch apply line, and the forward and neutral knockdown line. In this position, the manual selector valve exhausts the splitter direct clutch apply line to the sump.

In reverse gear, main oil pressure is directed to the reverse-range clutch apply line and the direct-drive clutch apply line. In this position, all other clutch apply lines are exhausted to the sump. The forward and neutral knockdown line is also exhausted which causes the pilot valve to move toward the main-pressure regulator valve, increasing main pressure. Thus, a higher main pressure is provided for reverse-range operation. Lockup can occur in reverse-range operation if sufficient speed is attained.

The hydraulic retarder may be applied in any gear. When the vehicle operator moves the retarder valve to the ON position, converter outlet oil from the cooler is directed to the retarder-in circuit to fill the retarder cavity. Retarder-out oil is directed by the retarder valve to the converter outlet oil circuit so that the retarder circuit continually flows through the cooler while the retarder is in operation.

Retarder-out signal pressure flows through an orifice to the end of the booster plug. If the transmission is in lockup, the pressure on the booster plug exerts a force on the spring side of the pilot valve, causing an increase in main oil pressure during retarder operation. If the transmission is in converter operation, retarder-out signal pressure forces a check valve to open and bleed off the signal pressure to the exhausted lockup clutch line and there is no increase in main pressure.

When the retarder valve is returned to the OFF position, lands on the valve, blocks the retarder passages so that no oil can enter the retarder circuit. Any oil remaining in the retarder is exhausted to the sump.

PARTIAL opening of the retarder valve will give partial retarder application. Thus, any degree of application is possible.

**Torque Paths**

Figures 9-43 through 9-50 show the paths by which torque is transmitted through the torque converter and the planetary gearing under various conditions.

In all torque paths, it is assumed that the engine is operating at its normal torque output and speed. Even if two clutches are engaged, the vehicle will not move when the engine is idling.

In neutral, the manual selector valve is in neutral position. (See fig. 9-43.) The torque from the engine passes through the torque converter by hydraulic action to the turbine shaft. Since only the splitter direct-drive clutch is

applied, there is no output torque. Recall that two clutches must be engaged to permit engine torque to pass through the transmission to the output shaft. The converter turbine is splined to the front of the turbine shaft, and the splitter planetary carrier is splined to its rear.

The splitter direct-drive clutch is engaged, causing the entire splitter planetary set to rotate as a unit. As a result, the splitter output shaft, to which the splitter planetary ring gear is attached, turns in the same direction and speed as the turbine shaft. Since no range clutch is applied, no torque is transmitted beyond the splitter output shaft. However, there is some free rotation of gears in the range planetary sets.

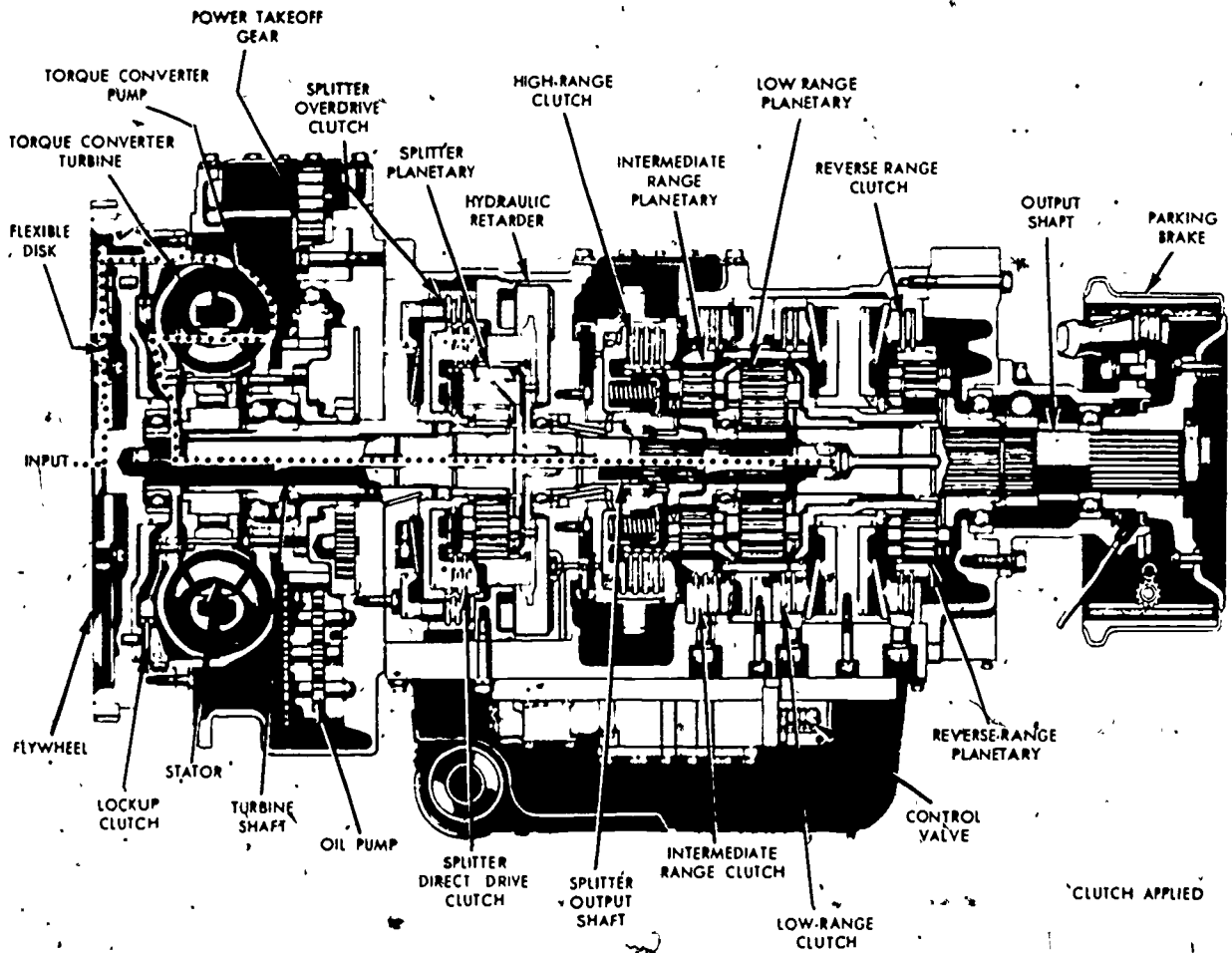

Figure 9-43. Neutral—torque path.

2.440X

In first-gear lockup, torque is transmitted from the flywheel to the turbine by a lockup clutch. Engagement of the clutch locks the hub of the turbine to the torque converter pump which is bolted to the engine flywheel. (See fig. 9-44.) With the pump and turbine locked together, they rotate as a unit at engine speed. The turbine is splined to the front of the turbine output shaft, and the splitter planetary carrier is splined to the rear of the shaft. Torque is transmitted from the turbine shaft, through the splitter planetary, and to the splitter, output shaft. The low-range sun gear is splined to the splitter output shaft. The low-range ring gear is applied, holding the low-range ring gear

stationary. This produces a simple planetary action in which the low-range sun gear is the driving member, the ring gear is stationary, and the low-range planetary is the driven member. The planetary carrier is connected to the output shaft. As the low-range sun gear rotates, the low-range planetary pinions must also rotate. This causes them to "walk" around the internal teeth of the ring gear, moving the carrier as they go. The shaft of the low-range carrier is the output of the range gearing.

In second-gear, converter torque is transmitted from the engine to the turbine shaft by the torque converter. (See fig. 9-45.) The torque path through the transmission is the same

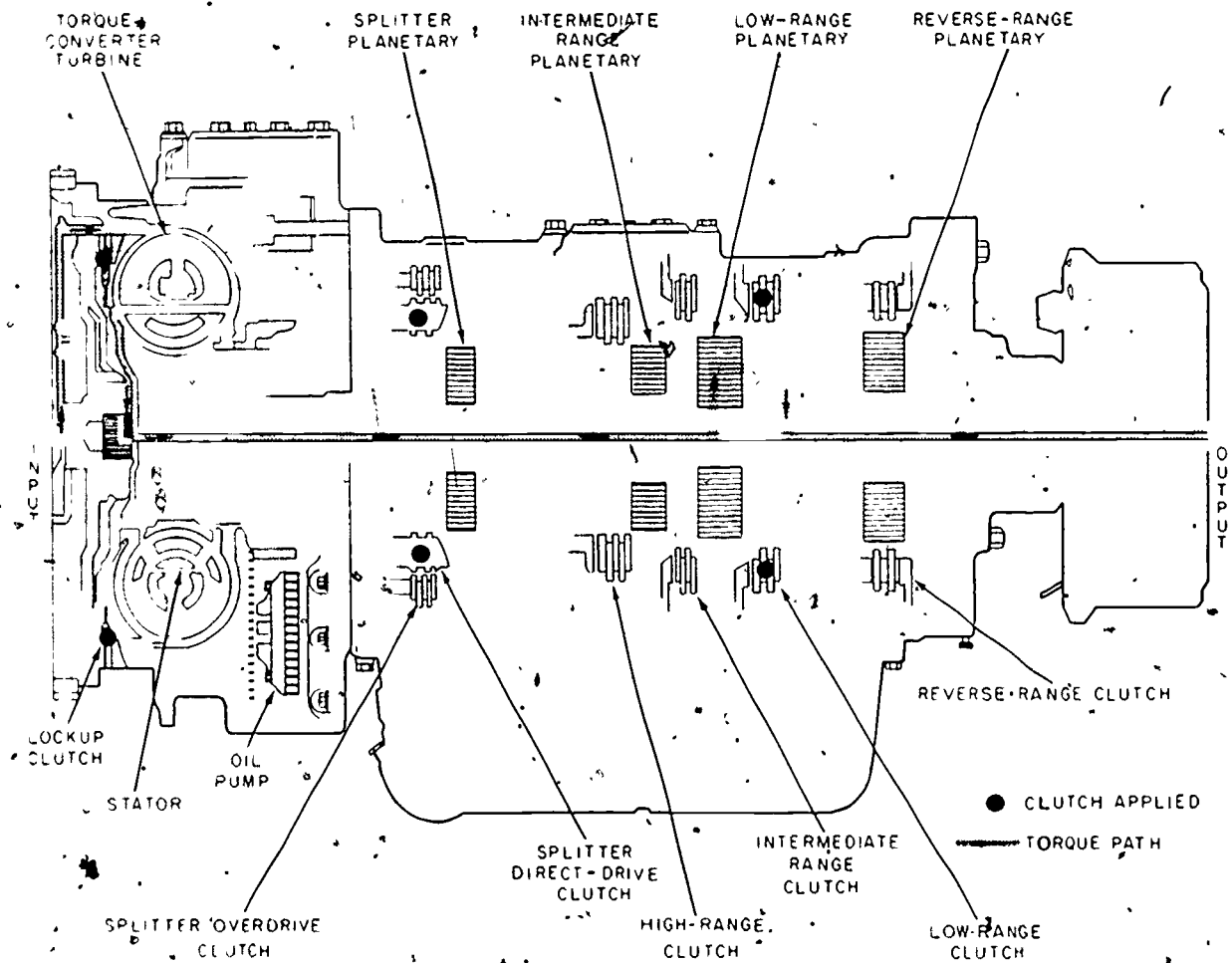
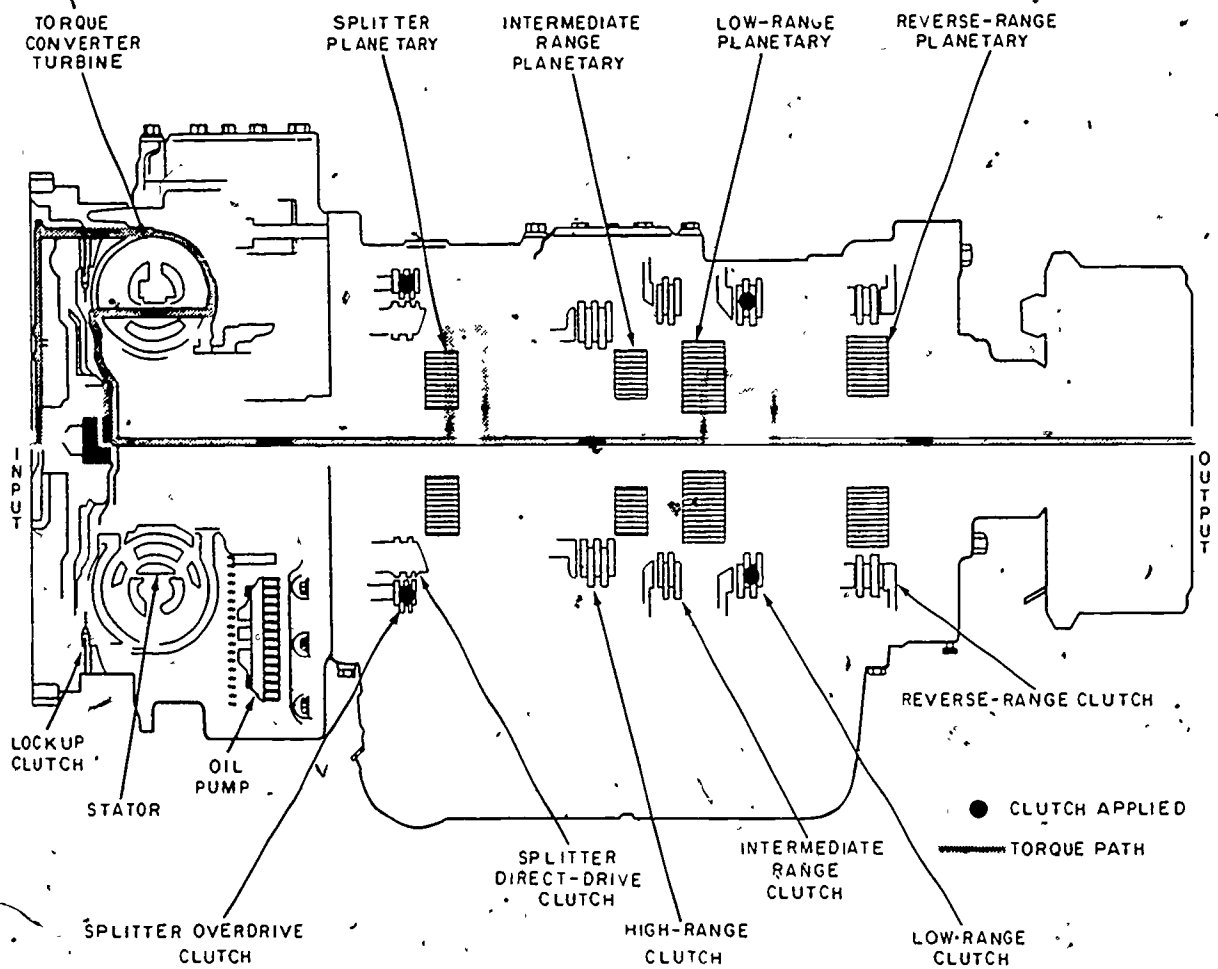

Figure 9-44.—First gear, lockup—torque path.

2.441



2.442

Figure 9-45.—Second gear, converter—torque path.

as in first gear, except that the splitter overdrive clutch is applied instead of the splitter direct-drive clutch. The splitter planetary sun gear is held stationary by the clutch. The splitter carrier, splined to the turbine shaft, rotates the pinions around the sun gear. The ring gear is driven by the pinions and rotates the splitter output shaft at a higher speed than in splitter direct drive.

In third-gear, lockup, torque is transmitted from the engine to the turbine shaft. (See fig. 9-46.) Torque is then transmitted from the turbine shaft, through the splitter, and to the splitter output shaft. The intermediate-range sun gear is splined to the splitter output shaft. The

intermediate-range clutch is applied, holding the intermediate-range ring gear stationary. As the sun gear rotates, the intermediate-range planetary pinions must also rotate. The rotation of the pinions causes them to "walk" around the internal teeth of the ring gear, moving the carrier as they go.

The intermediate-range carrier is splined to the low-range ring gear so that the rotation of the intermediate-range carrier is imparted to the low-range ring gear at the same speed. Thus, the two-planetary gear sets are compounded together. Since the low-range sun gear and the intermediate-range sun gear are splined to the same shaft, they rotate in the same direction and

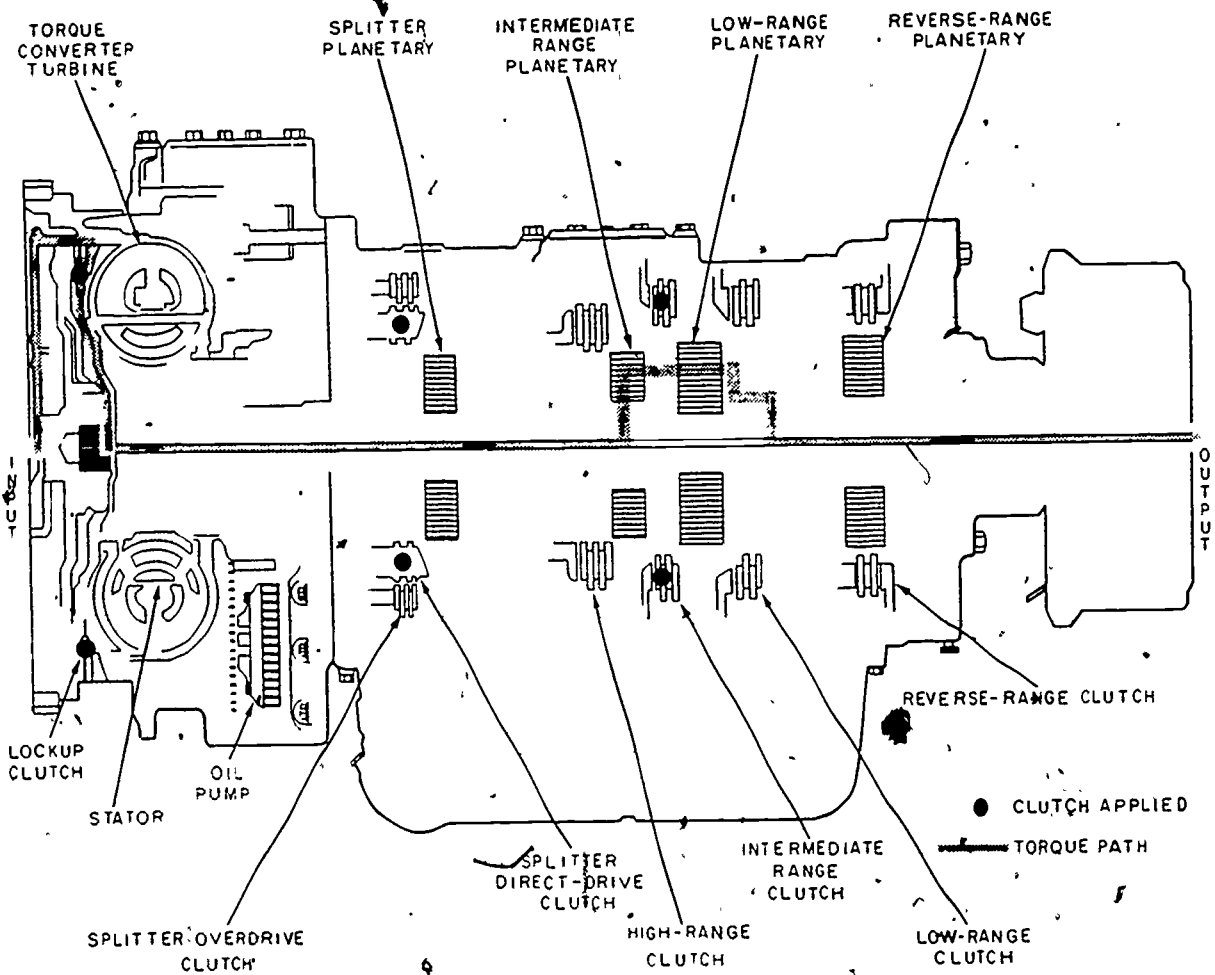

2.443

Figure 9-46.—Third gear, lockup—torque path.

at the same speed. However, the low-range ring gear will rotate at a slower rate of speed than its sun gear.

As a result, the low-range planetary carrier will rotate at a slower speed than the low-range sun gear, but at a greater speed than would be the case if the low-range ring gear were stationary.

In fourth-gear, converter torque is transmitted from the engine to the turbine shaft by the torque converter. (See fig. 9-47.) The torque path through the transmission is the same as described in third gear, except that the splitter overdrive clutch is applied instead of the splitter direct-drive clutch.

In fifth-gear, lockup torque is transmitted from the engine to the turbine shaft by the

torque converter. (See fig. 9-48.) Torque is transmitted from the turbine shaft through the splitter, and to the splitter output shaft as described in neutral which covers splitter direct drive. The application of the high-range clutch locks the intermediate-range sun gear to the intermediate-range carrier. This action locks the entire range planetary system together as one rotating unit.

In sixth-gear, converter torque is transmitted from the engine to the turbine shaft by the torque converter. (See fig. 9-49.) Torque is transmitted from the turbine shaft through the splitter planetary as described in second-gear converter. Torque is transmitted through the range planetary system from the turbine shaft to the low-range carrier shaft.

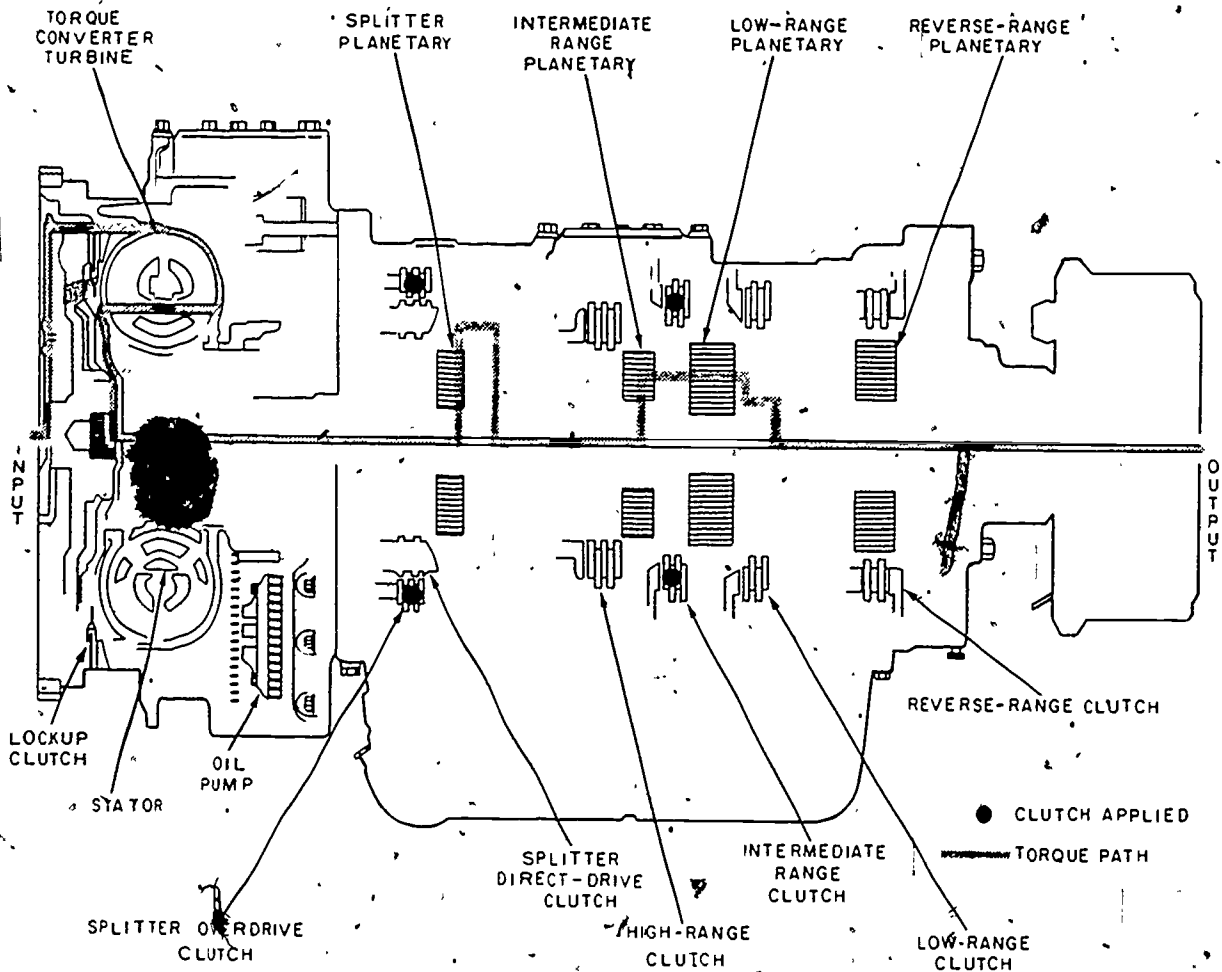

Figure 9-47.—Fourth gear, converter—torque path.

2.444

In reverse-gear, converter torque is transmitted from the engine to the turbine shaft. (See fig. 9-50) Torque is transmitted from the turbine shaft, through the splitter, and to the splitter output shaft. The reverse-range ring gear is applied, holding the reverse-range ring gear stationary. Torque is delivered to the reverse-range planetary set by the low-range planetary set. This means that reverse gear is a compound arrangement. Reversing is actually accomplished in the low-range planetary. The reverse-range planetary serves as a further speed reduction. Torque flows from the low-range sun gear just as it does in all other gears; however, the direction of rotation is reversed through the low-range planetary pinions and the ring gear. Torque for the reversing motion is transmitted

from the low-range ring gear to the reverse-range sun gear and to the reverse-range planetary pinions. Since the reverse-range ring gear is held stationary, the pinions "walk" around the ring gear, moving the reverse-range carrier in the reverse direction. The carrier is splined to the output shaft. The speed reduction is 4.77:1.

### Troubleshooting

The troubleshooting chart shown in table 9-4 will assist you in locating sources of trouble in the Allison torque-matic transmission (series 4460). It covers malfunctions of both the engine and transmission as they affect transmission performance.



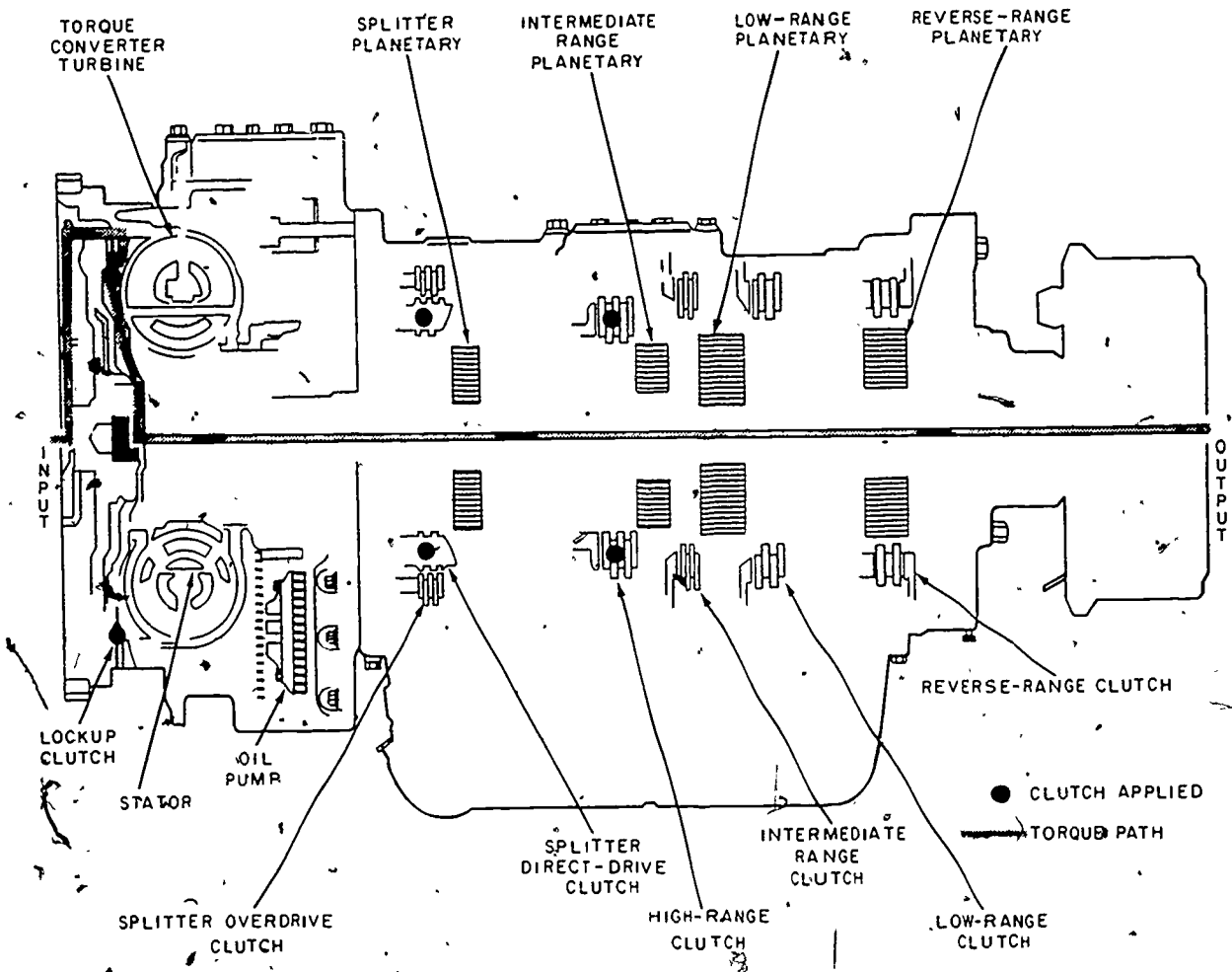

Figure 9-48.—Fifth gear, lockup—torque path.

2,445

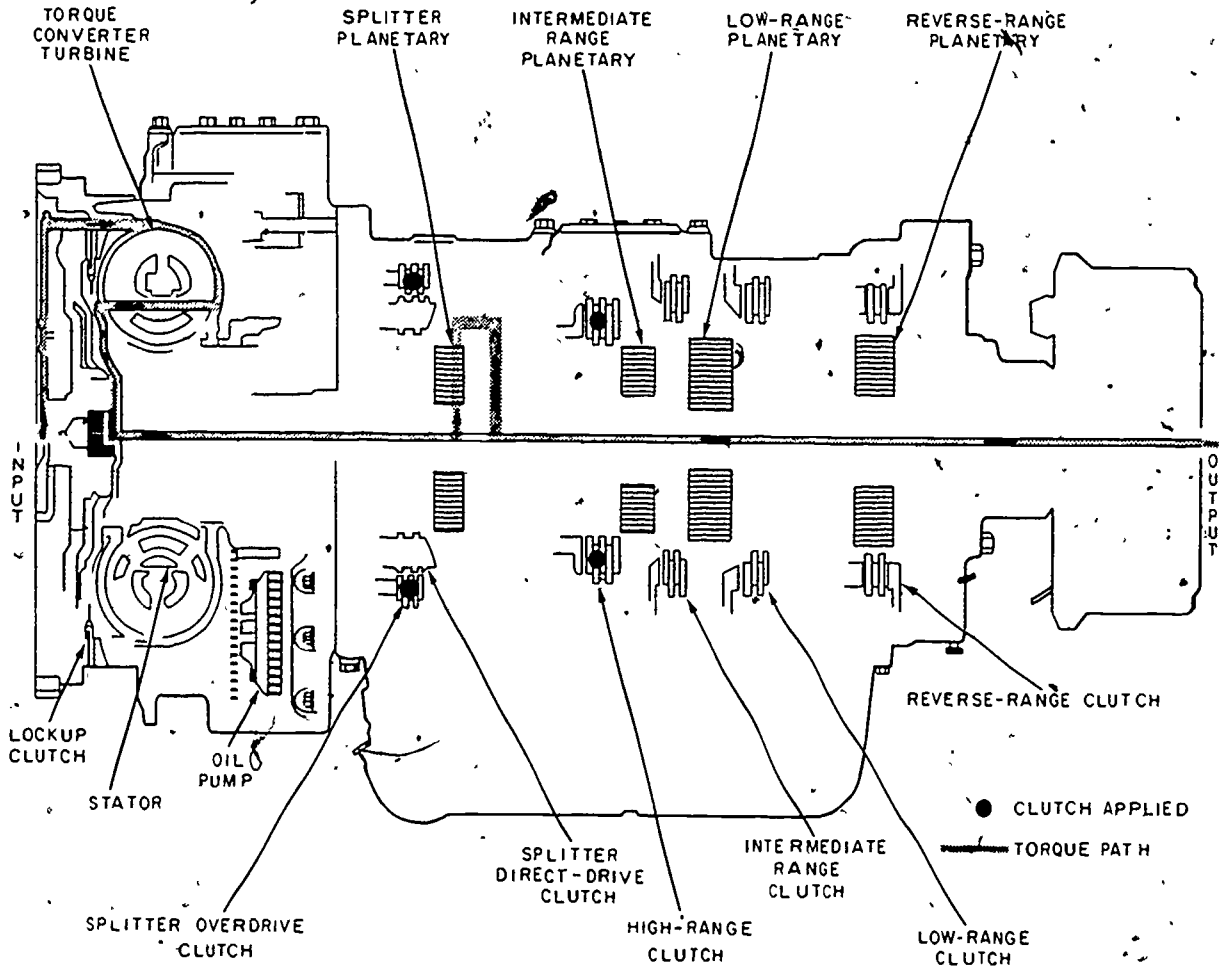

Figure 9-49.—Sixth gear, converter—torque path.

2.446

251

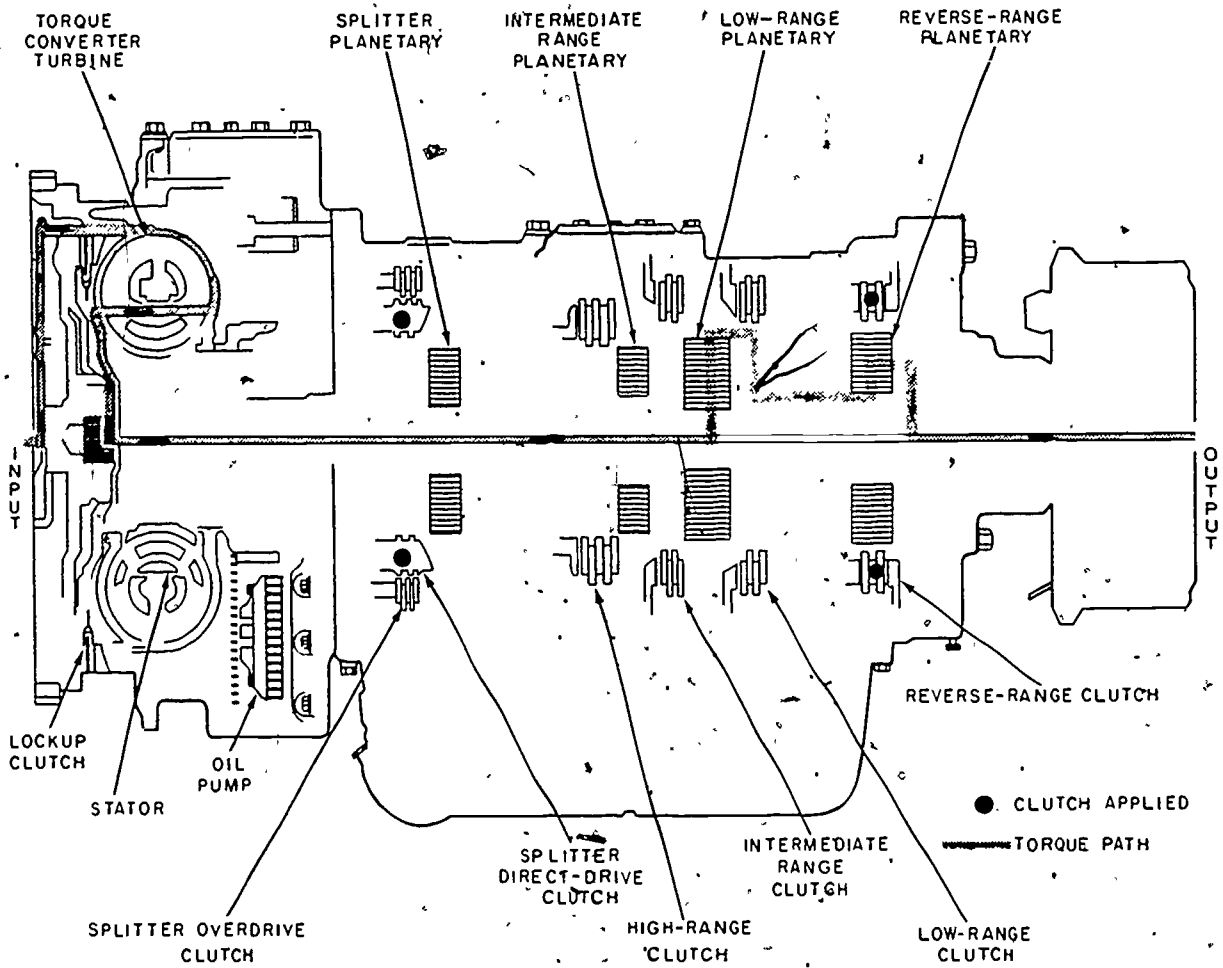

Figure 9-50.—Reverse gear, converter—torque path.

2.447

## CONSTRUCTION MECHANIC 1 & C

Table 9-4.—Troubleshooting Chart for Allison Torqmatic Transmission (Series 4460)

Trouble	Possible Causes	Corrective Measures
A. Low converter-out pressure.	<ol style="list-style-type: none"> <li>1. Low oil level.</li> <li>2. Oil line leakage (remote-mount cooler or filter),</li> <li>3. Plugged oil screen.</li> <li>4. Defective oil pump.</li>   <li>5. High oil temperature,</li> <li>6. Foaming oil.</li>   <li>7. Converter pressure regulator valve or lube regulator valve stuck open.</li> </ol>	<ol style="list-style-type: none"> <li>1. Add oil.</li> <li>2. Check for oil leaks—correct leaks.</li> <li>3. Clean screen.</li> <li>4. Repair or replace oil pump assembly.</li> <li>5. (Refer to B.)</li> <li>6. Clean or replace as necessary.</li> <li>7. Inspect valve for dirt or damaged parts.</li> </ol>
B. High oil temperatures.	<ol style="list-style-type: none"> <li>1. Low oil level.</li> <li>2. High oil level.</li>   <li>3. Low water level in cooling system.</li> <li>4. Low main pressure.</li> <li>5. Low converter-out pressure.</li> <li>6. Clogged or dirty oil cooler.</li> <li>7. Operating too slow in gear selected.</li> <li>8. Stator installed without rollers.</li> <li>9. Vehicle brakes dragging.</li>   <li>10. Clutch slipping.</li> <li>11. Restricted oil lines (remote filter or cooler).</li> <li>12. Retarder applied.</li> </ol>	<ol style="list-style-type: none"> <li>1. Add oil.</li> <li>2. Drain to proper level. Drain oil to the full mark.</li> <li>3. Add water, check for leaks.</li> <li>4. (Refer to G.)</li> <li>5. (Refer to A.)</li>   <li>6. Clean or replace as necessary.</li> <li>7. Downshift at a higher speed.</li> <li>8. Install rollers.</li>   <li>9. Check parking and service brakes.</li> <li>10. Replace clutch.</li> <li>11. Clean or replace as necessary.</li> <li>12. Check linkage.</li> </ol>
C. High engine speed at converter stall	<ol style="list-style-type: none"> <li>1. Low oil level.</li> <li>2. Low converter-out pressure.</li> <li>3. High oil temperature (above 250°).</li> <li>4. Clutch slipping—main oil pressure normal.</li> <li>5. Foaming oil.</li> </ol>	<ol style="list-style-type: none"> <li>1. Add oil.</li> <li>2. (Refer to A.)</li>   <li>3. (Refer to B.)</li> <li>4. Replace clutch.</li> <li>5. (Refer to E.)</li> </ol>
D. Low engine speed at converter stall	<ol style="list-style-type: none"> <li>1. Low engine output torque.</li> <li>2. Converter element interference.</li> </ol>	<ol style="list-style-type: none"> <li>1. Tune engine and check output; refer to engine service manual.</li> <li>2. Check for noise at stall; overhaul converter if necessary.</li> </ol>

## Chapter 9—POWER TRAINS AND AUTOMATIC TRANSMISSIONS

**Table 9-4.—Troubleshooting Chart for Allison Torqmatic Transmission (Series 4460)—Continued**

Trouble	Possible Causes	Corrective Measures
D. Low engine speed at converter stall (cont.)	<ol style="list-style-type: none"> <li>3. Stator installed without rollers.</li> <li>4. Transmission oil not up to operating temperature.</li> </ol>	<ol style="list-style-type: none"> <li>3. Install rollers.</li> <li>4. Warm transmission up to 160° to 200° F.</li> </ol>
E. Loss of power	<ol style="list-style-type: none"> <li>1. Low engine speed at converter stall.</li> <li>2. High engine speed at converter stall.</li> <li>3. Manual selector valve not positioned properly.</li> <li>4. Retarder partially applied.</li> <li>5. Vehicle brakes dragging.</li> </ol>	<ol style="list-style-type: none"> <li>1. (Refer to D.)</li> <li>2. (Refer to C.)</li> <li>3. Check linkage.</li> <li>4. Check linkage.</li> <li>5. Check parking and service brakes.</li> <li>6. <ol style="list-style-type: none"> <li>a. Check for low oil level; add oil.</li> <li>b. Check for worn input oil pump; rebuild or replace pump assembly.</li> <li>c. Check for air leaks at input oil pump; correct leaks.</li> <li>d. Check for water in oil; correct cause, clean system.</li> <li>e. Check for high oil level; drain to proper level.</li> </ol> </li> </ol>
F. No power transmitted in any range.	<ol style="list-style-type: none"> <li>1. Drive line failure.</li> <li>2. Manual selector valve not positioned properly.</li> <li>3. Low oil level.</li> <li>4. Low main pressure.</li> <li>5. Failed piston seals.</li> </ol>	<ol style="list-style-type: none"> <li>1. Check input and output of transmission.</li> <li>2. Check linkage; correct defects.</li> <li>3. Add oil.</li> <li>4. (Refer to G.)</li> <li>5. Overhaul transmission.</li> </ol>
G. Low main pressure.	<ol style="list-style-type: none"> <li>1. Low oil level.</li> <li>2. Leaks in hydraulic system.</li> <li>3. Failure in main pressure regulator.</li> <li>4. Worn input oil pump assembly.</li> <li>5. Clogged oil screen.</li> <li>6. Air leaks at suction side of input pump.</li> </ol>	<ol style="list-style-type: none"> <li>1. Fill to proper level.</li> <li>2. Check all external points for leaks; check each range for localizing internal leaks.</li> <li>3. Overhaul control valve assembly.</li> <li>4. Rebuild or replace oil pump assembly.</li> <li>5. Clean screen.</li> <li>6. Check input pump; correct leaks.</li> </ol>

## CONSTRUCTION MECHANIC 1 & C

Table 9-4.—Troubleshooting Chart for Allison Torqmatic Transmission (Series 4460)—Continued

Trouble	Possible Causes	Corrective Measures
H. No power transmitted in one range.	<ol style="list-style-type: none"> <li>1. Manual selector linkage out of adjustment.</li> <li>2. Low main pressure in one range.</li> <li>3. Clutch slipping.</li> </ol>	<ol style="list-style-type: none"> <li>1. Adjust linkage.</li> <li>2. Check for worn piston seals or broken housing.</li> <li>3. Replace clutch.</li> </ol>
I. Slow clutch engagement.	<ol style="list-style-type: none"> <li>1. Low oil level.</li> <li>2. Foaming oil.</li> <li>3. Worn piston seals.</li> <li>4. Low main pressure.</li> </ol>	<ol style="list-style-type: none"> <li>1. Fill to proper level.</li> <li>2. (Refer to E.)</li> <li>3. Overhaul transmission.</li> <li>4. (Refer to G.)</li> </ol>
J. Transmission locked in all gears.		This indicates "failed transmission parts and overhaul is required.
<p>(Note: "Failed," in respect to clutches, as used in K through P, below, does not indicate slippage. It indicates that the clutches are not releasing—that they are locked in some way.)</p>		
K. Vehicle drives in first, third, fifth, and reverse but stalls when shifted to second, fourth, or sixth.		The splitter direct drive clutch has failed and the transmission must be overhauled.
L. Vehicle drives in second, fourth, and sixth but stalls when shifted to first, third, fifth, or reverse.		The splitter overdrive clutch has failed and the transmission must be overhauled.
M. Vehicle drives in first or second and moves forward in neutral when engine is accelerated, but stalls in all other gears when engine is accelerated.		The low-range clutch has failed and the transmission must be overhauled.
N. Vehicle drives in third or fourth and moves forward in neutral when engine is accelerated, but stalls in all other gears when engine is accelerated.		The intermediate-range clutch has failed and the transmission must be overhauled.
O. Vehicle drives in fifth or sixth and moves forward in neutral when engine is accelerated, but stalls in all other gears when engine is accelerated.		The high-range clutch has failed and the transmission must be overhauled.

## Chapter 9—POWER TRAINS AND AUTOMATIC TRANSMISSIONS

Table 9-4.—Troubleshooting Chart for Allison Torqmatic Transmission (Series 4460)—Continued

Trouble	Possible Causes	Corrective Measures
P. Vehicle drives in reverse range and moves backward in neutral when engine is accelerated, but stalls in all other gears when engine is accelerated.		The reverse-range clutch has failed and the transmission must be overhauled.

## INDEX

### A

- A.c. electrical systems, 6-1 to 6-4
  - alternators, 6-1
  - rectifiers, 6-2
  - regulators, 6-2 to 6-4
- Accident prevention program, administering a company, 1-8 to 1-15
  - accident reporting, 1-10 to 1-15
  - safeguards and safety education, 1-9
  - safety inspections, 1-10
  - supervision and safety, 1-8 to 1-9
- Administration, 1-1 to 1-36
  - administering a company accident prevention program, 1-8 to 1-15
    - accident reporting, 1-10 to 1-15
    - safeguards and safety education, 1-9
    - safety inspections, 1-10
    - supervision and safety, 1-8 to 1-9
  - Advanced Base Functional Components, 1-34 to 1-35
    - correspondence, official, 1-15, 1-22 to 1-27
      - memorandums, 1-22, 1-25
      - messages, 1-25 to 1-27
      - speedletters, 1-25
      - standard naval letters, 1-22 to 1-24
  - Facilities Planning Guide, 1-33 to 1-34
    - tailoring components and facilities, 1-34
    - use and application, 1-34
  - Personnel Readiness Capability Program, 1-1 to 1-8
    - interviews, 1-4
    - skill inventory, 1-1 to 1-3
    - steps for interviewing, 1-6 to 1-8
    - using the Standards and Guides for individual rating skills, 1-4 to 1-6
  - Administration—Continued
    - training and development of subordinates, 1-27 to 1-33
      - on-the-job training, 1-29 to 1-33
      - training needs, 1-29
      - training organization, 1-27 to 1-28
  - Advanced Base Functional Components, 1-34 to 1-35
    - Air, brake systems, 8-11, 8-16, 8-18
    - Air induction system, 7-26 to 7-32
      - blowers, 7-26 to 7-28
      - superchargers, 7-28 to 7-29
      - turbochargers, 7-29 to 7-32
    - Air-over-hydraulic, brake systems, 8-16, 8-18 to 8-19
    - Air pollution control, 2-8
      - fuel combustion, 2-8
      - sprays and gases, 2-8
  - Allison torqmatic transmission (series 4460), 9-44 to 9-67
    - control valve bodies, 9-51
    - high-range clutch and converter-driven-power takeoff, 9-49
    - hydraulic system operation, 9-52 to 9-53
    - hydraulic retarder, 9-49
    - hydraulic system in action, 9-53 to 9-55
    - input drive, 9-48
    - intermediate-range planetary and clutch, 9-50
    - low-range planetary and clutch, 9-50
    - oil pan and screen, 9-52
    - oil pumps, 9-51
    - oil transfer plate, 9-51
    - output disconnect assemblies, 9-51
    - reverse-range planetary and clutch, 9-50
    - splitter planetary and clutches, 9-49
    - torque converter and lockup clutch, 9-48
    - torque converter housing and engine-driven power takeoff, 9-48



## CONSTRUCTION MECHANIC 1 & C

### Allison torqmatic transmission (series 4460)— Continued

- torque paths, 9-56 to 9-60
- transfer housing (drop box models), 9-51
- transmission model designation, 9-47
- troubleshooting, 9-60 to 9-67

### Alternator test, 6-5

### Alternators, 6-1

### American Bosch fuel pumps, 7-11 to 7-16

- checking the nozzle after reassembly, 7-16
- nozzle cleaning and inspection, 7-16
- nozzle operation, 7-14
- nozzle reassembly, 7-16
- nozzle troubleshooting, 7-14 to 7-16
- operation, 7-11 to 7-13
- troubleshooting, 7-13
- types of nozzles, 7-13

### Arrow diagram, construction schedule drawings, 4-26

### Automatic transmissions, 9-27 to 9-67

- Allison torqmatic transmission (series 4460), 9-44 to 9-67
- hydraulic torque converter, 9-33 to 9-35
- power shift transmission, 9-35, 9-38 to 9-44
- turbo Hydra-matic 400, 9-28 to 9-33

### Automotive repair supervisors, 4-5

### Auxiliary lights, inspection of lighting equipment, 8-8 to 8-9

### Auxiliary transmission, 9-11 to 9-13

### Axles, wheels, and tracks, propeller shaft assemblies, 9-24 to 9-26

## B

### Battalion equipment company shops supervisor, 4-1 to 4-32

#### Battalion Equipment Evaluation Program, 4-20 to 4-25

- joint responsibilities, 4-21, 4-25
- repair parts (BEEP), 4-25
- responsibilities of the battalion being relieved, 4-21
- responsibilities of the relieving battalion, 4-21

#### battalion maintenance program, 4-12 to 4-16

- Equipment Repair Order and continuation sheet, 4-16
- intermediate maintenance, 4-12 to 4-14
- organizational maintenance, 4-12
- scheduling maintenance, 4-14 to 4-16

### Battalion equipment company shops supervisor—Continued

#### construction schedule drawings, 4-26 to 4-32

- arrow diagram, 4-26
- critical path, 4-26
- network analysis, 4-27 to 4-29
- precedence diagram, 4-30 to 4-32
- embarkation, 4-25 to 4-26
- inspecting, 4-26
- preparing, 4-26
- scheduling, 4-25
- staging, 4-26
- transporting, 4-26

#### maintenance supervisors, 4-3 to 4-11

- automotive repair supervisors, 4-5
- cost control supervisors, 4-9 to 4-11
- heavy equipment repair supervisors, 4-6 to 4-7

#### shop inspectors, 4-4

- support section supervisors, 4-8 to 4-9
- technical librarian, 4-11

#### repair parts, 4-17 to 4-20

- prepackaged library, 4-17 to 4-19
- procedures for requesting repair parts, 4-19

#### setting up a maintenance branch, 4-1 to 4-3

- heat, light, and ventilation, 4-3
- safety, 4-2
- tools and equipment, 4-1 to 4-2

### Battalion shop inspector, 8-2

### Battery drain test, 6-8

### Battery starter test, troubleshooting the cranking system, 6-12 to 6-18

- cranking voltage test, 6-13
- solenoid switch circuit resistance test, 6-17 to 6-18

#### starter ground circuit resistance test, 6-16

#### starter insulated circuit resistance test (cables and switches) 6-14 to 6-16

#### starting motor current draw test, 6-14

### "BEEP" inspections, 8-23

### Blowers, air induction system, 7-26 to 7-28

### Bosch nozzles, 7-13 to 7-16

### Brake horsepower, 5-3

### Brake systems, inspection of, 8-9 to 8-20

### Bypass procedure, engine analyzer screen, 6-11

## INDEX

### C

- Camshaft, 5-28 to 5-29
  - checking, 5-28
  - replacing bearings, 5-29
- Capacitor discharge ignition system, 6-19
- Caterpillar fuel injection systems, 7-1 to 7-7
  - compact fuel system, 7-4 to 7-5
  - forged body fuel system, 7-1 to 7-4
  - sleeve metering system, 7-5 to 7-7
- Charging circuit diodes, 6-10
- Charging system, troubleshooting with a volt-ampere tester, 6-7 to 6-8
  - circuit resistance test, 6-7
  - ground circuit resistance test, 6-8
  - insulated circuit resistance test, 6-8
- Charting procedures and progress control, 3-11 to 3-12
- Clearance lamps, inspection of lighting equipment, 8-8
- Clutches, 9-1 to 9-5
  - troubleshooting, 9-3 to 9-5
- Compact fuel system, Caterpillar, 7-4 to 7-5
  - governor, 7-4
  - operation, 7-4
  - troubleshooting, 7-5
- Compression test, 5-13
- Connecting rod noise, 5-12
- Constant mesh transmission, 9-8
- Construction and specialized equipment shop foreman, 3-5
- Construction schedule drawings, 4-26 to 4-32
  - arrow diagram, 4-26
  - critical path, 4-26
  - network analysis, 4-27 to 4-29
  - precedence diagram, 4-30 to 4-32
- Controls, instruments, and warning devices, inspection of, 8-21 to 8-22
- Conventional/coil ignition system, troubleshooting, 6-22 to 6-24
- Conversion to metric, horsepower, 5-2 to 5-3
- Cooperation, development of, 2-5
- Correspondence, official, 1-15, 1-22 to 1-27
  - memorandums, 1-22, 1-25
  - messages, 1-25 to 1-27
  - speedletters, 1-25
  - standard naval letters, 1-22 to 1-24
- Cost control, 3-6 to 3-8
  - cost justification, 3-8
  - depth of maintenance, repair, and overhaul, 3-7
  - records and reports, 3-7

- Cost control supervisors, 4-9 to 4-11
- Cranking voltage test, 6-13
- Crankshaft knock, 5-13
- Crankshaft, servicing, 5-30 to 5-31
  - checking bearing fit, 5-30
  - checking end play, 5-31
  - checking journals and bearings, 5-30
  - removing bearing caps, 5-30
- Cummins Pressure Time fuel system, 7-22 to 7-25
  - injector maintenance and testing, 7-25
  - pump cleaning and inspection, 7-24
  - pump disassembly, 7-23
  - pump reassembly, 7-24
  - pump testing, 7-24
  - troubleshooting, 7-22
- Cylinder leakage test, 5-15
- Cylinder, servicing, 5-31 to 5-32
  - checking walls, 5-31
  - refinishing, 5-32
  - service, 5-31

### D

- Deadline equipment, inspection of, 8-23
- Delco-Remy, unit ignition system, 6-21
- Diagnosing engine problems, 5-11 to 5-21
  - engine noises, 5-12 to 5-13
  - excessive oil consumption, 5-11
  - low oil pressure, 5-12
  - micrometers, 5-17 to 5-21
  - testing, 5-13 to 5-17
- Diesel fuel systems, 7-1 to 7-32
  - air induction system, 7-26 to 7-32
    - blowers, 7-26 to 7-28
    - superchargers, 7-28 to 7-29
    - turbochargers, 7-29 to 7-32
  - American Bosch fuel pump, 7-11 to 7-16
    - checking the nozzle after reassembly, 7-16
    - nozzle cleaning and inspection, 7-16
    - nozzle operation, 7-14
    - nozzle reassembly, 7-16
    - nozzle troubleshooting, 7-14 to 7-16
    - operation, 7-11 to 7-13
    - troubleshooting, 7-13
    - types of nozzles, 7-13

Diesel fuel systems—Continued

Caterpillar fuel injection systems, 7-1 to 7-7

- compact fuel system, 7-4 to 7-5
- forged body fuel system, 7-1 to 7-4
- sleeve metering system, 7-5 to 7-7

Cummins-Pressure Time fuel system, 7-22 to 7-25

- injector maintenance and testing, 7-25
- pump cleaning and inspection, 7-24
- pump disassembly, 7-23
- pump reassembly, 7-24
- pump testing, 7-24
- troubleshooting, 7-22

General Motors fuel system, 7-16 to 7-21

- checking the injector after reassembly, 7-21
- injector cleaning and inspection, 7-21
- injector disassembly, 7-21
- testing, 7-17 to 7-21
- troubleshooting, 7-17

Roosa Master fuel injector pump, 7-7 to 7-11

- cleaning and inspection, 7-11
- disassembly, 7-10
- reassembly, 7-11
- removal, 7-10
- troubleshooting, 7-7 to 7-10

Differentials, propeller shaft assemblies, 9-19 to 9-24

- troubleshooting, 9-23 to 9-24

Diodes, 6-10 to 6-11

- charging circuit, 6-10
- open and shorted, 6-11
- weak, 6-11

Directional signals, inspection of lighting equipment, 8-7 to 8-8

Drawbar and belt horsepower, 5-4 to 5-5

Duties and responsibilities, supervisory, 2-2 to 2-3

E

Electrical systems and equipment, 6-1 to 6-26

a.c. electrical systems, 6-1 to 6-4

- alternators, 6-1
- rectifiers, 6-2
- regulators, 6-2 to 6-4

ignition systems, 6-18 to 6-21

- capacitor discharge ignition system, 6-19

Electrical systems and equipment—Continued  
ignition systems—Continued

Chrysler electronic lean burn system/  
electronic spark control, 6-20

electronic ignition system (Chrysler),  
6-19 to 6-20

transistor ignition system (breaker-  
point type), 6-18

transistor ignition system (magnetic-  
pulse type), 6-19

unit ignition system (Delco-  
Remy), 6-21

troubleshooting the alternator using the  
engine analyzer screen, 6-10 to 6-12

bypass procedure, 6-11

charging circuit diodes, 6-10

open and shorted diodes, 6-11

shorted windings, 6-12

weak diodes, 6-11

troubleshooting the charging system with a  
volt-ampere tester, 6-4 to 6-10

alternator test, 6-5

battery drain test, 6-8 to 6-10

charging system circuit resistance  
test, 6-7

charging system ground circuit resist-  
ance test, 6-8

charging system insulated circuit resist-  
ance test, 6-8

excessive output test, 6-7

generator test, 6-6

regulator ground circuit resistance  
test, 6-8

troubleshooting the cranking system using  
the battery starter test, 6-12 to 6-18

cranking voltage test, 6-3

solenoid switch circuit resistance test,  
6-17 to 6-18

starter ground circuit resistance  
test, 6-16

starter insulated circuit resistance test  
(cables and switches), 6-14 to 6-16

starting motor current draw test, 6-14

troubleshooting the ignition systems, 6-22  
to 6-26

conventional/coil ignition system, 6-22  
to 6-24

electronic ignition system, 6-25 to 6-26

transistor ignition systems, 6-24 to 6-25

Electronic ignition system (Chrysler), 6-19  
to 6-20

## INDEX

- Electronic ignition system, troubleshooting, 6-25 to 6-26
  - Electronic lean burn system/electronic spark control, Chrysler, 6-20
  - Embarkation, 4-25 to 4-26
    - inspecting, 4-26
    - preparing, 4-26
    - scheduling, 4-25
    - staging, 4-26
    - transporting, 4-26
  - Embarkation inspections, 8-22
  - Emergency, brake systems, 8-19 to 8-20
  - Engine analyzer screen, troubleshooting the alternator, 6-10 to 6-12
    - bypass procedure, 6-11
    - charging circuit diodes, 6-10
    - open and shorted diodes, 6-11
    - shorted windings, 6-12
    - weak diodes, 6-11
  - Engine overhaul, 5-1 to 5-35
    - diagnosing engine problems, 5-11 to 5-21
      - engine noises, 5-12 to 5-13
      - excessive oil consumption, 5-11
      - low oil pressure, 5-12
      - micrometers, 5-17 to 5-21
      - testing, 5-13 to 5-17
    - graphs and diagrams, 5-5 to 5-9
      - performance curves, 5-5
      - timing diagrams, 5-6 to 5-9
    - horsepower and horsepower ratings, 5-1 to 5-5
      - brake horsepower, 5-3
      - conversion to metric, 5-2 to 5-3
      - drawbar and belt horsepower, 5-4 to 5-5
      - friction horsepower, 5-4
      - indicated horsepower, 5-1
    - power losses and failure, 5-9 to 5-11
    - servicing pistons and rings, 5-32 to 5-35
      - cleaning pistons, 5-33
      - fitting pistons, 5-33
      - fitting piston pins, 5-33
      - fitting piston rings, 5-34 to 5-35
    - servicing the crankshaft and cylinders, 5-29 to 5-32
      - checking bearing fit, 5-30
      - checking crankshaft end play, 5-31
      - checking crankshaft journals and bearings, 5-30
      - checking cylinder walls, 5-31
      - cylinder service, 5-31
  - Engine overhaul—Continued
    - servicing the crankshaft and cylinders—Continued
      - refinishing cylinders, 5-32
      - removing bearing caps, 5-30
    - servicing valves, valve mechanisms, and cylinder heads, 5-21 to 5-29
      - checking the camshaft, 5-28
      - grinding valves, 5-23
      - grinding valve seats, 5-25 to 5-27
      - replacing camshaft bearings, 5-29
      - replacing valve seat inserts, 5-27
      - servicing rocker arms, 5-28
      - servicing valve guides, 5-24 to 5-25
      - servicing valve lifters, 5-28
      - testing valve springs, 5-28
      - timing the valves, 5-29
      - valve adjustments, 5-21 to 5-23
      - valve removal, 5-23
      - valve troubles, 5-21
  - Equipment Evaluation Program, Battalion, 4-20 to 4-25
    - joint responsibilities, 4-21, 4-25
    - repair parts (BEEP), 4-25
    - responsibilities of the battalion being relieved, 4-21
    - responsibilities of the relieving battalion, 4-21
  - Equipment maintenance branch, manager of, 3-3
  - Equipment Repair Order and continuation sheet, 4-16
  - Estimating procedures, 3-12
    - equipment, 3-12
    - manpower, 3-12
  - Excessive output test, 6-7
  - Exhaust systems; inspection of, 8-20 to 8-21
- ### F
- Facilities Planning Guide, 1-33 to 1-34
    - tailoring components and facilities, 1-34
    - use and application, 1-34
  - Fifth wheel and trailer, inspection of, 8-22
  - Forged body fuel system, Caterpillar, 7-1 to 7-4
    - testing, 7-2 to 7-4
    - troubleshooting, 7-2
  - Four-speed truck transmission, 9-5 to 9-8
  - Friction horsepower, 5-4

Fuel spillage, 2-9  
 bulk fuel spills, 2-9  
 field repair spills, 2-9  
 station fuel spills, 2-9

G

Gage care and maintenance, testing, 5-17  
 General Motors fuel system, 7-16 to 7-21  
     checking the injector after reassembly, 7-21  
     injector cleaning and inspection, 7-21  
     injector disassembly, 7-21  
     testing, 7-17 to 7-21  
     troubleshooting, 7-17  
 Generator test, 6-6  
 Graphs and diagrams, engine overhaul, 5-5  
     to 5-9  
     performance curves, 5-5  
     timing diagrams, 5-6 to 5-9  
 Grinding valve seats, 5-25 to 5-27  
 Grinding valves, 5-23  
 Ground circuit resistance test, 6-8

H

Headlights, inspection of lighting equipment,  
 8-4 to 8-7  
     using a headlight tester for checking head-  
     lights, 8-6 to 8-7  
     using a screen for aiming headlights, 8-4  
     to 8-6  
 Heat, light, and ventilation, maintenance  
 branch, 4-3  
 Heavy equipment repair supervisors, 4-6 to 4-7  
 Horsepower and horsepower ratings, engine  
 overhaul, 5-1 to 5-5  
     brake horsepower, 5-3  
     conversion to metric, 5-2 to 5-3  
     drawbar and belt horsepower, 5-4 to 5-5  
     friction horsepower, 5-4  
     indicated horsepower, 5-1  
 Hydraulic, brake systems, 8-10 to 8-16  
 Hydraulic torque converter, 9-33 to 9-35

I

Ignition systems, 6-18 to 6-21  
     capacitor discharge ignition system, 6-19  
     Chrysler electronic lean burn system/  
     electronic spark control, 6-20

Ignition systems—Continued  
     electronic ignition system (Chrysler), 6-19  
     to 6-20  
     transistor ignition system, 6-18 to 6-19  
         breaker-point type, 6-18  
         magnetic-pulse type, 6-19  
     unit ignition system (Delco-Remy), 6-21  
 Ignition systems, troubleshooting, 6-22 to 6-26  
     conventional/coil ignition system, 6-22  
     to 6-24  
     electronic ignition system, 6-25 to 6-26  
     transistor ignition system, 6-24 to 6-25  
 Indicated horsepower, 5-1  
 Injector, General Motors fuel systems, 7-21  
 Inspections, 8-2 to 8-23  
     brake systems, 8-9 to 8-20  
         air, 8-11, 8-16, 8-18  
         air-over-hydraulic, 8-16, 8-18 to 8-19  
         emergency, 8-19 to 8-20  
         hydraulic, 8-10 to 8-16  
         vacuum-assisted hydraulic brakes  
         (power), 8-11, 8-17  
         vacuum-over-hydraulic, 8-19  
     deadline equipment, 8-23  
     exhaust systems, 8-20 to 8-21  
     fifth wheel and trailer, 8-22  
     instruments, controls, and warning devices,  
     8-21 to 8-22  
     lighting equipment, 8-2 to 8-9  
         auxiliary lights, 8-8 to 8-9  
         clearance lamps, 8-8  
         directional signals, 8-7 to 8-8  
         headlights, 8-4 to 8-7  
         ICC regulations, 8-2 to 8-4  
         license plate lights, 8-7  
         taillights and stop lamps, 8-7  
     preserved equipment, 8-22  
     seat belts, 8-21  
     steering systems, 8-20  
     windshield wipers, glass, and defrost-  
     ers, 8-21  
 Inspector, vehicle, 8-1 to 8-2  
     battalion shop, 8-2  
     PW shop, 8-1  
 Insulated circuit resistance test, 6-8  
 Intermediate maintenance, 4-12 to 4-14

L

Leadership, principles of, 2-3 to 2-4  
     coordinate, 2-4

## INDEX

### Leadership, principles of—Continued

- delegate, 2-4
- organize, 2-3
- License plate lights, 8-7
- Lighting equipment, inspection of, 8-2 to 8-9

## M

- Maintenance and repair foreman, 3-4
- Maintenance branch, setting up, 4-1 to 4-3
  - heat, light, and ventilation, 4-3
  - safety, 4-2
  - tools and equipment, 4-1 to 4-2
- Maintenance, preventive, 3-5 to 3-6
  - safety inspections, 3-6
  - service station, 3-5
  - unscheduled maintenance service, 3-6
- Maintenance program, battalion, 4-12 to 4-16
  - Equipment Repair Order and continuation sheet, 4-16
  - intermediate maintenance, 4-12 to 4-14
  - organizational maintenance, 4-12
  - scheduling maintenance, 4-14 to 4-16
- Maintenance, repair, and overhaul cost control, 3-7
- Maintenance supervisors, 4-3 to 4-11
  - automotive repair supervisors, 4-5
  - cost control supervisors, 4-9 to 4-11
  - heavy equipment repair supervisors, 4-6 to 4-7
  - repair parts, 4-11
  - shop inspectors, 4-4
  - support section supervisors, 4-8 to 4-9
  - technical librarian, 4-11
- Materials and equipment; site deployment of, 2-7 to 2-8
  - handling fuels, 2-8
  - handling gases, 2-7
  - handling tires, 2-8
  - stowage of materials, 2-7
  - stowage of tools and equipment, 2-7
- Memorandums, official correspondence, 1-22, 1-25
- Messages, official correspondence, 1-25 to 1-27
- Micrometers, engine problems, 5-17 to 5-21
  - care, 5-21
  - measuring hole diameter with an inside micrometer, 5-20
  - reading a micrometer, 5-17 to 5-19
  - reading a vernier micrometer, 5-19 to 5-20
  - types, 5-17
- Morale, development of, 2-5

## N

- Naval letters, standard, 1-22 to 1-24
- Network analysis, construction schedule drawings, 4-27 to 4-29
- Noises, engine, 5-12 to 5-13
  - connecting rod noise, 5-12
  - crankshaft knock, 5-13
  - piston-pin knock, 5-12
  - piston-ring noise, 5-12
  - piston slap, 5-12
  - valve and tappet noise, 5-12

## O

- Oil consumption, excessive, 5-11
- Oil pressure, low, 5-12
- On-the-job training, 1-29 to 1-33
- Open and shorted diodes, 6-11
- Organizational maintenance, 4-12

## P

- Performance curves, graphs and diagrams, engine overhaul, 5-5
- Piston-pin knock, 5-12
- Piston-ring noise, 5-12
- Piston slap, 5-12
- Pistons and rings, servicing, 5-32 to 5-35
  - cleaning pistons, 5-33
  - fitting pistons, 5-33
  - fitting piston pins, 5-33
  - fitting piston rings, 5-34 to 5-35
- Planning, hints on supervision, 2-5 to 2-6
- Power losses and failure, engine overhaul, 5-9 to 5-11
- Power shift transmission, 9-35, 9-38 to 9-44
- Power trains and automatic transmissions, 9-1 to 9-67
  - automatic transmissions, 9-27 to 9-67
    - Allison torque transmission (series 4460), 9-44 to 9-67
    - hydraulic torque converter, 9-33 to 9-35
    - power shift transmission, 9-35, 9-38 to 9-44
    - turbo Hydra-matic 400, 9-28 to 9-33
  - clutches, 9-1 to 9-5
  - troubleshooting, 9-3 to 9-5
  - power takeoffs, 9-19

Power trains and automatic transmissions—  
Continued

propeller shaft assemblies, 9-19 to 9-26  
axles, wheels, and tracks, 9-24 to 9-26  
differentials, 9-19 to 9-23  
differential troubleshooting, 9-23  
to 9-24

service and maintenance, 9-26 to 9-27

transfer cases, 9-17 to 9-19

transmission, 9-5 to 9-17

auxiliary, 9-11 to 9-13

constant-mesh, 9-8

four-speed truck, 9-5 to 9-8

synchromesh, 9-8 to 9-11

troubleshooting, 9-13 to 9-17

PRCP, Personnel Readiness Capability Program, 1-1 to 1-8

interviews, 1-4

skill inventory, 1-1 to 1-3

steps for interviewing, 1-6 to 1-8

using the Standards and Guides for individual rating skills, 1-4 to 1-6

Precedence diagram construction schedule

drawings, 4-30 to 4-32

Preserved equipment, inspection of, 8-22

Production control supervisor, 3-3

Production, supervisory, 2-4

PW shop inspector, 8-1

PW transportation shops supervisor, 3-1 to 3-12

cost control, 3-6 to 3-8

cost justification, 3-8

depth of maintenance, repair, and overhaul, 3-7

records and reports, 3-7

department organization, 3-1

duties and responsibilities of supervisory personnel, 3-2 to 3-5

construction and specialized equipment shop foreman, 3-5

maintenance and repair foreman, 3-4

manager of the equipment maintenance branch, 3-3

production control supervisor, 3-3

transportation division director, 3-2

estimating procedures, 3-12

equipment, 3-12

manpower, 3-12

preventive maintenance, 3-5 to 3-6

safety inspections, 3-6

service station, 3-5

unscheduled maintenance service, 3-6

PW transportation shops supervisor—Continued

progress control and charting procedures, 3-11 to 3-12

storage, preservation, and depreservation of vehicles and equipment, 3-8 to 3-10

techniques of scheduling, 3-10 to 3-11

R

Records and reports, cost control, 3-7

Rectifiers, 6-2

Regulator ground circuit resistance test, 6-8

Regulators, 6-2 to 6-4

Repair parts, 4-16 to 4-20

prepackaged library, 4-17 to 4-19

procedures for requesting repair parts, 4-19

Repair parts, maintenance supervisors, 4-11

Respect, earning, supervisor, 2-1

Responsibilities, supervisory, 2-4 to 2-5

development of cooperation, 2-5

development of morale, 2-5

production, 2-4

safety, health, and physical welfare of subordinates, 2-4

training of subordinates, 2-5

Rocker arms, servicing, 5-28

Roosa Master fuel injection pump, 7-7 to 7-11

cleaning and inspection, 7-11

disassembly, 7-10

reassembly, 7-11

removal, 7-10

troubleshooting, 7-7 to 7-10

S

Safeguards and safety education, accident prevention, 1-9

Safety inspections, accident prevention, 1-10

Safety inspections, preventive maintenance, 3-6

Safety, maintenance branch, 4-2

Scheduling maintenance, 4-14 to 4-16

Scheduling, techniques of, 3-10 to 3-11

Seat belts, inspection of, 8-21

Service and maintenance, power trains, 9-26 to 9-27

Service station maintenance, 3-5

## INDEX

- Service the crankshaft and cylinders, 5-29  
to 5-32  
    checking bearing fit, 5-30  
    checking crankshaft end play, 5-31  
    checking crankshaft journals and bearings, 5-30  
    checking cylinder walls, 5-31  
    cylinder service, 5-31  
    refinishing cylinders, 5-32  
    removing bearing caps, 5-30
- Service valves, valve mechanisms, and cylinder heads, 5-21 to 5-29  
    checking the camshaft, 5-28  
    grinding valves, 5-23  
    grinding valve seats, 5-25 to 5-27  
    replacing camshaft bearings, 5-29  
    replacing valve seat inserts, 5-27  
    servicing rocker arms, 5-28  
    servicing valve guides, 5-24 to 5-25  
    servicing valve lifters, 5-28  
    testing valve springs, 5-28  
    timing the valves, 5-29  
    valve adjustments, 5-21 to 5-23  
    valve removal, 5-23  
    valve troubles, 5-21
- Shaft assemblies, propeller, 9-19 to 9-26  
    axles, wheels, and tracks, 9-24 to 9-26  
    differentials, 9-19 to 9-23  
    differential troubleshooting, 9-23 to 9-24
- Shop inspectors, 4-4
- Shorted windings, engine analyzer screen, 6-12
- Sleeve metering system, Caterpillar, 7-5 to 7-7  
    components, 7-5  
    governor, 7-6 to 7-7  
    operation, 7-5 to 7-6  
    troubleshooting and adjustments, 7-7
- Solenoid switch circuit resistance test, 6-17 to 6-18
- Speedletters, official correspondence, 1-25
- Starter ground circuit resistance test, 6-16
- Starter insulated circuit resistance test (cables and switches), 6-14 to 6-16
- Starting motor current draw test, 6-14
- Steering systems, inspection of, 8-20
- Storage, preservation, and de preservation of vehicles and equipment, 3-8 to 3-10
- Superchargers, air induction system, 7-28 to 7-29
- Supervision, 2-1 to 2-9  
    air pollution control, 2-8  
    fuel combustion, 2-8  
    sprays and gases, 2-8
- Supervision—Continued  
    daily work assignments, 2-6  
    fuel spillage, 2-9  
        bulk fuel spills, 2-9  
        field repair spills, 2-9  
        station fuel spills, 2-9  
    hints on planning, 2-5 to 2-6  
    principles of leadership, 2-3 to 2-4  
        coordinate, 2-4  
        delegate, 2-4  
        organize, 2-3  
    site deployment of materials and equipment, 2-7 to 2-8  
        handling fuels, 2-8  
        handling gases, 2-7  
        handling tires, 2-8  
        stowage of materials, 2-7  
        stowage of tools and equipment, 2-7  
    supervisor, the, 2-1 to 2-3  
        common mistakes, 2-1  
        earning respect, 2-1  
        fine line, the, 2-2  
        supervisory duties and responsibilities, 2-2 to 2-3  
        supervisory responsibilities, 2-4 to 2-5  
            development of cooperation, 2-5  
            development of morale, 2-5  
            production, 2-4  
            safety, health, and physical welfare of subordinates, 2-4  
            training of subordinates, 2-5  
    Supervisory personnel, duties and responsibilities, 3-2 to 3-5  
        construction and specialized equipment shop foreman, 3-5  
        maintenance and repair foreman, 3-4  
        manager of the equipment maintenance branch, 3-3  
        production control supervisor, 3-3  
        transportation division director, 3-2
- Support section supervisors, 4-8 to 4-9
- Synchromesh transmission, 9-8 to 9-11

## T

- Tachometer, 5-16
- Takeoffs, power, power trains, 9-19
- Taillights and stop lamps, inspection of lighting equipment, 8-7



## CONSTRUCTION MECHANIC 1 & C

Technical librarian, maintenance supervisors, 4-11  
Testing, engine problems, 5-13 to 5-17-  
    compression test, 5-13  
    cylinder leakage test, 5-15  
    gauge care and maintenance, 5-17  
    tachometer, 5-16  
    vacuum test, 5-14  
Timing diagrams, 5-6 to 5-9  
    four-stroke cycle engine timing, 5-6 to 5-7  
    multiple cylinder engines, 5-8 to 5-9  
    two-stroke cycle engine timing, 5-7 to 5-8  
Tools and equipment, maintenance branch, 4-1 to 4-2  
Training and development of subordinates, 1-27 to 1-33  
    on-the-job training, 1-29 to 1-33  
    training needs, 1-29  
    training organization, 1-27 to 1-28  
Training of subordinates, 2-5  
Transfer cases, power trains, 9-17 to 9-19  
Transistor ignition system, 6-18 to 6-19  
    breaker-point type, 6-18  
    magnetic-pulse type, 6-19  
Transistor ignition system, troubleshooting, 6-24 to 6-25  
Transmission, 9-5 to 9-17  
    auxiliary, 9-11 to 9-13  
    constant-mesh, 9-8  
    four-speed truck, 9-5 to 9-8  
    synchromesh, 9-8 to 9-11  
    troubleshooting, 9-13 to 9-17  
Transportation division director, 3-2  
Turbo Hydra-matic 400, 9-28 to 9-33  
    hydraulic operation, 9-32  
    planetary gears, 9-28  
    torque converter operation, 9-29 to 9-32  
    troubleshooting, 9-33  
Turbochargers, air induction system, 7-29 to 7-32

### U

Unit ignition system (Delco-Remy), 6-21  
Unscheduled maintenance service, 3-6

### V

Vacuum-assisted hydraulic brakes (power), 8-11, 8-17  
Vacuum-over-hydraulic, brake systems, 8-19

Vacuum test, 5-14  
Valves, 5-12, 5-21 to 5-29  
    adjustments, 5-21 to 5-23  
    hydraulically operated valves, 5-23  
    overhead valves, 5-22  
    valves in block, 5-22  
    grinding, 5-23  
    guides, servicing, 5-24 to 5-25  
    lifters, servicing, 5-28  
    noise, valve and tappet, 5-12  
    removal, 5-23  
    seat inserts, replacing, 5-27  
    seats, grinding, 5-25 to 5-27  
    springs, testing, 5-28  
    timing, 5-29  
    troubles, 5-21  
Vehicle inspections, 8-1 to 8-23  
    "BEEP" inspections, 8-23  
    embarkation inspections, 8-22  
    inspection of brake systems, 8-9 to 8-20  
        air, 8-11, 8-16, 8-18  
        air-over-hydraulic, 8-16, 8-18 to 8-19  
        emergency, 8-19 to 8-20  
        hydraulic, 8-10 to 8-16  
        vacuum-assisted hydraulic brakes (power), 8-11, 8-17  
        vacuum-over-hydraulic, 8-19  
    inspection of deadline equipment, 8-23  
    inspection of exhaust systems, 8-20 to 8-21  
    inspection of fifth wheel and trailer, 8-22  
    inspection of instruments, controls, and warning devices, 8-21 to 8-22  
    inspection of lighting equipment, 8-2 to 8-9  
        auxiliary lights, 8-8 to 8-9  
        clearance lamps, 8-8  
        directional signals, 8-7 to 8-8  
        headlights, 8-4 to 8-7  
        ICC regulations, 8-2 to 8-4  
        license plate lights, 8-7  
        taillights and stop lamps, 8-7  
    inspection of preserved equipment, 8-22  
    inspection of seat belts, 8-21  
    inspection of steering systems, 8-20  
    inspection of windshield wipers, glass, and defrosters, 8-21  
    inspector, 8-1 to 8-2  
        battalion shop inspector, 8-2  
        PW shop inspector, 8-1  
Volt-ampere tester, troubleshooting the charging system, 6-4 to 6-10  
    alternator test, 6-5

## INDEX

---

Volt-ampere tester, troubleshooting the charging system—Continued

· battery drain test, 6-8

charging system circuit resistance test, 6-7

charging system ground circuit resistance test, 6-8

charging system insulated circuit resistance test, 6-8

excessive output test, 6-7

Volt-ampere tester, troubleshooting the charging system—Continued

generator test, 6-6

regulator ground circuit resistance test, 6-8

### W

Weak diodes, 6-11

Windshield wipers, glass, and defroster, inspection of, 8-21

Work assignments, daily, supervision, 2-6

# CONSTRUCTION MECHANIC 1 & C

NAVEDTRA 10645-F

Prepared by the Naval Education and Training Program Development Center, Pensacola, Florida

Your NRCC contains a set of assignments and perforated answer sheets. The Rate Training Manual, Construction Mechanic, 1&C NAVEDTRA 10645-F, is your textbook for the NRCC. If an errata sheet comes with the NRCC, make all indicated changes or corrections. Do not change or correct the textbook or assignments in any other way.

## HOW TO COMPLETE THIS COURSE SUCCESSFULLY

Study the textbook pages given at the beginning of each assignment before trying to answer the items. Pay attention to tables and illustrations as they contain a lot of information. Making your own drawings can help you understand the subject matter. Also, read the learning objectives that precede the sets of items. The learning objectives and items are based on the subject matter or study material in the textbook. The objectives tell you what you should be able to do by studying assigned textual material and answering the items.

At this point you should be ready to answer the items in the assignment. Read each item carefully. Select the BEST ANSWER for each item, consulting your textbook when necessary. Be sure to select the BEST ANSWER from the subject matter in the textbook. You may discuss difficult points in the course with others. However, the answer you select must be your own. Remove a perforated answer sheet from the back of this text, write in the proper assignment number, and enter your answer for each item.

Your NRCC will be administered by your command or, in the case of small commands, by the Naval Education and Training Program Development Center. No matter who administers your course you can complete it successfully by earning a 3.2 for each assignment. The unit breakdown of the course, if any, is shown later under Naval Reserve Retirement Credit.

## WHEN YOUR COURSE IS ADMINISTERED BY LOCAL COMMAND

As soon as you have finished an assignment, submit the completed answer sheet to the officer

designated to grade it. The graded answer sheet will not be returned to you.

If you are completing this NRCC to become eligible to take the fleetwide advancement examination, follow a schedule that will enable you to complete all assignments in time. Your schedule should call for the completion of at least one assignment per month.

Although you complete the course successfully, the Naval Education and Training Program Development Center will not issue you a letter of satisfactory completion. Your command will make an entry in your service record, giving you credit for your work.

## WHEN YOUR COURSE IS ADMINISTERED BY THE NAVAL EDUCATION AND TRAINING PROGRAM DEVELOPMENT CENTER

After finishing an assignment, go on to the next. Retain each completed answer sheet until you finish all the assignments in a unit (or in the course if it is not divided into units). Using the envelopes provided, mail your completed answer sheets to the Naval Education and Training Program Development Center where they will be graded and the score recorded. Make sure all blanks at the top of each answer sheet are filled in. Unless you furnish all the information required, it will be impossible to give you credit for your work. The graded answer sheets will not be returned.

The Naval Education and Training Program Development Center will issue a letter of satisfactory completion to certify successful completion of the course (or a creditable unit of the course). To receive a course-completion letter, follow the directions given on the course-completion form in the back of this NRCC.

You may keep the textbook and assignments for this course. Return them only in the event you disenroll from the course or otherwise fail to complete the course. Directions for returning the textbook and assignments are given on the book-return form in the back of this NRCC.

## PREPARING FOR YOUR ADVANCEMENT EXAMINATION

Your examination for advancement is based on the Occupational Standards for your rating as found in the MANUAL OF NAVY ENLISTED MANPOWER AND PERSONNEL CLASSIFICATIONS AND OCCUPATIONAL STANDARDS (NAVPERS 18068). These Occupational Standards define the minimum tasks required of your rating. The sources of questions in your advancement examination are listed in the BIBLIOGRAPHY FOR ADVANCEMENT STUDY (NAVEDTRA 10052). For your convenience, the Occupational Standards and the sources of questions for your rating are combined in a single pamphlet for the series of examinations for each year. These OCCUPATIONAL STANDARDS AND BIBLIOGRAPHY SHEETS (called Bib Sheets), are available from your ESO. Since your textbook and NRCC are among the sources listed in the bibliography, be sure to study both as you take the course. The qualifications for your rating may have changed since your course and textbook were printed, so refer to the latest edition of the Bib Sheets.

## NAVAL RESERVE RETIREMENT CREDIT

This course is evaluated at 12 Naval Reserve retirement points. These points are creditable to personnel eligible to receive them under current directives governing retirement of Naval Reserve personnel.

Credit cannot be given again for this course if the student has previously received credit for completing another Construction Mechanic 1&C NRCC or ECC.

## COURSE OBJECTIVE

In completing this NRCC, you will demonstrate a knowledge of the subject matter by correctly answering items on the following: administration; supervision; PW transportation shops supervision; battalion equipment company shops supervision; engine overhaul; electrical systems and equipment; diesel fuel systems; vehicle inspections; and power trains and automatic transmissions.

While working on this correspondence course, you may refer freely to the text. You may seek advice and instruction from others on problems arising in the course, but the solutions submitted must be the result of your own work and decisions. You are prohibited from referring to or copying the solutions of others, or giving completed solutions to anyone else taking the same course.

Naval courses may include a variety of questions -- multiple-choice, true-false, matching, etc. The questions are not grouped by type, regardless of type, they are presented in the same general sequence as the textbook material upon which they are based. This presentation is designed to preserve continuity of thought, permitting step-by-step development of ideas. Some courses use many types of questions, others only a few. The student can readily identify the type of each question (and the action required) through inspection of the samples given below.

MULTIPLE-CHOICE QUESTIONS

Each question contains several alternatives, one of which provides the best answer to the question. Select the best alternative, and blacken the appropriate box on the answer sheet.

SAMPLE

- s-1. The first person to be appointed Secretary of Defense under the National Security Act of 1947 was
1. George Marshall
  2. James Forrestal
  3. Chester Nimitz
  4. William Halsey

Indicate in this way on the answer sheet:

	1	2	3	4	
	T	F			
s-1	<input type="checkbox"/>	<input checked="" type="checkbox"/>	<input type="checkbox"/>	<input type="checkbox"/>	---

TRUE-FALSE QUESTIONS

Mark each statement true or false as indicated below. If any part of the statement is false the statement is to be considered false. Make the decision, and blacken the appropriate box on the answer sheet.

SAMPLE

- s-2. Any naval officer is authorized to correspond officially with any systems command of the Department of the Navy without his commanding officer's endorsement.

Indicate in this way on the answer sheet:

	1	2	3	4	
	T	F			
s-2	<input type="checkbox"/>	<input checked="" type="checkbox"/>	<input type="checkbox"/>	<input type="checkbox"/>	---

MATCHING QUESTIONS

Each set of questions consists of two columns, each listing words, phrases or sentences. The task is to select the item in column B which is the best match for the item in column A that is being considered. Items in column B may be used once, more than once, or not at all. Specific instructions are given with each set of questions. Select the numbers identifying the answers and blacken the appropriate boxes on the answer sheet.

SAMPLE

In questions s-3 through s-6, match the name of the shipboard officer in column A by selecting from column B the name of the department in which the officer functions.

- |                               |                           |  |
|-------------------------------|---------------------------|--|
| A                             | B                         |  |
| s-3. Damage Control Assistant | 1. Operations Department  |  |
| s-4. CIC Officer              | 2. Engineering Department |  |
| s-5. Disbursing Officer       | 3. Supply Department      |  |
| s-6. Communications Officer   |                           |  |

Indicate in this way on the answer sheet:

	1	2	3	4	
	T	F			
s-3	<input type="checkbox"/>	<input checked="" type="checkbox"/>	<input type="checkbox"/>	<input type="checkbox"/>	---
s-4	<input checked="" type="checkbox"/>	<input type="checkbox"/>	<input type="checkbox"/>	<input type="checkbox"/>	---
s-5	<input type="checkbox"/>	<input type="checkbox"/>	<input checked="" type="checkbox"/>	<input type="checkbox"/>	---
s-6	<input checked="" type="checkbox"/>	<input type="checkbox"/>	<input type="checkbox"/>	<input type="checkbox"/>	---

# Assignment 1

## Administration

Textbook Assignment: Pages 1-1 through 1-36

In this course you will demonstrate that learning has taken place by correctly answering training items. The mere physical act of indicating a choice on an answer sheet is not in itself important; it is the mental achievement, in whatever form it may take, prior to the physical act that is important and toward which correspondence course learning objectives are directed. The selection of the correct choice for a correspondence course training item indicates that you have fulfilled, at least in part, the stated objective(s).

The accomplishment of certain objectives, for example, a physical act such as drafting a memo, cannot readily be determined by means of objective type correspondence course items; however, you can demonstrate by means of answers to training items that you have acquired the requisite knowledge to perform the physical act. The accomplishment of certain other learning objectives, for example, the mental acts of comparing, recognizing, evaluating, choosing, selecting, etc., may be readily demonstrated in a correspondence course by indicating the correct answers to training items.

The comprehensive objective for this course has already been given. It states the purpose of the course in terms of what you will be able to do as you complete the course.

The detailed objectives in each assignment state what you should accomplish as you progress through the course. They may appear singly or in clusters of closely related objectives, as appropriate; they are followed by items which will enable you to indicate your accomplishment.

All objectives in this course are learning objectives and items are teaching items. They point out important things, they assist in learning, and they should enable you to do a better job for the Navy.

This self-study course is only one part of the total Navy training program; by its very nature it can take you only part of the way to a training goal. Practical experience, schools, selected reading, and the desire to accomplish are also necessary to round out a fully meaningful training program.

---

Learning Objective: Describe techniques of conducting PRCP interviews and using data in assigning personnel.

---

1-1. The purpose of the Personnel Readiness Capability Program is to provide accurate up-to-date personnel information that will enable the NCF to

1. schedule day-to-day work assignments for individual crewmembers
2. combine the information relevant to the planning and scheduling of project functions into a single master plan
3. increase its capabilities to plan, make decisions, and control

● Use the following alternatives in answering items 1-2 through 1-6.

1. Individual General Skills
2. Individual Rating Skills
3. Military Skills
4. Crew Experience (Skills)

1-2. Skills related to two or more ratings which are primarily nonmanipulative are classified as

1-3. Skills you acquired as a result of working with others on a particular project are normally classified as

1-4. Skills you acquired as a result of training for combat are broadly classified as

1-5. Nontechnical skills you acquired by participating in a cross-rate training program are generally classified as

- 1-6. Technical skills specifically related to one of the Construction ratings are classified as
- 1-7. What management tool should you use in collecting crewmember skill data?
1. Volume I, PRCP Skill Definitions
  2. PRCP Standards and Guides
  3. Matrix Numbers 1 and 2
  4. Section II, Manual of Navy Enlisted Manpower and Personnel Classifications and Occupational Standards
- 1-8. If you collect any information through observation or an interview concerning an individual's skills, you must send it to FACSO, Port Hueneme on a/an
1. IBM card
  2. PRCP Skill Update Record
  3. 3 by 5 card
  4. message form
- 1-9. The Individual Rating Skill Interview and Other Interviews are types of interviews conducted by the PRCP interviewer.
- 1-10. Before conducting an individual rating skill interview, what must you do?
1. Review the appropriate section of the Occupational Standards Manual
  2. Prepare an interviewee's service record
  3. Prepare an interviewee's checkoff sheet
  4. Learn as much as you can about the skills and tasks explained in the interviewing guides
- 1-11. When introducing the skill material to an interviewee, you start by reading the skill definition.
- In answering items 1-12 through 1-14, assume you are a PRCP interviewer and are interviewing personnel for particular skill levels. Each item is to be judged true or false.
- 1-12. You should explain the purpose of the interview to each interviewee.
- 1-13. You should explain that your interviewees should not be embarrassed if they do not know everything expected of them about a specific skill level.
- 1-14. You should first read the task element, then the action statement to each interviewee.
- 1-15. Who decides whether a person does or does not have a skill?
1. PRCP coordinator
  2. PRCP interviewer
  3. Training officer
- 
- Learning Objective: Describe principles of administering a safety program.
- 
- 1-16. In establishing a safety organization, each unit of the NCF must develop an accident prevention program and enforce safe working practices.
- 1-17. When does a safety officer formulate safety doctrine and policy for the battalion?
1. After conducting on-the-job analyses
  2. After consulting with project supervisors
  3. Both 1 and 2 above
- 1-18. In addition to assigning crewmembers to equipment operation, project supervisors are also responsible for the crew's safety, health, and physical welfare.
- 1-19. Working your plan for controlling the hazards of a job will help you attain which of the following goals?
1. Upgrade production
  2. Prevent accidents
  3. Instill respect
  4. Each of the above
- 1-20. To help prevent accidents, you can review the previous accident experience in the shop, select the right methods and right personnel for the job, and make specific work assignments.
- 1-21. How often should you hold a standup safety meeting at the shop?
1. Weekly
  2. Biweekly
  3. Monthly
  4. Whenever an accident has been reported
- 1-22. Which of the following results should be obtained from a group discussion pertaining to an accident which happened on the job and resulted in an injury?
1. Kind of injury sustained
  2. Ways of preventing the accident
  3. Cause of the injury
  4. All of the above

- 1-23. Regularly scheduled standup safety meetings must be kept interesting. You can help keep them from becoming dull by taking which of the following actions?
1. Letting your crew air their gripes at the meetings
  2. Exceeding the time limits you set for the meetings
  3. Having the same crewmember conduct all meetings
  4. Showing good motion pictures and other visual aids on suitable subject matter
- 1-24. What information is included in the periodic safety report that you submit to the safety chief?
1. Time spent at safety meetings
  2. Attendance figures
  3. Subject matter covered
  4. Each of the above
- 1-25. In case of an accident to one of your crewmembers, you must answer the questions listed on OPNAV Form 5102/1.
- 1-26. What is the most important part of the OPNAV Form 5102/1, Accident Injury/Death report?
1. Block #23, Job Disposition After Injury
  2. Block #24, Number of Lost Work Days
  3. Block #33, Corrective Action Taken/Recommended
- 1-27. The most important reason for any accident investigation is prevention of a similar accident by correcting the cause.
- In answering items 1-28 through 1-30, refer to figures 1-5 through 1-8 of your textbook.
- 1-28. What block describes job disposition after the accidental injury?
1. 11
  2. 20
  3. 23
  4. 32
- 1-29. What block describes the employment status of the injured person?
1. 11
  2. 20
  3. 23
  4. 32
- 1-30. What block contains information pertaining to the circumstances and events that caused the accident?
1. 11
  2. 20
  3. 23
  4. 32
- 1-31. Slight vehicle damage noted at prestart inspection is reported on which form?
1. Standard Form 91A
  2. Standard Form 91
  3. OPNAV Form 5102/3
  4. Operator's Inspection Guide and Trouble Report, NAVFAC 9-11240/13
- 1-32. Accidents involving cranes and related equipment are handled routinely by the company safety petty officer.
- 1-33. When you are completing an injury/accident form, what would constitute an "unsafe act"?
1. Unguarded equipment
  2. Operating equipment without authority
  3. Absentmindedness or inattentiveness
  4. Hazardous arrangement
- 
- Learning Objective: Describe and prepare official Navy letters, messages, instructions, and prepare notices for use by subordinates.
- 
- 1-34. The copy of a standard naval letter prepared by CHARLIE or DELTA Company for the CO's signature is normally a
1. smooth copy
  2. rough copy
  3. perfect copy
- 1-35. Who is responsible for the finished correspondence prepared by you?
1. Drafting officer
  2. Department head
  3. Duty officer
  4. You
- 1-36. In correspondence requiring a classification, where is it shown?
1. Left-hand margin
  2. Right-hand margin
  3. Top of page only
  4. Top and bottom of page



- 1-37. When preparing a naval letter, you are NOT allowed to cover two or more subjects even though they are closely related.
- 1-38. Which paragraph, if any, of a 3-paragraph naval letter should state the purpose of the letter?
1. First
  2. Second
  3. Third
  4. None
- 1-39. When answering another letter, you should refer to it in the last paragraph of your letter.
- 1-40. As a writer of official correspondence, which of the following guidelines must you follow?
1. Maintain continuity when passing from one unit to another
  2. Arrange your units in satisfactory order
  3. Complete each unit before moving to the next
  4. Each of the above
- 1-41. Which of the following is a poor practice in preparing a naval letter?
1. Repeating yourself
  2. Using introductory phrases
  3. Deleting intensive words
  4. Cutting down on the use of big words
- In answering items 1-42 and 1-43, refer to textbook figure 1-15.
- 1-42. Which of the following lines of the standard naval letter may NOT be required in all correspondence being prepared?
1. "To"
  2. "From"
  3. "Subject"
  4. "Identification Symbol"
- 1-43. In a standard naval letter, which of the following abbreviations is NOT used?
1. Ref:
  2. Encl:
  3. Sub:
- 1-44. When a memorandum is typed on a plain sheet of bond paper, the word "memorandum" must appear on the sheet. This word is typed in which way?
1. In capital letters at the right margin above the "From" line
  2. In capital letters at the left margin above the "From" line
  3. In lowercase letters, two spaces below the "Subject" line
  4. In lowercase letters between the "From" and "To" lines
- 1-45. What is the chief purpose of the format of a speedletter?
1. To help disseminate information within the Navy Directives Issuance System
  2. To enable urgent correspondence to be transmitted by electrical means
  3. To point out the necessity for priority handling
  4. To make possible the transmission of classified documents
- 1-46. A speedletter may be handwritten instead of typed when
1. identifying blocks are used in it
  2. enclosures are listed in it
  3. time is critical
  4. it is classified
- 1-47. Who authorizes the transmission of a message?
1. The drafter
  2. The originator
  3. The releasing officer
  4. Each of the above
- 1-48. Messages that must be delivered promptly should be brief, concise, and contain a message heading and a message text.
- 1-49. What format correctly expresses a date/time group in a naval message?
1. 07 DEC 81 @ 1330
  2. 07 DEC 81; 1:30 P.M.
  3. 071330Z DEC 81
  4. DEC 071330Z 81
- 1-50. At most, how many spaces and characters are there per line of text in a naval message?
1. 49
  2. 57
  3. 69
  4. 98

1-51. Of the following symbols or punctuation marks, which is NOT used in a naval message?

1. \*
2. ?
3. &
4. /

---

Learning Objective: Show the procedure of implementing training for team crewmembers.

---

1-52. The priorities, patterns, and tempo of a battalion training program are usually established by the

1. Commanding Officer
2. Naval Education and Training Command
3. Chief of Naval Operations
4. COMCBPAC/COMCBLANT staff

1-53. Individual training administered to support personnel is the responsibility of the

1. platoon leader
2. training officer
3. battalion service department head
4. individual

1-54. Training conducted in an Amphibious Construction Battalion is exactly the same as that conducted in a Mobile Construction Battalion.

1-55. The battalion training plan and organization must NOT interfere with construction schedules as set forth by the deployment operation order.

---

Learning Objective: Describe the development of the on-the-job training program and daily work assignments.

---

1-56. The primary purpose of on-the-job training in a SEABEE organization is to

1. indoctrinate new personnel on a job
2. develop supervisors in management skills
3. help individuals acquire the necessary knowledge, skills, and habits to do a specific job
4. instill each person with interest and enthusiasm for the work to be done

1-57. Before setting up an on-the-job training program, you should

1. work up a set of lesson plans
2. select the type of training to be used
3. analyze the problem to determine the type of training required
4. rely on your experience to determine the training objectives

1-58. In determining the need for training, consider the specific job requirements and the individual skills of the trainee.

1-59. After an on-the-job training program has been implemented, how should followup on the program be maintained?

1. By keeping training records current
2. By insuring that the program does not lag
3. By insuring that newly developed skills are properly utilized
4. All of the above

1-60. When properly used, a most effective method for training workers on the job is

1. self-study
2. coach-pupil instruction
3. group instruction
4. academic-type instruction

1-61. In on-the-job training, the term group instruction means the same as classroom or academic-type instruction.

1-62. Of the following examples, which describes piecemeal instruction?

1. Letting others know what, when, where, and perhaps, how and why
2. Explaining regulations, procedures, and orders
3. Holding special meetings
4. Each of the above

1-63. Interviews between the trainee and the trainer in a developmental on-the-job training program do NOT help to do which of the following?

1. Disclose the training needs of the trainee
2. Formulate the overall training objectives
3. Assess the progress of the trainee
4. Resolve the trainee's questions concerning safety and skill techniques

1-4. Taking which of the following steps may aid you to plan and carry out a successful training program?

1. Using correct methods to insure learning
2. Measuring achievement at regular intervals
3. Recording results
4. All of the above

1-5. The essential part of a performance check is a typical work situation in which the trainee's work can be examined and evaluated.

---

Learning Objective: Point out principles in the use of the Facilities Planning Guide.

---

1-6. Included among the contents of NAVFAC P-437, Volume I, are which of the following factors?

1. Amounts of fuel required to operate components
2. Sizes of crews it takes to operate facilities
3. Drawings of facilities and assemblies
4. Acres of land a facility occupies

1-67. Volume II of NAVFAC P-437 is a source of information for planning an advanced-base component, facility, or assembly.

1-68. NAVFAC P-437 lists by national stock number the material requirements for which of the following units?

1. Facility
2. Assembly
3. Component
4. Each of the above

1-69. To make the P-437 compatible with other DOD planning guides, which related publication establishes category codes?

1. Table of AFGC's (OPNAV-41P3)
2. NAVFAC P-72
3. NAVFAC P-405
4. NAVFAC P-315

1-70. To find a facility that requires enlisted personnel quarters, under which of the following category codes should you look?

1. 300 - Research, Development and Evaluation
2. 700 - Housing and Community Support
3. 900 - Real Estate

1-71. Assemblies are grouped by numbers that relate to the Occupational Field 13 skill required to install them.

1-72. How can components or facilities be tailored?

1. By specifying requirements for tropical or northern temperate zones
2. By deleting or adding facilities or assemblies
3. Both 1 and 2 above

1-73. In the ABFC system, which code identifies assemblies required for use in northern temperate zones?

1. C
2. NT
3. N
4. T

1-74. How do you obtain fixtures that are not furnished with a facility or an assembly listed in NAVFAC P-437?

1. By picking them up at a supply depot
2. By ordering them separately
3. By purchasing them on the open market

1-75. Refer to textbook figure 1-19. Approximately how many man-hours should it take to construct a small helicopter landing pad?

1. 150
2. 244
3. 500

# Assignment 2

## Supervision and PW Transportation Shops Supervisor

Textbook Assignment: Pages 2-1 through 2-9 and 3-1 through 3-10

Learning Objective: Identify basic principles of supervision. Textbook pages 2-1 through 2-3.

- 2-1. A high level of production indicates good supervision only when it is accomplished willingly and with interest on the part of the working crew.
- 2-2. You can earn the respect of your crews by providing good supervision and proper direction and setting a good example.
- 2-3. Upon assuming duties as a supervisor, what should a CMI or CMC do?
1. Make it clear that all things will be changed
  2. Tell subordinates that foolishness will not be tolerated
  3. Tell subordinates that things will stay put for now
  4. Indicate that gripes will be handled efficiently
- 2-4. All the following are common mistakes of a new supervisor EXCEPT
1. using "new broom" tactics
  2. asserting authority to attract attention
  3. teaching subordinates what not to do
  4. playing favorites
- 2-5. As a new supervisor on the job, a CMI or CMC will be able to keep matters better in hand by
1. trusting subordinates
  2. letting subordinates know that the supervisor will not be responsible for their mistakes
  3. letting subordinates know immediately who is boss and that orders will not be questioned
  4. accepting full responsibility for anything that happens on the job

2-6. Which of the following practices should a supervisor observe in building the proper relationship with subordinates

1. Make clear by actions that the supervisor is a step above the subordinates
2. Have answers for everything and make it clear that no suggestions are needed
3. Be a regular person with the crew, both on and off the job
4. Maintain a friendly conservative manner, be consistent, demonstrate confidence in subordinates, and set a good example

2-7. Which of the following is a good practice for all supervisors?

1. Caring for tools and equipment
2. Training or developing subordinates
3. Delegating no authority to subordinates
4. Disregarding suggestions by subordinates

Learning Objective: Point out principles of leadership as they apply to supervision and identify the responsibilities of supervisors. Textbook pages 2-3 through 2-5.

2-8. Whether you become a good supervisor will depend on your ability to do which of the following tasks?

1. Organize
2. Delegate
3. Coordinate
4. Each of the above

2-9. Throughout military history, successful leaders have based their daily actions on

1. the golden rule
2. general principles
3. leadership principles
4. common knowledge

2-10. In planning a project, what should you do before making the man-hour estimate?

1. Prepare a list of repair parts
2. Determine the sequence of repairs
3. Assign your crews in accordance with their capabilities
4. Encourage your personnel to work faster

2-11. Before assigning work to your crews, you should have which of the following information?

1. Their experience
2. Leave schedules
3. Training required
4. All of the above

2-12. What is one of the common faults of a new supervisor?

1. Lack of coordination
2. Lack of organization
3. Failure to delegate authority

2-13. By delegating authority, you are relieved of the responsibility for a project.

2-14. Who has first or immediate responsibility for the safety, health, and welfare of a group of workers?

1. Safety officer
2. Department head
3. Job supervisor
4. Executive officer

2-15. What is the primary responsibility of every supervisor?

1. Plan and organize
2. Production
3. Make out daily man-hour reports
4. Train subordinates

2-16. Crews will produce more and be more willing to cooperate when

1. allowed to set their own start time
2. permitted to secure early
3. allowed to work without interruption
4. told the whats and whys of their work

2-17. Failure to keep your superiors informed may result in their lack of concern for you and your crewmembers.

2-18. High morale of your crewmembers is a direct result of their being confident and doing well on the job.

2-19. Which of the following factors could be indicators of low morale?

1. Equipment damages or losses due to carelessness
2. Absences without leave
3. Requests for transfer
4. All of the above

2-20. A battalion's training program is formed to provide naval personnel with skills to

1. prepare personnel for advancement
2. accomplish the current and mobilization missions of the battalion
3. accomplish the homeport projects only
4. prepare personnel for civilian life

2-21. Who must emphasize the importance of training to your crewmembers?

1. S-2 officer
2. Executive officer
3. You, the supervisor
4. Company training petty officer

---

Learning Objective: Indicate principles and techniques of administration or supervision in project planning and estimating. Textbook pages 2-6 through 2-8.

2-22. In planning, which of the following estimates should you be concerned with?

1. Equipment
2. Material
3. Manpower
4. Each of the above

2-23. Whether a construction project fails or succeeds may depend upon the accuracy of the calculations for each phase of development.

2-24. As petty officer in charge of the crew, you should confirm the planning for the next workday at the end of each workday.

2-25. To be an effective supervisor, which of the following factors should you consider in your day-to-day planning?

1. Keeping each crewmember fully occupied
2. Having enough equipment on hand to get the job done
3. Having enough supplies on hand to get started
4. All of the above

2-26. Planning should include time to handle personnel matters and military duties.

2-27. Rotating job assignments of mechanics achieves which of the following conditions?

1. Improves skills
2. Stimulates interest
3. Diversifies experience
4. All of the above

2-28. When locating maintenance materials, you should consider all the following EXCEPT

1. standardization
2. security
3. safety
4. frequency of use

2-29. Inventory control is justification for combining similar organic and augment repair parts.

2-30. Mount-out box lids and tiedown bands are considered expendable items.

2-31. Paint and lubricant inventory is a supply responsibility until drawn for use.

2-32. Toolkit inventories are normally conducted how frequently?

1. Monthly
2. Biweekly
3. Weekly
4. Daily

2-33. Safety and preventative inspections of portable power tools are to be conducted by the

1. battalion safety office
2. shop toolroom
3. battalion central toolroom
4. CESO inspection team

2-34. At a temporary site, fueling stations are set up using underground tanks.

2-35. Factors to be considered in determining the number of ready-for-issue tires required do NOT include the

1. types of tires on the ground
2. number of personnel in the tire shop
3. operating conditions
4. number and size on the ground

2-36. Inventory of spares for tactical vehicles is expedited by

1. storing them on pallets
2. turning them into supply
3. attaching tags and storing as collateral equipment
4. using them as ready-for-issue tires

---

Learning Objective: Identify procedures for controlling air pollution. Textbook page 2-8.

---

2-37. Construction mechanics are to be concerned with air pollution emitted from the following sources EXCEPT

1. vehicle exhaust
2. paint booths
3. boiler exhaust
4. parts washers

2-38. The preferred means of removing heavy exhaust gases from the shop is

1. a suction-ducting system
2. cross-ventilation
3. pedestal fans
4. hooded fans

2-39. Paint booths require an adequate ventilation system to remove paint fumes. Additional safety requires that they be equipped with

1. pedestal fans
2. reflective finished walls
3. explosionproof electrical connections
4. air-operated tools

---

Learning Objective: Identify means of containing or removing oil spills. Textbook page 2-9.

---

2-40. Synthetic sorbents can be made of which of the following materials?

1. Straw
2. Clay
3. Dry oil
4. Polymer

2-41. An effective means of absorbing bunker fuel at minimal cost is to use

1. polyurethane foam
2. straw
3. clay

2-42. Waste oil may be used to control dust and weeds without endangering water systems.

Learning Objective: Recognize basic work practices of a Public Works transportation maintenance shop. Textbook page 3-1.

2-43. Which of the following personnel will you contact in your work as PW transportation shop supervisor?

1. Mechanic
2. Military and civilian operators of equipment
3. Officers to whom you are responsible
4. All of the above

2-44. Which of the following statements best describes the work of a Public Works transportation maintenance shop?

1. The bulk of the work is of a one-time nature
2. Much of the work is of a continuing nature
3. The work is usually done by military personnel
4. Work methods are the same as those used in a battalion equipment maintenance shop

2-45. Civil service personnel are employed in a PW transportation shop to provide

1. jobs for the civilian community
2. experienced personnel who can be drafted in war
3. continuity of service

2-46. The location of shop tools and equipment will depend on the amount of the type of equipment to be maintained in your maintenance shops.

Learning Objective: Point out the duties and responsibilities of supervisory personnel of a Public Works Transportation Department. Textbook pages 3-2 through 3-6.

2-47. Who functions as a technical advisor in planning equipment required for the PW center?

1. Equipment operations general foreman
2. Production control supervisor
3. Transportation director
4. Equipment maintenance general foreman

2-48. Who takes over if the transportation director is absent?

1. Production control supervisor
2. Manager of the equipment branch
3. Maintenance and repair foreman
4. Construction and specialized equipment shop foreman

2-49. Besides being responsible for receiving, inspecting, and classifying all new and used equipment, the production control supervisor determines the

1. number of vehicles required for the activity
2. parts and tools needed to support this equipment during its life cycle
3. budgetary requirements for the maintenance division
4. workload for the transportation department

2-50. Scheduling the workload for the various centers of the Transportation Department is the responsibility of the

1. maintenance and repair foreman
2. manager of the equipment branch
3. production control supervisor
4. construction and specialized equipment shop foreman

In items 2-51 through 2-55, select from column B the supervisory personnel who is responsible for the duty in column A.

A. Duties

B. Supervisors

2-51. Supervises the tire shop, body and paint shop, and battery shop

1. Transportation director

2-52. Exercises full managerial and administrative responsibility of the PW transportation activity

2. Production control supervisor  
3. Maintenance and repair foreman

2-53. Issues and enforces safety practices and fire regulations

4. Construction and specialized equipment foreman

2-54. Maintains shop backlog records and vehicle history files

2-55. Supervises the machine shop

2-56. The maintenance and repair foreman and the construction and specialized equipment shop foreman have basically the same responsibilities. Which of these responsibilities is EXCEPTED for the construction equipment shop foreman?

1. Technical supervision of the work center
2. Analyzing and interpreting SRO's
3. Issuing and enforcing safety practices and fire regulations
4. Maintenance, repair, and major overhaul of specialized equipment

---

Learning Objective: Explain principles and techniques of preventive maintenance of equipment. Textbook pages 3-5 and 3-6.

---

2-57. What is the most important phase of preventive maintenance?

1. Scheduled command inspections
2. Unscheduled inspections
3. Scheduled periodic preventive maintenance
4. Unscheduled periodic preventive maintenance

2-58. The first line for preventive maintenance is the

1. unscheduled periodic inspection
2. scheduled command inspection
3. operator's daily maintenance
4. mechanic's minor repair

2-59. Your maintenance shop has noted that the operators are not performing proper daily PM's on their equipment. With whom should you consult to set up training periods?

1. Equipment operators
2. Equipment operation branch foreman
3. Maintenance shop inspector
4. Production control supervisor

2-60. When should your personnel inspect vehicles for safety and serviceability?

1. At the time a scheduled type A is performed only
2. At intervals not to exceed 6 months or 6,000 miles, whichever occurs first
3. At the time a scheduled type B is performed only
4. At the time a scheduled type C is performed

2-61. Which of the following points should you check during a vehicle brake inspection?

1. Brake pedal free travel
2. Brake line leakage
3. Brakedrum wear
4. All of the above

2-62. Which of the following items are NOT found on a motor vehicle safety inspection checklist?

1. Brakes, lights, and tires
2. Exhaust and steering system
3. Radiator and doors
4. Lights, windshield wipers, and warning devices

2-63. Tires should be removed from motor vehicles and replaced when the thickness of the tire tread is

1. 1/16 inch or less
2. 1/10 inch
3. 1/8 inch
4. 1/4 inch

2-64. What constitutes an unscheduled maintenance service?

1. Correcting troubles listed on the operator's daily trouble report
2. Correcting additional troubles found during this service period
3. Correcting safety deficiencies noted prior to releasing the vehicle
4. Each of the above

---

Learning Objective: Point out fundamentals of a Public Works cost control system. Textbook pages 3-6 through 3-8.

---

2-65. The cost control system provides a means for comparing the actual performance of maintenance work on transportation equipment to the hourly standards that are

1. derived from the man-hours accumulated in the use of the equipment
2. established by the equipment manufacturers and the Naval Facilities Engineering Command
3. derived from past work records
4. based upon the volume of work done



- 2-66. Which of the following costs are charged to allotments and appropriations in the cost control system?
1. Indirect labor and material costs of equipment maintenance and operation
  2. Direct labor and material costs of equipment maintenance and operation
  3. Costs of building maintenance, shop stores, and utilities
  4. All of the above
- 2-67. Transportation management reports include data for comparing actual maintenance costs and standard maintenance costs.
- 2-68. Textbook figure 3-2 is an example of a Shop Repair Order. One use of such an order is recording what type of information?
1. The cost of repairs
  2. The materials used
  3. The hours required to do the work
  4. Each of the above
- 2-69. The extent of the services that a PW maintenance shop will provide in maintaining, repairing, or overhauling an activity's automotive equipment depends on which of the following factors?
1. Economics
  2. Distance of the activity from commercial repair shops
  3. Size of the activity
  4. Each of the above
- 2-70. The cost of repair services by the preventive maintenance shop must be justified when the nature of the work is classified.
- 2-71. The level of preservation to apply to construction equipment depends on which of the following factors?
1. Information received as to how the equipment is to be handled, shipped, and stored
  2. Conditions to which the equipment will be subjected during its storage period prior to issue
  3. Physical characteristics of the equipment
  4. Each of the above.
- 2-72. All corrosion and contaminants must be removed from a piece of equipment before it is preserved.
- 2-73. Active storage equipment must be operated for short periods of time at regular intervals to keep it in serviceable condition.
- 2-74. Which of the following is NOT a step in the procedure for depreserving stored equipment before it can be operated?
1. Removing seals and closures
  2. Removing preservatives with abrasives
  3. Lubricating the movable parts of the equipment
  4. Reinstalling the components removed for storage
- 2-70. The cost of repair services by the preventive maintenance shop must be justified when the nature of the work is classified.

---

Learning Objective: Describe the procedures used in the preservation, depreservation, and storage of equipment. Textbook pages 3-9 and 3-10.

---

# Assignment 3

PW Transportation Shops Supervisor and Battalion Equipment Company Shops Supervisor

Textbook Assignment: Pages 3-10 through 3-12 and 4-1 through 4-25

---

Learning Objective: To point out procedures for P.W. preventative maintenance scheduling. Textbook pages 3-10 and 3-11.

---

- 3-1. In addition to safety inspections, vehicles should be inspected and serviced as
1. prescribed by the manufacturer
  2. often as mechanics are available
  3. little as possible to keep the cost down
  4. prescribed by the dealers
- 3-2. With 126 vehicles in PM Group 63, you would schedule what number of vehicles into the shop daily?
1. One
  2. Two
  3. Three
  4. Four
- 3-3. Direct labor available is the only factor to be considered when maintaining a workload control board.
- 3-4. Bar charts are used to monitor and control work progress.

---

Learning Objective: Recognize basic principles in the organization of the equipment maintenance branch in an NMCB. Textbook page 4-1.

---

- 3-5. What sections constitute the equipment maintenance branch of an NMCB?
1. Administration and automotive repair
  2. Heavy equipment repair and support
  3. Automotive repair and support
  4. Administrative, automotive repair, heavy equipment repair, and support

3-6. The equipment maintenance branch is normally under the overall supervision of a/an

1. EQCM
2. CMCS
3. Civil service employee
4. CMC

3-7. Who normally serves as a section head in a maintenance branch?

1. EQCM
2. CMCS
3. CM1 or CMC
4. CM2

---

Learning Objective: Point out factors in setting up a battalion maintenance branch. Textbook pages 4-1 through 4-3.

---

- 3-8. In planning for the location of a maintenance shop, you should consider which of the following factors?
1. Nearness to transportation facilities
  2. Room for expansion
  3. Size of parking area
  4. All of the above
- 3-9. Name two factors you should consider in deciding what type of tools and equipment to have on hand.
1. Goals and limitations set by regiment
  2. Layout of the shop and the qualifications of your mechanics
  3. Operational needs of the battalion and the cost of having work performed at an overhaul facility
  4. Cost plus factor and the expediency of the commercial facility

- 3-10. Deciding that work can be done more economically at a component overhaul facility than in the maintenance branch is based solely upon the
1. cost plus factor
  2. availability of the facility
  3. facts and figures in transportation maintenance management reports
  4. desires and goals of the regimental transportation officer
- 3-11. Where should you locate drill presses, bench grinders, and other common power tools for repairing many kinds of equipment?
1. In or near the main shop area
  2. In an area where ON-OFF switches are reached easily
  3. In an area where water is accessible, in case of fire
  4. In any section of the equipment maintenance branch
- 3-12. In which of the following places should you locate the master switch that controls all power in the maintenance shop?
1. A room that can be secured easily
  2. A space that is in full view of all shop personnel
  3. An area that can be controlled by a supervisor
  4. A location that can be reached quickly in an emergency
- 3-13. For the sake of safety, what should you do in the area where welding equipment is used?
1. Have the area screened and equipped with firefighting equipment.
  2. Locate the area away from the rest of the shop areas
  3. Have the area posted with hazard warning signs
  4. All of the above
- 3-14. Why should tire repair equipment be located in a separate section of the shop near one of the shop's entrances?
1. To eliminate the need for duplicate equipment
  2. To enable it to be used by patrons of the hobby shop after working hours
  3. To enable civil service employees, as well as CM's, to use it
  4. To allow the EO's to use it as readily as the CM's
- 3-15. Which of the following is a safe practice regarding the battery charging equipment in your maintenance branch?
1. Locating the equipment in a well-ventilated space
  2. Installing an exhaust fan near the equipment
  3. Having a water supply near the equipment
  4. Each of the above
- 3-16. To help prevent shop accidents, a supervisor makes sure the mechanics observe good housekeeping and safe working practices.
- 3-17. Doors at the front and rear of the shop and windows that can be opened will normally enable enough air to enter the shop and remove exhaust gases.
- 
- Learning Objective: Identify fundamentals of shop organization and responsibilities of the battalion maintenance supervisor and his subordinates. Textbook pages 4-3 through 4-9.
- 
- 3-18. Who has overall responsibility for insuring proper maintenance and repair of all automotive, construction, and materials-handling equipment assigned to a NMCB?
1. Maintenance supervisor
  2. Automotive shop supervisor
  3. Heavy equipment shop supervisor
  4. Support section supervisor
- 3-19. What else does the shop inspector do besides determining what repair work is to be done on a piece of equipment?
1. Note deficiencies on the SRO
  2. Complete record forms 1149 and 1250
  3. Make minor adjustments as necessary
  4. Perform the next scheduled PM inspection
- 3-20. The automotive repair supervisor has direct control and supervision over the personnel in his section. Other duties of the supervisor include all the following EXCEPT.
1. providing technical leadership
  2. providing the field maintenance crew
  3. maintaining records and reports
  4. insuring timely and quality work performance

3-21. In what situation is it worthwhile for the heavy equipment repair shop supervisor to shortchange himself as to shop personnel?

1. When furnishing additional personnel to the support section
2. When providing experienced field maintenance mechanics
3. When providing technical assistance to the logistic section with regard to repair parts

3-22. Who is responsible for furnishing the tools and equipment that the field mechanics require?

1. Senior mechanic
2. Automotive shop supervisor
3. Heavy equipment shop supervisor
4. Maintenance supervisor

3-23. Suppose a repair shop mechanic needs to use a tool not already in his custody. How does he obtain this tool?

1. By giving the tool issue room personnel the assigned job order number
2. By presenting an EWO to the toolroom personnel
3. By checking it out from the toolroom

3-24. PM lube racks should be located a distance from other shop areas as a means of

1. making lubrication services easy to perform
2. making it easy to inspect and clean equipment
3. guarding against fire
4. providing shelter to increase PM efficiency

---

Learning Objective: Describe fundamentals of operator maintenance, preventive maintenance, and cost control under the battalion maintenance program. Textbook pages 4-12 through 4-16.

---

3-25. The basic objective of the preventive maintenance program is to

1. provide a thorough inspection of each piece of equipment
2. insure that each piece of equipment is painted when required
3. keep records to obtain a complete history of the equipment
4. keep the equipment operating and to detect minor problems before they become major ones

3-26. Organizational maintenance of equipment includes which of the following?

1. Operator and preventive maintenance
2. Daily inspections, lubrications, and adjustments
3. Mechanics weekly inspections, lubrications, and adjustments

3-27. Any defect or unsafe condition found by any operator should be reported immediately to

1. the senior mechanic
2. the shop supervisor
3. any shop mechanic
4. the dispatcher

3-28. The Operator's Inspection Guide and Trouble Report, NAVFAC 9-11240/13 of textbook figure 4-1, is completed only when a breakdown occurs.

3-29. From a PM Report (textbook figure 4-2), the maintenance inspector can obtain which of the following information?

1. Fuel consumption
2. Services performed
3. Hours of operation
4. Each of the above

3-30. The operator's after-operation tasks may include participation in the PM.

3-31. The overhaul of equipment assemblies, subassemblies, and components is the responsibility of the maintenance shops at which level of the battalion maintenance program?

1. Organizational
2. Depot
3. Intermediate

3-32. What is the standard interval between PM service inspections for NCF equipment?

1. 30 working days, 1,500 miles, or 100 hours
2. 40 working days, 2,000 miles, or 120 hours
3. 50 working days, 2,500 miles, or 140 hours
4. 60 working days, 3,000 miles, or 150 hours

- 3-33. One step in establishing the initial standard interval between PM service inspections is to
1. group all similar types of equipment
  2. group all assigned equipment into 30 separate PM groups
  3. distribute all assigned equipment evenly among 40 separate PM groups
  4. divide the number of pieces of equipment into the number of work-days per month
- 3-34. Whose responsibility is it to determine whether the PM interval for a piece of equipment should be reduced?
1. Operator
  2. Mechanic
  3. Shop supervisor
  4. Maintenance supervisor
- 3-35. When, if ever, will the standard interval between PM service inspections be extended?
1. When a shortage of mechanics exists
  2. When the number of projects is excessive
  3. When the number of qualified inspectors assigned is insufficient
  4. Never
- 3-36. To insure that the PM program is being performed as prescribed, the maintenance supervisor will review the PM Record Card file at least
1. once a month
  2. every other month
  3. three times a year
  4. quarterly
- 3-37. How are the PM Record Cards maintained?
1. Alphabetically by type of vehicle
  2. Numerically by type of vehicle
  3. By PM group in a tickler file
  4. By date of scheduled PM's
- 3-38. What happens to the PM Record Card for a vehicle that is transferred?
1. Destroyed
  2. Held for 1 year, then destroyed
  3. Placed in the equipment history jacket
  4. Sent to the Equipment Records Division at Port Hueneme
- 3-39. What type of inspection is given a piece of NCF equipment at intervals of 40 working days?
1. A
  2. B
  3. C
  4. D
- 3-40. Which of the following is an interval for a type B inspection?
1. 2,000 miles
  2. 120 hours
  3. Two consecutive type A inspections
  4. Each of the above
- 
- Learning Objective: Point out procedures for preparing Equipment Repair Orders. Textbook page 4-16.
- 
- 3-41. Which of the following entries is NOT recorded in ERO's and their continuation sheets?
1. Cost of repairs
  2. Types of repairs
  3. Hours required for repairs, as well as the total time that an item of equipment is out of service
  4. Rate of the person doing the work (experience level)
- 3-42. What block number on the Equipment Repair Order should indicate the type of maintenance repair?
1. 6
  2. 8
  3. 10
  4. 12
- 3-43. What block number on the Equipment Repair Order should indicate the total funds expended for maintenance cost?
1. 16
  2. 20
  3. 26
  4. 30
- 3-44. Accumulation of data from the ERO's and their continuation sheets provide information for which of the following purposes?
1. Budget planning
  2. Determining economical life expectancies
  3. Predicting equipment and training requirements
  4. Each of the above

3-45. What difference, if any, is there between the authority to perform work in the field and the authority to do work in the shops?

1. An ERO must be filled out for work in the shops but not in the field
2. An ERO must be filled out for work in the field but not in the shops
3. An ERO and SRO must be filled out for work in the shops but not in the field
4. None

3-46. The ERO Log Sheet, textbook figure 4-6, shows the dozer received an interim repair and type B PM. What type PM, if any, is it next scheduled for?

1. A
2. B
3. C
4. None

Learning Objective: Point out factors that determine outfitting repair parts allowances for support of battalion equipment. Textbook pages 4-16 through 4-20.

3-47. The Consolidated SEABEE Allowance Lists (COSAL's) establish the support for which of the following assigned types of equipment based on USN-numbered listing?

1. Vehicular
2. Materials-handling
3. Organic and augment
4. Construction/weight-handling

3-48. Repair parts allowances are normally designed to provide what percentage of effectiveness for 90-day support of vehicles or equipment in new or like new condition?

1. 100 percent
2. 90 percent
3. 80 percent
4. 75 percent

3-49. General repair type items are referenced in the COSAL's as parts peculiar?

3-50. What are the respective high and low limits established for the stock items carried on the Stock Record Card of textbook figure 4-13?

1. 11 and 4
2. 12 and 1
3. 14 and 7
4. 16 and 9

In items 3-51 through 3-54, select from column B the description of the supply aid in column A.

A. Supply Aids    B. Descriptions

- |                           |  |
|---------------------------|--|
| 3-51. Summary item list   | 1. Repair parts no longer required by a previous COSAL |
| 3-52. NAVSUP 1114         | 2. A printed stock record card                         |
| 3-53. Delete item listing | 3. An item release or receipt document                 |
| 3-54. DD Form 1348-1      | 4. Items required by the old COSAL                     |

3-55. Which of the following materials are in a prepackaged library?

1. Manufacturers' parts manuals and operators' manuals
2. History jackets for assigned equipment
3. Technical manuals and shop manuals
4. All of the above

3-56. Which of the following data blocks of textbook figure 4-15 should indicate that a repair part was issued?

1. 5
2. 7
3. 12
4. 17

3-57. Which of the following forms is used as authorization for drawing or ordering repair parts?

1. NAVSUP 1250
2. NAVFAC 112110/4
3. NAVDOCK 1250
4. DD 120

3-58. After the Storekeeper in the repair parts section issues the requested part, the yellow copy of the 1250 is attached to the ERO.

3-59. Who authorizes placing on order a part which is not in stock and assigns a priority to the requisition?

1. Shop supervisor
2. Shop inspector
3. Senior mechanic
4. Maintenance supervisor

3-60. What action, if any, does cost control take when parts are being placed on requisition?

1. Assign a department order number for each part not in stock (NIS)
2. Assign a department order number for each group of similar items
3. Assign a department order to each part ordered
4. None

3-61. During an overseas deployment, the repair parts section ordered the raincap shown on the repair parts summary sheet (text-book figure 4-11). How many days should be allowed for delivery of the raincap to the parts department or for a status report on the requisition?

1. 8
2. 15
3. 20
4. 45

3-62. A repair parts summary sheet is maintained for parts pending action for each

1. requisition
2. part type
3. part
4. item of equipment assigned

3-63. The supply section normally forwards DD Form 1348-1 to cost control upon receipt of ordered parts. What does the cost control clerk do?

1. Store the parts in the DTO bin or issue the parts
2. Fill in the receiving date on the repair parts summary sheet and attach DD Form 1348-1
3. Tag the part with a USN number and PM group
4. All the above

---

Learning Objective: Indicate procedures for conducting the Battalion Equipment Evaluation Program. Text-book pages 4-21 and 4-25.

---

3-64. When does the Battalion Equipment Evaluation Program (BEEP) establish uniform procedures that are to be carried out?

1. During a battalion's onsite relief and equipment turnover
2. During the original equipping of a battalion before an overseas assignment
3. At an inspection conducted 3 months after the battalion arrives at a station
4. At each of the above times

---

In items 3-65 through 3-70, assume that Naval Mobile Construction Battalion 40 is scheduled to be relieved by Naval Mobile Construction Battalion 133. Match the task in column A by selecting from column B the battalion(s) responsible for accomplishing the task during the BEEP.

<u>A. Tasks</u>	<u>B. Battalions</u>
3-65. Reviewing maintenance correspondence not yet acted upon	1. NMCB 133 2. NMCB 40
3-66. Notifying higher authority of BEEP commencement date	3. NMCB 133 and NMCB 40
3-67. Providing tools and shop equipment for evaluation and repair of equipment	
3-68. Coordinating the scheduling of equipment for inspection	
3-69. Conducting a PM inspection of equipment attachments	
3-70. Inventorying all shop equipment	

3-71. Who is responsible for insuring that an ERO, a copy of the equipment evaluation inspection guide, and a copy of the attachment evaluation inspection guide are prepared for each piece of equipment being BEEPed?

1. NMCB 133 only
2. NMCB 40 only
3. NMCB 40 or NMCB 133
4. The COMCBPAC/COMCBLANT representative

3-72. During the BEEP, a preserved item of assigned USN-numbered equipment is de-preserved for testing after a visual inspection shows major discrepancies.

3-73. What code is given to a piece of dead-lined equipment to indicate that its repairs would cost more than 40 percent of its acquisition cost?

1. R4
2. R3
3. E4
4. X1

3-74. COMCBPAC/COMCBLANT Instruction 4040.1 series contains guidelines for accomplishing the repair parts portion of the BEEP.



# Assignment 4

## Battalion Equipment Company Shops Supervisor and Engine Overhaul

Textbook Assignment: Pages 4-25 through 4-32 and pages 5-1 through 5-35

---

Learning Objective: To point out the procedures of embarking equipment. Textbook pages 4-25 and 4-26.

---

4-1. The embarkation staff determines and adjusts load requirements to conform to the type of transporting unit.

4-2. Air detachment equipment will receive a low priority during a complete embarkation.

4-3. Equipment being embarked will NOT have which of the following actions performed as part of preparation?

1. Minor repairs
2. Collateral equipment installed
3. Spare tires installed
4. Complete repaint

---

Learning Objective: To become familiar with construction schedule drawings for preparation of equipment, manpower, and material estimates. Textbook pages 4-26 through 4-30.

---

4-4. The purpose of construction schedule drawings is to serve as a guide for managerial personnel.

4-5. Broken lines in an arrow diagram represent a/an

1. activity
2. event
3. dummy
4. critical path

4-6. The longest path in terms of time through a project defines the

1. activities
2. events
3. dummies
4. critical path

4-7. Network analysis is a working timetable added to an arrow diagram.

4-8. Factors to be considered when you develop a network analysis are critical items and all of the following EXCEPT

1. capability
2. frequency
3. sequence
4. continuity of work

4-9. To obtain total slack in network analysis, you use

1.  $T_E - T_L - t_e$
2.  $T_E - T_L$
3.  $T_L - T_E - t_e$
4.  $T_L - T_E$

4-10. Activities in precedence diagrams are represented by a

1. square box
2. triangle
3. circle
4. rectangular box

---

Learning Objective: Define types of horsepower and measure or compute each type. Textbook pages 5-1 through 5-8.

---

- 4-11. What is the horsepower equivalent of 66,000 foot-pounds of work per minute?
1. 1
  2. 2
  3. 3
  4. 4
- 4-12. How many foot-pounds of work per minute can a 6-horsepower engine produce?
1. 50,000
  2. 66,000
  3. 100,000
  4. 198,000
- 4-13. What kind of horsepower would an engine deliver if it were possible to eliminate all frictional losses?
1. Friction
  2. Indicated
  3. Drawbar
  4. Brake
- 4-14. To convert inches of stroke to centimeters, use the conversion factor of
1. 1.014
  2. 2.54
  3. 6.45
  4. 7.4
- 4-15. In figuring metric conversion of an engine, express mean effective pressure as
1.  $\text{CM}^3$
  2.  $\text{lb/in}^2$
  3.  $\text{kg/cm}^2$
  4.  $\frac{\text{PLK}}{450\text{K}}$
- In answering items 4-16 through 4-19, refer to figures 5-4 and 5-5 of your textbook.
- 4-16. What effect, if any, does an increase of engine speed above rated speed have on the torque produced?
1. Torque drops
  2. Torque rises
  3. None
- 4-17. In which of the following speed ranges does engine torque increase steadily?
1. 1200 to 1600 rpm
  2. 1600 to 2000 rpm
  3. 2000 to 2400 rpm
  4. 2400 to 2800 rpm
- 4-18. In which of the following speed ranges is engine torque falling while horsepower is rising?
1. 1000 to 1700 rpm
  2. 1800 to 2600 rpm
  3. 2700 to 2900 rpm
- 4-19. At what speed relative to rated speed is engine horsepower maximum?
1. About 200 rpm less than rated speed
  2. Rated speed
  3. About 200 rpm greater than rated speed
  4. About 500 rpm greater than rated speed
- 4-20. Which of the following events in the cycle of gasoline operation must be timed properly to insure correct engine timing?
1. Opening of intake and exhaust valves
  2. Closing of intake and exhaust valves
  3. Spark ignition of the fuel
  4. Each of the above
- 4-21. To determine all timing events in a four-stroke cycle diesel engine, how many clockwise revolutions must you trace on the timing diagram of textbook figure 5-6?
1. One
  2. Two
  3. Three
  4. Four
- 4-22. Refer to textbook figure 5-6. When does the intake valve of a four-stroke cycle diesel engine open?
1. A few degrees before TDC as the piston nears the end of its exhaust stroke
  2. A few degrees after TDC as the piston nears the end of its exhaust stroke
  3. Just as the piston reaches TDC on its exhaust stroke
  4. At 40° before TDC as the piston nears the end of its compression stroke
- 4-23. What stroke of a four-stroke cycle diesel engine begins slightly before TDC, continues through BDC, and ends during the next upstroke of the piston?
1. Power
  2. Exhaust
  3. Intake
  4. Compression

4-24. Refer to the timing diagram of textbook figure 5-7. What is the relationship between fuel injection timing and piston position?

1. When the piston is at TDC, fuel is about to be injected
2. When the piston is at TDC, fuel has already been injected
3. When the piston is at TDC, fuel is being injected
4. When the piston is at BDC, fuel is being injected

4-25. For how many degrees past TDC does a piston in a typical General Motors two-stroke cycle diesel engine deliver power to the crankshaft?

1. 17.5°
2. 44.5°
3. 92.5°
4. 132°

Learning Objective: Recognize principles and techniques of diagnosing engine malfunctions. Textbook pages 5-9 through 5-21.

4-26. Which of the following malfunctions can cause an engine to lose power?

1. Incorrect ignition timing
2. Excessive vacuum spark advance
3. Worn distributor cam
4. All of the above

4-27. Suppose the trouble with a diesel engine has been located inside a fuel injector. Who should get the task of repairing this injector?

1. Any mechanic who volunteers to do the task
2. Any experienced mechanic who has been trained to repair injectors
3. A qualified automotive engineer

4-28. Which of the following factors are related directly to the working parts of a diesel or gasoline engine and the capacity of the engine to produce its rated power?

1. Pressure and temperature of intake air
2. Ignition, compression, and carburetion
3. Quality of fuel and heat of compression
4. All of the above

4-29. Which of the following factors does NOT relate directly to the working parts of a diesel or gasoline engine but can contribute to loss of engine power?

1. Number of accessories or attachments operated by the engine
2. Pressure of intake air
3. Temperature of intake air
4. Each of the above

4-30. Which of the following is a means of locating the source of trouble in a gasoline engine?

1. Examining engine exhaust gases
2. Operating the engine under load
3. Shorting out spark plugs
4. Each of the above

4-31. Which of the following causes of excessive oil consumption by an engine is likely to result in a major engine overhaul?

1. A cracked vacuum pump diaphragm
2. Worn valve guides or stems
3. Worn piston rings or cylinder walls
4. Each of the above

4-32. A vehicle operator reports on his trouble card that his vehicle oil pressure gage shows a continuous low oil pressure reading. Which of the following engine problems could be indicated by the low reading?

1. Worn oil pump
2. Worn engine bearings
3. Weak relief-valve spring
4. Each of the above

In items 4-33 through 4-35, select from column B the method for locating the engine noise in column A.

A. Engine Noises

B. Methods

4-33. Valve and tappet clicking

1. Short out spark plugs one at a time while engine is floating

4-34. Piston-pin knocking

2. Short out spark plugs one at a time while engine is idling with advanced spark

4-35. Connecting rod pounding

3. Insert feeler gage while engine is idling

4-36. Suppose a heavy, dull, metallic knock is heard regularly while an engine is operating under load or is accelerating. Which of the following engine noises is indicated?

1. Piston-pin knock
2. Crankshaft knock
3. Main bearing knock
4. Piston slap

4-37. Which gage or tester will enable a mechanic to check the uniformity of pressures within the combustion chambers of an engine?

1. Vacuum gage
2. Compression gage
3. Cylinder leakage tester
4. Exhaust gas analyzer

4-38. In what range should a vacuum gage reading fall for a gasoline engine in good condition idling at 550 rpm at a 4,000-foot altitude?

1. 21 to 26 inches
2. 17 to 22 inches
3. 15 to 20 inches
4. 13 to 18 inches

4-39. A vacuum gage indicates an incorrect adjustment of the idle speed screw on a carburetor. Describe the behavior of the gage pointer in this case.

1. It remains steady on 10 inches
2. It remains steady on 18 inches
3. It varies slowly between 13 and 15 inches
4. It varies rapidly between 13 and 19 inches

4-40. A device for introducing compressed air into the cylinder of an engine can be made by removing the insulator from an old spark plug and welding a pneumatic valve stem to the threaded end of the plug.

4-41. When using compressed air to test an engine cylinder for leakage, you notice air bubbles in the radiator coolant. The bubbles indicate that air is probably being released through a

1. defective head gasket
2. leaking intake valve
3. defective exhaust valve
4. piston ring

4-42. A reading on the gage of the cylinder leakage tester shown in textbook figure 5-11 will indicate the

1. air pressure in a cylinder
2. percentage of air loss in a cylinder
3. air temperature in a cylinder
4. amount of carbon built up on a piston

4-43. What are the most common micrometers used by mechanics?

1. Outside
2. Inside
3. Depth
4. All of the above

4-44. When using a micrometer, you should know that the thimble has how many threads per inch?

1. 15
2. 25
3. 40
4. 60

4-45. The vernier micrometer is readable to

1. 0.1
2. 0.01
3. 0.001
4. 0.0001

4-46. Micrometers are precision measuring devices that require special handling and care.

---

Learning Objective: Indicate procedures for overhauling the valves, valve mechanisms, and cylinder heads of internal combustion engines. Textbook pages 5-21 through 5-29.

---

In items 4-47 through 4-50, select from column B the possible cause of the trouble in column A.

A. Troubles	B. Possible Causes
4-47. Broken valve	1. Insufficient valve tappet clearance
4-48. Burnt valve	2. Rich fuel-air mixture
4-49. Sticking valve	3. Clocked valve spring or retainer
4-50. Valve deposits	4. Insufficient oil

- 4-51. Which condition may be directly caused by a valve adjusted too tightly?
1. Cocked valve spring
  2. Damaged piston
  3. Loose adjustment locks
  4. Oil leaks
- 4-52. When valves are being adjusted, where is the piston positioned?
1. TDC of the compression stroke
  2. TDC of the intake stroke
  3. BDC of the intake stroke
  4. BDC of the compression stroke
- 4-53. Why do valve lifters of the type shown in textbook figure 5-24 provide ideal valve timing?
1. They operate at zero clearance
  2. They compensate for engine temperature changes
  3. They adapt automatically for minor wear at various points
  4. All of the above
- 4-54. A mechanic should measure the eccentricity of a valve before deciding whether to reuse or replace it.
- 4-55. Valves and their seats are refaced at exactly the same angle to help the valves cut through carbon deposits for improved sealing.
- 4-56. By what means is a valve seat grinder kept concentric with the valve guide during the process of grinding valve seats?
1. Upper and lower grinding stones
  2. Centered grinding stones in the chuck
  3. A self-centering pilot in the valve guide
  4. Centrifugal force
- 4-57. One method of checking the valve seating is to coat the valve face lightly with Prussian blue and twist the valve one-quarter turn in its seat. How can you tell whether the valve seat is concentric with the valve guide?
1. Prussian blue will transfer evenly to the valve seat
  2. There will be no trace of Prussian blue on either the valve or its seat
  3. The shade of Prussian blue will grow brighter
  4. Prussian blue will collect in a pile on the valve seat
- 4-58. What is the technique for inserting a new valve seat?
1. Heat the engine block or cylinder head to expand the valve opening, then drop the insert in place
  2. Shrink the insert by chilling, then drive it in place
  3. Hold the insert with pliers, then tap it in place with a hammer
  4. Squeeze the insert with a special insert tool, then drop it in place
- 4-59. What corrective action must be taken when the bore of a solid valve lifter becomes worn?
1. Reface the lifter, ream out the bore, then fit with an oversize lifter
  2. Ream out the bore, then fit with an undersized lifter
  3. Ream out the bore, then fit with an oversize lifter
  4. Replace the complete valve lifter assembly
- 4-60. What is the signal for the end of a leak down rate test on an hydraulic valve lifter?
1. Feeler gage loosens as the valve seats
  2. Feeler gage binds as the valve seats
  3. Oil leaks fast as the valve seats
  4. Oil leaks slow as the valve seats
- 4-61. Which of the following is an important step in the installation of new camshaft bearings?
1. Line reaming them before they are installed
  2. Lining up the oil holes with those in the block
  3. Staking them whether or not the old bearings were staked
- 4-62. How can you tell whether the timing gear keyed on the camshaft and the one keyed on the crankshaft are installed to insure proper valve timing?
1. The number of gear teeth between marks is divisible by three
  2. All the marks on the gear teeth fall on the same straight line
  3. There is an even number of teeth between gear marks
  4. The gears mesh so that the two marked teeth of one gear straddle the one marked tooth of the other gear

---

Learning Objective: Describe methods of servicing the crankshaft and cylinders of an internal combustion engine. Textbook pages 5-30 through 5-32.

---

- 4-63. The usual remedy for crankshaft bearings that appear to have worn uniformly is bearing replacement.
- 4-64. In measuring crankshaft journals, a mechanic finds one that has worn out of round by 0.004 inch. Wear on the other journals is negligible. What should the mechanic do?
1. Regrind the out-of-round journal only
  2. Regrind all the journals
  3. Replace the crankshaft
- 4-65. The shape of flattened Plastigage that was used to check bearing clearance shows a/an
1. excessive crankshaft end play
  2. locked or dragging crankshaft
  3. tapered or worn crankshaft journal or bearing
  4. loose bearing cap
- 4-66. Assume a sharp irregular knock is heard each time the clutch of a vehicle is engaged or released. The probable cause of this knock is
1. clutch plate damage
  2. worn thrust bearings
  3. a loose throwout bearing
- 4-67. What corrective action can be taken when cylinder walls show some taper but not enough to warrant reboring or honing cylinders?
1. Fit the pistons with special compression and oil-control rings
  2. Refinish the cylinders
  3. Fit the pistons with additional piston rings
  4. Reduce the piston size
- 4-68. The amount of taper and oval wear in a cylinder is measured with what instrument?
1. Inside micrometer
  2. Special dial indicator
  3. Telescopic gage and an outside micrometer
  4. Each of the above

4-69. The mechanic should hone the glaze on the cylinder walls when new rings are being installed to enable the

1. rings to seat slowly
  2. pistons to travel to TDC
  3. rings to seat quickly
  4. pistons to travel to BDC
- 

Learning Objective: Describe methods of fitting pistons, piston pins, and piston rings and cleaning pistons during a major overhaul. Textbook, pages 5-32 through 5-35.

---

- 4-70. A ridge around the upper cylinder wall must be reamed off to keep from damaging the piston and rings as they are removed through the top of the cylinder.
- 4-71. In removing carbon deposits from a piston, the mechanic should scrape the piston skirts to reduce wear on the cylinder wall.
- 4-72. The fit of a piston in its cylinder is measured accurately by means of a/an
1. outside micrometer
  2. piece of feeler stock and a spring gage
  3. dial indicator
- 4-73. Floating piston pins are fitted correctly when, at room temperature, slight thumb pressure is all it takes to push them through their bushings.
- 4-74. If a cylinder is worn tapered, which diameter of the cylinder serves as the guide for fitting piston rings?
1. Uppermost diameter
  2. Diameter that is halfway between the top and bottom
  3. Diameter through the point marking the lower limit of ring travel
  4. Diameter of the bottom
- 4-75. After a piston ring is installed in its proper groove, ring clearance is checked by inserting a feeler gage between the ring and the bottom of the groove.

# Assignment 5

## Electrical Systems and Equipment and Diesel Fuel Systems

Textbook Assignment: Pages 6-1 through 7-7.

---

Learning Objective: Explain the principles of operation for alternators, rectifiers, and regulators in an a.c. charging system. Textbook pages 6-1 through 6-3.

---

- 5-1. Why is the alternator preferred over the conventional generator for supplying electrical current in present-day automotive equipment?
1. Its usefulness in supplying current is limited only by its size
  2. It produces current that is fed to accessories without alternation
  3. Its larger size enables it to supply the additional power required
  4. It is small and can produce the power required for operating electrical accessories under nearly all conditions
- 5-2. The stator has the same function as the armature in the d.c. generator, because, by rotating in caged ball bearings instead of bushings, longer bearing life is obtained.
- 5-3. Alternator system stators connected in a "Y" produce lower voltage and higher current than delta-connected stators.
- 5-4. What device enables an alternator to produce direct current?
1. Commutator
  2. Rotor
  3. Rectifier bridge
  4. Stator
- 5-5. The composition of the silicon-diode rectifier permits current to flow in two directions at the same time.
- 5-6. In the automotive alternator using positive and negative silicon-diode rectifiers, how many rectifiers of each type are required?
1. One positive and one negative
  2. Two positive and one negative
  3. Two positive and two negative
  4. Three positive and three negative
- 5-7. How can a mechanic identify the polarity of silicon-diodes that are not marked with the plus or minus sign as shown in textbook figure 6-2?
1. Copper or silver lettering
  2. Blue or green lettering
  3. Black or red lettering
  4. Brown or yellow lettering
- 5-8. Which of the following is a type of regulator for the electrical output of an alternator?
1. Transistorized
  2. Electromagnetic
  3. Each of the above
- 5-9. The transistor regulator can be adjusted internally by
1. relocating a screw in the base of the regulator
  2. turning a screw on the potentiometer
  3. interchanging diode connections
  4. sliding the contacts of its resistors
- 
- Learning Objective: Explain principles and techniques of troubleshooting the charging system. Textbook pages 6-4 through 6-9.
-

5-10. In troubleshooting a charging system, the mechanic observes that the generator field coils are grounded externally at the regulator. Which type of field circuit will the mechanic be testing?

1. "A" circuit only
2. "B" circuit only
3. "A" or "B" circuit, depending on whether the system is positive or negative grounded

5-11. The output polarity of a d.c. generator is determined by the polarity of its

1. "A" circuit
2. "B" circuit
3. permanent field pole piece
4. silicon-diode

In answering items 5-12 through 5-21, which deal with troubleshooting a vehicle's charging system with a volt-ampere tester, refer to textbook figures 6-5 through 6-8.

5-12. Suppose that in the alternator output test, the ammeter scale indication stays at normal while engine speed is increased slowly. Which component needs replacement?

1. Alternator
2. Battery
3. Regulator

5-13. Assume that the ammeter shows no output at high voltage during a generator test and that the charging circuit is not fused at the regulator. Which component should be repaired or replaced?

1. Field lead of the wiring harness
2. Armature lead of the wiring harness
3. Regulator cutout relay
4. Generator field winding

5-14. When testing a 12-volt charging system, the mechanic measures the voltage output, getting a maximum voltmeter reading of 15 volts. What is the probable cause of this output?

1. Blown fuse
2. Shorted field wire
3. Grounded field
4. Defective regulator current limiter relay

5-15. You are testing a vehicle's voltage regulator. If the voltage output is too high or too low, which of the following troubles is indicated?

1. Damaged regulator resistor
2. Faulty regulator voltage limiter
3. Burned regulator contacts
4. Each of the above

5-16. One purpose of measuring the resistance of a negative charging system circuit is to determine how much voltage is lost between the

1. generator output terminal and the negative battery post
2. generator housing and the positive battery post
3. generator output terminal and the positive battery post or between the generator housing and the negative battery post

5-17. What condition contributes to voltage drop in a circuit?

1. Open circuit
2. Excessive resistance
3. Low resistance

5-18. Excessive resistance in a vehicle's charging system can be due to

1. an open circuit
2. burned or oxidized cutout relay contacts only
3. loose or corroded connections only
4. burned or oxidized cutout relay contacts, and loose or corroded connections.

5-19. Measuring the resistance of an insulated circuit is a means of isolating the cause of excessive resistance in a vehicle's charging system.

5-20. If the voltmeter reading for the test of textbook figure 6-14 is greater than 0.1 volt, there is too much resistance in the ground circuit between the regulator or generator.

5-21. Assume the mechanic is measuring the resistance of an insulated circuit in an a.c. charging system. With the engine running at 2,000 rpm, the mechanic should increase the load with the tester until the ammeter reading reaches

1. 24 amperes
2. 20 amperes
3. 10 amperes
4. 5 amperes



5-22. In a battery drain test, the ammeter scale reading is nonzero with all the vehicle's circuits turned off. This reading indicates a/an

1. electrical short circuit
2. electrical open circuit
3. blown fuse
4. corroded battery ground post

---

Learning Objective: Identify the procedures of troubleshooting with an analyzer. Textbook pages 6-11 through 6-12.

---

5-23. A single nonconducting diode in an alternator system may be detected by using a/an

1. voltmeter
2. analyzer screen
3. ammeter
4. microfarad meter

5-24. When using the bypass device (figure 6-18) to test a charging system, what step must you take?

1. Operate the engine at idle
2. Race the engine briefly
3. Operate the engine at high speed for 1 minute
4. Bring the alternator to rated output

5-25. A shorted diode reduces the output and also opposes the next pulse.

5-26. A weak diode may be detected on the analyzer screen by a consistent high and low peak.

5-27. Shorted windings and shorted diodes produce distinctly different patterns on an analyzer screen.

---

Learning Objective: Explain principles and techniques of troubleshooting the starter system. Textbook pages 6-13 through 6-18.

---

In answering items 5-28 through 5-36, which deal with troubleshooting a vehicle's starting system with a battery starter tester, refer to textbook figures 6-23 through 6-27.

5-28. When the battery starter tester is used for a quick overall test of a 12-volt starting system, which test is performed?

1. Battery starter
2. Starting motor current draw
3. Cranking voltage
4. Battery switch

5-29. Assume a vehicle is equipped with a 24-volt series-parallel starting system. Which of the following voltmeter readings is considered within normal limits for a cranking voltage test?

1. 20 volts
2. 16 volts
3. 14 volts
4. 12 volts

5-30. Which of the following is tested if the cranking voltage for a 12-volt system is 8 volts?

1. Battery capacity
2. Starter cranking current
3. Starter circuits
4. Each of the above

5-31. In a starting motor current draw test, the cranking speed of the motor is low and the current draw is normal. Check the

1. battery capacity
2. starting circuit resistance
3. starting motor cranking current

5-32. In tests where the engine is cranked with the ignition on, you must keep the engine from starting by connecting a jumper lead between the

1. battery posts
2. starting motor terminal and negative post of the battery
3. secondary terminal of the coil and ground
4. primary terminal of the coil and ground

5-33. A starter insulated circuit resistance test is being performed on a 12-volt starting system. The voltage loss in each of the circuits shown in views A, B, and C of textbook figure 6-25 should NOT exceed

1. 0.2 volt, 0.3 volt, and 0.4 volt, respectively
2. 0.4 volt, 0.3 volt, and 0.1 volt, respectively
3. 0.6 volt, 0.5 volt, and 0.4 volt, respectively
4. 0.2 volt, 0.3 volt, and 0.2 volt, respectively

5-34. What is usually indicated during a starter ground circuit resistance test if the measured voltage loss exceeds 0.2 volt or the loss given by the manufacturer's specifications?

1. Loose connection
2. Ground cable too small to carry the current
3. Dirty or corroded connection
4. Each of the above

5-35. High resistance in the circuit of the solenoid switch will, in most cases, result in increasing the current flow in the starter motor circuit.

5-36. A voltage loss of more than 1 volt, as measured in a solenoid switch circuit resistance test, is a sure sign of too much resistance.

---

Learning Objective: Describe the operating principles of the transistor, capacitor discharge, electronic, and unitized ignition systems. Textbook pages 6-18 through 6-22.

---

5-37. At high-engine speeds, which of the following drawbacks of the conventional ignition system is overcome by the transistorized ignition system (breaker point type)?

1. Incomplete saturation of the ignition coil only
2. Arcing across breaker points only
3. Incomplete saturation of the ignition coil and arcing across breaker points

5-38. Which of the following is a component of the magnetic-pulse transistor ignition system, replacing the breaker plate assembly of the conventional ignition system?

1. Iron timer core
2. Magnetic pickup assembly
3. Ignition pulse amplifier
4. Reluctor

5-39. One function of the transistors in the amplifier of the magnetic-pulse transistor ignition system is to

1. control current flowing between the coil primary and ground
2. desaturate the ignition coil
3. eliminate arcing across the breaker points

5-40. Which component is connected across the primary windings of the coil in a capacitor discharge system to help assure secondary voltage output during high engine speeds?

1. Ignition pulse amplifier
2. High-voltage condenser
3. Pickup coil
4. Electronic control unit

5-41. Of the following ignition system components, which is to be found in a conventional system, as well as in an electronic (Chrysler) system?

1. Pickup coil
2. Ignition coil
3. Reluctor
4. Condenser

5-42. Chrysler electronic ignition uses a magnetic pickup coil and a rotating reluctor to replace the

1. cam and rubbing block
2. condenser
3. primary coil
4. rotor

5-43. During starting, the compensating ballast resistor of the Chrysler electronic ignition system increases voltage to the electronic module.

5-44. To adjust the airgap, you align a reluctor tooth with the pickup coil tooth. Use a nonmagnetic gage 0.002 larger than specified to obtain a clearance of

1. go-no-go
2. loose
3. tight
4. 0.002

5-45. The purpose of the carburetor switch in the lean burn ignition system is to

1. measure incoming fresh air temperature
2. signal the computer for more vacuum
3. signal the computer a new throttle plate position
4. tell the computer the engine is at idle or off idle

5-46. Induced voltage signals the electronic module of a unitized ignition system to interrupt the primary circuit.

5-47. When the timer core teeth align with the pole piece of the HEI system, a voltage pulse is induced in the pickup winding.

5-48. A shorter spark duration is effective in firing lean or exhaust gas recirculation diluted fuel/air mixtures.

---

Learning Objective: Explain principles and techniques of troubleshooting the conventional ignition system. Textbook pages 6-22 through 6-25.

---

5-49. In troubleshooting a conventional ignition system, the mechanic tests the primary and secondary circuits separately.

Items 5-50 through 5-54 relate to troubleshooting the conventional 12-volt ignition system.

5-50. What should be the range of the voltmeter reading for an ignition switch in good condition (engine not running)?

1. 9.0 to 11.3
2. 7.0 to 9.5
3. 5.5 to 7.0
4. 5.0 to 7.5

5-51. In troubleshooting, which of the following are secondary circuit checkpoints?

1. Both coil terminals
2. Distributor contact points
3. Spark plugs

5-52. During secondary circuit testing, a spark plug cable resistance exceeds the manufacturer's recommended specifications. What causes this condition?

1. An unseated cable at the distributor cap tower
2. Spark plug cable damage
3. A defective spark plug connector
4. Each of the above

5-53. To test the secondary circuit of an ignition coil, the mechanic uses the low scale of an ohmmeter.

5-54. The mechanic gets a reading of 3,000 ohms when checking the secondary side of an ignition coil. This reading is an indication of

1. an open secondary circuit
2. a bad connection at either coil terminal
3. a short in the secondary turns of the coil
4. a good coil

5-55. The mechanic must be careful when checking electronic components of the breakerless ignition system since they are easily damaged by heat, shock, or reverse polarity.

5-56. While troubleshooting the breakerless transistor ignition system, the mechanic does not see a spark jump between the spark plug cable and the spark plug terminal. In sequence, what two components should be tested?

1. Ignition pulse transistor and ignition coil
2. Ignition coil and ignition pulse amplifier
3. Ignition coil and transistor
4. Transistor and ignition coil

5-57. In troubleshooting a breakerless ignition system distributor, the mechanic attaches one lead of his ohmmeter to one terminal on the distributor connector, and grounds the other ohmmeter lead. After opening the vacuum source to the distributor, the mechanic gets a finite ohmmeter reading. This reading indicates a/an

1. opening winding
2. defective pickup coil
3. worn center contact button

---

Learning Objective: Describe principles of troubleshooting and testing the injector pumps and capsule-type injector valves of the Caterpillar fuel injection system. Textbook pages 7-1 through 7-7.

---

5-58. The function of the capsule-type valve assembly of the Caterpillar fuel injection system is to

1. time the delivery of fuel
2. meter the fuel
3. inject and atomize the fuel
4. pressurize the system

5-59. To check engine performance for faulty fuel injection, you operate the engine at a speed that accentuates the fault. The next step is to try to get the cylinders to misfire by

1. preventing spark from reaching each cylinder
2. loosening the fuel line nut on each injector pump
3. cutting off the ignition switch
4. enriching the fuel supply to each cylinder

- 5-60. An injector pump should perform properly throughout the full range of rack travel when set within 0.025 inch of the full load setting of the engine.
- 5-61. Before proceeding with the final stage in testing a Caterpillar fuel injector pump, the mechanic must remember to
1. siphon fuel from the pump into the collector jar
  2. bleed air from the pump and collector assembly
  3. inspect the injector screen filter before attaching the collector assembly
- 5-62. After testing an injector pump, you see that the fuel level in the collector jar is above the good range. In what condition is the pump?
1. Its plunger and barrel are worn
  2. Its discharge capacity is below normal
  3. Its discharge measurement is not accurate
  4. It is good as new
- 5-63. The fuel injection test apparatus allows the mechanic to make which of the following checks on the capsule-type fuel injection valves?
1. Leakage rate
  2. Spray characteristics
  3. Valve opening pressure
  4. All of the above
- 5-64. An injector office damaged when carbon deposits are wirebrushed from an injector valve could result in
1. precombustion
  2. reduced power output
  3. improved fuel atomization
  4. no valve opening pressure
- 5-65. To be satisfactory, the injector valve opening pressure (as read on the test gage) should fall between
1. 100 and 200 psi
  2. 200 and 300 psi
  3. 300 and 400 psi
  4. 400 and 800 psi
- 5-66. The Caterpillar compact fuel system transfer pump delivers fuel to the
1. injection valve
  2. filter
  3. capsule
  4. manifold
- 5-67. The compact injection pump plungers complete a full stroke at which of the following speeds?
1. Idle only
  2. Fast idle only
  3. Governed speed only
  4. Idle, fast idle, and governed speed
- 5-68. Operating oil pressure has to react on the speed limiter before the compact governor control can be moved to high idle.
- 5-69. Which of the following faults does NOT cause a smoky exhaust?
1. Lack of air
  2. Lack of fuel
  3. Overloading
  4. Lack of compression
- 5-70. The sleeve position in the Caterpillar sleeve metering fuel system is controlled by the
1. plunger
  2. barrel
  3. priming pump
  4. governor
- 5-71. Sleeve metering injection begins when the rotation of the camshaft lifts the plunger far enough into the barrel to close the fuel inlet.
- 5-72. The reverse flow check valve in the pump is closed by
1. compression
  2. spring pressure
  3. residual pressure
  4. cam action
- 5-73. The volume of fuel injected is equal to the displacement of the plunger lift into the barrel between start and end of injection.
- 5-74. Most fuel problems may be traced to which of the following causes?
1. Dirty fuel filters only
  2. Broken fuel line only
  3. Poor quality fuel only
  4. Dirty fuel filters, a broken fuel line, and poor quality fuel
- 5-75. The Caterpillar sleeve metering system with injection pumps for each cylinder requires frequent balancing

# Assignment 6

## Diesel Fuel Systems

Textbook Assignment: Pages 7-7 through 7-32

Learning Objective: Explain the procedures for troubleshooting, disassembling, inspecting, and reassembling the Roosa Master, Bosch fuel injection pumps and the International Harvester or Bosch fuel injector. Textbook pages 7-7 through 7-16.

In items 6-1 through 6-8, select from column B the problem that is likely to be caused by the condition in column A.

<u>A. Conditions</u>	<u>B. Problems</u>
6-1. Hand primer installed backwards	1. Engine idles imperfectly
6-2. Throttle arm travel not sufficient	2. Engine starts hard
6-3. Pump housing not full of fuel	3. Fuel not reaching pump
6-4. One or more connector screws obstructed	4. Fuel reaching nozzles, but engine will not start
6-5. Tank valve closed	
6-6. Governor linkage broken	
6-7. Fuel line leaking or connected to wrong cylinder	
6-8. Governor spring worn or broken	
6-9. Pump test readings should be taken under low-idle, high-load conditions.	

- 6-10. During testing of the transfer pump, which of the following conditions will NOT cause a low-pressure reading on the test gage?
1. Air leaks on the suction side of the pump
  2. A restricted fuel return line
  3. A malfunctioning regulator valve
  4. Worn transfer pump blades
- 6-11. In testing for a restricted fuel supply on the suction side of the pump, the mechanic operates the engine at high idle.
- 6-12. During pump cleaning and inspection, it is NOT necessary to check for
1. distorted or damaged O-rings, seals, and gaskets
  2. worn, distorted, or broken springs
  3. opening pressure of the spray valve
  4. damaged bores, grooves, and seal seats
- 6-13. What is/are the features of the American Bosch fuel injection pump used on the multifuel engine?
1. Sleeve-controlled
  2. Constant-stroke
  3. Distributing-plunger
  4. All of the above
- 6-14. Fuels used in the multifuel engine pump require no special qualities.
- 6-15. The American Bosch Model PSB fuel supply pump is what type?
1. Centrifugal
  2. Positive displacement
  3. Diaphragm

6-16. The mechanical centrifugal advance unit provides how much advance timing?

1. 22 1/2°
2. 18°
3. 17 1/2°
4. 9°

6-17. Component parts are interchangeable between the American Bosch and Robert Bosch nozzles.

6-18. The groove in the top face of the nozzle valve body is referred to as

1. helix
2. orifice
3. annular

6-19. Assume you are using the test pump of textbook figures 7-22 to check the spray valve-opening pressure. The opening pressure specified for the check valve is 200 psi. Which of the following readings of the spray valve-opening pressure indicates a bad check valve or seat?

1. 195 psi
2. 180 psi
3. 160 psi
4. 140 psi

6-20. Before being installed in the engine, a nozzle is retested for which of the following defects?

1. Leakage
2. Spray angle and pattern
3. Valve-opening pressure
4. Each of the above

---

Learning Objective: Describe procedures for troubleshooting, testing, disassembling, inspecting and reassembling General Motors fuel unit injectors. Textbook pages 7-17 through 7-21.

---

6-21. In troubleshooting the GM fuel system, you learn that the fuel pump is not functioning satisfactorily. Before removing the fuel pump, you should make sure of which of the following conditions?

1. There is fuel in the tank
2. The filter cover bolt is tight
3. The fuel supply valve is open
4. All of the above

6-22. A likely cause of a sticking relief valve in the fuel pump is grit or foreign matter lodged between the relief valve and its seat or bore.

6-23. Suppose an engine lacks power, runs unevenly, or stalls at idle even after its fuel pump is reconditioned. What should you suspect?

1. Restricted fuel flow
2. Faulty injector
3. Excessive vacuum pressure
4. Dirty fuel filter

6-24. The mechanic should allow to remain in service a GM injector that passes all but one of its pressure tests.

---

In answering items 6-25 through 6-28, select from column B the injector test that corresponds with the purpose in column A.

A. Purposes

B. Injector Tests

6-25. Measure the pressure at which the valve opens and injection begins

1. Valve-opening pressure test

2. Valve-holding pressure test

6-26. Determine whether fuel leaks at the injector filter cap gaskets, body plugs, and nut seal ring

3. High-pressure test

6-27. Determine whether the injector plunger and bushing clearance is satisfactory

6-28. Determine whether lapped surfaces in the injector are sealing properly

6-29. Which of the valve-opening pressure readings given below is within the specified limits for the needle valve injector?

1. 450 psi
2. 800 psi
3. 3000 psi
4. 4000 psi

6-30. During the valve-holding pressure test of an injector, the opening pressure drops from 450 psi to 250 psi in 50 seconds. The drop rate is an indication of a/an

1. leak due to poor bushing-to-body fit
2. leaking valve assembly due to a damaged surface or dirt
3. loose filter cap gasket
4. injector whose lapped surfaces are sealing properly

- 6-31. During a high-pressure test, the condition of the injector plunger and bushing is determined at the time both ports close, the injector spray decreases, and the pressure rises.
- 6-32. During which of the following tests are the plunger bottom helix and the lower portion of the upper helix checked visually?
1. Spray pattern test
  2. Injector control rack and plunger movement test
  3. High-pressure test
  4. Fuel output test
- 6-33. Which device should the mechanic use to determine whether the fuel output of a GM injector falls within the manufacturer's recommended limits?
1. Fuel pump and fuel collector assembly
  2. GM injector tester
  3. Comparator
- 6-34. The GM injector spray tip is normally soaked in solvent for approximately 15 minutes to loosen the
1. dirt on the outside of the tip for easy cleaning
  2. carbon on the inside of the tip prior to reaming
  3. carbon on both the outside and inside of the tip before disassembly
- 
- Learning Objective: Explain the procedures for troubleshooting, disassembling, inspecting, reassembling, and testing the Cummins pressure-timed fuel injection system. Textbook pages 7-22 through 7-25.
- 
- 6-35. When troubleshooting a PT fuel system, how can the mechanic often eliminate the pump as a source of trouble?
1. By checking the suction side of the pump for proper vacuum
  2. By running the engine at low speed throughout the full range of rack travel and observing fuel delivery
  3. By adjusting the high idle stop screw until the specified high idle speed is obtained
  4. By checking manifold pressure to see that it is within specified limits
- 6-36. While troubleshooting the PT fuel pump on an engine, when should the mechanic measure manifold pressure?
1. Just before the governor cuts in
  2. Just after the governor cuts in
  3. When maximum engine speed is reached
- 6-37. When making both manifold and suction pressure checks, why should the mechanic operate the engine a minimum of 5 minutes between checks?
1. To clear the gages of excess fuel
  2. To clear the pump of any restrictions
  3. To clear the fuel system of air
  4. To create a lag in the fuel system so that the gages will readjust
- 6-38. Engine power loss can result from carboning of the PT injector metering orifices. How can the carbon be removed?
1. Soaking the injector in a clean solvent
  2. Wire brushing
  3. Smoothing with emery cloth
  4. Reverse flushing while the engine is warm
- 6-39. What device on the PT fuel system of a turbocharged Cummins engine aids in controlling engine smoke level?
1. Smoke arrester
  2. Catalytic converter
  3. Aneroid
  4. Scavenging blower
- 6-40. The mechanic should try to determine which parts of a PT fuel pump have to be replaced before disassembling it.
- 6-41. All component parts of the PT fuel pump must be replaced if a disassembly inspection shows that some of them are worn.
- 6-42. The mechanic uses which of the following means to prevent goring of the PT fuel pump and pump parts in reassembly?
1. Spring steel lockwashers
  2. Flat steel washers
  3. Extreme pressure lubricant
  4. Torque wrench
- 6-43. The test stand of textbook figure 7-30 enables the mechanic to simulate operation of the PT fuel pump and measure pressure that the pump develops.

- 6-44. Suppose while being tested a PT fuel pump fails to develop specified manifold pressure. Which of the following conditions could contribute to the failure?
1. Air leak in the suction line
  2. Closed valve in suction line
  3. Fuel oil temperature higher than 100°F
  4. Each of the above
- 6-45. You are trying to find maximum manifold pressure at full throttle of a newly rebuilt PT fuel pump. With the pump running at 1,500 rpm, you should turn the
1. rear throttle stop screw
  2. shims under the idle spring
  3. idle spring to a new position
  4. idle speed screw until the idle spring is compressed
- 6-46. After the PT fuel pump idle speed is set, the mechanic can change its idle pressure by
1. adding or removing shims from the idle spring
  2. turning the idle speed screw
  3. turning the throttle screws
  4. locking the throttle in the shutoff position
- 6-47. The amount of fuel that a PT injector delivers to the combustion chamber will be affected by which of the following changes?
1. The fuel pressure
  2. The size or shape of injector orifices
  3. Timing
  4. Each of the above
- 6-48. Which of the following is a bad practice in servicing a PT fuel injector?
1. Plugging the inlet and drain connection holes of the injector before mounting on the test stand
  2. Cleaning injector orifices with wire
  3. Dipping a solvent-cleaned injector into mineral spirits
  4. Inserting a new gasket between the cup and body of the injector during assembly
- 6-49. With the fuel flowing upward through the cup spray holes, what is the maximum pressure applied to check plunger clearance?
1. 500 psi
  2. 1,000 psi
  3. 1,500 psi
  4. 2,000 psi
- 6-50. To obtain a positive injector plunger set in the injector cup, the plunger and cup are to be lapped.
- 
- Learning Objective: Point out the procedures for removing, disassembling, inspecting, and reassembling air induction system blowers, superchargers, and turbochargers. Textbook pages 7-26 through 7-32.
- 
- 6-51. Superchargers and turbochargers pump a greater amount of air into an engine than could be supplied by normal atmospheric pressure. What is the effect on fuel consumption and power?
1. More fuel is burned, power is decreased
  2. Less fuel is burned, power is decreased
  3. More fuel is burned, power is increased
  4. Less fuel is burned, power is increased
- 6-52. What component, if any, must be removed before a blower-equipped air induction system can be inspected?
1. Air inlet housing or air silencer
  2. Flywheel housing
  3. Freshwater pump
  4. None
- 6-53. ~~Suppose the rotors of a blower are burred~~ but not too badly scored. What should the mechanic do in case the burrs interfere with operation of the blower?
1. Dress down the rotors after removing the blower from the engine
  2. Dress down the rotors without removing the blower from the engine
  3. ~~Remove the blower from the engine and~~ replace the rotors
- 6-54. In removing parts from rotor shafts, a mechanic should keep from damaging the blower rotors by pulling the blower drive, driven gears, and timing gears at the same time.
- 6-55. After washing a blower ball bearing with cleaning solvent, the mechanic cleans the balls and races of the bearing by
1. spinning them dry with compressed air
  2. directing air through the bearing and rotating it by hand
  3. wiping them with a clean cloth



In items 6-56 through 6-59, match the blower condition in column A by selecting from column B the cause of the condition.

A. Conditions

B. Causes

- |   |  |
|---|--|
| 6-56. Inside surface of the blower housing covered with oil | 1. Plugged drain tube                        |
| 6-57. Rotor lobes rubbing throughout their entire length    | 2. Loose rotor shafts or damaged bearings    |
| 6-58. Liquid on air box floor                               | 3. Leaking seal                              |
| 6-59. Scoring between rotors and blower housing             | 4. Excessive backlash in blower timing gears |

6-60. The mechanic replaces which of the following worn or damaged blower parts as a matched set?

1. Oil seals
2. Double-row bearing
3. Timing gears
4. End plates

6-61. The mechanic should replace blower parts that an inspection shows to be worn or excessively damaged.

6-62. When is it considered necessary to change supercharger seals?

1. Only when "wet" oil appears at the ends of the rotors
2. Only when "wet" oil appears at the ends of the supercharger outlet connectors
3. Only when oil from the vapor tube shows on the rotors
4. At any time oil appears inside the supercharger housing

6-63. What should a mechanic do in case the rotors, rotor shafts, and end plates of a supercharger are cracked or broken?

1. Discard the supercharger and replace with a new one
2. Replace only the rotors and shafts; repair the end plates
3. Replace the damaged parts separately, except for the rotors and shafts which are replaced as a matched set

6-64. Under which of the following conditions is the drive coupling of the supercharger replaced?

1. Coupling pins are worn
2. Hub surface is grooved
3. Rotors and gears are not within the required tolerances

6-65. When, if ever, should engine lubricating oil be added to the gear end plate of a supercharger that is being reconditioned?

1. After it is completely reassembled but before it is installed on the engine
2. After it is completely reassembled and installed on the engine
3. Never

6-66. Which of the following conditions can cause the thrust and journal bearings of a supercharger to overheat?

1. Foreign particles in the exhaust system
2. Not enough lubricating oil
3. Foreign matter in the air induction system

6-67. Under which of the following conditions can contaminated oil damage a turbocharger because the oil filter is bypassed?

1. Oil filter is clogged
2. Turbocharger lubrication valve is open
3. Filter bypass valve is malfunctioning
4. Each of the above

6-68. A mechanic can help prevent damage to the rotary parts of a turbocharger by cleaning thoroughly the inlet and the exhaust systems of the engine.

6-69. By what means should a mechanic remove carbon deposits that still remain on turbocharger parts after they have soaked in mineral spirits?

1. Steam
2. Wire brush
3. Soft bristle brush
4. Compressed air

6-70. What part, if damaged, may require replacement of the main turbocharger main casing?

1. Exhaust casing
2. Turbine casing
3. Floating bearing

6-71. The oil seal plates of a turbocharger are replaced often since they wear out fast.

6-72. The rotor assembly of a turbocharger must be rebalanced when which of the following parts are replaced?

1. Turbine wheel and shaft
2. Sleeve and compressor wheel
3. Thrust washer and locknut
4. All of the above

6-73. In mounting the turbocharger, the mechanic can make sure it is in the proper operating position on the engine by locating the

1. air inlet to the right of the turbocharger vertical centerline
2. air inlet to the left of the turbocharger vertical centerline
3. oil outlet 45° or more below the turbocharger horizontal centerline
4. oil outlet 45° or more above the turbocharger horizontal centerline

# Assignment 7

## Vehicles Inspections and Power Trains/Automatic Transmissions

Textbook Assignment: Pages 8-1 through 9-5.

---

Learning Objective: Recognize forms and instructions used with vehicle inspection. Textbook pages 8-1 and 8-2.

---

- 7-1. As a PW inspector, you will complete a Shop Repair Order on each unit inspected. Instructions for completing this form are contained in
1. NAVFAC P-300
  2. NAVFAC P-306
  3. NAVFAC P-404
  4. NAVFAC P-437
- 7-2. In addition to the COMCBPAC/COMCBLANT 11200.1 Instructions, an NMCB vehicle inspector must be thoroughly familiar with
1. NAVFAC P-238
  2. NAVFAC P-404
  3. NAVFAC P-405
  4. NAVFAC P-437
- 
- Learning Objective: Identify fundamentals of inspecting the lighting equipment of vehicles. Textbook pages 8-1 through 8-8.
- 
- 7-3. The lights of a vehicle are among the items that should be inspected during a regularly scheduled PM for the vehicle.
- 7-4. Identification lights are usually required on which of the following vehicles?
1. Station wagons
  2. Staff sedans
  3. 1/2-ton pickups
  4. 5-ton vans
- 7-5. How many clearance lamps does the ICC prescribe as the minimum for a truck 82 inches wide, weighing 3,500 pounds?
1. Six
  2. Two
  3. Twelve
  4. Four
- 7-6. What factors are headlights tested for?
1. Beam width and remaining life
  2. Output, beam deflection, and hotspot diameter
  3. Remaining life and brightness
  4. Candlepower, aim, and focus
- 7-7. Suppose object A is 150 feet ahead of your jeep, object B is 300 feet ahead, and object C is 600 feet ahead. Which object or objects must you be able to see at night with properly adjusted headlights?
1. A only
  2. A and B only
  3. A, B, and C
- When answering items 7-8 through 7-10, assume that you are using the screen of textbook figure 8-2 to aim the headlights of a passenger vehicle equipped with the two-headlight system.
- 7-8. If the headlamp centers of the vehicle are 28 inches above the ground, what should be the height of the horizontal reference line on the screen?
1. 23 in.
  2. 25 in.
  3. 28 in.
  4. 31 in.

9

- 7-9. How far should the screen be in front of the headlights?
1. 3 ft
  2. 10 ft
  3. 12 ft
  4. 25 ft
- 7-10. The distance between the lamp centers should be equal to
1. the distance between the floor and headlamp level on the screen
  2. one-half the distance between the vehicle axis line and one of the other vertical lines on the screen
  3. the distance between the vehicle axis line and one of the other vertical lines on the screen
  4. twice the distance between the vehicle axis line and one of the vertical lines on the screen
- 7-11. Refer to textbook figure 8-3. When aiming passenger vehicle headlights at the screen, how should you center the hotspot of the right-hand lamp?
1. Sideways on line C-C, up and down the vehicle axis
  2. 2 inches below the left-hand lamp hotspot
  3. Sideways on line C-C, up and down on line A-A
  4. Sideways on line B-B, up and down on line A-A
- 7-12. The headlight centers of an unloaded truck are 30 inches above the ground and the bright beams show on the test screen across a horizontal line 35 inches above the ground. How, if at all, should the headlamps be adjusted?
1. Lower the beams 5 inches
  2. Lower the beams 8 inches
  3. Lower the beams 10 inches
  4. Make no adjustment
- 7-13. With the aid of a screen, you are aiming the headlights of a vehicle equipped with a four-headlight system. The position of the screen of the lift edge of the hotspot of the outboard low beam should be between
1. straight ahead and 6 inches left of straight ahead
  2. 3 inches left of straight ahead and 3 inches right of straight ahead
  3. straight ahead and 6 inches right of straight ahead
- 7-14. Which of the following steps must the mechanic take to measure the candlepower of the headlight beam?
1. Center the hotspot of the light beam on the vertical line
  2. Position the photocell to touch the glass holding the screen
  3. Raise and lower the photocell to get the highest reading on the output meter
  4. All of the above
- 7-15. At night, Patrolman A is stationed along a road 150 feet behind your jeep; Patrolman B is 300 feet behind your jeep, and Patrolman C is 450 feet behind your jeep. Which of the patrolmen should be able to see your illuminated taillights?
1. A only
  2. A and B only
  3. A, B, and C
- 7-16. Night Patrolman A is stationed along a road 30 feet behind your jeep; Patrolman B is 60 feet behind your jeep, and Patrolman C is 90 feet behind your jeep. Which of the patrolmen should be able to read your illuminated license plate?
1. A only
  2. A and B only
  3. A, B, and C
- 7-17. Patrolman A is 75 feet in front of your truck; Patrolman B is 150 feet in front; Patrolman C is 90 feet to the rear of your truck, and Patrolman D is 180 feet to the rear. Which of these patrolmen should be able to see your illuminated directional signals?
1. A only
  2. A and B only
  3. A and C only
  4. A, B, C, and D
- 7-18. What is the maximum distance from the ground at which a directional signal unit may be mounted on the rear of a large truck?
1. 1 ft
  2. 1 1/2 ft
  3. 2 ft
  4. 2 1/2 ft

7-19. The signals that show the widest dimension of a truck are called

1. side-marker lamps
2. identification lamps
3. clearance lamps
4. reflector flares

7-20. The signals that indicate the longest dimension of a truck are called

1. side-marker lamps
2. identification lamps
3. clearance lamps
4. reflector flares

7-21. At which of these heights may a reflector be mounted on the back of a truck?

1. 12 in.
2. 36 in.
3. 48 in.
4. 60 in.

---

Learning Objective: Specify the principles of inspecting vehicle brakes and brake systems. Text-book pages 8-9 through 8-19.

---

7-22. At a speed of 60 mph, approximately how many feet does a vehicle travel between the time its driver sees a need for braking and the time brake pressure is first applied?

1. 44 ft
2. 55 ft
3. 88 ft
4. 186 ft

7-23. Which of the following sets of readings on the gages of a brake-testing machine indicates satisfactory brake adjustment?

1. 925, 1250, 1225, 1075
2. 1325, 1450, 1025, 1075
3. 1200, 1225, 1175, 1175
4. 1150, 1200, 1275, 1150

7-24. When a vehicle's brakes are tested by the marked line method, the braking distance is measured from the line to the

1. rear of the vehicle
2. front of the vehicle
3. center of the vehicle
4. driver's seat of the vehicle

7-25. When the pedal of a hydraulic brake system is pressed down, it creeps slowly downward after about a minute. This condition could be caused by

1. a weakened brakeshoe retracting spring
2. a completely severed brake hose
3. a leaking wheel cylinder
4. ill-fitting brakeshoes

7-26. Slightly out-of-round brakedrums may be made true by using a

1. boring mill
2. lathe
3. drum sander
4. router

7-27. Which of the following brake troubles is least likely to occur on a Navy truck?

1. Worn brakedrum
  2. Out-of-round brakedrum
  3. Wrong lining material
  4. Greasy brake linings
- 

Items 7-28 through 7-31 are related to the standard hydraulic brake system. Select from column B the possible remedy for the malfunction in column A.

A. Malfunctions

B. Possible Remedies

7-28. Pulsating brake pedal

1. Tighten backing plate

7-29. Springy, spongy pedal

2. Tighten brakedrum on hub

7-30. Brakes chatter

3. Bleed air from lines

7-31. Vehicle pulls to one side

4. Repair or replace wheel cylinder

---

7-32. What, if anything, should happen to the pedal of a vacuum-assisted hydraulic brake system that is being held down while the engine is started?

1. Move forward
2. Move backward
3. Nothing

7-33. Which of the following conditions in a vacuum-assisted hydraulic brake system can result in a hard pedal caused by vacuum failure?

1. Plugged or loose vacuum fitting
2. Collapsed or damaged vacuum hose
3. Damaged floating control valve
4. Each of the above

7-34. With the engine not running and the brakes applied, the pressure in an air-brake system is 70 psi. What is the condition of the system if the pressure drops to 65 psi in 1 minute?

1. It is satisfactory
2. It has an air leak
3. Its compressor is defective
4. One of its relief valves is improperly set

7-35. A drained airbrake system requires 8 minutes to build up a pressure of 60 psi. What is the condition of this system?

1. It is satisfactory
2. It has leaks
3. It has a defective compressor
4. Its low pressure relief valve is set too low

7-36. Which of the following operating troubles result from a malfunction of the air-over-hydraulic power cylinder?

1. Hard pedal and dragging brakes
2. Grabbing brakes and spongy pedal
3. Low pedal and severe braking
4. Fading brakes and pulsating brake pedal

When answering items 7-37 and 7-38, assume you are testing the power cylinder of a vehicle equipped with air-over-hydraulic brakes.

7-37. The air control pressure gage shows 60 psi and the hydraulic output pressure gage shows 1,000 psi with the brake pedal fully depressed. The gage readings indicate

1. air leakage and hydraulic fluid leakage
2. air leakage and air trapped in the hydraulic system
3. automatic adjusters not working
4. improperly adjusted compressor governor and hydraulic pressure drop

7-38. With the brake pedal released, you get readings greater than ZERO on the air control pressure gage and both hydraulic pressure gages. These readings show

1. continuing power cylinder problems
2. dragging brakes
3. a faulty vacuum cylinder

7-39. Which of the following conditions indicates a faulty vacuum cylinder within a vacuum-over-hydraulic brake system?

1. The brake pedal moves toward the floorboard after the engine is started
2. The brake pedal moves toward the floorboard before the engine is started
3. The brake pedal fails to move before the engine is started
4. The brake pedal fails to move after the engine is started

7-40. When road testing a vehicle, you apply the emergency brake to see whether it is effective enough to stop the vehicle. Within what distance must the brake stop the vehicle safely when it is traveling at a speed of 20 mph?

1. 85 ft
2. 75 ft
3. 65 ft
4. 55 ft

---

Learning Objective: Point out fundamentals of inspecting vehicular steering systems and accessories. Textbook pages 8-20 through 8-23.

---

7-41. During a routine inspection of a vehicle, you notice that one tire has worn spots which allow the cord fabric to show. What should you do with this tire?

1. Reverse its position on the wheel
2. Put it on the wheel that shows the least tire wear
3. Balance it
4. Replace it

7-42. Of the following conditions, which is LEAST likely to cause hard steering?

1. Underinflated tires
2. Improperly adjusted brakes
3. Worn universal joints
4. Loose tie rod ends

7-43. Which of the following factors affect steering but are NOT checked in routine safety inspections?

1. Tire inflation and wear
2. Play in steering wheel and condition of front wheel bearings
3. Brake adjustment and condition of ball joints
4. Wheel camber and caster and kingpin angle

7-44. If you have tightened up the tie rod ends of a steering system during the inspection of a vehicle, you will likely have to adjust the

1. front-wheel bearings
2. toe-in
3. front-wheel caster or camber
4. kingpin angle

7-45. Where must the discharge point of exhaust gases be on vehicles equipped with short bodies?

1. Beyond the rear bumper
2. Behind the rear axle
3. Rear of the cab and beyond any saddle fuel tanks

7-46. On inspecting a number of vehicles, you find some windshields are cracked and some are pitted. Which windshields, if any, should be replaced before the vehicles are approved for driving?

1. Pitted windshields only
2. Cracked windshields only
3. Pitted or cracked windshields
4. None

7-47. A bus, truck, or truck-tractor must be equipped with two rearview mirrors on each side and an interior rearview mirror.

7-48. Which of the following is part of a seat belt inspection?

1. Seeing that the belts are not frayed or worn
2. Seeing that no sharp metallic object is rubbing against the cloth part of a belt
3. Making sure belt anchors are secure and tight
4. Each of the above

7-49. A horn that does not sound when being inspected should be checked for proper ground and correct voltage.

7-50. Under which of the following conditions should the kingpin lock open on a truck-tractor and trailer?

1. The operator applies the trailer brakes
2. The air release valve is activated automatically
3. The operator activates the positive release lever by hand or it is activated automatically

7-51. Equipment that has the batteries removed, preservation lubricants installed, and all openings securely sealed is considered as what type?

1. Embarkation
2. Live storage
3. Deadlined
4. Preserved

7-52. Live storage equipment may be operated through all cycles.

7-53. Safety and operational inspections are not conducted as part of an embarkation inspection.

7-54. Configuration of some vehicles is a requirement for embarkation.

7-55. Major repairs and body work are normally completed during the "BEEP."

7-56. All parts and labor cost of items interchanged with deadlined equipment are charged to

1. project funds
2. the deadlined unit
3. overhead
4. the unit installed on

7-57. Deadlined equipment is inspected on a regular schedule to detect cannibalization.

---

Learning Objective: Describe techniques of troubleshooting an automotive clutch. Textbook pages 9-1 through 9-5.

---

In items 7-58 through 7-69, select from column B the type of clutch trouble that is caused by the condition in column A.

A. Conditions	B. Types of Trouble
7-58. Loose spring shackles	1. Clutch slippage
7-59. Broken pressure plate	2. Clutch drag
7-60. Excessive free pedal movement	3. Clutch grab or chatter
7-61. Worn pilot bearing	4. Clutch noise
7-62. Binding in clutch linkage	
7-63. Grease or oil on the facings	
7-64. Loose transmission mountings	
7-65. Worn engine mounts	
7-66. Binding of the friction disk hub	
7-67. Worn clutch facings	
7-68. Warped disk	
7-69. Worn clutch release bearing	
7-70. In checking for a slipping clutch, you set the handbrake, start the engine, and put the transmission in low gear. In which of the following ways should you release the clutch?	
<ol style="list-style-type: none"> <li>1. Rapidly while accelerating the engine</li> <li>2. Rapidly while maintaining constant engine speed</li> <li>3. Slowly while maintaining constant engine speed</li> <li>4. Slowly while accelerating the engine</li> </ol>	

7-71. When insufficient clutch pedal lash is noticed, have your mechanic check the

1. linkage adjustment
2. release bearing for wear or dryness
3. friction disk facing for surface condition

7-72. Which of the following practices is recommended to correct a stiff clutch pedal?

1. Oil the disk facings
2. Ride the clutch
3. Lubricate the clutch linkage
4. Adjust free travel of the pedal

7-73. When the clutch is being uncoupled, a series of slight movements (pulsations) can be felt on the clutch pedal. The trouble indicated may be caused by which of the following conditions?

1. A warped pressure plate or warped clutch disk
2. The flywheel not seated on the crankshaft flange
3. Misalignment of the engine and transmission
4. Each of the above

7-74. Broken or weak pressure springs in the clutch plate assembly will cause the clutch disk to wear rapidly.



# Assignment 8

## Power Trains/Automatic Transmissions (continued)

Textbook Assignment: Pages 9-5 through 9-65.

---

Learning Objective: Explain operating principles of the four-speed, constant-mesh, synchromesh, and auxiliary transmission. Textbook pages 9-6 through 9-12.

---

In items 8-1 through 8-4, select from column B the gear position that a four-speed transmission would be in when the gears are engaged as described in column A.

<u>A. Descriptions</u>	<u>B. Gear Positions</u>
8-1. The forward shift or sliding gear is engaged with the constant speed gear	1. First gear 2. Second gear 3. Third gear
8-2. The smallest countershaft gear engages with the largest sliding gear	4. Fourth gear
8-3. The second countershaft gear meshes with the forward slide gear	
8-4. The largest sliding gear is disengaged and the smallest countershaft gear is in mesh with the second largest sliding gear	

---

8-5. What feature of the constant-mesh transmission enables it to operate more quietly than the old-type transmission with its spur-tooth gears?

1. Double-row spur-tooth gears
2. Helical gears
3. Main shaft meshing gears that are able to move endwise
4. Soundproof padding around the transmission case

8-6. What component in a synchromesh transmission equalizes the speed of the driving and driven members?

1. Friction cone clutch
2. Dog clutch
3. Shifter fork
4. Sliding sleeve

8-7. Some trucks are powered by the same-sized engines you find in passenger cars. Why do these trucks have a greater mechanical advantage than the passenger cars have?

1. Their engine-to-axle gear ratio is greater
2. Their engine-to-axle ratio is smaller
3. They are equipped with synchromesh transmissions

8-8. Which type of transmission, if any, will increase the mechanical advantage of a truck?

1. Constant-mesh main transmission
  2. Auxiliary transmission
  3. Synchromesh main transmission
  4. None
- 

Learning Objective: Describe techniques of troubleshooting automotive transmissions. Textbook pages 9-14 through 9-16.

---

8-9. Which of the following conditions produces torsional vibrations that sound like noises in the transmission?

1. Worn universal joints
2. Loose U-bolts
3. Unbalanced wheels
4. Each of the above

8-10. What effect does the lockout mechanism in the transmission produce when it fails to exert enough spring pressure on the gears?

1. Slipping out of gear
2. Hard shifting
3. Gear clashing, low to second gear
4. Gear clashing, second to high gear

8-11. A diagnosis of misalignment between the transmission and engine is checked by

1. removing the transmission and examining the clutch shaft
2. measuring flywheel wobble with a dial indicator
3. rotating the crankshaft rapidly and looking for variations in the housing bore
4. counting clutch-pedal pulsations

8-12. Of the following conditions, which could cause the gear to clash when you are shifting into either second or high gear?

1. Excessive free travel of clutch pedal
2. Broken synchronizer spring
3. Gear sticking on the main shaft of the transmission
4. Each of the above

8-13. Assume you hear a noise coming from a vehicle. The vehicle is not moving, its engine is running, the clutch is engaged and the transmission is in neutral. How should you go about deciding that the noise is coming from the transmission only?

1. Disengage the clutch, and find that the noise stops
2. Disengage the clutch, and find that the noise continues
3. Put the transmission in gear, and find that the noise continues

---

Learning Objective: Explain operating principles and troubleshooting techniques for transfer cases. Textbook page 9-17.

---

8-14. In a six-wheel drive vehicle, an extra propeller shaft connects the drive shaft of the transfer case to the rearmost axle assembly. The extra shaft is connected to the transfer case through

1. the transmission brakedrum
2. the propeller shaft assembly and then to the live axles
3. direct connections between the input shaft and the main shaft

8-15. Whenever more traction is required of a four-wheel truck, the front wheel drive is engaged automatically by a/an

1. sprag unit
2. slip joint
3. two-way clutch
4. auxiliary transmission

---

Learning Objective: Identify the types of power takeoffs and propeller shaft assemblies and their uses in automotive vehicle operation. Textbook page 9-19.

---

8-16. The power takeoff units with gear arrangements that provide three or more forward speeds are used to operate

1. power trains
2. winches
3. tracklayers
4. front-wheel drives

8-17. Which component in the power train of a moving vehicle adjusts to changes in the distance between the transmission and the axle assembly?

1. Universal joint
2. Slip joint
3. Driving axle

---

Learning Objective: Explain fundamentals of automotive differentials. Textbook pages 9-21 and 9-22.

---

8-18. One purpose of the differential in the rear axle assembly of a wheeled vehicle is to

1. serve as a torque member
2. insure that the rear wheels always turn at the same speed
3. boost engine power transmitted to the wheels
4. enable the axles to be driven as a single unit although turning at different speeds

8-19. Compared to a standard differential, the high-traction differential for automotive vehicles combines pinions and side gears that have

1. fewer teeth but the same tooth form
2. more teeth but the same tooth form
3. fewer teeth and a modified tooth form
4. more teeth and a modified tooth form

8-20. Which parts of the standard differential distinguish it from the no-spin differential?

1. Ring gear and spider
2. Pinions and side gears
3. Two driven clutch members with side teeth
4. Spring retainer and trunnions.

In items 8-21 through 8-23, select from column B the type of axle that best fits the description in column A.

A. Descriptions	B. Types of Axles
8-21. The axle housing carries the weight of the vehicle because the wheels are supported by bearings on the outer ends of the housing	<ol style="list-style-type: none"> <li>1. Semifloating axle</li> <li>2. Three-quarter floating axle</li> <li>3. Full floating axle</li> </ol>
8-22. Each wheel is carried on the end of the axle tube on two ball bearings or roller bearings and the axle shafts are bolted to the wheel hub	
8-23. The wheels are keyed or bolted to outer ends of axle shafts and the outer bearings are between the shafts and housing	

Learning Objective: Point out good and poor practices in servicing power trains. Textbook pages 9-26 and 9-27.

8-24. At what level should the lubricant be maintained in the gear cases of vehicle power trains?

1. One inch below the inspection hole
2. Two inches below the inspection hole
3. Three inches below the inspection hole
4. Even with the bottom of the inspection hole

8-25. Which of the following practices could cause a clutch to slip?

1. Underfilling the transmission with oil
2. Filling the transmission with oil too light or too heavy
3. Overfilling the transmission with oil

8-26. Which of the following faults should mechanics look for when inspecting the power train of a vehicle?

1. Missing transmission bolts
2. Bent propeller shaft
3. Loose U-bolts
4. All of the above

Learning Objective: Identify the operating principles of the Turbo Hydra-matic 400 transmission. Textbook pages 9-29 through 9-37.

8-27. Which of the following is a part of the reaction member of this transmission?

1. Pump
2. Turbine
3. Sprag
4. Planetary gear

8-28. Maximum performance at all throttle openings is obtained by signals from

1. engine vacuum and revolutions
2. vehicle speed and engine torque
3. engine timing and vehicle speed
4. hydraulic pressure and engine torque

8-29. Holding the sun gear stationary and applying power to the internal gear in a clockwise direction will result in

1. overdrive
2. reverse
3. direct drive
4. reduction

8-30. The converter cover is attached to the engine by the use of a

1. slotted drive
2. flex-plate
3. flywheel ring
4. clutch plate

8-31. With the engine operating full throttle, transmission in gear, and the vehicle standing still, the converter is capable of multiplying engine torque by approximately

1. 4:1
2. 1:2
3. 2:1
4. 1:4

8-32. The Hydra-matic 400 employs what type of hydraulic pump to build pressure?

1. Positive diaphragm
2. Piston
3. Rotary vane
4. Internal-external gear

8-33. Oil returning from the converter is directed to the

1. transmission cooler
2. transmission sump
3. transmission pump inlet
4. converter inlet

8-34. The small area of the forward clutch serves to provide

1. final holding force
2. line pressure
3. smooth initial takeup
4. release pressure

8-35. The secondary weights of the governor act on the

1. regulating valve
2. output shaft
3. vacuum gear

8-36. To control upshift at a higher vehicle speed, a variable oil pressure is used and known as

1. governor pressure
2. torque pressure
3. modulator pressure
4. vacuum pressure

8-37. An operator has a complaint of slipping in reverse. The oil level, linkages, and modulator are normal. You should suspect the

1. governor feedline seals
2. detent solenoid
3. detent switch
4. reverse feed passage

---

Learning Objective: Specify the fundamentals of the power shift transmission as illustrated in the International Harvester TD-20 series B tractor and model 250 series B loader. Textbook pages 9-35 through 9-46.

---

8-38. The hi-lo shifting lever that controls shifting from one range to another is mounted on the

1. universal joint
2. torque converter
3. reverse clutch shaft
4. transmission front cover

8-39. On which shafts are the gears mounted?

1. Reverse clutch and forward clutch only
2. Reverse clutch and spline only
3. Spline and bevel pinion only
4. Reverse and forward clutch and spline and bevel pinion

8-40. Which shaft, serving as a mounting for gears, rotates on two straight roller bearings?

1. Bevel pinion shaft
2. Forward clutch shaft
3. Spline shaft
4. Reverse clutch shaft

---

Items 8-41 through 8-43 are related to troubleshooting the International Harvester (TD-20 series B tractor and model 250 series B loaders) hydraulic torque converter. Select from column B the possible cause of the trouble in column A.

<u>A. Troubles</u>	<u>B. Possible Causes</u>
--------------------	---------------------------

- |   |   |
|---|---|
| 8-41. Torque converter overheating                        | 1. Bearing failure allowing turbine or impeller blades to strike the fixed stator |
| 8-42. Loss of power                                       | 2. Operating too long in low efficiency ranges                                    |
| 8-43. Grinding or scraping noise inside converter housing | 3. Converter input pump inoperative   |
|   | 4. Leaking converter  |
-

- 8-44. For transmission gears, which shaft has a straight roller bearing at each end?
1. Bevel pinion shaft
  2. Spline shaft
  3. Forward clutch shaft
  4. Reverse clutch shaft
- 8-45. Which statement is true of the forward and reverse clutch when the transmission is in neutral?
1. Neither clutch is engaged
  2. The drive gear and drum assemblies are free
  3. No torque is transmitted through the clutch
  4. Each of the above
- 8-46. What function is performed by the entry of oil into the accelerator piston cavity?
1. Forcing the accelerator piston, reinforcing disk, and disk valve against the separator plate
  2. Forcing the accelerator piston to push the guide pins against the opposite accelerator piston, positioning this piston, reinforcing disk, and disk valve away from the separator plate
  3. Starting to move the force piston to the right
  4. Each of the above
- 8-47. Which unit holds the hi-lo shifting lever on the transmission cover in position?
1. Bolt
  2. Screw
  3. Poppet lock
  4. Ring
- 8-48. If the entry of air into the suction line causes the main oil pressure gage to show low or high pressure, which corrective measure should you take?
1. Clean suction filter and replace the pressure filter element
  2. Remove valve springs and replace with new ones
  3. Replace the Marmon clamp gasket and replace the "O" rings in the system
  4. Check number of washers, being sure that there are no more than four, and install new valve body gasket
- 8-49. Which of the following faults can cause noise in the transmission?
1. Worn gears, bearings, or gear and drum bushings
  2. Foreign material in oil
  3. Bevel gear and pinion not in proper mesh
  4. Each of the above
- 8-50. If the entry of air into the suction line causes the oil temperature to rise too high, what should you do?
1. Remove and clean the oil cooler
  2. Discard the valve assembly
  3. Replace the gage or sending unit
  4. Replace the Marmon clamp gasket and "O" rings
- 
- Learning Objective: Outline principles governing operation of the Allison Torqmatic Transmission (series 4460). Textbook pages 9-41 through 9-65.
- 
- 8-51. Which planetary of the torque converter gear train has two clutches?
1. Low-range
  2. Intermediate-range
  3. Reverse-range
  4. Splitter
- 8-52. The combination of planetary gears and clutches gives the transmission
1. three forward and one reverse ranges
  2. four forward and two reverse ranges
  3. five forward and two reverse ranges
  4. six forward and two reverse ranges
- 8-53. Which identification must be included when you are ordering parts for the transmission?
1. Serial number
  2. Assembly number
  3. Model number
  4. Each of the above

In items 8-54 through 8-56, select from column B the part of the input drive on which the assembly of column A is fastened.

<u>A. Assemblies</u>	<u>B. Input Drive Parts</u>
----------------------	-----------------------------

- |   |  |
|---|--|
| 8-54. Inner bolt circle of flex-disk assembly | 1. Front end of fly-wheel's outer diameter           |
| 8-55. Outer bolt circle of flex-disk assembly | 2. Hub assembly<br>3. Torque converter lockup clutch |
| 8-56. Engine starter ring gear                | 4. Flywheel  |

8-57. Which element of the torque converter is a torque-multiplying element?

1. Pump
2. Turbine
3. Stator

8-58. Which element of the torque converter is splined to the shaft that transmits power to the splitter planetary carrier?

1. Turbine
2. Stator
3. Pump

8-59. Which component of the splitter planetary is a part of the turbine output shaft?

1. Carrier
2. Sun gear
3. Pinion on roller
4. Ring gear

8-60. When a hydraulic retarder is actuated, the rotation of the rotor is resisted by the action of

1. oil churning between stators and rotor
2. miniature brakes forcing action to slow down
3. reversal of direction in which planetary pinions rotate
4. hydraulic pressure against the rotor

8-61. What is the correct combination of internal splined clutch plates, external-tanged plates, and piston return springs for the high-range clutch?

1. Three internal splined clutch plates, two external tanged plates, and 10 piston return springs
2. Four internal splined clutch plates, three external tanged plates, and 13 piston return springs
3. Two internal splined clutch plates, four external tanged plates, and 15 piston return springs
4. Five internal splined clutch plates, three external tanged plates, and 20 piston return springs

8-62. How many pinions rotate on rollers on spindles in the carrier of the intermediate-planet planetary gear?

1. Eight
2. Two
3. Six
4. Four

8-63. The low-range planetary gear set includes which of the following parts?

1. Carrier
2. Four pinions
3. Sun gear and ring gear
4. Each of the above

8-64. When the clutch piston receives hydraulic pressure, which element does NOT move?

1. Low-range ring gear
2. Pinions
3. Sun gear
4. Carrier assembly

8-65. All of the following are elements of the reverse-range planetary EXCEPT the

1. carrier
2. twelve pinions
3. sun gear
4. ring gear

8-66. Which units are parts of the output disconnect assembly?

1. Housing and shifter fork
2. Output shaft and shifter shaft
3. Driven and drive couplings
4. All of the above

8-67. After the oil flow stops, following the closing of the retarder valve, the oil left in the retarder is exhausted to the

1. transmission sump
2. oil pan
3. engine
4. ground

8-68. The oil flow and oil pressure provided by the hydraulic system serves which function for the Allison 4460 series transmission?

1. Hydraulic operation
2. Cooling
3. Lubrication
4. Each of the above

8-69. After leaving the retarder, the oil supply goes to the

1. converter-out circuit
2. oil cooler
3. main transmission housing
4. converter-out oil line

8-70. Which type of valve is the converter-in pressure regulator valve?

1. Globe
2. Pump
3. Stem
4. Umbrella

8-71. The pitot tube, after receiving the oil, directs it to the

1. pilot valve and lockup valve
2. collector ring and high-range clutch housing assembly
3. slotted shaft selector valve and oil pan
4. spool-type flow valve and collector ring

Items 8-72 through 8-75 are related to troubleshooting the Allison 4460 transmission and engine as they affect engine performance. Select from column B the possible cause of the transmission trouble in column A.

	<u>A. Transmission Troubles</u>	<u>B. Possible Causes</u>
8-72.	High oil temperature	1. Worn piston seals
8-73.	Loss of power	2. Low oil level
8-74.	Low main pressure	3. Clutch slipping
8-75.	No power transmitted in one range	4. Manual selector valve not positioned properly

★ U.S. GOVERNMENT PRINTING OFFICE: 1982-546-093/8

COURSE DISENROLLMENT

All study materials must be returned. On disenrolling, fill out only the upper part of this page and attach it to the inside front cover of the textbook for this course. Mail your study materials to the Naval Education and Training Program Development Center.

PRINT CLEARLY

NAVEDTRA NUMBER	COURSE TITLE
10645-F	RTM/NRCC Construction Mechanic 1&C

Name	Last	First	Middle
Rank/Rate		Designator	Social Security Number

COURSE COMPLETION

Letters of satisfactory completion are issued only to personnel whose courses are administered by the Naval Education and Training Program Development Center. On completing the course, fill out the lower part of this page and enclose it with your last set of answer sheets. Be sure mailing addresses are complete. Mail to the Naval Education and Training Program Development Center.

PRINT CLEARLY

NAVEDTRA NUMBER	COURSE TITLE
10645-F	RTM/NRCC Construction Mechanic 1&C

Name \_\_\_\_\_

ZIP CODE \_\_\_\_\_

MY SERVICE RECORD IS HELD BY:

Activity \_\_\_\_\_

Address \_\_\_\_\_ ZIP CODE \_\_\_\_\_

Signature of enrollee \_\_\_\_\_

351



**A FINAL QUESTION:** What did you think of this course? Of the text material used with the course? Comments and recommendations received from enrollees have been a major source of course improvement. You and your command are urged to submit your constructive criticisms and your recommendations. This tear-out form letter is provided for your convenience. Typewrite if possible, but legible handwriting is acceptable.

Date \_\_\_\_\_

From: \_\_\_\_\_  
(RANK, RATE, CIVILIAN)

\_\_\_\_\_ ZIP CODE \_\_\_\_\_

To: Naval Education and Training Program Development Center (PDB)  
Pensacola, Florida 32509

Subj: RTM/NRCC Construction Mechanic 1&C, NAVEDTRA 10645-F

1. The following comments are hereby submitted:

(Fold along dotted line and staple or tape)

(Fold along dotted line and staple or tape)

**DEPARTMENT OF THE NAVY**

**NAVAL EDUCATION AND TRAINING PROGRAM  
DEVELOPMENT CENTER (PD 8)  
PENSACOLA, FLORIDA 32509**

**OFFICIAL BUSINESS  
PENALTY FOR PRIVATE USE, \$300**

**POSTAGE AND FEES PAID  
NAVY DEPARTMENT  
DoD-316**



**NAVAL EDUCATION AND TRAINING PROGRAM DEVELOPMENT CENTER  
BUILDING 2435 (PD 8)  
PENSACOLA, FLORIDA 32509**

303

PRINT OR TYPE

CONSTRUCTION MECHANIC 1 & C.  
NAVEDTRA 10645-F

NAME \_\_\_\_\_ ADDRESS \_\_\_\_\_  
Last First Middle Street/Ship/Unit/Division, etc.

RANK/RATE \_\_\_\_\_ SOC. SEC. NO. \_\_\_\_\_ DESIGNATOR \_\_\_\_\_ ASSIGNMENT NO \_\_\_\_\_  
City or PPO State Zip

USN  USNR  ACTIVE  INACTIVE OTHER (Specify) \_\_\_\_\_ DATE MAILED \_\_\_\_\_

SCORE

	1	2	3	4		1	2	3	4		1	2	3	4		
	T	F				T	F				T	F				
1	<input type="checkbox"/>	<input type="checkbox"/>	<input type="checkbox"/>	<input type="checkbox"/>	---	26	<input type="checkbox"/>	<input type="checkbox"/>	<input type="checkbox"/>	<input type="checkbox"/>	51	<input type="checkbox"/>	<input type="checkbox"/>	<input type="checkbox"/>	<input type="checkbox"/>	---
2	<input type="checkbox"/>	<input type="checkbox"/>	<input type="checkbox"/>	<input type="checkbox"/>	---	27	<input type="checkbox"/>	<input type="checkbox"/>	<input type="checkbox"/>	<input type="checkbox"/>	52	<input type="checkbox"/>	<input type="checkbox"/>	<input type="checkbox"/>	<input type="checkbox"/>	---
3	<input type="checkbox"/>	<input type="checkbox"/>	<input type="checkbox"/>	<input type="checkbox"/>	---	28	<input type="checkbox"/>	<input type="checkbox"/>	<input type="checkbox"/>	<input type="checkbox"/>	53	<input type="checkbox"/>	<input type="checkbox"/>	<input type="checkbox"/>	<input type="checkbox"/>	---
4	<input type="checkbox"/>	<input type="checkbox"/>	<input type="checkbox"/>	<input type="checkbox"/>	---	29	<input type="checkbox"/>	<input type="checkbox"/>	<input type="checkbox"/>	<input type="checkbox"/>	54	<input type="checkbox"/>	<input type="checkbox"/>	<input type="checkbox"/>	<input type="checkbox"/>	---
5	<input type="checkbox"/>	<input type="checkbox"/>	<input type="checkbox"/>	<input type="checkbox"/>	---	30	<input type="checkbox"/>	<input type="checkbox"/>	<input type="checkbox"/>	<input type="checkbox"/>	55	<input type="checkbox"/>	<input type="checkbox"/>	<input type="checkbox"/>	<input type="checkbox"/>	---
6	<input type="checkbox"/>	<input type="checkbox"/>	<input type="checkbox"/>	<input type="checkbox"/>	---	31	<input type="checkbox"/>	<input type="checkbox"/>	<input type="checkbox"/>	<input type="checkbox"/>	56	<input type="checkbox"/>	<input type="checkbox"/>	<input type="checkbox"/>	<input type="checkbox"/>	---
7	<input type="checkbox"/>	<input type="checkbox"/>	<input type="checkbox"/>	<input type="checkbox"/>	---	32	<input type="checkbox"/>	<input type="checkbox"/>	<input type="checkbox"/>	<input type="checkbox"/>	57	<input type="checkbox"/>	<input type="checkbox"/>	<input type="checkbox"/>	<input type="checkbox"/>	---
8	<input type="checkbox"/>	<input type="checkbox"/>	<input type="checkbox"/>	<input type="checkbox"/>	---	33	<input type="checkbox"/>	<input type="checkbox"/>	<input type="checkbox"/>	<input type="checkbox"/>	58	<input type="checkbox"/>	<input type="checkbox"/>	<input type="checkbox"/>	<input type="checkbox"/>	---
9	<input type="checkbox"/>	<input type="checkbox"/>	<input type="checkbox"/>	<input type="checkbox"/>	---	34	<input type="checkbox"/>	<input type="checkbox"/>	<input type="checkbox"/>	<input type="checkbox"/>	59	<input type="checkbox"/>	<input type="checkbox"/>	<input type="checkbox"/>	<input type="checkbox"/>	---
10	<input type="checkbox"/>	<input type="checkbox"/>	<input type="checkbox"/>	<input type="checkbox"/>	---	35	<input type="checkbox"/>	<input type="checkbox"/>	<input type="checkbox"/>	<input type="checkbox"/>	60	<input type="checkbox"/>	<input type="checkbox"/>	<input type="checkbox"/>	<input type="checkbox"/>	---
11	<input type="checkbox"/>	<input type="checkbox"/>	<input type="checkbox"/>	<input type="checkbox"/>	---	36	<input type="checkbox"/>	<input type="checkbox"/>	<input type="checkbox"/>	<input type="checkbox"/>	61	<input type="checkbox"/>	<input type="checkbox"/>	<input type="checkbox"/>	<input type="checkbox"/>	---
12	<input type="checkbox"/>	<input type="checkbox"/>	<input type="checkbox"/>	<input type="checkbox"/>	---	37	<input type="checkbox"/>	<input type="checkbox"/>	<input type="checkbox"/>	<input type="checkbox"/>	62	<input type="checkbox"/>	<input type="checkbox"/>	<input type="checkbox"/>	<input type="checkbox"/>	---
13	<input type="checkbox"/>	<input type="checkbox"/>	<input type="checkbox"/>	<input type="checkbox"/>	---	38	<input type="checkbox"/>	<input type="checkbox"/>	<input type="checkbox"/>	<input type="checkbox"/>	63	<input type="checkbox"/>	<input type="checkbox"/>	<input type="checkbox"/>	<input type="checkbox"/>	---
14	<input type="checkbox"/>	<input type="checkbox"/>	<input type="checkbox"/>	<input type="checkbox"/>	---	39	<input type="checkbox"/>	<input type="checkbox"/>	<input type="checkbox"/>	<input type="checkbox"/>	64	<input type="checkbox"/>	<input type="checkbox"/>	<input type="checkbox"/>	<input type="checkbox"/>	---
15	<input type="checkbox"/>	<input type="checkbox"/>	<input type="checkbox"/>	<input type="checkbox"/>	---	40	<input type="checkbox"/>	<input type="checkbox"/>	<input type="checkbox"/>	<input type="checkbox"/>	65	<input type="checkbox"/>	<input type="checkbox"/>	<input type="checkbox"/>	<input type="checkbox"/>	---
16	<input type="checkbox"/>	<input type="checkbox"/>	<input type="checkbox"/>	<input type="checkbox"/>	---	41	<input type="checkbox"/>	<input type="checkbox"/>	<input type="checkbox"/>	<input type="checkbox"/>	66	<input type="checkbox"/>	<input type="checkbox"/>	<input type="checkbox"/>	<input type="checkbox"/>	---
17	<input type="checkbox"/>	<input type="checkbox"/>	<input type="checkbox"/>	<input type="checkbox"/>	---	42	<input type="checkbox"/>	<input type="checkbox"/>	<input type="checkbox"/>	<input type="checkbox"/>	67	<input type="checkbox"/>	<input type="checkbox"/>	<input type="checkbox"/>	<input type="checkbox"/>	---
18	<input type="checkbox"/>	<input type="checkbox"/>	<input type="checkbox"/>	<input type="checkbox"/>	---	43	<input type="checkbox"/>	<input type="checkbox"/>	<input type="checkbox"/>	<input type="checkbox"/>	68	<input type="checkbox"/>	<input type="checkbox"/>	<input type="checkbox"/>	<input type="checkbox"/>	---
19	<input type="checkbox"/>	<input type="checkbox"/>	<input type="checkbox"/>	<input type="checkbox"/>	---	44	<input type="checkbox"/>	<input type="checkbox"/>	<input type="checkbox"/>	<input type="checkbox"/>	69	<input type="checkbox"/>	<input type="checkbox"/>	<input type="checkbox"/>	<input type="checkbox"/>	---
20	<input type="checkbox"/>	<input type="checkbox"/>	<input type="checkbox"/>	<input type="checkbox"/>	---	45	<input type="checkbox"/>	<input type="checkbox"/>	<input type="checkbox"/>	<input type="checkbox"/>	70	<input type="checkbox"/>	<input type="checkbox"/>	<input type="checkbox"/>	<input type="checkbox"/>	---
21	<input type="checkbox"/>	<input type="checkbox"/>	<input type="checkbox"/>	<input type="checkbox"/>	---	46	<input type="checkbox"/>	<input type="checkbox"/>	<input type="checkbox"/>	<input type="checkbox"/>	71	<input type="checkbox"/>	<input type="checkbox"/>	<input type="checkbox"/>	<input type="checkbox"/>	---
22	<input type="checkbox"/>	<input type="checkbox"/>	<input type="checkbox"/>	<input type="checkbox"/>	---	47	<input type="checkbox"/>	<input type="checkbox"/>	<input type="checkbox"/>	<input type="checkbox"/>	72	<input type="checkbox"/>	<input type="checkbox"/>	<input type="checkbox"/>	<input type="checkbox"/>	---
23	<input type="checkbox"/>	<input type="checkbox"/>	<input type="checkbox"/>	<input type="checkbox"/>	---	48	<input type="checkbox"/>	<input type="checkbox"/>	<input type="checkbox"/>	<input type="checkbox"/>	73	<input type="checkbox"/>	<input type="checkbox"/>	<input type="checkbox"/>	<input type="checkbox"/>	---
24	<input type="checkbox"/>	<input type="checkbox"/>	<input type="checkbox"/>	<input type="checkbox"/>	---	49	<input type="checkbox"/>	<input type="checkbox"/>	<input type="checkbox"/>	<input type="checkbox"/>	74	<input type="checkbox"/>	<input type="checkbox"/>	<input type="checkbox"/>	<input type="checkbox"/>	---
25	<input type="checkbox"/>	<input type="checkbox"/>	<input type="checkbox"/>	<input type="checkbox"/>	---	50	<input type="checkbox"/>	<input type="checkbox"/>	<input type="checkbox"/>	<input type="checkbox"/>	75	<input type="checkbox"/>	<input type="checkbox"/>	<input type="checkbox"/>	<input type="checkbox"/>	---



**PRINT OR TYPE**

CONSTRUCTION MECHANIC 1 & C  
NAVEDTRA 10645-F

NAME \_\_\_\_\_ ADDRESS \_\_\_\_\_  
Last First Middle Street/Ship/Unit/Division, etc.

RANK/RATE \_\_\_\_\_ SOC. SEC. NO. \_\_\_\_\_ DESIGNATOR \_\_\_\_\_ ASSIGNMENT NO \_\_\_\_\_  
City or PFO State Zip

USN  USNR  ACTIVE  INACTIVE OTHER (Specify) \_\_\_\_\_ DATE MAILED \_\_\_\_\_

SCORE

	1	2	3	4
1	<input type="checkbox"/>	<input type="checkbox"/>	<input type="checkbox"/>	<input type="checkbox"/>
2	<input type="checkbox"/>	<input type="checkbox"/>	<input type="checkbox"/>	<input type="checkbox"/>
3	<input type="checkbox"/>	<input type="checkbox"/>	<input type="checkbox"/>	<input type="checkbox"/>
4	<input type="checkbox"/>	<input type="checkbox"/>	<input type="checkbox"/>	<input type="checkbox"/>
5	<input type="checkbox"/>	<input type="checkbox"/>	<input type="checkbox"/>	<input type="checkbox"/>
6	<input type="checkbox"/>	<input type="checkbox"/>	<input type="checkbox"/>	<input type="checkbox"/>
7	<input type="checkbox"/>	<input type="checkbox"/>	<input type="checkbox"/>	<input type="checkbox"/>
8	<input type="checkbox"/>	<input type="checkbox"/>	<input type="checkbox"/>	<input type="checkbox"/>
9	<input type="checkbox"/>	<input type="checkbox"/>	<input type="checkbox"/>	<input type="checkbox"/>
10	<input type="checkbox"/>	<input type="checkbox"/>	<input type="checkbox"/>	<input type="checkbox"/>
11	<input type="checkbox"/>	<input type="checkbox"/>	<input type="checkbox"/>	<input type="checkbox"/>
12	<input type="checkbox"/>	<input type="checkbox"/>	<input type="checkbox"/>	<input type="checkbox"/>
13	<input type="checkbox"/>	<input type="checkbox"/>	<input type="checkbox"/>	<input type="checkbox"/>
14	<input type="checkbox"/>	<input type="checkbox"/>	<input type="checkbox"/>	<input type="checkbox"/>
15	<input type="checkbox"/>	<input type="checkbox"/>	<input type="checkbox"/>	<input type="checkbox"/>
16	<input type="checkbox"/>	<input type="checkbox"/>	<input type="checkbox"/>	<input type="checkbox"/>
17	<input type="checkbox"/>	<input type="checkbox"/>	<input type="checkbox"/>	<input type="checkbox"/>
18	<input type="checkbox"/>	<input type="checkbox"/>	<input type="checkbox"/>	<input type="checkbox"/>
19	<input type="checkbox"/>	<input type="checkbox"/>	<input type="checkbox"/>	<input type="checkbox"/>
20	<input type="checkbox"/>	<input type="checkbox"/>	<input type="checkbox"/>	<input type="checkbox"/>
21	<input type="checkbox"/>	<input type="checkbox"/>	<input type="checkbox"/>	<input type="checkbox"/>
22	<input type="checkbox"/>	<input type="checkbox"/>	<input type="checkbox"/>	<input type="checkbox"/>
23	<input type="checkbox"/>	<input type="checkbox"/>	<input type="checkbox"/>	<input type="checkbox"/>
24	<input type="checkbox"/>	<input type="checkbox"/>	<input type="checkbox"/>	<input type="checkbox"/>
25	<input type="checkbox"/>	<input type="checkbox"/>	<input type="checkbox"/>	<input type="checkbox"/>

	1	2	3	4
26	<input type="checkbox"/>	<input type="checkbox"/>	<input type="checkbox"/>	<input type="checkbox"/>
27	<input type="checkbox"/>	<input type="checkbox"/>	<input type="checkbox"/>	<input type="checkbox"/>
28	<input type="checkbox"/>	<input type="checkbox"/>	<input type="checkbox"/>	<input type="checkbox"/>
29	<input type="checkbox"/>	<input type="checkbox"/>	<input type="checkbox"/>	<input type="checkbox"/>
30	<input type="checkbox"/>	<input type="checkbox"/>	<input type="checkbox"/>	<input type="checkbox"/>
31	<input type="checkbox"/>	<input type="checkbox"/>	<input type="checkbox"/>	<input type="checkbox"/>
32	<input type="checkbox"/>	<input type="checkbox"/>	<input type="checkbox"/>	<input type="checkbox"/>
33	<input type="checkbox"/>	<input type="checkbox"/>	<input type="checkbox"/>	<input type="checkbox"/>
34	<input type="checkbox"/>	<input type="checkbox"/>	<input type="checkbox"/>	<input type="checkbox"/>
35	<input type="checkbox"/>	<input type="checkbox"/>	<input type="checkbox"/>	<input type="checkbox"/>
36	<input type="checkbox"/>	<input type="checkbox"/>	<input type="checkbox"/>	<input type="checkbox"/>
37	<input type="checkbox"/>	<input type="checkbox"/>	<input type="checkbox"/>	<input type="checkbox"/>
38	<input type="checkbox"/>	<input type="checkbox"/>	<input type="checkbox"/>	<input type="checkbox"/>
39	<input type="checkbox"/>	<input type="checkbox"/>	<input type="checkbox"/>	<input type="checkbox"/>
40	<input type="checkbox"/>	<input type="checkbox"/>	<input type="checkbox"/>	<input type="checkbox"/>
41	<input type="checkbox"/>	<input type="checkbox"/>	<input type="checkbox"/>	<input type="checkbox"/>
42	<input type="checkbox"/>	<input type="checkbox"/>	<input type="checkbox"/>	<input type="checkbox"/>
43	<input type="checkbox"/>	<input type="checkbox"/>	<input type="checkbox"/>	<input type="checkbox"/>
44	<input type="checkbox"/>	<input type="checkbox"/>	<input type="checkbox"/>	<input type="checkbox"/>
45	<input type="checkbox"/>	<input type="checkbox"/>	<input type="checkbox"/>	<input type="checkbox"/>
46	<input type="checkbox"/>	<input type="checkbox"/>	<input type="checkbox"/>	<input type="checkbox"/>
47	<input type="checkbox"/>	<input type="checkbox"/>	<input type="checkbox"/>	<input type="checkbox"/>
48	<input type="checkbox"/>	<input type="checkbox"/>	<input type="checkbox"/>	<input type="checkbox"/>
49	<input type="checkbox"/>	<input type="checkbox"/>	<input type="checkbox"/>	<input type="checkbox"/>
50	<input type="checkbox"/>	<input type="checkbox"/>	<input type="checkbox"/>	<input type="checkbox"/>

	1	2	3	4
51	<input type="checkbox"/>	<input type="checkbox"/>	<input type="checkbox"/>	<input type="checkbox"/>
52	<input type="checkbox"/>	<input type="checkbox"/>	<input type="checkbox"/>	<input type="checkbox"/>
53	<input type="checkbox"/>	<input type="checkbox"/>	<input type="checkbox"/>	<input type="checkbox"/>
54	<input type="checkbox"/>	<input type="checkbox"/>	<input type="checkbox"/>	<input type="checkbox"/>
55	<input type="checkbox"/>	<input type="checkbox"/>	<input type="checkbox"/>	<input type="checkbox"/>
56	<input type="checkbox"/>	<input type="checkbox"/>	<input type="checkbox"/>	<input type="checkbox"/>
57	<input type="checkbox"/>	<input type="checkbox"/>	<input type="checkbox"/>	<input type="checkbox"/>
58	<input type="checkbox"/>	<input type="checkbox"/>	<input type="checkbox"/>	<input type="checkbox"/>
59	<input type="checkbox"/>	<input type="checkbox"/>	<input type="checkbox"/>	<input type="checkbox"/>
60	<input type="checkbox"/>	<input type="checkbox"/>	<input type="checkbox"/>	<input type="checkbox"/>
61	<input type="checkbox"/>	<input type="checkbox"/>	<input type="checkbox"/>	<input type="checkbox"/>
62	<input type="checkbox"/>	<input type="checkbox"/>	<input type="checkbox"/>	<input type="checkbox"/>
63	<input type="checkbox"/>	<input type="checkbox"/>	<input type="checkbox"/>	<input type="checkbox"/>
64	<input type="checkbox"/>	<input type="checkbox"/>	<input type="checkbox"/>	<input type="checkbox"/>
65	<input type="checkbox"/>	<input type="checkbox"/>	<input type="checkbox"/>	<input type="checkbox"/>
66	<input type="checkbox"/>	<input type="checkbox"/>	<input type="checkbox"/>	<input type="checkbox"/>
67	<input type="checkbox"/>	<input type="checkbox"/>	<input type="checkbox"/>	<input type="checkbox"/>
68	<input type="checkbox"/>	<input type="checkbox"/>	<input type="checkbox"/>	<input type="checkbox"/>
69	<input type="checkbox"/>	<input type="checkbox"/>	<input type="checkbox"/>	<input type="checkbox"/>
70	<input type="checkbox"/>	<input type="checkbox"/>	<input type="checkbox"/>	<input type="checkbox"/>
71	<input type="checkbox"/>	<input type="checkbox"/>	<input type="checkbox"/>	<input type="checkbox"/>
72	<input type="checkbox"/>	<input type="checkbox"/>	<input type="checkbox"/>	<input type="checkbox"/>
73	<input type="checkbox"/>	<input type="checkbox"/>	<input type="checkbox"/>	<input type="checkbox"/>
74	<input type="checkbox"/>	<input checked="" type="checkbox"/>	<input type="checkbox"/>	<input type="checkbox"/>
75	<input type="checkbox"/>	<input type="checkbox"/>	<input type="checkbox"/>	<input type="checkbox"/>

PRINT OR TYPE

CONSTRUCTION MECHANIC 1 & C  
NAVEDTRA 10645-F

NAME \_\_\_\_\_ ADDRESS \_\_\_\_\_  
Last First Middle Street/Ship/Unit/Division, etc.

City or PPO State Zip

RANK/RATE \_\_\_\_\_ SOC. SEC. NO. \_\_\_\_\_ DESIGNATOR \_\_\_\_\_ ASSIGNMENT NO. \_\_\_\_\_

USN  USNR  ACTIVE  INACTIVE OTHER (Specify) \_\_\_\_\_ DATE MAILED \_\_\_\_\_

SCORE

	1	2	3	4	
	T	F			
1	<input type="checkbox"/>	<input type="checkbox"/>	<input type="checkbox"/>	<input type="checkbox"/>	-----
2	<input type="checkbox"/>	<input type="checkbox"/>	<input type="checkbox"/>	<input type="checkbox"/>	-----
3	<input type="checkbox"/>	<input type="checkbox"/>	<input type="checkbox"/>	<input type="checkbox"/>	-----
4	<input type="checkbox"/>	<input type="checkbox"/>	<input type="checkbox"/>	<input type="checkbox"/>	-----
5	<input type="checkbox"/>	<input type="checkbox"/>	<input type="checkbox"/>	<input type="checkbox"/>	-----
6	<input type="checkbox"/>	<input type="checkbox"/>	<input type="checkbox"/>	<input type="checkbox"/>	-----
7	<input type="checkbox"/>	<input type="checkbox"/>	<input type="checkbox"/>	<input type="checkbox"/>	-----
8	<input type="checkbox"/>	<input type="checkbox"/>	<input type="checkbox"/>	<input type="checkbox"/>	-----
9	<input type="checkbox"/>	<input type="checkbox"/>	<input type="checkbox"/>	<input type="checkbox"/>	-----
10	<input type="checkbox"/>	<input type="checkbox"/>	<input type="checkbox"/>	<input type="checkbox"/>	-----
11	<input type="checkbox"/>	<input type="checkbox"/>	<input type="checkbox"/>	<input type="checkbox"/>	-----
12	<input type="checkbox"/>	<input type="checkbox"/>	<input type="checkbox"/>	<input type="checkbox"/>	-----
13	<input type="checkbox"/>	<input type="checkbox"/>	<input type="checkbox"/>	<input type="checkbox"/>	-----
14	<input type="checkbox"/>	<input type="checkbox"/>	<input type="checkbox"/>	<input type="checkbox"/>	-----
15	<input type="checkbox"/>	<input type="checkbox"/>	<input type="checkbox"/>	<input type="checkbox"/>	-----
16	<input type="checkbox"/>	<input type="checkbox"/>	<input type="checkbox"/>	<input type="checkbox"/>	-----
17	<input type="checkbox"/>	<input type="checkbox"/>	<input type="checkbox"/>	<input type="checkbox"/>	-----
18	<input type="checkbox"/>	<input type="checkbox"/>	<input type="checkbox"/>	<input type="checkbox"/>	-----
19	<input type="checkbox"/>	<input type="checkbox"/>	<input type="checkbox"/>	<input type="checkbox"/>	-----
20	<input type="checkbox"/>	<input type="checkbox"/>	<input type="checkbox"/>	<input type="checkbox"/>	-----
21	<input type="checkbox"/>	<input type="checkbox"/>	<input type="checkbox"/>	<input type="checkbox"/>	-----
22	<input type="checkbox"/>	<input type="checkbox"/>	<input type="checkbox"/>	<input type="checkbox"/>	-----
23	<input type="checkbox"/>	<input type="checkbox"/>	<input type="checkbox"/>	<input type="checkbox"/>	-----
24	<input type="checkbox"/>	<input type="checkbox"/>	<input type="checkbox"/>	<input type="checkbox"/>	-----
25	<input type="checkbox"/>	<input type="checkbox"/>	<input type="checkbox"/>	<input type="checkbox"/>	-----

	1	2	3	4	
	T	F			
26	<input type="checkbox"/>	<input type="checkbox"/>	<input type="checkbox"/>	<input type="checkbox"/>	-----
27	<input type="checkbox"/>	<input type="checkbox"/>	<input type="checkbox"/>	<input type="checkbox"/>	-----
28	<input type="checkbox"/>	<input type="checkbox"/>	<input type="checkbox"/>	<input type="checkbox"/>	-----
29	<input type="checkbox"/>	<input type="checkbox"/>	<input type="checkbox"/>	<input type="checkbox"/>	-----
30	<input type="checkbox"/>	<input type="checkbox"/>	<input type="checkbox"/>	<input type="checkbox"/>	-----
31	<input type="checkbox"/>	<input type="checkbox"/>	<input type="checkbox"/>	<input type="checkbox"/>	-----
32	<input type="checkbox"/>	<input type="checkbox"/>	<input type="checkbox"/>	<input type="checkbox"/>	-----
33	<input type="checkbox"/>	<input type="checkbox"/>	<input type="checkbox"/>	<input type="checkbox"/>	-----
34	<input type="checkbox"/>	<input type="checkbox"/>	<input type="checkbox"/>	<input type="checkbox"/>	-----
35	<input type="checkbox"/>	<input type="checkbox"/>	<input type="checkbox"/>	<input type="checkbox"/>	-----
36	<input type="checkbox"/>	<input type="checkbox"/>	<input type="checkbox"/>	<input type="checkbox"/>	-----
37	<input type="checkbox"/>	<input type="checkbox"/>	<input type="checkbox"/>	<input type="checkbox"/>	-----
38	<input type="checkbox"/>	<input type="checkbox"/>	<input type="checkbox"/>	<input type="checkbox"/>	-----
39	<input type="checkbox"/>	<input type="checkbox"/>	<input type="checkbox"/>	<input type="checkbox"/>	-----
40	<input type="checkbox"/>	<input type="checkbox"/>	<input type="checkbox"/>	<input type="checkbox"/>	-----
41	<input type="checkbox"/>	<input type="checkbox"/>	<input type="checkbox"/>	<input type="checkbox"/>	-----
42	<input type="checkbox"/>	<input type="checkbox"/>	<input type="checkbox"/>	<input type="checkbox"/>	-----
43	<input type="checkbox"/>	<input type="checkbox"/>	<input type="checkbox"/>	<input type="checkbox"/>	-----
44	<input type="checkbox"/>	<input type="checkbox"/>	<input type="checkbox"/>	<input type="checkbox"/>	-----
45	<input type="checkbox"/>	<input type="checkbox"/>	<input type="checkbox"/>	<input type="checkbox"/>	-----
46	<input type="checkbox"/>	<input type="checkbox"/>	<input type="checkbox"/>	<input type="checkbox"/>	-----
47	<input type="checkbox"/>	<input type="checkbox"/>	<input type="checkbox"/>	<input type="checkbox"/>	-----
48	<input type="checkbox"/>	<input type="checkbox"/>	<input type="checkbox"/>	<input type="checkbox"/>	-----
49	<input type="checkbox"/>	<input type="checkbox"/>	<input type="checkbox"/>	<input type="checkbox"/>	-----
50	<input type="checkbox"/>	<input type="checkbox"/>	<input type="checkbox"/>	<input type="checkbox"/>	-----

	1	2	3	4	
	T	F			
51	<input type="checkbox"/>	<input type="checkbox"/>	<input type="checkbox"/>	<input type="checkbox"/>	-----
52	<input type="checkbox"/>	<input type="checkbox"/>	<input type="checkbox"/>	<input type="checkbox"/>	-----
53	<input type="checkbox"/>	<input type="checkbox"/>	<input type="checkbox"/>	<input type="checkbox"/>	-----
54	<input type="checkbox"/>	<input type="checkbox"/>	<input type="checkbox"/>	<input type="checkbox"/>	-----
55	<input type="checkbox"/>	<input type="checkbox"/>	<input type="checkbox"/>	<input type="checkbox"/>	-----
56	<input type="checkbox"/>	<input type="checkbox"/>	<input type="checkbox"/>	<input type="checkbox"/>	-----
57	<input type="checkbox"/>	<input type="checkbox"/>	<input type="checkbox"/>	<input type="checkbox"/>	-----
58	<input type="checkbox"/>	<input type="checkbox"/>	<input type="checkbox"/>	<input type="checkbox"/>	-----
59	<input type="checkbox"/>	<input type="checkbox"/>	<input type="checkbox"/>	<input type="checkbox"/>	-----
60	<input type="checkbox"/>	<input type="checkbox"/>	<input type="checkbox"/>	<input type="checkbox"/>	-----
61	<input type="checkbox"/>	<input type="checkbox"/>	<input type="checkbox"/>	<input type="checkbox"/>	-----
62	<input type="checkbox"/>	<input type="checkbox"/>	<input type="checkbox"/>	<input type="checkbox"/>	-----
63	<input type="checkbox"/>	<input type="checkbox"/>	<input type="checkbox"/>	<input type="checkbox"/>	-----
64	<input type="checkbox"/>	<input type="checkbox"/>	<input type="checkbox"/>	<input type="checkbox"/>	-----
65	<input type="checkbox"/>	<input type="checkbox"/>	<input type="checkbox"/>	<input type="checkbox"/>	-----
66	<input type="checkbox"/>	<input type="checkbox"/>	<input type="checkbox"/>	<input type="checkbox"/>	-----
67	<input type="checkbox"/>	<input type="checkbox"/>	<input type="checkbox"/>	<input type="checkbox"/>	-----
68	<input type="checkbox"/>	<input type="checkbox"/>	<input type="checkbox"/>	<input type="checkbox"/>	-----
69	<input type="checkbox"/>	<input type="checkbox"/>	<input type="checkbox"/>	<input type="checkbox"/>	-----
70	<input type="checkbox"/>	<input type="checkbox"/>	<input type="checkbox"/>	<input type="checkbox"/>	-----
71	<input type="checkbox"/>	<input type="checkbox"/>	<input type="checkbox"/>	<input type="checkbox"/>	-----
72	<input type="checkbox"/>	<input type="checkbox"/>	<input type="checkbox"/>	<input type="checkbox"/>	-----
73	<input type="checkbox"/>	<input type="checkbox"/>	<input type="checkbox"/>	<input type="checkbox"/>	-----
74	<input type="checkbox"/>	<input type="checkbox"/>	<input type="checkbox"/>	<input type="checkbox"/>	-----
75	<input type="checkbox"/>	<input type="checkbox"/>	<input type="checkbox"/>	<input type="checkbox"/>	-----

**PRINT OR TYPE**

CONSTRUCTION MECHANIC 1 & C  
NAVEDTRA 10645-F

NAME \_\_\_\_\_ ADDRESS \_\_\_\_\_  
Last First Middle Street/Ship/Unit/Division, etc.

RANK/RATE \_\_\_\_\_ SOC SEC NO. \_\_\_\_\_ City of PPO State Zip  
DESIGNATOR \_\_\_\_\_ ASSIGNMENT NO. \_\_\_\_\_

USN  USNR  ACTIVE  INACTIVE OTHER (Specify) \_\_\_\_\_ DATE MAILED \_\_\_\_\_

SCORE

	1	2	3	4
	T	F		
1	<input type="checkbox"/>	<input type="checkbox"/>	<input type="checkbox"/>	<input type="checkbox"/>
2	<input type="checkbox"/>	<input type="checkbox"/>	<input type="checkbox"/>	<input type="checkbox"/>
3	<input type="checkbox"/>	<input type="checkbox"/>	<input type="checkbox"/>	<input type="checkbox"/>
4	<input type="checkbox"/>	<input type="checkbox"/>	<input type="checkbox"/>	<input type="checkbox"/>
5	<input type="checkbox"/>	<input type="checkbox"/>	<input type="checkbox"/>	<input type="checkbox"/>
6	<input type="checkbox"/>	<input type="checkbox"/>	<input type="checkbox"/>	<input type="checkbox"/>
7	<input type="checkbox"/>	<input type="checkbox"/>	<input type="checkbox"/>	<input type="checkbox"/>
8	<input type="checkbox"/>	<input type="checkbox"/>	<input type="checkbox"/>	<input type="checkbox"/>
9	<input type="checkbox"/>	<input type="checkbox"/>	<input type="checkbox"/>	<input type="checkbox"/>
10	<input type="checkbox"/>	<input type="checkbox"/>	<input type="checkbox"/>	<input type="checkbox"/>
11	<input type="checkbox"/>	<input type="checkbox"/>	<input type="checkbox"/>	<input type="checkbox"/>
12	<input type="checkbox"/>	<input type="checkbox"/>	<input type="checkbox"/>	<input type="checkbox"/>
13	<input type="checkbox"/>	<input type="checkbox"/>	<input type="checkbox"/>	<input type="checkbox"/>
14	<input type="checkbox"/>	<input type="checkbox"/>	<input type="checkbox"/>	<input type="checkbox"/>
15	<input type="checkbox"/>	<input type="checkbox"/>	<input type="checkbox"/>	<input type="checkbox"/>
16	<input type="checkbox"/>	<input type="checkbox"/>	<input type="checkbox"/>	<input type="checkbox"/>
17	<input type="checkbox"/>	<input type="checkbox"/>	<input type="checkbox"/>	<input type="checkbox"/>
18	<input type="checkbox"/>	<input type="checkbox"/>	<input type="checkbox"/>	<input type="checkbox"/>
19	<input type="checkbox"/>	<input type="checkbox"/>	<input type="checkbox"/>	<input type="checkbox"/>
20	<input type="checkbox"/>	<input type="checkbox"/>	<input type="checkbox"/>	<input type="checkbox"/>
21	<input type="checkbox"/>	<input type="checkbox"/>	<input type="checkbox"/>	<input type="checkbox"/>
22	<input type="checkbox"/>	<input type="checkbox"/>	<input type="checkbox"/>	<input type="checkbox"/>
23	<input type="checkbox"/>	<input type="checkbox"/>	<input type="checkbox"/>	<input type="checkbox"/>
24	<input type="checkbox"/>	<input type="checkbox"/>	<input type="checkbox"/>	<input type="checkbox"/>
25	<input type="checkbox"/>	<input type="checkbox"/>	<input type="checkbox"/>	<input type="checkbox"/>

	1	2	3	4
	T	F		
26	<input type="checkbox"/>	<input type="checkbox"/>	<input type="checkbox"/>	<input type="checkbox"/>
27	<input type="checkbox"/>	<input type="checkbox"/>	<input type="checkbox"/>	<input type="checkbox"/>
28	<input type="checkbox"/>	<input type="checkbox"/>	<input type="checkbox"/>	<input type="checkbox"/>
29	<input type="checkbox"/>	<input type="checkbox"/>	<input type="checkbox"/>	<input type="checkbox"/>
30	<input type="checkbox"/>	<input type="checkbox"/>	<input type="checkbox"/>	<input type="checkbox"/>
31	<input type="checkbox"/>	<input type="checkbox"/>	<input type="checkbox"/>	<input type="checkbox"/>
32	<input type="checkbox"/>	<input type="checkbox"/>	<input type="checkbox"/>	<input type="checkbox"/>
33	<input type="checkbox"/>	<input type="checkbox"/>	<input type="checkbox"/>	<input type="checkbox"/>
34	<input type="checkbox"/>	<input type="checkbox"/>	<input type="checkbox"/>	<input type="checkbox"/>
35	<input type="checkbox"/>	<input type="checkbox"/>	<input type="checkbox"/>	<input type="checkbox"/>
36	<input type="checkbox"/>	<input type="checkbox"/>	<input type="checkbox"/>	<input type="checkbox"/>
37	<input type="checkbox"/>	<input type="checkbox"/>	<input type="checkbox"/>	<input type="checkbox"/>
38	<input type="checkbox"/>	<input type="checkbox"/>	<input type="checkbox"/>	<input type="checkbox"/>
39	<input type="checkbox"/>	<input type="checkbox"/>	<input type="checkbox"/>	<input type="checkbox"/>
40	<input type="checkbox"/>	<input type="checkbox"/>	<input type="checkbox"/>	<input type="checkbox"/>
41	<input type="checkbox"/>	<input type="checkbox"/>	<input type="checkbox"/>	<input type="checkbox"/>
42	<input type="checkbox"/>	<input type="checkbox"/>	<input type="checkbox"/>	<input type="checkbox"/>
43	<input type="checkbox"/>	<input type="checkbox"/>	<input type="checkbox"/>	<input type="checkbox"/>
44	<input type="checkbox"/>	<input type="checkbox"/>	<input type="checkbox"/>	<input type="checkbox"/>
45	<input type="checkbox"/>	<input type="checkbox"/>	<input type="checkbox"/>	<input type="checkbox"/>
46	<input type="checkbox"/>	<input type="checkbox"/>	<input type="checkbox"/>	<input type="checkbox"/>
47	<input type="checkbox"/>	<input type="checkbox"/>	<input type="checkbox"/>	<input type="checkbox"/>
48	<input type="checkbox"/>	<input type="checkbox"/>	<input type="checkbox"/>	<input type="checkbox"/>
49	<input type="checkbox"/>	<input type="checkbox"/>	<input type="checkbox"/>	<input type="checkbox"/>
50	<input type="checkbox"/>	<input type="checkbox"/>	<input type="checkbox"/>	<input type="checkbox"/>

	1	2	3	4
	T	F		
51	<input type="checkbox"/>	<input type="checkbox"/>	<input type="checkbox"/>	<input type="checkbox"/>
52	<input type="checkbox"/>	<input type="checkbox"/>	<input type="checkbox"/>	<input type="checkbox"/>
53	<input type="checkbox"/>	<input type="checkbox"/>	<input type="checkbox"/>	<input type="checkbox"/>
54	<input type="checkbox"/>	<input type="checkbox"/>	<input type="checkbox"/>	<input type="checkbox"/>
55	<input type="checkbox"/>	<input type="checkbox"/>	<input type="checkbox"/>	<input type="checkbox"/>
56	<input type="checkbox"/>	<input type="checkbox"/>	<input type="checkbox"/>	<input type="checkbox"/>
57	<input type="checkbox"/>	<input type="checkbox"/>	<input type="checkbox"/>	<input type="checkbox"/>
58	<input type="checkbox"/>	<input type="checkbox"/>	<input type="checkbox"/>	<input type="checkbox"/>
59	<input type="checkbox"/>	<input type="checkbox"/>	<input type="checkbox"/>	<input type="checkbox"/>
60	<input type="checkbox"/>	<input type="checkbox"/>	<input type="checkbox"/>	<input type="checkbox"/>
61	<input type="checkbox"/>	<input type="checkbox"/>	<input type="checkbox"/>	<input type="checkbox"/>
62	<input type="checkbox"/>	<input type="checkbox"/>	<input type="checkbox"/>	<input type="checkbox"/>
63	<input type="checkbox"/>	<input type="checkbox"/>	<input type="checkbox"/>	<input type="checkbox"/>
64	<input type="checkbox"/>	<input type="checkbox"/>	<input type="checkbox"/>	<input type="checkbox"/>
65	<input type="checkbox"/>	<input type="checkbox"/>	<input type="checkbox"/>	<input type="checkbox"/>
66	<input type="checkbox"/>	<input type="checkbox"/>	<input type="checkbox"/>	<input type="checkbox"/>
67	<input type="checkbox"/>	<input type="checkbox"/>	<input type="checkbox"/>	<input type="checkbox"/>
68	<input type="checkbox"/>	<input type="checkbox"/>	<input type="checkbox"/>	<input type="checkbox"/>
69	<input type="checkbox"/>	<input type="checkbox"/>	<input type="checkbox"/>	<input type="checkbox"/>
70	<input type="checkbox"/>	<input type="checkbox"/>	<input type="checkbox"/>	<input type="checkbox"/>
71	<input type="checkbox"/>	<input type="checkbox"/>	<input type="checkbox"/>	<input type="checkbox"/>
72	<input type="checkbox"/>	<input type="checkbox"/>	<input type="checkbox"/>	<input type="checkbox"/>
73	<input type="checkbox"/>	<input type="checkbox"/>	<input type="checkbox"/>	<input type="checkbox"/>
74	<input type="checkbox"/>	<input type="checkbox"/>	<input type="checkbox"/>	<input type="checkbox"/>
75	<input type="checkbox"/>	<input type="checkbox"/>	<input type="checkbox"/>	<input type="checkbox"/>



**PRINT OR TYPE**

CONSTRUCTION MECHANIC 1 & C  
NAVEDTRA 10645-F

NAME \_\_\_\_\_ ADDRESS \_\_\_\_\_  
Last First Middle Street/Ship/Unit/Division, etc.

City or FPO State Zip

RANK/RATE \_\_\_\_\_ SOC. SEC. NO. \_\_\_\_\_ DESIGNATOR \_\_\_\_\_ ASSIGNMENT NO. \_\_\_\_\_

USN  USNR  ACTIVE  INACTIVE OTHER (Specify) \_\_\_\_\_ DATE MAILED \_\_\_\_\_

SCORE

	1	2	3	4
	T	F		
1	<input type="checkbox"/>	<input type="checkbox"/>	<input type="checkbox"/>	<input type="checkbox"/>
2	<input type="checkbox"/>	<input type="checkbox"/>	<input type="checkbox"/>	<input type="checkbox"/>
3	<input type="checkbox"/>	<input type="checkbox"/>	<input type="checkbox"/>	<input type="checkbox"/>
4	<input type="checkbox"/>	<input type="checkbox"/>	<input type="checkbox"/>	<input type="checkbox"/>
5	<input type="checkbox"/>	<input type="checkbox"/>	<input type="checkbox"/>	<input type="checkbox"/>
6	<input type="checkbox"/>	<input type="checkbox"/>	<input type="checkbox"/>	<input type="checkbox"/>
7	<input type="checkbox"/>	<input type="checkbox"/>	<input type="checkbox"/>	<input type="checkbox"/>
8	<input type="checkbox"/>	<input type="checkbox"/>	<input type="checkbox"/>	<input type="checkbox"/>
9	<input type="checkbox"/>	<input type="checkbox"/>	<input type="checkbox"/>	<input type="checkbox"/>
10	<input type="checkbox"/>	<input type="checkbox"/>	<input type="checkbox"/>	<input type="checkbox"/>
11	<input type="checkbox"/>	<input type="checkbox"/>	<input type="checkbox"/>	<input type="checkbox"/>
12	<input type="checkbox"/>	<input type="checkbox"/>	<input type="checkbox"/>	<input type="checkbox"/>
13	<input type="checkbox"/>	<input type="checkbox"/>	<input type="checkbox"/>	<input type="checkbox"/>
14	<input type="checkbox"/>	<input type="checkbox"/>	<input type="checkbox"/>	<input type="checkbox"/>
15	<input type="checkbox"/>	<input type="checkbox"/>	<input type="checkbox"/>	<input type="checkbox"/>
16	<input type="checkbox"/>	<input type="checkbox"/>	<input type="checkbox"/>	<input type="checkbox"/>
17	<input type="checkbox"/>	<input type="checkbox"/>	<input type="checkbox"/>	<input type="checkbox"/>
18	<input type="checkbox"/>	<input type="checkbox"/>	<input type="checkbox"/>	<input type="checkbox"/>
19	<input type="checkbox"/>	<input type="checkbox"/>	<input type="checkbox"/>	<input type="checkbox"/>
20	<input type="checkbox"/>	<input type="checkbox"/>	<input type="checkbox"/>	<input type="checkbox"/>
21	<input type="checkbox"/>	<input type="checkbox"/>	<input type="checkbox"/>	<input type="checkbox"/>
22	<input type="checkbox"/>	<input type="checkbox"/>	<input type="checkbox"/>	<input type="checkbox"/>
23	<input type="checkbox"/>	<input type="checkbox"/>	<input type="checkbox"/>	<input type="checkbox"/>
24	<input type="checkbox"/>	<input type="checkbox"/>	<input type="checkbox"/>	<input type="checkbox"/>
25	<input type="checkbox"/>	<input type="checkbox"/>	<input type="checkbox"/>	<input type="checkbox"/>

	1	2	3	4
	T	F		
26	<input type="checkbox"/>	<input type="checkbox"/>	<input type="checkbox"/>	<input type="checkbox"/>
27	<input type="checkbox"/>	<input type="checkbox"/>	<input type="checkbox"/>	<input type="checkbox"/>
28	<input type="checkbox"/>	<input type="checkbox"/>	<input type="checkbox"/>	<input type="checkbox"/>
29	<input type="checkbox"/>	<input type="checkbox"/>	<input type="checkbox"/>	<input type="checkbox"/>
30	<input type="checkbox"/>	<input type="checkbox"/>	<input type="checkbox"/>	<input type="checkbox"/>
31	<input type="checkbox"/>	<input type="checkbox"/>	<input type="checkbox"/>	<input type="checkbox"/>
32	<input type="checkbox"/>	<input type="checkbox"/>	<input type="checkbox"/>	<input type="checkbox"/>
33	<input type="checkbox"/>	<input type="checkbox"/>	<input type="checkbox"/>	<input type="checkbox"/>
34	<input type="checkbox"/>	<input type="checkbox"/>	<input type="checkbox"/>	<input type="checkbox"/>
35	<input type="checkbox"/>	<input type="checkbox"/>	<input type="checkbox"/>	<input type="checkbox"/>
36	<input type="checkbox"/>	<input type="checkbox"/>	<input type="checkbox"/>	<input type="checkbox"/>
37	<input type="checkbox"/>	<input type="checkbox"/>	<input type="checkbox"/>	<input type="checkbox"/>
38	<input type="checkbox"/>	<input type="checkbox"/>	<input type="checkbox"/>	<input type="checkbox"/>
39	<input type="checkbox"/>	<input type="checkbox"/>	<input type="checkbox"/>	<input type="checkbox"/>
40	<input type="checkbox"/>	<input type="checkbox"/>	<input type="checkbox"/>	<input type="checkbox"/>
41	<input type="checkbox"/>	<input type="checkbox"/>	<input type="checkbox"/>	<input type="checkbox"/>
42	<input type="checkbox"/>	<input type="checkbox"/>	<input type="checkbox"/>	<input type="checkbox"/>
43	<input type="checkbox"/>	<input type="checkbox"/>	<input type="checkbox"/>	<input type="checkbox"/>
44	<input type="checkbox"/>	<input type="checkbox"/>	<input type="checkbox"/>	<input type="checkbox"/>
45	<input type="checkbox"/>	<input type="checkbox"/>	<input type="checkbox"/>	<input type="checkbox"/>
46	<input type="checkbox"/>	<input type="checkbox"/>	<input type="checkbox"/>	<input type="checkbox"/>
47	<input type="checkbox"/>	<input type="checkbox"/>	<input type="checkbox"/>	<input type="checkbox"/>
48	<input type="checkbox"/>	<input type="checkbox"/>	<input type="checkbox"/>	<input type="checkbox"/>
49	<input type="checkbox"/>	<input type="checkbox"/>	<input type="checkbox"/>	<input type="checkbox"/>
50	<input type="checkbox"/>	<input type="checkbox"/>	<input type="checkbox"/>	<input type="checkbox"/>

	1	2	3	4
	T	F		
51	<input type="checkbox"/>	<input type="checkbox"/>	<input type="checkbox"/>	<input type="checkbox"/>
52	<input type="checkbox"/>	<input type="checkbox"/>	<input type="checkbox"/>	<input type="checkbox"/>
53	<input type="checkbox"/>	<input type="checkbox"/>	<input type="checkbox"/>	<input type="checkbox"/>
54	<input type="checkbox"/>	<input type="checkbox"/>	<input type="checkbox"/>	<input type="checkbox"/>
55	<input type="checkbox"/>	<input type="checkbox"/>	<input type="checkbox"/>	<input type="checkbox"/>
56	<input type="checkbox"/>	<input type="checkbox"/>	<input type="checkbox"/>	<input type="checkbox"/>
57	<input type="checkbox"/>	<input type="checkbox"/>	<input type="checkbox"/>	<input type="checkbox"/>
58	<input type="checkbox"/>	<input type="checkbox"/>	<input type="checkbox"/>	<input type="checkbox"/>
59	<input type="checkbox"/>	<input type="checkbox"/>	<input type="checkbox"/>	<input type="checkbox"/>
60	<input type="checkbox"/>	<input type="checkbox"/>	<input type="checkbox"/>	<input type="checkbox"/>
61	<input type="checkbox"/>	<input type="checkbox"/>	<input type="checkbox"/>	<input type="checkbox"/>
62	<input type="checkbox"/>	<input type="checkbox"/>	<input type="checkbox"/>	<input type="checkbox"/>
63	<input type="checkbox"/>	<input type="checkbox"/>	<input type="checkbox"/>	<input type="checkbox"/>
64	<input type="checkbox"/>	<input type="checkbox"/>	<input type="checkbox"/>	<input type="checkbox"/>
65	<input type="checkbox"/>	<input type="checkbox"/>	<input type="checkbox"/>	<input type="checkbox"/>
66	<input type="checkbox"/>	<input type="checkbox"/>	<input type="checkbox"/>	<input type="checkbox"/>
67	<input type="checkbox"/>	<input type="checkbox"/>	<input type="checkbox"/>	<input type="checkbox"/>
68	<input type="checkbox"/>	<input type="checkbox"/>	<input type="checkbox"/>	<input type="checkbox"/>
69	<input type="checkbox"/>	<input type="checkbox"/>	<input type="checkbox"/>	<input type="checkbox"/>
70	<input type="checkbox"/>	<input type="checkbox"/>	<input type="checkbox"/>	<input type="checkbox"/>
71	<input type="checkbox"/>	<input type="checkbox"/>	<input type="checkbox"/>	<input type="checkbox"/>
72	<input type="checkbox"/>	<input type="checkbox"/>	<input type="checkbox"/>	<input type="checkbox"/>
73	<input type="checkbox"/>	<input type="checkbox"/>	<input type="checkbox"/>	<input type="checkbox"/>
74	<input type="checkbox"/>	<input type="checkbox"/>	<input type="checkbox"/>	<input type="checkbox"/>
75	<input type="checkbox"/>	<input type="checkbox"/>	<input type="checkbox"/>	<input type="checkbox"/>

**PRINT OR TYPE**

CONSTRUCTION MECHANIC 1 & C  
NAVEDTRA 10645-F

NAME \_\_\_\_\_ ADDRESS \_\_\_\_\_  
Last First Middle Street/Ship/Unit/Division, etc.

RANK/RATE \_\_\_\_\_ SOC. SEC. NO. \_\_\_\_\_ DESIGNATOR \_\_\_\_\_ ASSIGNMENT NO. \_\_\_\_\_  
City or PPO State Zip

USN  USNR  ACTIVE  INACTIVE OTHER (Specify) \_\_\_\_\_ DATE MAILED \_\_\_\_\_

SCORE

	1	2	3	4
1	<input type="checkbox"/>	<input type="checkbox"/>	<input type="checkbox"/>	<input type="checkbox"/>
2	<input type="checkbox"/>	<input type="checkbox"/>	<input type="checkbox"/>	<input type="checkbox"/>
3	<input type="checkbox"/>	<input type="checkbox"/>	<input type="checkbox"/>	<input type="checkbox"/>
4	<input type="checkbox"/>	<input type="checkbox"/>	<input type="checkbox"/>	<input type="checkbox"/>
5	<input type="checkbox"/>	<input type="checkbox"/>	<input type="checkbox"/>	<input type="checkbox"/>
6	<input type="checkbox"/>	<input type="checkbox"/>	<input type="checkbox"/>	<input type="checkbox"/>
7	<input type="checkbox"/>	<input type="checkbox"/>	<input type="checkbox"/>	<input type="checkbox"/>
8	<input type="checkbox"/>	<input type="checkbox"/>	<input type="checkbox"/>	<input type="checkbox"/>
9	<input type="checkbox"/>	<input type="checkbox"/>	<input type="checkbox"/>	<input type="checkbox"/>
10	<input type="checkbox"/>	<input type="checkbox"/>	<input type="checkbox"/>	<input type="checkbox"/>
11	<input type="checkbox"/>	<input type="checkbox"/>	<input type="checkbox"/>	<input type="checkbox"/>
12	<input type="checkbox"/>	<input type="checkbox"/>	<input type="checkbox"/>	<input type="checkbox"/>
13	<input type="checkbox"/>	<input type="checkbox"/>	<input type="checkbox"/>	<input type="checkbox"/>
14	<input type="checkbox"/>	<input type="checkbox"/>	<input type="checkbox"/>	<input type="checkbox"/>
15	<input type="checkbox"/>	<input type="checkbox"/>	<input type="checkbox"/>	<input type="checkbox"/>
16	<input type="checkbox"/>	<input type="checkbox"/>	<input type="checkbox"/>	<input type="checkbox"/>
17	<input type="checkbox"/>	<input type="checkbox"/>	<input type="checkbox"/>	<input type="checkbox"/>
18	<input type="checkbox"/>	<input type="checkbox"/>	<input type="checkbox"/>	<input type="checkbox"/>
19	<input type="checkbox"/>	<input type="checkbox"/>	<input type="checkbox"/>	<input type="checkbox"/>
20	<input type="checkbox"/>	<input type="checkbox"/>	<input type="checkbox"/>	<input type="checkbox"/>
21	<input type="checkbox"/>	<input type="checkbox"/>	<input type="checkbox"/>	<input type="checkbox"/>
22	<input type="checkbox"/>	<input type="checkbox"/>	<input type="checkbox"/>	<input type="checkbox"/>
23	<input type="checkbox"/>	<input type="checkbox"/>	<input type="checkbox"/>	<input type="checkbox"/>
24	<input type="checkbox"/>	<input type="checkbox"/>	<input type="checkbox"/>	<input type="checkbox"/>
25	<input type="checkbox"/>	<input type="checkbox"/>	<input type="checkbox"/>	<input type="checkbox"/>

	1	2	3	4
26	<input type="checkbox"/>	<input type="checkbox"/>	<input type="checkbox"/>	<input type="checkbox"/>
27	<input type="checkbox"/>	<input type="checkbox"/>	<input type="checkbox"/>	<input type="checkbox"/>
28	<input type="checkbox"/>	<input type="checkbox"/>	<input type="checkbox"/>	<input type="checkbox"/>
29	<input type="checkbox"/>	<input type="checkbox"/>	<input type="checkbox"/>	<input type="checkbox"/>
30	<input type="checkbox"/>	<input type="checkbox"/>	<input type="checkbox"/>	<input type="checkbox"/>
31	<input type="checkbox"/>	<input type="checkbox"/>	<input type="checkbox"/>	<input type="checkbox"/>
32	<input type="checkbox"/>	<input type="checkbox"/>	<input type="checkbox"/>	<input type="checkbox"/>
33	<input type="checkbox"/>	<input type="checkbox"/>	<input type="checkbox"/>	<input type="checkbox"/>
34	<input type="checkbox"/>	<input type="checkbox"/>	<input type="checkbox"/>	<input type="checkbox"/>
35	<input type="checkbox"/>	<input type="checkbox"/>	<input type="checkbox"/>	<input type="checkbox"/>
36	<input type="checkbox"/>	<input type="checkbox"/>	<input type="checkbox"/>	<input type="checkbox"/>
37	<input type="checkbox"/>	<input type="checkbox"/>	<input type="checkbox"/>	<input type="checkbox"/>
38	<input type="checkbox"/>	<input type="checkbox"/>	<input type="checkbox"/>	<input type="checkbox"/>
39	<input type="checkbox"/>	<input type="checkbox"/>	<input type="checkbox"/>	<input type="checkbox"/>
40	<input type="checkbox"/>	<input type="checkbox"/>	<input type="checkbox"/>	<input type="checkbox"/>
41	<input type="checkbox"/>	<input type="checkbox"/>	<input type="checkbox"/>	<input type="checkbox"/>
42	<input type="checkbox"/>	<input type="checkbox"/>	<input type="checkbox"/>	<input type="checkbox"/>
43	<input type="checkbox"/>	<input type="checkbox"/>	<input type="checkbox"/>	<input type="checkbox"/>
44	<input type="checkbox"/>	<input type="checkbox"/>	<input type="checkbox"/>	<input type="checkbox"/>
45	<input type="checkbox"/>	<input type="checkbox"/>	<input type="checkbox"/>	<input type="checkbox"/>
46	<input type="checkbox"/>	<input type="checkbox"/>	<input type="checkbox"/>	<input type="checkbox"/>
47	<input type="checkbox"/>	<input type="checkbox"/>	<input type="checkbox"/>	<input type="checkbox"/>
48	<input type="checkbox"/>	<input type="checkbox"/>	<input type="checkbox"/>	<input type="checkbox"/>
49	<input type="checkbox"/>	<input type="checkbox"/>	<input type="checkbox"/>	<input type="checkbox"/>
50	<input type="checkbox"/>	<input type="checkbox"/>	<input type="checkbox"/>	<input type="checkbox"/>

	1	2	3	4
51	<input type="checkbox"/>	<input type="checkbox"/>	<input type="checkbox"/>	<input type="checkbox"/>
52	<input type="checkbox"/>	<input type="checkbox"/>	<input type="checkbox"/>	<input type="checkbox"/>
53	<input type="checkbox"/>	<input type="checkbox"/>	<input type="checkbox"/>	<input type="checkbox"/>
54	<input type="checkbox"/>	<input type="checkbox"/>	<input type="checkbox"/>	<input type="checkbox"/>
55	<input type="checkbox"/>	<input type="checkbox"/>	<input type="checkbox"/>	<input type="checkbox"/>
56	<input type="checkbox"/>	<input type="checkbox"/>	<input type="checkbox"/>	<input type="checkbox"/>
57	<input type="checkbox"/>	<input type="checkbox"/>	<input type="checkbox"/>	<input type="checkbox"/>
58	<input type="checkbox"/>	<input type="checkbox"/>	<input type="checkbox"/>	<input type="checkbox"/>
59	<input type="checkbox"/>	<input type="checkbox"/>	<input type="checkbox"/>	<input type="checkbox"/>
60	<input type="checkbox"/>	<input type="checkbox"/>	<input type="checkbox"/>	<input type="checkbox"/>
61	<input type="checkbox"/>	<input type="checkbox"/>	<input type="checkbox"/>	<input type="checkbox"/>
62	<input type="checkbox"/>	<input type="checkbox"/>	<input type="checkbox"/>	<input type="checkbox"/>
63	<input type="checkbox"/>	<input type="checkbox"/>	<input type="checkbox"/>	<input type="checkbox"/>
64	<input type="checkbox"/>	<input type="checkbox"/>	<input type="checkbox"/>	<input type="checkbox"/>
65	<input type="checkbox"/>	<input type="checkbox"/>	<input type="checkbox"/>	<input type="checkbox"/>
66	<input type="checkbox"/>	<input type="checkbox"/>	<input type="checkbox"/>	<input type="checkbox"/>
67	<input type="checkbox"/>	<input type="checkbox"/>	<input type="checkbox"/>	<input type="checkbox"/>
68	<input type="checkbox"/>	<input type="checkbox"/>	<input type="checkbox"/>	<input type="checkbox"/>
69	<input type="checkbox"/>	<input type="checkbox"/>	<input type="checkbox"/>	<input type="checkbox"/>
70	<input type="checkbox"/>	<input type="checkbox"/>	<input type="checkbox"/>	<input type="checkbox"/>
71	<input type="checkbox"/>	<input type="checkbox"/>	<input type="checkbox"/>	<input type="checkbox"/>
72	<input type="checkbox"/>	<input type="checkbox"/>	<input type="checkbox"/>	<input type="checkbox"/>
73	<input type="checkbox"/>	<input type="checkbox"/>	<input type="checkbox"/>	<input type="checkbox"/>
74	<input type="checkbox"/>	<input type="checkbox"/>	<input type="checkbox"/>	<input type="checkbox"/>
75	<input type="checkbox"/>	<input type="checkbox"/>	<input type="checkbox"/>	<input type="checkbox"/>

355



**PRINT OR TYPE**

CONSTRUCTION MECHANIC 1 & C  
NAVEDTRA 10645-F

NAME \_\_\_\_\_ ADDRESS \_\_\_\_\_  
Last First Middle Street/Ship/Unit/Division, etc.

RANK/RATE \_\_\_\_\_ SOC. SEC. NO. \_\_\_\_\_ City or PPO State Zip  
DESIGNATOR \_\_\_\_\_ ASSIGNMENT NO. \_\_\_\_\_

USN  USNR  ACTIVE  INACTIVE OTHER (Specify) \_\_\_\_\_ DATE MAILED \_\_\_\_\_

SCORE

	1	2	3	4
	T	F		
1	<input type="checkbox"/>	<input type="checkbox"/>	<input type="checkbox"/>	<input type="checkbox"/>
2	<input type="checkbox"/>	<input type="checkbox"/>	<input type="checkbox"/>	<input type="checkbox"/>
3	<input type="checkbox"/>	<input type="checkbox"/>	<input type="checkbox"/>	<input type="checkbox"/>
4	<input type="checkbox"/>	<input type="checkbox"/>	<input type="checkbox"/>	<input type="checkbox"/>
5	<input type="checkbox"/>	<input type="checkbox"/>	<input type="checkbox"/>	<input type="checkbox"/>
6	<input type="checkbox"/>	<input type="checkbox"/>	<input type="checkbox"/>	<input type="checkbox"/>
7	<input type="checkbox"/>	<input type="checkbox"/>	<input type="checkbox"/>	<input type="checkbox"/>
8	<input type="checkbox"/>	<input type="checkbox"/>	<input type="checkbox"/>	<input type="checkbox"/>
9	<input type="checkbox"/>	<input type="checkbox"/>	<input type="checkbox"/>	<input type="checkbox"/>
10	<input type="checkbox"/>	<input type="checkbox"/>	<input type="checkbox"/>	<input type="checkbox"/>
11	<input type="checkbox"/>	<input type="checkbox"/>	<input type="checkbox"/>	<input type="checkbox"/>
12	<input type="checkbox"/>	<input type="checkbox"/>	<input type="checkbox"/>	<input type="checkbox"/>
13	<input type="checkbox"/>	<input type="checkbox"/>	<input type="checkbox"/>	<input type="checkbox"/>
14	<input type="checkbox"/>	<input type="checkbox"/>	<input type="checkbox"/>	<input type="checkbox"/>
15	<input type="checkbox"/>	<input type="checkbox"/>	<input type="checkbox"/>	<input type="checkbox"/>
16	<input type="checkbox"/>	<input type="checkbox"/>	<input type="checkbox"/>	<input type="checkbox"/>
17	<input type="checkbox"/>	<input type="checkbox"/>	<input type="checkbox"/>	<input type="checkbox"/>
18	<input type="checkbox"/>	<input type="checkbox"/>	<input type="checkbox"/>	<input type="checkbox"/>
19	<input type="checkbox"/>	<input type="checkbox"/>	<input type="checkbox"/>	<input type="checkbox"/>
20	<input type="checkbox"/>	<input type="checkbox"/>	<input type="checkbox"/>	<input type="checkbox"/>
21	<input type="checkbox"/>	<input type="checkbox"/>	<input type="checkbox"/>	<input type="checkbox"/>
22	<input type="checkbox"/>	<input type="checkbox"/>	<input type="checkbox"/>	<input type="checkbox"/>
23	<input type="checkbox"/>	<input type="checkbox"/>	<input type="checkbox"/>	<input type="checkbox"/>
24	<input type="checkbox"/>	<input type="checkbox"/>	<input type="checkbox"/>	<input type="checkbox"/>
25	<input type="checkbox"/>	<input type="checkbox"/>	<input type="checkbox"/>	<input type="checkbox"/>

	1	2	3	4
	T	F		
26	<input type="checkbox"/>	<input type="checkbox"/>	<input type="checkbox"/>	<input type="checkbox"/>
27	<input type="checkbox"/>	<input type="checkbox"/>	<input type="checkbox"/>	<input type="checkbox"/>
28	<input type="checkbox"/>	<input type="checkbox"/>	<input type="checkbox"/>	<input type="checkbox"/>
29	<input type="checkbox"/>	<input type="checkbox"/>	<input type="checkbox"/>	<input type="checkbox"/>
30	<input type="checkbox"/>	<input type="checkbox"/>	<input type="checkbox"/>	<input type="checkbox"/>
31	<input type="checkbox"/>	<input type="checkbox"/>	<input type="checkbox"/>	<input type="checkbox"/>
32	<input type="checkbox"/>	<input type="checkbox"/>	<input type="checkbox"/>	<input type="checkbox"/>
33	<input type="checkbox"/>	<input type="checkbox"/>	<input type="checkbox"/>	<input type="checkbox"/>
34	<input type="checkbox"/>	<input type="checkbox"/>	<input type="checkbox"/>	<input type="checkbox"/>
35	<input type="checkbox"/>	<input type="checkbox"/>	<input type="checkbox"/>	<input type="checkbox"/>
36	<input type="checkbox"/>	<input type="checkbox"/>	<input type="checkbox"/>	<input type="checkbox"/>
37	<input type="checkbox"/>	<input type="checkbox"/>	<input type="checkbox"/>	<input type="checkbox"/>
38	<input type="checkbox"/>	<input type="checkbox"/>	<input type="checkbox"/>	<input type="checkbox"/>
39	<input type="checkbox"/>	<input type="checkbox"/>	<input type="checkbox"/>	<input type="checkbox"/>
40	<input type="checkbox"/>	<input type="checkbox"/>	<input type="checkbox"/>	<input type="checkbox"/>
41	<input type="checkbox"/>	<input type="checkbox"/>	<input type="checkbox"/>	<input type="checkbox"/>
42	<input type="checkbox"/>	<input type="checkbox"/>	<input type="checkbox"/>	<input type="checkbox"/>
43	<input type="checkbox"/>	<input type="checkbox"/>	<input type="checkbox"/>	<input type="checkbox"/>
44	<input type="checkbox"/>	<input type="checkbox"/>	<input type="checkbox"/>	<input type="checkbox"/>
45	<input type="checkbox"/>	<input type="checkbox"/>	<input type="checkbox"/>	<input type="checkbox"/>
46	<input type="checkbox"/>	<input type="checkbox"/>	<input type="checkbox"/>	<input type="checkbox"/>
47	<input type="checkbox"/>	<input type="checkbox"/>	<input type="checkbox"/>	<input type="checkbox"/>
48	<input type="checkbox"/>	<input type="checkbox"/>	<input type="checkbox"/>	<input type="checkbox"/>
49	<input type="checkbox"/>	<input type="checkbox"/>	<input type="checkbox"/>	<input type="checkbox"/>
50	<input type="checkbox"/>	<input type="checkbox"/>	<input type="checkbox"/>	<input type="checkbox"/>

	1	2	3	4
	T	F		
51	<input type="checkbox"/>	<input type="checkbox"/>	<input type="checkbox"/>	<input type="checkbox"/>
52	<input type="checkbox"/>	<input type="checkbox"/>	<input type="checkbox"/>	<input type="checkbox"/>
53	<input type="checkbox"/>	<input type="checkbox"/>	<input type="checkbox"/>	<input type="checkbox"/>
54	<input type="checkbox"/>	<input type="checkbox"/>	<input type="checkbox"/>	<input type="checkbox"/>
55	<input type="checkbox"/>	<input type="checkbox"/>	<input type="checkbox"/>	<input type="checkbox"/>
56	<input type="checkbox"/>	<input type="checkbox"/>	<input type="checkbox"/>	<input type="checkbox"/>
57	<input type="checkbox"/>	<input type="checkbox"/>	<input type="checkbox"/>	<input type="checkbox"/>
58	<input type="checkbox"/>	<input type="checkbox"/>	<input type="checkbox"/>	<input type="checkbox"/>
59	<input type="checkbox"/>	<input type="checkbox"/>	<input type="checkbox"/>	<input type="checkbox"/>
60	<input type="checkbox"/>	<input type="checkbox"/>	<input type="checkbox"/>	<input type="checkbox"/>
61	<input type="checkbox"/>	<input type="checkbox"/>	<input type="checkbox"/>	<input type="checkbox"/>
62	<input type="checkbox"/>	<input type="checkbox"/>	<input type="checkbox"/>	<input type="checkbox"/>
63	<input type="checkbox"/>	<input type="checkbox"/>	<input type="checkbox"/>	<input type="checkbox"/>
64	<input type="checkbox"/>	<input type="checkbox"/>	<input type="checkbox"/>	<input type="checkbox"/>
65	<input type="checkbox"/>	<input type="checkbox"/>	<input type="checkbox"/>	<input type="checkbox"/>
66	<input type="checkbox"/>	<input type="checkbox"/>	<input type="checkbox"/>	<input type="checkbox"/>
67	<input type="checkbox"/>	<input type="checkbox"/>	<input type="checkbox"/>	<input type="checkbox"/>
68	<input type="checkbox"/>	<input type="checkbox"/>	<input type="checkbox"/>	<input type="checkbox"/>
69	<input type="checkbox"/>	<input type="checkbox"/>	<input type="checkbox"/>	<input type="checkbox"/>
70	<input type="checkbox"/>	<input type="checkbox"/>	<input type="checkbox"/>	<input type="checkbox"/>
71	<input type="checkbox"/>	<input type="checkbox"/>	<input type="checkbox"/>	<input type="checkbox"/>
72	<input type="checkbox"/>	<input type="checkbox"/>	<input type="checkbox"/>	<input type="checkbox"/>
73	<input type="checkbox"/>	<input type="checkbox"/>	<input type="checkbox"/>	<input type="checkbox"/>
74	<input type="checkbox"/>	<input type="checkbox"/>	<input type="checkbox"/>	<input type="checkbox"/>
75	<input type="checkbox"/>	<input type="checkbox"/>	<input type="checkbox"/>	<input type="checkbox"/>

**PRINT OR TYPE**

CONSTRUCTION MECHANIC 1 & C  
NAVEDTRA 10645-F

NAME \_\_\_\_\_ ADDRESS \_\_\_\_\_  
Last First Middle Street/Ship/Unit/Division, etc.

RANK/RATE \_\_\_\_\_ SOC. SEC. NO. \_\_\_\_\_ DESIGNATOR \_\_\_\_\_ CITY or PPO \_\_\_\_\_ STATE \_\_\_\_\_ ZIP \_\_\_\_\_  
ASSIGNMENT NO. \_\_\_\_\_

USN  USNR  ACTIVE  INACTIVE OTHER (Specify) \_\_\_\_\_ DATE MAILED \_\_\_\_\_

SCORE

	1	2	3	4
	T	F		
1	<input type="checkbox"/>	<input type="checkbox"/>	<input type="checkbox"/>	<input type="checkbox"/>
2	<input type="checkbox"/>	<input type="checkbox"/>	<input type="checkbox"/>	<input type="checkbox"/>
3	<input type="checkbox"/>	<input type="checkbox"/>	<input type="checkbox"/>	<input type="checkbox"/>
4	<input type="checkbox"/>	<input type="checkbox"/>	<input type="checkbox"/>	<input type="checkbox"/>
5	<input type="checkbox"/>	<input type="checkbox"/>	<input type="checkbox"/>	<input type="checkbox"/>
6	<input type="checkbox"/>	<input type="checkbox"/>	<input type="checkbox"/>	<input type="checkbox"/>
7	<input type="checkbox"/>	<input type="checkbox"/>	<input type="checkbox"/>	<input type="checkbox"/>
8	<input type="checkbox"/>	<input type="checkbox"/>	<input type="checkbox"/>	<input type="checkbox"/>
9	<input type="checkbox"/>	<input type="checkbox"/>	<input type="checkbox"/>	<input type="checkbox"/>
10	<input type="checkbox"/>	<input type="checkbox"/>	<input type="checkbox"/>	<input type="checkbox"/>
11	<input type="checkbox"/>	<input type="checkbox"/>	<input type="checkbox"/>	<input type="checkbox"/>
12	<input type="checkbox"/>	<input type="checkbox"/>	<input type="checkbox"/>	<input type="checkbox"/>
13	<input type="checkbox"/>	<input type="checkbox"/>	<input type="checkbox"/>	<input type="checkbox"/>
14	<input type="checkbox"/>	<input type="checkbox"/>	<input type="checkbox"/>	<input type="checkbox"/>
15	<input type="checkbox"/>	<input type="checkbox"/>	<input type="checkbox"/>	<input type="checkbox"/>
16	<input type="checkbox"/>	<input type="checkbox"/>	<input type="checkbox"/>	<input type="checkbox"/>
17	<input type="checkbox"/>	<input type="checkbox"/>	<input type="checkbox"/>	<input type="checkbox"/>
18	<input type="checkbox"/>	<input type="checkbox"/>	<input type="checkbox"/>	<input type="checkbox"/>
19	<input type="checkbox"/>	<input type="checkbox"/>	<input type="checkbox"/>	<input type="checkbox"/>
20	<input type="checkbox"/>	<input type="checkbox"/>	<input type="checkbox"/>	<input type="checkbox"/>
21	<input type="checkbox"/>	<input type="checkbox"/>	<input type="checkbox"/>	<input type="checkbox"/>
22	<input type="checkbox"/>	<input type="checkbox"/>	<input type="checkbox"/>	<input type="checkbox"/>
23	<input type="checkbox"/>	<input type="checkbox"/>	<input type="checkbox"/>	<input type="checkbox"/>
24	<input type="checkbox"/>	<input type="checkbox"/>	<input type="checkbox"/>	<input type="checkbox"/>
25	<input type="checkbox"/>	<input type="checkbox"/>	<input type="checkbox"/>	<input type="checkbox"/>

	1	2	3	4
	T	F		
26	<input type="checkbox"/>	<input type="checkbox"/>	<input type="checkbox"/>	<input type="checkbox"/>
27	<input type="checkbox"/>	<input type="checkbox"/>	<input type="checkbox"/>	<input type="checkbox"/>
28	<input type="checkbox"/>	<input type="checkbox"/>	<input type="checkbox"/>	<input type="checkbox"/>
29	<input type="checkbox"/>	<input type="checkbox"/>	<input type="checkbox"/>	<input type="checkbox"/>
30	<input type="checkbox"/>	<input type="checkbox"/>	<input type="checkbox"/>	<input type="checkbox"/>
31	<input type="checkbox"/>	<input type="checkbox"/>	<input type="checkbox"/>	<input type="checkbox"/>
32	<input type="checkbox"/>	<input type="checkbox"/>	<input type="checkbox"/>	<input type="checkbox"/>
33	<input type="checkbox"/>	<input type="checkbox"/>	<input type="checkbox"/>	<input type="checkbox"/>
34	<input type="checkbox"/>	<input type="checkbox"/>	<input type="checkbox"/>	<input type="checkbox"/>
35	<input type="checkbox"/>	<input type="checkbox"/>	<input type="checkbox"/>	<input type="checkbox"/>
36	<input type="checkbox"/>	<input type="checkbox"/>	<input type="checkbox"/>	<input type="checkbox"/>
37	<input type="checkbox"/>	<input type="checkbox"/>	<input type="checkbox"/>	<input type="checkbox"/>
38	<input type="checkbox"/>	<input type="checkbox"/>	<input type="checkbox"/>	<input type="checkbox"/>
39	<input type="checkbox"/>	<input type="checkbox"/>	<input type="checkbox"/>	<input type="checkbox"/>
40	<input type="checkbox"/>	<input type="checkbox"/>	<input type="checkbox"/>	<input type="checkbox"/>
41	<input type="checkbox"/>	<input type="checkbox"/>	<input type="checkbox"/>	<input type="checkbox"/>
42	<input type="checkbox"/>	<input type="checkbox"/>	<input type="checkbox"/>	<input type="checkbox"/>
43	<input type="checkbox"/>	<input type="checkbox"/>	<input type="checkbox"/>	<input type="checkbox"/>
44	<input type="checkbox"/>	<input type="checkbox"/>	<input type="checkbox"/>	<input type="checkbox"/>
45	<input type="checkbox"/>	<input type="checkbox"/>	<input type="checkbox"/>	<input type="checkbox"/>
46	<input type="checkbox"/>	<input type="checkbox"/>	<input type="checkbox"/>	<input type="checkbox"/>
47	<input type="checkbox"/>	<input type="checkbox"/>	<input type="checkbox"/>	<input type="checkbox"/>
48	<input type="checkbox"/>	<input type="checkbox"/>	<input type="checkbox"/>	<input type="checkbox"/>
49	<input type="checkbox"/>	<input type="checkbox"/>	<input type="checkbox"/>	<input type="checkbox"/>
50	<input type="checkbox"/>	<input type="checkbox"/>	<input type="checkbox"/>	<input type="checkbox"/>

	1	2	3	4
	T	F		
51	<input type="checkbox"/>	<input type="checkbox"/>	<input type="checkbox"/>	<input type="checkbox"/>
52	<input type="checkbox"/>	<input type="checkbox"/>	<input type="checkbox"/>	<input type="checkbox"/>
53	<input type="checkbox"/>	<input type="checkbox"/>	<input type="checkbox"/>	<input type="checkbox"/>
54	<input checked="" type="checkbox"/>	<input type="checkbox"/>	<input type="checkbox"/>	<input type="checkbox"/>
55	<input type="checkbox"/>	<input type="checkbox"/>	<input type="checkbox"/>	<input type="checkbox"/>
56	<input type="checkbox"/>	<input type="checkbox"/>	<input type="checkbox"/>	<input type="checkbox"/>
57	<input type="checkbox"/>	<input type="checkbox"/>	<input type="checkbox"/>	<input type="checkbox"/>
58	<input type="checkbox"/>	<input type="checkbox"/>	<input type="checkbox"/>	<input type="checkbox"/>
59	<input type="checkbox"/>	<input type="checkbox"/>	<input type="checkbox"/>	<input type="checkbox"/>
60	<input type="checkbox"/>	<input type="checkbox"/>	<input type="checkbox"/>	<input type="checkbox"/>
61	<input type="checkbox"/>	<input type="checkbox"/>	<input type="checkbox"/>	<input type="checkbox"/>
62	<input type="checkbox"/>	<input type="checkbox"/>	<input type="checkbox"/>	<input type="checkbox"/>
63	<input type="checkbox"/>	<input type="checkbox"/>	<input type="checkbox"/>	<input type="checkbox"/>
64	<input type="checkbox"/>	<input type="checkbox"/>	<input type="checkbox"/>	<input type="checkbox"/>
65	<input type="checkbox"/>	<input type="checkbox"/>	<input type="checkbox"/>	<input type="checkbox"/>
66	<input type="checkbox"/>	<input type="checkbox"/>	<input type="checkbox"/>	<input type="checkbox"/>
67	<input type="checkbox"/>	<input type="checkbox"/>	<input type="checkbox"/>	<input type="checkbox"/>
68	<input type="checkbox"/>	<input type="checkbox"/>	<input type="checkbox"/>	<input type="checkbox"/>
69	<input type="checkbox"/>	<input type="checkbox"/>	<input type="checkbox"/>	<input type="checkbox"/>
70	<input type="checkbox"/>	<input type="checkbox"/>	<input type="checkbox"/>	<input type="checkbox"/>
71	<input type="checkbox"/>	<input type="checkbox"/>	<input type="checkbox"/>	<input type="checkbox"/>
72	<input type="checkbox"/>	<input type="checkbox"/>	<input type="checkbox"/>	<input type="checkbox"/>
73	<input type="checkbox"/>	<input type="checkbox"/>	<input type="checkbox"/>	<input type="checkbox"/>
74	<input type="checkbox"/>	<input type="checkbox"/>	<input checked="" type="checkbox"/>	<input type="checkbox"/>
75	<input type="checkbox"/>	<input type="checkbox"/>	<input type="checkbox"/>	<input type="checkbox"/>