

DOCUMENT RESUME

ED 217 234

CE 032 870

TITLE Trowel Trades Tools. Pre-Apprenticeship Phase 1 Training.

INSTITUTION Lane Community Coll., Eugene, Oreg.

SPONS AGENCY Employment and Training Administration (DOL), Washington, D.C.; Oregon State Dept. of Education, Salem.

PUB DATE 79

NOTE 24p.; For related documents see CE 032 866-930 and ED 213 887-905.

EDRS PRICE MF01/PC01 Plus Postage.

DESCRIPTORS Behavioral Objectives; Bricklaying; Building Trades; *Equipment; *Equipment Utilization; Individual Instruction; Learning Modules; *Masonry; Pacing; Postsecondary Education; Secondary Education; Tests; *Trade and Industrial Education; Two Year Colleges

IDENTIFIERS Cement Masons; *Drywall Construction; *Plasterers; Preapprenticeship Programs

ABSTRACT This self-paced student training module on trowel trades tools is part of the course, Trowel Trades, which was developed for Preapprenticeship Phase 1 Training. (A companion instructor's guide is available separately as CE 032 868.) The course is designed to provide students with an orientation to the trade and an opportunity to explore it. The purpose of the module is to teach students to identify, select, and understand proper use of common trowel trade tools. The module may contain some or all of the following: a cover sheet listing module title, goal, and performance indicator; study guide/checklist with directions for module completion; introduction; information sheets providing information and graphics covering the module topic(s); supplementary references; self-assessment; self-assessment answers; post assessment; and post-assessment answers. (YLB)

 * Reproductions supplied by EDRS are the best that can be made *
 * from the original document. *



ED217234



*PRE-APPRENTICESHIP
PHASE 1 TRAINING*

TROWEL TRADES TOOLS

030183

Goal:

Upon completion of this module, the student will be able to identify, select and understand the proper use of common trowel trade tools.

Performance Indicators:

The student will demonstrate his or her knowledge by successfully completing both a Self Assessment and Post Assessment exam covering the selection, use and maintenance of common trowel trade tools.

U.S. DEPARTMENT OF EDUCATION
NATIONAL INSTITUTE OF EDUCATION
EDUCATIONAL RESOURCES INFORMATION
CENTER (ERIC)

"PERMISSION TO REPRODUCE THIS
MATERIAL HAS BEEN GRANTED BY

- This document has been reproduced as received from the person or organization originating it
- Minor changes have been made to improve reproduction quality

C. Horstrup

• Points of view or opinions stated in this document do not necessarily represent official NIE position or policy.

TO THE EDUCATIONAL RESOURCES
INFORMATION CENTER (ERIC)."

CE 032870



Study Guide

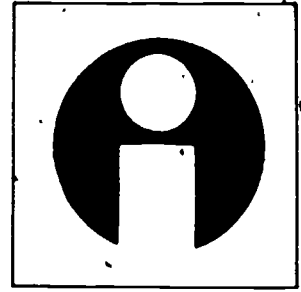

To successfully complete this module, complete the following tasks in the order listed. Check each one off as you complete it.

1. Read the Goal and Performance Indicators on the cover of this module. This will inform you of what you are expected to gain from completing this module and how you will demonstrate that knowledge. Read the Introduction section to understand why this module is important.
2. Study the Information section of this module to acquire the knowledge necessary to complete the Self and Post Assessment exams.
3. Complete the Self Assessment exam and compare your answers with those on the Self Assessment Answer Sheet on the page immediately following the exam. Re-study or ask your instructor for help on any questions you have trouble with. The Self Assessment exam will help you determine how well you are likely to do on the Post Assessment.
4. Complete the Post Assessment exam and turn your answers in to your instructor. It is recommended that you score 90% or better on the Post Assessment before going on to the next module.

Introduction

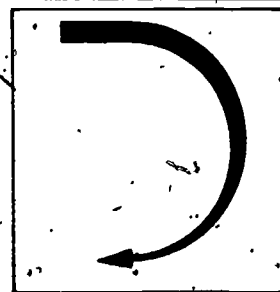

Whatever trowel trade one chooses to enter, a knowledge of the correct tools and their proper use is imperative as no job is done without them. Adequate care and maintenance will both extend the tools' useful life and allow for continued top performance.

Information

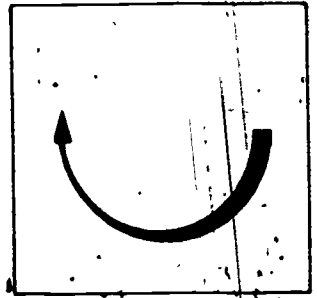

Trowel trade tools will be presented in four sections: plastering tools, cement finishing tools; bricklaying tools, and tile setting tools. The student should learn to recognize tools by name, know their function and how to use them, in order to successfully perform the tasks of the job. Some tools are used by more than one of the four areas. Therefore once a tool is introduced, future uses will be referred to the original description.

PLASTERING TOOLS

A Hawk is a tool used to hold and carry various mortars and other plastic (workable) materials. They are made from metal plates or wooden boards to provide a flat surface. Usually the hawk has a bracket used for mounting on post, pole or hand-held,

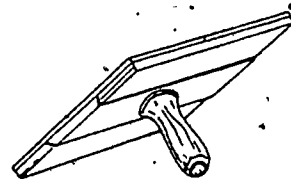
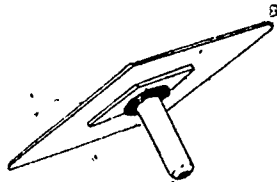

Trowels are metal-bladed tools that are used to apply and shape plaster. Trowels come in many sizes and shapes, and are hand-held. Plaster is placed on trowels from the hawk.

A Pointing Trowel is a metal bladed trowel and is pointed to reach and trowel into spaces regular trowels won't fit, using small pots of material. Very good for working in mitered corners. Pointing trowels are hand-held to transfer and spread plaster from hawk to work surface.

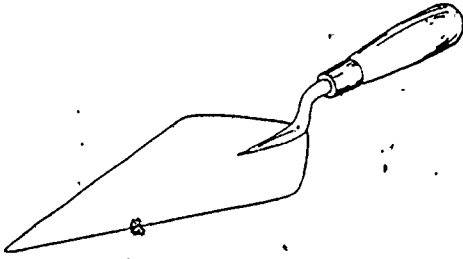

Pointing Trowel

Margin Trowel - The blade is square-ended, which aids in applying plaster in narrow places. Also used to clean other tools.

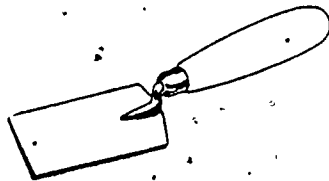

Scarifier (scratcher) - Metal, rake-like tool designed to scratch the surface of unset plaster to improve bonding between base and finish coats of plaster. Drawn across leveled base coat by hand.

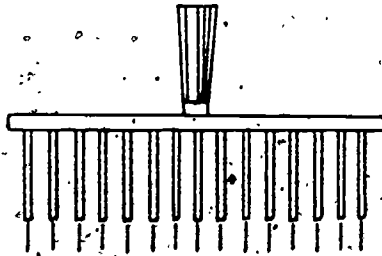

Straight Edge - The key to this tool is a true edge. They are made from wood or metal in various sizes and lengths with 5'8" the common length. Used to straighten and level the surface of walls and ceilings. The straight edge is drawn by hand over the freshly applied plaster to even out surface irregularities.

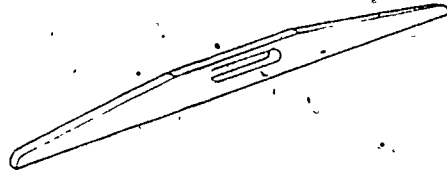

Darby - A wooden tool with flat base surface, with handles on the reverse side. This tool is used to float over fresh plaster after leveling, compacting and smoothing the surface. Available in several sizes.

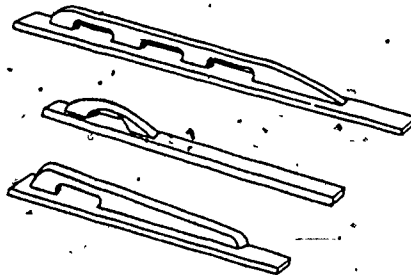

Feather Edge - Metal tool with a curved flange edge, available in various lengths. Generally used to straighten plaster surfaces in corners and finish coat. May be a substitute for the straight edge in the rodding (leveling) process. Hand-held and drawn away from the corner to leave a clean smooth surface.

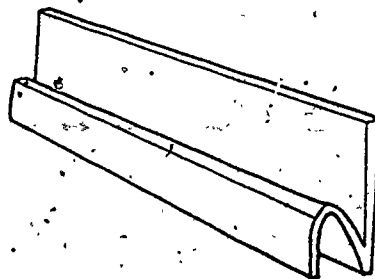

Floats - Used to level off the humps and depressions left by other tools and work. Made from metal or wood with handles on back for gripping. Various surface materials/textures are available, such as cork, rubber, smooth or textured. Stroked by hand over plaster surface to provide finished appearance.

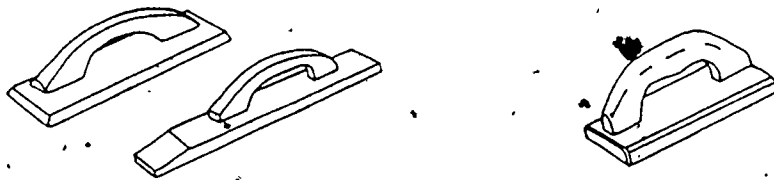

Brushes - Various styles are used in plastering. From browning brushes, ideally with 6 1/2" x 4" bristles, used to flick water onto plaster to aid finishing tools, to finish brushes for brushing water directly onto plaster surface.

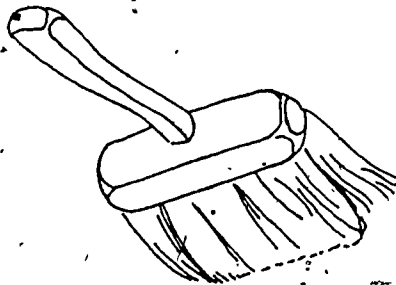

Angle Plane - Metal-tool with handle and multiple blades set at staggered angles. The angle plane is used to prepare surfaces, knocking down high spots, cleaning corners and angles and scraping down after the brown (base) coat has set.

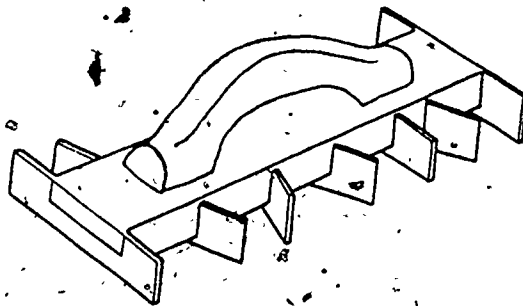

Spirit Level - This tool is used to check surfaces for level and plumb. Made from metal or wood of various lengths. Surfaces and angles on levels are smooth and true. There are usually 3 or more calibrated vials which indicate level or plumb. The level is placed flush against the surface to be checked and the bubble contained within the vial is "read." If the bubble centers itself within calibration works, surface is true and level or plumb.

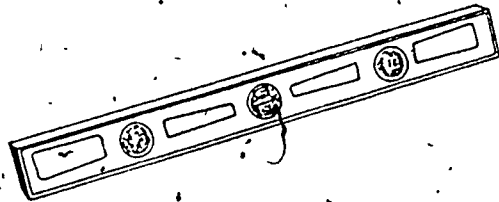

CEMENT FINISHING TOOLS

Hand Tamper - A flat surface with pole/handle is used to compact earth or fill for subgrade. It is made from various wood and/or metal parts. Often constructed on-site from available materials. Held in hands, the tamper is raised, then driven downward to compact subgrade.

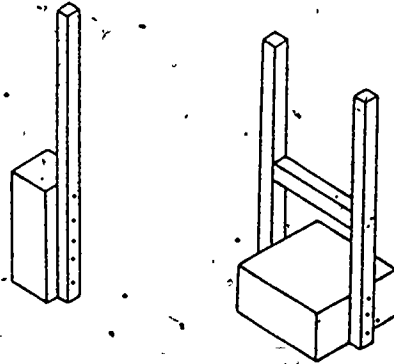

Square Nosed Shovel - This shovel has a flat nose, rather than pointed, and has a loop handle for gripping at right angle to handle length. It is used to distribute concrete during placement and for removing soil and roots while preparing sub-grade. Square nose is useful in cutting straight sides and edges with added downward thrust from foot.

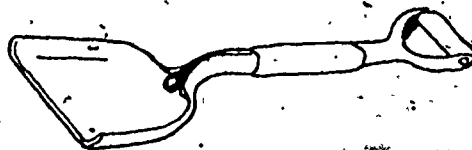

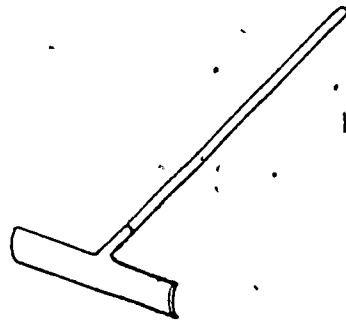

Kumalong ("Come-a-Long")

Kumalong ("come-a-long") - This tool has a curved blade and pole handle. It is designed to be used in spreading and distributing concrete without causing segregation by using a raking motion.

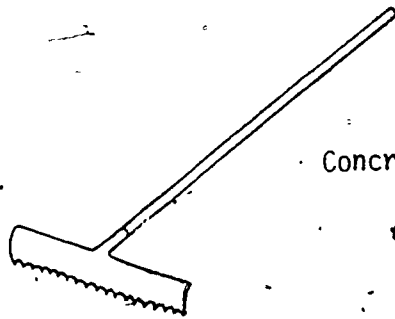

Concrete Rake

Concrete Rake - This tool is very similar to the kumalong, but has a serrated edge on the bottom of the curved blade. This is a special tool; a garden hoe or rake is not a substitute. It is used in the same manner as the kumalong.

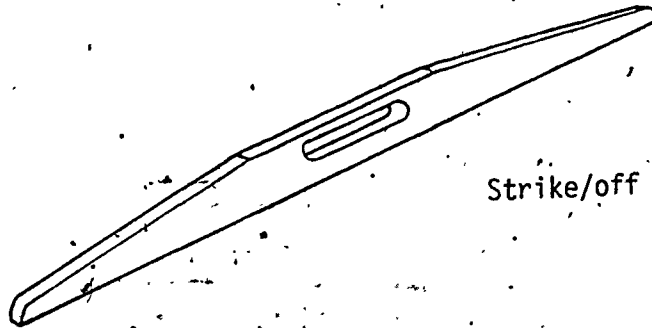

Strike/off

Strike Off - Sometimes called a screed, rod or straight edge, this tool is used to level the concrete surface immediately after it is placed in the forms. Using the forms as a guide, the strike off is drawn over the surface of the newly-poured concrete.

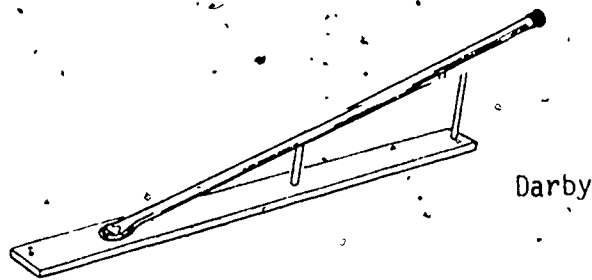

Darby

Darby - This tool has very similar construction characteristics to plaster darbies. It is used to even out high and low spots left by straight edge operations. The darby imbeds the coarse aggregate into the concrete through the use of pushing or drawing smooth arcs over the surface. This tool is used before the bleed water collects on the concrete surface.

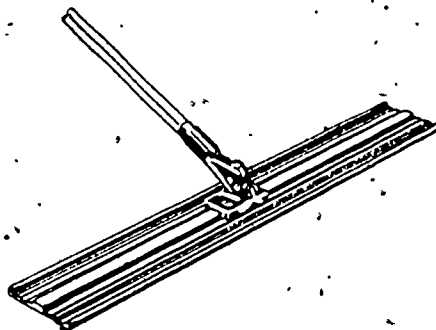

Bull Float

Bull Float - This tool has a long handle and a wide flat blade attached so that the blade can pivot. It is used to smooth out the concrete surface like the darby but its long handle allows access across broad surfaces too far to reach by hand-held darby. The bull float is used with long, smooth strokes (either pushing or drawing).

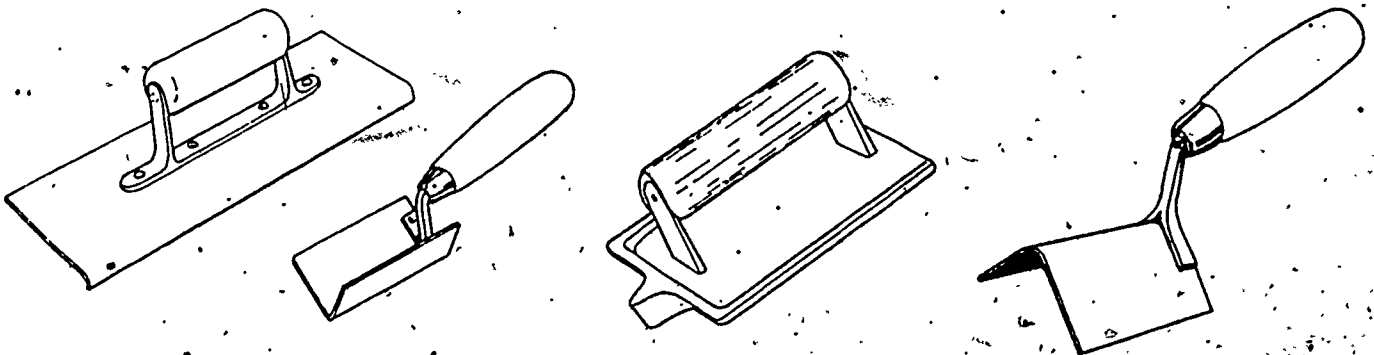

Finishing Tools - There are a wide range of hand-held finishing tools that are generally fabricated from metal and wood. They include the straight edge, radius corner tool, jointer, groover and trowels. They are used to provide neat, rounded edges that help prevent chipping or breaking off, to compact and harden concrete next to forms and to provide for control joints. These tools are usually involved after

the concrete has begun to set up and the forms are being removed.

Wheelbarrow - This is a heavy duty version with metal bed and strong wooden handles. It's generally equipped with a pneumatic tire to carry heavy loads. The wheelbarrow is used to mix and transport concrete. Care must be observed in using proper lifting techniques, as large weights are involved.

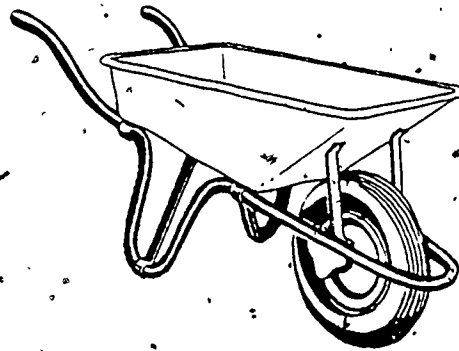

Mixing Board - This is basically any suitable flat clean surface used to mix the concrete. Size and composition vary greatly. It may or may not have a lip edge.

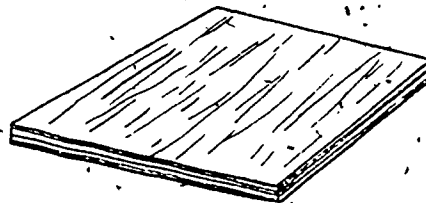

Screed Stakes - Used to establish the level to which concrete is to be poured. Often made from wood, they are set to the desired height before pouring cement and removed at the strike off stage.

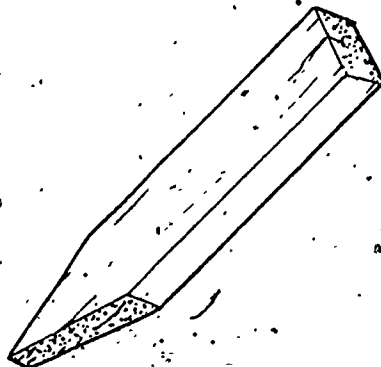

BRICKLAYING TOOLS

Trowels - This metal bladed tool with plastic or wood handle comes in a variety of sizes and shapes. There are buttering, gauging, duckbill, cross joint, margin and pointing trowels. Their primary use is to transfer mortar from mortar board to brick head or bed joint. The standard trowel has a pointed blade 9" to 12" long, and 4 1/2" to 7" wide.

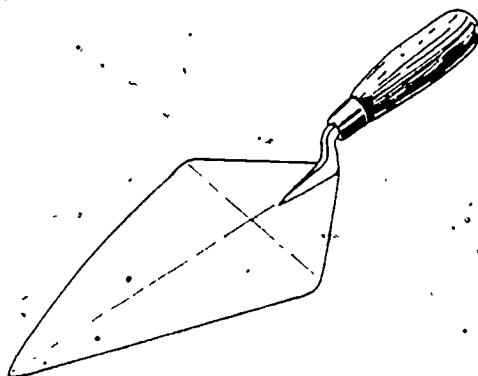

Mortar Boards - Basically a flat surface, generally made of wood, used to mix and store mortar close to the worker's side.

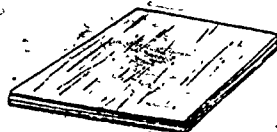

Jointer/Striker - This series of metal tools with wood handles are designed to finish mortar joints. Long, horizontal joints are most easily struck with the sled runner style, while vertical joints are better served by end handled styles.

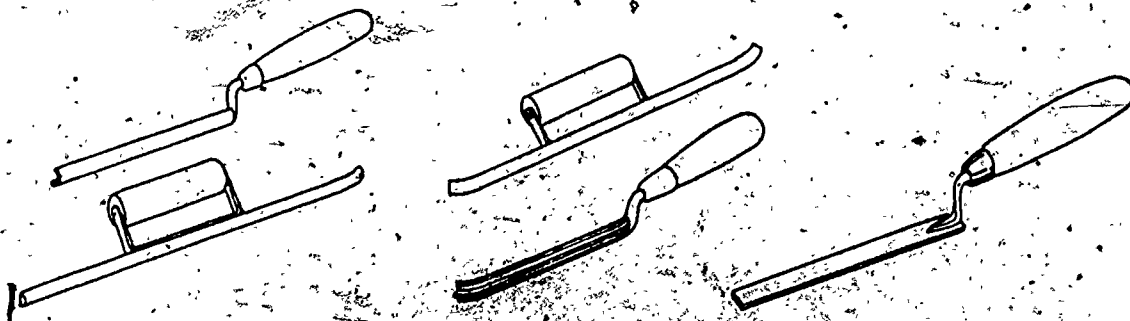

Brushes - Bricklayers use a variety of brushes, generally having stiff bristles. They are used to remove excess mortar from brick surface. Hand-held, using a back and forth stroking motion.

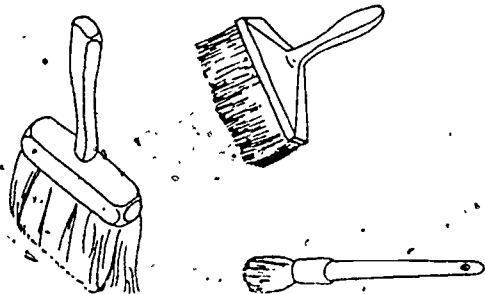

Spirit Level - See description under plastering tools. Levels are used to check for plumb and level while placing masonry units.

Line Level - This single vial level is designed to be suspended on a string or cord. Used for checking level over long distances such as corner to corner, while laying brick.

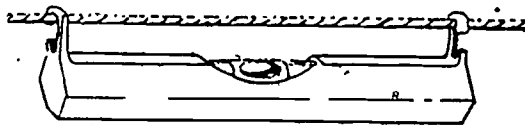

Chalk Line - A string covered with chalk which is used to mark straight lines between two points. Available either as loose string or in enclosed reel, self-chalking styles. Red and blue are the predominant colors used. This tool is used to mark layout lines for walls, etc. To use, the line is stretched between two end points, raised from surface and snapped. The resulting mark is a straight line between the points.

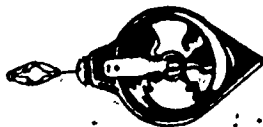

Brick Hammer - This specialized hammer has a flat head for striking, while the other side is drawn out like a chisel. Handles are made of wood, metal or fiberglass with rubber grips; they weigh from 12 to 24 oz. Masons use this hammer to drive nails, strike chisels and break or chip masonry materials.

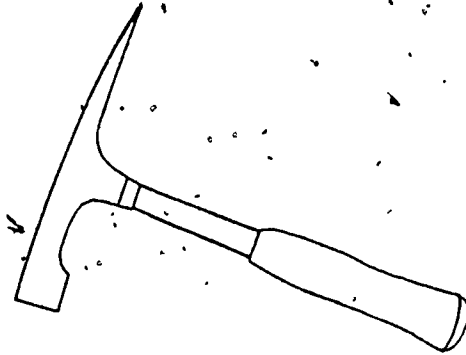

Chisels - Hardened steel striking tools that come in a variety of blade sizes and shapes. Hand-held and struck with a hammer to cut, chip or break masonry material. Special care to protect eyes must be used when using striking tools.

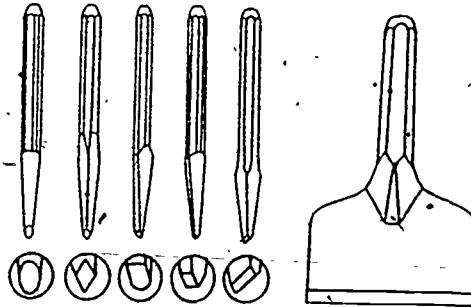

TILE SETTING TOOLS

Serrated Trowel - A flat, metal-bladed tool with serrated edge and wood or metal handle. Used to apply thinset or mastic. The serrated edge textures the surface to improve bonding.

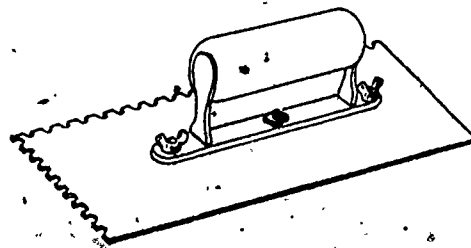

Margin Trowel - (See description under plastering tools.) Tile setters use the margin trowel to spread thinset or mastic along borders or edges. The blade is held at an angle and drawn across the surface to spread the material.

Spirit Level - (See description under plastering tools.)

Builder's Square (Carpenter's or Framing Square) - Made from metal, this measuring tool has two main sections, the blade and the tongue. They are set at 90° angles to each other so that they provide an accurate means of checking the squareness of corners. Both the tongue and the blade are calibrated to be used as measuring tools, generally to $1/16$ " gradations. In addition, there are usually tables of builders' information printed on the tool's surface. When held against the corner to be checked, there will be no gaps along tool edges (both tongue and blade) if the corner is square.

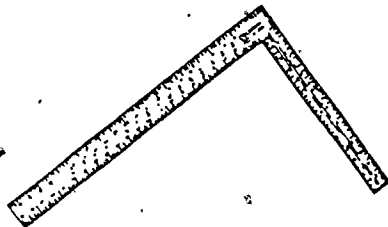

Tile Cutter - This tool is used to cut tile to desired size prior to installation. It has a flat, calibrated surface with a horizontal cutting blade. The tile is placed on tool surface, aligned, then the lever handle is depressed, which lowers the blade and cuts the tile.

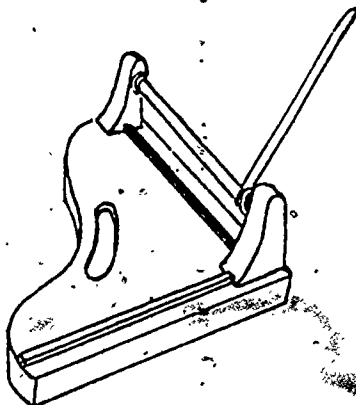

Straight Edge - (See description under Plastering.) Tile setters use this tool to level off dry pack to assure a level and uniform base for the tile to be set on.

Chalk Line - (See description under Bricklaying Tools.) Tile setters use the chalk line for layout functions, marking edges, center lines, etc.

Cloth, Sponge, Cheesecloth - These are all materials used to clean and polish tile after grout has been applied. Wiping is performed with water and a circular rubbing motion is used.



Tapping Block and Mallet - Flat blocks of wood (size varies) are used with wood or rubber mallets to imbed tiles into thinset or mastic.

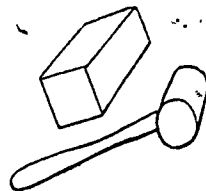

Tile Nippers - Using a scissors like action, these straight bladed cutting tools are used to cut tile to size and shape. Nipper-like devices are also used to clip small wires or wood.

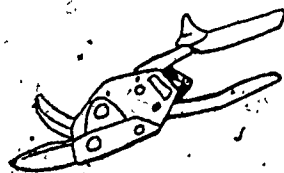

Saws - Tile setting will sometimes require the cutting of wood or metal, such as flashing or trim. On those occasions, a handsaw is used for wood and a hacksaw is used for metal cutting.

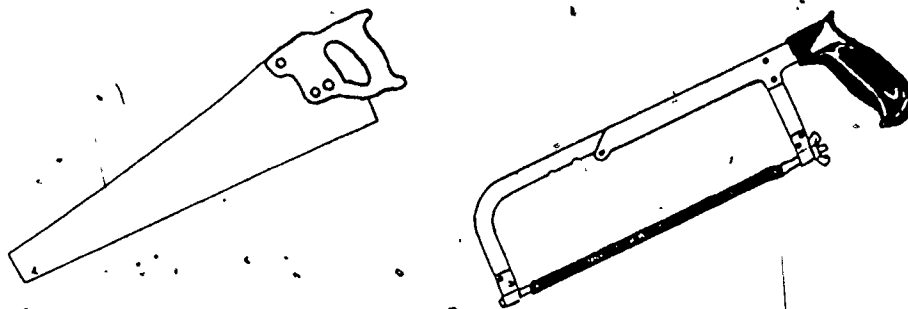

Mortar Hoe - This wooden-handled, metal-bladed tool is used to mix mortar and other dry ingredient based mixtures. The blade is perpendicular to the handle.

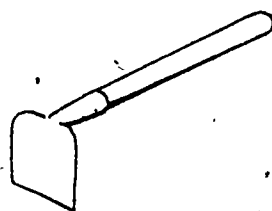

Shovel - The basic configuration of the shovel is wooden handle and metal blade. The length of handle and the size and shape of blade varies greatly. Selection depends on individual preference--what works best for you. It is used to prepare dry ingredients for mortar.

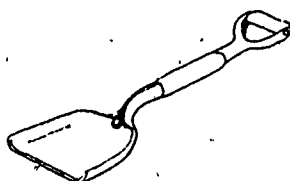

Mortar Board - (See description and use under Bricklaying Tools.)

Mortar Box - This is a wooden or metal container used to mix mortar.

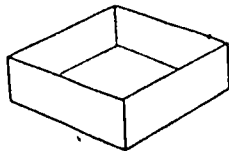

Hawk - (See description and use under Plastering Tools.)

Rubber Grout Float. - Generally this tool is wood backed and handled with a rubber base surface. It is used to surface grout joints by pressing the float down on the tiles and moving it in a circular motion.



Pointing Trowel - (See description and uses under Plastering Tools.)

Self Assessment

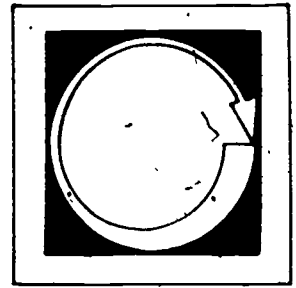

Given the following pictures of tools and their names, match the name and picture by drawing connecting lines.

Margin Trowel

Darby

Straight Edge

Pointing Trowel

Angle Plane

Kumalong

Hawk

Tile Cutter

Tile Nipper

Bull Float

Scarifier

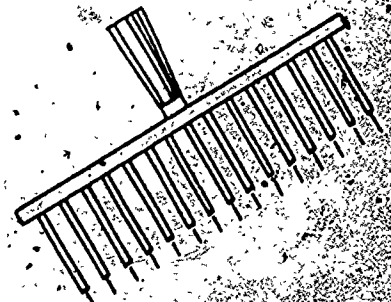
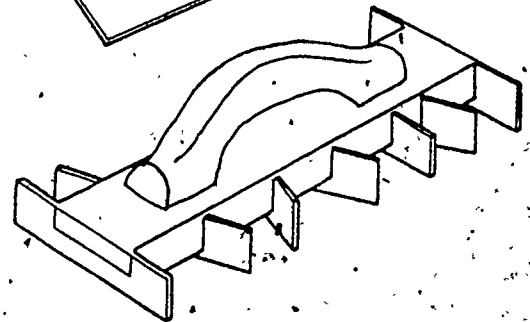
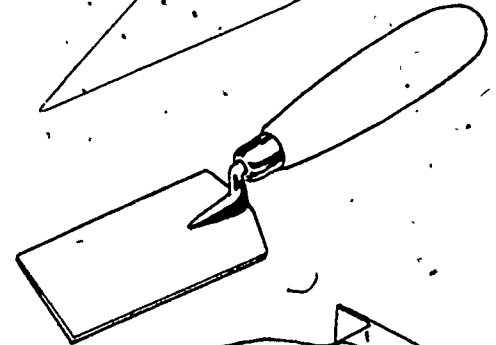
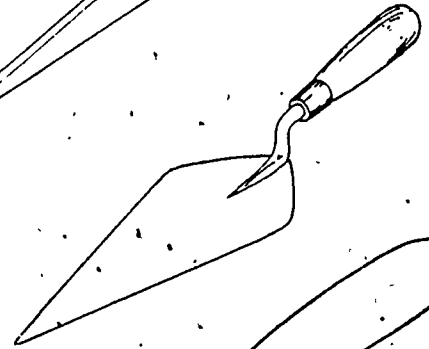
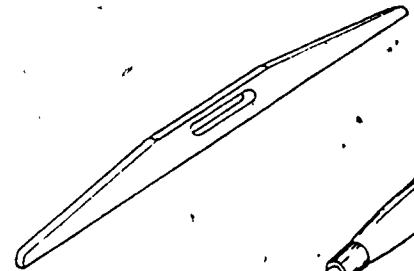
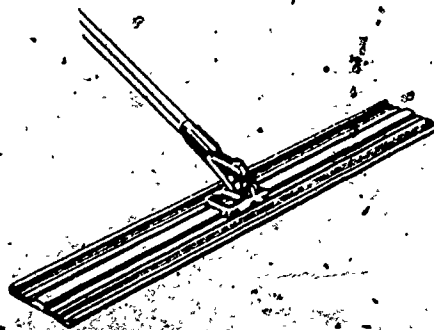
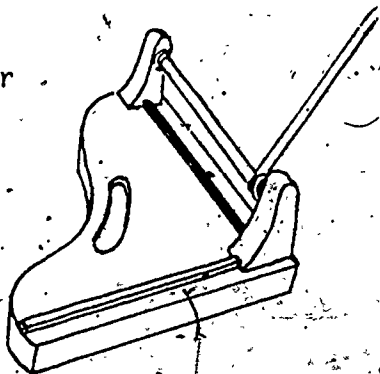
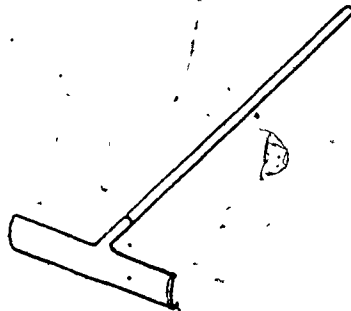
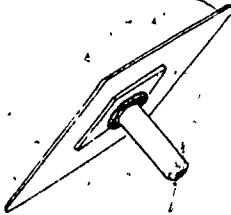
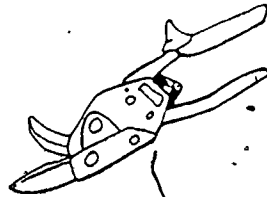
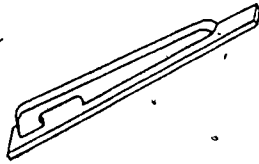

Post Assessment

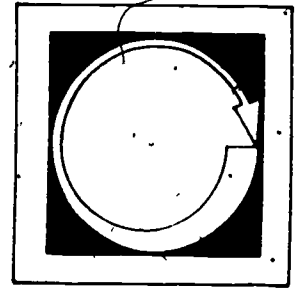

1. Describe the function of a spirit level.
2. When cleaning tile after the grout has been applied and floated, what type of motion is selected when using cloth, sponge or cheesecloth? (Circle your answer.)
 - a. back and forth
 - b. circular
3. What advantage does the pointing trowel offer?
4. What is the purpose of a scarifier?
5. Describe an angle plane.
6. What is the angle plane used for?
7. What is a kumalong used for?
8. How is a concrete rake different from a kumalong?
9. Is a darby used before or after bleed water collects on the concrete surface?

10. What advantage does the bull float have over a darby?
11. When preparing to move a wheelbarrow full of concrete, what cautions should be considered?
12. What is the purpose of screed stakes?
13. Name two types of trowels used in bricklaying.
14. Sled runner jointer/striker are best suited for: (circle your answer)
 - a. horizontal joints
 - b. vertical joints
15. Describe the main difference in the head of a brick hammer from a conventional claw hammer.
16. How does the bricklayer use this difference?
17. What purpose does the serrated edge serve on a tile setter's serrated trowel?

● Instructor Post Assessment Answers

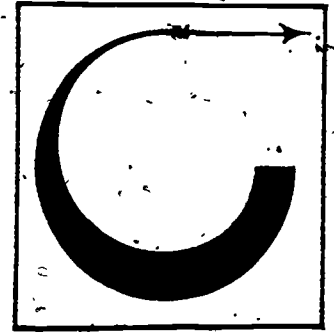

1. Used to check level and plumb surfaces
2. b. circular
3. Pointed nose can reach where regular trowels have difficulty, especially in mitered corners.
4. To scratch surface of base coat plaster to improve bonding of surface coat
5. Metal tool with handle on back, has metal blades set at staggered angles.
6. Used to prepare plaster surfaces by knocking down high spots and scraping down the base coat after it has set.
7. Kumalong is used to distribute concrete within forms.
8. It has a serrated lower edge on the blade.
9. Before
10. Its long handle allows access out of reach by darbies.
11. Proper lifting techniques as it is an extremely heavy object to move.
12. To establish the level to which concrete is to be poured.
13. Choose from: buttering, gauging, pointing, margin, duckbill, cross joint
14. a. horizontal joints

15. Back side is drawn out into a chisel point rather than claws

16. For cutting, chipping or breaking masonry units.

17. Improves bonding of thinset or mastic to tile.