



Full Text Provided by ERIC

DOCUMENT RESUME

ED 216 204

CE 032 551

TITLE Military Curriculum Materials for Vocational and Technical Education. Builders School, Ceramic Tile Setting 3-9.

INSTITUTION Ohio State Univ., Columbus. National Center for Research in Vocational Education.

SPONS AGENCY Office of Education (DHEW), Washington, D.C.

PUB DATE [78]

NOTE 119p.

AVAILABLE FROM Military Curriculum Project, The National Center for Research in Vocational Education, 1960 Kenny Rd., Columbus, OH 43210.

EDRS PRICE MF01/PC05 Plus Postage.

DESCRIPTORS Behavioral Objectives; *Building Trades; *Construction (Process); Course Content; Curriculum; Group Instruction; Individualized Instruction; Instructional Materials; Learning Activities; Lesson Plans; Postsecondary Education; Secondary Education; Teaching Guides; Teaching Methods; Technical Education; *Trade and Industrial Education; *Vocational Education

IDENTIFIERS Military Curriculum Project; *Tile Occupations

ABSTRACT

This course, for individualized or group instruction on ceramic tile setting, was developed from military sources for use in vocational education. The course provides students with skills in mortar preparation, surface preparation, tile layout planning, tile setting, tile cutting, and the grouting of tile joints. Both theory and shop assignments are included with the course materials. The materials are organized into two units. Unit 1, the introduction, covers safety. Unit 2, on ceramic tile setting, contains the following two sections covering 30 hours of class and shop time: mortar mixing and ceramic tile, and ceramic tile installation. Instructors guides are prepared for each section describing instructional materials, instructional aids, terminal and enabling objectives, criterion tests, and homework assignments. Each section includes an outline of instruction, instructor activities, and student activities. Four job sheets are prepared to accompany the last two sections. These involve a list of the tools, equipment, and materials needed for the assignment and a list of procedures. Text material is also provided. (KC)

 * Reproductions supplied by EDRS are the best that can be made *
 * from the original document. *

MILITARY CURRICULUM MATERIALS

The military-developed curriculum materials in this course package were selected by the National Center for Research in Vocational Education Military Curriculum Project for dissemination to the six regional Curriculum Coordination Centers and other instructional materials agencies. The purpose of disseminating these courses was to make curriculum materials developed by the military more accessible to vocational educators in the civilian setting.

The course materials were acquired, evaluated by project staff and practitioners in the field, and prepared for dissemination. Materials which were specific to the military were deleted, copyrighted materials were either omitted or approval for their use was obtained. These course packages contain curriculum resource materials which can be adapted to support vocational instruction and curriculum development.

The National Center Mission Statement

The National Center for Research in Vocational Education's mission is to increase the ability of diverse agencies, institutions, and organizations to solve educational problems relating to individual career planning, preparation, and progression. The National Center fulfills its mission by:

- Generating knowledge through research
- Developing educational programs and products
- Evaluating individual program needs and outcomes
- Installing educational programs and products
- Operating information systems and services
- Conducting leadership development and training programs

FOR FURTHER INFORMATION ABOUT Military Curriculum Materials

WRITE OR CALL

Program Information Office
The National Center for Research in Vocational
Education
The Ohio State University
1960 Kenny Road, Columbus, Ohio 43210
Telephone: 614/486-3655 or Toll Free 800/
848-4815 within the continental U.S.
(except Ohio)



THE NATIONAL CENTER
FOR RESEARCH IN VOCATIONAL EDUCATION
The Ohio State University - 1960 Kenny Road - Columbus, Ohio 43210
Tel. (614) 486-3655
Cable: CVOCEDOSU/Columbus, Ohio

Military Curriculum Materials for Vocational and Technical Education

Information and Field
Services Division

The National Center for Research
in Vocational Education



Military Curriculum Materials Dissemination Is . . .

an activity to increase the accessibility of military-developed curriculum materials to vocational and technical educators.

This project, funded by the U.S. Office of Education, includes the identification and acquisition of curriculum materials in print form from the Coast Guard, Air Force, Army, Marine Corps and Navy.

Access to military curriculum materials is provided through a "Joint Memorandum of Understanding" between the U.S. Office of Education and the Department of Defense.

The acquired materials are reviewed by staff and subject matter specialists, and courses deemed applicable to vocational and technical education are selected for dissemination.

The National Center for Research in Vocational Education is the U.S. Office of Education's designated representative to acquire the materials and conduct the project activities.

Project Staff:

Wesley E. Budke, Ph.D., Director
National Center Clearinghouse

Shirley A. Chase, Ph.D.
Project Director

What Materials Are Available?

One hundred twenty courses on microfiche (thirteen in paper form) and descriptions of each have been provided to the vocational Curriculum Coordination Centers and other instructional materials agencies for dissemination.

Course materials include programmed instruction, curriculum outlines, instructor guides, student workbooks and technical manuals.

The 120 courses represent the following sixteen vocational subject areas:

Agriculture	Food Service
Aviation	Health
Building & Construction	Heating & Air Conditioning
Trades	Machine Shop
Clerical	Management & Supervision
Occupations	Meteorology & Navigation
Communications	Photography
Drafting	Public Service
Electronics	
Engine Mechanics	

The number of courses and the subject areas represented will expand as additional materials with application to vocational and technical education are identified and selected for dissemination.

How Can These Materials Be Obtained?

Contact the Curriculum Coordination Center in your region for information on obtaining materials (e.g., availability and cost). They will respond to your request directly or refer you to an instructional materials agency closer to you.

CURRICULUM COORDINATION CENTERS

EAST CENTRAL

Rebecca S. Douglass
Director
100 North First Street
Springfield, IL 62777
217/782-0759

MIDWEST

Robert Patton
Director
1515 West Sixth Ave.
Stillwater, OK 74704
405/377-2000

NORTHEAST

Joseph F. Kelly, Ph.D.
Director
225 West State Street
Trenton, NJ 08625
609/292-6562

NORTHWEST

William Daniels
Director
Building 17
Airdustrial Park
Olympia, WA 98504
206/753-0879

SOUTHEAST

James F. Shill, Ph.D.
Director
Mississippi State University
Drawer DX
Mississippi State, MS 39762
601/325-2510

WESTERN

Lawrence F. H. Zane, Ph.D.
Director
1776 University Ave.
Honolulu, HI 96822
808/948-7834

BUILDERS SCHOOL, CERAMIC TILE SETTING

Table of Contents

Course Description	Page 1
<u>Builders School 167.1 Ceramic Tile Setting-</u> Instructor Guides	Page 3
<u>Builder 3 & 2</u> Chapter 14 - Plastering, Stuccoing and Tile Setting	Page 63



SPECIAL CONSTRUCTION BATTALION TRAINING

BUILDERS SCHOOL 167:1 CERAMIC TILE SETTING

FEB 1976



Developed by:
United States Navy

Development and
Review Dates
February 1976

D.O.T. No.:
840.884
Occupational Area:
Building and Construction
Target Audiences:
Grades 10-adult

Print Pages:
85
Cost:
\$2.00

Availability:
Military Curriculum Project, The Center
for Vocational Education, 1960 Kenny
Rd., Columbus, OH 43210

Contents:

Unit 1.1 - Introduction
1.1.2 Safety
Unit 1.2 - Ceramic Tile Setting
1.2.1 Mortar Mixing and Ceramic Setting Surface
1.2.2 Ceramic Tile Installation

Type of Materials:

Lesson Plans:	Programmed Text:	Student Workbook:	Handouts:	Text Materials:	Audio-Visuals:
					*
				*	*
				*	*

Instructional Design:

Performance Objectives:	Tests:	Review Exercises:	Additional Materials Required:
			*
			*

Type of Instruction:

Group Instruction:	Individualized:

* Materials are recommended but not provided.

2

Course Description

Students completing this short course will be trained in mortar preparation, surface preparation, tile layout planning, tile setting, tile cutting, and the grouting of tile joints.

Both theory and shop assignments are included with the course materials. The materials are organized into two units. The first section of the first unit is not suitable for vocational programs. This section deals with the military chain of command and reporting procedures and was deleted. The remaining three sections are suitable.

Unit 1.1 - Introduction contains a thirty minute section on safety. No shop time is required.

Unit 1.2 - Ceramic Tile Setting contains the following two sections covering 30 hours of class and shop time.

- 1.2.1 - Mortar Mixing and Ceramic Tile (3 hours class instruction, 7 hours shop)
- 1.2.2 - Ceramic Tile Installation (3 hours class instruction, 17 hours shop)

Instructors' guides are prepared for each section describing instructional materials, instructional aids, terminal and enabling objectives, criterion tests and homework assignments. Each section includes an outline of instruction, instructor activities and student activities. Four job sheets are prepared to accompany the last two sections. These involve a list of the tools, equipment, and materials needed for the assignment and a list of procedures.

The text is chapter 14 of a Navy training manual, *Builder 3 & 2, NAVPERS 10648-F*. This text material is provided. Four commercial references are given to supplement the course material. A list of course tools, equipment, and materials is provided as well as a list of training aids and devices and teacher prepared materials needed.

The following audio-visual support materials are recommended but not provided:

- The Gift of Life (GIF-001-18 min.)
- Lathe and Plaster (American Gypsum Company-22 min.)
- How to Get Better Clay Tile Installation (Tile Council of America-16 min.)

4

TITLE PAGE

TITLE: SPECIAL CONSTRUCTION BATTALION TRAINING COURSE 167.1
CERAMIC TILE SETTING.

COURSE NUMBER: SCBT 167.1

COURSE LENGTH: 32 HOURS.

TAUGHT AT: Naval Construction Training Center, Port Hueneme, California
93043

Naval Construction Training Center, Gulfport, Mississippi
39501

CLASS CAPACITY: Normal: 12
Maximum: 16
Minimum: 8

INSTRUCTOR REQUIREMENTS PER CLASS: Class 16/1
Pract: 8/1

COURSE CURRICULUM MODEL MANAGER: Naval Construction Training Center,
Port Hueneme, California 93043

CURRICULUM CONTROL: Chief of Naval Technical Training

QUOTA MANAGEMENT AUTHORITY: School at which taught.

QUOTA CONTROL: School at which taught.

APPROVAL/IMPLEMENTATION DATE: When approved by Chief of Naval Technical
Training.

5

TABLE OF CONTENTS

	<u>PAGE</u>
COPY OF APPROVED LETTER	i
RECORD OF CHANGE PAGE	11
TITLE PAGE	iii
HOW TO USE INSTRUCTOR GUIDES	v
COURSE DATA PAGE	1
OUTLINE OF INSTRUCTION	2
OUTLINE OF TRAINING OBJECTIVES	3
ANNEX I TEXTS	A-I-1
ANNEX II REFERENCES	A-II-1
ANNEX III TOOLS, EQUIPMENT AND MATERIALS	A-III-1
ANNEX IV TRAINING AIDS AND DEVICES	A-IV-1
ANNEX V TRAINING AIDS EQUIPMENT	A-V-1
ANNEX VI MASTER SCHEDULE	A-VI-1



Instructor guides (I.G.'s) are provided for each topic. They include supporting instructional material and aids identified by the topic number and a letter-code designation. The letter codes used in I.G.'s are as follows:

- | | |
|------------------------|-----------------------------|
| AS - Assignment Sheet | PE - Performance Evaluation |
| CN - Class Notes | PI - Programmed Instruction |
| DS - Diagram Sheet | PS - Problem Sheet |
| EG - Evaluation Guide | PT - Practical Test |
| FT - Final Test | T - Test |
| IS - Information Sheet | TR - Transparency |
| JS - Job Sheet | WS - Work Sheet |
| OS - Operation Sheet | |

The instructor guides are intended to be used as master lesson plans, but subject however to personalization by the individual instructor. The instructor should study and refer to the listing of references, materials and aids given in the appropriate enclosed annex when annotating the instructor guides.

The first page of each instructor guide contains the following functional information:

1. Topic of lesson
2. Average time in periods (class and practical)
3. Instructional materials such as texts, references, equipment, tools, training aids, etc.
4. Instructional materials such as job sheets, handouts, etc.
5. Terminal and enabling objectives.
6. Criterion Test
7. Homework assignment

The second page is the "Outline of Instruction" page whereby each instructor will develop an appropriate introduction for each topic that will: (1) create interest; (2) show the value of the topic to the student; (3) relate the topic to previous and future topics in the course; and (4) communicate the learning objectives to the student. Well prepared lesson introductions can provide direction for student motivation and establish readiness for learning.

7

The pages that follow the "Information" and "Outline of Instruction" pages is the body of the instruction guide. The pages are divided into three columns: the column on the left includes the outlines of instruction required by the objectives of the lesson; the center column is for listing instructor activity that corresponds to the particular portion of the lesson; and the right hand column contains student activity that corresponds to the particular portion of the lesson. Instructor creativity in designing learning exercises, techniques and training aids to meet course objectives can enhance the lesson and should be utilized and noted in the appropriate column. In addition, student comments pertaining to updating, additions, deletions, etc., to the lesson should be encouraged and noted for continual revision of the lesson.

8

COURSE DATA PAGE

COURSE MISSION: To train selected builders and builder strikers in mortar preparation, surface preparation, tile layout planning, tile setting, tile cutting and the grouting of tile joints.

PERSONNEL AND RATING ELIGIBLE: E-2 thru E-4.

OBLIGATED SERVICE: None

NEC EARNED: N/A

PHYSICAL REQUIREMENTS: N/A

SECURITY CLEARANCE REQUIRED: None

PREREQUISITE TRAINING AND/OR BASIC BATTERY TEST SCORE REQUIRED: None

RELATED TRAINING: None

FOLLOW-UP TRAINING: None

GRADING WEIGHT FACTORS: Performance of tasks throughout the course will be strictly on a go/no go basis.

9

OUTLINE OF INSTRUCTION

Topic	Unit 1.1	CLASS	PRACT	TOTAL	PAGE
	Introduction				
1.1.1	Orientation	1.5	0	1.5	3
1.1.2	Safety	$\frac{.5}{2}$	$\frac{0}{0}$	$\frac{.5}{2}$	3
	Unit 1.2				
	Ceramic Tile Setting				
1.2.1	Mortar Mixing and Ceramic Tile Setting Surface	3	7	10	3
1.2.2	Ceramic Tile Installation	$\frac{3}{6}$	$\frac{17}{24}$	$\frac{20}{30}$	3

- * Total Periods Classroom: 8
- * Total Periods Practical: 24
- Total Hours for Course: 32
- Total weeks for course: 1 Week

* Each period of instruction represents 60 minutes of actual instruction.

OUTLINE OF TRAINING OBJECTIVES

Unit 1.1 INTRODUCTION

Contact Hours: 2

Terminal Objectives: Upon completion of this unit the student will have reported to Builder School, received the school's orientation and safety procedures required to complete the assigned course of instruction as a SCBT student.

Topic 1.1.1 ORIENTATION

Contact Hours: 1.5

Enabling Objectives: Upon completion of this topic the student will have reported for the course and answered questions pertaining to key points on the organization, mission and regulations of NAVCONSTRACEN.

Topic 1.1.2 SAFETY

Contact Hours: .5

Enabling Objectives: Upon completion of this topic the student will be able to report accidents of fire, and state the safety practices that will be enforced in the school.

Unit 1.2 CERAMIC TILE SETTING

Contact Hours: 30

Terminal Objectives: Upon completion of this unit the student will have completed a ceramic tile project involving mortar preparation, surface preparation, tile layout planning, tile setting, tile cutting and the grouting of tile joints. Procedures, standards and conditions for all work will be set forth in the enabling objectives of individual topics.

Topic 1.2.1 MORTAR MIXING AND CERAMIC TILE SURFACE PREPARATION

Contact Hours: 10

Enabling Objectives: Upon completion of this topic the student will be able to mix mortar by hand and by using the 6 cubic foot mortar mixer, and prepare a concrete masonry wall to receive ceramic tile. All work is to be done by following procedures in accordance with Job Sheet SCBT 167.1 BU JS 1.2.1.1, Mortar Mixing by Hand, SCBT 167.1 BU JS 1.2.1.2, Operating the 6 cubic foot Mortar Mixer and SCBT 167.1 BU JS 1.2.1.3, Tile Setting Bed Application. The mixed mortar must have the consistency required to be applied to masonry surface, and the prepared tile setting bed surface must be smooth and plumb to 1/8 of an inch. Required job sheets will be provided for student use.

Topic 1.2.2 CERAMIC TILE INSTALLATION

Contact Hours: 20

Enabling Objectives: Upon completion of this topic the student will be able to install ceramic tile (field tile, base tile, cap tile, inside corner tile and quarry tile) over plaster, sheet rock, wood and concrete masonry wall surfaces with appropriate tile adhesive, lay out for tile setting and grout the tile project by following job sheet procedure. The completed ceramic tile project must be level, plumb, each tile must be individually seated, tile spacing will be within 1/16" of lug spacing and the tile grout must be without void. Job Sheet SCBT 167.1, 1.2.2.1 Installing Ceramic Tile, will be provided for student use.

ANNEX I

TEXTS

1. Builder 3 & 2, NAVPERS 10648-F.

A-I-1

ANNEX II

REFERENCES

1. Plastering Skills and Practices, Brand and Hartsel, American Technical Society.
2. Handbook for Ceramic Tile Installation, Tile Council of America.
3. Glazed Ceramic Tile, No. 105 15M-7/75, Standard Brand Paint Company, Inc.
4. Complete Do-it-Yourself Manual, Reader's Digest.

ANNEX III

TOOLS, EQUIPMENT AND MATERIAL

TOOLS:

1. Measuring Tape.
2. Trowel Pointing
3. Level, hand
4. Tile cutter
5. Tile nipper
6. Squeegee
7. Sponge..
8. Joint striking tool
9. Beating block
10. Notched trowel
11. Bucket
12. Shovel, flat nose.
13. Trowel, plastering
14. Hawk
15. Darby
16. Straight edge
17. Rake
18. Measuring box, 1 cubic foot
19. Float, wood

EQUIPMENT:

1. Mortar boat.
2. Mortar box

TOOLS, EQUIPMENT AND MATERIALS (CONT'D).

- 3. 6 cubic foot mortar mixer
- 4. Georgia buggy.

MATERIALS

- 1. Sand
- 2. Lime
- 3. Ceramic Tile
 - a. Field
 - b. Outside corner
 - c. Cap
 - d. Base
- 4. Quarry Tile



15

ANNEX IV

TRAINING AIDS AND DEVICES:

Films:

1. Lath and Plaster (22 min.) American Gypsum Company.

Slide Presentation:

1. How to get Better Clay Tile Installation (16 min.) Tile Council of America.

Locally Prepared Material:

1. Display Board.
 - a. Ceramic Tile set on water-resistant drywall with exposed portion on the surface.
2. Job Sheets.
 - a. SCBT 167.1 BU JS 1.2.1.1 Mortar Mixing by Hand.
 - b. SCBT 167.1 BU JS 1.2.1.2 Operating the 6 cubic foot Mortar Mixer.
 - c. SCBT 167.1 BU JS 1.2.1.3 Tile Setting Bed Application.
 - d. SCBT 167.1 BU JS 1.2.2.1 Installing Ceramic Tile
3. Samples.
 - a. Tiles.
 - (1) Glazed wall
 - (2) Quarry
 - (a) Waxed
 - (b) Non-waxed.
 - (3) Mosaic
 - (a) Paper backing.
 - (b) Outside corner.
 - (c) Rubber backing.

A-IV-1

16

Locally Prepared Materials: (Cont'd)

b. Common varieties of tiles:

- (1) Field
- (2) Outside corner
- (3) Inside corner
- (4) Cap
- (5) Base

c. Tools.

- (1) Hawk
- (2) Darby
- (3) Rake
- (4) Straight edge
- (5) Tile cutter
- (6) Tile nipper
- (7) Squeegee
- (8) Sponge
- (9) Joint striking tool
- (10) Beating block
 - (a) Ceramic tile
 - (b) Quarry floor tile
- (11) Notched trowel
- (12) Pointing trowel
- (13) Plastering trowel

17-

ANNEX V

Training Aids Equipment:

1. 16 mm projector.
2. Slide projector
3. Tape player
4. Movie screen

A-V-1

18

ANNEX VI

MASTER SCHEDULE

FIRST WEEK

<u>TOPIC NO.</u>	<u>TYPE</u>	<u>PERIOD</u>	<u>TITLE</u>	<u>RATIO</u>
------------------	-------------	---------------	--------------	--------------

FIRST DAY

1.1.1	C	1	Orientation	16/1
		2		
1.1.2	C	2.5	Safety	16/1
1.2.1	C	3	Mortar Mixing and Ceramic Tile	16/1
		4	Setting Surface	
1.2.2	C	5	Ceramic Tile Installation	16/1
		6		
		7		

SECOND DAY

1.2.1	P	8	Mortar Mixing and Ceramic Tile	8/1
			Setting Surface.	
		9		
	C	10		
	P	11		
		12		
		13		
		14		

THIRD DAY

1.2.1	P	15	Mortar Mixing and Ceramic Tile	8/1
			Setting Surface	
1.2.2	P	16	Ceramic Tile Installation	8/1
		17		
		18		
		19		
		20		
		21		

FOURTH DAY

1.2.1	P	22	Mortar Mixing and Ceramic Tile	8/1
			Setting Surface	
1.2.2	P	23	Ceramic Tile Installation	6/1
		24		
		25		
		26		
		27		
		28		

19.

FIRST WEEK (CONT'D)

<u>TOPIC NO.</u>	<u>TYPE</u>	<u>PERIOD</u>	<u>TITLE</u>	<u>RATIO</u>
<u>FIFTH DAY</u>				
1:2.2	P	29 30 31 32	Ceramic Tile Installation	8/1

A-VI-2

MODIFICATIONS

Instructor Guide

1.1.1 of this publication has (have) been deleted in adapting this material for inclusion in the "Trial Implementation of a Model System to Provide Military Curriculum Materials for Use in Vocational and Technical Education." Deleted material involves extensive use of military forms, procedures, systems, etc. and was not considered appropriate for use in vocational and technical education.

NAVAL CONSTRUCTION TRAINING CENTER
PORT HUENEME, CALIFORNIA 93043
SPECIAL CONSTRUCTION BATTALION TRAINING (SCBT) 167.1

Classification: Unclassified

Topic: Safety

Average Time: 0.5 Periods (Class)

Instructional Materials:

A. Texts: None.

B. References:

1. NAVCONSTRACENINST 5400.4, (current series)
"Organization Manual of NAVCONSTRACEN".
2. "Safety Practices for Shore Activities",
NAVMAT P5100, (Jan 1973).

C. Tools, Equipment and Materials: None.

D. Training Aids and Devices:

1. Film.
 - a. GIF-001, "The Gift of Life", (18 min.).

E. Training Aids Equipment:

1. 16mm movie projector.

Terminal Objective: Upon completion of this unit the student will have reported to Builder School, received the school orientation and safety procedures required to complete the assigned course of instruction as a SCBT student.

Enabling Objectives: Upon completion of this topic the student will be able to report accidents or fire, and state the safety practices that will be enforced in the school.

Criterion Test: The student will answer orally specific questions pertaining to the method of reporting and fighting fires as established by NAVCONSTRACEN and CBC regulations, and will conform to the safety policies for the duration of his assignment to Builder School.

Homework: None.

OUTLINE OF INSTRUCTION

INSTRUCTOR ACTIVITY

I. Introduction to the Lesson:

A. Establish contact.

- 1. Name:
- 2. Topic: Safety.

B. Establish readiness.

- 1. Purpose.
- 2. Assignment.

C. Establish effect.

- 1. Value.
 - a. Pass course.
 - b. Perform better on the job.

D. Overview.

- 1. You will be able to answer orally specific questions related to the methods of reporting and fighting fires as established by NAVCONSTRACEN and CBC regulations and conform to the safety practices that will be enforced in this school.
- 2. Ask questions.
- 3. Take notes.

I.A. Introduce self and topic.

I.B. Motivate student.

I.C. Bring out need and value of material being presented.

I.D. State learning objectives.

- 1. State information and materials necessary to guide student.



OUTLINE OF INSTRUCTION

INSTRUCTOR ACTIVITY

23
SCBT 167.1 BU IG 1.1.2
STUDENT ACTIVITY

II. Presentation:

A. Safety.

1. Reporting accidents..

- a. Class safety man.
- b. Instructor.
- c. School director.
- d. First aid when appropriate.

1.a. Pick safety man and explain job.

2. Fire safety.

- a. Evacuation routes.
- b. Reporting fires.
- c. Fighting fire.
 - (1) Location of extinguishers.

3. Field safety.

- a. Show film: GIF-001, "The Gift of Life."
- b. Discuss film highlights.

A.3. Introduce film.

a. Discuss key points to look for.

b. Show film.

3.b. Lead discussion.

1. Ask questions.

2. Stress safety.

3.b. Participate in discussion - ask questions as necessary.

(3 of 4)

OUTLINE OF INSTRUCTION

24
SCBT 167.1 BU IG 1.1.2
STUDENT ACTIVITY

INSTRUCTOR ACTIVITY

III. Application:

A. Discussion.

III.A. Questions to be developed by the instructor.

III.A. Answer and ask questions.

IV. Summary:

A. Safety.

1. Reporting accidents.
2. Fire safety.
3. Field safety.

V. Test:

A. None.

(4 of 4)

36

NAVAL CONSTRUCTION TRAINING CENTER
PORT HUENEME, CALIFORNIA 93043
SPECIAL CONSTRUCTION BATTALION TRAINING COURSE (SCBT) 167.1

Classification: Unclassified

Topic: Mortar Mixing and Ceramic Tile
Setting Surface.

Average Time: 3 Periods (Class) 7 Periods (Pract)

Instructional Materials:

A. Texts:

- 1. Builder 3 & 2, NAVPERS 10648-F, Chapter 14.

B. References:

- 1. Plastering Skills and Practices, Bränden and Hartsel, American Technical Society.

C. Tools, Equipment and Materials:

- 1. Tools.
 - a. Hoe, masons.
 - b. Shovel, flat nose.
 - c. Trowel, plastering.
 - d. Hawk.
 - e. Darby.

Terminal Objective: Upon completion of this unit the student will have completed a ceramic tile project involving mortar preparation, surface preparation, tile layout planning, tile setting, tile cutting and the grouting of tile joints. Procedure, standards and condition for all work will be set forth in the enabling objectives of individual topics.

Enabling Objectives: Upon completion of this topic the student will be able to mix mortar by hand and by using the 6 cubic foot mortar mixer, and prepare a concrete masonry wall to receive ceramic tile. All work is to be done by following procedures in accordance with Job Sheets SCBT 167.1 BU JS 1.2.1.1., Mortar Mixing by Hand. SCBT 167.1 BU JS 1.2.1.2, Operating the 6 Cubic Foot Mortar Mixer, and SCBT 167.1 BU JS 1.2.1.3, Tile Setting Bed Application. The mixed mortar must have the consistency required to be applied to masonry surfaces, and the prepared tile setting bed surface must be smooth and plumb to 1/8 of an inch. Required job sheets will be provided for student use.

Criterion Test: The student will mix mortar by hand and by using the 6 cubic foot mortar mixer, and prepare a concrete masonry wall to receive ceramic tile. The mixed mortar will have the consistency required to be applied to a masonry surface, and the prepared tile setting bed surface will be smooth and plumb to within 1/8 of an inch.



Homework: None

- f. Straight edge.
- g. Rake
- h. Level, hand
- i. Measuring box, 1 cubic foot.
- j. Pail
- k. Float, wood

2. Equipment.

- a. Mortar box.
- b. 6 cubic foot mortar mixer
- c. Georgia buggy
- d. Mortar boat.

3. Materials.

- a. Sand
- b. Lime

D. Training Aids and Devices:

1. Film

- a. Lath and Plaster (22 min.)
American Gypsum Company.

2. Locally Prepared Materials.

- a. Job Sheets.

- (1) SCBT 167.1 BU JS 1.2.1.1
Mortar Mixing by Hand
- (2) SCBT 167.1 BU JS 1.2.1.2,
Operating the 6 cubic foot
Mortar Mixer.
- (3) SCBT 167.1 BU JS 1.2.1.3,
Tile Setting Bed Application

b. Sample.

- (1) Hawk
- (2) Darby
- (3) Rake
- (4) Straight edge
- (5) Trowel, plastering

E. Training Aids Equipment.

- 1. 16 mm projector..
- 2. Movie screen.

OUTLINE OF INSTRUCTION

INSTRUCTOR ACTIVITY

SCBT 167.1 BU IG 1.2.1
STUDENT ACTIVITY

I. Introduction to the lesson.

A. Establish control

- 1. Name
- 2. Topic: Mortar Mixing and Ceramic Tile Setting Surface.

I.A. Introduce self and topic.

B. Establish readiness.

- 1. Purpose.
 - a. Mortar is used as building material for a setting bed. It is important that you be able to mix mortar by hand or with the use of a 6 cubic foot mortar mixer to a definite consistency.
 - b. A smooth surface on a setting bed is necessary so that the ceramic tiles installed on it will be of a flat even surface.

I.B. Motivate student.

2. Assignment.

- a. None

C. Establish effect.

1. Value.

- a. Pass course

I.C. Bring out need and value of material being used.

I.C.1. State learning objectives-
Upon completion of this topic you

OUTLINE OF INSTRUCTION

INSTRUCTOR ACTIVITY

STUDENT ACTIVITY

will be able to mix mortar by hand and with the use of the .6 cubic foot mortar mixer, and prepare ceramic tile setting surface.

- b. Perform better on the job.
- c. Get advanced.
- d. Be a better builder.

D. Overview:

- 1. Job Sheet.
 - a. Follow instructors presentation on job sheet for reinforcement.
 - b. Job sheets are to help clarify doubtful areas in the field.
- 2. Safety precaution in working with lime.
- 3. Ask questions anytime - raise your hand and be recognized.

II. Presentation.

A. Introduce job sheets.

- 1. SCBT 167.1 BU JS 1.2.1.1, Mortar Mixing by Hand.

II.A. Hand out job sheets.

OUTLINE OF INSTRUCTION

- 2. SCBT 167.1 BU JS 1.2.1.2, Operating the 6 Cubic Foot Mortar Mixer.
- 3. SCBT 167.1 BU JS 1.2.1.3, Tile Setting Bed Application.

B. Film

- 1. Introduce film.
 - a. Lath and Plaster.
- 2. Discuss key point.
- 3. Show the film.
- 4. Discuss film highlights.

C. Tools commonly used to apply tile setting bed.

- 1. Hawk.
- 2. Darby.
- 3. Rake.
- 4. Float, wood.
- 5. Trowel, masons.

INSTRUCTOR ACTIVITY

SCBT-167.1 BU IG 1.2.1

STUDENT ACTIVITY

II.B.1. Introduce film, explain that the principles of lath and plaster is identical to the application of tile setting bed.

II.B.2. Point out key points to look for in the film.

II.B.3. Operate projector to show film.

II.B.4. Lead discussion - ask questions.

II.B.4. Participate in discussion,

III.C. Give lecture on tools commonly used to apply tile setting bed. Show tools as each tool is being introduced to reinforce lecture.



OUTLINE OF INSTRUCTION

D. Steps of Procedure.

1. Mortar preparation by hand.

a. Prepare for mortar mixing.

- (1) Mortar box.
- (2) Water
- (3) Mortar ingredients.
 - (a) Lime
 - (b) Sand
- (4) Mixing tools.
 - (a) Shovel, flat nose.
 - (b) Hoe, masons.

b. Place dry mix in mortar box.

- (1) Sand
- (2) Lime

c. Mix mortar.

- (1) Uniform color of mix.

d. Add water.

e. Check mortar for consistency.

INSTRUCTOR ACTIVITY

II.D. Take class out to the field - call student attention to Job Sheet SCBT 167.1 BU 1.2.1.1

II:D.1.a. Select and supervise four students to mix mortar by hand. Simulate actual condition by using lime and sand vice cement, lime and sand.

31
SCBT 167.1 BU IG 1.2.1
STUDENT ACTIVITY ↗

II.D. Turn to job sheet and follow instruction.

II:D.a. If selected do a good job in mixing the mortar. If not, observe mixing procedures closely.

OUTLINE OF INSTRUCTION

INSTRUCTOR ACTIVITY

SCBT 167.1 BU IG 1.2.1
STUDENT ACTIVITY

- (1) Too dry.
- (2) Too wet.
- f. Clean up.
 - (1) Wash down
 - (2) Oil
 - (3) Store mortar box and tools.
- 2. Mortar preparation using the 6 cubic foot mortar mixer.
 - a. Introduce the 6 cubic foot mortar mixer.
 - b. Prestart - check mixer.
 - (1) Check oil
 - (2) Check fuel
 - (3) Lubricate moving parts.
 - (4) Spray inside and outside of drum with water.
 - c. Start mixer.
 - (1) Set choke to start position.
 - (2) Disengage clutch.

II.D.2. Call student attention to Job Sheet SCBT 167.1 BU JS 1.2.1.2

II.D.2. Turn to job sheet and follow presentation.



OUTLINE OF INSTRUCTIONINSTRUCTOR ACTIVITYSCBT 167.1 BU IG 1.2.1
STUDENT ACTIVITY

- (3) Insert pull rope in slot on pulley and wrap it around clockwise..
- (4) Pull sharply on the rope.
- (5) Shut off choke when engine starts.
- d. Engage clutch.
- e. Discharge water from drum.
 - (1) With one hand firmly grasping the discharge handle and the other hand on the locking lever, pull/push discharge lever toward the discharge side of the drum.
 - (2) After water is discharged, pull discharge lever back and lock.
- f. Charge the mixer.
 - (1) Add water.
 - (2) Add lime.
 - (3) Add sand.
 - (4) Mix until lime mortar is uniform in color.

II.D.2.f. Explain that this mix is for training purpose and that in an actual mixing of mortar, cement, lime and sand are used vice lime and sand.

OUTLINE OF INSTRUCTION

INSTRUCTOR ACTIVITY

SCBT 167.1 BU IG 1.2.1
STUDENT ACTIVITY

- g. Check mortar for consistency.
 - (1) Disengage clutch.
 - (2) Scoop a masons trowel of mortar.
 - (3) Settle mortar on trowel.
 - (4) Turn trowel over to check consistency of mortar.

- h. Discharge mortar.
 - (1) Place mortar boat in position.
 - (2) With one hand, firmly grasp the discharge handle and with the other hand on the locking lever, pull/push discharge lever toward the discharge lever toward the discharge side of mixer.
 - (3) Leave drum in discharge position and remove mortar boat.

- i. Secure mortar mixer.
 - (1) Hose out the drum with water.
 - (2) Return drum to charging position.
 - (3) Wash off entire mixer and fill drum 3/4 full with water.
 - (4) Remove hardened mortar.

35

OUTLINE OF INSTRUCTION

INSTRUCTOR ACTIVITY

SCBT 167.1 BU IG 1.2.1
STUDENT ACTIVITY

- (5) Discharge water and hose out drum.
- (6) Lock drum in upright position.
- (7) Disengage clutch.
- (8) Spray mixer with light oil.

3. Application of tile setting bed.

a. Setting bed application tools.

- (1) Trowel, plastering.
- (2) Hawk
- (3) Darby
- (4) Rake
- (5) Straight edge
- (6) Level, hand.

b. Apply 1st coat of setting bed.

- (1) Place mortar on hawk.
- (2) Starting at the top apply mortar with plastering trowel.

c. Scratch the surface of mortar with rake.

d. Install mortar screed.

II.D.3. Call student attention to Job Sheet SCBT 167.1 BU JS 1.2.1.3

II.D.3. Turn to job sheet and follow application procedures.

II.D.3.a. Show tools to reinforce lecture/demonstration.

II.D.3.b. Demonstrate application of setting bed.

OUTLINE OF INSTRUCTION

- (1) Starting at the top run a line of mortar screed $3/4$ " thick and 3 - 4 inches wide.
 - (2) Use hand level and a straight edge, plumb and cut the screed to $3/8$ " thickness.
 - (3) Run another mortar screed at the other end of the wall.
 - (4) At 3 foot interval, run as many screeds as necessary.
- e. Apply mortar between the screeds.
- (1) Apply mortar between the screeds, start at the top and working downward.
 - (2) Strike off excess portion with the straight edge on the screeds.
 - (3) Use darby to finish.

Note: One of the most important steps for tiling successfully is that the wall surface must be flat and smooth. Ceramic tile is rigid and will not bend with the contours. Tiling uneven, wavy or flexible surfaces will cause tile to crack.

INSTRUCTOR ACTIVITY

SCBT 167.1 BU IG 1.2.1
STUDENT ACTIVITY

II.D.3.3(3) Read statement on note to emphasize the importance of this task.

OUTLINE OF INSTRUCTION

III. Application .

- A. Student practice.
 - 1. Mixing mortar by hand.
 - 2. Mixing mortar with the 6 cubic foot mixer.
 - 3. Installing tile setting bed.

IV. Summary

- A. Mortar ingredients.
 - 1. Sand
 - 2. Lime
 - 3. Cement.
- B. Mortar mixing.
 - 1. Hand
 - 2. 6 cubic foot mortar mixer.
- C. Mortar
 - 1. Consistency.
- D. Tools
 - 1. Plastering trowel
 - 2. Hawk

INSTRUCTOR ACTIVITY

III.A. Assign student to mortar mixing tasks, issue tools, assign work area.

III.A.1. Be available to show, assist and supervise.

37
SCBT 167.1 BU IG 1.2.1
STUDENT ACTIVITY

III.A. Student practice.

OUTLINE OF INSTRUCTION

INSTRUCTOR ACTIVITY

SCBT 167.1 BU IG 1.2.1
STUDENT ACTIVITY

- 3. Darby
 - 4. Rake
 - 5. Straight edge.
 - 6. Hand level.
- E. Setting bed application
- 1. Prepare mortar.
 - 2. Apply scratch coat.
 - 3. Apply setting bed.
- V. Test:
- A. The student will perform Criterion Test.



NAVAL CONSTRUCTION TRAINING CENTER
PORT HUENEME, CALIFORNIA 93043
SPECIAL CONSTRUCTION BATTALION TRAINING (SCBT) 167.1

JOB SHEET

Title: Mortar Mixing by Hand

Introduction: This job sheet is to guide you in mixing mortar by hand.

Tools, Equipment and Material:

1. Tools.
 - a. 1 cubic foot measuring box.
 - b. Square nose shovel.
 - c. Mortar hoe.
 - d. Bucket.
2. Equipment.
 - a. Mortar box
3. Materials.
 - a. Lime
 - b.. Sand
 - c. Water

Procedures:

1. Prepare for mortar mixing.
 - a. Locate mortar box in the proximity of job site.
 - b. Have source of water close to the box.
 - c. Have lime and sand close to the box.
 - d. Gather tools for the job.
 - (1) Square nose shovel.
 - (2) Mortar hoe.
 - (3) 1 cubic foot measuring box.

(1 of 2)

(4) Bucket

- 2. Place dry ingredients into mortar box.
 - a. Three cubic foot of sand at one end of the box.
 - b. Place a sack of lime on the sand.
 - c. Place one (1) cubic foot of sand over the lime.

Note: In normal condition cement, lime and sand are used.

- 3. Mix dry ingredients.
 - a. Use short choppy strokes with the mortar hoe, cutting all the way to the bottom and moving the ingredients to the other end of the box.
 - b. Repeat this process until the mixed ingredients are uniform in color..

- 4. Add water to mix.
 - a. Add water a little at a time.
 - b. Mix material simultaneously until desired mortar consistency is acquired.

- 5. Check mix for consistency:
 - a. Scoop trowel full of mortar.
 - b. Tap trowel gently on mortar box to settle the mortar.
 - c. Turn trowel upside down to check for mortar consistency.

- 6. Check work with the instructor.
 - a. Mortar consistency must be within test specified to step 5.

- 7. Clean up tools, equipment and area.
 - a. Wash tools with water.
 - b. Apply light coat of oil on tools.
 - c. Wash out mortar box of all mortar deposits.
 - d. Store mortar box on its side, slightly tipped to keep dry.
 - e. Wash down work area.

NAVAL CONSTRUCTION TRAINING SCHOOL
PORT HUENEME, CALIFORNIA 93043
SPECIAL CONSTRUCTION BATTALION TRAINING COURSE (SCBT) 167.1

JOB SHEET

Title: Operating the 6 cubic foot Mortar Mixer.

Introduction: This job sheet is to guide you in the operation of the 6 cubic foot mortar mixer.

Tools, Equipment and Materials:

1. Tools.
 - a. One cubic foot measuring box.
 - b. Square nose shovel.
 - c. Bucket.
2. Equipment:
 - a. 6 cubic foot mortar mixer.
 - b. Mortar boat.
3. Materials
 - a. Fine sand (masonry)
 - b. Lime
 - c. Water

Procedures:

1. Prestart check mixer.
 - a. Check oil fuel level.
 - b. Lubricate all moving parts which contain a grease fitting.
 - c. Spray inside and outside of drum with water.
 - (1) To prevent mortar from sticking to drum.
2. Start mixer.
 - a. Set choke to start position by turning it clockwise.
 - b. Disengage clutch by pushing down clutch lever.

42

SCBT 167.1 BU JS 1.2.1.2

- c. Insert knot on pull rope in slot on the pulley and wrap rope around clockwise.
- d. Pull sharply on the rope to start engine.
 - (1) If engine fails to start, repeat steps 2c and 2d.
- e. Shut off choke when engine starts.
- 3. Engage clutch.
 - a. Raise clutch lever upward until it locks in position.
- 4. Discharge excess water from drum.
 - a. Firmly grasp discharge handle with one hand, using the other hand to raise locking lever, push or pull discharge lever toward discharge side of drum.
 - b. When discharge is complete, pull discharge lever back in lock position. If drum fails to lock automatically, position lever into locking groove manually.
- 5. Charge mixer.
 - a. Load the mixing drum with 3 cubic foot masonry sand, 1 cubic foot cement and 13 pounds lime.

Note: Blades should be engaged when charging mixer.

 - b. Mix dry ingredients until mix is uniform in color (a minimum of one minute.)
 - c. Add water slowly until mix is uniformly wet - do not add too much water before checking for consistency.
 - d. Mix mortar for at least three minutes before checking for consistency.
- 6. Check mortar consistency (workability).
 - a. Disengage clutch to stop blades.
 - b. Scoop some mortar from the drum with a masons trowel.
 - c. Test the mortar--mortar must be soft and plastic.

Note: Mortar mix consistency will be determined by the instructor.

7. Discharge mortar.
 - a. Discharge mortar into mortar boat by following procedures in step 4.
 - b. Leave drum in discharge position and remove mortar boat.
8. Secure mortar mixer.
 - a. Hose down drum with water.
 - b. Return drum to charge position.
 - c. With the blades turning, wash off the entire mixer and fill drum $3/4$ full with water.
 - d. Remove hardened mortar with a wire brush.
 - e. Discharge water and hose out drum.
 - f. Disengage clutch and stop engine.
 - g. Spray mixer down with a light weight oil to prevent rusting.

Note: The above information is for mixing actual cement mortar, for training purpose a lime mortar is to be mixed. The following instructions will be used in charging the mixer.

9. Charge mixer with lime mortar batch.
 - a. With the operating clutch engage and with the drum filled with three gallons of water, slowly add one sack of lime and mix until lime and water make a slurry.
 - b. Slowly charge the mixer with three cubic feet of masonry sand.
 - c. Mix the lime mortar until it becomes uniform in color, check with the instructor for desired consistency.

NAVAL CONSTRUCTION TRAINING CENTER
PORT HUENEME, CALIFORNIA 93043
SPECIAL CONSTRUCTION BATTALION TRAINING (SCBT) 167.1

JOB SHEET

Title: Tile Setting Bed Application

Introduction: This job sheet is to guide you in the application of tile setting bed to a concrete masonry wall surface.

Tools, Equipment and Materials:

1. Tools.
 - a. Wood float.
 - b. Masons trowel.
 - c. Hawk.
 - d. Straight edge.
 - e. Darby.
 - f. Rake.
 - g. Level, hand.
2. Equipment.
 - a. Mortar boat.
 - b. Mortar board.
3. Materials.
 - a. Sand and lime mortar.

Procedures:

1. Apply first coat of setting bed.
 - a. Scoop up some previously mixed mortar with masons trowel and place it on the hawk.
 - b. Starting at the top of the wall apply mortar to the CMU wall surface - with the masons trowel, push the mortar off the hawk and onto the wall, spreading the mortar with the trowel.
2. Scratch or mar the surface of mortar with a rake.
 - a. Wait until the mortar becomes hard and yet not dry.

(1 of 2)

45

3. Install mortar screed.
 - a. Starting at the top, run a line of mortar screed 3 or 4 inches wide down one side of the wall.
 - b. Use wood float to flatten the surface for mortar screed.
 - c. Use hand level and straight edge, plumb and cut the screed to 3/8 inch thick.
 - d. Run another mortar screed at the other end of the wall.
 - e. At three foot intervals, run as many screed as necessary.

Note: Screeds must be within 1/8 inch of being plumb.

4. Apply mortar between the screeds.
 - a. Start at the top and work downward.
 - b. Using the screed as a guide, strike off excess mortar with the straight edge.
 - c. Use darby to finish.
5. Check work with the instructor.
 - a. The finished tile setting bed surface must be plumb to the 1/8 of an inch.

NAVAL CONSTRUCTION TRAINING CENTER
PORT HUENEME, CALIFORNIA 93043
SPECIAL CONSTRUCTION BATTALION TRAINING COURSE (SCBT) 167.1

Classification: Unclassified

Title: Ceramic Tile Installation

Average Time: 3 Periods (Class) 17 Periods (Pract)

Instructional Materials:

A. Texts:

1. Builder 3 & 2, NAVPERS.10648-F, Chapter 14

B. References:

1. Plastering Skills and Practices, Brandon and Hartsel, American Technical Society.
2. Handbook for Ceramic Tile Installation, Tile Council of America.
3. Glazed Ceramic Tile, No.105 15M-7/75 Standard Brands Paint Company, Inc.
4. Complete Do-It-Yourself Manual, Reader's Digest.

C. Tools, Equipment and Materials:

1. Tools

Terminal Objectives: Upon completion of this unit the student will have completed a ceramic tile project involving mortar preparation, surface preparation, tile layout planning, tile setting, tile cutting and the grouting of tile joints. Procedures, standards and conditions for all work will be set forth in the enabling objectives of individual topics.

Enabling Objectives: Upon completion of this topic the student will be able to install ceramic tile (field tile, base tile, cap tile, inside corner tile and quarry tile) over plaster, sheet rock, wood and concrete masonry wall surface with appropriate tile adhesive, lay out for tile setting and grout the tile project by following job sheet procedures. The completed ceramic tile project must be level, plumb, each tile must be individually seated, tile spacing will be within 1/16" of lug spacing and the tile grout must be without void. Job Sheet SCBT 167.1 BU JS 1.2.2.1 Installing Ceramic Tile, will be provided for student use.

Criterion Test: The student will install ceramic tile (field tile, base tile, cap tile, inside corner tile, and quarry tile) on a masonry wall surface. The completed ceramic tile project will be level and plumb, each tile will be individually seated, tile spacing will be within 1/16" of lug spacing, and the tile grout must be without void.

- c. Level hand.
 - d. Tile cutter.
 - e. Tile nipper.
 - f. Squeegee.
 - g. Sponge.
 - h. Joint striking tool.
 - i. Beating block.
 - j. Notched trowel.
 - k. Bucket.
2. Equipment.
- a. Mortar boat.
3. Materials.
- a. Ceramic tile.
 - (1) Field tile
 - (2) Outside corner tile.
 - (3) Cap tile.
 - (4) Base tile.
 - b. Lime.

75

c. Sand

d. Quarry tile

D. Training Aids and Devices:

1. Slide presentation.

a. How to Get Better Clay Tile Installation
(16 min.) Tile Council of America, Inc.

2. Locally Prepared Materials.

a. Job Sheet.

(1) SCBT 167.1 BU JS 1.2.2.1,
Installing Ceramic Tile.

b. Display Board.

(1) Ceramic tile set on water-resistant
drywall with exposed portion of
organic tile adhesive on the surface.

(2) Three types of glazed tile.

(a) Matte glazed finish.

(b) Bisque (plain).

(c) Glazed.

c. Samples.

(1) Tiles.

- (a) Glazed wall tile.
- (b) Quarry tile
 - 1 Waxed
 - 2 Non waxed.
- (c) Mosaic
 - 1 Paper backing.
 - ~~2~~ Fiber backing
 - 3 Rubber backing.
- (2) Common variety of tiles.
 - (a) Field tile.
 - (b) Outside corner tile.
 - (c) Inside corner tile.
 - (d) Cap tile.
 - (e) Base tile.
- (3) Tools.
 - (a) Tile cutter
 - (b) Tile nipper.
 - (c) Squeegee.
 - (d) Sponge.

(4 of 13)

- (e) Joint striking tool
- (f) Beating block.
 - 1 Ceramic tile.
 - 2 Quarry tile.
- (g) Notched trowel
- (h) Bucket
- (i) Pointing trowel
- (j) Hawk.

E. Training Aids Equipment.

- 1. Slide projector
- 2. Tape player.
- 3. Movie screen.

OUTLINE OF INSTRUCTION

INSTRUCTOR ACTIVITY

5
SCBT 167.1 BU IG 1.2.2
STUDENT ACTIVITY

I. Introduction to the lesson.

A. Establish contact.

1. Name.
2. Topic: Ceramic Tile Installation.

B. Establish readiness.

1. Purpose
 - a. Ceramic tiles are used extensively as wall finishings in bathrooms, showers, and galleys in the battalions. It would be to your advantage to learn to do this well.
2. Assignment.
 - a. Although there is no assignment, review Job Sheet SCBT 167.1 BU JS 1.2.2.1

C. Establish effect.

1. Value
 - a. Pass course
 - b. Perform better on the job.
 - c. Get advanced
 - d. Be a better builder.

I.A. Introduce self and topic.

I.B. Motivate student by stating the purpose.

I.C.1. Bring out need and value of material being presented

OUTLINE OF INSTRUCTION

D. Overview

1. Job Sheet
 - a. Follow instructor's demonstration on the job sheet.
 - b. Job sheet is to help you in the field exercise. When in doubt, refer to it.
2. Safety precautions with tile cutting tools.
3. Ask questions anytime - raise your hand and be recognized.
4. Objectives of this lesson.

II. Presentation

A. Introduce Job Sheet.

1. SCBT 167.1 BU JS 1.2.2.1, Installing Ceramic Tile.

B. Slide presentation.

1. Introduce slide presentation.
 - a. How to Get Better Clay Tile Installation.
2. Discuss key points.
3. Show slide presentation.

INSTRUCTOR ACTIVITY

I.D.1. State learning objectives.

I.D.1. Upon completion of this topic you will be able to install ceramic tile on concrete masonry wall surface.

II.A.1. Hand out job sheet.

II.B.1. Introduce slide presentation.

II.B.2. Point out key points to look for in slide presentation.

52
SCBT 167.1 BU IG 1.2.2
STUDENT ACTIVITY

OUTLINE OF INSTRUCTION

Note: Tape does not have signal for change. This presentation must be previewed to coordinate with narration.

4. Discuss slide presentation highlights.
- C. Tools commonly used to install ceramic tile.
 1. Tile cutter.
 2. Tile nipper.
 3. Pointing trowel.
 4. Squeegee.
 5. Sponge.
 6. Joint striking tool.
 7. Beating block.
 8. Notched trowel.
- D. Types of tile
 1. Glazed wall tile.
 2. Quarry tile.
 3. Mosaic tile.
- E. Varieties of tile.
 1. Field tile.
 2. Outside corner tile.

INSTRUCTOR ACTIVITY

II.B.3. Operate slide projector and tape player.

II.B.4. Lead discussion - ask questions.

II.C. Give lecture on tools. Show tools to reinforce lecture.

II.D. Give lecture on types of tile - show samples of tile and display board on tiles to reinforce lecture.

II.E. Give lecture on the varieties of tiles - show variety samples to reinforce lecture.

53
SCBT 167.1 BU IG 1.2.2
STUDENT ACTIVITY

II.B.4. Participate in discussion.

OUTLINE OF INSTRUCTION

3. Inside corner tile

4. Cap tile.

5. Base tile.

F. Common tile adhesives.

1. Cement

2. Epoxy.

3. Organic.

G. Steps of procedure.

1. Lay out for tile placement.

a. Determine length of wall to be tiled.

b. Calculate width of end tiles.

(1) Divide length of room by $4 \frac{1}{4}$ " to determine number of full tiles needed.

(2) Add $4 \frac{1}{4}$ " to the remainder in step b (1) and divide this sum by 2 for width of end tiles.

Note: End tiles must be greater than one half the width of a tile.

c. Lay out vertical guide lines for tile placement.

INSTRUCTOR ACTIVITY

54
SCBT 167.1 BU IG 1.2.2

STUDENT ACTIVITY

II.F. Give lecture on adhesives - use display board on organic tile adhesives on dry wall to reinforce lecture.

II.G.1. Give lecture/demonstration on layout technique - use chalkboard to demonstrate calculating technique to reinforce lecture. Call student attention to Job Sheet SCBT 167.1 BU JS 1.2.2.1.

II.G.1 Turn to your job sheet.

OUTLINE OF INSTRUCTION

INSTRUCTOR ACTIVITY

55
SCBT 167.1 BU IG 1.2.2
STUDENT ACTIVITY

- (1) Divide the number of full tiles in step b (1) by 2. If half a tile is involved, drop to the next lower full number.
 - (2) Multiply this number by 4 1/4".
 - (3) Add width of end tile acquired in step b (2) to this product...
 - (4) From one end of the wall to be tiled, measure and mark dimension acquired in step c (3).
 - (5) Plumb this mark to desired height of the top tile.
 - (6) Locate highest point of elevation.
 - (7) Measure up the wall to the height of tiles to be applied.
 - (8) Draw a level line for the top of the tile.
2. Lay out a row of tile as a dry run - similar to chasing out the bond in concrete masonry work.
3. Preparation and application of wall tiles.
- a. Soak tiles.
 - (1) In a bucket of water for at least 1/2 hour prior to application.

II.G.1.c.(6) Explain that circumstances dictates the highest or the lowest point of elevation.

II.G.3. Take student out to field practice site and give lecture/demonstration on surface preparation.

56

OUTLINE OF INSTRUCTION

INSTRUCTOR' ACTIVITY

SCBT 167.1 BU, IG 1.2.2
STUDENT ACTIVITY

- b. Apply pure coat (neat cement).
 - (1) Allow water (cement) lime mix to stand for 20 minutes.
 - (2) Remix to creamy consistency.
 - (3) Apply pure coat over area where tile could be laid immediately.
- c. Lay out vertical guide lines.
- d. lay out horizontal guide lines.
 - (1) Lay out for top of second course of tile.
- e. Set first course of field tile to the horizontal guide line.
 - (1) Place the first two tiles with the inside edge against the vertical guide line and press into pure coat.
 - (2) Set the remaining course of tiles.
 - (3) Measure, cut, and set the two end tiles.
 - (4) Check entire course for level.
- f. Apply remaining courses of tile.

57

OUTLINE OF INSTRUCTION

INSTRUCTOR ACTIVITY

SCBT 167.1 BU IG 1.2.2
STUDENT ACTIVITY

- (1) Use the first course as guide and lay up three courses of tile.
 - (2) Check for level and seat tile as needed with the use of beating block.
 - (3) Before laying up three more courses, use trowel to cut through neat coat to setting bed mortar for control joint.
- g. Apply setting bed on floor.
- h. Apply neat cement.
- i. Install quarry (fiber) tile.
- (1) In this manner apply tile as required.
- j. Grout joints.
- (1) Mix white cement and water to a thick paste.
 - (2) Use sponge or your hand to work grout into joint.
 - (3) Allow grout to set for 20 - 30 minutes and clean entire surface with clean sponge, water, and squeegee.

58

OUTLINE OF INSTRUCTION

INSTRUCTOR ACTIVITY

SCBT 167.1 BU IG 1.2.2
STUDENT ACTIVITY

III. Application

A. Student practice.

III.A. Assign student to work site, issue tools and materials.

III.A. Student practice

III.A.1. Be available to show, assist and supervise.

IV. Summary.

A. Types of tile

1. Glazed wall tile.
2. Quarry tile
3. Mosaic tile.

B. Variety of tile.

1. Field tile.
2. Outside corner tile.
3. Inside corner tile.
4. Cap tile.
5. Base tile.

V. Test:

A. Student will perform Criterion Test as stated.

(13 of 13)

NAVAL CONSTRUCTION TRAINING CENTER
PORT HUENEME, CALIFORNIA 93043
SPECIAL CONSTRUCTION BATTATION TRAINING (SCBT) 167.1

JOB SHEET

Title: Installing Ceramic Tile.

Introduction: This job sheet is to guide you in installing ceramic tile to concrete masonry wall and quarry tile to the floor.

Tools, Equipment and Materials:

1. Tools.*
 - a. Tile cutter.
 - b. Tile nipper.
 - c. Squeegee.
 - d. Sponge.
 - e. Joint striking tool.
 - f. Beating block
 - (1) Ceramic tile
 - (2) Quarry tile.
 - g. Notched trowel
 - h. Bucket.
 - i. Pointing trowel
 - j. Hawk.
 - k. Measuring tape.
 - l. Level, hand.
2. Equipment.
 - a. Mortar boat.
3. Materials.
 - a. Lime mortar.
 - b. Ceramic tile.

(1 of 4)

60

- (1) Field tile:
 - (2) Outside corner tile.
 - (3) Cap tile.
 - (4) Base tile.
- c. Quarry tile.

Procedures:

1. Lay out for tile placement.

- a. Determine length of wall to be tiled.
- b. Calculate width of end tiles.

- (1) Divide length of room by $4\frac{1}{2}$ " to determine number of full tiles needed.
- (2) Add $4\frac{1}{2}$ " to the remainder from step b(1) and divide this sum by 2 for width of end tiles.

Note: End tiles must be greater than one half the width of a tile.

c. Lay out vertical guide line for tile placement.

- (1) Divide the number of full tiles in step b(1) by 2. If half a tile is involved, drop to the next lower full number.
- (2) Multiply this number by $4\frac{1}{4}$ ".
- (3) Add width of end tile acquired in step b(2) to this product.
- (4) From one end of the wall to be tiled, measure and mark dimension acquired in step c(3).
- (5) Plumb this mark to the desired height of the top tile.
- (6) Locate highest point of elevation.
- (7) Measure up the wall to the height of tiles to be applied.
- (8) Draw a level line for the top of the tile.

2. Lay out a row of tile as a dry run - similar to chasing out the bond in concrete masonry work.
3. Preparation and application of tile.
 - a. Soak tile.
 - (1) In a bucket of water for at least 1/2 hour prior to application.
 - b. Apply pure coat.
 - (1) Allow water (cement) lime mix to stand for 20 minutes.
 - (2) Remix to creamy consistency.
 - (3) Apply pure coat over area where tile could be applied immediately.
 - c. Lay out vertical guide line.
 - d. Lay out horizontal guide line.
 - (1) One full tile above the base tile from the highest point of elevation.
 - (2) Draw level line for top of second course of tile.
 - e. Set first course of field tile to horizontal guide lines.
 - (1) Place the first two tiles with the inside edge against the vertical guide line, the top of the tiles aligned to the horizontal guide line and press the into pure coat.
 - (2) Set the remaining course of tiles.
 - (3) Measure, cut and set the two end tiles in place.
 - (4) Check entire course for level.
 - f. Apply next three courses of tile.
 - (1) Use first course as guide.
 - (2) Check for level and seat tile as needed with the use of beating block.
 - (3) Use trowel to cut through next neat coat to setting bed mortar for control joint.

62

SCBT 167.1 BU JS 1.2.2.1

- g. Apply base tile.
- h. Apply course of tile as needed.
 - (1) Cut through neat coat to setting bed mortar every three course of tile.
- i. Apply setting bed on floor.
- j. Apply neat cement.
- k. Install quarry (floor) tile.
 - (1) Use beating block for quarry tile and seat tile.
- 3. Grout tile joints.
 - a. Mix white cement and water
 - (1) To thick paste.
 - b. Use sponge and/or hand to work grout into joint.
 - c. Allow grout to set for 20 - 30 minutes and clean entire surface with clean sponge, water, and squeegee.
- 5. Check work with instructor.
 - a. Tile work must be level to $\pm 1/16''$.
 - b. Tile must be individually seated.
 - c. Tile joints spacing must be within $1/16''$ of required specifications..
 - d. Grouting of tile joints must be without void.

101

CHAPTER 14 PLASTERING, STUCCOING AND TILE SETTING

PLASTER and STUCCO, like concrete, are construction materials which are applied in a plastic condition; and which harden in place after being applied. The fundamental difference between plaster and stucco is simply one of location; if the material is used internally it is called plaster; if it is used externally it is called stucco.

Again like concrete, the active ingredient in plaster is a CEMENTITIOUS material, or BINDER. If plaster is applied in more than one layer, the top layer is called the FINISH COAT and each of the lower layers is a BASE COAT. Plaster for a finish coat may consist of binder alone; however, most finish coat plaster and most base coat plaster contains AGGREGATE as well as binder. Plaster aggregate may consist of sand or one of several other materials. The aggregate in plaster, like the aggregate in concrete, provides additional bulk and stability.

You can see that plaster is to a large extent very much like concrete. The principal difference lies in the fact that concrete can, because of its high compressive strength, be used as a load-bearing structural material. The considerably lower strength of plaster has, up until now, confined its use principally to finish. However, experiments are being conducted with an eye to developing plasters with load-bearing strength.

A plaster mix, like a concrete mix, is made plastic for application by the addition of water to the dry ingredients. Again like concrete, it is a reaction of the binder to the water called HYDRATION that causes the mix to harden.

PLASTER INGREDIENTS

The binders most commonly used for plaster are GYPSUM, LIME, and PORTLAND CEMENT. Because gypsum plaster should not be exposed to free water or severe moisture conditions, it is usually confined to interior use. Lime and portland cement plaster may be used both internally and externally.

GYPSUM PLASTER

Gypsum is a naturally occurring sedimentary gray, white, or pink rock. The natural rock is crushed and then heated to high temperature, a process (known as CALCINING) which drives off about three-quarters of the WATER OF CRYSTALLIZATION which forms about 20 percent by weight of the rock in a natural state. The calcined material is then ground to a fine powder, to which certain ADDITIVES are added to control set, stabilization, and other physical or chemical characteristics.

For a type of gypsum plaster called KEENE'S CEMENT the crushed gypsum rock is heated until nearly all of the water of crystallization is driven off. To offset slow-setting caused by absence of so much WATER OF HYDRATION, an Englishman named Keene patented a process of adding alum as an accelerator. The resulting plaster, called Keene's cement, produces a very hard, fine-textured finish coat.

The removal of water of crystallization from natural gypsum is a DEHYDRATION process. In the course of setting, mixing water (water of hydration) added to the mix REHYDRATES with the gypsum, thus causing RECRYSTALLIZATION. Recrystallization causes the plaster to harden.

There are four common types of gypsum basecoat plasters, as follows:

GYPSUM NEAT plaster is gypsum plaster without aggregate, intended for mixing with aggregate on the job.

GYPSUM READY-MIXED plaster consists of gypsum and ordinary mineral aggregate; at the job it requires addition of only the water.

GYPSUM WOOD-FIBERED plaster consists of calcined gypsum combined with not less than 0.75 percent by weight of non-staining wood fibers. It may be used as is or mixed with 1 part sand to produce base coats of superior strength and hardness.

GYPSUM BOND plaster is so-called because it is designed to bond to properly prepared

monolithic concrete. It consists essentially of calcined gypsum mixed with from 2 to 5 percent of lime by weight.

There are five common types of gypsum finish coat plasters, as follows:

READY-MIX GYPSUM FINISH plasters are designed for use over gypsum plaster base-coats. They consist of finely ground calcined gypsum, some with and others without aggregate. At the job they require addition of water only.

GYPSUM ACOUSTICAL plasters are designed to reduce sound reverberation.

GYPSUM GAUGING plasters contain **LIME PUTTY**, the inclusion of which provides certain setting properties, increases dimensional stability during drying, and provides initial surface hardness. Gauging plasters are obtainable as **SLOW-SET**, **QUICK-SET**, and **SPECIAL HIGH STRENGTH**.

GYPSUM MOLDING plaster is used primarily in casting and ornamental plaster work. It is available neat (that is, without admixtures) or with lime. As with portland cement mortar, the addition of lime to a plaster mix makes the mix more "buttery."

KEENE'S CEMENT is a fine, high density plaster capable of creating a highly polished surface. It is customarily used with lime putty, and with fine sand which provides crack-resistance.

LIME PLASTER

LIME is obtained principally from the burning (called calcining) of **LIMESTONE**, a very common mineral. During the calcining process certain chemical changes occur which transform the limestone into what is called **QUICK-LIME**. Quicklime which meets certain requirements is pulverized for building use; other quicklime is further processed into **HYDRATED lime** for building use.

Before being used for plastering, quicklime must be **SLAKED**. Slaking consists of adding the quicklime to water. Be careful when adding quicklime to water because of a chemical change that will occur. For example, always add quick-slaking lime to water; when escaping steam appears, the lime should be hoed and just enough lime added to stop the steaming. When mixing medium-slaking and slow-slaking limes, the water should be added to the lime. The slow-slaking lime must be mixed under an

ideal temperature; thereby making it necessary to heat the water in cold weather. Magnesium lime is easily "drowned" so be careful when adding too much water to quick-slaking calcium lime. When too little water is added to either calcium or magnesium limes they can be "burned." Whenever lime is burned or drowned, a part of it is spoiled and it will not harden and the paste is not as viscous and plastic as it should be. The quicklime must be soaked for an extended period of as much as 21 days. The end-product is plastic **LIME PUTTY**.

Because of the delays involved in the slaking process, most building lime is hydrated lime. **NORMAL** hydrated lime is converted into lime putty by soaking for at least 16 hours. **SPECIAL** hydrated lime develops immediate plasticity when mixed with water and may be used right after mixing.

Like calcined gypsum, lime plaster tends to return to its original rock-like state after application.

For interior basecoat work, lime plaster has been largely supplanted by gypsum plaster. It is now used principally for interior finish coats. Because lime putty is the most plastic and workable of the cementitious materials used in plaster, it is often added to other less workable plaster materials to improve plasticity. For lime plaster, lime (in the form of either dry hydrate or lime putty) is mixed with sand, water, and a **GAUGING MATERIAL**. A gauging material is intended to produce early strength and to counteract shrinkage tendencies. The gauging material may be either **GYPSUM GAUGING PLASTER** or Keene's cement for interior work, or portland cement for exterior work.

PORTLAND CEMENT

Portland cement plaster is similar to the portland cement mortar used in masonry. It may contain cement, sand, and water only; however, lime, ground asbestos, or some other plasticizing material is usually added for "butteriness."

Portland cement plaster may be applied direct to exterior and interior masonry walls. Elsewhere it will be applied over metal lath. Never apply portland cement plaster over gypsum plasterboard or over gypsum tile. Portland cement plaster is recommended for use in plastering walls and ceilings of large walk-in refrigerators and cold storage spaces, basement

65

BUILDER 3 & 2

spaces, toilets, showers, and similar areas where an extra hard or highly water-resistant surface is required.

AGGREGATE

The aggregates most commonly used in plaster are SAND, VERMICULITE, and PERLITE. Generally speaking, any sand retained on the No. 4 sieve is too coarse to use in plaster, and only a small percentage of the material (about 5 percent) should pass the No. 200 sieve.

Sand

Sand for plaster, like sand for concrete, must be free of more than a specified minimum of organic impurities and harmful chemicals. Certain tests for these impurities and chemicals are conducted by qualified personnel.

Proper aggregate gradation influences plaster strength and workability, and likewise has an effect on the tendency of the material to shrink or expand while setting. For sand intended for use in gypsum plaster, recommended gradation is as follows:

Sieve Size	Percentage Retained by Weight	
	Max	Min
No. 4	0	-
No. 8	5	0
No. 16	30	5
No. 30	65	30
No. 50	95	65
No. 100	100	90

For sand intended for use in exterior plaster, recommended gradation is as follows:

Sieve Size	Percentage Retained by Weight	
	Max	Min
No. 4	0	-
No. 8	10	0
No. 16	40	10
No. 30	65	30
No. 50	90	70
No. 100	100	95

Plaster strength is reduced if excessive fine aggregate material is present in a mix. The greater quantity of mixing water required raises the water:cement ratio, thereby reducing the dry set density. The cementitious material becomes overextended, because it must coat a relatively larger overall aggregate surface.

An excess of coarse adversely affects workability; the mix becomes "harsh working" and difficult to apply.

Plaster shrinkage during drying may be caused by an excess of either fine or coarse. Because an excess of fine increases the aggregate total surface area, a larger quantity of binder paste is needed to coat all particles. The mix becomes too rich in cementitious material, and it is the cementitious material which is unstable after application. The end effect is much the same if there is too much coarse; in this case, there is not enough fine to fill the voids between coarse particles, and more cementitious material must be used to fill these voids. Again the result is a rich and relatively unstable material.

Vermiculite

VERMICULITE is a MICACEOUS mineral—meaning a mineral in which each particle is LAMINATED, or made up of adjoining layers. When vermiculite particles are exposed to intense heat, steam forms between the layers so as to force them apart; this causes each particle to increase from 6 to 20 times in volume. The expanded material is soft and pliable, with a color varying between silver and gold.

For ordinary plaster work, vermiculite is used only with gypsum plaster—therefore, in general, only for interior plastering. For acoustical plaster, vermiculite is combined with a special acoustical binder.

Expanded vermiculite is manufactured in five types (I, II, III, IV, and V) according to particle size. Only type III is used in plastering. It is the lightest of the standard plaster aggregates, weighing only from 6 to 10 lbs per cu ft. The approximate dry weight of a cu ft of 1:2 gypsum-vermiculite plaster is 50 to 55 lbs; the dry weight of a cu ft of comparable sanded plaster is 104 to 120 lbs.

For gypsum-vermiculite plaster the following gradation for the vermiculite is recommended:

Sieve Size	Percentage Retained by Volume	
	Max	Min
No. 4	0	-
No. 8	10	0
No. 16	75	40
No. 30	95	65
No. 50	98	75
No. 100	100	90

Perlite

Raw perlite is a volcanic glass which, when flash-roasted, expands to form frothy particles of irregular shape that contain countless minute air cells. Perlite ore is crushed and then heated to high temperature; as the particles soften, combined water turns to steam. This causes the particles to "pop," forming a frothy mass of glass bubbles 4 to 20 times the volume of the raw particle. The process is called **EXPANDING**; the color of expanded perlite ranges from pearly white to grayish white.

Perlite is used with calcined gypsum or portland cement for interior plastering; it is also used with special binders for acoustical plaster. The approximate dry weight of a cu ft of 1:2 gypsum-perlite plaster is 50 to 55 lbs, or about half the weight of a cu ft of sand-plaster.

For gypsum-perlite plaster the recommended gradation for the perlite is as follows:

Sieve Size	Percentage Retained by Volume	
	Max	Min
No. 4	0	-
No. 8	5	0
No. 16	60	10
No. 30	95	45
No. 50	98	75
No. 100	100	88

Other Aggregates

Although sand, vermiculite, and perlite constitute the great preponderance of plaster-aggregate, certain other materials are used. Wood fiber may be added to neat gypsum plaster at the time of manufacture, to improve the working qualities of the gypsum. **PUMICE** is a

naturally foamed volcanic glass similar to perlite, but heavier (28 to 32 lbs per cu ft, against 7.5 to 15 lbs for perlite). The weight differential gives perlite an economic advantage, and limits the use of pumice to localities near where it is produced.

WATER

The mixing water in plaster performs two functions. First, it transforms the dry ingredients into a plastic, workable mass; second, it combines mechanically and/or chemically with the binder to induce hardening. As is the case with concrete, there is a maximum quantity of water per unit of binder required for complete hydration, and an excess over this amount reduces the plaster strength below the maximum attainable.

However, in all plaster mixing more water is added than is necessary for complete hydration of the binder; the excess is necessary to bring the mix to workable consistency. The amount that must be added for workability depends on the character and age of the binder, the method of application, the drying conditions, and the tendency of the base to absorb water. A porous masonry base, for example, will draw a good deal of water out of a plaster mix. If this reduces the water content of the mix, below the maximum required for hydration, incomplete curing will result.

As a general rule, only the amount of water required to attain workability is added to a mix, and no more. The water should be clean and fresh, and it must contain no dissolved chemicals which might accelerate or retard the set. Water previously used to wash plastering tools should never be used for mixing plaster; such water may contain particles of set plaster which may accelerate setting. Stagnant water should be avoided, because such water may contain organic material which may retard setting and possibly cause staining.

PLASTER BASES

For plastering there must be a continuous surface to which the plaster can be applied and to which it will cling; such a surface is called a plaster **BASE**. A continuous concrete or masonry surface may serve as a base without the necessity for further treatment.

For plaster planes such as those defined by the inner edges of studs or the lower edges of



67

joists, however, base material must be installed to form a continuous surface which will span the spaces between the structural members. Material of this kind is called LATH. Lath formerly consisted of thin wooden strips which were nailed at right angles to the studs or joists. Narrow openings were left between adjacent laths, through which the plaster penetrated to form a KEY which bonded the plaster to the lath.

In modern plastering, wooden lath has been almost entirely superseded by GYPSUM lath and METAL lath.

GYPSUM LATH

Gypsum lath is made by sandwiching a core of gypsum plaster between two sheets of a fibrous, absorbent paper. For PLAIN (non-perforated) gypsum lath, bond is effected by absorption or suction of the face of the lath. This absorption draws in some of the cementitious material in the plaster. As the plaster sets, particles of this absorbed material interlock with nonabsorbed particles in the plaster. For PERFORATED (punched with 3/4-in. holes 4 in. apart) gypsum plaster, suction bond is supplemented by keys formed by plaster which penetrates the holes.

Standard sheet size for gypsum lath is 16 in. x 48 in., except in the western U.S., where it is 16 1/5 in. x 48 in. LONG LENGTH gypsum lath comes 16 or 24 in. wide and any length up to 12 ft as ordered. Available thicknesses are 3/8 in. and 1/2 in. INSULATING gypsum lath has aluminum foil bonded to the back of the sheet; this material provides thermal insulation and also serves as a vapor barrier.

Gypsum lath is nailed to studs, joists, or furring strips with 1 1/8-in. to 1-1/4 in. flat-headed GYPSUM LATH NAILS, 5 nails to each stud, joist, or strip crossing. It may also be attached with power-driven staples.

METAL LATH

Metal lath consists essentially of a metal screen. Bond is created by keys formed by plaster forced through the screen openings; as the plaster hardens, it and the metal become rigidly interlocked.

WIRE lath consists simply of wire screen, formed by weaving or welding intersecting wires together. SHEET metal lath consists of

sheet metal perforated with openings of various shapes. EXPANDED metal lath is manufactured by first cutting staggered slits in a sheet and then expanding (stretching) the sheet to form the screen openings. RIB EXPANDED metal lath contains V-shaped metal ribs for the purpose of furring the lath out from the surface to which it is attached. Ordinary unribbed expanded metal lath is called FLAT EXPANDED.

Types of Flat Expanded Lath

DIAMOND MESH lath, suitable for all types of plastering, comes in 24-in. x 96-in. and 27-in. x 96-in. sheets.

SELF-FURRING DIAMOND MESH contains DIMPLES which fur it out 1/4 in. from the surface to which it is attached. This lath may be nailed to smooth concrete or masonry surfaces, or wrapped around structural steel, without the necessity for previous furring. It is widely used for replastering old walls and ceilings when the removal of the old plaster is not desired. Standard sizes are the same as for diamond mesh.

PAPER-BACKED DIAMOND MESH is designed to receive plaster applied by machine.

STUCCO MESH has larger openings than diamond mesh; it is intended primarily for exterior plastering.

Types of Rib Expanded Lath

FLAT rib lath has ribs 1/8 in. deep; THREE-EIGHTHS INCH rib lath has ribs 3/8 in. deep; and THREE-QUARTER INCH rib lath has ribs 3/4 in. deep. Standard sheet sizes for flat and three-eighths are the same as for diamond mesh. For three-quarter the widths are the same, but lengths of 120 in. and 144 in. are available besides 96 in.

Attachment of Metal Lath

Metal lath is nailed to vertical wooden supports (such as wall studs or wall furring strips) with 4d common nails. It is nailed to horizontal wooden supports (such as ceiling joists or ceiling furring strips) with 1 1/2-in. barbed roofing nails. It may also be attached to wooden supports with power-driven staples. For attachment to metal supports, tie wires are used.

LATHING ACCESSORIES

LATHING ACCESSORIES consist of STRUCTURAL COMPONENTS and MISCELLANEOUS

68

ACCESSORIES. The principal use of structural components is in the construction of **HOLLOW PARTITIONS**. A hollow partition is one which contains no building framing members (such as studs and plates). Structural components are lathing accessories which take the place of the missing framing members in supporting the lath. They include prefabricated **METAL STUDS** and floor and ceiling **RUNNER TRACKS**. The runner tracks take the place of missing stud top and bottom plates; they usually consist of metal **CHANNELS**. Channels are also used for furring and bracing.

Miscellaneous accessories consist principally of various devices which are attached to the lath at corner and other locations, and which serve to define and reinforce corners, to provide dividing strips between plaster and the edges of baseboard or other trim, or to define plaster edges at unframed openings. **CORNER BEADS** are the most common miscellaneous accessories. Figure 14-1 shows a **STANDARD FLANGE** corner bead, in which the flanges are perforated metal. There are also **EXPANDED FLANGE** and **WIDE FLANGE** corner beads. **CASING BEADS** are similar devices for providing dividing strips between plaster edges and the edges of door and window casing. **BASE BEADS** (also called **BASE SCREEDS**) provide dividing strips between plaster edges and the edges of baseboards. All of these devices are attached to the lath before plaster is applied.

be especially noticeable. The grounds are designed to be used as guides for the plastering straightedge when the final basecoat is brought to the required thickness and line. Such miscellaneous accessories as casing beads and base beads serve as grounds, in addition to providing dividing strips between plaster edges and the edges of trim.

Edges of door and window jambs are often used as grounds; however, it is not advisable to plaster directly to the wood in such cases. Contact between the dimensionally unstable wood and the more stable plaster produces differential movement (additionally complicated by the shock of opening and closing of door or window) which may damage plaster edges. If casing beads are not used, the plaster should be struck away from the wooden jamb after the surface has been leveled.

PLASTER SCREEDS are grounds consisting of narrow strips of plaster 4 to 6 in. wide, placed at intervals on large wall or ceiling areas. **DOTS** of plaster of the proper thickness are placed first, then connected by bands of the proper thickness. The spaces between the bands are then filled in, after the band (that is, the screeds) have hardened enough to support the plastering straightedge. Dampness will damage plaster; therefore, plaster should not be applied directly to exterior masonry walls. However, in such a case, it is advisable to fur the plaster at least 1 inch from the masonry.

MIXING PLASTER

Much plaster comes ready-mixed, requiring only the addition of enough water on the job to attain minimum required workability. For job-mixing, tables are available which give recommended ingredient proportions for gypsum, lime, lime-portland cement, and portland cement plaster for base coats on lath or on various types of concrete or masonry surfaces, and for finish coats of various types. This course can present recommended proportions for only the more common types of plastering situations. In the following sections, 1 part of cementitious material means 100 lbs (1 sack) gypsum, 100 lbs (2 sacks) hydrated lime, 1 cu ft lime putty, or 94 lbs (1 sack) portland cement. One part of aggregate means 100 lbs sand or 1 cu ft vermiculite or perlite. Vermiculite and perlite are not used with lime plaster; therefore, while aggregate parts given for gypsum or portland cement plaster may be presumed to refer to

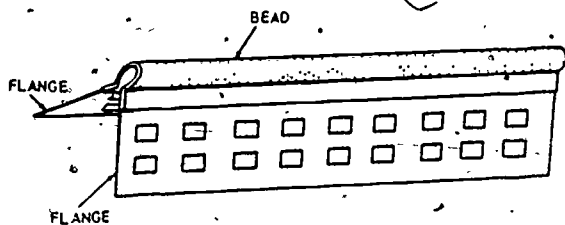

117.74

Figure 14-1.—Standard flange corner bead.

GROUNDS AND SCREEDS

GROUNDS are narrow strips of wood or metal that are placed around, and parallel to, the edges of surfaces and openings within the area to be plastered, principally to ensure that plaster will be applied to the correct thickness in locations where variations in thickness would

BUILDER 3 & 2

either sand or vermiculite/perlite, aggregate parts given for lime plaster mean sand only.

BASE COAT PROPORTIONS

TWO-COAT plaster work consists of a single base coat and a finish coat. THREE-COAT work consists of two base coats (the first called the SCRATCH coat, the second the BROWN coat) and a finish coat.

Portland cement plaster cannot be applied to a gypsum base. Lime plaster can in theory, but in practice only gypsum plaster is applied to gypsum lath as a base coat. For two-coat work on gypsum lath, the recommended base coat proportions for gypsum plaster are 1:2.5.

For two-coat work on a masonry (using this term to mean either monolithic concrete or masonry) base the recommended base coat proportions are as follows:

- Gypsum plaster: 1:3
- Lime plaster using hydrated lime: 1:7.5
- Lime plaster using lime putty: 1:3.5

Portland cement plaster is not used for two-coat work, and two-coat work is not usually done on metal lath.

For three-coat work on gypsum lath the recommended base coat proportions for gypsum plaster are: scratch coat 1:2, brown coat 1:3; or both coats 1:2.5.

For three-coat work on metal lath the recommended base coat proportions are as follows:

- Gypsum plaster: same as for three-coat work on gypsum lath
- Lime plaster using hydrated lime: scratch 1:6.75, brown 1:9
- Lime plaster using lime putty: scratch 1:3, brown 1:4
- Portland cement plaster: both coats 1:3 to 1:5

For three-coat work on a masonry base the recommended base coat proportions are as follows:

- Gypsum plaster: both coats 1:3
- Portland cement plaster: both coats 1:3 to 1:5

Lime plaster is not usually used for three-coat work on a masonry base.

FINISH COAT PROPORTIONS

A lime finish may be applied over a lime, gypsum, or portland cement base coat; other

finishes, however, should be applied only to basecoats containing the same cementitious material. A gypsum-vermiculite finish should be applied only to a gypsum-vermiculite base-coat.

Finish coat proportions vary according to whether the surface is to be finished with a TROWEL or with a FLOAT. These tools are described later. The trowel attains a smooth finish; the float attains a finish of a desired texture.

For a trowel-finish coat using gypsum plaster the recommended proportions are 200 lbs hydrated lime or 5 cu ft lime putty to 100 lbs gypsum gauging plaster.

For a trowel-finish coat using lime-Keene's cement plaster the recommended proportions are, for a medium-hard finish, 50 lbs hydrated lime or 100 lbs lime putty to 100 lbs Keene's cement. For a hard finish the recommended proportions are 25 lbs hydrated lime or 50 lbs lime putty to 100 lbs Keene's cement.

For a trowel-finish coat using lime-portland cement plaster the recommended proportions are 200 lbs hydrated lime or 5 cu ft lime putty to 94 lbs portland cement.

For a finish coat using portland cement-sand plaster the recommended ingredient proportions are 300 lbs sand to 94 lbs portland cement. This plaster may be either trowled or floated. Hydrated lime up to 10 percent by weight of the portland cement, or lime putty up to 25 percent of the volume of the portland cement, may be added as a plasticizer.

For a trowel-finish coat using gypsum gauging or gypsum neat plaster and vermiculite aggregate the recommended proportions are 1 cu ft vermiculite to 100 lbs plaster.

Recommended proportions for various types of float-finish coats are as follows:

- Lime putty 2: Keene's cement 1.5: sand 4.5, by volume
- Hydrated lime 1: gypsum gauging plaster 1.5: sand 2.3, by weight
- Hydrated lime 2: portland cement 1: sand 2.5, by weight
- Lime putty 1: sand 3, by volume
- Gypsum neat plaster 1: sand 2, by weight

PLASTER QUANTITY ESTIMATES

The total volume of plaster required for a job is, of course, the product of the thickness of the plaster times the net area to be covered.



Plaster specifications state a minimum thickness, which the plasterer must not go under, and which he should likewise exceed as little as possible, because a tendency to cracking increases with thickness. Specified minimum thickness for gypsum plaster on metal lath, wire lath, masonry/concrete walls and masonry ceilings is usually $5/8$ in.; on gypsum lath it is $1/2$ in.; on monolithic concrete ceilings it is $3/8$ in. For interior lime plaster on metal lath (3-coat work) the specified minimum thickness is usually $7/8$ in.; for exterior lime plaster on metal lath it is 1 in. For lime plaster on interior masonry walls/ceilings the minimum thickness is $5/8$ in.; for exterior lime plaster on masonry it is $3/4$ in. For lime plaster on interior concrete ceilings the minimum thickness is $1/16$ in. to $1/8$ in.; on interior walls, $5/8$ in. For lime plaster on exterior concrete the minimum thickness is $3/4$ in. For portland cement plaster, either interior or exterior, recommended thicknesses are $3/8$ in. for each base coat (3-coat work) and $1/8$ in. for the finish coat.

The YIELD for a given quantity of plaster ingredients, like the yield for a given quantity of concrete ingredients, amounts to the sum of the ABSOLUTE VOLUMES of the ingredients. The absolute volumes of typical plaster ingredients are as follows:

100 lbs gypsum	0.69 cu ft
1 cu ft lime putty	0.26 cu ft
100 lbs hydrated lime	0.64 cu ft
100 lbs sand	0.61 cu ft
94 lbs portland cement	0.48 cu ft

This list indicates that (for example) 94 lbs of portland cement, which has a loose volume of 1 cu ft, has an absolute volume (that is, a solid or exclusive-of-air-voids volume) of only 0.48 cu ft. Therefore, 94 lbs of portland cement contributes a volume of only 0.48 cu ft to a plaster (or concrete) mix.

The absolute volume of the last ingredient—the water—is the same as its "loose" volume: 0.13 cu ft per gallon.

Determining Yield

Suppose now that you want to determine the yield of a plaster mix containing 1 part of gypsum plaster to 2.5 parts of sand. One part of gypsum plaster is 100 lbs, with an absolute volume of 0.69 cu ft. Two and five-tenths parts

of sand means 250 lbs of sand. Sand has an absolute volume of 0.61 cu ft per 100 lbs; therefore, the absolute volume of the sand is 2.5×0.61 , or 1.52 cu ft.

The water will contribute 0.13 cu ft of volume to the mix for every gallon of water added. For approximate yield calculations, you can assume that 8 gals of water will be used for every 100 lbs of cementitious material. There are 100 lbs of gypsum plaster in question here, which means 8 gals of water. The water volume, then, will be 8×0.13 , or 1.04 cu ft.

The yield for a 1-sack batch of this mix will be the sum of the absolute volumes, or 0.69 cu ft (for the gypsum) plus 1.52 cu ft (for the sand) plus 1.04 cu ft (for the water), or 3.25 cu ft.

Estimating Ingredient Quantities

Suppose that the plastering job is a wall with a net area of 160 sq ft, with a specified total plaster thickness of $5/8$ in. and a finish coat thickness of $1/16$ in. You are doing two-coat work (only a single base coat), and you want to estimate ingredient quantities for the base coat. The thickness of the base coat will be $5/8$ in. minus $1/16$ in., or $9/16$ in., which equals about 0.046 ft. The volume of plaster required for the base coat, then, will be 160×0.046 , or about 7.36 cu ft.

The yield for a 1-sack batch is 3.25 cu ft; therefore, the job calls for a batch with sacks to the number indicated by the value of x in the equation $1:3.25::x:7.36$, or about 2.3 sacks. The number of parts of sand required equals the value of x in the equation $1:2.5::2.3:x$, or 5.75 parts. There are 100 lbs of sand in a "part," and 100 lbs of gypsum in a sack. Therefore, for the base coat you will need 230 lbs of gypsum and 575 lbs of sand.

MIXING PLASTER BY HAND

Equipment for plaster mixing by hand consists of a flat, shallow-sided MIXING BOX and a hoe; the hoe usually has a perforated blade. Mixed plaster is transferred from the mixing box to a MORTAR BOARD, similar to the one used in bricklaying. Men applying plaster pick it up from the mortar board.

In hand mixing, the dry ingredients are first placed in the mixing box and thoroughly mixed until a uniform color is obtained. The pile is then coned up and troughed, and the water is mixed in much as it is in hand concrete mixing.

71

Mixing is continued until the materials have been thoroughly blended and proper consistency has been attained. With experience a man acquires a "feel" for proper consistency. Mixing should not be continued for more than 10 or 15 minutes after the materials have been thoroughly blended, because excessive agitation may hasten the rate of solution of the cementitious material and thereby cause accelerated set.

Finish-coat lime plaster is usually hand-mixed on a small 5 ft x 5 ft mortar board called a FINISHING BOARD. If the lime used is hydrated lime, it is first converted to lime putty by soaking in an equal amount of water for 16 hours. In mixing the plaster, the lime putty is first formed into a ring on the finishing board. Water is then poured into the ring, and the gypsum or Keene's cement is then sifted into the water to avoid lumping. The mix is allowed to stand for one minute, after which the materials are thoroughly blended. Sand, if it is to be used, is then added and mixed in.

MIXING PLASTER BY MACHINE

A plaster mixing machine (fig. 14-2) consists primarily of a metal DRUM containing MIXING BLADES, mounted on a chassis equipped with wheels for road towing. Mixing is accomplished either by rotation of the drum or by rotation of the blades inside the drum. Discharge into a wheelbarrow or other receptacle is usually accomplished by tilting the drum as shown in figure 14-2.

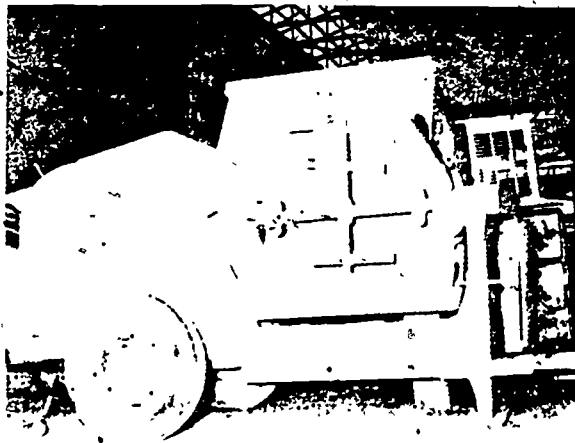

117.75

Figure 14-2.—Plaster mixing machine.

Steps in the machine mixing of gypsum plaster are as follows:

For job-mixed gypsum plaster:

1. Put in the approximate amount of water. Approximate water amounts for various gypsum-aggregate proportions and the common aggregates are as follows:

Aggregate	Gypsum-Aggregate Proportions		
	1:2	1:2.5	1:3
Sand	6.8 gals	7.4 gals	8.2 gals
Perlite	7.7 gals	8.5 gals	9.1 gals
Vermiculite	9.0 gals	10.0 gals	10.1 gals

2. If sand is used, add approximately one-half of the aggregate. If perlite or vermiculite is used, add all the aggregate.
3. Add all the cementitious material.
4. Add the remainder of the sand aggregate.
5. Mix to required consistency, adding more water IF NECESSARY.

For ready-mix gypsum plaster:

1. Put in the approximate amount of water, as prescribed by manufacturer's instructions printed on the sack.
2. Add the plaster.
3. Mix to the required consistency, adding water IF NECESSARY.

For machine mixing of lime and portland cement plaster, place the dry ingredients in the drum first and mix dry until a uniform color is attained. Then add the water and mix to the required consistency. Approximate water amount is 8 gals per 100 lbs cementitious material.

It is generally recommended that the mixer be allowed to run no longer than three minutes after all materials have been added.

APPLYING PLASTER

To attain complete structural integrity, a plaster layer must be uniform in thickness; also, a plane plaster surface must be flat enough to appear flat to the eye and to receive surface-applied materials (such as casings and other trim) without the appearance of noticeable spaces. Specified flatness tolerance is usually 1/8 in. in 10 ft.

PLASTERING TOOLS

Steel **TROWELS** are used to apply, spread, and smooth plaster. The shape and size of the blade of a trowel is determined by the purpose for which the tool is used and the manner of using it.

The four common types of plastering trowels are shown in figure 14-3. The **RECTANGULAR TROWEL**, with a blade approximately 4 1/2 in. wide by 11 in. long, serves as the principal conveyor and manipulator of plaster. The **POINTING trowel**, 2 in. wide by about 10 in. long, is designed for use in places where the rectangular trowel won't fit. The **MARGIN trowel** is another smaller trowel, similar to the pointing trowel, but with a square rather than a pointed end. The **ANGLE trowel** is used for finishing corner angles formed by adjoining right-angle plaster surfaces.

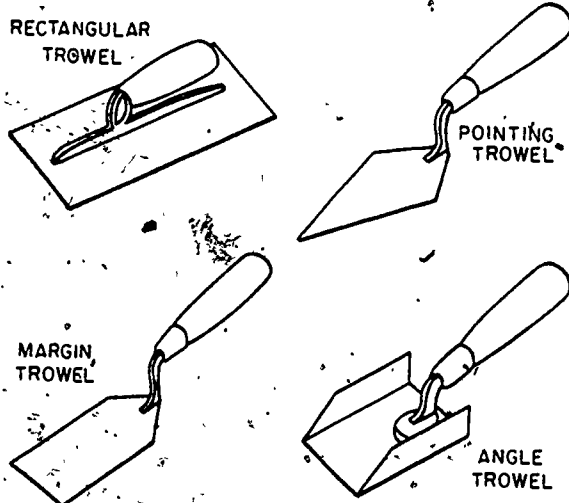

Figure 14-3.—Plastering trowels. 29.164

The **HAWK** (fig. 14-4) is a square lightweight sheet metal platform with a vertical central handle, used for carrying mortar from mortar board to the place where it is to be applied. The plaster is then removed from the hawk with the trowel. The size of a hawk varies from 10 in. square to 14 in. square.

The **FLOAT** is glided over the surface of the plaster, to fill voids and hollows or to level bumps left by previous operations, and to impart a texture to the surface. Common types of

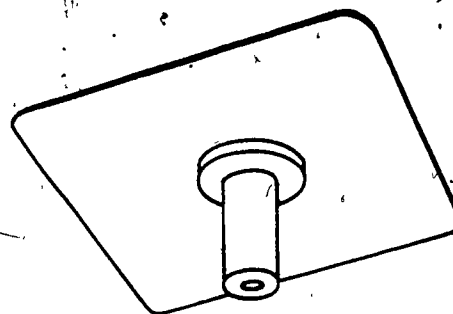

Figure 14-4.—Hawk. 117.76

floats are shown in figure 14-5. The **WOOD float** has a wood blade, the **ANGLE float** a stainless steel or aluminum blade. The **SPONGE float** is faced with foam rubber or plastic, intended to attain a certain surface texture. A **CARPET float** is similar to a sponge float, but faced with a layer of carpet material. A **CORK float** is faced with cork.

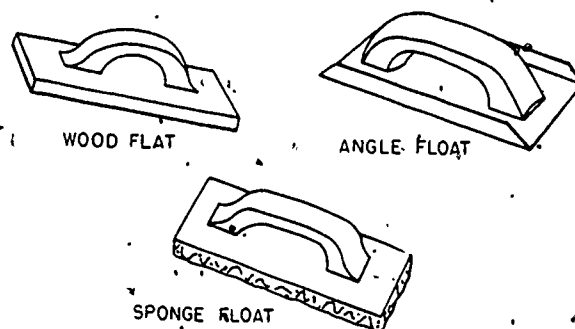

Figure 14-5.—Plastering floats. 29.161

A float blade is 4 or 5 in. wide and about 10 in. long.

The **ROD** and **STRAIGHTEDGE** consists of a wood or lightweight metal blade 6 in. wide by from 4 to 8 ft long. This is the first tool used in leveling and straightening applied plaster between the grounds. A wood rod has a slot for a handle cut near the center of the blade. A metal rod usually has a shaped handle running the length of the blade. A wood rod is shown in figure 14-6.

The **FEATHEREDGE** (fig. 14-6) is similar to the rod, except that the blade tapers to a sharp edge. It is used to cut in corners and to

BUILDER 3 & 2

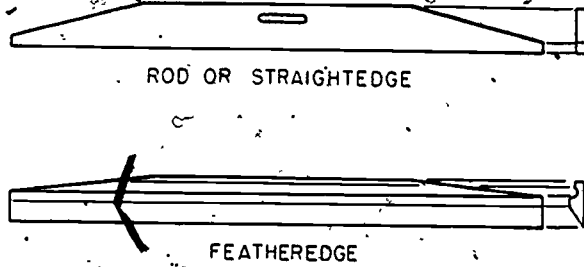

117.77

Figure 14-6.—Rod or straightedge and featheredge.

shape sharp, straight lines at corner lines of intersection.

The DARBY (fig. 14-7) is, in effect, a float with an extra-long (3 1/2 to 4 ft) blade, equipped with handles for two-handed manipulation. It is used for further straightening of the base coat after rodding is completed; also to level plaster screeds and to level finish coats. The blade of the darby is held nearly flat against the plaster surface, and in such a way that the line of the edge makes an angle of about 45° with the line of direction of the stroke.

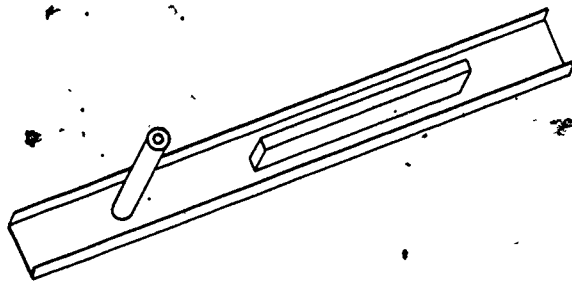

117.78

Figure 14-7.—Darby.

When a plaster surface is being leveled, the leveling tool must move over the plaster smoothly. If the surface is too dry, lubrication must be provided by moistening. In base coat operations this is accomplished by dashing or brushing water on with a water-carrying brush called a BROWNING brush. This is a fine-bristled brush about 4 or 5 in. wide and 2 in. thick, with bristles about 6 in. long. For finish coat operations a FINISHING brush with softer, more pliable bristles is used.

A MECHANICAL TROWEL (often called a POWER TROWEL) is an electrically operated

rotating trowel which weighs about 6 lbs and resembles a 6-bladed fan. There are usually two sets of blades, one more flexible than the other. The flexible set is used for preliminary troweling, the stiffer set for final troweling. Mechanical troweling can be done to within 1/2 in. of corner angles, leaving the angles to be finished by angle troweling.

There are two types of PLASTERING MACHINES. The WET MIX PUMP carries mixed plaster from the mixing machine to a hose nozzle. The DRY MIX machine carries dry ingredients to a mixing nozzle where water under pressure combines with the mix and provides spraying force. Most plastering machines are of the wet mix pump variety.

A wet mix pump may be of the WORM DRIVE, PISTON PUMP, or HAND HOPPER type. In a worm drive machine mixed plaster is fed into a hopper and forced through the hose to the nozzle by the screw action of a rotor and stator assembly in the neck of the machine. A machine of this type has a hopper capacity of from 3 to 5 cu ft, and can deliver from 0.5 to 2 cu ft of plaster per minute.

On a piston pump machine a hydraulic, air-operated, or mechanically operated piston supplies the force for moving the wet plaster. On a hand hopper machine the dry ingredients are placed in a hand-held hopper just above the nozzle. Hopper capacity is usually around 1/10 cu ft. These machines are used principally for applying finish plaster.

Machine application cuts down on the requirements for the use of the hawk and trowel in initial plaster application; however, the use of straightening and finishing hand tools remains about the same for machine-applied plaster.

PLASTERING CREWS

A typical plastering crew for hand application consists of a crew chief, 2 to 4 plasterers, and 2 to 4 TENDERS. The plasterers, under the crew chief's supervision, set all levels and lines and apply and finish the plaster. The tenders mix the plaster, deliver it to the plasterers, construct scaffolds, handle materials, and do cleanup tasks.

For machine application a typical crew consists of a NOZZLEMAN who applies the material, 2 or 3 plasterers leveling and finishing, and 2 or 3 tenders.

APPLICATION OF PLASTER

Lack of uniformity in the thickness of a plaster coat detracts from the structural performance of the plaster, and the thinner the coat, the smaller the permissible variation from uniformity. Specifications usually require that plaster be finished "true and even, within 1/8 in. tolerance in 10 ft, without waves, cracks, or imperfections." The standard of 1/8 in. appears to be the closest practical tolerance to which a plasterer can work by the methods commonly in use.

The importance of adhering to the recommended minimum thickness for the plaster cannot be overstressed. A plaster wall becomes more rigid as thickness over the minimum recommended increases—which means in effect that the tendency to cracking increases as thickness increases. However, tests have shown that a reduction of thickness from a recommended minimum of 1/2 in. to 3/8 in., with certain plasters, decreases cracking resistance by as much as 60 percent, while reduction to 1/4 in. decreases it as much as 82 percent.

Base Coat Application

GYPSUM BASE COATS.—The sequence of operations in three-coat gypsum plastering is as follows:

1. Install the plaster base.
2. Attach the grounds.
3. Apply the scratch coat approximately 3/16 in. thick.
4. Before the scratch coat sets, **RAKE** and **CROSS-RAKE**. This procedure consists of scratching with a tool that leaves furrows approximately 1/8 in. deep, 1/8 in. wide, and 1/2 to 3/4 in. apart. The furrows are intended to improve the bond between the scratch coat and the brown coat.
5. Allow the scratch coat to set firm and hard.
6. Apply plaster screeds if required.
7. Apply the brown coat to the depth of the screeds.
8. Using the screeds as guides, straighten the surface with a rod.
9. Fill in any hollows and rod again.
10. Level and compact the surface with a darby; then rake and cross-rake to receive the finish coat.

11. Define angles sharply with angle float and featheredge, and trim back plaster around grounds so that finish coat can be applied flush with grounds.

The two-coat method is used with gypsum plaster over a gypsum lath or a masonry base. Steps are as follows:

1. Install the base if necessary.
2. Attach the grounds and apply plaster screeds if necessary.
3. Apply the first thickness, and double back immediately with a second thickness to the depth of the screeds; because of this procedure, two-coat work is frequently called **DOUBLE-BACK**.

The remaining steps are similar to the last four steps discussed in three-coat work.

LIME BASE COATS.—Steps for lime base coat work are similar to the steps for gypsum work, except that for lime an additional floating is required the day after the brown coat is applied. This extra floating is required to increase the density of the slab and to fill in any cracks which may have developed because of shrinkage of the plaster. A wood float with one or two nails protruding 1/8 in. from the sole (called a **DEVIL'S float**) is used for the purpose.

The sequence of steps for three-coat lime plaster work over various bases is as follows:

1. Install the base if necessary, and attach the grounds.
2. Apply the scratch coat with sufficient plaster and pressure to evenly cover the plaster base and (for metal lath) provide positive keying.
3. Allow the scratch coat to become hard, but not dry, and scratch with metal scratching tool.
4. Apply plaster screeds if necessary. For interior lime plaster on metal lath grounds and screeds are usually established to provide for 7/8 in. plaster from the face of the plaster base.
5. Allow the scratch coat to dry and then apply the brown coat to the depth of the grounds.
6. Rod and darby the surface to a true plane and straighten all angles. Cut the brown coat back 1/16 in. at grounds to allow the finish coat to be plastered flush with the grounds.
7. Allow the brown coat to dry for 24 hours; then float the surface with a devil's float.

usually applied in two thin applications. After the first coat has been applied, all depressions, holes, or irregularities are touched up by hand to prevent their showing in the final coat.

Some special interior finish textures are obtained otherwise than by floating, or by procedures used in addition to floating. A few of these are as follows:

STIPPLED FINISH.—After the finish coat has been applied, additional plaster is daubed over the surface with a stippling brush.

SPONGE FINISH.—By pressing a sponge against the surface of the finish coat, a very soft, irregular texture can be obtained.

DASH COAT FINISH.—This texture is obtained by throwing plaster onto the surface from a brush. It produces a fairly coarse finish, which can be modified by brushing the plaster with water before it sets.

TRAVERTINE FINISH.—The plaster is jabbed at random with a whisk broom, wire brush, or other tool that will form a dimpled surface. As the plaster begins to set, it is troweled intermittently to form a pattern of rough and smooth areas.

PEBBLE DASH.—This is a rough finish obtained by throwing small pebbles or crushed stone against a newly plastered surface. If necessary, a trowel is used to press the stones lightly into the plaster.

CERAMIC WALL TILE

Some walls, especially in bathrooms, shower rooms, galleys, corridors, and the like, are entirely or partly covered with CERAMIC TILE. The type most commonly used is 3/8-in.-thick GLAZED INTERIOR tile, mostly in 4 1/4-in. or 6-in. squares. Margins, corners, and base lines are finished with TRIMMERS of various shapes. Available shapes and sizes of trimmers are shown on a TRIMMER CHART provided by the manufacturer.

Ceramic tile can be set in a bed of TILE MORTAR, or it can be set in a TILE ADHESIVE furnished by the manufacturer.

MORTAR APPLICATION

For mortar bed setting on a wall with wooden studs, a layer of waterproof paper is first tacked to the studs, and metal lath is then

nailed on over the paper. The first coat of mortar applied on a wall for setting tile is a scratch coat and the second a float, leveling, or brown coat. A scratch coat for application as a foundation coat must be not less than 1/4 inch thick and composed of 1 part cement to 3 parts sand, with the addition of 10 percent hydrated lime by volume of the cement used. While still plastic, the scratch coat is deeply scored or scratched and cross-scratched. The scratch coat should be protected and kept reasonably moist during the seasoning period. All mortar for scratch and float coats should be used within 1 hour after mixing. The retempering of partially hardened mortar will not be permitted. The scratch coat should be applied not more than 48 hours, nor less than 24 hours, before starting the setting of tile.

The float coat should be composed of 1 part cement, 1 part of hydrated lime, and 3 1/2 parts sand. It should be brought flush with screeds or temporary guide strips, so placed as to give a true and even surface at the proper distance from the finished face of the tile.

Wall tile should be thoroughly soaked in clean water before it is set. It is set by troweling a skim coat of neat portland cement mortar on the float coat, or applying a skim coat to the back of each tile unit, and immediately floating the tile into place. Joints must be straight, level, perpendicular, and of even width not exceeding 1/16 inch. Wainscots are built of full courses, which may extend to a greater or lesser height, but in no case more than 1 1/2 inches difference than the specified or figured height. Vertical joints must be maintained plumb for the entire height of the tile work.

All joints in wall tile should be grouted full with a plastic mix of neat white cement or commercial tile grout immediately after a suitable area of the tile has been set. The joints should be tooled slightly concave and the excess mortar cut off and wiped from the face of tile. Any interstices or depressions in the mortar joints after the grout has been cleaned from the surface should be roughened at once and filled to the line of the cushion edge (if applicable) before the mortar begins to harden. Tile bases or coves should be solidly backed with mortar. All joints between wall tile and plumbing or other built-in fixtures should be made with a light-colored calking compound. Immediately after the grout has had its initial set, tile wall surfaces should be given a protective coat of noncorrosive soap or other approved protection.

Application of tile in existing construction. Wall tile installed over existing and patched or new plaster surfaces in an existing building are completed as described, except that such wall tile is applied by the adhesive method.

Where wall tile is to be installed in areas subject to intermittent or continual wetting, the wall areas should be primed as recommended by the manufacturer of the adhesive used.

ADHESIVE APPLICATION

Wall tile may be installed either by the floating method or by the buttering method. In the floating method, apply the adhesive uniformly over the prepared wall surface, using quantities recommended by the adhesive manufacturer. Use a notched trowel held at the proper angle to ensure a uniformly spread coating of the proper thickness. Touch up thin or bare spots by an additional coating of adhesive. The area coated at one time should not be any larger than that recommended by the manufacturer of the adhesive. In the buttering method, daub the adhesive on the back of each tile in such amount that the adhesive, when compressed, will form a coating not less than 1/16 inch thick over 60 percent of the back of each tile.

SETTING TILE

Joints must be straight, level, plumb, and of even width not exceeding 1/16 inch. When the floating method is used, one edge of the tile is pressed firmly into the wet adhesive, the tile snapped into place in a manner to force out all air, then aligned by using a slight twisting movement. Tile should not be shoved into place. Joints must be cleaned of any excess adhesive to provide for a satisfactory grouting job. When the buttering method is used, tile is pressed firmly into place, using a "squeegee" motion to spread the daubs of adhesive. After the adhesive partially sets, but before it is completely dry, all tiles must be realigned so that faces are in same plane and joints are of proper width, with vertical joints plumb and horizontal joints level.

Wainscots are built of full courses to a uniform height. The wainscots height may be adjusted somewhat to accommodate full courses, but the adjustment should not exceed or be less than 1 1/2 inches from the top.

The adhesive should be allowed to set for 24 hours before grouting is done. Joints must be cleaned of dust, dirt, and excessive adhesive, and should be thoroughly soaked with clean water before grouting. A grout consisting of portland cement, lime, and sand, or an approved ready-mix grout may be used, but the grout should be water resistant and nonstaining.

Nonstaining calking compound should be used at all joints between built-in fixtures and tilework, and at the top of ceramic tile bases, to ensure complete waterproofing. Internal corners should be calked before corner bead is applied.

Cracked and broken tile should be replaced promptly to protect the edges of adjacent tile and to maintain waterproofing and appearance. Timely pointing of displaced joint material and spalled areas in joints is necessary to keep tiles in place.

Newly tiled surfaces should be cleaned to remove job marks and dirt. Cleaning should be done according to the tile manufacturer's recommendations to avoid damage to the glazed surfaces.

MODULAR LAYOUT OF TILE

The required number of acoustical or ceramic tiles required to cover a given area is estimated just as it is for floor tiles. For acoustical tile, a 2-man crew pattern is best, one man applying cement to the tile and moving and tending the platform, the other placing the tiles on the ceiling. The norm is an average of 250 12" x 12" tiles placed per man-day.

For ceramic tile a 2-man crew pattern is usually best, one man setting tile and the other mixing mortar, making cuts, grouting joints, and cleaning tile. The ideal construction norm is 20 4 1/4" x 4 1/4" x 3/8" units per man-hour, or about 200 units or 20 square feet per man-day and this includes the scratch coat, the brown coat, and the smooth coat of plaster.

GENERAL HINTS ON STUCCOING

Stucco is the term applied to plaster whenever it is applied on the exterior of a building or structure. Stucco can be applied over wood frames or masonry structures. The material is a combination of cement or masonry cement, sand and water, and frequently a plasticizing material. Color pigments are also often used in the finish coat, which is usually a factory

prepared mix. The end product has all the desirable properties of concrete. It is hard, strong, fire resistant, weather resistant, does not deteriorate after repeated wetting and drying, resists rot and fungus, and retains colors.

The material used in a stucco mix should be free of contaminants and unsound particles. Type I normal portland cement is generally used for stucco, although type II, type III, and air-entraining may be used. The plasticizing material added to the mix is hydrated lime and asbestos fibers. Mixing water should be clean. The aggregate used in cement stucco can greatly affect the quality and performance of the finished product. It should be well graded, clean, and free from loam, clay or vegetable matter, since these foreign materials prevent the cement paste from properly binding the aggregate particles together. The project specification should be followed as to the type of cement, lime, and aggregate to be used.

Metal reinforcement should be used whenever stucco is applied on the following: wood frame, steel frame, flashing, masonry or any surfaces not providing a good bond.

Stucco may be applied directly on masonry. The rough-floated base coat is approximately 3/8 inch thick. The finish coat is approximately 1/4 inch thick (see fig. 14-8). On open frame construction nails are driven 1/2 the length into the wood. Spacing should be 5 to 6 inches on center from the bottom. Nails should be placed at all corners and openings throughout the entire structure on the exterior, see figure 14-9. The next step is to place wire on

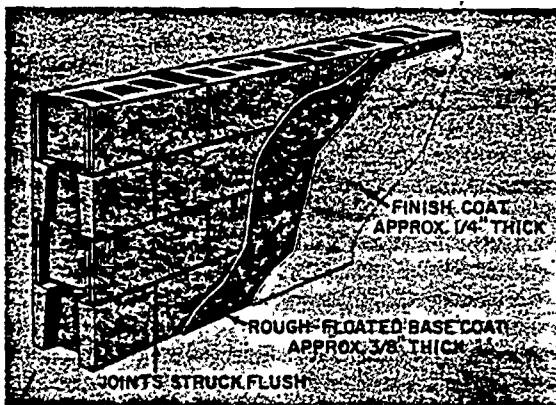

Figure 14-8—Masonry (2 coat work directly applied). 133.155

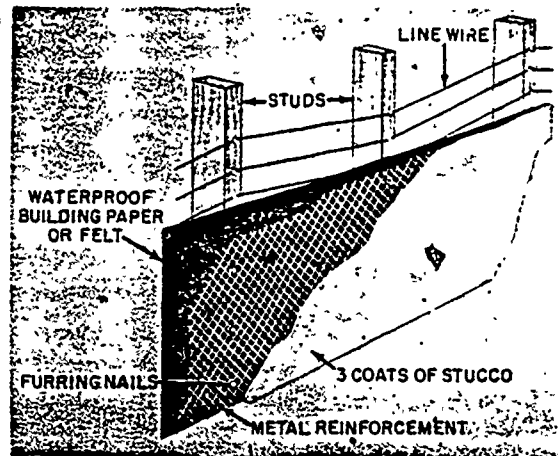

Figure 14-9.—Open frame construction. 133.156

the nails; this is called installing the line wire. Next, a layer of waterproof paper is applied over the line wire. Laps should be 3 to 4 inches and nailed with roofing nails. Next, install wire mesh (stucco netting) used as the reinforcement for the stucco. Furring nails are used to hold the wire away from the paper to a thickness of 3/8 of an inch. See figure 14-10. Stucco or sheathed form construction is the same as an open frame, except no line wire is required. The open and sheathed frame construction requires three coats of 3/8-inch scratch coat horizontally scored or scratched, a 3/8-inch brown coat, and a 1/8-inch finish coat.

PREPARATION OF BASE AND APPLICATION OF STUCCO

Stucco should be applied in three coats. The first coat is called the "scratch" coat; the second the "brown" coat; and the final coat the "finish" coat. However, on masonry where no reinforcement is used, two coats may be sufficient. Start at the top and work down the wall. This will eliminate the ball of mortar from falling on the completed work. The first "scratch" coat should be pushed through the mesh to ensure that the metal reinforcement is completely embedded for mechanical bond. The second or brown coat should be applied as soon as the scratch coat has set up enough to carry the weight of both coats (usually about 4 or 5 hours). The brown coat should be moist-cured for about 48 hours and then allowed to dry for about

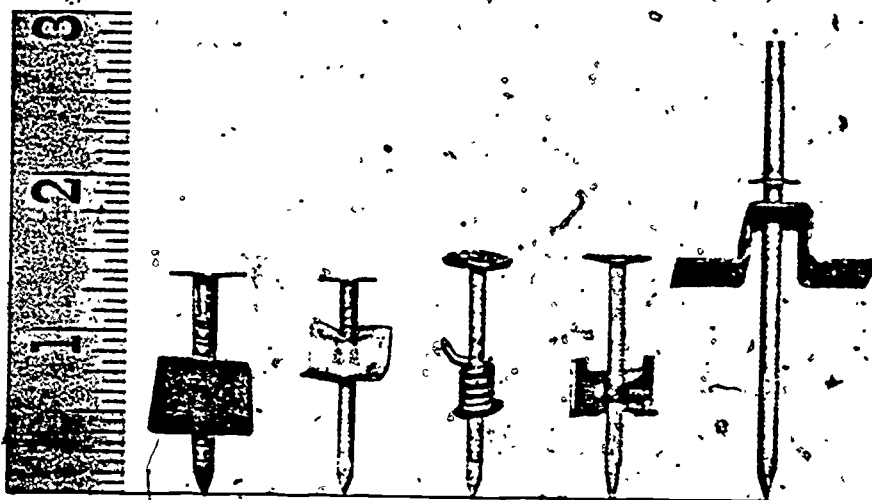

Figure 10.—Several types of furring nails.

29.121

5 days. Just prior to the application of the finish coat, the brown coat should be uniformly dampened. The third or finish coat is frequently pigmented to obtain decorative colors. Although the colors may be job mixed, a factory-prepared mix is recommended. The finish coat may be applied by hand or machine. Stucco finishes are obtainable in an unlimited variety of textures, patterns, and colors.

Before the various coats of stucco can be applied, the surfaces have to be prepared properly. Roughen the surfaces of masonry units enough to provide good mechanical key and clean off paint, oil, dust, soot, or any other material which may prevent a tight bond. Joints may be struck off flush or slightly raked. Old walls softened and disintegrated by weather action, surfaces that cannot be cleaned thoroughly (painted brick-work, etc.), and all masonry chimneys should be covered with galvanized metal reinforcement before applying the stucco. When masonry surfaces are not rough enough to provide good mechanical key, one or more of the following actions may be taken.

Old cast-in-place concrete or other masonry may be roughened with bush hammers or other suitable hand tools. Roughen at least 70 percent of the surface, with the hammer marks uniformly distributed. Wash the roughened surface free of chips and dust. Let the wall dry thoroughly.

Concrete surfaces may be roughened with an acid wash. Use a solution of one part of

muriatic acid to six parts of water. First wet the wall so that the acid will act on the surface only. More than one application may be necessary. After the acid treatment, wash the wall thoroughly to remove all acid. Allow the washed wall to dry thoroughly.

Rapid roughing of masonry surfaces may be accomplished by use of a power driven machine equipped with a cylindrical cage fitted with a series of hardened steel cutters (fig. 14-11). The cutters are so mounted as to provide a flailing action which results in a scored pattern. After roughing, wash the wall clean of all chips and dust and let it dry.

Suction is absolutely necessary in order to attain a proper bond of stucco on concrete and masonry surfaces. It is also necessary in first and second coats so that the following coats will bond properly. Uniform suction helps to obtain a uniform color. If one part of the wall draws more moisture from the stucco than another, the finish coat may be spotty. Obtain uniform suction by dampening the wall evenly, but not soaking, before applying the stucco. The same applies to the scratch and brown coats. If the surface becomes dry in spots, dampen those areas again to restore suction. Use a fog spray for dampening.

When the masonry surface is not rough enough to ensure adequate bond for a trowel applied scratch coat, use the dash method. Acid treated surfaces usually require a dashed scratch coat. Dashing on the scratch coat aids

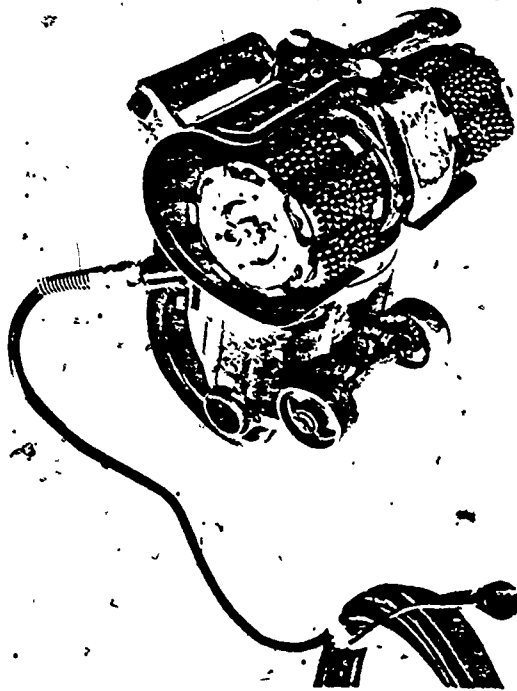

Figure 14-11.—Power driven roughing machine. 133.370

in getting a good bond by excluding air which might get trapped behind a trowel applied coat. Apply the dash coat with a fiber brush or whisk broom, using a strong whipping motion at right angles to the wall. A cement gun or other machine which can apply the dash coat with considerable force will produce a suitable bond. Keep the dash coat damp for at least two days immediately following its application and then allow it to dry.

Protect the finish coat against exposure to sun and wind for at least six days after application. During this time, keep the stucco moist by frequent fog-spraying.

There may be times, when the finish is not what you had expected. To help you understand the reasons for discoloration and stains in stucco, we will provide some reasons. Some of the common reasons for discoloration and stains are—

Failure to have uniform suction in either of the base coats.

Improper mixing of the finish coat materials.

Changes in materials or proportions during progress of the work.

Variations in the amount of mixing water.
Use of additional water to retemper mortar.
Corrosion and rust of flashings or other metal attachments, and failure to provide drips and washes on sills and projecting trim, often cause surface stains.

CONTROL JOINTS

Cracks can develop in stucco through many causes or combinations of causes, such as foundation-settlement, shrinkage, and building movement. It is difficult to prevent cracking, but this can be largely controlled by dividing the area into rectangular panels every 20 feet by means of metal control joints. See figure 14-12. The control joint is also used where frame construction joins masonry construction.

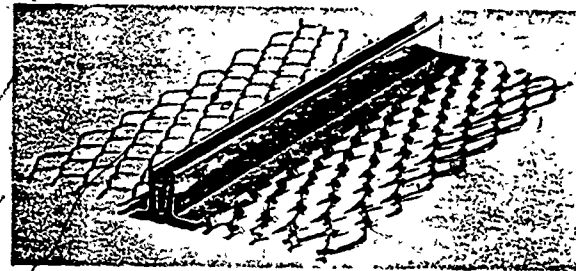

Figure 14-12.—Control joint. 133.157

Grounds are wood strips of uniform thickness installed around all openings and other places where trim is required. They serve as a guide in bringing the stucco to a uniform thickness. Temporary wood grounds are often used in gaging the thickness of scratch and brown coats of stucco.

STUCCO SAFETY

The observance of safety rules in plastering or stuccoing cannot be over emphasized. So to help prevent accidents and harm to yourself, we strongly suggest that you observe these following safety hints.

All material in bags or bundles should be stacked, blocked, interlocked, and limited in height so that the pile is stable and secure against sliding or collapsing.

Material stored inside a building under construction should be placed not less than 6 feet from hoistways or other inside floor openings.

BUILDER 3 & 2

When material is placed or encroaches upon passageways, it should be located so as to present the least possible hazard.

Bags of cement and lime should not be stacked more than 10 bags high without setback, unless restrained by walls of appropriate strength.

The outside row of bags should be placed with the mouths of the bags facing the center of the stack.

During unstacking, keep the entire top of the stack nearly level and maintain the necessary set-backs.

Handle paper sacks with care to prevent breaking and showering men with cement and dust.

Store lime and cement on off-the-floor platforms in dry spaces. Lime must be kept dry to

prevent possible premature slaking which could cause fire.

Wear heavy gloves when handling metal lath.

Wear goggles for eye protection when handling cement and lime.

Wear shirts with closed neck and wrist bands and be sure that exposed parts of the body do not come in direct contact with lime.

Avoid wearing clothing which has become stiff and hard with cement or lime, since such clothing irritates the skin and may cause infection.

Wear goggles, gloves, and other protective clothing and equipment when handling muriatic acid.

Practice personal cleanliness and frequent washing, which are effective preventive of skin ailments.