

DOCUMENT RESUME

ED 216 170

CE 032 432

AUTHOR Jaycox, Victoria H.; And Others
TITLE Effective Responses to the Crime Problem of Older Americans: A Handbook.
INSTITUTION National Council for Senior Citizens, Inc., Washington, D.C.
SPONS AGENCY Administration on Aging (DHHS), Washington, D.C.
PUB DATE Jan 82
CONTRACT DHHS-90-AT-0024/01 and 02
NOTE 272p.; For a related document see CE 032 433.
AVAILABLE FROM National Council of Senior Citizens, 925 15th Street NW, Washington, DC (\$8.00; \$7.00 each for 10 or more copies):

EDRS PRICE MF01/PC11 Plus Postage.
DESCRIPTORS Communication (Thought Transfer); Community Programs; Consumer Protection; *Crime; *Crime Prevention; Crisis Intervention; Fear; Guidelines; Individual Characteristics; *Individual Needs; *Older Adults; *Program Implementation; Psychological Needs; *Victims of Crime
IDENTIFIERS *Victim Assistance

ABSTRACT

This handbook is designed for use either as a guide for anyone personally or professionally concerned about the crime problem of America's elderly as a text in a training course on crime against the elderly. Following an introductory sketch of the crime problem facing America's elderly, a description is provided of the typical older American. Discussed next are patterns of crime against the elderly. The fear of crime and its consequences are addressed. After an examination of the basics of crime prevention and victim assistance, guidelines are set forth for preventing street and residential crimes against elderly adults as well as for preventing consumer fraud and con games. Outlined next are procedures for community crime prevention. Following a discussion of victimization and its aftermath, suggestions are given for meeting the needs of elderly crime victims, for communicating with groups on the topic of crime prevention education. (A related instructor's guide is available separately--see note.) (MN)

 * Reproductions supplied by EDRS are the best that can be made *
 * from the original document. *

ED216170

Effective Responses to the Crime Problem of Older Americans: A Handbook

U.S. DEPARTMENT OF EDUCATION
NATIONAL INSTITUTE OF EDUCATION
EDUCATIONAL RESOURCES INFORMATION
CENTER (ERIC)

- ✓ This document has been reproduced as received from the person or organization originating it.
- Minor changes have been made to improve reproduction quality.
- Points of view or opinions stated in this document do not necessarily represent official NIE position or policy.

PERMISSION TO REPRODUCE THIS MATERIAL HAS BEEN GRANTED BY

Victoria H. Jaycox

TO THE EDUCATIONAL RESOURCES INFORMATION CENTER (ERIC)

by
Victoria H. Jaycox
Lawrence J. Center
and
Edward F. Ansello

The National Council of Senior Citizens,
Legal Research and Services for the Elderly
Criminal Justice and the Elderly Program

January 1982

CE 032 432

Acknowledgments

This Handbook would not have been possible without the nearly five years of work by staff of the Criminal Justice and the Elderly Program (CJE) which preceded its publication. And so, while they are not technically its authors, a number of past and present CJE staff have made important contributions to the accumulation of knowledge which stands behind the work. They are:

James H. Ahrens	Althea L. Ray
Gregory T. Byrne	Regina H. Ryan
Rita Nitzberg Goodell	John H. Stein
Lisa Hoffman	Paul B. Wice
Richard Hoffrichter	Joanne L. Yancey

Rita Nitzberg Goodell, CJE's Training Manager, devoted great skill and effort to planning and supervising the production of the copy for this Handbook and the companion Instructor's Guide which she authored.

Sean Sweeney was project officer for the Administration on Aging grant which supported publication of the Handbook and Instructor's Guide. He and members of the Advisory Board for the grant were generous in their support and in the time they gave to review our plans and early drafts of the materials. Advisory Board members are:

David H. Marlin, Director
Legal Research and Services for the Elderly

Edward F. Ansello
Center on Aging, University of Maryland

Linda Beaver
Urban Elderly Coalition

Lynn Curtis
Eisenhower Foundation for the Prevention of Violence.

William Koester
New York State Office on Aging

Ann Lordeman
National Association of State Units on Aging

Joan Walter
SCAN, Franklin Research Institute

Victoria H. Jaycox, Director
and
Lawrence J. Center, Deputy Director
Criminal Justice and the Elderly Program

This project was supported by Cooperative Agreement #90-AT-0024/01 and 02 from the Administration on Aging, Department of Health and Human Services to the National Council of Senior Citizens. Points of view or opinions stated in this report are those of the authors and do not necessarily represent the official position of the Administration on Aging.

Effective Responses to the Crime Problem of Older Americans: A Handbook

Table of Contents

Preface	i
Chapter One Introduction	1
Chapter Two A Sketch of Older Americans	11
Chapter Three Patterns of Crime against the Elderly	31
Chapter Four Fear of Crime and Its Consequences	51
Chapter Five Introduction to Crime Prevention and Victim Assistance	71
Chapter Six Preventing Street Crimes against Elders	97
Chapter Seven Preventing Residential Crimes against Elders	121
Chapter Eight Preventing Consumer Fraud and Con Games	149
Chapter Nine Community Crime Prevention	171
Chapter Ten Victimization and Its Aftermath--The Victim in Crisis	193
Chapter Eleven Meeting the Needs of Elderly Crime Victims	209
Chapter Twelve Communicating with Older Individuals	243
Chapter Thirteen Communicating with Groups: Crime Prevention Education	259

Preface

We have written this book for a broad audience, basically anyone personally or professionally concerned about the serious crime problem of America's elderly. This would include people who work with older citizens on a daily basis, policymakers who must make decisions about funding and program design, program administrators who are searching for ways to respond to their clients' concerns about crime, and students of gerontology (the study of the aging processes) and criminal justice. It is meant for older people themselves, for those who are looking for ways to protect themselves against crime and to cope with the effects of victimization, and for seniors who want to take action in helping their peers. Ultimately, the entire community benefits.

This handbook reflects the combined efforts of a criminal justice expert, a lawyer, and a gerontologist. Consequently, we hope that it is sensitive to the complex needs of the elderly person in the community. This handbook also reflects the collaborations of others within the Criminal Justice and the Elderly Program, planners and trainers, community service agency workers, and community elders. We hope that it does them justice.

This book has been designed to stand on its own, or to be used as the text in a training or an introductory course on crime against the elderly. Ideally, this training or course would require sufficient contact or classroom hours, and could be offered in a variety of settings, such as in a neighborhood senior center, a continuing education program, or a community college. To assist instructors in presenting the information in this handbook as effectively as possible, we have prepared a companion volume, entitled Effective Responses to the Crime Problem of Older Americans: An Instructor's Guide. It presents a 30-hour curriculum for a course on this topic. The curriculum includes recommended techniques for presenting the information in a classroom setting, including audiovisual backup materials, and local resources for each of the various sessions. The Instructor's Guide, however, is meant to be used with this Handbook; all materials are cross-referenced to information in this volume. We believe that educators have available through this Handbook and the Instructor's Guide the basic knowledge they need on crime problems affecting the elderly, countermeasures which have proven most successful, and the skills required to teach others how to provide anti-crime services to the elderly.

The material included in this Handbook and the Instructor's Guide is a compilation of information gathered over a four-year period by the staff of the National Council of Senior Citizens' Criminal Justice and the Elderly (CJE) program. CJE's work has been supported by a number of federal and private sources: the Law Enforcement Assistance Administration (LEAA), the Community Services Administration (CSA), the Department of Housing and Urban Development (HUD), the Administra-

tion on Aging (AoA), the Ford Foundation, and the Edna McConnell Clark Foundation.

Since 1977, these agencies have together contributed over five million dollars to the support of a national research and demonstration program aimed at reducing the incidence and impact of crime against senior citizens. CJE was established by the National Council of Senior Citizens to play the leading role in this program, which also consisted of seven local demonstrations in six major cities. CJE coordinated and provided assistance to the seven local projects and, with the assistance of the Behavioral Sciences Laboratory (BSL) at the University of Cincinnati, evaluated their operations and impact. The demonstration projects included four funded by AoA in New York City, Chicago, Los Angeles, and Washington, D.C. and three funded by CSA in New York City, New Orleans, and Milwaukee. These projects engaged in a variety of anti-crime activities, including crime prevention education, victim assistance, hardware installation, security surveys, and the organization of Neighborhood Watch clubs.

The evaluation of this national program by CJE and BSL was designed to test both the feasibility of operating anti-crime projects focused on the elderly, and the effectiveness of anti-crime services with aged clients in the community. The results of this evaluation and of other studies in this field have been encouraging.

Based on these studies, CJE began to "spread the word" about anti-crime services for elderly people. One means was through a number of workshops it has conducted for professionals in the fields of aging and criminal justice and for representatives of aging-related community agencies. The goal of these efforts was to bring representatives of criminal justice and community service agencies together with older people to formulate constructive plans for improved anti-crime services to seniors. CJE then assisted selected agencies in carrying out the strategies identified under each plan. Response to the workshops indicates an extraordinary local commitment to mobilizing existing resources in order to reduce the deleterious consequences of crime on the aged.

Paralleling these CJE activities over the years have been several research projects and the publishing of some 20 monographs, research reports, scholarly papers, manuals, handbooks, and guides. CJE has also operated a national resource center on crime against the elderly, which included the CJE Newsletter, a quarterly journal reporting on research, legislative developments, and local anti-crime projects.

Thus, during its life span CJE has progressed from understanding the basic needs of the elderly for crime prevention and victim assistance to designing effective strategies to meet these needs, to promoting nationwide and in selected cities the desirability of employing those strategies, to helping selected local agencies implement the strategies. Throughout this process our motivation has been a commitment to improving the quality of life for older Americans.

It is our firm belief that all of us in the community, not just criminal justice professionals, must become experts in what to do about crime and its after-effects before real progress can be made against this threat to a peaceful older age for our citizens.

VHJ
LJC
EFA

Chapter One

Introduction

Chapter One Introduction

Think of what would be the perfect breeding ground for crime and victimization. It would be congested, so that there would be plenty of potential victims and ready opportunity for perpetrators to become lost in crowds or buildings. It would have a high concentration of physically vulnerable victims who would minimize the risks facing the criminals. It would have neighborhoods which are deteriorating, perhaps in the physical sense but certainly in the sense of there being a lack of community spirit. We have these conditions in too many inner cities.

The congestion and the concentration of numbers of people in inner cities help create a sense of anonymity which may be as helpful to the criminal as it is distressing to another, innocent resident. The deterioration and even the "renewal" of neighborhoods often means the destruction of the sense of community among residents. Friends move away or new people move in. Houses are razed or public buildings and parking lots are put in. The residents who remain can no longer tell fellow residents from strangers. When residents cannot distinguish strangers from neighbors, says Smith (1979), "their sense of responsibility for the area contracts from the neighborhood to their own dwelling." When this happens, fear rises and it's every man for himself.

Unfortunately, many of America's elderly live under these circumstances. One-third live in inner cities. Fortunately, two-thirds do not. In fact, in 28 of the 50 states, 40 percent or more of the state's older population lives in rural areas (Harbert and Wilkinson, 1979). But, as we know and shall discuss, crime in one way or another seems to affect most older people regardless of where they live. This is because of the reality of the fear of crime. Even elders who are not in high risk of victimization are afraid.

Most older Americans enjoy good or excellent health; they have no serious restrictions on their physical mobility; they have successfully retired and have adjusted to late life. Most older people are vital and able. They want to help themselves, they want to be self-sufficient. They are not wallowing in loneliness and self-pity as younger people may project (Harris, 1975, found that younger adults overestimated by 500 percent the amount of loneliness among elders). In fact, seniors are concerned about real-life, living issues--the problems of transportation, money, health, and crime. But dealing with crime, especially the fear of crime, is made more difficult by others projecting or assuming inadequacy on the part of older people. This book is meant to tap the energies of older people and of those who work with them.

In fact, seniors are victimized by crime less than other age groups, but their fear of crime is higher. Looking at the standard

categories of personal crimes (robbery, rape, assault, and theft) and household crimes (burglary, household larceny, and auto theft), we see low rates of victimization among the elderly. Of course, it may be that we are using the wrong categories and that there is an emerging, distinct pattern of crime against the aged. Smith (1979) suggests that medical "gap" insurance and health insurance swindles, get-well-quick quackery, bogus work-at-home offers, home repair schemes, etc., may be disproportionately aimed at older people. As he notes, however, there are no statistics as yet to support this observation. More to the point is that elders' levels of fear of crime bear little relationship to their known victimization; fears are dramatically higher than occurrences.

Fear of crime may be fueled by a number of social conditions, perhaps by older people's conscious or unconscious realization that they are considered "legitimate victims" by society because they are a social burden. This is suggested by Reiman (1976) who says that victimization is built into the aging process. Fear of crime may also be fueled by media attraction to violence. Studying the attention paid by newspapers and television to violent crimes, Jaehnig *et al.* (1981) found that readers' and viewers' fears of crime followed the patterns emphasized by the media. For example, one newspaper devoted nearly twice as many stories to violent crime as another newspaper; more than twice as many readers of the first paper (64 percent) as readers of the second (26 percent) expressed fears of becoming crime victims. While nonviolent burglaries and thefts occurred eight times more frequently than violent crimes in one city, Jaehnig *et al.* notes that stories on rape, assault, and murder accounted for almost 70 percent of its newspaper's crime reports. To be sure, these things heighten the older person's fear of crime. Self-perceived physical, emotional, or economic vulnerability makes things worse.

The net effect of all this is that seniors, whether living in the inner-city setting discussed at the opening, on a rural tract, or anywhere in-between, often cope with their fear of crime by limiting their activities. Fear constricts their behaviors. It diminishes their lives. This can lead to higher morbidity (illness) and mortality (death) rates. The community, in turn, loses the contributions of its elders; Medicare or Medicaid costs rise to pay for injuries and real or imagined illnesses related to isolation; businesses suffer due to cutbacks by would-be consumers; even social services face higher costs and expenses because of losing potential volunteers. And so, we can see that crime against the elderly affects the entire community in some way.

This book is intended to be an intervention, an attempt to get in and make a difference. And so, we will examine the fact and the fiction of crime against the aged: We will discuss the realities of growing older and of criminal victimization against the elderly in order to displace the myths that contribute to the fears. We will examine the patterns of crime against older people, on the street and in the home, in order to alert people to real vulnerabilities and, more importantly, to corrective actions. We will consider the needs of older victims and will propose assistance and counseling measures.

Finally, we believe that increases in crime prevention education mean improvements in the quality of lives for elders, so we will outline procedures for effective training sessions.

This book addresses a serious problem in the lives of the elderly -- crime. Time and again, surveys have shown that many elderly, especially in urban settings, consider crime their most fearsome concern, often ranking it above inflation, inadequate health care, loneliness, and other sources of distress in old age.

For years, however, aging-related public services have not given crime the same priority as do their elderly clients. Policymakers have been slow to react to older people's crime-related fears. One reason for this apparent neglect is that crime statistics show that senior citizens are victims of crime less frequently than their younger neighbors.

Now we are learning that these statistics mask some crucial facts. One is that, while elders overall are victimized at low rates, there are disturbing exceptions. The aged living in the centers of our major cities are afflicted at the same rate as younger residents, and both young and old are victimized at a much higher rate than people in rural areas. Another is that crime and the fear of crime alter the quality of the lives of America's elderly. Statistics fail to show the highly restrictive and isolated lifestyles many seniors have adopted in response to crime. Policymakers have begun to recognize that older people living "safely" as virtual prisoners in their own homes are casualties, and should properly be counted among the victims of crime.

Until now, there seemed to be few constructive things anyone could do to reduce these fears or to ease the victims' distress. That pessimism is receding as pilot anti-crime projects for and by the elderly show that their crime prevention and victim assistance services work.

The federal government, often through criminal justice agencies, has been largely responsible for putting these pilot programs into operation. Although the programs are few and reach only a small proportion of the population-in-need, they are a step in the right direction. The recent demise of the Law Enforcement Assistance Administration, however, makes it doubtful that criminal justice agencies will remain in the forefront in this field. In fact, the end to federal funding of pilot anti-crime programs will undoubtedly produce considerable attrition in the number and scope of such programs. Furthermore, given the current atmosphere of "budgetary austerity," progress in expanding the network of anti-crime programs for seniors would not seem to lie in mounting new programs under any kind of funding scheme.

On the other hand, it has been shown that people who work with the elderly on a daily basis -- nutrition workers, area agencies on aging personnel, visiting nurses, senior center staff, and the like -- can be taught to recognize and to deal with the problems of crime and

fear of crime experienced by their clients. These professionals and paraprofessionals can do more than fill the void. The community of aging-related agencies can be a great resource for continued reform-- if they can be effectively mobilized. This book is meant as a step toward mobilization.

Now that we have explained why this book was written, we should say something about how it is organized.

Goal and Objectives

The goal of this handbook is to educate the reader to recognize and respond to the crime-related needs of older Americans. The reader may be a worker in the field of aging, a community elder or family member, a criminal justice specialist, or anyone concerned about these needs. This book provides facts about the serious crime problems affecting the elderly, those countermeasures which work best, and the basic skills to provide anti-crime services to the elderly.

More specifically, the objectives of this book are to make the reader more knowledgeable about:

- The major crime problems of the elderly as a class of citizens, including their fear of crime, the consequences of criminal victimization, and the patterns of crimes committed against them.
- The needs of senior citizens which arise from the crime problem, including needs for home improvement measures, personal security advice, information on con games and frauds, and counseling to overcome the psychological effects of victimization.
- The actions which both older people themselves and aging-related programs can take to decrease the elderly's vulnerability to crime, to reduce fear, and to improve their chances of overcoming the effects of victimization.
- Other community resources which can be tapped to provide crime prevention and victim assistance services to the elderly.

Contents

This handbook is organized into four overlapping sections: first, the realities of aging and of crime against the elderly (Chapters One-Four); second, crime prevention in the street, in the home, in consumer fraud, and in community efforts (Chapters Five-Nine); third, victim assistance, meeting the needs of older victims (Chapters Five and Ten-Twelve); and fourth, crime prevention education, conducting effective training and expanding the network of trainers and the access of elders to information and advice (Chapter Thirteen).

In addition, chapters are intended to be free-standing. They can be read and used alone, or in combination to tackle a specific problem. For instance, Chapter Nine, within the crime prevention section, deals with community efforts in crime prevention. The infor-

tion in this chapter and that in Chapter Thirteen on conducting education sessions can be combined when planning a comprehensive community drive against crime.

Briefly, the chapters contain the following information:

Chapter One – Introduction

This chapter raises the issue of the role of criminal victimization in the lives of older Americans, states the need for effective community responses, and outlines the book's objectives, content, and methods.

Chapter Two – A Sketch of Older Americans

Here we provide a summary of the more important physical, social, and psychological conditions of this country's elders. The chapter looks at demographics, sex, marital status, income, health, mental health, and other facts of aging.

Chapter Three – Patterns of Crime against the Elderly

This chapter provides data on the types and frequencies of criminal victimization against the elderly. Personal and property crime rates are given. Sex and race of the victim cause variations from the overall low victimization rate of older people.

Chapter Four – Fear of Crime and its Consequences

Here we note that disagreement exists among researchers over whether the elderly's fear of crime is realistic. Regardless, when victimized, older people are likely to suffer physical, emotional, and psychological stresses. The fear of these reactions to crime may increase their vulnerability.

Chapter Five – Introduction to Crime Prevention and Victim Assistance

This chapter gives an overview of effective crime prevention and victim assistance projects. It outlines the concepts of prevention and assistance programs, practical components of these programs, and trends in program development.

Chapter Six – Preventing Street Crimes against Elders

Here we stress the fundamental ingredient in street crime prevention, awareness--self-awareness, awareness of the environment, and awareness of response options when in danger. We suggest general deterrents against street crime, as well as tips in foiling a purse snatcher, preventing mugging, preventing push-in robberies and rape.

Chapter Seven – Preventing Residential Crimes against Elders

This chapter examines the vulnerability of seniors to burglary, household larceny, and auto theft. It offers advice in reducing the

risk of residential crimes, providing numerous examples of "target hardening" and opportunity reduction. It contains many action steps.

Chapter Eight – Preventing Consumer Fraud and Con Games

We investigate a number of age-related factors which may make some older persons particularly vulnerable to fraud. The two most common types of fraud are discussed. We suggest effective individual and group actions against fraud.

Chapter Nine – Community Crime Prevention

Individual efforts in crime prevention are only part of the total approach needed to combat crime against elders. This chapter explains why community crime prevention is necessary, and what is involved in developing community programs. It lists effective crime prevention strategies for block or floor clubs.

Chapter Ten – Victimization and Its Aftermath – The Victim in Crisis

The psychological and emotional needs of older victims may well be greater and more pressing than those of their younger counterparts, so this chapter examines the concept and stages of crisis. We maintain that the ability to respond to crisis depends upon the stressful experience itself and the victim's experiences immediately afterwards.

Chapter Eleven – Meeting the Needs of Elderly Crime Victims

This chapter focuses on meeting the older victim's economic, physical, psychological, and criminal justice-related needs. We give numerous examples of successful efforts by individuals, community groups, and the criminal justice system. We urge greater advocacy for recognition of victim's rights and improved treatment of victims.

Chapter Twelve – Communicating with Older Individuals

Communication takes place on two levels, the verbal and the non-verbal. This chapter suggests basic skills necessary at both levels for effective counseling of elderly victims. To help concerned family and friends, as well as aging-related professionals and paraprofessionals, we consider the characteristics of successful victim assistance counselors; we also provide tips for counseling senior citizens.

Chapter Thirteen – Communicating with Groups: Crime Prevention Education

We close by detailing the need for community crime prevention education, and the elements of effective programs. These elements include planning a course to meet specific local needs and problems, selecting teaching techniques that will insure lasting learning, evaluating both the immediate and long-term effects of the education, and expanding the network of trainers and the access of elders to information and advice.

Readers' Aids

Each chapter in this handbook contains several aids designed to assist the reader in retaining what he or she learns from the chapter.

- **Advance Organizers.** At the beginning of each chapter, starting with Chapter Two, we will summarize the most important information of the chapter. We will highlight its most significant or controversial facts. We do this so that the reader will have a "sense" of what will follow, and will be better able to organize and integrate the information while reading.
- **Tables and Figures.** We have included these within the chapter. We believe that these visual aids make the topic being discussed more real and memorable.
- **Reading and Resources.** We hope that the chapter will stimulate the reader's interest, and that the reader will want more information. Naturally, no book tells the complete story on a subject, and ours is no exception. So, we conclude each chapter with references and suggested readings in other books, journal articles, project reports, and publications.

Reading and Resources

Harbert, A. S. and C. W. Wilkinson, "Growing Old in Rural America," Aging, January, 1979.

Harris, Louis, and Associates, The Myth and Reality of Aging in America, Washington, DC: National Council on the Aging, 1975.

Jaehnig, W. B., D. H. Weaver and F. Fico, "Reporting Crime and Fearing Crime in Three Communities," Journal of Communication, Winter 1981.

Reiman, J. H., "Aging as Victimization: Reflections on the American Way of (Ending) Life," J. Goldsmith and S. S. Goldsmith, Eds., Crime and the Elderly: Challenge and Response, Lexington, MA: D.C. Heath and Co., 1976.

Smith, R. J., Crime Against the Elderly: Implications for Policy-Makers and Practitioners, Washington, DC: The International Federation on Ageing, 1979.

Chapter Two

A Sketch of Older Americans

Chapter Two A Sketch of Older Americans

Advance Organizers

- In order to respond effectively to the needs of older Americans for crime prevention and victim assistance programs, we need to know more about the elderly--who they are, where and how they live.
- America's older segments are growing at faster rates than any other groups. For the first time in history, the average American can expect to live beyond the age of 65.
- As recently as 1930 there were as many men as women above age 65. Today women comprise the majority of older Americans, and their predominance increases with advancing ages; so while there are about 92 men for every 100 women between the ages of 45 to 64, the numbers drop to about 70 for every 100 above age 65, and about 56 for every 100 above age 75.
- Most older women are widows; most older men are married.
- Most older Americans live in family settings or alone--not in nursing homes or institutions--and in urban or inner city settings (although in 28 states 40 percent or more of the state's older population lives in rural areas).
- The majority of older Americans considers their health "good" or "excellent," especially white and/or upper-income elderly.
- Most elders have no serious restrictions on their physical mobility.
- A variety of stresses, including society's stereotypes about aging, interfere with the continued mental health of some elderly.

America is growing older. Like most Western industrialized nations it is experiencing population changes without precedent. Older segments are growing more rapidly than any other. The "Post War Baby Boom," an exception to a nearly century-long trend toward lower birth rates, has ended. And almost suddenly we are awakening to the "old age problem."

The problem is a new one. There have never been such large numbers of older people. It had been the pattern for centuries that life expectancy from birth for the average person would be four or five decades and that only a small number would survive to old age. Social systems, like marriage and work, were built upon this assumption. Now it's all changing, and the social systems are still adjusting. When life expectancies were shorter, being an elder was unusual and, potentially, carried importance. Today, for the first time in history, the average American can expect to become old; the majority of our citizens, black and white, male and female, reaches age 65; and at 65 life expectancy is another 14-18 years (Soldo, 1980). The fact of more people living longer is changing marital, family, and work patterns. For example, childrearing occupies a significantly smaller portion of adult life so that women, after their children leave home, have more adult years ahead of them than they ever had with children at home. And, for the first time, men upon retiring face the prospect of one-third to one-half as many retirement years as years spent in labor.

These changes in population and in life patterns have altered traditional values and support networks which reinforced the importance of the elder. At the same time these changes have occurred so rapidly that adequate social responses--responses by the community and government--are still forthcoming.

And so, we begin by noting that the increasing crime during this period against the elder may be a symptom of society going through an "adjustment period." With old age being essentially re-evaluated in a society in flux, older people may be more likely targets of crime. We also note that the absolute increases in the numbers of older Americans place greater and greater demands upon community and government for meaningful services and programs for the elderly.

This need for increased services, combined with currently diminishing resources in human services, makes it especially important that we plan and deliver crime prevention and victim assistance services based upon a clear knowledge of the characteristics of older Americans--i.e., their traits, strengths, problems, and needs--a knowledge which is grounded in fact rather than in myth.

This task is made more difficult, however, by the fact that our elders, besides being more numerous than ever before, are also the most diverse or heterogeneous segment of the population. And so, this chapter will present a composite of characteristics of older Americans. This composite is based on information from a variety of sources, especially the Fact Book on Aging published by the National Council on the Aging (NCOA) in 1978, a well-accepted summary of recent aging-related research and data.

Demographics

The growth of aging populations in this country can be illustrated by several statistics. In 1900, there were approximately three million persons 65 years and over, or one person in every 25. By 1980, the number had swollen to 24 million Americans, or one person in every nine. By the turn of the century, there will be 30-33 million, or one of every eight persons. More broadly, today there are six times as many 55-year olds, eight times as many 65 year olds, and ten times as many 75 year olds as in 1900. In contrast, the total population of the United States has barely tripled in this time (U.S. Bureau of the Census, 1976b).

What accounts for this tremendous growth? Three reasons have been suggested (NCOA, 1978):

- The high birth rate of the late 19th and early 20th centuries created a large "pool" of people who might grow old.
- The high immigration rate prior to World War I further increased this number.
- Dramatic increases in life expectancy during the 20th century enabled many of these people to reach age 65 and beyond.

The last factor, the increase in life expectancy, has been particularly significant. Since 1900, life expectancy at birth has increased approximately 25 years, a greater increase than that of the preceding 300 years! Interestingly, this increased life expectancy is due primarily to declining infant death rates and to the discovery of antibiotics which overcame previously fatal viral diseases like influenza and pneumonia, rather than to increased life expectancy in the later years. The illnesses of old age have proved much more difficult to cure than have the diseases of youth.

Sex

Women comprise the majority of older Americans, and their predominance increases with time and with advancing ages. Over time we see that in 1900 older men outnumbered older women. By 1930 their numbers were equal. By 1960 there were 83 men over 65 for every 100 women, and by 1975 the ratio had dropped to 69 to 100. If current trends continue, it is estimated that by 1990 there will be only 66 men for every 100 women over 65. As for advancing ages, we see that today, while there are about 92 percent as many men as women between the age of 45-64, the percentages drop to about 70 percent above age 65, and to about 56 percent above age 75 (Block et al., 1978; NCOA, 1978).

What has caused this significant change in the sex makeup of America's elderly population? Primarily, it is simply that women live longer than men; the average life expectancy at birth for women in 1978 was 77.2 years, while for men it was 69.5 (Soldo, 1980). Differences by sex in life expectancy, moreover, are getting larger. Besides having lower death rates at all age levels, females are not afflicted so much as men by the two main killers in our later years--cancer and heart disease. In addition, women's social support patterns and their own

body-monitoring may contribute to their superior longevity.

Marital Status

Most older women are widows, while most older men are married. In 1975, 53 percent of older women were widowed and only 39 percent married. However, nearly 79 percent of older men were married and only 13.6 percent were widowers (NCOA, 1978). Another perspective on this pattern is that for every man over 65 who is unmarried, there are four older women who are unmarried. Marital status 65 years and older is shown in Table 2.1.

Table 2.1
Marital Status of Males and Females
65 and Older: 1975 (By Percent)

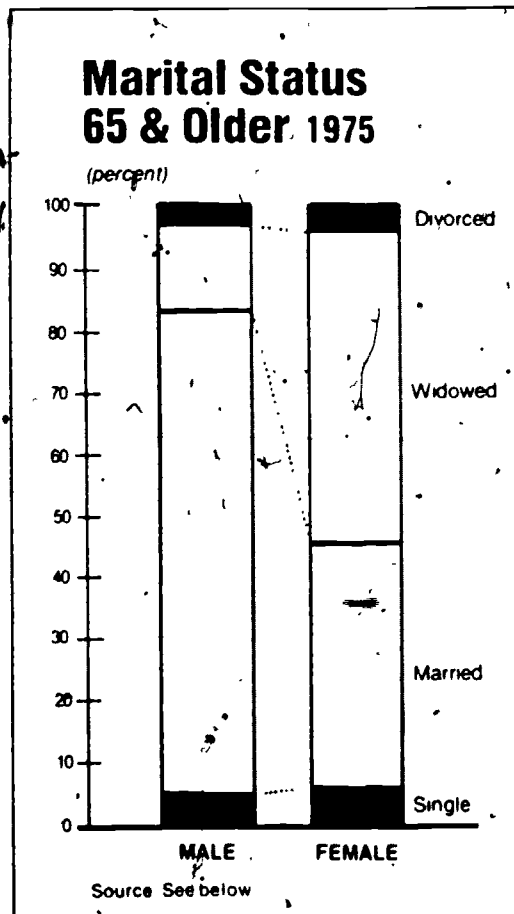

Source: National Council on the Aging, The Fact Book on Aging, p. 4, based on data from Status: A Monthly Chartbook of Social and Economic Trends, Bureau of the Census, September 1976.

Further, sex differences in marital status become more marked with increasing age. By age 75, 69 percent of women are widows, while only 23 percent of men are widowers. Other factors contributing to the lopsided ratio include the propensity for men to marry younger women, and the higher remarriage rate of widowers.

These statistics on sex and marital status indicate that elderly services are most likely to be for female, unmarried clients. Of course, this must influence the manner in which services--including anti-crime services--are provided. For example, someone preparing a crime prevention education lecture for a senior citizens group should be prepared to talk about purse snatching or fear of rape, two subjects of concern to many elderly women.

Living Arrangements

Services delivered to older persons should also take into account their living situations. As you might imagine from the previous review of marital status, significant differences in living arrangements exist for older men and women. While the one most common living arrangement for people over 65 is a husband and wife living by themselves, a higher percentage of older men than women live in a family environment. Eighty-one percent of all older men live in a family setting, while only 58 percent of older women do. As Table 2.2 illustrates, the percentage of older women living alone is much higher than that of males. Older widows prefer living alone (six out of ten widows live by themselves)

Table 2.2
Living Arrangements of Men and Women
65 and Over: 1975 (By Percent)

MALE			FEMALE		
65-74 YEARS					
Live w/ Family	Live Alone	Institutionalized (e.g., nursing home)	Live w/ Family	Live Alone	Institutionalized (e.g., nursing home)
85	12.1	2.9	64.6	32.9	2.5
OVER 75 YEARS					
74.5	18.2	7.4	49.4	40.6	10.0

Source: National Council on the Aging, The Fact Book on Aging, p. 21; based on data from U.S. Bureau of the Census, Current Population Reports, Special Studies Series P-23, No. 59, May, 1976, p. 48.

rather than with another family member (only two out of 10). From age 75, however, they are almost twice as likely to live with relatives as they were aged 65-74 (NCOA, 1978).

Obviously these facts contradict the common stereotype that senior citizens live in institutions. In providing anti-crime services to older persons, information frequently will have to be geared to the person living in an apartment or house, walking into a lobby or down a hallway, or even going out to do chores--and this person may be especially vulnerable because he or she is alone.

Area of Residence

Most older Americans live in urban or inner city settings, but the highest concentration of elders is seen in small towns; the elderly constitute a greater percentage of the total population in towns of 1,000 to 2,500 than they do in any other sized community. And in 28 of the 50 states, 40 percent or more of the state's older population lives in rural areas (Harbert and Wilkinson, 1979). These facts hold important, practical ramifications for service providers for the elderly. For most seniors, anti-crime strategies must be tailored to the unique characteristics of large, dense metropolitan areas. However, in small towns and in rural contexts strategies must differ, must not be simply a transplanting of urban techniques, and in fact can take advantage of the high concentration of older persons who may have time to devote to community crime prevention strategies.

Data from the 1970 U.S. Census show that over half the elderly persons in the country--11 of 20 million--reside in urbanized areas. And of this group, 60 percent, or one-third of all of our elders, live in inner city areas (NCOA, 1978). Compared to the general population, older Americans are disproportionately represented in these center city areas, areas which may be suffering from deteriorating housing, a poor sense of community, bad economic conditions, problems in transportation, and other conditions conducive to victimization of the elderly.

Income

Income is a critical factor in determining quality of life. Most older persons have low incomes, although only one in four is either "poor" or "near poor" (NCOA, 1978). The majority, however, is living on reduced and fixed incomes, and while some of their expenses are also lower, many expenses are actually increased upon reaching older age. Moreover, these higher expenses are often in those areas most affected by inflation: food, housing, medical treatment, and drugs. In the current era of soaring inflation, many older people are finding it more and more difficult to get by.

Regardless of whether they live alone or in family settings, since 1960 older Americans have had incomes about half that of their younger counterparts. Table 2.3 illustrates that this statistic remains true regardless of sex or race. In 1975, families headed by a person 65 years or older had a median income of \$8,057 compared to a \$14,698

Table 2.3
Median Incomes by Age of Head and Race, 1974

□ Population, Ages 18-64 ■ Population, Ages 65+

FAMILIES

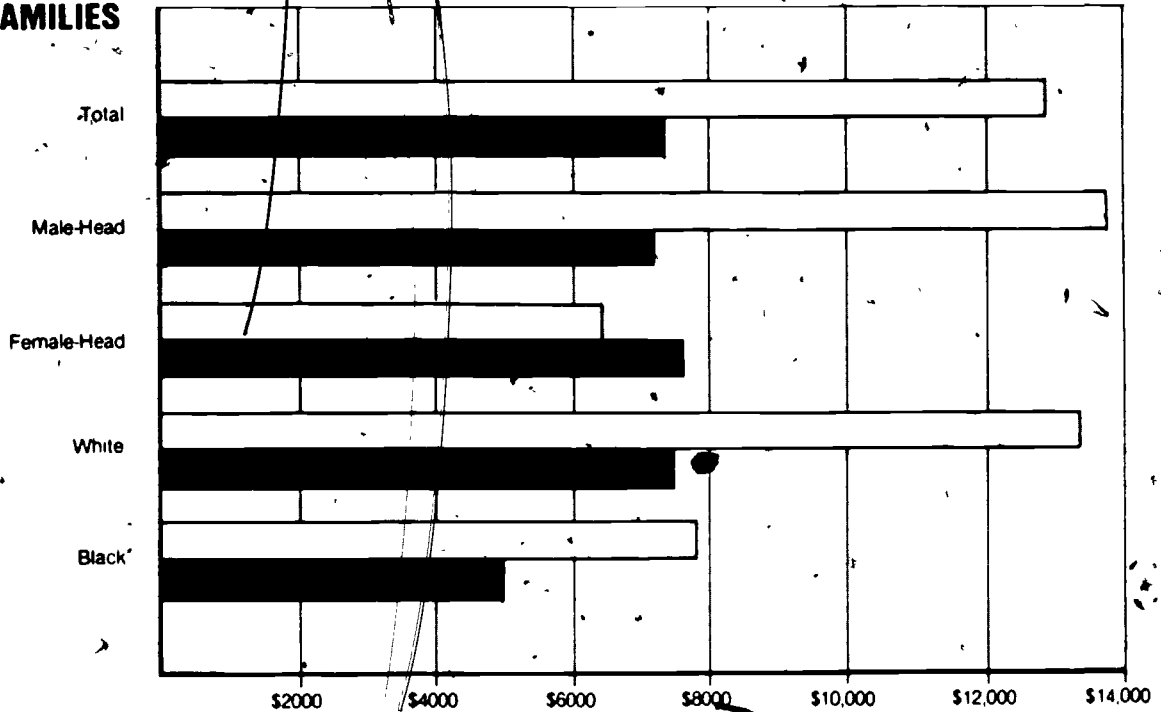

UNRELATED INDIVIDUALS

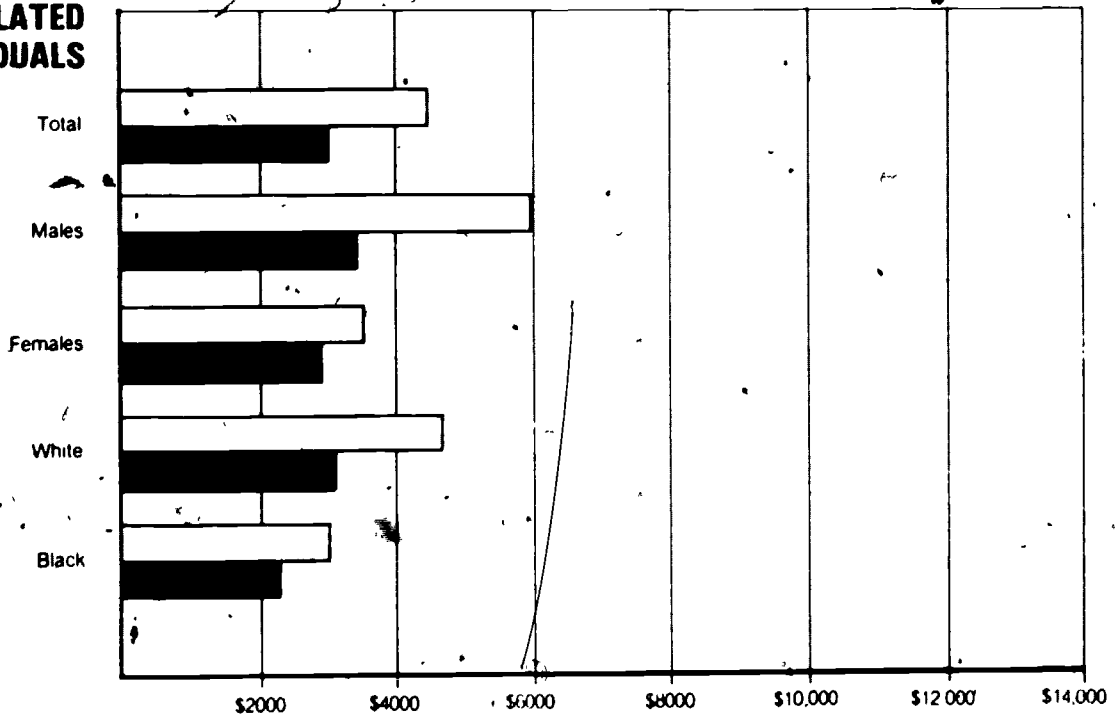

Source: National Council on the Aging, *The Fact Book on Aging*, p. 34, based on data from the U.S. Bureau of the Census, *Current Population Reports*, Series P-23, No. 59, May 1976.

median income for younger families. Elders living alone--usually widows--tend to have less income than those living with families. They are typically older and are less likely to receive retirement benefits or to work. Thus, the trend in recent years for older persons to live by themselves rather than in families may mean increasing numbers of elderly will be economically deprived.

Certain segments of the elderly population fare worse economically than others. These include older blacks and women. Elderly blacks had median incomes in 1974 which were two-thirds that of older whites; this comparison held both for those living alone and those living with families. Older women also tend to be seriously economically disadvantaged. According to 1974 data, median incomes for older women were one-half that of older men--\$2,642 to \$4,961 (NCOA, 1978). Elderly widows are in the worst economic positions; their income has often depended on their husbands' Social Security benefits or private pension and is reduced considerably at his death. As later chapters discuss, it becomes obvious that vulnerable older women living alone often can neither afford the losses that victimization causes nor the time and money required for crime prevention measures that have been recommended to them.

Income Sufficiency

The income status of older Americans is only one dimension of their economic profile. For a fuller picture of the financial hardships borne by this segment of the population, one should examine the relationship between the elderly's income and their needs.

Two realities--one encouraging and one discouraging--define the adequacy of income for older persons today. On the positive side, people reaching old age today are much better off financially than their predecessors. However, on the negative side, about one-quarter of the elderly population has an inadequate income level, compared to 18 percent of the overall population.

There are various measures used to define "poverty." Data compiled according to Bureau of the Census guidelines show that in 1975 a greater proportion of the elderly was poor--15 percent--than was poor in the total population--12 percent. Moreover, elderly persons living alone or with nonrelatives--a substantial group, as we have seen--were almost four times as likely to be poor as those living in families (31 percent to 8 percent, respectively), regardless of race. These Census Bureau data are shown in Table 2.4.

Another measure of poverty is one which recognizes that people with incomes marginally above the "official" poverty level still have difficulty meeting the basic necessities of life. Thus, the Department of Health, Education and Welfare several years ago established an income ranking termed the "near-poor" for those persons whose income is less than 25 percent above the poverty level. For 1975, if figures on the elderly "near-poor" are combined with the elderly poor, approximately one-fourth of all older persons--5.5 million--fall into those categories. For elderly people living alone, 48 percent could be considered

Table 2.4
Number and Proportion of Persons in Households
with Incomes Below the Poverty Level, All Ages and
65+, by Race and Family Status, 1975

(numbers in thousands)

Race and Family Status	All Ages		65+	
	Number	%	Number	%
	1975	1975	1975	1975
Total, all races	25,877	12.3	3,517	15.3
In families	20,789	10.9	1,492	8.0
Unrelated individuals	5,088	25.1	2,125	31.0
White	17,770	9.7	2,651	13.4
In families	15,799	8.5	898	6.7
Unrelated individuals	3,972	22.7	1,756	28.0
Black	7,515	31.3	652	36.5
In families	6,533	30.1	286	23.9
Unrelated individuals	1,011	42.1	366	61.1

Source: National Council on the Aging, The Fact Book on Aging, p. 44, based on data from Herman B. Brotman, "Income and Poverty in the Older Population in 1975," The Gerontologist, XVII, No. 1 (1977), 25, quoting U.S. Bureau of the Census data.

poor or near-poor (NCOA, 1978).

The racial differences evident in the previous income status figures extend to income adequacy estimates: Although in sheer numbers there are a great many more poor whites than poor blacks among the elderly, the proportion of elderly blacks who are poor is almost two-and-a-half times the proportion of elderly whites who are poor. In 1975 over half of the elderly blacks were ranked as either poor or near-poor (NCOA, 1978). The poorest segment of the elderly population is black women living alone. Two-thirds of these women are officially classified as poor, and 78 percent are at least near-poor. As will be seen later, these elderly are, unfortunately, likely victims of crime.

Despite the bleak picture painted by these numbers, the economic situation for America's older people is improving. Figure 2.5 shows the dramatic decline in the percentages of elderly poor during the past two decades. Between 1959 and 1975, there was a 7.6 percent drop in poverty among all U.S. families and a drop of 21 percent among unrelated people. During the same time span, the corresponding drops for the elderly population were 21 percent and 35 percent. Thus, until fairly recently, poverty among older people was decreasing at a faster rate than among the overall population. This rapid decline in poverty among the elderly has been due primarily to healthy increases since 1972 in Social Security benefits. Unfortunately, this encouraging trend is likely to slow down as Social Security and other support programs experience cutbacks, and as inflation in the 1980's continues while many older people remain on fixed incomes.

Older Americans are particularly hurt by inflation because they depend on resources whose prices bear the brunt of the inflationary spiral: food, housing, and medical care. While it is true that elders have to spend less on items such as education, transportation, clothing, or child care, it is also true that these differences are partially offset by the steadily increasing amounts they must spend on necessities. For example, a recent study of retired married couples aged 62 through 69 found that expenditures for food at home, fuel, and medical care increased from 44 percent of their total expenses in 1973 to 51 percent in 1980 (Barnes and Zedlewski, 1981). While their income after retirement is reduced on the average by approximately one-half, their needs for the basics do not decrease to the same extent.

Health

The majority of older Americans considers their health "good" or "excellent," especially white and/or upper income elderly. Further, most have no serious restrictions on their mobility. More Americans are living long lives than ever before. The latter is clear from the great increases in the populations over 65 and the dramatic changes in life expectancy during the 20th century. In 1900, the average life expectancy at birth was about 47 years, while a baby born in 1977 could expect to live until 73 years, an increase of 26 years or 55 percent.

Table 2.5
Percent of Families and Unrelated Individuals
Below Poverty Level by Age for the U.S., 1959-1975.

	1959	1960	1961	1962	1963	1964	1965	1966	1967	1968	1969	1970	1971	1972	1973	1974	1975
Families																	
Total population	18.5	18.1	18.1	17.2	15.9	15.0	15.9	11.8	11.4	10.0	10.4	10.1	10.0	9.5	8.8	9.2	10.9
65 yrs. and over	30.0	27.2	28.5	25.5	25.0	23.1	22.8	20.9	21.5	17.0	17.6	16.6	14.2	11.6	10.5	9.5	8.9
Unrelated Individuals																	
Total population	46.1	45.2	45.9	45.4	44.2	42.7	39.8	38.3	38.1	34.0	34.0	32.9	31.6	29.0	25.6	24.1	25.1
65 yrs. and over	66.0	65.5	66.2	61.5	59.9	60.6	56.6	53.8	55.2	48.8	47.4	47.2	42.5	37.1	31.9	31.8	31.0

Source: National Council on the Aging, *The Fact Book on Aging*, p. 53, based on data from U.S. Bureau of the Census, *Current Population Reports*, Series P-23, Nos. 57 (November 1975) and 59 (May 1976); Series P-60, Nos. 68 (December 1969), 76 (December 1972), 91 (December 1973), 102 (January 1976), 103 (September 1976).

But what do the statistics show about longevity after 65? As discussed previously in this chapter, while researchers have had great success in controlling diseases of younger people, they have had relatively little impact on the major causes of death in old age--heart disease, 44 percent; cancer, 19 percent; and stroke, 12 percent--which account for approximately 75 percent of all deaths. As a result, while the average person reaching a 65th birthday in 1900 could expect to live another 12 years, that person reaching 65 in 1979 could expect 16 more years, an increase of only 33 percent.

A common stereotype of older persons portrays them as frail and sickly. In reality, older Americans have a relatively low rate of "acute" conditions, and see doctors only slightly more often than younger people. "Chronic" health problems, defined as illnesses or conditions which are recurring in nature, are the primary health problem of older Americans. These conditions include: arthritis, hearing deficiency, vision difficulty, hypertension, heart condition, diabetes, long-term mental illness, and circulatory impairment.

While 72 percent of people in the 45-64 age group have one or more chronic conditions, the rate for those over 65 jumps to 86 percent (NCOA, 1978). Moreover, multiple chronic conditions frequently afflict older persons. As Table 2.6 illustrates, most older Americans have no limitation on activity. However, over a third of those suffer some limitation in, or are unable to carry on, a major activity due to one or more chronic conditions. The major limiting conditions are: heart conditions, diabetes, asthma, and arthritis.

The elderly suffer disproportionately from limitations in general mobility, and such limitations are significant in terms of their vulnerability to crime. While most older persons do not have serious mobility restrictions, many are limited in at least one way. Almost 18 percent of the noninstitutionalized elderly have some mobility limitation, compared to less than one percent for people 17-44 years old and less than 5 percent for people in the 45-64 age group (NCOA, 1978).

We should remember, however, that in spite of these illnesses, most people do not consider themselves seriously handicapped in their daily activities, and a large majority rate their own health as "good" or "excellent" compared to others their age (NCOA, 1978). As such, this positive outlook may make them good candidates for action-oriented crime prevention and victim assistance programs.

Mental Health

Old age is a rich, fulfilling experience for many people who have the resources to enjoy their later years. For others, it can be a very difficult period characterized by stress and strain. For almost all, old age represents radical changes in life circumstances. As discussed, the larger society itself is undergoing a period of adjustment in accommodating unprecedented changes in longevity and life patterns. And so, many older people have considerable difficulty in adjusting to these changes.

Table 2.6
Chronic Activity Limitations by Age and Sex,
United States, 1974 (By Percent)

Sex and age	Total Population	With no limitation of activity	Total	With limitation of activity		
				Limited but not in major activity ^a	Limited in amount or kind of major activity ^a	Unable to carry on major activity ^a
Percent Distribution						
<u>Both sexes</u>						
All ages	100.0	85.9	14.1	3.5	7.3	3.3
65 years and over	100.0	54.2	45.8	6.6	22.1	17.1
<u>Male</u>						
All ages	100.0	85.7	14.3	3.6	5.6	5.1
65 years and over	100.0	50.4	49.6	4.8	15.0	29.8
<u>Female</u>						
All ages	100.0	86.0	14.0	3.5	8.8	1.7
65 years and over	100.0	56.8	43.2	7.8	27.2	8.2

^a Major activity refers to ability to work, keep house or engage in school or preschool activities.

Source: National Council on the Aging, *The Fact Book on Aging*, p. 116, based on data from the National Center for Health Statistics, *Vital and Health Statistics, Series 10, No. 112 (Oct. 1976)*, "Health Characteristics of Persons with Chronic Activity Limitations."

These difficulties can manifest themselves in life crisis reactions, such as depression or anxiety, functional disturbances which may affect daily living, or even organic disorders. While the great majority of elderly people do not develop serious mental problems, an estimated 13 to 15 percent of the elderly population live in what psychiatrists call "conditions conducive to mental illness," that is, poverty and near-poverty, serious physical illness, or social isolation (Butler and Lewis, 1973).

Regardless of the kind of disorder, it is clear that much of the mental illness afflicting some older persons results from their inability to cope successfully with changes and losses in a period which geropsychiatrist Eric Pfeiffer has labeled a "season of loss." This season of loss produces a vicious cycle: crises may lead them to isolate themselves, yet isolation can lead to increased loneliness and anxiety or depression. And the losses can produce not only psychological symptoms, but physical ones as well. Before attempting a review of the losses which may threaten the mental health of older people, it is important to remember that diminished mental health may make certain elders more vulnerable to crime, and that the crime prevention/victim assistance program may be important as a means of crisis intervention.

One of the hardest losses to adjust to may be retirement itself, for people tend to define others by their jobs. Those without jobs--whether unemployed or retired--may be viewed as less important. For some elders, the loss of a job and its corresponding status can be a bitter one. Bitterness can give way to feelings of uselessness and a diminishing self-image (Butler and Lewis, 1973). Depression, low motivation, and a general decline in overall health can follow. The loss of a job and a regular paycheck may also result in deteriorating housing, a poor diet, or other inadequacies. In fact, studies have shown a positive correlation between lower socioeconomic status and mental illness among the elderly (Palmore, 1973).

Another loss is the loss of status or value which old age suffers in the public mind. The low status given to older Americans is reinforced by our technological, present-oriented, youth-oriented society. Constrictive stereotypes about physical, intellectual, sexual, and social functioning in old age abound in the media and elsewhere. Louis Harris and Associates (1975) determined that 60 percent of the public attributes loneliness and 51 percent attributes poor health to most people over 65, but only 12 percent and 21 percent respectively of Harris' older respondents said this was correct. Unfortunately, some older people internalize these limiting values; the same poll showed that 35 percent characterized the sixties and seventies as the "worst years of a person's life."

Loss of status may create internal feelings of uselessness, but externally the elderly are hit by losses which can be equally damaging, social losses which rob them of companionship and lead to increased isolation: the loss of a spouse, or of friends, relatives, and neighbors. As we have seen, about one-fifth of elderly men and over half of older women are widowed. Research indicates that the death of a spouse is the single most stressful event a person can undergo (Palmore, 1973).

Physical losses which become more evident in old age can also have psychological repercussions. The more frequent chronic conditions and loss of mobility which accompany the later years may produce a lack of control over life which the person is not used to. And some physical problems are particularly likely to produce depression. Significant hearing loss, which affects men more than women, occurs in about 30 percent of all older people and can lead to a number of serious problems, such as reduced awareness of the environment and suspiciousness. One National Institute of Mental Health study showed a significant relationship between hearing loss and depression. Visual loss can have the same effect. Of course, elderly people feel--and are--more vulnerable to crime when afflicted by sensory losses (Butler and Lewis, 1973).

On some occasions this "season of loss" and its associated stresses can also lead to mental illness. For example, the rate of psychopathology for persons over 65 is estimated at 24 per 10,000 as compared to a rate of 8 per 10,000 for persons 25 to 34 years old (NCOA, 1978). Because situational factors are frequently the cause of psychological disturbances in older people, geropsychiatrists like Eric Pfeiffer believe that emergency or crisis counseling can play an important role in preventing serious mental illness for seniors (Pfeiffer, 1978). Unfortunately, too often this need for help has been met with an insufficient response. One major reason has been the lack of mental health services.

The seriousness of the service shortage was evidenced by one recent study, which concluded that if current trends continue about 80 percent of older persons who need mental health assistance will not receive it (Butler, 1975a). The sad corollary to this prediction is that most of those older persons needing aid could be helped by short-term counseling or crisis intervention work. This type of counseling can be provided by properly trained paraprofessional workers and is not outside the range of services of a well-run crime prevention/victim assistance program, as we will explain in subsequent chapters.

In conclusion, the first step in designing effective crime prevention and victim assistance programs for the elderly is to understand the conditions--physical, psychological and social--in which they live. This chapter has attempted a brief overview of the major, relevant considerations in these areas. The next step in program design is to understand the typology of crime against the elderly, that is, the patterns and situations of crime to which they are most vulnerable.

Reading and Resources

Barnes, Roberta and Sheila Zedlewski, "The Impact of Inflation on the Income and Expenditures of Elderly Families," Washington, DC: The Urban Institute, 1981.

Block, M.R., J.L. Davidson, J.D. Grambs, and K.E. Serock, Uncharted Territories: Issues and Concerns of Women Over 40, College Park, MD: University of Maryland, Center on Aging, 1978.

Brotman, Herman B., "Every Ninth American," Developments in Aging, Special Committee on Aging, U.S. Senate, Washington, DC: U.S. Government Printing Office, 1980.

- Brotman, Herman B., "Income and Poverty in the Older Population in 1975," The Gerontologist, Vol. 17, No. 1, 1977.
- Butler, Robert N., "Psychiatry and the Elderly," The American Journal of Psychiatry, Vol. 132, No. 9, September 1975a.
- Butler, Robert N., Why Survive? Being Old in America, New York: Harper and Row, 1975b.
- Butler, Robert N. and Myrna I. Lewis, Aging and Mental Health: Positive Psychosocial Approaches, St. Louis, MO: C.V. Moseby Company, 1973.
- Fischer, David Hackett, Growing Old in America, New York: Oxford University Press, 1977.
- Harbert, A.S. and C.W. Wilkinson, "Growing Old in Rural America," Aging, January 1979.
- Harris, Louis, and Associates, The Myth and Reality of Aging in America, Washington, DC: National Council on the Aging, 1975.
- National Center for Health Statistics, U.S. DHEW, Vital and Health Statistics, Publication Series 10, No. 112, Washington, DC: October, 1976.
- National Council on the Aging, Fact Book on Aging: A Profile of America's Older Population, Washington, DC: NCOA, 1978.
- Palmore, Erdman, "Social Factors in Mental Illness of the Aged," Edward W. Busse and Eric Pfeiffer, Eds., Mental Illness in Later Life, Washington, DC: American Psychiatric Association, 1973.
- Pfeiffer, Eric C., "Psychotherapy of the Elderly," The National Association of Private Psychiatric Hospitals Journal, Vol. 10, No. 1, Fall 1978.
- Soldo, Beth J., "America's Elderly in the 1980s," Population Bulletin, Vol. 35, No. 4, Washington, DC: Population Reference Bureau, 1980.
- U.S. Bureau of the Census, "Demographic Aspects of Aging and the Older Population in the U.S.," Current Population Reports, Series P-23, No. 59, May 1976, Washington, DC: U.S. Government Print Office, 1976a.
- U.S. Bureau of the Census, Status: A Monthly Chartbook of Social and Economic Trends, September 1976, Washington, DC: U.S. Government Printing Office, 1976b.

Chapter Three

Patterns of Crime against the Elderly

Chapter Three

Patterns of Crime against the Elderly

Advance Organizers

- In order to respond effectively to the needs of older Americans for crime prevention and victim assistance programs, we need also to know about the patterns of criminal victimization that they are subjected to.
- Overall, older people are victimized by crime less frequently than the general population.
- In general, the elderly are subject more to property crimes, crimes against their possessions, than to personal crimes, which involve contact with the criminal.
- Sex and race of the victim and location of the crime cause variations from the overall low victimization rates of the elderly.
- Except for the crimes of rape and larceny with contact (which includes purse snatching), older men are victimized by personal crimes more frequently than older women.
- Older blacks suffer crimes of violence twice as often, and personal larceny with contact five times as often as older whites.
- Repeatedly, studies have shown that inner city elders are victimized by violent crimes at rates above the national averages for the elderly, and often as frequently as younger groups of urban dwellers.
- When they are victims of crime, older Americans are more likely than younger groups to be injured, to be victimized by strangers, by youths, and by persons of another race, and to be attacked in or around their homes. These patterns reinforce feelings of uncertainty, suspicion, and fear.

Introduction

As we have seen, America's populations are changing. They are aging in the midst of the "computer age." Yet, despite the many advances in technology, health care, and other areas, older people in the United States are beset with numerous problems. Many cannot keep up with inflation and are forced to live at only a subsistence level for the last years of their lives. Many are trapped in deteriorating housing with no avenues of escape. Others are restricted by increasing medical problems and cannot perform daily chores without difficulty. Yet in a recent national sample of America's elderly older persons said fear of crime was their most serious concern. More people ranked crime as a very serious problem than ranked any other category (Harris, 1975).

Since victimization statistics show that the elderly are victimized less than any other age groups, it is difficult to understand why older people are so afraid of crime. This chapter addresses that paradox.

Initially, it is important to understand the pattern of criminal victimization against the elderly. Review of crime statistics will show that while the elderly as a group are victimized less than others, some subgroups of older persons are victimized as much as and even more than younger age groups. With a grasp of crime patterns, it will be easier to understand senior citizens' fear of crime and how that fear has had a major impact on their lives. This chapter surveys the reasons for older Americans' fear of crime. The next chapter will build upon this overview and will further explore their vulnerability to victimization, and the consequences they suffer when crimes have occurred.

Patterns of Victimization against the Elderly

Crime Rates

In recent years, there has been some controversy among criminologists and other researchers about the amount of crime committed against older persons. Some have said that the elderly are easy targets of crime and thus have higher victimization rates. Others have said that the elderly are victimized less frequently than members of other age groups. This split of opinion is in part the result of inadequacies in the crime statistics.

The most commonly available crime statistics are those compiled by local police departments across the country for the Federal Bureau of Investigation's (FBI) Uniform Crime Report (UCR). Currently, the FBI does not require police departments to report the ages of crime victims for the UCRs. As a result, many police departments do not consistently record the age of a victim, nor do they tabulate and include victims' ages in their summary statistics. Other problems with UCR statistics are that they are subject to reporting inconsistencies across jurisdictions and only reflect those crimes which have been reported to the police. And so, criminologists now estimate that this reported crime represents only about half of all

Table 3.1
Victimization Rate of Elderly
vs.
Victimization Rate of Others, 1975

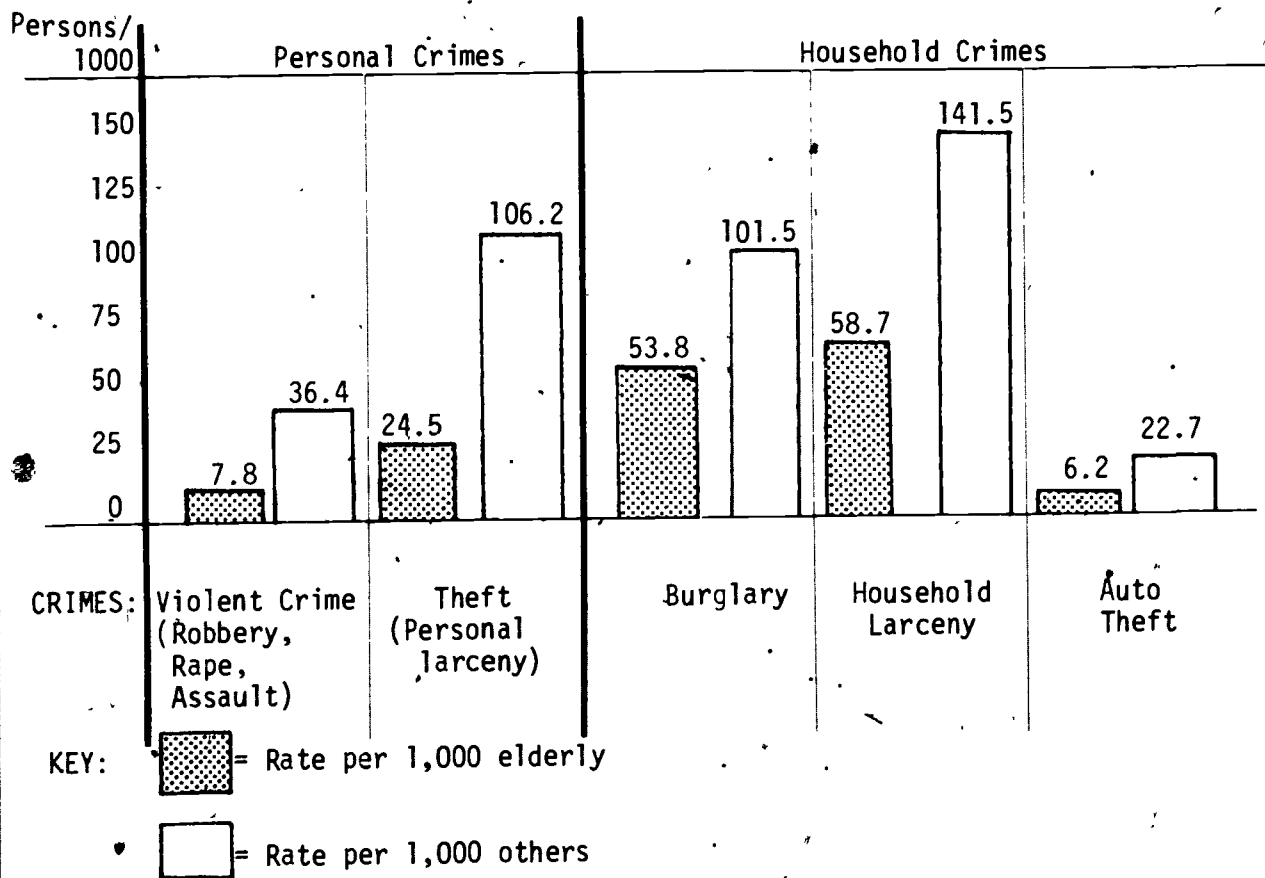

*"Others" describes individuals (personal crime) and heads of households (household crime) ages 12-64.

SOURCE: Original table, based on data from U.S. Dept. of Justice, Law Enforcement Assistance Administration, Criminal Victimization in the U.S., 1975, 1977.

For these reasons, researchers usually prefer data from nationwide surveys conducted since 1973 by the U.S. Census Bureau for the Law Enforcement Assistance Administration (LEAA). The surveys employ a rotating national panel of 60,000 sample households and include questions about all household members' experiences with crime during the past year. The statistics include crimes people have reported to the police as well as those not reported and thus not reflected in police statistics. These surveys have repeatedly shown that senior citizens are victimized at lower rates than other age groups.

Table 3.1, presenting national victimization data from 1975, shows that for every major crime category, the elderly are victimized less frequently than younger people. The data are quite similar for 1977, as Table 3.2 shows.

Table 3.2
Victimization Rate of Elderly
vs.
Victimization Rate of Others, 1977

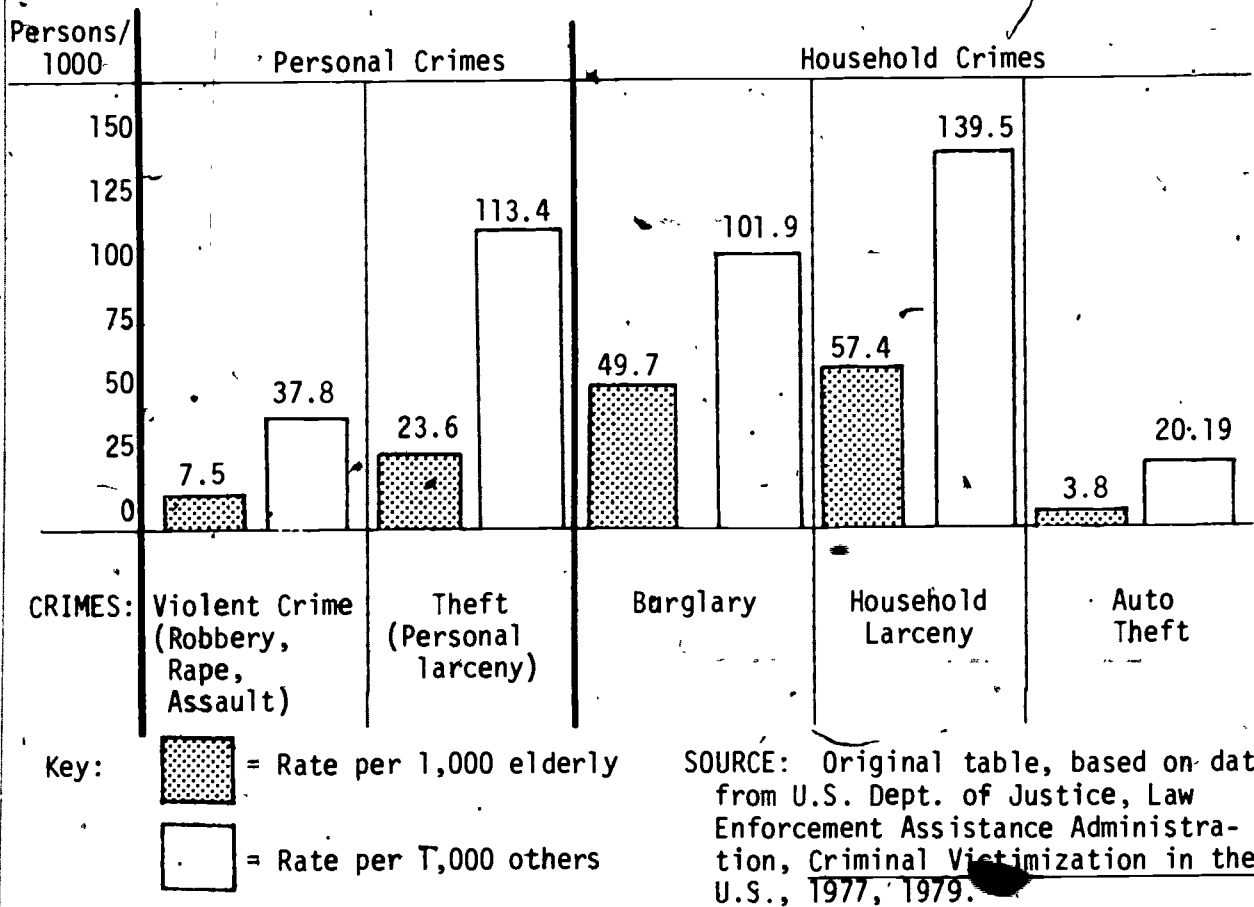

When the data are broken down into various age groupings (Tables 3.3 and 3.4), it is clear that there is a fairly orderly decrease in crime rates with increasing age, a progression which holds true for both household crimes and personal crimes.

Thus, if one were to depend on these numbers alone to reflect the scope of crime against the elderly, one might think crime is not a serious problem for older Americans. However, as we shall see, there are many other ways of viewing the crime problem.

Table 3.3
Household Crimes by Age, 1977
(Rates per 1,000 Population)

Age of Victimized Head of Household	Burglary	Household Larceny	Motor Vehicle Theft	TOTAL
12-19	234.6	193.5	26.3	454.4
20-34	120.0	169.4	24.1	613.5
35-49	91.9	143.8	20.2	255.9
50-64	69.6	95.4	15.1	180.1
65 +	49.7	57.4	3.8	110.9

Table 3.4
Personal Victimization by Age, 1977
(Rate per 1,000 Population)

Age of Victim	Rape	Robbery	Assault	Crimes of Theft (Personal Larceny)	TOTAL
12-15	1.6	10.9	44.0	144.2	200.7
16-19	2.7	9.5	55.5	149.8	217.5
20-24	1.7	9.1	52.5	153.9	217.2
25-34	0.9	6.3	34.8	114.7	156.7
35-49	0.4	4.5	15.1	87.0	107
50-64	0.1	4.3	8.4	57.4	70.2
65 +	0.1	3.4	4.0	23.6	31.1

Types of Crime Committed against the Elderly

There are two major types of crimes. Property crimes are those directed against a person's possessions, as when items are stolen from the home in a burglary or when a car is stolen. Personal crimes are directed against men or women themselves, and the victim comes in direct contact with the criminal. These include robbery, the forceful taking of property from a person; rape, forcible sexual relations; and assault, the purposeful injuring of someone in a fight. These contrast with personal crimes of theft; which include personal larceny-- the stealing of purses, wallets, or cash without force or the threat of force.

While older people are generally victimized less than others, their rates do vary for specific crimes. The national victimization surveys reveal that the elderly are victimized more by property crimes than by crimes against the person. As Table 3.5 illustrates, in 1974 the robbery rate against persons 65 years of age and older was 3.9 per 1,000, the rape rate 0.2, and the assault rate 4.9. The rate for theft, however, was 21.9, and the household crimes of burglary and household larceny were significantly higher rates of 54.4 and 57.9, respectively. The 1977 national victimization surveys show a similar pattern (Table 3.6).

The victimization surveys also show that older persons are victimized disproportionately for several types of crimes. Within the category of robbery, which is officially defined as the taking of property by force or threat of force, the elderly suffer a relatively high rate of robbery with injury. In fact, victims over 65 report higher rates of robbery with injury than do people in both the 35-49 and 50-64 age groups. Over half (55.8 percent) of robberies against persons over 65 result in injury, a ratio which is the highest of all age groups (Table 3.7). So, although older Americans are less likely to be robbed, when they are robbed, they are very likely to be injured.

In addition, for certain crimes like personal theft (i.e., picked pockets and snatched purses), older Americans are as likely to be victimized as are younger people. As Table 3.8 shows, older women are victims of purse snatching more often than women of any other age group.

Variations in Victimization Rates among the Elderly

The cited statistics on victimization of the elderly can be somewhat misleading because they do not reveal an important fact: certain segments of the elderly population are victimized much more frequently than others. Sex, location, and race of victim cause variations from the overall patterns of criminal victimization of the elderly.

A closer review of the 1977 national victimization survey, for example, shows that except for the crimes of rape and larceny with contact (which includes purse snatching), older men are victimized by personal crimes more frequently than older women. This fact surprises many people who are planning crime prevention and victim

Table 3.5

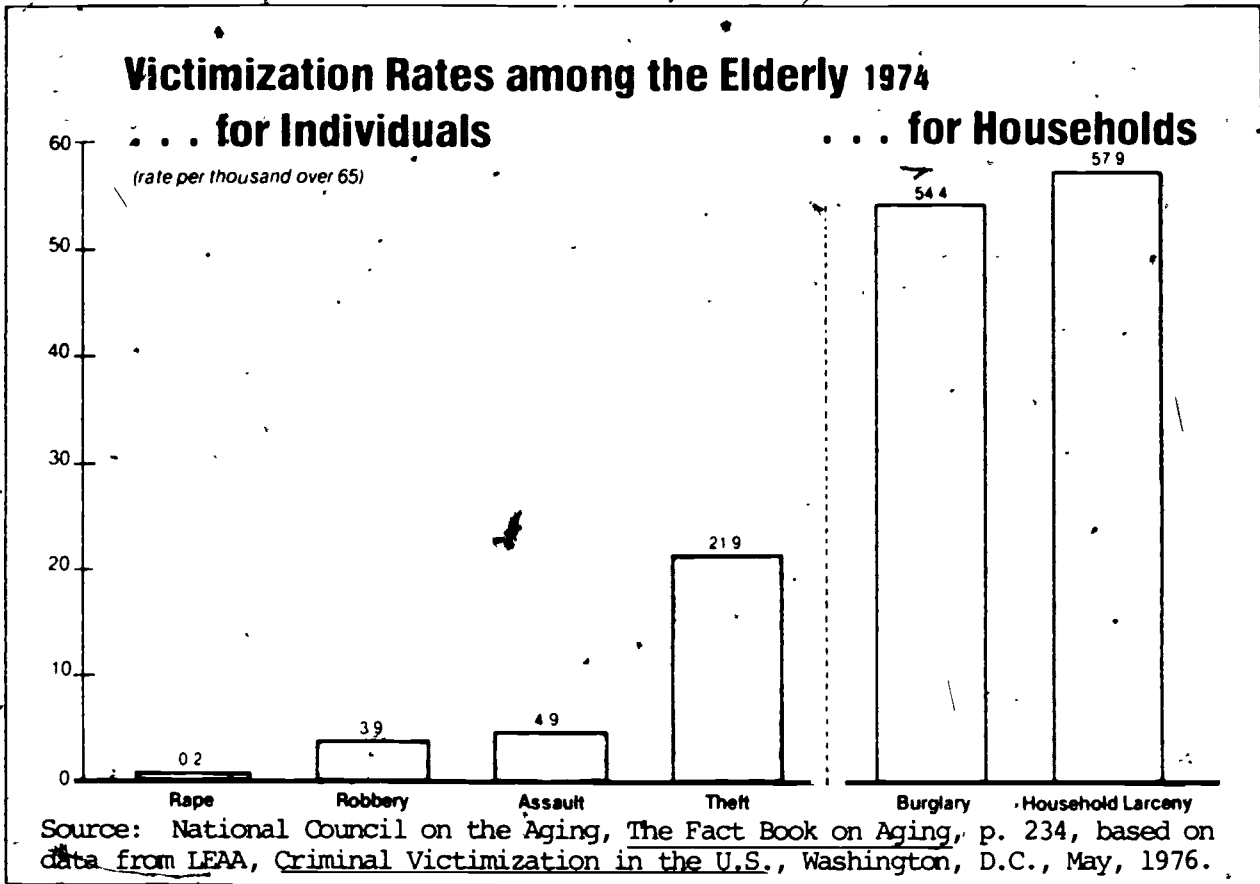

Table 3.6

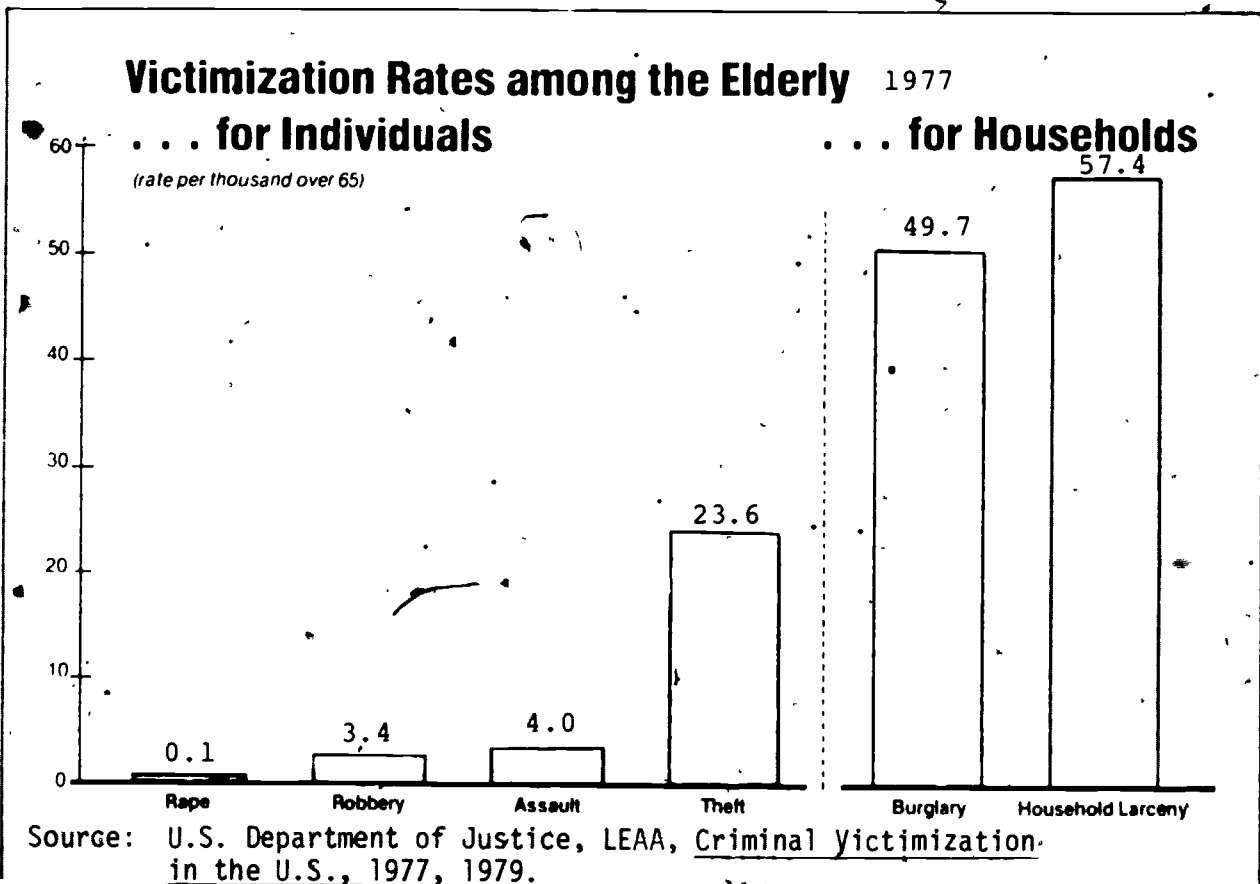

Table 3.7
Victimization Rates by Age for Robbery and Robbery with Injury and Percent of Robberies in which Victim Sustained Injury, 1977

<u>Age</u>	<u>Robbery Rate Per 1,000 Population</u>	<u>Robbery with Injury Rate Per 1,000 Population</u>	<u>Percent of Robbery With Injury</u>
12-15	10.9	2.7	24.7
16-19	9.5	3.2	33.6
20-24	9.1	3.7	40.6
25-34	6.3	2.6	41.2
35-49	4.5	1.4	31.1
50-64	4.3	1.3	30.2
65 +	3.4	1.9	55.8

Source: U.S. Department of Justice, Law Enforcement Assistance Administration, Criminal Victimization in the United States, 1977, 1979.

Table 3.8
Victimization Rate for Purse Snatching by Age of Woman Victim, 1977
(Rate per 1,000 Population)

<u>Age of Woman</u>	<u>Victimization Rate</u>
12-15	0.2
16-19	0.4
20-24	0.8
25-34	1.0
35-49	0.6
50-64	0.9
65 +	1.1

Source: U.S. Department of Justice, Law Enforcement Assistance Administration, Criminal Victimization in the United States, 1977, 1979.

assistance programs. Table 3.9 reveals that for most crimes older men are victimized at about twice the rate of older women. (We should note that household crimes like burglary are not categorized by the sex of victim, since the crimes are considered committed against everyone residing in the household.)

While older men are more frequently victimized than older women, trends in victimization suggest that older urban women are most vulnerable to personal theft while on the street and to burglary or robbery while in their homes (Davis and Brody, 1979).

Racial differences among elderly victims are also pronounced, as seen in Table 3.10. Older blacks are victimized by crimes of violence

Table 3.9
Personal Crimes: Victimization Rates for Persons
Age 12 and Over, by Sex and Age of Victims and
Type of Crime, 1977

(Rate per 1,000 population in each age group)

Sex and age	Crimes of violence	Rape	Robbery			Assault			Crimes of theft	Personal larceny	
			Total	With injury	Without injury	Total	Aggravated	Simple		With contact	without contact
Male											
12-15 (8,124,000)	76.5	10.5	17.2	4.3	12.8	58.8	19.4	39.3	160.8	1.1	457.6
16-19 (8,200,000)	92.0	10.2	13.3	4.8	8.6	78.5	37.2	41.3	165.5	1.6	161.8
20-24 (9,570,000)	87.5	10.5	12.8	5.0	7.8	74.2	29.9	44.3	176.6	1.6	173.0
25-37 (16,122,000)	54.8	10.1	8.5	3.6	4.9	46.2	19.8	26.4	117.7	1.8	115.9
35-49 (16,949,000)	24.8	10.0	5.9	2.0	3.9	19.1	7.8	11.2	88.4	2.3	86.1
50-64 (15,211,000)	16.8	10.1	5.2	1.6	3.6	11.5	4.9	6.5	64.5	1.8	62.8
65 and over (9,274,000)	10.5	10.1	4.2	2.1	2.0	6.4	1.7	4.7	30.2	1.8	28.4
Female											
12-15 (7,839,000)	35.8	2.7	4.4	10.9	3.4	28.8	6.6	22.2	126.9	1.3	125.6
16-19 (8,299,000)	43.7	5.3	5.8	1.6	4.2	32.7	9.9	23.7	134.2	1.9	117.4
20-24 (9,924,000)	40.1	2.9	5.6	2.4	3.2	31.6	9.9	21.7	132.1	3.4	128.7
25-34 (16,694,000)	29.7	1.8	4.1	1.6	2.5	23.8	7.1	16.7	111.8	3.6	108.2
35-49 (17,964,000)	15.2	0.8	3.2	0.9	2.3	11.3	3.5	7.8	85.6	2.6	83.0
50-64 (16,810,000)	9.2	10.1	3.4	1.1	2.3	5.7	1.9	3.8	51.0	3.2	47.8
65 and over (13,167,000)	5.4	10.2	2.8	1.8	1.0	2.3	0.9	1.4	19.0	2.9	16.1

NOTE: Detail may not add to total shown because of rounding. Numbers in parentheses refer to population in the group. Estimate, based on zero or on about 10 or fewer sample cases, is statistically unreliable.

Source: U.S. Department of Justice Law Enforcement Assistance Administration, Criminal Victimization in the United States, 1977, 1979.

(robbery, rape, and assault) almost twice as frequently as older whites. For robbery, the rate is even higher--two-and-a-half times the rate of older white victims. The ratios for crimes of theft are much closer. However, for elderly blacks the rate of personal larceny with contact (purse snatching and pocket picking) is extremely high. They are victimized by this crime more than any other age group; and among people aged 65 and above, blacks are victimized by this crime five times more often than whites.

Table 3.10
Personal Crimes: Victimization Rates for Persons
Age 12 and Over, by Race and Age of Victims
and Type of Crime, 1977

(Rate per 1,000 population in each age group)

Race and age	Crimes of violence	Rape	Robbery			Assault			Crimes of theft	Personal larceny	
			Total	With injury	Without injury	Total	Aggravated	Simple		With contact	Without contact
White											
12-15 (13,388,000)	55.0	1.6	8.8	1.9	6.9	44.6	12.4	32.2	153.8	2.0	151.8
16-19 (13,996,000)	71.0	3.0	9.4	3.1	6.4	58.5	23.7	34.9	157.6	2.6	155.1
20-24 (16,700,000)	64.3	1.6	9.1	3.7	5.4	53.7	19.8	33.9	158.4	2.7	155.6
25-34 (28,617,000)	41.1	0.9	5.6	2.2	3.4	34.6	12.5	22.2	113.8	3.3	111.5
35-49 (30,605,000)	19.4	0.4	3.9	1.1	2.7	15.2	5.5	9.7	87.6	2.1	85.6
50-64 (28,806,000)	11.1	1.0	2.9	0.7	2.2	8.1	3.0	5.2	57.3	2.4	54.9
65 and over (20,297,000)	7.0	10.1	3.0	1.8	1.1	3.9	1.1	2.8	23.1	1.7	21.5
Black											
12-15 (2,375,000)	69.2	11.7	23.4	7.2	16.3	44.1	18.6	25.6	94.0	4.5	89.5
16-19 (2,280,000)	49.7	11.2	11.1	14.0	7.1	37.4	20.0	17.4	99.4	14.1	95.2
20-24 (2,405,000)	61.1	12.2	10.1	13.8	6.3	48.7	21.5	27.2	122.6	7.6	114.9
25-34 (3,571,000)	52.6	11.6	12.3	6.0	6.3	38.8	21.7	17.1	125.2	6.0	119.3
35-49 (3,751,000)	23.1	10.5	9.0	3.6	5.4	13.6	6.8	6.8	84.4	6.0	78.4
50-64 (2,916,000)	28.5	10.0	18.0	7.7	10.3	10.5	6.4	4.1	59.8	3.4	56.4
65 and over (2,001,000)	13.5	10.0	7.9	13.4	14.4	5.6	12.8	12.8	27.0	9.0	17.9

NOTE: Detail may not add to total shown because of rounding. Numbers in parentheses refer to population in the group. Estimate, based on zero or on about 10 or fewer sample cases, is statistically unreliable.

Source: U.S. Department of Justice, Law Enforcement Assistance Administration, Criminal Victimization in the United States, 1977, 1979.

This brief look at victimization rates for subgroups within the elderly population shows that blacks and males are especially vulnerable to crime, with older females being subject to certain kinds of crimes. However, other considerations also affect victimization rates of older Americans. Where elders live is a basic factor: elderly living within core areas of America's large cities are victimized at disturbing rates.

Location of Crime against the Elderly

In crimes against the elderly, geography is fundamentally important. The relatively low victimization rates for the overall elderly population tend to mask high incidences of crime in certain locations. These are the inner areas of our cities—areas where deteriorating physical, economic, and community conditions contribute to the highest rate of crime, areas where the majority of offenders live. Elders tend to remain in the inner city after the younger generations moved to the suburbs. Now many of them live in isolation, making them susceptible to street crimes, burglaries, and confidence games, all crimes in which criminals can feel more secure if they are confronting a

solitary victim.

Table 3.11 supports this observation. It reveals that the victimization rate of those 65 and older for violent crimes is uniformly higher in the 13 major cities surveyed than in the country as a whole. For example, the robbery rate in Oakland is more than six times the national average. In San Francisco, the larceny with contact rate is almost 13 times higher than for the country as a whole. The robbery with injury rate for the elderly is highest or second-highest among persons over 65 in five of these cities, as is the rate for larceny with contact in 10 of the 13 (Lawton 1980).

Table 3.11
Robbery with Injury (R/I) and Larceny with Contact (L/C) Rates
by Age of Victim in Thirteen American Cities
(Rates per 1,000 Population 12 and Over)

City	Age													
	12-15		16-19		20-24		25-34		35-49		50-64		65 and over	
	R/I	L/C	R/I	L/C	R/I	L/C	R/I	L/C	R/I	L/C	R/I	L/C	R/I	L/C
Boston	9	4	8	31	10	32	6	25	8	25	11	27	10	32
Buffalo	7	3	8	5	6	6	6	7	4	8	6	8	3	7
Cincinnati	8	4	9	6	7	6	5	5	5	7	4	7	4	10
Houston	4	5	4	6	9	7	5	6	4	5	2	5	1	9
Miami	1	0	4	5	3	4	3	7	3	5	4	5	3	7
Milwaukee	7	5	6	9	5	6	5	5	6	9	8	8	7	9
Minneapolis	15	7	10	6	6	6	5	3	7	7	7	7	5	9
New Orleans	7	6	8	8	4	13	7	11	4	13	5	19	4	20
Oakland	8	1	6	10	7	13	4	9	4	8	7	13	12	14
Pittsburgh	4	4	9	9	5	7	5	7	4	7	8	9	4	6
San Diego	8	9	8	11	6	7	3	4	2	2	2	3	3	4
San Francisco	11	7	8	17	9	20	9	18	9	17	7	27	10	43
Washington, DC	4	4	7	9	4	11	5	11	4	11	4	13	3	21
National														
Sample 1974	3.3	3.1	3.5	3.7	3.3	3.4	2.1	2.6	2.1	2.6	1.5	3.5	1.9	3.4

Sources: U.S. Department of Justice, Law Enforcement Assistance Administration, Criminal Victimization Surveys in 13 American Cities, 1974, 1977.

U.S. Department of Justice, Law Enforcement Assistance Administration, Criminal Victimization in the United States, 1974, 1977.

In another survey of eight American cities conducted a year after the 13-city study, similar results were found. All cities showed their elderly residents to be victimized at rates higher than the national average, and a majority showed that these increases fell more heavily on the older age group than the younger ones. In four of the eight cities surveyed--Newark, Cleveland, Atlanta, and Denver--the elderly were more frequently victims of robbery with injury than younger

residents, and in the other four cities--Baltimore, Dallas, Portland, and St. Louis--the younger and older populations were almost equally subjected to these crimes (U.S. Department of Justice, 1975a).

Within our major cities, there are large differences in crime rates between neighborhoods and police precincts, a fact borne out in a number of single-city studies. One researcher working in Kansas City was especially impressed by the influence of location and concluded that:

"(E)lderly persons are more vulnerable to crime as a result of where they live and where they are at a certain time than by their age and its physical and psychological manifestations. But there is little comfort in that conclusion. A large component of the elderly population of most American cities is increasingly concentrated in, or on the periphery of higher crime areas." (Midwest Research Institute, 1977: V-8).

This study discovered that elderly residents of low income neighborhoods in Kansas City were robbed or burglarized at rates three to four times that of the overall city population.

Similarly, a New York City study of crime revealed that 41 percent of the survey sample of 1,552 people 60 years and older residing in the inner city had been victims of crime in the recent past (U.S. Congress, House Select Committee on Aging, 1977). Another study of elderly victimization in Flatbush in New York City found a crime rate of 16 percent among those surveyed, a statistic which was validated by the fact that the area's three police precincts ranked first, second, and fifth out of 73 New York City precincts in reported crime against the elderly (Bishop and Klecka, 1978). Moreover, older persons living in urban areas are victimized for certain crimes at rates six to ten times higher than the rates for younger people who live and work in nonurban areas (Davis and Brody, 1979).

Crime Circumstances Leading to Fear

The pattern of crimes committed against older persons includes several other factors which differentiate the elderly from younger age groups.

One study examined 1973 and 1974 national crime survey data in terms of the victim's age and various offender traits. It found that the pattern of violent crimes against the elderly was similar to other age groups with respect to the percentage of youthful offenders, the frequency of gang attacks, and the frequency with which offenders were armed. However, victimizers of the elderly were more likely to be strangers and more likely to be black when the victim was white. These data are reflected in Table 3.12. Smith (1979) has called this disturbing phenomenon the "violent stranger syndrome." For personal street crimes, or predatory crimes, older victims' attackers were more likely to be youths and blacks than were the assailants of victims in other age groups. This is seen in Table 3.13.

With these characteristics of crime against seniors in mind, we can better understand why senior citizens express a high level of fear

Table 3.12
Percentage of Violent Crime by
Age of Victim and Various Offender Variables

Age of Victim	12-16	17-20	21-26	27-32	33-39	40-49	50-64	65 +
<u>Violent Offender Variables</u>								
Percent by youths	86	50	20	15	24	23	28	28
Percent by gangs	23	18	12	11	15	16	17	16
Percent unarmed	71	63	65	68	67	67	74	74
Percent with gun	3	11	15	12	15	15	12	10
Percent by strangers	52	61	64	62	56	55	64	71
% Black on white crime	18	18	19	20	20	17	29	29

SOURCE: George Antunes, Fay Lomax Cook, Thomas D. Cook, and Wesley G. Skogan, "Patterns of Personal Crime Against the Elderly: Findings from a National Survey," The Gerontologist, Vol. 17, No. 4, 1977.

Table 3.13
Percentage of Predatory Crime by
Age of Victim and Various Offender Variables

Age of Victim	12-16	17-20	21-26	27-32	33-39	40-49	50-64	65 +
<u>Predatory Offender Variables</u>								
Percent by youths	89	46	34	32	37	33	45	51
Percent by gangs	37	20	23	11	27	24	28	21
Percent unarmed	74	50	45	45	45	42	55	60
Percent by gun	4	26	30	24	25	19	17	16
Percent by strangers	81	86	88	89	86	94	94	92
% Whites by blacks	46	39	50	58	45	49	61	65

SOURCE: George Antunes, Fay Lomax Cook, Thomas D. Cook, and Wesley G. Skogan, "Patterns of Personal Crime Against the Elderly: Findings from a National Survey." The Gerontologist, Vol. 17, No. 4, 1977.

of crime. Elders are actually victimized less in general. But the crimes against older people, being most often perpetrated by violent strangers, youths, or by persons of another race, present a pattern of strong unpredictability and danger. This pattern reinforces a sense of vulnerability, of uncertainty--a sense of fear.

To make matters worse, Antunes and his colleagues, examining the physical location where crimes occurred, found another distressing pattern. When violent crimes were committed against older persons, most took place in the victims' homes (32 percent) or a yard or common area of the building in which victims' homes were located (20 percent). In contrast, violent crimes against younger groups tended to occur more frequently away from home in the street or in commercial buildings. The authors suggest that some of the fear of older persons about crime may be due to their recognition that victimizations will more often than not involve an invasion of their home, their last bastion of support (Antunes et al., 1977).

References

- Antunes, George E., Fay Lomax Cook, Thomas D. Cook, and Wesley G. Skogan, "Patterns of Personal Crime against the Elderly: Findings from a National Survey," The Gerontologist, Vol. 17, No. 4, 1977.
- Bishop, George F. and William R. Klecka, "Victimization and Fear of Crime among the Elderly Living in High-Crime Urban Neighborhoods," Washington, D.C.: National Council of Senior Citizens, 1978.
- Davis, Linda J. and Elaine M. Brody, Rape and Older Women: A Guide to Prevention and Protection, Washington, D.C.: U.S. Government Printing Office, 1979
- Harris, Louis, and Associates, The Myth and Reality of Aging in America, Washington, D.C.: National Council on the Aging, 1975.
- Lawton, M. Powell, "Crime, Victimization, and the Fortitude of the Aged," Philadelphia, PA: Philadelphia Geriatric Center, 1980.
- Lawton, M. Powell, Lucille Nahemow, Silvia Yaffe, and Steven Feldman, "Psychological Aspects of Crime and Fear of Crime," Jack Goldsmith and Sharon S. Goldsmith, Eds., Crime and the Elderly: Challenge and Response, Lexington, MA: D.C. Heath and Co., 1975.
- Midwest Research Institute, Crimes against the Aging: Patterns and Prevention, Kansas City, MO: MRI, 1977.
- Smith, Robert J., Crime against the Elderly: Implications for Policymakers and Practitioners, Washington, D.C.: International Federation on Ageing, 1979.
- U.S. Congress, House Select Committee on Aging, Subcommittee on Housing and Consumer Interests, In Search of Security: A National Perspective on Elderly Crime Victimization, 95th

- Congress, First Session, Comm. Pub. No. 95-87, Washington, DC:
U.S. Government Printing Office, 1977.
- U.S. Department of Justice, Law Enforcement Assistance Administration,
Criminal Victimization in Eight American Cities, Washington, DC:
U.S. Government Printing Office, 1975a.
- U.S. Department of Justice, Law Enforcement Assistance Administration,
National Criminal Justice Information and Statistics Services,
Criminal Victimization in the United States: 1975, National
Crime Survey Report, No. SD-NCS-N-7, Washington, DC: U.S.
Government Printing Office, 1977.
- U.S. Department of Justice, Law Enforcement Assistance Administration,
Criminal Victimization in the United States, 1974, A National
Crime Survey Report, NCJ-39467, 1977.
- U.S. Department of Justice, Law Enforcement Assistance Administration,
Criminal Victimization in the United States, 1977, A National
Crime Survey Report, No. SD-NCS-N-12, Washington, DC: U.S.
Government Printing Office, 1979.
- U.S. Department of Justice, Law Enforcement Assistance Administration,
Criminal Victimization Survey in 13 American Cities, 1974, A
National Crime Survey Report, NCJ-18471, Washington, DC: U.S.
Government Printing Office, 1975b.

Reading and Resources

For more information on patterns of crime against the elderly, the reader is referred to the "Reading and Resources" section at the end of Chapter Four, "Fear of Crime and Its Consequences."

Chapter Four

Fear of Crime and its Consequences

Chapter Four

Fear of Crime and its Consequences

Advance Organizers

- Although elders are generally victims of crime less than other groups, many older Americans consider crime to be their most serious problem. In some recent polls, crime outranked inflation and physical health as an issue of concern.
- Older people are more fearful of crime than any other age group, and their fear increases as they grow older. Those most vulnerable are also most fearful: city dwellers, blacks, women, and the poor.
- Although victimized by property crimes much more often than by personal crimes, older persons are more fearful of personal attacks. This fear corresponds with their self-perceived vulnerability and the potential consequences of attack.
- Older persons fearful of crime often seriously limit their activities, thus increasing isolation and sometimes developing psychological symptoms from this chronic state of anxiety.

Disagreement exists among researchers about whether the elderly's fear of crime is "realistic," considering their low victimization rates. However, their limited exposure to risk suggests that they are disproportionately victimized compared to the frequency with which they leave home.

- Studies have shown that in particular neighborhoods, the elderly's fears of crime do correspond with their actual rates of victimization.
- Though the amount of money lost by older victims is relatively small, the proportion of income they lose is often devastating.
- Because of age-related physical traits, the elderly are more likely to be injured when attacked, to suffer internal injuries, and to receive cuts and bruises.
- Emotional and psychological fragility can make many older persons more vulnerable to crime and more susceptible to stressful, crisis reactions when victimized.

Introduction

As we have seen in the preceding chapter's brief overview, there are variations in the patterns of crime against the elderly, and circumstances which strongly reinforce a sense of fear among many.

Fear of crime can affect various aspects of people's lives. Some may limit their activities. Others may generalize their suspicion of strangers. Still others may experience disabling stress and anxiety, affecting their relationships with spouses, families, and friends.

Many of those who work in crime prevention and victim assistance programs for the elderly believe that fear of crime is a bigger problem than crime itself, because fear of crime affects people who may never have been victimized and because fear may have more of a negative impact on a person's life than one criminal incident. For these reasons, it is important to understand older people's fear of crime and the reasons behind it. In planning prevention and assistance programs, one must be aware of the real existence of the invisible problem--fear.

Incidence and Level of Fear

Unfortunately, older people are very fearful of crime. Just how fearful they are has been demonstrated by research studies of diverse elderly populations. The Louis Harris poll conducted for the National Council on the Aging in 1974 provided an early indication that older persons across the country are extremely afraid of criminal attack. Nearly one in four of the poll's sample rated crime as a "very serious" problem; it outranked poor health and lack of money in this regard (Harris, 1975).

Studies undertaken since the Harris poll confirm its findings. People who have examined the issue agree that high fear levels are more often reported by and appear to have a greater effect on, the elderly (Clemente and Kleiman, 1976; Sundeen and Mathieu, 1976). Again, some researchers and professionals in the field of aging believe that fear of crime among the elderly is a greater problem than crime itself (Cook and Cook, 1976).

Two recent studies demonstrate how widespread is the fear of crime among older groups. The first, a study of a number of large east-coast cities, found a pervasive fear of crime among the elderly populations (Godbey *et al.*, 1980). The samples surveyed were not representative of the urban elderly population. The majority was white, in better health than most elders, and better educated. They were also more affluent and more actively involved in outside activities than the average senior citizen. The high levels of fear this study uncovered become significant in light of findings of other surveys, which found that among older persons, blacks and the lower-income elderly are more afraid of crime than are whites and the more affluent (Clemente and Kleiman, 1976; Cook, *et al.*, In press).

Another recent study (Hahn and Miller, 1980) showed fear of crime to be the number one concern of the elderly residents of Cincinnati, Ohio. It found that more than 51 percent of the older city residents surveyed cited "safety against crime" as their most pressing concern out of a list of eleven problems. City residents rated crime as more worrisome than inflation and money problems, health care, transportation, or loneliness.

In this era of increasing crime rates, it is not surprising that the elderly are fearful of crime. However, the extent of their fear can be more clearly understood when compared to the fear felt by other age groups. Such comparisons reveal that older people are more fearful of crime than any other age group. A recent review of several major city and national surveys found that the elderly are more likely than all others to indicate high fear levels. Age comparisons are shown in Table 4.1. While the levels of fear vary from survey to survey, all show a sharp increase in fear among older persons.

Not only are the elderly more fearful than other age groups, but fear continues to increase as persons grow older. Fear levels have been found to be appreciably higher for people over 60 than for younger counterparts. And among people older than 60, fear levels increase with age. In fact, Cook and colleagues found that the increase in the level of fear recorded among the elderly is greater than that observed during the entire preceding four decades.

Another trend is the increase of fear among the elderly over time. One analysis of successive national surveys shows an increase in fear levels over a 10- to 15-year period, and another analysis focusing on change--which analyzed identical surveys conducted in 1965 and 1976--found a strong time-related increase over the 11 years, one which was greater for older persons than younger ones (Cutler, 1980). Another analysis of the national victimization surveys confirms this steady increase in fear of crime among the elderly, increasing from a low of 31 percent to a high of 45 percent. The largest increase occurred during 1967 to 1974. Furthermore, the difference in fear levels between the old and young has also increased over time (Cook, et al., In press).

While the older segments of the elderly may be more fearful than those closer to 60 years of age, they are not the only subpopulation among senior citizens with higher fear levels. Certain characteristics among the elderly seem to correlate with increased concern about crime. Not surprisingly, it is those older persons who are most vulnerable to crime and most seriously affected by it who have the worst fears, namely, city-dwellers, women, blacks, the poor, and those without social integration.

City Dwellers

Those elderly living in our large cities are more fearful of crime than other older persons. As we have seen, victimization rates are higher in these cities--especially inner city areas--than in nonurban communities. The relationship between age and fear becomes more pronounced as city size increases. For the elderly, the size of

Table 4.1
Age and Fear of Personal Crime

Percent Reporting "UNSAFE" on Street Alone in Neighborhood at Night

Age	Cumulative National National Opinion Research Center (NORG) Surveys (1973-1977)	Census Bureau Five-City Surveys (1973)	Census Bureau Thirteen-City Surveys (1974)	Northwestern Three-City Telephone Surveys (1977)
16-20	42%	40%	17%	18%
21-26	39	39	16	24
27-32	44	41	17	26
33-39	40	43	19	27
40-49	41	46	24	25
50-59	44	52	26	40
60 and older	52	63	41	54
(N)	(5951)	(11419)	(11818)	(1213)

SOURCE: Fay Cook, Wesley Skogan, Thomas D. Cook and George Antunes, Setting and Reformulating Policy Agendas: Criminal Victimization of the Elderly, (forthcoming from the Oxford University Press).

(Computed by the authors from original data. General Social Survey data are for the years 1973, 1974, 1976 and 1977.)

57

the city is a more important factor in their fear of crime than for younger age groups (Cook, et al., In press).

Women

Another subgroup of older persons which is more fearful, according to all large-scale surveys, is older women. However, the differences in fear levels between men and women in their older years are not so great as they are within younger age groups. Higher fear levels among older women may be a reflection of their greater isolation; more women--by nature of their longer life expectancies--are living alone. The increased similarity in fear levels between the sexes among the elderly may be due to their recognition that once they enter their later years, physical endurance or strength does not vary much between men and women. Both view themselves as very vulnerable to attacks by the typical offender--a younger stranger who usually is strong and fast.

Blacks and the Poor

While older blacks are more fearful than older whites, the differences are not substantial. In fact, the difference may be due more to neighborhood than to race itself (Cook, et al., In press; Hindelang and Richardson, 1978). Fear of crime is also related to low income for all ages. However, the poor may very well be more fearful for the same basic reason that blacks are more fearful than whites: they live in the high-crime neighborhoods. Additionally, poorer people are less able to cope with crime. They cannot afford good locks, cannot replace lost money or property, and often cannot afford insurance, especially in high-crime areas. The over-representation of the elderly among the nation's poor may account for the fact that the relationship between income and fear is even stronger for them than for the general population (Cook, et al., In press).

Social Integration

Several researchers and service providers have speculated about the effect of "social integration" on fear of crime among the elderly. By social integration we mean the extent to which people "fit" or "belong" within their neighborhoods: Do they have friends or neighbors they can call for assistance? Do they belong to social groups within the area? Do they have someone with whom to go on errands? Are they familiar with the structure and geography of the neighborhood? These observers maintain that such questions are even more important for older people who are more vulnerable to victimization and more susceptible to harmful effects from crime. While research has not yet shown a significant relationship between fear of crime and "social integration," many people have agreed that it plays a part in the elderly's perception of their safety, as well as their psychological health (Smith, 1979).

Finally, those elderly persons who own their own homes are less fearful of crime than renters (Cook, et al., In press). While this is true for all age groups, it is particularly significant for older people because the elderly are more likely to own their own homes

than those who are younger.

The fear of crime among the elderly--whether in high-crime areas or elsewhere--is centered mainly on personal crimes. Although the elderly's victimization rates are relatively higher for property crimes such as burglary and larceny, they are most fearful of personal attack. The reason for this is fairly obvious: as we shall see in a subsequent section, they are most afraid of those crimes with the greatest potential for harm to them.

Impact of Fear of Crime on the Elderly

Fear of crime can stimulate people to engage in various behaviors. They may choose not to go out at night, to avoid certain parts of their neighborhood, or to reduce the number of their daily outside activities. These are examples of "avoidance behaviors," in which people refrain from actions to avoid being victimized.

On the other hand, people may take affirmative actions to avoid being victimized. These may include buying and installing better door locks, going on errands with a friend or group, or forming a neighborhood watch club. All are examples of "mobilization behaviors," those in which people take positive actions to deter criminal attack.

Avoidance Behaviors

Researchers have uncovered a wide range of ways in which the elderly limit their behaviors because of fear of crime. Some elders do not walk outside after dark, and avoid particular areas of the city (Rifai, 1975); do not engage in certain community activities (Broderick and Harel, 1977), and even sell their homes or move businesses if they have been victimized (Midwest Research Institute, 1977); avoid certain sections of their own apartment buildings like the basement and laundry rooms (Bishop and Klecka, 1978); limit their use of public parks, recreation, or senior citizen centers; and try to get home before 3:00 p.m. when school lets out (Godbey, et al., 1980).

It should be realized that not all activity restraint engaged in by older persons is caused by their fear of crime. Much may be due simply to reduced strength or stamina, poor health, or limited access to transportation. Nevertheless, it is clear that for many elderly persons, fear of crime causes them to limit their behavior more than they otherwise would. While most may not make themselves virtual prisoners in their own homes, as some have suggested, many do circumscribe their activities to a large extent.

Unfortunately, the consequences of the elderly's fear of crime are not limited to reducing physical activity. Although not regularly revealed through scientific surveys, it has been found that accompanying the loss of mobility is an equally serious emotional stress, plus a series of indirect consequences like the following:

- By reducing mobility, they lose contact with friends and thus increase their degree of isolation.

- By limiting their outside activities, even during the daytime hours, they do not make necessary trips to grocery stores, doctors' offices, and drug stores. The result can be increased nutritional and health problems.
- The simple fact of not feeling free to get out into the fresh air and walk deprives many elderly of one of their most basic recreational activities.
- Even those who are able to relocate from their old neighborhoods because of fear of crime often undergo an emotional crisis because of the move (Center, 1979a).

Researchers have also found that, by constantly being in a state of fear or threat, elderly people can develop a debilitating mental state causing sufficient strain and anxiety to result ultimately in psychological and physical symptoms (Lawton, et al., 1976).

Mobilization Behaviors

The effects of fear of crime on the elderly are not entirely negative. To think that all elderly people are afraid to go out and are constantly fearful is to perpetuate the myth of the elderly as weak and powerless. Fear mobilizes some to take steps to lessen their chances of being victimized. For example, they may drive or be driven rather than walk places, walk with other people, or take something for protection when they do go out. One survey of several major cities (Cook, et al., In press) found that the most commonly employed of these methods is using a car. However, since less than half of all elderly households have a car this is obviously not a crime prevention strategy open to every senior citizen.

Older persons also take actions to increase the security of their homes. These include installing new locks or window bars, using timers or door viewers, having a security survey performed, or having property engraved with identification numbers.

Little research is available on this topic, but several studies are encouraging. One examined "territorial marking behavior" in older persons to determine if such active control over the environment lessens the fear of crime (Pollack and Patterson, 1979). Indicators of territorial marking included installing fences and one-way door viewers, as well as signs, welcome mats, and name plates. The study's conclusion was that older people who displayed such territorial behavior showed less fear of crime than those who did not. No such differential was found among people younger than 65 years old. An evaluation of a program to provide locks to senior citizens in St. Petersburg, Florida, showed a similar reduction in fear levels among persons receiving locks (Stein, Criminal Justice and the Elderly Newsletter, Spring 1980). Another review of mobilization behavior, confined almost completely to the elderly of one major city, found that older people are more likely to use home protection measures of several types (Cook, et al., In press). These include outside lights, light timers, special door locks, and special window bars or locks.

The lack of research on the extent of the elderly's mobilization in response to fear of crime is unfortunate in light of the vast literature and public attention paid to their avoidance behavior. While the serious restrictions seniors place on their activities because of fear of crime should not be minimized, it is also a mistake to believe that older persons in general will not take positive steps to reduce their chances of becoming crime victims. It is this realization that can spur senior citizen service providers and others to become actively involved in crime prevention training, persuading elders to take those steps to make their lives more safe.

The "Reality" of the Elderly's Fear of Crime

While an understanding of the scope and nature of the elderly's fear of crime is important, one question still must be addressed: What accounts for the paradox between the elderly's low victimization rates and their high levels of fear of crime? Many researchers have concluded, after studying victimization rates against older persons, that the elderly's fear of crime is unrealistic or irrational (Cook and Cook, 1976; Hindelang and Richardson, 1978). However, a closer analysis of victimization rates can dilute the strength of the argument.

One way to examine victimization rates is to look at the extent of victimization as compared to an individual's exposure to the risk of crime. Because of many age-related factors and a high fear of crime, older people do not venture out much, which reduces their risks of being victimized by a number of crimes. A review of national big-city survey data from this perspective suggests that personal victimization for the elderly is much higher than the level of exposure would lead one to expect. In other words, in comparison with how much they leave home, they seem disproportionately victimized (Cook *et al.*, In press).

Another perspective on victimization is provided by surveys at the neighborhood or local level. We have seen that in certain locations--big cities, especially inner areas within those cities--victimization rates of the elderly are much higher than national rates. Several of these local studies, using somewhat limited samples, have concluded that a significant relationship between the elderly's victimization rates and their fear of crime does exist in particular city neighborhoods (Jaycox, 1978; Lawton and Yaffe, 1980; Rifai, 1976). While more research on this subject is needed, the available findings indicate that the elderly's apprehensions are in response to real, not imagined, threats.

An alternate explanation for older persons' high fear of crime--one which makes victimization rates almost irrelevant--is based on older persons' vulnerability to criminal attack resulting in injury. To fully understand this concept, the reader should keep in mind the distinction between risk of crime and fear of crime. Risk measures the likelihood that people will be victimized by crime. Fear relates to people's apprehensions about what could happen if they were victimized by crime. The first is an objective view of probability; the second is often a subjective view of possibility.

It is the elderly's concern about what could happen to them which is the basis for their serious fear of crime. As one researcher who has done extensive work on fear and victimization of the elderly explains, "The older person undoubtedly perceives his limitations as representing heightened vulnerability. It seems reasonable to suggest that the age differentials in fear . . . represent about what one would feel is the proportional objective increase in vulnerability consequent to being old." (Lawton, 1980.) Skogan makes this point more directly: "One cannot use the fact of low victimization rates for the elderly to argue that their fears are 'inappropriate' or 'too high.' It appears that what could happen fuels people's efforts to reduce their exposure to risk and to minimize their chances of being victimized when they do take to the streets." (In Cook et al., In press.)

This expectation of what could happen is based on older persons' knowledge of their vulnerability and reduced ability to recover from injuries, both physical and psychological. Moreover, other factors also lead them to perceive their own increased vulnerability to crime: the victimization of friends and acquaintances; the proximity to high-crime areas or potential offenders; the perceived inadequacy of police protection; or the lack of available help if something were to happen.

Because it is their heightened vulnerability to crime and the potential consequences of criminal attack which in part underlie the elderly's great fear of crime, it is important to understand the nature of these concerns. Such an understanding will provide more specific answers to the question: Why are the elderly so fearful of crime?

Vulnerability to Crime and the Impact of Crime

Chapter Two presented an overview of the status and characteristics of the elderly population in the United States. That picture provides an excellent background for a discussion of the vulnerability of older persons to crime and the consequences they face because of victimization. This section relates the elderly's economic, physical, emotional, and environmental characteristics to their fear of crime and the severe impact crime can have on their lives.

Economic

From an economic perspective, it should be readily apparent that the elderly are poorly equipped financially to deal with economic or property loss. Compared to other age groups, they can be expected to suffer the most since they start with the least. While some people have found that the monetary loss of older people in actual terms is low compared to other age groups (Cook, et al., 1978), as a percentage of their monthly income, it is higher than for younger age groups, except for those 32 and under (U.S. Congress, House Select Committee on Aging, 1978b). One study in Kansas City found that elderly victims lost 23 percent of a month's income and those below the poverty line lost 100 percent (Midwest Research Institute, 1977). And for those older persons living on fixed incomes, there is no opportunity to recoup losses through future earnings. Even those older persons who do work are most likely to be clustered in low-paying jobs and

and are not necessarily able to recoup losses from crimes (U.S. Congress, Senate Subcommittee on Aging, 1976).

For the elderly, the amount of money lost through a crime is not the only economic hardship. The loss of certain pieces of property such as televisions and radios may take on great significance for older persons. Many rely on these items for companionship and entertainment, especially those who are isolated or have limited mobility. For them, television or radio may be their primary link to the outside world. And yet with a fixed income and fixed needs, a television may be nearly impossible to replace.

Additionally, the loss or destruction of items of sentimental value--items often treasured for a lifetime--can be catastrophic, considering the traumatic nature of the entire criminal incident. Unfortunately, a good number of older Americans do not trust banks and keep very valuable possessions at home rather than in safety deposit boxes.

Physical

The physical condition of older persons as a result of the normal aging process makes them more vulnerable both to victimization and to serious consequences of that victimization. The physical vulnerability of older persons has been summarized in the following manner:

Older people have diminished physical strength and stamina; hence, they are less able to defend themselves or to escape from threatening situations. Older people are far more likely to suffer from physical ailments such as loss of hearing or sight, arthritis, and circulatory problems which increase their vulnerability. Older people are physically more fragile and more easily hurt should they opt to defend themselves. For example, bones are more easily broken and recovery is more difficult. Thus, they are less likely to resist attackers. Potential criminals are aware of the diminished physical capacity and the physical vulnerability of the elderly and thus are more likely to seek out an elderly target whose age status is easily visible (Goldsmith and Tomás, 1974).

One recent analysis of national victimization survey data had these empirical findings: the elderly are more likely to be injured when attacked; they suffer wounds and broken bones less than others, but suffer more internal injuries and are more likely to lose consciousness or suffer cuts and bruises; and, they are not more likely to need medical care, but if they receive it, its cost will constitute a much larger proportion of their income than is the case for other age groups (Cook, *et al.*, 1978).

The data supporting these findings are shown in Tables 4.2 and 4.3.

Table 4.2
Personal Robbery and Assault: Percent of
Victimizations in Which Victims Sustained Physical
Injury, by Age of Victims and Type of Crime, 1977

<u>Characteristic</u>	<u>Robbery and Assault</u>	<u>Robbery</u>	<u>Assault</u>
<u>Age</u>			
12-15	31.2	24.4	32.9
16-19	31.6	33.0	31.4
20-24	31.7	40.6	27.1
25-34	26.9	41.3	24.3
35-49	29.0	31.3	28.3
50-64	25.5	31.3	22.5
65 and over	35.3	57.5	16.6

SOURCE: U.S. Department of Justice, Law Enforcement Assistance Administration, Criminal Victimization in the United States, 1977, 1979, p. 55.

Table 4.3
Personal Crimes of Violence: Percent of
Victimizations in Which Victims Received Hospital Care,
by Selected Characteristics of Victims and
Type of Crime, 1977

<u>Characteristic</u>	<u>Crimes of Violence</u>	<u>Robbery</u>	<u>Assault</u>
<u>Age</u>			
12-19	6.4	6.2	5.8
20-34	7.4	10.0	6.7
35-49	9.0	7.3	8.8
50-64	8.5	7.6	9.0
65 and over	8.1	14.9	2.7

SOURCE: U.S. Department of Justice, Law Enforcement Assistance Administration, Criminal Victimization in the United States, 1977, 1979, p. 57.

Psychological and Emotional

The emotional vulnerability and consequences of crime for the elderly are closely related to their physical difficulties and are also heightened by the problems inherent in the aging process, especially those relevant to the increasingly fragile nature of their emotional stability. The work of Dr. M. Powell Lawton and his associates at the Philadelphia Geriatric Center has shed light on the psychological traits of older people in relation to crime. On the one hand, these traits make them more vulnerable to crime. Because of limitations in vision and hearing, they may not readily recognize a threat. Conversely, in trying to compensate for their reduced capacity to appreciate risk, they may become oversensitized to the point of chronic anxiety. Even if they do recognize a threat accurately, they may not analyze the situation properly in terms of a response; usually an attempted crime happens quickly and suddenly, straining the limits of anyone's information-processing capacity, but especially that of the older person. Thus, the uncomprehending victim may remain passive when action should be taken or may take inappropriate action (Lawton, et al., 1976).

On the other hand, emotional and psychological fragility can produce very stressful reactions in older persons who are victimized. We have used Dr. Eric Pfeiffer's term "season of loss" to describe old age--a time of lost status and self-esteem, of loved ones lost forever, and of lost powers over the mind and body. While many older persons are extremely hard-hit by these losses, most are able to cope well with their losses. However, research has shown that old age tends to bring on dramatic reduction in the body's reserve capacities, those reserves called on whenever emotional upsets occur. One's physical tolerance to stress declines with age. Thus, people's physical and psychological "buffers" to deal with sudden shock generally grow weaker in old age. Because of their life situations, many elders develop maladaptive coping mechanisms which cause a continual devaluation of self and make them susceptible to additional stress (Lawton, et al., 1976).

These coping mechanisms include acute and chronic anxiety; denial of problems; projection, which helps people vent anger on outsiders who are made into scapegoats; withdrawal, which can reduce vulnerability to harm but can also reduce ability to cope with harm when it occurs; and depression, which can serve as a coping device by numbing the psyche and protecting oneself from further pain. There are also more extreme coping devices used by the elderly, such as paranoid reactions, overcompensation, alcoholism, hypochondriasis, or dependency. Many older persons are under so many life-induced stresses that the added stress of victimization can induce a crisis in which one or more of these coping mechanisms is employed (Pfeiffer, 1978).

It is the belief of a number of psychiatrists like Eric Pfeiffer and Martin Symonds that emergency counseling or crisis intervention is essential for those elderly who are not coping effectively with victimization in order to avoid psychological consequences which may be severe and long lasting (Stein, Criminal Justice and the Elderly

Environmentals

One of the most significant factors contributing to the vulnerability of the elderly is their social environment. Most importantly, many older persons live alone, and this makes them susceptible to street crimes, burglaries, and confidence games--all crimes in which the criminal can feel most secure if he is confronting a solitary victim. In addition, older Americans residing in urban areas are most likely to live either in or in close proximity to those sections of the city where the crime rate is highest.

Urban elderly who find themselves in undesirable areas often remain there for a variety of reasons. They are frequently economically unable to move out. Even those who can afford to move are sometimes too emotionally or culturally bound to these neighborhoods to do so.

Further, older people who live in inner city areas often must depend on public transportation for their errands. This is a means of travel which is becoming increasingly dangerous. They also find themselves living in older buildings. Although homes or apartments may have deteriorated to the point where they offer very little security, their older residents may simply be unable to afford the repairs.

Because of a number of factors such as their reduced mobility, limited incomes, and older housing, older people are more affected by their immediate environment than are younger people. Thus, if their environment is largely unsafe and nonsupportive, they become even more vulnerable to crime. Unfortunately, this is the case for millions of elderly city dwellers.

In summary, the planner of crime prevention and victim assistance programs should understand that older community members who have high levels of fear of crime may well be justified in their fears, especially considering their high levels of vulnerability. This vulnerability is widespread: physically, older victims are more likely to suffer personal injury when attacked; economically, their losses represent a high percentage of total monthly income; psychologically, a criminal attack may be more of an addition to already-present life stresses than they can endure.

The planner should be aware of the various avoidance and mobilization behaviors that are possible responses to increased vulnerability. When avoidance activities serve only to feed the older person's sense of powerlessness they should be discouraged. Because they represent "positive" actions and reinforce the sense of self-capability, mobilization behaviors may be more appropriate in planning strategies to combat crime and to assist its victims.

Reading and Resources

- Antunes, George E., Fay L. Cook, Thomas D. Cook, and Wesley Skogan, "Patterns of Personal Crime against the Elderly: Findings from a National Survey," The Gerontologist, Vol. 17, No. 4, 1977.
- Bishop, George F. and William R. Klecka, Victimization and Fear of Crime among the Elderly Living in High-Crime Urban Neighborhoods, Washington, D.C.: National Council of Senior Citizens, 1978.
- Broderick, K.M., and Z. Harel; "Reducing Victimization and Fear of Crime among Urban Aged," The Gerontologist, Vol. 17, No. 5, 1977.
- Burkhardt, John E., and Lee Norton, Crime and the Elderly: Their Perceptions and Reactions, Montgomery County, MD: Department of Police, 1977.
- Butler, Robert N., "Victimization of the Elderly," Why Survive? Being Old in America, New York: Harper and Row, 1975.
- Center, Lawrence J., Anti-Crime Programs for the Elderly: A Guide to Program Activities, Washington, D.C.: National Council of Senior Citizens, 1979a.
- Center, Lawrence J., Anti-Crime Programs for the Elderly: A Summary Evaluation Report, Washington, D.C.: National Council of Senior Citizens, 1979b.
- Clemente, F. and M.B. Kleiman, "Fear of Crime among the Aged," The Gerontologist, Vol. 16, No. 3, 1976.
- Conklin, J.E., "Robbery, the Elderly, and Fear: An Urban Problem in Search of Solution," Jack Goldsmith and Sharon S. Goldsmith, Eds., Crime and the Elderly--Challenge and Response, Lexington, MA: D.C. Heath and Company, 1976.
- Cook, Fay L., and Thomas D. Cook, "Evaluating the Rhetoric of Crisis: A Case Study of Criminal Victimization of the Elderly," Social Service Review, Vol. 50, 1976.
- Cook, Fay L., Wesley Skogan, Thomas D. Cook and George Antunes, "Criminal Victimization of the Elderly: The Physical and Economic Consequences," The Gerontologist, Vol. 18, No. 4, 1978.
- Cook, Fay L., Wesley Skogan, Thomas D. Cook and George Antunes, Setting and Reformulating Policy Agendas: Criminal Victimization of the Elderly, New York: Oxford University Press, In press.
- Cutler, S.J., "Safety on the Streets: Cohort Changes in Fear," International Journal of Aging and Human Development, Vol. 10, 1980.
- Dussich, John P.J. and Charles J. Eichman, "The Elderly Victim: Vulnerability to the Criminal Act," Jack Goldsmith and Sharon S. Goldsmith, Eds., Crime and the Elderly--Challenge and Response, Lexington, MA: D.C. Heath and Company, 1976.

- Geis, Gilbert, "The Terrible Indignity: Crimes against the Elderly," Marlene Young Rifai, Ed., Justice and Older Americans, Lexington, MA: D.C. Heath and Company, 1977.
- Godbey, Geoffrey, Arthur Patterson and Laura Brown, The Relationship of Crime and Fear of Crime among the Aged to Leisure Behavior and use of Public Leisure Services, Washington, D.C.: The NRTA/AARP Andrus Foundation, 1980.
- Goldsmith, Jack and Sharon S. Goldsmith, Eds., Crime and the Elderly-- Challenge and Response, Lexington, MA: D.C. Heath and Co., 1976.
- Goldsmith, Jack, and Noel E. Tomas, "Crimes against the Elderly: A Continuing National Crisis," Aging, Nos. 236-7, June/July 1974.
- Hahn, Paul H., Crimes against the Elderly: A Study in Victimology, Santa Cruz, CA: Davis Publishing Company, 1976.
- Hahn, Paul H., and Elizabeth R. Miller, Project Search and Inform, Cincinnati-Hamilton County, Ohio, 1979-80, Cincinnati, OH: Xavier University Graduate Corrections Department, 1980.
- Harris, Louis, and Associates, The Myth and Reality of Aging in America, Washington, D.C.: National Council on the Aging, 1975.
- Hindelang, M.J., and E.H. Richardson, "Criminal Victimization of the Elderly," Research into Crimes against the Elderly, Part 1, Joint Hearings before House Subcommittee on Domestic and International Scientific Planning, Analysis, and Cooperation, and Subcommittee on Housing and Consumer Interests, January 31, 1978, Washington, D.C.: U.S. Government Printing Office, 1978.
- Jaycox, Victoria H., "The Elderly's Fear of Crime: Rational or Irrational," Victimology, Vol. 3, Nos. 3-4, 1978.
- Jaycox, Victoria H., "Using Anti-Crime Services to Reach Elderly Women in Need," Paper presented at the Second Annual Women in Crisis Conference, June 6, 1980, Washington, D.C.: National Council of Senior Citizens, 1980.
- Klecka, William R. and George F. Bishop, Neighborhood Profiles of Senior Citizens in Four American Cities: A Report of Findings to the National Council of Senior Citizens, Washington, D.C.: NCSC, 1978.
- Lawton, M. Powell, "Crime, Victimization and the Fortitude of the Aged," Philadelphia, PA: Philadelphia Geriatric Center, 1980.
- Lawton, M. Powell, and Morton Kleban, "The Aged Resident of the Inner City," The Gerontologist, Vol. 11, 1971.
- Lawton, M. Powell, Lucille Nahemow, Sylvia Yaffe, and Steven Feldman; "Psychological Aspects of Crime and Fear of Crime," Jack Goldsmith and Sharon S. Goldsmith, Eds., Crime and the Elderly-- Challenge and Response, Lexington, MA: D.C. Heath and Co., 1976.
- Lawton, M. Powell and S. Yaffe, "Victimization and Fear of Crime in Elderly Public Housing Tenants," Journal of Gerontology, Vol. 35, 1980.

- Malinchak, Alan A. and Douglas Wright, "Older Americans and Crime: The Scope of Elderly Victimization," Aging, March-April 1978.
- Midwest Research Institute, Crimes against the Aging: Patterns and Prevention, Kansas City, MO: MRI, 1977.
- Pfeiffer, Eric C., "Psychotherapy of the Elderly," The National Association of Private Psychiatric Hospitals Journal, Vol. 10, No. 1, Fall 1978.
- Pollack, L.M., and A.H. Patterson, "Territoriality and Fear of Crime in Elderly and Nonelderly Homeowners," Journal of Social Psychology, Vol. 2, No. 3, 1979.
- Rifai, Marlene Young, Ed., Justice and Older Americans, Lexington, MA: D.C. Heath and Company, 1977.
- Rifai, Marlene Young, Older Americans' Crime Prevention Research Project--Final Report, Portland, OR: Multnomah County Division of Public Safety, 1976.
- Rifai, Marlene Young, Older Americans Crime Prevention Research--Preliminary Report No. 5, Portland, OR: Multnomah County Division of Public Safety, 1975.
- Sicker, Martin, "A Public Policy Perspective: The Elderly and the Criminal Justice System," Police Chief, Vol. 44, No. 2, 1977.
- Skogan, Wesley G., "The Fear of Crime among the Elderly," Research into Crimes against the Elderly, Part 2, Joint Hearings before House Subcommittee on Domestic and International Scientific Planning, Analysis, and Cooperation and Subcommittee on Housing and Consumer Interests, February 1, 1978, Washington, D.C.: U.S. Government Printing Office, 1978.
- Smith, Robert J., Crime against the Elderly: Implications for Policymakers and Practitioners, Washington, D.C.: International Federation on Ageing, 1979.
- Stein, John H., Ed., Criminal Justice and the Elderly Newsletter, Washington, D.C.: National Council of Senior Citizens, Fall 1978.
- _____, Ed., Criminal Justice and the Elderly Newsletter, Washington, D.C.: National Council of Senior Citizens, Spring 1980.
- Sundeen, R.A., "Fear of Crime and Urban Elderly," Marlene Young Rifai, Ed., Justice and Older Americans, Lexington, MA: D.C. Heath and Company, 1977.
- Sundeen, R.A. and J.T. Mathieu, "The Urban Elderly: Environments of Fear," Jack Goldsmith and Sharon S. Goldsmith, Eds., Crime and the Elderly--Challenge and Response, Lexington, MA: D.C. Heath and Company, 1976.

U.S. Congress, House Select Committee on Aging, In Search of Security: A National Perspective on Elderly Crime Victimization, Report by the Subcommittee on Housing and Consumer Interests, Ninety-fifth Congress, First Session, Comm. Pub. No. 95-87, Washington, DC: U.S. Government Printing Office, 1977.

Research Into Crime Against the Elderly (Part 1), Joint Hearings Before House Subcommittee on Domestic and International Scientific Planning, Analysis, and Cooperation and Subcommittee on Housing and Consumer Interests, January 31, 1978, Washington, DC: U.S. Government Printing Office, 1978a.

Research Into Crimes Against the Elderly (Part 2), Joint Hearings before House Subcommittee on Domestic and International Scientific Planning, Analysis, and Cooperation and Subcommittee on Housing and Consumer Interests, February 1, 1978, Washington, DC: U.S. Government Printing Office, 1978b.

U.S. Congress, Senate Subcommittee on Aging, Crime and the Elderly, 1975, Washington, 1976.

Chapter Five

Introduction to Crime Prevention and Victim Assistance

Chapter Five

Introduction to Crime Prevention and Victim Assistance

Advance Organizers

- Recently efforts have been made to help maintain the quality of life of community elderly. These efforts have included crime prevention and victim assistance programs.
- The more effective crime prevention projects aim at reducing the opportunities for crime. Individual and group activities include residential security surveys, property-marking and hardware programs, block and neighborhood clubs, escort services, and case monitoring.
- Victim assistance programs designed to help victims under stress primarily attempt to assist them in recovering from the emotional impact of the victimization, to obtain whatever benefits or compensation they are entitled to, and to obtain the services needed to help them regain their previous style of living.
- To function most effectively, comprehensive victim assistance programs need to identify and contact victims, assess needs of victims and provide appropriate responses, and follow up victims' progress.
- Combining both crime prevention and victim assistance creates a more complete service capacity for agencies, more knowledgeable and thorough educational programs for elders, and more likely acceptance by unvictimized and victimized elderly alike.
- Trends in crime prevention and victim assistance for older Americans include developing programs within the aging-related service network, employing elderly peer counselors, investigating issues of elder abuse and neglect, and establishing victim compensation programs.

Introduction

While a great deal of research has focused on the victimization of older persons and their fear of crime, very little attention has been paid to potentially effective responses to the elderly's crime problems. Only in the past several years have pilot programs, sponsored by government at all levels, been set up to attack older people's fears and losses resulting from crime.

These projects have usually been of one or two types: crime prevention and victim assistance. In this section we provide an introduction to the rationale for crime prevention and victim assistance services for seniors and recent trends in these areas. A full understanding of what crime prevention and victim assistance are-- and what they are not--should encourage both private citizens and agency officials to become more involved in these movements and to reduce dependence on the police.

The Crime Prevention Concept

In the past, "crime prevention" has referred to many kinds of strategies aimed at controlling criminal activity. Examples included: the use of standardized sentences and punishments as deterrents to criminal action; various treatments for the offender in order to rehabilitate him; and changing the social environment which spawns criminals.

This last approach encompasses a multitude of programs aimed at improving social conditions which are thought to breed crime; and so, ameliorative efforts have included job training and placement, rehabilitation and diversion of first offenders, remedial education, drug abuse treatment, and recreational activities. In recognition of the need for these efforts, a Presidential Commission said in a comprehensive report on crime:

Crime flourishes where the conditions of life are worst and therefore the foundation of a national strategy against crime is an unremitting national effort for social justice. Reducing poverty, discrimination, ignorance, disease and urban blight, and the anger, cynicism or despair those conditions can inspire, is one great step toward reducing crime (President's Commission on Law Enforcement and Administration of Justice, 1967: 279).

Such efforts to root out the causes of crime are important; at the same time, they are also expensive and demand extensive skill on the part of planners and administrators. Their impact is difficult to measure, partly because it may not be immediate. Moreover, as Smith (1979) has pointed out, a causal analysis approach to crime prevention may discourage people from taking action because they feel that the only true solution to crime is wholesale social change, a nearly impossible task. In contrast, Smith advocates a policy analysis approach which "deals with problems by focusing attention on the alterable symptoms, rather than the ultimate causes." (1979:26)

Crime prevention as discussed in this book is much more the latter, a practical and limited concept. It is geared more to private citizens, to their own capacity to control what happens to them. This approach to crime prevention does not require knowledge of the causal factors of crime, the characteristics of offenders and their susceptibility to rehabilitation, nor the workings of the criminal justice system. It only requires an understanding of the elements of crime and application of simple practical methods to address them.

The elements of crime are basically three:

- Desire or motivation on the part of the offender,
- The skills needed to commit the crime,
- The opportunity.

Trying to reduce criminal "desire" has proven very difficult. Certainly no one can be inoculated against criminal intent and, in recent years, programs aimed at doing so through rehabilitating offenders have come under greater scrutiny and criticism as recidivism rates rise.

It is also very difficult to attack crime by reducing criminal "skills." Research has shown that most criminals--especially those who victimize the elderly through muggings, purse snatches, and burglaries--are not professionals. Usually they are learning from each other and through trial and error. Furthermore, access to the "tools" of a criminal's trade cannot be inhibited when such tools are as commonplace as a blunt object, a kitchen knife, or a credit card.

Therefore, the most practical short-term approach to crime prevention is opportunity reduction. Importantly, it is also the approach most accessible to potential victims. One of the originators of the idea of crime prevention training puts it this way:

Potential victims can reduce their vulnerability to criminal attack by taking proper security precautions. It is not necessary to identify the criminal, to take any action to directly affect his motivation or his access to skills and tools. What is necessary is that potential victims reduce criminal opportunity by understanding criminal attack methods and taking precautions against them (National Crime Prevention Institute, 1978:1-3).

Crime prevention techniques are premised on two assumptions: criminal opportunities can be identified, and, many stranger-to-stranger personal and property crimes are committed by amateurs. When older persons can learn to identify criminal opportunities in their environment and assess their risk, they can then take simple precautions to divert the criminal's behavior. This will not make them immune to crime, which will always exist. However, the practice of crime prevention measures in the home and on the street can reduce crime and deter many people from victimizing older persons.

Components of Comprehensive Crime Prevention Programs for the Elderly

Crime prevention has the best chance of succeeding when a number of strategies are implemented together in a community by citizens, the police, and policymakers. Too often crime prevention efforts are fragmented, with the result that an older woman, for example, who takes great care to avoid risks when she is on the street, may come home to discover her apartment burglarized because her neighbor left the lobby door open or she did not have an adequate lock.

What is more, comprehensive crime prevention for the elderly cannot deal with older citizens and the police as the only appropriate parties to get involved. Rather, it should involve citizens of all ages, like the housing authority, the area agency on aging, and all social service and community agencies which deal with older persons.

The activities included in a comprehensive crime prevention program should be targeted to the specific crime problems in a defined geographic area. While these activities can be carried out by either individuals or groups, the most effective programs rely on both.

Individual crime prevention activities include:

Residential Security Surveys

These are home inspections by trained staff--police or others--to determine the security status of a home, to identify particular security risks, to recommend needed protective measures, and to suggest burglary prevention behavior. While it is usually the responsibility of the citizen to implement recommended changes, people working with older persons--often on low fixed incomes--have found it important to suggest sources of free or discount help to purchase and install new hardware. Otherwise, older clients unable to afford security changes may become more fearful.

Property-Marking Programs

This tactic, often referred to as Operation Identification or Operation ID, is frequently available through the local law enforcement agency. It involves the permanent marking of people's property so that it can be easily identified and more easily returned if stolen and recovered. Participants in these programs usually mount a decal on their home indicating their property has been marked, as a deterrent for burglars.

Improved Residential Security Hardware and Precautions

While security surveys may produce hardware upgrading recommendations, citizens can make such changes on their own. While many elderly cannot afford expensive new locks, they can take such measures as "pinning" windows and sliding doors, cutting down shrubbery, leaving

lights on, and, most importantly, using the locks which they have.

Increased Precaution on the Street

The best defense against street crime is cautious behavior. Usually senior citizen crime prevention programs advise clients to take steps such as: being aware of their appearance and environment; being alert to their surroundings; being accompanied on local errands; carrying no purse and little cash; avoiding potentially dangerous places; and appearing purposeful and confident whenever on the street.

In recent years, police and other traditionally burdened with the responsibilities of preventing crime have recognized the importance of cooperative citizen efforts as a supplement to their actions. These citizen efforts are based on the belief that increased neighborhood cohesion produces a safer neighborhood. Because elderly persons are often home during the day, they are prime participants in group or collective community programs. And because they are frequently more fearful of crime than anyone else in the neighborhood, these security-building programs can be most beneficial to them.

Group crime prevention strategies include:

Block Clubs

Block clubs serve to increase citizen awareness by encouraging street surveillance and close communication by neighbors. This approach has been working because citizens tend to have a clear interest in keeping crime out of their immediate surroundings and it is easier to get people together within a small radius. Familiarity about one's neighbors is also greater, so that suspicious people or behavior is easily recognized.

Neighborhood Watch

These programs often cover areas larger than the single block, but are based on the same concept as block clubs. Neighbors are urged to be watchful for unusual activities and to quickly report them to the police. Activities often include the exchange of names and telephone numbers among neighbors as well as the establishment of regular communications between the group and the "beat patrol officer."

Citizen Street Patrols

These patrols, usually manned by local volunteers, are intended to deter crime and, where possible, stop crimes in progress by notifying authorities quickly. Citizens patrol on foot or in cars, sometimes using citizen band radios.

Building Patrols

The main purpose of these patrols is to protect a building and

the surrounding grounds. They are often operated by tenant organizations which recruit volunteers to patrol hallways, lobbies, and other common areas. The objective is deterring unwanted strangers from entering the building or committing crimes around the building.

Whistle or Airhorn Programs

These programs, often called "Blow the Whistle on Crime," consist of the distribution of whistles or freon airhorns to residents of a small area and training them in how to use them. Citizens are urged to use the whistles or airhorns when they are victimized, observe a crime, or hear someone else blowing them. Those who hear the noise are supposed to call the police. The underlying assumptions of this program are that significant noise will deter criminals and alert neighbors who can help.

Telephone Assurance Programs

This strategy can be especially helpful to elderly citizens, many of whom are somewhat immobile. It includes local volunteers, working from a roster of clients, calling people regularly to check on their health and safety. The telephone contacts are also tools for providing crime prevention information to clients and for recruiting participants for block club and Neighborhood Watch programs.

Escort Service

This program is also particularly valuable for older citizens, since it reduces their isolation and their vulnerability to crime. Volunteers escort neighbors--elderly or others in need--to and from necessary destinations such as banks, supermarkets, social service agencies, and doctors' offices.

Safe Corridors

This is an alternative strategy to an escort service which can allow community residents to conduct their local business in safety. At specified hours and days of the week, volunteers are posted along certain main shopping corridors and routes to watch out for persons who want to do their errands and shopping along these routes.

Case Monitoring

In this strategy, groups of senior citizens go to court to observe proceedings in cases involving older victims. Its primary goal is to put the criminal justice system under public scrutiny, reserving the participants' right to criticize publicly officials who appear insensitive to legitimate concerns of older citizens. It also serves to educate citizens about the system, provide peer support for elderly victims and witnesses in the courtroom, and give senior citizens an opportunity to advocate for specific changes they believe are needed in the courts.

Environmental Design

This approach aims at redesigning the physical appearance of a neighborhood or building in order to enhance its residential character, increase use of public space by residents, and deter strangers from entering. Techniques include erecting fences, closing off streets, planting shrubbery, and installing lighting.

Crime prevention programs cannot absolutely prevent crime, even for those persons who adhere strictly to all of a program's prescriptions. For all those who are victimized, there has arisen in recent years a network of programs to address their needs. This network has been of particular value to senior citizens because, as Chapter Four emphasized, the relatively low rate of crime committed against older persons masks the serious impact of crime on this age group. Elderly people who are victimized suffer from economic, psychological, or physical harm which can affect them for considerable periods of time. Moreover, if help is not forthcoming, the crime itself can cause older persons to develop even greater fear and can further inhibit their lifestyles.

The Victim Assistance Concept

Crime has traditionally been a major domestic issue in the United States for both policymakers and citizens. Since the inauguration of the Law Enforcement Assistance Administration (LEAA) in the U. S. Department of Justice in the late 1960's, billions of dollars have been spent on components of the criminal justice system in an attempt to reduce crime and its impact. A great part of this money has been devoted to the individual needs and rights of the criminal offender. Little or no attention has been paid until recently to the victims of crime, who have a great many needs and very few rights within the American criminal justice system.

The imbalance in the attention paid to the offender and to the crime victim is reflected in Figure 5.1. This chart, entitled "The Criminal Injustice System," provides a fairly complete listing of the ways in which victims are routinely ignored and left to their own resources while careful consideration is paid to the rights of the accused at each stage of the criminal justice process.

In a related vein, a recent publication of the American Bar Association stated that the average crime victim's experience will probably include some, if not all, of the following:

- Official indifference concerning matters of little relevance to the "case," but of grave importance to the victim, such as retrieval of stolen property and advice about victim compensation;
- Insensitive, adverse questioning by police and other law enforcement officials who may harbor a "guilty victim" syndrome--a feeling that the victim is responsible for his or her victimization;

Figure 5.1
The Criminal Injustice System

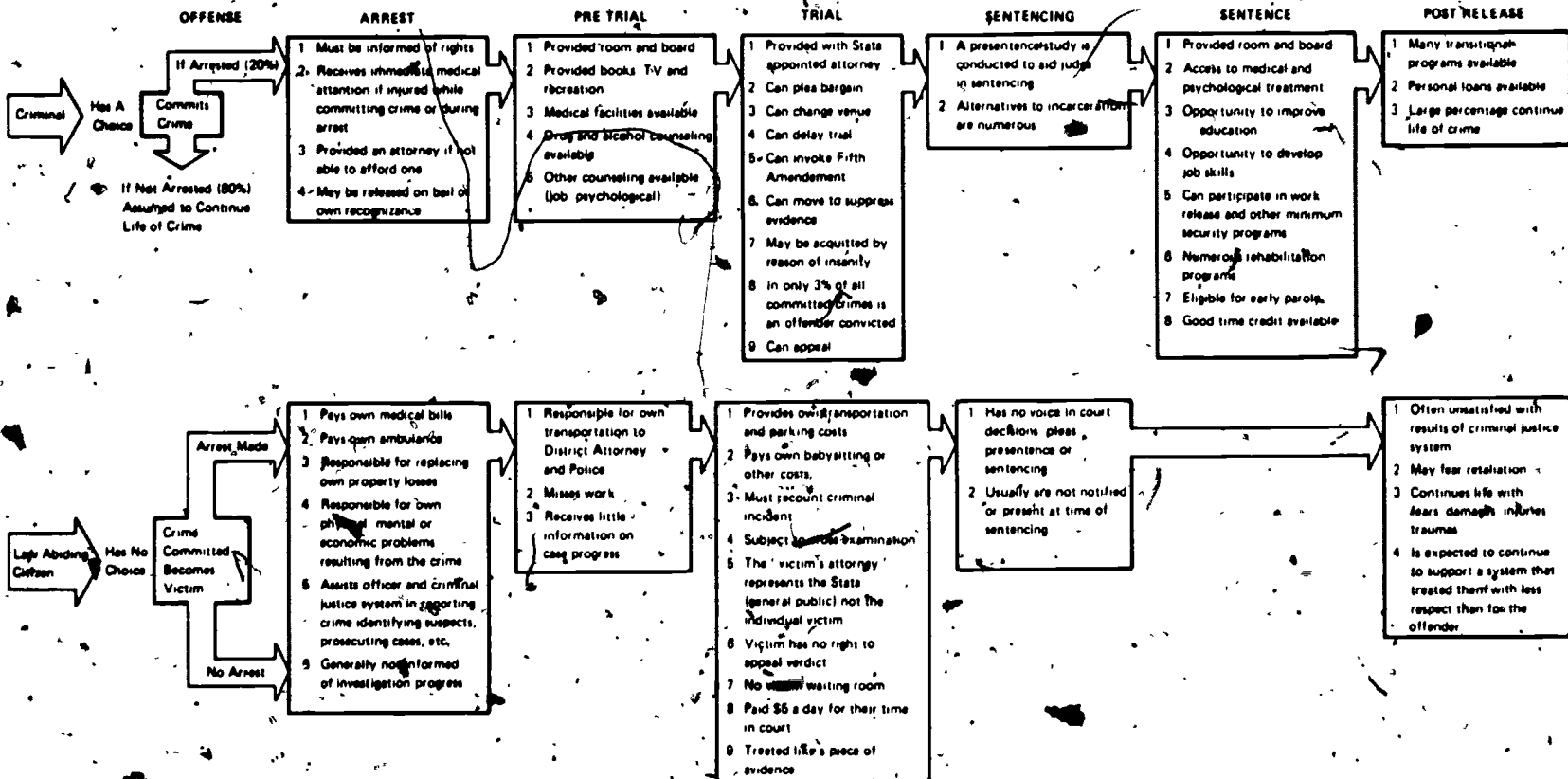

Source: Hari Haas, District Attorney, Multnomah County (Portland) Oregon, 1976.

- Perfunctory, summary, and insensitive interviewing by prosecutors who also may feel that the person has somehow asked to be victimized;
- Poorly coordinated, conflicting, repetitive, and usually unexplained summonses;
- Uncomfortable and insecure accommodations at the police station or in the courthouse, often involving close proximity to defendants, associates of defendants, or adverse witnesses;
- Lack of clear, lay explanations of proceedings and decisions during and after the case;
- Fear resulting from real or imagined intimidating threats and acts by defendants, or, in the case of defense witnesses, by police, prosecutors, or other persons with an adverse interest; and
- Lack of special services for special classes of crime victims, such as the elderly, abused children, and sexually-assaulted persons (ABA, Section of Criminal Justice, 1980).

Early Responses to the Needs of Victims

Grassroots programs at the local level in the early 1970's were the first sign that people were devoting some attention to crime victims. These programs, which grew out of the women's movement and similar citizen activities, focus on the crime victim as a person in distress. Programs which are primarily concerned with helping such people recover from their crime-induced stress usually offer counseling and social services, and may lobby for sensitive handling of victims by social agencies and criminal justice professionals. The most common examples of this approach to victim assistance are the rape crisis centers and family abuse centers that have been established across the country.

The second and probably larger group of victim service programs also grew out of a sense of concern for people who had been victimized, but these programs have been based on another equally strong concern: the improved management of criminal cases in the court system. The most common types of program in this category are prosecutors' victim/witness assistance units, which try to make witnesses' experiences as painless as possible and to reduce the negative side-effects of the system's typical delays. The theory is that better treatment for witnesses will benefit not only the witnesses but also the system, because their increased cooperation will lead to fewer dismissals and to increased conviction rates (Stein, 1980).

While both crisis-oriented and witness-oriented services are helpful to crime victims in general, the more important of the two in terms of sheer numbers of victims helped is the crisis services approach provided to victims after a crime has been reported to the police. The great majority of victims never see their complaints

result in an arrest. And since only a very small percentage of arrests results in an actual prosecution, even the best of the courthouse-based victim services is of no use to most victims. Additionally, recent research has suggested that the greatest impact of crime on older victims is on their physical and psychological well-being. This would suggest that rapid victim assistance services--delivered as soon as possible--are a high priority for elderly victims. (Jaycox, 1980).

The earliest counseling and victim-oriented programs were based in public and private agencies outside the criminal justice system. These included mental health centers, hospitals, and United Way-type organizations. Lately there has been a trend for law enforcement agencies to sponsor such services, partly to respond more fully to the frustrations their officers face daily and partly to serve some of their own investigatory needs. Police are finding that a victim who has had an opportunity to ventilate his emotions to a trained crisis worker makes a much better witness than one who is still agitated, shocked, or withdrawn (Stein and Ahrens, 1980).

In recent years, many states have also demonstrated a commitment to crime victims by enacting different kinds of victim compensation laws. In general, these programs provide awards to injured victims of violent crime to compensate them for unreimbursed losses of wages or for medical expenses. By the middle of 1981, 34 such state programs were authorized. While many of these programs are hampered by administrative difficulties and restrictive statutes (see section on "Trends"), they do represent a recognition that the crime victim deserves help. Some states have also established statewide victim assistance networks.

These networks have in many cases been funded by LEAA, the agency which has generally led efforts at the federal level to improve the plight of crime victims. It has funded victim/witness reception centers, witness telephone alert programs, victim counseling services, and property return programs. A great number of these programs are located in a prosecutor's office, for their focus is on the needs of witnesses and of the court system (Cronin and Bourque, 1980).

LEAA also funded several projects in the past few years specifically for elderly crime victims, because of the recognition that crime seriously challenges an older American's quality of life, inducing fear, restricting lifestyles, and often producing long-lasting, severe psychological after-effects. Thereafter, other agencies such as the Administration on Aging and the Community Services Administration also began sponsoring victim assistance programs for the elderly.

These programs share several purposes in common, the main objectives of victim assistance for older crime victims being:

- To assist them in recovering from the psychological and emotional impact of victimization;
- To help them obtain whatever benefits are available to

them as compensation for losses caused by crime; and

- To provide, directly and through referrals, services which they need to recover from victimization and to participate fully in the criminal justice process.

Victim assistance, whether performed by an assigned case worker or a concerned friend, also serves another important purpose. It may be the means of identifying senior citizens, most notably the isolated elderly, who are in need of a variety of social services, some of which may be unrelated to a victimization. The needs may be for services concerning housing, Social Security, transportation, medical problems, homemaking, or nutrition. In any of these cases, the person talking to the crime victim tries to see that the need is met by referring the victim to the appropriate social service agency or senior citizen organization.

Often the most valuable service that can be provided to crime victims is an empathetic, understanding ear. Victims need emotional support as soon after the victimization as possible. Simply to be told they did nothing wrong, that someone is sorry it happened, and that help is available can be of great comfort to older victims.

Even if friends or relatives do not have the time or skill to provide some of the services listed above, they can contact local agencies which do have the resources to help elderly crime victims. In themselves, such referrals can demonstrate concern and do much to ease the extreme stress felt too often by older victims of crime.

Thus, in practice we can all help crime victims, if equipped with a set of very basic skills.

Components of Comprehensive Victim Assistance Programs for the Elderly

Victim assistance programs which serve the elderly must accomplish several functions if they are to do an effective job. They are: identifying and contacting victims; assessing victim needs and providing direct service or referrals; and following up victims' cases.

Identifying and Contacting Victims

In performing victim assistance, the critical agency with which to coordinate is the local law enforcement agency, since it is the primary source of the identity of crime victims. So, law enforcement officials have first to be convinced of the value of victim assistance work. Only after this task has been accomplished can the police be approached about cooperating with a victim services program. (Stein and Ahrens, 1980)

Unfortunately, as we have seen, many elderly crime victims do not report their victimizations to the police. However, they may tell others about the crime, and these people can also refer them to a victim services project. People likely to be told of the victimization include friends or relatives of victims; staffs of social

service agencies; doctors, nurses, or staffs of clinics or hospitals; and familiar staffs at senior citizen centers, nutrition programs, retirement centers, housing projects, or apartment buildings. Victim identification should therefore include a publicity effort aimed at all of these people who comprise the social network of older community residents.

Assessing Needs and Providing Appropriate Responses

Once the victim has been contacted, a range of victim services can be provided either directly or by referral. Those services most often provided to older victims are advocacy, counseling, transportation, and home security assistance.

Advocacy

Advocacy means acting on behalf of someone in support of his or her needs. Even in "good times" some elderly citizens are unable to cope with bureaucracies. In times of crises, such as after criminal victimization, there is a heightened need for help in obtaining the services and attention to which they are entitled. Advocates can direct older victims of crime through the maze of social service referrals and can intervene when necessary to see that their needs are being met.

Counseling

When performed on an emergency basis, counseling is often called crisis intervention, and refers to the process by which someone helps a crime victim sort out his or her feelings in order to accept the experience and to return to a pre-crisis state of mind. Experience has shown that counseling need not be done just by professionals trained in the "art of counseling." The most important attributes for effective counseling of victims are courtesy, empathy, interest, and involvement.

Transportation

This is a relatively "easy" direct service to be provided to elderly crime victims. Many need to visit doctors, lawyers, the police, court, or social service agencies as a result of their victimizations. Often they must rely on public transportation, which can be slow or unreliable. Senior center vans, agency volunteer drivers, or other resources may be identified to help meet transportation needs.

Home Security Assistance

Especially needed by elderly burglary victims who are often as traumatized as victims of personal crimes, this assistance may range from the boarding up of a broken window to the installation of new doors, locks, or hardware. Once accomplished, it usually provides great relief to the victims.

Other assistance which can be provided through a program's direct

service component--or through the efforts of concerned citizens--include: the provision of emergency food or shelter; assistance in replacing lost documents; help in filing medical or legal claims (e.g., for insurance or victim's compensation); or help in communicating with representatives of the criminal justice system.

The provision of victim services by referral requires some knowledge on the part of the person making the referral, whether it be a social worker from a victim assistance project or a relative or neighbor of the victim. While the former may have time to develop relationships at local agencies and to examine and judge their relative effectiveness, the latter can make referrals if they have a resource directory or simply the telephone number of a local information and referral agency.

Following Up

The follow-up component of victim assistance programs serves as both a check and a reinforcement of the victim's recovery from the crime's effects. The objective of this component is to assist victims to become self-sufficient, or at least to cope at a level which matches that prior to the crime. In order to avoid making victims dependent on them for future support, though, assistance programs usually concentrate on connecting victims with the local senior citizens support network, e.g., senior centers and clubs, churches, nutrition sites, and local government services. Even though they are not professionally associated with victim assistance programs, friends and relatives of an older crime victim can also make efforts to tie elderly victims into the senior support network. Community aging-related agencies are often listed in telephone directories. Helping requires relatively little time for research and some telephone calls.

Combining Crime Prevention and Victim Assistance

A brief examination of the crime prevention and victim assistance movements sheds light on their different purposes. The former aims for better personal security and stronger neighborhood ties, while the latter seeks courtesy and compassion for those who have been victimized. Though both are tied to criminal justice, they have developed independently, and their roles are geared in great part to the needs of their clients. One deals with the concerns of potential crime victims, while the other focuses on the needs of actual crime victims.

However, for the older person who has serious fear of crime, who is vulnerable to incapacitating or limiting physical and emotional consequences of victimization, and who is often not sufficiently adept at using the social service system, a merger of the two movements is appropriate. Such a joining would address all the main crime-related concerns of older Americans.

In addition to meeting the needs of elders, combining crime prevention and victim assistance services can make each program more effective. For example, victim assistance service workers

often discover that victims have been hurt partially due to their own carelessness. They provide more complete service if they weave crime prevention advice into their counseling services. In practice, many victims are eager to get suggestions on how to make themselves less vulnerable in the future. It should be remembered, however, that such advice has to be given delicately and at the right time so that victims' feelings of self-blame are not reinforced.

Similarly, crime prevention workers are better able to get their points across if they are armed with victim assistance skills. Older persons who have already been victimized can be cynical of crime prevention advice, perhaps disrupting a crime prevention education session, a block meeting, or even an offer of a home security check. Knowledge of victim assistance skills can be effective in encouraging a group to be supportive of its victimized members or simply to be helpful to the victims themselves (Stein, 1979).

Special Programs for the Elderly

Recognizing the severe consequences which crime and fear of crime have on older people, a number of programs have begun across the country to combat that problem.

One major effort was the recent National Elderly Victimization Prevention and Assistance Program (Center, 1979b). This joint effort of several government agencies and the National Council of Senior Citizens included seven demonstration projects in six major cities. To respond to the distress and fear which victimization inflicts on the elderly, these comprehensive projects offered both victim assistance and crime prevention services.

All of the projects provided victim assistance to older victims whose names were obtained from local police and social service agencies. Project staff contacted victims immediately, assessing their needs. Case workers then tried to secure whatever help the elderly victims required, either directly or by referral. Services provided included counseling, transportation, home care, medical aid, replacement of lost documents, emergency food and clothing, temporary shelter, and legal aid.

Crime prevention strategies included educational sessions for groups of seniors, organizing block clubs, and home services. The latter included home security surveys, assistance in upgrading the quality of security hardware, engraving of valuables with personal identification numbers, and individualized suggestions on how to avoid being victimized.

Similar programs have been established which take direct aim at the crime problems of older people. For example, a national training program for police officers has been developed by the National Retired Teachers Association/American Association of Retired Persons. In this program, law enforcement personnel are sensitized to the older person's related situations, and trained to make use of senior volunteers (NRTA-AARP, 1980).

Additionally, a number of local projects have been implemented in both urban and rural areas of the country, sponsored by aging-related programs, law enforcement agencies, and community activist organizations. Among them are successful programs in: Las Vegas, Nevada, where both crime prevention and victim assistance services are a major focus of the local RSVP; Detroit, Michigan, where a network of senior center staffs provides crime prevention information and assistance on a continuing basis; and Tucson, Arizona, where the Pima County District Attorney's Office operates both a witness and a victim assistance component, with staff members and volunteers riding with detectives on night shifts, and next day follow-up work with victims who cannot be seen immediately (Criminal Justice and the Elderly Newsletter, Summer 1980 and Winter 1979-80; Lowenberg, 1980).

These projects are indications of a growing trend toward recognizing and working against the adverse effects crime has on so many of our nation's older people.

Trends in Crime Prevention and Victim Assistance for the Elderly

The fields of crime prevention and victim assistance for seniors are always changing as new issues arise, new problems develop, and more effective ways of delivering services to older persons are discovered. Whether they are friends, relatives, or agency staff members, those who wish to become involved in helping the elderly face their crime-related problems should remain aware of developments so that they can provide appropriate assistance or referrals when they are needed.

One very encouraging development is the institutionalization of crime prevention and victim assistance services by making them available through regular aging-related service providers. The states of Pennsylvania, Florida, and Michigan are trying variations of this concept. Training is being given to homemakers, senior center staffs, visiting nurses, and others so that they can effectively respond to the crime-related concerns of the elderly people with whom they come in contact. Possible contexts would include a senior center worker giving counseling to a small group of people who have been frightened by the mugging of one of their friends; a homemaker aide giving empathetic counseling and then making a referral for a woman who has just been robbed; or a visiting social worker checking the hardware, doors, and windows in an older man's home after he has heard about a local burglary. Because crime can be a survival issue for older people, it is appropriate that service providers who deal with them on a daily basis become knowledgeable about it and be able to help.

Another positive step is the emergence of peer counselors in anti-crime programs for the elderly. This is important both for those seniors who seek assistance and for their colleagues who wish to play a part in lessening the crime problems their age group faces. Peer counseling reinforces the positive sense of self-capability. It is important for older community residents to feel that they can contribute as well as receive (Jaycox, 1981).

All demonstration programs associated with the National Elderly Victimization Prevention and Assistance Program used Senior Aides for both victim assistance and crime prevention activities. With adequate training, those workers proved to be genuine assets because of the relationships of trust they were able to establish with their peers (Center, 1979b).

An extension of this concept is being used by the Victim Assistance Program for Older Adults (VAOA) in the city of Tampa and Hillsborough County, Florida. The core of that program is its staff of 26 neighborhood workers, generally nonprofessionals, all over age 55, who work on an hourly basis for a victim assistance program administered by a mental health center. They are all trained in Florida state law affecting the elderly, crisis intervention counseling, and the services available from local social service agencies. Each day these workers are assigned new victim assistance cases in their neighborhoods. They interview senior victims, counsel them, and make referrals for more intensive counseling and other services when needed. In its first year, nearly 75 percent of those victims contacted wanted help from VAOA. Most victims needed crime prevention education and crisis intervention counseling. The program made a major impression on the state's Bureau of Criminal Justice Assistance which has promoted it as a model for other areas. This peer-oriented approach offers several advantages: agencies can provide the service through volunteers or community aides at low cost; the decentralized neighborhood approach works well for both the clients and the workers; and older persons who want to become active in community work are helping their peers in a very important way (Criminal Justice and the Elderly Newsletter, Fall 1979).

Among the trends in crime prevention and victim assistance is a recent focus on domestic victimization. Recent reports indicate that older people may be abused by persons in their family or household. Estimates of the incidence of elder abuse range widely, for some estimators combine abuse and neglect cases. The abuse being uncovered includes physical abuse, psychological abuse, and material or financial abuse. Many of the reported victims suffer poor health and marginal mental competency, conditions putting family or household members under extreme, long-term pressure (Block and Sinnott, 1979). Victims rely on a family caretaker for basic needs. This dependency and inability to function on their own inhibits many elder-abuse victims from reporting their victimization.

Although all 50 states have child protective service laws, only 11 have comparable laws for the elderly. These laws mandate that all people who discover a suspected elder abuse case must report it; such provisions are aimed at doctors, lawyers, homemakers, and community service workers. In addition, they allow for access by social workers to investigate for abuse, fix penalties for violations, and allow for voluntary and involuntary provisions of protective services while safeguarding individuals' rights against inappropriate intervention (Meyers and Bergman, 1978).

As a result of the recent widespread focus on wife abuse, moreover, most states have passed legislation on domestic violence. New

laws in some 24 states have been written broadly enough to provide some type of protection to older persons abused by a family member (Lerman, 1980). In states without such laws, consent is the only avenue of help for the family. The first intervention priority is to keep the older person in the home and to provide counseling and medical and nursing care necessary for all parties. Removal of the abused elderly person is usually considered the last option and can only be achieved through legal proceedings.

Although several local studies of elderly abuse have suggested that it may be a serious problem, no national study has yet been undertaken. Without more extensive data, it is difficult to obtain a trustworthy picture of the extent of elderly abuse in the United States. As a stopgap measure, some local jurisdictions are concentrating on setting up crisis centers for abused older persons.

Another trend in the field of victim assistance concerning older Americans is the increasing attention being paid to elderly crime victims by several of the 34 state victim compensation programs. Lately, a number of national and state policymakers have pointed out that the ambitious goals of these programs have not always been realized. Only a very small portion of deserving victims receive compensation awards. The failure to compensate more victims is due primarily to the inherent limitations in the laws and to program characteristics such as: lack of public awareness, award denial conditions, and lack of linkages with more comprehensive victim assistance programs. The requirements and complexities inherent in many victim compensation programs affect all victims, especially the infirm, the poor, the inarticulate, and the socially isolated. A great number of elderly victims are included in these categories. Without personal intervention, few of these victims learn of the programs, or have sufficient skills to meet the requirements necessary to receive compensation awards (Hofrichter, 1979).

Policymakers, program officials, and private citizens interested in improving elderly victims' chances of receiving compensation for losses they suffer are lobbying for a number of changes in existing programs. Among the changes sought are greater publicity of state programs, perhaps through using law enforcement officers as referral agents; removal of "financial hardship" tests, which deter many older victims from applying because they are reluctant to list their assets or apply for "charity;" and the removal of minimum financial loss provisions, since for many older people the loss of a relatively small amount of money represents not an inconvenience but a critical shortage of food, medicine, or rent monies.

Other policy changes being pushed by older persons' advocates are: the establishment of effective pre-award provisions for deserving emergency cases, of special importance to older victims living on small, fixed incomes who cannot wait the 10 to 20 months needed for processing their claim; compensation including emergency cash, to replace or repair damaged or stolen property essential to an older person's physical or psychological health, like glasses, hearing aids, a door lock or a telephone; and the development of holistic service programs in which counseling and social services provision

are combined with efforts to secure compensation for victims. The movement toward recognizing the special needs of elder crime victims has been led by the states of New York, New Jersey, and California. Both New York and New Jersey have established special units to deal with the claims of elderly victims.

In summary, local communities and, at times, state agencies have undertaken a variety of crime prevention and victim assistance programs. The more effective crime prevention programs undertake a practical, policy analysis approach whereby crime opportunity reduction is emphasized. Individual and group crime prevention measures can significantly reduce the risk of crime. Victim assistance programs recognize that an older victim may be in crisis, as the criminal experience assaults his or her physical, psychological, or social well-being. The most meaningful approach is to combine crime prevention and victim assistance into cohesive, comprehensive programs that educate and rehabilitate the older victim. In each of these programs, all community members, including the elderly, are important for advocacy, program development, and service provisions.

Reading and Resources

American Bar Association, Section of Criminal Justice, Bar Leadership on Victim Assistance, Washington, DC: ABA, 1980.

Block, Marilyn R. and Jan D. Sinnott, Eds., The Battered Elderly Syndrome: An Exploratory Study, College Park, MD: University of Maryland Center on Aging, 1979.

Boston, Guy, Rita Nitzberg, and Marjorie Kravitz, Criminal Justice and the Elderly--A Selected Bibliography, Washington, DC: National Criminal Justice Reference Service, January, 1979.

Center, Lawrence J., Anti-Crime Programs for the Elderly: A Guide to Program Activities, Washington, DC: National Council of Senior Citizens, 1979a.

Center, Lawrence J., Anti-Crime Programs for the Elderly: A Summary Evaluation Report, Washington, DC: National Council of Senior Citizens, 1979b.

Center, Lawrence J., Anti-Crime Techniques for Elderly Apartment Dwellers: Organizing Strategies and Legal Remedies, Washington, DC: Criminal Justice and the Elderly, 1979c.

Crime Prevention and the Elderly: Special Information Package, Louisville, KY: National Crime Prevention Institute, 1978.

Crime Prevention Coalition, "Got a Minute? You Could Stop A Crime," Rockville, MD: Crime Prevention Coalition, Box 6700, 1979.

Crime Prevention Coalition, "Senior Citizens Against Crime," Rockville, MD: Crime Prevention Coalition, Box 6700, 1980.

Criminal Justice and the Elderly Newsletter, Washington, DC: National Council of Senior Citizens, Summer 1980.

_____, Washington, DC: National Council of Senior Citizens, Winter 1979-80.

_____, Washington, DC: National Council of Senior Citizens, Fall 1979.

Cronin, Roberta C. and Blair B. Bourque, National Evaluation Program Phase I Assessment of Victim/Witness Assistance Projects, Washington, DC: American Institutes for Research, 1980.

Duncan, J. T. Skip, Citizen Crime Prevention Tactics: A Literature Review and Selected Bibliography, Washington, DC: U.S. Government Printing Office, 1980.

Edgerton, J., Crime and Prevention Handbook for Senior Citizens, Washington, DC: U.S. Government Printing Office, 1977.

Franklin Research Center, Elder Abuse, Washington, DC: U.S. Department of Health and Human Services, National Clearinghouse on Aging, 1980.

Hofrichter, Richard, Victim Compensation and the Elderly: Policy, and Administrative Issues, Washington, DC: U.S. Government Printing Office, 1979.

Jaycox, Victoria H., Creating A Senior Victim/Witness Volunteer Corps: An Introductory Brochure, Washington, DC: National Council of Senior Citizens, 1981.

Jaycox, Victoria H., Using Anti-Crime Services to Reach Elderly Women in Need, Washington, DC: National Council of Senior Citizens, 1980.

Lerman, Lisa, G., "State Legislation on Domestic Violence," Response to Violence in the Family, Volume 3, Number 12, Washington, DC: Center for Women Policy Studies, 1980.

Lowenberg, David A., "Your Clients Will Be There Next Year. Will You?" Emilio C. Viano, Ed., Victim/Witness Programs: Human Services of the 80s, Washington, DC: Visage Press, 1980.

Meyers, Karen J., and James A. Bergman, An Analysis of the Laws Concerning Elder Abuse in Massachusetts and Other States, Boston, MA: Legal Research and Services for the Elderly, 1979.

National Crime Prevention Institute, The Practice of Crime Prevention, Louisville, KY: NCPI Press, 1978.

National Retired Teachers Association-American Association of Retired Persons, Law Enforcement and Older Persons, Revised Edition, Washington, DC: NRTA-AARP, 1980.

Nitzberg, Rita, Trainer's Manual: Crime Prevention for Senior Citizens, Washington, D.C.: National Council of Senior Citizens, 1979.

Piland, Richard, "Surviving Old Age--Criminal Justice Response to the Problem," Marlene Young Rifai, Ed., Justice and Older Americans, Lexington, MA: D.C. Heath and Company, 1977.

Powers, C., Your Retirement Anti-Crime Guide, Washington, D.C.: National Retired Teachers Association- American Association of Retired Persons, 1973.

President's Commission on Law Enforcement and Administration of Justice, The Challenge of Crime in a Free Society, Washington, D.C.: U.S. Government Printing Office, 1967.

Smith, Robert J., Crime against the Elderly: Implications for Policy-makers and Practitioners, Washington, D.C.: International Federation on Ageing, 1979.

Stein, John H., Anti-Crime Programs for the Elderly: Combining Community Crime Prevention and Victim Assistance Services, Washington, D.C.: National Council of Senior Citizens, 1979.

_____, Perspectives on the Victims' Movement: 1972-1980, Washington, D.C.: National Council of Senior Citizens, 1980.

Stein, John H., and James H. Ahrens, How to Win Law Enforcement Support for Victim Services Projects, Washington, D.C.: National Council of Senior Citizens, 1980.

U.S. Congress, House Select Committee on Aging, Elder Abuse: The Hidden Problem, Committee Publication Number 96-220, Washington, D.C.: U.S. Government Printing Office, 1980.

U.S. Department of Justice, National Advisory Commission on Criminal Justice Standards and Goals, Community Crime Prevention, Washington, D.C.: U.S. Government Printing Office, 1973.

Washington Crime Watch, "Outsmarting Crime: An Older Person's Guide to Safer Living," Olympia, WA: Washington State Crime Watch, 1978.

Wolf, Robert, "Senior Citizen Survey: An Aid to Designing Prevention Programs," Police Chief, Vol. 44 No. 2, February 1977.

Recommended Films on Crime Prevention in General

KEY: A = Abstract

C = Critique of Film for Suitability for Senior Citizens

FIGHTING CRIME: WE CAN DO IT, MTI Teleprograms Inc., 3710 Commercial Avenue, Northbrook, IL 60062, 16 mm., color, \$395, 1980.

A: The film shows that society has changed, and with this change has come an increase of crime, fear, and protective lifestyles for the elderly. But there are ways to reclaim one's neighborhood and life through crime prevention: home security inspections (with help from retired workers for installation of hardware), Operation Identification, Neighborhood Watch, escort services, and reporting of crime.

C: The film is excellent, using real people and real scenarios to depict the real alternatives. This is the most recent crime prevention film for seniors, and reflects the state of the art.

I'M ALONE, I'M AFRAID, 1973, New England Gerontology Center, 15 Garrison Avenue, Durham, New Hampshire 03824, 25 minutes, video, B&W, \$30/\$3.50.

A: Two major areas are examined where elderly people need help protecting themselves--on the street and in the home. Examples are given of existing security programs, showing how cooperation between police, housing authorities, and Title VII projects will greatly increase the safety of seniors.

C: The film basically depicts urban elderly in high rise buildings. By actually filming the day when the elderly all cash their Social Security checks, for example, the film has a firm grounding in reality--much different from films with actors and Hollywood sets. An escort service is also shown in actual practice. The quality of the film is erratic, but the lessons in block watch, crime prevention education, police department speeches, and rumor control are excellent.

OUTSMARTING CRIME: AN OLDER PERSON'S GUIDE TO SAFER LIVING, 1978, Harper and Row Media, Order Fulfillment-Customer Relations, 2350 Virginia Avenue, Hagerstown, MD 21740. Producer: Washington Crime Watch, 18 minutes, color, slides and audio cassettes.

A: The slide audio presentation defines crime prevention as "the practice of spotting criminal opportunities and then doing something to reduce or eliminate those opportunities in a common-sense way." Hans Conreid narrates, focusing on property marking, residential security and neighborhood action/block watch--offering specific tips geared particularly to the elderly.

C: The presentation was developed by professionals who are quite familiar with working with the elderly in crime prevention, and is a well-planned and effective tool. This is the only case in which access to a 16 mm. projector is not a prerequisite to a successful program.

SENIOR POWER AND HOW TO USE IT, 1975, William Brose Productions, Inc., 10850 Riverside Drive, North Hollywood, CA 91602, 19 minutes, color, 16 mm., \$330/\$60.

A: The purpose of the film is to educate senior citizens in crime prevention techniques and to illustrate that brains can defeat brawn. It covers most of the personal safety and home security tips for senior citizens to know to improve their safety as well as the motivation to take these steps. Included are purse snatching, armed robbery, home security surveys, and telephone harassment.

C: This film is the prototype of crime prevention films for senior citizens. The vignettes are simultaneously instructive and humorous, and the film is excellent. Although some techniques shown are no longer recommended (such as sitting down when you are being mugged), the spirit of the film makes it still worthwhile.

Chapter Six

Preventing Street Crimes against Elders

Chapter Six

Preventing Street Crimes against Elders

Advance Organizers

- The elderly are victimized by crime less than any other age group, but profess the highest fear of crime. Crime prevention programs should emphasize these facts in order not to fuel an already heightened sense of fear. Crime prevention strategies should not diminish the older person's quality of life, but should add to it by providing realistic advice.
- Although tips and techniques are important, the fundamental ingredient in street crime prevention is awareness--self-awareness, awareness of the environment, and awareness of response options when in danger.
- In order of increasing severity, the most serious street crimes are larceny (taking by stealth), assault (physically harming the victim), robbery (taking by force), and rape (carnal knowledge through force or threat). Of these crimes, personal larceny or theft is committed most often against older persons, with the violent crimes occurring less than one-third as frequently.
- The most common victim of assault is a young person, in part because the likely pre-conditions of assault--a domestic or alcohol-related fight--are circumstances older people are less likely to be in.
- One should consider how one's appearance may invite a criminal response: Do I look frightened, unsure, confused? One should also take steps to project or radiate purpose and confidence.
- Advance planning and being aware of the environment--both friendly respite and potential danger areas--help to minimize victimizations.
- In general, it is safer to: go places and do errands with a friend along; refrain from "flashing" money or jewelry in public; walk in the middle of the sidewalk against the flow of automobile traffic; stay inside one's car if it becomes disabled; sit near the driver or conductor on public transportation.

- You should consider in advance the likelihood of using various response options so that, when confronted by danger, you can react appropriately for yourself and the situation. Ask yourself if you could offer active resistance, could harm a would-be assailant, could create a diversion or initiate negotiation under stress.
- Purse snatching, the most frequent street crime against older women, can be minimized by not carrying a purse, sewing special pockets, or dividing valuables. Types of purses and methods of carrying them can affect the likelihood of injury in a purse snatch.
- Increasingly, authorities see rape as a crime motivated by aggression and violence, not by sexual desire. Older women are most unlikely victims, but they should consider several ways of responding to a sexual assault.
- Cooperation among community elders, social service staff, and law enforcement/crime prevention agencies has led to a substantial number of successful programs against aging-related street crime.

Introduction

The previous chapter gave a brief overview of crime prevention programs. The present chapter, and the three that follow, will analyze the major types of crime relevant to older people--street crime, residential crime, and consumer fraud/cón games--and will propose a feasible plan of community crime prevention.

Although the elderly are more likely, about two to fifty times more likely, to be victims of household crimes than of personal crimes, they are more fearful of personal attacks. As seen in Chapter Four, this fear corresponds with their self-perceived vulnerability and the potential consequences of attack. For this reason, we will examine street crimes first.

Vulnerability

Street crimes, like household crimes, are frequently crimes of opportunity. Those disposed to committing street crimes often will not do so unless they encounter an inviting target. So, as this book has emphasized, the goal of any crime prevention program should be to reduce vulnerability.

For some older Americans, crime prevention can be especially difficult because of a number of conditions in their lives which make them vulnerable to prospective criminals. Chapter Two discussed these: living alone; living in inner cities and being unable to relocate; having poor or chronic health conditions; being socially isolated.

Other common qualities make the elderly particularly vulnerable to street crimes. Because many live by themselves, they are out on the street alone. Physical frailties can cause a slow or unsteady gait. A dependence upon public transportation may require standing in public places for extended periods of time. An appearance of weakness--which can be reflected in stooped posture, slow movement, unsteadiness, or simply a lack of attention to their surroundings--gives some elderly persons an air of what some criminologists are calling "muggability."

Types of Street Crimes

The most serious street crimes being committed against older people are, in ascending order of seriousness, larceny, assault, robbery, and rape. Larceny may bring the victim into direct contact with the offender. Assault, robbery, and rape always do. Reviewing the definitions of these crimes will help us to understand how they differ, how they afflict the elderly, and how they can be prevented.

Larceny

Personal crimes of theft are called personal larcenies, and involve the taking of property or cash by stealth. These crimes may or may not put the victim into direct contact with the offender. Personal larceny with contact, according to the United States Crime

Surveys, includes purse snatching and pocket picking. Personal larceny without contact includes the theft by stealth of a variety of items, like the theft of an umbrella from a restaurant, food from a shopping cart left in front of a supermarket, or clothing or gifts from a car parked away from home. The key attribute of larceny without contact is a lack of force.

The circumstances or attributes of a crime determine its category. For instance, if an older woman becomes aware of an attempt to snatch her purse (personal larceny with contact), and the offender then uses force, the crime would be classified as a robbery.

✓ Purse snatching is the street crime which is most frequently perpetrated against older persons. It often consists of one or more offenders, very often youths, quickly approaching a woman walking down the street, grabbing her purse from her hand or off her shoulder, and then running away.

Assaults

Assaults, crimes in which the object is to do physical harm to the victim, are usually classified as "aggravated" or "simple." An aggravated assault is one carried out with a weapon, regardless of the degree of the victim's injury--if any. However, an assault committed without a weapon is also considered to be an aggravated assault if the attack results in serious injury. Simple assault occurs when the victim's injury, if any, is minor and no weapon is used. This distinction is made for practical reasons; to help police and others differentiate crimes by seriousness, ultimately to better measure the extent of crime, and to allow legislatures to set different punishments based on the severity of a crime.

Many older persons are fearful of a brutal attack by a stranger. As discussed in Chapter Three, when they are victims of crime, which is relatively less frequently, older Americans are more likely than younger people to be injured; and to be victimized by younger strangers. But overall, this form of assault is unusual. While there is some indication in crime reports and newspapers that brutal crime is occurring with more frequency, it is still very rare. The more common types of assaults are those in which the victim is involved in a fight, often alcohol-related, or a domestic argument. Inasmuch as older persons less often find themselves in these situations, they are victimized by assault less often than are younger persons.

Robbery

Personal robbery is a crime in which the purpose is to take property from someone by force or the threat of force. The force used may be a weapon, in which case the crime is referred to as an armed robbery, or physical strength, which is referred to as strong-armed robbery. In either case, the victim is placed in physical danger, with physical injury a distinct possibility.

The two kinds of robberies most frequently committed against older

persons are muggings and push-in robberies. Mugging is a common name for street robberies, although they may happen in places like subways, building lobbies, or buses. Usually the crime is committed in one of three ways: the mugger will show the victim a weapon and demand money or jewelry; the mugger will state that he has a weapon and will use it if the victim does not turn over the money; or the mugger will simply physically overpower the victim and indicate that if the victim does not part with his money, he will be beaten.

A "push-in" robbery occurs when a person returns to his or her home or apartment, opens the door, and gets shoved inside by someone who has been following or waiting. It can happen when someone responds to a knock on the door by opening it or by relying just on a chain guard to keep the door secure. It can also happen when someone pushes his way into another's automobile in order to take his belongings. The Honorable Claude Pepper, U.S. Senator and Representative from Florida, former Chairman of the House Crime Committee, current Chairman of the House Select Committee on Aging, and himself in his eighties, found out first-hand:

My wife and I were, on a Sunday a few months ago, driving from visiting a friend in the hospital to our home on the bay when we stopped for the light to change at Third Avenue and 20th Street; two men rushed up to the side of the car. My wife being wiser than I had the door locked on her side; I didn't have my door locked and the next thing I knew a young man was crawling over me. My first thought was that he was going to try to kidnap my wife and me and I began to figure what could I do. The next thing I saw was his hand reaching for my wife's handbag on the seat between her and me. I saw then that he was trying to get my wife's handbag. Well, I grabbed him around his shoulders as hard as I could and said: "No, no, no," but he had already got his hands on the handbag and was pulling out, and I had to turn him loose to keep from being pulled out myself. In seconds he ran away from the car. (U.S. Congress, House Select Committee on Aging, 1978:2).

Rape

Rape is defined as "carnal knowledge through the use of force or the threat of force." The two elements necessary to constitute rape are sexual intercourse and commission of the act forcibly and without freely given consent. It is important, however, to remember that the motivation for this crime may well be less sexual desire than physical aggression. Some authorities consider rape fundamentally a crime of physical violence. Many elderly women have a pronounced fear of being raped, although the incidence of rape among older women is very low. However, studies have shown that rape, a generally underreported crime, is especially underreported by older women and that it has a "profound and probably permanent impact on the physical and psychological well-being of this population." (Davis and Brody, 1979:38)

The Key to Prevention of Street Crime: Awareness

Crime prevention is often thought to be a series of specific tips designed to reduce a person's vulnerability to victimization. While these specific tips are important, efforts intended to promote safety must begin with an overall attitude, one of awareness. By being conscious of one's own vulnerability and environment, a person can avoid being in situations which present opportunities for crime. In addition, a state of awareness readies a person for whatever may occur--not just for situations for which "tips" were memorized.

Unfortunately, people often become aware of their vulnerability to crime only after they have become victims. The experience itself stimulates them to modify their habits or change their behavior. They suddenly realize how their behavior can "invite" offenders to select them as victims. Older Americans can avoid these painful lessons if they practice acting with awareness before there is an incident.

What are the things to be aware of when out on the street?

Own Appearance

First, one should be aware of one's own personal characteristics. "What do I look like?" "How do I appear to someone looking for a victim?" A realistic appraisal of one's demeanor, physical weak points and strengths, and general appearance is the first step to becoming aware of one's vulnerability. Overall demeanor on the street can play a vital role in one's safety. Criminals are attracted to people who appear uneasy, frightened, or unsure of themselves, who do not seem certain of their destination, or who appear to be weak and fragile. Conversely, they shy away from those who appear confident, who carry themselves purposefully and seem sure of themselves. The keys to appearing confident and alert are not necessarily a faster walk or a feeling of strength, but an overall attitude that radiates outward.

The vulnerability that a person identifies in herself or himself can be reduced by advanced planning. This might include: planning out trips ahead of time; placing keys and necessary cash in separate pockets; bringing a friend along; leaving valuables at home; and carrying a whistle. The physical and mental preparation can indicate to the criminally-minded that a person is purposeful, ready, and unafraid.

Environment

Older persons must also be aware of their environment when they are out on the street. Such awareness not only helps prevent victimizations, but also can help stop victimizations in progress. So, appropriate questions to ask oneself are:

"Who are the other people on the street?" Crossing the street to avoid a group of youths congregating on the sidewalk might avoid

a potential confrontation. On the other hand, greeting familiar people--friends, merchants, vendors--reflects a knowledge of the neighborhood and adds a temporary sense of security in the company of others.

"How safe is the neighborhood?" It helps to know the friendly, familiar places--stores, banks, post offices, or other places--where one can step in if being followed, where there might be help, or where one can just "collect oneself."

"What are the sources of danger or risk?" These include places such as unlighted streets, vacant lots, alleys, or deserted buildings--any place where a crime would probably be unobserved by other people. By noticing and being aware of such places, one can take steps to stay away from them--detour for one block, walk on the other side of the street or in the middle of the sidewalk, or walk on a well-lighted street.

This form of crime prevention through awareness is easy to follow, but it takes practice. It is based on an understanding of one's own characteristics--especially those which reflect a vulnerability to crime--and of one's environment, a common sense approach to crime prevention that applies equally to residential crimes. Older Americans and the agency staffs who work with them can together develop plans for practicing these procedures. Group discussions can identify potential "trouble spots" in appearance and environment, and can reinforce efforts at improved awareness.

Techniques for Preventing Street Crimes

Quite a number of police departments, crime prevention projects, and government agencies have published booklets or brochures on crime prevention. Most of them are not geared to the elderly and their special vulnerabilities, but are good references for the general public to learn more about preventing crime. We shall borrow from them. We shall also present highlights of the available literature specifically on crime prevention techniques for senior citizens. Remember, the success of tips or techniques depends upon there first being a sense of awareness.

General Deterrents against Street Crime

- One of the best techniques for combating street crime is to go places with a friend. In numbers there's strength.
- Do not show money; in fact, it is best to avoid cash whenever possible. To do this, open a checking account at a local bank and handle as many transactions as possible by check. Social Security, SSI, federal pensions, military retirement, and other checks can even be electronically deposited into your account directly by the government. (This is discussed more fully later in this chapter.)
- It also helps to walk in the middle of the sidewalk, neither close to buildings nor passing cars.

- To reduce the likelihood of an attack from a passing car, walk against the flow of traffic.
- Common things not to do include:
 - Don't talk to strangers.
 - Don't walk into a crowd of youths leaving school or hanging around a store.
 - Don't walk near dark places.
 - Don't allow yourself to be distracted when buying something and opening a purse.
 - Don't wait for a bus on a deserted street, especially at night.
- Money is not the only item to refrain from "flashing" when out in public. Do not wear expensive jewelry or watches while shopping or on other errands. Such accoutrements are fine for an evening out with friends, but are unnecessary invitations to prospective criminals when worn during the day.
- If someone is following you, the best thing to do is to go into a public place, like a neighborhood store or other business previously identified in your study of your environment, and call the police.
- If a car appears to be following you, walk in the other direction or cross the street. It is always safer to reply for directions from a distance, not getting too close to the car.
- When threatened by imminent danger, don't be too embarrassed to yell, scream, and create a commotion. Your life may be at stake! Screaming may be a great tool because the noise will often scare off the criminal. To get people's attention, it sometimes helps to yell "Fire!" Carry some kind of noisemaker-- a whistle or shriek alarm.
- As seen in Congressman Pepper's case, crimes can also occur when you are in an automobile. Therefore, always lock your car whether you are parked, driving, or stopped at red lights. Park in well-lighted areas, and check the back seat before getting in.
- Just as you should not walk home if you think you're being followed, neither should you drive home if you think a car is following you. Drive to a public place, the best being the closest police station.
- If your car breaks down, the safest course to follow is to: open the car hood or attach a white cloth to the car antenna, then wait for someone to stop. If someone stops to help, stay inside your locked car and ask the person to phone the police.

or a local garage from the closest telephone. If someone really wants to help, she or he will do that.

- Whenever using public transportation, it is always safer to travel with a companion than to travel alone. When waiting at a bus or subway stop, especially in an unfamiliar area, keep your back to the wall to avoid being approached from behind, and have change or token ready. On a bus, the safest seat is next to the bus driver; on a subway train, it is near a conductor or a uniformed transit police officer. If you are frightened or being followed, do not get off at a deserted stop, even if it is your normal stop. Even though it may be inconvenient and a little more expensive, it is safer to continue to a busy stop, to get off and to seek help from a local merchant, booth attendant, or police officer.

One good way to prevent being victimized is to imagine what you would do if someone tried to attack you. Consider the options, since there is very little time to think during an attack. Ask yourself: "Could I hurt someone who is trying to hurt me?" "Would I be willing to scream?" "Should I try to run?" "What resources would be available to me to cope with an attack?" If you are attacked, your foremost concern should always be your own safety.

Dobson (1981) has written a book on "life-saving" principles, the thrust of which is that there's no simple formula when encountering danger. It is not simply a matter of fighting back or stalling for time, he says, but of trusting one's instincts or intuition in selecting among response options. A recent Washington Post interview with him outlines six of these options:

- Fighting - Using physical force, with or without weapons. Most appropriate when a sudden, unprovoked attack is made on you at close quarters and you feel in danger of bodily harm.
- Flight - Escaping or using evasive action to separate you from your attacker. Typically, the people to run from are those most difficult to fight. Remember: Run towards safety, not away from danger.
- Negotiation - Opening a dialogue with your attacker to forestall or minimize the attack. "Spot and exploit offers of a relationship, and--if possible--don't grant acceptance unless your assailant is willing to compromise."
- No action - Carrying on as though nothing unusual is happening. Most appropriate when you can't do anything anyway, you can't decide what to do, you're surrounded, outnumbered, or surprised.
- Diversion - Employing actions to confuse, mislead, or startle the assailant. "Try doing or saying the weirdest, most unexpected thing you can think of." Don't attempt to surprise an attacker who seems professional or one who is jumpy and/or has

a weapon.

- Blending - Joining temporarily with your attacker's force to redirect it and gain control. Most appropriate when you have no other choice, and/or you need time to decide which of the other options is best (Krucoff, 1981:B5).

In most cases, it is not wise to resist a criminal. Of course, generalizations are of little help when someone is in the middle of a dangerous situation. Probably the best advice for someone, old or young, in the course of a crime is to act according to the situation. Elderly people especially should not take unnecessary risks, because physical confrontation will often produce more serious harm for them than for younger victims. In too many instances, an inappropriate response by a victim has led to serious injury and even death, where a course of nonresistance would have resulted in only the loss of money or property.

If you are victimized despite your best crime prevention efforts, you can do something positive for yourself--and for potential future victims. You can try to remember something about the mugger or robber in order to give the police some descriptive information. Points to remember about the perpetrator may be: a scar on the face, a distinctive tattoo, a physical deformity, an accent, or any unusual feature. Although victims most often remember the clothes of their assailants, clothes can be changed quickly; therefore, it is better to remember physical traits which cannot be changed. If a description given by a victim leads to the arrest and conviction of, for example, a habitual offender, that victim has played an important role in preventing crime against others.

Foiling a Purse Snatcher

The most frequent street crime against older women is purse snatching. It can occur anywhere: in the supermarket, on a bus, or in an apartment lobby. The following tips offer advice for reducing women's vulnerability to purse snatchers.

First, the easiest way to avoid purse snatchers is to avoid carrying a purse. Money, keys, and identification cards can and should be carried in pockets.

Second, an alternative is to sew special pockets on the inside of coats to hold cash or important cards. This strategy was successfully implemented on a large scale in Wilmington, Delaware, several years ago in a program called "Pocket-The-Purse." A description of the project and the procedure for sewing the pocket to the inside of a coat are presented in Figure 6.1.

Third, if you must carry a purse, there are still steps you can take to reduce your losses if you have your purse snatched. Divide your valuables among inside pockets, outside pockets, and the purse, keeping the least valuable items in the purse itself. Not only will this minimize losses if the purse is snatched, but

Figure 6.1 Pocket-the-Purse Task Force, Wilmington, Delaware

Please Read All Instructions Carefully Before Beginning!

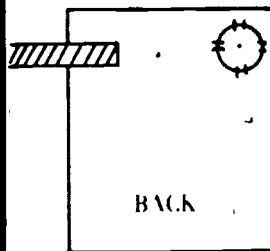
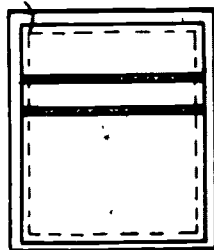
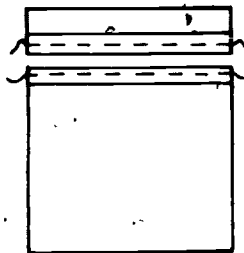
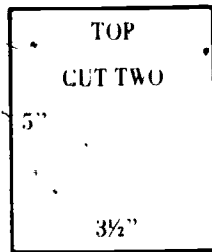

SUMMER POCKET

MATERIALS NEEDED:

1/4 yd muslin or sturdy lightweight fabric, 3 inch strip bias tape
1 snap

STEP 1 FOLD FABRIC in half and cut a rectangle measuring 3-1/2 x 5 inches. There will now be two 3-1/2 x 5 inch pieces. On one piece, measure 1" from top and cut across.

STEP 2 TURN UNDER and stitch 1/4" on bottom of 1" section, turn under and stitch 1/4" on top of 4" section. This will be the slit opening.

STEP 3 Lay these two sections WRONG SIDE OUT onto right side of uncut piece making all outer edges even.

STITCH all four sides 1/4" from edges use "15" stitch length on machine or small hand stitches.

STEP 4 Turn right sides to outside and press flap.

STEP 5 Use 3" piece of bias tape, fold edge under 1/4" and attach to left side on back of pocket. Sew snap on tape end and right side of pocket back.

SEE INSTRUCTIONS FOR SEWING SNAPS.

ATTACH POCKET TO BRA STRAP— Snap tape around strap. This will hold money, house key or credit cards, and avoid having to carry valuables in purse.

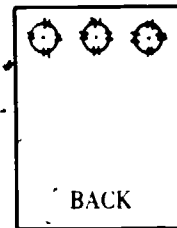

COAT

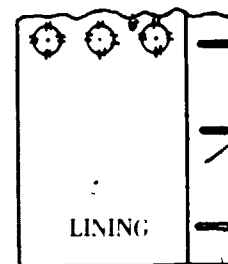

WINTER POCKET To be used inside coat

MATERIALS NEEDED:

1/4 yd denim, heavy lining fabric, or any dark sturdy fabric
3 snaps for each coat

STEP 1 FOLD FABRIC in half and cut rectangle 6 x 7-1/2 inches. There will then be two pieces 6 x 7-1/2 inches. Follow instructions for "summer pocket" through Step 4.

STEP 5 Attach ball section of snaps to back of pocket, 1" from top, and equally spaced. Attach socket sections to match on coat lining.

IF SOCKET SECTIONS OF SNAPS ARE APPLIED TO ALL WINTER COATS, THE POCKET CAN BE MOVED FROM ONE GARMENT TO ANOTHER.

SEWING SNAPS:

Attach the ball section of snap to end of bias tape, and socket section to right side of pocket back. Sew snap to pocket with small close overhand stitches through one hole, picking up garment thread with each stitch. Then carry thread under snap and repeat into next hole.

SOURCE: FBI, Crime Resistance, Washington, DC: FBI, 1976.

it will also make it easier to give the purse up, rather than to fight for it and risk injury.

Fourth, certain kinds of purses, such as bags that dangle from the shoulder, are an invitation to purse snatchers--they are very easy to grab. The safest type of pocketbook to carry is one with a short loop, held relatively close to the body, or tucked in the bend of the elbow. However, clutching a purse to your body as if your life's possessions were within can have the opposite effect, as seen in the following advice from an admitted purse snatcher.

Look for the person that's holding onto her pocketbook, either hanging on her arm or holding it in front of her chest or stomach. If a woman knows that somebody is around, and has money in her pocketbook, she will put it close to her body--that's one of the pocketbooks you need to hit because you can bet there is some cash in there. (F.B.I., 1976:45)

Fifth, never carry handbags or shopping bags with the loop wrapped around your wrist. If someone tries to pull the bag away, the loop will make it difficult to do, and you may be dragged to the ground. If enough force is used, a wrist may even be broken.

Sixth, the danger of a loop making it difficult to escape from a purse snatcher raises another important point: it is usually preferable to let go of your purse and to run away from a purse snatcher and towards safety than to engage him in a fight. Too many older women have been seriously hurt--even killed--fighting with purse snatchers. They feel a personal affront and lash out. However, it really is not worth risking serious injury in order to protect property, much of which can be replaced. Again, if you do not keep valuables in your purse, you may be less inclined to fight for it.

Although purse snatchings usually occur on the street, they can take place anywhere a woman is carrying a purse. Thus, if you go to the movies or stop for a meal at a restaurant, it is a good idea to keep your purse on your lap. Placing it on an adjoining chair, seat, or table only invites trouble. Frequently purses are stolen in restaurants because women leave them hanging out of their own sight on the back of a chair. Purses are also stolen in supermarkets or department stores, often after women put them down on a counter or in the top handle section of a shopping cart. While it may be difficult to carry a purse and push a cart at the same time, at a minimum one should avoid leaving a purse unattended when stepping away to select merchandise.

Unfortunately, purse snatchers are becoming more and more creative. In some instances, they have even entered public rest rooms and gone from stall to stall, reaching over and grabbing purses off the inside door hooks. The lesson to learn is: always keep a purse close by and in view, out of the reach of others.

These tips apply equally well when an older woman is trying to reduce the risks of being victimized by a robbery or mugging. These

crimes are traditionally thought to occur in alleys or on deserted streets, but they just as frequently occur on crowded streets, in the middle of the day or in someone's own apartment building.

Preventing Mugging

As with other crimes discussed, the best way to avoid muggings is to minimize opportunities for the mugger to attack. In addition to the general deterrents outlined earlier, some specifics follow.

First, never flash large sums of cash, even in banks. Instead, count money at the teller's window and then put it away. As mentioned, the best approach is to carry as little cash as possible, using personal checks to transact business.

Second, one of the best ways to lessen dependence on cash and to get into the habit of using checks is to participate in the U.S. Department of the Treasury's Direct Deposit program. Since 1972, this program has encouraged the automatic deposit of monthly federal checks, via a computerized system, into personal savings or checking accounts. Because the payments are electronically transferred, the chance of checks being stolen is virtually eliminated, and the chance of being mugged on the way to or from the bank is also diminished. It is common knowledge--especially to muggers--what days of the month those checks are delivered on (Goldsmith, 1975).

Social Security checks are not the only ones which can be deposited by mail through the Direct Deposit program. Anyone who receives the following can qualify: Supplemental Security Income, Railroad retirement, Civil Service retirement, Veterans Administration compensation and pension, Air Force active duty and retirement, Navy retirement, Army retirement, and federal salary. To sign up for Direct Deposit, all that people need do is to take their next check to wherever they do their banking, whether it be a commercial bank, savings bank, savings and loan association, or a federal- or state-chartered credit union. Bank personnel will answer all questions, help complete all necessary forms, and provide copies. Within 60 to 90 days, payments will begin going directly to the personal checking or savings account.

Over 12 million people already participate in the Direct Deposit program. However, effective participation depends on following the spirit as well as the procedures of the program. Too often, people who belong to the program go to the bank one day after computer deposit and withdraw all or most of the money just deposited from their checks. People simply like to see the cash, enjoy having it, and in some cases do not trust banks to safeguard their money properly. Such actions defeat the purpose of the Direct Deposit program.

Preventing a Push-in Robbery

There are a number of steps that can be taken to reduce the chances of being victimized by a "push-in" robbery. First, plan

ahead. Before leaving home on errands, tell your neighbors you are going and when you expect to return home. It also helps to ask if the neighbors will be there when you come back.

Second, when returning home to a house or an apartment building, look around before going in. If you feel the presence of something or someone that makes you uneasy, trust your intuition. Do not go inside. Rather, go to your neighbor's house or to the closest public place--a store, church, gas station, school--and call the police.

Third, if you are already in your apartment building, avoid being isolated with any stranger. If you see a suspicious person as you are walking toward your apartment door, do not go in. Instead, go to a neighbor's apartment on the same floor and ring the bell. If neighbors are not in, it is safest to walk to some common area of the building, an area where people congregate. This may be the lobby, the manager's office, the mail boxes, or the laundry room. In any event, stay away from your apartment until the suspicious stranger is gone, or until you are satisfied that his or her intentions are good.

Fourth, when answering the door at home, it is always best to use a door viewer. If the person knocking looks unfamiliar, never rely on the chain guard. Even if there is no door viewer, it is safer to speak through the door than to open it. If the visitor insists on seeing you, ask him or her to slip an identification card under the door. Do not hesitate to ask for the person's name and company. Call the company to verify identity and purpose of being there. Even if the person on the other side of the door cannot be heard, do not just open the door. If there really is something to deliver, the person should not mind slipping a note under the door which explains his or her purpose and company affiliation.

Fifth, another common ruse used by "push-in" robbers is that of the stranded motorist. A perpetrator pretends to have a disabled automobile. Out of kindness, the victim stops to help. An accomplice may then appear, or the "stranded" motorist alone takes advantage of the situation. Although it may sound unkind and even cruel, it is best not to open your car door. It is just as courteous, and certainly safer, to offer to make a telephone call for the person. Call the local police if anything about the person seems suspicious.

Rape Prevention

The crime of rape can be especially traumatic for older women. Bard and Sangrey (1979) point out, short of murder, rape is the ultimate assault, the invasion of the person's inner self. The brutal crime demeans its victim, and may be the final insult in an aging person's life. Unfortunately, it is sometimes difficult to take steps to avoid potential rapists, because they are often impossible to recognize in advance. As one author on rape states:

He could be an openly hostile teenager who roams with his gang purposely assaulting, vandalizing and raping on

impulse; on the other hand, he could be a well-groomed working man with a wife, children and a normal sex life, and will appear to the victim to be psychiatrically normal and capable of maintaining equilibrium in everyday situations (Davis and Brody, 1979:32).

There are several ways to respond to a sexual assault. These have been outlined recently by the Crime Prevention Coalition (1979b) as follows:

Submitting to the Attack. In all rapes, the rapist threatens the victim's safety, physical person, or life. If you believe you might get hurt by defending yourself, or are simply afraid to fight back, don't. Fighting can lead to physical injury, and research has shown that older women are more prone to physical rape injuries than younger ones. Submitting to a rape out of fear for your safety or life does not mean that you consented. It is still a rape, even if you do not have a cut or bruise, and should be reported to the police as soon as possible. If you choose not to resist, don't feel guilty or angry with yourself; direct your anger at the rapist who committed the violent crime.

Passive Resistance. Sometimes you may feel like resisting but are afraid that screaming or fighting back will incite the attacker to harm you even more. In this case, a "passive" kind of resistance may help to "defuse" the rapist's violence. It may be possible to calm the attacker by talking to him and trying to persuade him not to carry out the rape; if he hesitates or begins to trust you, you may be able to escape. You could claim to be sick to intimidate the attacker, or try to discourage the rapist by pretending to faint, crying hysterically, or acting insane.

Active Resistance. This strategy can be either the most effective or the most dangerous for the victim. Rape prevention counselors do not advocate active resistance as a response to a rapist with a weapon. In other cases, it is up to the individual victim how to respond. In some instances, fighting back can frighten or discourage an attacker. However, resistance can also convince the rapist to become more violent or increase his desire to subdue the victim. (Remember, increasingly law enforcement and criminal justice authorities maintain that rape is a violence-motivated and not a sexually-motivated crime.) Therefore, the choice must always depend on the particular circumstances surrounding each attempted rape.

As Dobson (1981) notes soberly, every situation is unique, and there are at least six response options to danger (fighting, flight, negotiation, no action, diversion, and blending) with which the individual should be familiar.

There are several kinds of active resistance. Screaming can surprise or frighten a rapist away if he is afraid that people will come to help; therefore, it is more appropriate in populated areas. In isolated locations, conversely, it is less likely to help. A forceful struggle may also discourage the rapist, but fighting back

is more difficult for many older women. However, if a woman can marshal the strength and is not afraid to hurt someone attacking her, then a strong kick or hit may provide an opportunity to escape. All attacks should be directed against the rapist's most vulnerable areas. Counselors recommend kicks to the groin or shin, pokes in the eyes, stamping on the instep, or hard chops against the front of the throat.

Another option for women is the use of self-defense techniques. Traditionally, women's social conditioning has taught them not to fight, and to be afraid to inflict injury on others--even to avoid grave injury to themselves. This notion seems to be changing in our society, as women are "taking control" of their lives. Increasingly, women are realizing their own individual and group strengths, and by defending themselves are breaking down sexual stereotypes.

It may not be advisable to teach some older women disciplines such as karate or judo, as they may be liable to injure themselves. However, there are various self-defense techniques, some less strenuous or demanding than others. Most have awareness--of self, the environment, and response options--as their core. More older women are taking these courses to protect themselves from attack. Above all, these courses teach a positive attitude, one that reflects that there is plenty that can be done to protect oneself, and that women have a right to do so.

Some women carry weapons such as guns, knives, or spray chemicals like mace to deter attackers. But this response should be chosen cautiously. Unless a woman is trained in the use of these weapons and is not afraid to employ them, they are very dangerous. An attacker can easily turn them against the victim. In a number of states, it is illegal to carry some weapons. So if a woman, after considering all options, decides she wants to carry a weapon, she should check with the local law enforcement agency.

All the crime prevention techniques presented in this chapter are means to reduce the opportunities for older people to be victimized by crime. They have proven themselves effective in crime prevention programs across the country. They are not difficult to practice, but there is an important prerequisite to their effectiveness: people must choose to use them. Crime prevention methods are only worthwhile if citizens practice them. Older community members and agency workers must work at street crime prevention.

Developing Programs against Street Crimes

Interested community members, elders, and social service personnel alike can link their individual efforts in combatting street crime with a range of programs sponsored by local public and private groups. Programs to make the streets safer for senior citizens have been conducted in a large number of cities by local agencies like the police department, the office on aging, and civic and community groups and organizations.

If no such program exists in a community, citizens or staff of an existing agency may want to set one up. The key to implementing a new program to reduce street crime against the elderly, of course, is to understand the nature and scope of the problem. Most law enforcement agencies have a crime analysis unit, which collects and reviews this kind of information. By working with the police, interested parties can learn which types of crimes are most frequently being committed against older people in the community, where they are being committed, and how they are committed. Once this knowledge is available, community elders, agencies, and police can plan anti-crime strategies which respond to particular crime problems.

Examples of the kinds of programs mounted to reduce seniors' chances of being victims of street crimes include:

- Establishing special senior citizen units within the police department, units specializing in crimes against older persons. Such units exist in New York City and Cleveland, for example.
- Organizing senior citizen volunteer corps to patrol the streets. These groups are operating effectively in Tucson, Arizona; Washington, DC; Huntington, West Virginia; and DuVal County, Florida, as well as in other cities.
- Keeping small "shriek alarms" in residents' pockets. When in trouble, one can push a button, and the alarm emits a loud noise. Bystanders or neighbors are alerted to take action or call the police.
- Using whistles instead of "shriek alarms." Police will often help establish these "Blow the Whistle on Crime" programs, and local merchants will donate whistles or offer discounts for large volume sales.
- Instituting within community senior citizen agencies special transportation programs for older persons who would otherwise have to travel alone. These programs not only serve as a social outlet, but also reduce the number of seniors out on the streets, thus reducing their chances of being victimized. In Washington, DC the police credited a senior citizen escort service with reducing crime in its target area.
- Escorting by private citizen volunteers of elders on errands to the store, bank, doctor, or senior citizen center. Even though they are not armed, these escorts (who may themselves be older community residents) reduce crime simply through their presence.
- Mounting community-wide crime prevention media campaigns, putting advertisements on radio and television and in the newspapers. This may often be done at no cost because of Federal Communications Commission requirements to broadcast "PSAs"--Public Service Announcements. New York City even held a senior citizens crime prevention week, which included workshops throughout the

city, placards on buses, and subways, and meetings of citizens task forces.

- Publicizing the special needs of elders in crime prevention through community events. Senior citizen agencies, in cooperation with the local police, have set up crime prevention fairs at shopping malls and banks, telling the public about the crime problems of seniors and what they can do to help. A fair in Milwaukee included the participation of a dozen crime-related volunteer and government programs, and many people signed up to contribute their efforts.
- Educating community groups in the facts of crime against the elderly. Several aging-related crime prevention programs have established speakers' bureaus, sending knowledgeable representatives to men's and women's groups, civic associations, and service clubs. These speakers publicize efforts being made to reduce seniors' risks of being victimized and to solicit volunteers.
- Conducting sensitivity training for the police. In Chicago, the Mayor's Office for Senior Citizens and the Handicapped conducts formal training for all recruits at the Chicago Police Academy. This training gives them background on the city's older population, informs them of services available to older citizens and how to use them, attacks stereotypes recruits might have toward older people, and sensitizes them to the special needs of elderly victims and potential victims.
- Implementing special patrol teams. In Brooklyn, New York, the police have special teams to patrol those bus stops most frequently used by elders and to ride as decoys on buses. This strategy has helped reduce purse snatchings and pickpocketing against seniors.

These are only a sampling of the kinds of programs community elders and agencies can establish if they are committed to reducing the victimization of older people. In fact, most of these street crime prevention programs are not difficult to plan or to implement. The essential ingredient is cooperation--cooperation among interested older community residents, social service staffs, and law enforcement/crime prevention agencies and groups. Street crime against elders can be reduced. The steps are self-awareness, awareness of the environment, and awareness of options in response to danger.

Reading and Resources

- American Transit Association, Vandalism and Passenger Security: A Study of Crime and Vandalism on Urban Mass Transit Systems in the United States and Canada, prepared for the Department of Transportation, Springfield, VA: National Technical Information Service, 1973.
- Bard, Morton and Dawn Sangrey, The Crime Victim's Book, New York, NY: Basic Books, 1979.
- Cónklin, John E., "Robbery, the Elderly, and Fear: An Urban Problem in Search of Solution," Jack Goldsmith and Sharon S. Goldsmith, Eds., Crime and the Elderly: Challenge and Response, Lexington, MA: D. C. Heath and Company, 1976.
- Crime Prevention Coalition, "How To Be 'Streetwise'--and Safe," Rockville, MD: Crime Prevention Coalition, Box 6700, 1979a.
- Crime Prevention Coalition, "How to Protect Yourself against Sexual Assault," Rockville, MD: Crime Prevention Coalition, Box 6700, 1979b.
- Davis, Linda J. and Elaine M. Brody, Rape and Older Women: A Guide to Prevention and Protection, Washington, DC: U.S. Government Printing Office, 1979.
- Dobson, T., Safe and Alive, Los Angeles, CA: J.P. Tarcher, Inc., 1981.
- Federal Bureau of Investigation, Crime Resistance, Washington, DC: F.B.I., 1976.
- Feeney, Floyd and Adrienne Weir, The Prevention and Control of Robbery--A Summary, Davis, CA: Center on Administration of Criminal Justice at the University of California, 1974.
- Fletcher, P., Criminal Victimization of Elderly Women: A Look At Sexual Assault, Syracuse, NY: Syracuse Rape Crisis Center, 1977.
- Goldsmith, Jack, "Community Crime Prevention and the Elderly: A Segmental Approach," Crime Prevention Review, California State Attorney General's Office, July 1975.
- Jones, Michael P., "Victimization on Portland's Skid Row," Marlene A. Young Rifai, Ed., Justice and Older Americans, Lexington, MA: D. C. Heath and Company, 1977.
- Krucoff, Carol, "Self-Defense: Disarming Tactics," The Washington Post, October 21, 1981.
- Mooney, Ruth, "A Dollar for the Mugger," Harpers Magazine, April 30, 1972.

Pace, Eric, "Patterns Seen in Theft Killings of the Lower East Side," New York Times, September 11, 1971.

Richardson, James B., "Purse Snatch: Robbery's Ugly Stepchild," Jack Goldsmith and Sharon S. Goldsmith, Eds., Crime and the Elderly: Challenge and Response, Lexington, MA: D. C. Heath and Company, 1976.

Siegel, M., "Wide Community Crime Traced to 'Singles' in Welfare Hotels," New York Times, November 16, 1972.

U.S. Congress, House Select Committee on Aging, Violent Crime Against the Elderly, Committee Publication Number 95-146, Washington, DC: U.S. Government Printing Office, 1978.

U.S. Department of Justice, LEAA, National Institute of Law Enforcement and Criminal Justice, The Crime of Robbery in the United States, Washington, DC: U.S. Government Printing Office, 1971.

U.S. Department of Justice, LEAA, National Institute of Law Enforcement and Criminal Justice, Research on Street Crime Control, Criminal Justice Monograph, Washington, DC: U.S. Government Printing Office, 1973.

Williams, Lena, "Youth Call Mugging Aged Easy, Profitable, Safe," New York Times, December 8, 1976.

Recommended Films on Street Crime

KEY: A = Abstract
C = Critique of Film for Suitability for Senior Citizens

MUGGING: YOU CAN PROTECT YOURSELF, 1977, Learning Corporation of America, 1350 Avenue of the Americas, New York, NY 10019.
Producer: New York Housing Authority, 30 minutes, 16 mm., color, \$395/\$50 for three-day period.

A: The film teaches self-defense techniques against street muggings. It is narrated by Liddon Griffith, a New York Housing Authority Police Officer who is quite familiar with the behavior of street muggers. After several scenes of muggings where the muggers use weapons and the victims get hurt, Officer Griffith then leads an actual class in self-defense techniques, using members of the audience of all ages for demonstrations of ways to escape from situations ranging from purse snatching to a knife in the stomach. Items to remember are continually repeated to make an impression on the class, e.g., "What is available to me?"

C: The initial high level of fear of the film (the mugging shots) decreases as the class progresses; fear gets transmuted into wisdom and action. The film leaves the audience with an impression that one is not totally helpless in the hands of an

assailant, with particular attention given to senior citizens. However, the techniques for dealing with situations that are not life-or-death are not covered adequately, e.g., when screaming is effective. Also, the prospect of a mugger coming back at a person after a successful escape is not discussed. Several of the techniques (e.g., poking at the mugger's eyes) seem easy in theory, but one questions whether a victim would be able to accomplish these in reality.

WALK WITHOUT FEAR, Sid Davis Productions. 1046 S. Robertson Blvd., Los Angeles, California 90035, 20 minutes, color, 16 mm.

A: The film opens with a police chief addressing a civic group. It then portrays recommended actions and practices that can reduce one's chances of being victimized by street criminals. As an example, the way a purse or handbag is carried may determine whether or not the bag will be snatched. The film suggests precautions that should be taken on the street, on buses, in cars, and in public places. The question of carrying weapons is discussed. The final message is that crime prevention is the best practice. Avoid crime by not giving the criminal the opportunity. The film was made with the technical assistance of the International Association of Chiefs of Police.

C: This is an excellent film for the elderly.

Chapter Seven

Preventing Residential Crimes against Elders

U

Chapter Seven Preventing Residential Crimes against Elders

Advance Organizers

- The residences of older Americans are burglarized about half as often as those of younger persons. But, for older people, household burglary is one of the most frequent types of victimization, the rate being twice that of their victimization by personal larceny.
- Burglary is actually the illegal entry or attempted entry of a home or structure. Even if nothing is taken by the burglar, the situation is still classified as a burglary.
- If something is taken from a residence by someone with no right to be there, the crime is considered a burglary. If it is taken by someone with a right to be there (delivery person, meter reader, guest), it is a household larceny. Overall, household larcenies occur slightly more frequently than burglaries.
- The two major ways of reducing the risk of a burglary are "target hardening," or reduction of opportunity, and surveillance.
- Target hardening efforts, such as window locks and reinforced doors, can lead to a "fortress mentality," in which the older person becomes more afraid to venture outside, or to a false sense of security. As with other crime prevention techniques, maintaining quality of life should be the overall goal.
- The most important part of a home security survey is carrying out the correction of the security defects uncovered. If an older person does not have the time, the money, or the opportunity to make the improvement, the home security survey can actually increase a sense of fear. This is where cooperative community projects can help.
- There are literally dozens of tips in this chapter and elsewhere on how to minimize the risks of burglary, household larceny, and auto theft; but, basically, the key ingredient is still awareness--awareness of circumstances inviting crime.

- Suggested home, apartment, and automobile security improvements must consider the physical and mental status of the older person to be helped. Can the person install the improvements, or manipulate locks once installed, or remember to use keys?
- Group community efforts have been found to be extremely helpful in arranging or conducting premises security surveys, buying hardware improvements in bulk, providing low- or no-cost installation, giving residential crime prevention education, monitoring potential residential crime activities in neighborhoods.

Introduction

There are literally dozens of tips in this chapter and elsewhere on how to minimize the risks of burglary, household larceny, and auto theft; but, basically, the key ingredient is still awareness--awareness of circumstances inviting crime. Burglaries are invited by: doors left open or unlocked; old, dried, or decayed putty in windows; unsecured window air conditioners; gaps between outside doors and frames. Household larcenies are invited by: jewelry and valuables left in plain view; too much information given to repair persons, movers, or salespeople over the phone or at the door; repair persons, etc. left alone in the residence. Auto thefts are invited by: keys in cars in one's driveway, outside a store, or elsewhere; valuables or presents lying on seats. In every instance, an aware elder can prevent these invitations. Sometimes the corrections may require assistance, as when physical repairs are beyond the elder's capacity or strength, or the cost of changes are greater than the person's resources. This is where cooperative community action comes in. But many corrections can be made quickly and inexpensively. Moreover, discussions of cost should not distract us from the basic point that an aware elder is the foundation in preventing residential crimes against older Americans.

Vulnerability

Perhaps even more than street crimes, residential crimes such as burglaries or household larcenies are crimes of opportunity. Those who commit residential crimes are very often amateurs looking for an unoccupied home "easy" to penetrate through an unlocked door or window, a weak door frame, or an open garage. As with street crime prevention, the key to household crime prevention is removing opportunities.

Certain conditions make some older Americans especially vulnerable to residential crime. Those who live in deteriorating housing in transitional neighborhoods are obviously easy targets for burglars. But, overall, senior citizens as a group may be less prone to burglaries and larcenies because their presence at home during the day acts as a deterrent to thieves. In fact, nationally the rate at which senior citizens are burglarized is less than one-half that of the burglary rate against younger persons. In 1975, for example, there were approximately 54 burglaries per thousand elderly compared with 127 burglaries per thousand younger persons (U.S. Department of Justice, 1978).

Types of Residential Crimes

What differentiates household crimes from street crimes is that the former do not involve personal confrontation. If such a confrontation occurs, the crime is classified as a personal crime, not a household crime. For example, if a woman comes home and surprises a burglar, he may threaten to harm her; such an act would be classified as an assault. If the offender takes cash or property from the woman, the crime would become a robbery instead

of a burglary.

There are three kinds of residential crime: burglary, household larceny, and auto theft. Of these, the most serious is burglary. Again, reviewing the definitions of these crimes will help us to understand how they differ, how they afflict the elderly, and how they can be prevented.

Burglary

Burglary is defined as the illegal entry or attempted entry of a structure. The underlying assumption is that the purpose of the illegal entry is to commit a theft. However, people often do not realize that once the person has entered the premises, no actual theft need take place for the crime to be classified as a burglary.

Additionally, the entry need not be made by force. It may be made through force, such as by picking a lock, breaking a window, or smashing a door. But it may also be committed simply by opening an unlocked door or walking into an open garage. As long as the person entering has no legal right to be there, a burglary occurs. Its definition also includes entry of any structure on the property, such as a tool shed, a guest house, or a detached garage. A structure need not be one's own property for a burglary to occur; an entrance into a hotel room or other vacation residence is still considered a burglary for the household members involved.

Household Larceny

Household larceny is the theft of cash or property by stealth in the home or its immediate surrounding areas. For a household larceny to occur within a home itself, the thief must be an individual with a right to be there, such as a maid, a delivery person, or a guest of one of the household members. If the offender does not have a right to be there, the crime is considered a burglary. Household larcenies include the theft of various types of property, including jewelry, clothes, small pieces of furniture, silverware, or clothing.

Auto Theft

The third kind of household crime is actually a special form of household larceny: auto theft. This includes both the theft and the unauthorized use of a motor vehicle. All types of motor vehicles are included under this definition, and attempted as well as completed acts of unauthorized entry or use are included. Auto theft is a relatively minor crime problem for older people. They are victimized by auto theft at much lower rates than younger persons primarily because of lower rates of car ownership.

The Key to Prevention of Residential Crime: Awareness

In the last chapter, it was explained that the critical factor in preventing street crimes is awareness--awareness of one's own

vulnerability, of the environment, and of response options. For household crimes, awareness also plays an important role. Here one needs to be aware of the home's vulnerability, and of the most likely ways in which crimes are committed.

Awareness of crime patterns is important mainly because of financial considerations. "Burglar-proofing" one's home can be expensive, and a number of older persons do not have the financial resources to pursue all recommended burglar-proofing steps. In order to discern which anti-burglary steps are most crucial, one must be aware of the nature of the burglary problem in the neighborhood.

Such an understanding entails obtaining answers to questions such as these:

- When are burglaries against the elderly being committed?
- Were burglaries accomplished mainly through forced or unforced entries?
- Of those entries into locked dwellings, were the majority accomplished by force or lock-picking?
- Of those unforced entries, were most made through windows or through doors?

It is often quite difficult to gain an awareness of these things. If the information can be obtained, it will probably be from the police.

This information is important whether a plan is to be implemented by the police, aging-related service providers, or older persons themselves. For example, if one discovers that most burglaries against the elderly in an area are accomplished through unforced entries, it makes sense to forego a traditional program like lock installation, conducting instead a massive community education campaign to teach people to use the locks they have. Or if one finds that entries are usually achieved by force rather than lock-picking, a program ought to include inspection of door frames in addition to the types of locks used. The point is that anti-burglary programs or activities should be built on an awareness of existing crime patterns.

Techniques for Preventing Household Crimes and Personal Crimes Committed in the Home

There are numerous tips and techniques to help people reduce their chances of being victimized by household crimes. Because burglary is the household crime of greatest concern to older persons, most of this section is devoted to anti-burglary efforts.

Anti-burglary efforts fall into two major categories: reduction of opportunity (often called "target hardening") and surveillance.

The first area includes strategies such as community education, home security surveys, property marking, and hardware upgrading, while the latter category includes police or civilian patrols, "buddy buzzers," and other kinds of alarms. Group surveillance techniques will be covered in more detail in Chapter Nine.

Target Hardening

Target hardening means just what it implies: making one's home a more difficult target for potential burglars. Most burglaries are committed by roving burglars looking for an easy target, such as a home or apartment which appears unoccupied, is easy to enter, and offers minimized chances of being detected. If all doors and windows are in plain view and there are persuasive signs that people are home, the burglar will likely move on. After a burglar decides to approach a home, if it appears it would take some time or effort to break into, the burglar will probably go elsewhere. Of course there is no guarantee that this will happen; but by making the burglar's task as difficult as possible, citizens significantly decrease their chances of being victimized.

Two words of caution should be expressed up front. First, when dealing with the problem of residential burglary, it is important to keep in mind possible negative effects from a heavy concentration on target hardening alone. Fortification of a house or apartment with window locks, more door bolts, and other security equipment can produce unhealthy attitudes in elders, resulting in a "fortress mentality" or a false sense of security. Either of these attitudes can lead to a constricted, isolated life style for seniors, one which undermines their quality of life. For this reason, hardware strategies are most advantageous when they are combined with crime prevention activities in the community.

Second, a home with a great number of locks and bars may be difficult to escape from quickly in case of fire--especially for an elderly person.

Premises Security Surveys

Premises security surveys are one of the most popular target hardening techniques. The survey consists of a careful, on-site examination of a house or apartment's "security status," during which security weaknesses are identified and recommendations made to correct them. Recommendations can range from certain measures the older resident can take at little or no cost to the more costly installation of hardware such as new doors, locks, door frames, or lighting.

In many communities, the police perform these surveys. Citizens telephone the department's crime prevention office to make an appointment for a survey, or they are referred to the police by a local social service agency. In a number of communities, other local agencies or projects conduct security surveys themselves. Senior citizens have been used very successfully in St. Petersburg, Florida and Phoenix,

Arizona to conduct these surveys. The usual items surveyed are doors, windows, garages, outside shrubbery, and lighting. Figure 7.1 shows a sample survey checklist. More detailed information on items to be checked in a security survey is given later in the section, "Recognizing a Vulnerable Burglary Target."

A common complaint among older persons about premises security surveys is that they are useful only for home owners, and are of small value to apartment tenants who have no authority to upgrade the physical security of their rented apartments. However, apartment dwellers can benefit from these surveys in several ways:

- Tenants on ground floors can learn of security measures they can take, such as leaving lights on in the evening, pinning windows (inserting a pin through window frames so the window cannot be opened from the outside), or asking management to trim shrubs.
- The results of a security survey can be sent to a landlord who may upgrade poor hardware to comply with the findings, especially if the upgrading is needed to conform to a local housing code.
- Even if unwilling to pay for improvements, owners may allow tenants to undertake them at their own expense.

Those who perform premises security surveys for older persons believe it is most appropriate to emphasize the goal of home security improvements--to reduce the opportunity for crime. Promising elders that if they take suggested steps they will never be burglarized will only promote a false sense of security.

Hardware Installation

What may be most important about security surveys is what occurs after the survey is completed. If a list of security defects is given to an older person and nothing more is done, it is likely that the survey will only increase the person's fear. After all, he or she has been made aware of all the ways in which a burglar can break into the home.

Very often, those seniors most in need of improved hardware and other security arrangements in their homes are the ones least likely to afford them. For this reason, communities have sponsored projects which purchase hardware such as deadbolt locks or peepholes in bulk, providing them, often along with free installation and other repairs, to low income seniors. These projects are popular not only because of their potential to reduce the burglary rate against seniors, but because of evidence that they can lower the levels of fear of crime among their recipients.

Often the agencies which can provide hardware do not possess the staff to install them. So, projects frequently use senior volunteers or part-time workers from a local Senior Community Service

Figure 7.1

Home Security Check List

EXTERIOR DOORS

- Are doors secured by good locks?
- Can hinge pins be removed from the outside?
- Can the burglar break glass, reach in, and open the door from the inside?
- Do you always lock your doors when leaving home?
- Do you have a wide-angle viewer?
- Do you leave your garage door closed at all times?
- Are wood exterior doors of solid core construction.

INTERIOR DOORS

- Is "security closet" secured by good lock?
- Is basement and garage door secured by good lock?

WINDOWS

- Can windows be "jimmied" or pried open easily?
- Can basement windows be forced open from the outside?
- Do you always lock your windows when leaving home?

SHRUBBERY

- Are shrubs trimmed low enough so burglar can't hide near windows and doors?

LIGHTING

- Do you leave at least one light on inside at night?
- Do exterior lights illuminate entrances to your home?

Other important security tips

1. Join Operation Identification. It works!
2. Control your keys. If key is lost or stolen, have tumblers in lock changed for new key immediately. Do not keep house keys and car keys on same ring. Do not hide "extra" key outside.
3. When going on vacation, notify police, stop mail and deliveries, and have a trusted neighbor make periodic checks. Always leave night lights on "timer."

"Security requires Imagination... Use yours to take the profit out of burglary."

Developed by the "Kentucky Crime Check" in cooperation with the Office of Crime Prevention, Kentucky Department of Justice, under a grant from the Kentucky Crime Commission.

Employment Program to upgrade the security of a home. Other resources which have been used include:

- Comprehensive Employment and Training Act of 1973 (CETA) Title III programs which employ in-school students and drop-outs supervised by a tradesman, such as a carpenter;
- Home security programs funded by the Law Enforcement Assistance Administration or under the Older Americans Act;
- Local crime prevention or victim/witness assistance programs which sometimes engage in home security activities;
- Trade schools, which may be amenable to giving students credit for performing work for a project or agency;
- Locksmiths who provide reduced rates for locks and installation to senior citizens in need;
- Local community colleges or universities, which may provide students to perform hardware installations;
- Retired carpenters, recruited through a local union or a community senior citizens center, who volunteer their services to provide hardware installation for other seniors.

Operation Identification

Operation Identification, or Operation ID, is another common strategy for reducing people's chances of being victimized. This technique usually consists of marking personal identification numbers onto valuable items of property and then displaying a sticker publicizing the resident's participation in the program. In most jurisdictions, authorities recommend the use of a person's driver's license number, since the police can easily locate an individual through this number. Non-drivers in some states obtain an identification card and number through the state department of motor vehicles or can use their Social Security numbers. The objectives of the program are to discourage burglaries before they occur, to identify whether property in the possession of a suspect is stolen, to expedite the identification and recovery of personal property, and to deter the fencing (sale by the burglar to others) of stolen property.

Property engraving programs operate several ways. Sometimes community-based anti-crime projects buy property engravers, then lend them out to citizens, tenant councils, groups of neighbors, or senior citizens groups. With these borrowed engravers, citizens can mark their own property. In other cases, the police department's crime prevention office marks citizens' property upon request. Or police officers or staff members of anti-crime programs go door-to-door with property engravers, trying to interest senior citizens and others in immediate engraving. This door-to-door effort seems especially well-received when it occurs just after a neighborhood or

apartment building burglary; at that time, crime and its impact are definitely on the minds of local residents. Another recent approach to property marking programs is to have property engravers available on loan in the public library just like books.

Items which cannot be engraved, such as jewelry, china pieces, silver, and other sentimental items can be photographed for identification purposes. As an additional precaution, citizens are asked to make a list of all household goods, including serial numbers of television sets, refrigerators, stereos, and cameras. This inventory, which can be stored in a safety-deposit box along with other important papers, proves its value if a burglary does occur. These procedures also help victims to complete both insurance claims and police reports quickly and accurately.

Recognizing a Vulnerable Burglary Target

During the last decade, crime prevention programming in this country has concentrated heavily on what can be done to decrease residential burglary. With strong federal backing, schools such as the National Crime Prevention Institute in Louisville, Kentucky, and others which followed its lead, have provided specialized, intensive training to police officers and citizens in ways to secure a residence so that burglaries can be deterred.

As a result of this emphasis, almost all large- and medium-sized police departments now have a number of officers, usually located in the department's community relations or crime prevention divisions, who are experts in the intricacies of target hardening for the home. Interested persons should contact these local specialists or any of a large number of crime prevention projects and associations which exist at the state and local levels. In addition, there are several excellent publications on the topic, some of which are listed in the bibliography at the end of the chapter.

A grounding in the basics of home security is important for people who work or live with senior citizens, so they can identify aspects of an elder's home which present risks of burglary. For this reason, introductory information on target hardening for the home is described briefly in this section. Descriptions and illustrations follow on: locks, doors, windows, and alarms.

Locks

- Good locks are probably the most important deterrent to burglars-- providing they are used. A recent study, however, found that almost half the residential burglaries in the United States are committed through unforced entries; teaching seniors to use the locks they have is an important first step.
- Most houses or apartments have inexpensive key-in-knob locks, which automatically keep the door locked when it is closed. These locks can be easily opened with a knife or a credit card slipped between the door and the frame, or the bolt can be

jimmied out of a door frame with a screw driver.

- The best kind of lock for deterring burglars is a deadbolt. When the lock is engaged, a metal bolt slides from the door into the door frame. The bolt has a square end which is set in the locked position either by a second turn of the key or by a thumb knob on the inside part of the door. The better deadbolt locks have a steel cylinder guard ring around the lock.
- Another good lock, pictured in Figure 7.2, is an auxiliary rim mounted lock with a deadbolt. This lock is attached to the door's surface with long sturdy screws, and the locking device on the door fits into the strike plate on the frame. When the key is turned, strong metal bars join the two parts of the lock.

Figure 7.2

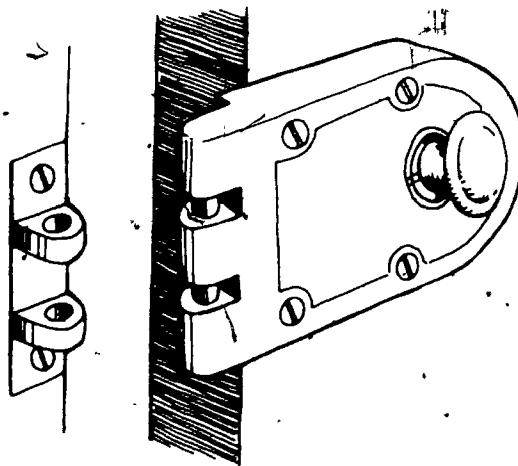

Source: U.S. Department of Justice, "Take a Bite Out of Crime: How To Crimeproof Your Home," 1979:7.

- Probably the best lock to install to improve security is a double cylinder deadbolt lock, pictured below (Figure 7.3) from the side and from above. These locks have two cylinders, one for opening the door with a key from inside the house, and one for opening it from the outside. Even if a burglar breaks the glass and reaches in, he will not be able to open the door without the key.

Figure 7.3



Source: Midwest Research Institute, Crime Prevention Handbook for Senior Citizens, 1977:18.

Source: U.S. Department of Justice, "Take a Bite Out of Crime: How to Crimeproof Your Home," 1979:7.

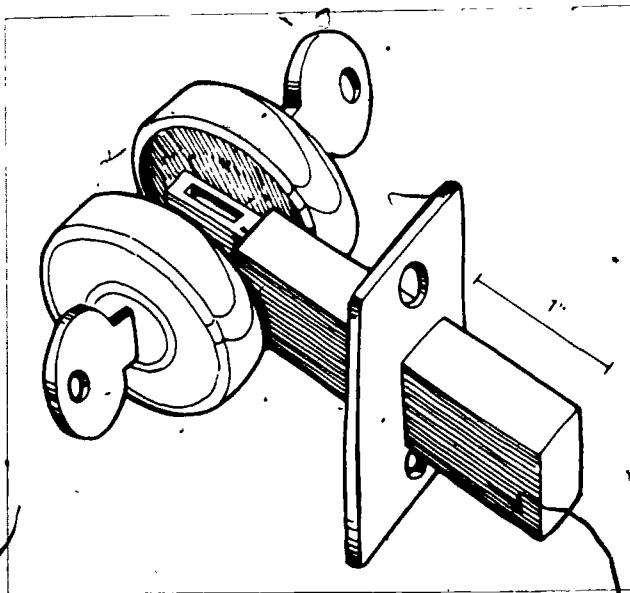

- This double cylinder deadbolt does have one significant disadvantage: one needs a key to get out. In an emergency such as a fire, a lost or misplaced key could create a real hazard to life. For this reason, most experts recommend that persons leave the inside key in the lock when at home, but remove it when going out. Alternatively, put the key on a nail far enough away from the door to prevent anyone from reaching in and grabbing it. Some jurisdictions, at the urging of fire safety officials, restrict the use of these double cylinder deadbolt locks.

- Many apartment units still have chain locks, but on their own these offer little protection. Used in conjunction with a good deadbolt, these guards can serve as an extra security measure.

Doors

- Good locks are important, but a strong lock is of little value if it is attached to a weak door, such as a hollow core one. An entry door should be solid core wood (at least 1 3/4 inches thick) or metal.
- Likewise, a good lock does little good if it is attached to a warped or corroded door frame. If screws are not long enough or if they bite into soft wood, the lock may be strong but the door will likely give way to the strength of a burglar.
- Gaps between the door and frame make it possible for the door to be forced open with a crowbar or other similar tool.
- A peephole or door viewer can be a very valuable aid in fighting crime. Good ones have a wide-angle (180-degree) field of vision, while some others may not allow a clear view of who is at the door. Like locks, door viewers must be used to be effective.
- A door with a glass or window panel is an inviting target for burglars, especially if the glass is within arm's reach of the door knob. Glass can be replaced or supplemented by Lexan break-resistant transparent plastic, or decorative grillwork can be installed over the glass. Also a double-cylinder lock can be installed (see locks).
- Sliding glass doors, the kind used on patios, are particularly attractive to burglars because they can be lifted off their tracks and removed and the locks can be pried open with a screw driver. Extra security measures like a piece of wood in the door track, a patio door bar, or a pin in the frame are needed. The pin can be inserted through the inside frame and part way through the metal door frame as pictured below in Figure 7.4. The homeowner can remove the pin from the inside, but no one can remove it from the outside.

Figure 7.4

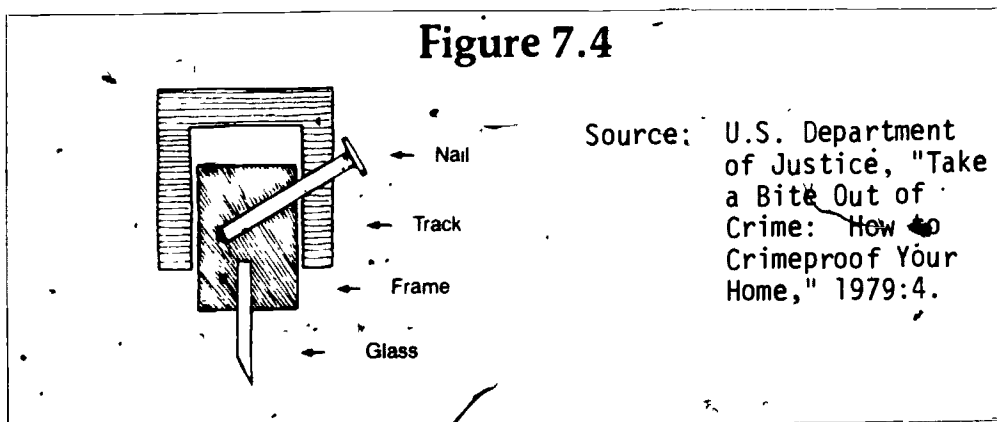

Source: U.S. Department of Justice, "Take a Bite Out of Crime: How to Crimeproof Your Home," 1979:4.

- A garage door should close tightly and lock. An overhead garage door needs a good quality padlock. Lighting in and around the garage is important. Windows should be opaque so that someone on the outside cannot determine whether a car is in the garage.
- The door between an inside garage and a house is often very weak, out of sight of the street, and especially vulnerable to forced entry. Securing it is often overlooked but important.
- Because a back door cannot be seen from the street, it is another prime target of burglars. The door, frame, and locks should be at least as good as those on the front door.

Windows

- Window entries cannot be absolutely prevented so long as glass can be broken. However, it takes time and noise to attempt such an entry, and the majority of would-be burglars will not try it.
- Any security improvements to windows need to take into consideration the need for an emergency exit in case of fire, which is equally important as deterring burglaries.
- The sliding double-hung window, where one or both of two window panels slides up and down or sideways, is most inviting to burglars. The small thumb-turn lock can be easily pried open by inserting a long blade of metal between the two frames. Any of these windows which are not used should be nailed or screwed shut.
- Double-hung windows which are used can be secured in a simple, inexpensive manner by "pinning" them closed as illustrated in Figure 7.5 below, inserting a long nail or eyebolt from the lower frame of the upper window part-way into the upper frame of the lower window. A second set of holes drilled with the window open four inches will allow the window to be pinned for security, even when it is open.

Figure 7.5

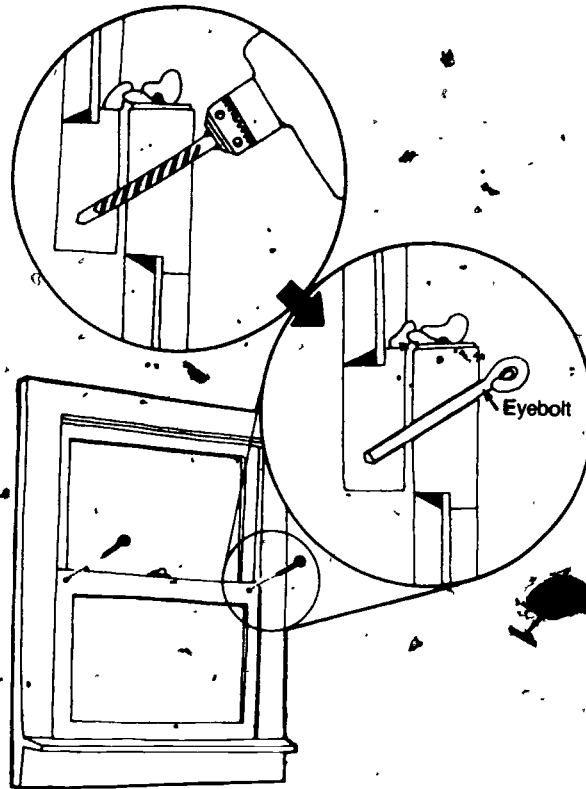

Source: U.S. Department of Justice, "Take a Bite Out of Crime: How to Crimeproof Your Home," 1979:10..

- The second, more expensive way to secure double-hung windows is to install key locks. The picture below (Figure 7.6) shows a regular window latch on the left and a key window lock on the right. The fire hazards from keyed window locks are the same as those for double cylinder deadbolt locks. Some jurisdictions may have restrictions on their use.
- Since neither window pinning nor a key lock will deter burglars once a window is broken (the key lock can be pried off with a screw driver), window glass can be replaced or supplemented by a break-resistant Lexan plastic.

Figure 7.6

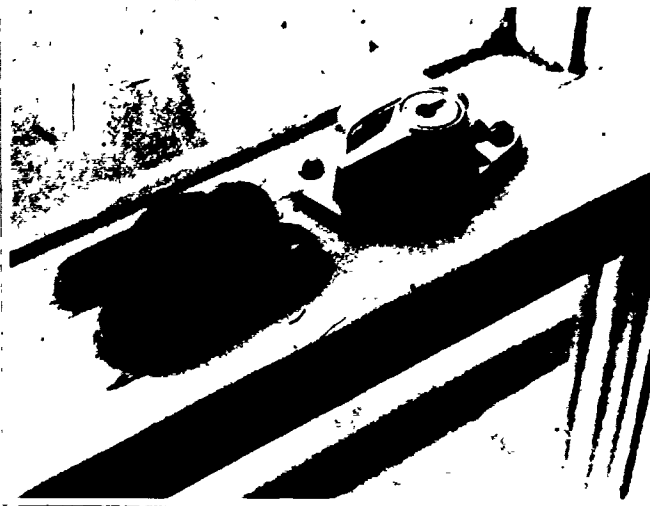

Source: Midwest Research Institute, Crime Prevention Handbook for Senior Citizens, 1977:23.

Caseament windows, which open with a crank and swing out from the window frame, are more difficult for burglars, because they must cut or break the glass. For unused windows, the crank should be removed and stored nearby. As an alternative for windows which are used, casement key locks can be installed, as illustrated in Figure 7.7.

Figure 7.7

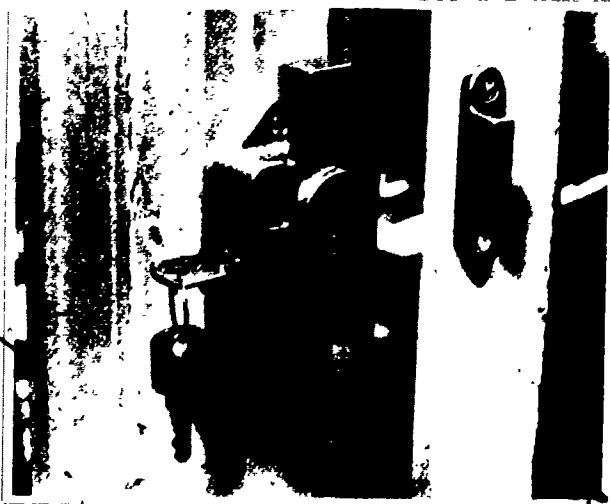

Source: Midwest Research Institute, Crime Prevention Handbook for Senior Citizens, 1977:23.

- Louvered windows offer poor security because the slats can often be removed quickly and with little noise. They can be made safer through the installation on the inside of a metal grate, grille, screen, or bars with removable screws. Once again, though, such devices can be a hazard in case of fire.
- Some windows slide on a track. Like sliding glass doors, they can be secured with a piece of wood snugly fitted into the bottom track and screws inserted in the top to prevent the window from being lifted off its track.
- Especially in an old house or apartment, the putty which holds a window in place may have dried out, leaving the window loose enough to push out.
- If window air conditioners are not held down by long, strong screws fastened into good wood, the unit can be removed for easy access to a home.

Alarms

- If considering the installation of a burglar alarm system, remember:
 - A good system can be expensive.
 - It needs to be set each time it will be used.
 - It has to be turned off after each use.
 - It has to be checked periodically to see if it is working correctly.
- Advice should be sought from an objective party who is knowledgeable about alarms, such as the police, rather than from someone marketing a product.

Special Considerations in Choosing Hardware for Older Persons

Hardware itself can prove to be a hurdle to some older people. A guide to rape prevention for older women prepared for the National Institute of Mental Health makes this conclusion for some older women, one which applies equally well to older men with similar problems:

Sensory losses, reduction in physical strength with age, and chronic illness such as osteoarthritis cause special problems for many older women in manipulating locks and keys. Compounding the physical problems are the memory changes sometimes associated with senescence. Older women with these symptoms have a tendency to lose or misplace keys, confuse one with another, fumble in trying

to find a key in a bag, and have difficulty in opening and closing locks because of stiff fingers or poor eyesight.

(Davis and Brody, 1979:87).

These limitations of some older persons have led researchers to suggest that no "universal" security improvements can be recommended for the elderly; rather, the characteristics of an individual client or a group of senior citizens within one building should be considered when recommendations are made. For those elderly with physical limitations, the following advice has been given:

- The number of keys should be kept at a minimum. For certain seniors, a single cylinder deadbolt with a large thumb turn on the inside may be preferable to a double cylinder deadbolt lock.
- For seniors living in apartment buildings, keys for the lobby door and the apartment unit can be color-coded.
- Pins may be easier to maneuver than keys for use in windows.
- Because good locks can keep out help as well as crime, housing personnel from an apartment building or neighbors should have a way to get into an older person's home. The safest solution is to give a key to a trusted friend or neighbor.

Other Tips

In addition to target hardening, elders--and all of us--can do a number of other things that will reduce the chances of burglary.

Many crime prevention tips are based on a general distrust of strangers. Constant caution is often recommended as a proper attitude to reduce vulnerability to crime. However, if such attitudes are overemphasized, the crime prevention information may increase an already high level of fear. So, it is important to emphasize that while suspicion is necessary, most people are trustworthy, and cautious behavior will protect against the few who are not (Davis and Brody, 1979).

The following tips represent habits to develop around the home and when away from home in order to make a house or apartment a less inviting target for burglars.

Outward Appearance

- Prune lower tree limbs that could help a burglar climb up to the second story of a house or into an apartment.
- Trim trees and bushes so that windows and doors are clearly visible.
- Draw draperies and blinds at night. Leave at least one inside light on to give the appearance that someone is at home. An automatic timer to control lights is best.

- Make sure to light all outside entrances at night, but turn them off during the day.

Traveling

- When going away for several days, take several precautions: cancel mail and newspaper deliveries, or have them picked up by a neighbor; ask a neighbor to keep an eye on the house; have a neighbor (or a timer) turn lights, radio, and television on and off at appropriate times; store garbage cans inside; close and lock all windows and the garage; park a neighbor's or your own car in the driveway rather than in the garage.
- Never announce vacations or social events before they happen, whether on the local paper's social page or in a church bulletin.
- If a death occurs in the family, find a housesitter for the day of the funeral.

Communicating

- Never give information to strangers over the telephone. Establish the identity of the caller before giving out any personal information by, for example, asking for a telephone number at which the identity of the caller can be verified.
- Never include a home address in a classified ad.

Keys

- Never carry identification tags on a key ring. Keep car keys and house keys separate.
- When moving into a new apartment or house, have the locks re-keyed or changed.
- Know who has every key to the home. Do not give one to anyone you cannot trust completely, but do give one to a trusted neighbor in case of an emergency.
- Never hide keys outside--under a mat, in the mail box, over the door, etc. Burglars know all these hiding places.

Strangers

- Screen everyone who comes to the door, either by asking for identification to be slid under the door or by telephoning the person's employer.
- If awakened by an intruder, pretend to be asleep and remain in the bedroom.

Telephone

- Keep a telephone and the police emergency telephone number next to the bed.
- If a woman is living alone, the telephone number should be listed using first name initials rather than full first name; use the same approach for the mail box.

Even if one is careful, a burglary can occur. If, on returning home, there is any sign that the house or apartment has been burglarized--or that a burglary is occurring--resist the temptation to rush inside. Instead, follow these steps:

- Do not go inside. The burglar may still be there. Go directly to a neighbor and call the police. Wait for them to arrive before doing anything else.
- If confronting a burglar, do not try to fight or corner him. If it is possible, escape, also without trying to impede the burglar's exit.
- If the burglar is armed, stay quiet and obey instructions.
- Try to remember as many of a burglar's physical characteristics as possible. Good descriptions will help the police.
- After a burglary, do not touch anything. Disturbing the crime scene may hamper police investigation of the crime.
- Always call the police immediately, before you call a friend or family. Even the shortest delays in contacting police can significantly lessen the police department's chances of apprehending the burglar.

Apartment-Dwellers

Elderly apartment-dwellers can be vulnerable to burglaries because of the carelessness of others. For example, if other tenants allow strangers to be "buzzed" into the building or there is no screening of visitors, older tenants' vulnerability to burglary is increased. Security tips for apartment dwellers include:

- Always lock doors, even when at home. Leaving a door open to the hall to receive better air circulation, for instance, invites intruders.
- Any unguarded, unlocked entrances to the building should be pointed out to management or, if necessary, to authorities such as the local city council representative, or the local housing department.
- The lobby door, intercom system, and garage door should be regularly checked to make sure they are working correctly.

- Avoid being in the laundry room or garage alone, especially at night.
- Never buzz visitors into the building via an automatic door-opening intercom without first checking their identity.
- If the building has a doorman or guard, ask the landlord to require and enforce a policy of "announcing all visitors" before they can leave the lobby.
- Stand near the emergency and floor buttons on elevators. Be ready to push all buttons in case of an emergency.
- Do not enter an elevator with a stranger. If you are going up, do not enter one that is going down to the basement.
- If accosted in an apartment building, yell "FIRE" not "HELP" or "RAPE," since people will be more likely to get involved.
- Buildings should be inspected to insure that they meet all requirements of the building code.
- Knowing one's neighbors will allow a cooperative effort in being more watchful of strangers. (See Chapter Nine on Community Crime Prevention.)

Auto Theft

While many older people no longer drive automobiles, those who do are subject just as much as younger drivers to auto theft. While some elderly drivers may not be able to afford the more sophisticated car alarms, there are steps they can take to deter auto theft. A sampling of these includes:

- Replace standard door lock buttons common in older model cars with the slim, tapered kind. They are extremely difficult to raise with a coat hanger.
- Do not leave valuables or tempting things in view within the car, things like a tape deck, a large gift, or expensive clothes. Use the trunk instead.
- Never leave a key in the ignition, even if stepping into a store for only a minute.
- Leave the car locked at all times, even when parked in the driveway or in front of the house.
- Never leave the engine running when out of the car.
- A parking claim check on the seat or the dash board is an invitation to a thief for an easy auto theft.

Household Larcenies and Other Crimes

Other crimes which can afflict elderly persons within their homes include larceny, robbery, and rape. Robbery and rape have been covered in some detail in the preceding chapter. Residential target-hardening practices should, of course, help prevent others from entering the home illegally, including would-be robbers and rapists. Household larcenies are very difficult to prevent because they are committed by people who are on the premises legally: housekeepers, delivery persons, acquaintances.

To reduce one's vulnerability to household larceny, one should follow these guidelines:

- Maintain a secure room within the home or apartment. Most people who do this use their bedroom for this purpose, installing a lock on the inside of the bedroom door. A good lock for this purpose is a deadbolt lock with a thumb turn on the inside. People need only use this lock when others will be in the home, such as a babysitter, or a repairman.
- As an alternative, maintain a security closet where valuables are kept. Things such as jewelry, furs, cameras, and silver can be stored in this closet.
- Obvious valuables like jewelry should not be kept in plain view.
- Obtain names and addresses of all people who will be in your home for any length of time: repair or delivery persons, painters, movers, etc. If anything is missing afterward, you will be able to contact the person or his or her employer.

What Agencies and Groups Can Do

This chapter has presented a variety of steps older persons can take to improve security within their houses or apartments. While all seniors can follow common sense tips such as locking all doors and checking the identity of visitors, the avenues open to some will be limited by financial or physical conditions. It is important that neighbors, program staff, and older persons themselves keep these limitations in mind when making recommendations on how senior citizens can reduce their vulnerability to household crimes. Service providers may want to seek help for home security programs so that they can assist elders who cannot afford to protect themselves from burglary. The local police can be an important resource in such a program. They are knowledgeable about the services reviewed in this chapter and can themselves provide many to older persons in the community. At the least, they should be able to train others in how to provide these services.

There are a variety of things that can be done if people are interested in improving home security for older Americans. They can lobby for changes in the local or state building code, changes which would incorporate security standards for locks, doors, and

windows and would require landlords to conform to a higher standard of safety from crime for their tenants." They can lobby for tax credits for expenses in home security improvements, much the way energy saving-related tax credits are given. Or they can work with a committee of concerned citizens, police, landlords, and others to implement "defensible space" programs which change the physical environment to increase the control of the residents and deter criminals. Examples of defensible space strategies include reducing automobile traffic through a neighborhood, fencing parks or private property, erecting "people flow" partitions in apartment buildings, and decreasing the amount of "open space" in a building (Newman, 1973).

Successful programs aimed at reducing residential crimes against seniors are plentiful across the country. A representative sampling:

- "Senior Citizen Poses," working with the local sheriff in Phoenix, Arizona, patrol their neighborhoods and canvas door-to-door to promote Operation Identification.
- In the Bronx, New York, government funding paid for the installation of "buddy buzzers" in each unit of a retirement apartment building. Residents in need of help only had to push a button, and the buzzer sounded in one or two other apartments.
- A New York City aging agency provided home repair service or hardware installation for eligible senior citizens.
- CETA programs in several cities have provided home repair service or hardware installation for eligible senior citizens.
- Some agencies on aging have hired retired carpenters as volunteers or part-time aides to perform hardware installations for other older persons.
- In St. Louis, Missouri, a team of 84 senior citizens trained by the police perform about 140 security inspections each month, helping other seniors install locks and door viewers and repair broken windows and doors.
- A Las Vegas Retired Senior Volunteer Program performs security surveys for seniors, and has funding from a foundation to pay for the installation of deadbolt locks.
- A Minneapolis program trained AFL-CIO members, such as utility workers and letter carriers, in surveillance and crime prevention techniques. The program then helped establish a procedure by which the police send crime information to all post offices on a route-by-route basis, so that letter carriers were aware of the operation of burglars in their areas.
- In Akron, Ohio police enrolled about 9,000 senior citizen "informants," each assigned an ID number to use in tipping off

police anonymously to suspicious occurrences in his or her neighborhood. Burglary rates against seniors dropped by 40 percent in two years. And in cooperation with an Older Americans Act-funded project, the police promoted the installation of 1,500 deadbolt locks and smoke alarms.

Again, these programs are examples of the efforts which can be undertaken by organizations interested in improving the residential safety of older persons. Awareness and cooperation are the keys to their success. Chapter Nine, "Community Crime Prevention," provides further illustrations of how interested agencies can work closely with private citizens themselves.

Reading and Resources

- Arnold, R. T., The Burglars Are Coming, Santa Ana, CA: Arnold Publishing, 1972.
- Brill Associates, William, Victimization, Fear of Crime and Altered Behavior: A Profile of the Crime Problem in Murphy Homes, Washington, DC: U.S. Government Printing Office, 1977.
- Cole, Richard B., Protect Your Property: The Applications of Burglar Alarm Hardware, Springfield, IL: Charles C. Thomas, 1971.
- Davis, Linda J. and Elaine M. Brody, Rape and Older Women: A Guide to Prevention and Protection, Washington, DC: U.S. Government Printing Office, 1979.
- "Door Locks" and "Window Locks," Consumer Reports, March, 1979.
- Fox, Harry, G., "Senior Citizens Castle: The New Crime Scene," Police Chief, Vol. 44, No. 2, February, 1977.
- Heller, Nelson B. et al., "Operation Identification Projects: Assessment of Effectiveness" (National Evaluation Program, Phase I, Summary Report, Series A, No. 1, LEAA), Washington, DC: National Criminal Justice Reference Service, August, 1975.
- "A Homeowner's Guide to Burglary Prevention," Hyannis, MA: The Delta Group, 1978.
- "Home Security--What You Should Know about It and How To Do It," Kansas City, MO: Midwest Research Corporation.
- Kingsbury, A. A., Introduction to Security and Crime Prevention Surveys, Springfield, IL: Charles C. Thomas, 1973.
- Leeds, Morton, "Residential Security Techniques," Marlene A. Young Rifai, Ed., Justice and Older Americans, Lexington, MA: D. C. Heath and Company, 1977.
- Midwest Research Institute, Crime Prevention Handbook for Senior Citizens, Washington, DC: U.S. Government Printing Office, 1977.

- Newman, Oscar, Defensible Space: Crime Prevention through Urban Design, New York: Collier Books, 1973.
- Patterson, Arthur, "Environmental Indicators: Territorial Behavior and Fear of Crime in the Elderly," Police Chief, Vol. 44, No. 2, February 1977.
- Sherman, Edmund, Evelyn S. Newman, and Anne D. Nelson, "Patterns of Age Integration in Public Housing and the Incidence and Fear of Crime among Elderly Tenants," Jack Goldsmith and Sharon S. Goldsmith, Eds., Crime and the Elderly: Challenge and Response, Lexington, MA: D. C. Heath and Company, 1976.
- U.S. Congress, House Select Committee on Aging, Subcommittee on Housing and Consumer Interests, Elderly Crime Victimization (Residential Security) - Hearing, Washington, DC: U.S. Government Printing Office, March 15, 1976.
- U.S. Department of Justice, Law Enforcement Assistance Administration, Take a Bite Out of Crime: How to Crimeproof Your Home, Washington, DC: U.S. Government Printing Office, 1979.
- U.S. Department of Justice, Law Enforcement Assistance Administration, National Criminal Justice Information and Statistics Service, Myths and Realities about Crime, Washington, DC: U.S. Government Printing Office, 1978.
- U.S. Department of Justice, Law Enforcement Assistance Administration, National Institute of Law Enforcement and Criminal Justice, Deterrence of Crime In and Around Residences, Washington, DC: U.S. Government Printing Office, 1973.
- _____, "Residential Security," Washington, DC: U.S. Government Printing Office, 1973.
- Van Buren, David P., "Public Housing Security and the Elderly: Practice Versus Theory," Jack Goldsmith and Sharon S. Goldsmith, Eds., Crime and the Elderly: Challenge and Response, Lexington, MA, D. C. Heath and Company, 1976.

Recommended Film on Property Protection

Key: A = Abstract

C = Critique of Film for Suitability for Senior Citizens

INVITATIONS TO BURGLARY, Aptos Film Productions, Inc., 729 Seward Street, Suite 203, Hollywood, California 90038, Producer: Charles S. MacCrone, 22 minutes, 16 mm., color, \$250.

A: Prevention is the citizen's responsibility. Law enforcement officials can show you how to do it. Raymond Burr narrates this film which illustrates how people create the opportunities for burglaries to occur, and what security devices and procedures can be used to prevent such crimes. The film attempts to motivate the audience to recognize and eliminate those invitations that are so clearly evident to the burglar.

C. The advice is practical and realistic for senior citizens.

Chapter Eight

Preventing Consumer Fraud and Con Games

Chapter Eight

Preventing Consumer Fraud and Con Games

Advance Organizers

- A number of age-related factors may make some older persons vulnerable to fraud. These include: physical problems like poor eyesight or hearing, social isolation or loneliness, pain or anxiety, lower formal educational level, fears of aging and dying, and poverty.
- Recent research on the elderly and consumer fraud has suggested that there does not seem to be a particular pattern of fraud directed at them. Older consumers were found to be, overall, self-reliant, well-informed, and more likely to be dissatisfied with simple purchases or repairs than to be duped or swindled.
- Some personal characteristics do make certain older people likely targets for particular frauds and cons: if they live in old homes, they may be drawn into "home improvement" deals; restricted mobility may make them easier prey for friendly, glib visiting salespeople; increasing chronic maladies may make them more likely to become involved with "sure cures" and medical quackery.
- The two most common types of fraud are consumer fraud and con games. Examples of the former include: home repair schemes, medical quackery, insurance fraud, hearing aid sales, land schemes, fly-by-night funeral services, door-to-door and mail fraud. The most common examples of con games are: The Bank Examiner, and The Pigeon Drop. As with other kinds of crime against elders, awareness is the key to preventing victimization.
- Consumer frauds depend upon people's normal desires to be healthy, befriended, wealthy or comfortable, and, ultimately, to get something for nothing (or for very little).
- Recent laws such as the Food and Drug Administration's 1977 regulations, Housing and Urban Development's "Statement of Record" requirement, and the Federal Trade Commission Cooling Off Period Door-to-Door Sales regulation reduce the risk of being swindled in hearing aid sales, land sales, and consumer purchases made in the home, respectively.

- If an elder is the victim of a consumer fraud or con game, he or she should report it immediately so that it can be investigated. The police or the consumer affairs agency may be able to detect a pattern to the fraudulent practices, enabling them to catch the perpetrators or prevent the victimization from happening as frequently in the community.

- Older people, social service staffs, and agencies can undertake a variety of effective group practices against fraud. Proven "collective action" activities include: consumer education courses, seminars and tips offered on the radio, in newspapers, in senior centers, tenant councils, and civic clubs; lobbying for stronger legislation and enforcement of anti-fraud measures; group analyses of newspaper and junk mail advertisements; and training professionals like ministers, doctors, and social workers to take stronger roles in helping older consumers.

Introduction

Most older persons who are asked about their concerns in the area of crime will respond that they are worried about being assaulted on the street or robbed in their homes (Conklin, 1975). However, a similar question put to persons who work with senior citizens will often produce a different response. These workers are most concerned about seniors' potential victimization at the hands of tricksters and con men.

There are currently few reliable statistics to back up the feelings of service providers and practitioners that older Americans are especially vulnerable to white collar crimes. Statistics are lacking partly because these kinds of crimes are seldom reported to the police. What is clear, though, is that the list of confidence artists who perpetrate frauds on older Americans is a long one. Unscrupulous characters have worked in door-to-door sales, real estate, hearing aid sales, quack medicine, home repairs, "miracle" drug firms, medical insurance, funeral services, and the like.

Vulnerability to Consumer Fraud and Its Impact

In his book, Why Survive? Being Old in America, Dr. Robert Butler, director of the National Institute on Aging, asks "Why are the elderly so susceptible to fraud?" Clearly, age alone does not make people susceptible. However, Butler states that a number of age-related factors contribute to making older persons particularly vulnerable. These include: physical problems, pain or anxiety, loneliness, grief and depression, the fear of aging and death, lower educational level, and poverty.

Chronic physical problems can increase one's susceptibility. Poor vision may prevent people from reading the "fine print" in contracts, while hearing impairments may make them miss part of an explanation. Although rarer, intellectual judgment can be impaired by organic brain damage, or simply by a high level of anxiety, either of which can produce confusion, memory loss, and disorientation. And a great desire to restore one's physical health and avoid pain at any cost increases susceptibility to medical frauds and quackery.

The loneliness of some older persons who have lost spouses, friends, and relatives, and who live alone, may also contribute to their vulnerability to friendly, understanding salespersons. Moreover, a person alone has no one to consult with before making a big purchase. The social isolation that accompanies loneliness also makes people more prone to victimization. This social isolation can be directly related to suggestibility, a quality which con artists and fraudulent rip-off artists seek in their potential victims.

A recent research project on consumer fraud, however, has suggested that at least some of the commonly-held beliefs that portray older persons as especially vulnerable to fraud are due more to stereotyping than to fact. The study, conducted by the Battelle

Law and Justice Study Center in Seattle, Washington, compared consumer complaints of older persons with a random sample of complaints from a matched group of younger consumers. The researchers found the two sets of complaints were very similar and that there was no evidence of a pattern of fraud directed specifically at the elderly. In fact, the study concluded that most older consumers were self-reliant, well-informed, and less likely to be tricked or duped than they were to be dissatisfied with simple purchase transactions and repair situations (Battelle Law and Justice Study Center, 1978b).

The findings of this study offered two additional lessons about the link between many age-related characteristics and victimization by consumer fraud:

That one need not be poor, uneducated, sick and alone to be the victim of consumer fraud and abuse . . . (T)he situation of having a comfortable to good income in one's advanced years, of being well-educated, active and healthy does not necessarily confer an immunity to consumer fraud and abuse, victimization . . . While such factors as poverty, lack of education, loneliness and illness may be associated with certain types of victimization, they are not necessary pre-conditions for all forms of consumer fraud and abuse (Battelle Law and Justice Study Center, 1978b:12).

Despite these conclusions, the researchers still found that some personal characteristics are important in consumer victimization because they can predict a consumer's participation in certain kinds of transactions. For example, because older people often reside in old homes in need of repair, they may be likely to be drawn into home improvement deals. Because they have increasingly common chronic maladies, they may be more likely to become involved with medical quackery. And their restricted mobility makes them more likely to deal with door-to-door salespersons or mail order firms, vendors who are traditionally linked with the possibility of fraud.

Perhaps older Americans are not the helpless prey-to-con-artists which some would have us believe. The Battelle study and others have confirmed, however, that the impact of consumer fraud is greater for the elderly than for the younger victim. Just as burglary or robbery can have a terrible impact on an older person because of fixed income, so can consumer fraud. As the authors of the Battelle study put it:

The economic loss associated with a consumer abuse may be devastating to an older person, sometimes because of its magnitude, but more often because of its relationship to the static financial condition of the aged . . . Hardships or inconveniences imposed upon older persons by (consumer abuses) may extend the impact of unsatisfactory transactions over time and in dramatic ways . . . Abuses which involve an element of intimidation of the consumer may serve to take what is essentially a nonviolent form of

victimization and make it a particularly harrowing, and terrifying experience (Battelle Law and Justice Center, 1978b:70).

Because of this impact, it is especially important that older persons be informed about the various possibilities for fraud so that it can be avoided. Moreover, older persons who have been victimized by consumer fraud may be as much in need of victim assistance counseling as victims of violent crime. Their experience with this kind of crime may shake their security as much as a confrontation with a mugger, if not more so.

Types of Consumer Fraud and Con Games

In this chapter we will focus on two of the most common types of fraud.

Consumer Fraud

Consumer fraud refers to illegal transactions between vendors and citizens, transactions in which there are false claims or misrepresentations, overcharging, or failure to deliver goods or to return a deposit. Obviously, the majority of merchants in the marketplace are honest and fair with customers. Consumer fraud cases involve a greedy minority who take advantage of the uneducated, naïve, or unwary.

Con Games

Con games are those schemes perpetrated against citizens by "nonlegitimate" hucksters--the confidence artists--who are not shielded by any professional ethics or business identity. Rather, they use their persuasive powers in "scams" and other types of swindles to gain the confidence of people and separate them from their money.

The losses suffered by victims of these crimes is apparently substantial. As examples, in a recent year in California, 117 cases of a con game called "the pigeon drop" were reported, with a total loss of \$362,000; and 24 "bank examiner" cons were reported with an average loss of \$5,169. Most importantly, police estimated that five cases occurred for every one reported.

Every citizen--old or young--is a potential victim of consumer fraud or con games. The people who commit these practices, both illegal and unethical, rely for success on people's normal desires to be healthy, wealthy, befriended, secure, and ultimately to get something for nothing (or for very little). To achieve their goals, these people try to convince their targeted victims of two points: that the would-be victims really want something, and that what the con artist has to offer will satisfy that desire. Their main advantage is the consumer's lack of knowledge.

The Key to Prevention of Consumer Fraud: Awareness

As already mentioned, consumer frauds are committed against all ages of our population, but the elderly may be particularly vulnerable to certain frauds. Kinds of fraud which frequently involve older persons include:

- Home repair and improvement schemes
- Medical quackery
- Insurance fraud
- Hearing aid sales practices
- Land sales schemes
- Funeral Practices
- Door-to-door, mail, and other consumer frauds

In the following section, we will highlight these seven major areas of consumer fraud affecting older persons, and will present guidelines for avoiding these kinds of shady practices. The references listed at the end of this chapter provide fuller details on these and other consumer problems of the elderly.

Home Repairs and Improvement

Home repair and improvement schemes are one of the most common frauds committed against all age groups. This consumer fraud can take various forms. Some people do not actually repair the defect but charge for it anyway. Some use inferior or phony parts. Others charge the customer for unnecessary work. Some even guarantee future work--they repair one problem, but arrange things so that something else will malfunction later.

Home improvement schemers, like other fraudulent businesspersons, often offer a deal "too good to be true," like performing extensive repairs for a very low price. Another common come-on line is that they "just happened to be in the area and noticed a possible problem." Often they will ask for partial or full payment in advance, then never deliver the service or do a shoddy job that only "looks good." Others may not ask for payment in advance, but will offer to do the repair or improvement work on the spot. After they are paid and leave, the consumer will discover a faulty repair job, no repair job, or a problem that never existed. A favorite tactic of these fraudulent outfits is to offer "free inspections" or surveys. Usually these inspections turn up the need for many expensive repairs. And then the cycle starts.

Older community residents and those who work with them should be alerted to some of the most common homeowner frauds: the bug inspector who may spread some termites or roaches around the home so he can show the homeowner that there is a problem; the driveway

sealer or roofer who notices some weaknesses in the driveway or roof; the soil seller who offers to cover the garden or lawn with top-quality soil, which is actually fill dirt or something worse; the free-lance trimmer who ends up trimming "everything" and then charges an exorbitant fee; and furnace or wiring "inspectors" who offer free inspections, then recommend extensive repairs. Home improvement schemers have even gotten into the crime prevention field, telling older homeowners that crime is rising in the neighborhood and they need a top-notch electronic burglar alarm.

It is easy (and typical) to believe that "this would never happen to me." However, fraud works because people do not recognize it until the job is done. To stop these home repair and improvement frauds, older homeowners need information. An aware homeowner is less likely to be taken advantage of. To avoid a home repair rip-off:

- Get several detailed written estimates for any work. Ask friends, neighbors, or relatives for recommendations of good firms or people. Compare job descriptions and materials on the different estimates. Find out if companies charge for estimates before you ask for one.
- Ask for old parts or equipment to make sure that replacements were really installed.
- Be sure to get a guarantee in writing for any work that is done.
- Before paying repairmen, inspect the work to make sure that it was done properly. Pay only in installments and never with cash. If paying in installments, carefully check the interest rate you will be paying.

Medical Quackery

Medical frauds and deceptions aimed at older persons are a growing industry, one costing older people millions of dollars every year. For example, it has been estimated that for every dollar spent on research on arthritis, as much as \$25 is spent on fraudulent home remedies or mail-order products by persons who are disappointed in their doctors' inability to cure their malady.

Arthritis patients are probably the most common target of fraudulent healers who promote "antidotes" such as copper bracelets, special beds, special diets, super vitamins, mineral baths, linament, and "super" aspirin. In fact, some of these aids may temporarily relieve the symptoms of arthritis; but none can cure the disease, since there is no known cure for it.

Other medical ailments upon which quacks thrive include anemia, bunions and corns, and cancer. They also promote: home repair kits for dentures, special diets, hair replacement lotions and creams, "super" laxatives, and all kinds of "miracle" gadgets.

The normal, chronic ailments of aging produce quite a few willing customers for these "sure cures."

The best way to avoid being victimized by quacks is to use common sense. However, there are other guidelines which senior citizens can be given to reduce further their chances of being conned by these phony medical schemes.

- Check with doctors, local health clinics, or medical societies before buying any medical "cures." Do not take a stranger's word.
- Do not trust anyone to diagnose and cure diseases through the mail.
- Go only to the medical laboratories and clinics recommended by a doctor or hospital.

Insurance Fraud

A related area of questionable ethics is health insurance. Many elders worry constantly about getting sick or being hospitalized and not having the money to pay the expenses that Medicare will not cover. In the last several years, companies have been advertising health insurance to cover such gaps. Cancer insurance is one example of an insurance which has been promoted through scare tactics and which is a very bad investment, according to a recent congressional study (U.S. Congress, House Select Committee on Aging, 1980). Many of these "medigap" policies have fine print which limits their coverage or provides coverage which duplicates Medicare, even though the policy states only one insurer will pay. It is best to take protective steps before signing any of these policies. Check with the State Insurance Commission, the Better Business Bureau, a local consumer affairs office, or a lawyer. The federal government is also setting up a voluntary certification program for the supplemental insurance industry. Soon it will become obvious to consumers which insurance policies adequately fill Medicare's gaps.

Hearing Aids

Hearing deficiencies affect millions of older people and as a result hearing aids--both good and poor ones--have become a big industry. For convenience or to save money, many elderly people do not use audiologists (trained hearing specialists) or otologists (medical doctors specializing in ear care) but instead rely on the advice of high-pressure door-to-door salespeople. These merchants offer in-home "testing," low prices, installment payments, and quick access to a choice of hearing aids.

There are, of course, many reputable and honest hearing aid dealers, but sometimes it is difficult to separate the honest ones from the dishonest ones. In recent years, federal regulations have lessened people's chances of being conned. The Food and Drug

Administration's regulations, which have been effective since August, 1977, require all hearing aids to be clearly and permanently marked with: the manufacturer's name, the year the hearing aid was made, and a "+" symbol to show the positive battery connection. Additionally, Federal Trade Commission 1979 regulations stipulate that hearing aid dealers must offer a trial period for customers to decide whether the device they have bought is right for them. Older consumers should know that contracts for hearing aids are cancellable within seven days, regardless of whether the hearing aid is bought at home or in the dealer's office.

There are other steps which seniors can take to reduce their chances of being taken advantage of.

- Check with your doctor if considering buying a hearing aid.
- Remember that reputable audiologists never go door-to-door to sell hearing aids.
- Check the reputation of a prospective hearing aid dealer with a doctor, consumer protection agency, or the Better Business Bureau.
- Shop around before buying a hearing aid. Make sure that the quoted price includes everything, including the ear mold for fitting the hearing aid. Check for a comprehensive guarantee. Ask for written instructions for using and caring for the aid.
- Be careful about signing medical waivers. Hearing aids can be sold in some states without prescriptions, if the buyer waives a medical exam. And, unfortunately, some unscrupulous dealers try to sell hearing aids for ailments, like nerve deafness, which cannot be helped by such devices.

Land Sales

Overpriced, underdeveloped, and sometimes worthless land has been bought by older people who are looking for a comfortable place for their retirement years. Using hard-sell tactics or inducements like gifts, free gas, and parties, developers try to conceal the land's true status by sending deceiving pictures, or describing "planned improvements," and not distributing full financial statements and property reports.

These statements and reports are important documents for a prospective buyer to review. Most land developers offering 50 or more lots (of less than five acres each) for sale or lease by mail or by interstate commerce are legally required to file a Statement of Record with the U.S. Department of Housing and Urban Development (HUD). This record tells prospective buyers most of what they need to know about the site; legal title; facilities in the area like schools, transportation, water, utilities, and sewage; and recreational plans.

In addition to reviewing the HUD report and financial statements, senior citizens who are considering buying land should follow these guidelines:

- Most important of all, view the property or hire a reputable local person to see it for you. Oral promises are worth nothing after a land contract is signed.
- Base the decision on facts, not promises. In the instance of land development, value depends on the developer fulfilling his promises.
- Determine what utilities are available and who will pay for installing them on site.
- Find out the cost of any needed property improvements like sidewalks, sewer or water facilities, and roads.
- Explore the financing and insurance costs for the area, including fire and flood insurance.
- Closely examine all possible added costs, such as property taxes and assessment for maintenance of common grounds.
- Always look into drainage and water conditions.
- Have a lawyer of your choosing review the land contract before signing it. Customers signing installment contracts receive neither title nor deed to the land until all payments are made. Those acquiring deeds with mortgages are liable for all property taxes as soon as they take title.
- Do not trust the fast-pitched gimmicks of land salespeople, things like estimates of current land appreciation, announcements of "tremendous" current sales, and any "free giveaways."

Funeral Practices

Perhaps the most vicious frauds committed against older Americans are those which take advantage of the grief of the recently widowed. Perpetrators include people who mail merchandise to the home saying they were ordered by the deceased, those who mail phony bills to the deceased, or people who pose as "cemetery agents" to demand payment for fulfillment of "official" procedures and regulations.

Most funeral homes or parlors are operated by honest and ethical business people. They base their business on neighborhood reputations. Unfortunately, there are also those who run fly-by-night operations which try to cheat mourning people out of all they can. Such people operate out of casket showrooms, hire part-time embalmers, rent funeral halls and hearses by the day or the hour, and persuade mourners to buy expensive caskets at exorbitant prices.

The average person is liable to fall victim to such frauds because of the lack of objective judgment which can accompany grief. Therefore, elderly persons who want to reduce their chances of falling prey to these schemers are advised to take these precautions:

- Plan in advance. Decisions about the funeral ceremony, casket, and burial are better made prior to a death, under nonemotional circumstances, than after a death has occurred.
- Do go comparison shopping. As with other purchases, it can save money. Review any contract in detail and be sure all terms and conditions are clearly understood.
- After selecting a reputable funeral home, leave written instructions for funeral arrangements.
- If plans have not been made in advance, take along someone who is further removed from the deceased and can be more objective to help make funeral arrangements.

Most states, as well as some counties and cities, have funeral directors' associations or cemetery boards. Any senior citizen who believes that she or he has been cheated can contact such groups. In addition, the older person can involve the local consumer protection agency.

Door-to-Door Mail and Other Consumer Frauds

The schemes described in this chapter represent only a small sampling of a seemingly limitless number to which senior citizens are exposed. Other types of fraud which are prevalent include: investment or business opportunity frauds which offer the "chance of a lifetime" to buy into a new venture that often only exists on paper; self-improvement frauds which promise miraculous changes with little or no effort; "Lonely Hearts" clubs, which provide companionship and excitement, but obviously not for free; charity frauds which collect for persons in need--usually those persons doing the collecting; door-to-door sales that offer inferior products on installment payments with astronomical interest rates; "pyramid" letters that require the recipient to mail money to a certain number of people; mail fraud, where an offer of something for nothing results in getting little or nothing for something; bait and switch, where merchandise which was advertised is criticized or unavailable, but a higher-priced version is available; and credit card scams which employ ruses to have the victim disclose his or her account number on a credit card, and which result in charges for expensive goods ordered by telephone or by mail using that number.

Tips for Avoiding Consumer Fraud

In these schemes, and all others, the keys to prevention are to stop and think, use common sense, and ask for the advice of trusted friends, relatives, or professionals. Other tips which can

apply to all areas of consumer fraud include:

- Remember the Cooling Off Period Door-to-Door Sales regulation by the Federal Trade Commission. Whenever one makes a purchase in the home totaling \$25 or more, the salesperson has to give the customer a written contract and two "Notice of Cancellation" forms. The customer has three days to change his mind and use one of those forms to cancel the contract.
- If in doubt, wait and think about it. This provides time to weigh advantages and disadvantages, check with other sources, and compare other prices. Delay will never void a good deal or send away an ethical salesperson.
- Read any contract before signing it. Be sure to understand all the language and conditions and check to see that all the blanks are filled in. If something is unclear, do not depend on the salesperson's explanation; ask for time to consult with an attorney or someone else. If the salesperson makes certain promises, make sure they are written into the contract.
- Obtain a receipt for all transactions.
- Check on the reputation and history of all salespeople or companies with the local consumer affairs office before authorizing any contract work or signing a contract. Ask for references and check them.
- Always be suspicious of high-pressure sales efforts.
- Comparison-shop for all services or products.
- Pay by check rather than by cash. This will provide a written record of the transaction. Always make the check out to the company and not to the salesperson.
- Beware of false or misleading advertising concerning discounts, sales, or free gifts. Compare these "bargains" with merchandise at other businesses.
- Remember these four questions every time you are thinking over any proposed transaction:
 - What are the facts and do they parallel the agent's representation of the product or service?
 - What are the promises or predictions being offered; are they reasonable ones?
 - What is the past record of the company or the salesperson; does that record merit confidence?
 - Does it feel like the deal is being rushed?

Most business people, merchants, and companies are honest and are committed to serving consumers. The tips contained in this section are not intended to alarm elders, but to alert them to the potential for fraud in today's business world. Awareness--knowledge and sound judgment--can do much to defeat both con artists and fraudulent business people.

The Key to Prevention of Con Games: Awareness

Con games which are perpetrated upon older persons all have one primary goal; to use people's own gullibility and greed to obtain their money.

For law enforcement and crime prevention specialists, one of the most frustrating aspects of con games is that new and more sophisticated scams are continually being devised to take advantage of people. For example, a recent scheme used effectively against older persons has involved someone posing as an agent of the Internal Revenue Service to collect "back taxes" from a newly bereaved widow or to extort money following a phony tax audit. Another recent scam involved con artists who posed as police officers investigating an outbreak of fraud cases. Older persons have entrusted their valuables to these "detectives" to have them inventoried and dusted with ultra-violet powder, never to see them again.

Several types of confidence schemes, often aimed at senior citizens, have been publicized widely for a number of years but still continue to claim new victims. These are briefly described here. More can be learned about them from the resources listed at the end of this chapter.

The Bank Examiner

Con artists seeking to execute this scheme frequently select single or widowed elderly females as targets by getting their names from telephone books or mail boxes. First names are popular in cycles, and con artists sometimes can guess another's age by that person's first name. Information can also be gained from discarded deposit or withdrawal slips at the bank.

One or two people contact the intended victim by telephone or in person. The swindlers usually identify themselves as bank officials or police and explain that they are trying to apprehend a dishonest bank teller. They ask the victim to help by going to the bank and withdrawing money from a particular teller. After the victim puts the money in an envelope, the con artists meet him or her outside the bank or back at home.

The "bank examiner" then shows the victim some fake identification, and may even pay the victim a small sum for his or her help. He then offers to return the victim's money to the bank, or asks to take the money, temporarily, to check the serial numbers. Often he gives the victim a "receipt" for the money, then takes the cash and leaves, all the while being courteous and appreciative.

He tells the victim to check the account in several days to make sure the new deposit is recorded. Only after contacting the bank and learning the money has never been returned does the victim realize he or she has been conned.

The Pigeon Drop

In this scheme, the victim is approached by the first of two con artists. After this person has gained the victim's confidence, another person appears. One of the team displays a large amount of cash in an envelope, explaining that he or she just found the money. Frequently, there is a note with the money, indicating that it was obtained through gambling. (This taints the money and gives the impression that the loss would not be reported to the police.)

The con artists then raise the issue of what to do with the money. One explains that he or she works for a reputable businessperson or a lawyer and will ask their employer what to do. After a short absence, the person returns to say that the boss suggested the three divide up the money equally.

However, the employer has also suggested that each person put up some money to show "good faith" before obtaining a share. One variation on this scam asks the victim to hold all of the "earnest money." To demonstrate that he or she does not need the found money to live on, the victim is usually asked to produce at least one-half of the money involved. When one of the strangers takes the envelope with the victim's cash to add his or her own, a switch is made and the victim is handed an identical envelope, which contains play money or just cut paper.

In the second variation, the boss is chosen to hold the funds: After the victim withdraws funds from the bank, one of the two strangers may take the money to the boss for counting, then direct the victim to the boss's office to obtain his or her share. This office turns out to be an empty lot or another fictitious address.

Tips for Avoiding Con Games

Community elders can avoid these and similar con games by using proper precautions and good sense. The following procedures will reduce one's likelihood of being conned:

- Check the identification of strangers before any kind of business deal. Call their company or agency to see if they are legitimate; look up their company in the phone book rather than calling a phone number they supply.
- Never withdraw cash from the bank at the suggestion of strangers, no matter how friendly they seem.
- An offer of something for nothing, or at a surprisingly low price, is a good tip-off to a con game.

- Do not get involved in anything where large sums of "good faith" cash are involved.

The only way the police can apprehend con artists is with good information supplied by the victim. Unfortunately, many citizens do not report these victimizations because they are embarrassed or feel guilty about having been duped. Yet, if the police are notified immediately, they will have a greater chance of catching the con artists, who may still be in the area running their con on other unsuspecting citizens.

Besides calling the police, the older victim should notify the local District Attorney. Many District Attorneys now have special consumer fraud or economic crime units which work with the police in attempting to catch and convict con artists.

Remedies for Victims

Again, once a fraud or con game has been committed, it is extremely important to report it to the authorities, so that it can be investigated and so that any patterns of fraudulent practices can be brought to light. It may well be too late or impossible to get one's money back. But, depending on what has occurred, the victim should contact agencies such as the police, the District Attorney, the Better Business Bureau, the Chamber of Commerce, the Consumer Affairs Office, and the State Attorney General's Office. At the least, this may prevent other older people from being victimized. Some communities have dispute resolution or mediation centers, sometimes called neighborhood justice centers, where trained mediators try to reach a compromise acceptable to both parties in a dispute.

It is advisable for consumers to complain loudly to the company with which they have a complaint. Sometimes a salesperson's or company's mistake looks very much like fraud. If it is a mistake or a dishonest practice by an individual salesperson, the company may be anxious to settle the complaint.

Collective Action against Consumer Fraud and Con Games

Actions against con games and fraud by individual citizens become much more effective when they are combined with activities sponsored by agencies or groups of citizens. For example, a group of concerned citizens in Philadelphia began a campaign to alert its citizens to the latest con games and fraudulent practices in the city by issuing regular bulletins which received wide publicity in the press and media. Other suggestions for kinds of collective activities follow.

- All agencies serving seniors, including employment programs, homemaker services, senior centers, nursing programs, and nutrition programs, can provide consumer education to clients and serve as referral agents for seniors they encounter who have been victimized by a con game or fraud.

Ageing-related agencies can train existing staff members in consumer protection skills and designate one or more as consumer protection workers; alternatively they can arrange to have a representative of the local consumer affairs office make regular visits to senior centers to answer people's complaints, help resolve problems, and provide education.

- Senior citizen organizations can lobby for representation in local, state, and national consumer organizations such as the Consumers Union, the Consumer League, and the Consumer Federation of America.
- A wide range of professionals can take a stronger role in educating and helping older consumers. For example, ministers can play an active part in advising about funeral arrangements, doctors and clinics can actively warn older patients against fraudulent and common phony remedies, and social workers can take an active part by providing information on good consumer habits.
- Coalitions of elder-serving agencies and senior citizens organizations can lobby for stronger legislation and enforcement of anti-fraud measures.
- Organizations can sponsor regular consumer education through the media, and can conduct seminars in accessible places like senior citizen centers, block clubs, tenant councils, or homeowner association meetings.
- Consumer education programs can be made more effective by employing "different" techniques, such as comparative shopping trips, group case studies, group analysis of newspaper and junk mail advertisements, and trips to the consumer protection agency.
- Consumer education programs can be most useful if based on the desires and needs of the seniors themselves. Agencies can survey their intended audience in order to pick from the many potential topics. These include:
 - Credit Contracts
 - Intelligent Buying Techniques
 - Health Insurance
 - Investments
 - Consumer Fraud
 - Door-to-Door Solicitation
 - Telephone Solicitation

- Guarantees and Warranties
- Promotional Games
- Consumer Protection by Local, State and Federal Agencies
- Consumer Legislation
- Consumer Action and Organization
- Repair Services
- Medical Care
- Funeral Costs

Agencies can work with local banks to train officers and tellers to recognize the warning signs of a con game so that they can intervene to prevent them.

These are steps that can be taken to protect seniors from economic exploitation. They are merely suggestions. The range of different strategies, community linkages and coalitions, and educational campaigns is limited only by the imaginations of the planners, administrators, older community members, and interested citizens working together to raise the awareness levels of elders and lower their victimization rates.

Reading and Resources

Anastasi, Anthony J., Gail Chipman, Charlotte Nyheim and Dan Ramelt, Consumer's Resource Handbook, Washington, DC: The White House Office of the Special Assistant for Consumer Affairs, 1979.

Battelle Law and Justice Study Center, Consumer Fraud and Abuse: Problems of the Elderly in the Marketplace: A Glossary of Terms and Annotated Bibliography, Seattle, WA: BLJSC, 1977.

Battelle Law and Justice Study Center, Final Report: Consumerism and the Aging: The Elderly as Victims of Fraud, Seattle, WA: BLJSC, 1978a.

Battelle Law and Justice Study Center, The Impact of Fraud and Consumer Abuse on the Elderly, Seattle, WA: BLJSC, 1978b.

Bingham, Barbara, "The Pigeon Drop: The Con Game Aimed at Older Women," Retirement Living, Vol. 15, September, 1975.

Boughourian, Gay and Alcantara, "Gypsy Confidence Schemes," Police Chief, June 1975.

Butler, Robert N., Why Survive? Being Old in America, New York: Harper and Row, 1975.

Conklin, John E., "Robbery, the Elderly, and Fear: An Urban Problem in Search of Solution," Jack Goldsmith and Sharon S. Goldsmith, Eds., Crime and the Elderly: Challenge and Response, Lexington MA: D. C. Heath and Company, 1975.

Dadich, G., "Confidence Games: Crime, the Elderly, and Community Relations," Police Chief, February, 1977.

Drury, Teresa Way and William L. Roper, Consumer Power, Los Angeles: Nash Publishing, 1974.

Ducovny, Amram, The Billion \$ Swindle: Frauds against the Elderly, New York: Fleet Press Corporation, 1969.

Edelhertz, Herbert, The Nature, Impact and Prosecution of White-Collar Crime, Washington, DC: U.S. Government Printing Office, 1970.

Farace, Theodore and Camera, "Confidence Games," Police Chief, January, 1975.

Federal Trade Commission, Division of Special Projects, Funeral Industry Practices: Proposed Trade Regulation Rule and Staff Memorandum, Washington, DC: Bureau of Consumer Protection, FTC, August, 1975.

Geis, Gilbert, "Defrauding the Elderly," Jack Goldsmith and Sharon S. Goldsmith, Eds., Crime and the Elderly: Challenge and Response, Lexington, MA: D. C. Heath and Company, 1976.

"Health Insurance for Older People: Filling the Gaps in Medicare," Consumer Reports, January, 1976.

Laverne-San Dimas Junior Women's Club, "Operation Con Game," San Dimas, CA.

Magnuson, Senator Warren G. and Jean Carper, The Dark Side of the Marketplace, Englewood Cliffs, NJ: Prentice-Hall, 1968.

Mendelson, Mary Adelaide, Tender Loving Greed: How the Incredibly Lucrative Nursing Home "Industry" is Exploiting America's Old People and Defrauding Us All, New York: Alfred A. Knopf, 1974.

Springer, John L., Consumer Swindlers and How to Avoid Them, New York, NY: Henry R. Regnery Co., 1970.

"Target the Elderly," Boston, MA: Consumer Affairs Foundation and Better Business Bureau, 1979.

Trump, Fred, Buyer Beware! New York, NY: Baingdon Press, 1965.

U.S. Congress, House Select Committee on Aging, Cancer Insurance: Exploiting Fear for Profit, Comm. Pub. No. 96-202, Washington, DC: U.S. Government Printing Office, 1980.

- U.S. Congress, House Select Committee on Aging, Confidence Games against the Elderly - Hearing, Washington, DC: U.S. Government Printing Office, January 13, 1976.
- U.S. Congress, Senate Special Committee on Aging, Subcommittee on Consumer Interests of the Elderly, Consumer Interests of the Elderly - Hearings, Part I, January 17 and 18, 1967, Washington, DC: U.S. Government Printing Office, 1967.
- U.S. Congress, Senate Special Committee on Aging, Subcommittee on Frauds and Misrepresentations Affecting the Elderly, Deceptive or Misleading Methods in Health Insurance Sales - Hearing, Washington, DC: U.S. Government Printing Office, May 4, 1964.
- U.S. Congress, Senate Special Committee on Aging, Frauds and Quackery Affecting the Older Citizen - Hearings (3 parts), Washington, DC: U.S. Government Printing Office, January, 1963.
- U.S. Department of Justice, Law Enforcement Assistance Administration, Take A Bite Out of Crime: How Not to Get Conned, Washington, DC: U.S. Government Printing Office, 1979.
- U.S. Postal Service, "Postal Inspection Service--Law Enforcement Report," Washington, DC: U.S. Postal Service, 1977.
- Waddell, Fred E., Ed., The Elderly Consumer, Columbia, MD: Antioch College, The Human Ecology Center, 1976.

Recommended Films on Con Games and Consumer Fraud

KEY: A = Abstract
C = Critique of Film for Suitability for Senior Citizens

THE BUNCO BOYS, Motorola Teleprograms, Inc., 3710 Commercial Avenue, Northbrook, IL 60062, (800) 323-5343, Producer: William Brose, 21 minutes, 16 mm., color, \$50/week.

A: The film portrays the "cons" which are often used against the elderly: the bank examiner, the pigeon drop, and the charity switch. Emphasized are the three G's: gullibility, greed, and goodness--which end up being the victim's downfall.

C: The film is unique in that each vignette has a happy ending, as the victims gain their wits and call the police. The viewer is spared the agonizing scene when the victim realizes his/her loss and suffers the pain of embarrassment and shame. An excellent omission! Recommended for suburban elderly.

ON GUARD: BUNCO, 1970, Aims Instructions Media, P.O. Box 1010, Hollywood, CA 90028, 27 minutes, 16 mm., color, \$330.

A: The film's objectives are to learn the modus operandi of bunco artists and to make the viewer aware of his/her own susceptibility. Both are accomplished--by pointing out that

that the actions of the criminal and the victim are both motivated by a human characteristic: greed. Four types of bunco schemes in suburbia are enacted. Bank embezzler, encyclopedia salesman (contract), phony home repair, and pigeon drop are covered. The victims are given a second chance to replay the incidences and act wisely and cautiously.

- C: The actions of criminals and their victims are realistic and interesting. The film is interesting and enlightening--intended to teach but not to scare.

Chapter Nine

Community Crime Prevention

U

Chapter Nine

Community Crime Prevention

Advance Organizers

- Individual efforts in crime prevention like increasing consumer awareness of fraud techniques or target hardening one's residence are only part of the total approach needed to combat crime against elders. Group efforts should complement those of individuals. Community crime prevention, however large or small the "community," helps to reduce the elder's sense of confronting crime alone.
- Because community crime prevention strategies depend upon people interacting with each other in facing a common problem, the individual's fear of crime tends to be lowered, while quality of life may be raised.
- Community crime prevention is necessary for a number of reasons: the already heavy responsibilities of the police; the fact that crime affects others in the neighborhood besides the victim, psychologically and financially; the reality that group efforts lighten the individual's burden, relieving some of the pressures of crime prevention implementation and some of the fears of criminal retaliation; the need to bring elders out of isolation.
- Older residents are often ideal for a community crime prevention program because: they tend to have lived in the neighborhood a long time and to have developed an attachment to it; they are usually free during the day to work in the program; they are less transient than younger members of the community, thus giving the program consistency; and the program requires positive action which in itself tends to relieve isolation and fear.
- Developing a successful community crime prevention program involves (1) an effective needs assessment focusing on the specific crime problem of the neighborhood and the needs of its residents, (2) identifying available resources in the community, for example, an existing apartment building tenants association, (3) recruiting others and organizing an initial meeting of concerned citizens, (4) creating a basic unit of involvement, a block club or floor club.

- The most effective crime prevention strategies employed by block or floor clubs are Neighborhood Watch, citizen patrols, tenant patrols, "buddy buzzers," whistle or airhorn programs, anonymous surveillance projects, telephone reassurance, escort services, court monitoring, and group lobbying.
- Most community programs do not require large amounts of money to succeed. The time and energy of concerned citizens are the basic ingredients of success.

Introduction

In previous chapters on street crime, residential crime, and consumer fraud, the focus has been on actions that older persons as individuals can take to reduce their chances of being victimized. However, these individual actions comprise only part of a total crime prevention approach. The other essential component is community crime prevention, in which citizens act together to confront crime in their neighborhood and their community. A Presidential Commission on Criminal Justice, studying ways to combat the country's crime problems, recognized the importance of this approach when it noted:

Important as it is, individual action independent of the efforts of others is not enough. Our society is built upon the premise that each person is responsible for himself and for the general welfare of others. Exclusive reliance on a self- or family-oriented approach to crime prevention causes individuals and family units to become isolated from one another. The result is that the crime prevention effectiveness of the community as a whole becomes considerably less than that of the sum of its parts . . . Without a sense of community, the crime prevention potential of mutual aid and mutual responsibility is unfulfilled (U.S. Department of Justice, National Advisory Commission on Criminal Justice Standards and Goals, 1974:10).

This community emphasis on controlling crime is not new; it existed long before our modern-day reliance on law enforcement agencies and has been revived in response to citizen demands for a safer environment in which to live. It is not possible, and probably not even desirable, to put a police officer on every street corner. The concept of community crime prevention reinforces a group responsibility for combatting crime; it provides support and assistance to the police by organizing citizens concerned for their own safety, for that of their neighbors and their property.

Goals of Community Crime Prevention

The goals of community crime prevention activities, like those of individualized strategies, are to lessen people's fear of crime and the likelihood that they will become crime victims. However, community crime prevention can produce another important result: the development of a neighborhood cohesion or unity which enables citizens to address many common concerns besides crime. A likely sequence of events leading to these outcomes might be: citizens become aware of their responsibility for crime prevention; they form neighborhood organizations to focus on their crime concerns; interactions among neighbors increase and they gain a familiarity and sense of community; they begin cooperative ventures against crime problems as well as other problems of mutual concern. In theory, the end of this process is that people will feel safer, be more likely to use their streets, and be more willing to go outside at night, and this active presence in the neighborhood can act as a real deterrent to criminal activity.

Reasons for Community Crime Prevention

Some people are not interested in becoming active in community crime prevention. As one older New Yorker explained at an anti-crime conference several years ago: "I don't want to cooperate with my neighbors and I don't want to know them. I just want them to leave me alone." It is this kind of penchant for privacy and suspicion of one's own neighbors that has led some elders to fortify themselves in their homes and apartments, while calling simultaneously for added protection by the main group charged with preventing crime--the police.

However, it is clear that the police alone cannot prevent crime. They simply do not have the time and resources to take on full responsibility for preventing crime in addition to their responsibilities to maintain order, enforce all laws, guarantee citizen protection, and apprehend criminals. Although the budgets for law enforcement now amount to about 65 percent of local criminal justice expenditures, they still only provide a few police officers for every 1,000 citizens (U.S. Department of Justice, Law Enforcement Assistance Administration, and U.S. Bureau of the Census, 1978). Even with more money, it is unlikely they could do the whole job. As the National Advisory Commission on Criminal Justice Standards and Goals stated:

Criminal justice professionals readily and repeatedly admit that, in the absence of citizen assistance, neither more manpower nor improved technology, nor additional money will enable law enforcement to shoulder the monumental burden of combatting crime in America (U.S. Department of Justice, National Advisory Commission on Criminal Justice Standards and Goals, 1974:1-2).

The heavy responsibilities of the police are only one reason why citizens need to get involved in crime prevention. A crime prevention program in Minneapolis, Minnesota, which conducted community crime prevention activities in all kinds of neighborhoods, reviewed its experiences and cited other reasons for people becoming active in community crime prevention:

- Because crime is more than an individual's problem.
 - A crime and housing values study conducted in Minneapolis indicated that when there is crime in a neighborhood (say, the size of a census tract), the value of every house in that neighborhood is depressed (\$533 for every one percent of residential burglary in a year and \$172 for each incident of vandalism per 1,000 population in a year) (Frisbie et al., 1977).
 - Therefore, while you may never have been a victim of either of these crimes you are being affected if you live in a neighborhood where crime is occurring. Even though property values are going up, they're not

going up as much as they could in neighborhoods with high percentages of crime.

- Crime attracts crime; if offenders get the impression that an area is "easy pickings," they'll spread the word.
- Because it's too big a job to tackle alone.
 - One person can't do it alone (just as the police can't do it alone); it's a task that requires many watchful eyes and much cooperation.
 - An individual tackling the crime problem alone often means that the individual will "target harden" his home; while good security is important (indeed, essential), if that is all that is done, an individual can become further isolated and afraid.
 - Locks, even good ones, only delay an offender who is determined and skillful enough to get in. Even the best security can be defeated if the offender is given enough time and enough privacy. But good security can deter and delay an offender long enough for watchful neighbors to call the police.
- Because there is strength in numbers and two heads are better than one.
 - If people learn that others share the same problems and fears, they can put their heads together to solve them. There are many ideas and many talents in a block (or an apartment building) that can be used in solving common problems.
 - The task of implementing can be shared and the burden can be lightened.
 - One of the reasons people don't report crimes is that they fear retaliation. But if several people are involved in reporting a crime (or at least support and back up the individual doing the reporting) there are a number of people against whom the offender must retaliate. An individual's fear can be lessened by group support.
- Because people need to be brought out of isolation.
 - Individuals in isolation cannot do much to prevent crime.
 - In isolation, people have lost their freedom of movement; they have given up control of their neighborhood to whomever wants to take control. Those who want to take control are aware of their power over isolated

individuals.

- Out of isolation, people can begin to take control, to cooperate, to feel part of something, to make new friends, and to increase their own sense of security and well-being (Minnesota Crime Prevention Center, 1978:1-4).

The reasons cited by the Minnesota program for why community crime prevention should work become even more convincing, because they are backed up by some recent research findings which indicate that, in fact, community crime prevention does work. Findings from the evaluation of the Minnesota program and similar programs in Seattle, Washington and Hartford, Connecticut have provided some fairly solid evidence that neighborhood efforts against crime can reduce burglary rates, as well as increase residents' feelings of safety and improve relations with the police (Minnesota Governor's Commission on Crime Prevention and Control, 1976; Cirel et al., 1977; Hollander et al., 1980).

Another study which interviewed confessed burglars also showed that neighborhood surveillance is effective in preventing burglaries; the majority of the inmates interviewed indicated that just being noticed by a neighbor would be sufficient to deter them and all said that they would leave an area if challenged by a neighbor (Palmer, 1978).

Involving Older Persons in Community Crime Prevention

This handbook is concerned with the crime problems of the elderly and strategies for reducing those problems. When discussing community crime prevention strategies, though, it is clear that elders cannot be treated as an isolated group, but must be viewed as part of the total mini-society in which they reside.

Although older persons usually comprise a small segment of a community, they often live clustered within defined sections of a city, especially in inner-city transitional areas. It is often these elderly urban residents who are most upset by crime, inflation, and the tensions which characterize changing neighborhoods. Their isolation, limited mobility, and high levels of fear of crime can be greatly ameliorated by community crime prevention activities which give them a sense of control over their environment and connect them with friendly neighbors, the police, and neighborhood organizations.

The Geographic Focus of Community Crime Prevention

Since community crime prevention is based on people in communities banding together to address common concerns, most successful programs have found it productive to focus their organizing on the smallest possible "community"--the neighborhood. Even though people today often think of neighborhood identity as a dying concept, a national poll taken fairly recently repudiates that belief. Querying citizens about their feelings for their neighborhoods, pollsters found that: a large majority of people (85 percent) take pride in

their neighborhoods; a majority do not want to leave their neighborhood and nearly 70 percent are certain they will be living there in five years; nearly half (42 percent) belong or would like to belong to a neighborhood organization; one-third already participate in a neighborhood improvement project and believe their involvement contributed to the solution of a problem; and a majority are willing to take direct action in defense of their neighborhood when it is threatened (Christian Science Monitor, 1977).

Sociologists have some evidence that as persons become older, they attach even more significance to the neighborhood where they are living than do younger persons (Regnier, 1975). Because of the importance of the neighborhood to them, and because decreased mobility can cause them to spend more time at home, older persons can provide the backbone of a neighborhood anti-crime effort. And in the end, they may stand to benefit the most from such an effort. These benefits apply to seniors living in cities, suburbs, and rural areas, to persons living in homes and to those living in apartments.

Planning a Community Effort against Crime

Assessing Needs

An effective community anti-crime effort should be neighborhood-based, focusing on the specific crime problem in that neighborhood and the needs and interests of the residents. In a high-crime neighborhood, residents face a range of problems which may include vandalism, juvenile gangs; consumer fraud, burglary, purse snatchings, drug abuse, and prostitution. The initial step in planning community anti-crime activities is simply to identify these local crime problems. Ways to do so using available crime data were described in some detail in the chapter on residential security. If crime data are not available, police officers, such as beat patrol officers who know the neighborhood, may be able to provide a summary "crime analysis." Valuable impressionistic information and advice can also be acquired from local people, including retailers, housing managers, building inspectors, elected officials, and school officials. Conversations with these people and with residents of the neighborhood can provide initial guidance to prioritize these problems, based on how disruptive people believe they are to the neighborhood. The interviews can also uncover other issues in the neighborhood about which people are concerned, and which can also be the focus of a group of citizens who have been organized to improve their neighborhood.

Identifying Resources

The second planning step is the identification of resources in the community. Where a local block or neighborhood organization already exists it can act as the prime sponsor for anti-crime activities in that neighborhood. Many local organizations have a past record of real accomplishments in organizing groups around issues such as housing, economic development, school, or social services. However, they may not have focused on crime prevention, having left

that up to the police. If, for example, an apartment building already has a tenants organization, addressing problems of tenant security in and around the building can be a natural outgrowth of the group's concern for other problems affecting all tenants. The group can use its contacts and resources to sponsor a meeting on the crime problem in the neighborhood and begin the process of organizing other activities at that meeting.

A whole range of other kinds of resources exist in most neighborhoods, which can be tapped for leadership and other kinds of support for a community anti-crime project. They include homeowner associations, public and private agencies, action projects like youth or crisis intervention projects, business organizations and retailers, apartment or housing project owners and managers, schools, local churches and synagogues, union chapters, and local chapters of national organizations like the National Council of Senior Citizens, the American Association of Retired Persons, the Gray Panthers, the National Organization for Women, the League of Women Voters, the U.S. Jaycees, the General Federation of Women's Clubs, the National Council of La Raza, and the Urban League.

Throughout the planning stages of community organizing, the local police can be one of the most valuable resources. Not only can they provide "crime analysis" information, but they can also help organize program strategies, train citizen volunteers, and keep citizens informed on recent crime trends and crime prevention techniques. Additionally, cooperation between citizens and the police can prevent misunderstandings or obstacles later in the program's development.

A word of caution: Cooperative efforts between citizens and the police are not always easy to establish, especially in high crime neighborhoods. Citizens may be suspicious of the police because of their own perceptions of police unfairness or lack of interest in their problems. On the other hand, some police departments are generally distrustful of organized citizen anti-crime activities. They fear vigilante by-products of such efforts, and are concerned about a potentially less-than-professional approach to crime control; it may be that they have had prior experiences with irresponsible citizen groups, and are reluctant to try again.

We should remember, however, that in most communities, even those in which the police are wary of citizen crime prevention programs, a modicum of support can be gained if the police are approached in an appropriate manner. Such an approach is based on a knowledge of the department structure, a recognition of the various police functions, a willingness to compromise on difficult issues, and a desire to "prove" the worth of a community crime prevention effort to the police.

The Basic Unit of Community Crime Prevention: The Block Club

Once the initial planning has been completed, a common strategy

used to bring residents together into groups is to organize block clubs or, in apartment buildings, floor clubs: A block club can be used as the basic structure for initiating a wide range of other anti-crime strategies which can exist under its umbrella. But even by itself, a block club can dramatically reduce the isolation and fear felt by citizens who participate. While size and structure of block clubs may vary, they usually have a block captain, different committees for various subjects, and scheduled meetings. And the means used to set them up is generally similar--through a lot of door-knocking, talking, and hard work.

"Block organizers" can be paid staff of an agency, volunteers, or residents. Their job is to make residents or tenants aware of both existing problems and possible solutions, explain how a block club might address their concerns, and convince people to attend a first meeting!

The key to effective block-club recruitment is interaction; successful organizing is built upon personal, face-to-face communication. The best recruitment efforts are founded on: learning people's own concerns and establishing rapport built upon their self-interest; knowing the facts about the crime problem and being able to explain them; offering the block club concept as a way to solve problems of all kinds, not merely crime problems; being pleasant, enthusiastic, and sincere with residents; and convincing people that the advantages of becoming involved outweigh the minimal loss of privacy and the commitment of time. Sponsorship of the meeting by an accepted neighborhood association will add to the legitimacy of the effort. In some neighborhoods, association with the police department will also act as a positive inducement.

The first important task for organizers is to set up and recruit attendance at the initial meeting of the block or floor club. Ideally, it should be held in a resident's home. The second best alternative is some neutral site, like a library, church, school, or apartment lobby. The meeting should be held in the evening, when everyone is free to attend. Recruiting for the meeting can begin with neighbors who might prove receptive, and these successful contacts may well lead to others. The best hours for door-knocking are the late afternoon in the winter and early evening in the summer. A written invitation to the meeting and other back-up materials are useful to offer. Neighbors who agree to come can be asked to bring a friend, or to act as an escort or to provide transportation for an older person. Signs posted on the block or in common areas in apartment buildings will serve as reminders of the meeting, as will a phone call or notice in the mailbox on the day of the meeting.

The agenda for the initial meeting should be planned in advance, and time should be allowed for neighbors to express their concerns. Time should also be set aside just for socializing. Topics which can be covered are: a review of the local crime statistics; the concept of community crime prevention; the idea of "block watch" and other strategies; election of "block captains"; and arranging the time and place for a second meeting.

Information on most of these topics can be obtained from the local police, from crime prevention books in the library, and from leaders of other block clubs in the community--as well as from national organizations like the Minnesota Crime Prevention Center, the National Crime Prevention Institute, and the National Sheriff's Association. Regardless of the agenda topics, several facts are important to communicate to people attending a first block club meeting. These include:

- Activities at the community level can make a difference, especially when residents take advantage of the local resources which already exist.
- Participants need not be nosy or meddlesome in order to be alert, aware, and concerned about neighbors' safety and security.
- A block club can serve as a forum for addressing other kinds of local issues, including sanitation, play space, building renovation and repair, fire hazards, traffic problems, and public utility complaints.
- One or two people need to assume responsibility as block captains to help organize meetings, encourage people's involvement, and maintain a communications link among residents, the local police, and other important resources.

Topics which can be addressed during the second block club meeting include: distribution of organizing materials such as a block map, membership list, and crime prevention checklist; discussion with a local police officer; and plans for the activities to be conducted by the block club.

The frequency with which block clubs meet varies with the specific crime prevention activities they have chosen and the extent of the crime problem in the neighborhood. A good way to keep members interested and involved between meetings is a regular newsletter. In the final analysis, the strength of block organizations rests on a combination of the leadership capacities of the block captains and the degree of involvement of citizens and local organizations.

Community Crime Prevention Strategies

The strategies which block clubs can adopt to reduce their members' chances of being victimized are many, and they are limited only by the time and manpower available. Those reviewed here are the most popular strategies, but others can be implemented to respond to special crime problems.

Neighborhood Watch

The most common strategy used by block clubs is Neighborhood Watch, really an extension of the block club concept. In this strategy, neighbors are trained in crime surveillance and urged to look out for each other by reporting to police any suspicious activity

they notice in the area. Block meetings lay the foundation for this approach by allowing neighbors to meet and recognize each other so that they will be more aware of strangers.

Some block clubs distribute materials to members which assist them in performing their surveillance function. These include: a block map, which shows the exact location of each home or apartment, and sometimes the name and telephone number of the citizens participating in the program; a premises security checklist, which helps people assess the security of their own house or apartment; suspect and vehicle identification forms, which present instructions for recording and reporting the details of suspicious people and vehicles seen on the block; and Neighborhood Watch stickers, which are available from the police and are posted by members so that outsiders know that the people on the block are watching out for one another.

The primary intent of Neighborhood Watch is to foster cooperation among neighbors and between citizens and the police. "Vigilantism" is never encouraged. Rather, residents are urged to call "911" or another emergency phone number at the first sign of suspicious activity. The police can then determine if the person has a legitimate reason for being in the area.

Citizen Patrols

Citizen patrols are both a popular and effective means of deterring crime. They can involve a large number of residents, and are equally well-suited for homeowners or apartment-dwellers, for urban and suburban residents.

A 1977 Department of Justice study of citizen patrol projects found over 800 patrols operating in the United States, most with very small budgets and volunteer staffs. The researchers concluded that these patrols can be susceptible to occasional acts of vigilantism, but not nearly so often as the media would suggest (Yin et al., 1977).

The three most common kinds of citizen patrols are building or tenant patrols, street foot patrols, and car patrols. Street and car patrols are somewhat more complicated to plan and implement than building patrols, because they cover public areas and their activities must be closely coordinated with the local police. Patrollers will also have more difficulty in distinguishing local residents from strangers.

There are a variety of ways these patrols can cover an area. Usually the approach depends on the size of the area and the number of participants. Regardless, it is always important that all volunteers fully understand their roles--to notice suspicious activity and call the police, not to stop criminal activities and detain suspects.

Suspicious behaviors are reported to the police, either by telephone or citizen band radio. Sometimes, where funding is adequate,

patrolling citizens use CB radios or walkie talkies to report periodically in to a base station; the person manning the station then notifies the police. Patrols also contact the local precinct to determine if any crimes have been reported within the area where the patrol operates. The types of crimes, the methods of entry, and exact locations are discussed by members of the patrol who can decide how to deter these crimes in the future.

It is difficult to operate a car patrol without some funding for gasoline and upkeep for the cars. Since some merchants like to become involved in civic affairs, block clubs sometimes try soliciting contributions from them. Others have received discounts from local gas stations or repair shops to service patrollers' cars, in return for publicizing their contribution.

Recruitment for patrols should result in more volunteers than may be needed, since people often drop off patrols, are sick, go on vacation, or for other reasons cannot fulfill their responsibilities. Schedules are followed by participants with greater commitment if certain steps are taken to help keep up their interest; people can be assigned to patrol with friends, making time pass more quickly; identifying apparel can be worn, instilling a sense of identity and pride in participants; regular meetings to build team unity can be held during which participants exchange ideas and advice; patrols can submit regular reports, making their contribution more tangible; and awards dinners can be held or plaques or certificates given out, giving participants increased recognition. To gain greater visibility and recruit new members, some patrols distribute a newsletter or flyer, which describes any recent suspicious activity in the area and presents crime prevention tips. Data which indicate a decreased crime rate in the neighborhood or building can be the greatest incentive to patrol members to continue their efforts.

Tenant patrols are those in apartment buildings or complexes and are usually sponsored by the tenant organization of the building being patrolled. Their main objective is to keep unwanted strangers away from and out of the building, and they operate in areas where police activity is either minimal or nonexistent.

In a building where floor clubs have been organized, these clubs can comprise an effective "building club." But even in buildings without floor clubs, a small core of interested tenants can be used to help guarantee increased security through lobby and hall patrols.

Skeptics of this strategy have claimed that it is not feasible because of the transiency of people who live in apartment buildings and their lack of commitment. It is possible though. One New York City housing official, commenting on tenant patrols, has stated:

In terms of effectiveness, interest and involvement of tenants, the tenant patrol program represents the most successful of the many approaches to the security problem beyond uniformed patrolmen and improved hardware (Granville, 1975:23).

It can often help, in organizing a tenant patrol, to work through a tenant council or committee if one exists. Such a group can call the first meeting, establish guidelines with housing management, and give the effort a stamp of formality.

The roles tenants play on building patrols vary:

- They can observe all lobby activity, checking the identification of residents and clearing visitors.
- They can record visitors or goods entering or leaving the building through all entrances.
- They can serve as a security grievance committee for all tenants (with the management, dealing with both tenant complaints about management policies and about other disorderly tenants.
- They can act as a liaison between beat patrol officers and tenants.
- They can provide an escort for tenants going to or from their apartments.

Senior citizens can be especially helpful participants. They often have been living in a building for many years, so they tend to know its residents and to make effective screeners of visitors. Often one or two older residents of apartments spend time sitting and talking in the lobby; they make ideal members of a tenant lobby patrol.

"Buddy Buzzers"

These buzzers are usually used by merchants, working together in pairs as mutual watchmen through an alarm which connects two stores. In an emergency, the alarm can be silently activated, signaling the "buddy" neighbor to call the police. These systems have also been used by residents of apartment buildings to increase their security. Buddy buzzers can provide a much needed sense of security to older persons who live alone.

The main decision to make when implementing this strategy concerns the kind of alarm system to use. Local crime prevention officers can usually help people choose the type best suited for their situation. People with some basic electrical knowledge-- neighbors, friends, superintendents, or maintenance people-- can install a wired bell system operated by a buzzer which has to be pressed. This simple system costs about \$35. A more expensive wireless sound wave alarm that can be carried in a pocket costs about \$150.

Residents are usually trained by the police in how to use the alarms and what to report to the police--descriptions of strangers, noises, or merely the "buddy's" name and address.

Whistle Airhorn Program

This idea was covered in Chapter Six, "Street Crime," as an individual crime prevention strategy. However, it is even more effective when employed by members of a block club who have been trained to keep an ear out for the whistle or horn and to call the police. The noise itself is intended to deter the completion of the crime in progress, and the quick phone call is designed to give the police a jump in apprehending the offender.

Special Telephone or Surveillance Projects

These projects are usually sponsored by police departments to encourage greater citizen involvement in crime prevention. They usually involve some anonymous reporting of suspicious or criminal activity. Some provide special telephone lines, others assign citizens an identifying number to use to tip off the police and some, like the "Crime Stoppers" program, even offer monetary rewards for information leading to convictions. The underlying premise is that people may be hesitant to become personally involved in cases, since such involvement may produce pressure or other negative reactions from their neighbors, but would be willing to take a quieter role.

A good example of this theory in practice is the "Senior Power" program operating for over three years in Akron, Ohio. This extremely successful effort has enrolled over 11,000 residents. Each member is assigned a number to use to tip off the police anonymously to suspicious activities in the neighborhood. In addition to a numbered identification card and a membership window sticker, members receive a crime prevention newsletter. In its first two years, the program saw burglary against senior citizens decline 15 percent, robbery 38 percent, purse-snatching 71 percent, and aggravated assault 19 percent.

Telephone Assurance

Telephone assurance is not as directly related to crime prevention as some other strategies, but it can strengthen the cohesion among tenants in a building or residents on a block, and can indirectly reinforce other block club strategies. Moreover, telephone assurance is especially valuable for those elders who may not be mobile or who feel under stress because of their isolation from neighbors.

Telephone assurance is a program in which volunteers regularly call other residents to check on their well-being. A volunteer coordinator arranges a schedule and matches other volunteers with clients. These volunteers receive or develop local resource manuals containing information on services available to their clients. These manuals are often available from community action agencies, the area agency on aging, the Red Cross, or other United Way agencies.

Telephone assurance frequently requires volunteers to counsel their clients about day-to-day problems, so sponsorship by a local social service agency is very helpful. The agency not only can help

screen and train volunteers to assure that clients receive the best possible assistance, but also can provide professional advice when problems occur which stump volunteers.

Because of these circumstances, telephone assurance volunteers have great potential in community crime prevention. They can distribute crime prevention information. They can serve as regular recruiters for other block club crime prevention strategies, such as patrols or home security surveys. In this manner, they can brief residents who may not have attended a block club meeting on what occurred. These volunteers can even organize an informal Neighborhood Watch force among all clients. Since recipients of telephone assurance calls are most likely home all day, they make excellent participants in this strategy.

Escort Service

An escort service, in which a person is accompanied by a neighbor to the store, a doctor's appointment, or any other local destination, can effectively reduce both fear of crime and victimization. It may be exactly the kind of help needed by an elder who is afraid or too frail to go out alone, or by someone who has been a recent crime victim and needs companionship to help overcome fear.

One federally-funded project in Washington, D.C. for senior citizens living in a high crime area provides a model for operating an escort service:

- One person was made responsible for coordinating the service.
- There was one telephone number for all volunteers and clients to call; an answering device was used to take messages when no one was home.
- There was a standardized method for arranging escorts. For example, clients could call on a regular basis (one or two days a week) or call at least 24 to 48 hours in advance to request an escort for a particular day and time.
- If escort clients were very frail or infirm, volunteers tried to obtain permission from various agencies to do things on their behalf, such as deposit checks in their bank accounts or sign for food stamps.
- If volunteer escorts were not known to the clients, the volunteers called the client a short time before picking them up to introduce themselves. Escorts wore some clear identification, which could be armbands, jackets, emblems, or informal ID badges.
- Clients in apartment buildings were escorted both to and from their own apartments to prevent hallway or elevator assaults or purse snatchings and push-in robberies.

In an escort service, timing is very important. Handicapped

persons may schedule an entire day around several errands and can have their day ruined if an escort does not appear as scheduled. Because of this, volunteers who can act as back-ups in an emergency are a necessary part of any escort service project.

Court Monitoring

Citizens who want to take a more active role in directly influencing their local judicial system are being recruited into voluntary court watching or court monitoring groups. These groups have an array of goals, ranging from simply educating citizens about the judicial process, to making judges and prosecutors aware that citizens are watching what they are doing, to identifying and achieving specific reforms in the judicial system. As mentioned earlier, elders in several cities have formed groups to follow the cases of persons accused of crimes against the elderly. Their intent is to keep those in the judicial system aware of the interests of the victim and to avoid leniency for the accused at any stage of the process. Some of these projects also act as a support group for older victims, accompanying them to court and providing them with information on the court process and available social services.

Most court watching projects are staffed by volunteers who have sufficient leisure time to devote to the time-consuming process of monitoring cases in the court. To be effective, these volunteers require extensive training in the complicated procedures used in courts and in observational techniques.

Because court monitoring programs require close coordination with the district attorney's office and the court, they are usually operated under the guidance of a program or agency and not by private citizens themselves. Groups like the League of Women Voters, the American Friends Service Committee, and the American Civil Liberties Union have been active in sponsoring court watch projects. Overall, this program is an excellent way for citizens to learn about the criminal justice system and to provide needed support to neighbors who have become victims.

Lobbying for Increased Security: A Strategy for Apartment Tenants

One of the most promising community crime prevention strategies is the organization of apartment dwellers to work as a group to convince their landlord to provide improved security. This approach can result in both better relations among neighbors and improved physical security in a building or project.

Ironically, aggressive advocacy by tenants as an approach to achieving security is often most useful in neighborhoods where it is most difficult to accomplish--low-income or transitional neighborhoods where many landlords have virtually ignored their responsibility to provide a safe living environment for their tenants, and where tenants cannot call on their own resources to move or to make up for existing deficiencies. However, these same tenants have the most to lose if an effort to pressure a landlord into changes backfires and

they find themselves with an eviction notice and no other affordable housing. So, negotiations with a landlord should always be undertaken with great care, with a knowledge of existing laws and building codes, and with the full backing of tenants.

The initial step in apartment dweller lobbying is usually an organizing meeting. Here, tenants are asked to detail the major security problems in their building. These may include poor outside locks, missing locks on some entrances, poor door locks for apartment units, a weak buzzer system, time gaps in security guard service, elevators without corner mirrors, or small door viewers.

If a building already has a tenants organization, it is most advisable to work with its leader to prepare a proposal or set of requests for the landlord. A petition signed by all interested tenants also lends weight to the group effort. If security surveys have been performed by the police or others, the results of these surveys can be attached as evidence of security weaknesses.

Reputable spokespersons then try to negotiate with the landlord for the requested security improvements. If the landlord is unwilling to consider the requests, he or she may be willing to allow the tenants to make their own improvements. If enough tenants are interested in the security upgrading, it may be that a small amount of money can be solicited from each to carry out the changes. If the management cannot be convinced to take action, tenants may initiate a tenant action. However, such a step is not usually taken until after conferring with an attorney. Before this occurs tenants might explore taking their complaints to the local media, which often have consumer hotlines or departments. Landlords may comply with tenant requests to avoid the embarrassment of negative coverage. Also, the intervention of a third party, such as a hotline investigator, often changes the tone of negotiations between tenants and the landlord and makes compromise possible.

No list of community crime prevention strategies is exhaustive. Tenant councils, homeowner associations, floor and block clubs may come up with strategies not mentioned here which are particularly appropriate for addressing the problems confronting them. Some likely projects have been described in detail in other chapters in this handbook. For example, Operation Identification, inscribing valuables with a driver's license number, is one of the most popular community crime prevention activities because it is a tangible service to deter burglars and can easily be accomplished by neighborhood volunteers. In New Orleans, for example, volunteers from a program called Women against Crime went door to door with the police to enroll all the residents of a housing project in Operation Identification. A large sign was then posted advertising this fact and burglaries in that project were reduced to almost zero.

Another popular community project described earlier is Home Security Surveys. In some jurisdictions, the police train citizens to conduct these surveys; these, in turn, become a welcome service of a block club.

The important thing to remember is that the community strategies outlined in this chapter need not cost money to succeed. The more basic ingredients of success are usually the time and energy of the citizens themselves. When concern is translated to action, when investments are made in recruiting and organizing community crime prevention strategies, the "payoff" is most often reduced crime and improved quality of life for the older citizen.

Reading and Resources

- Arnone, William J., "Mobilizing the Elderly in Neighborhood Anti-Crime Programs," Aging, March-April, 1978.
- Backrach, Catherine, "The Grassroots Action Handbook," Philadelphia, PA: Citizens' Local Alliance for a Safer Philadelphia, 1979.
- Bickman, Leonard, Paul J. Layrakas, et al., Citizen Crime Reporting Projects, National Evaluation Program, Phase I Summary Report, Washington, DC: U.S. Government Printing Office, 1977.
- Blubaum, Paul E., "Maricopa County Sheriff's Department Volunteer Program," Police Chief, Vol: 43, No. 2, February, 1976.
- Boston, Guy D., Community Crime Prevention: A Selected Bibliography, Washington, DC: U.S. Department of Justice, National Institute of Law Enforcement and Criminal Justice, 1977.
- Carlson, Kenneth, Lewis Morris, Robert Spangenberg, and Debra Whitcomb, Citizen Court Watching: The Consumer Perspective, Washington, DC: U.S. Government Printing Office, 1977.
- Christian Science Monitor, December 23, 1977, p: 37.
- Cirel, P., P. Evans, D. McGillis, and D. Whitcomb, Community Crime Prevention Program--Seattle, Washington--Exemplary Project, Washington, DC: U.S. Government Printing Office, 1977.
- Community Crime Prevention: A Neighborhood Action Guide, Washington, DC: Civic Action Institute, 1979.
- Crime Prevention Coalition, "How to Protect Your Neighborhood," Rockville, MD: Crime Prevention Coalition, Box-6700, 1979.
- Duncan, J. T. Skip, Citizen Crime Prevention Tactics, A Literature Review and Selected Bibliography, Washington, DC: U.S. Government Printing Office, 1980.
- Frisbie, Douglas W., Glen Fishbine, Richard Hintz, Mitchell Joelson, Julia Brown Nutter, Crime in Minneapolis: Proposals for Prevention, St. Paul, Minnesota: Governor's Commission on Crime Prevention and Control, 1977.
- Granville, Samuel, "New York's Experiment in Tenant Safety," HUD.

Challenge, May 1975.

Green, Gerson, Who's Organizing the Neighborhood? Community Organizations: A Report on their Structure, Accountability, Finance, Personnel, Issues and Strategies, Washington, DC: U.S. Government Printing Office, 1979.

Hollander, Brian, Francis X. Hartmann, Rinda R. Brown, and Robert Wiles, Reducing Crime and Fear: The Hartford Neighborhood Crime Prevention Program, Executive Summary, Washington, DC: U.S. Department of Justice, National Institute of Law Enforcement and Criminal Justice, 1980.

How to Organize and Operate a Citizens Crime Commission, Atlanta, GA: National Association of Citizens Crime Commissions, 1974.

Minnesota Crime Prevention Center, Block Club Organizing for Crime Prevention, Minneapolis, Minnesota: MCPC, 1978.

Minnesota Governor's Commission on Crime Prevention and Control, Minnesota Crime Watch: Evaluation Report, St. Paul, Minnesota: MGCCPC, 1976.

"National Neighborhood Watch Program--Information Packet," Washington, DC: National Sheriff's Association, 1976.

New York Self-Help Handbook, New York, NY: Citizens Committee for New York City, 1978.

Palmer, W. Peter, "Burglary Prevention: Inmate Interview Project," Lakewood, CO: Lakewood Department of Public Safety, 1978.

Regnier, Victor; "Neighborhood Planning for the Urban Elderly," Diana S. Woodruff and James E. Mirren, Eds., Aging: Scientific Perspectives and Social Issues, New York, NY: D. VanNostrand, 1975, pp. 295-312.

22 Steps to Safer Neighborhoods, New York, NY: National Alliance for Safer Cities and Alliance for a Safer New York, 1977.

U.S. Department of Justice, Law Enforcement Assistance Administration, The Community's Stake in Crime Prevention: A Citizen's Action Guide, Washington, DC: U.S. Government Printing Office, 1979.

U.S. Department of Justice, Law Enforcement Assistance Administration and U.S. Bureau of the Census, Trends in Expenditure and Employment Data for the Criminal Justice System, 1971-1976, Washington, DC: U.S. Government Printing Office, 1978.

U.S. Department of Justice, Law Enforcement Assistance Administration, National Institute of Law Enforcement and Criminal Justice, Establishing a Citizens' Watchdog Group, Washington, DC: U.S. Government Printing Office, 1979.

U.S. Department of Justice, National Advisory Commission on Criminal Justice Standards and Goals, A Call for Citizen Action: Crime Prevention and the Citizen, Washington, DC: U.S. Government Printing Office, 1974.

Community Crime Prevention, Washington, DC: U.S. Government Printing Office, 1973.

Washnis, George J., Citizen Involvement in Crime Prevention, Lexington, MA: D. C. Heath and Company, 1976.

Yin, Robert K., Mary E. Vogel, Jan M. Chaiken, Deborah R. Both, Citizen Patrol Projects, National Evaluation Program, Phase I Summary Report, Washington, DC: U.S. Government Printing Office, 1977.

Recommended Films on Community Crime Prevention

KEY: A = Abstract
C = Critique of Film for Suitability for Senior Citizens

NOT A WEAPON OR A STAR, 1978, Motorola Teleprograms, Inc., 3710 Commercial Avenue, Northbrook, IL 60062, 800-323-3543.
Producer: Chuck Loin, 28-1/2 minutes, 16 mm., color, \$395/\$50.

A: Successful crime prevention programs depend on citizen involvement in every phase of the criminal justice system. The film describes actual projects in the Chicago area, including citizen patrols, block clubs, Operation Whistlestop, court monitoring, and victim/witness assistance.

C: An excellent survey of citizen crime prevention programs is given, with applicability to urban, suburban, and rural communities.

WHOSE NEIGHBORHOOD IS THIS? Motorola Teleprograms, Inc., 3710 Commercial Avenue, Northbrook, IL 60062, 800-323-5343.
Producer: Mitchell Gebhardt Film Company, 20 minutes, 16 mm., color, \$360/\$50.

A: By using the approach of a documentary, this film presents real victims of burglary telling their stories of recent crimes. They all say that crime happens to "someone else" and they were not conscious of crime prevention. Cooperation between police and the public is continually emphasized in this film. Interviews with burglars themselves show that a burglar can get through any lock or any trap. Only an involved community shows real results. Discussion questions included for instructor.

C: This film is excellent, but not recommended for senior citizens because it is difficult to hear.

Chapter Ten
Victimization and Its Aftermath —
The Victim in Crisis

Chapter Ten

Victimization and Its Aftermath — The Victim in Crisis

Advance Organizers

- Increasingly, researchers and practitioners are finding that the most serious result of crime against elders is not lost property, time, or work, not bodily injury, but the mental or emotional stresses that set in after the crime.
- The psychological and emotional needs of older victims may well be greater and more pressing than those of their younger counterparts.
- Household and personal crimes can be seen as violations of the person's sense of "self." The more serious the crime, the greater the violation of self, and the greater the stresses placed on the victim. For example, burglary violates one's property, which is an extension of self; while rape violates in addition one's sense of autonomy or control, injures the external self, and violates the internal self.
- While many researchers believe that a person's ability to cope with a stressful situation (like criminal victimization) depends primarily upon his or her personality traits, others maintain that the ability to respond to crisis depends more on the stressful experience itself and the person's experiences immediately afterwards.
- Not all stressful life experiences produce a crisis in people. Generally, events which occur very suddenly, not allowing the person to prepare, in an arbitrary manner, and with no logical reason, create a crisis reaction.
- People in crisis, including crises brought on by criminal victimization, tend to react in predictable ways or stages. These progress from shock or disbelief; to denial or pseudo-calm; to confused adaptation with the person's mood alternating from resentment to rage to guilt and so forth; to regained control.
- Usually, the more serious the criminal violation, the longer it takes the victim to regain control.

- Concerned intervention and support seem to be necessary to help many older crime victims because of their thinner psychological "support buffers" to life stresses; however, some victim assistance workers report that emotionally mature older victims can tolerate stress better than younger victims.

Introduction

Efforts at crime control and prevention discussed so far need to be adopted broadly, for we must stem the rising tide of crime in this country. Reported violent crime has nearly tripled since 1960 (from 160 cases per 100,000 population in 1960 to 460 in 1977) and is continuing its rapid increase today (Chelimsky, 1981). Despite their relatively lower victimization rates, over two million people above the age of 65 were victims of crime in a recent year (Stein, 1981). Two million. We must not forget that these "numbers" are people, each with a personal experience as a victim, each touched in a personal way by crime. This chapter examines what may be the most serious result of crime against older persons: the severe psychological impact which victims experience, what we are calling the "victim in crisis."

Crisis has been defined as "a subjective reaction to a stressful . . . experience, one so affecting the stability of the individual that the ability to cope or function may be seriously compromised" (Bard and Ellison, 1974:69). Victim service counselors from across the country typically report that about one-third of their clients--of all ages--show signs of undergoing an emotional crisis, and that many others experience great distress, some having the seeds of a delayed crisis within them (Stein and Ahrens, 1980). In fact, researchers have found that the emotional after-effects of crime seem to be the most costly to the well-being of victims as a group (Knudten, *et al.*, 1977). In one recent survey ranking the most pressing needs of crime victims, mental health and emotional problems were rated as more serious than lost property, lost income, bodily injury, or lost time at work (Salasin, 1980). A recent summary of the literature concluded:

Above and beyond the immediate problems posed by physical injury, loss of valued property, and demeaning interactions with the criminal justice system, the victim is at risk for delayed psychological reactions with unexplained "flashbacks" of the event . . . continuing fear and a sense of loss, with depression and physical disabilities not necessarily related to injuries that occurred at the time of victimization, together with a much greater probability of premature aging and death (Salasin, 1981:21).

For those older persons who are already experiencing a "season of loss," the emotional after-shocks of a crime can be a terrible affront, magnifying all the other difficult circumstances they face. If psychological and emotional needs are indeed most important to crime victims in general, they are likely to be even more of a priority for older victims.

The Psychological Consequences of Victimization

Recent attempts to understand the psychological impact of crime have worked from the theory that all crimes can be viewed as a

violation of the self and of one's personal control over life. The "victim response" to this violation is typically a feeling of helplessness and vulnerability which leads to a loss of self-esteem. Psychologist Morton Bard (1980) has placed the various types of crime on a continuum in terms of the extent to which they violate the self. The greater the violation of self, the greater the resulting stresses put on the victim of such a crime (see Figure 10.1). The seriousness of the violation increases as the threat to the self becomes more direct, as we can see by examining burglary, robbery (without and with injury), rape, and murder.

Burglary

As discussed in Chapter Four, older persons are victimized more often by household crimes than by personal crimes of violence. From Bard's continuum of the relative impact of different crimes, we might assume that these household crimes would not have a severe impact on victims, but recent research shows otherwise. Bard himself points to the impact burglaries can have on victims:

Every crime against a person is an act of violation . . . Personal possessions can take on symbolic significance as expressions of self . . . We surround ourselves with extensions of ourselves that have emotional value because they express who we are. Logically, then, the destruction of a person's possessions can be experienced as a violation of self (Bard and Sangrey, 1979:10-12).

A recent study of the existence of crisis surrounding homicide, robbery, and burglary reached conclusions which support this theory. The researchers initially assumed that burglary would be the least likely of the three crimes to produce crisis reactions, since a victim's life is not lost or threatened and no one is physically harmed. However, they found instead that burglary has a more lasting impact on the victims' lives than robbery does, and the crisis reactions they discovered were not related to people's loss of property, but to their sense of violation.

Victims said things such as: "I can feel the person in my house all the time; when I enter the house, I know he's there;" and "I just cannot get over the fact that he touched my personal belongings" (Bourque, et al., 1978:35).

A Canadian study of burglaries also found evidence which convinced the researchers that many burglary victims view the crime in a very personal way. They discovered that the amount of destruction or disarrangement of property which occurred during a burglary had a significant impact on victims' feelings of anger, fear, confusion, helplessness, and outrage (Waller and Okihiro, 1978).

Robbery

A crime which is a greater threat to the self on Bard's continuum of crimes is robbery, which by definition involves the victim more

**Figure 10.1 •
Violation of Self in Personal Crimes**

<u>Burglary</u>	<u>Robbery</u>	<u>Robbery With Physical Assault</u>	<u>Rape</u>	<u>Homicide</u>
(1) Violates extension of self	(1) Violates extension of self	(1) Violates extension of self	(1) Violates extension of self	(1) Ultimate violation: destruction of self
	(2) Loss of autonomy	(2) Loss of autonomy	(2) Loss of autonomy	
		(3) Injury to external self	(3) Injury to external self	
			(4) Violates internal self	
-----Increasing Psychological Complexity/Severity of Stress-----				

SOURCE: Morton Bard, "The Psychological Impact of Personal Crime," in Victim-Witness Services: Human Services of the 80's (Viano, Ed.), Washington, DC: Visage Press, 1980.

directly with the offender than does burglary. Robbery is the taking of something from the victim by force or threat of force, so the victim encounters the criminal in a very personal way. Not only is an extension of the self, like money or property, taken from the victim, but the criminal also forcibly takes away all independence and sense of control; the victim's fate rests entirely in the criminal's hands. Because of this heightened sense of powerlessness, robbery victims can experience severe crisis reactions.

Robbery with Assault

Robbery with assault can be even more traumatic, especially for elderly victims. (A purse snatching in which an older woman is hurt would be classified under Bard's category of robbery with assault.) In this crime, victims are faced with a two-fold loss: the same loss of control, autonomy, and the extension of the self, and also a loss of physical "wholeness." When the body is injured, the external part of the self is violated. And because the external part is viewed as just as essential an aspect of the self as the inner part, the victim is hurt psychologically as well as physically. An injury's physical evidence is a constant reminder to victims of their loss of control and inability to defend themselves. Because it often takes older crime victims a long time to heal, this reminder can have very damaging psychic effects.

Rape

Rape is one step further along the continuum of violation of self. In this crime, the victim suffers not only loss of autonomy or control, and injury to the outer self, but also is forced to experience a violation of inner space, the most private part of the self. Researchers have found that the victims of rape can be expected to be in some stage of crisis for most of a year, even with excellent help.

The Concept of Crisis

In recent years, victim advocates have agreed that "crisis intervention" is one of the primary needs of crime victims. Yet often they have differed on what skills crisis intervention entails. To understand the need for and attributes of crisis intervention, one first needs to understand the characteristics of the crisis reaction in crime victims.

Morton Bard defines a crisis as existing when an experience is so threatening that it is able to disrupt seriously normal mental and social functioning (Bard and Sangrey, 1979). What is important to understand here is that the degree to which an event is a threat is completely subjective: what is threatening to one person may not be threatening to another, so that two persons may cope with the same event very differently. For years researchers have believed that a person's ability to cope with a very stressful situation was determined mainly by his or her own personality factors; more mature people could deal with stresses more easily than the immature, for example.

However, the earlier work of psychiatrist Erich Lindemann (1944) has been supported by subsequent researchers who have demonstrated that the ability to respond to crisis may be less related to pre-existing personality traits than to the particular context in which the stressful experience occurs and the person's experiences immediately after the threat. Consequently, these researchers believe that quick, skillful, and authoritative intervention in a crisis can prevent the long-term negative impact of the stress.

Not all stressful life experiences necessarily produce a crisis in people. For example, although the death of a spouse has traditionally ranked highest in the amount of stress placed on the surviving partner, it might not constitute a crisis if the death occurs after a lengthy illness rather than after a car accident or sudden heart attack. Events which occur so suddenly as to prevent any psychological preparation--like violent crimes--are usually the most threatening, and the most likely to have crisis impact.

Another characteristic of an event which can cause a person to experience a crisis is its arbitrariness. A threatening event which seems to have no rational explanation, to be completely random in nature, frequently leads the victim to ask: "Why me?" or "Why us?" In searching for a reason, victims put weight on themselves which sometimes leads to unhealthy self-blame and guilt.

Sudden and unpredictable threats associated with crisis produce disordered feelings and behavior in people. While these reactions are typical, persons in a state of crisis are often puzzled and angry by their sudden inability to carry out everyday routines. For example, reactions to a crisis can include a change in eating or sleeping habits, emotional outbursts, difficulty in thinking clearly, an inability to work, and problems in a marriage or with children. While these symptoms seem abnormal to the person experiencing them, those counseling victims in crisis consider them normal reactions to a shocking life event.

The Stages of Crisis

People in crisis exhibit reactions so common that professionals have been able to classify them into stages. Two practitioners who have devoted great effort to understanding the stages which crime victims experience are psychologist Morton Bard, and psychiatrist and ex-police officer Martin Symonds. Bard characterizes three stages of crisis for crime victims: impact, recoil, and reorganization. Symonds chooses to delineate four stages: shock, "frozen fright," depression, and recovery. While the number of stages differs, the responses of crime victims these researchers describe are basically the same.

- Immediately after a crime, especially a crime of violence, a victim may experience shock, disbelief, or denial. Common reactions are, "I don't believe it!" or "This couldn't have happened to me!" The victim is temporarily paralyzed and denies sensory impressions. As Bard and Sangrey express it, the victim "falls apart inside" and just refuses to accept what his or her common

sense-indicates, as illustrated in an excerpt from their Crime Victim's Book:

One woman explained: "As soon as I came in, I knew something was wrong, but I couldn't figure out what it was. Everything was out of place. I walked through the living room, and then it hit me: 'We've been robbed!'" Another victim . . . found the door to her house unlocked and wondered why she had left it that way; then she came into the kitchen, noticed that all the lights were on, and felt angry at her children' . . . ; finally she saw that the television was gone, and the impact of the crime struck her. She was so disoriented that she had to sit down and catch her breath (Bard and Sangrey, 1980:29-30).

In the initial period after a crime, victims often feel helpless and alone. They may be confused and unable even to describe what happened to them.

- In the next phase, victims begin to struggle to adapt to the victimization. Symonds calls the early parts of this phase "frozen fright," during which victims exhibit pseudo-calm, detachment, and "traumatic psychological infantilism, in which all recently learned behavior evaporates and only adaptive patterns from early childhood predominate," (Symonds, 1980:36). During this period the victim's behavior may seem ingratiating, appeasing, compliant, and voluntary. This can produce serious confusion. Symonds cites the case of a victim in a terrified state who offered her rapist a glass of water; later a judge took that act as an indication of voluntary compliance on the woman's part.
- This initial confusion is usually followed by one or more of a whole range of feelings which constitute the third stage of crisis: depression, anger, apathy, resentment, rage, fear, sadness, self-pity, and guilt. The victims' moods constantly change or vacillate. This, of course, can be unnerving to someone trying to help the victims. Sometimes victims are able to deal with these emotions and work at resolving them. At other times, they may exhibit behavior which shows that they simply cannot face their feelings. While friends or relatives may view such denial as unhealthy, Bard asserts that it is helpful:

Some denial is an essential part of the healing process in a crisis situation. It allows the victim to develop a gradual immunity to the onslaught of feelings that would be overwhelming if they had to be faced all at once. And both denying and facing feelings can be active processes that will use up the victim's energy and absorb his or her attention during this period (Bard and Sangrey, 1980:32).

During this stage, victims often recount the crime in their minds, "playing it back" over and over again. Frequently they have nightmares about it which can produce insomnia. These nightmares may reflect feelings of fear about the entire event, the criminal, or one part of the crime. Many victims are afraid that they will see the criminal again or that the criminal will return to victimize them. Fear of retaliation by the offender can become strong and keep victims from cooperating with the police or with the prosecutor if an arrest is made.

The anger felt during this period can be very intense. Typically, it is first felt toward the criminal and expressed in statements like: "How dare he do this to me!" This anger, which often becomes rage, can be very hard to deal with because victims usually have no direct way to vent their anger at the criminal; the vast majority of victims never see the criminal again.

A second common target for victims' anger is themselves. They often blame themselves for the crime, asking repeatedly: "Why didn't I do this?" or "Why did I let myself get into that situation?" Symonds labels this self-recrimination the "I am stupid" phase. Victims can have strong guilt about their behavior during and immediately following the crime. They:

review their wartime behavior under peacetime conditions, and won't accept that all individuals who experience a sudden and unexpected violent act, especially if it is accompanied by dramatic acts or threats to life, will be terrified--will freeze, submit, or run in panic or terror (Symonds, 1980:36).

In the final phase of crisis, victims begin to gain control of their feelings, resolve their conflicting emotions, and assimilate the fact of their victimization and return to their normal functioning prior to the crime. A sense of balance is regained. One indication this has occurred is that victims become less interested in talking about or in reliving the event.

The more serious the violation, the longer it usually takes a victim to reach this recovery stage. There are not time frames which can be predicted. In fact, the lines between these phases of crisis are often blurred, and victims may slip back to prior phases from the recovery phase; relapses are very common.

Victims never forget the crime. Their strong feelings will lessen, but other effects of the experience become permanent parts of the victims' psyches. Victims of very serious crimes often find that their outlook on life is changed; they are less optimistic, less trustworthy of other people, and less open to life's experiences.

However, the outcome for crime victims need not be wholly negative. Victimization, like other crises, forces people to reexamine their feelings and assumptions and provides an opportunity for personal

growth. Effective crisis intervention counseling, then, can help some to regain the psychic equilibrium they had prior to a crime. For others, it can help them to reorder the balance and to make changes of their own choosing.

Crisis and Elderly Crime Victims

The crisis reactions which are experienced by most crime victims can be even more serious in older victims. The reason for this is clear: the crime may be one more in a series of losses, one more loss of control, one more symptom of their powerlessness. For some, a violent crime may be the final loss which drives them to fortify themselves in their homes, become reclusive, severely restrict their interaction with the outside world, and lessen the quality of their lives.

It is easy to understand why older victims of burglary, robbery, and other crimes may consider the event "the last straw." As Dr. Eric Pfeiffer has said:

Losses are . . . predictable and ubiquitous in this phase of the life cycle. They commonly include loss of spouse; loss of friends (through death, illness, or loss of mobility); loss of job identity; loss of work and work-related roles and structured activities; decline in health; economic decrements; a contracting social network. While not each of these losses is experienced by every aging person, a substantial number of such losses predictably occur to the vast majority of elderly (Pfeiffer, 1978:43).

There is growing evidence from the literature on stress that these cumulative losses felt by elders and their accompanying tensions can lead to an inability to cope with future losses, including those resulting from criminal victimization (Appley and Trumbull, 1967; Fields, 1980). Symonds refers to the elderly's thinner psychological "support buffer" to stress, so that a sudden loss, such as from a victimization, can precipitate a crisis of serious proportions ("New CJE Counselor, Martin Symonds," 1978).

To defend against such a crisis, many elderly persons turn to passive defense mechanisms, such as depression and withdrawal, rather than attempt to change the stressful situation with which they are faced (Pfeiffer, 1978:45). And without skilled crisis intervention; this depression and withdrawal can be irreversible (Krupnick and Horowitz, 1980; Stein, 1980).

It is important to note here that while older persons show strong emotional reactions to criminal victimization, many are able to exercise the emotional maturity which they have cultivated over a lifetime and resolve the problems arising from victimization rather quickly. Victim assistance workers, recognizing this coping ability, feel that some mature older victims can tolerate stress better than younger victims--especially after what is often many

years in a high-crime, high-stress neighborhood.

On the other hand, one needs to remember that many older victims who appear to be coping with victimization very well may not be at all. The pseudo-calm which they exhibit to the police and others may in fact be a symptom of crisis rather than a sign of their excellent abilities to return to normal functioning. Older victims who show little panic or emotional upset after a crime may convince a counselor they need no assistance. They are maintaining their equilibrium by turning a serious misfortune into a minor incident, using denial or repression to reduce the emotional aspects of the experience.

So, counselors may find that some older victims are unable to recall much about the victimization and evidence a desire simply to carry on in a mood of resignation. Victim workers sometimes choose to accept this reaction at face value, leaving the victims to cope on their own. They believe that these older victims are coping well and do not need tangible assistance. Yet much of this "coping skill" the counselors see in older victims is not very skillful at all and does not bode well for victims' long-term recovery.

Therefore, it is well to view crisis intervention for elderly crime victims with a balanced perspective. Many victims will need crisis counseling, whether from a trained victim assistance worker or a mental health professional. Others may be able to cope well without such assistance, especially if they have the care of family and friends. And still others may appear to be coping well with the after-effects of the crime, but may actually need counseling to help them face the emotions they are denying or repressing.

Reading and Resources

Appley, M. H. and R. Trumbull, Psychological Stress: Issues in Research, New York, NY: Appleton-Century Crofts, 1967.

Bard, Morton, "The Psychological Impact of Personal Crime," Emilio C. Viano, Ed., Victim/Witness Programs: Human Services of the 80s, Washington, DC: Visage Press, 1980.

Bard, Morton and Katherine Ellison, "Crisis Intervention and Investigation of Forcible Rape," Police Chief, May, 1974.

Bard, Morton and Dawn Sangrey, The Crime Victim's Book, New York, NY: Basic Books, 1979.

_____, "Things Fall Apart: Victims in Crisis," Evaluation and Change (Special Issue on Services for Survivors), Minneapolis, MN: The Program Evaluation Resource Center, 1980, pp. 28-35. This article is a chapter reprinted from The Crime Victims Book (above):

Barkas, J. L., Victims, New York, NY: Charles Scribner's Sons, 1978.

- Bourque, Blair B., G.B. Brumback, Robert E. Krug, and Louis O. Richardson, Crisis Intervention: Investigating the Need for New Applications, Washington, DC: American Institutes for Research, 1978.
- Chelminsky, Eleanor, "Serving Victims: Agency Incentives and Individual Needs," Susan E. Salasin, ed., Evaluating Victim Services, Beverly Hills, CA: Sage Publications, 1981, pp. 78-97.
- Fields, Rona M., "Victims of Terrorism: The Effects of Prolonged Stress," Evaluation and Change (special issue on Services for Survivors), Minneapolis, MN: The Program Evaluation Resource Center, 1980.
- Knudten, Richard D., Anthony C. Meade, Mary S. Knudten, and William G. Doerner, Victims and Witnesses: Their Experiences with the Criminal Justice System, Washington, DC: U.S. Government Printing Office, 1977.
- Krupnick, Janice L. and Mardi J. Horowitz, "Victims of Violence: Psychological Responses, Treatment Implications," Evaluation and Change (special issue on Services for Survivors), Minneapolis, MN: The Program Evaluation Resource Center, 1980, pp. 42-46.
- Lindemann, Erich, "Symptomatology and Management of Acute Grief," American Journal of Psychiatry, 101, 1944, pp. 141-8.
- "New CJE Counselor, Martin Symonds," CJE Newsletter, Washington, DC: Criminal Justice and the Elderly, Fall, 1978, pp. 4-5.
- Pfeiffer, Eric C., "Psychotherapy of the Elderly," National Association of Private Psychiatric Hospitals Journal, Vol. 10, No. 1, Fall, 1978, pp. 41-46.
- Salasin, Susan E., "Caring for Victims: An Interview with Steven Sharfstein," Evaluation and Change (special issue on Services for Survivors), Minneapolis, MN: The Program Evaluation Resource Center, 1980.
- Salasin, Susan E., Ed., Evaluating Victim Services, Beverly Hills, CA: Sage Publications, 1981.
- Salasin, Susan E., "Services to Victims: Needs Assessment," Susan E. Salasin, Ed., Evaluating Victim Services, Beverly Hills, CA: Sage Publications, 1981, pp. 21-38.
- Stein, John H., "Better Services for Crime Victims: A Prescriptive Package," Evaluation and Change (special issue on Services for Survivors), Minneapolis, MN: The Program Evaluation Resource Center, 1980.
- Stein, John H., "Victim Crisis Intervention: An Evaluation Proposal," Susan E. Salasin, Ed., Evaluating Victim Services, Beverly Hills, CA: Sage Publications, 1981, pp. 98-112.

Stein, John H., and James H. Ahrens, How to Win Law Enforcement Support for Crime Victim Services Projects, Washington, DC: National Council of Senior Citizens, 1980.

Symonds, Martin, "The 'Second Injury' to Victims," Evaluation and Change (special issue on Services for Survivors), Minneapolis, MN: The Program Evaluation Resource Center, 1980.

Viano, Emilio C., Ed., Victim/Witness Programs: Human Services of the 80s, Washington, DC: Visage Press, 1980.

Waller, Irvin and Norman Okihiro, Burglary: The Victim and the Police, Toronto, Ontario: University of Toronto Press, 1978.

Recommended Films on Victimization and Its Aftermath

KEY: A = Abstract

C = Critique of Film for Suitability for Senior Citizens

THE AGED VICTIM: A CALL FOR UNDERSTANDING, Center for Studies in Aging, North Texas State University, Denton, Texas, 76203. Producer: North Texas State University. Video, B&W.

A: This videotape is intended for use in the context of a two-hour training program for law enforcement officers to increase officers' awareness of the special problems of the elderly and to provide tools for working with the elderly. It dramatizes four common situations in which the elderly and the police interact: (1) an elderly woman repeatedly imagines that she has a prowler and calls the police; (2) a woman with impaired vision has her purse snatched and cannot begin to identify the offender; (3) a man who has been robbed calls the police, only to be put on hold; and (4) a lonely woman is terrorized by neighborhood children and imagines a "gang of hardened criminals."

C: The film is useful to sensitize police to the unique problems of the elderly and to modify police behavior.

SOMEONE ELSE'S CRISIS, Motorola Teleprograms, Inc., 3710 Commercial Avenue, Northbrook, IL 60062, 800-323-5343. Producer: The Filmmakers. 25 minutes, 16 mm., color, \$375/\$50.

A: The film consists of five vignettes: a child who has lost his dog, a residential burglary, an armed robbery, a purse snatch, and a violent rape. The vignettes illustrate a police officer's role to provide psychological and emotional first aid to victims prior to investigating a crime. Instructor's manual included.

C: The crimes are portrayed extremely explicitly, to help the police officers to empathize more completely with the emotional states of victims, e.g., attachment to personal

belongings, total disorientation. The film is excellent.

WHEN WILL PEOPLE HELP: THE SOCIAL PSYCHOLOGY OF BYSTANDER INTERVENTION, 1976, Harcourt, Brace and Jovanovich, 757 Third Avenue, New York, New York 10017, 25 minutes, 16 mm., color, \$440/\$44 per week.

A: Using social psychology techniques, the film explores the reasons for bystander nonintervention (people are more likely to respond to emergencies when they are alone), shows how laboratory and field experiments have led to a reasonable explanation of the phenomenon, and suggests ways of getting people to help. The 1965 Kitty Genovese case is used as an example.

C: By showing that the witness to a crime is, in effect, a victim him or herself, the film offers invaluable and unique insights into bystander behavior. It is a must for police officers and victim/witness assistance workers and could effectively teach neighborhood groups the importance of looking out for one another.

Chapter 11

Meeting the Needs of Elderly Crime Victims

Chapter Eleven

Meeting the Needs of Elderly Crime Victims

Advance Organizers

- Older victims of crime need a comprehensive array of assistance services to address the economic, physical, psychological, and criminal justice consequences of victimization.
- A number of programs exist focusing on these needs, and elders, their friends and relatives, and various community service workers should know of their availability. Where no programs exist, cooperative efforts among these parties can establish them using available resources, the most important of which are concern and commitment.
- The loss of money or property due to crime may have particularly serious effects on older victims living on fixed incomes, who may have to cut back on necessities because of the loss, or who may simply be unable to replace the lost items.
- A number of state and community services offer models for addressing older victims' economic needs: victim compensation funds; small gift or loan programs; and offices for assisting victims in handling paperwork and dealing with bureaucracies.
- Most older victims are not physically hurt, but those who are tend to have more need for assistance than their younger counterparts. Crime-related physical problems may interfere with getting to doctors, pharmacies, groceries, and other necessary services.
- Various existing services, sometimes designed for other purposes, can be adapted to meet the physical needs of older victims. These include homemaker services, visiting nurses, friendly visitors, senior companions, telephone assurance, special transportation, escort services, and delivered meals. The local area agency on aging is a good source of information about these services.
- The psychological after-effects of criminal violation may well be most devastating for elders. Every

meaningful resource should be explored to aid an older victim in crisis. Sources of help include "natural" counselors among family and friends, area agencies on aging, community mental health centers, senior centers, and other aging-related groups. Effective crisis counselors need not be professional social workers, therapists, or psychologists.

- The criminal justice system, traditionally focused on the offender, has recently responded to the needs of older victims with a variety of intervention programs, most of which involve the police or the prosecutor's office.
- Police cooperation is fundamental in setting up victim services. Several models can be used in establishing a working relationship with the police; these include the "cooperation," "collaboration," and "comprehensive" models.
- Prosecutors' or district attorneys' offices have implemented a series of reforms and programs to improve the older victim's involvement with the court system. These involve more information on the court process, case status and disposition notices, witness alert systems, expediting the return of recovered stolen property, victim impact statements, and to-court and in-court escort services.
- The "victims' movement" is an effort at the national level to improve the treatment of victims of crime regardless of type of crime or age of victim. The National Organization for Victim Assistance (NOVA) has been one of the leaders in this advocacy, promoting reforms and training in the criminal justice system, as well as legislative changes to recognize victims' rights.

Introduction

As we discussed earlier in this handbook, victim assistance is an important service for older persons due to the severe impact crime has on them, economically, physically, and emotionally. From an economic perspective, the elderly are hurt severely because they are often least equipped to deal with monetary or property loss. Physically, simply because of the aging process, they suffer more from injuries associated with victimization than any other age group. As we pointed out in the preceding chapter, on crisis, the emotional consequences of crime for the elderly are closely related to their physical problems and other problems inherent in the aging process.

Chapter Five describes a number of existing special programs that address the needs of older crime victims. In addition to these specialized programs, over 200 communities now have programs which provide services to victims and witnesses of all ages. Some of these projects focus on emergency services to victims of personal crimes; others (usually housed in the district attorney's office) provide services to witnesses during the court process; a smaller number encompass a comprehensive package of services to victims and witnesses. Where these programs are available, a crime victim may only need to be referred to them in order to receive services. Where no programs exist, friends, neighbors, or service providers can act as substitute victim assistance workers if they have a knowledge of typical community resources and rudimentary counseling skills.

This chapter will examine the needs of elderly crime victims in greater detail and will outline existing and possible responses for older victims themselves, service providers, and concerned others. We will address ways of meeting the older victim's economic, physical, psychological, and criminal justice needs. However, one critically important response--counseling--will be treated separately in the following chapter on communicating with individuals.

Meeting a Victim's Economic Needs

Because older persons are frequently living on low, fixed incomes derived from pensions, annuities, or other sources, the theft of money or property can create serious economic problems. While younger crime victims may have to take money out of the bank or refrain from unnecessary expenditures for a while, many elderly people who are victims of a robbery may find there is no money for food or rent.

The loss of property may also have a critical economic impact for senior citizens. Items like televisions and radios may be an older person's lifeline to the outside world. When they are stolen, the victim is faced with a sudden, frightening isolation. Those living on fixed incomes and tight budgets may find it difficult or impossible to replace these stolen items. Even stolen property which is recovered is often held by the police as evidence until a trial is held, which can be a year or more.

Programs which help elderly crime victims have found that victims'

economic needs are frequently the most difficult to fulfill. The great majority of programs or agencies cannot make cash loans or grants to victims. Yet resources do exist to ease the economic burden of older crime victims.

One resource available to older crime victims is state victim compensation funds. These programs, currently operating in 34 states, make awards to victims of personal crimes for unreimbursed medical expenses or loss of wages resulting from their victimization. However, the problems with these programs are considerable. They are not well-known, application forms and procedures are cumbersome, eligibility is often defined very narrowly, field investigations are time-consuming, and the review process can take over a year. Even "emergency awards" can take several months to be processed.

Nevertheless, these 34 state programs are a substantial resource for financial aid. If an elder victim injured in a crime is unable to apply personally, a friend or neighbor can help obtain state victim compensation by contacting the program, sending for application forms, helping the victim fill them out, and acting as an intermediary for the victim if needed. A list of all the state crime victim compensation programs is included at the end of this chapter.

In many communities, there are charities which provide small gifts or loans to crime victims. Frequently these funds are administered by churches or synagogues. However, they are not widely publicized for fear they will be taken advantage of by undeserving people. While these funds are not available in most communities, their success in some cities bodes well for their future use elsewhere. An example of one such municipally-sponsored program is in New York City where the Victim Services Agency operates an emergency cash fund for older crime victims. It provides "dignity money" for older victims in the form of gifts, loans, or vouchered payments. Minimal documentation of loss is required, there is no "means test," and victims frequently receive their money within several weeks. Similar emergency cash funds are available for the needs of older crime victims in Pasadena, California, and Las Vegas, Nevada.

Victims who have had money stolen may also need to contact their landlord, telephone and utility companies, or other creditors to explain the loss and work out a delayed payment plan. If a Social Security check or food stamps have been lost, the appropriate agencies should be contacted immediately. Some older victims may need assistance in dealing with the bureaucracies and circumventing parts of the process. For example, it can take several months for a stolen Social Security check to be replaced. However, a creative solution to this problem was used by one victim assistance program in Florida which arranged for all replacement checks to be sent within three days by having the request for these checks come from the office of the local Congressman.

Meeting a Victim's Physical Needs

The majority of older crime victims are not physically hurt.

However, those who are hurt tend to take longer to heal and are more likely to suffer from cuts, bruises, and internal injuries than younger victims, and to need hospital care.

The resources available for meeting these needs are the clinics and hospitals in the community. However, older crime victims often need more than in-patient or out-patient medical treatment in order to cope successfully with the crime's effects. They may find it hard to get to a doctor's office or to a pharmacy, or even to the grocery store because of weakness or restricted mobility. It may be difficult for victims who are bedridden or confined to a wheelchair to keep their homes clean and to prepare meals for themselves.

Fortunately, programs exist in most communities to assist elderly crime victims who are experiencing physical problems. These include: homemaker services, visiting nurses, friendly visitors, senior companions, telephone assurance, special transportation, escort services, and delivered meals.

In most communities, the area agency on aging subcontracts with local organizations to provide homemaker services for older persons who are ill or otherwise unable to move around. These aides visit the home regularly to clean, cook, and perform other routine tasks for the client. Similarly, aging agencies sponsor visiting nurse programs in which professional nurses visit older clients and take care of their medical needs, whether it be filling a prescription, changing a bandage, applying medication, or taking the elder to a doctor's office.

Friendly visitor, senior companion, and telephone assurance programs all have the same purpose: to provide companionship and friendship for older persons, in order to reduce their isolation. For elderly crime victims, these services can be particularly valuable, especially if they are feeling depressed after a victimization. Older persons in the program can look forward to the regular companionship of someone other than a service provider or worker, just a friend who wishes to spend time with them. For victims, this support can help speed the emotional recovery process, and, in turn, physical recovery.

Many localities also offer special transportation services for senior citizens. Arrangements must usually be made anywhere from several days to a week in advance, but exceptions can be made in emergencies. These programs most often use vans or mini-buses to pick up elderly persons at common rendezvous points and later return them to their homes. Some areas have expanded this concept and provide escort services for seniors. People staffing an escort service pick up elderly clients in their houses or apartments, go with them to doctors' offices or banks, stay with them, then later return them home. One such service in Washington, D.C. even obtained permission to pick up clients' food stamps for them, deposit or withdraw money from the bank for them, and perform other tasks which less mobile elderly people found burdensome.

The most common meals program for the elderly is "Meals on Wheels."

in which one or two hot meals a day are delivered to one's home. However, those not wishing to participate in this program can sometimes arrange through another of the local aging agency's services to have their grocery shopping done for them. More inventive projects have provided food directly to elderly crime victims. For example, a Los Angeles victim assistance project solicited food as charitable contributions from local merchants. Nonperishable items were stored at project offices and distributed to victims who could not afford food or were unable to shop for themselves.

Other "physical" needs of elderly crime victims are emergency housing, property repair, or replacement. These needs are most frequently found among victims of abuse who need to move out of the home, victims of robberies whose windows and/or doors have been rendered useless, or rape victims who are simply too afraid to stay in the same home overnight.

Most communities have a shelter for battered women; unfortunately, they seldom take in victims of other kinds of crime. However, crisis telephone hotlines operating in most large communities will have information on available emergency housing facilities. People under stress who wish to stay in their homes but need emergency repair work can easily fall prey to profiteering locksmiths or home repairmen. To avoid this possibility, the police, the nearest senior citizens center, or the area agency on aging should be able to provide advice and information about a local, inexpensive home repair service; an increasing number of large cities have such assistance available for senior citizens.

Meeting a Victim's Psychological Needs

Criminal victimization can have harmful psychological effects for victims of all ages. Shock, denial, depression, guilt, and anger are common after-effects. However, because of other factors in their lives, some older crime victims may be less able to cope with these emotions, may experience a crisis, and may need specific kinds of emotional help. Sources of help include family and friends, area agencies on aging, mental health centers, senior centers, and other agencies or groups concerned for older persons.

Even those older victims who do not have a crisis reaction still need moral support and encouragement, for which they usually turn to their friends or family. These informal helpers can, however, unwittingly compound an older victim's problems. Well-meaning relatives may, for example, point out what the victim did to precipitate the crime, confirming the victim's "I am stupid" belief. They may also shy away from the victim, as if victimization is somehow contagious, making the victim feel more guilty and anxious. These examples of negative "support" for victims, called the "second injury" by Morton Bard (1979) and others, provide an additional justification for crisis intervention or emergency counseling following a crime.

Effective crisis counselors need not be professional social workers, therapists, or psychologists. There are certain lay people

who, by virtue of their temperament and background, are "natural" crisis counselors for friends or relatives who have been victimized (Stein, 1980). Victim assistance programs in a number of cities have illustrated that, with proper training in the use of listening skills and in how to stay within their limitations, lay workers or volunteers can become effective victim assistance counselors (Jaycox, 1981a).

The basic "how-tos" of counseling older crime victims are covered in the next chapter on communicating with individuals. In general, good counselors have empathy, which is the ability to understand what the victim is feeling, can establish trust and rapport, can identify and interpret feelings, and can explore those feelings in a supportive way. If there is any doubt about one's ability to do these things or about the severity of the victim's problems, a referral can be made to a local social services or mental health agency.

Probably the best sources for locating aging services in the community are the state office on aging, and the local area agency on aging or mayor's office on aging. Every state has an office on aging and there are more than 660 area agencies on aging throughout the United States. A primary function of these agencies is to provide information and referral services to direct older people to appropriate agencies where help can be obtained.

Most communities have at least one community mental health center, and recent federal legislation mandates that each center employ a specialist in the problems of the elderly. Frequently these centers also have specialists who provide free counseling to persons going through crises of varying degrees, and ongoing therapy at fees which reflect the income levels of their clients. Many of these communities also have crisis hotlines, an emergency telephone assistance service, for persons experiencing all kinds of problems. These hotlines are usually staffed by volunteers who have received some training in crisis counseling and who have access to local resource directories. In some cities, there are telephone hotlines just for older citizens.

Another source of aid for elders who have been victimized and are experiencing emotional difficulties is the local senior citizen center. These centers, operated under contracts from the area agency on aging, do not customarily offer psychological counseling. However, they do have a network of excellent contacts with other agencies and services and should be able to secure needed help for a victim.

If crisis services for older persons are not available in a community, they can be started. Local aging-related provider agencies can set up their own services for older crime victims. Establishing crisis services requires close cooperation with the police, typically the first ones to learn the identity of victims and to contact them. With a good relationship with the police, it is possible for a variety of organizations to sponsor crisis intervention service. Stein (1980) gives the following examples:

- In Glendale, Arizona, the city manager's office sponsored a comprehensive assistance program for crime victims.

- Probation officers in several California counties decided to add crisis intervention counseling to their regular victim work of interviewing for pre-sentence reports and restitution plans.
- A few district attorneys, expanding their role in the victim/witness field, have sponsored crisis intervention projects.
- As a result of support from the Iowa State Association of Counties, several county welfare agencies trained their workers to offer counseling to crime victims.
- In Denver, staff of the visiting nurse program made house calls on rape victims and on elderly victims. The nurses were trained in both crisis counseling and social service provision and referral.
- Workers in senior citizen multi-purpose centers throughout Los Angeles learned victim assistance and, after making connections with local precincts, began counseling and helping older victims in their neighborhoods.
- In Pennsylvania, staff members of a wide range of elder service provider agencies were trained in victim assistance so that they could perform this role in the regular course of their work.
- In Little Rock, the Presbyterian Urban Council taught staff to serve as crisis intervention specialists for victims of all denominations.
- The West Philadelphia Block Association, a group of block clubs organized by neighbors, set up a crisis intervention service called "Friends in Need." In this way, victims did not have to leave their neighborhood or contact an official agency in order to receive assistance.

These are just a few examples of the range of crisis counseling services that can be operated for crime victims. They need not be elaborate, costly, or formal, yet they can be of immeasurable value to older victims.

Meeting a Victim's Criminal Justice-Related Needs

The criminal justice system has traditionally been structured to focus on the offender; the victim has been viewed mainly as a tool to assist in the offender's arrest and conviction. Only in recent years, with the advent of police-sponsored victim assistance programs, and courtroom witness assistance and restitution programs, has there been a slight shift in the system's priorities toward a greater emphasis on the needs and rights of victims. Still, more has to be done to make victims feel better about dealing with the police and the courts following a crime.

Older victims in particular are often intimidated by their lack of knowledge about the criminal justice process. They may be afraid

to cooperate because of their fear of retaliation. They may have great difficulty in getting to court for all scheduled appearances. They may be treated by police and prosecutors as "poor witnesses" from the start, so they are not afforded the attention needed to act as effective witnesses. Efforts to remedy these situations have focused primarily on the police and on the prosecutor's office.

Police Services

The police play an especially critical role in helping crime victims. Being the first representatives of the criminal justice system to contact them, they set the tone for victims' feelings about the crime in general and the system in particular. A recent study of New York City victims found that police perceived as having gone out of their way to help victims had a marked positive impact on their attitudes (Friedman et al., 1982). These attitudes, of course, in large part determine the degree of victim cooperation throughout subsequent involvement with the system.

Because of their unique role as the first "officials" who contact victims, police have great potential to assist victims in all areas of need. Unfortunately, police rarely have the training, information, or time to offer crisis counseling, social service referrals, and the like. However, many police departments across the country are becoming aware of victims' needs and have begun to work with existing victim services programs to see that victims receive proper attention.

Stein and Ahrens (1980) point out that working relationships between the police and victim services programs tend to follow several "models." The first is the "cooperation" model. Here the police allow victim service programs access to the names of reported crime victims. These programs then provide follow-up services to the victims they consider to be most in need.

In what has been termed a "collaboration" model, the police take a more active role and call a victim assistance counselor to the scene of the crime when in their judgment the victim needs help. Such teams operate in Tucson and Scottsdale, Arizona.

A "comprehensive" model of victim assistance combines the previous two methods. Victim counselors actively contact clients and are on call to help police officers in the field with people in crisis. This approach ensures immediate aid for victims who need it, plus a backup service for victims who do not need emergency help but may well have serious social service needs.

None of these models is easy to implement. Each requires extensive homework by victim advocates on the crime problem and the police department, delicate planning meetings with police policymakers, the development of compromise strategies, and, finally, the willingness of program staff to "prove" themselves before they are fully accepted. However, successful programs in different areas of the country using all three models demonstrate the value of police cooperation with victim services programs. Both parties benefit.

In fact, good relations between those performing victim assistance and the police can greatly improve the chances of victims receiving other comprehensive services from the police. In various communities, police conduct home security surveys for victims, help with emergency repairs, provide protective services against intimidation, teach crime prevention information to victims, and bring victims into organized neighborhood watch programs.

The American Bar Association Section on Criminal Justice (1980) suggests that good cooperation allowed programs and police to work together to set up the following programs:

- Police in-service training on problems of elderly victims. Departments in cities like Los Angeles, Chicago, and New York provide information and sensitivity training to recruits and officers so that they can deal more effectively with older persons who have been victimized. The National Retired Teachers Association (1980) has devised a training program for the police entitled Law Enforcement and Older Persons which deals with these topics as well as with the use of senior volunteers in criminal justice.
- Elderly victim units. In several cities, notably New York, the police have implemented special units to render intensive investigative interview, counseling, and referral services to elderly crime victims.
- Victim prevention programs. Many police departments have set up comprehensive prevention programs in which officers visit different senior citizen gathering places to make presentations on reducing risk, reacting to victimization situations, and using services available to victims.
- Intimidation response teams. These police teams are designed to reduce the incidence of acts and threats of intimidation against victims and witnesses by informing defense lawyers, investigating allegations, warning alleged intimidators, filing official reports with appropriate prosecution agencies, and coordinating victim/witness protection services. These programs can include telephone responses to all complaints, hotline counseling, personal responses to cases of serious threats, investigations and interviews, and the provision of security.
- Victim transportation and assistance units. These units provide free transportation to victims and witnesses to and from the police station or court appearances. Sometimes the service is coordinated among police, prosecutors, and court personnel.
- Victim/witness notification system. This is a formal system to advise victims (or their families) and witnesses of final police disposition, and the reasons for it. The notification can be provided by form letters, telephone calls, or personal visits by members of a police community relations unit.

Court-Based Services

The prosecutor's office of a criminal court can also play a significant role in assisting elderly crime victims. Outside of the police, staff in the district attorney's office have more routine contact with crime victims than any other segment of the criminal justice system. Like the police, they can contribute a great deal toward making victim involvement with the system less overwhelming, while simultaneously improving the efficiency and effectiveness of the court process. In recent years, increasing numbers of prosecutors' offices have realized the value of victim/witness services and have implemented wide-ranging reforms and programs.

One of the simplest services is information on the court process in general and the victim's case in particular. Too often an older victim's first knowledge that someone has been arrested in his or her case comes with a summons to appear in court. The victim may have no idea of what this means.

Many prosecutors' offices have set up case status and disposition notification systems which routinely inform victims of happenings at each major point in the process. Some prosecutor offices operate telephone witness alert systems. These are directed specifically at reducing those instances in which victims and witnesses spend considerable time in court waiting for their cases to be called, only to be told that the case has been postponed or will not be heard. To avoid these delays and unnecessary appearances, witnesses agree to be available on a certain date at a particular telephone number and agree to be at the court within a specified time after being called.

These services let the victims know that something is actually happening, which can be reassuring. They also increase the likelihood that victims will appear as scheduled, and in a broader sense improve relations between the criminal justice system and the public. Moreover, victims who are kept informed will be more likely to cooperate if their assistance is needed in the future.

Another form of assistance which can be of enormous aid to older victims is expediting the return of their stolen property. Under normal criminal justice procedures, property which is taken as evidence is often held until after trial, so that it can be used as an exhibit in the case. However, this procedure is not always necessary. Some victim assistance programs have persuaded court officials to allow early release of victims' property by substituting a photograph for the property where this is possible. The service requires cooperation between the police and the prosecutor, since the "chain of evidence" must always be preserved.

Allowing older crime victims to participate in the decision-making regarding their cases is beneficial. Not only does this make the victim feel more a part of the criminal justice process, but also it helps the court gain a more complete understanding of the victim's situation, leading perhaps to a more equitable judgment. Some states

and localities have begun to use "victim impact" statements and other means of acknowledging the rights of victims. For example, in Multnomah County, Oregon, a victim assistance program works with the Oregon Corrections Division to take victim testimony for the presentence report required for the judge before sentencing. Victims have a chance to explain their reactions to the violation, their losses, and the emotional after-effects. Additionally, the victim is usually consulted by the deputy district attorney handling the case before plea negotiations and often before sentencing recommendations. These procedures not only give victims an opportunity to be active participants in the criminal justice process, but also provide victims an outlet for their feelings of powerlessness and loss of control resulting from the crime.

Help in getting to and from court is another common need of elderly crime victims. Some victim/witness programs offer an escort service for victims, picking them up at home and taking them to court. As transportation is generally a problem for older Americans, especially in rural areas, this service is especially significant. Providing transportation can also increase the participation rate of witnesses and ultimately reduce the number of cases dismissed for lack of witness cooperation.

Court buildings themselves can be very intimidating places for older people who have never been there. They may have trouble finding the right room or even understanding how a trial works. To help them, some prosecutor victim/witness programs operate "friends in court" or "escort" services within the court. Assigned workers, frequently volunteers, greet victims on their arrival and accompany them to the witness reception room. They often sit with the victims throughout the day, answering questions, explaining procedures and providing general support. This type of service can have an important impact on the problems of intimidation of victims and witnesses. Intimidation can be quite subtle and difficult to prove, but it does require that the witness be alone.

The services outlined here are only some of those which can be offered to meet older victims' criminal justice-related needs. The American Bar Association Section on Criminal Justice (1980) recommends other actions which prosecutors, police, and courts can take to ease the problems of crime victims. These include:

- A central telephone number which victims and witnesses can call to get information on their cases.
- Victim/witness form letter notification systems. Form letters can be used to notify victims and witnesses of developments in their cases such as: formal charging decision; subpoena; continuances; pleas of guilty; final adjudication or jury findings; and sentencing. The letters can also include other useful information, such as telephone numbers for assistance with various problems.
- Social service referral system. This is a system within the

prosecutor's office to identify the particular needs of crime victims and to refer them to appropriate social service and assistance agencies.

- A victim/witness reception center. Courts can offer a safe, comfortable, and pleasant atmosphere for victims or witnesses to await court appearances and to confer with attorneys.
- Informational programs to explain case dispositions. Courts can provide a formal opportunity for victims and witnesses to meet with a trained court official who will discuss and explain the resolution of their particular case.
- A victim questionnaire to identify needs. Court officials can use a questionnaire to determine whether victims have problems which can be addressed by the court and to gain victims' perceptions of the system.

These programs are examples of the many services which can meet the needs of crime victims. For older victims and witnesses, who often have limited mobility, lack of knowledge about the system, fear of retaliation, and other age-related factors, these services can be especially beneficial.

Advocacy for Improved Treatment of Victims

The preceding sections of this chapter have dealt with actions that can be taken on behalf of individual victims to help them gain needed services. Over and above this form of advocacy, there is the larger issue of advocacy for the recognition of the rights of victims and the support of policies and programs which implement such rights. These efforts, which can be categorized as the "victims' movement," are only about a decade old, but their energy and effectiveness can be seen in the advancement of the cause of victims of rape and domestic violence, and in the recognition and beginnings of remedies for victims of child abuse and elder abuse.

The National Organization for Victim Assistance is an organization set up in 1975 by victim/witness assistance programs to spearhead this advocacy. NOVA has recommended an agenda for improving the treatment of victims and witnesses. Basically, these changes involve promoting reforms and additional training within all of the major criminal justice agencies, especially in law enforcement and prosecutors' offices. NOVA further proposes new state and local legislation in at least four areas:

- Laws which provide financial or other assistance to victims (e.g., compensation, restitution, property return, witness fees).
- Laws which recognize certain victim rights, such as rights to protection from intimidation and harm, to reparations, to the preservation of property and employment, to due process in criminal court proceedings, and to dignity and compassion.

- Laws to improve the victims' standing within the system, such as requirements for victim impact statements in court proceedings, and the provision of counsel in specific situations.
- Laws to provide statewide funding and structure for ongoing assistance programs.

In addition to NOVA, there are programs set up in a number of states (California, Connecticut, Florida, Kentucky, New Jersey, New York, and Wisconsin are examples) to coordinate victim services. Other nongovernmental organizations with a natural interest in victim/witness issues (like the American Bar Association and the National District Attorney's Association) have taken an interest in promoting changes in this area. And there are signs of an emerging interest in victim issues among senior citizens, as evidenced in several of the committee reports which emerged from the 1981 White House Conference on Aging.

Some progress in this movement is reflected in President Reagan's declaring the week of April 19, 1981, National Victim Rights Week, an event celebrated by some 35 states. NOVA prepared a package of materials for use by advocates during this week. It is a good, educational catalog of the full range of options that can be pursued to obtain improved equity for victims of all ages. Parts of NOVA's package are attached as appendices to this chapter.

In all, members of the community must recognize the complexities of older victims' needs. These range from economic to physical, to emotional, to criminal justice support. Older victims tend to have special needs, but frequently existing community services can be adapted to help them. Where no services exist, community residents of all ages can work together to establish programs, so long as real commitment is present. The emergence of a national victims' rights movement offers additional resources for help and program implementation, and should advance the recognition of older victims' needs.

Reading and Resources

American Bar Association, Section on Criminal Justice, Bar Leadership on Victim Witness Assistance, Washington, DC: ABA, 1980.

_____, Reducing Victim/Witness Intimidation: A Package, Washington, DC: ABA, 1979.

_____, Victim/Witness Legislation: Considerations for Policymakers, Washington, DC: ABA, 1981.

Bard, Morton and Dawn Sangrey, The Crime Victim's Book, New York, NY:

Brostoff, Phyllis M., "Police Connection: A New Way to Get Information and Referral Services to the Elderly," Jack Goldsmith and Sharon S. Goldsmith, Eds., Crime and the Elderly: Challenge and Response, Lexington, MA: D.C. Heath and Company, 1976.

Calvin, Mary Lou and Marilyn Wagner Culp, "Crime Services Programs," Marlene A. Young Rifai, Ed., Justice and Older Americans, Lexington, MA: D.C. Heath and Company, 1977.

Carrow, Deborah M., Crime Victim Compensation Program Models, Washington, D.C.: U.S. Government Printing Office, 1980.

Center, Lawrence J., Anti-Crime Programs for the Elderly: A Guide to Program Activities, Washington, D.C.: National Council of Senior Citizens, 1979.

Chappell, Duncan and L. Paul Sutton, "Evaluating the Effectiveness of Programs to Compensate the Victims of Crime," Israel Drapkin and Emilio Viano, Eds., Victimology: A New Focus, Volume 2, Society's Reaction to Victimization, Lexington, MA: D.C. Heath and Co., 1974.

Fletcher, P., "Criminalization of Elderly Women--A Look at Sexual Assault," Syracuse, NY: Syracuse Rape Crisis Center, 1977.

Friedman, Kenneth, Helen Bischoff, Robert Davis and Andresa Person, Victims and Helpers: Reactions to Crime, New York, NY: Victim Services Agency, 1982.

Galaway, Burt and Joe Hudson, "Restitution and Rehabilitation--Some Central Issues," Crime and Delinquency, Vol. 18, No. 4, October 1972.

Geis, Gilbert, "Compensation for Victims of Violent Crimes," Crimes of Violence, Volume 13, National Commission on the Causes and Prevention of Violence, Washington, D.C.: U.S. Government Printing Office, 1969.

Goldsmith, Jack, "Police and the Older Victim: Keys to a Changing Perspective," Police Chief, Vol. 43, No. 2, February 1976.

Hofrichter, Richard, The Practice of Restitution: A Victim Perspective, Washington, D.C.: The National Council of Senior Citizens, 1980.

, Victim Compensation and the Elderly: Policy and Administrative Issues, A Report by the Criminal Justice and the Elderly Program, National Council of Senior Citizens to the Select Committee on Aging, U.S. House of Representatives, Washington, D.C.: U.S. Government Printing Office, 1979.

Hudson, Joe, and Burt Galaway, Considering the Victim: Readings in Restitution and Victim Compensation, Springfield, IL: Charles C. Thomas, 1973.

Jaycox, Victoria H., Creating a Senior Victim/Witness Volunteer Corps: An Introductory Brochure, Washington, D.C.: The National Council of Senior Citizens, 1981a.

_____, Testimony before the Special Committee on Aging, United States Senate, September 22, 1981, Older Americans Fighting the Fear of Crime, Washington, D.C.: U.S. Government Printing Office, 1981b.

MacNamara, Donald E., and John J. Sullivan, "Making the Crime Victim Whole: Composition, Restitution, Compensation," Terence P. Thornberry and Edward Sagarin, Eds., Images of Crime: Offenders and Victims, New York, NY: Praeger Publishers, 1974.

McGowan, Robert H., "Our Senior Citizens: Now a Way to Help," Police Chief, Vol. 44, No. 2, February 1977.

Marlin, David H., Testimony before the Subcommittee on Criminal Justice, Committee on the Judiciary, U.S. House of Representatives, February 28, 1979, on H.R. 1899, Compensating Crime Victims, Washington, D.C.: U.S. Government Printing Office, 1980.

Mid-America Regional Council Commission on Aging, Aid to Elderly Victims of Crime, Washington, D.C.: U.S. Department of Justice, 1976.

National Criminal Justice Reference Service, Victim/Witness Assistance: A Selected Bibliography, Washington, D.C.: U.S. Department of Justice, 1978.

National District Attorneys Association, Commission on Victim/Witness Assistance, The Victim Advocate, Chicago, IL: NDAA, 1978.

National Retired Teacher's Association-American Association of Retired Persons, Law Enforcement and Older Persons, Revised Edition, Washington, D.C.: NRTA-AARP, 1980.

Reiff, Robert, The Invisible Victim: The Criminal Justice System's Forgotten Responsibility, New York, NY: Basic Books, 1979.

Rosenblum, Robert H. and Carol Holliday Blew, Victim/Witness Assistance, Washington, D.C.: U.S. Department of Justice, 1979.

Salasin, Susan, Ed., Evaluating Victim Services, Beverly Hills, CA: Sage Publications, 1981.

_____, Ed., Evaluation and Change, (Special Issue on Services for Survivors), Minneapolis, MN: The Program Evaluation Resource Center, 1980.

Silberman, Charles E., Criminal Violence, Criminal Justice, New York, NY: Random House, 1978.

Stein, John H., "Better Services for Crime Victims: A Prescriptive Package," Susan Salasin, Ed., Evaluation and Change, (Special Issue on Services for Survivors), Minneapolis, MN: The Program Evaluation Resource Center, 1980.

Stein, John H., and James H. Ahrens, How to Win Law Enforcement Support for Victim Services Projects, Washington, DC: National Council of Senior Citizens, 1980.

U.S. Department of Housing and Urban Development, "The Federal Crime Insurance Program," Washington, DC: HUD No. 77-188, June 21, 1977.

Viano, Emilio C., Ed., Victim/Witness Programs: Human Services of the 80s, Washington, DC: Visage Press, Inc., 1980.

Victim Compensation Programs in the United States December 1981

Ms. Nola K. Caop
Administrator
Violent Crime Compensation
Board
Pouch N
Juneau, Alaska 99811

Mr. Richard A. Godegast
Assistant Executive Secretary
Victims of Crime Program
State Board of Control
926 J Street, Suite 300
Sacramento, California 95814

Ms. Priscilla Conrad
Executive Director
Crime Victims Compensation
Denver District Attorneys Office
929 West Colfax
Denver, Colorado 80204

Mr. James D. O'Connor
Chairman
Victim Compensation Program
Criminal Injuries Compensation
Board
80 Washington Street
Hartford, Connecticut 06115

Mr. Oakley Banning, Jr.
Violent Crime Compensation Board
800 Delaware Avenue, Suite 601
Wilmington, Delaware 19801

Mr. Herbert G. Parker
Crimes Compensation Commission
Montgomery Building, Suite 201
2562 Executive Center Circle E.
Tallahassee, Florida 32301

Honorable David B. Poythress
Secretary of State
Chairman, Claims Advisory Board
State Capitol Building, Rm. 214
Atlanta, Georgia 30334

Mr. Wilfred S. Pang
Executive Secretary
Criminal Injuries Compensation
Commission
P.O. Box 399
Honolulu, Hawaii 96809

Ms. Pat Goldman
Director
Crime Victims Program
Department of the Attorney General
22nd Floor - Suite 2200
188 West Randolph
Chicago, Illinois 60601

Mr. Lon C. Woods
Director
Violent Crime Compensation Division
17 West Market Street, Suite 546
Indianapolis, Indiana 46204

Ms. Betty Bomar
Director
Crime Victims Reparations Board
503 Kansas Avenue, Suite 343
Topeka, Kansas 66603

Crime Victims Compensation Board
113 East Third Street
Frankfort, Kentucky 40601

Mr. Martin I. Moylan
Executive Director
Criminal Injuries Compensation Board
1123 North Eutaw Street
601 Jackson Towers
Baltimore, Maryland 21201

Mr. Paul J. Donaher
The Commonwealth of Massachusetts
Assistant Attorney General
Torts Division
One Ashburton Place
Boston, Massachusetts 02108

Mr. Thomas E. Woods
Chairman & Executive Director
Crime Victims Compensation
Board
The Plaza Hotel, Suite 809
111 South Capitol Avenue
P.O. Box 30026
Lansing, Michigan 48909

Mr. Duane E. Woodworth
Executive Director
Crime Victims Reparations
Board
702 American Center Building
160 E. Kellogg Boulevard
St. Paul, Minnesota 55101

Ms. Paula V. Smith
Missouri Department of Labor
and Industrial Relations
Jefferson City, Missouri 65101

Ms. Cheryl Bryant
Director
Crime Victims Unit
Workmen's Compensation Division
815 Front Street
Helena, Montana 59601

Ms. Imogene Bruce
Crime Victims Reparation Board
State Capitol - Sixth Floor
Lincoln, Nebraska 68509

Mr. Howard E. Barrett
Director of Administration
Board of Examiners
Blasdel Building, Room 205
209 East Musser Street
Carson City, Nevada 89710

Mr. Thomas A. Kaczmarek
Chairman
Violent Crimes Compensation
1180 Raymond Boulevard, Em. 802
Newark, New Jersey 07102

Ms. Edith Sugin
c/o Crime Victims Assistance
Organization
P.O. Box 9411
Albuquerque, New Mexico 87119

Mr. Ronald A. Zweibel
Chairman
Crime Victims Compensation Board
270 Broadway
New York, New York 10007

Richard J. Gross, Esquire
General Counsel and
Executive Administrator
Crime Victims Reparations
Workmen's Compensation Bureau
Russel Building - Highway 83 North
Bismarck, North Dakota 58505

Mr. Robert B. Belz
Director
Victims of Crime Division
Court of Claims
255 East Main Street, 2nd Floor
Columbus, Ohio 43215

Mr. Charles "Butch" Wood
3033 North Walnut Street, Suite 100W
Oklahoma City, Oklahoma 73105

Mr. Jack Parks
Director
Crime Victims Compensation Fund
SAIF Building
Salem, Oregon 97312

Mr. Marvin E. Miller
Crime Victims Compensation Board
Justice Department
Strawberry Square
Harrisburg, Pennsylvania 17120

*Mr. Robert Harold
Office of State Court Administrator
Providence County Court House
250 Benefit Street
Providence, Rhode Island 02903

Mr. Keith Jordan
Assistant Attorney General
Criminal Injuries Compensation Board
State Board of Claims
450 James Robertson Parkway
Nashville, Tennessee 37219

Mr. Jerry Belcher
Texas Industrial Accident Board
Crime Victim Division
P.O. Box 12757
Capital Station
Austin, Texas 78701

Mr. Robert W. Armstrong
Director
Division of Crime Victims
Compensation
Department of Workmen's
Compensation
Industrial Commission of Virginia
P.O. Box 1794
Richmond, Virginia 23214

Mr. Calvin Winslow
Administrator
Crime Victims Division
Department of Labor and
Industries
Olympia, Washington 98504

Ms. Becky A. O'Fiehf
Deputy Clerk
Court of Claims
State of West Virginia
State Capitol
Charleston, West Virginia 25305

Mr. John Byrnes
Deputy Administrator
Crime Victims Compensation Bureau
P.O. Box 7951
Madison, Wisconsin 53707

*The Rhode Island program will not be implemented until a Federal
crime victims compensation bill has been enacted.

Why Victim Rights?

Crime In The United States

231

In a country where crime is a prevalent part of daily life and a growing source of fear and destruction, it is disturbing that we have not been more sensitive to the rights of the victims who suffer the direct consequences of that crime. The irony is that the phrase "the criminal justice system" depicts precisely the major way in which our society has responded to the crime problem: by providing justice for the criminal.

While crime may be the product of social injustices, and while prevention of crime and criminal rehabilitation are crucial efforts in the reduction of crime, the major impact of crime on our society cannot be alleviated by the way the criminal justice system traditionally operates.

When crime prevention fails, the problem of crime becomes the problem of the victim.

Victims of Crime

The plight of the victim has been left to the whims of circumstance and there has been little concern for alleviating the burdens imposed on innocent victims and witnesses.

Crime can be life threatening for the victim whether the crime involves personal violence or property invasion. The violation of individual privacy and dignity pierces the security of daily living. Often the initial damage sustained by property loss or physical injury is compounded by the treatment of the victim in the criminal justice system and his community.

Physical Injury

The consequences of a criminal assault can range from minor abrasions to crippling paralysis -- to death. While many people understand the seriousness of mutilation, disfigurement, paralysis or death, the general public is not aware of the extent of physical injury in even "minor" crimes, nor of the increasing incidence of physical violence.

- **Minor physical injuries** can be crippling or deadly. An elderly woman in Portland was a victim of a pursesnatch and broke her elbow in the fall. She has been reduced to dependent nursing care for the rest of her life.
- **Permanent injury** can change the entire life of a victim. A young man in Minnesota has been condemned to a life of paralysis and confinement to a wheelchair as a result of an assailant's bullet through his spinal cord. Over 15 million Americans suffer injury as a result of robbery or assault each year.
- **Death** is the ultimate violation. The senselessness of murder. In Baltimore, the owner of a small grocery store had an argument one day with a customer over increasing prices. The next day the customer walked in the store and shot the man in the head.

Financial Loss

The financial costs to the crime victim can be staggering. Financial loss may include property destruction, direct dollar loss, loss of income, medical expenses, retraining or rehabilitation costs.

- **Direct dollar loss** can impose a severe burden on the average victim living on a fixed budget. The average family's grocery bill is currently \$45 a week. Over 11 million burglaries, thefts, and personal larcenies in the United States each year involve more than \$50 in stolen property.

- **Property destruction and loss** can cause serious financial hardship on the victim. The victim suffers not only from the immediate loss of the use of property, but also must earn the necessary cash to pay for replacement.
- **Medical costs** are often borne by the victim. They may include hospitalization, surgery, psychiatric treatment, doctor bills, and nursing care. Even if the victim is covered by an insurance program, he typically must pay many related medical expenses.

Trauma and Stress

Despite the high crime statistics, most Americans do not expect crime to happen to them, and often feel that if it does, they could handle it. A sense of shock followed by feelings of anger, fear, shame, and depression commonly occur in the immediate aftermath of a victimization, and sometimes lead to long-term disabilities.

- **Stress** caused by feelings of humiliation, violation, and fear affects both personal relationships and other aspects of a victim's life. Crime victims often display a lack of concentration and have difficulty meeting the most ordinary of responsibilities.
- **Isolation and withdrawal** may be a part of a victim's reaction because few understand the stresses they are experiencing, and that can be frightening. It can be hard to communicate and even close friends may not seem to understand the victim's behavior.
- **Depression and physical ailments** can result from the tension. Severe headaches, dizziness, nausea, and fatigue are typical symptoms of stress.

Dealing with the Criminal Justice System

The problems of a victim or a witness are increased by many difficulties which arise in working with the criminal justice system. Court delay, postponements, and inadequate case preparation contribute to distress and despair.

- **No information** is given to most victims or witnesses on the progress of the investigation or the prosecution of the case.
- **No victim advice** is sought regarding decisions made on bail, plea bargaining, or sentencing.
- **No education** is provided to victims and witnesses concerning legal language or procedures. Typically, no one is available to explain what is happening.
- **Court postponements** may require witnesses to be called to court several times and endure repeated continuances. The average criminal court case will be processed over 4 months. Slower courts will take a year or more.
- **Court delay** may cause witnesses to wait unnecessarily and suffer sustained absences from work. Witnesses may be expected to pay for their own transportation, meals, for day care, and parking expenses.
- **Fear of retaliation** can affect a victim's or witness's participation in a case. The offender's right to face his accuser is all too often seriously threatening to the victim or witness. Actual intimidation or harm is not uncommon.

Why Victim Rights?

We cannot prevent all crime, or eliminate all its adverse effects. But we can reduce many of the burdens borne by victims, witnesses and their communities.

The recognition of the rights of victims and witnesses to be free from fear and pain and the support of policies and programs that implement such rights are responsibilities of us all.

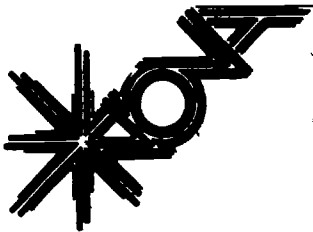

Rights for Victims and Witnesses

233

As a just and humane people, Americans should support rights for those victimized by crime with the same pride as we provide protections to those accused of crime.

Rights which are designed to reduce the hardships and losses that many victims suffer are as important to the distribution of justice as rights which ensure fair and equal treatment of all citizens.

Victims which are entitled to such rights include not only the direct victim of a crime but dependents and family members. Witnesses, whether or not they are victims, need to be accorded many of the same rights in their dealings with the criminal justice system.

The National Organization for Victim Assistance supports the adoption of a bill of rights for victims and witnesses in every local and state jurisdiction. The following sample listing is a summary of many rights, proposed and adopted, that have been advanced in recent years. It does not carry the endorsement of NOVA or its affiliated advisors. Nonetheless, we hope that the listing will help local victim advocates and policy makers formulate their own bill of rights for victims and witnesses

1. Victims and witnesses have a right to protection from intimidation and harm.

- A victim or witness has the right to be free from intimidation when involved in the criminal justice system.
- The victim or witness has the right to receive the maximum available protection from threats and harm when such intimidation cannot be prevented

2. Victims and witnesses have a right to be informed concerning the criminal justice process.

- A victim or witness has a right to be informed about the procedures and practices of the criminal justice system.
- A victim or witness has a right to be informed of financial assistance and other social services available to victims and witnesses.
- A victim or witness has a right to be informed of any compensation or fees to which they are entitled.
- A victim or witness has the right to know the status and progress of his/her case from the police investigation to final disposition
- A victim or witness has a right to be informed of a defendant's release on bail.
- A victim or witness has a right to be informed of post sentence hearings affecting the probation or parole of the offender.
- A victim or witness has the right to be informed when the convicted offender is released from prison.
- A victim or witness has the right to be informed of all hearings and procedures in time to exercise his/her right to attend.
- A victim or witness has the right to be informed of whatever rights to legal counsel are available to him/her in that state.

3. Victims and witnesses have a right to counsel.

- A victim or witness has a right to receive confidential counsel from persons outside of the criminal justice system such as a counselor, clergyman, or victim advocate.

- A victim has the right to participate in the criminal justice process directly or through representation.
- A victim, witness or a representative of either have the right to discuss their case with the prosecutor and to have it explained in non-technical language
- A victim or witness has the right to retain counsel with standing in court to represent him/her in cases involving the victim's reputation.
- A victim has a right to be informed of available civil rights and remedies respecting his or her case.
- A victim has the right to discuss his or her case with the District Attorney and be informed of any offers to plea bargain with the defendant

4. Victims and witnesses have a right to reparations

- A victim or witness has the right to receive a reasonable witness fee plus reimbursement for necessary out-of-pocket expenses associated with lawfully observing a subpoena.
- A victim or his or her surviving dependents have the right to receive financial compensation for physical and/or emotional injuries suffered as a result of being a victim of crime
- A victim has the right to receive restitution for expenses or property loss incurred as the result of the crime, and when restitution is ordered, to have the order diligently and fairly enforced
- A victim has a right to proceed in civil suits for recovery for damages and to place a lien on any profits received by his assailant as a result of publications or media coverage resulting from the crime

5. Victims and witnesses have a right to preservation of property and employment.

- A victim or witness has the right to respond to a subpoena without fear of retaliation or loss of wages from his or her employer.
- A victim has the right to have recovered, identifiable property returned quickly, whenever possible using photographs as evidence in any criminal proceeding.

6. Victims and witnesses have a right to due process in criminal court proceedings.

- A victim or witness has the right to be notified in advance when a court proceeding has been rescheduled or cancelled.
- A victim or witness has the right to a speedy disposition of the case so as to minimize the stress, cost, and inconvenience resulting from his or her involvement in a prosecution
- A victim has the right to have a victim impact statement presented and considered prior to sentencing.

7. Victims and witnesses have a right to be treated with dignity and compassion.

- A victim has a right to basic human services to meet emergency and long term needs caused by financial, physical, or psychological injury.
- A victim or witness has a right to be treated with dignity by human service professionals who provide basic assistance.
- A victim or witness has a right to receive courteous assistance as they cooperate with criminal justice personnel



Victim Rights Week

235

Legislation and Advocacy:

The challenge: Victims have long been forgotten by the legal system. While people may give lip service to the need for victim rights, few states have legislation which effectively guarantees those rights and victims rarely have advocates.

The response: The National Organization for Victim Assistance suggests the following 15 ways in which a concerned public can respond to this challenge. NOVA is ready to help you act on these recommendations:

Establish and Support a Coalition for Victim Rights in Your State

- 1 Identify programs, agencies and services in your state that work with victims and witnesses of crime
- 2 Call a meeting of representatives from those services to discuss the needs of victims and witnesses in your state and the current public policy issues that might be addressed to meet those needs
- 3 Organize the coalition by developing an agenda for the year, a meeting schedule, and choosing officers who will take responsibility for getting people together
- 4 Notify others in your community that the coalition is forming and that they can help by supporting the coalition's advocacy of victim rights.
- 5 Announce the formation of a permanent coalition on victim rights during Victim Rights Week and release media notices on the event

Prepare and Advocate for Needed Legislation in Your State

- 6 Identify and study legislative needs for victim service funding, revisions in the criminal code, and victim compensation.
- 7 Find out who are the legislative leaders, who are your potential legislative allies and opponents, and the basics of legislative politics in your state
- 8 Become familiar with legislative procedure and the lobbying laws in your state
- 9 Prepare needed legislation for introduction with the help of your legislative staff and potential sponsors.
- 10 Select a spokesperson for your coalition who will develop and maintain visibility at the legislature on behalf of your bills.
- 11 Organize people to testify at hearings on critical legislative issues -- particularly solicit assistance from former victims, national organizations, and practitioners in the field
- 12 Prepare yourself with back-up research in support of your legislative issues.
- 13 Develop media exposure for victim issues in general and your pieces of legislation during Victim Rights Week

-
- 14 Encourage local legislators and your governor to support Victim Rights Week so that you can use that support in later advocacy efforts.
-

**Support NOVA'S Efforts
to Advocate for
Victim Rights Legislation**

- 15 Support nationwide efforts to address victim issues through federal, state and local public policy. NOVA and other national organizations, like the National Council on Crime and Delinquency, the American Bar Association, and the National District Attorneys Association, can help you make your support count.

If you would like samples of legislation which has been enacted in Wisconsin, Connecticut, and California and provides for a statewide funding program for victim services, write or call:

**The National Organization for Victim Assistance,
Attention: Legislation and Litigation Committee
918 16th Street, N.W. Suite 503,
Washington, D.C., 20006**

(202) 466-NOVA

If you would like a summary of state legislation relating to the field of victim and witness issues, write:

**Susan Hillenbrand
Victim/Witness Project
American Bar Association
1800 M. Street, N.W.
Washington, D.C. 20007**

Law Enforcement:

The Challenge: No one can prevent all crime. But, the police form our first line of defense against its growth. The challenge of reducing the effects of crime faces us all, but it is the law enforcement officer who is usually the first person who must deal with the stress, anger and pain of a victim.

The Response: How well the law enforcement officer responds to the distress of victims may determine whether the perpetrator is arrested, prosecuted, and convicted. The National Organization for Victim Assistance suggests the following 20 ways in which law enforcement can respond to the challenge. NOVA is ready to help concerned agencies act on these recommendations:

Improve Service to Victims Within Your Law Enforcement Agency

- 1 Train police operators to identify emergency calls for assistance on the basis of the described crime and the distress of the victim.
- 2 Provide a private room at the station for victims and witnesses to use while making a report.
- 3 Patch emergency calls directly to the responding officers so that they can talk to the victim on the way to the scene.
- 4 Train officers to make sure that the victim's medical and emergency needs are taken care of before beginning an interview.
- 5 Conduct interviews without interruption and in privacy, and train officers to be alert to all harm done to the victim, including emotional distress.
- 6 Explain to the victim briefly the police procedures at the scene as well as what he or she can expect later.
- 7 Avoid unnecessary procedures like lifting fingerprints when there is little chance of an arrest. Try to conduct follow-up interviews at the victim's convenience.
- 8 Try to arrange for transportation for victims if they are needed at the police station.
- 9 Have investigators leave calling cards so that victims may contact them easily.
- 10 Establish a record keeping system which includes notification to a victim when an unsolved case is moved to an inactive status

Support Existing Victim Services Within Your Community

- 12 Identify local programs that provide services to victims and witnesses of crime and circulate the names of such programs to field officers.
- 13 Help your local victim program work more effectively by providing them with information on new crime victims immediately.
- 14 Work with local victim programs to coordinate their services with the needs of effective police response.
- 15 Offer to train local victim service workers to understand more fully the requirements of good police work.

-
- 16 Offer to train local victim service workers in crime prevention techniques and coordinate your crime prevention program with the delivery of victim services.
 - 17 Distribute information at the police station on available services for victims and witnesses
 - 18 Invite victim service workers to provide training to police officers in special victim problems
 - 19 Work with local prosecutors and/or victim and witness services to establish a protection unit for witnesses in cases of harassment and intimidation.

**Support NOVA'S Efforts
to Assist Victims
of Crime**

- 20 Support nationwide efforts to reduce the effect of crime on its victim. NOVA and other organizations, like the National Council on Crime and Delinquency, the National Sheriff's Association, the International Association of Chiefs of Police, can help you make your support count.

If you would like further information on how law enforcement can work with Victim Service Programs during Victim Rights Week or throughout the year, write or call:

**The National Organization for Victim Assistance,
Attention: Law Enforcement Committee
918 16th Street, N.W. Suite 503,
Washington, D.C., 20006**

(202) 466-NOVA

or write for:

**How to Win Law Enforcement Support
for Victim Services Project
Criminal Justice and the Elderly
1511 K. Street, N.W.
Washington, D.C. 20005
Price: \$10.00**

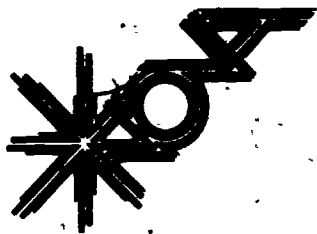

The Challenge to Business . . .

239

We cannot prevent all crime, or eliminate all its adverse effects. But we can reduce many of the costs and burdens borne by the victims and their communities. That challenge faces us all — including American business leaders.

. . . And the Opportunity to Respond

The National Organization for Victim Assistance suggests twenty-five ways in which the business community can respond to the challenge. NOVA is ready to help concerned executives act on all the following recommendations:

Establish Victim Assistance Programs Where None Now Exist

- 1 Bring the needs of crime victims to the attention of your professional associations, business groups, and service clubs. Urge them to support the establishment of needed programs.
- 2 Encourage public prosecutors to improve victim and witness cooperation through a number of service innovations — including a telephone alert system.
Offer employees paid leave to serve as witnesses.
Support the establishment of victim compensation and offender restitution programs.
- 3 Persuade criminal justice professionals to return immediately to the victim stolen property recovered by the police, and to authorize "return-to-shelf" policies in shoplifting cases.
- 4 Support the widespread use of commercial and personal crime prevention measures.
- 5 Teach personnel specialists, employee counselors, and medical staff about crisis-induced stress and about community agencies which can help employees manage those stresses more successfully.
- 6 Support the establishment of crisis intervention and similar service programs.

Support Existing Victim Assistance Programs

- 7 Help your community's victim and witness programs work more effectively by providing them management advice, financial assistance, and the public support of community leaders.
- 8 File criminal complaints against shoplifters and other criminals. Encourage employees to serve as witnesses in cases involving crime at their worksite or elsewhere.
- 9 Participate in "executive loan programs" that use the skills of executives to improve the planning and management of criminal justice services.
- 10 Print victim assistance programs' educational messages and public service announcements in company publications.
- 11 Provide management advice to programs of victim compensation and offender restitution.
- 12 Encourage employees to get insurance protection against crime, and provide employees some assistance when needed to file insurance and compensation claims.

-
- 15 Sponsor a workshop on crime prevention and other loss-prevention strategies which employers and employees can use.
 - 16 Serve as an advisor to, or board member of, a non-profit program offering assistance to victims of crime.
 - 17 Contribute to, and help organize fundraising campaigns for, such programs.
 - 18 Provide in-kind donations to such programs, such as printings, mailings, or supplies to meet emergency victim needs.

Support NOVA's Efforts to Assist Victims of Crime

- 19 Sponsor and support regional and nationwide efforts to reduce the needless, costly effects of victimization. NOVA and other organizations, like the American Bar Association, the National Association of Counties, and the National Council on Crime and Delinquency, can help you make your support count.
- 20 Sponsor and support the design and distribution of materials on victim/witness management.
- 21 Sponsor and support education programs aimed at improving witness cooperation.
- 22 Sponsor and support national efforts to modernize victim compensation and offender restitution programs.
- 23 Sponsor and support the distribution of information on crime prevention techniques.
- 24 Sponsor and support public service messages to educate the public about victim stress.
- 25 Sponsor and support programs to develop professional training in stress management for employee counselors and others.

If you would like a copy of NOVA'S Business Awareness Manual, write or call:

**The National Organization for Victim Assistance
918 16th Street, N.W., Suite 503
Washington, D.C., 20006**

(202) 466-NOVA



Victim Rights Week

Prosecution:

241

The challenge: The participation of victims and witnesses is critical to the effective administration of justice. But, despite the growing recognition of the need for victim and witness cooperation, problems which reduce cooperation still plague the criminal justice system.

The response: The National Organization for Victim Assistance suggests the following 20 ways in which prosecution can respond to the challenge. NOVA is ready to help prosecutors act on these recommendations:

Establish Victim and Witness Assistance Services in your Office

- 1 Designate one or more staff persons victim advocates to work with victims and witnesses of crime.
- 2 Have the advocates help victims with any necessary forms that must be filled out in cooperating with the criminal justice system or receiving compensation or fees.
- 3 Have the advocates explain the court process and other procedures to victims and witnesses.
- 4 Develop a record keeping system which includes automatic notification of the victim/witness of any changes in case progress.
- 5 Assess the needs of the victim/witness and refer him or her to appropriate social service agencies.
- 6 Provide personal assistance to victims/witnesses who are having difficulty coping with emotional stress or who need help in arranging their personal affairs.
- 7 Provide a special room for witnesses to wait to participate in court proceedings and arrange for transportation, day care, and meals on days when they must come to court.
- 8 Develop a telephone alert system so that witnesses do not have to come to court more than necessary.
- 9 Make arrangements with local employers to allow witnesses to come to court without sacrificing pay or other benefits.

Support Existing Programs that Work With Victims

- 10 Work with law enforcement agencies to provide witness protection in cases of harassment and intimidation.
- 11 Identify existing social service and crisis intervention agencies that can help victims and witnesses deal with their problems.
- 12 Distribute information in your office on programs that may be of use to victims and witnesses.
- 13 Help local crisis intervention services work more effectively by providing them access to information on current cases as quickly as possible.
- 14 Sponsor and support public service announcements on behalf of agencies and programs working to provide services to victims.

-
- 15 Help develop a coalition of agencies and programs working in your community on behalf of victims and witnesses and coordinate service efforts.
 - 16 Distribute information to the public through brochures and posters on the criminal justice system, crime prevention, and available victim assistance programs.
 - 17 Contribute to National Victim Rights Week by sponsoring programs on victim issues such as sexual assault, domestic violence, and child abuse.
 - 18 Assist in advocacy efforts on behalf of victim rights, victim service, and victim compensation legislation.
 - 19 Provide space in your office for local volunteers who wish to assist in providing service to victims and witnesses of crime
-
- 20 Support nationwide efforts to deal with the hardships that victims and witnesses endure. NOVA and other national organizations, like the National District Attorneys Association, the American Bar Association, and the National Council on Crime and Delinquency, can help you make your support count
-

**Support NOVA'S Efforts
to Assist Victims
of Crime**

If you would like additional information on how to start a victim/witness program in your office or ideas on how to improve current services, write or call:

**The National Organization for Victim Assistance,
Attention: Committee on Prosecution
918 16th Street, N.W. Suite 503
Washington, D.C. 20006**

(202) 466-NOVA

and

**The National District Attorneys Association
666 North Lake Shore Drive
Chicago, Illinois 60611**

(312) 871-0844

Chapter Twelve

Communicating with Older Individuals

Chapter Twelve

Communicating with Older Individuals

Advance Organizers

- Overall, communicating with older persons does not differ substantially from communicating with persons of any age.
- For elders with diminished hearing or failing vision, communication can be accommodated or adapted to ensure effective interaction.
- Communication takes place on two levels: the verbal and the nonverbal. How something is said nonverbally can be as important as what is said verbally. In communicating with an older person, important nonverbal behaviors include: eye contact, smiling, head movements, posture, seating, gestures, and touching.
- In counseling older victims, the most basic skills required of the helper are: empathy (understanding from the other's point of reference), respect (believing in the worth of the other), and concern (giving genuine attention to the other's communications). These qualities may be developed with experience.
- The victim assistance counselor needs to be especially sensitive to the role of feelings in the victim's recovery. The counselor should: allow a range of feelings from confusion to guilt to hostility; be patient with someone who may feel a unique sense of tragedy or violation; comfort or take care of the victim's immediate needs; avoid imposing his or her own values or standards on the victim; understand anger vented by the victim at helpers; and listen actively to the verbal and nonverbal cues of the victim.
- Active listening is a very productive counselor skill for improving verbal communication. Applications of this strategy include: "mirror responses," "paraphrasing," open-ended questions, and "feeling responses."

- Certain techniques seem particularly helpful with older clients. In general, these reflect counselor awareness of and sensitivity to the older victims' needs for support, reassurance, and individuality.
- Group counseling may provide the support and identity victims need for recovery and improvement of quality of life.

Introduction

For too many older Americans, one social problem in particular--crime--is a major cause of stress in old age. This conclusion is reinforced by a number of polls and surveys taken among persons over 65, and is also supported by many gerontologists and geropsychiatrists. For example, in a recent psychiatric journal, Dr. Bennett Gurian described a visit he made in 1967 to an elderly housing project in Boston.

About 100 elderly people were sitting in their lounge. I asked them what I as a psychiatrist could do for them and they began to tell me: "Well . . . could you walk with me to the grocery store?" "Could you put a lock on my door?" "Could you see that my Social Security check is not stolen from my mailbox?" "Can you help me not to be afraid to be alone in my apartment?" (Gurian, 1978:52)

Dr. Gurian did not dismiss these concerns about past and future victimizations as outside the range of his services. Instead, he began a program which social service and criminal justice professionals would easily recognize.

Four years ago we started a mobile mental health unit for the isolated elderly . . . Its manifest purpose is to provide transportation to elderly people that other transportation services will not provide, for example, to do their food shopping or get their checks cashed . . . Our hidden purpose is case-finding. People asked, where are the isolated elderly? We said let us see if we can find them.

Dr. Gurian continues:

(We) have developed a new program for those elderly who have had recent trauma, for example, a house broken into, a purse snatched, a death of someone close. Those people are visited within 24 hours by a member of the staff who asks, 'What do you need and how can we help?' The staff person tries to mobilize the neighborhood support system around the elderly person (Gurian, 1978:54).

Thus, Dr. Gurian discovered on his own what criminal justice professionals have also discovered in their work with the elderly: that crime prevention and victim assistance can do much to relieve the stresses that accompany the fear of victimization among large segments of the older population. Moreover, he found that the service requirements can be met by trained paraprofessionals and volunteers--exactly the kinds of staffs drawn in large numbers to the aging field. Additionally, people who work individually with the elderly, such as visiting nurses, homemakers, and counselors, can be taught this subject matter and can use their "crime resistance" knowledge in the

course of their work without becoming overwhelmed by new responsibilities.

Providing crime prevention and victim assistance services on a one-to-one basis, though, requires the use of effective communication and counseling techniques. This chapter will offer a brief introduction to communication techniques with individuals, outlining skills that are helpful in dealing with people in any stressful situation as well as tips for counseling older victims.

Communicating with Older Individuals

Overall, communicating with older persons does not differ substantially from communicating with persons of any age, unless one has to accommodate a particular handicap.

Two common handicaps of old age are diminished hearing and failing eyesight. If severe enough, each of these conditions can interfere with good communication if the counselor does not recognize them early. An older person may not mention these conditions, even if they are disabilities, so counselors will need to be especially alert to signs that they exist and then act accordingly.

Certain gross conditions indicate that an older person has trouble with his or her vision: difficulty in walking or other signs of poor coordination, squinting of the eyes or uncontrolled eye movements, or the inability to recognize someone or to distinguish an object from its background (like a hand put forward for a handshake). If these signals are present, it becomes especially important to make the older person aware of the counselor's position in the room to alleviate any anxiety. And since hearing would then be doubly important, the counselor should be careful to speak clearly and at a normal speed. Less dramatic vision problems can still have an impact on the victim assistance counselor's effectiveness. For example, extreme nearsightedness could render written instructions or diagrams for target-hardening a home virtually useless. The counselor should be alert for these possibilities, to the point perhaps of asking the elder client to read a segment before leaving.

In communicating with an older person who is hard of hearing, pacing and enunciation become important. Take time. Shouting usually does not help either, since many elders have lost their hearing in the high frequencies. Pronouncing each word clearly and deliberately, with some expression, and at the lower frequencies, is much more effective. In addition, the counselor should face the person so that lip reading is possible. A slight touch to get the older person's attention before speaking is also helpful.

As with a visual impairment, there are certain gross tell-tale signs of a hearing loss. Tipping the head to one side or trying to place the speaker on the side of one's "good" ear are such signs. Blank looks, inappropriate answers to questions, and asking for things to be repeated are others. When any of these signs is present, counselors should assume that the older person may be hard of hearing

and should accommodate their communication style to that possibility.

Whether disabilities are present or not, and usually they will not be, in counseling or providing advice or information to a senior citizen, it is well to remember that communication can take place on two levels: verbal and nonverbal. They may be equally important. Nonverbal communication takes place through the body, which can sometimes send messages different from--or even contrary to--spoken statements. How something is said nonverbally can be as much a message as what is said verbally.

Gerontologists have identified several nonverbal communication techniques which can be helpful when used by people counseling elderly persons (Greenberg et al., 1976). While these techniques may be thought of as normal social interaction skills, they deserve attention when interacting with an older person.

Eye Contact

It is helpful, whenever possible, to establish periodic eye contact with clients, especially when they are talking. Comfortable eye contact lets them know the counselor is interested in them and wants to understand them. Also, this eye contact will allow a counselor to pick up the clients' nonverbal messages, and notice whether they seem uncomfortable or nervous, pleased or angry.

Smiling

Another strong nonverbal signal is smiling. Naturally, smiling would be inappropriate if an older person is recounting how she was mugged or explaining why she is so fearful of crime. However, used at the proper times, smiling while listening indicates to clients that the counselor enjoys being with them.

Head Movements

A counselor can also communicate signals of interest in the clients and acknowledgement of their feelings simply by nodding the head. When the counselor nods, he or she is not necessarily saying that "I agree with your opinion or perception of the situation," but that, "yes, I hear what you are saying and I think I understand." This reinforcement can be very reassuring to an older person.

Posture

Posture can be very important in communicating with another. If an elder is sitting rigidly, moving constantly, or leaning away from the counselor, it may reflect the older person's nervousness or tension. On the other hand, if the counselor adopts an aggressive "leaning up to the client" posture, this may be threatening, just as a slouching, over-relaxed posture may be interpreted by the elder as lack of real interest or concern on the counselor's part. To indicate that one is really interested, it helps to lean forward slightly or, when standing, to incline one's head toward the person.

Seating

We have found that an older person often finds it easier to be interviewed sitting down; and, while most people seem to be more comfortable sitting at right angles to one another in conversation, as opposed to directly opposite each other, we find that it is generally more helpful to position oneself squarely in front of the older person. This ensures that the counselor will be seen and heard better. (Also, as mentioned, because higher pitch sounds are lost sooner for hard-of-hearing elders, lowering the pitch, speaking more deeply, will enable counselors, especially females, to be understood better than speaking in a normal pitch but in a louder volume.)

Gestures

Controlled gestures, when combined with verbal responses, can also help get points across better. Simply pointing to an object being talked about--like a lock or a window--can help. Conversely, nervous gestures like foot-tapping or playing with a pencil or other small object may indicate discomfort.

Touching

Older clients may often touch a person counseling them, or hold their arm or hand because of a desire for human contact or an implied need for support. Sometimes it is helpful to touch them as a means of reassurance or comfort, but only if there is an explicit or implicit invitation to make this kind of friendly contact, and if such contact is not contrary to the older person's ethnic background.

Relative to ethnic backgrounds, some European-born older Americans customarily communicate very close to each other. But most elders do not like their personal space--the area immediately surrounding their bodies--"invaded." In fact, some feel quite strongly about this. However, it is sometimes necessary to sit close to an elderly person with impaired sight or hearing, or at least to be ready to adjust position and move closer.

The key to nonverbal communication lies not in using a particular signal described here, but in recognizing the great communicative power of such signals as a whole. Anyone who wishes to interact with an older person can take advantage of this awareness of body language. This includes the full range of professional and paraprofessional helpers, as well as relatives, friends, neighbors, and the like.

We now move on to the "stuff" of counseling older victims, the skills and techniques of the counseling process. Because of the scope of this handbook, we can outline briefly the more important elements of successful victim-assistance counseling. The reader is strongly encouraged to pursue supplemental reading, suggestions of which are included at the chapter's end.

Counseling the Older Crime Victim

The psychological needs of elderly crime victims will vary depending upon the extent to which they have been affected by the victimization. As we explained in Chapter Ten, many crime victims enter a crisis period after the crime. Older persons who suffer from a severe crisis following a victimization should be referred to a professional counselor for diagnosis and treatment. For others for whom the reaction may be less debilitating, there are a number of common sense skills which can be used by social service providers, friends, relatives, or others who come into contact with older victims.

Basic Skills

The skills most commonly cited as being important for counseling are empathy, respect, and concern for one's clients. Alpaugh and Haney (1979) have defined these terms, in a counseling context, in the following ways:

Empathy: A counselor is empathic when he understands in the fullest way the counselee's deepest feeling, his frame of reference and his world-view. Empathy involves "feeling into and feeling with" the client. At moments when a person is truly and deeply empathic, he fuses with the thinking and feeling of the other person while maintaining the awareness that he is a separate person. To be empathic with someone is to be fully with him in his deepest moments.

Respect: When a counselor is respectful of the client, he truly believes in the worth of that client. He accepts the client AS HE IS. He may not like everything the client says or does, but he trusts that the client is the way he is for very good reasons. He respects the client for his humanness, and he conveys to the client his respect for the client's potential as a free individual.

Concern: When the counselor takes the client and his problem seriously, he is showing concern. The counselor also demonstrates concern when he is mentally and physically attentive to the client's communications. Concern for the client means being interested in his welfare and being willing to stick with the client even when the client is difficult to be with. Concern must be genuine. Since counselors are no less human than any other individual, it sometimes happens that the counselor cannot feel concern for a certain client, or cannot abide certain behavior. If this situation should arise, the counselor may want to work it through with the client, or refer the client to a different counselor.

These are the necessary preconditions or ingredients in the effective counselor. We may recognize these qualities in friends or relatives of the victim, and should encourage this "natural" support.

At other times, the established social service system in the community may be called upon to counsel a victim in need. In either event, the best assistance is most likely to come from the helper with empathy, respect, and concern for the older victim. These qualities are, fortunately, skills which can be developed with experience.

Allowing Expression of Feelings

Counseling older persons who have been victimized requires a special sensitivity to their feelings, which, as we discussed in the last chapter, can vary tremendously. Expressed feelings may include anger, shock, confusion, apathy, resignation, resentment, guilt, fear, and hostility. It is especially important in counseling to be able to identify these emotions and to let them be expressed. Untrained victim counselors may be inclined to accept victims' statements of "perfect health" at face value, or tell victims they should not be feeling certain emotions, or try to change the subject if victims continue to talk about the crime. These reactions, while well meant, are not especially helpful to persons whose emotions are out of balance as a result of the stress of victimization. Most professional therapists would agree that a counselor should be aware of several notions:

Feelings are neither good nor bad; they just are; everyone has a right to his or her feelings; feelings always make sense when considered in the context of the individual's 'world view;' feelings are not (like actions) dangerous; and denying feelings does not make them go away. (Alpaugh and Haney, 1978:3)

By following these guidelines, counselors will be giving a clear message to victims that they and their feelings are normal and "okay."

Being Patient

A most important skill in victim assistance is the ability to be patient and civil, regardless of how angry, hysterical, or withdrawn the victim is. In fact, merely telling victims that you are sorry the crime happened, that you are glad they are all right, and that they did nothing wrong can be of enormous comfort. Similarly, describing the kinds of feelings and reactions crime victims and others in crisis normally have can be very helpful, for it relieves the sense of aloneness or uniqueness.

Taking Care

In the stage immediately after a crime, friends or neighbors can be of great value to elderly crime victims just by "taking care of them." When the victims say they don't believe what has happened or that they cannot deal with it yet, they are also really reaching for help. And there are many routine tasks a concerned friend can perform: call the police, call relatives, call credit card companies or the insurance company, clean up any mess left by the

criminal, accompany the victim to the police station, and notify a doctor, if necessary.

Avoiding Imposing Own Values

Many who think of themselves as "helping people" may try to do this and more. Unfortunately, these people, even professionals, may try to impose their own values and standards on victims, instituting what they feel the victims want rather than what the victims say they need. Bard calls this kind of "crisis counseling" the "rescue fantasy," and cautions that it has several dangers.

Helpers who see themselves as rescuers derive important ego benefits from the victim's dependency. They may unwittingly encourage the victim to continue to lean on them long after their support is no longer needed. And . . . the helper may be wrong about what the victim needs. (Bard and Sangrey, 1980:30-31).

By imposing their own interpretation and values on victims' experiences, these well-meaning people--police officers, social workers, relatives, or friends--can end up adding to victims' problems rather than alleviating them. Good helpers strictly discipline themselves to pay full attention to what the victim is communicating, both verbally and nonverbally, and not to interject personal judgments or perceptions of the situation. Moreover, responding to victims' problems and planning actions to be taken must be viewed as a participatory process in which the victim and the helper work together. It is at this time, when victims often feel they have lost control over life and seem to be at loose ends, that their participation in planning a course of action can help them regain a sense of control.

Understanding Anger

One common result of victimization is that victims experience a wide range of feelings--everything from self-pity to rage. It is best during this period simply to support the victims, allowing them to experience their feelings and letting them know that these emotions are to be expected. It is very common for the victims' anger to be directed at various helpers--police, hospital personnel, friends, and provider agencies--as substitute targets for the anger they feel toward the criminal. Helpers need to recognize what is happening and allow the victims to vent these emotions, as the first step toward an acceptance of how angry they are about the crime.

Venting emotions can also take another form in which victims, in an attempt to come to grips with their feelings about the crime, tell their story over and over in every detail. Even if it is painful for a friend or relative to hear the story repeatedly, this venting can be a necessary part of the healing process.

Listening Actively

One means of effective communication with persons under stress

is "active listening," a counseling technique which can be used by both professionals and nonprofessionals. Active listening means paying very close attention to the verbal and nonverbal cues given by the client, and responding appropriately. Responses to the client include trying to rephrase or restate the exact meaning of what the person has said, refraining from adding opinions or feelings of one's own unless the client asks for them, and never downplaying the client's comments or ideas.

Active listening on the part of a counselor can show a client respect, attention, and recognition. For someone who has been victimized, the technique can help give back to the victim a feeling of control. A recent NIMH-sponsored publication is an important tool for training would-be counselors in the use of active listening techniques through practice exercises in the classroom. Entitled Helping Skills: A Basic Training Program, it was developed to train counselors and others in how to treat victims of natural disasters, skills which are equally helpful in dealing with crime victims (Danish et al., 1980).

There are special verbal techniques which, when used in conjunction with active listening, can enhance the communication process. The following are some of the more helpful.

In "mirror responses," the counselor repeats to the client what he or she just said, such as "Let me make sure I have this right; you're saying . . ." These responses can be useful in clearing up the client's uncertainty or confusion, and can help the person to get an orderly grip on things which are stressful.

"Paraphrasing" can also be helpful in active listening, for here the counselor repeats the sense of what she is hearing, thereby clarifying for the client what he or she is saying. Restating what the client has said using different words can serve both to reorder the ideas and to indicate to the client that the counselor is getting his or her message.

Open-ended questions, which cannot be answered briefly or in "yes" or "no," lead to more complete responses. They often allow victims to talk more openly or take the conversation in a direction that is important to them. A question such as, "What happened?" is a good example.

Questions which require a client to give a "feeling response" can be especially useful. Crime or the fear of crime often creates strong feelings in older persons, feelings which percolate and need to be released before "boiling over." Elderly victims may state clearly what happened, without being conscious of how they feel about it. By using questions such as, "It sounds like you are very . . ." the counselors can check out their own hunches, help to make the older clients aware of feelings underlying conversations, and provide acceptance for these feelings. (This acceptance does not necessarily mean that the counselor agrees with or approves of the client's feelings, but merely accepts that they exist.) A statement

such as, "I gather you're pretty worried about all the neighborhood kids . . ." is an example of a statement which can lead a client to get those feelings into the open.

These communication techniques are presented as guides for people helping older persons cope with victimization. Most important of all, though, is to reinforce three basic ideas: that you are sorry it happened; that you are glad they're all right; and that they did nothing wrong.

Tips for Counseling Senior Citizens

In addition to the general counseling skills listed above, people working with older victims have discovered that certain specific behaviors help establish the rapport which makes good communication possible. The tips presented below, some of which were touched upon earlier, are only a sampling of such behaviors. The resources listed at the conclusion of this chapter provide more specific details.

- When coming into an elderly person's home, a would-be "helper" should always identify himself or herself and his or her program agency. It may ease things to show an ID or card. The helper should simply explain his or her role and desire to help.
- "Small talk" seems to be a reliable technique for establishing good rapport with an older person. Small talk, which can prevent relationships from becoming strained, involves a 10 to 15 minute conversation wherein the counselor engages in conversation about something in the older adult's life. The topic chosen can be based on observation of objects or persons in the client's surroundings. Photographs, a flower garden, a nice piece of furniture, antiques, etc. are appropriate objects to elicit a personal response. Ecology, traffic, or even the weather are other alternatives. The older person must be allowed sufficient time to respond, or the counselor's sincerity in asking the question will be doubted.
- Effective information gathering generally requires controlling digression--but not too quickly. The counselor should not break off too quickly what appears to be an older person's rambling discourse. Elders sometimes take longer to process information, and therefore to organize and report facts about a crime or about their daily behavior. Premature interruptions on the part of the counselor may keep important things from being revealed.
- If writing on a form or even a pad during the interview, the counselor may find that the client becomes more interested in watching what is being written than in talking freely. Or, the older person may become hesitant to divulge information if everything he says is being written down. By listening first and writing afterwards, a counselor can sometimes circumvent these problems.

- During a conversation, an older person may not remember all the things he wishes to say about his victimization or his fear of crime. Or, he may be sensitive about vision and hearing difficulties and not want to let the counselor know about them. A victim may be embarrassed by his own confusion. Certain approaches are especially good for breaking down these barriers to communication. Saying, for example, "I know how confusing the experience must have been," or sharing the information that many victims have some difficulty in recalling the events right away can encourage continued communication. Offering to be available at a later date can also relieve some of this stress.
- Counselors should not decide on their own how to counsel older victims. Include them in that process--work toward satisfying their needs as expressed by them. By the same token, make it a habit to ask permission in interviews, like, "May I sit down?" and to offer choices like, "Would you like me to call her now or perhaps a little later?" These actions give victims a needed sense of control.

At this point, we should acknowledge that historically very little attention has been given the older counselee in general, let alone the older crime-victim counselee. Ganikos (1980) reports that during the late 1970s the number of counselor education programs in higher education dealing with counseling the elderly, or even offering an elective in the subject, remained about six percent of all programs. So, whatever meaningful steps are undertaken in counseling the older victims are filling a void. Ganikos' own work, Counseling the Aged: A Training Syllabus for Educators, is an important resource in this regard. While her text does not address crime *per se*, it does contain 11 training modules on counseling older persons, each module listing rationale and objectives, implications for the counselor, training activities, references, and evaluation techniques. Particularly appropriate for would-be victim assistance workers are the modules on "Counseling Older Adults: Suggested Approaches" and "The Role of Paraprofessional Peer Counselors in Working with Older People."

Finally, we should not overlook the proven track-record of groups of individuals working together in resolving crises. Weiss (1973, 1979), writing about group counseling of widows after loss of spouses, offers a model for helping people through crises; this model can be applicable to the crisis of criminal violation. Weiss found that two elements were very important to the success of his group counseling. The first was information. He gave his groups as much data as he could about the facts and stages of grief and about what it was normal to feel after such a great loss as loss of spouse. This made participants in the group feel all right about themselves. They weren't "crazy" to feel the rage or guilt they felt. Others had done similar things before them and had gotten through the tough times. The second element was support. All of the others in the group were experiencing the same traumatic transition. In numbers there was strength; there was a common identity; there was a pool of others to lean on.

These elements of information and support are readily adaptable to the problems of older victims of crime. Several senior-serving agencies, in Jamaica and Yorkers, New York, for example, have already recognized its potential and are using group counseling as a supplement to the individual counseling they offer to older crime victims.

Others who have written on the effectiveness of group work include Caplan and Killilea (1976) and Burnside (1978). Burnside's book is oriented toward institutionalized elders, but she does give principles of group work, including contracts for group work; factors in group membership like settings, number of members, member selection, and personality dynamics of members; and problems in leadership.

As mentioned, counseling the older person has not been well explored. But group counseling of older victims can help the victims to make sense of things, can provide a base of support for recovering from the trauma of criminal violation, and can lead to group action steps (like block groups described earlier) that improve security and quality of life.

Reading and Resources

- Alpaugh, Patricia and Margaret Haney, Counseling the Older Adult: A Training Manual for Paraprofessionals and Beginning Counselors, Los Angeles, CA: University of Southern California, The Ethel Percy Andrus Gerontology Center, 1978.
- Bard, Morton, and Dawn Sangrey, "Things Fall Apart: Victims in Crisis," Evaluation and Change (special issue on Services for Survivors), Minneapolis, MN: Program Evaluation Resource Center, 1980.
- Bib, S., M. Ernest Baggett, and H. J. Friedsam, Police/Older Victim Relations, Denton, TX: North Texas State University, 1977.
- Burnside, Irene M., Working with the Elderly: Group Processes and Techniques, North Scituate, MA: Duxbury Press, 1978.
- Caplan, G. and M. Killilea, Support Systems and Mutual Help, New York, NY: Green & Stratton, 1976.
- Danish, Steven J., Anthony R. D'Augelli, and Allen L. Hauer, Helping Skills: A Basic Training Program, Second Edition, New York, NY: Human Sciences Press, 1980.
- Ganikos, Mary L., Ed., Counseling the Aged: A Training Syllabus for Educators, Falls Church, VA: American Personnel and Guidance Association, 1980.
- Greenberg, Lois, Betty Fatula, Dennis R. Hameister, and Tom Hickey, Communication Skills for the Gerontological Practitioner,

University Park, PA: Pennsylvania State University Gerontology Center, 1976.

Gurian, Bennett, "An Overview of Geropsychiatry," National Association of Private Psychiatric Hospitals Journal, Vol. 10, No. 1, Fall 1978.

International Association of Chiefs of Police, "Crime and the Elderly," Training Key #280, 1979.

Pfeiffer, Eric C., "Psychotherapy of the Elderly," Journal of the National Association of Private Psychiatric Hospitals, Vol. 10, No. 1, Fall, 1978.

Symonds, Martin, "Victims of Violence: Psychological Effects and After Effects," American Journal of Psychoanalysis, Vol. 35, 1975.

Weiss, Robert S., Going It Alone: The Family Life and Social Situation of Single Parents, New York, NY: Basic Books, Inc., 1979.

Weiss, Robert S., Loneliness: The Experience of Emotional and Social Isolation, Cambridge, MA: MIT Press, 1973.

Chapter Thirteen

Communicating with Groups: Crime Prevention Education

Chapter Thirteen

Communicating with Groups: Crime Prevention Education

Advance Organizers

- Crime prevention education for groups is a growing phenomenon. Police institutes, media campaigns, and community training sessions now focus on reducing the opportunities for victimization. Despite the proliferation of these efforts, however, crime prevention education is not as effective as it might be. Reasons for this include the length and the method of delivery of standard training sessions.
- Crime prevention education for older people should consider their needs and should be tailored to them. Otherwise, standard crime prevention education sessions may actually increase already high levels of fear among the elderly.
- Effective crime prevention education involves at least four elements: planning a course to meet specific local needs and problems; selecting teaching techniques that will produce lasting learning; evaluating both the immediate reaction and the long-term impact of the training; and expanding the access of senior citizens to this education.
- Planning should ensure that the training addresses the real and felt concerns of the community's elders. This requires: conducting a needs assessment, a "who," "what," "where," "when," "why," and "how" of the crimes against elders in the community, as well as a profile of the senior participants; setting general goals and specific objectives for the training based on the findings of the needs assessment; and choosing the content and the order of the training materials.
- Teaching or conducting the training session should be done in ways that hold on to the participants' attention, involve them in activity, and increase their learning of the information. Lectures, audiovisuals, roleplay, guest speakers, small group exercises, homework, and combinations of these are good for these purposes. In addition, there are tips specifically for training with older people.

- Evaluation determines how the information is being retained and put into practice by elderly participants. Participant reaction and trainer self-assessment taken immediately after a session gauge basically the "process" of the training. Follow-up measurements taken some time later show whatever lasting effect or "impact" there might be:
- Expanding the opportunities for crime prevention education for seniors requires the involvement of others besides the police and related professionals. By including aging-related community service people and elders themselves in crime prevention education, the number of trainers increases, so that each topic can be covered more thoroughly and a larger number of the elderly can be reached. Their addition also increases the sources of information and advice available for older people with crime-related concerns.

Introduction

Educating citizens about how they can prevent crimes has become increasingly popular in recent years as more and more people realize that the police cannot combat crime by themselves. The basic concept of crime prevention education is to teach people that crime rates can be lowered by reducing the number of opportunities which criminals have. Opportunities for property and street crimes are pointed out to citizens and various steps they can take to "harden" the criminal target are described.

Crime prevention education received its initial support from the Law Enforcement Assistance Administration (LEAA) which funded the National Crime Prevention Institute (NCPI) at the University of Louisville in Kentucky to train police officers in crime prevention education for citizens. Since 1971, NCPI has trained over 8,000 law enforcement personnel, and now every major police department in the United States has one or more officers, located either in the crime prevention or community relations department, who specialize in teaching citizens how to make their homes more secure and avoid street crimes.

As a result of two more recent programs added by LEAA, the Citizens' Initiative, and the Community Anti-Crime Programs, community residents have also been added to the ranks of crime prevention trainers. NCPI and other organizations, like the National Sheriff's Association, the American Association of Retired Persons, and the General Federation of Women's Clubs, work with citizens and community groups to spread the message about crime prevention. In 1979, the National Council on Crime and Delinquency brought together these and a number of other national organizations to work with the National Advertising Council on a crime prevention education campaign, following the model of the Ad Council's forest fire prevention campaign with Smokey the Bear. Employing McGruff, a trench-coated detective dog (Figure 13.1), the campaign works through all of the mass media and provides back-up crime prevention literature and training to make Americans aware of crime prevention techniques and ideas.

Training sessions in crime prevention typically cover the same subjects addressed in this handbook: home security, security on the street, consumer fraud and con games, and community crime prevention. Whether taught by civilians or by the police, the training tries to impress upon its audience the importance of close cooperation with the police. Cooperative actions for citizens to take include watching out for suspicious people or activities, reporting these activities to the police, notifying the police immediately if a crime has occurred, providing thorough descriptions of criminals to police officers, and calling upon available police crime prevention resources.

Despite this proliferation of crime prevention education, however, there is little evidence that the training sessions themselves have done much to reduce crime rates. The problem may lie in training's failure to change the long-held attitudes and behaviors of the students which attract victimization.

Figure 13.1
Advertising Materials in the National
Citizen's Crime Prevention Campaign



We support the National
Citizens' Crime Prevention Campaign.
**TAKE A BITE OUT OF
CRIME™**

There have not been long-term studies of this effectiveness, but from what we know about educational theory, it is very likely that these training courses are not as effectual as they could be. One reason is that the courses are usually short--one to two hours in length--and a great deal of material is covered very quickly, making it unlikely that all of the information will be remembered and even less likely that it will be acted upon. Furthermore, the most commonly used training techniques--a lecture and a film--probably lead to more superficial learning than would be the case with participatory training techniques which involve students in the subject matter and lead, in theory, to deeper understanding and retention.

Both of these drawbacks, length and mode of training, can make crime prevention education particularly ineffective for senior citizens. These habits of older persons which increase their vulnerability to crime may require even more time and practice to change than those of younger people. Furthermore, there is some preliminary evidence from the experiences of crime prevention educators that standard crime prevention education sessions can actually increase already high levels of fear among older persons (Nitzberg, 1979).

For these reasons, this chapter will approach the topic of crime prevention education for senior citizens from the viewpoint of improving the current state-of-the-art. The chapter contains four sections: the first describes how to go about planning a meaningful crime prevention course, and discusses specific local needs and problems, objectives, and possible content of training sessions; the second focuses on conducting the training, and outlines teaching techniques which should lead to good retention of the materials and

to changes in behavior outside of the classroom; the third looks at the consequences of the training, and suggests ways to evaluate whether the training has had its desired effect; finally, the fourth sketches ways to improve the access of older persons to crime prevention information and education.

Planning for Crime Prevention Education

Needs Assessment

Crime prevention education is most useful when the course is planned to meet the specific needs and concerns of those who will be trained. The type of analysis which seeks to determine what these concerns are is usually called a "needs assessment," and here it involves two parts: learning the specifics of the local crime problem; and identifying the crime-related concerns, and the characteristics, of those who might be trained. The three primary sources of data for this needs assessment are the police, key community people, and the local planning department.

For information on the local crime problem, the police are easily the best resource, although they may be less accessible in some communities than in others. Whether information is obtained by reviewing crime reports or talking to individual police officers and officials, the same questions must be answered: What are the most common crimes being committed against older people in the neighborhood? When during the day or evening are these crimes being committed? Where are they being committed? How do they occur?

Other questions which are helpful to answer while planning crime prevention education are: Which older people are being victimized (e.g., apartment-dwellers, women, people on several blocks, etc.)? Are elderly victims suffering serious physical harm from the crimes? Is the rate of local crime against the elderly increasing or decreasing? Are there trends in the types of crimes being committed against the elderly?

Impressionistic information from other people in the community can also be important in learning about the severity of the crime problem for senior citizens. Good sources include: directors of senior citizen centers, staff of the prosecutor's office, local business people, clergymen, and the crime reporter for the local newspaper.

The second part of a needs assessment is an attempt to learn prior to a training session about the group of seniors who will participate in the session, in order to target the materials more specifically to the audience. Ideally, trainers would like to know: how aware their students are of the crime problem in the community; what kinds of crimes they are worried about; their knowledge of the senior service network; their living arrangements, educational background, and socio-economic characteristics. All of these factors can affect the choice of content or techniques used in a crime prevention education session.

266

Many of the same people who are queried about the local crime problem can also be asked for information about the seniors who will be participating in the training. If a session is to be held at a senior citizen center, it is very helpful to talk beforehand to the director or staff about the seniors who use the facility. Likewise, the president of a senior citizen club, resident manager of an apartment building, or clergyman can be interviewed ahead of time if the sessions are to be held with seniors from any of these organizations. Advance copies of club agendas for the day of the training can suggest the mood of the audience and the best time for the training.

It is, of course, sometimes impossible to obtain this information in advance of crime prevention education sessions. When this is the case, trainers often ask participating seniors questions about themselves and their beliefs at the start of training sessions, then tailor their approach on an ad hoc basis.

Using Training Objectives

The second step in planning for a crime prevention education course is to use the findings from the needs assessment to develop goals and learning objectives for the course. Goals are general statements of overall purposes; objectives are specific intentions of change, and are best when tied to some behavioral measure. Setting goals and objectives can help both the instructor and the students. The instructor can determine his or her rate of progress and ultimate accomplishment, while students can obtain an overall view of the session and assess their own achievements.

Goals. Those conducting crime prevention education for older persons may set general purposes or goals for the training to be conducted, like:

- To provide an elementary knowledge of typical crimes and frauds to which the elderly are subjected.
- To change imprudent habits and behaviors so that personal security will be increased.
- To build an increased sense of control over the potential threats to safety in their daily lives.
- To reduce feelings of isolation by connecting seniors to the network of services available to them.

Objectives. After developing such general goals, crime prevention educators can use them to set specific instructional or learning objectives for each session to be taught. Specific objectives for crime prevention topics of interest to the elderly are relatively easy to develop if sufficient thought is given to what the instructor wants the participants to remember and use, and to whether accomplishment of the objectives can be measured at the end. For example, under the topic of personal security, objectives might be that students can state three personal characteristics which are attractive to muggers; identify one precaution to take on buses, in cars,

and in public places; list three steps to take before going on the street; and describe the procedures for enrolling in a direct deposit program. For a home security presentation, similar objectives are that students can: state three ways of making one's home more secure when not at home; name three ways to protect one's home when at home; declare how to make an appointment for a home security survey; and list and order the steps to take if one arrives home and finds it has been burglarized.

In instructional objectives like these, usual words like "learn" or "understand" do not appear, for these are considered too general. Rather, the intended outcome of the educational session is phrased in terms which can provide a measure of what is learned.

Choosing the Content

Once the needs assessment and goal-setting has been completed, the planner should decide the contents of the crime prevention course. To allow for good understanding and retention of the materials, it is best to divide the course contents into a number of different sessions. Simple assignments can be made which require the students to practice between sessions to promote assimilation of the new information.

One logical way of dividing the content of the course is to focus on the steps of crime prevention:

- Becoming aware of crime;
- Protecting yourself on the street;
- Protecting your home and property;
- Avoiding consumer fraud and con games;
- Collective action against crime.

Perhaps the most important session for senior citizens is the first one on awareness of crime, for here the students are given an opportunity to express their concerns and interests and to discuss the local crime problem. Because of the already high levels of fear of crime among many elders, it is clearly not appropriate for a trainer to use this session to expound on how dangerous the problem of crime is in that locality. Instead, the session can be used to bring out some of the older participants' free-floating fears about victimization.

Trainers can acknowledge these fears, much as a counselor acknowledges the feelings of the person who has been a victim of crime. The next step, though, is to present the actual crime patterns in the community as an objective way of showing what the real risks of crime are, and what people should be most alert to.

For example, older women are usually very concerned about being assaulted or raped. In fact, their real risks of victimization are from household theft or burglary. Acknowledging that many women are

frightened about personal crimes like rape and assault can be followed by a presentation on local and national statistics on the low incidence of these kinds of crimes. In this way the session can be used as an effective way to lower fear levels, while at the same time imparting information that is important for crime prevention.

At this and some of the other sessions, it is often very helpful to have a representative from the local police department present. His or her presence will serve several purposes. It will provide a resource person who may be able to answer some tough questions about local police activities and limitations. Questions like "Why aren't there more police on the street?" "Why can't the police respond faster to calls?" or "Why can't they catch more criminals?" may need authoritative responses before participants are ready and willing to get around to the business of taking crime prevention into their own hands. The law enforcement officer can also acquaint seniors with the most recent information on the crimes in their community, can set the tone for the importance of citizens cooperating with the police, and can give the training an automatic credibility in the eyes of many senior citizens.

The content for the sessions following the first one can be divided into the various types of crimes which should be addressed: street crime, household crimes of burglary and larceny, and consumer fraud. Finally, since collective or community crime prevention techniques have been shown to be very effective and to have the best chance of continuing over the long term, a whole session can be devoted to just this approach to crime prevention.

It is important to gear each of these sessions to the characteristics of the seniors present. For example, if most of the people live in apartments, the trainer can present information on home security for tenants, including safety in elevators and hallways, organization of tenant patrols, enforcement of building codes, dealing with the landlord or management, and preventing push-in robberies. A different set of topics would be appropriate for older people who are primarily homeowners, including how to make a home look lived-in when away, pruning shrubs and large bushes to make doors and windows visible from the street, obtaining a home security survey and organizing a block club. For seniors living alone, it would be important for the training sessions to discuss the network of services available to elders, including escort services, senior centers, homemaker and companion services, and telephone assurance programs; safety when answering the door; and con games directed at the isolated elderly.

Conducting Training

Selecting the Techniques

Having planned the content of the training sessions with an eye toward the characteristics of the older participants, the next step is selecting the best training methods to convey the information. For some time research has indicated that people learn best when they

actively participate in the learning process. And so, Edgar Dale has devised a "Cone of Experience" (Figure 13.2) which rates various kinds of learning experiences by the amount of learner activity involved, and estimates the amount of material people remember who have had such an experience. According to this theory, those who experience only verbal cues, as in reading and listening to words, remember the least, while those who are exposed only to visual cues remember slightly more. Dale maintains that when one is exposed to both verbal and sight cues, however, learning is raised to about 50 percent of what is presented. When student participation through writing is added to the visual and verbal experiences, learning is raised further to 70 percent. But when an actual task is added to the visual and verbal cues, about 90 percent of the materials are remembered by the student. Applying this theory to the most common training techniques used in crime prevention education, we can understand why standard crime prevention training sessions are relatively ineffective.

Lecture or presentation. The typical crime prevention education session relies heavily on a lecture or speech (hearing cues) resulting, according to Dale, in only about 20 percent retention of the materials. Thus, a lecture should be supplemented with as many appropriate visual aids as possible, such as props and flip charts. Moreover, the materials in a lecture need to be reinforced with other types of training experiences for better retention.

Films and slide/audio-cassette presentations are recommended as effective learning devices and are generally well-received by seniors. The combination of visual and verbal input increases the chances that participants will remember information presented.

However, care needs to be taken in showing the films and slides. It usually takes an older eye longer to adapt to darkness. So when starting slides or films in a dark room, wait a minute or two. Because older persons have reduced sensitivity to light and greater sensitivity to glare, certain conditions can make seeing and reading easier for them. These include: high illumination without glare, enlarged figures, and figures which contrast sharply with their background. With regard to the last point, red or black figures against a yellow background seem to provide the best contrast for older eyes. Trainers should also assess the quality of the sound in advance to determine whether it will be difficult to understand by the hearing-impaired.

After showing a film or slides, a question-and-answer period or some other form of discussion can reinforce the information presented in the film. Generally, discussion guides are included in film packages. There are many films and slide presentations on crime prevention available, a number of which are quite suitable for older audiences. Some are listed at the end of Chapter Five.

Role play. A role play is a training exercise which simulates a real life situation. Participants act out the characters who are involved, imitating their attitudes and behaviors. This technique

Figure 13.2
Cone of Experience

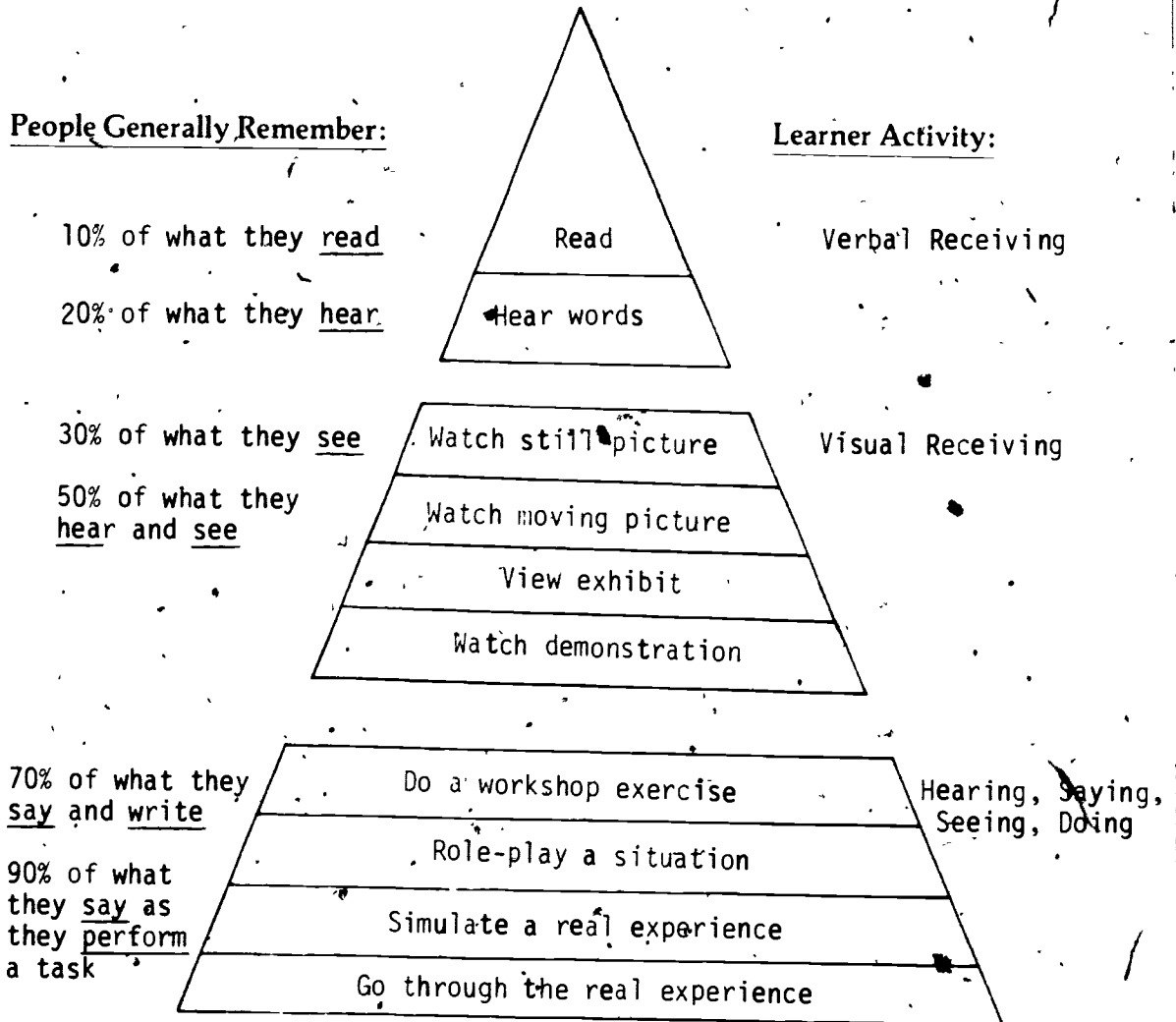

(Adapted from materials produced by Dr. Katherine Tift for the National Drug Abuse Training Center. For further information on Dale's "Cone of Experience," see Wiman, Raymond V., Educational Media, Columbus, OH: Charles Merrill Co., 1969.)

is excellent in crime prevention training for seniors because it:

- Provides a context for participants to express themselves. It is often less threatening to speak through another character than to speak for oneself.
- Sensitizes the players to a variety of different attitudes and motivations. By playing a character with a different viewpoint from one's own, a person can develop an understanding for others.
- Gives the participants an opportunity to practice crime prevention techniques in a close-to-real-life situation. This greatly facilitates the actual adoption of the techniques in the real world.

Variations on a role play can be used. For example, two volunteers can do a role play in front of the rest of the group. This is called the "fishbowl" technique. The audience responds to the two players at the end, and then additional sets of volunteers can role play. It is always helpful to conclude role plays with a "debriefing" or group discussion of what occurred.

Guest speakers are often quite effective, especially if they are celebrated or respected members of the community. Police officers in uniform, for example, represent authority and security to many seniors; if they give positive suggestions or advice about reporting crime or crime prevention tips, they will likely be very well-received.

To maintain the focus of a class, training leaders usually interview guest speakers in advance in order to give them ideas on how to reach the audience most effectively, as well as to discuss and review the topics the speakers wish to cover.

Small group exercise. This technique allows all those present to participate, even with a large number of people. However, it requires a "flexible" room or rooms in which seating can be rearranged to form small groups.

After people are divided into groups, they can engage in a variety of training techniques, such as solving hypothetical problems, coming up with answers to questions, or doing role plays. Trainers find it helpful to have each group select a recorder, one who can take notes on what happens. After the groups disband and the large group is together again, the groups can pool information and share their experiences.

Combination exercises. As mentioned, effective trainers have found that participatory techniques tend to produce better results than other kinds of formats. They have also discovered that a combination of several techniques will reinforce the information learned, as well as maintain the participants' interest level (Wiman, 1969). For example, if a trainer were offering a 90-minute crime prevention

session on home security, he or she might use three different techniques, perhaps allotting a half-hour each for a small group exercise, a film, and a role play. Likewise, a homework assignment can also reinforce learning and allow time for it to be assimilated and digested. Participants might be asked to make a list of locks in the home; describe the occasions when they feel afraid on the street; write down what kinds of people come to their door. Reviewing the homework at the next session reinforces this learning.

Other considerations. Trainers also consider other factors when choosing techniques to use. These include the physical space for the class, size of the group, time frames, available resources, educational background of participants, and so on. For any training, it is important to make sure the facilities will have all the equipment or tools needed, adequate lighting, chairs, tables, electric outlets, extension cords, and ventilation. And trainers should allow enough time before the meeting to "set up."

It is worth noting that money is not absolutely essential for an effective training program, although several training tools can cost money. The most expensive, films, may often be available from a local library. If they are not, they can be rented from the distributor. A second item requiring some funds is the printing of handouts. It is usually very helpful to give participants something to take home, such as a list of important numbers to keep by the telephone or a checklist of home security precautions to read. Often the police department's crime prevention section provides free copies of these.

Training Tips

After conducting a needs assessment, developing objectives for the training, selecting appropriate subjects to cover, and deciding on the most appropriate training techniques to use, trainers are then ready to begin the crime prevention training session.

Even with the best possible preparation, though, not all audiences will be equally interested in or capable of benefitting from the subject of the training session. Seasoned trainers use a number of different ways to gain and keep the interest of participants during the training sessions (Center, 1979).

- Try to use anecdotes or stories to which seniors in the audience can relate. For example, use local newspaper articles to illustrate local crime programs.
- Stop the training occasionally to take questions from the audience or ask your own questions. This will tell you if the seniors are understanding the training and are applying it to their needs.
- Circulate around the room rather than stand behind a lectern or sit at a table throughout the sessions; this helps you to stay aware of the audience's attentiveness and makes things more

- personal.
- Use props. Even if you can't use them during your training session, try to work with them during a question-and-answer period. They help senior citizens relate better to the tips you've given them.
- Don't forget the value of humor. It can reduce tension, make serious subjects seem less threatening, and allow you to communicate better with people attending the training session.
- Try to maintain as much eye contact with people in the audience as possible. This can make the elders feel more involved in the training; they'll know you are talking to them and not at them.
- Be outgoing and friendly; if you are too formal in your approach, would-be participants may easily be "turned off" to the entire session.
- Watch the tone of your voice. Make sure you treat your listeners with respect and do not talk down to them.
- Speak distinctly. Many older persons have impaired hearing or vision.
- Don't be impatient or operate on a strict time schedule. Simple tasks may require more time, effort, and energy than you anticipate. When chairs have to be turned around to watch a film, for example, it may take a good five minutes for everyone to get settled.
- Attention spans vary; response time may be slow, and memories may be fading. To maximize the amount of information learned and retained, use watchwords. Consider including a number of breaks, especially for the participants to stretch.
- Isolation often creates an increased need for attention. Some older people take advantage of opportunities to get this attention in class by interrupting, offering commentary, relating opinion, and so forth. This impedes the group process. Make sure you include a question-and-answer session at the end, and if earlier sections of the presentation are getting bogged down, gently interrupt and ask if the discussion can be taken up again later. By writing the subject on a blackboard or easel, the presenter acknowledges the importance of the point and makes it possible to move on.
- Poor literacy skills are common among senior citizens, so written questionnaires are sometimes ineffective evaluation tools. If you use questionnaires, have participants check things off. Otherwise, it is possible to present a questionnaire orally, asking for a show of hands. It is sometimes useful to have someone other than the presenter ask the questions and record the group's answers.

These tips are by no means exhaustive. The most important thing for trainers to do during crime prevention sessions is to be flexible. Maintain a "feel" for the group--their mood, interest, and comprehension--and adjust the content and techniques accordingly.

Evaluating the Training

If crime prevention education is to be considered as a serious approach to reducing crime against older persons, it will be necessary to begin to track more carefully whether the information is being retained and used by the students. Evaluation can take a number of different forms. The most simple types--immediate participant reaction and self-assessment--produce only limited information on the process of the training session. To measure whether there were any lasting effects, follow-up measurements need to be made some time after the session has taken place to gauge "impact."

Immediate Participant Reaction

A written questionnaire or an oral survey at the end of a crime prevention session is useful primarily in assessing "process" considerations such as content, method, and organization. Experienced trainers recognize while constructing such surveys that most people hesitate to be critical and that vague questions produce little information. Questions such as "Did you enjoy the meeting?" are almost always answered, "Yes." In order to gain better information, use very specific questions, such as:

- Could you hear the speaker clearly?
- Was the meeting too long?
- Was the room too crowded?
- Would you recommend the session to a friend?
- Would you like more information on the subject?
- Will you come to the next session?

Since few people respond to a request for "general comments," trainers sometimes conclude with the open-ended question, "How would you suggest that the presentation be improved?"

Self-Assessment

This form of evaluation has the trainers analyzing their own sessions. They ask themselves how the training went. Examples of things trainers review are:

- Participation
 - Did the number of participating seniors increase as the session progressed?

- Were the elders alert and attentive? At what parts did they appear to lose interest?
- Did attendance drop off from the last class?
- Organization
 - Did the training accomplish all that was planned? (Meet objectives?)
 - Did the trainer stick to the schedule?
 - If not, was the change a good one?
 - What went worse than expected?
 - What went better than expected?
- Training skills
 - Did the trainer appear confident?
 - Did the trainer know the material?
- Content
 - Did the participants appear to understand the content?
 - Did participants remember information from the last session?
 - Did anyone offer insights or information new to the trainer? Did the trainer learn?

Questions of this kind are subjective; i.e., did the trainer feel satisfied that he performed well? Self-assessment works particularly well if the trainers are working in pairs and can exchange this type of feedback.

Impact

The most significant type of training evaluation is that of "impact." Impact must be measured at a later point in time, since trainers want to find out:

- Did the participants remember anything--and if so, what is it?
- Have the participants converted what they've learned into action, whether through changes in behavior or use of new resources?

If trainers are conducting a number of sessions, the easiest and most productive time to conduct this kind of impact evaluation is at the next session in the series, a week or two after the first.

For example, if the first class concerned awareness of crime and how it affects people, a trainer could, at the second class:

- Ask how many people changed something about the way they usually do things because of what they learned at the last class. The trainer could then focus on these individuals and ask them specifically what they have changed.
- Ask people to list what they learned last time.
- Ask if they have done their homework assignments. Then, discuss their assignments.

Similar techniques can be used by trainers after each class in a series. The trainers can even return to the site of a training series several weeks after the final class to assess the impacts of both that one class and the overall training, asking the former participants specific things: Did they change any behaviors? Did they arrange for a home security survey or Operation Identification? Did they obtain new locks? Do they keep important phone numbers by their telephone? Did they arrange for direct deposit of checks?

Expanding the Opportunities for Crime Prevention Education for Seniors

Crime prevention trainers have generally found that organized groups of senior citizens are eager for opportunities to learn about crime prevention. With relatively little publicity, police crime prevention trainers are able to fill their schedules with clubs, chapters, or organizations of older people who want to focus one of their meetings on the topic. But, effective crime prevention requires the efforts of others besides the police and related professionals. There is a need to expand the opportunities for crime prevention education, so that each topic is covered in greater depth and larger numbers of elders are reached. To do this, the population of persons who can provide the service must expand.

Some communities are finding that aging-related community service professionals and seniors themselves can become effective crime prevention trainers or educators. These educators have been found among the participants and staffs of senior citizen centers, nutrition sites, clubs, and even among the management of buildings that house large numbers of older persons. The addition of these people to the ranks of crime prevention educators enables the police to make better use of their scarce resources, affords opportunities for repeat and varied training, and provides an easily available resource of information and advice for seniors with crime-related concerns.

States and localities are making good use of these human resources, incorporating crime prevention education into their existing services in imaginative and cost-effective ways.

- Representatives of all of the major agencies that offer services to senior citizens in Newark, New Jersey have been trained as crime prevention educators:

- The entire network of Walter Reuther Senior Centers in Detroit provides in-depth crime prevention education to its members;
- The New York State Office for the Aging is acting as a "go-between;" it coordinates efforts between aging agencies and the police to develop crime prevention packages for elderly clients;
- The states of Florida, Michigan, and Pennsylvania are training professionals throughout their aging networks in crime prevention for seniors.

Even with a large roster of well-trained crime prevention education specialists, however, there will still exist the problem of reaching isolated, home-bound elderly with information on how to reduce their vulnerability to crime. One solution comes from a recent evaluation which found that crime prevention information is effectively transmitted to senior citizens through television. Elderly respondents reported that they remember and acted upon crime prevention information that they had seen on television (Bishop et al., 1979). A second solution, discussed in more detail in Chapter Twelve, is to ensure that all the service providers who come into contact with isolated individuals are knowledgeable about the kinds of advice and assistance they should provide. For this reason, crime prevention education is coming to be recognized as an essential part of the education of those who work regularly with the frail or the isolated elderly.

Finally, of course, it is our belief that books such as this handbook can serve the needs of older people, whatever their context, by giving elders and aging-related staffs the facts and the tools of meaningful crime prevention education. We believe that a logical, comprehensive discussion of crime and the elderly can replace myths and fear with understanding and action. And so, we have discussed the realities of aging and of crime in America, the patterns of crime and their prevention, the forms of victim assistance, and the means of expanding these messages. It is our hope that these efforts contribute to improving the quality of life of today's elders, and that of tomorrow's.

Reading and Resources

- Baggett, Sharon, and Marvin Ernst, "From Research to Application: Development of Police and Older Adult Training Modules," Police Chief, Vol. 44, No. 2, February 1977.
- Bishop, George F., William R. Klecka, Robert W. Oldendick, and Alfred J. Tuchfarber, An Impact Evaluation of the National Elderly Victimization Prevention and Assistance Program, Cincinnati, OH: Behavioral Sciences Laboratory, 1979.
- Center, Lawrence J., Anti-Crime Programs for the Elderly: A Guide to Program Activities, Washington, DC: National Council of Senior

Citizens, 1979.

Goodell, Rita Nitzberg, Effective Responses to the Crime Problem of Older Americans: An Instructor's Guide, Washington, DC: National Council of Senior Citizens, 1982.

Guthrie, Eileen and Sam Miller, Making Change: A Guide to Effectiveness in Groups, Minneapolis, MN: Interpersonal Communication Programs, Inc., 1978.

Mager, Robert, Preparing Instructional Objectives, Palo Alto, CA: Fearon Publishers, 1962.

Maler, Norman R. F., Allan R. Solem, and Syesha A. Maier, The Role Play Technique: A Handbook for Management and Leadership Practice, San Diego, CA: University Associated, Inc., 1978.

Nitzberg, Rita, Guide to Training Materials in Criminal Justice and the Elderly, Washington, DC: National Council of Senior Citizens, 1978.

Nitzberg, Rita, Trainer's Manual: Crime Prevention for Senior Citizens, Washington, DC: National Council of Senior Citizens, 1979.

Shaw, Malcom E., Raymond J. Corsisi, Robert Blake, and Jane S. Mouton, Role Playing: A Practical Manual for Group Facilitators, San Diego, CA: University Associates, Inc., 1980.

Wiman, Raymond V., Educational Media, Columbus, OH: Charles Merrill Co., 1969.