

DOCUMENT RESUME

ED 213 902

CE 031 576

AUTHOR Nama, Joe
 TITLE Cement Finishing. Pre-Apprenticeship Phase 2 Training. Student Training Modules.
 INSTITUTION Lane Community Coll., Eugene, Oreg.
 SPONS AGENCY Employment and Training Administration (DOL), Washington, D.C.; Oregon State Dept. of Education, Salem.
 PUB DATE 81
 NOTE 323p.; For related documents see CE 031 561-579.
 EDRS PRICE MF01/PC13 Plus Postage.
 DESCRIPTORS Behavioral Objectives; *Building Trades; *Cement Industry; Check Lists; Construction Materials; *Finishing; Job Skills; Learning Activities; Learning Modules; Pacing; Postsecondary Education; Tests; *Trade and Industrial Education; Two Year Colleges; Vocabulary
 IDENTIFIERS *Cement; *Preapprenticeship Programs

ABSTRACT

These 20 Student Training Modules on cement finishing comprise one of nine sets of self-paced learning modules developed for Pre-Apprenticeship Phase 2 Training. (A companion instructor's guide is available separately as CE 031 575.) The modules are designed to impart trade knowledge and skills to the student. Each module contains some or all of the following: cover sheet listing module title, goals, and performance indicators; study guide/checklist with directions for module completion; introduction; vocabulary listing and defining new trade or technical terms; supplementary references, information sheet(s); job sheet(s) listing materials and tools necessary to complete tasks designed to develop manipulative skill; post assessment; and post assessment answers. Topics covered in the module include concrete characteristics and properties; concrete types and uses; air-entrained concrete; aggregates and water; design of concrete mixtures; concrete reinforcing; layout; building simple forms; estimating; mixing concrete; testing plastic concrete; placing concrete; consolidating and striking off; finishing concrete; curing; forming and finishing steps; cold and hot weather placing, finishing and curing; forming and finishing curbs; and patching. (YL3)

 * Reproductions supplied by EDRS are the best that can be made *
 * from the original document. *

ED213902



PRE-APPRENTICESHIP PHASE 2 TRAINING Student Training Modules

Cement Finishing

U.S. DEPARTMENT OF EDUCATION
NATIONAL INSTITUTE OF EDUCATION
EDUCATIONAL RESOURCES INFORMATION
CENTER (ERIC)

This document has been reproduced as received from the person or organization originating it.
Minor changes have been made to improve reproduction quality.

Points of view or opinions stated in this document do not necessarily present official NIE position or policy.

PERMISSION TO REPRODUCE THIS MATERIAL HAS BEEN GRANTED BY

C. Hostrup

TO THE EDUCATIONAL RESOURCES INFORMATION CENTER (ERIC)

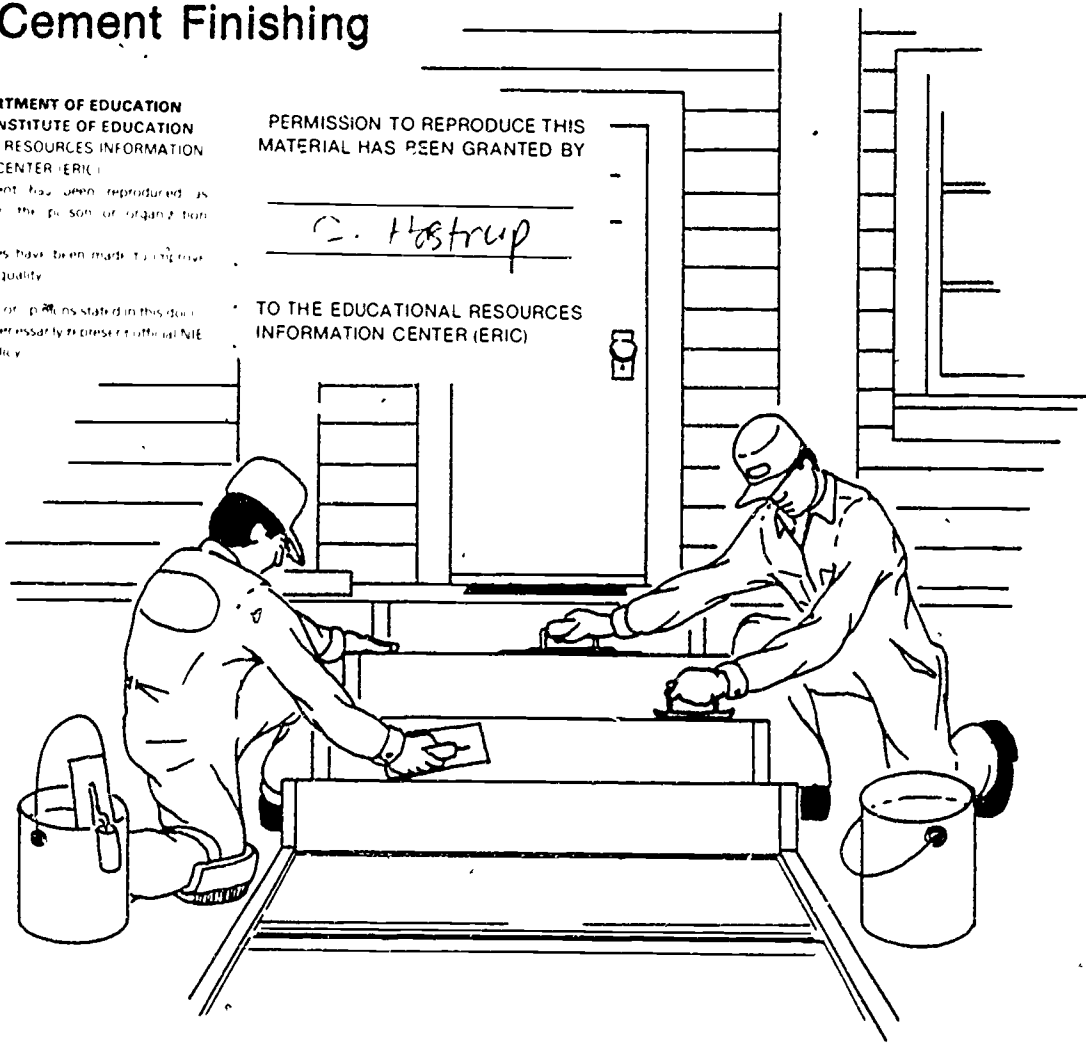

CE031576

Cement Finishing Module Writer:

Joe Nama

Technical Assistance: Joe Chadek

Graphics: Ralph Bentley

Editorial, Proofreading and Pasteup:

Dick Ingram, Ron Hamblen, Debi Carroll

Typing:

Strandlien Typing Service

This project was developed under a sub-contract for the Oregon Department of Education by Lane Community College, Community Education Division, Eugene, Oregon. Funds were provided by the Governor of Oregon from the Educational Linkages Component of the CETA Governor's Grant.

STATEMENT OF ASSURANCE

It is the policy of the Oregon Department of Education that no person be subjected to discrimination on the basis of race, national origin, religion, sex, age, handicap or marital status in any program, service or activity for which the Oregon Department of Education is responsible. The Department will comply with the requirements of state and federal law concerning non-discrimination and will strive by its actions to enhance the dignity and worth of all persons.

Lane Community College

4000 E. 30th Avenue
Eugene, Oregon 97405
(503) 726-2200

Office of the President

July 27, 1981

On behalf of Lane Community College, I wish to express our pride and gratitude for the opportunity to participate in the development of the Pre-Apprenticeship training materials. We also wish to commend the Oregon Department of Education for its original concept and continued support; and, the Educational Linkages Component of the CETA Governor's Grant for funding.

The goals of this project are many, but none are more important than that of producing valid, understandable vocational curriculum material. We congratulate the tradespeople and production staff for their accomplishments.

Finally, I recommend this material to anyone exploring Pre-Apprenticeship as an entry into the vocational work world, with the hope and belief that it will go a long way toward producing skilled craftspeople who are dedicated to their work.

Sincerely,

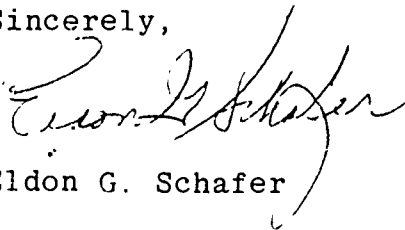

Eldon G. Schafer

CONCRETE CHARACTERISTICS AND PROPERTIES

Goal:

The student will be able to explain what concrete is made from and the properties desired in plastic and hardened concrete.

2

Performance Indicators:

The student will demonstrate knowledge of the topic by successfully completing a Self Assessment, an Assignment and a Post Assessment.

5

Study Guide

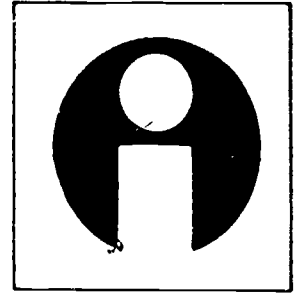

In order to finish this module, do the following tasks. Check each item off as you complete it.

1. Read the Goal and Performance Indicators on the cover of the module. This will tell you what you will learn by studying the module, and how you will show you've learned it.
2. Read the Introduction. The Introduction will tell you why the module is an important part of the cement finishing trade.
3. Study the Vocabulary section. Vocabulary words are important for a good understanding of the trade. After you have studied the vocabulary, ask your teacher to quiz you on the words and their meanings.
4. Study the Information section. This section will give you the information you need to understand the subject.
5. Take the Self Assessment exam. This is a test for you to prove to yourself that you have learned the material you have studied. Compare your answers with the answers on the Self Assessment Answer Sheet, which is on the page following the Self Assessment. If you scored poorly, re-study the Information section or ask your teacher for help.
6. Do the Assignment page. Follow the instructions at the top of the Assignment page.
7. Take the Post Assessment exam. Give the exam to your teacher after you have completed it. Your teacher will grade it for you.

Introduction

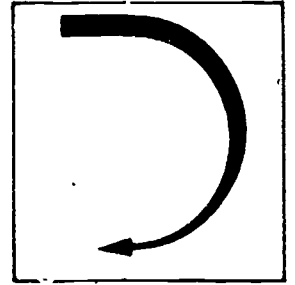

Today concrete is the most widely used of all building materials. It is extremely strong, needs no maintenance, and resists fire and insect damage.

The final appearance, quality, and other features of concrete depend on the concrete worker. For this reason the student should become familiar with the properties of both plastic and hardened concrete.

Vocabulary

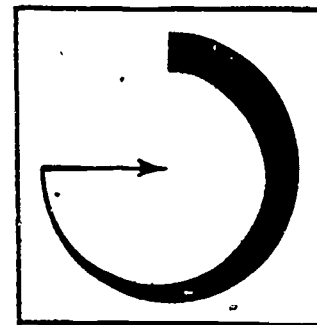

Trade terms are very important for a good understanding of the trade. Study these words and meanings. When you have learned them, ask your teacher to quiz you on the words and their meanings.

AGGREGATE--Sand, pebbles, gravel or crushed rock.

AIR ENTRAINMENT--The forcing of billions of air bubbles into concrete.

CONCRETE--A combination of cement, aggregates and water.

HYDRATION--A chemical reaction between cement and water that causes the mixture to harden.

INERT MATERIALS--Materials which have no chemical effect on anything they are mixed with. Inert materials used in concrete are (a) fine aggregates; for example, sand and (b) large aggregates; for example, gravel or crushed rock.

PLASTIC CONCRETE--Plastic concrete is a term used to describe freshly mixed concrete.

POROSITY--How easily a material can absorb water.

PORTLAND CEMENT--A finely-ground powder. The basic ingredients are lime, silica, alumina, and iron. It gets its name from the similarity of its appearance to the portland stone of England.

PORTLAND CEMENT PASTE--A combination of portland cement and water.

WATER-CEMENT RATIO--The amount of water compared to the amount of cement in the mix.

CURING--The chemical process that hardens the concrete into a stone-like substance.

Supplementary References

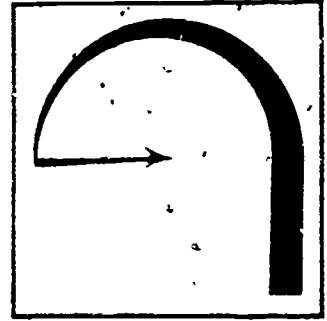

1. Concrete Technology. Instructor's Guide. Portland Cement Association, 1965. pp. 5-16.
2. Concrete Construction Handbook. McGraw-Hill, 1968. Unit I, pp. 3-13.

Information

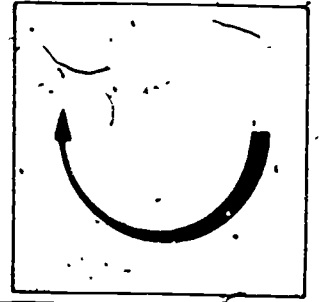

Freshly-mixed concrete is a combination of cement, small and large aggregates, (usually sand and gravel) and water. Aggregates, such as sand and gravel, are inert materials. They have no cementing value of their own. Their function is to serve as a filler. When mixed with cement and water they are permanently held in the concrete because of chemical reactions between water and cement.

PORTLAND CEMENT

Portland cement is a type of cement, not a brand name. All portland cements will set and harden under water. There are five types of portland cement available. Which type is used will depend on what is being built. For example, low heat portland cement produces little heat in the chemical reaction that occurs during the process. This type is used for massive concrete structures such as dams, because a higher heat cement might cause the dam to explode during the curing period.

Portland cement and aggregates are available in all parts of the country.

AGGREGATES

The size and grade of the aggregates affect:

1. The water-aggregate-cement proportions in the concrete.
2. The cost of the used concrete.
3. The porosity of the concrete.
4. The shrinkage of the concrete when fully cured.

Freshly-mixed concrete and hardened concrete have different properties. Freshly mixed concrete is plastic only for a short time. During this time it can be formed and molded into any shape at normal temperatures. Freshly mixed concrete

should have the following 3 qualities:

1. All the ingredients in the concrete should be mixed thoroughly, until it is uniform in appearance.
2. The mix should be neither too dry nor too wet. (The wetness or dryness of the mix is referred to as the consistency or slump.)
3. The mix should have good workability. Workability is the ease with which concrete can be poured. In the case of concrete slabs poured for patios, sidewalks, garage floors, etc., this term would include how well the top surface can be smoothed (called finished).

The 4 qualities desired in hardened concrete are:

1. Durability.
2. Watertightness.
3. Strength.
4. Abrasion resistance.

All of these are influenced by the water-cement ratio of the portland cement paste. The amount of water and cement used in the paste is the water-cement ratio.

Durability

For concrete, the most destructive force is freezing and thawing while it is wet or moist. This may be caused by the expansion of the materials in the concrete. Introducing entrained air into the concrete can help prevent this destruction. Air-entrained concrete has microscopic bubbles that provide pockets which relieve the pressure as excess water is forced into them. This kind of concrete is more resistant to the bad effects of de-icing chemicals.

Concrete is used widely outdoors and is exposed to the destructive actions of the weather, therefore it must be durable enough to repeatedly withstand extreme heat and cold with little upkeep or repair.

Watertightness

Most important need of a durable (long-lasting) concrete is to be watertight. If water cannot penetrate the concrete, freeze-thaw cycles will cause little or no damage.

Most materials deteriorate when they become wet, but concrete actually gains strength in the presence of water (unless the water is alternately freezing and thawing). This characteristic is important in the construction of structures, especially footings and foundations, in wet locations.

Strength

Concrete must be strong enough to carry heavy loads. Strength is the quality most easily controlled during construction and most easily checked by tests of samples taken on the job. The same things which increase the strength of concrete also improve its durability and watertightness to the same degree. It is possible for concrete to be strong enough for its intended purpose, but not sufficiently durable or watertight under certain conditions.

Abrasion Resistance

For certain uses concrete should be able to resist the abrasive action of wheeled vehicles, foot traffic and flowing water. The same factors that increase durability, strength and watertightness also increase the concrete's ability to withstand abrasion or wear. When wearing away of the concrete may be a problem, the aggregates used in the concrete mix should be tough and hard. They should be as hard as the cementing paste.

SUMMARY

The desirable properties of hardened concrete are durability, watertightness, strength and abrasion resistance. These are controlled by the amount of water in proportion to the amount of the cement in the mix. The quality of the hardened concrete will depend on the quality of the plastic concrete which should be well mixed and neither too wet nor too dry. There are 5 types of portland cement. The type chosen will depend on what the concrete will be used for.

The size of aggregates affect the relative proportions, workability, economy, porosity and shrinkage of concrete. Air-entrained concrete is more resistant to the bad effects of freezing and thawing, as well as to the damaging effects of de-icing chemicals. Air entrained concrete is more watertight than ordinary and is the best choice where the concrete will be saturated with water.

Self Assessment

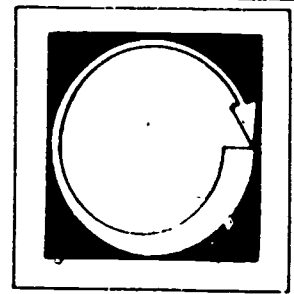

LISTED BELOW ARE SEVERAL STATEMENTS. IF THE STATEMENT IS TRUE, PLACE A "T" IN THE BLANK PROVIDED. IF THE STATEMENT IS FALSE, PLACE AN "F" IN THE BLANK.

1. ___ Concrete will not harden in water.
2. ___ Freshly mixed concrete can be formed into practically any shape.
3. ___ Portland cement and aggregates are not always available in most parts of the country.
4. ___ There is no difference between concrete and cement.
5. ___ Aggregates are used as fillers and binders in concrete.
6. ___ In hardened concrete, air-entrainment makes concrete more watertight than concrete with no air-entrainment.
7. ___ Plastic concrete is hardened concrete.
8. ___ Portland cement consists primarily of a mixture of lime, silica, and iron.
9. ___ Aggregate is another word for cement.

Self Assessment Answers

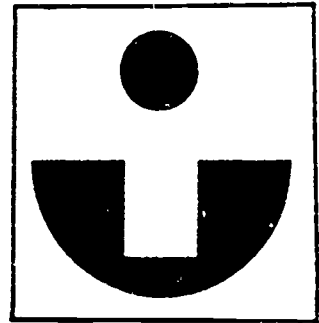

1. F
2. T
3. F
4. F
5. T
6. T
7. F
8. T
9. F

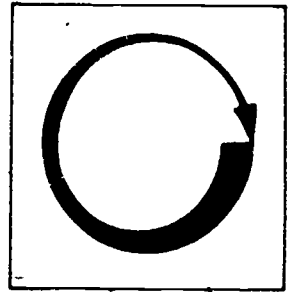

Assignment

COMPLETE THE FOLLOWING ASSIGNMENTS.

1. Visit a redi-mix concrete plant. Write a report on how concrete is mixed and the different aggregates used.
2. Go to a construction site where concrete is being used. List the different ways concrete is used.
3. Discuss in class the properties desired in plastic and hardened concrete.

Post Assessment

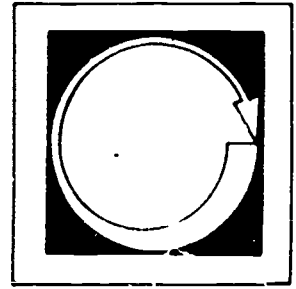

WRITE AN ANSWER TO THE FOLLOWING QUESTIONS.

1. What is the difference between cement and concrete?
2. What properties are desired in fresh concrete?
3. Name four properties desired in hardened concrete.
4. Why is concrete firesafe?
5. (Re-read Vocabulary section.) Where does portland cement get its name?
6. What is plastic concrete?
7. What is meant by water-cement ratio?

8. What function do aggregates serve when used in concrete?

9. What are the "inert" materials in concrete?

10. Name 3 advantages of air entrainment in hardened concrete.

Instructor Post Assessment Answers

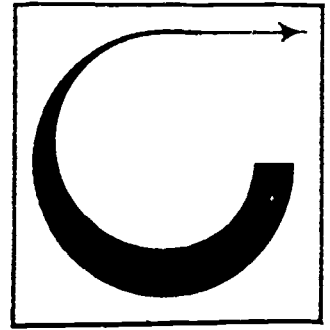

1. The difference between cement and concrete is-- cement is a finely ground material. Concrete is cement, water, and aggregates mixed together.
- 2.—The properties desired in fresh concrete are: Good consistency, good workability, and uniformity.
3. The four properties desired in hardened concrete are: (1) durability, (2) strength, (3) watertightness, and (4) resistance to abrasion.
4. Concrete is firesafe because it is made of materials that will not burn.
5. Portland cement is named after portland stone in England.
6. Plastic concrete is freshly mixed concrete that has not hardened.
7. The water-cement ratio is the amount of water in proportion to the amount of cement used in the mix.
8. Aggregates when used in concrete act as a filler and binder when added to water and cement.
9. Inert materials are the aggregates that have no cementing values when used alone.
10. The three advantages of air entrainment in hardened concrete are:
 1. Improves concrete resistance to freezing.
 2. Effective in preventing serious surface scaling caused by de-icing chemicals.
 3. More watertight than concrete without entrained air.

CONCRETE TYPES AND USES

Goal:

The student will be able to explain the common types and uses of concrete.

Performance Indicators:

The student will show an understanding of the topic by successfully completing a Self Assessment, two Assignments and a Post Assessment.

Study Guide

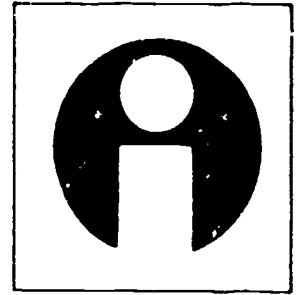

In order to finish this module, do the following tasks. Check each item off as you complete it.

1. Read the Goal and Performance Indicators on the cover of the module. This will tell you what you will learn by studying the module, and how you will show you've learned it.
2. Read the Introduction. The Introduction will tell you why the module is an important part of the cement finishing trade.
3. Study the Vocabulary section. Vocabulary words are important for a good understanding of the trade. After you have studied the vocabulary, ask your teacher to quiz you on the words and their meanings.
4. Study the Information section. This section will give you the information you need to understand the subject.
5. Take the Self Assessment exam. This is a test for you to prove to yourself that you have learned the material you have studied. Compare your answers with the answers on the Self Assessment Answer Sheet, which is on the page following the Self Assessment. If you scored poorly, re-study the Information section or ask your teacher for help.
6. Do the Assignment page. Follow the instructions at the top of the Assignment page.
7. Take the Post Assessment exam. Give the exam to your teacher after you have completed it. Your teacher will grade it for you.

Introduction

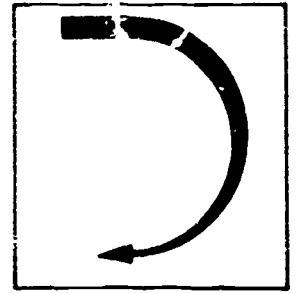

The good worker will need to know the different uses and types of concrete used in construction in order to be competent in the field. Each job may demand a different type of concrete.

Vocabulary

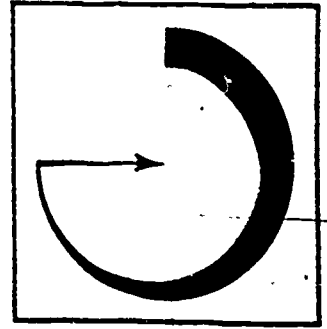

Trade terms are very important for a good understanding of the trade. Study these words and meanings. When you have learned them, ask your teacher to quiz you on the words and their meanings.

PLAIN CONCRETE--Concrete containing no reinforcement.

REINFORCED CONCRETE--Concrete containing reinforcement to increase its tensile strength.

REINFORCEMENT--This term is used to describe steel bars or welded wire fabric (mesh) placed in concrete to increase tensile strength.

PRE-STRESSED CONCRETE--Pre-stressing force is applied by stretching high-strength steel reinforcement.

PRECAST CONCRETE--When concrete is taken out of a form and placed in a building.

LIGHTWEIGHT CONCRETE--Concrete containing lightweight aggregates or gas generating chemicals.

THIN SHELLS--Sections of concrete as thin as $2\frac{1}{2}$ inches.

SHOTCRETE--Term used to designate pneumatically applied portland cement plaster and concrete.

TILT-UP CONSTRUCTION--Walls of concrete that are cast in sections or panels, flat on the floor. When they're cured, they are tilted to their vertical positions in a building.

SANDWICH WALLS--Wall panels that have insulation between two sections of concrete.

LIFT SLAB--Floor slabs of a building cast on the ground, one on top of the other.

~~TENSILE STRENGTH--When steel is put in concrete to keep it from bending or being pulled apart.~~

Supplementary References

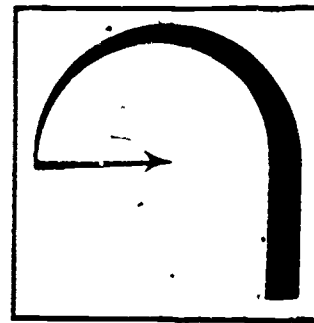

Concrete Technology. Instructors guide, Portland Cement Association, 1965.
pp. 28-30.

Information

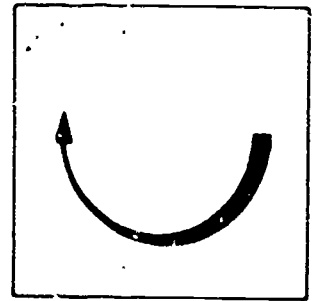

There are about ten common types of concrete used in construction. They are:

1. Plain concrete: Has no reinforcement. It is usually used for sidewalks and ground floors where traffic is light.
2. Reinforced Concrete: Is concrete containing reinforcement to increase its tensile strength. Concrete is very strong for supporting loads placed upon it (compression strength), but sometimes requires steel reinforcement to help it resist stresses or forces that tend to bend or pull it apart.
3. Pre-cast Concrete: Popular because of the economy and quality control. Pre-casting can be done on the job or at a plant site. When a number of identical units are required a considerable savings can be realized, especially on forms as they can be re-used. Pre-casting can also be done during slack periods and stock piled for later use. Units such as beams, girders and columns are then used when needed.
4. Pre-stressed Concrete: Generally applied to concrete units that are subjected to loads that cause bending, such as girders, beams and slabs. The concrete is compressed by stretching steel wires through the unit. In reinforced concrete, all tensile stresses are carried by reinforcing steel. In a pre-stressed unit, the entire cross-section supports the load. Pre-stressed concrete is used for industrial buildings, highway and railroad bridges, pressure pipe, poles, pre-cast joists, pilings and water tanks. The savings in materials by pre-stressing are substantial. Up to 50% of the concrete and 75% of the steel used in a conventional reinforced building can be saved. There are two basic methods of pre-stressing concrete: Pre-tensioning and post-tensioning. In pre-tensioning, the steel wire strand is stretched in the form before placing the concrete. After the concrete hardens and has cured, the wires are released,

transferring the stress to the concrete by means of a bond between the concrete and the steel. In post-tensioning, steel cables are located in ducts in the concrete. After the concrete has reached the required compressive strength, the steel cable in the duct is stretched by hydraulic jacks. This puts the concrete in compression, and the ducts are usually grouted.

5. Tilt-up Concrete Construction: The forms for the wall panels are placed flat on the floor or on a smooth bed of sand. After the forms are poured and the concrete cured, the wall panels are tilted in a vertical position to form the building walls. Panels are joined by leaving a space between them. A tie is created by casting a column between the panels. Pier footings are usually used.
6. Concrete Sandwich Wall: Wavy panels that are cast flat. The insulated panel has a 1½-inch section of polystyrene or styro-foam between two 2½-inch sections of concrete, making a 6-inch wall. Panels are tilted to their vertical positions and are tied together by columns much like tilt-up construction.
7. Lift Slab: A method of construction where the floor slabs of a building are cast on the ground, one on top of another. The slabs are then jacked into place by hydraulic jacks and fastened to columns. Buildings several stories high have been built by this method.
8. Lightweight Concrete: Made either by using gas-generating chemicals or by using lightweight aggregates such as expanded shale, slag, and clay. Concretes that contain aggregates such as perlite and vermiculite are very light in weight and are used as an insulating material. Lightweight concrete is used for structural and insulating applications that include cast-in-place and pre-cast walls, floors, roof sections and fire-proofing. Lightweight concretes are sometimes classified according to weight per cubic foot. These include:
 - a. insulating lightweight concrete--20 to 70 lbs. per cubic foot and compressive strengths seldom exceeds 1000 lbs. per square inch.
 - b. structural lightweight concrete--up to 115 lbs. per cubic foot and compressive strength exceeding 2000 lbs. per square inch.

- c. semi-lightweight concrete--weighs 115 to 130 lbs. per cubic foot. Normal weight sand is used as a partial or complete replacement for lightweight fine aggregate. To control the uniformity of lightweight concrete, the cement content, slump and dry aggregates per cubic yard should be kept constant.
9. Shotcrete: Portland cement plaster or concrete applied by a gun operated by compressed air. The mixture is cement, water and aggregate. The water may be added to the dry materials as they pass through the nozzle of the gun or as the materials are mixed. Shotcrete is an extremely strong, dense concrete that is highly resistant to weathering. Because its absorption is low it is excellent for waterproofing. Its resistance to abrasion is comparable to cast-in-place concrete containing the same aggregates.
10. Thin Shells: Concrete placed in sections as thin as $2\frac{1}{2}$ -inches. In the United States, building codes usually prescribe a minimum of $2\frac{1}{4}$ inches thick. Thin shells are used primarily as roof sections because of their lighter weight. The shape of thin walls makes them strong. The three most popular thin shells are:
 - a. Barrel shells. Two types: Long and short barrels. Long barrels have short chord widths compared to the span between supporting ribs. Short barrels have large chord widths in proportion to the span between ribs.
 - b. Dome shells are a portion of a sphere.
 - c. Folded plate, V type.

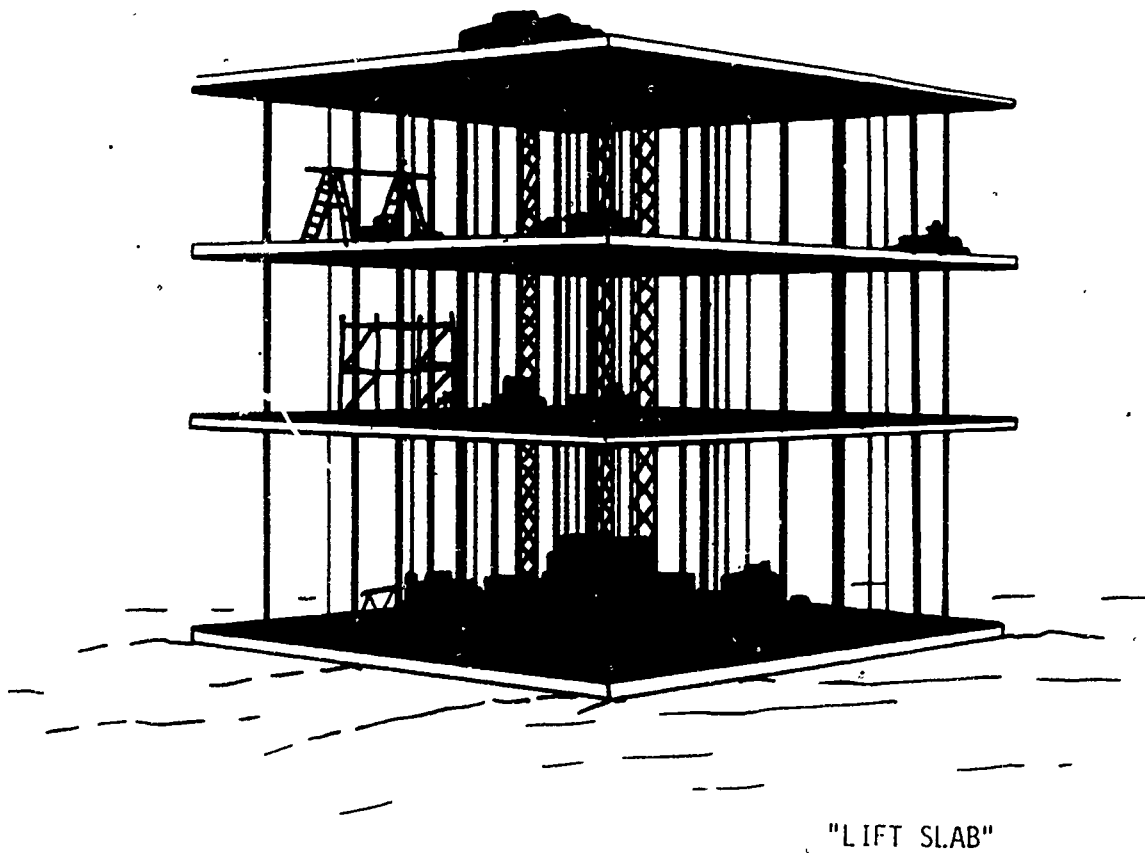
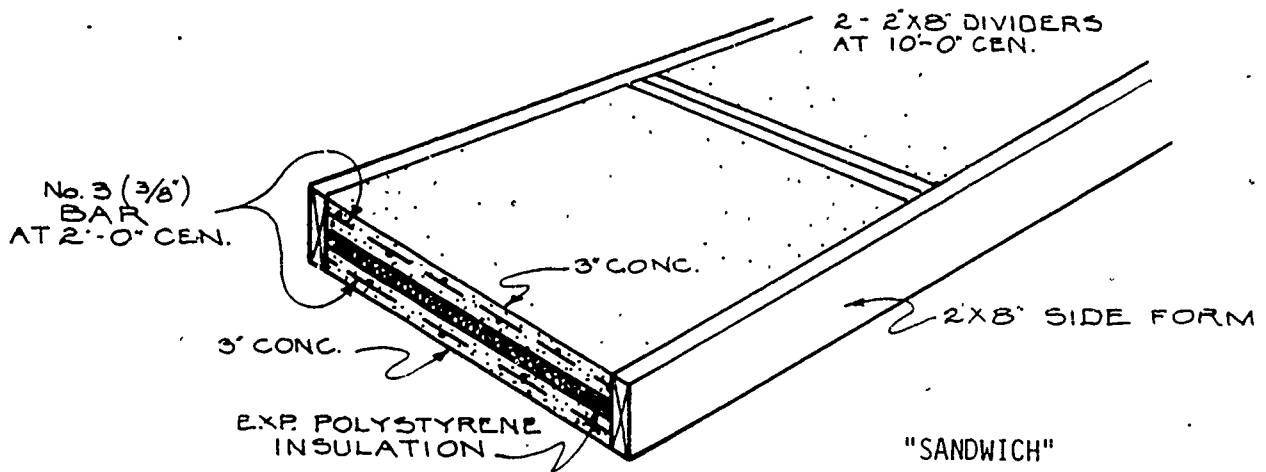

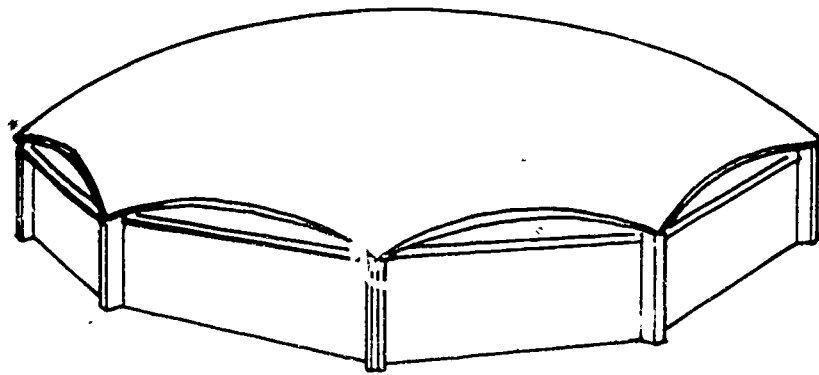

DOMES

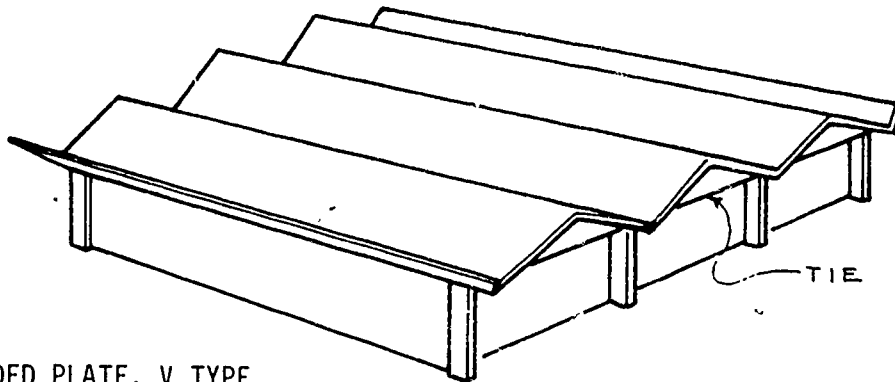

FOLDED PLATE, V TYPE

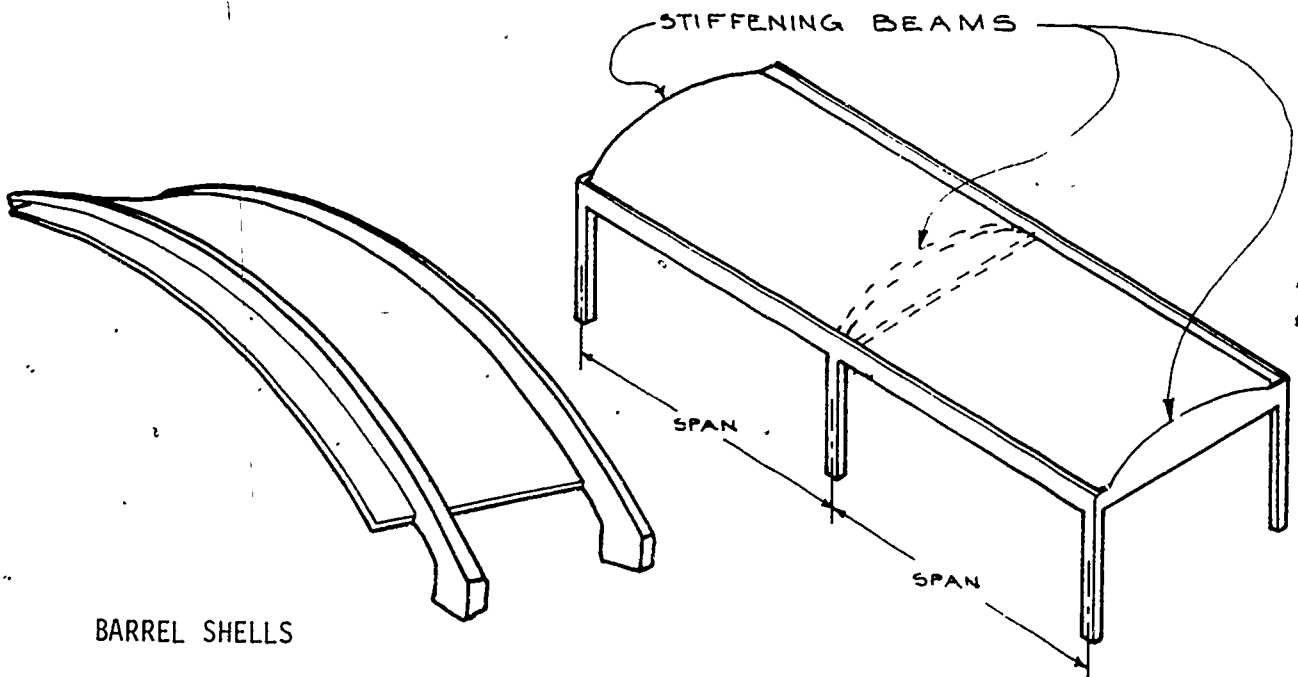

BARREL SHELLS

Self Assessment

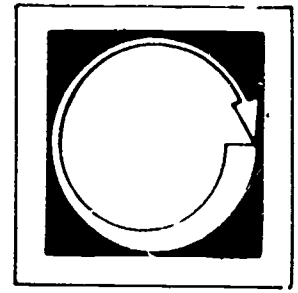

WRITE AN ANSWER TO THE FOLLOWING QUESTIONS.

1. What is plain concrete?
2. What is reinforcement and why is it used in concrete?
3. Describe the 2 basic ways lightweight concrete is made.
4. How is shotcrete made?
5. What is the difference between reinforced concrete and pre-stressed concrete?
6. Why is precast concrete popular?

7. What is tilt-up construction?

8. What are thin shells?

9. Name the 3 common types of thin shells.

Self Assessment Answers

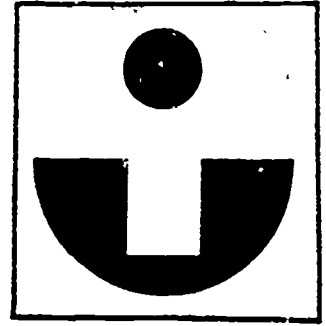

1. Concrete that has no reinforcement.
2. Reinforcement is steel bars or welded wire (wire mesh) placed in concrete. It is used to increase the tensile strength of concrete.
3. By substituting lightweight materials such as perlite or expanded shale in place of heavier aggregates such as gravel and sand. Or by using air bubble generating chemicals in the concrete.
4. Cement plaster or concrete is applied with a gun operated by compressed air.
5. Reinforced concrete has steel bars or welded wire placed in the concrete. Pre-stressed concrete is squeezed or compressed by steel cables stretched inside the forms before the concrete is poured.
6. It is popular because it is cheaper and it can be done on the job or at a factory.
7. It's a fast, economical way to build concrete walls by precasting them and then standing them in place.
8. Thin sections of specially shaped concrete often used for roofs.
9.
 - a. barrel shells
 - b. dome shells
 - c. folded plates

Assignment

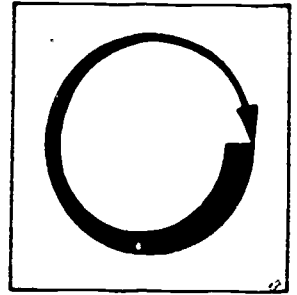

COMPLETE THE ASSIGNMENTS .BELOW.

1. Visit a ready-mix concrete plant. Write a one-page report on the different types and uses of the concrete you saw.
2. Take a field trip to different construction sites to view special concrete uses. Discuss with the class the different uses of concrete you saw.

Post Assessment

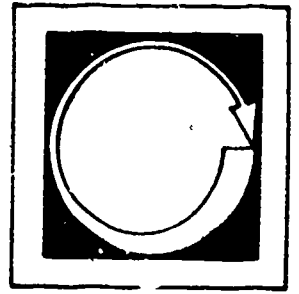

WRITE AN ANSWER TO THE FOLLOWING QUESTIONS.

1. Name the two general methods of pre-stressing.
2. Briefly explain the two methods of pre-stressing.
3. What is the weight of regular concrete per cubic foot?
4. How is lightweight concrete made?
5. Explain the lift slab method of construction.
6. Describe how tilt-up construction is accomplished.

7. What are sandwich walls?

8. What is the purpose of reinforcement in concrete?

Instructor Post Assessment Answers

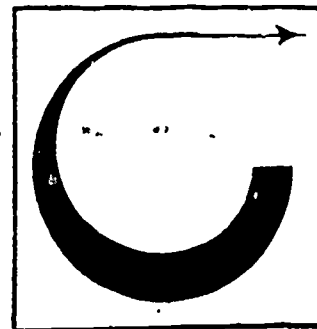

1. Pre-tensioning and post-tensioning.
2. a. Pre-tensioning--High strength steel wire strand is stretched in the form before pouring the concrete. Concrete is then cast and allowed to harden. The wires are then released allowing them to contract, transmitting compressive stresses to the concrete because it is bonded to the concrete.
b. Post-tensioning--Steel cables are located in ducts in concrete. The steel is stretched by hydraulic jacks after the concrete has hardened.
3. 150 lbs. per cubic foot.
4. Lightweight concrete is made either by placing gas generating chemicals into the concrete or by using lightweight aggregates such as expanded shale, clay, and slag.
5. The floor slabs of a building are cast on the ground, one on top of another. Then the slabs are jacked into place by hydraulic jacks and fastened to columns.
6. The walls of a tilt-up building are cast in sections or panels, flat on the floor. After wall panels are cured they are tilted to their vertical positions and fastened together to make a wall.
7. Walls that are insulated concrete panels that are cast flat.
8. Concrete is extremely strong in compression or for supporting loads placed directly upon it, but it requires steel bars or other metal reinforcement to increase its tensile strength when subjected to loads that tend to bend or pull the concrete apart.

AIR-ENTRAINED CONCRETE

Goal:

The student will develop an understanding of air-entrained concrete, how it is made and its main advantages.

35

Performance Indicators:

The student will show an understanding of the topic by successfully completing a Self Assessment, an Assignment Sheet and a Post Assessment.

38

Study Guide

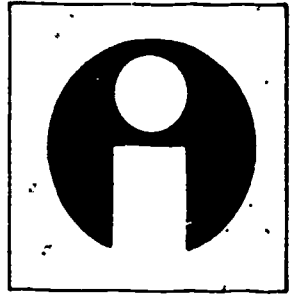

In order to finish this module, do the following tasks. Check each item off as you complete it.

1. Read the Goal and Performance Indicators on the cover of the module. This will tell you what you will learn by studying the module, and how you will show you've learned it.
2. Read the Introduction. The Introduction will tell you why the module is an important part of the cement finishing trade.
3. Study the Vocabulary section. Vocabulary words are important for a good understanding of the trade. After you have studied the vocabulary, ask your teacher to quiz you on the words and their meanings.
4. Study the Information section. This section will give you the information you need to understand the subject.
5. Take the Self Assessment exam. This is a test for you to prove to yourself that you have learned the material you have studied. Compare your answers with the answers on the Self Assessment Answer Sheet, which is on the page following the Self Assessment. If you scored poorly, re-study the Information section or ask your teacher for help.
6. Do the Assignment page. Follow the instructions at the top of the Assignment page.
7. Take the Post Assessment exam. Give the exam to your teacher after you have completed it. Your teacher will grade it for you.

Introduction

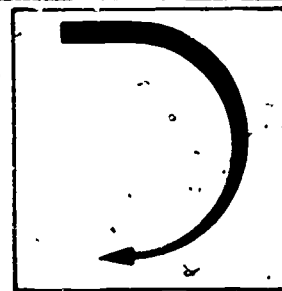

Advancements in concrete technology are being made all the time. A major improvement in concrete has been the development of air-entrained concrete. Air-entrained concrete will last even longer than ordinary concrete. This is because it is more resistant to freezing and thawing, more water tight and more resistant to the scaling that results from freezing and thawing and the use of de-icing agents.

Vocabulary

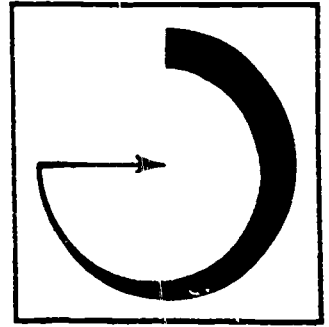

Trade terms are very important for a good understanding of the trade. Study these words and meanings. When you have learned them, ask your teacher to quiz you on the words and their meanings.

ADMIXTURE--Anything added to concrete to change strength, color or workability.

BLEEDING--The forming of water on the surface of concrete after placing.

POZZOLAN--An admixture used to air entrain concrete.

FLY ASH--Burned powder; used as Pozzolans.

LEAN MIX--Concrete with less cement than normal.

PASTE--Cement, water and entrained air.

PUMICITES--Rock containing pumice ground into a powder. A Pozzolan material.

Supplementary References

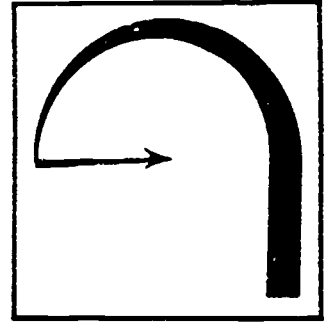

1. Concrete Technology. Instructor's Guide. Portland Cement Association, 1965. pp. 71-80.
2. Waddell, Joseph J. Concrete Construction Handbook. McGraw-Hill Book Co. 1968. pp. 4-8, pp. 46-50.

Information

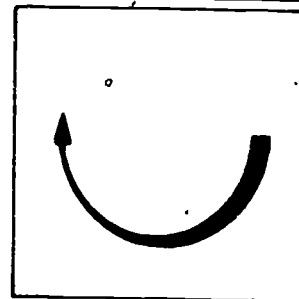

One of the greatest advancements in concrete technology is the introduction of air entrainment. Air-entrained concrete was first discovered in the mid-1930s. The use of entrained air is recommended in concrete for nearly all purposes.

Air-entraining improves concrete's resistance to freezing and thawing damage, improved workability, and reduced bleeding.

Air-entrained concrete is produced by using air-entraining cement (the air-entraining agent is mixed with the cement by the manufacturer) or by adding an air-entraining admixture during the mixing of concrete. When the air-entraining agent is mixed with water in the mixing process it produces air bubbles. These air bubbles are very small, about a thousandth of an inch to about a hundredth of an inch in diameter. These air bubbles are not connected and are distributed throughout the paste. As many as 400 to 600 billion bubbles may be present in a cubic yard of air-entrained concrete.

Air-entrained concrete requires less water to mix to a smooth consistency than non air-entrained concrete. Entrained air improves the workability of concrete by increasing the volume of the paste. Entrained air greatly improves the workability of concrete with lean mixes. Workability of mixes with poorly graded aggregates is also improved. Because of improved workability, less water and sand is needed.

Concrete's resistance to freezing and thawing, and to various de-icing chemicals, is improved several hundred per cent over non air-entrained concrete. As water freezes, it expands (up to 9 per cent) producing pressures that can crack the concrete and cause scaling. Because the air bubbles are round they do not completely fill with water. As water freezes, its expansion is relieved by the air space in the bubble, preventing damage to the concrete. The air

bubbles continue to serve their purpose during repeated cycles of freezing and thawing.

Entrained air prevents scaling from de-icing chemicals, and is recommended for all concrete that comes in direct or indirect contact with de-icing chemicals.

Watertightness of air-entrained concrete is superior to that of non air-entrained concrete. Air-entrained concretes generally have lower water-cement ratios and are more watertight.

Mixes should be designed to contain more air than desired when the concrete is placed. A good rule of thumb is to use 6 percent plus or minus 1 percent. ($\pm 1\%$)

Aggregate size and mix proportions affect the percentage of entrained air. There is little change in air content when aggregate size is over 1 1/2". Increasing the amount of the fine aggregate results in a need for more entrained air.

Slump and vibration affect the amount of air retained in the finished concrete. Air content is lost rapidly when the slump exceeds 6 inches. A normal amount of vibration does not affect the amount of entrained air. For most concrete, the desired consolidation should be obtained in 5 to 15 seconds.

Less air is entrained when the temperature of the concrete increases. A decrease in air content can be offset by increasing the quantity of air entraining admixture.

The amount of entrained air also varies with the type and condition of the mixer, the amount of concrete being mixed, and the rate of mixing.

Pozzolans is the name given to admixtures that entrain air in concrete. Materials used as Pozzolans are fly ash, shales and pumicites.

Self Assessment

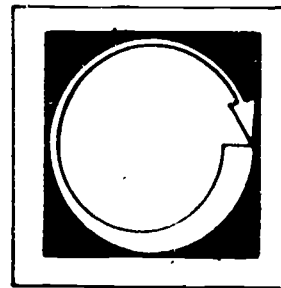

LISTED BELOW ARE SEVERAL STATEMENTS. IF THE STATEMENT IS TRUE, PLACE A "T" IN THE BLANK PROVIDED. IF THE STATEMENT IS FALSE, PLACE AN "F" IN THE BLANK.

1. ___ Air-entrained concrete is produced by pumping air into the mixer.
2. ___ Air-entrained concrete can be produced by two different methods.
3. ___ One of the greatest advancements in concrete technology is the introduction of entrained air.
4. ___ Fly ash is burned wood ashes.
5. ___ Pozzolans are an admixture used to produce air-bubbles in concrete.
6. ___ When water freezes it expands up to 20 percent.

Self Assessment Answers

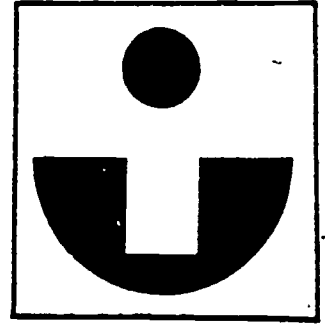

1. F

2. T

3. T

4. F

5. T

6. F

Assignment

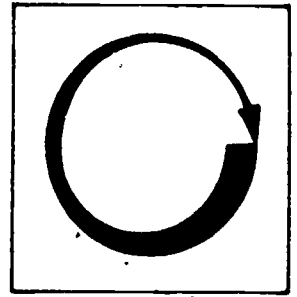

COMPLETE THE FOLLOWING ASSIGNMENTS.

Write a report on the advantages of using air-entrained concrete, and how it resists freeze/thaw action.

Post Assessment

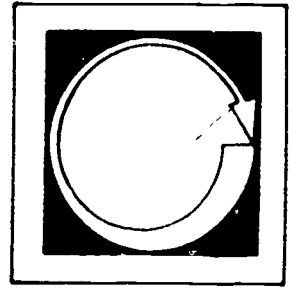

WRITE AN ANSWER TO THE FOLLOWING QUESTIONS.

1. What are the two methods used to air-entrain concrete?
2. How much air should air-entrained concrete mixes contain? (as a percentage)
3. What is the principal reason for using air-entrained concrete?
4. Name three effects air-entrainment has on fresh concrete.
5. How does air-entrainment effect the workability of concrete?
6. Why is entrained air recommended for all concretes that come in contact with de-icing chemicals?

7. Name two factors that affect the percentage of entrained air.

Instructor Post Assessment Answers

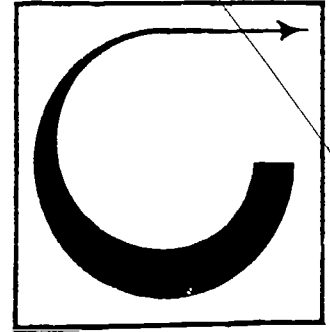

1. The two methods used to entrain air in concrete are:
 - a. by using air-entraining cement.
 - b. by using an air-entraining admixture during mixing.
2. Mixes should be designed to contain 6 percent (plus or minus 1 percent) air.
3. The principal reason for using air-entrained concrete is to improve the concrete's resistance to freezing and thawing.
4. Three effects air-entrainment has on fresh concrete are :
 - a. needs less water.
 - b. improved workability.
 - c. less segregation and bleeding.
5. Air-entrainment improves the workability of concrete by increasing the volume of the paste.
6. Air-entrained concrete is recommended for all concretes that come in contact with de-icing chemicals because entrained air prevents surface scaling from contact with chemicals.
7. Two factors that affect the percentage of entrained air are slump and vibration. Slump should not exceed 6 inches, and concrete should be vibrated 5 to 15 seconds.

AGGREGATES AND WATER

Goal:

Upon completion of this module the student will be able to explain the function of aggregates and water in concrete.

Performance Indicators:

The student will show a knowledge of the topics by successfully completing a Self Assessment, an Assignment and a Post Assessment.

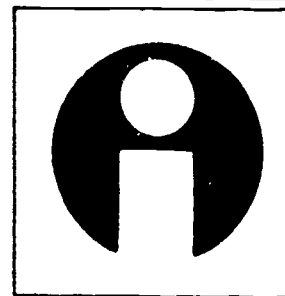

Study Guide

In order to finish this module, do the following tasks. Check each item off as you complete it.

1. Read the Goal and Performance Indicators on the cover of the module. This will tell you what you will learn by studying the module, and how you will show you've learned it.
2. Read the Introduction. The Introduction will tell you why the module is an important part of the cement finishing trade.
3. Study the Vocabulary section. Vocabulary words are important for a good understanding of the trade. After you have studied the vocabulary, ask your teacher to quiz you on the words and their meanings.
4. Study the Information section. This section will give you the information you need to understand the subject.
5. Take the Self Assessment exam. This is a test for you to prove to yourself that you have learned the material you have studied. Compare your answers with the answers on the Self Assessment Answer Sheet, which is on the page following the Self Assessment. If you scored poorly, re-study the Information section or ask your teacher for help.
6. Do the Assignment page. Follow the instructions at the top of the Assignment page.
7. Take the Post Assessment exam. Give the exam to your teacher after you have completed it. Your teacher will grade it for you.

Introduction

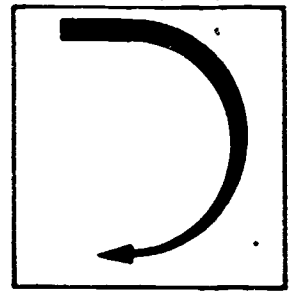

Aggregates and water are the two ingredients that are combined with cement to make concrete. Both have important but different jobs to do. The aggregates are the main ingredient by volume and it is by bonding them together that the concrete is formed. The water is the activating ingredient. By mixing the cement with the water the chemical action that causes the bonding of the ingredients into a stone-like substance is started. An understanding of how these two materials react to the cement and to each other is necessary for effectively making and using concrete. This module will help you to learn about the different types of aggregates commonly used and how to use the right proportion of aggregate to suit the needs of the specific job. You will also learn about the relationship of the amount of water used to the quality of the finished product.

Vocabulary

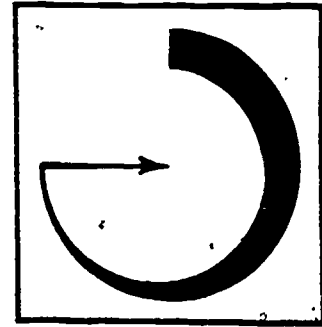

Trade terms are very important for a good understanding of the trade. Study these words and meanings. When you have learned them, ask your teacher to quiz you on the words and their meanings.

FINE AGGREGATES--Fine aggregates are natural and manufactured sands 1/4 inch and less in size.

COURSE AGGREGATES--Course aggregates are usually crushed stone or gravel 1/4 inch and up to the maximum size permitted for the job.

LIGHTWEIGHT AGGREGATES--Aggregates that are lighter in weight than sand and gravel - usually containing materials such as expanded shale, clay, slate and slag.

INSULATING LIGHTWEIGHT AGGREGATES--Lightweight materials such as cinders, pumice, scoria, vermiculite and perlite.

SEGREGATION OF AGGREGATES--Separation of the different sizes of aggregates.

PPM--Parts per million - referring to the amount of foreign matter (dirt, etc.) in aggregates.

HYDRATION--The chemical combining of water and cement to form the material that bonds the aggregate together.

Supplementary References

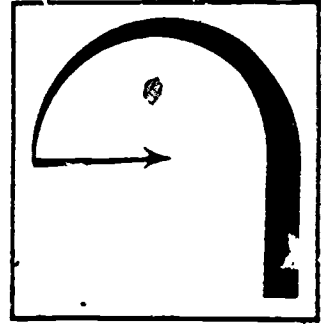

1. Concrete Technology - Instructor's Guide. Portland Cement Assoc., 1965. pp. 45-70.
2. Concrete Construction Handbook. McGraw-Hill Book Co., 1968. Joseph J. Waddell. 2-1 through 2-3.

Information

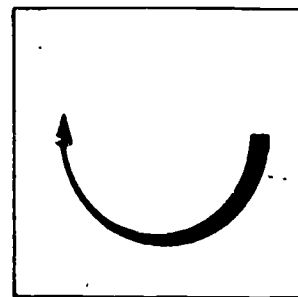

The aggregates most commonly used in concrete are sand, gravel, and crushed stone. Because aggregates make up approximately three-fourths of the volume of concrete, they are called a filler material. They should consist of materials that will give the concrete strength and resistance to exposure conditions such as temperature extremes. They should be graded in size to secure the best economy from the cement paste. The aggregates should not contain materials that can weaken the concrete, such as dirt, clay, coal, or organic (vegetable) matter. Even very small amounts of these substances (called contaminants) can cause problems. Testing results for these substances are expressed in parts of contaminants per million parts counted, or P.P.M.

There are five characteristics of good aggregates that produce strong, workable, and economical concrete. These five characteristics are:

1. Resistance to freezing and thawing--Alternate freezing and thawing can cause the concrete to crack and scale. Aggregates that do not absorb (soak up) water are therefore best.
2. Abrasion resistance--Often used as an index of aggregate quality. Motor vehicle traffic and even pedestrian traffic can wear concrete out. For long lasting streets and floors aggregates that can withstand abrasion should be used.
3. Compressive strength--The ability of an aggregate to withstand heavy loads.
4. Chemical stability--Indicates that the aggregate will not react chemically with cement.
5. Particle shape and surface texture--These influence the properties of fresh concrete more than they affect the properties of hardened concrete. Roughly textured or long flat particles require more cement paste to make the concrete workable than do round or square aggregates. Crushed and uncrushed aggregates generally give the same strength for the same amount of cement.

Besides being hard and durable, the best aggregates are clean and free from loam, clay, fine dust, and vegetable matter, as these materials prevent the cement paste from binding the aggregate particles together. This reduces the strength of the concrete. Concrete made with dirty aggregates hardens more slowly or may never harden enough to serve its intended purpose. When concrete is mixed on the job it is the responsibility of the user to see that the aggregates are clean.

Aggregates are classified as "fine" and "course." Fine aggregates are particles (pieces) 1/4 inch and less in size. They have particles ranging from 1/4 inch down to some that will pass through a sieve having 100 holes to the square inch. Course aggregates are usually gravel or crushed stone ranging in size from 1/4 inch up to the maximum size allowed for the job. The maximum size of course aggregate is governed by two factors: 1) size and shape of concrete members, and 2) amount and distribution of the reinforcing steel.

Most concrete contains both fine and large aggregates. It is necessary to use both fine and large because the finer aggregates fill the voids (holes or air pockets) between the larger ones. This is called proportioning. Properly proportioned aggregates require less cement paste to make quality concrete.

Aggregates should be stored so that they remain free of dust and other harmful materials. They should be stockpiled in uniform layers to prevent separation of sizes. They should not be stockpiled in cone-shaped piles as this can cause separation of sizes. Damp fine aggregates will separate less than dry material.

Substances other than gravel, crushed rock and sand are sometimes used as aggregates to make concrete for special uses. For example, when lighter weight concrete is needed, light weight aggregates such as expanded shale or slate are used. In other cases, where the concrete needs to provide some insulation from noise or temperature extremes, materials such as perlite or vermiculite are used.

Water used for mixing concrete should be neither alkaline nor acidic unless tests or experience indicates that the concentrations of either of these in the water are not of a high enough level to be harmful to concrete. Oil and vegetable matter of any kind should also be avoided. Any contamination of

the water can prevent the concrete from setting properly. Water suitable for drinking is usually specified for mixing concrete.

The amount of water also has an affect on the quality of the concrete. Too much or too little water will produce concrete with poor workability. The strength of the cured concrete can a'so be affected by using the wrong amount of water. Adding water to the concrete mixture changes the dry cement into a paste. This paste sets and hardens, holding the aggregates together to produce the concrete. The setting and hardening is due to a chemical reaction between the cement and water called hydration.

Before,
grading

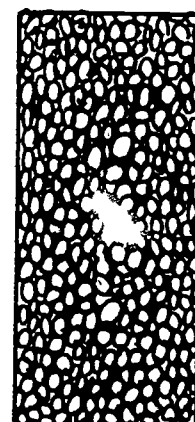
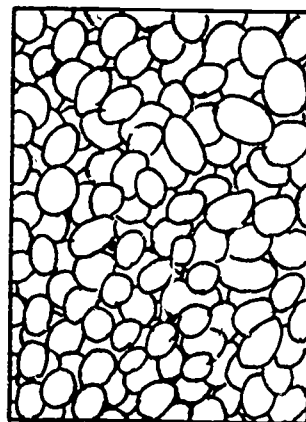
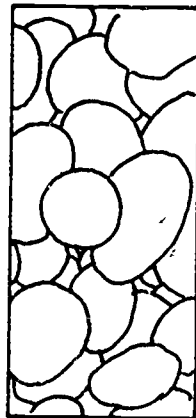
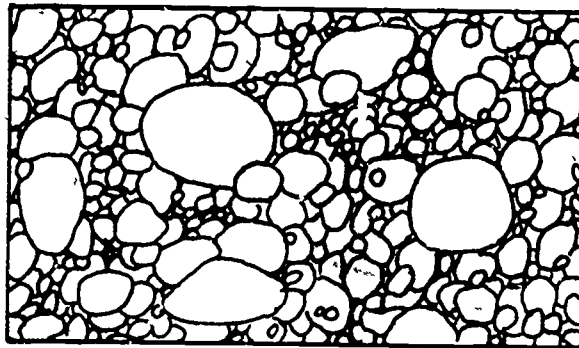

After grading

Self Assessment

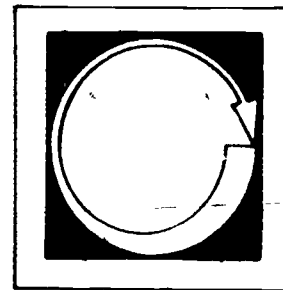

LISTED BELOW ARE SEVERAL STATEMENTS. IF THE STATEMENT IS TRUE, PLACE A "T" IN THE BLANK PROVIDED. IF THE STATEMENT IS FALSE, PLACE AN "F" IN THE BLANK.

1. Dirty aggregates do not reduce the strength of concrete.
2. Aggregates are classified as "fine" and "coarse."
3. By adding water to a stiff mix you could make the concrete more workable.
4. Dirty water has no affect on the strength of concrete.
5. Aggregates should not be stockpiled in cone shaped piles.
6. Fine aggregates are 1/4 inch and larger.
7. Concrete made with dirty aggregates can prevent the cement paste from bonding the aggregate particles together.
8. Concrete made with dirty aggregates hardens too fast.
9. Damp aggregates will separate less than dry aggregates.

Self Assessment Answers

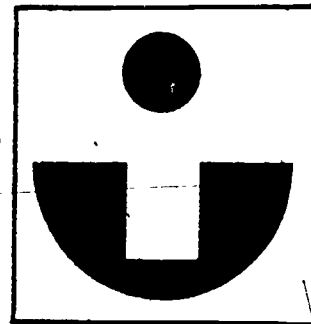

1. F

2. T

3. T

4. F

5. T

6. F

7. T

8. F

9. T

Assignment

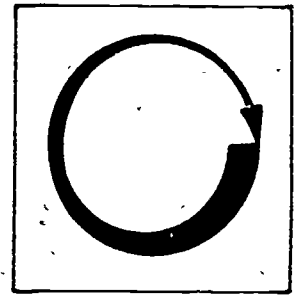

COMPLETE THE ASSIGNMENT BELOW.

Go to a sand and gravel company storage yard. Write a report on the different types and sizes of aggregates you saw and how they were stockpiled.

Post Assessment

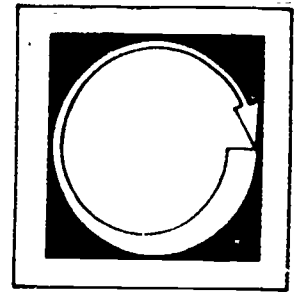

WRITE AN ANSWER TO THE FOLLOWING QUESTIONS.

1. Why should aggregates be clean and free from dirt, clay, coal, or organic (vegetable) matter?
2. What are the five characteristics of good aggregates for concrete?
3. Explain abrasive resistance.
4. Why is it usually necessary to use both "fine" and "coarse" aggregates when mixing concrete?
5. Why should clean water be used when mixing concrete?
6. What is the purpose of using water in the mixing of concrete?

7. How should aggregates be stockpiled for future use?

8. What aggregates are most commonly used in concrete?

9. Why are aggregates called filler material?

● Instructor Post Assessment Answers

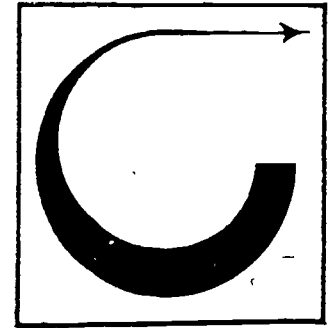

1. Aggregates should be clean and free from dust, clay, coal, or organic matter because these materials prevent the paste from bonding the aggregate particles.
2. The five characteristics of good aggregates are: 1) resistance to freezing and thawing, 2) abrasion resistance, 3) compressive strength, 4) chemical stability and 5) particle size and surface texture should be round or square to produce more workable concrete.
3. Abrasive resistance are materials that can withstand abrasions when used in concrete for floors and pavements.
4. It is usually necessary to use both "fine" and "coarse" aggregates in concrete because the finer aggregates fill the voids between the coarse aggregates.
5. Clean water should be used when mixing concrete as dirty water may cause the concrete not to set properly.
6. The purpose of using water in concrete is to change the cement into a paste which makes the mixture more workable and triggers the chemical action called hydration.
7. Aggregates should be stockpiled in uniform layers to prevent separation of the different sizes.
8. The aggregates most commonly used in concrete are sand, gravel and crushed stone.

9. Aggregates are called filler material because they make up approximately three-fourths of the volume of concrete.

DESIGN OF CONCRETE MIXTURES

Goal:

The student will be able to explain the unit weight method of designing economical concrete mixes. The student will be able to explain the relationship of the ratio of the ingredients to the workability and quality of the concrete product.

Performance Indicators:

The student will show knowledge of the topic by successfully completing a Self Assessment, an Assignment and a Post Assessment.

Study Guide

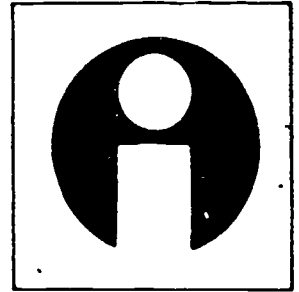

In order to finish this module, do the following tasks. Check each item off as you complete it.

1. Read the Goal and Performance Indicators on the cover of the module. This will tell you what you will learn by studying the module, and how you will show you've learned it.
2. Read the Introduction. The Introduction will tell you why the module is an important part of the cement finishing trade.
3. Study the Vocabulary section. Vocabulary words are important for a good understanding of the trade. After you have studied the vocabulary, ask your teacher to quiz you on the words and their meanings.
4. Study the Information section. This section will give you the information you need to understand the subject.
5. Take the Self Assessment exam. This is a test for you to prove to yourself that you have learned the material you have studied. Compare your answers with the answers on the Self Assessment Answer Sheet, which is on the page following the Self Assessment. If you scored poorly, re-study the Information section or ask your teacher for help.
6. Do the Assignment page. Follow the instructions at the top of the Assignment page.
7. Take the Post Assessment exam. Give the exam to your teacher after you have completed it. Your teacher will grade it for you.

Introduction

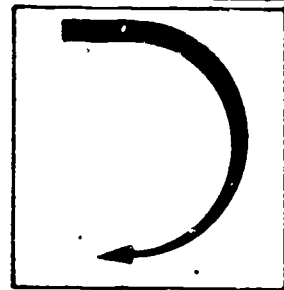

There are many methods used to design (make up) concrete mixtures. Different uses of concrete require the concrete to have different properties. The mixture design determines how the concrete will stand up to the demands of the structure that it is used in. The design also affects the cost of making the concrete, and its workability.

The unit weight method of designing concrete mixes is commonly used in the industry. It is a method that uses weight ratios of the ingredients to make concrete with consistent qualities such as workability and hardness.

Vocabulary

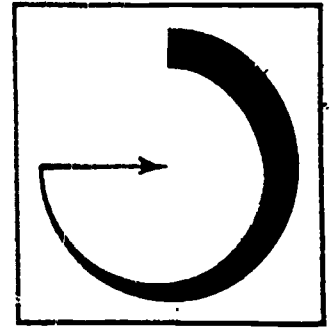

Trade terms are very important for a good understanding of the trade. Study these words and meanings. When you have learned them, ask your teacher to quiz you on the words and their meanings.

MIX DESIGN--A recipe for the proportions of the ingredients of concrete.

UNIT WEIGHT METHOD--A method of mixing concrete using the weight of the different ingredients to determine the amount of each that is to be used.

YIELD--The volume of the concrete produced from 1 bag of cement.

WORKABILITY--The consistency of the concrete which determines the amount of work required to fully place and finish the concrete.

CURING--The hardening process.

ECONOMY--Obtaining the best mix at the least cost.

TRIAL BATCHES--Small amount of mixed materials used to test the quality of the concrete and to determine the desired mix design.

WATER-CEMENT RATIO--The amount of water needed to mix with one bag of cement to obtain a suitable paste.

OPTIMUM PROPORTIONS--The most satisfactory amounts of materials to obtain a proper mix.

SLUMP--The fluidity of plastic concrete stiffness or softness measured in inches.

INGREDIENTS--The different materials used in concrete, such as cement, sand, gravel or crushed stone, water, and additives.

P.S.I.--Pounds per square inch. Used in compressive strength tests.

Supplementary References

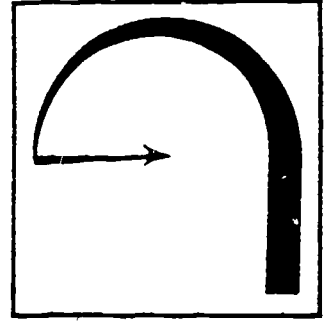

1. Concrete Technology Instructor's Guide. Portland Cement Company, 1965.
pp. 83-101.
2. Hedderich, H. F. and Artuso, J. F. Concrete Construction Handbook.
McGraw - Hill Book Company, 1968. Unit 11, pp. 3-33.

Information

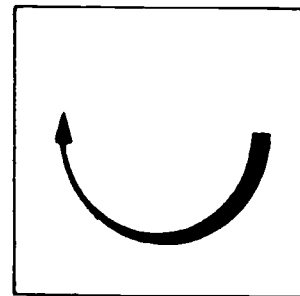

The mix design of concrete is like the recipe for baking a cake. If you mix the batter for a cake using too many eggs or not enough milk or sugar, the cake will turn out wrong and no one will eat it. If your mix design when making concrete isn't right your concrete may end up with air pockets in it or be weak and crumble. In both cases, both time and money are wasted. The mix design gives you a method of controlling the exact amounts of each of the ingredients that are added to the mix. By maintaining this control over the ingredients you also control:

1. The workability of the concrete in its plastic state.
2. The required qualities (hardness and strength) of the cured concrete.
3. Economy, producing the desired qualities at the least expense.

Workability of plastic or wet concrete determines the amount of work required to place and finish the concrete. An understanding of workability is best learned through experience.

The design of a concrete mix is an art as well as a science.

When mixing concrete, the quality of the ingredients must be maintained. If their quality is kept the same, then the quality of the hardened concrete (such as resistance to freezing, thawing and abrasion, watertightness and strength) can be controlled by varying the water-cement ratio, the amount of entrained air introduced and the curing conditions. Many factors must be kept in mind in deciding on the mix design. For example, the method and length of time of curing should be known to select the proper cement-water ratio. The air content desired in the concrete will determine the amount of paste used. When deciding on the amount of paste to be used, the maximum size of coarse aggregate must be considered. Because the cement is the most expensive ingredient in concrete, to achieve the best economy the concrete mix design used

should be the one using the least amount of cement without lowering the concrete's quality. Varying the cement-water ratio is the most important factor in determining the quality of the cured concrete. Using less water will reduce the amount of cement needed. Three ways to minimize the water and cement requirements can be used. They are:

1. Use the stiffest possible mixture.
2. Use the largest aggregate size possible.
3. Maintain the optimum ratio of fine to coarse aggregates.

To achieve the best economy the relative costs of fine and coarse aggregates should also be considered.

Before a concrete mixture can be designed, certain information must be known. First the size, shape, and strength requirements of the concrete structure must be known. Exposure conditions must also be known. Because most of the desired properties of hardened concrete depend on the quality of the cement paste, the first step in the designing the concrete mix is selecting the proper water-cement ratio.

The water-cement ratio should be selected on the basis of concrete strength needed. When possible, tests should be made with the job materials. This will enable you to determine the relationship between the water-cement ratio and strength of the materials actually being used.

The size of the aggregates also affects the strength and economy and must also be taken into account when designing the mix. The maximum size of the coarse aggregate that can be used depends on the size and shape of the concrete members and the distribution of the reinforcing steel within them. The maximum aggregate size should not exceed one-fifth the minimum dimension of the member, nor three-fourths the clear space between the individual pieces of reinforcing steel or between the reinforcing steel and the forms. For ground slabs where no reinforcement is needed, the maximum size of the aggregate should not exceed one-third the slab thickness. The illustrations show how well-graded aggregates look before and after being separated according to size. (See the illustrations on the following page.)

The amount of water needed to produce a cubic yard of concrete of a desired slump (fluidity, thickness) depends on the maximum size of the aggregate. When smaller aggregates are used, then more water is needed. By testing the largest maximum

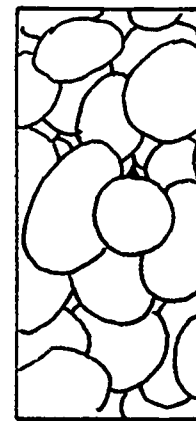
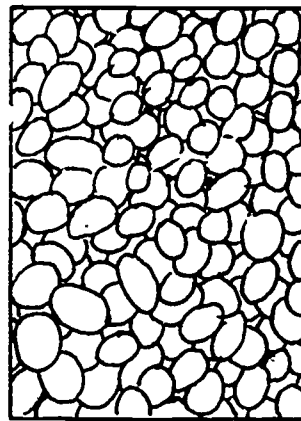
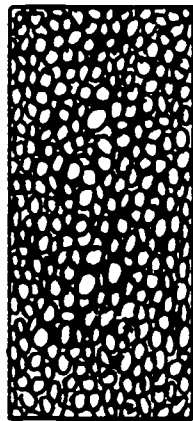
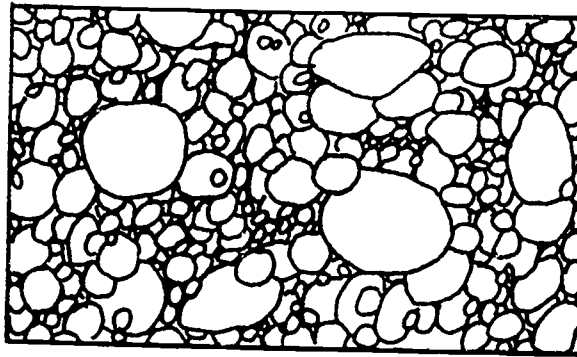

size of coarse aggregate, you can make a mix that requires less water, and therefore less cement and achieve better economy. When strength is the main consideration in the design of the concrete mix, then the maximum size of aggregate allowed for strength is also suggested.

Entrained air helps concrete to withstand temperature extremes. Entrained air should always be used where such conditions exist. It may be used for mild exposure conditions to improve workability. Either air-entraining portland cement or an air-entraining admixture must be used to entrain the air into the concrete mixture.

The slump test is used as a measure of the fluidity of the plastic or wet concrete. Under conditions of uniform controlled mixing, changes in slump will indicate when changes in the materials, mix proportions, or water content have taken place.

To determine the optimum mixing proportions for good economical use of the materials, trial batches should be made. By varying ratios of the fine to coarse

aggregates and water to cement, and then testing the quality of the concrete, the best mix design can be established. Trial batches may be small batches made with laboratory precision or job size batches made during normal concrete production. By comparing the workability and economy of the different batches, the best design mix is selected.

The following is a chart of trial mix data. It shows the different quantities of the ingredients per cubic yard of concrete. (See the chart on the following page.)

SUGGESTED TRIAL MIXES

Non-air-entrained concrete of Medium Consistency 3-4 Inch Slump

Type	Water Gallon Per Cu. Yd.	Cement Bags Per Cu. Yd.	Fine Aggregate lbs. Per Cu. Yd.	Course Aggregate lbs. Per Cu. Yd.	Maximum Size Course Aggregate	Approximate Strength P.S.I. in 28 Days
Floors Sidewalks	41	6	1360	1650	3/4"	3000
Footings	36	5	1220	2030	1 1/2"	3000
Walls	39	5.5	1310	1820	1"	3000

Self Assessment

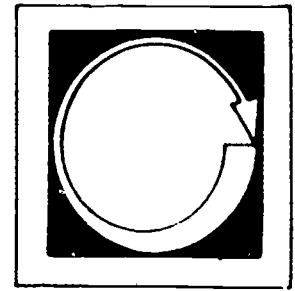

LISTED BELOW ARE STATEMENTS FOLLOWED BY A NUMBER OF POSSIBLE COMPLETIONS. SELECT THE COMPLETION WHICH COMPLETES THE STATEMENT CORRECTLY AND PLACE THE LETTER IN THE BLANK PROVIDED.

1. ____ The ____ of concrete mixtures is like the recipe for baking a cake.
 - a. quality
 - b. design
 - c. ratio

2. ____ The volume of the concrete produced from one bag of cement is the ____.
 - a. economy
 - b. slump
 - c. yield

3. ____ The ____ of plastic concrete determines the amount of work required to place and finish the concrete.
 - a. workability
 - b. strength
 - c. freezing and thawing

4. ____ The quality of concrete is dependent on the ____ ratio.
 - a. fine aggregate
 - b. water-cement
 - c. coarse aggregate

5. ____ To determine the optimum proportions for ____ of materials, trial batches should be made.
- a. quality
 - b. fluidity
 - c. economy
6. ____ The smaller the maximum size of ____, the greater the amount of water.
- a. trial batches
 - b. aggregate
 - c. reinforcing
7. ____ The setting or hardening process is called ____.
- a. yield
 - b. slump
 - c. curing
8. ____ The ____ test is used as a measure of the fluidity of the plastic concrete.
- a. quality
 - b. slump
 - c. economy

● Self Assessment Answers

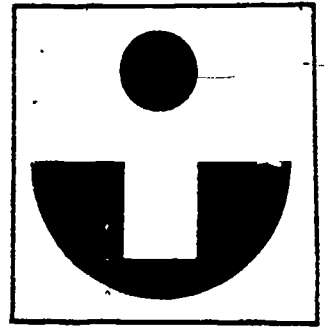

1. design
2. yield
3. workability^o
4. water-cement
5. economy
6. aggregate
7. curing
8. slump

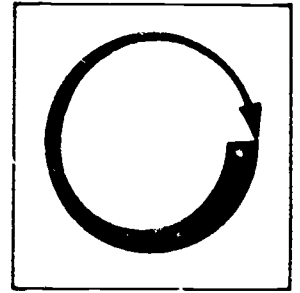

Assignment

COMPLETE THE FOLLOWING ASSIGNMENT.

Write a one-page explanation of the unit weight method of selection and design of a concrete mixture.

Post Assessment

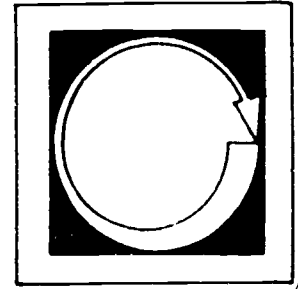

WRITE AN ANSWER TO THE FOLLOWING QUESTIONS.

1. What is the first step in the design of a concrete mix?
2. What information must be known before a concrete mixture can be designed?
3. Name the three objectives of a properly designed concrete mixture.
4. What are the three steps to minimize water and cement requirements and still mix quality concrete?
5. Explain why trial batches should be made when designing a concrete mix.
6. When should entrained air be used in concrete?

7. What is the design of a concrete mixture?
8. Explain what "quality" refers to in a mix design.
9. On what basis should the water-cement ratio be selected?

Instructor Post Assessment Answers

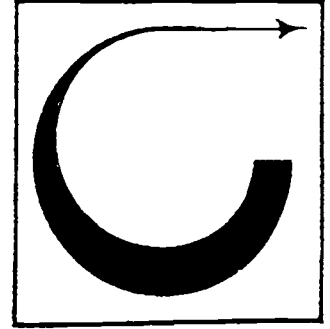

1. The first step in the design of a concrete mix is selecting the proper water-cement ratio.
2. Before a concrete mixture can be designed, the size, shape, and required concrete of the structure and its exposure condition strength must be known.
3. The three objectives of a properly designed concrete mix are:
 - a. workability
 - b. the required qualities of the hardened concrete
 - c. economy
4. The three steps to minimize water and cement requirements in concrete are:
 - a. make the mixture as stiff as possible
 - b. use the largest aggregate size possible
 - c. maintain the optimum ratio of fine to course aggregates.
5. Trial batches should be made when designing a concrete mix to determine the optimum proportions for economy of the materials.
6. Entrained air should be used in concrete when it is exposed to freezing and thawing, and to improve its workability.
7. The purpose of the design of the concrete mixture is to ensure the most economical and practical combinations of concrete ingredients, to maintain workability and to develop the required qualities when hardened.
8. Quality in a mix design refers to hardened concrete that will have a resistance to freezing, thawing and abrasions, will have water tightness and strength.

9. The water-cement ratio should be selected on the basis of strength of the concrete desired.

CONCRETE REINFORCING

Goal:

The student will develop an understanding of how and why reinforcement is used in concrete.

Performance Indicators:

The student will show an understanding of the topic by successfully completing a Self Assessment, an Assignment and a Post Assessment.

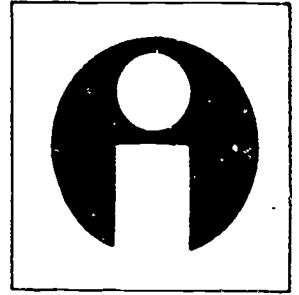

Study Guide

In order to finish this module, do the following tasks. Check each item off as you complete it.

1. Read the Goal and Performance Indicators on the cover of the module. This will tell you what you will learn by studying the module, and how you will show you've learned it.
2. Read the Introduction. The Introduction will tell you why the module is an important part of the cement finishing trade.
3. Study the Vocabulary section. Vocabulary words are important for a good understanding of the trade. After you have studied the vocabulary, ask your teacher to quiz you on the words and their meanings.
4. Study the Information section. This section will give you the information you need to understand the subject.
5. Take the Self Assessment exam. This is a test for you to prove to yourself that you have learned the material you have studied. Compare your answers with the answers on the Self Assessment Answer Sheet, which is on the page following the Self Assessment. If you scored poorly, re-study the Information section or ask your teacher for help.
6. Do the Assignment page. Follow the instructions at the top of the Assignment page.
7. Take the Post Assessment exam. Give the exam to your teacher after you have completed it. Your teacher will grade it for you.

Introduction

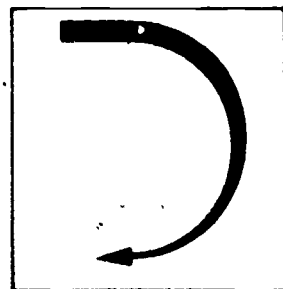

Concrete has high compression strength (strength to withstand heavy loads). But it has much less tensile strength (ability to withstand loads that bend or pull it apart). By using reinforcement in concrete its tensile strength can be greatly increased. If enough reinforcing is used the tensile strength can be made to equal or exceed the compressive load.

Vocabulary

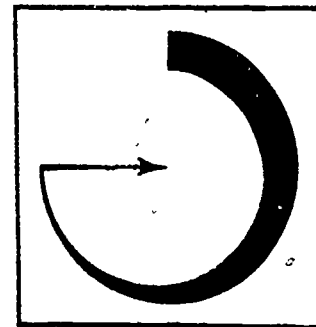

Trade terms are very important for a good understanding of the trade. Study these words and meanings. When you have learned them, ask your teacher to quiz you on the words and their meanings.

REINFORCEMENT--Steel bars or welded wire fabric positioned in concrete to increase its tensile strength.

TENSILE STRENGTH--The ability of concrete to withstand bending or pulling apart.

COMPRESSION STRENGTH--The ability of concrete to withstand heavy loads pressed down on it.

EXPANSION--Swelling or getting larger. In concrete, commonly caused by changing temperature.

CONTRACTION--Shrinking or getting smaller due to temperature changes.

DEFORMED BARS--Reinforcing steel with lug-like ridges that increase the bond to the concrete.

POSITIONING--Placing the reinforcing steel where the concrete will be in tension.

LAPPING--Splicing reinforcing bars when one bar is not long enough and more than one is used.

A.C.I.--American Concrete Institute

LINTEL--A beam that supports the weight over an opening. Also called a header.

Supplementary References

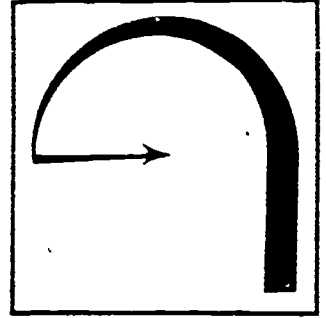

Concrete Technology. Instructor's Guide.* Portland Cement Association, 1965.
pp. 209-220.

Information

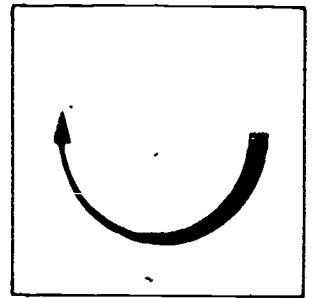

Steel bars and welded wire fabric positioned in concrete are called reinforcement.

Concrete has great compressive strength so it can support heavy loads that are placed directly upon it. However, steel bars or other steel reinforcement is needed in most structures to increase the concrete's ability to resist stresses that would bend or pull it apart. The compressive strength of concrete is about 10 times greater than its tensile strength.

Reinforcement is used in concrete to withstand tensile pull. Tensile strength can be made to equal or exceed the compressive strength depending on how much reinforcement is used and how it is placed.

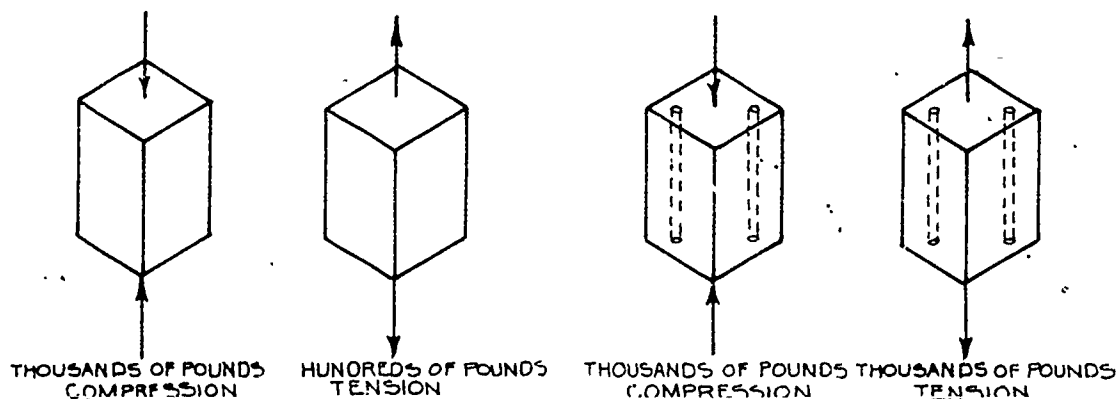

Steel is the most universally accepted and used reinforcement material. One important advantage steel has over other metals is that it reacts to temperature changes by contracting and expanding about the same amount as concrete does.

Reinforcing steel can be purchased either in bars or welded wire fabrics. Bars may be smooth or deformed. Smooth bars usually are only available in small

diameters. Deformed bars have lug-like ridges that increase the bond between the concrete and the steel. Bars come in many standard sizes which are designated by numbers. The number and size of the bars needed will depend on the amount of tensile force the concrete will need to resist. Figure 2 gives the standard bar size up to 1 inch in diameter, the steel area each provides, and the weight of 100 feet of bar. Larger bars are also available for extremely heavy construction.

BAR NUMBER	BAR DIAMETER INCHES	BAR AREA SQ. IN.	APPROXIMATE WEIGHT OF 100 FT.
2	1/4	0.05	17
3	3/8	0.11	38
4	1/2	0.20	67
5	5/8	0.31	104
6	3/4	0.44	150
7	7/8	0.60	204
8	1	0.79	267

Bars usually come from the steel mill in 60-foot lengths, but local building material suppliers stock 20-foot and 40-foot lengths.

Welded wire fabric is made in many types and sizes. It is used where light reinforcement is required. The most commonly available is 6, 8, and 10 gauge (the numbers refer to the size of the wire in the mesh). Commonly the wires are spaced on 6-inch centers both ways, which form 6-inch squares.

Tensile forces are created in a structure in many ways and place different demands on the concrete. Concrete can be subjected to a straight tensile pull, to bending, or to temperature and moisture changes.

Round structures such as silos or water tanks are examples of concrete being subjected to a straight tensile pull. The pressure inside tends to push the walls apart. The reinforcing steel in the concrete holds the walls together. The steel is usually placed near the center of the wall cross-section, slightly outside the centerline.

The lower side of concrete beams and lintels are subjected to tensile forces. Therefore, in concrete lintels and beams the reinforcement is placed near the

lower side, which tends to bend or pull apart when the member is subjected to weight from above.

Welded wire fabric is sometimes used in concrete to reduce cracking due to temperature changes. The reinforcement will not completely prevent the cracks, but it will distribute them more evenly and keep them smaller.

The size, location and spacing of the reinforcement is usually specified by the job engineers. But the important job of placement is done by the concrete mason.

The reinforcement is placed in the forms before the concrete is placed in the forms. When the concrete dries and hardens, the reinforcement becomes part of the concrete mass. All reinforcement should therefore be placed so that it will be protected by an adequate cover of concrete.

CONCRETE PROTECTION FOR REINFORCEMENT

MEMBERS	MINIMUM CONCRETE PROTECTION
1. FOOTINGS	3 IN.
2. CONCRETE SURFACE EXPOSED TO WEATHER	2 IN. FOR BARS LARGER THAN NO. 5, 1-1/2 IN. FOR NO. 5 BARS & SMALLER
3. SLABS AND WALLS	3/4 IN.
4. BEAMS AND GIRDERS	1-1/2 IN.
5. JOISTS	3/4 IN.
6. COLUMNS	NOT LESS THAN 1-1/2 IN. OR 1-1/2 TIMES THE MAXIMUM SIZE AGGREGATE
7. CORROSIVE ATMOSPHERES OR SEVERE EXPOSURES	PROTECTION SHALL BE SUITABLY INCREASED
AMERICAN CONCRETE INSTITUTE ACI 318, "BUILDING CODE REQUIREMENTS FOR REINFORCED CONCRETE."	

When the reinforcing bar is not long enough to go the full length of the form, then the bar must be spliced. The bar must be lapped at the splice if it is to give the concrete tensile strength. The overlap should always be at least 12 inches or 24 times the diameter of the bar for deformed bars. Smooth bars need to be overlapped even more.

Welded wire fabric should be lapped at least one full stay spacing plus 2 inches. A 6" X 6" fabric would need an 8-inch lap.

Reinforcement is used in floor slabs under the following conditions.

1. Load bearing partitions are more than 4 feet from the center of the slab.
2. If the slab is placed on more than 2 feet of fill or if more than 10 per cent of the area inside the foundation wall has been excavated and backfilled.
3. If heat ducts or pipes are embedded in the slab.
4. If unheated slabs are longer than 30 feet.

Concrete should be placed around and under all reinforcement and embedded fixtures. Tapping the form with a rubber or wood mallet will make the concrete settle around and under the reinforcement.

When using reinforcement in concrete, these general rules should be followed:

1. Use clean steel free from rust, paint, scale, etc.
2. Place steel as recommended in Figure 3.
3. Aggregate size (the size of the gravel in the concrete mix) should be limited to $3/4$ of the minimum spacing between reinforcing and forms.
4. Lap all bars a minimum of 12 inches or 24 times their diameter.
5. Place reinforcement where concrete will be in tension.

Reinforcing bars are constantly being improved. The lugs have been changed to adhere better to the concrete. Also, high-strength steel reinforcing bars have been developed. When high-strength bars are used less steel is needed.

Self Assessment

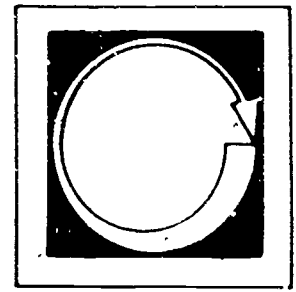

LISTED BELOW ARE SEVERAL STATEMENTS. IF THE STATEMENT IS TRUE, PLACE A "T" IN THE BLANK PROVIDED. IF THE STATEMENT IS FALSE, PLACE AN "F" IN THE BLANK.

1. Without reinforcement concrete has the same compressive and tensile strength.
2. Reinforcing steel can be purchased in the form of reinforcing bars or welded wire fabric.
3. A lintel is a beam that supports weight over an opening.
4. Expansion is shrinking due to changes in temperature.
5. Concrete has great compressive strength.
6. Compressive strength in concrete is the ability to withstand the forces that tend to bend or pull it apart.
7. Steel is the most universally accepted and used reinforcement material.
8. A No. 8 bar is 3/4 inch in diameter. (Hint: Refer to Figure 2.)

Self Assessment Answers

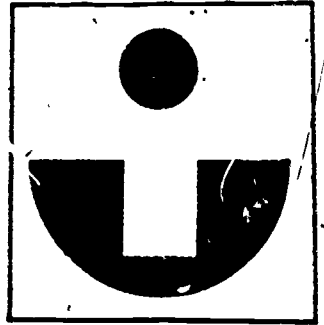

1. F

2. T

3. T

4. F

5. T

6. F

7. T

8. F

Assignment

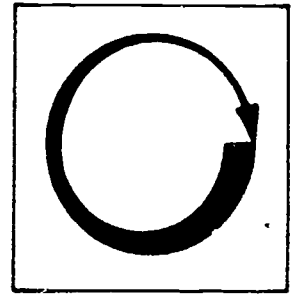

COMPLETE THE FOLLOWING ASSIGNMENT.

Discuss and illustrate by drawings the purposes of reinforcing concrete and methods for placing bars and fabric.

Post Assessment

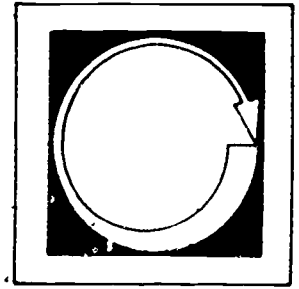

WRITE AN ANSWER TO THE FOLLOWING QUESTIONS.

1. What is reinforcement?
2. Define tensile strength.
3. What important advantage does steel have when used in concrete?
4. What is the purpose of lug-like ridges on deformed bars of steel?
5. What is the diameter ϕ of a No. 4 bar of steel?
6. How can concrete be worked around and under steel reinforcement?

7. What is the rule for lapping bars and welded wire fabric?

8. What part of a concrete beam or lintel is most affected by tensile forces?

9. What are the three most commonly available gages of welded wire fabric?

Instructor Post Assessment Answers

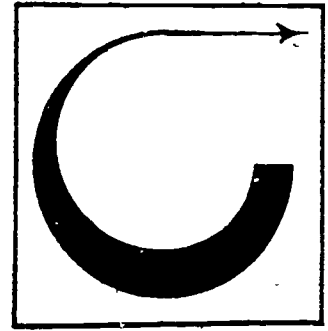

1. Steel bars or small or large welded wire fabric placed in concrete.
2. Tensile strength is the ability to withstand forces that tend to bend or pull apart.
3. It has nearly the same contraction and expansion characteristics as the concrete.
4. They increase the bond between concrete and steel.
5. 1/2 inch
6. By tapping the forms with a heavy wooden or rubber mallet.
7. When splicing steel, the bars should be lapped 24 times the bar diameter but never less than 12 inches. For welded wire fabric, lap at least one full stay spacing (usually 6 inches) plus 2 inches.
8. The bottom.
9. 6, 8 and 10 gage fabric.

LAYOUT

Goal:

The student will develop an understanding of the importance of laying out jobs properly.

Performance Indicators:

The student will show an understanding of the topic by successfully completing a Self Assessment, Two Assignments, a Job Sheet and a Post Assessment.

Study Guide

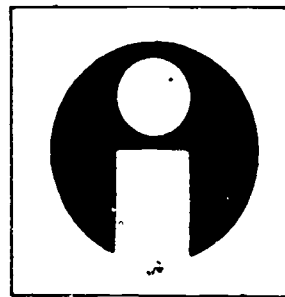

In order to finish this module, do the following tasks. Check each item off as you complete it.

1. Read the Goal and Performance Indicators on the cover of the module. This will tell you what you will learn by studying the module, and how you will show you've learned it.
2. Read the Introduction. The Introduction will tell you why the module is an important part of the cement finishing trade.
3. Study the Vocabulary section. Vocabulary words are important for a good understanding of the trade. After you have studied the vocabulary, ask your teacher to quiz you on the words and their meanings.
4. Study the Information section. This section will give you the information you need to understand the subject.
5. Take the Self Assessment exam. This is a test for you to prove to yourself that you have learned the material you have studied. Compare your answers with the answers on the Self Assessment Answer Sheet, which is on the page following the Self Assessment. If you scored poorly, re-study the Information section or ask your teacher for help.
6. Do the Assignment page. Follow the instructions at the top of the Assignment page.
7. Do the Job Sheet. Follow the instructions at the top of the Job Sheet. The tasks listed on the Job Sheet will help you develop skills which will be helpful to you.
8. Take the Post Assessment exam. Give the exam to your teacher after you have completed it. Your teacher will grade it for you.

Introduction

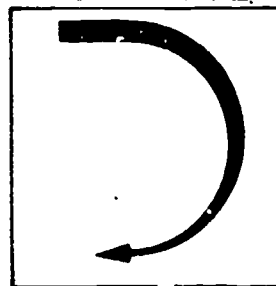

There are times when a worker must lay out a job before forms can be set.

It is important that he or she has a basic understanding of how to set the grade stakes so that:

1. The finished concrete will be at the correct elevation.
2. The finished concrete level will be sloped enough to allow for proper drainage in the right direction.

Vocabulary

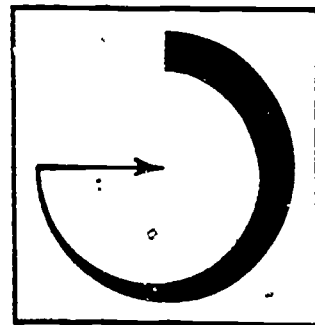

Trade terms are very important for a good understanding of the trade. Study these words and meanings. When you have learned them, ask your teacher to quiz you on the words and their meanings.

TRIPOD--The three legged stand that supports the builders' level or transit.

BUILDERS' LEVEL--A telescope-like instrument with a bubble level that mounts on a tripod. Used to set stakes at the right grade.

TRANSIT--A telescope-like instrument used to level and set vertical lines or angles.

CARPENTER LEVEL OR SPIRIT LEVEL--A bubble level mounted in a wooden or metal beam. Used to level horizontal surfaces or plumb vertical surfaces.

DUPLEX NAILS--Double headed nails with an extra head 1/2 inch below the first.

LINE LEVEL--A bubble level designed to hook on a string.

SCREED--A marker to show the right grade for the finished slab. Also refers to striking off the concrete to the right grade.

GRADE--Elevation, height.

CROSSED HAIRS--What you see when you look into a builder's level or transit.

LASER LEVEL--A laser light-beam to determine level.

STAKE--Wood or metal stick pointed on one end driven into the ground to support forms, screeds or string line.

WET SCREED--Strips of wet, stiff concrete, 12 inches to 16 inches wide, that are struck off to the correct grade.

MEASURING ROD--A 8-foot pole with a rule attached; used with builder's level or transit.

Supplementary References

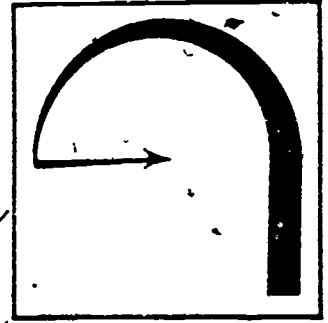

1. Polivchak, Philip. Incentive Apprenticeship Training for Cement Masons. National Association of Homebuilders, 1979. Unit 9, pp. 6-17.

Information

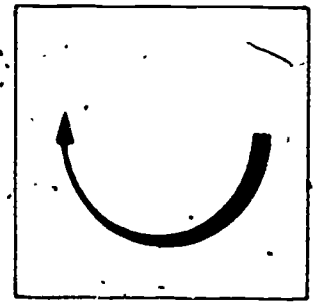

When using the builder's level to set stakes, the instrument should be set up near the center of the area to be formed. Because the tripod holding the level is unlikely to be level the instrument is then leveled by adjusting the leveling screws. First, release the locking mechanism. Turn the instrument until it is directly over two opposite screws. Adjust the screws until the bubble in the level is in the center. Rotate the instrument a quarter turn until it is over the other two leveling screws and adjust until bubble in level is in the center. Rotate instrument and repeat process until it reads level from any direction.

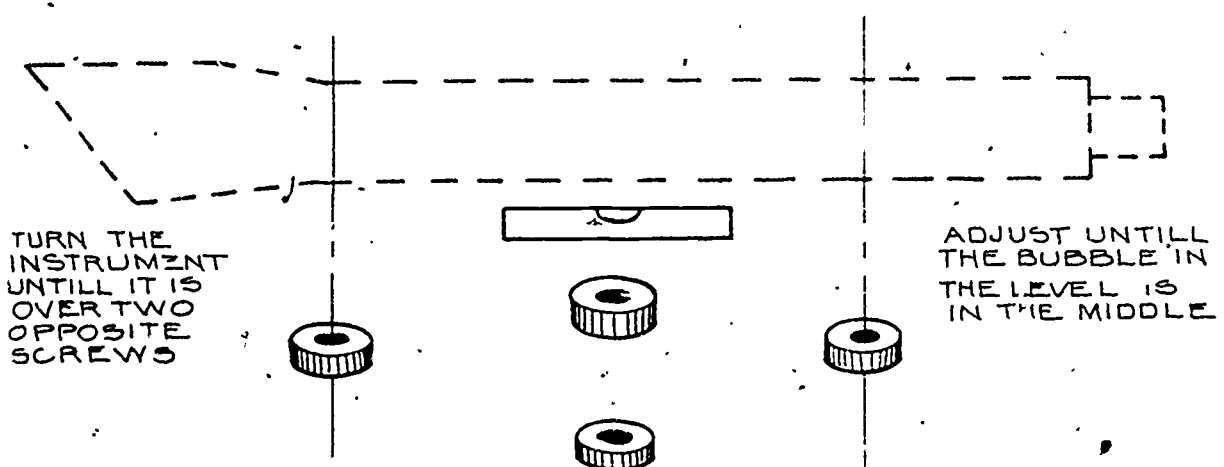
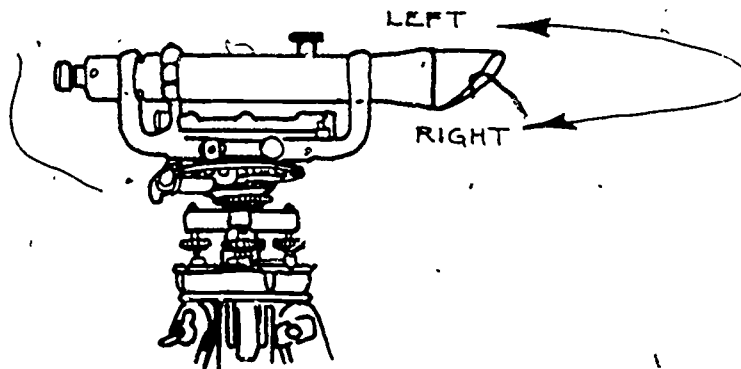

Before establishing grade points for a slab, a bench mark must be determined. The builder's prints or the job engineer should tell you what to use as a bench mark.

The cement mason takes a reading of the bench mark using the builder's level and uses this reading in setting the stakes for the entire job.

One person holds a measuring rod or rule on the stake or grade point to be checked. Another person looks through the telescope of the level at the measuring rod or rule and reads the feet and inches where the cross hairs cross the ruler. The person holding the measuring rod will move to the next stake or grade point to be checked. If the reading is the same as the first reading, the two points are level. If the readings are different, you subtract the difference. If the second reading is higher, then the grade is lower. If the second reading is lower, the grade is higher. Put grade marks on the stakes and stretch a line between the stakes at the grade marks. Drive stakes as needed to the height of the line.

Be sure the measuring rod is always held straight up and down. Shoot the grade on stakes about 30 feet apart. The stakes in between, which support the form sides,

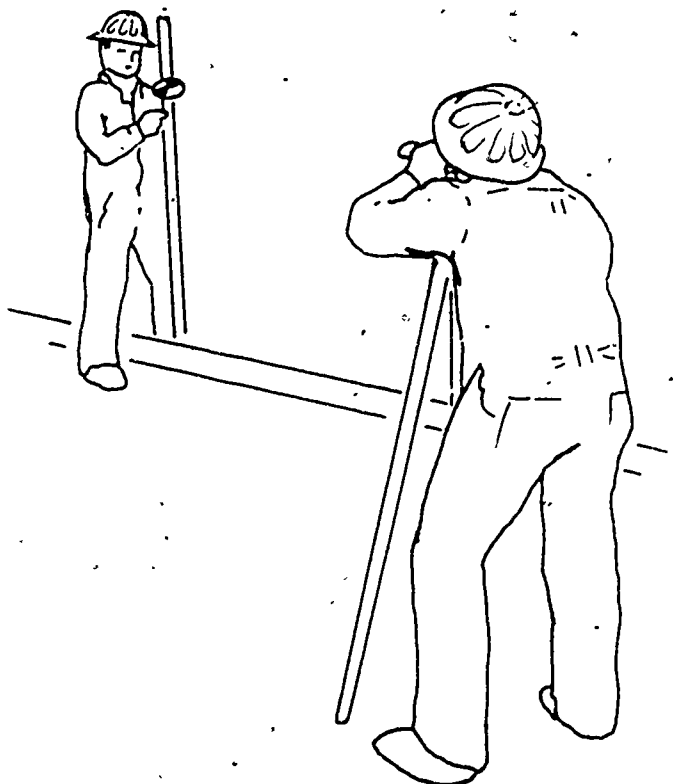

should be placed so the joints of the forms can be nailed to the stakes. Use duplex nails as the nails are not driven all the way into the form and this makes it easy to pull them out when the job is completed.



DUPLEX NAIL

Be sure to allow for the slope you are giving to the slab, driveway, walk, or whatever you are forming.

For smaller areas, a level and straightedge can be used to set the stakes. Drive a stake at the point you will begin the grade layout. Drive it into the ground until the top of the stake is at desired grade. Drive other stakes where grade needs to be established. Put the straightedge on top of established grade stake and other end on stake to be established. Put level on straightedge and drive stake into correct grade. Go from stake to stake, reversing level and straightedge to check level. Go all around layout until you are back at the first stake. If the grade stakes are all level, then the last stake and first stake should be level with each other. Adjust stakes to allow for slope needed.

Laying out with wet screeds is a very important method to learn. It is fast and efficient. The concrete is used as a screed or grade marker. Drive grade stakes about 10 feet apart and pour concrete to top of stakes. Strike off concrete between stakes by running straightedge from stake to stake. Do small section at a time and place concrete between screeds as this prevents a cold joint between concrete and wet screed. Sometimes spots of concrete are used instead of stakes.

There are two methods for squaring corners.

1. The diagonal method. First measure one diagonal of the rectangle. Then measure the other diagonal and if they are the same

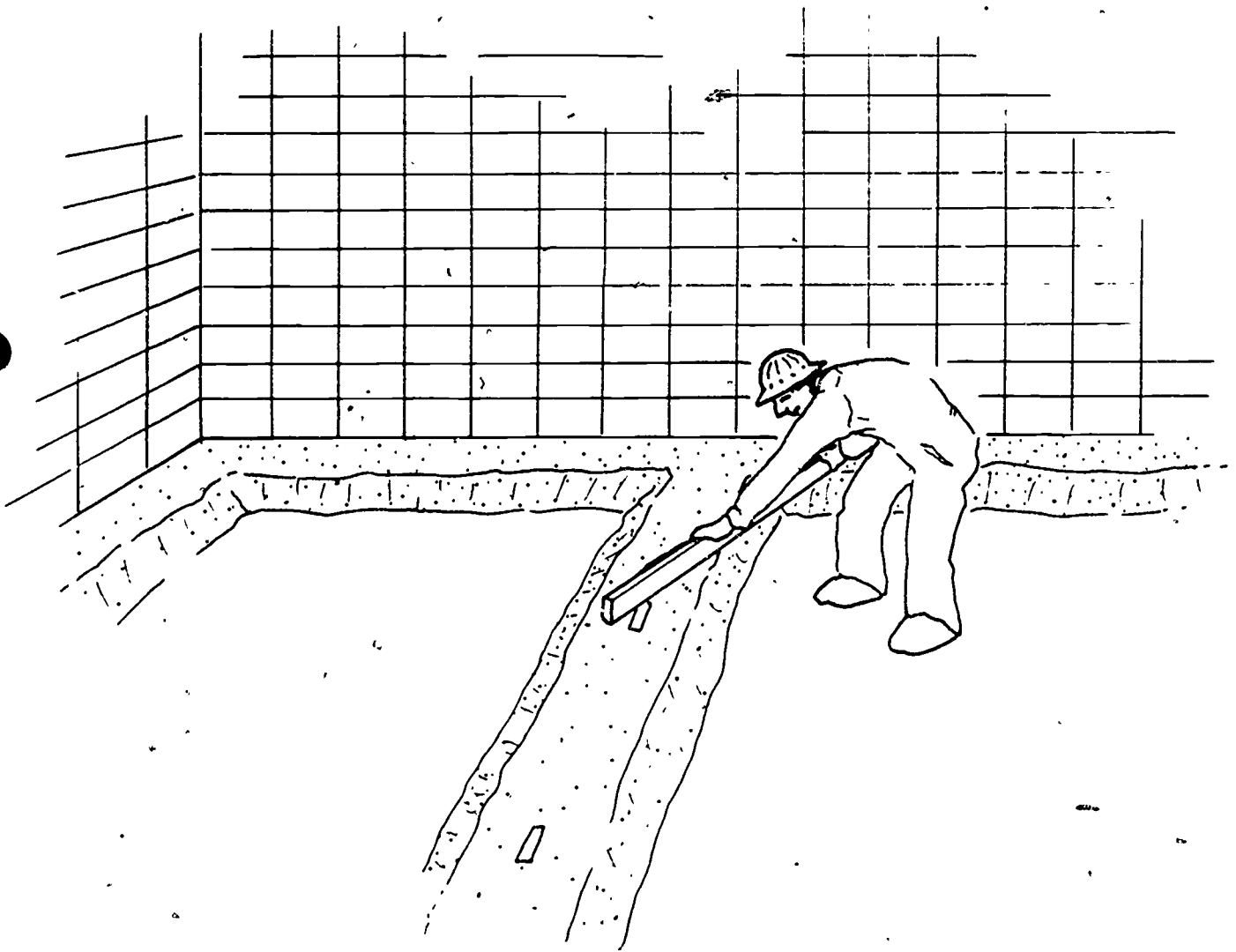

the corners are square. If they are not the same, adjust all four corners, while still keeping the right length and width, until the diagonals are equal.

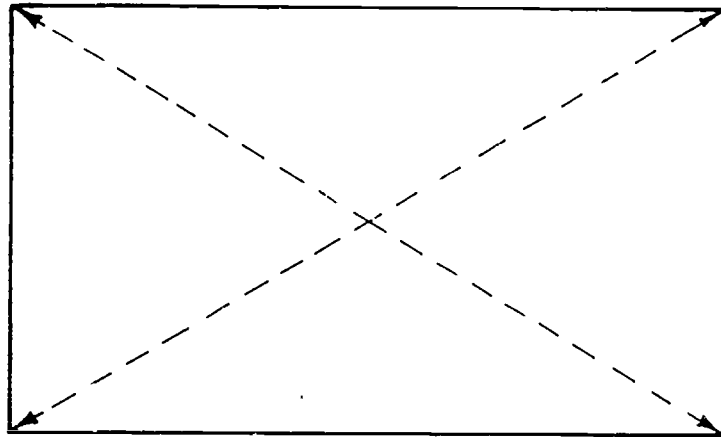

2. The triangle method. You can form a triangle if the corner is perfectly square. Measure 3 feet along one side and 4 feet along the other; measure the diagonal line between these points. If it is square it will measure 5 feet. To be more accurate use a triangle with larger sides to check your corners. The size of triangle you choose will depend on the size of the layout, but always keeps the sides in the same 3-4-5 ratio.

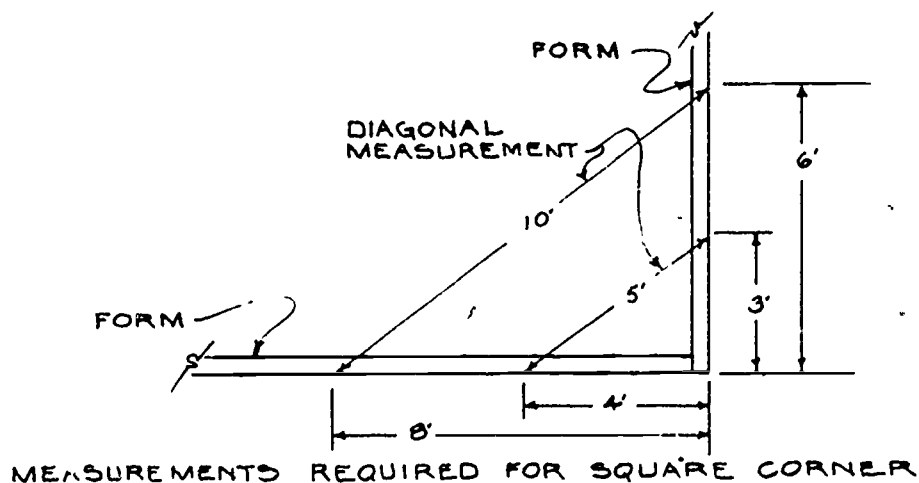

A slope of 1/4 inch per foot is recommended for outside work. This may be toward the street, from one side to another, from the middle to both sides, or from both sides to the middle. Always slope away from the house or buildings. Basement floors should slope toward basement door, drain, or sump. Slope should be at least 1 inch in 8 feet.

Self Assessment

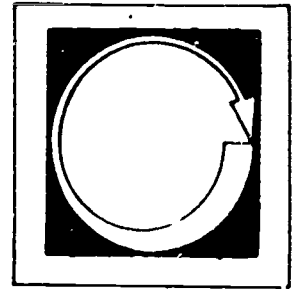

COMPLETE THE FOLLOWING STATEMENTS BY WRITING THE CORRECT WORD OR WORDS IN THE BLANKS PROVIDED.

1. A _____ is a three-legged stand that supports the builder's level or transit.
2. Special nails with an extra head 1/2 inch below the first are called _____ nails.
3. A _____ is a marker to show the right grade for the finished slab.
4. A bubble level mounted in a wooden or metal beam is called a _____ or _____.
5. A line level is a _____ level designed to hook on a line.
6. When you look into a builder's level or transit you see _____.

Self Assessment Answers

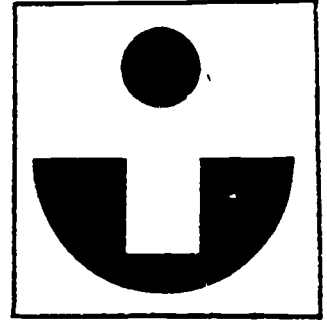

1. tripod
2. duplex headed
3. grade stake
4. carpenter's level or spirit level
5. bubble
6. crossed hairs

Assignment

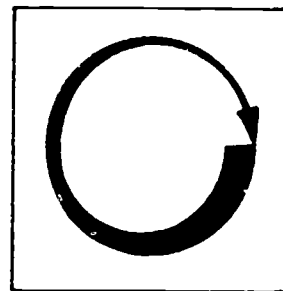

COMPLETE THE FOLLOWING ASSIGNMENTS.

1. Write a report on why it is important to lay out properly.
2. Discuss two ways to determine if the corners are square for a rectangular or square slab.

Job Sheet

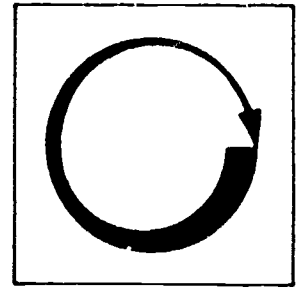

COMPLETE THE FOLLOWING TASK.

Materials and Tools

hammer.

spirit level

straightedge

4 wooden stakes

Using the spirit level and the straightedge, drive 4 stakes 10 feet apart and at the same level. Double check by leveling back to first stake.

Post Assessment

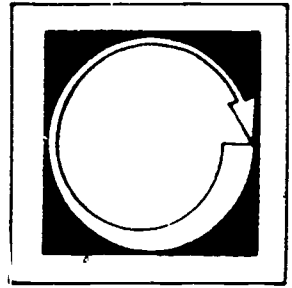

WRITE AN ANSWER TO THE FOLLOWING QUESTIONS.

1. What must be determined before establishing grade points for a concrete slab?
2. How many people does it take to set grade stakes with a builder's level, and what does each person do?
3. How do you know what to use as a bench mark?
4. How should the measuring rod be held and why?
5. Why are duplex-headed nails used when placing forms?
6. What are the two methods for squaring corners of forms?

7. What slope is recommended for outside concrete slabs?

8. Why should slabs always slope away from the buildings?

114

117

Instructor Post Assessment Answers

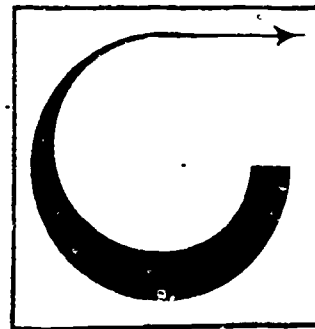

1. Before establishing grade points for a slab a bench mark must be determined.
2. It takes two people to set grade stakes with a builder's level. One person reads the the instrument and the other holds the measuring rod.
3. A bench mark is established by the builder's prints or by the job engineer.
4. The measuring rod should always be held straight up and down, otherwise you will not get a correct reading.
5. Duplex-headed nails are used in forming because the lower head keeps the nail from going all the way into forms, making it easier and quicker to pull out when finished.
6. The two methods for squaring forms are the diagonal method and the triangle method.
7. A slope of $1/4$ inch per foot is recommended for outside work.
8. Slabs should be sloped away from buildings so water and dirt doesn't go into the buildings.

BUILDING SIMPLE FORMS

Goal:

The student will be able to build simple forms for concrete construction.

Performance Indicators:

The student will demonstrate a knowledge of the topic by completing a Self Assessment, an Assignment, a Job Sheet, and a Post Assessment.

Study Guide

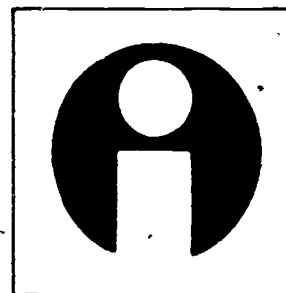

In order to finish this module, do the following tasks. Check each item off as you complete it.

1. Read the Goal and Performance Indicators on the cover of the module. This will tell you what you will learn by studying the module, and how you will show you've learned it.
2. Read the Introduction. The Introduction will tell you why the module is an important part of the cement finishing trade.
3. Study the Vocabulary section. Vocabulary words are important for a good understanding of the trade. After you have studied the vocabulary, ask your teacher to quiz you on the words and their meanings.
4. Study the Information section. This section will give you the information you need to understand the subject.
5. Take the Self Assessment exam. This is a test for you to prove to yourself that you have learned the material you have studied. Compare your answers with the answers on the Self Assessment Answer Sheet, which is on the page following the Self Assessment. If you scored poorly, re-study the Information section or ask your teacher for help.
6. Do the Assignment page. Follow the instructions at the top of the Assignment page.
7. Do the Job Sheet. Follow the instructions at the top of the Job Sheet. The tasks listed on the Job Sheet will help you develop skills which will be helpful to you.
8. Take the Post Assessment exam. Give the exam to your teacher after you have completed it. Your teacher will grade it for you.

Introduction

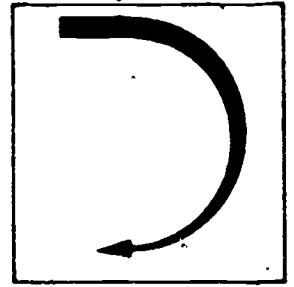

The building of forms for concrete construction is usually done by carpenters. But on smaller jobs the cement mason will usually build and erect the forms. For this reason it is necessary for a cement mason to know how to build simple forms.

Vocabulary

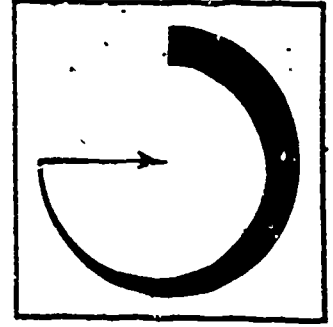

Trade terms are very important for a good understanding of the trade. Study these words and meanings. When you have learned them, ask your teacher to quiz you on the words and their meanings.

POWER SAW--A portable electric rotary power hand saw.

SAW KERF--A saw cut in a board which only goes $\frac{1}{3}$ to $\frac{1}{2}$ way through the board.

FORM RELEASE AGENT--An oil, wax or chemical made especially to paint on wooden forms to prevent them from rotting or sticking to the concrete.

STRIKING OFF--Levelling the concrete with the top of the forms by dragging a straightedge across the top of the forms.

SUBGRADE--Ground that is below where the concrete will be placed.

Supplementary References

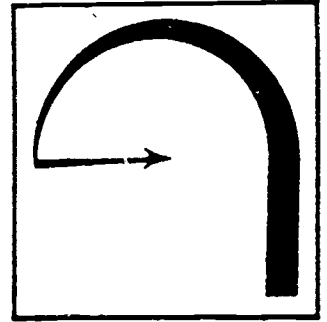

Incentive Apprenticeship Training for Cement Masons. 1979. Laurence Miller,
Producer. NAHB Research Foundation, Inc. Unit 10, pp. 1-15.

Information

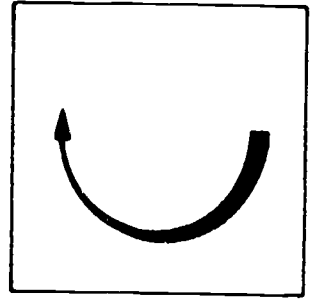

The three basic rules for designing and setting forms are:

1. Make the form so it can be removed easily without damaging the concrete. Use duplex headed nails because they are easy to pull.
2. Design the form so that it is strong enough to hold the concrete. If the forms spread or break apart the job will not be satisfactory.
3. Design forms so the form materials can be used many times. Never cut materials unless job requirements demand it.

When building forms that are not very high, 2-inch thick material (such as 2 X 4s or 2 X 6s) is usually used. This is especially true for straight forms for sidewalks and footings. When forming curves and bends, thinner, more flexible material, is used. Hardboard, sheet metal or 1/4" plywood is ideal for forming curves. Boards 3/4" inch can also be used to form curves by cutting 1/3 or 1/2 the way through, across the grain, on the side that will be away from the concrete. These cuts are called saw kerfs. The sharper the curve the closer together the saw kerfs need to be. Also soaking the form boards in water overnight will make them more flexible.

When forming is done where the ground level changes, such as a driveway that slopes to the street, the form can be kerfed or wedge cuts can be taken out of the bottom of the form board. Try to keep curves or slopes gentle on driveways.

After the grade is established by marks on the stakes from the layout, put the forming material so the stakes will be on the outside of the concrete where possible. Stretch a line between the grade marks on the stakes, and put the top of the form level with the line. Put stakes at all butt joints of the form pieces. Drive the nails at a slant so they don't split the form boards. Do not cut form boards if it can be avoided. Again, any cut in the form boards will have to be supported with a stake.

Attach the forms to the stakes with duplex headed nails. Drive the nail through the stake and into the form. (See Figure 1)

Hold the form firmly against the stake and level with the string, holding it with your foot, and then nail. Stakes are usually set 3 to 5 feet apart, depending on depth of concrete and softness of subgrade. Cut the top of the stakes off level with the forms. This makes it easier when striking off and finishing after the concrete is placed.

When more bracing is necessary to strengthen the form, drive a stake at a 45° angle into the ground and against the stake. Then nail through the brace into the stake.

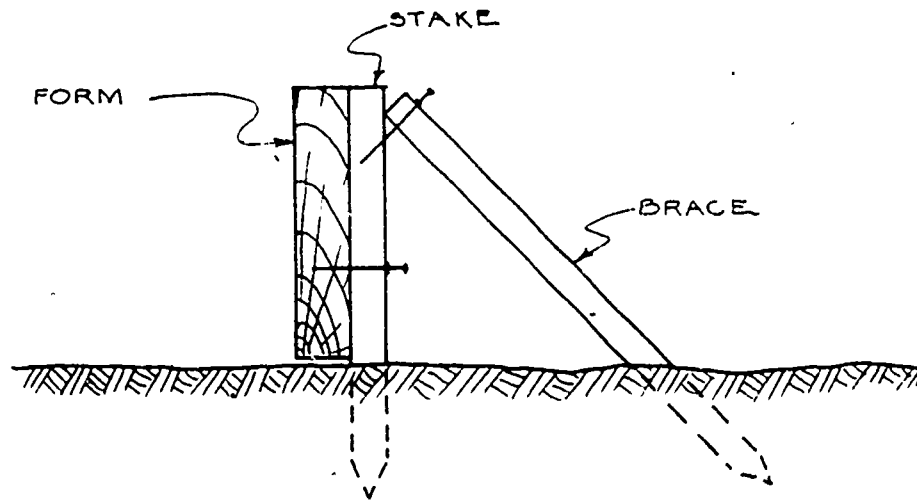

All forms should be treated with a form release agent. This will allow the forms to be removed cleanly from the hardened concrete. It also protects the forms, and produces a hard, stain-free concrete surface. There are several types of form release agents, such as oils, waxes and other chemical release agents.

Do not use old motor oil as this can stain the concrete and ruin the forms. Be careful not to get any form release agents on reinforcing steel, as the steel will not stick to the concrete.

A power saw is often used by a cement mason when building forms. It can be a very dangerous tool if not used correctly. Always remember the following general rules when using a portable rotary saw.

1. The wood to be cut should be firmly supported and held so that the cut will not close on and bind the blade. If the piece of wood being cut off can not drop free from the saw as the cut is completed the saw will kick back. Direct the saw across the board so that the weight of the saw is supported by the larger of the two pieces that the cut will make. In most cases the smaller piece can be allowed to simply fall to the ground. When very long or large boards are being cut, splitting can be prevented by having another person hold the piece that is being cut off so that it drops off only as the blade completes the cut.
2. Adjust the saw blade cutting depth so it only cuts 1/8 inch deeper than thickness of the board being cut.
3. Always use grounded electrical outlets and keep the cord from tangling in the work.
4. Check the electrical cord for frayed spots or cuts that expose the wires. Do not use any electrical tool that has a cord in poor repair.
5. Use a sharp blade, so the saw glides through the wood. If you have to apply a lot of force to make the cut, then the blade is too dull and should be sharpened.
6. While cutting, stand to one side of the cutting line. Never reach under the material being cut.
7. Always unplug the saw's cord while changing blades or making adjustments.
8. While resting the front edge of the saw base on the board, start the saw so that the blade is turning at full speed before it touches the board to be cut.
9. Be sure that the blade guard returns freely after cutting.

Self Assessment

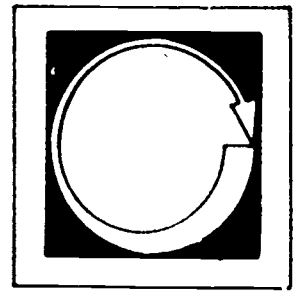

PLACE THE CORRECT WORD, FROM THE LIST PROVIDED, IN EACH BLANK TO COMPLETE THE SENTENCES.

ten
saw kerf
safety
level
stakes
duplex headed
forms
three

1. The _____ should be nailed to the form so that they are on the outside of the concrete.
2. The top of the form should be _____ with the line.
3. There are _____ basic rules for designing forms.
4. A _____ is a saw cut in a board $1/3$ to $1/2$ the thickness of the board.
5. When building forms _____ nails are used because they are easy to pull out when removing the forms.
6. It is important for _____ reasons to use a sharp, properly set blade.

Self Assessment Answers

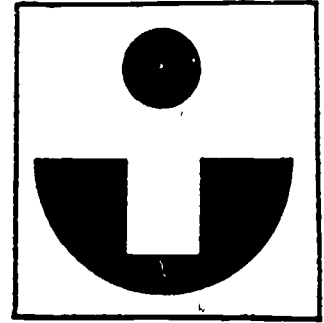

1. stakes
2. level
3. three
4. saw kerf
5. duplex headed
6. safety

Assignment

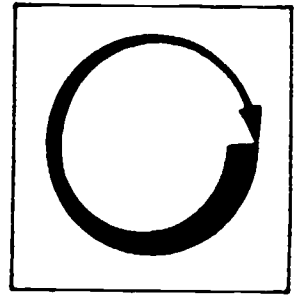

COMPLETE THE FOLLOWING ASSIGNMENT.

Write a report on all the safety precautions that need to be taken when using a portable electric rotary saw.

Job Sheet

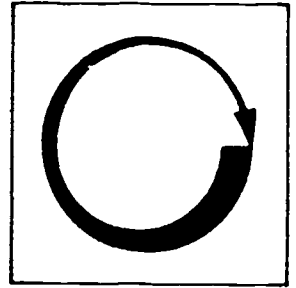

COMPLETE THE FOLLOWING TASK.

Materials and Tools

hammer

duplex headed nails

saw

4--8 foot 2" X 4s"

10 wooden stakes

Build a rectangular form 6 feet by 8 feet. Do not cut the 8 foot 2 X 4s. Stake and nail properly. See suggested layout in Figure 2 below.

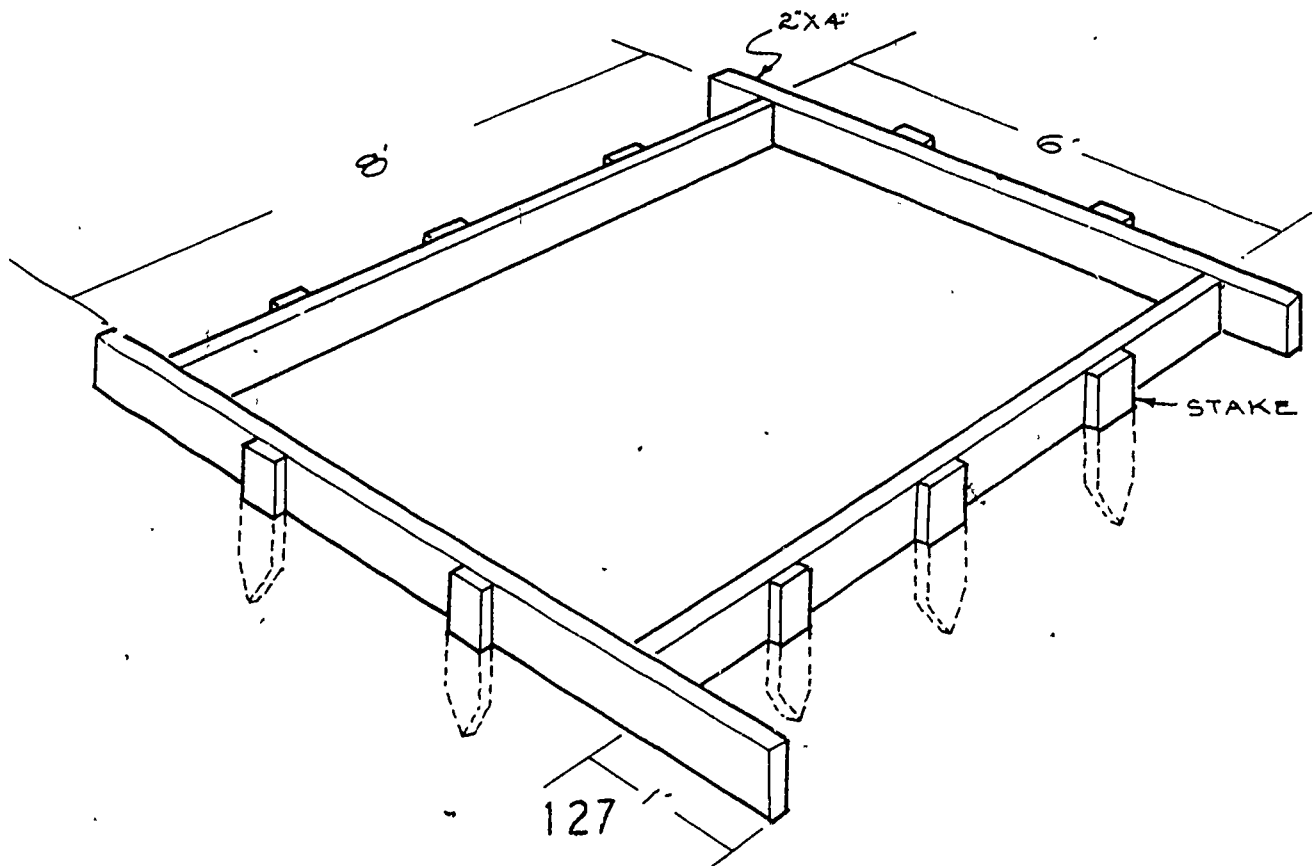

Post Assessment

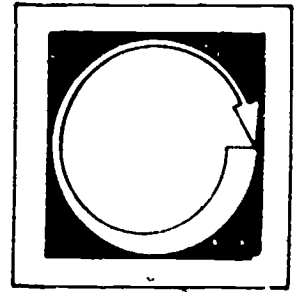

WRITE AN ANSWER TO THE FOLLOWING QUESTIONS.

1. Name the three basic rules for designing forms.
2. When forming curves, what other step can be taken besides cutting saw kerfs in the forming boards to bend the forms?
3. How far apart are stakes set to hold forms?
4. Why should forms be treated with a form release agent?
5. Why should form release agents be kept off of reinforcing steel?
6. When using a power saw what precautions should be taken with respect to the power cord?

7. Why shouldn't old motor oil be used as a form release agent?

8. When using a power saw, what safety precaution should be taken before changing blades or making adjustments?

Instructor Post Assessment Answers

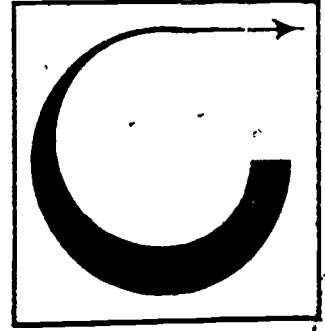

1. The three basic rules for designing forms are:
 - a. The forms must be strong enough to hold the concrete in place.
 - b. The forms must be easy to remove or strip from the concrete without damaging the concrete.
 - c. The forms should be constructed so that the form materials will be reusable.
2. Another step to be taken when forming curves is to soak the wood in water overnight to make it more flexible.
3. Stakes are usually set 3 feet to 5 feet apart, depending on the depth of the concrete to be placed and the condition of ground. The deeper the concrete, the closer together the stakes should be.
4. Forms should be treated with a form release agent 1) to permit a clean release of the forms from the hardened concrete, 2) to protect the form, 3) to produce a hard, stain-free surface on the concrete.
5. Form release agents should be kept off of reinforcing steel as they will keep the steel from bonding to the concrete.
6. When using a power saw the power cord should be checked for frayed spots or cuts that expose the wires and only properly grounded outlets should be used.
7. Old motor oil should not be used as a form release agent as it can stain the concrete and rot the forms.
8. When changing a blade or making adjustments to a power saw always unplug the power cord for safety.

ESTIMATING

Goal:

Upon completion of this module the student will be able to explain the method of figuring the amount of concrete needed for a job.

Performance Indicators:

The student will show an understanding of the topic by successfully completing a Self Assessment, two Assignments and a Post Assessment.

Study Guide

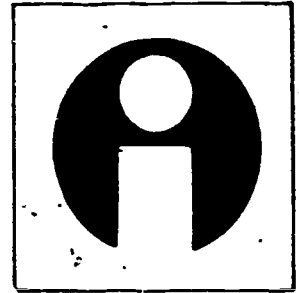

In order to finish this module, do the following tasks. Check each item off as you complete it.

1. Read the Goal and Performance Indicators on the cover of the module. This will tell you what you will learn by studying the module, and how you will show you've learned it.
2. Read the Introduction. The Introduction will tell you why the module is an important part of the cement finishing trade.
3. Study the Vocabulary section. Vocabulary words are important for a good understanding of the trade. After you have studied the vocabulary, ask your teacher to quiz you on the words and their meanings.
4. Study the Information section. This section will give you the information you need to understand the subject.
5. Take the Self Assessment exam. This is a test for you to prove to yourself that you have learned the material you have studied. Compare your answers with the answers on the Self Assessment Answer Sheet, which is on the page following the Self Assessment. If you scored poorly, re-study the Information section or ask your teacher for help.
6. Do the Assignment page. Follow the instructions at the top of the Assignment page.
7. Take the Post Assessment exam. Give the exam to your teacher after you have completed it. Your teacher will grade it for you.

Introduction

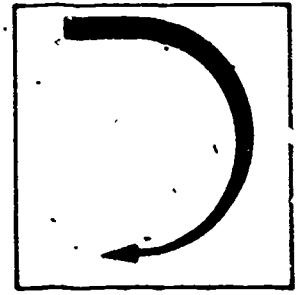

A cement mason should know how to work out the amount of concrete needed for a job. This module will explain the methods used to accurately calculate the amount. An additional 5 to 10 per cent should be added to cover waste and variations in thickness.

Vocabulary

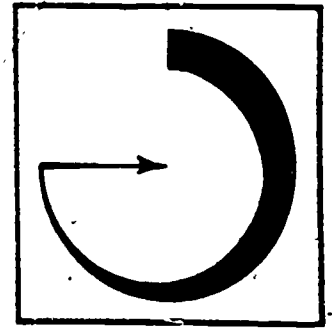

Trade terms are very important for a good understanding of the trade. Study these words and meanings... When you have learned them, ask your teacher to quiz you on the words and their meanings.

CUBIC YARD--A unit of measurement. A cube 3 feet wide, 3 feet long, and 3 feet deep.

VOLUME--The cubic contents. The amount of concrete needed to fill an area.

DETERMINE--Find out.

FORMULA--A method for doing something.

VARIATIONS--Changes.

Supplementary References

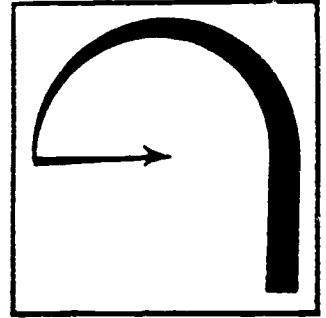

Concrete Technology Instructor's Guide. Portland Cement Association. 1965.

Information

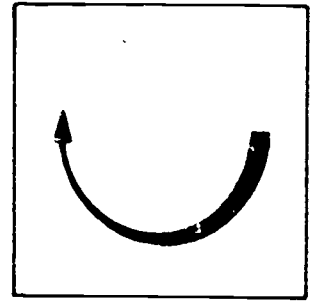

The unit of measure for concrete is the cubic yard, which contains 27 cubic feet. Concrete mixed on the job is also figured by the cubic yard. To determine the amount of concrete needed to cover a specific area, find the volume in cubic feet and divide this figure by 27. The following formula can be used to determine the amount of concrete in cubic yards needed for any square or rectangular area:

Cubic yards of concrete = width in feet X length in feet X thickness in feet ÷ 27.

For example, a 4" thick floor for a 20 X 60 foot building would require:

$$\frac{20 \times 60 \times 1/3}{27} = 14.81 \text{ cubic yards of concrete.}$$

The above formula does not allow for waste or variations in thickness of the concrete. Add 5 to 10 per cent to cover these factors.

The thickness dimension must be changed from inches or centimeters to feet or parts of a foot. Either the fractional or decimal part of a foot can be used. Chart 1 gives both the fractional and decimal parts of a foot for several common thicknesses. (See the chart on the top of the following page.)

When concrete is mixed on the job, the quantities of cement, and fine and coarse aggregate must be figured separately for each cubic yard of concrete needed. Figure 2 shows the number of bags of cement, cubic feet of fine aggregate, and cubic feet of coarse aggregate needed to produce 1 cubic yard of concrete for the different trial mixes. The example shows how to compute amounts of materials needed.

(See the second chart on the following page.)

Inches	As a Fraction of a Foot	As a Decimal a Foot
4	4/12 or 1/3	0.33
5	5/12	0.42
6	6/12 or 1/2	0.50
7	7/12	0.58
8	8/12 or 2/3	0.67
10	10/12 or 5/6	0.83
12	1	1.00

How to Change Thickness in Inches to Fractions and Decimal Parts of a Foot for Use in Calculating Quantities of Concrete.

Maximum Aggregate Size	Suggested Mixtures for Trial Batches.			Materials Required for one Cubic Yard of Cement.				
	Cement	Aggregates		Cement	Aggregates			
	Bags (one bag cement equals 1 cu. foot)	Fine (sand) cu.ft.	Coarse (gravel) cu.ft.	Bags	Fine cu.ft. lb.	Coarse cu.ft. lb.		
3/4"	1	2	2 1/4	7 3/4	17	1550	19.5	1950
1"	1	2 1/4	3	6 1/4	15.5	1400	21	2100
1-1 1/2"	1	2 1/2	3 1/2	6	16.5	1500	23	2300
1-1 1/2" (alternate mix)	1	3	4	5	16.5	1500	22	2200

Materials Needed per Cubic Yard of Concrete Made with Separated Aggregates

Example: How much material will be needed to place a 4" thick concrete floor in a building 20 X 24 feet? Find the number of cubic feet of concrete required by multiplying the length times the width times the thickness in feet. (4" = 1/3 foot). Then divide by 27 to change the cubic feet into cubic yards.

$$20 \times 24 \times 1/3 = \frac{160 \text{ cu. ft.}}{27} = 5.93 \text{ cu. yd.}$$

Figure 2 shows the amount of materials needed for 1 cubic yard of concrete. To determine the amount of material needed for the floor in the building 20 X 24 feet, multiply each of the materials needed for 1 yard times 5.93.

Figure 3 below shows some concrete estimating short cuts:

CONCRETE ESTIMATING SHORT CUTS
1 Cu. Yd. of Concrete Will Place

Depth in inches	Sq. ft.	Depth in inches	Sq. ft.	Depth in inches	Sq. ft.
1	324	4 3/4	68	8 1/2	38
1 1/4	259	5	65	8 3/4	37
1 1/2	216	5 1/4	62	9	36
1 3/4	185	5 1/2	59	9 1/4	35
2	162	5 3/4	56	9 1/2	34
2 1/4	144	6	54	9 3/4	33
2 1/2	130	6 1/4	52	10	32.5
2 3/4	118	6 1/2	50	10 1/4	31.5
3	108	6 3/4	48	10 1/2	31
3 1/4	100	7	46	10 3/4	30
3 1/2	93	7 1/4	45	11	29.5
3 3/4	86	7 1/2	43	11 1/4	29
4	81	7 3/4	42	11 1/2	28
4 1/4	76	8	40	11 3/4	27.5
4 1/2	72	8 1/4	39	12	27

Figure 3 shows that 1 cubic yard of concrete will place 81 square feet of concrete if it is 4 inches thick. Since most floors and slabs are 4 inches thick, another method of estimating the amount of concrete needed is to find the area by multiplying the length times the width and then divide by 81. This gives you the answer in cubic yards. To find the amount of concrete needed for an area 24 X 20 feet, 4 inches thick, use this formula:

$$24 \times 20 \div 81 = 5.93 \text{ cu. yds.}$$

Small concrete calculators can also be used to determine the amount of concrete needed to cover an area. These are small slide rules that are not completely accurate, but they are useful for quick estimating for smaller jobs and for checking estimates.

Self Assessment

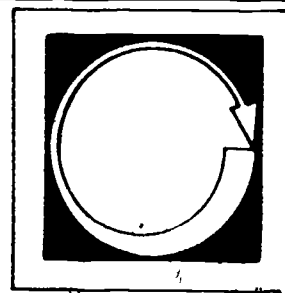

LISTED BELOW ARE SEVERAL STATEMENTS. IF THE STATEMENT IS TRUE, PLACE A "T" IN THE BLANK PROVIDED. IF THE STATEMENT IS FALSE, PLACE AN "F" IN THE BLANK.

1. ___ A cubic yard of concrete contains 29 cu. ft.
2. ___ The unit of measure of concrete is the cubic yard.
3. ___ There are 27 cu. feet in a cubic yard of concrete.
4. ___ The thickness of a concrete slab in inches must be changed to feet or parts of a foot for estimating purposes.
5. ___ A concrete calculator is a small slide rule.
6. ___ The decimal part of a foot of a 4" floor is 0.42.
(Hint--Use Figure 1.)

Self Assessment Answers

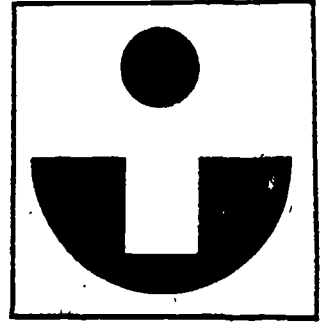

1. F

2. T

3. T

4. T

5. T

6. F

Assignment

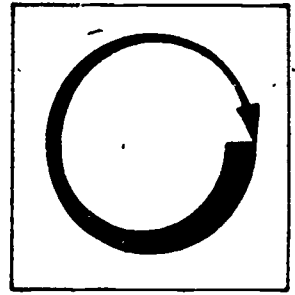

COMPLETE THE FOLLOWING ASSIGNMENTS.

1. Discuss the different methods of estimating concrete for a job.
2. Practice using a small concrete calculator to estimate the amount of concrete needed for different sized jobs.

Post Assessment

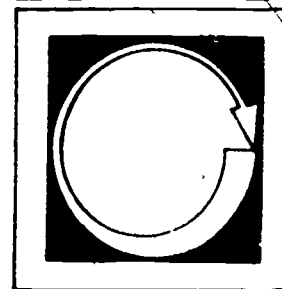

WRITE AN ANSWER TO THE FOLLOWING QUESTIONS.

1. What is the unit of measure for estimating concrete requirements?
2. What are the dimensions of a cubic yard?
3. How many cubic feet are in a cubic yard?
4. What is the formula for figuring the amount of concrete needed for any square or rectangular area?
5. For mixing on the job, which materials need to be figured separately?
6. What percentage should be added to the estimating formula to allow for waste and thickness variations?

7. Why are small concrete calculators useful?

144

147

Instructor Post Assessment Answers

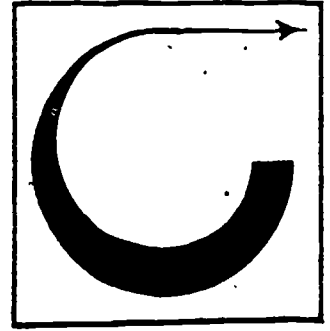

1. The unit of measure for estimating concrete is the cubic yard.
2. The dimensions of a cubic yard are 3 feet by 3 feet by 3 feet.
3. There are 27 cubic feet in a cubic yard.
4. The formula for figuring concrete requirements is $\text{cubic yards of concrete} = \frac{\text{width in feet} \times \text{length in feet} \times \text{thickness in feet}}{27}$
5. For job mixing, the amount of cement, sand, and gravel must be figured separately for each cubic yard.
6. 5 to 10 per cent should be added for waste and variations in thickness.
7. Small concrete calculators are useful for checking estimates and for smaller jobs.

MIXING CONCRETE

Goal:

The student will be able to explain the methods of specifying, producing, and controlling ready mixed concrete. He or she will also be able to outline the necessary steps for mixing quality concrete on the job.

Performance Indicators:

The student will demonstrate a knowledge of the topic by successfully completing a Self and Post Assessment, 3 Assignments and a Job Sheet.

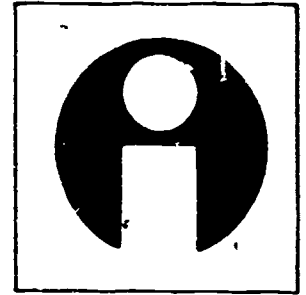

Study Guide

In order to finish this module, do the following tasks. Check each item off as you complete it.

1. Read the Goal and Performance Indicators on the cover of the module. This will tell you what you will learn by studying the module, and how you will show you've learned it.
2. Read the Introduction. The Introduction will tell you why the module is an important part of the cement finishing trade.
3. Study the Vocabulary section. Vocabulary words are important for a good understanding of the trade. After you have studied the vocabulary, ask your teacher to quiz you on the words and their meanings.
4. Study the Information section. This section will give you the information you need to understand the subject.
5. Take the Self Assessment exam. This is a test for you to prove to yourself that you have learned the material you have studied. Compare your answers with the answers on the Self Assessment Answer Sheet, which is on the page following the Self Assessment. If you scored poorly, re-study the Information section or ask your teacher for help.
6. Do the Assignment page. Follow the instructions at the top of the Assignment page.
7. Do the Job Sheet. Follow the instructions at the top of the Job Sheet. The tasks listed on the Job Sheet will help you develop skills which will be helpful to you.
8. Take the Post Assessment exam. Give the exam to your teacher after you have completed it. Your teacher will grade it for you.

Introduction

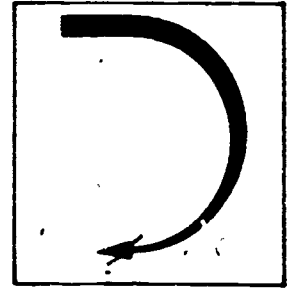

Most of the concrete used in construction today is delivered ready mixed by trucks. For some jobs it is, however, more economical to mix the concrete at the job site. For very large projects, such as dam construction, it pays to set up a temporary mixing plant on the site. For very small jobs concrete mixed by hand or with a small mixer can cost less than delivered ready mix. When job mixed concrete is used, the person that mixes the concrete is responsible for selecting the mix design and materials, to ensure that the ingredients are pure. When formulating the mix design, many factors, including strength and exposure of the cured concrete, must be considered.

The quality of ready mixed concrete is the responsibility of both the producer and the user. It is up to the job engineer, architect or user to specify the proper mix. It is up to the producer to make the design meet these requirements. Once the concrete is delivered by truck to the job, it becomes the user's responsibility to place, finish, and cure the concrete. The user, by understanding his or her responsibilities, can assure quality concrete construction.

Vocabulary

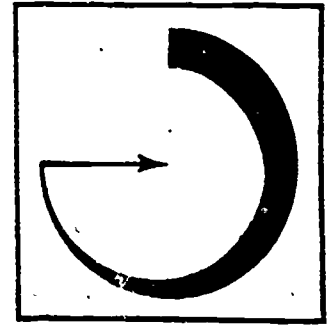

Trade terms are very important for a good understanding of the trade. Study these words and meanings. When you have learned them, ask your teacher to quiz you on the words and their meanings.

READY MIXED CONCRETE--Concrete that is mixed at a plant and delivered in a plastic or wet state.

MILD EXPOSURE--Conditions where concrete is not subjected to abrasions or severe weather.

TRANSIT MIXED CONCRETE--Concrete that is mixed completely in a truck mixer.

ASTM--The American Society for Testing and Materials.

SEVERE EXPOSURE--When the concrete is subjected to one or more of the following conditions: Severe (heavy) wear, extreme weather conditions and exposure to acids or alkali solutions.

JOB MIXED CONCRETE--Concrete that is mixed at the job site by hand or with a small mixer.

LABORATORY DESIGN--The concrete mix is designed by commercial laboratories for ready mix plants and specific projects.

FIELD DESIGN--The mix design is made by the user on the job.

TOP QUALITY CONCRETE--Concrete that has been well designed and correctly mixed.

CONSISTENCY--Several separate batches of plastic concrete that have been mixed so that they are all the same.

BATCH--The amount of material mixed in one operation.

INGREDIENTS--The materials used in mixing concrete such as sand, gravel and cement.

P.S.I.--Pounds per square inch. A measure of compressive strength.

Supplementary References

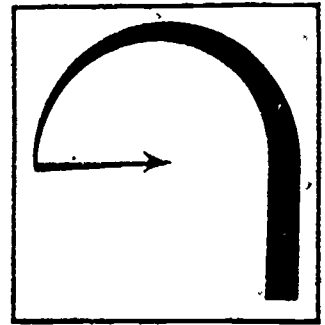

Concrete Technology. Instructor's Guide, Portland Cement Assn., 1965.
pp. 119-147.

Information

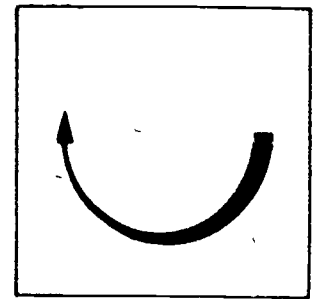

Most concrete used in construction is mixed at a ready mix plant and then delivered to the job site by trucks. Only when the job requires either a very large or a very small amount is it practical to mix the concrete on the job. In these cases the delivery costs can be greater than the costs of job mixing. For very large projects, such as dam construction, temporary mixing plants are set up at the job site. For small jobs, such as setting fence posts or patching jobs, a small portable mixer or even a wheel barrow can be used.

Ready mix plants, using precision scales to weigh the materials, make batches of portland cement, coarse and fine aggregates, and water for mixing concrete that will have the desired qualities.

The operator of the ready mix plant is responsible for selecting and proportioning the ingredients as specified by the purchaser. It must then be promptly delivered to be kept in good condition. Once it is delivered to the job site, the user takes over by placing, finishing, and curing the concrete. Cooperation between the mixing plant workers and the user is needed to produce high quality concrete products.

Ready mix concrete is mixed for delivery to the job site in a plastic and unhardened state. Three methods of mixing are used. They are:

1. Transit-mixed. Concrete which is mixed completely in a truck mixer.
2. Central-mixed. Concrete which is completely mixed in a stationary mixer and then delivered in a mixer truck operating at agitating (stirring) speed, or in a special non-agitating truck.
3. Shrink-mixed. Concrete which is partially mixed in a stationary mixer and then placed into a mixer truck where the mixing is completed while being delivered to the job.

Standards established by the American Society for Testing Materials (ASTM) are often used. The specifications cover all of the producer's responsibility for ready mixed concrete, from ensuring material purity to the delivery to the job site. The standards include: basis of purchase, materials, quality of concrete, slump, material measuring, etc. The standards do not cover the placement, finishing, curing or protection of the concrete after delivery. These are the user's responsibility.

When the job engineer or architect has not provided specifications, then the purchaser must provide them. The specifications of the mix design can be stated in two ways. Either the number of bags of cement per cubic yard or the desired compressive strength must be given. The amounts of the other ingredients and the properties desired must also be stated. The following is a list of questions which must be answered in preparing a mix design.

1. How many bags of cement per cubic yard are to be used or what should the compressive strength (P.S.I.) be?
2. What size or sizes of coarse aggregate are needed?
3. How much water, measured in gallons, per bag of cement should be used?
4. What is the slump desired?
5. What are the maximum and minimum limits for air content?

The three advantages ready mixed concrete has are: 1) a uniform product, 2) convenience and 3) economy.

Ready mixed concrete should be placed in the forms as soon as possible. Within 1 1/2 hours after mixing the concrete will begin to stiffen and become difficult to work with. In hot weather there may be even less time.

It usually takes 2 to 3 hours for concrete to start setting after being mixed. If it begins to stiffen, water can be added and the concrete mixed again to make it workable. Care must be taken to not add too much water because this will change the slump, strength, watertightness, and durability of the finished concrete. Too much water also makes it more difficult to finish the concrete. This will add to the cost of the job because more man hours will be needed for finishing.

Job mixing concrete places all responsibility for the quality of the concrete on the user. He or she must select the materials, design the mix, mix, place, finish and cure the concrete.

The selection of the design should be based on the kind of work or exposure condition the concrete will be subjected to. Exposure conditions fall into three classifications.

1. Mild exposure--The concrete is not subjected to severe weather or abrasion conditions. Foundations and other installations where the concrete is not subjected to freezing temperatures would have mild exposure.
2. Normal exposure--The concrete is used for watertight structures and exposed to abrasion and/or freezing weather (floors, sidewalks and other building components in moderate climates usually receive normal exposure).
3. Severe exposure--The concrete is exposed to severe wear, weather, weak acids or alkali solutions such as in silos, mangers, floors in dairy plants and in any application in colder climates.

When making job mixed concrete, just as in plant mixed concrete, the quality of the cured concrete depends on the quality of the materials used. The aggregates should be clean, sound and well graded. The mixing water should be clean enough to drink. If it isn't fit to drink then tests should be made to determine if it is suitable for use. The portland cement should be free of hard lumps.

You must also evaluate the moisture content of the sand you are using. The amount of water in the sand will affect the total amount of water that you will need to add to the mix. By squeezing a handful of the sand you can get a good idea of its water content. Use the following classifications to help you evaluate your sands moisture content:

Dry Sand--is seldom available for concrete work. This is sand as dry as it would be if it were spread in a thin layer and dried in the sun or warm air.

Damp Sand--feels damp to the touch but leaves very little moisture on the hands. Damp sand usually contains about 1/4 gallon of water per cubic foot (2 percent by weight).

Wet Sand--Feels wet and will leave moisture on hands. A handful of wet sand can be squeezed into a ball, Wet sand contains about 1/2 gallon of water per cubic foot (about 4 percent by weight).

Very Wet Sand--is dripping wet when delivered on the job. Squeezing a handful will leave your hands wet and the sand sparkles. It contains about 3/4 gallon of water per cubic foot.

The following two charts show typical slump range for various types of construction and trial mix proportions.

Some Typical Slump Ranges for Various Types of Construction

TYPES OF CONSTRUCTION	SLUMP, IN INCHES	
	MAX.	MIN.
Reinforced foundation walls, footings	4	2
Non-reinforced footings, sub-structure walls	3	1
Reinforced beams, slabs,	5	2
Building columns	5	3
Pavement	2	1
Sidewalk, driveway, ground slabs	4	2
Heavy mass construction	2	1

Trial Mix Proportions

	Gal. of water added to 1-bag batch if sand is:			Suggested mixture for 1-bag trial batches	
	Dry	Wet W. sand	Very Wet	Cement bags Cu.ft.	Aggregates Fine Coarse Cu.ft. Cu.ft.
FOR MILD EXPOSURE 7 gal. of water per bag of cement	For 1-1/2-in. max. size aggregate 5-1/4	5-1/2	4-3/4	1	3 1
FOR NORMAL EXPOSURE 6 gal. of water per bag of cement	For 1-in. max. size aggregate 5-1/2	5	4-1/4	1	2-1/4 3
FOR SEVERE EXPOSURE 5 gal. of water per bag of cement	For 1-in. max. size aggregate 4-1/2	4	3-1/2	1	2 2-1/4

Concrete should be thoroughly mixed. The materials should appear to be uniformly distributed after all materials have been put into the mixer. The concrete should be mixed from 1 to 3 minutes. There is little advantage to mixing for more than 3 minutes.

When mixing concrete put 10 per cent of the water into the drum before adding the dry materials. The water should then be added a little at a time as the dry materials are added. Save about 10 percent of the water and add it after all the other materials are in the drum. To get uniform batches of quality concrete the materials, including the water must be accurately measured. The concrete usually looks drier in the mixer than it does after being placed.

Mixers used on the job vary in size from 1/2 cubic foot to 2-bag mixers, or larger. Mixers should not be overload. Trying to mix more than the mixer drum has been rated for will result in incomplete mixing and lower quality concrete.

The mixer and all tools and equipment that come into contact with the concrete should be kept clean during use and thoroughly cleaned after use.

The inside of the mixer drum should be washed with water, and all build-up should be brushed or scraped off. Do not use a hammer to chip off the build-up in a drum because this can cause damage to the drum and mixing blades. Any build-up that develops can be loosened by using a solution of 3 parts water to 1 part muriatic acid. Allow the solution to work about 30 minutes before scrubbing with a brush. Rinse the drum thoroughly with water. Be sure to completely dump all water out of the mixer to prevent rusting.

It is possible to mix concrete ingredients by hand, but it usually isn't done in the trade except for small batches used in patching. Hand mixing generally doesn't mix the materials properly. For this reason most job specifications call for machine mixing. Hand mixing will be covered in a later module.

Self Assessment

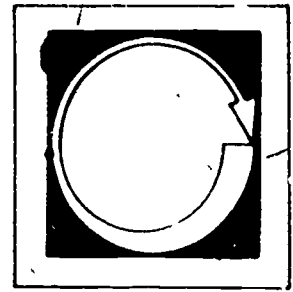

LISTED BELOW ARE SEVERAL STATEMENTS. IF THE STATEMENT IS TRUE, PLACE A "T" IN THE BLANK PROVIDED. IF THE STATEMENT IS FALSE, PLACE AN "F" IN THE BLANK.

1. ___ Most concrete used in construction is job mixed.
2. ___ The producer is responsible for placing, finishing and curing the concrete properly.
3. ___ Damp sand contains about 1/4 gallon of water per cubic foot.
4. ___ Concrete that is mixed completely in a truck mixer is called transit mixed concrete.
5. ___ Concrete that is mixed on the job site with a mixer is called ready-mixed concrete.
6. ___ Plastic concrete is consistent when all batches are the same.
7. ___ Ingredients are the different materials used in mixing concrete.
8. ___ Water cannot be added to concrete once it begins to stiffen.
9. ___ Too much water in concrete can lower the strength of the hardened concrete.
10. ___ The selection of the design is based on the kind of work or exposure conditions the concrete will be subjected to.

Self Assessment Answers

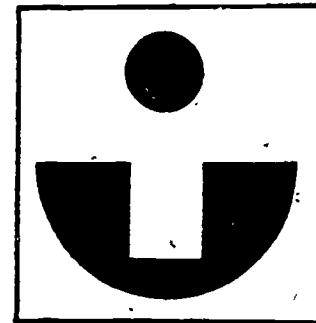

1. F

2. F

3. T

4. T

5. F

6. -T

7. T

8. F

9. T

10. T

Assignment

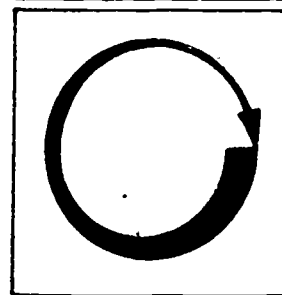

COMPLETE THE FOLLOWING ASSIGNMENT:

1. Tour a ready mix concrete plant.
2. Discuss quality ready mixed concrete with the plant operator.
3. Write a short paper comparing the qualities of job-mixed and plant-mixed concrete.

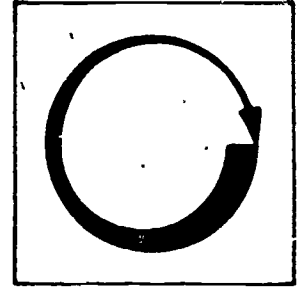

Job Sheet

COMPLETE THE TASK BELOW.

Materials and Tools

shovel (square nosed)

1 sack concrete mixer

wheel barrow

1 stiff brush

1 sack portland cement

2 1/4 cubic feet of wet sand (average)

3 cubic feet of 1" maximum course aggregate

5 gallons water

6 cardboard or wooden pier pad forms.

1. Following the directions in the Information section of this module, mix a 1 sack batch of concrete for normal exposure.
2. Unload mixer into the wheelbarrow for placing.
3. Place the concrete into the pier pad forms and finish.
4. Clean all tools and equipment.

● Post Assessment

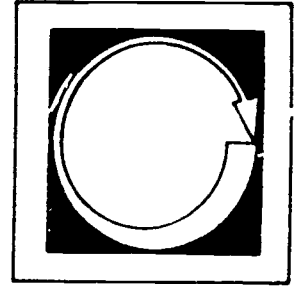

WRITE AN ANSWER TO THE FOLLOWING QUESTIONS.

1. Name 3 advantages of using ready mixed concrete.
2. What are the three methods used for delivering ready mixed concrete?
3. When using job mixed concrete, what are the user's responsibilities?
4. Name the three classifications of exposure conditions.
5. Why must care be taken to add only the right amount of water to the concrete?
6. In job mixed concrete, how many minutes should the concrete be mixed after all materials have been placed into the mixer?

7. What are the user's responsibilities once ready mixed concrete has been delivered to the job site?

8. How much water does wet sand contain?

9. Explain field design.

Instructor Post Assessment Answers

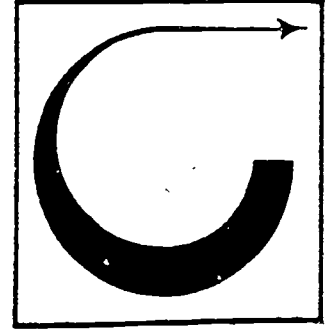

1. a. uniform product
b. convenience
c. economy
2. a. transit-mixed
b. central-mixed
c. shrink-mixed
3. When using job mixed concrete, the user is responsible for selecting quality materials and using the proper mix design.
4. a. mild exposure
b. normal exposure
c. severe exposure
5. The volume of water in the mix directly affects the slump, strength, durability, and water tightness of the hardened concrete.
6. three minutes
7. placing, finishing, curing
8. 1/2 gallon of water per cubic foot (about 4% by weight)
9. Concrete mix designed by the user on the job when it is not practical or economical to use a laboratory design.

TESTING PLASTIC CONCRETE

Goal:

The student will be able to explain how to perform the standard tests to determine the slump and strength of plastic concrete.

Performance Indicators:

The student will demonstrate knowledge of the topic by successfully completing a Self Assessment, an Assignment, a Job Sheet and a Post Assessment.

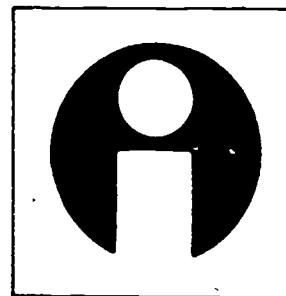

Study Guide

In order to finish this module, do the following tasks. Check each item off as you complete it.

1. Read the Goal and Performance Indicators on the cover of the module. This will tell you what you will learn by studying the module, and how you will show you've learned it.
2. Read the Introduction. The Introduction will tell you why the module is an important part of the cement finishing trade.
3. Study the Vocabulary section. Vocabulary words are important for a good understanding of the trade. After you have studied the vocabulary, ask your teacher to quiz you on the words and their meanings.
4. Study the Information section. This section will give you the information you need to understand the subject.
5. Take the Self Assessment exam. This is a test for you to prove to yourself that you have learned the material you have studied. Compare your answers with the answers on the Self Assessment Answer Sheet, which is on the page following the Self Assessment. If you scored poorly, re-study the Information section or ask your teacher for help.
6. Do the Assignment page. Follow the instructions at the top of the Assignment page.
7. Do the Job Sheet. Follow the instructions at the top of the Job Sheet. The tasks listed on the Job Sheet will help you develop skills which will be helpful to you.
8. Take the Post Assessment exam. Give the exam to your teacher after you have completed it. Your teacher will grade it for you.

Introduction

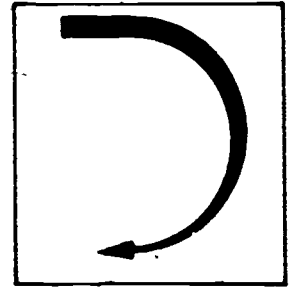

Concrete specifications are used so the buyer can state exactly what he or she wants and the producer can know what he or she has to deliver. It's important that the user understand the basic procedures for testing plastic or fresh concrete. The user can then make sure the concrete used meets the buyer's specifications. Testing is also useful to make sure each batch of concrete is the same as all the others.

Vocabulary

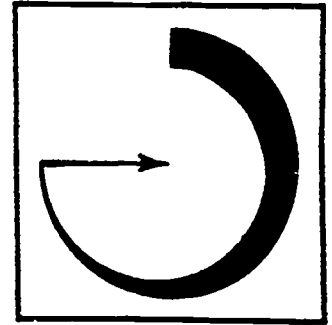

Trade terms are very important for a good understanding of the trade. Study these words and meanings. When you have learned them, ask your teacher to quiz you on the words and their meanings.

PLASTIC CONCRETE--Freshly mixed concrete that hasn't begun to harden.

ASTM C172--Reference number for the standard method of sampling fresh concrete in the ASTM Manual. This entry in the reference manual tells you how to obtain samples of fresh concrete from mixers, or dump trucks.

ASTM C143--Standard method of slump test for consistency of concrete.

ASTM C138--Standard test for unit weight of fresh concrete. Field test.

ASTM C39--Standard test of compressive strength of molded concrete.

MOLDED CONCRETE--Concrete that has been put in a round mold for testing.

STANDARD MOLD--A round tube 12 inches long, 6 inches in diameter, open at both ends. Holds 1/2 cubic foot of concrete.

SAMPLE--A small amount of concrete placed in a tube for testing purposes.

SPECIMEN--A sample of concrete for testing.

TAMPING ROD--A steel rod 24 inches long, 5/8 inch in diameter with a bullet point.

RODDING--An up and down puddling using the tamping rod.

SPECIFICATIONS--Detailed description of a product. The specifications for concrete would include the height of the slump, the unit weight, and the compressive strength required.

AGES--Various times during the curing process.

Supplementary References

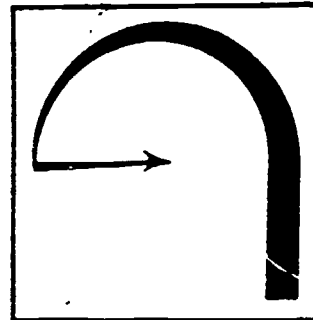

Concrete Technology. Instructor's Guide. Portland Cement Association, 1965.
pp. 103-117.

Information

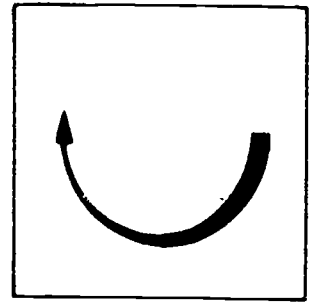

The American Society for Testing Materials (ASTM) was formed because there was a need for standards for testing building materials.

ASTM C172 covers the procedure for obtaining samples of and testing fresh concrete from truck mixers, agitators, dump trucks, stationary or paving mixers.

The sample size must be at least 1 cubic foot when testing for strength. Smaller samples may be used for air entrainment and slump tests.

Always take care that the sample you take represents the true nature and condition of the concrete. Use one of these four methods, depending on what kind of mixer the concrete is being delivered in.

1. Stationary mixers, except paving mixtures: Take the sample from the middle of the batch.
2. Paving Mixers: Collect sample after mixer has discharged onto the subgrade.
3. Revolving drum truck mixers or agitators: Take three samples from the batch, one at the beginning, one at the middle and the 3rd from the end of the batch.
4. Open top truck mixers, or dump trucks: Any of the three ways just mentioned may be used to get a good sample of the batch. Choose the one that will give you the best idea of what the rest of the concrete mix is like.

Take the sample to where the test specimens are to be molded as quickly as possible. Then remix with a shovel to ensure a uniform mixture before you place the concrete in the mold. The sample must be protected from sunlight and wind during the period between taking and using. There should be no more than 15 minutes between taking a sample and putting the concrete in a mold.

The test method for determining the slump of the concrete in the laboratory and on the jobsite is ASTM designation C-143. The slump test is used as a rough measure of the consistency of concrete--how wet or dry it is. The test should not be considered as a measure for workability, nor should it be used to compare mixes of different proportions, or mixes containing different kinds of aggregates. A change in slump on the job indicates a change in grading or proportioning of aggregates or in the water content. The mix can be corrected to get the proper consistency by changing the amount of sand and coarse aggregate. The amount of water specified for mixing with each bag of cement should not be changed.

The test specimen for a slump test is made in a mold or "slump cone" of 16-gage galvanized metal. (See Figure 1.) The diameter is 8 inches at the base and tapers to 4 inches at the top and the height is 12 inches. The base and top are open. The mold is provided with handles and foot pieces as shown.

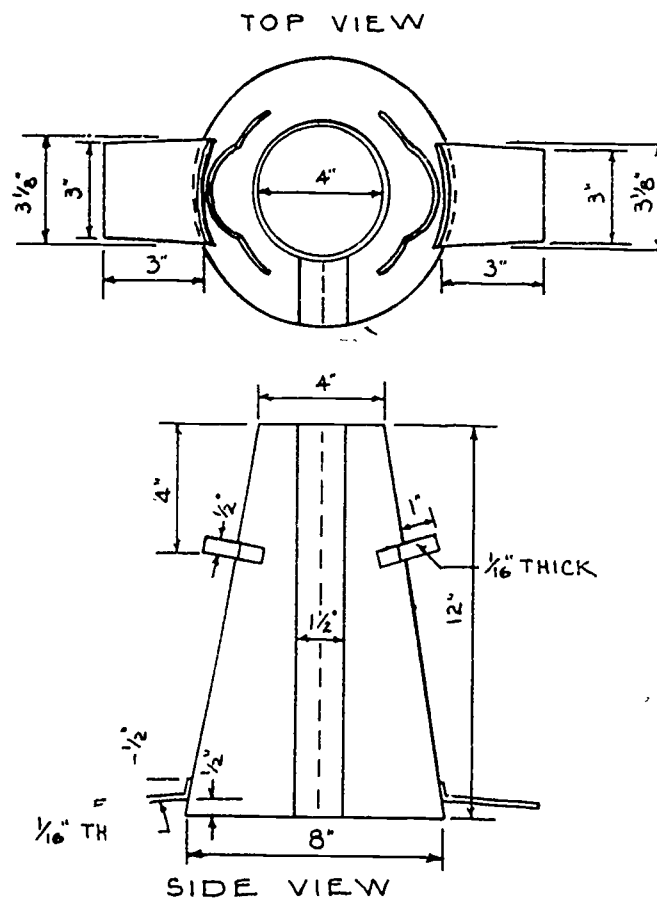

The concrete sample for a slump test should be taken right before placing the concrete in the forms. The mold is dampened and placed on a flat surface. Hold the mold down by standing on the foot pieces. Fill the mold 1/3 full.

The concrete is rodded (up and down motion) 25 times with a tamping rod. Do not use a reinforcement rod. Complete the filling in with two more layers. Each layer is rodded 25 times and each stroke should penetrate through to the lower layer. After the top layer has been rodded, it should be struck off by screeding (back and forth motion) and rolling motion of the tamping rod. Remove the metal mold by gently raising it vertically immediately after filling and screeding. Gently place the empty mold by the concrete sample. Lay the tamping rod horizontally on top of the mold. Measure distance from top of the concrete to the bottom of the rod. This gives you the slump in inches.

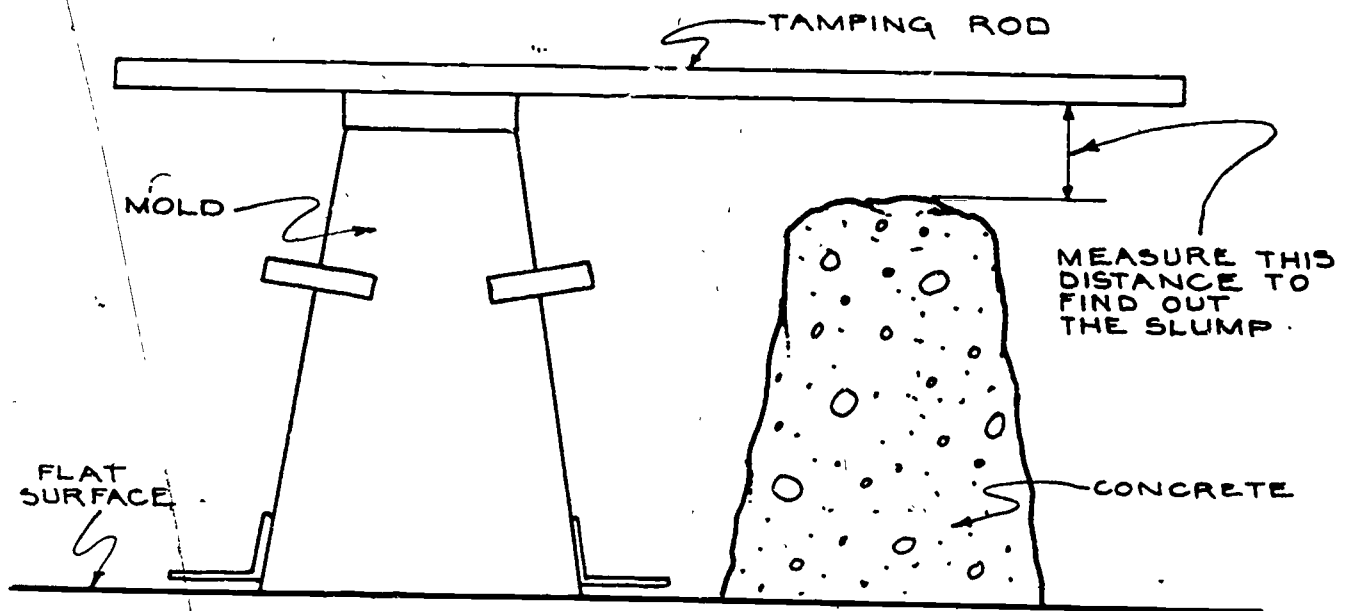

ASTM method C360, "Tentative Method of Test for Ball Penetration in Fresh Portland Cement Concrete" is a supplementary test for the consistency of concrete, but is not a substitute for the slump test. This test is sometimes referred to as the "Kelly Ball" test. It involves determining the depth that a 6-inch diameter ball weighing 30 pounds will sink in the fresh concrete. The advantage of this test is that no molds are used, and it can be made in a wheelbarrow or large container or even when the concrete is in the forms. This provides a quick and convenient method for determining the consistency for control purposes.

The ASTM method requires that the concrete be at least 8 inches deep and 18 inches wide. The sample should not be disturbed or vibrated during the test, and the ball should be allowed to settle freely but not dropped. Take the average of three tests.

ASTM C138 is the standard test for unit weight of plastic concrete. This method is used mostly in laboratories. A 1/2 cubic foot container is used when aggregate size in the concrete mix is 2 inches or less. A 1 cubic foot container is used when the aggregates exceed 2 inches in diameter. Concrete is placed in the container in three equal layers, each layer is rodded and the side of the container is tapped 10 to 15 times to remove large air bubbles. The container is then struck off and the net weight determined.

The three standard tests for measuring air content in concrete are:

ASTM C231: (This is the pressure method.) Practical for on-the-job (field) testing concrete except those made with highly porous and lightweight aggregates.

ASTM C173: Volumetric method is practical for lightweight and porous aggregate concrete.

ASTM C138: Gravimetric method. This method has already been mentioned.

A field test for checking changes in air content or mix proportions is the unit weight test. The equipment needed is a sturdy container of known volume, (1/4 or 1/2 cubic foot) and an accurate balance. Changes in air content will generally result in changes in the unit weight of concrete from one batch to another. Samples for air content should be taken from concrete that has been placed and consolidated.

Follow-up tests are made on many jobs to determine the effectiveness of field control methods. These tests are for compressive and flexural (tensile) strength in accordance with ASTM C31, "Standard Method of Making and Curing Concrete Compression and Flexural Test Specimens in the Field."

The compressive strength test molds are cylindrical, 6 inches in diameter and 12 inches tall, open at both ends, and watertight. They can be used if the coarse aggregate does not exceed 2 inches.

Self Assessment

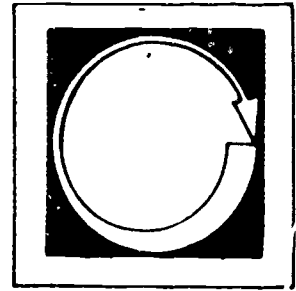

COMPLETE THE FOLLOWING SENTENCES BY CHOOSING THE CORRECT WORD FROM THE LIST AND WRITING IT IN THE BLANKS PROVIDED.

molds
standard
plastic
tapping rod
slump cone
15
ASTM
C39

1. The _____ was formed because there was a need for a standard for the testing of building materials.
2. ASTM _____ is the reference number of the ASTM standard test for testing the compression strength of concrete.
3. Freshly mixed concrete that hasn't begun to harden is called _____ concrete.
4. A _____ test is used to determine the consistency of fresh concrete.
5. A _____ mold holds 1/2 cubic foot of fresh concrete.
6. _____ should be placed on a rigid horizontal surface free from vibrations.

7. The time between taking and using concrete samples should not exceed _____ minutes.

8. A _____ is the mold used for a slump test.

Self Assessment Answers

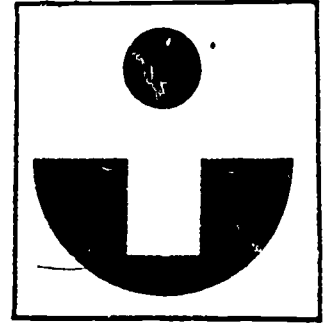

1. ASTM
2. ASTM C39
3. plastic
4. slump
5. standard
6. molds
7. 15
8. slump cone

In making the compressive strength field test, a sample of concrete is taken at three different times throughout the unloading of the entire batch. Samples are not to be taken at the beginning or end of the unloading. The individual portions of the sample should be remixed with a shovel to ensure uniformity. Note the location, air temperature, and any unusual conditions.

Fill the mold in three equal layers. Each layer is puddled 25 strokes with a tamping rod. (Do not use reinforcing bar.) When rodding the second and third layers, the rod should just break through the lower layer. After the top layer has been rodded, the surface of the concrete is struck off with a trowel and covered with glass or a metal plate to prevent evaporation.

Molds should be placed on a rigid horizontal surface that will be free from vibrations or other disturbances. Test specimens should not be moved for 24 hours, and should be stored under conditions that will prevent the loss of moisture and maintain a temperature of 60° to 80° Fahrenheit. Send the cylinders to the laboratory as soon as possible for standard curing.

Concrete samples at all ages should be kept upright and be protected from rough handling. Otherwise the specimens will show a lower than normal strength.

At the laboratory, compression tests are made in accordance with ASTM C39 "Standard Method of Test for Compressive Strength of Molded Concrete Cylinders."

The specimen is placed in a testing machine where a load is applied and increased until the specimen begins to crumble. The compressive strength of the specimen is determined to the nearest 10 pounds per square inch (p.s.i.).

Assignment

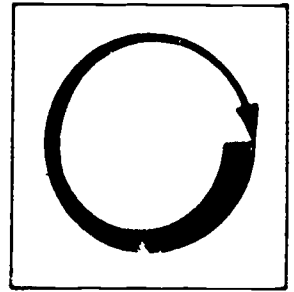

COMPLETE THE FOLLOWING ASSIGNMENT.

1. Visit a testing laboratory in your area.
2. Discuss with the class different molds and methods you saw being used.

Job Sheet

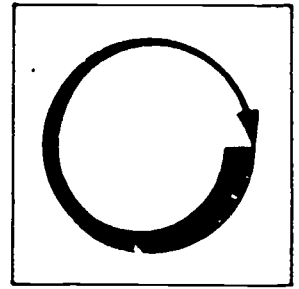

COMPLETE THE FOLLOWING TASK.

Materials and Tools

wheelbarrow

slump cone

tamping rod

shovel

measuring tape

Take a slump test of concrete following procedures in the information section.

Post Assessment

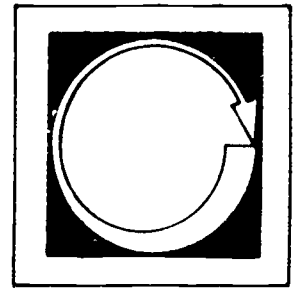

WRITE AN ANSWER TO THE FOLLOWING QUESTIONS.

1. What does a change of slump on the job indicate?
2. What are the dimensions of a "slump cone?"
3. How many layers does it take to fill the "slump cone?"
4. How many times should each layer of concrete be rodded in the slump cone?
5. What is the size of a compressive strength test mold?
6. What temperature should the compressive strength test molds be maintained at when filled?

7. What can result if the compressive strength test molds are handled roughly?
 8. When should a sample of plastic concrete be taken for a slump test?
 9. What are the advantages of using the ball penetration test?
-

Instructor Post Assessment Answers

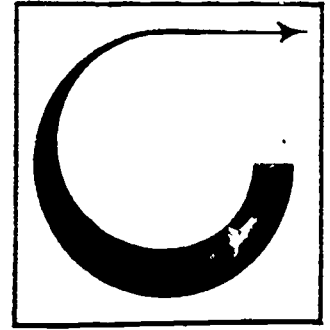

1. A change of slump on the job indicates a change in grading or proportioning of aggregates or a change in the amount of water in the mix.
2. The size of a slump cone is 8 inches in diameter at the bottom tapering to 4 inches at the top. The height is 12 inches.
3. The slump cone should be filled with three equal layers.
4. Each layer in the slump cone should be rodded 25 times and the second and third layers should be rodded to penetrate the lower layer.
5. The size of a compressive strength test mold is 6 inches in diameter, 12 inches in height, cylindrical in shape and open at both ends. To be used if aggregates do not exceed 2 inches.
6. The test molds should be maintained at a temperature between 60 and 80 degrees Fahrenheit.
7. If the test molds are handled roughly a lower than normal strength can be recorded.
8. A sample of concrete for a slump test should be taken immediately before placing the concrete in the forms.
9. The advantages of using the ball penetration test are: 1) no molds are used, 2) can be done in a wheelbarrow or even in the forms.

PLACING CONCRETE

Goal:

The student will be able to explain the proper procedures for placing concrete.

Performance Indicators:

The student will demonstrate a knowledge of the topic by successfully completing a Self Assessment, an Assignment, a Job Sheet and a Post Assessment.

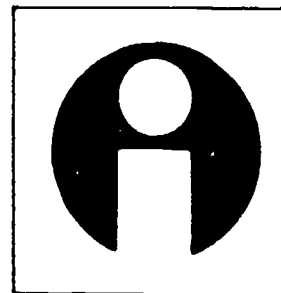

Study Guide

In order to finish this module, do the following tasks. Check each item off as you complete it.

1. Read the Goal and Performance Indicators on the cover of the module. This will tell you what you will learn by studying the module, and how you will show you've learned it.
2. Read the Introduction. The Introduction will tell you why the module is an important part of the cement finishing trade.
3. Study the Vocabulary section. Vocabulary words are important for a good understanding of the trade. After you have studied the vocabulary, ask your teacher to quiz you on the words and their meanings.
4. Study the Information section. This section will give you the information you need to understand the subject.
5. Take the Self Assessment exam. This is a test for you to prove to yourself that you have learned the material you have studied. Compare your answers with the answers on the Self Assessment Answer Sheet, which is on the page following the Self Assessment. If you scored poorly, re-study the Information section or ask your teacher for help.
6. Do the Assignment page. Follow the instructions at the top of the Assignment page.
7. Do the Job Sheet. Follow the instructions at the top of the Job Sheet. The tasks listed on the Job Sheet will help you develop skills which will be helpful to you.
8. Take the Post Assessment exam. Give the exam to your teacher after you have completed it. Your teacher will grade it for you.

Introduction

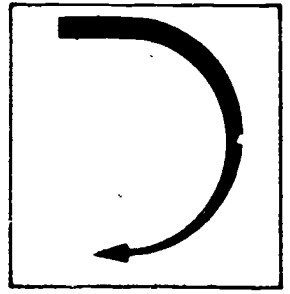

One of the most important processes in obtaining quality concrete is the placing.

Concrete is never poured. It is placed. Handling and placing concrete requires work, but it can make the difference between a poor job and a good one.

Vocabulary

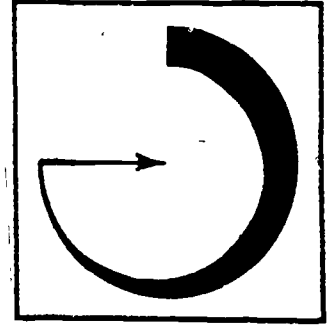

Trade terms are very important for a good understanding of the trade. Study these words and meanings. When you have learned them, ask your teacher to quiz you on the words and their meanings.

CONSOLIDATION--The flowing together of concrete in a solid mass.

VIBRATOR--A gas, electric, or air powered piece of equipment used to consolidate the concrete.

DROP CHUTE--A chute with a hopper at the top used to place concrete in forms over 4 feet deep.

COMPACTION--The tamping of rock and gravel to provide a solid bed for the concrete to be placed upon.

SUBGRADE--The base or bed that the concrete is placed on.

SEGREGATION--The separation of aggregates from the cement paste.

PLACING--The process of putting concrete in the forms and spreading it.

Supplementary References

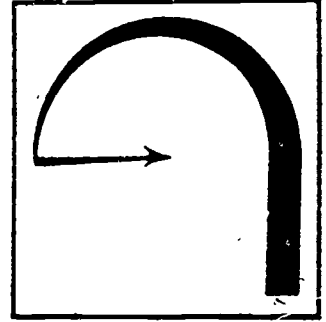

1. Waddell, Joseph J. Concrete Construction Handbook. McGraw-Hill Book Co., 1968. Unit 24, pp. 3-23.
2. Concrete Technology Instructors Guide. Portland Cement Association, 1965. pp. 159-167.

Information

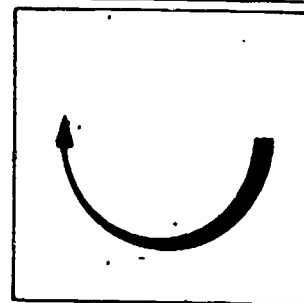

The following tasks must be done before concrete can be placed.

1. Forms must be built.
2. The base must be compacted.
3. Forms should be oiled for easier removal.
4. The subgrade must be moist.
5. Reinforcing steel (if it is to be used) must be set in place.

When and how concrete is placed in forms is very important.

The job conditions will determine the right method to use to move the concrete from the mixer or truck to the forms.

Concrete is handled by many methods. Wheelbarrows can be used on small jobs. Other methods include the use of chutes, buggies (hand or motor operated), buckets handled by cranes, and concrete pumps which can pump the concrete through hoses many feet long.

Care should be taken to prevent segregation of the aggregate as the concrete is being moved. The use of a stiff mix and smooth runways will help prevent segregation.

Plan the job so the redi-mix truck can get as near to the forms as possible. This saves time and the extra work of moving the concrete.

Forms should be clean, tight and adequately braced. Wood forms should be moistened before placing the concrete, otherwise they will absorb moisture from the concrete and swell.

Concrete must be delivered and emptied from the truck or mixer within 1 1/2 hours after water has been added to the mixture. In hot weather, or where

conditions tend to stiffen the concrete, less time should pass. A good practice is to place the concrete in the forms within 30 to 60 minutes after mixing. Excessive mixing and hydration may cause the concrete to stiffen and be difficult to place and finish.

To consolidate concrete it should be mechanically vibrated or spaded as it goes into the form, then spaded next to the forms to eliminate voids or honeycombing at the sides. In areas hard to get at, tapping lightly with a hammer on the forms will help consolidate the concrete. This makes a dense concrete surface by forcing the coarse aggregates away from the form. If concrete is overworked while in its plastic stage too much water and fine material will be brought to the surface, later causing scaling or dusting.

In slab construction, start at the far end of the forms and dump each batch against concrete already poured. Don't dump concrete in piles and then try to level or push or pull it over a long distance.

In deep forms the concrete should be placed in layers not more than 12 to 18 inches thick. Consolidate each layer before placing the next one. When concrete is placed in tall forms at a rapid rate there is likely to be bleeding of water to the top surface, especially with non-air-entrained concrete. Bleeding can be reduced by using concrete of a lower slump (concrete that contains less water). When pouring in layers more concrete should be placed before the bottom layer starts to set. This prevents formation of a cold joint.

The old rule that concrete should be placed not poured should be continuously in mind. Place concrete where needed, and do not push, flow, or drag it in place.

A drop chute should be used when concrete must be dropped more than three or four feet. If concrete is allowed to drop, hit the form and bounce off, it will separate and cause stone pockets and sand streaking. Drop chutes are made in several lengths with a hopper on top. (See the illustration on the following page.)

Immersion-type vibrators, commonly referred to as spud vibrators, are excellent to use to consolidate fresh concrete in walls or other formed work. The spud vibrator is a metal tube-like device that vibrates at several thousand cycles

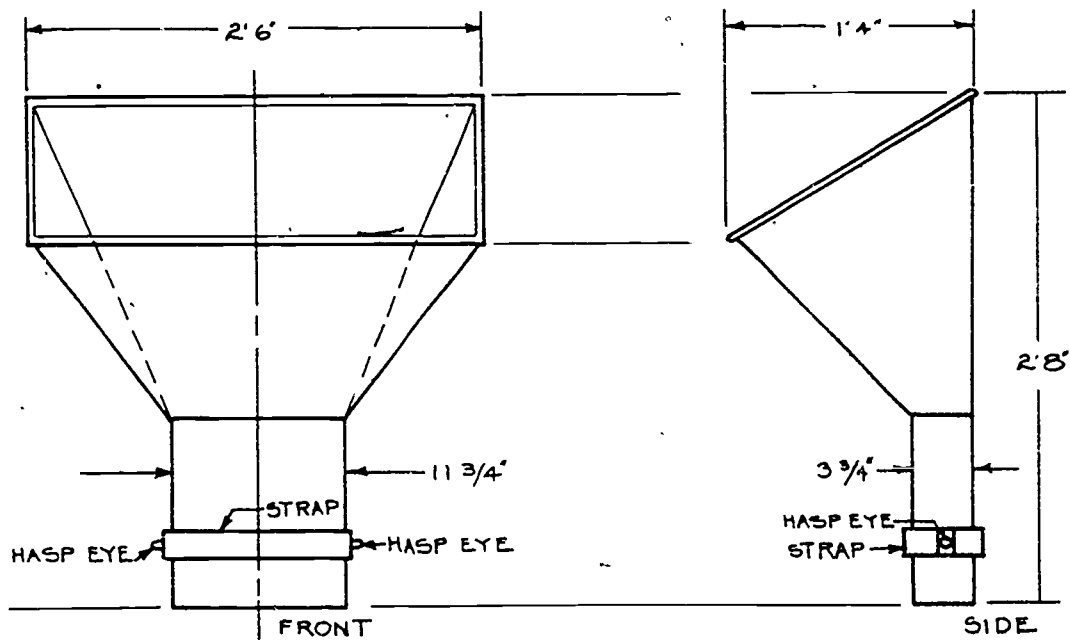

A RECTANGULAR DROP CHUTE
WITH HOPPER AT TOP FOR PLACING
CONCRETE IN NARROW WALLS

per minuté. It is usually powered by electricity, air, or gasoline. Concrete should not be vibrated more than 5 to 15 seconds. Over vibrating can bring the water and fine sand to the surface of the concrete. It can also spread or tear the forms apart.

Form vibrates may be attached to the outside of the forms. They are useful in consolidating concrete in thin walls and where metal forms are used.

Self Assessment

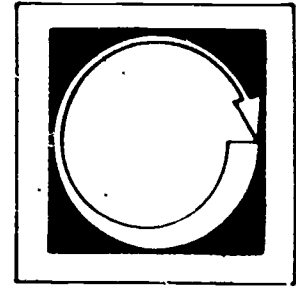

LISTED BELOW ARE SEVERAL STATEMENTS. IF THE STATEMENT IS TRUE, PLACE A "T" IN THE BLANK PROVIDED. IF THE STATEMENT IS FALSE, PLACE AN "F" IN THE BLANK.

1. ___ Consolidation is the separation of aggregates from the cement paste.
2. ___ Vibrators are used in placing concrete to consolidate it.
3. ___ The sub-grade is the bed the concrete is placed on.
4. ___ Concrete should be poured, not placed.
5. ___ Vibrators placed on forms are called spud vibrators.
6. ___ Placing concrete is one of the most important processes in obtaining quality concrete.
7. ___ Bleeding is when the concrete has too high a slump and water comes to the surface.

Self Assessment Answers

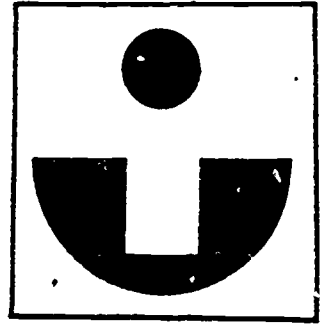

1. F
2. T
3. T
4. F
5. F
6. T
7. T

Assignment

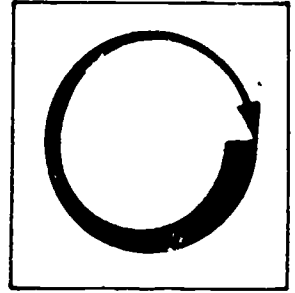

COMPLETE THE FOLLOWING ASSIGNMENT.

Visit a construction site where concrete is being placed. (Call a redi-mix batch plant for information on where their deliveries are that day). Write a report on how concrete was moved, placed, and consolidated in the forms.

Job Sheet

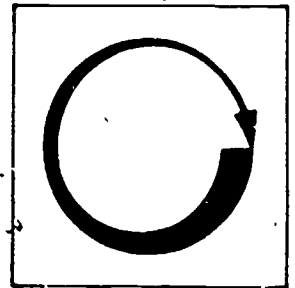

COMPLETE THE FOLLOWING TASK.

Tools

shovel

Place concrete that was mixed in the mixing module into a form and consolidate it by spading.

Post Assessment

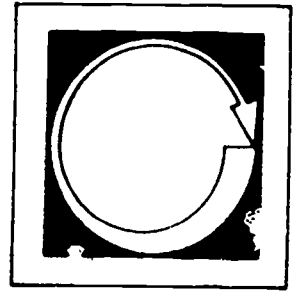

WRITE AN ANSWER TO THE FOLLOWING QUESTIONS.

1. What are the methods for handling concrete?
2. What should one do to save time and extra work of moving concrete?
3. Why should wood forms be dampened before placing concrete in them?
4. What is the maximum time in which concrete must be delivered and emptied from the truck after water has been added to it?
5. What are two ways to consolidate concrete in forms?
6. What happens to concrete if it is over-worked with a vibrator or spade?

2.

7. Explain how concrete is placed in slab construction.

8. How can bleeding of the concrete be reduced when placing concrete?

Instructor Post Assessment Answers

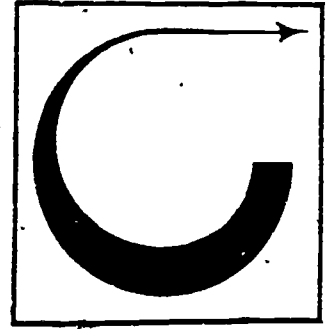

1. Wheelbarrows on small jobs, chutes, buggies (hand or motor operated) buckets handled by cranes, and concrete pumps.
2. Plan the job so the redi-mix trucks can get as near to the forms as possible.
3. To prevent absorbing moisture from the concrete and swelling.
4. Within 1 1/2 hours after water has been added.
5.
 - a. by using a vibrator
 - b. by spading it with a shovel
6. Too much water and fine material will come to the surface, later causing scaling or dusting.
7. Start at far end of forms and dump each batch against concrete already poured.
8. By using concrete of a lower slump (stiffer).

CONSOLIDATE AND STRIKE-OFF

Goal:

The student will learn the proper procedures for consolidating and striking off concrete after it has been placed in a form.

Performance Indicators:

The student will demonstrate a knowledge of the topic by successfully completing a Self Assessment and a Post Assessment, and by doing the Assignments and the Job Sheet.

Study Guide

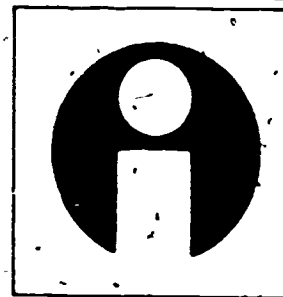

In order to finish this module, do the following tasks. Check each item off as you complete it.

1. Read the Goal and Performance Indicators on the cover of the module. This will tell you what you will learn by studying the module, and how you will show you've learned it.
2. Read the Introduction. The Introduction will tell you why the module is an important part of the cement finishing trade.
3. Study the Vocabulary section. Vocabulary words are important for a good understanding of the trade. After you have studied the vocabulary, ask your teacher to quiz you on the words and their meanings.
4. Study the Information section. This section will give you the information you need to understand the subject.
5. Take the Self Assessment exam. This is a test for you to prove to yourself that you have learned the material you have studied. Compare your answers with the answers on the Self Assessment Answer Sheet, which is on the page following the Self Assessment. If you scored poorly, re-study the Information section or ask your teacher for help.
6. Do the Assignment page. Follow the instructions at the top of the Assignment page.
7. Do the Job Sheet. Follow the instructions at the top of the Job Sheet. The tasks listed on the Job Sheet will help you develop skills which will be helpful to you.
8. Take the Post Assessment exam. Give the exam to your teacher after you have completed it. Your teacher will grade it for you.

Introduction

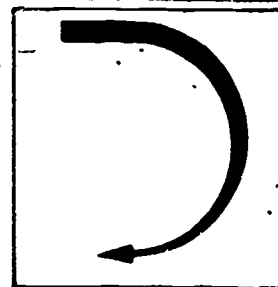

To produce quality concrete it is necessary that certain operations be performed at the proper time. Consolidating and striking off are one of the necessary steps taken to produce durable, good-looking concrete.

Vocabulary

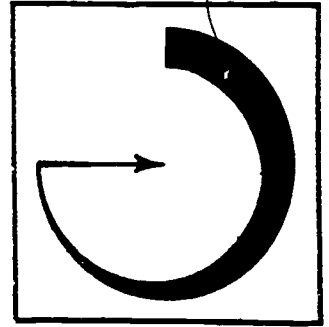

Trade terms are very important for good understanding of the trade. Study these words and meanings. When you have learned them, ask your teacher to quiz you on the words and their meanings.

CONSOLIDATE--Working the concrete to compact it and force the aggregate (gravel) down.

GRADE STAKES--Wood or metal stakes used as a guide for placing concrete to a specific grade (or height).

STRIKING-OFF--Levelling the concrete to the right grade with a straightedge. Also called screeding.

STRAIGHTEDGE--A striking-off tool of wood or magnesium usually 16' long. Often just a 2 X 4.

JITTERBUG--A tool used to compact fresh concrete and force the aggregate down. A tamper.

SCREED--(can mean 3 things)

- A. Stakes, forms, pipes, piles of wet concrete, that mark the final grade.
- B. The striking off to grade.
- C. The tool used to strike-off concrete to the right grade.

TOLERANCE--The maximum allowance for error. Usually plus or minus 1/8 inch in 10 feet in concrete work.

SEGREGATE--The separation of the aggregates (gravel, sand) from the paste (cement and water).

ROLLER BUG--A round tamper that rolls over the fresh concrete to compact it.

Supplementary References

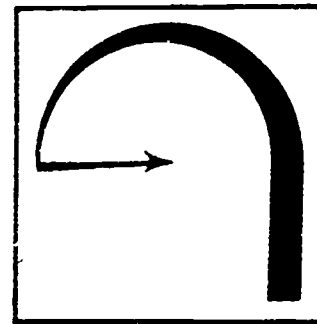

1. Polivchak, Philip and Wolf, Gilbert. Incentive Apprenticeship Training for Cement Masons. National Association of Home Builders, 1979. Unit 11.
2. Concrete Technology Instructors Guide. Portland Cement Association, 1965. p. 179.

Information

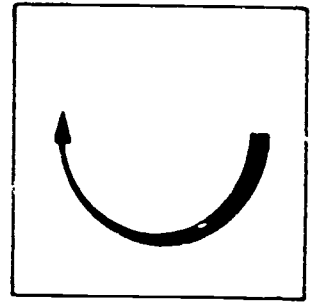

Consolidation of concrete is necessary to make a uniform, plastic mass. It eliminates stone pockets and large air spaces. Many tools are used to consolidate concrete. The most common method is the use of a straightedge or strike-off board. Often a 2 X 4 will be used as the straightedge.

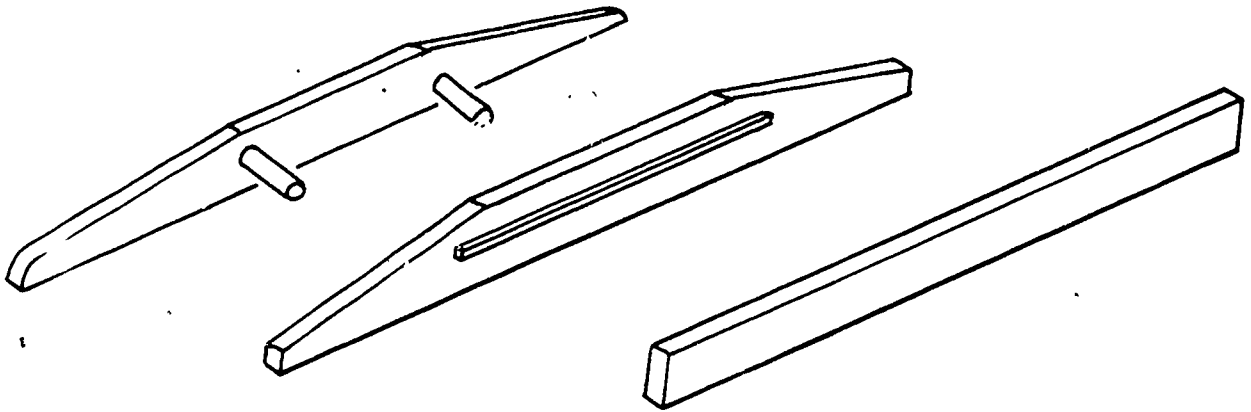

Other tools used are tampers, jitterbug, roller bug, and vibrating screed. (See the illustration on the following page.)

Tampers such as the roller bug and jitterbugs should only be used with low slump concrete (3 inch or less slump), otherwise the concrete may tend to segregate.

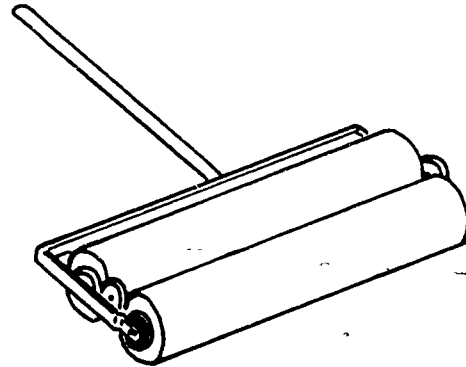
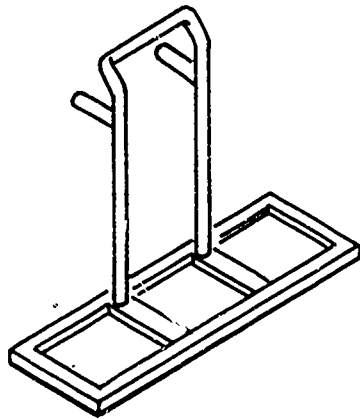

These tools should not be used on lightweight concrete as it may bring the aggregates to the surface.

Striking-off or screeding is a leveling operation that removes humps and hollows and gives an even, flat surface to the concrete. Consolidation and striking-off are often combined in one operation by using the strike-off rod or straightedge. The straightedge should be 1 to 2 feet wider than the section being finished. The surface of the concrete is struck off by moving the straightedge back and forth in a saw-like motion across the forms, advancing a short distance with each movement. The straightedge should be tilted slightly towards the concrete not yet consolidated. Push a small amount of concrete ahead of the straightedge to fill in the low spots. The grade stakes, if wooden should be pulled out or driven below the finished level of the concrete, to be removed later. If they cannot be removed they may be driven into the ground until they disappear. If the stakes are steel (3/8 inch reinforcing rod) they may be driven a few inches below the surface of the concrete.

Consolidation and striking-off should begin as soon as the concrete is placed, or being placed. It should begin and end quickly so that it is over before

bleeding water appears on the surface of the concrete. Bleeding can cause the surface to scale or dust when it dries.

The acceptable tolerance for accuracy in striking-off should be no more than 1/8 inch in a 10-foot distance.

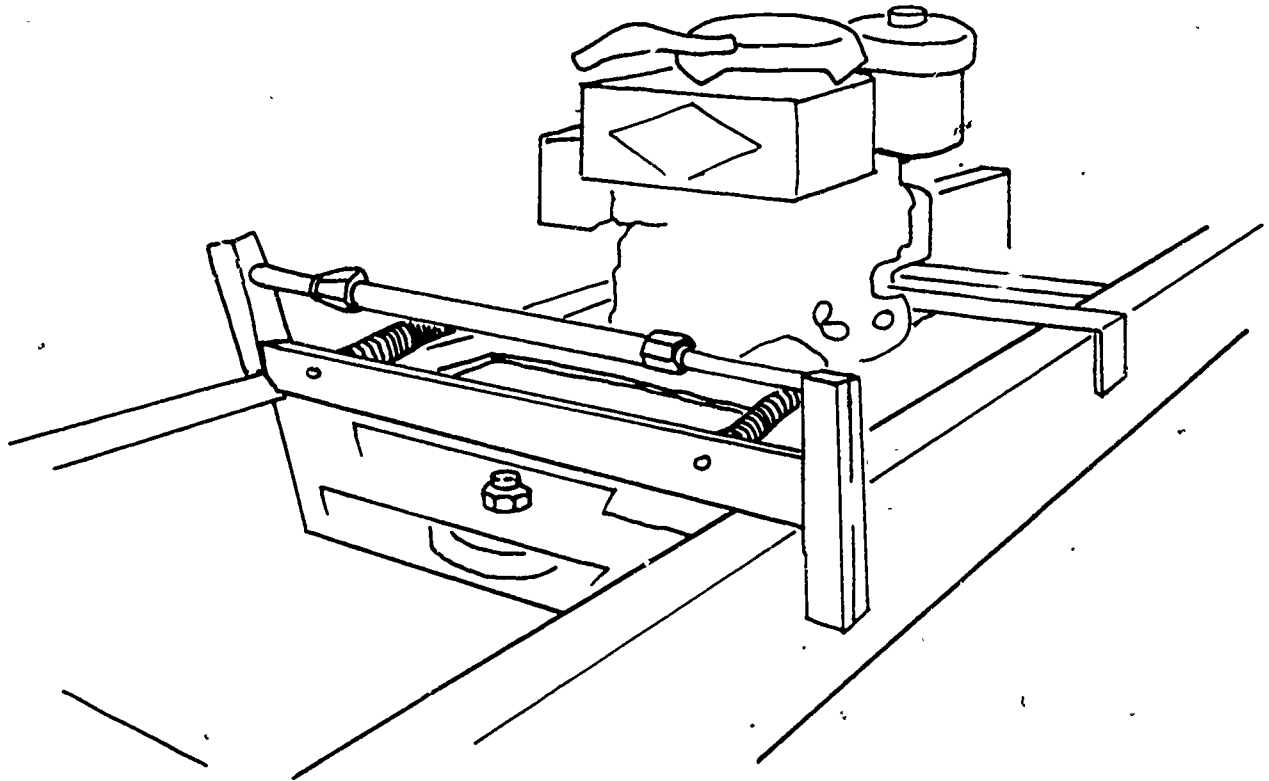

A vibrating screed or strike-off is an engine which rides on rails or forms with clamps for attaching vibrating strike-off boards. Controls on the machine can adjust speed and frequency. Slump should not exceed 3 inches when using vibrating screed. This will help to avoid problems of over vibration and segregation.

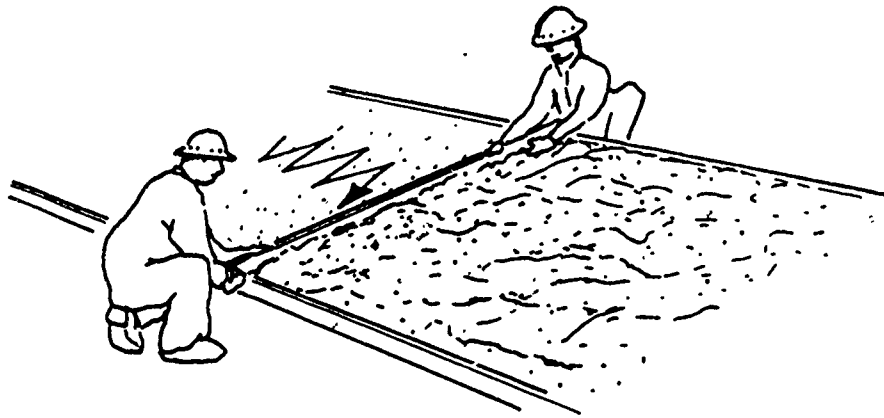
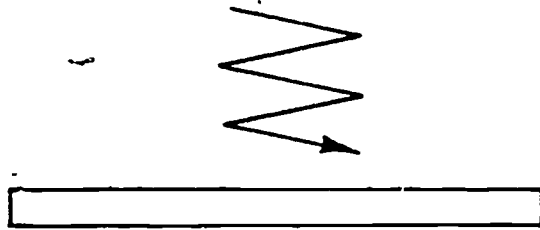

USING A
HAND-TAMPER

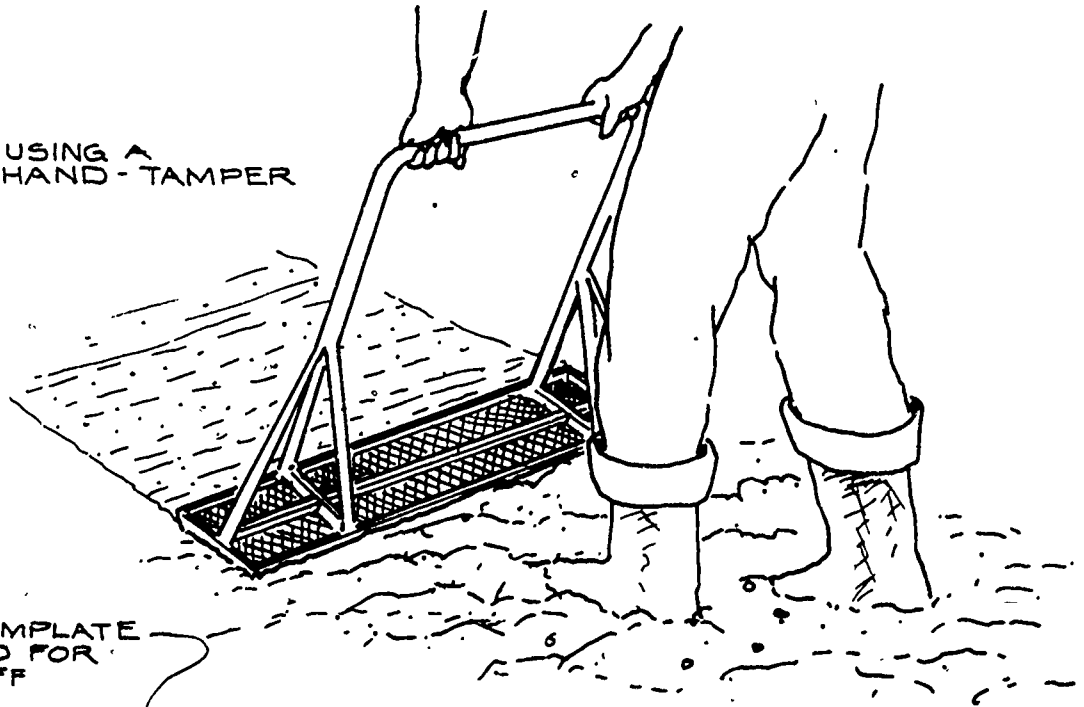

A WOOD TEMPLATE
CAN BE USED FOR
STRIKING-OFF
A CURB

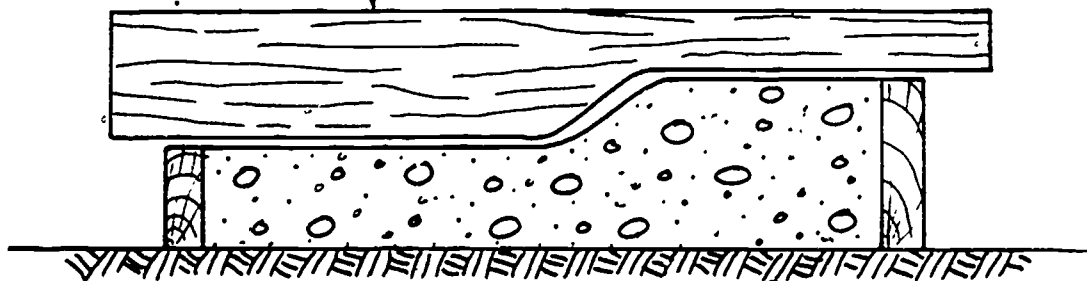

Self Assessment

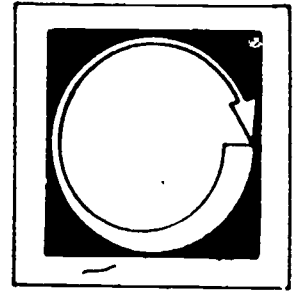

CHOOSE THE CORRECT WORD OR WORDS FROM THE LIST GIVEN AND PLACE THEM IN THE BLANKS TO COMPLETE THE SENTENCES.

straightedge
tolerance
roller bug
grade stakes
consolidation

1. _____ of concrete is necessary to give a uniform, plastic mass.
2. A _____ is a striking-off tool of wood or magnesium.
3. _____ are used as a guide for placing concrete to a specific grade.
4. _____ is the maximum allowance for error.
5. A round tamper that rolls over fresh concrete to compact it is called a _____.

Self Assessment Answers

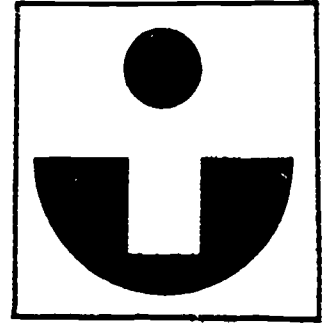

1. consolidate
2. straightedge
3. grade stakes
4. tolerance
5. roller bug

Assignment

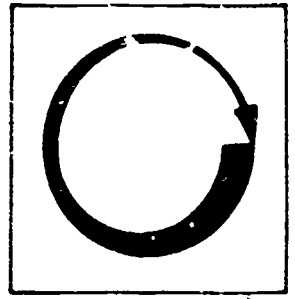

COMPLETE THE FOLLOWING ASSIGNMENTS.

1. Visit a construction site where concrete is being placed.
2. Write a report on the different methods of consolidation and striking-off of concrete that you saw.

Job Sheet

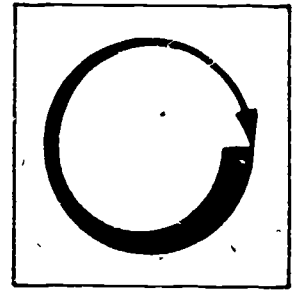

COMPLETE THE FOLLOWING TASK.

Materials and Tools

shovel

straightedge (a long 2 X 4 will work well)

a wooden form in which to place the concrete

wheelbarrow of concrete

After placing concrete in forms, consolidate and strike off concrete according to information sheet.

Post Assessment

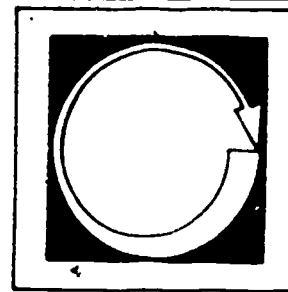

WRITE AN ANSWER THE FOLLOWING QUESTIONS.

1. What is the most common method used to consolidate concrete?
2. Why is consolidation of concrete necessary?
3. Why should striking-off begin and end as soon as possible?
4. When should a vibrating screed be used?
5. Why is striking-off necessary?
6. Why should a small amount of concrete be kept ahead of the straightedge all the time?

7. When striking-off concrete what do you do with the grade stakes.

8. What is the acceptable tolerance of accuracy when striking off.

214

217

Instructor Post Assessment Answers

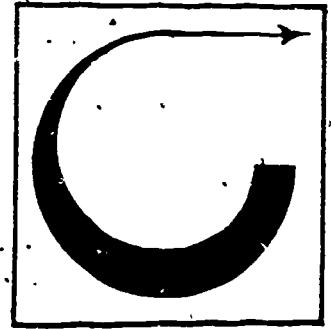

1. The most common method used to consolidate concrete is the straightedge or strike-off board.
2. Consolidation of concrete is necessary to give a uniform, plastic mass. It eliminates stone pockets and large air voids.
3. Striking-off should begin and end as soon as possible so that it is over before bleeding water appears on the surface.
4. A vibrating screed should be used when the slump is 3 inches or less.
5. Striking-off is necessary in leveling off the concrete and, in removing the humps and filling in the hollows.
6. A small amount of concrete should be kept ahead of the straightedge to fill in the low spots and to maintain a level surface.
7. If grade stakes are wooden, pull them out. If it is not possible to pull them out you can hammer them down until the tops are flush with the earth. Steel stakes can be pulled out or driven a few inches below the concrete's surface.
8. The acceptable tolerance of accuracy when striking-off is 1/8 inch off in a 10 foot distance.

FINISHING CONCRETE

Goal:

Upon completion of this module, the student will be able to explain and demonstrate the proper procedure for finishing concrete.

Performance Indicators:

The student will demonstrate knowledge of the topic by successfully completing a Self Assessment, two Assignments, a Job Sheet and a Post Assessment.

Study Guide

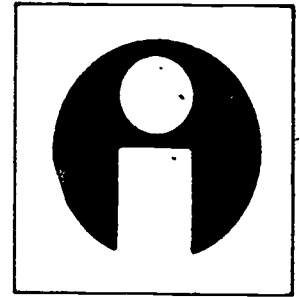

In order to finish this module, do the following tasks. Check each item off as you complete it.

1. Read the Goal and Performance Indicators on the cover of the module. This will tell you what you will learn by studying the module, and how you will show you've learned it.
2. Read the Introduction. The Introduction will tell you why the module is an important part of the cement finishing trade.
3. Study the Vocabulary section. Vocabulary words are important for a good understanding of the trade. After you have studied the vocabulary, ask your teacher to quiz you on the words and their meanings.
4. Study the Information section. This section will give you the information you need to understand the subject.
5. Take the Self Assessment exam. This is a test for you to prove to yourself that you have learned the material you have studied. Compare your answers with the answers on the Self Assessment Answer Sheet, which is on the page following the Self Assessment. If you scored poorly, re-study the Information section or ask your teacher for help.
6. Do the Assignment page. Follow the instructions at the top of the Assignment page.
7. Do the Job Sheet. Follow the instructions at the top of the Job Sheet. The tasks listed on the Job Sheet will help you develop skills which will be helpful to you.
8. Take the Post Assessment exam. Give the exam to your teacher after you have completed it. Your teacher will grade it for you.

Introduction

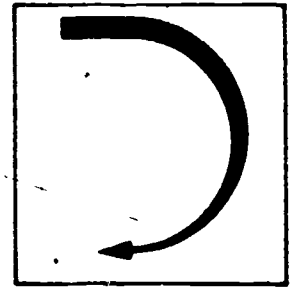

To obtain quality concrete jobs, it is essential to know when and how to use the finishing tools (float, edger, jointer) to eliminate surface defects, and produce a smooth, durable, attractive concrete surface.

Vocabulary

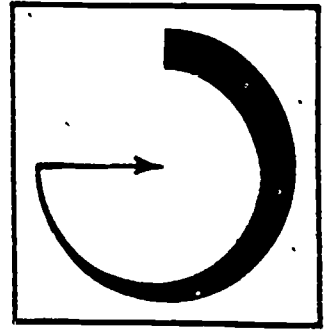

Trade terms are very important for a good understanding of the trade. Study these words and meanings. When you have learned them, ask your teacher to quiz you on the words and their meanings.

SPALLING--The chipping off of concrete, especially around sharp edges.

WATER SHEEN--The glossy appearance on the surface of concrete.

CRAZING--A network of fine surface cracks on the concrete.

PERPENDICULAR--At right angles to a given line or plane.

CHATTER--A wash board effect on the concrete surface.

KNEE BOARDS--Flat wooden boards 12 inches wide, 24 inches long; used to get on concrete to finish.

Supplementary References

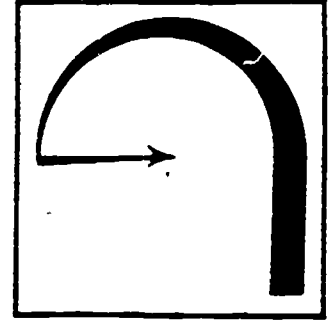

1. Concrete Technology Instructors' Guide. Portland Cement Association, 1965. pp. 179-183.
2. Polivchak, Philip. Incentive Apprenticeship Training for Cement Masons. National Association of Homebuilders, 1979. Units 3, 4 and 5.

Information

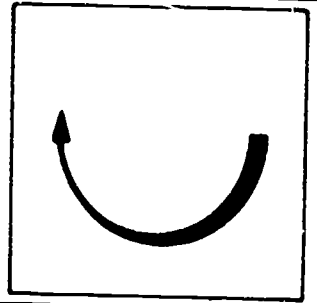

The first step in finishing concrete is to darby or bull-float immediately after screeding or striking-off. This should be done before any free water has bled to the surface. The bull float is popular because it has a long handle and is easy to use on wide slabs.

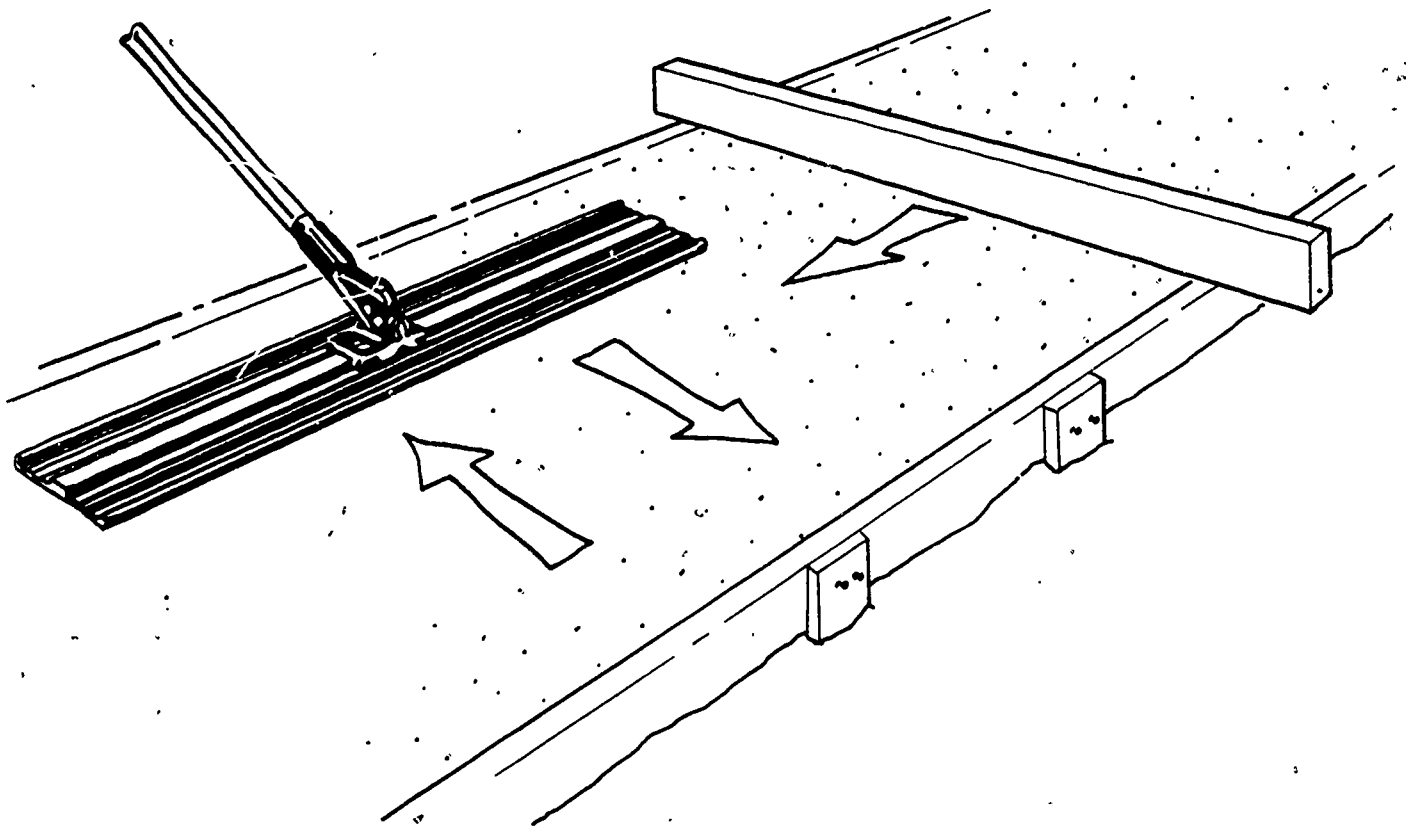

The cement finisher should bullfloat perpendicular to the direction of the strike-off of the concrete. This will remove the ridges or valleys left by the strike-off operation.

The bull float should be pushed with the front of the float raised slightly so that it will not dig into the concrete surface. Near the end of the forward

stroke jiggle the bull float slightly to help loosen it for the return and help prevent dishing of the concrete surface. On the return stroke raise the handle so the back of the bull float is raised slightly. Continue back and forth across the slab, and overlap a minimum of 6 inches each time. This helps embed large aggregate beneath the surface and brings sufficient paste to the surface to prepare for other finishing operations. Do not overwork the surface as this can seal off the surface and bring up too much weak paste.

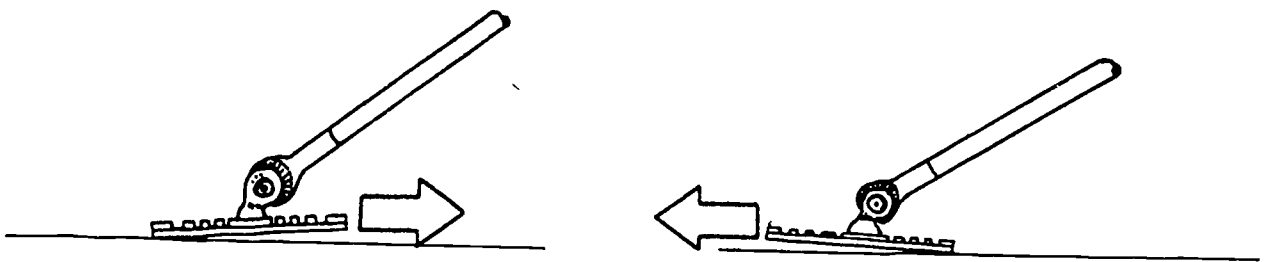

Bull floats are made of wood or lightweight metal, usually aluminum or magnesium. Wooden bull floats tend to be better when you want to open up the surface instead of to seal it. Using a wooden bull float opens up the concrete surface and lets the bleed water out. You want to let the bleed water out, especially if the weather is cool and the concrete is setting slowly. In hot, dry or windy weather, you may want to keep the bleed water in, because of too fast evaporation. Then it is best to use a magnesium or aluminum bull float.

Magnesium or aluminum bull floats are recommended on air-entrained or lightweight concrete as wooden bull floats tend to tear the surface too much.

When all bleed water and water sheen have left the surface, and the concrete has started to stiffen, it is time for the rest of the finishing operations.

The bleed water test by itself is not always reliable. As air-entrained concrete does not have much bleed water. The best test to find out if the concrete is firm enough to finish is to stand on the surface. If your foot only makes a 1/4" deep imprint, then the concrete is ready to finish.

Concrete expands and contracts due to temperature changes. It may also shrink as it hardens. Control joints, or contraction joints are cut across large areas of concrete, at regular intervals, to control cracking. Control joints are generally placed 10 to 15 feet apart on floor slabs, driveways, and feeding floors. On side walks they are placed 4 to 5 feet apart. Control joints should be cut soon after the concrete has been placed to work the larger pieces of coarse aggregate away from the joint. Lay a straightedge across the fresh concrete and cut the joint to a depth of $1/4$ to $1/5$ of the slab. A finisher will sometimes use a brick masons trowel to cut the joint, as it has a sharp V-shaped point. A groover is then used to finish the joint.

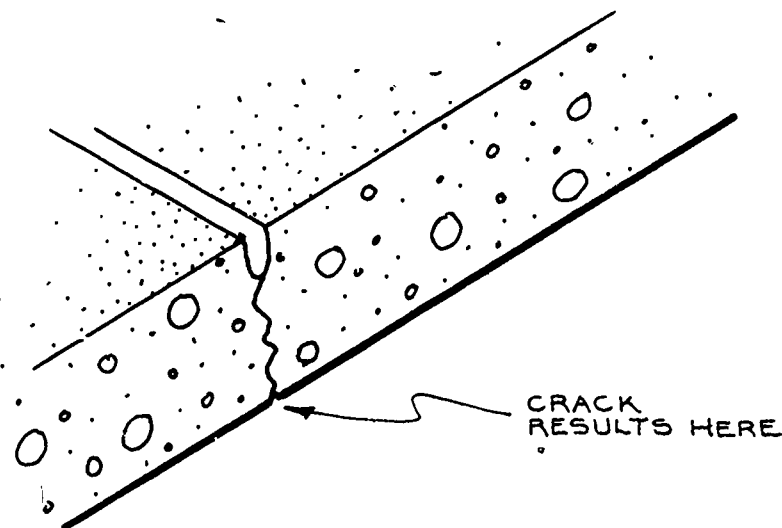

A control joint doesn't prevent cracks, but controls where cracks will occur as the part of concrete where control joint is cut is the weakest spot.

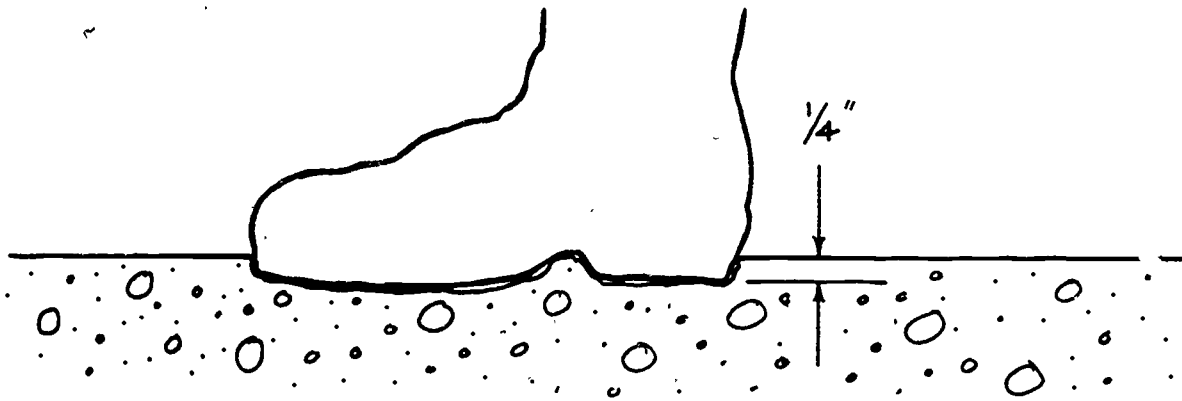

All open edges should be rounded off with an edger to prevent spalling. Run the edger back and forth until all coarse aggregate particles are covered and a finished edge is produced. Do not leave too deep an impression in the top of the slab as it may be difficult to remove later. The marks left by an edger or jointer should be removed by floating.

Generally, you will start floating and troweling at the edge as concrete usually sets up there quicker.

Using a hand float and a hand trowel, go around the edges first as this part tends to stiffen sooner. The hand float is used in a slight sawing motion to eliminate humps and imperfections, while swinging in a wide arc. Continue

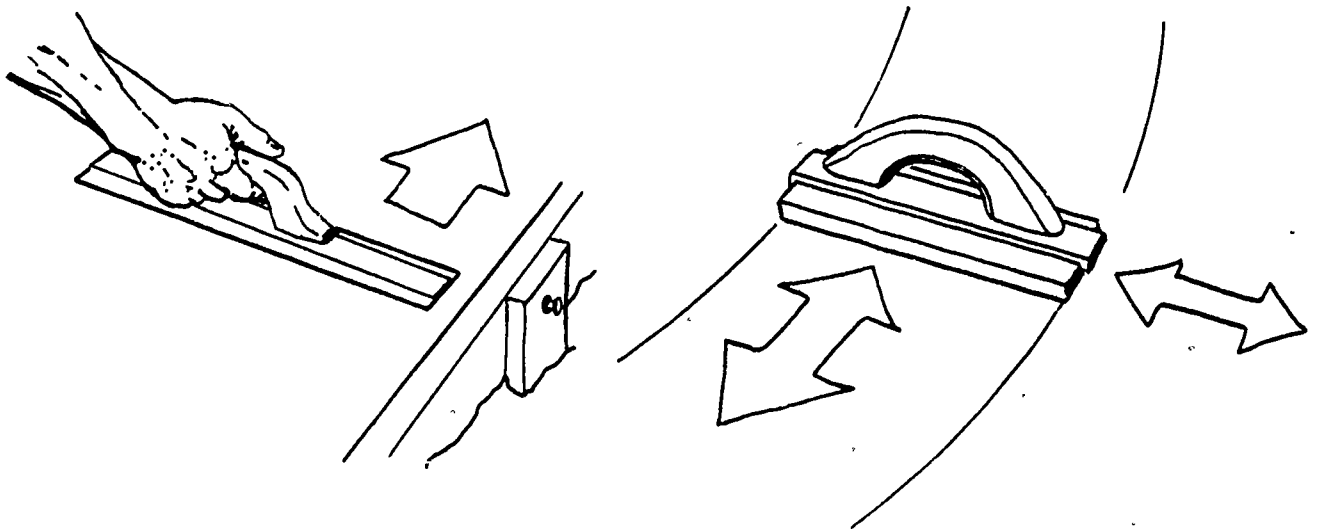

224

227

floating until low spots are filled in and ridges are smoothed. Follow with the steel trowel with the blade flat against the concrete. Usually a larger, older trowel is used on the first pass. The older trowel is worn at the edges and will not cut into the concrete. Float and trowel until all imperfections are removed.

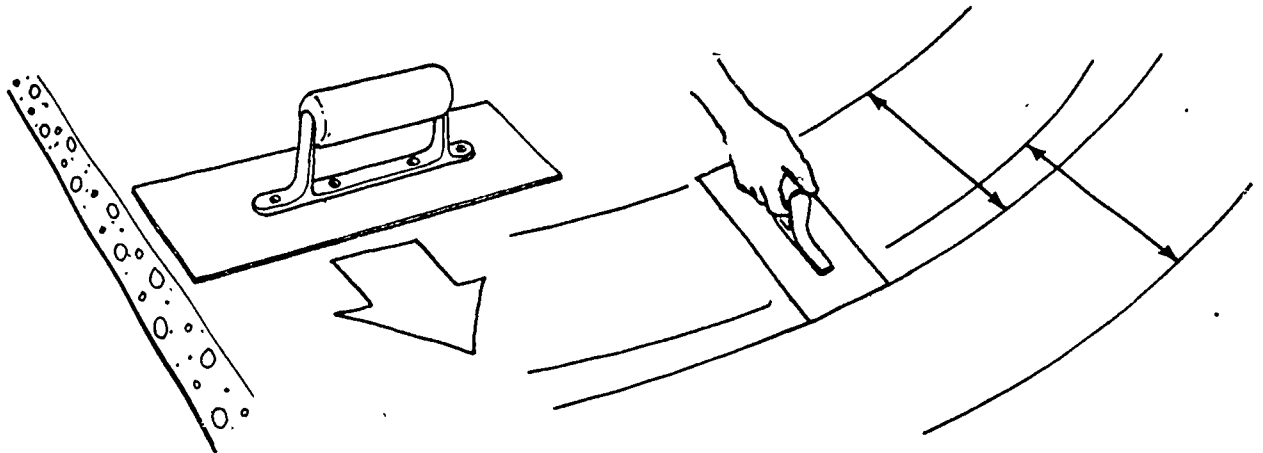

To get on the concrete further in from the edges, wooden knee boards are used. Always work backward so you do not mar the finish. Work out the kneeboard marks and other imperfections as you go. On the first pass use a float in one hand followed by a steel trowel in the other. Use one tool to keep your balance. On the second and following passes, use two trowels instead of a float and trowel. Excessive troweling when concrete is too soft may cause dusting and/or crazing, and can result in a surface that will not wear well.

Whether troweling by power or hand the blade of the trowel must be kept as flat against the surface as possible.

If the trowel blade is tilted at too great an angle it can cause a washboard or chatter surface.

The second troweling is done after the concrete has become hard enough to produce a ringing sound when the trowel is passed over the surface. There should be a lapse of time between troweling to permit the concrete to increase its set.

On the second and third passes, the trowel should be held at increased angles.

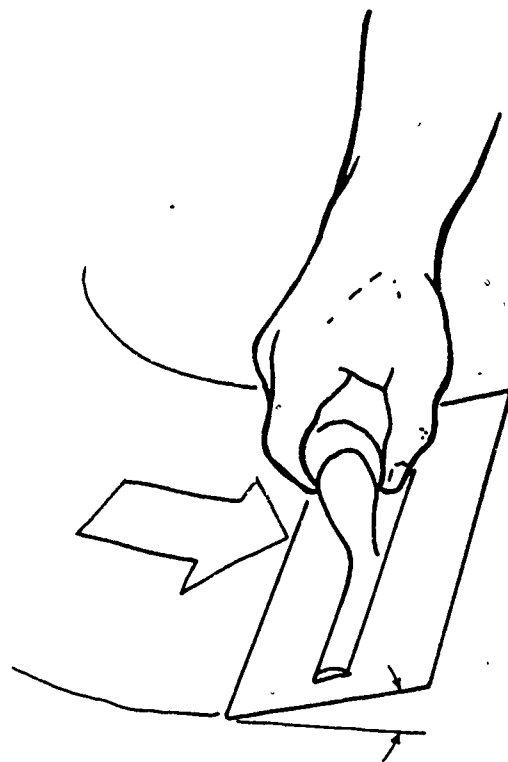
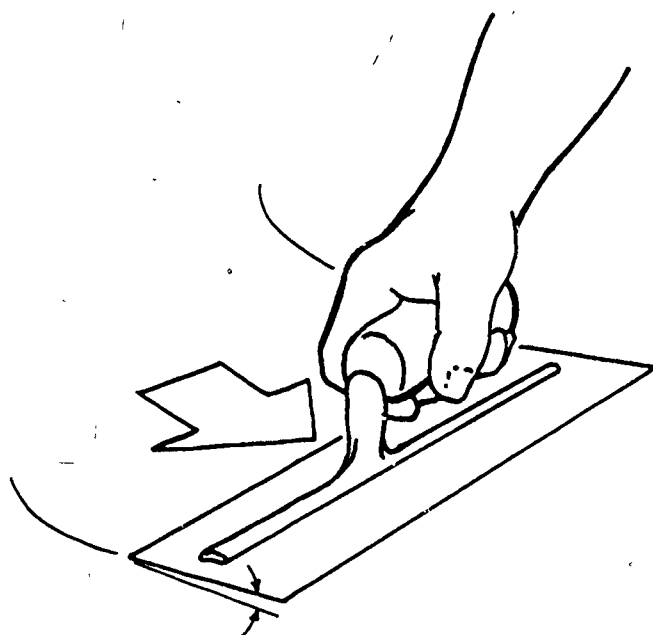

When using a power trowel the concrete should be firm enough to hold the power trowel.

On projects such as sidewalks, driveways, walks, feeding floors and ramps, a coarse, scored finish is desirable for safety. A rough texture can be obtained by pushing a stiff broom across the slab crosswise to the direction of traffic. Many degrees of coarseness or scoring can be obtained by using various types of brooms and using different amounts of pressure.

Exposed aggregate (gravel) finishes also provide a rugged non-skid surface. Use gravel uniform in size, 3/8 inch and larger, and spread evenly on the surface immediately after the slab has been bull-floated or darbied. The aggregates are embedded in the concrete by lightly tapping with a flat board. After the surface hardens enough to support a finisher on kneeboards, the surface should be hand-floated with a magnesium float or darby. The aggregate is then exposed by brushing and flushing with water.

Self Assessment

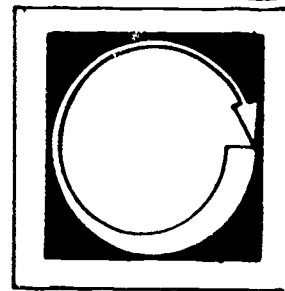

LISTED BELOW ARE SEVERAL STATEMENTS. IF THE STATEMENT IS TRUE, PLACE A "T" IN THE BLANK PROVIDED. IF THE STATEMENT IS FALSE, PLACE AN "F" IN THE BLANK.

1. ___ Bull-floating should begin immediately after striking off.
2. ___ A wood float should be used on air-entrained concrete.
3. ___ Floats are made from wood, aluminum or magnesium.
4. ___ Concrete expands and contracts due to temperature changes.
5. ___ Always use a new trowel for the first troweling.
6. ___ Control joints keep the concrete from cracking.
7. ___ Chatter is the term used to describe a wash board effect on concrete.

Self Assessment Answers

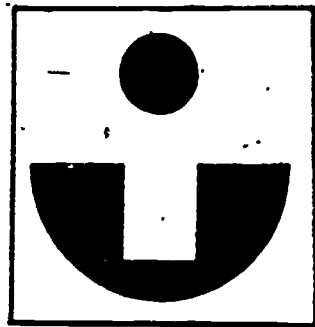

1. T

2. F

3. T

4. T

5. F

6. F

7. T

Assignment

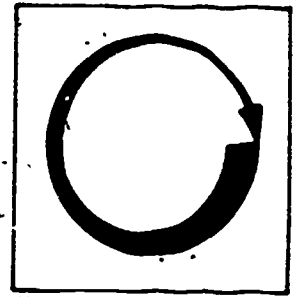

COMPLETE THE FOLLOWING ASSIGNMENT.

1. Visit a construction site where concrete has been placed and is being finished.
2. Write a report on the different operations performed for finishing.

Job Sheet

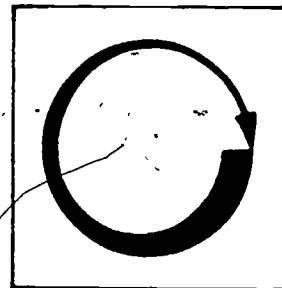

COMPLETE THE FOLLOWING TASK.

Materials and Tools

bull float

hand float

2 trowels

edger

After placing, consolidating and striking-off the concrete as shown in previous modules, bull float, float and edge, and finish slab by following steps in this information section.

Instructor Post Assessment Answers

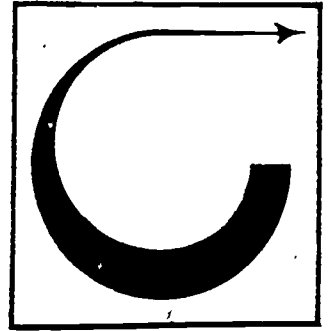

1. The purpose of floating concrete is to remove slight imperfections, fill in small hollows, help level and compact, embed large pieces of aggregates beneath the surface and to bring up the paste to the surface for other finishing operations.
2. Control joints are necessary to control where the cracking will occur so that it does not show if concrete shrinks or expands.
3. The right time to start floating is, immediately after screeding or striking-off, before bleed water appears on the surface.
4. Bull-floating should be done perpendicular to the direction of the strike-off.
5. Control joints should be cut $\frac{1}{4}$ to $\frac{1}{5}$ the depth of a slab.
6. The best test is when a person stands on the concrete and makes only a $\frac{1}{4}$ inch deep imprint in it.
7. All open edges should be rounded off with an edger to prevent spalling.
8. The second troweling should begin after the concrete has set enough to produce a ringing sound when the trowel is passed over it.

Post Assessment

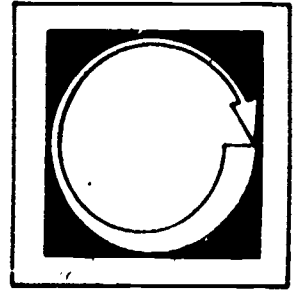

WRITE AN ANSWER TO THE FOLLOWING QUESTIONS.

1. What is the purpose of floating concrete?
2. Why are control joints necessary?
3. When is the right time to start floating?
4. In what direction does the cement finisher bull-float?
5. How deep should control joints be cut?
6. What is the best test to determine when to hand float and trowel the concrete?

7. Why should all open edges be rounded off with an edger?

8. How do you determine when to begin the second troweling?

Instructor Post Assessment Answers

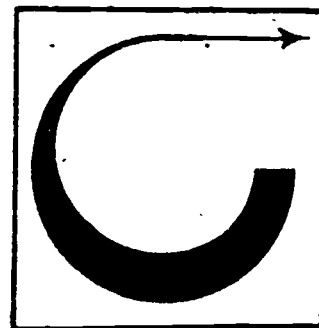

1. To remove slight imperfections, to fill in small hollows, help level and compact, embed large pieces of aggregates and to bring the paste up to the surface for future finishing operations.
2. To control where the cracking will occur.
3. Immediately after screeding or striking-off, before bleed water appears.
4. Perpendicular to the direction of the strike-off.
5. $\frac{1}{4}$ to $\frac{1}{5}$ the depth of the slab.
6. When the concrete is firm enough so a person will make a $\frac{1}{4}$ " imprint when standing on the surface.
7. All open edges should be rounded off with an edger to prevent spalling.
8. The second troweling should begin after the concrete has set enough to produce a ringing sound when the trowel is passed over it.

CURING

Goal:

The student will develop an understanding of the acceptable methods of curing concrete.

235

Performance Indicators:

The student will show an understanding of the methods of curing concrete by successfully completing a Self Assessment, an Assignment and a Post Assessment.

238

Study Guide

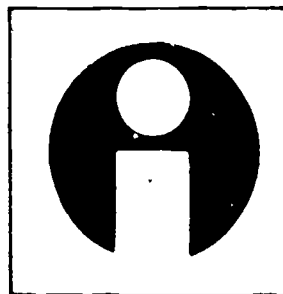

In order to finish this module, do the following tasks. Check each item off as you complete it.

1. Read the Goal and Performance Indicators on the cover of the module. This will tell you what you will learn by studying the module, and how you will show you've learned it.
2. Read the Introduction. The Introduction will tell you why the module is an important part of the cement finishing trade.
3. Study the Vocabulary section. Vocabulary words are important for a good understanding of the trade. After you have studied the vocabulary, ask your teacher to quiz you on the words and their meanings.
4. Study the Information section. This section will give you the information you need to understand the subject.
5. Take the Self Assessment exam. This is a test for you to prove to yourself that you have learned the material you have studied. Compare your answers with the answers on the Self Assessment Answer Sheet, which is on the page following the Self Assessment. If you scored poorly, re-study the Information section or ask your teacher for help.
6. Do the Assignment page. Follow the instructions at the top of the Assignment page.
7. Take the Post Assessment exam. Give the exam to your teacher after you have completed it. Your teacher will grade it for you.

Introduction

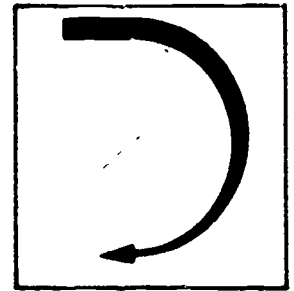

Proper curing of concrete is very important to make sure that there is always enough water to combine with the cement as the concrete dries. This makes the concrete very hard and durable. Moist curing can increase the strength of concrete up to 50 percent in 7 days.

Vocabulary

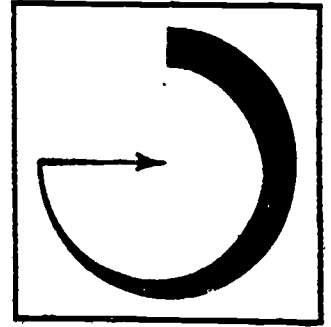

Trade terms are very important for a good understanding of the trade. Study these words and meanings. When you have learned them, ask your teacher to quiz you on the words and their meanings.

HYDRATION--A chemical reaction between portland cement and water causing it to harden.

CURING--The procedure used to slow down evaporation of moisture in concrete.

LEAN MIXTURES--Concrete that has a small amount of cement in proportion to the aggregates.

CURING COMPOUNDS--Chemicals sprayed on concrete immediately after finishing to prevent evaporation.

MEMBRANE--A thin skin-like covering.

TRANSLUCENT--Clear. Can be seen through.

EVAPORATION--Loss of water into the air.

Supplementary References

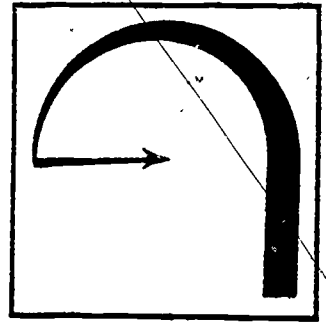

1. Concrete Technology Instructor's Guide. Portland Cement Association, 1965. pp. 185-190.
2. Concrete Construction Handbook. McGraw-Hill Book Co., 1968. Unit 29, pp. 1-5.

Information

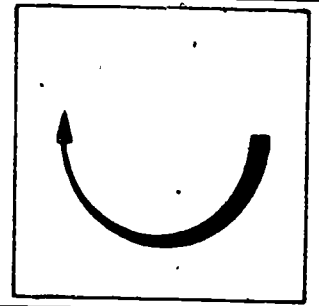

Curing is the method used to assure that there is enough water present in concrete to provide for continuous hydration of the cement. If the mixing water disappears as a result of evaporation, hydration of the cement will stop and there will be no further gain in strength and durability of the concrete.

All of the desired properties of concrete are improved by proper curing. After concrete has been placed its strength increases rapidly for the next 3 to 7 days. Concrete that is moist cured for 7 days is about 50 percent stronger than concrete exposed to dry air. If concrete is kept moist for 30 days, it's twice as strong as concrete exposed only to dry air. The reasons are as follows:

1. As concrete dries it shrinks, and if drying occurs when concrete has little if any strength, cracks are sure to result.
2. Since drying occurs first on the surface, the cement will not be hydrated there, but will be present as dust having no strength to hold the aggregates together.

There are two common methods for curing concrete. They are:

1. Water Curing--applying water directly or through some material that holds water in contact with the surface.
2. Applying a seal to prevent or slow down the escape of moisture from the concrete.

Water Curing Methods

Water curing by flooding, mist spraying, or ponding is the most effective of all curing methods to prevent evaporation of mix water, but it is not always practical because of job conditions. On flat surfaces such as floors, sidewalks and pavements, the flooding or ponding method may easily be accomplished. A small dam of earth or other water retaining materials is placed around the edges of the concrete and the enclosed area is flooded with water. Continuous sprinkling of water is also an excellent method of curing. If sprinkling is not

continuous do not let the concrete dry between applications of water. Constant moisture prevents the possibility of crazing or cracking caused by alternate wetting and drying.

Water retaining methods involve use of coverings that are kept wet, such as sand, burlap, canvas or straw. The entire concrete surface must be covered. Materials used for water retention must be kept damp at all times while curing. If the covering is allowed to dry out it will then start to absorb water from the concrete itself--exactly what we are trying to avoid! A simple way to prevent concrete from drying out in vertical formed concrete is to leave the forms in place.

Moisture Barrier Methods

Mechanical barriers of waterproof paper or plastic sheets (visquene) seal in the water and prevent evaporation. One advantage of this method is that additions of water are not required. These materials are added as soon as the concrete has hardened enough to prevent surface damage. Edges of the sheet should be overlapped to insure a good seal. Cover with boards at edges and where overlapped or taped together.

Curing compounds are a chemical membrane that is sprayed on the concrete as soon as it is finished. The concrete must be moist or the membrane will not form properly. Care must be taken to cover the surface evenly and completely with the chemical. In most cases two applications are required. Never thin the compound. One gallon of curing compound will cover 200 square feet on flat surfaces, and 150 square feet on vertical surfaces. The life of the curing membrane should be only 30 days or less, after which it will be worn, washed, blown away or removed with a stiff brush. Membranes have little curing value after 14 days.

Curing compounds are of four general types: Clear or translucent, white pigmented, light gray pigmented, and black. Curing compounds can be used to prevent bond between hardened and fresh concrete. It should not be used if bonding is necessary. Concrete should be cured for at least three days and preferably for a week after it is placed. The most favorable temperature range for curing concrete is from 55 to 73 degrees F. At higher temperatures, hydration takes place more quickly, but the concrete does not attain its full strength. There is practically no hydration when the temperature is near freezing. At 33°F, it takes more than three times as long to develop a given strength as it does at

70°F. If concrete freezes within the first 24 hours after it is finished it is almost certain to result in permanent damage.

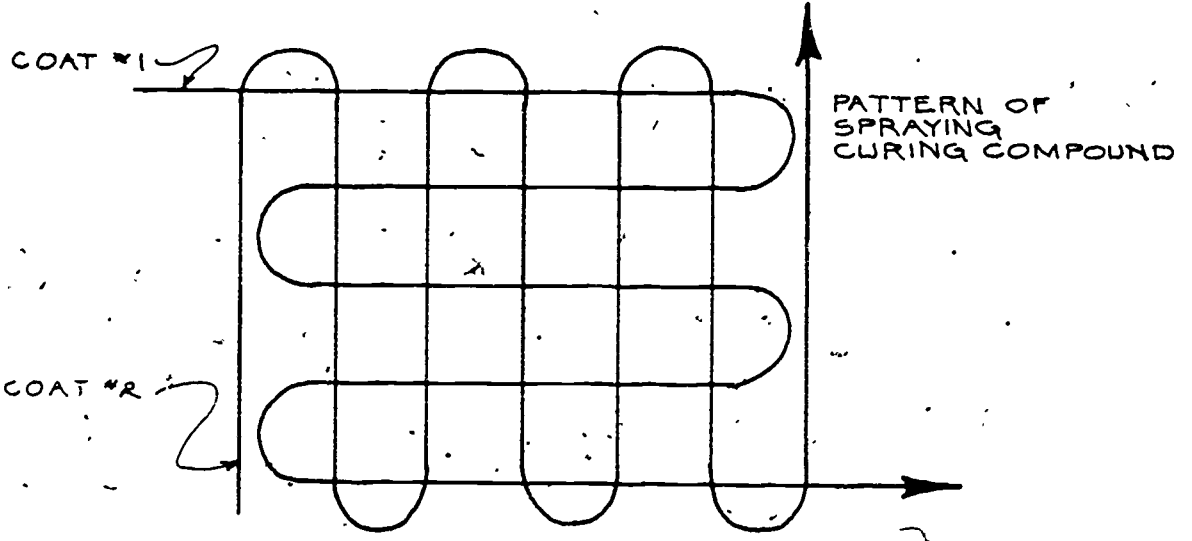

THE GREENHOUSE EFFECT CAN DISCOLOR CONCRETE. BE SURE THE COVERING IS ON THE CONCRETE SURFACE.

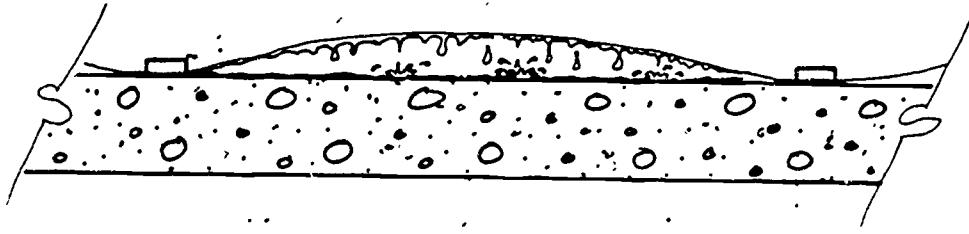

Self Assessment

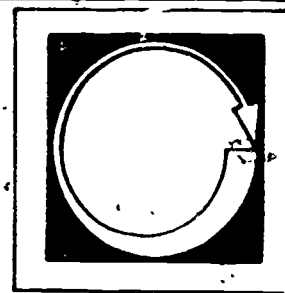

COMPLETE THE FOLLOWING STATEMENTS BY WRITING THE CORRECT WORD OR WORDS IN THE BLANKS PROVIDED.

1. The chemical reaction between portland cement and water causing it to harden is called _____.
2. Concrete should not be allowed to _____ within the first 24 hours after it is finished.
3. Curing compounds should be sprayed on concrete while it is still _____.
4. There are _____ principle methods of curing concrete.
5. Concrete that is moist cured for 7 days is about _____ percent stronger than concrete exposed to dry air.
6. All of the desired properties of concrete are improved by proper _____.
7. Concrete dries first on the _____.

1. hydration

2. freeze

3. moist

4. two

5. 50

6. curing

7. surface

● **Self Assessment
Answers**



Assignment

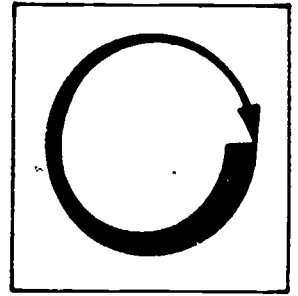

COMPLETE THE FOLLOWING ASSIGNMENT.

Write a report on the different methods of water or moist curing of concrete and explain how each is accomplished.

Post Assessment

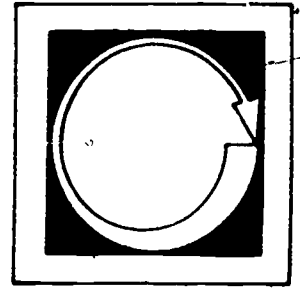

WRITE AN ANSWER TO THE FOLLOWING QUESTIONS.

1. What is curing?
2. Why does concrete need to be cured?
3. What is the most favorable temperature range for curing concrete?
4. If concrete is kept moist for 30 days how would its strength compare to that cured by dry air?
5. Name the two methods used to cure concrete.
6. Which method of curing is the most effective?

7. How many square feet of horizontal surface will one gallon of curing compound cover?

8. When should curing compounds be sprayed on the concrete?

Instructor Post Assessment Answers

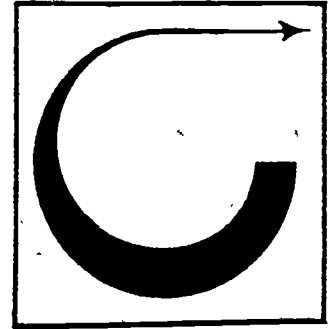

1. Curing is any method used to assure that there is enough water present in concrete to provide continuous hydration of the cement.
2. Concrete needs to be cured to gain strength and durability.
3. The most favorable temperature range for curing concrete is between 55° and 73°F.
4. Concrete that has been kept moist for 30 days has double the strength of concrete dry air cured.
5. The two methods for curing concrete are:
 - a. Water curing--applying water directly or through some material that holds water in contact with the surface.
 - b. Moisture barrier--applying a seal to prevent or slow down the escape of moisture from the concrete, such as curing compounds.
6. The most effective method of curing is water curing by flooding, spraying or ponding.
7. One gallon of curing compound will cover 200 square feet of horizontal surface.
8. Curing compound should be sprayed on concrete immediately after finishing--before it dries.

FORMING AND FINISHING STEPS

Goal:

The student will develop an understanding of procedures for forming and finishing steps.

249

Performance Indicators:

The student will show an understanding of the topic by successfully completing a Self Assessment, two Assignments, a Job Sheet and a Post Assessment.

252

Study Guide

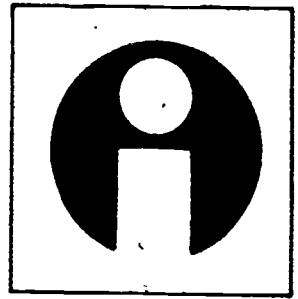

In order to finish this module, do the following tasks. Check each item off as you complete it.

1. Read the Goal and Performance Indicators on the cover of the module. This will tell you what you will learn by studying the module, and how you will show you've learned it.
2. Read the Introduction. The Introduction will tell you why the module is an important part of the cement finishing trade.
3. Study the Vocabulary section. Vocabulary words are important for a good understanding of the trade. After you have studied the vocabulary, ask your teacher to quiz you on the words and their meanings.
4. Study the Information section. This section will give you the information you need to understand the subject.
5. Take the Self Assessment exam. This is a test for you to prove to yourself that you have learned the material you have studied. Compare your answers with the answers on the Self Assessment Answer Sheet, which is on the page following the Self Assessment. If you scored poorly, re-study the Information section or ask your teacher for help.
6. Do the Assignment page. Follow the instructions at the top of the Assignment page.
7. Do the Job Sheet. Follow the instructions at the top of the Job Sheet. The tasks listed on the Job Sheet will help you develop skills which will be helpful to you.
8. Take the Post Assessment exam. Give the exam to your teacher after you have completed it. Your teacher will grade it for you.

Introduction

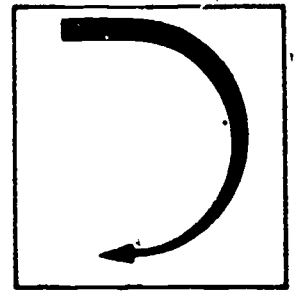

The cement mason needs to know the different methods of forming and finishing steps. Local building codes must be followed to establish the dimensions of the treads, risers and landings. Precision in step construction makes them safer and easier to use.

Vocabulary

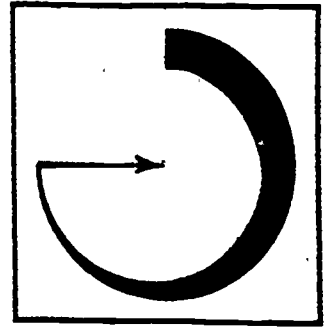

Trade terms are very important for a good understanding of the trade. Study these words and meanings. When you have learned them, ask your teacher to quiz you on the words and their meanings.

LANDING--A platform often placed between flights of steps and in front of door openings.

TREAD--The horizontal surface of a stair. The part of a step that you place your foot on.

RISER--The vertical part of a stair.

SKIRT BOARDS--The sides of a stair form.

NOSING--Riser slope.

INTEGRAL--Necessary.

VARIATION--Change, difference.

Supplementary References

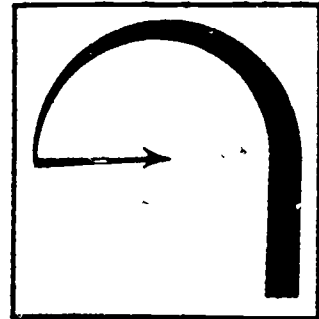

1. Incentive Apprenticeship Training for Cement Masons. National Plasterers
Apprenticeship Fund, 1979. Unit 12.

Information

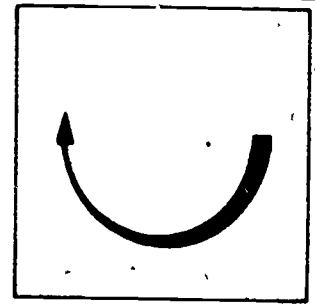

Local building codes set the guidelines for the dimensions of stairs such as the width, height of flights, where landings are needed, height of risers, depth of treads and the relationship between riser and tread size of steps.

Steps for homes are usually 48" wide. Steps should be at least as wide as the door and walk which they serve.

A landing is desirable to divide flights that are more than 5 feet high. It should be no shorter in the direction of travel than 3 feet.

For flights less than 30" high, maximum riser size is usually 7 1/2", and minimum tread width 11".

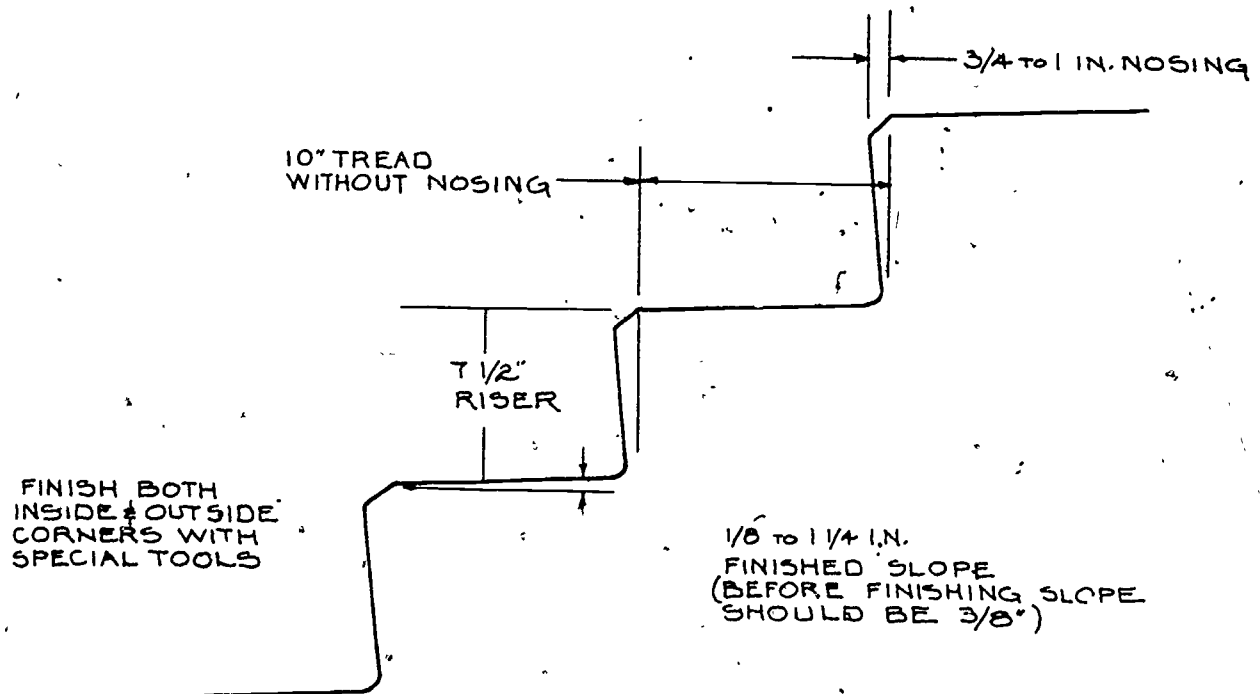

TYPICAL STEP DIMENSIONS
FOR STAIRS 30" OR LESS HIGH

For higher flights, the riser may be limited to 6", with a minimum tread width of 12". When deciding on the choice of riser and tread size you should consider how the steps are to be used. In some cases such as long, sloping approaches, a ramp or stepped ramp can be substituted for stairs.

Many studies have been made to find the best combination of riser and tread size for comfort and safety. a basic rule coming from these studies is that the sum of the height of the riser and depth of the tread should equal 17 1/2". Larger steps may be desirable in areas such as patios, gardens, and terraces. The following combinations of riser-to-tread sizes (in inches) can be used:

- 4 to 19
- 4 1/2 to 18
- 5 to 17
- 5 1/2 to 16
- 6 to 15.

The closer the climbing step comes to the normal walking stride, the safer and easier it is for people of all ages to use. There should be no variation in the height of the risers and the width of the treads within any flight or set of stairs.

Before you can build stair forms, you must first determine the total rise and run of stairs by making on-site measurements of the space available. Combine this information with the intended use of the stairs for your rise and run dimensions.

1. Lay out the skirt boards.
2. Lay out treads and risers on the skirt boards and fasten in place with duplex nails.
3. Brace skirt boards as needed. (See the illustration on the next page.)
4. Check dimensions, level and plumb.
5. The forms should be treated with a form release agent for easy removal.
6. The stair footing must be on firm, undisturbed soil--or have a firm gravel sub-base. This will minimize the chances of cracking and separation from the building foundation wall because of settling.

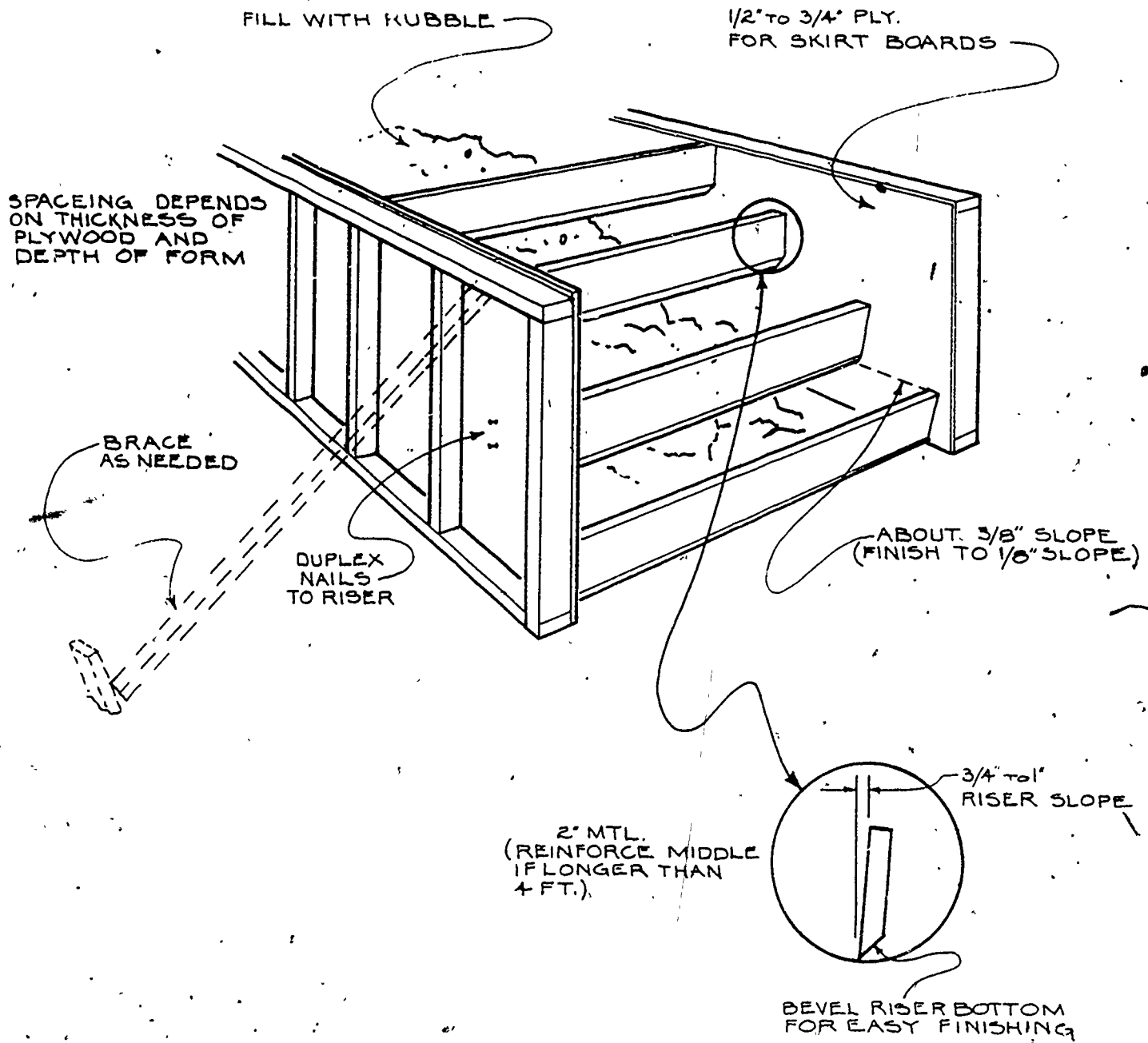

7. The footings should be at least 6" below the prevailing frost line.
8. To prevent new steps that are added to an existing building from sinking, two or more 6-to-8" diameter holes should be dug beneath the bottom tread and filled with concrete.

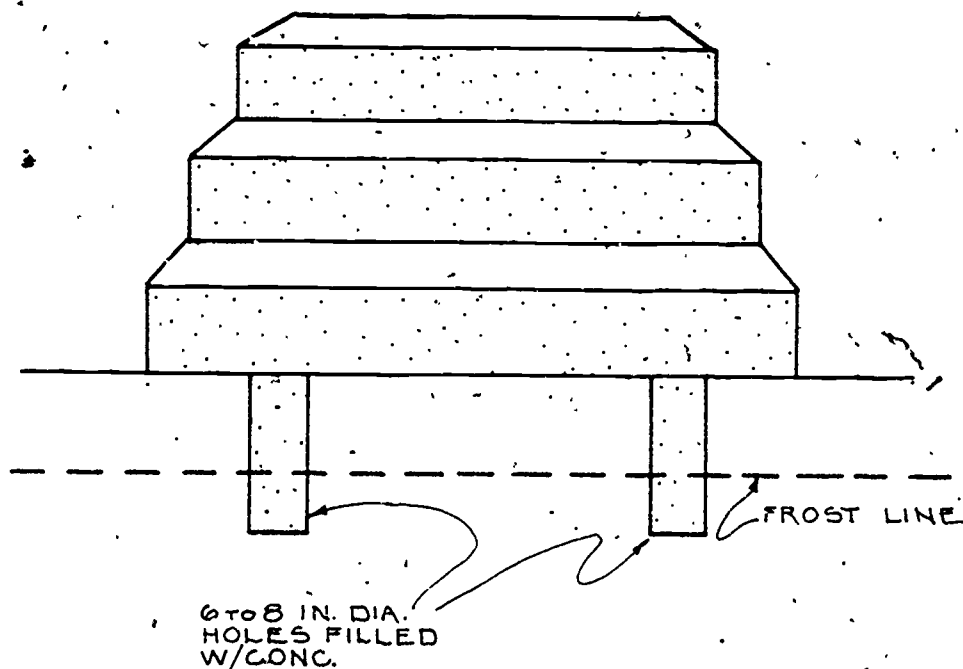

When working a new construction, the stair footing can be cast along with the foundation wall. The footing is cast against the foundation wall, and held in place with reinforcement. (See the illustration on the following page.)

The concrete used for steps is the same as that used for driveways, sidewalks, and patios, except aggregate size should not exceed 1", and the slump height should not exceed 3" (4" in hot weather).

When placing the concrete, begin at the bottom of the forms and work up. Carefully spade or vibrate the concrete, especially next to the forms. Each tread should be struck off level as it is filled and the form tapped lightly to get rid of air bubbles. After the concrete has been placed, strike off and darby the top tread or landing. When the concrete has set up enough to support a

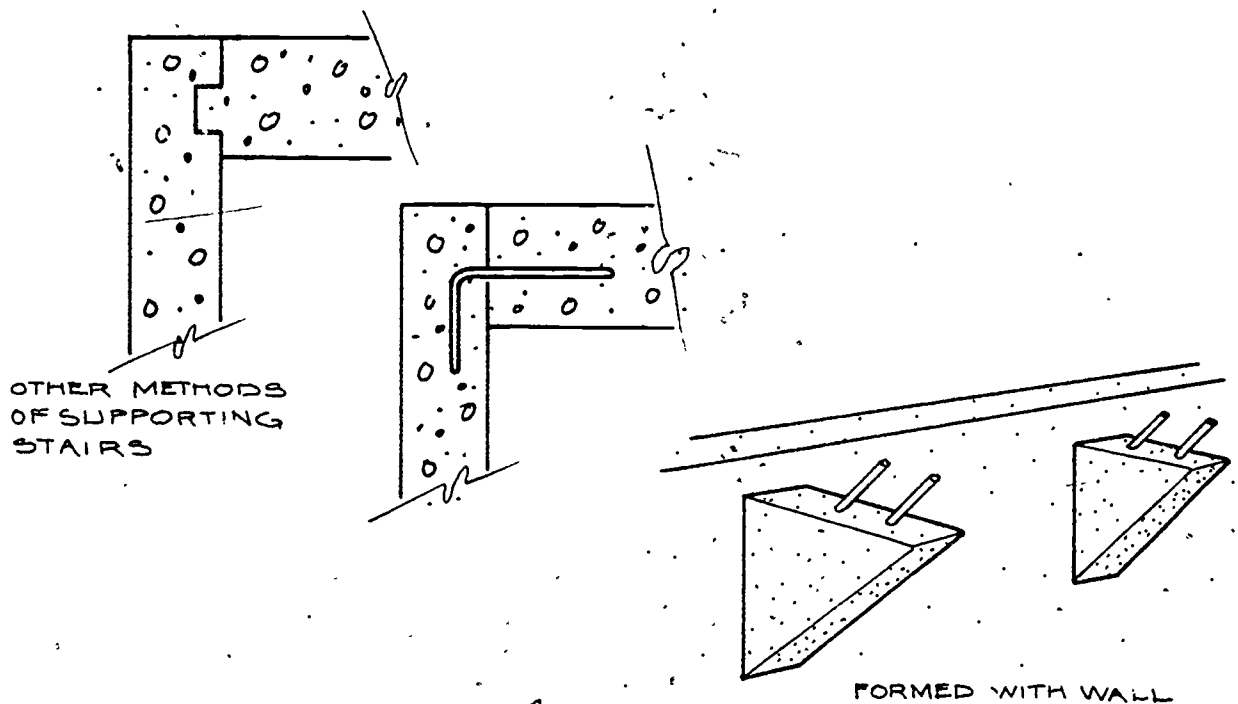

OTHER METHODS
OF SUPPORTING
STAIRS

FORMED WITH WALL

person so that only a 1/4" impression is made by the foot, it should be edged, floated and troweled. Continue down the steps, repeating the process. Use a 1/4 to 1/2 inch radius edger.

When the steps have set to the point where they will hold their form when the riser boards are removed, remove the top riser form. Finish this step and riser before going down to the next. Use matching corner or cove tools to finish the inside and outside corners. The radius should be the same for both tools. If you need to add mortar for the inside corner, use one part portland cement to 1 1/2 parts fine screened sand for the mortar mixture.

After trowelling, a damp brush can be drawn across the tread and riser to produce a non-skid surface. Move down to the next riser and repeat the process.

When all the riser forms are removed and the stairs have been finished, remove the skirt boards. Float the side surfaces, then plaster them with a 1/8 to 1/4" coat of mortar. Spread it with a trowel, then float it with a cork or rubber float. This surface may be troweled or brushed to match the risers.

Another method called the late stripping method is often used in cooler weather. All the forms are left in place for several days while the concrete is curing.

After removing the forms, all projections should be removed by chipping and hand-stoning. Honeycombed areas should be chipped out and patched with a stiff mortar to match the concrete. If treads and risers are not uniform in color, a grout clean down may be used.

Surfaces for grout clean down should be soaked with water, and a grout mixture of 1 part portland cement and 1 1/2 to 2 parts fine sand applied to the surface by brushing or floating. Rub grout into all holes and then scrape off the excess grout. After the surface has dried, rub it with clean, dry burlap to remove all the loose grout.

Self Assessment

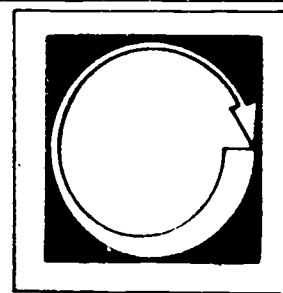

COMPLETE THE FOLLOWING STATEMENTS BY WRITING THE CORRECT WORD OR WORDS IN THE BLANKS PROVIDED.

1. Footings for steps should be at least _____ below the frost line.
2. A _____ is desirable to divide flights of more than 5 feet.
3. Minimum tread width is _____.
4. Maximum riser size is usually _____.
5. There should be no _____ in the height of the risers and the width of the treads in any one set of stairs.
6. The horizontal part of a stair is called a _____.
7. _____ are the sides of a stair form.

Self Assessment Answers

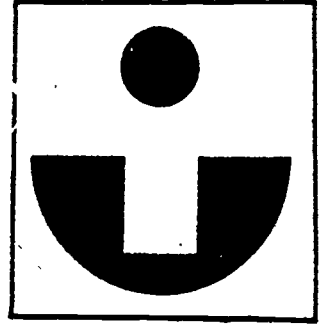

1. 6 inches
2. landing
3. 11 inches
4. 7 1/4 inches
5. variation
6. tread
7. skirt boards

Assignment

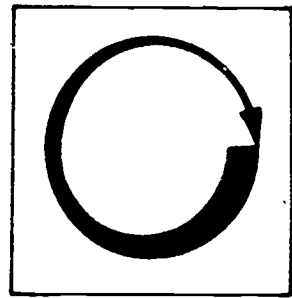

COMPLETE THE FOLLOWING ASSIGNMENTS.

1. Write a report describing the "early stripping" method and "late stripping" method of finishing steps.
2. Describe the method used to add steps to an existing building.

Job Sheet

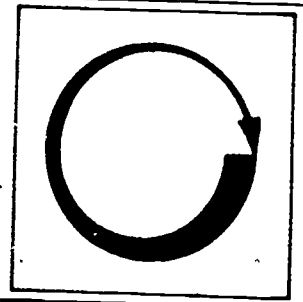

Materials and Tools

residence blueprint

paper, pencil

lumber, tools and hardware as described in this module

- 1) From a blueprint of a house with steps, sketch an isometric drawing of the steps. When you have completed it and shown it to your teacher for approval, build the forms for the steps.

Post Assessment

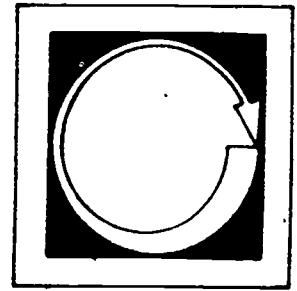

WRITE AN ANSWER TO THE FOLLOWING QUESTIONS.

1. Guide lines for the dimensions of stairs such as the width, height and size of the steps and landings can be found in what publication?
2. In what condition should the subgrade for stair footings be?
3. When placing concrete for steps what procedure is followed?
4. Why are steps and risers finished with a damp brush?
5. What is the recommended slump of concrete for steps?
6. The best combination of riser and tread size for comfort and safety when added together will equal what number of inches?

7. Where do you begin floating and finishing stairs?

8. What are the two methods of form stripping?

Instructor Post Assessment Answers

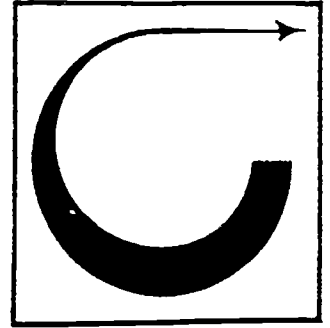

1. Dimensions for steps and landings are part of the local building codes.
2. The subgrade for footings must be on firm undisturbed soil, or on a firm gravel sub-base.
3. When placing concrete for steps, begin at the bottom and work the concrete up.
4. Steps and risers are finished with a damp brush to produce a non-skid surface for safety.
5. The slump of concrete for steps should be 3" (4" in hot weather).
6. 17 1/2"
7. Floating and finishing should begin at the top and work down.
8. The two methods of form stripping are early stripping and late stripping.

COLD WEATHER PLACING, FINISHING AND CURING

Goal:

The student will be able to explain the methods of protecting concrete while placing, finishing and curing during cold weather.

Performance Indicators:

The student will show an understanding of the topic by successfully completing a Self Assessment, two Assignments and a Post Assessment.

267

270

Study Guide

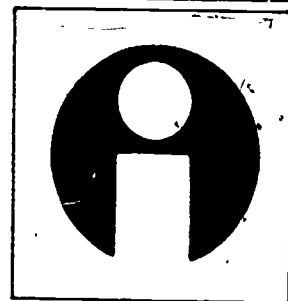

In order to finish this module, do the following tasks. Check each item off as you complete it.

1. Read the Goal and Performance Indicators on the cover of the module. This will tell you what you will learn by studying the module, and how you will show you've learned it.
2. Read the Introduction. The Introduction will tell you why the module is an important part of the cement finishing trade.
3. Study the Vocabulary section. Vocabulary words are important for a good understanding of the trade. After you have studied the vocabulary, ask your teacher to quiz you on the words and their meanings.
4. Study the Information section. This section will give you the information you need to understand the subject.
5. Take the Self Assessment exam. This is a test for you to prove to yourself that you have learned the material you have studied. Compare your answers with the answers on the Self Assessment Answer Sheet, which is on the page following the Self Assessment. If you scored poorly, re-study the Information section or ask your teacher for help.
6. Do the Assignment page. Follow the instructions at the top of the Assignment page.
7. Take the Post Assessment exam. Give the exam to your teacher after you have completed it. Your teacher will grade it for you.

Introduction

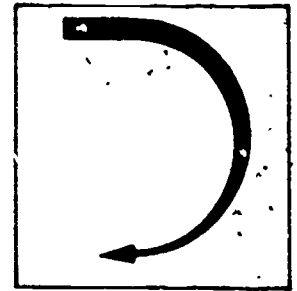

Concrete work of all kinds has been done in extremely cold weather. However, the user must learn the proper methods and precautions to take while placing, finishing and curing the concrete to avoid freezing damage.

Vocabulary

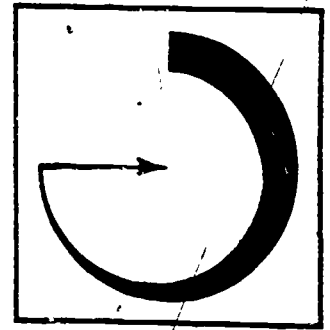

Trade terms are very important for a good understanding of the trade. Study these words and meanings. When you have learned them, ask your teacher to quiz you on the words and their meanings.

ACCELERATORS--A chemical admixture used to shorten the setting time and increase early strength in concrete.

CALCIUM CHLORIDE--A popular admixture used as an accelerator.

FLASH SET--Concrete hardening before it can be consolidated, screeded, or finished.

SALAMANDER--Oil burning space heater that needs no other power to run.

Supplementary References

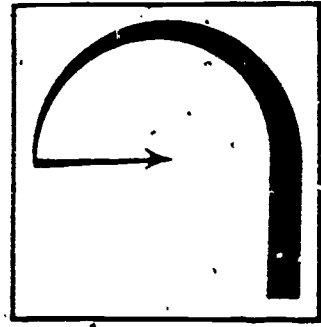

1. Concrete Technology Instructor's Guide. Portland Cement Association, 1965. pp. 235-246.
2. Concrete Construction Handbook. McGraw-Hill Book Co., 1968. Unit 5, p. 9; Unit 30, pp. 7-13.

Information

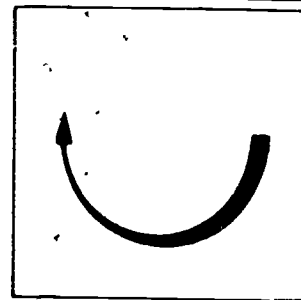

When placing concrete in winter months or during cold weather certain precautions should be taken. When temperatures of 40°F. or lower occur during placing and during the early curing period adequate protection must be provided.

The cement mason should plan in advance to protect fresh concrete from freezing and to maintain minimum curing temperatures. Proper equipment should be on hand ready to use for heating the concrete materials, enclosing the area, and for maintaining favorable temperatures for curing.

Temperature affects the rate at which hydration of cement occurs and, therefore the rate of hardening. Low temperatures slow down concrete hardening and strength gain. Near 32°F. the rate is very slow and at temperatures below freezing there is almost no increase in strength. At higher temperatures but below 73°F., strengths are lower at early ages but higher at later periods. Concrete made and cured at 55°F. has little strength for the first few days, but after 28 days it has slightly higher strengths than the concrete cured at 73°F. Concrete made at 40°F. and cured for 28 days at 25°F. has very little strength at early ages, but if favorable curing is provided the concrete develops strength comparable to that of concrete cured at 73°F.

When moisture required for curing is no longer available, the strength gain practically stops. Concrete placed at low temperatures (above freezing) may develop higher strengths than concrete placed at higher temperatures, but curing must continue for a longer period.

High strength at an early age is frequently desired during winter construction to reduce the length of time protection is needed. High early strength may be obtained by using one or a combination of the following.

1. High-early-strength cement.
2. Additional portland cement.

3. Higher curing temperatures.

The advantages of using high-early-strength cement during cold weather are: Early reuse of forms, savings in cost of additional heating and protection, and earlier use of the finished concrete.

There is no known concrete admixture that will prevent freezing of concrete or freezing damage of concrete freshly placed and exposed to 30°F. weather with temperature falling. The admixture coming closest is the accelerator. It has merit only because it increases the hydration rate of 40°F. to that of 60°F. concrete. Concrete with an accelerator in it, can resist the effects of 30°F or lower temperatures in one day instead of three, or in three days instead of seven.

The most widely used accelerator is calcium chloride. The recommended amount to use is 1 percent to 2 percent by weight of the cement. Amounts greater than 2 percent can cause problems such as flash setting, increased drying shrinkage, and corrosion of reinforcement.

Calcium chloride should be added in solution as part of the mixing water.

Calcium chloride or admixtures containing soluble chlorides should never be used under the following conditions:

1. In prestressed concrete construction. Corrosion of steel strands may result.
2. Concrete containing embedded aluminum, such as conduit. Corrosion may result.
3. Lightweight insulating concrete placed over metal decks.
4. Concrete in contact with soils or water containing sulfites.

The temperature of freshly mixed concrete in cold weather should never exceed 70°F. The temperature of the concrete should be in the 40°F. to 60°F. range. This will prevent flash setting of the concrete.

Do not place concrete on frozen ground as unequal settling will occur when the ground thaws, and this can cause the concrete to crack. Remove all frost and ice from forms and reinforcing before placing the concrete.

Insulation without artificial heat, such as a blanket of straw, is often enough protection for slabs on the ground. At lower temperatures, housing and artificial heat is needed. Circulate moist warm air between concrete slabs and housing. Enclosures may be heated by live steam, steam in pipes, oil-fired burners, salamanders and other heaters. Salamanders are easily handled and economical to operate. They are convenient for small jobs but have some disadvantages. They produce dry heat and should be elevated and the concrete near them should be protected with damp sand, as moisture for curing is still very important.

Fuel-burning heaters produce carbon dioxide, which combines with calcium hydroxide in fresh concrete to form a weak layer of calcium carbonate. When this occurs, the surface of the concrete floor will dust under traffic. Fuel-burning heaters should not be used for the first 24 to 36 hours unless the enclosure is properly vented.

Do not remove forms until the concrete has attained strength to sustain its own weight in addition to any load placed on it during construction. Removing forms too soon can cause corners and edges to chip.

Self Assessment

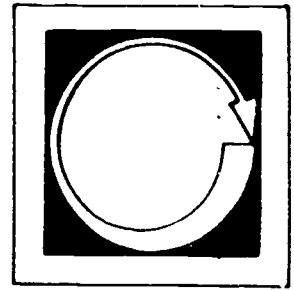

COMPLETE THE FOLLOWING STATEMENTS BY WRITING THE CORRECT WORD OR WORDS IN THE BLANKS PROVIDED.

1. The strength gain of concrete practically stops when _____ required for curing is no longer available.
2. There is no known admixture that will prevent concrete from _____.
3. The most widely used _____ is calcium chloride.
4. Fuel burning heaters should not be used during the first 24 to 36 hours after placing the concrete unless properly _____.
5. _____, such as a blanket of straw, without artificial heat is often enough protection for slabs on the ground.
6. The temperature of freshly-mixed concrete in cold weather should never exceed _____ degrees F.
7. Calcium chloride should not be used in _____ concrete.

Self Assessment Answers

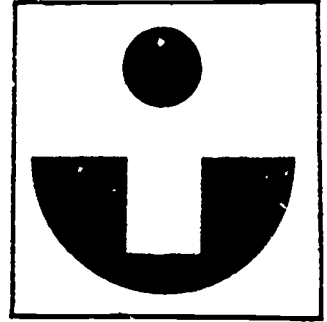

1. moisture
2. freezing
3. accelerator
4. vented
5. insulation
6. 70
7. prestressed

Assignment

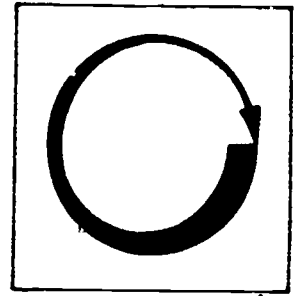

COMPLETE THE FOLLOWING ASSIGNMENTS.

1. Write a report naming several things to do before and after placing concrete in cold weather.
2. Explain the methods for obtaining high-early-strength concrete.

Post Assessment

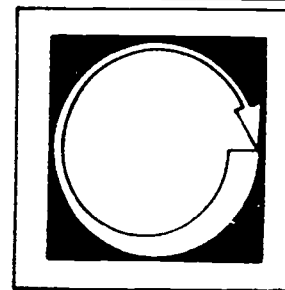

WRITE AN ANSWER TO THE FOLLOWING QUESTIONS.

1. What is the effect of temperature on concrete?
2. What are three methods for obtaining high-early-strength concrete?
3. What problems can be caused by using accelerators improperly?
4. When using calcium chloride in concrete what percent is recommended?
5. What are the advantages of high-early-strength concrete?
6. How long should forms remain in place?

7. At what temperature should you take steps to protect concrete during cold weather?

8. What precautions should be taken when using salamanders?

● Instructor Post Assessment Answers

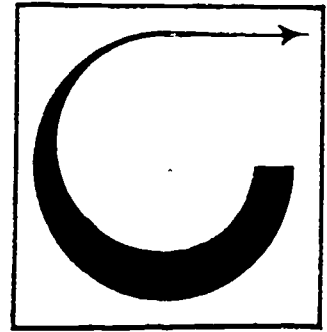

1. Temperature affects the rate at which hydration of the cement occurs and, therefore, the rate of hardening.
2. The three methods for obtaining high-early-strength concrete are:
 - a. Using high-early-strength cement.
 - b. Using additional portland cement.
 - c. Higher curing temperatures.
3. Problems caused by using accelerators improperly are: Flash setting of the concrete, increased drying shrinkage, and corrosion of reinforcement.
4. The recommended amount of calcium chloride to use is 1 percent to 2 percent by weight of the cement.
5. The advantages of high-early-strength concrete are: Early reuse of forms, savings in cost of additional heating and protection, and earlier use of the finished concrete.
6. Forms should remain in place until the concrete has enough strength to sustain its own weight in addition to any load placed on it during construction.
7. Provisions should be made to protect concrete when the temperature is 40°F. and falling.
8. Salamanders should be elevated and the concrete near them should be protected with damp sand.

HOT WEATHER PLACING, FINISHING AND CURING

Goal:

The student will be able to explain the recommended practices when placing, finishing and curing concrete in hot weather.

Performance Indicators:

The student will show an understanding of the topic by successfully completing a Self Assessment, two Assignments and a Post Assessment.

Study Guide

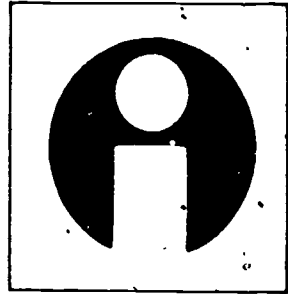

In order to finish this module, do the following tasks. Check each item off as you complete it.

1. Read the Goal and Performance Indicators on the cover of the module. This will tell you what you will learn by studying the module, and how you will show you've learned it.
2. Read the Introduction. The Introduction will tell you why the module is an important part of the cement finishing trade.
3. Study the Vocabulary section. Vocabulary words are important for a good understanding of the trade. After you have studied the vocabulary, ask your teacher to quiz you on the words and their meanings.
4. Study the Information section. This section will give you the information you need to understand the subject.
5. Take the Self Assessment exam. This is a test for you to prove to yourself that you have learned the material you have studied. Compare your answers with the answers on the Self Assessment Answer Sheet, which is on the page following the Self Assessment. If you scored poorly, re-study the Information section or ask your teacher for help.
6. Do the Assignment page. Follow the instructions at the top of the Assignment page.
7. Take the Post Assessment exam. Give the exam to your teacher after you have completed it. Your teacher will grade it for you.

Introduction

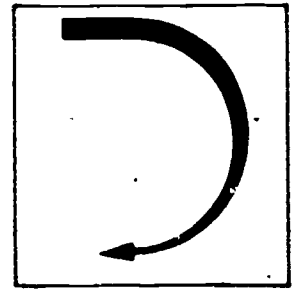

Concrete construction proceeds all year, therefore it is important for the cement mason to know the precautions to take when working concrete in hot weather.

Vocabulary

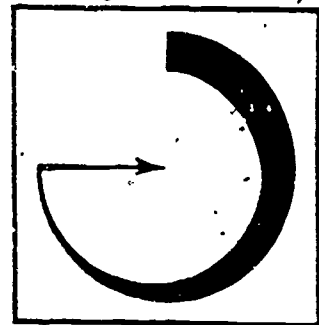

Trade terms are very important for a good understanding of the trade. Study these words and meanings. When you have learned them, ask your teacher to quiz you on the words and their meanings.

RELATIVE HUMIDITY--The percent of moisture in the air.

EVAPORATION--Loss of water or moisture from the concrete.

WIND VELOCITY--The speed of the wind in miles per hour.

HYDRATION--A chemical reaction between portland cement and water causing it to harden.

RETARDER--Admixture used to delay setting time of concrete. (Slows down evaporation.)

Supplementary References

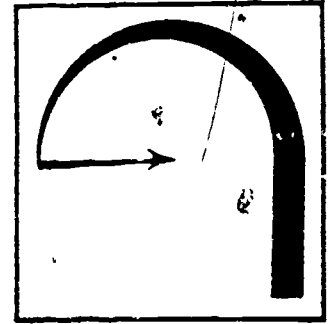

1. Concrete Construction Handbook. McGraw-Hill Book Co., 1968. pp. 5-9, Unit 30-4, 30-6, 30-7.
2. Concrete Technology Instructor's Guide. Portland Cement Association, 1965. pp. 221-233.

Information

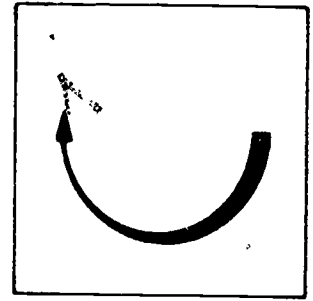

Construction goes on all year, so during hot weather concrete must be handled and placed. Steps must be taken during hot windy days to prevent rapid evaporation of water from the concrete. Concrete should be protected during and after placing and finishing operations so that hydration can proceed normally. Otherwise, high temperatures will result in lowered strength of concrete. This is because rapid loss of moisture from the concrete at the surface can cause cracks to form within the first day, and often within the first few hours. Rapid setting can cause the concrete to stiffen before it is consolidated, making it difficult to finish flat surfaces.

The rate of evaporation of water from concrete is influenced by the concrete and air temperatures, relative humidity, and wind velocity.

When the relative humidity changes from 90 to 50 per cent, the rate of evaporation is increased five times. If the humidity is reduced to 10 per cent, evaporation is increased nine times.

When both concrete and air temperature increase from 50 to 70 degrees F., evaporation is doubled. If increased to 90°F., evaporation is increased four times.

When the wind velocity increases from 0 to 10 MPH the rate of evaporation is four times greater, and is nine times greater when wind velocity increases to 25 MPH.

The rate of evaporation is highest when the relative humidity is low, when concrete and air temperatures are high, when the concrete temperature is higher than the air temperature, and when the wind is blowing over the concrete surface. This combination during summer months removes moisture from the surface faster than it can be replaced by normal bleeding.

Before placing and finishing concrete in hot weather there are several positive steps to take:

1. Cooling of aggregates and cement. Wet aggregates with cold water a few hours before batching so evaporation of moisture will cause their temperature to be reduced. Cement can be cooled only by storing in the shade.
2. Use cool mixing water. Sometimes flaked ice can be used in place of water (by weight). The concrete should be mixed until all ice has melted before being placed.
3. Spray the mixing drum with cold water. Also, if mixing drum is painted white it will absorb less heat.
4. Shorten the mixing time. Dry batch until on the job site before adding water. Avoid overmixing.
5. Use of admixtures. Use approved water reducer retarders. Concrete placing and finishing does not have to be hurried unnecessarily.
6. Thoroughly moisten sub-grade, reinforcing steel, and wood forms just before placing concrete. This will keep them from absorbing water from the concrete. However, before placing concrete there should be no puddles or standing water on the sub-grade.

Mixing temperatures should be kept between 55 and 80°F. and the concrete should be protected in its early life.

After placing concrete, strike it off and darby or bullfloat it at once. Floating and final finish should be done as soon as possible.

Curing should start the moment the final finishing is completed. It should not dry out at all until it has attained the desired strength. Formed concrete such as walls and columns can be cured almost immediately after concrete has set by supplying water at the top of the forms. When forms are removed, wetted burlap or polyethylene sheeting (viscane) will provide continued curing if the concrete is covered completely.

The use of a curing compound is recommended if it is applied immediately after the last finishing operation is complete and not before the finish will be marred by the work involved in the application.

Keep the concrete surface constantly wet. Avoid alternate wetting and drying during the curing period. Continue curing for at least 3 days and preferably

for a week. Water not only cures but also cools the slab. (See the "Concrete Curing" module for further details on these curing methods.)

In hot weather any delays in finishing air-entrained concrete usually leads to formation of a rubber-like surface which is difficult to finish without leaving ripples or ridges.

Spring and fall are considered the ideal seasons for concrete construction because temperature extremes are not found.

Self Assessment

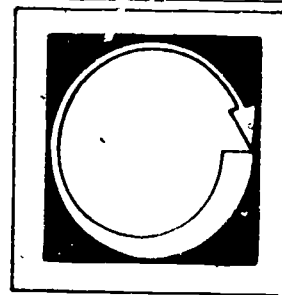

LISTED BELOW ARE SEVERAL STATEMENTS. IF THE STATEMENT IS TRUE, PLACE A "T" IN THE BLANK PROVIDED. IF THE STATEMENT IS FALSE, PLACE AN "F" IN THE BLANK.

1. ___ Summer is considered an ideal season for concrete work.
2. ___ Loss of moisture or water from concrete is called hydration.
3. ___ Retarders are admixtures used in concrete to delay setting time.
4. ___ High temperatures can result in lowered strength of concrete.
5. ___ The rate of evaporation is lowest when the relative humidity is low.
6. ___ Curing of concrete is not necessary during hot weather.
7. ___ In hot weather, concrete should be cured for 3 days and preferably for 7 days.

Self Assessment Answers

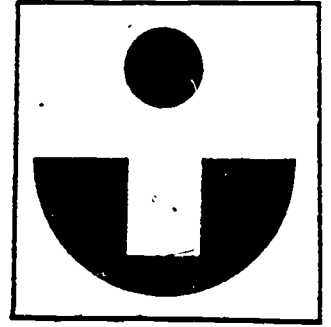

1. F
2. F
3. T
4. T
5. F
6. F
7. T

Assignment

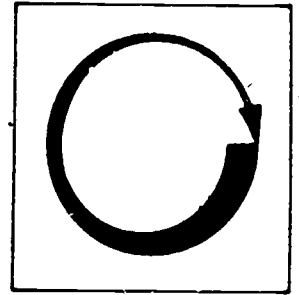

COMPLETE THE FOLLOWING ASSIGNMENTS.

1. Write a report on the curing of concrete during hot weather.
2. Discuss with the class positive steps to take before placing and finishing concrete in hot weather.

Post Assessment

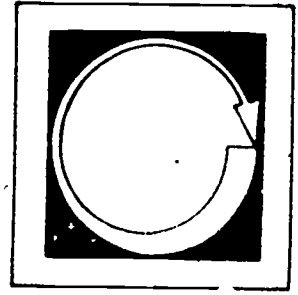

WRITE AN ANSWER TO THE FOLLOWING QUESTIONS.

1. What should the mixing temperatures of concrete be kept at during hot weather?
2. When should curing of concrete start?
3. What can be done to prevent water being absorbed from the mix after the concrete is placed?
4. Name three positive steps that can be taken before or during the mixing of concrete in hot weather.
5. When is the rate of evaporation highest?
6. What problems are caused by rapid drying of concrete?

2.
7. What seasons are considered ideal for concrete construction and why?

8. How long should concrete be cured during hot weather?

Instructor Post Assessment Answers

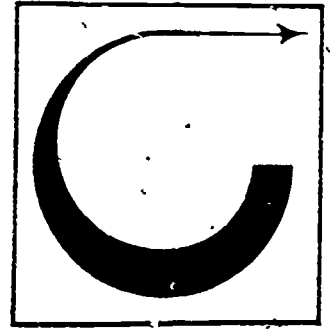

1. The mixing temperatures of concrete should be kept between 55 and 80°F.
2. Curing should start the moment the final finishing is completed.
3. To prevent water from being absorbed from the mix, thoroughly moisten subgrade, reinforcing steel, and wood forms.
4. Three positive steps that can be taken before placing and finishing concrete in hot weather are:
 - a. Cooling of aggregates and cement.
 - b. Use cool mixing water.
 - c. Use of approved water reducer retarders.
5. The rate of evaporation is highest when the relative humidity is low, concrete and air temperatures are high, when the concrete temperature is higher than air temperature, and when the wind is blowing over the concrete surface.
6. Problems caused by rapid drying are strength reduction, cracking, and ~~the~~ concrete stiffens before it can be consolidated, making it difficult to finish.
7. Spring and fall are considered the ideal seasons for concrete construction because temperature extremes are not encountered.
8. Concrete should be cured for at least 3 days and preferably for a week in hot weather.

FORMING AND FINISHING CURBS

Goal:

Upon completion of this module, the student will be able to explain and demonstrate the steps necessary to form and finish curbs and gutters.

295

Performance Indicators:

The student will show an understanding of the topic by successfully completing an Assignment, a Job Sheet and a Post Assessment.

298

Study Guide

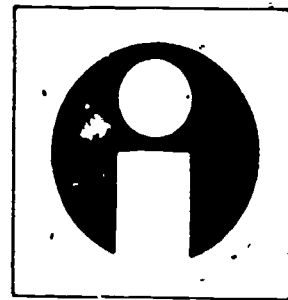

In order to finish this module, do the following tasks. Check each item off as you complete it.

1. Read the Goal and Performance Indicators on the cover of the module. This will tell you what you will learn by studying the module, and how you will show you've learned it.
2. Read the Introduction. The Introduction will tell you why the module is an important part of the cement finishing trade.
3. Study the Vocabulary section. Vocabulary words are important for a good understanding of the trade. After you have studied the vocabulary, ask your teacher to quiz you on the words and their meanings.
4. Study the Information section. This section will give you the information you need to understand the subject.
5. Do the Assignment page. Follow the instructions at the top of the Assignment page.
6. Do the Job Sheet. Follow the instructions at the top of the Job Sheet. The tasks listed on the Job Sheet will help you develop skills which will be helpful to you.
7. Take the Post Assessment exam. Give the exam to your teacher after you have completed it. Your teacher will grade it for you.

Introduction

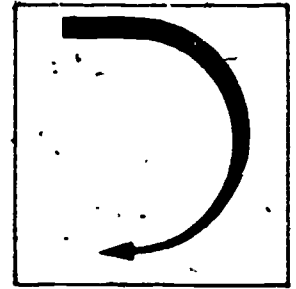

Construction of curbs and gutters is part of highway, street and residential construction. Small jobs are usually done by hand. It is necessary for the cement mason to have an understanding of how to properly form, place and finish concrete curbs and gutters.

Vocabulary

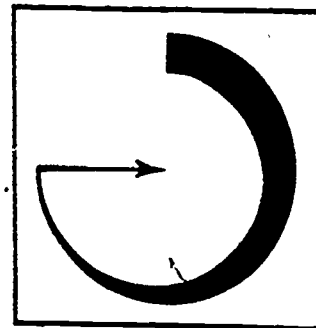

Trade terms are very important for a good understanding of the trade. Study these words and meanings. When you have learned them, ask your teacher to quiz you on the words and their meanings.

CURB--The outer edge of a street, formed of concrete. Usually 6" higher than the gutter.

GUTTER--A concrete slab next to the curb, approximately 14" wide, sloping toward the curb for drainage.

1. Concrete Construction Handbook. McGraw-Hill Book Co., 1968. pp. 26-27.
2. Incentive Apprenticeship Training for Cement Masons. Miller, 1979.
Unit 12.

●

Supplementary References

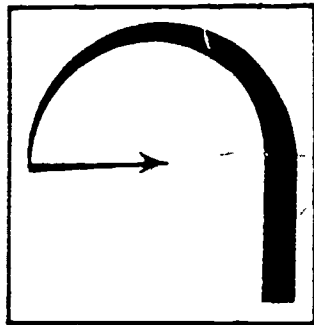

Information

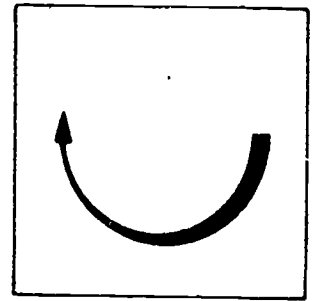

Small jobs of curb and gutter forming are done by hand, where slipforms or other manufactured curb forms are not available. The forms are placed after excavation, fine grading and compaction are completed.

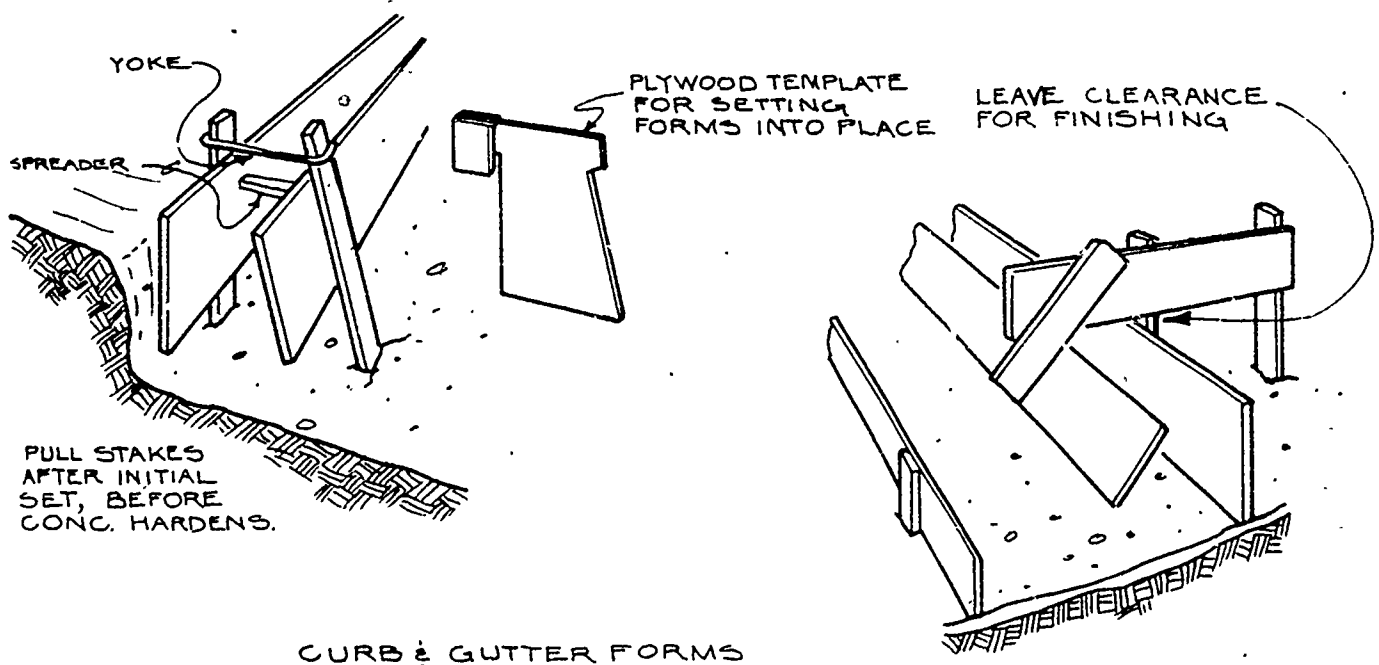

Concrete is placed in the forms, compacted, screeded and hand-finished by conventional methods.

The curb is usually 6" high and the gutter about 14" wide, with a slight slope toward the curb to allow for proper drainage. Joints in curbs and gutters should be spaced no more than 15 feet apart, or as specified by the plans. (Joints in curbs and gutters should match up with joints in the street.)

Concrete should have a slump of no more than 4".

On larger jobs, slipforms or paving equipment, which will do the work, is available. There is equipment available that can place concrete in curbs, curbs and gutters, sidewalks, roll curbs and gutters.

Illustrations 2 and 3 show examples of integral and separated curb and gutter.

Concrete should be properly cured after finishing.

Air-entrained concrete should be used in climates and locations where durability is a must.

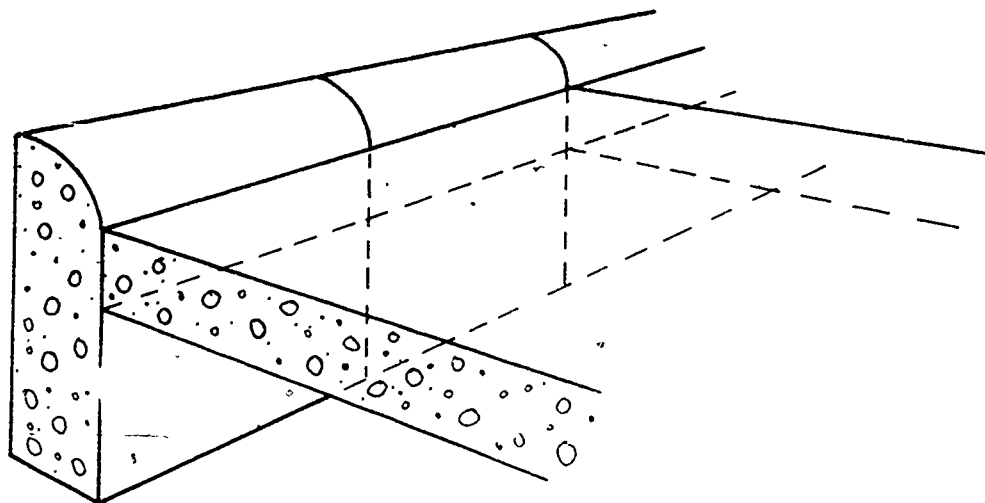

SEPARATE CURB AND GUTTER

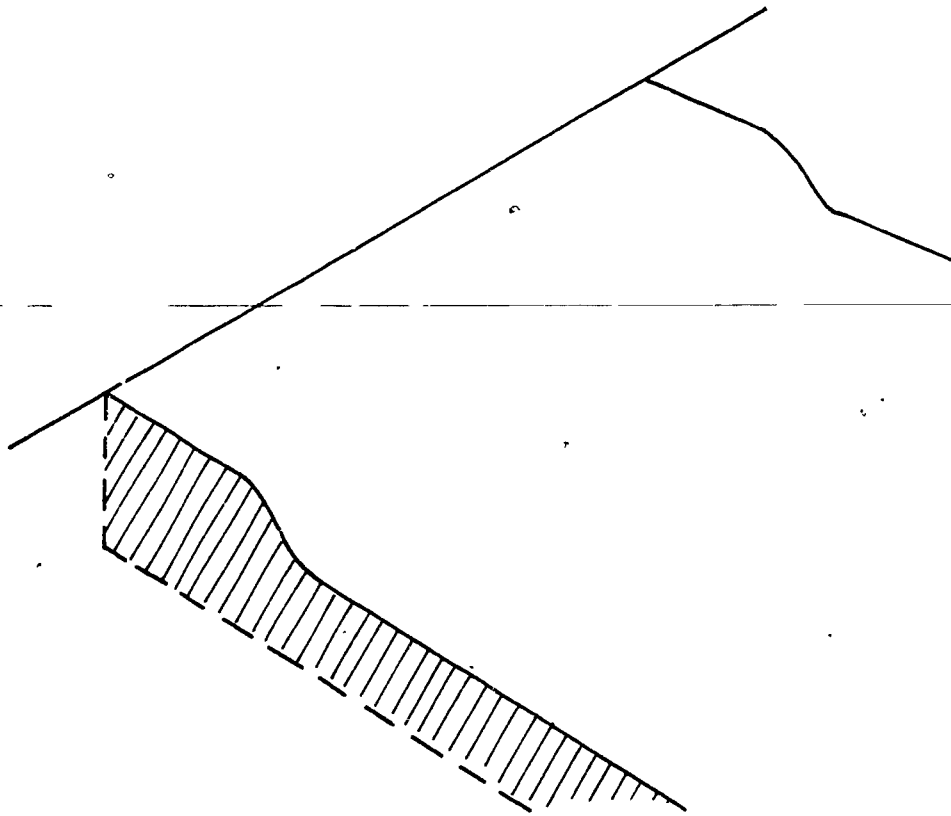

INTEGRAL CURB AND GUTTER

302
305

302

305

Assignment

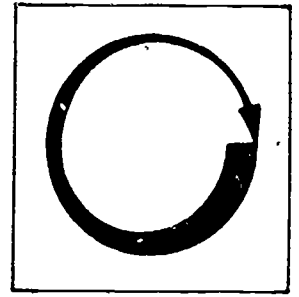

COMPLETE THE FOLLOWING ASSIGNMENT.

Discuss with your class the steps necessary to form, finish, and cure curbs and gutters.

Job Sheet

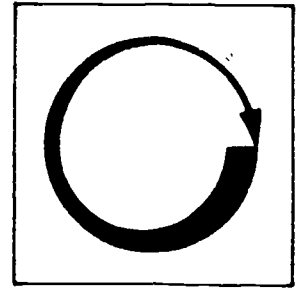

COMPLETE THE FOLLOWING TASK.

Materials and Tools

Wood:

- 2 - 4 foot long 1" X 6"
 - 1 - 4 foot long 1" X 8"
 - 1 - 6 foot long 1" X 4"
 - 1 - 10 foot long 1" X 2"
- braces for stairs

Hardware:

- duplex nails as needed
- hammer
- handsaw
- sledge hammer (maul)

Build a 4 foot long curb and gutter form. See Figure 1.

Post Assessment

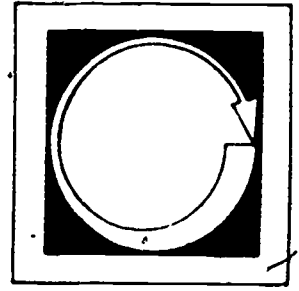

ANSWER THE FOLLOWING QUESTIONS.

1. When are curb forms placed?
2. What is the maximum spacing for joints in a curb and gutter?
3. What is the highest slump concrete should have when placing in curb forms?
4. What is the purpose of gutters on streets?
5. Where durability is a must, what precaution should be taken?
6. How do joints in the street match up with joints in the curb and gutter?

Instructor Post Assessment Answers

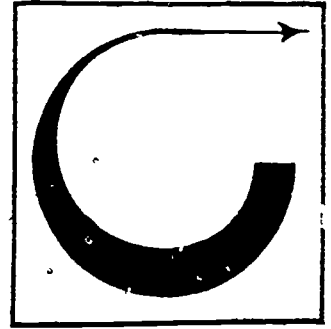

1. Curb forms are placed after excavation, fine grading and compaction are completed.
2. 15 feet.
3. No higher than 4' for curbs.
4. For drainage.
5. Air-entrained concrete should be used.
6. The joints in the street should match up exactly with those in the curb and gutter.

PATCHING

Goal:

The student will develop an understanding of the methods used for patching and repairing concrete.

Performance Indicators:

The student will demonstrate knowledge of the topic by successfully completing a Self Assessment, an Assignment and a Post Assessment.

307

310

Study Guide

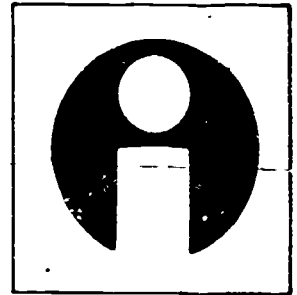

In order to finish this module, do the following tasks. Check each item off as you complete it.

1. Read the Goal and Performance Indicators on the cover of the module. This will tell you what you will learn by studying the module, and how you will show you've learned it.
2. Read the Introduction. The Introduction will tell you why the module is an important part of the cement finishing trade.
3. Study the Vocabulary section. Vocabulary words are important for a good understanding of the trade. After you have studied the vocabulary, ask your teacher to quiz you on the words and their meanings.
4. Study the Information section. This section will give you the information you need to understand the subject.
5. Take the Self Assessment exam. This is a test for you to prove to yourself that you have learned the material you have studied. Compare your answers with the answers on the Self Assessment Answer Sheet, which is on the page following the Self Assessment. If you scored poorly, re-study the information section or ask your teacher for help.
6. Do the Assignment page. Follow the instructions at the top of the Assignment page.
7. Take the Post Assessment exam. Give the exam to your teacher after you have completed it. Your teacher will grade it for you.

Introduction

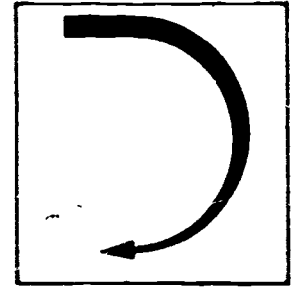

Concrete is one of the most durable building materials, but it can be damaged. Sometimes more weight is placed on it than it was built for. Excessive freezing and thawing can also cause damage. It is therefore necessary to know the proper methods to make permanent repairs.

Vocabulary

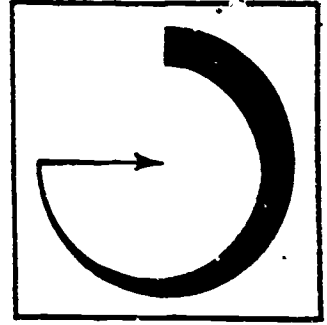

Trade terms are very important for a good understanding of the trade. Study these words and meanings. When you have learned them, ask your teacher to quiz you on the words and their meanings.

GROUT--A mixture of portland cement, fine sand, and water mixed to a creamy texture.

"NEAT" CEMENT GROUT--A mixture of portland cement and water.

EPOXY-RESIN COMPOUNDS--A patching compound of high bonding properties and great strength.

BONDED--Fastened to, stuck together.

LATEX EMULSIONS--A rubber emulsion mixed with portland cement and water used for patching.

Supplementary References

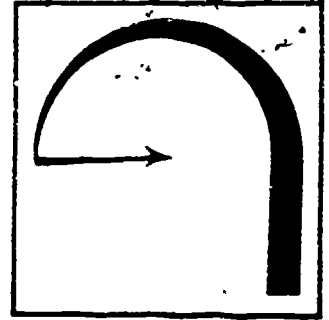

1. Incentive Apprenticeship Training For Cement Masons. National Association of Homebuilders and National Plasterers Apprenticeship Fund, 1979. Unit 14.
2. Concrete Construction Handbook. McGraw-Hill Book Co., 1968.. pp. 48-5, 48-15, 48-16.

Information

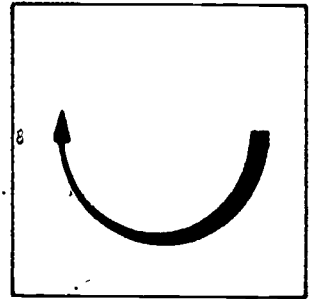

REPAIRING HOLES IN CONCRETE

To make a good patch in concrete the damaged area must be prepared properly so that the patch will stick to the older concrete. The edges of the damaged area should be sawed on a 90 degree angle at least 1/2" deep as shown in Figure 1.

SIDE VIEW OF HOLE
TO BE PATCHED



CUT AROUND EDGE
SO THAT SIDES
ARE VERTICAL



AT LEAST
1/2" DEEP

The chipped area should be left rough and then cleaned by blasting air or by vacuuming. After it is thoroughly cleaned of dust, debris, oil or other foreign matter, fill the hole with water and let it stand. Mix a grout of 1 part portland cement, 1 to 2 parts fine sand (not mortar sand), and enough water to make a creamy mix. The water should soak in the hole at least an hour.

312

315

Remove the water from the hole. The concrete should be left damp, but with no standing water. Brush the grout over the entire area to be patched. Mix a batch of concrete the same as the original concrete, except:

1. The slump should be almost zero--really dry.
2. The maximum size of aggregate should be 1/2 the depth of the hole to be repaired.
3. Let the patch mix set for 15 to 30 minutes to minimize shrinkage before placing in the hole.

Place the mix in the hole, compact it, overflowing slightly. Finish the patch with a float and trowel. Cure the patch at least 3 days or longer. A water curing method is recommended.

A number of synthetic rubber latexes have been developed to use with portland cement. These latexes are usually dissolved in water (called water emulsions). Compressive strengths of latex mortars are less, but the flexural and tensile strength is greater than that of plain portland cement. Latex mortars also increase initial bonding qualities on most surfaces.

When patching with latex mortars the same procedures are used as with portland cement mortars, except:

1. Paint the entire area with the pure latex emulsion.
2. Then use the latex with the mixing water in the concrete mix according to the manufacturer's recommendations.

One of the newest developments in concrete repair is the use of synthetic materials in bonding and patching. The most important are the epoxy-resin compounds which have high bonding properties and great strength. The cost of epoxy-resin binders is quite high, but because of a short curing time the overall cost might not exceed conventional methods. Epoxy-resin binders are especially useful if the patch is in a high traffic area. If high strength bond is required and moist curing is not practical, then epoxy mortars should be used.

Whatever type of patching concrete you use, always follow these general rules:

1. The surface must be roughened.
2. The surface to be patched must be cleaned.
3. If the old concrete contains rebars (reinforcement steel) and the patch is as deep as the rebars, go around the steel about 3/4" with the patching mix.

4. If the patched area is over a joint, cut a joint through the patch.
5. Using zero slump concrete and curing slowly with water can reduce the shrinkage problems.

ADDING A NEW SURFACE TO EXISTING CONCRETE

Badly pitted or worn concrete can be restored by adding a concrete topping. Toppings can either be bonded or unbonded to the old surface. Usually, if the concrete is to get heavy traffic then bonding is recommended. If bonded, it should be bonded completely over the entire surface. The depth of toppings is 3/4" to 1" minimum when bonded and 2 1/2" minimum when unbonded.

The surface of the old concrete should be roughened, by chipping, rough grinding, jackhammer or a scarifying machine. Clean the surface by vacuuming, wash with water and brush. The concrete surface may be dampened before the grout is applied with a brush, especially if the temperature is 60°F. or warmer. There should be no standing water when placing the grout. The grout mix is made of 1 part portland cement, 1 part fine concrete sand, and 1/2 part water. Mix to a thick creamy consistency. Broom the mix on the surface 1/16" to 1/8" thick. The grout should not dry to a whitish color before the topping is placed on bonded topping.

Concrete for the topping mix should contain 1 part portland cement, 1 part sand, and 1 1/2 to 2 parts coarse aggregate. The diameter of the coarse aggregate should not be larger than 1/2 the topping mix. Use as little mixing as possible. Tamping may be needed to pack the topping in place to insure a good bond between old and new surfaces. A power float is recommended because you can use a stiffer mix to reduce shrinkage and compact the concrete better.

The joints of the topping should match any joints of the slab below.

Curing of bonded topping is more important than in ordinary concrete because of the thinness of the slab, and because curing affects the bond. Wet curing is recommended. Start curing as soon as possible. Cure for at least 4 days in hot weather or with high-early-strength cement.

Self Assessment

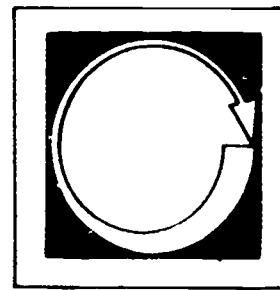

COMPLETE THE FOLLOWING STATEMENTS BY WRITING THE CORRECT WORD OR WORDS IN THE BLANKS PROVIDED.

1. _____ is a mixture of portland cement, fine sand, and water.
2. A mixture of portland cement and water is _____ cement grout.
3. The maximum size of aggregate should be _____ the patch depth.
4. The patch should cure at least _____ days or longer
5. Synthetic rubber latexes are usually _____ emulsions.
6. The _____ of the patching mix should be almost zero.
7. _____ mortars increase initial bonding qualities on most surfaces.

Self Assessment Answers

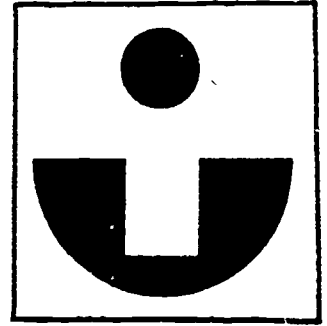

1. grout

2. "neat"

3. 1/2

4. 3

5. water

6. slump

7. latex

Assignment

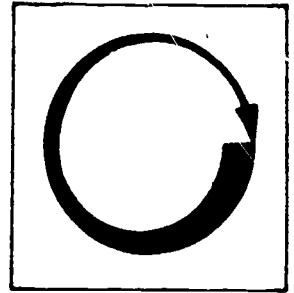

COMPLETE THE FOLLOWING ASSIGNMENT.

Describe, sketch, or demonstrate the proper procedures for patching concrete.

Include:

1. Depth and angle of the cut.
2. Surface preparation.
3. Wetting (before and at time of grouting).
4. Grouting. Give mix and application procedure.
5. Concrete mix and slump.
6. Placing and finishing.
7. Curing.

Post Assessment

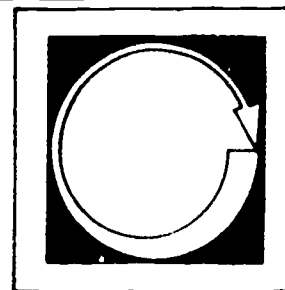

WRITE AN ANSWER TO THE FOLLOWING QUESTIONS.

1. What is the maximum size of aggregate in a patch?
2. Why is proper surface preparation important for patching and topping?
3. What is the basic rule when using synthetic rubber latexes?
4. What is one of the newest and most important patching compounds?
5. What are 3 properties of epoxy resin compounds?
6. What is the design of a grout mix for patching?

7. Why should the surface of an area to be patched be left rough?

8. How far around rebar should the patching mix go?

Instructor Post Assessment Answers

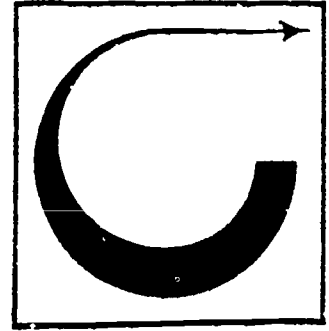

1. The maximum size of aggregate in a patch is $1/2$ the patch depth.
2. Surface preparation is important, otherwise the bond may be weak.
3. The basic rule in using latexes is to follow the manufacturer's recommendations.
4. One of the newest and most important patching compounds is the epoxy-resin compound.
5. Three properties of epoxy-resin compounds are:
 - a. high bonding.
 - b. great strength.
 - c. short curing time.
6. The design of a grout mix for patching is one part portland cement, 1 to 2 parts fine sand, and enough water to make a creamy solution.
7. The surface of the patch should be left rough so the patching mix will stick to the old concrete.
8. The patching mix should go around the rebar about $3/4$ ".