

DOCUMENT RESUME

ED 213 900

CE 031 574

AUTHOR Moore, Doug  
TITLE Drywall. Pre-Apprenticeship Phase 2 Training. Student Training Modules.

INSTITUTION Lane Community Coll., Eugene, Oreg.  
SPONS AGENCY Employment and Training Administration (DOL), Washington, D.C.; Oregon State Dept. of Education, Salem.

PUB DATE 81  
NOTE 294p.; For related documents see CE 031 561-579.

EDRS PRICE MF01/PC12 Plus Postage.  
DESCRIPTORS Adhesives; Behavioral Objectives; \*Building Trades; \*Ceilings; Check Lists; \*Construction Materials; Job Skills; Learning Activities; Learning Modules; Pacing; Postsecondary Education; Structural Elements (Construction); Tests; \*Trade and Industrial Education; Two Year Colleges; Vocabulary; Welding  
IDENTIFIERS \*Drywall Construction; \*Preapprenticeship Programs

ABSTRACT

These 18 Student Training Modules on drywall comprise one of nine sets of self-paced learning modules developed for Pre-Apprenticeship Phase 2 Training. (A companion instructor's guide is available separately as CE 031 573.) The modules are designed to impart trade knowledge and skills to the student. Each module contains some or all of the following: cover sheet listing module title, goals, and performance indicators; study guide/checklist with directions for module completion; introduction; vocabulary listing and defining new trade or technical terms; supplementary references; information sheet(s) providing information and graphics covering the module topic(s); self-assessment; self-assessment answers; assignment sheet(s); job sheet(s) listing materials and tools necessary to complete tasks designed to develop manipulative skill; post assessment; and post assessment answers. Topics covered in the module include drywall; lifting, carrying, and handling drywall; drywall codes and ratings; plans, schedules, and specification; measuring and marking drywall; scoring, breaking, and edge treatments; attaching drywall with nails, screws, and adhesives; metal edge and corner trim; power-actuated tools; welding applications; installing cold-rolled channel runner; self-supporting drywall partitions; installing metal and structural studs; installing carrying channels for suspended ceilings; furring channel; and installing suspended grid and tile ceilings. (YLB)

\*\*\*\*\*  
\* Reproductions supplied by EDRS are the best that can be made \*  
\* from the original document. \*  
\*\*\*\*\*

ED213900



# PRE-APPRENTICESHIP PHASE 2 TRAINING Student Training Modules

## Drywall

U.S. DEPARTMENT OF EDUCATION  
NATIONAL INSTITUTE OF EDUCATION  
EDUCATIONAL RESOURCES INFORMATION  
CENTER (ERIC)

✓ This document has been reproduced as  
received from the person or organization  
originating it.  
Minor changes have been made to improve  
reproduction quality.

• Points of view or opinions stated in this docu-  
ment do not necessarily represent official NIE  
position or policy.

PERMISSION TO REPRODUCE THIS  
MATERIAL HAS BEEN GRANTED BY

Lorstrup

TO THE EDUCATIONAL RESOURCES  
INFORMATION CENTER (ERIC)™

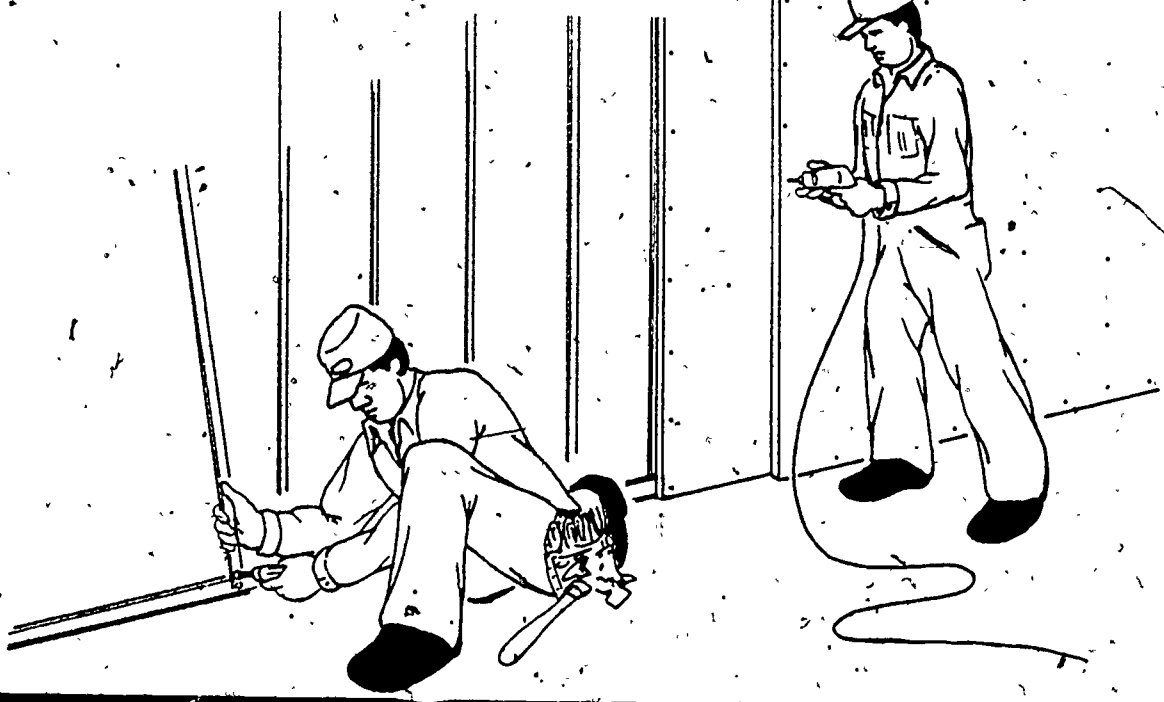

CE031574

Drywall Module Writer:

• Doug Moore

Technical Assistance:

Ray Jackson

Graphics: Ralph Bentley

Editorial, Proofreading and Pasteup:

Shannon Kracht, Ron Hamblen, Debi Carroll

Typing:

Strandlien Typing Service

This project was developed under a sub-contract for the Oregon Department of Education by Lane Community College, Community Education Division, Eugene, Oregon. Funds were provided by the Governor of Oregon from the Educational Linkages Component of the CETA Governor's Grant.

#### **STATEMENT OF ASSURANCE**

It is the policy of the Oregon Department of Education that no person be subjected to discrimination on the basis of race, national origin, religion, sex, age, handicap or marital status in any program, service or activity for which the Oregon Department of Education is responsible. The Department will comply with the requirements of state and federal law concerning non-discrimination and will strive by its actions to enhance the dignity and worth of all persons.

# Lane Community College

4000 E 30th Avenue  
Eugene, Oregon 97405  
(503) 726-2200

Office of the President

July 27, 1981

On behalf of Lane Community College, I wish to express our pride and gratitude for the opportunity to participate in the development of the Pre-Apprenticeship training materials. We also wish to commend the Oregon Department of Education for its original concept and continued support; and, the Educational Linkages Component of the CETA Governor's Grant for funding.

The goals of this project are many, but none are more important than that of producing valid, understandable vocational curriculum material. We congratulate the tradespeople and production staff for their accomplishments.

Finally, I recommend this material to anyone exploring Pre-Apprenticeship as an entry into the vocational work world, with the hope and belief that it will go a long way toward producing skilled craftspeople who are dedicated to their work.

Sincerely,

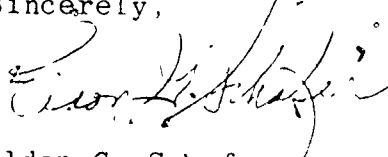

Eldon G. Schafer

## DRYWALL: THE MATERIAL

### Goal:

Upon completion of this module, the student will:

1. Understand the major steps in processing raw gypsum for use in drywall.
2. Identify the major applications of gypsum drywall in conventional construction.
3. Identify and explain the advantages offered by gypsum drywall.

2

### Performance Indicators:

The student will demonstrate a knowledge of this module by successfully completing and reviewing a Self Assessment, an Assignment and a Post Assessment.

5

# Study Guide

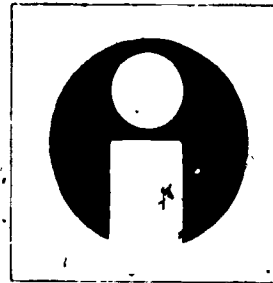

In order to finish this module, do the following tasks. Check each item off as you complete it.

1.  Read the Goal and Performance Indicators on the cover of the module. This will tell you what you will learn by studying the module, and how you will show you've learned it.
2.  Read the Introduction. The Introduction will tell you why the module is an important part of the drywall trade.
3.  Study the Vocabulary section. Vocabulary words are important for a good understanding of the trade. After you have studied the vocabulary, ask your teacher to quiz you on the words and their meanings.
4.  Study the Information section. This section will give you the information you need to understand the subject.
5.  Take the Self Assessment exam. This is a test for you to prove to yourself that you have learned the material you have studied. Compare your answers with the answers on the Self Assessment Answer Sheet, which is on the page following the Self Assessment. If you scored poorly, re-study the Information section or ask your teacher for help.
6.  Do the Assignment page. Follow the instructions at the top of the Assignment page.
7.  Take the Post Assessment exam. Give the exam to your teacher after you have completed it. Your teacher will grade it for you.

# Introduction

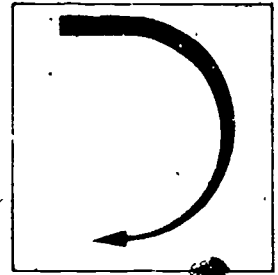

The use of drywall in construction today is widespread. It is a popular choice for many different applications.

It is important to understand the reasons why drywall is so popular. To do so, we must study the advantages and uses made of drywall in the construction trades today.

# Vocabulary

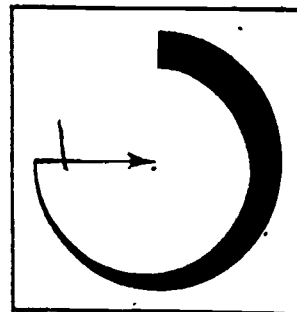

Trade terms are very important for a good understanding of the trade. Study these words and meanings. When you have learned them, ask your teacher to quiz you on the words and their meanings.

**CALCINED**--Heating to remove combined water during processing of gypsum.

**COMBINED WATER**--Water containing the chemical structure of the mineral gypsum.

**HYDROUS**--Containing water.

**COE DRIER**--Drying machine used to process gypsum drywall.

**DIMENSIONAL STABILITY**--Ability to resist warping and cracking due to minor movements in building structure.

**TYPE X DRYWALL**--Fire-resistant drywall.

**W/R DRYWALL**--Water-resistant drywall material.



# Supplementary References

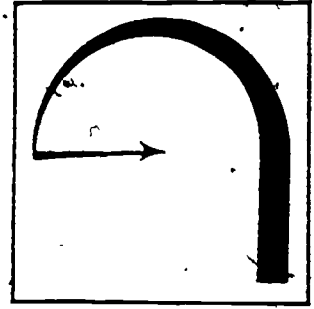

1. Drywall Construction Workbook Pt. 1. California State Dept. of Education 1974. pp. 69-77.
2. Gypsum Construction Handbook. U.S. Gypsum, 1978. pp. 6-15.
3. Using Gypsum Board for Walls and Ceilings. Gypsum Assoc., 1970.

# Information

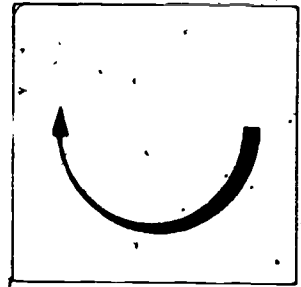

In order to begin to understand why drywall is so popular and has so many uses, you must first learn what drywall is made from and how it is made. It is the special chemical make-up of the base material gypsum that makes it desirable.

The key to gypsum drywall popularity and success is that gypsum is a non-combustible material. It also gives off water in the form of steam when subjected to heat or fire and this acts as a fire retardant. Both of these properties are highly desirable for a building material.

Now let's see how the natural material is transformed into the usable building material.

Gypsum, a gray-to-white rock known as hydrous calcium sulfate, is mined or quarried and then crushed and ground to a fine powder similar to flour in appearance. It is then calcined (heated) to drive off part of the water that was combined within the chemical structure of natural gypsum. This water is known as combined water. Only a part, not all of this water, is removed through calcining. This calcined gypsum is now ready to be used to make the drywall product itself. This material is often referred to as "Plaster of Paris" in this refined state.

Processed calcined gypsum is then remixed with water and other additives in a preparation to make the core or filler material for drywall boards. This core material is mechanically placed between two continuous sheets of paper in a highly automated conveyor process. The board is shaped and formed along the conveyor and then cut to length. Then it is transferred to special driers known as Coe driers. When removed from the drier, gypsum drywall boards are ready for the construction industry.

As manufactured, drywall comes in several standard dimensions and surface papers and/or coverings. The standard width of drywall is 4 feet. Thicknesses of 1/4", 3/8", 1/2" and 5/8" are standard drywall thicknesses, with 1" used when making coreboard. Lengths of 8', 9', 10', 12', 14' and 16' are regularly available from commercial suppliers.

Drywall products may be specially treated and prepared to increase their fire resistance ("Type-X") and/or water resistance ("W/R"). These special treatments are selected on the basis of job requirements and/or needs.

Drywall is selected for a variety of uses within the construction process. Primarily it is used to provide interior wall and ceiling covering over wood and/or metal framing. It can also be applied over interior masonry surfaces. It is used as exterior sheathing and for surfaces indirectly exposed to weather, such as soffits and carport ceilings. In each case, careful matching of job requirements and the specific drywall product is necessary. An incorrect choice will seriously affect the success or failure of the job.

Considering the range of applications and products available, it is important that the other advantages of gypsum drywall are also known and recognized.

In addition to properties of non-combustion and fire resistance, drywall offers many other advantages to the construction process. Gypsum is durable and relatively light in weight compared to other materials offering similar properties. Drywall systems have high speeds of installation with ease of decoration as a real plus. Since it is easy to cut, drywall lends itself to wall openings and irregular edges. In addition, drywall has high dimensional stability, so it resists cracking and warping. All of these advantages lead individually and collectively to drywall's other significant advantage: lower installation cost. In light of rising costs, this advantage cannot be overlooked.

The simple mineral gypsum, transformed into drywall products, is extremely functional and an attractive choice for the building industry.

# Self Assessment

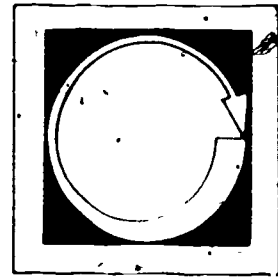

LISTED BELOW ARE SEVERAL STATEMENTS. IF THE STATEMENT IS TRUE, PLACE A "T" IN THE BLANK PROVIDED. IF THE STATEMENT IS FALSE, PLACE AN "F" IN THE BLANK.

1. \_\_\_ The process of cooling gypsum is called calcining.
2. \_\_\_ Wallboard is dried in a Coe Drier.
3. \_\_\_ Raw gypsum is crushed and ground before calcining.
4. \_\_\_ Gypsum is a combustible material.
5. \_\_\_ Drywall comes in standard 4' widths.

# Self Assessment Answers

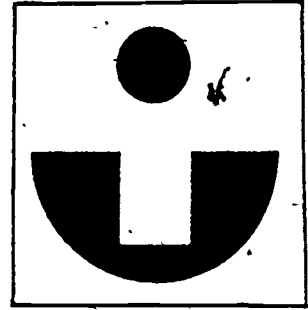

1. F

2. T

3. T

4. F

5. T

# Assignment

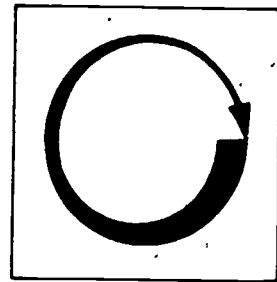

COMPLETE THE FOLLOWING ASSIGNMENTS.

1. Describe the major steps required to transform raw gypsum into its Plaster of Paris state.
2. List three major applications of drywall in conventional residential construction.
3. Besides non-combustibility, list at least 5 significant advantages of drywall. Include a brief explanation of why each is an advantage.

# Post Assessment

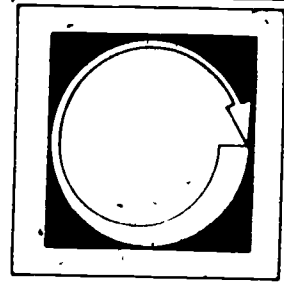

COMPLETE THE FOLLOWING STATEMENTS BY WRITING THE CORRECT WORD OR WORDS IN THE BLANKS PROVIDED.

1. Hydrus calcium sulfate is known as \_\_\_\_\_.
2. During calcining, \_\_\_\_\_ water is removed.
3. \_\_\_\_\_ of this water is removed during calcining.  
Only part/all
4. Drywall is made \_\_\_\_\_  
in continuous strip/one piece at a time
5. Standard drywall comes in
  - a. widths of \_\_\_\_\_ feet.
  - b. thicknesses of \_\_\_\_\_ inch to \_\_\_\_\_ inch.
  - c. lengths of \_\_\_\_\_ feet to \_\_\_\_\_ feet.
6. Drywall offers a \_\_\_\_\_ installment cost.  
high/low

# Instructor Post Assessment Answers

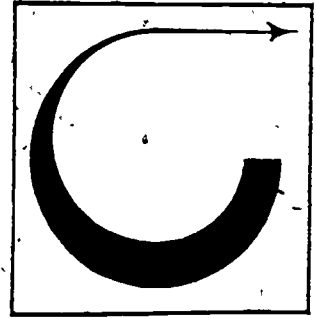

1. gypsum
2. combined
3. Only part
4. in continuous strips
5. a. 4'  
b. 1/4" - 5/8" (1" for coreboard)  
c. 8'--16'
6. low



## LIFTING, CARRYING AND HANDLING DRYWALL

### Goal:

Upon completing this module, the student will:

1. be able to identify and demonstrate proper and safe techniques for lifting drywall to avoid injury.
2. explain the importance of careful handling of drywall to limit damage and loss of material.
3. identify and explain the advantages to be gained from careful material placement on the jobsite.

14

### Performance Indicators:

The student will demonstrate an understanding of the subject by successfully completing a Self Assessment, an Assignment, Job Sheet and a Post Assessment.

17

# Study Guide

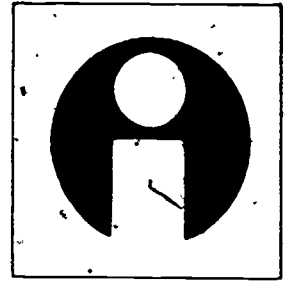

In order to finish this module, do the following tasks. Check each item off as you complete it.

1.  Read the Goal and Performance Indicators on the cover of the module. This will tell you what you will learn by studying the module, and how you will show you've learned it.
2.  Read the Introduction. The Introduction will tell you why the module is an important part of the drywall trade.
3.  Study the Vocabulary section. Vocabulary words are important for a good understanding of the trade. After you have studied the vocabulary, ask your teacher to quiz you on the words and their meanings.
4.  Study the Information section. This section will give you the information you need to understand the subject.
5.  Take the Self Assessment exam. This is a test for you to prove to yourself that you have learned the material you have studied. Compare your answers with the answers on the Self Assessment Answer Sheet, which is on the page following the Self Assessment. If you scored poorly, re-study the Information section or ask your teacher for help.
6.  Do the Assignment page. Follow the instructions at the top of the Assignment page.
7.  Do the Job Sheet. Follow the instructions at the top of the Job Sheet. The tasks listed on the Job Sheet will help you develop skills which will be helpful to you.
8.  Take the Post Assessment exam. Give the exam to your teacher after you have completed it. Your teacher will grade it for you.

# Vocabulary

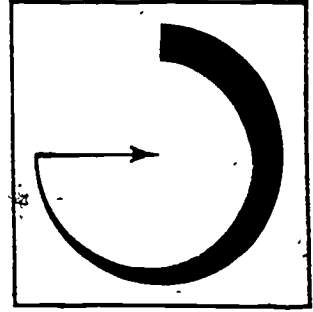

Trade terms are very important for a good understanding of the trade. Study these words and meanings. When you have learned them, ask your teacher to quiz you on the words and their meanings.

**WARPING**--Curving drywall surface caused by improper handling and/or storage. This may cause permanent damage.

**EDGE ROUGHNESS**--Damage to edge surface of drywall. This is often caused by careless handling.

**DRYWALL DOLLY**--Wheeled carrying device for moving drywall sheets at the jobsite.

**SAGGING**--Deforming of drywall sheets while stacked; caused by improper support to sheets.

**DUNNAGE**--Waste material often used for support material under stacks of drywall.

**LEVERAGE**--Gaining advantage in lifting by using gravity and balance rather than pure strength.

# Supplementary References

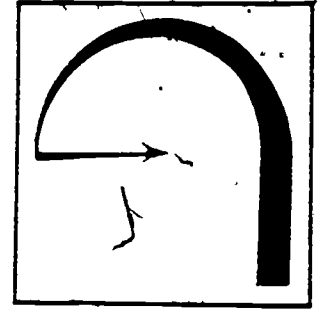

1. Gypsum Construction Handbook. U.S. Gypsum, 1978. pp: 88-89.
2. Drywall Construction Workbook Part 1. California State Dept. of Education, 1974. page 124.
3. Using Gypsum Board for Walls and Ceilings. Gypsum Association, 1970. page 6.

# Information

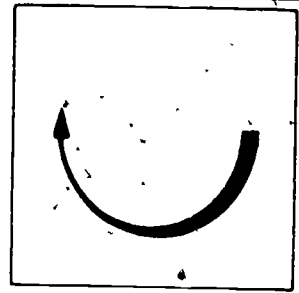

Drywall is heavy, awkward and fairly easy to damage. Most jobs will require many sheets to complete them. Careful planning, estimating and correct handling are very important and can save time, material and help avoid jobsite accidents and injuries.

After the correct type and amount of material has been ordered, it will be delivered to the jobsite. Upon arrival, this material will need to be stored until it's applied to the walls and ceiling.

Knowing where the drywall will be used (and in what amounts) will allow you to place the drywall around the jobsite when it is delivered. This can save a lot of handling and moving material later.

The sheets should be stacked against a wall for ease in cutting. Be careful not to block doorways and other openings. Material for the walls should be stacked first. Sheets of ceiling material should be stacked on top since they will be used first.

Before you stack drywall sheets, make sure that the floor is level and clean. Drywall can be placed directly on dry wood surfaces but on a masonry surface it should be stacked on dunnage. Be sure to provide support to avoid sagging which can lead to warping or even breakage. Drywall sheets may be leaned against a wall, resting on the long edge, but not for long periods of time as warping can occur.

Besides warping, there are 3 other types of damage common to drywall sheets.

1. Breakage: caused by careless handling (dropping, bumping into things) or from uneven stacking, leaving exposed corners to break off.
2. Cracking: caused by careless handling, dropping things on sheets, dropping the sheet itself or stepping on unsupported edges.

3. Edge roughness: caused by sliding the drywall sheets over flooring or through framing openings.

Damaged drywall can be cut down to eliminate the broken sections and the pieces can be patched in. This will lessen the cost due to lost material but won't eliminate it.

Another important type of damage in drywall work is personal injury to the worker caused by improper handling techniques. A sheet of 4' X 8' X 1/2" gypsum drywall weighs about 60 pounds and comes taped together in bundles of two. Our bodies can lift and carry weights like this if proper methods are used and followed.

#### Lifting by Hand

1. Use leverage to make movements.
2. Pivot sheet from horizontal (flat) to vertical (upright) position.
3. Bend at the knees, not at the waist. The long muscles in the legs were designed for lifting.
4. Place one hand under the sheet along the long edge.
5. Place the other hand on top of the sheet.
6. Be sure you have balance and control of the sheet before you start to lift upwards.
7. Keep the load close to your body.
8. Know your path and be sure it is clear. Jobsite clean-up is important.
9. Do not make blind moves (those where your vision is blocked by the drywall sheet). Damage to the drywall, yourself and others frequently occurs during such movements.
10. Rise slowly and steadily by straightening your legs.
11. If a turn is required while lifting, shift your feet to make the turn. Don't twist with your waist or back.

#### Setting the Sheet Down

1. Select the site where the sheet will be set.
2. Stop moving.
3. Begin lowering the sheet by bending at the knees. Do not bend over at the waist.
4. Maintain control of the sheet to avoid damage to corners and edges.

5. Bring sheet to rest on the floor along the long edge.
6. Lay the sheet down flat or up on edge only for short periods of time.

In addition to carrying drywall by hand around the jobsite, specialized dollies are made to ease the task of moving drywall.

# Self Assessment

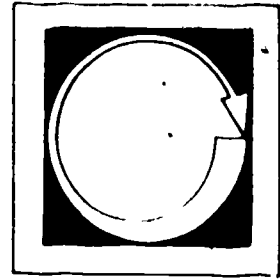

COMPLETE THE FOLLOWING STATEMENTS BY CIRCLING THE CORRECT RESPONSE.

1. Lifting is best done by bending at the waist/knees.
2. Drywall is best stored on the jobsite by stacking it vertically/horizontally.
3. A sheet of 1/2" X 4' X 8' drywall weighs approximately 30 lbs./60 lbs./90 lbs.
4. Sliding drywall sheets along the floor is a common cause of warping/edge roughness.
5. In a stack containing drywall sheets for both ceiling and wall locations, the sheets for the ceiling should be stacked on top/on the bottom.



# ● Self Assessment Answers

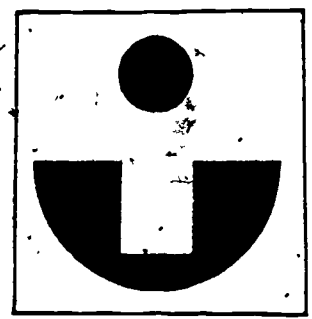

1. Knee
2. Horizontally
3. 60 lbs.
4. Edge roughness
5. Top

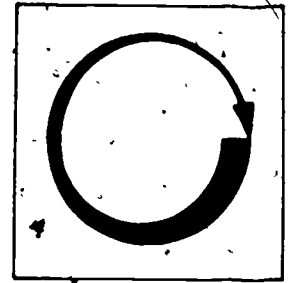

# Assignment

COMPLETE THE FOLLOWING ASSIGNMENTS WITH SHORT ANSWERS.

1. Why should lifting be performed by the legs and not the back?
2. List and explain 4 major types of damage to drywall.
3. Explain why careful location of drywall storage on the jobsite is important.

# Job Sheet

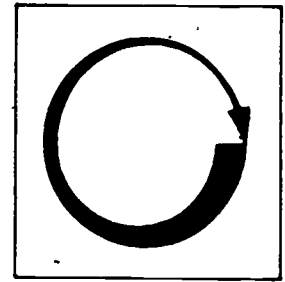

FOLLOW THE STEPS BELOW TO STACK DRYWALL:

1. Plan location site.
2. Clean site.
3. Check for flat, level, dry surface.
  - a. Drywall may be laid directly on a wood surface.
  - b. If a surface is masonry, stack on dunnage and be sure enough support is provided to avoid sagging that can cause warping.
4. Lay sheets down on stack.
  - a. Wall sheets first.
  - b. Ceiling sheets last.
5. Check for even stacking.
6. Be sure longer sheets are supported and/or stacked separately.

FOLLOW THE STEPS BELOW TO LIFT AND CARRY DRYWALL.

1. Select sheet to move.
2. Determine path.
  - a. Be sure it is clean.
3. Shift sheet from horizontal to vertical position.
4. Bend at knees with back straight.
5. Place one hand under the sheet.
6. Place one hand on top of the sheet.
7. As lifting begins:
  - a. Check for proper balance.
  - b. Move slowly and steadily until upright.

8. Travel with a clear view ahead--do not make blind moves.
9. When setting drywall down:
  - a. Select resting place before starting to set it down.
  - b. Lower the sheet slowly, bending at the knees--do not bend over at the waist.
10. Be sure to rest sheet on the long edge with support at both the top and bottom edge to avoid damage.

# Post Assessment

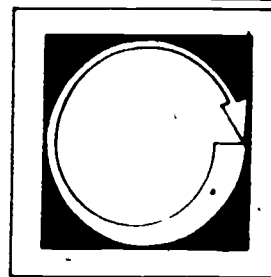

COMPLETE THE FOLLOWING STATEMENTS BY CIRCLING THE CORRECT WORD OR WORDS.

1. To make a turn while lifting a sheet of drywall, the feet should be shifted/  
the body twisted at the waist.
2. Jobsite clean-up is/is not important for carrying drywall sheets safely.
3. Warping is often caused by incorrect stacking/carrying drywall.
4. The best location for a stack of drywall in a room is: along a wall/  
in the center of the room.
5. Drywall can/should not be leaned against framing in a vertical position  
for short periods.

# ● Instructor Post Assessment Answers

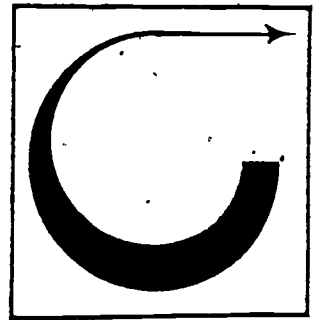

1. Feet should be shifted.
2. Is
3. Stacking
4. Along the wall
5. Can

25,

## DRYWALL CODES AND RATINGS

### Goal:

Upon completion of this module, the student will:

1. Understand the function of building codes and ratings as they relate to drywall.
2. Be able to identify and explain the advantages gained by following building codes.
3. Be able to identify the types of activities covered by the building codes affecting the drywall trade.

29

### Performance Indicators:

The student will complete a Self Assessment, an Assignment and a Post Assessment.

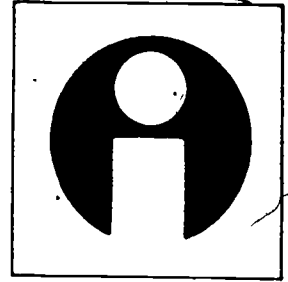

# Study Guide

In order to finish this module, do the following tasks. Check each item off as you complete it.

1.  Read the Goal and Performance Indicators on the cover of the module. This will tell you what you will learn by studying the module, and how you will show you've learned it.
2.  Read the Introduction. The Introduction will tell you why the module is an important part of the drywall trade.
3.  Study the Vocabulary section. Vocabulary words are important for a good understanding of the trade. After you have studied the vocabulary, ask your teacher to quiz you on the words and their meanings.
4.  Study the Information section. This section will give you the information you need to understand the subject.
5.  Take the Self Assessment exam. This is a test for you to prove to yourself that you have learned the material you have studied. Compare your answers with the answers on the Self Assessment Answer Sheet, which is on the page following the Self Assessment. If you scored poorly, re-study the Information section or ask your teacher for help.
6.  Do the Assignment page. Follow the instructions at the top of the Assignment page.
7.  Take the Post Assessment exam. Give the exam to your teacher after you have completed it. Your teacher will grade it for you.



# Introduction

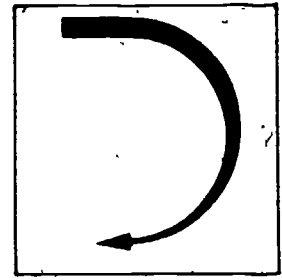

Building codes affect every phase of construction. Workers must be aware of the codes that affect their trade. The choice of materials and methods of construction will be directed by code requirements.

Building codes are designed to protect the health and safety of the building's occupants but also serve to protect the owners' investment and the workers' safety while on the job.

# Vocabulary

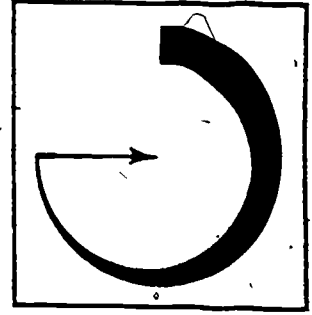

Trade terms are very important for a good understanding of the trade. Study these words and meanings. When you have learned them, ask your teacher to quiz you on the words and their meanings.

**SPECIFICATION**--Technical description of a particular material, procedure or building method.

**STANDARD**--A specification that becomes adopted by large portions of the building trade as accepted practice.

**CODE**--Organized collection of building standards.

**CONFORMING**--Building practice completed according to the code.

**CLASSIFICATION**--Category of structures listing which section of the codes will apply.

**GROUP**--Designation of structures by their occupancy or intended use.

**TYPE**--The degree of fire resistance of a building's materials or structure.

# Supplementary References

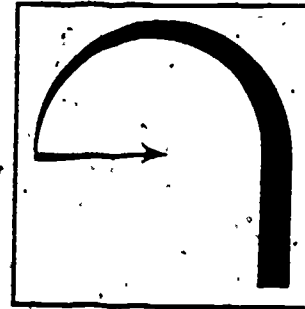

1. Drywall Construction Handbook. California State Dept. of Education, 1975. Part I, page 156 and Part II, page 6.
2. Uniform Building Code. 1979. International Conference of Building Officials.
3. Dwelling Construction Under the Uniform Building Code. International Conference of Building Officials. pp. 12, 31, 52, 70.

# Information

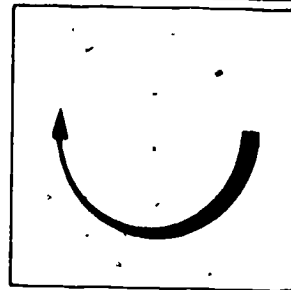

It takes more than good intentions to construct a sound and long-lasting structure. It requires the use of adequate materials and good building methods. Knowing the correct methods and materials to use can be difficult. Products, methods and types of construction are constantly changing.

To keep up with available materials and methods, technical information describing building materials is gathered with careful testing. This yields specifications. When specifications are accepted by the building industry, they are finally considered standards. Even with standards established, keeping track of them all can be impossible for the builder. Fortunately, sets of standards for the materials and methods to be used in construction have been created. These standards are known as building codes.

A building code is a set of rules that regulates the construction and repair of buildings. Each town, county, or state will have its own code and each is constantly being revised.

Updating the code may be too large a task for cities or counties. This has led to the establishment of national codes which may be accepted on a local level. There are four major standardized codes. They are:

1. Uniform Building Code
2. Basic Building Code
3. National Building Code
4. Southern Standard Building Code

What frequently happens is the local government agency will adopt one of these standardized codes and then change it to include regional needs. Examples might include deeper holes for foundations in colder climates or more bracing in hurricane-prone areas.

Using the Uniform Building Code as an example, structures are divided into groups defined by the occupancy and intended use. They are also classified by type. This defines the degree of structure or fire resistance of the materials used. The group breakdown is:

<u>Group</u>	<u>Use</u>
A	Large assembly buildings
B	Small assembly buildings
C	Schools
D	Jails
E	Public garages, planing mills and storage places for flammable materials
F	Stores and Service Stations
G	Factories
H	Hotels and apartment houses
I	Dwellings
J	Private garages and fences over 6 feet high.

The 5 major types of construction are:

I	Fire resistive
II	Heavy timber
III	Ordinary masonry
IV	Light, incombustible frame
V	Wood frame

For example, the average wood frame house is classified as a Group I Class V.

Only a portion of the building code refers to any specific trade and the worker needs to pay close attention to those sections.

For the drywall worker, there are highly specific codes relating to:

1. The type of drywall (for example Type X or W/R).
2. The thickness of drywall.
3. Method of application.
4. Type and/or length of fasteners.

5. Nailing (spacing).

6. Fire resistance.

Work not complying with codes is called non-conforming and will not be accepted by local inspectors.

Builders must remember that building codes protect both the future occupant of the structure they are building and themselves. This protection covers the worker on the job. Perhaps more importantly, it protects the worker against others willing to use sub-standard materials or methods merely to gain a price advantage and the contract for work.

Keep in mind that building codes do not necessarily prescribe the best materials or methods available, only those minimums which provide for safe and sound buildings. Local governments may choose to upgrade these minimums and therefore it is important to check for any local differences from the Uniform Code.

# Self Assessment

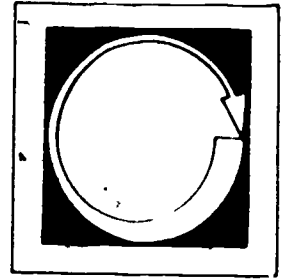

LISTED BELOW ARE SEVERAL STATEMENTS. IF THE STATEMENT IS TRUE, PLACE A "T" IN THE BLANK PROVIDED. IF THE STATEMENT IS FALSE, PLACE AN "F" IN THE BLANK.

1.  Building codes protect only the occupants of new buildings.
2.  There is only one standard code.
3.  Standards and specifications are the same.
4.  Local or regional modifications to standard building codes are often needed.
5.  Codes may prescribe the type of fastener you use to apply drywall.

# Self Assessment Answers

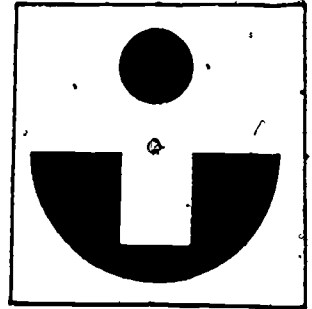

1. F

2. F

3. F

4. T

5. T



# Assignment

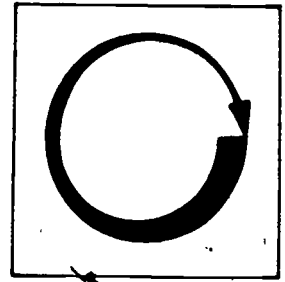

COMPLETE THE ASSIGNMENT BELOW.

## Materials

Dwelling Construction Under the Uniform Building Code. 1979. (or most current edition)

Read pages 12, 31, 66, 67, 70 and answer the following questions with short answers from the information section and this additional reading.

1. Fasteners must be spaced not less than \_\_\_\_\_ inches from edges and ends of drywall sheets.
2. Besides the health and safety of the occupants, what other advantages are provided by building codes to the builder?
3. How must a dwelling be protected from an attached garage?
4. On 1/2" single-ply gypsum with vertical application, what type of nail and spacing are required by the code?
5. Give at least two examples of changes that might be necessary to adapt a uniform code to a local or regional code.
6. How do spacing requirements differ for nails and screws under the Uniform Building Code?

# Post Assessment

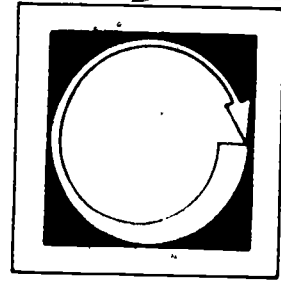

COMPLETE THE FOLLOWING STATEMENTS BY CIRCLING THE CORRECT RESPONSE.

1. Fire resistance of materials or a structure defines its group/type.
2. Technical information on materials or methods is first considered a specification/standard.
3. A group I type V structure refers to a(n) apartment building/dwelling.
4. Failure to comply with building codes means your work is conforming/non-conforming.

WRITE A SHORT ANSWER TO THE FOLLOWING.

5. List at least three specific areas covered by building codes that affect the drywall trade.

# ● Instructor Post Assessment Answers

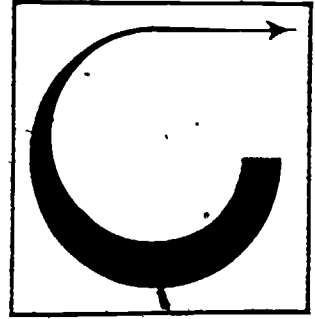

1. type
2. specification
3. dwelling
4. non-conforming
5. type of drywall  
thickness  
method of application  
fasteners  
fastener spacing

PLANS, SCHEDULES AND SPECIFICATIONS

**Goal:**

The student will be able to identify, describe and explain the importance of the 8 major categories of working drawings.

**Performance Indicators:**

The student will demonstrate knowledge by successfully completing a Self Assessment, an Assignment and a Post Assessment.

# Study Guide

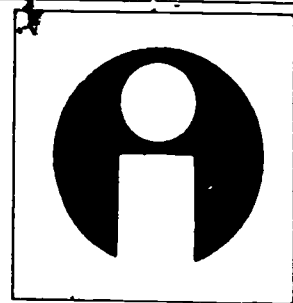

In order to finish this module, do the following tasks. Check each item off as you complete it.

1.  Read the Goal and Performance Indicators on the cover of the module. This will tell you what you will learn by studying the module, and how you will show you've learned it.
2.  Read the Introduction. The Introduction will tell you why the module is an important part of the drywall trade.
3.  Study the Vocabulary section. Vocabulary words are important for a good understanding of the trade. After you have studied the vocabulary, ask your teacher to quiz you on the words and their meanings.
4.  Study the Information section. This section will give you the information you need to understand the subject.
5.  Take the Self-Assessment exam. This is a test for you to prove to yourself that you have learned the material you have studied. Compare your answers with the answers on the Self Assessment Answer Sheet, which is on the page following the Self Assessment. If you scored poorly, re-study the Information section or ask your teacher for help.
6.  Do the Assignment page. Follow the instructions at the top of the Assignment page.
7.  Take the Post Assessment exam. Give the exam to your teacher after you have completed it. Your teacher will grade it for you.

# Introduction

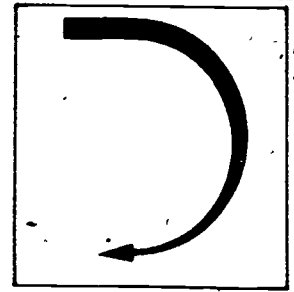

Most plans drawn up for a construction project include working drawings, schedules and specifications. The drywall worker must understand how to read and interpret all three to succeed at the trade.

# Supplementary References

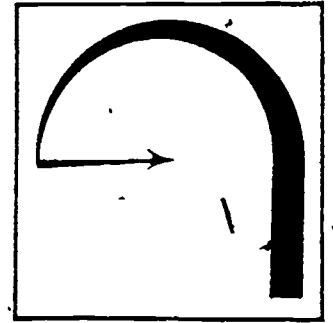

1. Drywall Construction Workbook, Part I. California State Department of Ed., 1975. pp. 114, 231.
2. Drywall Construction Workbook, Part II. California State Department of Ed., pp. 8, 96, 99.
3. Standard Specifications. Construction Specifications Institute. Part 6. Section 6B.

# Vocabulary

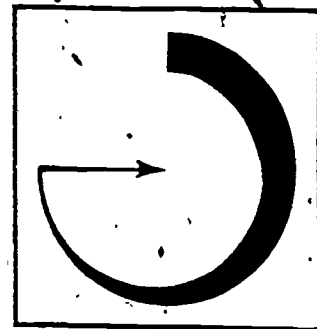

Trade terms are very important for a good understanding of the trade. Study these words and meanings. When you have learned them, ask your teacher to quiz you on the words and their meanings.

**SCHEDULES**--Charts or tables detailing the size, type and manufacturer of materials to be used.

**DETAIL**--Drawings used to show special features within the plans.

**SPECIFICATION**--Written instructions used to explain the quality of work or methods to be used.

**ELEVATION**--Vertical details of the exterior of the building shown in the plans.

**PLANS**--Set of working drawings, schedules and specifications.



# Information

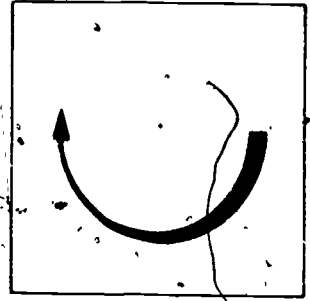

In order to assure both the builder and the owner of a building project that the final product will be satisfactory, they will prepare a contract. This agreement is based on a set of working drawings, schedules and specifications which define the type, quality and the amount of work to be performed.

Tradespeople must understand the roles that each part of the plans performs. There are 8 main categories that make up the plans for a project:

1. Plot Plan

Plot plans show the position of the building on the lot.  
(See plot plan on next page.)

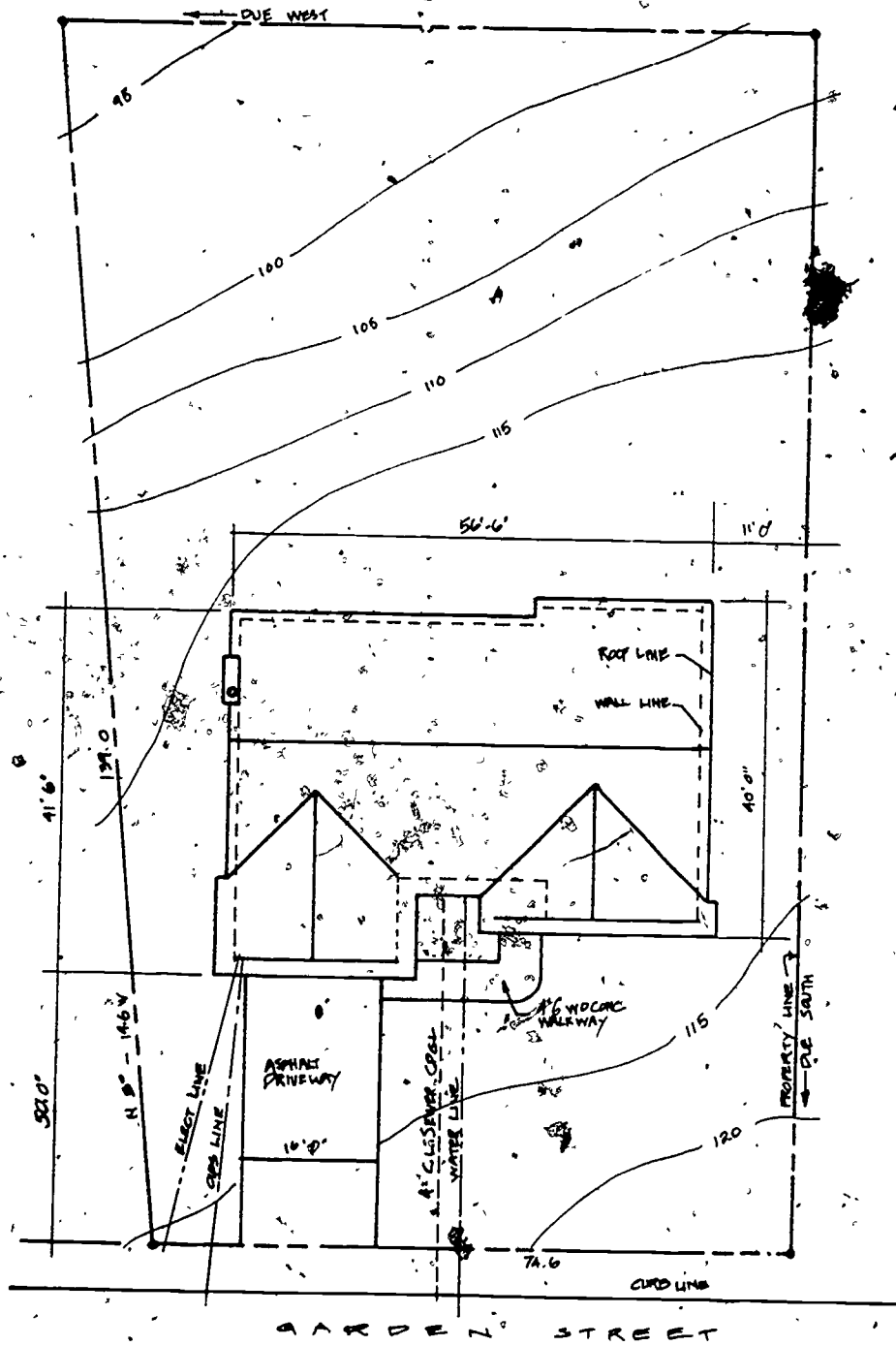

48

50



### 3. Floor Plan

This shows the overall horizontal (top view) shape of the building and the layout of the rooms.

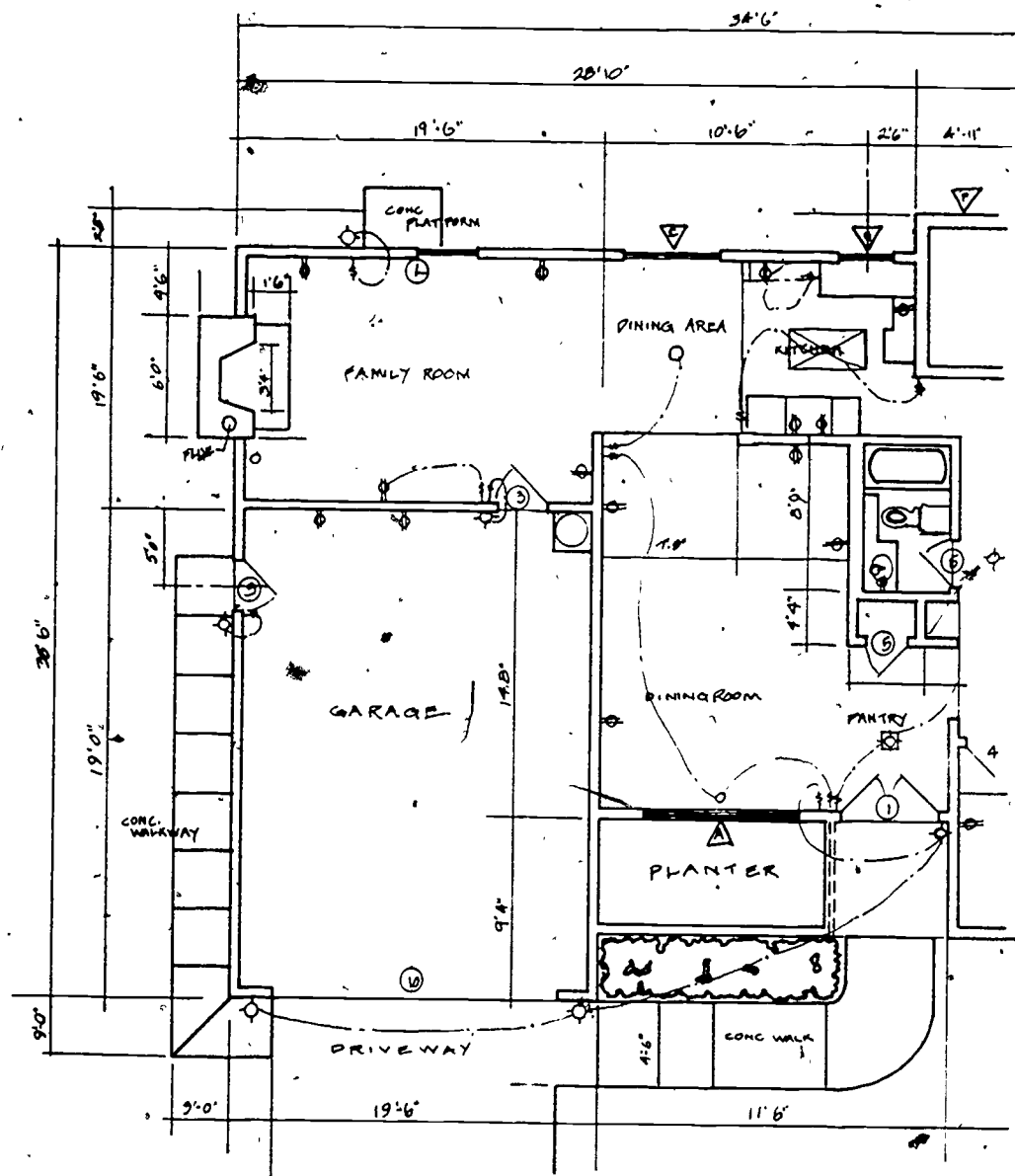

4. Elevations

These plans give exterior views from the foundation to the roof for all sides of the building. Each view is labeled to indicate side, front or rear view. }

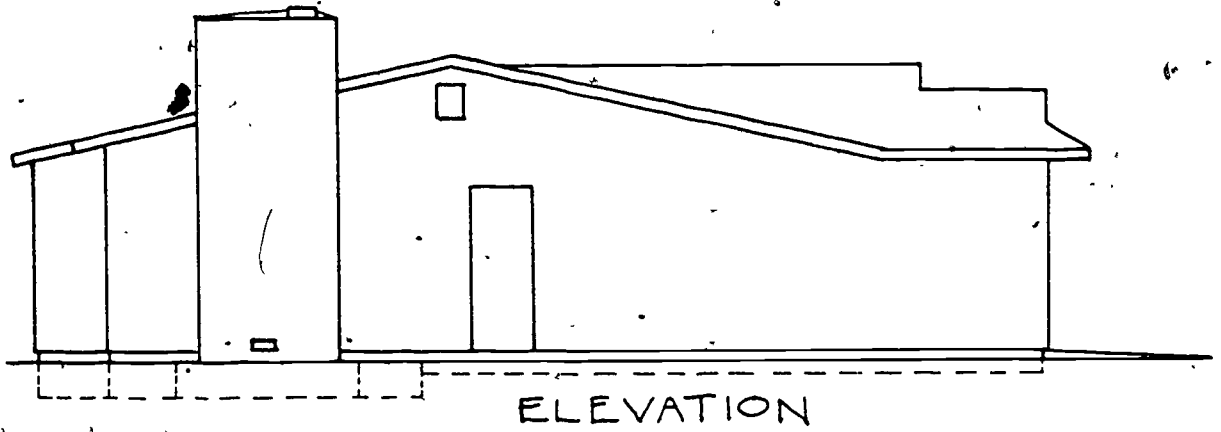

5. Details

Drawings used to show special features within the plan or to show typical construction techniques for walls.

5 1/2 X 8 BOSTITCH  
REINFORCING PL.

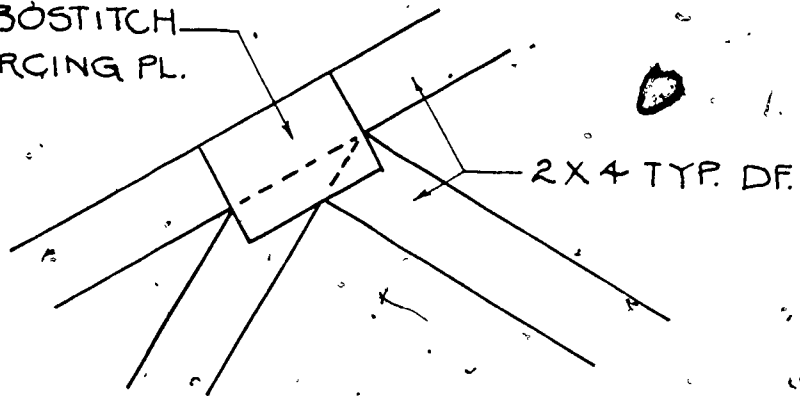

(A) DETAIL

6. Sections

Drawings used to show special features or requirements such as those necessary for building fireplaces. Trusses, door and window framing and stairways are often shown in sectional drawings.

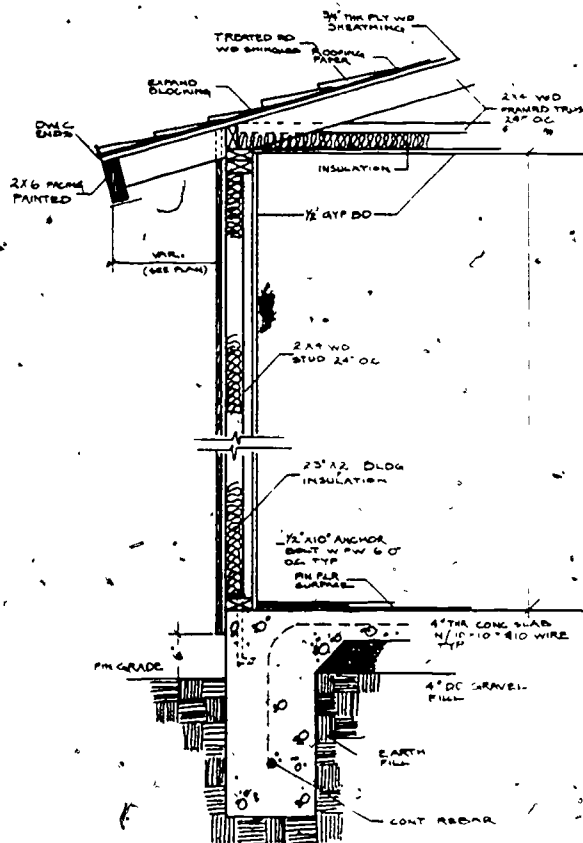

## 7. Schedules

Charts or tables giving detailed data on windows, doors and special equipment. The information generally includes the size, type, identifying symbol and manufacturer. Of special interest to the drywall worker are finish schedules which give information about the types of material used on each interior wall, floor and ceiling.

ROOM NAME	BASE		FLOOR	WALLS				CEILING	CLIGHT	KD
	HT	MTL		N	E	S	W			
ENTRY	1 1/2	WD	CARPET	STP	STP	STP	-	TEXTURED	8'-0"	
COAT ROOM	1 1/2	WD	CARPET	PK	PK	PK	PK	CARPET	7'-11 1/2"	
LINEN	1 1/2	WD	CARPET	PK	PK	PK	PK	TEXTURED	8'-0"	
HALL	1 1/2	WD	CARPET	STP	STP	STP	STP	TEXTURED	8'-0"	
BATH	2	SPR	CORATILE	ST	STP	STP	STP	PAINTED STP	8'-0"	WALLS CO
HALF BATH	2	RUBBR	CORATILE	ST	STP	STP	STP	PAINTED STP	7'-6"	WALLS CO
MASTIC DOOR	1 1/2	WD	CARPET	STP	WT	STP	STP	TEXTURED	7'-6"	
CLOSETS	1 1/2	WD	CARPET	PK	PK	PK	PK	CARPET	8'-0"	
STORAGE ROOM	1 1/2	WD	PAINTED	PK	PK	PK	PK	PAINTED	8'-0"	
BATHROOM	1 1/2	WD	VINYL TILE	PK	PK	PK	PK	PAINTED	8'-0"	
BEDROOM 2	1 1/2	WD	CARPET	STP	WT	STP	STP	TEXTURED	9'-0"	
BEDROOM 3	1 1/2	WD	CARPET	STP	STP	STP	STP	TEXTURED	8'-0"	
KITCHEN	4	Vt.	VINYL TILE	STP	STP	STP	-	PAINTED	8'-0"	
DINING AREA	1 1/2	WD	VINYL TILE	STP	STP	STP	STP	TEXTURED	8'-0"	
LINEN ROOM	1 1/2	WD	CARPET	STP	STP	PK	PK	TEXTURED	8'-0"	
FAMILY ROOM	1 1/2	WD	CARPET	STP	STP	PK	PK	TEXTURED	8'-0"	WARD PK
CLOSET	2	CONC	CONC	STP	STP	STP	STP	PAINTED	8'-0"	

NOTE: ALL WD DIMS TO ST & GINEN & CARP CLK VARIOUS UNLESS OTHERWISE NOTED.

## 8. Specifications

Written instructions are used to explain any aspect of the building that is not easily shown in the drawings. The level of quality expected would be detailed in the specifications. (See the illustration on the next page.)

All aspects of the plans must be carefully checked to make sure they conform to the building codes.

Of these, 5 categories are of particular interest to the drywall worker. They are:

1. Floor plan
2. Details
3. Sections
4. Schedules
5. Specifications

## 6B: Gypsum Wallboard Walls and Ceilings

### 1. General

The contractor shall furnish all labor, material, and equipment to install and finish all interior wall and ceiling surfaces. All interior nonload-bearing wall systems shall be erected as indicated on the drawings and in accordance with the finish schedule and the specification. All work shall be coordinated with the electrical contractor and the other trades.

### 2. Materials

The materials furnished shall include gypsum wallboard, gypsum ribs, metal studs, metal furring channels, floor and ceiling runners or track, rough door bucks, metal door frames, corner stiffening, internal reinforcing for attachment of cabinets and fixtures, laminating adhesives, and joint finishing systems. All gypsum wallboard materials and system components shall be as recommended by the Gypsum Association.

### 3. Work Specified Elsewhere

The following materials and systems and their installation are specified in other sections of the specifications: interior wood studs, exterior wall furring, suspended ceilings, acoustical work, doors, finish hardware, vinyl wall covering, and painting.

### 4. Delivery, Handling, and Storage

All materials shall be delivered in their original, unopened packages, containers, or bundles that clearly identify the manufacturer or supplier. Materials shall be kept dry and in a protected location prior to installation. Care shall be taken to avoid damage to edges, ends, and surfaces of the gypsum wallboard.

### 5. Gypsum Wallboard Installation

Conventional methods of stud construction shall be used

**Materials.** For a nonfire-rated installation  $\frac{1}{2}$ -inch-thick tapered-edge regular gypsum wallboard shall be used. For a fire-rated installation  $\frac{5}{8}$ -inch-thick tapered-edge Type X gypsum wallboard shall be used. The installer shall use an approved joint finishing system.

The drywall contractor shall check all framing for bowed, warped, or misaligned members prior to the installation of wallboard or gypsum lath and shall report in writing to the general contractor any conditions that are unsatisfactory for the proper application of wallboard or gypsum lath and the concealment of joints or nail heads. Wallboard shall be applied face side out, either vertically or horizontally, and nailed using

First, the plans are used to estimate the material and labor necessary to complete the job and to make the bid. Once the job is given to the contractor(s) the plans serve as the instruction guide and reference to make sure of the accuracy and/or the correctness of the work. Another very important function of the plans is to allow for the successful cooperation between the various trades that must work together to complete the project. Careful study of the plans will reveal what work must be completed and what inspections must be made before the drywall work is begun. Framing (carpentry), heating, electrical,



plumbing and sheet metal are examples of work that must be partly or fully finished before drywall work begins. A checklist is often used to make sure that all necessary work has been done, inspected and is free of defects that might get in the way of a successful application of drywall. Such items as warped framing, protruding plumbing and incomplete work are examples of things that should be checked before continuing with drywall application.

Failing to check the completeness or satisfactory quality of earlier work (before beginning to apply drywall) has several drawbacks. First, you may interfere with other tradespeople by getting in their way or covering their work before they are done. This will interrupt both schedules, causing delays and added expense.

Perhaps more importantly, if work proceeds before the required inspections, the inspector can and may require the removal of all work done so that the inspection may take place. This is a total waste of time, material and energy.

It should be the responsibility of each tradesperson to assure the readiness of each phase of work before beginning to make the necessary corrections or before starting a new step in building.

Construction will proceed much more smoothly, schedules will be more easily kept and cooperation from other tradespeople will also improve.

# Self Assessment

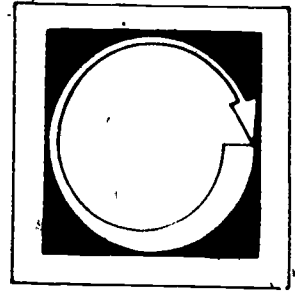

ANSWER THE FOLLOWING QUESTIONS BY CIRCLING THE CORRECT ANSWER OR BY WRITING A "T" (TRUE) OR "F" (FALSE) IN THE BLANK PROVIDED.

1. Of the 8 categories of the working plans, how many are of special interest to the drywall trade? 5 / 3 / 7
2. The foundation plan / floor plan shows the horizontal shape of the building and room layout.
3.  True or False. Fireplaces and stairways are often shown in sectional drawings.
4.  True or False. Schedules and Specifications are the same.
5.  True or False. Foundation plans are of special interest to the drywall trade.

# ● Self Assessment Answers

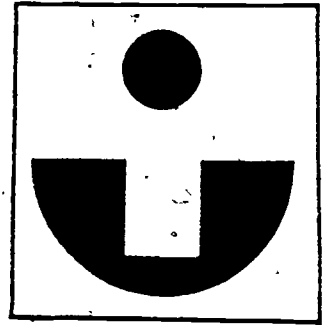

1. 5
2. floor plan
3. T
4. F
5. F

# Assignment

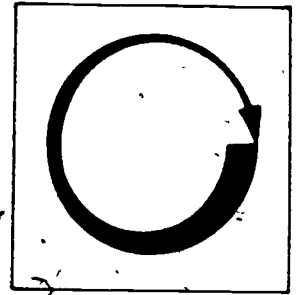

WRITE THE ANSWER IN THE SPACE PROVIDED AND GIVE THIS PAGE TO YOUR INSTRUCTOR.

1. Describe the difference between schedules and specifications.
2. Explain why cooperation between tradespeople is important.
3. Describe the major reasons a drywall worker should be able to understand the various parts of the plans for a building.
4. List and explain the importance of the 5 major categories of building plans which are of special interest to the drywall worker.

5. Describe what happens when drywall application begins before other work is properly completed or inspected.

# Post Assessment

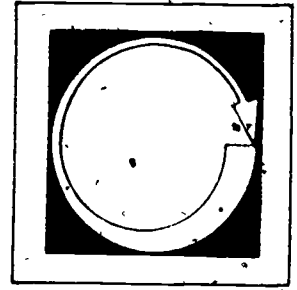

ANSWER THE FOLLOWING BY CIRCLING THE CORRECT ANSWER, BY LISTING THE CORRECT ANSWER, OR BY WRITING A "T" (TRUE) OR "F" (FALSE) IN THE BLANK PROVIDED.

1. Charts or tables listing specific sizes, types and/or manufacturers are found in specifications/schedules.
2. List some typical things to check for before starting drywall application
  - a.
  - b.
  - c.
  - d.
3.  True or False. Building inspectors can require the removal of covering work if earlier work had not been inspected and checked off.
4. The quantity / quality of work to be performed is outlined in specifications.
5.  True or False. Plans need not comply with local building codes.

# ● Instructor Post Assessment Answers

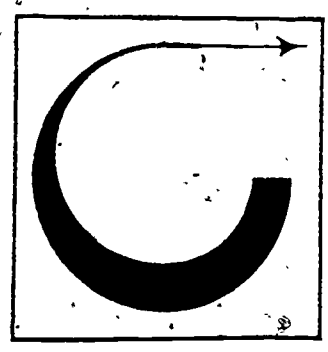

1. schedules
2. a. framing irregularities  
b. plumbing alignment  
c. building inspections  
d. completion of other trades work
3. T
4. Quality
5. F

## MEASURING AND MARKING DRYWALL

### Goal:

The student will be able to describe and demonstrate the techniques required to accurately and efficiently measure drywall.

### Performance Indicators:

The student will demonstrate a knowledge of measuring and marking techniques by successfully completing the Self Assessment, completing 3 Assignments, 3 Job Sheet tasks and a Post Assessment.



# Study Guide

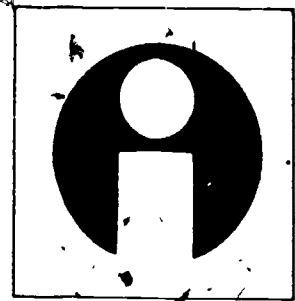

In order to finish this module, do the following tasks. Check each item off as you complete it.

1.  Read the Goal and Performance Indicators on the cover of the module. This will tell you what you will learn by studying the module, and how you will show you've learned it.
2.  Read the Introduction. The Introduction will tell you why the module is an important part of the drywall trade.
3.  Study the Vocabulary section. Vocabulary words are important for a good understanding of the trade. After you have studied the vocabulary, ask your teacher to quiz you on the words and their meanings.
4.  Study the Information section. This section will give you the information you need to understand the subject.
5.  Take the Self Assessment exam. This is a test for you to prove to yourself that you have learned the material you have studied. Compare your answers with the answers on the Self Assessment Answer Sheet, which is on the page following the Self Assessment. If you scored poorly, re-study the Information section or ask your teacher for help.
6.  Do the Assignment page. Follow the instructions at the top of the Assignment page.
7.  Do the Job Sheet. Follow the instructions at the top of the Job Sheet. The tasks listed on the Job Sheet will help you develop skills which will be helpful to you.
8.  Take the Post Assessment exam. Give the exam to your teacher after you have completed it. Your teacher will grade it for you.

# Introduction

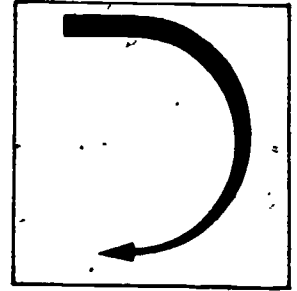

Accurately marking drywall is the important first step in its application. Failure at the measuring point creates many unwanted problems, wasting time and materials.

# Vocabulary

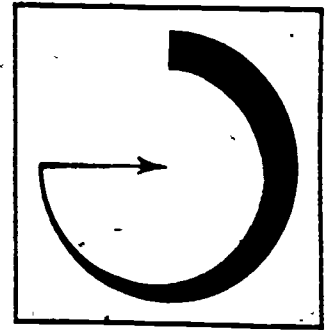

Trade terms are very important for a good understanding of the trade. Study these words and meanings. When you have learned them, ask your teacher to quiz you on the words and their meanings.

PERPENDICULAR--At a right angle to the side or edge.

PARALLEL--In-line with the edge and equal distant at all points.

BUTT--Cut to be made perpendicular to the papered edge of a drywall sheet.

RIP--Cut to be made parallel to drywall sheet's edge.

RISE--Vertical gain in height of a roof or ceiling.

RUN--Horizontal distance traveled from plate to center line of ridge in ceiling.

REVERSE CUT--Measuring and marking the portion of a sheet of drywall that is being removed (not used).

HIGH--Measurement of the longer of 2 widths on a sheet of drywall with angle to be cut.

LOW--Measurement of the shorter of 2 widths on sheet of drywall with angle to be cut.

# Supplementary References

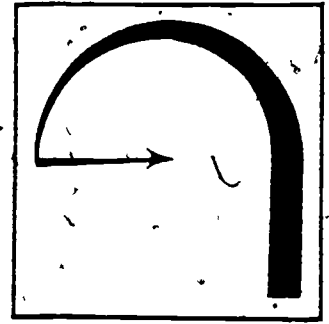

1. Gypsum Construction Handbook. U.S. Gypsum, 1978. p. 379.
2. Using Gypsum Board for Walls and Ceilings. Gypsum Assoc., 1970. p. 7.
3. Drywall Construction Workbook. Part I. California State Dept. of Ed., 1975. pp. 56-63, 132-137, 152-155.

# Information

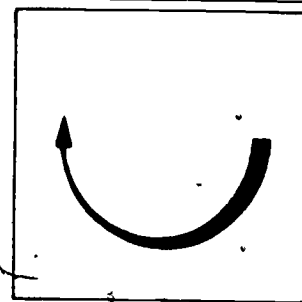

Careful planning and accurate measurements are very important to successful drywall installation. Time carefully spent at this stage of the job can save much effort, materials and more time from being wasted later on in the project. All of these savings mean lower costs as well as less work.

Drywall workers must know both the tools and methods for using them to achieve the required accuracy for marking drywall.

The most common marking tools are:

1. 4' T-square.

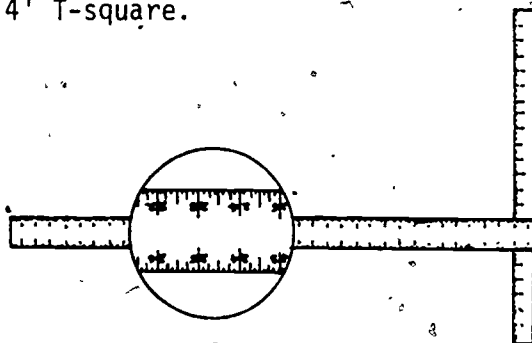

2. Steel tape

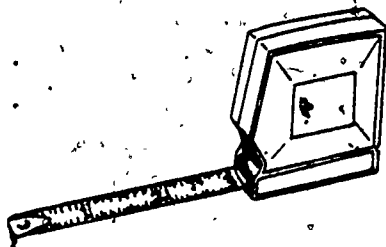

3. Chalkline.

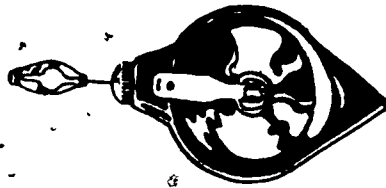

4. Straightedge.

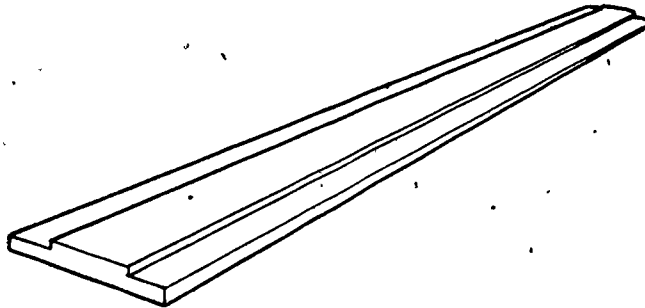

5. Markers: Pencils

As with all tools, care should be taken to protect them from damage. Damaged or broken tools, especially measuring and marking tools can seriously hurt the accuracy of any markings. Then even the best measuring and/or marking methods may be of little use.

Starting with an accurate measurement at the precise location, on the wall or ceiling is very important. Drywall installers should first look for any irregularities in the surface being covered.

Checking for plumb and square surfaces is quite useful in discovering these types of potential problems. It will also cut down on improperly marked and cut sections of drywall that, when cut "square," fail to fit. Depending on

the type and degree of the problem, the drywall installer will either fix the problem or call in the right tradesperson to fix the problem before continuing.

Most such troubles should already have been removed through quality work and proper inspections.

Another point is to try to use the largest sheets practical for the job. As an example, use sheets that span an entire wall or ceiling. This tends to minimize marking and cutting and later joint treatment.

When the planning, inspection and measurements have been done, lay out the measurements on the drywall sheet. Double check the measurements. Make certain to take the measurements from the last piece of drywall installed. This will help make sure that any irregularities that still exist are being considered. Be sure that proper allowances for overlapping of framing members (what the drywall is attached to) is included in your measurements.

A special technique used for transferring measurements to drywall materials is known as "reverse cut." In this method the desired measurement is subtracted from the length or width of the drywall sheet being used. This way, only the unused portion is measured. This saves stretching the tape out the full length or width measurement.

This method requires the drywall installer to be able to subtract amounts quickly from standard drywall dimensional figures such as 48", 96", 120", 144", 168", 192". This subtraction must also include fractions of an inch.

When using the reverse cut method, the width dimension is generally called out first by the measurer and then marked off on the sheet by the marker. The length is then measured off and marked the same way. This allows for measuring and marking to occur at the same time. This method works best when dealing with basically straight line marking. Dealing with angles and other irregular shapes takes more time and care.

Walls to sloped ceilings are a common example of angles that must be calculated and marked by the drywall installer. The "pitch" or slope of the roof measured in the vertical drop in inches per foot of horizontal travel must be calculated. This is determined by the rise and run of the roof. These figures may be

obtained from the plans or found directly from measuring the wall itself. These figures will allow the installer to figure the measurements for each piece in advance. There will be 3 measurements for each angled piece required for this sloped wall section. They are known as:

1. The low
2. The high
3. The length

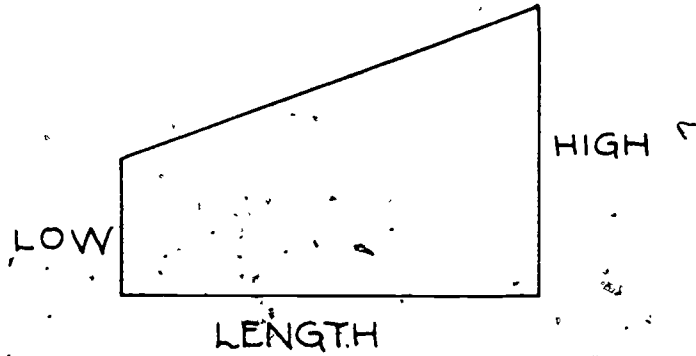

Given the length, either the high or low and the roof's slope in inches, the remaining measurement can be calculated. If this method of precalculating is used, it may be done by an alternating layout on a drywall sheet to cut down on waste.

HIGH	LOW	
12'	0'	①
24'	12'	②
36'	24'	③
48'	36'	④



SHEET OF DRYWALL

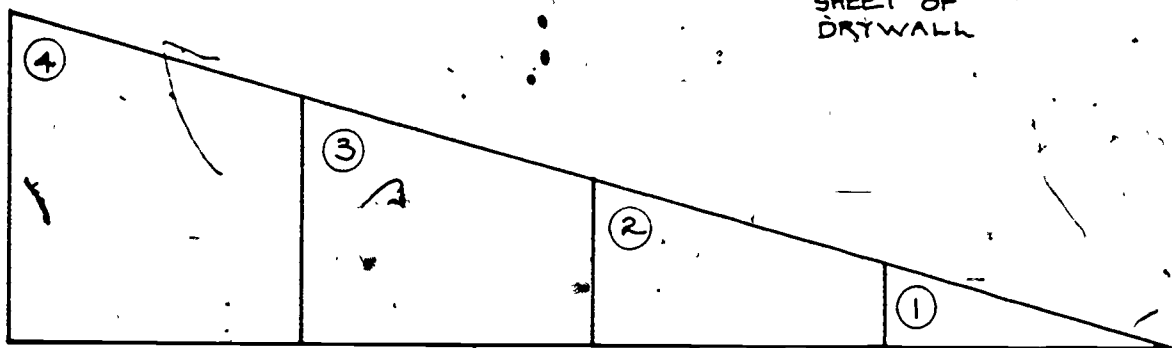

PIECES REQUIRED FOR WALL



When marking angles longer than 4', a straight edge or chalkline should be used.

Another important point when marking and measuring drywall is to carefully mark the location of outlets, fixtures, plumbing and other items that will be behind the drywall. There are two main reasons for this type of marking. First, any cutouts to be made will be more easily and accurately made if they are carefully located in advance. Accidents and/or damage caused by attaching (such as nailing through copper plumbing pipe) will be reduced or avoided entirely.

The methods required for successfully marking drywall are not difficult, but really require care and common sense.

# Self Assessment

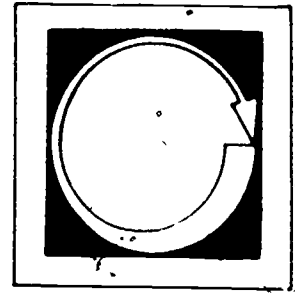

CIRCLE THE CORRECT WORD OR WORDS TO COMPLETE EACH STATEMENT. PLACE "T" OR "F" IN THE BLANK PROVIDED FOR THE TRUE OR FALSE STATEMENT (2).

1. When marking a drywall sheet for a butt cut, the line will be parallel / perpendicular to the papered edge.
2.  True or False. Measurements for cutting drywall can be taken off the working drawings.
3. Accurate / Speedy measurements are most important.
4. When marking angles longer than 4', what tool should be used?  
steeltape / chalkline / T-square
5. When measuring drywall, allowances for overlapping the next sheet / framing members must be considered.

# ● Self Assessment Answers

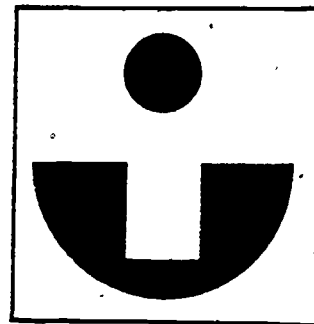

1. perpendicular
2. F
3. Accurate
4. chalkline
5. framing members

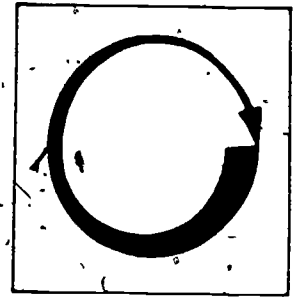

# Assignment

COMPLETE THE ASSIGNMENT BELOW.

Given the diagram below:

1. Figure the number of 4' X 8' sheets required.
2. Give the high, low and length of each angle cut piece.
3. List the dimensions of the scrap.

Rip Pieces

Butt Pieces

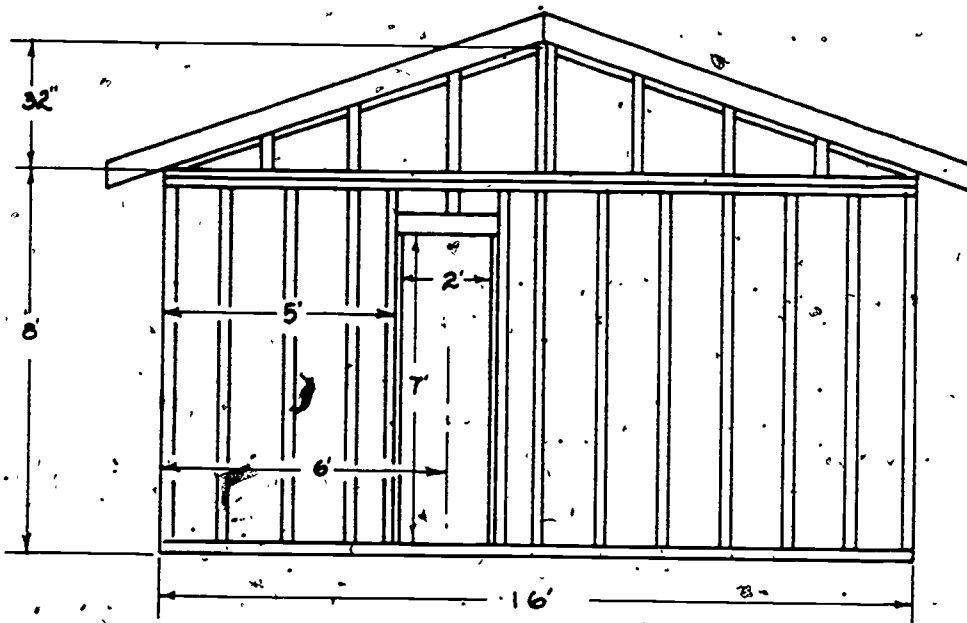

# Job Sheet

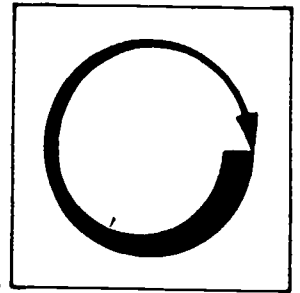

COMPLETE THE FOLLOWING TASKS.

## Materials and Tools

drywall sheets  
 electrical outlet box (or template same size)  
 steel tape  
 4' T-square  
 chalkline  
 straightedge

1. Measure and mark a drywall sheet using the reverse cut method for the following:

<u>Widths</u>	<u>Lengths</u> (from 96" length)
26 1/2"	54"
32"	60"
38 3/4"	72"
	80"

2. Measure and mark for these angle cuts given:

<u>High</u>	<u>Low</u>	<u>Lengths</u>
18	12	48"
36	22	84"

3. Locate and mark an outlet box that is 16 3/4" square.  
 (See the illustration on the next page.)

OUTLET BOX 16 3/4" SQ.

A = 16 3/4"  
B = 18"

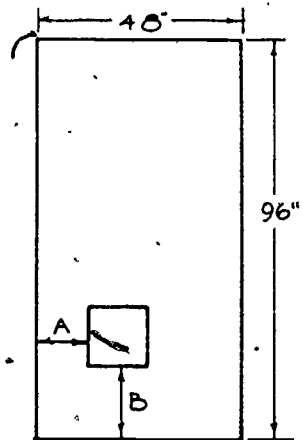

# Post Assessment

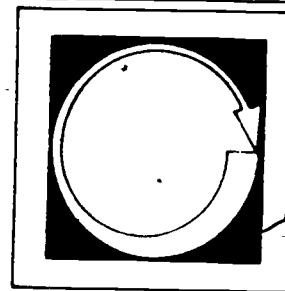

ANSWER THE QUESTION WITH A SHORT RESPONSE AND COMPLETE THE STATEMENTS BY CIRCLING THE CORRECT RESPONSE OR BY FILLING IN THE BLANK.

1. Besides the length and width measurements for a sheet of drywall what else needs to be checked-out on the framing?
2. Using the rise and run of a ceiling allows for computing \_\_\_\_\_.
3. Correcting irregularities in framing discovered during measurement should be corrected before / after making final measurements.
4. The longest / shortest length sheets of drywall should be used when planning and measuring.
5. When measuring for an angle cut, the high is the longer / shorter of the 2 widths.

# Instructor Post Assessment Answers

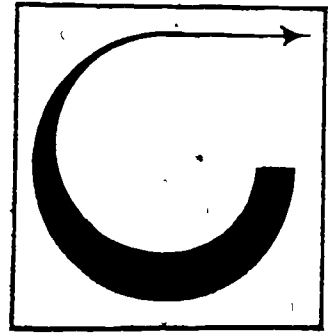

1. Is framing square?
2. angles
3. before
4. longest
5. longer

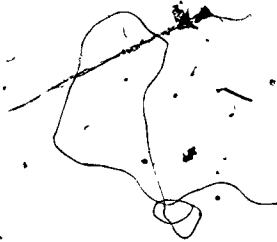



## SCORING, BREAKING AND EDGE TREATMENTS

### Goal:

The student will:

1. Be able to demonstrate the techniques used to properly cut drywall sheets. This will include rip, butt, angled, curved and cut out cuts.
2. Identify and properly apply water resistant sealant to required drywall edges and surfaces.

### Performance Indicators:

The student will successfully complete and review a Self Assessment test, successfully complete a Job Sheet and successfully complete the Post Assessment exam.

# Study Guide



In order to finish this module, do the following tasks. Check each item off as you complete it.

1.  Read the Goal and Performance Indicators on the cover of the module. This will tell you what you will learn by studying the module, and how you will show you've learned it.
2.  Read the Introduction. The Introduction will tell you why the module is an important part of the drywall trade.
3.  Study the Vocabulary section. Vocabulary words are important for a good understanding of the trade. After you have studied the vocabulary, ask your teacher to quiz you on the words and their meanings.
4.  Study the Information section. This section will give you the information you need to understand the subject.
5.  Take the Self Assessment exam. This is a test for you to prove to yourself that you have learned the material you have studied. Compare your answers with the answers on the Self Assessment Answer Sheet, which is on the page following the Self Assessment. If you scored poorly, re-study the Information section or ask your teacher for help.
6.  Do the Job Sheet. Follow the instructions at the top of the Job Sheet. The tasks listed on the Job Sheet will help you develop skills which will be helpful to you.
7.  Take the Post Assessment exam. Give the exam to your teacher after you have completed it. Your teacher will grade it for you.

# Introduction

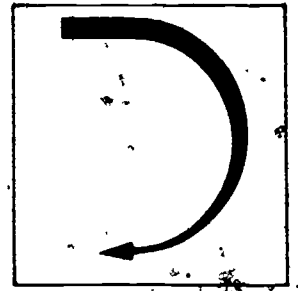

Clean and precise cutting of drywall sheets is critical to (necessary for) the proper fitting and final finishing of applied drywall sections. Care must be taken to properly treat and seal edges to ease fitting and give longer life to the drywall installation.

# Vocabulary

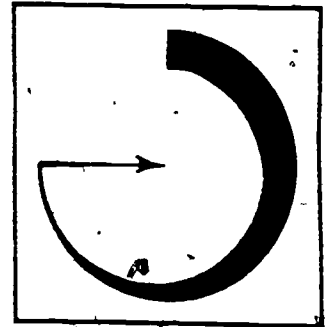

Trade terms are very important for a good understanding of the trade. Study these words and meanings. When you have learned them, ask your teacher to quiz you on the words and their meanings.

**KERF**--Slit or notch made with a saw that does not pass all the way through the material being cut.

**RIP CUT**--Cut made along the length of a sheet of drywall.

**BUT CUT**--Cut made across the width of a sheet of drywall.

**ARCH SOFFITS**--Underside of arch is inside buildings.

**ARRISES**--Sharp edges formed by the meeting of 2 surfaces (i.e. the joint between a wall and an arch).

# Supplementary References

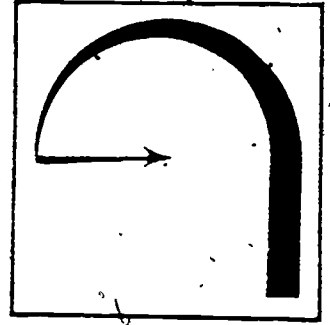

1. Gypsum Construction Handbook. U.S.G., 1978. pp. 14, 110-112, 161.
2. Using Gypsum Board for Walls and Ceilings. Gypsum Association, 1970. pp. 7-8.
3. Drywall Construction Handbook. Part I. California State Dept. of Ed., 1974. pp. 77, 132, 152, 156.

# Information

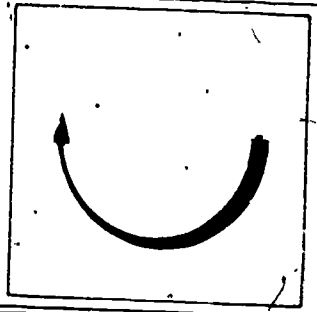

Successful cutting of drywall into the many shapes required depends on using both the proper tools and the correct techniques.

In addition, special edge treatments are required for areas such as tub and shower enclosures. They must be done at the cutting stage.

The most important tool for the drywall installer is the utility knife.

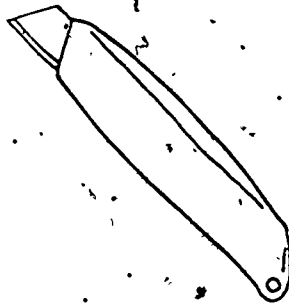

Most basic cuts are performed with this tool. Attention must be given to keep the blade sharp and clean at all times. A dull blade takes more force to penetrate the material and is likely to catch or tear the face paper. At the same time, take care to avoid cuts or other injuries caused by this tool. In addition, there are several other tools used in cutting drywall. They include:

Circle Cutter: Used to cut circular holes 1" to 14".

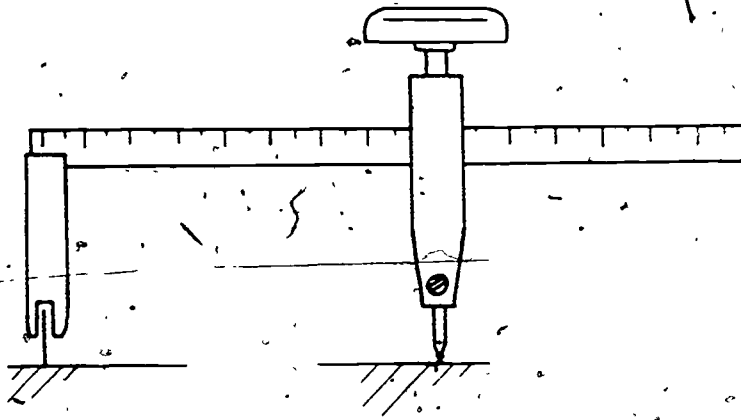

Drywall Saw: Pointed nose, short blade and coarse teeth.

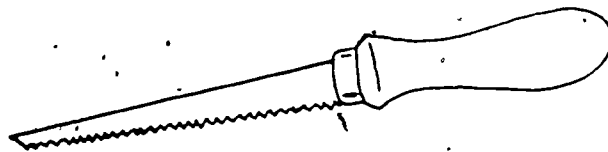

Utility Saw: Similar in design to a keyhole saw. Used for small openings and irregular cuts.

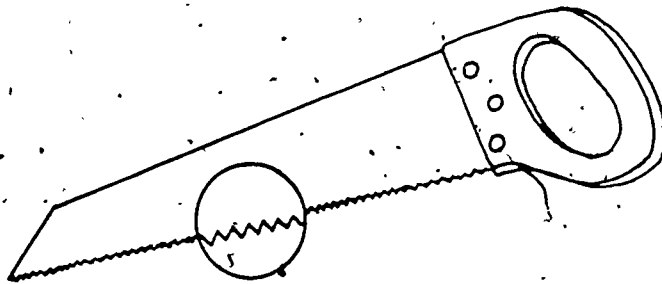

Wall Board Ripper: Used to cut strips from drywall 4 1/2" or less in width.

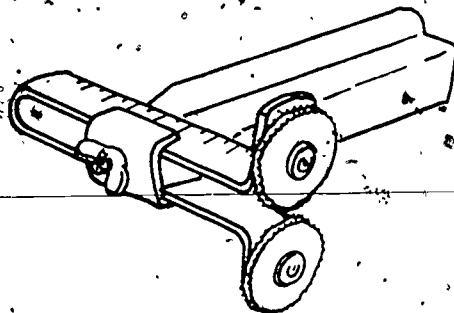

Tape Guide and Tip: Installed on steel tape, blade of utility knife is placed in tip and cut is made.

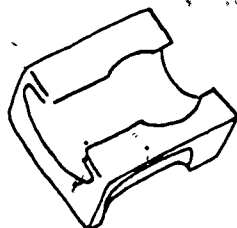

TAPE GUIDE

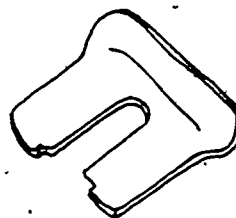

TAPE TIP

Straightedge and T-square: Used to assist cutting with utility knife.



Light Box Cutter: Used to make cutouts for electrical outlet boxes.

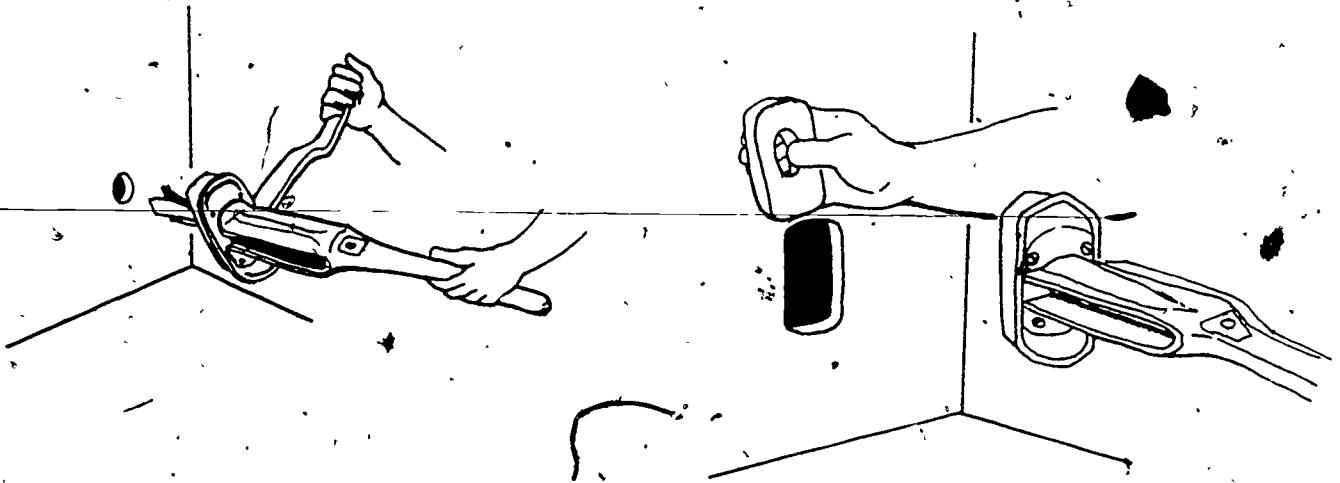

After the cuts have been made, rasps, hook billed knives and sandpaper are used to clean and smooth the edges for improved fit.

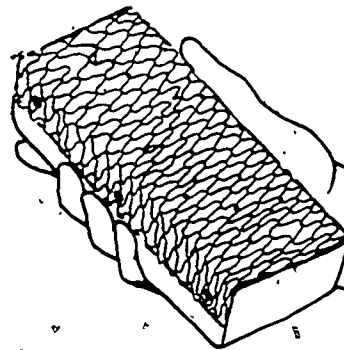
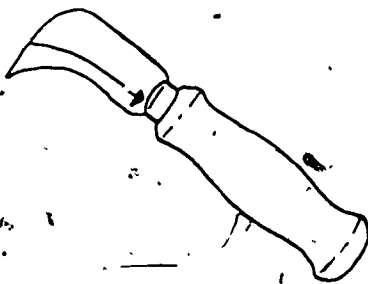

Rasping block--  
made with metal  
lath over wood  
block

#### STRAIGHT LINE CUTS

After proper marking, straight line cuts are usually made using the following procedure:

1. Score face paper with utility knife.
  - a. use T-square for butt cuts
  - b. use straightedge or tape guide and tip for rip cuts

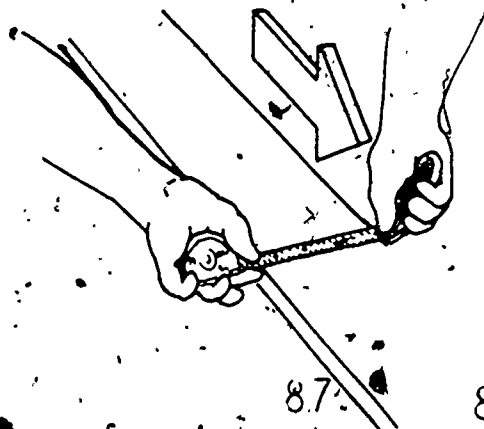

2. Snap the core.

- a. for butt cuts, drywall sheet is:
- (1) rested on edge
  - (2) grasped one hand on each side of scoring
  - (3) snapped with a twist of the wrist

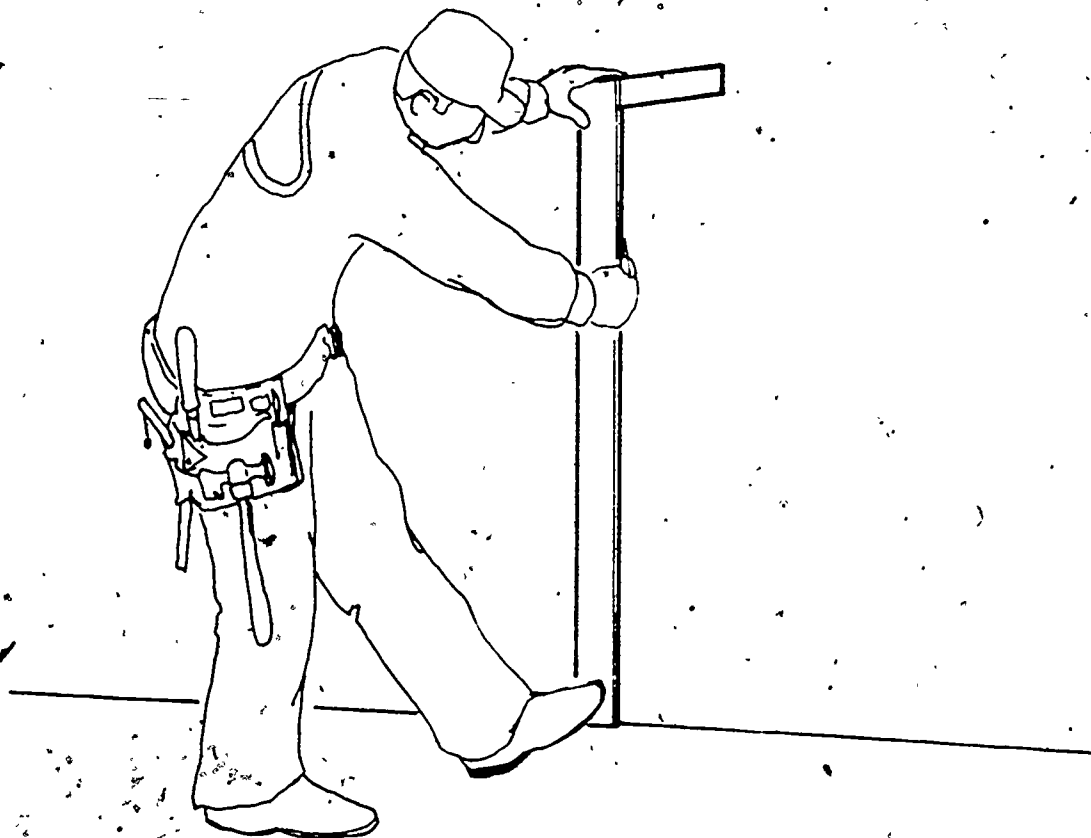

- b. for rip cuts, the drywall sheet is:
- (1) supported horizontally
  - (2) broken downward away from scoring
- (See the illustration on the top of the next page.)

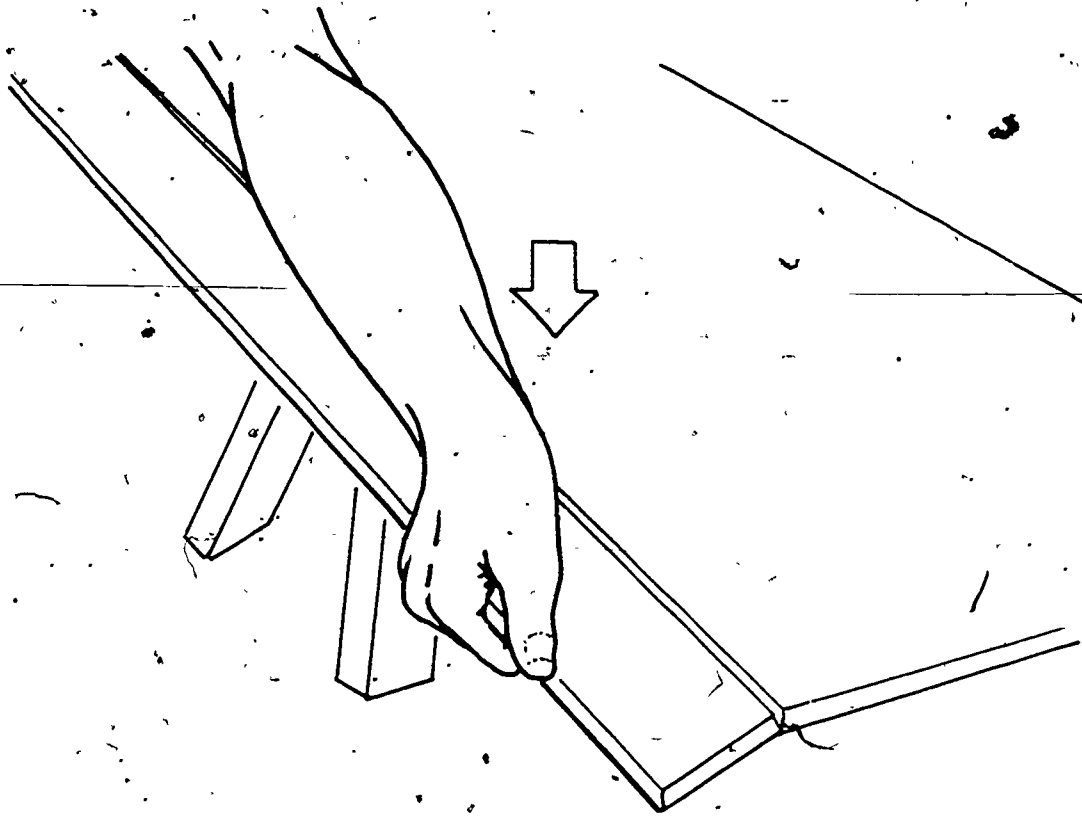

3. Cut the backing paper.

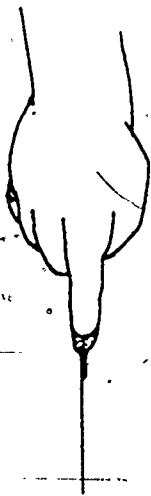

4. Edges should be smoothed with rasp or sandpaper. For straight-line cuts of less than 4 1/2", a drywall ripper may be used. (See the illustration on the top of the next page.)

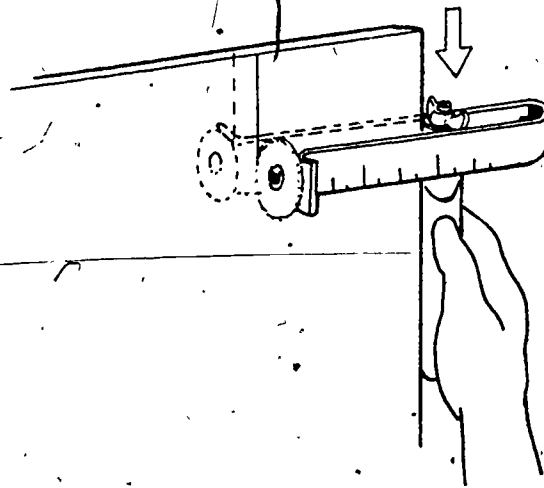

### IRREGULAR SHAPES/CUTOUTS

A utility saw or drywall saw is used to make many irregular cuts. Be sure to cut through from the face paper side of the sheet to assure a clean cut.

Light box cutters are used to make uniform cutouts for electrical outlet boxes. Circle cutters are used to make precise openings for pipes, ducts, etc.

### CURVING DRYWALL FOR INSIDE CURVES (arches)

Arch soffits require drywall to be curved in a fairly tight radius. This means that the drywall sheet must either be steam bent or kerfed to allow for sufficient bending to occur.

1. Kerf backing 1" on center (at right angle to curve) by cutting through backing paper.

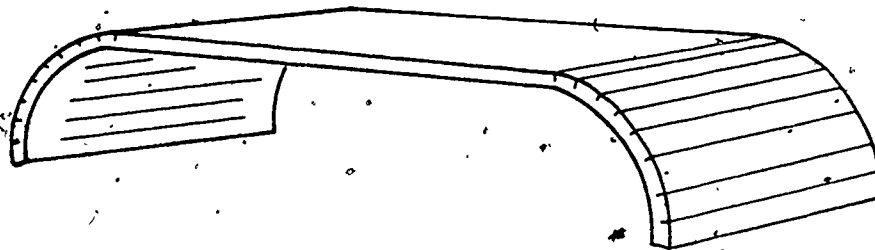

- a. do not cut through face paper.
2. Snap-Core.
3. Board is then ready to apply.
  - a. care must be taken to allow for reinforcing at the arrises of the arch as is done for corner moldings.

#### CURVING DRYWALL FOR OUTSIDE CURVES

Rounded corners or pillars require an outside curving of drywall. Again the sheets must be steam bent, or kerfed from the backside to allow for sufficient bending to take place.

1. Kerf through backing paper 1/2" on center using a radial arm saw.
  - a. be sure not to cut through facing paper.
2. Carefully bend drywall to desired curvature.

A special set of considerations are required when cutting drywall sheets for tub and shower enclosures.

First, full sheets are to be used. There should not be any joints between edges of surfaces to be covered over by tile or other materials. Second, the sheets should be cut to allow horizontal application. All cut or exposed edges at joints and holes, including the intersection of walls, must be treated with approved water resistant sealer. This material is brushed on like paint.

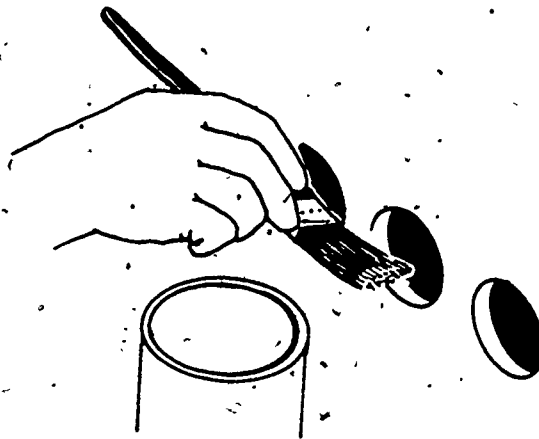

As an additional precaution, clear tape may be applied over the treated edges of cutouts to further protect against moisture.

The type of cut to be made will indicate both the best method to use and the most effective tools, as well.

# Self Assessment

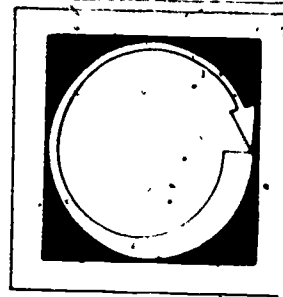

LISTED BELOW ARE SEVERAL STATEMENTS. IF THE STATEMENT IS TRUE, PLACE A "T" IN THE BLANK PROVIDED. IF THE STATEMENT IS FALSE, PLACE AN "F" IN THE BLANK.

1.  Rip cuts are made across the width of a drywall sheet.
2.  Drywall is scored (cut) through the backing paper first.
3.  Dull knife blades should be sharpened or replaced.
4.  Drywall sheets are cut all the way through with only one cut.
5.  All cut edges on drywall sheets require sealant.

# Self Assessment Answers

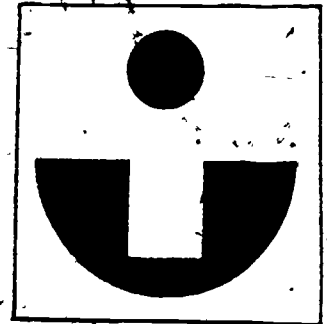

1. F
2. F
3. T
4. F
5. F



# Job Sheet

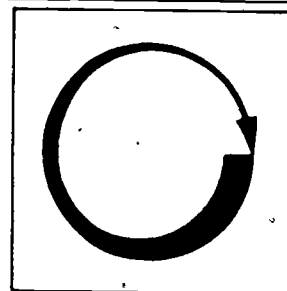

COMPLETE THE TASKS BELOW BY PERFORMING THE FOLLOWING TYPES OF CUTS ON DRYWALL SHEETS USING APPROPRIATE TOOLS AND METHODS.

## Materials and Tools

drywall sheets  
water resistant sealant  
utility knife  
circle cutter  
drywall saw  
straightedge  
utility saw  
steel tape with guide and tip  
T-square  
rasp  
wall board ripper  
light box cutter  
hook bill knife

## Types of Cuts

1. Make a butt cut
  - a. free hand
  - b. with T-square
  - c. with edge ripper
  
2. Make rip cuts and treat
  - a. free hand
  - b. with straightedge
  - c. with edge ripper
  - d. with tape guide and tip

3. Make angle cuts
  - a. free hand
  - b. with T-square or straightedge
4. Make circular cutout
  - a. with utility saw
  - b. with circle cutter
5. Kerf drywall sheet for:
  - a. inside curve (use 1" spacing)
  - b. outside curve (use 1/2" spacing)

Procedure

- A. Mark drywall sheet for cut.
- B. Select proper tools for cut.
- C. Complete cut.
- D. Treat edge with rasp, hook billed knife or sandpaper.
- E. Apply water resistant sealant to cut edge.

# Post Assessment

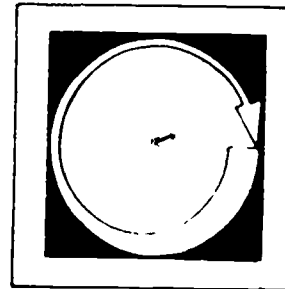

COMPLETE THE FOLLOWING STATEMENTS BY CIRCLING THE CORRECT WORD OR WORDS.

1. Recommended spacing for kerfing drywall sheets when covering an inside curve is 1" / 1/2".
2. Butt cuts on drywall are often made with the sheet resting along its length / width.
3. When covering tub and showers, regular / W/R type drywall should be used.
4. Water resistant sealant is applied to most / all cut or exposed edges for tub and shower enclosures.
5. When cutting the access to electrical wall outlets, the circle cutter / light box cutter is the best tool for the job.

# ● Instructor Post Assessment Answers

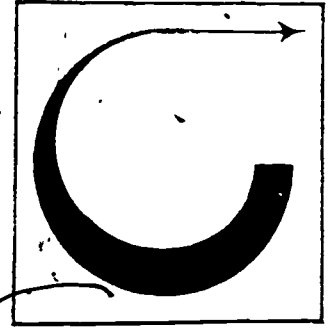

1. 1"
2. length
3. W/R
4. all
5. light box cutter

ATTACHING DRYWALL WITH NAILS

**Goal:**

The student will be able to describe and perform the steps required to attach drywall with nails on vertical and horizontal wood framed backing.

**Performance Indicators:**

The student will successfully complete a Self Assessment, a Job Sheet and a Post Assessment.

# Study Guide

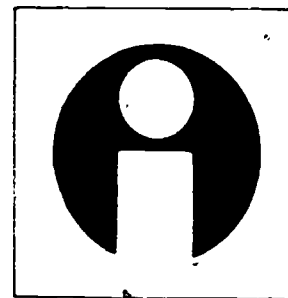

In order to finish this module, do the following tasks. Check each item off as you complete it.

1.  Read the Goal and Performance Indicators on the cover of the module. This will tell you what you will learn by studying the module, and how you will show you've learned it.
2.  Read the Introduction. The Introduction will tell you why the module is an important part of the drywall trade.
3.  Study the Vocabulary section. Vocabulary words are important for a good understanding of the trade. After you have studied the vocabulary, ask your teacher to quiz you on the words and their meanings.
4.  Study the Information section. This section will give you the information you need to understand the subject.
5.  Take the Self Assessment exam. This is a test for you to prove to yourself that you have learned the material you have studied. Compare your answers with the answers on the Self Assessment Answer Sheet, which is on the page following the Self Assessment. If you scored poorly, re-study the Information section or ask your teacher for help.
6.  Do the Job Sheet. Follow the instructions at the top of the Job Sheet. The tasks listed on the Job Sheet will help you develop skills which will be helpful to you.
7.  Take the Post Assessment exam. Give the exam to your teacher after you have completed it. Your teacher will grade it for you.

# Introduction

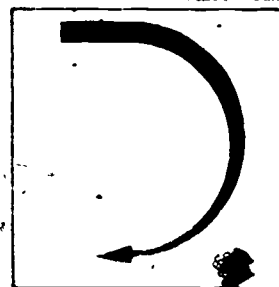

Nail-on application of drywall over wood framing is quite common. The drywall worker must be familiar with nail selection, nailing patterns and spacing, and the correct application process to make sure of a quality job.

# Vocabulary

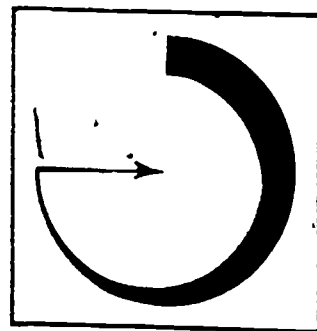

Trade terms are very important for a good understanding of the trade. Study these words and meanings. When you have learned them, ask your teacher to quiz you on the words and their meanings.

**CUPPED**--Concave shape of nail head used in drywall application.

**DIMPLED**--Depression or dent in drywall surface when nail is properly set with final hammer blow.

**FIELD**--The surface area of drywall sheet away from edges.

**FINGERING**--The action used to ready nails for driving into drywall.

**NAIL POPPING**--Surface defect caused when nail head shifts outward from the drywall sheet.

**SHRINKAGE**--Change in size of wood framing material due to differing moisture contents.



# Supplementary References

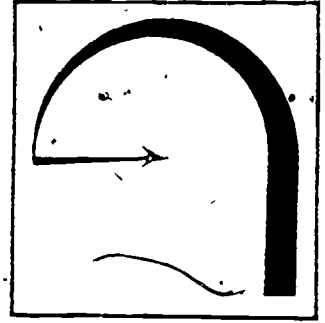

1. Drywall Construction Workbook Part I. California State Dept. of Education, 1975. p. 137.
2. Gypsum Construction Handbook. United States Gypsum. pp. 55, 107, 348-355.
3. "Nail Pop Control in Gypsum Drywall." Technical Report, C517. U.S. Gypsum.
4. Using Gypsum Board for Walls and Ceilings. Gypsum Association, 1970. pp. 14, 16, 24.

# Information

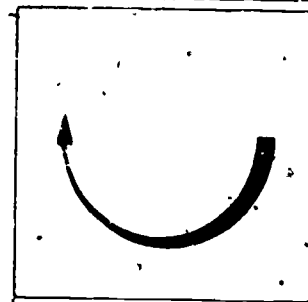

Attaching drywall to wood framing is most commonly done with nails. Applications are generally considered to be vertical for walls and horizontal for ceilings. While the type of nail, its length, the nailing pattern and required spacing may differ for vertical and horizontal applications, the process of applying is nearly the same.

The type and length of nail to be used is quite important for the overall success of the application. A poor choice of nail may lead to a poor job, which may cause a short life before repairs are required. Nails are described by:

1. Shape of their point.
2. Shank.
  - a. hardness of metal used.
  - b. surface treatment.
  - c. diameter.
3. Head.
  - a. diameter.
  - b. shape.
4. Overall length.

A great deal of research has been done on what makes up the "best" nail for drywall. A composite or average description of the best nail would be:

1. Point--Medium long diamond point.
2. Shank--Etched smooth, un-coated surface or annular ringed; 13-gage.
3. Head-- $19/64$ " diameter, cupped shape.
4. Length--Nail should penetrate wood framing (beyond drywall thickness).
  - a.  $7/8$ " for smooth shank
  - b.  $3/4$ " for annular ring nail

A nail fitting this description should provide good penetration and holding power, and not work loose if the wood shrinks. Another factor that may affect nail selection is when fire ratings are involved. Heat transmitted to wood framing by the nail shank may cause the wood to be charred and possibly weaken its holding power. Special nails may be required in these cases.

When the correct nail has been chosen, the nailing pattern and maximum spacing must be determined.

There are two basic nailing patterns: Single nailing and double nailing.

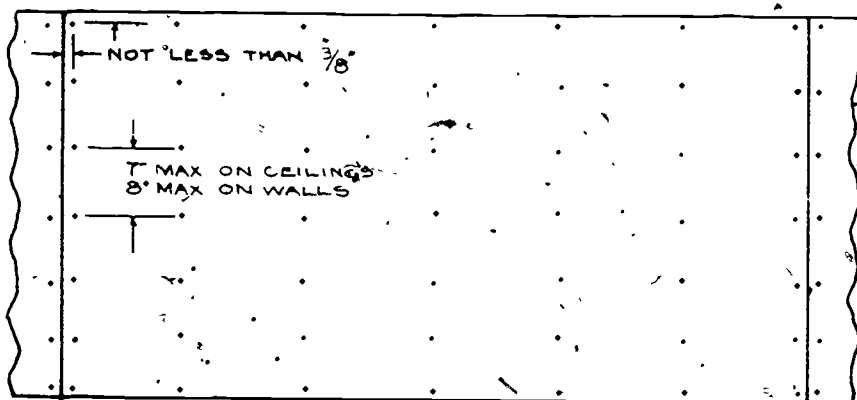

SINGLE NAILED GYPSUMBOARD

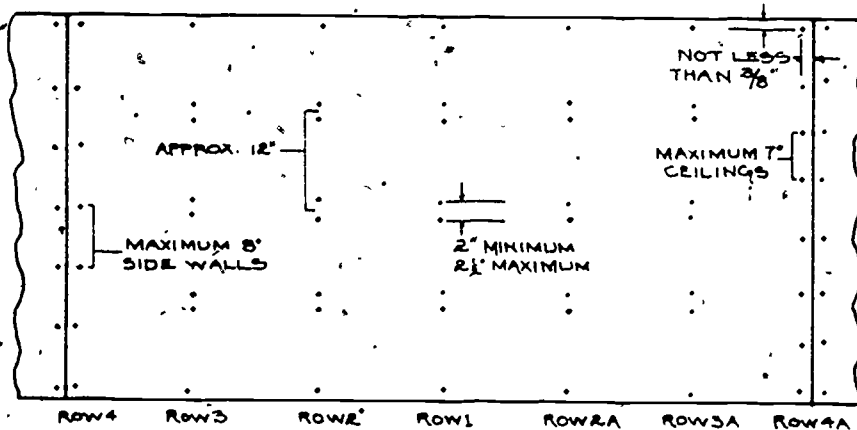

DOUBLE NAILED GYPSUMBOARD

The difference between the two methods is seen in the maximum spacing of nails in the field of the drywall sheet (see diagrams above). Spacing of nails around the edges is the same for both methods. Maximum 7" apart for horizontal (ceiling) and 8" apart for vertical (walls). Nails should not be applied less than  $\frac{3}{8}$ " from the edge of the drywall sheet. Double nailing has the advantage of wider spacing and it reduces the chance of loose spots between drywall and framing.

The procedure to follow in applying drywall is:

1. Check for any surface irregularities and correct them.
2. Start nailing near the center of the sheet and work outward.
3. Hold the sheet close to the framing when nailing.
4. Nail should be recessed--"dimpled" into drywall surface approximately 1/32".

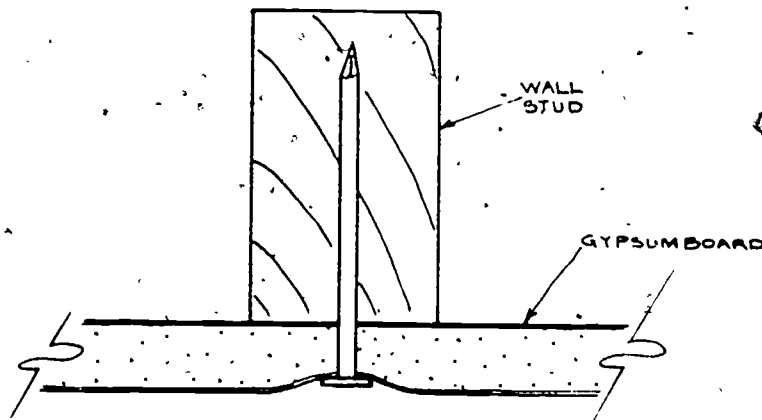

5. Be careful not to overdrive the nail and cut or tear the surface paper; this weakens the holding power.
6. Check for any loose spots.
  - a. re-nail to tighten.
  - b. give original nail extra tap to reset.
7. If nailing on both sides of a wall:
  - a. check first side for loosening after finishing second side.
  - b. give extra hammer blows to any loose nails to reset them.

Even when great care has been taken to use the correct nails, nailing patterns and application techniques, defects or surface failures may occur.

The most common defect arising from nail-on applications is "nail popping." (See the illustration on the next page.) The drywall surface moves in relation to the nail head and the surface covering is damaged and must be repaired. The usual reason this happens is that the wood framing member shrinks and allows the nail to "creep" or work loose. This happens when the moisture content of the wood changes.

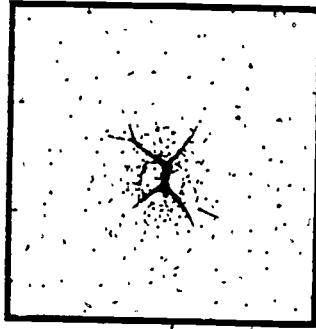

Major steps to be considered to prevent nail popping are:

1. Use framing lumber of low moisture content.
2. After framing is completed and the house is enclosed, wait as long as you can before applying drywall. This will allow the moisture content of the wood to stabilize and will lower the potential shrinkage.
3. Check for, and correct, any surface irregularities in the framing base.
4. Cut sheets for a loose fit.
5. Nail from center of the sheet outward.
6. Push in against the sheet near the point where you are nailing.
7. Dimple the nail into surface.
8. Check for loose spots and re-nail them if required.

# Self Assessment

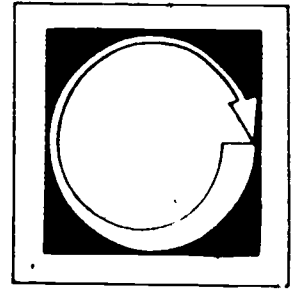

LISTED BELOW ARE SEVERAL STATEMENTS. IF THE STATEMENT IS TRUE, PLACE A "T" IN THE BLANK PROVIDED. IF THE STATEMENT IS FALSE, PLACE AN "F" IN THE BLANK.

1. \_\_\_\_ The longer the nail, the better the resistance to popping.
2. \_\_\_\_ Checking for protrusions and other surface irregularities in wood framing should be considered as routine.
3. \_\_\_\_ Nail spacing (maximum) is the same for wall and ceiling application.
4. \_\_\_\_ Double nailing helps to reduce loose boards in drywall.
5. \_\_\_\_ When applying a drywall sheet, nailing should start at the center of the field and work toward the edge and ends.

# Self Assessment Answers

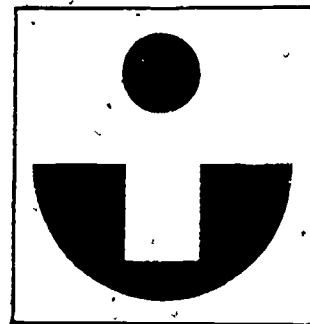

1. F

2. T

3. F

4. T

5. T

# Job Sheet

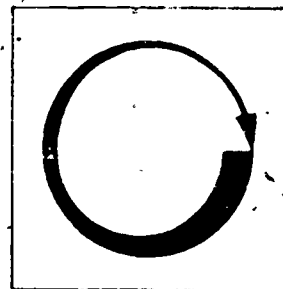

COMPLETE THE FOLLOWING 2 TASKS.

### Materials and Tools

drywall--various thicknesses

hammer.

tape measure

chalkline

drywall nails--various lengths

### Physical Requirements

wood stud work 16" o.c. (need not be 8' tall)

wood ceiling joists 16" to 24" o.c.

1. Apply sheet of drywall to vertical stud work.
  - A. Check stud wall for irregularities, unevenness.
  - B. Select drywall sheet to be applied.
  - C. Select nails.
    - (1) determine thickness of drywall
    - (2) add 7/8" to drywall thickness for smooth shanked nails, or add 3/4" to thickness for annular ring shank nails.
  - D. Move sheet into position on wall.
    - (1) be sure proper overlap of sheet edge over stud is maintained on each side (should cover 1/2 the stud face).
  - E. Mark position of studs.
    - (1) first, you may need to use a chalkline and tape until practice and feel become your guide.
      - a. mark 16" from edge of sheet top and bottom
      - b. snap a vertical line.
      - c. repeat steps 1 and 2 32" from same edge.



- (2) this will give you a visual nailing guide to line up nails with the studs behind the sheets of drywall.
  - (3) on future practice nailings, try to nail off the sheet without the help of the chalkline.
- F. Beginning at the center of the field, nail off the sheet. Be sure that:
- (1) nails are hitting the stud.
  - (2) drywall is held close to the stud when nailing.
  - (3) spacing between nails is not more than 8 inches.
  - (4) edge nails are not closer than 3/8" from edge.
  - (5) nails are dimpled into surface without cutting or tearing the surface paper.
- G. When nailing is completed, check entire sheet for any loose nails or loose spots between drywall and studs.

2. Attaching drywall to horizontal joist work.

A. Repeat steps A-D of 1st task, above.

B. Step 5, marking position of joists.

(1) verify joist spacing.

a. mark sheet top and bottom; distance equal to joist spacing over from edge of sheet.

b. double the distance from edge and repeat step 1.

(2) repeat steps E 1 and 2 from 1st task, above.

(3) repeat steps F and G from 1st task, above.

# Post Assessment

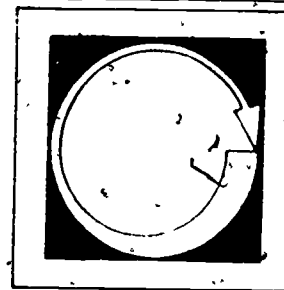

CIRCLE THE CORRECT ANSWER.

1. Nails (along edge of the drywall sheet should not be less than (1/4, 3/8, 1/2) inch away from the edge.
2. Double nailing allows for a (larger, shorter) maximum spacing of nails in the field.
3. Fire rated applications may require special nails because the heat transferred by the (drywall, nail shank) during a fire may weaken the nails' holding power.
4. Nails properly driven in drywall will be (flush to the surface, set into a "dimple" depression).
5. Maximum spacing of nails in the field in horizontal application is (7", 8", 9").
6. Is this the same as for vertical applications? (yes, no)

# Instructor Post Assessment Answers

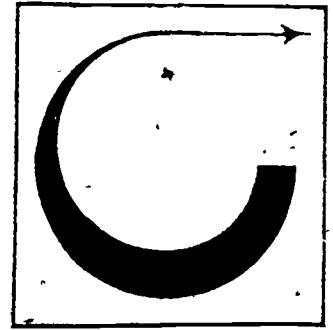

1. 3/8
2. larger
3. nail shank
4. set into a "dimple" depression
5. 7"
6. no

## ATTACHING DRYWALL WITH SCREWS

### Goal:

The student will be able to identify, select and properly use screws to attach drywall to various base materials.

### Performance Indicators:

The student will successfully complete a Self-Assessment, an Assignment, a Job Sheet and a Post Assessment.

# Study Guide

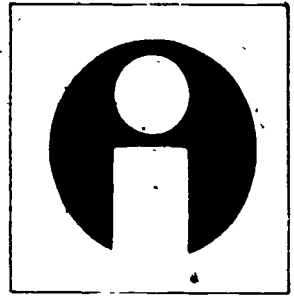

In order to finish this module, do the following tasks. Check each item off as you complete it.

1.  Read the Goal and Performance Indicators on the cover of the module. This will tell you what you will learn by studying the module, and how you will show you've learned it.
2.  Read the Introduction. The Introduction will tell you why the module is an important part of the drywall trade.
3.  Study the Vocabulary section. Vocabulary words are important for a good understanding of the trade. After you have studied the vocabulary, ask your teacher to quiz you on the words and their meanings.
4.  Study the Information section. This section will give you the information you need to understand the subject.
5.  Take the Self Assessment exam. This is a test for you to prove to yourself that you have learned the material you have studied. Compare your answers with the answers on the Self Assessment Answer Sheet, which is on the page following the Self Assessment. If you scored poorly, re-study the Information section or ask your teacher for help.
6.  Do the Assignment page. Follow the instructions at the top of the Assignment page.
7.  Do the Job Sheet. Follow the instructions at the top of the Job Sheet. The tasks listed on the Job Sheet will help you develop skills which will be helpful to you.
8.  Take the Post Assessment exam. Give the exam to your teacher after you have completed it. Your teacher will grade it for you.

# Introduction

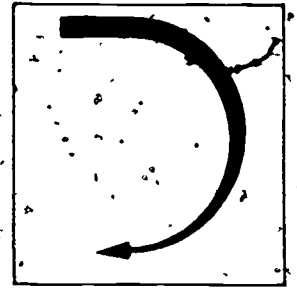

Screw-on application of drywall makes for tighter bonding of sheets to framing, with fewer fasteners required and usually less surface finishing required. Future defects, such as nail pops, are also reduced. Costs are often higher, but this method usually results in a longer-lasting job, which may balance the higher cost.

# Vocabulary

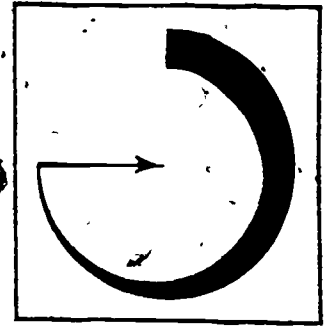

Trade terms are very important for a good understanding of the trade. Study these words and meanings. When you have learned them, ask your teacher to quiz you on the words and their meanings.

**SELF-DRILLING**--Property of the screw where it is able to "drill" or start its own hole in the metal stud.

**SELF-TAPPING**--Property of the screw to be threaded through the hole it drills and still keep its holding power and not strip out.

**CLUTCH MECHANISM**--Part of the electric screwdriver that allows the bit to remain stationary while the motor is running so the screw can be put on the bit and then drive the screw when pressure is applied to the screw point. (This is called engaging the clutch.)

**TYPE "W" SCREWS**--Specially developed screws for attaching drywall to wood framing.

**TYPE "S" SCREWS**--Specially developed screws for attaching drywall to metal framing and resilient channels.

**TYPE "G" SCREWS**--Specially developed screws for attaching drywall face ply to drywall base ply.

# Supplementary References

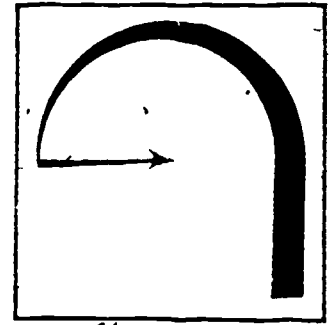

1. Using Gypsum Board for Walls and Ceilings. U.S. Gypsum Association, 1970. p. 14.
2. Drywall Construction Workbook. Part I. California State Dept. of Education, 1974. pp. 145-148.
3. Gypsum Construction Handbook. U.S. Gypsum Association, 1978. pp. 51-54, 113, 120.



# Information

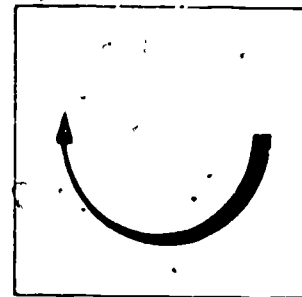

The increased use of high-rise construction and a concern for better fire-resistant building methods led to the development of metal studwork. Lower fire risks (compared to wood framing) and installed weight (compared to concrete or masonry partitions) were also advantages.

This method required the development of special screws and equipment such as the electric screw driver for screw-on attachment. Further development has led to screws for both wood framing and drywall-to-drywall attachment.

The drywall worker must be able to perform four important tasks for a successful screw-on application. They are:

1. Select proper screw.
2. Determine required spacing.
3. Locate underlying framing members.
4. Proper use of electric screw driver.

Selecting the proper screw depends on the type of application and the thickness of the drywall sheets being used. A common characteristic of drywall screws is the cupped Phillips head, which is chosen because it prevents screwdriver bits from slipping out of the slots.

The three major types of screws change shape and design to improve their effectiveness with specific framing base materials.

1. Type "W" is used for applications over wood framing. A diamond point and special threads improve both driving ease and holding power. Length selection should allow for a minimum of 5/8" penetration into the wood framing.
2. Type "S" screws are designed to attach drywall to metal stud framing and resilient channels. They are made with a hardened tip and are "self-drilling"

and self-tapping. Type "S" screws should have enough length to penetrate 3/8" into metal framing.

3. Type "G" screws have a similar design to type "W" screws, but have a deeper thread design for better holding power in the drywall sheet. These screws must penetrate a minimum of 3/8" into the drywall base.

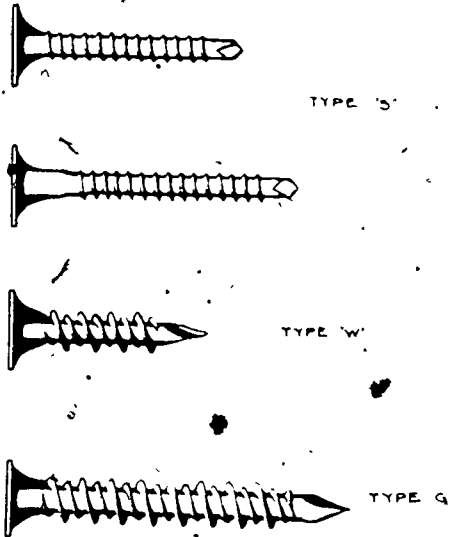

Spacing requirements for screws are wider than for nails. Screws should be spaced 12" O.C. for ceilings and 12" O.C. for walls with 16" framing spacing. When framing is 24" O.C. screws should have 12" O.C. maximum spacing for both walls and ceilings, also.

The ability to judge the location of underlying framing members is a process of "touch" and experience. The drywall worker needs to develop a "feeling" for what 12, 16 and 24 inches of length really are--by sight. For parallel applications this means visually dividing up the sheet into thirds for 16" O.C. framing and in half for 24" O.C. framing. Light tapping on the sheet will also help show where studwork is. (See the illustration on the following page.)

Failure to properly locate framing will result in screws missing their mark, which will result in loose spots.

With the screw selected, the spacing determined and the framing located, all that remains is to drive the screws. This could be done by hand, but it takes a long time and is not economical. Most drywall screws are driven with electric screwdrivers. Proper care, safety precautions and use are all important to the

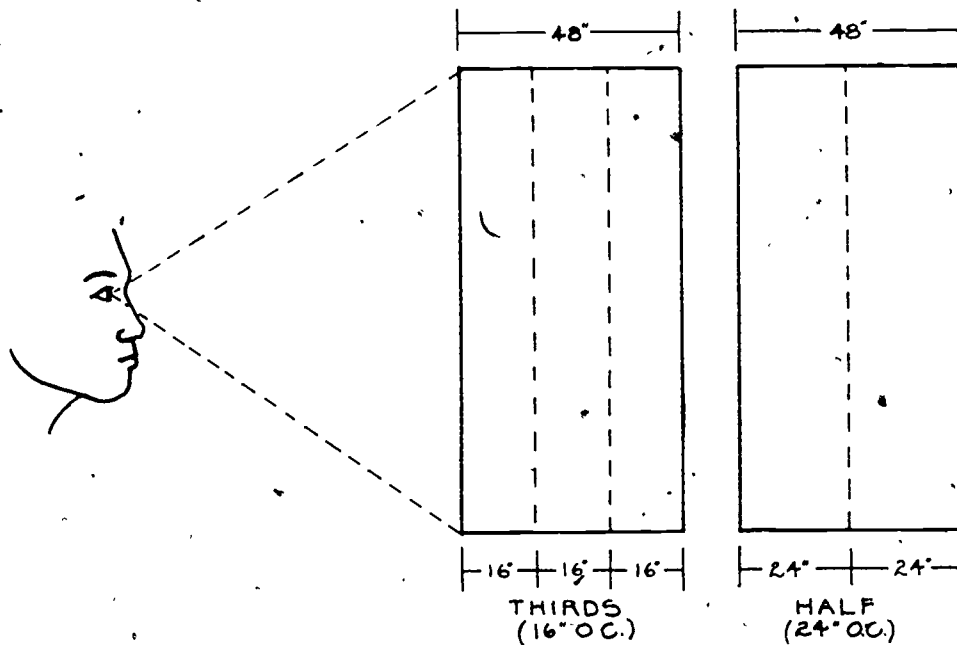

drywall worker. Before use, the electric screwdriver should be checked out to make sure it's in good working order and no electrical shorts exist. This may seem important only for work on metal stud work, but you should not forget that plumbing and electrical wiring could be behind any work you do.

The electric screwdriver is a specialized power tool much like an electric drill. The special feature is the adjustable positive clutch mechanism. This feature allows the Phillips head bit to remain stationary (not turning) while placing the screw onto the bit, even though the drill itself is turning.

The bit starts to turn only when the clutch is engaged. The clutch engages when the bit contacts the wall.

The clutch has a depth-adjustment feature which automatically disengages the clutch when the screw has been driven to the proper depth. This reduces the chances of overdriving the screw and damaging the drywall surface.

Improper depth adjustment can lead to "stripping out" the screw hole and causing loose spots.

Proper technique of use is important to the drywall worker both for safety and for proper installation.

Before using the electric screwdriver:

1. Inspect screw gun for any safety defects such as loose wires, cut cords, etc.
2. Inspect for proper electrical connection and safe power sources.

To drive screws:

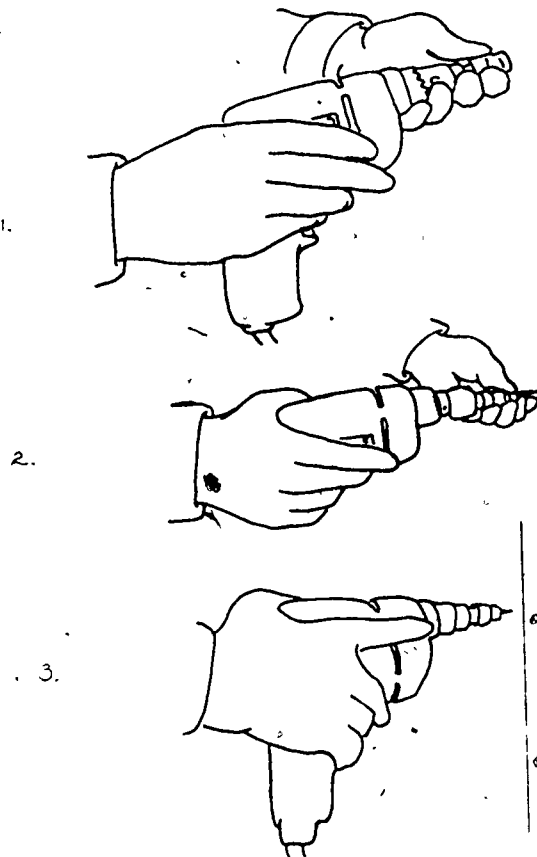

1. Get a firm grip on the screwdriver.
  - a. Avoid unnecessary stress to the wrist by gripping the body of the electric screwdriver, rather than the pistol grip.
2. Adjust depth control according to manufacturer's recommendations.
3. Put screw slots onto bit.
4. Find location where screw is to be driven.

5. Put screw point to drywall.
6. Be sure that electric screwdriver and screw are perpendicular (at a 90° angle) to drywall surface.
7. Apply pressure toward wall.
  - a. Clutch will engage and drive screw.
  - b. Clutch will disengage when screw is fully driven.

Properly done, screw-on attachment provides tighter attachment, less surface finishing treatments and reduces "nail pop" surface failures.

# Self Assessment

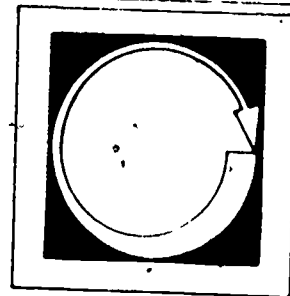

LISTED BELOW ARE SEVERAL STATEMENTS. IF THE STATEMENT IS TRUE, PLACE A "T" IN THE BLANK PROVIDED. IF THE STATEMENT IS FALSE, PLACE AN "F" IN THE BLANK.

1.  Both the type of framing base and the thickness of drywall being used determines the type and length of screw.
2.  Minimum depth of penetration is the same for type "S", "G" and "W" screws.
3.  The electric screwdriver should be held by its body rather than the pistol grip to reduce stress to the wrist.
4.  Type "S", "G" and "W" are interchangeable for any application.
5.  Drywall screws have slotted, rather than Phillips heads.

# Self Assessment Answers

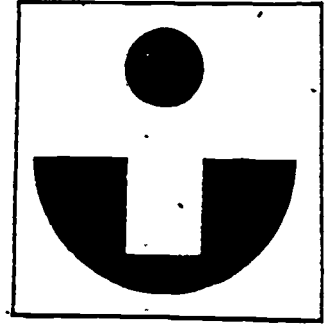

1. T

2. F

3. T

4. F

5. F

# Assignment

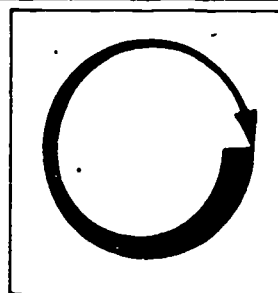

COMPLETE THE FOLLOWING ASSIGNMENT.

Tape a large piece of blank paper (butcher paper) on a wall. Try to mark off (with a pencil) spacings of 16" and 24" O.C. as if you were locating framing members behind a drywall sheet. Do this "by eye" and then measure with a tape to see how accurate you are. Then, using these "lines," try to mark off 12" and 16" spacing along the lines to simulate where each screw belongs. Check your accuracy. Repeat these steps until you start to get a "feel" for these spacings.



# Job Sheet

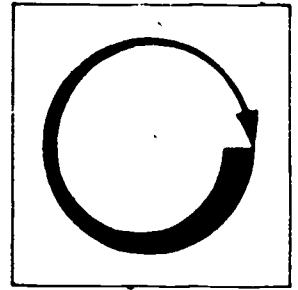

COMPLETE THE FOLLOWING TASKS:

Materials and Tools

drywall sheets  
assorted drywall screws  
steel tape  
electric screwdriver  
bare wood framing  
bare metal studwork  
existing drywall surface

1. Attach drywall to wood framing.
  - a. Select proper screws.
    - (1) allow for proper penetration when choosing length.
  - b. Check out electric screwdriver.
  - c. Set depth adjustment according to manufacturers instructions.
  - d. Place sheet against framing or base ply.
  - e. Locate screw placement.
  - f. Put screw on bit.
  - g. Drive screw.
  - h. Repeat steps e-g until sheet is attached.
2. Attach drywall to metal studs.
  - a. Repeat steps a-h of task 1.
3. Attach drywall to drywall base ply.
  - a. Repeat steps a-h of task 1.

# Post Assessment

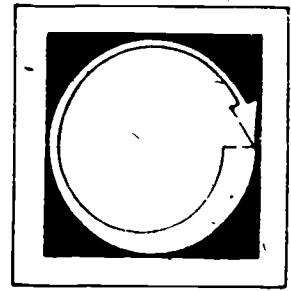

CIRCLE THE CORRECT ANSWER.

1. Maximum spacing over 16" O.C. framing on walls is 8" / 12" / 16".
2. Minimum penetration for type "W" screws is 1/4" / 1/2" / 5/8".
3. The Phillips head design of drywall screws was chosen because of its looks / its improved resistance to bit "slip out."
4. Type "G" screws have deeper / shallower thread designs than type "W" screws.
5. Depth adjustment on the electric screwdriver prevents: missing the framing member / surface damage and stripping out.
6. When using the electric screw driver, the first thing to do is: plug it in / check for any defects.

# Instructor Post Assessment Answers

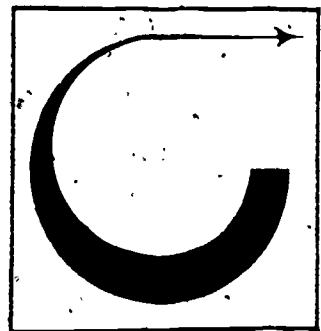

1. 12"
2. 5/8"
3. improved resistance to bit "slip out"
4. deeper
5. surface damage and stripping out
6. check for any defects

## ATTACHING DRYWALL WITH ADHESIVES

### Goal:

The student will be able to select and apply adhesives, and attach drywall with adhesives.

### Performance Indicators:

The student will successfully complete a Self-Assessment, a Job Sheet and a Post Assessment.

130

132

# Study Guide



In order to finish this module, do the following tasks. Check each item off as you complete it.

1.  Read the Goal and Performance Indicators on the cover of the module. This will tell you what you will learn by studying the module, and how you will show you've learned it.
2.  Read the Introduction. The Introduction will tell you why the module is an important part of the drywall trade.
3.  Study the Vocabulary section. Vocabulary words are important for a good understanding of the trade. After you have studied the vocabulary, ask your teacher to quiz you on the words and their meanings.
4.  Study the Information section. This section will give you the information you need to understand the subject.
5.  Take the Self Assessment exam. This is a test for you to prove to yourself that you have learned the material you have studied. Compare your answers with the answers on the Self Assessment Answer Sheet, which is on the page following the Self Assessment. If you scored poorly, re-study the Information section or ask your teacher for help.
6.  Do the Job Sheet. Follow the instructions at the top of the Job Sheet. The tasks listed on the Job Sheet will help you develop skills which will be helpful to you.
7.  Take the Post Assessment exam. Give the exam to your teacher after you have completed it. Your teacher will grade it for you.

# Introduction

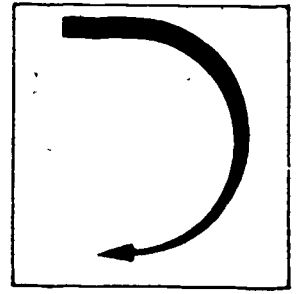

The use of adhesives improves the bonding strength of drywall to base drywall layers or framing members and reduces the number of fasteners required by at least 50%. This means less finish treatments and reduced chances for fastener failure and repairs.

# Vocabulary

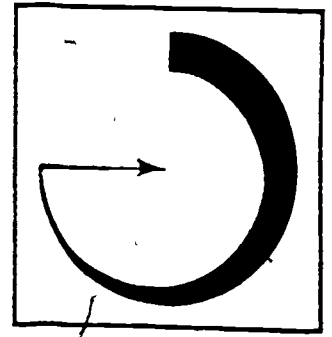

Trade terms are very important for a good understanding of the trade. Study these words and meanings. When you have learned them, ask your teacher to quiz you on the words and their meanings.

**BEAD**--Strip of adhesive squeezed out of applicator.

**BOND**--Attachment of two surfaces by the adhesive applied in between.

**PRE-BOWING**--Bending or curving drywall sheets before use to improve final bonding.

**OPEN TIME**--Time drywall worker has from application of adhesive until surface hardening of bead occurs and bonding effectiveness decreases.

**SOLVENTS**--Chemicals used to clean up or thin adhesives.

# Supplementary References

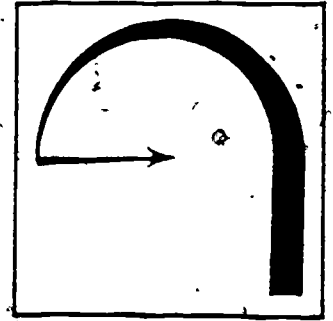

1. Using Gypsumboard for Walls and Ceilings. U.S. Gypsum Association, 1970. p. 14.
2. Drywall Construction Workbook, Part I. California State Department of Education, 1974. pp. 145-148.
3. Gypsum Construction Handbook. U.S. Gypsum Association, 1978. pp. 51-54, 113-120.



# Information

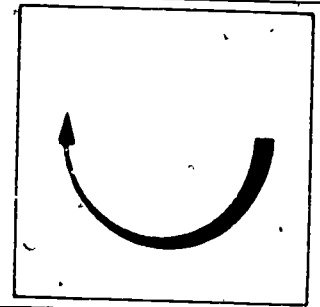

Adhesives are used in many types of drywall applications because of the many advantages they give the finished job. Careful selection, following product instructions and proper application, all help the success of the job.

Adhesives, when used in bonding drywall, offer the following advantages:

1. Increased bonding strength.
2. Evens out minor framing irregularities.
3. Reduces the number of fasteners required.
4. Reduces the amount of surface treatment required.
5. Reduces loose spots.

In order to have these advantages, the proper adhesive must be selected for different types of drywall application. Be sure to read and understand the product information and instructions before starting any adhesive job. Pay special attention to the open time for each product. It is very important that you cover only as much area with adhesive as you can finish within the open time. Be sure to have clean-up solvents on hand.

There are 4 main categories of drywall installation that use adhesives for part or all of the bonding process. The tools and methods of application are different with each type.

## ADHESIVE NAIL- OR SCREW-ON APPLICATIONS

The use of adhesives over wood framing can cut the number of nails required in the field by at least 50%. A bead of adhesive approximately  $\frac{3}{8}$ " in. diameter is applied directly to the wood framing. The tip of the applicator should have a double cut, diamond shape when the bead is applied to walls and a single bevel cut for ceiling applications. (See the illustration on the top of the following page.)

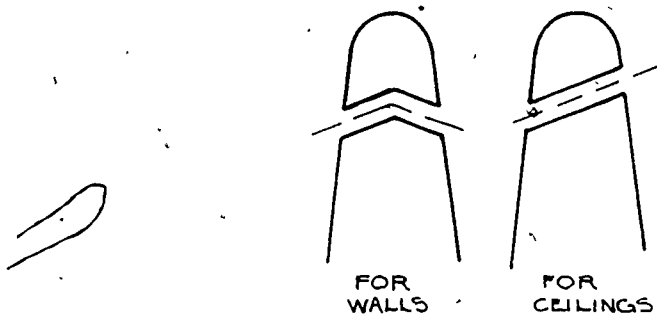

Some additional pressure should be applied to the bead to "wipe on" the ceiling bead in order to prevent dripping.

The correct position or angle of the applicator is also important.

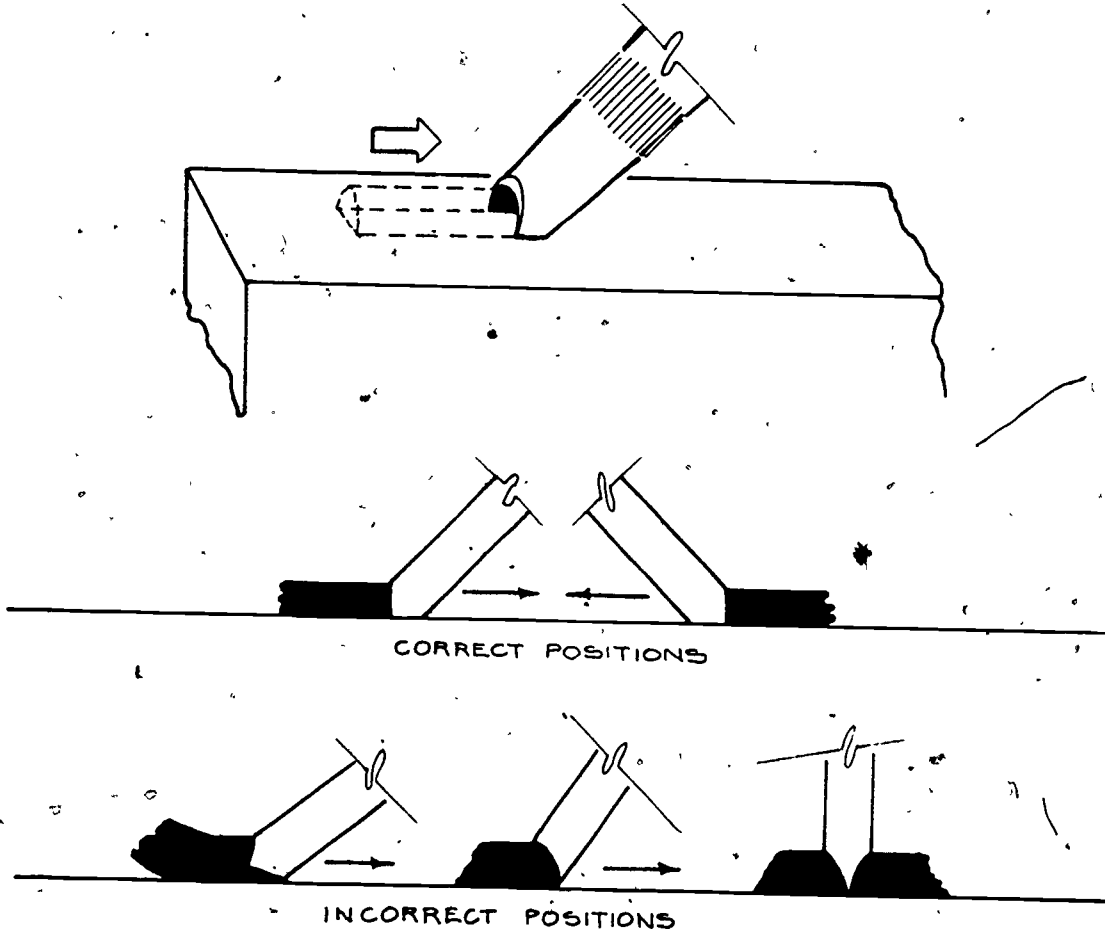

When the applicator is loaded and the tip prepared the proper bead pattern should be chosen. There are three bead patterns used for applying adhesive beads to studs, metal or wood.

1. A single bead centered along the edge of the stud for internal (non-edge) studs. (See below.)
2. Waving pattern from side to side along stud edge for places where joints occur and the joint will receive taping.
3. Twin parallel beads on studs where predecorated joints occur.

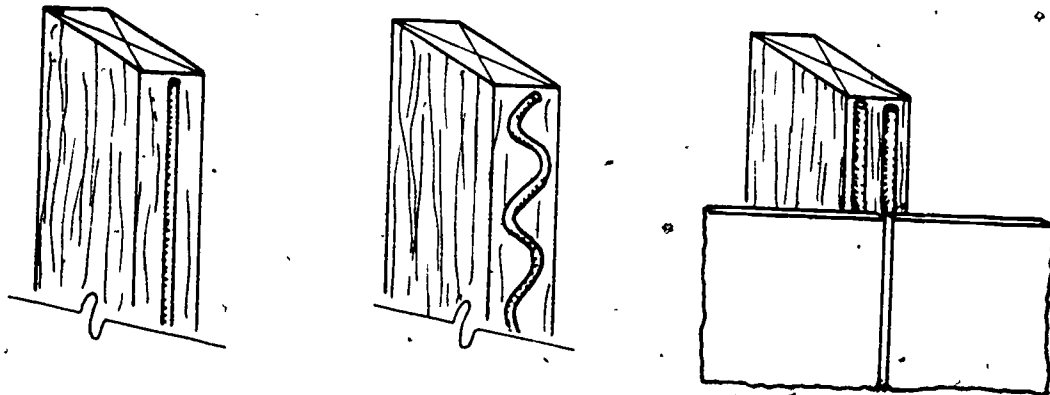

Correctly applied adhesive beads will provide a film 1" wide and 1/16" thick when the drywall is applied.

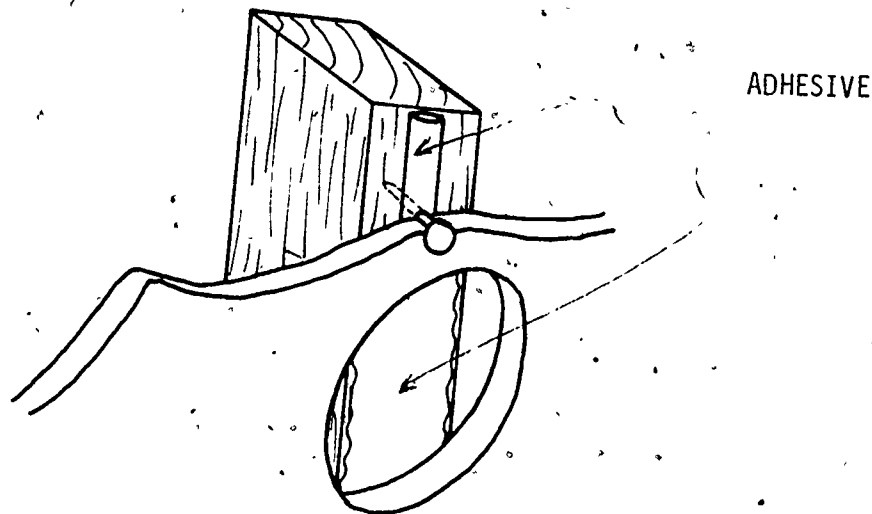

Drywall sheets should be cut and prefit before adhesive is applied and then installed quickly after adhesive is in place.

The same pressure should be applied over the entire surface to make sure of complete bonding. Finally, fasteners should be installed. Nail spacing is 16" o.c. around the perimeter (outside) of sheets (and may be eliminated in the field for wall applications), and 24" o.c. in the field for ceilings. A special

technique called "pre-bowing", where the drywall sheet is curved concave from end to end, allows for the elimination of fasteners on vertical (up and down) edge joints on wall applications.

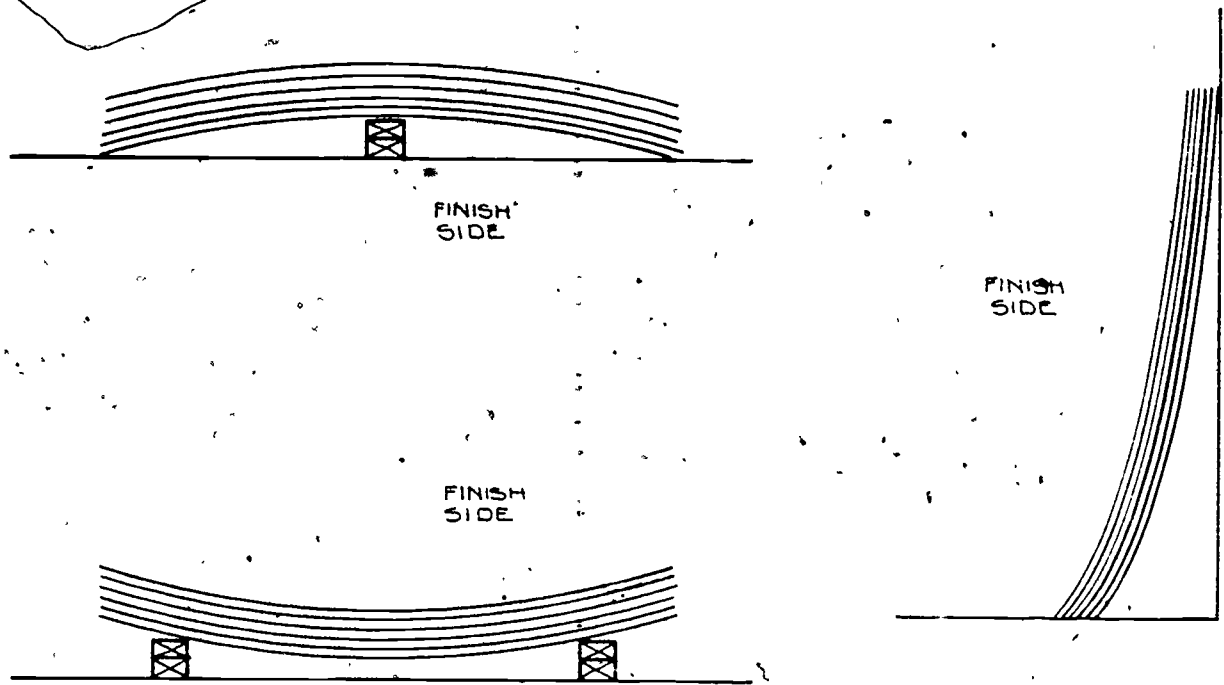

Adhesives must be allowed to dry fully before joint treatment.

#### FACE PLY APPLICATION WITH JOINT COMPOUND

The face ply of a multi-layer drywall installation can be applied with joint compound.

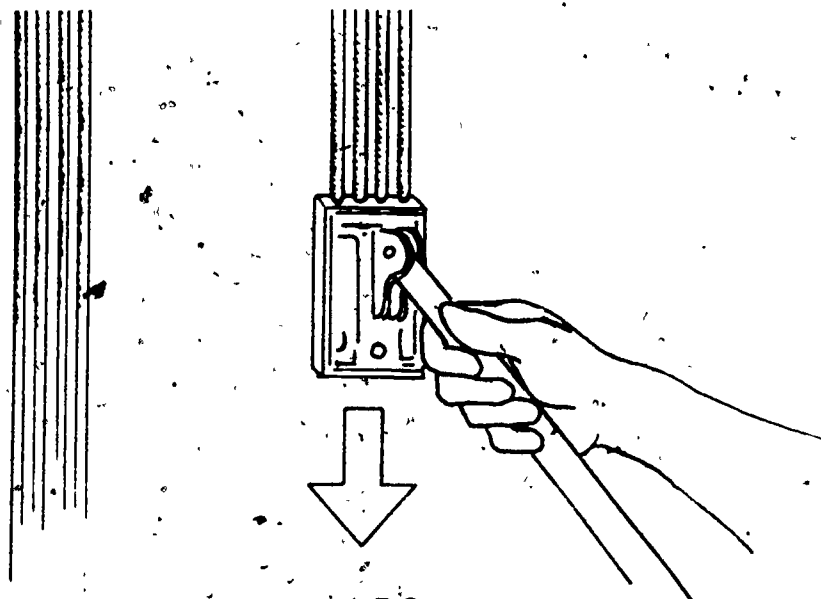

The application of the base ply is done as required for single layer applications. Then the face layer is applied either parallel or perpendicular (right angles) to the base ply. Perpendicular is the preferred method. (If parallel is used, a minimum 10" offset between joints of each layer must be allowed for.)

Drywall sheets should be cut and pre-fit before applying joint compound to base ply. Using a compound spreader that meets the requirements of the compound being used, notches of compound 3/8" wide 1/2" high, spaced 1/2" to 2" o.c. are applied. Place drywall sheet into place and install fasteners as required.

For ceiling applications, fasteners are needed 24" o.c. over field edges and ends. Nails must penetrate 3/4" into wood framing, and screws 3/8" into metal. On walls, perimeter nail 24" o.c. except when pre-bowed panels are used--then only ends require fasteners.

Temporary fasteners (double headed nails or type "G" screws) 24" o.c. should be used in the field to give good and even bonding.

Joint compound gives the advantage of leveling action for the face ply that you can't get by using thinner adhesives.

#### CONTACT CEMENT FOR FACE PLY APPLICATION

Adhesives should be applied to the base and the back of the face-ply drywall after cutting and pre-fitting is done. Be sure to follow manufacturer's instructions and wait until the cement is properly dried.

1. When sheets are ready, carefully align face-ply before making contact. Re-alignment will be extremely difficult, if not impossible.
2. Press face-ply into base-ply firmly.
3. Install fasteners 16" o.c. at top and bottom of parallel applications on walls; ceilings require permanent fasteners 24" o.c. around perimeter and on intermediate framing.

#### SINGLE LAYER DIRECT OVER MASONRY

Drywall should be cut and pre-fit. Any surface holes 1/4" deep by 4" wide or larger in masonry should be filled and allowed to dry.

1. Adhesive is applied with some type of notched spreader having 4 openings 3/8" wide and 1/2" high. Adhesive should be applied to back of face ply, along both edges and down the center of the sheet.
2. Press sheet firmly against the wall.
3. Apply fasteners at top and bottom as required.

The final step for all adhesive applications is clean up. Remove any excess adhesive from joints and be sure to thoroughly clean all tools.

# Self Assessment

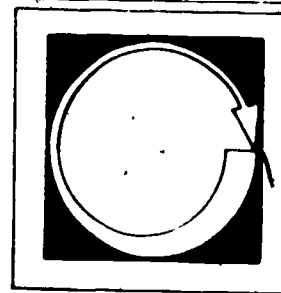

LISTED BELOW ARE SEVERAL STATEMENTS. IF THE STATEMENT IS TRUE, PLACE A "T" IN THE BLANK PROVIDED. IF THE STATEMENT IS FALSE, PLACE AN "F" IN THE BLANK.

1.  Open time for the adhesive will determine how much surface area is covered at one time before applying the drywall.
2.  The applicator tip is prepared the same way for beads of adhesive for walls and for ceilings.
3.  Pre-bowing increases the number of fasteners required.
4.  For proper bonding, the drywall sheet should be applied after the open time has passed.
5.  Adhesive is not required for inside corners.
6.  Joint treatment should always follow immediately after drywall is applied over adhesive.

# Self Assessment Answers

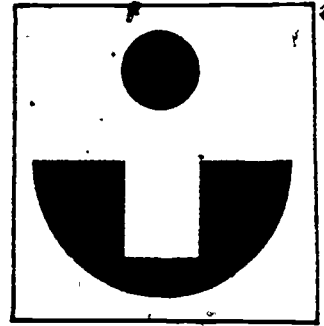

1. T

2. F

3. F

4. F

5. T

6. F



# Job Sheet

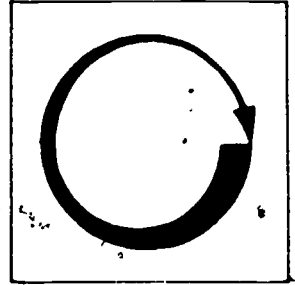

COMPLETE THE FOLLOWING TASKS.

## Materials and Tools

drywall sheets

drywall nails

drywall screws

drywall adhesives

contact cement

drywall hammer

electric screwdriver

adhesive applicator(s)

wood framing

metal studwork (optional)

drywall base ply surface (may be surface covered for task 1)

### I. Attach Drywall Over Wood Framing.

A. Identify studs to be covered by drywall sheet.

B. Select adhesive.

1. Read instructions.

2. Prepare applicator tip for wall or ceiling application.

C. Apply bead(s) to stud work.

1. Use proper bead for internal stud or joint where sheets overlap on stud.

D. Apply sheet to wall.

E. Put even pressure on sheet.

F. Drive fasteners.

1. Use proper spacing.

II. Attach Drywall to Metal Studs.

A. Repeat steps A-F of task I.

III. Apply Face-ply to Base-ply with adhesive.

A. Spread adhesive on back of face-ply.

1. Use proper bead spacing.

B. Place sheet against base-ply.

C. Apply even pressure.

D. Attach fasteners:

IV. Apply Drywall Face-ply with Contact Cement.

A. Cover both base-ply surface and face-ply back with cement.

1. Wait until cement is ready (follow manufacturer's directions).

B. Position sheet very carefully. (You don't get a chance to re-position face-ply with contact cement!)

C. Apply even pressure to face ply.

D. Drive temporary fasteners.

# Post Assessment

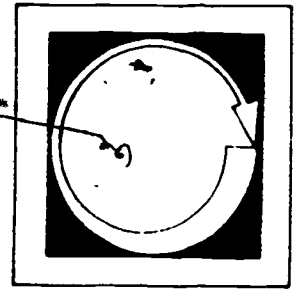

COMPLETE THE FOLLOWING STATEMENTS BY CIRCLING THE CORRECT WORD OR WORDS.

1. The adhesive bead should be approximately 1/16" / 1/4" / 3/8" in diameter for proper bonding.
2. When multi-ply drywall applications are used, parallel / perpendicular application of the face ply is preferable.
3. Nailing requirements for base plies of multi-ply applications are the same as / different than for single ply applications.
4. When applying a pre-bowed sheet of drywall, the ends should curve toward / away from the wall being covered.
5. Proper applicator tip shape for walls is 
6. The proper bead pattern on studs where joints are to receive finish taping is: a single bead / parallel beads / waving bead.

# Instructor Post Assessment Answers

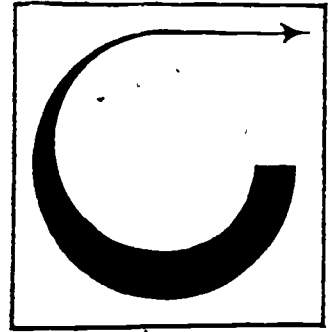

1.  $3/8$ "
2. perpendicular
3. the same as
4. away
5. the first illustration.
6. waving bead

## POWDER-ACTUATED TOOLS

### Goal:

The student will be able to:

1. Identify the applications of powder-actuated fastening tools for drywall.
2. Describe the process of applying material to metal and masonry.
3. Be aware of safety precautions for using powder-actuated fastening tools.

147

### Performance Indicators:

The student will successfully complete a Self Assessment, an Assignment and a Post Assessment.

149

# Study Guide

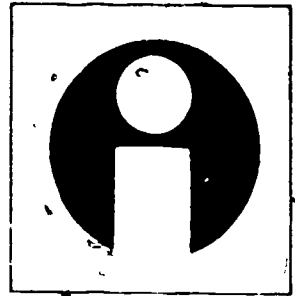

In order to finish this module, do the following tasks. Check each item off as you complete it.

1.  Read the Goal and Performance Indicators on the cover of the module. This will tell you what you will learn by studying the module, and how you will show you've learned it.
2.  Read the Introduction. The Introduction will tell you why the module is an important part of the drywall trade.
3.  Study the Vocabulary section. Vocabulary words are important for a good understanding of the trade. After you have studied the vocabulary, ask your teacher to quiz you on the words and their meanings.
4.  Study the Information section. This section will give you the information you need to understand the subject.
5.  Take the Self Assessment exam. This is a test for you to prove to yourself that you have learned the material you have studied. Compare your answers with the answers on the Self Assessment Answer Sheet, which is on the page following the Self Assessment. If you scored poorly, re-study the Information section or ask your teacher for help.
6.  Do the Assignment page. Follow the instructions at the top of the Assignment page.
7.  Take the Post Assessment exam. Give the exam to your teacher after you have completed it. Your teacher will grade it for you.

# Introduction

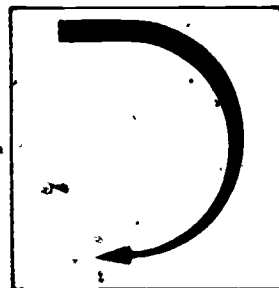

Drywall jobs often require the worker to fasten items to metal or concrete. The easiest method is to use a powder-actuated fastening tool to "drive" the fastener. Careful selection of the right fastener diameter-length, as well as proper application procedures, both contribute to a successful attachment. Extreme attention to safety precautions is necessary when using powder-actuated fastening tools to help insure safety for the operator and any co-workers.

# Vocabulary

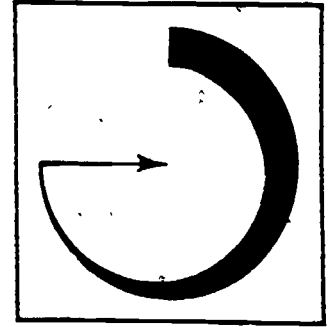

Trade terms are very important for a good understanding of the trade. Study these words and meanings. When you have learned them, ask your teacher to quiz you on the words and their meanings.

POWDER-ACTUATED--Driven or set off by powder.

DIRECT ACTING--Exploding gas acts directly on the fastener being driven.

INDIRECT ACTING--Exploding gas pushes on the piston of the gun which in turn pushes the fastener.

CLASS--Grouping of powder-actuated tools based on velocity of fastener.

SPALL--Tendency of concrete to chip or break out at entry point of fastener.

KNURLED SHANK--Scoring or roughening up of fastener shank to improve holding power to resist pullout.



# Supplementary References

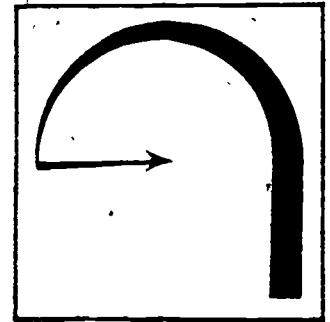

1. Gypsum Construction Handbook. U.S. Gypsum. 1978.
2. Drywall Construction Handbook. California Department of Education. 1974.  
p. 87-100.
3. Powder-Actuated Tool Manufacturers Institute. 337 Madison Ave. N.Y., N.Y.  
10017.

# Information

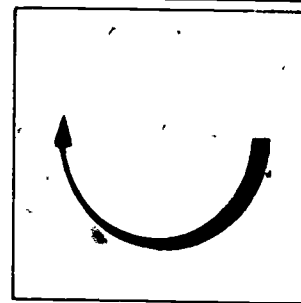

Drywall jobs often require that items be fastened securely into steel, concrete or mortar joints. Floor and ceiling runners, furring strips, resilient channel, eye pins for hanger wire on suspension channel are some of the uses.

Powder-actuated tools provide the most efficient and effective means for doing these tasks. Successful use of the tool requires that the drywall mechanic be able to match the correct fastener and power charge with the base material and the material being attached.

The main types of powder-actuated tools are basically types of guns.

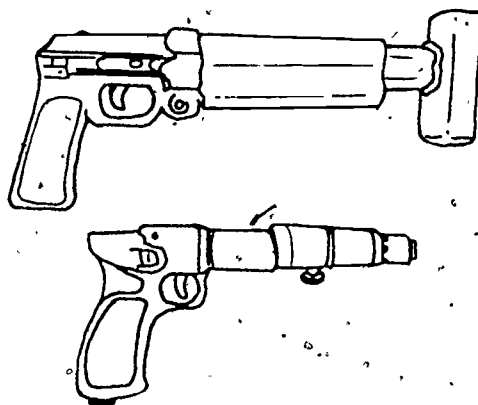

They are either direct acting, where exploding gases from the powder charge push directly on the fastener, or indirect acting, where the gases push on a piston within the gun, which pushes on the fastener. (See the illustrations at the top of the following page.)

Powder-actuated tools are also divided into three classes, based on the velocity of the fastener when fired. Drywall applications most often use low velocity class tools. The other two classes are medium and high velocity.

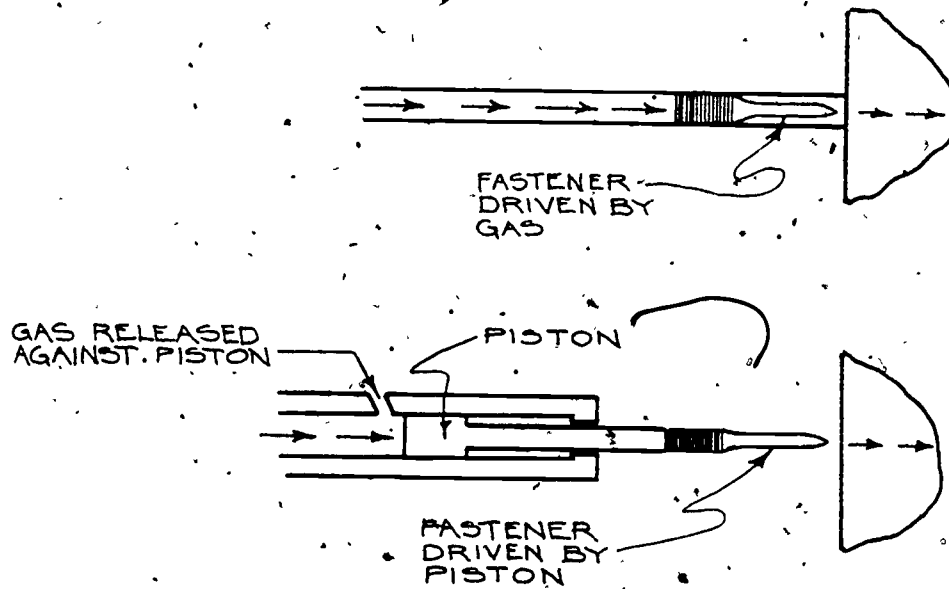

As with any gun-like device, a great deal of caution must be used. Part of each gun is a shield or series of special shields designed to help protect the operator and fellow workers from accidental injury. Powder-actuated tools should never be used without the appropriate shield in place.

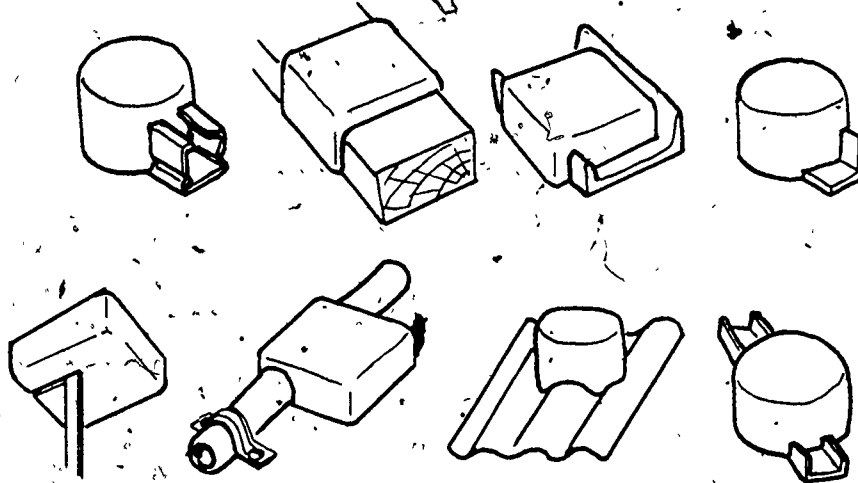

SHIELDS AND SPECIAL FIXTURES

With the shield selected and in place (follow manufacturer's recommendation) it is time to select the power load that will be used to propel the fastener into the base material. Power loads come in two styles--Cased and uncased. These two styles both come in numbered, color-coded load levels (the lower power level has lower identification number).

Correct selection procedure means you try to use the lowest power load possible. When in doubt, use a low-level charge. If it doesn't do the job, try the next higher charge. This is much safer than taking the highest charge and working downward. Excess power may lead to accidents and injury from flying debris or escaping fasteners. Each tool's manufacturer's recommendations should be used as the best guide for selection of power loads.

Fasteners also must be carefully selected for each job. These fasteners are specially designed and made from heat-treated steel to penetrate concrete or steel without breaking. The most common styles of fasteners are drive pins, threaded studs, and eye pins.

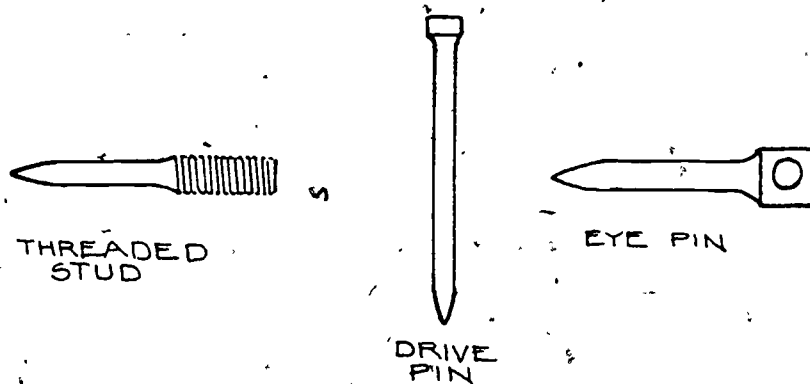

Drive pins provide permanent attachment to the base material.

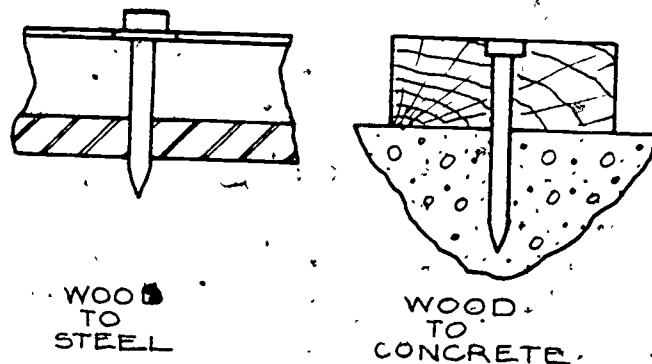

Threaded studs allow for the attached material to be removed and/or reattached. (See the illustration on the top of the following page.)

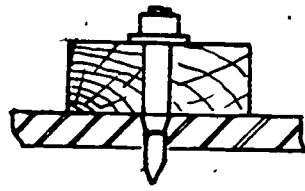

WOOD  
TO  
STEEL

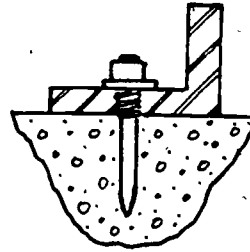

STEEL  
TO  
CONCRETE

Eye pins are designed to allow hanger wire or chain to be attached.

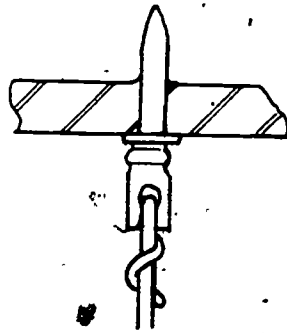

EYE PIN  
TO  
STEEL

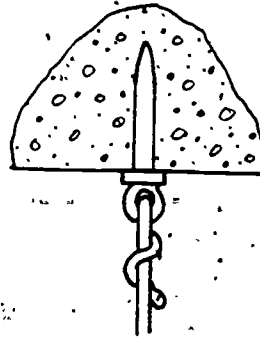

EYE PIN  
TO  
CONCRETE

All fasteners generally come with some types of tip, washer or other guiding device, which holds the fastener straight and keeps the fastener in the tool before it is driven. Length and shank diameter are both considered when selecting the correct fastener.

Probably the most important factor in choosing the fastener is the base material that the fastener will be driven into. The drywall mechanic must be able to determine if the base material is too hard, too soft or too brittle. Bases with these qualities will not provide good holding power. By testing a fastener used as a punch tool, driven with a regular hammer, 4 different results may appear:

1. Fastener point will be blunted, meaning the base material is too hard.

2. Base material cracks, splinters or shatters, meaning the material is too brittle.
3. Fastener drives into base with normal hammer stroke, meaning the base is too soft.
4. Base material shows clear point impression without dulling fastener point; meaning the base is probably a good one for the fastener.

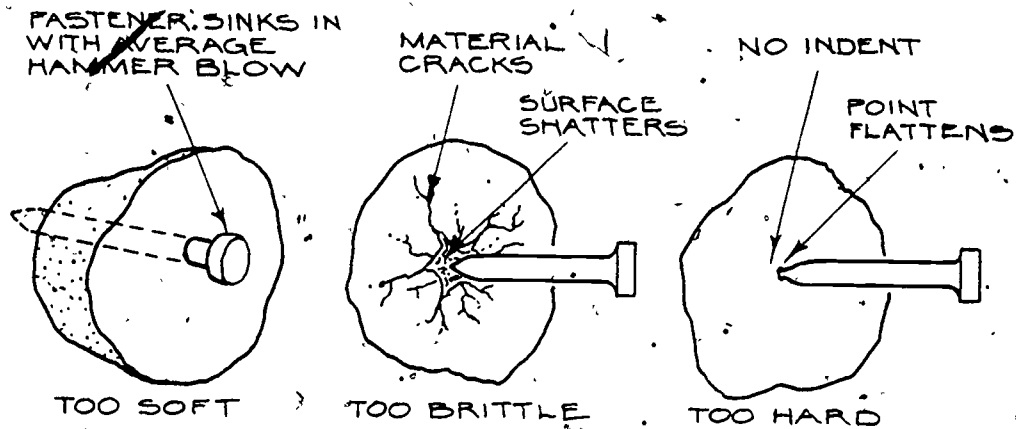

There are special things to remember for each of the major base materials (or bases) that receive powder-driven fasteners:

#### CONCRETE/MORTAR

1. Keep fasteners at least 3" away from edge to prevent cracking or masonry loosening.
2. Maintain minimum spacing based on shank diameter.

#### Shank Diameter

#### Minimum Spacing

1/8" - 5/32"

3"

11/64" - 3/16"

4"

7/32" - 1/4"

6"

3. Fastener penetration should not be more than 1/3 the base thickness.
4. Drive fasteners into horizontal mortar joints since vertical joints frequently lack the thickness to provide good holding power.
5. Fish hooking (bending or deflection of the fastener in base material) can be reduced by:
  - a. Increasing shank diameter.
  - b. Decreasing length.
  - c. Use metal disc to hold surface down.
  - d. Check power level to be sure you are not "over-driving" the fastener.

6. Spall prevention.
  - a. Try to drive fastener exactly perpendicular (at a 90° angle) to base material.
  - b. Drive fastener through steel disc, which acts to hold down concrete surface as the fastener enters the base.
  - c. Shank diameter and length may be reduced to reduce spalling.

#### STEEL

1. Shanks on fasteners are given special knurled surfaces to increase their holding power.
2. Holding power is determined by the total contact area between base and fastener.
3. Maintain sufficient distance from the edge of metal to avoid fracturing (breaking) steel base or stretching the metal between fastener and edge (which reduces holding power).

Shank Diameter

1/8" - 5/32"

Distance from Edge

1/4" (low velocity tools only)

4. Maintain minimum spacing of fasteners.

Shank Diameter

1/8" - 5/32"

11/64" - 3/16"

7/32" - 1/4"

Minimum Spacing

1"

1 1/8"

1 1/2"

5. Shank diameter of fastener should not exceed base material thickness.
6. Avoid areas that have been welded or torch cut, since these areas are often too hard to drive fasteners.
7. Do not "over drive" fasteners by using too high power loads, since holding power is reduced.
8. Select fastener that will fully pierce (go through) the base metal, but avoid excess length.

When load level and fastener have been selected, the mechanic must understand the basic steps in using the powder-actuated tool.

1. Open the tool.
  - a. Check for clear barrel.
  - b. Insert proper fastener.

- c. Insert proper cartridge.
2. Close tool.
3. Hold tool firmly against work surface.
4. Check shield for coverage.
5. Check alignment (perpendicular to base).
6. Squeeze the trigger.

All power tools require proper handling to avoid accidents, but powder-actuated tools require even more concentration. The following list of rules should be learned and followed by anyone using powder-actuated tools.

1. Never point the tool at anyone; unloaded or loaded tools.
2. Always wear safety goggles while loading or operating.
3. Never leave a loaded tool unattended.
4. Use ear plugs when firing in a confined area.
5. Always check all tools before each day's use to be sure they are in proper working condition.
6. If a tool fails to fire when the trigger is squeezed (hangfire)
  - a. Hold the tool to the work surface for 15 seconds.
  - b. Squeeze the trigger again. If the tool fails to fire, continue holding it to the work surface.
  - c. After another 15 seconds open the breech mechanism.
  - d. Remove the cartridge, and put it in a bucket of water.
7. If a tool is dropped, take it apart and inspect it. If the tool is dropped when loaded, first follow the procedure given above for a hangfire; then take the tool apart for inspection.
8. Remove a defective tool from service immediately. Have the tools inspected and serviced regularly.
9. Store and carry powder charges in the containers they come in.
10. Never use powder-actuated tools in an area where flammable materials or explosive vapors are present.
11. Make sure the bore of the tool is clear before loading.
12. Use an extension barrel only with a gun that is equipped with a safety device.
13. Make sure that no one is in the line of fire on the other side when fastening to walls or ceilings.
14. Before firing into concrete, inspect the material for cracks.



15. Do not use powder-actuated tools to penetrate brittle materials such as cast iron, high carbon steel, or ceramic tile. Always know the base material, especially in older buildings where it may be concealed.
16. When fastening through thin material, use a steel disc to prevent the pin from passing through the material.
17. Always use the safety shield on the gun. When it is necessary to fire in a "half-shield" position, use the work itself to provide protection.
18. Remove the cartridge from a tool that will not be fired immediately.
19. Load the tool carefully.
20. Check power loads for color before using.
21. Know the holding power of the fastener, and select the correct fastener.
22. Use minimum power.
23. Hold the tool correctly.
24. Keep the entire body behind the tool when firing.
25. Keep properly balanced and braced against recoil.
26. Always follow the rules for edge distance, fastener spacing, and material thickness.
27. Never dispose of faulty cartridges in burnable waste.
28. Clean the tool before stowing it away.
29. Store guns unloaded.

#### A WORD ABOUT POWDER-ACTUATED TOOLS

Powder-actuated tools are really guns which "shoot" anchoring devices and fasteners into hard materials. (See the illustration on the top of the following page.)

On the job site, only those workers who have been certified or licensed may operate the powder-actuated tools. Licensing comes after a demonstration, practice and an exam conducted by an industry representative. Your instructor may wish to arrange this for the class.

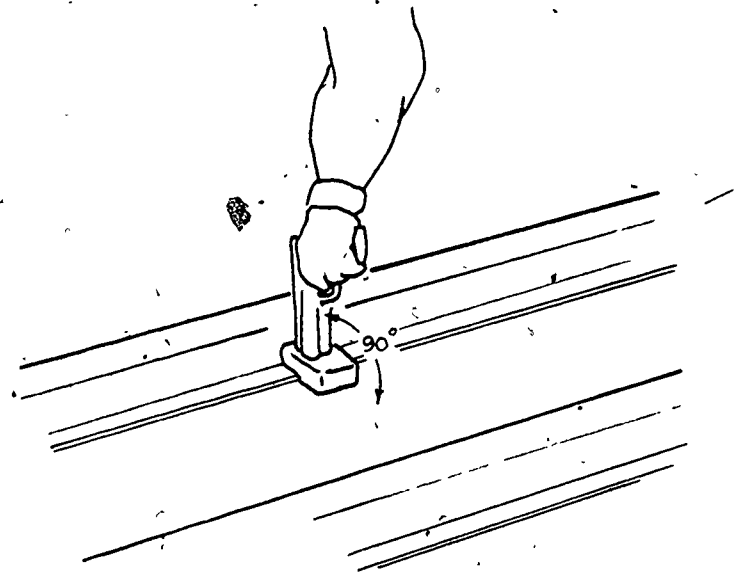
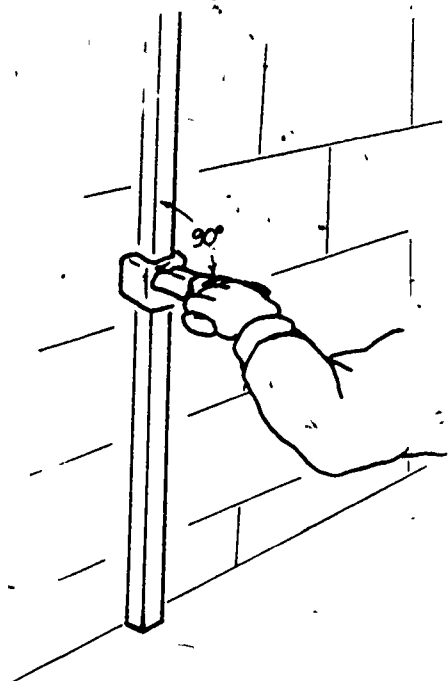

160

162

# Self Assessment

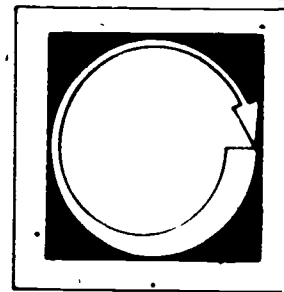

LISTED BELOW ARE SEVERAL STATEMENTS. IF THE STATEMENT IS TRUE, PLACE A "T" IN THE BLANK PROVIDED. IF THE STATEMENT IS FALSE, PLACE AN "F" IN THE BLANK.

1. \_\_\_ Always select the highest charge available for the job.
2. \_\_\_ Use of shields should never be considered optional.
3. \_\_\_ Failing to consider minimum spacing of fasteners can lead to reduced holding power.
4. \_\_\_ When choosing a fastener to drive into masonry, its length should exceed the thickness of the masonry unit.
5. \_\_\_ Driving a fastener into concrete to near the edge may cause a safety hazard.
6. \_\_\_ Eye protection should always be considered mandatory, even when proper shields are used.

# ● Self Assessment Answers

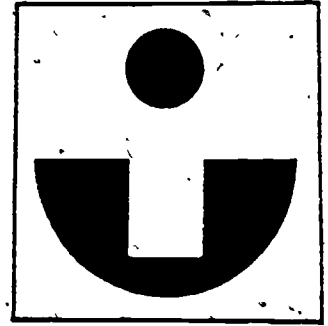

1. F

2. T

3. T

4. F

5. T

6. T

# Assignment

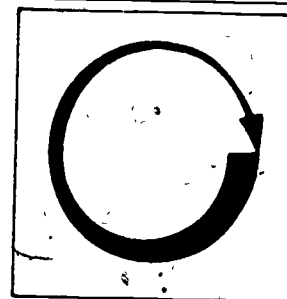

COMPLETE THE FOLLOWING ASSIGNMENTS IN THE SPACE PROVIDED.

1. Describe the test used to determine if base materials are suitable for powder driven fasteners. Explain what the various results mean in terms of hardness, softness and brittleness.
2. Describe the steps of basic operation of the powder-actuated tool.
3. List at least 15 safety precautions for safe use of the powder-actuated tool.

Give this page to your instructor.

# Post Assessment

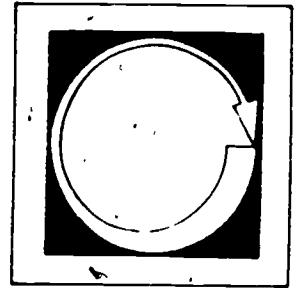

COMPLETE THE FOLLOWING STATEMENTS BY CIRCLING THE CORRECT WORD OR WORDS.

1. Knurling on the fastener shank is designed to increase / decrease holding power.
2. Driving fasteners into welded or torch cut areas should be handled normally / avoided.
3. Steel discs placed against a concrete surface before driving the fastener may decrease holding power / spalling.
4. When fastening into steel, the fastener shank diameter should exceed / be less than the thickness of the steel receiving the fastener.
5. When fastening into mortar joints, the fastener should be driven into vertical / horizontal joints.
6. Fasteners should not be placed closer than 1/2" / 1" / 3" from edge of concrete.

# Instructor Post Assessment Answers

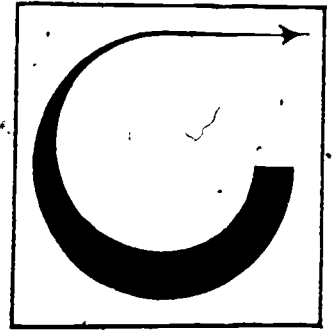

1. increase
2. avoided
3. spalling
4. be less than
5. horizontal
6. 3"

METAL EDGE AND CORNER TRIMS FOR DRYWALL

**Goal:**

The student will be able to select and install metal edge and corner trim on drywall.

**Performance Indicators:**

The student will successfully complete a Self Assessment, a Job Sheet and a Post Assessment.



# Study Guide

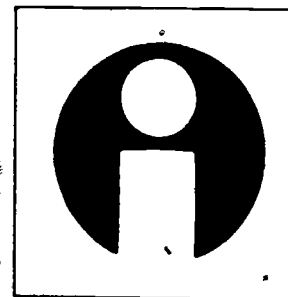

In order to finish this module, do the following tasks. Check each item off as you complete it.

1.  Read the Goal and Performance Indicators on the cover of the module. This will tell you what you will learn by studying the module, and how you will show you've learned it.
2.  Read the Introduction. The Introduction will tell you why the module is an important part of the drywall trade.
3.  Study the Vocabulary section. Vocabulary words are important for a good understanding of the trade. After you have studied the vocabulary, ask your teacher to quiz you on the words and their meanings.
4.  Study the Information section. This section will give you the information you need to understand the subject.
5.  Take the Self Assessment exam. This is a test for you to prove to yourself that you have learned the material you have studied. Compare your answers with the answers on the Self Assessment Answer Sheet, which is on the page following the Self Assessment. If you scored poorly, re-study the Information section or ask your teacher for help.
6.  Do the Job Sheet. Follow the instructions at the top of the Job Sheet. The tasks listed on the Job Sheet will help you develop skills which will be helpful to you.
7.  Take the Post Assessment exam. Give the exam to your teacher after you have completed it. Your teacher will grade it for you.

# Introduction

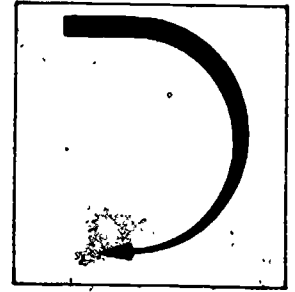

Edges and ends of drywall sheets do not resist damage from blows or abrasion well. In order to provide better protection and longer lasting installations, a variety of metal trims are available. Proper selection and application is very important for a successful installation.



170

# Vocabulary

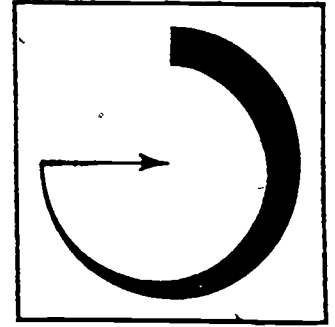

Trade terms are very important for a good understanding of the trade. Study these words and meanings. When you have learned them, ask your teacher to quiz you on the words and their meanings.

ABUT--Come into contact along the edge, generally at right angles.

KERF--Saw cut or notch, not made completely through the wood.

CRIMP--Attach by squeezing corner metal into drywall surface.

MESH--Metal expanded by slots in the metal to create spaces or holes.

L AND U METAL--Metal fabrications whose shapes look like the letters L and U.

\*L metal is also called kerf jamb; it's made especially for kerfed jambs.

L metal is generally used where gypsum board terminates against a different material.

# Supplementary References

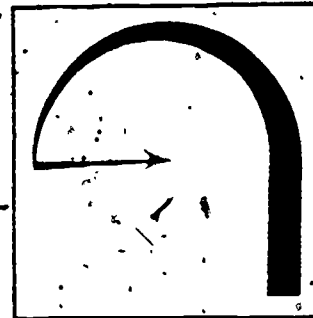

1. Using Gypsum Board for Walls and Ceilings. Gypsum Association, 1970.  
p. 33.
2. Drywall Construction Workbook-Part 1. California State Department of  
Education. 1974. pp. 110-113.
3. Gypsum Construction Handbook. U.S. Gypsum, 1978.

# Information

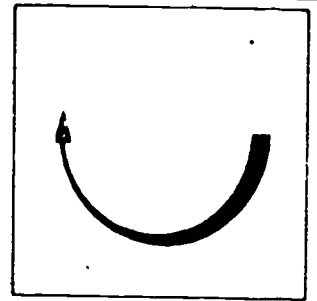

Edge trim and corner beads are designed and made to improve the appearance and durability of drywall installations. Drywall itself does not resist damage along its edges well and must have additional protection. There are many types of specialized metal products used today. Four styles or shapes are the most common. They are:

1. Corner beads for outside corner protection.
2. "L" metal for edge protection.
3. "U" metal for edge protection.

The metal fabrications get their names from the shape these trims are made into. Looking at them from an end view, they have the shape of the letters L and U. Their sizes are determined by the lengths and widths of their respective flanges.

Corner beads are designed to provide true 90° corners that will protect the drywall from damage. They also help the final finishing process by providing the base for a better hidden finish joint.

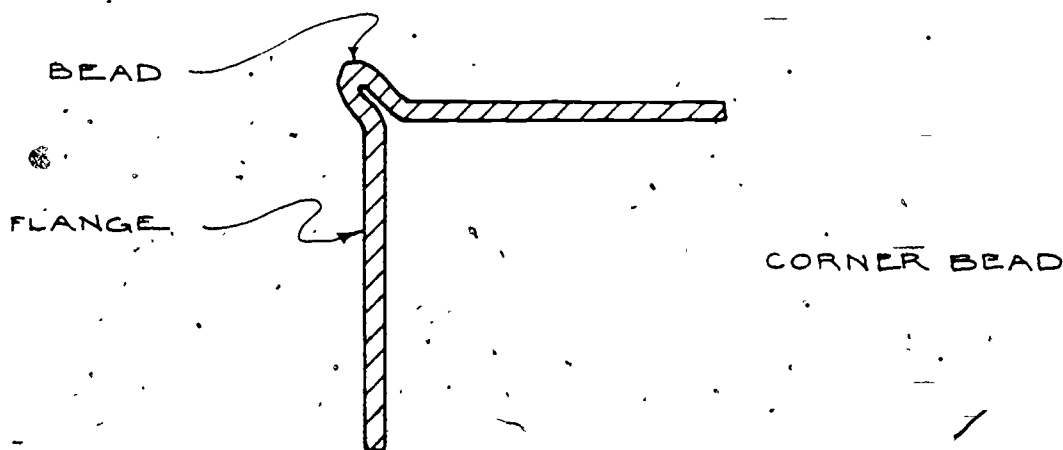

Formed into a 90° or "L" shape, the corner bead has a round bead or ridge that runs down the fold of the metal. This raised bead allows the final finishing to more fully hide the joint. The edges, or flanges of the corner bead come in different widths. The flanges also come in different styles. Some have the holes for the fasteners already made,

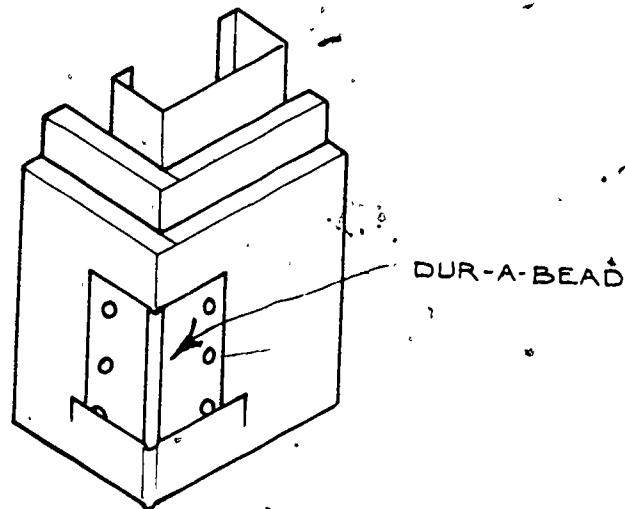

while others are made from expanded metal mesh.

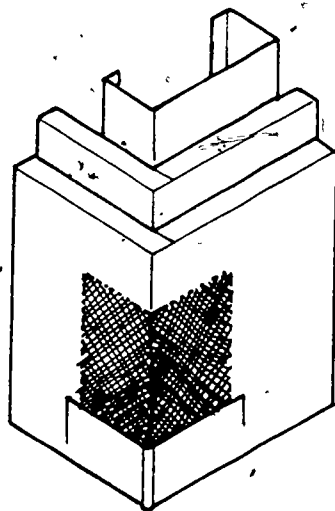

The mesh style may be nailed, screwed or stapled in place. (See the illustration on the top of the following page.) The expanded mesh design gives improved bonding of the finishing joint compound. Corner bead with pre-punched holes for fasteners may be applied with a special crimping tool which securely locks the flanges to the drywall.

(See the second illustration on the following page.)

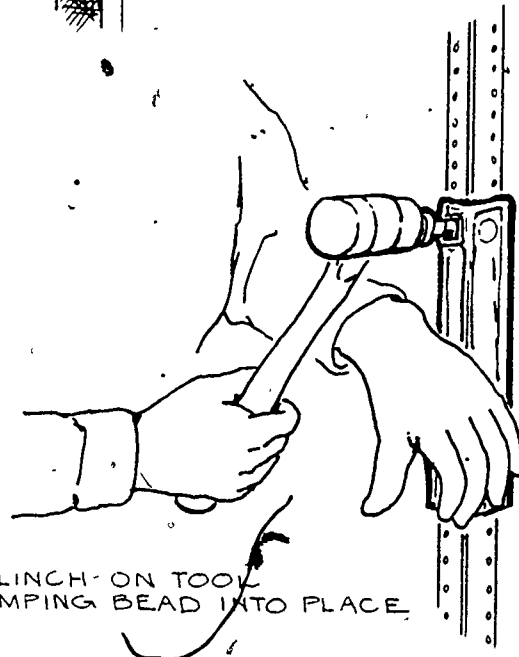
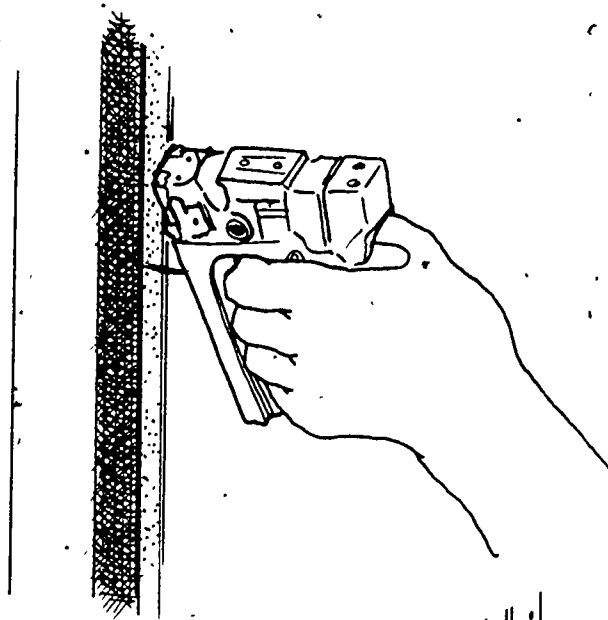

CLINCH-ON TOOL  
CRIMPING BEAD INTO PLACE.

Edge trims are designed to cover exposed edges on drywall and where panels abut other walls or surfaces. Selection of a specific trim may depend on final finish to be used on the job. Job specifications will generally spell out which style is to be used. Without these guidelines the drywall worker will have to choose the trim that is best suited to the particular application.

"L" metal is basically metal formed into two flanges at 90°. (See the illustration at the top of the following page.) The wide flange goes over the finish surface of the drywall. The other flange covers the edge. This style of edge trim often means a kerf will have to be cut in the door or window jamb: The edge flange is then inserted into the kerf to help hide the joint.

When applying the drywall sheet that will receive the edge trim, don't use any of the fasteners along the edge to be covered. Instead, the metal is measured

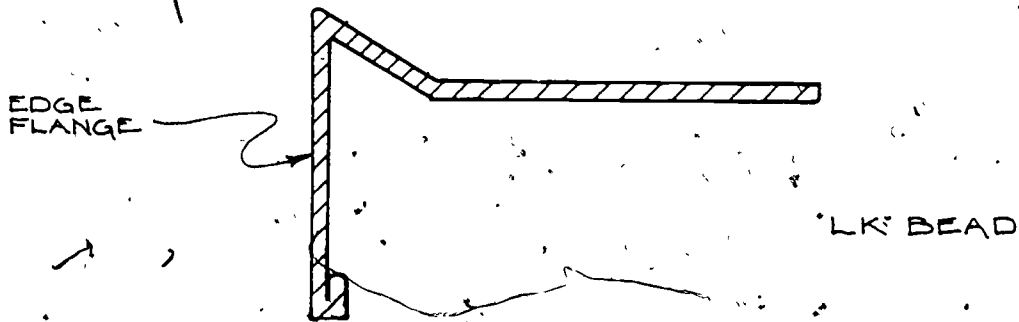

and cut to length and attached with the same fasteners used for the rest of the panel.

"U" metal is installed in the same way as "L" metal except that the shorter flange is inserted behind the panel and the longer flange, over the face of the panel.

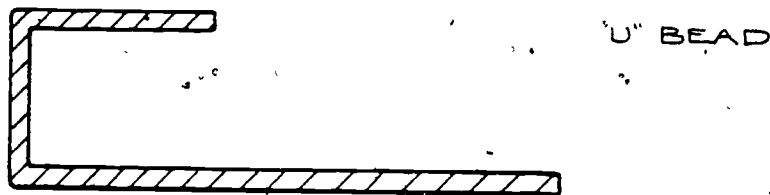

"L" metal is then attached with required fasteners with 9" o.c. maximum spacing.

With all edge and corner trim installation, care should be taken against leaving sharp edges, especially where cuts have been made. Whenever possible, use continuous (long) lengths of trim, rather than short ones pieced together. Short pieces do not give the same protection or even surface for finishing.



The final step for edge and corner trim is applying the finish joint compound. Three coats are generally recommended. The three coats give better hiding power for the trim.

# Self Assessment

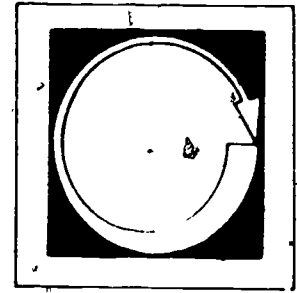

LISTED BELOW ARE SEVERAL STATEMENTS. IF THE STATEMENT IS TRUE, PLACE A "T" IN THE BLANK PROVIDED. IF THE STATEMENT IS FALSE, PLACE AN "F" IN THE BLANK.

1.  Good outside corner joints can be made without corner trim.
2.  Edge fasteners may be omitted (not used) on outside corners when corner metal has been crimped on.
3.  Panel edges, where edge trim is to be applied, are fastened down first before applying edge trim.
4.  Single, continuous strips of metal are preferred instead of several pieces along an edge.
5.  Caution against sharp edges of metal trim--especially when cuts are made--is important.

# Self Assessment Answers

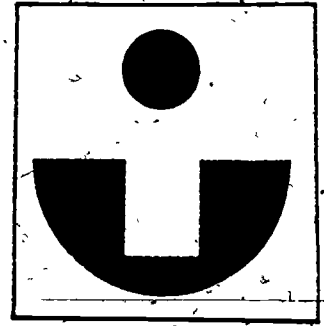

1. F

2. F

3. F

4. T

5. T

# Job Sheet

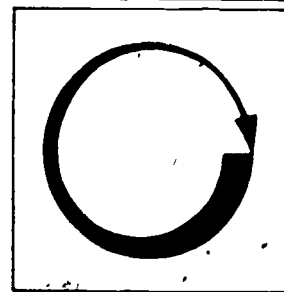

COMPLETE THE FOLLOWING TASKS.

### Materials and Tools

assortment of metal trim pieces  
drywall  
hammer  
electric screwdriver (optional)  
crimping tool  
steel tape  
metal cutters  
rubber mallet

### Physical Requirements

Framing or framing mock-ups that include:

1. Window and/or door jambs with drywall attached, except on edge to receive edge trim.
2. Outside corners with drywall attached.

### 1. Attach corner bead to outside corner.

- a. Measure length of edge to be covered.
- b. Cut corner bead to length.
- c. Select fasteners.
- d. Place corner bead over corner.
- e. Nail or screw in place; use a 9" o.c. maximum spacing.

### 2. Apply corner bead with crimping tool.

- a. Repeat steps a and b of 1st task.
- b. Place bead over corner.
- c. Set the corner bead by hitting crimping tool with hammer.

d. Repeat crimping at required intervals until entire length has been crimped.

3. Installing edge trim.

a. Apply drywall sheet to edge of framing; omit fasteners at exposed edge.

b. Select edge trim.

c. Kerf door or window jamb if required.

d. Measure edge to be protected.

e. Cut edge trim to length.

f. Put trim into place.

g. Apply fasteners at required spacing.

# Post Assessment

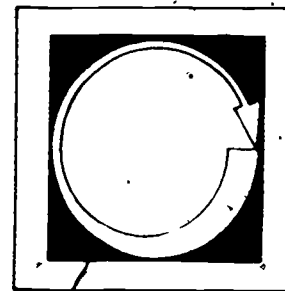

SELECT AND CIRCLE THE CORRECT WORD OR WORDS TO COMPLETE THE STATEMENTS BELOW.

1. Maximum spacing for attaching corner trim is 3" / 6" / 9".
2. Expanded mesh on metal fabrication flanges is designed to save metal / improve bonding surface for finishing.
3. With "J" metal; the wide / narrow flange is installed on the finish (face) side.
4. 1 / 2 / 3 coats of finishing is recommended over edge and corner trim (which requires finishing).
5. When attaching "U" or "L" metal, special fasteners / same fasteners as drywall panel itself are required.

# Instructor Post Assessment Answers

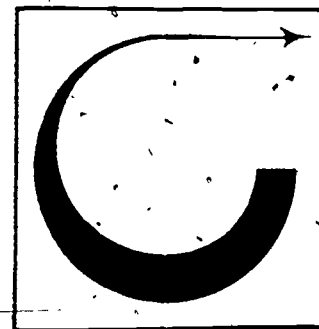

1. .9"
2. improve bonding surface for finishing
3. wide
4. 3
5. same fasteners as drywall panel itself

## WELDING APPLICATIONS IN DRYWALL CONSTRUCTION

### Goal:

The student will be able to describe and explain:

1. Welding terminology.
2. Types of welding used in drywall work.
3. Applications of welding on drywall jobs.
4. Safety precautions for welding.
5. Use of templates/jigs for welded assembly work.

182

### Performance Indicators:

The student will successfully complete a Self Assessment, an Assignment and a Post Assessment.

184



# Study Guide

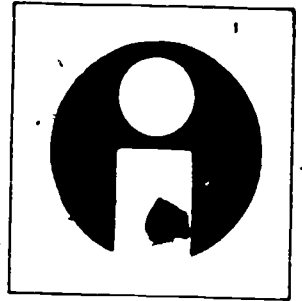

In order to finish this module, do the following tasks. Check each item off as you complete it.

1.  Read the Goal and Performance Indicators on the cover of the module. This will tell you what you will learn by studying the module, and how you will show you've learned it.
2.  Read the Introduction. The Introduction will tell you why the module is an important part of the drywall trade.
3.  Study the Vocabulary section. Vocabulary words are important for a good understanding of the trade. After you have studied the vocabulary, ask your teacher to quiz you on the words and their meanings.
4.  Study the Information section. This section will give you the information you need to understand the subject.
5.  Take the Self Assessment exam. This is a test for you to prove to yourself that you have learned the material you have studied. Compare your answers with the answers on the Self Assessment Answer Sheet, which is on the page following the Self Assessment. If you scored poorly, re-study the Information section or ask your teacher for help.
6.  Do the Assignment page. Follow the instructions at the top of the Assignment page.
7.  Take the Post Assessment exam. Give the exam to your teacher after you have completed it. Your teacher will grade it for you.

# Introduction

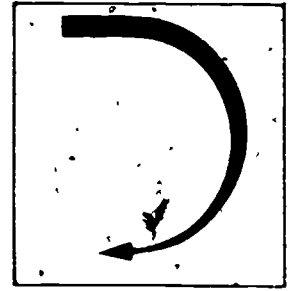

Certain jobs performed by drywall mechanics require the use of electrical welding skills. It is not always necessary to use a welding specialist if the drywall mechanic has knowledge of the correct welding techniques and the related safety precautions. The value of a drywall mechanic who can also perform these welding tasks goes up both to the employer and to the drywall worker.

# Vocabulary

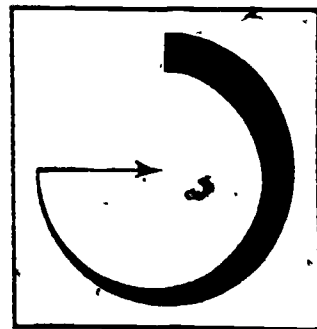

Trade terms are very important for a good understanding of the trade. Study these words and meanings. When you have learned them, ask your teacher to quiz you on the words and their meanings..

**ADHESION**--When molten metal only sticks to base metal rather than being fused to it.

**AUTOGENOUS WELDING**--Fusing two or more pieces of metal without the use of additional metal, pressure or pounding.

**BASE METAL**--Metal being welded.

**BRAZING**--Using non-ferrous metal or alloy with a melting point less than the base metal.

**BUTT JOINT**--Welding joint where edges or ends of metal parts join in the same plane.

**COLD SHUT**--Poor fusion between layers of weld metal or between base metal and weld.

**CONDUCTIVITY (HEAT)**--Speed at which metal transmits the heat applied to it.

**CORNER JOINT**--Joining two parts at approximately right angles (L-shaped).

**FILLET WELD**--Weld made in a corner as in a lap or "T" joint.

**LAP JOINT**--Joining two overlapping pieces.

PENETRATION--The depth to which fusion occurs in a welded joint.

"T" JOINT--Joining two pieces at approximately right angles in the shape of a "T".

# Supplementary References

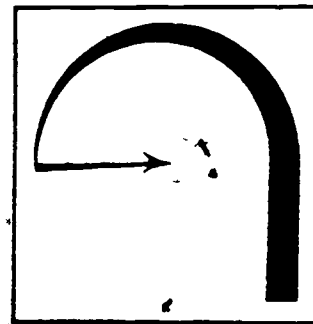

1. Drywall Construction Workbook, Part II. California State Department of Education. 1975; pp. 223-260.
2. U.S.G. Light Steel Framing. United States Gypsum Folder SA-510; 1981.
3. Welding Skills and Practices. 5th Edition. American Technical Society. 1976.

# Information

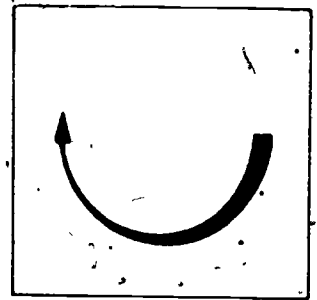

Welding is a skill that can be very useful to the drywall mechanic. There are many direct applications found in almost every drywall job that involves metal assembly work. It is very important that the drywall worker is familiar with welding vocabulary, welding types, welding techniques and safety precautions.

It is only then that the worker can safely match the proper welding method to the job.

There are several major welding applications that are found in the drywall trade. Metal assemblies which provide support for drywall units or create ceilings, soffits, ducts or building decorations, often require welding.

Metal stud framing systems may be assembled by welding.

The installation of door jambs in metal framing requires welding.

Each of these may require a different type of welding depending on the material being joined and the type of joint required. It is important that the worker be aware of the various types of welding methods in order to make the proper selection.

Although oxygen-acetylene welding (gas) is quite well known and common, it is not used much in the drywall trade. More often, some form of electrical arc welding is used. Oxy-acetylene systems burn a combination of gases to produce heat to melt metal, electrical arc methods rely on changing electrical current to make an arc or gap to produce the required heat to melt metal to form a joint.

There are 5 major types of electric arc welding commonly used in the construction trades.

1. Metallic Arc--In this process, the arc heats the base metal and the electrode and the force of the arc carries the molten drops of the electrode onto the base metal where it acts as filler material in the weld. Electrodes in this process are considered a consumable type.
2. Carbon Arc--A carbon rod is used as an electrode and filler material is added to the weld, similar to gas welding.
3. Atomic Hydrogen--This process uses two tungsten electrodes which cause the hydrogen gas to break up into individual atoms giving off a great deal of heat--enough to fuse the base metal together.
4. Inert Gas--A stream of inert gas (non-reacting) such as helium or argon surrounds and shields the arc from the atmosphere. There are two types of this process: TIG welding (tungsten inert gas) uses a tungsten electrode; MIG (metal inert gas) where the electrode is fed through the torch at regulated speeds, creating a supply of molten filler metal. MIG welding is a more convenient method to use than TIG welding and is more common in drywall work.
5. Submerged Arc--A granular (grainy) flux is spread over the weld site. The electrode and the arc are kept under the flux as welding occurs.

In addition to these five methods of electric arc welding, several styles of spot welding tools have been developed. These tools are quite useful in drywall applications. Operation is often quite simple, thus cutting down the training time for those who were previously untrained in welding.

A button-sized weld is created when the tip of the tool is put into contact with one of the two pieces of metal being joined. This method is often used to join most light metal assemblies in the drywall trade.

Of these welding methods, metallic arc, MIG and spot welding are the most frequently used in drywall work.

There are some basic subjects common to all welding that the worker must become familiar with before doing any practical welding. Metal preparation, welding positions, bead formation and the use of templates (jigs) are 4 of these subjects.

1. Metal Preparation. Metal to be joined by welding must be clean and free of rust, scale, dirt, grease or other surface obstructions. Special care should be used to remove any residue that may be flammable before any welding begins.
2. Welding Positions. There are 4 basic welding positions. They are listed in order of difficulty to the welder.
  - a. Flat welds: Work is flat or tilted less than  $45^\circ$ .

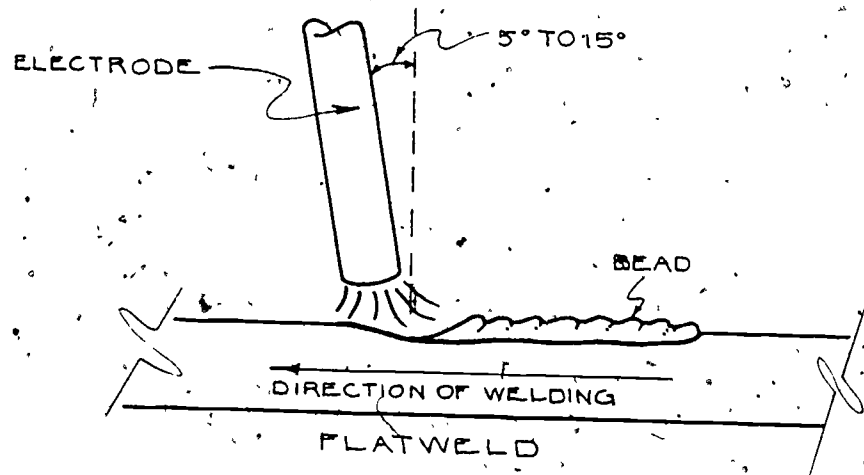

- b. Horizontal welds: Material tilted more than  $45^\circ$  with seam to be welded running in a horizontal direction (side to side).

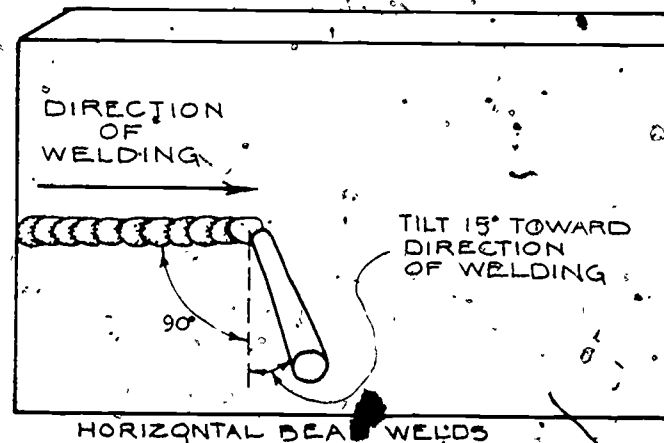
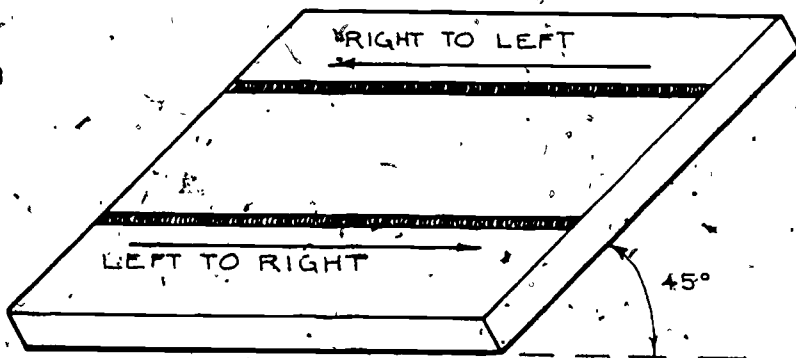

- c. Vertical welds: Material tilted more than  $45^\circ$  with joint running vertically (top to bottom).

(See the illustration on the top of the following page.)



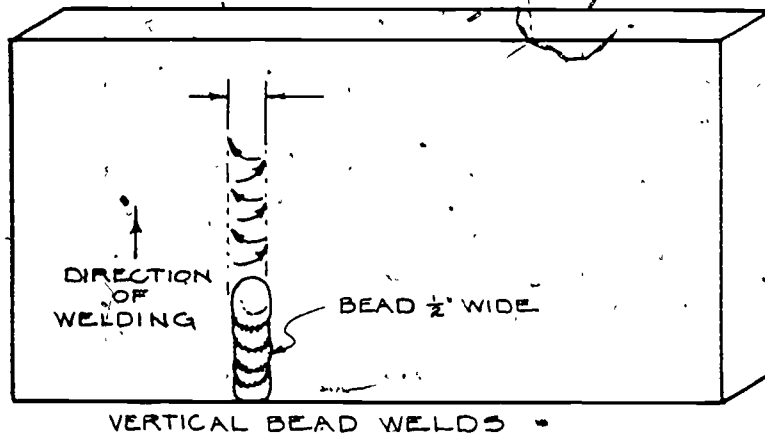

- d. Overhead weld: When a horizontal weld is done from below. This is the most difficult and presents the greatest danger to the welder and others around.

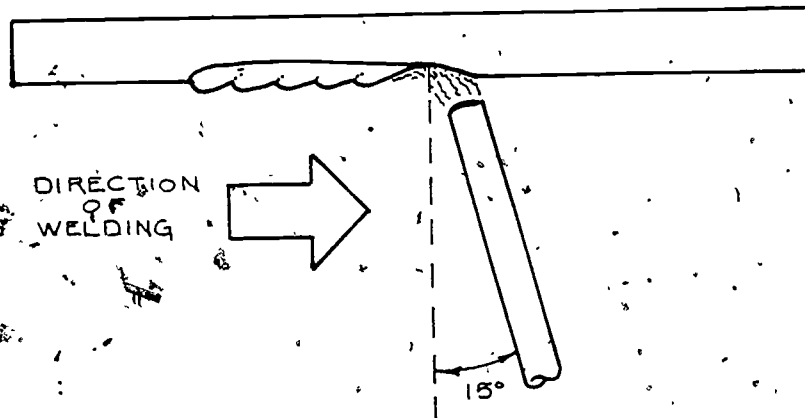

3. Bead Formation. This is the basis for strong welds. Success depends on 3 factors:
- Proper current selection: Too high results in spattering. Too low results in poor penetration.
  - Proper arc length should generally be equal to electrode diameter.
  - Rate of travel (speed) that is used to form the bead. Too slow results in a high bead. Too fast results in a shallow bead.

4. Templates (jigs). These devices are used to hold pieces of metal in proper alignment before and during the welding process. Careful assembly of a template will allow for quick and accurate assembly of welded units, especially when several duplicate items are required.

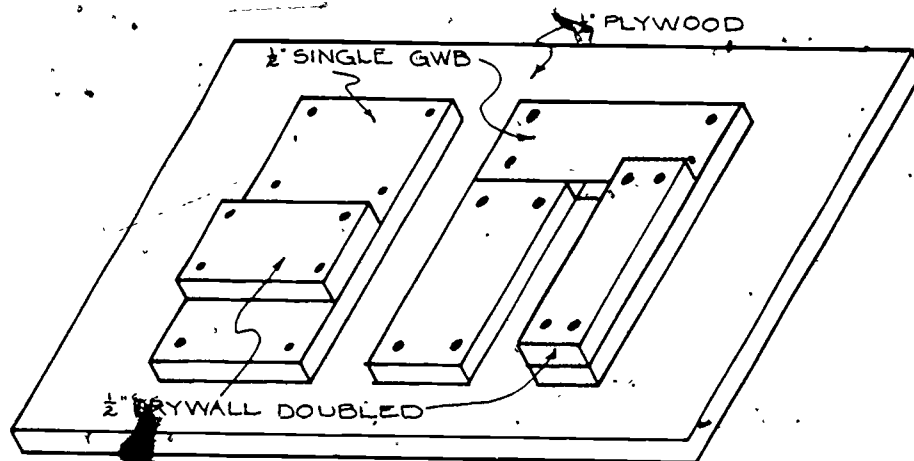

When given the opportunity, the worker should try to practice these welds. When working on bead formation, begin with flat welding on a steel plate, working from left to right until you get uniform beads. Repeat this from right to left. Proceed to horizontal beads and then vertical beads (go from bottom to top). Last, with careful supervision, try the overhead position. Be sure to use caution at all times.

The last topic to be covered here is not the least important. Welding safety must come first, last and always for anyone working with or around welding equipment. The student must learn to guard against:

1. Electrical Shock.
2. Burns.
3. Toxic fumes.
4. Eye damage.
5. Fire/explosions.

Some basic rules to minimize the dangers presented by these hazards:

1. Wear non-flammable clothing that is close fitting but flexible.
2. Wear proper eye protection, which may mean goggles, shields or a hood with the proper colored lens.
3. Wear heavy duty gloves, such as leather or heavy canvas with cuffs that extend over shirt sleeves.

4. Work with proper ventilation.
5. Be sure work is properly grounded.
6. Avoid working in wet areas if possible.
7. Do not work with welding equipment in the presence of any flammable liquids or fumes.

With proper care and caution, welding can be an extremely useful skill to the drywall mechanic, even though it may not be part of each day's work.

# Self Assessment

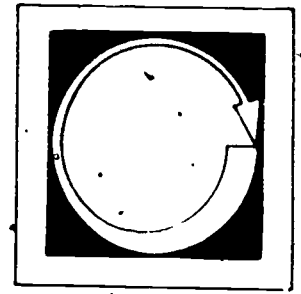

LISTED BELOW ARE SEVERAL STATEMENTS. IF THE STATEMENT IS TRUE, PLACE A "T" IN THE BLANK PROVIDED. IF THE STATEMENT IS FALSE, PLACE AN "F" IN THE BLANK.

1.  Overhead welding is the easiest position to weld.
2.  Electrodes used in metallic arc welding are not consumed (used up) in the process.
3.  MIG welding is more commonly used in drywall construction than TIG welding.
4.  Spot welding equipment generally requires less training time to learn than other methods of welding.
5.  Grease or other residue should be removed from surfaces to be welded in order to avoid flames or explosions.
6.  Templates can be used to improve uniformity of multiple or duplicate parts.

# Self Assessment Answers

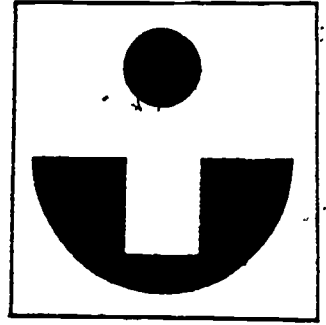

1. F

2. F

3. T

4. T

5. T

6. T

# Assignment

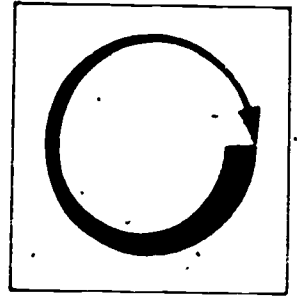

COMPLETE THE FOLLOWING ASSIGNMENT.

1. Describe in detail the safety precautions necessary when welding on a drywall job.
2. List at least 4 applications of welding used in the drywall trade.
3. Describe the four basic welding positions.

4. List and briefly describe at least 4 types of electric arc welding.

# Post Assessment

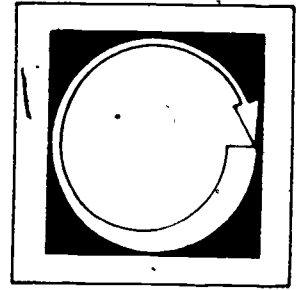

COMPLETE THE FOLLOWING STATEMENTS BY CIRCLING THE CORRECT WORD OR WORDS.

1. Gas / electrical arc welding is most commonly used for drywall applications.
2. A weld is considered flat, even if the work is tilted 45° / 60°.
3. Spot welding is generally used to join heavy / light metal assemblies.
4. When performing a vertical weld, the bead should start at the top / bottom and proceed.
5. Arc length should be adjusted to be equal to / greater than electrode diameter.



# Instructor Post Assessment Answers

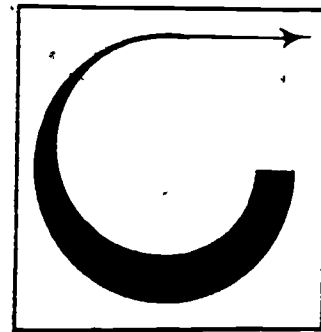

1. electrical arc

2.  $45^\circ$

3. light

4. bottom

5. equal to

INSTALLING COLD ROLLED CHANNEL RUNNERS

**Goal:**

The student will be able to mark the location, cut and install floor and ceiling metal channel runners.

**Performance Indicators:**

The student will successfully complete a Self Assessment, a Job Sheet and a Post Assessment.

# Study Guide

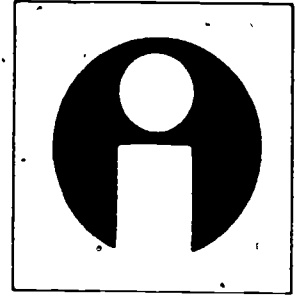

In order to finish this module, do the following tasks. Check each item off as you complete it.

1.  Read the Goal and Performance Indicators on the cover of the module. This will tell you what you will learn by studying the module, and how you will show you've learned it.
2.  Read the Introduction. The Introduction will tell you why the module is an important part of the drywall trade.
3.  Study the Vocabulary section. Vocabulary words are important for a good understanding of the trade. After you have studied the vocabulary, ask your teacher to quiz you on the words and their meanings.
4.  Study the Information section. This section will give you the information you need to understand the subject.
5.  Take the Self Assessment exam. This is a test for you to prove to yourself that you have learned the material you have studied. Compare your answers with the answers on the Self Assessment Answer Sheet, which is on the page following the Self Assessment. If you scored poorly, re-study the Information section or ask your teacher for help.
6.  Do the Job Sheet. Follow the instructions at the top of the Job Sheet. The tasks listed on the Job Sheet will help you develop skills which will be helpful to you.
7.  Take the Post Assessment exam. Give the exam to your teacher after you have completed it. Your teacher will grade it for you.

# Introduction

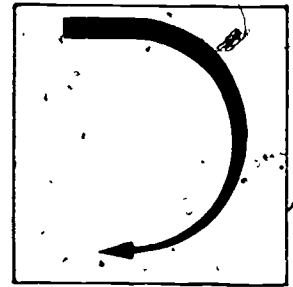

Metal framing is becoming more common in commercial and residential construction. Floor and ceiling runner installation is the beginning of the framing process. Incorrect or poorly aligned placement of runners will result in a poor job and a tough job to correct the problem.

# Vocabulary

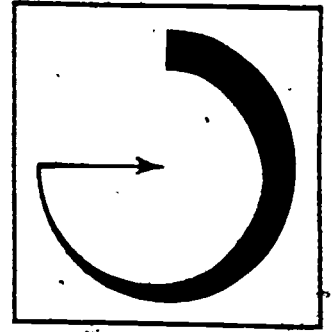

Trade terms are very important for a good understanding of the trade. Study these words and meanings. When you have learned them, ask your teacher to quiz you on the words and their meanings.

FLANGE--Edge turned up at an angle to form a lip.

ACOUSTICAL--Relating to the control of sound.

MITERED--Cut at an angle to mate or match another piece to form a joint.

ROUGH OPENING--Measurement used for windows and doors that allows for jambs, sills and flanges.

PLUMB--Proper vertical alignment. Checked for accuracy by the use of a weighted line or "plumb bob."

# Supplementary References

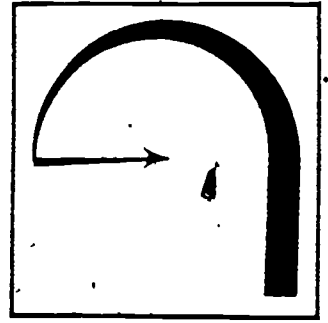

1. U.S.G. Light Steel Framing. U.S. Gypsum System Folder SA-510.
2. Drywall Construction Workbook, Part II. California State Department of Education. 1974. p. 58.
3. Gypsum Construction Handbook. United States Gypsum, 1978. pp. 29-33.
4. Using Gypsum Board for Walls and Ceilings. Gypsum Association. 1970. pp. 10-12.

# Information

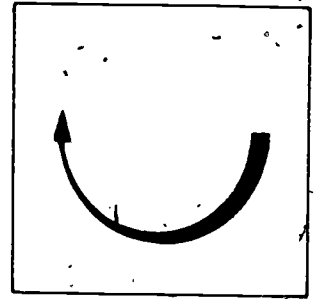

Successful metal framing begins with correct floor and ceiling runner placement. Accurate layout with proper allowances for rough openings, along with true vertical alignment and good, clean cuts, are all important for a successful installation.

Knowledge of the available runner material and fastener spacing requirements are also important to every drywall mechanic.

Metal runners are made from cold rolled galvanized steel in 14- to 22-gage metal. Runners are available in widths of 1 to 6 inches. On runners with equal flanges, the flanges are 1" to 1 1/4" high.

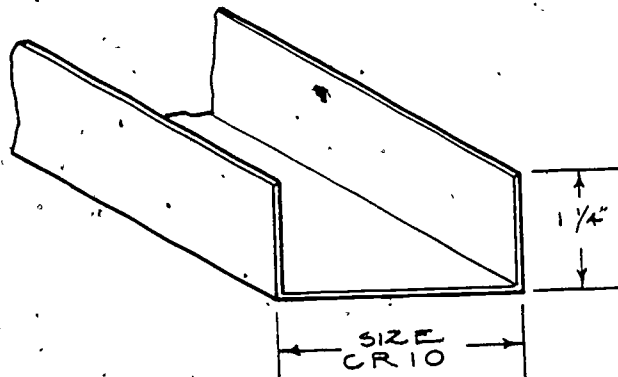

On 4" runners, where the flanges are different heights, the short flange is usually 1", with the taller flange ranging from 2" to 2 1/4." (See the illustration on the following page.)

Runners are commonly available in 10' or 12' lengths. The proper size runner for a job depends on the plans and specifications for the job.

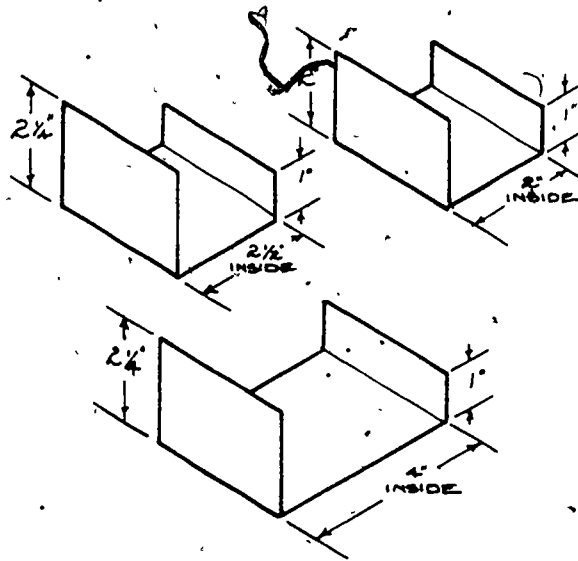

With the runner material selected, the next process is to layout and mark the runners on both floor and ceiling.

The steps to follow are:

1. Read plans and determine wall layout.
2. Determine proper rough opening dimensions for any required openings.
3. Measure and mark all wall lines on floor.
  - a. Measure ends for each wall.
    - (1) allow for face material thickness.
  - b. Snap chalkline for each wall.
4. Mark each corresponding ceiling runner.
  - a. Measure and mark as in step 3 for floor runner.
  - b. Verify correct alignment with plumb bob.
    - (1) if correct, proceed.
    - (2) if incorrect, adjust, remark and verify.
5. Measure and cut runners to length.
  - a. Cut with tin snips.
  - b. Make clean, square cuts.
  - c. Use care to avoid injury from sharp metal edges.
  - d. Verify accuracy of cut by holding in place.
    - (1) if accurate, proceed.
    - (2) if inaccurate, repeat step 5 until correct.
6. Layout proper fastener location.
  - a. Two fasteners are required at the end of a runner at an opening. They are to be 2" from the runner's end.
  - b. Intermediate spacing is 24" o.c. maximum.



7. Drive fasteners to attach runners
  - a. Concrete--manual.
    - (1) use hammer and concrete nails.
  - b. Concrete--powder-actuated drive.
    - (1) use powder-actuated tool with recommended power load and fastener.

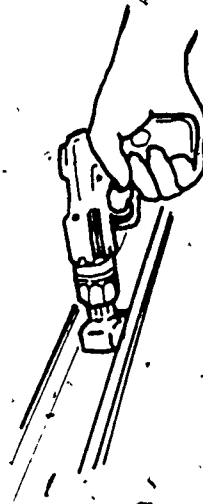

FASTENING  
CHANNEL  
RUNNERS

- c. Suspended ceilings.
  - (1) use Molly bolts or Type S screws.

8. For sound rated systems, apply accoustical sealant at base of each flange against floor or ceiling.
  - a. Bead should be 1/4".

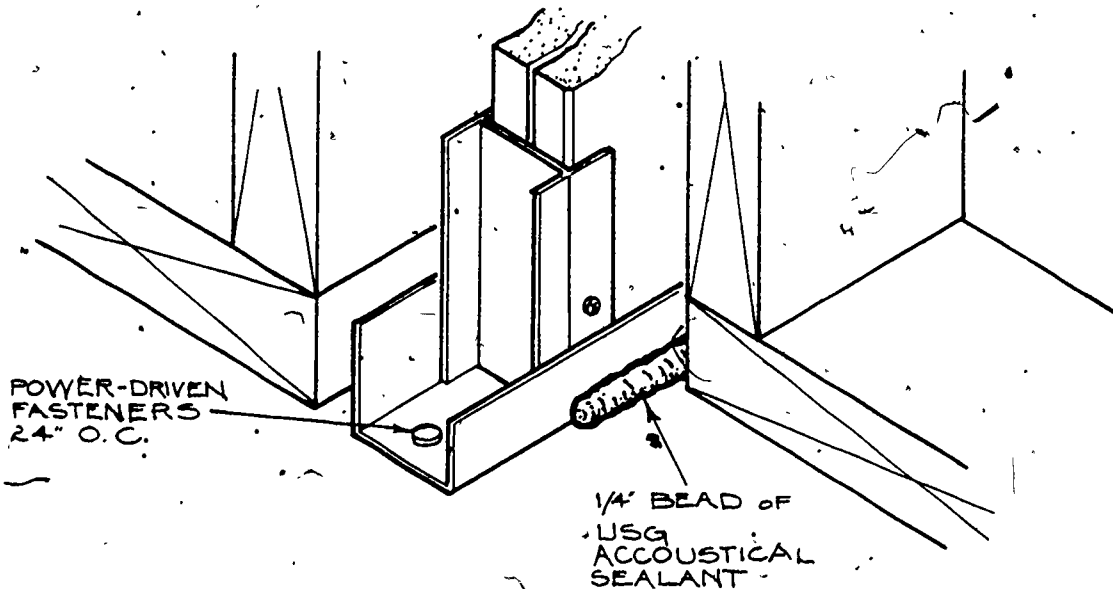

Runners forming corner joints need some special considerations. First, these joints should not be mitered. Instead, one runner should be laid out to run

completely into the corner. Butt the adjoining runner up to the first runner.  
Check for proper alignment.

Following these steps will provide for successful runner installation. Repeated practice will improve speed and accuracy.

# Self Assessment

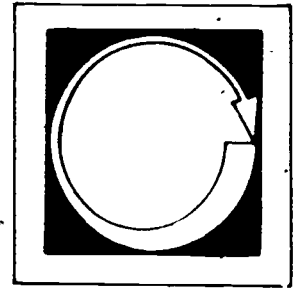

LISTED BELOW ARE SEVERAL STATEMENTS. IF THE STATEMENT IS TRUE, PLACE A "T" IN THE BLANK PROVIDED. IF THE STATEMENT IS FALSE, PLACE AN "F" IN THE BLANK.

1.  When possible, corner joints should be mitered.
2.  Both runner flanges are generally 1" or 1 1/4" wide except on "J" runners.
3.  Fasteners placed at the end of the runner should be 3" from runner end..
4.  When marking locations for runners, careful attention to the thickness of the facing material is quite important.
5.  When leaving an opening for a 30" wide door, a 30" gap in the floor runner is made.

# Self Assessment Answers

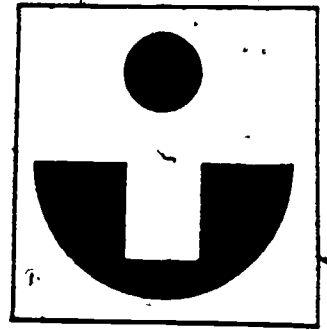

1. F

2. T

3. F

4. T

5. F

# Job Sheet

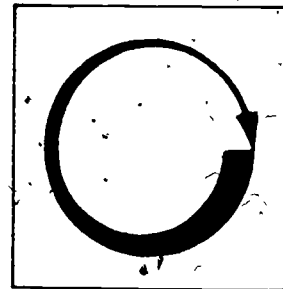

COMPLETE THE FOLLOWING TASKS.

## Materials and Tools

metal runner stock

assorted fasteners--assorted nails for wood and concrete, powder-actuated fastener (optional), toggle bolts or screws (for gypsum ceiling) 1 1/4"

Type S

steel tape

plumb bob

chalkline

hammer

powder-actuated tool

tin snips

framing square

power drill and steel bits

pencil or other marking tool

ladder

eye protection

## Physical Requirements

Open space with smooth, level concrete floor. Ceiling of wood, concrete or gypsum.

### 1. Marking runner placement.

- a. Mark an 8' long line on the floor and ceiling that is parallel to and 4' from an existing wall.
- b. Snap both lines with chalkline.
- c. Verify alignment with plumb bob. If out of alignment, re-mark lines and re-check.

d. You will use these lines as your guide for the outside edge of the runners.

2. Measuring and cutting runners.

a. Select runner material.

b. Measure and mark each runner to be used.

c. Cut runner to length.

(1) Be accurate to get a true and square cut.

(2) Be careful to avoid injury when cutting runners. Sharp edges can cut very easily.

d. Check runners for correct length.

(1) Hold floor runner along chalkline and snug at one end.

(2) Have another worker check the other end for proper length.

(3) If accurate, continue. If not, correct error and re-check.

(4) Follow last 3 steps for the ceiling runner.

3. Attaching runners.

a. Floor runners.

(1) Verify correct runner placement.

(2) Mark fastener placement locations.

(a) Two fasteners, two inches from each end.

(b) Fasteners 24" on center between the ends.

(3) Select proper fasteners.

(a) Concrete nails for hand application.

(b) Powder-actuated fastening. (This is optional and should be used only if student is certified for tool use.)

(4) Drive fasteners.

(a) Wear eye protection.

(b) Drive each fastener completely.

b. Ceiling runners.

(1) Repeat steps 1-4 of part "a" for ceiling runner.

(a) Use another student for assistance.

(b) Careful location of the ladder is important to avoid over-reaching.

# Post Assessment

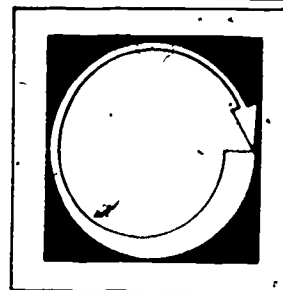

COMPLETE THE FOLLOWING STATEMENTS BY WRITING THE CORRECT WORD OR WORDS IN THE BLANKS PROVIDED.

1. Metal runners are most commonly made from \_\_\_\_\_-gauge to \_\_\_\_\_-gauge galvanized steel.
2. \_\_\_\_\_ fastener(s) are required at the end of a runner at a door frame.
3. Maximum fastener spacing on metal runners is \_\_\_\_\_ inches.
4. Runners are commonly supplied in \_\_\_\_\_ ft. and \_\_\_\_\_ ft. lengths.
5. Instead of mitering runner corner joints, one runner should be laid full length into the corner and the other runner should \_\_\_\_\_ into the first.

# Instructor Post Assessment Answers

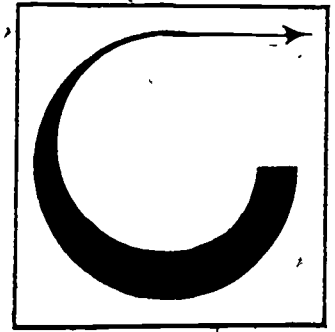

1. 14, 22

2. 2

3. 24

4. 10, 12'

5. butt



## SELF-SUPPORTING DRYWALL PARTITIONS

### Goal:

The student will be able to identify, describe and carry out the installation of semi-solid, solid, double- and triple-solid partitions.

### Performance Indicators:

The student will successfully complete a Self Assessment, a Job Sheet and a Post Assessment

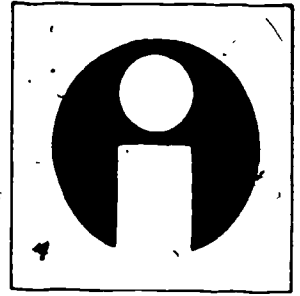

# Study Guide

In order to finish this module, do the following tasks. Check each item off as you complete it.

1.  Read the Goal and Performance Indicators on the cover of the module. This will tell you what you will learn by studying the module, and how you will show you've learned it.
2.  Read the Introduction. The Introduction will tell you why the module is an important part of the drywall trade.
3.  Study the Vocabulary section. Vocabulary words are important for a good understanding of the trade. After you have studied the vocabulary, ask your teacher to quiz you on the words and their meanings.
4.  Study the Information section. This section will give you the information you need to understand the subject.
5.  Take the Self Assessment exam. This is a test for you to prove to yourself that you have learned the material you have studied. Compare your answers with the answers on the Self Assessment Answer Sheet, which is on the page following the Self Assessment. If you scored poorly, re-study the Information section or ask your teacher for help.
6.  Do the Job Sheet. Follow the instructions at the top of the Job Sheet. The tasks listed on the Job Sheet will help you develop skills which will be helpful to you.
7.  Take the Post Assessment exam. Give the exam to your teacher after you have completed it. Your teacher will grade it for you.

# Introduction

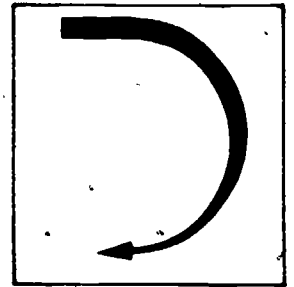

Drywall partitions can provide a less expensive, lower weight non-load-bearing divider for the builder. In addition, installation time is often less than for fully-framed dividers.

# Vocabulary

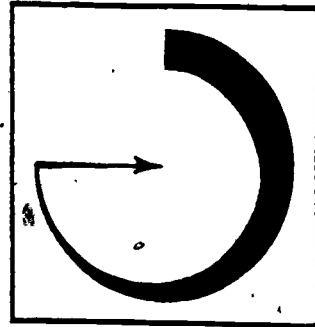

Trade terms are very important for a good understanding of the trade. Study these words and meanings. When you have learned them, ask your teacher to quiz you on the words and their meanings.

**RIBS**--Strips of drywall made from pre-scored coreboard sheets used in centers of semi-solid partitions.

**PARTITIONS**--Non-load-bearing drywall unit used to divide spaces without stud-work framing.

**LADDER BLOCKING**--The bracing required when partition runs parallel and in between ceiling joists; allows for adequate stability for ceiling runners.

**SOLID**--Coreboard centered partition with face plies directly attached to each side.

**DOUBLE SOLID**--A partition with "dead air" gap between interior coreboard sheets.

# Supplementary References

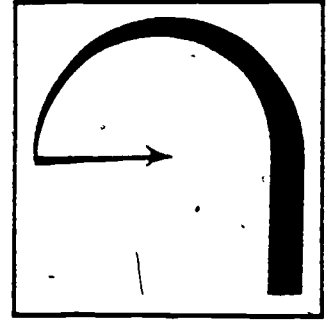

1. Using Gypsum Board for Walls and Ceilings. Gypsum Association, 1970. pp. 27-28.
2. Gypsum Construction Handbook. U.S. Gypsum, 1978. pp. 33, 94, 210, 219, 227.
3. U.S. Gypsum Technical Trade Folder #C515.
4. Drywall Construction Handbook, Part I. California State Dept. of Education, 1975. pp. 180, 193.
5. Handbook of Noise Control. Cyril M. Harris, 1957. Section 20.

# Information

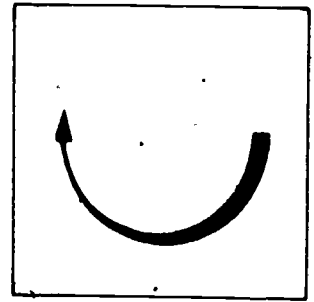

Self-supporting drywall partitions are widely used in buildings because they offer many advantages. They are easier to erect, and installation time is usually less. They are self-supporting and require only floor and ceiling runners.

Runners are generally made from "J" or "L" metal fabrications. 22 to 26-gage metal is used to make up these fabrications. Wooden runners may also be used, but these reduce the fire resistance rating of the partition.

These drywall units may be used only in non-load-bearing situations.

There are three classes of self-supporting drywall partitions. They are semi-solid, solid and double-or triple-solid partitions. Each partition has its own particular installation methods, requirements and advantages. The minimum recommended thickness for these partitions is 2".

Semi-solid partitions are made up of face plies of drywall sheets laminated to coreboard ribs by using embedding type joint compound. The ribs are either 6 or 8 inches wide and are to be spaced no more than 24 inches on center along the partition. The recommended thickness for the ribs is 1 5/8", although 1" ribs may also be used. Care must be taken to use the proper electrical boxes if required in the partition.

Panels can either be laminated before installing or during the installation process. Electrical conduit and outlets can be included inside semi-solid partitions.

The basic steps involved in the preparation and erection of a semi-solid partition are:

1. Mark floor runner according to the plan.

2. Mark ceiling runner using a level or plumb line.

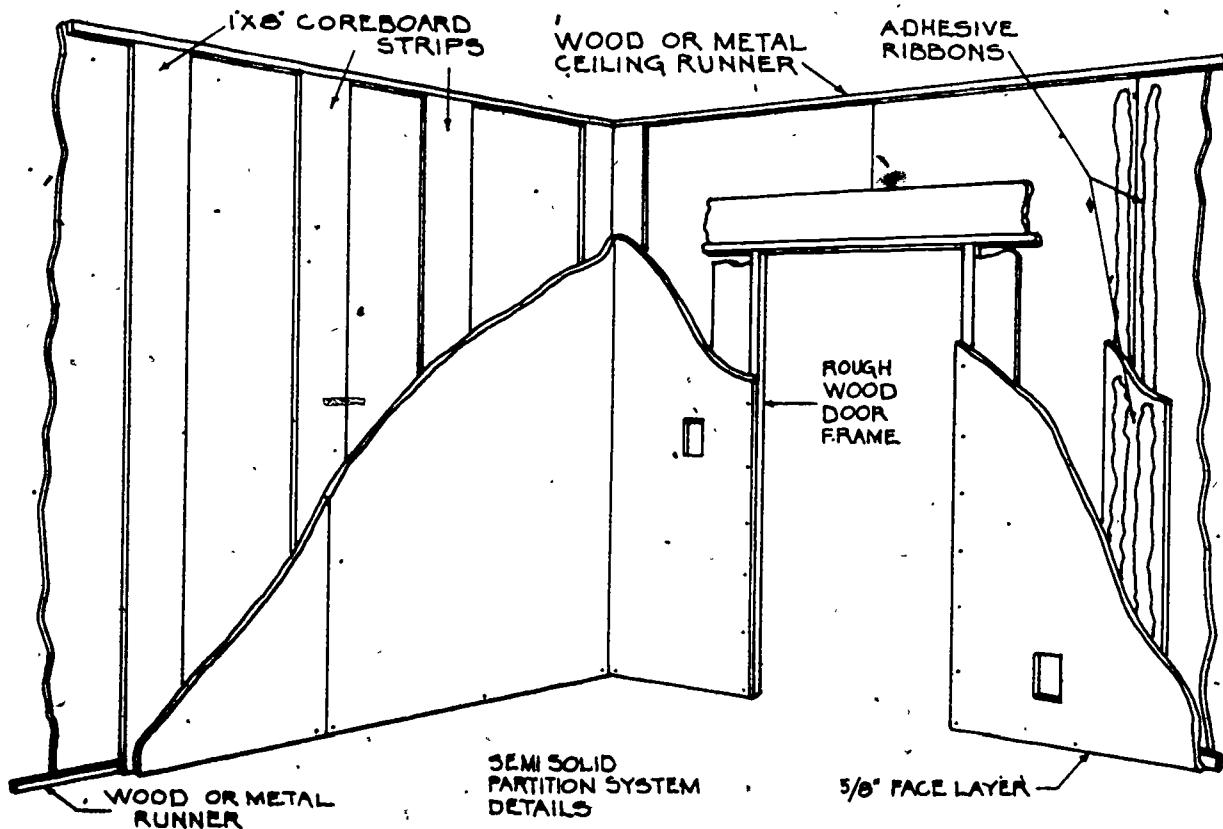

3. Install floor and ceiling runners with appropriate fasteners.
  - a. Be sure to place fasteners no more than 6" from partition ends, spaced no more than 24" apart.
  - b. When attaching to concrete, be sure to use safety glasses or goggles.
4. Prepare semi-solid panels to the runners with drywall-to-metal screws.

Solid drywall partition is a stronger wall unit than semi-solid units and has higher ratings for both sound transmission loss and fire resistance. (See the illustration on the following page.) The greater strength means it can be used in taller walls. Where 10 feet is generally the maximum height for semi-solid partitions, certain solid partitions may reach 14 feet in height.

Installation steps are:

1. Mark floor runners according to plans.

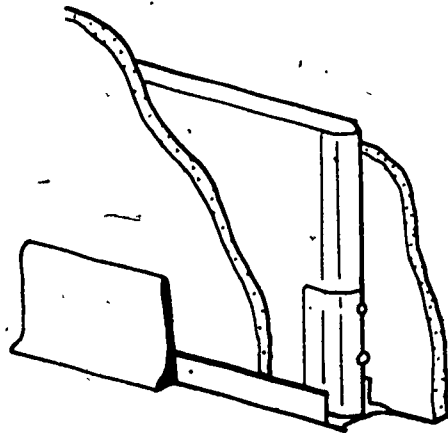

SOLID  
PARTITION

2. Mark ceiling runners using levels and/or plumb line.
3. Install floor and ceiling runners using appropriate fasteners.
  - a. Spacing for fasteners is the same as for semi-solid partitions.
  - b. Use precaution for eye protection when fastening into concrete.
4. Attach coreboard center ply to the floor and ceiling runners.
5. Attach face ply (or plies) to each side of the coreboard using either adhesives or screws.

Double and triple partitions provide for even further advantages in fire resistance and sound transmission loss ratings. This is because of more layers of non-combustible drywall material and the enclosed "dead air" space(s). (See the illustrations on the following page.)

Multiple-runners for both the floor and ceiling are required. Steps for installation of runners are the same as for solid partition runners.

Attach coreboard inner plies to runners and then attach face plies to coreboard. Additional sound-deadening panels may be placed between coreboard center plies.

A final advantage for double and triple solid partition is the ability to provide enough spacing to enclose plumbing and other mechanical units that the other self-supporting units may not provide room for.



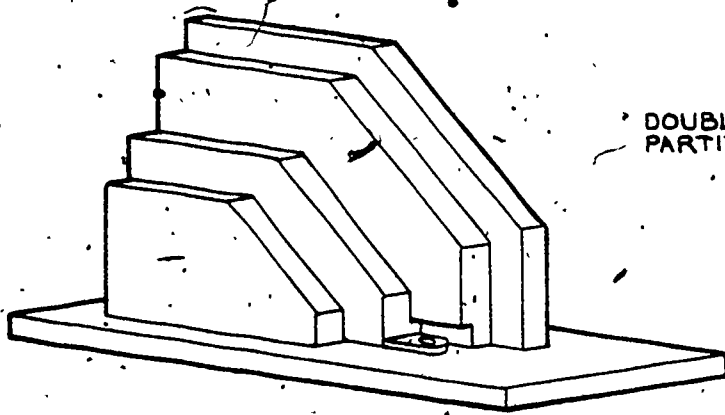

DOUBLE SOLID  
PARTITION

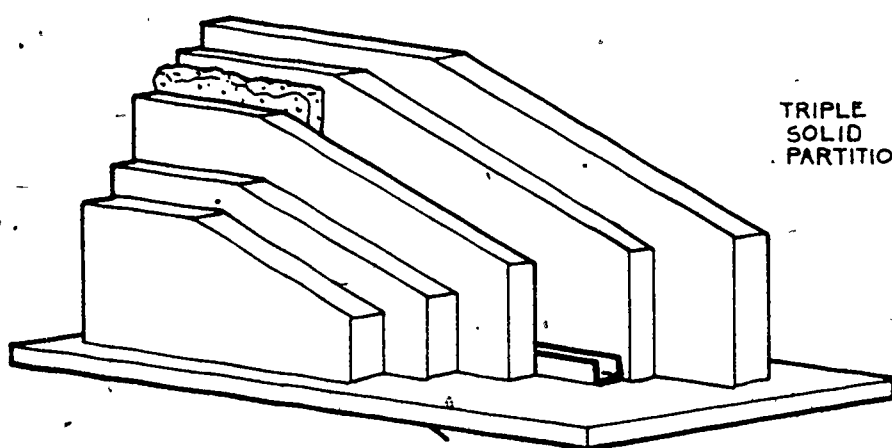

TRIPLE  
SOLID  
PARTITION

# Self Assessment

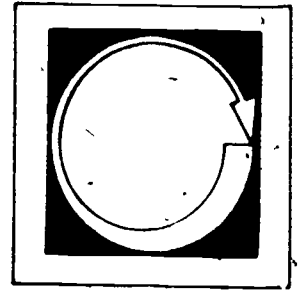

LISTED BELOW ARE SEVERAL STATEMENTS. IF THE STATEMENT IS TRUE, PLACE A "T" IN THE BLANK PROVIDED. IF THE STATEMENT IS FALSE, PLACE AN "F" IN THE BLANK.

1. \_\_\_ Maximum height of semi-solid partitions is 12 feet.
2. \_\_\_ Floor and ceiling runners must be fastened at 24" intervals or less.
3. \_\_\_ Solid and semi-solid partitions may not include wiring or plumbing.
4. \_\_\_ Semi-solid partitions have higher ratings for sound transmission loss.
5. \_\_\_ Double-solid partitions require 2 runners, top and bottom.

# Self Assessment Answers

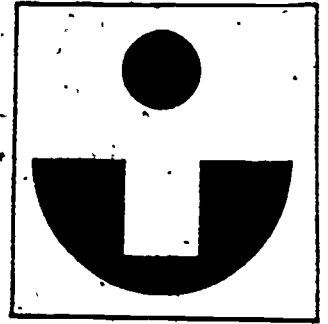

1. F

2. T

3. F

4. F

5. T

# Job Sheet

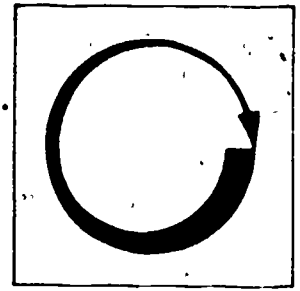

COMPLETE THE FOLLOWING TASKS.

## Materials and Tools

drywall face panels (1/2" or 5/8")

coreboards

metal "J" or "L" runners

embedding type joint compound

1 1/4" drywall-to-metal screws

12<sup>d</sup> nails

8<sup>d</sup> nails

drywall application tools

plumb bob or level

joint spreader box or roller

hand or powder-activated tools for fastening runners

screwdrivers (hand or power screw gun)

1. Install runners and erect a semi-solid partition.
  - a. measure and mark floor runner
  - b. use level or plumb bob to accurately mark ceiling runner
  - c. attach ceiling runner
  - d. attach floor runner (if attaching to concrete, use concrete nail fasteners and use eye protection mask)
  - e. Snap individual ribs from coreboard sheets

(See the illustration on the following page.)

SNAPPING  
INDIVIDUAL  
RIBS FROM  
COREBOARD  
SHEETS

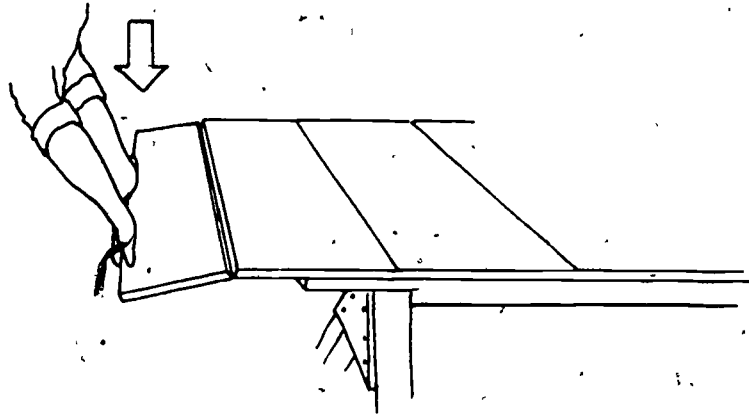

- f. lay down one piece of 4' X 8' face ply drywall on flat, even surface
  - g. spread joint compound on both sides of ribs using the spreader
  - h. lay ribs on face ply 24" O.C.
  - i. lay top ply on top, being careful to align edges
  - j. place additional sheets of drywall on top of the laminated sheets to apply pressure until joint compound is dry
  - k. lift semi-solid unit to vertical position
  - l. attach partition to runners (being sure to keep section 3/8" to 1/2" above floor level) securing with at least 3 fasteners, top and bottom.
2. Install runners and erect a solid drywall partition.
- a. follow step a-d in task 1
  - b. attach coreboard to runners
  - c. spread joint compound on each face of coreboard using notched spreader
  - d. carefully align each face ply
  - e. to insure a good and continuous bonding, face plies should be temporarily attached to coreboard, using nails or screws

# Post Assessment

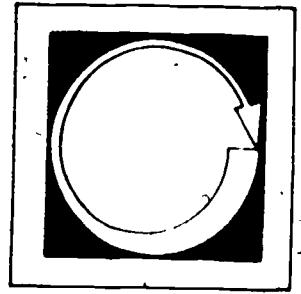

LISTED BELOW ARE SEVERAL STATEMENTS. IF THE STATEMENT IS TRUE, PLACE A "T" IN THE BLANK PROVIDED. IF THE STATEMENT IS FALSE, PLACE AN "F" IN THE BLANK.

1. \_\_\_ Fasteners for runners must be placed within 6" from each runner end.
2. \_\_\_ Runners are generally made from 14-18 gage "L" or "J" metal angle.
3. \_\_\_ Coreboard ribs are usually 6 or 8" wide.
4. \_\_\_ Solid partitions can be used in load-bearing applications.
5. \_\_\_ The recommended minimum thickness for solid partitions is 2".

# ● Instructor Post Assessment Answers

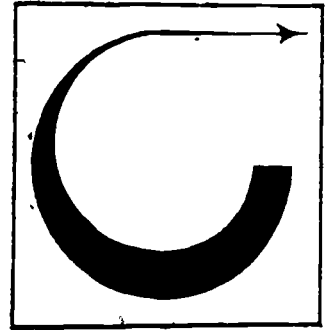

1. T

2. F

3. T

4. F

5. T

## INSTALLING METAL AND STRUCTURAL STUDS

### Goal:

The student will be able to:

1. Identify and describe the advantages of metal studs over conventional wood studs.
2. Identify, describe and perform the steps required to install metal studs.

### Performance Indicators:

The student will successfully complete a Self Assessment, a Job Sheet and a Post Assessment.



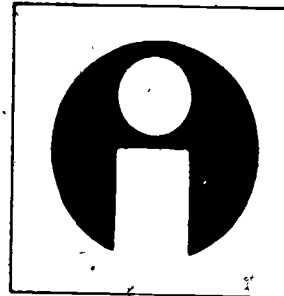

# Study Guide

In order to finish this module, do the following tasks. Check each item off as you complete it.

1.  Read the Goal and Performance Indicators on the cover of the module. This will tell you what you will learn by studying the module, and how you will show you've learned it.
2.  Read the Introduction. The Introduction will tell you why the module is an important part of the drywall trade.
3.  Study the Vocabulary section. Vocabulary words are important for a good understanding of the trade. After you have studied the vocabulary, ask your teacher to quiz you on the words and their meanings.
4.  Study the Information section. This section will give you the information you need to understand the subject.
5.  Take the Self-Assessment exam. This is a test for you to prove to yourself that you have learned the material you have studied. Compare your answers with the answers on the Self-Assessment Answer Sheet, which is on the page following the Self Assessment. If you scored poorly, re-study the Information section or ask your teacher for help.
6.  Do the Job Sheet. Follow the instructions at the top of the Job Sheet. The tasks listed on the Job Sheet will help you develop skills which will be helpful to you.
7.  Take the Post Assessment exam. Give the exam to your teacher after you have completed it. Your teacher will grade it for you.

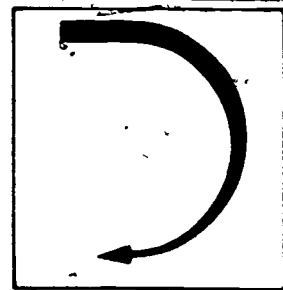

# Introduction

Metal and structural metal studs provide an alternative to conventional wood framing members. There are many advantages offered by the use of metal such as weight, installation time and cost.

# Vocabulary

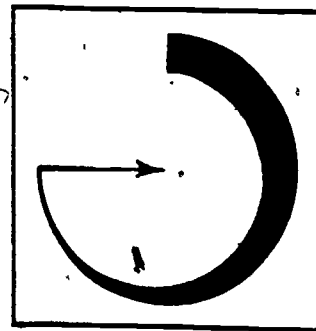

Trade terms are very important for a good understanding of the trade. Study these words and meanings. When you have learned them, ask your teacher to quiz you on the words and their meanings.

**CLINCH**--The fastening of a metal stud to a runner without using separate fastener or welding. Metal flanges are cut and bent over to provide firm bonding.

**STRUCTURAL STUD**--Metal stud designed to be used in load-bearing applications.

**NESTING**--Multiple studs overlapped to provide more strength and rigidity.

**SPLICE**--Joining shorter lengths to provide one continuous (long) piece.

**MIG**--Metal-inert gas welding process.

**CRIPPLE**--Short stud used under window openings.

# Supplementary References

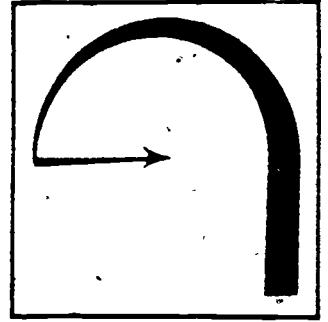

1. U.S.G. Light Steel Framing. (United States Gypsum Folder SA-510)  
January 1981.
2. Gypsum Construction Handbook. U.S.G. 1978.
3. Drywall Construction Handbook, Part I. California State Department of  
Education. 1975. pp. 182-184.
4. Drywall Construction Handbook, Part II. California State Department of  
Education. 1975. pp. 58-65.

# Information

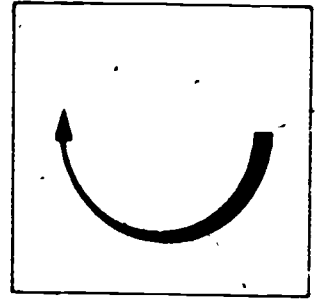

Metal studs, both light-weight and structural, are used a lot for framing bases in drywall construction. There are four areas of knowledge that the drywall mechanic should be familiar with to understand and be able to work with metal studs:

1. Advantages over wood framing.
2. Description and characteristics of metal studs.
3. Tools used for installation.
4. Installation process.

Metal studs are being used more and more often these days because of all the advantages they offer over conventional wood. Here is a list of advantages and benefits they give:

1. Non-combustible (won't burn), for better fire ratings.
2. Termite/rot-resistant.
3. True, uniform dimensions-reduces framing irregularities and warping.
4. Moisture content problems of wood are eliminated.
5. Light in weight.
6. Wider stud spacing is allowed (24" o.c.).
7. Wide range of standard dimensions and lengths and pre-cut custom lengths to reduce waste.
8. Faster installation, which lowers cost.
9. Galvanized for corrosion resistance (rust, etc.).
10. Structural load-bearing units are available.
11. Can be nested to increase strength when needed.
12. Pre-punched holes for conduit speeds up electrical installation.
13. Can be spliced to reduce waste.

In order to understand how a product can offer all these advantages, you must know characteristics of the product itself.

Metal studs are made from roll formed steel. They are hollow channel shaped and come in several standard widths and lengths.

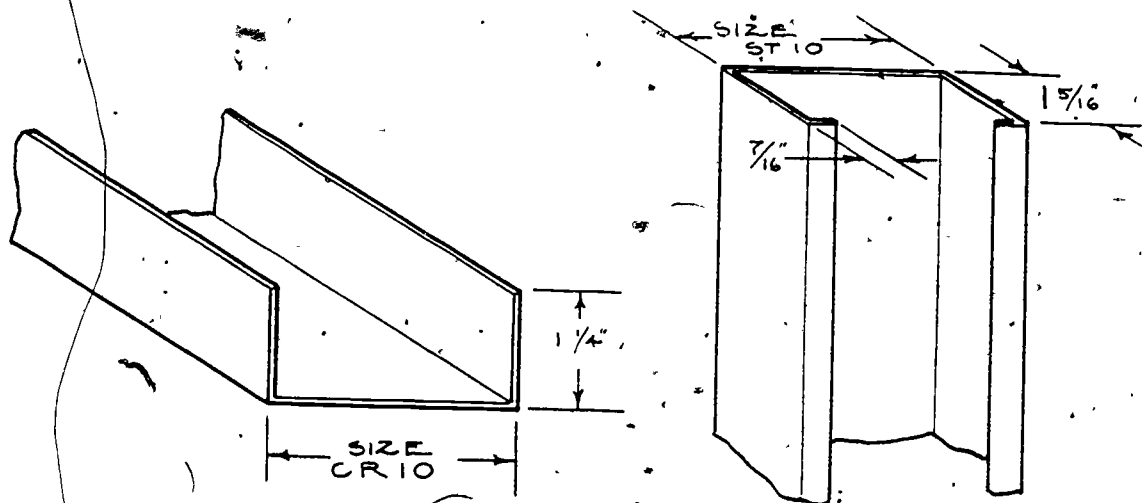

Common widths are 1 5/8", 2 1/2" and 3 5/8"; and they are color coded for easy identification.

Standard lengths--8', 10', 12', 14', 16', with lengths to 30', are available. The studs are made of 22- to 26-gage steel for non-load bearing uses; also down to 16-gage steel for load-bearing uses.

Metal studs come with pre-punched utility holes. These holes are used to install additional horizontal bracing when required, and for easier installation of electrical conduit. These studs are designed to be either screw-assembled, welded or clinched. (3/8" or 1/2" Type S pan-head screws are generally used for screw assemblies. Mig welding is used on metal up to .04" [4/100] thick; resistance type welding is used for heavier metal units. A specialized clinching tool has been designed to attach stud to runner.)

Proper installation of metal studs requires the use of several tools, some of which are specifically designed for the task of metal working. The drywall mechanic must have access to (and the ability to use) the following tools for metal stud installation, in addition to the regular drywall tools.

(See the illustrations on the following page.)

1. Electric screw gun (for screw assembly).

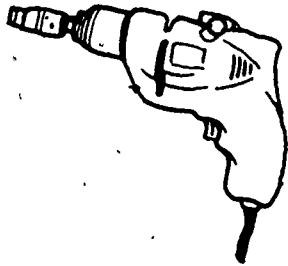

2. Tin Snips.
  - a. Straight.
  - b. Curved.

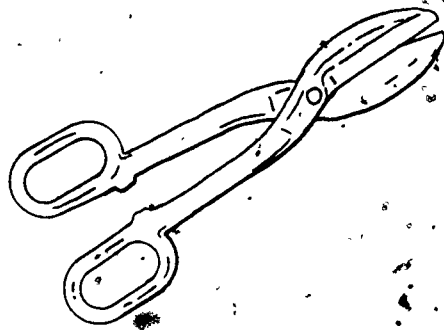
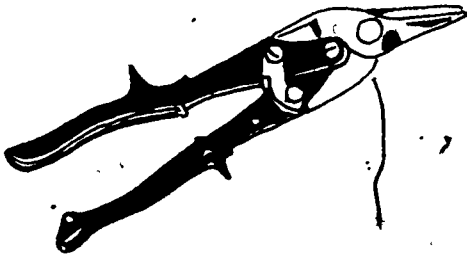

3. Powder-actuated tool.

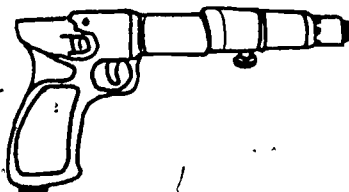
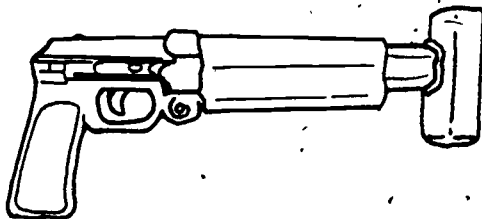

4. Phillips screwdriver.
5. Builder's level.
6. Plumb bob.
7. Clincher (for clinch assembly).

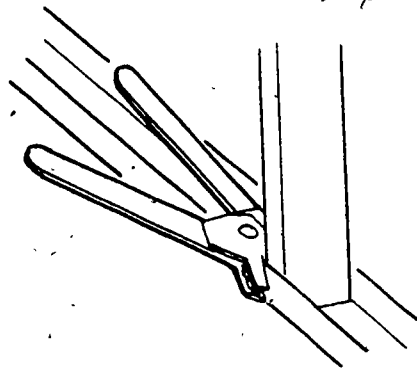

8. Mig or resistance-type welder (for welded assembly).
9. Hammer.

A word of caution about the use of tools around or with metal studs: The risk of electrical shock exists at all times with power tools, but more so when drilling or cutting metal. Be sure that your equipment is well-maintained, cords are safe and that the tool is properly grounded. Another danger to watch out for is cuts from sharp edges and corners of metal assemblies. This can be painful and can cause time lost from work. Use caution when working and handling these materials.

The last area of concern to the drywall mechanic is the actual assembly or installation process. The steps are fairly simple to follow. Accuracy is more important than speed, however.

1. Mark wall layout from plans using steel tape and chalkline for both floor and ceiling runners.
2. Carefully cut floor and ceiling runners to length, using tin snips.
3. Lay out runner pieces to check for accurate fit.
4. Attach runners with appropriate fasteners (with powder-actuated tool to floor and ceiling).
5. From plans and specification, mark stud layout along runner.



6. Cut studs to length if required-- (for cripples or if studs were not pre-cut to required length.)
7. Install the stud.
  - a. Put one end into floor runner with stud held at an angle (not vertical).
  - b. Align other end with ceiling runner.
  - c. Straighten stud to vertical position.
  - d. Twist stud into place at right angle to runner. It should be snug.
8. Check position and plumb; use tape and level. Adjust position if necessary.
9. Attach stud to runner on each face at the top and bottom by one of these methods.
  - a. Screw.
  - b. Clinch.
  - c. Weld.

This installation process can be changed to allow for the entire wall assembly to be put together first on the floor and then raised into place and attached. Care must be taken with this method to avoid twisting or bending the assembly when raising it up to vertical.

Metal studs can provide advantages and can be fairly quick and easy to install.

# Self Assessment

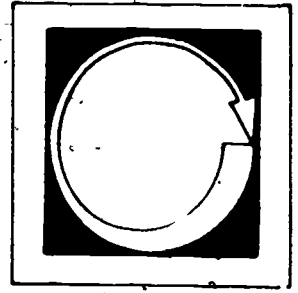

LISTED BELOW ARE SEVERAL STATEMENTS. IF THE STATEMENT IS TRUE, PLACE A "T" IN THE BLANK PROVIDED. IF THE STATEMENT IS FALSE, PLACE AN "F" IN THE BLANK.

1. \_\_\_ Metal studs are designed only for non-load-bearing applications.
2. \_\_\_ Stud spacing for metal studs is closer than for wood studs.
3. \_\_\_ Metal studs are color-coded for width.
4. \_\_\_ Mig welding is used for any thickness of metal stud.
5. \_\_\_ Metal studs can be spliced to reduce waste.
6. \_\_\_ Speed is more important than accuracy in stud installation.

# Self Assessment Answers

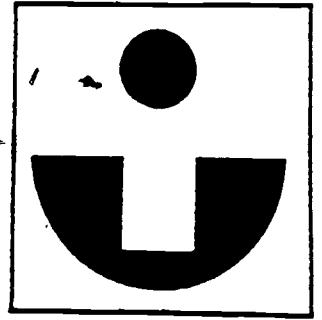

1. F
2. F
3. T
4. F
5. T
6. F

# Job Sheet

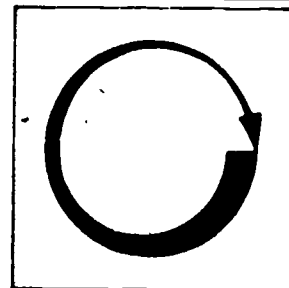

COMPLETE THE FOLLOWING TASK.

Materials and Tools

Metal runners and studs of matching dimensions

Type "S" pan-head screws

Powder-actuated fasteners required to attach runner to floor and ceiling  
steel tape

chalkline

tin snips

powder-actuated tool

Phillips screwdriver

level

plumb bob

electric screw gun

clinch tool (optional)

hammer

welding outfit (optional)

1. Assemble non-load-bearing wall or partition with metal studs using screw assembly. (Task may use clinch or weld assembly as options if equipment is available.)

# Post Assessment

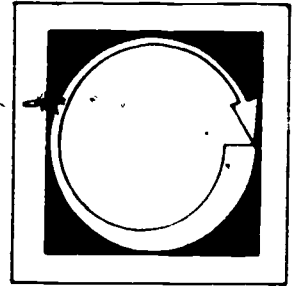

COMPLETE THE FOLLOWING STATEMENTS BY WRITING THE CORRECT WORD OR WORDS IN THE BLANKS PROVIDED.

1. Nesting studs increase the unit \_\_\_\_\_ without greatly increasing its \_\_\_\_\_.
2. Non-load-bearing studs are made from \_\_\_\_\_ gage steel and structural metal studs use metal up to \_\_\_\_\_ gage.
3. Type \_\_\_\_\_ pan-head screws are used for stud assembly.
4. Caution and concern for \_\_\_\_\_ and \_\_\_\_\_ must be taken by drywall mechanics when working with metal studs.
5. List at least 6 advantages of metal studs over conventional framing.
  - a.
  - b.
  - c.
  - d.
  - e.
  - f.

# Instructor Post Assessment Answers

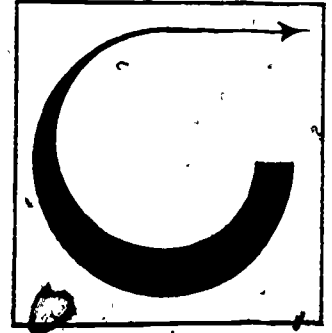

1. strength, size
2. 22-26, 16
3. S
4. electrical shock, sharp edges
5. Any six of the following:
  - a. Non-combustible.
  - b. Termite/rot-resistant.
  - c. True.
  - d. Moisture content problems of wood are eliminated.
  - e. Light in weight.
  - f. Wider stud spacing is allowed.
  - g. Wide range of standard dimensions and lengths and pre-cut custom lengths to reduce waste.
  - h. Faster installation, which lowers cost.
  - i. Galvanized for corrosion resistance.
  - j. Structural load-bearing units are available.
  - k. Can be nested to increase strength when needed.
  - l. Pre-punched holes for conduit speeds up electrical installation.
  - m. Can be spliced to reduce waste.

---

INSTALLING CARRYING CHANNELS FOR SUSPENDED CEILINGS

---

**Goal:**

The student will be able to describe and perform the tasks required to hang carrying channels from concrete, steel decking, I beams and metal joists.

**Performance Indicators:**

The student will successfully complete a Self Assessment, a Job Sheet and a Post Assessment.

# Study Guide

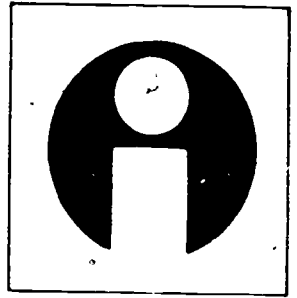

In order to finish this module, do the following tasks. Check each item off as you complete it.

1.  Read the Goal and Performance Indicators on the cover of the module. This will tell you what you will learn by studying the module, and how you will show you've learned it.
2.  Read the Introduction. The Introduction will tell you why the module is an important part of the drywall trade.
3.  Study the Vocabulary section. Vocabulary words are important for a good understanding of the trade. After you have studied the vocabulary, ask your teacher to quiz you on the words and their meanings.
4.  Study the Information section. This section will give you the information you need to understand the subject.
5.  Take the Self Assessment exam. This is a test for you to prove to yourself that you have learned the material you have studied. Compare your answers with the answers on the Self Assessment Answer Sheet, which is on the page following the Self Assessment. If you scored poorly, re-study the Information section or ask your teacher for help.
6.  Do the Job Sheet. Follow the instructions at the top of the Job Sheet. The tasks listed on the Job Sheet will help you develop skills which will be helpful to you.
7.  Take the Post Assessment exam. Give the exam to your teacher after you have completed it. Your teacher will grade it for you.



# Introduction

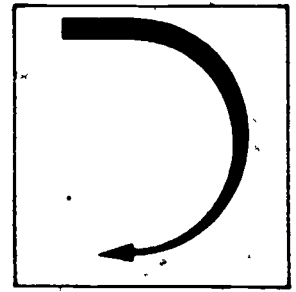

Suspended ceilings are common jobs for drywall mechanics today. Installing cold rolled carrying channel is the first step in the process of installing these ceiling systems.

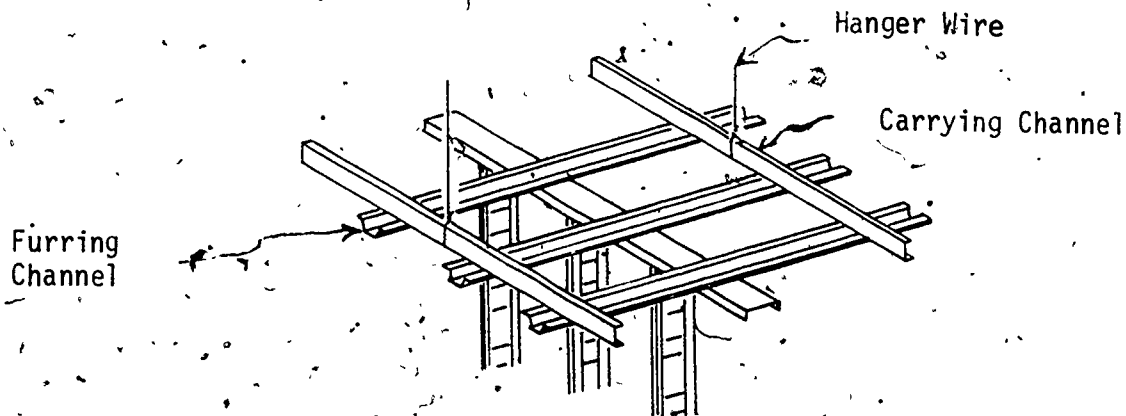

This module and the next few will introduce the various components of suspended ceiling systems and the proper installation techniques.

# Vocabulary

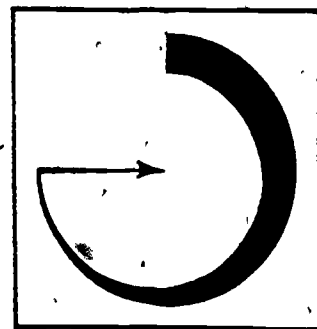

Trade terms are very important for a good understanding of the trade. Study these words and meanings. When you have learned them, ask your teacher to quiz you on the words and their meanings.

**WATER LEVEL**--A clear plastic tube filled with water; used to mark points of equal height to that of a reference point.

**DOUBLE-WRAP**--Method of tying carrying channel with hanger wire where the wire is passed around the channel 2 times.

**TRANSIT**--A tool used to sight and transfer elevation marks from a reference point; based on a level and sighting scope.

**PARALLEL**--Two lines that are level and equal distant from each other at all points.

**PERPENDICULAR**--At right angles.

# Supplementary References

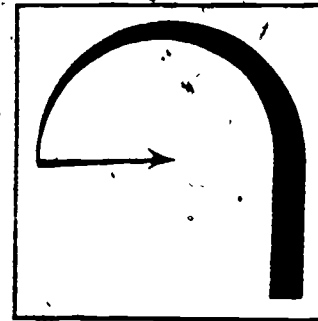

1. Gypsum Construction Handbook. United States Gypsum. 1978. p. 33.
2. Drywall Construction Workbook, Part 2. California State Department of Education. 1975. pp. 154-159.
3. Using Gypsum Board for Walls and Ceilings. Gypsum Association. 1970. pp. 10-12.

carrying channels used with these furring types:

<u>Furring Material</u>	<u>Channel Spacing (Max.)</u>
Drywall furring	4'
1 3/8" metal stud	5'
2 1/2" metal stud	6'
3 1/2" metal stud	8'

When the spacing is determined and the size of the room (or job) is known, the amount of channel required may be determined.

Finding the proper height for the carrying channel is the next phase in the process. First, the finish height of the ceiling must be taken from the plans. Also, the thicknesses of both the ceiling/surface material and the furring channel must be determined from the job specifications. These two dimensions must be added to the finished ceiling height to determine the proper level to suspend the carrying channel.

When correct height is calculated, it must be transferred to the walls to be used as a reference guide.

1. First, measure and mark the correct height at one point.
2. Indicate (by marking) that this is the guide or reference point.
3. This reference point must be transferred to other parts of the room so that a chalkline can be snapped on the walls to provide a continuous guide. There are several methods of doing this transfer.

#### METHOD ONE: WATER LEVEL

A water level need not be more than a long, clear plastic tube filled with water. One end is raised to the reference mark and the other end is held up to another point along the wall. When the water level is at the reference point level, the water level at the other end of the tube will accurately indicate the same height. This mark may then be transferred to the wall with a pencil. This same process is repeated at different points until enough points are available to snap a continuous chalkline around the job.

METHOD TWO: TRANSIT LEVEL

Using the transit level begins with marking the guide or reference height as was done for the water level. Then the transit is adjusted to this height. Additional guidemarks are then marked by sighting on a horizontal line through the transit. When enough marks have been transferred around the room, snap a chalkline to connect the marks to form a continuous guide line.

With the guide line ready, the hanger wire must now be hung from the roof. Hanger methods will depend on the type of roof construction. In concrete, the wire is sometimes embedded into the concrete when it is poured, or an eye pin is attached with a powder-actuated tool:

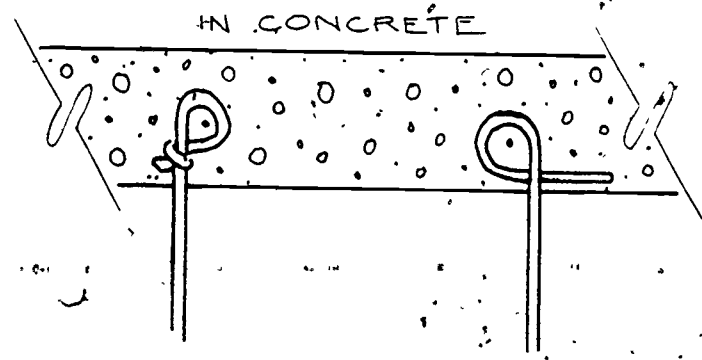

In steel decking, the wire can be passed through holes drilled into the decking.

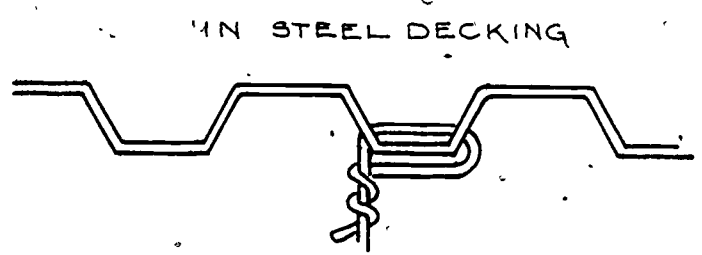

Eye pins can be driven into steel "I" beams with a powder-actuated tool.

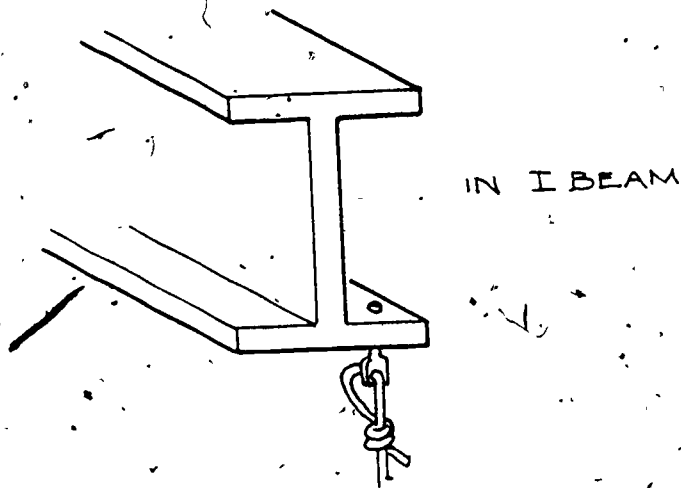

The hanger wire can be passed through steel joists.

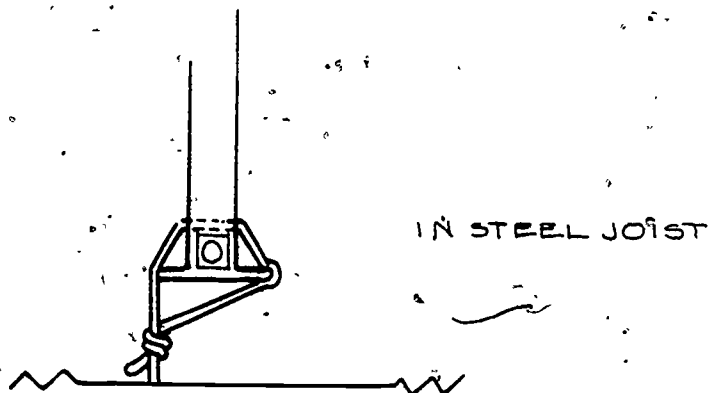

Hangers must be spaced 4' o.c. maximum along the length of the carrying channel. Tying off the wire at the hanger should include two twists or wraps around the wire after passing through the hanger.

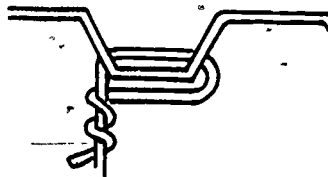

Using the chalkline as a guide, bend the hanger wire at a right angle at the correct hanging height. Allow about 12" of wire to tie off around the carrying channel. When hanger wire is installed, carefully raise channel into place and tie off, using the double-wrap method. Regularly check chalkline to make sure that the carrying channel is level and at the proper height.

Repeating these steps will complete the process of hanging carrying channel.

# Self Assessment

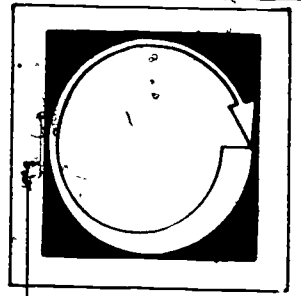

LISTED BELOW ARE SEVERAL STATEMENTS. IF THE STATEMENT IS TRUE, PLACE A "T" IN THE BLANK PROVIDED. IF THE STATEMENT IS FALSE, PLACE AN "F" IN THE BLANK.

1.  One twist or wrap around the hanger wire at either end is all that is needed to secure the attachment.
2.  Hanger wires must be spaced 4 feet on center or less.
3.  Carrying channel is hung so that its bottom edge is at the ceiling level indicated on the plans.
4.  Carrying channel used in suspended ceilings is generally 2" wide.
5.  Spacing for carrying channel is determined by the furring channel that is used for the job.



# ● Self Assessment Answers

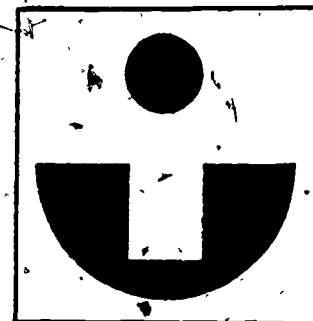

1. F

2. T

3. F

4. F

5. T

# Job Sheet

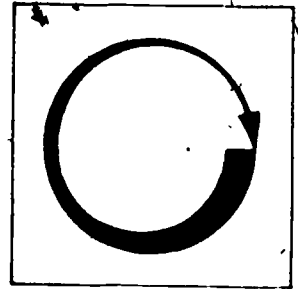

COMPLETE THE FOLLOWING TASKS.

## Materials and Tools

channel stock  
9-gage hanger wire  
water level  
transit (optional)  
wire cutters  
chalkline  
ladder(s)

## Physical Requirements

Open ceiling with wire hangers installed with at least 1 wall close by for reference.

1. Measure and mark ceiling line on wall(s).
  - a. Carefully measure and mark a point 8' from the floor line. This is the finished ceiling height.
  - b. The completed job calls for 1/2" drywall ceiling material and the use of 7/8" thick furring channels.
  - c. Make a new mark that allows for the material in step "b" above your first mark. This will be the level for the lower edge of the carrying channel.
  - d. Using either a water level or transit level, mark several additional reference marks along the same wall.
  - e. Stretch a chalkline along the reference marks on the wall and snap a line.
  - f. Repeat steps c-e for the other walls.

2. Hanging carrying channel.

- a. Measure the distance from hanger attachment on the roof down to the chalkline.
- b. Add to this length an allowance for tying off at both the top and the bottom (approx. 16"). This will give you the length of hanger wire needed.
- c. Count the number of hangers required and cut the hanger wires with wire cutters.
- d. Tie off hanger wires at roof hanger points. Be sure to put at least 2 twist wraps around the wire.
- e. Using the chalkline as a guide, bend the other end of the hanger wire at a right angle ("L" shaped) at the proper hanging height.
- f. With help, raise the carrying channel up to the hanger wires.
- g. Tie off each end using the double-wrap method.
- h. Check the chalkline for accuracy; if not correct, adjust it before continuing.
- i. Tie off the remaining hanger wires.
- j. Repeat step h.
- k. The final test will be to use either the water level or transit level to check the accuracy of your work. Adjust your tie-offs if required.

# Post Assessment

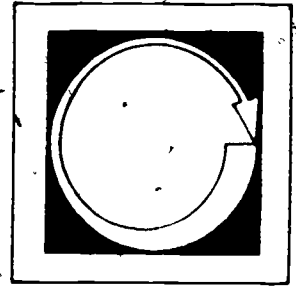

COMPLETE THE FOLLOWING STATEMENTS BY WRITING THE CORRECT WORD OR WORDS IN THE BLANKS PROVIDED.

1. Carrying channel is generally made from \_\_\_\_\_-gauge steel.
2. Standard spacing of carrying channel when using drywall furring channel is \_\_\_\_\_ feet, while the spacing may be increased to \_\_\_\_\_ feet when using 3 1/2" metal studs for furring channel.
3. Either a \_\_\_\_\_ level or a \_\_\_\_\_ level may be used as devices for determining additional reference points for ceiling height.
4. Hanger wire that is used to suspend carrying channel is generally made from \_\_\_\_\_-gauge wire.
5. When tying off the hanger wire around the carrying channel, the \_\_\_\_\_ method is commonly used.
6. When determining the height at which the carrying channel is hung, both the thickness of \_\_\_\_\_ material and \_\_\_\_\_ material must be considered.

# Instructor Post Assessment Answers

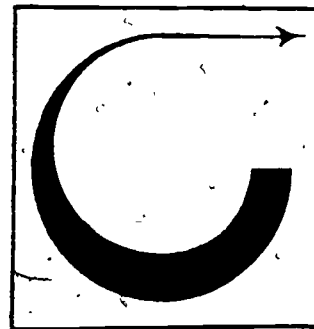

1. 16

2. 4, 8

3. transit, water

4. 9

5. double-wrap

6. surface, furring

FURRING CHANNEL

**Goal:**

The student will be able to identify and describe the different types of furring channels and their uses in the drywall trade.

**Performance Indicators:**

The student will successfully complete a Self Assessment, a Job Sheet and a Post Assessment.

# Study Guide

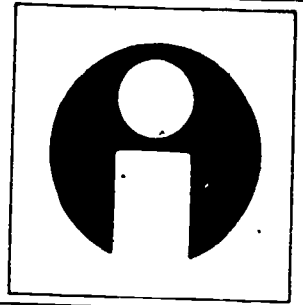

In order to finish this module, do the following tasks. Check each item off as you complete it.

1.  Read the Goal and Performance Indicators on the cover of the module. This will tell you what you will learn by studying the module, and how you will show you've learned it.
2.  Read the Introduction. The Introduction will tell you why the module is an important part of the drywall trade.
3.  Study the Vocabulary section. Vocabulary words are important for a good understanding of the trade. After you have studied the vocabulary, ask your teacher to quiz you on the words and their meanings.
4.  Study the Information section. This section will give you the information you need to understand the subject.
5.  Take the Self Assessment exam. This is a test for you to prove to yourself that you have learned the material you have studied. Compare your answers with the answers on the Self Assessment Answer Sheet, which is on the page following the Self Assessment. If you scored poorly, re-study the Information section or ask your teacher for help.
6.  Do the Job Sheet. Follow the instructions at the top of the Job Sheet. The tasks listed on the Job Sheet will help you develop skills which will be helpful to you.
7.  Take the Post Assessment exam. Give the exam to your teacher after you have completed it. Your teacher will grade it for you.

# Introduction

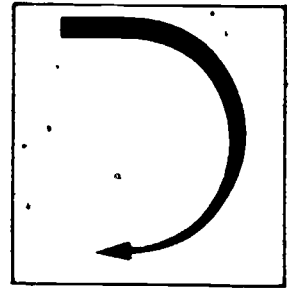

Furring channels provide an easy, fast, low cost method for attaching drywall over difficult wall and ceiling surfaces.



# Vocabulary

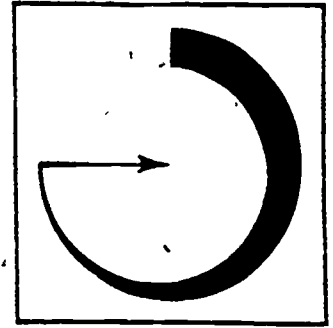

- Trade terms are very important for a good understanding of the trade. Study these words and meanings. ~~When~~ you have learned them, ask your teacher to quiz you on the words and their meanings.

RESILIENT--Flexible, allowing some give or movement; not rigid.

FURRING--Application of wood or metal strips to level for final surface covering.

MONOLITHIC CONCRETE--Single, unbroken section; without joints.

CHASE SPACE--Free space between outer wall covering and surface below furring, allowing for pipes, conduit and other obstructions.

# Supplementary References

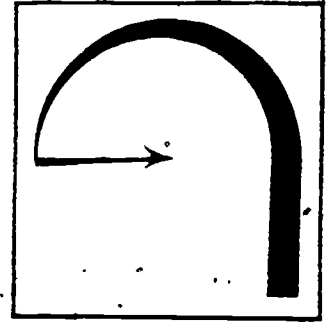

1. Gypsum Construction Handbook. U.S. Gypsum, 1978. pp. 98-102.
2. Drywall Construction Handbook, Part 2. California State Department of Education, 1974. pp. 150-152.
3. Using Gypsum Board for Walls and Ceilings. Gypsum Association, 1970. p. 12.

# Information

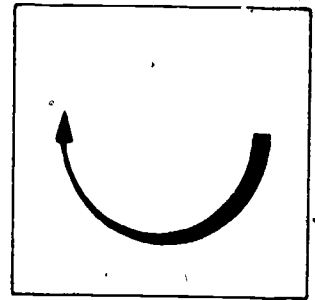

Furring channel is specifically designed to provide easy screw attachment of backing board or drywall panels over a variety of wall and ceiling surfaces. Installation cost and work time are also reduced.

There are two main types of furring channel used in the drywall trade: "Hat" channel and resilient channel. "Hat" channel is made from roll-formed 25-gage galvanized metal. The dimensions are 2 3/4" wide, 7/8" deep and it comes in 12' lengths.

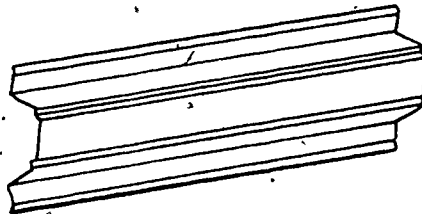

Resilient channel is made in different cross sectional shapes and is designed to improve sound deadening properties. It also tends to reduce the amount of surface damage to finish wallboard. This is done by allowing for some movement or flexing to occur without stressing the fastener or joint directly. (See the illustration on the top of the following page.)

Furring channel may be used to provide a leveling effect over rough surfaces such as brick, block or monolithic concrete as long as the irregularities are not too great. Furring channel may also be used to provide chase space (clearance) for pipes and conduit.

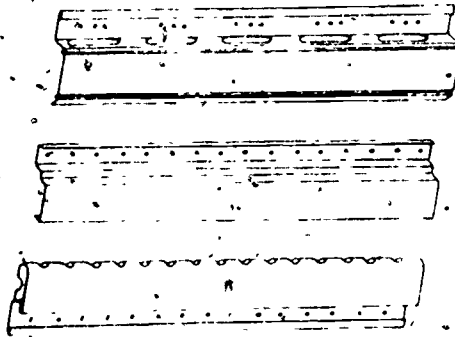

For surfaces that are not plumb or are too irregular, for furring channel, free standing metal stud walls may be erected to act as furring for drywall panels.

Furring channels should be attached over wood framing at right angles (90°) to framing members and at 2' intervals. On walls, the lowest channel should be within 2" of the floor and the top channel should be within 6" of the ceiling.

Drywall panels should be attached with Type "S" screws 16" o.c., no closer than 3/8" from edges or ends of panels. The panels' long dimension should be perpendicular to the furring channel. (See the illustration on the top of the following page.)

When attaching furring channel to brick or block walls, concrete-stub nails should be driven into mortar joints along the brick or block edge. Powder actuated fasteners may also be used over masonry walls or monolithic concrete.

Fasteners should be driven 24" o.c. along furring channel on alternate sides through the flanges. Channels may be attached either horizontally or vertically

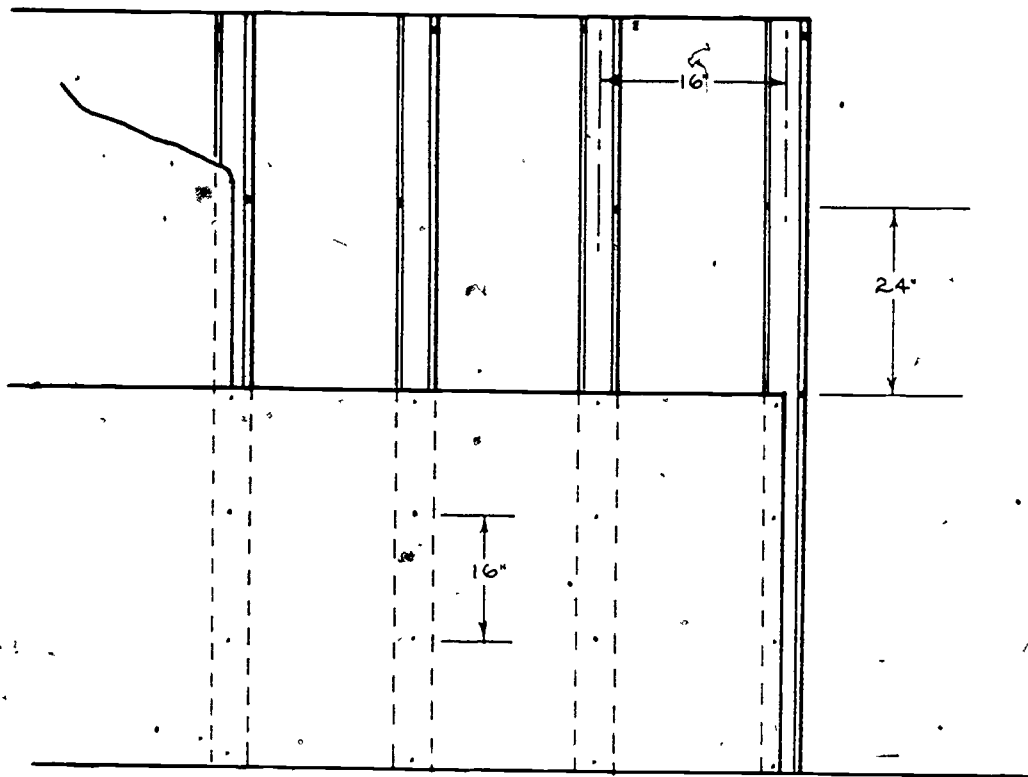

on-masonry or concrete. Drywall panels are attached to furring channel over masonry or concrete similar to wood framing.

Furring channel is also used in several types of ceiling systems. It is usually attached to carrying channel with special wire clips.

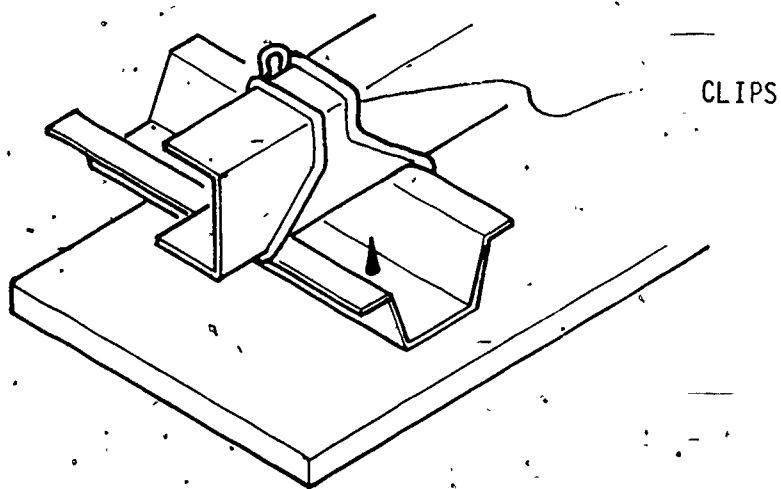

Spacing of furring channel will vary with the type of surface panel(s) applied.

# Self Assessment

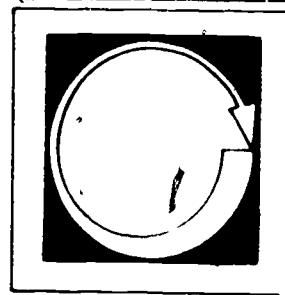

LISTED BELOW ARE SEVERAL STATEMENTS. IF THE STATEMENT IS TRUE, PLACE A "T" IN THE BLANK PROVIDED. IF THE STATEMENT IS FALSE, PLACE AN "F" IN THE BLANK.

1.  Furring channel should be installed perpendicular to wood framing members.
2.  Nails or powder-actuated fasteners should be attached on the same flange (side) of the furring channel.
3.  Resilient furring channel can help reduce surface damage to finished drywall.
4.  Furring channel is attached to wood framing with 16<sup>d</sup> nails.
5.  Installation cost and time to attach are lowered with furring systems.

# Self Assessment Answers

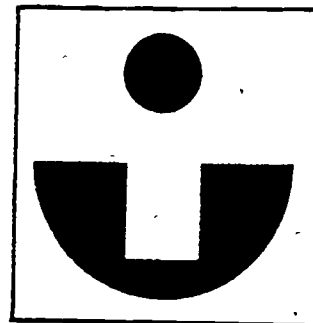

1. T

2. F

3. T

4. F

5. T

# Job Sheet

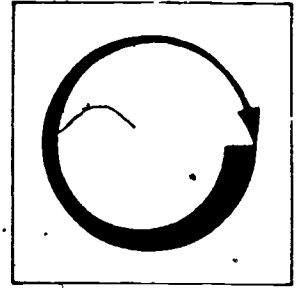

COMPLETE THE FOLLOWING TASKS.

## Materials and Tools

furring channel

Type "W" 1 1/4" screws

Type "S" 1" screws

1/2" drywall panel(s)

metal cutters

electric screwdriver

measuring tape

drywall knife

## Physical Requirements

8' tall open wood stud framing wall.

- I. Lay out and attach furring channel to wall.
  - A. Locate, lay out.
    1. Locate lower channels 2" maximum from floor.
    2. Locate upper (top) channel within 6" of ceiling.
    3. Intermediate channels located at 24" or less intervals between top and bottom channels ✓
  - B. Measure and cut channels to length.
    1. If splicing is required, be sure it falls on stud.
    2. Cut channels to overlap for fastening splice on stud.
  - C. Attach channels to studs.
    1. Use Type "W" screws and electric screwdriver.



II. Attach drywall to furring channel.

- A. Measure, mark and cut drywall panels.
- B. Apply panels to furring channels.
  1. Be sure panels' long dimension is at a right angle (perpendicular) to furring channel.
- C. Attach panel to furring.
  1. Use Type "S" screws.
  2. Spacing 12" o.c. maximum.
  3. No closer than 3/8" from edges on ends of panels.

# Post Assessment

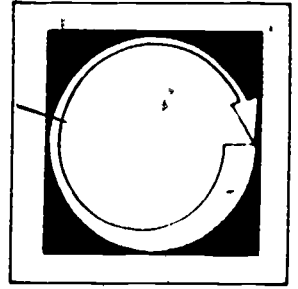

COMPLETE THE FOLLOWING STATEMENTS BY CIRCLING THE CORRECT WORD OR WORDS.

1. Fastener spacing for furring channel on walls is 12" / 16" / 24" on center.
2. Free-standing stud walls for furring units are used anytime / when surface to be covered is uneven.
3. Drywall panels should be attached long dimension parallel / at right angle to furring channels.
4. Panel fastener spacing over furring strips is 8" / 12" / 16" o.c. maximum.
5. Furring channel spacing in walls and ceiling should not exceed 16" / 24" / 36".

# Instructor Post Assessment Answers

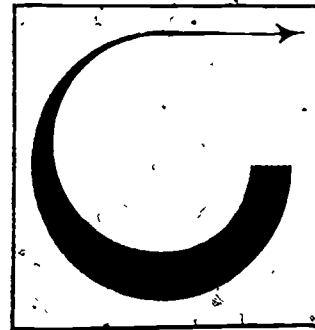

1. 24"
2. when surface to be covered is uneven
3. at right angle
4. 16"
5. 24"

## INSTALLING SUSPENDED GRID AND TILE CEILINGS

### Goal:

The student will be able to:

1. Recognize and describe the various types of suspended grid ceilings.
2. Identify the materials required for each system.
3. Describe and demonstrate the steps required to lay out a grid system.
4. Describe and explain the steps involved in the installation of a grid ceiling system.

275

### Performance Indicators:

The student will successfully complete a Self Assessment, an Assignment and a Post Assessment.

276

# Study Guide

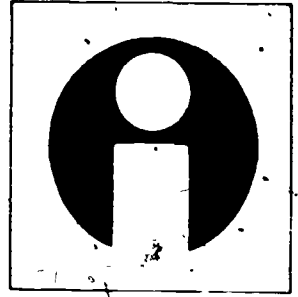

In order to finish this module, do the following tasks. Check each item off as you complete it.

1.  Read the Goal and Performance Indicators on the cover of the module. This will tell you what you will learn by studying the module, and how you will show you've learned it.
2.  Read the Introduction. The Introduction will tell you why the module is an important part of the drywall trade.
3.  Study the Vocabulary section. Vocabulary words are important for a good understanding of the trade. After you have studied the vocabulary, ask your teacher to quiz you on the words and their meanings.
4.  Study the Information section. This section will give you the information you need to understand the subject.
5.  Take the Self Assessment exam. This is a test for you to prove to yourself that you have learned the material you have studied. Compare your answers with the answers on the Self Assessment Answer Sheet, which is on the page following the Self Assessment. If you scored poorly, re-study the Information section or ask your teacher for help.
6.  Do the Assignment page. Follow the instructions at the top of the Assignment page.
7.  Take the Post Assessment exam. Give the exam to your teacher after you have completed it. Your teacher will grade it for you.

# Introduction

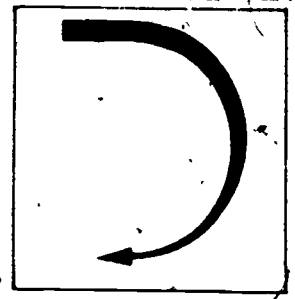

Drywall jobs often include the installation of suspended grid and/or tile ceilings. Knowing the various styles and methods of installing these systems is important to drywall mechanics who wish to perform well.

# Vocabulary

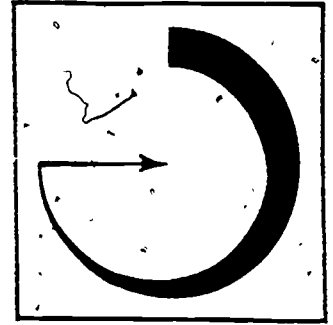

Trade terms are very important for a good understanding of the trade. Study these words and meanings. When you have learned them, ask your teacher to quiz you on the words and their meanings.

**MAIN RUNNERS**--Used as tile-carrying members in acoustical tile systems; they come in various cross sectional shapes such as H, G, 2 and T.

**CROSS RUNNERS**--Used with main runners to support acoustical panels. They usually have a "T" shape and are installed at right angles to main runners.

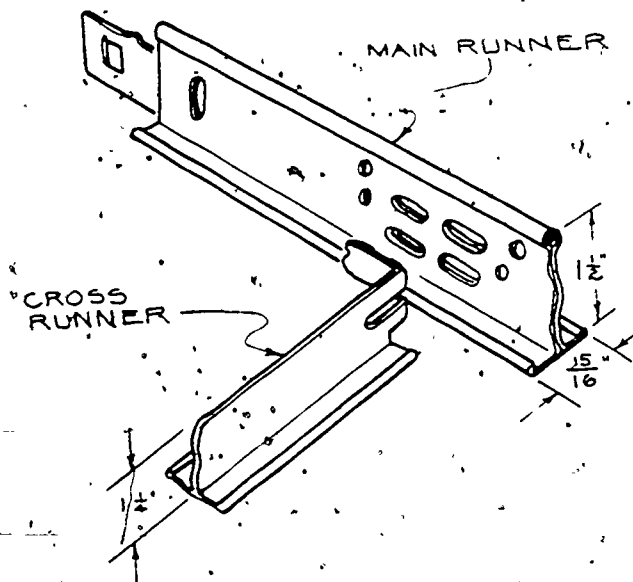

**FURRING BARS**--Either nail or screw channels, used to hold backing material (drywall sheets) in suspended ceiling systems.

(See the illustration on the top of the following page.)

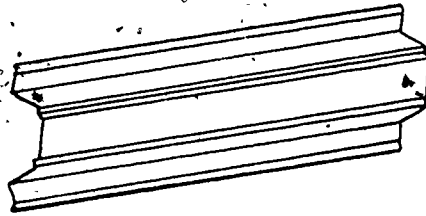

KERF--Slot made in the edge of acoustical tiles to receive either the runner edge or splines.

SPLINE--Metal or fiber material formed into thin strips that are inserted into the kerfed edge of ceiling tile to form a concealed joint.

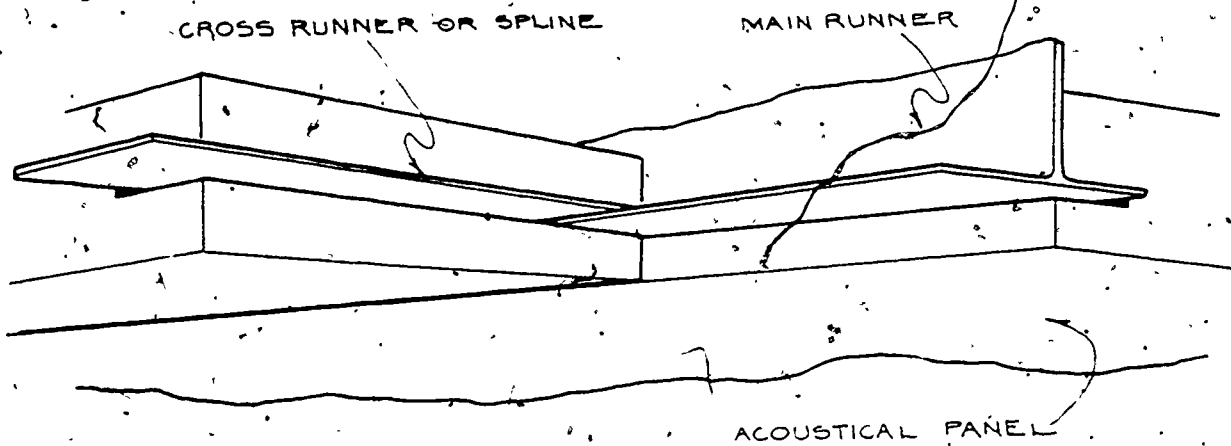



# Supplementary References

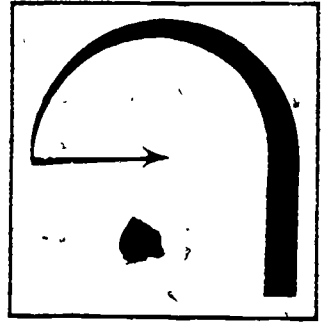

1. Drywall Construction Handbook, Part II. California State Department of Education. 1975. pp. 161-172.
2. Gypsum Construction Handbook. U.S. Gypsum. 1978. pp. 232-235.

# Information

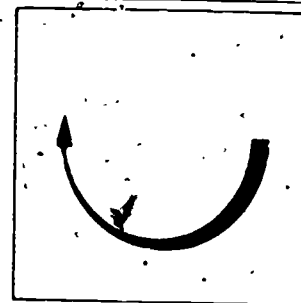

Suspended grid/tile ceiling systems offer many advantages to the finished building. These systems are light weight, can provide improved fire ratings, usable duct areas and can be very decorative. For any or all of these reasons, these systems are a frequent part of many drywall jobs. It is important that drywall mechanics are aware of the many systems in use, the materials used in each and the proper layout and installation procedures.

There are 7 major types of suspended grid ceiling systems:

1. Direct Hung Suspension.
2. Attached Concealed System without backing board.
3. Indirect Hung Suspension.
4. Furring Strip.
5. Furring Bar Suspension.
6. Furring Bar Attached.
7. Cement-Application System.

## DIRECT HUNG SUSPENSION

(See the illustration on the top of the following page.)

This system consists of main runners, cross runners and wall molding used to support the tile panels. There is no carrying channel used in this system, thus it is known as direct hung. There are 8 basic steps to installing a Direct Hung ceiling:

- Step 1. Determine ceiling height from blueprint and snap a chalkline around the room at the proper height.
- Step 2. Determine the room layout. This will depend on the panel size used (generally 24" X 48").
  - a. Decide direction of main runners (usually perpendicular to ceiling joists and parallel to the long wall).

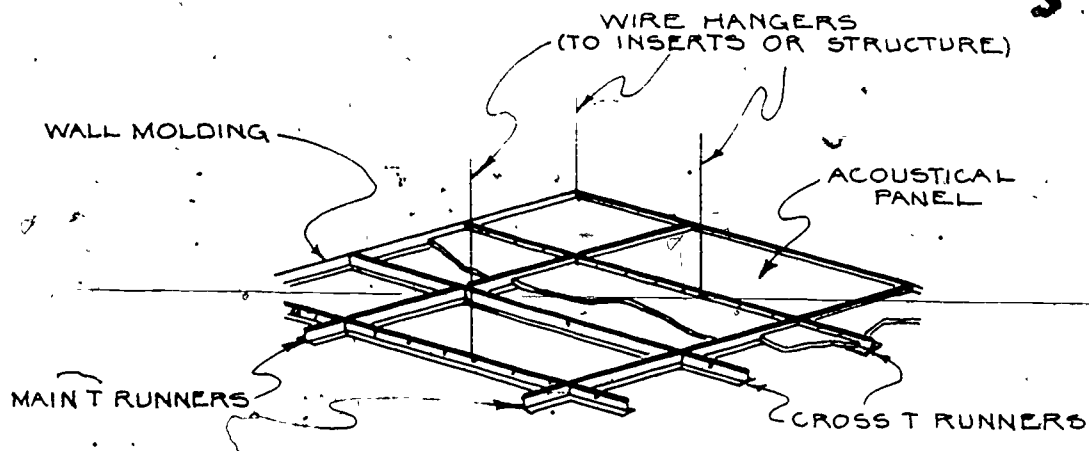

- b. Determine position of main runner from long wall, using the following formula:
  1. Measure length of short wall (in inches).
  2. Divide by 48.
  3. Take any remainder and add 48" to it.
  4. Divide this figure by 2. This will give the distance from the long wall to the first main runner. It is also the length of the border panels.
  5. With the figure from step 4, install a temporary reference string parallel to the long wall at exactly the calculated number of inches away from it.
  6. Additional main runners will be placed at 48" intervals.
- c. Determine Cross-Tee location.
  1. Measure length of short wall in inches.
  2. Divide by 24.
  3. Take any remainder and add 24.
  4. Divide by 2. This will give the number of inches from the short wall to the first Cross-tee.

5. Install a second reference string using the calculated distance from step #4. Be sure that the two reference strings are at exactly  $90^\circ$  (right angles to each other).

Step 3. Install wall molding.

- a. Attach wall molding using ceiling height chalklines as a guide.
  1. Nail directly to the wall if possible; otherwise, hang a main runner in its place.
  2. When nailing into concrete block walls, stub nails should be driven into masonry joints at block edge.
3. Corner joint treatment.
  - (a) Inside corners should be made by overlapping two pieces of molding.

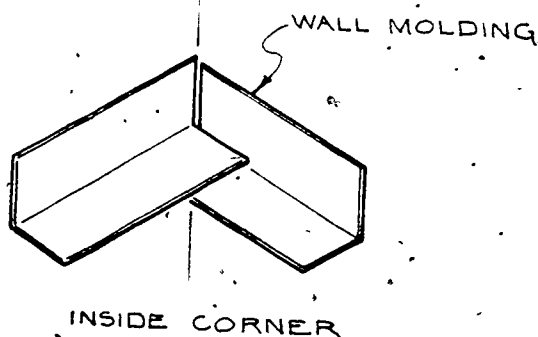

- (b) Outside corners should be formed by mitering the ends of two pieces of molding.

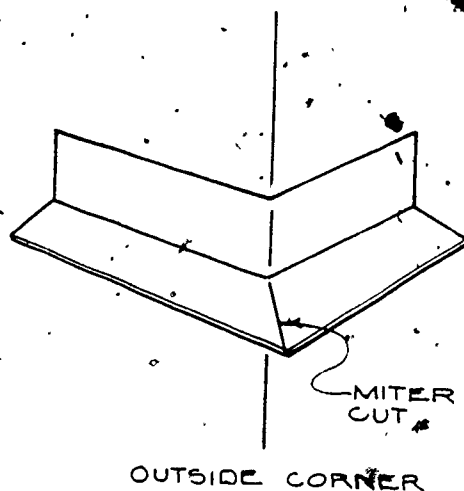

Step 4. Install first main runner.

a. Special attention to cutting main runners must be taken to make sure of border panel spacing at the proper dimension.

1. Take short wall border measurement found in step 2-C and subtract from 24".

2. Add 6" to this figure.

3. Cut off this length from main runner.

b. Attach hanger wires at 4' intervals through ceiling hangers over main runner location.

c. Tie off wire through main runner holes.

1. Take special care to make sure runners remain level along the entire length.

Step 5. Install remaining main runners.

Step 6. Attach Cross-Tees.

a. Cut Border Cross-Tees to length equal to distance from long wall to reference line.

b. Install Cross-Tees according to manufacturer's instructions for their specific locking tabs.

Step 7. Cutting Panels.

a. Care should be taken to keep panels clean when cutting and installing.

b. Border panels must be measured and cut individually.

1. Cut face up with a coping saw or very sharp fiberboard knife.

Step 8. Installing Panels.

a. Lift panel above grid and then let the panel rest on main runner and Cross-Tee flanges.

ATTACHED CONCEALED SYSTEM WITHOUT BACKING BOARD

(Refer to kern and spline diagram in Vocabulary.)

This system uses hangers, main runners (2-bar shape), cross runners or splines, wall molding and acoustical panels.

INDIRECT-HUNG SUSPENSION SYSTEM

(See the illustration on the top of the following page.)

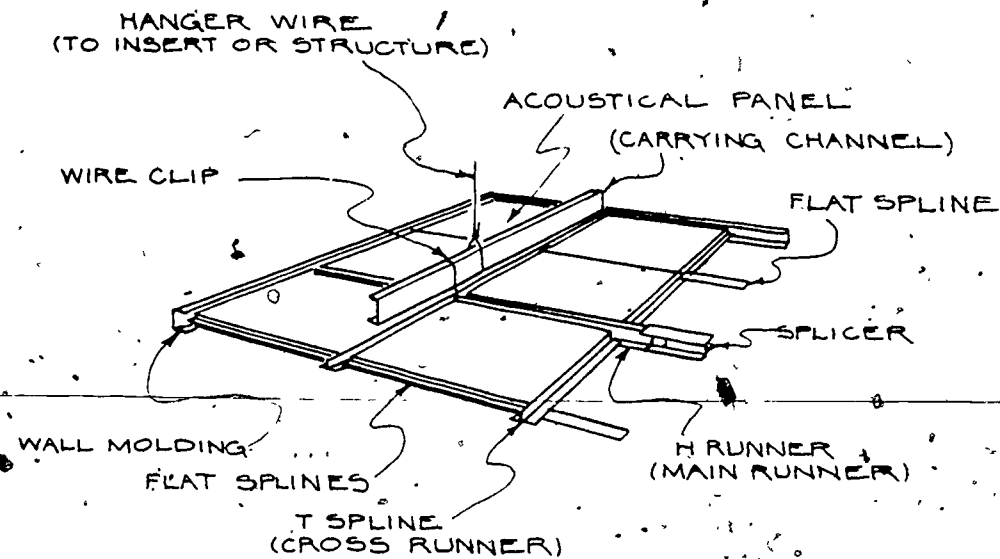

This system is similar to the direct hung system except that carrying channel is used between hanger wire and main runners. Carrying channel and furring bars are attached with wire clips.

#### FURRING STRIP SYSTEM

(See the illustration on the top of the following page.)

This system consists of wood strips fastened to existing ceilings. Acoustic tiles are nailed, stapled or cemented to these strips. The key to this system is proper layout of the furring strips to provide for secure attachment of tiles.

#### FURRING BAR SUSPENSION SYSTEM

(See the second illustration on the following page.)

This system uses drywall carrying channel, hanger wire furring bar (nail-screw bars or "Hat Channel", backing board or drywall panels and acoustical panels.)

Carrying channels are hung from inserts or structural members with hanger wire. Furring bars are attached to carrying channels with specially designed wire



FURRING STRIP SYSTEM

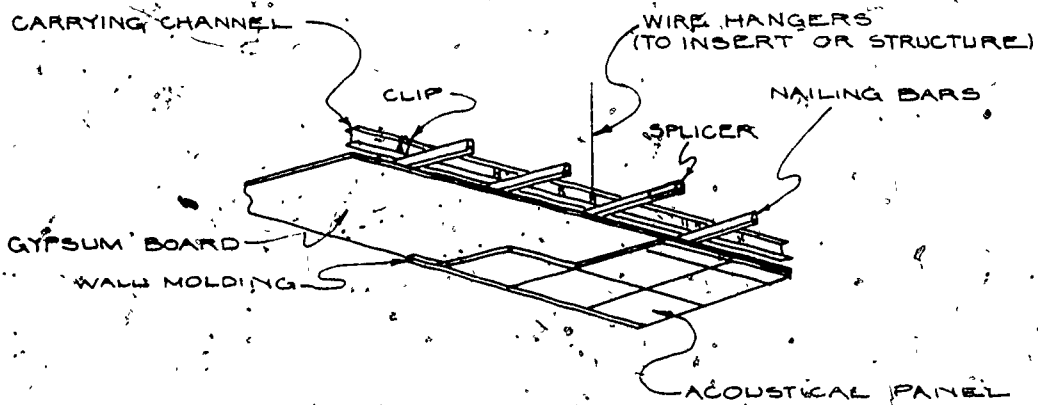

clips. The backing board is nail- or screw-attached to furring bars; the tiles can be nailed, stapled or cemented to the backing board.

#### FURRING BAR ATTACHED SYSTEM

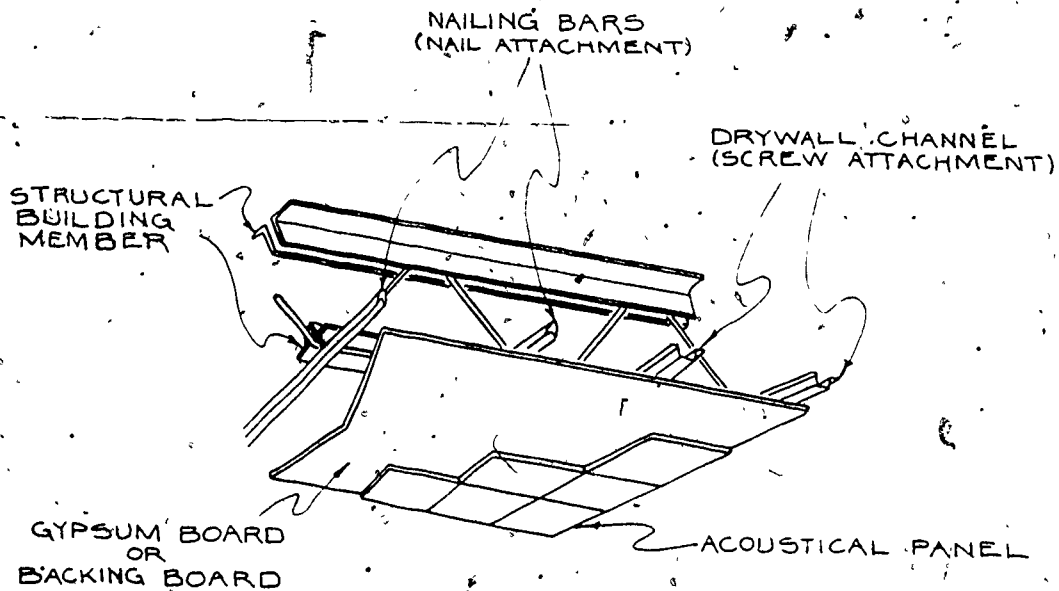

The only difference between this and the suspended system is that carrying channels are attached directly to the building's structural members.

#### CEMENT APPLICATION SYSTEM

This system is used when the existing ceiling surface is smooth and is only being re-surfaced. Care must still be taken in layout and in cutting tiles. When using tongue and groove tiles, brush-on ceiling cement is recommended. If butt joint tiles are used, acoustic cement should be used.

It can be seen that there are many similarities with these systems. Both materials and installation techniques are quite similar. Once one system has been learned and used, other systems can easily be learned.



# Self Assessment

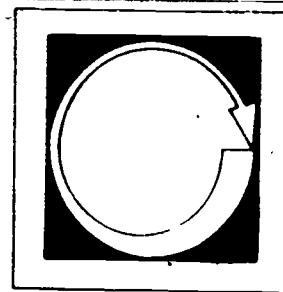

LISTED BELOW ARE SEVERAL STATEMENTS. IF THE STATEMENT IS TRUE, PLACE A "T" IN THE BLANK PROVIDED. IF THE STATEMENT IS FALSE, PLACE AN "F" IN THE BLANK.

1.  Direct hung systems include the use of carrying channels.
2.  When attaching wall molding to block walls, nails should be driven into joints rather than the blocks.
3.  Cross-Tees are hung on hanger wire.
4.  Runners and Cross-Tees must be perpendicular to each other.
5.  Reference lines help establish the runner layout.

# Self Assessment Answers

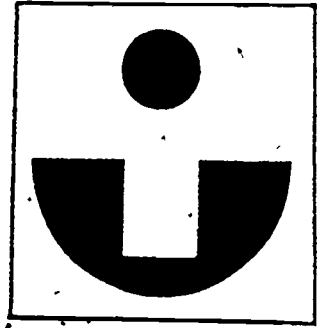

1. F

2. T

3. F

4. T

5. T



3. Briefly describe the 8 steps involved in the installation of a Direct Hung Suspension system.

291

292

# Post Assessment

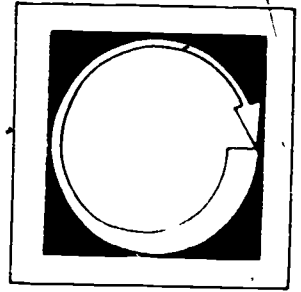

COMPLETE THE FOLLOWING STATEMENTS BY CIRCLING THE CORRECT WORD OR WORDS.

1. Hanger wires in direct hung systems should be spaced 2' o.c. / 4' o.c. / 6' o.c.
2. When cutting the first runner, in order to arrive at the correct length, you take the border measurement, subtract from 24" and add 0" / 6" / 8" to arrive at the correct amount to cut off.
3. When cutting acoustical tiles, they should be face up / down.
4. With the indirect hung system, the main runners are attached to hanger wires / carrying channel.
5. The attached concealed system is called "concealed" because the Runners and Cross-Tees / structural members are hidden.

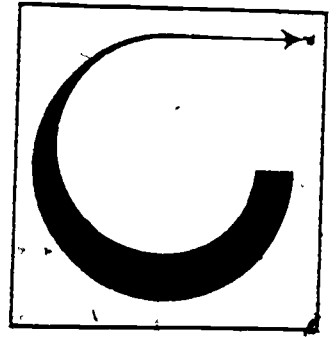

# Instructor Post Assessment Answers

1. 4' o.c.
2. 6"
3. up
4. carrying channel
5. Runners and Cross-Tee