

DOCUMENT RESUME

ED 213 894

CE 031 568

AUTHOR Cholewinski, Scott
TITLE Bricklaying. Pre-Apprenticeship Phase 2 Training. Student Training Modules.
INSTITUTION Lane Community Coll., Eugene, Oreg.
SPONS AGENCY Employment and Training Administration (DOL), Washington, D.C.; Oregon State Dept. of Education, Salem.

PUB DATE 81
NOTE 315p.; For related documents see CE 031 561-579.

EDRS PRICE MF01/PC13 Plus Postage.
DESCRIPTORS Behavioral Objectives; *Bricklaying; *Building Trades; Check Lists; Job Skills; Learning Activities; Learning Modules; Masonry; Pacing; Postsecondary Education; Tests; *Trade and Industrial Education; Two Year Colleges; Vocabulary
IDENTIFIERS *Preapprenticeship Programs

ABSTRACT

These 23 Student Training Modules on bricklaying comprise one of nine sets of self-paced learning modules developed for Pre-Apprenticeship Phase 2 Training. (A companion instructor's guide is available separately as CE 031 567.) The modules are designed to impart trade knowledge and skills to the student. Each module contains some or all of the following: cover sheet listing module title, goals, and performance indicators; study guide/checklist with directions for module completion; introduction; vocabulary listing and defining new trade or technical terms; supplementary references; information sheet(s); self-assessment;; self-assessment answers; assignment sheet(s); job sheet(s) listing materials and tools necessary to complete tasks designed to develop manipulative skill; post assessment post assessment answers. Topics covered in the module include mixing and applying mortar; jointing and brushing; brick and block; bonds; level and transit; layout; squaring; leads; grouting and reinforcing; ties and anchors; masonry saw; cutting brick and block units; clearing brickwork; rotary hammer; pneumatic hammer; stone; caulking; codes; fireplace footings, firebox, and smokeshef; flashing; and artistic masonry. (YLB)

 * Reproductions supplied by EDRS are the best that can be made *
 * from the original document. *

ED213894

CE031568



PRE-APPRENTICESHIP PHASE 2 TRAINING Student Training Modules

Bricklaying

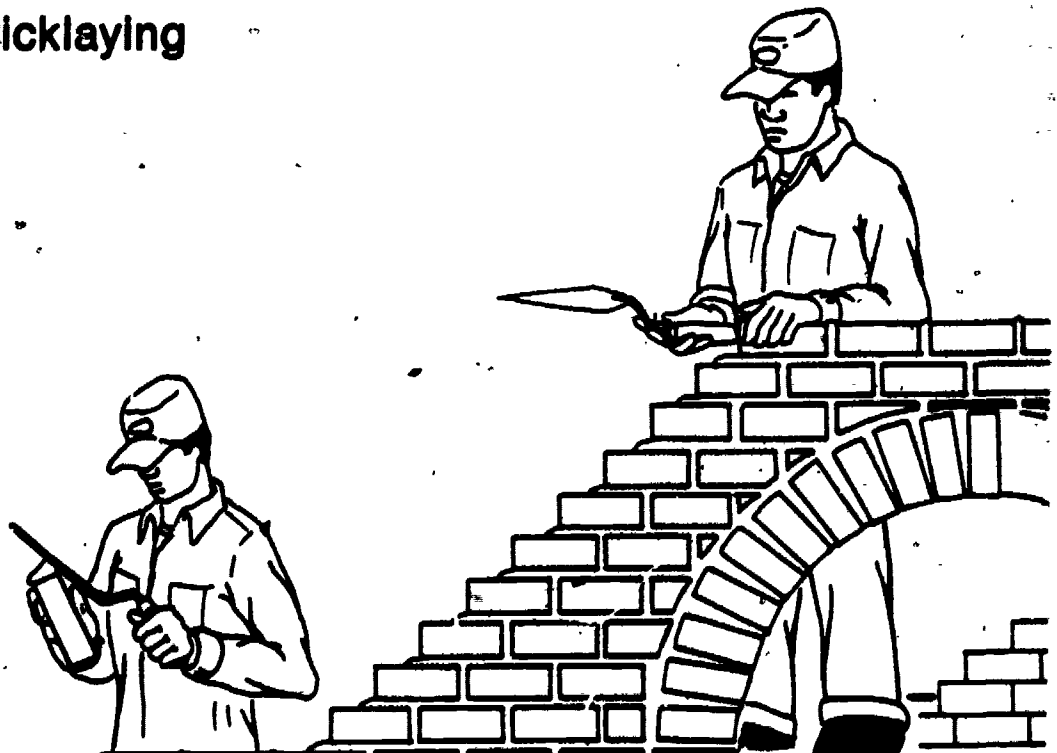

U.S. DEPARTMENT OF EDUCATION
NATIONAL INSTITUTE OF EDUCATION
EDUCATIONAL RESOURCES INFORMATION
CENTER (ERIC)

This document has been reproduced as
received from the person or organization
originating it.

Minor changes have been made to improve
reproduction quality.

• Points of view or opinions stated in this docu-
ment do not necessarily represent official NIE
position or policy.

"PERMISSION TO REPRODUCE THIS
MATERIAL HAS BEEN GRANTED BY

C. Hostrup

TO THE EDUCATIONAL RESOURCES
INFORMATION CENTER (ERIC) "

Bricklaying Module Writer:

Scott Cholewinski

Technical Assistance:

Joe Nama, Dave Summers, Mike Lathrop
Gerald "Hap" Relling, B.A.C. Local #6

Graphics: Ralph Bentley

Editorial, Proofreading and Pasteup:

Ron Hamblen, Debi Carroll,
Shannon Kracht

Typing:

Strandlien Typing Service

This project was developed under a sub-contract for the Oregon Department of Education by Lane Community College, Community Education Division, Eugene, Oregon. Funds were provided by the Governor of Oregon from the Educational Linkages Component of the CETA Governor's Grant.

STATEMENT OF ASSURANCE

It is the policy of the Oregon Department of Education that no person be subjected to discrimination on the basis of race, national origin, religion, sex, age, handicap or marital status in any program, service or activity for which the Oregon Department of Education is responsible. The Department will comply with the requirements of state and federal law concerning non-discrimination and will strive by its actions to enhance the dignity and worth of all persons.

Lane Community College

4000 E. 30th Avenue
Eugene, Oregon 97405
(503) 726-2200

Office of the President

July 27, 1981

On behalf of Lane Community College, I wish to express our pride and gratitude for the opportunity to participate in the development of the Pre-Apprenticeship training materials. We also wish to commend the Oregon Department of Education for its original concept and continued support; and, the Educational Linkages Component of the CETA Governor's Grant for funding.

The goals of this project are many, but none are more important than that of producing valid, understandable vocational curriculum material. We congratulate the tradespeople and production staff for their accomplishments.

Finally, I recommend this material to anyone exploring Pre-Apprenticeship as an entry into the vocational work world, with the hope and belief that it will go a long way toward producing skilled craftspeople who are dedicated to their work.

Sincerely,

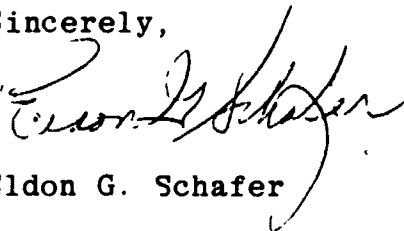

Eldon G. Schafer

MIXING MORTAR FOR BRICKLAYING

Goal:

The student will be able to mix mortar to a proper consistency for different types of construction.

Performance Indicators:

The student will mix mortar and will complete a Self and Post Assessment and a Job Sheet.

Study Guide

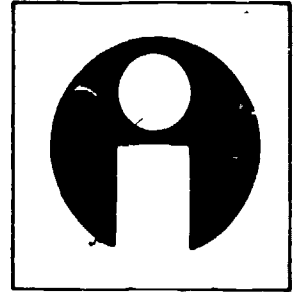

In order to finish this module, do the following tasks. Check each item off as you complete it.

1. ___ Read the Goal and Performance Indicators on the cover of the module. This will tell you what you will learn by studying the module, and how you will show you've learned it.
2. ___ Read the Introduction. The Introduction will tell you why the module is an important part of the bricklaying trade.
3. ___ Study the Vocabulary section. Vocabulary words are important for a good understanding of the trade. After you have studied the vocabulary, ask your teacher to quiz you on the words and their meanings.
4. ___ Study the Information section. This section will give you the information you need to understand the subject.
5. ___ Take the Self Assessment exam. This is a test for you to prove to yourself that you have learned the material you have studied. Compare your answers with the answers on the Self Assessment Answer Sheet, which is on the page following the Self Assessment. If you scored poorly, re-study the Information section or ask your teacher for help.
6. ___ Do the Job Sheet. Follow the instructions at the top of the Job Sheet. The tasks listed on the Job Sheet will help you develop skills which will be helpful to you.
7. ___ Take the Post Assessment exam. Give the exam to your teacher after you have completed it. Your teacher will grade it for you.

Introduction

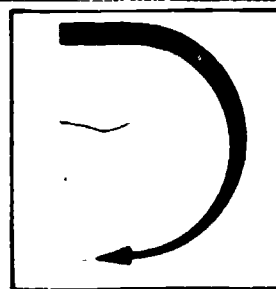

Mixing mortar to the proper consistency is important for the ease and the speed the bricklayer needs to work. Mortar that is too dry tends to separate, making it difficult to spread. Mortar that is mixed too wet has a tendency to slide off the trowel instead of sticking to it. If too much sand is added, the mortar will not stick, and too much lime and cement will cause it to be too sticky. Properly mixed mortar will help the bricklayer to keep up production and keep work clean and neat.

Supplementary References

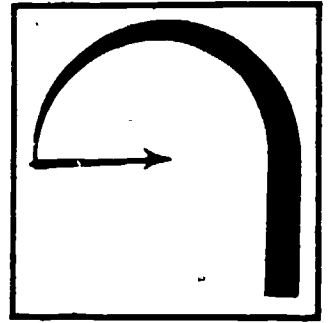

1. Condit, Carl W. The New Book of Knowledge. Grolier, Inc., Copyright 1979. pp. 391-394.
2. Taylor, Merlin and Harlin Randolph. I.M.A.T. Brick and Block Construction. Copyright 1976. pp. 19-28.

Information

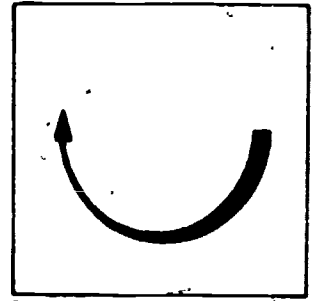

The first known mortar was nothing more than just a paste of mud. About 3200 B.C., Egyptian bricklayers added sand to make it stronger. Still it had real strength. Bricklayers relied mostly on the weight of the walls to hold the bricks in place. Later on, about 200 B.C., cement was discovered by the Romans, modernizing the bricklaying industry.

Most mortar is made up of four ingredients:

1. cement.
2. lime.
3. sand.
4. water.

Cement gives the mortar its strength. Cement is made up of five elements: a powder of alumina, silica, lime, iron oxide and magnesia. They are burned together in a kiln and finely pulverized.

Cement commonly used for bricklaying is Portland cement. It gets its name from Portland, England, where the process for making it began.

Lime is the second ingredient, made up of calcium oxide, often together with magnesia, which is obtained by pulverizing limestone. Lime is the ingredient that holds the other ingredients together and makes it workable. Care should be taken in adding lime to the mixture because the more lime that is added, the less strength the mortar will have.

The third ingredient is sand. Hardened mortar is approximately 75 percent sand. However, sand has no cementing value. Its main purpose is as a mortar filler. Sand also prevents the mortar from shrinking.

Last, but not least, is the water. Water is the ingredient that combines all ingredients into what is called mortar. Water must be clean.

A good rule of thumb is any water that is clean enough for drinking is clean enough for mortar. There is no set amount for water to be used. Experience in mixing and working with mortar will help you judge how much water to add. Too little water will make mortar dry, hard to spread, and create a weak bond, because the units that are to be laid will absorb even more water out of it and not allow it to cure slowly and evenly.

Too much water will make mortar soupy and hard to handle. Wet or soupy mortar will shrink as the water evaporates, causing it to crack.

Different types of mortar

There are 5 different types of mortar. The architect will decide the type of mortar to be used, after considering the type of structure to be built. The five different types are:

Type M

This type of mortar has the greatest strength of the five. It is used mainly for masonry that is built below grade. It is also recommended for general use.

Type S

This is a pretty high strength mortar which is most often used in reinforced masonry and in non-reinforced masonry where flexible strength is required.

Type N

Type N is a medium strength mortar, that is used above grade in masonry that is exposed to severe weather.

Type O

This is a medium-to-low-strength mortar that is generally used for non-bearing walls. This type should not be used when freezing will occur.

Type K

This type of mortar and other sand mortars are not used much and only on unimportant work, such as interior walls, which are not load-bearing.

A comparison of the strength of these mortars is given below:

Mortar Type	Average Compressive Strength at 28 Days.
	Pounds per Square Inch
M	2500
S	1800
N	750
O	350
K	75

The National Building Code has classified the types of mortar according to where they should be used in a structure.

Types of Mortar for Classes of Masonry

Kind of Masonry	Type of Mortar Required
Foundations:	
Footings	M or S
Walls of solid units	M, S, or N
Walls of hollow units, hollow walls	M or S
Masonry other than foundation masonry:	
Piers of solid masonry	M, S, or N
Piers of hollow units	M or S
Walls of solid masonry	M, S, N, or O
Walls of solid masonry, other than parapet walls or rubble stone walls, not less than 12" thick nor more than 35' in height, supported laterally at intervals, not exceeding 12 times the wall thickness	M, S, N, O, or K
Walls of hollow units, loadbearing or exterior, and hollow walls 12" or more in thickness	M, S, or N
Hollow walls, less than 12" thick where assumed design wind pressure:	
(a) exceeds 20 lb per sq ft	M or S
(b) does not exceed 20 lb per sq ft	M, S, or N
Non-bearing partitions or fireproofing composed of structural clay tile or concrete masonry units	M, S, N, O, or gypsum
Gypsum partition tile or block	Gypsum
Firebrick	Refractory air setting mortar
Linings of existing masonry	M or S
All other masonry, including fire walls	M, S, or N

Only type M and S can be used in footings and foundations where it will be exposed to ground, stress and freezing.

Steps in Mixing Mortar

Mortar can be mixed by hand or by machine. Mixing by hand involves:

1. Placing the ingredients in a mortar box.
2. Using a mortar hoe, mix without water until ingredients are thoroughly combined.
3. Add water, and mix to the desired consistency.

Mixing by hand is a lot of work and takes a lot of time.

Machine mixing is much easier and faster. Mixing by machine also insures a completely mixed batch.

No matter which method is used, there are four general steps which are to be followed:

1. Select the mortar.
2. Measure the ingredients.
3. Mix the ingredients.
4. Test to insure proper mixture.

Mortar selection is specified by the architect along with other building materials.

Measuring Ingredients

Once the type of mortar has been specified, the ingredients for that type of mortar must be measured. Mortar ingredients are measured by volume.

The basic unit of measure is one cubic foot. Cement and lime are packaged so that one bag equals one cubic foot. A bag of portland cement weighs 94 lbs., equalling one cubic foot, and a bag of lime weighs 50 lbs., equalling one cubic foot. One cubic foot of dry sand weighs about 85 lbs.

When mixing the batch of mortar, sand should be measured by shovelfulls.

This is done by counting how many shovelfulls it takes to fill a cubic-foot measuring box.

The amount of water required to mix mortar to the proper consistency depends on the richness of the mix desired, how soon the mortar will be used, and the temperature of the area. When working in hotter temperatures, the water will evaporate faster than when working in cooler temperatures. In all cases, the water should be clean enough to drink. Any impurities or dirt in the water might weaken or discolor the mortar. The amount of mortar produced by a batch will be about equal to the amount of sand used. The reason is that the cement, lime and water in the mortar-mix will fill the spaces already present between the grains of sand. The following table gives the ratios of cement, lime and sand for the types of mortar commonly used in masonry.

MORTAR PROPORTIONS BY VOLUME

Portland Cement-Lime Mortars

Type	Portland Cement	Hydrated Lime or Lime Putty	Sand
M	1	$\frac{1}{2}$	3
S	1	$\frac{1}{2}$	$4\frac{1}{2}$
N	1	1	6
O	1	2	9

Masonry Cement Mortars

Type	Portland Cement	Masonry Cement Type II	Sand
M	1	1	6
S	$\frac{1}{2}$	1	$4\frac{1}{2}$
N	--	1	3
O	--	1	3

Mixing Mortar By Hand

1. Spread half the sand to be used into the tub.
2. Spread the required amount of lime over the top of the sand.
3. Spread the required amount of cement over the lime.
4. Spread the remaining half of the sand over the cement.

5. Turn the dry ingredients over with the hoe until they are thoroughly and completely mixed.
6. Pull all the mixture to one end of the tub (mortar box).
7. Add the water to the empty end of the tub and mix ingredients into it.
8. Continue adding water this way until the right consistency is obtained.
9. Push and pull the hoe through the mixture to thoroughly mix the ingredients.

Mixing Mortar By Machine

The amount of mortar mixed in a mechanical mixer will depend on the size of the mixer. You may have to divide the ingredients into smaller quantities so you don't over load the mixer. The following steps should be followed when mixing mortar by machine.

1. Turn on start mixer and close engine cover.
2. Add 1/2 to 3/4 of water that will be needed.
3. Add 1/2 the sand required.
4. Add required amount of lime. (Lime should be added slowly to prevent it from lumping up.)
5. Slowly add cement.
6. Add remaining sand.
7. Carefully add remaining water until desired consistency is reached.
8. Continue mixing for at least 3 to 5 minutes after all ingredients have been added.
9. In some instances, mortar-mix is used instead of cement and lime. If so, mix according to directions on bag.

Testing the Mortar

1. After mortar is made, one of the first checks is to make sure all ingredients have been added.
2. Too much sand is the most common problem in mortar. If too much sand is added, the mortar is harsh (rough, too sandy) and unworkable. This is known as lean mortar.
3. Too little sand, or fat mortar, has a sticky consistency and will stick to the hoe, trowel or shovel.
4. The mortar should be like mud without streaks. The mortar must stay on the trowel, being easy to pick up, but it must also slide off without sticking so it will be easy to spread. Being soft enough to spread, it must be firm enough to support the brick or block unit's weight and not smear on the wall.

Self Assessment

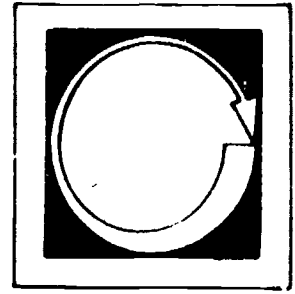

LISTED BELOW ARE QUESTIONS FOLLOWED BY A NUMBER OF POSSIBLE ANSWERS. SELECT THE ANSWER WHICH ANSWERS THE QUESTION CORRECTLY AND PLACE THE LETTER IN THE BLANK PROVIDED.

1. _____ Who discovered cement?
 - a. Chinese
 - b. Egyptians
 - c. Romans
 - d. Russians

2. _____ How many properties make up cement?
 - a. 8
 - b. 4
 - c. 15
 - d. 5

3. _____ Which ingredient does not belong?
 - a. cement
 - b. water
 - c. pumice
 - d. sand

4. _____ What type of mortar is recommended for general use?
 - a. Type K
 - b. Type O
 - c. Type M

ANSWER THE FOLLOWING QUESTIONS.

5. What is the advantage of machine mixing over hand mixing?

6. The basic unit of measure for mortar is cubic yards. True or False.

7. Too much sand cause mortar to be harsh and unworkable. True or False.

Self Assessment Answers

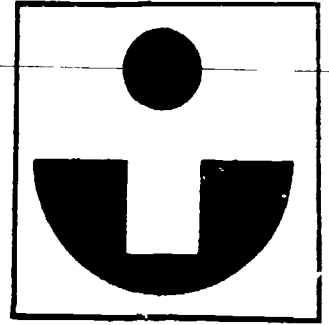

1. C
2. D
3. C
4. C
5. Less work, faster process, thoroughly mixed mortar.
6. False--Basic measurement is cubic feet.
7. True.

Job Sheet

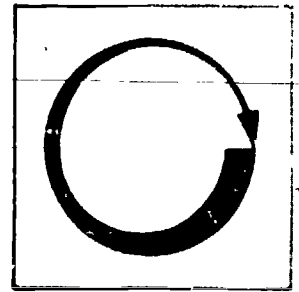

COMPLETE THE FOLLOWING TASK.

Materials and Tools

- one cubic foot measuring box.
- shovel
- machine mixer or mortar box and hoe
- cement
- lime
- sand
- water

Following the steps outlined in the Information section, mix a batch of type M mortar to proper consistency.

Post Assessment

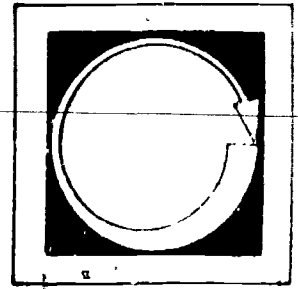

ANSWER THE FOLLOWING QUESTIONS.

1. Where did Portland cement originate?
2. Approximately what percentage of hardened mortar is sand?
3. What two types of mortar can be used in footings and foundations?
4. Who selects the mortar to be used?
5. How much does a cubic foot of cement weigh?
6. What is the most common defect or problem in mortar?
7. What causes mortar to crack?

Instructor Post Assessment Answers

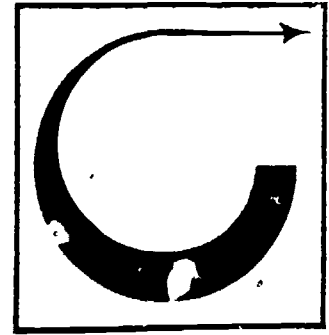

1. Portland, England
2. 75%
3. Types M and S
4. The architect
5. 94 lbs.
6. Too much sand
7. Water evaporating from mortar which has been mixed too wet.

APPLYING MORTAR

Goal:

The student will be able to apply mortar skillfully to different types of masonry units.

Performance Indicators:

The student will practice applying mortar and will complete a Self Assessment a Job Sheet and a Post Assessment.

Study Guide



In order to finish this module, do the following tasks. Check each item off as you complete it.

1. Read the Goal and Performance Indicators on the cover of the module. This will tell you what you will learn by studying the module, and how you will show you've learned it.
2. Read the Introduction. The Introduction will tell you why the module is an important part of the bricklaying trade.
3. Study the Vocabulary section. Vocabulary words are important for a good understanding of the trade. After you have studied the vocabulary, ask your teacher to quiz you on the words and their meanings.
4. Study the Information section. This section will give you the information you need to understand the subject.
5. Take the Self Assessment exam. This is a test for you to prove to yourself that you have learned the material you have studied. Compare your answers with the answers on the Self Assessment Answer Sheet, which is on the page following the Self Assessment. If you scored poorly, re-study the Information section or ask your teacher for help.
6. Do the Job Sheet. Follow the instructions at the top of the Job Sheet. The tasks listed on the Job Sheet will help you develop skills which will be helpful to you.
7. Take the Post Assessment exam. Give the exam to your teacher after you have completed it. Your teacher will grade it for you.

Introduction

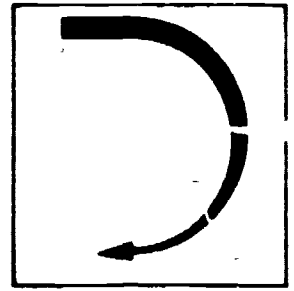

Applying mortar skillfully is necessary in bricklaying. Applying it includes loading the trowel with mortar, spreading the mortar to the joint surface and cutting off excess mortar without chipping or defacing the surface of the units.

Vocabulary

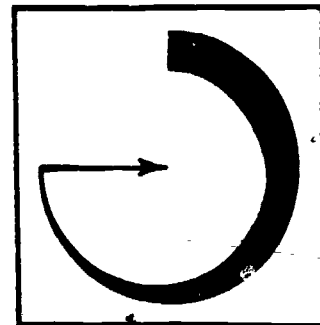

Trade terms are very important for a good understanding of the trade. Study these words and meanings. When you have learned them, ask your teacher to quiz you on the words and their meanings.

COURSE--A layer of brick or block.

UNIT--One brick or one block.

VOIDS--A hole or empty spot.

FLUSH--Edge to edge.

BOND--To join and hold together, lapping of brick or blocks in the wall.

Supplementary References

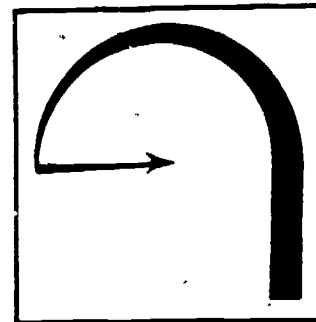

Taylor, Merlin and Harlin Randolf. I.M.A.T. Brick and Block Construction.
1976. pp. 29-44.

Information

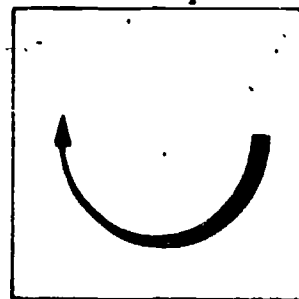

TOOLS

Several tools may be used in applying mortar. The trowel is the main tool, but others are also used. For example; a mortar board (or mortar pan) is used at the station of each bricklayer. The line is used as a guide to keep the brick in a straight row. The level is used to keep the corners straight from where the line is stretched.

The trowel is used as an extension of the arm. By loading the trowel, the mortar can be transferred from the mortar board to the units. If the unit cannot be pressed down, the trowel can be used to tap the unit into place.

The trowel is the tool you will be using the most. Therefore, it is important that the trowel is held right. (Think of the trowel as an extension of your arm.) It should be held firmly but relaxed. Also, keep your hand as close to the front of the handle as possible, without getting your thumb and fingers in the mortar. (See the illustration on the following page.)

Also, all tools should be kept from building up dry or excess mortar. This can be prevented by cleaning them at the end of each day.

LOADING THE TROWEL

Experience is the key to loading the trowel. You will find that too much mortar makes it difficult to bring the unit to proper course (or layer) heights, and it will take extra effort to align or straighten the unit. Too little mortar may leave voids or make it necessary to remove the unit and apply additional mortar.

There are several ways for loading the trowel. You can cut mortar from the top, the front and the sides.

NO



YES

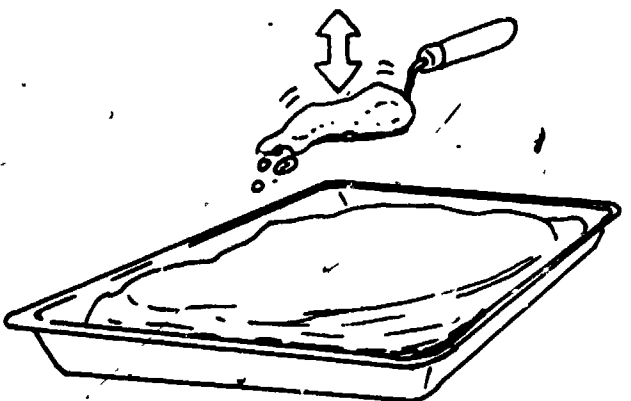
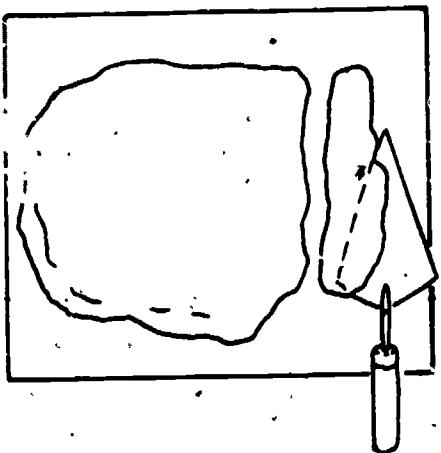
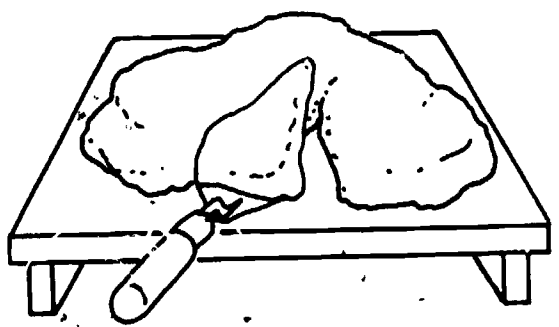
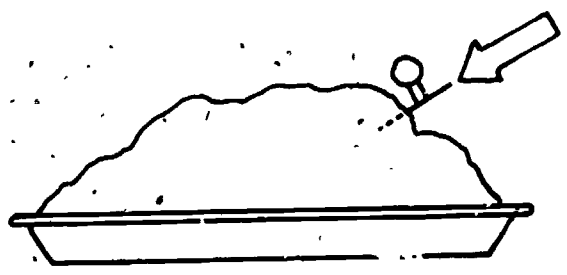

When cutting mortar from the top, the trowel is inserted to the depth that will provide the correct amount of mortar. It is then scooped up and given a light jerk or snap of the wrist. This lets the excess mortar fall off the trowel onto the pile of mortar, leaving enough for the required joints.

Cutting mortar from the side is done by cutting the required amount from the mortar pile. Roll or shape the mortar into a long tapered form; a shape that is easy to pick up. Then, in one motion, slide the trowel under the mortar and lift.

Cutting from the front requires two cuts. One cut is made from the edge to the center. The other cut is from the center to another point on the edge. The mortar should have the shape of the blade the trowel has. Slide the trowel under the "cut" mortar and lift. Each method has its advantages. When enough mortar is on the board or pan, cutting from the top will provide adequate coverage. As the mortar is used, cutting from the front will provide enough mortar to butter joints and fill small holes. Sometimes it is necessary to cut from side to side.

APPLYING MORTAR FOR BRICKWORK

Mortar that is applied between the bricks is known as joints. You will be working mostly with two types of joints. They are:

1. Bed joints, which are horizontal.
2. Head joints, which are vertical.

Applying mortar to bed joints is also known as spreading. Most bricklayers can spread mortar three or four bricks at a time. This is done by:

1. Load the trowel with mortar.
2. Move the trowel slowly over the brick.
3. Turn the trowel sideways 180° and allow the mortar to slide off.

(See the illustration on the top of the next page.)

Spreading mortar takes a lot of practice and skill to be done right. After the mortar is spread, hold the trowel blade flat and smooth out the mortar. (See the second illustration on the next page.)

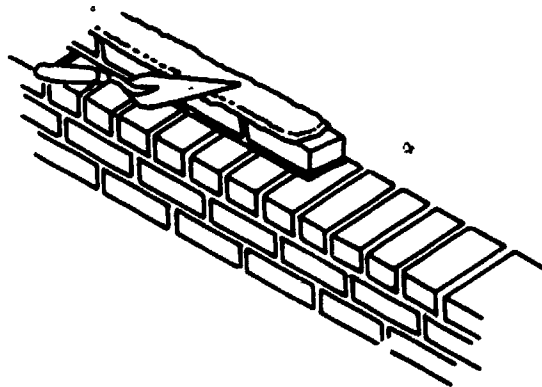
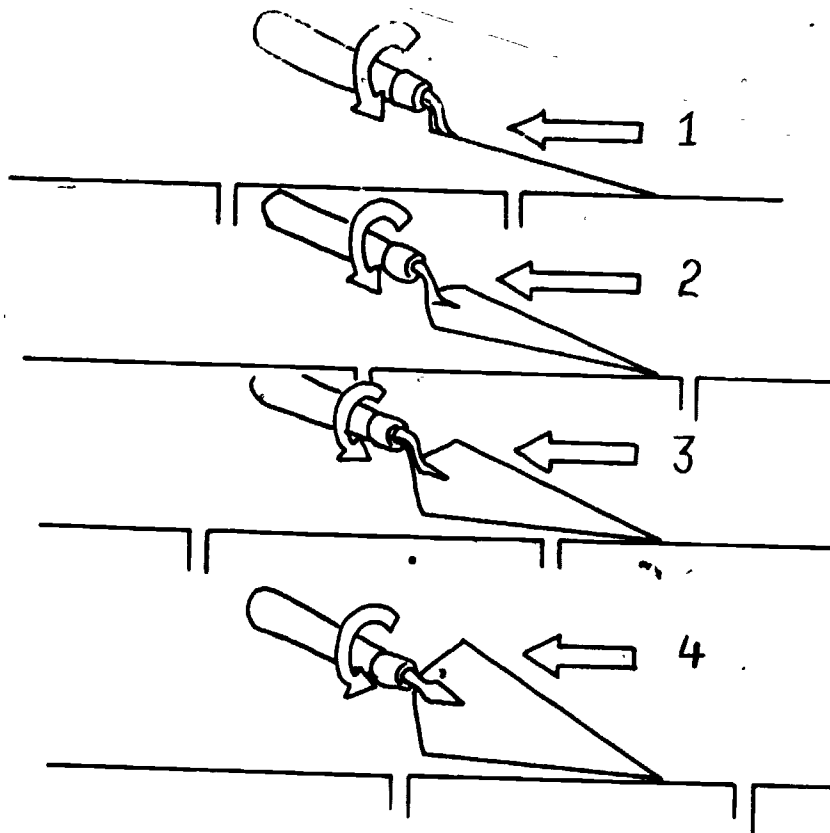

The mortar for the head joint can be applied either before or after the brick is set or laid. This is done by:

1. Evenly distribute a small amount of mortar over the trowel.
2. Apply or scrape mortar on the head or the small end of the brick. This is also known as buttering. (See the illustration on the top of the next page.)

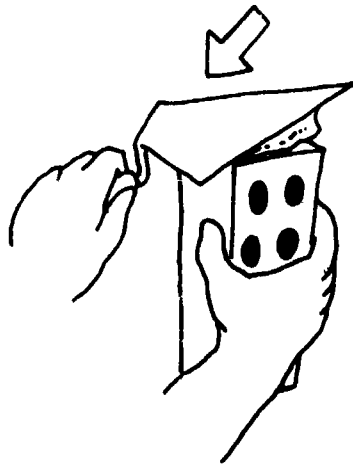

3. The brick is then shoved into position. This compresses mortar in the head joint and into the bed joint.

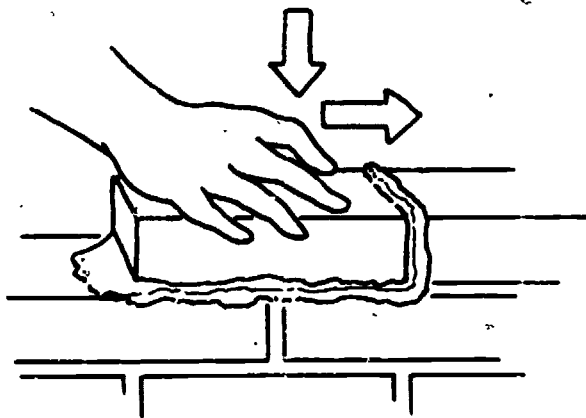

Excess mortar will ooze out the sides. This mortar should be cut off. It is done by holding the trowel with the top of the blade up and the edge of the blade flush against the brick. This will prevent smearing and catch the mortar. Use this extra mortar to butter the opposite end of the brick. (See the illustrations on the following page.)

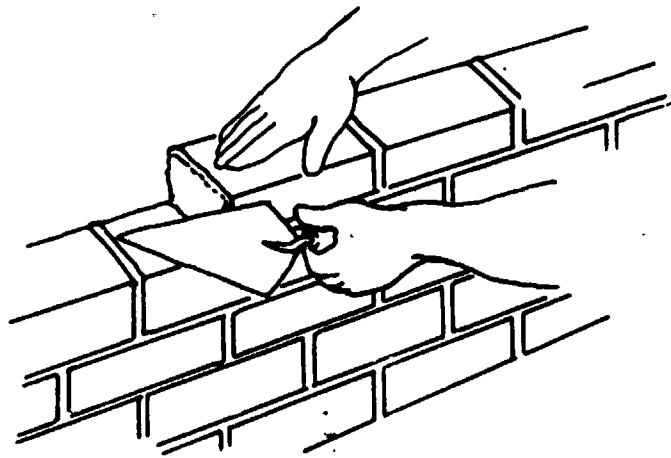
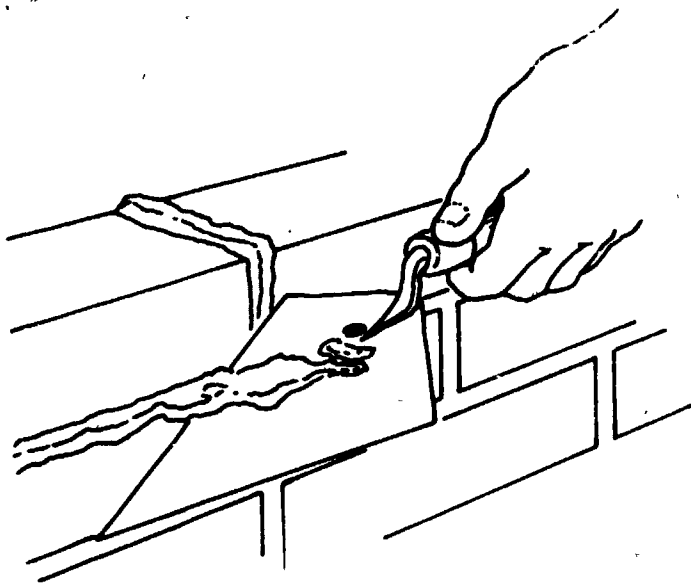

APPLYING MORTAR TO BLOCK

Applying mortar to block is very much the same as applying mortar to brick. The block is somewhat larger, so slightly different methods are used. Blocks come in many sizes and shapes. The type used most often measures 8 X 8 X 16 inches. This is known as an 8-inch block.

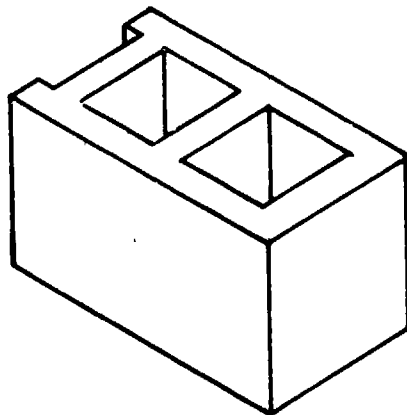

Applying mortar to the block is done by:

1. Load the trowel with mortar. Give the trowel a snap or jerk to get rid of excess mortar. This snapping motion also creates a suction that will hold the mortar on the trowel.
2. The mortar is then spread on the top sides of the block. This is done by placing the tip of the trowel against the top of the block. Then, in one smooth motion slide the trowel back over the block while pushing down.

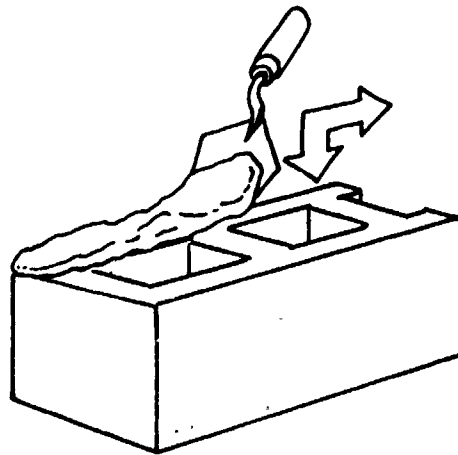

This takes a lot of practice to be done skillfully. Most bricklayers can spread one-and-a-half to two blocks at time.

3. To apply or butter headjoints: Before placing the block, stand it on end and spread mortar for the joint.

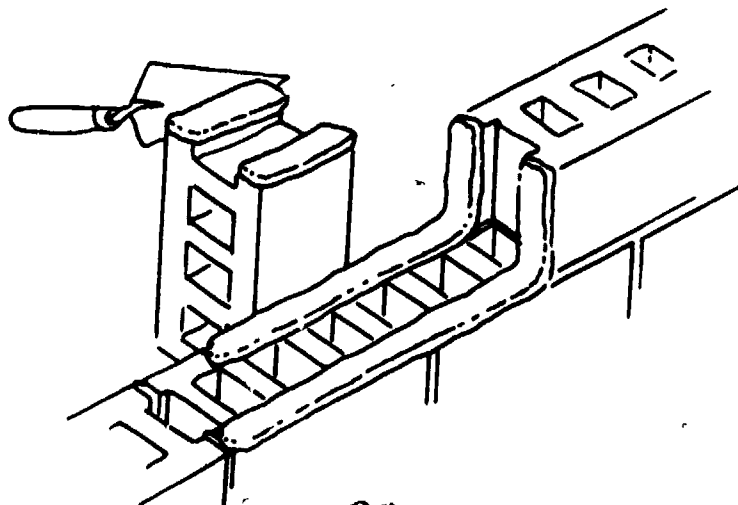

4. Place the block in the same manner as brick, compressing the mortar in the head and bed joints.

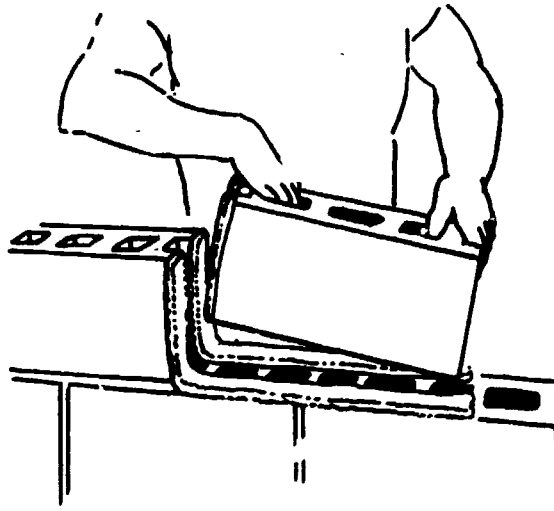

5. Excess mortar that oozes out is then cut off. This excess mortar is then used to butter the other end of the block.

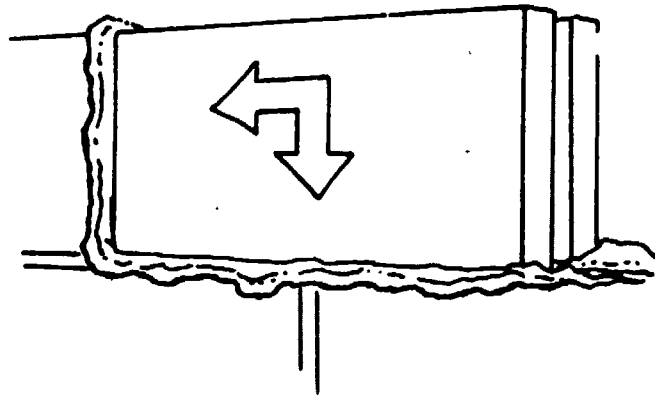

When applying mortar it is important that all joints be full. This insures a good bond, resistance to moisture penetration and good appearance.

Self Assessment

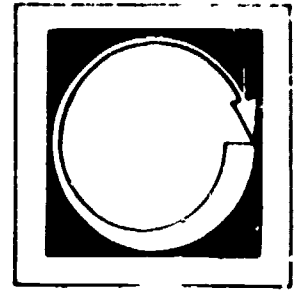

COMPLETE THE FOLLOWING STATEMENTS BY WRITING THE CORRECT WORD OR WORDS IN THE BLANKS PROVIDED.

1. The trowel should be held _____ but _____.
2. All tools should be kept from building up _____ or _____.
3. Too little mortar may leave _____ or make it necessary to remove the unit and _____.
4. A snap of the wrist, or a slight jerk of a trowel full of mortar will _____.
5. Mortar that is applied between the brick is called _____.

Self Assessment Answers

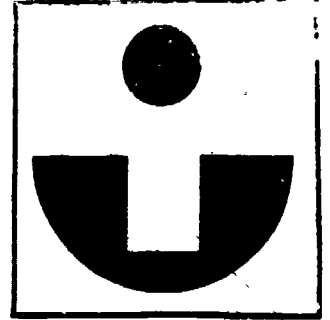

1. firmly, relaxed
2. dry or excess mortar
3. voids, apply additional mortar
4. Will let the excess mortar fall off the trowel. Also will create a suction to hold the mortar on.
5. joints

Job Sheet

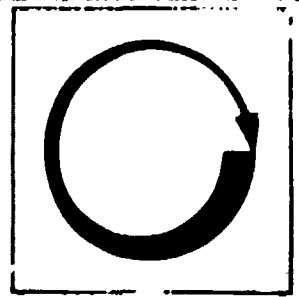

COMPLETE THE FOLLOWING TASKS.

Materials and Tools

materials listed in mixing mortar

trowel

mortar board

bricks (25 or 30)

blocks (15 or 20)

2" X 4" and 4" X 8" pieces of wood about 8' to 10' long

1. Following the steps outlined in the information section, spread mortar on a 4 X 8 piece of wood (as you would for block).
2. Following the steps outlined in the information section, spread mortar on a 2 X 4 (as you would for brick).
3. Following the steps outlined in the information section, spread, butter and place 25 bricks.
4. Following the steps outlined in the information section, spread, butter and place 15 blocks.

Post Assessment

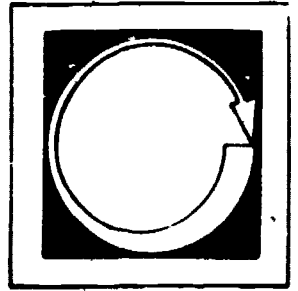

LISTED BELOW ARE STATEMENTS FOLLOWED BY A NUMBER OF POSSIBLE COMPLETIONS. SELECT THE COMPLETION WHICH COMPLETES THE STATEMENT CORRECTLY AND PLACE THE LETTER IN THE BLANK PROVIDED.

1. ____ Bed joints are:
 - a. vertical
 - b. parallel
 - c. horizontal
 - d. diagonal
2. ____ Head joints are:
 - a. vertical
 - b. parallel
 - c. horizontal
 - d. diagonal
3. ____ Applying mortar to bed joints is also known as:
 - a. cutting
 - b. loading
 - c. buttering
 - d. spreading
4. ____ All joints should be full to insure:
 - a. good bond
 - b. resistance to moisture penetration
 - c. good appearance
 - d. all of the above
5. ____ The trowel is used as:
 - a. an extension of the hand
 - b. an extension of the arm
 - c. as a chipper to deface the surface of the unit
 - d. none of the above

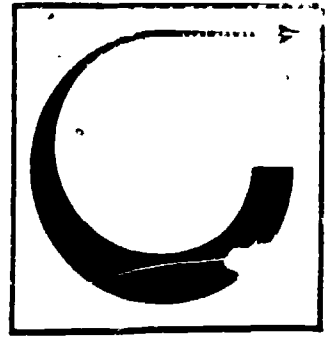

Instructor Post Assessment Answers

1. c
2. a
3. c
4. d
5. b

JOINTING AND BRUSHING--BRICKLAYING

Goal:

The student will be able to joint and brush his or her work. The student will also know different types of joint finishes and tools used.

Performance Indicators:

The student will complete a Self Assessment, a Job Sheet and a Post Assessment.

Introduction

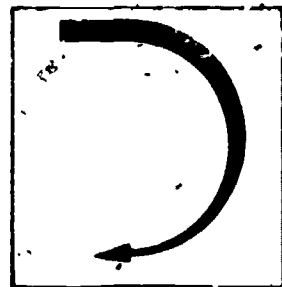

In order to finish this module, do the following tasks. Check each item off as you complete it.

1. Read the Goal and Performance Indicators on the cover of the module. This will tell you what you will learn by studying the module, and how you will show you've learned it.
2. Read the Introduction. The Introduction will tell you why the module is an important part of the bricklaying trade.
3. Study the Vocabulary section. Vocabulary words are important for a good understanding of the trade. After you have studied the vocabulary, ask your teacher to quiz you on the words and their meanings.
4. Study the Information section. This section will give you the information you need to understand the subject.
5. Take the Self Assessment exam. This is a test for you to prove to yourself that you have learned the material you have studied. Compare your answers with the answers on the Self Assessment Answer Sheet, which is on the page following the Self Assessment. If you scored poorly, re-study the Information section or ask your teacher for help.
6. Do the Job Sheet. Follow the instructions at the top of the Job Sheet. The tasks listed on the Job Sheet will help you develop skills which will be helpful to you.
7. Take the Post Assessment exam. Give the exam to your teacher after you have completed it. Your teacher will grade it for you.

Introduction

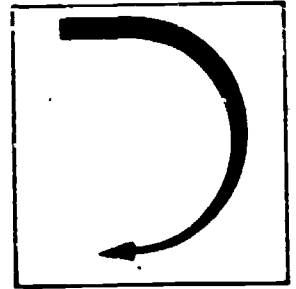

It is important that all joints be brushed and jointed properly. In the information section we will cover the following:

1. Types of finished joints.
2. Tools used to form these joints.
3. The advantages and disadvantages of each of these joints.

Vocabulary

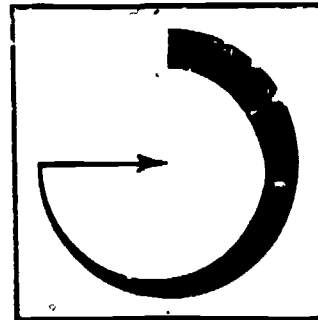

Trade terms are very important for a good understanding of the trade. Study these words and meanings. When you have learned them, ask your teacher to quiz you on the words and their meanings.

SET--Mortar starts to dry.

TOOLED--Smoothed-out joints (jointing).

RUBBER HEEL--A boot heel.

JOINTED--Finished product (striking, jointing).

Supplementary References

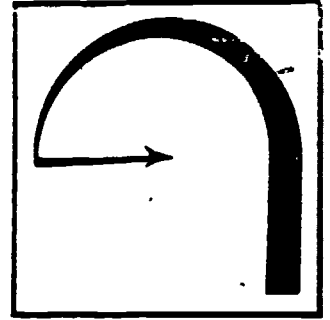

1. Randall Jr., Frank and William C. Panarese. Concrete Masonry Handbook.
1976. pp. 136-138.
2. Taylor, Merlin and Harlin Randolph. IMAT Brick and Block Construction.
1976. pp. 51-52.

Information

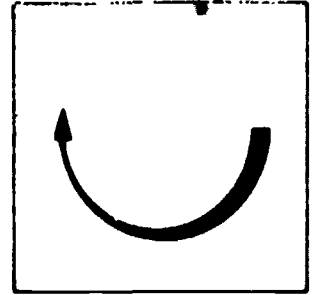

After a wall section has been laid, the mortar will start to set. It is important that the jointing (also known as striking or tooling) is done at the right time. A good test to tell when joints are ready is the "thumb print test." This is done by pressing your thumb on the joint. If, when pulled away, the mortar doesn't stick to your thumb, it is ready to be jointed.

While hardening, the mortar has a tendency to shrink and slightly pull away from the units. This may cause hairline cracks to appear. The tool used for jointing will compress the mortar into the joints. This helps to:

1. Strengthen the bond.
2. Eliminate cracks.
3. Prevent water penetration.
4. Produce uniform joints with clean, sharp lines.

TYPES OF JOINT FINISHES AND TOOLS USED

Weather Joints

The trowel is the tool used to strike weather joints. The full edge of the blade is used, not just the rip. The trowel is held at the angle you intend the joint to be. Press mortar into the joint. Be careful not to break the unit, loose from the joint. This is one of the best trowel finishes because the downward slant allows water to drain off instead of into the wall.

Struck Joints

These joints should be used only for interior walls since they do not shed water very fast. They are tooled the same as the weather joints, but from the bottom instead of the top. (See illustration on the top of the next page.)

Concave Joint

Special tools are required for this joint. (See illustrations--bottom of next page.)

Weathered

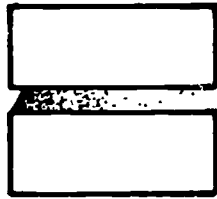

Stuck

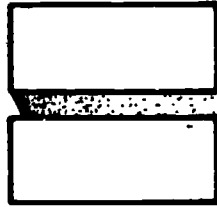

Concave

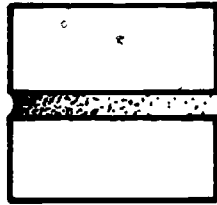

Deep Concave

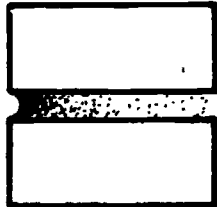

Flush

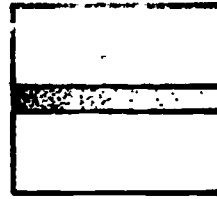

Squeezed

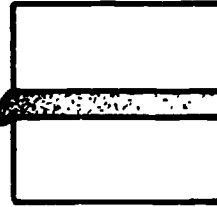

Raked

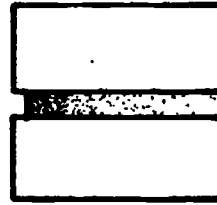

V

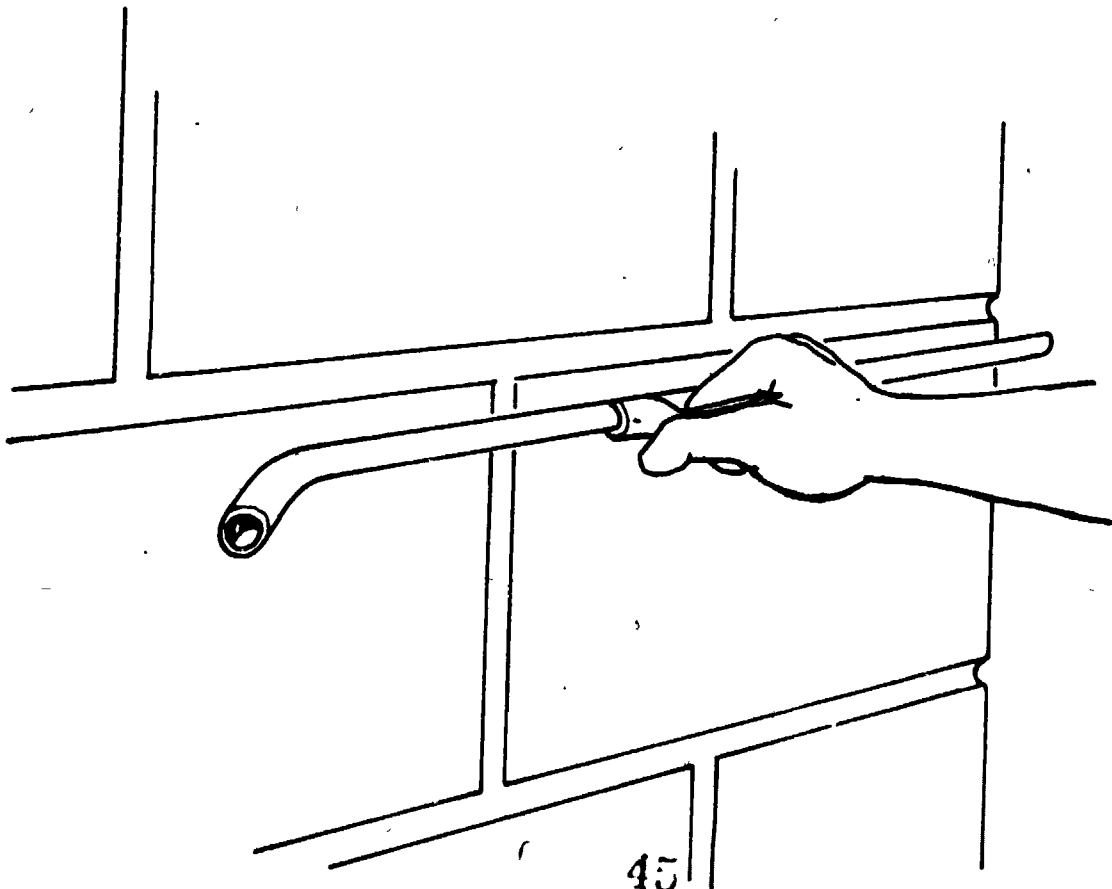
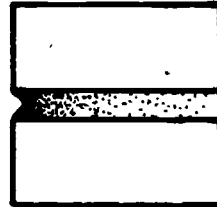

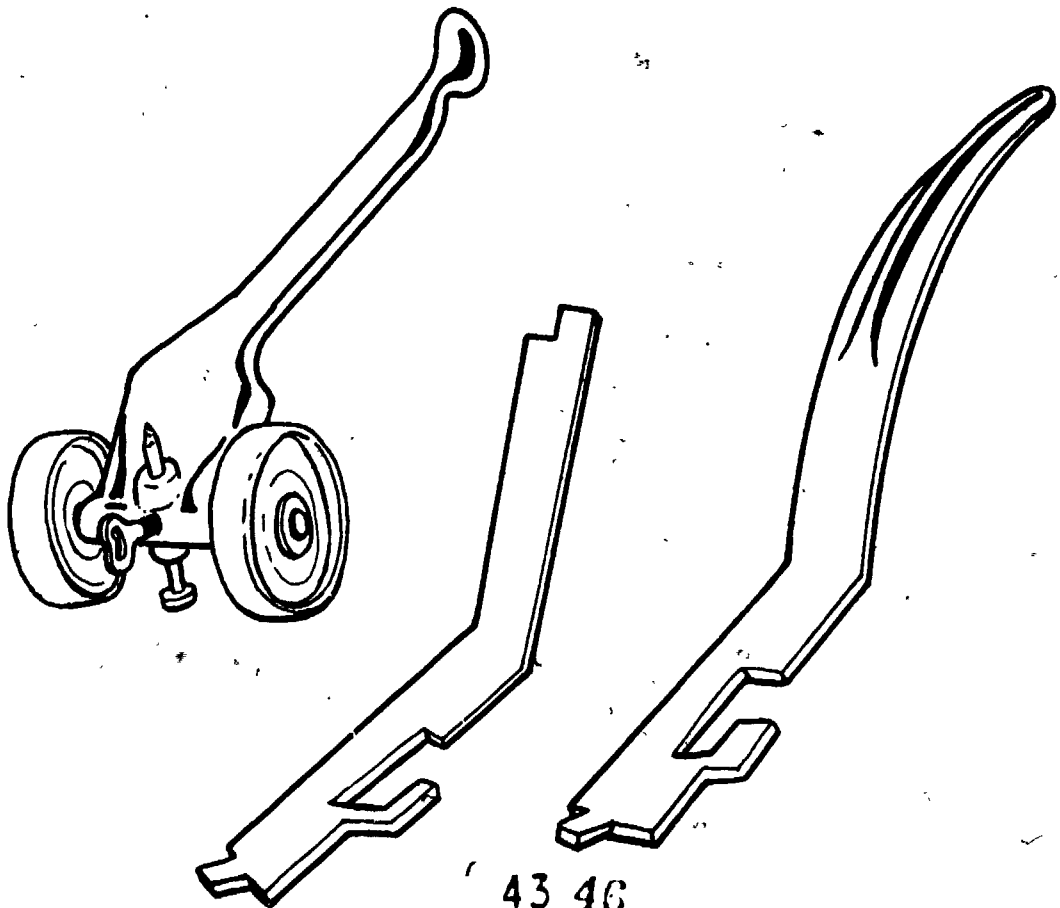
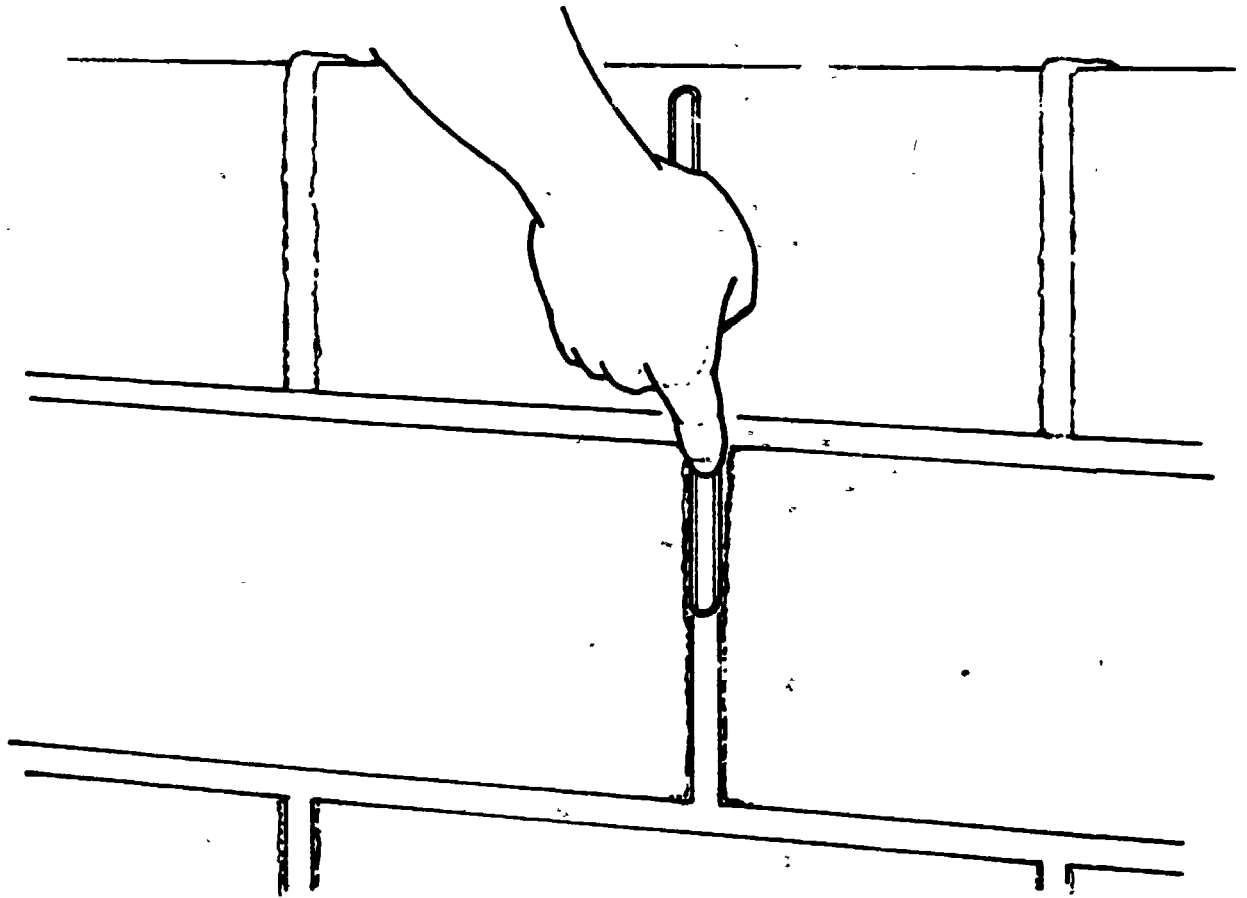

43 46

The concave joint is the best tooled joint. This is because the tool used compresses the mortar and compacts it against the edges of the unit. This seals cracks, assuring a good bond and prevents moisture penetration. A sled runner is used for the bed joints. It is approximately 16 to 24 inches long. This tool spans 2 or 3 bricks or blocks at a time making it easy to keep straight lines. It has a handle in the center. The base is slightly larger than the mortar joint. A 5/8-inch round bar makes a 3/8-inch joint. An "S-shaped" jointer is used for matching vertical joints. Joints come in different sizes and shapes to match the size and shape of the mortar joint.

Flush Joints.

The joint is usually finished when the bricklayer cuts away excess mortar. This is because the mortar is cut flush with the face of the brick. After the mortar is set, a rubber heel can be run along the joint to smooth and compact the mortar.

Squeezed Joints.

In this joint the excess mortar that oozes out when the unit is laid is the finish. The mortar is not cut off, but allowed to harden. This joint is not waterproof and should not be used where it is exposed to weather.

Raked Joints.

The mortar on this joint is normally raked out to a depth of 1/4 inch to 1/2 inch. The mortar is removed with a square edging tool. (See illustration on top of the following page.) The ledge created by raking the joint may collect water and dirt. This joint should not be exposed to weather. Strength is reduced from the wall when mortar has been raked. Therefore, this joint should not be used for load bearing walls.

V Joints.

"V" joints are finished in a similar manner as concave joints. The difference is that horizontal and vertical jointers have a "V" instead of a rounded base. (See illustration on the bottom of the following page.)

Brushing Joints.

All joints except squeezed joints should be brushed. A soft fiber brush is used in a diagonal direction over the wall. Brushing in this direction will prevent digging out too much mortar. "V" joints and concave joints should be jointed a second time for a finished look.

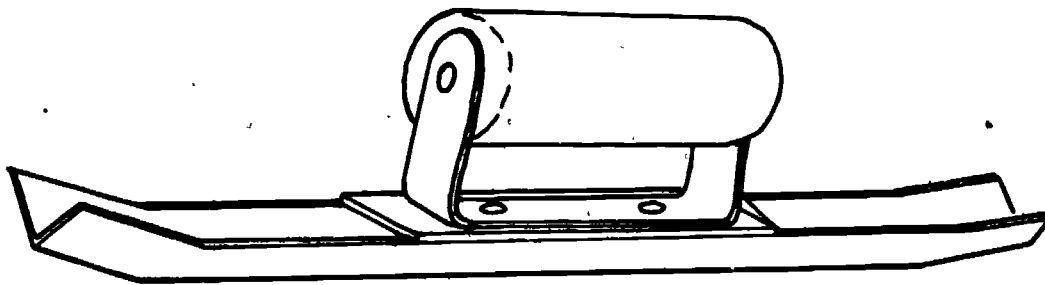

SUMMARY

Horizontal joints should be jointed first. It is important that all joints are inseparable, weather tight and have a clean, straight appearance.

Self Assessment

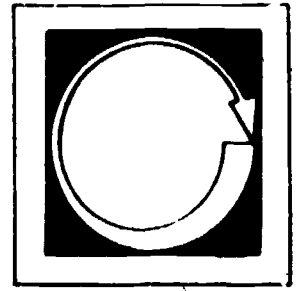

LISTED BELOW ARE STATEMENTS FOLLOWED BY A NUMBER OF POSSIBLE COMPLETIONS. SELECT THE COMPLETION WHICH COMPLETES THE STATEMENT CORRECTLY AND PLACE THE LETTER IN THE BLANK PROVIDED.

1. ____ A sled runner is used for the:
 - a. bed joints
 - b. concave joints
 - c. flush joints

2. ____ An "S-shaped" jointer is used for:
 - a. diagonal joints
 - b. horizontal joints
 - c. vertical joints

3. ____ The thumb print test shows if the joints are:
 - a. straight
 - b. finished
 - c. ready to be jointed

4. ____ Brushing in a diagonal direction will prevent:
 - a. digging out mortar
 - b. leaving an unfinished look
 - c. moisture penetration

5. ____ On a raked joint the removed mortar will:
 - a. collect water and dirt
 - b. reduce strength
 - c. both a & b

Self Assessment Answers

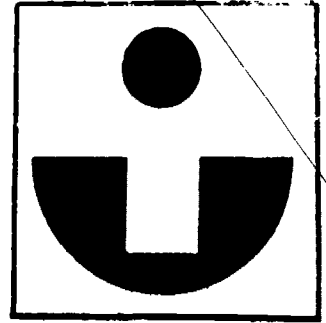

1. a

2. c

3. c

4. a

5. c

Job Sheet

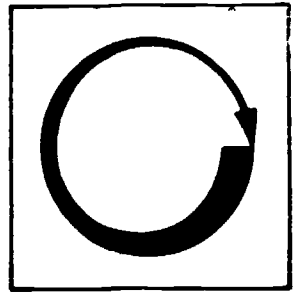

FOLLOWING THE STEPS OUTLINED IN THE INFORMATION SECTION, COMPLETE TWO OF THE FOLLOWING TASKS.

Materials and Tools.

materials listed in mixing mortar

materials listed in applying mortar, excluding wood

concave sled runner

concave "S" jointer

"V" sled runner

"V" and "S" jointer

1. Build a 2' X 4' wall with a squeezed joint finish.
2. Build a 2' X 4' wall with a "V" joint finish.
3. Build a 2' X 4' wall with a concave joint finish.
4. Build a 2' X 4' wall with a rake joint finish.

Post Assessment

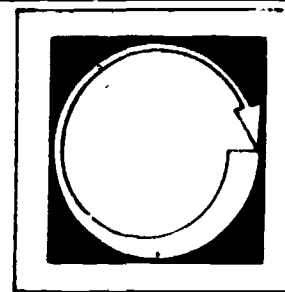

LISTED BELOW ARE SEVERAL STATEMENTS. IF THE STATEMENT IS TRUE, PLACE A "T" IN THE BLANK PROVIDED. IF THE STATEMENT IS FALSE, PLACE AN "F" IN THE BLANK.

1. ___ Weather joints are one of the best trowel finishes.
2. ___ A soft fiber brush is used in a horizontal direction over the wall.
3. ___ Walls with a raked finish are as strong as other walls.
4. ___ In flush joints, the joint is usually finished when the bricklayer cuts away excess mortar.
5. ___ A sled runner is used for vertical joints.
6. ___ Struck joints can be used in both interior or exterior walls.
7. ___ Walls with a squeezed joint finish are waterproof and can be used anywhere.

Instructor Post Assessment Answers

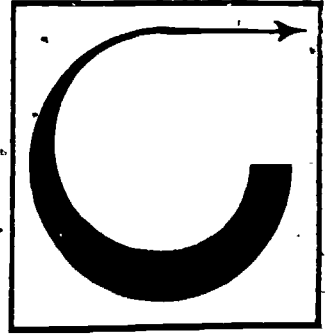

1. T

2. F

3. F

4. T

5. F

6. F

7. F

53

50

BRICK AND BLOCK

Goal:

The student will be able to identify the characteristics of brick and block and the uses of each.

Performance Indicators:

The student will be able to identify brick and block, complete a Self and Post Assessment and an Assignment.

Study Guide

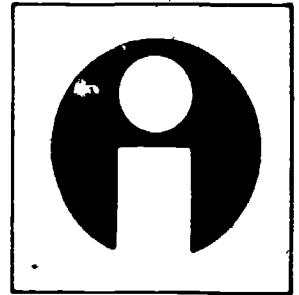

In order to finish this module, do the following tasks. Check each item off as you complete it.

1. Read the Goal and Performance Indicators on the cover of the module. This will tell you what you will learn by studying the module, and how you will show you've learned it.
2. Read the Introduction. The Introduction will tell you why the module is an important part of the bricklaying trade.
3. Study the Vocabulary section. Vocabulary words are important for a good understanding of the trade. After you have studied the vocabulary, ask your teacher to quiz you on the words and their meanings.
4. Study the Information section. This section will give you the information you need to understand the subject.
5. Take the Self Assessment exam. This is a test for you to prove to yourself that you have learned the material you have studied. Compare your answers with the answers on the Self Assessment Answer Sheet, which is on the page following the Self Assessment. If you scored poorly, re-study the Information section or ask your teacher for help.
6. Do the Assignment page. Follow the instructions at the top of the assignment page.
7. Take the Post Assessment exam. Give the exam to your teacher after you have completed it. Your teacher will grade it for you.

Introduction

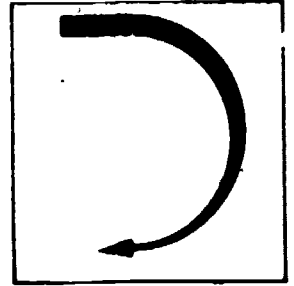

Brick and block make an attractive building. They are strong and durable. Little maintenance is required; they will not burn, rot, peel, dent, corrode, rust or warp.

Brick and block also serve as a good insulator. There are thousands of sizes, types, shapes, colors and textures.

The following section provides information on:

1. How brick and block are made.
2. Sizes and shapes.
3. Characteristics.

Vocabulary

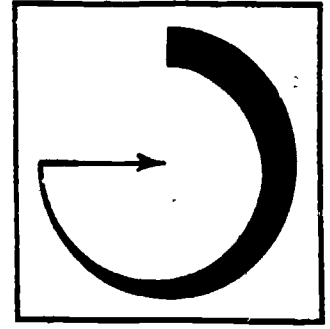

Trade terms are very important for good understanding of the trade. Study these words and meanings. When you have learned them, ask your teacher to quiz you on the words and their meanings.

ADOBE--Sun dried brick.

DIE--A machine that presses the clay together to form brick.

RETAINING WALLS--Walls built to hold something back: dirt, grave], etc.

P.S.I.--Pounds per Square Inch.

A.S.T.M.--American Society for Testing and Materials.

Supplementary References

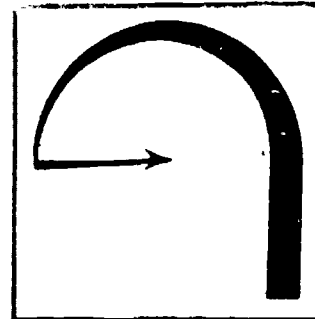

Taylor, Merlin and Harlin Randolf. IMAT Brick and Block Construction, 1976.
pp. 95-116.

Information

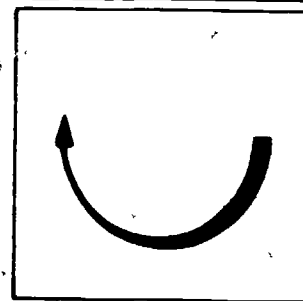

The history of brick and block go back as far as civilization. Brick was first used about 3500 B.C. by the people who lived in low lying plains between the Tigris and Euphrates rivers. The area is now known as Iraq.

Wood was very scarce in the area, however, there was plenty of clay. These people made this clay into shapes that resembled loaves of bread. They used these oddly shaped bricks to build their great cities.

The basic ingredient in brick is clay. Clay is a mineral made of very small rock particles.

BRICK

Brick is made by three processes:

1. Soft mud process.
2. Stiff mud process.
3. Dry-pressed process.

These processes are similar in that all materials are mixed, molded, dried and burned. The difference is the amount of water added to the clay and the method of molding.

In the soft mud method, the clay contains 20 to 30% water and is forced into a mechanical mold. After the clay is in the mold the excess amount is scraped flush with the top of the mold. The brick is then burned in a kiln at a temperature of 1500° to 2100° F. This brick may also be sun-dried. This is called adobe brick.

In the stiff mud process, less water is used. The clay is just wet enough to stick together. The clay is then forced through a die forming three of the

brick's four sides. This clay comes out in a long ribbon. The clay ribbon is then cut by wires, forming the fourth side. The brick is then burned in a kiln.

In the dry press process, a plunger that exactly fits the shape of the mold is used to shape the clay to a specific size. Hardly any water is used in this process. Pressure is used to compact the clay particles together into the mold. The plunger forms the fourth side and the brick is then burned.

Sizes and Shapes

By varying the width, height and length, it is possible to make brick in many different sizes and shapes. The most common shape for brick is rectangular.

The most common sizes for brick are:

1. Common Brick-- $3 \frac{3}{4}$ " X $2 \frac{1}{4}$ " X 8".
2. Rough Face-- $3 \frac{3}{4}$ " X $2 \frac{1}{4}$ " X 8".
3. Smooth Face-- $3 \frac{7}{8}$ " X $2 \frac{1}{4}$ " X 8".

Brick can be made into thousands of different shapes simply by changing or altering the mold.

Standard or common sizes are used to make it easier to identify the brick needed. For example, when a common brick is measured, it may be $7 \frac{1}{2}$ " long. To get the standard dimension, it is necessary to add the width of a mortar joint. So a brick that measures $7 \frac{1}{2}$ " long is layed with a $\frac{1}{2}$ " mortar joint. The standard size is 8". This also helps the bricklayer to plan his or her work.

For example, if a wall is $32 \frac{1}{2}$ bricks long, the bricklayer can tighten the head joint from $\frac{1}{2}$ " to $\frac{3}{8}$ " and lose 4" or $\frac{1}{2}$ brick. This will eliminate some cuts or small pieces in the wall. This is also true in measuring block, but the measurement will be longer.

Characteristics and Classification

Brick is classified by its ability to withstand weather conditions. The American Society for Testing and Materials (A.S.T.M.) has classified brick in three different grades:

1. SW--severe weathering.
2. MW--medium weathering.
3. NW--no weathering.

The degree of burning is the main factor in the brick's ability to withstand weather. Brick that is adequately burned stands up better than underburned brick.

Severe Weather Brick

This is the hardest of all three grades. The brick has been burned until the pores are completely closed. This will enable the brick to resist water penetration.

These bricks are durable even in extreme changes in temperature. They are used where these weather conditions exist for retain-wall, sewers and foundations. These bricks have a high compressive strength and can resist heavy loads.

Medium Weather Brick

Because of underburning, these bricks should be used on walls which are not exposed to severe weather. They are not as strong, and should be used for walls with minimal weight stress (such as planters or decorative walls). When exposed to severe weather, these bricks may change in appearance by chipping, flaking, or powdering.

No Weathering Brick

These bricks should be used only inside. They should not be exposed to any weight stress because of their low compressive strength. "No weathering" brick will disintegrate if exposed to alternating freezing and thawing.

Resistance to weather is achieved by burning. Burning also determines the strength of brick.

A.S.T.M. has several ways of testing brick. Two of the tests are:

1. Transverse.
2. Compressive.

It is important that the bricks are strong enough to support large amounts of weight. Testing brick that will be laid vertically is called the transverse strength. (See illustration on the following page.)

This is done by putting pressure on both ends of the brick until it breaks and then measuring the amount of pressure used. These tests range approximately from the low of 115 P.S.I. to the high of 2,900 P.S.I.

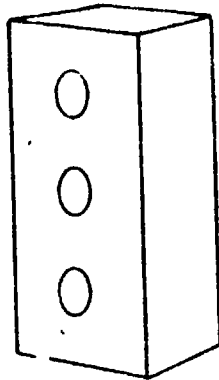

Compressive strength is tested by putting pressure on the top or sides of the brick until it breaks. Those tests range approximately from a low of 700 P.S.I. to a high of 22,000 P.S.I.

BLOCK

Block is made by combining cementing materials and an aggregate. Portland or masonry cement mixed with water makes up the cementing materials. Different materials, or the aggregate, are mixed well with the cementing materials. Types of aggregate include: sand, gravel, slag, cinders, pumice, shale and fly ash.

Both vibration and pressure are used to form the materials to different sizes. The mold in which the block is shaped is set on pallets.

The block is formed in the same way as bricks are in the dry press process, because the ingredients are compacted in the mold. When the unit is formed, the mold is removed, but the block remains on the pallet.

The block and pallet are then sent to the kiln. The block is set in the kiln to cure. Blocks are left to set for two to four hours at a normal temperature (usually 70 to 90 degrees). This allows them to take an initial set.

Steam is then injected into the room to gradually raise the temperature (150° to 180°). Steam also prevents the moisture from being drawn out of the blocks too quickly, causing them to shrink or crack. This process takes approximately 24 hours.

knowing the material and understanding how and where it is used helps the bricklayer to do a good job and make sure that the structure is strong and durable.

Self Assessment

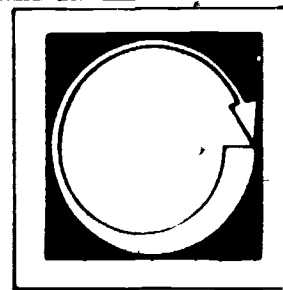

LISTED BELOW ARE QUESTIONS OR STATEMENTS FOLLOWED BY A NUMBER OF POSSIBLE ANSWERS OR COMPLETIONS. SELECT THE ANSWER OR COMPLETION WHICH ANSWERS THE QUESTION OR COMPLETES THE STATEMENT CORRECTLY AND PLACE THE LETTER IN THE BLANK PROVIDED.

1. ____ What is the basic ingredient in brick?
 - a. bark
 - b. clay
 - c. water

2. ____ When making brick with the soft mud method, the clay contains:
 - a. 20 to 30% water
 - b. 40 to 60% water
 - c. no water

3. ____ Sun-dried brick are called:
 - a. common
 - b. clinker
 - c. adobe

4. ____ The initials A.S.T.M. stand for:
 - a. American Society for Testing and Materials
 - b. American School for Training and Masons
 - c. American Society for Transfers and Movers

5. ____ The most common shape for brick is:
 - a. square
 - b. circular
 - c. rectangular

6. _____ Block is burned at temperatures from:

a. 4850° to 5260° F.

b. 2700° to 3720° F.

c. 1500° to 2100° F.

Self Assessment Answers

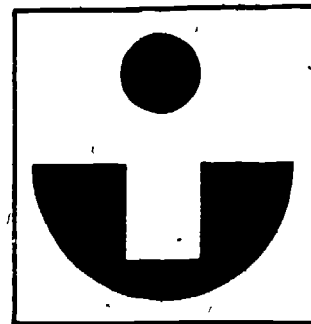

1. b
2. a
3. c
4. a
5. c
6. c

Assignment

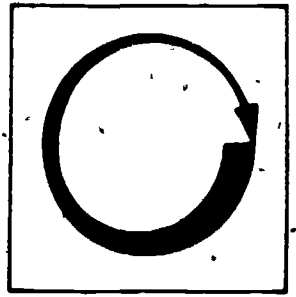

COMPLETE THE FOLLOWING ASSIGNMENTS.

From the information section decide which brick is the best for each situation:

1. You are building a torpedo storage building at the North Pole. What type of weather rating should these bricks have?
2. You are building an interior wall in an automobile factory. This wall will have very little weight on it. What weather rating should this brick have?

Make a report to your instructor on the following.

3. On your way home tonight, observe the houses and buildings. Count how many different types and sizes of brick you see.

Post Assessment

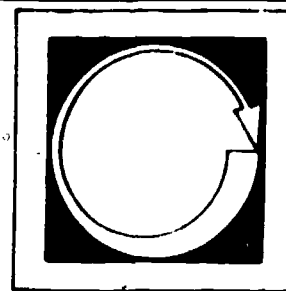

LISTED BELOW ARE SEVERAL STATEMENTS. IF THE STATEMENT IS TRUE, PLACE A "T" IN THE BLANK PROVIDED. IF THE STATEMENT IS FALSE, PLACE AN "F" IN THE BLANK.

1. Compressive strength is tested by putting pressure on the top or sides of a brick until it breaks.
2. Transverse strength is tested by putting pressure on both ends of the brick until it breaks.
3. No weathering bricks are strong and will not have any problems with bad weather.
4. Severe weather bricks resist weather well, but they are soft and should not be used for load-bearing walls.
5. Brick is classified by its ability to withstand weather conditions.
6. In the stiff mud process, more water is used than in the other two processes.
7. The history of brick and block started in about the 1800s.

Instructor Post Assessment Answers

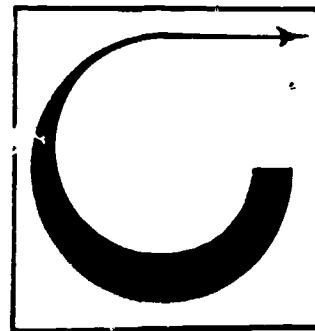

1. T
2. T
3. F
4. F
5. T
6. F
7. F

69

66

BRICKLAYING BONDS

Goal:

The student will be able to lay out and identify various bonds.

Performance Indicators:

The student will practice lay out and identification of different bonds, and will complete a Self and Post Assessment and a Job Sheet.

Study Guide

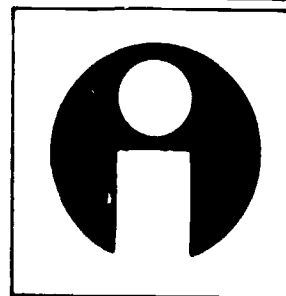

In order to finish this module, do the following tasks. Check each item off as you complete it.

1. Read the Goal and Performance Indicators on the cover of the module. This will tell you what you will learn by studying the module, and how you will show you've learned it.
2. Read the Introduction. The Introduction will tell you why the module is an important part of the bricklaying trade.
3. Study the Vocabulary section. Vocabulary words are important for a good understanding of the trade. After you have studied the vocabulary, ask your teacher to quiz you on the words and their meanings.
4. Study the Information section. This section will give you the information you need to understand the subject.
5. Take the Self Assessment exam. This is a test for you to prove to yourself that you have learned the material you have studied. Compare your answers with the answers on the Self Assessment Answer Sheet, which is on the page following the Self Assessment. If you scored poorly, re-study the information section or ask your teacher for help.
6. Do the Job Sheet. Follow the instructions at the top of the Job Sheet. The tasks listed on the Job Sheet will help you develop skills which will be helpful to you.
7. Take the Post Assessment exam. Give the exam to your teacher after you have completed it. Your teacher will grade it for you.

Introduction

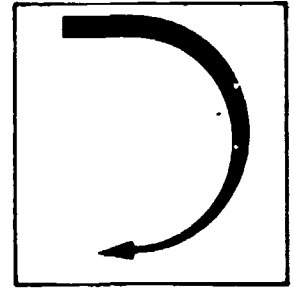

Bonding is a general term meaning to bind or tie things together. It is also the systematic lapping of brick (or block) in a wall. It is important that the bricklayer be familiar with different types of bonds. The Information section will cover different types of bonds and how they are laid out.

72

69

Vocabulary

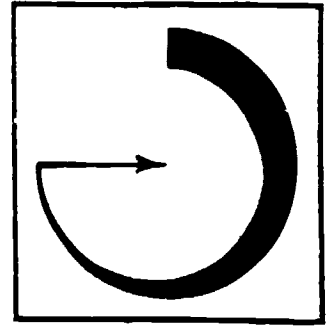

Trade terms are very important for a good understanding of the trade. Study these words and meanings. When you have learned them, ask your teacher to quiz you on the words and their meanings.

SYSTEMATIC--Repeating the lapping of brick.

WYTHE--A single wall.

COURSE--One layer of brick.

73

70

Supplementary References

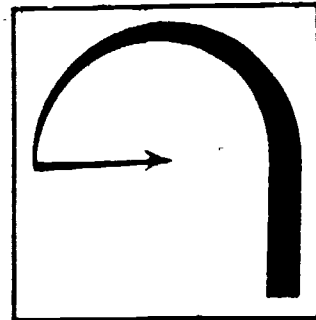

Taylor, Merlin and Harland Randolph. IMAT Brick and Block Construction.
1976. pp. 53-61.

74
71

Information

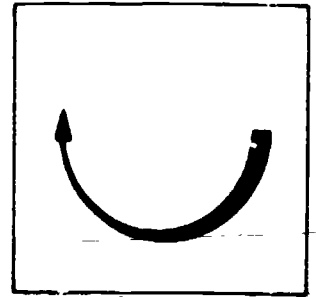

The pattern that you see on the face of a brick wall is called a bond, or pattern bond. This results from the different arrangements of the brick or block and the mortar joints.

The type of bond used is chosen by the architect after checking local building codes. These codes are checked because all bonds do not have the same strengths. The bond must insure that the wall is strong enough to resist stress that is put on it.

Bricklayers can lay up any bond (decorative or pattern) if they understand a few basic bonds. These basic bonds are:

1. Stacked
2. Stretcher
3. American
4. English
5. Flemish

In these bonds, the units and mortar joints are all arranged differently. They form different patterns on the wall face. This makes an easy means of identifying these different types of bonds.

STACKED BOND

In a stacked bond pattern, no unit is overlapped. They are stacked one on top of the other. All bed and head joints form continuous lines. This is not a structural bond because weight is not evenly distributed. (See the illustration on the top of the next page.)

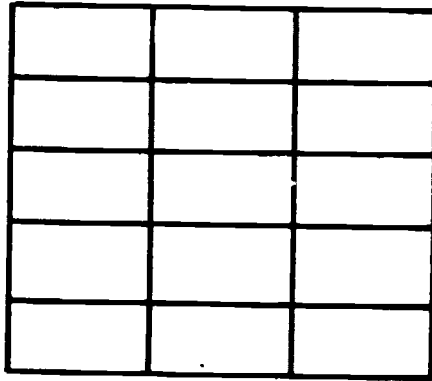

STRETCHER OR RUNNING BOND

This is a structural bond because the weight placed on the wall is evenly distributed. The weight is distributed through the brick to the lower courses as shown below

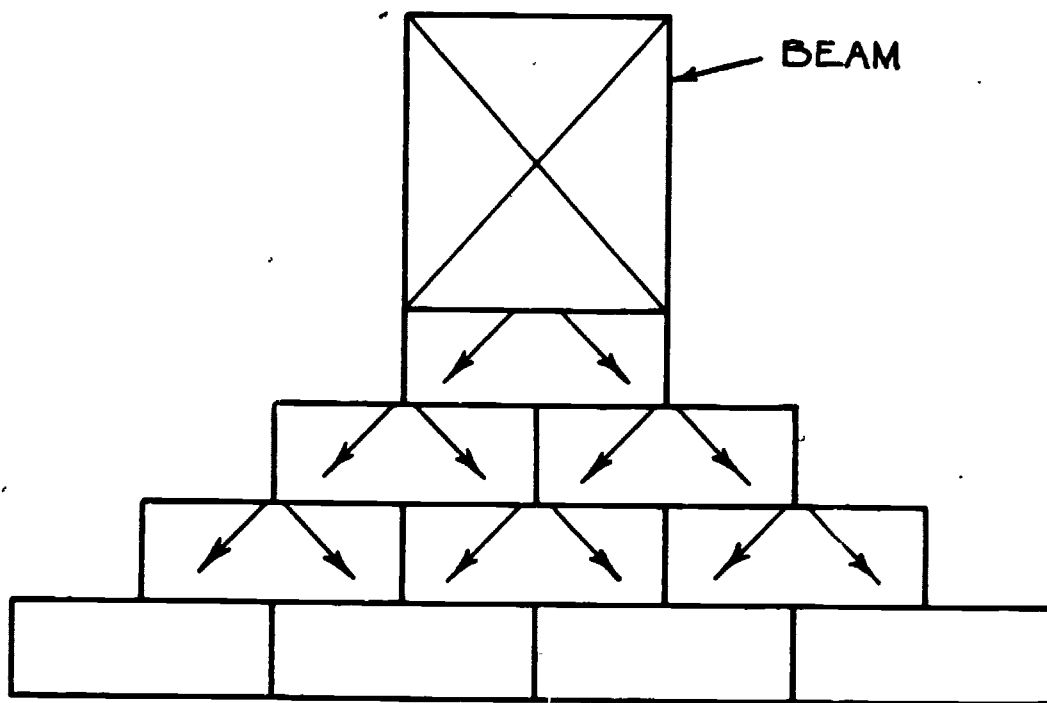

In a stretcher bond, each brick is laid as a stretcher. A stretcher is a brick that is placed in line so its length is parallel to the wall. The head joints are located on the center of the brick below a one-half lap.

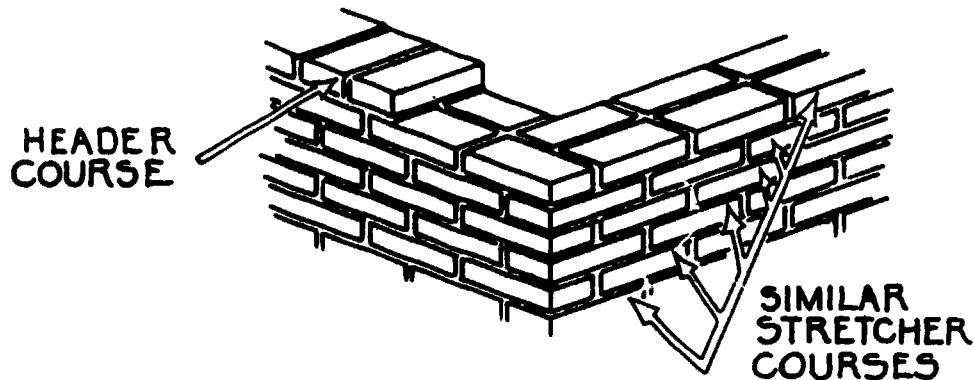

The corner will show a header brick at every other course. A header brick bonds the face work to the backing or back wall. (Left part of drawing above.) It is laid with the head of the brick to the face of the wall.

AMERICAN OR COMMON BOND

American bond consists of both stretcher and header brick. Head joints are placed on the center of brick in the stretcher courses. Header courses are laid 1 to every 6 or 7 stretcher courses. This bond is used to tie in the face wall to the back wall. When structural strength is not required (single walls), snap headers are used. (See the illustration on the next page.)

A snap header is a brick that is snapped or clipped in half so that its length covers only one wythe of the wall. It is laid so that the head end shows in the face of the wall.

ENGLISH BOND

English bond is similar to American bond, only more headers are used. English bond alternates courses. The first course is a stretcher course. The second is a header course. The third is a stretcher, and the fourth is a header, and so on. Snap headers can also be used where structural strength is not required. (See the illustration on the page after next.)

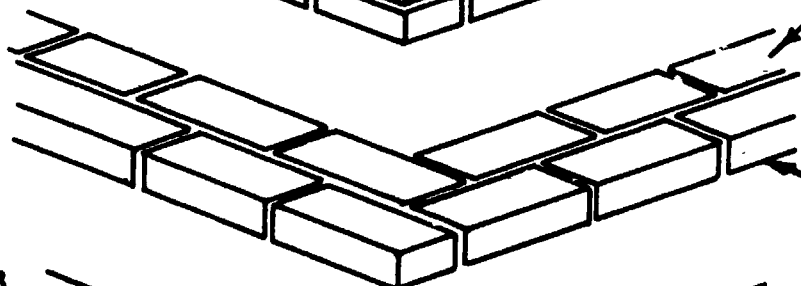
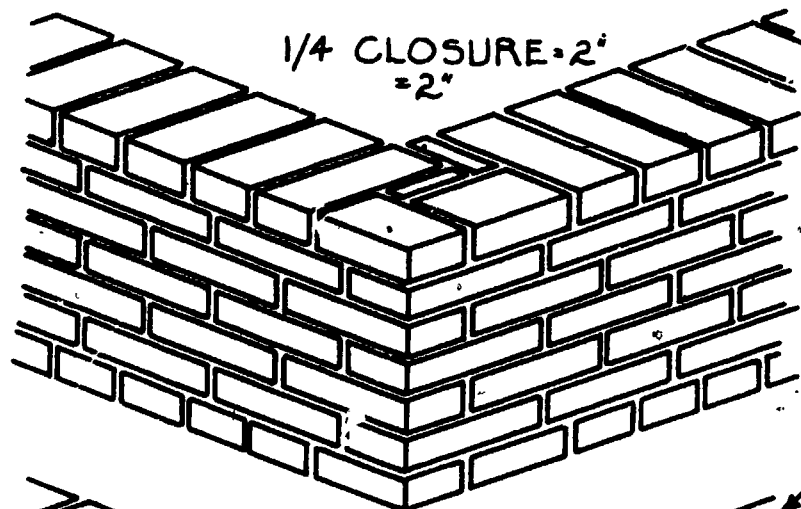

STRETCHER COURSES

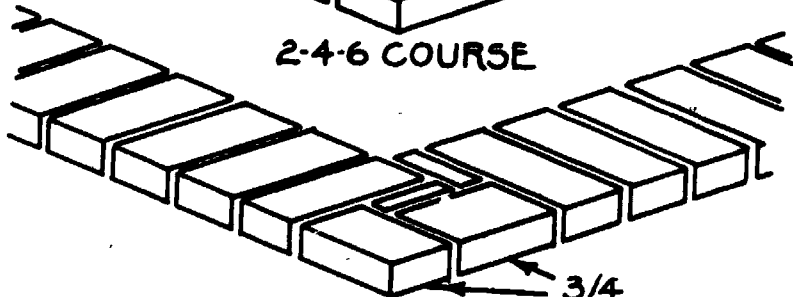
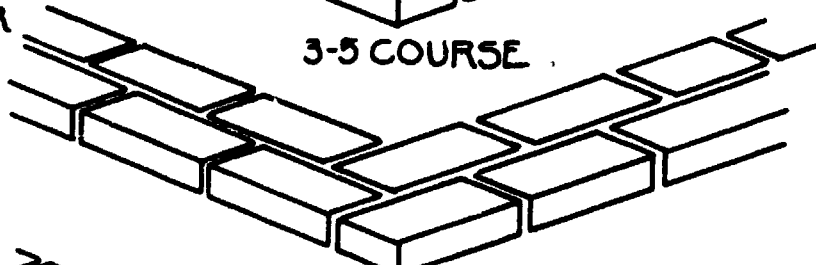

1ST & HEADER COURSES

3/4

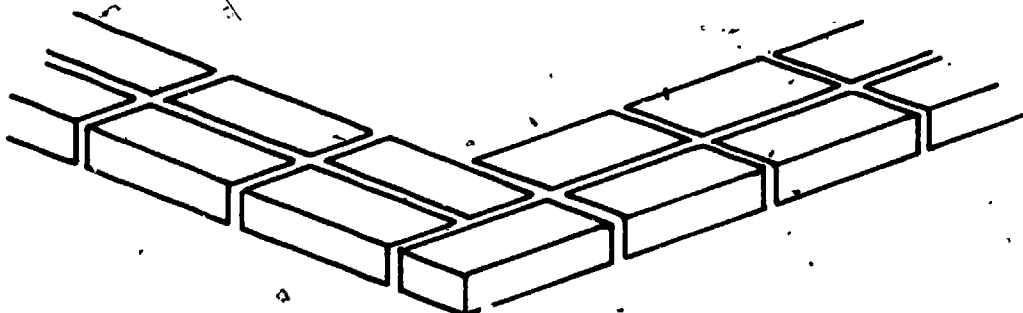
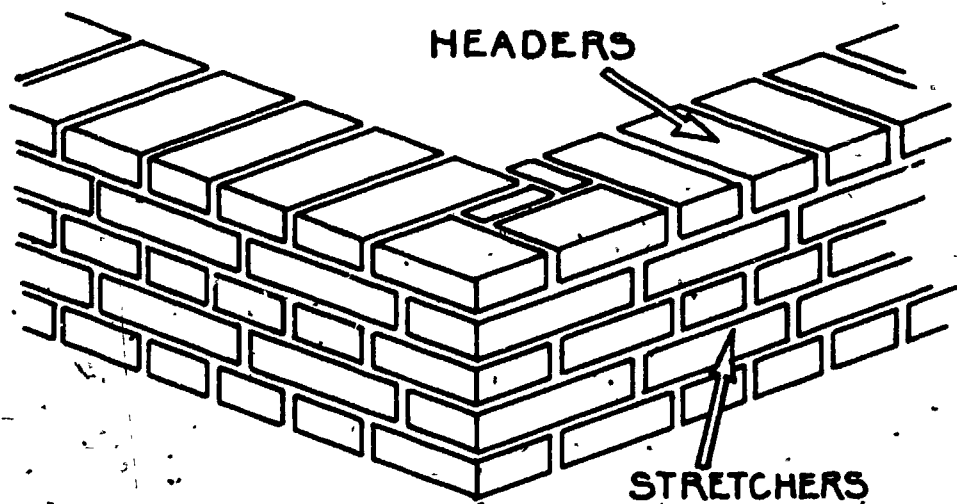

2, 4, 6, ETC. COURSES

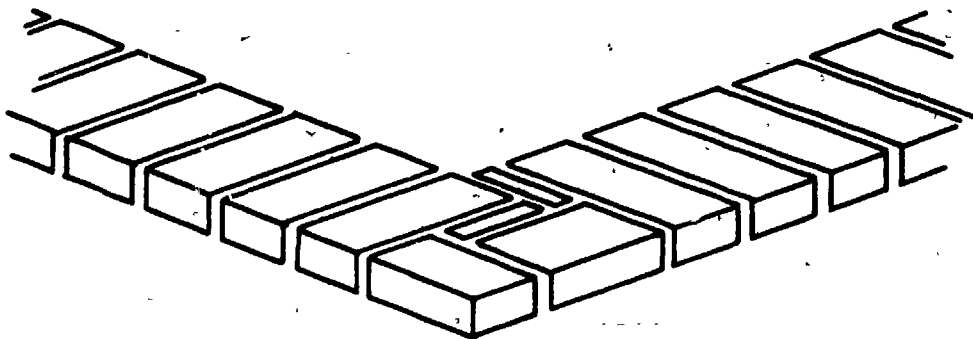

1, 3, 5, ETC. COURSES

FLEMISH BOND

In the other bonds, the units were laid in one direction, but the courses were different. In Flemish bond the courses are the same, and the units are laid in different directions. In Flemish Bond, the units in a course alternate with a stretcher and then a header, a stretcher, a header, etc.

Snap headers can be used where structural strength is not required.

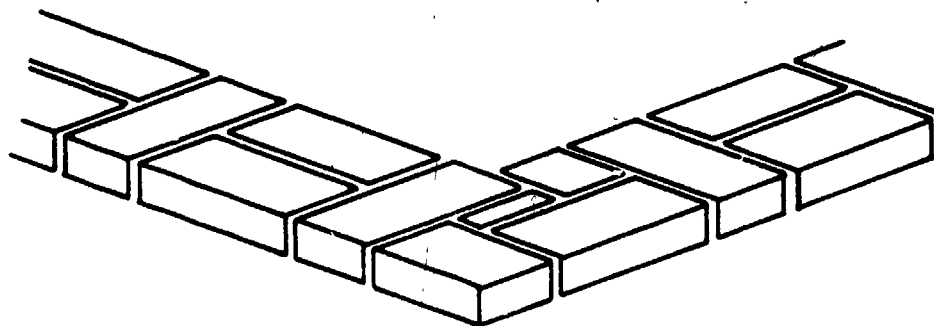
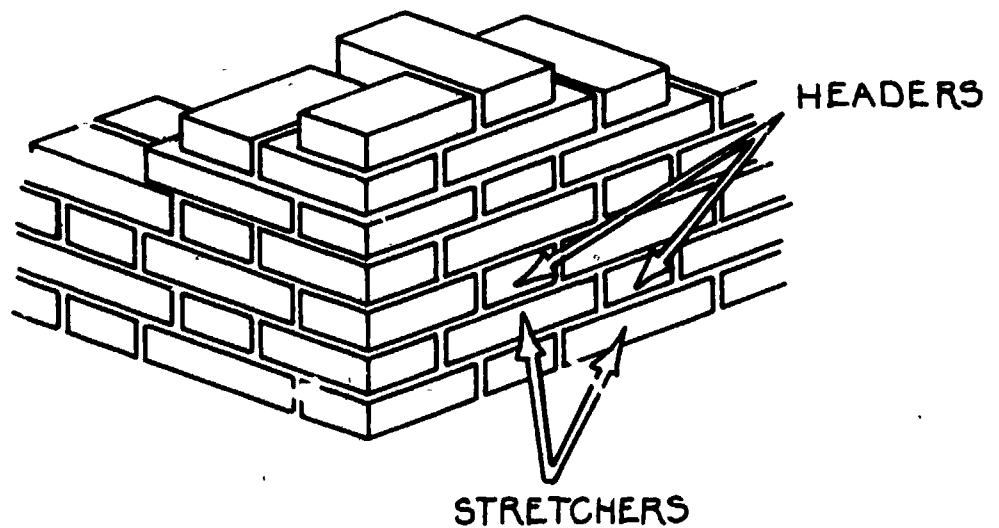

2, 4, 6, ETC. COURSES

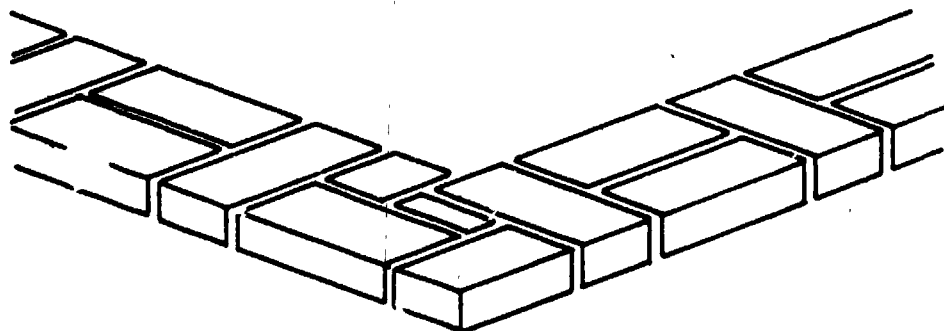

1, 3, 5, ETC. COURSES

Changing the arrangement of brick can form different patterns on the face of the wall. Overlapping brick can form a solid wall that is stable and can resist large amounts of weight. It is important that a bricklayer be familiar with these bonds. This will help him or her to build walls on many different types of jobs.

Self Assessment

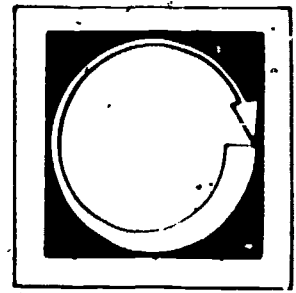

LISTED BELOW ARE QUESTIONS OR STATEMENTS FOLLOWED BY A NUMBER OF POSSIBLE ANSWERS OR COMPLETIONS. SELECT THE ANSWER OR COMPLETION WHICH ANSWERS THE QUESTION OR COMPLETES THE STATEMENT CORRECTLY AND PLACE THE LETTER IN THE BLANK PROVIDED.

1. ____ The pattern you see on the face of a wall is called a:
 - a. course
 - b. wythe
 - c. bond

2. ____ Who decides which bond to use?
 - a. bricklayer
 - b. fireman
 - c. architect

3. ____ Which term does not belong?
 - a. English
 - b. Flemish
 - c. Basket
 - e. Stretcher

4. ____ A stretcher is laid _____ to the wall.
 - a. parallel
 - b. vertical
 - c. diagonal

5. ____ American bond consists of:
 - a. only headers
 - b. only stretchers
 - c. both headers and stretchers

Self Assessment Answers

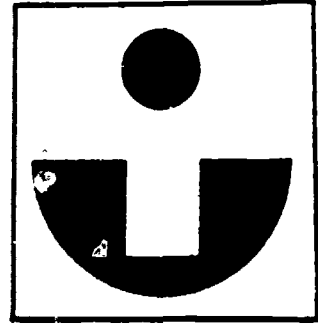

1. c
2. c
3. c
4. a
5. c

Job Sheet

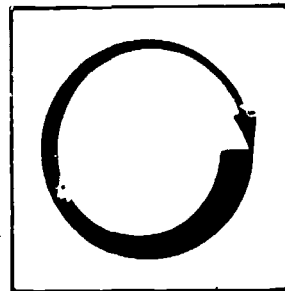

FOLLOWING THE DIRECTIONS OUTLINED IN THE INFORMATION SECTION, DO ONE OF THE FOLLOWING TASKS.

Materials and Tools

All materials used in applying mortar, excluding the wood.

1. Build a 2' X 4' wall using an English bond pattern.
2. Build a 2' X 4' wall using a stacked bond pattern.
3. Build a 2' X 4' wall using a stretcher bond pattern.

Post Assessment

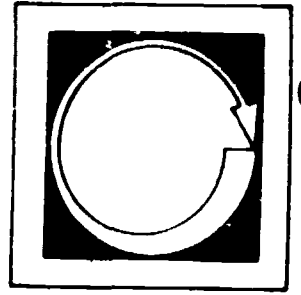

LISTED BELOW ARE SEVERAL STATEMENTS. IF THE STATEMENT IS TRUE, PLACE A "T" IN THE BLANK PROVIDED. IF THE STATEMENT IS FALSE, PLACE AN "F" IN THE BLANK.

1. ____ A snap header is the same as a stretcher.
2. ____ A header brick bonds two walls together.
3. ____ English bond and American bond are the same with the exception that English bond has more headers.
4. ____ In the Flemish bond the courses are the same but the units are different.
5. ____ Snap headers can be used where structural strength is not required.
6. ____ Stack bond should not be used as a structural bond because it does not distribute weight evenly.

Instructor Post Assessment Answers

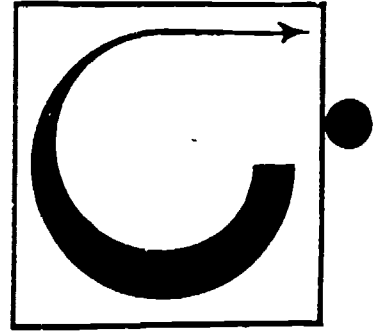

1. F
2. T
3. T
4. T
5. T
6. T

LEVEL AND TRANSIT

Goal:

The student will be able to explain the use of a transit and level.

Performance Indicators:

The student will complete a Job Sheet and a Self and Post Assessment and a Job Sheet.

Study Guide

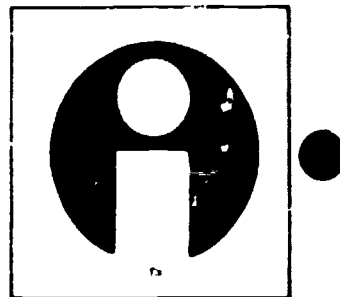

In order to finish this module, do the following tasks. Check each item off as you complete it.

1. Read the Goal and Performance Indicators on the cover of the module. This will tell you what you will learn by studying the module, and how you will show you've learned it.
2. Read the Introduction. The Introduction will tell you why the module is an important part of the bricklaying trade.
3. Study the Vocabulary section. Vocabulary words are important for a good understanding of the trade. After you have studied the vocabulary, ask your teacher to quiz you on the words and their meanings.
4. Study the Information section. This section will give you the information you need to understand the subject.
5. Take the Self Assessment exam. This is a test for you to prove to yourself that you have learned the material you have studied. Compare your answers with the answers on the Self Assessment Answer Sheet, which is on the page following the Self Assessment. If you scored poorly, re-study the Information section or ask your teacher for help.
6. Do the Job Sheet. Follow the instructions at the top of the Job Sheet. The tasks listed on the Job Sheet will help you develop skills which will be helpful to you.
7. Take the Post Assessment exam. Give the exam to your teacher after you have completed it. Your teacher will grade it for you.

Introduction

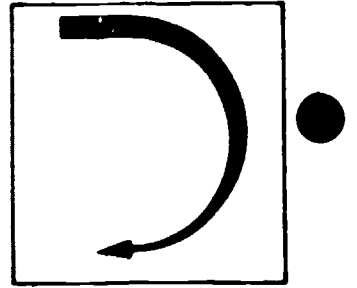

It is important in bricklaying that all work look pleasing to the eye. That is, all mortar joints should be straight and brick square. This section will cover the tools used to accomplish this task.

Vocabulary

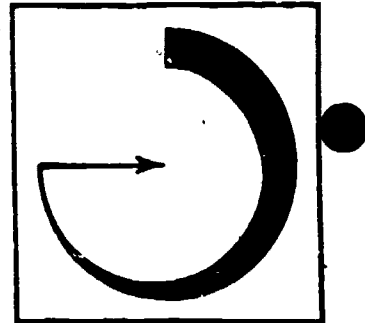

Trade terms are very important for a good understanding of the trade. Study these words and meanings. When you have learned them, ask your teacher to quiz you on the words and their meanings.

PLUMB--A wall that is vertical.

LEVEL--A wall that is horizontal.

Supplementary References

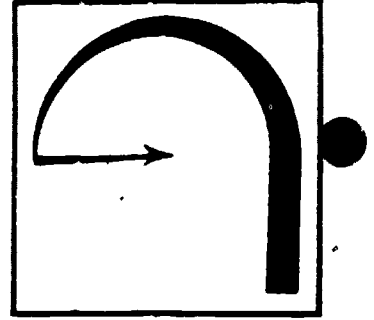

Taylor, Merlin and Harlin Randolph. IMAT, Brick and Block Construction, 1976.
pp. 122-124.

Information

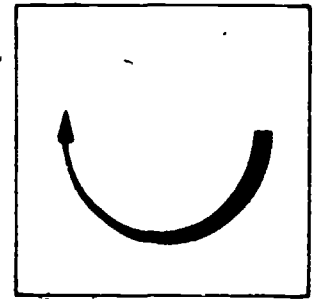

It is very important that the work the bricklayer does be 1) plumb, 2) level and 3) straight. To do this the bricklayer uses a level. A level is also known as a plumb rule or a spirit level. (See Fig. 1)

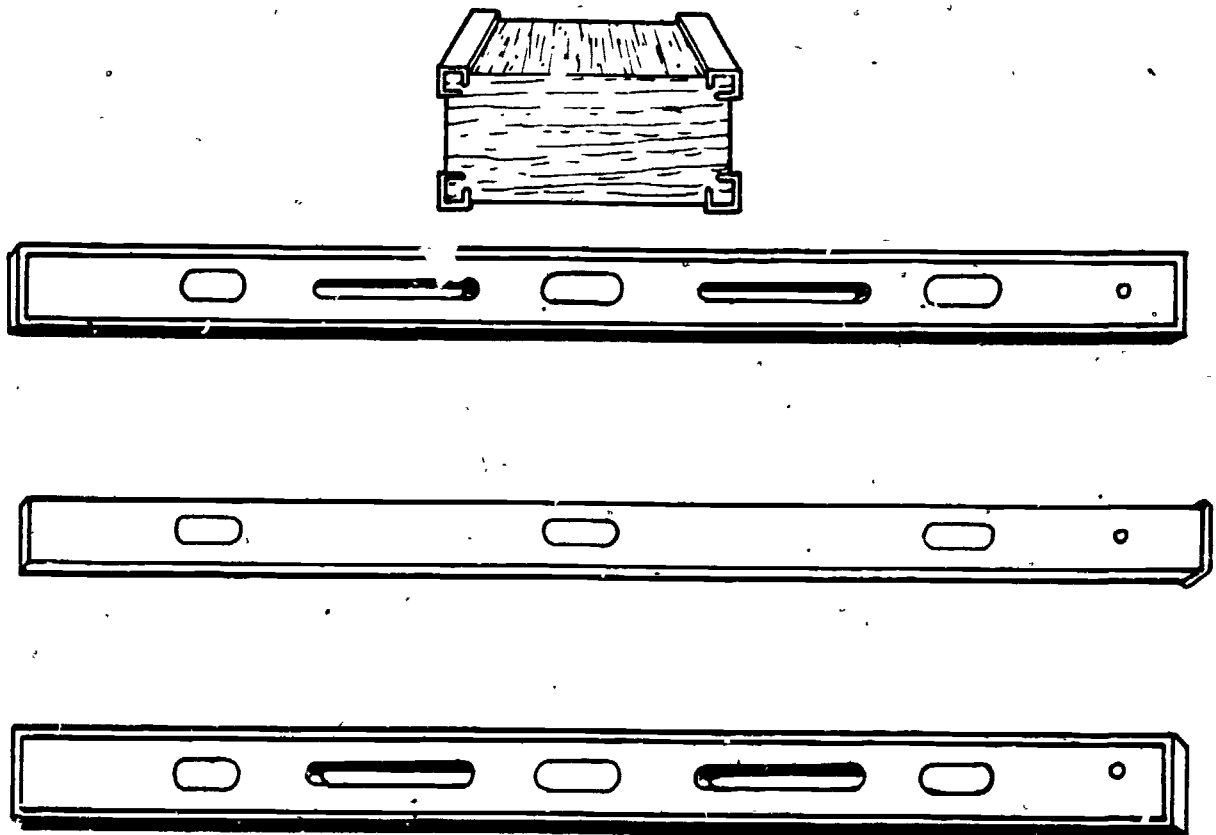

Levels are made from several different materials. Seasoned wood encased in metal, plastic, or fiberglass. Levels come in different sizes ranging from 12 to 48 inches.

Each level has 4 to 6 vials. These vials are filled with a liquid with just enough liquid left out to form an air bubble. In the center of this vial

there are two lines. When the level is placed up against a wall or a flat surface and the bubble is in the center, the wall is level or plumb.

LEVEL

To check if a surface is level, the level is placed in a horizontal position on its edge. The air bubble should be in the center of the level vial between the lines.

It is important that the bricklayer's work be level. If it's not level the bed joints and units will be slanted up or down. (See Fig. 2)

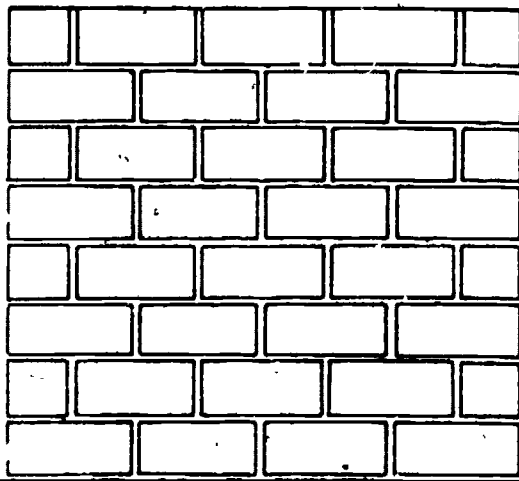

ACCEPTABLE

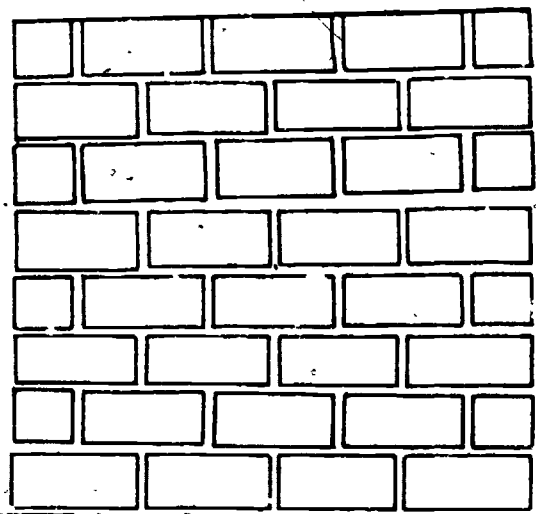

UNACCEPTABLE

The units should be laid as straight as possible. Place the level on top of the work. With your trowel, tap the units down until all units are flat and the level vial reads level.

PLUMBS

To check if a surface is plumb, the level is placed in a vertical position on its edge. The air bubble should be in the center of the plumbvial between the lines. It is important that the bricklayer's wall be plumb. If it is not, it will slant either in or out. (See Fig. 3)

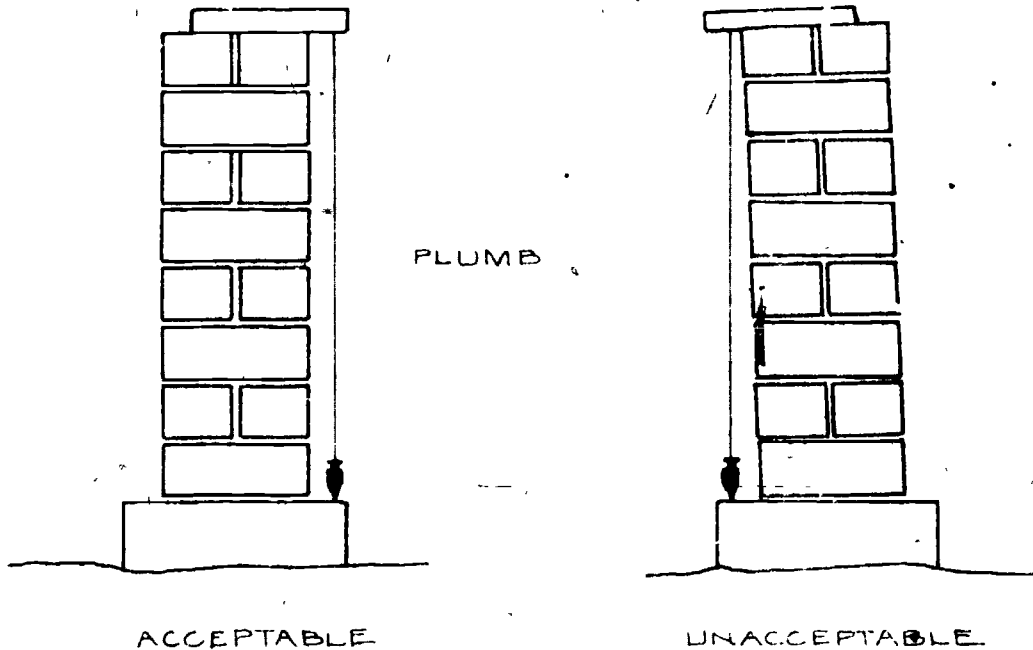

Place the level up against the work. Tap the front or back of the brick until the face of the brick is flat against the level. Adjust the brick so the vial reads plumb.

A level is a very accurate tool and should be taken care of. The level should not be dropped or beaten to straighten units. Wood levels should be given a light coat of oil periodically. This will help prevent moisture penetration which may cause it to warp.

TRANSIT

It is important that the bricklayer be familiar with a transit. The transit is not used as much as a level but the functions are somewhat the same.

A transit is a very accurate instrument used mainly to survey and measure distances and heights before and during construction. The transit can also show how level and plumb a wall or building is.

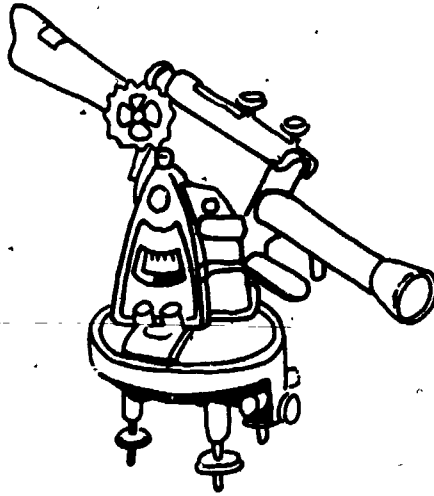

A transit has a telescope which can be moved from side to side or up and down. It is mounted on a base that holds it securely. This base has adjustments on it. These adjustments are used to level the telescope so it will give accurate results.

All of this is mounted on a tripod. The tripod is used to hold the transit and to keep it from moving. Special training is required for its proper use.

The transit and the level are very useful tools for bricklayers. They help the bricklayers to do their jobs accurately. These tools should be used with care. This will ensure the long life and the accuracy of them.

Self Assessment

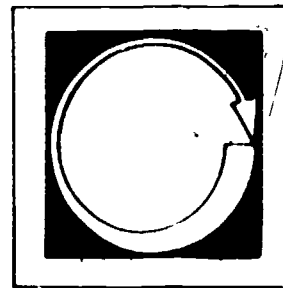

COMPLETE THE FOLLOWING STATEMENTS BY WRITING THE CORRECT WORD OR WORDS IN THE BLANKS PROVIDED.

1. A level is also called _____ and _____.
2. A bricklayer's work should be _____, 2) _____ and 3) _____.
3. Levels range from _____ to _____ inches in length..
4. Levels have _____ to _____ vials.
5. When the level is in the horizontal position the vial is showing how _____ the wall is.
6. The transit can be used _____ and _____ construction.

Self Assessment Answers

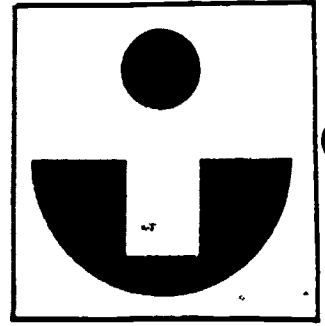

1. plumb rule and spirit level.
2. level, plumb, straight
3. 12 to 48 inches
4. 4 to 6
5. level
6. before and during

Job Sheet

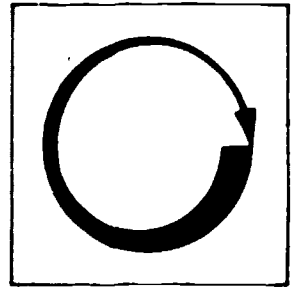

COMPLETE THE FOLLOWING TASK.

Materials and Tools

materials listed in bond section

4' level

Construct a wall 2' X 4'. Be sure the wall is level and plumb.

Post Assessment

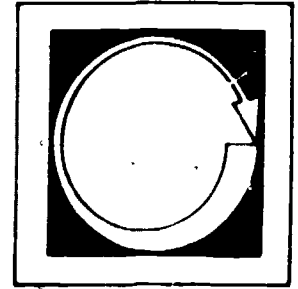

COMPLETE THE FOLLOWING STATEMENTS BY WRITING THE CORRECT WORD OR WORDS IN THE BLANKS PROVIDED.

1. Level vials are filled with _____.
2. When the level is held vertically it is in the _____ position.
3. Adjustments on the base of the transit are used to _____ the telescope.
4. The _____ is used to hold the transit and to keep it from moving.
5. Wood levels should be given a light coat of _____ to prevent moisture penetration.
6. The transit is used mostly to _____ and _____.

Instructor Post Assessment Answers

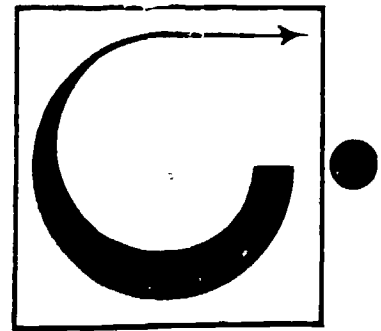

1. liquid
2. plumb
3. level
4. tripod
5. oil
6. survey and measure distances

LAYOUT

Goal:

The student will explain and demonstrate the procedure for the layout of a project.

Performance Indicators:

The student will be able to lay out a project and complete a Self and Post Assessment and a Job Sheet.

Study Guide

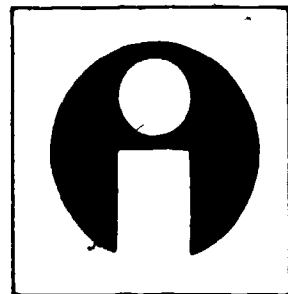

In order to finish this module, do the following tasks. Check each item off as you complete it.

1. Read the Goal and Performance Indicators on the cover of the module. This will tell you what you will learn by studying the module, and how you will show you've learned it.
2. Read the Introduction. The Introduction will tell you why the module is an important part of the bricklaying trade.
3. Study the Vocabulary section. Vocabulary words are important for a good understanding of the trade. After you have studied the vocabulary, ask your teacher to quiz you on the words and their meanings.
4. Study the Information section. This section will give you the information you need to understand the subject.
5. Take the Self Assessment exam. This is a test for you to prove to yourself that you have learned the material you have studied. Compare your answers with the answers on the Self Assessment Answer Sheet, which is on the page following the Self Assessment. If you scored poorly, re-study the Information section or ask your teacher for help.
6. Do the Job Sheet. Follow the instructions at the top of the Job Sheet. The tasks listed on the Job Sheet will help you develop skills which will be helpful to you.
7. Take the Post Assessment exam. Give the exam to your teacher after you have completed it. Your teacher will grade it for you.

Introduction

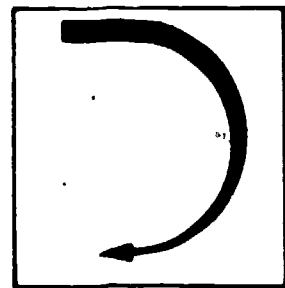

It is important that the bricklayer knows how to lay out a project. When laid out proper, the openings will be in the right places and the wall will be straight. The following section will cover how this is done.

Introduction

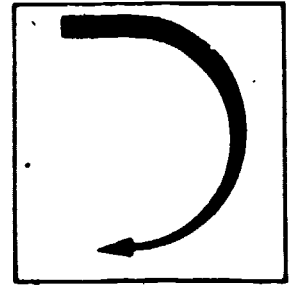

It is important that the bricklayer knows how to lay out a project. When laid out proper, the openings will be in the right places and the wall will be straight. The following section will cover how this is done.

Vocabulary

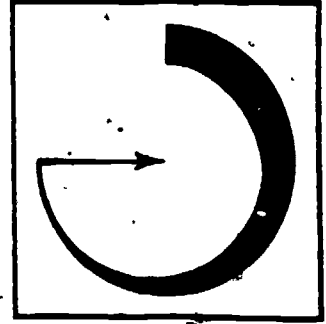

Trade terms are very important for a good understanding of the trade. Study the words and meanings. When you have learned them, ask your teacher to quiz you on the words and their meanings.

BLUEPRINTS--Drawings which are plans for the structure to be built.

DIMENSIONS--Distances (heights and lengths).

FOUNDATION--Usually a cement pour upon which bricks are laid.

Supplementary References.

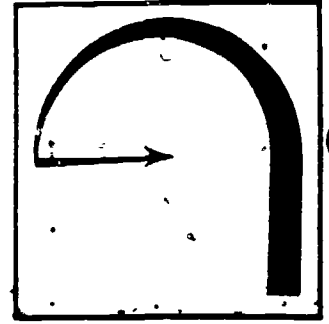

Taylor, Merlin and Harlin Randolph. IMAT, Brick and Block Construction, 1976.
pp. 181-182.

Information

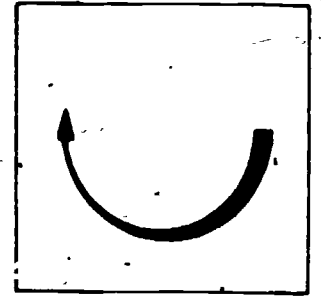

Before starting a job, the bricklayer must check the blueprints to find out what to do. The blueprints will give the bricklayer the length of the wall (or walls) to be built. They also give the measurements of where the openings are to be made and the heights (such as windows, doors, etc.).

These prints range from very basic drawings to very complicated and precise drawings. The complicated drawings require special training to be able to read properly.

The basic drawings are fairly easy to read. The dimensions are given mostly with horizontal and vertical lines. The distance of these lines gives the heights or the lengths of the walls. (See Fig. 1) The distance between a and b is 3 feet.



When the length of the wall has been established, the next step is the layout of the project.

The foundation that the wall will be built on should be clean and as flat as possible. This will ensure a good bond between the units and the foundation. The face of the wall is marked on the foundation by a chalkline. Once the two points have been measured, a chalkline is stretched between them. The line is picked up in the center and is let go to snap on the foundation. This will leave a line of chalk. The face of the wall will be laid to this line.

Laying the first course is usually done first by laying the units dry. This is done by laying the units without using mortar. The bricklayer starts by placing the units on the corner points. Be sure that the units are straight and parallel with the chalkline on the foundation. The bricklayer then lays the remaining units between the corner units, leaving a $\frac{3}{8}$ to $\frac{1}{2}$ inch head joint between them. A cut may be needed to complete the wall. If the cut is too small, the head joints may be spaced wider to avoid any small cuts in the wall.

During the dry layout, the units are laid the entire length of the wall, even where openings will be. This will determine if the bond will be maintained over the openings.

Some bricklayers will then remove the units where the openings are to be. They then mark the exact point of the openings.

It is important that the bricklayer knows how to lay out a job. This will ensure that the openings be in the proper locations and the bond will be the same throughout the height of the wall.

Self Assessment

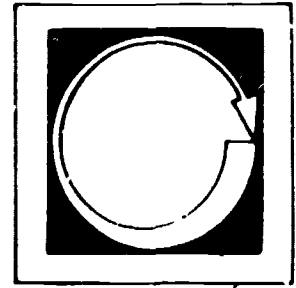

COMPLETE THE FOLLOWING STATEMENTS BY WRITING THE CORRECT WORD OR WORDS IN THE BLANKS PROVIDED.

1. The foundation the wall is to be laid on should be _____ and _____.
2. Before starting a job, the bricklayer must check the _____ to find out what to do.
3. The dimensions are given mostly with _____ and _____ lines.
4. The face of the wall is marked on the foundation by a _____.
5. Laying the first course is usually done first by laying the _____.

Self Assessment Answers

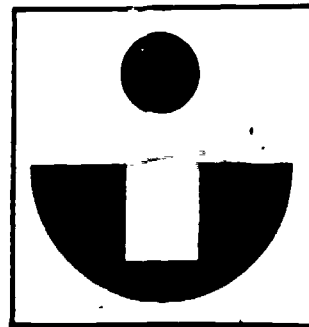

1. clean and flat
2. blueprints
3. horizontal and vertical
4. chalkline
5. units dry

Job Sheet

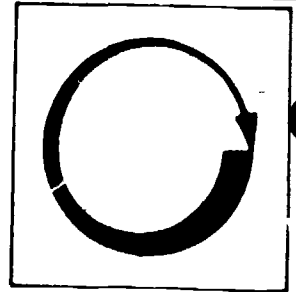

COMPLETE THE TASK BELOW.

Materials and Tools

chalkline

20 or 30 8' blocks

Following the steps outlined in the Information section, lay out the diagram below.

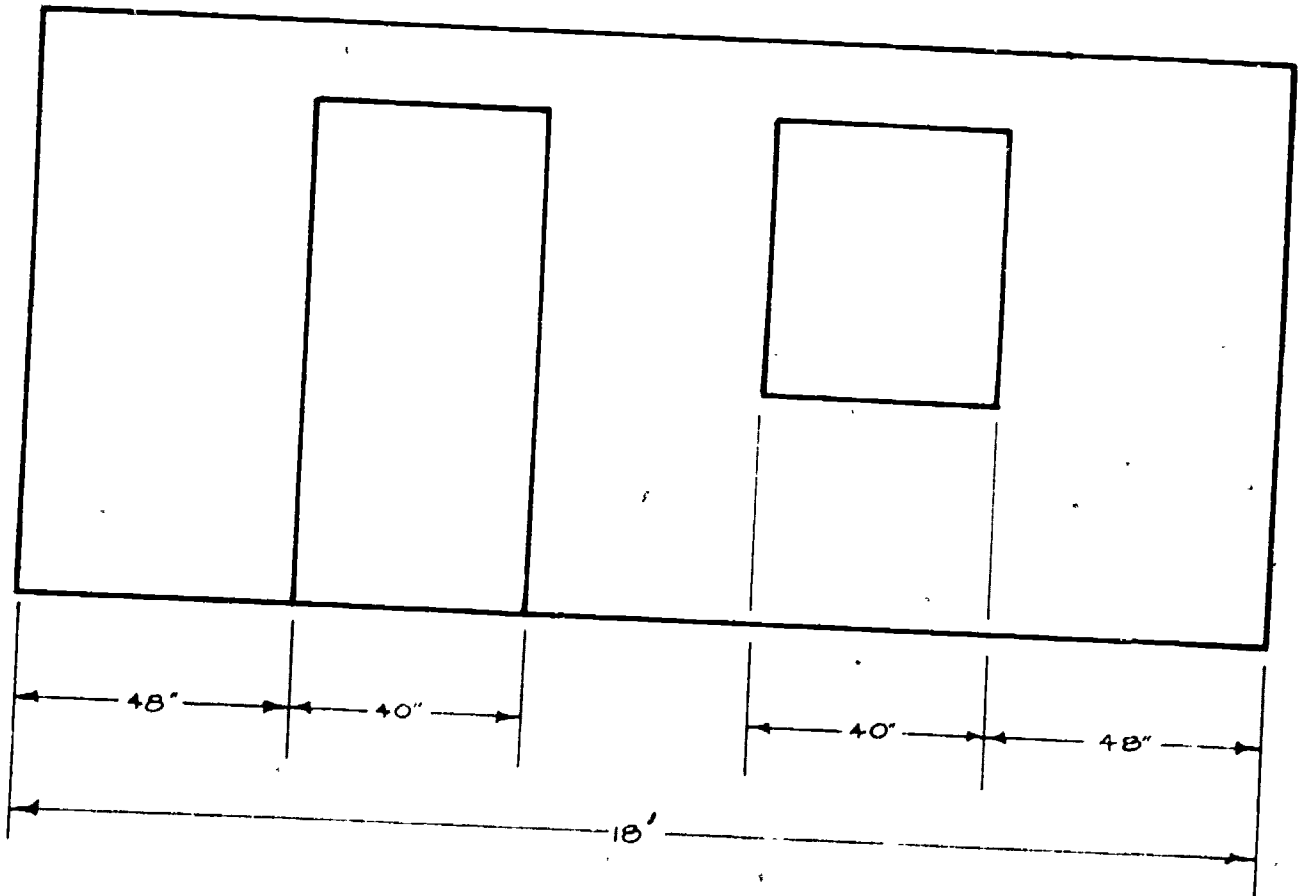

Post Assessment

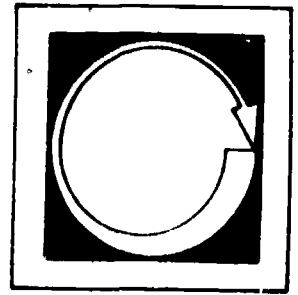

COMPLETE THE FOLLOWING STATEMENTS BY WRITING THE CORRECT WORD OR WORDS IN THE BLANKS PROVIDED.

1. The blueprints give the bricklayer the _____, _____ and measurements of the _____.
2. The bricklayers start by laying the units on the _____ points.
3. There should be _____ to _____ inch head joints between units.

Instructor Post Assessment Answers

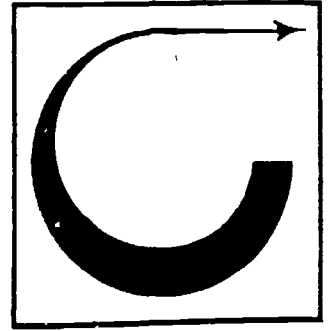

1. length, height, openings
2. units, corner
3. $\frac{3}{8}$ to $\frac{1}{2}$ inch

SQUARING

Goal:

The student will be able to explain and demonstrate the different procedures and techniques for squaring a project.

Performance Indicators:

The student will demonstrate different procedures for squaring a project by completing two tasks on a Job Sheet, and will complete a Post Assessment.

Study Guide

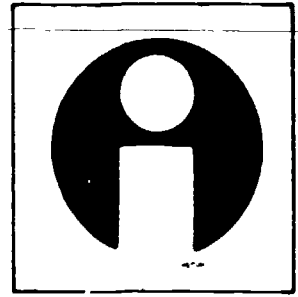

In order to finish this module, do the following tasks. Check each item off as you complete it.

1. Read the Goal and Performance Indicators on the cover of the module. This will tell you what you will learn by studying the module, and how you will show you've learned it.
2. Read the Introduction. The Introduction will tell you why the module is an important part of the bricklaying trade.
3. Study the Information section. This section will give you the information you need to understand the subject.
4. Do the Job Sheet. Follow the instructions at the top of the Job Sheet. The tasks listed on the Job Sheet will help you develop skills which will be helpful to you.
5. Take the Post Assessment exam. Give the exam to your teacher after you have completed it. Your teacher will grade it for you.

Supplementary References

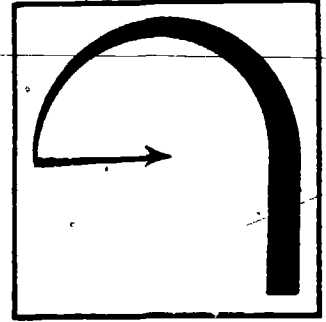

1. Dalzell, J. Ralph and Gilbert Townsend. Masonry Simplified, Vol. 1.
p. 35.
2. Ulrey, Harry F. Carpenters & Builders Library. p. 95.

introduction

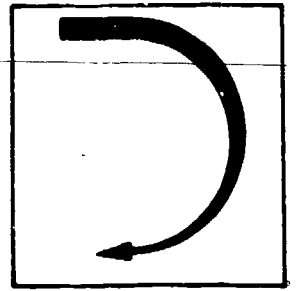

Squaring up projects can be done easily with very few tools. There are many different ways of squaring a project.

Three of these methods are:

1. Steel square.
2. 3, 4, 5, method.
3. Criss-cross method.

113117

Information

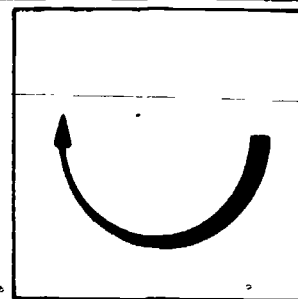

STEEL SQUARE METHOD

A steel square is used by bricklayers when laying up (constructing) corners to assure a perfect 90-degree (square) corner. It is also used to set the corner bricks or blocks in the dry layout of the first course in a project. The steel square is the same tool as the carpenter's framing square.

It is properly called a framing square because with its framing table and some other scales, it is adapted especially for use in house framing.

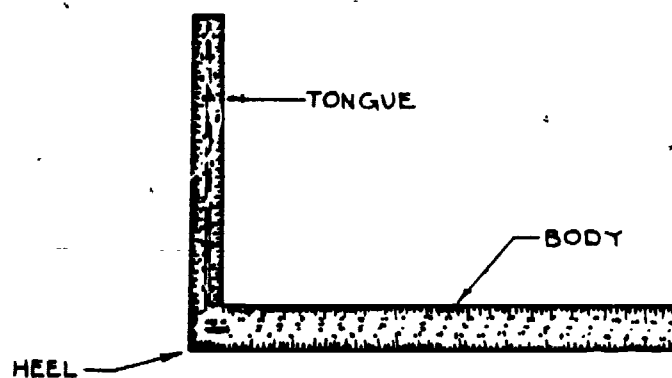

The framing square consist of two essential parts--the tongue and the body, or blade. The tongue is the shorter, narrower part, and the body is the longer, wider part. The heel is the part where the tongue and body meet on the outside edge.

The square is simply held around the corner of the project to be sure it forms a 90° angle.

(See the illustration on the top of the next page.)

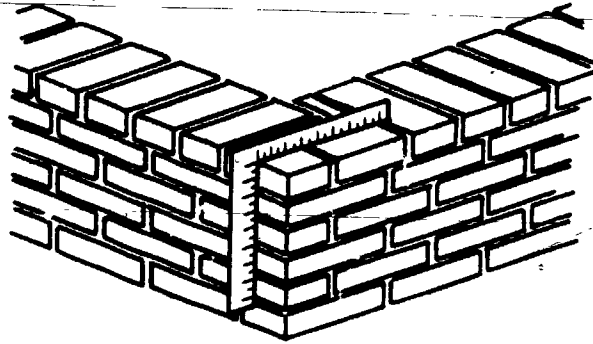

3, 4, 5 METHOD

Another method of squaring a project can be done by using a ruler or tape measure. This type of squaring is called the 3, 4, 5 method. It is done by first measuring out in one direction 3 inches, or in any multiple of 3 (3, 6, 9, 12, etc.) from the corner point. Place a mark at this point. Next, approximately 90 degrees from the first mark, measure out 4 inches (or any multiple of 4). Place another mark here. Taking a measurement across the two points, and adjusting in or out will produce 5 inches (or any multiple of 5). When measurements are aligned, these points will form a 90-degree square corner.

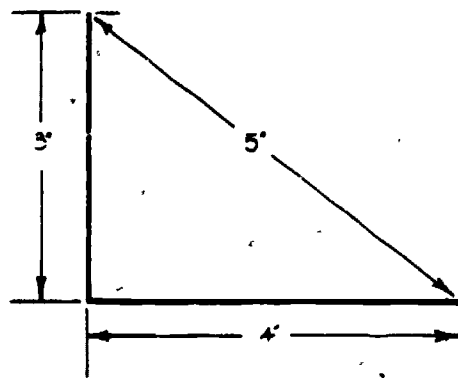

3-4-5 METHOD

IN ALL CASES, THE MULTIPLE SHOULD BE THE SAME (3, 4, 5,--6, 8, 10--9, 12, 15).

CRISS-CROSS METHOD

To check if a project is square, a criss-cross method is used. This is done with a steel tape.

1. Start from one corner and stretch the tape diagonally to the other corner.
2. Do the same with the opposite two corners.
3. These two measurements should read the same if the project is square.

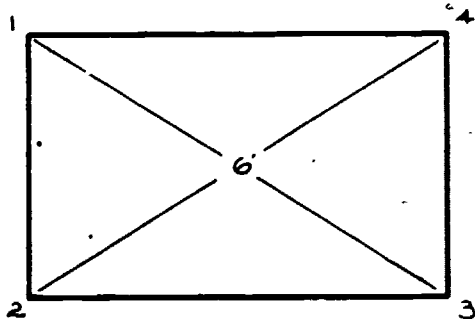

MEASURE OPPOSITE CORNERS:

1 AND 3
2 AND 4

In bricklaying it is important that the project be square. These methods will insure a good appearance and proper construction.

Job Sheet

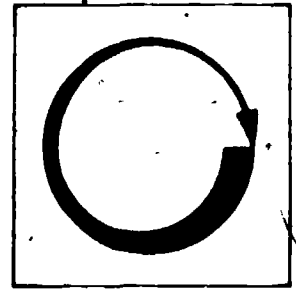

FOLLOWING THE STEPS OUTLINED IN THE INFORMATION SECTION DO THE FOLLOWING TASKS.

Materials and Tools

tape measure

steel square

four 1" X 1" X 2' slats of wood

1. Using the wood slats, use the steel square to make a 90° corner.
2. Make a square corner using the 3, 4, 5 method, with the wood slats.

Post Assessment

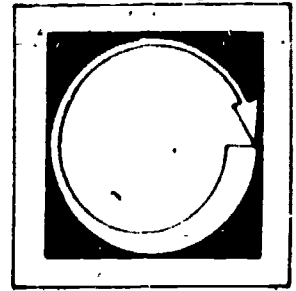

LISTED BELOW ARE STATEMENTS FOLLOWED BY A NUMBER OF POSSIBLE COMPLETIONS. SELECT THE COMPLETION WHICH COMPLETES THE STATEMENT CORRECTLY AND PLACE THE LETTER IN THE BLANK PROVIDED.

1. ____ The steel square is also called
 - a. framing square
 - b. level edge
 - c. both 1 and 2

2. ____ The framing square consists of 2 parts; they are:
 - a. tongue
 - b. body
 - c. both of above

3. ____ The body of the steel square is the:
 - a. short, narrow part
 - b. long, wider part
 - c. none of the above

4. ____ The steel square is also called a framing square because:
 - a. of the framing table
 - b. other scales
 - c. both a and b

5. ____ The tongue of the steel square is the:
 - a. shorter, narrow part
 - b. long, wider
 - c. none of the above

6. ____ The part where the tongue and body meet on the outside edge is the
- a. toe
 - b. heel
 - c. ankle
7. ____ The squaring method that is done by measuring three points is called the
- a. 3, 4, 5 method
 - b. criss-cross method
 - c. steel square method

Instructor Post Assessment Answers

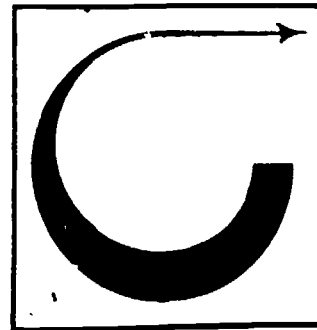

1. a

2. c

3. b

4. c

5. a

6. b

7. a

LEADS

Goal:

The student will be able to build a lead to correct length and height.

Performance Indicators:

The student will be able to build a lead properly and complete a Self and Post Assessment and a Job Sheet.

121125

Study Guide

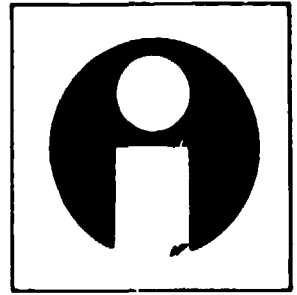

In order to finish this module, do the following tasks. Check each item off as you complete it.

1. Read the Goal and Performance Indicators on the cover of the module. This will tell you what you will learn by studying the module, and how you will show you've learned it.
2. Read the Introduction. The Introduction will tell you why the module is an important part of the bricklaying trade.
3. Study the Vocabulary section. Vocabulary words are important for a good understanding of the trade. After you have studied the vocabulary, ask your teacher to quiz you on the words and their meanings.
4. Study the Information section. This section will give you the information you need to understand the subject.
5. Take the Self Assessment exam. This is a test for you to prove to yourself that you have learned the material you have studied. Compare your answers with the answers on the Self Assessment Answer Sheet, which is on the page following the Self Assessment. If you scored poorly, re-study the Information section or ask your teacher for help.
6. Do the Job Sheet. Follow the instructions at the top of the Job Sheet. The tasks listed on the Job Sheet will help you develop skills which will be helpful to you.
7. Take the Post Assessment exam. Give the exam to your teacher after you have completed it. Your teacher will grade it for you.

Introduction

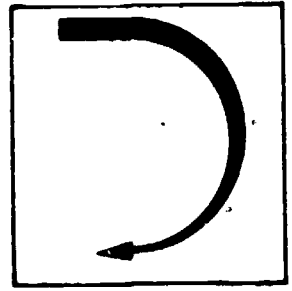

It is important that the leads are built properly. This will ensure that the remaining length of the wall will be straight and to the proper height. This section will explain how this is done and the tools are used.

Vocabulary

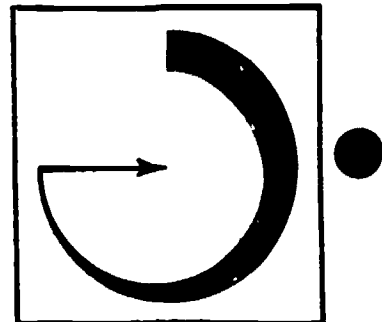

Trade terms are very important for a good understanding of the trade. Study these words and meanings. When you have learned them, ask your teacher to quiz you on the words and their meanings.

LINE--Nylon (or similar strength) string.

GAIN--To make joints wider.

LOSE--To make joints tighter.

BENCH MARK--A mark that the wall is started from, usually made by the engineer.

TOPPED-OUT--Finished.

Supplementary References

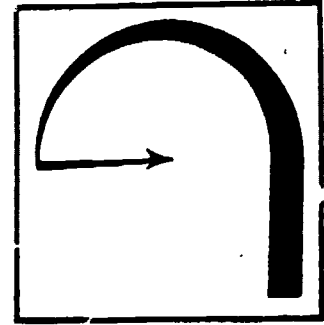

Taylor, Merlin and Randolph, Harland. Brick and Block Construction. 1976.

Information

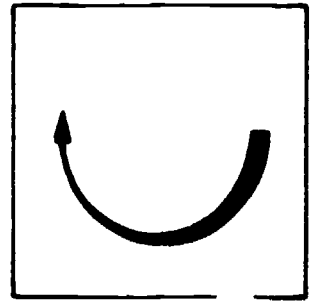

A lead is the starting point of a project. After the bond has been laid out the leads are built on the corners. A line is then stretched between them and the units are laid to the line.

Several tools are used to build a lead depending on what material you are working with. Some of these tools are:

1. Level, transit.
2. Story Pole.
3. Spacing (brick) rule.

LEVEL

Before starting the lead it is important that the foundation be level (not all foundations are). The bed joints can be adjusted wider to gain, or tighter to lose heights to level the wall. To get these different heights the transit is used. It will show which corners are high and which are low.

STORY POLE

The story pole is used to check heights of the wall. A story pole is a straight piece of wood (1" X 2"; 1 X 4 X 10') with the course heights marked on it. It is placed in the plumb position up against the lead. The marks should be lined up with the tops of the courses. (See the illustration on the top of the following page.)

SPACING (BRICK) RULE

A spacing rule is a folding ruler. It has feet and inches marked on one side. On the other side is a series of marks that represent different course heights. These marks are used to control the height of the various size courses. (See the second illustration on the following page.)

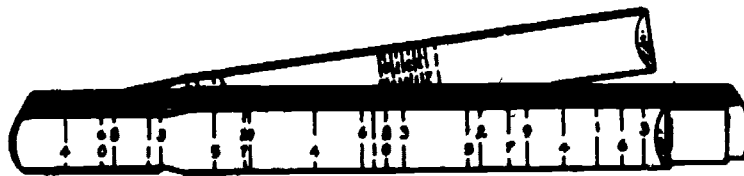
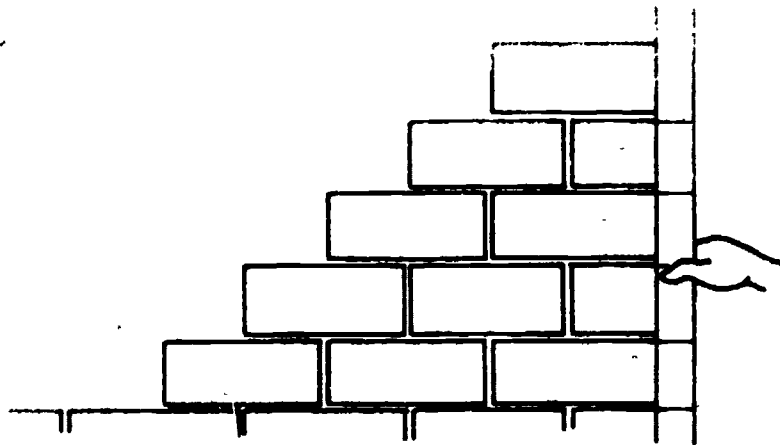

For example, the coursing is spaced out on 5s. If the thickness of the bed joint is increased, 6s or 7s may be used to mark different course heights. The construction plans will tell the number of inches that should be reached in a given number of courses. For instance, four courses to 11 inches. Find 11 inches on the feet and inch side of the rule. Turn the rule over to the spring side and find the number which is at the same height as 11 inches. In this case it is 6. This is the mark to use for each course height. (See Figure 3 on the following page.)

Building the Lead

After the heights and the bond have been established, the lead is built. From the bench mark (the mark on the footing made by the engineer), the units are laid the length of the level. (See Figure 4 on the following page.)

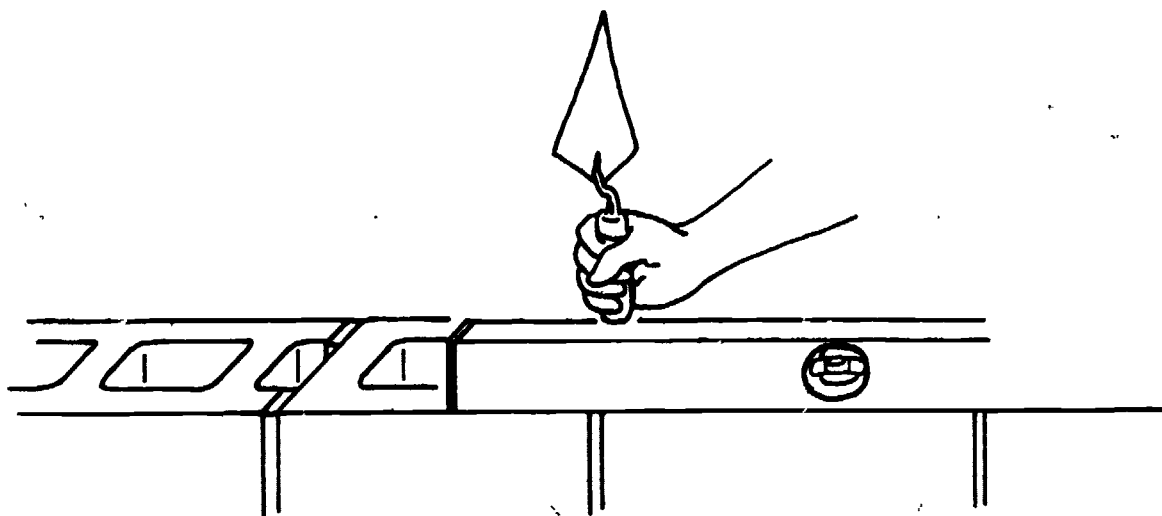
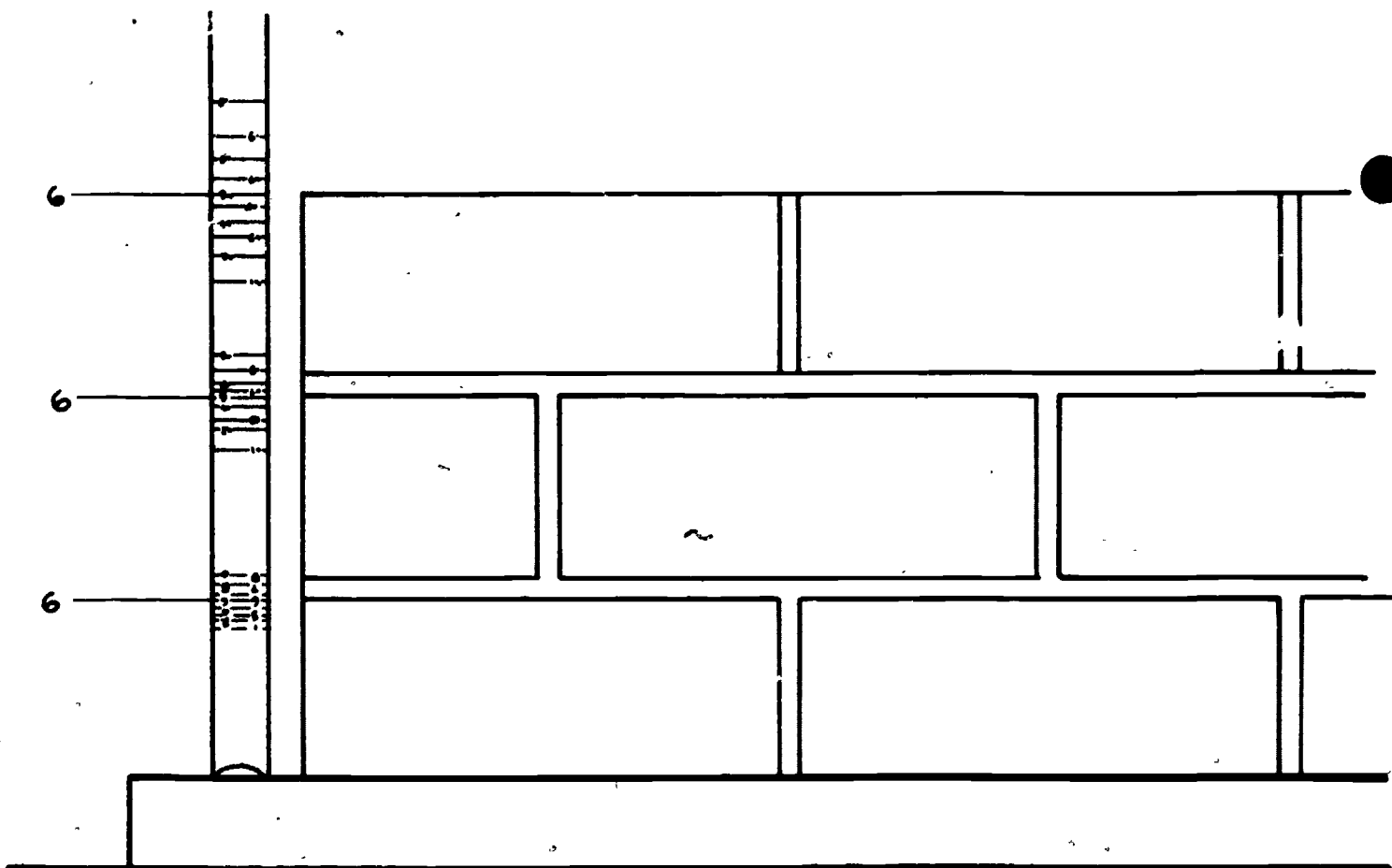

Be sure they are level and plumb. It is important that the first course is right. This is continued until the lead is topped out. (See Figure 5 on the following page.)

After the corner leads have been built, the wall between them is laid. A line is stretched between the two leads and is held by line holders hooked on the edge of the units. (See Figure 6 on the following page.)

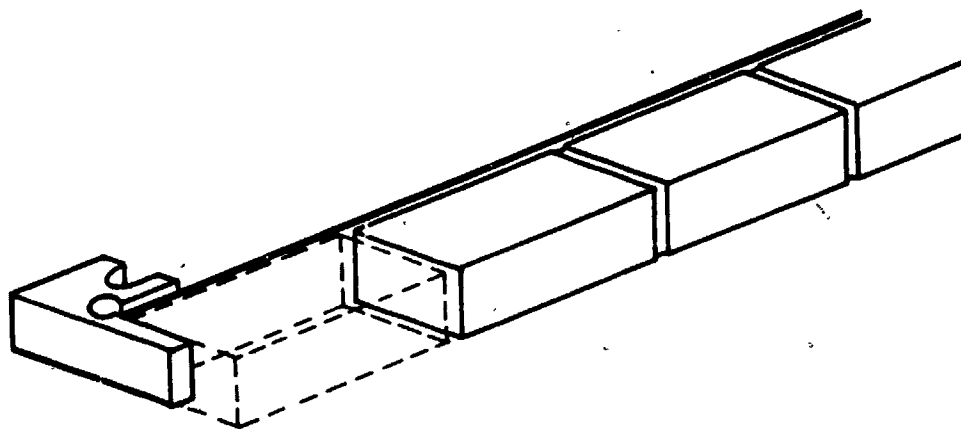
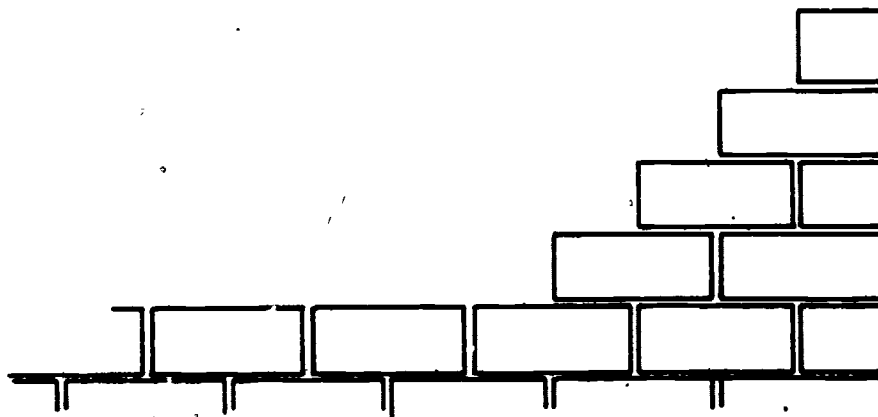

It is adjusted to the top edge of the block. The wall is then filled in. The bricklayer lays the unit so that the bottom edge of the unit is on the chalkline (already established in the layout) and the top edge is about $\frac{1}{2}$ the line's width away from the line.

It is important that the lead is plumb, level and in line. This will make the rest of the wall as straight or as crooked as the lead is.

Self Assessment

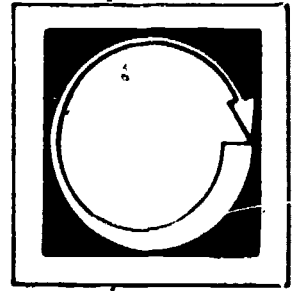

COMPLETE THE FOLLOWING STATEMENTS BY WRITING THE CORRECT WORD OR WORDS IN THE BLANKS PROVIDED.

1. The leads are built on the _____.
2. The bench mark is made by the _____.
3. The line is held by _____.
4. A tool used to control the heights of various courses is the _____.
5. A tool used to check the heights of the wall is the _____.
6. Before starting the lead it is important that the foundation be _____.

Self Assessment Answers

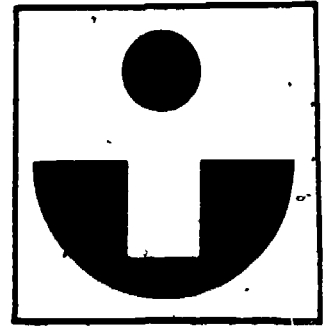

1. corners
2. engineer
3. line blocks
4. spacing rule
5. story pole
6. level

Job Sheet

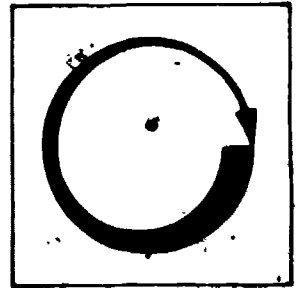

FOLLOWING THE STEPS OUTLINED IN THE INFORMATION SECTION, DO ONE OF THE FOLLOWING TASKS.

Materials and Tools

1" x 2" x 10' piece of wood

spacing rule

150 bricks

materials listed in mixing mortar

trowel

mortar board

1. Build 2 block leads parallel to each other, 4 feet apart. Be sure they are level and plumb. Fill in the wall between the leads.
2. Build 2 brick leads parallel to each other, 4 feet apart. Be sure they are level and plumb. Fill in the wall between the leads. Run courses up on 5s.

Post Assessment

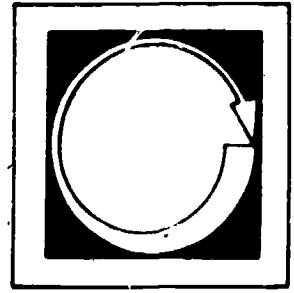

EXPLAIN WHY IT IS IMPORTANT THAT THE LEAD BE BUILT RIGHT.

2

133

137

GROUTING AND REINFORCING

Goal:

The student will be able to grout and reinforce walls and be able to identify different kinds of reinforcement.

Performance Indicators:

The student will be able to grout and reinforce walls and complete a Self Assessment and Post Assessment and a Job Sheet.

Study Guide

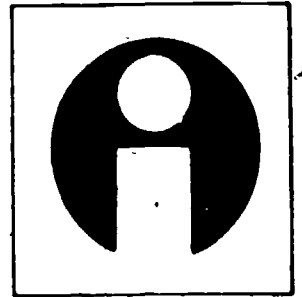

In order to finish this module, do the following tasks. Check each item off as you complete it.

1. Read the Goal and Performance Indicators on the cover of the module. This will tell you what you will learn by studying the module, and how you will show you've learned it.
2. Read the Introduction. The Introduction will tell you why the module is an important part of the bricklaying trade.
3. Study the Vocabulary section. Vocabulary words are important for a good understanding of the trade. After you have studied the vocabulary, ask your teacher to quiz you on the words and their meanings.
- Study the Information section. This section will give you the information you need to understand the subject.
5. Take the Self Assessment exam. This is a test for you to prove to yourself that you have learned the material you have studied. Compare your answers with the answers on the Self Assessment Answer Sheet, which is on the page following the Self Assessment. If you scored poorly, re-study the Information section or ask your teacher for help.
6. Do the Job Sheet. Follow the instructions at the top of the Job Sheet. The tasks listed on the Job Sheet will help you develop skills which will be helpful to you.
7. Take the Post Assessment exam. Give the exam to your teacher after you have completed it. Your teacher will grade it for you.

Introduction

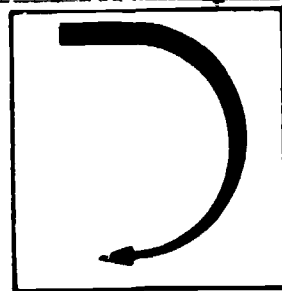

It is important that masonry structures be grouted and reinforced. This will ensure strong and sturdy walls. The information section will tell how this is done and explain different types of reinforcements which are used.

Vocabulary

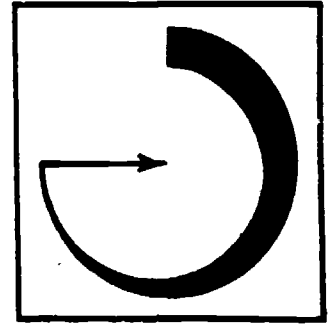

Trade terms are very important for a good understanding of the trade. Study these words and meanings. When you have learned them, ask your teacher to quiz you on the words and their meanings.

PROJECTIONS--Parts that stick out.

PROTRUSIONS--Parts that indent.

P.S.I.--Pounds per square inch.

SANDWICHING--To place between two units.

GROUT SPACE--The space grout is to be poured.

Supplementary References

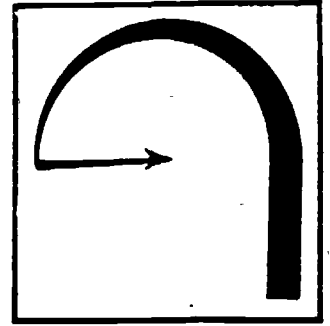

1. Taylor, Merlin and Randolph, Harland. Brick and Block Construction. 1976. pp. 220-274.
2. Randall and Panarese. Concrete Masonry Handbook. 1976. pp. 39-40.

Information

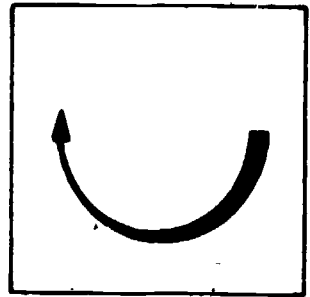

In masonry, the units supply much of the strength to a wall. To get the maximum strength, the wall or structure is reinforced and grouted. It is important that the bricklayer be familiar with the materials used for reinforcing and grouting.

There are several different types of reinforcing. The two types of reinforcing used the most are:

1. Deformed steel bar.
2. Cold drawn steel.

DEFORMED STEEL BARS

Deformed steel bars come in different sizes and patterns. Sizes range from 1/4 to 1 1/8 inches. The strength of the bars depends on the size and the grade of the steel. Each bar has identification marks stamped on them by the manufacturer. These marks identify:

1. Manufacturer.
2. Bar size.
3. Type of steel.
4. Grade.

(See Figure 1 on the following page.)

Bar size is marked in numbers from 2 to 9. Each time the number increases, the diameter of the bar is increased by 1/8 of an inch. (See Figure 2 on the following page.)

Letters are used to mark the types of steel.

1. "N" is used for billet type steel.
2. "A" is used for axle steel.
3. A rail symbol is used for rail steel.

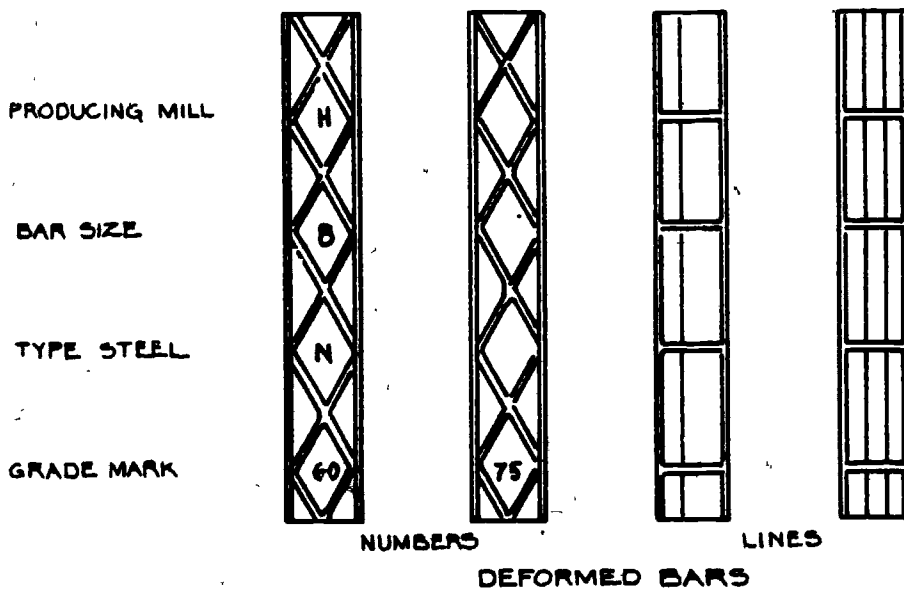

NOMINAL DIMENSIONS - ROUND SECTIONS

BAR SIZE NUMBERS	DIAMETER- INCHES	WEIGHT POUNDS PER FOOT
2	1/4"	.167
3	1/3"	.376
5	5/8"	1.043
7	7/8"	2.044
9	1 1/8"	3.400

There are two different ways to determine the grade of the steel. One system uses lines to identify grades while the other uses numbers.

One vertical line means the bar will withstand 60,000 P.S.I.; two lines mean it will withstand 75,000 P.S.I. In the number system, the number 40 means it will withstand 40,000 P.S.I.; 50 will withstand 50,000 P.S.I.; 60--60,000 P.S.I.; etc.

The deformed bars have all but taken the place of the plain bars. This is because the projections and protrusions on the deformed bars provide a bigger surface for bonding. This also prevents any movement when a load is applied.

Placement of Steel Bars

Reinforcement is placed:

1. Around openings.
2. At footings.
3. At floor heights.
4. At roof heights.
5. Wall supports (bond beams).
6. Pilasters.
7. Columns.

The placement of the steel is given by the architect in the plans. The masonry wall or structure is used as a form. The steel is placed between masonry walls or into the hollow cells of the wall. Grout is then poured into the wall and around the steel. (See Figure 3.)

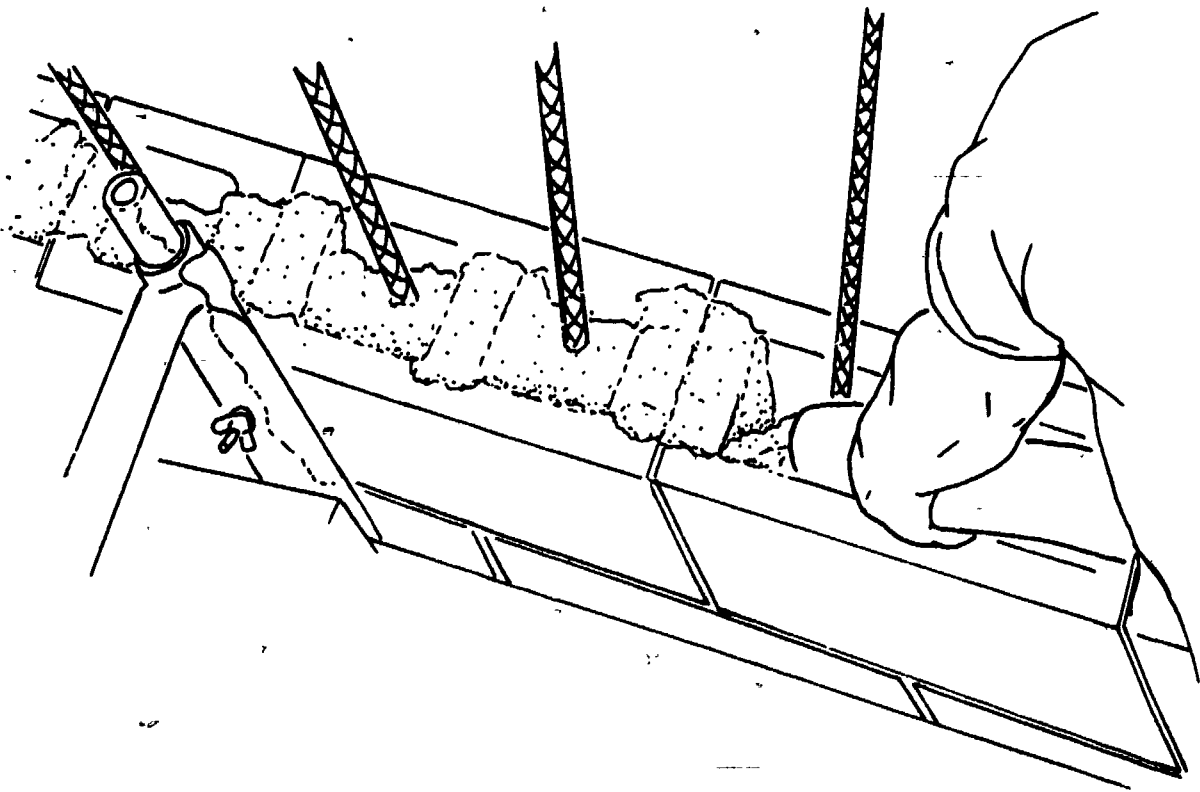

COLD DRAWN STEEL

Cold drawn steel is used in a reinforced masonry wall. That is, the reinforcing steel and the masonry units are bonded with mortar. The reinforcement is placed on top of the units, then the next course is laid on top of it sandwiching it between the two courses. (See Figure 4.)

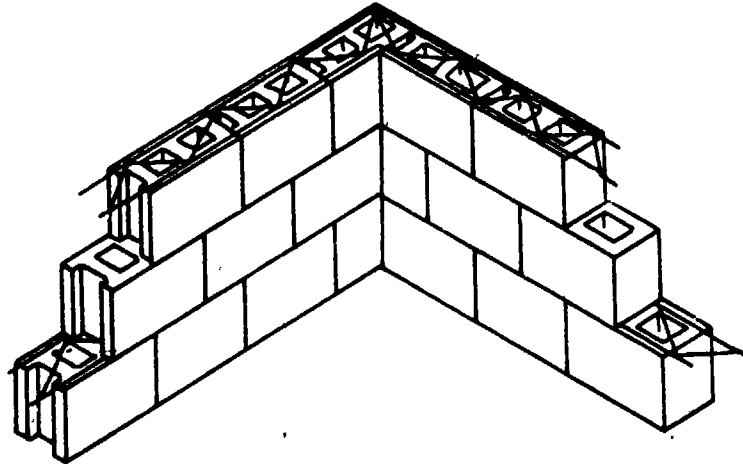

Grout

Spaces between the walls and around the steel are completely filled with grout. This bonds the steel, units, mortar and grout into one mass.

Grout is made up of three properties:

1. Portland cement.
2. Aggregate.
3. Water

GROUT INGREDIENTS

Ingredients	Grout Space		
	2" or less	2-4"	4" or more
Portland Cement	1 (part)	1	1
Sand	3	3	0
Pea Gravel		2	0
Aggregate			4-4 1/2

The ingredients and their amounts vary depending upon the size of grout space. Grout is mixed about the same as mortar. To mix grout, add about 1/2 the water and sand required into the mixer. Then add cement and the balance of sand, water, and aggregate. Grout should be mixed for 3 to 5 minutes to be sure all ingredients are mixed thoroughly. To check if grout is to the proper consistency, this test should be used:

1. It should not stick to the bottom of the trowel as mortar will.
2. If water forms on top of the grout in the tub or wheelbarrow, the grout is either too wet or the ingredients have separated. It should be re-mixed before pouring.
3. All tools and equipment should be washed thoroughly to avoid excessive grout build up.

It is important that the bricklayer place the steel properly and mix the grout to the proper consistency. This will ensure strong, sturdy masonry structures.

Self Assessment

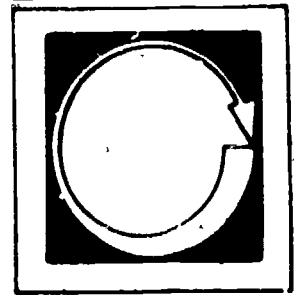

WRITE AN ANSWER TO THE FOLLOWING QUESTIONS.

1. Why is the wall grouted and reinforced?
2. What are the two types of reinforcement used most often?
3. What is the size range for deformed bar steel?
4. To identify the grade of steel, what two methods are used?
5. What is the purpose of grout?
6. How long should grout be mixed?
7. What two things may be wrong if water forms on top of the grout?

Self Assessment Answers

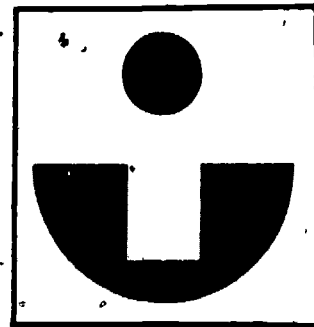

1. To obtain maximum strength.
2. Deformed steel bar, cold drawn steel.
3. 1/4 inch to 1 1/8 inch.
4. Lines and numbers.
5. To bond steel, units, mortar and grout into one mass.
6. 3 to 5 minutes.
7. It is too wet and ingredients separate.

Job Sheet

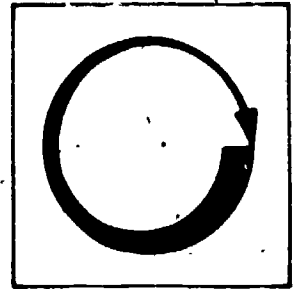

COMPLETE THE FOLLOWING TASK.

Material and Tools

Materials and tools used in lead section

pea gravel

4 - #4 steels bars, 39" long

Build a block wall 4 feet long and 3 ft. 6 in. high. Place reinforcement two feet on center. Mix and grout the wall.

Post Assessment

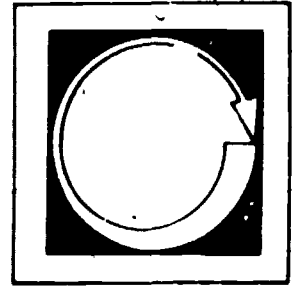

LISTED BELOW ARE QUESTIONS OR STATEMENTS FOLLOWED BY A NUMBER OF POSSIBLE ANSWERS OR COMPLETIONS. SELECT THE ANSWER OR COMPLETION WHICH ANSWERS THE QUESTION OR COMPLETES THE STATEMENT CORRECTLY AND PLACE THE LETTER IN THE BLANK PROVIDED.

1. _____ What do identification marks show?
 - a. grade
 - b. bar size
 - c. type of steel
 - d. all of the above

2. _____ Bar size is marked by
 - a. numbers
 - b. letters
 - c. symbols

3. _____ Types of steel are marked by
 - a. numbers
 - b. letters
 - c. symbols
 - d. both b and c

4. _____ If a piece of steel is marked with a 40, it will withstand
 - a. 400 P.S.I.
 - b. 40,000 P.S.I.
 - c. 4000 P.S.I.

5. _____ Who determines where the steel is placed?

- a. bartender
- b. architect
- c. bricklayer

6. _____ Grout is made up of

- a. Portland cement
- b. aggregate
- c. water
- d. all of the above

Instructor Post Assessment Answers

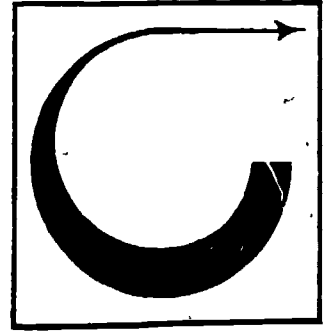

1. d
2. a
3. d
4. b
5. b
6. d

TIES AND ANCHORS

Goal:

The student will be able to identify different types of anchors and ties and explain the use of each.

Performance Indicators:

The student will successfully complete a Self Assessment, a Job Sheet and a Post Assessment.

150

154

Study Guide

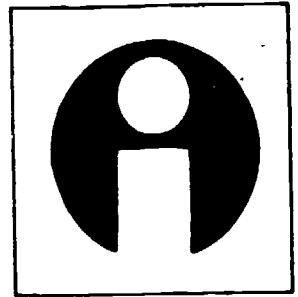

In order to finish this module, do the following tasks. Check each item off as you complete it.

1. Read the Goal and Performance Indicators on the cover of the module. This will tell you what you will learn by studying the module, and how you will show you've learned it.
2. Read the Introduction. The Introduction will tell you why the module is an important part of the bricklaying trade.
3. Study the Vocabulary section. Vocabulary words are important for a good understanding of the trade. After you have studied the vocabulary, ask your teacher to quiz you on the words and their meanings.
4. Study the Information section. This section will give you the information you need to understand the subject.
5. Take the Self Assessment exam. This is a test for you to prove to yourself that you have learned the material you have studied. Compare your answers with the answers on the Self Assessment Answer Sheet, which is on the page following the Self Assessment. If you scored poorly, re-study the Information section or ask your teacher for help.
6. Do the Job Sheet. Follow the instructions at the top of the Job Sheet. The tasks listed on the Job Sheet will help you develop skills which will be helpful to you.
7. Take the Post Assessment exam. Give the exam to your teacher after you have completed it. Your teacher will grade it for you.

Introduction

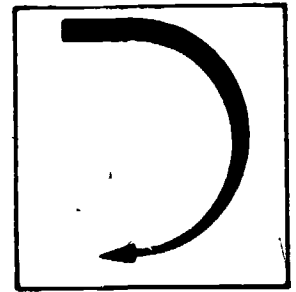

In bricklaying, the bricklayer should be able to use and identify wall ties and anchors. Ties will hold composite and multi-wythe walls together to form one wall. Anchors will hold down two structures together to form one structure. The following section explains how these are done.

Vocabulary

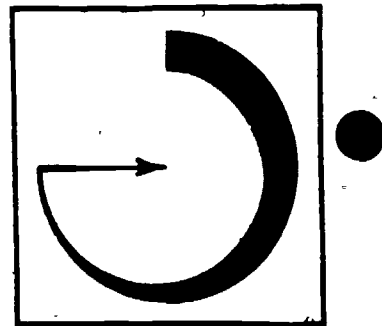

Trade terms are very important for a good understanding of the trade. Study these words and meanings. When you have learned them, ask your teacher to quiz you on the words and their meanings.

COMPOSITE WALL--Any bonded wall with wythes constructed of different masonry material.

MULTI-WYTHE WALL--A wall that's more than one unit thick.

WYTHE--A wall that's one unit thick.

CAVITY WALL--A wall built to provide continuous air space between two wythes.

JOIST--Lumber or metal used to support a ceiling or floor.

Supplementary References

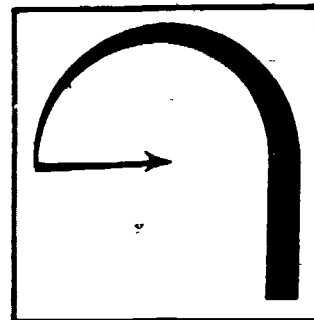

1. I.M.A.T. Brick and Block Construction. Taylor and Randolph, 1976.
pp. 76-91.
2. Dur-O-Wall, Pamphlet #4, Unit Masonry Ties and Reinforcing, G/C 1981.

Information

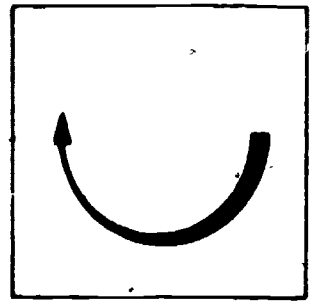

It is important that multi-wythe walls be tied together so that the walls act as a single unit. If the wall is to act as one unit and be structurally strong, the brick facing has to be tied to the block backing. For this, wall ties are used. Wall ties are made of corrosive-resistant cold-drawn steel. Sizes range from 1/8 inch to 3/16 inches in diameter. The wall tie is placed across the two wythes and embedded in the mortar so that it bonds the two walls together.

TYPES OF TIES

There are two principle types of wall ties:

1. Horizontal.
2. Lateral.

Horizontal ties are the better of the two. This is because they give bonding across the walls and down along each wall.

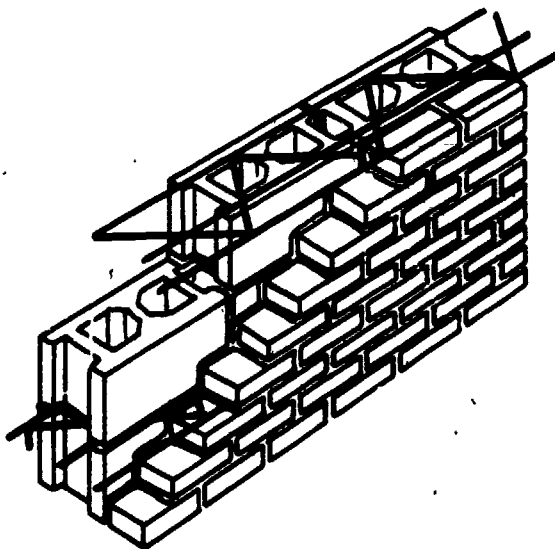

12" TIED WALL
STACK BOND BACKUP
No. 12 DURO-WALL TRIROD
16" C.T.O.C.

Lateral ties do not provide as much strength as horizontal ties. They are used across the walls. They work about the same as a masonry header tying two walls together.

Both lateral and horizontal ties come in many different shapes and sizes.

Different Kinds of Ties

"Z" Ties: "Z" ties are lateral ties. "Z" ties have two 2" legs. Both are at 90-degree angles used as hooks when embedded in the mortar.

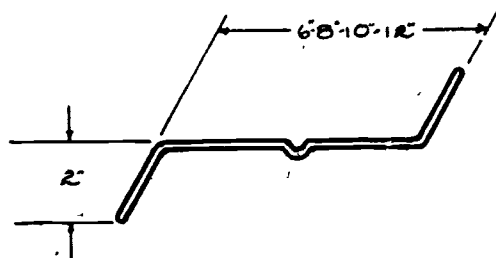

Rectangular Ties: The ends of the rectangular ties, another lateral tie, are also used as hooks. They are used the same way as the "Z" tie.

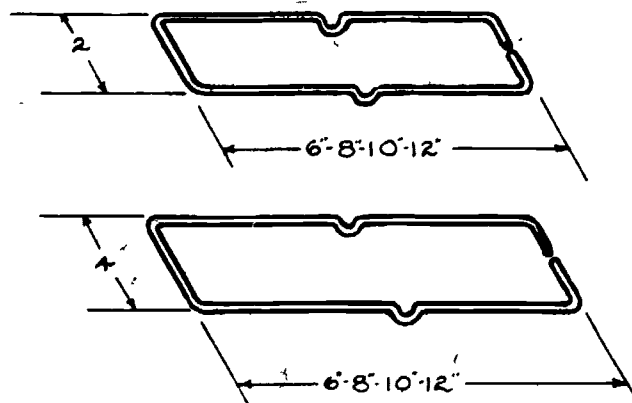

The "Z" tie and the rectangular tie come in sizes ranging from 6 to 12 inches. These ties are also available with or without a drip. A drip is a small bend in the center which will allow water to drip off.

Truss Shape: Truss shape ties are horizontal ties which are frequently used in composite wall and cavity wall construction. They are also used in stack bond where the units do not overlap. These are called truss shape because of the "V" shape between the outer rods. (See the illustration on the top of the next page.)

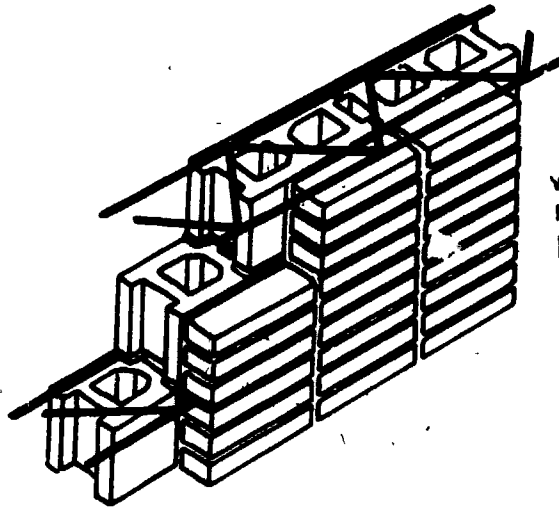

12" TIED WALL
WITH STACK BOND
FACING No. 12 DUR-O-WALL
16" c.t.o.c.

Ladur Shape: The ladur shape ties are used like, and serve the same purpose, as the truss. The difference is that it is shaped like a ladder.

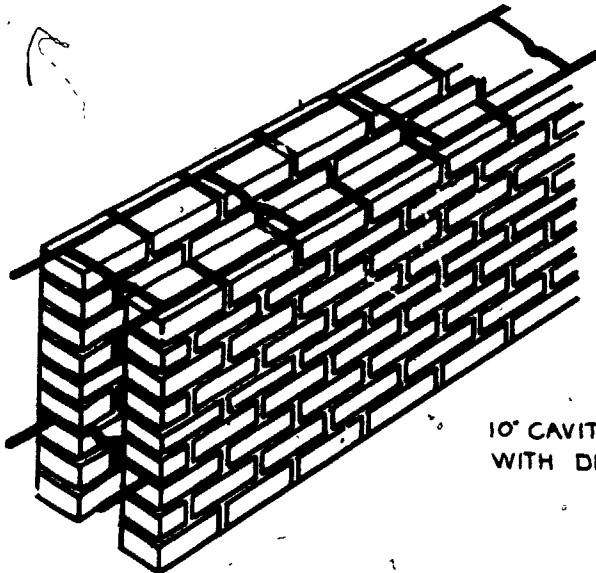

10" CAVITY WALL No. 10 LADUR TYPE
WITH DRIP 16" c.t.o.c.

Horizontal ties come in widths of 3 to 16 inches and in lengths of 8 to 12 feet.

ANCHORS

Anchors are used to tie or anchor the masonry wall to a stable, sturdy structure. Walls must be anchored so that the load of the wall is transferred to the footing. The bricklayer must also know how to install straps, rods and anchoring bolts.

Straps

When anchoring a load bearing wall to other parts of the building, an anchor strap may be used. One end of the anchor strap is embedded in the mortar. The

other end is attached to another part, such as a steel beam or a joist.

Rods

Anchoring rods are made of the same material as the bars used in reinforcing. The differences are that the reinforcing steel bars are straight; the anchoring rods are bent into different shapes for different anchoring situations. A 90-degree angle bar is usually used for walls that intersect. Horizontal rods from the face are bent 90 degrees to extend into the intersecting wall.

A "C" Shape is sometimes used to tie together two walls. The hooks on both ends of the "C" are hooked around the vertical steel.

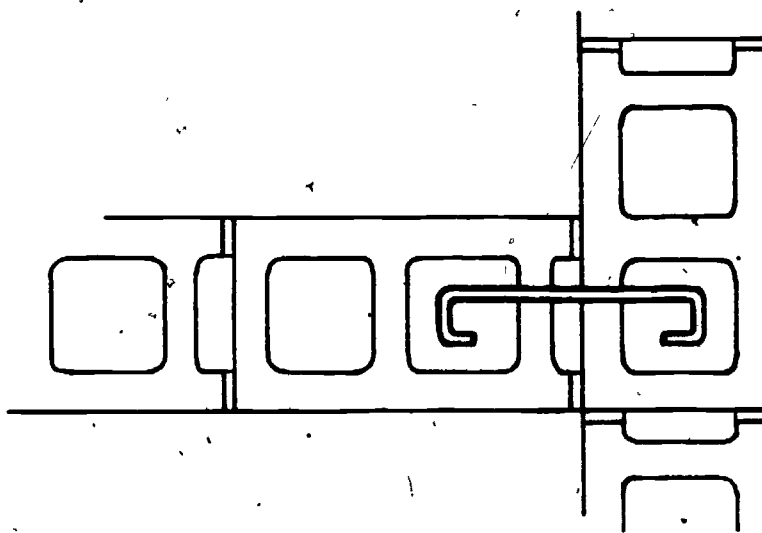

In all cases, grout or mortar, depending on specification, should completely surround these anchors.

Anchor Bolts

With anchor bolts the bricklayer can attach practically anything to masonry (wood, steel, plastic, etc.). Bolts come in many different sizes and shapes.

Most bolts have the same four basic parts:

1. Head.
2. Shaft.
3. Washer.
4. Nut.

The head must be big enough so that when the nut is tightened, it won't pull out.

The shaft has to be strong enough so that when stress is put on it, it will not break.

The washer is wide enough to spread the impact or bearing area as the bolt is tightened.

The shaft is threaded on one end and the nut is tightened on the threads. The size and shape of the bolt is decided by the architect.

These bolts are installed when work nears sills or finished height, or when specified by the architect. The head and most of the shaft of the bolt are embedded in grout or mortar which is placed in the cores of the units. The top of the shaft is placed through the holes of the member to be anchored.

The washer and nut are then tightened, anchoring the part to the masonry wall.

When anchoring to existing masonry walls is necessary, an expanding bolt is used.

A hole is drilled slightly larger than the diameter of the bolt. The hole must be deep enough so the full length of the bolt will fit in the wall. As the nut is tightened, the end of the bolt will expand. This will put pressure on the sides of the hole and prevent the bolt from pulling out.

It is important that walls be tied and anchored properly to insure strong and sturdy walls and structures.

Self Assessment

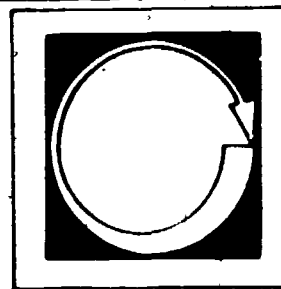

WRITE AN ANSWER TO THE FOLLOWING QUESTIONS.

1. Why are multi-wythe walls tied together?
2. What kind of bolt is used when anchoring an existing wall?
3. What diameters do wall ties usually come in?
4. What are the four parts of an anchor bolt?
5. What are the two principle types of wall ties?

164

160

Self Assessment Answers

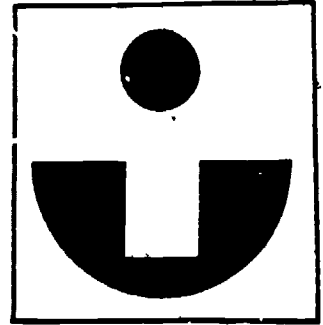

1. To act as a single unit.
2. Expansion bolt.
3. 1/8 to 3/16 inches
4.
 - a. Head.
 - b. Shaft.
 - c. Washer.
 - d. Nut.
5.
 - a. Lateral.
 - b. Horizontal.

165

161

Job Sheet

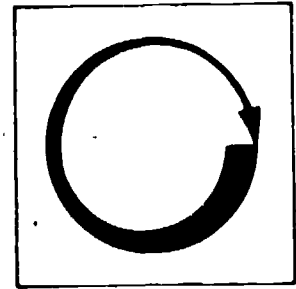

FOLLOWING THE STEPS OUTLINED IN THE INFORMATION SECTION, DO THE FOLLOWING TASK.

Materials and Tools

materials and tools used in bond section

"Z" ties

truss ties

Build a composite wall of block tie walls with every course alternating horizontal and lateral ties.

166

162

Post Assessment

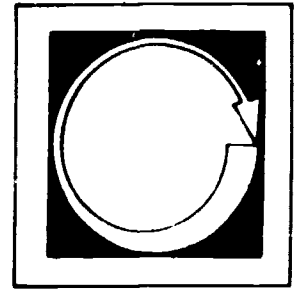

WRITE AN ANSWER TO THE FOLLOWING QUESTIONS.

1. What are the two ends of the anchor straps attached to?
2. Where is the weight distributed to when walls are anchored?
3. What widths do horizontal ties come in?
4. What length do horizontal ties come in?
5. Lateral ties work about the same as _____.
6. Which of the two types of ties is better?
7. Why is it important that the walls be tied and anchored properly?

Instructor Post Assessment Answers

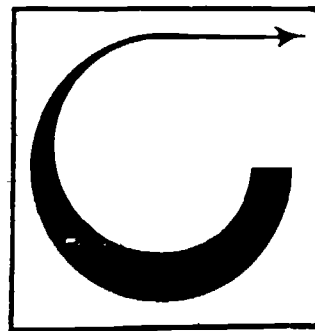

1. One end is embedded in the mortar and the other end is tied to a part of the building.
2. The footing.
3. 3" to 16"
4. 8' to 12'
5. A masonry header.
6. Horizontal.
7. To insure strong, sturdy structures.

MASONRY SAW, CUTTING BRICK AND BLOCK UNITS

Goal:

The student will be able to operate a masonry saw and also cut units using a hammer and a brick set.

Performance Indicators:

The student will successfully complete a Self Assessment, a Job Sheet and a Post Assessment.

Study Guide

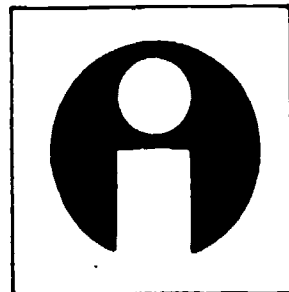

In order to finish this module, do the following tasks. Check each item off as you complete it.

1. Read the Goal and Performance Indicators on the cover of the module. This will tell you what you will learn by studying the module, and how you will show you've learned it.
2. Read the Introduction. The Introduction will tell you why the module is an important part of the bricklaying trade.
3. Study the Vocabulary section. Vocabulary words are important for a good understanding of the trade. After you have studied the vocabulary, ask your teacher to quiz you on the words and their meanings.
4. Study the Information section. This section will give you the information you need to understand the subject.
5. Take the Self Assessment exam. This is a test for you to prove to yourself that you have learned the material you have studied. Compare your answers with the answers on the Self Assessment Answer Sheet, which is on the page following the Self Assessment. If you scored poorly, re-study the Information section or ask your teacher for help.
6. Do the Job Sheet. Follow the instructions at the top of the Job Sheet. The tasks listed on the Job Sheet will help you develop skills which will be helpful to you.
7. Take the Post Assessment exam. Give the exam to your teacher after you have completed it. Your teacher will grade it for you.

Introduction

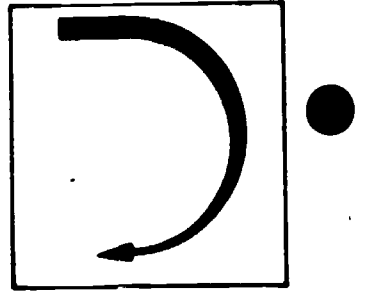

In bricklaying, sometimes it is necessary to cut masonry units. This section will explain how it is done using a masonry saw and using a brick set.

Vocabulary

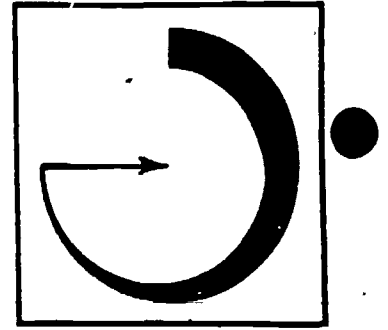

Trade terms are very important for a good understanding of the trade. Study these words and meanings. When you have learned them, ask your teacher to quiz you on the words and their meanings.

ROUGH CUT--A cut that is not straight (hammer cut).

SCORE--To make a groove on the face of a masonry unit.

Supplementary References

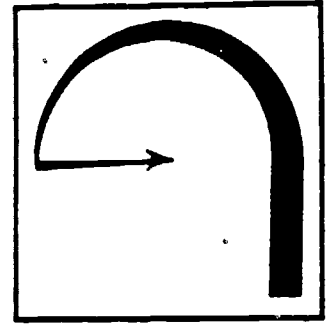

Brick and Block Construction, I.M.A.T., 1976. pp. 69-75, 128-129.

Information

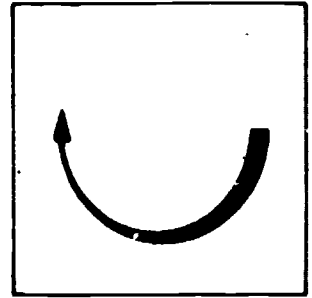

When building masonry projects, a bricklayer tries to lay out a project using full units. This is not always possible. In cases where full units cannot be used (such as doors, windows, and other openings), a cut is made. A cut may also be necessary to reach the correct dimensions and form different types of bonds. A bricklayer can make cuts by using several different tools:

1. Brick hammer.
2. Brick set.
3. Masonry Saw.

BRICK HAMMER

Cutting the units with a hammer should be done only when a rough cut can be used. For example,

1. When cutting a snap or clipped-header where only the head will be exposed.
2. When cutting used brick where a straight sharp cut would look out of place.

The hammer has a head made of hard tempered steel. One end of the hammer head is flat with sharp edges. The other end, called the peen, is chisel-shaped.

The cut is made by holding the brick firmly in the hand. Using the peen end of the hammer, the bricklayer scores the brick. This is done by lightly tapping the brick on the line where the brick is to be cut. If brick is not scored, the unit may break unevenly or it may cause the unit to shatter.

The brick is then broken by striking the scored line with the flat end of the hammer. It should be hit hard enough to break it with one blow. This will ensure a clean cut. (Remember to keep thumb and fingers out of the way when scoring or breaking units.)

If the cut is too rough it can be finished or straightened by lightly tapping the rough edge with either end of the hammer.

When cutting units, goggles should be worn to protect eyes from flying brick chips.

BRICK SET

When more precise cutting is required and a saw is not available a brick set is used. A set is used with either a brick hammer or a sledge hammer.

1. The unit is placed on a flat surface.
2. It is marked with a pencil where it is to be cut on both face sides of the brick.
3. The set is then placed on the mark and tapped lightly with the hammer on both sides.
4. This will leave a score about 1/32" to 1/16" deep.
5. The part of the brick that is to be used as the cut should be closest to the bricklayer when being cut.
6. The set is placed on the score mark.
7. One blow of the hammer on top of the set should be enough to cut the brick.

Goggles should also be worn when using the hammer and set.

MASONRY SAW

For bigger jobs where a large number of cuts are required, a masonry saw is used. The saw is much faster than the set and much more accurate than either the hammer or brick set method. An adjustable guide can be fastened to the saw table. This device can be set to make different size cuts. Once it is adjusted, it can be tightened. This will allow the bricklayer to make a large number of cuts the same size.

Operating the Saw

Before operating the saw, there are a few things to check:

1. Make sure the electrical cord is free from breaks, loose or broken connections, and is plugged in.
2. Most portable saws come in different voltages, such as 115 and 220 volts. It is important that they be hooked up to the proper power source.

3. Be sure the blade is tight. Different types of blades can be used.
 - a. A wet blade is used for harder materials. It is a steel blade with industrial diamonds set in the edges of the blade. Water is pumped over the blade to keep it cool. The water also keeps the dust down. Ear protection should be used when using this blade.
 - b. A dry blade or carborendum blade is used for cutting softer material. No water is used with this blade. A dust mask should be worn when working with the dry blade.
4. Make sure all belts are covered and all parts are working properly.

The brick saw has a sliding table onto which the unit is placed. The unit is marked and adjusted under the blade so the blade will cut accurately. This is done with the saw turned off.

The blade is approximately 1/8" thick. The cut should be made on the side of the line (unit) that is not to be used as a cut. (Shown below.) This will compensate for the blade width.

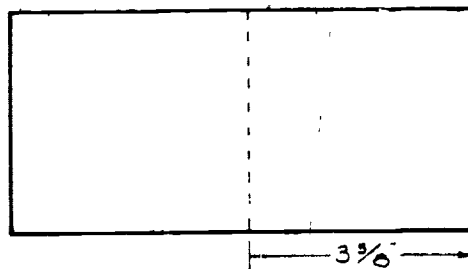

The cut should be made on the left side of the line.

(If more than a few cuts of the same size are to be made, a guide is used.)

After checking and marking, the unit to be cut is then slid back away from the blade. The saw is turned on and the blade is brought into contact with the unit. The unit (on the sliding table) is pushed and pulled back and forth while applying

gentle pressure. The unit must be held firmly against the table to avoid movement which would cause the unit to be pushed backwards. Keep applying pressure and moving the unit until it is cut. (The operator should always wear safety glasses. Gloves and heavy duty shoes should be worn when necessary.)

In all three methods (the hammer, hammer and set, and the masonry saw), a number of cuts should be made ahead of time. This will speed up production and make the work much easier.

Self Assessment Answers

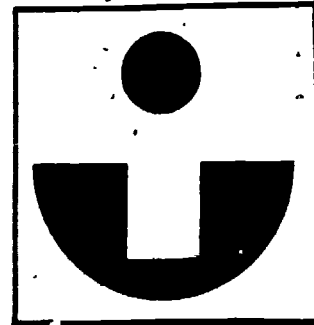

1. T

2. F

3. T

4. F

5. T

6. F

Job Sheet

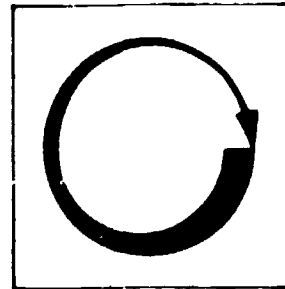

FOLLOWING THE STEPS OUTLINED IN THE INFORMATION SECTION, DO THE FOLLOWING TASKS.

Materials and Tools

hammer
brick set
masonry saw
8" block
brick
tape measure
pencil

1. Using the brick set, cut a brick $6 \frac{1}{2}$ " long.
2. Using a hammer, cut a brick approximately 4 inches long.
3. Using a masonry saw, make 3 cuts:
 - a. $3 \frac{5}{8}$ "
 - b. $6 \frac{1}{4}$ "
 - c. $11 \frac{5}{8}$ "

Post Assessment

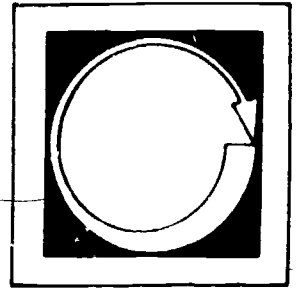

LISTED BELOW ARE STATEMENTS FOLLOWED BY A NUMBER OF POSSIBLE COMPLETIONS. SELECT THE COMPLETION WHICH COMPLETES THE STATEMENT CORRECTLY AND PLACE THE LETTER IN THE BLANK PROVIDED.

1. ____ Cutting the units with a hammer should be done only when a _____ cut may be used.
 - a. straight
 - b. smooth
 - c. rough

2. ____ The hammer head is made of _____.
 - a. rubber
 - b. tempered steel
 - c. T.N.T.

3. ____ A dry blade is used for cutting _____ material.
 - a. softer material
 - b. harder material
 - c. neither a nor b

4. ____ A brick set is used when _____.
 - a. saw is not available
 - b. precise cutting is necessary
 - c. both a and b

5. ____ When using a wet blade, water is pumped onto the blade to _____.
 - a. cool the blade
 - b. cool the unit
 - c. cool the saw motor

Instructor Post Assessment Answers

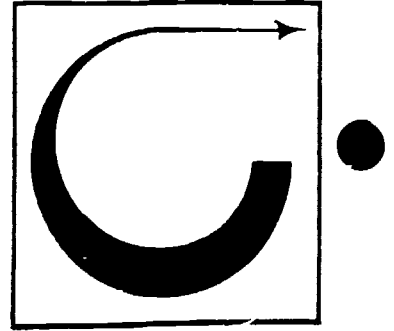

1. c
2. b
3. a
4. c
5. a

181178

CLEANING BRICKWORK

Goal:

The student will be able to identify and clean common masonry stains.

179

Performance Indicators:

The student will complete a Self Assessment, an Assignment and a Post Assessment.

182

Study Guide

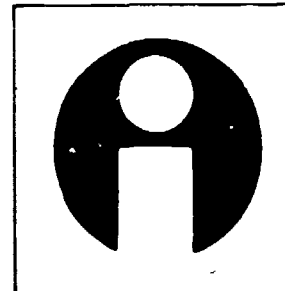

In order to finish this module, do the following tasks. Check each item off as you complete it.

1. Read the Goal and Performance Indicators on the cover of the module. This will tell you what you will learn by studying the module, and how you will show you've learned it.
2. Read the Introduction. The Introduction will tell you why the module is an important part of the bricklaying trade.
3. Study the Information section. This section will give you the information you need to understand the subject.
4. Take the Self Assessment exam. This is a test for you to prove to yourself that you have learned the material you have studied. Compare your answers with the answers on the Self Assessment Answer Sheet, which is on the page following the Self Assessment. If you scored poorly, re-study the Information section or ask your teacher for help.
5. Do the Assignment page. Follow the instructions at the top of the Assignment page.
6. Take the Post Assessment exam. Give the exam to your teacher after you have completed it. Your teacher will grade it for you.

Introduction

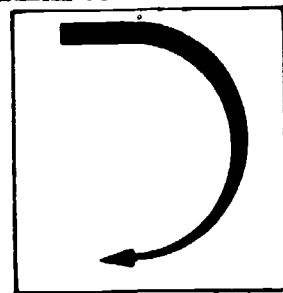

A bricklayer must be able to clean new or existing brickwork. It must be clean enough to satisfy the architect, the owner and the contractor. This section will cover how to identify and properly clean masonry.

Supplementary References

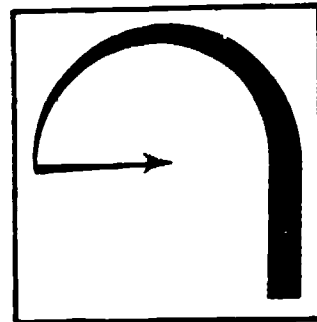

Brick and Block Construction, I.M.A.T. Taylor and Randolph. pp. 198-205.

182

185

Information

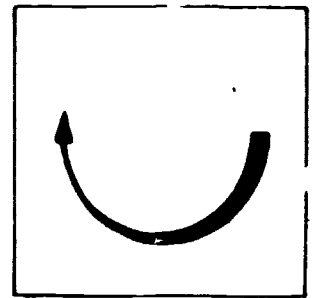

A bricklayer must know what materials are needed to clean masonry and how these materials are used. Properly cleaning brickwork depends on the type of surface to be cleaned and the matter or type of material to be removed.

Smooth-textured units are much easier to clean than rough-surfaced units. A cleaning agent that will work fine for cleaning the brick could damage the mortar joint.

When trying to clean brickwork, the bricklayer should keep three things in mind:

1. The type of units to be cleaned.
2. The foreign matter to be removed.
3. Cleaning and cleaning agents used.

TYPE OF UNIT TO BE CLEANED

Brick with different textures may require different cleaning methods. Mortar and grout smears and other stains on smooth surface units can be very easy to clean. This is because there is less surface for the matter to stick to or become embedded in. For example, glazed units or tile can be wiped clean with a soft cloth; rough units may require a pressure washer, acid, or sandblasting to remove stains and matter. This is because the foreign substances have penetrated the pores. Both rough and smooth surfaced units must be rinsed thoroughly.

FOREIGN MATTER

Most stain on brickwork comes from salt deposits or minerals in the brick. Studies show that only a very small amount of the bricks made in the United States contain enough soluble (able to be dissolved) salts to cause these stains.

Efflorescence

This is the deposit of water soluble salts in the pores or on the surface of the unit. It is usually a white powder or crystallization, but, in some cases, it may be green or brown. The water that is used when making or setting the unit brings efflorescence to the surface. The salts are left behind after the water evaporates. Efflorescence may also come from the mortar, the wet ground surrounding the work, or salts in any cleaning agents that are not thoroughly rinsed from the wall.

Vanadium

This salt stain is a green cast (tint) and may appear on the bricks after they have been washed with acid. This appears because of a chemical reaction with a metallic deposit inside the brick caused by the cleaning acid or by drying. This stain appears mostly in lighter-colored brick.

Manganese

Manganese stain is a brownish, oily stain that appears on the mortar joint and drips down on the masonry work. It is caused by a reaction between rain and the minerals or color additives in the unit.

CLEANING AND AGENTS USED

Cleaning methods and cleaning agents are different for each stain.

Efflorescence Stain

Some efflorescence will disappear with normal weathering. It can also be brushed away with a dry brush. In severe cases, it should be washed with a diluted solution of hydrochloric (muriatic) acid (usually 9 parts water to 1 part acid).

When washing masonry work, the weather should be as dry as possible. This will help prevent more efflorescence from coming out of the units because they will dry faster.

Vanadium Stain

For cleaning vanadium stain, the wall must be wet first. The wall is scrubbed with a solution of

1. Potassium.

or

187

184

2. Sodium hydroxide (Drano).

(Mix two pounds per gallon of water. Leave the solution on the wall for 2 to 3 days. It should dry to a white powder or salt and be hosed off.)

Manganese Stain

This stain is one of the hardest to remove. It can be removed quickly with very strong acid, but doing this will destroy the mortar joint. One recommended method is to wash it with a mixed solution of:

- 1 part acetic acid
- 1 part hydrogen peroxide
- 6 parts water

To prevent stain from reappearing, rinse off solution with water and brush on

- 1 part organic acid
- 3 parts water

This solution should be left on the wall.

Mortar, Grout and Dirt Stains

Dirt stains will usually come right off by using a scouring powder or detergent and a scrub brush. Mortar and grout stains may have to be scraped off. On rough textured units, a pressure or steam washer may be used. The water and steam pressure will "blow" the mortar and grout off the brick. Care should be taken that pressure is not strong enough to damage mortar joints.

In some pressure or steam washers, muriatic acid may be added to clean stubborn stains.

On new construction, cleaning can be made easier by keeping the work clean while building the project. Care should be taken when washing with acid not to use too much, since it will damage the surface of the unit and mortar joints. When washing with acid, rubber gloves should be worn.

Self Assessment

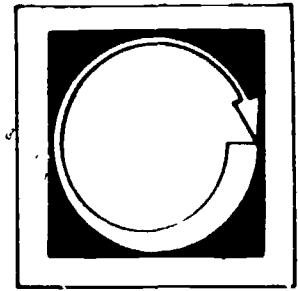

LISTED BELOW ARE STATEMENTS FOLLOWED BY A NUMBER OF POSSIBLE COMPLETIONS. SELECT THE COMPLETION WHICH COMPLETES THE STATEMENT CORRECTLY AND PLACE THE LETTER IN THE BLANK PROVIDED.

1. ____ Brickwork must be clean enough to satisfy the:
 - a. architect
 - b. owner
 - c. both a and b

2. ____ Cleaning brickwork depends on:
 - a. type of surface to be cleaned
 - b. matter to be removed
 - c. both a and b

3. ____ On new construction, cleaning can be made easier by:
 - a. keeping work clean
 - b. using no mortar
 - c. using a stick for a trowel

4. ____ Too much pressure in a pressure washer may:
 - a. get everything wet
 - b. damage mortar joints
 - c. waste water

5. ____ For removing dirt stains, _____ is/are used:
 - a. detergent
 - b. scouring powder
 - c. both a and b

Self Assessment Answers

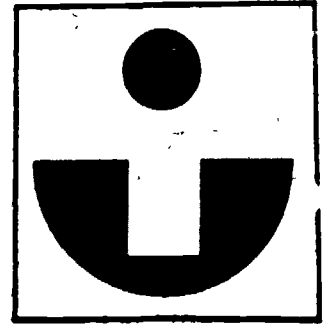

1. c

2. c

3. a

4. b

5. c

Assignment

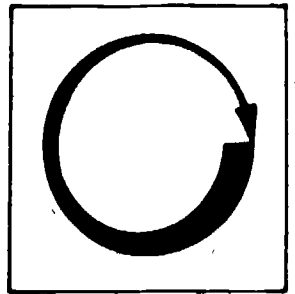

FROM THE INFORMATION SECTION, DECIDE WHICH CLEANING METHOD IS BEST FOR EACH SITUATION.

1. You are hired to clean a stone veneer building in Sidney, Australia. The wall has brown streaks running out of the mortar joints. Identify stain and tell how you would clean this building.
2. You are hired to clean the London Bridge. it has white powder all over it. How would you clean it?
3. On your way home, look at the brick buildings along the way. See if you can identify any stains you may see.

Post Assessment

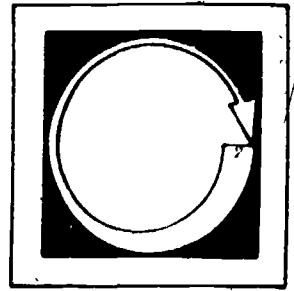

COMPLETE THE FOLLOWING STATEMENTS BY WRITING THE CORRECT WORD OR WORDS IN THE BLANKS PROVIDED.

1. Which stain is usually the hardest to remove? _____
2. What color is manganese stain? _____
3. What color is an efflorescence stain? _____
4. What color is a vanadium stain? _____
5. Most stains on brickwork occur from: _____
6. What three things should a bricklayer keep in mind when cleaning brickwork?
 - a. _____
 - b. _____
 - c. _____

Instructor Post Assessment Answers

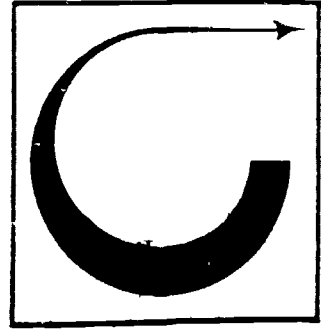

1. manganese stain
2. brown
3. white
4. green
5. soluble salt deposits
6.
 - a. the foreign matter to be removed
 - b. type of unit to be cleaned
 - d. cleaning and agents used

ROTARY HAMMER

Goal:

The student will be able to assemble and operate a rotary hammer.

Performance Indicators:

The student will complete a Job Sheet and a Post Assessment.

Study Guide

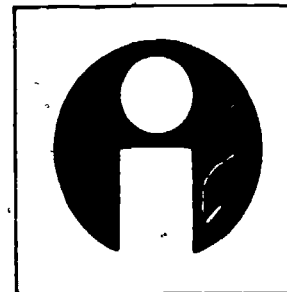

In order to finish this module, do the following tasks. Check each item off as you complete it.

1. Read the Goal and performance Indicators on the cover of the module. This will tell you what you will learn by studying the module, and how you will show you've learned it.
2. Read the Introduction. The Introduction will tell you why the module is an important part of the bricklaying trade.
3. Study the Information section. This section will give you the information you need to understand the subject.
4. Do the Job Sheet. Follow the instructions at the top of the Job Sheet. The tasks listed on the Job Sheet will help you develop skills which will be helpful to you.
5. Take the Post Assessment exam. Give the exam to your teacher after you have completed it. Your teacher will grade it for you.

Introduction

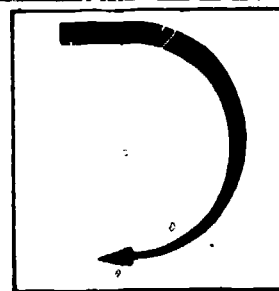

In bricklaying, sometimes it is necessary to drill holes into walls or to remove masonry by chiseling. This section will explain how this is done with a rotary hammer.

Supplementary References

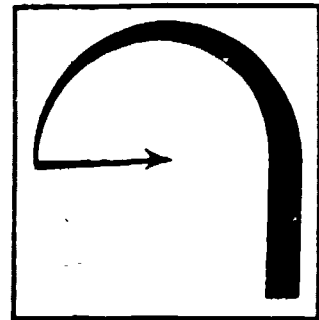

Bosch Power Tools Pamphlet, 1980. pp. 3-10.

Information

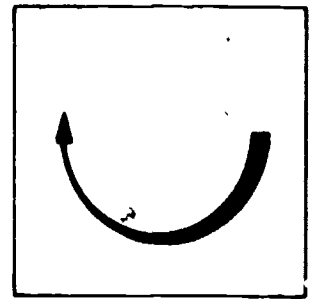

DRILLING

A rotary hammer is a drill with a hammering device inside. It is used to drill holes into masonry walls. The most commonly used rotary hammer is the medium heavy duty. (They range from light to heavy duty.) All hammers are different, but also alike in many ways. A regular drill may not be able to drill into masonry, but with a rotary hammer, the hammering device pounds the bit into the wall as the bit turns. The drill turns at approximately 450 r.p.m. (r.p.m. = revolutions per minute), and hammers approximately 3000 blows a minute. Most newer hammers are equipped with safety features such as:

1. Hammer shuts off when servicing is necessary.
2. Safety clutch; drill will stop if bit binds.
3. Double insulation gives maximum electrical safety.

A special bit is used for drilling into masonry walls. The tip of this bit is carbide. Carbide is a very durable (long-lasting) compound containing carbon. These bits range in size from 3/16" to 1 1/2" for the medium heavy duty hammer.

Drilling holes is necessary for expansion bolts and anchor bolts. Sometimes it is necessary to drill larger holes through walls for plumbing. In these cases, a core bit is used. Up to a 3" hole can be drilled with a medium heavy duty hammer. Carbide teeth are staggered around the core bit.

CHISELING

Sometimes it is necessary to tear down existing walls or to smooth out rough footings. For small jobs a hammer and a chisel can be used. For larger jobs a rotary hammer with a chisel bit may be used. The carbide bit is removed from the rotary hammer, and a chisel bit is put in. The chisel (or flat chisel) is inserted into the rotary hammer the same way as the carbide bit. The difference

is that the chisel bit does not turn. The hammering action of the rotary hammer forces the bit into the wall, breaking up the structure. Chisel bits come in various sizes and shapes for different jobs. ▽

A rotary hammer, if used right, will help make the bricklayer's job easier. Goggles should be worn at all times while operating the rotary hammer. This will help prevent injury to the eye.

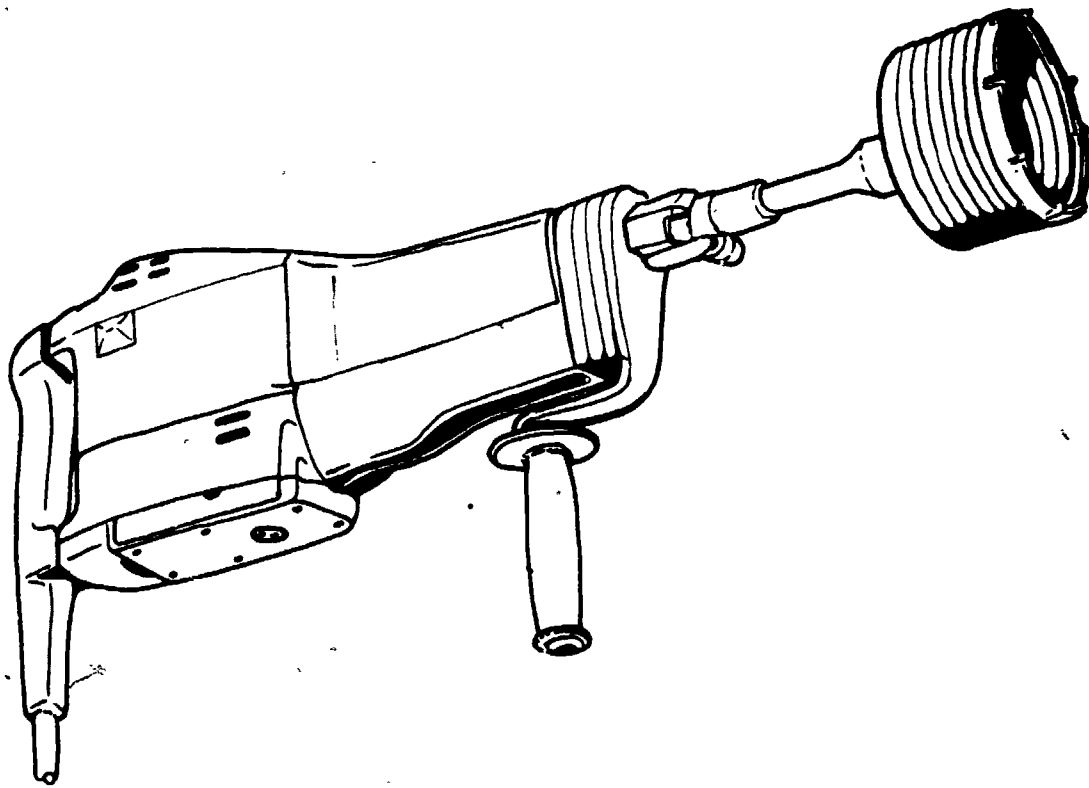

Job Sheet

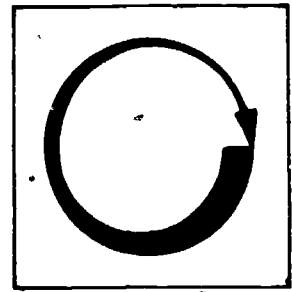

FOLLOWING THE STEPS OUTLINED IN THE INFORMATION SECTION, COMPLETE THE FOLLOWING TASKS.

Materials and Tools

masonry wall
carbide bits
chisel bits

1. Using the rotary hammer, drill two holes in a masonry wall.
2. Using the rotary hammer with a chisel bit, tear down a small masonry wall.

Post Assessment

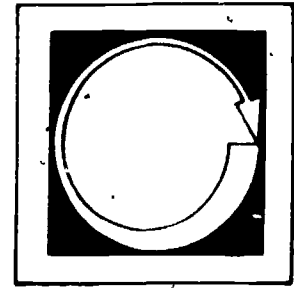

LISTED BELOW ARE QUESTIONS OR STATEMENTS FOLLOWED BY A NUMBER OF POSSIBLE ANSWERS OR COMPLETIONS. SELECT THE ANSWER OR COMPLETION WHICH ANSWERS THE QUESTION OR COMPLETES THE STATEMENT CORRECTLY AND PLACE THE LETTER IN THE BLANK PROVIDED.

1. ____ What is the most commonly used hammer?
 - a. light duty
 - b. medium heavy duty
 - c. heavy duty

2. ____ Approximately how many r.p.m. does the rotary hammer turn?
 - a. 750 r.p.m.
 - b. 450 r.p.m.
 - c. 1450 r.p.m.

3. ____ Approximately how many blows per minute does the rotary hammer produce?
 - a. 3000
 - b. 5300
 - c. 7200

4. ____ What kind of bit is used for drilling into masonry?
 - a. diamond
 - b. carbide
 - c. titanium

5. _____ The drilling bits for the medium heavy duty rotary hammer range in size from:
- a. $3/16$ to $1\ 1/2$ inches
 - b. $1\ 1/2$ to $5\ 1/2$ inches
 - c. $2\ 3/8$ to $2\ 5/8$ inches
6. _____ When are goggles necessary for operating the rotary hammer?
- a. whenever you remember.
 - b. after your teacher reminds you.
 - c. at all times.

Instructor Post Assessment Answers

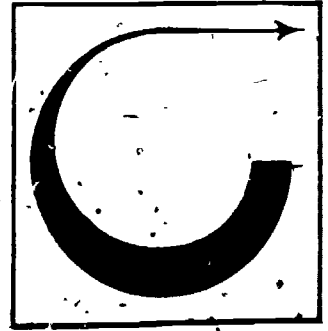

1. b

2. b

3. a

4. b

5. a

6. c

PNEUMATIC HAMMER

Goal:

The student will be able to assemble and demonstrate the correct use of a pneumatic hammer.

Performance Indicators:

The student will complete a Job Sheet and a Post Assessment.

Study Guide

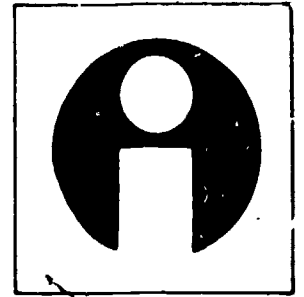

In order to finish this module, do the following tasks. Check each item off as you complete it.

1. ___ Read the Goal and Performance Indicators on the cover of the module. This will tell you what you will learn by studying the module, and how you will show you've learned it.
2. ___ Read the Introduction. The Introduction will tell you why the module is an important part of the bricklaying trade.
3. ___ Study the Vocabulary section. Vocabulary words are important for a good understanding of the trade. After you have studied the vocabulary, ask your teacher to quiz you on the words and their meanings.
4. ___ Study the Information section. This section will give you the information you need to understand the subject.
5. ___ Do the Job Sheet. Follow the instructions at the top of the Job Sheet. The tasks listed on the Job Sheet will help you develop skills which will be helpful to you.
6. ___ Take the Post Assessment exam. Give the exam to your teacher after you have completed it. Your teacher will grade it for you.

Introduction

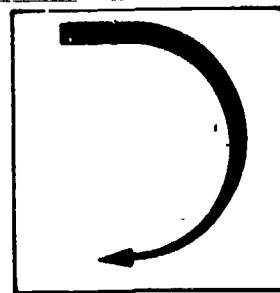

In bricklaying it is sometimes necessary to tear down existing walls. In these cases a bricklayer may use a pneumatic hammer. This module will explain how.

Vocabulary

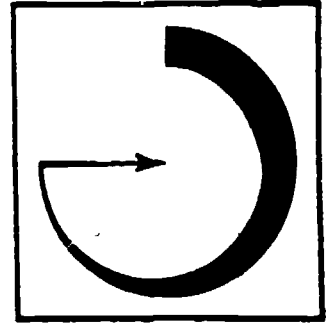

Trade terms are very important for a good understanding of the trade. Study these words and meanings. When you have learned them, ask your teacher to quiz you on the words and their meanings.

CONSUMPTION--To use up.

204²⁰⁷

Supplementary References

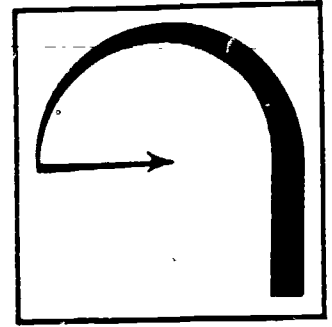

Construction Tools (Pamphlet). American Pneumatic Tool Company, 1977.

208
205

Information

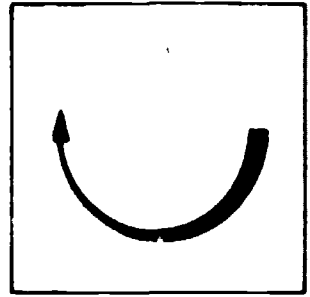

A pneumatic (air) hammer is used on larger jobs where a rotary hammer is too small. The air hammer must be used with a compressor to operate.

The compressor pumps air through hoses connected to the hammer. Average size hammers are about 24" long and weigh from 30 to 100 lbs. The hammer's air consumption is anywhere from 30 to 80 c.f.m. (cubic feet per minute) at 90 p.s.i. (pounds per square inch). That is, the compressor pushes air through the hose at a pressure of 90 p.s.i. and the hammer uses the air pressure at a rate of 30 to 80 c.f.m. depending on the size of the hammer.

The hammer has a trigger on the handle which releases air into the hammer. The air goes through a flapper valve that opens and closes as the hammer fills with air. This operates the hammering mechanism inside the hammer.

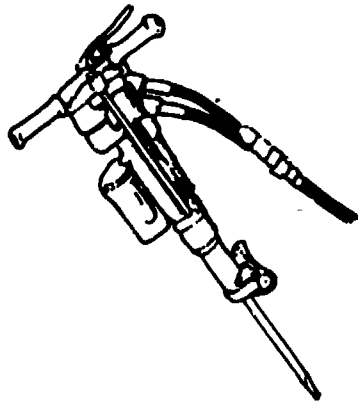

Chisels (chucks) are inserted into the end of the hammer. Chucks come in many different sizes and shapes and are made for many different uses. There are chucks for chipping, pave breaking, clay digging, pipe driving and more.

Whenever using the pneumatic hammer, goggles and ear protection should be worn.

Job Sheet

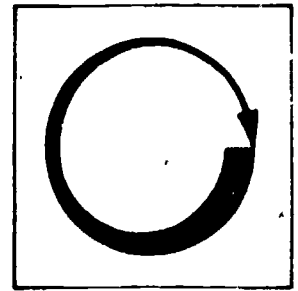

Materials and Tools

pneumatic hammer

compressor

hoses and chisels (cnucks)

goggles

ear protection

Following the steps outlined in the information section, do the following task.

1. Using the pneumatic hammer, chisel (tear down) the wall that was built in the grouting and reinforcing section.

Post Assessment

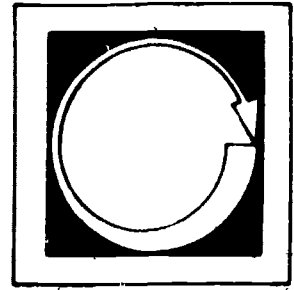

LISTED BELOW ARE STATEMENTS FOLLOWED BY A NUMBER OF POSSIBLE COMPLETIONS. SELECT THE COMPLETION WHICH COMPLETES THE STATEMENT CORRECTLY AND PLACE THE LETTER IN THE BLANK PROVIDED.

1. ____ A pneumatic hammer is usually used on _____ jobs.
 - a. smaller
 - b. medium
 - c. larger

2. ____ The average length of the hammer is about
 - a. 15"
 - b. 17"
 - c. 24"

3. ____ The weight of the hammer ranges from
 - a. 30 to 100 lbs.
 - b. 100 to 300 lbs.
 - c. 15 to 20 lbs.

4. ____ The pneumatic hammer has a trigger on the
 - a. compressor
 - b. hose
 - c. handle

5. ____ C.f.m. means
 - a. cubic feet per minute
 - b. celsius fahrenheit measurement
 - c. none of the above

6. _____ Chisels or chucks are inserted into the

a. side

b. end

c. back

Instructor Post Assessment Answers

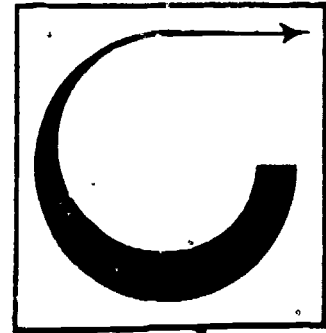

1. c

2. c

3. a

4. c

5. a

6. b

STONE

Goal:

The student will be able to lay different types of stone and know the characteristics of those types.

Performance Indicators:

The student will complete a Self Assessment, a Job Sheet, an Assignment and a Post Assessment.

Study Guide

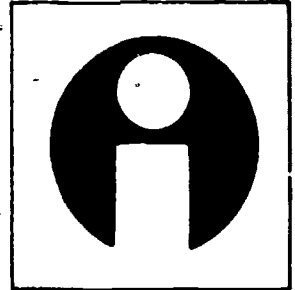

In order to finish this module, do the following tasks. Check each item off as you complete it.

1. Read the Goal and Performance Indicators on the cover of the module. This will tell you what you will learn by studying the module, and how you will show you've learned it.
2. Read the Introduction. The Introduction will tell you why the module is an important part of the bricklaying trade.
3. Study the Vocabulary section. Vocabulary words are important for a good understanding of the trade. After you have studied the vocabulary, ask your teacher to quiz you on the words and their meanings.
4. Study the Information section. This section will give you the information you need to understand the subject.
5. 1 Take the Self Assessment exam. This is a test for you to prove to yourself that you have learned the material you have studied. Compare your answers with the answers on the Self Assessment Answer Sheet, which is on the page following the Self Assessment. If you scored poorly, re-study the Information section or ask your teacher for help.
6. Do the Assignment page. Follow the instructions at the top of the Assignment page.
7. Do the Job Sheet. Follow the instructions at the top of the Job Sheet. The tasks listed on the Job Sheet will help you develop skills which will be helpful to you.
8. Take the Post Assessment exam. Give the exam to your teacher after you have completed it. Your teacher will grade it for you.

Introduction

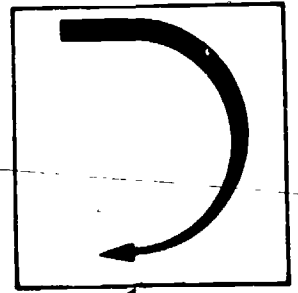

Stone which supports heavy loads must be strong. The weight which a stone wall can support depends on the strength of the stone. This section will cover the characteristics and will explain how stone is laid.

Vocabulary

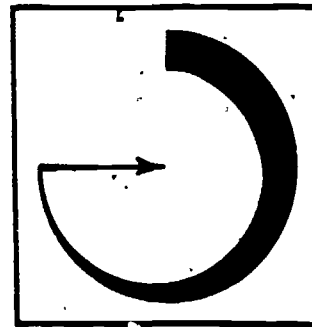

Trade terms are very important for a good understanding of the trade. Study these words and meanings. When you have learned them, ask your teacher to quiz you on the words and their meanings.

LAMINATED FORM--Layers or layered material.

COMPOSITION--Make up, structure.

QUARRIED--Dug up from the ground.

Supplementary References

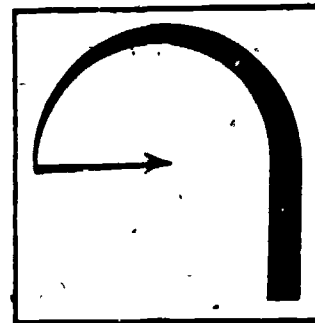

Lane Community College Bricklaying Apprenticeship Correspondence Course,
Lesson 5. pp. 73-75.

Information

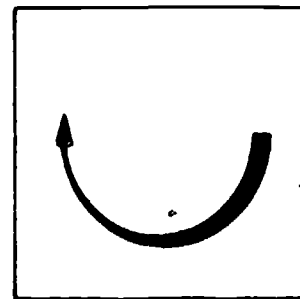

Stone is found on top of the ground and in formations in the ground, from which many types of stone are quarried. Stone varies in hardness, depending mostly on the chemical composition. When used with mortar, stones can be laid to form strong, sturdy structures.

TYPES OF STONE

There are many, many different types of stone. We will discuss four types:

1. Sandstone.
2. Limestone.
3. Granite.
4. Slates.

Sandstone

Sandstone is made of grains of sand cemented together by silica, alumina, carbonate, of lime or iron oxide. The best sandstone is the close-grain type, which contains silica. The stones may be blue, brown, grey, pink or red. Stone containing too much iron oxide should not be used because the iron may be oxidized by the weather and leave rust stains.

Limestone

Limestone is a rock that is made mostly of organic remains (coral or shells). It consists mainly of calcium carbonate and magnesia carbonate. The stones may be fine-grain, medium grain or coarse grain. The coarseness of the grain depends on whether clay, sand or shale is in the stone. (When burned, limestone will make the lime which is used in mortar.)

Granite

Granite is one of the strongest stones. Especially the ones containing quartz. Granite also contains feldspar, a crystalline mineral that contains aluminum

silicates with either potassium, sodium calcium or borium mica.

Granite stone is used for foundations because it is so strong. It is also used for columns, pavings and other such structures.

Slate

Slate is made mostly of a combination of sand and clay. It is a close-grained stone. It is in laminated form and is split into sheets for use. Slate is used for roof facing, blackboards and other forms of building stone.

HOW TO LAY STONE

Stone is usually laid up with type "S" mortar. Less water is used to keep the mortar stiffer, which helps to hold the units up. Each stone should be laid on its longest side (long side down). Thicker stones should be laid on the lower courses. Smaller and larger stones should be staggered (large-small-large-small, etc.) so that the wall looks uniform. The lap of the vertical joints should be at least 4".

The thickness of the bed joints depends on the stone used. When making bed joints, enough mortar is spread to completely fill the space between the two stones. The head joints are made by slushing mortar between the joints with a trowel. Before the stone is laid, it is shaped with a hammer. Safety goggles should always be worn when shaping stone.

FINISHING JOINTS

Because of the uneven weight distribution of stone, the mortar should be allowed to set a little longer than it would for brick or block. Jointing is done with a trowel. The mortar is cut off and compressed (held or pushed) to the wall until the joints have a smooth consistency. Then the joints are brushed.

Stone should be laid straight and be kept as plumb as possible. Because of the different shapes and thicknesses of the stone, some parts of the stone will stick out from the face of the wall.

Self Assessment

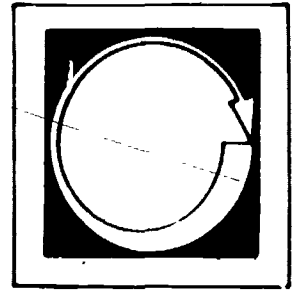

LISTED BELOW ARE QUESTIONS OR STATEMENTS FOLLOWED BY A NUMBER OF POSSIBLE ANSWERS OR COMPLETIONS. SELECT THE ANSWER OR COMPLETION WHICH ANSWERS THE QUESTION OR COMPLETES THE STATEMENT CORRECTLY AND PLACE THE LETTER IN THE BLANK PROVIDED.

1. ___ What is the best sandstone for stonework?
 - a. cut grain
 - b. close grain
 - c. no grain

2. ___ What does the best sandstone contain?
 - a. fools gold
 - b. silica
 - c. all of above

3. ___ Granite is usually used for:
 - a. foundations
 - b. columns
 - c. both a and b

4. ___ Slate is used for:
 - a. blackboards
 - b. facing
 - c. both a and b

5. ___ The lap of the vertical joint should be at least
 - a. 4"
 - b. 2 3/8"
 - c. 8"

Self Assessment Answers

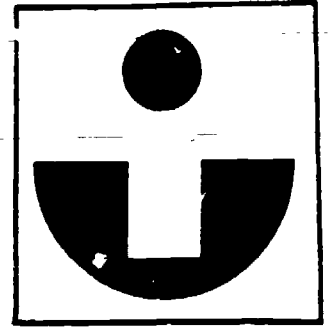

1. b

2. b

3. c

4. c

5. a

Assignment

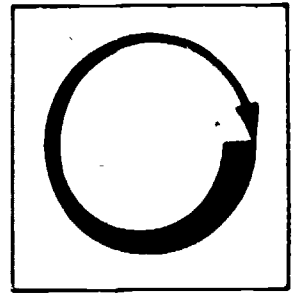

COMPLETE ONE OF THE FOLLOWING.

1. Ask your instructor to bring in samples of the four types of st discussed in this module. Examine them so you will be able to identify them later.
2. Find examples of walls or fireplaces which are made from the four types of stone covered in this module. Examine them for quality of workmanship. Write a brief report and give it to your instructor.

Job Sheet

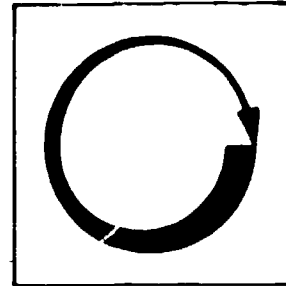

Materials and Tools

trowel

hammer

tuck pointer

material and tools listed in "mixing mortar"

stone

Following the steps outlined in the information section, complete the following.

1. Build a wall 3' X 3'. Be sure the ends of the wall are plumb.

Post Assessment

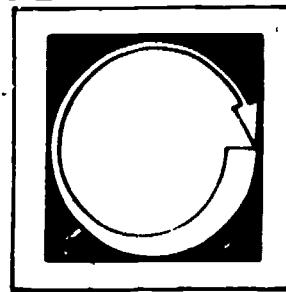

LISTED BELOW ARE QUESTIONS OR STATEMENTS FOLLOWED BY A NUMBER OF POSSIBLE ANSWERS OR COMPLETIONS. SELECT THE ANSWER OR COMPLETION WHICH ANSWERS THE QUESTION OR COMPLETES THE STATEMENT CORRECTLY AND PLACE THE LETTER IN THE BLANK PROVIDED.

1. ___ Limestone is made up mostly of:
 - a. organic remains
 - b. lime and stone
 - c. concrete

2. ___ The coarseness of the grain depends on whether _____ is in the stone.
 - a. sand
 - b. shale
 - c. all of the above

3. ___ Granite is one of the _____ of stones.
 - a. strongest
 - b. lightest
 - c. weakest

4. ___ Slate is made up mostly of:
 - a. sand
 - b. clay
 - c. both a and b

5. ___ Stone is usually laid with type _____ mortar.
 - a. "S"
 - b. "M"
 - c. "K"

Instructor Post Assessment Answers

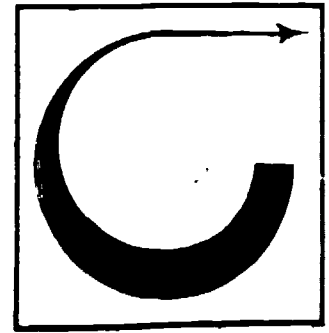

1. a
2. c
3. a
4. c
5. a

CAULKING

Goal:

The student will be able to work a caulking gun and explain where and why caulk is used.

Performance Indicators:

The student will complete a Job Sheet and a Self and Post Assessment.

Study Guide

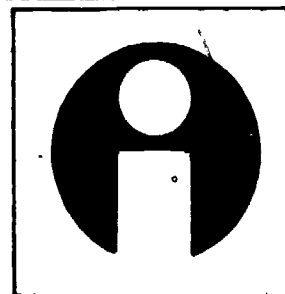

In order to finish this module, do the following tasks. Check each item off as you complete it.

1. Read the Goal and Performance Indicators on the cover of the module. This will tell you what you will learn by studying the module, and how you will show you've learned it.
2. Read the Introduction. The Introduction will tell you why the module is an important part of the bricklaying trade.
3. Study the Vocabulary section. Vocabulary words are important for a good understanding of the trade. After you have studied the vocabulary, ask your teacher to quiz you on the words and their meanings.
4. Study the Information section. This section will give you the information you need to understand the subject.
5. Take the Self Assessment exam. This is a test for you to prove to yourself that you have learned the material you have studied. Compare your answers with the answers on the Self Assessment Answer Sheet, which is on the page following the Self Assessment. If you scored poorly, re-study the Information section or ask your teacher for help.
6. Do the Job Sheet. Follow the instructions at the top of the Job Sheet. The tasks listed on the Job Sheet will help you develop skills which will be helpful to you.
7. Take the Post Assessment exam. Give the exam to your teacher after you have completed it. Your teacher will grade it for you.

Introduction

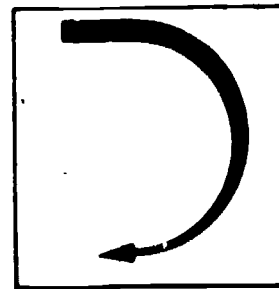

Caulking is used around doors, windows, expansion joints and other places. Its main purpose is to protect the building from moisture penetration. This module will cover how this is done and different types of caulk which are used.

Vocabulary

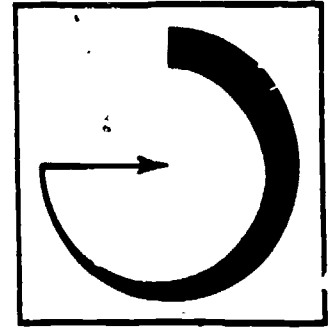

Trade terms are very important for a good understanding of the trade. Study these words and meanings. When you have learned them, ask your teacher to quiz you on the words and their meanings.

NON-TOXIC--Not poisonous.

Supplementary References

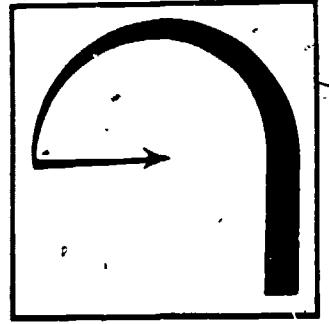

Brick and Block Construction, I.M.A.T., 1976. pp. 210-215.

Information

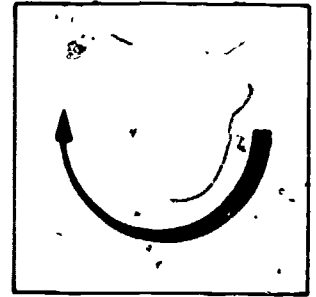

It is important that a bricklayer be able to apply caulk to cracks and openings. This must be done properly to insure that the caulk stays in place after being applied. When using caulk, 3 things are done:

1. Preparing the surface.
2. Applying caulk.
3. Smoothing caulk.

PREPARING THE SURFACE

Most caulking requires a clean and dry surface for it to adhere properly. Caulking should be done at temperatures above 40°, otherwise it may not spread or set properly. It should also be done on dry days because moisture might prevent the caulking from sticking.

Clean the area with a stiff brush. This will clean out most dirt and mortar. For surfaces with oil or grease, a cloth soaked in mineral spirits should be used.

The minimum recommended size opening for applying caulking is 1/4" to 3/8". Sometimes the openings are not the recommended size. They may be larger or smaller. Too small an opening can be made larger by using a hammer and chisel, knife or raking tool. Too large an opening can be filled with a joint filling compound.

If the space to be caulked is too deep (more than 1/4" to 3/8"), it may be necessary to "chink" it. Chinking is filling the joint to the proper depth (if the space is 2" or deeper). In chinking, mortar is used to place and hold small pieces of brick, block or slate in the space. (For spaces less than 2" deep, a joint filler can be used. This joint filler is made of closed cell vinyl and

polyethylene foam. The joint filler is pressed into the joint to form a bed for the caulking compound.)

APPLY CAULKING

Two tools most commonly used to apply caulk are the caulking knife and the caulking gun.

The Caulking Knife

Knife grade caulking is used when using a knife. It comes in a can. It is almost a solid material resembling putty. A spatula, putty knife or a tool very similar is used to apply this caulking.

The caulk is taken from the can and placed onto the joint. The knife is then pressed firmly on the wall and worked downward, smoothing the joint.

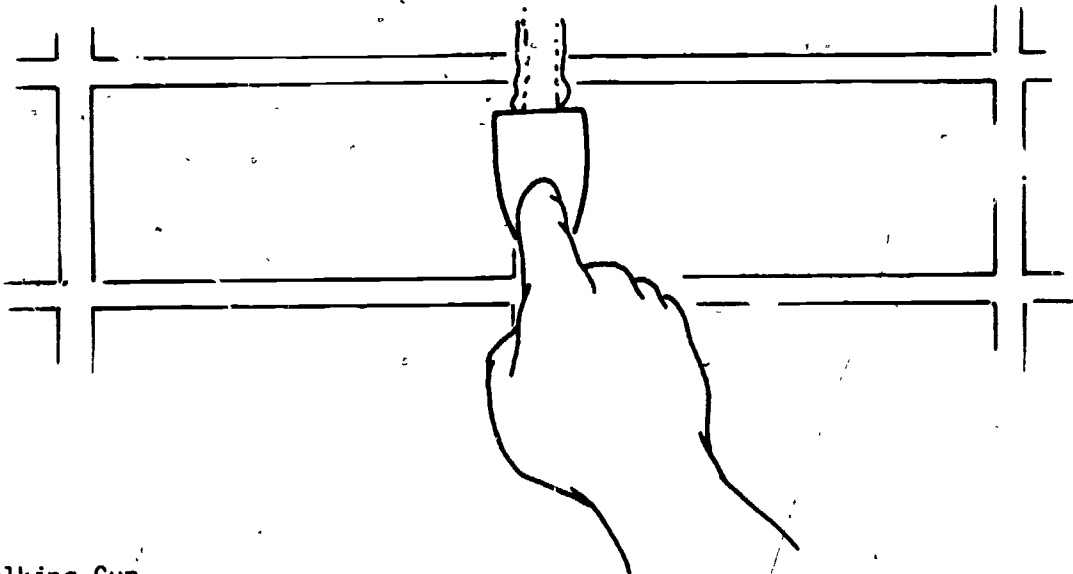

Caulking Gun

Gun grade caulk is used with caulking guns. This type of caulk comes in two different containers:

1. Tubes.
2. Large container (5 gallon bucket).

Gun grade caulking is thinner than the knife grade caulking. It is more of a paste and moves smoothly through the gun onto the surface.

The tube-type caulk is used in what is called a half-barrel gun. The tube is placed in the gun so that the push rod will force the caulk out of the nozzle.

The nozzle is cut at a 45 degree angle. This makes it easier to guide the gun along the surface. The tubes are sealed, so it is necessary to puncture the end with a nail or wire.

The caulk that comes in bulk containers is used with a full barrel gun. To load this gun:

1. The nozzle is removed.
2. The tip of the gun is placed about 1/2" into the caulk.
3. The plunger is then pulled, creating a suction and pulling the caulk into the gun.
4. After filling, the end is cleaned and the nozzle is replaced.
5. Full barrel guns have set nozzles. Each has a different size opening.

Some pressure is required to force the caulk into the opening. The speed of movement along the joint or crack should be adjusted so that the opening is filled in one pass.

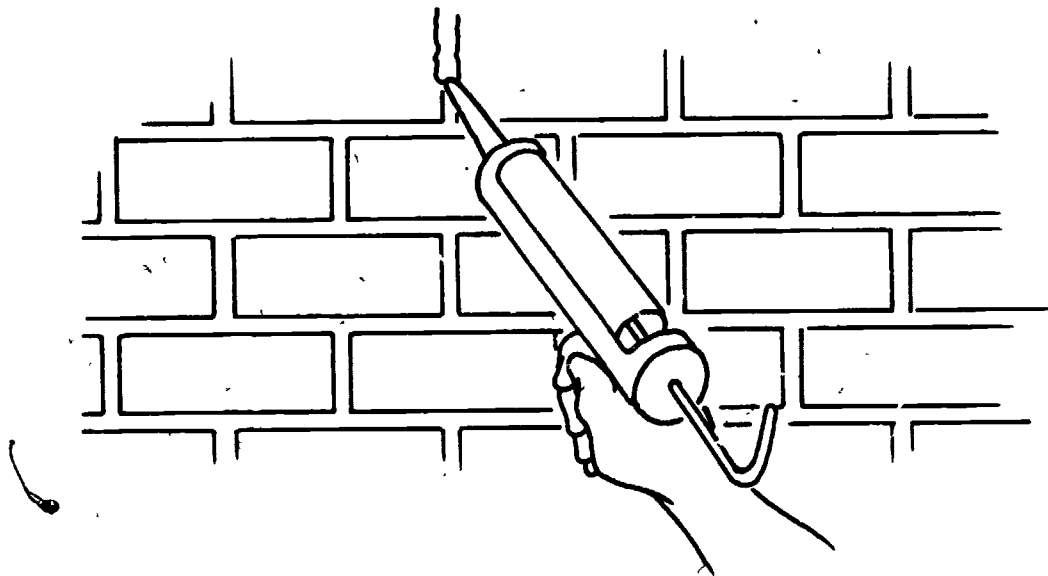

SMOOTHING CAULK

Caulking can be given a neat and smooth appearance by smoothing with a spoon or some round object. If caulk is non-toxic, the finger may be used. When using any type of caulk, be sure that it adheres to both surfaces.

SUMMARY

Caulking is a very important part of bricklaying. It helps lower the cost of maintenance and operation. For example, a crack 1/32" around a door can add up

to a space of approximately 8". If there are too many cracks of this size, it could be very costly to maintain.

232

235

Self Assessment

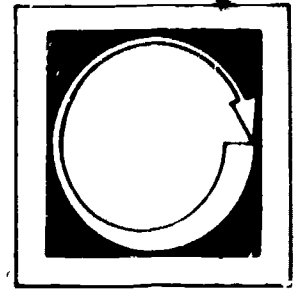

LISTED BELOW ARE STATEMENTS FOLLOWED BY A NUMBER OF POSSIBLE COMPLETIONS. SELECT THE COMPLETION WHICH COMPLETES THE STATEMENT CORRECTLY AND PLACE THE LETTER IN THE BLANK PROVIDED.

1. _____ Caulking should be done at temperatures above:
 - a. 45°
 - b. 160°
 - c. 40°
 - d. 212°

2. _____ The weather condition must be _____ so the caulking will:
 - a. stick properly
 - b. spread or set properly
 - c. adhere properly
 - d. all of the above

3. _____ The minimum size opening recommended for caulking is:
 - a. 1/2 to 5/8"
 - b. 1/4 to 3/8"
 - c. 1/3 to 7/9"

4. _____ To clean surfaces with oil or grease, _____ should be used.
 - a. stiff brush
 - b. cloth soaked in mineral spirits
 - c. rubbing compound

5. ____ For joints too small, a ____ may be used to widen them to recommended width.
- a. hammer and chisel
 - b. raking tool
 - c. knife
 - d. all of the above
6. ____ Two tools most commonly used for applying caulk are:
- a. knife and gun
 - b. raking tool and hammer
 - c. chisel and pliers

Self Assessment Answers

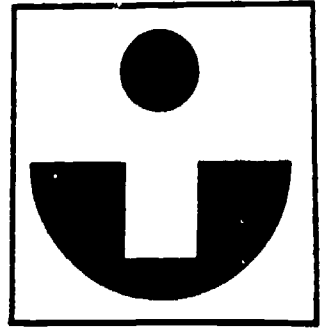

1. c
2. d
3. b
4. b
5. d
6. a

Job Sheet

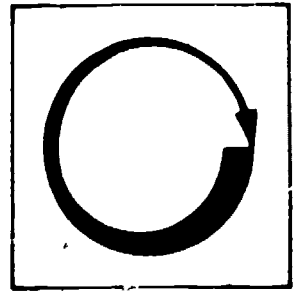

FOLLOWING THE STEPS OUTLINED IN THE INFORMATION SECTION, DO THE FOLLOWING TASKS.

Materials and Tools

caulking gun (full or half barrel)
caulking knife (putty knife, spatula, etc.)
caulk (knife and gun grade)
stiff brush
rag soaked in mineral spirits

1. Caulk or re-caulk an expansion joint. Be sure the space is clean and caulking adheres to both surfaces.
2. Check the doors around your building. Re-caulk if necessary.

Post Assessment

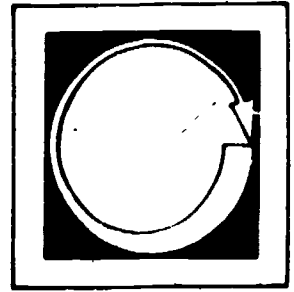

WRITE AN ANSWER TO THE FOLLOWING.

1. Explain the difference between a half barrel caulking gun and a full barrel caulking gun.

Instructor Post Assessment Answers

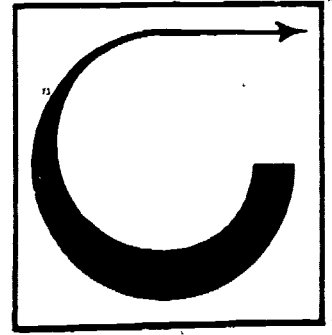

A half-barrel caulking gun uses tubes of caulking compound. A push rod forces caulk out the barrel nozzle. A full-barrel gun must be loaded by placing the gun tip into caulk and pulling a plunger.

CODES

Goal:

The student will be able to identify types of codes and explain the purpose for them.

Performance Indicators:

The student will complete an Assignment and a Post Assessment.

239

242

Study Guide

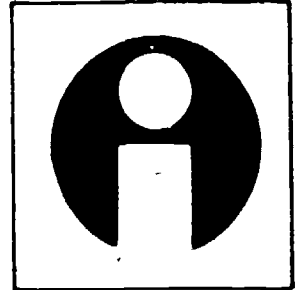

In order to finish this module, do the following tasks. Check each item off as you complete it.

1. Read the Goal and Performance Indicators on the cover of the module. This will tell you what you will learn by studying the module, and how you will show you've learned it.
2. Read the Introduction. The Introduction will tell you why the module is an important part of the bricklaying trade.
3. Study the Vocabulary section. Vocabulary words are important for a good understanding of the trade. After you have studied the vocabulary, ask your teacher to quiz you on the words and their meanings.
4. Study the Information section. This section will give you the information you need to understand the subject.
5. Do the Assignment page. Follow the instructions at the top of the Assignment page.
6. Take the Post Assessment exam. Give the exam to your teacher after you have completed it. Your teacher will grade it for you.

Introduction

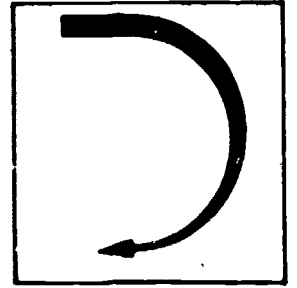

The building codes are made to add greater safety to the public and better building construction by uniformity of building codes. This section will help you become familiar with a few of these building codes and the reasons for them.

Vocabulary

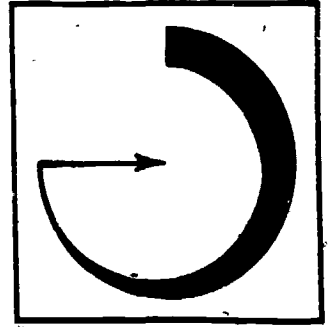

Trade terms are very important for a good understanding of the trade. Study these words and meanings. When you have learned them, ask your teacher to quiz you on the words and their meanings.

~~UNIFORMITY~~--The same all over.

REVISED--Updated.

RELATED--Similar.

TERMINATION--To stop.

Supplementary References

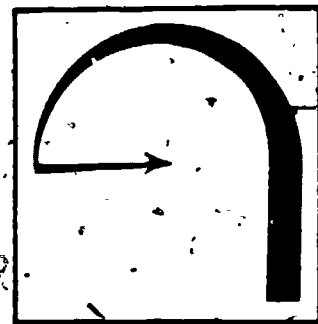

"Uniform Building Code" (State of Oregon) Copyright - 1976. Amended - 1979.

Information

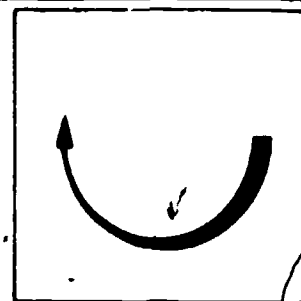

Uniform Building Codes (UBC) were first started in 1927. The code was made up by the International Conference of Building Officials in Phoenix, Arizona. These codes are revised and updated every 3 years. The UBC covers fire, life and structural safety of all buildings and related structures.

Along with the UBC, there are several other publications: Uniform Mechanical Code, Uniform Housing Code, Uniform Sign Code, etc. If these codes are not followed, the building official (inspector) may order the work stopped until the work is corrected. The building official has the powers of a police officer in these situations.

Before any building is started, the builder must obtain a building permit. When an inspection is necessary, the builder calls the building department and an inspector is sent out. After the inspector approves the structure, the builder can resume building.

With over 70 chapters in the UBC, it would take months to cover all the material. This section will cover a few codes on masonry.

SEC. 3703 A.

Chimney shall be designed, anchored, supported and reinforced as required in this chapter. A chimney shall not support any structural load other than its own weight unless designed as a supporting member.

This code makes sure that the chimney will be built correctly so that it will be a strong, sturdy structure. It also makes sure that the masonry and wood are not built together. This is because the wood and masonry do not shrink or settle together. If built together, the difference of settling may cause cracks.

SEC. 3703 P.

The footing is required to be 8" thick and extend 6" beyond the sides of the fireplace foundation walls.

This code insures that the footings for the fireplace are thick enough and wide enough to support the weight of the entire fireplace.

SEC. 3704 D.

Chimney Offsets

This section permits chimney offsets at an angle not to exceed 45 degrees from the vertical position.

This code makes sure that the chimney is not slanted too much. Too much slant may prevent air from circulating properly.

SEC. 3703 F.

Chimney Termination

Chimneys must extend no less than 2 feet above any part of a building within 10 feet, measured horizontally.

This code insures that the chimney is built high enough so that any sparks or fire will not come into contact with the roof.

SUMMARY

Codes were made to protect the consumer by making sure all buildings are constructed pretty much the same (uniform). This is done by following the best codes for the type of building at that time.

As construction improves, the codes will change, keeping the methods of construction uniform all over the country.

Assignment

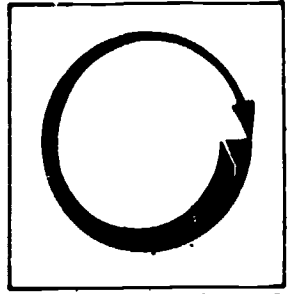

COMPLETE THE FOLLOWING ASSIGNMENT.

Material

Revised edition UBC

1. Write out one code for two of the following that you think are important.
Why?
 - a. masonry
 - b. hangars, air-craft
 - c. motion picture machine booth
 - d. demolition

Post Assessment

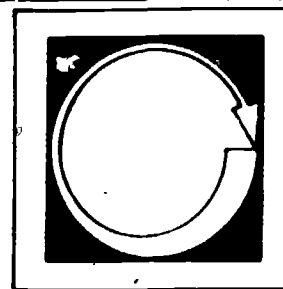

LISTED BELOW ARE STATEMENTS FOLLOWED BY A NUMBER OF POSSIBLE COMPLETIONS. SELECT THE COMPLETION WHICH COMPLETES THE STATEMENT CORRECTLY AND PLACE THE LETTER IN THE BLANK PROVIDED.

1. _____ The UBC covers
 - a. fire
 - b. life
 - c. structural safety
 - d. all of the above

2. _____ In situations concerning building, the inspector has the same powers as a
 - a. fireman
 - b. police officer
 - c. minister
 - d. all of the above

3. _____ Chimneys shall be designed, anchored, supported and reinforced so that they:
 - a. won't fall over
 - b. will be strong sturdy structures
 - c. function as the book says

4. _____ The footing is required to be a certain size so that:
 - a. it is thick and wide enough to support the weight
 - b. it will use up concrete
 - c. it will withstand nuclear attack

5. ___ Chimney angles do not exceed 45 degrees because it
- a. may prevent proper circulation
 - b. may slant
 - c. both a and b
6. ___ Chimneys must extend no less than 2 feet above or 10 feet away because
- a. the wind might blow them over
 - b. sparks may cause a fire
 - c. you can then see a chimney from the front of your house.

Instructor Post Assessment Answers

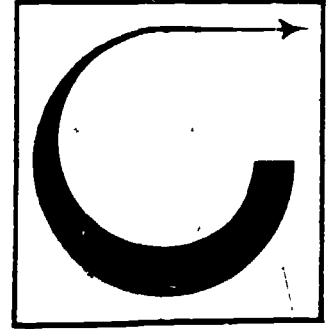

1. d

2. b

3. b

4. a

5. a

6. b

FIREPLACE FOOTINGS

Goal:

The student will be able to explain why a footing is structurally sound and will demonstrate the procedure.

Performance Indicators:

The student will complete an Assignment and a Post Assessment.

Study Guide

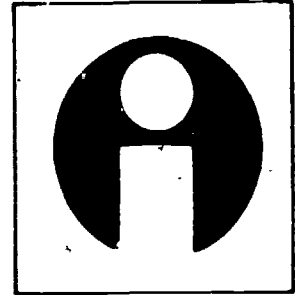

In order to finish this module, do the following tasks. Check each item off as you complete it.

1. ___ Read the Goal and Performance Indicators on the cover of the module. This will tell you what you will learn by studying the module, and how you will show you've learned it.
2. ___ Read the Introduction. The Introduction will tell you why the module is an important part of the bricklaying trade.
3. ___ Study the Vocabulary section. Vocabulary words are important for a good understanding of the trade. After you have studied the vocabulary, ask your teacher to quiz you on the words and their meanings.
4. ___ Study the Information section. This section will give you the information you need to understand the subject.
5. ___ Do the Assignment page. Follow the instructions at the top of the Assignment page.
6. ___ Take the Post Assessment exam. Give the exam to your teacher after you have completed it. Your teacher will grade it for you.

Introduction

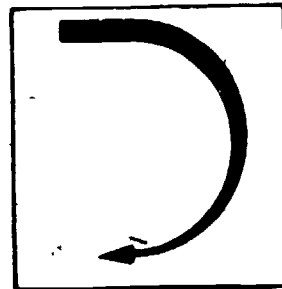

Fireplaces are becoming more popular because of the high cost of heating. Along with the heating value of a fireplace, it also increases the beauty and value of a building.

This section will deal not with the fireplace but with the footing on which the fireplace sits. Because of the great weight that will be resting on the footing, the footing must be strong and immobile (non-movable).

Vocabulary

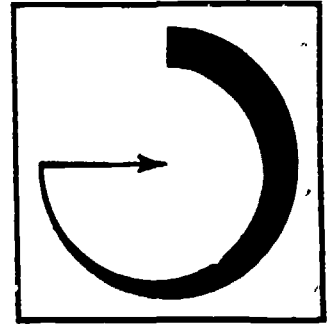

Trade terms are very important for good understanding of the trade. Study these words and meanings. When you have learned them, ask your teacher to quiz you on the words and their meanings.

PSF--Per square foot

EXPANSIVE--Soil that expands and contracts with moisture.

Supplementary References

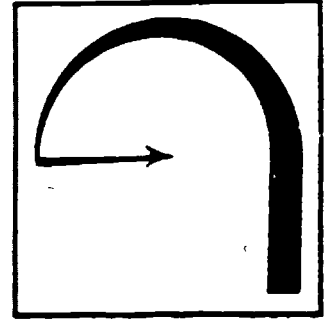

1. IMAT Brick and Block Construction, Vol. III. Taylor and Randolph, 1977.
pp. 210-212.
2. Uniform Building Code. Chapter 37. Masonry Chimneys and Fireplaces, 1979.

Information

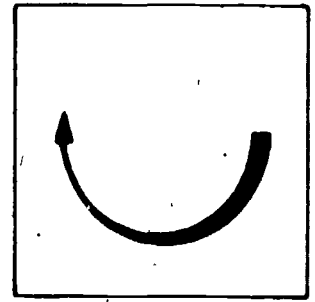

Although bricklayers rarely build a fireplace footing, it is important that they be familiar with it. This is because once the fireplace is built on it, it more or less becomes the bricklayer's responsibility.

First of all, the soil should be checked to see if it can withstand the weight. The weight is the combination of the footing (that weighs an average of 144 lbs. PSF), and the fireplace, which weighs approximately 70 lbs. per gross cubic foot.

Expansive soil should be avoided; that is soil that is made of clay. This soil cracks when it dries (shrinks) and expands when it gets wet. Expansive soil may cause cracks in the fireplace and the building foundation.

The fireplace footing is required by code to be at least 8" thick for single standing fireplaces, and 12" thick for multiple standing fireplaces (when one is above the other). It must also extend at least 6" past the fireplace foundation walls. (See the illustration on the following page.)

The footing should be poured separately from the building's foundation walls. Cracks may be caused if an uneven load is placed on the foundation if they are poured together.

Fireplace footing is for the fireplace only. Other loads, such as floor loads, should not be rested on the 6" lip.

Footings must withstand large loads so it is important that they are constructed correctly, from the proper type soil to the differences in thickness. Even though bricklayers do not usually build the footings, it is important that they know how they are built correctly so that damage to the fireplace will not result.

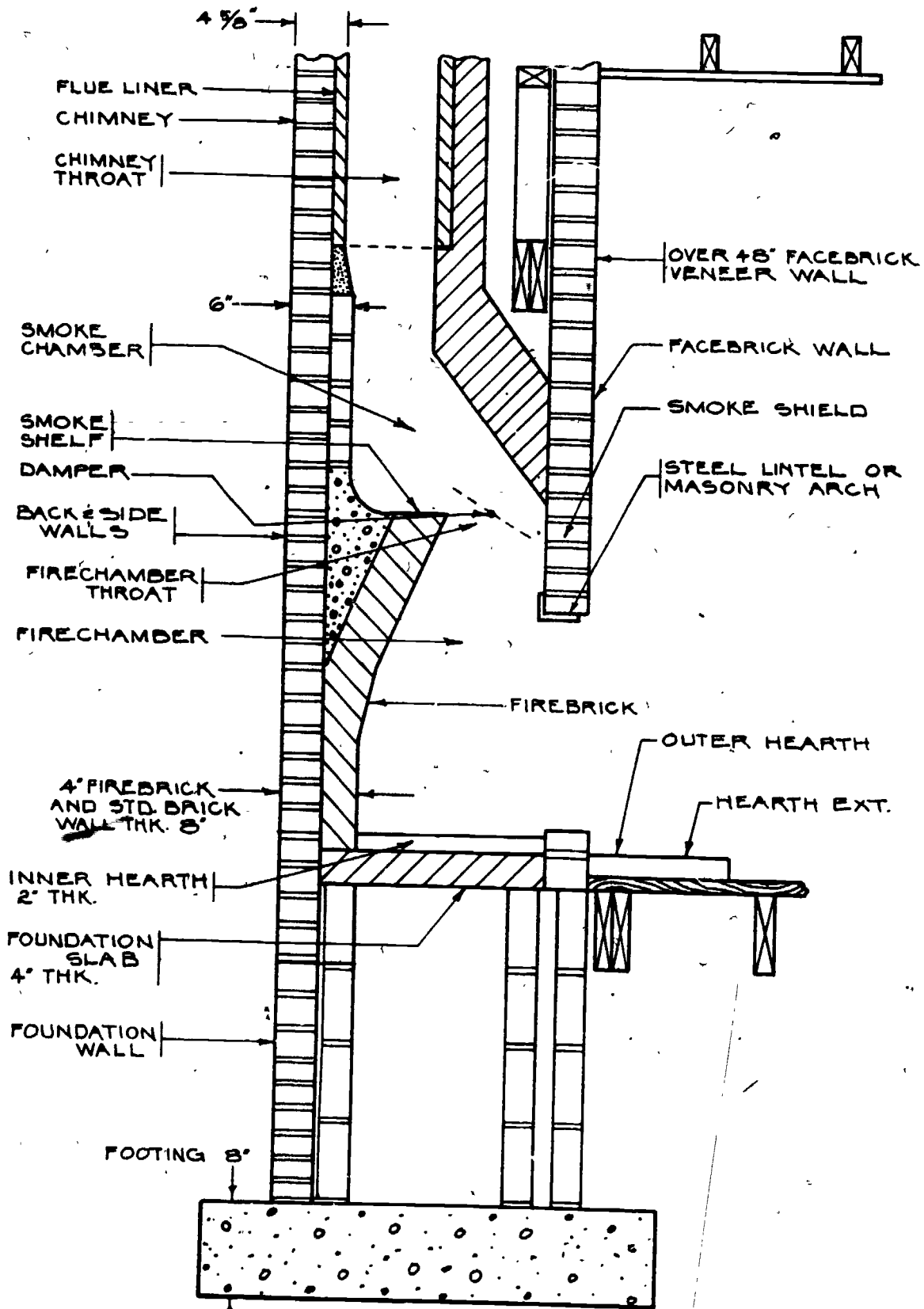

CROSS SECTION SHOWING
FOOTING, FOUNDATION, FIREPLACE,
AND CHIMNEY

Assignment

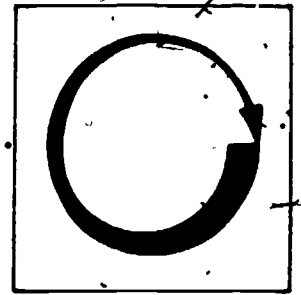

FROM WHAT YOU HAVE STUDIED IN THE INFORMATION SECTION, DO THE FOLLOWING TASK.

1. Visit a construction site where a fireplace is being built. Compare the footing you see with what you have read in this section. Tell your teacher the differences you see, or write a report.

Post Assessment

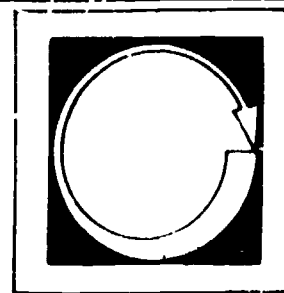

LISTED BELOW ARE STATEMENTS FOLLOWED BY A NUMBER OF POSSIBLE COMPLETIONS. SELECT THE COMPLETION WHICH COMPLETES THE STATEMENT CORRECTLY AND PLACE THE LETTER IN THE BLANK PROVIDED.

1. ____ The first thing that should be checked for a footing is the
 - a. soil
 - b. concrete
 - c. wood around it

2. ____ A fireplace weighs approximately ____ per gross cubic foot.
 - a. 200 lbs.
 - b. 144 lbs.
 - c. 70 lbs.

3. ____ The fireplace footings weighs approximately _____ per square foot.
 - a. 2000
 - b. 144
 - c. 70

4. ____ A footing is required by code to be at least _____ inches thick.
 - a. 12
 - b. 8
 - c. 3 5/8

5. ____ A footing should extend approximately 6" beyond the _____.
 - a. building foundation walls
 - b. fireplace foundation wall
 - c. neither a or b

- 6 _____ If a building foundation and footing are poured together, an uneven load set on it may cause
- a. explosions
 - b. earthquakes
 - c. cracks

Instructor Post Assessment Answers

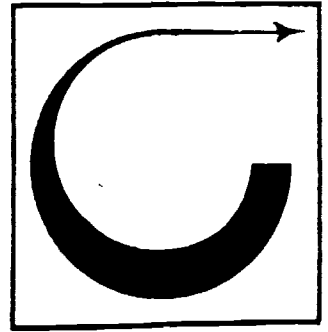

1. a
2. c
3. b
4. b
5. b
6. c

260 263

FIREPLACE FIREBOX

Goal:

The student will be able to build a fire-box with the correct type of brick.

Performance Indicators:

The student will complete a Self Assessment, a Job Sheet and a Post Assessment.

261

264

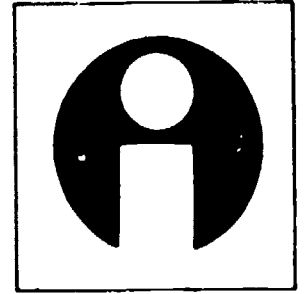

Study Guide

In order to finish this module, do the following tasks. Check each item off as you complete it.

1. Read the Goal and Performance Indicators on the cover of the module. This will tell you what you will learn by studying the module, and how you will show you've learned it.
2. Read the Introduction. The Introduction will tell you why the module is an important part of the bricklaying trade.
3. Study the Vocabulary section. Vocabulary words are important for a good understanding of the trade. After you have studied the vocabulary, ask your teacher to quiz you on the words and their meanings.
3. Study the Information section. This section will give you the information you need to understand the subject.
4. Take the Self Assessment exam. This is a test for you to prove to yourself that you have learned the material you have studied. Compare your answers with the answers on the Self Assessment Answer Sheet, which is on the page following the Self Assessment. If you scored poorly, re-study the Information section or ask your teacher for help.
5. Do the Job Sheet. Follow the instructions at the top of the Job Sheet. The tasks listed on the Job Sheet will help you develop skills which will be helpful to you.
6. Take the Post Assessment exam. Give the exam to your teacher after you have completed it. Your teacher will grade it for you.

Introduction

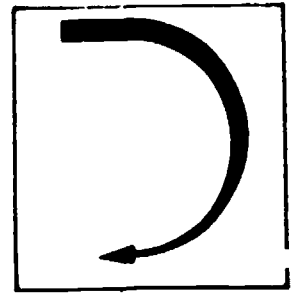

The opening in the fireplace where the fire is built is called the firebox.

The firebox is made up of side walls and the inner hearth. Each firebox must be built to plans and specifications, but some building requirements apply to nearly all fireplaces. The section will cover these requirements.

Vocabulary

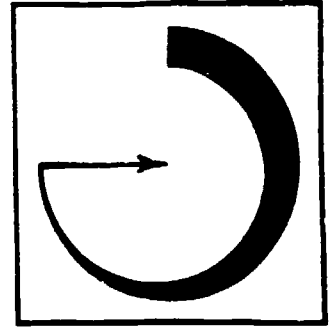

Trade terms are very important for a good understanding of the trade. Study these words and meanings. When you have learned them, ask your teacher to quiz you on the words and their meanings.

COMPOSITION--What the material or unit is made of.

SEQUENCE--In the proper order.

Supplementary References

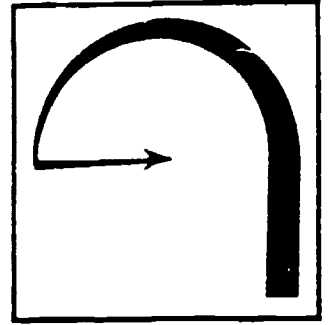

1. IMAT Brick and Block Construction Vol. III. Taylor and Randolph, 1977.
pp. 226-234.
2. Uniform Building Codes - Chapter 37. Masonry Chimneys and Fireplaces.
Based on the 1976 Oregon Structural Code. Printed - 1979.

Information

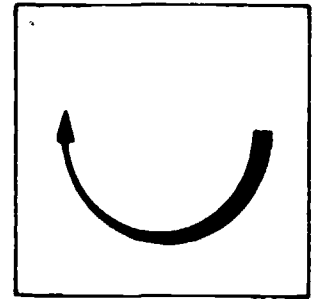

After the fireplace foundation walls are built up high enough to enclose the firebox, an inner foundation is built up to support the firebox. This is built with regular block or brick to the proper height. A concrete slab is then poured, or it may be decked off with 75% solid block where the firebox will sit.

The inner hearth is then laid

There are two different methods used for the hearth. Some bricklayers use no mortar, but lay the bricks tight against each other. Other bricklayers use mortar. With the mortar method, joints should be very tight--3/16" or less. Tight joints reduce chances of heat or fire from escaping from the firebox. The fire brick are laid to cover the entire floor area of the firebox.

Firebrick is made from clay or shale that is almost completely free of impurities. Firebrick can withstand temperatures of 2,200°F. or more, depending on the composition.

The side and the back walls are laid on the firebrick hearth. (See the illustration at the top of the following page.)

First, the firebox walls are laid out. The outer part of the firebox will be the same size opening as the face of the fireplace (interior measurements). On most fireboxes the side walls are 2 to 2 1/2 firebricks deep. The building code calls for the depth to be not less than 18" from the inside of the face.

Side walls should slant inward to the back wall. (Shown in Figure 1.) The side walls are laid up 4 courses. After the 4th course, the back wall slants in, toward the front. The back wall must slant in for the damper to rest on

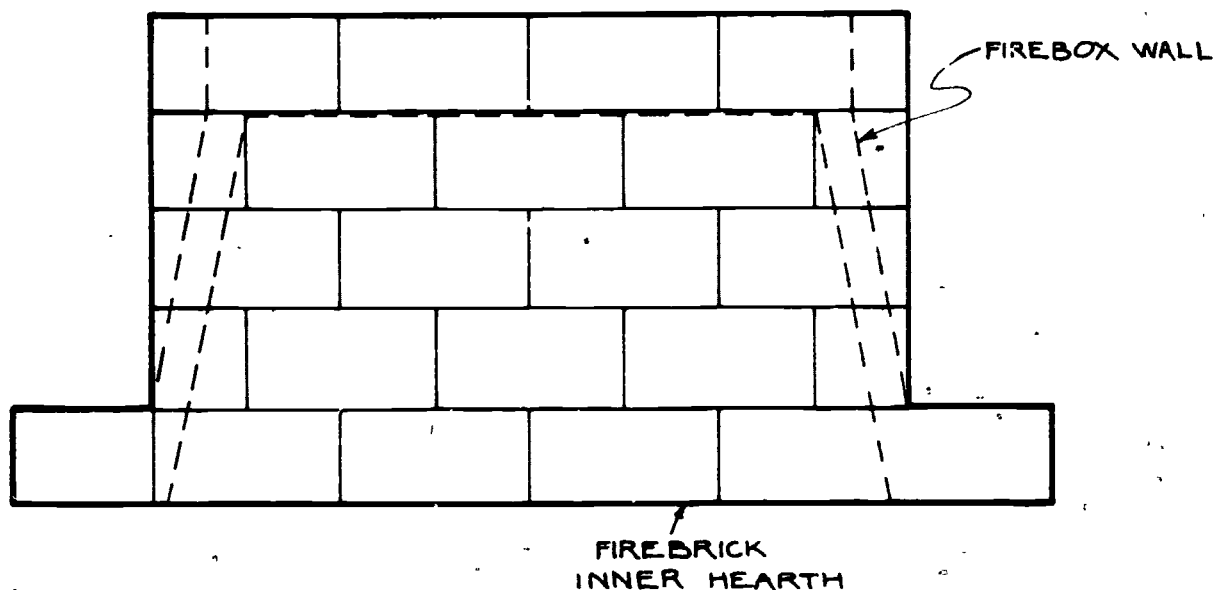

the top. An average damper depth is 10 inches. This means that the back wall must slant in from the original depth to the 10" size.

By laying out and cutting the side walls dry to the required slope, it is possible to lay up side walls and use the side walls as a guide to lay the back wall, too. This is done by laying out the fire brick to the specified depth and height; usually 9 bricks. Measure over on the top of the brick the depth of the damper and place a mark. Using a straightedge, mark with a heavy duty pencil a line from this mark to the lower corner (shown in Figure 2). This is the slope, but only for one side.

After a brick is cut, place it on a full brick and mark the cut with a pencil on the other brick. This is the proper slope for the other side. (See the illustration at the top of the following page.)

Be sure to number the bricks. This will insure the bricks do not get mixed up and laid in the wrong sequence.

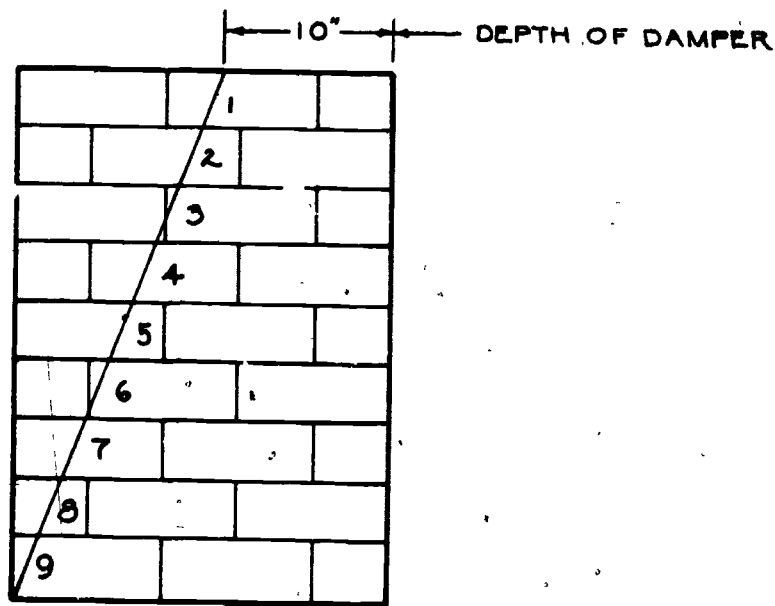

Side and back walls are laid with mortar or fireclay, making joints no more than 3/16". Fireclay is the most recommended mortar for fireboxes. Fireclay is made of the same material as firebrick.

Firebrick should be laid as tight as possible. To do this, a hammer is generally used to form the joint and align the unit. Care should be taken not to chip the brick.

Using a damp sponge or a piece of burlap, rub excess fireclay off the firebricks. Rubbing fills in small holes in the joints.

Self Assessment

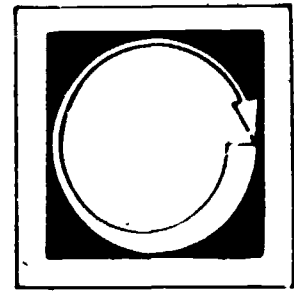

LISTED BELOW ARE STATEMENTS FOLLOWED BY A NUMBER OF POSSIBLE COMPLETIONS. SELECT THE COMPLETIONS WHICH COMPLETES THE STATEMENT CORRECTLY AND PLACE THE LETTER IN THE BLANK PROVIDED.

1. ___ The opening of the fireplace (where the fire is built) is called the:
 - a. chimney
 - b. firebox
 - c. footing

2. ___ Joints should be _____ of an inch or less.
 - a. 9/32
 - b. 7/16
 - c. 3/16

3. ___ Firebrick is made from:
 - a. clay
 - b. shale
 - c. both a and b

4. ___ Firebrick can withstand temperatures of over:
 - a. 600°
 - b. 2200°
 - c. 750°

5. ___ The side or back walls are laid on the:
 - a. building foundation
 - b. fireplace foundation
 - c. inner hearth

6. _____ The firebox opening is the same size opening as:
- a. the face of the fireplace
 - b. inner wall
 - c. side wall

270

273

Self Assessment Answers

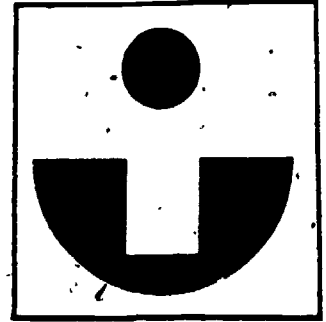

1. b

2. c

3. c

4. b

5. c

6. a

Job Sheet

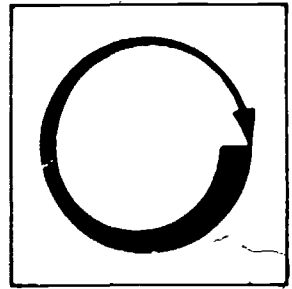

FOLLOWING THE STEPS OUTLINED IN THE INFORMATION SECTION, COMPLETE THE FOLLOWING TASK.

Materials and Tools

firebricks

saw

tape

pencil

straightedge

1. Following the steps in this section, lay out and build a firebox.

Post Assessment

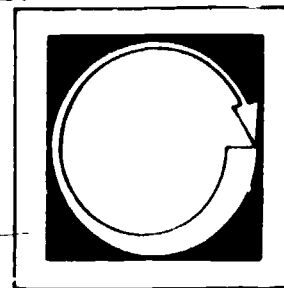

LISTED BELOW ARE SEVERAL STATEMENTS. IF THE STATEMENT IS TRUE, PLACE A "T" IN THE BLANK PROVIDED. IF THE STATEMENT IS FALSE, PLACE AN "F" IN THE BLANK.

1. ___ The average damper width is 10 inches.
2. ___ Tight joints reduce chances of heat and fire from escaping from the firebox.
3. ___ The firebricks are laid to cover the entire floor area of the firebox.
4. ___ Code calls for the depth of the firebox to be not less than 18 inches deep.
5. ___ Fireclay is the most recommended mortar for fireboxes.
6. ___ Fireclay is made up of the same material as firebrick.

Instructor Post Assessment Answers

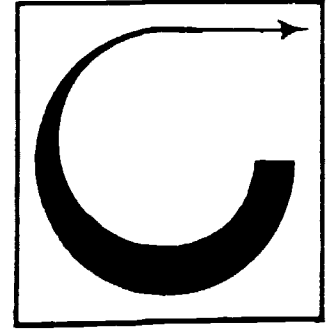

1. T
2. T
3. T
4. T
5. T
6. T

FIREPLACE SMOKESHELF

Goal:

The student will be able to identify the purpose and the placement of the smoke-shelf and will construct a smokeshef.

Performance Indicators:

The student will complete a Job Sheet and a Post Assessment.

Study Guide

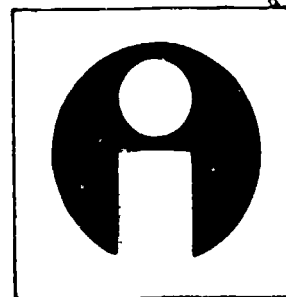

In order to finish this module, do the following tasks. Check each item off as you complete it.

1. Read the Goal and Performance Indicators on the cover of the module. This will tell you what you will learn by studying the module, and how you will show you've learned it.
2. Study the Vocabulary section. Vocabulary words are important for a good understanding of the trade. After you have studied the vocabulary, ask your teacher to quiz you on the words and their meanings.
3. Study the Information section. This section will give you the information you need to understand the subject.
4. Do the Job Sheet. Follow the instructions at the top of the Job Sheet. The tasks listed on the Job Sheet will help you develop skills which will be helpful to you.
5. Take the Post Assessment exam. Give the exam to your teacher after you have completed it. Your teacher will grade it for you.

Vocabulary

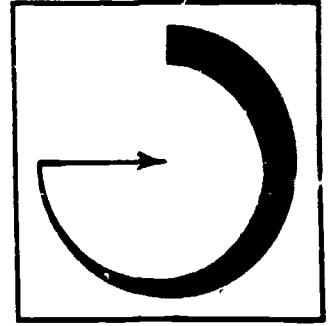

Trade terms are very important for a good understanding of the trade. Study these words and meanings. When you have learned them, ask your teacher to quiz you on the words and their meanings.

VOID--Open space

FLUE--A passageway for carrying smoke and gas vapors to the outside atmosphere.

PARGE--To spread mortar in an even coat over brick.

277 280

Supplementary References

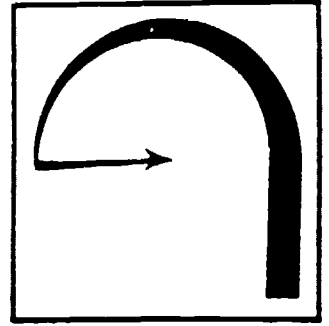

1. Brick and Block Construction. Taylor and Randolph. 1977. p. 234.
2. Uniform Building Codes. Chapter 37. Masonry Chimneys and Fireplaces.
Based on 1976 Oregon Structural Code. Printed 1976.

Information

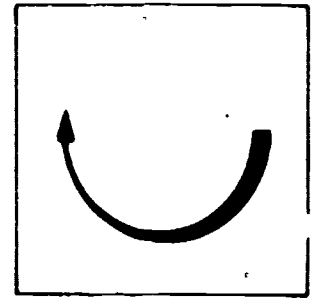

As the back wall of the firebox slopes in, it leaves a void between the back firebox wall and the back fireplace wall. This is where the smokesheff is placed. It is located in back and just below the damper.

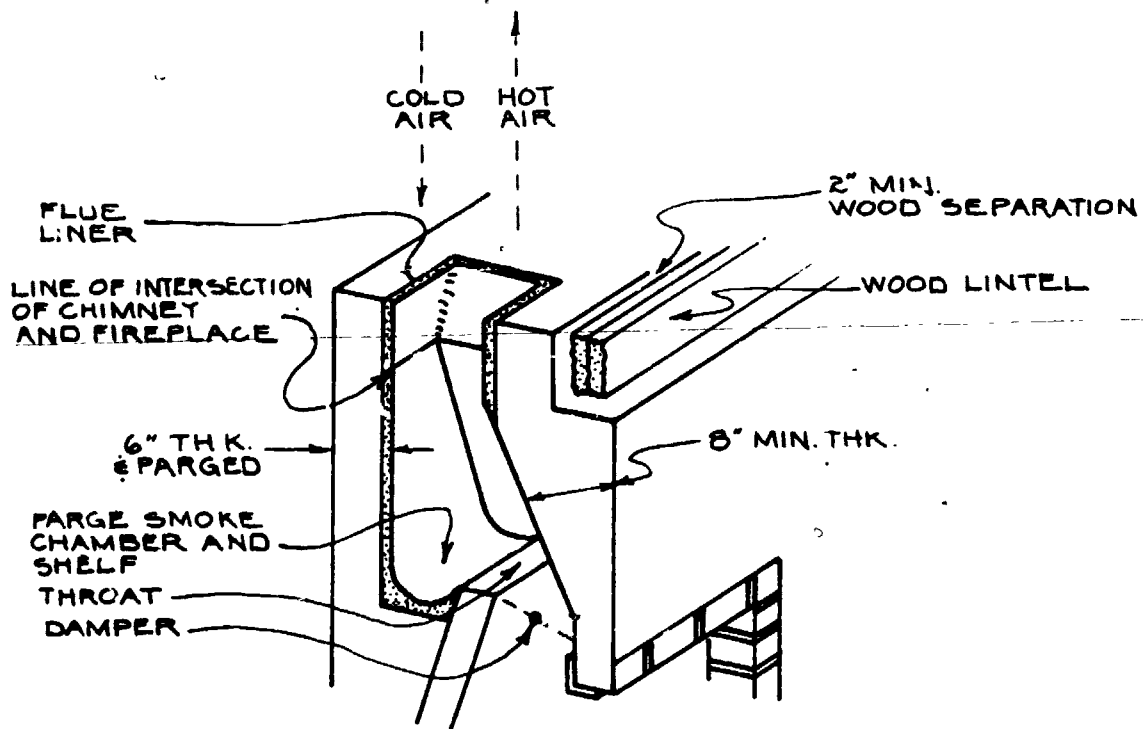

CROSS SECTION OF SMOKE CHAMBER

The smokesheff is important because it helps the continuous circulation of air within the flue. This creates what is called the chimney effect.

CHIMNEY EFFECT

As the warm air rises, it draws cold air down the flue. The warm air and cold air mix when they reach the smokesheff. This causes a draft to flow up the

chimney. When there is no warm air in the fireplace, the cold air may enter the room unless blocked by the smokesheff or damper.

The smokesheff connects the rear wall of the firebox to the fireplace. This is done by placing mortar and brick into the void to fill it up.

~~Curve the top of the smokesheff by shaping the mortar. It is also important that the rear wall be parged. (Depending on the slope and the size of the firebox wall, the smokesheff's depth varies. Usually it is anywhere from 3" to 8".)~~

The smokesheff is important in combination with the damper. If there was nothing but a big hole up to the chimney it would always be drawing warm air out. This means if there is no fire in the firebox, it will pull the warm air out of the room. The loss of warm air is avoided by the smokesheff and damper.

Job Sheet

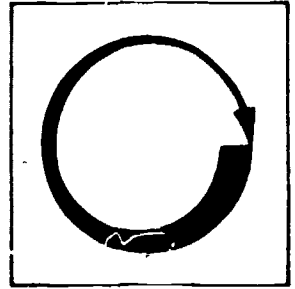

FOLLOWING THE STEPS OUTLINED IN THE INFORMATION SECTION, DO THE FOLLOWING TASK.

Materials and Tools

firebox built in previous section

mortar

common brick

1. Build a false wall on the back side of the firebox to take the place of the fireplace wall. Then build a smokesheff.

Post Assessment

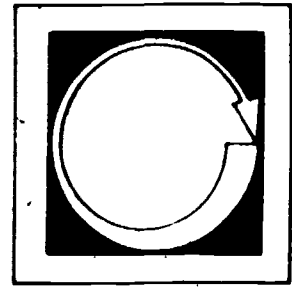

LISTED BELOW ARE SEVERAL STATEMENTS. IF THE STATEMENT IS TRUE, PLACE A "T" IN THE BLANK PROVIDED. IF THE STATEMENT IS FALSE, PLACE AN "F" IN THE BLANK.

1. The smokeshelf is placed between the rear fireplace wall and the back wall of the firebox.
2. The smokeshelf aids in the continuous circulation of air within the flue.
2. The smokeshelf connects the rear wall of the fireplace to the side wall of the firebox.
4. The void between the firebox and fireplace wall is filled with tar and a solution of acetic acid.
5. The smokeshelf and damper prevent warm air from escaping when there is no fire in the firebox.
6. Warm air rises.

Instructor Post Assessment Answers

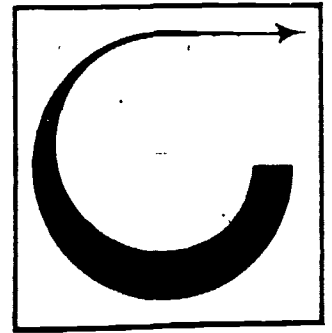

1. T
2. T
3. F
4. F
5. T
6. T

FLASHING

Goal:

The student will be able to install flashing on a chimney and explain the purpose of flashing.

Performance Indicators:

The student will complete a Job Sheet and a Post Assessment.

284

287

Study Guide

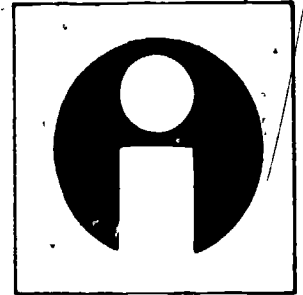

In order to finish this module, do the following tasks. Check each item off as you complete it.

1. Read the Goal and Performance Indicators on the cover of the module. This will tell you what you will learn by studying the module, and how you will show you've learned it.
2. Study the Vocabulary section. Vocabulary words are important for a good understanding of the trade. After you have studied the vocabulary, ask your teacher to quiz you on the words and their meanings.
3. Study the Information section. This section will give you the information you need to understand the subject.
4. Do the Job Sheet. Follow the instructions at the top of the Job Sheet. The tasks listed on the Job Sheet will help you develop skills which will be helpful to you.
5. Take the Post Assessment exam. Give the exam to your teacher after you have completed it. Your teacher will grade it for you.

Vocabulary

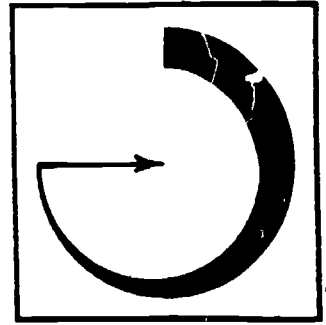

Trade terms are very important for a good understanding of the trade. Study these words and meanings. When you have learned them, ask your teacher to quiz you on the words and their meanings.

PREFABRICATED--Made before, or put together before use.

Supplementary References

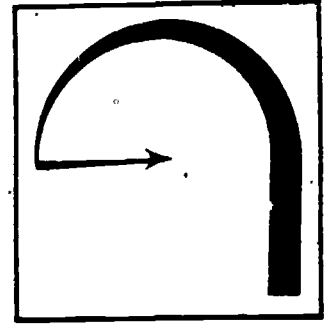

IMAT; Brick and Block Construction. Taylor and Randolph, 1977. pp. 260-262.

Information

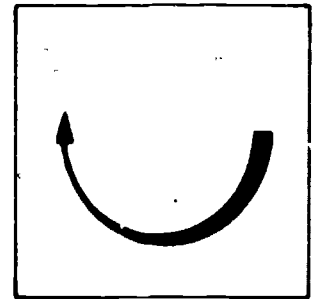

It is important that a bricklayer understand how to flash a chimney properly. This will insure that no moisture (rain, snow, condensation) will enter the structure through the hole where the chimney meets the roof line.

Flashing is made from corrosive-resistant material such as zinc, lead or copper.

Flashing must be installed properly to avoid leaks. This is done by placing the base flashing on the roof.

1. This piece must extend 3 to 4" up the side of the chimney and must extend at least 4" onto the roof.

The counter flashing extends down from the chimney and laps over the base flashing. The top of the counter flashing is embedded into the bed joints of the chimney. Edges of the flashing and counter flashing should be sealed to form weather-tight joints. (See the illustration at the top of the following page.)

Unless the flashing is prefabricated, the bricklayer must cut and shape the sheet metal to form flashing and counter flashing. Flashing is usually installed in this manner:

1. The base flashing is cut (unless prefabricated) and bent at a 90-degree angle so that it will extend up the side of the chimney 3 to 4" and onto the roof 4 to 8".
2. It is placed around the entire chimney.
3. The base flashing is bonded to the roof with nails and a specified adhesive.
4. After the base flashing is in place, the counter flashing is installed.
5. First the counter flashing for the front of the chimney is placed. It is bent in the same manner as the base flashing. It extends from a bed joint above the base flashing and over it.

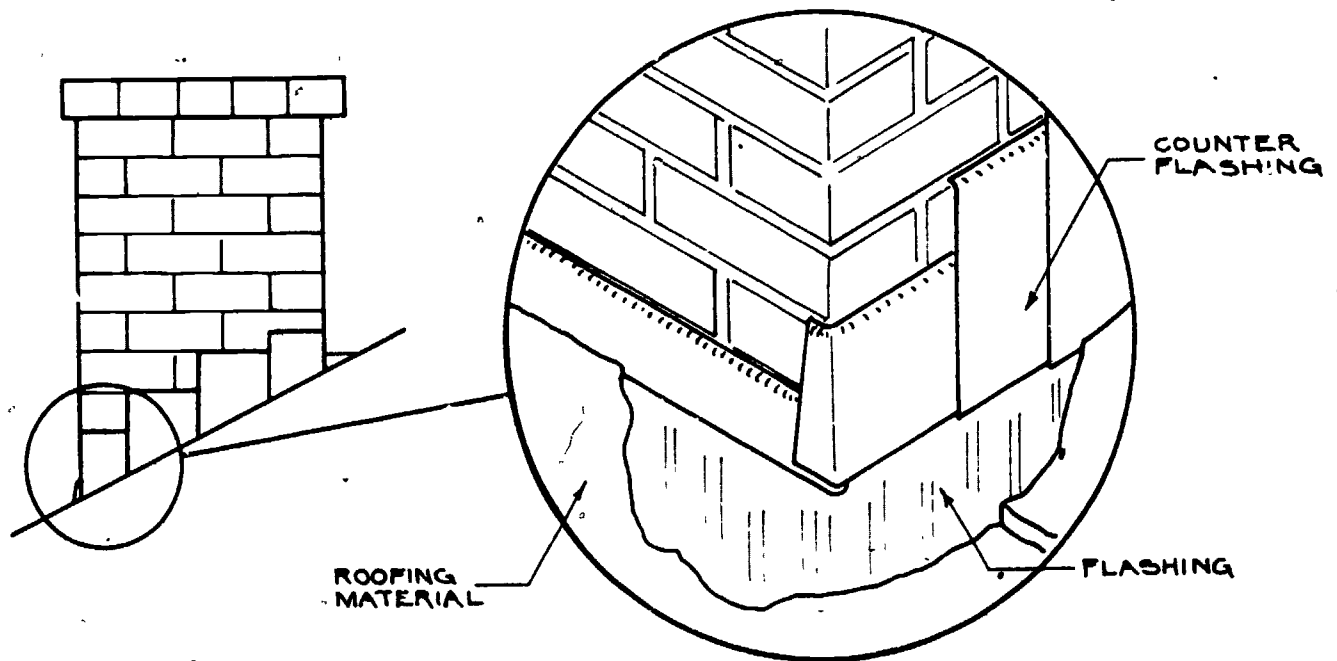

6. Masonry units are laid on top of the counter flashing.
7. Next, the front corners of the chimney are covered with counter flashing; then the sides, and finally the back.

To shape corners on the counter flashing, a "V" is cut on the bed joint side. This will allow the counter flashing to bed around the corner without buckling.

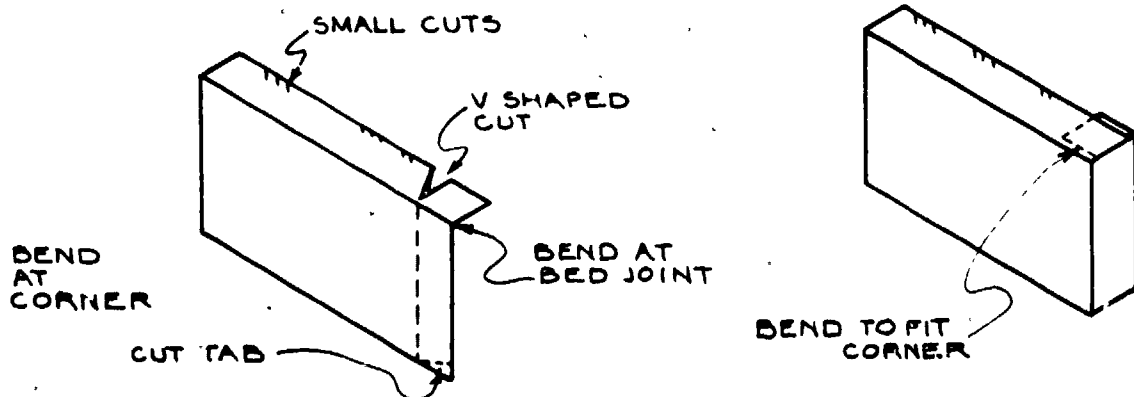

On the sides of the chimney it may be necessary to use several pieces of counter flashing. These pieces are called "shingles." These shingles can all be cut to the proper size by doing the following:

1. Draw an outline of the chimney.

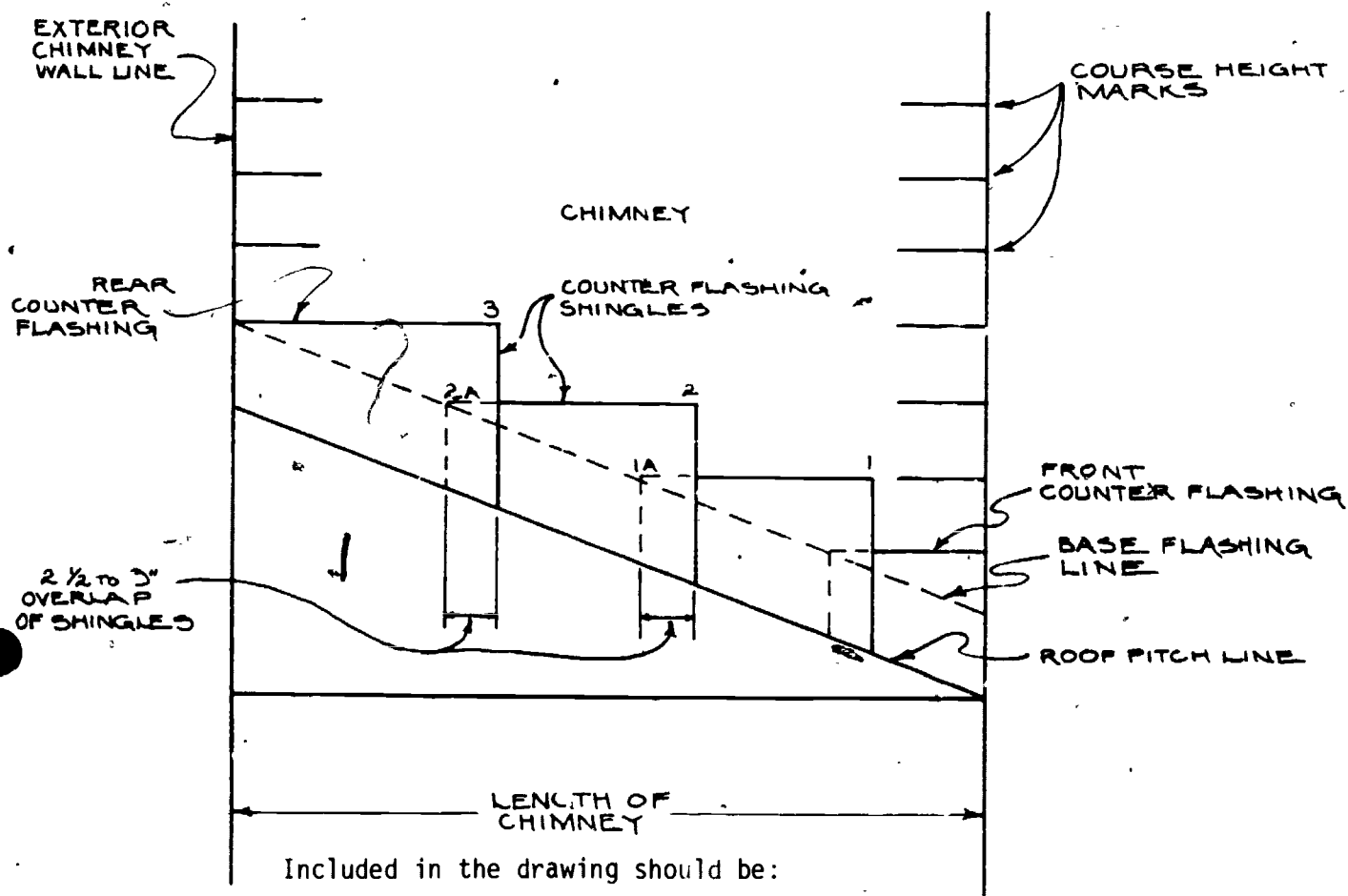

Included in the drawing should be:

- a. the length of the chimney.
- b. the height of the base flashing.
- c. several courses of the chimney.
- d. the pitch of the roof.

2. Measure and mark off the shingles on the layout.

Start at point 1 (shown in Fig. 3). Measure to point 1a, which touches the base flashing. The second shingle is measured from 2 to 2a. Point 2 should overlap point 1a at least 2 to 3". Continue this process for the entire length of the chimney.

Measure each shingle from the point of overlap to the point where that shingle touches the base flashing. The last shingle is overlapped by the rear counter flashing.

Job Sheet

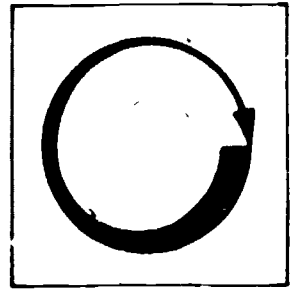

FOLLOWING THE STEPS OUTLINED IN THE INFORMATION SECTION, DO THE FOLLOWING TASK.

Tools and Materials

flashing (roll)

tin snips

straightedge

1. Layout and flash the chimney built in the previous section. The roof has a 4/12 pitch--that is, for every 12 inches, it slants up 4 inches.

Post Assessment

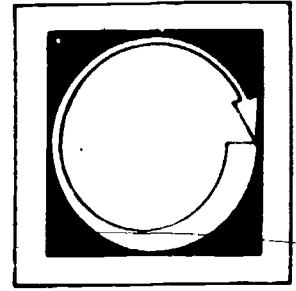

LISTED BELOW ARE SEVERAL STATEMENTS. IF THE STATEMENT IS TRUE, PLACE A "T" IN THE BLANK PROVIDED. IF THE STATEMENT IS FALSE, PLACE AN "F" IN THE BLANK.

1. ____ When flashing is installed properly, moisture penetration will be prevented.
2. ____ Flashing is made from corrosive-resistant materials.
3. ____ The counter flashing is embedded into the bed joints.
4. ____ The base flashing is bonded to the roof with nails and a specified adhesive.
5. ____ The pieces of counter flashing that cover the sides of the chimney are called shingles.
6. ____ The last shingle is overlapped by the rear counter flashing.
7. ____ In most cases, water will run uphill.
8. ____ Flashing must be installed properly to avoid leaks.
9. ____ When laying out flashing, the bricklayer should compensate for the curvature of the earth.

Instructor Post Assessment Answers

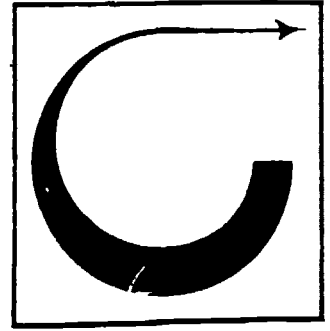

1. T

2. T

3. T

4. T

5. T

6. T

7. F

8. T

9. F

ARTISTIC MASONRY

Goal:

The student will be able to identify different types of artistic masonry and be able to explain the basics of how the work is done.

294

Performance Indicators:

The student will complete a Self Assessment, a Job Sheet and a Post Assessment.

297

Study Guide

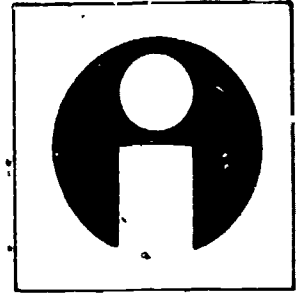

In order to finish this module, do the following tasks. Check each item off as you complete it.

1. ___ Read the Goal and Performance Indicators on the cover of the module. This will tell you what you will learn by studying the module, and how you will show you've learned it.
2. ___ Read the Introduction. The Introduction will tell you why the module is an important part of the bricklaying trade.
3. ___ Study the Vocabulary section. Vocabulary words are important for a good understanding of the trade. After you have studied the vocabulary, Ask your teacher to quiz you on the words and their meanings.
4. ___ Study the Information section. This section will give you the information you need to understand the subject.
5. ___ Take the Self Assessment exam. This is a test for you to prove to yourself that you have learned the material you have studied. Compare your answers with the answers on the Self Assessment Answer Sheet, which is on the page following the Self Assessment. If you scored poorly, re-study the Information section or ask your teacher for help.
6. ___ Do the Job Sheet. Follow the instructions at the top of the Job Sheet. The tasks listed on the Job Sheet will help you develop skills which will be helpful to you.
7. ___ Take the Post Assessment exam. Give the exam to your teacher after you have completed it. Your teacher will grade it for you.

Introduction

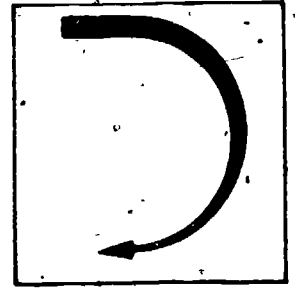

Brickwork is limited only by the imagination of the bricklayer. Walls can be made to curve; brick can appear to be suspended in the air, and pictures may even be embedded into the brick. This section will explain how some of this advanced work is done.

Vocabulary

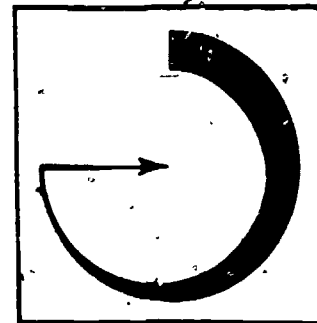

Trade terms are very important for a good understanding of the trade. Study these words and meanings. When you have learned them, ask your teacher to quiz you on the words and their meanings.

BAY--One full curve.

SCRIBE--To draw around.

FLUSH--To lay evenly with.

Supplementary References

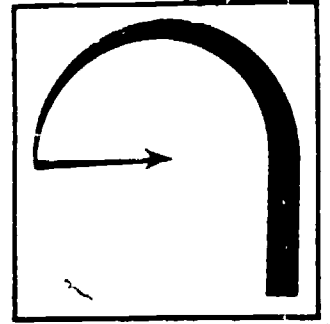

Brick and Block Construction. I.M.A.T. Volume II and III. Taylor and Randolph.
Volume II - pp. 82-146. Volume III - pp: 3-28. 1976-1977.

Information

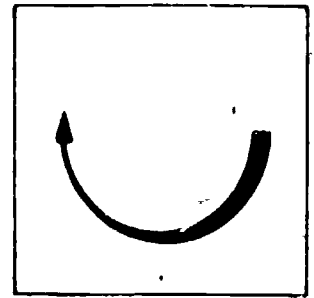

A serpentine wall is easily identified by its "S" shape or a series of connecting curves. This type of wall is generally used as a fence or decorative divider. Because of its shape, a serpentine wall, when constructed properly, will be more sturdy than a straight wall of the same thickness. On each end of the wall a pilaster should be built to help steady the wall.

In order to lay out a serpentine wall it is necessary for the bricklayer to know different types of dimensions. (These are in addition to length and height dimensions):

- a. Center line.
- b. Radius point.
- c. Radius lines.
- d. Arc.
- e. Depth.
- f. Span.

CENTER LINE

This is a straight line extending the length of the wall. It marks the center of the wall and the starting point of each bay.

Radius Point

A radius point is the center of the circle for the arc. Each bay has its own radius point. Usually, radius points are uniformly located o.c. (on center) along the length of the center line.

Radius Line

The radius line is the distance from the radius point to the arc of the bay. These points are usually the same.

Arc

The arc is the wall line. To get a continuous wall line, the arcs are connected with the radius line. Units are laid flush with the wall line.

Depth

The depth is the distance between the center line and the farthest point. This is known as the crown.

Span

The span is the distance along the center line from one bay to the next. It is used to check the layout of the wall. If the radius lines are all equal, the span of the bays will be equal.

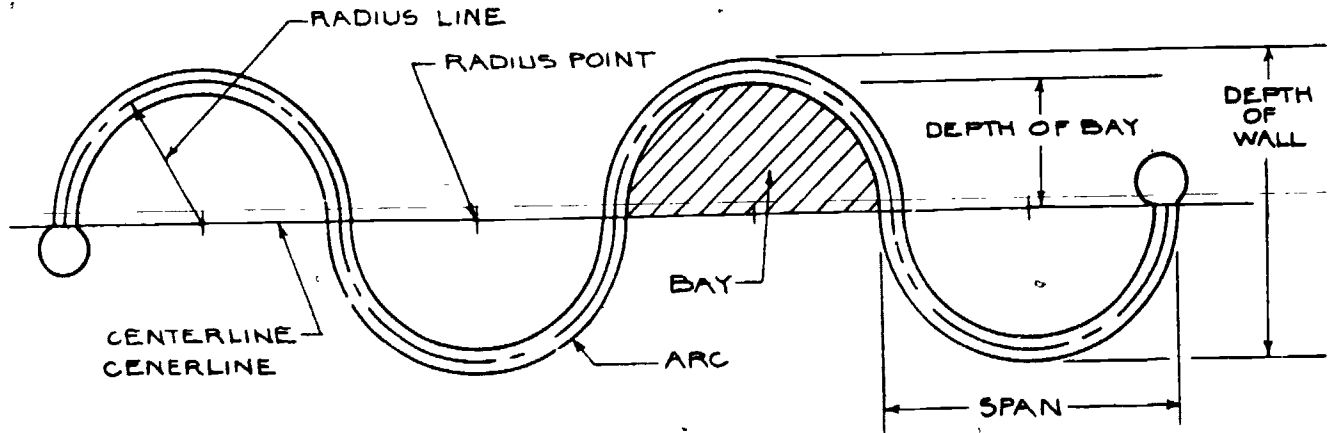

LAYOUT

The following procedure can be used to lay out a serpentine wall that has semi-circular bays with radius points located 8 feet o.c. along the center line.

1. Locate and mark center line. (See figure below.)



2. Locate and mark the length of the wall points a and b.
3. Measure and mark radius points. Using a ruler, mark the radius points on the center line 8 feet o.c.
4. The radius line is a piece of line (string) that has been marked to the exact distance of the radius. One end is looped around a nail at the radius point. By stretching the line tight, it can be used as a compass to mark the arc for the bay.

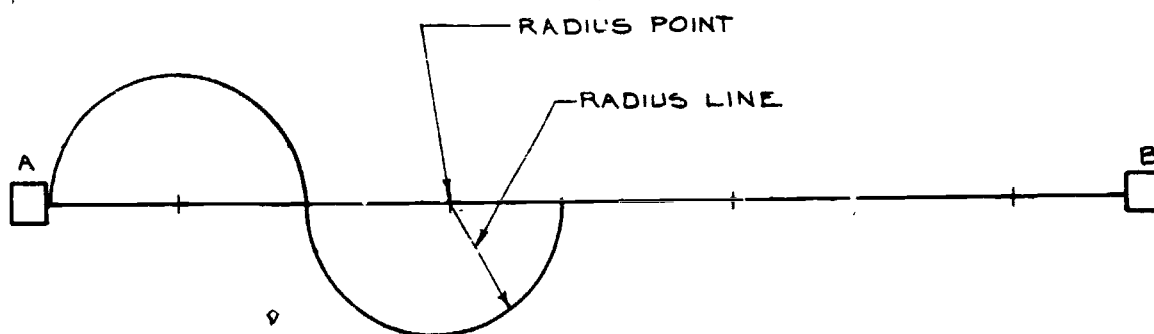

5. Marking the arc: Holding a heavy duty pencil on the opposite end of the radius line, mark the first arc. Be sure the pencil or marker is held straight up and down (vertical). Alternating from one side of the center line to the other, mark the arcs for the rest of the length of the wall.

The units must be laid flush with these lines. Units should be laid out dry to establish the bond.

Serpentine walls must be plumb and level and to proper course heights. To obtain proper course height, a story pole or a spacing rule is used. For proper aligning, a level and a template are used. The template is a piece of wood (or rigid material) cut to the same arc as the wall line. Plumb points are used. (See the illustration on the following page.)

At these points, the bricks are leveled and plumbed. The template is then held up to the points to align the remainder of the units. (See the second illustration on the following page.)

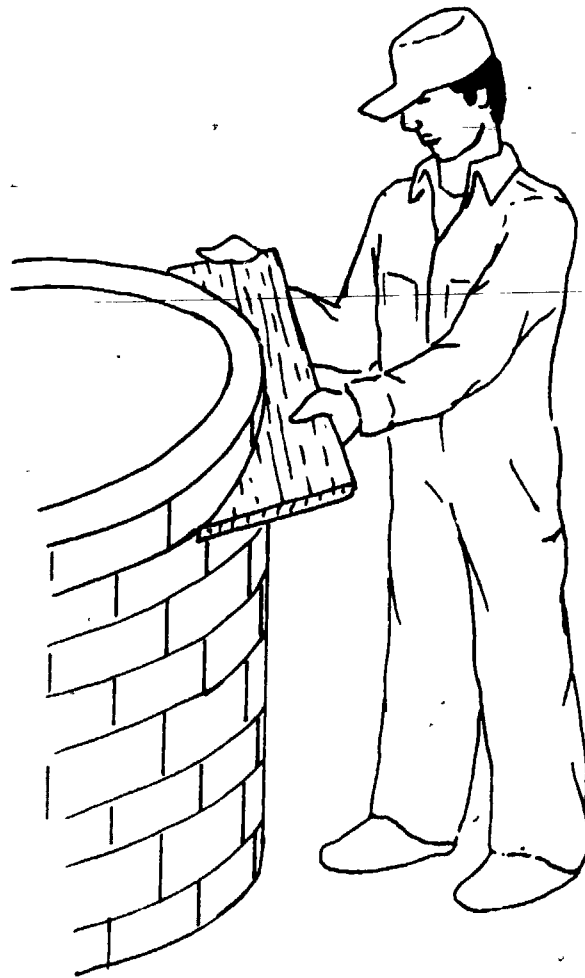
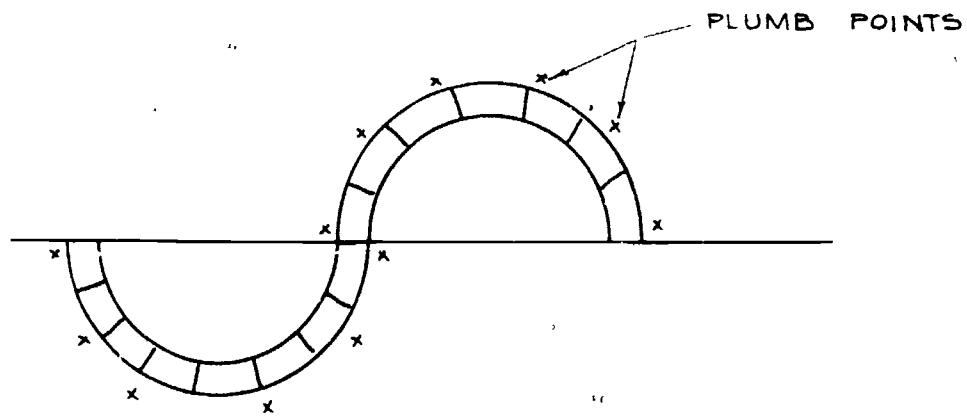

It is important that serpentine walls be laid out and built properly to give the wall a uniform, flowing effect, instead of a choppy, short-angled effect.

ARCHES

Arches can be used for decorative purposes such as windows, tops of walls and fireplace openings. Arches may also be used for structural purposes, such as roofs and bridges.

Arches have great load-bearing capability. They can hold a great amount of weight. This is because of the curvature of the arch and the masonry unit. A solid masonry unit is difficult to crush. The curvature of the arch compresses (forces) the units together, spreading the weight through the whole arch.

Arches can be built in many different shapes and sizes. The difference in the curve of the arch is the difference of the type of arch. Half or semi-circles are called Roman Arches. Multi-center (more than one center) arches are called elliptical arches. As the arch or span changes, so does the name.

Parts of an Arch

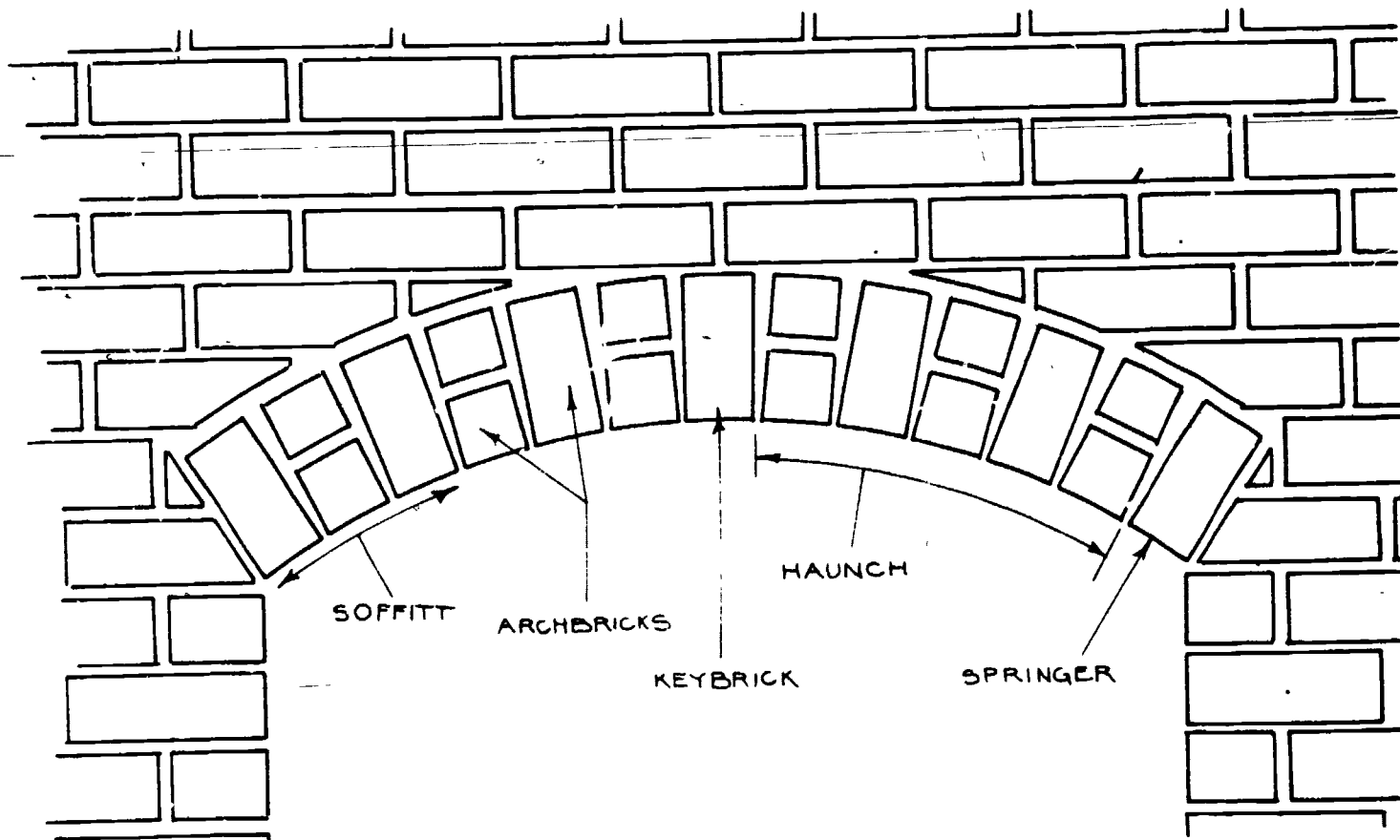

1. Crown: The crown of the arch is the highest point of the arch ring. It is also known as the apex.
2. Arch Brick: Arch brick are the units that make up the arch.
3. Keybrick: The keybricks are the bricks that wedge the arch brick into a stable position. They are usually laid at the crown of the arch.

4. Springer: The springer is the first unit laid on both ends of the arch.
5. Soffitt: The soffitt is the surface or face on the inner ring.
6. Haunch: The haunch is the part of the ring between the keybrick and the end of the arch ring. There is a left and a right haunch.

Layout and Constructing the Arch

After the piers or jams are built for the arch to rest on, a form for the arch must be built. This form is made from plywood. The form should be the same size as the distance between the inner jams. The center point is then established and marked on the plywood. This is the radius point. A radius line is then marked and an arc line is drawn onto the plywood. This arc is then cut out of the sheet of plywood.

Place the cutout arc on top of ~~another sheet of plywood~~ and scribe the arc onto the second sheet. Then cut out the second arc. These two plywood arcs are then connected together--separated by 2 X 4 studs a little smaller than the width of the units to be laid.

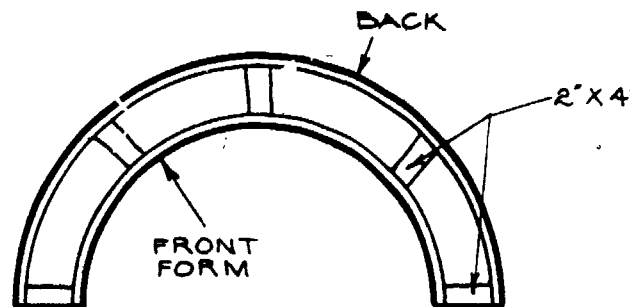

Be sure the studs are flush with the top of the plywood.

The brick spacing is then marked out onto the form, using a spacing rule. The form is then set between the jams or supporting walls using kickers to hold up the form. (The kickers are wood studs cut one joint higher (3/8") than the jams or supporting walls.)

The forms and the kickers should be braced so that they are immobile (can't be moved). The bricks or units are then laid with mortar up both sides of the form to the top where the key or wedge bricks are laid. Use no mortar between form and brick. Be sure to follow spacing mark to avoid having a cut brick on top.

After the arch has been built, ~~the joints must be tooled.~~ If the supporting walls or jams are sturdy, the forms may be removed after the key bricks are laid. Because of the weight and curvature of the arch, the units will compress against each other and support themselves. Care should be taken in tooling joints in the soffitt to prevent moving the units.

Self Assessment

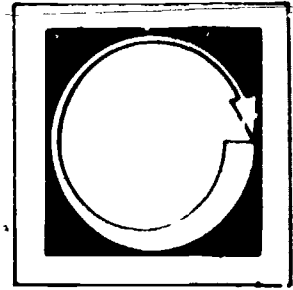

LISTED BELOW ARE STATEMENTS FOLLOWED BY A NUMBER OF POSSIBLE COMPLETIONS. SELECT THE COMPLETION WHICH COMPLETES THE STATEMENT CORRECTLY AND PLACE THE LETTER IN THE BLANK PROVIDED.

1. ___ Serpentine walls are identified by:
 - a. the "S" shape
 - b. the "T" shape
 - c. the "L" shape

2. ___ If constructed properly, a serpentine wall is _____ than a straight wall.
 - a. just as strong
 - b. weaker
 - c. sturdier

3. ___ The center line:
 - a. marks the center of the wall
 - b. is a straight line extending the length of the wall.
 - c. both a and b

4. ___ The arc is:
 - a. the wall line
 - b. the distance between the center line and the farthest point
 - c. both a and b

5. ___ One end of the radius line is:
 - a. looped around a nail at the radius point
 - b. used for marking the arc.
 - c. both a and b

6. _____ To obtain proper coarse heights, a:

- a. spacing ruler is used
- b. a story pole is used
- c. either a or b

7. _____ A template is made out of:

- a. wood
- b. rigid material
- c. both a and b

Self Assessment Answers

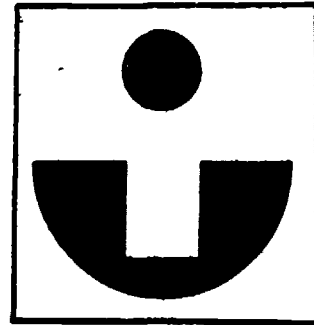

1. a

2. c

3. c

4. a

5. c

6. c

7. c

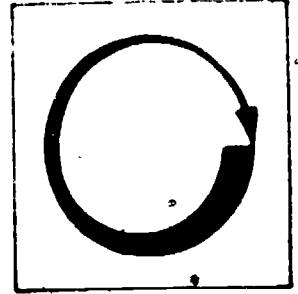

Job Sheet

FOLLOWING THE STEPS OUTLINED IN THE INFORMATION SECTION, DO ONE OF THE FOLLOWING TASKS.

Materials and Tools

materials and tools used in bond section

brick

ruler

pencils

plywood, 2 X 6 lumber

nails

- a. Layout and build a serpentine wall.
- or
- b. Layout and build an arch.

Post Assessment

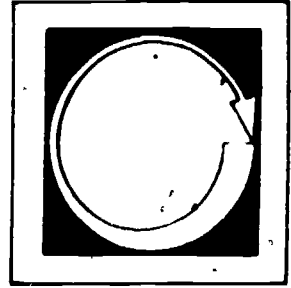

LISTED BELOW ARE STATEMENTS FOLLOWED BY A NUMBER OF POSSIBLE COMPLETIONS. SELECT THE COMPLETION WHICH COMPLETES THE STATEMENT CORRECTLY AND PLACE THE LETTER IN THE BLANK PROVIDED.

1. ____ The crown is the:
 - a. lowest point of the arch ring
 - b. highest point of the arch ring
 - c. mid-point of the left haunch

2. ____ The keybrick is:
 - a. a brick shaped like a key
 - b. a brick that wedges the arch brick into position
 - c. neither a nor b

3. ____ The center point marked on the plywood for the arch is:
 - a. radius point
 - b. the arc
 - c. both a and b

4. ____ Kickers are
 - a. plastic blocks
 - b. wood studs cut to height
 - c. special shoes

5. ____ After the arch is built, the joints are:
 - a. removed
 - b. tooled
 - c. neither a nor b

6. ____ After the keybricks are laid:
- a. the forms may be removed
 - b. they should be removed and cleaned up
 - c. more forms are added
7. ____ Care should be taken in tooling joints in the soffitt:
- a. to prevent fire by rubbing bricks together
 - b. to prevent moving the units
 - c. neither a nor b

Instructor Post Assessment Answers

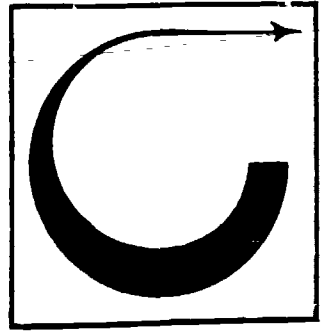

1. b

2. b

3. a

4. b

5. b

6. a

7. b

315

312