

DOCUMENT RESUME

ED 213 892

CE 031 566

AUTHOR Hamblen, Ron
TITLE Floor Covering Pre-Apprenticeship Phase 2 Training. Student Training Modules.

INSTITUTION Lane Community Coll., Eugene, Oreg.
SPONS AGENCY Employment and Training Administration (EOL), Washington, D.C.; Oregon State Dept. of Education, Salem.

PUB DATE 81
NOTE 386p.; For related documents see CE 031 561-579.

EDRS PRICE MF01/PC16 Plus Postage.
DESCRIPTORS Behavioral Objectives; *Building Trades; Carpeting; Check Lists; *Flooring; *Floor Layers; Job Skills; Learning Activities; Learning Modules; Pacing; Postsecondary Education; Tests; *Trade and Industrial Education; Two Year Colleges; Vocabulary
IDENTIFIERS *Preapprenticeship Programs

ABSTRACT

These 21 Student Training Modules on floor covering comprise one of nine sets of self-paced learning modules developed for Pre-Apprenticeship Phase 2 Training. (A companion instructor's guide is available separately as CE 031 565.) The modules are designed to impart trade knowledge and skills to the student. Each module contains some or all of the following: cover sheet listing module title, goals, and performance indicators; study guide/checklist with directions for module completion; introduction; vocabulary listing and defining new trade or technical terms; supplementary references; information sheet(s) providing information and graphics covering the module topic(s); self-assessment; self-assessment answers; assignment sheet(s); job sheet(s) listing materials and tools necessary to complete tasks designed to develop manipulative skill; post assessment; and post assessment answers. Topics covered in the module include resilient sheet materials and tiles; adhesives; carpet materials; padding materials; plastic laminates; surface preparation; layout; installing wall base and cutting tile; spreading adhesives; installing vinyl-asbestos tile; seaming sheet goods; installing sheet covering; installing tack strip; installing padding; cutting, trimming, and seaming carpet; using knee kicker and power stretcher; installing carpeting; measuring and cutting plastic laminate and metal trim; router and power tools; and installing plastic laminate. (YLB)

* Reproductions supplied by EDRS are the best that can be made *
* from the original document. *

ED213892



PRE-APPRENTICESHIP PHASE 2 TRAINING Student Training Modules

Floor Covering

U.S. DEPARTMENT OF EDUCATION
NATIONAL INSTITUTE OF EDUCATION
EDUCATIONAL RESOURCES INFORMATION
CENTER (ERIC)

This document has been reproduced as received from the person or organization originating it. Minor changes have been made to improve reproduction quality.

- Points of view or opinions stated in this document do not necessarily represent official NIE position or policy.

"PERMISSION TO REPRODUCE THIS MATERIAL HAS BEEN GRANTED BY

C Hostrup

TO THE EDUCATIONAL RESOURCES INFORMATION CENTER (ERIC)."

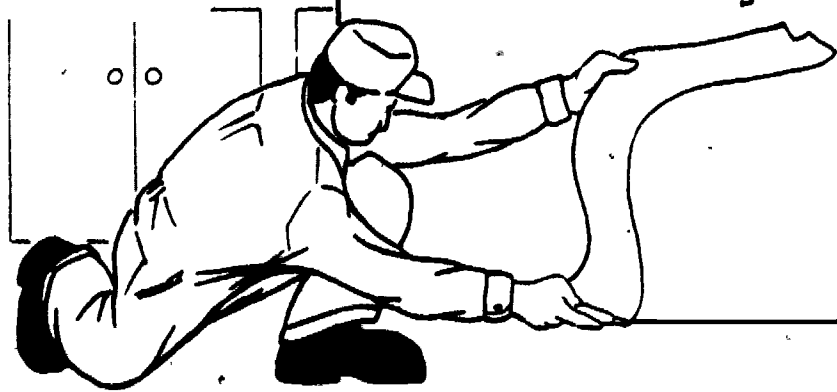
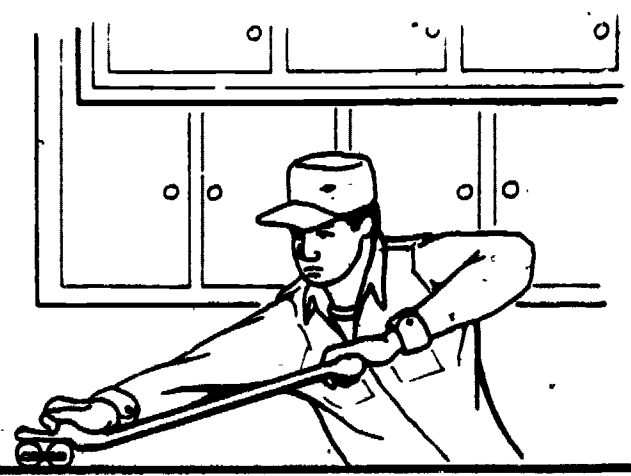

CE 03/56

Floor Covering Module Writer:

Ron Hamblen

Technical Assistance:

Doug Dinsmore

Graphics: Ralph Bentley

Editorial, Proofreading and Pasteup:

Debi Carroll, Shannon Kracht

Typing:

Strandlien Typing Service

This project was developed under a sub-contract for the Oregon Department of Education by Lane Community College, Community Education Division, Eugene, Oregon. Funds were provided by the Governor of Oregon from the Educational Linkages Component of the CETA Governor's Grant.

STATEMENT OF ASSURANCE

It is the policy of the Oregon Department of Education that no person be subjected to discrimination on the basis of race, national origin, religion, sex, age, handicap or marital status in any program, service or activity for which the Oregon Department of Education is responsible. The Department will comply with the requirements of state and federal law concerning non-discrimination and will strive by its actions to enhance the dignity and worth of all persons.

Lane Community College

4000 E. 30th Avenue
Eugene, Oregon 97405
(503) 726-2200

Office of the President

July 27, 1981

On behalf of Lane Community College, I wish to express our pride and gratitude for the opportunity to participate in the development of the Pre-Apprenticeship training materials. We also wish to commend the Oregon Department of Education for its original concept and continued support; and, the Educational Linkages Component of the CETA Governor's Grant for funding.

The goals of this project are many, but none are more important than that of producing valid, understandable vocational curriculum material. We congratulate the tradespeople and production staff for their accomplishments.

Finally, I recommend this material to anyone exploring Pre-Apprenticeship as an entry into the vocational work world, with the hope and belief that it will go a long way toward producing skilled craftspeople who are dedicated to their work.

Sincerely,

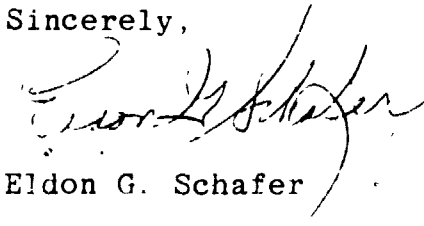

Eldon G. Schafer

COMMON RESILIENT SHEET MATERIALS

Goal:

The student will be able to identify common sheet material coverings used in floor laying and explain their proper use.

Performance Indicators:

The student will successfully complete a Self Assessment, an Assignment and a Post Assessment.

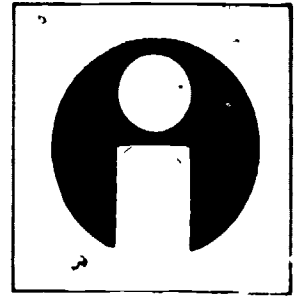

Study Guide

In order to finish this module, do the following tasks. Check each item off as you complete it.

1. Read the Goal and Performance Indicators on the cover of the module. This will tell you what you will learn by studying the module, and how you will show you've learned it.
2. Read the Introduction. The Introduction will tell you why the module is an important part of the floor laying trade.
3. Study the Vocabulary section. Vocabulary words are important for a good understanding of the trade. After you have studied the vocabulary, ask your teacher to quiz you on the words and their meanings.
4. Study the Information section. This section will give you the information you need to understand the subject.
5. Take the Self Assessment exam. This is a test for you to prove to yourself that you have learned the material you have studied. Compare your answers with the answers on the Self Assessment Answer Sheet, which is on the page following the Self Assessment. If you scored poorly, re-study the Information section or ask your teacher for help.
6. Do the Assignment page. Follow the instructions at the top of the Assignment page.
7. Take the Post Assessment exam. Give the exam to your teacher after you have completed it. Your teacher will grade it for you.

Introduction

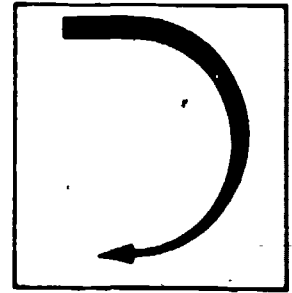

Many floors have resilient sheet coverings because it is easy to take care of this kind of floor. Resilient sheet coverings come in many colors and patterns. They resist water or other liquids spilled on them. Resilient floor coverings come in two forms: sheet and tile. Sheet coverings come in a roll. Resilient tile will be covered in another module.

The floor layer has to know how to spread this very common floor covering. This module has information on the kinds and different uses of resilient sheet floor coverings.

Vocabulary

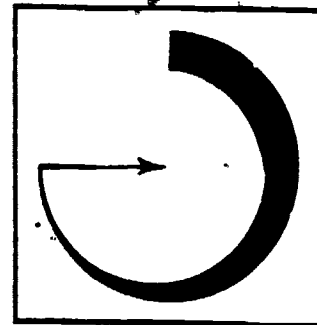

Trade terms are very important for a good understanding of the trade. Study these words and meanings. When you have learned them, ask your teacher to quiz you on the words and their meanings.

RESILIENT--Has "give" in it so it can "bounce" back into original condition.

A sharp blow will damage it.

UNDERLAYMENT--A material, often particle board, that is put over the subfloor.

Floor covering is laid on the underlayment.

ADHESIVE--Used to attach covering to underlayment or subfloor if underlayment is not used.

MASTIC--Same as adhesive.

VINYL--Man-made plastic material used to make sheet floor covering.

BOND--To attach or fasten things together, often with glue.

SEAM--Place where two pieces of flooring material are joined.

ON GRADE--At ground level.

ABOVE GRADE--Above ground level.

SUSPENDED--Same as above grade.

BELOW GRADE--Below ground level.

GAUGE--Thickness of the wear layer of vinyl sheet goods.

SHEET GOODS--Any floor covering material that comes in a roll.

PATTERN REPEAT--Distance on sheet goods before the pattern repeats itself.

Most common is a repeat in the pattern every 9 inches.

CUSHION--A layer under the vinyl pattern. It absorbs sound and makes the flooring material more resilient.

LINOLEUM--Flooring material that is no longer being made.

INSTALL--To put in a finished floor

INLAID VINYL--Resilient flooring material made with vinyl chips and heat

- PRINT VINYL--Resilient flooring material. Printing may be done by rotogravure with vinyl inks or by a stencil process with vinyl granules.
- ROTOGRAVURE--Printing done with a special printing press.
- VINYL GRANULES--Very small pieces of colored vinyl material.
- HYDROSTATIC PRESSURE--Pressure created by water in a concrete slab as the water rises to the surface of the slab.
- COVE FLASHING--Technique of curving sheet goods up the side of the wall to get rid of the "corner." Makes cleaning easier.
- SUBFLOOR--The construction floor on which underlayment and finished floor are installed. May also refer to everything underneath the flooring material being installed.
- WEAR LAYER--Protective surface or coating added to a resilient flooring material.
- MANUFACTURER'S SPECIFICATIONS--What the maker of the product says can (or cannot) be done with the product.
- PERFECTS--A roll that is not less than 30 yards long. Contains at least 60 to 80 square yards. Must be in one piece and without serious mistakes.
- SECONDS--A roll without any flaws serious enough to affect the use of the product. Must be all one piece. No manufacturer's warranty.
- REMNANTS--Roll with 2 to 6 pieces of the same pattern. No piece is smaller than 6 square yards. Colors do not have to be matched perfectly as to shade.
- MILL TRIALS--A roll of material that was made at the start of a run. Patterns may be off register. Shade may also be off.
- CUTTINGS--Imperfect material. Pieces are in sizes from 2 to 6 square yards.

Supplementary References

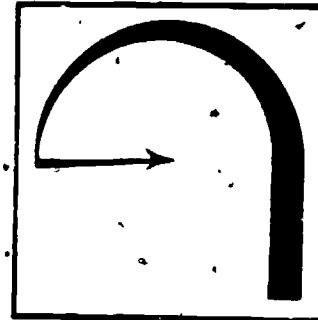

1. Floor Coverings. Fairchild Market Research Division. Scribner. 1978

Information

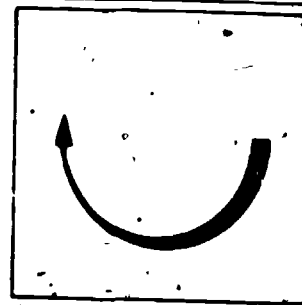

Rolls of resilient floor coverings can be different lengths and widths. Vinyl is the most popular kind of resilient floor covering. One roll may weigh as much as 700 pounds. The most common widths are 6 feet and 12 feet; less common widths are 9 feet and 15 feet. Most rolls are from 60 to 100 feet long.

These numbers are important because one example of installing a good floor is using as few seams as possible. If a room is 12 feet wide, a good floor installation would use one piece of the 12-foot sheet flooring. Using two pieces of 6-foot sheet flooring would mean making a seam that might pick up dirt and make the floor look bad.

Sheet goods should always be stored on end and rolled up, with the face (or pattern surface) on the outside. This is how the dealer gets it from the manufacturer. Before the manufacturer ships any goods, they are graded as to quality.

The grades are:

1. perfects.
2. seconds.
3. remnants.
4. mill trials or cuttings.

Only "perfects" have a manufacturer's warranty.

Most modern vinyl flooring has a built-in cushion. The overall thickness and quality of the flooring depends on the type and use recommended by the manufacturer. The salesperson's job is to match these things with the customer's needs. The three main things that determine price are:

1. depth of cushion.
2. gauge of wear layer.
3. method of manufacturing.

Vinyl sheet floor coverings have improved so much that older products have been priced off the market. Vinyl has replaced linoleum. Today, the only time a floor layer will work with linoleum is when an old floor is being removed to spread a new vinyl floor.

MODERN VINYL FLOORS ARE MADE IN TWO WAYS

Inlaid

Colored vinyl chips are heated and pressed together. A wear layer is on top. The color goes all the way through to the backing.

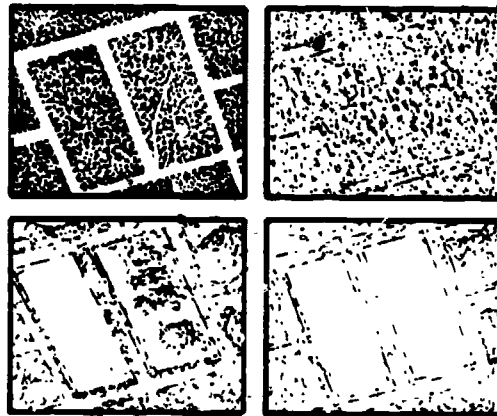
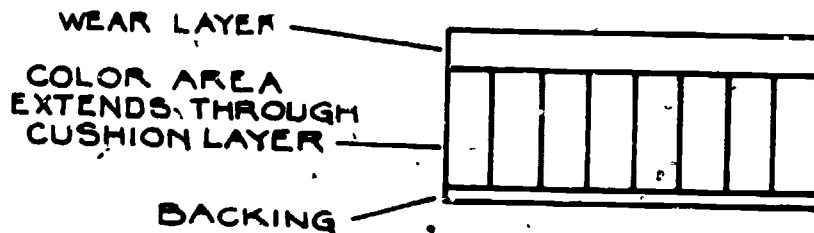

Print

There are two ways of making vinyl print floor covering. They are the rotogravure method and the stencil method.

- a. Rotogravure--Vinyl ink and a printing press are used to make the pattern.
- b. Stencil--A stencil is used to shape vinyl granules into the pattern.

As with inlaid vinyl floor covering, print vinyl has a wear surface on top, and a cushion layer. Heat is used to make the cushion layer expand.

(See illustration on following page.)

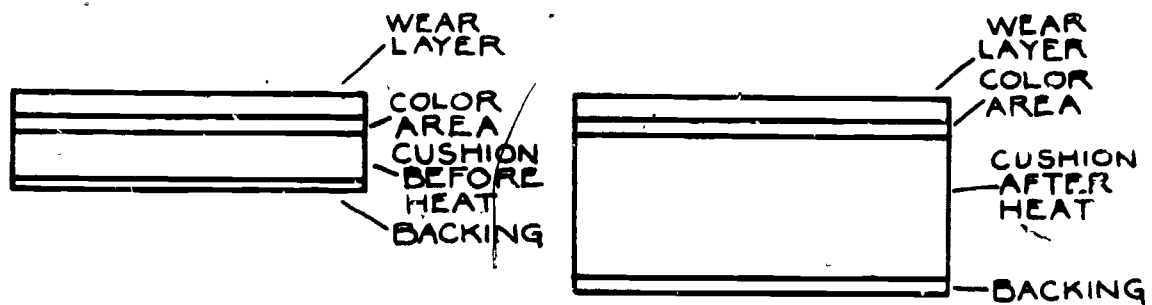

SOME ADVANTAGES OF RESILIENT SHEET FLOORING

1. Can resist water. It is good for kitchens, bathrooms and laundry rooms.
2. Roll widths up to 12 or 15 feet are available. Many floors can be spread without any seams.
3. Many colors and patterns are available.
4. Relatively low cost of materials and installation.
5. Repeating pattern can give a floor a decorative "all over" look.
6. Sheet flooring can be "flushed" (curved up the wall) to make cleaning easier.
7. Seams can be made waterproof.

SOME DISADVANTAGES OF RESILIENT SHEET FLOORING

1. When a "built-in" item (such as a cabinet) sticks out into a room, a piece of the sheet material has to be cut out. This creates waste. (See illustration on following page.)
2. High traffic areas wear faster. This means part of the sheet flooring may wear out before the rest does.
3. Hydrostatic pressure and water can make the flooring rot or mildew.

▨ CABINET AREAS

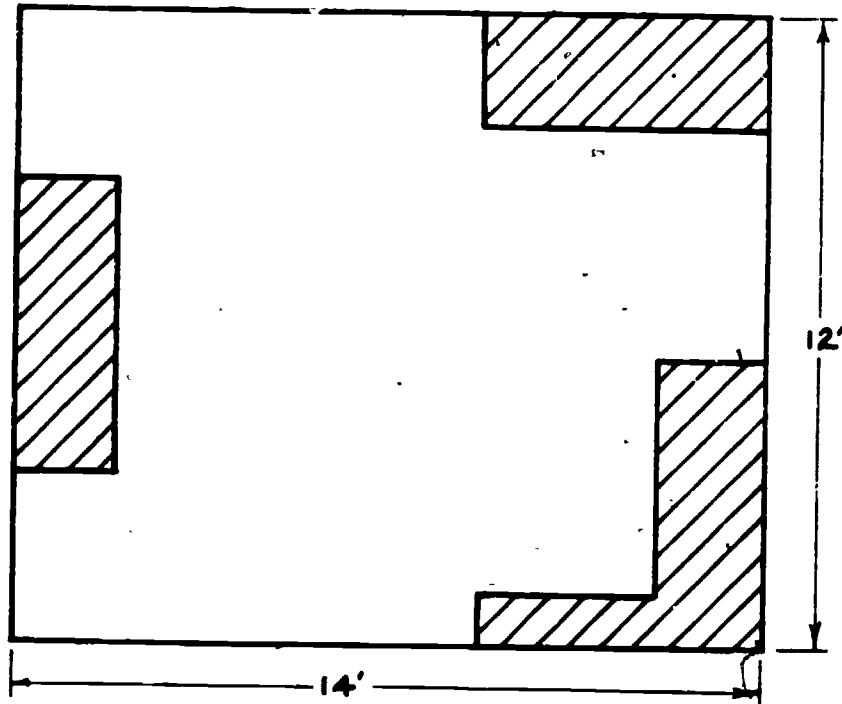

INLAID AND PRINT VINYL SHEET GOODS

In many ways, the two are much the same. Both usually have a wear layer on top and a cushion layer underneath. The "good look" of inlaid sheet goods may wear better than print vinyl. An inlaid pattern lasts longer because it is thicker. Rotogravure and stencil patterns are both surface decoration only.

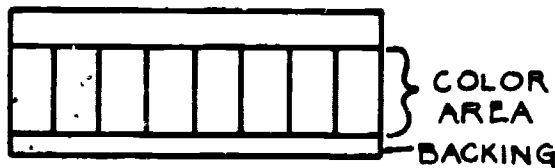

INLAID
VINYL
METHOD

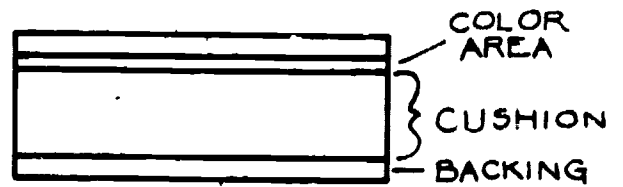

PRINT
VINYL
METHOD

Inlaid patterns resist surface tears and cuts better. But, the print vinyl methods are better for making special designs. If it can be photographed, the rotogravure method can print it on floor covering.

Both inlaid and print vinyls offer a "no-wax" wear surface. This is a special feature of many wear layers. The wear layer also can resist stains from many spilled liquids. Sometimes vinyl floor cleaners and dressings are used, even on "no-wax" wear layers.

READ THE MANUFACTURER'S SPECIFICATIONS

Manufacturer's specifications include things like:

1. The grade levels on which the flooring material was made to be installed.
2. Whether the goods are for commercial, light industrial or only residential use.
3. The thickness of the wear layer.
4. The thickness of the cushion layer.
5. Overall thickness (useful if you are trying to make a new floor level with the floor in another room).

The thickness of the cushion and wear layers will be different for different brands of floor covering goods. A thicker wear layer and cushion layer are needed in a high traffic area. More cushioning also helps to insulate against cold subfloors and helps to absorb household or industrial sounds.

Also, a moisture or dampness test may be needed on any concrete subfloor. Moisture can cause mildew or rot and can destroy the adhesive bond. Some vinyl goods have special backings (such as Hydrocord) which resist dampness. Even this kind of backing won't work where water and hydrostatic pressure can make problems.

Some sheet covering backings (such as Interflex) are made to bridge minor flaws in the subfloor surface. Other sheet coverings are made for use in areas where radiant heating is used. Flooring material which has not been rated for such use by the manufacturer may fade from the concentrated heat. These areas are

near things like hot air registers, laundry dryers and baseboard heaters. Not reading the manufacturer's specifications can make some unhappy customers.

Sheet covering is bonded to the floor with adhesive. When using adhesive, always check the manufacturer's specifications--use only recommended adhesives. Some sheet covering may only need to be bonded on the edges with a staple gun and adhesive (for hard-to-reach places). Some sheet covering does not need any bonding. This is known as "loose-laid." The method will be decided by the customer and the salesperson.

Loose-laid installation is recommended only with sheet covering made to be loose-laid. If it can be loose-laid, this will be mentioned in the manufacturer's specifications.

Many jobs will be for edge, or "perimeter," installation. This means spreading the floor covering and trimming it. Adhesive is used in places where a staple gun cannot reach. Last, the rest of the floor covering is stapled on the edges all around the room.

Some backings use asbestos as a filler because it works well to block out dampness and has a lot of "bounce" or resilience. You should check the manufacturer's specifications to determine if asbestos is present and follow recommended safety steps.

OTHER KINDS OF SHEET FLOOR COVERINGS

Static-conductive

May be made of vinyl or rubber. The floor covering keeps static electricity from causing sparks. It is used in places where explosive materials are stored or used. Operating rooms and explosives storerooms are places where static-conductive materials are used.

Seamless Resilient

This is a solid coat of material. It comes in a semiliquid state and is poured on the floor. It makes a seamless floor covering of almost any size. Seamless resilient is made with vinyl, glass fibers and resins. It can be troweled, sprayed on or brushed on. The thickness of the flooring is increased by adding more coats. It can be used anywhere, but would most often be used in very large areas where many seams would be needed with other floor coverings.

SUMMARY OF INLAID SHEET VINYL

Selling Features

- Wears well
- Bright colors
- Many patterns
- Few seams needed
- Easy to clean and to maintain
- No special finishing needed
- Ready for use when applied
- Very resistant to soil, grease, acids, alkali

Installation Features

- May be used on all grade levels
- Can be used on counter tops and walls

Common Roll Widths

6 feet and 12 feet

Thickness range

.065 inches to .140 inches

How It Wears

Depends on type and thickness of wear layer and cushion layer. The inlaid method makes a pattern that resists surface cuts and scratches.

SUMMARY OF PRINT SHEET VINYL

This material is similar to sheet inlaid vinyl. It is the way the pattern is made that is different. Print patterns can be made by rotogravure or stencil. With rotogravure printing, it is possible to take a picture of just about anything and print a floor pattern.

Selling Features

Same as inlaid.

Installation Features

Same as inlaid.

Common Roll Widths

Same as inlaid.

Thickness Range

.080 inches and .084 inches

How It Wears

Depends on type and thickness of wear layer and cushion layer. Since the pattern is only printed on, it will be damaged if the wear surface is damaged.

Self Assessment

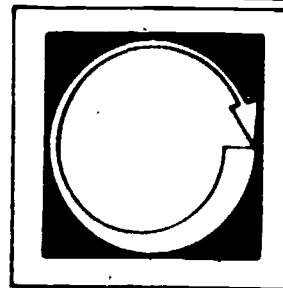

Follow the directions for each section of this Self Assessment.

1. Complete this sentence: The _____ insulates against a cold _____ and helps _____ household _____.
2. Name two rooms in which the ability of sheet covering to resist spilled liquids is useful.

3. Which resists surface tears better? (circle one)
Print vinyl Inlaid vinyl
4. What are the two most common widths of vinyl sheet goods? (circle them)
6 feet 9 feet 12 feet 15 feet 733 feet
5. Mark the following True or False by placing a "T" or "F" in the blank provided.
____ Patterns and colors in vinyl sheet goods are almost unlimited.
____ The more seams a floor has, the better the floor is.
____ Print vinyl has the pattern printed on with vinyl inks or vinyl granules.
6. Mark only those things which you would check the manufacturer's specifications to learn about.
____ Pattern repeat distance.
____ Recommended grade level for installation.
____ If the sheet material can be flashed.
____ Thickness of the wear layer.

- If the backing was made to resist dampness.
- If there is asbestos in the material.
- If the cushion will absorb household sounds.
- If the covering can be used in a kitchen.
- What kind of adhesive to use.
- If the roll is a resilient sheet covering.
- Thickness of the cushion.
- Recommendation for use near radiant heating.
- If covering can be loose-laid.
- If the design or pattern looks good.
- If the colors go with other colors in the room.

Self Assessment Answers

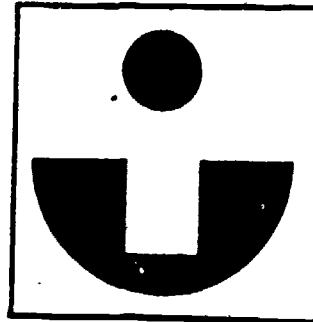

1. The cushion insulates against a cold subfloor and helps absorb household sounds.
2. kitchen, laundry room, or bathroom
3. Inlaid vinyl
4. 6 feet and 12 feet
5. T
F
T
6. a. i.
b. k.
d. l.
e. m.
f.

Following are some comments about the remaining statements.

- c. All sheet floor covering can be flashed.
- g. All cushioning absorbs sound. A thicker cushion absorbs more sound.
- h. All sheet covering can be used in a kitchen.
- j. You know this already.
- n. Customer decision.
- o. Customer decision.

Assignment

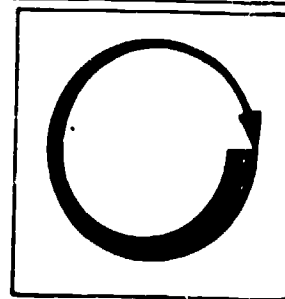

COMPLETE THE FOLLOWING ASSIGNMENTS.

1. The instructor will provide a box of small-vinyl sheet pieces. Examine these pieces. Can you see the difference between the inlaid and print patterns? Look at the edge of a piece. If the color goes all the way through, it was made by the inlaid process. Separate the inlaid pieces from the print pieces.
2. Describe the best vinyl sheet floor covering you can imagine for a busy dynamite factory. Then describe the worst vinyl sheet floor covering you can imagine. Explain your answers.

Post Assessment

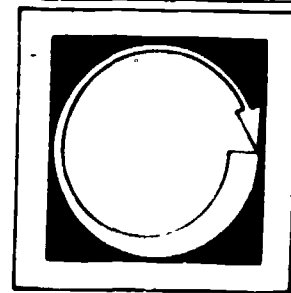

YOU HAVE TEN ROOMS AND ONLY THE KINDS OF SHEET COVERING LISTED. YOU CAN ONLY PUT ONE KIND IN EACH ROOM. DECIDE HOW TO BEST USE YOUR MATERIALS AND MATCH THE ROOM DESCRIPTIONS WITH THE ROLLS OF SHEET COVERING BY PLACING THE CORRECT NUMBER IN THE BLANK PROVIDED.

<u>Room Description</u>	<u>Covering Descriptions</u>
a. ___ A basement that floods every winter.	1. Heavy wear layer Print vinyl
b. ___ A kitchen 10 feet wide.	2. Heavy wear layer 6 foot width
c. ___ A weapons factory.	3. Light wear layer 12 foot width
d. ___ A floor that will be exposed to the danger of surface tears.	4. Heavy wear layer Inlaid vinyl
e. ___ Home bathroom 5 feet wide.	5. Light wear surface 6 foot width
f. ___ Home of a millionaire who wants pictures of his cars as the pattern.	6. Heavy wear layer 12 foot width
g. ___ An office meeting room.	7. Rotogravure print vinyl
h. ___ Workroom 20 feet wide.	8. Installation not recommended
i. ___ Restaurant bathroom 4 feet wide.	9. Seamless Resilient
j. ___ Hotel lobby measuring 500 feet by 750 feet.	10. Static-conductive

PUT THESE STEPS FOR PERIMETER INSTALLATION OF SHEET FLOORING IN THE RIGHT ORDER. (1 is first, 4 is last)

- a. ___ Using the adhesive
- b. ___ Trimming
- c. ___ Spreading the floor covering
- d. ___ Using the staple gun

● Instructor Post Assessment Answers

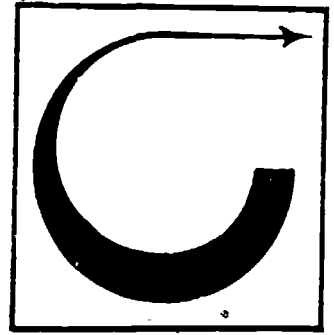

1. Answers for first section.

a. 8

b. 3

c. 10

d. 4

e. 5

f. 7

g. 1

h. 6

i. 2

j. 9

2. Answers for first section.

a. 3

b. 2

c. 1

d. 4

COMMON RESILIENT TILES

Goal:

The student will be able to identify common tiles used in floor laying and explain their common use.

22

Performance Indicators:

The student will successfully complete a Self Assessment, an Assignment and a Post Assessment.

25

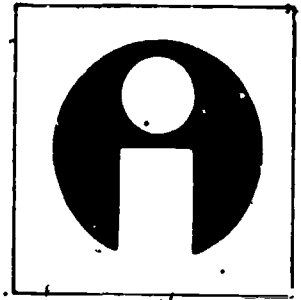

Study Guide

In order to finish this module, do the following tasks. Check each item off as you complete it.

1. Read the Goal and Performance Indicators on the cover of the module. This will tell you what you will learn by studying the module, and how you will show you've learned it.
2. Read the Introduction. The Introduction will tell you why the module is an important part of the floor laying trade.
3. Study the Vocabulary section. Vocabulary words are important for a good understanding of the trade. After you have studied the vocabulary, ask your teacher to quiz you on the words and their meanings.
4. Study the Information section. This section will give you the information you need to understand the subject.
5. Take the Self Assessment exam. This is a test for you to prove to yourself that you have learned the material you have studied. Compare your answers with the answers on the Self Assessment Answer Sheet, which is on the page following the Self Assessment. If you scored poorly, re-study the Information section or ask your teacher for help.
6. Do the Assignment page. Follow the instructions at the top of the Assignment page.
7. Take the Post Assessment exam. Give the exam to your teacher after you have completed it. Your teacher will grade it for you.

Introduction

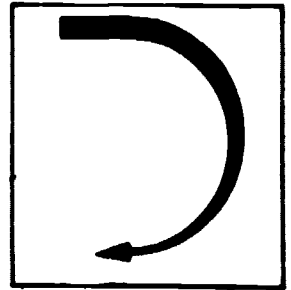

Resilient tiles are a growing market. Many styles and patterns offer the look of ceramic tile. With the right adhesive and tile choice, a resilient tile floor can be laid on any grade level.

The floor layer needs special knowledge of what the different kinds of tiles can and can not do. This module will help you learn to identify the proper use of common resilient tiles.

Vocabulary

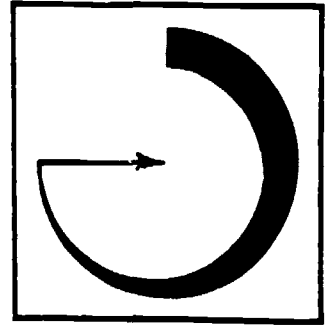

Trade terms are very important for a good understanding of the trade. Study these words and meanings. When you have learned them, ask your teacher to quiz you on the words and their meanings.

STATIC-CONDUCTIVE--Any flooring material which is made to avoid building up static electricity.

CHALKLINE--A string or line which is coated with chalk. When it is stretched and then snapped, it leaves a line where it hits the floor.

NOTCHED TROWEL--Trowel with notches cut in the spreading edge. The width of the notches controls the amount of the material being spread.

RADIANT HEAT SYSTEM--Hot water pipe buried in a floor (usually concrete) as a heating system.

Supplementary References

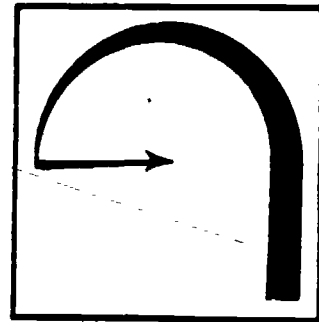

1. "Floor Tiles." Changing Times. June 1980.
2. "Floor Tiles." Consumers Research Magazine. January 1979.

Information

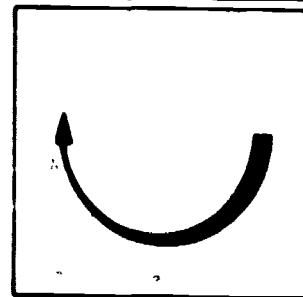

There are two main kinds of resilient floor tiles: vinyl and vinyl-asbestos. Resilient tiles may be thicker than resilient sheet covering. Non-resilient tile would include ceramic, mosaic and wood (or parquet) tiles. The professional floor layer usually does not work with non-resilient tiles.

Many resilient tiles are available with an adhesive backing. They are more expensive than the same tiles without the adhesive backing, so it is usually only the hobbyist who works with them. Tiles without an adhesive backing are in all other ways the same as tiles with an adhesive backing.

The most common size for all resilient tiles is 12 inches by 12 inches. Many types and patterns are also available in a 9-inch by 9-inch size. The tile size that will be used will be determined by the customer and the salesperson. They will consider pattern, quality and the size of the area to be covered. In some cases, a 9-inch tile could fill a floor space better than the larger 12-inch size.

VINYL-ASBESTOS TILE

Vinyl-asbestos tile has asbestos in it to make it wear better. This kind of tile is made $1/8$ inch thick for commercial use and $3/32$ inch thick for light commercial or household use. Many colors and patterns are available.

Some styles include embossing of the pattern. This means some parts of the pattern are higher or lower than other parts. Vinyl-asbestos tile is also called V-A tile.

V-A tile is easy to install and easy to clean. It resists grease and oil very well. Because of this, V-A tile is often used in car showrooms, restaurants and other places where grease or oil might be a problem. Some styles of V-A

tile have a "no-wax" surface which is the same as the surface on "no-wax" sheet floor covering materials.

This kind of tile can be installed on any grade level and on concrete when the recommended adhesives are used. If necessary, V-A tile is available that will conduct static electricity. It may be used in the same places that static-conductive resilient sheet materials are used.

The spatter and cork-style patterns of V-A tile often use the "through-chip" technique. This is when chips of color go all the way through the material. "Through chip" is made by sprinkling chips on the surface of the tile. Then the chips are rolled into the tile with heat and pressure during the final step of manufacture.

VINYL TILE--TWO TYPES

Vinyl tile is much like V-A tile. The difference is that no asbestos is used. The lack of asbestos can make vinyl tile a little easier to bend (more pliable). Because of this, vinyl tiles are sometimes chosen for places where a lot of curves will have to be cut.

A room with many pipes coming out of the floor would be a good place to use vinyl tile. However, it is easier to scar or scratch a vinyl tile than a vinyl-asbestos tile.

All vinyl tiles are made with the same materials. Some are made with pieces of vinyl that are heated and pressed together. Others are made with a liquid vinyl. Even though they are both made with the same materials, they do not both look the same.

Vinyl composition tile is made with vinyl pieces and pressure. It looks much like vinyl-asbestos tile. It can be 1/8 inch thick, 3/32 inch thick or 1/16 inch thick. Vinyl composition tile that is only 1/16 inch thick is recommended for household use only.

Vinyl tile is made with liquid vinyl. This kind of vinyl tile can be easier to bend than vinyl-asbestos or vinyl composition tile. Almost any style or pattern

can be made. There are many bright colors available. The surface can be textured to make it look like brick or like-slate.

Vinyl tile can be made to look like wood by using a wood grain pattern. Opaque (you can't see through it) colors can be made to look like marble. It can be made with swirls of color for the pattern. A three dimensional look can be given by adding a see-through vinyl-coat.

A "no-wax" wear surface is on many vinyl and vinyl composition tiles. A static-conductive type is also available. Vinyl and vinyl composition tiles may be installed on any grade level when the recommended adhesive is used.

Vinyl tiles can be cut, but vinyl-asbestos tiles sometimes have to be heated before cutting. The heat softens the material and makes it easier to cut.

SOME ADVANTAGES OF TILE

1. In rooms that are odd-shaped, there may be less waste of materials.
2. If one tile is damaged, it is easier to replace that tile than it would be to mend sheet vinyl.
3. A mistake in laying the floor may only mean the loss of a few tiles instead of damage in a room-size sheet of floor covering

SOME DISADVANTAGES OF TILE

1. Sheet covering protects better when liquid spills may be a danger: kitchen, laundry room, bathroom. This is because liquid could go between the tiles and damage the adhesive.
2. Use of a wall base is needed because tile cannot be flashed.
3. Resilient sheet materials may offer a wider range of available designs.

4. The loose-laid and perimeter installation methods are not possible with tile.

BAISC STEPS IN LAYING TILE

1. Use a chalkline to make straight guide lines.

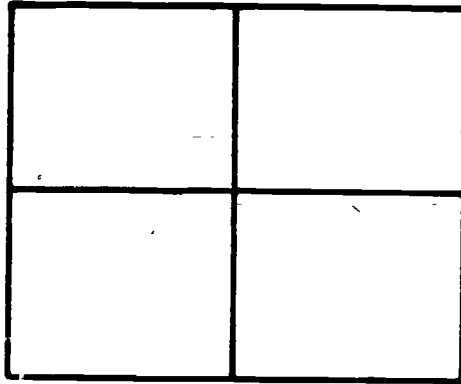

2. Spread adhesive with notched trowel in small sections.

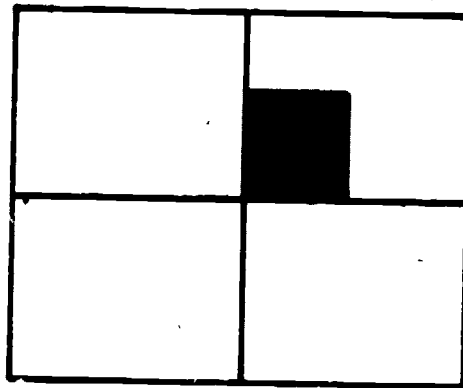

3. Lay tile on the adhesive, using the chalklines to keep the rows straight.

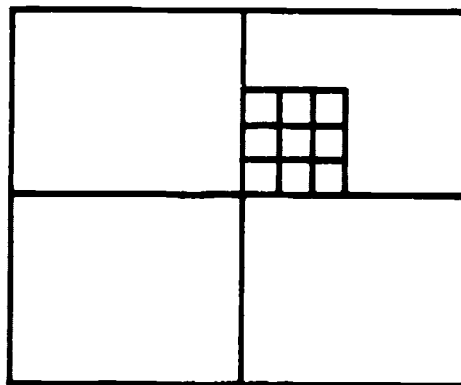

4. Repeat spreading adhesive and laying tile until the floor is covered.
5. Roll the floor to make a good bond and to make sure no air is trapped under the tiles.

Later modules will cover tile laying in more detail.

OTHER KINDS OF TILE

Rubber Tile

This tile is very resilient. It bends and cuts easily. So, shaping rubber tiles to fit unusual places is easy. The pattern in a rubber tile will not wear off because the colors run through the tile. It can be made with natural or synthetic rubber and filler. The filler is often asbestos.

When the recommended adhesive is used, rubber tiles may be installed on any grade level. A static-conductive rubber tile is available. The comfort and quietness of rubber tile is second only to cork tile.

Cork Tile

Cork tile is made from the bark of the cork-oak tree. The bark is ground up, mixed with glue and pressed together to make the tiles. Vinyl-asbestos tile is also available in a cork pattern. Most people now use vinyl-asbestos cork pattern instead of true cork tile.

True cork tile is very resilient and quiet. When a vinyl wear layer is used, true cork resists water well. The wear layer will make the tile less resilient. It has been made in sizes from 6 inches by 6 inches to 12 inches by 24 inches. The thickness can be from 1/8 inch to 1/2 inch.

Asphalt Tile

The best thing about asphalt tile is the low cost. It costs less than all other kinds of tile. Asphalt tile is easy to install, but there is only a limited range of colors. Asphalt tile may be used on all grade levels. It is made with asbestos fibers, ground limestone, mineral pigments and asphalt as a binder. It is brittle and that makes it hard to cut. Oil and grease can soften or stain it, so its use is limited. The thickness may be 1/2, 1/8 or 1/32 inch.

Nylon or Polyester Tile

Nylon or polyester tiles (such as Peblon) may be bonded to a latex-asbestos backing. These tiles can be cut, shaped and fitted with sheet metal snips or carpet scissors. They are made with polyester or nylon, resins and pigments. Individual tiles may be cut from large sheets that are pre-shrunk. Available sizes are 24 inches by 24 inches, 16 inches by 16 inches, 12 inches by 12 inches. The thickness is 1/8 inch.

SUMMARY OF VINYL-ASBESTOS TILE

Selling Features

- Moderate cost
- High stain and grease resistance
- Bright colors
- Easy to apply and clean
- The cork style pattern is replacing true cork tile
- Ready for use when laid
- May be waxed
- May have embossed pattern

Installation Features

- May be used on all grade levels and on concrete, lightweight concrete and wood
- Can be shaped to fit

Sizes

9" x 9" and 12" x 12"

Thickness

1/16", 1/8", 3/32"

SUMMARY OF VINYL & VINYL COMPOSITION TILE

Selling Features

- Long wearing
- Wide variety of bright colors
- Many patterns
- Easy to clean
- Easy to apply

Very resistant to soil, grease, acids and alkali
High gloss vinyl surface needs no finishing
May be waxed
May have embossed pattern

Installation Features

May be installed on all grade levels
May be used on concrete
May be used with radiant heat systems
May be used on counter tops

Sizes

9" x 9" and 12" x 12"

Thickness

1/2"

RESILIENT FLOOR TILES CHARACTERISTICS, COMPARISONS

Material	Characteristics	Cost
Vinyl	Highly resilient. Durable. Easy to maintain with damp mopping and occasional waxing. Resists damage from grease, alkalis, solvents and household cleaners.	MEDIUM
Vinyl-asbestos	Moderately resilient. Very durable. Easy to clean. Good resistance to household alkalis, grease, acid and oil.	LOW
Asphalt	Poor resilience. Good durability. Requires much maintenance. Can be damaged by grease, oil and solvents.	VERY LOW
Rubber	Good resilience. Durable. Must be mopped, waxed and carefully cared for: Good stain resistance.	VERY HIGH
Natural Cork	Good resilience. Good sound-deadening qualities. Poor durability. Requires careful maintenance. Can be damaged by grease and alkalis.	HIGH

RESILIENT TILE PERFORMANCE RATING CHART

Type	Location	Grease	Alkalis	Stain	Cigarette Burns	Indentation	Resilience	Quietness	Ease of Maintenance	Durability
V-A Tile	BOA	2	2	4	2	5	6	6	2	2
Vinyl	BOA	1	1	1-2	1-5	1-4	2-5	2-5	3	1
Rubber	BOA	3	3	2	1	4	2	2	3	2
Cork	OA	4	4	5	4	4	1	1	5	5
Cork with Vinyl wear layer	OA	1	3	1	5	3	3	3	1	4

38

B = Below grade

O = On grade

A = Above grade

1 = Best rating

39

Self Assessment

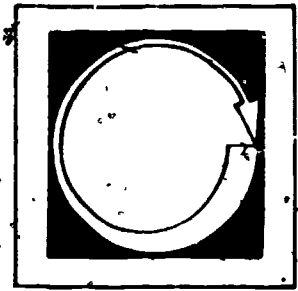

Follow the directions for each section of this Self Assessment.

1. MARK THE FOLLOWING TRUE OR FALSE BY PLACING A "T" OR "F" IN THE SPACE PROVIDED.

- a. ___ The two main kinds of resilient floor tile are vinyl and vinyl asbestos.
- b. ___ The 9" x 9" size tile is more common than 12" x 12".
- c. ___ Many resilient tiles have a "no-wax" wear layer.
- d. ___ V-A means "vacuum-added."
- e. ___ Many tiles can be installed on any grade level.
- f. ___ Use of tile might mean less waste of materials in an odd-shaped room.
- g. ___ One advantage of tile is that it can be loose-laid.
- h. ___ Adhesive should be spread in small sections and the tile laid before starting another section.
- i. ___ The last step in laying a tile floor is to roll it.
- j. ___ Rolling a floor helps to get more air trapped under the tiles.

2. COMPLETE THE DESCRIPTIONS BY FILLING IN THE BLANKS.

The _____ style pattern of vinyl-asbestos tile is _____ true _____ tile.

Vinyl composition tile is made with vinyl _____ and does not have any _____ in it.

Oil and grease can _____ or _____ asphalt tile.

Rubber tile is easy to _____. It may have _____ in it as a filler.

Vinyl tile is made with _____ vinyl.

Self Assessment Answers

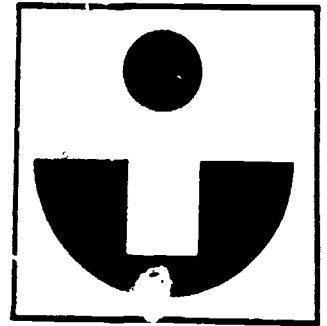

1. Answers

- a. T
- b. F
- c. T
- d. F
- e. T
- f. T
- g. F
- h. T
- i. T
- j. F

2. Answers

The cork style pattern of vinyl-asbestos tile is replacing true cork tile.

Vinyl composition tile is made with vinyl pieces and does not have any asbestos in it.

Oil and grease can stain or soften asphalt tile.

Rubber tile is easy to cut (or bend). It may have asbestos in it as a filler.

Vinyl tile is made with liquid vinyl.

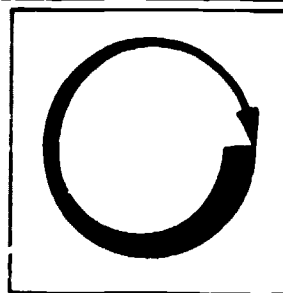

Assignment

MATERIALS NEEDED

Assortment of sample tiles.

Your instructor will give you some sample tiles. Do the experiments described and use the chart to show your answers.

TILE TESTS

Type	Pliability	Resilience	Spill	Stain	Impact	Your Choice

1. Test how well all of the tiles bend (pliability). Rate them on the chart.
2. Stand on each of the tiles. See if any "give" more under foot. Rate them on resilience.
3. Spill a liquid on the tiles. Which clean up easiest? Which stain? Rate them on the chart.
4. Drop a ball bearing from about 3 feet onto the tiles. Rate them for any Impact Damage.
5. Add one test of your own and rate the tiles.

Post Assessment

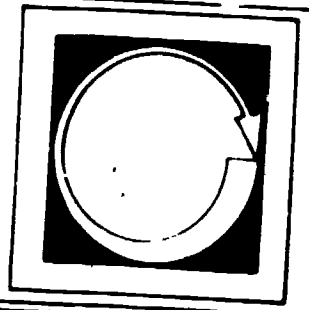

MATCH EACH TILE NAME WITH THE RIGHT DESCRIPTION BY PLACING THE CORRECT LETTER IN THE BLANK PROVIDED.

- | | |
|---------------------------|--|
| 1. ____ Vinyl-asbestos | a. Made with ground-up tree bark. |
| 2. ____ Vinyl Composition | b. Bends easily. May use asbestos as a filler. |
| 3. ____ Vinyl | c. Can be cut with metal snips or carpet scissors. |
| 4. ____ Rubber | d. Made with vinyl pieces. Does not have asbestos in it. |
| 5. ____ Cork | e. Oil and grease can soften or stain it. |
| 6. ____ Asphalt | f. The cork-style pattern is replacing true cork tile. |
| 7. ____ Polyester | g. Made with liquid vinyl. Does not have asbestos in it. |

LIST IN ORDER AND DRAW DIAGRAMS TO DESCRIBE THE BASIC STEPS IN LAYING A TILE FLOOR.

● Instructor Post Assessment Answers

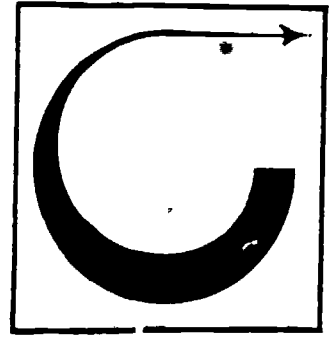

1. f

2. d

3. g

4. b

5. a

6. e

7. c

COMMON ADHESIVES

Goal:

The student will be able to identify common adhesives and explain their uses.

Performance Indicators:

The student will successfully complete a Self Assessment, an Assignment and a Post Assessment.

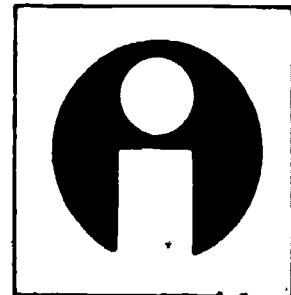

Study Guide

In order to finish this module, do the following tasks. Check each item off as you complete it.

1. Read the Goal and Performance Indicators on the cover of the module. This will tell you what you will learn by studying the module, and how you will show you've learned it.
2. Read the Introduction. The Introduction will tell you why the module is an important part of the floor laying trade.
3. Study the Vocabulary section. Vocabulary words are important for a good understanding of the trade. After you have studied the vocabulary, ask your teacher to quiz you on the words and their meanings.
4. Study the Information section. This section will give you the information you need to understand the subject.
5. Take the Self Assessment exam. This is a test for you to prove to yourself that you have learned the material you have studied. Compare your answers with the answers on the Self Assessment Answer Sheet, which is on the page following the Self Assessment. If you scored poorly, re-study the Information section or ask your teacher for help.
6. Do the Assignment page. Follow the instructions at the top of the Assignment page.
7. Take the Post Assessment exam. Give the exam to your teacher after you have completed it. Your teacher will grade it for you.

Introduction

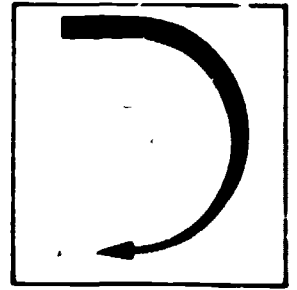

Adhesives bond things together. Two edges may be bonded together, as in making a seam. Two surfaces may be bonded together, as in bonding tile to the subfloor. Using an adhesive may be the best way to bond something to a curved surface. In all cases, the quality of the whole job will depend on how good the bond is. It does no good to perfectly fit a piece of flooring material if that material does not stay bonded to the subfloor.

In order to have a perfect floor installation, the floor layer has to pick the right adhesive for the job. This module will help you learn to identify the proper use of common adhesives.

Vocabulary

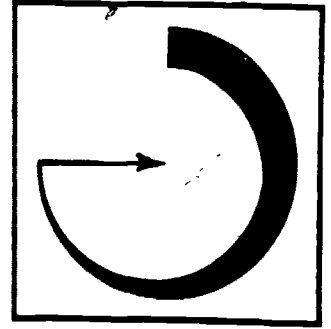

Trade terms are very important for a good understanding of the trade. Study these words and meanings. When you have learned them, ask your teacher to quiz you on the words and their meanings.

FLAMMABLE--Will burn easily.

POROUS--Having a surface covered with many tiny holes. Will soak liquids up easily. A sponge is porous.

POWDER OUT--When a surface turns into a powder right under the adhesive layer.

EFFLORESCENCE--When the top layer of any surface turns into a powder.

WATER-SOLUBLE--Something that will dissolve in water.

IGNITE--To catch on fire.

TOXIC--A poison.

EMULSION--When something is suspended instead of dissolved in a liquid. The butterfat in milk is an emulsion.

HEAT-ACTIVATED ADHESIVE TAPE--The adhesive does not stick until heat is applied.

PRESSURE-ACTIVATED ADHESIVE TAPE--The adhesive will stick when the tape is pressed against something.

Supplementary References

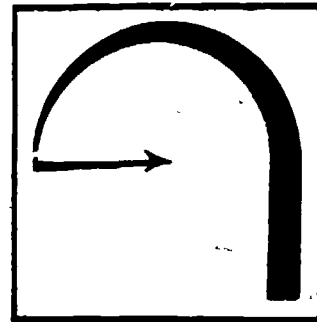

1. Resilient Coverings Workbook. California State Department of Education. 1973.
2. Training Manual. Southern California Floor Covering Joint Apprenticeship and Training Committee. n.d.

Information

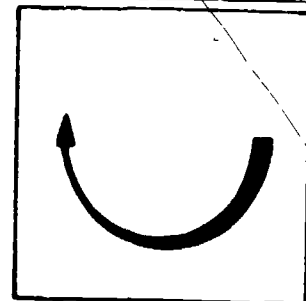

Installing a floor can turn out bad if the materials are poorly fitted--or because the wrong adhesive was used. In order to have a perfect floor, there has to be perfect bonding. There are at least two things that can go wrong when an adhesive is used:

1. The wrong adhesive is picked.
2. The right adhesive is used in the wrong way.

There are many different kinds of adhesives used in floor covering. Some can be used for several different kinds of floors and materials. Some have very special uses. Since each floor is different, the floor layer has to be able to recognize the special problems of each floor. Learning about adhesives also means learning about subfloors and underlayment. It is important to remember that all adhesives do not work on all subfloors. (See chart next page.)

Categories of Adhesives

There are many different ways adhesives can be put into categories. One way is to think of them in terms of flammable and non-flammable.

Flammable Adhesives:

1. Need good ventilation.
2. Fumes can ignite easily.
3. Some are toxic to the skin.
4. Use an alcohol base or solvent.
5. Breathing the fumes can also be toxic.

Non-flammable Adhesives:

1. Longer drying time.
2. Usually can be dissolved in water.
3. Use a latex base or chlorinated solvent.

TYPES OF FLOORS

Floor Type	Comments
WOOD	<p>Good adhesive surface.</p> <p>PROBLEM: Poor grades of wood particle board may "powder out." The surface can turn to a powder right under the adhesive layer.</p>
CONCRETE (above grade or suspended)	<p>PROBLEM: May still have moisture in the concrete.</p> <p>PROBLEM: Surface can be dusty or porous.</p>
CONCRETE (on or below grade)	<p>PROBLEM: Hydrostatic pressure can make water push through concrete to the surface.</p> <p>PROBLEM: Alkalis are a common problem with a concrete floor.</p>
ASPHALT LIGHTWEIGHT CONCRETE	<p>PROBLEM: Surface may "powder out." The surface can turn to a powder right under the adhesive layer.</p>
NON-POROUS SURFACES	<p>PROBLEM: Hard for many adhesives to get a good "bite." With surfaces like steel, marble or ceramic, follow the recommendations of the flooring material manufacturer.</p>
MAGNESITE	<p>PROBLEM: Magnesite has chlorine in it. This can damage some adhesives.</p>

To Use An Adhesive

1. Use the adhesive recommended by the maker of the flooring material being installed.
2. Follow the directions of the adhesive manufacturer.
3. The floor must be clean, dry, free from paint, concrete curing compounds or efflorescence (when the top layer of the floor surface turns to powder).

Common Adhesive Materials

Water-Soluble Paste Adhesives:

1. Can be dissolved by water after it has dried.
2. Use above grade only.
3. May be used on walls and some counter tops.
4. DO NOT USE with vinyl or asphalt covering materials.

Asphalt-Based Adhesives:

1. Usually black color.
2. For installing asphalt or vinyl-asbestos tiles.

Asphalt emulsion adhesives can be mixed with water. They can be used on and above grade level. To remove dried spots, use steel wool or a cleaning solvent. Some are made to be used on all grade levels. If this kind is used below grade level, it should not be mixed with water. Water should not be used on grade level concrete floors. Dried spots are removed with a cleaning solvent. Some of the asphalt-based adhesives can be applied with a paint roller. A feature of this kind may be that it will become "see-through" when it has dried. This will let snapped chalklines show through.

Waterproof Adhesives:

1. For installing rubber, vinyl, cork.
2. Use on or above grade floors.
3. May be used for installing rubber cove bases.
4. May be used for installing counter tops.

An alcohol-resin emulsion adhesive will be almost completely waterproof. It may be used for bonding asbestos-backed sheet goods on any grade level. This type may be used on wood or concrete floors. Use a cleaning solvent to remove dried spots. The color can range from cream to gray. It may dry very quickly.

Epoxy Cement:

1. To cement sheet vinyl at the seams and perimeter.
2. May be toxic to the skin.
3. Installer should wear rubber gloves.
4. Mix only enough for immediate use.

Once the epoxy has dried, it cannot be dissolved for using again. It is hard to remove once it has dried. While epoxy is wet, spots or excess can be removed with soap and water.

Contact Bond Cement:

1. Used to bond materials to small areas which have either non-porous or very porous surfaces.
2. Can be used to bond materials to rounded surfaces such as steps.
3. Directions:
 - a. Apply to both bonding surfaces.
 - b. Let both surfaces dry.
 - c. Press the two bonding surfaces together.

Cove Base Cement:

1. Has a high initial tack.
2. Was developed for installation of the top set cove base.

Pressure-Sensitive Film:

1. For laying tile.
2. Is made in a continuous length.
3. May be up to 54 inches wide.
4. Is reinforced with a resin-treated, open-weave rope fabric.
5. Directions:
 - a. Film is put on the floor with the paper side up.
 - b. It is rolled with a heavy roller.
 - c. The paper is peeled off.
 - d. Tile is laid on the film.
 - e. Tile is rolled.

Adhesive Tape:

1. May be heat-activated or pressure-activated.
2. Adhesive is bonded to a backing strip.
3. Used to bind pieces of carpet together.

Adhesive tape is faster than sewing pieces of carpet together. The adhesive usually has a "peel-off" paper covering. This is taken off to expose the adhesive. The carpet pieces are then pressed onto the tape. Final bonding is made either by applying pressure or by applying heat (depending on the kind of adhesive tape). The backing is made from a tough material. It may be anything from pre-shrunk jute to nylon.

Primers and Sealers:

1. Prepares a surface for the use of an adhesive.
2. May be needed on floors or walls.
3. May be used as a moisture barrier.

Concrete sealers are used to seal dusty or porous surfaces. The dusty or porous surface may absorb too quickly. This dries out a paste or cement very rapidly.

A GENERAL GUIDE TO ADHESIVES

Multi-Purpose White Latex

The most common adhesive. It allows time to place materials, has good strength, is waterproof and water will clean it up while it is wet. Recommended for:

1. Solid vinyl tile and sheet goods.
2. Asphalt and vinyl-asbestos tile.
3. Rubber tile.
4. Also used for carpet installation.

White Waterproof Cement

Will bond to almost any clean, dry, structurally sound surface. It allows time to position goods, does not stain, is waterproof and will clean up with alcohol or a solvent. It is an economical adhesive recommended for:

1. Solid vinyl tile and sheet goods.
2. Rubber tile.
3. Cork tile.

Clear Multi-Tile Adhesive

This waterproof latex adhesive is often used to install vinyl tile over an existing resilient floor. Recommended for:

1. Vinyl tile.

2. Asphalt tile.
3. Vinyl-asbestos tile.
4. Rubber tile.

Remember this: There are many different types, many different brand names, of adhesive. Each type or brand will have special characteristics and these special characteristics should be matched with the specific installation you are planning. The best way to make sure you have the best adhesive for the job you are planning is to follow the recommendations of the manufacturer of the floor cover material you will be installing.

Self Assessment

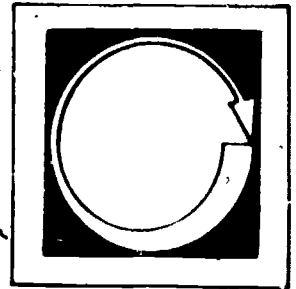

SELECT THE STATEMENT WHICH ANSWERS THE QUESTION CORRECTLY AND PLACE THE LETTER IN THE BLANK PROVIDED.

1. ____ Which of the following is NOT TRUE about a flammable adhesive?
 - a. Has a longer drying time
 - b. Needs good ventilation.
 - c. Some are toxic to the skin.
 - d. The fumes ignite easily.

2. ____ Which one of the following is NOT A PROBLEM when an adhesive is used on concrete?
 - a. Hydrostatic pressure.
 - b. Surface may be non-porous.
 - c. Surface may be dusty.
 - d. Concrete may be porous.

3. ____ Which statement is NOT TRUE?
 - a. There are many adhesives.
 - b. Each floor has special needs.
 - c. There's only one thing that can go wrong when an adhesive is being used.
 - d. In order to have a perfect floor there has to be perfect bonding

4. ____ Which one of the following is TRUE about a water-soluble adhesive?
 - a. Can be used with vinyl or asphalt materials.
 - b. Can be used on any grade level.
 - c. Can be dissolved by water after it has dried.
 - d. It is used to prevent "powder out" condition.

5. _____ Which one of the following is TRUE about asphalt-based adhesives?
- Are usually white in color.
 - Cannot be mixed with water.
 - Are for installing asphalt or vinyl-asbestos tiles.
 - Can only be used above grade.
6. _____ Which one of the following IS TRUE about water-proof adhesives?
- Cannot be used for installing vinyl.
 - Can be used with asbestos-backed sheet goods on any grade level.
 - Cannot be used to install counter tops.
 - Are completely water-proof.
7. _____ Which one of the following is TRUE about epoxy cement?
- Is not toxic to the skin.
 - Can be dissolved for reuse with chlorinated water.
 - Can be used to cement sheet vinyl seams.
 - Excess can't be cleaned up, even when still wet.
8. _____ Which one of the following IS TRUE about contact bond cement?
- Is applied to one surface and allowed to dry.
 - Can only be used on flat surfaces.
 - Is used for small non-porous or very porous areas.
 - Is put on one surface, dried, and then both surfaces are pressed together for 2 hours.
9. _____ Which one of the following IS TRUE about pressure sensitive film?
- Is made in short pieces.
 - Does not have any kind of reinforcement.
 - Is never more than 12 inches wide.
 - Is used for laying tile.
10. _____ Which one of the following IS TRUE about adhesive tape?
- Does not have a reinforced backing.
 - May be heat or pressure activated.
 - Is never used for binding carpet pieces.
 - Is slower than sewing pieces together.

Self Assessment Answers

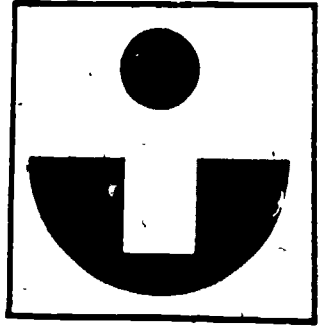

1. a
2. b
3. c
4. c
5. c
6. b
7. c
8. c
9. d
10. b

Assignment

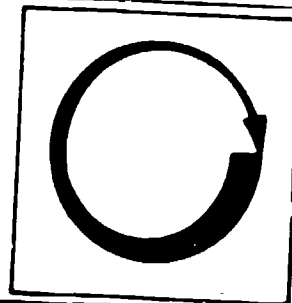

COMPLETE THE FOLLOWING ASSIGNMENTS.

Materials

3 kinds of adhesives

3 samples of floor covering materials

1. The instructor will give you 3 kinds of adhesives. By reading the adhesive manufacturer's recommendations and using what you have learned in other modules, make a list of the different right uses for each of the three.

2. The instructor will give you 3 samples of floor covering materials. Contact floor covering dealers in your area and try to get at least 2 brand names of adhesives that could be used with each of the material samples.

Post Assessment

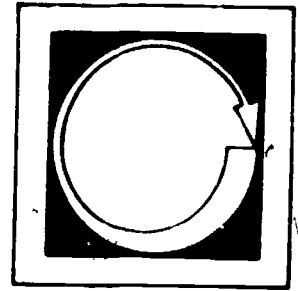

MATCH EACH OF THE TERMS LISTED BELOW WITH ITS DEFINITION BY PLACING THE CORRECT LETTER IN THE BLANK PROVIDED.

<u>Term</u>	<u>Definitions</u>
1. ___ Water-soluble Paste.	a. When a layer of the subfloor right under the adhesive turns to dust.
2. ___ Asphalt-based Adhesive.	b. Is spread on the subfloor and rolled with a heavy weight.
3. ___ Water-proof Adhesive.	c. Not for use with vinyl goods.
4. ___ Epoxy.	d. For installing rubber or vinyl goods.
5. ___ Contact Cement.	e. Often has problems as a bonding surface.
6. ___ Cove Base Cement.	f. Makes water push through concrete to the surface.
7. ___ Pressure Sensitive Film.	g. To clean; use steel wool or a cleaning solvent.
8. ___ Heat or Pressure Sensitive Tape.	h. Usually presents a very good bonding surface.
9. ___ Primers and Sealers.	i. Is put on both bonding surfaces and allowed to dry.
10. ___ Hydrostatic Pressure.	j. A floor type that has chlorine in it.
11. ___ Clean, Paint-free Surface.	k. Is used for bonding pieces of carpet together.
12. ___ "Powder Out."	l. Developed with a high tack to do a specific thing.
13. ___ Magnesite.	m. The surface of something like steel, marble or ceramic goods.
14. ___ Wood.	n. Used to prepare a surface for the use of an adhesive.
15. ___ Concrete.	o. Easy for adhesives to get a "good bite" on this.
16. ___ Non-porous Surfaces.	p. Mix only enough for immediate use

Instructor Post Assessment Answers

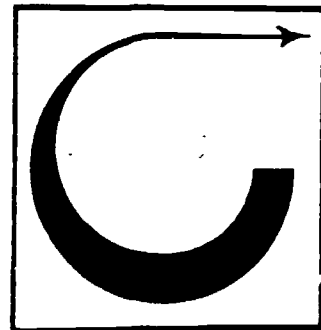

1. c
2. g
- e. d
4. p
5. i
6. l
7. b
8. k
9. n
10. f
11. o
12. a
13. j
14. h
15. e
16. m

COMMON CARPET MATERIALS

Goal:

The student will be able to identify common carpet materials and explain their common use.

Performance Indicators:

The student will successfully complete a Self Assessment, an Assignment and a Post Assessment.

Study Guide



In order to finish this module, do the following tasks. Check each item off as you complete it.

1. Read the Goal and Performance Indicators on the cover of the module. This will tell you what you will learn by studying the module, and how you will show you've learned it.
2. Read the Introduction. The Introduction will tell you why the module is an important part of the floor laying trade.
3. Study the Vocabulary section. Vocabulary words are important for a good understanding of the trade. After you have studied the vocabulary, ask your teacher to quiz you on the words and their meanings.
4. Study the Information section. This section will give you the information you need to understand the subject.
5. Take the Self Assessment exam. This is a test for you to prove to yourself that you have learned the material you have studied. Compare your answers with the answers on the Self Assessment Answer Sheet, which is on the page following the Self Assessment. If you scored poorly, re-study the Information section or ask your teacher for help.
6. Do the Assignment page. Follow the instructions at the top of the Assignment page.
7. Take the Post Assessment exam. Give the exam to your teacher after you have completed it. Your teacher will grade it for you.

Introduction

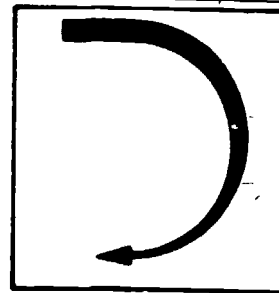

Carpeting looks good and feels good. When a carpet is well installed, it will keep on looking good and feeling good for years. That makes the customer happy. The important thing is to match the kind of carpet with the kind of wear it will take. This module will give you information about picking carpeting that will make a customer happy.

Vocabulary

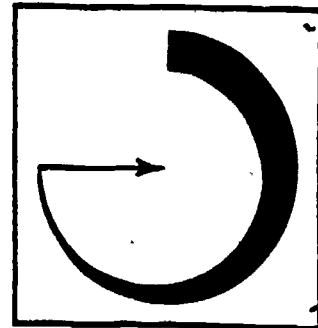

Trade terms are very important for a good understanding of the trade. Study these words and meanings. When you have learned them, ask your teacher to quiz you on the words and their meanings.

ABRASION--Carpet "abrasion" refers to the action of dirt being ground into the fibers and cutting or tearing them.

FILAMENT--Thin fiber of a material.

ELASTICITY--How much a thing will stretch.

NON-ALLERGENIC--Does not cause or make an allergy worse.

FLOCKED CARPETING--A carpet type in which the carpet fibers are glued onto squares of a backing material. Sizes of the backing pieces are 9" X 9", 12" X 12", or larger. The adhesive coated backing is placed over an electrically charged plate. The fibers are given an opposite charge. "Just like a magnet, the backing pulls the fibers to it. One end of the fibers will stick in the adhesive. Flocked carpets can have as many as 20,000 ends of yarn per square inch.

HEAT-SETTING--A manufacturing process that uses heat and steam to put a permanent twist in yarn. The twist makes the yarn stronger.

PERIMETER--Around the edges.

Supplementary References

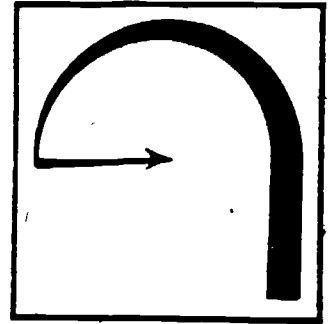

1. Duffin, D. F. The Essentials of Modern Carpet Installation. 1962
2. Carpeting Floor Covering Workbook. California State Department of Education, 1972. pp. 13-18, 97-124.

Information

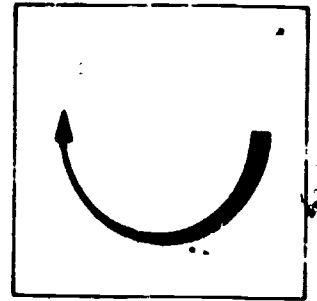

Carpets can be made by weaving on a loom or by tufting into backing material. There are several main fibers from which most carpeting is made. There are special tests for safety and performance. There are installing hints for different kinds of carpeting. This module will cover 5 main things about carpet floor covering materials.

1. Fiber types and characteristics.
2. The way carpeting is made.
 - a. Weaving
 - b. Tufting
3. The backing and its purpose.
4. Enhancements.
 - a. Adding color
 - (1) Printed on
 - (2) Dyed
 - b. Performance and safety tests
5. Installing hints.
 - a. Perimeter installing
 - b. Glue-down installing

FIBER TYPES AND CHARACTERISTICS

Natural Fiber: Wears Best, Costs More.

Wool is a natural fiber. All of the other fibers you will learn about are human-made. Wool wears well but is very expensive. It is more of a specialty carpet material. Wool carpets that are 15 years old have looked new after being cleaned.

Human-Made Fibers: High Quality, Lower Cost.

There are four major human-made fibers: nylon, polyester, polypropylene (also called olefin), acrylic. It may seem that there are more, because each

manufacturer uses "brand names." But these four types and wool are the main fibers used to make carpeting.

General performance characteristics.

NYLON: More than 70% of all carpets are made with nylon fiber. Nylon is tough and long wearing. It has good abrasion resistance and resists crushing and matting. There are two types of nylon filaments being made.

1. Continuous filament nylon
2. Staple nylon

Continuous filament nylon is the strongest form of nylon. It is made in unbroken (continuous) lengths. This makes the chance of breaking much less. Staple nylon is made in short lengths. These short lengths can be spun like natural fiber. The short lengths make the finished carpet feel softer.

Nylon does conduct static electricity. Special nylon fibers that have protection against this are made. These fiber carpets cost more. Nylon can fade when exposed to light for a long time. The fiber is naturally moth-proof.

ACRYLIC: This fiber looks and feels more like wool than the other human-made fibers. It has good elasticity. There is little static electricity build up. Acrylic fibers accept color dyes very well. An acrylic carpet will clean easier than wool. Acrylic tends to get dirty faster than nylon or polyester. It does not resist crushing as well as wool.

POLYESTER: This fiber feels a bit like wool and resists wear well. It makes very little static electricity. Polyester yarn can be made heavy and dense at less cost than nylon. It has a high-luster look. Polyester does not resist crushing as well as other fibers. It is mothproof and non-allergenic.

POLYPROPYLENE (OLEFIN): This fiber is almost as tough as nylon. The amount of static electricity it makes is very small. It resists stain better than other fibers.

Polypropylene is one of the hardest fibers to dye. It has only fair resilience. This is why it is used mainly in level-loop and bonded-fiber carpets. These kinds are often used in high traffic areas. It is moth-proof and non-allergenic.

FIBER BLENDS: This is a carpet that is made with several fiber types. The idea of a "fiber blend" is to combine the strong points of several different fibers. The end result can be a carpet that wears better than one made with only one fiber type. This kind of carpet can often provide quality at lower cost than a single fiber carpet.

THE WAY CARPETING IS MADE

How well a carpet wears depends on:

1. How it is made.
2. Where it is put.

Most carpets are made to go in certain places in the home. A carpet that was made for the light traffic of a bedroom does not belong in a high-traffic hallway. To help judge a carpet, look at these three things:

1. Density: How many tufts are in each square inch.
2. Pile Height: Low pile carpets show less crushing. They may not be as soft as higher pile, but they will wear better in high-traffic areas.
3. Yarn Treatment: If the yarn of a carpet has been heat-set to lock a twist into the yarn ends, the carpet will wear better. Heat-setting helps stop unraveling of the yarn and makes the pile more flexible. Tightly twisted yarn can spring back from crushing foot traffic more easily. Yarn that has no twist, or only a loose twist, will break open more easily. It will fall down when pressure is put on it.

Woven Carpet

Woven carpet has been made on a loom or weaving machine. Different weaves are made on different kinds of looms, or by different ways of using loom. Woven carpet making is different from tufted carpet making, which is done by punching (or sewing) fibers into a backing.

(See the illustrations on the following page.)

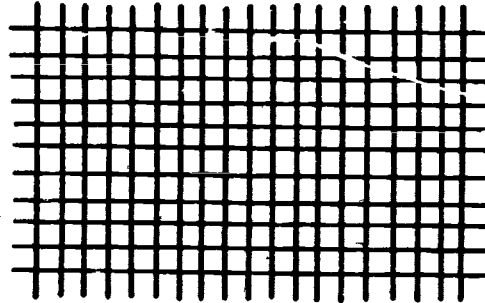

Weave Method

Fibers are crisscrossed or otherwise bound to each other.

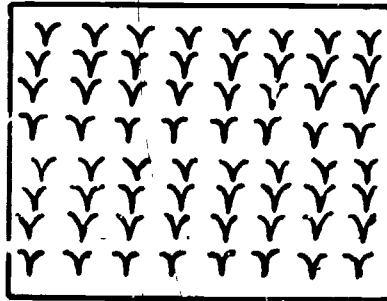

Tuft Method

Fibers are bound to a backing by punching them through the backing (like a sewing machine puts thread into cloth).

Tufted Carpet

About 90% of all carpets sold are made by the tufting method. Tufted carpet can be made 10 to 20 times faster than woven carpet.

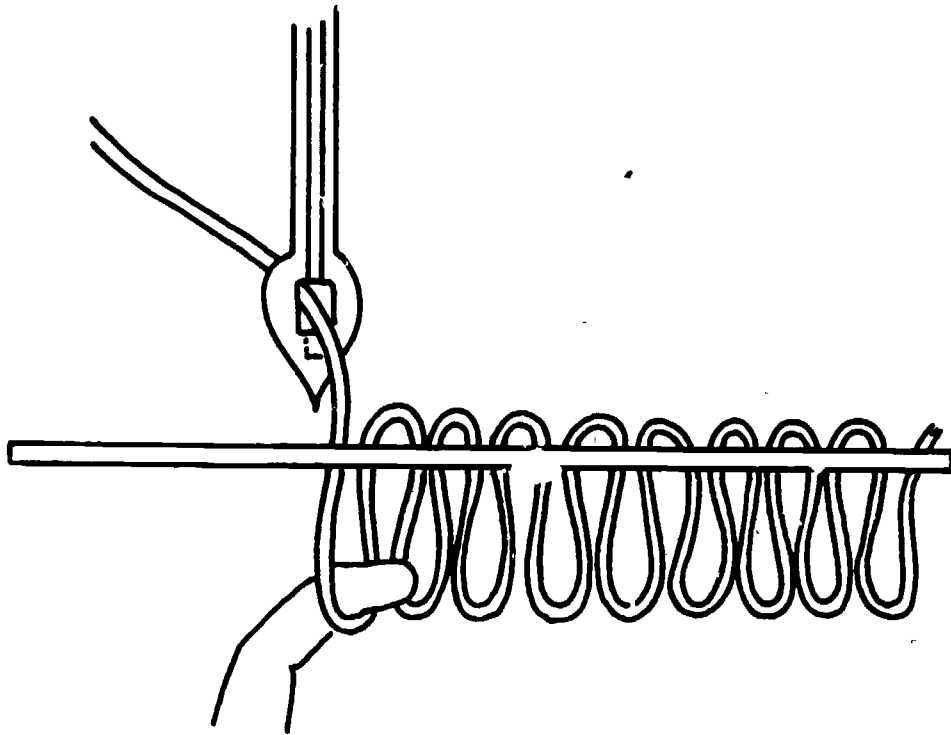

Needles push yarn into a backing. The tension of the yarn can be changed. This means the yarn can be made to lock in different lengths into the backing. The result is a series of continuous loops. These loops are the finished "tufts" of the carpet. Cut pile carpet is made by cutting the loops or tufts. A latex coat on the backing holds the tufts in place.

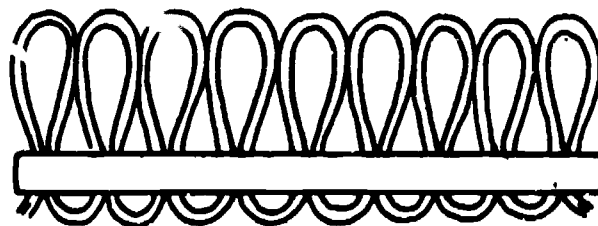

Level-loop Tuft

The level-loop style is heavy duty. Level-loop carpets have a dense, heavy yarn. A low pile height makes a tough texture. Dirt tends to stay on top of the pile. This makes it easier to clean. This kind of carpet is often used in offices, lobbies, waiting rooms or heavy traffic areas of the home.

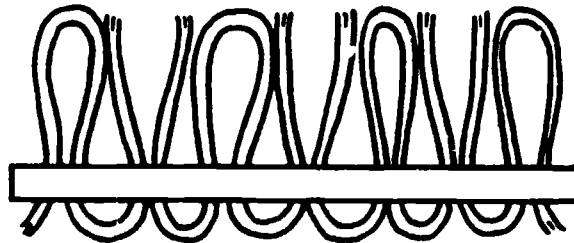

Two-Level-Loop: Random Sheared

Loops are made on two different levels. The higher loops are cut off. This style provides many of the wear and care advantages of level-loop tufting, with some additional softness.

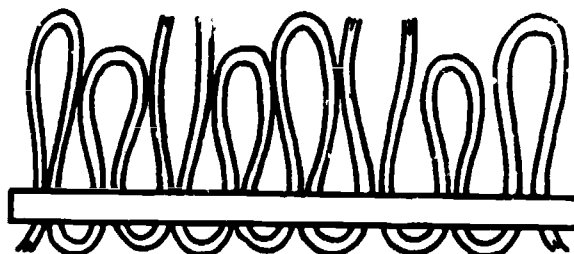

Three-Level-Loop: Random Sheared

The loops are formed on three different levels and the highest loops are cut off. This style makes a soft carpet, as well as giving it a three-dimensional look.

The style called "plush pile" is very dense. The loops are cut and tufts are packed close together. This makes the tufts stand up and help support each other. It wears well in moderate traffic areas. The denser the carpet, the better it will wear. It usually has a deep pile which may shade. Shading is where the fibers are brushed to one side by traffic or a vacuum cleaner. In these places, the color may look deeper.

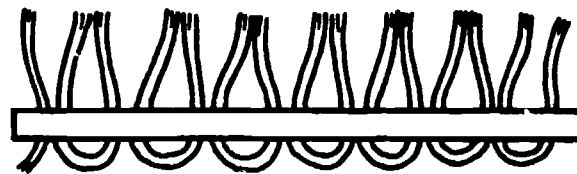

Saxony Plush

Most saxonies are made with plied yarns. They are often heat-set to lock in the twist. Saxony plush is a popular cross between a short shag and a plush. Like saxony wears very much like a plush. The pile is often dense which makes it comfortable to walk on.

Shag is a tall, loose plush. It is made with the tufts farther apart. A shag is made to wear differently from other carpets. The tall yarn ends are supposed to overlap or fall over each other. When traffic hits the pile, it hits the sides (or shafts) of the yarn rather than the tips. The heaviest shag with the lowest pile height will work the best. (See the illustration on the next page.)

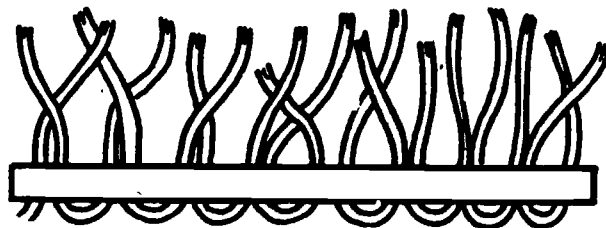

Shag

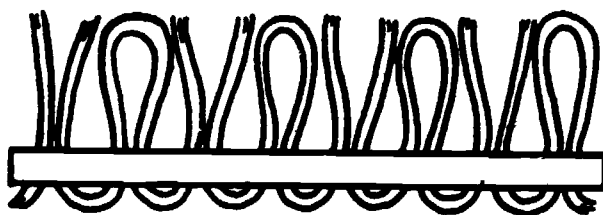

Cut-and-Loop (or Sculptured)

A cut-and-loop carpet is a plush that has a random pattern of loops that are visible in the pile. The wear characteristics are much like those of a plush.

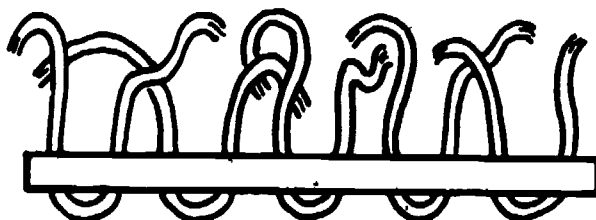

Frieze (or Twist)

The surface texture of the frieze style is rougher and more grainy than that of a plush. Frieze has a much tighter twist in the yarn than regular plush. The twist is heat-set. This style will not show footsteps or shade like a plush. Frieze is one of the best wearing of all cut-pile carpets. It is a good choice for high-traffic areas like halls or stairways.

THE BACKING

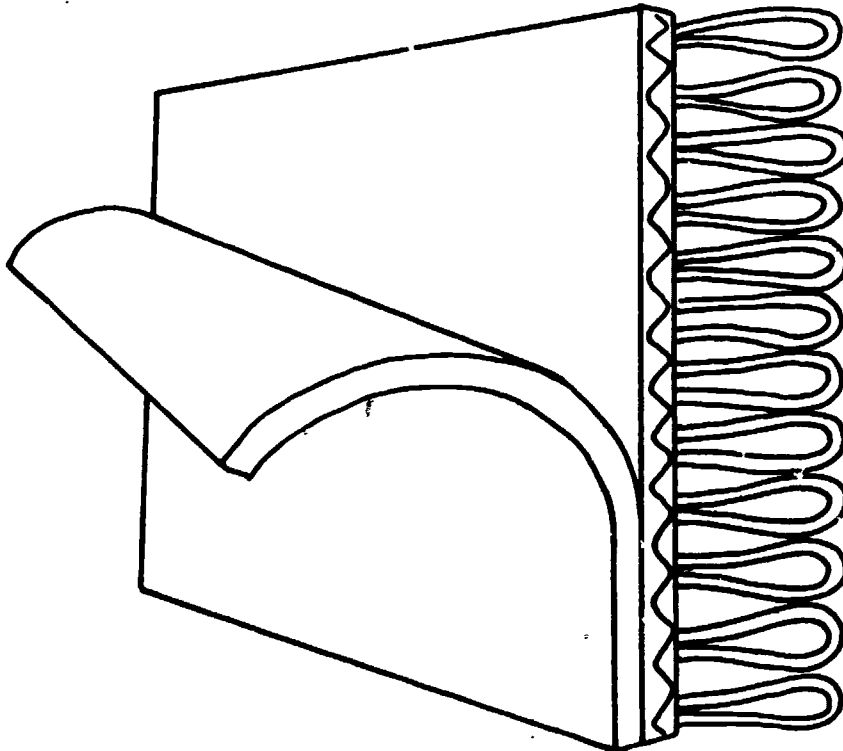

It is the backing that keeps a carpet the same size and shape all the time. It makes the whole thing a lot more solid.

The backing is usually a primary backing and a secondary backing. The tufts are punched into the primary backing. The most common primary backing is a woven polypropylene which is covered with a coat of latex or rubber. The latex or rubber coat locks the tufts into the backing.

The secondary backing is often made of woven jute or polypropylene. It is added to give extra help in keeping the carpet the same size and shape.

ENHANCEMENTS

Adding Color

The oldest form of adding color to a carpet is to dye the yarn before the carpet is made. Then the colors are woven together to make a pattern, design or picture. This method takes a great deal of time.

Newer methods of adding color involve adding the color after the carpet has been made into one piece (either by weaving or by tufting). There are two ways in which this may be done:

1. Mechanical Printing of the design by using screens or rollers to apply the dye to the carpet surface.
2. Electronic Needle Injection of the dye with needles that are controlled by a computer program. The dye is injected into the tuft and colors more than the surface of the carpet.

To change the mechanical method requires changing the screen containing the design, cleaning the rollers, and so on. With the electronic needle injection method, a pattern can be changed by switching to another program for the computer-controlled injection needles.

Performance and Safety Tests

1. Fire Resistance. A TABLET TEST checks the resistance to ignition when it is exposed to fire. A FLAME SPREAD TEST checks how fast flame will spread across the surface of the carpet. A SMOKE TEST finds out how much smoke is produced when the carpet ignited.
2. Colorfastness. A carpet sample is exposed to prolonged light. The sample is then measured to find out how much it has faded.
3. Shrinkage. The carpet is tested to make sure it will not shrink or change shape if it gets wet.
4. Static Buildup. Carpets are tested to find out how easily they will make static electricity. The degree of static buildup varies with the fiber type. Nylon has more static buildup than other human-made fibers.
5. Tuft Bind. This test makes sure the tufts are locked firmly into the backing.
6. Torture Tests. These are tests to find out what kind of traffic the carpet can withstand. Among the things tested are the ability to resist abrasion, soiling, stains and how well it cleans.

INSTALLING HINTS

The two main ways of installing a carpet are "glue-down" and "perimeter."

A GLUE-DOWN CARPET is installed by spreading adhesive over the entire floor. The carpet is put on top. With this method, the carpet is completely bonded to the floor.

A PERIMETER INSTALLED CARPET is stretched to the edges of the room (the perimeter). Tack strips have been put around the edges. The carpet is hooked onto the "spikes" coming out of the tack strips.

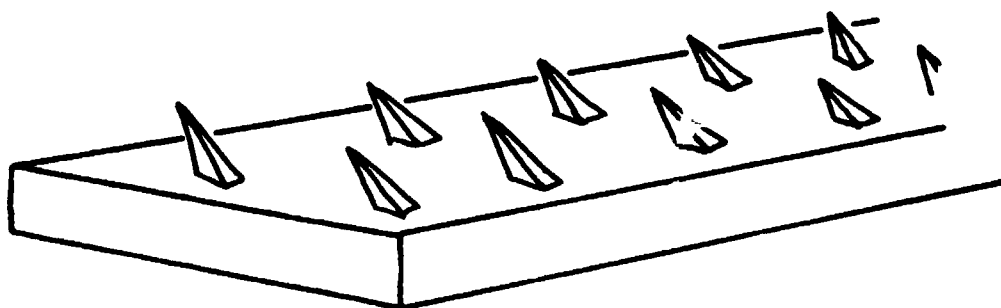

Different kinds of carpeting materials behave in different ways. There are special things to know about each type. The tools used in an installation may be the same, but the handling methods will be different.

Tufted Carpeting

If it has a short nap and a single back, tufted carpeting tends to tear when side pressure is applied to the pins of the carpet stretcher.

Woven Carpeting

There are rows of nap across the width of the material. These rows have to be kept straight when the carpeting is being installed. AXMINSTER WEAVE has almost no stretch in the width. It has a lot of stretch in the length. KNITTED AND VELVET WEAVES have more stretch in the width. WILTON WEAVES have almost equal stretch in width and length.

Self Assessment

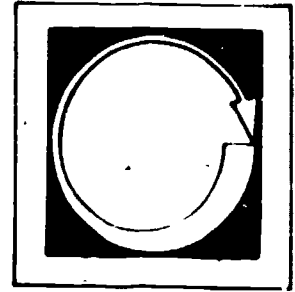

COMPLETE THE FOLLOWING STATEMENTS BY WRITING THE CORRECT WORD OR WORDS IN THE BLANKS PROVIDED.

1. Carpeting can be made by _____ or _____.
2. In a _____ carpet, the fibers are crisscrossed.
3. In a _____ carpet, the fibers are punched through a backing.
4. Making a carpet by _____ is _____ to _____ times faster than making a carpet by _____.

CIRCLE THE CORRECT ANSWER.

5. How many main human-made fiber types are there?

2 4 6 8

6. Circle the names of the main human-made fiber types.

neomyacin

polyester

polypropylene

nylon

acrylic

rayon

acetate

antacidic

MATCH THE TERMS AND THE DEFINITIONS BY PLACING THE CORRECT LETTER IN THE BLANK PROVIDED.

- | | |
|-----------------------|--|
| 7. ____ wool | a. a fiber type not mentioned in this module |
| 8. ____ level loop | b. plush pile with a random pattern of loops. |
| 9. ____ saxony | c. used in over 70% of all carpets. |
| 10. ____ frieze | d. a natural fiber. |
| 11. ____ shag | e. heavy duty carpet pile. |
| 12. ____ 2-level-loop | f. cross between short shag and plush. |
| 13. ____ cut-and-loop | g. cut pile carpet that wears very well. |
| 14. ____ rayon | h. a bit softer than level loop pile. |
| 15. ____ nylon | i. traffic is supposed to hit the yarn shafts. |

Self Assessment Answers

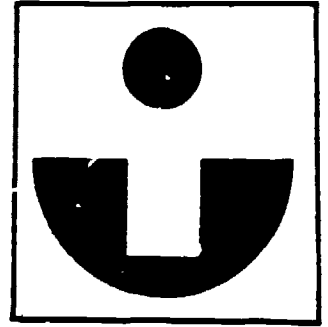

1. weaving or tufting
2. woven
3. tufted
4. tuft is 10 to 20, weaving
5. 4
6. polypropylene
acrylic
polyester
nylon
7. d
8. e
9. f
10. g
11. i
12. h
13. b
14. a
15. c

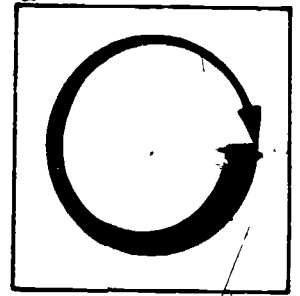

Assignment

COMPLETE THE ASSIGNMENTS BELOW.

Materials

Carpet samples made from a variety of materials, and with a variety of styles, etc.

Carpet Sample Number	Woven	Tufted	Loop Tufts	Cut Loop	Type of Fibers	Pile Height	Other Categories

PART I

Complete the chart analysis for each carpet sample. Use the "Other Categories" space to add any other categories or tests you want.

PART II

Based on your analysis of the carpet samples, decide what would be a good place for each sample to be used. This may be done in writing or in discussion with your instructor.

Post Assessment

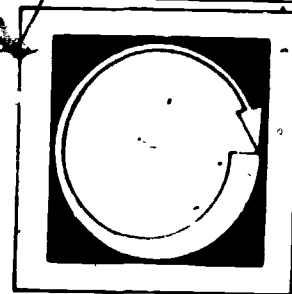

LISTED BELOW ARE SEVERAL STATEMENTS. IF THE STATEMENT IS TRUE, PLACE A "T" IN THE BLANK PROVIDED. IF THE STATEMENT IS FALSE, PLACE AN "F" IN THE BLANK.

1. ___ Nylon tends to have more static buildup than other human-made fibers.
2. ___ A glue-down carpet is only glued down on the edges.
3. ___ The smoke test finds out if smoke will damage a carpet.
4. ___ There are 4 main human-made fiber types.
5. ___ In a tufted carpet, fibers are punched through a backing.
6. ___ High pile carpet shows less crushing.
7. ___ Polypropylene resists stain better than other fibers.
8. ___ More than 70% of all carpets are made with polyester.
9. ___ Level loop tufting is for heavy duty carpet.
10. ___ The backing helps a carpet keep the same size and shape.
11. ___ Electronic needle injection puts dye on the surface of the carpet only.
12. ___ Natural fiber carpets cost less than human-made fiber carpets.
13. ___ Acetate is one of the four main human-made fiber types.
14. ___ In a woven carpet, the fibers are crisscrossed.
15. ___ Fiber blend is not a fiber type.
16. ___ Frieze is a cut-pile carpet that wears very well.
17. ___ When spreading woven carpet, the rows of nap have to be kept straight.
18. ___ A perimeter-installed carpet is hooked onto tack strips around the edges of the room.
19. ___ Heat-setting refers to putting a permanent twist in the yarn of a carpet.
20. ___ Heat-setting will also help stop yarn from unraveling.

● Instructor Post Assessment Answers

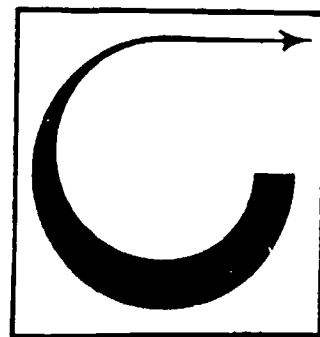

1. T
2. F
3. F
4. T
5. T
6. F
7. T
8. F
9. T
10. T
11. F
12. F
13. F
14. T
15. T
16. T
17. T
18. T
19. T
20. T

COMMON PADDING MATERIALS

Goal:

The student will be able to identify common carpet paddings and explain their uses.

Performance Indicators:

The student will successfully complete a Self Assessment, an Assignment and a Post Assessment.

Study Guide

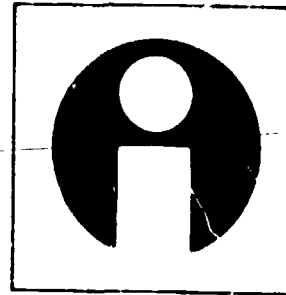

In order to finish this module, do the following tasks. Check each item off as you complete it.

1. Read the Goal and Performance Indicators on the cover of the module. This will tell you what you will learn by studying the module, and how you will show you've learned it.
2. Read the Introduction. The Introduction will tell you why the module is an important part of the floor laying trade.
3. Study the Vocabulary section. Vocabulary words are important for a good understanding of the trade. After you have studied the vocabulary, ask your teacher to quiz you on the words and their meanings.
4. Study the Information section. This section will give you the information you need to understand the subject.
5. Take the Self Assessment exam. This is a test for you to prove to yourself that you have learned the material you have studied. Compare your answers with the answers on the Self-Assessment Answer Sheet, which is on the page following the Self Assessment. If you scored poorly, re-study the Information section or ask your teacher for help.
6. Do the Assignment page. Follow the instructions at the top of the Assignment page.
7. Take the Post Assessment exam. Give the exam to your teacher after you have completed it. Your teacher will grade it for you.

Introduction

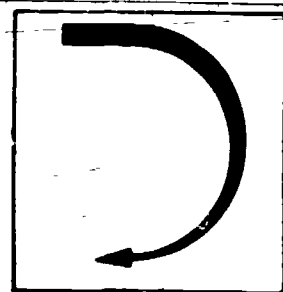

The padding that is used with a carpet can control the feel and wear of the carpet. Often the customer, even if he or she knows a lot about carpet, has not done much thinking about the padding to be used. In cases like this, the expert judgement of the carpet layer will become a big part of giving the customer a carpet that makes the customer happy. This module will help you learn about common carpet padding--so you can help the customer make the best choice.

Supplementary References

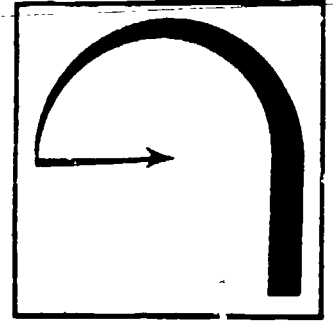

1. Duffin, D. J. The Essentials of Modern Carpet Installation. 1962. pp. 96-107.
2. Carpeting Floor Covering Workbook. California State Department of Education, 1972. pp. 19-22.

Vocabulary

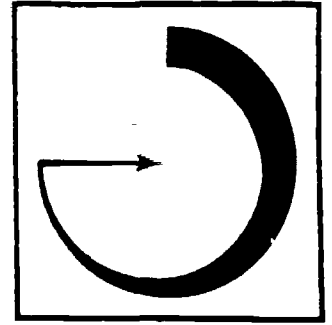

Trade terms are very important for a good understanding of the trade. Study these words and meanings. When you have learned them, ask your teacher to quiz you on the words and their meanings.

FELTING--Fibers are pressed together and steam is used to make the fibers mat and stick together.

SCRIM COAT--A layer added to many rubber and urethane paddings that makes it easier to stretch carpet. The scrim coat helps keep the carpet from dragging on the surface of the padding.

DIMENSIONAL STABILITY--How well something keeps its original shape. If a square has good dimensional stability, it will stay in a square shape.

Information

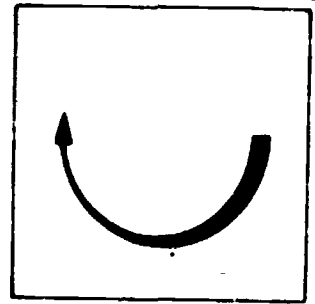

Padding may also be called lining, underlay, pads or cushion. It is installed underneath carpet materials. Carpet padding and rug cushion both refer to the same thing. The only difference is that carpet padding is a wall-to-wall installation, but rug cushion is not.

Function of Padding

1. Cushions against the shock of walking.
2. Makes a carpet last longer by absorbing the grinding and crushing of the pile in everyday use.
3. Makes any carpet feel softer and more luxurious.
4. Helps to fill in if there is any unevenness in the floor.
5. Makes vacuum cleaning more effective by creating pockets of air which the vacuum cleaner can draw through the carpet material.
6. Provides insulation against extreme heat or cold.
7. Helps carpet absorb sound.
8. Helps a carpet keep its texture.

Padding Materials

1. ALL HAIR--Any padding made with 100% felted cattle hair.
2. COMBINATION--Any padding material made with both cattle hair and jute fiber. This type of padding combines the spring and resilience of cattle hair with the strength and durability of jute. Jute is a plant fiber.
3. FOAM--Padding materials made from rubber, sponge or plastic materials. Foam padding may be added as an outer layer to ALL HAIR or COMBINATION to give extra spring. May also be used alone, without any other padding material.
4. JUTE--A padding made from woven plant fibers. May be dyed to look like ALL HAIR.

Hair padding and other paddings are measured by weight rather than by thickness. Weights are given in terms of how much one square yard of the padding will weigh. The thickness will be different for different weights. Common weights of hair padding are: 32, 40, 50, 64 and 86 ounces per square yard. Hair padding will give off an unpleasant odor when it is wet. So this type of padding is not recommended for use where it might get wet.

Combination padding is less expensive than all-hair padding. This is one reason it is used more than all-hair padding. ~~Combination padding is made with~~ a jute backing and a hair layer on top. *When combination padding is dyed, the layman or amateur can not tell the difference between all-hair and combination padding. When it can be used in place of all-hair padding, the savings to the dealer can be very large. The layer of cattle hair works best next to the carpet. The hair has adhesive qualities, and this lessens wear due to friction. The amount of hair in combination padding can be a very thin layer, or as much as 80% of the padding thickness.

Jute padding is made with plant fibers that are woven on a needle punching machine to make a pad of any desired thickness or weight. A waffle-type pattern is embossed or printed on one side. More expensive grades of jute padding are given a latex coat on one or both sides to increase dimensional stability. The less expensive grades of jute padding are called "contract" padding. A thin coat of glue size is put on one side of contract padding. Jute contract is usually not given a latex coat.

Jute padding may be dyed to look more like hair padding, but the dye can stain a floor if the padding gets wet. Undyed jute or contract is not affected by water. If these paddings are flooded, pull the carpet back. Then padding can then be allowed to dry.

Rubber padding is made in slab form, waffle form and combinations of the two. It can be colored for customer appeal. Foam or waffle type padding is made by injecting air into the liquid rubber before it gets the waffle imprint. Resistance of rubber padding is determined by the waffle depth combined with the density and thickness of the rubber.

Waffle-type rubber padding is used mainly in homes. Slab rubber padding is more often used in commercial or heavy foot traffic areas. As with any rubber

product, there is a "rubber smell" for the first few days after installation. If this smell does not go away, the padding will have to be removed. Some gases used to get rid of termites can damage rubber padding.

Advantages of Rubber Padding

1. Resiliency.
2. Instant return of indentations.
3. Insulation.

Disadvantages of Rubber Padding

Rubber padding may tend to pulverize in areas where there is heavy traffic. Because of this, it is not the best product to use on steps.

Widths of Rubber Padding

3 feet, 4½ feet, 9 feet, 12 feet.

Weight of Rubber Padding

It will weigh from 20 to 100 ounces per square yard.

Urethane padding is also used as padding for seat cushions, car visor and dashboard padding, mattress padding and for backing in quilted-look bedspreads and upholstery. It is available in both a foam type and a rebonded type.

The foam type is made by heating liquid urethane to make bubbles. The thickness varies from ¼" to just over ½". But density of the padding is often more important than thickness. A padding with 3/8 inch thickness and high density will cushion better than a ½-inch padding with low density.

Rebonded urethane padding is urethane chopped up and glued back together. Baked urethane has a crust on top. This crust is cut off. It is ground up and a binding liquid is added. Rebonded padding has a resilience much like that of rubber, but does not have the odor of rubber.

Advantages of Urethane Padding

1. Odor-free.
2. Non-allergenic.
3. It is easy to handle and install.

Disadvantages of Urethane Padding

1. Inferior or lower grades do not wear well
2. It will burn readily if ignited.
3. If it does not have a scrim coat, it is hard to stretch carpet over it

Installation of Padding

The techniques and methods for installing padding are very much like those for installing carpeting. One big difference is that padding is not visible. Since no one will see it, padding can be pieced together much more than carpet. Any of the available carpet tapes may be used for seaming, with the exception of those that have built in grippers. This kind of tape is made only for seaming carpet.

SUMMARY

Rubber Padding

Several weights available. Can be used in any area. Soft feel underfoot. Main problems are that it dries out and starts to deteriorate and the rubber smell may not go away. Normally lasts the life of one carpet.

Hair Padding

Recommended for floors with radiant heating. Feels very hard, like there is no pad underneath. If it gets wet, it will smell.

Jute Padding

Wears well. Not damaged by water. Available in less expensive "contract" grades.

Combination Padding

Has wear characteristics similar to hair padding, but may cost much less.

Urethane Foam Padding

Comes in many different thicknesses. An economical padding normally used in rentals or bedrooms. Feels very soft underfoot. Flammable

Urethane Rebond Padding

Made with chips of urethane rebonded together. Is considered a very good value. May be used in all carpet areas. About 85% of all carpet jobs today use rebond padding. Feels soft underfoot. Normal life is equal to that of 2 carpets. Flammable.

Self Assessment

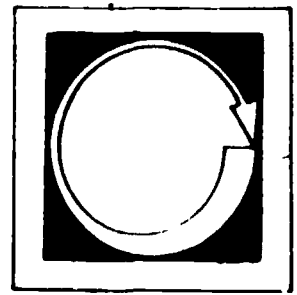

COMPLETE THE FOLLOWING STATEMENTS BY WRITING THE CORRECT WORD OR WORDS IN THE BLANKS PROVIDED.

1. _____ of padding is often more _____ than thickness.
2. _____ padding may be _____ to look more like hair padding
3. _____ can be pieced together much more than _____.
4. Hair _____ is made with _____ hair.
5. Some gases used to get rid of _____ can damage _____ padding.
6. More _____ grades of jute padding are given a _____ coat.
7. Urethane padding is available in a _____ type and a _____ type.
8. Combination padding is made with _____ and _____.

LISTED BELOW ARE SEVERAL STATEMENTS. IF THE STATEMENT IS TRUE, PLACE A "T" IN THE BLANK PROVIDED. IF THE STATEMENT IS FALSE, PLACE AN "F" IN THE BLANK.

9. _____ Padding makes vacuum cleaning more effective.
10. _____ Padding helps a carpet keep its texture.

11. ___ Padding makes the colors in carpet brighter.
12. ___ Padding cushions against the shock of walking
13. ___ Padding helps a carpet absorb sound.
14. ___ Padding helps a carpet to last longer.
15. ___ Padding can help insulate the floor.
16. ___ Padding keeps tufted carpet from shading. /
17. ___ Padding makes any carpet feel softer.
18. ___ Padding helps to fill in if there is any unevenness in the floor.

Self Assessment Answers

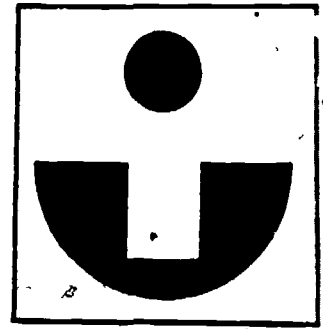

1. density, important
2. jute, dyed
3. padding, carpet
4. padding, cattle
5. termites, rubber
6. expensive, latex
7. foam, rebonded
8. cattle hair, jute fibers
9. T
10. T
11. F
12. T
13. T
14. T
15. T
16. F
17. T
18. T

Assignment

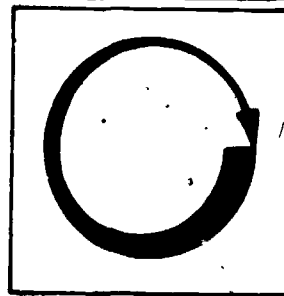

COMPLETE THE FOLLOWING ASSIGNMENTS.

Materials

A box containing sample pieces of different kinds of padding material.
Fire extinguisher and open place for burning.

1. Sort and identify the sample pieces of padding material given to you by your instructor.
2. Wet a piece of hair padding to see if it does smell.
3. If it can be done safely, ignite a piece of urethane padding. Ignite a piece of a different kind of padding. How do the two compare in "flammability?"
4. Wet a piece of jute padding that has been dyed. What happens to it?
5. Wet a piece of jute padding that has not been dyed. What happens to it?

Post Assessment

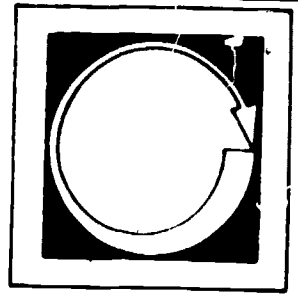

LISTED BELOW ARE SEVERAL STATEMENTS. IF THE STATEMENT IS TRUE, PLACE A "T" IN THE BLANK PROVIDED. IF THE STATEMENT IS FALSE, PLACE AN "F" IN THE BLANK.

1. ___ Almost all carpet seaming tapes can be used to seam pieces of padding.
2. ___ Another name for padding is "underlay."
3. ___ Rubber padding tends to pulverize in heavy traffic areas.
4. ___ Jute padding is made with plant fibers.
5. ___ Combination padding wears like hair padding but is more expensive.
6. ___ Waffle-type rubber padding is used mainly in residential installations.
7. ___ Rebonded urethane padding has a resilience much like that of rubber padding.
8. ___ Carpet padding and rug cushion both refer to the same thing.
9. ___ Jute padding falls apart if it gets wet.
10. ___ Paddings are measured by the weight of one square foot in pounds.
11. ___ Urethane padding is not flammable.
12. ___ Dyed jute padding will smell if it gets wet, but won't stain the floor.
13. ___ Hair padding is recommended for floors with radiant heating.
14. ___ Padding makes it harder to vacuum carpeting.

15. ____ When jute is dyed, it is hard to tell it from hair padding.
16. ____ Rubber padding smells for about 3 months after being installed.
17. ____ Padding can help absorb sound.
18. ____ Jute padding may have a latex coat on one side, two sides, or no sides.
19. ____ The density of padding can be more important than the thickness.
20. ____ Hair padding is made with horse hair.

● Instructor Post Assessment Answers

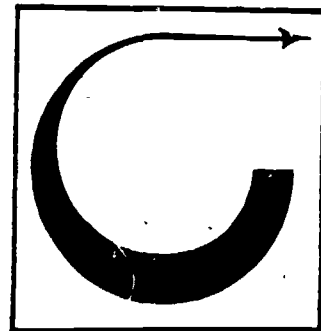

1. T
2. T
3. T
4. T
5. F
6. T
7. T
8. T
9. F
10. F
11. F
12. F
13. T
14. F
15. T
16. F
17. T
18. T
19. T
20. F

COMMON PLASTIC LAMINATES

Goal:

The student will be able to identify common plastic laminates and explain their common uses.

Performance Indicators:

The student will successfully complete a Self Assessment, an Assignment and a Post Assessment.

Study Guide

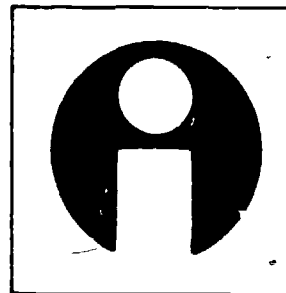

In order to finish this module, do the following tasks. Check each item off as you complete it.

1. Read the Goal and Performance Indicators on the cover of the module. This will tell you what you will learn by studying the module, and how you will show you've learned it.
2. Read the Introduction. The Introduction will tell you why the module is an important part of the floor laying trade.
3. Study the Vocabulary section. Vocabulary words are important for a good understanding of the trade. After you have studied the vocabulary, ask your teacher to quiz you on the words and their meanings.
4. Study the Information section. This section will give you the information you need to understand the subject.
5. Take the Self Assessment exam. This is a test for you to prove to yourself that you have learned the material you have studied. Compare your answers with the answers on the Self Assessment Answer Sheet, which is on the page following the Self Assessment. If you scored poorly, re-study the Information section or ask your teacher for help.
6. Do the Assignment page. Follow the instructions at the top of the Assignment page.
7. Take the Post Assessment exam. Give the exam to your teacher after you have completed it. Your teacher will grade it for you.

Introduction

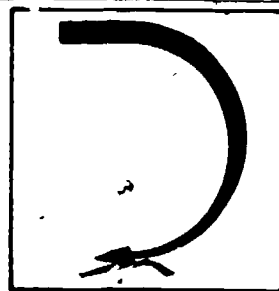

A plastic laminate counter top can look very good. As a floor layer, you may be installing counter tops, or covering cabinets or tub enclosures. To do a good job--and to help the customer choose materials with which he or she will be happy--you will need to know about plastic laminates.

This module will help you learn why a laminate is good and where it is good. You will learn about how plastic laminate is made, the grades of laminate, how to prepare a surface, sizes of sheets and about cleaning plastic laminate.

Vocabulary

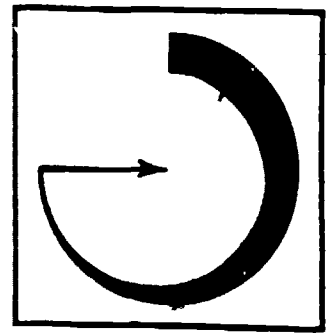

Trade terms are very important for a good understanding of the trade. Study these words and meanings. When you have learned them, ask your teacher to quiz you on the words and their meanings.

MAT FINISH--Also "matte" finish. A surface that is not very shiny.

GLOSS FINISH--A very shiny surface.

HONEYCOMB CORE--A material that looks solid all the way through from the outside, but is not. Some doors are made with a honeycomb construction.

HORIZONTAL--A level surface, such as the floor.

VERTICAL--An up-and-down surface, such as the wall.

COVERED--When a material is bent from one plane to another plane, as from a horizontal surface to a vertical surface. Means the same as "flushed."

PREFABRICATION--Something made in the shop or factory that is ready to use or be installed.

NONPOROUS--Very smooth.

SELF-EDGED--Laminate is cemented to the vertical edge. The top laminate is lapped over the vertical piece. The top edge is then trimmed flush. Use of a router makes this job much easier.

Supplementary References

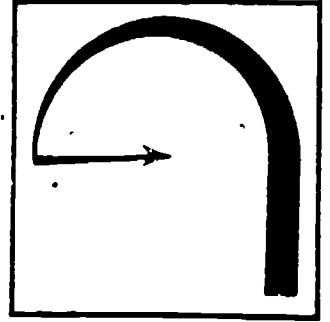

Resilient Coverings Workbook. California State Department of Education, 1973.
pp. 243-248.

Information

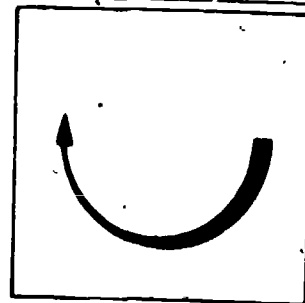

Plastic laminates are sold under different brand names. Some of the names are: Formica, Consoldweld, Textolite, Panelyte, Micarta, Nevamar. Plastic laminate materials are used to cover counter tops, doors, walls, cabinets, furniture and so on. The plastic laminate materials are available with many surface patterns, such as: Wood grain, veined marble, solid colors, slate, leather and metallic tones. The surface may have a mat or gloss finish.

A plastic laminate material would be installed in places where these things are needed:

1. Good appearance.
2. Durability.
3. Can resist stain.
4. Can resist burns.
5. Can resist alkali and acid better than vinyl.
6. Can resist rot and mildew.
7. Is easy to clean.

But plastic laminate materials are brittle. They will break if used alone. A plastic laminate, if it is installed the right way, must be glued onto a backing material. Some backing materials that are used with plastic laminates are: Plywood, particle board, hardboard and honeycomb core materials.

HOW PLASTIC LAMINATE IS MADE

1. Kraft paper is soaked in a resin.
2. A certain number of the Kraft paper sheets (often 13 sheets) are put together.
3. A sheet with a color or pattern is put on top.
4. A sheet of clear plastic goes on top of everything else.
5. All of the sheets are fused together using heat and pressure.

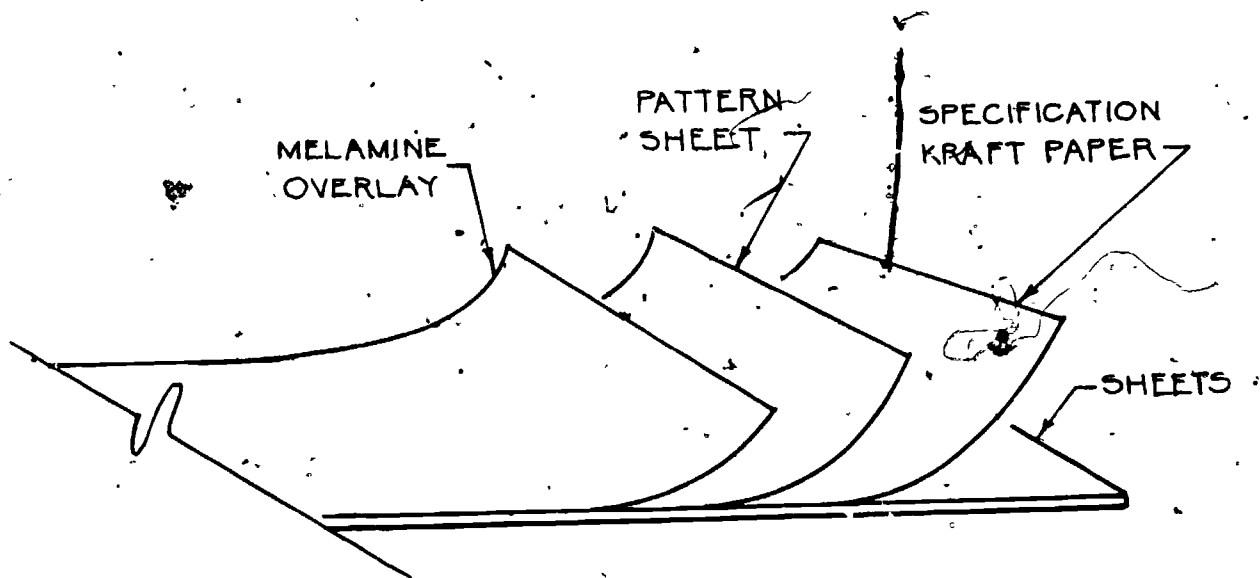

THE 3 BASIC GRADES OF PLASTIC LAMINATE

1. General Purpose Grade.

This grade of plastic laminate can be used to cover horizontal and vertical surfaces.

Thickness: 1/16"

Bend: Can be bent to a 9" radius without heat. Can be bent to a 2 1/2" radius when heated.

Standard grade materials are often metal trimmed. They may also be self-edged. This grade of plastic laminate is not usually coved, but it can be coved under special conditions.

2. Forming Grade.

This grade is made to be able to bend very well. It can be used to make a coved backsplash or the rolled front edge of a counter. Bending the plastic in a cove up the back wall or over the counter edge means that seams do not have to be used.

Thickness: 1/20"

Forming grade materials are thinner than general purpose grade materials. Forming grade materials are often used in prefabrication work. In the shop, workers can apply heat and pressure to form the material to the base to which it is bonded.

3. Vertical Grade.

This grade is made to be used on vertical surfaces. Vertical surfaces do not get as much wear as horizontal surfaces, so this grade is very thin. It can be used to cover things like kitchen and vanity cabinets.

Thickness: .1/32"

Bend: Can be bent to a 3" radius without the use of heat.
Can be bent to a 3/4" radius when heat is used.

PREPARING A SURFACE FOR PLASTIC LAMINATE INSTALLATION

These preparation guides are for the two surfaces that will be bonded together. These surfaces are the back of the laminate and the front of the backing material.

1. Surfaces must be clean, dry and smooth.
2. Remove any old surface covering, paint, or varnish.
3. Replace warped, rough, or split parts of the surface.
4. Fill any holes and sand the area smooth.
5. For metal and other nonporous surfaces:
 - a. Surface must be free of grease.
 - b. Surface must be made rough.
 - c. Phosphate treatment of metal surfaces makes the bond better and helps prevent rust.

SIZES OF PLASTIC LAMINATE SHEETS

Width: Varying from 24" to 60".

Length: Varying from 60" to 144".

Note that the sizes that are listed for a sheet of laminate material are not the actual sizes. In both length and width, the sheet will be from 1/2" to 1" more than the size given. This means that a sheet listed as 24" by 60" in the manufacturer's specifications will be 24 1/2" by 60 1/2" or larger.

CLEANING A PLASTIC LAMINATE SURFACE

Care must be used when a plastic laminate surface is being cleaned. The plastic laminate surface is very durable, but it must be cleaned only with recommended cleaning agents. Often, only soap and water are needed. If anything else is to be used, check the manufacturer's recommendations about cleaning before using it.

Self Assessment

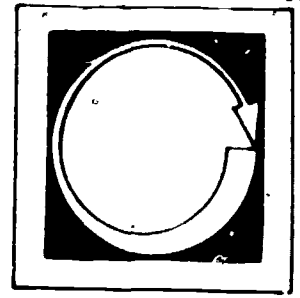

A. NUMBER THE 5 STEPS OF MAKING A SHEET OF PLASTIC LAMINATE IN THE RIGHT ORDER.

- ___ Put a sheet of clear plastic on top of everything.
- ___ Soak Kraft paper in resin.
- ___ Fuse the sheets with heat and pressure.
- ___ Put the Kraft sheets together.
- ___ Put a color or pattern sheet on top.

B. LIST THE 3 BASIC GRADES OF LAMINATE, THE BEST USE AND THE THICKNESS OF EACH GRADE.

<u>Grade</u>	<u>Best Use</u>	<u>Thickness</u>

C. LIST THE 4 THINGS THAT HAVE TO BE DONE TO PREPARE A WOOD SURFACE.

- 1.
- 2.
- 3.
- 4.

D. WHAT 3 THINGS SHOULD BE DONE TO A METAL SURFACE?

- 1.
- 2.
- 3.

Self Assessment Answers

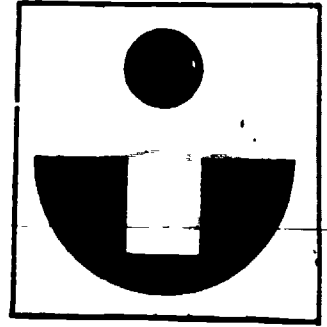

A. 4

1

5

2

3

B. General Purpose	Where coving not needed	1/16"
Forming	Where coving is needed	1/20"
Vertical	On vertical surfaces only	1/32"

- C.
1. Make sure surface is clean and dry.
 2. Remove any old surface covering.
 3. Replace warped, rough, or split parts.
 4. Fill holes and sand.

- D.
1. Make sure surface is free of grease.
 2. Make surface rough.
 3. Apply phosphate treatment.

Assignment

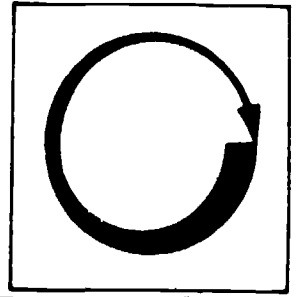

COMPLETE THE ASSIGNMENT BELOW.

Materials:

Samples of plastic laminate, including several different brand names and different grades.

Select some things from the information section which describe qualities of plastic laminate. Test different brands and grades of laminate for the qualities you have picked from the Information section.

BRAND NAME	GRADE	(QUALITY) _____	(QUALITY) _____	(QUALITY) _____	(QUALITY) _____

Post Assessment

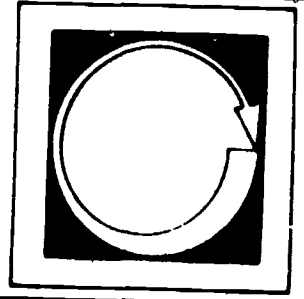

LISTED BELOW ARE SEVERAL STATEMENTS. IF THE STATEMENT IS TRUE, PLACE A "T" IN THE BLANK PROVIDED. IF THE STATEMENT IS FALSE, PLACE AN "F" IN THE BLANK.

1. ___ Vertical grade materials are thinner than the other grades.
2. ___ Heat should not be used to make plastic laminate bend better.
3. ___ Soap and water usually work best to clean plastic laminate.
4. ___ Plastic laminate is never used to cover cabinets.
5. ___ Vertical grade can be bent to a 3/4 inch radius when it is heated.
6. ___ If a sheet is listed as being 24 inches wide and 60 inches long, you know it is at least 24 1/2 inches by 60 1/2 inches.
7. ___ Laminate can resist stain and burns well.
8. ___ Forming grade is the thickest kind of laminate.
9. ___ A nonporous surface must be sanded smooth.
10. ___ The front of the backing material and the back of the laminate both have to be prepared.
11. ___ Laminate materials are very brittle.
12. ___ General purpose grade is best for coving.

13. ___ Paint can be left on a prepared surface.
14. ___ Laminate does not resist alkali and acid very well.
15. ___ A prepared surface must be clean and dry.
16. ___ Kraft paper, a color or pattern and a sheet of clear plastic are fused with steam to make laminate.
17. ___ Plywood does not make a good backing material.
18. ___ Vertical grade is made for places with heavy wear.
19. ___ Sand warped, rough or split parts smooth.
20. ___ A plastic laminate surface can be cleaned with any solvent.

Instructor Post Assessment Answers

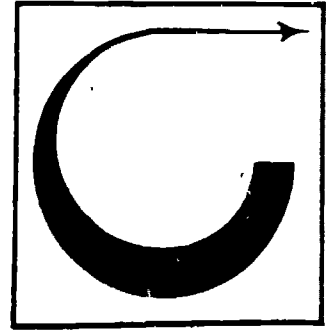

1. T
2. F
3. T
4. F
5. T
6. T
7. T
8. F
9. F
10. T
11. T
12. F
13. F
14. F
15. T
16. F
17. F
18. F
19. F
20. F

SURFACE PREPARATION

Goal:

The student will be able to identify common surface flaws, explain the need for common surface preparation techniques and demonstrate these techniques by preparing a surface (including filling cracks, smoothing and cleanup) for laying a floor.

Performance Indicators:

The student will successfully complete a Self Assessment, a Job Sheet and a Post Assessment.

Study Guide

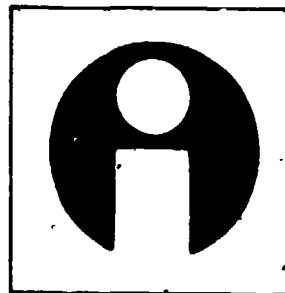

In order to finish this module, do the following tasks. Check each item off as you complete it.

1. Read the Goal and Performance Indicators on the cover of the module. This will tell you what you will learn by studying the module, and how you will show you've learned it.
2. Read the Introduction. The Introduction will tell you why the module is an important part of the floor laying trade.
3. Study the Vocabulary section. Vocabulary words are important for a good understanding of the trade. After you have studied the vocabulary, ask your teacher to quiz you on the words and their meanings.
4. Study the Information section. This section will give you the information you need to understand the subject.
5. Take the Self Assessment exam. This is a test for you to prove to yourself that you have learned the material you have studied. Compare your answers with the answers on the Self Assessment Answer Sheet, which is on the page following the Self Assessment. If you scored poorly, re-study the Information section or ask your teacher for help.
6. Do the Job Sheet. Follow the instructions at the top of the Job Sheet. The tasks listed on the Job Sheet will help you develop skills which will be helpful to you.
7. Take the Post Assessment exam. Give the exam to your teacher after you have completed it. Your teacher will grade it for you.

Introduction

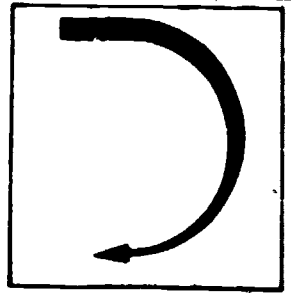

Modern floor covering materials are as good as the surface on which they are laid. If they are put on a surface that has been prepared right, they will give many years of very good service. If they are put on a surface that has not been prepared right, they will give you years and years of problems, customer complaints and costly repairs.

The floor layer is the one who has to get the surface ready for laying the flooring material. This module will give you information on how to do this, and practice in doing it.

Vocabulary

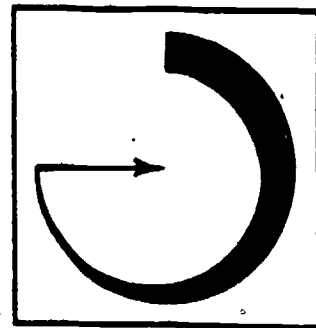

Trade terms are very important for a good understanding of the trade. Study these words and meanings. When you have learned them, ask your teacher to quiz you on the words and their meanings.

REPAIRABLE--Can be fixed.

UNREPAIRABLE--Cannot be fixed.

UNDERLAYMENT--A floor base installed to make a smooth surface for the floor covering.

PLYWOOD UNDERLAYMENT--Plywood sheet, often 4' X 8'. Use an exterior grade that has no center ply voids. Should be sanded and plugged on one side. This side is laid face up. Sheets 1/4" thick may be used over a smooth sub-surface. Use 3/8" to 1/2" if subsurface is irregular. Nail from the center of the sheet out to the edge.

HARDBOARD UNDERLAYMENT--Also called Masonite, Temboard, fiberboard. Made by pressing wood fiber. Check to be sure nails can be countersunk in the type chosen. Some may be so brittle that they will shatter if a staple gun is used. The screen (rough side) is laid face up. This lets adhesive get a better hold. Follow same layout and nailing procedures as for plywood.

PARTICLE BOARD UNDERLAYMENT--Particle board must meet FHA specification FHA-UM28 or its equivalent. Minimum thickness that should be used is 3/8". Boards should be sanded on both sides. Follow general procedures for plywood.

POWDER OUT--Both hardboard and particle board have had this problem, especially with sheet or tile vinyl installations.

FLAW--Something that needs fixing: crack, hole, raised area, adhesive not working, etc.

TELEGRAPHING--When a flaw in the subfloor shows on the surface of a floor covering material. Resilient coverings and glue-down carpets will show flaws very quickly.

Supplementary References

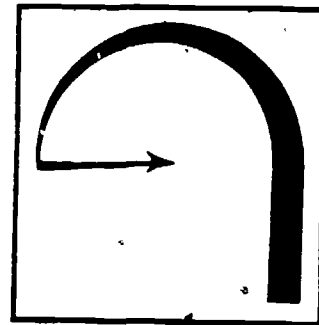

1. Bogart, John J. "How to Lay Resilient Flooring," The Family Handyman. 1981.
2. Duffin, D. J. The Essentials of Modern Carpet Installation. 1962. p. 170

Information

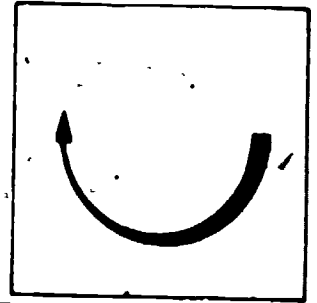

The general methods of preparing a surface are the same for all floor covering materials. Whether it is a resilient floor covering or a carpet material, it is just a good work habit to start with the best possible surface you can make.

The first step is the same as the last step: clean up the area. A floor layer has to clean up before starting a job to find out what needs to be fixed before laying the floor covering. The clean up after laying a floor is the final sign of a job well done.

When preparing a floor surface, the floor layer has to work with many different kinds of floors. But all of them can be put in either of two categories:

1. Repairable floors.
2. Unrepairable floors.

The second group needs to have a new underlayment installed before the floor covering can be laid. The first group may need only minor patching, or it may need major repair work.

REPAIRABLE FLOORS

The first step is always: The floor must be clean. This means all traces of paint, old adhesive, wax and so on have to be removed. The floor has to be clean to see all of the flaws, and a clean floor is necessary to get a good adhesive bond.

Repairable Wood Floor

Mend with wood patching materials as needed. Nail loose boards and replace any worn materials. Fill holes and cracks. Use caution when driving nails. They should be driven even with the floor surface. Any "dimples" caused by the hammer striking the wood will work their way through the floor covering material and show on the surface (telegraphing). Dimples and nails driven deep enough to

Leave holes in the surface have to be patched the same as holes or cracks.

Repairable Concrete Floor

High areas need to be sanded. Low areas need to be made level with the surface. Cracks and holes have to be filled. Rough spots need to be smoothed (either by sanding or filling). Check for efflorescence and take any needed action. Check for presence of moisture or alkalis. Determine if it will be necessary to apply a primer or sealer coat to prevent later damage to the floor covering by moisture.

1. Dig out the areas to be filled with a hammer and chisel (or power hammer).
2. This makes an area where the filling compound can "bite" the surface well. Good "tooth anchoring" action makes a good patch.
3. Clean prepared area thoroughly with a brush or vacuum.
4. The surrounding area must also be cleaned. This keeps stray bits from getting into the filling agent.
5. Fill the prepared area to floor level with the recommended filler.
6. When the fill has dried properly, scrape or sand it smooth and level with the floor surface around it.

Repairable Floor with Old Resilient Covering

An old, embossed covering is not a good surface to lay a new floor on. The embossing of the old covering will work its way to the surface of the new material (telegraphing the embossed design). An old resilient surface can be used only if it is well-bonded and there are no cracks, holes or other flaws. If any flaws are present, they will have to be fixed before laying the new floor covering. Any wax or other coating which will prevent a good adhesive bond has to be removed. Since there can be the danger of breathing asbestos fibers, always follow the safety procedures when preparing a resilient surface.

Sweep and vacuum the surface on which the new floor covering will be installed.

UNREPAIRABLE FLOORS

When a floor cannot be repaired, this means new underlayment has to be installed. The following are general guidelines for installing underlayment:

1. Use exterior grade wood products (plywood, hardboard, and so on). Other grades may delaminate or otherwise be damaged if exposed to water. This can happen when a carpet is being shampooed, as well as from the flooding of a room.
2. Ordinary plywood may telegraph its grain through to the surface of the new flooring in less than a year. Underlayment plywood is sanded smooth on one side to prevent this.
3. When laying the sheets, stagger them so that a crack does not run both the length and width of the room.

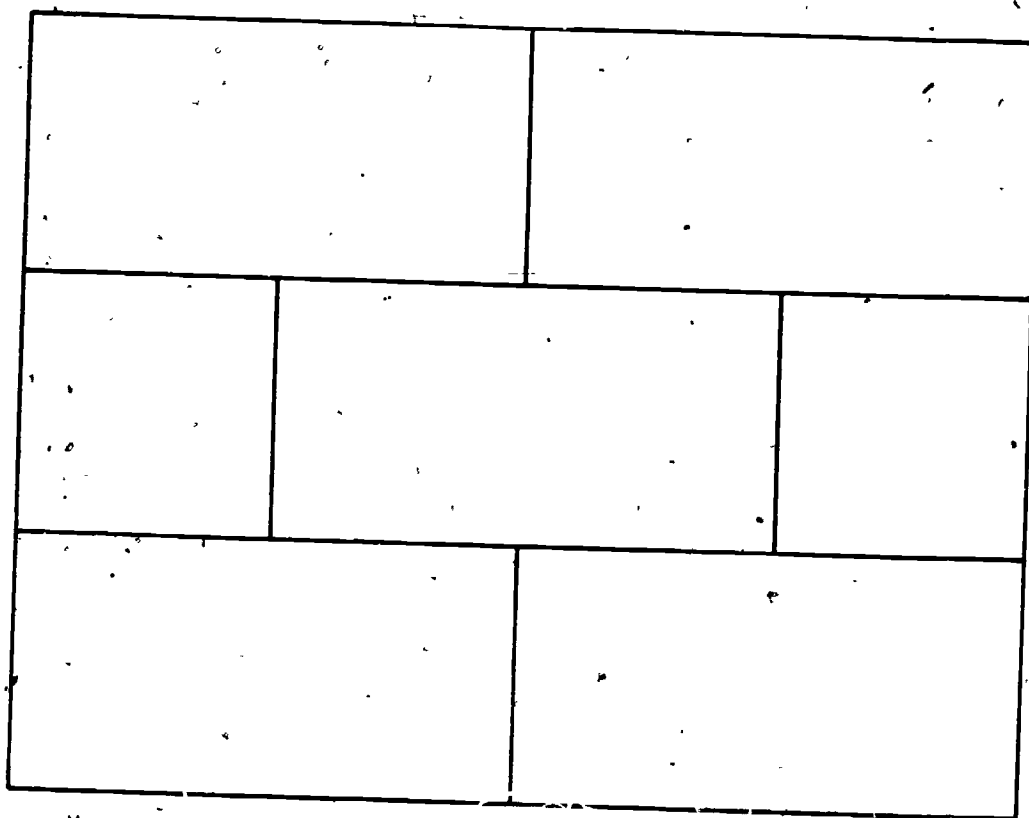

You may have to cut half sheets to break up the pattern.

4. Leave about 1/8 inch (width of a matchbook cover) between the sheets. This provides space for expansion and contraction during weather changes. (Some resilient and glue-down carpets may need to have these cracks filled and sanded smooth.)
5. Use annular-ringed nails which are long enough to go at least 3/4 inch into the subfloor. (See the first illustration on the next page.)

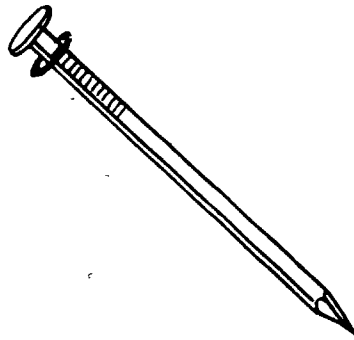

6. The sheets should be laid at right angles to existing floor boards.

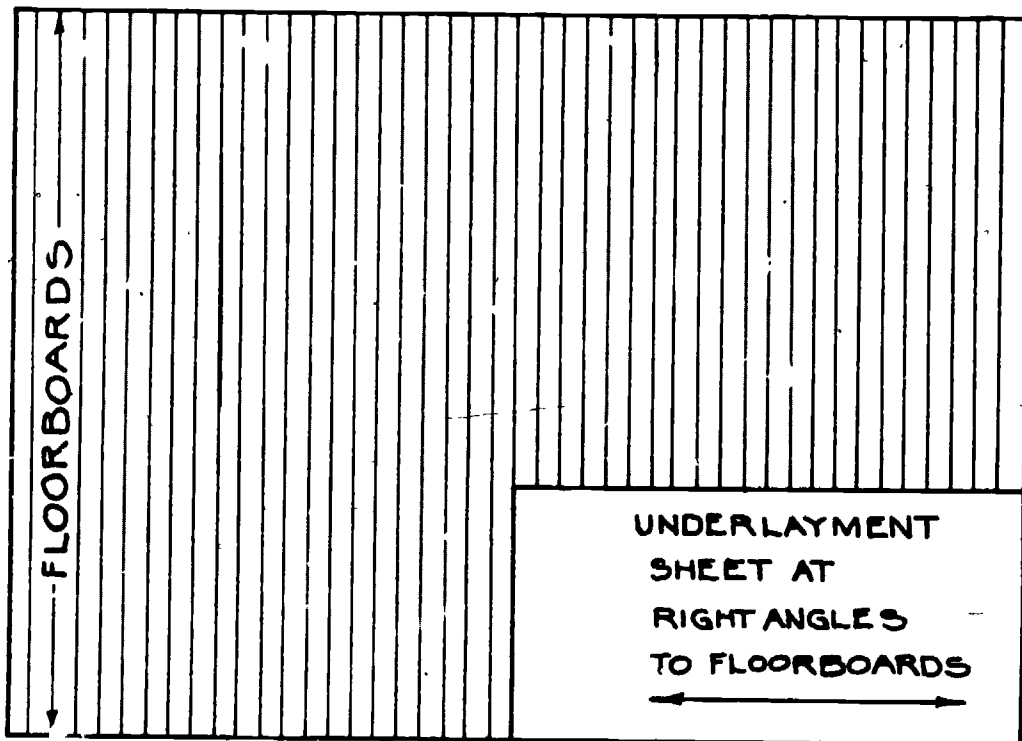

7. Space nails every 6 inches and no closer than 1/2 inch to the edge of each sheet. Also nail rows across the sheet, aligning nails to penetrate the joists.
8. Drive nails flush (even) with floor surface. Nails driven too deep and hammer blows to the surface have to be treated as flaws and repaired before laying the flooring material.

9. Now treat the surface as a repairable wood floor; patch where needed and so on.
10. Sweep and vacuum the underlayment you have prepared.

Self Assessment

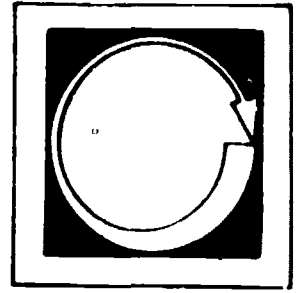

COMPLETE THE FOLLOWING STATEMENTS BY WRITING THE CORRECT WORD OR WORDS IN THE BLANKS PROVIDED.

1. When nailing underlayment plywood sheets, space nails every _____ inches and no closer than _____ inch to the edge of each sheet.
2. Good "tooth anchoring" action makes a good _____.
3. The first thing to do is _____ the floor and the last thing to do is _____ the floor.
4. _____ floors may need only minor repair work.
5. The two categories of floors are _____ and _____.
6. Ordinary plywood may _____ its _____ through to the _____ of the new flooring in less than a _____.
7. For _____ repairs, dig out the areas to be filled with a _____ and _____.
8. _____ floors need a new _____ installed.

CIRCLE THE CORRECT ANSWER

9. Which kind of old resilient floor should not be used as a base for new flooring?

vinyl

tile

embossed

rotovinyl

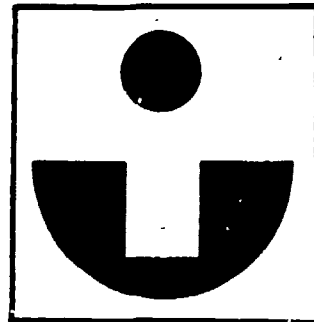

● Self Assessment Answers

1. 6, 1/2
2. patch
3. clean, clean
4. repairable
5. repairable, unrepairable
6. telegraph, grain, surface, year
7. cement, hammer, chisel
8. unrepairable, underlayment
9. embossed

Job Sheet

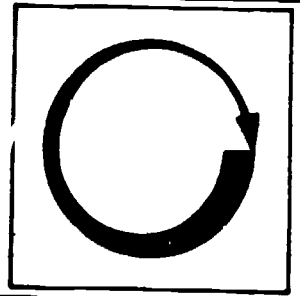

COMPLETE THE FOLLOWING TASK.

Materials

A piece of plywood at least 2' X 4' that has several surface flaws.
Sections of 2 X 4s, either cut to size or to be cut by the student.

The sheet of plywood is your underlayment material. Nail the sheet to the 2 X 4s as if you were laying it on an old floor. Then prepare the surface of the plywood sheet: patching, leveling, sanding, and so on as needed.

OPTIONAL: Repair a concrete surface by making a hole and filling it, following the manufacturer's directions for the filling compound you will use.

Post Assessment

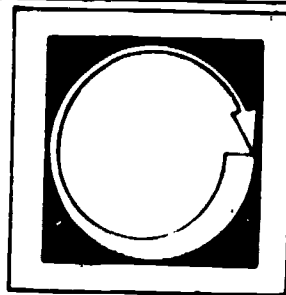

LISTED BELOW ARE SEVERAL STATEMENTS. IF THE STATEMENT IS TRUE, PLACE A "T" IN THE BLANK PROVIDED. IF THE STATEMENT IS FALSE, PLACE AN "F" IN THE BLANK.

1. Cleaning up before a job helps the floor layer see any flaws.
2. The underlayment sheets should be laid at right angles to existing floor boards.
3. A sealer coat may be needed on a concrete floor.
4. Ordinary plywood may telegraph its grain through to the surface of the new floor.
5. An embossed design on an old resilient floor can telegraph through a new floor covering.
6. The two categories of floors are wood and concrete.
7. Moisture and alkalis can be a problem in all kinds of concrete floors.
8. "Dimples" caused by hammer blows to the surface of the old floor are not deep enough to "telegraph."
9. Traces of paint, old wax and adhesive do not have to be removed from the old floor.
10. Nails should be driven below the floor surface.
11. Holes need to be filled: cracks do not.

12. ___ It is not a good idea to dig out a concrete area before filling it.
13. ___ Flaws are hard to telegraph through to the surface of the new floor.
14. ___ An exterior grade of plywood is used because it won't be damaged by water.
15. ___ Wax left on the old floor makes a better adhesive bond.

Instructor Post Assessment Answers

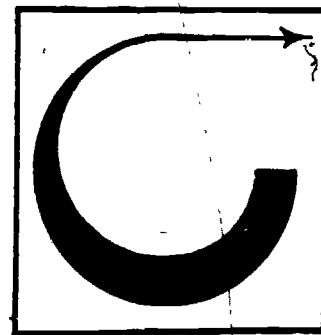

1. T
2. T
3. T
4. T
5. T
6. F
7. T
8. F
9. F
10. F
11. F
12. F
13. F
14. T
15. F

BASIC LAYOUT

Goal:

The student will be able to identify, explain and demonstrate the techniques of layout used in laying common floor covering materials. The steps will include squaring, measuring, marking, fitting pieces, ensuring carpet nap matches and similar details.

Performance Indicators:

The student will successfully complete a Self Assessment, a Job Sheet and a Post Assessment.

Study Guide

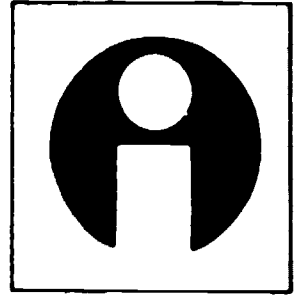

In order to finish this module, do the following tasks. Check each item off as you complete it.

1. Read the Goal and Performance Indicators on the cover of the module. This will tell you what you will learn by studying the module, and how you will show you've learned it.
2. Read the Introduction. The Introduction will tell you why the module is an important part of the floor laying trade.
3. Study the Vocabulary section. Vocabulary words are important for a good understanding of the trade. After you have studied the vocabulary, ask your teacher to quiz you on the words and their meanings.
4. Study the Information section. This section will give you the information you need to understand the subject.
5. Take the Self Assessment exam. This is a test for you to prove to yourself that you have learned the material you have studied. Compare your answers with the answers on the Self Assessment Answer Sheet, which is on the page following the Self Assessment. If you scored poorly, re-study the Information section or ask your teacher for help.
6. Do the Job Sheet. Follow the instructions at the top of the Job Sheet. The tasks listed on the Job Sheet will help you develop skills which will be helpful to you.
7. Take the Post Assessment exam. Give the exam to your teacher after you have completed it. Your teacher will grade it for you.

Introduction

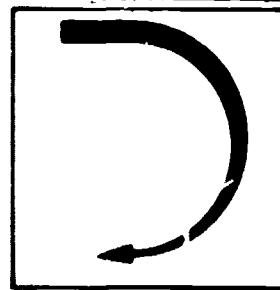

The pieces of floor covering material that are put on the floor have to be cut properly first. They should also be cut properly the first time. Second times cost your employer extra money.

To get everything right the first time takes a lot of careful planning. This planning is called "layout." This module will help you learn how to plan to get things done right the first time.

*Note: In the floor covering trade, amounts of floor covering are figured in square yards, not square feet. Tile is figured in square feet. To keep the math simple, amounts of all covering are discussed in square feet. There are 9 square feet in a square yard.

Vocabulary

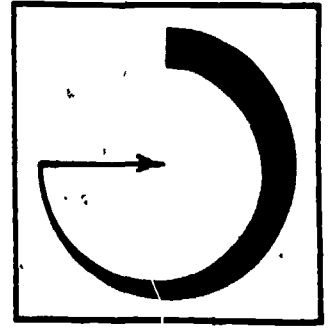

Trade terms are very important for a good understanding of the trade. Study these words and meanings. When you have learned them, ask your teacher to quiz you on the words and their meanings.

LOOKING INTO PILE--When the pile is leaning toward you. The carpet looks darker this way.

LOOKING OVER PILE--When the pile is leaning away from you. The carpet looks lighter this way.

PARALLEL--Two lines that are opposite each other. Parallel lines will never meet, no matter how long you make them.

IRREGULAR--The opposite of regular. An irregular room will have built-in cabinets, alcoves, etc.

}
C
3

Carpet Training Manual. Southern California Joint Apprenticeship and Training
Committee. Chapters "P" and "J."

Supplementary References

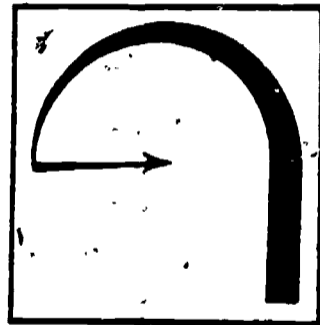

Information

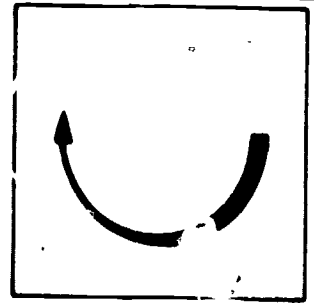

The five general kinds of material the floor layer works with are:

1. Resilient sheet goods.
2. Resilient tile.
3. Woven carpet.
4. Tufted carpet.
5. Laminated goods.

There are special things you need to think about and do for each type of material. But the general things that have to be done when you are getting ready to cover an area are the same for all the materials. This process of getting the material ready is called layout. In general, the following steps will be used for any area to be covered and with all materials you will use:

1. Determine size (length and width) of all areas to be covered, including irregular features of the spaces.
2. Determine direction of pile or pattern.
3. Determine which of the available sizes of the material would be the best for cutting out the needed pieces.
4. Mark the pieces to be cut.
5. Cut and lay out the pieces.

DETERMINING SIZE OF THE SPACE

The three things needed for good measurement are:

1. Accuracy.
2. Detail.
3. Neatness.

There are also two rules of measurement that you should remember:

1. Never assume that two walls are equal in length. Always measure everything.

2. Make sure you have the shortest straight line and that there are no wrinkles in your measuring tape.

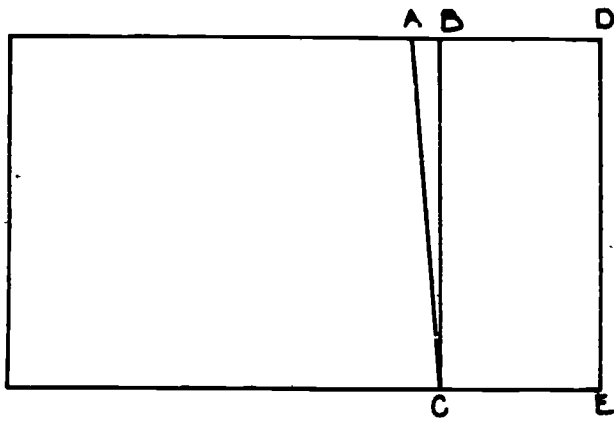

LINE AC IS LONGER
THAN LINE BC
BECAUSE LINE AC
IS NOT PARALLEL
TO LINE DE.

Rooms always start out "square" (with parallel sides being equal in length) when they are planned on paper. But you cannot be sure the room was actually made the way it was drawn on paper.

A job may be bid from blueprints. The blueprints can be used when the cost of putting in carpet or other floor material is being estimated. But planning the actual installation means going into the building and measuring everything. Blueprint and real life measurements may have only one or two inches difference, or they may be a foot or more different.

There is a "shorthand" way to record feet and inches. This is done by showing the feet as regular numbers and the inches as a smaller superscript: 17^6 means 17 feet and 6 inches.

Record your measurements in the form of a sketch of the room. The sketch does not have to be drawn to scale (but some shops will do this). The measurements, however, do have to be accurate. There are several different ways of doing it. The one you will use will depend on what is accepted at the shop where you work. Some samples follow: (See the three illustrations on the following pages.)

You need to include everything in the sketch that will affect the different parts of the job:

1. Estimating amount of floor covering material needed.
2. Planning to get the best wear from the floor covering.
3. Planning to get the best appearance of the floor covering.

If the walls are not parallel, the area has to be squared off.

A to B	17 ⁹ / ₁₆	H to J	2 ¹⁰ / ₁₆
B to C	0 ¹ / ₁₆	J to K	0 ⁵ / ₁₆
D to E	5 ² / ₁₆	H to L	1 ⁰ / ₁₆
E to F	0 ⁷ / ₁₆	H to M	3 ⁸ / ₁₆
D to G	1 ¹¹ / ₁₆	A to N	4 ² / ₁₆

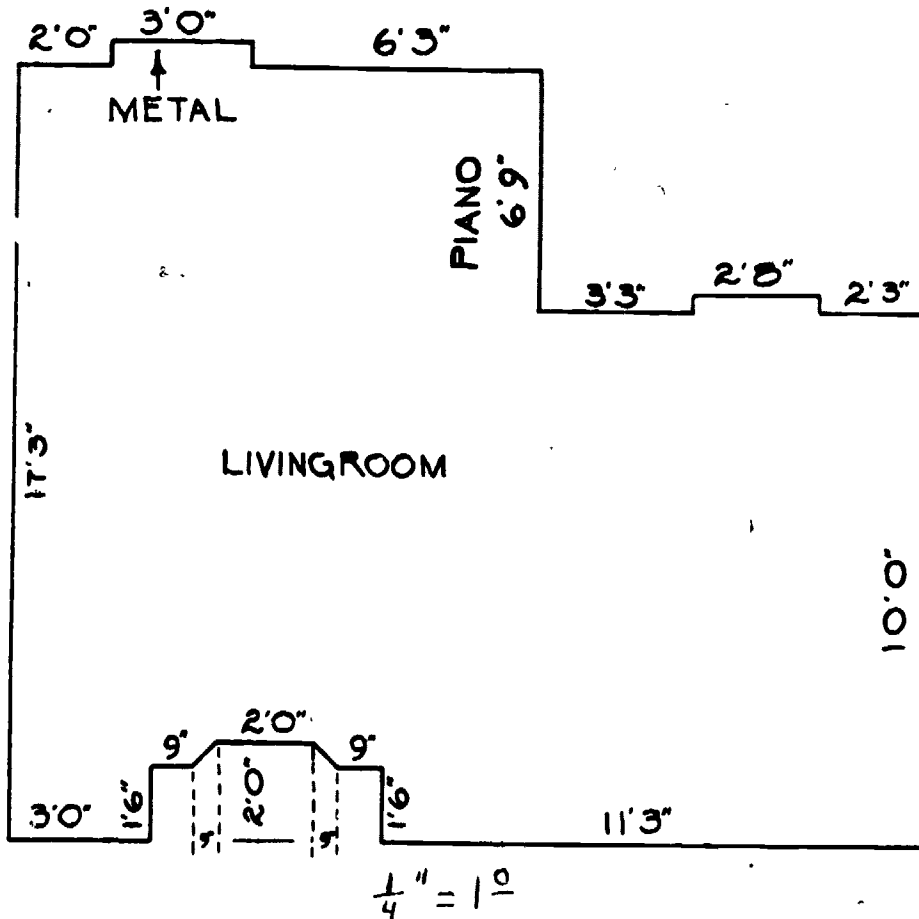
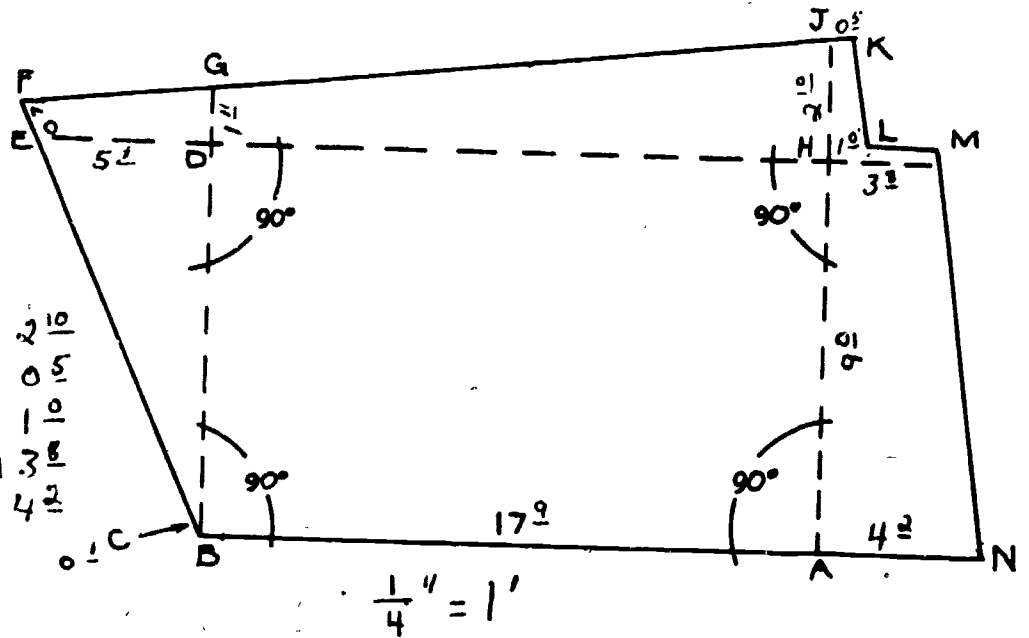

Name: James John
 Address: 333 Street,
 This city (past
 33rd Ave)
 Phone: 555-1111

Remove old carpet
 and pad
 Wood floor
 Piano

When working with resilient tile, a major thing to think about is the size of the border around the room. Usually the tiles laid next to the wall will have to be cut. So the planning goal is to make a border of cut tile all around the room. As near as possible, the border tile should be the same size on all sides of the room. A room with border tiles 7 inches wide all around the room will look better than a room with borders of 5 inches, 9 inches, 7 inches and 3 inches. When working with tile the following points should be kept in mind:

1. Keep the border balanced on all sides.
2. Keep tile waste to a minimum.
3. Measure across length and width of the room at both ends of each wall. This will tell you if the room is square.
4. If the room is not square, the layout will have to be changed to keep the field (overall pattern) square and to have a good-looking border.

DETERMINE DIRECTION OF PILE OR PATTERN

The pile on woven carpet all leans in one direction. Pieces of woven carpet have to be put together with the pile running the same direction on all of the pieces. If this is not done, the color shade of the pieces will not match. Woven carpet looks darker when you are "looking into the pile" than when you are "looking over the pile." This effect on the carpet color is not the same as the "shading" effect seen in tufted carpet. The lean of the pile in woven carpet is a part of how the carpet is made. Tufted carpet is made to stand upright, and shading of tufted carpet happens when the fibers are pushed to one side by traffic or the vacuum cleaner.

One way to check the direction of pile lean on woven carpet is a "marker thread." Some manufacturers weave a marker thread into the backing. It is a thread that is different from the others in the backing. It will run all along the length of the carpet several inches from the right hand side.

Check to find out if the manufacturer of the carpet you are installing uses the marker thread or some other method to show right/left sides of the material. When laying out several pieces, make sure the marker thread or other indicator is in the same corresponding place on all of the pieces.

When you are laying out several pieces of tufted goods, check to make sure the pile height is the same where two pieces come together to make a seam. Sometimes there may be flaws in the backing that will make one piece lower than the other.

If the nap of both pieces is not the same height at the seam, it will not make a good seam. If you do find a piece with a flawed backing, try to arrange the layout so that the flaw is next to the wall. This way, the flaw can be trimmed off.

Special Considerations

A tile pattern can be one tile, or it can be made with several tiles laid next to each other. If the pattern is only one tile, the tiles should be laid at right angles to each other.

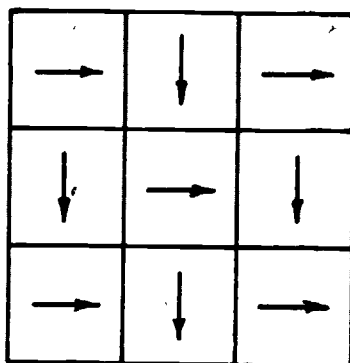

This spreads out the wear stress. All tile tends to expand and contract in certain directions. If they are all laid with the grain running the same direction, the effect is much greater. If they are laid at right angles to each other, there is much less chance of the adhesive failing (peaking).

For the purpose of planning "rows" of tile, a pattern made with more than one tile is still thought of as "one tile." (See the illustration on the next page.)

DETERMINE WHICH OF THE AVAILABLE SIZES WOULD BE BEST FOR CUTTING OUT THE NEEDED PIECES

In nearly all cases, the less seaming done, the better--both in terms of time spent doing the job and the durability of the finished job. You have to think

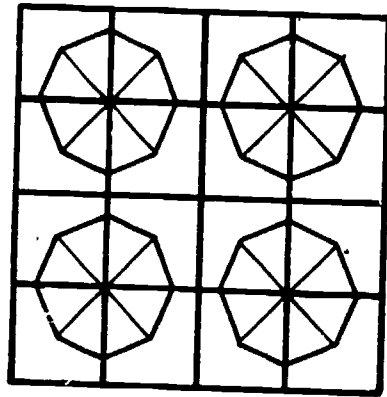

16 TILE PIECES
MAKE A
"FOUR TILE PATTERN"

about saving materials and about meeting the specific needs of the job.

EXAMPLE: If you are laying a floor in a high traffic hallway, the needs of the job say that two seams on the sides of the hallway are better than one seam down the middle.

A CHECKLIST FOR SEAMS

1. Traffic patterns.
2. General appearance.
3. Pile lay or pattern direction.
4. Pile or pattern match.
5. Customer's wishes.
6. Economy in cutting.
7. More light means it is easier to see seams.
8. Commercial: Design so that seams wear best.
9. Residential: Design so that seams show least.

A CHECKLIST FOR WOVEN CARPET

1. If customer wants to see a darker, richer color when entering the room, pile should be leaned toward the main entrance to the room.
2. If the customer prefers the darker, richer look after coming into the room, the pile should be leaned away from the entrance (or toward the light).
3. STAIRWAYS: Pile that is leaned down the stairs wears better.

This sketch shows both broken and overall measurements.

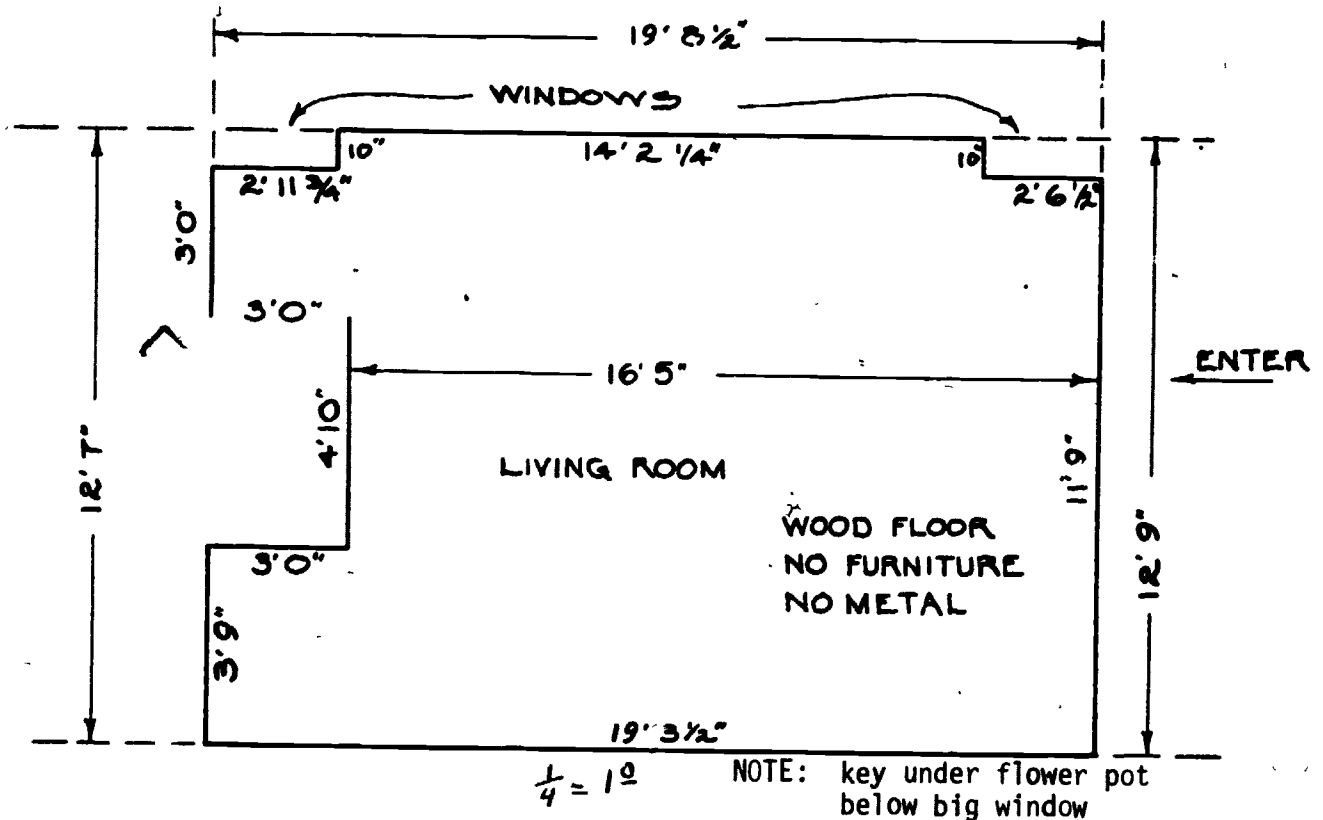

4. Showing any special problems that will have to be dealt with when installing the floor covering.
 - a. Type of floor.
 - b. Location of heavy furniture.
 - c. Access to job site (steps or elevator, etc.)
 - d. Location of doorways.
 - e. Strong sources of light (that might show seams).
 - f. Traffic patterns.
 - g. Other special notes or customer requests.

Special Considerations

When estimating the amount of sheet goods (resilient or carpet) that will be needed, you have to allow for irregular features of the room. This is a "waste" factor. If the room is 20 feet long and 12 feet wide, you will need 240 square feet of sheet goods. If a built-in cabinet goes 2 feet out into the room and is 10 feet long (20 square feet) you still need 240 square feet of sheet goods. The 20 square feet of space taken up by the cabinet are "waste."

LAYING A FLOOR WITH AN OVERALL PATTERN

If the floor material has an overall pattern, layout should be planned to make sure the pattern looks "right side up." Lay the material so that the top of the pattern is away from the main entrance. This way you will see the overall pattern right side up when you enter the room.

MARKING THE PIECES TO BE CUT

Before starting, check the order or job sheet. Make sure you have the right material. Be sure you understand everything you will be asked to do FOR THE WHOLE JOB of installation.

Spread sheet materials on a flat surface for marking and for cutting to rough size. Carpet materials can be marked with a chalkline for long, straight cuts. Color match needs to be planned before cutting. Keep the shade differences as small as possible when planning to put two pieces of carpet next to each other.

All materials should be checked for flaws before cutting anything. It is also smart to double check the width of the material before marking cuts. "Factory Measurements"--the ones listed on the label--may not be the real measurements of the material. There may be an inch or more difference between listed and actual measurements.

When you are marking cuts, allow a margin for turning material under if that will be done. It is best to figure about 3 inches for turnunder. When tack strips are used instead of turnunder, the "tuck-in" margin is a little bit less than the pile height of the carpet.

CUT AND LAYOUT PIECES

Resilient sheet materials should be cut in a room that is the same temperature as the room where the goods will be installed. The best temperature would be at least 70°F. Do not begin cutting any sheet goods until you know where all of the pieces will go and all of the pieces have been marked. When possible, leftover pieces should be cut and used before starting full rolls.

Never snap a chalkline on the face of carpeting. Always mark the back.

The pieces cut should be marked on the backing in the order they will be installed or seamed together.

After the pieces have been cut and marked to show where they will go, final preparations for installation are made. Some carpet seaming may be done in the workroom before the carpet is taken to the job site. A complex job may need to be seamed at the job site when it is being installed. Glue-down carpet is often seamed at the job site. It is smart to lay out the materials to check nap, shading and pattern matches before starting "final" things like seaming, gluing or installing with tack strips.

Self Assessment

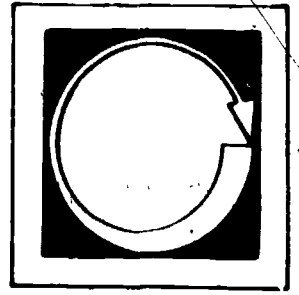

COMPLETE THE FOLLOWING STATEMENTS BY WRITING THE CORRECT WORD OR WORDS IN THE BLANKS PROVIDED.

Some steps for all areas and all materials are:

1. Determine size (_____ and _____) of all areas to be covered, including _____ features of the spaces.
2. Determine _____ of pile or pattern.
3. Determine which of the available _____ of the material would be the _____ for cutting out the needed pieces.
4. _____ the pieces to be cut.

Some special things that should be shown on the sketch are:

5. Type of _____.
6. Location of _____ furniture.
7. Access to _____ site.
8. Location of _____.
9. Strong sources of _____.
10. _____ patterns.
11. _____ requests.

Fill in the missing words:

12. The pile on woven carpet all _____ in _____ direction.
13. Pieces being cut should be marked on the _____ to show the _____ in which they will be _____.
14. All materials should be checked for _____ before _____ anything.
15. With tack strips, the tuck in margin is a little bit _____ than the pile _____.
16. A _____ thread shows the direction of pile _____ in woven carpet.
17. Factory measurements may not be the _____ measurements.
18. The best temperature for cutting _____ goods is at least 70°F.
19. When working with resilient tile a _____ thing is the size of the _____.
20. Spread sheet materials on a _____ surface for _____ and _____.
21. Figure about _____ inches for carpet turnunder.
22. When matching tufted carpet, the pile _____ has to be checked.

Circle the correct answer.

23. Woven carpet looks darker when you are:
(looking over the pile) (looking into the pile)

Complete the two rules of measurement by filling in the missing words.

24. Always _____ everything.
25. Make sure you have the _____ straight line.

List the three things needed for good measurement:

26.

27

28.

Write the following measurements in "shorthand."

29. 12 feet, 6 inches

30. 8 feet, 11 inches

31. 144 feet, 0 inches

Self Assessment Answers

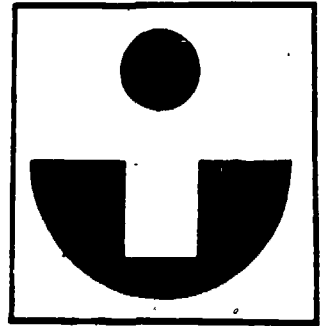

1. length, width, irregular
2. direction
3. sizes, best
4. mark
5. floor
6. heavy
7. job
8. doorways
9. light
10. traffic
11. customer
12. leans, one
13. back, order, installed
14. flaws, cutting
15. less, height
16. marker, lean
17. real
18. resilient
19. major, border
20. flat, marking, cutting
21. 3
22. height
23. looking into the pile
24. measure
25. shortest
26. accuracy
27. detail
28. neatness
29. 12^6
30. 8^{11}
31. 144^0

Job Sheet

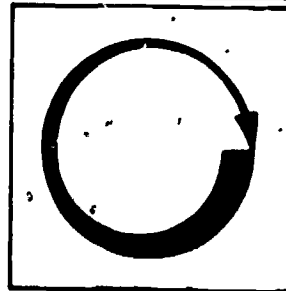

COMPLETE THE FOLLOWING TASKS.

Materials

rolls of butcher paper, newsprint paper, or wall paper (can be used for matching patterns)

1. Measure a space picked out by your instructor.
2. Measure and mark materials supplied by your instructor.
3. BEFORE STARTING:
Use the space below to describe what you will be doing. (You may want to review this module.)

Post Assessment

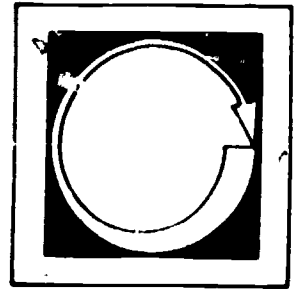

LISTED BELOW ARE SEVERAL STATEMENTS. IF THE STATEMENT IS TRUE, PLACE A "T" IN THE BLANK PROVIDED. IF THE STATEMENT IS FALSE, PLACE AN "F" IN THE BLANK.

1. ___ One of the three things needed for good measurement is a 400-foot tape measure.
2. ___ The pile on woven carpet all leans in one direction.
3. ___ A marker thread along the right hand side of woven carpet tells you it is a factory reject.
4. ___ Tile that are all laid with the grain in the same direction are stronger.
5. ___ The reason for thinking about traffic patterns is to plan access to the job site.
6. ___ Always plan color matches after cutting the pieces.
7. ___ Glue-down carpet is seamed at the job site, not in the shop.
8. ___ When tack strips are used, allow a 3-inch margin for turn under.
9. ___ One nice thing about pattern goods is that you don't have to worry about installing the goods upside down.
10. ___ With a good set of blueprints, there is no need to ever make any measurements on the job.

11. ___ The floor layer works with 15 general kinds of materials.
12. ___ The process of getting materials ready is called layout.
13. ___ Special customer requests should never be put on the measurement drawings.
14. ___ There are no general rules that cover all the different kinds of materials a floor layer works with.
15. ___ Making seams takes more time, but they make sure the final job will last longer.
16. ___ One problem with tufted carpet is that there can be flaws in the backing.
17. ___ To get a darker color when entering a room, lean the pile toward the entrance.
18. ___ Carpet is marked with a chalkline on the face for hand cutting.
19. ___ The first thing to do is check the job sheet to make sure you know the customer's name.
20. ___ Factory measurements are always very accurate.
21. ___ For best wear, lean pile down the stairs.
22. ___ One of the three things needed for good measurement is neatness.
23. ___ A sketch does not have to be drawn to scale.
24. ___ Woven carpet looks lighter when you are looking over the pile.

● Instructor Post Assessment Answers

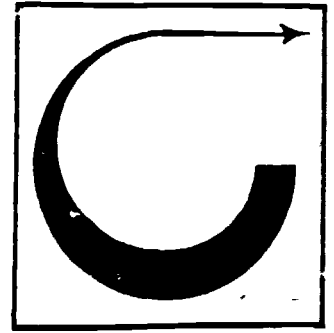

1. F
2. T
3. F
4. F
5. F
6. F
7. T
8. F
9. F
10. F
11. F
12. T
13. F
14. F
15. F
16. T
17. T
18. F
19. F
20. F
21. T
22. T
23. T
24. T

INSTALLING WALL BASE AND CUTTING TILE

Goal:

The student will identify the steps of installing wall base, making simple tile cuts and will execute the installation of each of these.

Performance Indicators:

The student will successfully complete a Self Assessment, a Job Sheet and a Post Assessment.

Study Guide

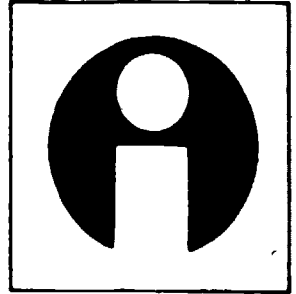

In order to finish this module, do the following tasks. Check each item off as you complete it.

1. Read the Goal and Performance Indicators on the cover of the module. This will tell you what you will learn by studying the module, and how you will show you've learned it.
2. Read the Introduction. The Introduction will tell you why the module is an important part of the floor laying trade.
3. Study the Vocabulary section. Vocabulary words are important for a good understanding of the trade. After you have studied the vocabulary, ask your teacher to quiz you on the words and their meanings.
4. Study the Information section. This section will give you the information you need to understand the subject.
5. Take the Self Assessment exam. This is a test for you to prove to yourself that you have learned the material you have studied. Compare your answers with the answers on the Self Assessment Answer Sheet, which is on the page following the Self Assessment. If you scored poorly, re-study the Information section or ask your teacher for help.
6. Do the Job Sheet. Follow the instructions at the top of the Job Sheet. The tasks listed on the Job Sheet will help you develop skills which will be helpful to you.
7. Take the Post Assessment exam. Give the exam to your teacher after you have completed it. Your teacher will grade it for you.

Introduction

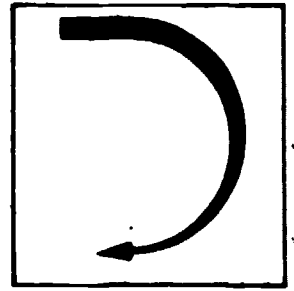

Wall base can give the final professional touch to a floor installation. This module will help you learn how to give your work this professional touch.

Most tile laying for an installation involves putting down whole tiles. But border tile, tile that have to fit door jambs and so on, all have to be cut. When you have learned the proper techniques for cutting tile, this part of laying tile will go as smoothly as the rest. This module will help you learn the techniques you will need to do a professional job of cutting tile.

Vocabulary

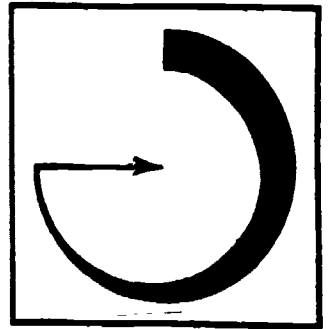

Trade terms are very important for a good understanding of the trade. Study these words and meanings. When you have learned them, ask your teacher to quiz you on the words and their meanings.

CORRUGATED--A surface that has one-half high spots and one-half low spots.

BEVEL--To cut something at an angle.

TEMPLATE TILE--A tile used to help mark a second tile so the second tile can be cut.

FIELD TILE--All full size tile that are not part of the border.

INTERSECTION--Where two things meet or cross each other.

Supplementary References

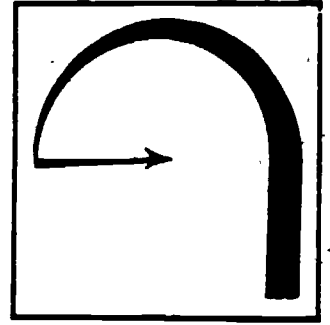

1. Resilient Floor Coverings Workbook. California State Department of Education, 1973. pp. 127-160, 193-195.

Information

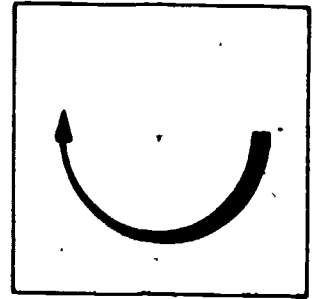

THE BASIC STEPS OF INSTALLING WALL BASES

1. Clean the surfaces that will be touching each other.
2. Fit the wall base material to the wall.
3. Cut the wall base material to size.
4. Apply adhesive (either to the wall or to the wall base).
5. Install and finish.

WALL BASE IS PRACTICAL

The use of wall base material gets rid of sharp corners and crevices. It will make cleaning easier. Wall base, when properly installed, will also make a job look better.

COMMON SIZES

- * 2 1/2, 4, 6 inches high.
- * Variable lengths available.

KINDS OF WALL BASE MATERIAL

Wall bases are made with rubber or vinyl. The vinyl base material may be more shiny (have a higher gloss). Vinyl base is also stiffer (more rigid) than the rubber base material. Wall base made with pure rubber is easier to work with because it is more flexible. Since rubber wall base bends so easily, it is not very hard to make it fit irregular walls.

Most wall base products have a corrugated back. This back makes a good key that holds the adhesive--which makes for a good bond between the wall and the wall base material. When installing, be sure to use the adhesive recommended by the

manufacturer and to follow the installation steps recommended by the manufacturer of the wall base product you are using.

APPLYING WALL BASE MATERIAL

In general, adhesive can be applied either to the back of the base or to the wall. If you are going to put the adhesive on the wall, make a chalkline on the wall. The line should be about 1/4 inch below the height of the base material.

When applying adhesive, spread it up to (but not above) the chalkline. Apply the wall base material. Then wipe away excess cement from the wall and the face of the base material.

After cleaning up any excess cement, roll the base material firmly with a small steel roller. Polishing wax can be used to get rid of dirt marks that get on the wall base material while it is being installed.

Corners

Pre-made corners: These are pieces of wall base material that have been shaped into corners. All you have to do is install them. Pre-made corners are available for both inside and outside corners. The hardest part of using a pre-made corner is to be sure that the ends of the corner piece fit tight with the straight pieces. Straight pieces of wall base material can be used to make corners if the pre-made kind is not available in the size or color that you need.

Forming inside corners:

1. Put a piece of straight wall base material all the way into the corner.
2. Fit a second strip to the corner at a right angle to the first. Do not cement it yet.
3. Use a pair of dividers to scribe the end of the second piece with the profile of the first piece.
4. Use a sharp knife and cut the second piece on the scribe marks. Bevel as you make the cut.
5. Apply adhesive. Paste the second piece against the first piece and against the wall.

(See the illustration on the top of the following page.)

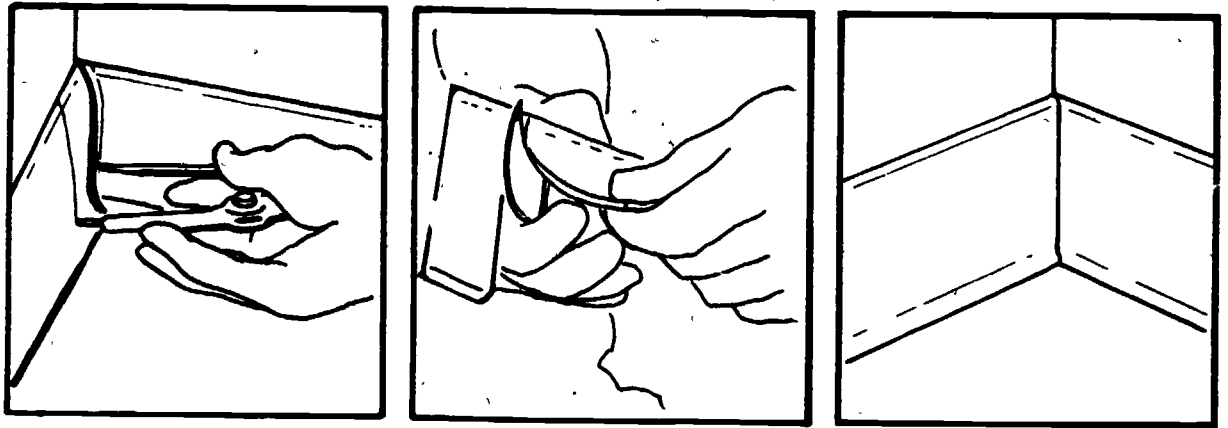

Forming outside corners: There are two ways to make an outside corner. One way is by bending a piece of wall base around the corner. The other way is to fit pieces of wall base material together (something like forming an inside corner). The first method can sometimes make the wall base material discolor at the bend point. This is from the stress of bending the wall base material. To avoid this stress, the second method is often used instead.

***METHOD #1**

1. Use a straight strip that goes well past the corner.
2. Fit this piece to the wall and draw a line where the corner will be on the back of the strip.
3. Bend the strip on this line. Bend the strip so that the faces of the 2 parts of the strip are touching each other.
4. Use a sharp knife to cut away 1/2 the thickness of the strip.
 - a. Make a single cut.
 - b. Start at the top and cut to the bottom.
 - c. Keep all of the cutting on the turn side of the line you marked.

To install this kind of corner, wrap the strip around the corner after putting on the recommended adhesive. Hold the strip tight to the wall. Use a downward pressure to help the foot (bottom of the wall base strip) keep its shape.

(See the illustration on the top of the following page)

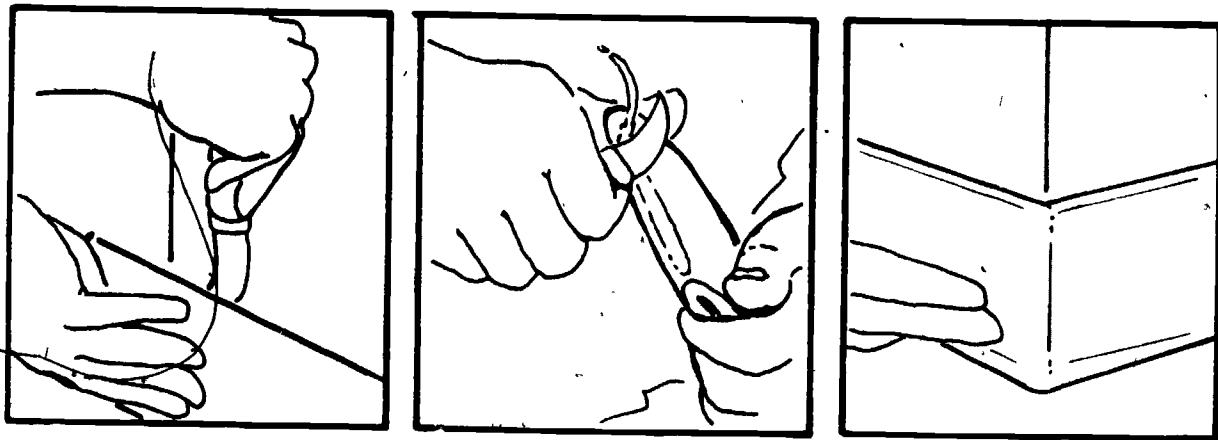

*METHOD #2

1. Fit the first piece so that it goes 3/4 inch past the corner line.
2. Use a scrap piece and butt it against the back of the first piece.
3. Trace the profile of the scrap piece onto the first piece.
4. Use a sharp knife and cut along the line.
5. When cutting, bevel at a 60° angle.
6. Replace the scrap piece with a good piece of base material.
7. Trace the profile of the first piece onto the second piece.
8. Cut the second piece as above with a 60° bevel.
9. The pieces can now be installed.

FITTING TILE

How to Fit a Border Tile

Before you can cut the tile, you have to know exactly where it should be cut. The tile has to fit into the space between the wall and the field tile. It has to fit exactly. The following diagrams show how this can be done.

(See the illustrations on the following page.)

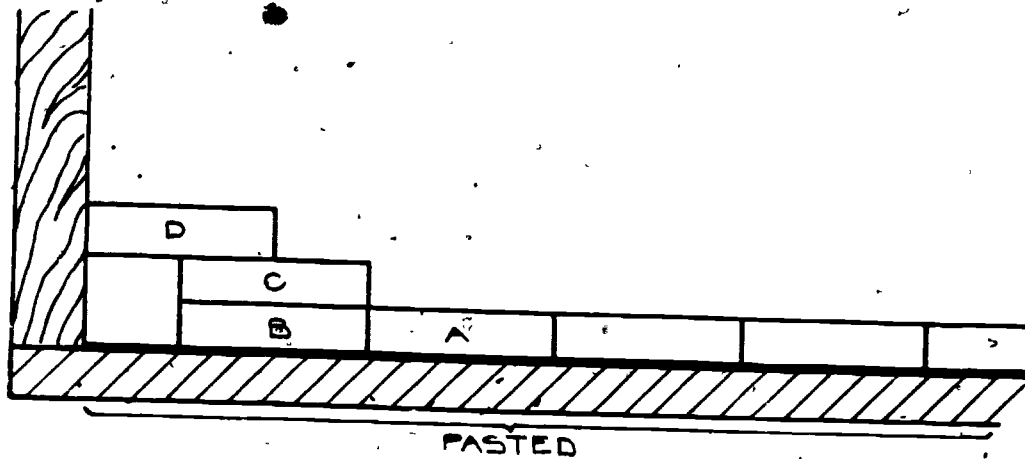

Place Tile C directly over Tile B. Place Tile D against wall. It will overlap Tile C.

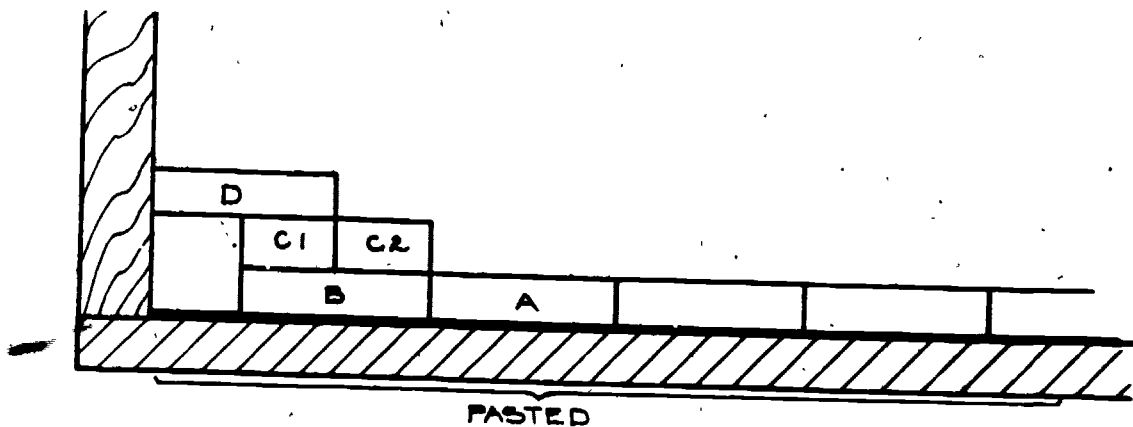

Scribe Tile C using edge of Tile D as a guide. Cut Tile C into 2 parts (C-1 and C-2).

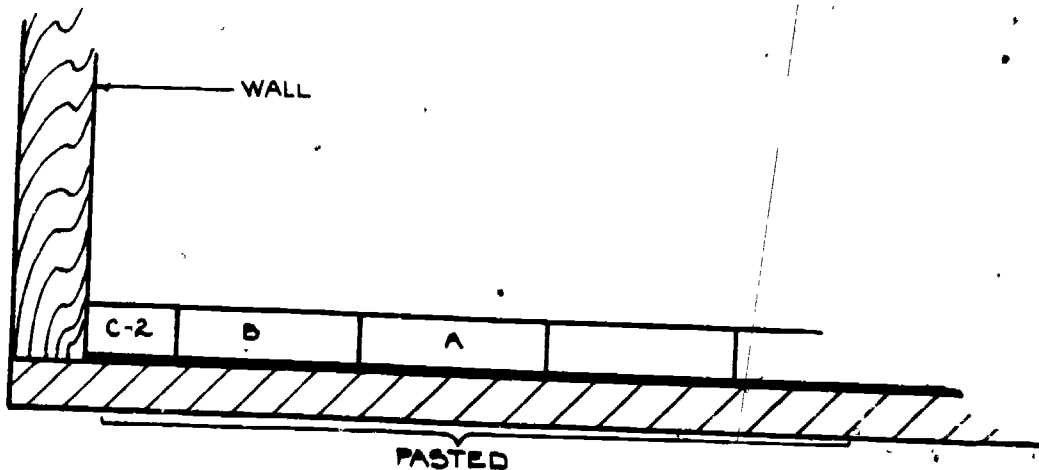

Remove Tile D. Snap part C-2 of Tile C into place. Throw part C-1 away.

How to Fit a Corner Tile

Measure the tile by first putting it on one side of the corner over the border tile. This border tile should already be in place. Then put the corner tile over the border tile on the other side of the corner. Follow the steps given above.

How to Make Fancy Cuts

These cuts are made when you have to fit a tile into an irregular-shaped place. One such place would be the floor space next to a door jamb.

To mark out the line on which you will cut, you will have to plot points and then connect the points. You can plot the points by using a template tile which works the way Tile D did in the drawings that show how to fit a border tile. It helps you find where to mark points. Then you connect the points to make a cut line.

The tile that will be cut and fitted into place is put over a field tile as shown below. Then the first set of marks is made on it. After the first set of marks has been made, this tile is placed over a second field tile as shown. Then a second set of marks is made. The points that will be connected to make the cut lines are made at the places where the two sets of marks for each point cross each other. These are the point intersections.

The template tile is moved from one projection (a part that sticks out) of the door jamb to another. Each time you move the template, make a mark. It will take a lot of practice to get the whole thing working right.

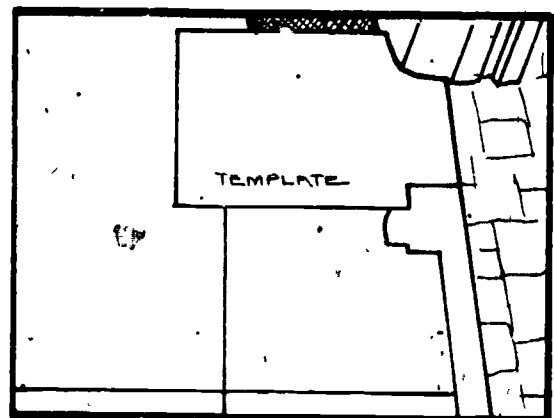
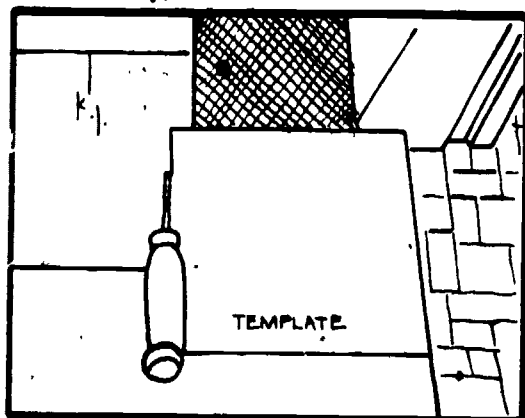

General Rules for Cutting Tile

Tile is often cut with a tile cutter machine rather than by hand. The tile cutter can be set to cut any length you want. It works only for straight cuts. These straight cuts can be across the length or width or the diagonals of a tile.

Hard tiles can often be scored and then snapped if you want to make a straight cut. Softer tiles (vinyl, rubber or cork) can be cut through by hand.

If the cut you need is not a straight line, you may have to heat the tile first. Then it can be cut with snips or a utility knife.

It is a good idea to always fit the cut edge of the tile against the wall. This makes it harder to see any little parts that were not cut just right.

Self Assessment

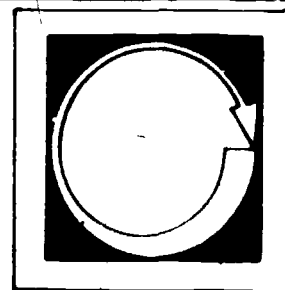

COMPLETE THE FOLLOWING STATEMENTS BY WRITING THE CORRECT WORD OR WORDS IN THE BLANKS PROVIDED.

1. A tile cutter can be set to any _____.
2. Common sizes of wall base are _____, _____, and _____ inches high.
3. Tile can be _____ to cut an irregular line.
4. Polishing wax can be used to get rid of _____ on wall base.
5. The tile cutter will only make _____ cuts.
6. Using wall base gets rid of _____ corners.
7. Hard tiles can be scored and then _____.
8. A corrugated back on wall base makes a good key for _____.
9. A basic step of installing wall base is to _____ the surfaces that _____ each other.
10. Bending wall base to form an outside corner can make it _____ at the bend point.
11. Always fit the cut edge against the _____.

12. Wall bases are made with _____ or _____.
13. The tile cutter can cut _____ the length or on the _____.
14. When putting adhesive on the wall, make a _____ on the wall.
15. Wall base made with _____ is easier to work with.
16. Softer tiles can be cut by _____.

Self Assessment Answers

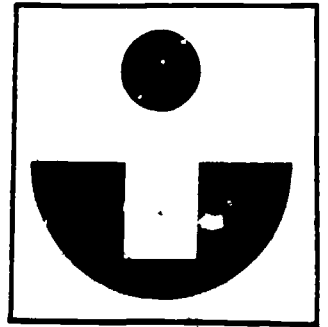

1. length
2. 2 1/2, 4, 6
3. heated
4. dirt marks
5. straight
6. sharp
7. snapped
8. adhesive
9. clean, touch
10. discolor
11. wall
12. rubber, vinyl
13. across, diagonal
14. chalkline
15. rubber
16. hand

Job Sheet

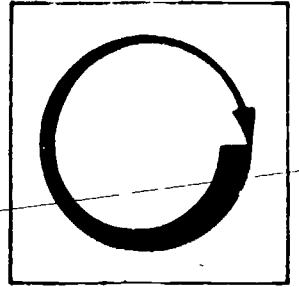

COMPLETE THE FOLLOWING TASKS.

Materials and Tools

strips of wall base
pre-made wall base corners
utility knives
different types of tile
tile cutter

As directed by your instructor:

1. Cut, fit and install wall base strips in at least 4 of the following ways.
 - a. With pre-made outside corner.
 - b. With pre-made inside corner.
 - c. By making own outside corner.
 - d. By making own inside corner.
 - e. By applying adhesive to the wall base material.
 - f. By applying adhesive to the wall.

2. Cut tile in at least 4 of the following ways.
 - a. Straight line with a utility knife.
 - b. Score and snap method.
 - c. By use of the tile cutter.
 - d. On an irregular line.
 - e. Make a fancy cut to fit a door jamb.

Post Assessment

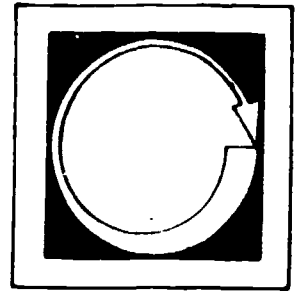

LISTED BELOW ARE SEVERAL STATEMENTS. IF THE STATEMENT IS TRUE, PLACE A "T" IN THE BLANK PROVIDED. IF THE STATEMENT IS FALSE, PLACE AN "F" IN THE BLANK.

1. ___ Straight cuts can be made by hand or with a tile cutter.
2. ___ An outside corner can be formed only by bending a piece of straight wall base.
3. ___ Adhesive should be applied only to the wall base material.
4. ___ The cut edge of a tile should be put next to another tile.
5. ___ If a border tile doesn't fit exactly, it will still work well.
6. ___ If you put adhesive on the wall base, put a chalkline on the wall.
7. ___ Softer tile can only be cut by heating.
8. ___ Wall base makes cleaning easier and the job looks better.
9. ___ A template tile is used for marking to make a fancy cut.
10. ___ If the cut you need is not a straight line, you may have to heat the tile.
11. ___ There are no problems with using pre-made wall base corners.
12. ___ For fancy cuts, the points to be connected are made at places where two sets of marks cross each other.

13. ___ Wall base is only available in 4 and 6 inch heights.
14. ___ Do not score-and-snap hard tile.
15. ___ An inside corner can be formed by bending a piece of straight wall base.
16. ___ Vinyl wall base bends easier than rubber wall base.
17. ___ The tile cutter can only cut across the length of a tile.
18. ___ Wall base should be rolled after it is put on the wall.
19. ___ Vinyl wall base is more shiny than rubber wall base.
20. ___ You have to plot points to make the cut line for a fancy cut.

● Instructor Post Assessment Answers

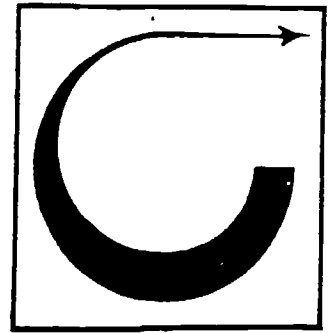

1. T
2. F
3. F
4. F
5. F
6. F
7. F
8. T
9. T
10. T
11. F
12. T
13. F
14. F
15. F
16. F
17. F
18. T
19. T
20. T

SPREADING ADHESIVES

Goal:

The student will be able to identify the steps involved in spreading adhesives and be able to execute these steps.

Performance Indicators:

The student will successfully complete a Self Assessment, an Assignment and a Post Assessment.

Study Guide

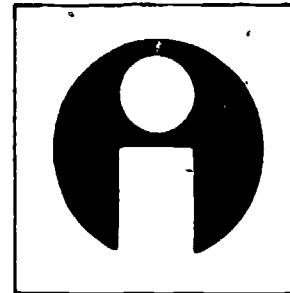

In order to finish this module, do the following tasks. Check each item off as you complete it.

1. Read the Goal and Performance Indicators on the cover of the module. This will tell you what you will learn by studying the module, and how you will show you've learned it.
2. Read the Introduction. The Introduction will tell you why the module is an important part of the floor laying trade.
3. Study the Information section. This section will give you the information you need to understand the subject.
4. Take the Self Assessment exam. This is a test for you to prove to yourself that you have learned the material you have studied. Compare your answers with the answers on the Self Assessment Answer Sheet, which is on the page following the Self Assessment. If you scored poorly, re-study the Information section or ask your teacher for help.
5. Do the Assignment page. Follow the instructions at the top of the Assignment page.
6. Take the Post Assessment exam. Give the exam to your teacher after you have completed it. Your teacher will grade it for you.

Introduction

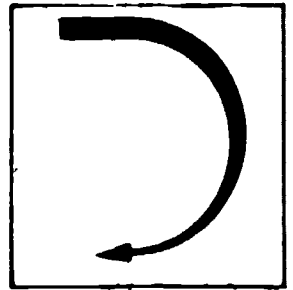

The best adhesive in the world will not do a good job if it is not applied in the proper way. A floor can not be properly installed if the adhesive is not put on properly. This module will help you learn proper techniques for applying adhesives.

Supplementary References

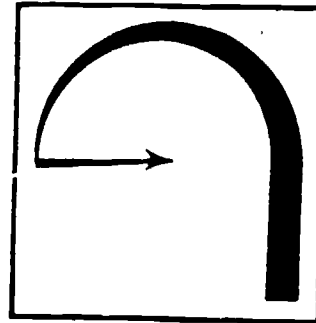

1. Resilient Floor Coverings Workbook. California State Department of Education, 1973. pp. 127-160.
2. Carpeting Floor Coverings Workbook. California State Department of Education, 1972. pp. 101-104, 115-124.

Information



SPREADING ADHESIVES

The following are directions for using adhesives with tile. However, in general, you should follow these directions when you are spreading adhesives for any purpose.

Many adhesives are spread with a notched trowel. The size of the notches in the trowel control how much of the adhesive will be spread. Bigger notches will spread a thicker layer of adhesive. Smaller notches spread a thinner layer. The amount you should spread will be specified in the recommendations by the adhesive manufacturer. Follow these recommendations carefully.

Latex adhesives that are often used with vinyl asbestos tile may be spread with a roller. Check the manufacturer's recommendations. If a trowel is used to spread the adhesive, press down hard enough to make sure that the notches make beads of adhesive material. There should be lines of adhesive, not a layer of it. Adhesive should not be allowed to appear under the flat areas of the notched trowel. When you are applying adhesive with a trowel, use sweeping motions. Make the sweeping motions in both directions.

Some Guidelines

1. Find out how long it will take the adhesive to develop a "live bond." A live bond is when the adhesive will stick to the floor and to the tile.
2. Find out exactly how much adhesive to use. If you use too little, the bond can fail. If you use too much, the extra will seep up through the seams and make a mess. This will take extra clean up time.
3. Find out the drying time of the adhesive. This will tell you how much of the adhesive you can safely spread at one time. If the adhesive dries fast, you will want to spread less at a time. If it dries slower, you can spread more at a time.

4. Make sure the adhesive is recommended for use on the grade level where you are installing the flooring material.
5. Make sure the adhesive will work with the kind of flooring material you are using.
6. Before starting, make a last check of the floor surface to see if there are any flaws that need fixing.
7. Radiant floor heating systems will make the adhesive dry faster than normal.

NOTE: Adhesive can be spread over the whole area at one time, or in small areas. If you cannot use an adhesive with a longer drying time, you will have to spread small areas and lay the tile as you go.

If you cover the whole area with adhesive, the adhesive will cover up the chalklines you made to lay out the room. You will have to be sure that you do not cover up the marks you will need to snap new chalklines.

Large Areas

This is the most common method for spreading adhesive over the whole floor area at one time:

1. Lay out the floor and snap chalklines.
2. Check the layout.
3. Spread adhesive over the whole area. But leave adhesive off the places marking the starting points of your chalklines.
4. When the adhesive has set up, snap new chalklines. NOTE: After the adhesive has set, you may carefully walk on it to snap the new chalklines.

(See the illustration at the top of the next page.)

Small Areas

The most common way of spreading adhesive in a small area uses a straightedge.

1. Place the straightedge along the chalklines. It will work as a guide for keeping the tile straight.
2. Spread an area as far as you can reach.
3. Lay tiles into the adhesive immediately.
4. Do not do the last two rows.
5. Clean up any extra adhesive along the edge of the last row laid.
6. Dry lay the next row of tile.

Tile is laid along the chalkline.

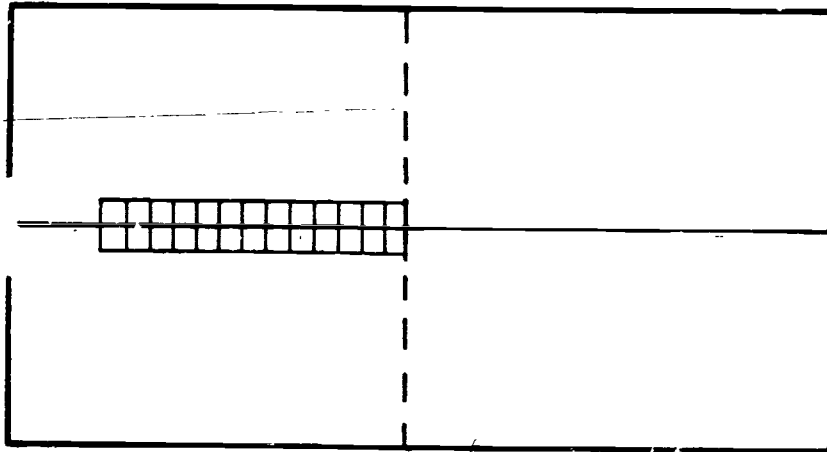

Tile laying pattern when the whole floor is to be covered with adhesive.

7. Scribe and cut the last row.
8. Spread adhesive and lay the last 2 rows.

SPREAD AND LAY
FROM CENTER
ALL FIELD TILE
EXCEPT LAST
TWO ROWS

CUTAWAY SHOWS
SPREAD ADHESIVE

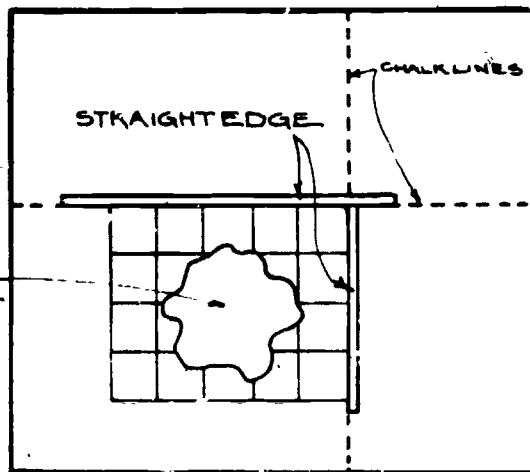

Tile laying pattern when only a part of the floor is covered with adhesive at one time.

To Lay Tile

1. Fit each tile against the ones already laid.
2. Do not force the tile into tight contact with each other.
3. Let each tile gently drop into place.
4. All four edges of the tile must be in the adhesive.

5. Make sure all lines stay at right angles.
6. If you have to walk on laid tile, make sure they don't move when you do it. Always check them.

The Final Step

When the adhesive has set, it won't come up through the joints. Then you should roll the surface in both directions with a 150-pound roller.

Self Assessment

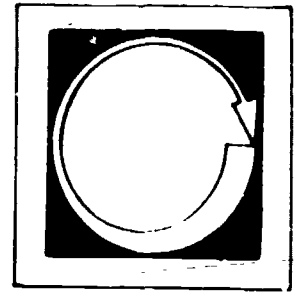

COMPLETE THE FOLLOWING STATEMENTS BY WRITING THE CORRECT WORD OR WORDS IN THE BLANKS PROVIDED.

1. The most common way of spreading adhesive in a _____ area uses a straightedge.
2. When applying adhesive with a trowel, use _____ motions.
3. When spreading adhesive over the whole area, you will have to _____.
4. Latex adhesives can sometimes be spread with a _____.
5. If the adhesive dries _____, spread less at one time.
6. Do not _____ tile into tight contact with each other.
7. Many adhesives are spread with a _____ trowel.
8. When spreading adhesive over the whole area, do not put it on the places that mark the _____ points of the _____.
9. A _____ is when the adhesive will stick to the floor and to the tile.
10. Make sure all lines stay at _____ angles.
11. When using a _____ trowel, there should be lines of adhesive, not a _____.

12. Radiant floor heating will make adhesive dry _____.
13. Bigger notches spread _____ adhesive.
14. Before using an adhesive, check the _____ recommendation.
15. If you use too little adhesive, the bond can _____.
16. All _____ of the tile must be in the adhesive.

Self Assessment Answers

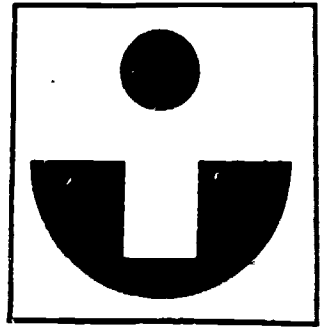

1. small
2. sweeping
3. snap new chalklines
4. roller
5. fast
6. force
7. notched
8. starting, chalkline
9. live bond
10. right
11. notched, layer
12. faster
13. more
14. manufacturer's
15. fail
16. edges

Assignment

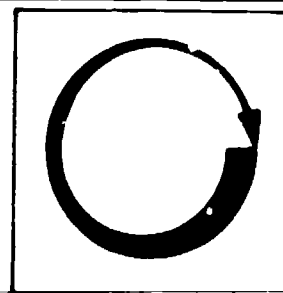

COMPLETE THE FOLLOWING ASSIGNMENTS.

Materials and Tools

notched trowel
roller for spreading adhesive
tile samples
manufacturer's directions.

- A. In an area designated by the instructor:
1. Demonstrate the correct way to spread adhesive with a trowel.
 2. Demonstrate the correct way to spread adhesive with a roller.
- B. Find the proper adhesive to be used with a vinyl-asbestos tile product designated by your instructor. Complete the following:
1. Brand name of the vinyl-asbestos tile.

 2. Manufacturer of the tile.

 3. Adhesive(s) recommended for use with the tile for an on-grade surface.

 4. List the directions for applying the adhesive on a separate sheet.
- C. Repeat exercise B for a tile that is not vinyl-asbestos.

Post Assessment

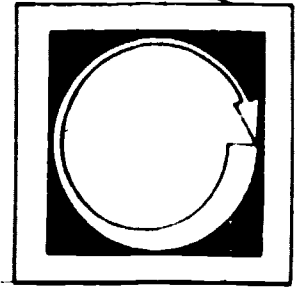

LISTED BELOW ARE SEVERAL STATEMENTS. IF THE STATEMENT IS TRUE, PLACE A "T" IN THE BLANK PROVIDED. IF THE STATEMENT IS FALSE, PLACE A "F" IN THE BLANK.

1. ___ If an adhesive dries slower, then you should spread more of it at one time.
2. ___ When spreading a small area with adhesive, lay tiles into the adhesive immediately.
3. ___ The notched trowel is supposed to make lines of adhesive, not a layer.
4. ___ All four edges of a tile have to be in the adhesive.
5. ___ Bigger notches spread a thicker layer of adhesive.
6. ___ Adhesive has to be cleaned up before starting a new spread of adhesive.
7. ___ Most adhesives are spread with a roller.
8. ___ Radiant floor heating makes an adhesive dry faster.
9. ___ Tile should be forced to fit tightly together.
10. ___ Thinner notches spread a thicker layer of adhesive.
11. ___ After adhesive has set, it can be walked on to snap chalklines.
12. ___ A "live bond" is the way a floor should be before the adhesive is spread.

13. ___ Latex adhesives can only be spread with a notched trowel.
14. ___ One advantage of covering the whole area with adhesive is that you don't have to snap new chalklines.
15. ___ When applying adhesive, move the trowel with sweeping motions in both directions.

● Instructor Post Assessment Answers

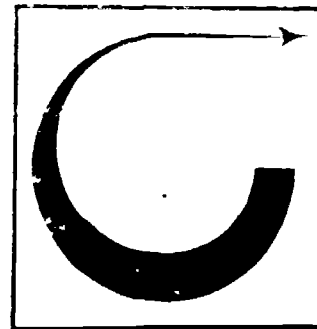

1. T
2. T
3. T
4. T
5. T
6. T
7. F
8. T
9. F
10. F
11. T
12. F
13. F
14. F
15. T

INSTALLING VINYL-ASBESTOS TILE

Goal:

The student will install vinyl-asbestos tile on a surface.

Performance Indicators:

The student will successfully complete a Self Assessment, a Job Sheet and a Post Assessment.

Study Guide



In order to finish this module, do the following tasks. Check each item off as you complete it.

1. Read the Goal and Performance Indicators on the cover of the module. This will tell you what you will learn by studying the module, and how you will show you've learned it.
2. Read the Introduction. The Introduction will tell you why the module is an important part of the floor laying trade.
3. Study the Vocabulary section. Vocabulary words are important for a good understanding of the trade. After you have studied the vocabulary, ask your teacher to quiz you on the words and their meanings.
4. Study the Information section. This section will give you the information you need to understand the subject.
5. Take the Self Assessment exam. This is a test for you to prove to yourself that you have learned the material you have studied. Compare your answers with the answers on the Self Assessment Answer Sheet, which is on the page following the Self Assessment. If you scored poorly, re-study the Information section or ask your teacher for help.
6. Do the Job Sheet. Follow the instructions at the top of the Job Sheet. The tasks listed on the Job Sheet will help you develop skills which will be helpful to you.
7. Take the Post Assessment exam. Give the exam to your teacher after you have completed it. Your teacher will grade it for you.

Introduction

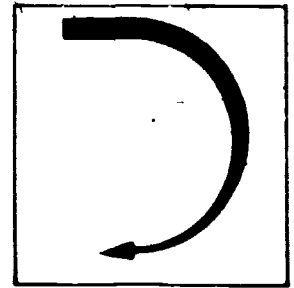

Tile can be put on the floor in many different ways. Each way will have advantages and disadvantages. This module will help you learn about several ways to lay tile.

Vocabulary

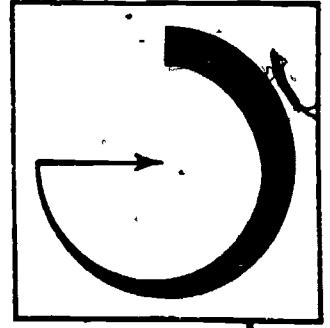

Trade terms are very important for a good understanding of the trade. Study these words and meanings. When you have learned them, ask your teacher to quiz you on the words and their meanings.

PERPENDICULAR--When one line meets or crosses through another to make a 90° angle.

PARALLEL--Two lines next to each other that will never meet (no matter how long you make them) are parallel.

Supplementary References

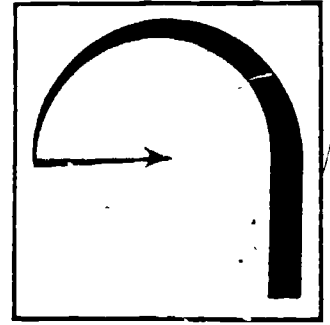

1. Carpet Training Manual. Southern California Joint Apprenticeship and Training Committee, n.d. pp. P-6 to P-9.
2. Resilient Floor Coverings Workbook. California State Department of Education. 1973. pp. 127-129, 133-135, 145.

Information

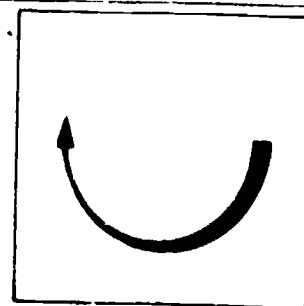

SPECIAL LAYOUT PROBLEMS

This module will help you learn how to meet special problems that can come up when you are laying tile. Sometimes it can be hard to find the middles of all the walls in a room. If there are columns or other things in the way, you might want to use a different way of dividing the room.

Making a Perpendicular Line

1. Measure and find the center of each end wall. These will be points A and B.
2. Snap a chalkline between points A and B.
3. Find the center of line AB. This will be point C.

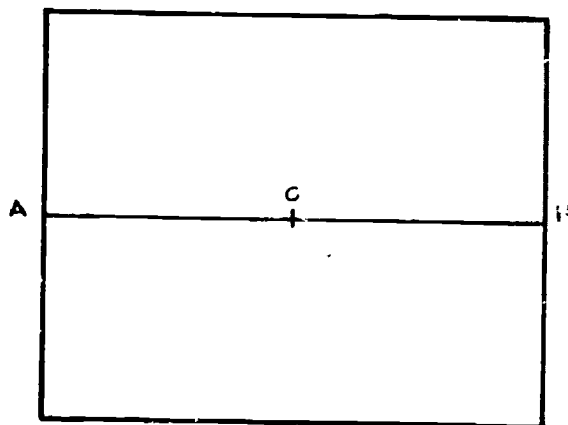

4. Measure out an equal distance on each side of point C. How far out you measure does not matter. These will be points D and E. NOTE: Points D and E must be the same distance from point C. But it does not matter what that distance is.

(See the illustration at the top of the following page.)

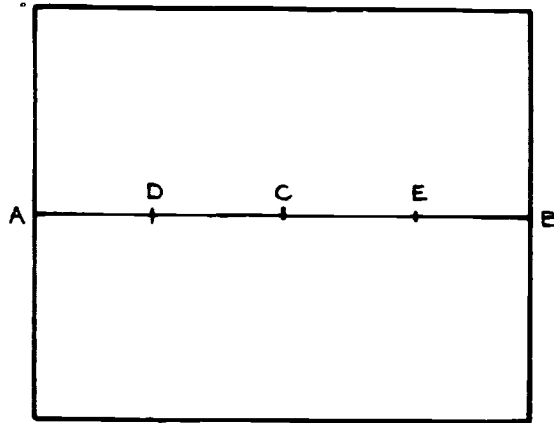

5. Use a steel tape measure to draw an arc from point D and from point E. Do not use a cloth tape measure or a string because they can stretch. To make both arcs the same size, you can pin the tape measure to each point. Then measure out the same distance from each point and make an arc. The two arcs will cross at one place. This is point F.

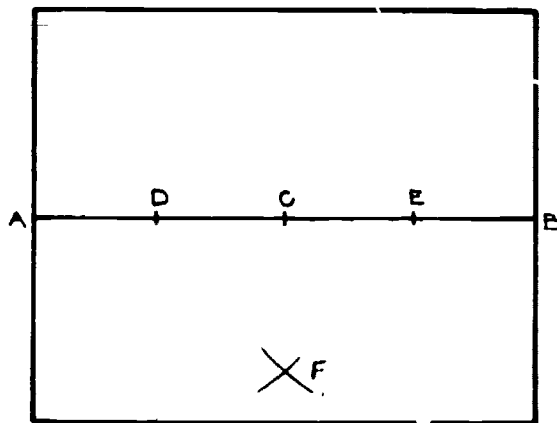

6. To make a line perpendicular (at a 90° angle) to line AB, make a straight line through points C and F. Run this straight line all the way to both walls.

(See the illustration at the top of the next page.)

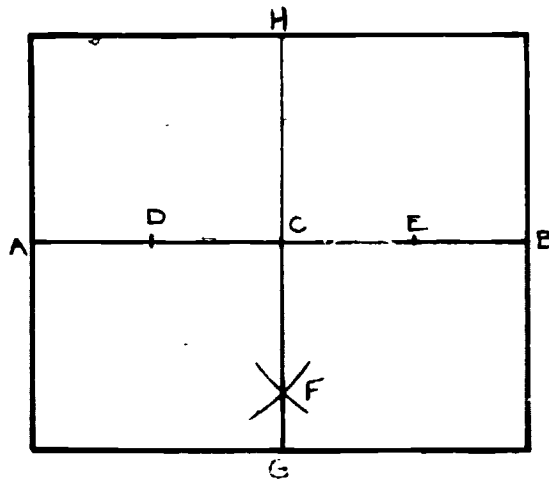

A line through the points C and F will make a line GH. Line GH is perpendicular to line AB.

NOTE: These directions are for dividing a space into four equal parts. Point C was picked as the middle of line AB. You can put point C anywhere on line AB. As long as you follow the directions, you can make a perpendicular line through point C. It does not matter where point C is on the line AB.

Layout for a Circular Room

The basic way of finding the center of a circular room follows the rules for making a perpendicular line.

1. Snap a chalkline between any two points on the circle. They will be points A and B in the diagram.
2. Find the center of line AB. This will be point C.
3. Then make a line perpendicular to line AB that goes through point C. This will be line EF.

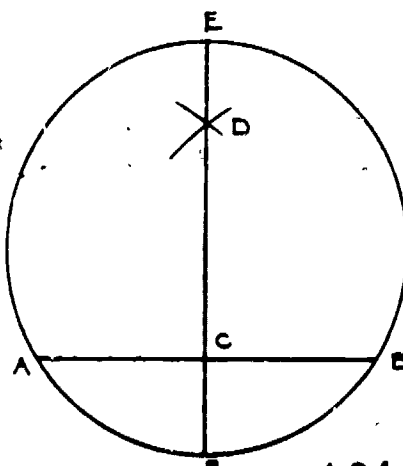

4. Now find the center of line EF. This will be point G. Point G is the center of the circular room. If you make a line perpendicular to line EF that goes through point G, you will divide the room into four equal parts.

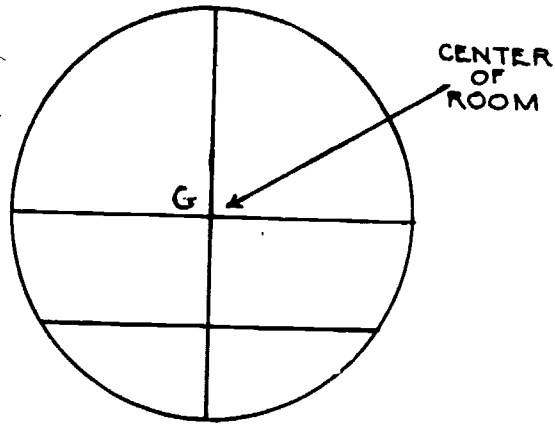

DIAGONAL LAYOUT

What will your pattern look like?

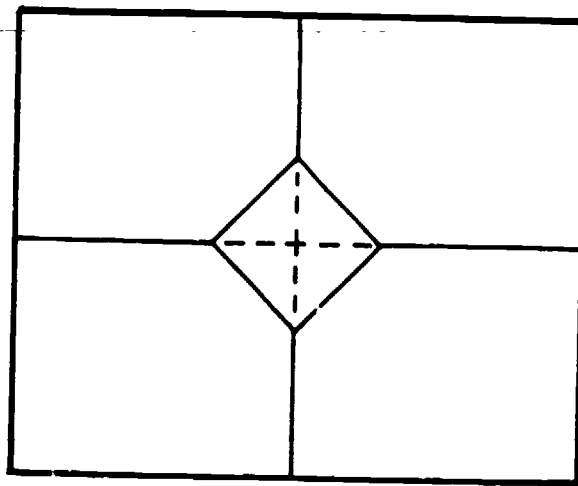

If the first tile is started right on the middle point of the room, you will end up with a pattern like this:

(See the illustration on the top of the following page.)

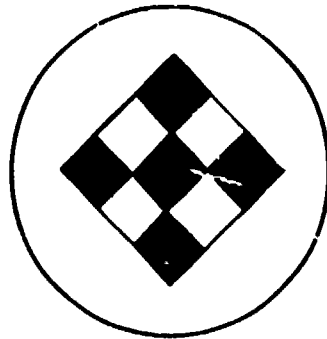

If you start with the corners of four tiles on the middle of the room, you will have a pattern like this:

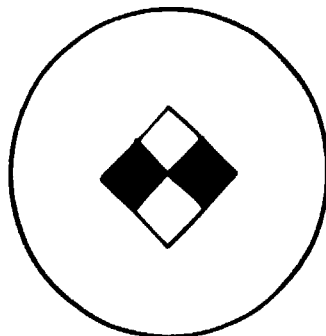

General Guidelines

1. When contrasting colors are used, the border has to be the same color on all sides of the room. If all the sides do not have the same color, the room will look unbalanced.
2. To find out how wide the border will be, you can divide the length and then the width of the room by the diagonal length of the room by the diagonal length of the tile.
 - a. The diagonal length of a 9" X 9" tile is $12 \frac{3}{4}$.
 - b. The diagonal length of a 12" X 12" tile is 17".
3. Adjust the center layout as needed to make the border equal on all sides.

4. You can also dry lay the tile to find out what the border will have to be.

The 45° guideline

The ways of diagonal installation that have been talked about so far have the diagonal of the tile right on the chalkline.

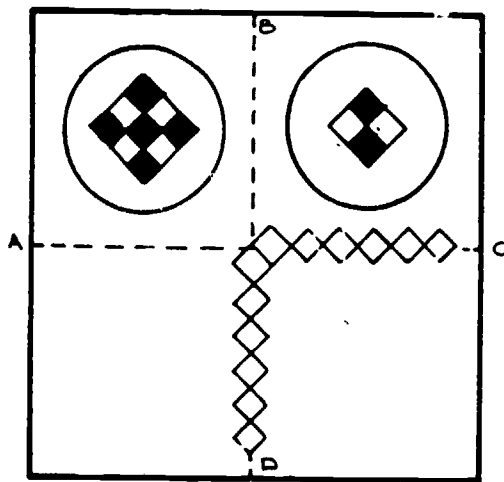

The following is a way to make a line on which the edge of the tile can be put.

1. Mark points B, C, D and E. They are all the same distance from point A.

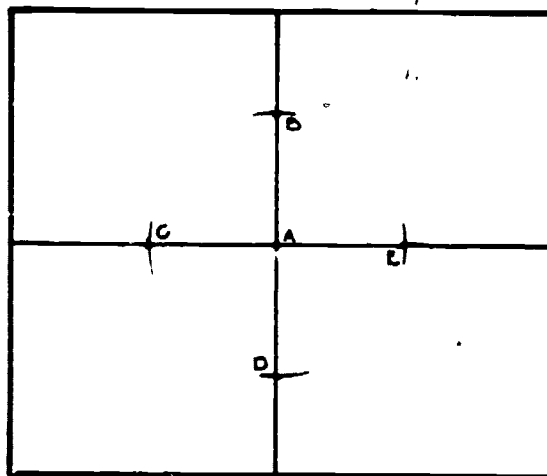

2. Make an arc from point B. Make an arc from point C that crosses the arc from point B.
3. Make an arc from point D. Make an arc from point E that crosses the arc from point E.

4. Keep the lengths of all the arcs the same.

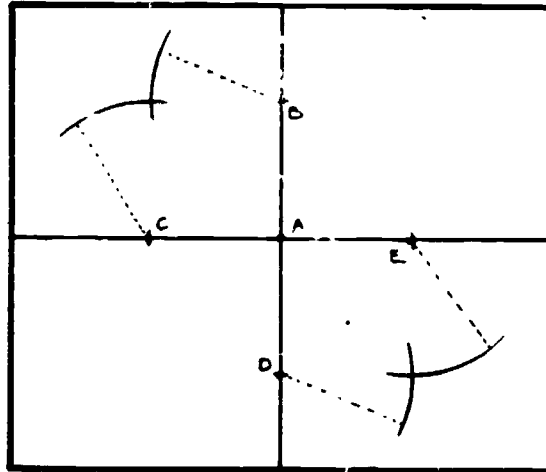

5. Connect point F with point G, going through point A. This divides the 90° angles into 2 equal parts, making 45° angles.

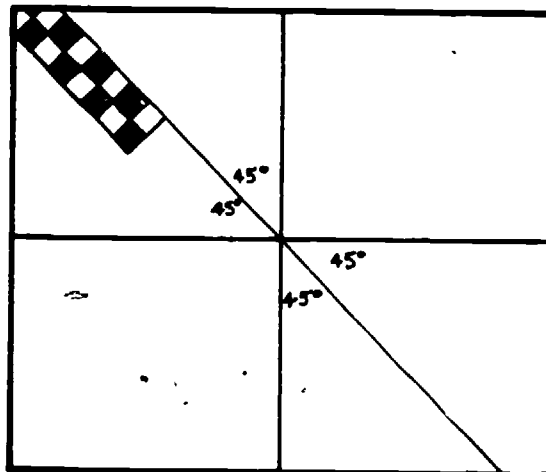

6. The edge of the tile can be placed along the chalkline HI.

Moving a 45° Guideline

You may need to move this 45° guideline off the center of the room to adjust the borders. To do this, measure from at least two points on the line in the direction you want to go. Use a square to keep the measured points parallel to the 45° line. Then make a new chalkline through the new points.

(See the illustration at the top of the following page.)

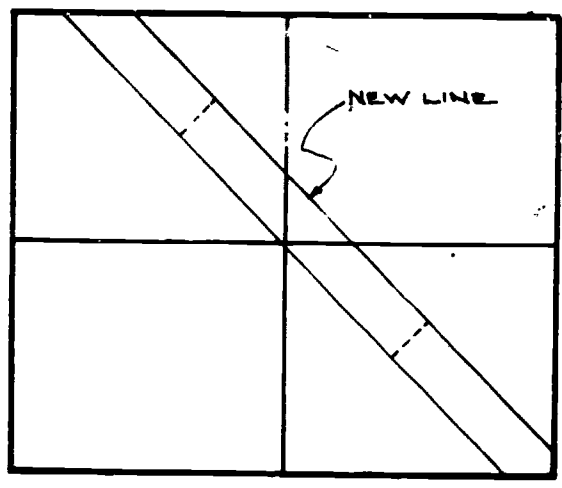

INSTALLING THE BORDER OF DIAGONAL-LAID TILE

1. Make a square template. Each side of the template should equal the diagonal measurement of the tile size you are using.

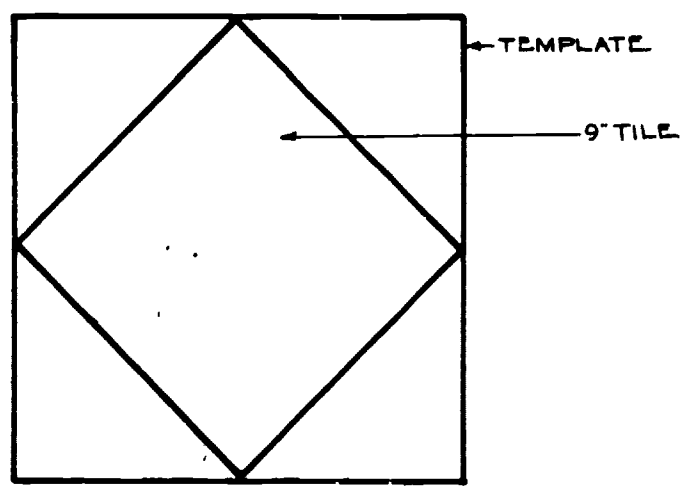

2. Do not cement the last 3 rows of tile.
3. Dry lay tile as shown below.
4. Mark and cut the dry-laid tile as shown below.

(See the illustration on the top of the following page.)

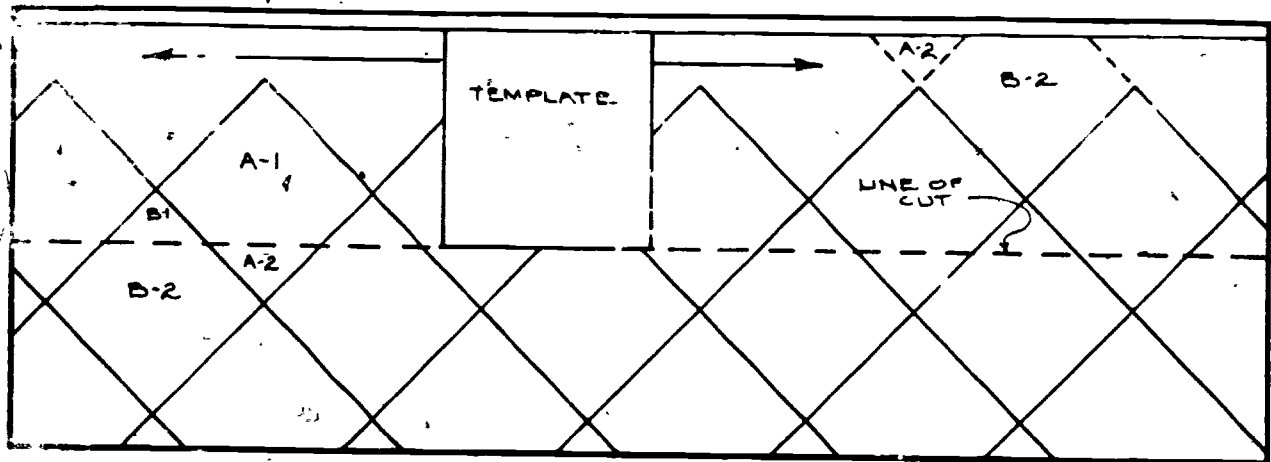

5. Spread adhesive for the last 3 rows.
6. Install remaining rows.
7. Install parts A-2 and B-2 of the cut tiles as shown. Throw parts A-1 and B-1 away.

Self Assessment

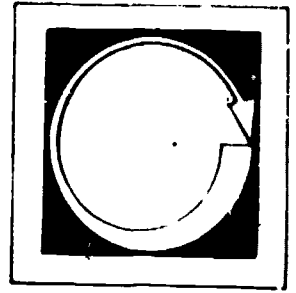

COMPLETE THE FOLLOWING PROBLEMS.

1. Use a compass and ruler to construct a line perpendicular to line AB that goes through point C.



2. Make a line at 45° angle that goes through point C in problem #1.
3. Move the 45° line made in problem #2 two inches to the left.
4. Find the center of this circle.

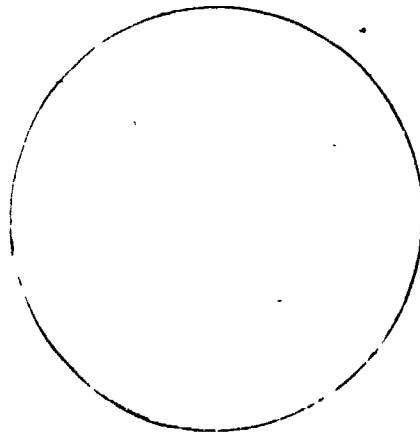

Job Sheet

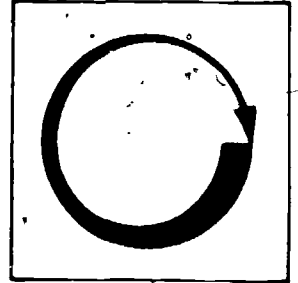

COMPLETE THE FOLLOWING TASKS.

Materials and Tools

Everything required to install vinyl-asbestos tile.

1. Complete all the steps of layout and planning for an installation of diagonally-laid tile.
2. Find the center of a circular area marked out by your instructor.
3. With cardboard, make a border template for 12" X 12" diagonally-laid tile.
4. Lay out an area designated by your instructor for a square layout pattern installation. Install vinyl-asbestos tile in this area.

Use the space below to plan what you will be doing.

Post Assessment

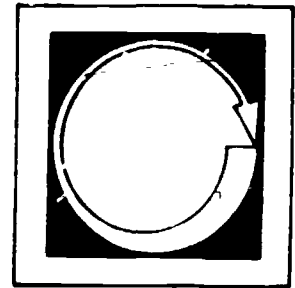

COMPLETE THE FOLLOWING STATEMENTS BY WRITING THE CORRECT WORD OR WORDS IN THE BLANKS PROVIDED.

1. A border should be _____ on all sides.
2. When one line meets or crosses through another to make a 90° angle, the lines are _____ to each other.
3. The diagonal measurement of 12" X 12" tile is _____ inches.
4. When making an arc, use a _____ tape measure.
5. Two lines that are _____ will never meet.
6. If the border is not even, you will have to adjust the _____ layout.
7. When making a template for the border of diagonally-laid tile, each side of the template should equal the _____ measurement of the tile size.
8. A _____ tape measure can stretch.
9. The diagonal measurement of 9" X 9" tile is _____ inches.
10. When contrasting colors are used, the border has to be _____
_____ on all sides.

● Instructor Post Assessment Answers

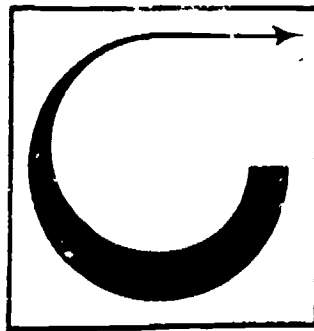

1. equal
2. perpendicular
3. 17
4. steel
5. parallel
6. center
7. diagonal
8. cloth
9. $12 \frac{3}{4}$
10. the same color

SEAMING SHEET GOODS

Goal:

The student will be able to identify the steps in seam cutting and straight-edge trimming of sheet goods and will execute these steps.

Performance Indicators:

The student will successfully complete a Self Assessment, a Job Sheet and a Post Assessment.

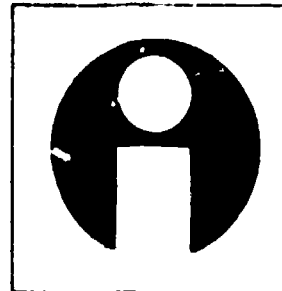

Study Guide

In order to finish this module, do the following tasks. Check each item off as you complete it.

1. Read the Goal and Performance Indicators on the cover of the module. This will tell you what you will learn by studying the module, and how you will show you've learned it.
2. Read the Introduction. The Introduction will tell you why the module is an important part of the floor laying trade.
3. Study the Vocabulary section. Vocabulary words are important for a good understanding of the trade. After you have studied the vocabulary, ask your teacher to quiz you on the words and their meanings.
4. Study the Information section. This section will give you the information you need to understand the subject.
5. Take the Self Assessment exam. This is a test for you to prove to yourself that you have learned the material you have studied. Compare your answers with the answers on the Self Assessment Answer Sheet, which is on the page following the Self Assessment. If you scored poorly, re-study the Information section or ask your teacher for help.
6. Do the Job Sheet. Follow the instructions at the top of the Job Sheet. The tasks listed on the Job Sheet will help you develop skills which will be helpful to you.
7. Take the Post Assessment exam. Give the exam to your teacher after you have completed it. Your teacher will grade it for you.

Introduction

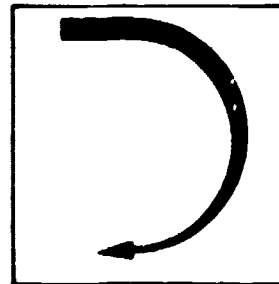

Sheet goods are usually large enough to fit a residential room without seaming. But commercial installations may take 3, 4 or more sheets of goods. As a floor layer, you will have to know how to match patterns, cut and make seams. This module will help you learn about these things.

Vocabulary

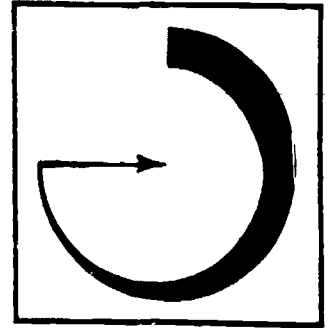

Trade terms are very important for a good understanding of the trade. Study these words and meanings. When you have learned them, ask your teacher to quiz you on the words and their meanings.

SEAM--Place where two pieces meet.

MATCH POINTS--The points on a pattern that are matched together when making a seam.

MATCH--How often the pattern repeats itself along the seam edge to form a side match. May also be called "repeat."

REPEAT--The distance before a pattern repeats itself. Most common are 3, 18 and 36 inch repeats.

DROP MATCH--Found in diagonal patterns. The second repeat of the pattern from the edge is $1/2$ of the distance of the repeat in from the edge and $1/2$ the distance of the repeat.

CROSS MATCH--When the pattern is matched so that the match points meet when seen from a point 90° to the seam.

ON MATCH--An exactly right match when the pattern is seen from 90° to the seam.

OFF MATCH--When the match points do not meet right. Most easily seen when standing to the side of the seam.

SIDE MATCH--When match points right on the seam of two pieces meet each other.

Supplementary References

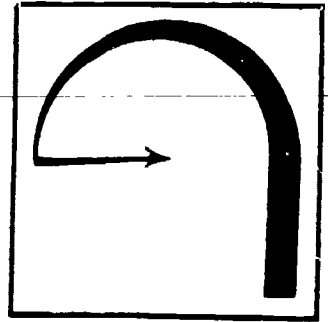

1. Resilient Floor Coverings Workbook. California State Department of Education, 1973. pp. 175-192.
2. Carpet Training Manual. Southern California Joint Apprenticeship and Training Committee, n.d. pp. T-1 to T-5.
3. Installation Tips on Pattern Matching Sheet Vinyl Floors. Armstrong Cork Co., 1976. 4-page pamphlet.

Information

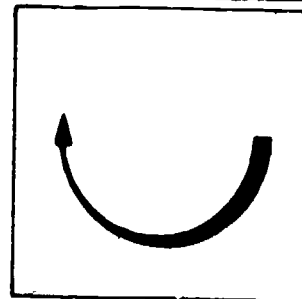

Before you cut or trim anything, always plan the steps of what you will do.
This rule will save many dollars worth of materials.

The shade of color in sheet goods is not always the same all the way through a roll. So when pieces are being used they should be checked at the seam for a good color match. This should be done even if the pieces come off the same roll. If possible, it is a good idea to lay out all the strips and sight check them before installing them.

When pieces are taken off a roll and have to be seamed, they should be switched end-for-end as shown below (unless the manufacturer tells you not to do this). For example, if a room needs five strips, pieces #1, #3 and #5 can be laid just as they are cut from the roll. But you should turn pieces #2 and #4 end-for-end.

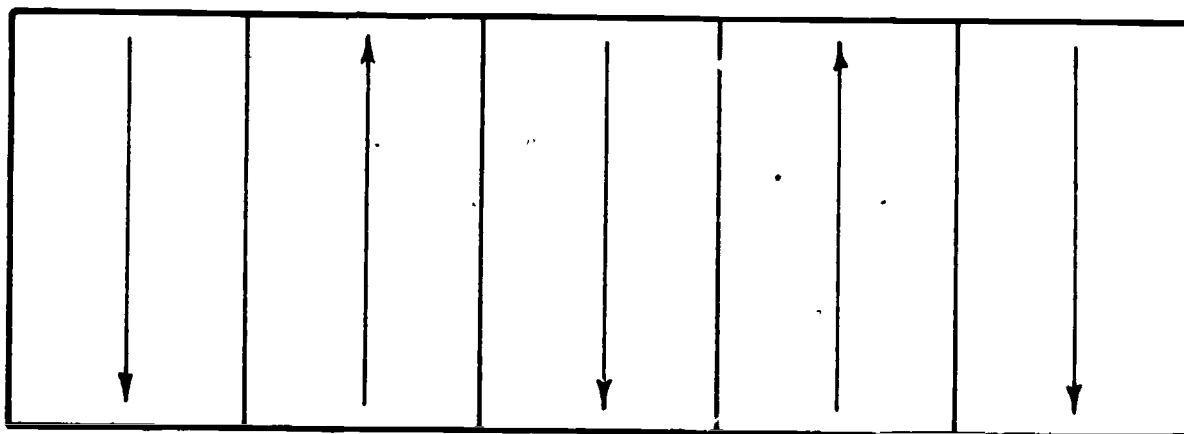

This can be an easier job to do if the sheet goods have a trade mark on only one side of the sheet goods. If the trade mark is only on one side, lay out the goods so that the edges with the trade marks are next to each other, and the edges without trade marks are next to each other.

This rule of switching directions should be used for "nondirectional" patterns such as mottling, graining, or spatter effect as well as for patterns and colors when this is possible. NOTE: The switching directions rule does not always work. Some sheet goods should not be switched. Always read the manufacturer's specifications before cutting anything.

Double Cutting Nondirectional Patterns

The edges of the 2 pieces being seamed should be overlapped by about 3/4 of an inch. Strike a chalkline along the length of the piece on top. This chalkline should be at least 1/2-inch from the edge of the top sheet.

Use a straightedge to cut through the top layer and to mark the bottom layer by cutting at least half way through it. Then remove the cut off top material and finish cutting the bottom piece. NOTE: If the thickness of the material will let you, cut all the way through the bottom piece when you cut through the top piece.

When cutting, be sure the knife blade is held at a 90° angle to the goods. If the blade is tilted away from the edge of the top sheet there will be an open seam. If the blade is tilted toward the edge of the top sheet there will be a tight seam. Only when the blade is held at 90° will you make a true seam (also called a "net" seam).

Matching A Pattern

If you are working with a new pattern, study it carefully before starting anything. Try to find a key or match point in the pattern. Sometimes the manufacturer will show where the match points are with marks on the edges of the material. You will also have to figure out how much material will be needed to make a seam.

Work from the baseline (the longest wall). On the floor, mark off where the seams will be. Then the length of each sheet will have to be carefully figured before it is cut.

All of the sheets except the last one have to be cut extra long. How much extra will be needed is decided by the repeat distance of the pattern. You will have to cut enough for the length of the baseline plus enough extra to make a full pattern repeat.

EXAMPLE: The baseline is 15' 4".

The pattern repeat is every 18".

You will have to cut an extra 14 inches ($18" - 4" = 14"$) to reach the next pattern repeat. Each piece (except the last one) will have to be cut 16' 6" long. You will have 14" of waste material on each of the pieces cut extra long.

Steps for matching a pattern:

1. Find out which direction the sheets will run when they are installed.
2. Decide which will be the base wall.
3. Find the longest distance that will be covered. All sheets must be figured for length based on this distance.
4. Cut all sheets (except the last) to a length that equals a whole multiple of the pattern repeat. (With a length of 15' 4" and a Pattern repeat of 18", the nearest whole multiple is 198" or 16' 6".)

TYPES OF SEAMS

Butt Seam

This type of seam is made by butting the edges of two pieces together. Before this is done the selvage should be cut off the edges that will go together. This method works best when the seam will be 6 feet long or less. This is because the standard straightedge is only 6 feet long.

If the butt seam is to be longer than 6 feet, be very careful to keep the straightedge true. If it is off even a little bit, the seam will not work right. If you do have to make a butt seam longer than 6 feet:

1. Place a 4-foot straightedge alongside the 6-foot straightedge.
2. Use the 4-foot one as a guide to slide the 6-footer forward.

Double Cut Seam

Overlap the 2 pieces at least 1 inch and match the pattern using match points. Some manufacturers do not allow a full inch for overlap. Check the manufacturer's specifications to find out. Check for cross match as well as for side match.

When you have the 2 pieces on match, use a straightedge and cut through both layers at the same time. NOTE: If the materials are too thick to allow cutting both at the same time, cut at least half way through the bottom layer with the first cut. Then remove the extra top material and complete the cut on the bottom piece. When you are cutting, always make sure the blade is held at a 90° angle to the edge of the material.

Underscribed Seam

1. Straightedge the first piece before cementing to the floor.
2. Match the second sheet, overlapping at least 3/8 inch.
3. Fit the top sheet into the throat of the underscriber tool.
4. Hook the guide button over the edge of the first sheet.
5. Draw the scriber toward you. Use a little side pressure to make sure the guide button follows the edge right. Use a little downward pressure to make sure the needle makes a mark on the surface of the second sheet. NOTE: Do not push the scriber away from you. It is too hard to control when it is moving this way.
6. After marking about 2 inches, cut in the seam to make sure the fit is right.
7. Adjust the scriber if it is needed.

Never scribe a whole seam without checking it for fit first. Sometimes soft-cushion vinyls will "recover" from the mark made by the scriber. By the time you are ready to start cutting, the scribe mark has disappeared. The scriber needle can be sharpened to an egg-shaped point to keep the scribe line from disappearing. If you push down too hard on the scriber, it can tear the vinyl instead of scratching it. This will leave a jagged edge.

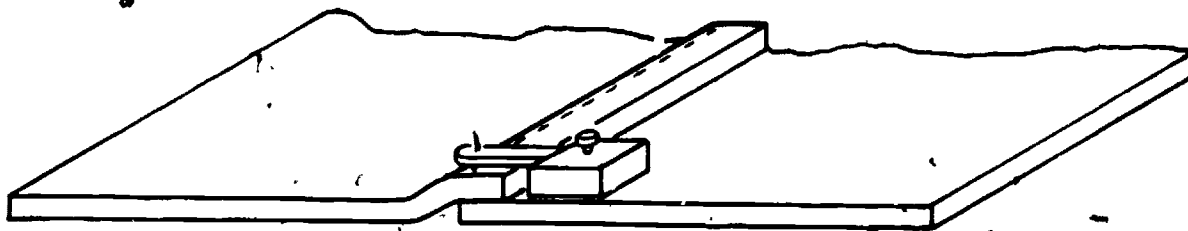

UNDERSCRIBED OR HINGED SEAM

Cutting Tools

A hawk bill linoleum knife tends to plow through vinyl and distort the edge. This can be avoided by rounding off the point so that it slides through the material better.

The utility knife is very popular. If the blade sticks out of a flat base, this base can be butted against the straightedge. This works well for double cutting, making a good 90° cut without any jagged edges.

Any of the notched or hooked knives will work on material that has been scored with a scribe or another knife. Be careful to hold the knife at 90°. If the material is undercut, it will make a gully at the seam.

Electric cutters are also available. These can save a lot of time on very large jobs.

Making the Seam

Each manufacturer has special directions for making and sealing seams. Be sure to read these before starting a job. Vinyl seams are often sealed with a special adhesive and applicator. This applicator has a part that fits into the seam so that the welding liquid gets on both pieces. Always read the manufacturer's directions and do not try to substitute one type of seam sealer for another one.

These materials will always be needed to make a good seam:

1. The sealing tool suggested by the manufacturer.
2. Welding liquid or adhesive suggested by the manufacturer.
3. Solvents.
4. Clean white rags.
5. Masking tape.
6. Protective cover for the freshly sealed seam.
7. Technical data (directions from the manufacturer).

Sealing the Seam

NOTE: The following directions are for example purposes only. The directions will be different for different products. Read the manufacturer's directions for how to use the recommended seam sealing kit.

1. Seam sealing may be either the first step or the last step of installing resilient sheet covering. Check the manufacturer's directions.

2. Cut the seam and make sure it is clean, dry and free of floor bonding adhesives.
3. Fill the applicator bottle with the recommended amount of seam sealer cement. Fill the bottle over a rag so that none of the cement will spill on the new flooring material. Use good ventilation and avoid breathing the fumes.
4. Attach the nozzle to the applicator bottle. If the nozzle gets clogged, use the wire to unplug it. Do not squeeze the bottle too hard to unplug the nozzle.
5. Start at one end of the seam. Insert the nozzle. Gently squeeze the bottle and move it along the seam. Leave a 1/8 inch bead of cement along the surface of the seam.
6. Do not remove extra cement on the surface of the seam. Do not allow traffic on the seam for at least 2 hours.
7. When finished, pour the unused cement back into the metal container. Clean the applicator bottle and nozzle with lacquer thinner.

SAFETY

1. All knife blades should be kept sharp.
2. Seam liquids and solvents can be toxic or flammable (or both). Follow all recommended precautions.

Self Assessment

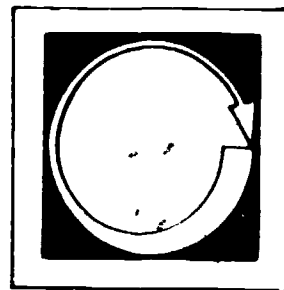

COMPLETE THE FOLLOWING STATEMENTS BY WRITING THE CORRECT WORD OR WORDS IN THE BLANKS PROVIDED.

1. When cutting, be sure the blade is at a _____ angle.
2. The underscriber's _____ makes a mark on the _____ sheet.
3. Lay out goods so that the edges with trade marks are _____ each other.
4. There may be marks on the _____ to show match points.
5. A roll is not always the same _____ through the whole roll.
6. Electric cutters can be used on _____ jobs.
7. Soft-cushion vinyls may "recover" from the _____ mark.
8. If the blade is tilted toward the edge of the top sheet there will be a _____ seam.
9. Before cutting anything, _____ the steps of what will be done.
10. When _____ cutting, try to cut through both layers.
11. The underscriber's guide button is hooked over the edge of the _____ sheet.

12. Always read the _____ directions.
13. Some sheet goods should not be _____.
14. If the blade is tilted away from the top edge, there will be an _____ seam.
15. Seam _____ may be either the first step of the last step.
16. All sheets except the _____ one have to be extra long.
17. To double cut nondirectional patterns, overlap the two pieces about _____ inch.
18. A "net seam" is one made at a _____ angle.
19. Do not remove _____ cement on the surface of a seam without checking the manufacturer's directions.
20. The standard straightedge is only _____ feet long.

● **Self Assessment
Answers**

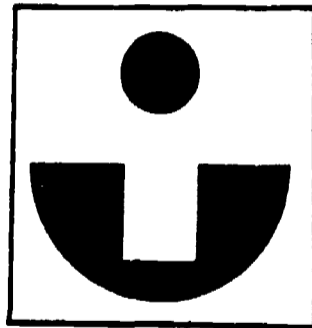

1. 90°
2. needle, second
3. next to
4. edge
5. shade
6. large
7. scriber
8. tight
9. plan
10. double
11. first
12. manufacturer's
13. switched
14. open
15. sealing
16. last
17. 3/4
18. 90°
19. extra
20. 6

215

219

Job Sheet

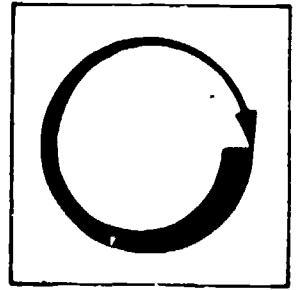

COMPLETE THE FOLLOWING TASKS.

Materials and Tools

several pieces of sheet goods, preferably from different manufacturers
seam sealing kits for each piece
tools required for cutting and sealing seams

- A. Your instructor will provide a sample piece of sheet goods. Below, list the manufacturer and the trade name of the material. Also describe the manufacturer's recommendations for making a seam.

- B. Complete at least 6 of the following:

1. Make a butt seam.
2. Make an underscribed seam.
3. Make a seam using the double cut technique.
4. Match and seam two pieces of patterned goods.
5. Seam two pieces of nondirectional patterned goods.

Post Assessment

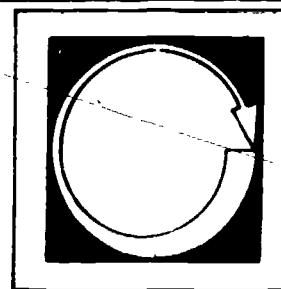

LISTED BELOW ARE SEVERAL STATEMENTS. IF THE STATEMENT IS TRUE, PLACE A "T" IN THE BLANK PROVIDED. IF THE STATEMENT IS FALSE, PLACE AN "F" IN THE BLANK.

1. ___ When making a double cut, the selvage has to be trimmed off first.
2. ___ When double cutting, you should try to cut through both pieces at the same time.
3. ___ Some manufacturers will show match points with marks in the center of the goods.
4. ___ An underscribed seam is made with the sheet goods upside down.
5. ___ Pieces should always be laid out just as they come off the roll.
6. ___ You have to cut pieces as long as the baseline plus one extra full pattern repeat.
7. ___ When double cutting, you have to be careful not to cut the second piece.
8. ___ The standard straightedge is only 4 feet long.
9. ___ Seam cements are never toxic.
10. ___ A true seam is called a "wet seam."
11. ___ It is a good idea to check color match even if pieces come off the same roll.

12. ___ Always begin planning from the longest wall, which is called the baseline.
13. ___ If the side match is okay, then you know the cross match will be okay.
14. ___ When making a butt seam, the selvage has to be trimmed off first.
15. ___ If the knife blade is held at 90° you will get a good cut.

● Instructor Post Assessment Answers

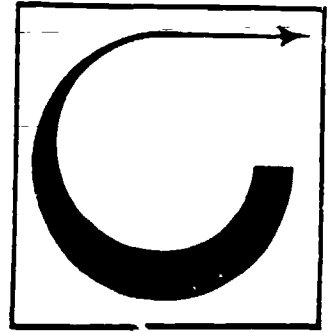

1. F
2. T
3. F
4. F
5. F
6. T
7. F
8. F
9. F
10. F
11. T
12. T
13. F
14. T
15. T

INSTALLING SHEET COVERING

Goal:

The student will install sheet covering on a surface.

220

Performance Indicators:

The student will successfully complete a Self Assessment, a Job Sheet and a Post Assessment.

224

Study Guide

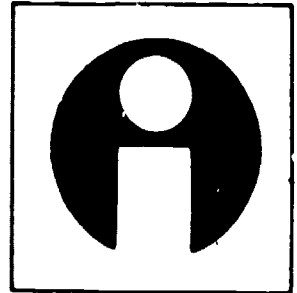

In order to finish this module, do the following tasks. Check each item off as you complete it.

1. ___ Read the Goal and Performance Indicators on the cover of the module. This will tell you what you will learn by studying the module, and how you will show you've learned it.
2. ___ Read the Introduction. The Introduction will tell you why the module is an important part of the floor-laying trade.
3. ___ Study the Information section. This section will give you the information you need to understand the subject.
4. ___ Take the Self Assessment exam. This is a test for you to prove to yourself that you have learned the material you have studied. Compare your answers with the answers on the Self Assessment Answer Sheet, which is on the page following the Self Assessment. If you scored poorly, re-study the Information section or ask your teacher for help.
5. ___ Do the Job Sheet. Follow the instructions at the top of the Job Sheet. The tasks listed on the Job Sheet will help you develop skills which will be helpful to you.
6. ___ Take the Post Assessment exam. Give the exam to your teacher after you have completed it. Your teacher will grade it for you.

Introduction

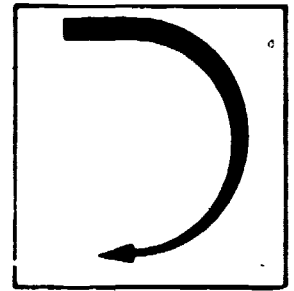

This module will give you a chance to put what you have learned into practice. You will be asked to install sheet material on a surface.

Supplementary References

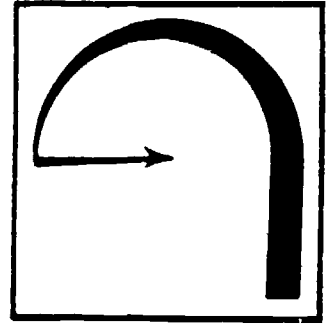

1. Resilient Floor Coverings Workbook. California State Department of Education, 1973. pp. 19-24, 111-126, 167-186.

Information

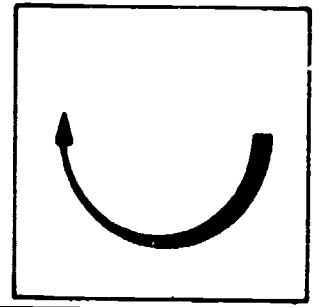

Preparing the Room

The floor area should be clean and dry. The temperature should be over 65° F. Floor adhesives do not bond well to floors that are cold, dirty, oily or rough. Concrete should be vacuumed. Also, be sure there is no water seepage. Take furniture and all other moveable items out of the room. Remove moldings as needed.

Inspect and prepare the floor area. If you have to, take up old vinyl or carpet, strips and staples. Fill cracks and holes and smooth them to surface level.

Using a Pattern

A pattern can be made for a small room, such as a bathroom. This pattern is then laid on the sheet material. The sheet material is marked and cut to the exact size. You may use #15 felt paper (or special pattern stock) to make the pattern.

Without a Pattern

1. Measure floor area with a steel tape measure.
2. Measure and mark sheet material to size. Be sure the material's design is square to the door opening. If the design is not square, or parallel, to the door, it will not look right.
 - a. Small room--square material from the factory edge and then cut to size (within 1/8" of all walls).
 - b. Large room--seaming will be needed. Square first piece from the factory edge. Match other pieces to the design on the first piece.

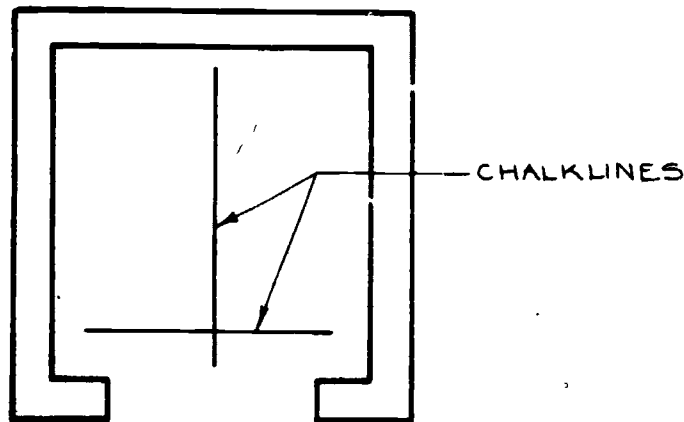

Squaring a Design to the Door

1. Snap a chalkline parallel to the door.
2. Construct a second line at 90° to the first line.
3. With straightedge and knife, cut material to size. The cut sheet material should fit to within 1/8" of the base of the wall.
4. Lay sheet material in place. Set a 75-lb. roller on the half nearest the door.
5. Pull the other half of the sheet material back. Spread adhesive with a notched trowel up to the walls.
6. Roll sheet material back on top of the adhesive.
7. Push roller back and forth, side to side, toward the walls. This will force air bubbles out and will make a good contact between the sheet material and the adhesive. Roll almost to the center glue line.
8. Leave the roller on the half you have just rolled. Pull the other half of the sheet material back just past the glue line.
9. Apply adhesive as you did for the first half.
10. Roll this half, beginning at the center glue line and moving outward to the walls.
11. Check for air bubbles.
12. Check the edges to see if any trimming is required.
13. Cap edges at doorways.
14. Replace moldings; nail them to the wall, not to the floor.
15. Clean up.

Seams

1. Lap one piece over the other and match the pattern.
2. Use a sharp knife and straightedge to cut through both pieces.
3. Check seam for smoothness and bonding to floor surface.

Self Assessment

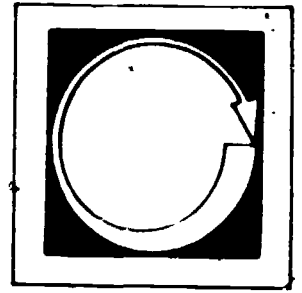

COMPLETE THE FOLLOWING STATEMENTS BY WRITING THE CORRECT WORD OR WORDS IN THE BLANKS PROVIDED.

1. When installing sheet material, the room temperature should be _____ F.
2. Allow _____ inch(es) clearance on walls to be covered with molding.
3. Concrete should be _____.
4. Cap edges at the _____.
5. Before spreading adhesive, the floor area should be clean and _____.
6. A pattern for small, irregular-shaped rooms can be made from _____ felt.
7. Sheet material is squared to the _____.
8. Moldings should be re-nailed to the _____.

Self Assessment Answers

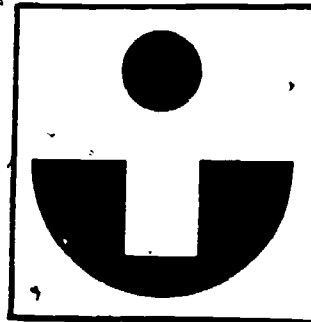

1. over 65°
2. 1/8
3. vacuumed
4. doorways
5. dry
6. #15
7. door opening
8. wall

Job Sheet

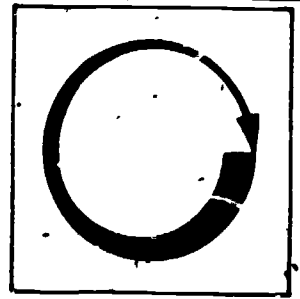

COMPLETE THE TASK BELOW

1. In a space designated by your instructor, prepare, lay out and install sheet material.

Use the space below to plan what you will do.

Post Assessment

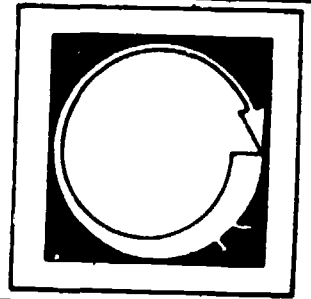

LISTED BELOW ARE A NUMBER OF STATEMENTS. IF THE STATEMENT IS TRUE, PLACE A "T" IN THE BLANK PROVIDED. IF THE STATEMENT IS FALSE, PLACE AN "F" IN THE BLANK.

1. ___ Allow 1/8" clearance when trimming if no molding will be installed.
2. ___ Edges at doorways should be covered with molding.
3. ___ Molding should be nailed to the floor.
4. ___ Cement should be spread all around the edges of the floor.
5. ___ Oil on the floor will not hurt an adhesive bond.
6. ___ The temperature in the room must not be over 50° F.
7. ___ A linoleum knife and straightedge are used to cut seams.
8. ___ You should always bond the half of the sheet material nearest the door before bonding the half farthest away from the door.

● Instructor Post Assessment Answers

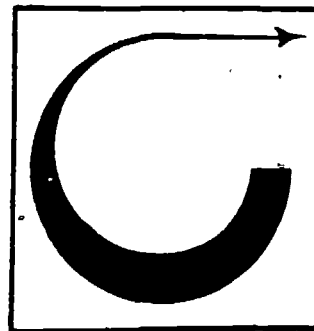

1. F

2. F

3. F

4. F

5. F

6. F

7.

8. F

INSTALLING PADDING

Goal:

The student will be able to identify the steps involved in laying out and attaching padding of different materials and will execute those steps.

232

Performance Indicators:

The student will successfully complete a Self Assessment, a Job Sheet and a Post Assessment.

236

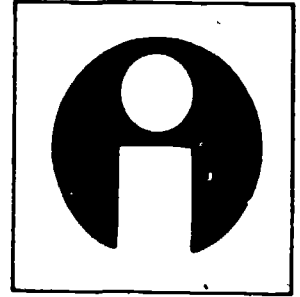

Study Guide

In order to finish this module, do the following tasks. Check each item off as you complete it.

1. Read the Goal and Performance Indicators on the cover of the module. This will tell you what you will learn by studying the module, and how you will show you've learned it.
2. Read the Introduction. The Introduction will tell you why the module is an important part of the floor covering trade.
3. Study the Information section. This section will give you the information you need to understand the subject.
4. Take the Self Assessment exam. This is a test for you to prove to yourself that you have learned the material you have studied. Compare your answers with the answers on the Self Assessment Answer Sheet, which is on the page following the Self Assessment. If you scored poorly, re-study the Information section or ask your teacher for help.
5. Do the Job Sheet. Follow the instructions at the top of the Job Sheet. The tasks listed on the Job Sheet will help you develop skills which will be helpful to you.
6. Take the Post Assessment exam. Give the exam to your teacher after you have completed it. Your teacher will grade it for you.

Introduction

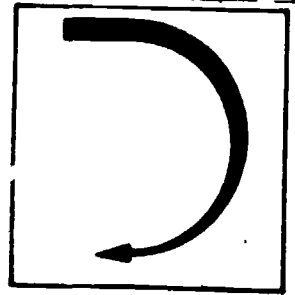

Padding makes a carpet feel softer when it is walked on. When padding is properly installed, it can add to the life of the carpet. If padding is not installed properly, the carpet may show flaws like telegraphing. The carpet may even wear out faster. This module will help you learn about the proper ways to install padding.

Supplementary References

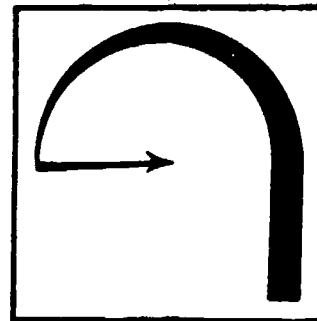

1. Duffin, D. J. The Essentials of Modern Carpet Installation. 1962.
pp. 96-107.
2. Carpeting Floor Covering Workbook. California State Department of Education.
1972. pp. 19-22, 93-96.

Information

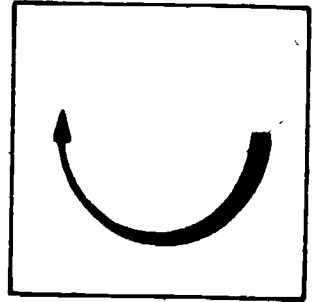

There is one "safety step" that should be taken before starting to cut the padding. This step is to check the floor one last time to be sure it is clean and that it is even.

ESTIMATING THE AMOUNT OF PADDING

You will need as much padding material as you do carpet. There is one difference: Padding pieces can be seamed together more than carpet pieces can. So you can use up some of the remnant pieces that might be around. A WORD OF WARNING: If the seams are not made right, they can show through the carpet by being telegraphed.

CUTTING THE PADDING

When padding is laid out for trimming, it may be flashed up the walls. Then you will have to turn it back for cutting. But be careful not to cut the layer of padding under the layer you are cutting.

General Rules for Cutting Padding

1. The padding knife can scar the floor under the padding material.
 - a. If the finish of the floor has to be protected for later use, do not cut all the way through the padding material.
 - b. Cut part way through with the knife.
 - c. Finish the cutting with shears.
2. If the finish of the floor under the padding has to be protected, be careful how and where you staple the padding. Use the minimum number of staples.
3. If the padding material is put on top of something else to be cut, be careful that you do not cut the other material.

4. Cut on the job when possible. Cutting on the job often makes for a better fit.
5. Cut so that the padding comes right to the edge of the tack strip.

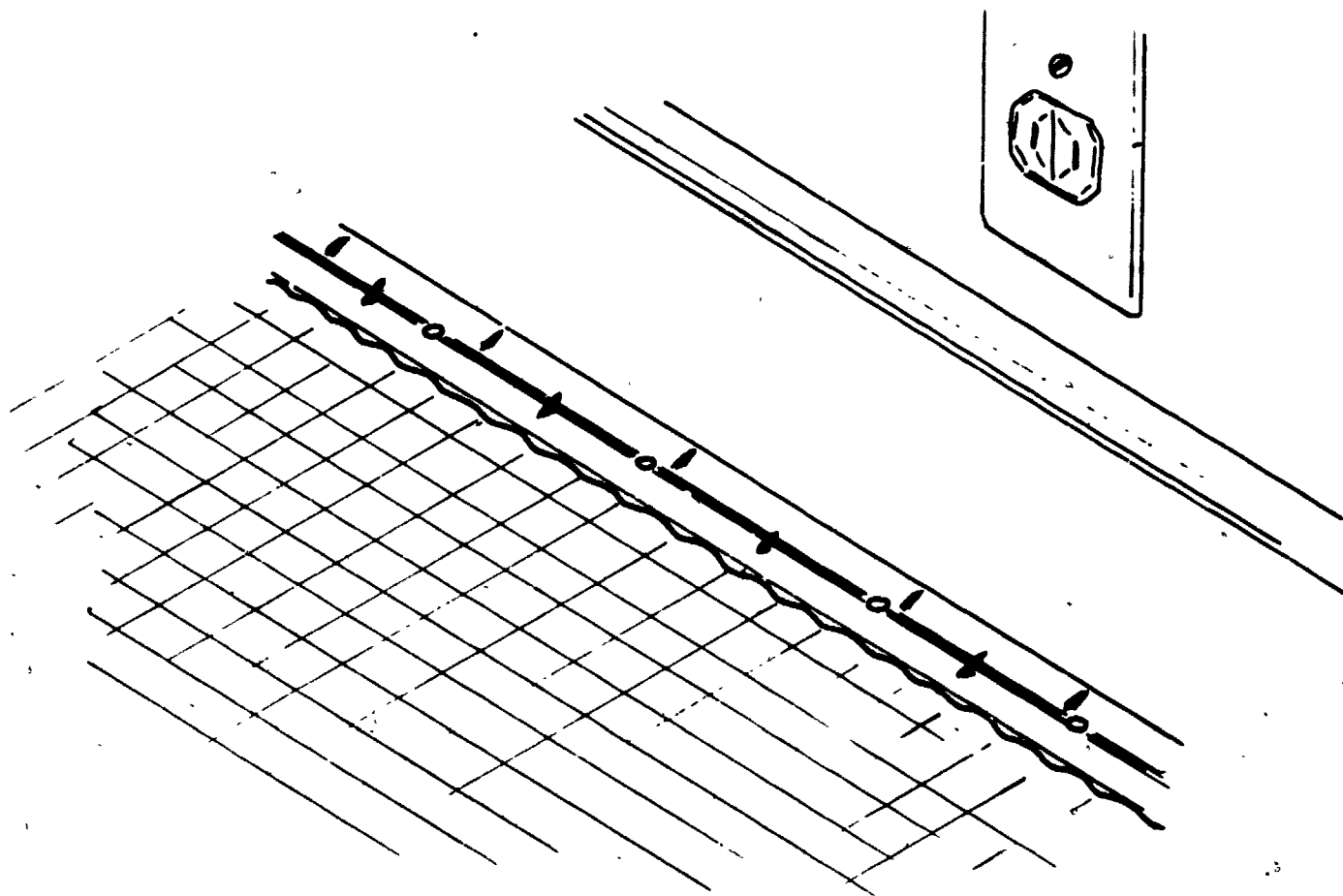

6. If a turn-and-tack installation is being done, fit the padding so that there is a 1 1/2 inch space between the padding and the wall.
7. Cut padding to fit the largest areas first.
8. Plan your work so that padding seams are not in the same places there will be carpet seams.
9. Cutting can be done with shears, a padding knife, or an electric rotary knife.
10. To cut:
 - a. Make a 1/2-inch cut on each side of the unrolled padding.
 - b. Snap a chalkline between the 1/2-inch-cuts.
11. Don't try to cut by following the waffle design on the padding. Always snap a chalkline.

LAYOUT OF THE PADDING

All of the padding in a room should be laid out before you start seaming or attaching it to the floor. This is when you can decide how to use up the small pieces of padding. Also, many paddings are printed with a design on one side. This design is called the "waffle." Some installers like to put the waffle side facing down (next to the floor). Others like to put the waffle side facing up (next to the carpet). There are points in favor of doing it both ways.

Points in Favor of Putting the Waffle Side Up

1. The carpet feels more cushiony. This is because the pockets made by the waffle design are next to the carpet, not pressed to the floor.
2. It can be easier to stretch the carpet. There is less surface area to pull on the carpet when it is being stretched.
3. The carpet may be easier to vacuum clean. The air space made by the waffles is next to the carpet. This means the air is drawn only through the carpeting. The vacuum cleaner does not have to pull air through the padding, too.
4. The waffle will hold the carpet. This means there may be less wear. After a few weeks, the carpet is pushed into the waffle design. This helps keep the carpet from sliding around. Less friction between the carpet and the padding means the carpet may wear better.
5. The air space between the padding and the carpet makes for added insulation protection.

Points in Favor of Putting the Waffle Side Down

1. If the waffle design is up, the design may telegraph through the carpet. Plain or solid color carpets may do this more than other kinds.
2. If the waffle is down, it can mean less shading and pile crushing of the carpet.
3. When the waffle is next to the floor, there is better suction. This can make the carpet more resilient.
4. Having the waffle side down makes a smoother surface under the carpet. This makes it easier to see if there is something wrong when the carpet is being stretched.

5. If the waffle design is telegraphed, this may make the carpet wear faster.

There are good things about having the waffle side up and about having the waffle side down. You will have to learn which is best for you and the customer.

PIECING PADDING

1. This is often done in the smaller areas, such as a hallway.
2. Always be sure to use the biggest pieces first.
3. When you are putting pieces together, be sure that the edges fit together well.
4. The only kind of tape that cannot be used has built-in grippers. This type is for seaming carpet only.

STRETCHING PADDING

Some types of foam rubber padding may need to be stretched to keep out ridges. Padding that has a foam rubber coating should not be stretched.

Most other kinds of padding do not need to be stretched unless the roll has been damaged. To fix wrinkled padding, tack down one end. It can be tacked or weighted with something such as sand bags. Then use the knee kicker to gently push the padding flat. REMEMBER: Padding is not woven like carpet. Padding is only pressed together, so padding will tear much easier than carpet.

To Get Rid of a Wrinkle

1. Hold the wrinkle flat.
2. Staple on both sides of the wrinkle.

If there is a lot of slack in the wrinkle:

1. Cut out the wrinkled part.
2. Butt the edges together.
3. Tape and staple as for a seam.

ATTACHING THE PADDING

DO NOT staple any padding to a floor covered with resilient tile. The staples can hit the concrete if they go all the way through the tile. This may raise the tile up from the floor. The raised tile will telegraph through the carpet. Or, the tile can come loose. If the tile comes loose, the padding can move around under the carpet. This friction will make the carpet wear out faster.

Hair padding may be tacked, stapled or glued to a wood floor. It must be glued to a cement floor. When cementing, be sure to spread the cement thin. If ridges of cement are formed, they may telegraph through the carpet.

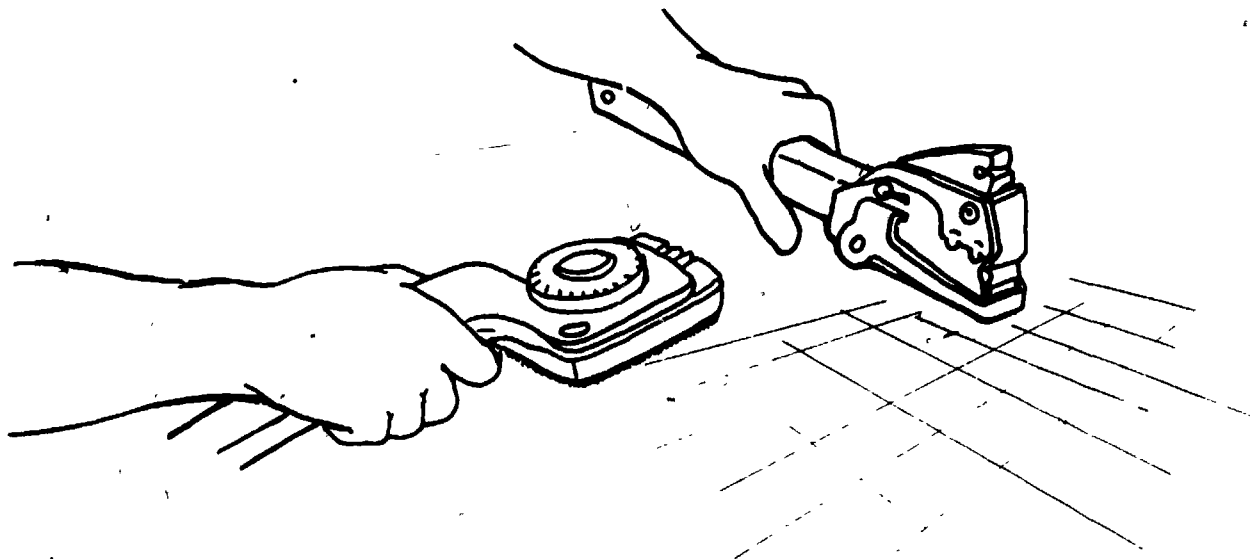

The automatic stapling hammer. It is held in one hand and used like a hammer.

The First Step is to Tape the Seams

1. Walking on the carpet and padding can make puffs of dirt shoot up from the floor. These puffs will go through the padding seams and into the carpet fibers. This will discolor the carpet.
2. The seams may telegraph through the carpet. They can show up on the carpet face as ridges or as gulleys.
3. Seams that are taped and then stapled are stronger.
4. Staples are not going to tear the padding as much if the staples are also held by the tape.

To Fasten the Padding:

1. Tape all seams with carpet tape at least two inches wide. Make sure the padding pieces are firmly butted together at the seams.

On wood floors:

2. Staple on both sides of all seams. Staples should be about 3 inches apart.
3. Staple around the outside edges of the padding. Space the staples about 6 inches apart.
4. Trim the padding where it meets the tack strip.
5. Trim the padding 1 1/2 inches from the wall if the carpet will be installed with the turn-and-tack method.
6. Randomly staple throughout the rest of the area.

On concrete floors:

2. Use padding cement or linoleum paste.
3. Put beads of cement around the perimeter of each sheet.
4. Add a row of beads across the center of areas that will be covered with long sheets.
5. Smooth out the adhesive.
6. Drop the padding into the adhesive.
7. Make sure the adhesive is recommended for use with the padding. Some adhesives, if used with rubber or urethane padding, can dry and make noises when people walk on the floor.

NOTE: In places where the carpet will have to be carefully cut and fitted (such as around pipes), make sure the padding is well fastened to the floor.

ALSO: If you have to use a lower grade of padding, use more staples or glue. Lower grades will fall apart easier. The extra staples or glue will help stop it from falling apart.

PADDING ON STAIRS

The standard stair width is 27 inches. Padding for this size stair should be cut in strips that are 25 inches by 14 inches. Lay the padding as shown and tack under the tread nose. (See the illustration on the following page.)

You can use padding cement or linoleum paste instead of tacks on stairs with hard surfaces.

The heavier paddings are better for stairs. Padding should weigh from 64 oz. to 82 oz. per square yard. Lighter padding can be used in very low traffic

TOP VIEW OF A STAIR

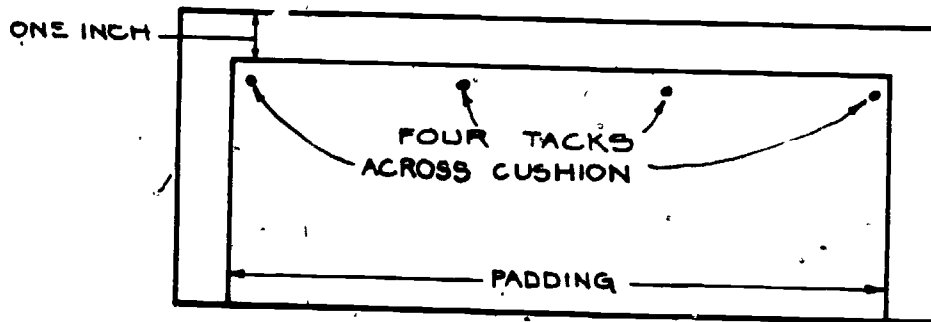

areas. Some lighter weights can be doubled up if the tread nose is not too round to be safe. A 32 oz., 38 oz. or 45 oz. padding can be doubled up.

SIDE VIEW OF STAIR

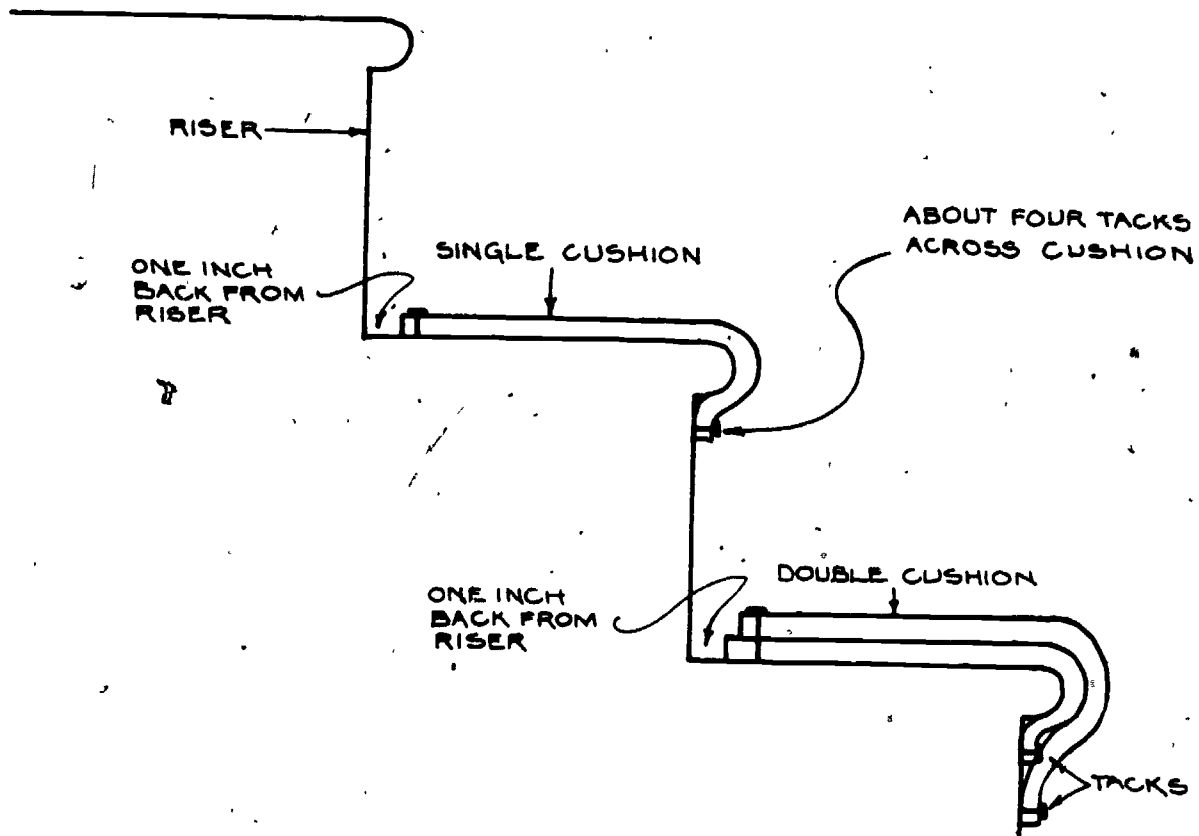

When installing padding be sure the tacks are firmly seated in the wood. Be sure the tacks are long enough.

HEAVY TRAFFIC STAIRS

Padding can get flat when it is in a high traffic area. This means the carpet itself will start taking more of the shock of being walked on. Then the carpet wears out faster. Also, as the padding gets flatter, the carpet can get looser. The carpet may pull loose from the pins if it is attached with tack strips. Also, there will be more friction between the carpet and the padding. The friction can make the carpet wear out faster. One way to help stop this problem is to use a foam rubber underpad.

Using Foam Rubber on Heavy Traffic Stairs

1. Use foam rubber that is about 1/4 inch thick.
2. Cut strips of foam rubber the same size as the padding strips you will use.
3. Cement the foam rubber strips to the treads with a latex cement.
4. Use a 64 oz. padding over the rubber. Fasten it with padding cement or linoleum paste.

NOTE: If the padding is too thick, it can make the stair tread too narrow. There can also be the danger of having too much roll over the nose of the tread.

Self Assessment

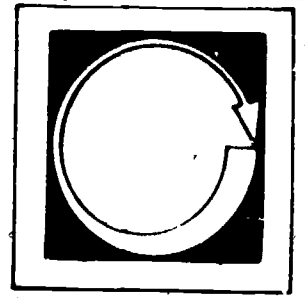

LABEL THE FOLLOWING STATEMENTS "UP" IF THEY DESCRIBE THE WAFFLE SIDE BEING UP AND "DOWN" IF THEY DESCRIBE THE WAFFLE SIDE BEING DOWN.

- _____ 1. Can mean less shading and pile crushing.
- _____ 2. The carpet may be easier to vacuum clean.
- _____ 3. The carpet feels more cushiony.
- _____ 4. The design can't telegraph through the carpet.
- _____ 5. The waffle will hold the carpet.
- _____ 6. There is better suction.
- _____ 7. There is a smoother surface under the carpet.
- _____ 8. It can be easier to stretch the carpet.

COMPLETE THE FOLLOWING STATEMENTS BY WRITING THE CORRECT WORD OR WORDS IN THE BLANKS PROVIDED.

9. Piecing is most often done in the _____ areas.
10. Cut padding to fit the _____ areas first.
11. Padding can get flat in a _____ traffic area.

12. Padding seams can _____ through the carpet.
13. Don't try to cut by following the _____.
14. Padding will _____ easier than carpet.
15. Padding seams should be _____ to keep puffs of dirt from shooting up.
16. Padding can be seamed _____ than carpet.
17. Cutting on the _____ makes for a better fit.
18. The standard stair width is _____ inches.
19. Snap a _____ to guide your cut.
20. The padding knife can _____ the floor.

Self Assessment Answers

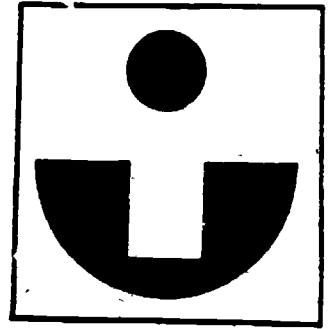

1. down
2. up
3. up
4. down
5. up
6. down
7. down
8. up
9. smaller
10. largest
11. high
12. telegraph
13. waffle design
14. tear
15. taped
16. more
17. job
18. 27
19. chalkline
20. scar

Job Sheet

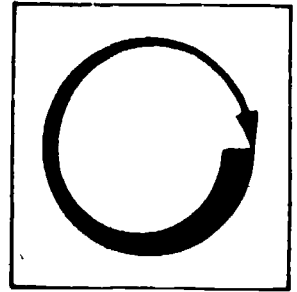

COMPLETE THE FOLLOWING TASKS.

Materials and Tools

Materials, tools and equipment necessary to allow the student to install padding. Both fiber and foam types of padding material should be available.

1. Cut and install a piece of padding around a pipe coming out of the floor.
2. Seam two or more pieces of padding.
3. Install padding on a concrete floor at least 8' by 10'.
4. Install padding on a wood floor or underlayment in an area designated by your instructor.
5. Use the space below to describe the installation of a padding material as the manufacturer recommends it should be installed.

Post Assessment

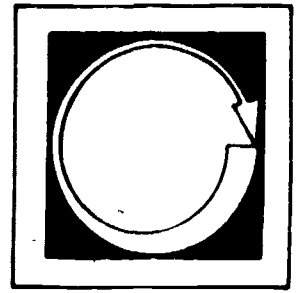

LISTED BELOW ARE SEVERAL STATEMENTS. IF THE STATEMENT IS TRUE, PLACE A "T" IN THE BLANK PROVIDED. IF THE STATEMENT IS FALSE, PLACE AN "F" IN THE BLANK.

1. ___ Wrinkles cannot be cut out of padding.
2. ___ Some adhesives can dry and make noises when people walk on the carpet.
3. ___ Some padding has a "pancake" design printed on it.
4. ___ All grades of padding material are installed the same way.
5. ___ Padding should be cut in the shop because you have more room.
6. ___ Carpet tape used to tape a padding seam should be at least two inches wide.
7. ___ Some types of foam rubber padding may have to be stretched.
8. ___ Lighter weight paddings are better for stairs.
9. ___ Do not staple any padding to a floor covered with resilient tile.
10. ___ It is better to cut padding for the largest areas first.
11. ___ Foam rubber padding can be used under other padding on stairs.
12. ___ All seaming tapes are okay to use on padding.

13. ___ The automatic stapling hammer is held in one hand and used like a hammer.
14. ___ Lay out all padding before attaching to floor or seaming.
15. ___ The standard stair width is 37 inches.

● Instructor Post Assessment Answers

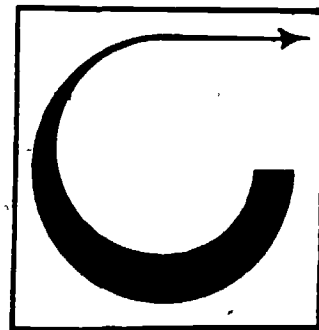

1. F
2. T
3. F
4. F
5. F
6. T
7. T
8. F
9. T
10. T
11. T
12. F
13. T
14. T
15. F

INSTALLING TACK STRIP

Goal:

The student will be able to identify the steps involved in installing tack strips and will execute these steps.

Performance Indicators:

The student will successfully complete a Self Assessment, a Job Sheet and a Post Assessment.

Study Guide

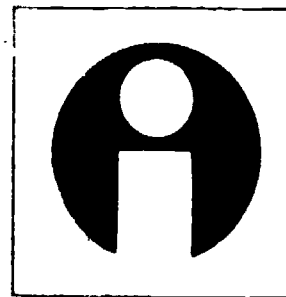

In order to finish this module, do the following tasks. Check each item off as you complete it.

1. Read the Goal and Performance Indicators on the cover of the module. This will tell you what you will learn by studying the module, and how you will show you've learned it.
2. Read the Introduction. The Introduction will tell you why the module is an important part of the floor laying trade.
3. Study the Information section. This section will give you the information you need to understand the subject.
4. Take the Self Assessment exam. This is a test for you to prove to yourself that you have learned the material you have studied. Compare your answers with the answers on the Self Assessment Answer Sheet, which is on the page following the Self Assessment. If you scored poorly, re-study the Information section or ask your teacher for help.
5. Do the Job Sheet. Follow the instructions at the top of the Job Sheet. The tasks listed on the Job Sheet will help you develop skills which will be helpful to you.
6. Take the Post Assessment exam. Give the exam to your teacher after you have completed it. Your teacher will grade it for you.

Introduction

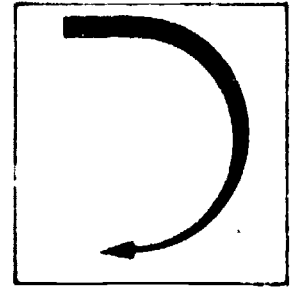

The use of tack strip makes it easier to install carpet. Tack strip also makes it possible to give the carpet a smooth edge finish. The professional floor layer has to know how to install tack strip. This module will give you experience in installing tack strip.

Supplementary References

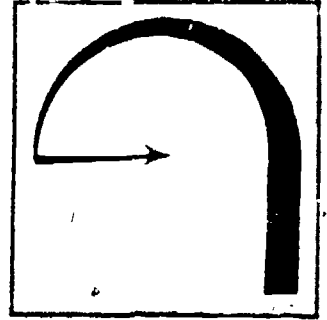

1. D. J. Duffin. The Essentials of Modern Carpet Installation. 1962.
pp. 108-117
2. Carpeting Floor Covering Workbook. California State Department of Education.
1972. pp. 89-90.

Information

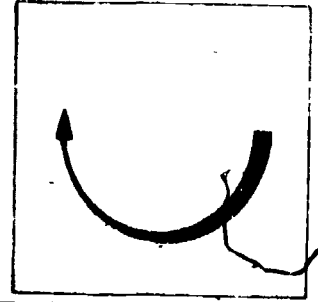

TYPES OF TACK STRIP

There are several different "brand names." Most come in 4-foot long pieces. There are also standard 5-inch and 6-inch pieces that are used for some concrete installations.

The wood tack strips are made of 3-ply plywood. They have two rows of steel pins. The pins are pointing up out of the wood at about a 60° angle. These pins grip the stretched carpet and hold it firmly. Tack strip is installed before the padding is installed. The pins on the tack strip are installed pointing toward the wall.

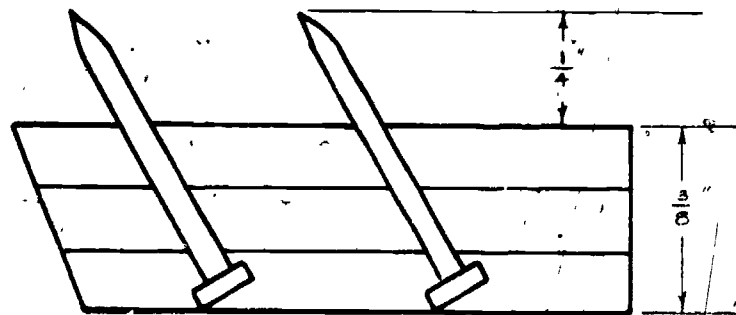

Type 1.

3/8 inch thick.

Pins stick up 1/4 inch.

Used with padding weighing more than 40 ounces per square yard.

Used with heavy-backed carpet such as Chenille.

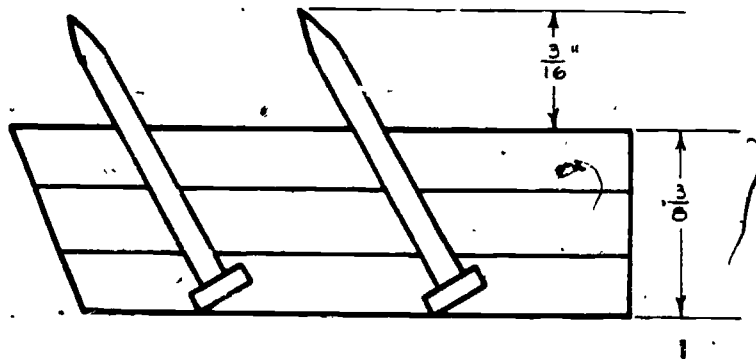

Type 2.

3/8 inch thick.

Pins stick up 3/16 inch.

Used with padding weighing more than 40 ounces per square yard.

Used with average-backed carpet.

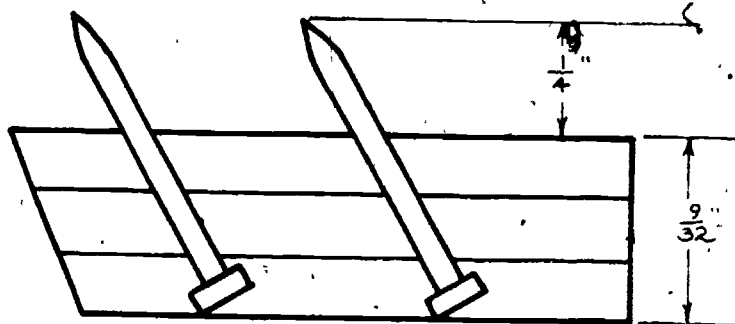

Type 3.

9/32 inch thick.

Pins stick up 1/4 inch.

Used with regular padding (28, 32, 40 ounces).

Used with rubber padding.

Used with heavy-backed carpet such as Chenille.

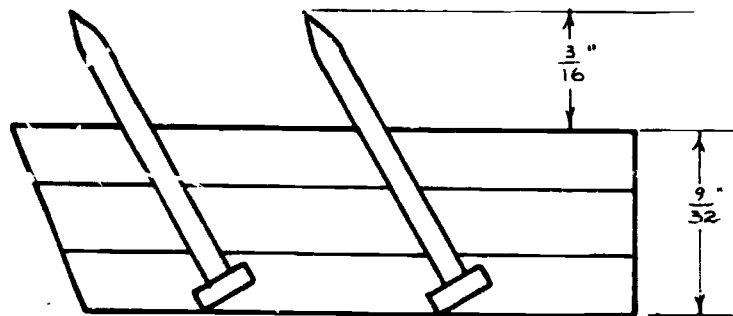

Type 4.

The type used the most often.

$9/32$ inch thick.

Pins stick up $3/16$ inch.

Used with regular padding (28, 32, 40 ounces).

Used with rubber padding.

Used with most average-backed carpet.

Common Tools

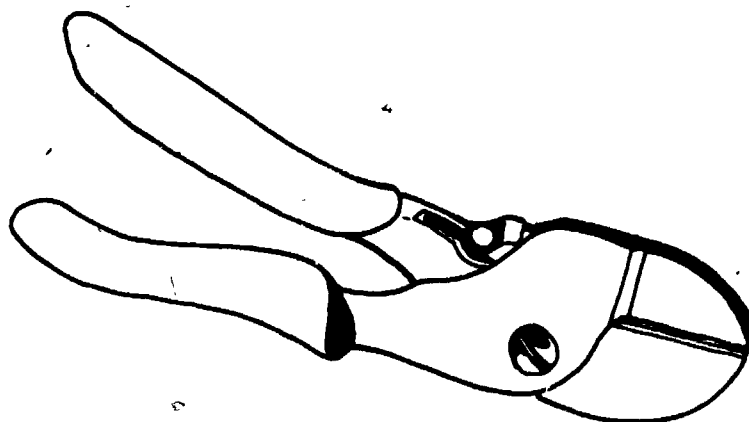

These are special strip cutters. They are used to cut tack strip. They work quickly and will make a straight cut.

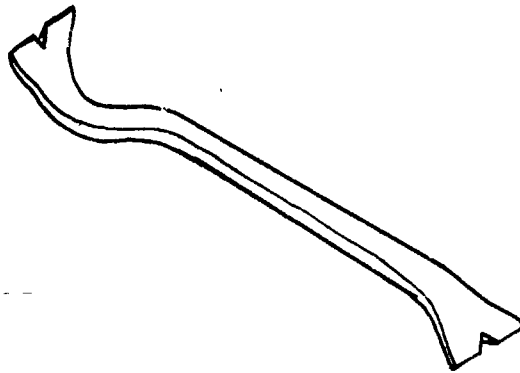

The base shoe remover is used to remove molding. When used in the right way, it will not mar the paint or crack the molding.

Installing Tack Strip

A very heavy carpet can get unhooked from the starting end of the tack strip while it is being stretched. One way to stop this is to lay a heavy object along the wall, or have someone stand on the strip directly behind you, or use small tacks or staples that are carefully put in the carpet face. Also there is a special tack strip with three rows of pins. It is used for large commercial jobs.

Tack strip is never installed right next to the wall. There is always a gully left between the wall and the tack strip. How big the gully is depends on how thick the carpet is. Thickness is the distance from the top of the pile to the bottom of the backing. The gully is always a little bit less than the thickness of the carpet (about 2/3 as thick). Tack strip is installed before the padding is installed. (See the illustration on the top of the following page.)

Always install tack strip with the pins pointing toward the wall. The molding should be removed before installing tack strip.

To remove molding:

1. Slit paint along paint line to keep the paint on the molding from cracking.

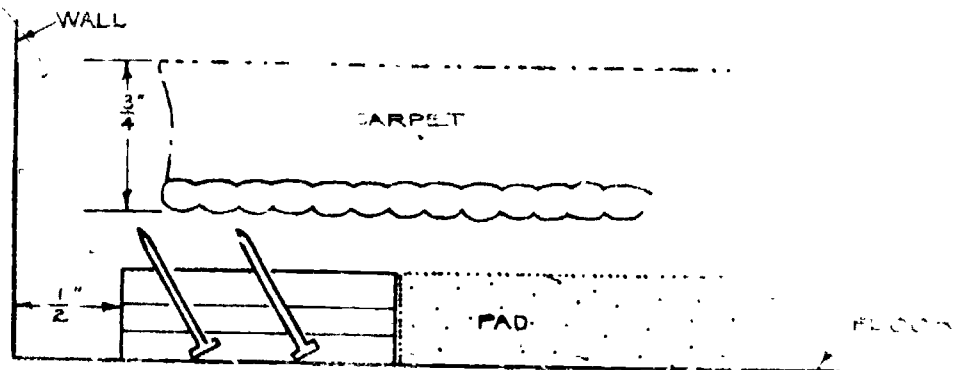

MAINTAIN A UNIFORM GULLY WIDTH IN PROPORTION TO THE CARPET THICKNESS

The distance out from the wall should be the same all around the room. If the tack strip is too close to the wall, you will not be able to get the cut edge into the gully and get the even, "finished" look.

2. Pry moldings loose with the base shoe remover. Use an upward and outward motion.
3. Remove all brads by pulling them from the unfinished side of the molding and replace them with new ones when you put the molding back on.

NOTE: Before removing the molding you should tell the customer what you are going to do. Point out that this will make a neater looking job. While, the customer may still want the carpet installed outside the

Use full-length pieces of tack strip where this is possible. In places such as cupboards, cabinets and so on, you may have to use smaller pieces. These can be cut with pruning shears, large tin snips, or the special shear mentioned above.

If a doorway does not have a raised sill, or enough clearance, you will need a tack strip. In these places the carpet will have to be fastened with a tool, such as the Ankorite tool, or with door metal.

(See the illustration on the top of the following page.)

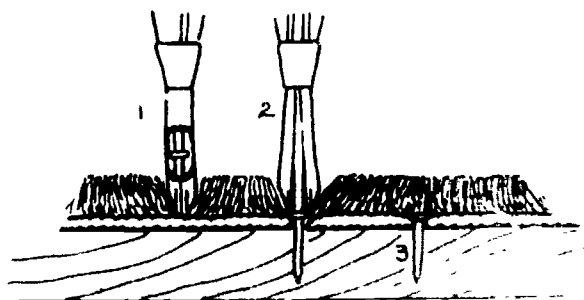
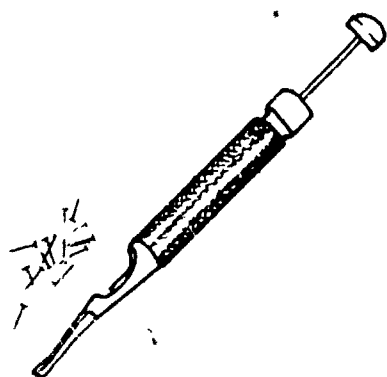

Some tack strip comes "prenailed." There are two types of prenailed strips. One is for wood floors, the other is for concrete floors.

If you do not use prenailed tack strip, you will have to use your own nails. For wood, use 3-penny lath nails. Place them 6 to 9 inches apart for installation on hardwood floors. Place them 5 to 7 inches apart for installation on softwood floors. Make sure your nails go through the guide line that is printed on the tack strip. This will keep the strip from tilting when the carpet is stretched.

When nailing, hold the hammer handle parallel to the floor. You can use a board as a guard to keep the wall from being damaged. The guard board should be at least as thick as the gully. That way you can slide the board along with your work.

You may want to use a driving bar when you are working around glass, rock or brickwork. The driving bar is also used to get at hard-to-reach places such as under a counter.

Installing Tack Strip on Concrete

On concrete, tack strip can be glued instead of nailed. Some types of tack strip do come prenailed with concrete nails. You can also use your own concrete nails. There are also power stud drivers which can be used to install tack strip on hard tile, terrazo, brick and other hard floors, holes can be drilled for nails or for plugs.

But it is often easier to glue the tack strip to the surface. When installing tack strip on concrete or other hard surface floors, there are some special things to remember.

1. Check the manufacturer's directions on how to use any adhesive.
2. You may have to let the adhesive dry for 48 hours on old concrete.
3. It may take longer for the adhesive to dry on new concrete.
4. Clean up dirt, dust, oil, grease and so on before using any adhesive.
5. If the floor is not perfectly level, you can use small pieces of tack strip. This helps it fit high and low spots better.
6. Use concrete nails as well as cement if there will be oil, water or dust around much of the time.
7. Never use just one nail in a tack strip. Always use at least 2 nails to make sure the strip stays level and does not rock.
8. Adhesive installation is better on concrete made with lightweight aggregates (perlite or vermiculite).
9. Concrete nails should be driven with a heavy hammer. One blow should be enough to drive the nail. There is more risk of bending the nail if you have to hit it several times. Also, extra blows can break up the concrete. This means the nail won't hold right.

Steps to Install Tack Strip

1. Install tack strip before installing padding.
2. Remove wall moldings.
3. Make sure floor is clean and level.
4. Space tack strip to get proper gully (about 2/3 the thickness of the carpet).
5. Use long pieces where you can.
6. Use short pieces on uneven concrete.
7. Use adhesive on concrete and hard surface floors.
8. Install with pins pointing toward the wall.

Tack Strip for Stair Carpet

1. Cut tack strip 2 inches smaller than the width of the carpet.
2. Install as shown.

(See the illustration on the top of the following page.)

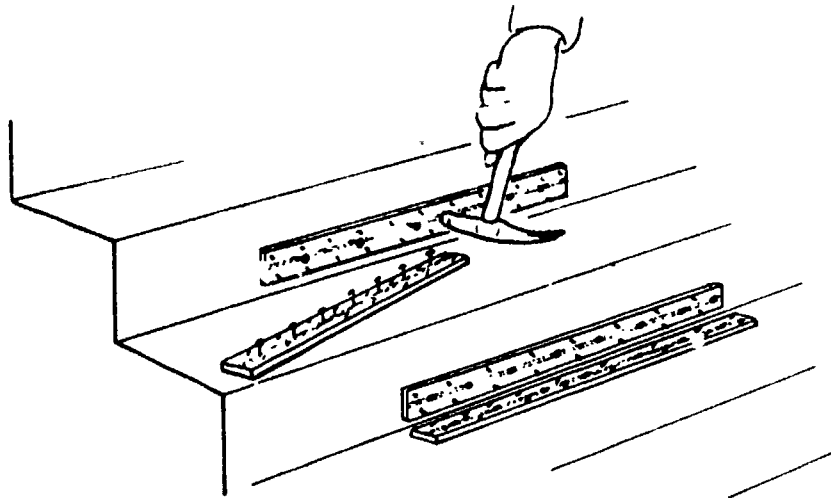

3. All pins should point toward the crotch of the step. This is the gully made by the two pieces of tack strip next to each other.
4. The size of this gully depends on how thick the carpet is. For average carpet, put the strip on the riser up about $\frac{5}{8}$ inch high. The strip on the stair tread should be about $\frac{5}{8}$ inch from the riser.
5. If the carpet is thinner, move the two strips closer to the crotch.
6. If the carpet is thicker, move the tack strips farther away from the crotch.

Self Assessment

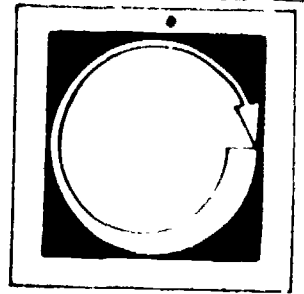

COMPLETE THE FOLLOWING STATEMENTS BY WRITING THE CORRECT WORD OR WORDS IN THE BLANKS PROVIDED.

1. The _____ should be removed before installing tack strip.
2. The pins on tack strip point _____ the wall.
3. The gully should be about _____ the thickness of the carpet.
4. _____ strips are made of _____ and have _____ rows of pins.
5. The base shoe remover is used with an _____ and _____ motion.
6. There are _____ main types of tack strip.
7. _____ pieces of tack strip will fit high and low spots on a concrete floor.
8. The pins point out of the tack strip at a _____ angle.
9. _____ be used with _____ tack strip.
10. A _____ is always left between the tack strip and the wall.
11. Tack strip for stairs is cut _____ inches smaller than the carpet.

12. Tack strip is installed _____ the padding is installed.
13. On terrazo floors, _____ can be _____ for plugs.
14. Tack strip with 3 rows can be used for _____ jobs.
15. A _____ board will keep the wall from getting _____.

Self Assessment Answers

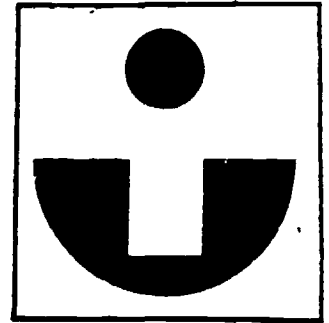

1. molding
2. toward
3. 2/3
4. plywood, 2
5. upward, outward
6. 4
7. small
8. 60°
9. cut
10. gully
11. 2
12. before
13. holes, drilled
14. commercial
15. guard, damaged

Job Sheet

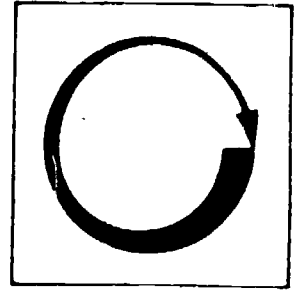

COMPLETE THE FOLLOWING TASKS.

Materials and Tools: Samples of the 4 basic kinds of tack strip, tools and materials for installing tack strip.

1. Install at least 10 feet of tack strip on a wood floor.
2. Install at least 10 feet of tack strip on a concrete floor.
3. Prepare a room, including the removal of any molding, and install tack strip. The room should contain at least one cabinet or cupboard with a toe space.

Post Assessment

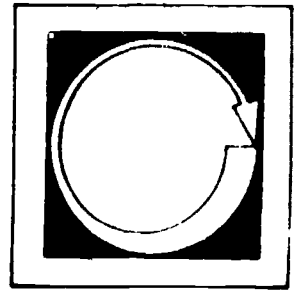

LISTED BELOW ARE SEVERAL STATEMENTS. IF THE STATEMENT IS TRUE, PLACE A "T" IN THE BLANK PROVIDED. IF THE STATEMENT IS FALSE, PLACE AN "F" IN THE BLANK.

1. ___ The guard board should be about as thick as the gully.
2. ___ The gully on the starting wall should be 1/2 inch larger than the other gullys.
3. ___ Before removing the molding you should tell the customer what you are going to do and why it is being done.
4. ___ Always use at least 4 nails in a piece of tack strip.
5. ___ It may take adhesive more time to dry on new concrete than on old concrete.
6. ___ If the tack strip is not far enough out, you won't get an even finished look.
7. ___ Tack strip is installed with the pins pointing away from the wall.
8. ___ When nailing, hold the hammer handle parallel to the floor.
9. ___ Adhesive is better for installing tack strip on concrete made with lightweight aggregates.
10. ___ A driving bar is used to get at hard-to-reach places, but should not be used around glass or brickwork.

11. ___ Use full length pieces of tack strip when possible.
12. ___ The width of the gully is about $\frac{2}{3}$ the thickness of the carpet.
13. ___ One blow with a heavy hammer should be enough to drive a concrete nail.
14. ___ If a doorway does not have a raised sill, tack strip cannot be used.

● Instructor Post Assessment Answers

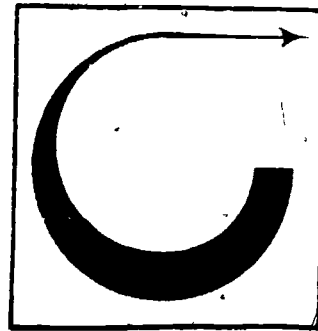

1. T
2. F
3. T
4. F
5. T
6. T
7. F
8. T
9. T
10. F
11. T
12. T
13. T
14. T



CUTTING, TRIMMING AND SEAMING CARPET

Goal:

The student will be able to identify the steps involved in cutting, trimming and seaming carpet materials and will execute the cutting and seaming of carpet materials.

Performance Indicators:

The student will successfully complete a Self Assessment, a Job Sheet and a Post Assessment.

Study Guide

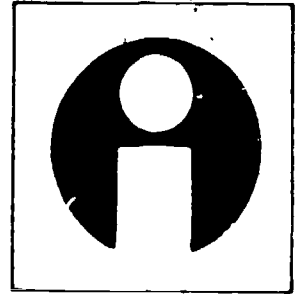

In order to finish this module, do the following tasks. Check each item off as you complete it.

1. Read the Goal and Performance Indicators on the cover of the module. This will tell you what you will learn by studying the module, and how you will show you've learned it.
2. Read the Introduction. The Introduction will tell you why the module is an important part of the floor laying trade.
3. Study the Vocabulary section. Vocabulary words are important for a good understanding of the trade. After you have studied the vocabulary, ask your teacher to quiz you on the words and their meanings.
4. Study the Information section. This section will give you the information you need to understand the subject.
5. Take the Self Assessment exam. This is a test for you to prove to yourself that you have learned the material you have studied. Compare your answers with the answers on the Self Assessment Answer Sheet, which is on the page following the Self Assessment. If you scored poorly, re-study the Information section or ask your teacher for help.
6. Do the Job Sheet. Follow the instructions at the top of the Job Sheet. The tasks listed on the Job Sheet will help you develop skills which will be helpful to you.
7. Take the Post Assessment exam. Give the exam to your teacher after you have completed it. Your teacher will grade it for you.

Introduction

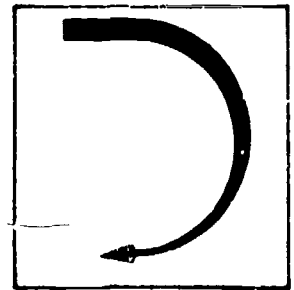

Carpet is made in standard sizes. The space where the carpet is installed cannot change size, so you have to be able to change the size of the carpet.

To make the carpet fit some spaces, it has to be either cut down in size or seamed together. This module will help you learn techniques you will need to make the carpet fit the space.

Vocabulary

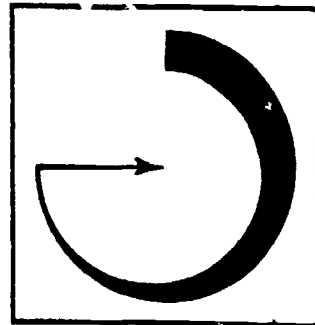

Trade terms are very important for a good understanding of the trade. Study these words and meanings. When you have learned them, ask your teacher to quiz you on the trade words and their meanings.

WARPS AND WEFTS--Yarn strands or strings on which the other yarn is woven to make a carpet.

Supplementary References

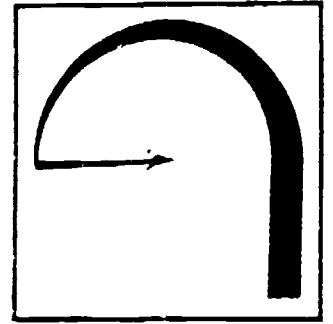

1. Carpet Floor Covering Workbook. California State Department of Education, 1972. pp. 71-78.
2. Duffin, D. J. The Essentials of Modern Carpet Installation. 1962. pp. 51-87.

Information

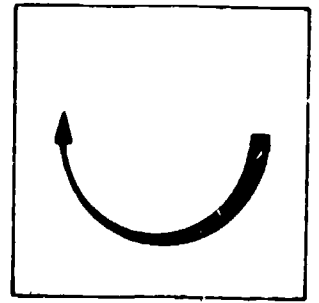

CUTTING CARPET

All woven carpet must be cut from the back. Try to make all cuts go between the warps or the wefts. When any carpet is cut, the pieces should be numbered so you will know where they go in the installation. Always avoid getting chalk (especially blue chalk) on the carpet face.

The first cuts are sometimes done in the shop. If there is a workroom cutting floor, this can save time. Final cutting and special cutting, such as for stair installations, are almost always done at the job site.

Shears, an electric cutter, a hand knife, or special cutting tools can be used to cut the carpet. Any tool that is used should be very sharp.

Some Cutting Tools

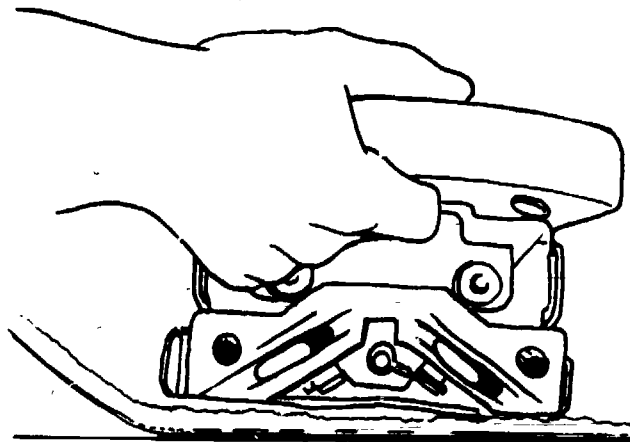

Cushion Back Trimmer. Trims cushion-backed carpet to the wall. Can be adjusted to different heights.

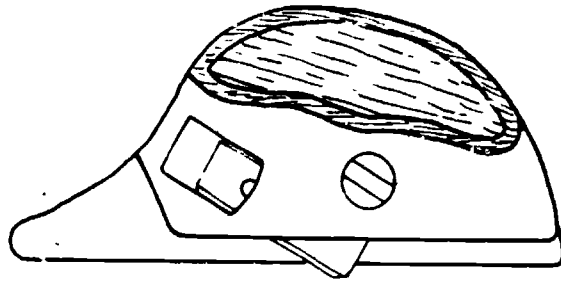

Cushion Back Cutter. Cuts cushion-backed carpet for seaming.

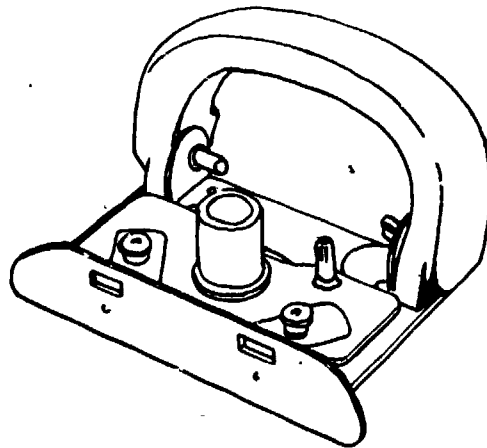

Carpet Trimmer. Cuts carpet to the wall and tucks it in the gully.

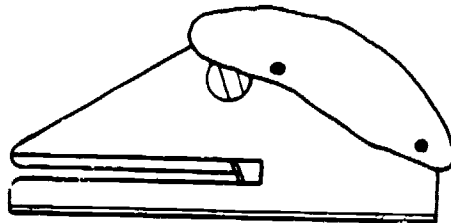

Loop Pile Cutter. Used for cutting down the length of straight row pile fabrics.

BINDING CARPET

Binding is done on the edges of woven carpet after the carpet has been cut. The binding helps keep the woven fibers in the raw edge from coming loose. Binding can be done by sewing pieces of special cloth or tape on the edge. It can also be done by overseaming the edge.

Overseaming is also called serging. It is a bit like the way a button hole is sewed. Serging does not wear as well as binding with tape. Serging costs less to do than tape binding, but it is not recommended for use in heavy traffic areas.

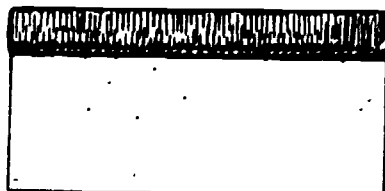

Tape binding can be done by hand or with a machine. Machine binding takes several machines to do the whole job. There is a different machine for each part of the job: Overedging, attaching the tape, corner-tacking, sewing tape to the back of the carpet.

Steps for attaching the binding tape:

1. Use a heavy needle and carpet thread.
2. Put the carpet face down.
3. To start, fasten the thread with a few short stitches. Put one on top of the other.
4. Lay the right side of the binding tape on the face of the carpet.
5. Put the edge of the binding tape even with the edge of the carpet.
6. Have 1 1/2 inches extra binding tape at each end to be turned under.

7. Push the needle from the back through to the face. Do this with the needle slanted.
 - a. It should go in the back about $\frac{3}{8}$ to $\frac{1}{2}$ inch from the edge.
 - b. It should come out the face about $\frac{1}{8}$ inch from the edge.
8. Hold the binding tape between thumb and forefinger to guide it along the edge.
9. Stitches should be about $\frac{1}{2}$ inch apart.
10. To fasten the thread after the binding is attached:
 - a. Make 2 or 3 stitches backward to form an "X" over the edge.
 - b. When you make the last stitch, put the thread around the needle. Draw it up tight. This will keep the binding from ripping.
11. Fold the tape on the diagonal so that the $1\frac{1}{2}$ inches at the end goes over onto the back. This will keep the corner from showing when the binding is turned over the edge of the carpet.

Steps for finishing the binding tape:

1. Fold the binding over the edge to the backing.
2. Be careful not to draw it too tight. If it is too tight, the binding can slip over the raw edge.
3. Fasten the binding end with small stitches through the selvage.
4. Sew the loose edge to the carpet back.
 - a. Catch only a few backing yarns of the carpet.
 - b. Catch about $\frac{1}{8}$ inch of binding.
 - c. Stitches should be $\frac{1}{2}$ to 1 inch apart.
5. When finished, the face will show only a narrow edge of binding. There will be an inch or more of binding on the back.

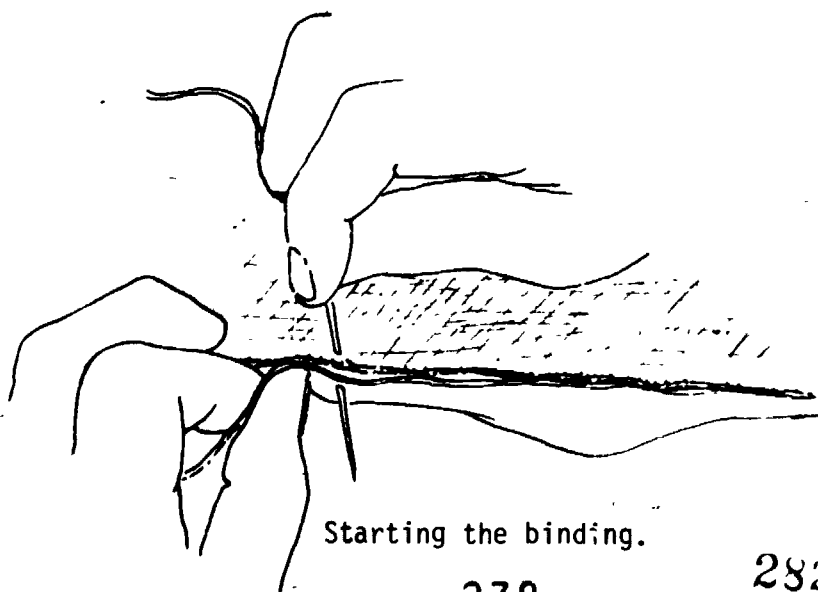

Starting the binding.

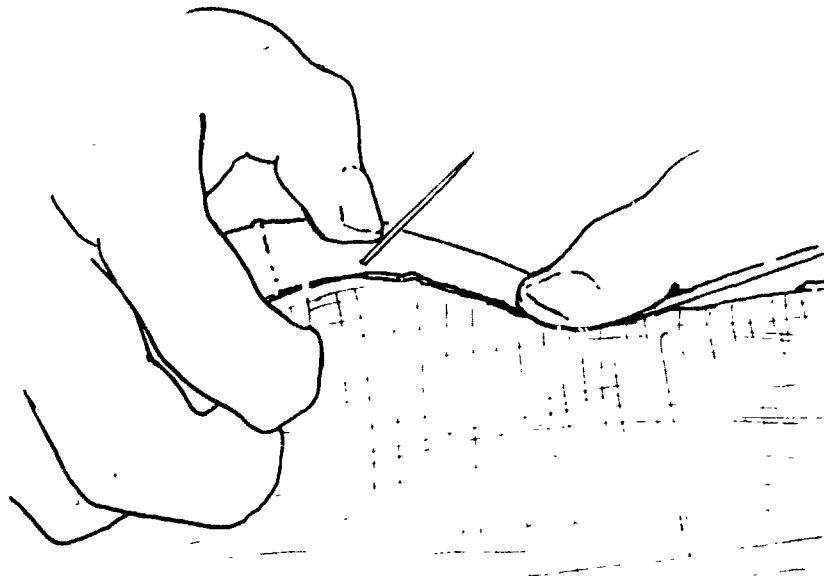

Finishing the binding.

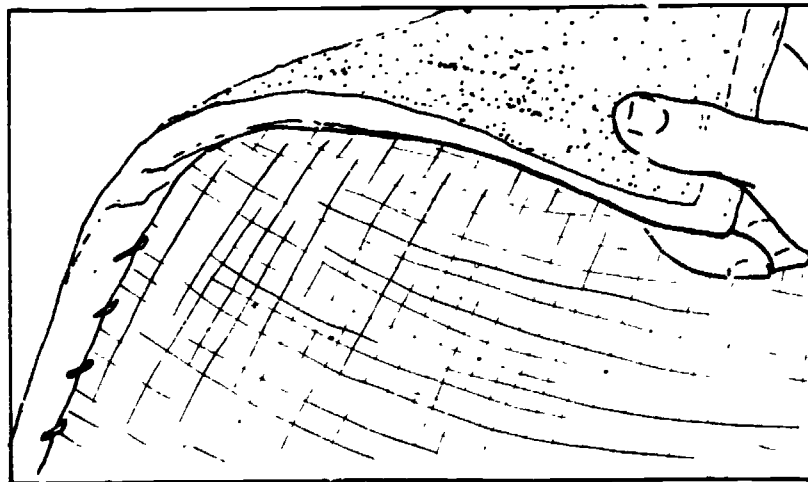

The finished binding.

Adhesive tape bindings, such as the Reiling E-Z Bind Rug Binder, are also available. Adhesive tape is used instead of sewing to make the binding.

(See the illustration on the top of the following page.)

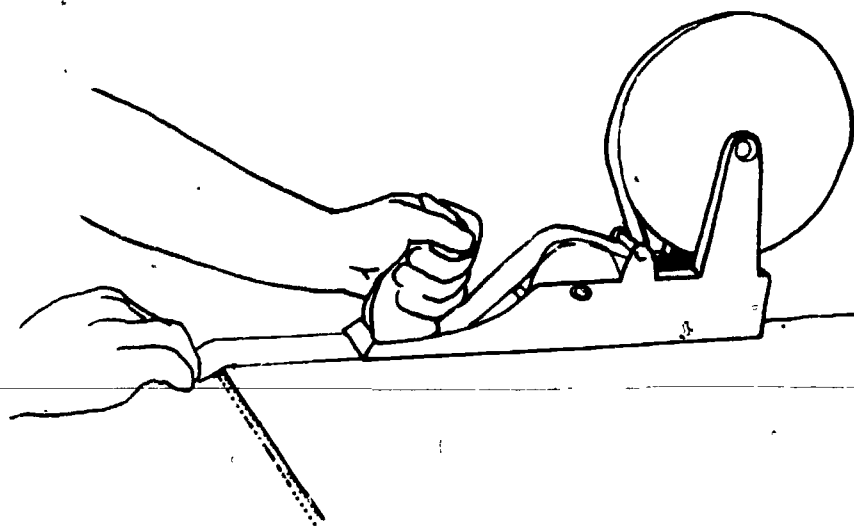

Adhesive tape binder machine.

SEWED SEAMS

Seams can be made by sewing or with seaming tape. Sewing can be done by machine or by hand. Most machine seaming is done on 27-inch and 36-inch carpet. Broadloom carpet is too heavy. Machine sewing is not recommended for carpets with double backs or without selvage edges. Machine seams are not invisible and they are not completely flat. They are not recommended for use in residential installations.

The selvage is sometimes trimmed off, or trimmed down very close, before sewing a seam. This can help to stop the wear track that can show up on carpet if the selvage is left on.

Sewed Face Seam Stitch

1. Stay tack the two edges so they are just touching.
2. Use a curved needle.
3. Start from the back and push needle through to the face.
4. Put the needle back into the face, very close to the place it came out.
5. Push needle through and into the other piece.
6. Repeat. Keep stitches about 1/2 inch apart.

(See the illustration on the top of the following page.)

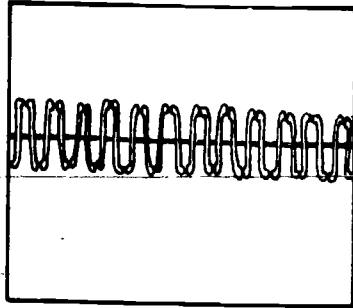

Back of carpet showing the Face Seam Stitch.

Crowfoot Stitch

This stitch works with Axminster, Wilton, or velvet carpet. It does not work well with the most common types of carpet used today.

1. Stay tack edges firmly together.
2. Use a curved needle.
3. Start from the back.
4. Bring needle across face.
5. Push needle into the back of the other piece.
6. At end of seam, lock with a buttonhole stitch.

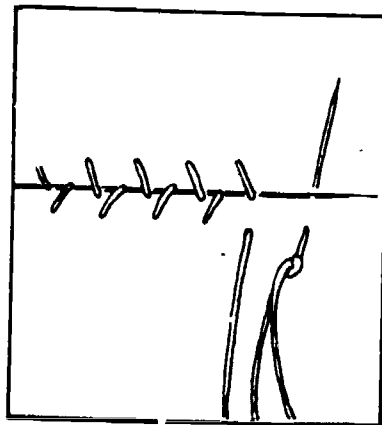

Back of carpet showing the Crowfoot Stitch.

Buttonhole Stitch

This stitch is used to cover a raw edge. It is not a seam stitch.

1. Tack and use a straight needle.
2. Start from the back. After the needle comes out on the face side, loop the thread over the needle.
3. Bring the thread down over the raw edge at an angle.

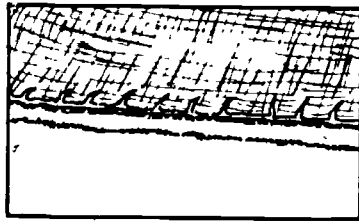

The Buttonhole Stitch.

Baseball Stitch

This stitch is like the Crowfoot Stitch. But this one is done all from the face of the carpet. The stitch is like the one on a baseball - but it should no show up as much.

Overcast Stitch

This is the most common stitch used today. It is used when seaming two selvage edges together.

1. Place both pieces face to face.
2. Use a straight needle and doubled thread.
3. Push the needle straight through both pieces.
4. Make sure no tufts come through the seam.
5. Angle thread back across the seam about 1/2 inch.
6. Repeat.

(See the illustration on the top of the following page.)

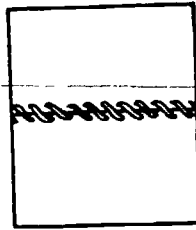

The Overcast Stitch.

Cross Stitch

This stitch is the Overcast Stitch that is made by going in both directions. It is used for extra strength. It is used in areas of heavy traffic or when a weak fabric is used. It can also be used for seaming two raw edges.

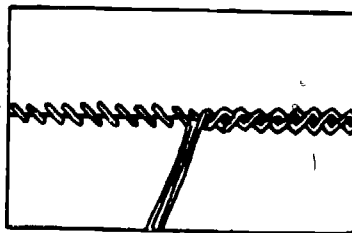

Finishing a Cross Stitch.

Flat Seam on a Pole

This is also called the Gettley Stitch. It is used for places of special wear such as an end seam or a doorway seam. Making this seam is slow work. Tape is more often used today.

1. Stay tack the two pieces on a wood pole. The paper core around which some carpet is wrapped can also be used.
2. Make a tight seam.
3. Make sure no yarn comes through.
4. Use a straight needle and double thread.
5. Attach the two pieces with a Cross Stitch.

Flat Invisible Stitch on a Pole

The stitch is much like making a flat seam on a pole. But the stitch is woven into the two pieces. An example of how the weaving goes would be: Start at the sixth shot (thread) from the seam. Go under the 6th, over the 5th, under the 4th, over the 3rd, under the 2nd and over the 1st and the seam. Go under the 1st shot of the second piece, over the 2nd, under the 3rd, over the 4th, under the 5th. Then pull the needle through the backs of the two pieces with pliers. Repeat, going back the other way.

Finishing a Sewed Seam

Some shops apply a latex to the sewed seam. This gives the seam more strength. The latex dries almost invisible in about an hour. NOTE: The latex will make some yarns change color when it dries. The yarn will show as a different color when the latex dries. The only way to be sure what will happen is to put on latex and let it dry.

Tape can also be put on a sewed seam to make it stronger. Also, some shops like to press the seams on the back with a pressing iron or a roller.

TAPED SEAMS

When you are using tapes and adhesives to make seams, it is very important to make sure you use the right ones. Tape is made with many different types of material: Burlap, canvas, linen, fiber glass and Kraft cord. Pin tape is a special kind that has metal pins in it. After the seam is made using an adhesive, the pins are tapped down with a hammer. The pins lock the tape to the carpet.

Always be sure to check the manufacturer's recommendations for both taped back seams and taped face seams. Back seams are made with the carpet face down. Face seams are made with the carpet face up. The following are general rules

for making seams. In all cases, whatever the manufacturer of the carpet or the tape/adhesive says is more important than these rules.

Taped Back Seams

Back seams are often done in the shop. The carpet pieces are worked on upside down.

1. Stay tack one end of the first piece.
 - a. Use 3 or 4 tacks.
 - b. Place them about 2 inches apart.
 - c. The first tack should be at least 3 inches in from the edge.
2. Stay tack the other end of the first piece. Use the knee kicker to gently make the carpet lay flat.
3. Stay tack the whole edge.
 - a. Place tacks 3 or 4 inches from the edge.
 - b. Place tacks 6 to 8 inches apart.
4. Follow steps 1-3 for the second carpet piece.
 - a. Hand fit the seam as you do it.
 - b. Make sure the pieces join - but do not overlap or buckle.
5. Roll the carpet with a roller up to the stay tacks.
6. Follow directions of the manufacturer of the sealer you will use. Apply sealer to back of carpet.
7. Unroll tape about 3 feet at a time and apply to the seam. Follow the manufacturer's directions.
8. Seal the tape to the back of the carpet. Remove any wrinkles. Apply a second coat of sealer onto the tape. Make sure there are no puddles or high places. Do not let any sealer get into the stay tack holes.
9. Let the seam dry. Follow the manufacturer's directions on drying time.

Taped Face Seams

Face seams are made when the carpet is being installed. Some advantages of face seaming are:

1. The carpet is handled less.
2. If you are working in a dirty area, the carpet face can be kept clean.

3. Carpet is laid flat against the floor instead of face down on pile which can be very thick and soft.
4. You can see that the seam works to make a good pattern match.

To make a face seam:

1. Apply a precoating material to the seaming area if this is recommended by the manufacturer. Follow all other manufacturer directions.
2. Stay tack first piece at one end.
 - a. Use 3 or 4 tacks about 2 inches apart.
 - b. The first tack should be at least 6 inches from the edge.
3. Use the knee kicker to gently make it lie flat and tack the other end.
4. Stay tack the whole edge.
 - a. Place tacks 6 inches back from the edge.
 - b. Place tacks 6 to 8 inches apart.
5. Overlap the second piece about 1/2 inch onto the first piece. Follow steps 2-4.
6. Roll the carpet with a roller up to the stay tacks.
7. Fold one piece back to its stay tacks. Weight it to keep it from flopping back.
8. Unroll the tape for the whole seam. Tack at both ends and follow any special directions from the manufacturer.
9. Fold back the second piece and fix.
(See the illustration on the top of the following page.)
10. Apply sealer to tape following the manufacturer's directions.
11. Fit the two pieces together. Do not shove the pieces together. This will force adhesive up through the seam and onto the face of the carpet. Follow any special manufacturer's directions.
12. Weight or apply pressure to the seam, following the manufacturer's directions. Some recommend rolling the seam with a porcupine roller. Then let the seam dry.
(See the second illustration on the following page.)

Most tape seams will be cured in a few weeks. After that, they can be dry cleaned just like a sewed seam. But it is always a good idea to check which cleaning solvents the manufacturer recommends.

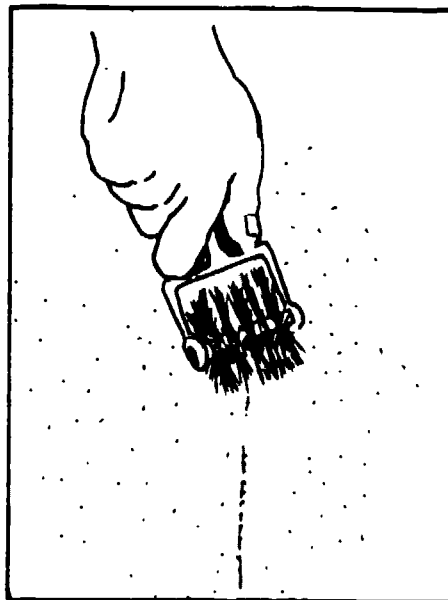
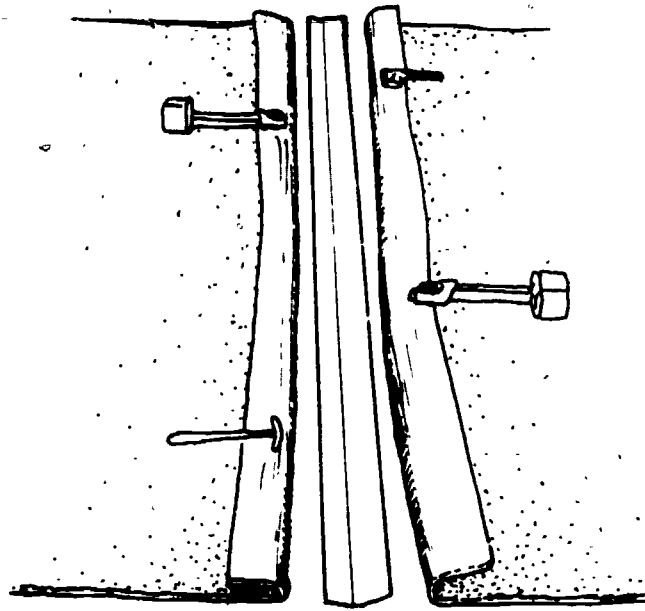

Using the porcupine roller to bury the seam.

Heat Seam Tape

If you are using a heat seam tape, the general rules will be the same. Heat seam tape is a type of tape that needs heat to make the adhesive stick to the carpet:

If the iron is too hot or too cold, heat seam tape will not work right. An iron that is too hot can damage synthetic fibers. It is a good idea to test the heat setting of the iron on a scrap piece of carpet. Then you can adjust the thermostat on the iron to the best temperature. Check for melting or color changes in the fibers, and to see if the carpet has come loose from its backing. NOTE: When using top-seaming heat tape, be sure the heat does not melt the padding under the carpet.

Different manufacturers will have special directions. Be sure to follow them.

TRIMMING AND FINISHING

Trimming and finishing are done after the carpet has been stretched. There are two kinds of edge finishes. One is where the baseboard molding is put over the edge of the carpet. This is called the sealed edge finish. The other kind of finish is when no molding is used. Instead the carpet is rolled into the gully left when the tack strip was installed. This is called a rolled edge finish.

The first step is to trim the carpet to the right fit. Use a knife with a thin, flexible blade that is very sharp to do this. There are also special tools, such as the Smoothedge Trimmer which will cut and roll the carpet at the same time.

Sealed Edge Finish

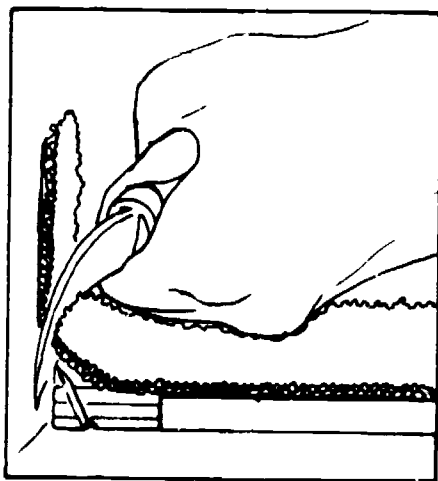

The carpet edge is smooth and level. The base molding seals the edge to make the finish.

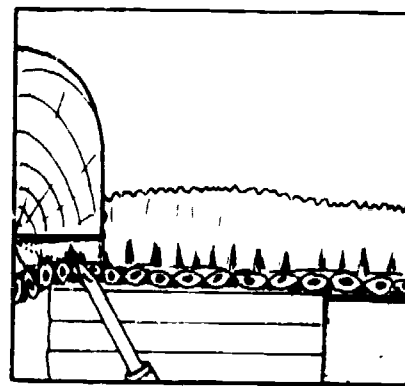

Rolled Edge Finish

- This finished edge is used on all walls. The carpet is stretched, rubbed on the pins of the tack strip, trimmed to length with a wall trimmer and tucked with a stair tool to get the even, rolled finish look.

Too much gully.

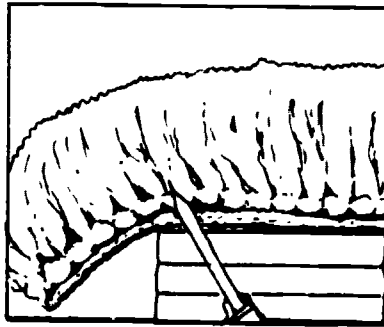

Not enough gully.

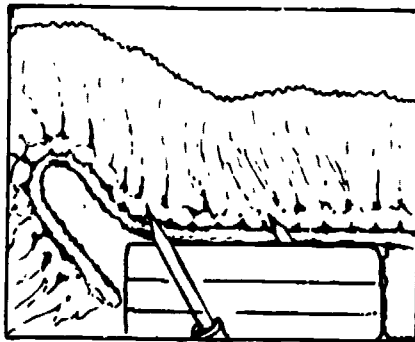

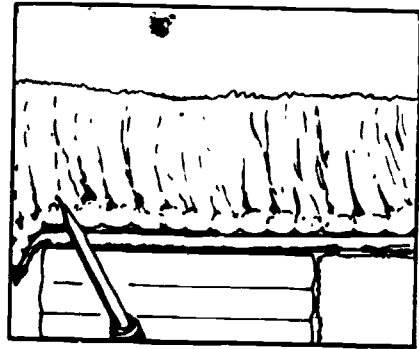
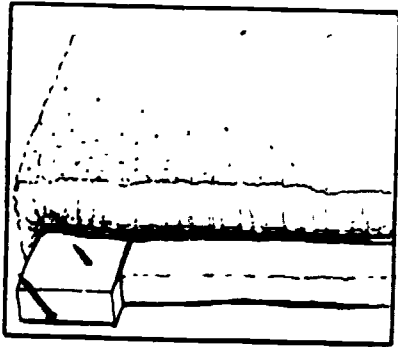

Perfect gully. The carpet goes to the floor at a right angle.

Self Assessment

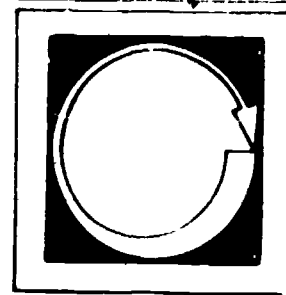

COMPLETE THE FOLLOWING STATEMENTS BY WRITING THE CORRECT WORD OR WORDS IN THE BLANKS PROVIDED.

1. When using top-seaming heat tape, be sure the heat does not melt the _____.
2. An iron for heat seaming that is too _____ can damage synthetic fibers.
3. When sewing the loose edge of binding to the back of the carpet, stitches should be _____ to _____ inch apart.
4. When any carpet is cut, the pieces should be _____ so you know where they go when they are installed.
5. _____ is used more often than the slower flat seam on a pole.
6. A _____ edge finish is made when the carpet is tucked into the gully.
7. When heat seaming, check for _____ or _____ changes and to see if the carpet has come _____ from its _____.
8. Most tape seams will be cured in a few _____.
9. Binding helps keep the woven fibers in the _____ edge from coming _____.

- 2
10. Most machine seam sewing is done on carpet _____ and _____ inches wide.
 11. Some shops apply a _____ to a sewed seam.
 12. A _____ edge finish is made by putting molding over the edge of the carpet.
 13. When you are making a binding, the needle goes in the back about _____ to _____ inch from the edge.
 14. When fitting face seamed carpet pieces, do not _____ the two pieces together.
 15. The most common stitch used today is the _____ stitch.
 16. When binding with tape, allow _____ inches extra at each _____.
 17. Machine seams are not _____ or _____.
 18. Back taped seams are made with the carpet face _____.
 19. The Crowfoot Stitch starts from the _____ and the Baseball Stitch starts from the _____.
 20. Face taped seams are often done _____ the _____.

Self Assessment Answers

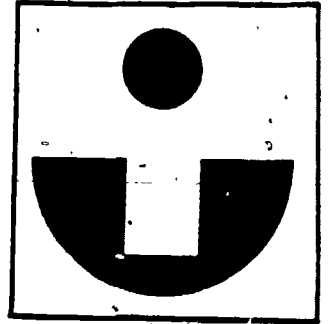

1. padding
2. hot
3. 1/2 to 1
4. numbered
5. tape
6. rolled
7. melting, color, loose, backing
8. weeks
9. raw, loose
10. 27 and 36
11. latex
12. sealed
13. 3/8 to 1/2
14. shove
15. overcast
16. 1 1/2, end
17. invisible, flat
18. down
19. back, front
20. on, job

Job Sheet

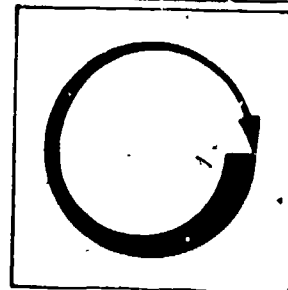

COMPLETE THE FOLLOWING TASKS.

Materials and Tools

carpet pieces

cutting tools

seaming materials and equipment

1. Practice cutting carpet pieces.
2. Seam carpet pieces using at least 3 of these stitches:
 - Face Seam Stitch
 - Crowfoot Stitch
 - Baseball Stitch
 - Overcast Stitch
 - Cross Stitch
3. Apply latex to your finished seams.
4. On all 4 edges, bind pieces of carpet at least 4' X 6'.
 - a. By sewing on tape.
 - b. By using an adhesive tape machine.
5. Make taped seams at least 8 feet long by using both face and back seaming techniques.
6. Make a taped seam at least 8 feet long using heat tape.

Post Assessment

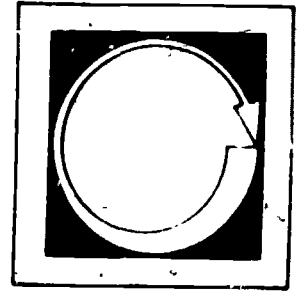

LISTED BELOW ARE SEVERAL STATEMENTS. IF THE STATEMENT IS TRUE, PLACE A "T" IN THE BLANK PROVIDED. IF THE STATEMENT IS FALSE, PLACE AN "F" IN THE BLANK.

1. ___ The Buttonhole Stitch is used to make a very strong seam.
2. ___ Machine sewed seams are most often done for broadloom carpet installations.
3. ___ The Flat Invisible Stitch on a pole is woven into the two pieces of carpet.
4. ___ One problem with heat seaming is that the tape used melts easily.
5. ___ Tape for a face seam is unrolled all at once and tape for a back seam is unrolled about 3 feet at a time.
6. ___ The Cross Stitch is like the Overcast Stitch but going in both directions.
7. ___ Usually face seams are made in the shop and back seams are made on the job.
8. ___ Special cutting, such as for stair installations, is almost always done in the shop.
9. ___ Machine sewed seams are not recommended for commercial installations.

10. ___ Pin tape is a special kind of tape that has to be pinned on until it dries.
11. ___ The Flat Seam on a pole is also called the Gettley Stitch.
12. ___ Binding can be done by sewing on tape, serging, or with adhesive tape.
13. ___ Each manufacturer has different directions for seaming.
14. ___ The Crow foot Stitch does not work well with the most common types of carpet used today.
15. ___ Latex is a good way to make a seam stronger, but it can make some yarn change color.

Instructor Post Assessment Answers

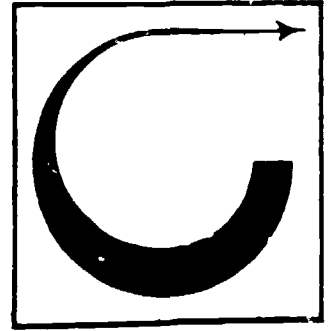

1. F
2. F
3. T
4. F
5. T
6. T
7. F
8. F
9. F
10. F
11. T
12. T
13. T
14. T
15. T

USING THE KNEE KICKER AND POWER STRETCHER

Goal:

The student will be able to identify the steps involved in using a knee kicker and a power stretcher and will demonstrate these steps.

Performance Indicators:

The student will successfully complete a Self Assessment, a Job Sheet and a Post Assessment.

Study Guide

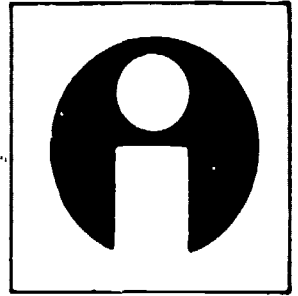

In order to finish this module, do the following tasks. Check each item off as you complete it.

1. Read the Goal and Performance Indicators on the cover of the module. This will tell you what you will learn by studying the module, and how you will show you've learned it.
2. Read the Introduction. The Introduction will tell you why the module is an important part of the floor laying trade.
3. Study the Information section. This section will give you the information you need to understand the subject.
4. Take the Self Assessment exam. This is a test for you to prove to yourself that you have learned the material you have studied. Compare your answers with the answers on the Self Assessment Answer Sheet, which is on the page following the Self Assessment. If you scored poorly, re-study the Information section or ask your teacher for help.
5. Do the Job Sheet. Follow the instructions at the top of the Job Sheet. The tasks listed on the Job Sheet will help you develop skills which will be helpful to you.
6. Take the Post Assessment exam. Give the exam to your teacher after you have completed it. Your teacher will grade it for you.

Introduction

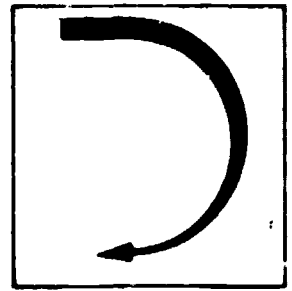

The carpet has to be tight so that it will hook on the tack strip pins. The two tools used to make the carpet tight are the power stretcher and the knee kicker. This module will give you experience using the power stretcher and the knee kicker.

● Supplementary References

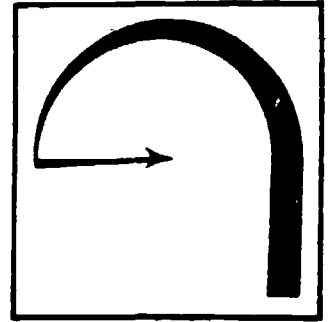

D. F. Duffin. The Essentials of Modern Carpet Installation. 1962. pp. 119-141.

Information

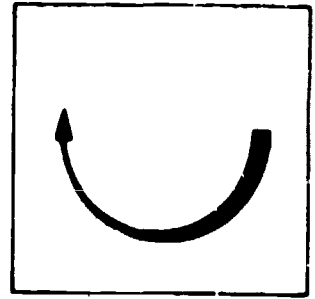

The knee kicker is made to give carpet a little bump. It is not made to stretch carpet over any distance. The power stretcher is used to stretch carpet. It will hold the stretch until the carpet edge is hooked on the pins of the tack strip. You should not use the knee kicker to do the work of a power stretcher. You will wear yourself out--and do a second-best job.

Power stretchers come in different sizes. You will use the smaller sizes for smaller jobs and bigger sizes for bigger jobs. Power stretchers work well for stretching carpets up to 100 feet long. You may want to use the plank method of stretching carpets that are more than 100 feet long.

HOW TO USE THE POWER STRETCHER

With the smaller models, you will work in a kneeling position. You should be on the left side of the stretcher so that your weight will be on the part of the carpet that has already been stretched. (See the illustration on the top of the following page.)

The stretcher head should be about 4 inches from the wall. At this distance, the knee kicker will not have to be used very much. Always have the abutment block against the baseboard. Do not put it against the plaster wall. Use a wood board between the wall and the abutment block if you have to have some protection. The wood board can be covered with scrap carpet to protect painted surfaces.

Lift the stretcher head by the handle with your left hand. At the same time, use the fingers of your right hand to lift the head block. The head block should be gently but firmly dropped onto the carpet. This will push the teeth through the nap and into the backing of the carpet.

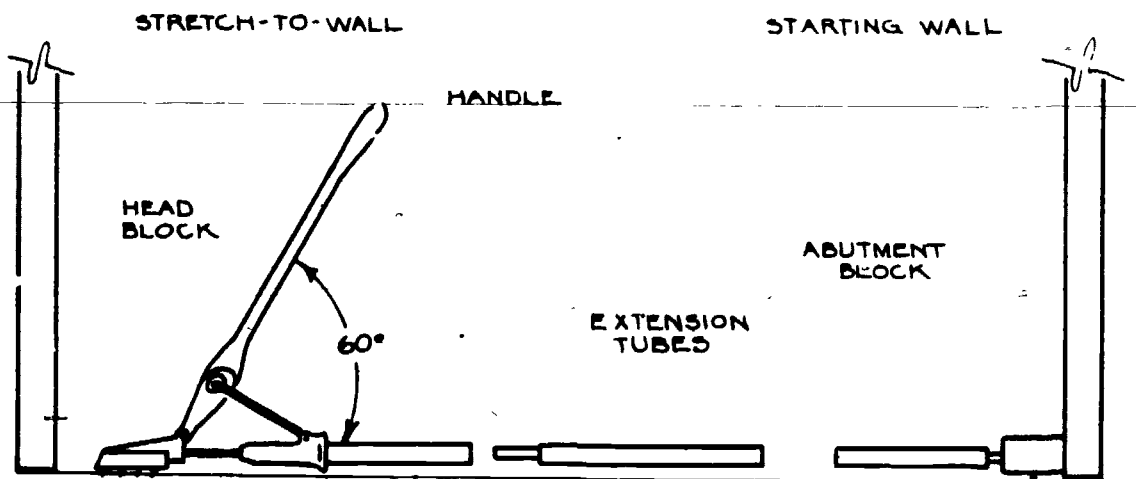

The stretcher handle should be at a 60° angle to the floor. Pump the stretcher handle. When you get it into the "down" position, it will lock automatically. If you took too big of a "bite" it will be hard to get the handle to lock. To correct this, start over again. Before you drop the head onto the carpet, press the handle down a few degrees.

Keep the stretch at a right angle to the "stretch to wall" when you can. This will depend in part on the type of carpet you are stretching. Do not attach more than 2/3 of the width of the stretcher head to the tack strip pins. Use an awl to lock in the part that has been hooked.

To move the stretcher to make the next stretch, first release the handle. Then lift the head assembly by its handle with your right hand. Push the extension tubing with your left hand to move the abutment block.

NOTES:

1. If you are making a long pull, try fanning air under the carpet or use the knee kicker in the middle area of the pull. This will save strain on the power stretcher.

2. Don't use a light weight stretcher to do a heavy weight job.
3. Overlap the tubing sections instead of having them at full extension. This will help make the tubing stronger.
4. If you don't have a bag or case for the stretcher, fasten a piece of carpet or plywood over the teeth when the stretcher is not in use.
5. Oil regularly, using the oil holes.

Some Things that Control the Amount of Stretch

1. Weave or construction of the carpet.
2. Type of backing used on the carpet.
3. Kind of fibers in the backing.
4. Carpet qualities such as density of construction, workmanship, etc.
5. Pretreating work done at the mill such as moth proofing, shrinking, etc.
6. Temperature and humidity of the room.
7. The outdoor temperature.
8. The padding under the carpet.
9. Condition of flooring and sub-flooring.

These are some of the things that you will have to think about when you are planning a stretch. There will be different things for each job

It is best to always know what the carpet manufacturer recommends. Some manufacturers even have tables worked out which can tell you the number of inches to be stretched. Generally, better-quality carpets will need to be stretched less to get the right tension. They will hold on the tack strip pins without having to be quite so tightly stretched. Some carpet stretches better in length than width. Some stretches better the other way. There are two main things that you will learn to rely on:

1. The manufacturer's recommendations.
2. Your own experience on the job.

Locking the Carpet onto the Tack Strip

1. Stretch using power stretcher techniques.
2. Hold stretch. Use the spreader tool to press down on the part of the carpet that is over the gully. This brings the carpet into contact with the pins.

3. Release the stretch to firmly hook the carpet backing onto the pins.
4. Move the awl forward to lock the stretch-and-hook in place after the stretcher is released.

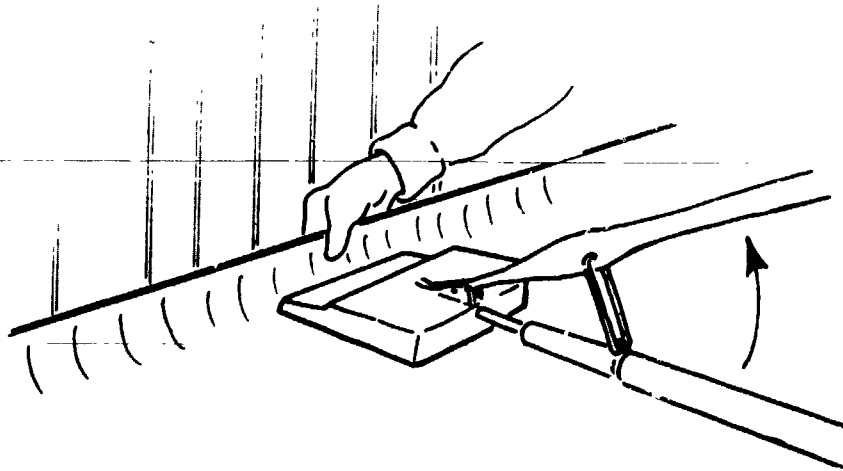

Use the spreader to bring the carpet in contact with the pins.

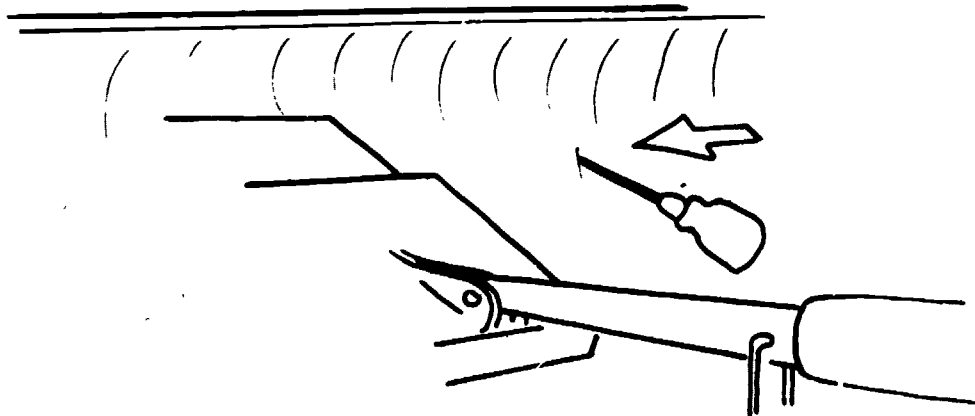

The awl has locked the stretch-and-hook. Now the stretcher is moved forward to make the next stretch.

KNEE KICKER

1. Adjust teeth to the depth of the carpet. The teeth have to reach through the pile to the backing. The carpet has to be able to slide over the padding. So the teeth should not go all the way through the carpet. If they do, the teeth will bite into the padding and pull it, too.

2. Kick the knee kicker once or twice and hold it there. Strike the knee kicker with the muscle on the inside of the knee. Do not hit the knee kicker with your knee-cap. Hitting the knee kicker with your knee-cap can damage your knee.
3. Grip the knee kicker by the neck. Use downward pressure to hook the teeth into the carpet warp. You can use your left hand in place of the awl to hold carpet that has already been hooked.

Compressed Starting Edge Technique

The following pictures show how to hook carpet onto tack strip pins to start a carpet stretch.

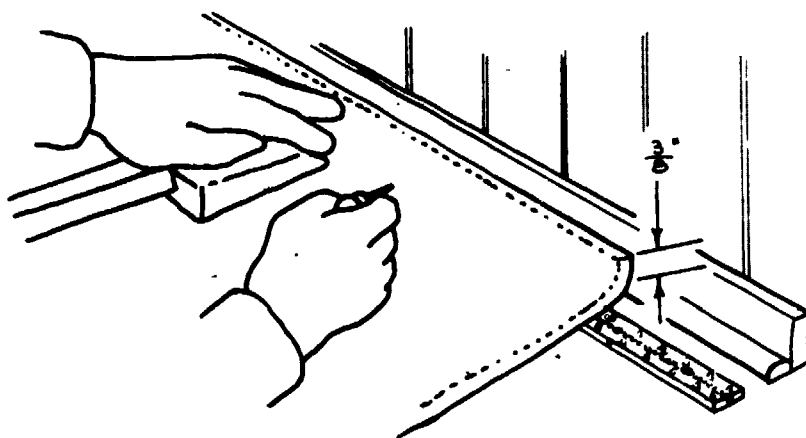

Carpet selvage is lapped up wall about 3/8 inch.

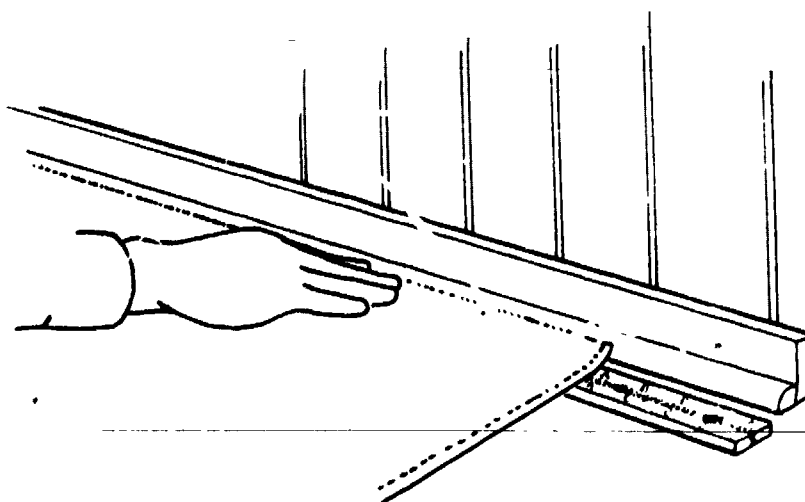

Rub fingers along edge to make pins stick in the carpet backing.

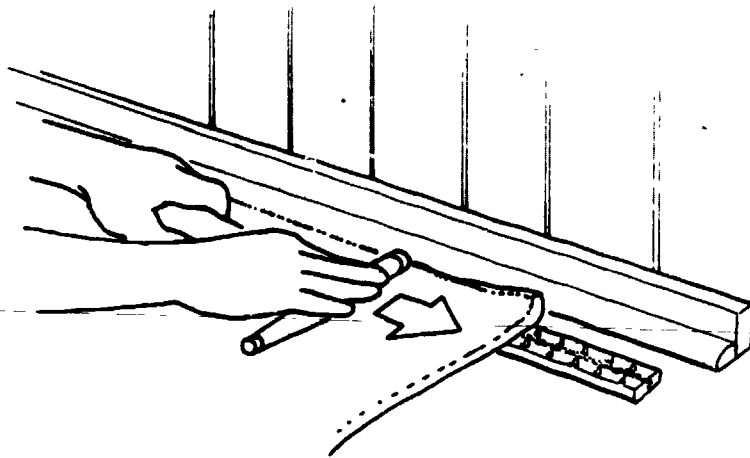

Iron edge of carpet with hammer. This pushes the carpet all the way down on the pins. Hammer face has to be kept flush to the wall. Don't tilt the hammer. It should be kept flat to the carpet.

Self Assessment

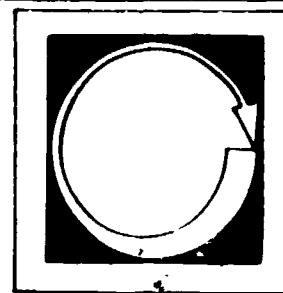

COMPLETE THE FOLLOWING STATEMENTS BY WRITING THE CORRECT WORD OR WORDS IN THE BLANKS PROVIDED.

1. The _____ is used to press down the carpet that is over the gully.
2. The stretcher head should be about _____ inches from the wall.
3. Do not hit the knee kicker with your _____.
4. On very long carpet you can stay tack the _____ and pull from _____.
5. You should not use the _____ to do the work of the _____.
6. The stretcher handle should be at a _____ angle to the floor.
7. Carpet over 100 feet long is stretched with a _____.
8. Use an _____ to lock in the part of the carpet that has been hooked on the pins.
9. Grip the knee kicker by the _____ and press downward.
10. Power stretchers work well for carpet up to _____ feet long.
11. The head block should be _____ but _____ dropped on the carpet.

12. The teeth of the knee kicker go into the _____ but not into the _____.

13. Always have the abutment block against the _____.

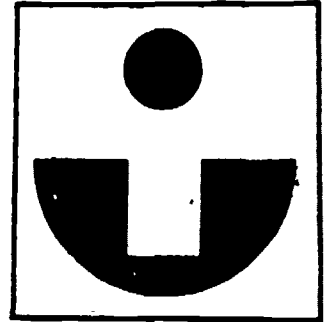

● Self Assessment Answers

1. spreader
2. 4
3. knee cap
4. middle, each side
5. knee kicker, power stretcher
6. 60°
7. plank
8. awl
9. neck
10. 100
11. gently, firmly
12. backing, padding
13. baseboard

Job Sheet

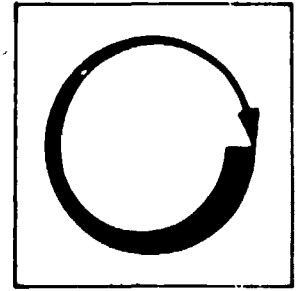

COMPLETE THE FOLLOWING TASKS.

Materials and Tools: All equipment and tools needed to install carpet. A carpet type with equal width and length stretch is recommended. The carpet pieces need not be room size.

1. Prepare a floor space, including the installation of tack strip on all four sides. Use a power stretcher to stretch a piece of carpet.
2. Prepare a floor space, including the installation of tack strip on all four sides. Use a knee kicker to hook the carpet.
3. Trim and finish #1 and #2 using the rolled edge technique.

Post Assessment

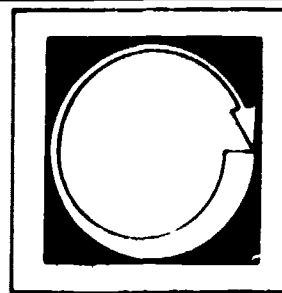

LISTED BELOW ARE SEVERAL STATEMENTS. IF THE STATEMENT IS TRUE, PLACE A "T" IN THE BLANK PROVIDED. IF THE STATEMENT IS FALSE, PLACE AN "F" IN THE BLANK.

1. ___ The knee kicker can be used in the middle of a long pull to save strain on the power stretcher.
2. ___ The spreader tool is used to unhook carpet from tack strip.
3. ___ The teeth of the knee kicker should go through the backing into the padding.
4. ___ With the smaller models of the power stretcher, you work in the kneeling position.
5. ___ Generally, better quality carpet should be stretched more to get the right tension.
6. ___ The knee kicker is used to hold carpet until it can be stretched.
7. ___ The teeth of the knee kicker have to be adjusted to the depth of the carpet.
8. ___ The knee kicker should be hit with the muscle on the inside of the knee.
9. ___ The tubing sections can be made stronger by overlapping them.

10. ___ It is best to have the abutment block against the plaster wall.

11. ___ The stretch in any carpet is about the same for both length and width.

● Instructor Post Assessment Answers

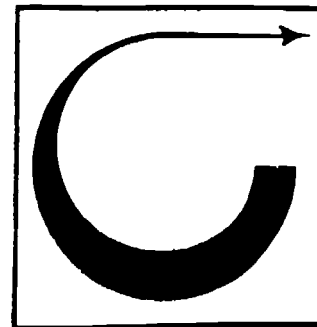

1. T
2. F
3. F
4. T
5. F
6. F
7. T
8. T
9. T
10. F
11. F

INSTALLING CARPETING

Goal:

The student will install carpeting, regular and glue-down.

Performance Indicators:

The student will successfully complete a Self Assessment, a Job Sheet and a Post Assessment.

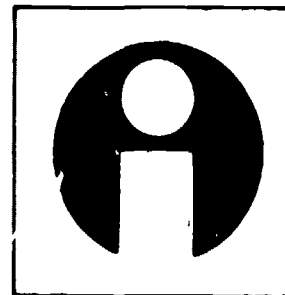

Study Guide

In order to finish this module, do the following tasks. Check each item off as you complete it.

1. Read the Goal and Performance Indicators on the cover of the module. This will tell you what you will learn by studying the module, and how you will show you've learned it.
2. Read the Introduction. The Introduction will tell you why the module is an important part of the floor laying trade.
3. Study the Vocabulary section. Vocabulary words are important for a good understanding of the trade. After you have studied the vocabulary, ask your teacher to quiz you on the words and their meanings.
4. Study the Information section. This section will give you the information you need to understand the subject.
5. Take the Self Assessment exam. This is a test for you to prove to yourself that you have learned the material you have studied. Compare your answers with the answers on the Self Assessment Answer Sheet, which is on the page following the Self Assessment. If you scored poorly, re-study the Information section or ask your teacher for help.
6. Do the Job Sheet. Follow the instructions at the top of the Job Sheet. The tasks listed on the Job Sheet will help you develop skills which will be helpful to you.
7. Take the Post Assessment exam. Give the exam to your teacher after you have completed it. Your teacher will grade it for you.

Introduction

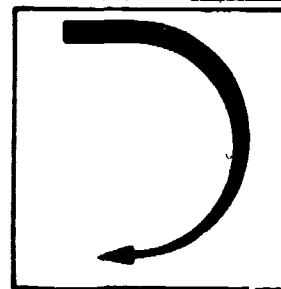

This module will give you practical experience in installing carpet. You will be asked to put to use all that you have learned about carpet types and installing carpet. In this module you will be asked to prepare for and completely install several types of carpeting materials.

Vocabulary

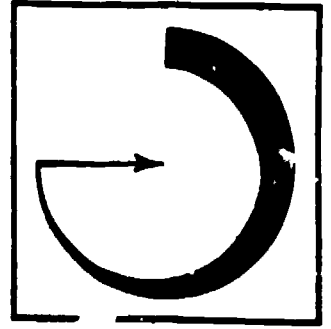

Trade terms are very important for a good understanding of the trade. Study these words and meanings. When you have learned them, ask your teacher to quiz you on the words and their meanings.

BREADTH--The distance across something. The width.

CATERPILLAR--Strips of woven material. They are woven onto a separate base made of jute or wool to make Chenille carpet.

Supplementary References

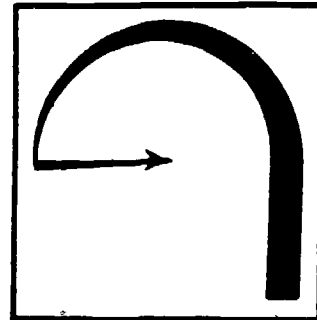

1. D. J. Duffin. The Essentials of Modern Carpet Installation. 1962. pp. 130-185.
2. Carpeting Floor Covering Workbook. California State Department of Education. 1972. pp. 97-124.

Information

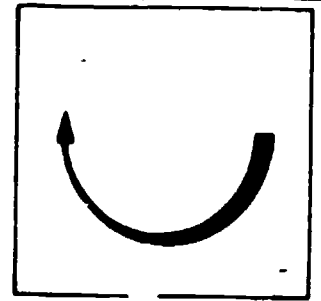

Many different things control how much a carpet will stretch. Some of them are:

1. How tight the weave is.
2. The type of fiber used.
3. Amount of coating on the backing; if double backed, there will be much less stretch.
4. Friction between carpet and padding.

Friction between carpet and padding is often the greatest problem. There are several ways to help overcome the friction problem.

1. Powdered talc can be sprinkled on rubber padding.
2. Other workers can lift and shake the carpet to get an air flow between the padding and the carpet.
3. You can start in the middle of a very large area. This will reduce the distance the carpet has to be stretched by 50%. The center is stay tacked. This center then becomes the first wall of "two rooms" when you do the stretching.
4. Some large rooms have natural break points such as posts or partitions. You can treat the area made by each set of natural break points as a separate room. Be sure to plan so that cuts can be either top sewed or top taped. A carpet length is stretched and hooked, then the carpet for the next area is joined to it. The next piece is stretched and hooked, and so on.

INSTALLING TUFTED CARPET

Tufted carpet stretches about the same in both length and width. (There is one inch of stretch in 12 to 15 lineal feet.) The key to getting a good stretch is using the diagonal. Stretch the carpet at an angle to the wall toward which it is being stretched.

Carpet with a cotton-and-jute backing stretches almost the same in length and width. Carpet with a cotton backing stretches a bit more in length than in width. The exact amount of stretch needed is something you will learn by working with the materials.

Be careful when picking up the stretcher head after it has been in contact with the carpet nap. The yarns may be pulled and untwist. This can leave the carpet looking fuzzy.

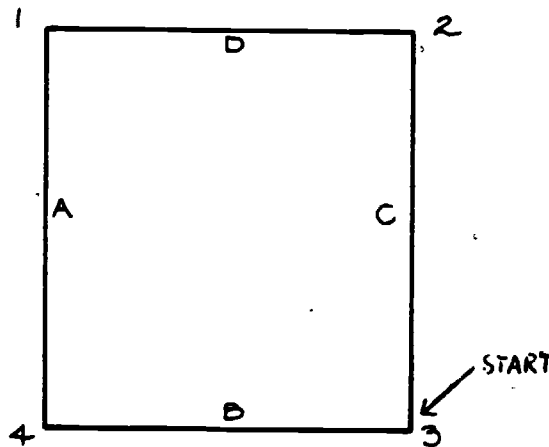

1. Hook carpet at starting point 3.
2. Butt end of power stretcher is placed on wall B, about 4'6" out from the corner.
3. Stretch diagonally to corner 2.
4. Hook corner 2.
5. Butt end of power stretcher is placed on wall C about 4'6" from corner 3.
6. Stretch diagonally to corner 4.
7. Hook corner 4.
8. Use knee kicker to hook carpet on walls B and C.
NOTE: Knee kicker force should be at a 15° angle, not directly at the wall. If the stretch is not angled properly, the tuft rows may get out of line.
9. Butt end of power stretcher is placed at corner 3.
10. Stretch diagonally to corner 1.
11. Hook corner 1.
12. Stretch carpet diagonally from wall C to wall A and toward corner 1.

13. Hook along wall D, with knee kicker at 15° angle.
14. Stretch carpet diagonally from wall B to wall D toward corner 1.
15. Hook along wall A, with knee kicker straight to the wall.
16. Cut and finish the edges of the carpet.

For a Large Room

Hook corner one as above. Then make a diagonal stretch from wall D to wall B and toward corner 3. Most of the stretch happens in the last 4 feet of carpet. This reverse stretch helps make the stretch equal throughout all of the carpet. Then hook carpet along wall A with the knee kicker at 15°. Last, use the knee kicker square at the wall to hook the carpet along wall D.

Seaming

Heat seaming tapes that need a very high temperature should not be used with tufted carpet. To hand sew tufted carpet seams, use 3 stitches per inch and do not get closer than 5/8 inch to the edge.

INSTALLING WOVEN CARPET

Axminster (See illustration on next page.)

1. Hook carpet at point A about 1 foot along each wall. Use the compressed edge starting technique.
2. Power stretch to hook carpet at point C.
3. Iron carpet onto tack strip pins along wall AC. Make sure the pattern is straight. It can be very hard to bend this carpet along the side of the roll, so it has to be securely hooked.
4. Power stretch from B to D. Hook the corner at point D.
5. Hook carpet along wall AB. Make sure the pattern is straight.
6. Power stretch and hook along wall CD.
7. The carpet can sometimes be stretched enough in width to use the knee kicker along wall BD. If this is not the case, you will have to use the power stretcher.
8. Check to make sure the seams and pattern are straight.
9. Trim edges and tuck into the gully.

Knitted, Velvet, Wilton (See illustrations on next page.)

The way to stretch these carpet types is basically the same as for Axminster,

except for steps 4 and 6. Knitted and velvet can be stretched more in width. Wilton is about the same in length and width.

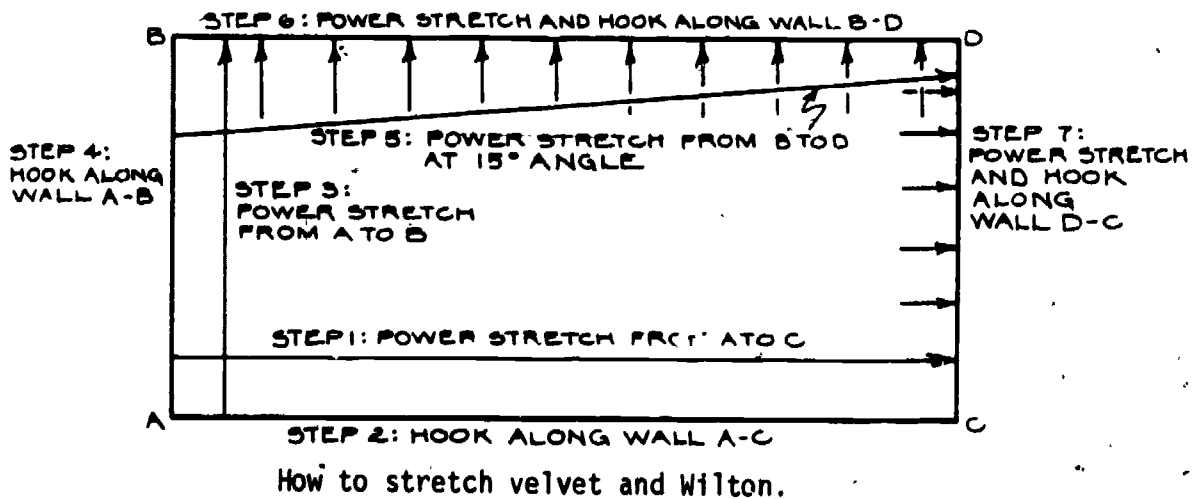
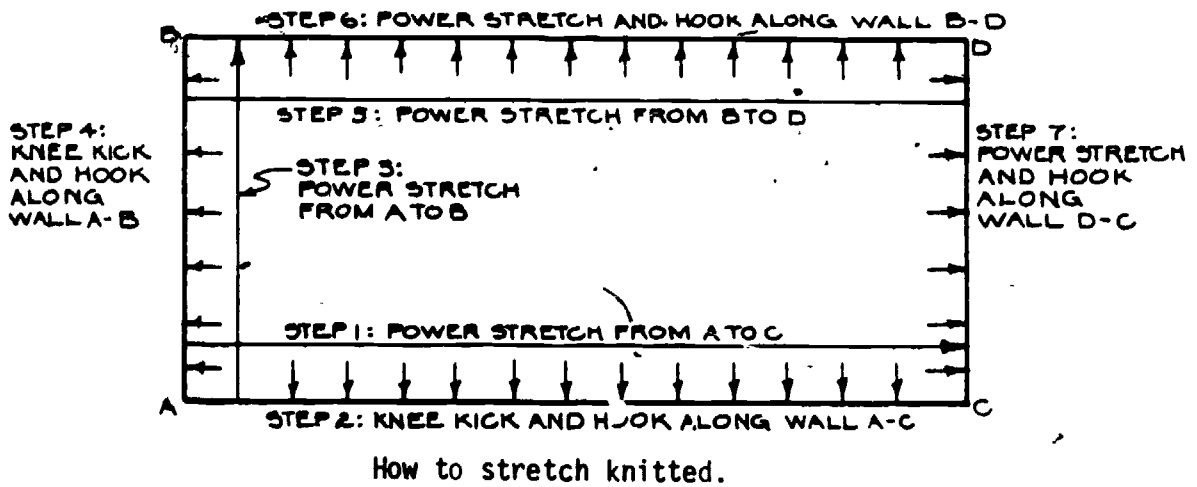
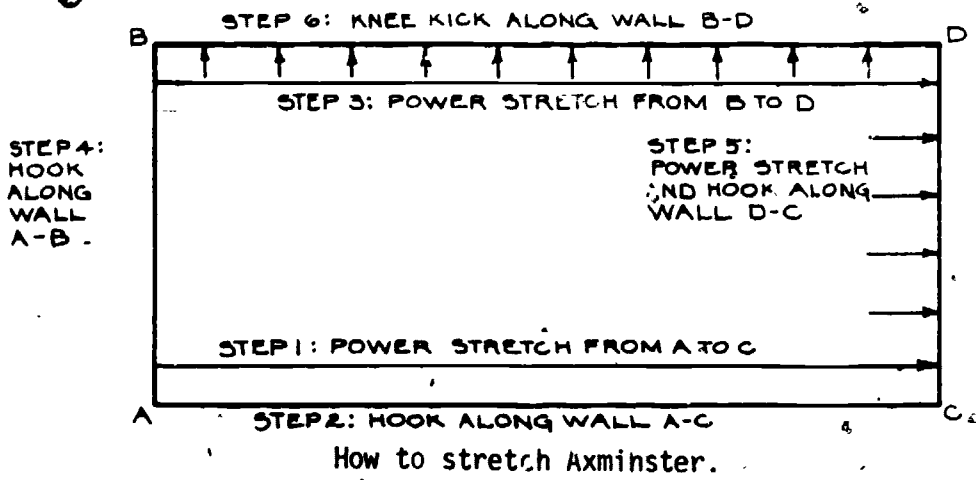

GLUE-DOWN CARPET

There are many types of glue-down carpet available. These directions are general ones. The directions of the manufacturer of the carpet being installed are more important--be sure to read and follow those directions.

Pieces should be cut to allow 1 to 1 1/2 inches extra to go up all walls or other vertical surfaces. The floor must be clean. Glue-down carpet needs a 98% adhesion rate to work well.

The floor also must be smooth. Be sure to use recommended fillers for holes. The adhesive used can destroy a filler that is not recommended. You should also strike a chalkline to guide the first breadth laid and keep it straight.

The manufacturer of the carpet will recommend one or more brands of floor adhesive. If you do not follow this recommendation, the manufacturer's warranty may be voided.

One gallon of adhesive will cover 15 to 20 square yards of floor area. When covering a very dry, porous floor, it is often best to mop the floor first. Use one tablespoon of ammonia in a pail of water. This slows down the rate at which the floor absorbs water and makes a longer "open" time for the adhesive.

The adhesive is usually spread with a trowel. Notches on the trowel should be 3/32 to 1/8 inch deep and 1/8 inch apart. The following are 3 general rules for spreading adhesives:

1. A scum must not form on the adhesive.
2. The back of the carpet must be thoroughly coated with adhesive.
3. You must be able to move the carpet on the adhesive with the knee kicker.

Seam cement is often applied before the carpet is installed. Cement should be put only on the edge of the backing. The seam cement seals the edges to keep the carpet from unraveling. It also joins the two pieces so that they will remain at the same level.

The 1/3 - 2/3 Installation

1. The lengths of the first 2 pieces are folded back 1/3 of the width.

2. Adhesive is spread in the area exposed.
3. Carpet is put back on top.
4. Remaining pieces will be glued down sections: 1/3 of a new piece and 2/3 of a partly glued piece.
5. Advantages of this system:
 - a. Breadths are less likely to shift their position.
 - b. There is more freedom for working the carpet to the chalk line.

Air can be trapped under the carpet when it is laid on the adhesive. To remove these bubbles, use a 2 X 4 or the tool box tray and "sweep" the air toward the edge of the carpet.

Use the knee kicker to adjust the carpet so that the pieces butt properly at the seams. Finish the seams at this time. If a section of the seam springs open, it can be pulled together with the knee kicker. Stay tack until the adhesive sets up to make a permanent seam.

If a few tufts are turned down into the seam, release and clean them. Use the solvent recommended for the adhesive you are using.

Roll-in Method

This method usually needs three people to do the job

1. Snap the chalkline.
2. Place all breadths in position.
3. Roll up each breadth half way across the room.
4. First person spreads adhesive.
5. Second person unrolls carpet onto adhesive.
6. Third person uses knee kicker to keep first breadth lined up with the chalkline.
7. Apply seam cement to each breadth after laying and before next breadth is unrolled.
8. Repeat steps 3-7 to complete the job.

Making Cross Seams

1. Cut breadths long enough so pieces can overlap 4 to 6 inches where the seam will be made.

2. Cement breadths to floor, leaving 6 to 9 inches on each side of the cross seam.
3. Use a straightedge and double cut both pieces at the same time.
4. Turn back the ends and apply adhesive.
5. Finish and clean seam in usual manner.

Fitting to the Walls

A sharp knife is used to cut the carpet around door jambs and other irregular features. Trimmers such as the Viking Cut Wall Finisher are used to cut along straight walls.

1. Form a 90° angle with the carpet between the floor and the wall.
2. Set the blade depth and heel plate angle on the trimmer tool to the correct places.
3. Trim with a smooth, even stroke. Using a slight downward pressure squeezes the cushion. It will spring up after cutting and hide any blade marks on the wall.

Wall Trimmers.

NOTES:

1. Material trimmed off sponge-backed carpet should be pulled downward to remove it. Dense foam-backed trim material should be pulled to the side to remove it.
2. Be sure to keep all cuts square. Seams will not work well if they are not.
3. When stay tacking, a piece of scrap carpet can be used upside down. This makes it easier to see the tacks and keeps them from sinking into the carpet nap.

4. To guide for a cut line, you can use a screwdriver to open a row in the nap. Cut along the line made.
5. After laying out the pieces, check to make sure all nap is running the same direction. Check to make sure shading matches are good. Check to make sure two pieces that will be seamed are the same height.
6. All adhesive should be cleaned up as soon as possible. Once it dries, it can be very hard to remove.

INSTALLING REVERSIBLE CHENILLE CARPET

Today, chenille is not a very common carpet material. Most work will be re-installing after cleaning or repairs.

1. Use a type 3 tack strip. Install it about 3/8 to 1/2 inch from the wall.
2. Make sure the padding is securely fastened.
3. At the starting wall unravel the caterpillar back 4 inches from the end of the carpet.
4. Brush the warp ends with quick drying latex. Hook firmly to the tack strip and caulk in behind the strip.
5. Power stretch toward the wall opposite the starting wall. Do not stretch in the normal way with the head near the wall. Set the head at several points across the room and stretch to get a uniform tightness.
6. Repeat steps 3 and 4. Also follow the same steps if there are any cut outs in the room.
7. First cut in the side of the room with offsets or cut outs. Brush these side cuts with latex.
8. Hook on the tack strip and repeat on the other side of the room.

Sewing End Seams

1. Open the stitching in the jute header with a knife. Unfold the jute factory hem.
2. Unravel the jute back to the caterpillars.
3. Unravel the caterpillars back to the place where the seam will be made.
4. Brush the unraveled warp threads with quick drying latex.
5. Sew seam using the baseball stitch.

6. The result should be an invisible stitch made by the needle traveling over and under, over and under--as in a figure 8.

Sewing Side Seams

1. Butt the selvage edges of 2 carpets together.
2. Sew with a figure 8 motion of the needle.
3. Excess material at the side seam can be cut off. An opaque latex 's put on the side of the cut. After the latex has dried, the seam can be sewed using the baseball stitch.

"Thumbs" or "Ends":

This is an end of a chenille caterpillar that comes up through the warp thread. They can show up after vacuuming during the installation. To correct, clip the caterpillar close to the surface with scissors.

"Flats":

Sometimes part of a caterpillar will lose its twist. Then a "flat" occurs that exposes the back of the caterpillar and the warp threads. To fix a "flat," insert a pointed tool (such as a screwdriver) between the warp threads. Turn the caterpillar on its side to expose the nap.

Self Assessment

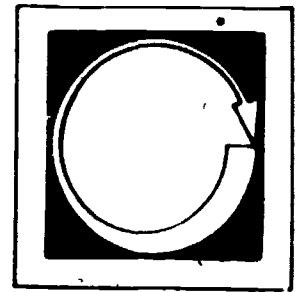

COMPLETE THE FOLLOWING STATEMENTS BY WRITING THE CORRECT WORD OR WORDS IN THE BLANKS PROVIDED.

1. Heat seaming tapes that need a very high temperature should not be used on _____ carpet.
2. To fix a "flat" in Chenille, turn the _____ on its side to _____ the _____.
3. Powdered talc can be spread on _____ padding to make the friction less.
4. One _____ of glue-down adhesive will cover about 15 to 20 square _____ of floor area.
5. Knitted and velvet carpet can be stretched more in _____.
6. If carpet is double backed, it will stretch _____.
7. Material trimmed off sponge-backed carpet should be pulled _____ to remove it.
8. The _____ can be used for stretching tufted carpet.
9. Glue-down carpet needs a _____ adhesion rate to work well.
10. Tufted carpet is stretched at an _____ to the wall to which it is being stretched.

11. The seam cement seals the _____ to keep the carpet from _____.
12. Friction between _____ and _____ is often the greatest problem.
13. Today, Chenille is not a very _____ carpet material.
14. The adhesive used for glue-down carpet can destroy a _____ that is not _____.
15. As a rule of thumb: There is _____ of stretch for each length _____ of carpet.

Self Assessment Answers

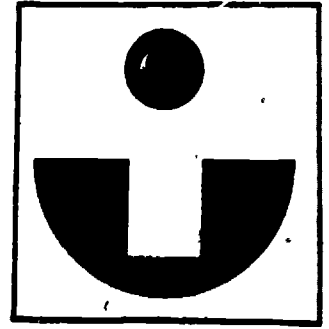

1. tufted
2. caterpillar, expose, nap
3. rubber
4. gallon, yards
5. width
6. less
7. downward
8. cotton head
9. 98%
10. angle
11. edges, unraveling
12. carpet, padding
13. common
14. filler, recommended
15. 1", 12-15'

Job Sheet

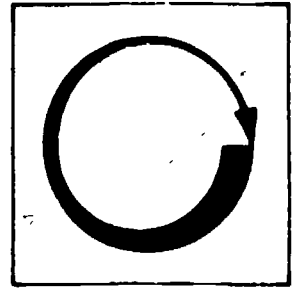

COMPLETE THE FOLLOWING TASKS.

Materials and Tools: All tools and equipment needed for carpet installation. Several room-size or larger pieces of carpet. Different types of carpet material will be necessary.

1. Prepare for and do a complete installation of at least 3 of the following types of carpet materials.

Tufted

Axminster

Knitted

Velvet

Wilton

Glue-down

Use the space below to plan what you will do.

Post Assessment

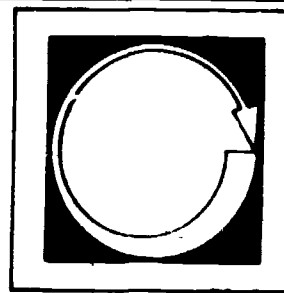

LISTED BELOW ARE SEVERAL STATEMENTS. IF THE STATEMENT IS TRUE, PLACE A "T" IN THE BLANK PROVIDED. IF THE STATEMENT IS FALSE, PLACE AN "F" IN THE BLANK.

1. ___ Tufted and Wilton carpet each will stretch as much in length as it will in width.
2. ___ Mopping with ammonia in a pail of water can make a longer "open" time for the glue-down adhesive.
3. ___ To remove air trapped under glue-down carpet, poke the air bubbles with an awl.
4. ___ One thing that controls the amount of stretch in carpet is the height of the pile.
5. ___ To hand sew tufted carpet, use 3 stitches per inch. Do not get closer than 5/8 inch to the edge.
6. ___ A scum must form on glue-down adhesive before it is ready for the carpet.
7. ___ Most Chenille work today is in doing new installations.
8. ___ A carpet for a large room has to be stretched and installed in one piece.
9. ___ It usually takes 3 people to install glue-down carpet using the roll-in method.

10. _____ Glue-down carpet should be cut to allow 1 to 1 1/2 inches extra for flashing up the wall.
11. _____ sharp knife is used to trim along straight walls and special tools are available for irregular features such as door jambs.
12. _____ When installing tufted carpet, the knee kicker is used at a 15° angle to all walls except the last wall.
13. _____ When stretching carpet, each wall should be trimmed and tucked at the same time it is stretched.

Instructor Post Assessment Answers

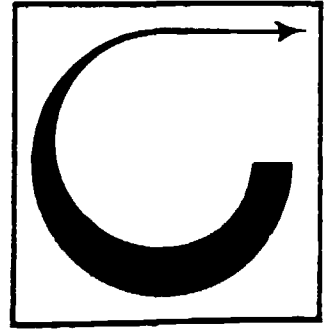

1. T
2. T
3. F
4. F
5. T
6. F
7. F
8. F
9. T
10. T
11. F
12. T
13. F

MEASURING AND CUTTING: PLASTIC LAMINATE AND METAL TRIM.

Goal:

The student will be able to identify the steps involved in measuring and cutting plastic laminate and metal trim and will be able to execute these steps.

Performance Indicators:

The student will successfully complete a Self Assessment, a Job Sheet and a Post Assessment.

Study Guide

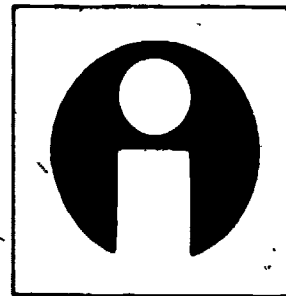

In order to finish this module, do the following tasks: Check each item off as you complete it.

1. Read the Goal and Performance Indicators on the cover of the module. This will tell you what you will learn by studying the module, and how you will show you've learned it.
2. Read the Introduction. The Introduction will tell you why the module is an important part of the floor laying trade.
3. Study the Information section. This section will give you the information you need to understand the subject.
4. Take the Self Assessment exam. This is a test for you to prove to yourself that you have learned the material you have studied. Compare your answers with the answers on the Self Assessment Answer Sheet, which is on the page following the Self Assessment. If you scored poorly, re-study the Information section or ask your teacher for help.
5. Do the Job Sheet. Follow the instructions at the top of the Job Sheet. The tasks listed on the Job Sheet will help you develop skills which will be helpful to you.
6. Take the Post Assessment exam. Give the exam to your teacher after you have completed it. Your teacher will grade it for you.

Supplementary References

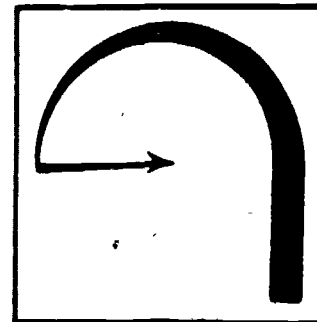

Resilient Coverings Workbook. California State Department of Education, 1973.
pp. 29-31, 199-202.

Information

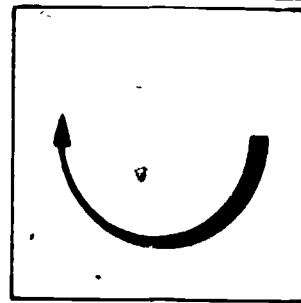

MEASURING AND CUTTING PLASTIC LAMINATE GOODS

There are 3 things that have to be done to get plastic laminate goods ready for installing. If these things are done well, the installation is easier, won't cost more than it should, and will please the customer. If these things are not done well, the installation is harder, may lose money, and most likely will not please the customer.

These three things are:

1. Choose the most economical size of plastic laminate sheet to be cut.
2. Layout and mark the sheet for cutting in the most economical way.
3. Cut out the pieces close to the size you need. The following are general rules for cutting to size:
 - a. With **HAND CUTTING**, your cut piece should be no more than $1/16$ " off your measurements.
 - b. With **POWER TOOL CUTTING**, your cut piece should be no more than $1/32$ " off your measurements.
 - c. Pieces should be marked out a bit larger than the size you will need.

1. The Most Economical Size

To choose the most economical size of sheet to be cut, you need to know the length and width of all the areas that are going to be covered. This is to make sure that you get a piece that is both long enough and wide enough.

If the pattern of the plastic laminate has a grain, that has to be thought about, too. You will have to plan the layout so that the grain is always going the right way. Grain is often laid going the long way on the thing to be covered (either length or width). This, however, is a customer's choice.

You will also have to find out what size sheets are available. After you have done all these things, then you can decide what size sheet to use.

2. Layout and Marking

Layout is planning how the pieces will be marked for cutting out the sheet of plastic laminate. You may want to plan this by using graph paper and a scale drawing before buying the plastic laminate materials. When you are marking the pieces to be cut out, you should use a square and a straightedge. The lines can be made with pencil, grease pencil, or felt pen.

When you are marking the pieces, make them bigger than the size you will need. You should allow 1/4" to 1/2" extra. This can be trimmed after the plastic laminate has been installed.

3. Cutting the Pieces

Hand Cutting Methods

1. Scoring with an awl can be used when a piece that is the full length or width of the sheet is being cut. Score the laminate material several times using an awl with a carbide cutter. Use a straightedge to guide the scoring. Then break the plastic laminate along the scored line by bending the sheet toward the scored surface.

When scoring, you get a better break by making the scoring marks on the finished surface side.

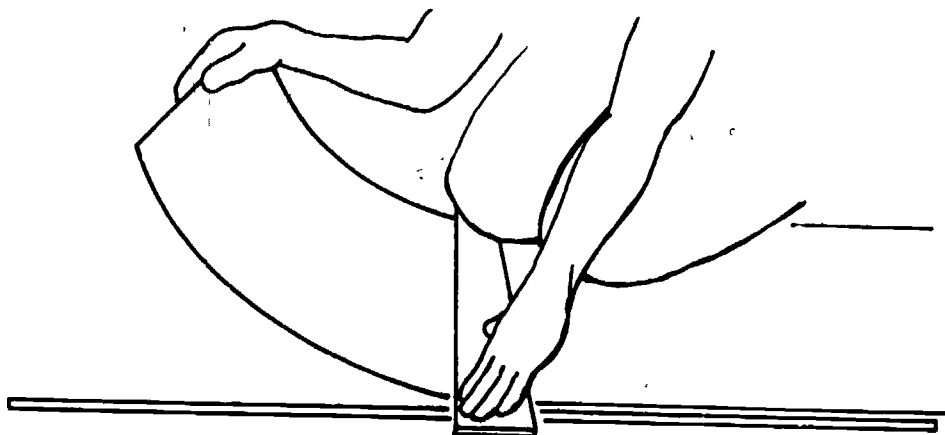

2. Cutting with a hacksaw works well. But you are limited by the depth of the hacksaw frame. So the hacksaw works best for short cuts or small pieces.

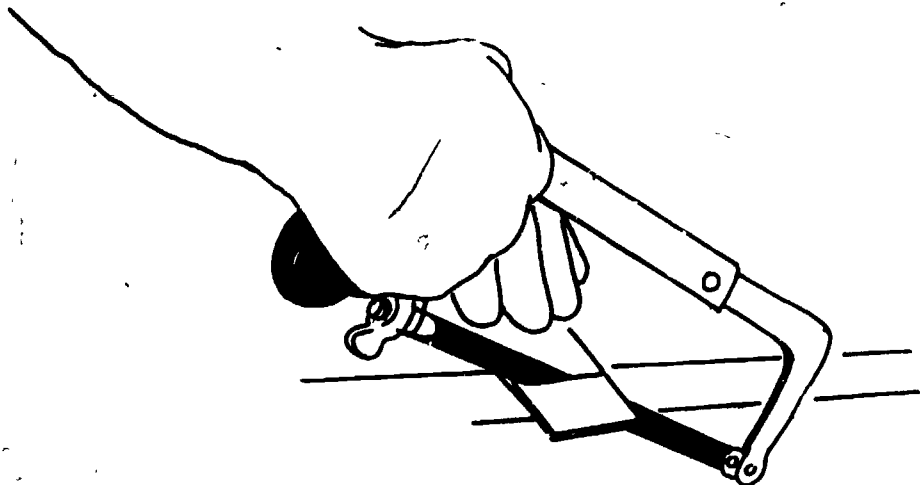

3. A hand saw with a 12-point blade can be used. But the hand saw blade will get dull very quickly.

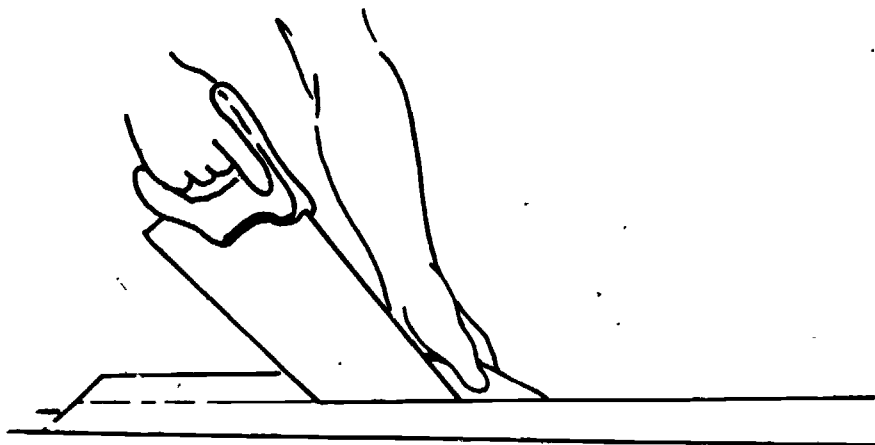

4. Tin snips or aviation snips can be used to cut narrow pieces down to the right length. The aviation snips work best. Snips do not work well for cutting large pieces.

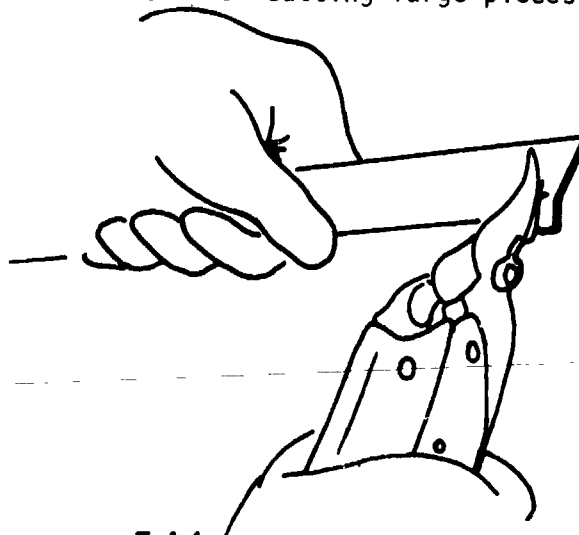

Power Tool Cutting

1. A table saw can be used. This tool needs extra safety care, however. The guard on the table saw is not used. It would scratch the surface of the laminate material. Also, the blade has to be set fairly high. This is to keep the laminate from chipping. It also helps keep the blade from getting too hot.

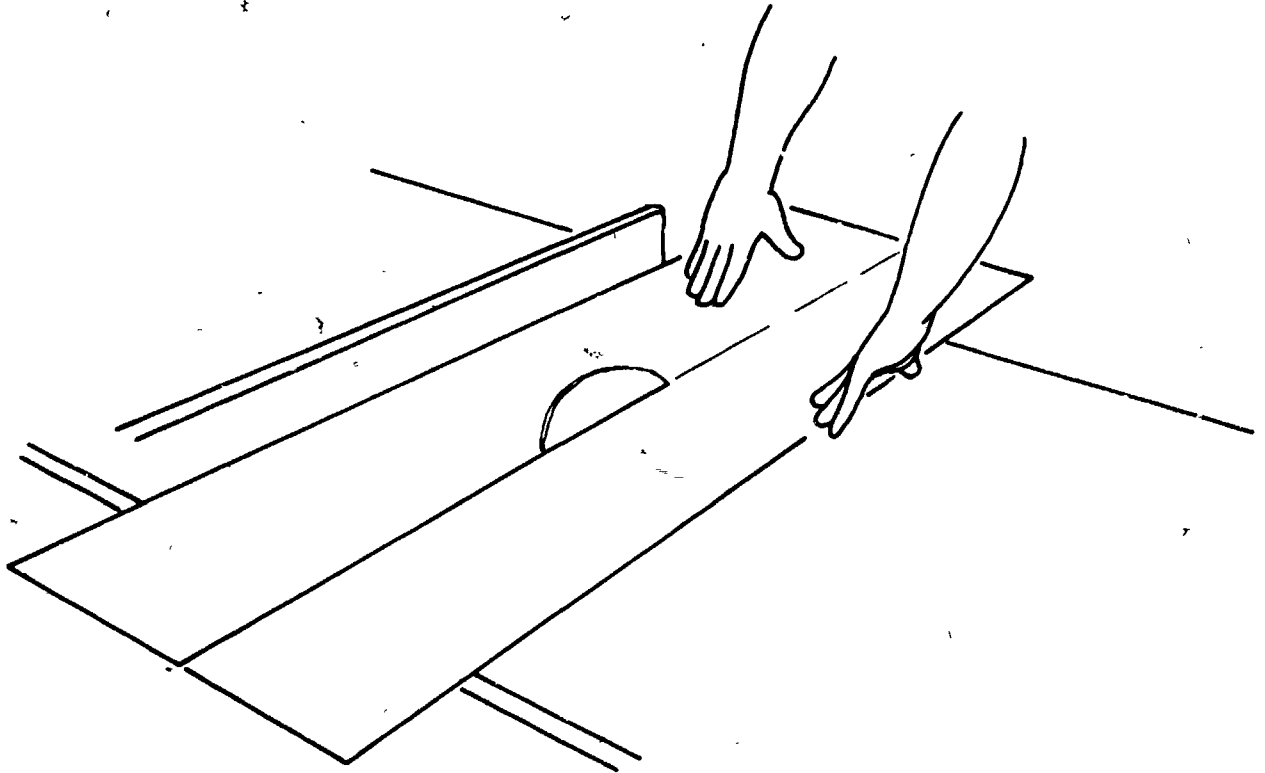

2. A portable circular saw can also be used. When you are cutting with this power tool, you will have to use a straightedge as your guide. Be sure the straightedge is firmly clamped in place.

(See the illustration on the top of the next page.)

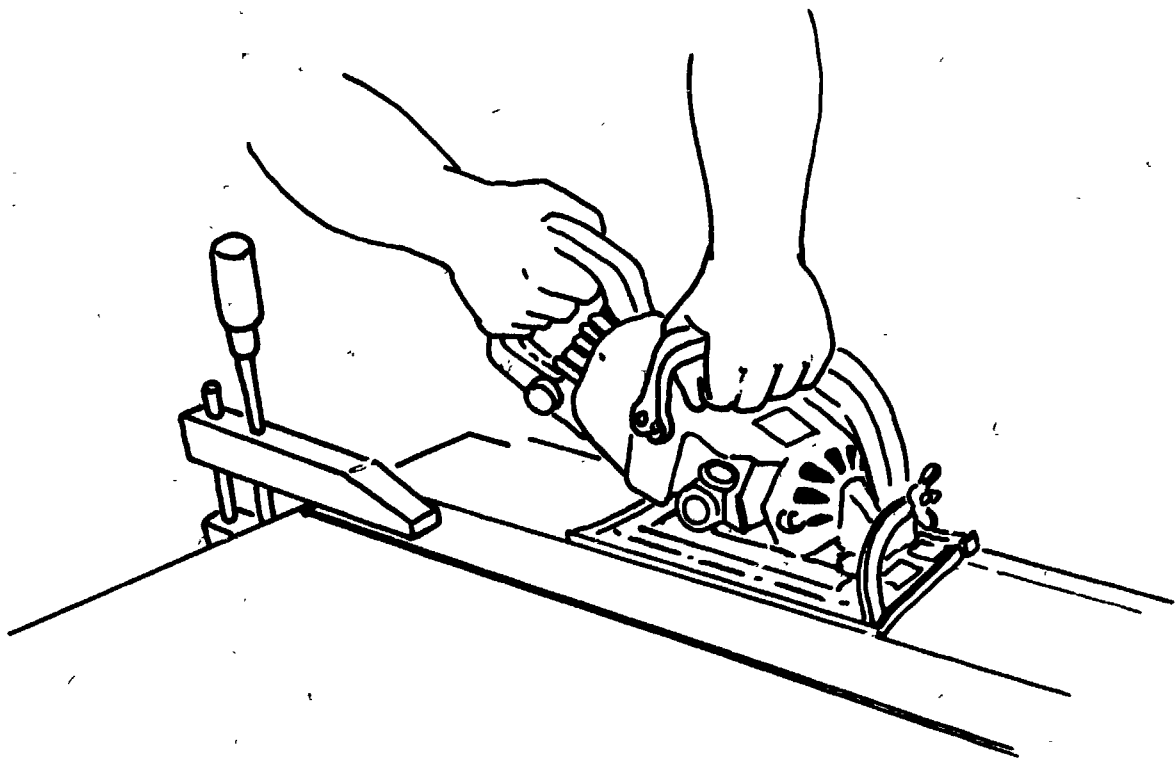

3. The router, with a straight carbide bit, can be used. It is also used for final trimming after the laminate material has been glued to the backing material.

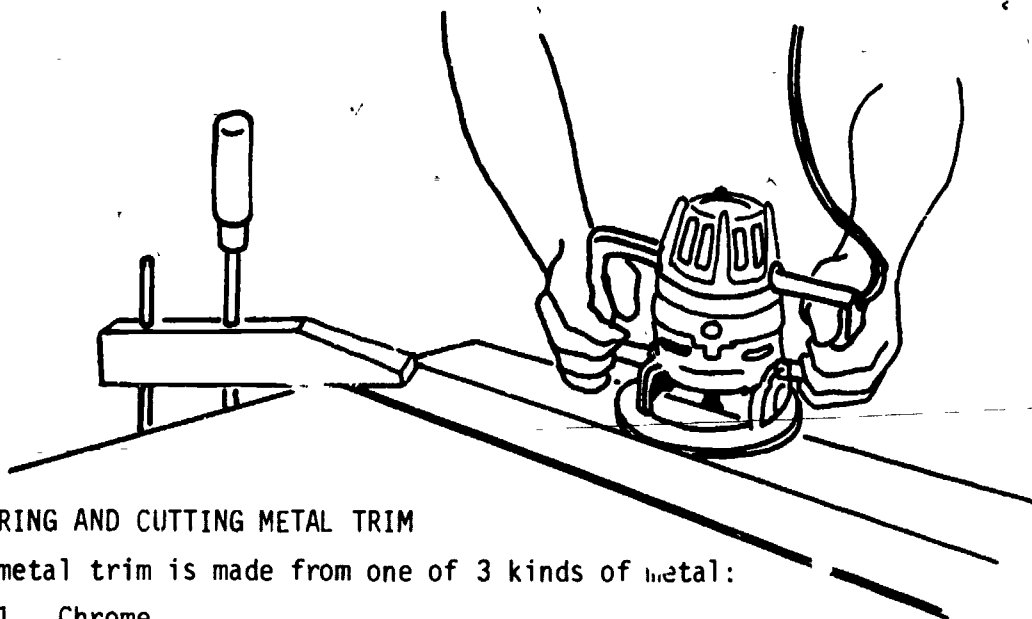

MEASURING AND CUTTING METAL TRIM

Most metal trim is made from one of 3 kinds of metal:

1. Chrome.
2. Aluminum alloy.

3. Stainless steel.

The main tools you will need for cutting metal trim are:

1. Hacksaw
 - a. Blade with 18-24 teeth per inch for chrome.
 - b. Hardened blade with 32 teeth per inch for stainless steel.
2. Miter box
3. Metal miter tool (looks something like a pair of pliers. It comes with a set of changeable dies. The dies are used to cut special notch shapes in the metal.)
4. Tinsnips

It is very important that metal trim be measured right. The trim is out in plain sight for everyone to see. If 2 pieces don't meet, or a corner is not made correctly, everyone will see it. Also, ending up with a piece that is too long is almost as bad as having a piece that is too short. It is not easy to take off "just a bit more." Often the piece that was too long ends up too short. Because of this, always try to make the right cut the first time.

Making Corners

The cutting method of making corners is the simplest. You need to use a miter box. Also, the outside corners made with this corner method tend to be very sharp and dangerous.

1. Measure the length needed.
2. Hold or clamp metal firmly in miter box.
3. Cut by applying pressure on the forward stroke of the hacksaw.
4. Cut exactly on the measured mark and at the correct angle.
5. Where two pieces meet, be sure the cut angle does match.

The notching and bending method of making corners seems harder than it really is. The important thing to remember is that the thickness of the metal becomes a part of your measurement. You may have to add the thickness of the metal to your measurement, or you may have to subtract it from your measurement. In a way, the thickness becomes part of the length. The following table can be used to help decide where to mark places for making corners.

(See the table on the next page.)

METAL TRIM
MEASURING CHART

Distance Being Measured	Length of Trim That Will Be Needed
Distance from an inside corner to another inside corner.	Take the distance measured and subtract 2 times the thickness of the metal.
Distance from an inside corner to an outside corner.	Take the distance measured, add the width of any top and subtract the thickness.
Distance from a dead end to an inside corner.	Take the distance measured and subtract the thickness.
Distance from an outside corner to an outside corner.	Take the distance measured and add 2 times the width of any top.
Distance from a dead end to an outside corner.	Take the distance measured and add the width of the top.

Using the Metal Miter Tool

CUTTING OUTSIDE CORNERS

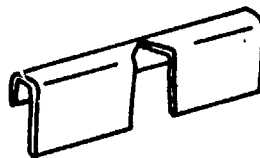
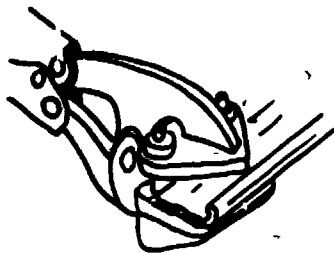
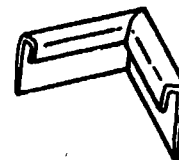
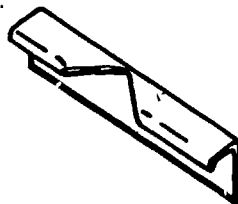
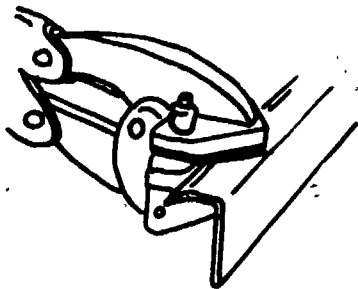

CUTTING INSIDE CORNERS

NOTE: A square metal file may also be used to make the notches

Different Kinds of Metal Trim

There are more than 150 kinds of metal trim used by the floor layer. Metal trim can be used to install floor coverings, drainboards, cabinets, tub enclosures, and so on. On coved goods, a metal cap strip makes a decorative finish and provides a stopping point on the wall. Metal trim is also used to protect edges, as a joiner, or to insure a water resistant area (such as a counter top).

The most common types of metal trim are:

1. Cap and cove moldings--cap moldings are used to hide an exposed vertical edge. It can be put on before or after the material is installed. Cove moldings are used to protect exposed material that has been coved.

2. Nosings--used to cover exposed counter top edges.
3. Divider bar--can be used to join sheets of laminated plastic.
4. T-type rims--these are easy to install on sinks. They are installed after the top covering material is in place. No rabbeting or scribing or special tools are needed. They are sanitary, watertight and self-sealing.
5. Tap-down rim--also called the roll-down rim. As its name hints, it is tapped flush with the edge of the material to make a protected edge.
6. Snap-on metal--is made out of stainless steel. It can be a hard material to saw or to form into corners. The sections are fitted into place and do not need nails or screws to hold them. It is often used for counter tops.
7. T-molding--is made for shop work rather than on-the-job sites. Part of it is put into a groove cut in the plywood top. Nails or screws are not needed.

Self Assessment

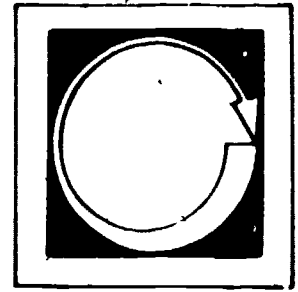

COMPLETE THE FOLLOWING STATEMENTS BY WRITING THE CORRECT WORD OR WORDS IN THE BLANKS PROVIDED.

1. Cuts made with hand tools should be no more than _____ inch off the measurements.
2. There are more than _____ kinds of metal _____ used by the floor layer.
3. Choosing the most economical size means knowing the _____ and _____ of all the areas to be covered.
4. When marking pieces to be cut, use a _____ and a _____.
5. The main tools needed for cutting metal trim are a _____, a _____, a _____ and _____.
6. A metal _____ tool is used for making corners with the _____ and _____ method.
7. Power tool cuts should be no more than _____ inch off the measurements.
8. Grain direction is a _____ choice.
9. A _____ box is used for making corners with the _____ method.
10. Lines can be made on plastic laminate with _____, grease pencil or _____.

MATCH EACH CUTTING METHOD WITH THE COMMENT ABOUT THAT METHOD BY PLACING THE CORRECT LETTER IN THE BLANK PROVIDED.

- | | |
|----------------------|--|
| ___ 11. Awl | a. Do no work well for cutting large pieces. |
| ___ 12. Hacksaw | b. Used for final trimming. |
| ___ 13. Hand saw | c. Break the laminate along the scored line. |
| ___ 14. Snips | d. Guard will scratch finish. |
| ___ 15. Table saw | e. Be sure straightedge is firmly clamped. |
| ___ 16. Portable saw | f. Gets dull quickly. |
| ___ 17. Router | g. Limited by depth of frame. |

Self Assessment Answers

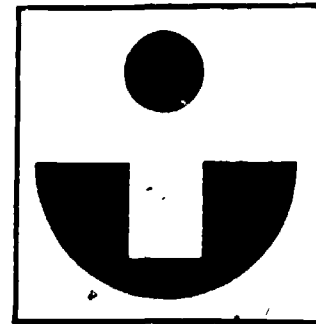

1. 1/16
2. 150, trim
3. length, width
4. square, straightedge
5. hacksaw, miter box, metal miter tool, tin snips
6. miter, notching, bending
7. 1/32
8. customer's
9. miter, cutting
10. pencil, felt pen
11. c
12. g
13. f
14. a
15. d
16. e
17. b

Job Sheet

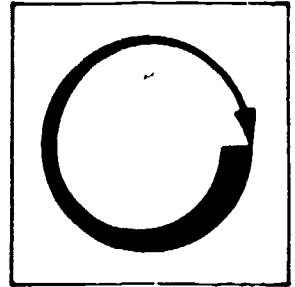

COMPLETE THE FOLLOWING TASKS.

1. Measure and mark sheets of plastic laminate for at least 3 different installations in places suggested by your instructor.
2. Measure for installing metal trim in places suggested by your instructor. Make different kinds of corners using at least 3 different types of metal trim.

Post Assessment

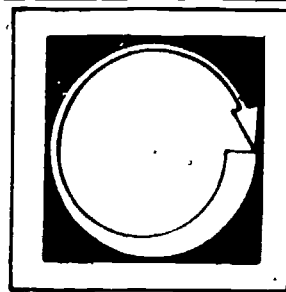

LISTED BELOW ARE SEVERAL STATEMENTS. IF THE STATEMENT IS TRUE, PLACE A "T" IN THE BLANK PROVIDED. IF THE STATEMENT IS FALSE, PLACE AN "F" IN THE BLANK.

1. ___ Most metal trim is made with chrome, aluminum or stainless steel.
2. ___ The T-molding is made for shop work.
3. ___ A hacksaw blade with 18-24 teeth per inch should be used for chrome trim.
4. ___ Pieces cut with power tools should be no more than 1/16" off the measurements.
5. ___ A portable circular saw should never be used
6. ___ There are only a few kinds of metal trim.
7. ___ A hardened hacksaw blade with 32 teeth per inch is used for stainless steel trim.
8. ___ When marking pieces to be cut out, allow 1/4" to 1/2" extra.
9. ___ The hacksaw works best for short cuts or small pieces.
10. ___ The cutting method of making corners can make very sharp outside corners.
11. ___ A table saw blade should be set a bit high to keep the blade from chipping the laminate.

12. ___ Metal trim should not be used to join 2 pieces of plastic laminate.
13. ___ Scoring with an awl should be done only with small pieces.
14. ___ The metal miter tool looks like a pair of pliers.
15. ___ When using the notching and bending method, the thickness of the metal becomes part of the length.
16. ___ A hand saw should have a 36-point blade.
17. ___ If trim is not measured right, it is easy to make it right.
18. ___ A better break is made by scoring with the awl on the finish side.
19. ___ A square metal file can also be used to make notches in metal trim.
20. ___ Snips should not be used to cut narrow pieces down to the right length.

Instructor Post Assessment Answers

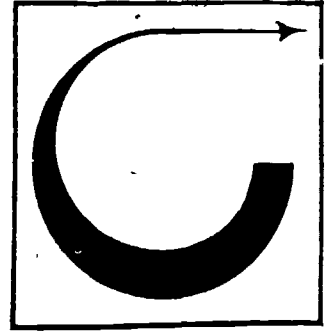

1. T
2. T
3. T
4. F
5. F
6. F
7. T
8. T
9. T
10. T
11. T
12. F
13. F
14. T
15. T
16. F
17. F
18. T
19. T
20. F

THE ROUTER AND OTHER POWER TOOLS

Goal:

The student will be able to identify common power tools and demonstrate the steps of using the router tool with plastic laminate.

355

Performance Indicators:

The student will successfully complete a Self Assessment, a Job Sheet and a Post Assessment.

359

Study Guide

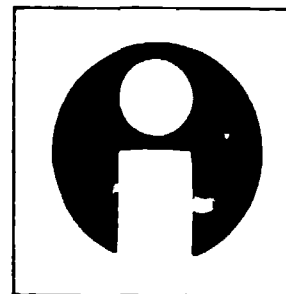

In order to finish this module, do the following tasks. Check each item off as you complete it.

1. Read the Goal and Performance Indicators on the cover of the module. This will tell you what you will learn by studying the module, and how you will show you've learned it.
2. Read the Introduction. The Introduction will tell you why the module is an important part of the floor laying trade.
3. Study the Information section. This section will give you the information you need to understand the subject.
4. Take the Self Assessment exam. This is a test for you to prove to yourself that you have learned the material you have studied. Compare your answers with the answers on the Self Assessment Answer Sheet, which is on the page following the Self Assessment. If you scored poorly, re-study the Information section or ask your teacher for help.
5. Do the Job Sheet. Follow the instructions at the top of the Job Sheet. The tasks listed on the Job Sheet will help you develop skills which will be helpful to you.
6. Take the Post Assessment exam. Give the exam to your teacher after you have completed it. Your teacher will grade it for you.

Introduction

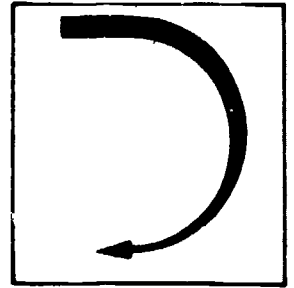

This module will help you learn how to use the router to trim and make seams in laminate materials. It will also briefly talk about other common power tools used by the floor layer.

Being able to use the router well will make working with plastic laminate materials much easier. A job can also be done faster with the router. This module will help you learn how to let the router make your job easier and faster.

Supplementary References

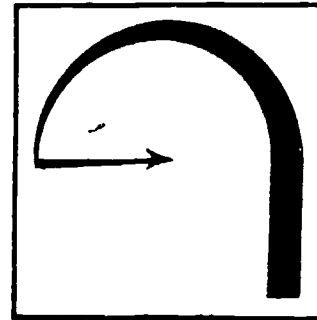

1. Resilient Floor Coverings Workbook. California State Department of Education, 1973. pp. 46-47.
2. Carpeting Floor Covering Workbook. California State Department of Education, 1972. pp. 45-46.

Information

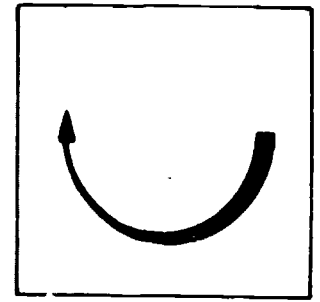

THE ROUTER

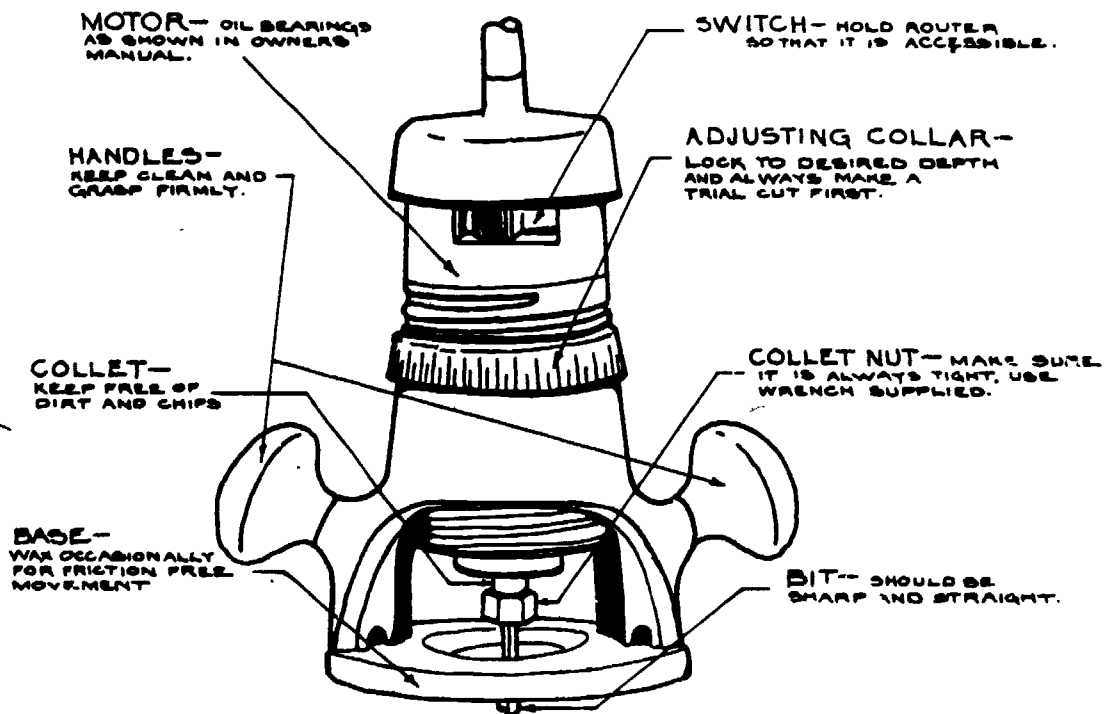

The router bit revolves at about 24,000 revolutions per minute (RPM). Its motor may be rated as high as 1 horsepower. Since the motor, shaft and bit revolve clockwise, the tool should be moved from left to right when cutting. The bit can be set for different depths of cut by a machine adjustment.

When the tool is being used, the bit should cut easily. The speed of the motor should be reduced only a little bit when the cut is being made. If you notice

more than a little speed loss, the bit may be dull. To protect the motor, always use a sharp bit.

Moving too fast while cutting can overheat the router. Moving too slow can burn the material being cut. Only practice will let you develop the right "feel" for cutting. Remember, if the motor slows down it is telling you that the cut is being forced.

Once you are familiar with how the tool works, you will be able to tell by the sound of the motor if everything is working right. You should also read and follow the manufacturer's directions for inserting the bit, adjusting depth, and using other features. The exact way these things are done may be different for different brands of routers.

POWER TOOLS USED BY THE FLOOR LAYER

Gasoline-powered.

The engine should be set up outside the building. Exhaust fumes can make workers dizzy and sick.

Air-powered.

The tool has to rest firmly on the surface that will be worked before the tool is turned on. Always disconnect the tools when they are not in use.

Hot Tools.

Heat can do as much damage as a sharp blade. Never believe that a "hot" tool has cooled down until you have checked it. If you do touch a tool to find out if it is cold, use the back of your hand. It is "natural" to jerk away from something. You can test this for yourself and find out that jerking away from something is easier when the back of your hand is touching it.

Electric-powered.

Follow all safety rules for the use of electric tools. In addition

1. Before hooking into any customer's house circuit, make sure the breaker system will bear the load. The danger is more than tripping a breaker. You may get the customer angry.
2. Do not hook 110 volt tools into 220 volt circuits or try to run 220 volt equipment on a 110 volt circuit.

- a. Floor sander. Two kinds are used, a drum sander for general field work and an edge sander for small places that are hard to reach.
- b. Buffer. Used for general polishing. May also be used to grind and clean concrete, with special attachments.
- c. Electric drill. A multi-purpose tool.
- d. Circular saw. The table model may be used for "in-shop" work. The portable model can be used for counter work and many small cutting jobs at the installation site.
- e. Saber saw. Used mainly to make cutouts in counter tops.
- f. Jamb saw. Used to undercut door jambs. Will also cut off doors without removing them.
- g. Power stapler, power nailer. For fastening materials.
- h. Rotary rug cutter. Can be used to cut carpet from either the front or the back. The circular blade rotates so that it pulls the material into it (toward the back of the machine). This machine can be very dangerous. If your hand is in front (holding down the carpet, for example), the blade can jerk some material--and your hand--into it.

NOTES ON USE OF POWER TOOLS

Each tool has its own dangers. Some of them will be obvious; others are not. Before using a new tool, read (and always follow) the manufacturer's directions for use.

If small pieces are coming off the material you are working, the only thing that will prevent eye damage is wearing safety goggles.

Safety guards are put on because tools pull on the material going through them. A tool tends to pull things in the direction it is moving. If possible, do not put your hand on the part of the material that is being pulled into the tool.

TRIMMING PLASTIC LAMINATE WITH THE ROUTER

1. Select and install the edge trimming attachment and cutter bit you need. Follow the manufacturer's directions.

2. Set the router for a rough cut.
3. Trim, leaving about 1/16" for the finish cut.
4. Adjust the router so that it will cut flush with the edge.
5. Make the finish cut.
6. Finish by hand, using a fine file. Make the edge a little bit round.

WARNING: The edge of the plastic laminate piece will be very sharp until you have finished step 6 and rounded the edge.

MAKING SEAMS WITH A ROUTER

Plastic laminate seams made by hand methods take a lot of fitting and filing. This can mean a loss of time on the job. Using the router is quick and easy.

The steps are:

1. Use a straight-tipped bit.*
2. Overlap the 2 pieces to be seamed. Allow 4 inches at the seam.
3. Clamp the 2 pieces together.
4. Cut through both layers at one time.

*NOTE: Steel bits will heat up. If they do, the edge of the laminate material will burn. This makes a poor fit at the seam.

Self Assessment

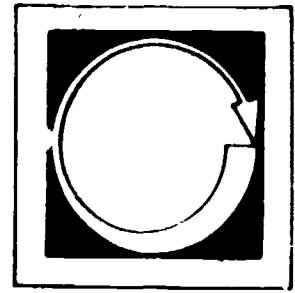

COMPLETE THE FOLLOWING STATEMENTS BY WRITING THE CORRECT WORD OR WORDS IN THE BLANKS PROVIDED.

1. If you touch a tool that might be hot, use the _____ of your hand.
2. Moving too slow can _____ the material.
3. Always _____ air-powered tools when they are not in use.
4. Steel bits will _____ and may _____ the material.
5. The router's motor, shaft and bit revolve _____.
6. Set up a gas-powered engine _____.
7. Each tool has its own _____.
8. The _____ of the motor can tell you if everything is working _____.
9. Blowing a circuit may make the _____.
10. If there is speed loss, the bit may be _____.
11. Only _____ will prevent eye damage.

12. List the 6 steps for trimming plastic laminate.

13. List the 4 steps for making a seam.

Self Assessment Answers

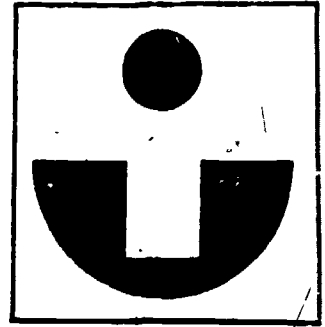

1. back
2. burn
3. disconnect
4. heat, burn
5. clockwise
6. outside
7. dangers
8. sound, right
9. customer angry
10. dull
11. safety goggles
12. Select and install edge trimming attachment and cutter bits.
Set router for rough cut.
Trim. Leave 1/16".
Adjust to cut flush with edge.
Make finish cut.
Finish with fine hand file.
13. Use straight-tipped bit.
Overlap pieces about 4 inches.
Clamp pieces together.
Cut through both layers at the same time.

Job Sheet

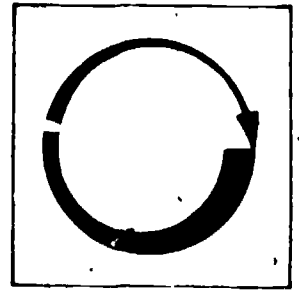

COMPLETE THE TASK BELOW.

Making and trimming a practice edge.

Materials and Tools

plastic laminate

box

adhesive

dowels

router

file

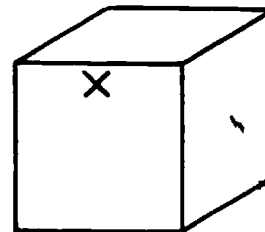
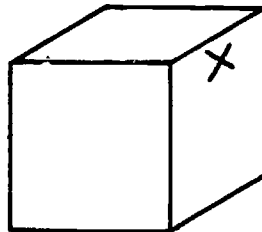
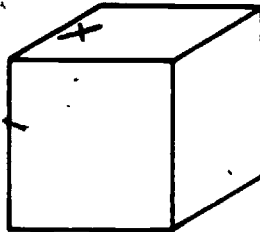

X MARKS
EDGE TO BE
LAMINATED
AND TRIMMED

1. Use scrap pieces of plastic laminate.
2. Prepare the surface of a box or other object for gluing on a piece of laminate material.
3. Following the manufacturer's instructions, apply adhesive.
4. Bond a strip of scrap plastic laminate.
5. Trim and finish the edge following the steps listed in the information part of this module.
6. Remove the plastic laminate and repeat these steps for added practice using the router.

NOTE: You may want to use a box shape for installing the plastic laminate. It can be turned to different positions. This will give you practice working at different angles. (See illustrations on this page.)

Post Assessment

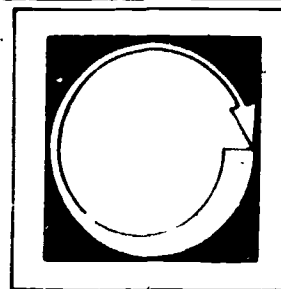

LISTED BELOW ARE SEVERAL STATEMENTS. IF THE STATEMENT IS TRUE, PLACE A "T" IN THE BLANK PROVIDED. IF THE STATEMENT IS FALSE, PLACE AN "F" IN THE BLANK.

1. ___ There are 6 steps to making a laminate seam.
2. ___ There are 4 steps to trimming plastic laminate.
3. ___ The first trim cut with a router should leave about 1/16 inch left for the final trim.
4. ___ The safest place to put your hand is on the part of the material that is being pulled into the tool.
5. ___ The router bit revolves at about 240 rpm.
6. ___ Moving too slow can make the bit burn the material being cut.
7. ___ Laminate trimming is finished with a fine hand file.
8. ___ A tool tends to pull things in the direction it is moving.
9. ___ The router should be moved in the same direction the bit is turning.
10. ___ A drum sander is used for hard-to-reach places.
11. ___ A curve-tipped bit should be used for making a laminate seam.
12. ___ Loss of motor speed might happen if the bit is dull.

13. ___ An air-powered tool should rest firmly on the working surface before the tool is turned on.
14. ___ The edge of plastic laminate is never very sharp.
15. ___ The dangers of a power tool are not always obvious.
16. ___ The faster you move the router, the less chance there is of overheating it.

17. ___ When making a seam, overlap the two pieces by about 4 inches.
18. ___ Making a laminate seam by hand is easier, but slower, than with a router.
19. ___ It is okay to hook a 110 volt tool into a 220 volt circuit for a short time.
20. ___ A jamb saw is one with a special guard that keeps it from jamming.

● Instructor Post Assessment Answers

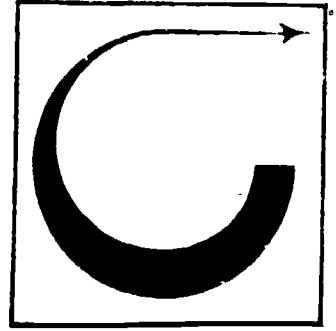

1. F
2. F
3. T
4. F
5. F
6. T
7. T
8. T
9. T
10. F
11. F
12. T
13. T
14. F
15. T
- 16.
17. T
18. F
19. F
20. F

INSTALLING PLASTIC LAMINATE

Goal:

The student will install plastic laminate on a surface.

Performance Indicators:

The student will successfully complete a Self Assessment, a Job Sheet and a Post Assessment.

Study Guide

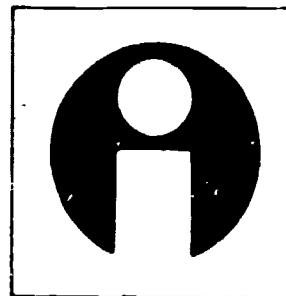

In order to finish this module, do the following tasks. Check each item off as you complete it.

1. Read the Goal and Performance Indicators on the cover of the module. This will tell you what you will learn by studying the module, and how you will show you've learned it.
2. Read the Introduction. The Introduction will tell you why the module is an important part of the floor laying trade.
3. Study the Vocabulary section. Vocabulary words are important for a good understanding of the trade. After you have studied the vocabulary, ask your teacher to quiz you on the words and their meanings.
4. Study the Information section. This section will give you the information you need to understand the subject.
5. Take the Self Assessment exam. This is a test for you to prove to yourself that you have learned the material you have studied. Compare your answers with the answers on the Self Assessment Answer Sheet, which is on the page following the Self Assessment. If you scored poorly, re-study the Information section or ask your teacher for help.
6. Do the Job Sheet. Follow the instructions at the top of the Job Sheet. The tasks listed on the Job Sheet will help you develop skills which will be helpful to you.
7. Take the Post Assessment exam. Give the exam to your teacher after you have completed it. Your teacher will grade it for you.

Introduction

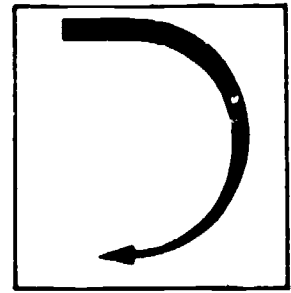

This module will help you put together all of the things you have learned about plastic laminate materials. The Job Sheet asks you to plan the steps of installing plastic laminate before going ahead and installing the laminate on a surface. It is important that you do it this way. The steps you will have to go through are the same as the steps any professional floor layer would go through.

Vocabulary

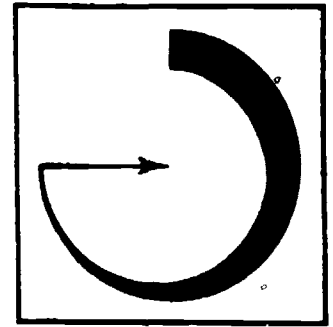

Trade terms are very important for a good understanding of the trade. Study these words and meanings. When you have learned them, ask your teacher to quiz you on the words and their meanings

SCRIBE--To mark a line. A counter top is scribed by marking where it needs to be cut to fit.

BACKSPLASH--The area of the wall at the back of the counter top that might get splashed.

Supplementary References

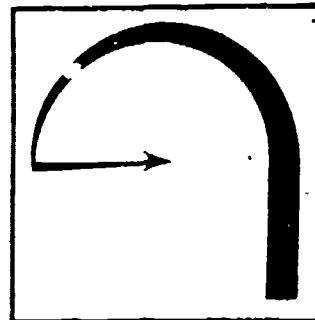

Resilient Coverings Workbook. California State Department of Education, 1973.
pp. 243-249.

374

375

Information

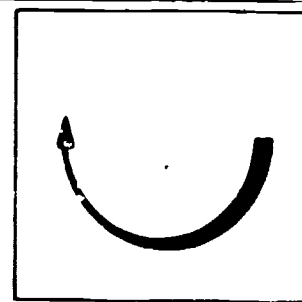

INSTALLING PLASTIC LAMINATE ON A COUNTER TOP

These are general steps. You may want to review the other modules on plastic laminates as well as read the following part on adhesives.

1. Install any self-edge banding.
2. Prepare the top surface while waiting for the adhesive to dry.
3. When the self-edge adhesive is dry, trim the self-edge banding.
4. Scribe counter top to the wall.
5. Install.
6. Trim edge.
7. Install metal cove molding if it is being used.
8. Cut and fit any backsplash pieces.
9. Cut and fit any metal trim.
10. Apply adhesive to metal trim and to wall and backsplash.
11. Install backsplash and metal trim at the same time.
12. Finish trimming and filing edges.

PLASTIC LAMINATE ADHESIVES

The most common adhesive is contact cement. This is because slow-setting glues (polyvinyl, casein and resins) need to be clamped under pressure. The clamping lets the adhesive cure.

As a general rule, adhesives can be applied with any of several tools: notched trowel, brush, or roller. The method depends on the adhesive and the surface to be glued. It is important to read and follow the manufacturer's directions.

Using Contact Cement

1. Apply the cement to both of the bonding surfaces.
2. Allow the cement to dry.

- a. Wait 15 to 20 minutes, or until the adhesive will not stick to your fingers.
- b. Avoid breathing the fumes if possible.
3. Lay clean, dry sticks on the coated surface of the counter top.
(NOTE: wood dowels work well.)

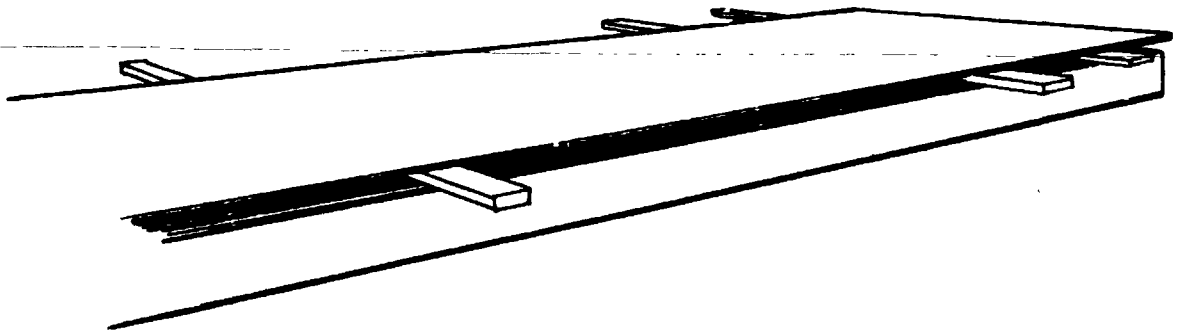

4. Place the laminate material on top of the dowels.
5. Adjust the position of the laminate material. (WARNING: Once the 2 bonding surfaces touch, they cannot be moved. So make sure that it is right the first time.)
6. Remove the dowels one at a time. Make sure that nothing (dirt, wood chips, etc.) gets between the counter top surface and the laminate materials.
7. After all of the dowels are out, roll the surface. A rubber roller works well.

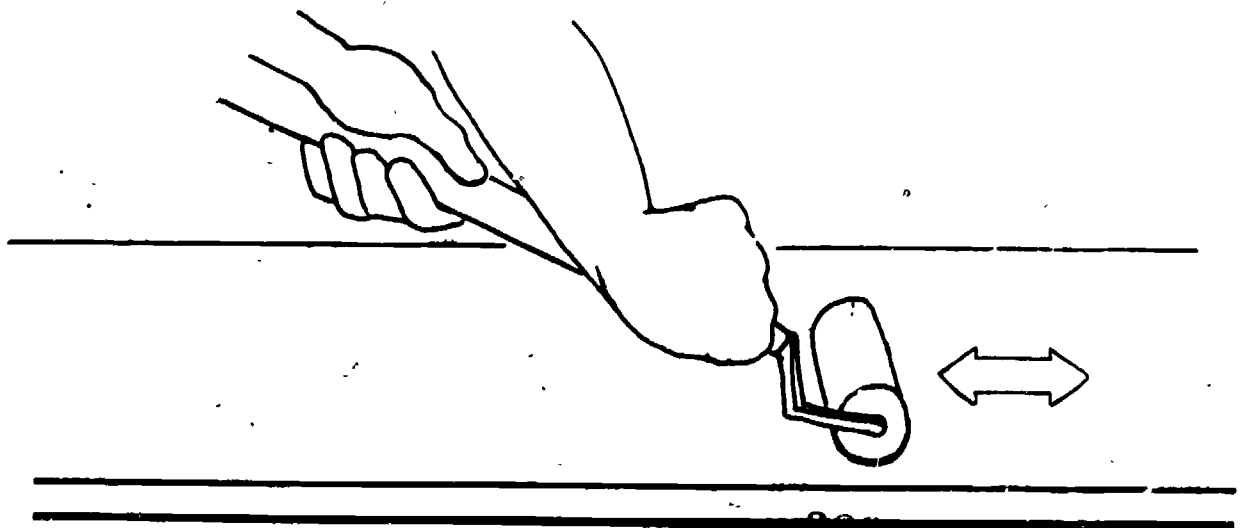

Self Assessment

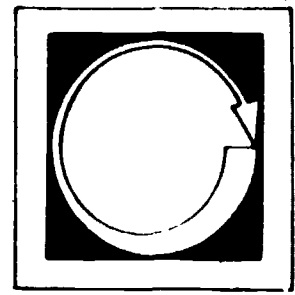

COMPLETE THE FOLLOWING STATEMENTS BY WRITING THE CORRECT WORD OR WORDS IN THE BLANKS PROVIDED. THESE ARE THE STEPS IN INSTALLING LAMINATE.

1. Install any _____-edge banding.
2. Prepare the _____ surface while waiting for the _____ to _____.
3. When the self-edge _____ is _____, trim the _____ banding.
4. _____ counter top to the wall.
5. _____.
6. Trim _____.
7. Install metal _____ molding if it is being used.
8. Cut and fit any _____ pieces.
9. Cut and fit any _____.
10. Apply _____ to metal trim and to wall and backsplash.
11. Install _____ and _____ at the same time.
12. Finish _____ and _____ edges.

Self Assessment Answers

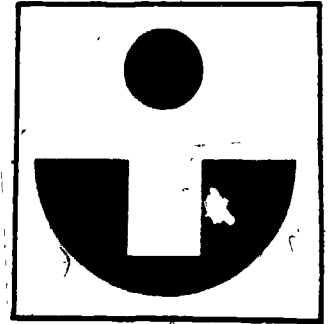

1. self
2. top, adhesive, dry
3. adhesive, dry, self-edge
4. scribe
5. Install
6. edge
7. cove
8. backsplash
9. metal trim
10. adhesive
11. backsplash, metal trim
12. trimming, filing

Job Sheet

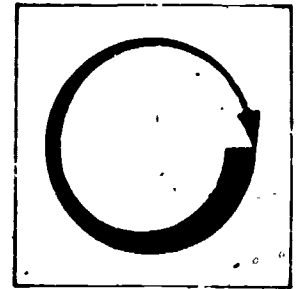

COMPLETE THE TASK BELOW.

Materials and Tools

plastic laminate

contact cement

metal trim

dowels

1. Install plastic laminate with contact cement. Install it on a surface that is picked out by your instructor.
2. Use metal trim and self-edging as needed.
3. Finish and clean up.
4. Before starting, use the space below to describe what you will be doing. Refer to other modules on plastic laminates as needed.

Post Assessment

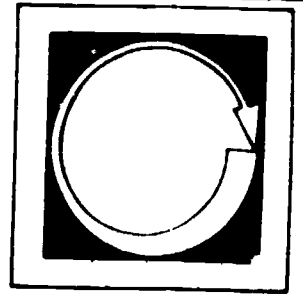

THE STEPS FOR USING CONTACT CEMENT AND FOR USING OTHER KINDS OF ADHESIVE ARE MIXED TOGETHER. LABEL THE STEPS FOR CONTACT CEMENT WITH A "CC." LABEL THE STEPS FOR OTHER ADHESIVES WITH AN "O." THERE WILL BE 7 "CC'S" AND 7 "O'S."

1. Apply the adhesive to both of the bonding surfaces.
2. If needed, mix the adhesive.
3. Make sure both bonding surfaces are clean and dry.
4. Apply adhesive to the surface on which the laminate will be installed.
5. Allow adhesive to dry.
6. Position the plastic laminate.
7. Lay clean dry dowels on the surface of the counter top.
8. Place the laminate material on the dowels.
9. Adjust the position of the laminate.
10. Put a pressure pad on top of the laminate.
11. Remove the dowels one at a time.
12. Use clamps or weights.

13. ___ Roll the surface.
14. ___ Remove the clamps or weights.

THE LAST TWO STEPS ARE THE SAME FOR ALL KINDS OF ADHESIVES.

15. Name the last two steps: _____, _____.

MARK THE FOLLOWING TRUE OR FALSE BY PLACING A "T" OR "F" IN THE BLANK PROVIDED.

16. ___ Self-edge banding is installed first.
17. ___ The counter top is trimmed after installing the backsplash.
18. ___ The backsplash and metal trim are installed at the same time.
19. ___ The counter top is scribed after it is installed.
20. ___ The top surface should not be prepared until the self-edged areas have dried.

Instructor Post Assessment Answers

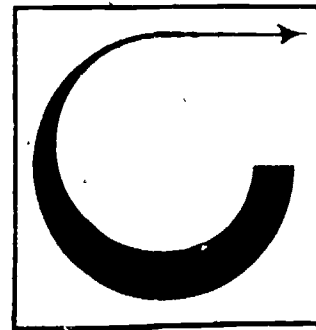

1. CC
2. 0
3. 0
4. 0
5. CC
6. 0
7. CC
8. CC
9. CC
10. 0
11. CC
12. 0
13. CC
14. 0
15. trim edges, clean up
16. T
17. F
18. T
19. F
20. F