

DOCUMENT RESUME

ED 213 890

CE 031 564

**AUTHOR** Ausland, Greg  
**TITLE** Tilesetting. Pre-Apprenticeship Phase 2 Training. Student Training Modules.  
**INSTITUTION** Lane Community Coll., Eugene, Oreg.  
**SPONS AGENCY** Employment and Training Administration (DOL), Washington, D.C.; Oregon State Dept. of Education, Salem.  
**PUB DATE** 81  
**NOTE** 475p.; For related documents see CE 031 561-579.  
**EDRS PRICE** MF01/PC19 Plus Postage.  
**DESCRIPTORS** Behavioral Objectives; \*Building Trades; Check Lists; \*Flooring; Job Skills; Learning Activities; Learning Modules; Masonry; Pacing; Postsecondary Education; Tests; \*Trade and Industrial Education; Two Year Colleges; Vocabulary  
**IDENTIFIERS** \*Preapprenticeship Programs; \*Tile Occupations

**ABSTRACT**

These 24 Student Training Modules on tilesetting comprise one of nine sets of self-paced learning modules developed for Pre-Apprenticeship Phase 2 Training. (A companion instructor's guide is available separately as CE 031 563.) The modules are designed to impart trade knowledge and skills to the student. Each module contains some or all of the following: cover sheet listing module title, goals, and performance indicators; study guide/checklist with directions for module completion; introduction; vocabulary listing and defining new trade or technical terms; supplementary references; information sheet(s) providing information and graphics covering the module topic(s); self-assessment; self-assessment answers; assignment sheet(s); job sheet(s) listing materials and tools necessary to complete tasks designed to develop manipulative skill; post assessment; and post assessment answers. Topics covered in the module include safety; manufacture of ceramic tile, types of tiles; mortar, tile adhesives, backings, layout and leveling tools, tile cutting and drilling tools, mortar tools, specialty tools, adhesive application and beating in, grouts, grout and mortar additives, sealers and cleaners, expansion joints, tile layout, how to grout, tub enclosures, counter tops, screeds, floors and wall installation, applying wall and floor mortar, and setting tile to cement mortar. (YLB)

\*\*\*\*\*  
 \* Reproductions supplied by EDRS are the best that can be made \*  
 \* from the original document. \*  
 \*\*\*\*\*

FD213896



# PRE-APPRENTICESHIP

## PHASE 2 TRAINING

### Student Training Modules

07031564

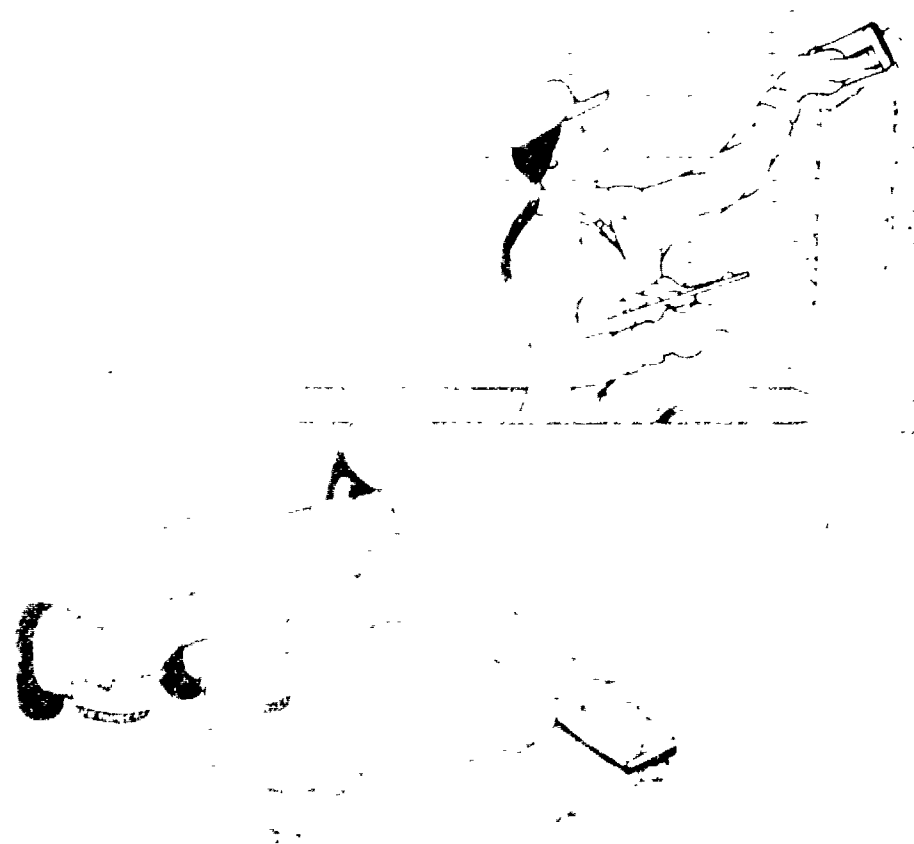

**Typesetting Module Writer:**

Greg Ausland

**Technical Assistance:**

George Grainger

**Graphics:** Ralph Bentley

**Editorial, Proofreading and Pasteup:**

Dick Ingram, Debi Carroll

Ron Hamblen, Shannon Kracht

**Typing:**

Strandlien Typing Service

This project was developed under a sub-contract for the Oregon Department of Education by Lane Community College, Community Education Division, Eugene, Oregon. Funds were provided by the Governor of Oregon from the Educational Linkages Component of the CETA Governor's Grant.

**STATEMENT OF ASSURANCE**

It is the policy of the Oregon Department of Education that no person be subjected to discrimination on the basis of race, national origin, religion, sex, age, handicap or marital status in any program, service or activity for which the Oregon Department of Education is responsible. The Department will comply with the requirements of state and federal law concerning non-discrimination and will strive by its actions to enhance the dignity and worth of all persons.

# Lane Community College

4000 E. 30th Avenue  
Eugene, Oregon 97405  
(503) 726-2200

Office of the President

July 27, 1981

On behalf of Lane Community College, I wish to express our pride and gratitude for the opportunity to participate in the development of the Pre-Apprenticeship training materials. We also wish to commend the Oregon Department of Education for its original concept and continued support; and, the Educational Linkages Component of the CETA Governor's Grant for funding.

The goals of this project are many, but none are more important than that of producing valid, understandable vocational curriculum material. We congratulate the tradespeople and production staff for their accomplishments.

Finally, I recommend this material to anyone exploring Pre-Apprenticeship as an entry into the vocational work world, with the hope and belief that it will go a long way toward producing skilled craftspeople who are dedicated to their work.

Sincerely,

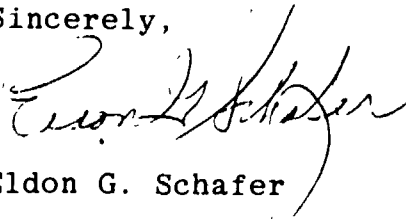

Eldon G. Schafer

## HISTORY AND SCOPE OF THE TRADE

### **Goal:**

The student will be able to identify the historical events which affected the development of the tilesetting trade. He or she will be able to explain why tile is considered a basic material for many types of construction. The student will also be able to identify the major processes used by tilesetters.

2

### **Performance Indicators:**

The student will successfully complete a Self Assessment and a Post Assessment.

5

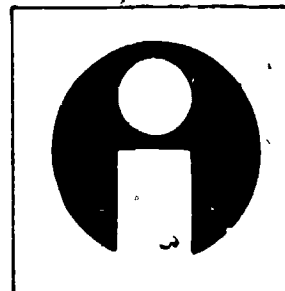

# Study Guide

In order to finish this module, do the following tasks. Check each item off as you complete it.

1.  Read the Goal and Performance Indicators on the cover of the module. This will tell you what you will learn by studying the module, and how you will show you've learned it.
2.  Read the Introduction. The Introduction will tell you why the module is an important part of the tilesetting trade.
3.  Study the Vocabulary section. Vocabulary words are important for a good understanding of the trade. After you have studied the vocabulary, ask your teacher to quiz you on the words and their meanings.
4.  Study the Information section. This section will give you the information you need to understand the subject.
5.  Take the Self Assessment exam. This is a test for you to prove to yourself that you have learned the material you have studied. Compare your answers with the answers on the Self Assessment Answer Sheet, which is on the page following the Self Assessment. If you scored poorly, re-study the Information section or ask your teacher for help.
6.  Take the Post Assessment exam. Give the exam to your teacher after you have completed it. Your teacher will grade it for you.

# Introduction

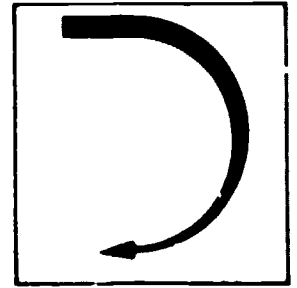

Because properly installed tile can provide floor and wall coverings that can outlast other materials, tilesetting has become recognized as one of the basic trades in the construction industry. Tile and the tilesetting trade have been in existence for thousands of years. Knowing something of the birth of the trade and its growth can give apprentice tilesetters pride in the trade they have selected.

# Vocabulary

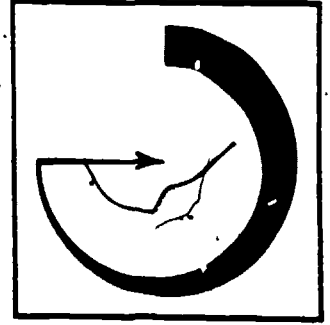

Trade terms are very important for a good understanding of the trade. Study these words and meanings. When you have learned them, ask your teacher to quiz you on the words and their meanings.

**MOSQUE**--A moslem house of worship.

**PHARAOH**--A title given to the rulers of ancient Egypt.

**TOMB**--Grave for the dead, a burial monument.

**PYRAMID**--a structure with a square base and four triangular sides meeting at a point, built by the ancient Egyptians as a royal tomb.

**ARCHAEOLOGIST**--Someone who scientifically studies the life and culture of ancient people.

**KILN**--An oven, furnace, a heated enclosure used for baking clay to make it hard. This baking process is called burning, firing, or drying.

**CERAMICS**--Is the art of making useful articles from clay (such as pots and tile).

**LUG**--An ear-like projection from a piece of tile, by which the tile may be attached.

**TILE FIRING**--The process of heating clay to form tile.

**CATHEDRAL**--A large church.



MOOR--A person of mixed Arabian and Berber descent living in northwest Africa.

MOORISH--Anything constructed in the style of the Moors.

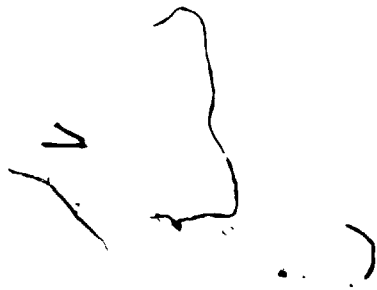

# Supplementary References

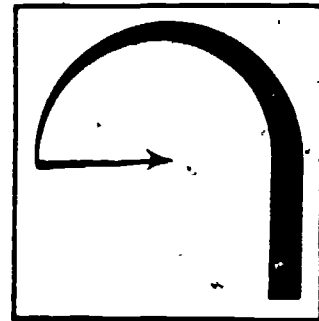

1. McCollam, Harold C. The Brick and Tile Industry in Stark County, Ohio 1809-1976. The Stark County Historical Society, 1976.
2. Newcomb, Rexford. Architectural Monographs on Tile and Tilework. Nos. 1-7. Associated Tile Manufacturers, 1924.

# Information

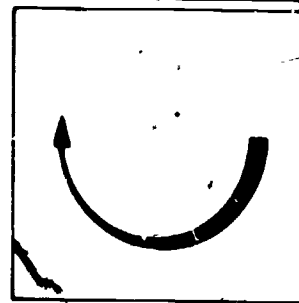

The art of tilemaking is believed by many historians to be as old as civilization itself. It began in the valley between the Tigris and Euphrates rivers in southwest Asia known as Mesopotamia. Who actually made the first household articles of baked or fired clay, no one knows. It is possible that a primitive person seated near a fire idly tossed a piece of wet clay into the flames. When that first piece of clay was dug out of the ashes and found to be hard, the ceramics craft was born.

Proof of the skill of the ancient tilemakers and setters was discovered by modern archaeologists when the stepped pyramid of the Egyptian Pharaoh Zoser was opened. Zoser ordered the pyramid built for his tomb in approximately 3000 B.C. He chose tile to decorate his tomb because he wanted a material that would last forever. Centuries later when the stepped pyramid was opened the tiles were found to be in perfect condition. Blue tiles decorated the walls of one of the mummy chambers and on three rows of tile around the doorway were recorded the deeds and the titles won by the pharaoh. Because of these tiles a part of Egyptian history has been preserved.



Stepped Pyramid of Sakkara

The tiles used in the pyramids had special anchoring devices. Each tile was made with a lug on the back which had a hole through it. Reeds were fastened to the stone walls and then other reeds were looped behind the first reeds and through the hole in the lug on the back of each tile.

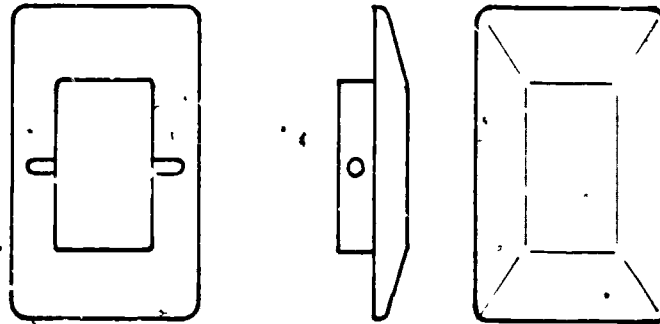

Although the Egyptians continued to use tiles for many centuries, the Persians were the first to develop tilemaking into an Art. The Persians were the first to perfect the process of glazing. Glazes are chemicals that are baked onto the surface of the clay to give it color and a glossy finish. They perfected glazes for rich reds, yellows and blues.

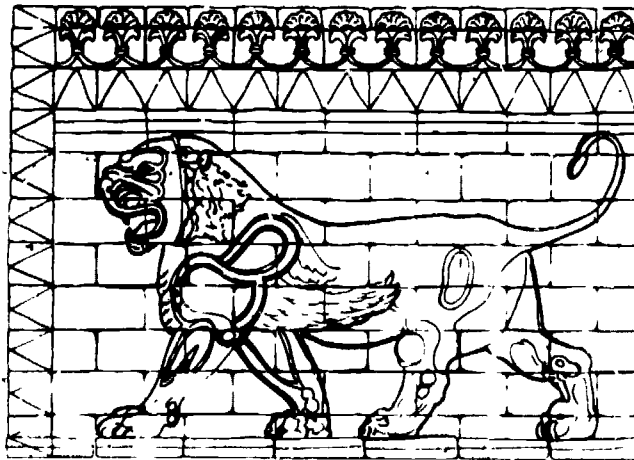

The Arabs, who built mosques that are famous for their beautiful tile work used Persian workmen to manufacture their tiles. The Arabs built mosques in many of the territories that they ruled. As their skills developed they used more and more tilework on all the building surfaces. Because the Arabian people were

not skilled in the art of tilemaking, they took Persian craftsmen with them into the areas that they conquered. Once the Moslems were firmly in power in a new area they would establish tile factories to make the tiles needed to adorn their buildings. The Moslem reign throughout the Mediterranean produced buildings overlaid with tile work that is still unrivaled in the world. The Alhambra, the fortress palace of Moorish kings in Granada, Spain is considered to be one of the finest existing specimens of Moorish architecture. Tile proved to be so popular in Spain that it was soon used extensively in the homes of the wealthy. The Spanish found floors paved with tile attractive and cool and soothing to the feet in their warm climate.

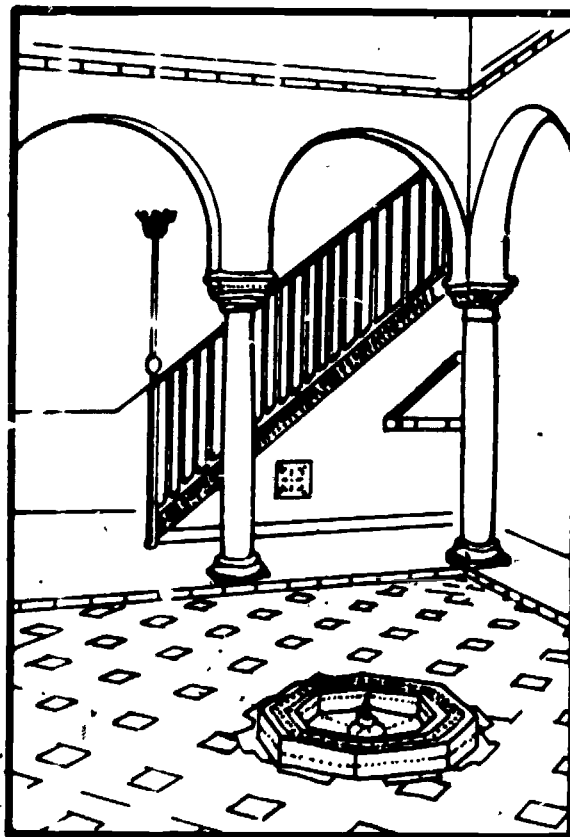

The manufacture of tile in Europe began during the 12th Century. It was, however, at that time so expensive that its use was confined mostly to pavements in the great cathedrals of the old world.

Not until American tile manufacturers began to use modern industrial techniques, did tile products become affordable to the average homeowner. The extensive use of tilework in homes, such as in bathrooms, kitchens and utility rooms, is a fairly recent development.

Tile has been successfully manufactured in this country only since 1876. Samuel Keys, an English immigrant, set up America's first large-scale tilemaking plant in Pittsburgh, Pennsylvania. Within a few years other plants sprang up in Ohio, New Jersey, and New York. California did not become an important tile manufacturing center until after World War I. The American tile industry has grown since then and now the use of tile is common in American homes.

Tilework is installed not only in homes, but also in most public and commercial buildings, including swimming pools, showers, hospital surgery rooms, chemical laboratories, and dairy and meat processing plants.

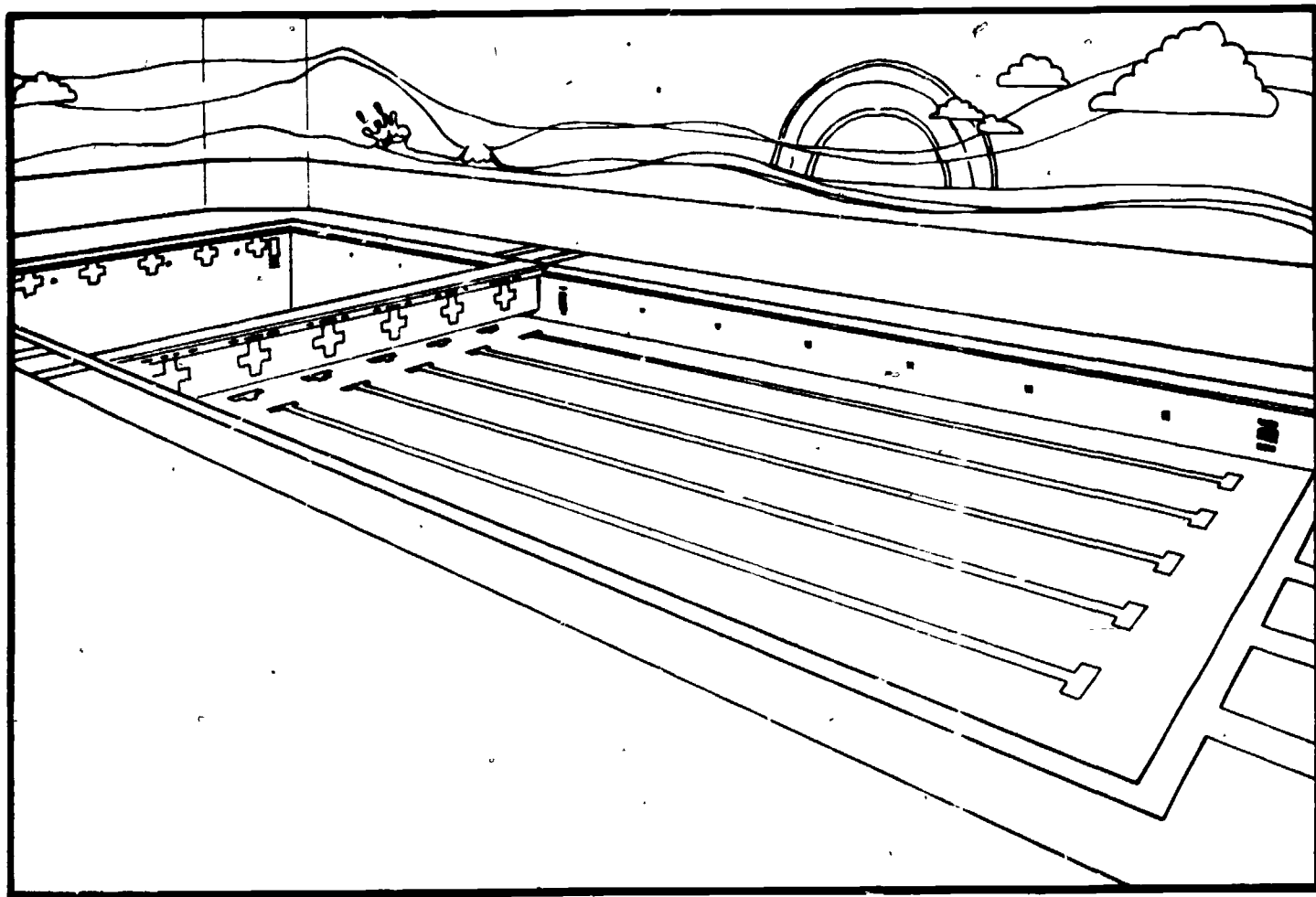

Tile, which was once only available to pharaohs and kings is being used today anywhere beauty and durability with a minimum of maintenance is required. Ceramic tile's hard surface makes it tough enough to last for centuries, resist cuts, bumps, gouges and most stains. Tile often costs no more than other materials to install and yet, in the long run saves you money and work because it never needs painting, polishing or much maintenance.

Today's tilesetter serves a three-year apprenticeship. During this apprenticeship the apprentice tilesetter receives instruction and experience in all branches of the trade to become a practical and skilled tilesetter. The craftsman today must know how to lay out work and repair work of all kinds.

The first year apprentice usually does simple tasks to help the journeymen use their skills. As the years progress, his or her work becomes more challenging until he or she can complete all the necessary processes involved in tile-setting. Once the apprentice's training is completed he or she becomes a journeyman and earns about the same as a trained auto mechanic. Following is a list of the major processes an apprentice tilesetter learns.

1. Preparing surfaces to be tiled.
2. Floating, screeding and scratching.
3. Performing layout work of all kinds.
4. Setting all types of tile.
5. Reading blueprints from simple shop drawings to the commercial type required for schools and industrial buildings.
6. Doing thin-set installations of all kinds.
7. Setting tile on walls, floors, ceilings, countertops, showers, mantels, swimming pools, domes and arches.
8. Repairing existing installations.
9. Removing existing work and replacing it with new.

# Self Assessment

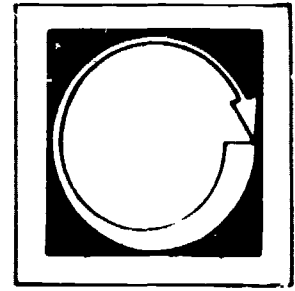

LISTED BELOW ARE STATEMENTS FOLLOWED BY A NUMBER OF POSSIBLE COMPLETIONS.  
SELECT THE COMPLETION WHICH COMPLETES THE STATEMENT CORRECTLY AND PLACE THE  
LETTER IN THE BLANK PROVIDED.

1. \_\_\_\_ Historians believe tilemaking originated in the valley of the \_\_\_\_  
and \_\_\_\_ rivers.
  - a. Snake and Cannabis
  - b. Tigris and Euphrates
  
2. \_\_\_\_ The \_\_\_\_ were the first to develop tilemaking to an art by the  
use of glazes.
  - a. Persians
  - b. Mexicans
  - c. Egyptians
  
3. \_\_\_\_ The manufacture of tile in Europe began in the \_\_\_\_ century.
  - a. twentieth
  - b. twelfth
  - c. first
  
4. \_\_\_\_ Tile was first successfully manufactured in this country by Samuel Keys  
in the year \_\_\_\_.
  - a. 1876
  - b. 1276
  - c. 1976



5. \_\_\_\_ California became an important tile manufacturing center after \_\_\_\_.
- World War II
  - the Civil War
  - World War I
6. \_\_\_\_ Tile is commonly installed in \_\_\_\_.
- swimming pools
  - hospital surgery rooms
  - homes
  - commercial buildings
  - showers
  - dairy plants
  - all of the above
7. \_\_\_\_ The first year as an apprentice is usually spent on work doing \_\_\_\_.
- completion of all the necessary processes involved in tilesetting
  - simple tasks which aid the journeymen
  - banquet dinners and signing autographs
8. \_\_\_\_ A journeyman is considered a \_\_\_\_.
- traveler
  - a trained craftsman in a trade.
  - trained mechanic
  - both b and c
9. \_\_\_\_ There were \_\_\_\_ major processes given that an apprentice tile-setter would learn.
- 18
  - 10
  - 9

# Self Assessment Answers

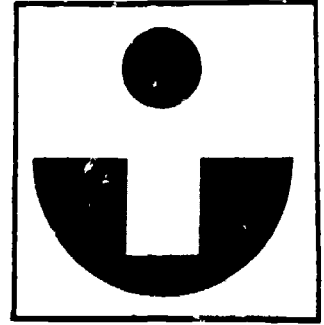

1. b

2. a

3. b

4. a

5. c

6. g

7. b

8. d

9. c

# Post Assessment

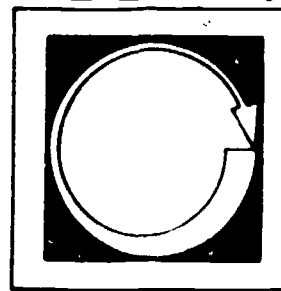

LISTED BELOW ARE SEVERAL STATEMENTS. IF THE STATEMENT IS TRUE, PLACE A "T" IN THE BLANK PROVIDED. IF THE STATEMENT IS FALSE, PLACE AN "F" IN THE BLANK. WRITE THE CORRECT ANSWERS FOR THE STATEMENTS THAT ARE FALSE.

1. \_\_\_ An archaeologist is someone who is a specialist in the scientific study of marine resources and technology.
2. \_\_\_ A pyramid is a structure with a square base and four triangular sides meeting at a point, built by the ancient Egyptians as royal tombs.
3. \_\_\_ A kiln is a substance often used to heat an enclosure.
4. \_\_\_ A tomb is a burial building and monument.
5. \_\_\_ A mosque is a mummy covered with tile.
6. \_\_\_ Pharaoh is a title given to the rulers of ancient Egypt.
7. \_\_\_ Ceramics is the art of making useful articles from clay--such as pots and tile.
8. \_\_\_ Moor is a term given to ancient Greeks who never could get enough of a good thing.
9. \_\_\_ Moorish s in the style of the moors.
10. \_\_\_ A cathedral is a large church.

11. \_\_\_\_\_ tilefiring is basically a large fire made by stacking tile and lighting it.
12. \_\_\_\_\_ A lug is a ear-like projection from a piece of tile, by which it may be attached.

# Instructor Post Assessment Answers

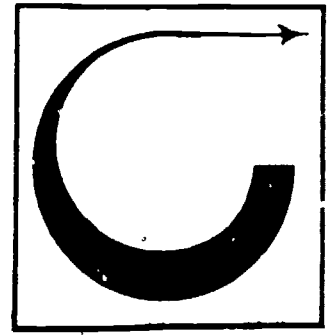

1. F An archaeologist is someone who is engaged in the scientific study of the life and culture of ancient people.
2. T
3. F A kiln is an oven, furnace, or heated enclosure used for processing a substance by burning, firing or drying.
4. T
5. F A mosque is a house of worship--a temple.
6. T
7. T
8. F Moor is a moslem person with mixed Arabian and Berber descent coming from northwest Africa.
9. T
10. T
11. F Tilefiring is the process of heating clay to form tile.
12. T

## SAFE WORKING PRACTICES

### **Goal:**

The student will be able to explain the importance of on-the-job safety and good housekeeping.

### **Performance Indicators:**

The student will successfully complete a Self Assessment, an Assignment page and a Post Assessment.

# Study Guide

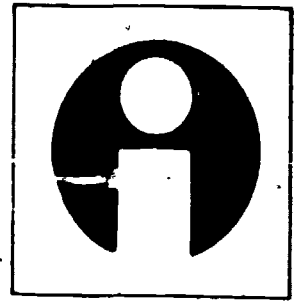

In order to finish this module, do the following tasks. Check each item off as you complete it.

1.  Read the Goal and Performance Indicators on the cover of the module. This will tell you what you will learn by studying the module, and how you will show you've learned it.
2.  Read the Introduction. The Introduction will tell you why the module is an important part of the typesetting trade.
3.  Study the Vocabulary section. Vocabulary words are important for a good understanding of the trade. After you have studied the vocabulary, ask your teacher to quiz you on the words and their meanings.
4.  Study the Information section. This section will give you the information you need to understand the subject.
5.  Take the Self Assessment exam. This is a test for you to prove to yourself that you have learned the material you have studied. Compare your answers with the answers on the Self Assessment Answer Sheet, which is on the page following the Self Assessment. If you scored poorly, re-study the Information section or ask your teacher for help.
6.  Do the Assignment page. Follow the instructions at the top of the Assignment page.
7.  Take the Post Assessment exam. Give the exam to your teacher after you have completed it. Your teacher will grade it for you.

# Introduction

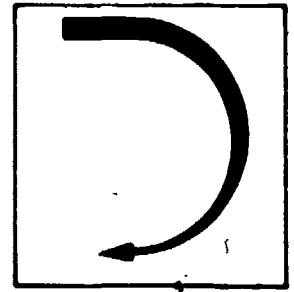

Tilesetting requires the use of many potentially dangerous tools and substances. The hazards involved with the use of electric saws, drills, scaffolds and other equipment must always be kept in mind. Care must also be taken when handling concentrated acid solutions and toxic epoxies. In addition, at every construction site, hazards exist that can cause injuries. Every tilesetter must learn to work keeping safety always in mind.



# Vocabulary

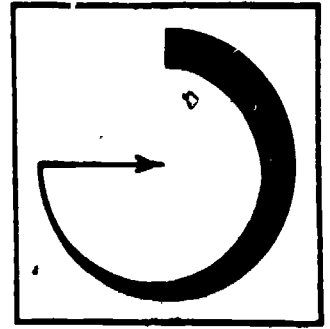

Trade terms are very important for a good understanding of the trade. Study these words and meanings. When you have learned them, ask your teacher to quiz you on the words and their meanings.

**ATTITUDES**--Responses, favorable or unfavorable, to a person, group, idea, or situation.

**HABITS**--A usual manner of behavior. A behavior pattern.

**HAZARDOUS**--Dangerous, the chance of exposing yourself to a risk and possible accident.

**FOUNDATION**--A body or grounds upon which something is built.

**ENVIRONMENT**--The circumstances, objects, or conditions by which you are surrounded.

**TOXIC**--Poisonous.

**EPOXY**--An adhesive used to glue certain materials together.

**MASTIC**--A pasty material also used as an adhesive to glue certain materials together.

**DROP-CLOTH**--A protective sheet of cloth or plastic used to cover floors and furniture.

**DOLLY**--A platform on a roller or on wheels used for moving heavy objects.

PULLEY--A wheel with a grooved rim, used with a rope or chain for lifting weights.

SCAFFOLD--A temporary, sometimes movable, platform for workpeople to stand or sit on when working up high.

SHOCK--To subject to an electrical discharge.

VOLTAGE--A unit of electrical potential.

RESISTANCE--An opposing force, that slows down an electrical current.

ELECTRIC CIRCUIT--The path taken by electricity through wires.

GROUND--An object that makes an electrical connection with the earth is grounded.

INSULATION--A material used to prevent the transfer of electricity, heat, or sound.

"HOT" OR LIVE-WIRE--Electrically energized with high voltage.

# Supplementary References

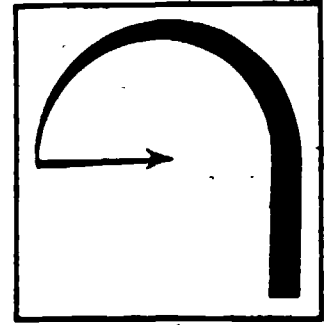

1. The American National Red Cross. Standard First Aid and Personal Safety. Doubleday and Company Inc., 1975.
2. Worick, W. Wayne. Safety Education--Man, His Machines, and His Environment. Prentice - Hall, Inc., 1975. pp. 1-45, 111,116.

# Information

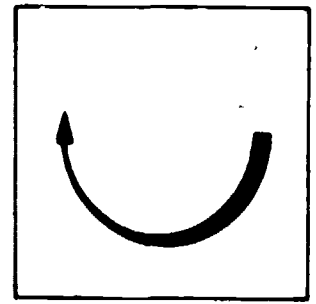

Safety is everyone's responsibility. Employers are responsible for providing safe and healthful working conditions for their employees. Under no circumstances can they require or permit an employee to work where safety and health standards are not met. It is the responsibility of the worker to practice safety on the job and to use good common sense in dealing with unhealthy situations that arise when the employer is not at the jobsite. It is up to each worker to learn, respect, and practice safe working habits.

Understanding the basic or root causes of accidents is the first step toward avoiding accidents. Accident causes can be divided into the five general areas outlined below:

1. Not enough knowledge.
2. Not enough skill.
3. Environmental hazards.
4. Bad habits and attitudes.
5. Unsafe behavior.

Of these five, knowledge is the foundation for understanding safety hazards. It is the key to the development of safe behavior. Every worker should learn and appreciate rules. Knowledge is vital if a worker is to avoid hazardous situations and be able to react properly when caught in such a situation. Proper knowledge enables the worker to recognize and evaluate dangerous situations. A worker's skill level also affects safety. Attempting to perform tasks beyond one's ability level creates high-risk situations. Skill level is important when doing any task and should be given consideration during both work and play.

A perfectly safe environment is not possible. Despite our inability to completely control our environment, the impact of environmental hazards can be kept to a minimum if common sense is used. Just as an airplane pilot always

checks the weather before flying, every worker should be sure his or her working environment is safe before starting to work.

Bad work habits and attitudes are the main causes of accidents. A worker with bad habits does things that are hazardous without thinking. Workers with bad attitudes don't think safety is important. Unsafe behavior is the end result of a worker's failure to develop proper knowledge, skill, habits and attitudes concerning safety. Safe behavior means to respond correctly under all circumstances, and avoid, when possible, high-risk situations. There is no excuse for purposely engaging in unsafe behavior.

The foundation of good safety practices is built with a knowledge of basic safety principles and rules. Upon these general rules can be built a framework of specific guidelines for dealing with actual on-the-job conditions and situations. Practicing the following seven rules will help you to avoid accidents and injury:

1. Keep the work area clean and free of unneeded tools and materials.
2. Always wear the right clothes for the job.
3. Always wear protective gear whenever engaged in hazardous work.
4. Stack and store materials so that they cannot fall over.
5. When lifting heavy objects keep your back straight and lift with your legs. Use handling tools such as lift trucks or pulley hoists for very heavy objects.
6. Use tools only in the way they were designed to be used.
7. Exercise special care whenever working with power equipment and electricity.

Good housekeeping is necessary for keeping the work area safe. Floors, aisles, stairways, and ramps must be kept clear of materials. All work areas must be kept clean and clear of unneeded materials and equipment. Oil, grease, mud, or anything slippery that could cause falls must be cleaned up immediately. Any material or object that could be stumbled over should be removed from the work area or guarded if it cannot be removed. Lumber with nails sticking out should be kept away from work areas and passageways. The nails should be pulled out or bent flat. Open ditches must be bridged or roped off. There must be good lighting for work areas and passageways. Enclosed spaces must have enough ventilation to prevent air stagnation and the build up of polluted air.

Cleanliness should always be on your mind. The bottom of your shoes should always be checked to make sure that you are not tracking mud, grease, oil or other dirt onto finished surfaces, such as carpet, hardwood flooring or tile. Floors should be protected with a drop-cloth or heavy-duty construction paper whenever it is not possible to keep them clean. You should also be careful to avoid leaving dirty fingerprints on finished surfaces.

You should wear clothing that is right for the work you are doing. Pant legs should not be torn, bulky, or have turned up cuffs that could catch on something and cause a fall. Generally pants made from a thick denim type material give good protection against materials that can be harmful to the skin. Wear leather shoes or boots with thick soles and good heels to reduce the chance of stumbling, slipping, or cutting your feet on sharp objects that would puncture light weight shoes.

Eye protection is a must when you are chipping and repairing old work. Goggles should be worn not only to protect your eyes from flying pieces but also to keep out the fine cement dust that such work makes. A respirator or dust-filtering mask should be worn whenever the job you're doing creates a lot of dust. It should also be worn when you're working around paint spraying. A hard hat should be worn when construction is going on overhead. When you have to kneel to do a job knee pads should be worn. They will protect your knees from injury from hard surfaces and debris such as tile chips or nails.

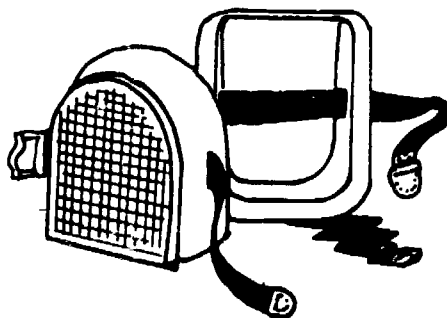

The correct handling and piling of materials is important to prevent them from falling. Stacks of bricks, tiles, building blocks and the like should have spacers at least every sixth layer. This helps to keep the stack square. When

cement or other sacked materials are stacked more than five feet high, the stack should be leaned into a wall or braced.

Unsafe methods of lifting, lowering, and carrying materials can cause strains, sprains, and hernia. If the strain is serious, dislocations and even breaks can result. Wet and cluttered floors can make lifting and carrying hazardous and cause bad falls or smashed fingers and toes. When lifting, use your back as little as possible. You should bend at the knees keeping your back straight and your head up. Slowly, without jerking, lift the load by straightening your legs. You should not try to lift or carry very heavy loads without help. You can carry much more weight safely when equipment for lifting or carrying such as rope and pulley hoists, rollers, dollies and hand trucks are used.

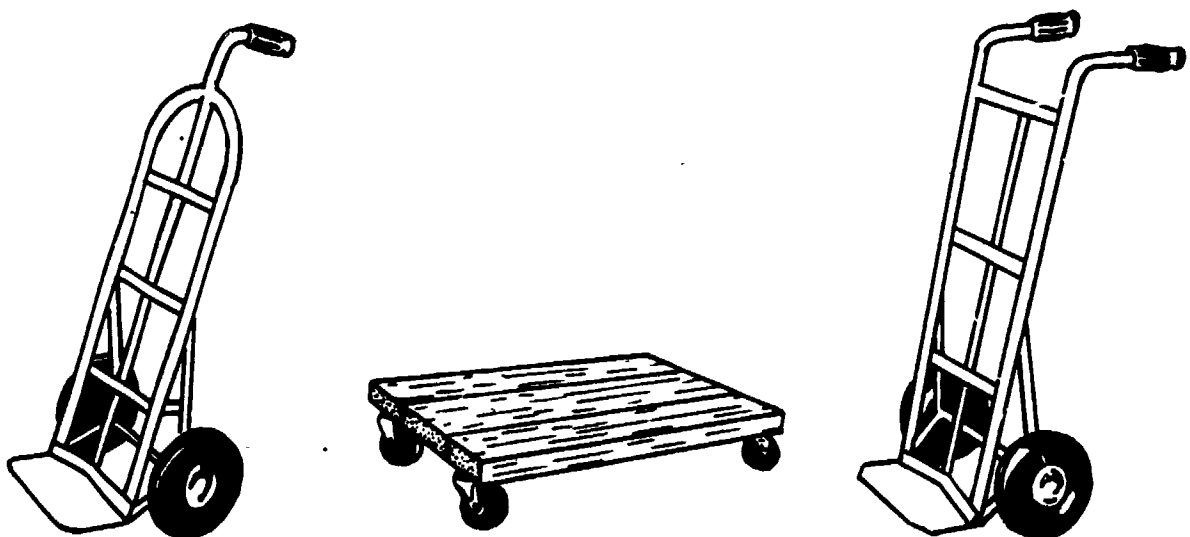

Incorrectly used or poorly maintained hand tools are dangerous. The following is a list of hazards associated with the use of hand tools:

1. Being struck by the tool being used.
2. Being struck either by chips from a tool or from the worked material.
3. Being struck by a tool that has come off its handle.
4. Stumbling over, or being struck by, a tool carelessly left on the floor, a workbench, or a scaffold.

Almost all injuries that occur while using hand tools can be avoided if a few basic rules are followed:

1. Use the right tool for the job.
2. Learn how to use the tool correctly.
3. Keep tools in their best condition.
4. Keep each tool in its proper place.

Your tools will last a lot longer if, after they are used, you take the time to clean and dry them.

Tilesetting often requires using electric tile saws, drills and hand mixers.

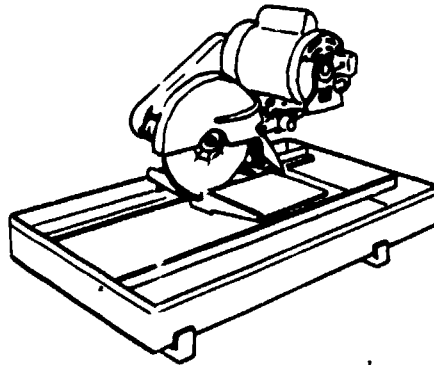

Electric shock is always dangerous. A shock can cause burns or other serious injury. Under certain conditions a shock can kill you. Electric shock happens when all or part of a person's body becomes part of a live electric circuit. The seriousness of the injury you get from a shock depends upon how much current passes through your body. This is affected by two things. One is voltage and the other is the electrical resistance made by your body at the moment of the shock.

Electric shock will result when you do any of these things:

1. Touch a live wire and a grounded object or surface, such as a water pipe or the earth itself.
2. Touch a live and neutral wire at the same time, for example by grabbing both exposed wires of a badly frayed power cord.
3. Indirectly, by touching an object, especially a metal object, which is carrying a current to ground or is touching a "hot" wire.

Most electric shocks happen when you touch a live wire while touching or standing on a grounded object or surface. Wet hands or feet can make the shock worse by reducing your body's resistance. This allows more current to flow through it. On the other hand, any dry insulating material that comes between you and the ground or the live wire will reduce the severity of the shock. Rubber, wood, cloth, and other non-metallic materials are good electrical insulators if they



are dry; wet insulating materials do not work.

The insulation on tool cords must be in good condition and all noncurrent-carrying metal parts of electric tools must be grounded. The danger of electric shock can be minimized if the following rules are observed.

1. Consider all electric wires "live" or "hot" unless they are known to be otherwise.
2. Do not work on electrical circuits unless you are qualified to do so.
3. Do not make repairs to electrical equipment unless you are qualified to do so.
4. Double-check to ensure that main switches are off before touching electrical wires or other potentially "hot" electrical components. Lock the switch box, and place a warning sign on it to ensure that the main switches will not be turned on by another person.
5. Be sure your hands are dry. If you must work on a wet surface, wear rubber-soled shoes and rubber gloves.
6. Use only heavy-duty extension cords.
7. Do not hang or bend an extension cord across nails or sharp surfaces. Do not lay cords in water or where a truck could run over them.
8. Make sure that all portable electrical tools, such as the tile saw and drill, are grounded.

There are some hazards that tilesetters need to pay special attention to. One is the danger of working with scaffolds. Scaffolds must be provided for all work that cannot be done safely by standing on the ground. Scaffolds must have railings. Scaffolds, to be safe, must be strong, rigid and anchored or braced to prevent swaying, tipping or collapsing. Special care should also be taken when working with epoxies and mastics. Some of them are flammable, toxic and irritating to the skin. When these materials are being used, the following precautions should be taken:

1. Ensure that epoxies and mastics are properly labeled.
2. Read and follow the label directions carefully.
3. Use in areas where the ventilation is good and avoid prolonged breathing of fumes.
4. Avoid prolonged contact with the skin; if any of the material does get on you wash it off immediately with water.

5. Do not use near a flame or in a room that contains an open flame.
6. Wash hands thoroughly after using these materials, particularly before eating.

# Self Assessment

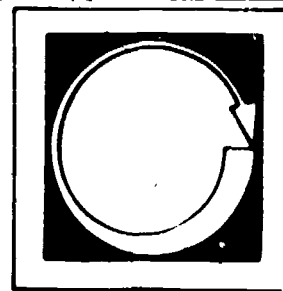

LISTED BELOW ARE STATEMENTS FOLLOWED BY A NUMBER OF POSSIBLE COMPLETIONS. SELECT THE COMPLETION WHICH COMPLETES THE STATEMENT CORRECTLY AND PLACE THE LETTER IN THE BLANK PROVIDED.

1. \_\_\_\_\_ When we say good housekeeping is necessary for safety on the job we mean
  - a. keep your room clean, bed made, and parents happy or you may not be safe.
  - b. keep floors, aisles, stairways, work areas, passageways and equipment clean.
  - c. if the maid does a good job cleaning the house, she will be much safer on the job.
  
2. \_\_\_\_\_ Nails sticking out from lumber should be
  - a. pushed to the side or thrown away.
  - b. pulled out or bent flat.
  - c. left alone or ignored.
  
3. \_\_\_\_\_ Wearing the correct type of shoe or boot is very important. They should be
  - a. made of leather and have thick soles.
  - b. made very light, for as quick an exit as possible.
  - c. tennis shoe type--so they can be washed.
  
4. \_\_\_\_\_ When chipping tile, you should protect your eyes from flying pieces and from
  - a. insects
  - b. infrared light.
  - c. fine cement dust.

5. \_\_\_\_\_ Knee pads should be worn to
- protect your knees from injury from hard surfaces and sharp pieces of debris.
  - to prevent tiredness in your legs that can cause accidents.
  - to make you look like a basketball star.
6. \_\_\_\_\_ When lifting heavy objects, a person should use his or her \_\_\_\_\_ as much as possible.
- arms.
  - back.
  - legs.
7. \_\_\_\_\_ Lifting or carrying can be made safer by
- using a hand truck or dolly.
  - dragging the object with a rope.
  - cutting the object into little pieces.
8. \_\_\_\_\_ Injuries from hand tools can be avoided if a few basic rules are followed. They are:
- use the right tool for the job and learn to use the tool correctly.
  - keep tools in good working condition and out of the way in their box when not in use.
  - both 1 and 2.

LISTED BELOW ARE SEVERAL STATEMENTS. IF THE STATEMENT IS TRUE, PLACE A "T" IN THE BLANK PROVIDED. IF THE STATEMENT IS FALSE, PLACE AN "F" IN THE BLANK.

9. \_\_\_\_\_ Electric shock happens when all or part of the body becomes part of a live electric circuit.
10. \_\_\_\_\_ Most electric shocks result when you touch a live wire while touching or standing on a grounded object or surface.
11. \_\_\_\_\_ If a worker's hands or feet are wet, the severity of an electric shock will be worse.
12. \_\_\_\_\_ Rubber and wood are two insulating materials that will reduce the severity of shock.

13. \_\_\_ Wet insulating materials reduce the severity of shock.
14. \_\_\_ A scaffold is a tool used to remove broken shower tile.
15. \_\_\_ Epoxies and mastics should not be used in a room that has bad ventilation or an open flame.

# Self Assessment Answers

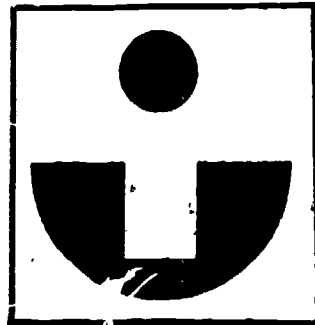

1. b
2. b
3. a
4. c
5. a
6. b
7. a
8. c
9. T
10. T
11. T
12. T
13. F
14. F
15. T

# Assignment

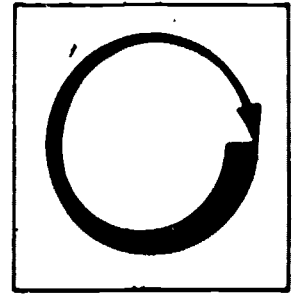

COMPLETE THE FOLLOWING ASSIGNMENT.

In this module you were given five general areas of accident causes. List all five--then on two of the five write what they mean. Show the list to your instructor.

1.

2.

3.

4.

5.

# Post Assessment

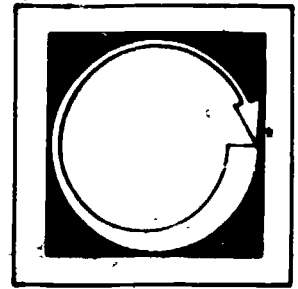

LISTED BELOW ARE SEVERAL STATEMENTS. IF THE STATEMENT IS TRUE, PLACE A "T" IN THE BLANK PROVIDED. IF THE STATEMENT IS FALSE, PLACE AN "F" IN THE BLANK.

1.  An attitude is a response, favorable or unfavorable, to a person, group, idea or situation.
2.  Something toxic is very good for you.
3.  A drop-cloth is a protective cloth put under your scaffold in case you fall.
4.  A header is a span across the top of something to supply support for the weight of what is above.
5.  A dolly is a platform for workmen to stand or sit on when working at a height above the ground.
6.  Epoxy and mastics are used to glue certain materials together.
7.  Resistance is a force of power subject to the action of an electrical discharge.
8.  A pulley is a wheel with a grooved rim, used with a rope or chain to lift weights.
9.  An electric circuit is a circuit that transfers heat, or sound to the ground.



10. \_\_\_ Insulation is a material used to prevent the transfer of electricity, heat, or sound.
11. \_\_\_ "Hot" or "live" wires are wires electrically energized with high voltage.
12. \_\_\_ Grounded in this case is when materials clutter the aisles, hallways, and passageways.
13. \_\_\_ Voltage is a unit of electrical potential.
14. \_\_\_ Shock in this case means to subject to the action of an electrical discharge.

WRITE THE CORRECT ANSWER FOR THE ANSWERS THAT WERE FALSE.

# Instructor Post Assessment Answers

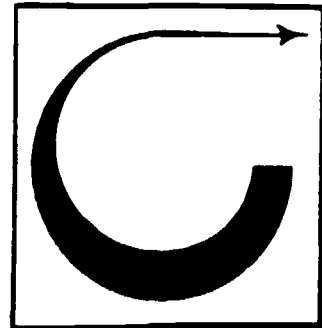

1. T
2. F Toxic means poisonous.
3. F A scaffold is a temporary or movable platform for workmen to stand or sit on when working at a height above the ground.
4. T
5. F A dolly is a platform on a roller or on wheels used for moving heavy objects.
6. T
7. F Resistance is an opposing force, something that slows down electrical current.
8. T
9. F Electric circuit is a circuit operated by electricity.
10. T
11. T
12. F Grounded is when an object makes an electrical connection with the earth.
13. T
14. T

## THE MANUFACTURE OF CERAMIC TILE

### **Goal:**

The student will be able to identify and explain:

1. The four main tile forming processes.
2. What a "green" tile is.
3. The firing process.
4. Different tile shapes.

40

### **Performance Indicators:**

The student will successfully complete a Self Assessment, an Assignment, and a Post Assessment.

43

# Study Guide

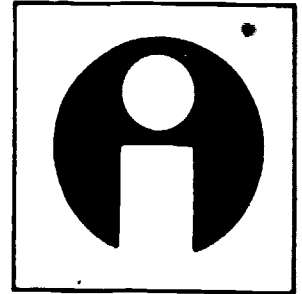

In order to finish this module, do the following tasks. Check each item off as you complete it.

1.  Read the Goal and Performance Indicators on the cover of the module. This will tell you what you will learn by studying the module, and how you will show you've learned it.
2.  Read the Introduction. The Introduction will tell you why the module is an important part of the tile setting trade.
3.  Study the Vocabulary section. Vocabulary words are important for a good understanding of the trade. After you have studied the vocabulary, ask your teacher to quiz you on the words and their meanings.
4.  Study the Information section. This section will give you the information you need to understand the subject.
5.  Take the Self Assessment exam. This is a test for you to prove to yourself that you have learned the material you have studied. Compare your answers with the answers on the Self Assessment Answer Sheet, which is on the page following the Self Assessment. If you scored poorly, re-study the Information section or ask your teacher for help.
6.  Do the Assignment page. Follow the instructions at the top of the Assignment page.
7.  Take the Post Assessment exam. Give the exam to your teacher after you have completed it. Your teacher will grade it for you.

# Introduction

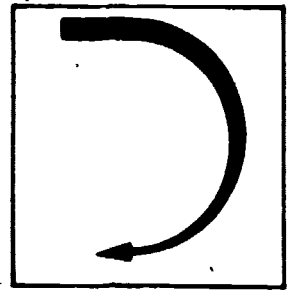

The tilesetter needs to understand the manufacture of tile, the processes involved and be able to recognize and identify different tile shapes to be knowledgeable in the tilesetting trade.

# Vocabulary

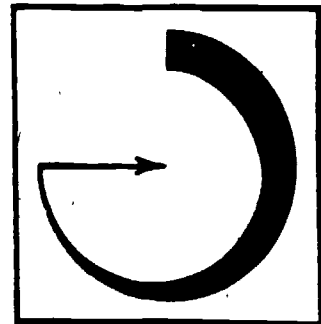

Trade terms are very important for a good understanding of the trade. Study these words and meanings. When you have learned them, ask your teacher to quiz you on the words and their meanings.

**NATURAL CLAY**--A material mined from the earth that is plastic-like when wet and becomes hard when fired.

**GREEN TILES**--Fresh dust-pressed, dry-pressed and ram-pressed tiles.

**TALC**--A soft mineral mined from the earth that is white, green, or gray in color with a soapy feel.

**BISQUE**--Any fired tile shape that is ready to be glazed.

**FEATHEREDGE**--A thin sharp edge.

**GLAZE**--A coat of glaze that gives a hard, glossy and usually smooth surface to tile.

**PUG-MILL**--A machine in which clay and water are mixed and blended into a desired consistency.

**AUGER**--A device used for forcing (as a meat grinder).

**BIN**--A box, frame, an enclosed place used for storage.

**GRANULATE**--To make into small particles.

TEMPERED--To mix elements together to get the desired condition (like clay and water in the pug-mill).

EXTRUDE--To force, press, or push out.

SCREEN--A wire mesh that is used to filter out the larger pieces of material so only the fine material is left.

HYDRAULIC PRESS--A press that uses hydraulics as its force with lots of pressure.

SHALE--A natural material that is made of clay, mud, or silt.

QUARRY TILE--A natural unglazed tile that is very hard and usually vitreous.

CERAMIC MOSAIC--Small ceramic tiles used to form a certain design or pattern.

VITREOUS--Resembling glass: Hard, brittle and almost non-absorbent.

ABSORB--The ability to mop up like a sponge.

PERCENTAGE--A part of a whole expressed in hundredths. For example, 10 percent of 100 is 10.

BOND--To hold together (as glue bonds things together).

# Supplementary References

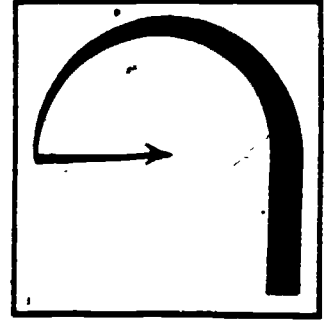

1. Plummer, Harry C. and Edwin F. Wanner. Tile Engineering--Handbook of Design. Structural Clay Products Institute, 1947. pp. 7-27.
2. Smith, Clyde. The Manufacture of Brick, Tile and Kindred Products--Bulletin #189. U.S. Bureau of Labor Standards, 1956. pp. 4-9.



# Information

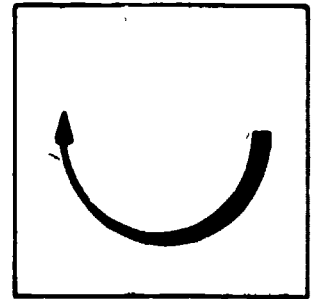

Tilesetters will not be called upon to manufacture tiles but they should have a good understanding of the ways tiles are made, the materials used and be able to identify different tile shapes.

The four main processes of forming ceramic tiles:

1. The dust-press process, also known as the dry-press process.
2. The extrusion process, also known as the "stiff-mud" process.
3. The slush-mold process, also known as the "soft-mud" process.
4. The ram-press process.

All the processes begin in the clay pits. The clay is moved from the pits in storage cars or on conveyor belts to storage bins where it is held until needed by the factory. Sometimes when the clay is naturally quite wet (like the type used in the slush-mold or soft-mud process) the clay is delivered directly to the preparation plant.

The preparation of clays is much the same in all the processes. The clay is moved from the storage bins to a machine called the granulator, which is a large, usually round tank. A steel shaft goes through it that revolves with knives attached at angles that break up the large chunks of clay. It mixes, granulates, and leaves the clay at one end of the machine, ready for the next step. The rocks and pebbles are removed, the clay is ground and then screened into a fine material. Next the clay is tempered by a pug-mill. From here the individual processes are all different.

Most wall tiles and trim shapes are made by the dust-press or dry-press process. The tile body is a mixture of finely ground talc and natural clays with different mixes used for different types of tile. The mixture is dried to almost a dust consistency. Then, with lots of pressure, the mixture is pressed into different

tile shapes by steel molds mounted on hydraulic presses. After it has been pressed each tile is inspected for smoothness, size and defects. At this point the tile is called "green."

The next steps involve drying, firing and glazing, if a glaze is required. Some manufacturers use a process that requires two firings of the green tiles to reach the desired hardness and glaze. A process that requires only one firing for hardness and glaze is used by other manufacturers. Both methods are described later in this module.

In the extrusion or stiff-mud process of forming and molding, a mixture of clays, and sometimes shale, is mixed with water in the pug-mill to form a stiff mud. The mixture is then put into an auger machine which forces it through a mold that is the desired shape for the tile. As the tile is extruded, it passes through a machine that cuts it to the desired lengths.

After the tiles have been extruded and cut they are inspected. The perfect ones are sent on to be dried, the imperfect ones are returned to the pug-mill to go through the process again. Nearly all quarry tiles and some ceramic mosaic tiles are produced by this process.

In the slush-mold or soft-mud process, a wet mixture of clay is poured by machine into molds. After waiting a certain amount of time for drying, the molds are removed and the tiles are placed in a kiln and fired at the right temperature. The glaze in this process is usually applied before firing.

The ram-press process is very much like the dust-press process but is for larger pieces of tile. The clay mixture is dried to almost a dust consistency, then with lots of pressure it's pressed by two metal molds to form the green tile. There are two reasons for this: (1) To get any desired shape and (2) to control the thickness.

Two firings are required as in the dust-press process. The ram-press process is used mainly to make large pieces of tile (such as 12" X 12" and larger) and some of the decorative tiles.

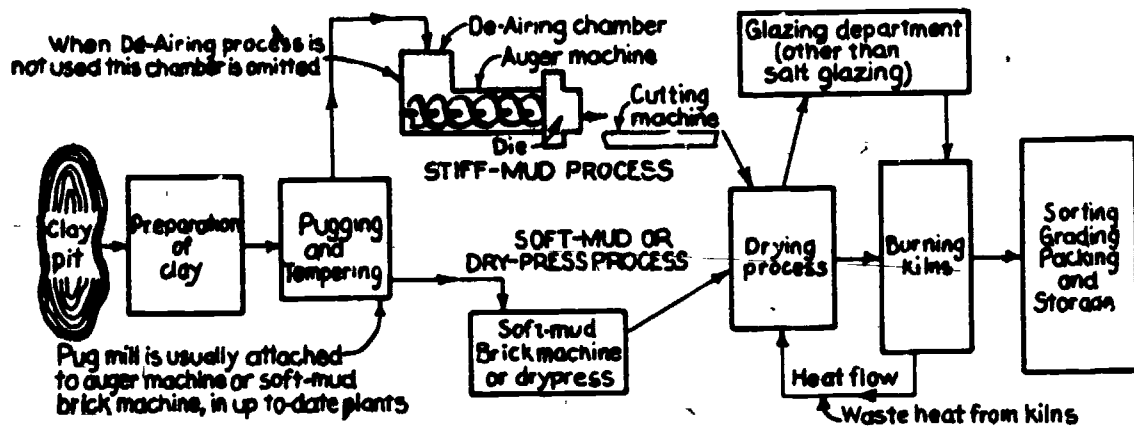

## FIRING PROCESS

Green tiles are fired at a high initial temperature to form a bisque. Then the glaze is sprayed onto the bisque and a second firing at a lower temperature (called the glass firing) bonds the glaze with the bisque. Thus the glazed finish and color are controlled by the glass firing. Tiles that are not glazed require only a single firing.

There is a process that eliminates a second firing for glazed wall tiles and trim shapes. After the green tile has been inspected and passed, the glaze is added to the surface to be glazed and fired in the kiln. This eliminates the bisque firing.

The size and finish of the tiles are controlled by the amount of heat and the time spent in the kiln. Being able to complete the tile in a single firing saves the manufacturer time and money.

There are two types of tile manufactured: Vitreous and non-vitreous. Vitreous tile will absorb very little moisture or none at all (.5 to 3 percent). A semi-vitreous tile will absorb between 3 and 7 percent. These are usually given a single firing. Non-vitreous tile will absorb 7 percent or more. The less amount of moisture a tile can absorb makes the tile hard. The higher the percent of moisture a tile can absorb makes it softer and easier to break. A vitreous tile is much harder than a non-vitreous tile.

The tilesetter needs to know what kind of tile is being used (vitreous or non-vitreous). For example, a different type of grout is used for vitreous tiles, than is used for the highly absorbent non-vitreous tiles.

There are a couple of easy tests the tilesetter can use to determine what category the tile is in:

1. A small amount of water is put on the back of the tile. If the water just sits there or takes a long time to absorb, it would be a vitreous or semi-vitreous tile. If the water is almost immediately absorbed and disappears, then the tilesetter knows it is a highly absorbent non-vitreous tile.
2. Touch your tongue to the back of the tile. If your tongue is drawn to the tile, or you get the feeling your tongue has just been stuck to the tile, you will know the tile is non-vitreous. If you touch your tongue to the back of the tile and nothing happens, you know it is a hard, dense vitreous tile.

#### TILE SHAPES

Tiles are made in many different shapes. Being able to identify these is important for the tilesetter.

Illustrated below are some tile shapes that a tilesetter will come across in the trade. Look them over carefully so you will be able to easily identify them. These types of tiles are available in different sizes. (See illustration on the following page.)

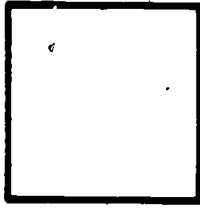

SQUARE

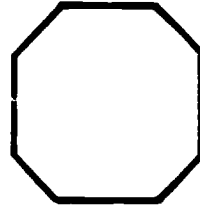

OCTAGON

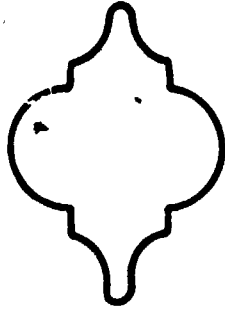

VALENCIA

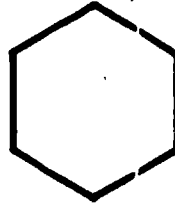

HEXAGON

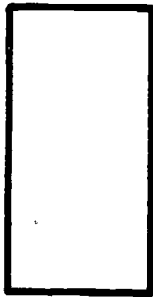

OBLONG  
RECTANGLE

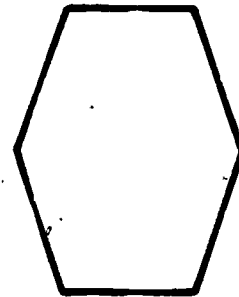

ELONGATED  
HEXAGON

# Self Assessment

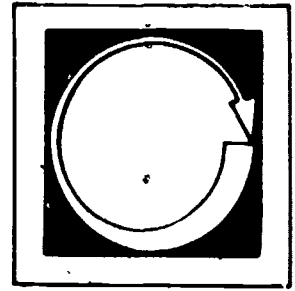

LISTED BELOW ARE TRUE-FALSE, SHORT ANSWER AND MULTIPLE CHOICE QUESTIONS.  
PLACE YOUR ANSWER IN THE SPACE PROVIDED.

1. List the four main processes used to form ceramic tiles.
  - a.
  - b.
  - c.
  - d.
  
2. The wettest clay is usually used in the \_\_\_\_\_ process.
  - a. ram-press
  - b. dust-press
  - c. slush-mold
  - d. stiff-mud
  
3. \_\_\_\_\_ True or False. The preparation of clays is much the same in all the processes.
  
4. A pug-mill is \_\_\_\_\_.
  - a. A mill where feed is made and processed for farm animals.
  - b. A machine in which clay and water are mixed and blended.
  - c. A large tank, usually round, that breaks up large chunks of clay.
  
5. Most wall tiles and trim shapes are made by the \_\_\_\_\_ process.
  - a. dust-press
  - b. soft-mud
  - c. slush-mold
  - d. extrusion

6. After a tile has been pressed out it is called a \_\_\_\_\_ tile.
- new
  - molded
  - extruded
  - green
7. A bisque is any tile ready to \_\_\_\_\_.
- start the process over again
  - be sold at a store
  - be glazed
  - be put through the pug-mill
8. Nearly all quarry tiles are produced by the \_\_\_\_\_ process.
- stiff-mud
  - soft-mud
  - ram-press
  - extrusion
  - both a and d
9. Two processes that are very much alike but not exactly the same are:
- \_\_\_\_\_.
- dust-press and dry-press
  - slush-mold and soft-mud
  - dust-press and ram-press
  - both a and b
10. \_\_\_\_\_ True or False. The glass firing bonds the glaze with the bisque.
11. \_\_\_\_\_ True or False. All tiles are glass-fired.
12. \_\_\_\_\_ Tiles can be fired and have the glaze put on at the same time.
13. Tile with water absorption of 3 percent or less is called \_\_\_\_\_.
- soft body
  - vitreous
  - non-vitreous
  - clay

14. Generally vitreous tiles are given \_\_\_\_\_ firing(s).

- a. three
- b. two
- c. one

15. The higher the percent of moisture a tile can absorb, the \_\_\_\_\_ the tile will be.

- a. harder
- b. softer
- c. heavier
- d. both b and c



# Self Assessment Answers

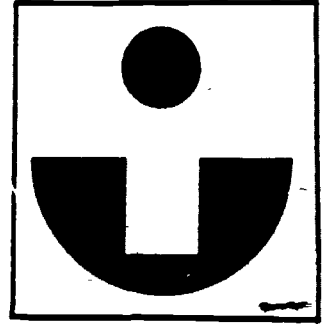

1. a. dust-press and dry-press process  
b. the extrusion and stiff-mud process  
c. the slush-mold and soft-mud process  
d. the ram-press process
2. c
3. T
4. b
5. a
6. d
7. c
8. e
9. c
10. T
11. F
12. T
13. b
14. one
15. b

# Assignment

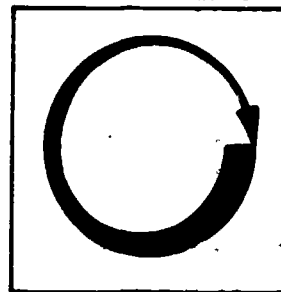

COMPLETE THE ASSIGNMENT BELOW.

There are two easy tests listed in the module that a tilesetter can use to determine which type (vitreous or non-vitreous) of tile is being used. Obtain at least five different types and sizes of tiles. Perform both tests on each of the five pieces. On each piece of tile write which type it is, how you know what type it is, and the dimensions of each piece of tile (length, width, and thickness). Turn them in to your instructor.

Most ceramic shops have samples of tiles that you can borrow to perform the tests. You can also perform the tests right at the store taking down the information on a piece of paper, or your instructor might be able to furnish the class with different tile samples.

# Post Assessment

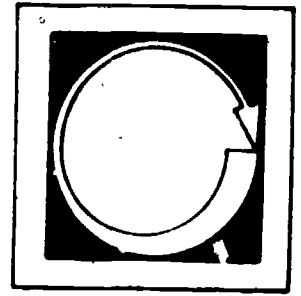

WRITE A SHORT ANSWER TO THE FOLLOWING.

1. List four different tile shapes.
  - a.
  - b.
  - c.
  - d.

LISTED BELOW ARE SEVERAL STATEMENTS. IF THE STATEMENT IS TRUE, PLACE A "T" IN THE BLANK PROVIDED. IF THE STATEMENT IS FALSE, PLACE AN "F" IN THE BLANK. WRITE IN THE CORRECT ANSWER(S) FOR THE STATEMENT(S) THAT ARE FALSE.

2. \_\_\_ To extrude is to force, press, or push out.
3. \_\_\_ Shale, natural clays and talc are all found naturally on the earth.
4. \_\_\_ An auger is an unfriendly person to be around, especially when operating an extrusion or stiff-mud machine.
5. \_\_\_ When we talk about putting a glaze on a piece of tile, we mean we're giving it a hard, glossy surface.
6. \_\_\_ A glaze is bonded to a piece of tile. That means the tile has some sort of defect and it has to go back to the bisque stage.
7. \_\_\_ Feather edges are small pieces of tiles added to the clay to make mosaics.
8. \_\_\_ A tile that absorbs between 3 and 7 percent of moisture is considered a semi-vitreous tile.

# Instructor Post Assessment Answers

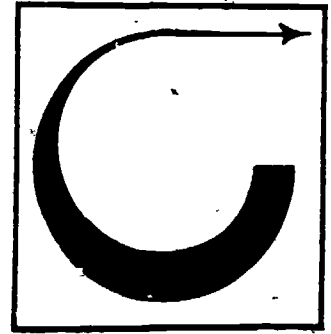

1. Any four of these.
  - a. square
  - b. rectangle
  - c. circle
  - d. triangle
  - e. hexagons
  - f. octagons
  - g. valencia
2. T
3. T
4. False--An auger is a device used for forcing (like a meat grinder).
5. T
6. False--That means the glaze has been stuck, fused and glued together.
7. False--Featheredges are thin sharp edges.
8. T

TYPES OF TILE

**Goal:**

The student will be able to identify and explain the use of common tiles.

**Performance Indicators:**

The student will successfully complete a Self Assessment, an Assignment and a Post Assessment.

# Study Guide

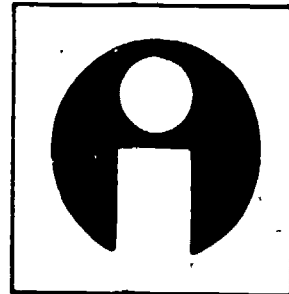

In order to finish this module, do the following tasks. Check each item off as you complete it.

1.  Read the Goal and Performance Indicators on the cover of the module. This will tell you what you will learn by studying the module, and how you will show you've learned it.
2.  Read the Introduction. The Introduction will tell you why the module is an important part of the tile setting trade.
3.  Study the Vocabulary section. Vocabulary words are important for a good understanding of the trade. After you have studied the vocabulary, ask your teacher to quiz you on the words and their meanings.
4.  Study the Information section. This section will give you the information you need to understand the subject.
5.  Take the Self Assessment exam. This is a test for you to prove to yourself that you have learned the material you have studied. Compare your answers with the answers on the Self Assessment Answer Sheet, which is on the page following the Self Assessment. If you scored poorly, re-study the Information section or ask your teacher for help.
6.  Do the Assignment page. Follow the instructions at the top of the Assignment page.
7.  Take the Post Assessment exam. Give the exam to your teacher after you have completed it. Your teacher will grade it for you.

# Introduction

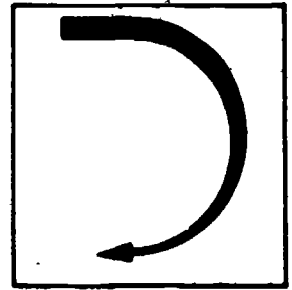

The different types and sizes of tile used today vary from 3/8" X 3/8" paper and nylon mounted mosaic tiles to the 48" X 48" ceramic veneer tiles. The combinations of shape, size, and color of tiles used are unlimited. For these reasons it is important for the tilesetter to be able to identify and explain the use of common tiles.

# Vocabulary

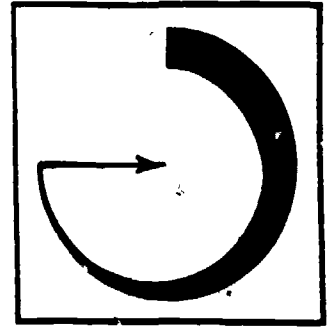

Trade terms are very important for a good understanding of the trade. Study these words and meanings. When you have learned them, ask your teacher to quiz you on the words and their meanings.

**TILE BODY**--Everything on the tile except the glazed surface: the Bisque.

**TUB ENCLOSURE**--A bathtub that has a backwall and two side walls with tile on them (also know as a tubsplash).

**VANITY**--A small bathroom countertop.

**BACKSPLASH**--A backwall of a countertop or vanity that has tile on it.

**ABRASIVE**--Something rough, not smooth.

**MOSAIC**--A surface decoration, made up of smaller pieces of tile that come together to make a pattern or form.

**MOLTEN**--Something melted and turned to liquid by heat.

**MURAL**--A work of art (as a painting or tilework) applied to a wall or ceiling.

**MURALIST**--Someone who makes murals.

**TERRAZZO**--A mosaic flooring made by embedding small pieces of marble or granite in mortar.



TERRA-COTTA--A glazed or unglazed fired clay, brownish-orange in color used as veneer or facing material.

TRIM PIECES--Special pieces of tile used for angles and corners of tilework and for leaving a finished edge to tilework.

COLUMN--A round vertical pillar (one that is straight up and down).

MESH--A paper or nylon matting similar to a screen that tiles such as mosaics, are mounted on.

WARPED--Something that is not flat or flush. A piece of tile that sticks up or out above the rest.

# Supplementary References

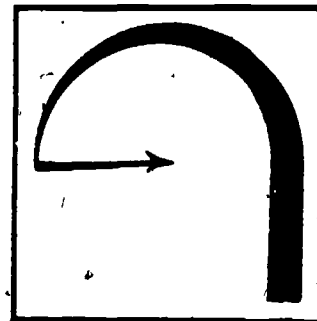

1. Plummer, Harry C. and Edwin F. Wanner. Tile Engineering. Structural Clay Products Institute, 1947. pp. 27-64.
2. American Olean is Ceramic Tile 1980 Catalog. American Olean Tile Company.
3. Dal-tile Presents an Adventure in Color, Form and Texture! 1980 Catalog. Dal-tile Corporation.

# Information

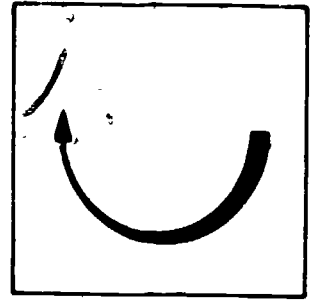

## MAJOR TYPES OF TILE

The most common types of tiles used are:

1. Glazed interior tile.
2. Quarry tile.
  - a. natural-unglazed
  - b. glazed
  - c. soft body-glazed
3. Ceramic mosaic (glazed and unglazed).

Glazed interior tile (also called glazed wall tile) has a smooth glass-like surface. Some of it is given a second coat of glaze that gives the tile a two-tone look. The tile body is white clay type. It is a non-vitreous tile and tends to be soft. This tile is made by the dust+press process. The most commonly used sizes are 4 1/4" X 4 1/4" and 6" X 6" and in thickness from 3/16" to 3/8". The colors and shades available are almost unlimited.

Glazed interior tile is most often used in the kitchen for countertops and backsplashes, in bathrooms for showers, tub enclosures and vanities. The grout joint (the space between pieces of tile) is usually 1/16" to 1/4" in width. Many different trim pieces are available for glazed wall tile which makes it possible to do several kinds of installations.

Quarry tile (natural clay-unglazed) is made of clay and shale. It is vitreous, usually very hard and it comes in sizes from 3" X 3" to 12" X 12" and in thickness from 3/8" to 3/4". The most common sizes are 6" X 6" and 4" X 8". The color of the unglazed quarry tile depends on the clay and shale used in the body of the tile. Whatever color they make together is what the tile will be. It is manufactured by the extrusion or stiff-mud process.

Quarry tile is very tough and durable and can last for more than a lifetime. Quarry tile is commonly used for floors of restaurants, kitchens, large food processing plants and on patios and outside decks. There are special-purpose quarry tiles: (1) the ship and galley quarry tile that's made with an indentation on the face to prevent slipping, (2) a packing house quarry tile which is thicker than regular quarry tile and used where heavy objects might have to be rolled across the floor. Generally quarry tile can be used anywhere durability is a must.

The body of the quarry tile (glazed) and the sizes and thicknesses that it comes in are the same as that of the quarry tile (natural unglazed). The only difference is glazed quarry has a glaze fixed on the face of the tile which could be a glossy or dull finish. But since it does have a glaze to it there is a much greater selection of colors.

Glazed quarry tile is more expensive than natural unglazed quarry tile. It is commonly used for floors in restaurants, banks and homes.

Quarry tile (soft body-glazed) is imported from and made mainly in Italy. It is non-vitreous, not very hard, comes in sizes of 4' X 8", 6" X 6", 8" X 8", 10" X 10" and 12" X 12", and in thickness from 3/8" to 1/2". It has a smooth, glass-like and sometimes textured, scratch-proof surface. There are many colors and patterns (that take four pieces of tile to complete) available. Since its tile body is much softer than that of regular quarry tile, it isn't as tough and durable. Its main use is for floors of homes and fireplaces. Ceramic mosaic is a term given to small tiles that range in size from 3/4" X 3/4" to 3" X 3" and from 1/8" to 1/4" thick. There are a few as large as 4" X 4" and still considered ceramic mosaic tiles.

They are manufactured by both the dust-pressed and extrusion process. They are anywhere from vitreous to semi-vitreous and always very hard. They can have either a glazed or unglazed surface, from smooth and glass-like to fairly abrasive and slip-resistant.

Ceramic mosaics come in many different shapes and sizes. There are hexagons, squares, circles, rectangles and L-shapes. Ceramic mosaics all have one thing in common; they are all sheet-mounted, usually on 12" X 12" sheets of paper or nylon mesh. This makes it easier for the tilesetter. If the tilesetter had to set each small, individual piece of tile, it would waste time.

Ceramic mosaics have many uses. They are commonly used for kitchen countertops, floors, showers, vanities and murals. Most any design is possible with ceramic mosaics. Table tops, columns, swimming pools and the outside of buildings have all been done with ceramic mosaics.

#### MINOR TYPES OF TILE

Some types of tiles that are not used so often are:

1. Glass mosaic tile.
2. Smalti-type glass mosaic tile.
3. Paver tile.
4. Cement tile.
5. Ceramic veneer tile.
6. Faience tile.
7. Handmade tile.

Glass mosaic tiles are available in an unlimited number of colors, are used primarily on vertical surfaces and in similar areas where ceramic mosaic would be used. They are different from ceramic mosaic because they are made from glass. In this process molten glass is poured into waffle-type molds. Once

cooled, the glass is broken into individual tiles and mosaics. Most of the glass mosaic tiles used today are imported from Italy, but some are shipped from Spain, Mexico and Japan.

The individual pieces of glass mosaic tiles are not as large as the ceramic mosaics. They range in size from  $3/4"$  X  $3/4"$  to  $1\ 1/4"$  X  $1\ 1/4"$  and in thicknesses of  $3/16"$  to  $1/4"$ . A popular size is  $5/8"$  X  $1\ 1/4"$ . They are mounted on sheets of paper and nylon mesh like ceramic mosaics. The sheet sizes usually are  $12\ 1/4"$  X  $12\ 1/4"$ . Glass mosaic tiles are vitreous and very hard.

There is an older, rarely used glass mosaic tile that looks like plate glass with a gold leaf between two sheets of glass. This tile is called gold venetian glass tile and is very expensive.

Smalti-type glass mosaic tiles, have a rough, irregular surface and range from  $1/8"$  to  $3/8"$  in thickness. The average size of this type of tile is  $3/8"$  X  $5/8"$ . Smalti-type tiles come in many colors and are used for murals, letters and different designs. They have been used by Europeans for centuries for murals such as those found in St. Mark's Cathedral in Venice, Italy.

Paver tiles are made by both the dust-press and extrusion processes. They are a vitreous tile and very hard. They come in sizes of  $4"$  X  $4"$ ,  $6"$  X  $6"$ , and  $4"$  X  $8"$  and in thicknesses of  $3/8"$  to  $1"$ . The most commonly used size is  $4"$  X  $8"$ .

Paver tiles look like and actually are thin solid bricks. They have the same type of rough surface and texture. They are very tough and durable, and like the quarry tile, are used for floors that need to be strong.

Cement tiles are made from a mix of cement and sand. They are formed by a dry-press or slush-mold process. Cement tiles come in plain colors, patterns and terrazzo designs. However, these colors and designs fade under sunlight. Cement tile is not used much anymore.

Ceramic veneer tiles are made from terra-cotta, a brownish-orange clay. This type of tile is used for exteriors and interiors of buildings. Though not intended for floors, ceramic veneer can be used for floors in homes if the tiles are made to withstand special conditions.

In the early 1930s, manufacturers of terra-cotta found that by using the extrusion process they could make large tiles that could not be made by the dry-press process. As a result of this, manufacturers began making tiles of terra-cotta as large as 48" X 48" and as thick as 2". These tiles were called ceramic veneer. The ceramic veneer with which the tilesetter works is a smaller size. Terra-cotta that is to be used for ceramic veneer is made into large pieces by either the ram-press or extrusion process. The pieces are allowed to dry. After drying, the faces are sanded to a fine surface. The pieces then are glazed and placed in the kilns for firing. The terra-cotta body has a very fine texture that can be glazed with an extra heavy finish. This makes ceramic veneer tiles excellent for exterior building use.

Faience tiles have a special glazed surface that gives the tile a handmade look. Quite often the glazed surface will be what's known as "crazed" (small, thin spidery cracks that occur in the glazed surface of a tile). This gives the tile a natural rustic look. Some of the glazed surfaces have hand-painted designs and patterns on them. Faience tiles are used for special decorative effects. They can be specially ordered for specific areas, like tabletops or a section of a wall. They are usually expensive.

Faience tiles range in size from 4" X 4" to 12" X 12", and in thickness from 1/4" to 5/8". They have a soft bisque and are not used where wear and tear or real heavy objects might cause problems.

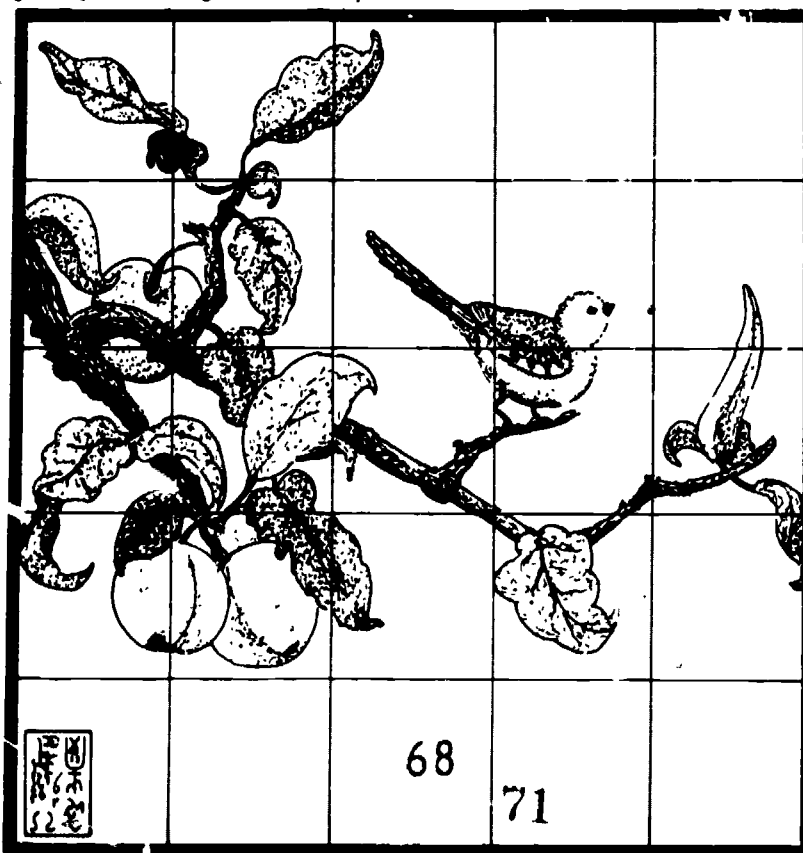

Handmade tiles are formed by being beaten into simple molds. The glaze is hand-applied to the dried bisque, and then kiln-fired. The sizes and thicknesses available are left up to the imagination of the tile maker. The most common sizes made are 8" X 8", 10" X 10", and 12" X 12". Most glaze colors are an earthy brown.

Handmade tiles are not very durable and some may be warped. Their main use is for floors of homes. A lot of handmade tile is imported from Mexico.



# Self Assessment

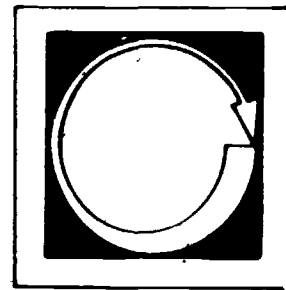

LISTED BELOW ARE TRUE AND FALSE AND MULTIPLE CHOICE SELECTIONS. CHOOSE THE CORRECT ANSWER AND PLACE IT IN THE BLANK PROVIDED.

1. \_\_\_ Glazed interior tile is also called:
  - a. glazed wall tile
  - b. glazed tub enclosure tile
  - c. glazed floor tile
  - d. glazed countertop tile
  
2. \_\_\_ The glaze of glazed interior tile is:
  - a. abrasive and slip-resistant
  - b. rough, like a brick
  - c. glass-like and smooth
  - d. easily scratched
  
3. \_\_\_ True or False. The glazed interior tile's body is very hard.
  
4. \_\_\_ True or False. The most commonly used sizes are 4 1/4" X 4 1/4" and 6" X 6".
  
5. \_\_\_ Glazed interior tile is most often used:
  - a. in hallways and utility rooms
  - b. in kitchens and bathrooms
  - c. on patios and decks
  - d. none of the above

6. \_\_\_ A grout joint is:
- something that is smoked
  - what happens to a tilesetter's knees after years of setting tile
  - an artificial joint made from grout
  - the space between pieces of tile
7. \_\_\_ True or False. Quarry tile is made from clay and shale.
8. \_\_\_ True or False. The most commonly used sizes of quarry tile are 3" X 3" and 12" X 12".
9. \_\_\_ True or False. Quarry tile is manufactured by the slush-mold or soft-mud process.
10. \_\_\_ If the clay and shale that make up the natural-unglazed quarry tile's body are green, the color of the finished tile will be:
- not sure--no way to tell
  - green
  - brownish-orange
  - natural colored
11. \_\_\_ True or False. Ship and galley quarry tile has sandpaper type nubs on the surface to prevent slipping.
12. \_\_\_ True or False. Quarry tile (glazed) is harder and more durable than quarry tile (soft body-glazed).
13. \_\_\_ The body of the quarry tile (glazed) is:
- the same as that of the quarry tile unglazed
  - different from that of the quarry tile unglazed
  - softer than that of the quarry tile unglazed
  - both b and c
14. \_\_\_ A pattern made of quarry tile (soft body-unglazed) usually takes:
- a long time to make
  - two coats of glaze to complete
  - form pieces of tile to complete

15. \_\_\_\_ True or False. Most quarry tile (soft body-glazed) is imported from France.
16. \_\_\_\_ The smallest and largest sizes of ceramic mosaics are:
- a. 3/4" X 3/4" to 4" X 4"
  - b. 1/8" X 1/8" to 1 1/4" X 1 1/4"
  - c. 3" X 3" to 12" X 12"
  - d. anywhere up to 48" X 48"
17. \_\_\_\_ Ceramic mosaics come:
- a. with abrasive and slip resistant surfaces
  - b. with glazed and unglazed surfaces
  - c. on 12" X 12" sheets of paper or nylon mesh
  - d. in circles
  - e. All of the above
18. \_\_\_\_ Murals are made with:
- a. ceramic mosaics
  - b. smalti-type and regular glass mosaics
  - c. ceramic veneer tile
  - d. both a and b
19. \_\_\_\_ Paver tiles look like and actually are:
- a. large, soft bricks
  - b. thin, solid bricks
  - c. a bad joke
  - d. quarry tiles
20. \_\_\_\_ Cement tiles are made from a mix of:
- a. clay and shale
  - b. terra-cotta
  - c. cement and sand
21. \_\_\_\_ Ceramic veneer tiles are use:
- a. in showers and backsplashes
  - b. on columns and tabletops
  - c. for exteriors and interiors of buildings.

22. \_\_\_ A "crazed" tile is one with:
- a. small, thin cracks in the glaze
  - b. a crazy defective shape to it
  - c. indentations in the surface for good traction
23. \_\_\_ True or False. Handmade tiles are not very durable.
24. \_\_\_ True or False. Handmade tiles can be made only in 8" X 8", 10" X 10" and 12" X 12" sizes.
25. \_\_\_ True or False. A handmade tile's main use is for floors of homes.

# Self Assessment Answers

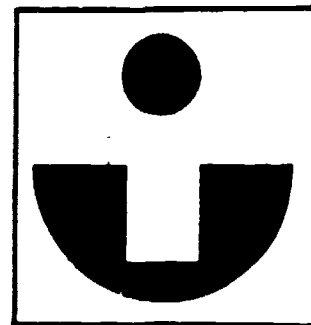

- |       |       |
|-------|-------|
| 1. a  | 23. T |
| 2. c  | 24. F |
| 3. F  | 25. T |
| 4. T  |       |
| 5. b  |       |
| 6. d  |       |
| 7. T  |       |
| 8. F  |       |
| 9. F  |       |
| 10. b |       |
| 11. F |       |
| 12. T |       |
| 13. a |       |
| 14. c |       |
| 15. F |       |
| 16. a |       |
| 17. e |       |
| 18. d |       |
| 19. b |       |
| 20. c |       |
| 21. c |       |
| 22. a |       |

# Assignment

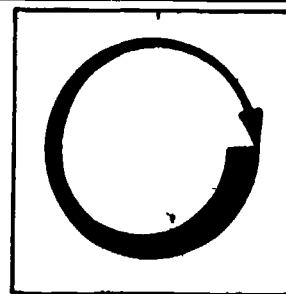

COMPLETE THE ASSIGNMENT BELOW.

Go to a ceramic tile store, maybe with a partner, and find at least two different tiles (shape, size, color) that fall into each of the major tile groups listed below:

1. Glazed interior tile
2. Quarry tile
  - a. natural unglazed
  - b. glazed
  - c. soft body-glazed
3. Ceramic mosaics (glazed and unglazed)

That's at least 12 different kinds.

On a piece of paper describe each of the tiles by:

1. Shape: square, rectangular, hexagon etc.
2. Size: height, width, and approximate thickness.
3. Color.
4. Is it vitreous or non-vitreous?

Turn the assignment in to your instructor.

# Post Assessment

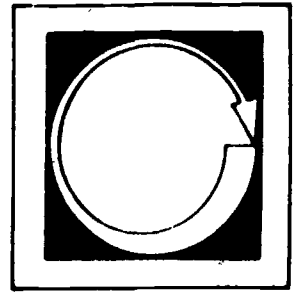

LISTED BELOW ARE SEVERAL STATEMENTS. IF THE STATEMENT IS TRUE, PLACE A "T" IN THE BLANK PROVIDED. IF THE STATEMENT IS FALSE, PLACE AN "F" IN THE BLANK AND WRITE IN THE CORRECT ANSWER.

1. \_\_\_ Tile body is a name given to a person who is strong and tough.
2. \_\_\_ A tiled tub enclosure is the same thing as a tubsplash.
3. \_\_\_ A vanity is the same thing as a countertop, but much larger.
4. \_\_\_ A tiled backsplash is a backwall of a countertop or vanity that has been tiled.
5. \_\_\_ A mosaic is a house of worship, a religious building.
6. \_\_\_ A mural is a work of art applied to a wall, floor or ceiling.
7. \_\_\_ A muralist is someone who makes murals.
8. \_\_\_ Molten is what happens when animals like dogs and cats lose their hair.
9. \_\_\_ Terrazzo is a mosaic flooring made by embedding small pieces of marble or granite in mortar.
10. \_\_\_ Terra-cotta is the type of clay that cement tiles are made from.
11. \_\_\_ Trim pieces are pieces of tile used for angles, corners and for putting a finished edge to the tilework.

12. \_\_\_\_ A mesh can have a criss-cross type pattern, like a screen or fish net.
13. \_\_\_\_ A column is a type of quarry tile that has indentations on it that go straight up and down.



# Instructor Post Assessment Answers

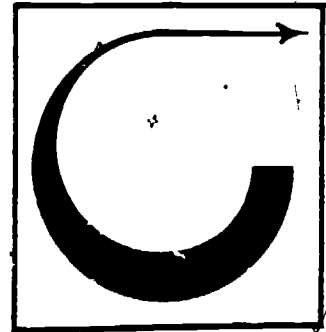

1. False: Tile body is everything about the tile, except the glazed surface-- "the bisque."
2. True
3. False: A vanity is a small bathroom countertop.
4. True
5. False: A surface decoration, smaller pieces of tile that come together to make a pattern or form.
6. True
7. True
8. False: Something melted and turned to liquid by heat.
9. True
10. False: Terra-cotta is a fired clay brownish-orange in color used as a veneer or facing material.
11. True
12. True
13. False: A column is a round vertical pillar.

---

PORTLAND CEMENT MORTAR MIXES

**Goal:**

The student will be able to identify, explain the use of, and mix both wall and floor type mortars.

**Performance Indicators:**

The student will successfully complete a Self Assessment, a Job Sheet, an Assignment and a Post Assessment.

# Study Guide

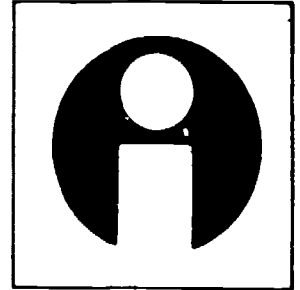

In order to finish this module, do the following tasks. Check each item off as you complete it.

1.  Read the Goal and Performance Indicators on the cover of the module. This will tell you what you will learn by studying the module, and how you've learned it.
2.  Read the Introduction. The Introduction will tell you why the module is an important part of the typesetting trade.
3.  Study the Vocabulary section. Vocabulary words are important for a good understanding of the trade. After you have studied the vocabulary, ask your teacher to quiz you on the words and their meanings.
4.  Study the Information section. This section will give you the information you need to understand the subject.
5.  Take the Self Assessment exam. This is a test for you to prove to yourself that you have learned the material you have studied. Compare your answers with the answers on the Self Assessment Answer Sheet, which is on the page following the Self Assessment. If you scored poorly, re-study the Information section or ask your teacher for help.
6.  Do the Assignment page. Follow the instructions at the top of the Assignment page.
7.  Do the Job Sheet. Follow the instructions at the top of the Job Sheet. The tasks listed on the Job Sheet will help you develop skills which will be helpful to you.
8.  Take the Post Assessment exam. Give the exam to your teacher after you have completed it. Your teacher will grade it for you.

# Introduction

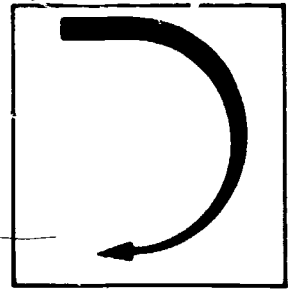

Being able to properly mix portland cement mortar used to glue tiles to floors and walls is one of the most important procedures a tilesetter must know.

It is a procedure used for many different types of tile installations, for example shower walls and shower floors.

# Vocabulary

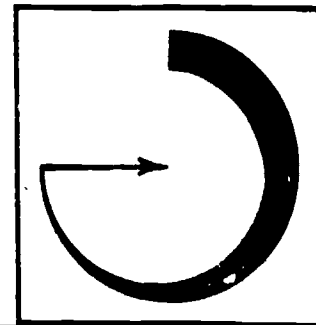

Trade terms are very important for a good understanding of the trade. Study these words and meanings. When you have learned them, ask your teacher to quiz you on the words and their meanings.

**CONSISTENCY**--Firmness or stickiness of a mixture.

**RATIO**--The amount of one thing compared to the amount of another thing or things. For example, if a mix calls for a ratio of 1 part cement to 2 parts sand, for every 1 bucket of cement in the mix you would add 2 buckets of sand. The ratio of cement to sand is often written as 1:2.

**STONE MASON**--A skilled person who builds with stones.

**JACUZZI**--A large bathtub with forced water jets that relax you.

**SULFATE**--A salt or compound of sulfuric acid, a chemical that will break down and eat away at cement.

**ALKALI**--A salt. Too much in the water or soil will also eat away at cement.

**BATCH**--The quantity of material prepared at one time.

# Supplementary References

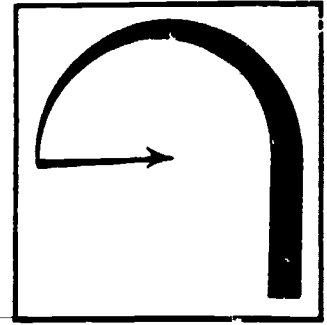

1. Plummer, Harry C. and Edwin F. Wanner. Tile Engineering. Structural Clay Products Institute, 1947. pp. 65-71.
2. Riles, Wilson. Tilesetting Workbook. California State Department of Education, 1975. pp. 29-32.

# Information

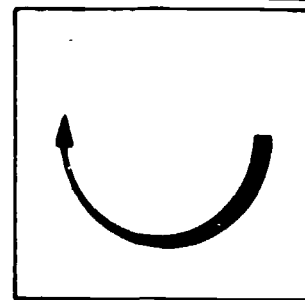

This is the same portland cement used in making concrete. The name portland is not a brand name and is not the name of a city. The name was given to the product in 1824 by Joseph Aspdin, an English stonemason, because he thought the concrete made with it looked like the stone dug from the region called Portland in England. When portland cement is mixed with water, it makes a paste that will bond together such materials as sand and gravel, thus forming concrete. The paste hardens as it ages, and in time can become harder than the sand and gravel that have been mixed with it. There are five types of portland cement.

Type 1 portland cement is generally the type of cement to use for tilesetting. Portland cement mortar used by tilesetters for floors and walls is like concrete, but it does not contain the rocks or gravel found in concrete. The materials used by tilesetters to mix different types of portland cement mortars are:

1. Cement: Type 1 portland cement.
2. Water:
3. Sand.
4. Lime.

## Water

If the water used to mix the mortar comes directly from a supply that is intended for human use, (like out of a water faucet) then you can be sure it will work fine. However if the water is really dirty (such as water that has been used to clean equipment) it should not be used for mixing mortar. The dirty water will make the overall strength of the mortar weaker.

## Sand

Any good, clean high-grade sand is suitable for tilework. When buying, ask for mason's sand.

## Lime

Lime or hydrated lime is in a white powder form. When lime is added to the mortar it makes the mortar hold together better; it makes it stickier. Lime is used only in mortar that will be used for walls or ceilings, not for floors.

## FLOOR MORTAR MIXES

Floor mortar, which is also called "deck mud" by tilesetters, is a mixture of portland cement, sand and water. In a ratio of 1 part cement to 4-6 parts sand. Both mixtures work fine. The mixture of 1 part cement to 4 parts sand is probably a little stronger, but that doesn't necessarily mean that the more cement you have in the mixture compared to sand, the stronger the mixture will be. Too much cement in the mixture will sometimes cause cracks in the mortar as it hardens. There are two main reasons why one tilesetter mixes deck mud in a certain cement-to-sand ratio, and another one mixes in a different ratio. The first is because that's how the tilesetter was taught and so now he or she prefers to do it that way. And secondly, all sand is not alike. A correct mixture may be achieved by a different cement-to-sand ratio. It depends on the quality of sand being used. Floor mortar is used on floors and countertops, anywhere a flat or horizontal surface is to get cement mortar. Lime is not used because the mortar does not need to hold together or be as sticky as wall mortar. Floor or drypack mortar does not need very much water in the mixture for it to reach the proper consistency. Properly mixed floor mortar looks like unpacked wet sand. A good test to see if there is the right amount of water in the mixture, is to grab a handful and squeeze it together. If, when squeezed, the mortar falls apart and doesn't hold together it is too dry. Add a little bit more water until you reach the correct consistency. If when squeezed together you can squeeze water out of it, it is too wet. Add a little bit more sand and cement until you reach the correct consistency. When the mortar is the correct consistency it should hold together like a dry snowball when squeezed in the hand. If you were to throw it, it would fall apart.

## WALL MORTAR

Wall mortar, which is also called "Fat Mud" by tilesetters, is a mixture of portland cement, sand, lime, and water, in a ratio of 1 part cement, 3 parts sand, and 1 part lime. The amount of sand can vary from 3 parts to 6 parts. The different ratios used depend on the tilesetter's preference and the quality of sand being used.



Wall mortar is used for walls, ceilings (which are not tiled very much anymore) and for forming anything that needs to be hand shaped, such as a custom-made jacuzzi bathtub. Anywhere mortar needs to hold together really well, wall mortar is used.

Whenever cement mortar has been applied to a surface like a wall or floor we say that surface has been floated. For example, when a tilesetter is applying cement mortar to a wall, we say he or she is floating the wall.

The proper consistency of wall mortar is much different from that of floor mortar. Properly mixed wall mortar looks like wet, but firm, mud. A good test to determine if there is the right amount of water in the mixture is to fill a bucket with the mortar; then dump the mortar out onto a board. If, when dumped, the mortar stays the same shape as the bucket (like a sand castle), it is too dry. Add a little bit more water until you reach the correct consistency. If when dumped the mortar flattens out on the board, it is too wet. Add a little bit more cement, sand, and lime until you reach the correct consistency. You have made it correct when the mortar slightly flattens out and looks like wet, but firm, mud when dumped onto a board.

#### MIXING FLOOR AND WALL MORTAR

There are two methods used to mix cement mortar for tilesetting.

1. Mortar box and hoe method.
2. Mortar mixer method.

#### Mortar Box and Hoe Method

The mortar box and hoe method is done by hand; that is, it is the tilesetter's muscle that mixes the mortar. A mortar box is a large, usually metal, box

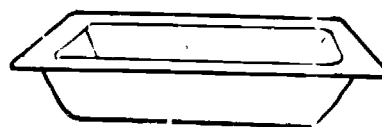
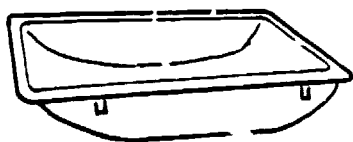

anywhere from 24" wide X 33" long X 6" deep to 30" wide X 60" long X 12" deep in size. Both ends are curved up, to permit a rolling type of action while mixing. This type of end is also easier to scoop the mortar from, and much easier to clean.

A mortar hoe is a hand tool that has a blade on one end with two 1 3/4" holes in it. The holes are needed to help make a good mix. The mortar box and hoe

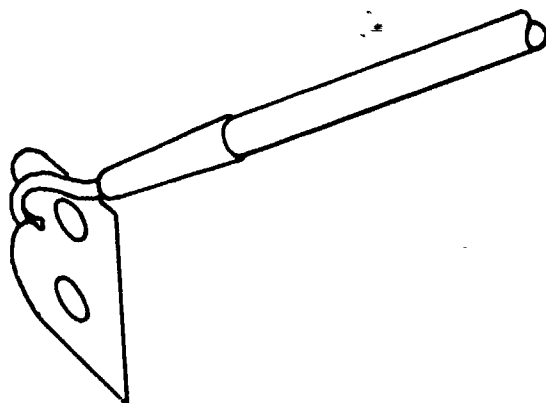

method of mixing mortar is generally used when the area to be floated is not very large. Depending on its size, a mortar box can hold from 4 to 20 buckets of mixing materials (using a 3 1/2 gallon bucket). First put the proper ratio of portland cement, sand, and lime (if you are mixing wall mortar) into the mortar box, using a bucket for measurement. Then stand at one end of the mortar box. Using the hoe slice down into, and pull towards you, small sections of the mortar mixture until you've sliced and pulled the entire mixture to your end of the mortar box. Then go to the other end of the mortar box and do the same thing. This is continued until the mixture becomes one solid well-mixed color. This is called "dry mixing" the mortar.

Next, add the water. It is done differently for floor and wall mortar. Adding water for floor mortar--(1) level off or make flat the mixture in the mortar box; (2) pour from 1/4 to 1 full bucket of water into the mixture (the amount of water used will depend on how dry the mixture is and how many buckets of dry ingredients were used). Let the water sink into the mixture until no more water is floating on the surface. (3) Then with the hoe use the same procedure used to dry mix. Mix until you've reached the proper consistency.

Adding water for wall mortar--there are 2 differences when adding water for wall mortar: (1) you will need about 3 times more water and (2) you don't

first level off the mixture in the mortar box. Instead simply pour the water in the end of the mortar box opposite the mixture. Then start on the end where the water is. With the hoe use the same procedure used to dry mix. Mix until you've reached the proper consistency.

The mortar box and hoe should be thoroughly cleaned with water after each use.

### Mortar Mixer Method

Mortar mixers are gasoline or electric powered machines that do the mortar mixing for you. The average-size mortar mixer mixes about the same amount as a large mortar box can, but much faster. And the quality of machine-mixed mortar generally is better than hand-mixed mortar. Mortar mixers are generally used by tilesetters anywhere a large area needs to be floated.

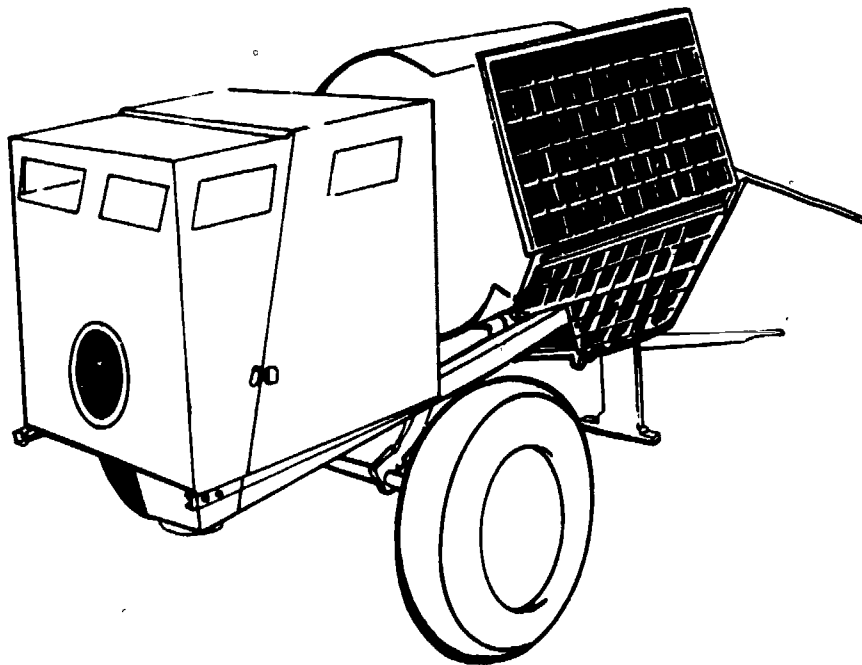

After you learn how to operate the mortar mixer the mixing procedure is as follows:

1. Pour into the mixer the proper ratio of portland cement, sand and lime (if needed).

2. As the mixer mixes add water until the proper consistency is reached.

When finished with the mixer clean it out with plenty of water. If the mortar were allowed to dry in the mixer, it would ruin it, or it would be very expensive to have cleaned.

# Self Assessment

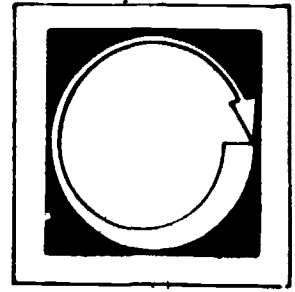

DETERMINE THE CORRECT ANSWER AND PUT THE CORRESPONDING LETTER IN THE BLANK PROVIDED. SOME QUESTIONS WILL BE TRUE OR FALSE. IF THE STATEMENT IS TRUE PLACE A "T" IN THE BLANK AND IF THE STATEMENT IS FALSE PLACE A "F" IN THE BLANK.

1.  Portland cement gets its name from
  - a. a city in Oregon
  - b. it's a brand name of cement
  - c. both a and b
  - d. a stone mason who thought concrete made with it looked like stone from Portland in England.
  
2.  TRUE OR FALSE. Cement paste can become harder than a rock
  
3.  Portland cement mortar is a lot like concrete but it does not contain \_\_\_\_\_ found in concrete.
  - a. mud
  - b. sand and lime
  - c. rocks or gravel
  - d. type 1 portland cement
  
4.  Dirty water can make the overall strength of mortar
  - a. stronger
  - b. weaker
  - c. last longer
  - d. both a and c
  
5.  TRUE OR FALSE. Any clean high-grade sand is suitable for tilework.

6. \_\_\_ TRUE OR FALSE. Lime in the mortar mixture makes the mixture fluffier, like a dry snowball.
7. \_\_\_ Floor mortar is also called
- a. fat mud
  - b. dry mortar
  - c. wet mortar
  - d. deck mud
8. \_\_\_ TRUE OR FALSE. Floor mortar requires no lime in its mixture.
9. \_\_\_ TRUE OR FALSE. In all cases the more cement you put into the mixture the stronger the mortar will be.
10. \_\_\_ TRUE OR FALSE. All sand is not alike. There are different qualities of sand.
11. \_\_\_ Floor mortar is used
- a. for walls and ceilings
  - b. anywhere a flat surface is to get mortared
  - c. anywhere it can be used for floors or walls
12. \_\_\_ If, when a handful of floor mortar is squeezed, it holds together, its consistency is
- a. too dry, add more water
  - b. good--leave alone
  - c. too wet--it should fall apart add more cement and sand
  - d. none of the above
13. \_\_\_ Wall mortar is also called
- a. fat mud
  - b. deck mud
  - c. wet mortar
  - d. sticky mortar
14. \_\_\_ Wall mortar is used anywhere
- a. floor mortar is used and more
  - b. lime is required
  - c. the mortar needs to hold together well

15. \_\_\_\_ TRUE OR FALSE. Wall mortar is a mixture of cement, sand, and lime.
16. \_\_\_\_ When large areas are to be floated, which is the best mixing method to use
- a. mortar box and hoe method
  - b. mortar mixer method.

Tell why.

# Self Assessment Answers

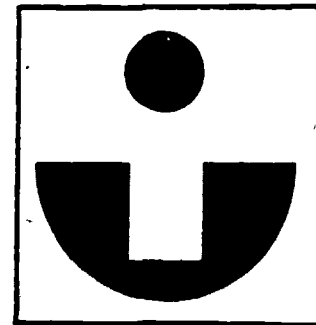

1. d
2. T
3. c
4. b
5. T
6. F
7. d
8. T
9. F
10. T
11. b
12. b
13. a
14. c
15. T
16. b Because the mortar can be mixed much faster.



# Job Sheet

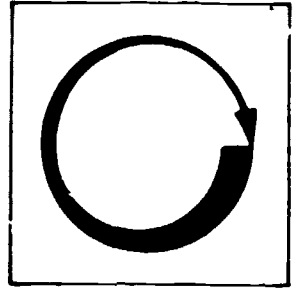

COMPLETE THE FOLLOWING TASK.

## Materials and Tools

- 1 - 95 lb. bag of portland cement
- at least 1 bucket (preferably 14 quart size)
- at least 8 buckets of sand
- 1 mortar box (preferably a large one)
- 1 mortar hoe
- easy access to water
- 1/2 bag of lime

Follow the procedures written in the module for mixing floor and wall mortar using the mortar box and hoe method.

1. For the floor mortar, mix a batch with a ratio of 1 part cement to 4 parts sand.
2. For the wall mortar, mix a batch with a ratio of 1 part cement, 3 parts sand, and 1 part lime.

In both batches slowly add the water until you reach the proper consistency. After each mixture wash the mortar box and hoe off very carefully. You should be careful when cleaning and throwing away the mixture, that you don't leave any cement stains anywhere. Use plenty of water to clean up. Preferably mix the batches in a field of grass or on dirt, not on cement.

You should do this project with the supervision of your instructor.

# Assignment

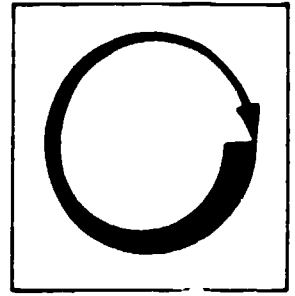

COMPLETE THE FOLLOWING ASSIGNMENTS.

In your own words, describe each of the mixtures you made in the Job Sheet.

1. What does it look like?
2. What does it feel like?
3. How much water did it take to reach the proper consistency?
4. What problems did you run into if any?
5. How or what would you do differently next time to make it easier? or better?

Give your answers to your instructor.

# Post Assessment

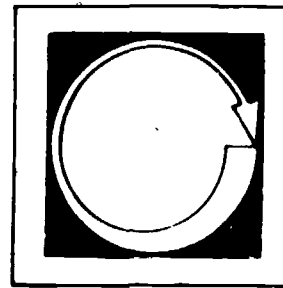

LISTED BELOW ARE SEVERAL STATEMENTS. IF THE STATEMENT IS TRUE, PLACE A "T" IN THE BLANK PROVIDED. IF THE STATEMENT IS FALSE, PLACE AN "F" IN THE BLANK. IF THE STATEMENT IS FALSE WRITE IN THE CORRECT ANSWER.

1. \_\_\_ A ratio is a relationship in quantity and amount between two or more things.
2. \_\_\_ A stone mason is a building built with stones.
3. \_\_\_ A jacuzzi is a swimming pool that is hand-floated with floor mortar.
4. \_\_\_ Sulfates and alkalis are salts that can eat away at cement.
5. \_\_\_ A batch of something could be--15 cookies baked at one time or 4 loaves of bread baked at one time.

# Instructor Post Assessment Answers

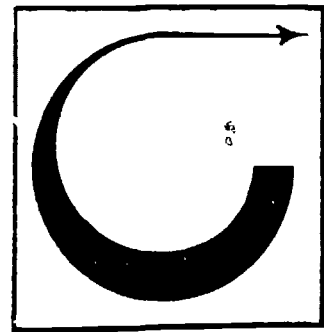

1. T
2. F A stone mason is a skilled workman who builds with stones.
3. F A jacuzzi is a bathtub, that has forced water that relaxes you.
4. T
5. T

TILE ADHESIVES

**Goal:**

The student will be able to name and prepare the major types of tile adhesives.

**Performance Indicators:**

The student will demonstrate knowledge of the subject by successfully completing a Self Assessment, an Assignment, a Job Sheet and a Post Assessment.

# Study Guide

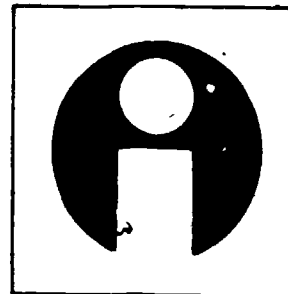

In order to finish this module, do the following tasks. Check each item off as you complete it.

1.  Read the Goal and Performance Indicators on the cover of the module. This will tell you what you will learn by studying the module, and how you will show you've learned it.
2.  Read the Introduction. The Introduction will tell you why the module is an important part of the tilesetting trade.
3.  Study the Vocabulary section. Vocabulary words are important for a good understanding of the trade. After you have studied the vocabulary, ask your teacher to quiz you on the words and their meanings.
4.  Study the Information section. This section will give you the information you need to understand the subject.
5.  Take the Self Assessment exam. This is a test for you to prove to yourself that you have learned the material you have studied. Compare your answers with the answers on the Self Assessment Answer Sheet, which is on the page following the Self Assessment. If you scored poorly, re-study the Information section or ask your teacher for help.
6.  Do the Assignment page. Follow the instructions at the top of the Assignment page.
7.  Do the Job Sheet. Follow the instructions at the top of the Job Sheet. The tasks listed on the Job Sheet will help you develop skills which will be helpful to you.
8.  Take the Post Assessment exam. Give the exam to your teacher after you have completed it. Your teacher will grade it for you.

# Introduction

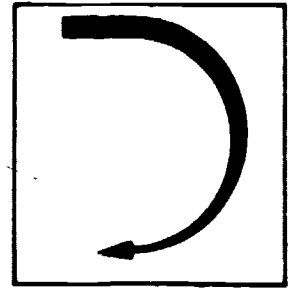

There are many different types of surfaces tile can be bonded to. The main types are plywood, portland cement mortar, concrete, sheetrock, and wonderboard.

Tilessetters must be able to identify, select, and mix the proper type of tile adhesive needed for a good bond on any surface.

# Vocabulary

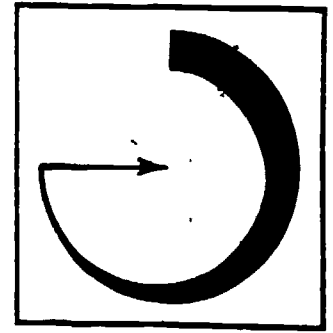

Trade terms are very important for a good understanding of the trade. Study these words and meanings. When you have learned them, ask your teacher to quiz you on the words and their meanings.

**SHEETROCK**--Gypsum board, plasterboard. A bonded plaster-like board that comes in 4' by 8' sheets used to build walls.

**WONDERBOARD**--A bonded mortar-type board that comes in 3' X 5' sheets. It is used as a substitute for cement mortar.

**MASONRY SURFACE**--A surface made from any type of material a mason works with; concrete, brick, concrete blocks, cement mortar, etc.

**SLURRY**--Portland cement mixed with water to a creamy paste-like consistency.

**PURE COAT**--A slurry used as an adhesive to bond tile to a still wet cement mortar surface.

**ASPHALT**--A black concrete-type mixture used for pavements and roadways.

**SYNTHETIC**--Is something made artificially, not naturally. A product made chemically rather than naturally.

**TROWEL**--A type of hand tool used to apply, spread, shape, mix, or smooth materials such as concrete and mortars.

**MARGIN TROWEL**--A trowel with an offset handle and a 5' to 6" long by 1 1/2" to 2" wide blade. (See the illustration on top of the next page.)



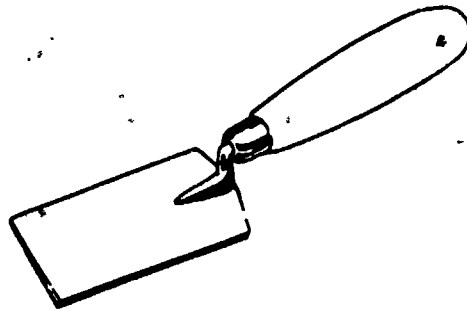

BACKING--Any material used as a base or surface to which tile is to be adhered.

THINSET ADHESIVES--Are thin bond coats applied with a notched trowel. Thinset is the same thing as thinbed.

MASTIC--Quick drying pasty cement used to glue tile to walls, etc.

# Supplementary References

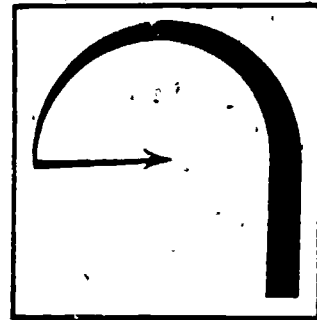

Typesetting Workbook. California State Department of Education, 1975. pp. 29-32.

# Information

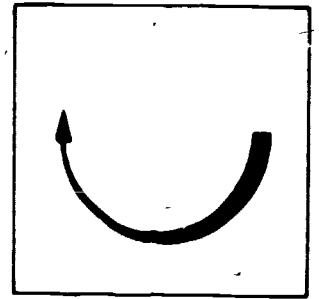

Different tile adhesives have different uses. The correct tile adhesive to use depends on three factors:

1. The type of backing the tile will be bonded to.
2. How resistant to certain chemicals and/or water the tile adhesive needs to be.
3. How strong a bond is needed.

## TILE ADHESIVES

The different types of tile adhesives are:

1. Portland cement--the only tile adhesive not considered a thin-setting adhesive.
2. Thin-bed mortar mixed with water.
3. Thin-bed mortar mixed with a liquid latex or acrylic additive.
4. Thin-bed mortar mixed with an epoxy additive.
5. Wall and floor mastic.

Portland cement is used as an adhesive to bond ceramic tile to a cement mortar surface only when it is still wet. This is why it is not considered a thin-setting adhesive. Thin-setting adhesives are used for surfaces that are dry and hard. Portland cement, when used as an adhesive, is known as a "pure coat." It can be used wet or dry. When used wet the cement is mixed with water to form a paste with a creamy consistency, which tilesetters call a slurry. When used dry a thin layer is sprinkled by hand onto the cement mortar surface. Again portland cement is used as an adhesive only for wet cement mortar surfaces. It is usually used for small-area floors such as shower floors. It can only be used where the tilesetter does not have to get on the surface to set the tile.

Thinbed mortar, which is factory pre-mixed, is a mixture of portland cement, sand, and different chemical additives in powder form. The additives give the adhesive a stronger bond so that the tile can be applied to a variety of surfaces,

Thin-bed mortar mixed with water can be used to bond ceramic tile to different masonry type surfaces such as cement mortar surface (wet or dry), bricks and concrete. Thinbed mortar mixed with water should not be used over any surface that is not a masonry type surface. It is not used for setting tile over surfaces such as plywood, asphalt, linoleum or hardwood.

Thinbed mortar mixed with water has the least resistance to chemicals:

Thinbed mortar can be mixed with two similar additives, liquid latex or liquid acrylic. Both additives are white synthetic liquids. When either is mixed with thin-bed mortar, its overall strength, flexibility and resistance to chemicals and water is improved over thin-bed mortar mixed with water. It can be used for a stronger bond to masonry surfaces and many other types of backing including plywood, linoleum and sheetrock. It can be used to bond tile to almost any hard solid surface. But it is not the best tile adhesive for heavy duty commercial use such as in breweries, dairies and food processing plants.

Thin-bed mortar mixed with epoxy is the strongest, toughest tile adhesive there is. It has high bond strength. It is waterproof, weatherproof, shockproof, and will resist most chemicals. It will bond tile to any hard solid surface. It can be used outside and for heavy duty commercial use.

#### MIXING THIN-BED MORTAR ADHESIVES

Whenever mixing any type of thin-bed mortar adhesive read and follow the directions on the label carefully. Make sure it is the right type of tile adhesive to use for the job you are doing. There are differences between different brands.

#### How to Mix

Use a large bucket to mix the adhesive. No matter which liquid is used, always pour it into the bucket first. Add a small amount of liquid at first and then a small amount of thin-bed mortar until you can see how much it will make. Kneel down holding the bucket between your knees and, using a strong stick or margin trowel, stir the mixture. Add more liquid or powder until it becomes a creamy paste. It must be fairly easy to stir but not runny. It is now ready to use.

All mastics come pre-mixed in containers ready to be used. They have a thick creamy paste-type consistency and range in color from cream to white. They

create a fairly strong bond and are resistant to water and freezing when dry. Even while the mastic is still wet, the tile won't slip or move very easily. Mastic can be used to bond tile to sheetrock, plywood and masonry surfaces. The main use of mastic is for bonding tile to the sheetrocked walls in bathtub enclosures. Because it gives good protection from water it is also used over plywood for countertops and backsplashes. Because thinbed mortar adhesives create a stronger and more durable bond, mastics are not often used for floors, outside surfaces, or for masonry surfaces. Mastic is never used for floors that will get heavy traffic, or for any type of heavy duty commercial use.

Before any type of tile adhesive is used to bond tile to a surface, that surface must be clean and dust-, wax-, and oil-free. It must be solid and secure.

# Self Assessment

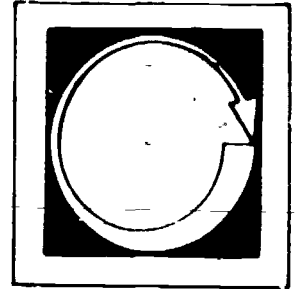

LISTED BELOW ARE STATEMENTS FOLLOWED BY A NUMBER OF POSSIBLE COMPLETIONS. SELECT THE COMPLETION WHICH COMPLETES THE STATEMENT CORRECTLY AND PLACE THE LETTER IN THE BLANK PROVIDED.

1. \_\_\_\_\_ is not considered a main type of backing?
  - a. plywood
  - b. cement mortar
  - c. linoleum
  - d. wonderboard
  - e. sheetrock
  
2. \_\_\_\_\_ The correct tile adhesive to use depends on \_\_\_\_\_.
  - a. the type of surface to be bonded to
  - b. the kind of conditions the tile will be subjected to
  - c. both a & b
  - d. none of the above
  
3. \_\_\_\_\_ is not considered a thin-setting adhesive.
  - a. thin-bed mortar mixed with water
  - b. portland cement
  - c. mastic
  
4. \_\_\_\_\_ Thin-bed mortar mixed with water can be used for \_\_\_\_\_ surfaces.
  - a. concrete
  - b. brick
  - c. cement mortar
  - d. all of the above

5. \_\_\_\_ Liquid latex and liquid acrylic are both \_\_\_\_.
- a. white synthetic liquids
  - b. used with thin-bed mortar
  - c. better additives than plain water
  - d. all of the above
6. \_\_\_\_ Thin-bed mortar mixed with \_\_\_\_ makes the best tile adhesive to use for heavy-duty commercial use.
- a. liquid latex or acrylic
  - b. epoxy
  - c. water
  - d. none of the above
7. \_\_\_\_ Thin-bed mortar mixed with \_\_\_\_ makes the strongest, toughest tile adhesive there is.
- a. water
  - b. acrylic
  - c. epoxy
  - d. none of the above
8. \_\_\_\_ When mixing tile adhesives you should always put the \_\_\_\_ in first.
- a. powder
  - b. stick or margin trowel
  - c. liquid
9. \_\_\_\_ All mastics are sold \_\_\_\_.
- a. pre-mixed
  - b. ready to mix
  - c. complete with stirring stick and directions
10. \_\_\_\_ The main use of mastic is for \_\_\_\_.
- a. floors of bathrooms
  - b. tub enclosures
  - c. heavy-duty commercial use
  - d. all of the above
  - e. none of the above

11. \_\_\_\_\_ Before any type of tile adhesive is used to bond tile to any type of surface, that surface must be \_\_\_\_\_.
- a. dusty and oily
  - b. plywood or concrete
  - c. still wet, but drying
  - d. clean and solid



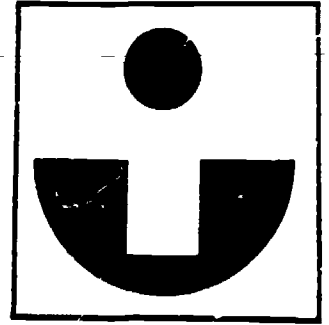

# ● Self Assessment Answers

1. c
2. c
3. b
4. d
5. d
6. b
7. c
8. c
9. a
10. b
11. d

# Assignment

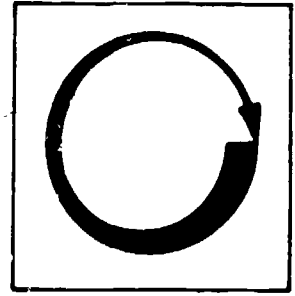

COMPLETE THE FOLLOWING ASSIGNMENT.

Go to a local tile shop. Look at three different types of tile adhesives.

Write a report on all three including the following information:

1. The type of the tile adhesive.
2. The type(s) of surfaces it can be used on.
3. Its resistance to chemicals and water.
4. What needs to be done to make the tile adhesive ready for use?
5. Which of the three types reported on would be best for commercial use?
6. Which type would be the best for a bathtub enclosure?

# Job Sheet

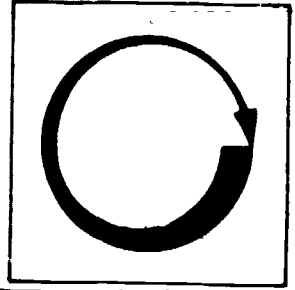

COMPLETE THE FOLLOWING TASK.

Materials and Tools

- large clean bucket
- sturdy stick at least 3' long
- access to water
- thin-bed mortar

Using the information on how to mix in the Information section, mix thin-bed mortar to the proper consistency.

# Post Assessment

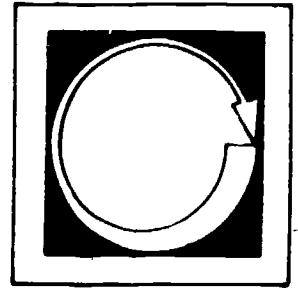

FROM THE FOLLOWING LIST OF WORDS SELECT THE ONE WHICH COMPLETES EACH SENTENCE BELOW. WRITE THE CORRECT WORD IN THE BLANK PROVIDED.

sheet rock

pure coat

wonderboard

trowel

slurry

margin trowel

linoleum

asphalt

synthetic

backing

masonry surface

1. A wall made from brick or cement mortar is called a \_\_\_\_\_ surface.
2. Cement mixed with water to form a paste is called a \_\_\_\_\_.
3. \_\_\_\_\_ is a thin floor covering with a shiny surface.
4. Something \_\_\_\_\_ is made artificially.
5. A \_\_\_\_\_ is any type of hand tool used to apply, spread, shape, mix, or smooth such material as mortars.
6. \_\_\_\_\_ can be used as a substitute for cement mortar.
7. A \_\_\_\_\_ is a mixture of cement and water used as an adhesive to bond tile.
8. \_\_\_\_\_ is a black concrete-type mixture.

9. A trowel used by tilesetters that has a 5 to 6 inch-long blade is called a \_\_\_\_\_.
10. \_\_\_\_\_ is a plaster-like board used as a backing for walls.
11. A \_\_\_\_\_ is any type of material used as a base or surface.

# Instructor Post Assessment Answers

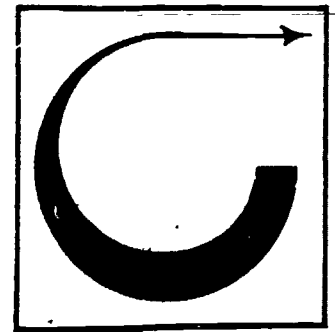

1. masonry surface
2. slurry
3. linoleum
4. synthetic
5. trowel
6. wonderboard
7. pure coat
8. asphalt
9. margin trowel
10. sheetrock
11. backing

## BACKINGS

### **Goal:**

The student will be able to identify, explain the use of and select the proper backing required.

116

### **Performance Indicators:**

The student will demonstrate knowledge of the subject by successfully completing a Self Assessment, an Assignment, and a Post Assessment.

119

# Study Guide

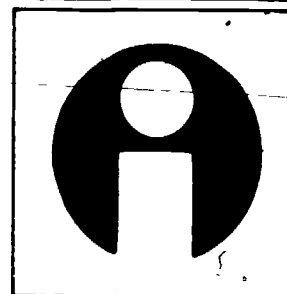

In order to finish this module, do the following tasks. Check each item off as you complete it.

1.  Read the Goal and Performance Indicators on the cover of the module. This will tell you what you will learn by studying the module, and how you will show you've learned it.
2.  Read the Introduction. The Introduction will tell you why the module is an important part of the tilesetting trade.
3.  Study the Vocabulary section. Vocabulary words are important for a good understanding of the trade. After you have studied the vocabulary, ask your teacher to quiz you on the words and their meanings.
4.  Study the Information section. This section will give you the information you need to understand the subject.
5.  Take the Self Assessment exam. This is a test for you to prove to yourself that you have learned the material you have studied. Compare your answers with the answers on the Self Assessment Answer Sheet, which is on the page following the Self Assessment. If you scored poorly, re-study the Information section or ask your teacher for help.
6.  Do the Assignment page. Follow the instructions at the top of the Assignment page.
7.  Take the Post Assessment exam. Give the exam to your teacher after you have completed it. Your teacher will grade it for you.



# Introduction

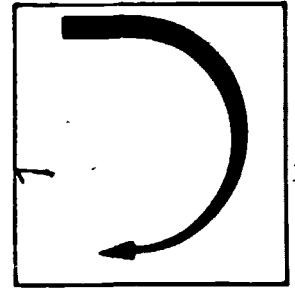

A tile installation is only as strong as the base or foundation on which it is set (the backing). The cause of most tile failures is the use of the wrong backing materials, therefore, it is very important for a tilesetter to learn what types of backings there are and how and where they are used.

# Vocabulary

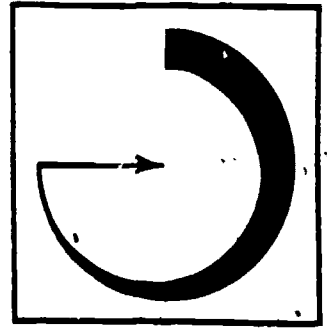

Trade terms are very important for a good understanding of the trade. Study these words and meanings. When you have learned them, ask your teacher to quiz you on the words and their meanings.

**REINFORCE**--To strengthen, make stronger.

**FELT**--A heavy building paper.

**SATURATED**--When no more liquid can be absorbed, or retained. Saturated asphalt felt has been soaked in asphalt until no more can be soaked up.

**CURE**--When cement is allowed to cure it means it is allowed to dry out slowly so that it becomes very durable.

**GALVANIZED**--Metal that has a coat of zinc on it.

**ZINC**--A bluish-white metal that does not rust.

**STUD**--One of the uprights used in the framing of walls in a building. Some type of finishing material such as paneling or sheetrock is nailed to them.

**VIBRATE**--To move quickly to and fro or from side to side. To shake.

**FORMICA**--A hard plastic material used as a surface finish on such things as kitchen countertops or bathtub enclosures.

**FASTENERS**--Nails, screws, staples, bolts, etc.

# Supplementary References

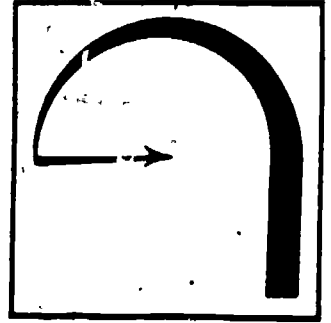

1. Tilesetting Workbook. California State Department of Education, 1975. pp. 34-37.
2. 1980 Handbook for Ceramic Tile Installations. Tile Council of America, Inc., 1980. pp. 1-32.

# Information

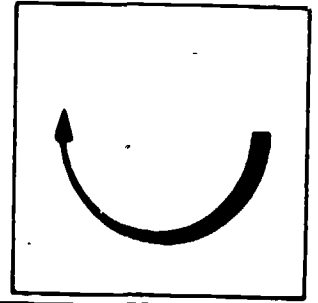

The different types of backings to which tile is bonded are listed below:

1. Cement mortar surfaces.
2. Wonderboard.
3. Concrete slab.
4. Plywood.
5. Gypsum plaster.
6. Sheetrock.
7. Concrete blocks and bricks.
8. Existing surfaces.

## CEMENT MORTAR SURFACES

We know that cement mortar can be used for many things such as kitchen counter-tops, showers, floors, and walls, and that cement mortar is a mixture of portland cement and sand (remember, for walls lime is added).

Cement mortar is not waterproof and may need to be made stronger. To make cement mortar waterproof and strong enough, certain types of cement mortar backing materials are used.

1. Waterproof layer.
2. Metal lath reinforcement.
3. Wire mesh reinforcement.
4. Fasteners.

(See the illustration on the top of the following page.)

### Waterproof Layer

Different types of waterproof building papers are used for a waterproof layer. These include: a) 15-lb. asphalt saturated waterproof felt, b) 13-lb. coal-tar saturated waterproof felt, and c) waterproof plastic building paper. The 15-lb. felt waterproof paper is the one used most. It is called tar-paper by

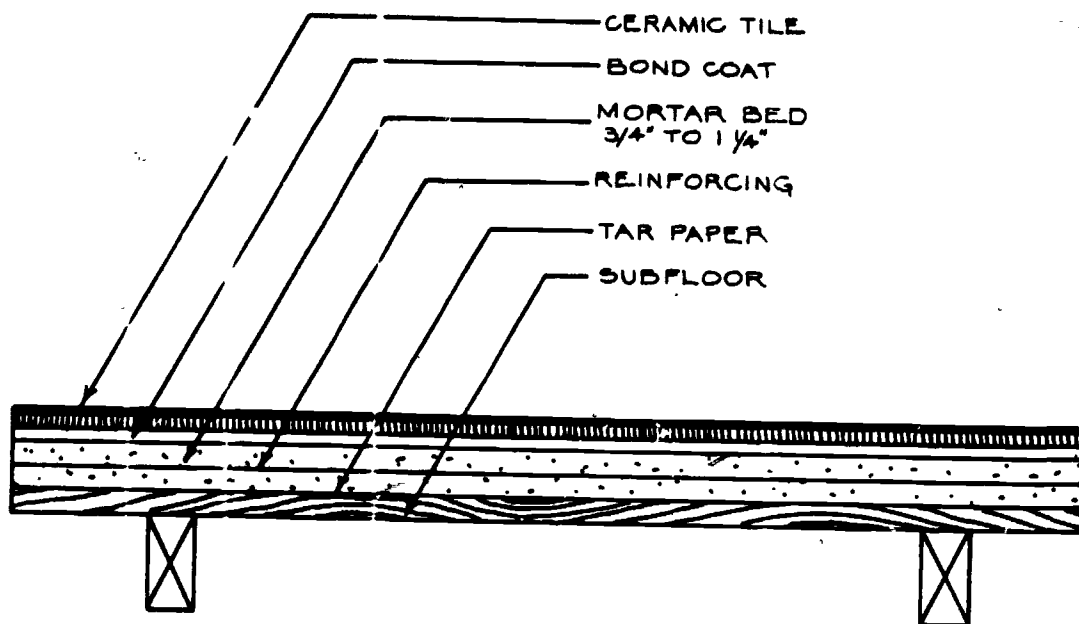

tilesetters. Tilesetters use tar-paper behind cement mortar for the following reasons:

1. It has been proven that if the moisture is held in the cement mortar as long as possible, the mortar has a better chance to cure or harden properly. The tar-paper helps prevent the mortar from drying out too fast.
2. Cement mortar shrinks and tightens when it cures; if it dries too fast it could cause hairline cracks in the tilework.
3. The tar-paper gives an extra layer of protection to the surface behind the cement mortar. If it is made of wood, the surface could rot if water were allowed to get to it.

Tar-paper is used over any solid backing that requires waterproofing.

Another product used as a waterproof layer is pan material. This is a thick plastic waterproof material. It is used as a waterproof layer under cement mortar shower floors. No holes are allowed in the pan material.

### Metal Lath

Metal lath is a reinforcing material that strengthens cement mortar. It comes in 26" by 96" metal mesh sheets. It is fastened on top of the tar-paper. Both are behind the cement mortar. The cement mortar is applied directly to the metal lath. Metal lath has two main purposes: a) It acts as a grip for the mortar (something for it to cling to), b) it keeps the mortar from cracking by strengthening it.

To prevent rust from forming, which can cause the metal lath to rot, a rust-inhibiting (not allowing rust to form) type metal lath should be used. Metal lath that has a coating of zinc (a type of metal that does not rust) is the type used most often. It is called galvanized metal lath.

### Wire Mesh

Wire mesh which is also called chicken wire or stucco mesh is also, like metal lath, a reinforcing material for cement mortar. It comes in different-sized rolls, not in sheets like metal lath. The main difference is--the metal used to make metal lath is much thicker and stronger than the wire used to make wire mesh. Wire mesh is cheaper and can be used successfully in place of metal lath. But metal lath is often required to be used. Generally, some type of metal or wire mesh reinforcing material is always used with cement mortar as a strengthener.

### Fasteners

Nails and staples are used as fasteners for attaching metal lath and wire mesh to wood surfaces. Common 4d or 6d box nails can be hammered three-quarters of their lengths into the wood, then bent over to secure the metal lath or wire mesh. A much faster nail to use for metal lath is a lathing nail. Lathing nails have extra large heads on them. When hammered into the wood the large head holds the metal lath in place.

A staple gun or staple hammer can be the fastest way to fasten metal lath or wire mesh to a wood surface. The staples should be large enough, at least 1/2" in length. Staples are also used as fasteners for attaching tar-paper to wood surfaces.

Special screws are used to attach metal lath or wire mesh to steel studs. Wire ties or metal clips can also be used. Steel studs are being used more and more in all kinds of construction. Steel stud framing is stable and never changes its size or shape after installation.

## WONDERBOARD

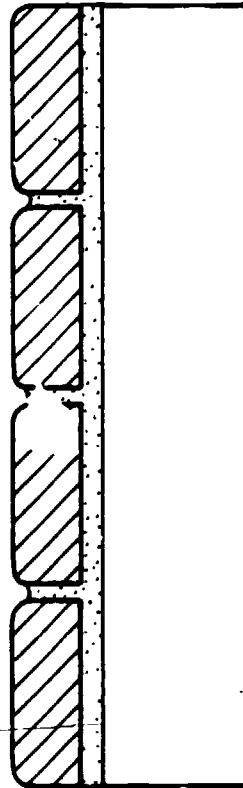

Wonderboard is a glass fiber mesh reinforced concrete backing board. It can be used in place of portland cement mortar for walls and floors. It is available in various sizes and thicknesses. The size most often used is 3' by 5' sheets that are 1/2" thick. It can be nailed in place over wood surfaces; and screwed in place over metal studs. It can be used as a backing for ceramic tile in wet areas.

## CONCRETE SLAB

A concrete slab is concrete, which we know is a hardened mixture of portland cement, sand, gravel, and water. Garage floors, driveways and roadways in general are often concrete slabs. Commercial buildings and homes will often have concrete slab floors and may want tile over the top. A concrete slab is an excellent backing for tile. But before you set tile over a concrete slab you should make sure that: a) There are no cracks in the slab. If there are, it is quite possible the tile will crack in the same place. b) The slab is free from any type of coatings--wax, oil, dirt, etc. If there are any of these things in or on the slab they should be removed with an etcher before setting

tile. An etcher is a type of liquid acid that will clean the surface of a concrete slab.

#### PLYWOOD

Plywood is only used as a backing for ceramic tile floors in homes. Plywood is never used as a backing for heavy commercial floor use. Plywood can be a very good backing for home use if a few rules are followed.

1. Never skimp on the thickness or grade of the plywood. 3/4" exterior grade plywood should be used.
2. Plywood should not be used if it will often come in contact with water.
3. Plywood should be well nailed over a solid, secure surface. If it is not, the tile could possibly vibrate loose. Always sink the heads of the nails well into the surface of the plywood.

#### GYPSUM PLASTER

Gypsum plaster is a paste-like mixture of lime, water, and sand that hardens and is used for coating walls and ceilings. Usually walls and ceilings that have been plastered will be used as a backing for paint or wallpaper. Even though plastered walls and ceilings are not necessarily used as a backing for ceramic tile they can be a very good one. A really good mastic or thin-bed mortar tile adhesive should be used to bond tile to gypsum plaster.

#### SHEETROCK

(See the illustration on the top of the following page.)

Sheetrock is basically a plaster mixture that is in a hardened sheet form. Sheetrock is also called gypsum board, wall board, and plaster board. There is a type of sheetrock that is called water resistant; it is often called W.R. board. Whenever sheetrock is to be used as a backing for ceramic tile, W.R. board should be used. Sheetrock comes in various sizes. The most common size used is 4' by 8' sheets that are 5/8" thick. Sheetrock is used for walls and ceilings like gypsum plaster. But for tile use, it is much faster and more convenient.

Sheetrock is nailed in place over wood studs. Sheetrock is used mainly as a backing for ceramic tile in areas that are not exposed to moisture. A good mastic is usually used to bond tile to sheetrock.



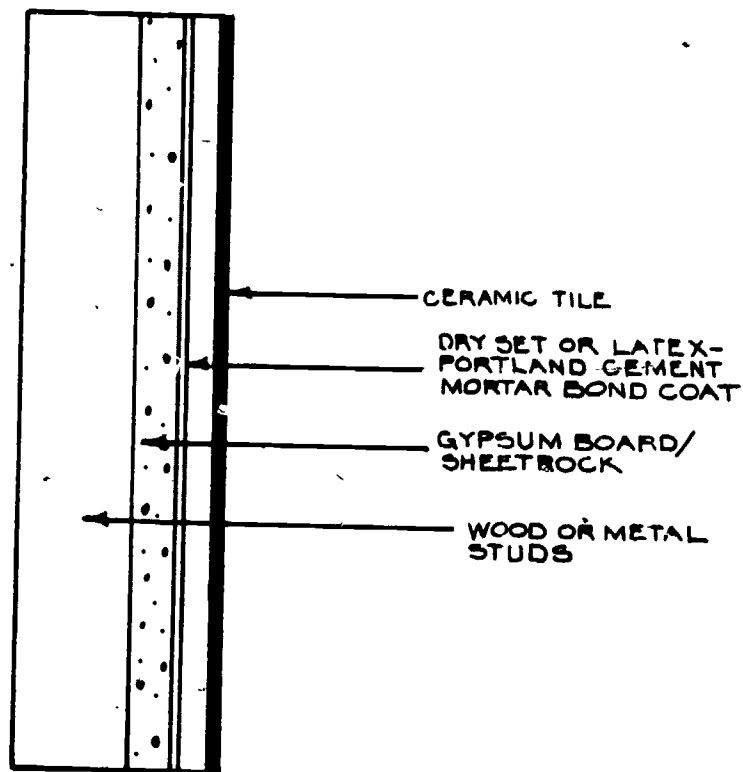

### CONCRETE BLOCKS AND BRICKS

If concrete blocks and bricks are used as a backing for ceramic tile, that backing will most likely be an existing wall. They provide an excellent backing for ceramic tile. Like a concrete slab they would need to be smooth and clean, free from any cracks and coatings like wax, dirt, and oil. Thin-bed mortar mixed with a liquid latex, acrylic, or other additives should be used to bond the tile to them.

### EXISTING SURFACES

Existing surfaces, such as linoleum, formica, hardwood floors, metal, and even old tile can have new tile applied to them. It is usually best to completely remove the old surface before setting tile. However, this is not always that easily done and can be very expensive. To be able to set tile to the existing surface that surface must be:

1. Solid, secure, and well-fastened down; if it's not you can't expect the tile to stay bonded very long.

2. Dry and in good shape; if the surface is at all rotten it should be removed and completely redone.
3. Free from any cracks, soap scum, wax, oil, dirt, and coatings. If it's not, tile should not be set to it.

# Self Assessment

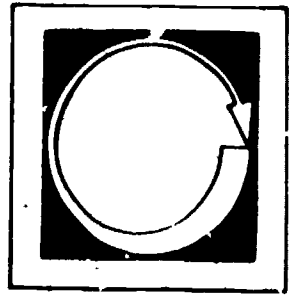

LISTED BELOW ARE STATEMENTS FOLLOWED BY A NUMBER OF POSSIBLE COMPLETIONS. SELECT THE COMPLETION WHICH COMPLETES THE STATEMENT CORRECTLY AND PLACE THE LETTER IN THE BLANK PROVIDED.

1. \_\_\_\_ Backing materials for cement mortar are used to
  - a. keep the cement mortar from rotting
  - b. waterproof and reinforce it
  - c. both a and b
  - d. none of the above
  
2. \_\_\_\_ Tilesetters call the waterproof building paper they use
  - a. concrete paper
  - b. mortar paper
  - c. waterproof paper
  - d. tar-paper
  
3. \_\_\_\_ If moisture is held in cement mortar for as long as possible, the mortar has a better chance
  - a. to cure properly
  - b. of cracking
  - c. that it will never harden properly
  
4. \_\_\_\_ Both \_\_\_\_ and \_\_\_\_ are reinforcing materials for cement mortar.
  - a. tar-paper and shower pan material
  - b. sand and gravel
  - c. metal lath and wire mesh
  - d. both a and c

5. \_\_\_\_\_ Tilesetters use \_\_\_\_\_ metal lath most often.
- rusty
  - galvanized
  - saturated
  - pure metal
6. \_\_\_\_\_ comes in sheets and \_\_\_\_\_ comes in rolls.
- wire mesh and metal lath
  - tar-paper and shower pan material
  - metal lath and wire mesh.
7. \_\_\_\_\_ The fastest way to fasten metal lath or wire mesh to a wood surface is to use
- a staple gun
  - lathing nails
  - 4d and 6d common nails
  - a tile adhesive
8. \_\_\_\_\_ Tilesetters call a glass fiber mesh reinforced concrete backing board
- variety board
  - fiberglass board
  - clear board
  - wonderboard
9. \_\_\_\_\_ Wonderboard can be used in place of
- plywood
  - cement mortar
  - wire mesh
10. \_\_\_\_\_ Before tile is set on any surface that surface must
- be clean and free from dirty coatings.
  - have no cracks in it
  - be secure and well fastened down.
  - all of the above

11. \_\_\_\_\_ Plywood's main use as a backing for ceramic tile is for
- a. heavy commercial use
  - b. floors in homes
  - c. outside decks and patios
  - d. tubsplashes
12. \_\_\_\_\_ Sheetrock is recommended for areas that are
- a. exposed to moisture
  - b. not exposed to moisture
  - c. to be made into a shower
13. \_\_\_\_\_ is used most often to bond tile to sheetrock.
- a. mastic
  - b. thin-bed mortar
  - c. portland cement
  - d. epoxy

LISTED BELOW ARE SEVERAL STATEMENTS. IF THE STATEMENT IS TRUE, PLACE A "T" IN THE BLANK PROVIDED. IF THE STATEMENT IS FALSE, PLACE AN "F" IN THE BLANK.

14. \_\_\_\_\_ It is usually best to completely remove the old existing surface before setting new tile.
15. \_\_\_\_\_ It is impossible to set new tile over old tile.

# Self Assessment Answers

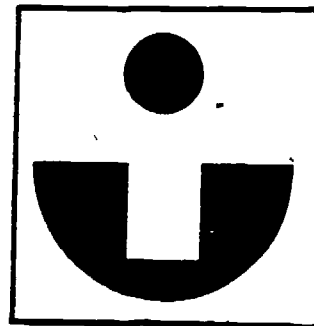

1. b
2. d
3. a
4. c
5. b
6. c
7. a
8. d
9. b
10. d
11. b
12. b
13. a
14. T
15. F

# Assignment

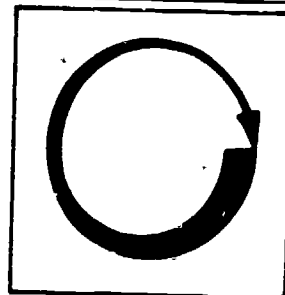

COMPLETE THE ASSIGNMENT BELOW.

Where you live, pick a floor (it can be any floor--a certain room, a hallway, wherever); a wall (any interior wall); and a countertop. Then answer these questions about each one.

1. What floor, wall, and countertop is it? (hallway, bedroom, bathroom, kitchen, etc.)
2. What type of finished surface does it have. (tile, paint, concrete, wood, linoleum, formica, etc.)
3. Would it make a good or bad backing for ceramic tile just the way it is? Explain.
  - a. Is it solid, secure, and well fastened down? Explain.
  - b. Is it in good shape? Explain.
  - c. Are there any cracks or holes in it? Explain.
  - d. Is it clean and free from wax, oil, dirt, etc.? Explain.
4. If it would not make a good backing for tile the way it is, what would have to be done to make it a good one.
  - a. Would it have to be redone? Explain.
  - b. Would the surface just have to be cleaned? Explain.
5. Suppose it is a good backing for ceramic tile just the way it is--what type of tile adhesive would you use to bond tile to it? Why?

# Post Assessment

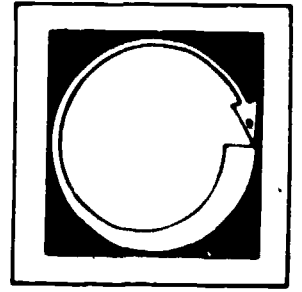

LISTED BELOW ARE SEVERAL STATEMENTS. IF THE STATEMENT IS TRUE, PLACE A "T" IN THE BLANK PROVIDED. IF THE STATEMENT IS FALSE, PLACE AN "F" IN THE BLANK.

1. \_\_\_ Formica is a hard plastic material used as a surface finish.
2. \_\_\_ Something galvanized fizzes and will eventually rot if it is soaked in water.
3. \_\_\_ Felt building paper is paper that is used to soak up water.
4. \_\_\_ When something is strengthened and made stronger, we can say it has been reinforced.
5. \_\_\_ A stud is a material that can be used as a finished surface to bond tile to.
6. \_\_\_ Something that vibrates moves quickly to and fro.
7. \_\_\_ Zinc is a type of nail used to fasten metal lath.
8. \_\_\_ When something is saturated it cannot absorb any more liquid.
9. \_\_\_ If cement is cured it is allowed to harden slowly.



# Instructor Post Assessment Answers

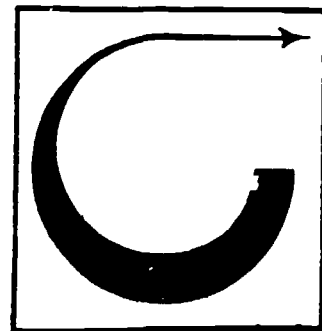

1. T
2. F
3. F
4. T
5. F
6. T
7. F
8. T
9. F

---

LAYOUT AND LEVELING TOOLS

---

**Goal:**

The student will be able to identify, select and explain the use of tools commonly used to layout and level tile-work.

135

**Performance Indicators:**

The student will successfully complete a Self Assessment, an Assignment page, a Job Sheet, and a Post Assessment.

138

# Study Guide

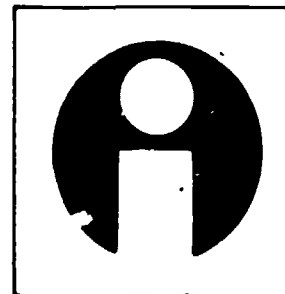

In order to finish this module, do the following tasks. Check each item off as you complete it.

1.  Read the Goal and Performance Indicators on the cover of the module. This will tell you what you will learn by studying the module, and how you will show you've learned it.
2.  Read the Introduction. The Introduction will tell you why the module is an important part of the tilesetting trade.
3.  Study the Vocabulary section. Vocabulary words are important for a good understanding of the trade. After you have studied the vocabulary, ask your teacher to quiz you on the words and their meanings.
4.  Study the Information section. This section will give you the information you need to understand the subject.
5.  Take the Self Assessment exam. This is a test for you to prove to yourself that you have learned the material you have studied. Compare your answers with the answers on the Self Assessment Answer Sheet, which is on the page following the Self Assessment. If you scored poorly, re-study the Information section or ask your teacher for help.
6.  Do the Assignment page. Follow the instructions at the top of the Assignment page.
7.  Do the Job Sheet. Follow the instructions at the top of the Job Sheet. The tasks listed on the Job Sheet will help you develop skills which will be helpful to you.
8.  Take the Post Assessment exam. Give the exam to your teacher after you have completed it. Your teacher will grade it for you.

# Introduction

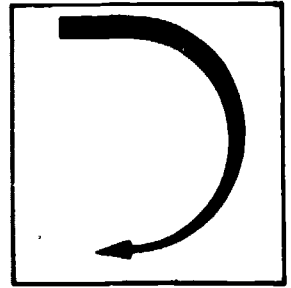

In this module, we will discuss the tools used by tilesetters in laying out their work and making sure it is level and plumb. To get a good-looking finished job, it is important to know how to properly use the tools.

# Vocabulary

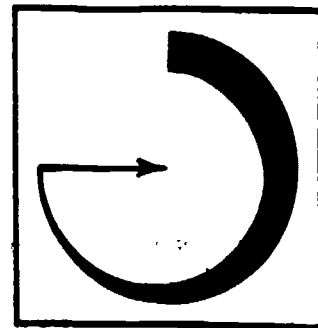

Trade terms are very important for a good understanding of the trade. Study these words and meanings. When you have learned them, ask your teacher to quiz you on the words and their meanings.

**LAYOUT**--The steps in planning and arranging the tiles so they will fit a design.

**VERTICAL**--Straight up and down.

**HORIZONTAL**--Level, flat, straight, left to right, like a tabletop.

**PLUMB**--Perfectly straight up and down.

**LEVEL**--Perfectly flat horizontally.

**DEGREES**--A unit measure that indicates the size of an angle.

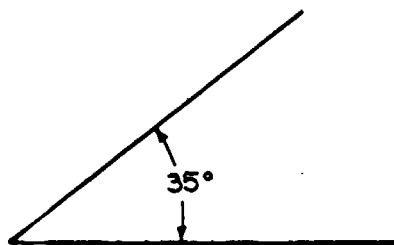
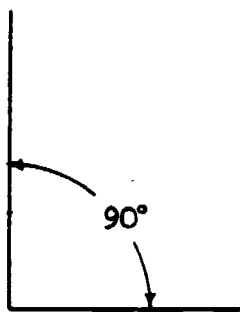

**BISECT**--To divide an angle into two equal parts.

**INTERSECT**--To meet and cross at a point.

**PENTAGON**--A shape having five equal sides and angles.

**FLOAT STRIP**--A strip of wood usually about 1/4" thick and 1 1/4" wide, used as a guide to level mortar surfaces.

**SCREED**--Cement mortar put down as a guide to making the tile level.

**SIPHON**--The transferring of liquid from one place to another, by a continuous flow. Usually through some type of flexible tubing.

**DIAMETER**--The distance across a circle measured through the center.

# Supplementary References

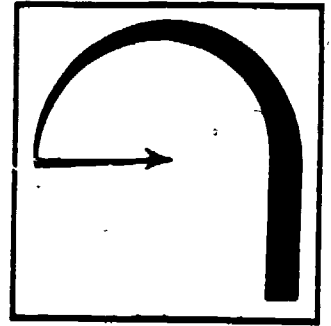

Typesetting Workbook. California State Department of Education, 1975.  
pp. 38-43.

# Information

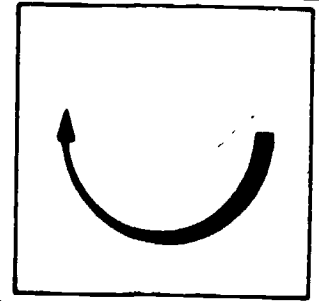

## LAYOUT TOOLS

1. Measuring tape.
2. Chalk line.
3. Story pole.
4. Steel square.
5. Combination square.
6. Trammel bar.
7. Angle divider.

The most frequently used layout tools are the measuring tape, chalk line, story pole, and steel square.

The measuring tape is the most frequently used tilesetting tool. A 12', 16', or 20' long steel tape is preferred by most tilesetters.

The chalk line has many uses. It is used for laying down working lines, finish lines, plumb lines, and level lines. It is usually a cotton or nylon cord enclosed in a chalk-filled metal case. To use, stretch the cord across the surface, hold tight at both ends and snap the cord to make the chalk mark a straight line. It makes marking long walls and floors easier. The colors of chalk available are red, white, and blue.

A story pole, which is also called a layout stick, is a long strip of wood that is marked with the tile size and joint space. (See the illustration at the top of the next page.) The story pole is used to measure the length, width, and height for tilework. It is also used to work out the best size tile cut for the best looking tile job.



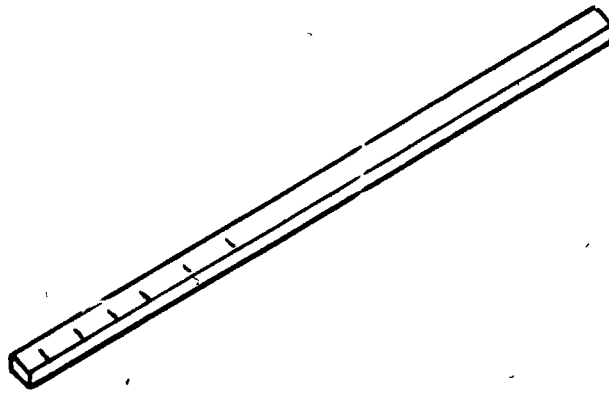

The steps in making a story pole are:

1. Use a long strip of wood (preferably a 1" X 4" straightedge) and the tile you need to set.
2. Decide what size joint space you want (from  $\frac{3}{16}$ " for 6" X 6" tile to  $\frac{1}{2}$ " for 10" X 10" or 12" X 12" tile).
3. Start by marking the width of the joint size on one end of the wood strip.
4. Lay down a piece of tile next to that mark, and mark the other side of the tile onto the wood strip.
5. Then mark a joint size and so on, until the wood strip is completely marked.

The steel square is one of the most important tilesetting tools. The size square used most often has a large arm that is 2" wide and 24" long called the body or blade, and a smaller arm that is at a 90-degree angle to the blade and is 1 1/2" wide and 16" long; it is called the tongue. The point where the outside edges of the blade and tongue join is called the heel. The surface with the measure on it is called the face; the other surface is called the back.

The tilesetter can use a steel square:

1. To layout and draw different angles.
2. To bisect angles.
3. To find the center of a circle.
4. To draw a pentagon.
5. To divide a space between two lines, as a straightedge.

To use a steel square to draw different angles you would:

1. Mark a point at the 12" mark.
2. Find the distance in the table that corresponds to the angle you want to make.
3. Mark another point on the tongue at the distance in inches that is shown in the table for the desired angle.

<u>Angle--degrees</u>	<u>Distance--inches</u>
5	1 1/16
10	2 3/32
15	3 7/32
20	4 3/8
22 1/2	4 31/32
25	5 19/32
30	6 15/16
35	8 13/32
40	10 1/16
45	12
50	14 5/16
55	17 1/8
60	20 25/32

In the following illustration, point "A" is marked at 12" on the tongue, and point "B" is marked at 12" on the blade. Angle B-A-C is 90 degrees. Angles O-C-A and O-C-B are 45 degrees.



To use a steel square to bisect an angle, the procedure is as follows:

1. Lay the square so that the same number is on the tongue and blade at the points where they cross OA and OB.
2. Draw line OC through the heel of the square. Line OC bisects angle AOB.

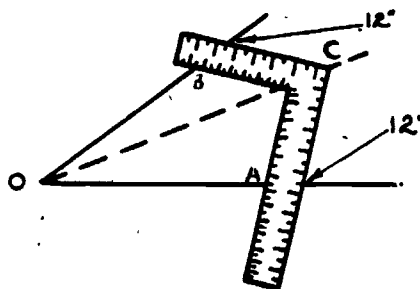

The steel square and a straightedge can be used to find the center of a circle.

The procedure is as follows:

1. Place the heel of the square on the exact center of the straightedge.
2. Draw a line along the blade.
3. Shift the straightedge to another position as shown in the drawing.
4. Repeat steps 1 and 2. The center of the circle will be where the two lines cross.

(See the illustration on the following page.)

The combination square is a small square that has an adjustable tongue. The blade is usually 1" X 12". It is used to mark straight lines on tiles that need to be cut, and where a large square is not suitable.

A trammel bar, which is easy to make, can be used to make any size circle needed. To make a trammel bar, a notch is cut at one end of a stick, and a line is drawn down the center of it. A nail is driven in the center of the line through the stick, this will be the center of the circle. (See the second illustration on the following page.)

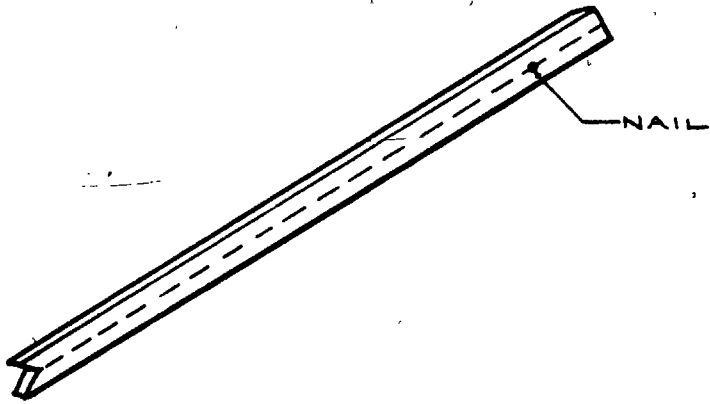
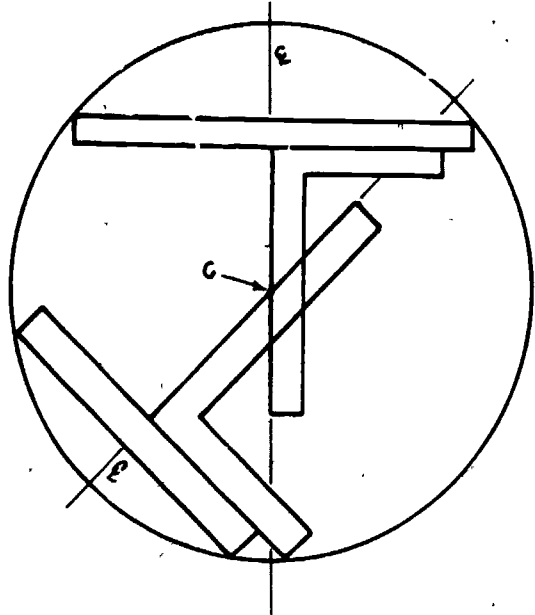

TRAMMEL BAR

A pencil is secured in the notch. Turn the stick around the nail until you've drawn a circle. The diameter of the circle will be twice the distance of the notch to the nail.

The angle divider is used by the tilesetter to determine the degree of an angle to cut a piece of tile. A corner angle is measured by adjusting the divider to fit the corner. This angle is then transferred to the tile that is to be cut for the corner.

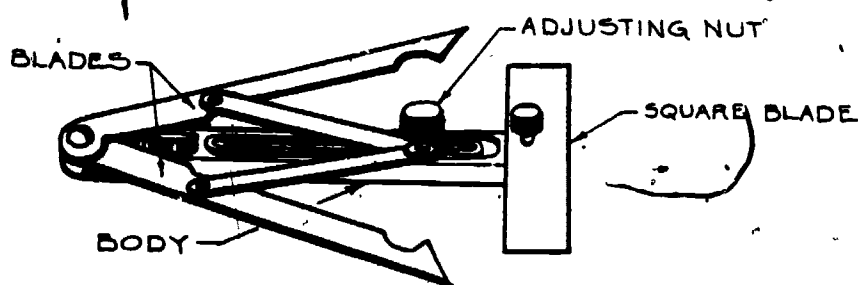

#### LEVELING TOOLS

1. Level.
2. Water level.
3. One-man water level.
4. Straightedge.
5. Plumb bob.

The most frequently used leveling tools are the level and the straightedge.

The level is used by the tilesetter for many things. It is used to level and plumb different tilesetting surfaces, such as wall and floor float strips and the screed strips for floors. The 1', 2', and 4' levels are generally used most often.

You should be sure to buy an accurate level; not all levels are.

There is a way to test a level in the store before you buy it--to make sure it gives an accurate plumb and level reading. Place the level against

a surface that looks to be either plumb or level and read the bubble. Mark the outside edges with a pencil, flip the level over, and place it between the marks; the bubble should be in the same position on both sides. If it is not, the level probably is not accurate. Always check each level on at least two different horizontal and vertical surfaces.

The water level is a piece of clear plastic hose usually  $3/8$ " to  $1/2$ " in diameter and usually 50' in length. It is filled with water, from which all air must be removed. Air bubbles in the hose compress when the level is used, and may cause a false reading.

The water level can be checked to see if it is accurate by placing the two ends together.

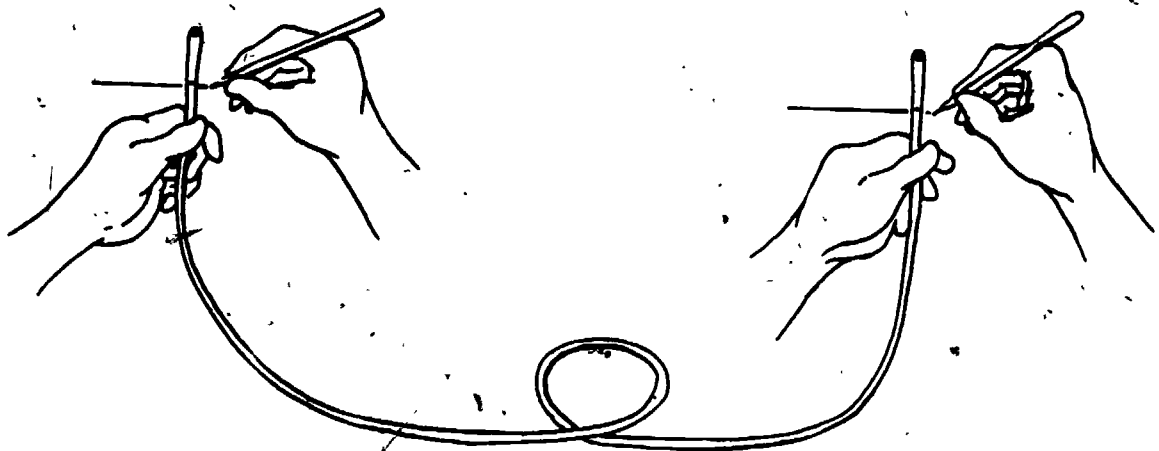

If the level is accurate, the top of the water will be at the same height on both ends. If the height is not the same, most likely an air bubble is in the hose. The best way to remove air bubbles is to siphon the water into the hose, letting it run until no more bubbles are seen.

The water level is a fast and easy way to make level marks in large indoor and outdoor areas. As the water level is moved from mark to mark, the ends of the hose should be plugged with the fingers, so that no water is lost. The top of the water in the hose has a high point and a low point. The two tilesetters should be sure they are both taking the reading from the same point because there is a difference of about 1/8" between the two points. Be careful not to leave one end of the water level in the hot sun when the other end is in the shade. The water in the hot end will expand causing a false reading. To avoid this, the hose should not be left partly in the sun and partly in the shade for any length of time. If there is any doubt check both ends together.

The one-man water level is accurate if it is operated properly. It consists of a container (preferably clear) that holds water, and clear plastic tubing or a water hose with a 6" glass tube inserted in one end. A one-man water level can be bought or one can be made inexpensively.

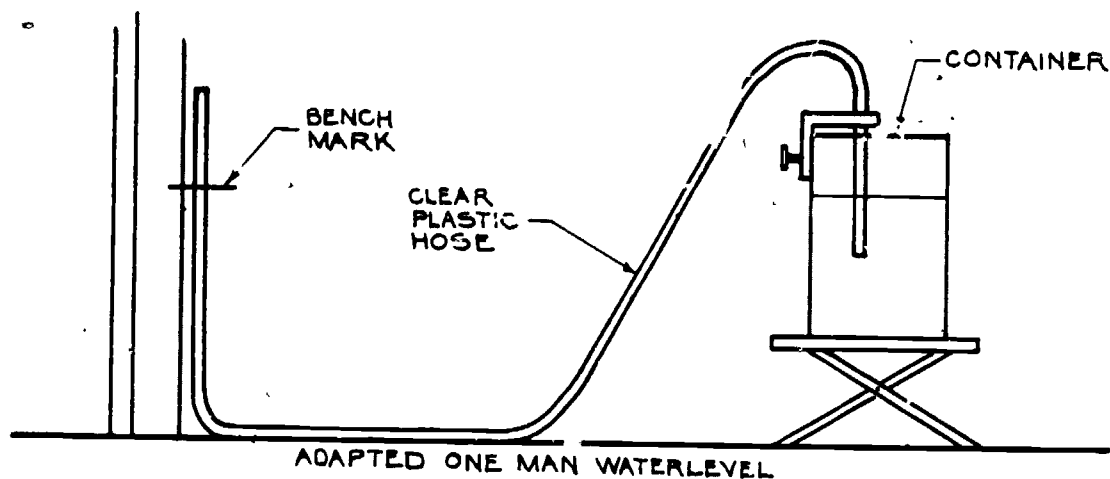

The procedure for filling and using the one-man water level is as follows:

1. Secure one end of the hose near the bottom of the container so that it will not move while you are working with the level around the walls.
2. Fill the container with water.
3. Siphon water out of the other end of the hose, which must be lower than the container. When all air bubbles are gone, plug the hose, and raise it to the level of the container. The level is now ready to use.

Straightedges are made of either metal or wood. They vary in thickness and are usually around 4" wide and range in length from 2' to 16'. Straightedges can be used with the level for an extension to plumb and level different surfaces, like float strips. They can be used to straighten and screed mortar beds, and they can be used to make a story pole.

A plumb bob is basically a weight (called the bob) that hangs on the end of a line. The line is fastened to the ceiling and the bob is let down almost to the floor, but not touching it. The line is plumb and a mark can be made on the wall for the tilesetter to go by.



# Self Assessment

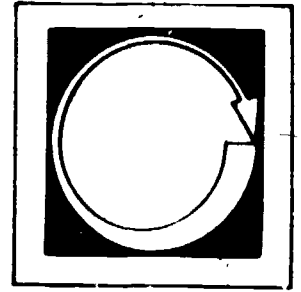

LISTED BELOW ARE STATEMENTS FOLLOWED BY A NUMBER OF POSSIBLE COMPLETIONS. SELECT THE COMPLETION WHICH COMPLETES THE STATEMENT CORRECTLY AND PLACE THE LETTER IN THE BLANK PROVIDED.

1. \_\_\_\_ The most frequently used layout tools are the
  - a. level and straightedge.
  - b. water level, steel square, and trammel bar.
  - c. measuring tape, chalk line, story pole, and steel square.
  - d. none of the combinations above.
  
2. \_\_\_\_ The most frequently used leveling tools are the
  - a. level and straightedge.
  - b. measuring tape, chalk line, story pole, and steel square.
  - c. water-level, straightedge, and angle divider.
  - d. none of the combinations above.
  
3. \_\_\_\_ If you put a 12" mark on the tongue and a 17 1/8" mark on the blade, what size of angle would be made by the tongue?
  - a. 22 1/2 degrees.
  - b. 90 degrees.
  - c. 60 degrees.
  - d. none of the above--the correct answer is \_\_\_\_\_.
  
4. \_\_\_\_ The story pole can help you determine the best size
  - a. tile to use.
  - b. tile cut to make.
  - c. of travel to use.
  - d. book to read.

5. \_\_\_\_ The large arm of a steel square is called the
- a. blade.
  - b. tongue.
  - c. heel.
  - d. face.
6. \_\_\_\_ A trammel bar can be used to make
- a. tropical drinks.
  - b. level marks on walls.
  - c. a good straight line to go by.
  - d. different size circles.
7. \_\_\_\_ You should be careful when buying a level, because sometimes it
- a. will be priced too low.
  - b. will be too heavy or too light.
  - c. won't be accurate.
  - d. will be an imported level.
8. \_\_\_\_ All air bubbles must be removed from the water level, because
- a. the air could expand and spill the water.
  - b. they could cause a false reading.
  - c. the air could be polluted.
  - d. none of the above.

# Self Assessment Answers

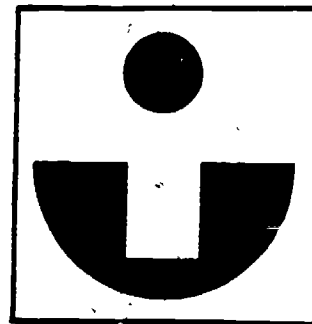

1. c
2. a
3. d The correct answer is  $55^\circ$ .
4. b
5. a
6. d
7. c
8. b

# Assignment

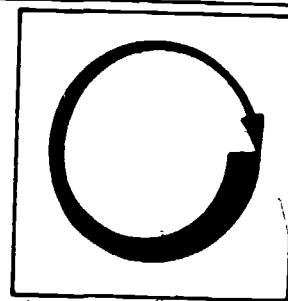

COMPLETE THE FOLLOWING ASSIGNMENT.

Go to a building supply store that sells levels. Check out 3 different levels to see how accurate they are. Use the procedure given in the information section. Then answer the following questions.

1. What lengths were the levels?
2. What were they made from--wood, a metal, both?
3. Where did you check them to see if they were accurate? (Outside wall, inside floor, countertop, a beam etc.)
4. For each level checked how accurate was it? Explain.

# Job Sheet

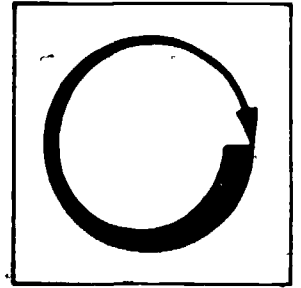

COMPLETE THE FOLLOWING TASKS.

Materials and Tools

1 long wood strip preferably a 1" by 4' straightedge

pencils

a tile (at least a 6" X 6" piece)

1 square

paper

1 water level (clear tubing at least 20' long)

water

1. Construct a story pole.
2. Practice making angles with a square (use the tables given).
3. Practice using a two-man water level.

# Post Assessment

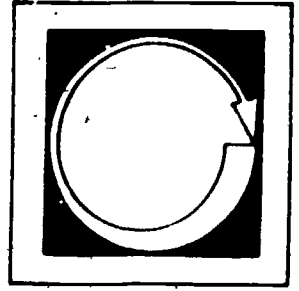

LISTED BELOW ARE SEVERAL STATEMENTS. IF THE STATEMENT IS TRUE, PLACE A "T" IN THE BLANK PROVIDED. IF THE STATEMENT IS FALSE, PLACE AN "F" IN THE BLANK.

1. \_\_\_ A table top, a football field, and a race track are all vertical surfaces.
2. \_\_\_ Something level is perfectly flat horizontally.
3. \_\_\_ Plumb is perfectly straight up and down.
4. \_\_\_ Something that is horizontal can also be vertical, they are almost the same thing.
5. \_\_\_ If an angle is divided into two equal parts you can say it has been bisected.
6. \_\_\_ A degree is a unit measure that indicates the length of a line that goes through the center of a circle.
7. \_\_\_ To intersect is to meet and cross at a point.
8. \_\_\_ A pentagon has eight sides and angles.
9. \_\_\_ A float strip is a strip of wood used as a guide to align mortar surfaces.
10. \_\_\_ One way to get gasoline out of a gas tank is to siphon it.
11. \_\_\_ The diameter is the size of an angle.
12. \_\_\_ Cement mortar put down as a leveling guide (something to go by) is a screed.

# Instructor Post Assessment Answers

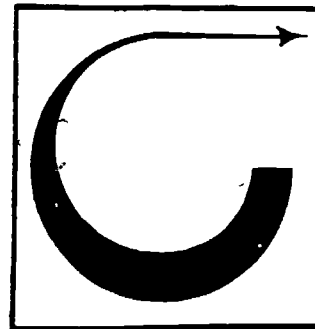

1. F
2. T
3. T
4. F
5. T
6. F
7. T
8. F
9. T
10. T
11. F
12. T

## TILE CUTTING AND DRILLING TOOLS

### **Goal:**

The student will be able to identify, select, and use the correct tools required to make tile cuts.

157

### **Performance Indicators:**

The student will demonstrate knowledge of the subject by successfully completing the Self Assessment, a Job Sheet and a Post Assessment.

160



# Study Guide

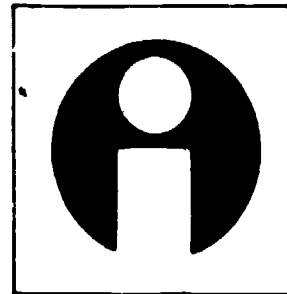

In order to finish this module, do the following tasks. Check each item off as you complete it.

1.  Read the Goal and Performance Indicators on the cover of the module. This will tell you what you will learn by studying the module, and how you will show you've learned it.
2.  Read the Introduction. The Introduction will tell you why the module is an important part of the tilesetting trade.
3.  Study the Vocabulary section. Vocabulary words are important for a good understanding of the trade. After you have studied the vocabulary, ask your teacher to quiz you on the words and their meanings.
4.  Study the Information section. This section will give you the information you need to understand the subject.
5.  Take the Self Assessment exam. This is a test for you to prove to yourself that you have learned the material you have studied. Compare your answers with the answers on the Self Assessment Answer Sheet, which is on the page following the Self Assessment. If you scored poorly, re-study the Information section or ask your teacher for help.
6.  Do the Job Sheet. Follow the instructions at the top of the Job Sheet. The tasks listed on the Job Sheet will help you develop skills which will be helpful to you.
7.  Take the Post Assessment exam. Give the exam to your teacher after you have completed it. Your teacher will grade it for you.

# Introduction

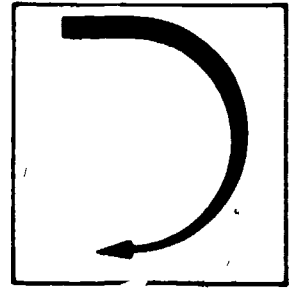

In this module we will cover what tools are used by tilesetters to cut and make holes in tiles.

To get a good-looking finished tile job it is important to know how to properly use these tools.

# Vocabulary

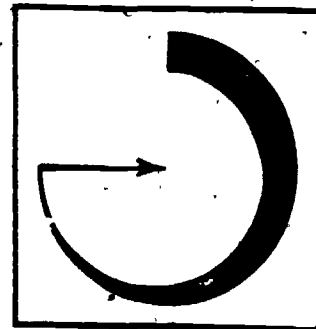

Trade terms are very important for a good understanding of the trade. Study these words and meanings. When you have learned them, ask your teacher to quiz you on the words and their meanings.

**PRESSURE**--Force, weight applied to something.

**CARBIDE**--A very hard metal compound often used as a coating for metal cutting edges to give them strength.

**JAW**--Two parts of a tool that open and close for holding, crushing, or biting something between them.

**PARTICLES**--Small portions of something whole, very small chips, pieces, dust.

**EMBEDDED**--An object stuck in something else.

**ABRASIVE**--Something rough, used for smoothing or polishing, such as sandpaper.

**GRIT**--A measure of abrasiveness.

**COMMERCIAL DIAMOND**--Synthetic crystallized carbon used as a heavy duty abrasive because of its hardness.

**FIXTURE**--Something that is attached to something.

**DIAGONAL**--The line from corner to opposite corner of a rectangle. (See the illustration on the following page.)

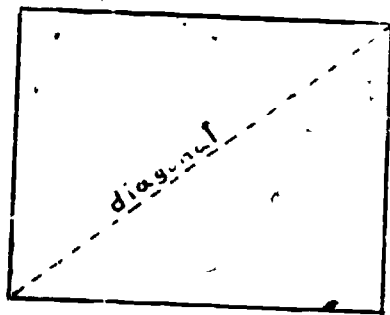

SCORE--It's a line scratched into a surface such as glass or tile which enables you to break the glass or tile at that line.

# Supplementary References

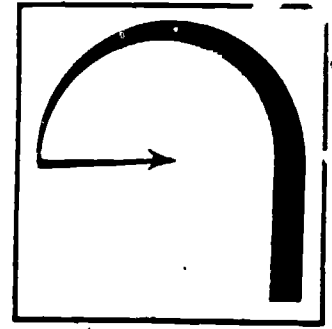

Typesetting Workbook. California State Department of Education, 1975. pp. 44-47.

# Information

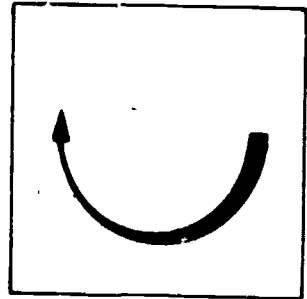

The most frequently used tools for cutting tiles are:

1. Tile cutter.
2. Nippers.
3. Chipping hammer.
4. Rod saw.
5. Electric tile saw.

## TILE CUTTER

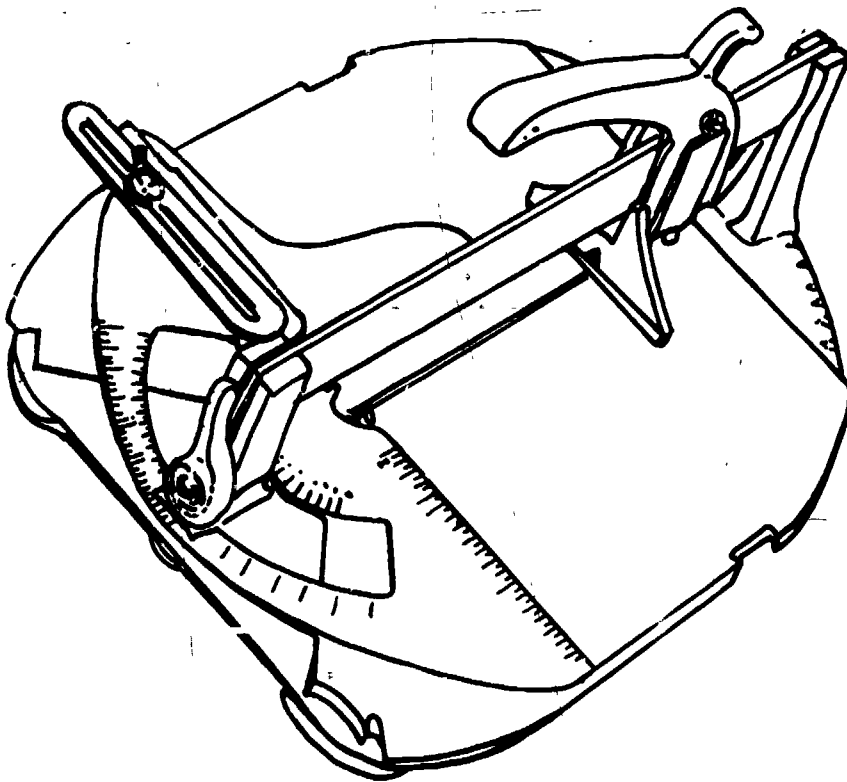

163

166

The tile cutter, which is also called a tile cutting board, is one of the most often used tilesetting tools. A tile job rarely works out full tile (which means no tile cuts are needed); therefore, most of the time tile cuts need to be made. Tile cutting boards can be used for tiles that range in size from small 1-inch mosaics to large 2-foot long ceramic sheet tile.

There are many different shapes and sizes of tile cutting boards, but they are all basically the same. They consist of a metal board that usually has a rubber top surface. The base of the board has a guide marked in inches. There are various types of side guides--they enable you to make straight or angled tile cuts. It has a handle with a carbide-tipped scoring wheel on the end of it. The wheel is similar to the type used to score glass. The handle, which also breaks the tile after it has been scored, is fitted above a metal bar in the center of the board.

#### Cutting the Tile

Using an upward pressure on the handle--in a smooth motion--score the tile from top to bottom--then immediately push down on the handle towards the bottom of the tile to break it. Never score the tile more than once, it will dull the cutting wheel.

Being able to properly use the tile cutter takes a little practice--but, you will soon get the hang of it.

A tile cutting board can be used to cut most tiles; but it won't work for:

1. Tiles that are too large or thick for the cutter. These would have to be cut with an electric tile saw.
2. Anything but straight cuts--it won't cut curves, circles, or holes in tile. They would have to be made with either nippers, a rod saw, or a drill.

#### NIPPERS

(See the illustration on the following page.)

Nippers which are also called biters by tilesetters come in two different jaw designs--1) centered jaw and 2) offset jaw. The jaws which are the cutting edges of the nippers are usually carbide tipped to resist breaking. The handles have plastic grips.

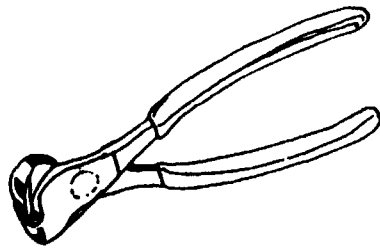

Nippers are used to--

1. Trim tile edges for a proper fit.
2. Cut curves in tile.
3. Make straight cuts that cannot be made with the tile cutter.

Nippers are a very important tilesetting tool; again it takes a fair amount of practice to be able to use them well.

To use--simply hold the piece of tile that needs to be cut firmly in one hand, with the other hold the nippers. Mark on the tile the cut you are going to make so you have something to go by. Nip off small pieces (called bites) at a time. Squeeze and pull down firmly with the nippers on each bite.

#### CHIPPING HAMMER

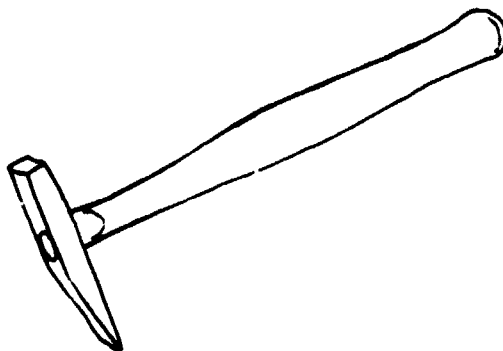



The chipping hammer is a lightweight hammer that comes in a variety of sizes. The head and back of the hammer are sometimes capped with carbide for strength. It is used by tilesetters to chip away some of the excess material and body from the backs and edges of tiles. This process is called featheredging and backing-off tile by tilesetters. The purpose is to make the tile lay flat on a surface where it would otherwise stick out beyond the level of the surrounding tile.

The chipping hammer does not have to be used very much.

#### ROD SAW

(See the illustration on the following page.)

The rod saw is a fairly new tool used for the cutting of tile. It is a steel rod approximately 1/8" in diameter. The rod has carbide particles embedded in its surface. A hacksaw frame is used to hold the rod tight for easy use. The rod saw is used to cut circles and irregular curves in tile. You use the rod saw in the same manner that you use any type of handsaw.

#### ELECTRIC TILE SAW

(See the 2nd illustration on the following page.)

There are many different types of tile saws. They are a very useful tool in the tilesetting trade.

A tile saw consists of a motor that turns a diamond-bonded steel rim cutting blade. The outer rim of the blade has commercial diamonds bonded to it. This

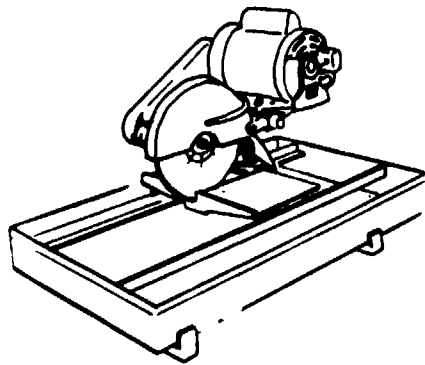
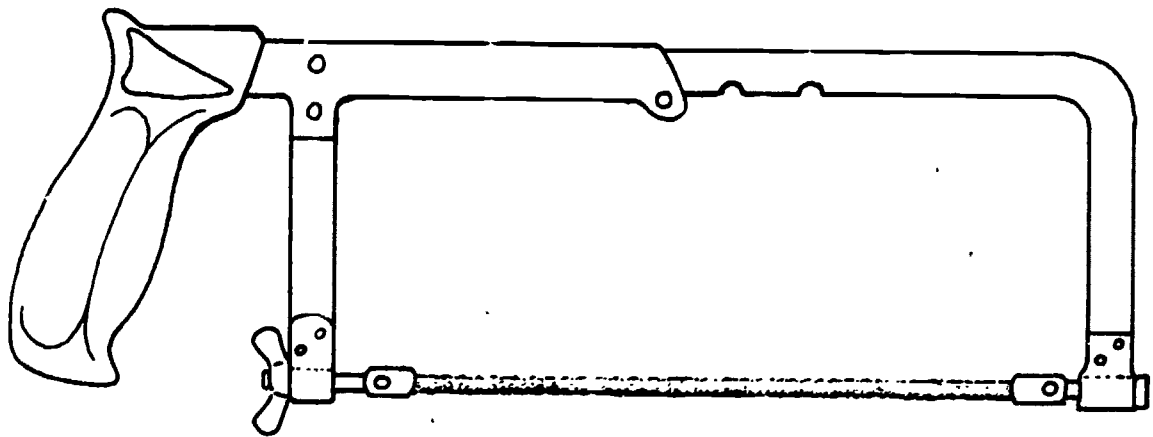

167

170

type of cutting blade is not very dangerous as far as cutting yourself, because the cutting edge of the blade is smooth. However, you should always be very careful when working around any electric power tools. The tile saws have water pumps that sit in a tray or tub full of water. The pump keeps the water circulating onto the blade to keep it cool. The tile to be cut sits on an adjustable guide that rides on steel tracks. The guide, which can be adjusted for straight or angled tile cuts, is pushed slowly forward through the wet, rotating blade. Someone with experience should show you how to properly use the tile saw for the first time.

Tile saws are used to cut tiles that could not be cut by any other type of tile cutter. They are especially nice for making what tilesetters call "L" cuts. An "L" cut is a piece of tile cut or shaped to look like the letter L. They are needed around corners.

#### RUBBING STONE

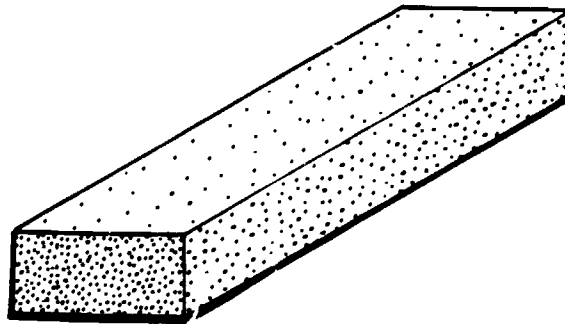

Tilesetting abrasive rubbing stones are used to smooth the rough edges of tiles that have been cut. They come in different sizes and the surfaces come in different grits. The grits range from a very coarse no. 20 for grinding to no. 90 for fine rubbing. One of the most popular is a 6" X 2" X 1" double-faced rubbing stone; it has no. 60 grit on one side, and no. 90 grit on the other. To use-- simply hold the tile that has been cut firmly in one hand, with the other hold the stone and rub it back and forth over the rough edge until it is smooth.

## PORTABLE ELECTRIC DRILL

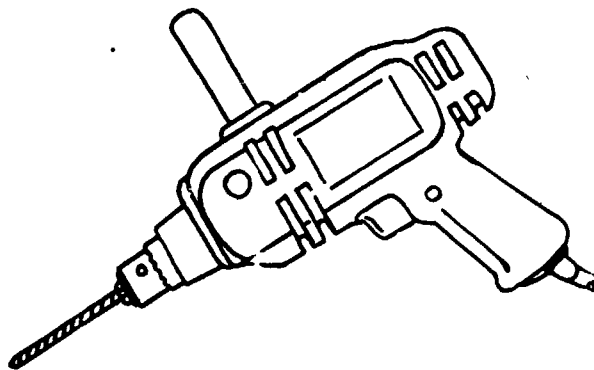

The portable electric drill is used by the tilesetter to drill small holes in tile, wood, and mortar for installing certain fixtures and accessories like curtain rods and towel bars that are fastened with screws and bolts. It is also used to drill large holes in tile so that it will fit over a fixture.

## DRILL BITS



When holes are to be drilled through masonry, concrete, or tile a carbide tipped drill bit should be used. It is used only at low speeds. There are a couple of types of special drill bits used to drill large holes in tile. The cutting edges of the bits are carbide bonded for long wear and clear cuts. One type is 1 3/8" in diameter. Just the right size for water outlet pipes. Another type can be adjusted for 1/4" to 1 1/2" holes.

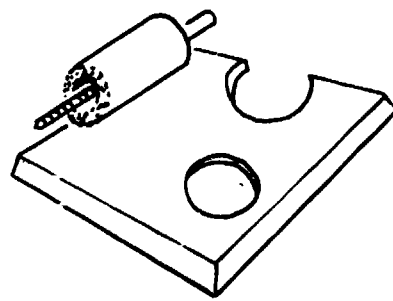
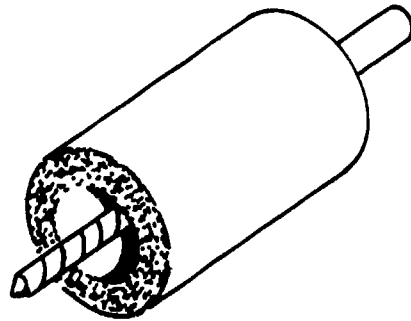

# Self Assessment

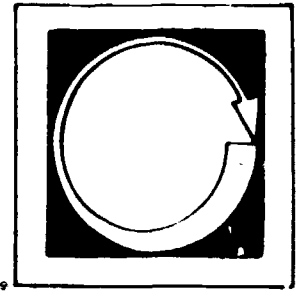

LISTED BELOW ARE QUESTIONS OR STATEMENTS FOLLOWED BY A NUMBER OF POSSIBLE ANSWERS OR COMPLETIONS. SELECT THE ANSWER OR COMPLETION WHICH ANSWERS THE QUESTION OR COMPLETES THE STATEMENT CORRECTLY AND PLACE THE LETTER IN THE BLANK PROVIDED.

1. \_\_\_ A tile job that works out full-tile means
  - a. no tile joint was used.
  - b. no tile cuts were needed.
  - c. no tile was left over at the end of the job.
  
2. \_\_\_ Never score the tile more than once because
  - a. it will dull the cutting wheel.
  - b. it can crack the tile.
  - c. it takes too much time.
  
3. \_\_\_ A tile cutting board is used to make
  - a. "L" cuts.
  - b. holes in tiles.
  - c. straight tile cuts.
  - d. all of the above.
  
4. \_\_\_ One of the things nippers are used for is to
  - a. bite holes in tiles.
  - b. trim tile edges for a proper fit.
  - c. bite curves in fixtures so the tile may fit.
  - d. none of the above.

5. \_\_\_\_\_ The tool used to chip the back off a tile is the
- chipping hammer.
  - drill.
  - rubbing stone.
  - tile cutter.
6. \_\_\_\_\_ What grit rubbing stone is best for fine rubbing the edges of tile?
- no. 20 grit.
  - no. 60 grit.
  - no. 90 grit.
  - anywhere from 20 to 100, it doesn't matter.
7. \_\_\_\_\_ Electric tile saws are used to
- make "L" cuts.
  - cut tile that couldn't be cut by any other type of tile cutter.
  - cut backings from tile for a proper fit.
  - both a and b.
8. \_\_\_\_\_ What type of drill bit is best to drill through tile.
- any type of bit will work fine.
  - a high speed bit.
  - a carbide tipped bit.
  - a short sturdy one.

# Self Assessment Answers

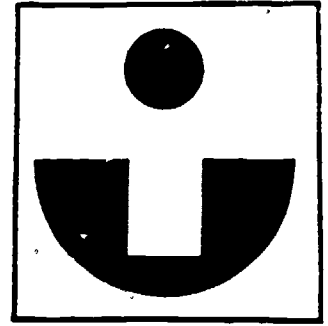

1. b

2.

2. a

3. c

4. b

5. a

6. c

7. d

8. c



# Job Sheet

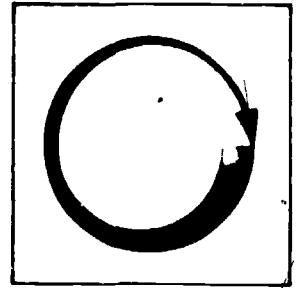

COMPLETE THE FOLLOWING TASKS.

## Materials and Tools

- 20 pieces of 4 1/4" X 4 1/4" pieces of tile
- 1 tile cutting board
- 1 pair of nippers
- 1 felt tip pen to mark tile
- 1 rubbing stone

1. Practice making tile cuts with a tile cutting board. Make at least four 1" cuts, four 3" cuts, and four diagonal cuts. Practice until your cuts are perfectly straight.
2. Practice using the nippers--draw two different sized circles on two pieces of tile and, using the nippers, bite around the line. With another piece of tile, using the tile cutting board, score the tile 1/2" from its edge. Instead of breaking it with the tile cutter; bite off that 1/2" piece with the nippers. Do this at least three times.
3. Practice using the rubbing stone. Smooth at least six rough edges of tile using the rubbing stone.

## Questions

1. Which of the three cuts--1", 3", and diagonal--did you find easiest, which the most difficult? Why?
2. Do you feel that you can now use the tile cutter fairly well?
3. Could you use the nippers to bite the circle out of the piece of tile without cracking the tile?

# Post Assessment

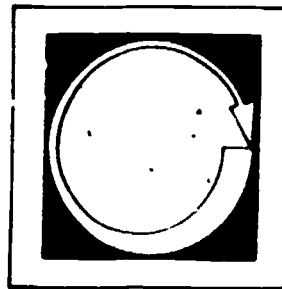

LISTED BELOW ARE SEVERAL STATEMENTS. IF THE STATEMENT IS TRUE, PLACE A "T" IN THE BLANK PROVIDED. IF THE STATEMENT IS FALSE, PLACE AN "F" IN THE BLANK.

1. \_\_\_ When scoring a tile with the tile cutter, you should use a jerky motion.
2. \_\_\_ Carbide coated tools are stronger and more durable than regular steel tools.
3. \_\_\_ Large tile chips are called particles.
4. \_\_\_ Two parts to something that opens and closes could be called a jaw.
5. \_\_\_ If a lot of dirt were in a carpet, you could say the dirt is embedded in the carpet.
6. \_\_\_ An abrasive is something rough used for smoothing something.
7. \_\_\_ A grit is something smooth used with an abrasive.
8. \_\_\_ A fixture is something that can be moved around.
9. \_\_\_ A commercial diamond is artificially made, and used as a strong abrasive because it is so hard.

# Instructor Post Assessment Answers

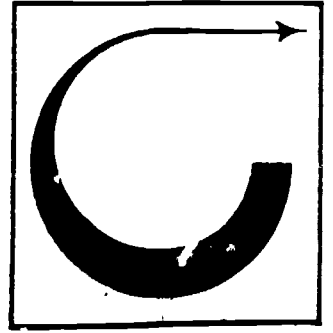

1. F

2. T

3. F

4. T

5. T

6. T

7. F

8. F

9. T

---

---

MORTAR TOOLS

---

---

**Goal:**

The student will be able to identify, select and use the common tools used for mortar work.

**Performance Indicators:**

The student will successfully complete the Self Assessment, the Job Sheet and the Post Assessment.

177

160

# Study Guide

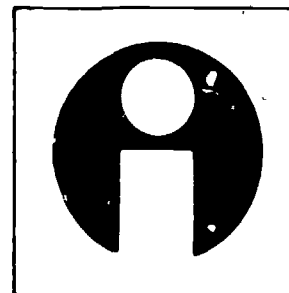

In order to finish this module, do the following tasks. Check each item off as you complete it.

1.  Read the goal and Performance Indicators on the cover of the module. This will tell you what you will learn by studying the module, and how you will show you've learned it.
2.  Read the Introduction. The Introduction will tell you why the module is an important part of the tilesetting trade.
3.  Study the Vocabulary section. Vocabulary words are important for a good understanding of the trade. After you have studied the vocabulary, ask your teacher to quiz you on the words and their meanings.
4.  Study the Information section. This section will give you the information you need to understand the subject.
5.  Take the Self Assessment exam. This is a test for you to prove to yourself that you have learned the material you have studied. Compare your answers with the answers on the Self Assessment Answer Sheet, which is on the page following the Self Assessment. If you scored poorly, re-study the Information section or ask your teacher for help.
6.  Do the Job Sheet. Follow the instructions at the top of the Job Sheet. The tasks listed on the Job Sheet will help you develop skills which will be helpful to you.
7.  Take the Post Assessment exam. Give the exam to your teacher after you have completed it. Your teacher will grade it for you.

# Introduction

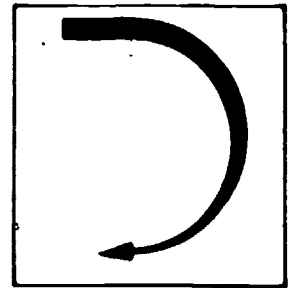

This module will cover what specific tools are used with mortar--for the application of mortar--and how to use them.

These are some of the tilesetter's most important tools. There will always be the need for a tilesetter who is good at applying wall mortar to walls, using the hawk and flat trowel.

# Vocabulary

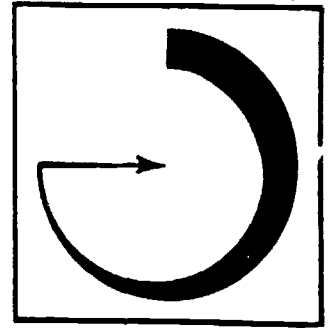

Trade terms are very important for a good understanding of the trade. Study these words and meanings. When you have learned them, ask your teacher to quiz you on the words and their meanings.

**DEFECTIVE**--Faulty, not perfect or normal.

**BUTTERING**--The spreading of a bond coat (some type of tile adhesive) to the backs of tiles just before the tile is to be placed.

**WARPED**--A twist or curve that has developed in something originally flat or straight.

**TINE**--A slender pointed, projecting part, like a prong.

**SCRATCH COAT**--The first coat of cement mortar on a wall. Its surface is roughened so a bond can be formed with another coat of mortar.

**FLUSH**--Flat, straight across the surface, no indentations.

**SWOOP**--To move with a fast sweeping motion.

# Supplementary References

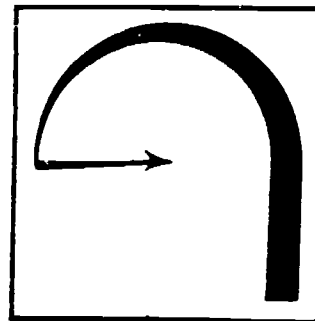

Typesetting Workbook. California State Department of Education, 1975. pp. 48-53



# Information

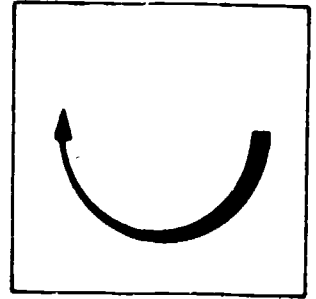

Tools used with mortar are:

1. Pointing trowel.
2. Buttering trowel.
3. Brick trowel.
4. Flat trowel.
5. Hawk.
6. Wood float.
7. Mortar board and stand.
8. Kneeling boards.
9. Scratcher (scarifier).

Other tools that are used with mortar but have already been covered in an earlier module are--the mortar box, mortar hoe, mortar mixer, and buckets, covered in module titled "Portland Cement Mortar Mixes."

## 1. POINTING TROWEL

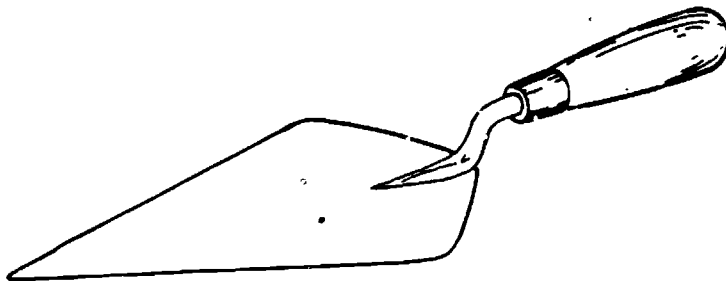

The pointing trowel, which is called a pointer by tilesetters, is one of the most often used tools of the trade. It comes in sizes ranging from 4" to 7" in length, with the 6" trowel being the most popular. The tilesetter uses this trowel for the following:

1. Straightening tiles on walls and floors.
2. Removing defective tiles from a fresh bond coat.
3. Marking floated surfaces.
4. Filling small holes on floated surfaces.
5. Buttering tiles and trim work.
- ~~6. Placing mortar in areas that are too small for the flat trowel.~~
7. The end or butt of the handle is used for tapping in tiles that are sticking out from the rest of the tilework.

The pointer should not be used to pry or chop hardened materials such as concrete or plaster because the tip of the trowel could easily be snapped off.

When buttering the backs of tiles, use enough tile adhesive to get a good bond, but not too much to cause the tile adhesive to squeeze out of the joint between tiles.

## 2. BUTTERING TROWEL

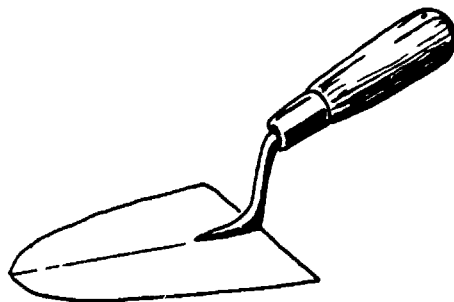

The blade of the buttering trowel is 4 1/2" wide and 7" long, which makes it a little larger than the pointing trowel. It is used for buttering pure cement to tile that is to be bonded to a fresh cement mortar surface, a method commonly used in the eastern states of the United States.

Because of the larger blade this trowel is better than the pointer for buttering large tiles.

### 3. BRICK TROWEL

The brick trowel is larger than the buttering trowel. It looks like a large pointing trowel. The most popular size used by tilers is 5" wide and 11" long. It is used to prepare brick work to be done, and because of the blade's large surface area, it is the best trowel for buttering very large tiles.

### 4. FLAT TROWEL

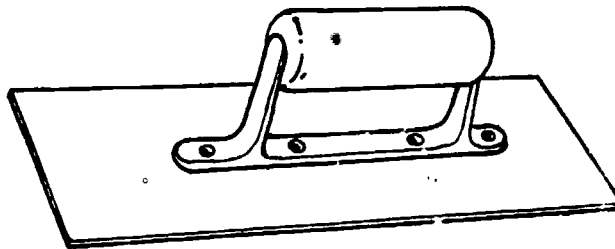

The flat trowel is rectangular in shape and comes 4 1/2" wide and 10 1/2" to 11 1/2" long. It is used, together with the hawk, for the transferring of wall mortar from the mortarboard to the wall.

The flat trowel is also used for spreading floor mortar on floor surfaces before tiles are set.

### 5. HAWK

(See the illustration on the top of the following page.)

The hawk ranges in size from 10" to 14" square; the most popular size for tilers is the 11" square hawk.

Hawks are made of aluminum with a wooden handle at the center. A rubber pad fits over the handle and covers the area of the hawk that would otherwise

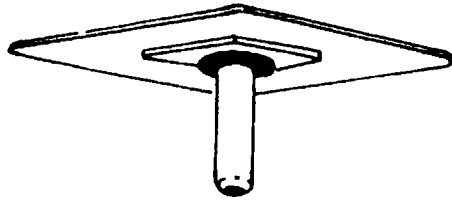

come in contact with the hand.

The hawk is used to hold wall mortar, which enables the tilesetter to move around with the mortar while holding the hawk. The mortar is taken off the hawk with the flat trowel and applied to the wall.

#### 6. WOOD FLOAT



The wood float is rectangular like the flat trowel and comes 3 1/2" wide and 12" to 14" long.

It is mainly used to spread and compact floor mortar on floor surfaces. It can be used in place of the flat trowel for floating mortar. It is also good for smoothing out rough spots left on the mortar bed.

## 7. MORTARBOARD AND STAND

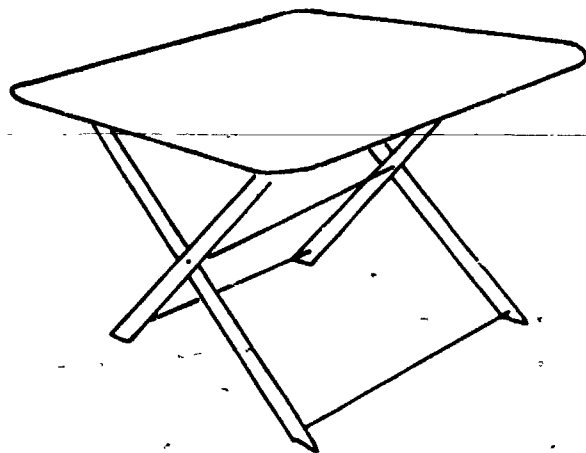

The mortarboard sits on a raised, adjustable metal stand and is used as a table to hold wall mortar. It is usually 30" square. The mortarboard is at a height which makes it easier for the tilesetter to work with wall mortar.

## 8. KNEELING BOARDS

Kneeling boards are usually made of 3/4" plywood and are 30" to 36" long and 12" to 15" wide. They are put on top of finished floor mortar, which enables the tilesetter to walk and kneel on them while installing floor tile. Only boards that are unwarped, straight and clean should be used.

## 9. SCRATCHER

(See the illustration on the top of the following page.)

The scratcher, which is also called a scarifier, is a piece of thin sheet metal with long teeth notched in one of the two long edges, and a metal handle centered in the other edge. The long notched teeth are called tines. Scratchers are 4" to 8" wide with 3 1/4" long tines. The scratcher is used to roughen the surface of one coat of mortar (the scratch coat) to provide for a good bond for

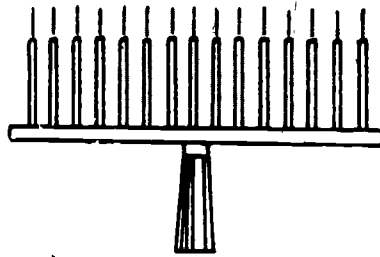

the next coat of mortar. The mortar has to be roughened before it is completely dry. To use, run the scratcher either horizontally or vertically on the mortared surface; use enough pressure to make at least a 1/8" groove in the mortar.

Surfaces that are to get another coat of portland cement mortar should always be scratched.

How to transfer wall mortar from the mortarboard to the hawk, then from the hawk to the flat trowel--

Stand over the mortarboard. If you're right-handed, hold the hawk in your left hand and the flat trowel in your right. If you're left-handed, do it the other way.

1. At first it's easier to transfer the mortar to the hawk if the mortar is somewhat flattened out on the mortarboard; do that with the flat trowel.
2. With the hawk, come in about 4" from one of the outside edges of the mortar; chop down into it. Push the hawk and flat trowel together with the 4" of mortar in between. Push the mortar onto the hawk.
3. Transferring the mortar from the hawk to the flat trowel and having it ready to apply to a wall takes more practice than anything else in the tilesetting trade.

Settle the mortar on the hawk by giving it a few upward ricks. Then evenly flatten it out with the flat trowel. In one quick, smooth motion, dip the hawk slightly down inward toward you, swoop and chop upwards with the flat trowel at the same time, taking off the top outside few inches of mortar from the hawk.

Again, this has to be done in one smooth motion. Rotate the hawk 1/4 turn each time you take off some mortar. This takes a lot of practice, and at first the mortar will be falling all over the place; just keep practicing.

A hawk full of mortar takes anywhere from 3 to 8 flat trowel swoop and chops to empty it.

# Self Assessment

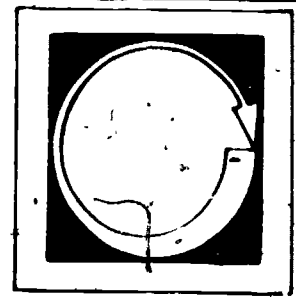

CHOOSE THE CORRECT WORD FROM THE LIST BELOW AND WRITE IT IN THE BLANK PROVIDED.

right  
brick  
pointing  
11-inch  
rectangular  
wood float  
mortarboard

scratcher  
more practice  
larger  
flat  
kneeling boards  
left

1. The \_\_\_\_\_ trowel should not be used to pry or chop hardened materials.
2. The \_\_\_\_\_ trowel is best for buttering very large tiles.
3. The most popular size hawk is the \_\_\_\_\_ square hawk.
4. The trowel used with the hawk for transferring mortar from the mortarboard to the wall is the \_\_\_\_\_ trowel.
5. In comparative size, the buttering trowel is \_\_\_\_\_ than the pointing trowel.
6. The flat trowel and wood float are \_\_\_\_\_ in shape.
7. The \_\_\_\_\_ is used as a table to hold wall mortar.
8. \_\_\_\_\_ are used by tilesetters to walk and kneel on while installing floor tile over floor mortar.



9. The \_\_\_\_\_ is used mainly to spread and compact floor mortar.
10. The \_\_\_\_\_ is used to roughen the surface of the first coat of mortar to provide for a good bond for the next coat.
11. If you are right handed, you should hold the hawk in your \_\_\_\_\_ hand and the flat trowel in your \_\_\_\_\_ hand when working with wall mortar.
12. Transferring the mortar from the hawk to the flat trowel takes \_\_\_\_\_ than anything else involved in the tile setting trade.

# Self Assessment Answers

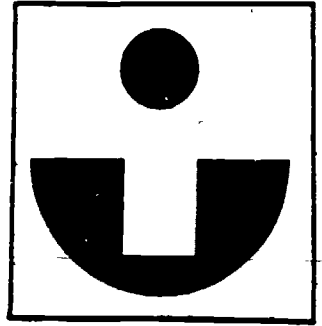

1. pointing
2. brick
3. 11-inch
4. flat
5. larger
6. rectangular
7. mortarboard
8. kneeling boards
9. wood float
10. scratcher
11. hawk in left hand, flat trowel in right
12. more practice

# Job Sheet

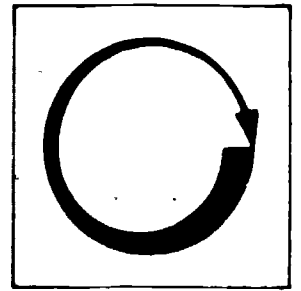

COMPLETE THE FOLLOWING TASKS.

## Materials and Tools

small mortar box  
mortar hoe  
large bucket  
access to water  
1 bucket of sand  
1/3 bucket of cement  
1/3 bucket of lime  
mortarboard and stand  
hawk  
flat trowel  
scratcher  
pointing trowel  
4 pieces of 4 1/4" X 4 1/4" tile  
small amount of mastic  
12" X 12" piece of wood

1. Set up mortarboard and stand. Use the procedure for mixing wall mortar from module titled "Portland Cement Mortar Mixes." Mix 1 bucket of sand, 1/3 bucket of lime in a mortar box. Add enough water, gradually, to make the mixture the right consistency. Put the mixed mortar in a bucket, then pour the bucket of mortar onto the mortarboard.
2. With the hawk and flat trowel, practice transferring the mortar from the mortarboard to the hawk, then from the hawk to the flat trowel. Practice until you can successfully transfer the mortar from the hawk to the flat trowel without dropping any of the mortar. Work over the mortarboard so

that when the mortar does drop it falls back onto the mortarboard. If the mortar starts to get too stiff, transfer back to the mortarbox and mix in a small amount of water.

3. After you can successfully transfer the mortar to the flat trowel, practice using the scratcher. Spread the mortar with the flat trowel evenly on the mortarboard. Scratch the mortar until you get the feeling of how much pressure it takes to make about a 1/8" groove in the mortar.
  
4. Practice buttering the backs of tiles with mastic using a pointer. Butter the backs of four pieces of 4 1/4" X 4 1/4" pieces of tile. Set the tiles two across and two down making a square on about a 12" by 12" piece of wood. Press down firmly. If the mastic squishes up and out through the joints you've used too much mastic. Pry the tiles off using the pointer, then clean the backs of the tiles using water, then dry them and try again. When you pry the tiles up, see if there are any spots on the backs of the tiles that do not have mastic on them. If there are, you have not used enough mastic. Practice buttering and setting the tiles until you can make the surfaces of the tiles flush with one another and no mastic squishes up through the joints.

# Post Assessment

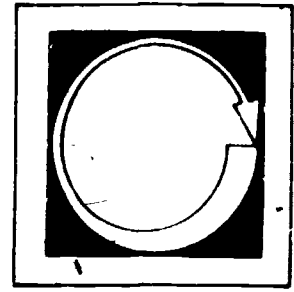

WRITE AN ANSWER TO THE FOLLOWING QUESTIONS CONCERNING THE JOB SHEET.

1. Could you successfully transfer the mortar from the hawk to the flat trowel without dropping the mortar? If yes, how long did it take you before you could.
2. What was your main problem when making the transfer? Explain.
3. You will get a chance later (in module no. 23) to apply the mortar from the flat trowel to the wall. What do you think will be the most difficult part about that?
4. Did you get the feeling of how much pressure it takes to roughen the mortar with the scratcher? If not, why? Explain.

LISTED BELOW ARE SEVERAL STATEMENTS. IF THE STATEMENT IS TRUE, PLACE A "T" IN THE BLANK PROVIDED. IF THE STATEMENT IS FALSE, PLACE AN "F" IN THE BLANK.

6.  Something that was originally flat or straight but has developed a twist or curve to it is said to be warped.
7.  A piece of tile with a abnormal crack in the glaze is a defective tile.
8.  The second coat of cement mortar on a wall is called the scratch coat.

9. \_\_\_ The long projecting metal parts of a scratcher are called forks.
10. \_\_\_ Surfaces that are flat, even, and straight across the top with each other are flush.
11. \_\_\_ Swoop means to dig down deep, such as digging a ditch.

# Instructor Post Assessment Answers

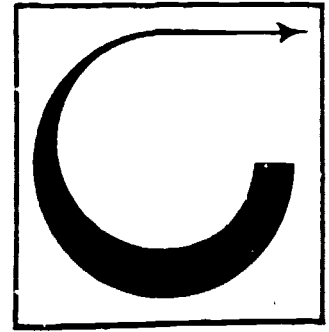

6. T
7. T
8. F The first coat is
9. F They are called tines
10. T
11. F Means to move with a fast sweeping motion

SPECIALTY TOOLS

**Goal:**

The student will be able to identify, select, and explain the proper use of the specialty tools required in tile-setting.

**Performance Indicators:**

The student will demonstrate knowledge of the subject by successfully completing a Self Assessment, a Job Sheet and a Post Assessment.



# Study Guide



In order to finish this module, do the following tasks. Check each item off as you complete it.

1.  Read the Goal and Performance Indicators on the cover of the module. This will tell you what you will learn by studying the module, and how you will show you've learned it.
2.  Read the Introduction. The Introduction will tell you why the module is an important part of the tilesetting trade.
3.  Study the Vocabulary section. Vocabulary words are important for a good understanding of the trade. After you have studied the vocabulary, ask your teacher to quiz you on the words and their meanings.
4.  Study the Information section. This section will give you the information you need to understand the subject.
5.  Take the Self Assessment exam. This is a test for you to prove to yourself that you have learned the material you have studied. Compare your answers with the answers on the Self Assessment Answer Sheet, which is on the page following the Self Assessment. If you scored poorly, re-study the Information section or ask your teacher for help.
6.  Do the Job Sheet. Follow the instructions at the top of the Job Sheet. The tasks listed on the Job Sheet will help you develop skills which will be helpful to you.
7.  Take the Post Assessment exam. Give the exam to your teacher after you have completed it. Your teacher will grade it for you.

# Introduction

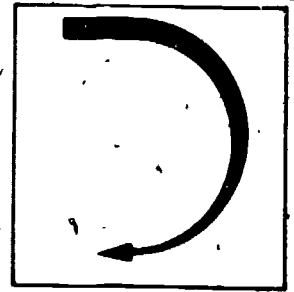

This module will cover tools, each having their own specific use within the tilesetting trade. Knowing all the different tools available will help you to do each job in the best possible way.

Learning about the tools in this module, along with the tools you have already learned about, is an important part of becoming knowledgeable about the trade.

# Vocabulary

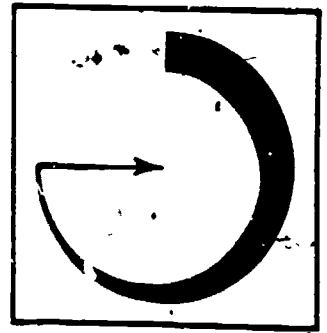

Trade terms are very important for a good understanding of the trade. Study these words and meanings. When you have learned them, ask your teacher to quiz you on the words and their meanings.

**JAMB MATERIAL**--An upright piece of wood that forms the side of an opening, like for a door or window.

**OUNCE**--An ounce is a measure of weight. 16 ounces equals 1 pound.

**BEAT IN**--The process of tapping the tiles into the tile adhesive.

**TENSION**--Something that has been stretched and tightened to a certain degree, like guitar strings.

**CAULKING**--Waterproof material used to fill and seal seams.

**GROUND WIRE**--An electrical wire that makes a connector with an object; a safety wire so you can't be shocked.

**RETRACT**--To draw back in.

**ENAMEL**--A glossy surface coating.

**INDENTATION**--A recess in a surface; notches in a surface.

**GAUZE**--A thin woven cotton fabric.

# Supplementary References

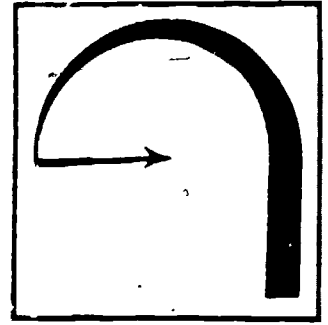

Typesetting Workbook. California State Department of Education, 1975. pp. 44-53.

# Information

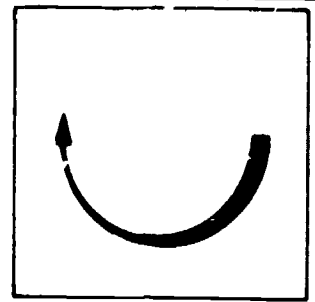

The following lists those tools that will be discussed in this module. Some you will use much more than others, but you will have a use for all of them sooner or later.

1. Handsaw
2. Claw Hammer
3. Notched Trowel
4. Tin Snips
5. Rubber Mallet
6. Hacksaw
7. Rubber Grouting Float
8. Caulking Gun
9. Screwdrivers
10. Extension Cord and Light
11. Chisels
12. Grout Saw
13. Beating Block
14. Utility Knife
15. Razor Blade Scraper
16. Metal Quarry Tile Rack
17. Grout Bag
18. Tile Striker
19. Tool Box
- (Cleaning Tools)
20. Scrub Brush
21. Water Brush
22. Steel Wool
23. Duster
24. Cheese Cloth
25. Sponges
26. Tape Masker

### 1. HANDSAW

The straight blade handsaw is a very useful tool to the tilesetter. It is used to cut wood to size, such as: 1) Wood Straightedges, 2) jamb material, 3) wood float strips, 4) any wood that may get in the way of setting tile.

A handsaw with a cutting edge of 8 teeth per inch makes a good general saw for the tilesetter.

### 2. CLAW HAMMER

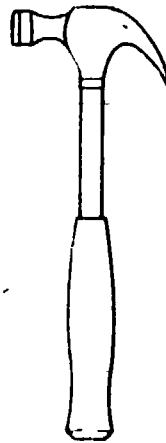

The claw hammer is a hammer with one end of its metal head slightly curved down and forked for pulling out nails, and the other end solid for pounding. The tilesetter uses the claw hammer for--1) nailing up sheetrock, 2) nailing down plywood and wonderboard, 3) ripping up and removing old surfaces and bonded tile, 4) anywhere nails need to be pounded in or pulled out.

The claw hammer's handle is made from either wood, fiberglass or metal. The head of the hammer comes in different weights, with the 16 ounce being the most popular.

### 3. NOTCHED TROWEL

(See the illustration on the top of the following page.)

The notched trowel is used for spreading whatever type of thin-setting tile adhesive is needed to bond tile to a surface. In other words, the notched trowel is a very important tilesetting tool. The only time it isn't used to bond tile is when pure cement is used as a bond coat over a fresh cement mortar surface.

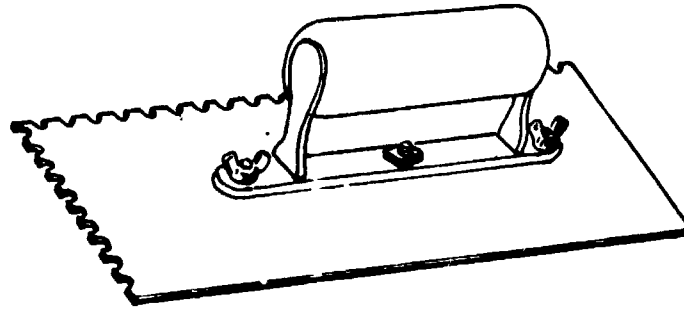

Notched trowels are available with either a V-notch or a square notch tooth design. The teeth are made in various sizes, ranging from a very small notch of 1/16" wide by 1/16" deep to a very large notch of 1/2" wide by 5/8" deep. The correct tooth size and depth depends on the kind of tile adhesive being used and the size and type of tile being installed. You will learn more about that in module titled "Adhesive Application and Beating In."

#### 4. TIN SNIPS

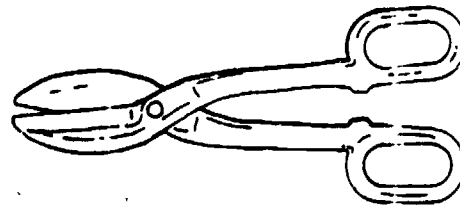

Tin snips are made of metal and have two strong cutting edges. Tin snips range in size from an overall length of 7" to 14 1/2" and a cutting edge length of from 1 3/4" to 4". The tilesetter uses tin snips for cutting metal lath and wire mesh to size. Some tin snips are better than others. It is a good idea

for tilesetters to buy a good quality pair of tin snips. Cheap snips can warp, bend, and chip.

#### 5. RUBBER MALLET



A rubber mallet is a hammer with a barrel-shaped head of rubber and a hardwood handle. The sizes and weights vary from a head length of 3", a face diameter of 2", a handle length of 10", and a weight of 12 ounces to a head length of 4 1/2", a face diameter of 2 1/2", a handle length of 13", and a weight of 28 ounces. The rubber mallet is used along with a beating block to "beat in" tile (the process of tapping the tiles into the tile adhesive for a better bond). You will learn the technique and the importance of beating in tile in module titled "Adhesive Application and Beating In."

#### 6. HACKSAW

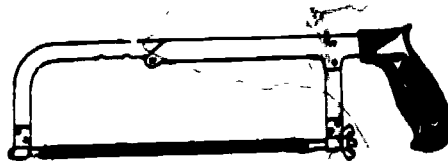



The hacksaw is a fine-toothed saw that has a blade under tension in a frame used for cutting hard materials, mainly metal. The frame is usually adjustable for 10" and 12" blades. The hacksaw is used by tilsetters to:

1. Cut metal towel and shower curtain bars to size.
2. Remove any metal that gets in the way of the proper installation of tile.

#### 7. RUBBER GROUTING FLOAT

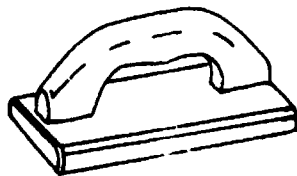

The rubber grouting float is usually just called either a rubber float or grout float by tilsetters. The rubber float consists of a hard-rubber-face mounted on a metal back with a wood handle. The size of the float is 4" wide, 9" long, and 3/4" thick. It is used to force grout firmly into tile joints and to remove the excess before the final cleaning. This process is called grouting. Because all tile needs to be grouted, this is a very important tilsetting tool. You will learn how to grout in module titled "How to Grout."

#### 8. CAULKING GUN

(See the illustration on the top of the next page.)

The caulking gun is used by tilsetters to fill corners and edges of tilework with caulking to seal and make them watertight. The caulking gun is made of metal. When you squeeze the trigger, a notched metal rod moves forward pushing the caulking out of its tube through a nozzle. You will learn how and where to use caulking in module titled "Sealers."

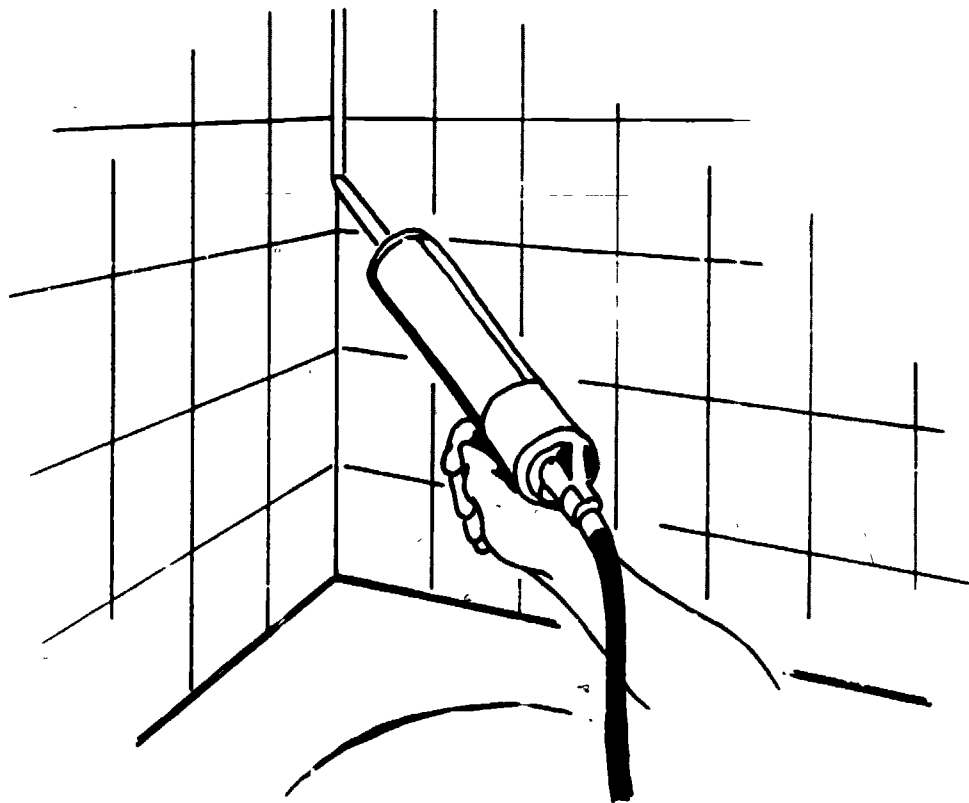

## 9. SCREWDRIVERS

(See the illustration on the top of the next page.)

The tilesetter should always carry a couple of screwdrivers (a regular type and a Phillips) in his or her toolbox. They are used by the tilesetter to:

1. Unscrew tubsplash fixture guides.
2. Screw and unscrew drain fixtures for shower floors.
3. Tighten or change certain tool parts, like the tile cutter's scoring wheel.

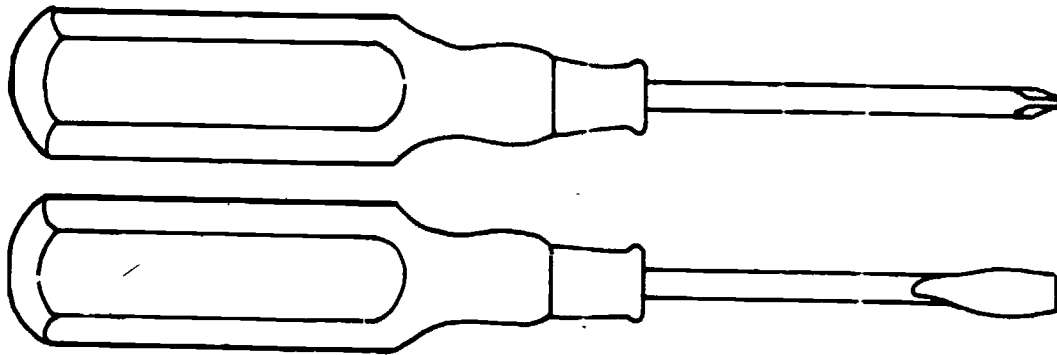

#### 10. EXTENSION CORD AND LIGHT

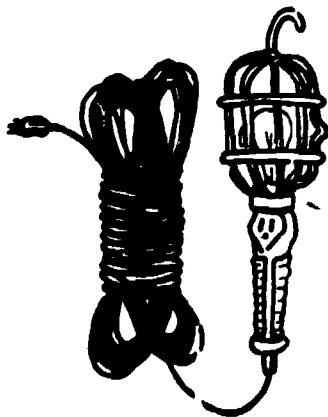

The tilesetter uses an extension cord and light for any area that is too dark to accurately work in. The extension cord is also used to reach power outlets to run the electric tile saw and any electric hand tools that may need to be used, like a drill. A 3-wire grounded type extension cord should be used at all times for safety.

#### 11. CHISELS

(See the illustration at the top of the following page.)

A chisel is a metal tool with a cutting edge at the end of a blade used for working with solid materials like wood, concrete, and metal. There are many different kinds of chisels. The tilesetter may need to use, at one time or

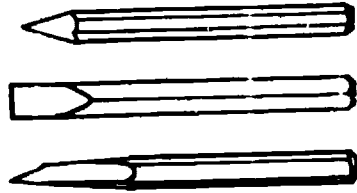

another, 3 or 4 different kinds. The kinds the tilesetter might use are:

1. The socket paring chisel--used for shaping wood.
2. The cold chisel--a very sturdy chisel used for chipping or cutting metal.
3. The box chisel--used for breaking out old tile or cement mortar and for prying. It is usually long for good leverage.
4. The floor chisel--it has a wide cutting edge on it. All the chisels can be used to remove bonded tiles.

The tip of the chisel is placed under the tile to be removed and the end of the chisel is pounded with a hammer. Always wear something to protect your eyes when working with chisels.

## 12. GROUT SAW

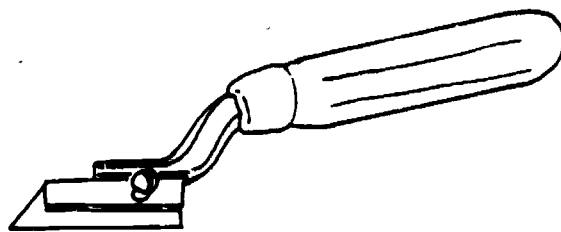

The grout saw is a carbide chip bonded steel blade mounted on a wooden handle. The tilesetter uses the grout saw to remove hardened grout from tile joints. It is used for patch work and for total regrouting jobs where the grout first needs to be dug out before the tile can be regrouted.

### 13. BEATING BLOCK

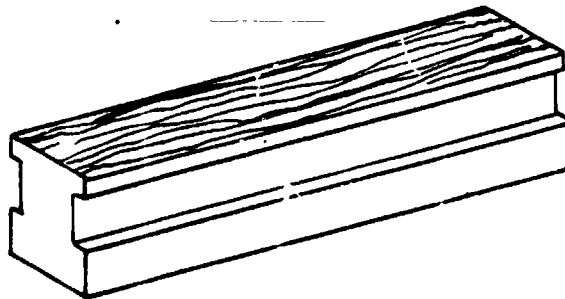

The beating block is a piece of smooth hardwood used with a rubber mallet to "beat in" tile into tile adhesives. A 5" wide by 12" long by 1 3/4" thick piece of hardwood makes a good beating block. You will learn the technique and the importance of beating in tile in module titled "Adhesive Application and Beating In."

### 14. UTILITY KNIFE

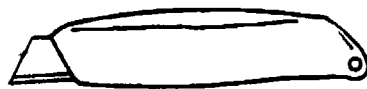

The utility knife is a replaceable sharp blade held in a hand sized metal case. The tilesetter uses the utility knife mainly for trimming and cutting sheetrock to size. It is a handy tool, used for cutting and trimming many things.

15. RAZOR BLADE SCRAPER

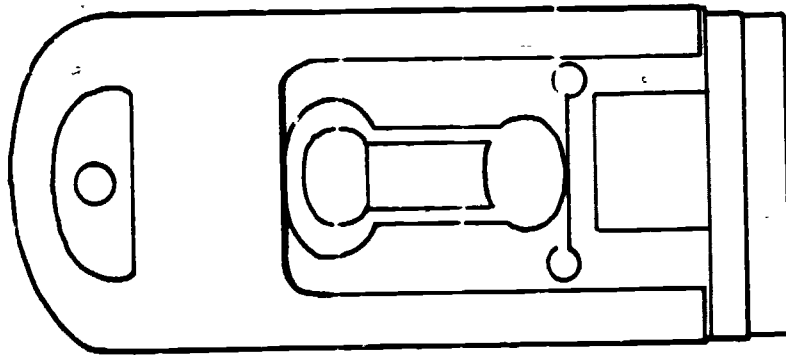

The razor blade scraper is a replaceable razor blade held in a small metal case. The blade can be retracted in the case for safety when not in use. The tilesetter uses the scraper for scraping and cleaning materials off smooth surfaces; such as plaster, paint, glue, and mortar from glass, tile, or enameled bathtubs.

16. METAL QUARRY TILE RACK



The metal quarry tile rack, which is just called a quarry rack by tilesetters, is available in many patterns. They make setting quarry tile faster and easier by maintaining the same joint size between the quarry tiles. For setting quarry tile in a large area, quarry racks are a must. 6" by 6" quarry tile is the most common size quarry tile set with a quarry rack.

#### 17. GROUT BAG

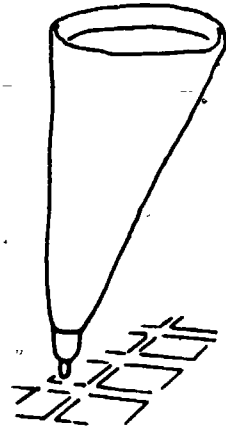

The grout bag is a cone shaped heavy vinyl bag. The top of the bag is usually around 12" wide and the length around 22". It holds plenty of grout. It is used by tilesetters for filling grout into the joints of tile and brick surfaces that are rough or have indentations, therefore, making it hard or impossible to clean any excess grout off them. The grout bag is filled with grout, then with hand pressure the grout is squeezed out of the bag's small opening and into the joints. The grout bag is not used very much.

#### 18. TILE STRIKER

(See the illustration on the top of the next page.)

The tile striker is used for grout joints that have been filled with a grout bag. The tile striker compacts and forms the grout into the joint. Strikers can be made from either wood, plastic, or metal and come in various thicknesses to match the common joint thicknesses. To use, run the striker along the grout joints using hand pressure to compact the grout.



#### 19. TOOL BOX

The tool box allows for good organization of and easy access to your tools. You can buy a metal tool box or you can custom-build one out of wood.

#### 20. SCRUB BRUSH

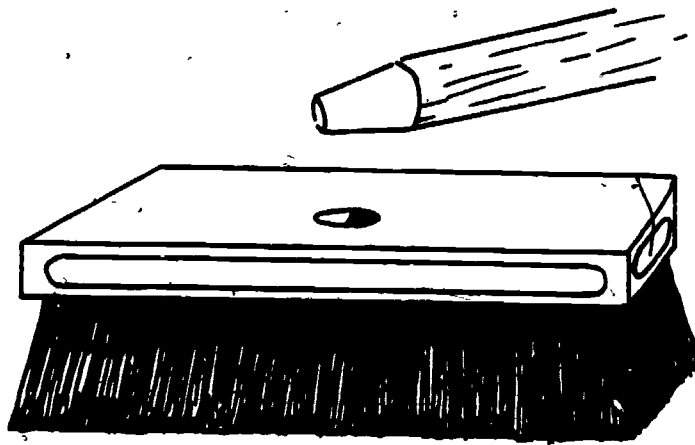

The scrub brush is an important tool. Acid resistant plastic bristles are the best for tilesetting. They are stronger, firmer, and more durable than natural bristle brushes. There are basically two designs of scrub brushes, one has a solid block type grip with the bristles directly underneath; the other has a handle with the bristles up front. Scrub brushes are used by tilesetters for:

1. Cleaning cement mortar, grout, and different tile adhesives from buckets.



2. Cleaning tools after use.
3. Acid cleaning the grout off the surface of certain tile. You will learn more about that in module titled "How to Grout."

#### 21. WATER BRUSH

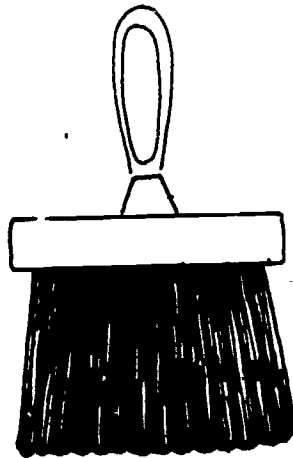

The water brush is basically a large paint brush. It is used with a bucket of water by tilesetters to:

1. Clean the edges of walls around fresh cement mortar work.
2. Spread grout into the joints of a freshly set shower floor.

You will learn how to use the water brush to grout in module titled "How to Grout."

#### 22. STEEL WOOL

Steel wool is used by tilesetters to clean hardened materials such as grout, cement mortar, and different tile adhesives off their tools. Using steel wool on your tools will help keep them rust-free and looking new.

#### 23. DUSTER

(See the illustration on the top of the next page.)

You can buy a duster which has a 14" long handle with 8" of bristles; or a large soft-bristled paint brush will work fine. A duster is used by tilesetters to:

1. Clean the surface to be tiled before applying the tile adhesive.
2. Clean-up, along with a dustpan, tile chips and whatever mess may have been made at the end of a tile job.



#### 24. CHEESE CLOTH

Cheese cloth is a cotton gauze type material used by tilesetters both as a general cleanup cloth, and for cleaning the grout off the surfaces of certain types of floor tile. You will learn how to clean grout off floor tile with cheesecloth in module titled "How to Grout."

#### 25. SPONGES

Sponges are used by tilesetters to clean grout off the surface of tiles. This will be covered in module titled "How to Grout."

#### 26. TAPE MASKER

The tape masker, which is also called a taping gun, is a device that holds a roll of masking tape and a roll of paper on separate rollers. With the tape masker, the tape and the paper can be applied to a surface at the same time. Painters use this device to protect areas they don't want to paint or stain. Tilesetters use it to protect areas they don't want to get grout on.

# Self Assessment

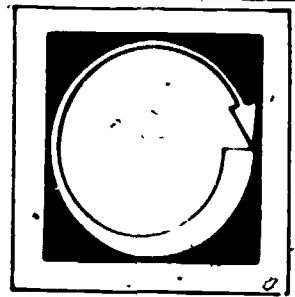

CHOOSE WHICH WORD (OR WORDS) FROM THE LIST BELOW BEST FITS IN THE BLANKS FOR EACH SENTENCE.

beating block

caulking gun

cheese cloth

compacts

duster

eyes

grout

grout bag

grout saw

hacksaw

handsaw

joint

light

notched trowel

pull out

razor blade scraper

rubber mallet

scrub brush

sponge

tape masker

tin snips

tool box

utility knife

1. The \_\_\_\_\_ is used to cut jamb material and wood straightedges.
2. \_\_\_\_\_ are used to cut metal lath.
3. The \_\_\_\_\_ is used to cut metal.
4. The claw hammer is used to pound in or \_\_\_\_\_ nails.
5. To accurately work in a dark area a \_\_\_\_\_ should be used.
6. The \_\_\_\_\_ is used to spread tile adhesives before bonding tile.

7. A \_\_\_\_\_ and a \_\_\_\_\_ are used together to beat in tile.
8. The rubber float is used to force \_\_\_\_\_ into tile joints.
9. The \_\_\_\_\_ is used to fill and seal corners and edges of tilework.
10. You should always protect your \_\_\_\_\_ when working with chisels.
11. The \_\_\_\_\_ is used mainly for trimming and cutting sheetrock.
12. The quarry rack speeds up the setting of quarry tile by maintaining the same \_\_\_\_\_ size between tiles.
13. The \_\_\_\_\_ is used to remove hardened grout from tile joints.
14. The \_\_\_\_\_ is used for scraping and cleaning materials off smooth surfaces.
15. The \_\_\_\_\_ is used for filling the joints of tile and brick by hand.
16. The tile striker \_\_\_\_\_ and forms the grout into the joint.
17. The \_\_\_\_\_ allows for easy access to and good organization of your tools.
18. The \_\_\_\_\_ is used for cleaning buckets and tools.
19. The \_\_\_\_\_ is used to clean up at the end of a tile job.
20. \_\_\_\_\_ is a cotton gauze type of material used for cleaning the grout off the surface of tiles.
21. A \_\_\_\_\_ is also used to clean the grout off the surface of tiles.

22. The \_\_\_\_\_ is used to apply tape and paper to a surface at the same time.

# Self Assessment Answers

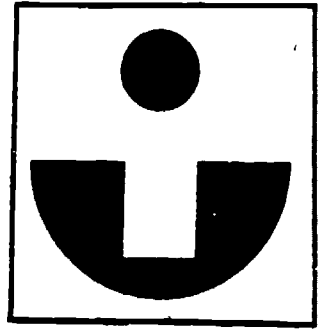

1. handsaw
2. tin snips
3. hacksaw
4. pull out
5. light
6. notched trowel
7. rubber mallet and a beating block
8. grout
9. caulking gun
10. eyes
11. utility knife
12. joint
13. grout saw
14. razor blade scraper
15. grout bag
16. compacts
17. tool box
18. scrub brush
19. duster
20. cheese cloth
21. sponge
22. tape masker

# Job Sheet

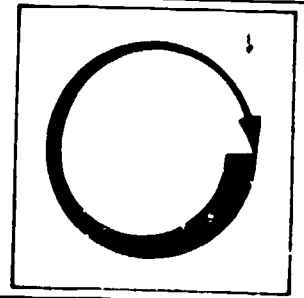

COMPLETE THE FOLLOWING TASKS.

Materials and Tools

claw hammer

hacksaw

handsaw

scraps of wood

scraps of metal pipe

10 nails long enough to nail through two of the pieces of scrap wood when placed together

1. Practice cutting the metal pipe.
2. Practice cutting the scraps of wood in half with the handsaw.
3. Practice nailing two of the scraps of wood together with the claw hammer.
4. Practice pulling the nails out of the scraps of wood using the claw hammer.

# Post Assessment

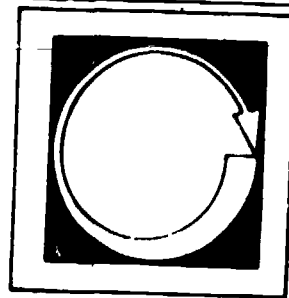

LISTED BELOW ARE SEVERAL STATEMENTS. IF THE STATEMENT IS TRUE, PLACE A "T" IN THE BLANK PROVIDED. IF THE STATEMENT IS FALSE, PLACE AN "F" IN THE BLANK. WRITE IN THE CORRECT ANSWERS TO THE FALSE STATEMENTS.

1. \_\_\_ If sixteen identical nails together weigh 1 pound, then each nail must weigh 1 ounce.
2. \_\_\_ An untied shoe lace has lots of tension.
3. \_\_\_ A jamb is a well-formed door or window.
4. \_\_\_ The process of tapping tile into tile adhesive is called beating in.
5. \_\_\_ The ground wire of an extension cord is a safety wire against electrical shock.
6. \_\_\_ A rough and rusty surface is called an enameled surface.
7. \_\_\_ Gauze is thin woven cotton fabric.
8. \_\_\_ An example of indentations are cleats on a football shoe or the noses on our faces.
9. \_\_\_ To retract is to draw back in.
10. \_\_\_ Caulking is material that is used to glue down tile.



# Instructor Post Assessment Answers

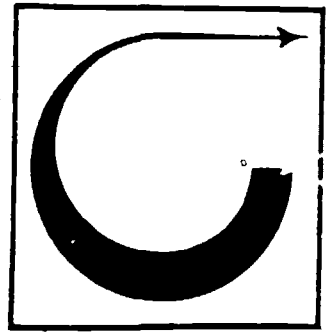

1. T
2. F Has no tension.
3. F A jamb forms the side of an opening like for a door or window.
4. T
5. T
6. F An enameled surface is smooth.
7. T
8. F An indentation is a recess in the surface, not something that protrudes.
9. T
10. F Caulking seals and waterproofs.

---

ADHESIVE APPLICATION AND BEATING IN

---

**Goal:**

The student will be able to select, explain the uses of, and demonstrate the use of the notched trowel; and will be able to beat tile in.

223

**Performance Indicators:**

The student will successfully complete a Self Assessment, a Job Sheet and a Post Assessment.

226

# Study Guide

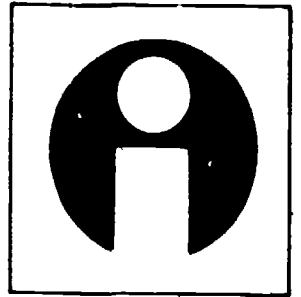

In order to finish this module, do the following tasks. Check each item off as you complete it.

1.  Read the Goal and Performance Indicators on the cover of the module. This will tell you what you will learn by studying the module, and how you will show you've learned it.
2.  Read the Introduction. The Introduction will tell you why the module is an important part of the tilesetting trade.
3.  Study the Vocabulary section. Vocabulary words are important for a good understanding of the trade. After you have studied the vocabulary, ask your teacher to quiz you on the words and their meanings.
4.  Study the Information section. This section will give you the information you need to understand the subject.
5.  Take the Self Assessment exam. This is a test for you to prove to yourself that you have learned the material you have studied. Compare your answers with the answers on the Self Assessment Answer Sheet, which is on the page following the Self Assessment. If you scored poorly, re-study the Information section or ask your teacher for help.
6.  Do the Job Sheet. Follow the instructions at the top of the Job Sheet. The tasks listed on the Job Sheet will help you develop skills which will be helpful to you.
7.  Take the Post Assessment exam. Give the exam to your teacher after you have completed it. Your teacher will grade it for you.

# Introduction

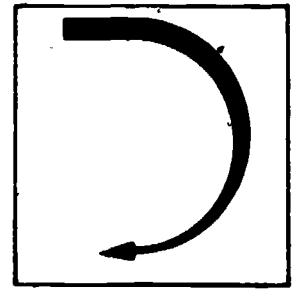

Every tilesetter must know how to use the notched trowel and the correct size to use for a job.

# Vocabulary

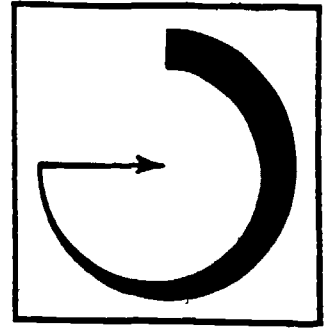

Trade terms are very important for a good understanding of the trade. Study these words and meanings. When you have learned them, ask your teacher to quiz you on the words and their meanings.

**BEAD**--A projecting rim, a ridge.

**UNIFORM**--Always the same, not varying.

**COMPRESS**--To press or squeeze together.

**COMPRESSIVE STRENGTH**--The amount of downward pressure something can withstand before it breaks.

**NUB**--A knob or lump that protrudes.

**RUSTIC**--Rough, coarse; not perfectly even, flat or square.

**COMBING**--The process of spreading tile adhesive with the notched trowel.

**CONCENTRATED FORCE**--A lot of weight, or power centered on a small area.

# Supplementary References

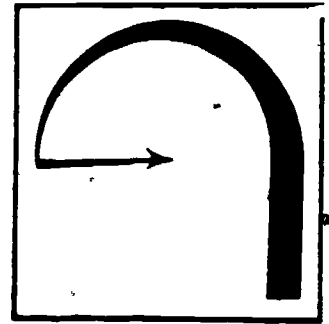

1. Krupp, Dick. The Purpose of Using Different Notched Trowels. Gazette, 1979.
2. Tilesetting Workbook. California Department of Education, 1975. p. 107.

# Information

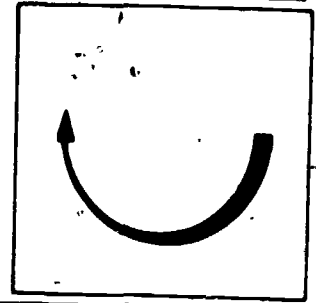

## TYPES OF NOTCHED TROWELS

The type of notched trowel used for a tile job depends on the kind of tile adhesive being used and the size and type of tile being installed.

There are a few general things to remember when choosing the type of trowel to use for a particular tile installation.

1. The notched trowel forms a bead in the tile adhesive (a uniform thickness) which allows for full, even contact with the tile after it is beat in.
2. Small, smooth-backed tiles, such as ceramic mosaics, do not require as much tile adhesive for bonding as do larger tiles.
3. Hard vitrous tiles, including ceramic mosaics, need enough tile adhesive to grip their edges as well as their backs, because the tiles themselves don't absorb any moisture.

There are two types of notched trowels: 1. The V-notched trowel, and 2. The square-notched trowel.

(See the illustration on the top of the following page.)

V-notched trowels are usually used with a mastic which is non-sanded and soft and can be easily compressed when tiles are beaten in. Mastic is used mainly for sheetrocked walls, never as a tile adhesive for areas that need great compressive strength. Therefore, V-notched trowels are used mainly for residential tile jobs.

Square-notched trowels can be used with any type of tile adhesive. They are recommended to be used with sanded thin-setting mortars, because the square bead of mortar formed breaks open easily during the beating-in process. This can give a better bond.

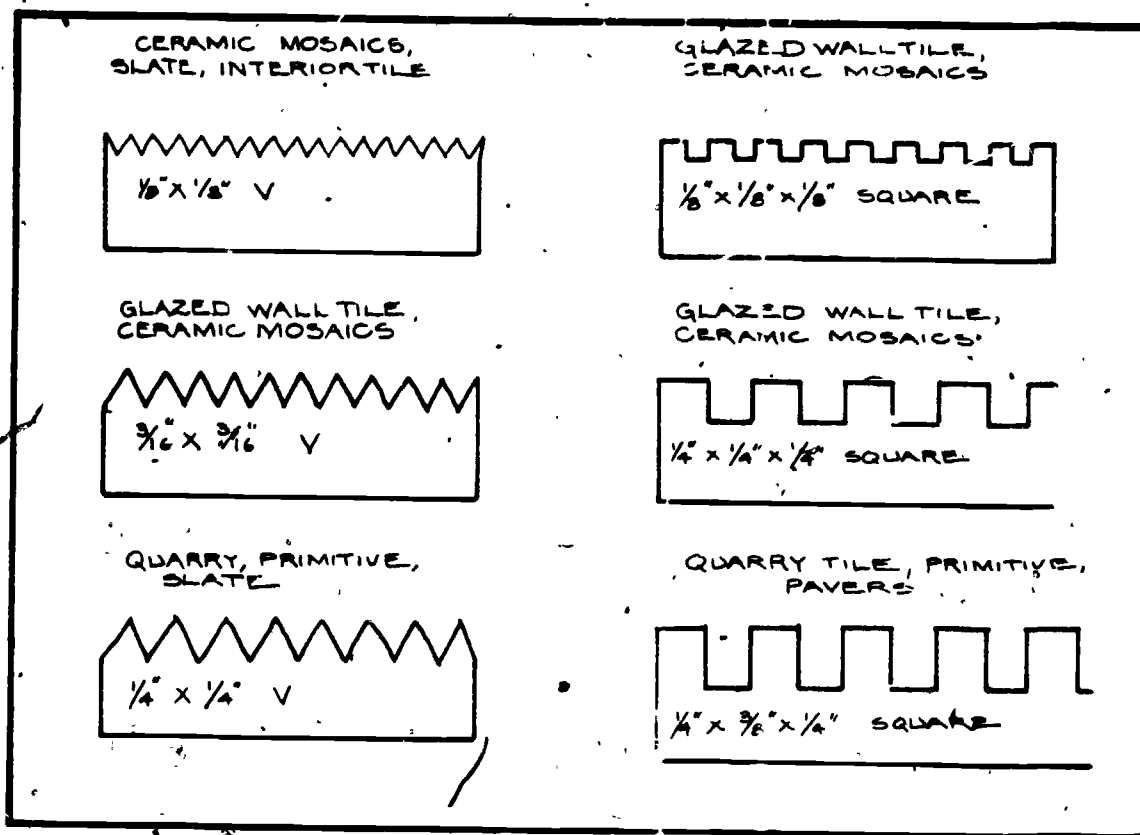

Square notched trowels should be used in areas that require greater compressive strengths.

The square-notched trowel is a good trowel to use with any type of tile adhesive, anywhere.

#### Choosing the Correct Size of Notched Trowel

It is necessary to use a 1/2" deep notched trowel to get good contact with all points of some "rustic hand-made" type tiles, and still have enough tile adhesive for a good bond. Generally, the more uneven the back of the tile is, the deeper the notched trowel is needed.

When using very uneven-backed tile, it is often necessary to butter the backs of tiles with the tile adhesive to make sure of complete contact and a good bond with the backing.

It is especially important to get the proper amount of tile adhesive beneath uneven backed tiles to insure against later tile breakage.



Breakage can also occur with nub- or button-backed tiles which have not been set with enough tile adhesive beneath them.

The depth of the "nub or button" determines the size of the trowel needed. Generally, there should be a thin layer (about 1/32") of tile adhesive between the tile and the backing after the tile has been beaten in. This will insure a good bond. Unless completely backed with tile adhesive, nub- or button-backed tiles may crack under concentrated force like the narrow heel of a woman's shoe.

Generally, the tilesetter needs four different sized trowels.

1. 1/8"-deep, V-notch or square notch; used for setting smooth-backed tiles, such as ceramic mosaics and some thin glazed wall tile.
2. 3/16" V-notch or square notch; used for setting larger ceramic mosaics and glazed wall tile.
3. 3/8"-deep square-notch; used for setting nub-backed tiles such as glazed and unglazed quarry tiles and most floor tiles.
4. 1/2"-deep, square-notch or V-, used for setting rustic, hand-made tiles.

#### How to Use the Notched Trowel

1. Apply the tile adhesive to the long, notched edge of the notched trowel with a margin trowel.
2. Comb the adhesive with the notched trowel at about a 60-degree angle to the backing.
3. Use enough adhesive so that the bead formed by the notch is full and even.

#### OPEN TIME AND COMBING

Different tests have been done to see how the bonding strength of a thin-setting tile adhesive is affected by open time. Open time is the period of time between the combing of the tile adhesive and the application of the tile.

A test done by the Ceramic Tile Institute is shown on the following page.

TABLE 1  
Results of Bond Testing

Condition of tile	Open time of thin-set mortar, min.	Number of taps	Bonded area, sq. in.	Load, lb.	Bonding strength, psi
Dry	10	8	18.06	600	33.2
Dry	15	8	18.06	545	30.2
Dry	20	8	18.06	195	10.8
Dry	30	8	18.06	90	5.0
Dry	35	8	18.06	Failed	--
Dry	40	10	18.06	75	4.2
(Mortar recombined)					
Dry	50	8	18.06	400	22.2
Dry	60	8	18.06	315	17.4
Dry	70	8	18.06	260	14.4
Dry	75	10	18.06	45	2.5

231

234

235

In Part I of the tests, tiles were placed on the adhesive 10 minutes after it had been combed. Tiles were then placed on the same adhesive at different times. Final placement of tile was made 45 minutes after combing.

In Part II of the tests, the original adhesive was recombed after 50 minutes and more tiles were set. This was also done at 60, 70, and 75 minutes.

The results of the tests showed that placement of the tiles on freshly combed adhesive provided the best bond. Results also showed that if the adhesive has been in place for 15 minutes before the tile is placed, it should be recombed.

Another test showed pretty much the same results but indicated even more how much stronger the bond will be if the tile is set immediately in the freshly-combed adhesive.

To test to make sure the tile adhesive is still "open" (able to bond tile), place your finger in the combed adhesive. If no adhesive comes off on your finger, it will not bond to the tile. If this happens, either:

1. Remove the adhesive completely and apply fresh adhesive, or
2. Recomb the adhesive with fresh adhesive.

#### BEATING IN

Always beat in the tile to seat it firmly in the adhesive. A square-notched trowel gives 50% surface contact with the tile before beating in. A V-notched trowel gives less than 10% contact if the tiles are laid on the pinpoint ridges of the combed tile adhesive. It takes a great deal more beating in.

The amount of beating in determines the amount of contact between the tile adhesive and tile. The more beating in, the better the bond.

It is a good idea to check the tiles from time to time during installation to be sure they have been properly beaten in and that there is a strong bond. Do this by removing a tile to be sure the adhesive is sticking to it.

#### How to Beat In

1. Beat in the tiles in the adhesive after about 15 minutes of setting time. Always beat in the tiles before you apply more tile adhesive.

2. Hold the beating block flat to the tile. With the rubber mallet, hit the beating block with a firm tap.

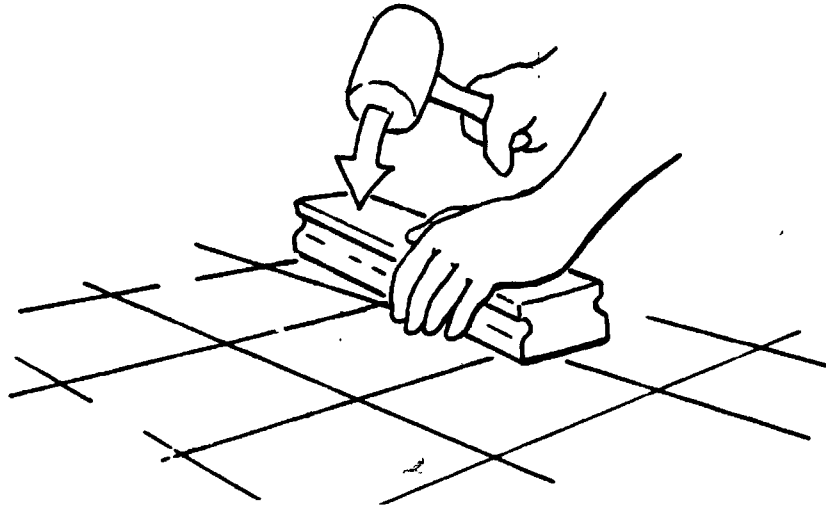

3. Move and hit the beating block at the same time, until all the tiles have been beaten in.

# Self Assessment

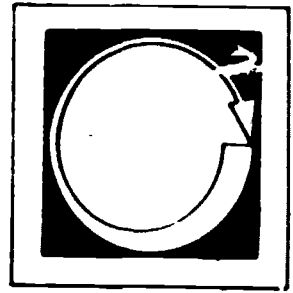

COMPLETE THE FOLLOWING STATEMENTS BY WRITING THE CORRECT WORD OR WORDS IN THE BLANKS PROVIDED.

1. The type of notch trowel to use depends on the kind of tile adhesive being used and the \_\_\_\_\_ of tile being installed.
2. Small smooth-backed tiles require \_\_\_\_\_ tile adhesive for bonding as do larger tiles.
3. The two types of notched trowels are the \_\_\_\_\_ and \_\_\_\_\_ trowels.
4. Compressive strength is the amount of pressure a tile can withstand before it \_\_\_\_\_.
5. Generally, the more uneven the back of the tile, the \_\_\_\_\_ the notched trowel needed.
6. Generally, the tilesetter uses four different size (depth) notched trowels. What are they? \_\_\_\_\_, \_\_\_\_\_, \_\_\_\_\_, and \_\_\_\_\_.
7. Open time is the period of time between the combing of the tile adhesive and the \_\_\_\_\_ of the tile.
8. The strongest, best possible bond is achieved when the tile is set \_\_\_\_\_ in the combed adhesive.
9. A \_\_\_\_\_ notched trowel gives 50% contact with the tile before beating in.

10. The more beating in, the \_\_\_\_\_ the bond.
11. If tile adhesive is still "open," that means it is still able to \_\_\_\_\_ tile.
12. A 1/2" deep notched trowel is often needed for setting \_\_\_\_\_ hand-made type tiles.

# Self Assessment Answers

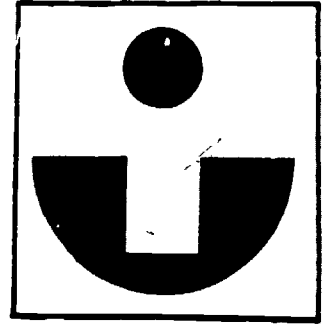

1. size
2. less
3. V-notched and square notched
4. breaks
5. larger or deeper
6. 1/8", 3/16", 3/8" and 1/2" deep trowel
7. application (setting)
8. immediately
9. square
10. better
11. bond
12. rustic

# Job Sheet

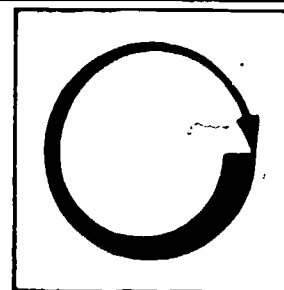

COMPLETE THE FOLLOWING TASKS.

Materials and Tools

1/8" deep V-notched trowel

1/4" deep V-notched or square notched trowel

3/8" deep square notched trowel

one bag of thinset mortar

access to water

one large bucket

one margin trowel

backings to work on--plywood, sheetrock, concrete, wood surfaces, etc.

rubber mallet

hardwood beating block

2 to 4 square feet 1" X 1" mosaics

4 to 10 square feet 4 1/4" X 4 1/4" glazed wall tile

4 to 10 square feet 8" X 8" or 10" X 10" quarry tile--floor tile

scrub brush and steel wool to clean tools

broom and/or duster to clean up working area

1. On a suitable backing (plywood, sheetrock, or concrete) practice applying a thinset mortar type tile adhesive.
2. With a 1/8" deep V-notched trowel, comb and set 2 to 4 square feet of 1" X 1" ceramic mosaics.
3. With a 3/16" deep V-notched or square-notched trowel, comb and set 4 to 10 square feet of 4 1/4" X 4 1/4" glazed wall tile.



4. With a 3/8" deep square notched trowel, comb and set 4 to 10 square feet of 8" X 8" or 10" X 10" nub-backed quarry tile--floor tile.
5. Practice beating in the tiles in no. 1 through no. 4 using a beating block and rubber mallet.
6. Test a few of the beaten in tiles in no. 1 through no. 4 to make sure they are bonding. (Lift them up to see if the adhesive is sticking.)
7. Comb one area with tile adhesive, let stand for 15 minutes, then practice recomb with fresh adhesive.

Clean up tools and working area when you are done.

# Post Assessment

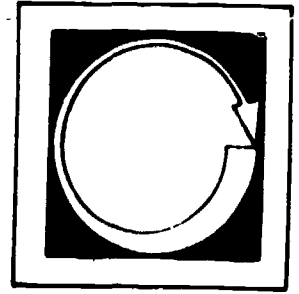

WRITE AN ANSWER TO THE FOLLOWING QUESTIONS.

1. When beating in the tiles did you have a problem of the tile adhesive squishing through the joints? Explain.
2. If so, what should you do so that it won't happen again?

LISTED BELOW ARE SEVERAL STATEMENTS. IF THE STATEMENT IS TRUE, PLACE A "T" IN THE BLANK PROVIDED. IF THE STATEMENT IS FALSE, PLACE AN "F" IN THE BLANK.

3.  To press or squeeze something together is to compress it.
4.  Something that varies a lot and never has the same form is uniform.
5.  City centers are considered residential areas.
6.  A rustic look is one that's rough and coarse, not perfectly even.
7.  Combing is the process of spreading tile adhesive with a notched trowel.
8.  A nub is something that recesses.
9.  A bead formed by a notch trowel is a projecting ridge or rim.

10. \_\_\_\_ Compressive strength is the amount of downward pressure something can withstand before it breaks.
11. \_\_\_\_ Concentrated force is a large powerful force spread over a great area.

# Instructor Post Assessment Answers

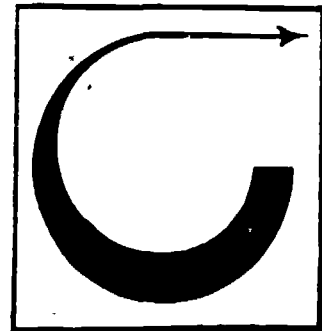

- 3. T
- 4. F
- 5. F
- 6. T
- 7. T
- 8. F
- 9. T
- 10. T
- 11. F

GROUTS

**Goal:**

The student will be able to identify, select, explain the use of, and prepare commonly used sanded and non-sanded grouts.

**Performance Indicators:**

The student will successfully complete a Self Assessment, an Assignment, a Job Sheet, and a Post Assessment.

# Study Guide

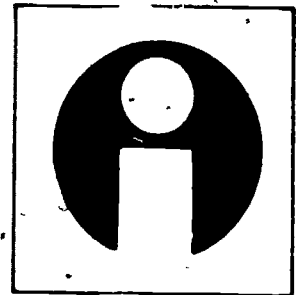

In order to finish this module, do the following tasks. Check each item off as you complete it.

1.  Read the Goal and Performance Indicators on the cover of the module. This will tell you what you will learn by studying the module, and how you will show you've learned it.
2.  Read the Introduction. The Introduction will tell you why the module is an important part of the tilesetting trade.
3.  Study the Vocabulary section. Vocabulary words are important for a good understanding of the trade. After you have studied the vocabulary, ask your teacher to quiz you on the words and their meanings.
4.  Study the Information section. This section will give you the information you need to understand the subject.
5.  Take the Self Assessment exam. This is a test for you to prove to yourself that you have learned the material you have studied. Compare your answers with the answers on the Self Assessment Answer Sheet, which is on the page following the Self Assessment. If you scored poorly, re-study the Information section or ask your teacher for help.
6.  Do the Assignment page. Follow the instructions at the top of the Assignment page.
7.  Do the Job Sheet. Follow the instructions at the top of the Job Sheet. The tasks listed on the Job Sheet will help you develop skills which will be helpful to you.
8.  Take the Post Assessment exam. Give the exam to your teacher after you have completed it. Your teacher will grade it for you.

# Introduction

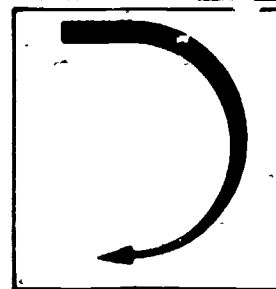

This module covers different types of grouts, including: What their uses are, requirements for different kinds of tile, types of exposures or conditions, and how to mix.

A tilesetter needs to learn about all the different types of grouts in order to know the best one for each job.

# Vocabulary

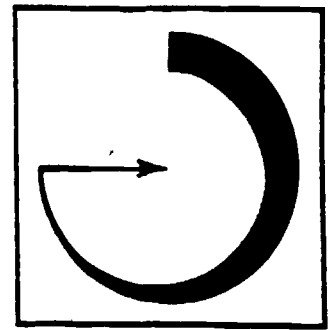

Trade terms are very important for a good understanding of the trade. Study these words and meanings. When you have learned them, ask your teacher to quiz you on the words and their meanings.

**BASE**--The main or supporting ingredient.

**QUALITY**--A feature, essential character, or property.

**CUSHION-EDGED TILE**--Tile on which the face edges curve down. The result is a slightly recessed grout joint.

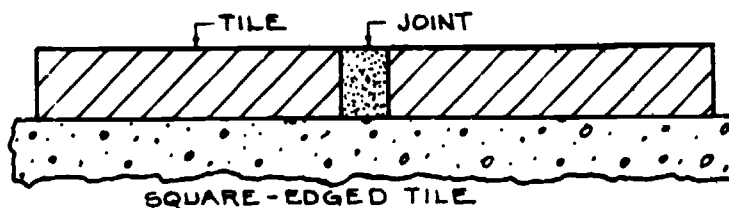
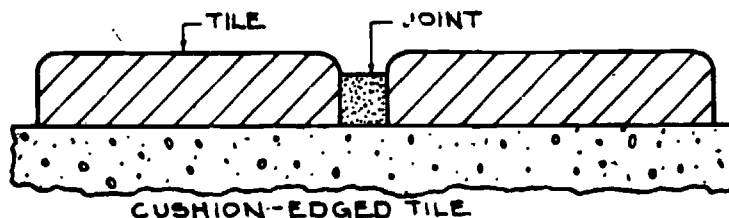

**SQUARE-EDGED TILE**--Tile on which the face edges are flat and square.

**FURAN**--A liquid obtained from wood oils of pine trees, or made synthetically.

**DENSE**--Compact and hard; concentrated.



DAMP CURE--A process of curing by keeping the surface wet with water for a few days.

SET-UP--A grout "sets up" when it first hardens.

STIFF MIXTURE--Too hard-not enough water.

SILICA SAND--A white fine grade of sand.

DRY-MIX--A process of mixing dry ingredients together in the correct proportions before adding water.

GROUT SAMPLE--A small sample of different colors of grout.

# Supplementary References

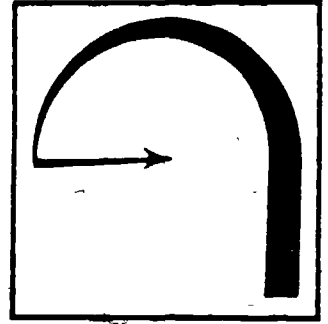

1. Tilesetting Workbook. California Department of Education, 1975. pp. 54-57.
2. 1980 Handbook for Ceramic Tile Installation. Tile Council of America, Inc., 1980. pp. 7 and 10.

# Information

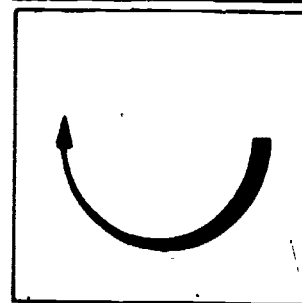

Portland cement is the base (main) ingredient for the most often used grouts. The cement is modified (changed) so that the grout may have special qualities, such as uniform color, whiteness, hardness, flexibility and water retentivity. (Water retentivity means that the water used to mix is held long enough within the grout mix for the grout to properly cure and set.)

There are also different types of non-cement-based grouts which are usually more expensive and harder to work with. (They are used for special tile installations where a cement-based grout would not meet the requirements.)

No matter what type of grout you are using, it is important to always follow the grout manufacturers' instructions.

## GROUT JOINT GUIDELINES

The proper grout is important. A grout joint can only be considered correct when these five guidelines are followed.

1. Uniform in color.
2. Cured to the maximum possible hardness.
3. Smooth without pinholes, high or low spots.
4. Finished flush to the top of square-edged tile and finished just slightly recessed with cushion-edged tile.
5. Clean--there should be no grout on the face of the tile when the job is finished.

## TYPES OF GROUTS

The portland cement-based grouts consist of:

- \* Dry-set grout.
- \* Commercial portland cement grout.

- \* Natural cement grout.

The non-cement based grouts consist of:

- \* Mastic grout.
- \* Epoxy grout.
- \* Silicone rubber grout.
- \* Furan resin grout.

### Portland Cement Based Grouts

1. Dry-set Grout; the most often used type of grout. It is manufactured by many different companies and comes in every basic color from white to black. It is water resistant and dense and used for grouting all walls and floors that are going to receive regular use. It is not a good grout to use for heavy industrial and commercial floors. Dry-set grout can be broken up into two categories:

1. Sanded.
2. Non-sanded.

Sanded dry-set grout is a pre-mixed mixture of portland cement, fine sand, and additives which provide water retentivity. Sanded grout is used for tile joints from 1/8" to 1/2" wide.

Sand is needed for tile joints 1/8" and over because it prevents the grout from shrinking. Shrinking would cause cracks in the grout joints. Shades of brown are the most often used colors.

Non-sanded dry-set grout is a pre-mixed mixture of portland cement and additives. It is used for tile joints no larger than 1/8" wide.

Non-sanded grout is also known as wall grout because it is mainly used with glazed ceramic wall tile. Non-sanded grout also comes in a large range of colors. The color most often used is white.

How to mix dry-set grout--Since dry-set grout comes in a pre-mixed form, it is very easy to mix.

1. In a clean bucket, add a small amount of clean water (tap water).
2. Add a small amount of dry-set grout.
3. Thoroughly mix and stir with either a margin trowel or suitable mixing stick. ALWAYS ADD THE WATER FIRST.

4. The grout should have a fairly stiff creamy consistency when perfectly mixed. (You will probably have to add either more water or grout to bring the mixture to the desired consistency.)

Too wet a mixture:

- a. Weakens the final strength of the grout joint.
- b. May not "set up" for a long time.
- c. May leave small air bubbles in the surface of the grout joint.

Too stiff a mixture:

- a. Is hard to properly pack in the tile joints.
- b. May set up too fast and cause hairline cracks in the grout joint.

2. Commercial portland cement grout; a pre-mixed mixture of portland cement and other ingredients to make a water-resistant, dense, uniformly colored grout--especially designed for tiles that had to be soaked in water before they could be installed, and for floor tile that had to be damp-cured.

Because tiles do not have to be soaked before application, this type of grout is not used much anymore. Commercial portland cement grout is mixed the same way as dry-set grout.

3. Natural cement grout; also called quarry tile grout and natural grout. It is a grout which is mixed on-the-job.

Consists of, 1 part portland cement to 1 part fine graded sand for joints up to 1/8" wide; 1 part cement to 2 parts sand for joints up to 1/2" wide; 1 part cement to 3 parts sand for joints over 1/2" wide.

Natural cement grout is used with ceramic mosaic tile, paver tile, and with quarry tile on floors and walls. It is very popular with quarry tile.

There are basically three colors that can be mixed:

1. White, a mixture of specially formulated white portland cement and silica sand.
2. Grey, a mixture of regular grey portland cement and white silica sand.

3. Natural mortar, a mixture of regular grey portland cement and a fine graded dark mortar sand.

#### How to mix natural cement grout--

1. Determine the size of the joint.
2. With a measuring device (an empty peanut can or old cup works nicely), put the appropriate amount of cement and sand into a clean, dry bucket.
3. With a margin trowel or suitable mixing stick, mix the cement and sand together until they are well blended into each other. This is called dry-mixing.
4. In another clean bucket, mix as you would dry-set grout; add a small amount of water then a small amount of the dry-mix.
5. The grout should have a fairly stiff creamy consistency when perfectly mixed.
6. If the grout stiffens up too much in the bucket, just add and mix in a little more water to bring back to the desired consistency.

When natural cement grout is mixed with water, damp curing is necessary. There are liquid additives that can be mixed with natural cement grout which eliminates the damp curing process. They are covered in the module called "Additives for Grouts and Mortars."

#### Non-cement Based Grouts

Mastic grout. Like the tile adhesive types of mastics, mastic grout is used directly from the container, no mixing is necessary. It does not need to be damp cured.

It is more flexible and stain resistant than regular cement-based grouts. It is also more expensive and much harder to work with. Mastic grout is used only if it is required.

Epoxy grout. It comes in two parts: An epoxy resin and a hardener, both of which are heavy liquids.

Epoxy grouts can be used both for bonding the tile and for grouting. When mixed together, the pot life (the amount of time before it hardens) is short. It is very hard to work with. Epoxy grout is specially made and used for heavy industrial and commercial tile installations.

Tests have shown that it is highly chemical resistant. It suffers no effects from acids or from alkaline materials such as washing soda and strong detergents. It is also highly resistant to greases, oils, and alcohol. It is a very expensive grout.

Silicone rubber grout. It is a grout that resembles rubber. It is a ready-to-use, pre-mixed silicone rubber system which, when cured, is resistant to staining, moisture, mildew, cracking and shrinking.

It adheres very strongly to ceramic tile. It cures fast. It withstands exposure to hot cooking oils and steam, as well as withstanding subfreezing and scorching hot temperatures.

Like the other non-cement based types of grouts, silicone grout is more expensive and takes special skills by the tilesetter. White is the color most often used, but it comes in brown and black, too.

Furan resin grout. It is used mainly with quarry tile, packing house tile, and paver tile.

Like epoxy grout, furan grout comes in two parts, a furan resin and a hardener, both of which are heavy liquids.

Furan grout is probably the most difficult of all the grouts to work with. It is used for heavy industrial and commercial tile installations. Like epoxy grout, it is highly resistant to chemicals, greases, oils, and alcohol. Furan grout comes in only one color--black.

# Self Assessment

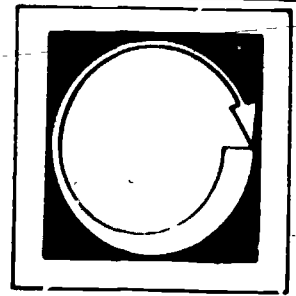

COMPLETE THE FOLLOWING STATEMENTS BY WRITING THE CORRECT WORD OR WORDS IN THE BLANKS PROVIDED.

1. \_\_\_\_\_ is the main ingredient for the most often used grouts.
2. \_\_\_\_\_ grout is the most often used type of grout.
3. Sanded grout is used for tile joints from \_\_\_\_\_ inch to \_\_\_\_\_ inch wide.
4. Non-sanded grout is used mainly for grouting \_\_\_\_\_.
5. Sand is needed for larger grout joints because it prevents the grout from \_\_\_\_\_, which would cause \_\_\_\_\_ in the grout joints.
6. Too wet a grout mixture can \_\_\_\_\_ the strength of the grout joint.
7. Too stiff a grout mixture may set up too fast and cause hairline \_\_\_\_\_ in the grout joint.
8. Commercial portland cement grout is not used very much anymore because tiles do not have to be \_\_\_\_\_ before application.
9. Natural cement grout is very popular with \_\_\_\_\_ tile.



10. Mastic grout is used directly from the \_\_\_\_\_.
11. Epoxy grout can be used both for \_\_\_\_\_ the tile and for \_\_\_\_\_ it.
12. Epoxy and Furan grouts are highly \_\_\_\_\_ resistant.
13. Non-cement based grouts are basically \_\_\_\_\_ to work with and \_\_\_\_\_ expensive.
14. \_\_\_\_\_ or \_\_\_\_\_ grout is the best type of grout to use for heavy industrial and commercial tile installations.

# Self Assessment Answers

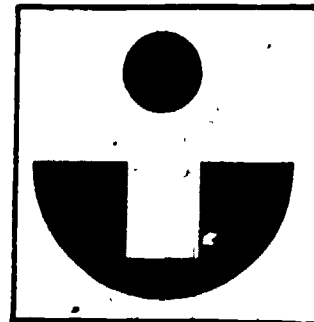

1. portland cement
2. dry-set
3. 1/8" to 1/2"
4. glazed wall tile or 4 1/4" X 4 1/4" tile or wall tile
5. shrinking, cracks
6. weaken
7. cracks
8. soaked
9. quarry
10. container
11. bonding, grouting
12. chemical or oil or alcohol, or alkaline, etc.
13. harder, more
14. epoxy or Furan

# Assignment

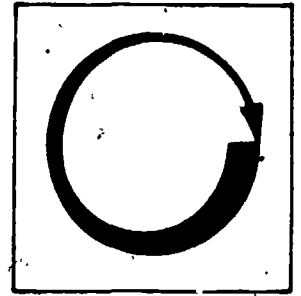

COMPLETE THE FOLLOWING ASSIGNMENT.

Visit a local tile shop. Ask to see their grout samples (samples of different colors of grout) so that you may compare them with different types of tiles. Compare the grout samples with different sizes, surface finishes (glazed, unglazed, etc.), and colors of tiles.

Make and fill in a chart that shows the color of grout you liked first, second and third best with a certain type of tile. Compare with at least six different types of tiles.

For your first choice of grout color for each tile, write a few words on why you liked that color of grout best with that type of tile. Hand in to your instructor.

TILE--GROUT COLOR CHART

	Tile #1	Tile #2	Tile #3	Tile #4	Tile #5	Tile #6
Color of the Tile	Light Brown	Reddish Orange	etc.			
Surface Finish (Glazed, Unglazed, Rough, Smooth)	Glazed Smooth	Unglazed Porous				
Size of the Tile	3" X 8"	2" X 2"				
Color of Grout Preferred with Tile						
First Choice	Dark Brown	Natural Grey				
Second Choice	Medium Brown	Black				
Third Choice	White	Dark Red				

# Job Sheet

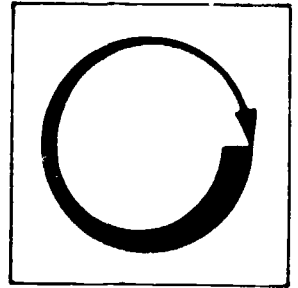

COMPLETE THE FOLLOWING TASK.

Materials and Tools

clean bucket

suitable mixing stick or margin trowel

about 5 pounds of a colored dry-set grout

access to water

Using the information and procedure for mixing dry-set grout, mix to the proper consistency about 5 pounds of a colored dry-set grout.

\* Begin with a small amount of water.

Thoroughly clean up when finished.

# Post Assessment

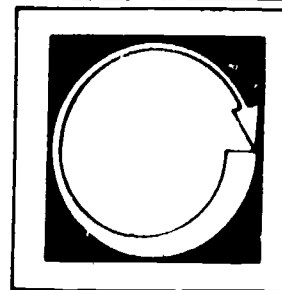

WRITE AND ANSWER TO THE FOLLOWING QUESTIONS CONCERNING THE JOB SHEET.

1. Did you have any problems mixing the dry-set grout? Explain.
2. What was the grout's consistency? Was it creamy, stiff, like mud, like a rock, like thick water? Explain.

CONCERNING THE ASSIGNMENT

3. What was your overall very best combination of type of tile and color of grout.

LISTED BELOW ARE SEVERAL STATEMENTS. IF THE STATEMENT IS TRUE, PLACE A "T" IN THE BLANK PROVIDED. IF THE STATEMENT IS FALSE, PLACE AN "F" IN THE BLANK.

4. \_\_\_\_ A cushion-edged tile is a tile on which the face edges of the tile are coated with rubber to give the tile a softer feel when walking on it.
5. \_\_\_\_ Furan can be made naturally out of pine trees, or synthetically.
6. \_\_\_\_ A process of curing a surface by keeping it wet with water is called damp curing.

7. \_\_\_\_ A very light and fluffy type of object like a pillow is considered to be dense.
8. \_\_\_\_ When a grout "sets up" is when it first hardens.
9. \_\_\_\_ Silica sand is a fine grade of dark river sand.
10. \_\_\_\_ The process of mixing ingredients together in the correct proportions before adding water is called dry-mixing.

# Instructor Post Assessment Answers

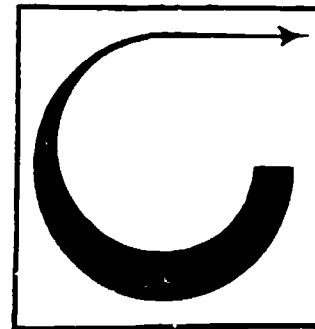

- 4. F
- 5. T
- 6. T
- 7. F
- 8. T
- 9. F
- 10. T



---

GROUT AND MORTAR ADDITIVES

---

**Goal:**

The student will be able to identify, explain the use of, and select the proper additive for grouts and mortars.

**Performance Indicators:**

The student will successfully complete a Self Assessment, an Assignment and a Post Assessment.

# Study Guide

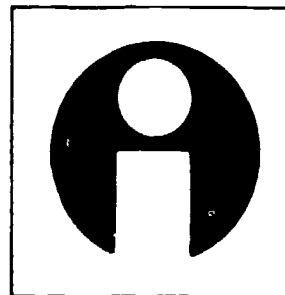

In order to finish this module, do the following tasks. Check each item off as you complete it.

1.  Read the Goal and Performance Indicators on the cover of the module. This will tell you what you will learn by studying the module, and how you will show you've learned it.
2.  Read the Introduction. The Introduction will tell you why the module is an important part of the tilesetting trade.
3.  Study the Vocabulary section. Vocabulary words are important for a good understanding of the trade. After you have studied the vocabulary, ask your teacher to quiz you on the words and their meanings.
4.  Study the Information section. This section will give you the information you need to understand the subject.
5.  Take the Self Assessment exam. This is a test for you to prove to yourself that you have learned the material you have studied. Compare your answers with the answers on the Self Assessment Answer Sheet, which is on the page following the Self Assessment. If you scored poorly, re-study the Information section or ask your teacher for help.
6.  Do the Assignment page. Follow the instructions at the top of the Assignment page.
7.  Take the Post Assessment exam. Give the exam to your teacher after you have completed it. Your teacher will grade it for you.

# Introduction

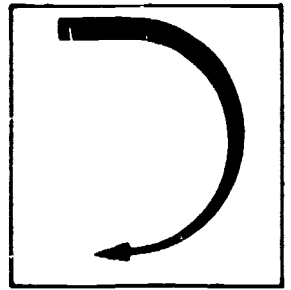

Several types of mortar and grout additives are available for tilework. It is important to be able to identify and select the best one for the condition that exists. The correct additive can help make for a strong, long-lasting tile job.

# Vocabulary

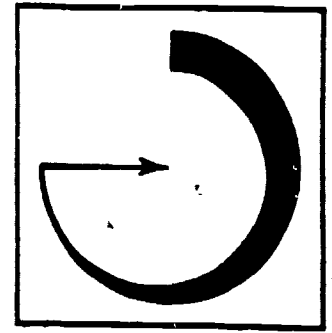

Trade terms are very important for a good understanding of the trade. Study these words and meanings. When you have learned them, ask your teacher to quiz you on the words and their meanings.

**EXPAND**--To increase in size or volume.

**CONTRACT**--To reduce to a smaller size or volume.

**REGULATE**--To fix or adjust the time, temperature, degree or rate of something.

**CHEMICAL**--A substance (as a chemical compound) used for producing a chemical effect.

**CONCENTRATED**--Condensed; strong, not dilute.

**DILUTE**--To make thinner with more liquid; to weaken the strength of.

**LATEX**--Milky white fluid with qualities like rubber and/or plastic.

**ACRYLIC**--Plastic-like material used for coatings, adhesives, and additives.

**POLYVINYL**--Vinyl compound, resin and or plastic often used in combination; used as an additive.

**BERYLEX**--Trademark name of a chemical compound used as the base for different types of additives.

ACCELERATOR--Additive that speeds up the setting of mortar or grout.

RETARDANT--Additive that slows down the setting of mortar or grout.

# Supplementary References

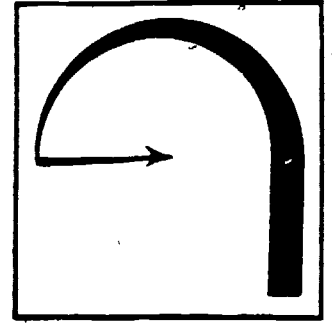

1. Tilesetting Workbook. California Department of Education, 1975. pp. 30-31.
2. 1980 Handbook for Ceramic Tile. Tile Council of America, 1980. pp. 5-9.

# Information



There are many types of additives for grouts and mortars manufactured by many different companies. Each claims to have the best additive and, of course, some are better than others. Each additive basically has a specific use, although some can be used for many things.

Quite often, the grout or mortar doesn't need an additive, so how do you know when to use one?

Basically, an additive is needed when some sort of special quality or property is desired or required for the grout or mortar. For example, additives can help make the grout or mortar:

1. Stand up better to extreme hot or cold temperatures.
2. Expand and contract to temperature changes and freezing conditions.
3. Harder and stronger by making it more dense.
4. More flexible and shock resistant.
5. Bond better and stronger.
6. Set up and cure faster.
7. Set up slower.
8. More chemical resistant.
9. Waterproof.

Some of the reasons additives may not be used is:

1. The pre-mixed portland cement based grouts, like dry-set grout, often have enough additives already in the mixture.
2. The tilesetter uses portland cement mortar mainly as a backing for interior tile installations where the temperature is regulated and the mortar can set up and cure properly. In these two cases (or any case), a tilesetter may decide to use an additive just for extra strength and security.

## TYPES OF LIQUID ADDITIVES

1. Latex.
2. Acrylic.
3. Polyvinyl.
4. Berylex grout additive.

The four liquid additives are all synthetically made (man-made) and have many things in common. The main difference between them is that they are different chemically. Most of the additives come concentrated and need to be diluted with water before mixing. The most common mixture is 3 parts water to 1 part additive, but follow the instructions carefully.

The latex based additive is the most popular type of additive used. Latex-portland cement mortars have been used for installing tile since the early 1920s and latex-portland cement grout has been used for many years.

The latex additive is a milky white liquid with some qualities of rubber and plastic. There are different types of latex additives designed to work with portland cement mortar, thin-set adhesive and portland cement-based grouts. Latex has a tendency to accelerate the setting and curing of portland cement products. Latex additives produce a denser, more flexible, shock resistant, water resistant, and hard mortar and grout. In addition, it enables the grout and mortar to be able to stand up to extreme temperatures better and also speeds up the development of maximum mortar strength.

The acrylic additive is new on the market--only a couple years old. It is also a white milky liquid with rubber and plastic qualities. It is different chemically from the latex additive.

It has been proven to work as well with portland cement based products as latex additives, and maybe even better.

Polyvinyl is a chemical compound of resin and plastic often used in combination. It's an older additive, not used much anymore, but it does make mortar more water resistant and, when used in grout, produces a better bond to the tile and gives some flexibility.



Berylex grout additives come in two different formulas.

1. The regular formula, which is a white milky liquid designed for grouting in normal temperatures.
2. The green formula, which is a green liquid designed for grouting in excessively hot temperatures and dry conditions. It is a retardant additive that slows up the setting of the grout.

Both help make the grout shrinkproof, waterproof, denser, stain resistant. And they give greater bond strength.

Whenever deciding on a particular additive, carefully read the information and instructions on how to use.

# Self Assessment

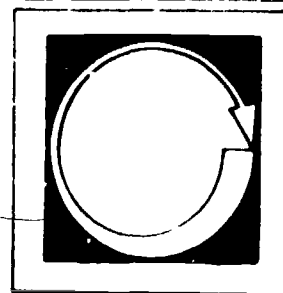

COMPLETE THE FOLLOWING STATEMENTS BY WRITING THE CORRECT WORD OR WORDS IN THE BLANKS PROVIDED.

1. To help you decide what type of additive (if at all), you should read the \_\_\_\_\_.
2. A tilesetter may decide to use an additive just for extra \_\_\_\_\_ and \_\_\_\_\_.
3. The difference between additives is that they are different \_\_\_\_\_.
4. The \_\_\_\_\_-based additive is the most popular type of additive used.
5. \_\_\_\_\_ additives are new on the market and are considered as good as latex additives.
6. Latex has a tendency to \_\_\_\_\_ the setting and curing of portland cement products.
7. \_\_\_\_\_ is a chemical compound of resin and plastic often used in combination.
8. Berylex grout additives come in two different formulas: The regular formula designed for grouting in \_\_\_\_\_ temperatures and the \_\_\_\_\_ formula designed for grouting in \_\_\_\_\_ temperatures.

# Self Assessment Answers

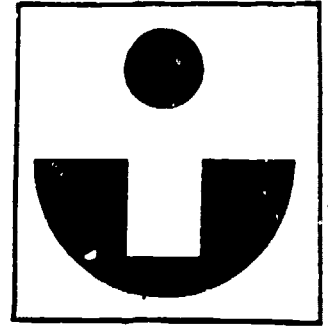

1. information
2. strength and security
3. chemically
4. latex
5. acrylic
6. accelerate
7. polyvinyl
8. normal, green, hot

# Assignment

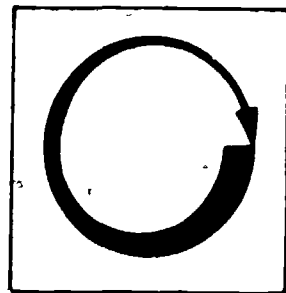

COMPLETE THE FOLLOWING ASSIGNMENT.

Go to a local tile shop. Write on two or three different mortar or grout additives in stock. Include:

1. Brand name.
2. Type--latex, acrylic, etc.
3. What it is used for--mortar, grout.
4. How to use it--do you have to dilute it with water? If so, what's the ratio?
5. What does it claim to do--harden, speed up, slow down, waterproof, make better bond? Explain.

# Post Assessment

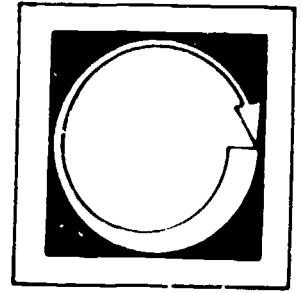

LISTED BELOW ARE SEVERAL STATEMENTS. IF THE STATEMENT IS TRUE, PLACE A "T" IN THE BLANK PROVIDED. IF THE STATEMENT IS FALSE, PLACE AN "F" IN THE BLANK.

1. \_\_\_ Something concentrated means that it has been made thinner with liquid. It has been weakened.
2. \_\_\_ When the temperature of a room is fixed or adjusted at 65 degrees, you can say the temperature has been regulated.
3. \_\_\_ Contract is to increase in size and expand is to reduce in size.
4. \_\_\_ Berylex is an additive that is the trademark name of a chemical compound.
5. \_\_\_ To make thinner or weaken with more water is to dilute.
6. \_\_\_ An accelerator speeds up the setting of mortar or grout.
7. \_\_\_ A retardant additive should be used in very cold temperatures to help slow down the setting of mortar or grout.

# ● Instructor Post Assessment Answers

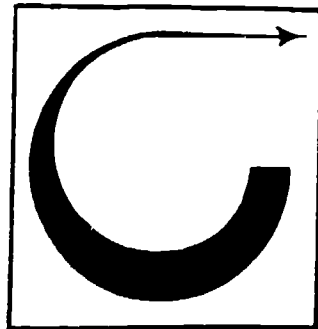

1. F Concentrated is strong, condensed.
2. T
3. F The other way around.
4. T
5. T
6. T
7. F Should be used in hot temperatures to slow down the setting.

## SEALERS AND CLEANERS

### **Goal:**

The student will be able to identify, explain the use of, select and apply commonly used sealers and cleaners.

### **Performance Indicators:**

The student will successfully complete a Self Assessment, an Assignment, a Job Sheet and a Post Assessment.

# Study Guide



In order to finish this module, do the following tasks. Check each item off as you complete it.

1. \_\_\_ Read the Goal and Performance Indicators on the cover of the module. This will tell you what you will learn by studying the module, and how you will show you've learned it.
2. \_\_\_ Read the Introduction. The Introduction will tell you why the module is an important part of the tilesetting trade.
3. \_\_\_ Study the Vocabulary section. Vocabulary words are important for a good understanding of the trade. After you have studied the vocabulary, ask your teacher to quiz you on the words and their meanings.
4. \_\_\_ Study the Information section. This section will give you the information you need to understand the subject.
5. \_\_\_ Take the Self Assessment exam. This is a test for you to prove to yourself that you have learned the material you have studied. Compare your answers with the answers on the Self Assessment Answer Sheet, which is on the page following the Self Assessment. If you scored poorly, re-study the Information section or ask your teacher for help.
6. \_\_\_ Do the Assignment page. Follow the instructions at the top of the Assignment page.
7. \_\_\_ Do the Job Sheet. Follow the instructions at the top of the Job Sheet. The tasks listed on the Job Sheet will help you develop skills which will be helpful to you.
8. \_\_\_ Take the Post Assessment exam. Give the exam to your teacher after you have completed it. Your teacher will grade for you.



# Introduction

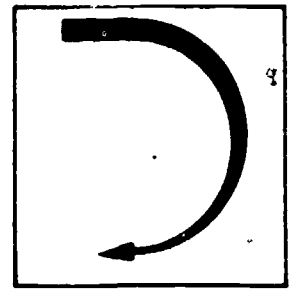

This module covers types of heavy duty masonry and grout cleaners as well as mild glazed tile cleaners. It also covers different types and methods of sealing unglazed tile such as quarry tile, pavers, brick and hand-made tile, as well as how to caulk.

For a tilesetter to be considered knowledgeable in the trade, he or she must know how to properly clean and seal, and in what situation it is practical or necessary to seal.

# Vocabulary

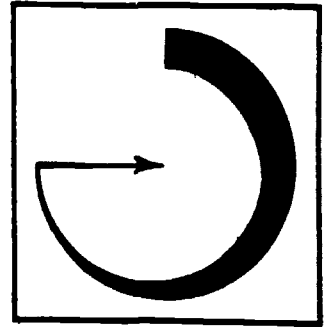

Trade terms are very important for good understanding of the trade. Study these words and meanings. When you have learned them, ask your teacher to quiz you on the words and their meanings.

**IMPURE**--Unclear, not pure.

**SOLUTION**--Usually a liquid mixture.

**SQUEEGE**: -A blade of rubber set on a handle and used for spreading, pushing, or wiping liquids.

**ETCH**--The result or effect of an etching acid on a surface.

**PORE**--A small opening in surfaces that absorb liquids.

**CAULK**--To stop up, seal and make watertight the seams, corners or edges.

**WAINSCOT**--Usually the lower 3 or 4 feet of an interior wall; is finished differently from the rest of the wall.

**DENATURED ALCOHOL**--Alcohol that is changed (made unfit for drinking), but still useful for other purposes like cleaning.

# Information

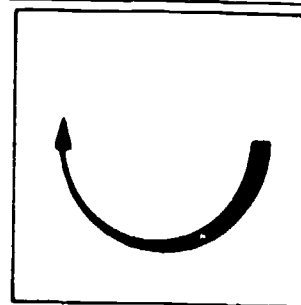

## CLEANERS

### Glazed Tile and Grout Cleaners

Glazed ceramic tile is one of the most permanent and easiest to maintain.

For general cleaning of walls and floors, wipe with a clean, damp sponge, cloth or mop. Dry and polish with a soft, dry towel. For soap scum, dirt, most stains and mildew, an all-purpose type cleaner such as Mr. Clean, Fantastik, Ajax Liquid, Comet or X-14 can be used.

The cleaner usually should be applied, allowed to set for a few minutes, scrubbed with a sponge or soft scrub brush, then wiped off and rinsed with clean water. Harder-to-clean deposits, such as hard water spots, may require a commercial tile cleaner. A mixture of vinegar and water can make a good cleaner; a small area should be tested first since it can etch some tiles.

If an all-purpose cleaner won't adequately clean and a commercial tile cleaner has to be used, carefully follow the directions on the container. Some cleaners may be too strong for the job.

• Rough materials such as steel wool and sand paper should never be used to clean any type of tiled surface, especially a glazed surface where scratching is very easy.

### Masonry Cleaners

Masonry cleaners are acid-based and a lot stronger than all-purpose cleaners. Muriatic, hydrochloric and phosphoric acids are the base acids for most masonry cleaners.

Many brands of masonry cleaners are available. Some are designed to remove excess mortar (which includes grout) and job dirt from masonry and tile surfaces.

Others will remove excess mortar, oil, grease, wax, soaps, job dirt and other impurities.

Each is different, but most need to be diluted with water before using. Follow directions on container.

1. Pour on area to be cleaned.
2. Scrub with a (preferably) plastic-bristled brush for 1 to 3 minutes.
3. Rinse thoroughly with clean water.
4. Clean off with squeegee or mop.

If the cleaner isn't completely rinsed, it's possible that the tile and/or grout joint could be permanently discolored.

A test area should always be cleaned and inspected before overall cleaning, and all surrounding non-masonry surfaces should be protected.

Special care should be taken when using acid-based cleaners. Wear rubber gloves, thick-soled boots and avoid splashes to skin and eyes.

#### ACID ETCHERS

Acid etchers are very strong liquid acid solutions that prepare concrete surfaces for bonding tiles by the thin-set method.

Etchers work by roughing and opening up the pores of a concrete surface. A roughed-up surface makes a much better bonding surface than a smooth, non-porous one.

If the concrete surface has been sealed, a suitable masonry cleaner needs to be used before applying the etcher.

#### How to Apply Etcher

1. Spread the etcher over the cleaned concrete surface.
2. Use a (preferably) plastic-bristled scrub brush and scrub into the surface.
3. Let stand until soaked up and dried. A white haze or film will form.
4. Wash off with clean water.

5. After the surface dries, it is ready for tilework.

#### How to Clean Stained Unglazed

The best method of cleaning quarry tile is: Don't let it get dirty in the first place!

Grease and oil stains cannot be removed from unsealed quarry tile, but they can be lightened and made less visible by applications of sealers like Watco filler, Lestoil, linseed oil and others. Also, acid burns are often impossible to correct. Pick a small area and try the following method before cleaning the entire floor.

1. Wet with clean water and apply an undiluted liquid soap, such as Hillyard's Super Shine, All or Ajax Liquid.
2. Leave it on as long as possible, preferably overnight.
3. Mop over the undiluted soap with properly diluted liquid soap and sprinkle on a scouring powder such as Comet.
4. The soap and scouring powder become a wet slurry which should be thoroughly scrubbed.
5. Rinse off with plenty of clean water, and buff the floor with cotton type towels before it dries. Buff it completely dry.
6. Seal.

#### SEALERS

Never seal glazed ceramic tile. The glaze is very hard and doesn't need it.

Grout joints, in normal conditions, do not need to be sealed. If the grout needs to be totally waterproof or chemical resistant, use a suitable good quality grout and/or grout additive.

Unglazed tile such as quarry tile, pavers and hand-made tiles should be sealed, but don't necessarily have to be.

#### Reasons for Sealing

1. To waterproof by sealing the pores of the tile.
2. To keep the tile from staining.
3. To generally protect the surface for easier maintenance.

### Reasons for Not Sealing

1. It can be tricky, if the tile is not perfectly clean before sealing, then the stains on the tile will be sealed in forever.
2. Sealers can blotch, which makes the surface color look uneven.

### Types of Sealers

There are many different types of sealers. There is wax, silicone, Watco filler, Thompson's Water Seal, acrylics, Lestoil, linseed oil and others. These can be divided into two categories:

1. Sealers that seal immediately with one or two coats. They include: Wax, silicone, acrylics, Thompson's Water Seal, and Watco filler; all the sealers except the oil-base sealers.
2. Oil-base sealers. They include: Lestoil, linseed oil and others. They seal by eventual buildup over many applications.

### How to Apply

Before any type of sealer is applied, the tiled surface must be totally clean and dry.

The one-or-two-coat type sealers are applied by either a brush, roller, mop or other suitable applicator where an even coat is spread and allowed to dry. Most sealers are applied this way. Each type may be applied a little differently.

The silicone sealer also comes in a spray can. It is NOT recommended. It is only practical for a very small area.

Oil-base sealers are also applied in an even coat with a brush, roller or mop. The difference is, for best results, the oil sealers should be applied once every day for two to three weeks. This is a lot of work, but it may be the best way to seal a quarry tile floor.

### Grout Release

Grout releases, also known as pre-sealers, are applied to unglazed tiles before grouting and are designed to keep the grout from staining the surface of the tiles. They come off in the process of cleaning grout.

The problem is, they don't always work. None of them are guaranteed. For those reasons, most tilesetters won't touch them.

When grouting very porous tiles where there is a possibility of staining, two things can be done besides taking a gamble with a grout release.

1. Soak the surface of the tiles with water before grouting.  
This is the most practical procedure.
2. Seal the surface of the tiles with an immediate sealer.

This procedure should be done only if the tiles have severe pits or ridges and must be clean when finished grouting. This procedure can be very expensive and isn't done unless there's no other alternative.

#### HOW TO CAULK

The caulking gun is used by tilesetters to fill corners and edges of tilework with a silicone sealer to make them watertight.

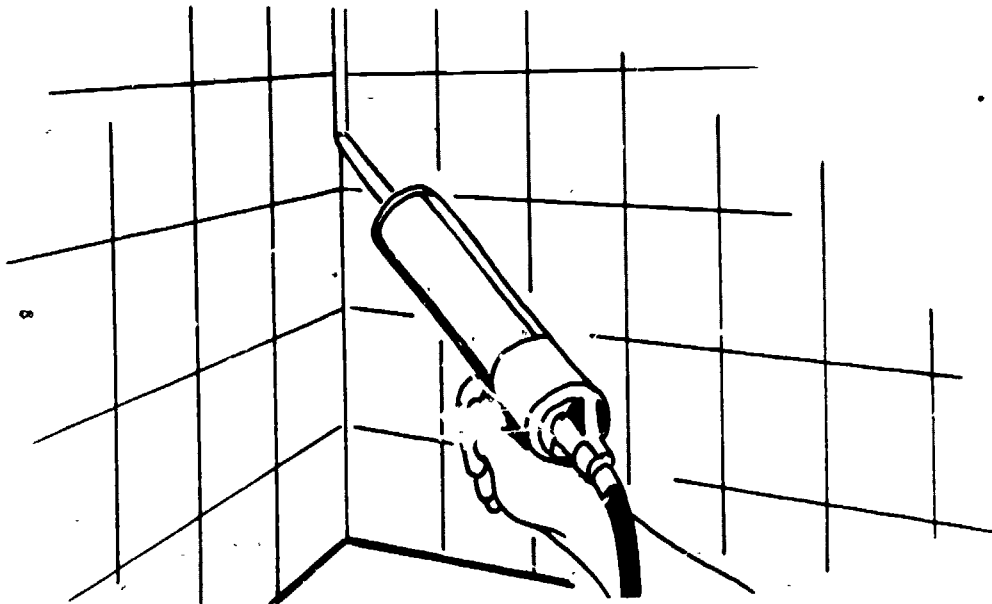

Caulking silicone sealers come in cartridges that fit into the caulking gun. The tilesetter uses the caulking gun mainly to fill the corners of tilework on walls around tubsplashes, showers, backsplashes and wainscots. To use:

1. Cut the end of the cartridge nozzle at an angle and put into gun.
2. Squeeze trigger with even pressure and apply sealer.
  - a. From top to bottom for corners. Try to use just enough to evenly fill the corner or edge.
3. Using your index finger as a tool, run it along the sealed corner or edge and evenly form the sealer.
4. Clean your finger off every 8 inches or so. This prevents the sealer from building up and flowing out onto the edges of the

tiles. Some sealers form better and easier if you dip your finger  
in denatured alcohol each time after cleaning it.



# Self Assessment

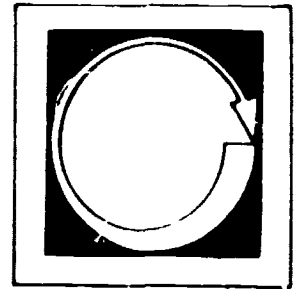

COMPLETE THE FOLLOWING STATEMENTS BY WRITING THE CORRECT WORD OR WORDS IN THE BLANKS PROVIDED.

1. \_\_\_\_\_ cleaners are designed to remove excess mortar from masonry and tile surfaces.
2. If an acid-based cleaner isn't thoroughly rinsed, it's possible the tile or grout joint could be permanently \_\_\_\_\_.
3. Acid etchers are used to prepare \_\_\_\_\_ surfaces for bonding tiles.
4. Whenever you are trying a new product, you should always test a \_\_\_\_\_ area first.
5. Grout joints, in normal conditions, \_\_\_\_\_ need to be sealed.
6. Quarry tile, pavers, and hand-made tiles should be \_\_\_\_\_, but don't necessarily have to be.
7. \_\_\_\_\_ are applied to unglazed tiles before grouting and are designed to keep the grout from staining the surfaces of the tiles.
8. Tiles should be totally \_\_\_\_\_ before applying sealer, or the dirt will be sealed in.

# Self Assessment Answers

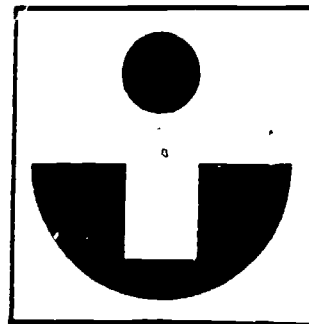

1. masonry
2. discolored
3. concrete
4. small
5. do not
6. sealed
7. grout releases
8. cleaned

# Assignment

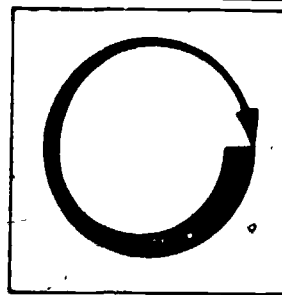

COMPLETE THE FOLLOWING ASSIGNMENT.

Go to a local tile installation shop or building supply store and pick the three different types of sealers listed below.

1. Silicone sealer in a spray can.
2. A one-or-two-coat liquid sealer; Watco Filler, wax, acrylic, Thompson's Water Seal, etc.
3. An oil-based sealer; lestoil, linseed oil or some other.

The sealers are to be tested in the Job Sheet.

# Job Sheet

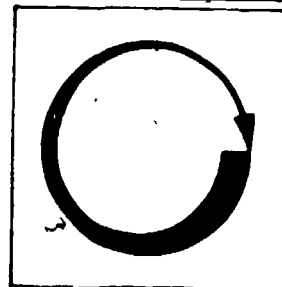

COMPLETE THE FOLLOWING TASKS.

## Materials and Tools

silicone in spray can

liquid sealer one-or-two-coat type

oil-based sealer

12 pieces of 6" X 6" unglazed quarry tile

2 paint brushes, one for each of the liquid sealers

access to water

a small amount of dark grout

a small amount of a masonry acid cleaner.

a dark color food dye.

1. Use the instructions given on the sealer's container and the information given in this module and seal four pieces of tile with each of the 3 types of sealers. Compare the sealed tiles and answer these questions:
  - A. What were the changes in the surfaces of the tiles--shiny, did it change the color? Explain for each different type of sealer.
  - B. What type of sealer do you think will be the most durable (the best) by looking at the tiles? Explain and give some reasons.
2. You have 12 sealed tiles--4 sealed with each type of sealer.

Test #1--Test 1 of each of the 3 types of sealed tiles by letting water stand on the surface for at least 1 hour, then clean off and dry.

Test #2--Test 1 of each of the 3 types of sealed tiles by letting a wet mixture of dark grout sit on the surface for at least 1 hour. Then clean with clean water, sponge and dry.

Test #3--Test 1 of each of the 3 types of sealed tiles by letting a small amount of masonry acid cleaner sit on the surface for at least 1 hour. Then clean with clean water, sponge and dry.

Test #4--Test 1 of each of the 3 types of sealed tiles by letting a small amount of dark food dye sit on the surface for at least 1 hour. Then clean with clean water, sponge and dry.

Write the results of what happened to the tiles after they were cleaned in the appropriate blanks on the test chart. Answer the questions concerning the tests in the Post Assessment.

TEST CHART

Impurities				
Sealer Type	Test #1 Water 1 hour	Test #2 Dark grout 1 hour	Test #3 Acid Cleaner 1 hour	Test #4 Food dye 1 hour
Silicone in a spray can				
	Tile #1	#2	#3	#4
One-or-two-coat type liquid sealer				
	Tile #5	#6	#7	#8

Oil-base Sealer				
	Tile #9	#10	#11	#12

# Post Assessment

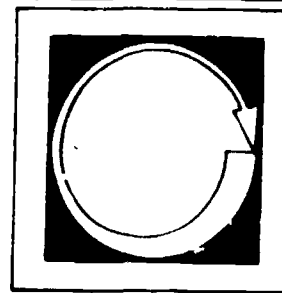

ANSWER THE FOLLOWING QUESTIONS FROM YOUR TESTS ON THE JOB SHEET.

1. What sealer was the most durable (best) and least durable (worst)? Explain.
  - A. Did any of the tiles stain? If so what was the type of sealer used and what was the impurity?
  - B. Did any, or all, of the sealers work for every impurity (no tile staining)? If so, which one(s)?
  - C. Did any, or all, of the tiles stain with a certain type of sealer?
2. Did any of the tiles with the same type of sealer on them react differently to the same impurity? If so, why do you think this happened?
  - A. Was the sealer applied differently?

LISTED BELOW ARE SEVERAL STATEMENTS. IF THE STATEMENT IS TRUE, PLACE A "T" IN THE BLANK PROVIDED. IF THE STATEMENT IS FALSE, PLACE AN "F" IN THE BLANK.

3.  Denatured alcohol is the type of alcohol found in booze.
4.  Something impure is unclean, dirty, not pure.
5.  A wainscot is a type of interior wall covered with the same finish from top to bottom.
6.  A squeegee has a rubber blade that is used for spreading, pushing, or wiping liquids.
7.  An etcher is a type of sealer used to seal concrete.



# Instructor Post Assessment Answers

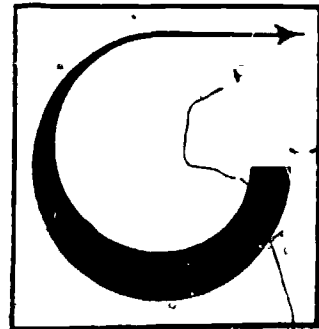

3. F Not for drinks, for cleaning
4. T
5. F Lower 3 or 4 feet of an interior wall finished differently.
6. T
7. F Etcher is used to etch--roughen up concrete.

## EXPANSION JOINTS

### **Goal:**

The student will be able to explain when and where to use expansion joints, and how to install them.

### **Performance Indicators:**

The student will successfully complete a Self Assessment, a Job Sheet and a Post Assessment.

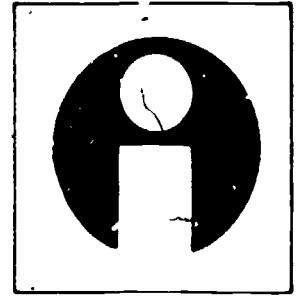

# Study Guide

In order to finish this module, do the following tasks. Check each item off as you complete it.

1.  Read the Goal and Performance Indicators on the cover of the module. This will tell you what you will learn by studying the module, and how you will show you've learned it.
2.  Read the Introduction. The Introduction will tell you why the module is an important part of the tilesetting trade.
3.  Study the Vocabulary section. Vocabulary words are important for a good understanding of the trade. After you have studied the vocabulary, ask your teacher to quiz you on the words and their meanings.
4.  Study the Information section. This section will give you the information you need to understand the subject.
5.  Take the Self Assessment exam. This is a test for you to prove to yourself that you have learned the material you have studied. Compare your answers with the answers on the Self Assessment Answer Sheet, which is on the page following the Self Assessment. If you scored poorly, re-study the Information section or ask your teacher for help.
6.  Do the Job Sheet. Follow the instructions at the top of the Job Sheet. The tasks listed on the Job Sheet will help you develop skills which will be helpful to you.
7.  Take the Post-Assessment exam. Give the exam to your teacher after you have completed it. Your teacher will grade it for you.

# Introduction

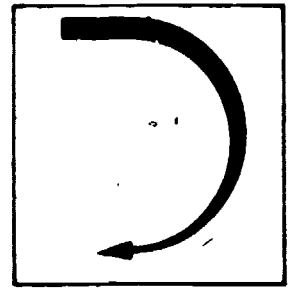

This module covers what expansion joints are and why they are needed, as well as the materials involved and the process to prepare and form one.

The tilesetter who knows what to look for and how to properly install a good expansion joint will avoid many potential tile installation problems and repairs.

# Vocabulary

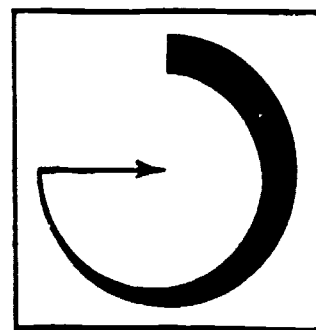

Trade terms are very important for a good understanding of the trade. Study these words and meanings. When you have learned them, ask your teacher to quiz you on the words and their meanings.

**ELASTOMERIC**--Resembling rubber; capable of easy expansion or contraction and resuming former shape.

**ON CENTER (O.C.)**--The distance from center to center, like from stud to stud or joint to joint.

**BUTT JOINT**--A joint made by parts (tile) end to end without overlap, regular tile joint.

**LAP JOINT**--A joint made by overlapping two ends or edges.

**SUBFLOOR**--The base floor, underneath the backing and the tile, also known as the substrate.

**STRUCTURAL JOINT**--A joint made by the structure of something coming together in two parts; meeting together.

**BASEBOARD**--A board (molding, trim) that covers the joint of a wall and adjoining floor; where the wall and floor come together at the bottom.

**PERIMETER**--The boundary of an area. The outer lines of an area.

**BUTYL RUBBER**--A synthetic rubber.

POLYETHYLENE--A thermoplastic that is resistant to chemicals and moisture,  
and has good insulating properties.

# Supplementary References

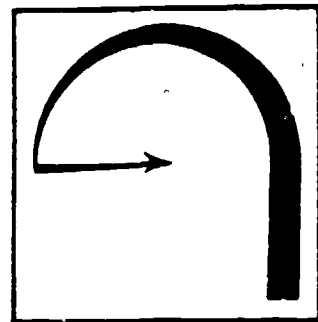

1. TILESETTING WORKBOOK. California Department of Education, 1975. pp. 61-70.
2. 1980 HANDBOOK FOR CER/MIC TILE INSTALLATION. Tile Council of America, Inc., 1980. p. 28.

# Information

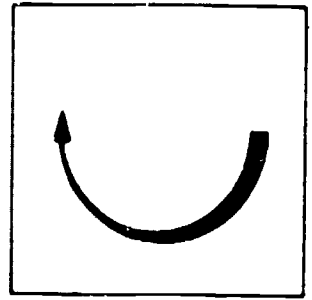

An expansion joint is a certain joint space that is filled with an elastomeric caulking sealant instead of grout.

Any structure, new or old, is constantly being subjected to vibrations, weight stresses and settling. Also, temperature changes create a certain amount of contraction and expansion in all types of building materials (including tile) to cause problems. Past and present failures in the tile installations (tiles popping up, cracking or splitting) can often be traced to the fact that expansion joints were not used.

A completed tile surface is a fixed, sound structure. To help keep it that way (free from failures), it has to have a certain amount of space to move so that the vibrations, weight stresses, settling, expansion and contraction won't cause any sort of tile failure.

The expansion joint allows the tiled surface to have a certain amount of space to move. Certain things should be thought about when allowing for "space" in which the tile surface may move. The tilesetter should consider carefully:

1. The size of joint.
2. The frequency of joints.
3. The backup strip filler.
4. The caulking sealant.

The tilesetter who considers each of these factors will be able to produce good expansion joints and avoid many of the most frequent problems.

## SIZE OF JOINT

The size of a butt (regular) joint can range from a minimum of 1/4" wide by 1/4" deep to a maximum of 1" wide by 1/2" deep. Anything deeper than 1/2" needs a



backup filler. A lap joint can be from 1/8" to 1/2" in width. The depth of all expansion joints should extend to the subfloor.

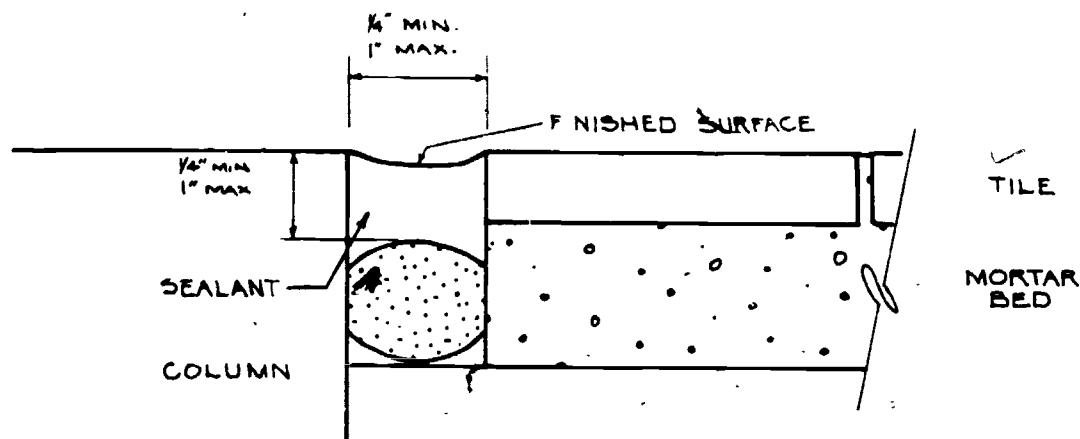

#### FREQUENCY OF JOINTS

Expansion joints are needed over any structural joints. In other words, anywhere there is a separation or change in the backing material: Like form concrete to plywood, steel to concrete, concrete slab to concrete slab, etc. An expansion joint is needed over the place where the two backings meet.

The expansion joint should never be narrower than the structural joint.

The expansion joints for exterior tile installations should be placed 16 ft. to 20 ft. on center. Interior tile joints should be placed 30 ft. to 40 ft. on center.

Expansion joints should also be placed on the perimeter (outside) of a horizontal tile surface (floor). On floors where a baseboard will cover the perimeter joint, the joint can be left unfilled.

#### BACK-UP STRIP FILLER

A back-up strip must be used to support the caulking sealant when the depth of the joint exceeds 1/2".

The back-up strip material should be a flexible and compressible type of closed-cell foam polyethylene or butyl rubber. It should be rounded on the top where it contacts the sealant. It must fit neatly into the joint without

compacting so it will not force the sealant out, and the sealant must not be able to bond to it.

A back-up strip should be used whenever possible to prevent the sealant from bonding to the subfloor, and because its cheaper than sealant.

#### CAULKING SEALANT

Regardless of how well designed the expansion joint may be, its success depends on the quality of the sealant used.

The sealant must be able to absorb all movements in the joint without rupturing and without separating from the side of the joint. It must seal out moisture, retain its color and keep these characteristics over a period of many years.

Caulking sealants made of silicore have proved to be the best; they are recommended for all interior and exterior applications.

#### PREPARATION

Tile edges must be thoroughly clean and dry. Sometimes the sealant manufacturer will have special recommendations on how to prepare the joint. Read and follow the instruction.

#### HOW TO FORM AND INSTALL

Expansion joints can be formed in two ways:

1. Setting the compressible back-up strip at the same time the mortar is floated.
2. Setting a removable wood strip to provide space for a backup strip after the mortar has cured.

Apply the sealant using a caulking gun, after the tile and grout are dry. (See the illustration on the following page.)

#### EXTERIOR JOINTS

Whenever the tile surface ends at a concrete curb or retaining wall, an expansion joint is needed. (See the 2nd illustration on the following page.)

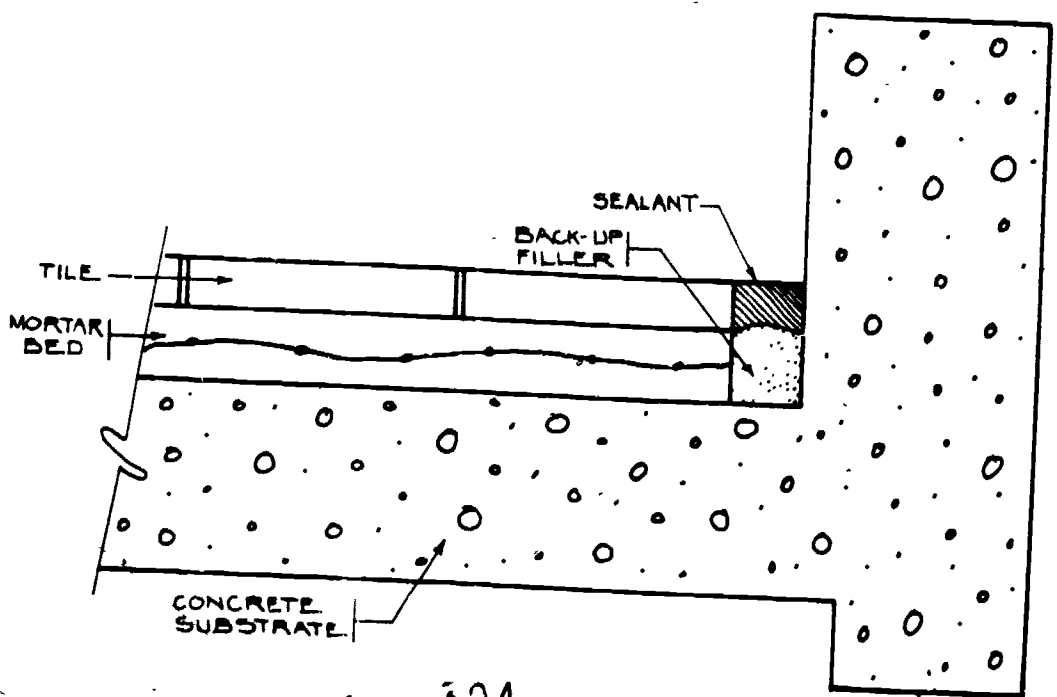
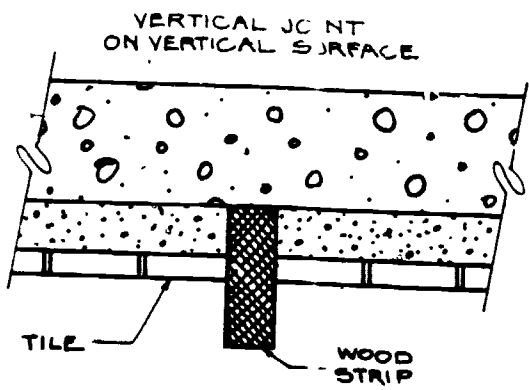
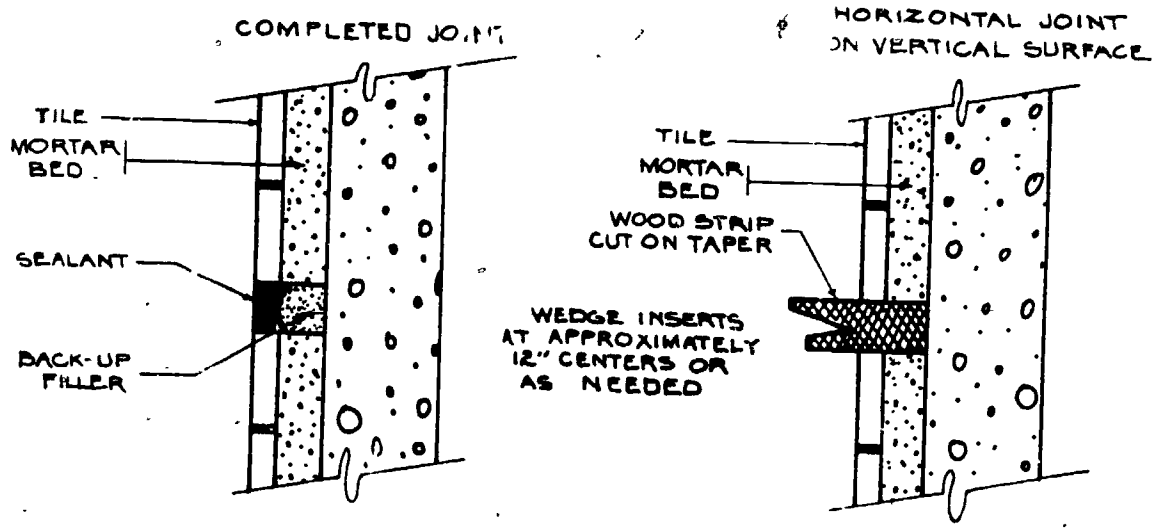

Exterior tile joints should be located every 16 ft. They should not exceed 20 ft. on center.

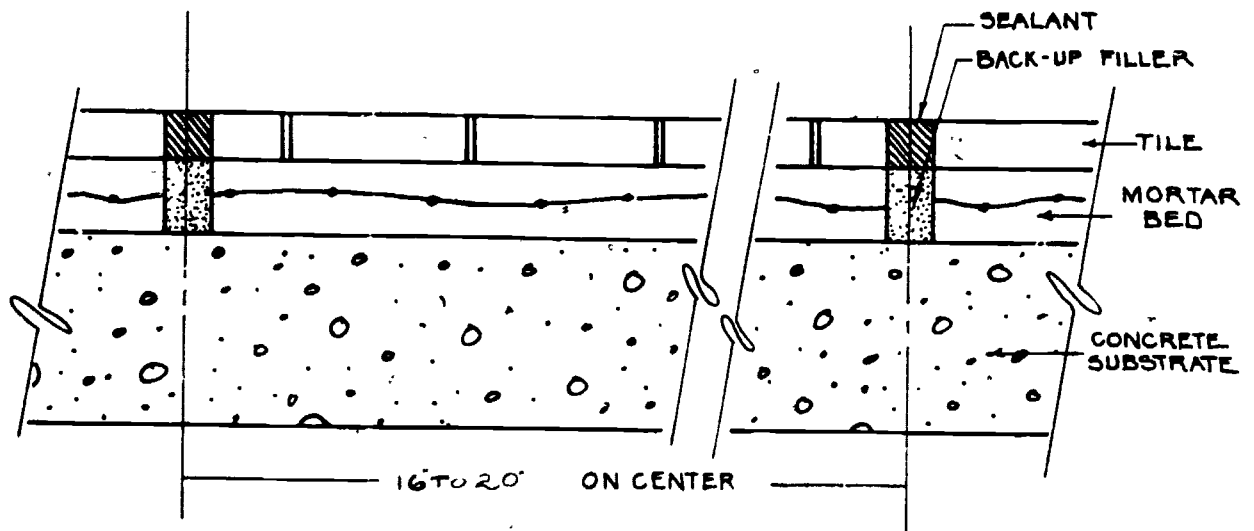

#### INTERIOR JOINTS

Interior tile joints can be placed every 30 ft. to 40 ft. on center.

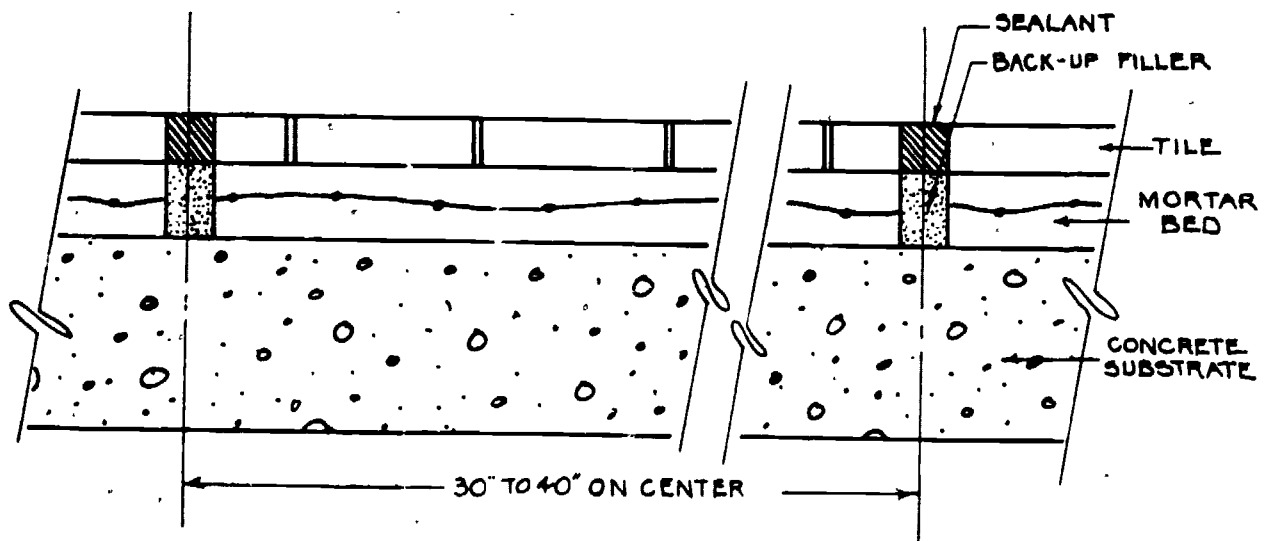

# POINTS OF INSTALLATION FOR EXPANSION JOINTS

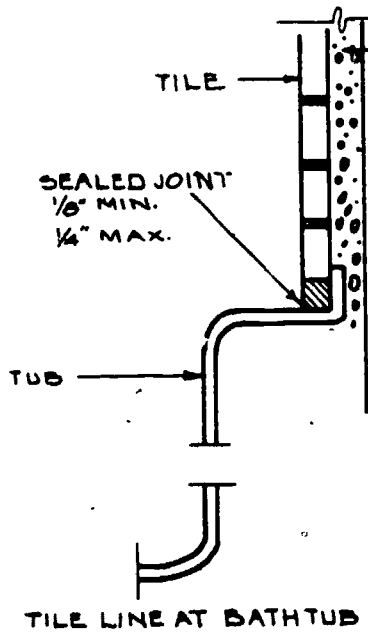

TILE LINE AT BATHTUB

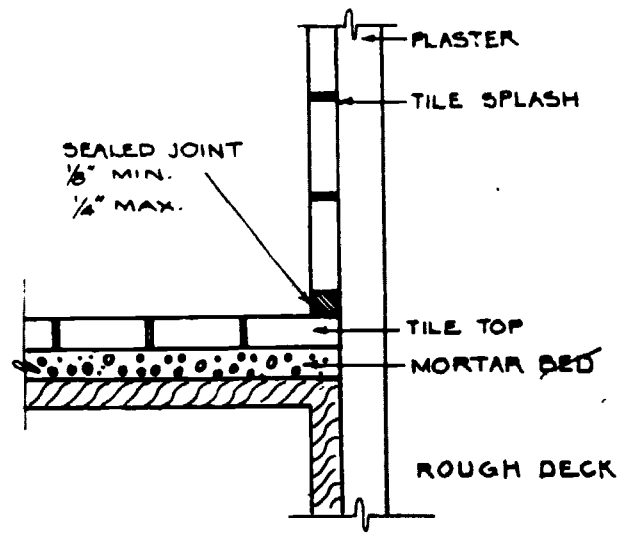

DECK AND SPLASH JOINT LINE

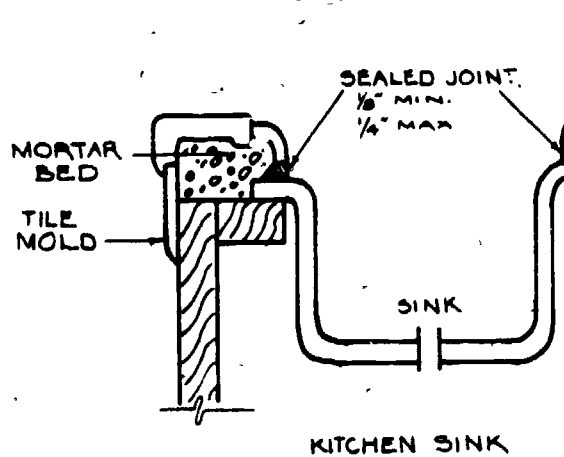
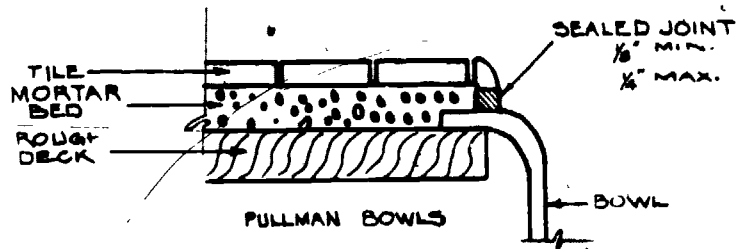

KITCHEN SINK

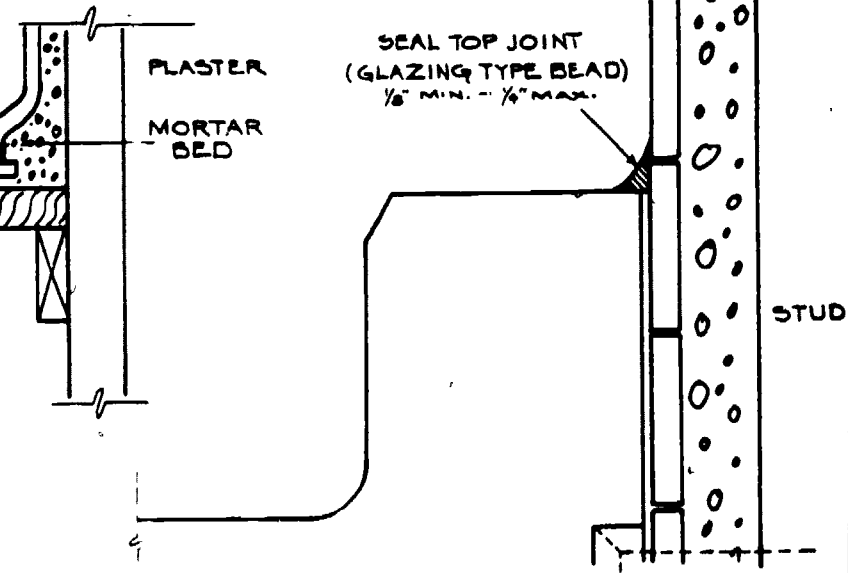

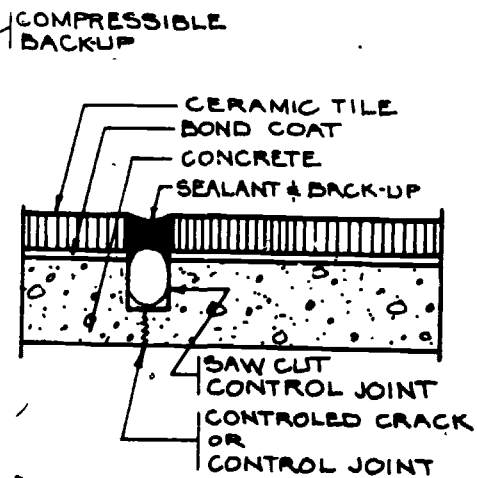
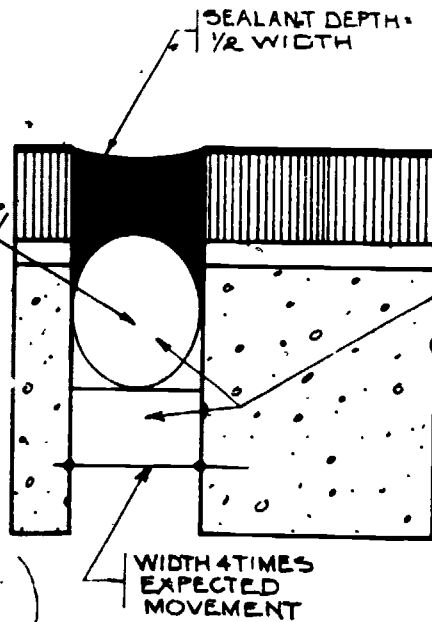
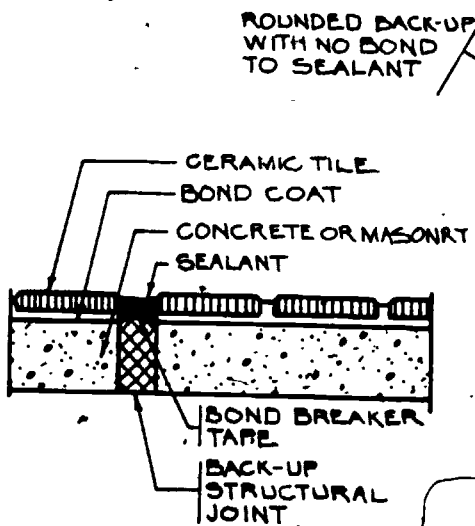
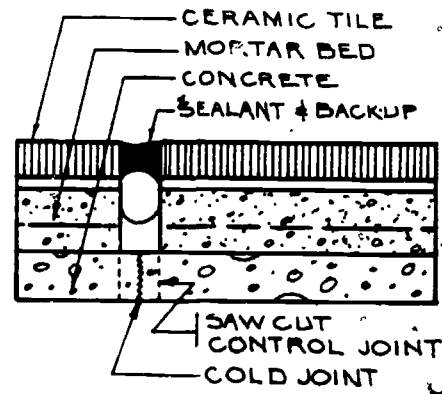
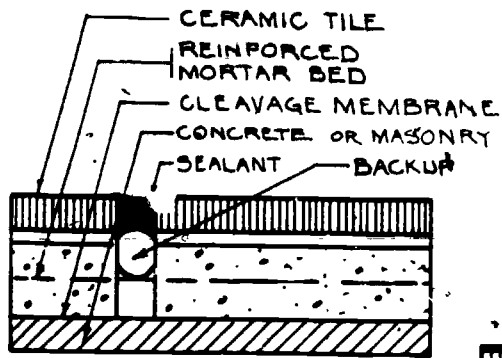

# Self Assessment

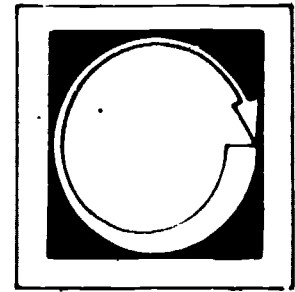

COMPLETE THE FOLLOWING STATEMENTS BY WRITING THE CORRECT WORD OR WORDS IN THE BLANKS PROVIDED.

1. Temperature changes create a certain amount of \_\_\_\_\_ and \_\_\_\_\_ in all types of building materials.
2. An expansion joint allows a tiled surface to have a certain amount of \_\_\_\_\_ to move.
3. A regular (butt) joint can range from a minimum of \_\_\_\_\_ inch wide to a maximum of \_\_\_\_\_ inch wide.
4. Any expansion joint deeper than \_\_\_\_\_ inch needs a back-up filler.
5. An expansion joint is needed over any \_\_\_\_\_ joint.
6. Exterior expansion joints should be placed \_\_\_\_\_ to \_\_\_\_\_ feet on center.
7. Interior expansion joints should be placed \_\_\_\_\_ to \_\_\_\_\_ feet on center.
8. On floors where a baseboard will cover the perimeter joint, the joint can be left \_\_\_\_\_.
9. The back-up strip material should be \_\_\_\_\_.
10. The caulking sealant must not be able to \_\_\_\_\_ to the backup material.

11. Caulking sealants made of \_\_\_\_\_ have proven to be the best.

12. The sealant should be applied \_\_\_\_\_ the tile and grout are dry.



# Self Assessment Answers

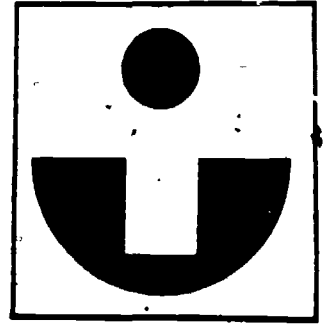

1. expansion and contraction
2. space
3.  $1/4$ " to 1"
4.  $1/2$ "
5. structural
6. 16' to 20'
7. 30' to 40'
8. unfilled, or empty
9. flexible, or compressible
10. bond
11. silicone
12. after

# Job Sheet

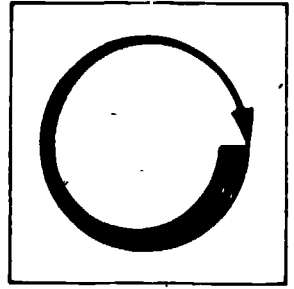

COMPLETE THE FOLLOWING TASK.

## Materials and Tools

8 pieces of the same size tile

1 cartridge colored silicone caulking sealant  
caulking gun

4' X 4' piece of backing material plywood, sheetrock, etc.

tile adhesive to bond the 8 tiles to the backing

denatured alcohol

toilet tissue or rags

1 appropriately sized notch trowel

1 margin trowel

### 1. Practice caulking and sealing joints:

A. On the piece of backing material, bond 4 of the tiles in a square pattern with a 1/4" wide joint, and the other 4 in a square pattern with a 1/2" wide joint.

B. After the tiles have set, practice sealing the joints with the colored silicone.

C. If your finger is too small to properly form the joint, try using the back of an old spoon or a 1"-diameter dowel.

# Post Assessment

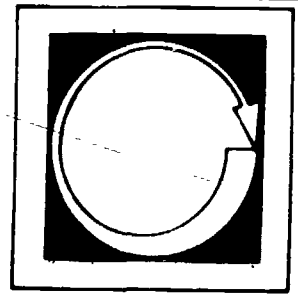

WRITE AN ANSWER TO THE FOLLOWING QUESTIONS.

1. Did you have any problems applying and forming the silicone sealant. Explain.
2. Was your joint smooth and fairly flush with the surface of tiles?
3. Did the denatured alcohol help you form and smooth the joint?

LISTED BELOW ARE SEVERAL STATEMENTS. IF THE STATEMENT IS TRUE, PLACE A "T" IN THE BLANK PROVIDED. IF THE STATEMENT IS FALSE, PLACE AN "F" IN THE BLANK.

4. \_\_\_ An elastomeric material is one which can expand and contract and resume its former shape.
5. \_\_\_ A baseboard is used as a backing for tile surfaces that need expansion joints.
6. \_\_\_ The base floor, the floor underneath the backing is called the subfloor.
7. \_\_\_ A lap joint is made by materials coming together end-to-end.

8. \_\_\_\_ A butt joint is made by overlapping ends or edges.
9. \_\_\_\_ The distance from center to center of something is called on center.
10. \_\_\_\_ The distance from the outer edges to the center of something is known as the perimeter distance.
11. \_\_\_\_ A structural joint is made by the structure of something coming together in two parts.
12. \_\_\_\_ Polyethylene is a synthetic rubber.

# Instructor Post Assessment Answers

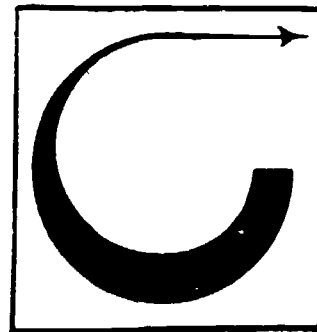

4. T
5. F Used as a base molding.
6. T
7. F Overlapping ends or edges.
8. F Materials come together end to end.
9. T
10. F The boundary of an area.
11. T
12. F Is a thermoplastic.

## TILE LAYOUT

### **Goal:**

The student will learn the importance of good tile layout, how tile layouts are planned, how showers are squared, and how to use a diagonal layout.

315

### **Performance Indicators:**

The student will successfully complete a Self Assessment, a Job Sheet and a Post Assessment.

320

# Study Guide

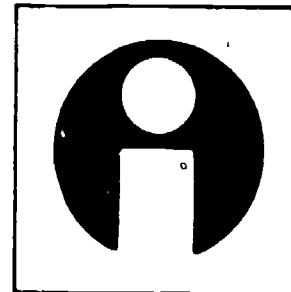

In order to finish this module, do the following tasks. Check each item off as you complete it.

1.  Read the Goal and Performance Indicators on the cover of the module. This will tell you what you will learn by studying the module, and how you will show you've learned it.
2.  Read the Introduction. The Introduction will tell you why the module is an important part of the tilesetting trade.
3.  Study the Vocabulary section. Vocabulary words are important for a good understanding of the trade. After you have studied the vocabulary, ask your teacher to quiz you on the words and their meanings.
4.  Study the Information section. This section will give you the information you need to understand the subject.
5.  Take the Self Assessment exam. This is a test for you to prove to yourself that you have learned the material you have studied. Compare your answers with the answers on the Self Assessment Answer Sheet, which is on the page following the Self Assessment. If you scored poorly, re-study the Information section or ask your teacher for help.
6.  Do the Job Sheet. Follow the instructions at the top of the Job Sheet. The tasks listed on the Job Sheet will help you develop skills which will be helpful to you.
7.  Take the Post Assessment exam. Give the exam to your teacher after you have completed it. Your teacher will grade it for you.

# Introduction

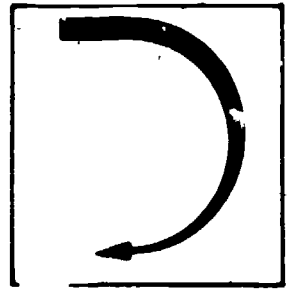

A proper tile layout will increase the beauty of a finished tile job. Mistakes in layout are easy to see and mar the beauty. Tilers must master layout processes if they are to succeed in the trade.

This module covers the processes involved in various tile layouts.



# Vocabulary

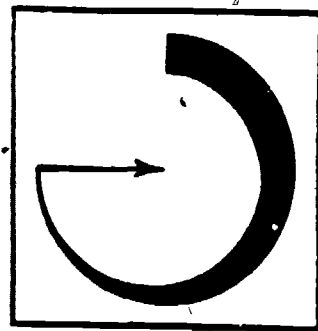

Trade terms are very important for a good understanding of the trade. Study these words and meanings. When you have learned them, ask your teacher to quiz you on the words and their meanings.

**FIELD TILE**--An area of tile-covered surface; field tile is bordered by trim tile.

**OUTCORNER**--A corner that runs out in two directions, usually at a 90° angle.

**PARALLEL**--Extending in the same direction, everywhere the same distance apart, never meeting.

**DUTCHMAN CUT**--A tile cut used as a filler in the run of a wall or floor area.

**FIVE-POINT HEXAGONAL CUT**--One with five points, larger than a three point cut; a half cut is a five-point cut.

**MITER**--A surface forming the beveled edge of material where a joint is made, like tile or wood.

# Supplementary References

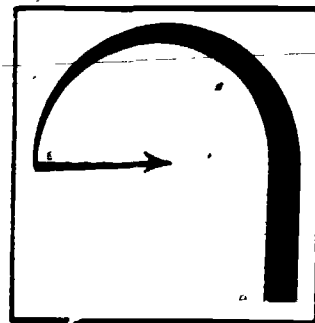

Typesetting Workbook. California Department of Education, 1975. pp. 95-100,  
112-113, 119-121.

# Information

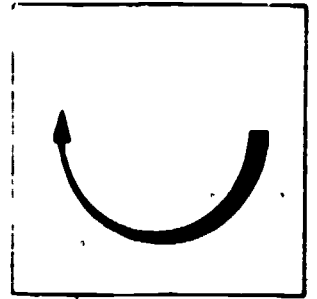

## CENTERING TILE ON WALLS

To center tile in a course on a vertical surface, the tiler must first determine the number of tiles it will take to fill the course. One of the ways this is done is by measuring the distance across the wall, then laying a course of tile with the proper joint size on the floor and measuring to see the size of cut needed. Another way is to exactly center the tile on the area to be covered. This layout results in an even number of full-size tiles and cuts. The center line of the course is on a joint, but the course may come out with less than half a tile at each end.

Whenever possible, no tile should be cut smaller than half its size.

Shifting one of the middle tiles over from the joint to the center of the tile course will result in end cuts of half a tile plus the size of the old cut. For example, if  $4\frac{1}{4}$ " tiles are used and the layout results in  $1\frac{1}{2}$ " cuts on each end of the wall, shifting the center tile by half a tile will give cuts at each end of the wall of  $2\frac{1}{8}$ " plus  $1\frac{1}{2}$ ", or  $3\frac{5}{8}$ ". (See the illustration on the following page.)

When the tiler is working with decorative tile that has a continuous pattern, he or she should start setting tile on the adjoining wall (in the corner) with the piece of tile cut off from the previous wall; otherwise, the pattern will not match.

When working on two walls that run from an outcorner, the tiler should begin at the outcorner with full-size tiles and proceed to the ends of the walls, unless the tile at the other end of the course would end up as less than half a tile. In that case, the tiler should handle the situation like any other centering problem covered earlier.

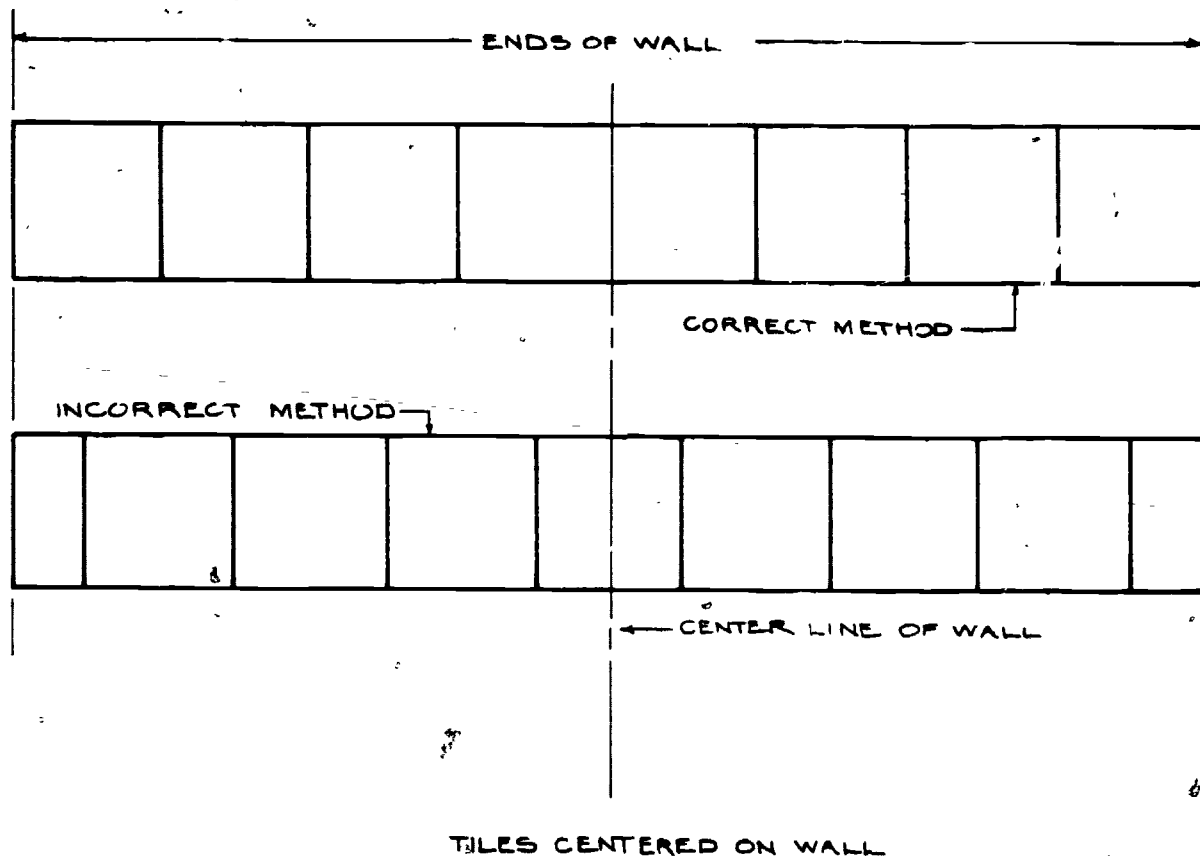

The tilesetter should always follow the "larger-than-half-tile" rule when laying out tile on a vertical surface.

#### SQUARING A SHOWER

The tile shower is one of the "bread and butter" items of the tilesetter's trade. A tilesetter who can install a tile shower successfully regardless of the shape or size is in constant demand.

There are basically two types of showers: 1) A shower with door jambs, 2) a shower without door jambs, called a three-wall shower.

The procedure for squaring a shower with door jambs is:

1. With your (preferably) 4' level, check for plumb of wall A at the shower entrance. Determine points (if any) where the wall is out of plumb. (See the illustration at the top of the next page.)

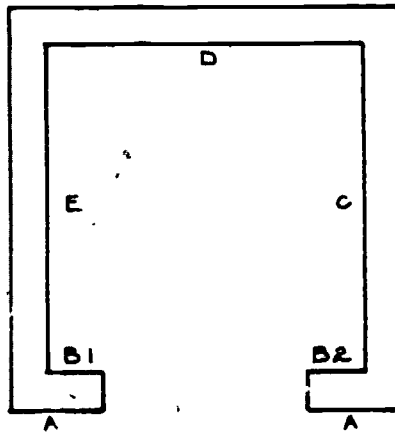

2. Hold straightedge #1 across the opening, and secure by nailing straightedges #2 and 3 on the face of the jambs the same distance from straightedge #1. Straightedges #2 and 3 must be same length.

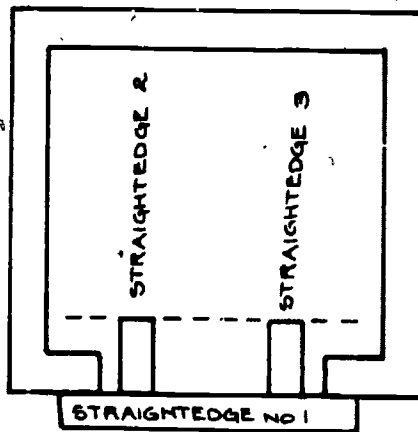

3. Set float strips on wall D the same distance from straightedges #2 and 3. Always plumb the float strips. You will learn how to set and plumb float strips in a later module

(See the illustration on the top of the next page.)

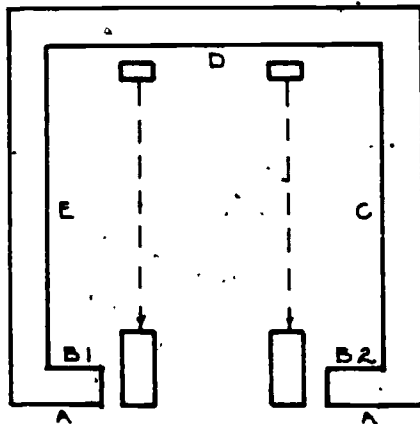

- Use framing square and appropriate length straightedges #4 and 5 to set float strips on wall E square to wall D. Use straightedges and square to see if jamb edge B<sup>1</sup> is square with wall E.

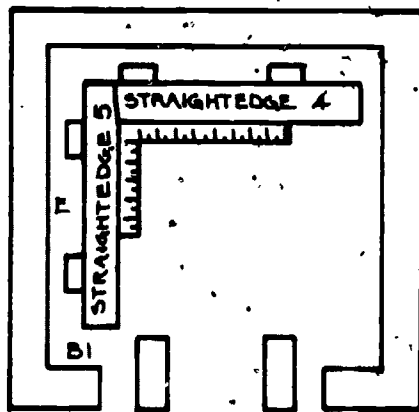

- Use framing square and straightedges #4 and 5 to set float strips on wall C square to wall D. Use tape measure to make sure float strips on wall C are parallel to float strips on wall E. Measure from top to bottom on the float strips. Use

straightedges and square to see if jamb edge B<sup>2</sup> is square with wall C.

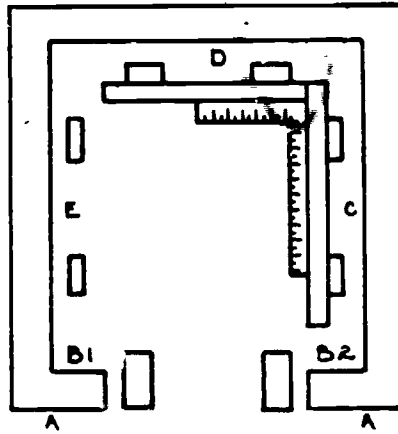

6. If the level, framing square, tape measure and straightedges have been used correctly, you will have a square window. Always doublecheck your readings. Adjustments may need to be made.

The procedure for squaring a 3-wall shower is as follows.

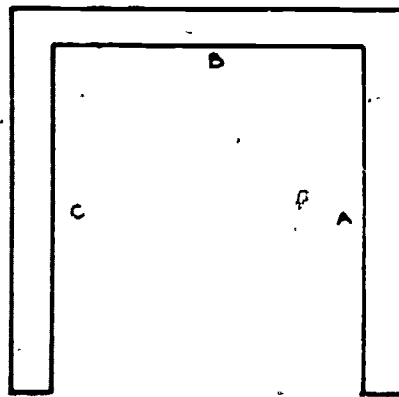

1. Hold or temporarily secure straightedge #1 across the shower opening, set float strips on wall B the same distance from straightedge #1. Plumb the float strips.

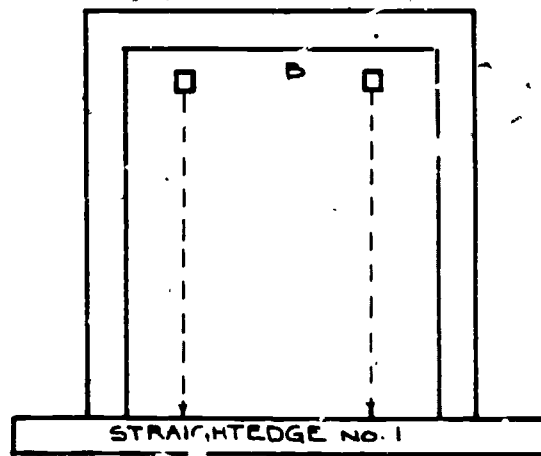

2. Remove straightedge #1. From here, the procedure is the same as before. Use square and straightedges to set float strips on walls A and C square to wall B, and use tape measure to make sure float strips on walls A and C are parallel.

### SETTING TILE DIAGONALLY

Tiles can be set diagonally for backsplashes, walls, ceilings and floors. There are two main reasons why tiles are set diagonally:

1. It can give a very nice decorative effect.
2. On floors and ceilings it can give a nice effect, while preventing the tilesetter from having to match the wall joints with some very bad-looking tile cuts.

Always start a diagonal layout with diagonal half cuts. A diagonal half cut of a  $4 \frac{1}{4}'' \times 4 \frac{1}{4}''$  piece of tile is 6" long from end to end.

All horizontal areas that are laid in a diagonal pattern should be centered in the same way that vertical surfaces are centered. The end cuts should be larger than half. (Diagonal cuts are made on the tile cutting board by properly adjusting the angle guide.)



Some tilesetters prefer a straight tile border around their diagonal floor or ceiling. If the floor or ceiling has a border and the wall is also tiled, the border should be set so that its joints fall at the same places as the joints of the wall tile. Then the diagonal layout should be started by butting the diagonal half cuts against the border.

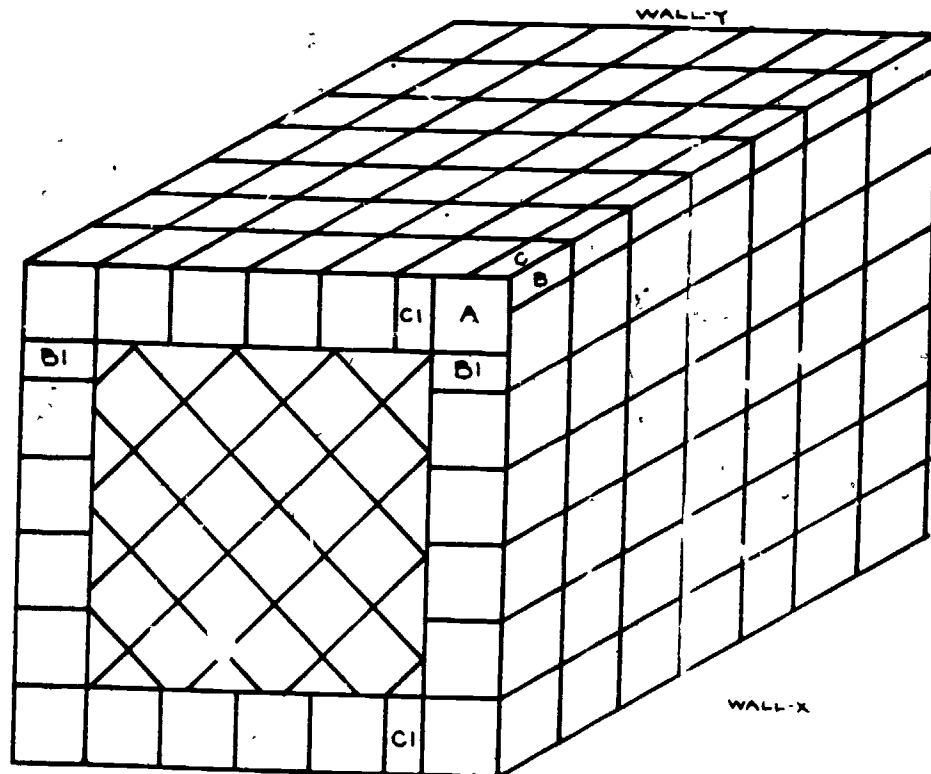

#### CLOSING DECORATIVE TILE

When tile with a continuous pattern overlaps to such an extent that it cannot be corrected by spreading or narrowing the joints, the tilesetter should cut an equal amount off the last two tiles that finish the complete border around the pattern. This will close the pattern. For example, when a tile with a swirl pattern is being set in place, the last two tiles should be cut; this will create a lesser swirl, but the remaining tiles will match. (See the illustration on the top of the next page.)

A closure formed by cutting only one tile is referred to as a "Dutchman cut." They should be avoided.

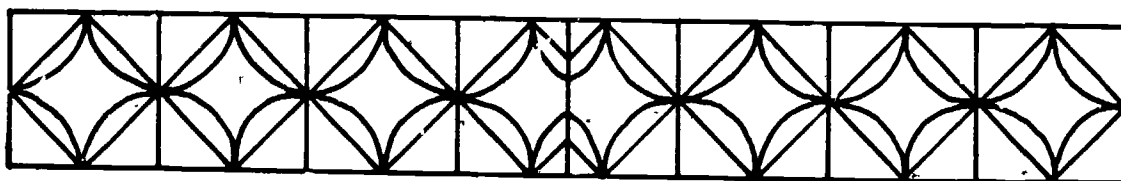

CLOSURE IN DECORATIVE TILE WITH CONTINUOUS PATTERN

All the courses of tile should be cut at the same place so that the joints will line up.

#### LAYING OUT HEXAGONAL TILE

When setting hexagonal tile, the tilesetter should use the same procedure as for diagonal layouts. The pattern should be started with half cuts.

If the cuts on the tile edges eventually result in tiles that are smaller than halves or five-point cuts, the next course can be converted into elongated hexagons that are cut to fit.

Five-point cuts or full halves then can be used along the edges.

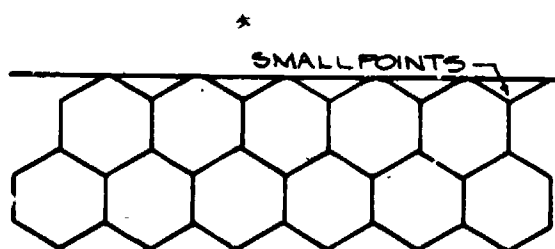

INCORRECT METHOD

#### ELONGATED HEXAGON MADE BY CUTTING

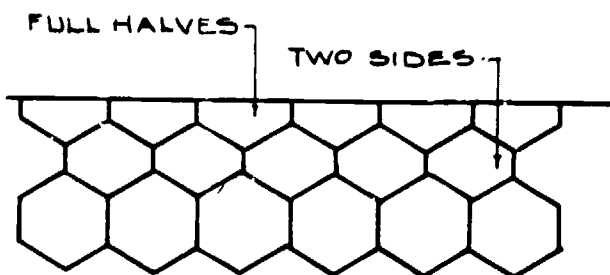

CORRECT METHOD

## LAYING OUT A CLOSURE

A closure is used when tile is to be set around a door or window. The tile-setter can use a full tile or a large tile cut around the opening.

To lay out a closure, center the opening and set the equal sized cuts at the center of the opening or at either side of the door or window. If a ceiling is to be tiled, a closure cannot be used.

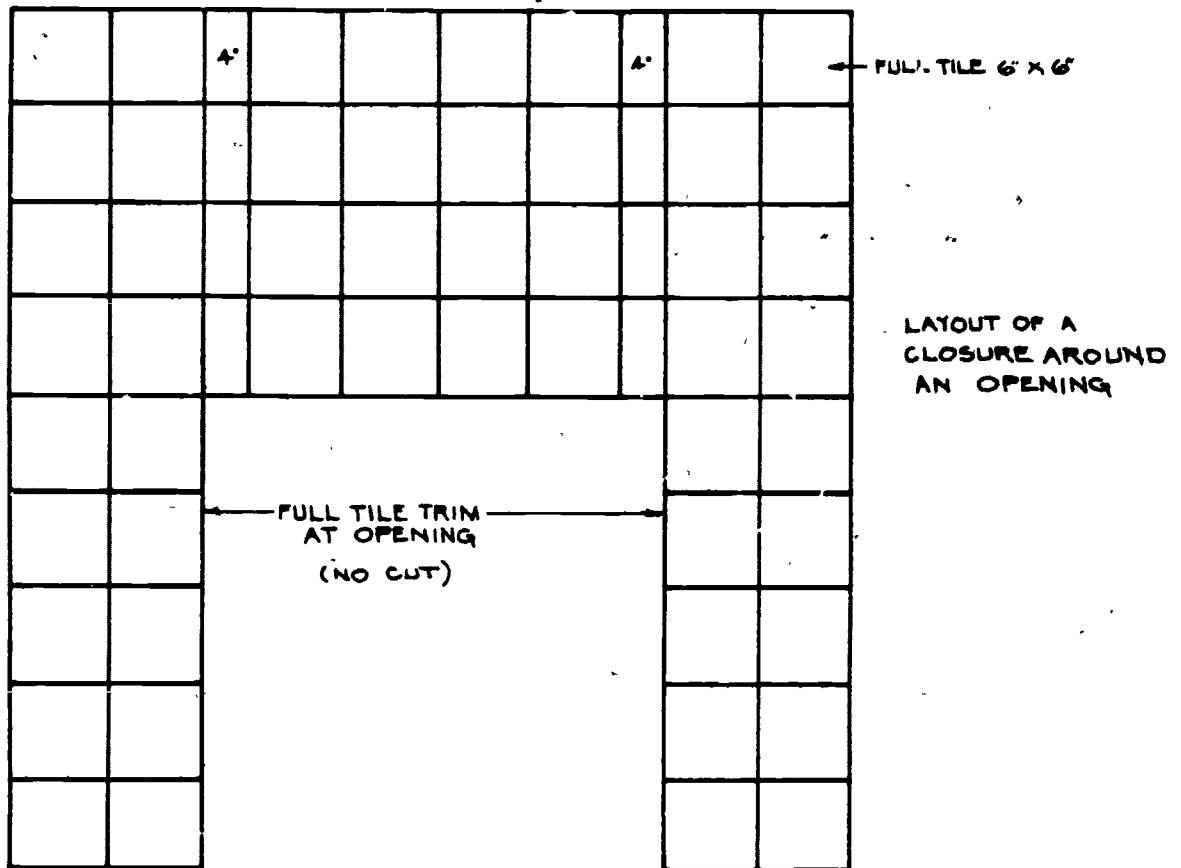

## FITTING DECORATIVE TILE AT CORNERS

To set decorative or sculptured tiles, the tilesetter must decide how to make the design look as good as possible in the corners.

When these tiles meet in the corner between two walls, the joint does not look good if the tiles are cut square or butted. The tilesetter can do one of two things to make the tiles look good in the corners.

1. Use plain tile for the cuts at the corners.
2. Miter the corner tiles. A good miter job usually gives the best looking corner. (See the illustration on the top of the next page.)

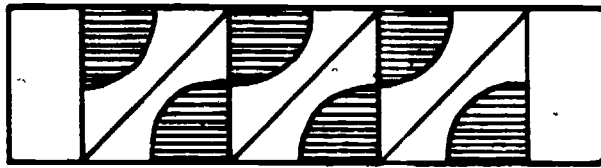

PLAIN CUTS AT CORNERS

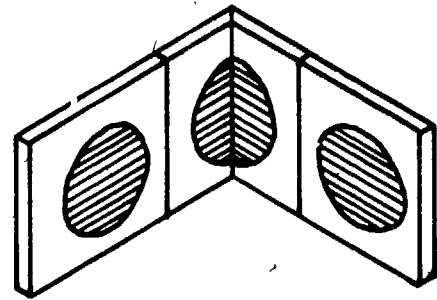

MITERED CORNERS

#### DETERMINING WIDTHS OF JOINTS

When sheets of paper or nylon mesh-mounted ceramic mosaic tiles are being laid, the mounted width should be maintained between sheets. All other tiles should be installed with joint widths shown below:

#### JOINT SIZES FOR TILE

<u>Size and Type of Tile</u>	<u>Joint Size</u>
Mounted, 2 3/16" square or smaller	1/16" to 1/8"
Mounted, larger than 2 3/16" square	1/16" to 1/4"
Unmounted, 2 3/16" to 4 1/4" square	1/16" to 1/4"
Unmounted, 6" X 6" and larger	1/4" to 3/4"
Quarry tile, unmounted	1/4" to 3/4"
10" X 10' and larger and large hand-made tile	3/8" to 3/4"

The widths should not vary from those shown in the table, unless you are required to do so, either by specifications or by the architect. Variations in joint widths may be made by a skilled tilesetter who determines that the tile will layout and look better if he or she varies the joint size.

# Self Assessment

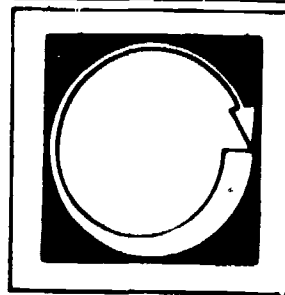

COMPLETE THE FOLLOWING STATEMENTS BY WRITING THE CORRECT WORD OR WORDS IN THE BLANKS PROVIDED.

1. To center tile in a course, the tilesetter must first determine the number of \_\_\_\_\_ it will take to fill the course.
2. Whenever possible, no tile should be cut smaller than \_\_\_\_\_ its size.
3. If the end cuts are smaller than halves, the tilesetter can \_\_\_\_\_ the center tile over by \_\_\_\_\_ a tile to make the cuts larger than halves.
4. With continuous pattern decorative tile, the tilesetter should start setting tile on the adjoining wall (in the corner) with the \_\_\_\_\_ of \_\_\_\_\_ cut off from the previous wall. Otherwise, the pattern will not match.
5. A tilesetter who can successfully install a tile \_\_\_\_\_ <sup>9</sup> is in constant demand.
6. The tilesetter needs to correctly use the level, square, tape measure and straightedges to successfully \_\_\_\_\_ a shower.
7. A diagonal pattern can prevent the tilesetter from having to \_\_\_\_\_ joints.
8. Always start a diagonal layout with diagonal \_\_\_\_\_ cuts.

9. If a tilesetter needs to cut continuous pattern tile to make it fit, he or she should cut an equal amount off the \_\_\_\_\_ tiles.
10. When setting hexagonal tile, the tilesetter should use the same procedure as the one for \_\_\_\_\_ layouts.
11. A \_\_\_\_\_ is used when tile is to be set around a door or window.
12. No tile joint should ever be smaller than \_\_\_\_\_ of an inch and larger than \_\_\_\_\_ of an inch in width.

# Self Assessment Answers

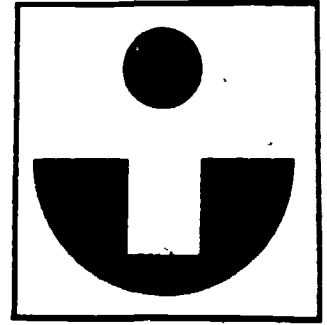

1. tiles
2. half
3. shift or move, half
4. piece, tile
5. shower
6. square
7. match
8. half
9. last two
10. diagonal
11. closure or Dutchman
12.  $1/16''$ ,  $3/4''$

# Job Sheet

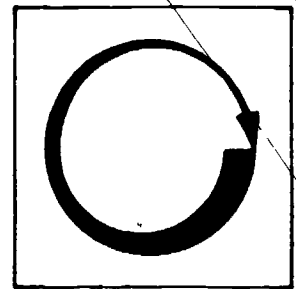

COMPLETE THE FOLLOWING TASK.

## Materials and Tools

tile cutting board

piece of backing, from 2' X 2' to 4' X 4' in size

appropriately sized notch trowel

tape measure and pencil

enough 4 1/4" X 4 1/4" field tile to cover backing

enough tile adhesive to bond tile to backing

margin trowel

bucket, if needed for tile adhesive

beating block and mallet

Practice laying diagonal floor on the backing you have selected. Set the tiles, using a diagonal pattern. Start with diagonal half cuts along one of the edges of the backing and lay out so the end cuts are larger than half size. Complete pattern from there. Beat tiles into the adhesive for a good bond.



# Post Assessment

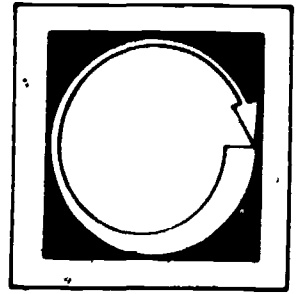

WRITE AN ANSWER TO THE FOLLOWING QUESTIONS.

1. Did you run into any problems laying out and setting the diagonal pattern? Explain.
2. Can you successfully make straight diagonal half cuts?
3. What was the smallest size cut you had to make to complete the pattern?
4. Would you lay out and set the diagonal pattern differently if you were to do it again? If so what would you do differently?

LISTED BELOW ARE SEVERAL STATEMENTS. IF THE STATEMENT IS TRUE, PLACE A "T" IN THE BLANK PROVIDED. IF THE STATEMENT IS FALSE, PLACE AN "F" IN THE BLANK.

5. \_\_\_\_ An outcorner is one that runs out in two directions, usually at a  $90^\circ$  angle.
6. \_\_\_\_ A Dutchman cut is a diagonal cut larger than half size, used as a starting cut for a diagonal pattern.

7. \_\_\_\_ A miter cut is one that is beveled and forms a joint.
8. \_\_\_\_ Field tile is normal-edged tile which is bordered by trim tile.
9. \_\_\_\_ Two lines that perfectly intersect and make four equal quadrants (sections) are parallel lines.
10. \_\_\_\_ A half-hexagonal cut is a five-point cut.

# Instructor Post Assessment Answers

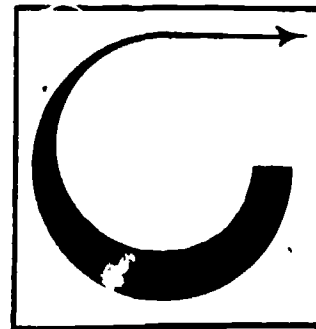

5. T

6. F

7. T

8. T

9. F

10. T

## HOW TO GROUT

### **Goal:**

The student will be able to properly select and apply grout to different types of tile, and clean the job properly.

### **Performance Indicators:**

The student will successfully complete the Self Assessment, the Job Sheet, and the Post Assessment.

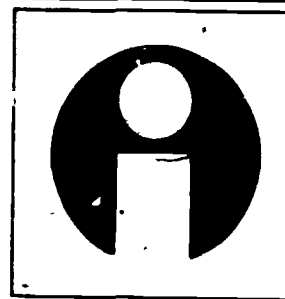

# Study Guide

In order to finish this module, do the following tasks. Check each item off as you complete .

1.  Read the Goal and Performance Indicators on the cover of the module. This will tell you what you will learn by studying the module, and how you will show you've learned it.
2.  Read the Introduction. The Introduction will tell you why the module is an important part of the typesetting trade.
3.  Study the Vocabulary section. Vocabulary words are important for a good understanding of the trade. After you have studied the vocabulary, ask your teacher to quiz you on the words and their meanings.
4.  Study the Information section. This section will give you the information you need to understand the subject.
5.  Take the Self Assessment exam. This is a test for you to prove to yourself that you have learned the material you have studied. Compare your answers with the answers on the Self Assessment Answer Sheet, which is on the page following the Self Assessment. If you scored poorly, re-study the Information section or ask your teacher for help.
6.  Do the Job Sheet. Follow the instructions at the top of the Job Sheet. The tasks listed on the Job Sheet will help you develop skills which will be helpful to you.
7.  Take the Post Assessment exam. Give the exam to your teacher after you have completed it. Your teacher will grade it for you.

# Introduction

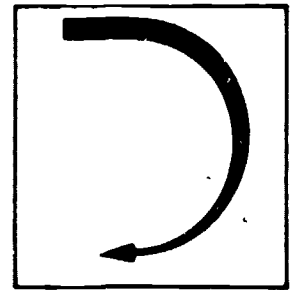

Grouting, or filling the tile joints, is a very important procedure. A poor grouting job can ruin the appearance of any tilework.

In this module you will learn how to apply the grout and use the various cleaning methods for portland cement-based grouts.

A good grout job is a critical step toward a professional looking finished tile job.

# Vocabulary

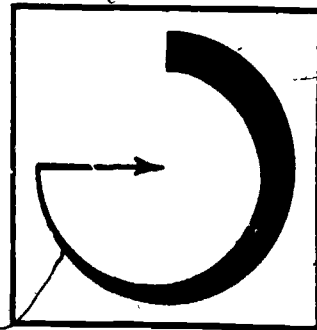

Trade terms are very important for a good understanding of the trade. Study these words and meanings. When you have learned them, ask your teacher to quiz you on the words and their meanings.

**STRIKING**--The process of removing excess grout and pressing the grout further into the joint with a tool.

**BURLAP**--A course, heavy, plain-woven fabric. Often used for feed and seed bags.

**CHEESECLOTH**--A lightweight soft cotton cloth.

**BLEACH**--To make whiter or lighter, especially by using chemicals.

# Supplementary References

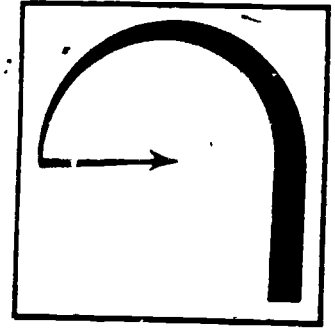

1. Tilesetting Workbook. California Department of Education, 1975. pp. 54-57.
2. How to Install Ceramic Tile Counter Tops. American Olean Co., 1980. pp. 5, 7, 11, 14.

346

341



# Information

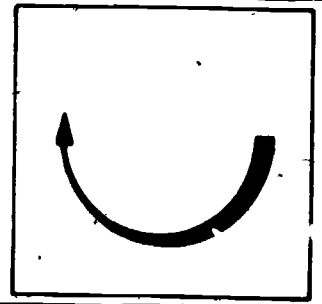

A grout joint can be considered good and correct only when these five standards are met:

1. Uniform in color.
2. Cured to the maximum possible hardness.
3. Smooth without pinholes, high or low spots.
4. Finished flush to the top of square-edged tile and finished slightly recessed with cushion-edged tile.
5. Clean--there should be no grout on the face of the tile when the job is done.

## WHEN TO GROUT

It is necessary to wait at least one day for most tile adhesives to set and firm up before grouting. When grouting floor tile, it is best to wait two days before grouting. When mastic is used for bonding ceramic wall tile, it is possible to grout as soon as the tile has been applied.

## METHODS OF APPLYING GROUT

There are three methods:

1. Rubber grout float
2. Grout bag
3. Margin trowel

### Rubber grout float

The rubber grout float is the tool most often used to apply grout.

#### To use

1. Mix the grout to the proper creamy consistency
2. For walls, put some grout onto the float before spreading. For floors, put the grout directly on the floor.

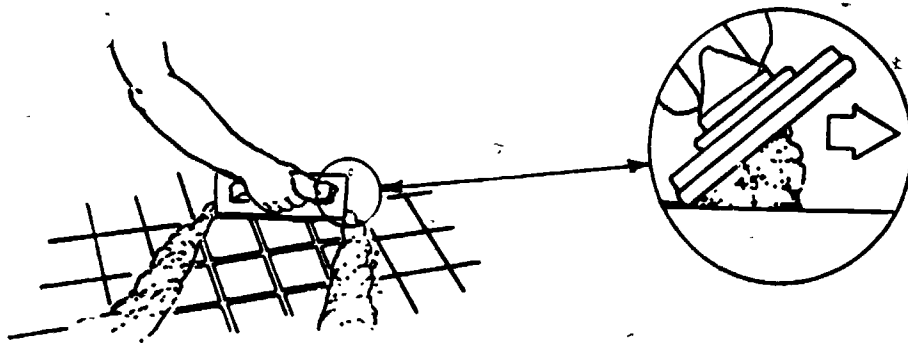

3. With one edge of the float slightly tilted up, force the grout deep into the tile joints by running the float across the joints diagonally.
4. The joints should be full, with no holes, before finishing the spreading.
5. Remove excess grout from tile with the float after filling the joints.

#### Grout bag method

The grout bag is used mostly for filling brick or stone joints, but is sometimes used for tilework. It is used to fill joints without getting grout on the tile surface. It is not used much because it is slower and most tile surfaces can easily be cleaned. A grout bag may be used for tiles with ridged surfaces or grooves in which grout could easily bond and be almost impossible to clean.

#### To use

1. Fill grout bag with properly mixed grout (it may need to be wetter).
2. Squeeze grout from the bag and into the joint, slightly overfilling the joint.
3. Let the grout firm up a bit (not set up).

4. To assure maximum joint compaction, strike the joints. A wood spatula can be used for a flush joint; a wood dowel can be used for slightly recessed joints.

#### Margin trowel method

The margin trowel is not a specific grouting tool. It is a good tool to use to force grout into joints that the rubber float won't reach, like under some cabinets, ledges or corners. It's used like the rubber float is used.

#### Before cleaning

Before you begin to clean, always check grout joints by pressing with your finger. The joints should feel "firm" to "hard."

Generally, the narrower the joint is, the faster the grout sets up. The wider the joint, the slower it sets up. (Refer to the module titled "Grouts" to match the proper grout with the width of joint and type of tile.)

If cleaning begins when the grout is too soft, it is likely that some of the grout will be washed away, leaving a low, recessed joint. If cleaning begins when the grout has set too long and is too hard, it can be very difficult and take a lot of time to clean.

#### Cleaning methods

There are four main methods used to clean grout joints and tile:

1. Sponge-polish cloth
2. Dust-burlap-sawdust-sponge
3. Sponge-drag cheesecloth
4. Acid clean-haze

#### Sponge-cheesecloth

This method is the most often used for cleaning grout. It can be used for any type of tile under any circumstances. Certain "tile-grout-area" conditions may mean that another method could be faster and more efficient, but this method is used most often.

#### To perform

After grout has been applied and firmed up:

1. Fill a large bucket with clean water.
2. With a hand-sized sponge, remove grout film by washing diagonally.

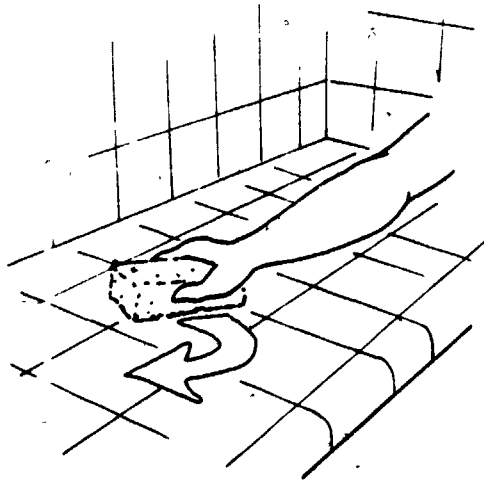

3. Rinse sponge frequently in bucket of clean water.
4. Wipe joints as smooth--and tile as clean--as possible. The sponge should be squeezed fairly dry (damp) before cleaning. If it is too wet, it can cause the joints to soften up again.
5. It is best to keep the water in the bucket fairly clean. In a large area, or with dark grout, the water should be changed often.
6. Finally, wait until the remaining grout haze is dry, then clean off and polish with a soft, clean, dry cloth. Cheesecloth makes an excellent polishing cloth.

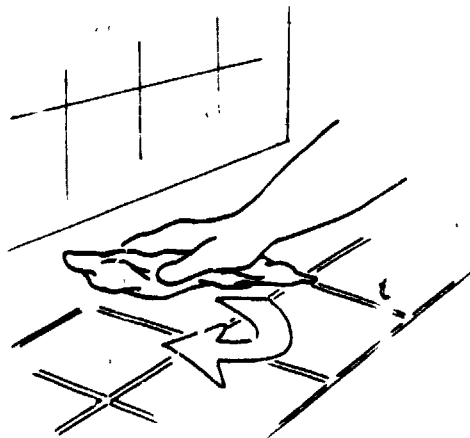

7. Be sure the surface of each tile is completely clean.

#### Dust-burlap-sawdust-sponge

This method is not used as much as the sponge and polish cloth method, but, in certain conditions, it does have advantages. The following reasons or conditions could require this method to be used:

1. You don't have to let the grout firm up. Right after the grout has been spread, this cleaning method can begin. It can save time.
2. When there are larger joint sizes ( $\frac{1}{2}$ " and up) and with very dense tile, the grout can take a long time to firm up.
3. In large areas or on commercial jobs, where the dusted grout and sawdust won't cause a mess problem, as they might in a smaller area.

#### To use

1. After spreading joints full, take dry grout powder directly from grout bag and "dust" with duster brush evenly over tiled areas to about 1/32" uniform thickness.
2. Use a burlap pad (can be cut from a burlap bag) and, in a circular motion, rub dry grout powder into joints over surface of all freshly grouted tile.
3. Rubbing compacts and fills in joints, makes them full and flush with tile surface, dries out grout evenly and helps loosen surface grout film to make final cleaning easier.
4. With dust brush, sweep off excess grout powder.
5. Sprinkle dry sawdust over grout film on surface; use the same burlap pad to rub sawdust over damp grout film.
6. The sawdust will absorb the colored grout film and clean the tile surface. It will not press into already dry grout powder rubbed joints.
7. Use dustpan and dust brush to remove sawdust from surface. Tile surface should now be completely clean.
8. Remove any remaining grout haze with light touch of damp sponge.
9. If sawdust is not available, it can be replaced by applying a second dusting of dry grout powder instead.

#### Sponge-drag cheesecloth

This method is almost always used only with unglazed quarry tile in a large area, and is much more practical when a light-colored grout is used. Dark grout tends to smear and shows on the surface of the tile.

#### To use

1. Spread grout and let it firm up.
2. Fill a large bucket with clean water. With a damp sponge, smooth the joints and loosen the haze on the surface by rubbing back and

forth diagonally across the surface..

3. Before grout hazes over, fill another large bucket with clean water, soak a large (2 foot by 4 foot) piece of cheesecloth and squeeze almost completely dry.
4. Shake out cheesecloth to full form and drag it with hands held low to the surface across the tilework.
5. Rinse cheesecloth frequently (often) in the fresh water.
6. Repeat by dragging across surface until completely clean.
7. If this method is performed carefully, no polishing or acid cleaning will be necessary.

#### Acid clean-haze

There are many types of acid cleaners (module on "Sealers and Cleaners"). Choose one that will clean dry grout haze from tile.

Use acid cleaner only on tile surfaces that were not adequately cleaned by a cleaning method--one where a grout haze has formed and the grout is fully set up. Acid cleaning tile is a procedure that should not have to be done, but because of poor cleaning methods, will have to be done from time to time.

#### To use

If haze or smears appear and grout is hardened in joints (at least one day later):

1. Wet down area to be cleaned with plenty of clean water; this prevents the grout joints from being bleached by the acid.
2. Wear protective rubber gloves and protect eyes if working above your head.
3. Dip scrub brush into diluted solution of acid cleaner and water (about 10 parts water to 1 part acid) and vigorously scrub the dirty area until it is clean.
4. When area is clean, wash acid off tile with plenty of clean water at least twice.
5. If acid is left on grout joints, the grout may bleach to white.

# Self Assessment

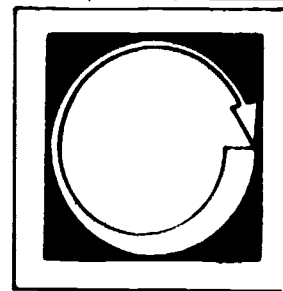

COMPLETE THE FOLLOWING STATEMENTS BY WRITING THE CORRECT WORD OR WORDS IN THE BLANKS PROVIDED.

1. Before grouting, it is necessary to wait at least \_\_\_\_\_ day(s) for most tile adhesives to set up.
2. When mastic is used to bond wa<sup>r</sup> tile, it is possible to grout as soon as the tile has been \_\_\_\_\_.
3. The main tool used to apply grout is the \_\_\_\_\_.
4. When applying or cleaning grout, the tool being used should be moved across the joints \_\_\_\_\_.
5. A grout bag's main purpose is to be able to fill joints without getting \_\_\_\_\_ on the \_\_\_\_\_ of the tile.
6. The grout joints should feel \_\_\_\_\_ to \_\_\_\_\_ before cleaning with a sponge.
7. The method most often used for cleaning grout is which of the following? Place the letter corresponding to the correct answer in the blank provided.  
\_\_\_\_\_
  - a. dust - burlap - sawdust - sponge
  - b. sponge - polish cloth
  - c. sponge - drag cheesecloth
  - d. sponge - sponge - clean

8. Only tile surfaces that were not adequately cleaned by a cleaning method need to be \_\_\_\_\_.
9. If the grout joint isn't completely cleaned of all acid with plenty of clean water, the joint may \_\_\_\_\_.



# Self Assessment Answers

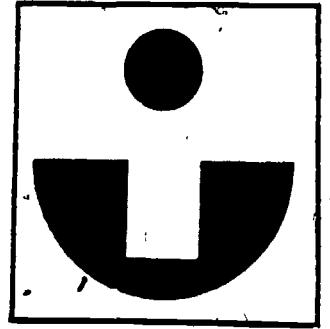

1. one
2. applied
3. rubber - grout - float, or rubber float
4. diagonally
5. grout on the surface
6. firm to hard
7. b. - sponge - polish cloth
8. acid cleaned
9. bleach

# Job Sheet

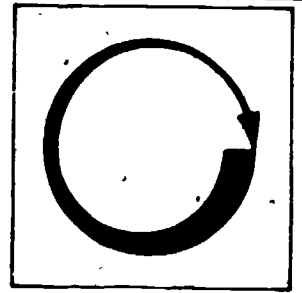

COMPLETE THE FOLLOWING TASKS.

## Materials and Tools

enough tile adhesive for 33 square feet

3/16" notch trowel

3/8" notch trowel

margin trowel

piece of backing at least 36" X 36"

" " " " " 26" X 26"

" " " " " 51" X 51"

" " " " " 14" X 26"

tape measure

4' long straightedge

framing square

rubber grout float

access to water

2 buckets

16 pieces 4½" X 4½" ceramic wall tile

16 pieces 3" X 3" glazed mosaics

16 pieces 6" X 6" unglazed quarry tile

9 pieces 4" X 8" X 1" thick pavers

sponge

white (non-sanded) grout

dark brown sanded grout

white silica sand

dark mortar sand

cement

polish cloth (cheesecloth)

burlap cloth (bag)

sawdust

2 pieces cheesecloth 2' X 4'

grout bag

striking tool (1" diameter  
wooden dowel)

1. Set 16 pieces of  $4\frac{1}{4}$ " X  $4\frac{1}{4}$ " ceramic wall tile on a suitable sized backing (at least 36" X 36") in a square pattern of 8 across and 8 down with a  $\frac{1}{8}$ " joint. (Butt tiles together if they have side nubs.) Let tile set-up, then grout with white non-sanded grout and clean and finish using the sponge polish cloth method.
2. Set 16 pieces of 3" X 3" glazed mosaics on a suitable sized backing (at least 26" X 26") in a square pattern of 8 across and 8 down with a  $\frac{1}{4}$ " joint. Let tile set-up, then grout with a dark brown sanded grout and clean and finish using the dust - burlap - sawdust - sponge method.
3. Set 16 pieces of 6" X 6" unglazed quarry tile on a suitable sized backing (at least 51" X 51") in a square pattern of 8 across and 8 down with a  $\frac{5}{16}$ " joint. Let tile set-up, then grout with natural gray cement grout in a ratio of 1 part cement to 2 parts white silica sand. Let grout firm up, then clean and finish using the sponge - drag cheesecloth method.
4. Set 9 pieces of 4" X 8" X 1" thick pavers on a suitable sized backing (at least 14" X 26") in a pattern of 3 across and 3 down with a 1" wide joint. Let pavers set up, then grout with natural mortar cement grout in a ratio of 1 part cement to 3 parts dark sand. Use the grout bag and striking method.

# Post Assessment

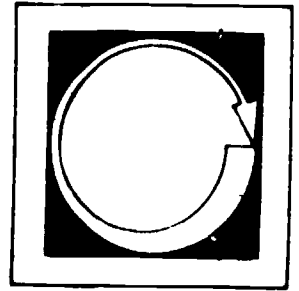

WRITE AN ANSWER TO THE FOLLOWING QUESTIONS CONCERNING THE JOB SHEET.

1. For each method of grouting which did you find-- (Explain your answers.)
  - a. fastest?
  - b. most difficult?
  - c. was the way you'd prefer to grout?
  - d. looked the best when finished?
2. Do you agree or disagree that the sponge - polish cloth method is the most practical way to clean grout? Explain.
3. Did you have any problem squeezing the natural mortar grout out of the grout bag? Explain. What did you do to correct it?

LISTED BELOW ARE SEVERAL STATEMENTS. IF THE STATEMENT IS TRUE, PLACE A "T" IN THE BLANK PROVIDED. IF THE STATEMENT IS FALSE, PLACE AN "F" IN THE BLANK.

4.  Burlap is a lightweight soft cotton cloth.
5.  When something is bleached, it is made whiter or lighter in color.
6.  Cheesecloth is a coarse, heavy, plain-woven fabric.
7.  The only thing "striking" means is when typesetters go on strike for more money.

# Instructor Post Assessment Answers

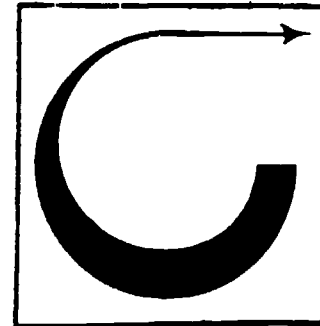

4. F It's a coarse heavy fabric.
5. T
6. F It's a lightweight soft cloth.
7. F It's main meaning is it's the process of removing excess grout and pressing grout into joints.

## TUB ENCLOSURES

### **Goal:**

The student will be able to install a ceramic tile tub enclosure, and be able to identify and explain the three different backing methods.

### **Performance Indicators:**

The student will successfully complete a Self Assessment, a Job Sheet and a Post Assessment.

# Study Guide

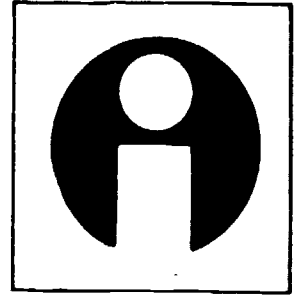

In order to finish this module, do the following tasks. Check each item off as you complete it.

1.  Read the Goal and Performance Indicators on the cover of the module. This will tell you what you will learn by studying the module, and how you will show you've learned it.
2.  Read the Introduction. The Introduction will tell you why the module is an important part of the tilesetting trade.
3.  Study the Vocabulary section. Vocabulary words are important for a good understanding of the trade. After you have studied the vocabulary, ask your teacher to quiz you on the words and their meanings.
4.  Study the Information section. This section will give you the information you need to understand the subject.
5.  Take the Self Assessment exam. This is a test for you to prove to yourself that you have learned the material you have studied. Compare your answers with the answers on the Self Assessment Answer Sheet, which is on the page following the Self Assessment. If you scored poorly, re-study the Information section or ask your teacher for help.
6.  Do the Job Sheet. Follow the instructions at the top of the Job Sheet. The tasks listed on the Job Sheet will help you develop skills which will be helpful to you.
7.  Take the Post Assessment exam. Give the exam to your teacher after you have completed it. Your teacher will grade it for you.



# Introduction

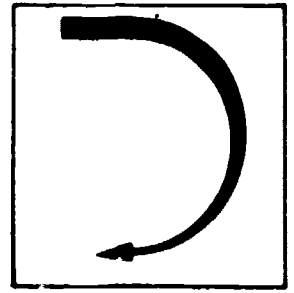

This module covers the three methods for the application of ceramic tile tub enclosures.

The tub enclosure (tubsplash) is a basic tilesetting installation.

# Vocabulary

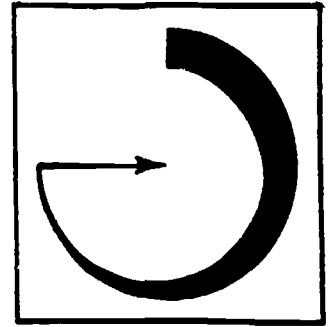

Trade terms are very important for a good understanding of the trade. Study these words and meanings. When you have learned them, ask your teacher to quiz you on the words and their meanings.

**POLYETHYLENE**--Plastic sheeting that is resistant to chemicals and moisture; often used for insulation.

**MEMBRANE**--A thin sheet or layer.

**SCRATCH COAT**--The first coat of mortar on a wall. Its surface usually is scratched so it will bond better with other coats of mortar.

**BUILDING CODES**--Principles, rules and laws that govern the methods and materials for the way something can be, or has to be built.

**REMODEL JOB**--Reconstruction, fixing or replacing with something new.

**OUT CORNER**--Piece of tile with two joining bullnose edges.

**BULLNOSE**--Piece of tile with one of its edges having a sloping finish, used to cap or finish tile work.

**ENAMEL**--A glossy vitreous composition applied to the surface of metal, glass or pottery; a hard coating.

**WICK UP**--The action of drawing up moisture, like the wick in an oil lamp.

**MASTIC LINE**--The line to follow and stay within when spreading mastic on a wall.

# Supplementary References

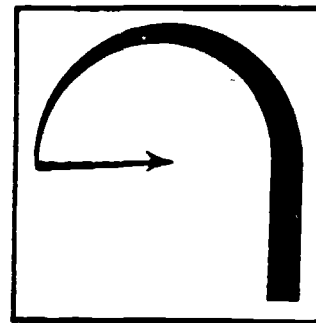

1. Tilesetting Workbook. California Department of Education, 1975. pp 101-116.
2. Handbook for Ceramic Tile Installation. Tile Council of America, 1981. pp. 18-23.

# Information

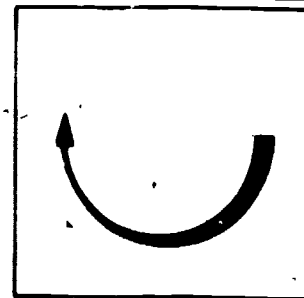

The tub enclosure (the tiled walls surrounding a bathtub) is one of the tilesetter's most common residential installations.

The bathtub will be properly set in place by the builder or plumber, and will be left for the tilesetter to finish. The walls around the tub will be made of wood or metal studs. Wood is easier to work with.

The three most common backing methods used are the;

- \* Two-coat cement mortar method
- \* One-coat cement mortar method
- \* Gypsum Board, mastic method

The gypsum board, mastic method is the most often used method for installing a tub enclosure where local building codes permit. (Water resistant gypsum board, called W/R board, is required.) It's the cheapest, fastest and easiest method of the three. It's also the least durable, but it's durable enough for most conditions and situations.

Cement mortar tub enclosures take longer, are more expensive and more durable, usually last longer and are required for many situations where a stonger backing is needed.

## TWO-COAT CEMENT MORTAR METHOD

Consists of:

1. Covering the studs from the top of the bathtub to the desired or required height (usually to the ceiling) with a waterproof membrane-- usually 15 lb. roofing felt (tar paper). Four mil thick polyethylene plastic may also be used.

2. Start from the top of the bathtub and work upward. Run the tar paper horizontally, starting at one side wall, to the backwall, across the backwall, across the other sidewall.

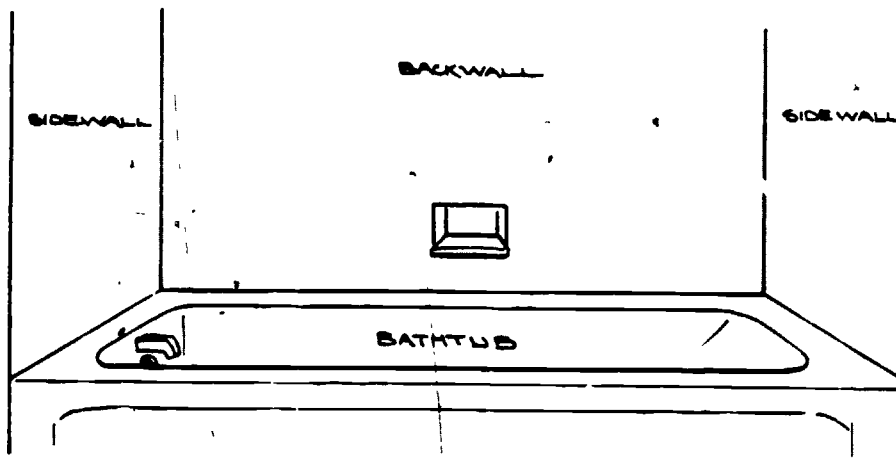

3. Overlap the edges at least 4", as you work up. Use a staple gun to tack the tar paper to the wood studs. (It usually takes three courses of tar paper to reach the ceiling.)
4. Staple preferably 3.4 lb. galvanized metal lath over entire surface; 2" x 2" wire mesh may also be used. Allow about 1/8" clearance from the top of the tub, ceiling and wall edges. Overlap metal reinforcing at least one full mesh. Cut with tin snips.
5. Apply the first cement mortar coat, called the "scratch" coat (you'll learn how to apply the scratch coat in the module titled "Applying Wall and Floor Mortar").
6. Scratch the first coat's surface with a scratcher. This is done so that the second coat will bond better to the surface.
7. Let the scratch coat set at least overnight before continuing.

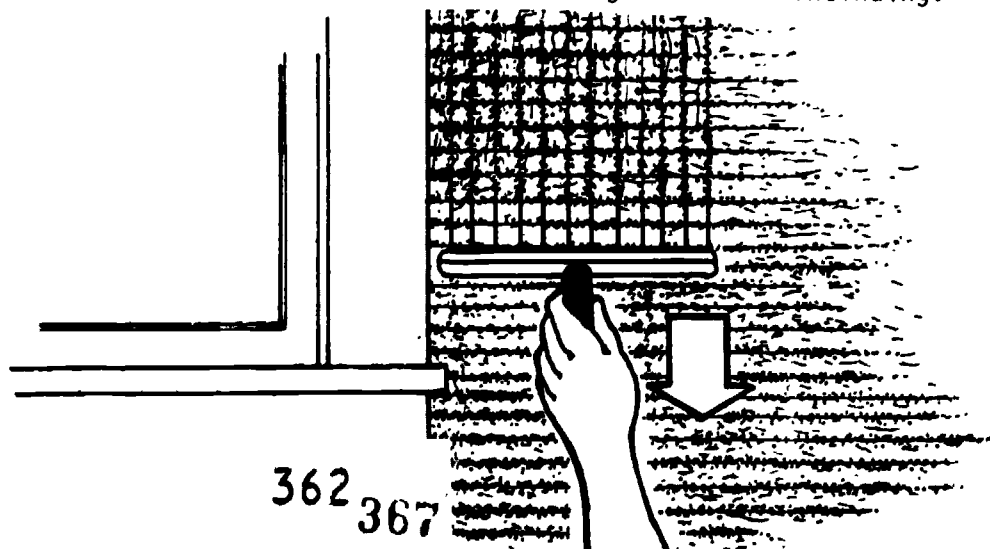

8. Apply the second coat of cement mortar. It's called the mortar bed (you'll learn how in the module titled "Applying Wall and Floor Mortar").
9. Finally, apply a thinset mortar adhesive, mixed with water. This is used to bond tile to the mortar coat. It's called the "bond coat." (This will also be covered in a later module.)

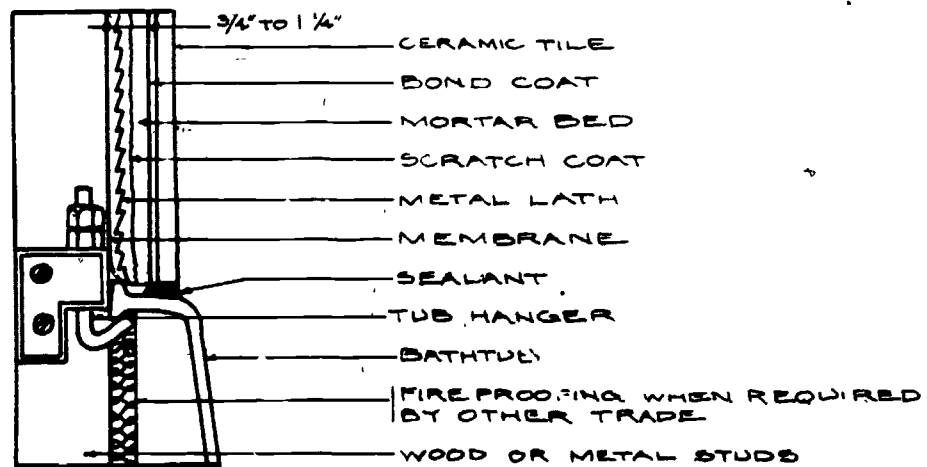

#### ONE-COAT CEMENT MORTAR METHOD

The one-coat cement mortar method has everything the two-coat method has except there is no scratch coat. Instead, some sort of solid backing (usually water resistant gypsum board [W/R Board] ) is nailed directly onto the studs. Over the W/R board is applied, in order:

1. tar paper
2. metal lath
3. mortar bed
4. bond coat
5. tile

The one-coat method takes less time than the two-coat method; it's less expensive and is probably just as durable, but in certain building code areas, a scratch coat is required, so this method can't be used. (See illustration top of next page.)

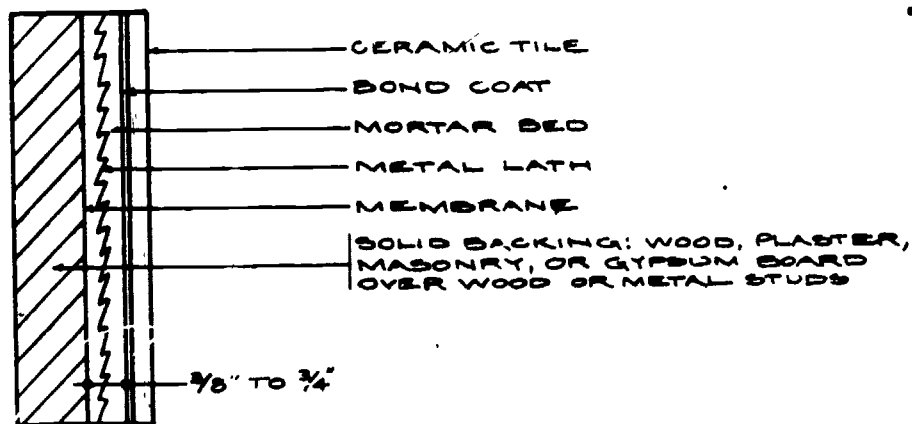

#### GYPSUM BOARD, MASTIC METHOD

The W/R board, mastic method has the following:

- 1 W/R board is nailed directly onto the studs.
2. The boards' joints are caulked (sealed) and finished. (This step is done by a sheetrock or plasterer tradesperson. The tilesetter may have to apply W/R board only on a re-model job.)
3. The tile is bonded directly onto the W/R board with mastic.

(See illustration top of next page.)

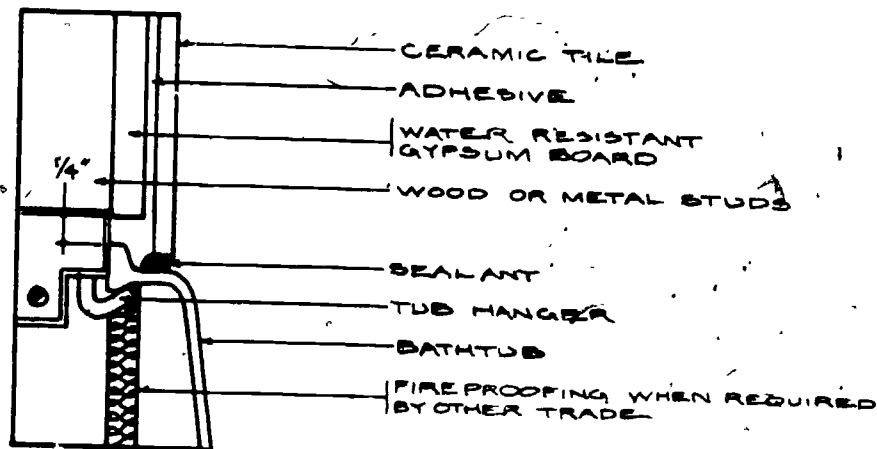

### How to lay out, set and finish a standard W/R board tub enclosure

A standard tub enclosure is one on which the walls are tiled 5 feet above the top of the tub, or at least one row of tile above the shower head (which usually is right around 5 feet).

#### Preparation

1. Get together all of the tools and materials that are needed to complete the job.
  - tile cutting board
  - nippers
  - tape measure
  - 3' to 4' level
  - abrasive stone (fine to medium grit)
  - 3/16" deep notch trowel
  - margin trowel
  - pointing trowel
  - pencil
  - utility knife
  - razor blade scraper
  - 2 bucket,--to grout



rubber grout float  
 duster brush and pan  
 damp rag  
 caulking gun and white caulking  
 good quality mastic  
 white, non-sanded grout  
 polish cloth (cheesecloth)  
 48 sq. ft.  $4\frac{1}{2}$ "x $4\frac{1}{2}$ " glazed wall tile  
 64 pieces  $4\frac{1}{2}$ "x $4\frac{1}{2}$ " bullnose cap  
 2 out corners  
 soap dish  
 sponge

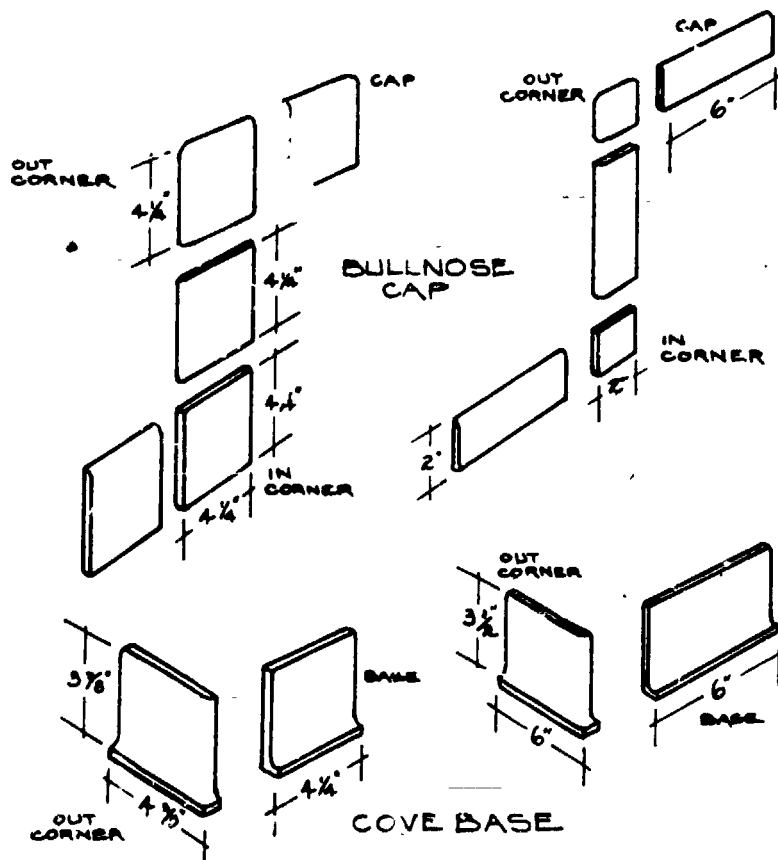

2. With razor blade scraper, remove anything stuck to the tub (plaster, caulking, etc.) and check for chips in the enamel finish. (If there are any, make sure the builder or homeowner knows about it before you begin.
3. With the margin trowel and duster brush, scrape off and remove anything stuck to the W/R board; the surface of the walls must be clean and dry--no loose or flaked paint, or dust.
4. There should be a gap of at least  $\frac{1}{4}$ " between the W/R board and the tub on top of the tub and on the sides. If there is not, use the utility knife to cut the proper sized gap. Without the gap, it is possible that water could wick up the W/R board and cause rot.
5. With duster brush and dust pan (or flat trowel), clean tub inside and out. To protect the bottom of tub from scratching from tile chips, lay a drop cloth or suitable sized piece of cardboard over the surface.

#### Layout

1. Find the lowest point on the tub ledge by placing the level on top of tub and both sidewalls. Place one piece of tile at this point.
2. Draw a mark on the wall above the tile.
3. Using the level, extend the line around the tub walls. This is the base line for the walls. If the tub is perfectly level, you don't need this line. Tubs are usually not level.

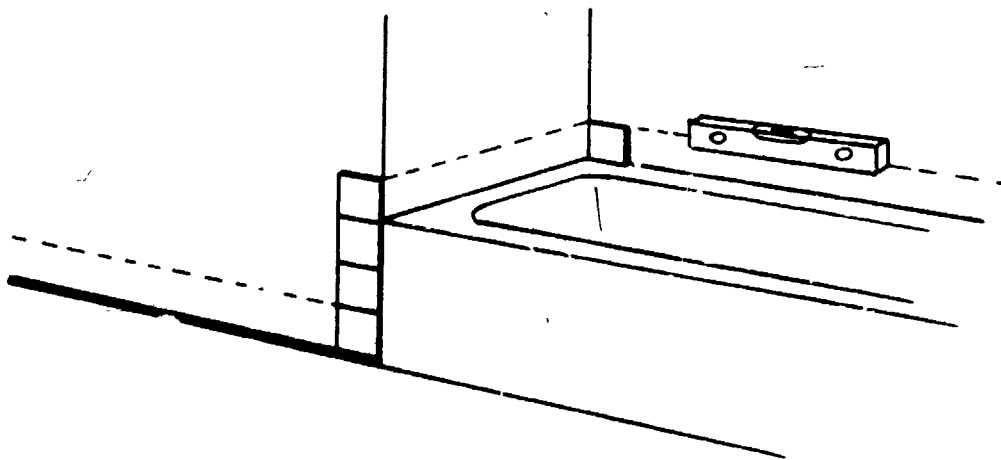

4. Find the center line of the back wall by measuring from corner to corner. Draw a mark on the wall.
5. Using the level, draw a 5-foot high plumb center line. This is the starting point. You will set the tile from the center line to the corners on the back wall, corners will have the same sized cuts.

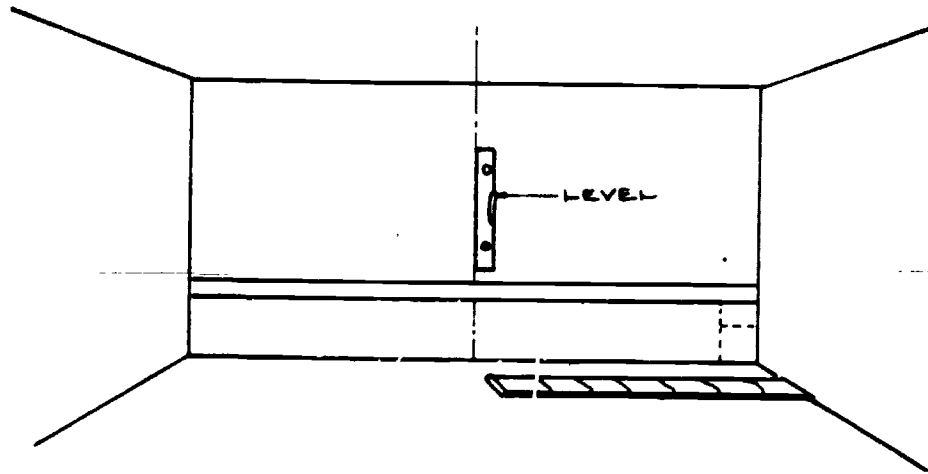

6. Draw plumb mastic lines on both sidewalls.
7. Place a piece of bullnose cap against the lower outside edge of the tub on both sidewalls.
8. Draw a mark  $\frac{1}{2}$ " in from the outside edge of the bullnose.
9. From the mark--using the level--draw a plumb line extending from the floor to 5 feet above the top of the tub. This is the line to follow when spreading mastic on the sidewalls.

#### Adhesive application

1. With the flat (non-notched) side of the notched trowel, fill the gap between W/R board and tub with mastic; fill flush to seal and waterproof.
2. With the notched trowel held at a  $45^{\circ}$  angle, spread the mastic from the center line and base line toward the corners of the wall.
3. Spread only what you think you can cover in about 30 minutes ( or not more than half way up the back wall.
4. Trowel firmly against the wall to form full, even adhesive ridges.
5. The base line cuts can be put in after each wall has been set, using the buttering method. (See illustration top of next page.)

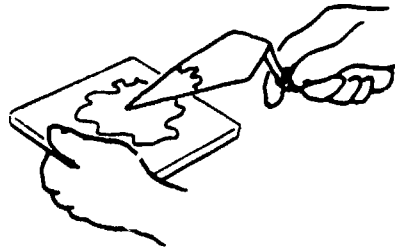

BUTTERING METHOD

### Setting tile

1. Start setting tile on back wall, on the base line, with the edge of the first tile at the plumb center line.
2. Set tile on the back wall from the center to the corners.
3. Press tile firmly into place with a slight twisting motion. Do not slide or press tiles too hard since it will force the mastic up on the edges of the tile; if this happens, clean with a damp rag.
4. Set the tile in rows, being careful to keep the joints lined up and the rows level.

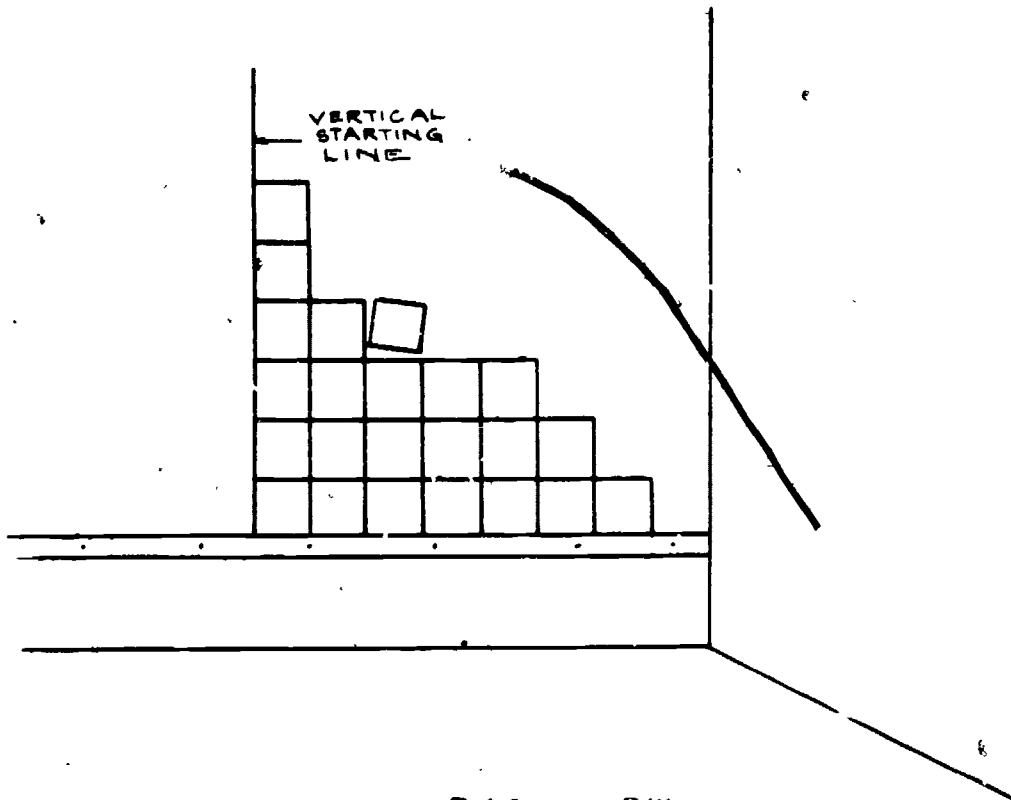

5. Use the pointing trowel to adjust the tiles. Align and level the joints horizontally first, then align the joints vertically.
6. Make corner cuts and set them as you go.
7. Spread the mastic and set tile until back wall is complete. Make sure the top row is tiled with bullnose caps.
8. Cut in the bottom row of wall tile below the base line.
9. The back wall is now complete, unless a soap dish is required.
10. If so, plan where the soap dish will go (usually in the center of the back wall, two rows up from the top of the tub.
11. Pull two tiles, one on each side of the center line.
12. Measure soap dish and determine what size each of the two cuts must be, cut and set them. (It usually takes a 1/4" cut on both sides.)  
THE SOAP DISH IS SET IN LAST on the back wall.
13. Set tile on sidewalls, starting with bullnose cap at the outside edge of the tub and work toward the corner. This will allow all cuts to be in the corners with full tile at the tub line.
14. Spread only what you can set in around 30 minutes.
15. Use the level to make sure the bullnose cap is plumb.
16. Where the bullnose caps meet horizontally at the top, and vertically on the sides, use an out corner.
17. Cuts for round or irregular shaped openings on the fixture wall (the sidewall with the shower head and water fixtures) are made with tile nippers.
  - 1) mark the outline of the opening on the tile
  - 2) take small bites to avoid cracking or breaking tile
  - 3) always smooth the cut edges of tile with an abrasive rubbing stone
18. Clean up all tile chips before grouting.

### Grouting

It is probably best to let the tile set overnight, but it is not necessary. To grout tub enclosures, use the information and instructions from the module titled "How to Grout." Use the sponge-polish cloth method.

### Caulk and set soap dish

1. Make sure tile is thoroughly polished before caulking. Use information and instructions for caulking from module titled "Sealers and Cleaners."
2. Caulk corners where tile meets and on top and sides of tub, where tile meets tub.

3. Set soap dish by running caulking along edges of tile and inside edges of soap dish. Set dish in wall. Press and twist firmly into place.
4. Caulk around the outside of dish. Tool and smooth caulk with your finger.
5. Use masking tape to prevent dish from slipping and to hold it until caulking has set up. The tub enclosure is now complete.

A journeyman tilesetter should be able to complete two or three tub enclosures a day.

# Self Assessment

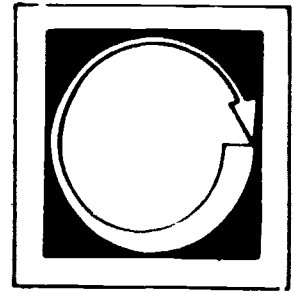

COMPLETE THE FOLLOWING STATEMENTS BY WRITING THE CORRECT WORD OR WORDS IN THE BLANKS PROVIDED.

1. Cement mortar backings are more \_\_\_\_\_ than gypsum board.
2. Most tub enclosures have \_\_\_\_\_ backings.
3. In certain areas, the building codes require a cement mortar \_\_\_\_\_ to be used for a tub enclosure.
4. The second coat of a two-coat cement mortar method is called the \_\_\_\_\_.
5. The one-coat cement mortar method consists of everything the two-coat cement mortar method has, except there is no \_\_\_\_\_ coat.
6. \_\_\_\_\_ is used to bond tile to W/R gypsum board.
7. A standard tub enclosure is one on which the walls are tiled about \_\_\_\_\_ feet above the top of the tub.
8. List in order the six steps involved in completing a tub enclosure, beginning with number 1--preparation.
  - (1) preparation
  - (2)
  - (3)

(4)

(5)

(6)

373

378



# ● Self Assessment Answers

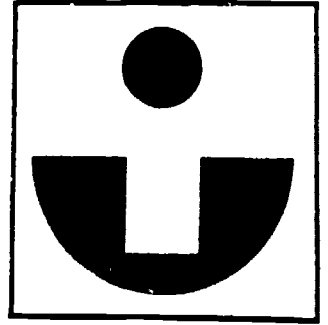

1. durable
2. gypsum board
3. backing
4. mortar bed
5. scratch
6. mastic
7. five
8. (1) preparation  
(2) layout  
(3) adhesive application  
(4) setting tile  
(5) grouting  
(6) caulk and set soap dish.

# Job Sheet

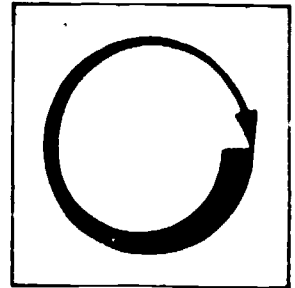

COMPLETE THE FOLLOWING TASK.

## Materials and Tools

tile cutting board  
tile nippers  
tape measure  
3' to 4' level  
abrasive rubbing stone (fine to medium grit)  
3/16" deep notched trowel  
margin trowel  
pointer trowel  
pencil  
utility knife  
razor blade scraper  
duster brush and dust pan  
damp rag  
caulking gun  
tube of white caulking  
mastic  
white non-sanded grout  
polish cloth (chessecloth)  
48 square feet of 4½" X 4½" glazed wall tile  
64 pieces of 4½" X 4½" bullnose cap  
2 buckets (to grout)  
sponge  
rubber grout float  
access to water

Using the information and instructions in this module, set and finish a standard W/R gypsum board tub enclosure.

# Post Assessment

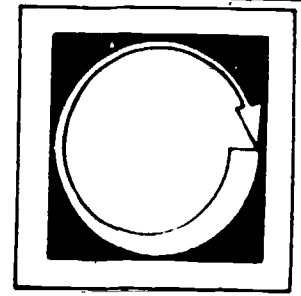

WRITE AN ANSWER TO THE FOLLOWING QUESTIONS CONCERNING THE JOB SHEET.

1. How many hours did it take you to complete the tub enclosure?
2. How did it turn out?
3. What part or area of completing the tub enclosure took the longest time?
4. Do you think the next one would be easier? Why?

LISTED BELOW ARE SEVERAL STATEMENTS. IF THE STATEMENT IS TRUE, PLACE A "T" IN THE BLANK PROVIDED. IF THE STATEMENT IS FALSE, PLACE AN "F" IN THE BLANK.

5.  The scratch coat is the final coat of a cement mortar backing.
6.  Building codes need to be obeyed.
7.  Polyethylene is plastic sheeting that is resistant to moisture.
8.  The membrane is the combination of all layers of materials that makes up the backing.
9.  An out corner is a piece of tile used for the base or bottom of tile-work.

10. \_\_\_ The mastic line is the boundary to stay within when spreading mastic.
11. \_\_\_ A remodel job is one in which you reconstruct, fix, or replace with something new.
12. \_\_\_ Enamel is a sticky substance which often has to be cleaned from the surface of a bathtub.
13. \_\_\_ A bullnose is a piece of tile with one of its edges having a sloping finish; used to cap tilework.

# Instructor Post Assessment Answers

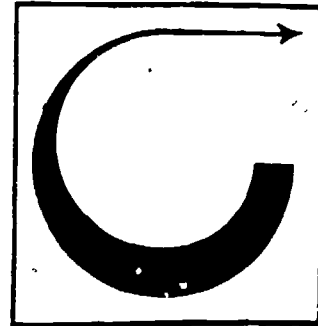

5. F The first coat has scratched surface.
6. T
7. T
8. F Is a thin sheet or layer.
9. F Used where bullnose comes together, for corner.
10. T
11. T
12. F A glossy vitreous, hard coating.
13. T

## COUNTER TOPS

### **Goal:**

The student will be able to identify, explain and perform the main installation methods.

### **Performance Indicators:**

The student will successfully complete the Self Assessment, a Job Sheet and a Post-Assessment.

1.0

45

28

2.5

30

32

2.2

33

36

32

40

2.0

35

37

38

39

41

42

43

44

1.8



2.5

1.4

1.6

# Study Guide

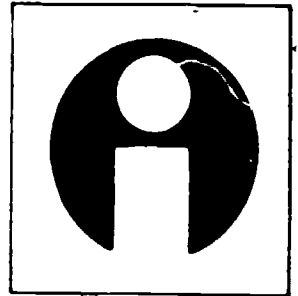

In order to finish this module, do the following tasks. Check each item off as you complete it.

1.  Read the Goal and Performance Indicators on the cover of the module. This will tell you what you will learn by studying the module, and how you will show you've earned it.
2.  Read the Introduction. The Introduction will tell you why the module is an important part of the tilesetting trade.
3.  Study the Vocabulary section. Vocabulary words are important for a good understanding of the trade. After you have studied the vocabulary, ask your teacher to quiz you on the words and their meanings.
4.  Study the Information section. This section will give you the information you need to understand the subject.
5.  Take the Self Assessment exam. This is a test for you to prove to yourself that you have learned the material you have studied. Compare your answers with the answers on the Self Assessment Answer Sheet, which is on the page following the Self Assessment. If you scored poorly, re-study the Information section or ask your teacher for help.
6.  Do the Job Sheet. Follow the instructions at the top of the Job Sheet. The tasks listed on the Job Sheet will help you develop skills which will be helpful to you.
7.  Take the Post Assessment exam. Give the exam to your teacher after you have completed it. Your teacher will grade it for you.



# Introduction

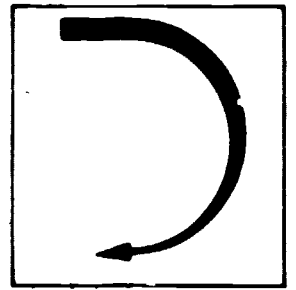

This module covers four methods for the most common applications of ceramic tile on counter tops.

Counter tops are one of the most often performed jobs in the tilesetting trade. Every tilesetter must know the basics of laying out and setting counter tops.

# Vocabulary

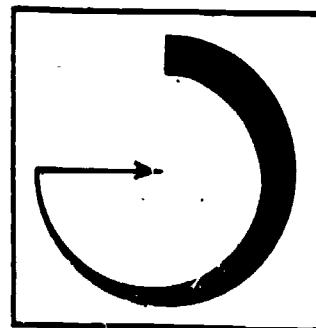

Trade terms are very important for a good understanding of the trade. Study these words and meanings. When you have learned them, ask your teacher to quiz you on the words and their meanings.

**V-CAP**--Type of trim piece, used for counter tops; it overlaps the front edge (face) of a counter.

**DUTCHMAN**--A cut tile used as a filler in the run of a wall or floor area.

**LAMINATE**--A thin, hard covering, often used for counter tops (formica is an example).

**SCREED**--A strip of some material (wood, mortar, plaster, metal) used as a guide for the proper thickness for a coat of mortar.

**SHIM**--To fill out or level up by the use of a shim (a thin piece of material; wood, metal, or stone).

# Supplementary References

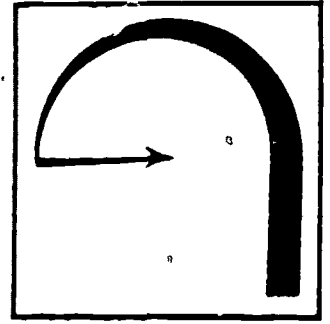

1. How to Install Ceramic Tile Counter Tops. American Ocean Company, 1980.  
pp. 1-15.
2. Tilesetting Workbook. California Department of Education, 1975. pp. 138-146.
3. Handbook for Ceramic Tile Installation. Tile Council of America, 1981.  
p. 26.

# Information

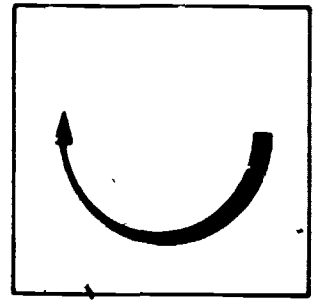

There are three types of layout used for common counter tops:

1. Straight counter top
2. L-shaped counter top
3. U-shaped counter top

## STRAIGHT COUNTER TOP

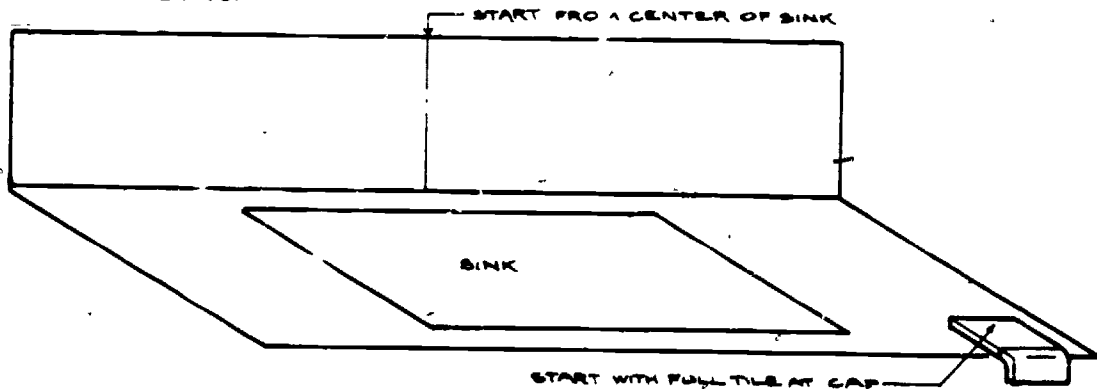

## LAYOUT OF A 90° CORNER

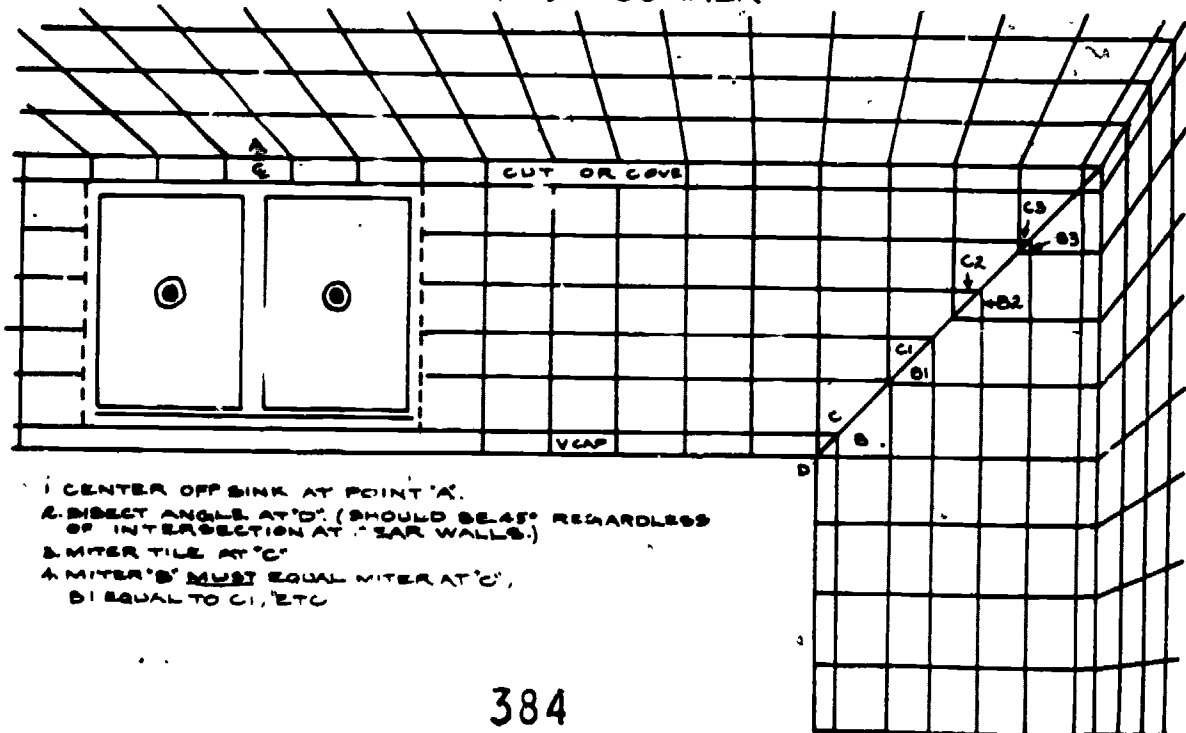

1. The straight counter top can be laid out with either a straight or diagonal tile pattern.
2. The layout should start with a full tile at the cap.
3. If there is no cap the layout should start with a full tile at the front edge of the counter.
4. Rows of tiles are then laid from the front to the back of the counter, allowing for desired joint width.
5. The back cuts may be less than half a tile; it still looks better than cutting the front edge tile. Mark the exact location of the cut on the last back tile. Make the cuts either before setting or as you go.
6. Lay out lengthwise starting from the center of the sink.
7. If the cuts are less than half tiles at the sides of the counter, shift the layout over a half tile.

#### L-SHAPED COUNTER TOP

1. The layout for an L-shaped counter generally begins by starting with full tile where the corner is formed.
2. Proceed in each and every direction; there is no control over the size of the cuts at each end of the counter, but the tile will be full in the corner.

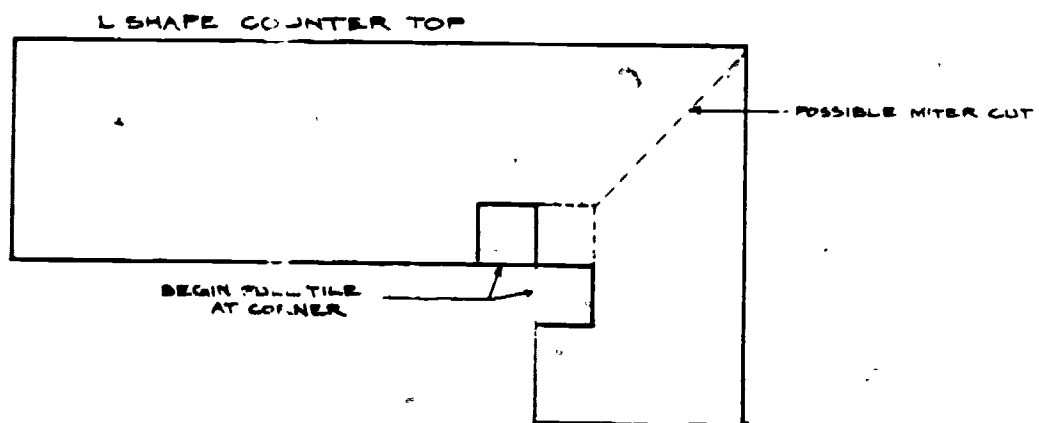

3. If the cuts at the ends of the counter need to be very small, a layout adjustment may have to be made. You might try starting with full tile at either or both ends of the counter and see if that works out.
4. Any adjustment or change from starting with full tile where the corner is formed will mean a miter joint will have to be made in the corner.

- This may look better than tiny end cuts. Each job is different; the tilesetter should avoid small cuts whenever possible. In many cases, the tilesetter's judgment on what looks best will have to be used.
5. If miter cuts need to be made, make them with the same size joint as the rest of the tile; smooth the rough cut edge with a rubbing stone.

#### U-SHAPED COUNTER TOP

1. The layout for a U-shaped counter top is basically the same as for an L-shaped one.
2. Begin by starting with full tile where the corners are formed.

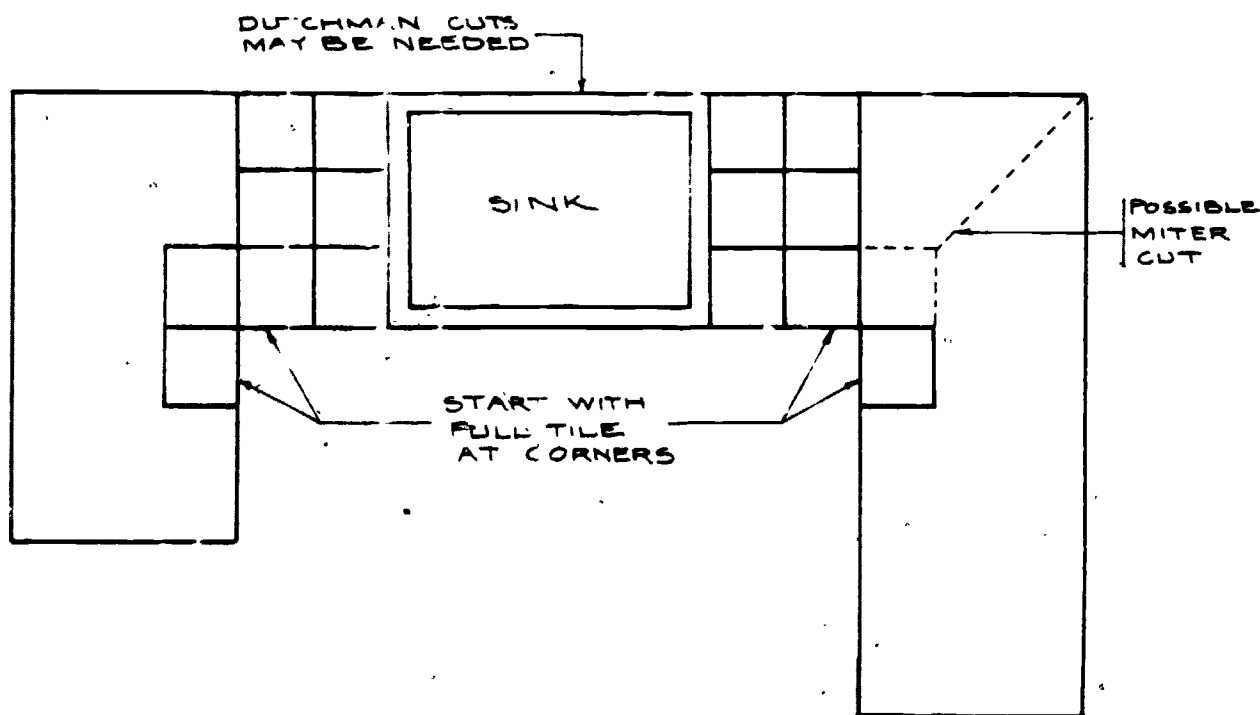

3. Proceed in every direction from there; there is no control over the size of the cuts at each end of the counter, and Dutchman cuts may be needed for the sink area of the counter, but the tile will work out full in both corners.
4. (As with the L-shaped counter), if the tile isn't started full where the corners are formed, miter cuts will be needed for the corners.

#### Cuts for sink opening

1. The sink hole will usually be cut to the right size for the sink

- 2
- to fit snugly. The sink will have a 1/8" to 3/4" overlap on its edge.
  2. If the sink or rim to the sink is at the job site, test it in the hole to see how much overlap there is to work with before setting any tile.
  3. If it's not available, as a general rule, cut the tile no farther than 1/8" from the edge opening. The sink corner cuts can be made with either the tile nippers or a tile saw.

### Installation methods

The four methods for the most common applications of ceramic tile to counter tops are:

1. Adhesive on plywood
2. Adhesive on plastic laminate (formica)
3. Cement mortar on wood base
4. Wonderboard over plywood

### Adhesive on plywood

This is the most often performed method of installing ceramic tile on counter tops. For new construction it costs less for materials, yet--if done right--it's very durable.

### Steps to completion

- 1) Backing--A 3/4" (minimum thickness) exterior grade plywood should be used, not chipboard or interior plywood. The bottom edge of the counter top trim must be set the proper distance above the finish floor to allow enough clearance for dishwashers, compactors, etc. Make sure plywood is set at proper height.
- 2) Lay out counter top, as described before
- 3) Spread adhesive--remove all dust, dirt, etc. from plywood surface. With the right sized notch trowel (3/16" to 1/4" deep notch), spread latex-, acrylic-, or epoxy-based thinset mortar for best possible bond. (Mastic may also be used, but it won't give as strong a bond.)
- 4) Set counter tile--set tile to your layout requirements.

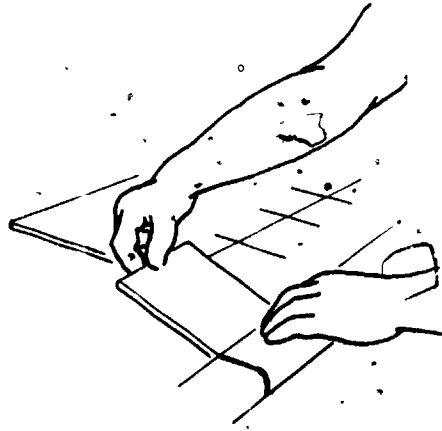

5) Set backsplash tile--follow counter top tile joints when setting backsplash. If cutting tile is required, cut those tiles in the top row. These cuts won't be as noticeable, unless the tile does not butt under overhang. If it doesn't, cut bottom row of tile. Most backsplash backings are either wood or gypsum board; mastic is the most common adhesive used to set backsplashes, because the tile won't slip or move like it could if thinset mortar were used. Backsplashes don't need to be as durable as the counter top.

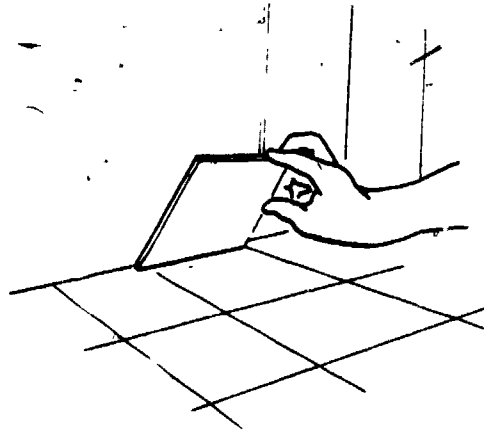

6) Grout and polish--let counter set at least overnight before grouting. Use sponge and polish cloth method.

7) Caulk--caulk in all corners. Use clear caulking unless tile and grout are white--then you can use white caulking. COUNTER IS COMPLETE.

#### Adhesive on plastic laminate method

This method is used when setting tile over an older plastic laminate (formica) counter top.



### Steps to completion

- 1) Preparation of backing--make sure the laminate is solid, not peeling or loose. If it's loose, remove it or re-glue it. Lightly sand the laminate surface with coarse abrasive paper. Remove all dust with duster brush. This will make a rough surface which will give a good bond.
- 2) Lay out counter top, as described before
- 3) Spread adhesive--with appropriate notch trowel, spread latex-, acrylic-, or epoxy-based thinset mortar for best bond.
- 4) Set counter tile--set tile to your layout requirements. Do front counter trim tiles first.
- 5) Set backsplash tile--Use mastic; follow counter top tile joints; make cuts (usually) in top row.
- 6) Grout and polish--same as "adhesive on plywood" method
- 7) Caulk

### Cement mortar on wood base method

Cement mortar counter tops are preferred or required for many situations. They take longer to install, and are more expensive, but are more durable than the first two methods.

### Steps to completion

- 1) Backing--Use 3/4" exterior grade plywood. (Since bottom edge of plywood will also be bottom of tile trim in front, be sure height from floor allows clearance for dishwasher or compactor.)
  - a) Cover plywood surface, including counter edge, with waterproof membrane (15 lb. tar paper or 4 mil thick polyethylene). Lap edges at least 4", extend 2" up backsplash and sidewall to protect against moisture from mortar. Use staple gun to tack tarpaper.
  - b) Lay 3/4 lb. metal lath or 2" by 2" wire mesh over entire surface. Allow 1/8" clearance from walls and front edge. Lap metal reinforcing at least one full mesh. Staple or nail in place.
  - c) Nail special punched metal trim strip to face of plywood. Lower edge of metal strip should be flush with bottom edge of plywood. This strip is a guide to use when floating counter top mortar.

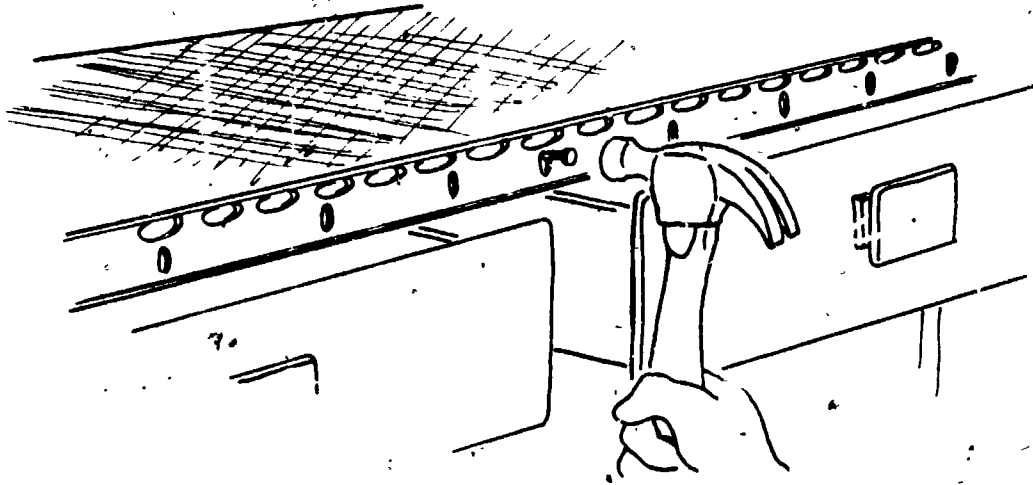

- d) Along back of counter, about 1" from back wall, nail temporary wood screed strip. (You will learn about screeds in module titled "Screeds.") Level and shim wood strip to the same height as metal trim strip along front.
- e) Install screed strips around sink, about 1" from cut for sink opening; level and shim to proper height.

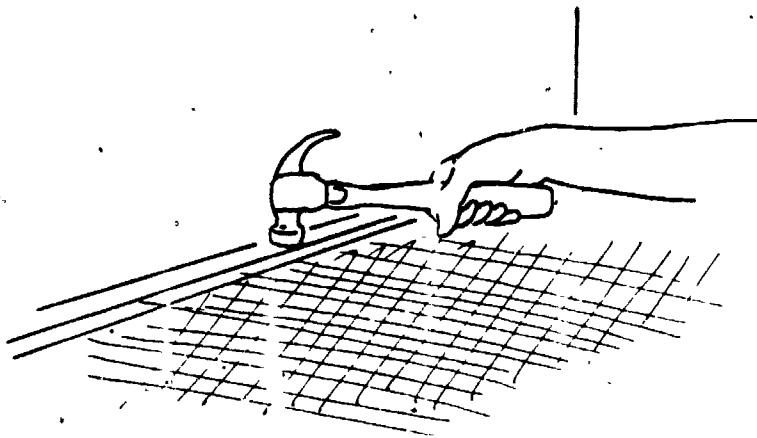

- f) Mix portland cement floor mortar: 1 part portland cement to 4-6 parts sand. (Refer to module titled "Portland Cement Mortar Mixes.")
- g) Compact mortar behind metal strip. (See illustration top of next page.)

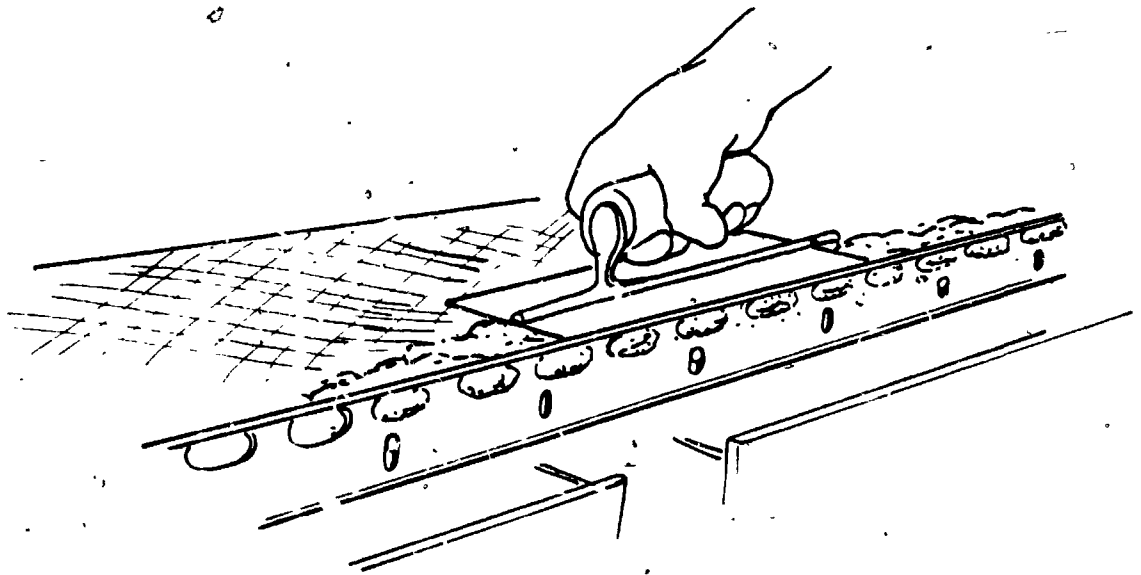

- h) Place mortar on surface of counter and spread evenly to thickness of about  $\frac{1}{4}$ ' above screed height. Tamp uniformly to compact entire mortar bed. (You will learn more about floating wall and floor mortar in module titled "Applying Wall and Floor Mortar.")
- i) Use back and front strips to guide wood or metal straightedge as you screed off the surface.

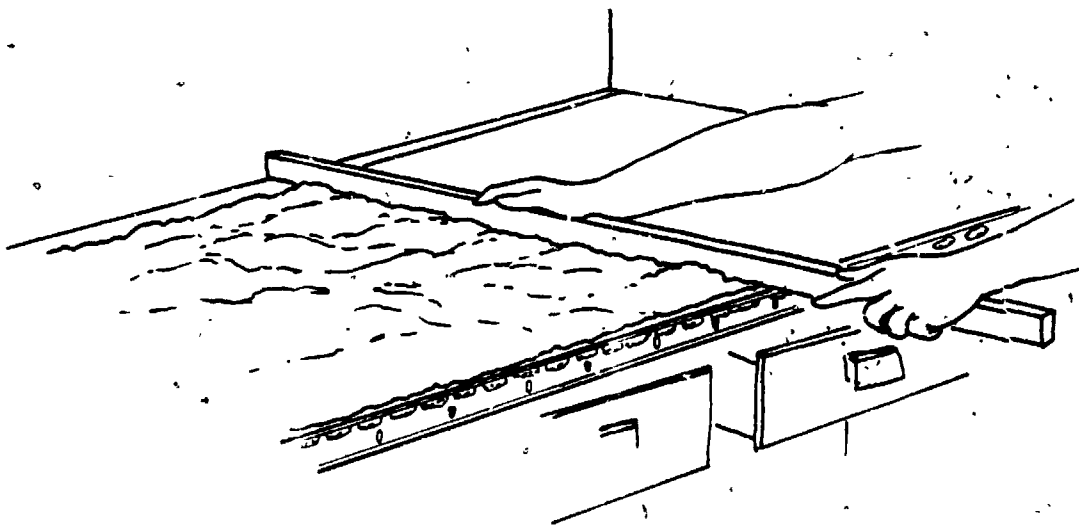

- j) Remove temporary wood screed strips from back and around sink.
  - k) Fill in openings (where strips were) with mortar, compact in place; use flat trowel and smooth off flush with mortar bed surface.
  - l) Counter top mortar bed should now be flat, level and smooth enough to continue.
- 2) Lay out counter top
  - 3) Spread adhesive

- 4) Set counter tile--use rubber mallet and beating block to beat in tile
- 5) Set backsplash--use mastic, follow counter top tile joints
- 6) Grout and polish
- 7) Caulk

#### Wonderboard over plywood method

Wonderboard over plywood makes a good substitute for a cement mortar over plywood backing. (Wonderboard is a combination of a lightweight concrete core, reinforced with fiberglass mesh, with both sides coated with high-density portland cement. It is very strong and can be used in place of a cement mortar bed.)

#### • Steps to completion

1) Backing--Use 3/4" exterior grade plywood; make sure there is enough clearance for a dishwasher, etc.

- a) Cut wonderboard with a skill saw fitted with a special masonry blade (or by hand, using a plastic laminate scoring cutter)

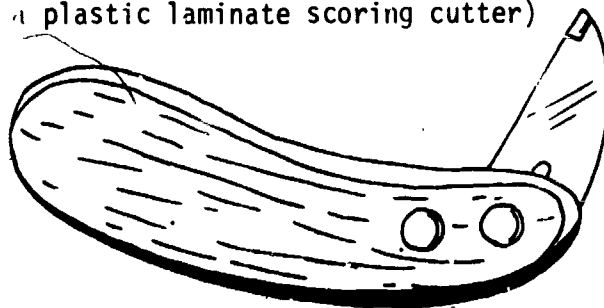

- b) Cover entire plywood surface with waterproof membrane (15 lb. tar paper or 4 mil thick polyethylene).

- c) Nail wonderboard over plywood, spacing 1 1/2" galvanized nails every 12" along every edge and on counter surface.

2) Lay out counter tile

3) Spread adhesive

4) Set counter tile--use wood beating block and mallet to compact tile in thinset mortar.

5) Set backsplash tile

6) Grout and polish

7) Caulk

# Self Assessment

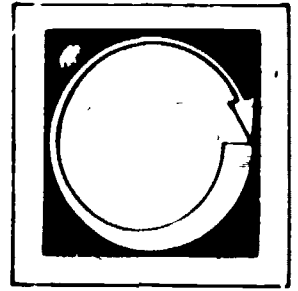

COMPLETE THE FOLLOWING STATEMENTS BY WRITING THE CORRECT WORD OR WORDS IN THE BLANKS PROVIDED.

1. You can make the back tile cuts either \_\_\_\_\_ setting tile or as you \_\_\_\_\_.
2. The layout for an \_\_\_\_\_ and \_\_\_\_\_ counter generally begins with full tile where the \_\_\_\_\_ (:) is (are) formed.
3. \_\_\_\_\_ will have to be used in the corner if full tile isn't started where the corner(s) is (are) formed for an L-shaped and U-shaped counter top.
4. In many cases the tilesetter's \_\_\_\_\_ on what layout looks best will have to be used.
5. The layout for a U-shaped counter top is basically the same as that for an \_\_\_\_\_ counter top.
6. As a general rule, cut the tile no farther away than \_\_\_\_\_ inch from a sink opening.
7. The most often performed method of installing tile on a counter top is which of the following? \_\_\_\_\_ Place the letter corresponding to the correct answer in the blank.
  - a. cement mortar on wood base
  - b. wonderboard over plywood
  - c. adhesive on plywood
  - d. check, guess and install

8. \_\_\_\_\_ inch thick exterior grade plywood should be used.
9. \_\_\_\_\_ is the most common adhesive used for bonding backsplash tile.
10. If tiles need to be cut for the backsplash, then usually the \_\_\_\_\_ row should be cut.
11. Lightly sand a \_\_\_\_\_ surface with coarse sandpaper before bonding tile to it.
12. Wonderboard makes a good substitute for \_\_\_\_\_.

# Self Assessment Answers

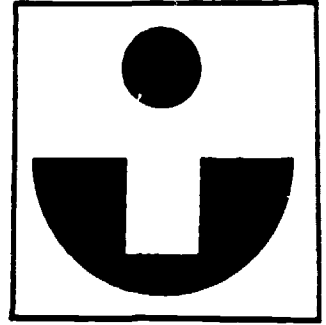

1. before, progress or go
2. L-shaped and U-shape; corner(s)
3. miter cuts
4. judgment
5. L-shaped
6. 1/8"
7. c. adhesive on plywood
8. 3/4"
9. mastic
10. top
11. laminate
12. cement mortar

# Job Sheet

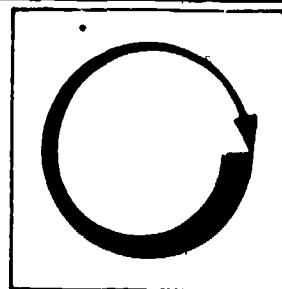

COMPLETE THE FOLLOWING TASK.

## Materials and Tools

if mock up, 2' X 4' X 3/4" thick piece exterior grade plywood

8 square feet counter top tile

enough tile for a two-tile-high backsplash

latex, acrylic, or epoxy thinset mortar

3/16" notch trowel

margin trowel

tile cutting board

nippers

2 buckets

access to water

mastic for backsplash

grout

sponge

polish cloth (cheesecloth)

caulking gun and caulk

tape measure

pencil

Use the information and instructions in this module. Set and finish a small (2' X 4') counter top. Do the "adhesive on plywood" method. Make a "two-tile-high" backsplash. The counter top may or may not have a sink hole.



# Post Assessment

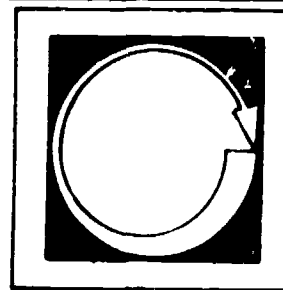

WRITE AN ANSWER TO THE FOLLOWING QUESTIONS CONCERNING THE JOB SHEET.

1. What type, size, color, and joint width of tile did you use?
2. Where was this counter top set--(at home, school, etc.)?
3. Was it a remodel or new construction?

LISTED BELOW ARE SEVERAL STATEMENTS. IF THE STATEMENT IS TRUE, PLACE A "T" IN THE BLANK PROVIDED. IF THE STATEMENT IS FALSE, PLACE AN "F" IN THE BLANK.

4. \_\_\_ A dutchman cut is one that's used as a filler tile in the run of a wall or floor area.
5. \_\_\_ A shim is a strip of something used as a guide for the proper thickness for a coat of mortar.
6. \_\_\_ To screed is to fill out or level up something by the use of a screed.
7. \_\_\_ A type of trim piece of tile used to overlap the front edge of a counter top is called V-cap.
8. \_\_\_ Plastic laminate is also called formica.

# ● Instructor Post Assessment Answers

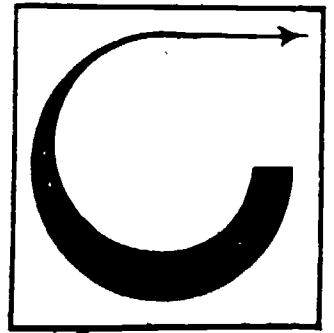

4. T

5. F

6. F

7. T

8. T

## SCREEDS

### **Goal:**

The student will be able to identify, explain the purpose of, and set horizontal and vertical screeds.

399

### **Performance Indicators:**

The student will successfully complete the Self Assessment, the Job Sheet and the Post Assessment.

404

# Study Guide

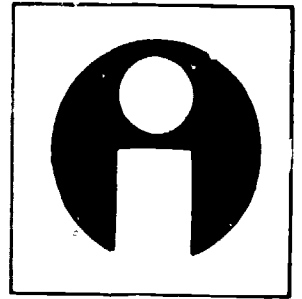

In order to finish this module, do the following tasks. Check each item off as you complete it.

1.  Read the Goal and Performance Indicators on the cover of the module. This will tell you what you will learn by studying the module, and how you will show you've learned it.
2.  Read the Introduction. The Introduction will tell you why the module is an important part of the tilesetting trade.
3.  Study the Vocabulary section. Vocabulary words are important for a good understanding of the trade. After you have studied the vocabulary, ask your teacher to quiz you on the words and their meanings.
4.  Study the Information section. This section will give you the information you need to understand the subject.
5.  Take the Self Assessment exam. This is a test for you to prove to yourself that you have learned the material you have studied. Compare your answers with the answers on the Self Assessment Answer Sheet, which is on the page following the Self Assessment. If you scored poorly, re-study the Information section or ask your teacher for help.
6.  Do the Job Sheet. Follow the instructions at the top of the Job Sheet. The tasks listed on the Job Sheet will help you develop skills which will be helpful to you.
7.  Take the Post Assessment exam. Give the exam to your teacher after you have completed it. Your teacher will grade it for you.

# Introduction

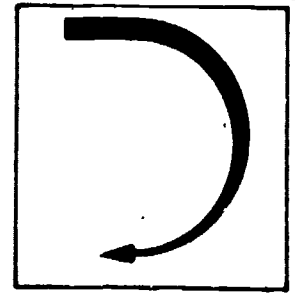

It is very important to learn how to set screeds. The proper installation of screeds--making them the proper thickness and height, even and level or plumb--is directly related to the outcome of the thickness, height, evenness and levelness or plumbness of the finished mortar bed.

# Vocabulary

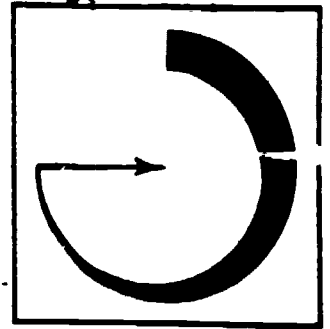

Trade terms are very important for a good understanding of the trade. Study these words and meanings. When you have learned them, ask your teacher to quiz you on the words and their meanings.

**SCREED**--A strip of wood, metal, mortar, or other material applied to a surface. Screeds are used as guides, on which a straightedge is worked to obtain a "true" mortar surface.

**SCREED OFF**--"Screeding off" is the action of working a straightedge, using screeds as guides, to remove excess mortar, to produce a flat, level, smooth finished mortar bed.

**FLOAT STRIP**--A strip of wood from 1/8" to 1/4" thick and 1 1/4" to 1 3/4" wide. It is used as a guide to float mortar surfaces.

**TRANSIT**--A telescope-like instrument; used by surveyers to make accurate readings for construction purposes.

**FLOAT**--The process of applying and screeding off cement mortar.

**MISCELLANEOUS**--[iverse or various things or parts.

# Supplementary References

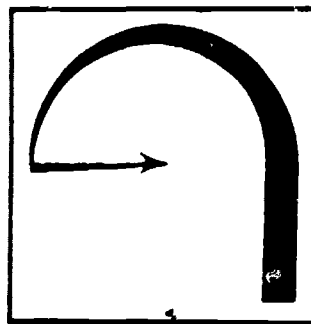

Typesetting Workbook. California Department of Education, 1975. pp. 101-124.

# Information

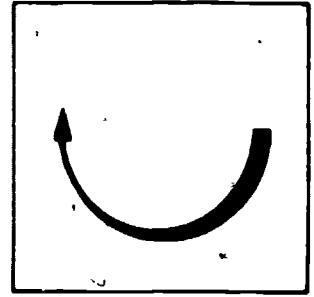

The tilesetter must learn how to perform several different types of screed work and methods.

1. Float strip method
2. Mortar spot method
3. Miscellaneous methods

## FLOAT STRIP METHOD

The float strip method is by far the most often used screed method. It is used for both horizontal and vertical surfaces.

### Vertical surfaces

For vertical surfaces (walls), this, the float strip method, is basically the only method used. Screeds are applied to walls after the walls have been prepared with a backing, a waterproof membrane, and metal lath or a scratch coat. Applying screeds is the first step toward applying the mortar bed.

A vertical float strip screed consists of a ridge of wall mortar that runs from the floor to the desired height of the finished mortar bed. On top of the ridge is a float strip which has been plumbed and set at the proper thickness.

Float strips are usually applied near the end of the walls (close to the corners); this makes it easier to screed off and still keep the strips plumb.

### How to apply vertical float strip screed

1. Mix mortar--mix a batch of cement wall mortar (1 part portland cement to 1-3 parts lime and 3-6 parts sand).
2. Apply mortar ridge--hold mortar on hawk; with flat trowel, apply a full-length vertical mortar ridge (about 3/4" to 1 1/4" thick, by 1 1/2" to 2 1/2" wide) on



each end of wall.

3. Cut and wet float strips--cut float strips to proper length and wet both sides with water. This makes them easier to remove from mortar and to clean.

4. Apply float strips--place float strips in center of ridges and lightly tap into mortar from top to bottom.

5. Plumb--

a) place 4' level on outside of float strip and determine which way float strip must be adjusted to become plumb.

b) place a full-length straightedge against float strip and tap where needed. (Level may be damaged if it is tapped.)

c) take another reading from level, tap where needed to make plumb.

d) continue until full length of float strip is plumb.

e) do same for float strip at other end of wall.

6. Thickness--make sure float strips are proper thickness (refer to module titled "Tile Layout"). If adjustments must be made, make sure strips are plumb when finished.

There are now two float strip screeds that can be used as guides to "float" a cement mortar wall (refer to module titled "Applying Wall and Floor Mortar").

#### Horizontal surfaces

The process for setting float strip screeds on horizontal surfaces (floors, counter tops, etc.) is basically the same as for walls, except floor mortar is used instead of wall mortar and the strips are leveled instead of plumbed.

#### How to apply horizontal float strip screed

1. Prepare surface--properly prepare surface, apply waterproof membrane and metal lath (refer to module titled "Cement Mortar Methods").

2. Mix mortar--mix a batch of cement floor mortar (1 part portland cement to 4-6 parts sand [module titled "Portland Cement Mortar Mixes"]).

3. Determine proper height or thickness--determine the height of finish tile and make screed that height minus the thickness of the tile minus roughly 1/32" for the bond coat.

4. Apply mortar ridge--pour mortar out of bucket in a line where screed will go. With wood float or flat trowel, form and compact a straight ridge roughly 1 1/2" to 2" wide and 1/2" higher than finish screed will be.

5. Cut to length and wet both sides of float strips

6. Apply float strips--place float strips in center of ridges and lightly tap full length into mortar.

7. Height and level--place straight edge on float strip; with rubber mallet, tap end of screed to proper height. Tap entire length of strip to correct screed level. (Again, tap on straight edge, not on level.) Perform same procedure for all other screeds in order to make a good, solid riding surface for the straight edges when screeding off.

It is now ready to be "floated."

#### MORTAR SPOT METHOD

The mortar spot method is generally used only for large floor areas. Spots of floor mortar are set in line at certain intervals on the floor. With a water level (module titled "Layout and Leveling Tools") or transit, the spots are leveled to the correct height. The spots are then used as guides for the straight edges after they are tamped firmly with a wood float.

The proper height can be determined by floating a small test section, laying a tile or sheet of tile, and beating it down with a rubber mallet and beating block. When mortar spots are being used, extreme care must be taken not to dig below or ride above them when screeding off.

After all the mortar spot screeds are set, the mortar is poured in between the screeds and the floor floated.

#### MISCELLANEOUS METHODS

EXAMPLE: For a cement mortar counter top, a reinforcing, punched metal trim strip doubles as a screed strip on the face, and a wood strip nailed near the back wall is used as the opposite screed strip. By running a straight edge over the two, the tilesetter can screed off and float the counter top (refer to the module titled "Counter Tops").

EXAMPLE: For very large floors, screeds (usually made of metal) can be raised and secured above the mortar surface. A special straight edge is used to screed off the mortar. Once the mortar sets, the screeds can be removed. Only tilesetters doing large commercial work will use this method. (See illustration top of next page )

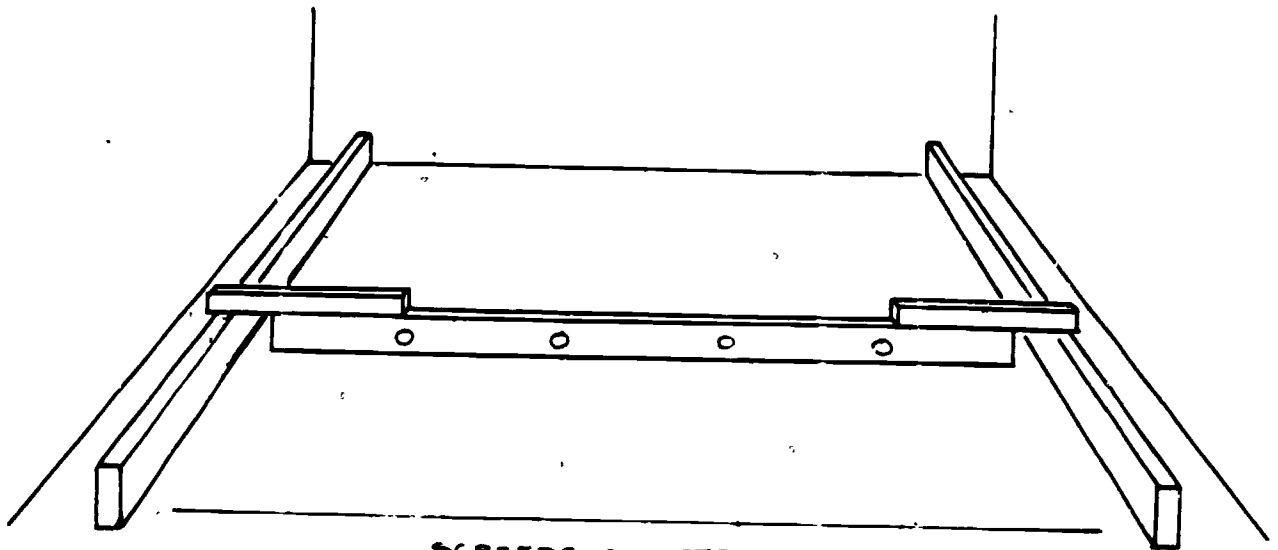

SCREEDS AND STRAIGHTEDGE  
IN PLACE FOR SCREEDING OFF

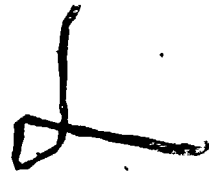

EXAMPLE: For mortar areas such as fireplace hearths, wood screeds can be used both as a screed and as a form for the mortar.

# Self Assessment

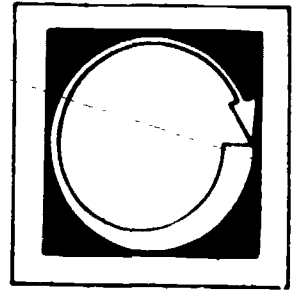

COMPLETE THE FOLLOWING STATEMENTS BY WRITING THE CORRECT WORD OR WORDS IN THE BLANKS PROVIDED.

1. The \_\_\_\_\_ method is the most often used screed method.
2. For walls, the \_\_\_\_\_ method is basically the only method used.
3. For walls, the float strips need to be plumb and for floors, \_\_\_\_\_.
4. To make adjustments in the plumbness or levelness of the float strips, tap on a straightedge, never on a \_\_\_\_\_.
5. The \_\_\_\_\_ method is generally only used for large floor areas.
6. A \_\_\_\_\_ or transit is used to make spots of mortar level with each other.

# Self Assessment Answers

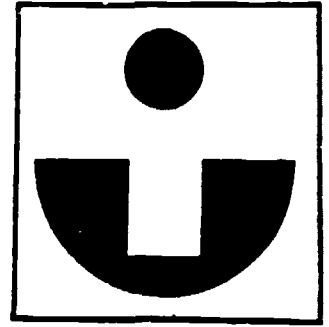

1. float strip
2. float strip
3. level
4. level
5. mortar spot
6. water level

# Job Sheet

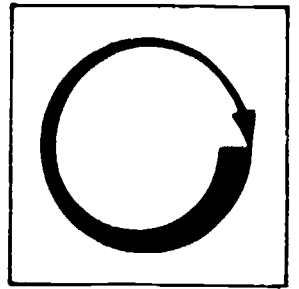

COMPLETE THE FOLLOWING TASKS.

## Materials and Tools

mortar box and mortar hoe

access to water

sand, cement, and lime (small amount)

two large (3 1/2 gallon) buckets

four 1/8" to 1/4" thick (at least 6' long) float strips

one 6' long wooden straightedge

3' to 4' level

rubber mallet

wooden float

flat trowel

hawk

metal lath or wire mesh (chicken wire)

staple gun or hammer and nails

tape measure

1. Set both vertical and horizontal float strip screeds. Use the information and procedure in this module to perform
  - a. Vertical screeds: Set two parallel 6-foot-long float strip screeds about 3 feet apart. Attach to a temporary backing some metal lath or wire mesh and set the screeds over it.
  - b. Horizontal screeds: Set two parallel 6-foot-long float strip screeds about 3 feet apart. Set on any temporary surface that can be cleaned up when finished. Make sure strips are same thickness and are level.

# Post Assessment

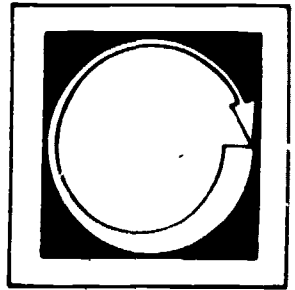

WRITE AN ANSWER TO THE FOLLOWING QUESTIONS CONCERNING THE JOB SHEET.

1. Which did you find harder to set--the horizontal or vertical float strips? Why?
2. Applying mortar from the hawk to the flat trowel to the wall to make a mortar ridge for the screed takes a lot of practice and can be difficult. Explain what problems you had during the procedure.

LISTED BELOW ARE SEVERAL STATEMENTS. IF THE STATEMENT IS TRUE, PLACE A "T" IN THE BLANK PROVIDED. IF THE STATEMENT IS FALSE, PLACE AN "F" IN THE BLANK.

3. \_\_\_ Screeds are not used as guides, but as a means of removing excess mortar to produce a flat, smooth mortar bed.
4. \_\_\_ A transit is a telescope-like instrument used to make accurate readings.
5. \_\_\_ A float strip is made of thin, straight metal so it can be used over and over.
6. \_\_\_ Floating is the process of applying and screeding off cement mortar.
7. \_\_\_ Screeding off is the action of working a straightedge to remove excess mortar.

# Instructor Post Assessment Answers

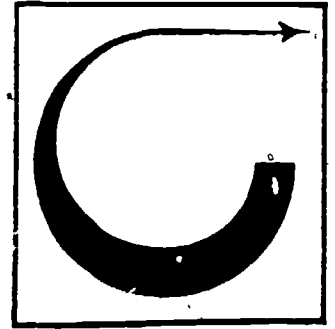

3. F

4. T

5. F

6. T

7. T



## FLOOR AND WALL INSTALLATION METHODS

### **Goal:**

The student will be able to identify, select, and explain the use of commonly used tile installation methods for floors and walls.

### **Performance Indicators:**

The student will successfully complete the Self Assessment, an Assignment and the Post Assessment.



# Study Guide

In order to finish this module, do the following tasks. Check each item off as you complete it.

1. \_\_\_ Read the Goal and Performance Indicators on the cover of the module. This will tell you what you will learn by studying the module, and how you will show you've learned it.
2. \_\_\_ Read the Introduction. The Introduction will tell you why the module is an important part of the tilesetting trade.
3. \_\_\_ Study the Vocabulary section. Vocabulary words are important for a good understanding of the trade. After you have studied the vocabulary, ask your teacher to quiz you on the words and their meanings.
4. \_\_\_ Study the Information section. This section will give you the information you need to understand the subject.
5. \_\_\_ Take the Self Assessment exam. This is a test for you to prove to yourself that you have learned the material you have studied. Compare your answers with the answers on the Self Assessment Answer Sheet, which is on the page following the Self Assessment. If you scored poorly, re-study the Information section or ask your teacher for help.
6. \_\_\_ Do the Assignment page. Follow the instructions at the top of the Assignment page.
7. \_\_\_ Take the Post Assessment exam. Give the exam to your teacher after you have completed it. Your teacher will grade it for you.

# introduction

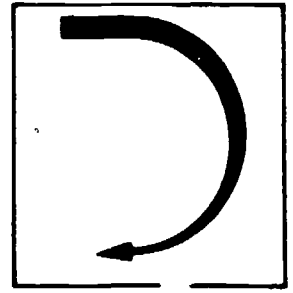

This module covers different installation methods for walls and floors. Some methods are better than others and some are required for certain conditions. Tilesetters need to be able to identify and select the best method for existing conditions in order to produce a strong tile installation that will last many years.

# Vocabulary

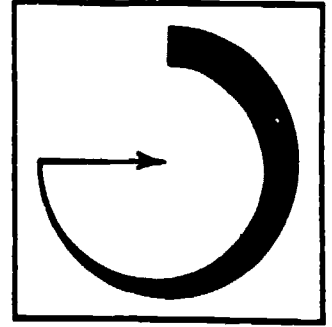

Trade terms are very important for a good understanding of the trade. Study these words and meanings. When you have learned them, ask your teacher to quiz you on the words and their meanings.

**SPECIFICATION**--Designed for a particular purpose (e.g. building codes).

**STRUCTURAL**--Relating to the structure of a building; the materials used and the way a building is constructed.

**EROSION**--To wear away by the action of water, wind or ice.

**CONDUCTIVE**--The quality of being able to transmit electricity.

**FLASHING**--Sheet metal used to waterproof roof valleys or hips, or the angle between a chimney and a roof.

# Supplementary References

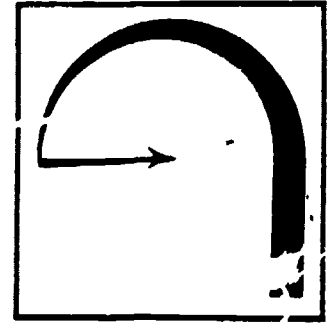

1. Handbook for Ceramic Tile Installation. Tile Council of America, Inc., 1980.  
p. 11-31.

# Information

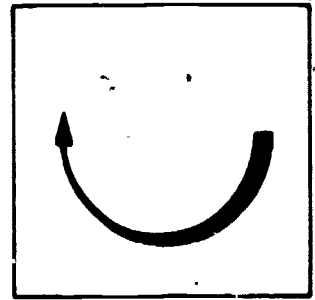

Before starting any certain method of installation, a qualified tilesetter will know that the ceramic tile installation must conform to local building codes, trade practices and climatic conditions. If these 3 factors are considered, he or she is almost certain to end up with the best possible installation.

The installation methods have been broken down into 4 broad categories:

1. Floors, interior
2. Floors, exterior
3. Walls, interior
4. Walls, exterior

## FLOORS, INTERIOR

The following few pages cover 15 different installation methods for interior floors, their recommended uses and the requirements. Numbers 1-11 have concrete sub-floors; numbers 12-15 have wood subfloors.

1. cleavage membrane, metal reinforcing, mortar bed, bond coat, tile

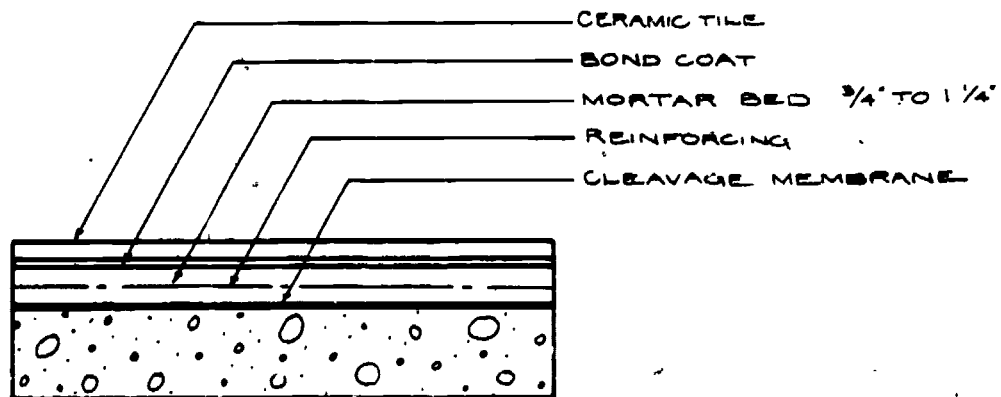

RECOMMENDED USES: over structural floors that are subject to bending and moving.

REQUIREMENTS:

- a) metal reinforcing has to be used
- b) mortar bed thickness needs to be uniform
- c) mortar bed should be at least  $1\frac{1}{4}$ " thick
- d) use thinset mortar with additive for best bond

2. mortar bed, bond coat, tile

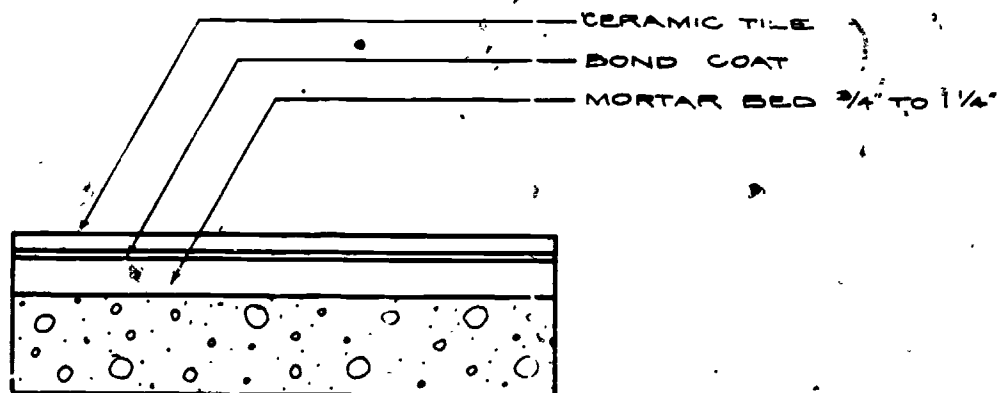

RECOMMENDED USES: on concrete slab where no bending stresses occur, also on smaller areas

REQUIREMENTS:

- a) mortar bed should be at least  $1\frac{1}{4}$ " thick and uniform
- b) thinset mortar with additive should be used, for best bond

3. bond coat, tile

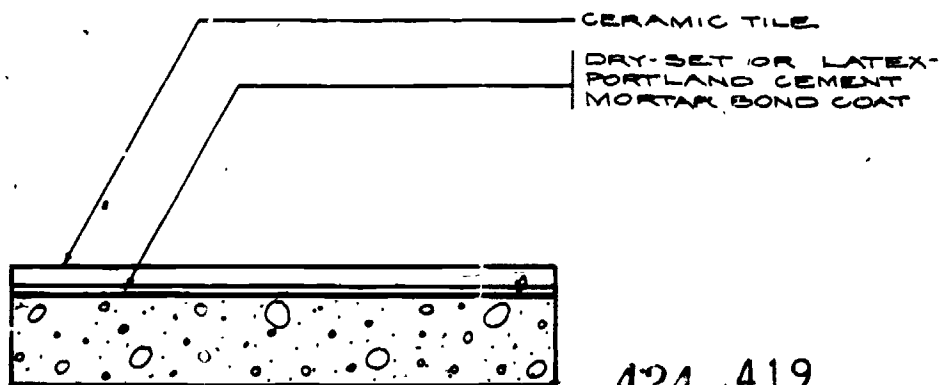

RECOMMENDED USES: on plain, clean concrete, or on concrete slab where no bending stresses occur (expansion joints used where needed)

REQUIREMENTS:

- a) concrete slab to be well cured, free from cracks, waxy or oily films and sealers
  - b) thinset mortar with additive for best bond
4. cleavage membrane, metal reinforcing, mortar bed, bond coat, epoxy or furan grout, tile

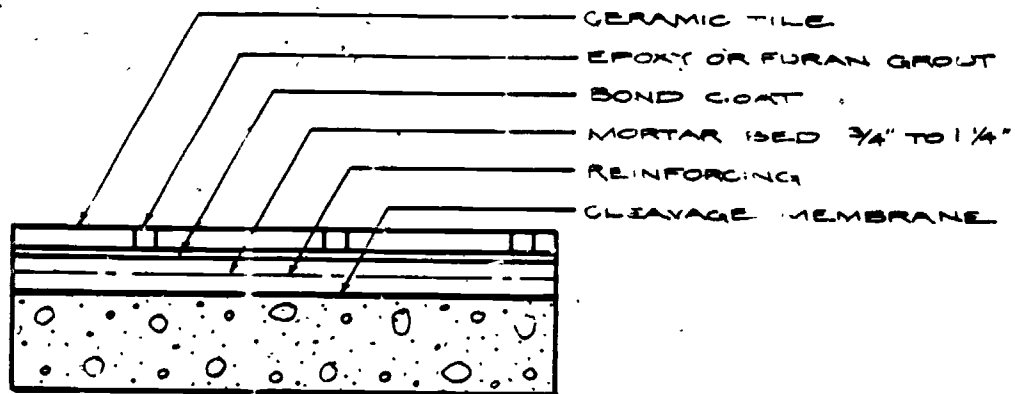

RECOMMENDED USES: for floors that require good strain resistance and resistance to erosion caused by occasional contact with mild chemicals like those found in restaurants, photo darkrooms, public toilets, or for use with quarry tile and paver tiles

REQUIREMENTS:

- a) tile surface must be totally waxed if furan grout is used to grout
- b) use thinset mortar to bond



5. bond coat, epoxy or furan grout, tile

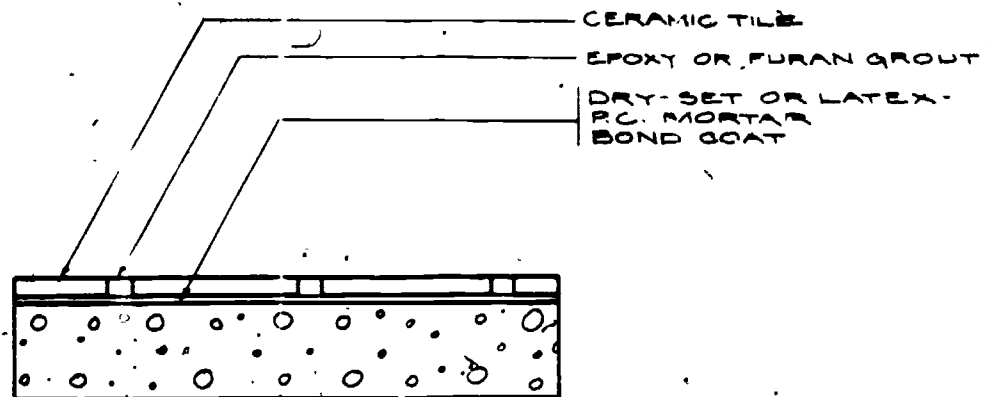

RECOMMENDED USES: same as No. 3 and No. 4

REQUIREMENTS: same as No. 4

6. mastic bond coat, tile

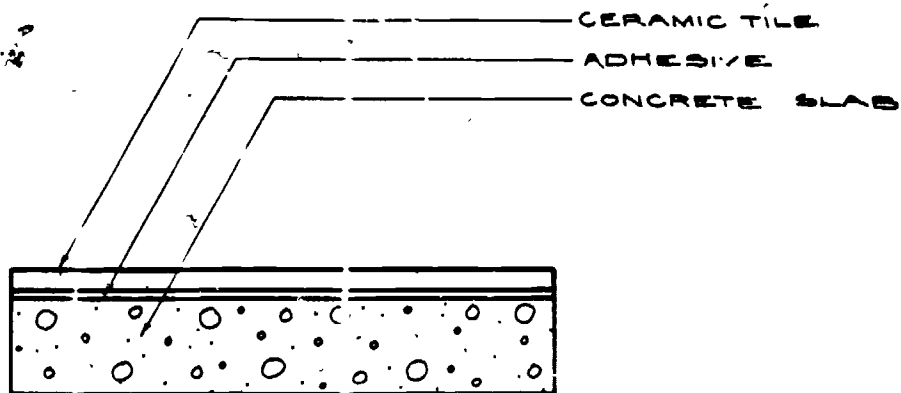

RECOMMENDED USES: for use over concrete floors in residential construction only

LIMITATIONS: will not withstand high impact or wheel loads; mastic is not recommended for areas exposed to temperatures above 140°

REQUIREMENT:

a) concrete slab to be well-cured, free of cracks, waxy or oily films, sealers

7. waterproof membrane, metal reinforcing, mortar bed, bond coat, tile

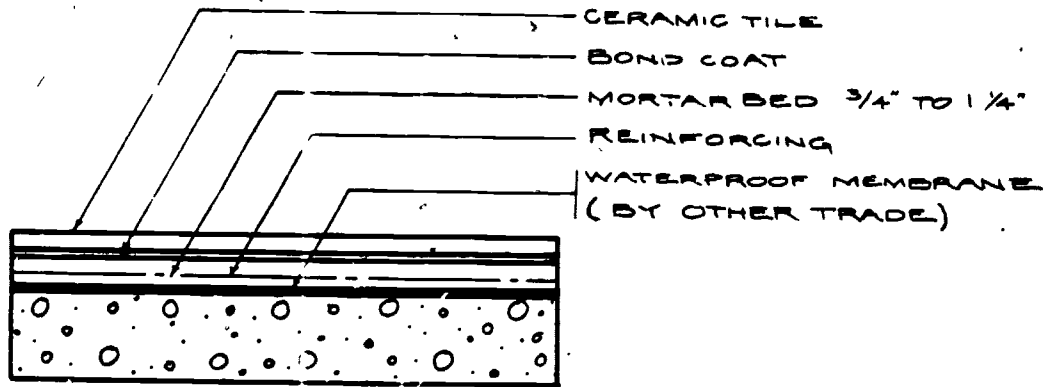

RECOMMENDED USES: wherever a positively waterproof interior floor is required, or over structural floors subject to bending or moving

REQUIREMENTS:

- a) metal reinforcing is mandatory
- b) mortar bed must be at least 1 1/4" thick and uniform

8. conductive cement mortar method

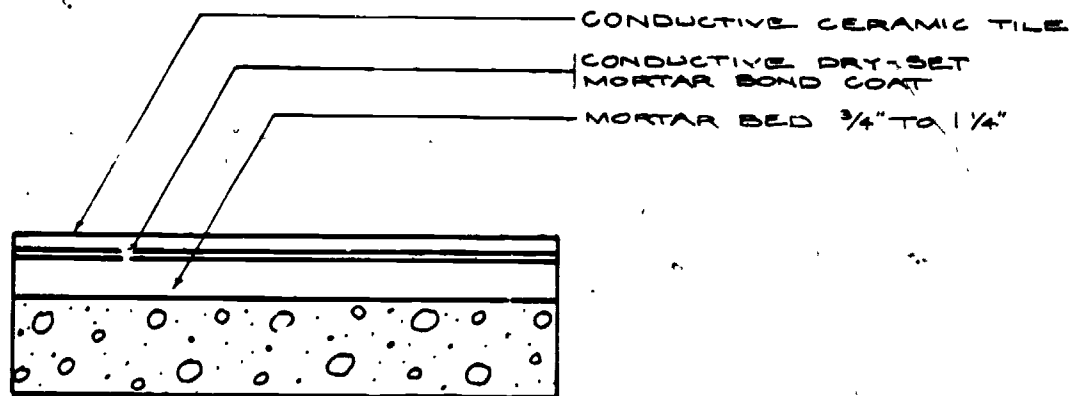

RECOMMENDED USES: preferred method of installing conductive tile in new construction, in hospital operating rooms, labs, etc.; perimeter expansion joints recommended

REQUIREMENTS:

- a) concrete slab must not exceed a variation of 1/4" in height for every 10 feet
- b) mortar bed should be damp cured for 3 days under vapor-proof membrane, and allowed to dry 4 additional days before installing tile

- c) mortar bed must not exceed a variation of 1/8" for every 10 feet
- d) use expansion joints where required

9. chemical resistant mortar method: epoxy mortar bond coat, epoxy grout, tile

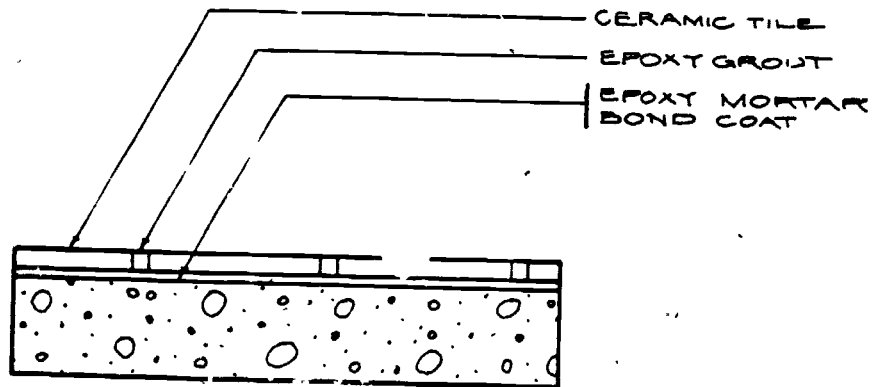

RECOMMENDED USES: where moderate chemical exposure and severe cleaning methods are used, such as in commercial kitchens, dairies

LIMITATIONS: for severe chemical exposure and where complete protection is needed, refer to No. 11

REQUIREMENTS:

- a) uniform, structurally sound sub-floor
- b) surfaces to receive epoxy mortar must be free of sealers, wax, etc, and must be dry

10. chemical resistant mortar method: mortar bed, epoxy mortar bond coat, epoxy grout, tile

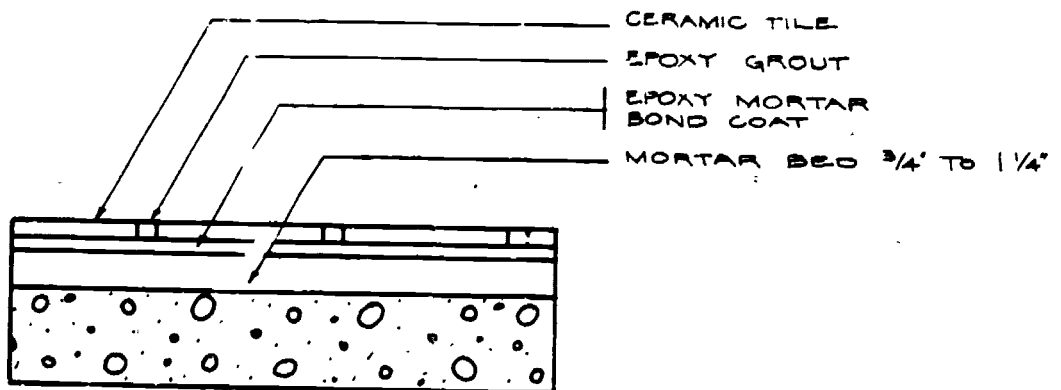

RECOMMENDED USES: where leveling of sub-floor is required, where moderate chemical exposure and severe cleaning methods are used

LIMITATIONS: same as No. 9

REQUIREMENTS: same as No. 9 (over structural floors subject to bending or moving, use cleavage membrane under mortar bed--No. 1)

11. most chemical-resistant mortar method: mortar bed or concrete over sub-floor,  $\frac{1}{4}$ " thick acid-proof membrane, acid-proof mortar, acid-proof grout,  $1\frac{1}{2}$ "-thick packing house tile

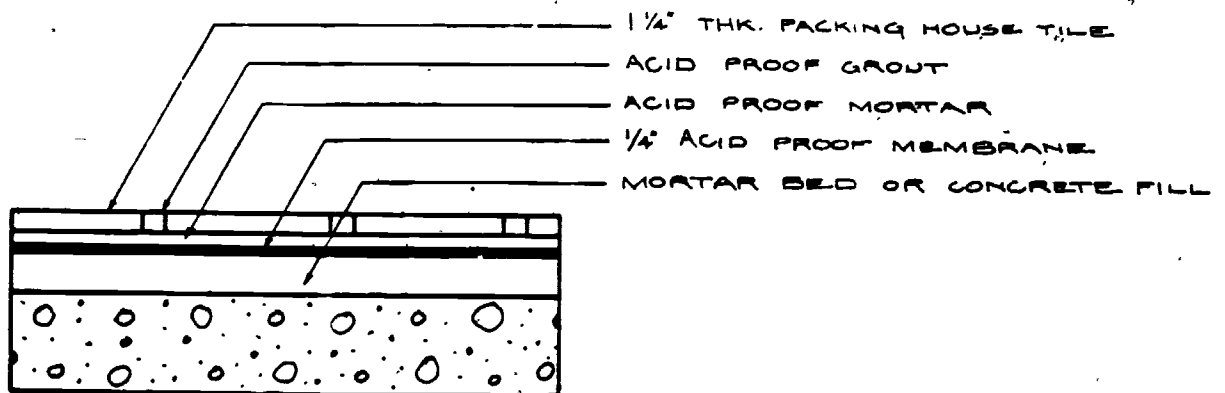

RECOMMENDED USES: for setting  $1\frac{1}{2}$ " thick packing house tile in areas of continuous or severe chemical exposure where protection against leakage or damage to concrete sub-floor is required

REQUIREMENTS:

- requires acid-proof membrane
- structurally sound sub-floor
- use epoxy or furan acid-proof grout and thinset mortar to bond

FOLLOWING ARE WOOD SUB-FLOOR METHODS

12. cleavage membrane, metal reinforcing, mortar bed, bond coat, tile

(See illustration top of next page.)

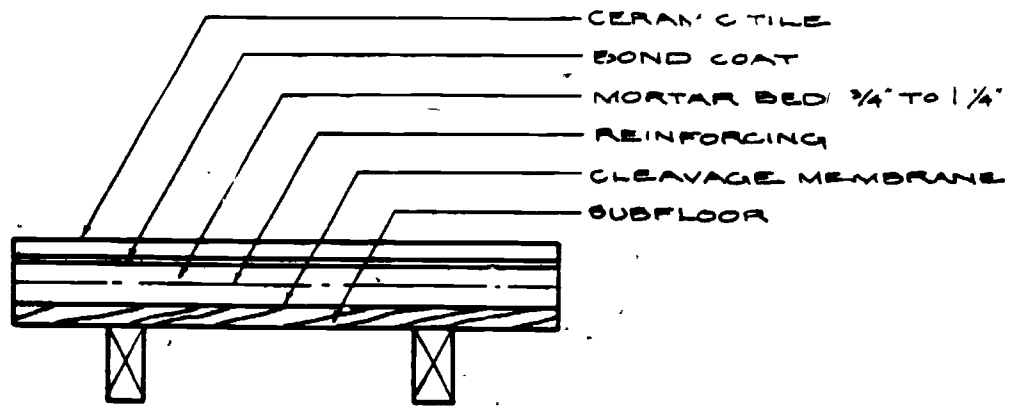

RECOMMENDED USES: over all wood floors that are structurally sound

REQUIREMENTS:

- a) metal reinforcing and cleavage membrane are required
- b) best bond with thinset mortar

13. double wood floor, mastic bond coat, tile

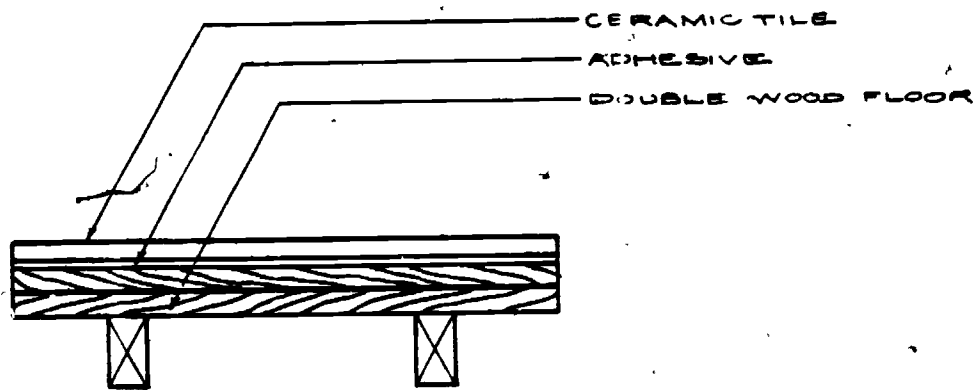

RECOMMENDED USES: over wood floors exposed to residential traffic only  
 (for heavier traffic, use no. 12 )

LIMITATIONS: will not withstand high impact or wheel loads, not recommended  
 for use in wet areas

REQUIREMENTS:

- a) double wood floor is required
- b) grout should have hardener additive, or use epoxy grout

14. double wood floor, gap between plywood sheets, epoxy mortar bond coat, epoxy grout, tile

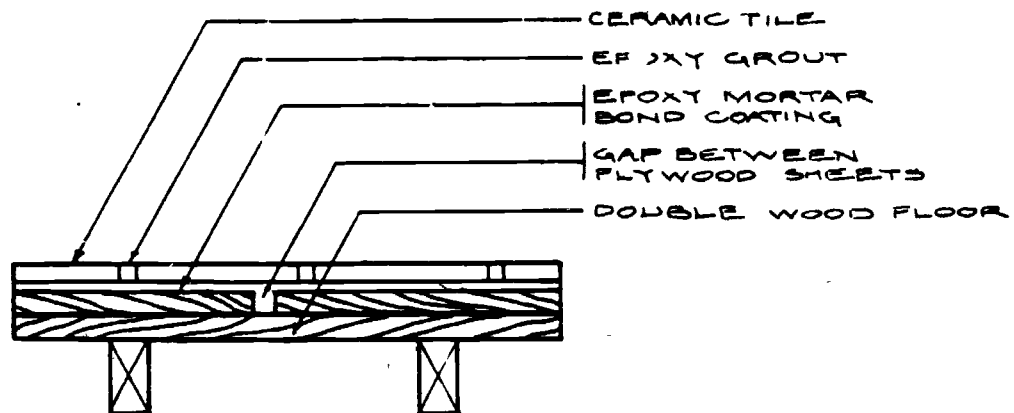

RECOMMENDED USES: over wood floors where heavy residential, normal commercial and light institutional use is desired; also where water, chemical and stain resistance is desired

REQUIREMENTS:

- a) double wood floor, except in residential use
- b) gap in top layer of exterior grade plywood required, and to be filled in with epoxy when spread for setting tile

15. plywood sub-floor, wonderboard, thinset mortar bond coat, tile

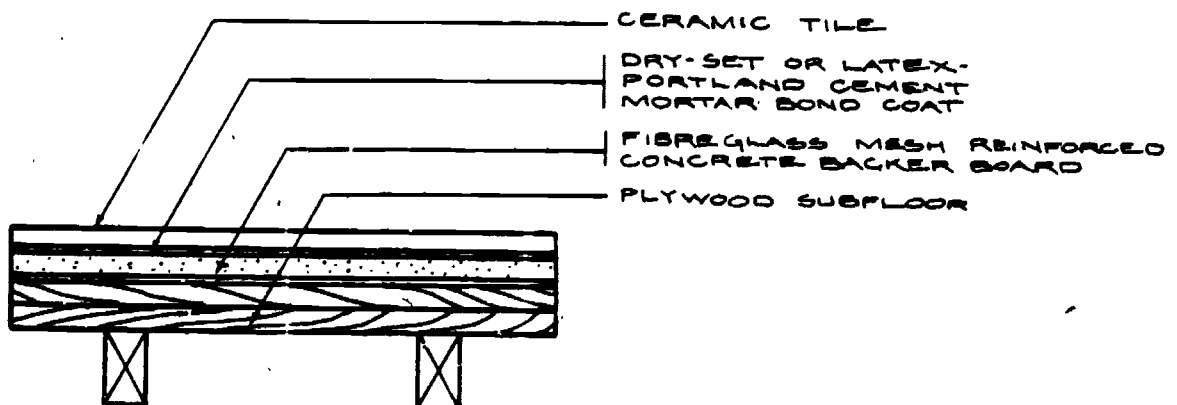

RECOMMENDED USES: over structurally sound plywood and where light weight construction is desired; also when water resistance is desired

REQUIREMENTS:

- a) only use thinset mortar with additive
- b) waterproof membrane required if a waterproof floor is desired
- c) surface to be clean and free of dirt, dust or oily film
- d) used galvanized nails or screws to fasten wonderboard to plywood

FLOORS, EXTERIOR

Following are 2 different installation methods for exterior floors, their recommended uses and requirements. PATIOS AND WALKWAYS are covered.

1. gravel bed, concrete slab, mortar bed, bond coat, tile

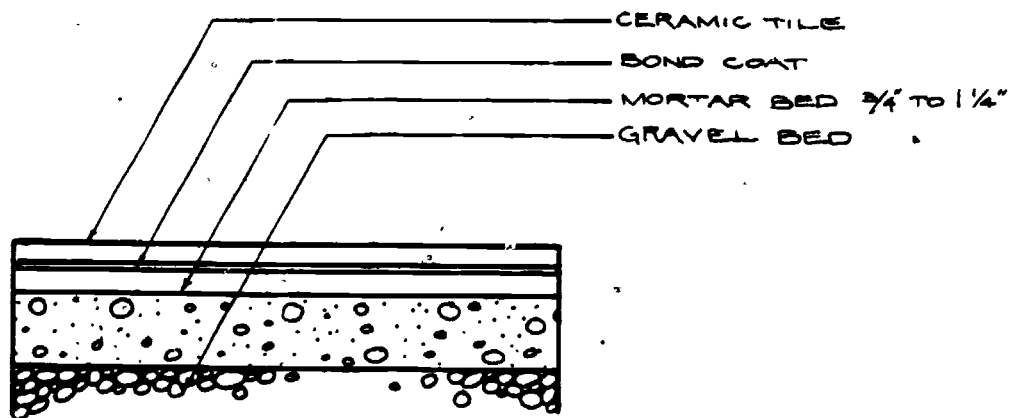

RECOMMENDED USES: exterior floors, decks or patios where membrane is not used and where positive drainage below slab is provided

REQUIREMENTS:

- a) sloped slab required to provide complete drainage
- b) gravel bed or other means of drainage is required below concrete slab
- c) expansion joints are mandatory
- d) cover completed tile work and keep damp for 7 days

2. gravel bed, concrete slab, thinset mortar with additive bond coat, tile

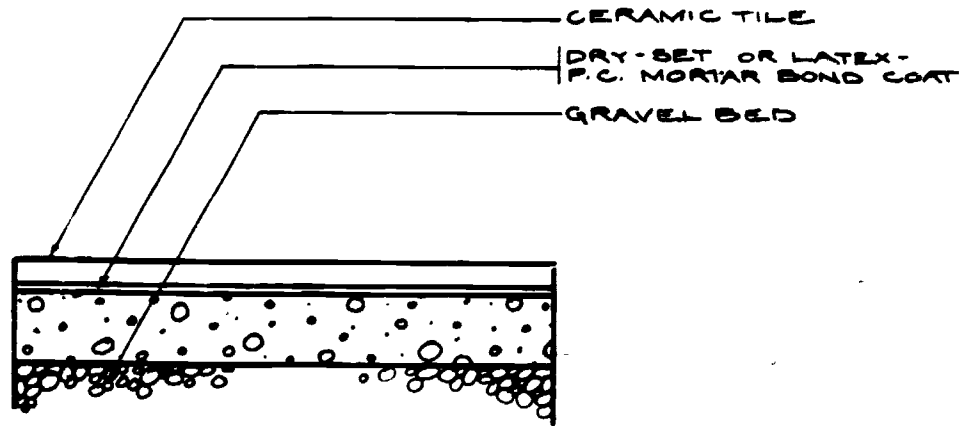

RECOMMENDED USES: exterior floors, decks or patios where membrane is not used and where positive drainage below slab is provided

REQUIREMENTS: same as exterior No. 1

### WALLS, INTERIOR

Following are 8 different installation methods for interior walls, their recommended uses and requirements.

1. masonry or concrete backing, mortar bed, latex or acrylic thinset bond coat, tile

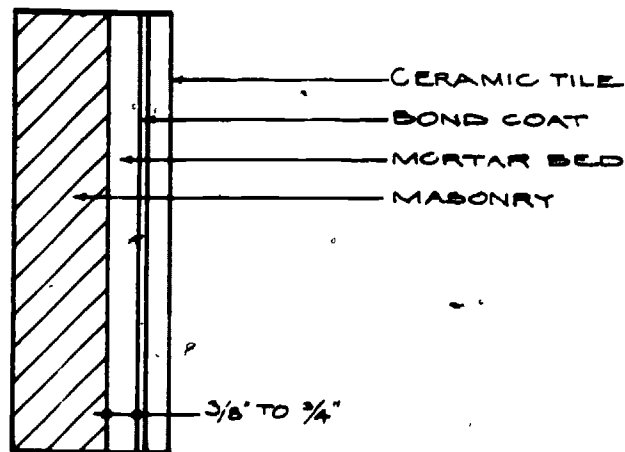

RECOMMENDED USES: over clean, sound, stable masonry or concrete



LIMITATIONS: do not use if surface is cracked

REQUIREMENTS:

- a) a patch coat is required if surface is irregular or if mortar bed thickness exceeds 3/4"

- 2. masonry or concrete backing, leveling coat, latex or acrylic thinset mortar bond coat, tile

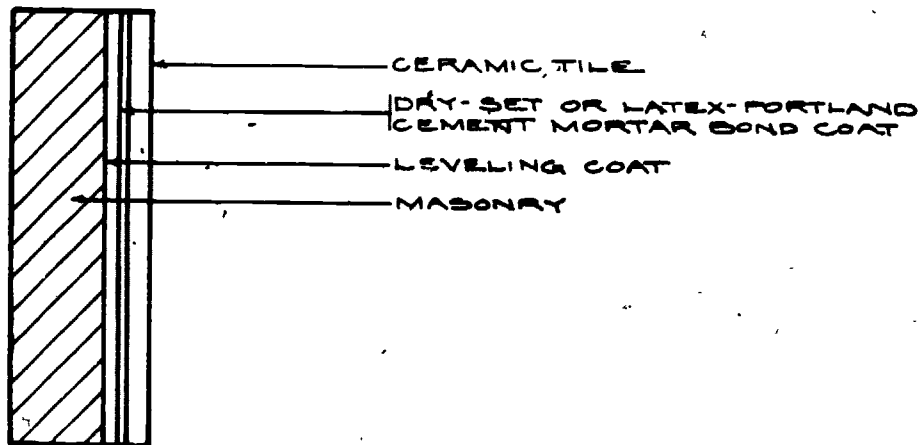

RECOMMENDED USES: over clean, sound, stable concrete or masonry if it varies more than 1/4" in 8 feet.

LIMITATIONS: do not use over cracked surface

REQUIREMENTS:

- a) level coat should be plumb, even, and allowed to cure at least 24 hours before tile is applied

- 3. masonry or wonderboard backing, latex or acrylic thinset mortar bond coat, tile

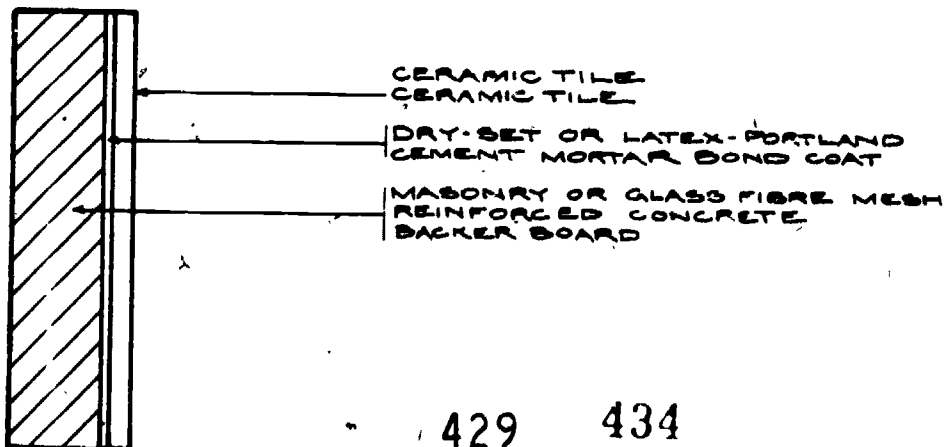

RECOMMENDED USES: over clean, sound, stable masonry or wonderboard

LIMITATIONS: same as No. 1 and No. 2

REQUIREMENTS:

a) surface must be plumb and even

4. two-coat method: solid backing, wood, plaster, masonry or gypsum board, waterproof membrane, metal lath, scratch coat, mortar bed, thinset mortar bond coat, tile

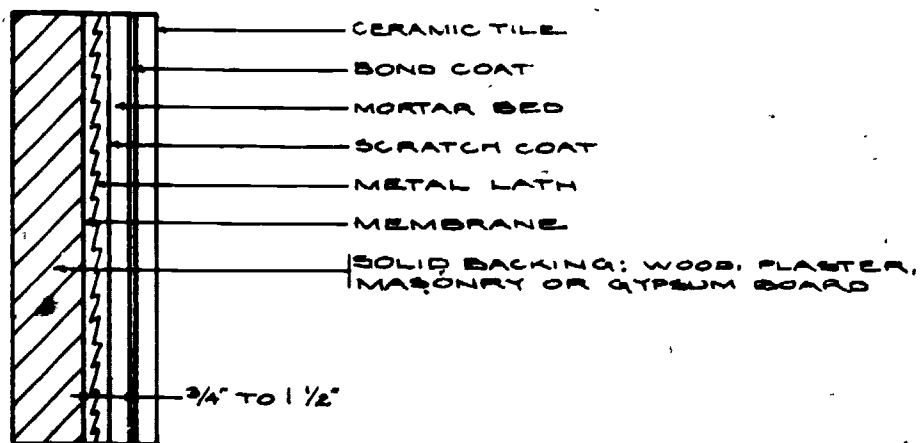

RECOMMENDED USES: over solid backing where metal lath can be firmly fastened; also ideal for remodeling or on surfaces that present bonding problems.

REQUIREMENTS:

a) cut metal lath at all expansion joints

5. one-coat method: solid backing (wood, plaster, masonry, or gypsum board over wood or metal studs), waterproof membrane, metal lath, mortar bed, bond coat, tile

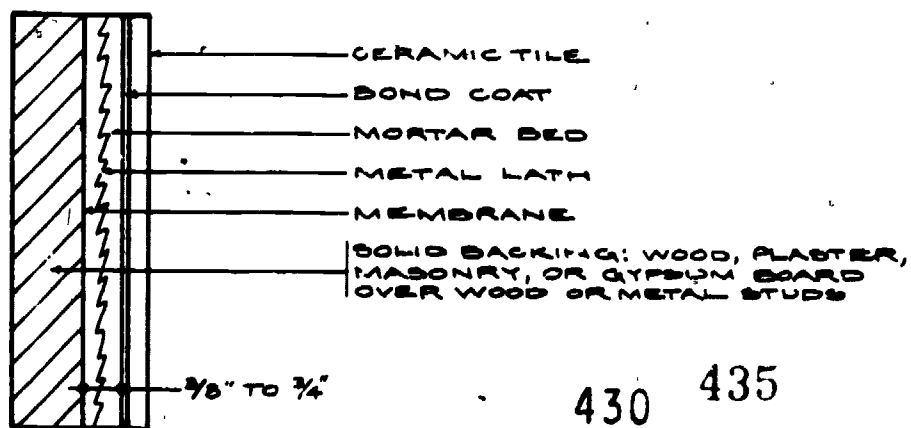

RECOMMENDED USES: over solid backing; ideal for remodeling; ideal for remodeling where space is limited; preferred method of applying tile over gypsum board in showers and mortar tub enclosures

REQUIREMENTS:

a) same as No. 4

6. solid backing (plaster, masonry or gypsum board over wood or metal studs), mastic, tile

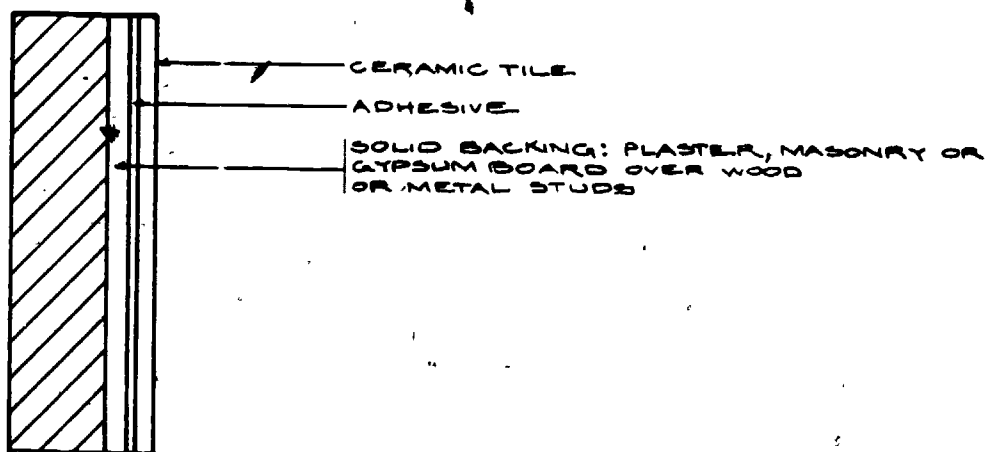

RECOMMENDED USES: over clean, smooth and even interior surfaces; popular method of applying tile over gypsum board in tub enclosures.

LIMITATIONS: mastic is not recommended in areas that exceed 140°

REQUIREMENTS:

a) surface must not be irregular

7. studs: wood studs, waterproof membrane, metal lath, scratch coat, mortar bed, bond coat, tile (over metal studs, no membrane is needed)

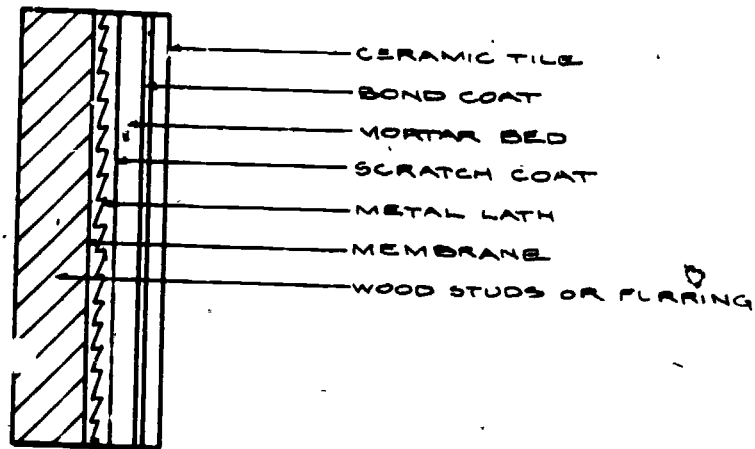

RECOMMENDED USES: over dry wood studs; preferred method of installation over wood studs in showers and tub enclosures.

REQUIREMENTS:

a) wood studs must be protected with waterproof membrane

8. wood or metal studs, gypsum board, mastic, tile

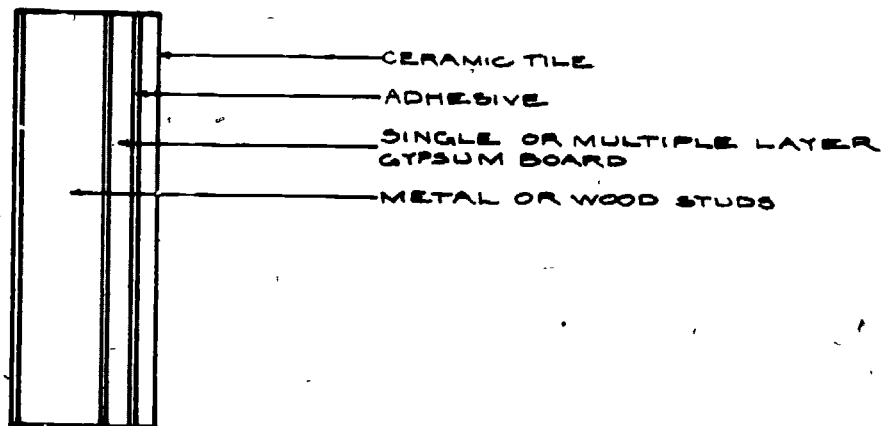

RECOMMENDED USES: over clean, smooth and even interior surfaces; preferred method of applying tile over W/R gypsum board in tub enclosures.

LIMITATIONS: mastic is not recommended in areas that exceed 140°

REQUIREMENTS:

a) W/R gypsum board should be 1/2" minimum thickness

## WALLS, EXTERIOR

Following are 2 different installation methods for exterior walls.

1. masonry backing, waterproof membrane, metal lath, scratch coat, mortar bed, bond coat, tile

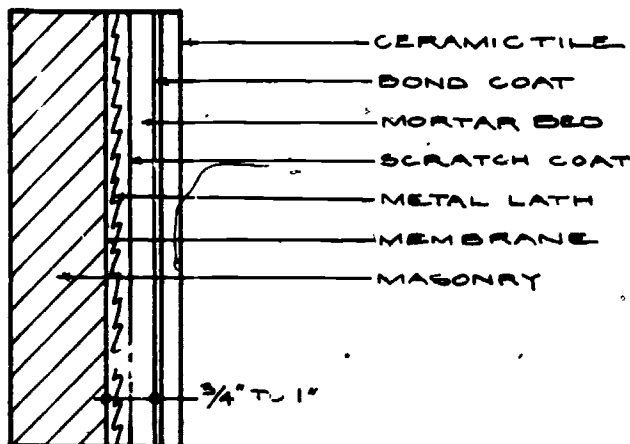

RECOMMENDED USES: over exterior masonry or concrete surfaces.

### REQUIREMENTS:

- a) flashing and membrane are necessary to exclude moisture from mortar bed
- b) expansion joints are mandatory
- c) cut metal lath at all expansion joints
- d) a scratch coat is not required if backing is plumb and even and mortar bed does not exceed 3/4" thickness

2. masonry backing, latex or acrylic thinset mortar, bond coat, tile

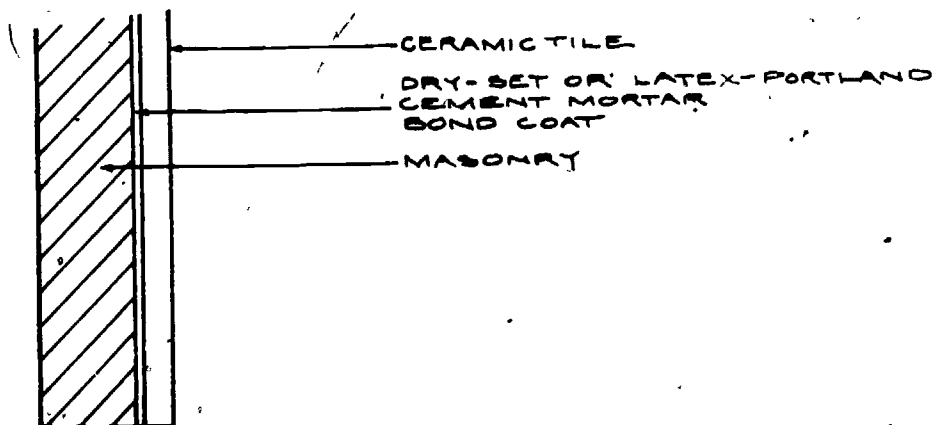

RECOMMENDED USES: over clean, sound, stable masonry or concrete

LIMITATIONS: do not use over cracked surface

REQUIREMENTS:

- a) surface must be free of coatings, oil, wax
- b) expansion joints are often required

# Self Assessment

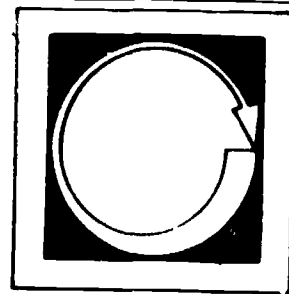

LISTED BELOW ARE SEVERAL STATEMENTS. IF THE STATEMENT IS TRUE, PLACE A "T" IN THE BLANK PROVIDED. IF THE STATEMENT IS FALSE, PLACE AN "F" IN THE BLANK.

1. \_\_\_ Concrete-mastic-tile is a preferred method for exterior walls.
2. \_\_\_ The two-coat cement mortar method can be used successfully for interior and exterior applications.
3. \_\_\_ The conductive cement mortar method may be used in hospital operating rooms.
4. \_\_\_ 1/4" thick acid-proof membrane, acid-proof mortar, acid-proof grout and 1 1/4" thick packing house tile should be the method used in residential construction.
5. \_\_\_ The one-coat mortar method for interior walls is ideal for remodel construction and is a preferred method of applying tile over W/R gypsum board in showers.
6. \_\_\_ Tile bonded with mastic to W/R gypsum board is a popular method for tub enclosures.

# Self Assessment

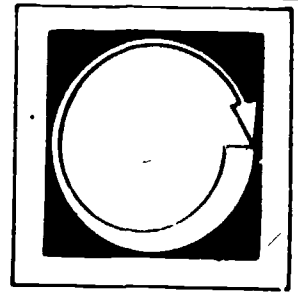

LISTED BELOW ARE SEVERAL STATEMENTS. IF THE STATEMENT IS TRUE, PLACE A "T" IN THE BLANK PROVIDED. IF THE STATEMENT IS FALSE, PLACE AN "F" IN THE BLANK.

1.  Concrete-mastic-tile is a preferred method for exterior walls.
2.  The two-coat cement mortar method can be used successfully for interior and exterior applications.
3.  The conductive cement mortar method may be used in hospital operating rooms.
4.  1/4" thick acid-proof membrane, acid-proof mortar, acid-proof grout and 1 1/4" thick packing house tile should be the method used in residential construction.
5.  The one-coat mortar method for interior walls is ideal for remodel construction and is a preferred method of applying tile over W/R gypsum board in showers.
6.  Tile bonded with mastic to W/R gypsum board is a popular method for tub enclosures.



# Self Assessment Answers

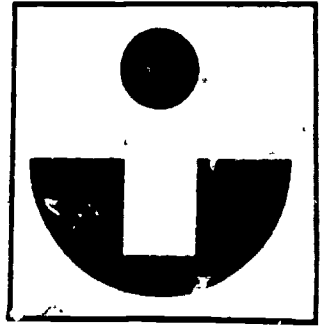

1. F
2. T
3. T
4. F
5. T
6. T

# Assignment

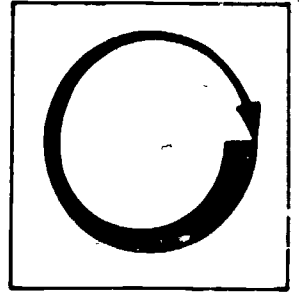

COMPLETE THE FOLLOWING ASSIGNMENTS.

Check out at least 3 different construction sites.

- A. A residential site: House, apartment, etc.
  - B. A commercial site: Any large construction project--hospital, school, store, etc.
  - C. A remodel site of any size job.
- 
1. For each one, decide what would be the best installation method to use for the largest floor and wall area in the building. Also determine at least one more good alternative method that could be used.
  2. Write down the type of backing or existing wall and floor the tile installation would be applied to (plywood, masonry, gypsum board, etc.) and what type of condition it is in (smooth, rough, old, new).

There will be a total of six methods you have to select and write information on: A wall and floor installation method for each of the 3 buildings.

# Post Assessment

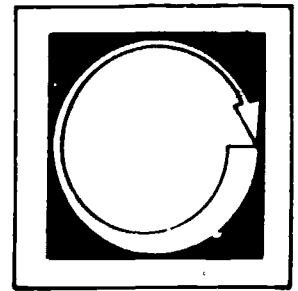

WRITE AN ANSWER TO THE FOLLOWING QUESTIONS CONCERNING THE ASSIGNMENT.

1. What were the buildings you chose for the residential, commercial and remodel construction site? (House, dairy, hospital, etc.)
2. What was the type of backing (in each building) of the floor and wall you chose?
3. What type of condition was each one in? Explain.
4. What were other contributing factors in choosing the method for each of the 6?

LISTED BELOW ARE SEVERAL STATEMENTS. IF THE STATEMENT IS TRUE, PLACE A "T" IN THE BLANK PROVIDED. IF THE STATEMENT IS FALSE, PLACE AN "F" IN THE BLANK.

5. \_\_\_\_ Erosion of the side of a hill is when the hill slowly wears away and diminishes.
6. \_\_\_\_ The structural characteristics of a building have to do with the furnishings and interior design of the building.

7. \_\_\_ Something conductive has the quality of being able to transmit electricity.
8. \_\_\_ Flashing is made of plastic and got its name from people who run around naked (or wrapped in clear plastic) during public gatherings.

# ● Instructor Post Assessment Answers

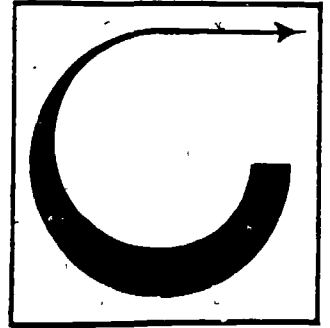

5. T

6. F

7. T

8. F

---

APPLYING WALL AND FLOOR MORTAR

**Goal:**

The student will be able to apply wall and floor mortar.

**Performance Indicators:**

The student will successfully complete a Self Assessment, a Job Sheet and a Post Assessment.

441

447

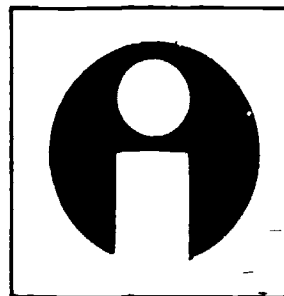

# Study Guide

In order to finish this module, do the following tasks. Check each item off as you complete it.

1.  Read the Goal and Performance Indicators on the cover of the module. This will tell you what you will learn by studying the module, and how you will show you've learned it.
2.  Read the Introduction. The Introduction will tell you why the module is an important part of the tilesetting trade.
3.  Study the Vocabulary section. Vocabulary words are important for a good understanding of the trade. After you have studied the vocabulary, ask your teacher to quiz you on the words and their meanings.
4.  Study the Information section. This section will give you the information you need to understand the subject.
5.  Take the Self Assessment exam. This is a test for you to prove to yourself that you have learned the material you have studied. Compare your answers with the answers on the Self Assessment Answer Sheet, which is on the page following the Self Assessment. If you scored poorly, re-study the Information section or ask your teacher for help.
6.  Do the Job Sheet. Follow the instructions at the top of the Job Sheet. The tasks listed on the Job Sheet will help you develop skills which will be helpful to you.
7.  Take the Post Assessment exam. Give the exam to your teacher after you have completed it. Your teacher will grade it for you.

# Introduction

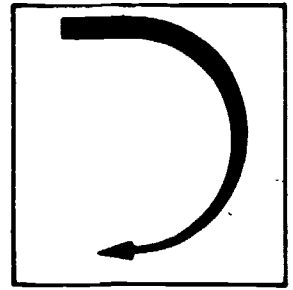

This module covers the step-by-step procedures involved in applying wall and floor mortar, using float strip screeds.

Applying mortar--especially wall mortar--takes lots of practice, and is considered one of the bread-and-butter skills of the tilesetting trade.



# Vocabulary

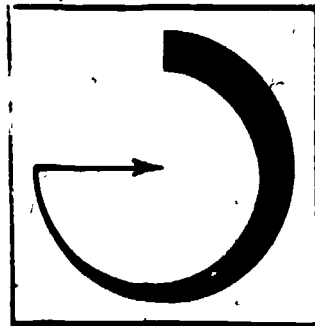

Trade terms are very important for a good understanding of the trade. Study these words and meanings. When you have learned them, ask your teacher to quiz you on the words and their meanings.

**EYEBALLING**--Looking at something intently; lining up something with your eyes, seeing if it is straight or uneven.

**VOID**--Containing nothing; an empty space.

# Supplementary References

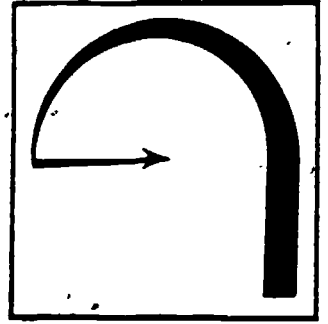

Tilesetting Workbook. California Department of Education, 1975. pp. 101-124.

445 451

# Information

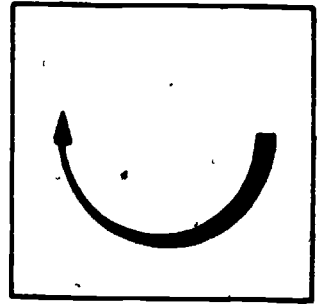

## HOW TO APPLY FLOOR MORTAR

First, the tilesetter needs to determine which cement mortar installation method to use (refer to module titled "Floor and Wall Installation Methods"). The following steps lead through a cement mortar over wood sub-floor installation.

### Procedure

1. Apply waterproof membrane over entire wood surface to be mortared.
2. Secure (nail down) metal reinforcing over membrane. Metal lath or wire mesh may be used.
3. Determine the required finish height of the mortar bed.
4. Mix floor mortar. (Depending on conditions, could range from 1 part cement to 4 parts sand up to 1 part cement to 6 parts sand).
5. Set float strip screeds to proper height.
6. Float mortar bed. Float a section at a time (usually first floating the outer sections of the floor between the screed and the wall. Float inner sections last.

### Steps to floating

- a. pour mortar in section you will float first.
- b. using either a wood float or flat trowel, spread the mortar evenly within the section and tamp down firmly.
- c. along the wall edge and door opening edge(s), use the top or bottom thin edge of the float or trowel and tamp mortar firmly down into the corner.
- d. the tamping procedure will prevent air pockets and hollow spots
- e. the finished, tamped mortar should be slightly higher than the float strip in order to be sure there are no low spots when the mortar is screeded off.
- f. use a suitable length straightedge to screed off mortar.
  - . one which reaches across two float strips in the section being screeded.

- g. hold the straightedge firmly against the float strips to prevent riding above, or digging below, the mortar.
- h. pull the straightedge toward yourself.
- i. the bottom edge of the straightedge must be cleaned from time to time to make sure the mortar bed is true.
- k. repeat with each section that will be screeded

After floating, the strips should be removed and the voids filled with mortar. (You can not put your weight on fresh mortar, so, if the area is big, you can remove the strips and fill the voids with mortar as you go.)

To fill the voids, apply a small amount of mortar in the void, use a wood float in a circular motion to pack and fill. Do not dig into the fresh mortar bed with the float.

Allow the mortar bed to cure for at least 24 hours before proceeding. When it is necessary to put your weight on the mortar bed (after 24 hours) wear flat-soled shoes or boots.

#### HOW TO APPLY WALL MORTAR

Determine the installation method to use (refer to module titled "Floor and Wall Installation Methods"). The following steps lead through a two-coat cement mortar method (scratch coat and mortar bed) over studs.

#### Procedure

1. Apply waterproof membrane over studs.
2. Secure metal lath over membrane.
3. Mix wall mortar (depending on conditions--from 1 part cement, 1 part lime and 3 parts sand to 1 part cement, 3 parts lime and 5 parts sand).
4. Apply scratch coat
  - a. set up mortar board and stand; pour mortar onto it
  - b. use hawk and trowel; scoop mortar from mortar board to hawk, from hawk to flat trowel
  - c. apply mortar from flat trowel to metal lath in upward motion, pressing firmly into metal lath. Cover entire metal lath area with mortar.
  - d. use flat trowel to smooth mortar; eyeball wall to get even coat; scratch coat should be between 1/8" and 1/4" thick.

- e. use a scratcher to scratch mortar; mortar should be firm before scratching; scratch horizontally
  - f. allow scratch coat to set at least overnight before continuing
5. Set float strip screeds to proper height and location.
  6. Before applying mortar bed, wet scratch coat with water (use water brush). This prevents the mortar bed from drying out too fast. (Float strips are set first [before watering] so they will dry fast and be hard enough to allow screeding.)
  7. Float mortar bed
    - a. float a section at a time. First, float outer sections of wall, then inner sections.

#### Steps to floating

- a. apply mortar bed mortar same way as you applied scratch coat mortar; the mortar should be thicker than the float strip to be sure there are no low spots when the mortar is screeded off
- b. use long enough straightedge to reach across two float strips
- c. hold straightedge firmly against float strips to prevent riding above, or digging below, the mortar
- d. clean mortar from bottom of straightedge (on mortar board) after each screeding off pass
- e. continue until section is finished
- f. repeat until wall has been floated

After the wall(s) have been floated, the float strips are removed and the voids are filled with mortar. Use the flat trowel to fill the voids, applying a small amount to the void with an upward motion. The voids should be filled flush with the rest of the mortar bed. Do not dig into the fresh mortar with the trowel.

It is best to let mortar cure overnight before setting tile. If you are very careful, it is possible to set tile several hours after floating.

# Self Assessment

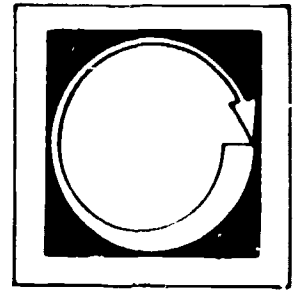

COMPLETE THE FOLLOWING STATEMENTS BY WRITING THE CORRECT WORD OR WORDS IN THE BLANKS PROVIDED.

1. When using float strip screeds you float a \_\_\_\_\_ at a time.
2. You should float the \_\_\_\_\_ sect. (s) first, then float the \_\_\_\_\_ section(s).
3. After pouring the mortar in the appropriate section on the floor, the mortar should be spread and \_\_\_\_\_ firmly to prevent air pockets.
4. The mortar should be \_\_\_\_\_ than the float strip to be sure there are no \_\_\_\_\_ spots when screeded off.
5. When screeding off, the straightedge should ride on \_\_\_\_\_ float strips.
6. After floating, the \_\_\_\_\_ should be removed and the voids filled with mortar.
7. A floor mortar bed should cure for at least \_\_\_\_\_ hours before setting tile.
8. If you are careful, it is possible to set tile on wall mortar a few hours after \_\_\_\_\_.

# Self Assessment Answers

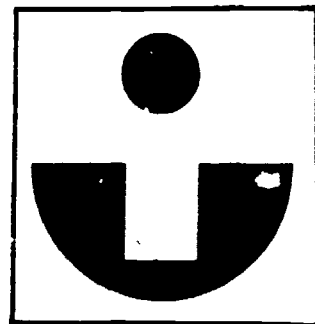

1. section
2. outer, inner
3. tamped (packed)
4. higher (thicker), above
5. two
6. float strips
7. 24
8. floating

# Job Sheet

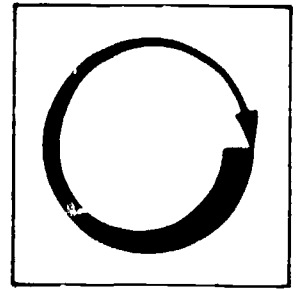

COMPLETE THE FOLLOWING TASKS.

## Materials and Tools

solid wall and floor backing

mortar box and hoe

proper amount of sand, cement and lime

2 buckets and access to water

mortar board and stand

wood float, flat trowel and hawk

straightedges

float strips

metal lath

staple gun

3' to 4' long level

rubber mallet

(If this is to be a permanent installation, additional materials may be needed.)

1. On a solid floor backing, practice applying floor mortar. The area should be at least 4' by 4'. Set float strip screeds (module titled "Screeds"). Use the information and instructions from this module to float floor. (For a permanent installation use a proper installation method). Be sure to fill in float strip voids.
2. On a solid wall backing, practice applying wall mortar. Use a one-coat cement mortar method and apply the mortar over metal lath. Float at least a 3' X 4' area. Set float strip screeds. Use the information and instructions from this module to float the wall. (For a permanent installation use a proper installation method.) Be sure to fill in float strip voids.



# Post Assessment

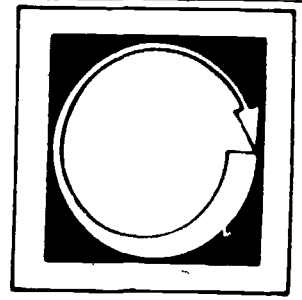

WRITE AN ANSWER TO THE FOLLOWING QUESTIONS CONCERNING THE JOB SHEET.

1. What type(s) of backing did you float over (for the wall and the floor)?
2. Were the floor and wall applications temporary or permanent? If permanent, which installation method was used, and what is it used for?
3. Which was more difficult, floating the wall or floor? Explain.
4. What was the mortar mix (proportions) you used for the floor and wall mortar? Do you think a little different mix ratio could have made either application easier? Explain.

LISTED BELOW ARE SEVERAL STATEMENTS. IF THE STATEMENT IS TRUE, PLACE A "T" IN THE BLANK PROVIDED. IF THE STATEMENT IS FALSE, PLACE AN "F" IN THE BLANK.

5.  A void is an area that contains nothing; an empty space.
6.  Eyeballing is a ti esetting safety term used to call attention to someone who doesn't look where he or she is going.

# Instructor Post Assessment Answers

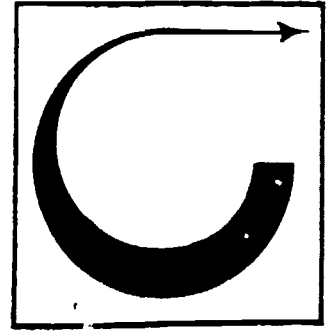

5. T

6. F

---

SETTING TILE TO CEMENT MORTAR

---

**Goal:**

The student will be able to set tile to cement mortar backings.

**Performance Indicators:**

The student will successfully complete the Self Assessment, the Job Sheet and the Post Assessment.

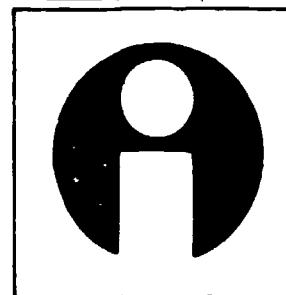

# Study Guide

In order to finish this module, do the following tasks. Check each item off as you complete it.

1.  Read the Goal and Performance Indicators on the cover of the module. This will tell you what you will learn by studying the module, and how you will show you've learned it.
2.  Read the Introduction. The Introduction will tell you why the module is an important part of the tilesetting trade.
3.  Study the Vocabulary section. Vocabulary words are important for a good understanding of the trade. After you have studied the vocabulary, ask your teacher to quiz you on the words and their meanings.
4.  Study the Information section. This section will give you the information you need to understand the subject.
5.  Take the Self Assessment exam. This is a test for you to prove to yourself that you have learned the material you have studied. Compare your answers with the answers on the Self Assessment Answer Sheet, which is on the page following the Self Assessment. If you scored poorly, re-study the Information section or ask your teacher for help.
6.  Do the Job Sheet. Follow the instructions at the top of the Job Sheet. The tasks listed on the Job Sheet will help you develop skills which will be helpful to you.
7.  Take the Post Assessment exam. Give the exam to your teacher after you have completed it. Your teacher will grade it for you.

# Introduction

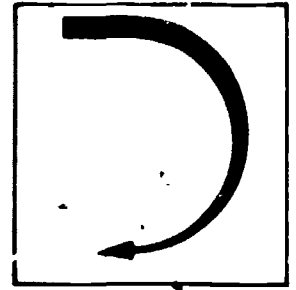

This module covers the procedures involved in setting tile to horizontal and vertical cement mortar backings, when the cement mortar is still fresh (just applied) and when it is hard (set up).

# Vocabulary

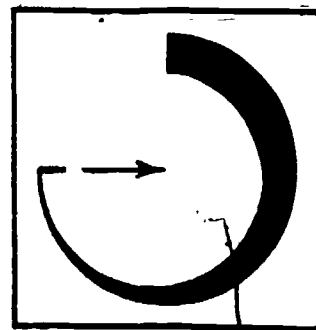

Trade terms are very important for a good understanding of the trade. Study these words and meanings. When you have learned them, ask your teacher to quiz you on the words and their meanings.

SLURRY--A watery mixture of cement or lime and water.

DUSTING--Applying dry portland cement to a wet cement mortar floor.

# Supplementary References

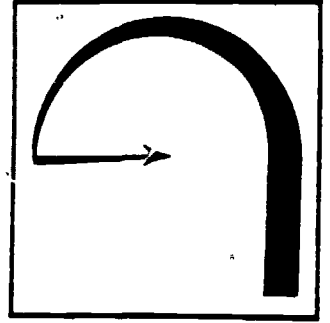

— Typesetting Workbook. California Department of Education, 1975. pp. 101-124.

458

464

# Information

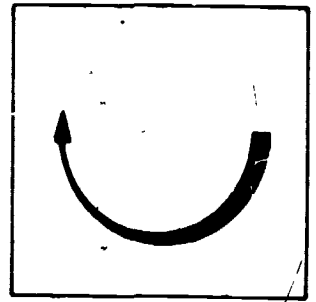

Tile may be set to a cement mortar backing at two times:

1. Right after the mortar bed is finished (cement mortar is still fresh).
2. After the mortar bed has set up and is hard.

There are many different reasons and factors which the tilesetter thinks about before deciding when to set the tile. There are also different reasons for both horizontal and vertical installations.

One of the differences is the type of adhesive used. When the mortar bed is still fresh, pure cement is used; when it has hardened, thinset mortar, mixed with water, is used. Not too many years ago (before thinset mortar was developed), all tiles had to be set to cement mortar when it was still fresh.

## SETTING TILE TO A VERTICAL (WALLS) CEMENT MORTAR BACKING

There are two categories:

1. Setting tile after mortar bed has hardened.
2. Setting tile when mortar bed is still fresh.

Tile is set to a vertical mortar bed almost always after it has hardened. The solid backing is much easier to work with.

### Preparation and setting

1. Make sure mortar bed surface is as smooth and even as possible. Use a rough grit (No. 20) rub brick on the surface to smooth it. Clean with a duster brush before applying bond coat.
2. Set screed: the first course (base row) of tile is set on a screed that is absolutely level.



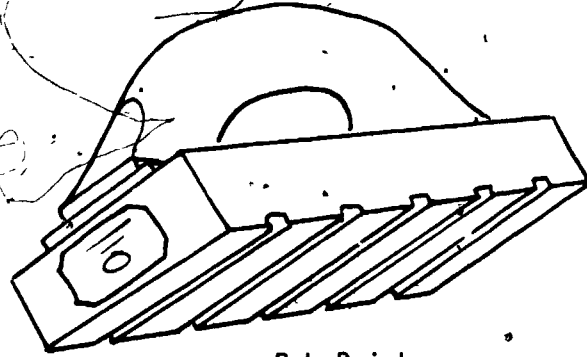

Rub Brick

#### How to set screed

- a. mix up a small amount of floor mortar in ratio of 1 part cement to 6 parts sand.
- b. pour an even amount of mortar around the bottom of the wall(s).
- c. with a wood float, spread out and tamp down firmly, making a screed that's about 1" to 1½" high and ½" to ¾" wide.
- d. determine the height which the base tile should be; consider the type and thickness of the floor to be installed (if one is not in already).
- e. start at either end of screed, with a small (2 foot) builder's level; tap one end down to the starting height, then tap the other end down until it reads level.
- f. continue working around the screed with the builder's level, leveling out the rest of the screed to the starting height. (The first course of tile is set right on [above] the screed.)
- g. mix thinset mortar with water; spread with appropriate sized notch trowel (usually 3/16" or 1/4" deep notches).
- h. set the first row of tile around the screed; make sure it's straight; continue setting tile (if it's a shower, work only on the back wall).
- i. an important rule to follow when setting tile to cement mortar is to spread only as much adhesive as you can set tile over in 10 to 15 minutes (3 to 6 rows of tile at a time).
- j. after setting each section (10 to 15 minutes of work), use beating block and rubber mallet to beat in tiles. At this time, adjust and check tiles to make sure they are running straight, level, plumb.

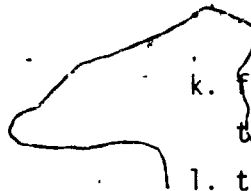
- 
- k. Flat toothpicks make great tile spacers for wall tile and allow the tilesetter to accurately align the tiles.
  - l. tiles tend to slip down, after they are raised to adjust them (when using thinset mortar). Watch closely.
  - m. continue setting, beating in and adjusting tiles until entire surface area is set.
  - n. let tile set at least overnight before grouting

SETTING TILE TO A VERTICAL (WALLS) SURFACE WHEN MORTAR BED IS STILL FRESH  
Even though vertical surfaces are almost always allowed to harden before tile is set over them, a tilesetter still needs to know how to set tile on a fresh surface.

#### Preparation and setting

1. After mortar bed is finished, mix mortar and apply screed as described before.
2. Mix a slurry of pure cement and water; this will be the adhesive bond coat. Allow the slurry to stand for about 20 minutes, then re-mix to a creamy consistency.
3. Very carefully trowel on mixture with a small (1/8" to 3/16") square notch trowel. Do not use too much pressure or you may dig into the fresh mortar with trowel. This mixture glazes over very fast so spread only what you can set tile over in 5 to 10 minutes.
4. Every move must be made very carefully. If the mortar bed firms up too much and is not allowing a bond with the pure cement slurry, dash the mortar bed lightly with water (use a water brush) and, with circular motions, rub the mortar bed with a wood or rubber float or beating block to re-soften the surface. Then continue setting.
5. For small areas like cuts or trim pieces, you may have to backbutter the tiles with pure cement before beating in.
6. Beat in tiles as sections are completed.
7. Allow to set at least overnight before grouting.

#### SETTING TILE TO A HORIZONTAL CEMENT MORTAR BACKING

Again, there are two different categories: setting tile to hard mortar, and setting tile to fresh mortar.

On vertical surfaces, most tile is set on horizontal cement mortar surfaces

after the mortar bed has hardened, using thinset mortar as a bond coat. There are definite exceptions. The tilesetter MAY set tile to any fresh surface WHICH HE OR SHE WON'T PUT WEIGHT ON. For example, if the tilesetter is working on a shower floor AND CAN STAND OUTSIDE THE SHOWER AREA, he or she may float, set and grout in the same day. A counter top can also be started and finished in the same day. Large floor areas will almost always be set AFTER THE MORTAR BED HAS HARDENED at least overnight.

#### SETTING TILE WHEN MORTAR BED IS HARD

##### Preparation and setting

1. There are no special requirements for setting tile on a hard mortar bed.
2. Use thinset mortar for a bond coat.
3. Don't spread more adhesive than you can set tile over in 10 to 15 minutes.
4. Beat in tile when each section is done.
5. Walk carefully on mortar bed in flat-soled shoes or boots.
6. Let tile set overnight before grouting.

#### SETTING TILE WHEN MORTAR BED IS STILL FRESH

##### Preparation and setting

There are 2 ways or methods in which pure cement can be used as a bond coat for fresh horizontal mortar beds:

1. in a slurry form with water, spread with a square notch trowel (just like for vertical (wall) surfaces). THIS IS PRETTY TOUCHY AND ONLY A SKILLED TILESETTER SHOULD TRY IT.
2. as a dust, sprinkled over the mortar bed about 1/16" thick right before setting tile. THIS IS THE PREFERRED METHOD. IT'S HOW MOST SHOWER FLOORS ARE TILED.
3. You can determine if the fresh mortar bed has the correct amount of moisture by seeing what happens to the 1/16" layer of pure cement dust when it is applied.
  - a. if the moisture is correct, the dust will wet and darken evenly
  - b. if the bed is too dry, the dry cement dust will remain dry; dash the bed lightly with water and, with circular motions, rub the bed with wood float, rubber block or beating block to re-soften. Continue dusting with pure cement.
  - c. if the bed is too wet, the cement will immediately darken and seem to disappear; add more pure cement to dry up the moisture. If it's extremely wet allow the bed to harden.

4. After surface is dusted, tiles can be laid in place, then beat in. Since the mortar is still fresh, the beating in process will adjust and make the surface flush and smooth.
5. An instant bond should occur when the tiles are beat in. To check, occasionally lift the edge of a tile or sheet of tile to see.
  - a. an instant bond has happened if the bond coat and a little bit of the mortar is stuck to the bottom of the tile
  - b. an instant bond has not happened if the bottom of the tile is clean; if no bond is happening, check to see if the mortar bed is too dry or if enough pure cement is being used.
6. When all tiles have been laid you CAN GROUT RIGHT AWAY OR ALLOW THE TILE TO SET OVERNIGHT.
7. TO GROUT RIGHT AWAY
  - a. use a grout mixture of 1 part cement and 1 part fine sand, or use a colored dry-set sanded grout
  - b. sweep dry grout mixture into joints with duster brush
  - c. dampen grout with a little water
  - d. use duster brush to work the grout around until joints are full
  - e. beat in tile again, making sure tile surface is flush and smooth
  - f. clean surface carefully with damp cheesecloth
8. TO GROUT LATER, FOLLOW NORMAL METHOD

# Self Assessment

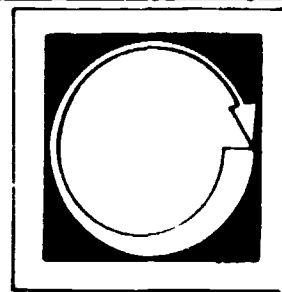

COMPLETE THE FOLLOWING STATEMENTS BY WRITING THE CORRECT WORD OR WORDS IN THE BLANK(S) PROVIDED.

1. A cement mortar backing can have tile set to it when the mortar is still \_\_\_\_\_ or when it has \_\_\_\_\_.
2. \_\_\_\_\_ mortar is used to bond tile to a hardened cement mortar backing and \_\_\_\_\_ is used to bond tile to a still fresh cement mortar backing.
3. A hardened cement mortar surface should have a \_\_\_\_\_ used on it to make it smooth before setting tile.
4. The first course of tile (base) on a cement mortar wall is set on a \_\_\_\_\_ that is level.
5. You should spread only the amount of thinset mortar that you can set tile over in \_\_\_\_\_ to \_\_\_\_\_ minutes.
6. \_\_\_\_\_ make good spacers for raising and adjusting wall tile.
7. A pure cement slurry glazes over very fast so you should spread only what you can set tile over in \_\_\_\_\_ to \_\_\_\_\_ minutes.
8. For both horizontal and vertical cement mortar installations nearly all tile is set after the mortar bed has \_\_\_\_\_.
9. The procedure used for bonding tile to a fresh floor mortar bed consists of \_\_\_\_\_ pure cement about \_\_\_\_\_ inch thick.

# Self Assessment Answers

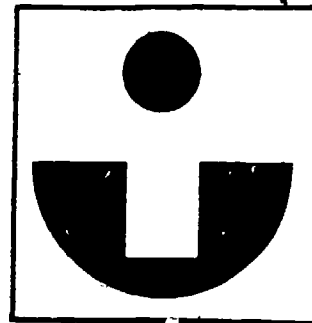

1. fresh (plastic), hardened (set, cured)
2. thinset, cement
3. rub brick
4. screed
5. 10 to 15
6. toothpicks
7. 5 to 10
8. hardened (set, cured)
9. dusting, 1/16"

# Job Sheet

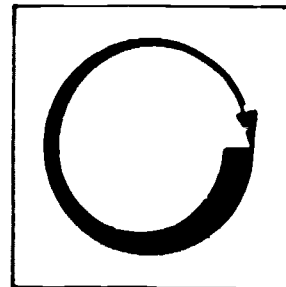

COMPLETE THE FOLLOWING TASKS.

## Materials and Tools

mortar box and hoe  
sand, cement, lime and access to water  
mortar board and stand  
2 buckets  
wood float and flat trowel  
float strips  
straightedges  
2' and 4' level  
rubber mallet and beating block  
tape measure  
tile cutting board  
28 square feet of tile  
thinset mortar  
3/16" deep, square-notch trowel  
toothpicks  
metal lath  
staple gun  
rub brick  
duster brush  
dry-set grout  
sponge and cheesecloth

1. Practice setting tile to a cement mortar wall. On a temporary or permanent solid backing, set at least a 4' by 4' cement mortar wall. Apply float strip screeds. Float wall. Use the information and instructions from module to set the tile. Let the cement mortar wall set at least overnight,

then use a 3/16" deep square notch trowel and thinset mortar to set tile. Beat in the tile. Let set at least overnight, then grout using the sponge-cheesecloth method.

2. Practice setting tile to a cement mortar floor. On a temporary or permanent solid backing, set at least a 3' by 4' cement mortar floor. Apply float strip screeds. Float floor. Use the information and instructions from this module to set the tile. Set the tile when the mortar is still fresh by dusting the surface with pure cement. Beat in the tiles. Check to make sure the tiles are bonding. Then grout with duster brush and dry-set grout. Clean with cheesecloth.



# Post Assessment

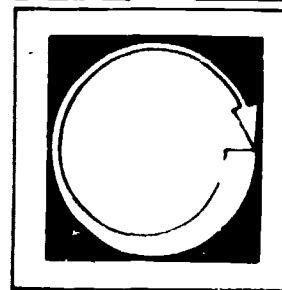

WRITE AN ANSWER TO THE QUESTIONS CONCERNING THE JOB SHEET.

1. What type(s) of backing did you float over?
2. Was the floor and/or wall application temporary or permanent? If permanent, what will it be used for?
3. Did you have any problems setting either the wall or floor tile? Explain.
4. Which procedure was easiest for you--the wall (thinset) installation or the floor (dusting pure cement) installation? Why was one easier than the other? Explain.

LISTED BELOW ARE SEVERAL STATEMENTS. IF THE STATEMENT IS TRUE, PLACE A "T" IN THE BLANK PROVIDED. IF THE STATEMENT IS FALSE, PLACE AN "F" IN THE BLANK.

5. \_\_\_ Dusting is the application of putting pure cement on a wet cement mortar floor.
6. \_\_\_ A slurry is a dry mixture of sand and cement used for wall screeds.

# Instructor Post Assessment Answers

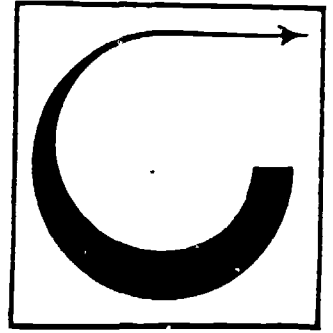

5. T

6. F

469

475