

DOCUMENT RESUME

ED 213 888

CE 031 562

AUTHOR Kracht, Shannon
TITLE Painting. Pre-Apprenticeship Phase 2 Training. Student Training Modules.
INSTITUTION Lane Community Coll., Eugene, Oreg.
SPONS AGENCY Employment and Training Administration (DOL), Washington, D.C.; Oregon State Dept. of Education, Salem.
PUB DATE 81
NOTE 312p.; For related documents see CE 031 561-579.
EDRS PRICE MF01/PC13 Plus Postage.
DESCRIPTORS Behavioral Objectives; *Building Trades; Check Lists; Job Skills; Learning Activities; Learning Modules; Pacing; *Painting (Industrial Arts); Postsecondary Education; Safety; Tests; *Trade and Industrial Education; Two Year Colleges; Vocabulary
IDENTIFIERS *Preapprenticeship Programs

ABSTRACT

These 21 Student Training Modules on painting comprise one of nine sets of self-paced learning modules developed for Pre-Apprenticeship Phase 2 Training. (A companion instructor's guide is available separately as CE 031 561.) The modules are designed to impart trade knowledge and skills to the student. Each module contains some or all of the following: cover sheet listing module title, goals, and performance indicators; study guide/checklist with directions for module completion; introduction; vocabulary listing and defining new trade or technical terms; supplementary references; information sheet(s) providing information and graphics covering the module topic(s); self-assessment; self-assessment answers; assignment sheet(s); job sheet(s) listing materials and tools necessary to complete tasks designed to develop manipulative skill; post assessment; and post assessment answers. Topics covered in the module include paint ingredients and characteristics; abrasives; primer selection; preparing wood, masonry, drywall, and metal surfaces for painting; safety; preparing oil-base and latex paints for application; brush and roller selection and use; using spray guns and airless spray system; wood stains; clear finishes; paint failures; colors and mixing; and blueprints and specifications. (YLB)

 * Reproductions supplied by EDRS are the best that can be made *
 * from the original document. *

ED0213888



PRE-APPRENTICESHIP PHASE 2 TRAINING Student Training Modules

Painting



U.S. DEPARTMENT OF EDUCATION
NATIONAL INSTITUTE OF EDUCATION
EDUCATIONAL RESOURCES INFORMATION
CENTER (ERIC)

This document has been reproduced as
received from the person or organization
originating it.
Minor changes have been made to improve
reproduction quality.

• Points of view or opinions stated in this docu-
ment do not necessarily represent official NIE
position or policy.

PERMISSION TO REPRODUCE THIS
MATERIAL HAS BEEN GRANTED BY

C. Hostrup

TO THE EDUCATIONAL RESOURCES
INFORMATION CENTER (ERIC) "

CE031562

Painting Module Writer:

Shannon Kracht

Technical Assistance:

Ron Gillette, Steve Bosteder

Graphics: Ralph Bentley

Editorial, Proofreading and Pasteup:

Ron Hamblen, Debi Carroll

Typing:

Strandlien Typing Service

This project was developed under a sub-contract for the Oregon Department of Education by Lane Community College, Community Education Division, Eugene, Oregon. Funds were provided by the Governor of Oregon from the Educational Linkages Component of the CETA Governor's Grant.

STATEMENT OF ASSURANCE

It is the policy of the Oregon Department of Education that no person be subjected to discrimination on the basis of race, national origin, religion, sex, age, handicap or marital status in any program, service or activity for which the Oregon Department of Education is responsible. The Department will comply with the requirements of state and federal law concerning non-discrimination and will strive by its actions to enhance the dignity and worth of all persons.

Lane Community College

4000 E. 30th Avenue
Eugene, Oregon 97405
(503) 726-2200

Office of the President

July 27, 1981

On behalf of Lane Community College, I wish to express our pride and gratitude for the opportunity to participate in the development of the Pre-Apprenticeship training materials. We also wish to commend the Oregon Department of Education for its original concept and continued support; and, the Educational Linkages Component of the CETA Governor's Grant for funding.

The goals of this project are many, but none are more important than that of producing valid, understandable vocational curriculum material. We congratulate the tradespeople and production staff for their accomplishments.

Finally, I recommend this material to anyone exploring Pre-Apprenticeship as an entry into the vocational work world, with the hope and belief that it will go a long way toward producing skilled craftspeople who are dedicated to their work.

Sincerely,

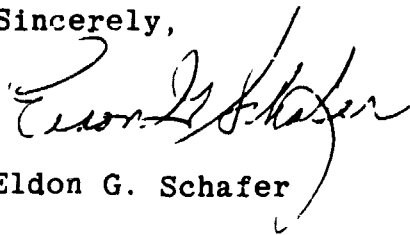

Eldon G. Schafer

PAINF--INGREDIENTS AND CHARACTERISTICS

Goal:

The student will be able to identify the ingredients found in paints and paint coverings, explain their characteristics and common uses.

2

Performance Indicators:

The student will demonstrate knowledge of the subject by completing a Self Assessment and a Post Assessment.

5

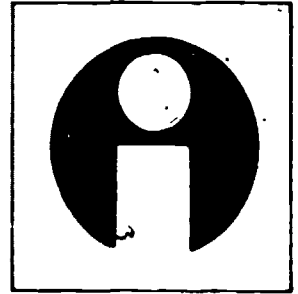

Study Guide

In order to finish this module, do the following tasks. Check each item off as you complete it.

1. Read the Goal and Performance Indicators on the cover of the module. This will tell you what you will learn by studying the module, and how you will show you've learned it.
2. Read the Introduction. The Introduction will tell you why the module is an important part of the painting trade.
3. Study the Vocabulary section. Vocabulary words are important for a good understanding of the trade. After you have studied the vocabulary, ask your teacher to quiz you on the words and their meanings.
4. Study the Information section. This section will give you the information you need to understand the subject.
5. Take the Self Assessment exam. This is a test for you to prove to yourself that you have learned the material you have studied. Compare your answers with the answers on the Self Assessment Answer Sheet, which is on the page following the Self Assessment. If you scored poorly, re-study the Information section or ask your teacher for help.
6. Take the Post Assessment exam. Give the exam to your teacher after you have completed it. Your teacher will grade it for you.

Introduction

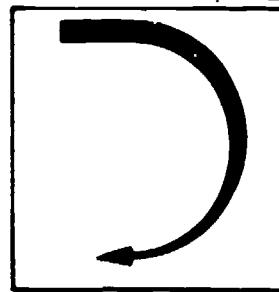

The act of painting is easy. A good worker can become better by being able to tell the difference between paints and by being able to apply the proper paint covering to the correct surface.

Vocabulary

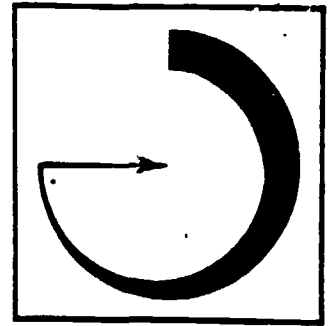

Trade terms are very important for a good understanding of the trade. Study these words and meanings. When you have learned them, ask your teacher to quiz you on the words and their meanings.

ADHESIVE--The ability to cling to an object without falling off.

PIGMENTS--Very small colored particles which color the paint. Pigments may be any color or white. Pigments do not dissolve, they remain solid particles.

BINDER--The part of the paint that causes pigments to stick to each other and to the surface being painted.

DYES--Colored particles that dissolve in paint.

RESINS--Natural resins or man-made, they are used to add hardness to oils, to decrease drying time, etc.

OPACITY--The ability of a paint to cover or hide the surface being painted.

GLOSS--The shine on a paint surface, high gloss means the paint surface is very shiny when light strikes it.

LATEX--The name usually given to water base paints.

VISCOSITY--The thickness of a paint

Information

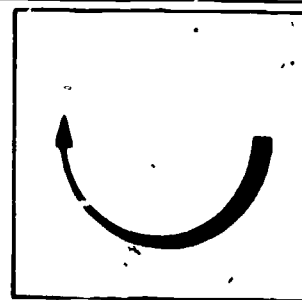

Paint is an adhesive coating which is applied to surfaces. Paints may be colored or they may be clear or tinted, such as varnishes and shellacs.

The two main ingredients of paint are pigments and the vehicle. The pigments give the paint its color. The vehicle is really all of the rest. The vehicle is made up of oils or resins and thinners, solvents and driers.

Even though the modern painter usually buys paints which are already mixed, it is important to understand what goes into paints to be able to explain their differences and to choose the right paint for a job.

PIGMENTS

As the Vocabulary page said, pigments are very small particles which don't dissolve in the paint. Pigments make up every color you've ever seen painted. It's not important that you know everything about pigments, but here are a few facts you should remember:

White pigments can be made up of many chemical compounds. White pigments are the base to which many other pigments may be added to color the paint.

The type of white pigment used in a paint determines, to a degree, where the paint can best be used. Some last well on the outside of a house, some don't. Some have the ability to "chalk," which means the outer surface gradually turns to dust and is washed away by rain. Pigments which chalk are good for paints used on building exteriors because "chalking" keeps the surface clean.

Some white pigments have good hiding power. Some mix well with oils. Some can be mixed well with other colored pigments. Some dry harder than others.

Extender pigments are pigments which have very little hiding power. They are used to improve the paint by making it flow better, by making it lay more level on the surface and by making sure it can be applied to a proper thickness.

Extender pigments come from many minerals. Using too many extender pigments can result in bad paint.

Earth pigments are natural pigments mined from the earth. Some examples of these are reds and browns. Earth pigments are very stable, that is, they are not affected too much by weather, heat or chemicals drifting in the air.

Other colored pigments--blue and red and yellow and green and black--are made in many different ways.

Pigments affect the characteristics of the paint in which they're used.

As was mentioned in this module earlier, the vehicle is the second major part of any paint. Vehicles are of three kinds: 1) oil, 2) resin, 3) water. Some of these may be combined.

OILS

Many different oils are used as vehicles in paints.

Oils have different characteristics--some dry harder and quicker than others, some are more resistant to acids. The common oils are soybean oil, linseed oil, tung oil, castor oil and fish oil.

Linseed oil dries to a tough film when exposed to air. It will yellow with age (and would also tint or yellow light paints), so it is used mostly in dark paints or outside where the sun can bleach it.

Soybean oil is often mixed with resins. It holds the color very well.

Tung oil dries quickly and is used in varnishes. It may be used in paints where quick drying is necessary. Tung oil is durable.

Fish oil, oil actually removed from fish such as sardines, is used as an extender and mixed with more expensive oils.

RESINS

Resins, both natural and man-made, are noted because they form a hard surface when dry and they dry quickly. They are usually mixed with oil to form varnish, which then may be made into paint by adding color pigments. Paint vehicles may be made with resins without mixing them with oils.

WATER

Thus far, we have talked about oils or resins forming the vehicle or base for paints. Water became important as a base for paints after World War II.

The water-based paints make use of man-made rubber binders. Water is mixed in to make the paint easy to spread. These are called latex paints.

In later modules we will discuss these topics in detail.

It is important to have more than just vehicles and pigments in most modern paints. Other things added include solvents and thinners and driers.

Solvents and thinners are used to reduce the viscosity of paints--to make it more watery and spreadable. Alcohol and turpentine are two thinners. Any, paint can be ruined by mixing in the wrong thinner or solvent.

Driers speed up the drying of oils and resins or varnishes. Driers are metals which have been chemically changed so they dissolve in paint. The painter just about never has to add driers.

Paint is put on by brushing, rolling or spraying. In water-based paint, the water evaporates, leaving a thin film of coating on the painted surface. Other paints dry as the solvents evaporate or as the driers combine with the base materials. It is important that the paint doesn't dry too fast or too slow. It is very important that the correct solvents and thinners are used, or the paint may never dry.

Self Assessment

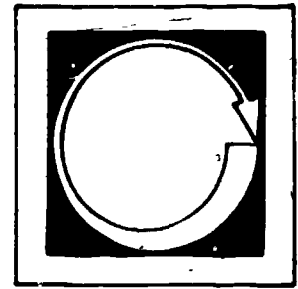

Listed below are several statements. If the statement is true, place a T in the blank provided. If the statement is false, place an F in the blank.

1. ___ All paints are made of thinners and pigments.
2. ___ Pigments are small particles which dissolve in paints.
3. ___ The vehicle gives paint its color.
4. ___ Chalking happens when the outer surface of paint slowly begins breaking up.
5. ___ Extender pigments generally aren't used for coloring paint.
6. ___ The three kinds of paint vehicles are oil, turpentine and solvent.
7. ___ Varnish is made when oil is mixed with resin.
8. ___ Resins are always mixed with oils.
9. ___ Latex paints are all oil-based.
10. ___ Earth pigments are affected by the weather and should never be used.
11. ___ One example of oil used in paint is linseed oil.
12. ___ Resins form a soft surface when dry and should be used on chairs.

Self Assessment Answers

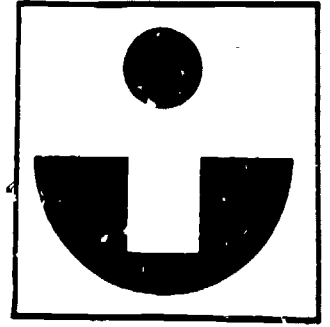

1. F

2. F

3. F

4. T

5. T

6. F

7. T

8. F

9. F

10. F

11. T

12. F

Post Assessment

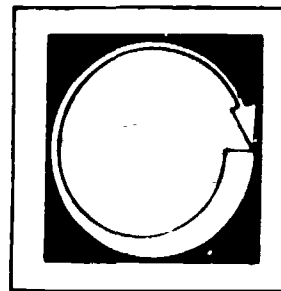

Select the answer or completion which answers the question or completes the statement correctly and place the letter in the blank provided.

1. ___ Latex paints became popular:
 - a. after World War I.
 - b. after World War II.
 - c. about two years ago.

2. ___ Binder is that part of a paint which:
 - a. makes it stick to a wall.
 - b. makes it dry.
 - c. thins it.

3. ___ A dye is:
 - a. a cleaning agent.
 - b. a pigment which doesn't dissolve in paint.
 - c. a pigment which dissolves in paint.

4. ___ A paint vehicle is made of:
 - a. everything but solvent.
 - b. everything but the pigments.
 - c. white and colored pigments.

5. ___ Extender pigments come from:
 - a. animals.
 - b. minerals.
 - c. vegetables.

6. ____ Linseed oil is not recommended for:
- a. dark paints.
 - b. exterior paints.
 - c. light interior paints.
7. ____ Which of the following is known as a durable oil?
- a. tung oil.
 - b. latex oil.
 - c. fish oil.
8. ____ Extender pigments are used for:
- a. making earth pigments brighter.
 - b. extension ladders.
 - c. improving some qualities of paints.
9. ____ Resins are sometimes:
- a. mixed with varnish to form oil.
 - b. mixed with oil to form varnish.
 - c. removed from oil to form latex.
10. ____ Turpentine is a thinner or solvent that should be added to:
- a. some paints.
 - b. all varnishes.
 - c. all paints.

Instructor Post Assessment Answers

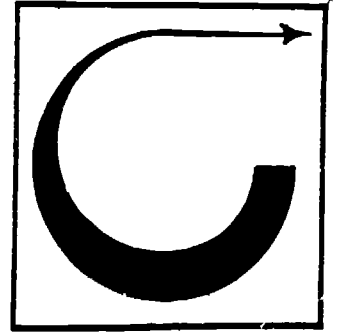

1. b
2. a
3. c
4. b
5. b
6. c
7. a
8. c
9. b
10. a

ABRASIVES USED IN PAINTING

Goal:

The student will be able to identify, select, explain and demonstrate the use of common painting abrasives.

Performance Indicators:

The student will show knowledge of the subject by completing a Self Assessment, Job Sheet and a Post Assessment.

Study Guide

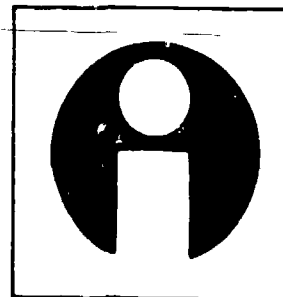

In order to finish this module, do the following tasks. Check each item off as you complete it.

1. ____ Read the Goal and Performance Indicators on the cover of the module. This will tell you what you will learn by studying the module, and how you will show you've learned it.
2. ____ Read the Introduction. The Introduction will tell you why the module is an important part of the painting trade.
3. ____ Study the Information section. This section will give you the information you need to understand the subject.
4. ____ Take the Self Assessment exam. This is a test for you to prove to yourself that you have learned the material you have studied. Compare your answers with the answers on the Self Assessment Answer Sheet, which is on the page following the Self Assessment. If you scored poorly, re-study the Information section or ask your teacher for help.
5. ____ Do the Job Sheet. Follow the instructions at the top of the Job Sheet. The tasks listed on the Job Sheet will help you develop skills which will be helpful to you.
6. ____ Take the Post Assessment exam. Give the exam to your teacher after you have completed it. Your teacher will grade it for you.

Introduction

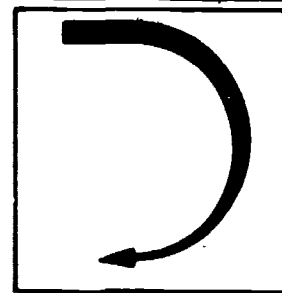

Abrasives are used by painters for three kinds of work. The first is to smooth out very rough surfaces so the paint can be applied smoothly. The second is to slightly "rough up" very smooth surfaces so the paint will stick to the ~~surface~~. The third is to finish varnish or lacquer coats: the abrasive is actually used to polish the painted surface when it has dried.

It is important to know when to use an abrasive and what kind of abrasive to use if the finished job is to look nice and last a long time.

Supplementary References

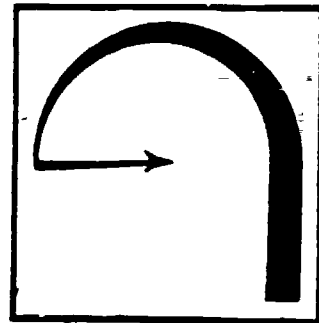

1. Painting and Decorating Encyclopedia. Goodheart-Willcox Co., 1973, pp. 46-48.
2. Painting and Decorating Craftsman's Manual and Textbook. Painting and Decorating Contractors of America, 1975, pp. 289-291.

Information

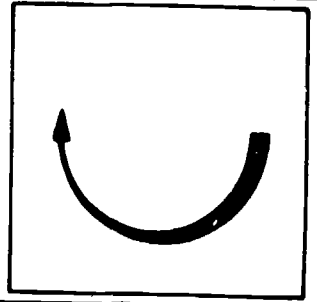

Abrasives used by painters today are advanced far beyond what they used to be. We have all heard of the word "sandpaper." Years ago, sandpaper was made of sand glued to a paper backing. Today papers are coated with other abrasives. Some are natural abrasives and some are man-made. Even though these abrasives look like sandpaper, they are called "coated abrasive papers" or sometimes "garnet paper."

Abrasive papers that painters use include:

1. Flint
2. Garnet
3. Emery
4. Aluminum oxide
5. Silicon carbide

Another abrasive that painters use is steel wool.

All abrasives are small particles or grits of very hard material which can cut through wood and metal. In a very coarse abrasive, the particles are larger or coarser than in a fine abrasive. Coarse abrasives can cut faster than fine abrasives, but they also leave a rough surface. Usually this rough surface must be sanded with finer abrasive paper to be ready for painting, or the cutting marks will show through the paint.

Abrasive papers (and steel wool) are numbered according to how coarse or fine they are. The higher the number, the finer or smaller the grit; the lower the number, the larger or coarser the grit. The number is usually printed on the back of the sheet of abrasive papers.

Following is a list of types of coated abrasives and the numbering system used to identify them.

	Silicon Carbide	Aluminum Oxide	Grit	Equivalent in Synthetic Series	Flint	Emery
FINE	400			12 0		
	500	500		11 0		
	400	400		10 0		
	360					
	320	320				
	280	280	280			
	240	240	240	7 0		
	220	220	220	6 0	4 0	
					3 0	
		30	180	180	5 0	
COARSE	150	150	150	4 0	2 0	2 0
	120	120	120	3 0		1 0
					1 0	
	100	100	100	2 0	1 2	1 2
	80	80	80	1 0	1	1
	60	60	60	1 2		1 1 2
	50	50	50	1	1 1 2	2
	40	40	40	1 1 2	2	2 1 2
	36	36	36	2	2 1 2	3
	30	30	30	2 1 2	3	
	24	24	24	3		
	20	20	20	3 1 2		
16	16		4			
12			4 1 2			

There are two types of grain or grit coating on abrasive papers, closed coat and open coat. In closed coat the grains completely cover the coatside surface of the backing. In open coat materials, around 50% of the surface is covered with grit.

Open coat abrasives are used for removing paint and varnish and in situations when material tends to clog and stick to the abrasive.

One other thing about abrasive paper should be known. The backing paper to which abrasive grit is attached come in different weights or thicknesses. Thin paper is used generally with fine grit and may be held in the hand to smooth curves and details. Heavy paper usually has coarser grit and is used with sanding blocks or in electric sanders for rough work.

Following is a summary of different abrasives, their characteristics and uses:

Flint paper: light tan in color, the abrasive is quartz. Inexpensive compared to other abrasive papers, but not as good. Has a short working life, is not used much anymore.

Garnet paper: reddish in color, lasts longer than flint paper. Pretty useful.

Emery paper: slow-cutting and short-lived. Is not used much in painting trade today.

Aluminum oxide: reddish-brown in color, very hard, very sharp. The best all-around abrasive paper to use on bare wood or metal. Very economical, produces high quality finishes. Aluminum oxide is man-made.

Silicon carbide: man-made, shiny black in color, very hard and brittle. Used mostly on soft metals and plastics and glass for preparing. Silicon carbide paper is made in two forms--for dry sanding, and as a waterproof paper to use with lubricants. Waterproof (wet) paper can also be used dry. Silicon carbide in fine grits, when used with a light oil, can be used on lacquer and varnish to polish the surface and make it shine.

Steel wool: used to clean and polish. Also to remove old finishes and rust and to smooth rough, rounded surfaces. Comes in varying degrees of fineness, from 4/0, which is very fine, to No. 5, which is very coarse.

Wire brushes: have short steel wire tufts set in hardwood blocks or handles. Useful for cleaning plaster off sub-flooring, removing rust from metal.

METHODS OF USING ABRASIVES

There are three basic ways in which abrasive papers can be used:

1. In electric sanders, either oscillating or belt sanders.
2. Attached to wood blocks and used by pushing with hand and arm.
3. Without blocks, simply held in the hand and pushed (or pulled) over the surface.

A number of things determine which method should be used. First, the area to be sanded, smoothed or polished. Second, how rough the surface is. Third, how many angles or curves there are. Fourth, what the surface is made of. There are more considerations, but those are the major ones.

On new construction, the carpenter or plasterer will make sure that the surface is nearly ready to be painted. Usually, the only thing a painter will have to do is use fine grit abrasive and smooth the surface. Steps leading up to sanding will be covered in later modules.

Painters may have to use electric sanders, but usually not that much. Manufacturer's recommendations should be followed and you should always sand with the grain.

Coated abrasive paper may be attached to small blocks by tack, small nail, staple or may be held in place with the worker's fingers. The abrasive paper is wrapped around the block firmly and attached. Sanding, or cutting through unwanted wood, is done by pushing the block firmly (but not too heavily) over the surface with the grain of the wood.

Many painters use a larger block to which a handle can be attached (a lot like a push broom) for reaching up a wall or door. Again, sanding is with the grain of the wood.

When sanding without a block, the coated abrasive paper may be held a number of ways. Most common is holding it cupped in the fingers and palm of the hand, held firmly by the thumb.

The paper then is flexible enough to bend with any curves. Often the fingertips are used to apply pressure when sanding corners or grooves.

Wire brushes and steel wool are used by holding in the hand and rubbing over the surface.

Self Assessment

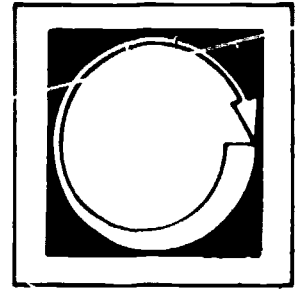

Listed below are several statements. If the statement is true, place a T in the blank provided. If the statement is false, place an F in the blank.

1. ___ Abrasives are used by painters for five kinds of work.
2. ___ Sandpaper is still used widely in the painting trade.
3. ___ Coated abrasives are identified by the size of the grit used on the paper.
4. ___ Closed grit is good to use when sanding paint or varnish.
5. ___ The weight of paper used as a backing is really the thickness of the paper.
6. ___ Flint paper has a shiny black surface.
7. ___ The best all-around coated abrasive in the painting trade is silicon carbide.
8. ___ No. 600 paper is coarser than No. 250.
9. ___ Steel wool is good for removing rust.
10. ___ Wood should always be sanded across the grain.

Self Assessment Answers

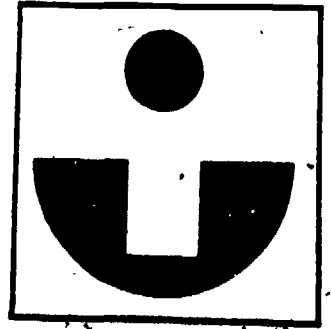

1. F
2. F
3. T
4. F
5. T
6. F
7. F
8. F
9. T
10. F

Job Sheet

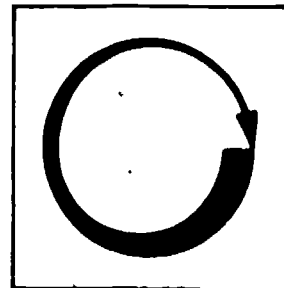

Complete the following tasks.

MATERIALS AND TOOLS

selection of abrasive papers

block

rough flat wood surface to be sanded

rough curved wood surface to be sanded

1. Attach coated abrasive paper to wood block and sand flat wood with grain. Change abrasives from coarse to fine and smooth surface.
2. Hold abrasive paper in hand and sand curved surface. Change abrasives from coarse to fine and smooth surface.

Post Assessment

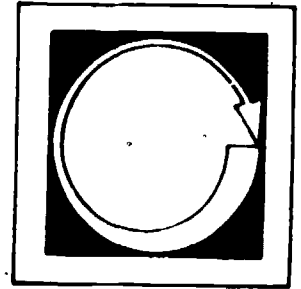

Answer the following questions.

1. Is 500 silicon carbide abrasive paper coarser than 600 silicon carbide abrasive paper?
2. What is the paper to which abrasives are attached called?
3. If you were going to sand a desk that had been painted three years ago, would you use open coat abrasives or closed coat abrasives? Why?
4. Which coated abrasive comes in two forms--one which can be used with liquid?
5. Which coated abrasive is reddish brown in color?
6. Which abrasive would you use to clean large chunks of rust off a water tank?
7. If you wanted to find out what the classification (how rough) of a coated abrasive paper is, where would you look?
8. Is 100 aluminum oxide abrasive paper considered coarse or fine?
9. If you were asked to sand 20 doors, what materials and tools would you use? Why?
10. Is 1/0 silicon carbide the same as 80 silicon carbide?

Instructor Post Assessment Answers

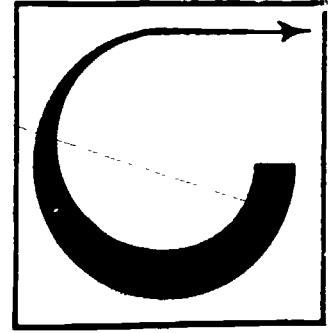

1. Yes.
2. Backing paper.
3. Open coat abrasives. The paper would clog less than closed coat paper.
4. Silicon carbide coated abrasives.
5. Aluminum oxide abrasive paper.
6. Wire brush.
7. On the backing paper.
8. Coarse.
9. Most likely a fine grit abrasive and a large block to which a handle could be attached. It would be faster and easier.
10. Yes.

PRIMER SELECTION

Goal:

The student will be able to identify, select and explain the use and characteristics of primers used commonly in the painting trade.

27

Performance Indicators:

The student will complete an Assignment and a Post Assessment.

30

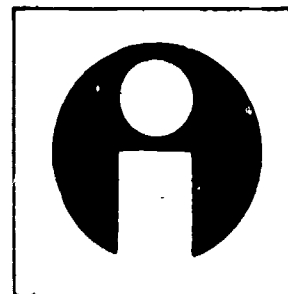

Study Guide

In order to finish this module, do the following tasks. Check each item off as you complete it.

1. Read the Goal and Performance Indicators on the cover of the module. This will tell you what you will learn by studying the module, and how you will show you've learned it.
2. Read the Introduction. The Introduction will tell you why the module is an important part of the painting trade.
3. Study the Vocabulary section. Vocabulary words are important for a good understanding of the trade. After you have studied the vocabulary ask your teacher to quiz you on the words and their meanings.
4. Study the Information section. This section will give you the information you need to understand the subject.
5. Do the Assignment page. Follow the instructions at the top of the Assignment page.
6. Take the Post Assessment exam. Give the exam to your teacher after you have completed it. Your teacher will grade it for you.

Introduction

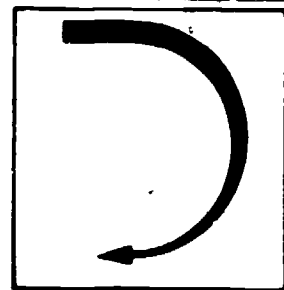

So far, you have learned a few things about paint and how it's used and how and what to use to prepare different surfaces for painting.

Primers have been mentioned a lot. Primers or priming coat is the first coat applied to a surface. Primers do many things. Among them they:

1. Help smooth out rough surfaces.
2. Fill small holes, making a good, smooth base which other coats of paint can be applied over.
3. Provide "tooth"--a good surface for the paint film to adhere to.
4. Seal the original surface, making sure no chemicals or alkalis can get to the paint and cause it damage.
5. Bind very well to the surface being covered, making sure there's a stable (non-moving) surface to paint over.

Learning which primer to use is in many ways as important as knowing how to apply it. The wrong primer will sooner or later result in a bad paint job.

Vocabulary

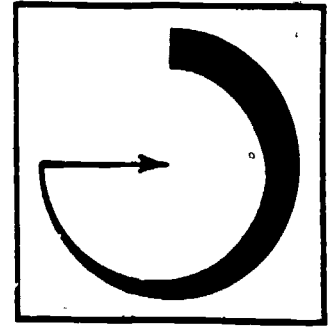

Trade terms are very important for a good understanding of the trade. Study these words and meanings. When you have learned them, ask your teacher to quiz you on the words and their meanings.

WEATHERED--Wood or other material which has been exposed to the weather (wind, rain, sun).

PRIMER--The 1st coat applied to a surface.

UNDERCOAT--Usually the primer, the underbody is a coat or coats below the finish coat. It is also called "undercoat."

FLASHING--An uneven absorption of paint. When you look at a painted wall which has shiny spots and dull spots, the surface was not primed or sealed properly and too much or too little paint was absorbed.

ALKYD--A man-made resin used in paints, varnishes and lacquers.

RUST INHIBITIVE--Prevents rust or slows down the formation of rust.

COVER SYSTEM--Refers to the surface preparation, selection and application of primers, sealers and finish coats.

SPOT PRIME--Apply primer in one spot. May be followed by priming the whole surface or by applying finish coat.

PRIMER-SEALER--A product which primes the surface and seals it to prevent the finish coat from being absorbed too much or too quickly.

SOLVENT--What a material may be dissolved in or thinned with. Water is the solvent for latex paints (they are known as water-based or water soluble). Other solvents (for oil or alkyd finishes) are turpentine, paint thinner, mineral spirits.

ENAMEL--A type of paint made by grinding pigments and mixing them with varnishes or lacquers to form glossy or semi-glossy surfaces. Enamels are used a lot for finish or topcoats because they dry very hard and can be washed easily. There are both oil and latex enamels.

Supplementary References

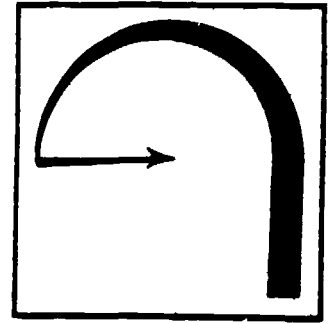

1. Painting and Decorating Encyclopedia. Goodheart - Willcox Co., 1973. pp. 87-88.
2. Painting and Decorating Craftsman's Manual and Textbook. Painting and Decorating Contractors of America, 1975. pp. 127-129, 133.

Information

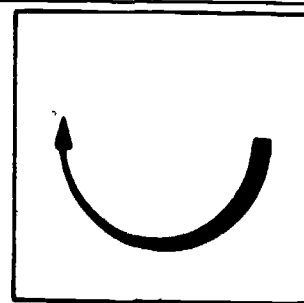

"PLEASE READ LABEL AND FOLLOW DIRECTIONS"

Unlike many trades, directions are given to the painter by the product he or she uses. The quote that's at the top of this page came from the lid of a paint can. Around the paint can is a label telling how to mix the paint, how to apply it, how long to wait before applying another coat, how to prepare different surfaces, etc. If you can read a paint can label, you can choose the proper paint and primer.

There are many primers made by many paint manufacturers. Some primers are made especially for masonry, some for drywall (wallboard), some for metal. Some primers can be used to prime just about any type of surface. Sometimes, you can even use the paint that will be used as the finish coat as a primer coat.

Every paint manufacturing company has what it calls a cover system. A cover system is a method that has been tried and proved effective and durable or long-lasting for painting an object. A system takes into account:

1. The object being painted.
2. Preparing the surface.
3. The primer (if any) to be used.
4. How long it should dry.
5. The finish to be used.
6. The color it will be.

Systems are also based on the exposure the painted object will receive. Will it be indoors or out? Will it be exposed to rain, hot sun, salt water? How hard does the paint have to be? Should it chalk? Will anyone sit on the object or rub against it?

Systems have all been proved by the paint manufacturers to work if directions are followed. Most paint manufacturers' products are alike in many ways, but each manufacturer will tell you to use its products from primer to finish coats.

Following is a list of some of the paint manufacturers:

Dutch Boy
Sherwin-Williams
Parker
Fuller-O'Brien
Benjamin Moore
Glidden
Pittsburgh

They all make a line of paints which are to be used in a system.

This module cannot cover all of the priming products produced by each company, nor can it recommend one company over another. This module will cover primers in general and include one of the manufacturer's line of primers.

Exterior Wood Primers

Oil Base wood primers are usually drying oils and alkyd varnish with pigments that are free of lead. They dry fast and can be painted over in 15-18 hours. On new wood, they prevent natural dyes found in the wood from staining the paint. They also even the porosity of the wood to prevent flashing. They can be used if the finish will be either latex or oil-based paint.

Latex Base wood primers are usually acrylic resins and lead-free pigments. They will seal wood and not allow dyes to stain the paint. They dry fast (are ready for painting over in 6-8 hours). They're rarely used under oil-base finishes.

Plaster and Drywall

These primers contain alkyd resins or PVA (Polyvinyl Acetate) resins to give good sealing ability.

4. PVA--For interior use, dries in 1 hour. A water-soluable primer and sealer.

Recommended for use on porous material like wallboard and plaster. Not recommended for use on bare metal or on painted wood.

May be applied by brush, spray gun or roller. Finish coats can be latex or oil-based paints.

5. Primer--For exterior use. An alkyd-based, pigmented primer for unpainted wood or wood which has weathered a long time, or for cured masonry.

Can be used under latex paints, alkyd enamels or house paints. (House paints were developed to be used on the exteriors of houses--both wood and aluminum siding.) The primer is also good for house trim, shutters, sidewalks.

6. Latex Exterior Primer--For exterior use. An alkyd and acrylic-base for use on both new and previously painted siding and trim. The primer is water soluble. It may be applied by brush, roller, spray gun or pad.

7. Rust Inhibitive Paint--For interior and exterior use. This is an alkyd base primer used on steel, aluminum, galvanized iron and other metals. It may also be used as a finish coat. It is mineral spirit soluble.

8. Several of this manufacturer's "finish" paints may also be used as primer coats, and after dry, other coats of the same paint are used to finish.

You can see that many of these primers may be used on surfaces which are alike and many of them may be used for both latex and oil-based finish coats.

The methods used for adding color to paints are covered in another module, but here are some basics:

Paint comes to the paint store as bases, or paints which are white or a plain color. Tints are added to them to produce the many colors of paint in the world.

Primers should be tinted too, in most cases. Often, the finish paint won't have enough hiding power to completely cover the undercoat. Primers are very often tinted to the same color as the finish coat, or as near the same color as possible.

Assignment

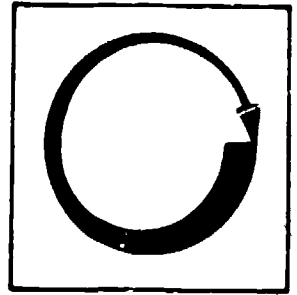

COMPLETE THE ASSIGNMENT BELOW. SHOW THE RESULTS TO YOUR INSTRUCTOR.

Have your instructor arrange a visit to a paint store or a store that carries all painting materials and equipment. While there, you will read labels of many primers to find the right one for each of the following. Write the products's name and make notes about how it is to be used.

What primer would you select for:

- A. Aluminum eaves trough?
- B. Your new driveway?
- C. 4-year-old brick planter?
- D. New plaster walls?
- E. Plaster walls which have been painted with latex finish?
- F. The outside of a wood house that hadn't been painted in 40 years?
- G. A new cabinet in your living room?

H. A new wood fence?

I. A new metal fence?

J. A 10-year-old wood deck?

K. The outside of a new wood house?

L. The sills or sash around the interior windows of a 30-year-old house?

M. The sills or sash around the exterior of the same house?

N. Your red bicycle which is rusty, and which you want to paint light green?

Post Assessment

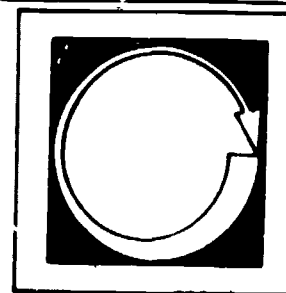

LISTED BELOW ARE QUESTIONS OR STATEMENTS FOLLOWED BY A NUMBER OF POSSIBLE ANSWERS OR COMPLETIONS. SELECT THE ANSWER OR COMPLETION WHICH ANSWERS THE QUESTION OR COMPLETES THE STATEMENT CORRECTLY AND PLACE THE LETTER IN THE BLANK PROVIDED.

1. ____ Primers are always used:
 - a. for finish coats
 - b. to provide "tooth"
 - c. in at least 2 coats

2. ____ An inhibitive is something that:
 - a. prevents
 - b. lengthens
 - c. helps

3. ____ Mineral spirits are sometimes used to:
 - a. dissolve or thin
 - b. add a smell to latex paints
 - c. avoid paint cramping

4. ____ Enamel is:
 - a. always an oil-base paint
 - b. always a water-base paint
 - c. both oil-base and latex

5. ____ Directions for using paints are found:
 - a. in painting catalogs which painters always carry
 - b. on the paint can
 - c. on the paint can lid

6. _____ Which of the following prevents natural wood dyes from mixing with paint?
- a. alkyds
 - b. phenolic latex
 - c. oil base wood primers
7. _____ Which of the following primers would most likely have red lead and iron oxide?
- a. sash primer
 - b. metal primer
 - c. drywall primer
8. _____ Why do good plaster primers contain PVA?
- a. to seal the plaster surface
 - b. to polish, ventilate and asphyxiate the surface
 - c. PVA is recommended by journeyman painters
9. _____ Most primers must be applied with:
- a. brush, roller or spray gun
 - b. spray guns
 - c. priming brushes
10. _____ If you wanted to paint a wall red, you should tint the primer color to:
- a. white
 - b. black
 - c. red

Instructor Post Assessment Answers

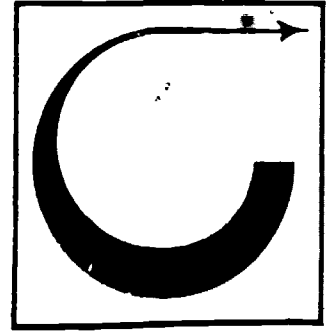

1. b
2. a
3. a
4. c
5. b
6. c
7. b
8. a
9. a
10. c

PREPARING WOOD SURFACES FOR PAINTING

Goal:

The student will be able to identify, explain and demonstrate the steps necessary to prepare wood surfaces for painting.

Performance Indicators:

The student will show an understanding of the subject by:

1. successfully completing a Self Assessment.
2. completing 5 tasks on a Job Sheet.
3. successfully completing a Post Assessment.

Study Guide

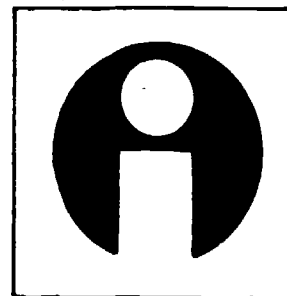

In order to finish this module, do the following tasks. Check each item off as you complete it.

1. Read the Goal and Performance Indicators on the cover of the module. This will tell you what you will learn by studying the module, and how you will show you've learned it.
2. Read the Introduction. The Introduction will tell you why the module is an important part of the painting trade.
3. Study the Vocabulary section. Vocabulary words are important for a good understanding of the trade. After you have studied the vocabulary, ask your teacher to quiz you on the words and their meanings.
4. Study the Information section. This section will give you the information you need to understand the subject.
5. Take the Self Assessment exam. This is a test for you to prove to yourself that you have learned the material you have studied. Compare your answers with the answers on the Self Assessment Answer Sheet, which is on the page following the Self Assessment. If you scored poorly, re-study the Information section or ask your teacher for help.
6. Do the Job Sheet. Follow the instructions at the top of the Job Sheet. The tasks listed on the Job Sheet will help you develop skills which will be helpful to you.
7. Take the Post Assessment exam. Give the exam to your teacher after you have completed it. Your teacher will grade it for you.

Introduction

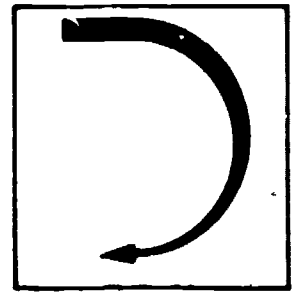

You have learned that preparing the surface for painting is as important as the painting itself. It doesn't matter what kind of surface there is, most of them have to be prepared or the paint or stain job won't look good and won't last.

Wood is the material that is most often painted in the Northwest. As you know, there are many kinds of wood, and it's used in many different ways.

There are generally two areas in which wood must be painted--indoors and outdoors. There are also two types which must be painted--new wood, which hasn't been painted yet, and already painted wood.

Vocabulary

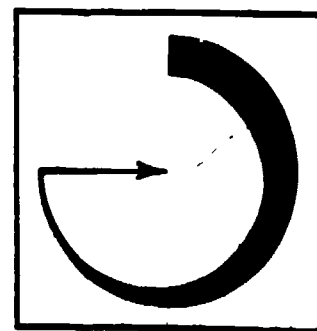

Trade terms are very important for a good understanding of the trade. Study these words and meanings. When you have learned them, ask your teacher to quiz you on the words and their meanings.

INTERIOR--On the inside of a house or building.

EXTERIOR--On the outside of a house or building.

SPACKLE--A paste which is used to fill cracks or holes.

CAULK--Or caulking; a thin paste which is squeezed from a tube. It hardens and seals cracks.

CHALK--The normal wear of some exterior paints. The outer film dries and chips off in very small particles like chalk.

BLEEDING--The color of a base coat, existing paint, or stain becomes liquid and stains new paint.

KICK--The term used by painters describing paint that has chipped, buckled, or come loose from the surface.

PRIMING--Or prime or primer; the first coat (or sometimes first 2 coats) of paint applied to a surface.

RECESSED--Below the surface.

Supplementary References

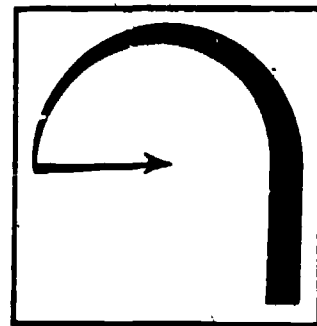

1. Painting and Decorating Encyclopedia. Goodheart - Willcox Co. Inc., 1973.
pp. 75-80.
2. Painting and Decorating Craftsman's Manual and Textbook. Painting and
Decorating Contractors of America, 1975. pp. 451-459.

Information

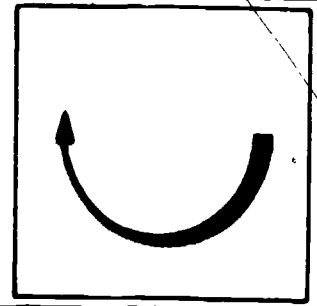

Three things are important for a good paint job:

1. A good bond between surface and paint.
2. A good paint film.
3. A good surface to receive paint.

No paint job will look professional or last long unless all three are present.

Since paint is applied in a thin film, the surface underneath must be cleaned of almost all small objects or they will show through. Also, dirt, grease and cobwebs will either be caught up in the paint or will not allow a good bond between the surface and the paint. Paint which has been applied before can also cause problems if painted over. Wet or moist surfaces can cause real problems if you apply paint over them.

This module will cover the preparation of wood surfaces for painting. There are four different instances when wood must be prepared before painting:

1. Interior new wood (never been painted or stained).
2. Exterior new wood.
3. Interior wood which has already been painted or stained.
4. Exterior wood which has already been painted or stained.

INTERIOR NEW WOOD

It is the painter's job to paint. It is the carpenter's job to build. Most new wood (new construction) will be finished by the carpenter and left in pretty good shape for the painter. The painter may have to do a few things to make sure the surface is ready. These are things to look for and steps to follow to make sure the wood is prepared correctly:

1. Make sure the wood is dry. Don't continue until it is.
2. Use a putty knife to scrape off any chunks of dirt or plaster,

Sand down the entire area with a course (2/0 or 3/0) abrasive paper.

3. Depending on the type of finish to be applied, the following steps will be performed.
 - a. If the wood is open-grained, brush on wood filler; scrape or wipe off with clean rag. This will fill the pores.
 - b. If there are holes or cracks present and you will use Fixall or something similar (NOT spackling paste or putty) to fill them, do it now.

Fixall is a brand name of a plaster-like material that can be used to fill cracks and holes in plaster, wood, plasterboard, stucco and porous metals. To use:

- (1) Make sure the wood surface is free from dirt, grease, oil and loose material.
- (2) Mix 3 parts Fixall with 1 part water in clean container; stir to a smooth consistency and apply with a putty knife or trowel level with wood surface. Mix only as much as can be applied in 15-20 minutes. It can't be re-used and will harden quickly. Apply it and wipe off excess.
- (3) Sand within 30 minutes after it hardens.

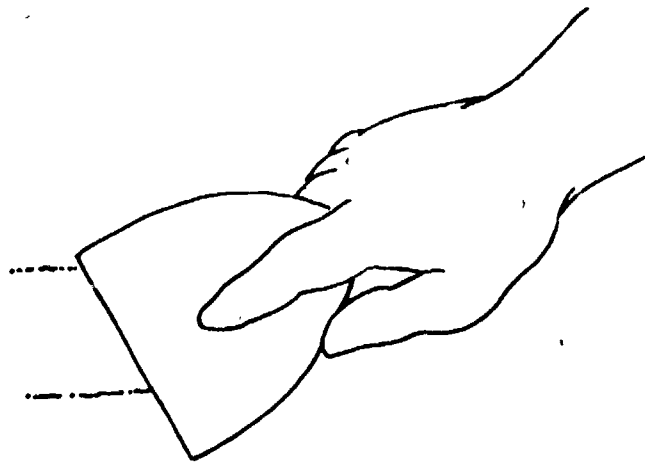

- (4) If the wood surface is to be stained, Fixall should be tinted (with cement color or mortar color) by adding tint to the water before mixing.
 - (5) The surface may be painted with water-based (latex) paints right after sanding. Since oil doesn't react well with water, you should wait until the Fixall patch is completely dry before using oil-based paints.
- c. If, instead of Fixall, you will use putty or spackling paste (also called spackle), do the following.
- (1) Sand the wood to the necessary smoothness.
 - (2) Remove all dirt, grease, loose material.
 - (3) Apply primer by brush or spray. Allow to dry.
 - (4) Apply putty with fingers (over nail holes) and with trowel or putty knife over cracks and holes. Putty has oil in it and unless the wood around it is primed or sealed, all the oil will be drawn into the wood, the spackle will dry, crumble and fall out. Spackle shrinks as it dries, so you should always leave a little hump. Some spackle can be used with spackle powder, which helps the paste stick better and dry faster.

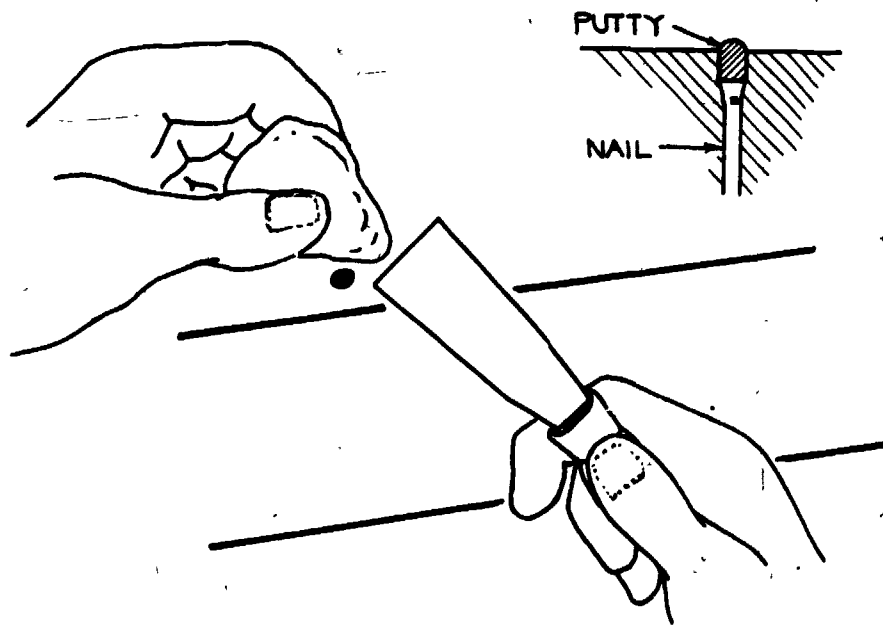

Putty may also be tinted before using. Deep cracks may require two applications to make sure it dries properly.

- (e) When the putty dries, the entire surface should be sanded down for painting.

EXTERIOR NEW WOOD

New wood on the exterior presents fewer problems than it does on the interior of a building. For one thing, you usually only paint or stain the outside, so you don't have to worry about tinting putty or fine sanding. These are the steps to follow:

1. Make sure all nails are hammered in below the surface and wood is free from dirt.
2. Sand down any rough spots.
3. Make sure wood is dry before priming. This can't be said enough: moisture will ruin paint jobs. (One contractor will not paint after a rain until the building has set in reasonably warm, dry weather for 7 straight days.) Morning dew should evaporate before any painting on the exterior.
4. Apply the primer coat by brush or spray.
5. Seal all knots and resin streaks (pitch pockets) with shellac. (See the illustration on the top of the next page.)
6. Caulk joints around widow and door frames. (See the illustration on the bottom of the next page.)
 - a. Caulking material is a water-resistant paste that comes already mixed in a tube.
 - b. Remove dirt, dust, grease oil and loose material from area to be caulked.
 - c. Clip the spout of the caulk tube to the size of the desired bead. If the tube is one which is to be put into a caulking gun, do so.
 - d. Apply caulk in a steady bead by squeezing on caulking gun handle, or by squeezing tube (if not designed for caulking gun).
 - e. Smooth with putty knife, wipe off excess with damp cloth.
 - f. Caulk surface begins to skim over in 15 minutes. It may be painted over in 2 hours. Caulking material should not be applied if the temperature is below 40°.

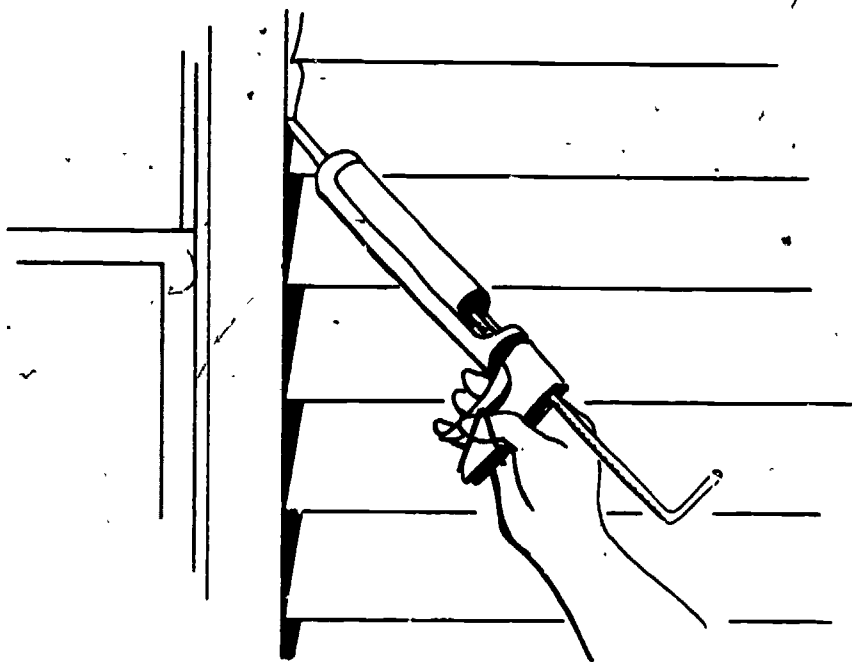
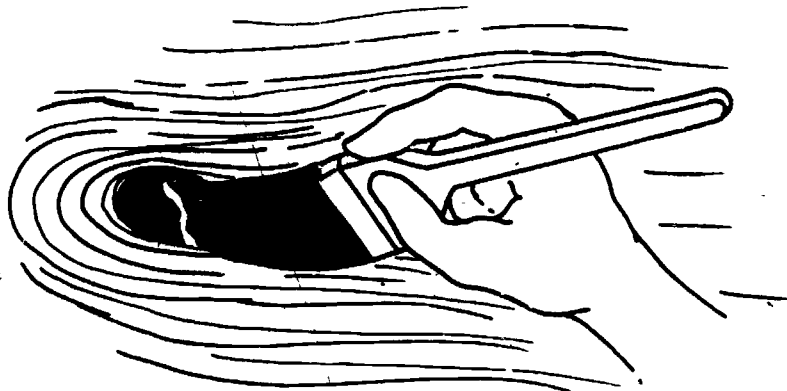

52

54

INTERIOR WOOD ALREADY PAINTED

If the already painted wood surface is in pretty good shape there are several simple steps to prepare it for re-painting.

1. Wipe away all dirt and loose particles.
2. Clean with a commercial washing solution. There are many different brand names available: Prep-Kite and Gre-Sof are two. When mixed with warm water and rubbed on a paint surface, they will remove dead paint (chalk), grease, wax and paste. They will usually also "de-gloss" enamelled finish. De-glossing means that the very smooth enamel finish will be "roughed up" a little so that it will be a good surface for new paint to stick to.
3. Rinse with clean water and wipe down with a sponge or rag.
4. Sand any rough areas.
5. Allow wood to dry.
6. Prime spots where sanded through to bare wood. Use slightly less oily primer (or one with less binder).

If the paint is badly checked or cracked, the entire paint job may have to be removed.

If the new paint is to be applied to a wood surface that has been stained, these steps should be followed:

1. Clean stained surface with commercial cleaner.
2. Apply a small amount of paint in a spot on stained area. If stain does not bleed, entire surface may be painted. If stain "bleeds" after drying, the entire area should be sanded free of gloss with fine (00) abrasive paper.
3. After sanding the surface, apply a full coat of stain sealer such as shellac. Let sealer dry, sand, then proceed with painting.

If painting over wood which has been varnished:

1. Clean the surface to be painted.
2. Either remove varnish finish by sanding,

or

Mix varnish-softening additive or small amount of toluol with paint. This will provide a good bond between varnish and new paint.

EXTERIOR SURFACES ALREADY PAINTED

1. If the paint already on the wood is in good shape (if it's not flaking and is still bound to the wood) merely remove dust and dirt by brushing or washing.
2. All that has to be done for exterior re-painting is to remove loose paint, dirt and dust. If loose paint spots are obvious, they can be removed by brushing with a wire brush or coarse abrasive paper, or by scraping with a broad knife.

Broad Knife

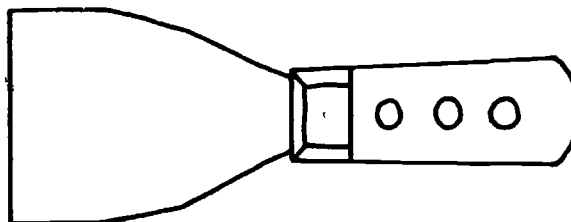

Putty Knife

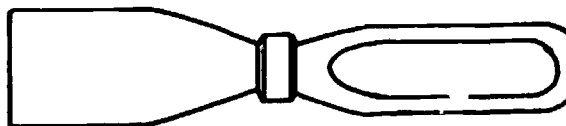

3. One method used by house painters is:
 - a. Mix clorox, liquid dish detergent and hot water.
 - b. Apply all over to painted wood by scrubbing with a heavy duty bristle brush.
 - c. Wash surface at high pressure with clean water.
 - d. Let sit for 5 to 7 days. Any paint that will ever come loose, or "kick", will do so in that time.
 - e. Scrape, wire-brush, sand.
 - f. Prime bare wood spots.
 - g. paint.
4. Liquid paint remover may be used in small areas.
5. Blowtorches used to be used to heat paint so it could be scraped off easily. Due to the danger of fire, BLOW TORCHES ARE NO LONGER USED IN THE PAINTING TRADE.
6. If putty or caulking around windows or doors is loose and has to be replaced, do it after priming the entire surface.
 - a. Remove old putty with putty knife and fingers.
 - b. Prime.
 - c. Replace putty or caulking.

Self Assessment

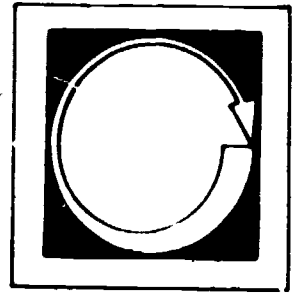

LISTED BELOW ARE SEVERAL STATEMENTS. IF THE STATEMENT IS TRUE, PLACE A "T" IN THE BLANK PROVIDED. IF THE STATEMENT IS FALSE, PLACE AN "F" IN THE BLANK.

1. ___ You should always use a blowtorch to remove old paint.
2. ___ Caulking should be done before priming.
3. ___ Wet wood can cause problems if painted.
4. ___ A product like Gre-Sof is good for removing large areas of loose paint.
5. ___ Wood filler is used to fill large holes.
6. ___ Caulking material comes in a tube.
7. ___ If you wanted to tint or color a material like Fixall, you would apply tint to the water before mixing.
8. ___ The first thing you do to prepare a wood surface for painting is prime it.
9. ___ Fixall shrinks when it dries.
10. ___ Spackle shrinks when it dries.
11. ___ You should always apply spackle to recessed nail heads before priming.

12. ____ Caulk can be mixed with primer to form a water-resistant paint.
13. ____ If a stain bleeds into new paint, you should change to a dark-colored paint.
14. ____ You can apply paint over varnish without preparing the surface if you add Toluol to the primer.
15. ____ You should wait no more than 3 days after a rain to paint the exterior of a house.
16. ____ Using a wire brush is a good way to remove loose paint.

Self Assessment Answers

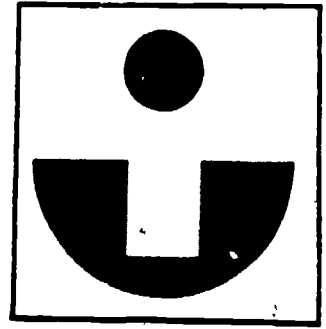

1. F
2. F
3. T
4. F
5. F
6. T
7. T
8. F
9. F
10. T
11. F
12. F
13. F
14. T
15. F
16. T

Job Sheet

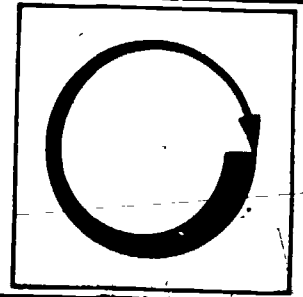

COMPLETE THE FOLLOWING TASKS.

Material and Tools

Fixall (or other brand name)

water

pail

putty knife

D-Grade plywood or other wood with holes and cracks
abrasive paper

1. Mix and apply Fixall to holes and cracks in wood surface, making surface paintable. Refer to Information section for directions.

Material and Tools

putty knife

spackle

primed wood with holes and cracks

abrasive paper

2. Apply spackle to 1/2 of the holes and cracks level with wood surface. As spackle dries, note how far it shrinks beneath surface. Apply spackle to remaining holes and cracks, leaving amount above surface, as recommended. As it dries, note how it becomes level with wood surface.

Materials and Tools

caulking gun or tube

putty knife

suitable frame to practice on

4. Practice applying and smoothing caulking material along horizontal and vertical planes.

Materials and Tools

putty knife

broad knife

wire brush

large surface with scaled paint

5. Practice removing scaled paint using the three tools listed above.

Post Assessment

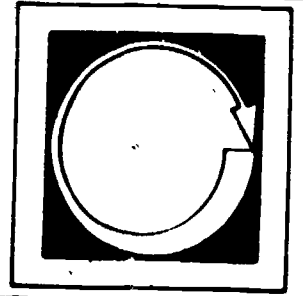

WRITE AN ANSWER IN THE SPACE PROVIDED.

1. What are the three things necessary for a paint job to look good and last well?
2. If someone asked you to paint the west side of his house at 7 a.m. on a spring day, would you do it? Why, or why not?
3. If a woman asked you to finish her beautiful new oak table, what is the first material you would put on the table?

4. What are the steps involved in using a material like Fixall to patch a 2"-wide crack in a wall?

5. If you were going to paint a living room wall on which the paint was in pretty good shape, how would you prepare it?

6. If you were sanding down a door for staining, would you begin with 2/0 abrasive paper or 600 wet/dry abrasive paper.

Instructor Post Assessment Answers

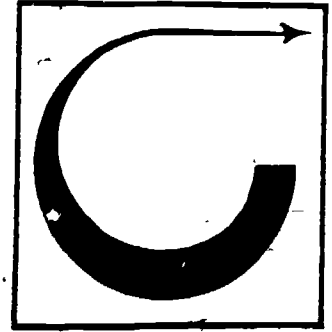

1. (a) good bond between surface and paint
(b) good paint film
(c) good, well-prepared surface to receive paint
2. Probably shouldn't, because the morning dew might affect the paint job.
3. Wood filler, to fill the open grains or pores.
4. (a) clean crack, remove loose material, clean oil, grease, etc.
(b) mix materials
(c) apply, using putty knife
(d) allow to dry for 35 to 45 minutes
(e) sand, if necessary
5. (a) wash it down with a commercial cleaner
(b) rinse with clean water and sponge or rag
(c) sand any real rough spots
(d) apply primer to any bare wood
6. 2/0. You probably wouldn't ever need anything as fine as 600 for a door.

WOOD IDENTIFICATION--PAINTING

Goal:

The student will be able to identify and explain the characteristics of woods commonly painted in the Northwest.

63

Performance Indicators:

The student will complete a Self Assessment, three Assignments and a Post Assessment.

65

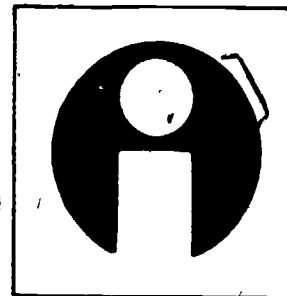

Study Guide

In order to finish this module, do the following tasks. Check each item off as you complete it.

1. Read the Goal and Performance Indicators on the cover of the module. This will tell you what you will learn by studying the module, and how you will show you've learned it.
2. Read the Introduction. The Introduction will tell you why the module is an important part of the painting trade.
3. Study the Vocabulary section. Vocabulary words are important for a good understanding of the trade. After you have studied the vocabulary, ask your teacher to quiz you on the words and their meanings.
4. Study the Information section. This section will give you the information you need to understand the subject.
5. Take the Self Assessment exam. This is a test for you to prove to yourself that you have learned the material you have studied. Compare your answers with the answers on the Self Assessment Answer Sheet, which is on the page following the Self Assessment. If you scored poorly, re-study the Information section or ask your teacher for help.
6. Do the Assignment page. Follow the instructions at the top of the Assignment page.
7. Take the Post Assessment exam. Give the exam to your teacher after you have completed it. Your teacher will grade it for you.

Introduction

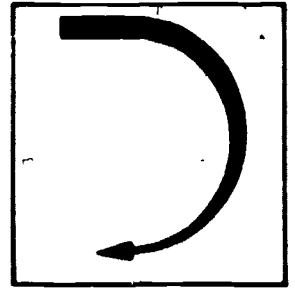

The average person may feel that it is not important to be able to identify different kinds of wood. To the average person, wood identification isn't important, but to the painter it is very important.

Even though wood will be covered with paint or stain or some clear sealer, the wood underneath can determine what the finish will look like. Some woods, for example, have to be sealed or the paint material will be absorbed into the wood instead of forming a film on the wood surface as it's supposed to.

Vocabulary

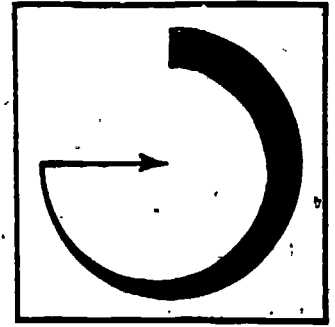

Trade terms are very important for a good understanding of the trade. Study these words and meanings. When you have learned them, ask your teacher to quiz you on the words and their meanings.

OPEN-GRAINED WOODS--Lumber which has many small openings or pores which can absorb paint materials.

CLOSE-GRAINED WOODS--Lumber in which the pores are so small and so few that the wood does not absorb paint materials.

HARDWOOD--Wood which generally comes from broad-leaf trees.

SOFTWOOD--Wood which generally comes from needle-leaf or evergreen trees.

RESINS--Solid or semi-solid substances produced in trees; pitch is an example.

Supplementary References

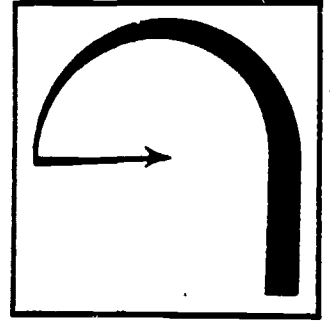

1. Painting and Decorating Encyclopedia. Goodheart-Willcox, South Holland, Illinois, 1973. pp. 111-113.

Information

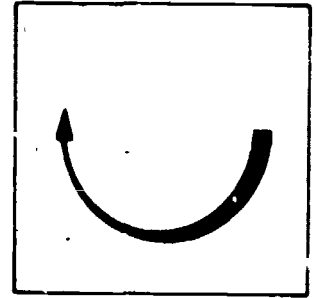

There are many different kinds of wood used in building homes and buildings. These woods can be classified in many different ways, but the beginning painter need only know the basic facts about classifying wood. It is more important that beginning painters learn to identify wood by sight.

There are two main kinds of wood: hardwood and softwood. In the northwest part of the United States, softwoods are used a lot on the exteriors of buildings. The reason is that a lot of softwood grows in this part of the country. Fir and pine are two kinds of softwoods.

Hardwoods are usually used to make cabinets, doors or shelves. Oak and birch are two kinds of hardwoods.

Both hardwoods and softwoods may be classified into other groups. They may be open-grained (which means the wood has small pores which absorb too much paint material) or close-grained. Close-grained woods usually don't absorb too much paint material.

The reason it's important to know a close-grained wood from an open-grained wood is that many of them must be treated before painting or staining. Before it is painted or stained, wood must be able to absorb enough of the paint material to make a good bond between paint and wood. If the wood absorbs too much paint material, the job won't last and won't look good.

Woods are treated by applying a wood filler or sealer or both to fill up or seal off the pores. Even a few close-grained woods may require filler or sealer.

The kinds of woods you would probably see as a painter are: (See the chart on the following page.)

Softwoods

Alder (Close-grained)
Aspen (Close-grained)
Cedar (Close-grained)
Fir (Close-grained)
Pine (Close-grained)

Hardwood

Ash (Open-grained)
Beech (Close-grained)
Birch (Close-grained)
Cherry (Close-grained)
Elm (Open-grained)
Mahogany (Open-grained)
Maple (Close-grained)
Oak (Open-grained)
Walnut (Open-grained)

You can just about be sure that all open-grained woods will need a filler or sealer before they are stained or painted.

Certain woods may require other preparation before painting and staining. For example, all woods have resins and oils. Pitch pockets are an example of resins. Some of the resins and oils affect certain kinds of paint. Pine wood has a resin which shortens the life of paints containing zinc oxide. Oils in some woods may not allow certain paints to ever dry completely.

Another thing which may affect paint is the property of wood itself. A house may have wood siding of fir, but after several years, paint may begin to chip or peel away in places, even though it's the same kind of paint on the same kind of wood.

WOOD CHARACTERISTICS

Trees grow in cycles (they grow fast for awhile, slow down, speed up again). This is how rings are formed. On a piece of lumber or board, the rings look like streaks or designs. (See illustration on top of the following page.)

The dark streaks are called summerwood because it grows late in the growing season. The lighter wood is called springwood because it grows in the spring, during the early part of the growing season.

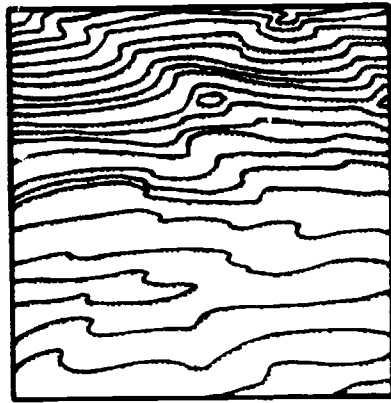

Paint oils penetrate farther into the dark summerwood than they do in the springwood. The problem is that they may penetrate so far that the oil is separated from the paint coloring and the bond between wood and paint is broken. After several years, as the paint dries, it will become brittle and begin to break away from the wood.

Many logs are cut so that there is only a small amount of summerwood showing on the surface. This is good because the paint can usually form a "bridge" over narrow summerwood bands if there is a lot of springwood to hold the paint firm.

In hardwoods, the main concern is the size of the pores.

WOOD IDENTIFICATION

It is impossible to identify wood by studying a module. It is impossible to attach wood to the module to be studied, but it is very important that you become familiar with different kinds of wood. The Assignment page, which you will do after the Self Assessment, will help you study the differences found in wood.

Self Assessment

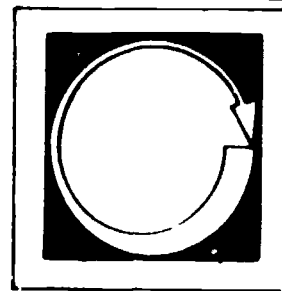

LISTED BELOW ARE QUESTIONS OR STATEMENTS FOLLOWED BY A NUMBER OF POSSIBLE ANSWERS OR COMPLETIONS. SELECT THE ANSWER OR COMPLETION WHICH ANSWERS THE QUESTION OR COMPLETES THE STATEMENT CORRECTLY AND PLACE THE LETTER IN THE BLANK PROVIDED.

1. ____ Most softwood is used on the ____ of a building.
 - a. interior
 - b. exterior
 - c. roof
 - d. basement

2. ____ Hardwood comes from what kind of trees?
 - a. coniferous
 - b. evergreen
 - c. broad-leaf
 - d. needle-leaf

3. ____ All woods produce _____.
 - a. pitch and zinc oxide
 - b. softwoods
 - c. latexes
 - d. resins and oils

4. ____ Two kinds of hardwoods are:
 - a. ash and beech
 - b. alder and aspen
 - c. cedar and elm
 - d. pine and mahogany

5. ____ Two close-grained woods are:
- a. ash and beech
 - b. oak and elm
 - c. birch and cedar
 - d. pine and walnut
6. ____ The resin in pine affects what type of paint?
- a. oils
 - b. latexes
 - c. paint with zinc oxide
 - d. only blue paint
7. ____ What are the two types of wood usually found in evergreen trees?
- a. bark and leaves
 - b. fallwood and deadwood
 - c. oakwood and tarwood
 - d. summerwood and springwood
8. ____ What is the darkwood on a fir board?
- a. hardwood
 - b. summerwood
 - c. resinwood
 - d. springwood
9. ____ Summerwood usually absorbs ____ oil than the other wood on a fir board.
- a. less
 - b. more
 - c. not much more
 - d. not much less
10. ____ Open-grained woods may have to be ____ before painting or staining.
- a. filled or sealed
 - b. cut to size
 - c. soaked in oil
 - d. etched by oxide

● Self Assessment Answers

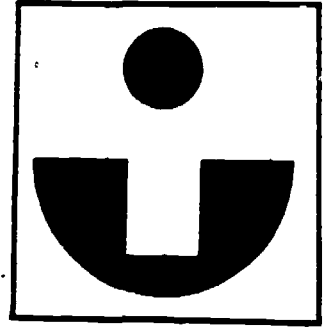

1. b
2. c
3. d
4. a
5. c
6. c
7. d
8. b
9. b
10. a

Assignment

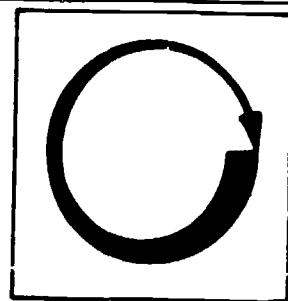

COMPLETE ALL THREE OF THE FOLLOWING ASSIGNMENTS.

1. Ask your instructor to bring in at least 10 different kinds of cut wood: fir, birch, oak, pine, etc. Examine these pieces of wood closely. On a piece of paper, write the color of the wood, whether it is open- or close-grained, and whether you would have to fill or seal the wood before painting.

2. Have your instructor quiz you on wood identification by pointing out pieces of wood and asking what kind they are.

3. Visit a building site or wood house and write a short report on the kinds of wood used on:
 - a. the side of the house
 - b. interior panels
 - c. deck
 - d. cabinets or cupboards
 - e. chairs and tables and bookcases
 - f. doors
 - g. stair railings
 - h. anything else made of woodInclude in your report whether you think the right wood was used and whether you think it was prepared correctly before painting or staining.

Post Assessment

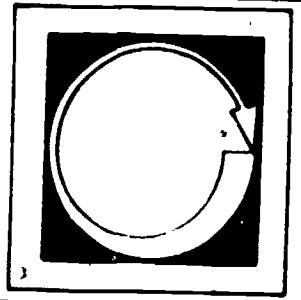

BELOW ARE 10 DIFFERENT TYPES OF WOODS. IN THE BLANK PROVIDED, WRITE WHETHER THEY ARE HARDWOOD (HW) OR SOFTWOOD (SW) AND WHETHER THEY ARE CLOSE-GRAINED (CG) OR OPEN-GRAINED (OG).

	<u>HW or SW</u>	<u>CG or OG</u>
1. Alder	_____	_____
2. Ash	_____	_____
3. Cherry	_____	_____
4. Fir	_____	_____
5. Mahogany	_____	_____
6. Pine	_____	_____
7. Maple	_____	_____
8. Oak	_____	_____
9. Cedar	_____	_____
10. Birch	_____	_____

Instructor Post Assessment Answers

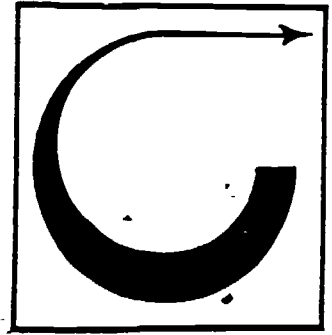

1. SW, CG
2. HW, OG
3. HW, CG
4. SW, CG
5. HW, OG
6. SW, CG
7. HW, CG
8. HW, OG
9. SW, CG
10. HW, CG

PREPARING MASONRY SURFACES FOR PAINTING

Goal:

Upon completing this module, the student will be able to identify and demonstrate the steps involved in preparing common masonry surfaces to receive paint.

Performance Indicators:

The student will complete 2 Assignments, a Job Sheet and a Post Assessment.

Study Guide

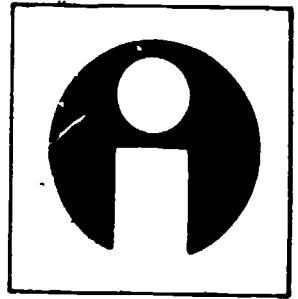

In order to finish this module, do the following tasks. Check each item off as you complete it.

1. Read the Goal and Performance Indicators on the cover of the module. This will tell you what you will learn by studying the module, and how you will show you've learned it.
2. Read the Introduction. The Introduction will tell you why the module is an important part of the painting trade.
3. Study the Vocabulary section. Vocabulary words are important for a good understanding of the trade. After you have studied the vocabulary, ask your teacher to quiz you on the words and their meanings.
4. Study the Information section. This section will give you the information you need to understand the subject.
5. Do the Assignment page. Follow the instructions at the top of the Assignment page.
6. Do the Job Sheet. Follow the instructions at the top of the Job Sheet. The tasks listed on the Job Sheet will help you develop skills which will be helpful to you.
7. Take the Post Assessment exam. Give the exam to your teacher after you have completed it. Your teacher will grade it for you.

Introduction

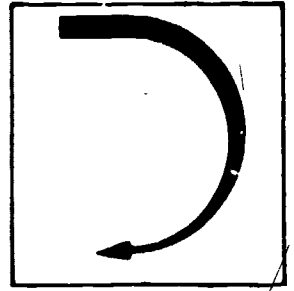

In addition to painting wood, the journeyman worker must also learn to prepare and paint surfaces which fall into the category of masonry. Masonry includes brick, cement block, plaster, stucco, cement (concrete) and rock or stone.

The steps for preparing these surfaces to receive paint or a paint covering are different from the steps involved in preparing wood surfaces.

Vocabulary

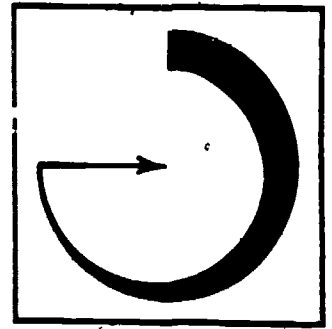

Trade terms are very important for a good understanding of the trade. Study these words and meanings. When you have learned them, ask your teacher to quiz you on the words and their meanings.

LUSTER--Shine; a high luster finish has a lot of shine.

POROUS--Has pores or small holes. These pores absorb a lot of paint and suck out many binders in paint products.

FEATHER--Means to smooth the edge. Filling a hole with Fixall will leave a rough, abrupt edge; feathering the edge will smooth out the edge and make it "flow" into its surroundings.

NEUTRALIZE--To overcome. Chemicals which are harmful to paints must be neutralized or erased.

ALKALI--Brought about by chemical reaction, alkali actually "eats away" at the binders in paint, making it chip away. Lye is a harsh alkali.

EFFLORESCENCE--The white, powdery salts which stain the surface of bricks. Efflorescence is harmful to paints.

ADMIXTURE--Something that can be mixed in with a paint to make it better for a given job.

TRANSPARENT--Something you can see through.

CURES--Materials like plaster and cement take a long time to dry completely or cure. Materials produce chemical reactions until they cure.

Supplementary References

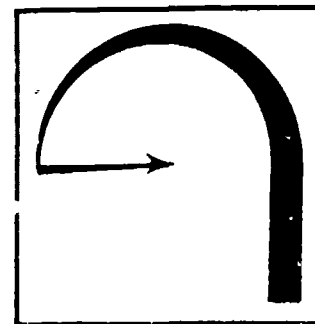

1. Painting and Decorating Encyclopedia. Goodheart--Willcox, 1973. pp. 79-82.
2. Painting and Decorating Craftsman's Manual and Textbook. Painting and Decorating Contractors of America, 1975. pp. 124-127 and 456-461.

Information

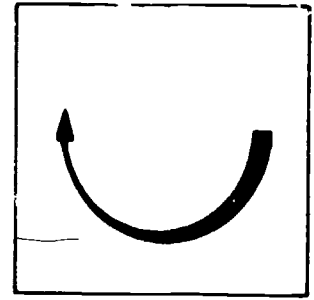

The big problem in preparing masonry surfaces for painting is figuring out how bad or good the surface is, and how to fix it if it isn't good enough. This module will look at common masonry surfaces separately, and discuss correct preparation methods.

NEW PLASTER

Often the painter will be called on to paint the interior of a home or apartment where the walls and ceilings have been freshly plastered. Plasterers use many different "systems" or methods, but all of them produce a surface with these three characteristics:

1. The surface is rough and porous.
2. The material will be moist for some time as it cures.
3. Plaster produces a chemical (alkaline) reaction as it is mixed and as it cures.

Under certain weather conditions, plaster will harden enough to allow paint to be applied within hours. If the air is damp and cold, it may take a day or longer. Experience is the only way to be able to tell if a newly plastered surface is dry enough to paint. If the plaster is to be painted with a latex (water-based paint), you can almost always begin immediately.

Following are the steps for painting with latex:

1. Be sure wall doesn't have nicks, holes, cracks, etc. If it does, contact the plasterer or contractor to have it fixed. (Plasterers are expected to, and usually do, leave the wall in good condition for painting.)
2. Be sure the wall is dry enough for painting. (Latex paint systems can be applied on wet plaster.)

3. Spray or brush on a primer-sealer such as PVA. This will seal off the plaster and make it less porous, and will also provide a good priming coat.
4. As the primer-sealer dries, examine the wall and ceiling surface for spots or areas of different gloss or color. Re-prime those areas which are different.
5. When the primer coat(s) has dried, the surface is ready for a finish coat.

If an oil-based paint is required:

1. Check walls for cracks, holes, lumps, etc.
2. Allow surface to dry enough to apply primer-sealer.
3. Apply primer-sealer.
4. As it dries, examine for gloss or color differences; re-prime where necessary.
5. The surface is ready for finishing, generally two coats.

PLASTER WHICH HAS ALREADY BEEN PAINTED (RE-PAINTING)

If the already painted wall is sound, free of chips or cracks, the preparation is simple:

1. Wash down entire area with commercial cleaning product (Prep-Rite, Gre-Sof, etc.) to remove dirt and grease and to remove high luster.
2. Rinse (as required by product brand).
3. Allow to dry.
4. The surface is ready for re-painting.

If there are chips, cracks or holes visible in the plaster, you will have to do the following:

1. Wash the entire surface with a commercial cleaner. Rinse.
2. Sand or feather edges of very shallow nicks,

or

Patch all cracks, holes, etc. with patching plaster or Fixall or some other brand (NOTE: In some instances, sand can be mixed with caulking material and applied to masonry walls.

3. Allow to dry.

4. Sand and texture patched areas. Texturing means to make the new, patched surface look like the old surface. In some instances, texturing may be done while the patching material is still wet.
5. Prime patched areas.
6. The surface is ready to be painted.

In patching some holes or cracks, the surface may have to be undercut, or dug out, to be properly patched. Big patching jobs require the attention of a plasterer, not a painter with a bucket of plaster. Directions for small patching jobs are explained elsewhere in the modules and on the boxes or cans the patching materials come in.

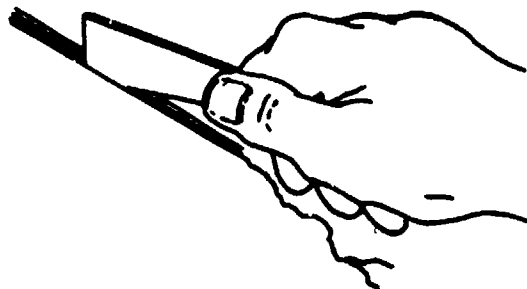

Undercutting a Crack

CEMENT OR CONCRETE

Concrete presents no special problems. New concrete, like new plaster, produces an alkali reaction which is harmful to paint. Complete curing of concrete may take months or years, and very few people will wait that long to paint.

New Concrete

New concrete may be aged and neutralized by taking these steps:

1. Apply a wash coat (of 2 lbs. of zinc sulphate crystals dissolved in one gallon water) to concrete.
2. Allow to dry (deposit will form on surface).
3. Brush off deposits.
4. The surface is ready to be painted.

Old Concrete

The same wash as used on new concrete may be used to fill pores.

Holes and cracks should be filled with cement or Fixall.

There are water-resistant materials available to use on just about any surface which will be exposed to rain or water. "Thompson's Water Seal" is one favorite of the painting industry. Thompson's is applied to masonry surfaces (and other types) by brush, roller, spray or by dipping. It penetrates and seals pores and can be painted over easily. Many such materials or liquids can also be added to paints before painting.

NEW AND OLD BRICK SURFACES

As with plaster and cement, the mortar used in brickwork produces a chemical reaction which is harmful to paints. It is called efflorescence. It should be removed by brushing on (with a bristle brush) muriatic acid and rinsing with clear water. (Muriatic acid is dangerous to work with. Always follow directions very carefully and wear rubber gloves and goggles.)

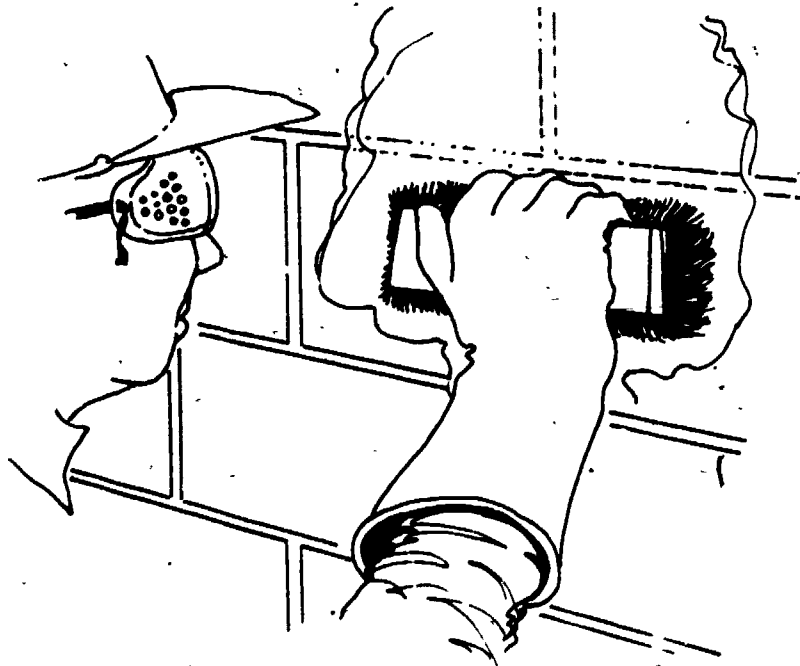

The surface should be dry before painting. Drying may take as long as a month.

Old brick surfaces which are in good shape should be brushed down (with thick bristle and wire brush) to remove dirt and loose particles. If the joints are in bad condition, all loose mortar should be removed.

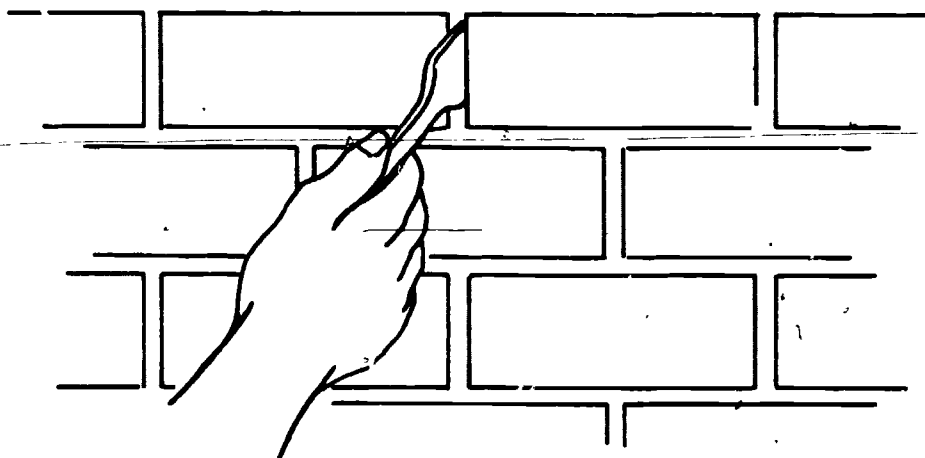

Then, the cracks and holes should be re-filled or "tuckpointed" with cement mortar.

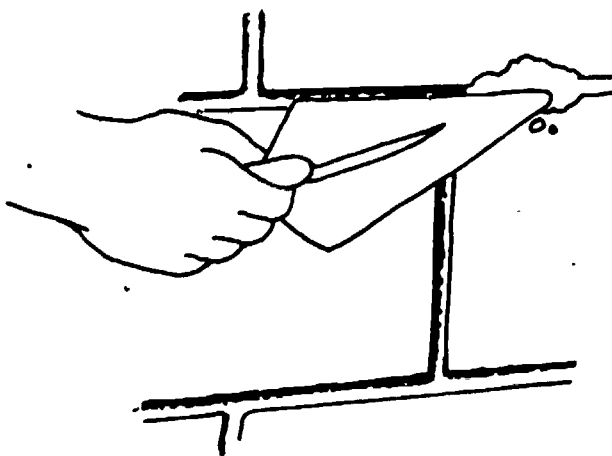

Allow the mortar to cure or neutralize it (just like you do concrete) before painting.

CEMENT BLOCKS

Cement blocks present many of the same problems as bricks. Cement blocks are porous, and the mortar used to hold them together produces alkali reactions.

They should be cleaned, painted with a sealer-primer, and allowed to dry before painting.

At times, the job may call for joints to be filled flush with the surface before painting. A block filler material (comes in 50-lb. bags and is mixed with water) can be rolled on. It is generally applied with a roller in two coats: The first, a heavier, thicker coat, the second a thinner, lighter coat. If done correctly, block filler can present a very smooth, non-porous surface for painting. The same roller technique is used as is used in rolling on paint.

STUCCO

Stucco is a lot like plaster. Exterior stucco finishes must be cleaned free of dirt and oil (and old, chipping paint) before painting. Holes and cracks can be patched with Fixall or exterior spackling paste mixed with sand. Prime patched spots. The surface is ready for painting.

MASONRY SURFACES IN GENERAL

There are many factors involved in selecting a paint for a masonry surface and in finishing the surface. These will be looked at in some detail in the modules on "primers" and "paints."

Assignment

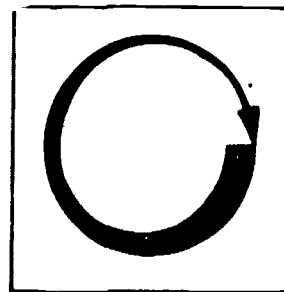

COMPLETE BOTH OF THE ASSIGNMENTS.

1. Visit a painting supply store. Make a list of all of the putties, plaster materials and crack fillers the store has.

Which one would you use for:

- a. repairing a 2" crack in a stucco wall?
- b. patching a small hole in your plastered bedroom wall?
- c. repairing mortar joints in your brick fireplace?
- d. resurfacing your badly-worn concrete patio?
- e. patching a large crack in your concrete garage floor?

Why?

Discuss your answers with your teacher and the class.

2. Have your instructor arrange a class visit to a construction site where new plaster or stucco walls will be painted. While there, determine how the painter could tell if the surface was ready to be painted. Discuss your findings in class.

Job Sheet

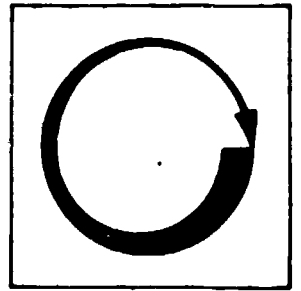

COMPLETE THE FOLLOWING TASKS.

1. Materials and Tools

cement mortar mix, board
pointing trowel
chisel or knife
small brick object in need of tuckpointing

Practice removing old, loose mortar and replacing with new mortar. A bricklayer will usually be called in on a big project, but a painter should be able to do a small repair job.

2. Materials and tools

patching plaster or other suitable filler
knife, chisel
broad knife or putty knife
plaster object needing repair of cracks or holes

Practice filling and feathering (undercut where necessary) cracks and holes.

Post Assessment

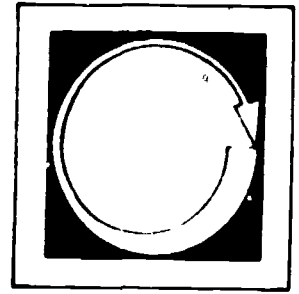

LISTED BELOW ARE SEVERAL STATEMENTS. IF THE STATEMENT IS TRUE, PLACE A "T" IN THE BLANK PROVIDED. IF THE STATEMENT IS FALSE, PLACE AN "F" IN THE BLANK.

1. ___ Alkali and porous mean the same thing.
2. ___ Oil-based paints may be applied directly over fresh, wet plaster.
3. ___ Plaster walls should be washed with a commercial cleaner before patch work is done.
4. ___ Plaster walls should be washed with a commercial cleaner after patch work is done.
5. ___ Primer-sealers should be used on new plaster before either oil-based or water-based paints are applied.
6. ___ You should always wash down new plaster walls with a commercial cleaner immediately before painting.
7. ___ An alkali eats away at the binders in paint.
8. ___ Feathering means to smooth something out, to make it fit into its surroundings.
9. ___ Oil-based paints can be applied to wetter surfaces than water-based paints.
10. ___ Patches should be primed before painting.
11. ___ Drying brickwork before painting should never take longer than 8 hours.
12. ___ If a brick wall is in good shape, you don't have to use muriatic acid on it.

Instructor Post Assessment Answers

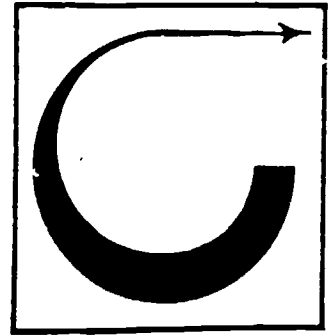

1. F
2. F
3. T
4. F
5. T
6. F
7. T
8. T
9. F
10. T
11. F
12. T

PREPARING DRYWALL SURFACES FOR PAINTING

Goal:

The student will be able to identify, explain and demonstrate the steps for preparing drywall for painting.

Performance Indicators:

The student will complete two Assignments and will successfully complete a Post Assessment.

Study Guide

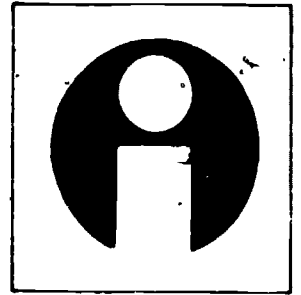

In order to finish this module, do the following tasks. Check each item off as you complete it.

1. Read the Goal and Performance Indicators on the cover of the module. This will tell you what you will learn by studying the module, and how you will show you've learned it.
2. Read the Introduction. The Introduction will tell you why the module is an important part of the painting trade.
3. Study the Vocabulary section. Vocabulary words are important for a good understanding of the trade. After you have studied the vocabulary, ask your teacher to quiz you on the words and their meanings.
4. Study the Information section. This section will give you the information you need to understand the subject.
5. Do the Assignment page. Follow the instructions at the top of the Assignment page.
6. Take the Post Assessment exam. Give the exam to your teacher after you have completed it. Your teacher will grade it for you.

Introduction

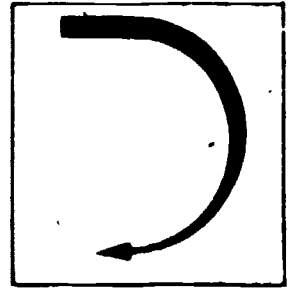

Drywall is the common name given to a material which is used in 80% to 85% of residences being built today. Drywall is fire-resistant and is treated for water-resistance when it will be used around showers and baths. The painter must know how to prepare it correctly to make sure the paint job is professional looking and long-lasting.

Vocabulary

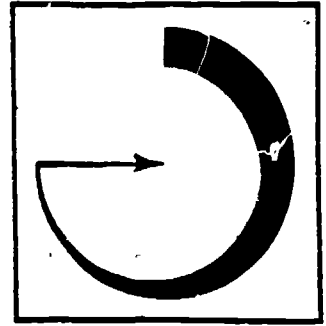

Trade terms are very important for a good understanding of the trade. Study these words and meanings. When you have learned them, ask your teacher to quiz you on the words and their meanings.

STUDS--Wooden 2" X 4"s to which drywall is sometimes attached to form a solid wall.

SUSPENSION METAL--Metal pieces which are welded, screwed or wired together. Drywall is then attached.

BROADKNIFE--Like a putty knife with a very wide (8" - 10") blade. It is used to smooth out compound and tape over joints.

JOINT COMPOUND--A glue-like material which is spread over clean up joints; it hardens and covers up imperfections.

DRYWALL TAPING--Using joint compound and tape to fill clean up joints and make an entire wall ready for painting or plastering.

Supplementary References

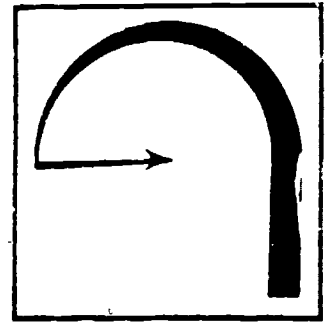

1. Painting and Decorating Encyclopedia. Goodheart - Willcox, 1973.
pp. 79-80.
2. Painting And Decorating Craftsman's Manual and Textbook. Painting and
Decorating Contractors of America, 1975. pp. 603-623.

Information

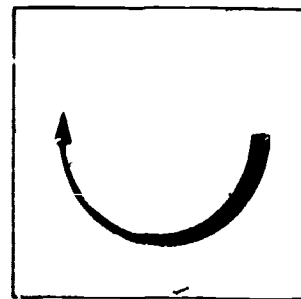

Drywall is one of the most common materials used in construction today. Drywall is processed gypsum (a mineral) covered with paper.

Drywall is installed or "hung" on interior walls and ceilings by nail, screw or glue to wood or metal studs or suspension metal. It is installed by people who are called drywall hangers, carpenters or lathers. Plaster is often spread over drywall by plasterers.

Sometimes paint or wallpaper is applied directly over drywall--both of these are jobs the painter will do.

In most trades, it is the responsibility of the trade that installs the material to make sure it is finished well enough for the next trade to work on it. Drywall is the same. Drywall installers are responsible for making sure their work is left in good enough condition for the trades which will follow. There are a couple of things about drywall that you should know.

First, drywall comes in 4-foot widths. It takes many pieces to cover a wall or ceiling and pieces don't fit together tightly--there is a slight gap or joint (that's not supposed to be more than 1/8" wide) between the pieces. These joints are filled with a joint compound, then covered by a strip of tape. Then the tape is covered by one or two thin coats of compound. The second and third coats are applied when the first has dried--in about a day. (See the illustration on the following page.)

The second thing you should know is that painters don't have to fill the gaps or apply the tape. This is done by the drywall installers or, in most areas, by a tradesperson called a drywall tapper. Drywall tappers are part of the painting trade, but they are not painters. They do everything--including most sanding--so the painter can paint.

When drywall is attached by nails, the nails are recessed below the surface and the "dent" made by the nail is filled with joint compound, smoothed and sanded when dry.

The painter must make sure that the drywall is firmly attached, that nail holes are full, joints are secure, and the surface is smooth enough for the finish.

When the surface is in good shape, you should follow these steps:

1. Apply a primer coat, allow it time to dry.
2. Sand down the entire surface with a fine abrasive paper attached to a block.

The surface is now ready for painting.

Drywall that has already been painted, but needs a new coating, should be treated like interior wood.

Filling Joing Covering
Nail Heads

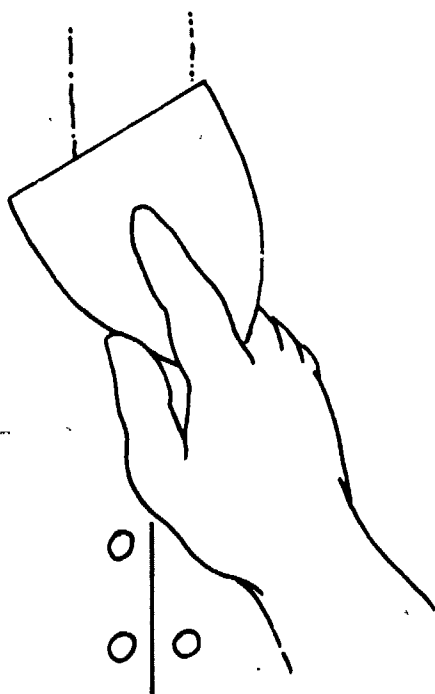

Embedding Tape

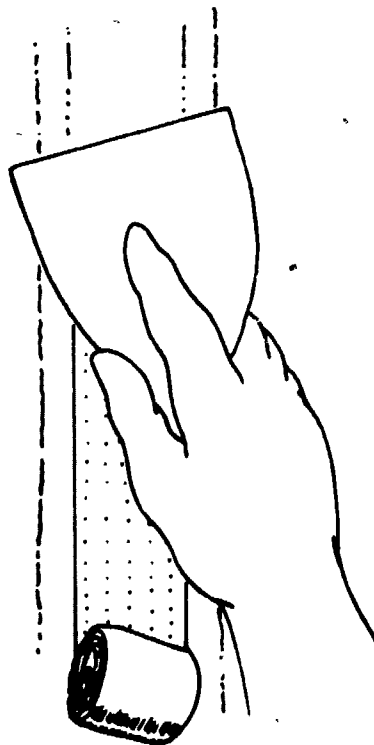

Assignment

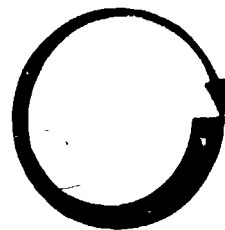

COMPLETE THE FOLLOWING ASSIGNMENTS.

1. Have your instructor arrange a visit to a building site where drywall is being installed. While there, notice the methods by which it is attached. Visit the site when drywall tapers are working. Note how the taper handles the broadknife or trowel when flattening the tape into the compound. See how the edges are "feathered" to provide a smooth surface with no abrupt edges.
2. Have your instructor bring in various thicknesses of drywall material. Examine them and discuss your findings.

Post Assessment

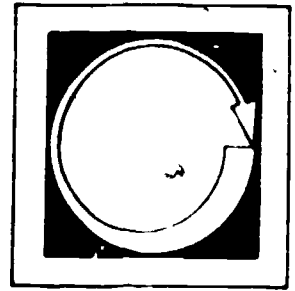

LISTED BELOW ARE STATEMENTS FOLLOWED BY A NUMBER OF POSSIBLE COMPLETIONS. SELECT THE COMPLETION WHICH COMPLETES THE STATEMENT CORRECTLY AND PLACE THE LETTER IN THE BLANK PROVIDED.

1. ____ One of the good things about drywall is:
 - a. it's always water resistant
 - b. it's thicker than plywood
 - c. it's fire resistant
 - d. it's dryer than plywood

2. ____ The spaces between drywall attached to a wall are called:
 - a. dry spaces
 - b. headers
 - c. crevasses
 - d. joints

3. ____ Drywall is made of:
 - a. gypsum
 - b. lather
 - c. tape and compound
 - d. waterproof coatings

4. ____ The painter is responsible for:
 - a. hanging drywall
 - b. painting drywall
 - c. taping drywall
 - d. suspending drywall

5. ____ If a painter finds many huge holes in new drywall, the painter should probably:
- a. go ahead and paint it
 - b. fill in all the holes with glue
 - c. apply 30 or 40 coats
 - d. get a drywall hanger back in to fix it
6. ____ Drywall comes in:
- a. 64" widths
 - b. 2' 6" widths
 - c. 12' widths
 - d. 4' widths
7. ____ The painter should make sure drywall is:
- a. firmly attached to the wall and ready for painting
 - b. firmly attached to the wall and ready for plastering
 - c. loose enough to be taken off the wall for spraying
 - d. filled with scratches and 1/4" holes so the paint will adhere
8. ____ The painter should sand drywall:
- a. before primer is applied
 - b. after primer is applied
 - c. before the drywall taper has shown up
 - d. while the joint compound is still wet

Instructor Post Assessment Answers

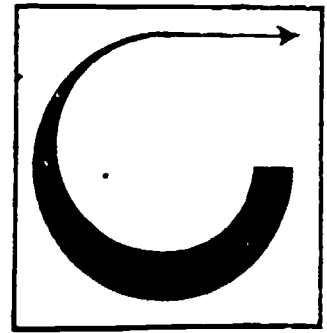

1. c
2. d
3. a
4. b
5. d
6. d
7. a
8. b

PREPARING METAL SURFACES FOR PAINTING

Goal:

The student will be able to explain and demonstrate the proper procedures for preparing metal surfaces for painting.

103

Performance Indicators:

The student will complete an Assignment, a Job Sheet and a Post Assessment.

105

Study Guide

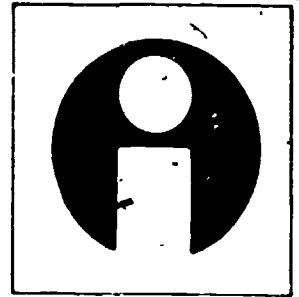

In order to finish this module, do the following tasks. Check each item off as you complete it.

1. Read the Goal and Performance Indicators on the cover of the module. This will tell you what you will learn by studying the module, and how you will show you've learned it.
2. Read the Introduction. The Introduction will tell you why the module is an important part of the painting trade.
3. Study the Vocabulary section. Vocabulary words are important for a good understanding of the trade. After you have studied the vocabulary, ask your teacher to quiz you on the words and their meanings.
4. Study the Information section. This section will give you the information you need to understand the subject.
5. Do the Assignment page. Follow the instructions at the top of the Assignment page.
6. Do the Job Sheet. Follow the instructions at the top of the Job Sheet. The tasks listed on the Job Sheet will help you develop skills which will be helpful to you.
7. Take the Post Assessment exam. Give the exam to your teacher after you have completed it. Your teacher will grade it for you.

Introduction

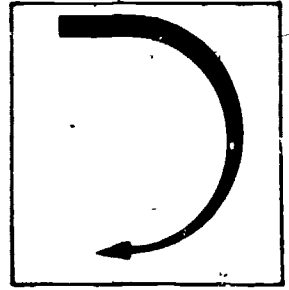

Preparing metal surfaces for painting usually means only cleaning. Metal, of course, is less brittle than plaster or cement, less likely to be dented or scratched than wood. The preparation and priming of metal is very important.

Vocabulary

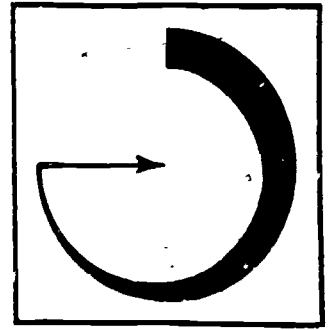

Trade terms are very important for a good understanding of the trade. Study these words and meanings. When you have learned them, ask your teacher to quiz you on the words and their meanings.

ADHERE, ADHESION--The ability to cling to a surface; good holding ability.

PNEUMATIC--Powered by air. Pneumatic tools are run by an electric or gasoline-engine generator or compressor which increases the air pressure.

SCALE--Rust in big pieces.

HYDROCHLORIC ACID--A cleaning solution.

MURIATIC ACID--A cleaning solution used on metal and on brick and block masonry work.

Supplementary References

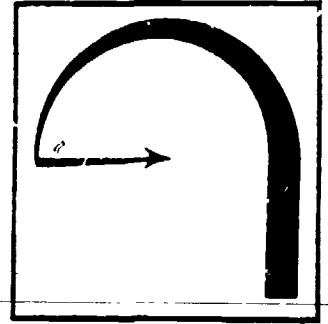

1. Painting and Decorating Encyclopedia. Goodheart - Willcox, 1973. pp. 82-85.
2. Painting and Decorating Craftsman's Manual and Textbook. Painting and Decorating Contractors of America, 1975. pp. 461-463.

Information

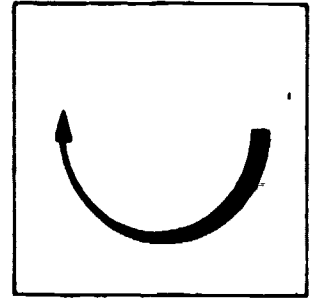

If you look around a typical house, you won't find much metal to be painted. Perhaps an eaves trough and downspouts, possibly a metal fence. Barns and large commercial buildings may have more metal that needs to be painted--steel girders or metal siding. There doesn't seem to be much work for a painter.

But there are metal bridges, water towers and pieces of heavy equipment and machinery which need to be maintained. There are also boats and ships which need paint, not only for good looks, but for protection against the harmful effects of salt water.

The painting industry has developed paints and primers which adhere very well to metal.

Metal surfaces have many small pores to which the paint film can attach itself. What causes problems are dirt particles, rust, oil and scale which clog up the pores and surface of the metal. The solution is to get rid of those unwanted particles and leave the metal surface clean and smooth.

PREPARING METAL

New metal requires no preparation. Simply apply an epoxy primer and the metal surface is ready for finish coats, if, of course, the new metal is clean.

Metal which has been previously painted, or which has been exposed to the weather, does present preparation problems.

There are many ways of preparing metal for painting. Following are the most common:

1. Using a wire brush or abrasive paper. This works well on small rust areas.

2. Using a cold chisel. The cold chisel is good for removing large rust scales.
3. Using regular scrapers or knives works well to remove scaling paint and dirt.

None of the first three methods will remove grease or oil.

4. Sandblasting will remove rust and grease or oil. Sandblasting is used on big jobs to remove everything--old paint, rust, scale. A sandblaster is a pneumatically-powered machine which blows sand at high speed onto a surface. Sandblasting is used to clean bricks and blocks, too.
5. Fire or flame will remove old paint, oil, grease and some rust on metal. Remember, due to fire hazard, blowtorches aren't used on wood.
6. Some solvents work well. Kerosene may be rubbed on metal surfaces to remove grease and dirt. The surface may then be flushed and rubbed with steel wool.
7. Some acids and alkali work well. Depending on the type of metal to be painted, dilutions of hydrochloric or muriatic acids, or ammonia may be used to clean the surface. Vinegar, straight from the bottle, is often used by painters to prepare aluminum. The vinegar removes grease and oil and forms a "tooth" (something the paint can stick to) on aluminum.

There are many commercial cleaners available for cleaning special metals. Each has a special set of directions. They should be followed closely.

Following the cleaning of metal surfaces, a primer coat is applied, followed by one or more finish coats. These may be sprayed, brushed or rolled on. More about these paints will be covered in later modules.

Assignment

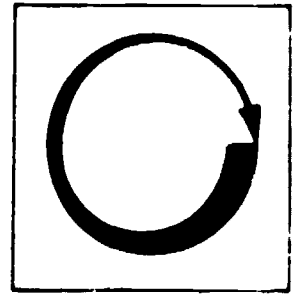

COMPLETE THE FOLLOWING ASSIGNMENTS.

Visit a painting goods store and write down a list of commercial products available for cleaning and preparing metal. Find at least one product which works on:

1. Steel
2. Galvanized iron
3. Tinplate
4. Copper
5. Aluminum

Write a report or tell your instructor how you would use each product on the metal. Tell your instructor what other methods (vinegar, steel wool, flame) you might use if you didn't want to use the product.

Job Sheet

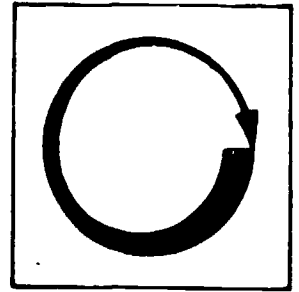

COMPLETE THE FOLLOWING TASK.

Materials and Tools

wire brush

blow torch

metal heavy with scale

1. Prepare the metal surface so it is suitable for painting.

Post Assessment

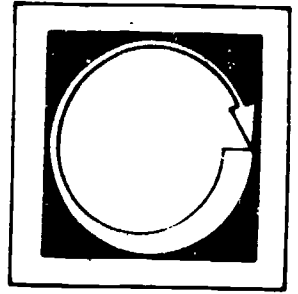

LISTED BELOW ARE SEVERAL STATEMENTS. IF THE STATEMENT IS TRUE, PLACE A "T" IN THE BLANK PROVIDED. IF THE STATEMENT IS FALSE, PLACE AN "F" IN THE BLANK.

1. ___ Vinegar is a good cleaner for brass.
2. ___ Metal has lots of little holes or pores to which the paint can adhere.
3. ___ Metal surfaces should be very hot when painted.
4. ___ A cold chisel is good for removing grease.
5. ___ Using a blowtorch is recommended for removing paint from wood.
6. ___ Sandblasting will remove rust, grease and old paint.
7. ___ Gasoline can be used to remove grease and oil from metal surfaces.
8. ___ Muriatic acid is used only for cleaning bricks.
9. ___ "Tooth" increases the ability of paint to stick to a surface.
10. ___ No primers are used on metal.

Instructor Post Assessment Answers

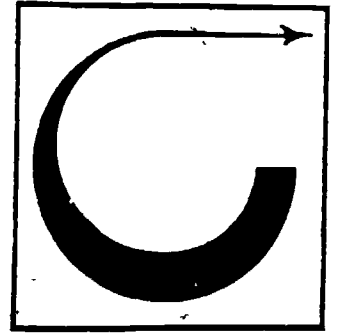

1. F
2. T
3. F
4. F
5. F
6. T
7. T
8. F
9. T
10. F

PAINING SAFETY

Goal:

The student will be able to identify and practice common safety techniques in using tools, equipment and related equipment--ladders, scaffolds, etc.

114

Performance Indicators:

The student will demonstrate knowledge of trade safety by completing an Assignment and a Post Assessment.

116

Study Guide

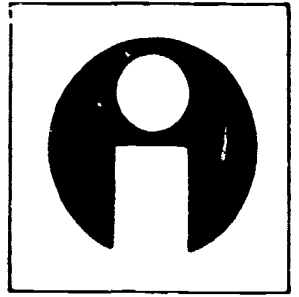

In order to finish this module, do the following tasks. Check each item off as you complete it.

1. Read the Goal and Performance Indicators on the cover of the module. This will tell you what you will learn by studying the module, and how you will show you've learned it.
2. Read the Introduction. The Introduction will tell you why the module is an important part of the painting trade.
3. Study the Information section. This section will give you the information you need to understand the subject.
4. Do the Assignment page. Follow the instructions at the top of the Assignment page.
5. Take the Post Assessment exam. Give the exam to your teacher after you have completed it. Your teacher will grade it for you.

Introduction

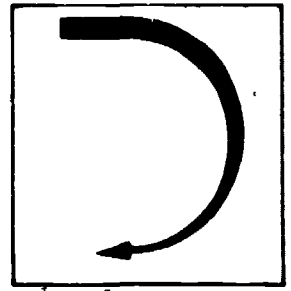

There are thousands of ways you can be safe while working on the job. Safety isn't any good unless you do everything safely. It only takes one accident to harm you enough to become a non-productive painter.

This module on safety covers a few highlights of safety in the painting trade. More about safety is written into every painting module that you will study.

Information

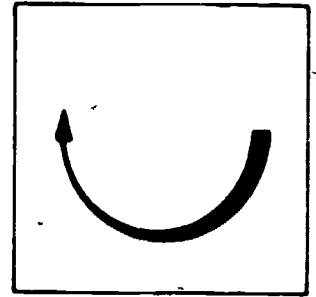

Safety is something that can be learned, but does no good unless it is practiced. You have to approach safety by having a good attitude toward avoiding accidents and removing hazards.

There are many different areas in which safety can be practiced. All of the areas must be looked at individually and practiced as a whole. This module will cover basic safety rules in several areas. Learning the rules isn't enough. The rules must be obeyed.

CAUSES OF ACCIDENTS TO PAINTERS

Nearly 7 out of 10 serious accidents are because of falls from ladders, scaffolds, etc. Being hit by a falling object or by a moving object results in serious injuries, too. Being exposed to harmful materials--fumes, splashes, strong solvents--also causes serious accidents.

GENERAL RULES

1. Be aware of all safety hazards on jobs. At times, other workers will still be on the job with their equipment. Sometimes the other trades' pieces of equipment get in the way and cause problems.
2. Clean up after yourself. Be sure you don't cause safety hazards.
3. Don't smoke around flammable materials.
4. Don't horseplay on the job.

SCAFFOLDING AND LADDER SAFETY

1. Be sure scaffolds are erected correctly. Be sure ladders are sturdy and are equipped with safety feet.

2. Don't try to over reach to paint "that last 6-inch strip."
3. Keep materials and tools which are not in use out of the way.
4. Don't drop or throw things from ladders, scaffolds, or other rigging.

EQUIPMENT

1. Be sure any equipment (compressors, etc.) you use has ASME labels, stating it was built to standard and has been inspected.
2. Test safety relief valves on air pressure equipment routinely.
3. Be sure electrical equipment is grounded.
4. Replace or repair frayed hoses or valves or electric cords.
5. Don't exceed recommended air or fluid pressure when using spray equipment.
6. Don't point spray gun or airless gun at anyone or yourself. The pressures can be such that these guns can shoot paint into human flesh.

MATERIALS

1. Store paints in cool, ventilated places. Store them away from heaters or machines that produce heat or cause sparks.
2. Many solvents, thinners and painting materials produce fumes which are poisonous. Don't breathe them when mixing or applying.
3. Make sure area is well ventilated when applying materials with poisonous fumes.
4. Wear respirators or filters when fumes cannot be completely removed by ventilation.
5. Wear rubber gloves and skin protection when mixing or applying materials which can burn the skin.
6. Wear safety goggles when sanding, scraping, or applying materials that can fall or be blown into your eyes.
7. Don't go into areas which aren't free of strong solvent odor.
8. When painting in homes, make sure pilot lights and other flames are extinguished if using anything but latex materials.
9. Use explosion-proof electrical equipment when using flammable materials in confined areas.

10. Wash skin (face, hands, arms) regularly. Wash immediately if splattered by strong solvent. Use soap and water.
11. Store materials in closed containers at all times.
12. If fumes cause headache or dizziness, inform boss and leave immediately. Work area should be ventilated.
13. Wear hard hat when required.
14. Make sure scaffolds and ladders can't be bumped by or cause harm to bystanders. Rope area off if necessary.

ACCIDENTS TO OTHERS

1. Don't bump or move ladders or scaffolds without permission.
2. Practice safe use and operation of equipment.
3. Make sure equipment cannot fall or be accidentally kicked off scaffolds or platforms above the ground.
4. Be careful with hoses. Avoid entangling them with other workers.
5. Don't allow others to breathe poisonous fumes and vapors. Make sure they know what materials you're using.
6. Store materials safely.

USE TOOLS SAFELY

1. Use correct tool for the job.
2. Be careful of others while you work. Be sure they won't get splattered by paint.

RESPECT PROPERTY OF OTHERS

The job of a painter is to beautify and protect--not just the surface he or she is painting, but other things that are not being painted. It does no good to paint walls beautifully and have paint drip onto the floor or wall moulding. The owner of a house won't like the professional job you did of varnishing the living room wall panels if you spray varnish all over the fireplace or piano. You have to protect those things which aren't to be painted--sinks, electrical outlets and light switches, lamps and lights, mouldings, floors, carpets, appliances and furniture. There are two ways to do this.

Drop Cloths

Drop cloths are large sheets of plastic, canvas or plastic-backed cotton that are used to protect large areas. They are laid out flat to protect finished floors, or they may be draped over furniture or appliances to protect them from paint. Drop cloths may even be used outdoors to protect flowers and shrubs from paint.

Masking

Masking is using tape, or tape and paper, to cover specific areas. It's hard to hang a drop cloth over vertical door moulding or an electrical outlet. It is easy to run tape the length of these, or around windows to protect sills and sash from getting painted.

Masking tape comes in many widths. Over large areas, such as windows, wide strips of paper are taped on to give protection from paint.

Masking is usually done more when the paint will be applied by spray. Spraying by conventional gun produces a lot of strong air currents which blow little drops of paint around. If a room is ventilated well, air currents can carry paint spray many feet. The painting job is always easier if all areas are protected before the painting begins.

When painting exteriors, especially with spray equipment, be sure the wind isn't blowing too hard. The wind can carry off a lot of paint before it hits the house, which wastes materials. Also, the paint may land on automobiles or lawn furniture.

LADDERS

Ladders are used when the painter must reach places too high to reach with a brush or an extension pole and roller. There are many different kinds of ladders used by painters, depending on the job that must be done. All ladders used to be made with wood, but now more and more of them are aluminum or a magnesium alloy. Following is a list of commonly-used ladders:

(See the illustrations starting on the next page.)

Straight Ladder

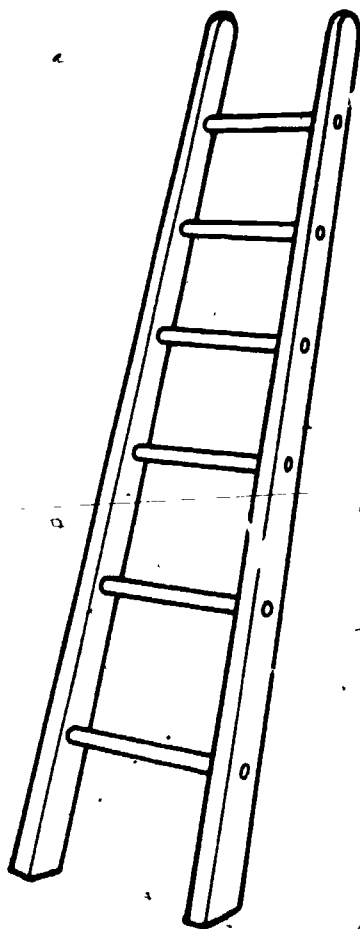

1. One straight section, not adjustable in length, won't support itself. Must be leaned against wall.
2. Straight ladders over 30' long should not be used.

Extension Ladder

(See the illustration on the top of the next page.)

1. Two or more sections.
2. Some have rope and pulley system for extending.
3. Should have automatic locks for safety.

(See the second illustration on the next page.)

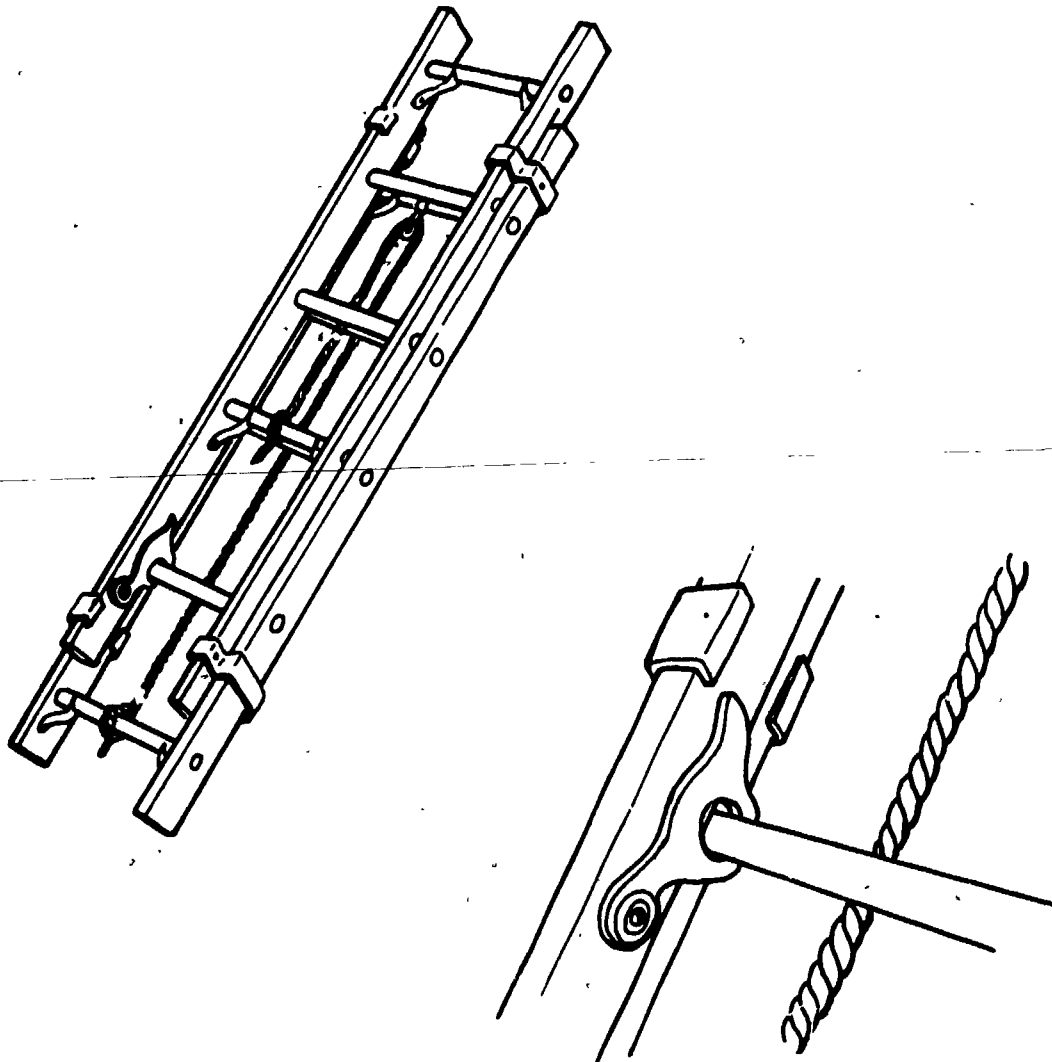

4. Always use enough overlap when extension is made.
 - a. 38' and less, use a 3' overlap.
 - b. 44' and less, use a 4' overlap.
 - c. 46' and less, use a 5' overlap.
5. Extension ladders over 46' long should not be used.
6. Must be leaned against wall.

Step Ladder

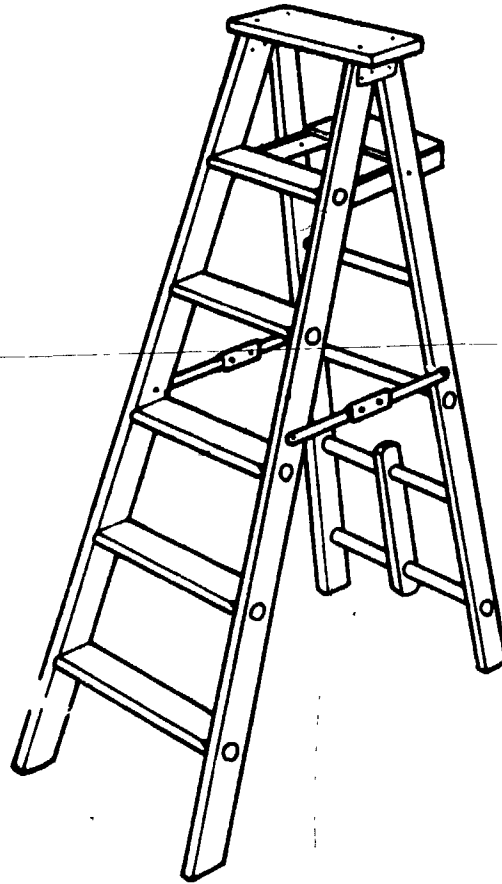

1. Not adjustable in length.
2. Self-supporting.
3. Have racks to rest pot or bucket on.

Trestle Ladder

(See the illustrations on the top of the next page.)

1. Self-supporting.
2. Hinged at top, longer ones (12' length) have metal locking device (spreader) to hold trestle in open position.
(See the second illustration on the next page.)

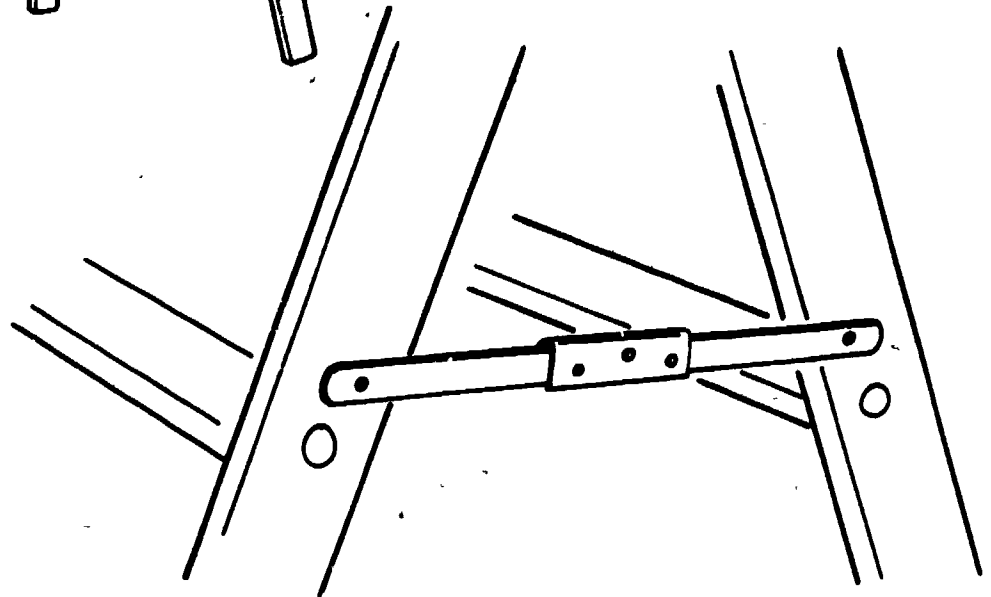
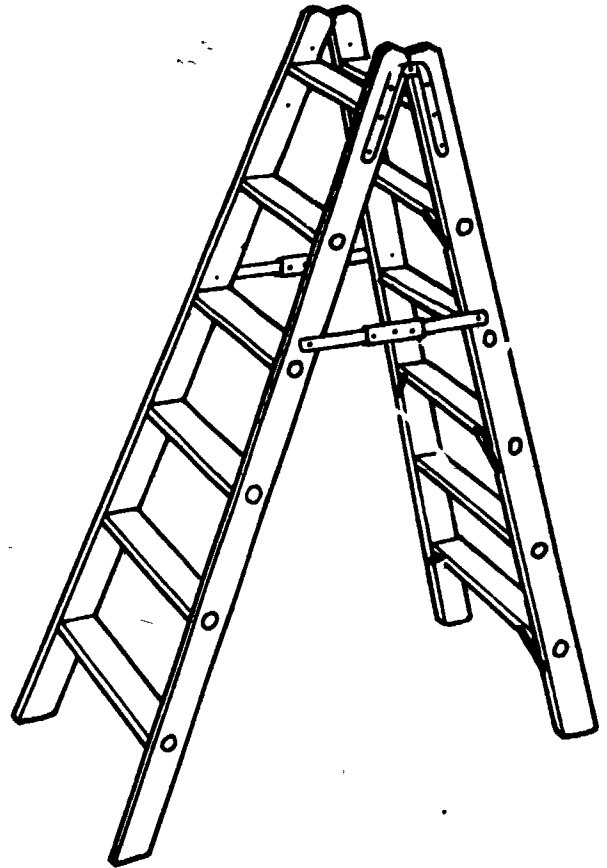
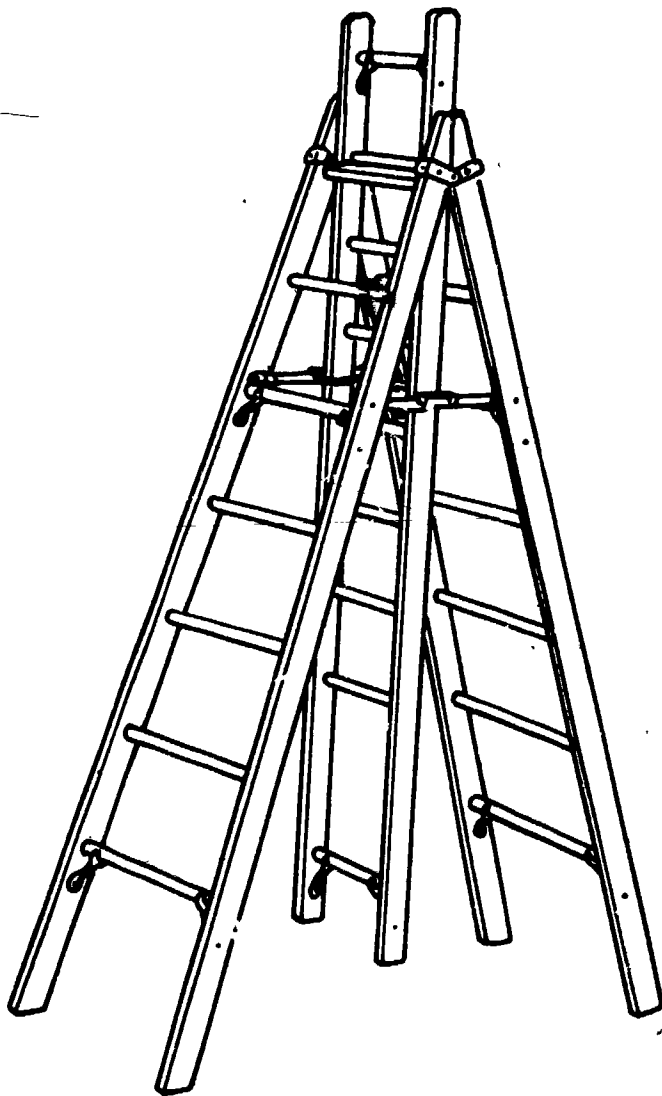

3. Extensions must be locked into place.
4. Trestles may be used to support planking or stages.

(See the illustrations on the top of the next page.)

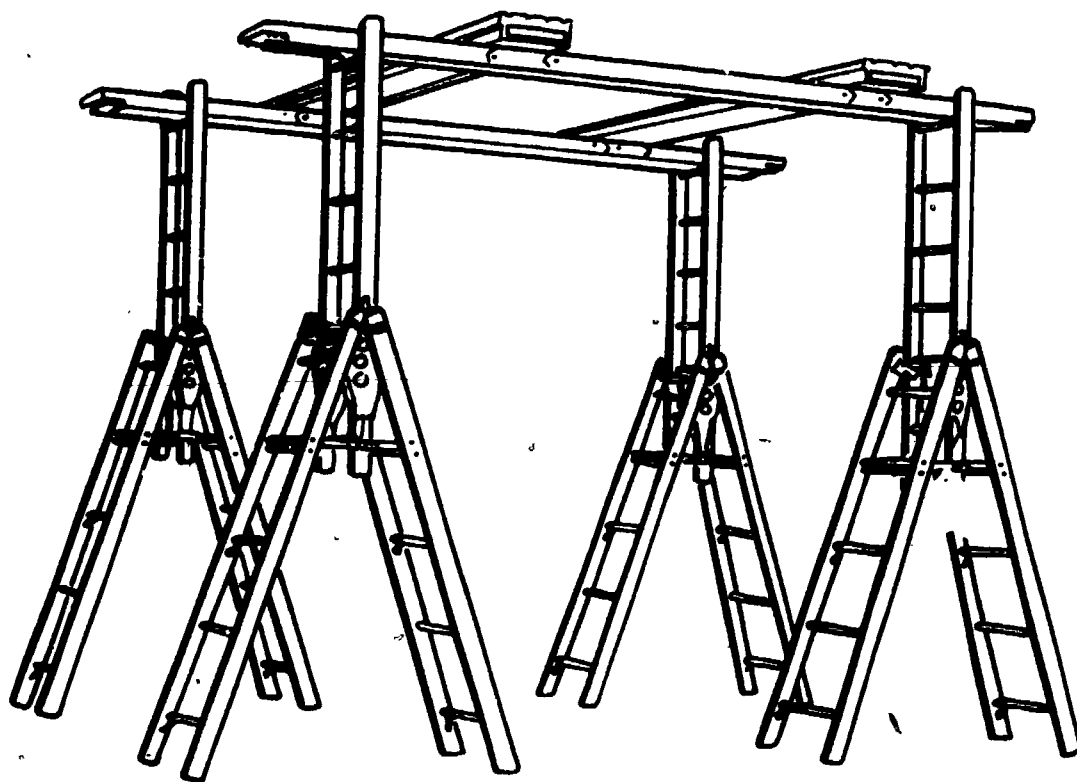

Ladder Safety

1. Inspect ladders for secure fittings, rust, cracks in wood rungs, etc.
2. Don't use metal ladders near electrical lines.
3. Don't rest ladders on window sash.
4. Use ladder safety shoes on slippery surfaces.

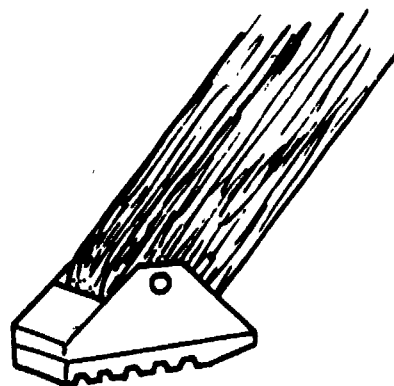
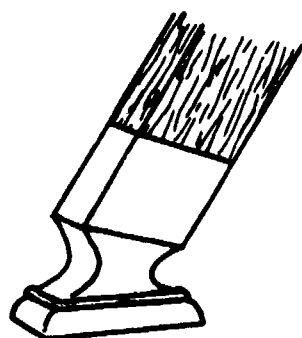

5. Face ladder when climbing up or down.
6. Keep hands free to hold onto rungs.
7. Don't stand ladders in mud or loose dirt. Set them on wood panels.
8. Use bucket hooks to hold paint.

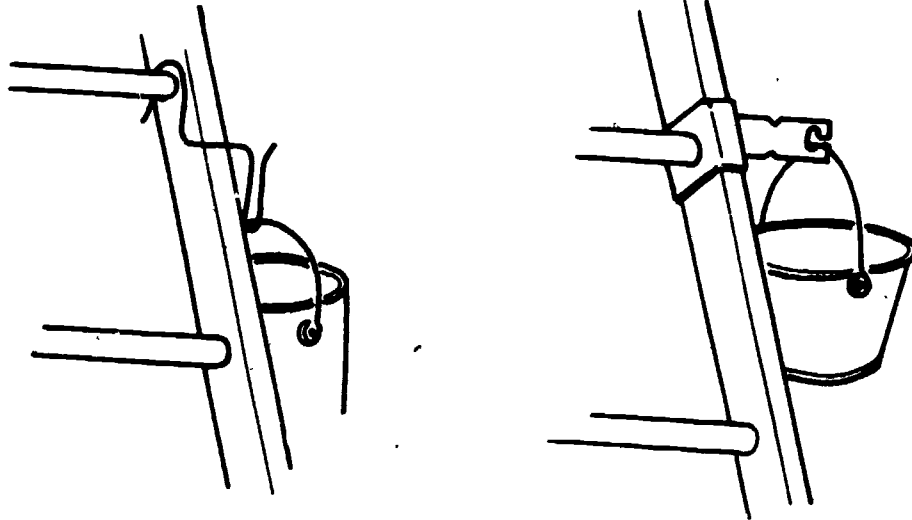

9. Select proper ladder for the job.
10. "Walk straight or extension ladders up" to raise them. Lay ladder on ground with base resting against foundation wall; lift opposite end over head; walk toward wall, changing hands from rung to rung.
11. Don't lean straight or extension ladders at too great an angle. The base should be about 1/4 the distance of the ladders's height.

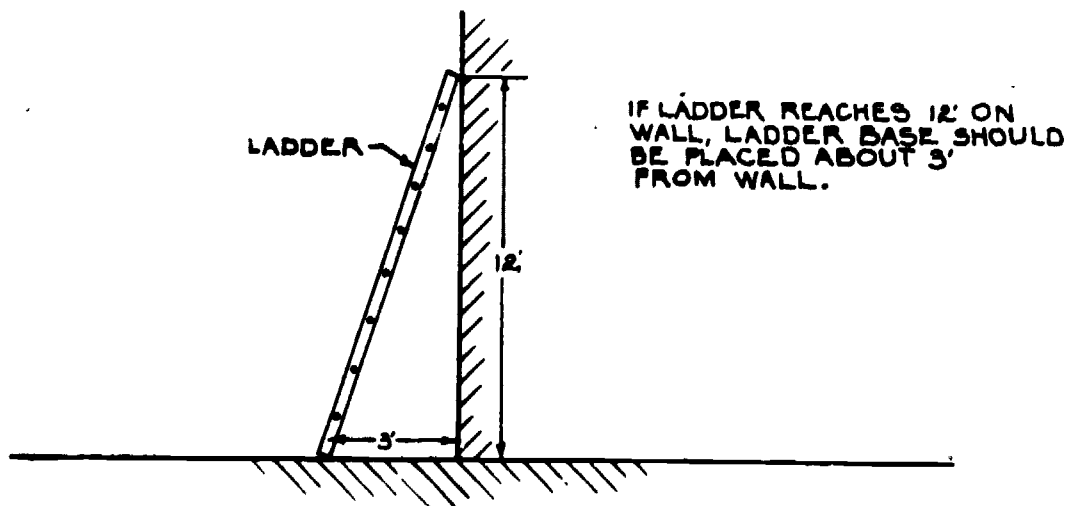

12. Don't place ladders in front of busy doorways.

SCAFFOLDS

There are many types of aids other than ladders to help the painter work on high places. They should be used when you can't safely use a ladder. These are usually all called scaffolds.

There are many types of scaffolds made of wood, steel or aluminum. This module will list some of them, but will discuss only the two types you are likely to use for quite awhile.

1. Outrigger scaffold--Is actually built into the wall, and supported by wood from below.

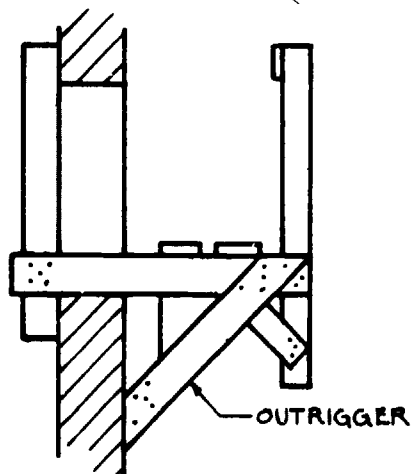

2. Suspended scaffolds--Scaffolds which are suspended from above by rope or cable. They can be raised or lowered.

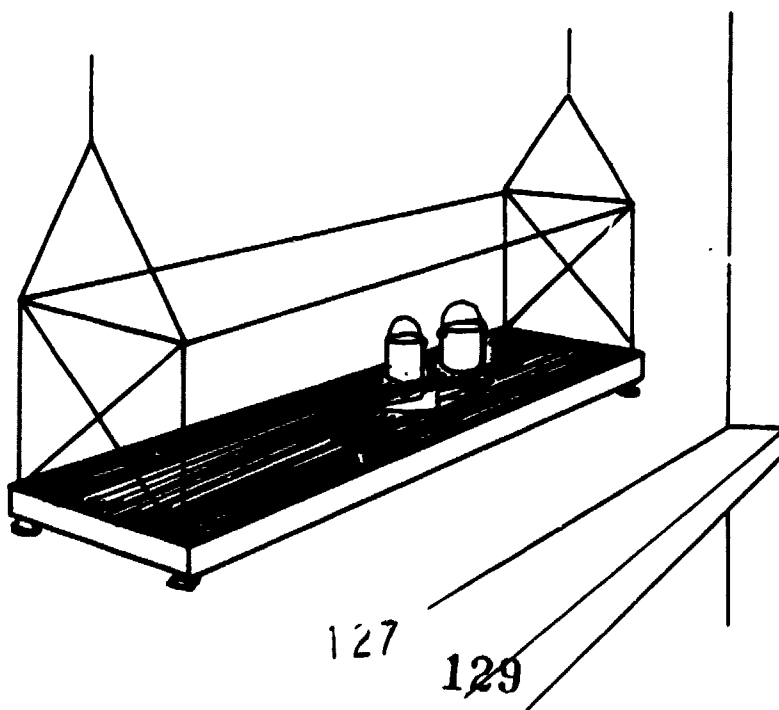

3. Ladder Jack Scaffold--Is a scaffold built on ladders.
 - a. Jacks are attached to ladder.

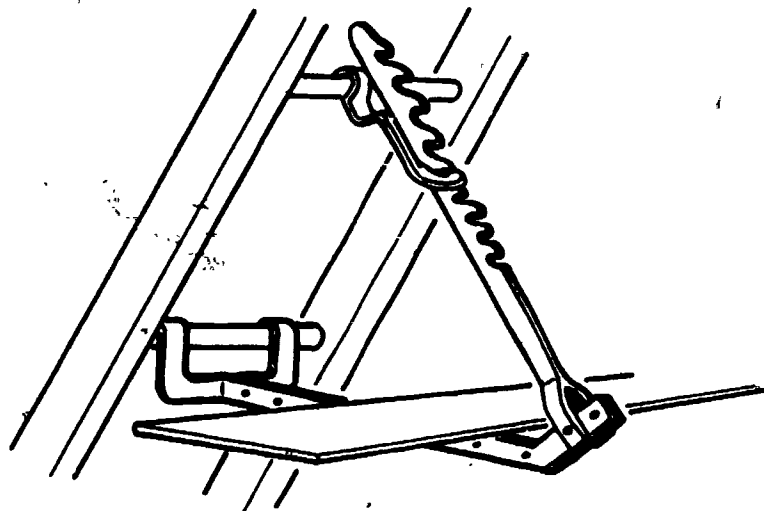

- b. Planking is laid over 2 jacks on 2 ladders.
 - c. Cannot be used over 18' off the ground.
4. Small Stee' Trestles.

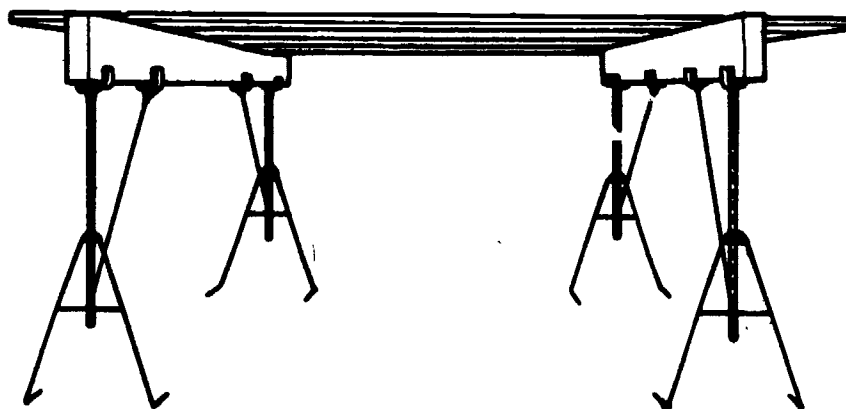

5. Metal Scaffolds.
 - a. Usually erected (raised) by scaffold company.
 - b. Made of high-strength steel or aluminum tubing, welded.
 - c. Consist of end frames and diagonal braces, with wood planks used as floors.

(See the illustrations on the next two pages.)

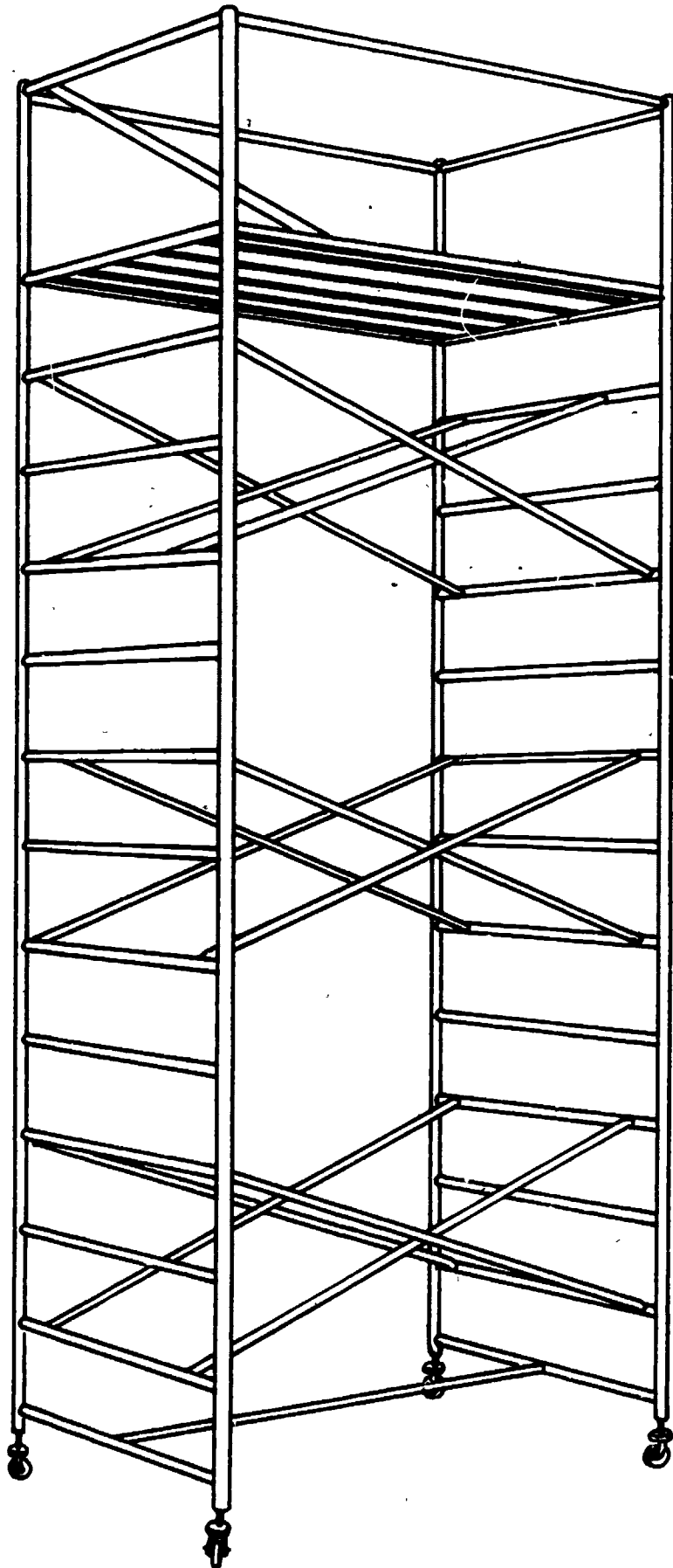

129 131

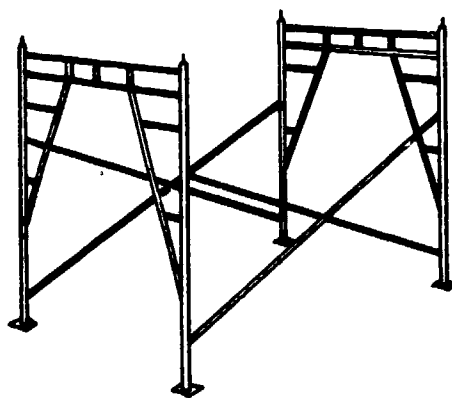
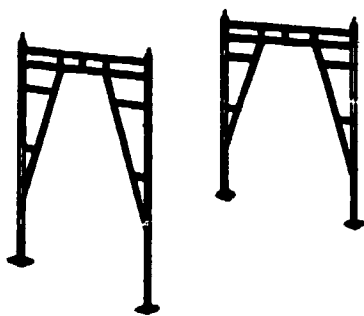

4. Have adjusting legs to make level setup.
5. OSHA has established rules about toeboards, guard rails, etc. These rules change. Consult the latest rules.

Assignment

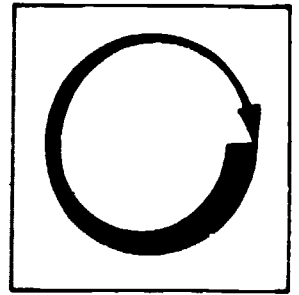

COMPLETE THE FOLLOWING ASSIGNMENT.

Visit a site where professional painters are working. Write a list of no less than 5 safe practices or 5 unsafe practices (or both) in each of the following areas:

Ladders and Scaffolds

- 1.
- 2.
- 3.
- 4.
- 5.

Equipment

- 1.
- 2.
- 3.
- 4.
- 5.

Materials

- 1.
- 2.
- 3.
- 4.
- 5.

Respecting Property of Others

- 1.
- 2.

- 3.
- 4.
- 5.

132

134

Post Assessment

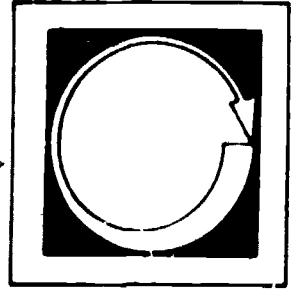

LISTED BELOW ARE QUESTIONS OR STATEMENTS FOLLOWED BY A NUMBER OF POSSIBLE ANSWERS OR COMPLETIONS. SELECT THE ANSWER OR COMPLETION WHICH ANSWERS THE QUESTION OR COMPLETES THE STATEMENT CORRECTLY AND PLACE THE LETTER IN THE BLANK PROVIDED.

1. _____ About _____ % of serious injuries to painters are caused by falls.
 - a. 50
 - b. 30
 - c. 70
 - d. 95

2. _____ Compressors should have _____ labels, certifying their safety.
 - a. six
 - b. ASME
 - c. UL
 - d. colored

3. _____ Airless compressors can shoot paint
 - a. about 6 feet
 - b. about 1 foot
 - c. with very little pressure
 - d. into human flesh

4. _____ All electrical equipment should be properly
 - a. grounded
 - b. shorted
 - c. cabled
 - d. spliced

5. _____ Paints should be stored in
- 5-gallon drums
 - air-tight places
 - moist places
 - cool places
6. _____ Some solvents produce
- electrical failure
 - fumes and vapors
 - loose scaffolding
 - respirators
7. _____ Masking is very important when a painter is
- brushing
 - rolling
 - spraying
 - dipping
8. _____ Hoses used in spray painting should be
- checked
 - blue
 - red
 - frayed
9. _____ An extension ladder 40' long should have an overlap of
- 5'
 - 3'
 - 4'
 - 10'
10. _____ If you place a straight or extension ladder against a wall so it reaches 16' high, how far away from the wall should the base of the ladder be placed?
- 5'
 - 4'
 - 3'
 - 10'

11. ___ Which of the following has an extension that must be locked in place?
- a. step ladder
 - b. trestle ladder
 - c. straight ladder
 - d. ladder jack
12. ___ Safety devices that can be attached to the bottoms of straight and extension ladders to prevent slipping are called
- a. jacks
 - b. feet
 - c. shoes
 - d. hooks
13. ___ If you were trying to paint a 9' ceiling, which aid would be the simplest and most helpful?
- a. metal scaffold
 - b. outrigger scaffold
 - c. step ladder
 - d. ladder jack scaffold
14. ___ When climbing a ladder, you should
- a. face the rungs
 - b. face away from the rungs
 - c. use one hand
 - d. never look down
15. ___ What is the longest extension ladder you should use?
- a. 18'
 - b. 36'
 - c. 40'
 - d. 46'
16. ___ If you were standing on a 6' step ladder to paint, where should your paint bucket be?
- a. on the next-to-the-top rung
 - b. on the top rung
 - c. on the floor
 - d. on the rack

Instructor Post Assessment Answers

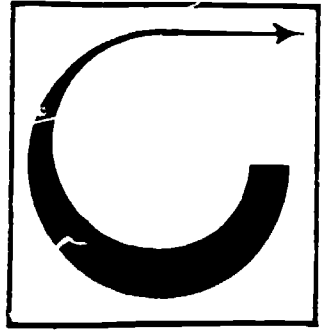

1. c
2. b
3. d
4. a
5. d
6. b
7. c
8. a
9. c
10. b
11. b
12. c
13. c
14. a
15. d
16. d

PREPARING OIL-BASE PAINTS FOR APPLICATION

Goal:

The student will be able to identify solvents and thinners commonly used for preparing oil-base paints, explain safety factors and demonstrate preparation techniques.

Performance Indicators:

The student will complete an Assignment, a Job Sheet and a Post Assessment.

Study Guide

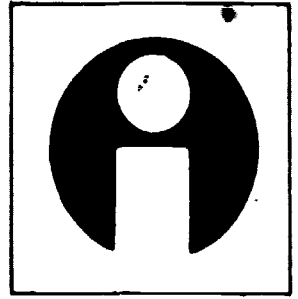

In order to finish this module, do the following tasks. Check each item off as you complete it.

1. Read the Goal and Performance Indicators on the cover of the module. This will tell you what you will learn by studying the module, and how you will show you've learned it.
2. Study the Information section. This section will give you the information you need to understand the subject.
3. Do the Assignment page. Follow the instructions at the top of the Assignment page.
4. Do the Job Sheet. Follow the instructions at the top of the Job Sheet. The tasks listed on the Job Sheet will help you develop skills which will be helpful to you.
5. Take the Post Assessment exam. Give the exam to your teacher after you have completed it. Your teacher will grade it for you.

Supplementary References

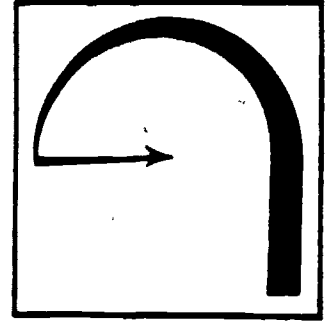

1. Painting and Decorating Encyclopedia. Goodheart - Willcox Co., Inc., 1973.
pp. 38-40.
2. ILS Module "Construction: 2300-18 Solvents and Thinners." Oregon Dept. of
Education.

Information

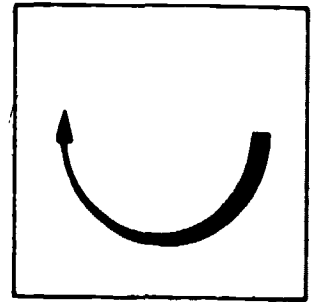

Oil-based paints are one of the major types of paints used today. Even though latex paints have taken over much of the work done in the past by oils, oils are still used a lot.

The first module in the painting trade covered paint properties and characteristics. It said that all paints have a number of things in common. They all are made up of vehicles or binders, pigments, and some have added driers, extenders, etc.

The vehicles or binders are the way in which the pigment particles are bound together and bound to the surface of the object being painted. In oil-based paints the binder is oil. (You will remember that there are different oils used in paint--linseed, tung, soybean, fish, etc.)

Resins are often added to or combined with the oil to help it dry, to help give a hard, shiny coat, etc. Alkyd resins are a good example.

Every paint also may be dissolved or "watered down" a little by use of a solvent. This is called "thinning." Paints which are given to the painter in a can are usually ready to be applied. They need only be stirred and they're ready.

There are several occasions when paint might need to be thinned:

1. If the can has been open for some time and the paint has thickened.
2. If it's a little cold and the paint has thickened.
3. If the paint can label calls for thinning. Some do, if the paint is to be applied over certain surfaces.
4. If the paint is to be sprayed on with a conventional spray gun and compressor, the paint will almost always need thinning.

5. If the painting contractor is trying to save on costs by thinning out the paint. You can cover more square feet by applying thinned paint (which goes on in thinner coats).

Never apply more thinner or solvent than the paint can says. Thinning affects the drying time, adhesion and protective qualities of the paint.

Paint thinner is a name given to many different liquids which are solvents or thinners. Turpentine is a solvent; Benzol, Ketone, denatured alcohol and mineral spirits are solvents. There is also a solvent called paint thinner.

Many of these solvents are used in varnishes and resins. Mineral spirits is being used more and more as a thinner for oil-based paints. The paint can will always tell you what thinner to use and the maximum amount that can be used without hurting the paint. Follow those directions carefully.

Safety

Most solvents are extremely dangerous. They are flammable (can catch on fire) and give off toxic (poisonous) fumes. The fumes are also flammable. Never use or store solvents where there are gas or electric motors, heaters, or any fire hazard. Never smoke while using solvents. Don't allow them to come in contact with your skin. If they do, wash the skin in water immediately. Don't breathe solvents. The fumes can make you sick (or worse). Always work with solvents where there is plenty of ventilation (fresh air). Painters often use big fans to circulate fresh air when they are using these thinners or paints containing them for interior work.

PREPARING PAINT FOR APPLICATION

Paint cans are opened by inserting an old screwdriver or specially designed lid opener beneath the lid and pushing down on the handle. Following are the steps for preparing oil-based paint:

- * 1. The paint must be stirred to make sure color pigments are mixed evenly. Pigments may settle in the bottom of the can.
 - a. Dip a stirring stick into the can and stir slowly, checking for even coloring.
 - b. Occasionally, an electric hand drill may be equipped with a special bit to stir paint. Insert bit and pull drill trigger.

2. If the paint is to be thinned, often another container is used.
 - a. The paint is poured from the can into a clean pail.
 - b. Thinner is added to the can, sloshed around or stirred to remove all pigments and vehicle, then dumped into the pail.
 - c. The paint and thinner is dumped back and forth into can and pail (or two pails) and occasionally stirred until the paint is consistent and mixed well.
 3. Paint cans that have been opened in the past may allow the paint surface to skin. That is, a tough surface may form over the paint similar to the skin that forms over pudding as it cools.
 - a. Carefully remove the skin.
 - b. Stir paint, while adding thinner (if it is needed). Any paint with lumps, skins or other particles should also be strained through a nylon or cheesecloth filter.
 4. Always mix material (including thinning) in a separate container before being put into spray gun cup or pot.
- * Some people suggest that if the oil and pigment have separated in the can, you pour off the oil into a clean container, stir the pigments and slowly stir in the oil again. Commercial painters do this rarely. It takes time and requires extra containers. They will usually pour the entire can into a larger pail where mixing can be done without fear of slopping over the edge.

After the paint has been prepared, it is ready for applying by brush, roller, conventional spray gun, airless spray, or, rarely, by pad.

One final word. Many old-time painters still refer to oil-base paints as "enamels." While years ago it was true, it isn't now. Some oil-base paints are enamels, some latex paints are enamels.

Assignment

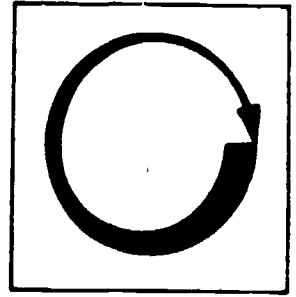

COMPLETE THE FOLLOWING ASSIGNMENT.

Visit one or more paint product stores and write down all of the solvents and thinners recommended for thinning oil-base paints for at least four of the following paint manufacturers:

- Glidden
- Pittsburgh
- Dutch Boy
- Fuller-O'Brien
- Sherwin-Williams
- Benjamin Moore
- Parker

Give the written information to your instructor.

Job Sheet

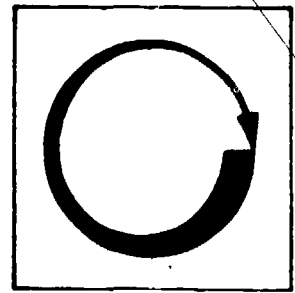

COMPLETE THE FOLLOWING TASKS.

Materials and Tools

can of paint, unopened

can of paint, previously opened, with skin on paint surface

appropriate thinner

stirring stick

pail

1. Following directions on the can, mix the can of new paint for use in a conventional spray gun.
2. Do the same with the paint in the previously opened can.

144
146

Post Assessment

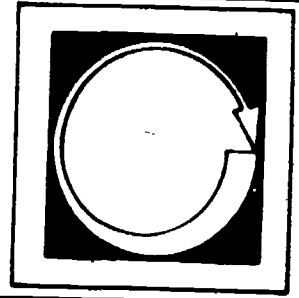

LISTED BELOW ARE QUESTIONS OR STATEMENTS FOLLOWED BY A NUMBER OF POSSIBLE ANSWERS OR COMPLETIONS. SELECT THE ANSWER OR COMPLETION WHICH ANSWERS THE QUESTION OR COMPLETES THE STATEMENT CORRECTLY AND PLACE THE LETTER IN THE BLANK PROVIDED.

1. ____ A binder is:
 - a. a solvent
 - b. a thinner
 - c. the same thing as a vehicle

2. ____ What is often combined with oil to produce a good binder?
 - a. resins
 - b. solvents
 - c. driers

3. ____ Thinning is the act of mixing _____ with paint.
 - a. oils
 - b. binders
 - c. thinners

4. ____ "Skin" is sometimes formed in:
 - a. previously opened cans of paint
 - b. new cans of paint
 - c. paint with too much binder

5. ____ Which of the following is a common solvent for oil-base paints?
 - a. water
 - b. mineral spirits
 - c. oil

6. ____ Where do you get information about the proper thinner to use with a paint?
- a. from the thinner can
 - b. from the paint can
 - c. from the solvent can
7. ____ Using too much thinner
- a. can't hurt the paint
 - b. can hurt the paint
 - c. won't affect the paint because it will evaporate
8. ____ When should you thin paint?
- a. when it's used in a conventional spray gun
 - b. when it's used in an airless gun
 - c. when there isn't enough left to complete the job

● Instructor Post Assessment Answers

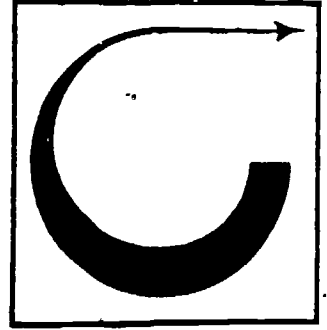

1. c

2. a

3. c

4. a

5. b

6. b

7. b

8. a

PREPARING LATEX PAINTS FOR APPLICATION

Goal:

The student will be able to identify common latex paints and explain and demonstrate their preparation.

148

Performance Indicators:

The student will complete an Assignment and a Post Assessment.

150

Study Guide

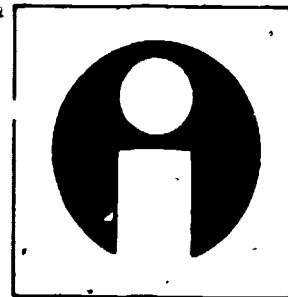

In order to finish this module, do the following tasks. Check each item off as you complete it:

1. Read the Goal and Performance Indicators on the cover of the module. This will tell you what you will learn by studying the module, and how you will show you've learned it.
2. Study the Vocabulary section. Vocabulary words are important for a good understanding of the trade. After you have studied the vocabulary, ask your teacher to quiz you on the words and their meanings.
3. Study the Information section. This section will give you the information you need to understand the subject.
4. Do the Assignment page. Follow the instructions at the top of the Assignment page.
5. Take the Post Assessment exam. Give the exam to your teacher after you have completed it. Your teacher will grade it for you.

Vocabulary

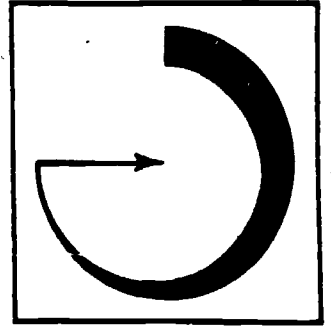

Trade terms are very important for a good understanding of the trade. Study these words and meanings. When you have learned them, ask your teacher to quiz you on the words and their meanings.

SYNTHETIC--Man-made, not found in nature.

BREATHE--The ability of a paint to allow moisture to escape into the air, but not to allow moisture to penetrate into paint.

Supplementary References

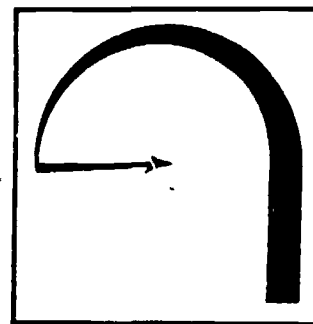

1. Painting and Decorating Craftsman's Manual and Textbook. Painting and Decorating Contractors of America, 1975. pp. 72-74, 141-147.
2. ILS Module "Construction 2300-6 Water Base Paints and Their Application." Oregon Department of Education, 1973.

Information

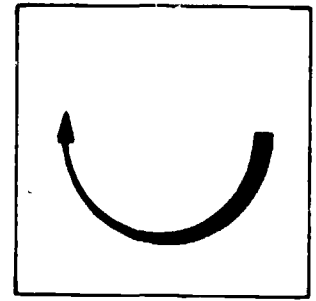

Latex is the name given to a number of water-based paints which use synthetic resins as a binder. These resins, if magnified, have many of the same properties as synthetic rubber. In fact, that's what latex paint is, little particles of man-made rubber suspended in water. Latex paints are all thinned by water, so they are called water-base paints.

They fall into three basic groups:

1. Butadiene-styrene (BDS). These paints adhere well to surfaces and can be used on stucco, cement, asbestos shingles, cinder-block, brick mortar and wood. They can be applied to wet surfaces like new plaster and can be applied in colder temperatures than can other paints. The film which forms when the paint dries (as the water evaporates) can breathe, so moisture can escape from below the surface.
2. PVA (Polyvinyl acetate). This paint has many of the same properties as BDS. It dries very quickly and, like all latex paints, can be cleaned up with soap and water. You will remember that PVA is the name of a primer produced by one paint manufacturer. PVA is a very popular primer, which is being used more and more in the painting industry.
3. Acrylic Latex. It adheres well, breathes, and has the ability to hold color very well. The film surface dries fast and is durable.

There are other synthetic resins which are used in latex paints, but these are the major ones.

SAFETY

Latex paints are safer to use than oil-base paints for several reasons.

1. Water is used as a thinner instead of harsh, toxic solvents.
2. The paint isn't flammable--it won't catch fire.
3. It doesn't give off toxic fumes.
4. It cleans up easier.

Latex is used a lot indoors because of these factors. It is used outdoors because it's a tough, durable paint.

PREPARING LATEX PAINT FOR APPLICATION

Latex paint comes prepared the same way as oil-base paint. It should be stirred to mix the pigments. (Be careful not to produce air bubbles in the paint.) If thinning is necessary, cool, clean water should be used.

Latex paint may be applied like oil-base paint--by brush, roller or spray. Application techniques and selection will be covered in later modules, but beware of this: If you use a brush to apply latex, always use a damp nylon-bristle brush. Natural bristles will be ruined by latex.

Any paint with lumps or other particles should be strained through a wire mesh, a nylon, or cheesecloth.

Assignment

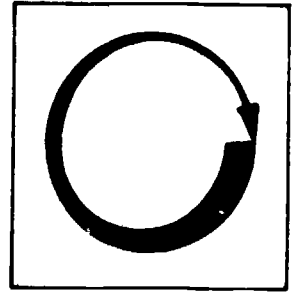

COMPLETE ONE OF THE FOLLOWING ASSIGNMENTS.

1. Read the material listed under Supplementary References and write a one-page report on the development, types and uses of commonly used latex paints.
2. Visit a paint store and, after reading labels or talking to the people there, write a one-page report on the uses for all the different latex paints the store carries.

Post Assessment

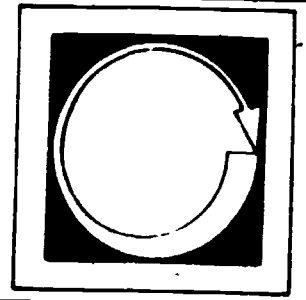

LISTED BELOW ARE SEVERAL STATEMENTS. IF THE STATEMENT IS TRUE, PLACE A "T" IN THE BLANK PROVIDED. IF THE STATEMENT IS FALSE, PLACE AN "F" IN THE BLANK.

1. ___ Latex paints can be thinned with synthetic resins.
2. ___ PVA, BDS and acrylics are all water-base paints.
3. ___ Clean-up of latex paint requires strong solvents.
4. ___ Latex paints can be used near electric or gasoline motors.
5. ___ Acrylic latex doesn't breathe well.
6. ___ Latex paints are made of synthetic resins.
7. ___ Latex paints dry more slowly than oil-based paints.
8. ___ Latex paints don't allow moisture below the surface to escape.
9. ___ Latex paints give off stronger fumes than do oil-based paints.
10. ___ You should always use a natural bristle brush to apply latex paints.

Instructor Post Assessment Answers

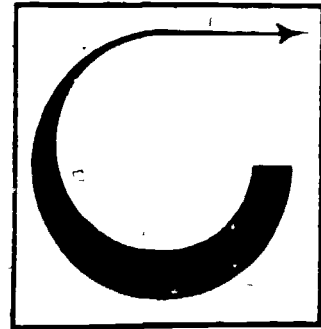

1. F
2. T
3. F
4. T
5. F
6. T
7. F
8. F
9. F
10. F

BRUSH SELECTION AND USE

Goal:

The student will identify, select and demonstrate the correct use of brushes commonly used in the painting trade.

157

Performance Indicators:

The student will successfully complete a Self Assessment and will practice 9 painting projects until he or she can apply a professional finish. (A professional finish is one which is executed correctly to a trade standard commonly accepted in the Pacific Northwest.)

159

Study Guide

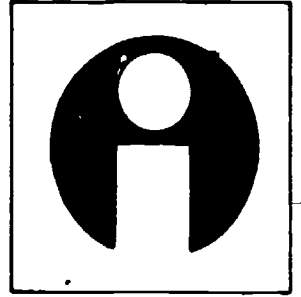

In order to finish this module, do the following tasks. Check each item off as you complete it.

1. Read the Goal and Performance Indicators on the cover of the module. This will tell you what you will learn by studying the module, and how you will show you've learned it.
2. Read the Introduction. The Introduction will tell you why the module is an important part of the painting trade.
3. Study the Vocabulary section. Vocabulary words are important for a good understanding of the trade. After you have studied the vocabulary, ask your teacher to quiz you on the words and their meanings.
4. Study the Information section. This section will give you the information you need to understand the subject.
5. Take the Self Assessment exam. This is a test for you to prove to yourself that you have learned the material you have studied. Compare your answers with the answers on the Self Assessment Answer Sheet, which is on the page following the Self Assessment. If you scored poorly, re-study the Information section or ask your teacher for help.
6. Do the Job Sheet. Follow the instructions at the top of the Job Sheet. The tasks listed on the Job Sheet will help you develop skills which will be helpful to you.

Introduction

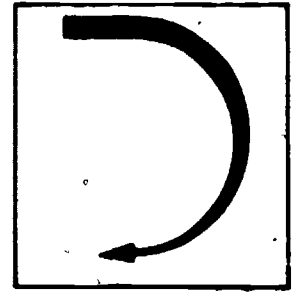

Up to now, you have studied many of the materials used by painters. Knowing about the materials is only the first step to becoming a painter. Being able to apply the materials correctly, accurately and quickly is the final step.

There are many kinds and sizes of brushes to choose from. Each of these has its own special use. The good painter can choose the correct brush for the job.

Vocabulary

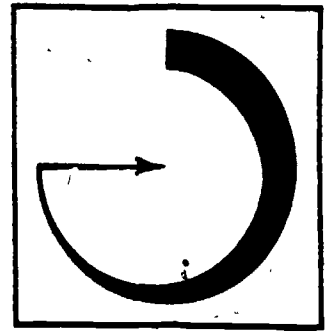

Trade terms are very important for a good understanding of the trade. Study these words and meanings. When you have learned them, ask your teacher to quiz you on the words and their meanings.

FLAGGING--Or Flag ends. These are the natural splits that occur in pig bristles, which are used for paint brushes.

SASH--An area surrounding nearly all windows (See graphic in Information section.)

MULLIONS--Usually wood slats found in some older windows or in special designed widows. (See Information section.)

OVERBRUSHING--The act of brushing too long in one place.

Supplementary References

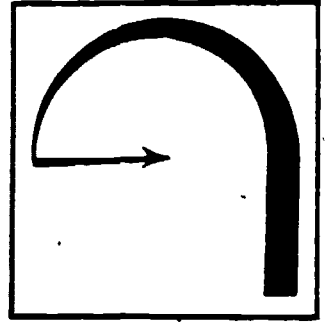

1. Painting and Decorating Encyclopedia. Goodheart - Willcox Co., 1973.
pp. 49-55, 105-118.
2. ILS Module: "Construction 2300-12, The Use and Care of the Paint Brush."

161

163

Information

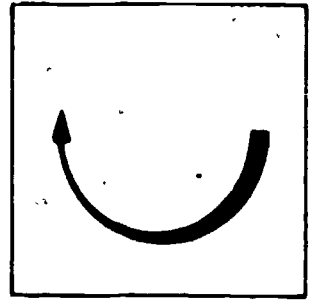

Brushes are the main tools of a painter. A painter uses brushes for dusting and for applying primer, finish coats, clear finishes and some stains to nearly every surface.

There are a lot of things you should know about brushes. The main thing you should know is that the bristles in brushes are of two types:

1. Natural bristle.
2. Nylon bristle.

The purpose of a brush is to pick up paint from a can, carry it to a surface and apply it evenly and smoothly over the surface with a good clean edge.

Natural bristle brushes are the best and are fine tools for spreading paint, but they do have limitations.

If you walk into a paint supply store you will see paint brushes of 1/2" or 1" in width to 6" or 8" in width. The prices can range anywhere from around \$1.50 to over \$40.00. The price depends on the size and quality (including types of bristle) of the brush.

NATURAL BRISTLE

Bristles are the hair-like strands in paint brushes that spread the paint. (See the illustration on the top of the next page.)

High quality natural bristles come from wild pigs in China. The bristles are called China Boar bristles. All pig or hog bristles have one feature which other bristles don't: One end of the bristle is split into branches called flagging. A flag end smooths paint better, can carry more paint and cut a nice, even edge without splattering paint. (See 2nd illustration on next page.)

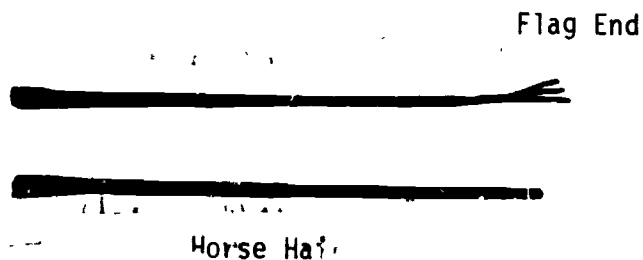
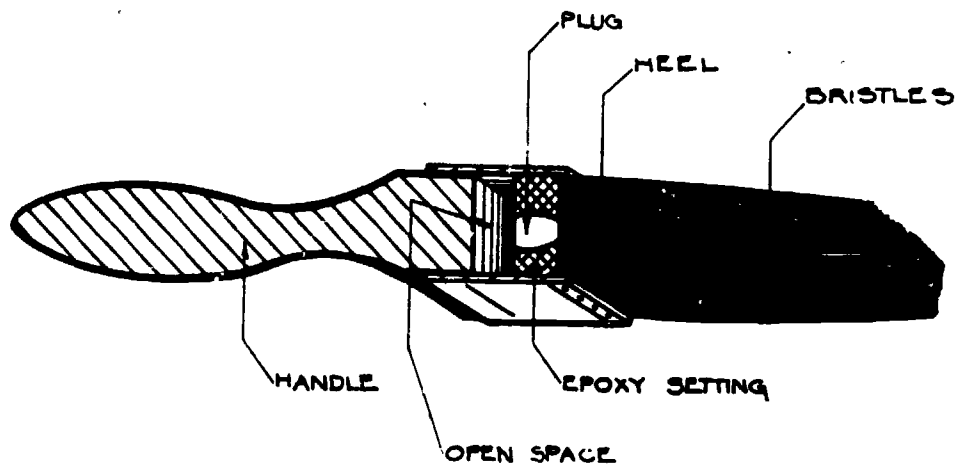

The bristles from China pigs are longer, tougher and more flexible than hog bristles from just about anywhere else.

Other natural bristles today are actually hairs from animals. They include:

- * Horsehair: Used in cheap brushes: doesn't hold firmness when dipped in paint.
- * Bear, weasel, etc.: Used in small artist's brushes.
- * Badger hair: Blended with other bristles for varnish and really smooth work.

RULES FOR USING HOG BRISTLE BRUSHES:

1. Never use them for applying latex paint. The water in latex paints will cause the bristles to mat together and will ruin them quickly.
2. When breaking in a new brush, dip in oil or oil base paints (or with no oil or paint) and stroke it over a rough board

several times in both directions, using a lot of hand and arm pressure. This will remove loose bristles which might mar a finished surface.

3. Try to use each side of the brush about the same number of times during a day or week. The flag ends and even the whole bristle will eventually wear out. Using both sides equally will make the brush last longer.
4. Don't use new brushes or brushes in good shape on really rough masonry surfaces. This will ruin a good brush quickly.
5. Never store a brush resting on its bristles. This will deform the bristles and can break off flag ends.
6. Don't use a brush to poke paint into corners or holes.
7. Always clean the brush when you are finished with it.
 - a. Remove excess paint by gently wiping brush against wire screen or a dull straight edge.
 - b. Slop brush around in the proper solvent for the paint you've used. Many painters have 3 or 4 cans of solvent in which they wash brushes. This keeps the last bath of solvent reasonably clean, since most of the paint is washed off in the earlier solvent baths. The painter might also have to work the bristles gently with his or her fingers to be sure all the paint is removed.
 - c. Shake the brush lightly and spin it around between your hands to remove excess solvent.

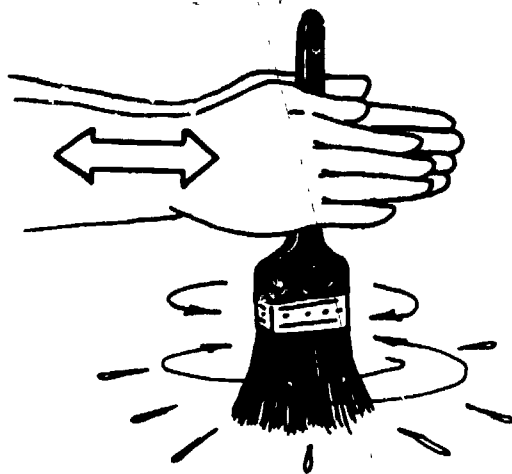

- d. Replace the original cardboard wrapper over the bristles (or use other paper). Store the brush laying flat, or suspend it in air by inserting a wire through the hole in the handle.
- e. If the brush is to be used again soon, some painters will suspend their brushes in a can of linseed oil after cleaning. The brush then needs only to have the excess oil spun out and it's ready to use again. (For very short breaks between painting, it is all right to wrap the brush in a tightly secured plastic bag.)

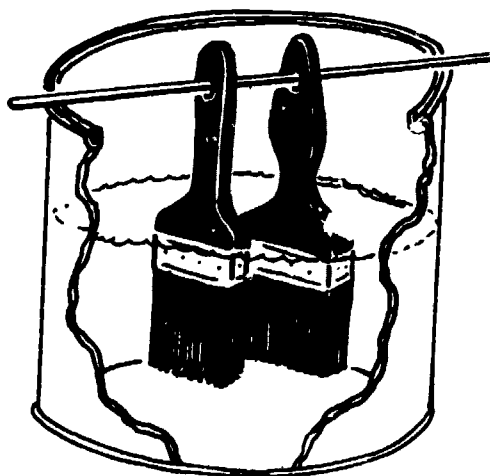

NYLON BRISTLES (SYNTHETIC OR MAN-MADE)

In recent years, more brushes made of nylon fibers have been used in place of natural bristles. Nylon doesn't carry paint as well and there is no such thing as a natural nylon flag end to smoothen it.

Much progress has been made in making nylon fibers more usable. The fibers have been split; the tips have been exploded and sanded. This has formed a softer fiber which can carry more paint and a tip which can smooth paint onto a surface better than before.

Water won't soften nylon the way it does bristle, so it is excellent for latex paints. Nylon bristles can be used for oil paints with excellent results too.

Nylon does have several drawbacks. It can't be used with shellac dissolved in certain alcohols. Also, certain chemicals in strong solvents or creosote will damage the bristle. Some chemicals in strong paint removers will damage or destroy nylon.

RULES FOR USING NYLON FIBER BRISTLES

The same rules apply for nylon as for natural bristles. There are a couple of other points:

1. When cleaning brushes used with latex paint, warm water and soap should be used.
2. When cleaning brushes used with oil based paints, the correct solvent should be used to remove the paint. Then the nylon brush should be washed in water and soap, and rinsed with clean water before storing.

BRUSH SELECTION

There are several different types of brushes commonly used in painting.

Wall Brush

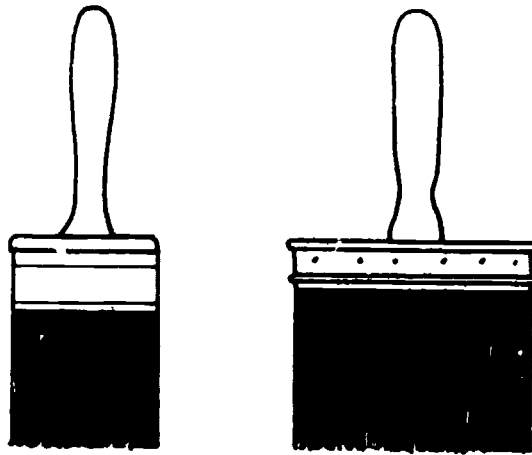

Flat Wall Brushes

1. Used for applying paint and stain to large surfaces.
2. 3"-6" wide.
3. 3/4"-1 1/2" thick.
4. Flat bristle surface.
5. Bristles 2"-7" long.

Trim Brush

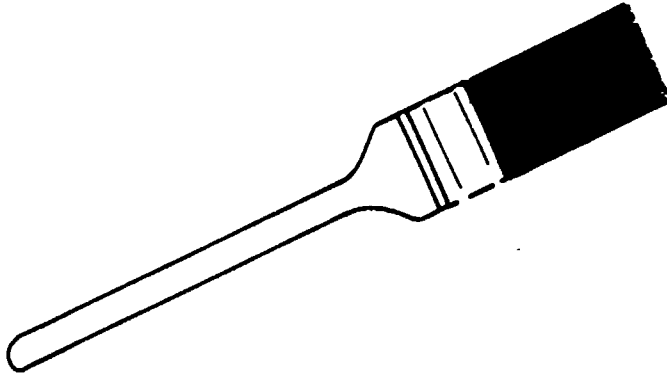

1. Used for window frames, narrow strips, corners.
2. 1"-3 1/2" wide.
3. Usually chiseled edges.
4. Bristles 2"-5" long.

Sash Brush or Sashtool

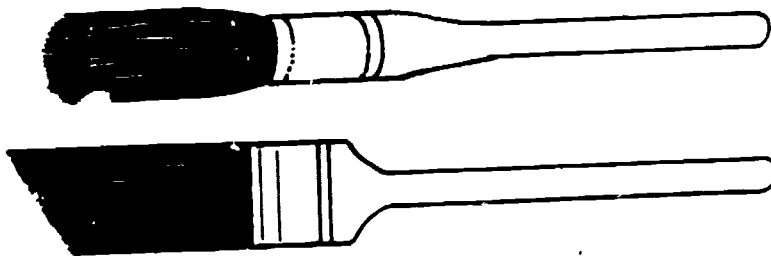

1. Just like trim brushes, only narrower, 1"-2" wide.
2. Angled sash brushes have bristles 1"-3" long.

Enamel and Varnish Brush

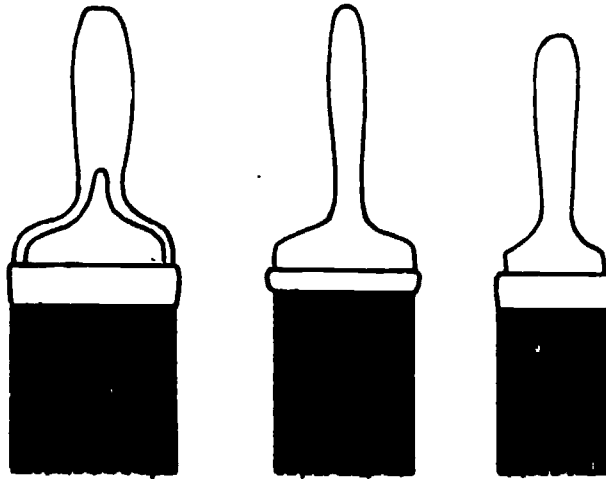

1. Used for fine work, where smoothness is a must.
2. 2"-3" wide.
3. Flat or semi-oval edge.
4. Bristles are shorter, narrower than normal.

APPLYING PAINT

Gripping the Paint Brush

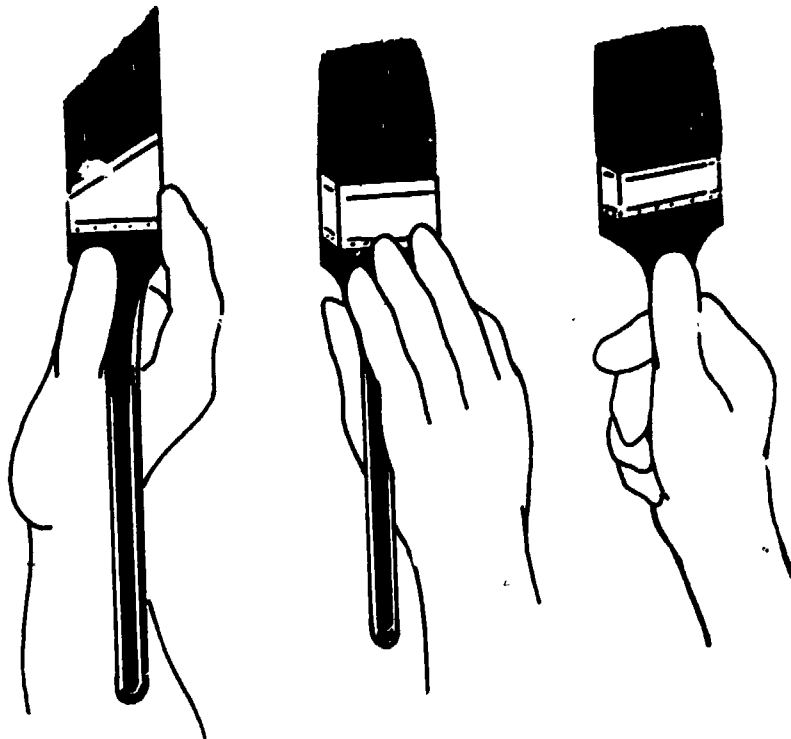

Pencil Grip

Walls & Floors

Ceilings.

These are only recommendations for proper grip. You will develop your own style.

To Apply the Paint

1. Dip brush into paint so that between $1/5$ and $1/2$ of bristle length is covered. (Dipping too deep will "load up" brush and result in dripping.)
2. Tap brush against inside of paint container to remove excess paint.

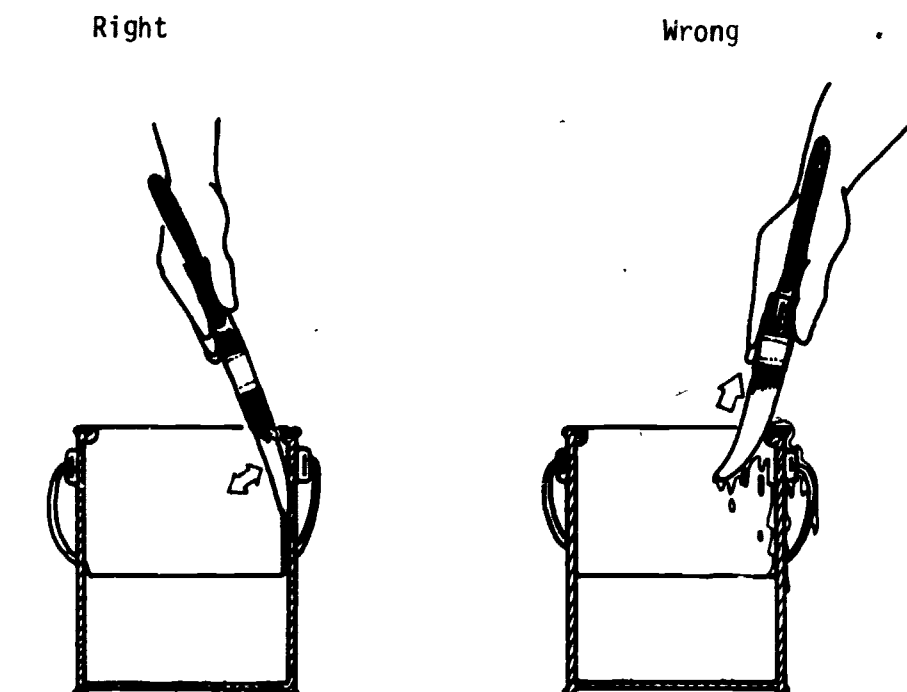

You are now ready to apply paint to surfaces.

Walls and Siding

1. "Cut in" before you paint large surfaces.
2. Face wall or surface.

(See illustration on top of the next page.)

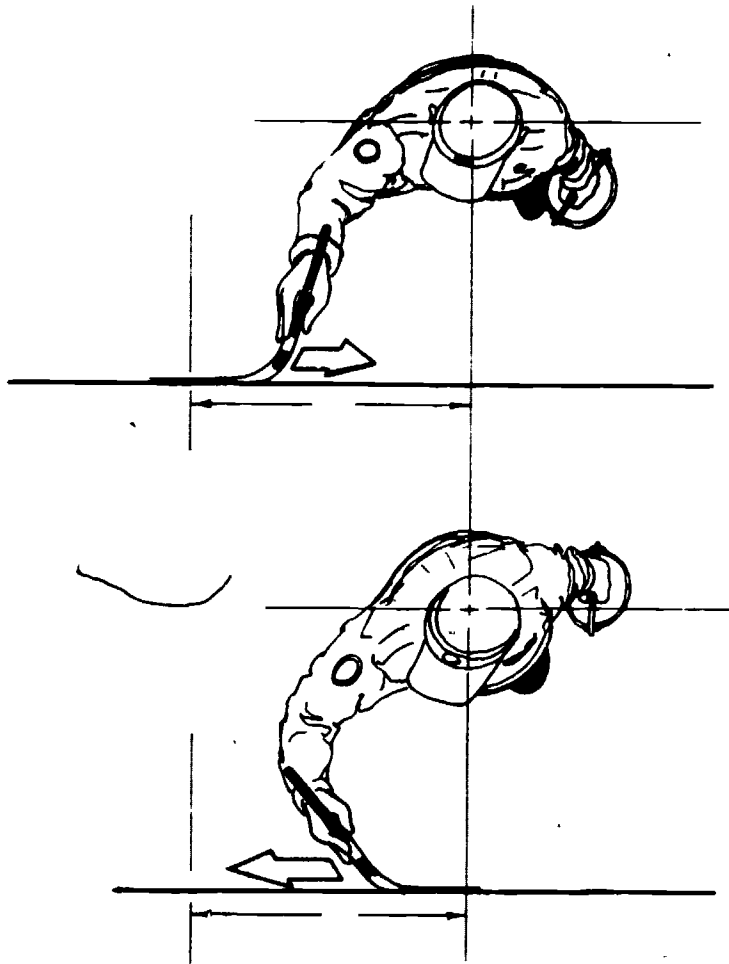

3. Starting at a top corner, apply and spread paint in 1 1/2'-2' strokes.
 - a. Avoid overbrushing as it will spread paint too thin and may leave brush marks. Several passes or strokes over an area will spread oil paints; one or two will spread latex.
4. Re-dip the brush as required as you move either left or right across the surface.
5. Paint on a wet edge.
 - a. Lapping wet paint over on to dried paint areas produces lap marks. Paint only on a surface which you can finish in a quick painting (before the edge dries). Natural breaks in walls (corners) are a good place to stop.
6. On lap board siding, paint only a couple (or three) boards at a time.

(See the illustration on top of the next page.)

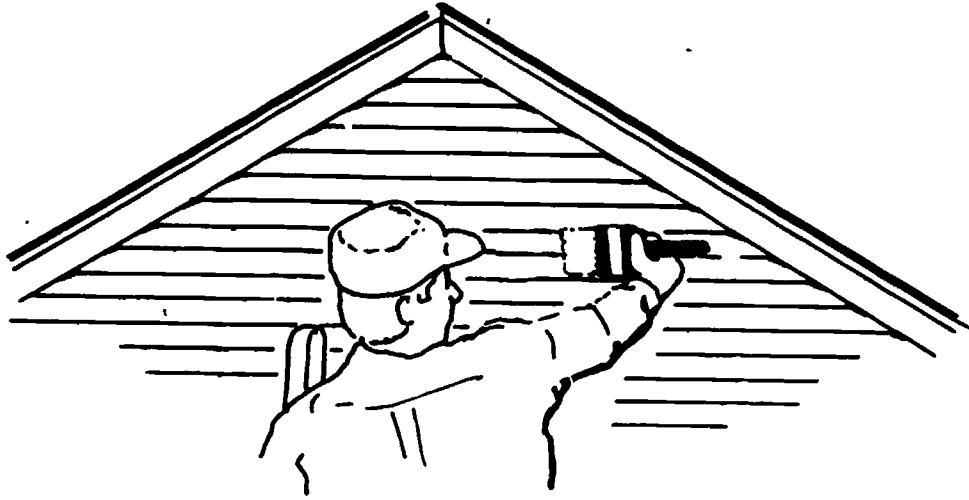

Paint underside of boards first, then paint areas between.
Paint on a wet edge.

7. On exteriors, paint in the shade whenever possible. Hot sun may not allow the paint to be spread correctly and will dry too fast.

Painting Ceilings

Ceilings should always be the first large surface painted. This is done so that if paint drips down on a wall, the splatter can be wiped off and the wall will be painted later.

Paint with the narrowest part of the ceiling, never lengthwise. Stop at natural breaks.

Often, electric ceiling heat will burn or discolor both primer and finishing coats if applied while the heat is on. It has happened more than once. Be sure the heat is off and the ceiling is not hot.

"Cut ins"

"Cut ins" or "cutting in" is the first thing done when painting the interior of a building.

An angle is formed where walls meet walls and where walls meet ceilings. A wall brush is difficult to use in small or tight areas, and may cause splashing from wall to wall or ceiling. Cutting in, or painting a 2"-2 1/2" strip on both walls of

these corners or the ceiling avoids splashing. A sash or trim brush is used to cut in.

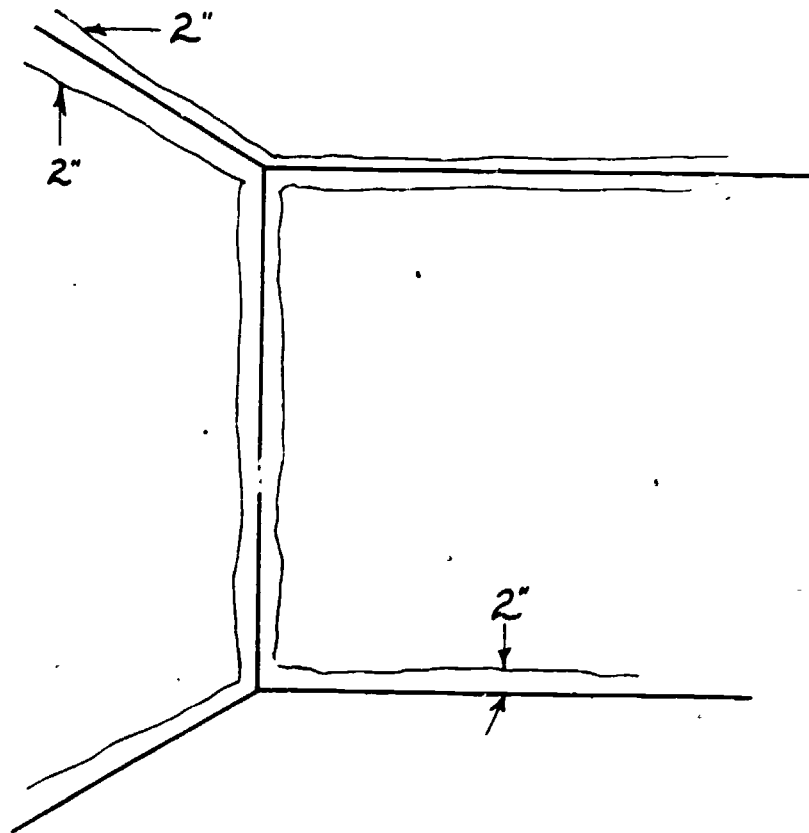

Painting Paneled Doors

1. Paint molded edges of panels. Paint top edges first.

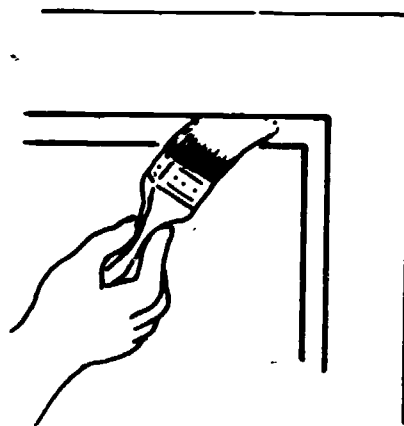

2. Paint panels with light up and down strokes.

(See illustration on top of the next page.)

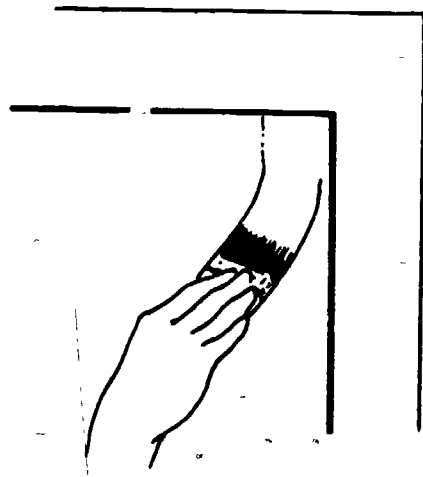

3. Paint crossboards.

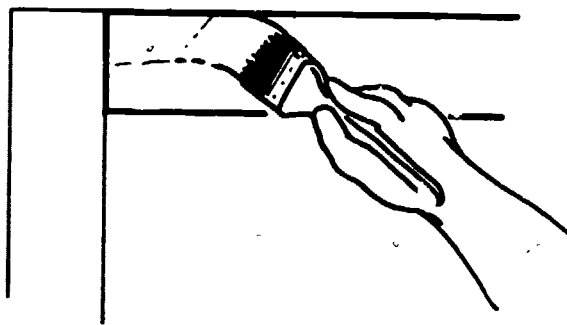

4. Paint sideboards.

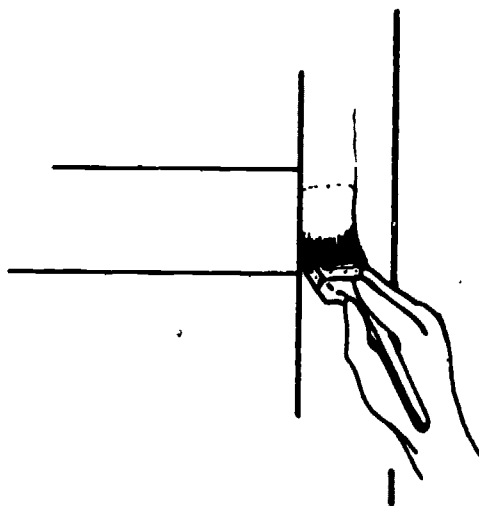

Painting Window Sills

On regular windows:

1. Paint horizontal sash.
2. Paint vertical sash.
3. Paint vertical frame.
4. Paint horizontal frame.

If mullions are present, always paint them first, then follow order above.

Mullions

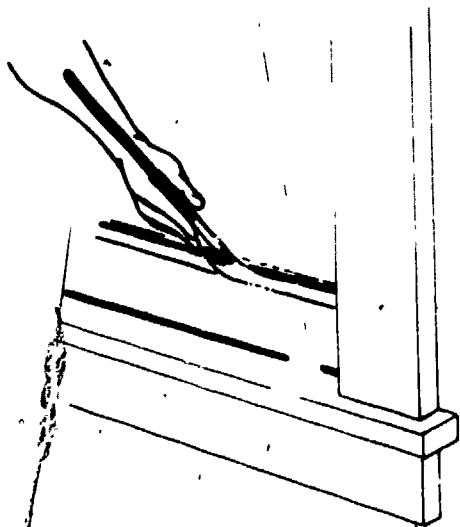
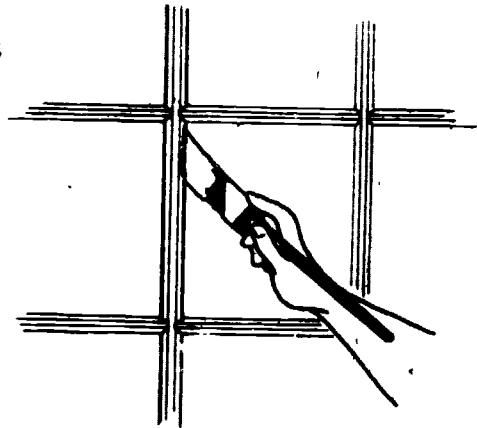

Horizontal Sash

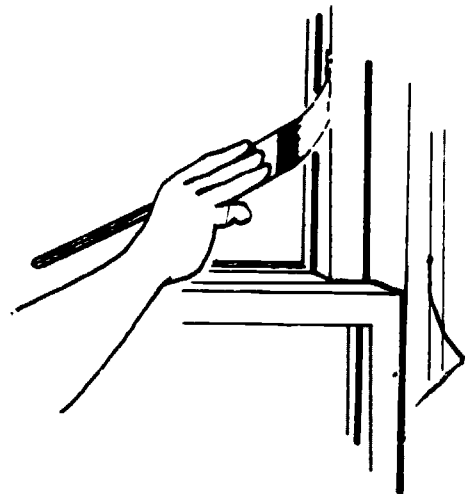

Vertical Sash

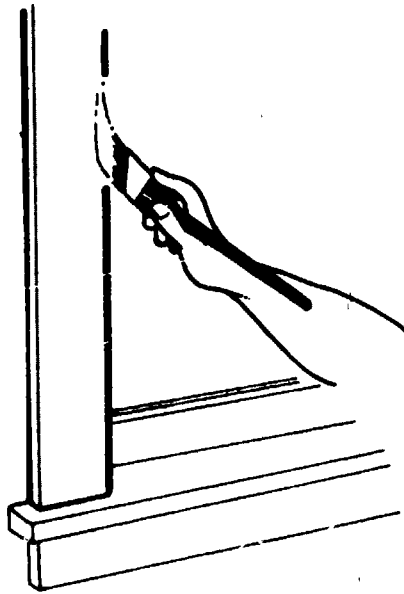

Vertical Frame

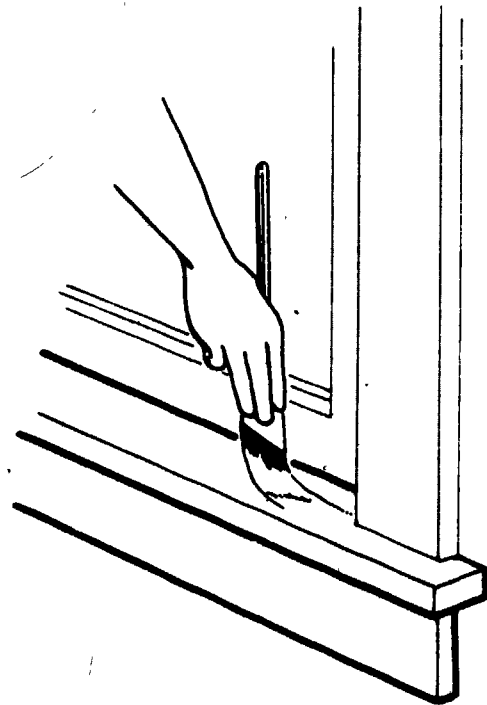

Horizontal Frame

Painting Floors

Work toward an opening through which you can exit while the paint dries.

Painting Cylindrical Objects

Start at the top and paint around the circumference of the object.

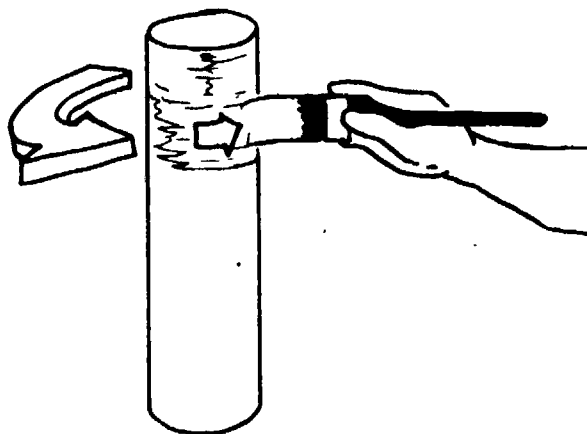

Painting Rough Masonry

Use an old or inexpensive brush. Paint strokes in several directions to fill pores and tiny cracks; then finish with a stroke or two in the same direction to smooth it out.

Self Assessment

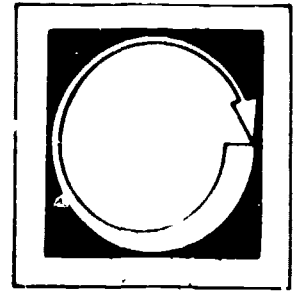

LISTED BELOW ARE QUESTIONS OR STATEMENTS FOLLOWED BY A NUMBER OF POSSIBLE ANSWERS OR COMPLETIONS. SELECT THE ANSWER OR COMPLETION WHICH ANSWERS THE QUESTION OR COMPLETES THE STATEMENT CORRECTLY AND PLACE THE LETTER IN THE BLANK PROVIDED.

1. ____ A sash brush is:
 - a. made of beaver fur
 - b. a smaller trim brush
 - c. never beveled
 - d. none of the above

2. ____ In painting around windows the first thing to be painted is:
 - a. vertical frame
 - b. vertical sash
 - c. horizontal sash
 - d. it doesn't matter

3. ____ A natural bristle brush should never be used with:
 - a. oil-based paint
 - b. water-based paint
 - c. enamels
 - d. any of the above

4. ____ A wall brush may be how wide?
 - a. 3"-6"
 - b. 1"-12"
 - c. 1 1/2"-3 1/2"
 - d. none of the above

5. _____ What animal's hair is used for varnish brushes?

- a. boar
- b. beaver
- c. badger
- d. billygoat

Self Assessment Answers

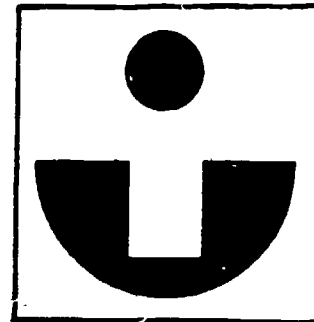

1. b
2. c
3. b
4. a
5. c

Job Sheet

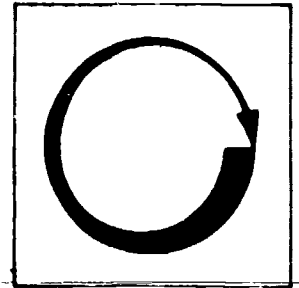

COMPLETE ALL OF THE FOLLOWING TASKS.

Materials and Tools

wall brush (nylon or both nylon and natural bristle)

primer

oil-based paint

latex paint

fine grit abrasive paper

large vertical wood surface

solvent

1. Following the steps you have learned, coat the wood surface with both oil-based paint and latex paint. The job must be professional, free of runs and splatters and must completely cover the surface. Clean tools.

Materials and Tools

sash brush

fine grit abrasive paper

enamel

window frame and sill or mock up

solvent

2. Following the steps you have learned, paint the sill and frame assembly to a professional finish. Clean tools.

Materials and Tools

wall brush

primer

exterior or house paint

suitable exterior lap siding

suitable solvent or water and soap

3. Following the steps you have learned, paint the exterior lap siding to a professional finish. Clean tools.

Materials and Tools

varnish or enamel brush

clear finish product

very fine grit abrasive paper

suitable thinner and solvent

table, desk, chair, etc.

4. Following the steps you have learned, clear finish the project to a professional finish. Clean tools.

Materials and Tools

wall brush

trim brush

primer

interior paint

abrasive paper

suitable solvent or water and soap

interior room or mockup

5. Following the steps you have learned, paint the entire interior of a room to a professional finish.

Materials and Tools

wall brush
primer
exterior or house paint
wire brushes
putty
caulking compound
range of abrasive papers.
wood building

6. Following the steps you have learned, prepare and paint to a professional finish the exterior of a wood structure.

Materials and Tools

masonry brush or old nylon bristle brush
primer
exterior paint
fixall, caulk or suitable cement patching materials
exterior masonry project (planter, fence, etc.)

7. Following the steps you have learned, paint the masonry to a professional finish.

Materials and Tools

enamel brush
primer
enamel paint
fine grit abrasive paper
wire brush
metal object (fence, small gas tank, etc.)

8. Following the steps you have learned, paint the metal object to a professional finish.

Materials and Tools

wall brush

primer

latex paint

plaster wall or mockup

9. Following the steps you have learned, paint the plaster wall to a professional finish.

PAIN T ROLLER SELECTION AND USE

Goal:

The student will be able to select and demonstrate the use of the proper roller for a given job.

184

Performance Indicators:

The student will complete an Assignment, two tasks on a Job Sheet and a Post Assessment. The tasks on the Job Sheet will be completed to a professional finish as defined by trade standards in the Pacific Northwest.

186

Study Guide

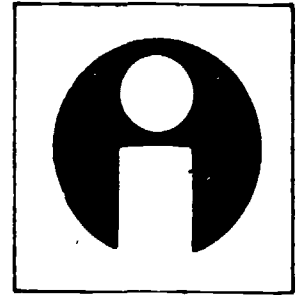

In order to finish this module, do the following tasks. Check each item off as you complete it.

1. Read the Goal and Performance Indicators on the cover of the module. This will tell you what you will learn by studying the module, and how you will show you've learned it.
2. Read the Introduction. The Introduction will tell you why the module is an important part of the painting trade.
3. Study the Vocabulary section. Vocabulary words are important for a good understanding of the trade. After you have studied the vocabulary, ask your teacher to quiz you on the words and their meanings.
4. Study the Information section. This section will give you the information you need to understand the subject.
5. Do the Assignment page. Follow the instructions at the top of the Assignment page.
6. Do the Job Sheet. Follow the instructions at the top of the Job Sheet. The tasks listed on the Job Sheet will help you develop skills which will be helpful to you.
7. Take the Post Assessment exam. Give the exam to your teacher after you have completed it. Your teacher will grade it for you.

Introduction

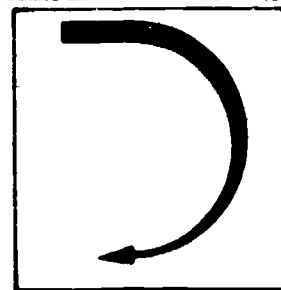

In addition to brushes, rollers are used by many painters to apply paint to some surfaces. Rolling paint on a surface may not give the smooth finish of professional brushing but it produces very fine results.

Also, a skilled painter can cover as much as 4 times the area with a roller as with a brush. Applying paint with rollers is an excellent choice for covering uneven or rough surfaces. Sometimes the job calls for it instead of brushing.

Vocabulary

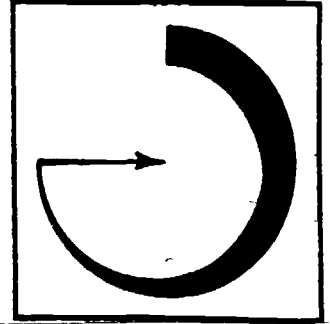

Trade terms are very important for a good understanding of the trade. Study these words and meanings. When you have learned them, ask your teacher to quiz you on the words and their meanings.

TELESCOPING--Something that extends; the way a car's radio antenna does.

NAP--The material which covers the surface of paint rollers. Nap picks up paint and spreads it over surfaces.

IMMERSE--To place into a fluid or liquid.

Supplementary References

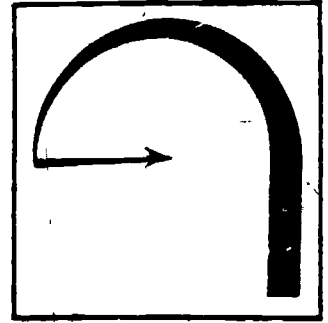

1. Painting and Decorating Encyclopedia. Goodheart - Willcox Co., 1973. pp. 56-57, 100, 110, 123.
2. Painting and Decorating Craftsman's Manual and Textbook. Painting and Decorating Contractors of America. 1975, pp. 226-240.

Information

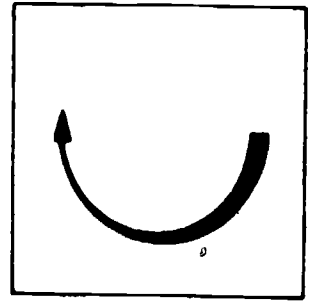

There are three types of rollers available today, but two of them aren't used much by professional painters. The three are:

1. Dip roller: Dipped into a pan to load the paint.
2. Magazine roller: Paint is poured into the cylinder of the roller and forced outward onto the surface.
3. Pressure: Paint is stored in an air-powered container and fed into the roller through a hose.

Now, forget about the second and third types. They aren't used much at all because of problems of paint build-up, etc. The type that is used most is the dip roller, which is dipped into a tilted pan of paint, then applied.

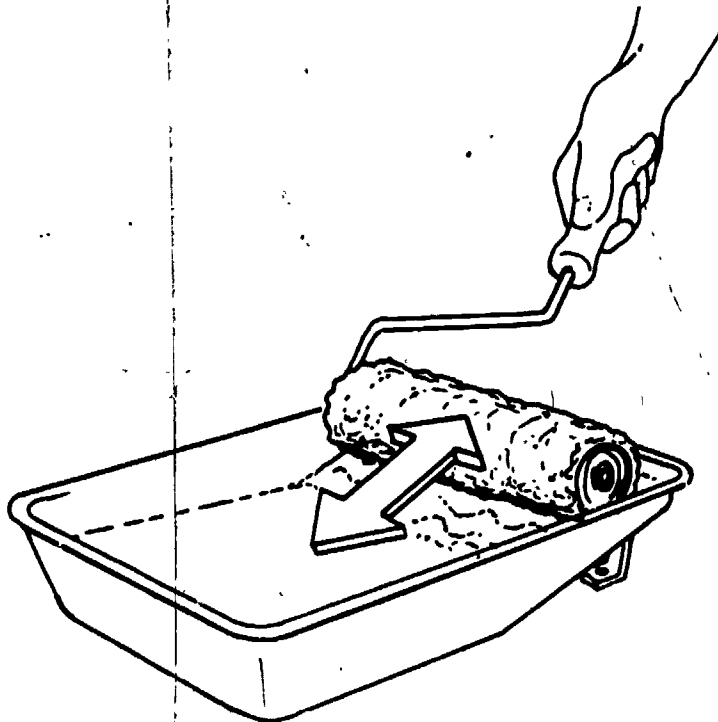

Rollers consist of a metal or wire cylinder which is attached to, and rotates on an axle. The cylinder is covered with a replaceable cover. The axle is fitted with a short handle for one hand use, or with a pole handle or telescoping handle (which extends to several feet in length) for work on ceilings, high places, etc.

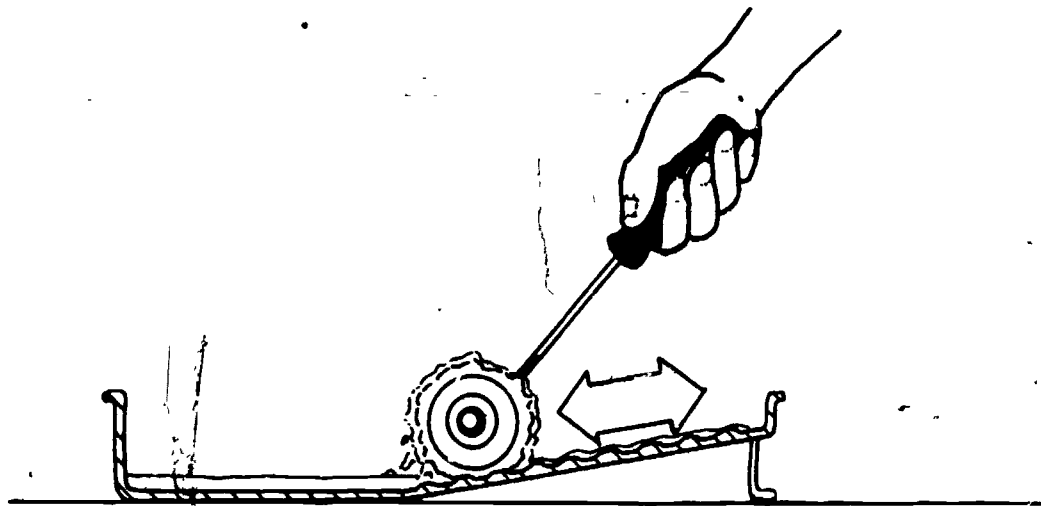

Sizes

The rollers come in many different widths, from a narrow 1" for corners and trim, to a wide 18" for covering large spaces.

The most commonly used size is around 8" wide.

Nap Length

The coverings on rollers which actually carry and apply the paint are made of different fabrics. The fabrics are called naps and they come in different lengths.

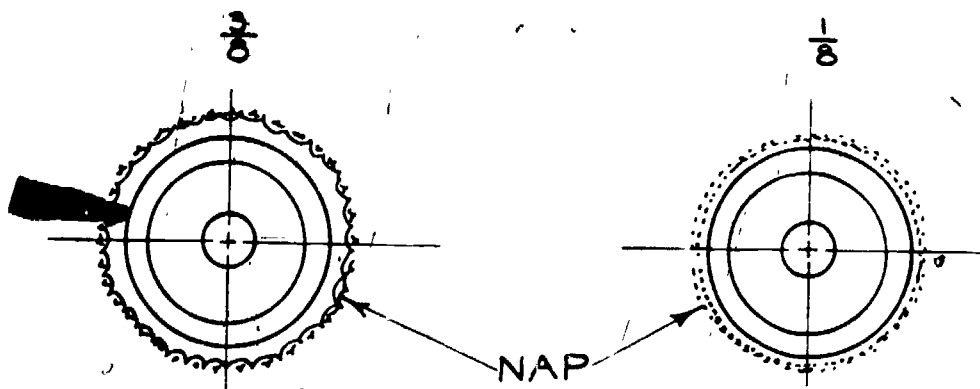

Nap length determines what the roller may be used on to produce a professional finish:

Long nap, 3/4"-1 1/4": Used on rough surfaces to make sure all uneven areas have been covered. Shorter nap (3/4") is used with enamel paints and longer nap (1" plus) is used with flat coats.

Short nap 3/16"-3/8": Used on smooth surfaces to make sure coat is flat and reasonably smooth. Shorter nap lengths are again used with enamel finishes.

Nap Material

The nap which carries the paint is composed of many different materials:

1. Wool nap holds a lot of paint and is used mostly for solvent-thinned paints (oil-based). Water will mat the nap, making it nearly unusable.
2. Acrylic (a synthetic material) and nylon naps are used with water-based paints. They hold up well when sopped with water. Synthetic naps are long lasting and wear well, and should be used on rough and porous surfaces like masonry.
3. Sponge rubber rollers can be used to apply either latex or oil-based paints, but they are used mostly in cases where special effects and texturing are necessary.

In addition, there are several other nap materials, including cotton, mohair, rayon and polyester. Rollers come wrapped in plastic or cardboard wrappers. These wrappers usually identify the material used for the nap and what kind of paint it can be used with for best results. These should always be read before using the roller cover.

Application Techniques

1. Fill paint tray to between 1/3 and 1/2 full.
2. If roller is to be used with oil-based paint, dip in linseed oil and spin out. This prepares the roller for picking up paint.
3. Roll roller into paint to depth of nap. (If the nap is 1/2" deep, the roller should be rolled into 1/2" of paint.) Do this several times to saturate the roller.
4. Run the roller back and forth over the upper ramp of the tray several times to remove excess paint.

5. Repeat step 4 as paint is needed.
6. Run roller several times firmly over newspaper to pull out loose nap.
7. Applying paint works best when done in a "V" pattern.

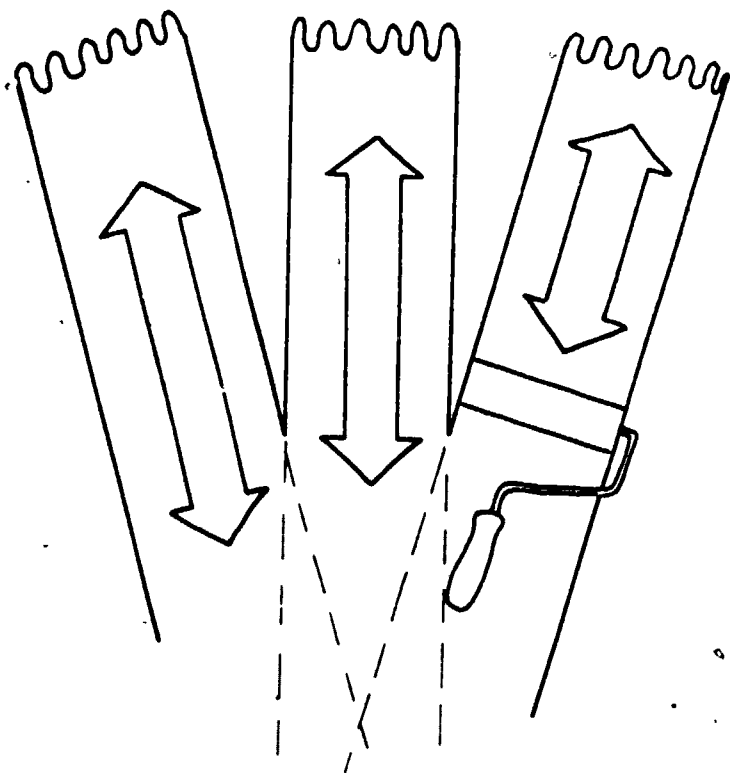

8. The paint should be applied or worked in different directions and then finished (if desired) in one direction.
9. Always work with a wet edge and overlap strokes to make sure paint is applied evenly.
10. Don't remove roller quickly or abruptly from the surface. This will leave a blob of paint on the surface.
11. Don't roll too fast or paint will splatter.
12. Stop only at natural breaks.

Order of Covering

1. Cut-ins. Either with narrow roller or brush.
2. Ceilings. Work across narrow part, overlapping to make sure coating is even.

3. Walls. Start on one side, using long strokes up and down the wall. Always work with a wet edge. Work quickly to cover maximum space.
4. Floors. Techniques similar to those listed above.

At times, instead of finishing with a roller, a brush will be used. The technique is known as "roll-and-lick." The paint is applied by a roller, then licked or feathered out with a brush. On large areas and with quick drying paint two workers do the work; one with a roller, the other with a brush.

Clean Up

If used with oil-based paints, wash the roller in the thinner used for thinning the paint being applied.

1. Scrape off excess paint with stirring stick.
2. Immerse the roller in thinner, working out pigment with fingers. Repeat until clean, using clean thinner.
3. Squeeze out excess thinner, wash with soap and water, rinse.
4. Wipe with rag. Store in plastic bag. Hang in air to prevent flat spots.
5. Clean frame and pan with thinner.

If used with latex, wash in warm, soapy water. Rinse. Dry with rag. Store in plastic bag. Clean pan and frame.

Assignment

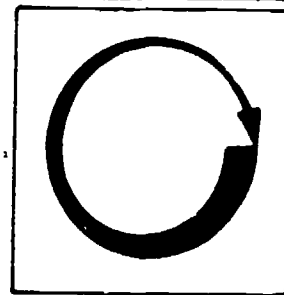

COMPLETE THE FOLLOWING ASSIGNMENT.

.Visit a paint supply store. Examine the nap roller covers. Write down the materials they are made with and what paints they can be used with. Turn the report in to your instructor.

Job Sheet

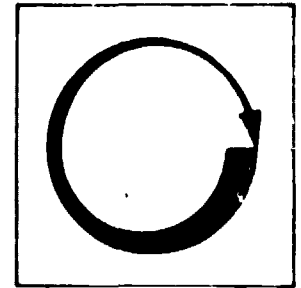

COMPLETE THE FOLLOWING TASKS.

Materials and Tools

linseed oil

latex paint--flat and enamel

oil-based paint

suitable thinner

paint trays

9" rollers of various nap materials and lengths

brick structure, prepared for painting

block structure, " " "

plaster wall, " " "

wood surface, " " "

1. Following the techniques described in this module, apply paint to the prepared surfaces. Use different nap materials (where possible) and different nap lengths and note the texture differences on the surfaces. Note also the ease or difficulty in covering the surface with different nap lengths.

Materials and Tools

rollers and paint as listed above

building interior

2. Following the preparation and painting techniques you have learned, prepare and paint with a roller the entire building's interior to a professional finish.

Post Assessment

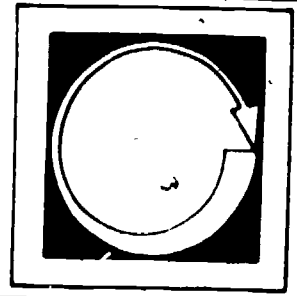

LISTED BELOW ARE SEVERAL STATEMENTS. IF THE STATEMENT IS TRUE, PLACE A "T" IN THE BLANK PROVIDED. IF THE STATEMENT IS FALSE, PLACE AN "F" IN THE BLANK.

1. ___ A good painter can cover about 8 times as much space with a roller as with a brush.
2. ___ The material on the roller which applies the paint is called nap.
3. ___ A wide roller is used to apply paint to corners.
4. ___ When putting paint on a roller, always dip it to twice the depth of the nap.
5. ___ Short nap is used on smooth surfaces.
6. ___ Long nap is used on rough surfaces.
7. ___ 3/4" is short nap.
8. ___ You should always dampen the nap with water before using oil-based paint.
9. ___ Roll and lick requires a paint brush and a spray gun.
10. ___ Roller strokes should overlap.

Instructor Post Assessment Answers

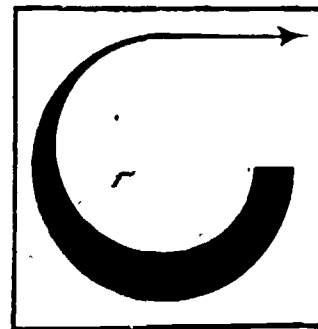

1. F
2. T
3. F
4. F
5. T
6. T
7. F
8. F
9. F
10. T

2

USING THE CONVENTIONAL SPRAY GUN FOR PAINTING

Goal:

The student will be able to identify and demonstrate the steps in operating a conventional spray gun.

Performance Indicators:

The student will complete a Job Sheet and a Post Assessment. The Job Sheet will have 2 tasks, the second of which will be done to a professional finish.

Study Guide

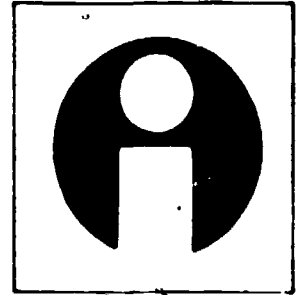

In order to finish this module, do the following tasks. Check each item off as you complete it.

1. Read the Goal and Performance Indicators on the cover of the module. This will tell you what you will learn by studying the module, and how you will show you've learned it.
2. Study the Vocabulary section. Vocabulary words are important for a good understanding of the trade. After you have studied the vocabulary, ask your teacher to quiz you on the words and their meanings.
3. Study the Information section. This section will give you the information you need to understand the subject.
4. Do the Job Sheet. Follow the instructions at the top of the Job Sheet. The tasks listed on the Job Sheet will help you develop skills which will be helpful to you.
5. Take the Post Assessment exam. Give the exam to your teacher after you have completed it. Your teacher will grade it for you.

Vocabulary

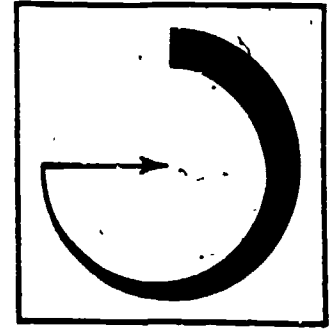

Trade terms are very important for a good understanding of the trade. Study these words and meanings. When you have learned them, ask your teacher to quiz you on the words and their meanings.

MASKING--To use tape and paper or plastic to cover objects not to be painted - windows, sills, electrical outlets, etc.

ATOMIZE--When air under pressure hits a small amount of paint it breaks it up into small particles which form spray.

INTERNAL--Inside. Paint is atomized inside the tip of a spray gun.

EXTERNAL--Outside. Paint is atomized outside the tip.

REDUCE--To add thinner or solvent to a paint material. Reducing is sometimes called cutting.

SANDING--The effect when spray painting from too far away. Sanding happens when the paint isn't sprayed on in a wet coat and not enough atomized particles hit the surface. It is a little rough to the touch.

FOG--Paint particles which don't adhere to the surface being painted, but blow around.

Supplementary References

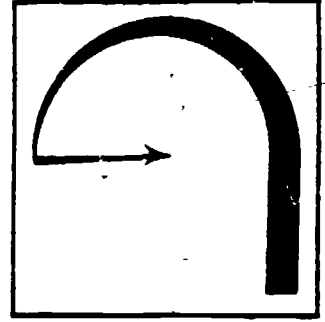

1. Painting and Decorating Encyclopedia. Goodheart.- Willcox Co., 1973.
pp. 129-135.
2. ILS Module "Construction 2300-13, The Use of the Spray Gun." Oregon
Department of Education, 1973.

Information

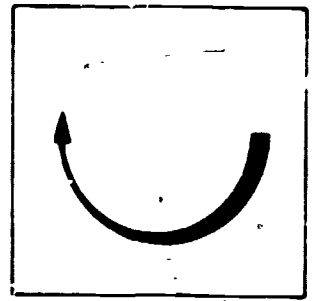

Spraying on paint is the fastest way to apply paint to large areas. Things that you don't want to be painted have to be masked, though, and masking takes a long time. Be sure that painting by spray is the best method of applying painting materials.

Spraying can be done up to 10 or 12 times as fast as painting by brush, but if the area to be painted is small and there are many things to be masked, it may not be the best way.

There are several parts to a conventional spray system:

1. Air compressor, either electric or gasoline, which provides power to move the paint and to atomize it.
2. Hoses. One for the air supply, the other for the paint supply. Both are attached to the spray gun.
3. Spray gun. With adjusting valves and tip, it applies desired amount of paint.
4. Air regulator. Adjusts the amount, or pressure of air going to the gun.
5. Paint container. Either a cup or pressure tank.

(See the drawing on top of the next page.)

Note that the air hose comes through the handle of the gun. The paint hookup (dotted lines) may be a small container called a suction feed cup. This is attached directly to the gun, or a hose from a large pressure tank which contains paint. The pressure tanks may hold from 2 to 60 gallons of material.

The attached cups are suction types and are attached to suction feed guns. The pressure tanks and hoses are sprayed through pressure feed guns. Pressure feed guns are used by most painters on most jobs. (See drawing on bottom of next page.)

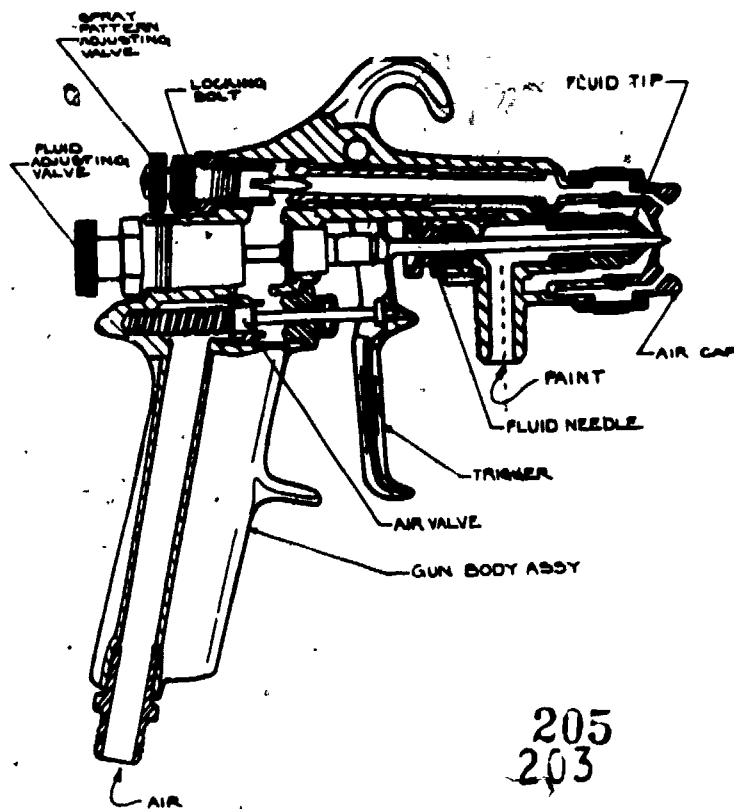
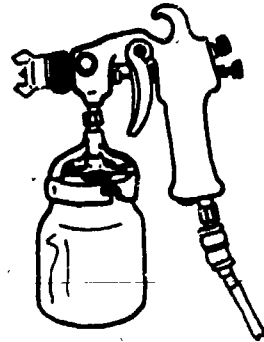
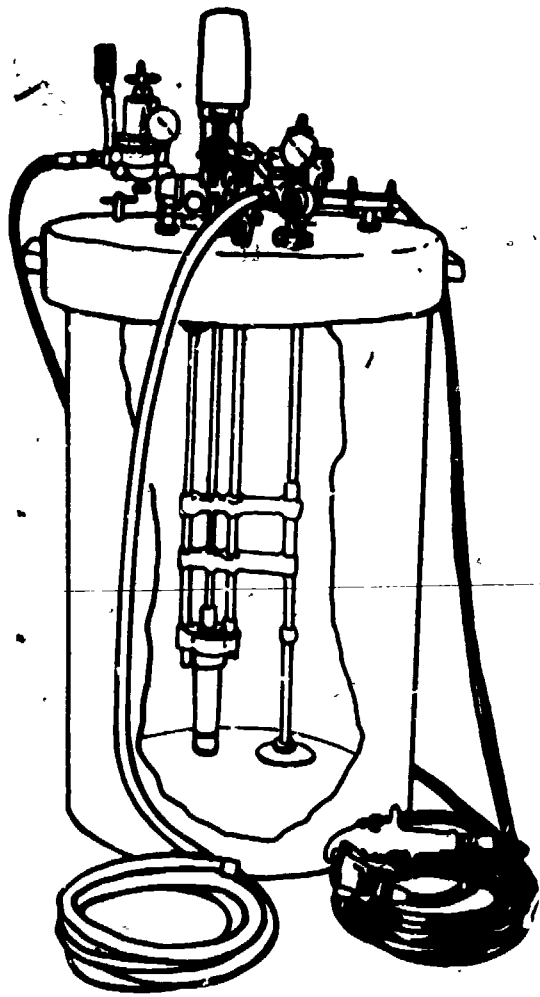

205
203

The spray gun works on the following principle:

- A. When the spray gun's trigger is squeezed, a fluid and an air valve are opened.
- B. Paint is forced by pressure to the fluid tip of the gun.
- C. At the same time, regulated air is forced to the tip of the gun to the air cap.
- D. The air hits the paint, atomizing it (breaking the paint into small particles) and a spray pattern is formed.

There are two different places where the air and paint mix with each other, depending on the type of gun.

1. Internal Mix--The paint is atomized inside the nozzle.
2. External Mix--The paint is atomized just outside the nozzle by air holes on the horns of the air cap.

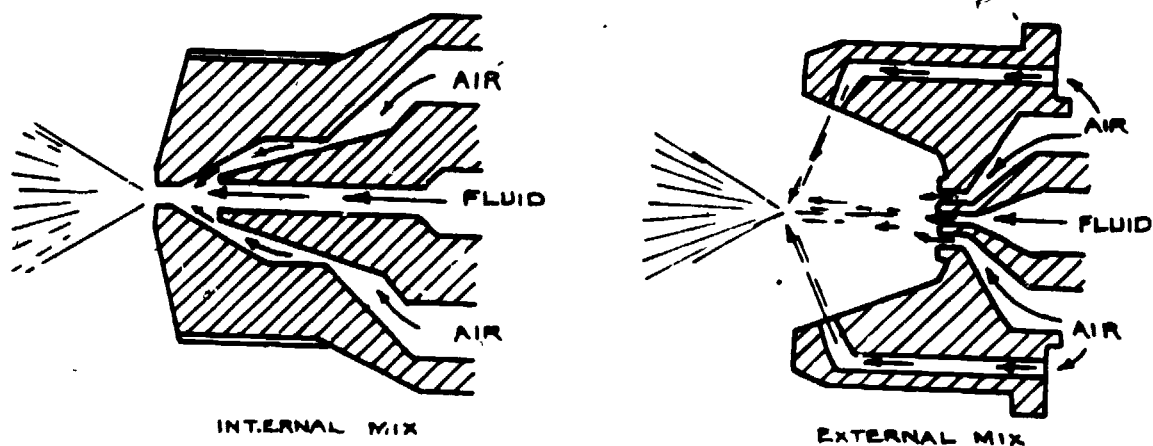

The amount of paint and air allowed into the gun are controlled by two adjusting valves at the rear of the gun. Also, one of these valves, the spray adjuster, gives control over the size and shape of the pattern. The air cap can be turned at 90° angles to change the pattern of the spray. (See the drawing on the next page.)

Spray Gun Operation

1. Attach hoses.
2. Strain paint through mesh, cheesecloth or nylon to remove lumps.
3. Fill pots or pressure tanks. It is recommended that, unless the paint manufacturer specifies it, paint materials shouldn't be cut or reduced. Any mixing should be done outside the spray container and then poured in.

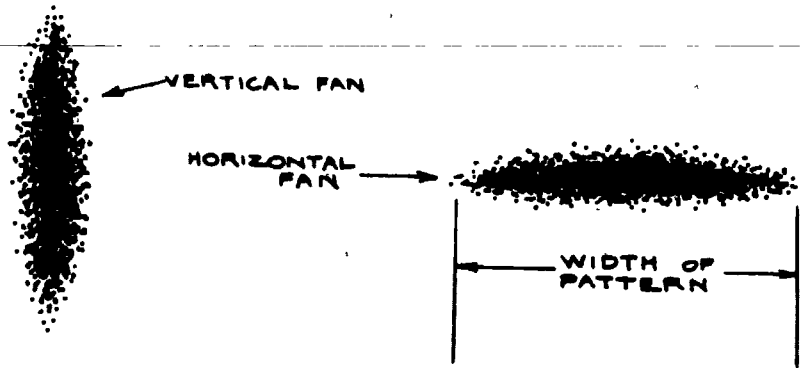
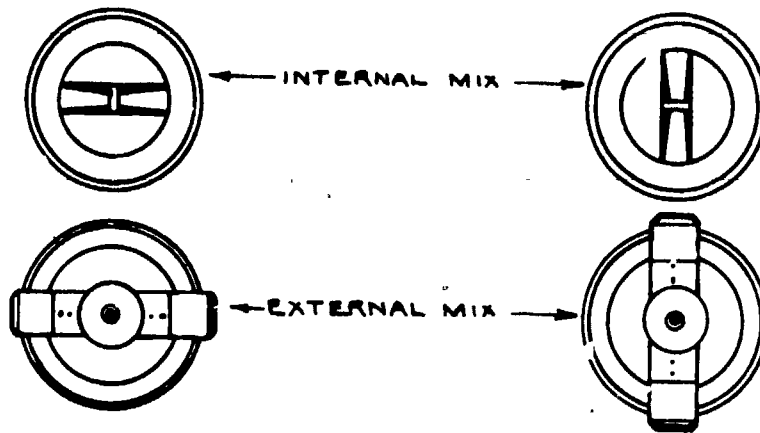

4. Start compressor and adjust regulator.
 - a. Use lowest fluid and air pressure possible for job.
 - b. Fluid pressure should be adjusted from a starting point where a solid stream of paint will flow about 2' with air turned off.
 - c. It is important to always have the right ratio between fluid and air pressure. Following is a recommendation. It will change depending on fluid hose length and temperature.
 - (1) Latex--shoot at 15 lbs. air pressure.
 - (2) Alkyd flat paint--25 lbs.
 - (3) Enamels--35 lbs.
 - (4) Lacquers--40 lbs.
5. Test spray to make sure the viscosity or fluid thickness is correct for the job.
 - a. Control amount of fluid.
 - b. Control amount of air.
 - c. Adjust spray pattern and speed of gun travel.

Spray Technique

Using a spray gun takes a while to get used to. Hours and hours of practice are necessary to be able to control it professionally. Always mask objects not to be painted.

1. Face object to be sprayed: Stand proper distance away.
 - a. Most materials should be shot (sprayed) at about 6"-8".
 - b. Standing too close will produce gummy, runny surfaces.
Standing too far away will produce a sandy finish and fog.
2. Spray parallel to surface at correct distance. Use steady arm movement.
 - a. Start stroke outside of object to be sprayed. Squeeze trigger when spray will reach object.
 - b. Hold gun at 90° angle to surface.
 - c. Don't vary distance of gun to surface. It wastes paint and causes sanding.
 - d. Release trigger at end of stroke.

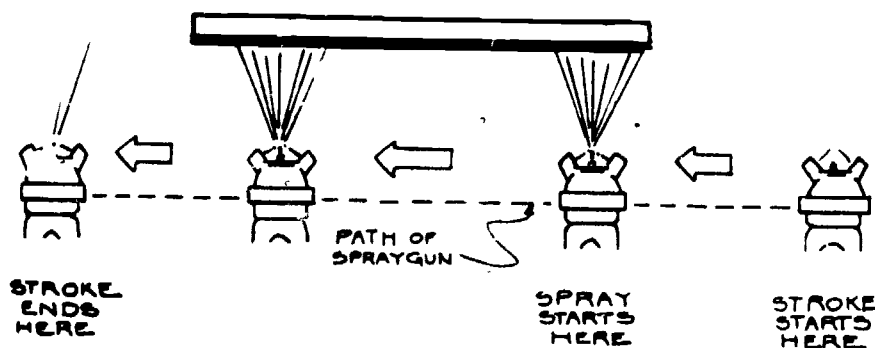

3. Start at top.
4. Work from left to right, then right to left, etc.
 - a. Spraying is nearly always done horizontally.
5. Overlap strokes by 1/2. In other words, aim the center of the spray at the spray line caused by the last stroke. (See the drawing on the top of the next page.)
6. Make sure a full, wet coat is applied.
7. The edges of objects should be sprayed first, then the panel or large surface.

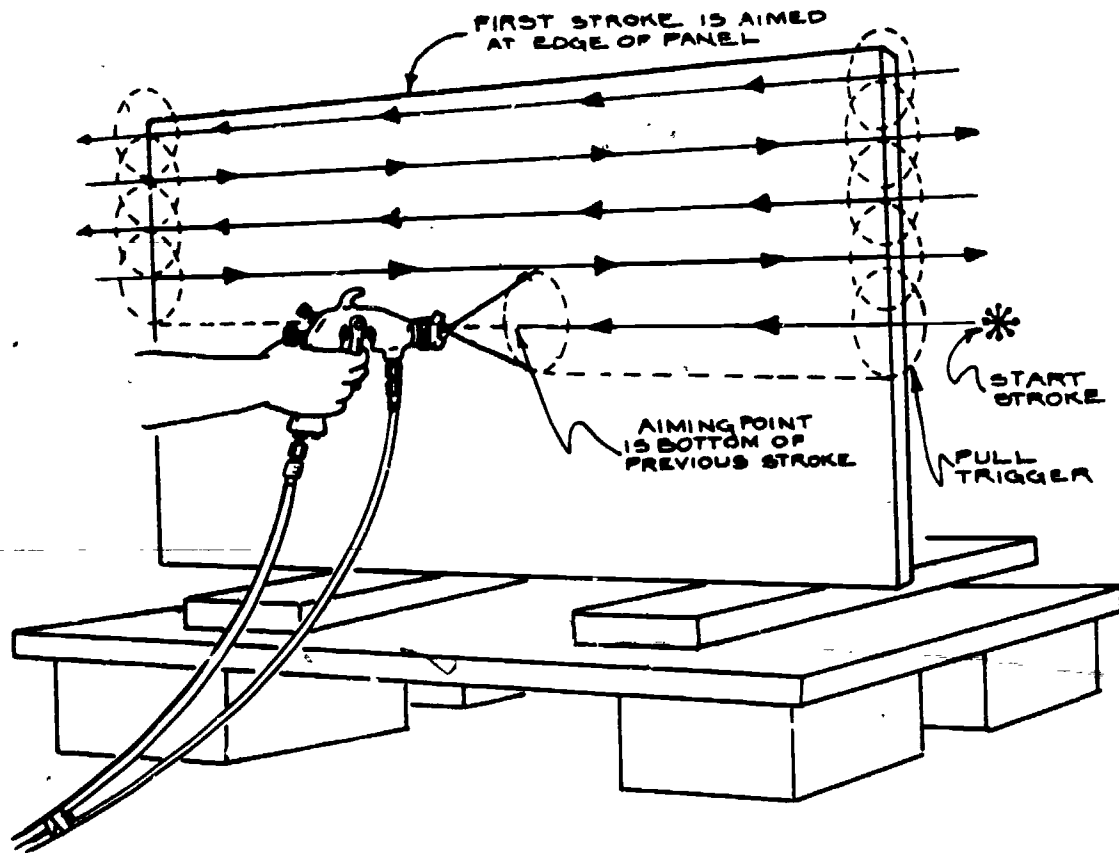

8. When spraying horizontal surfaces, begin near yourself and spray away from yourself. This will prevent sanding, as the spray is carried over the already wet surface.

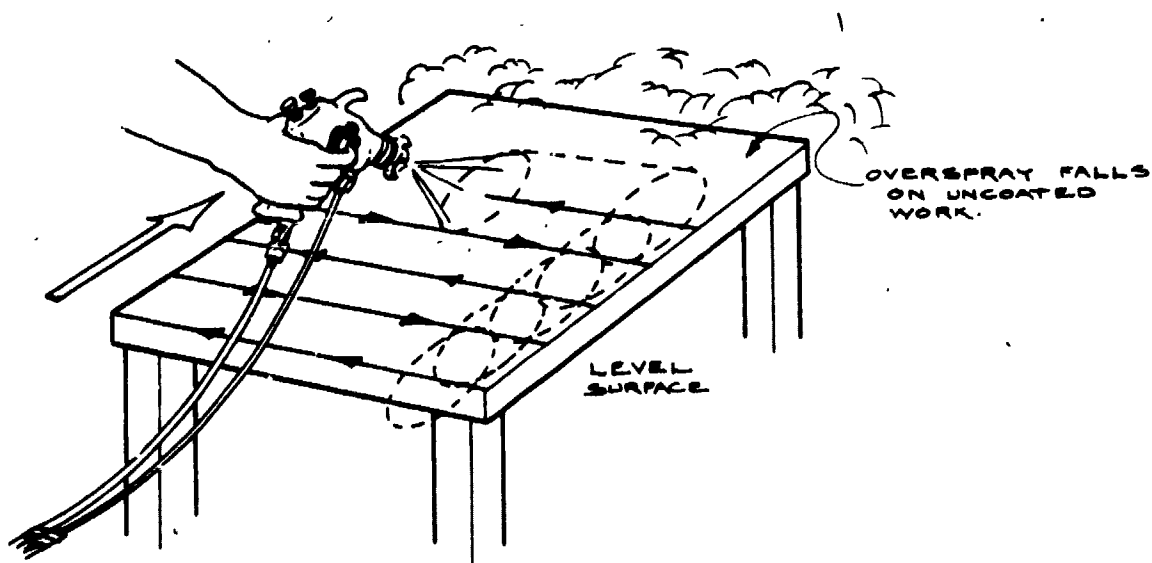

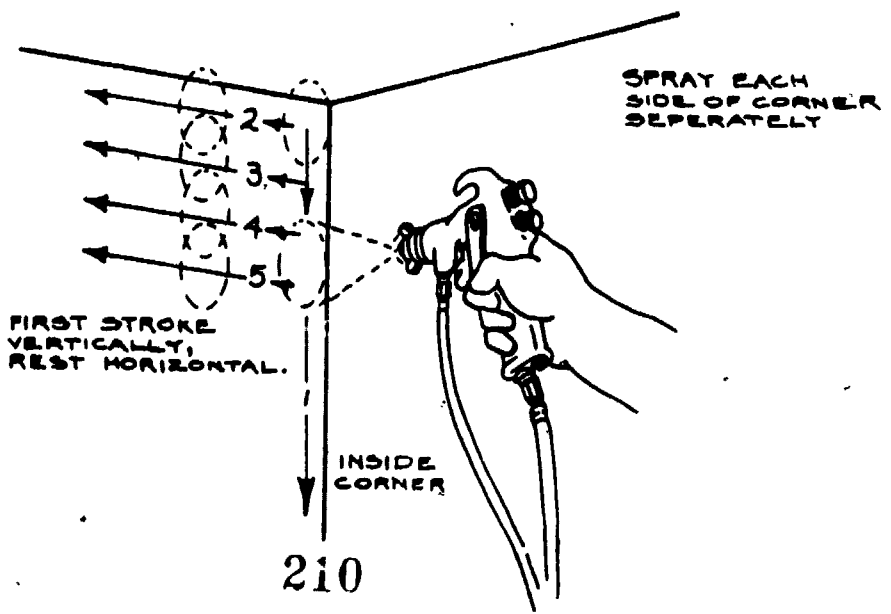
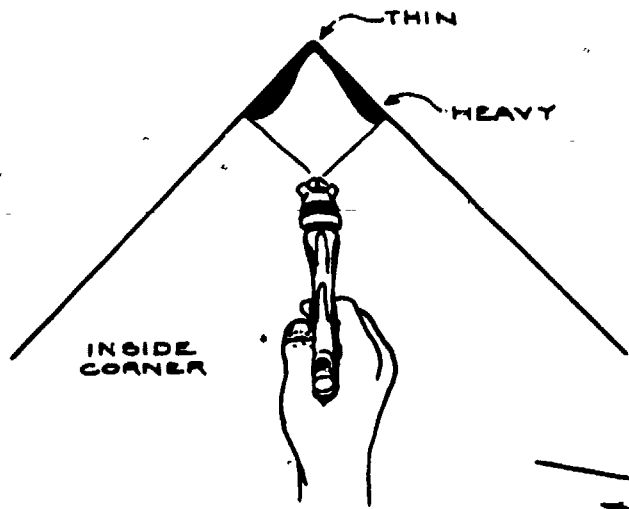
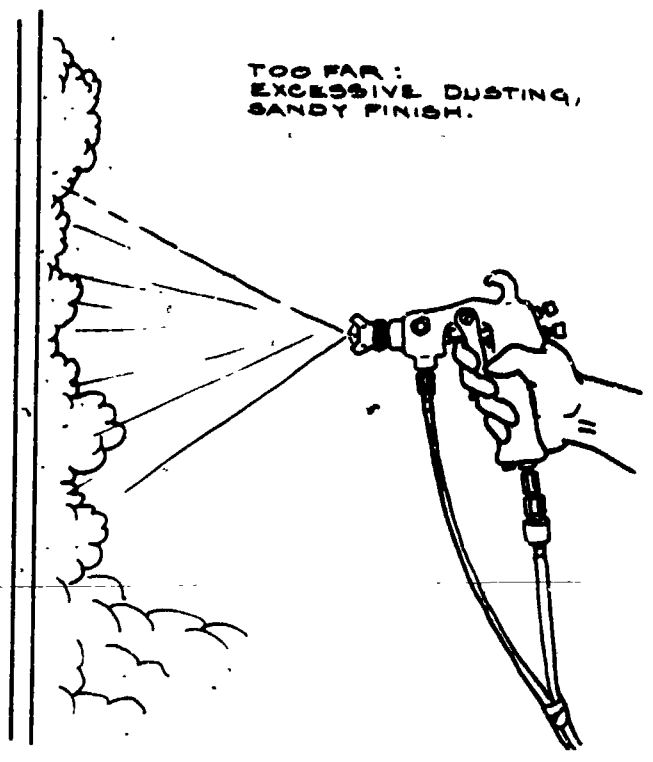
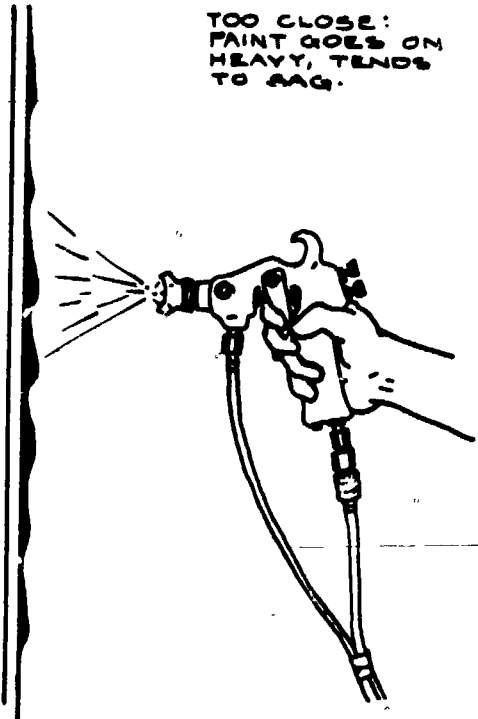

In spraying some paints or paint materials, a suction gun works better than a pressure feed gun. Some materials look better with interior mix, some with exterior mix. The Job Sheet will allow you to experiment.

Clean-up

The following steps should be followed as soon as spraying is finished. Real problems can be caused if paint hardens in the gun.

For suction guns:

1. Empty out any material still in spray cup.
2. Rinse out cup with the solvent used with the finish being applied.
3. Pour a little clean solvent into spray cup, attach to gun, spray solvent through gun to clean out passage-ways.
4. Reduce air pressure to 25 lbs. or less. Remove spray cup. Place finger over nozzle, squeeze trigger to force solvent out of gun.

For pressure guns, run solvent through fluid line in the same manner.

5. To further clean gun (see diagram of spray gun).
 - a. Remove spray-head assembly.
 - b. Remove air cap and fluid tip.
 - c. Pull out needle from rear.
 - d. Rinse everything in clean solvent, wipe dry.
 - e. Assemble gun.

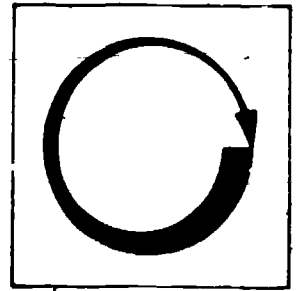

Job Sheet

COMPLETE ALL OF THE FOLLOWING TASKS.

1. Materials and Tools

spray equipment with various internal-external mix tips
latex paint
lacquer
varnish
enamel
housepaint
necessary solvents, thinners
flat wood surface

1. Assemble and adjust spray equipment.
2. Apply paint to pot or pressure container (reduce if called for by paint product manufacturer).
3. Spray each of the materials through each of the tips, following the steps outlined in the module.
4. Clean equipment with each paint change.
5. Discuss with your teacher and class members which tip or tips works best with each paint material.

2. Materials and Tools

spray equipment
latex or oil-based paint
cardboard boxes

Following the steps learned in this module, practice painting with a conventional spray gun. Pay close attention to distance, coverage and cutting down waste by squeezing trigger at the right time. Make air, fluid, arm speed and distance adjustments as necessary.

Practice until you get it right.

211

213

Post Assessment

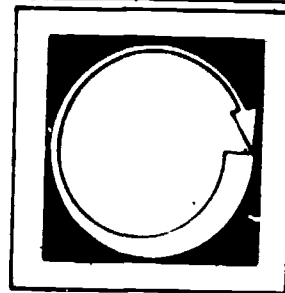

LISTED BELOW ARE QUESTIONS OR STATEMENTS FOLLOWED BY A NUMBER OF POSSIBLE ANSWERS OR COMPLETIONS. SELECT THE ANSWER OR COMPLETION WHICH ANSWERS THE QUESTION OR COMPLETES THE STATEMENT CORRECTLY AND PLACE THE LETTER IN THE BLANK PROVIDED.

1. _____ Painting by spray can be _____ times faster than painting by brush.
 - a. 20
 - b. 21
 - c. 12

2. _____ It's necessary to mask objects when spraying
 - a. always
 - b. indoors
 - c. outdoors

3. _____ The purpose of the regulator is to:
 - a. adjust the pressure of the air going to the gun
 - b. regulate the speed of painting
 - c. help you spray from a great distance

4. _____ Squeezing the trigger of a spray gun
 - a. starts the compressor
 - b. fills the spray cup
 - c. opens the air and fluid valve

5. _____ The air cap is
 - a. a connector between the gun and compressor
 - b. at the nozzle of a spray gun
 - c. on top of the spray gun

6. _____ Atomizing is
 - a. when the paint breaks up into small pieces
 - b. attaching a filter to remove lumpy atoms
 - c. painting with a pump-type gun

7. _____ Most paints should be shot at a distance of
 - a. 3 feet
 - b. 14"
 - c. 8"

8. _____ Dusting happens when you
 - a. don't strain the paint before spraying
 - b. stand too close while painting
 - c. stand too far away while painting

9. _____ The air cap which has "horns" is
 - a. internal mix
 - b. external mix
 - c. used only for spraying outdoors

10. _____ If you spray paint a door, what should you shoot first?
 - a. the upper left corner of the door
 - b. the lower half of the door
 - c. the edges of the door

Instructor Post Assessment Answers

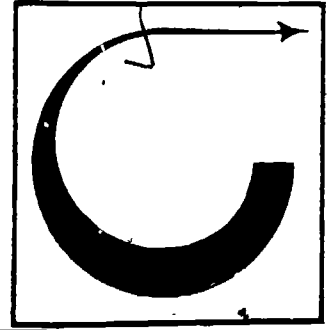

1. c
2. a
3. a
4. c
5. b
6. a
7. c
8. c
9. b
10. c

USING THE AIRLESS SPRAY SYSTEM FOR PAINTING

Goal:

The student will be able to identify and select proper airless spray equipment, and will demonstrate its use.

Performance Indicators:

The student will complete an Assignment on orifice sizes, a Job Sheet on application, and a Post Assessment. The application of materials will be done to a professional finish.

Study Guide



In order to finish this module, do the following tasks. Check each item off as you complete it.

1. Read the Goal and Performance Indicators on the cover of the module. This will tell you what you will learn by studying the module, and how you will show you've learned it.
2. Read the Introduction. The Introduction will tell you why the module is an important part of the painting trade.
3. Study the Vocabulary section. Vocabulary words are important for a good understanding of the trade. After you have studied the vocabulary, ask your teacher to quiz you on the words and their meanings.
4. Study the Information section. This section will give you the information you need to understand the subject.
5. Do the Assignment page. Follow the instructions at the top of the Assignment page.
6. Do the Job Sheet. Follow the instructions at the top of the Job Sheet. The tasks listed on the Job Sheet will help you develop skills which will be helpful to you.
7. Take the Post Assessment exam. Give the exam to your teacher after you have completed it. Your teacher will grade it for you.

Introduction

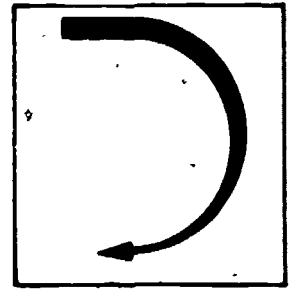

What's called airless spray isn't really airless or spray. The system runs on a hydraulic principle, powered by air. Because of the hydraulics involved, airless is also called hydraulic or "hydro" painting.

Airless is used on a lot of big jobs where there aren't color changes or a lot of stops and starts. Big warehouses and buildings are examples of where airless spray can be used well.

Airless application of paint is about twice as fast as with a conventional spray gun. A good painter has to be as skilled in using airless as he or she is with a brush.

217

219

Vocabulary

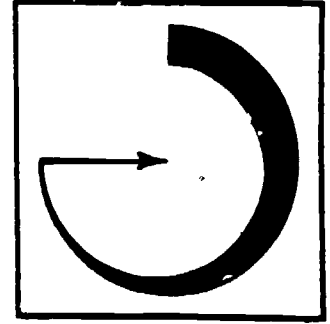

Trade terms are very important for a good understanding of the trade. Study these words and meanings. When you have learned them, ask your teacher to quiz you on the words and their meanings.

FAN--The width of a spray pattern. Fan is measured in both inches (8" at 1 foot) and angles (20°).

HYDRAULIC--Liquid or fluid under pressure. Hydraulic equipment is powered by fluid.

VISCOSITY--The thickness or stickiness of a liquid. Cold maple syrup is thicker than cold water. It is said to be more viscous, or to have higher viscosity.

ORIFICE--A hole or opening.

MASTIC--Protects from water (a vapor barrier).

Supplementary References

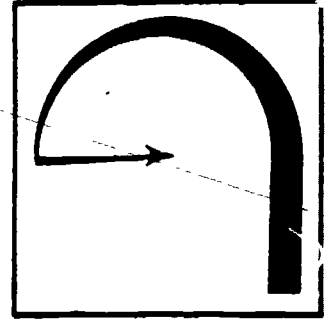

1. Painting and Decorating Encyclopedia. Goodheart - Willcox Co., 1973.
pp. 135-136.
2. Painting and Decorating Craftsman's Manual and Textbook. Painting and
Decorating Contractors of America, 1975. pp. 245-268.
3. A Catalog for the Professional Painting Contractor, Grayco Inc.

Information

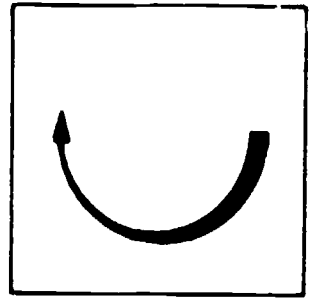

The airless spray technique has been part of the painting trade for about a hundred years. Only in the last 20 years or so has it been refined to the point where it can be used quickly with professional results.

The airless system is made up of:

1. A gun with changeable tips.
2. A pump and regulator.
3. High-pressure hoses.
4. A paint container.

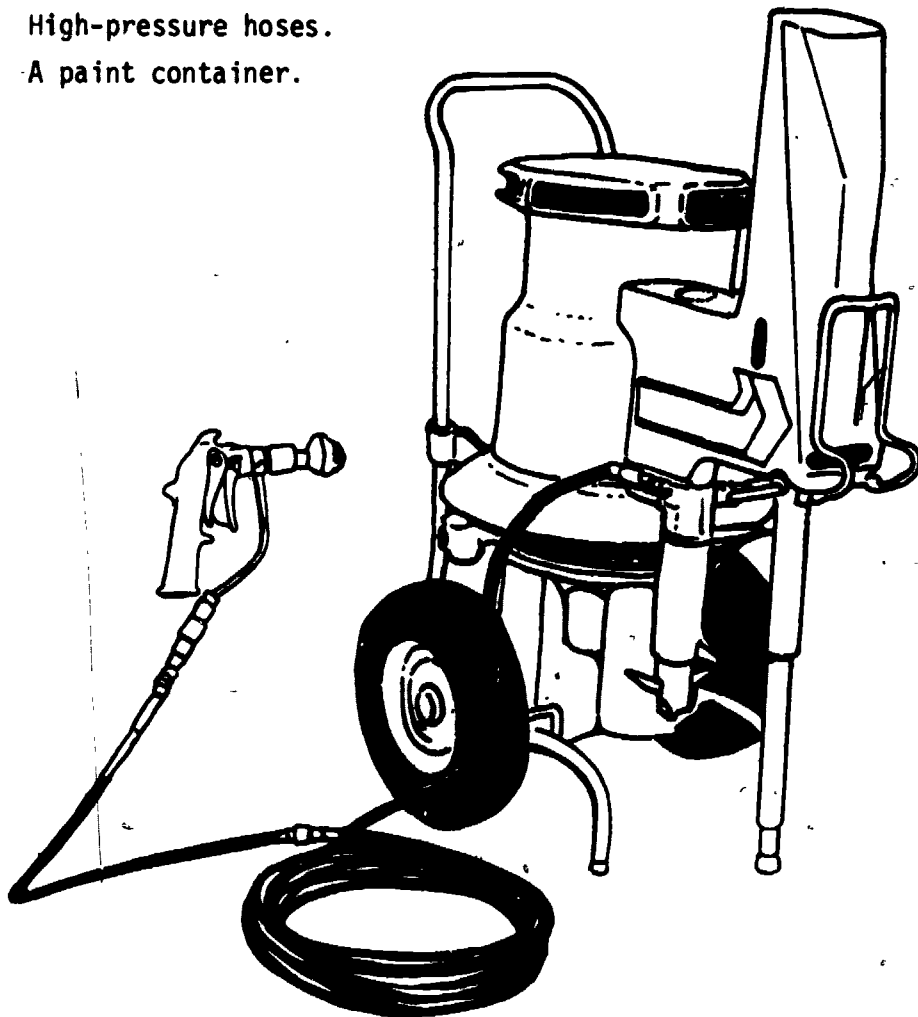

220

222

The heart of the system is the pump. Its job is to carry the paint from the paint container to the gun and increase the pressure by a huge amount.

The pressure is what makes the airless system work. Conventional spray painting relies on high pressure air to atomize the paint stream into small particles and then blow them onto the surface. Airless systems rely on paint under pressure to pass through a small opening and atomize itself. There is no air pushing paint or blowing it onto a wall. There is only paint pushing paint in front of it.

There is less waste with the mist because high pressure air is not blowing it around and onto the surface.

What really comes out the tip of the spray gun isn't a spray, it is a sort of mist.

The airless gun looks a lot like the conventional spray gun, but there are differences. Only one hose (the paint or fluid hose) enters the airless gun. The airless gun also is built to handle far, far higher pressure.

The systems are a little different. On the airless gun, the only way to change the spray pattern or angle, or to run a thicker or thinner material through, is to change the tip.

AIRLESS GUN TIPS

Most good tips are made of a metal substance called tungsten carbide. These tips are designed and machined very accurately and precisely. There are two things which control the spray pattern.

1. The size of the hole in the tip.
2. The shape of the tip, which produces the fan.

The size obviously controls how much painting material can pass through the gun in any amount of time. Hole sizes vary from .007" (seven thousandths of an inch) to .079" (about eight hundredths of an inch) in diameter.

Small tip holes are generally used for materials with thin viscosity, such as varnishes, stains and lacquers.

Medium tip holes are for oil-base paints.

Larger holes atomize latex paints well.

In addition to the size of the tip hole, the tips also are slanted so the paint will fan out in different widths. Tips may fan the material out from 3" spread to a little over 20" at a one-foot distance from the wall.

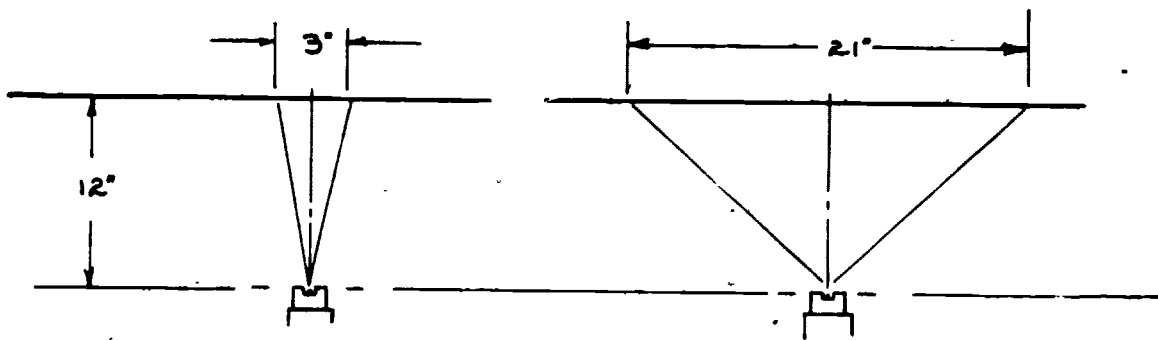
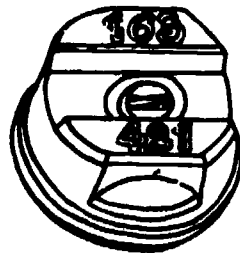

A general rule is to hold the airless gun a little further from the object to be painted than you would conventional spray equipment. It depends on the viscosity of the material, how fast the gun is moving, how thick the coat should be, etc. Most materials are sprayed with airless at 18" to two feet, but it depends.

The spray technique is the same as for conventional spray. As with air spray, heavy coats, or recoating before first coat has set, will cause runs or sags.

223

225

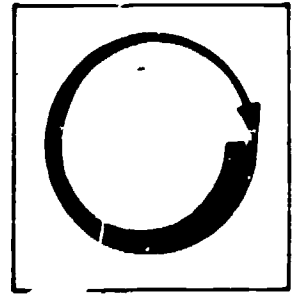

Assignment

COMPLETE THE FOLLOWING ASSIGNMENT.

Look through the catalog listed on the Supplementary References page (or one published by another manufacturer). Locate the range of tip hole sizes that can be used on the following and write the sizes where indicated:

<u>Material</u>	<u>Orifice Size</u>
_____ Lacquer	_____
_____ Alkyd	_____
_____ Latex	_____
_____ Shellac	_____
_____ Vinyls	_____
_____ Enamel	_____
_____ House Paint	_____
_____ Block Filler	_____
_____ Mastics	_____

In the blank to the left of each paint material, write whether the material is high, extra high, medium, or low viscosity.

Turn the finished Assignment in to your instructor.

Job Sheet

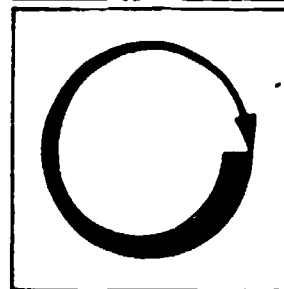

COMPLETE THE FOLLOWING TASK.

Materials and Tools

complete airless system, either electric or gas-powered
various tip orifice sizes

selection of high to low viscosity painting materials
surfaces to be painted

- a. masonry
 - b. wood
 - c. drywall
 - d. metal
 - e. cardboard
1. Following the steps you have learned, practice painting until you can cover the objects to a professional finish. Clean equipment as necessary.

Post Assessment

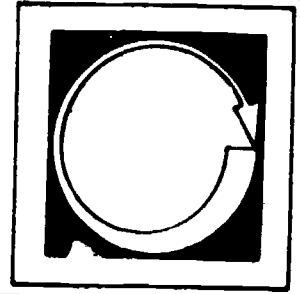

LISTED BELOW ARE SEVERAL STATEMENTS. IF THE STATEMENT IS TRUE, PLACE A "T" IN THE BLANK PROVIDED. IF THE STATEMENT IS FALSE, PLACE AN "F" IN THE BLANK.

1. ___ The airless gun should be held closer to the surface than a conventional gun.
2. ___ A bigger orifice is generally used for lacquer rather than for housepaint.
3. ___ Fan means the same thing as spray pattern.
4. ___ The pump used in the airless system pushes air into the gun.
5. ___ Airless is used on smaller projects.
6. ___ Airless is about twice as fast as conventional spray.
7. ___ The airless gun is held farther from the surface than a conventional spray gun.
8. ___ The pump atomizes the paint.
9. ___ Good fluid tips are made of tungsten carbide.
10. ___ Orifice sizes determine what material can be run through the airless gun professionally.

Instructor Post Assessment Answers

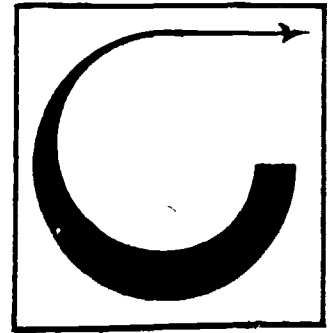

1. F
2. F
3. T
4. F
5. F
6. T
7. T
8. F
9. T
10. T

WOOD STAINS

Goal:

The student will be able to identify and explain the use and characteristics of common stains used in painting, and will demonstrate their use.

Performance Indicators:

The student will successfully complete an Assignment, a Job Sheet and a Post Assessment. The Job Sheet tasks will be done to a professional finish.

Study Guide

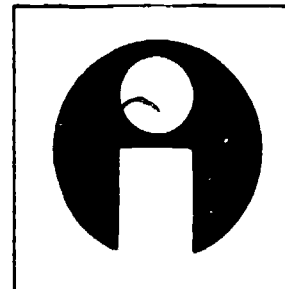

In order to finish this module, do the following tasks. Check each item off as you complete it.

1. Read the Goal and Performance Indicators on the cover of the module. This will tell you what you will learn by studying the module, and how you will show you've learned it.
2. Study the Information section. Vocabulary words are important for a good understanding of the trade. After you have studied the vocabulary, ask your teacher to quiz you on the words and their meanings.
3. Study the Information section. This section will give you the information you need to understand the subject.
4. Do the Assignment page. Follow the instructions at the top of the Assignment page.
5. Do the Job Sheet. Follow the instructions at the top of the Job Sheet. The tasks listed on the Job Sheet will help you develop skills which will be helpful to you.
6. Take the Post Assessment exam. Give the exam to your teacher after you have completed it. Your teacher will grade it for you.

Vocabulary

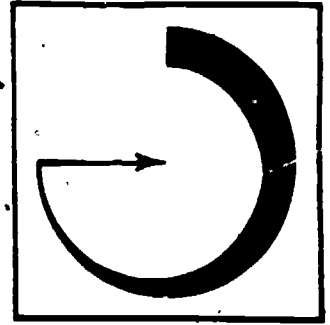

Trade terms are very important for a good understanding of the trade. Study these words and meanings. When you have learned them, ask your teacher to quiz you on the words and their meanings.

SUSPENDED--Held apart in liquid.

PENETRATE--Go into.

DILUTING--The same as cutting, reducing or thinning.

LIBERALLY--Freely, a lot of.

BLEED-- Stain accidentally.

TRANSPARENT--Can be seen through, doesn't hide or obscure.

Supplementary References

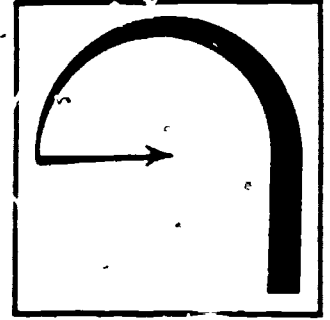

1. Painting and Decorating Encyclopedia. Goodheart - Willcox Co., 1973. pp. 191-193.
2. ILS Module: "Construction 2360-3 Water Stains and Applications," Oregon Department of Education.
3. Complete Book of Woodfinishing. McGraw - Hill, 1956. pp. 72-87.

Information

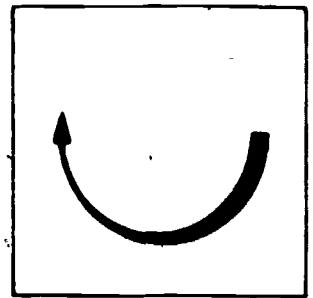

Staining wood is an important part of wood finishing. Staining darkens wood grain.

Stain is classified not by color or use, but by which solvent or liquid is used to hold the dye or pigment. There are three main types.

1. Oil stains.
2. Alcohol stains.
3. Water stains.

OIL STAINS

There are two types of oil stains on the market--pigmented or wiping stain and penetrating oil stain.

Wiping Stain

Wiping stains are a little like thinned paints. They have pigments suspended in oil and solvent. The pigments don't penetrate the wood, they are bound to the surface by the oil binder. You can make wiping stains by diluting some oil-based paint (any color) with turpentine until it's as thin as water. Wiping stains may also be purchased.

Uses

Wiping stains work better with close-grained woods. They are sometimes used, in fact, to cover up or hide the grain.

To use:

1. Stir well.
2. Apply with gun, brush, or rag.
 - a. Apply liberally.

- b. Allow to set for several minutes; (The setting time depends on how thin the stain is, how dark you want the wood, etc.) You should practice on waste wood of the same type.
- c. Wipe off with a clean rag. Wipe with the grain. Wipe so it is colored evenly.

Penetrating Oil Stain

Penetrating oil comes already mixed in cans or in a powder or dye which can be dissolved in turpentine or light oils.

It works well for staining open-grained woods. It does have two disadvantages. It may bleed into clear finishes which are applied over it, and sun light can change its color or bleach it out. It is, however, very easy to use.

Use

Following are the steps in using penetrating oil stain:

1. Sand to smooth surface. Remove all old coverings.
2. End grain will absorb more oil and darken more than the rest of the wood. If you don't want that, apply stain and wipe off quickly, or
Seal end stock with thinned lacquer or sealer. Apply thin coat, being careful not to seal any of the rest of the wood.
3. Apply stain all over surface with brush.
 - a. Brush with grain.
 - b. Use long strokes.
 - c. Start strokes on unstained wood; don't overlap.
4. Let stain stay on surface, as recommended by manufacturer.
5. Wipe off with clean rag. Wipe with grain.
 - a. If stain is too dark, it may be lightened by wiping with a rag soaked in turpentine.
 - b. If surface isn't dark enough, you can apply a second coat.
6. These stains may be mixed to create different colors.
7. Apply filler, if necessary, before finishing.

SPIRIT STAINS

Spirit stains are made of dyes dissolved in spirits such as alcohol. They are rarely used alone as stains the way other stains are. They dry quickly. They

streak when applied by brush; they bleed into almost every clear finish that could be applied over them. And, they fade when strong light shines on them.

They are used for shading--darkening, lightening or tinting areas. They are generally mixed with lacquer and sprayed on in decorative work.

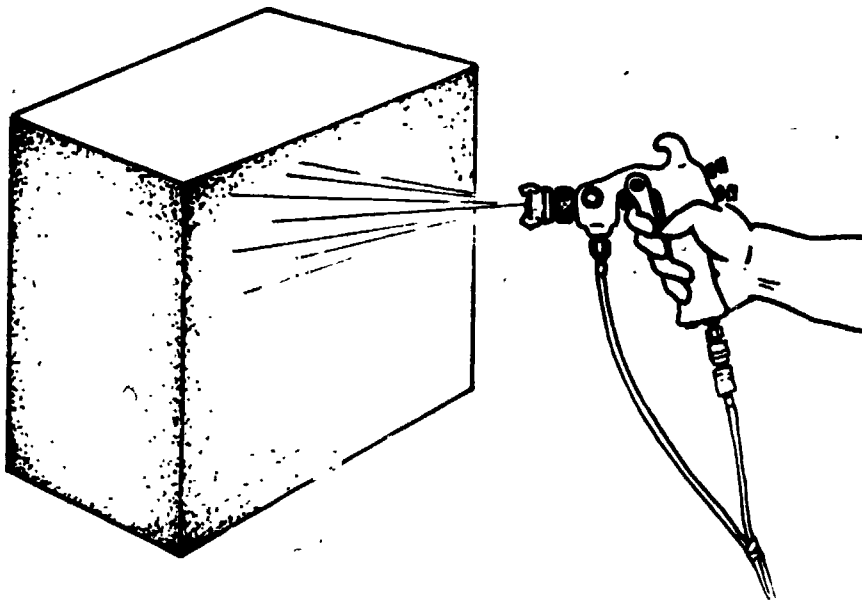

WATER STAINS

Water stains offer the best and the worst of all stains.

The Best:

1. Offers the most transparent stain available. It allows the grain to show through better.
2. Low in cost.
3. Penetrates wood deeply to provide long-lasting stain.
4. Stain won't bleed into clear finishes.
5. Stain won't fade.
6. Available in brilliant colors and wood tones.
7. Tones can be lightened by adding water.

The Worst:

1. Stain must be mixed. One ounce of dye powder is added to one quart of hot (165°F) water.
2. Water will raise grain in wood, which will require extra sanding.
3. May be applied using a gun or brush. If brush is used, be careful. Lap marks will show as dark areas. Spatters will show as dark spots.

To Use

Following are the steps in applying water stain:

1. Sand wood to smooth.
2. Sponge wood surface with warm water on sponge.
 - a. Don't over-wet. A damp sponge will work.
3. Allow surface to dry for about an hour.
4. Sand with 3/0 abrasive paper. Grain should not raise again when stain is applied.
5. Seal end grain pieces with thinned shellac or stain with watered-down water stain.
6. Apply stain with stiff brush or with spray.
 - a. If brush is used, use stiff bristles, work with full brush with grain. Use long, straight strokes.
 - b. Don't lap brush strokes. Avoid splatters. Try to work on horizontal, level surfaces to avoid drips, runs, etc.
7. Remove excess stain (heavily stained areas) with a clean cloth immediately.
8. Allow to dry thoroughly--4 hours, or more. If grain raises, sand lightly.
9. Apply filler, if necessary, and finish.

There are stains available which have many of the same benefits as water stains. These are made by dissolving dyes in solvents other than water. They are called NGR stains (non-grain-raising).

NGR stains dry a lot faster than water stains. They should be applied by brushing or spraying, and should be wiped off immediately.

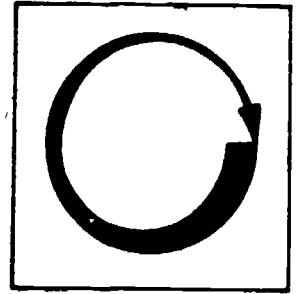

Assignment

COMPLETE BOTH OF THE FOLLOWING ASSIGNMENTS.

1. Make a list of 10 different objects or surfaces in your home or school that have been stained. Beside the object, write what type of stain you think was used and a short explanation of why you think that stain was used. The stains will be oil, water or spirit stains.

	<u>Object</u>	<u>Stain</u>	<u>Why</u>
1.	_____	_____	_____
2.	_____	_____	_____
3.	_____	_____	_____
4.	_____	_____	_____
5.	_____	_____	_____
6.	_____	_____	_____
7.	_____	_____	_____
8.	_____	_____	_____
9.	_____	_____	_____
10.	_____	_____	_____

2. Ask a painter from your area what types of stains he or she has used, and about how much of the time.

% of time

Oil _____

Water _____

Spirit _____

Give this page to your instructor.

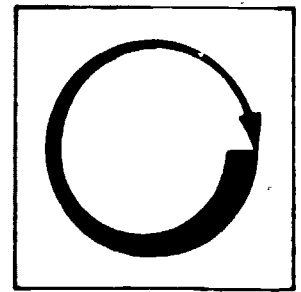

Job Sheet

COMPLETE THE FOLLOWING TASK

Materials and Tools

spirit stain

water stain

penetrating oil stain

suitable brushes

conventional spray system

fine abrasive paper 3/0

clean rags

shellac and thinner

clean containers

wood surfaces and objects--chairs, tables, boxes

1. Following the steps and techniques you have learned,
 - a. Prepare the surfaces for staining.
 - b. Stain 3 objects, using the 3 stains and their brushing techniques discussed in this module.
 - c. Stain objects or surfaces using spray techniques discussed in this module and the module titled "Using the Conventional Spray Gun for Painting."

Post Assessment

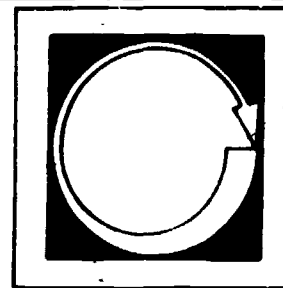

LISTED BELOW ARE QUESTIONS OR STATEMENTS FOLLOWED BY A NUMBER OF POSSIBLE ANSWERS OR COMPLETIONS. SELECT THE ANSWER OR COMPLETION WHICH ANSWERS THE QUESTION OR COMPLETES THE STATEMENT CORRECTLY AND PLACE THE LETTER IN THE BLANK PROVIDED.

1. ____ The type of stain that raises the grain on wood is
 - a. oil
 - b. water
 - c. NGR
 - d. spirit

2. ____ The stain that is mixed with lacquer and sprayed is
 - a. oil
 - b. water
 - c. NGR
 - d. spirit

3. ____ The stain that doesn't penetrate the wood surface is
 - a. wiping stain
 - b. spirit stain
 - c. non-penetrating stain
 - d. surface stain

4. ____ Which of the following stains aren't bleached by sun light?
 - a. spirit
 - b. alcohol
 - c. oil
 - d. water

5. _____ Spirit stains are made of dyes dissolved in
- alcohol
 - water
 - linseed oil
 - tung oil
6. _____ Which of the following is not true of water stains?
- will bleed into finishes
 - is transparent
 - won't fade
 - can be lightened by adding water
7. _____ In brushing on oil-penetrating stains you should
- never overlap strokes
 - always overlap strokes
 - make sure they were mixed at 165°F
 - wipe off immediately after brushing on
8. _____ Oil stains on wood may be lightened by
- applying a second coat
 - wiping on lacquer
 - wiping with oil
 - wiping with turpentine
9. _____ When using _____ stain, you should wipe the wood surface with a wet sponge.
- wiping
 - NGR
 - water
 - spirit
10. _____ Which stain has pigments suspended in oil and solvent?
- wiping
 - NGR
 - water
 - spirit

Instructor Post Assessment Answers

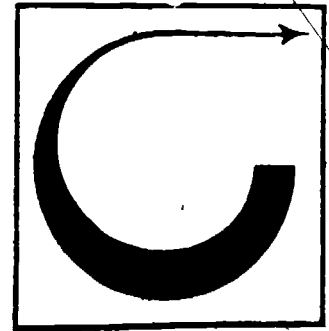

1. b
2. d
3. a
4. d
5. a
6. a
7. a
8. d
9. c
10. a

CLEAR FINISHES

Goal:

The student will be able to identify, select and explain the use of clear finishes commonly used by painters.

Performance Indicators:

The student will successfully complete a Self Assessment, an Assignment and a Post Assessment.

241

243

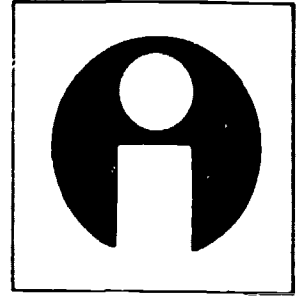

Study Guide

In order to finish this module, do the following tasks. Check each item off as you complete it.

1. Read the Goal and Performance Indicators on the cover of the module. This will tell you what you will learn by studying the module, and how you will show you've learned it.
2. Study the Vocabulary section. Vocabulary words are important for a good understanding of the trade. After you have studied the vocabulary, ask your teacher to quiz you on the words and their meanings.
3. Study the Information section. This section will give you the information you need to understand the subject.
4. Take the Self Assessment exam. This is a test for you to prove to yourself that you have learned the material you have studied. Compare your answers with the answers on the Self Assessment Answer Sheet, which is on the page following the Self Assessment. If you scored poorly, re-study the Information section or ask your teacher for help.
5. Do the Assignment page. Follow the instructions at the top of the Assignment page.
6. Take the Post Assessment exam. Give the exam to your teacher after you have completed it. Your teacher will grade it for you.

Vocabulary

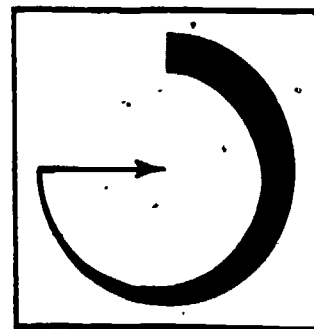

Trade terms are very important for a good understanding of the trade. Study these words and meanings. When you have learned them, ask your teacher to quiz you on the words and their meanings.

TRANSLUSCENT--Partly transparent. It will allow light through, but what you see is sort of hazy.

EVAPORATE--When liquid changes to a vapor or gas.

WASHCOAT--A very thin coat of finishing material, usually a shellac.

VOLATILE--Will evaporate when exposed to air. Will explode if heated.

DISSOLVED--Melted, becoming part of.

DURABILITY--Long-lasting.

CELLULOSE--made of the cell walls of plants.

SILICONE--A resin made by chemically treating quartz. Has very good water-resistant qualities.

BARRIER--A film which cannot be penetrated.

ELASTIC OR ELASTICITY--Flexible, can expand or contract without cracking or breaking.

Painting and Decorating Craftsman's Manual and Textbook. Painting and
Decorating Contractors of America, 1975. pp. 116-124.

244 246

Supplementary References

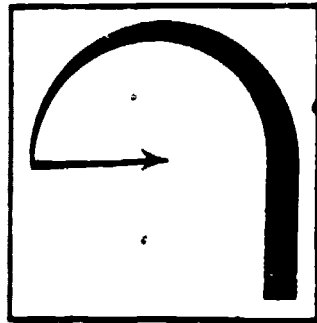

Information

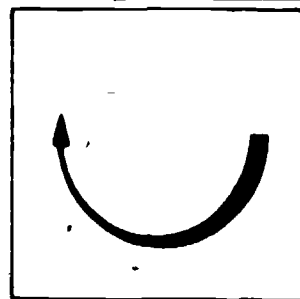

Clear finishes are used to protect wood and still allow the grain of the wood to show through. Clear finishes are also used on metals and different kinds of masonry.

Most often, clear finishes are used to protect wood furniture, wood trim, floors, panels and boats. They are all either transparent or translucent.

There are a number of clear finishes on the market. They fall under the main categories of sealers, shellacs, varnishes, lacquers, and water-repellent materials.

Clear finishes usually require more application coats because the work must be fine and very smooth. They are made, for the most part, of resins, oils, solvents and driers. There are formulas for every use, and the painter must know which finish to use for a desired result.

SHELLAC

Shellac is probably the first transparent finish ever used. It is a clear resin which is dissolved in alcohol. As the alcohol evaporates, the shellac forms a film. Drying time is usually very fast--five minutes or so.

Shellac is available in many "cuts." A cut indicates the amount of resin (in pounds) added to a gallon of alcohol. A four-pound cut has 4 lbs. resin to a gallon. It nearly always has to be reduced or thinned to be applied. A solution of one part alcohol to one part shellac (as it comes in the can) is good for many uses.

Shellac dries very brittle and stains when exposed to water. It can be used as a sealer or washcoat, as a primer coat, or as a finish. It works best when

sprayed. Each coat should be lightly sanded before another coat is applied. It is common for as many as six coats of shellac or more to be applied.

VARNISHES

Varnishes are widely used in the painting industry. Some may be used on industrial buildings to protect against toxic chemicals; others may be used to produce the fine finish on a piano. They may be used in homes, on building exteriors, or even boats. Some varnishes are even added to paint to increase its hardness or gloss. There are two major types of varnish.

1. Spirit Varnish--Is made of a solution of resins in a volatile liquid. As the liquid evaporates, a film of resins is left on the surface.
2. Oleoresinous Varnish--Is a mixture of a drying oil (soy, linseed, tung) which is cooked with resins, and then dissolved in a thinner. The thinner or solvent evaporates, leaving a film which dries hard as the oil is dried by the air.

Both natural resins and synthetic resins provide hardness, durability and gloss.

The types of resins and oils, and the amount of each used, determines what the varnish can be used for. Will it dry hard? Can it stand up to weather or water? Will it become sticky in hot weather, etc.? The amount (and type) of oils determines elasticity. The amount (and type) of resins determines hardness.

Varnishes may be measured or referred to by the amount of oil they contain.

1. A long-oil varnish contains between 30 and 50 gallons of oil for each 100 lbs. of resins. They are generally used on the exterior, where the oil provides elasticity and resistance to weathering.
2. A medium-oil varnish contains from 20 to 30 gallons of oil for each 100 lbs. of resin. They are usually used for furniture and interior trim.
3. A short-oil varnish contains less than 20 gallons of oil per 100 lbs. of resin. They are used where hardness and resistance to acids, alkalis or alcohol is important. Short-oil varnishes are not too elastic.

Following are a few types of varnish available today:

- a. Spar Varnish--Used on boats and exterior metal because it weathers well. Never used indoors because it becomes sticky in warm weather. Will screen out harmful rays of the sun.
- b. Interior Varnish--Used on floors, finishes, interior trim. Dries hard. Shouldn't be used outdoors because it is not too elastic.
- c. Flat Varnish. Varnish comes in many degrees of gloss--high gloss, medium gloss, low gloss, satin sheen, etc. Flat varnish is a low gloss material.
- d. Mixing Varnish--Added to paint to add luster or gloss. Also adds hardness.
- e. Rubbing Varnish--Used on interiors only. They are short-oil varnishes which can be polished and smoothed for extra-fine work.

Varnish should never be applied over shellac. The solvents in varnish will break up the shellac and cause problems. Varnishes may be applied by brush or roller, although spraying gives the smoothest surface. They may be applied over stained wood, paste-filled wood, or any other wood surface that is smoothly prepared. Varnishes usually require several coats to produce a smooth and protected surface.

LACQUERS

Lacquer is the fastest drying clear finish on the market. The surface it forms is tough and durable and it is now used mainly as an industrial finish. There are many home uses--floors, furniture, etc.

It is made by combining a cellulose material with alcohol, ketone, or ester solvents, adding resins and a plasticizer and thinning with solvent combinations.

Lacquers are often colored or tinted by adding finely-ground pigments--very similar to the pigments used in paint.

Nearly all lacquers are made to be sprayed on a surface. It takes many coats to form a film that is thick enough to protect the surface.

Lacquers should not be applied over other paint finishes because their very strong solvent, will soften and wrinkle them. Be especially careful with lacquers. The same strong solvents can cause serious injury to the painter.

URETHANE FINISHES

Made of newer synthetic resins, urethane provides very good flexibility (elasticity) and resistance to chemicals. Is used a lot for outdoor work, floor work and in boats.

OTHER CLEAR FINISHES

There are a number of clear, penetrating finishes which are used by painters. Some are silicone-based and used for masonry or wood. They penetrate the surface, dry and form a barrier which prevents water or moisture from entering. Most paint manufacturers have developed a line of clear, penetrating wood sealers to be used on natural wood siding, shakes and shingles. They are generally an oil- or alkyd-base, thinned by a solvent such as mineral spirits.

Self Assessment

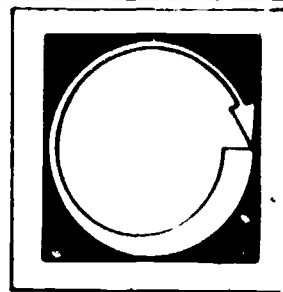

LISTED BELOW ARE SEVERAL STATEMENTS. IF THE STATEMENT IS TRUE, PLACE A "T" IN THE BLANK PROVIDED. IF THE STATEMENT IS FALSE, PLACE AN "F" IN THE BLANK.

1. ___ Most clear finishes are applied by roller.
2. ___ Lacquer is the first clear finish ever used.
3. ___ Shellac is the fastest drying clear finish.
4. ___ Shellac nearly always must be reduced to be applied.
5. ___ A washcoat is a paint film that is used to clean the paint sprayer.
6. ___ Fine sanding is important between coats of clear finishes.
7. ___ A long-oil varnish has more oil than a short-oil varnish.
8. ___ Spirit varnish is a long-oil varnish.

Self Assessment Answers

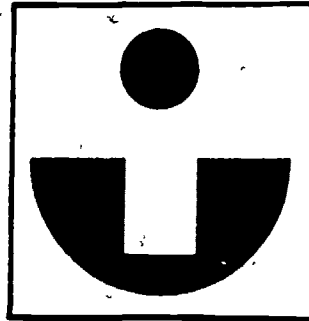

1. F

2. F

3. F

4. T

5. F

6. T

7. T

8. F

Assignment

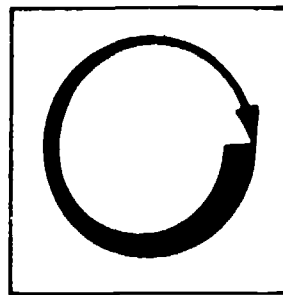

COMPLETE THE FOLLOWING ASSIGNMENT.

Visit a paint store. Write down a list of all the clear finishes the store carries. Include in your list the name of the product, what can be used to thin it, whether it is for interior or exterior use, how it can be applied. When you get back to class, have a class discussion and write which finish you would use on the objects listed below. Give this sheet to your instructor.

1. Wood deck--
2. Living room oak chair--
3. Antique desk--
4. New cedar chest--
5. Birch cabinets--
6. Antique music box--
7. Maple wall panels--
8. Oak floor--
9. Wooden rowboat--
10. Interior wood trim--

Post Assessment

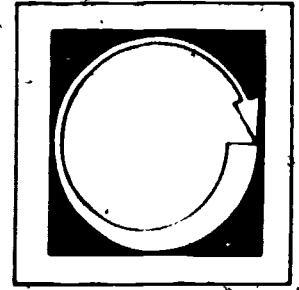

LISTED BELOW ARE SEVERAL QUESTIONS OR STATEMENTS FOLLOWED BY A NUMBER OF POSSIBLE ANSWERS OR COMPLETIONS. SELECT THE ANSWER OR COMPLETION WHICH ANSWERS THE QUESTION OR COMPLETES THE STATEMENT CORRECTLY AND PLACE THE LETTER IN THE BLANK PROVIDED.

1. ____ Transparent means
 - a. cloudy
 - b. you can see through it
 - c. protective
 - d. it never dries

2. ____ What is the first transparent finish ever used?
 - a. shellac
 - b. lacquer
 - c. varnish
 - d. antique silicone

3. ____ Which finish is available in "cuts"?
 - a. lacquer
 - b. varnish
 - c. resin
 - d. shellac

4. ____ Shellac is made of
 - a. alcohol and resins
 - b. silicone and resins
 - c. oil and resins
 - d. alkyd and resins

5. _____ Which of the following stains when it is exposed to water?
- a. varnish
 - b. lacquer
 - c. shellac
 - d. spar varnish
6. _____ There are two main types of varnish. They are:
- a. lacquer and shellac
 - b. spar and rubbing
 - c. long and short-oil
 - d. spirit and oleoresinous
7. _____ If a liquid is volatile, it can
- a. never really dry
 - b. evaporate
 - c. dry hard
 - d. be used in silicone
8. _____ A long-oil varnish is _____ than a short-oil varnish.
- a. less elastic
 - b. harder
 - c. more elastic
 - d. better
9. _____ Which of the following is made with cellulose, alcohol, resins and a plasticizer?
- a. shellac
 - b. lacquer
 - c. varnish
 - d. silicone
10. _____ Which of the following should always be sprayed, not brushed or rolled on?
- a. lacquer
 - b. shellac
 - c. varnish
 - d. silicone

11. _____ Which of the following should never be applied over another paint material?

- a. shellac
- b. varnish
- c. urethane
- d. lacquer

256

254

Instructor Post Assessment Answers

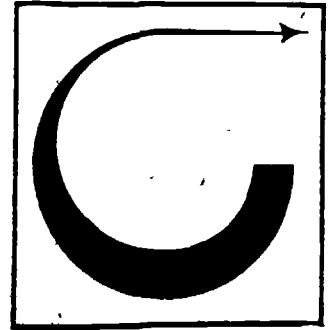

1. b
2. a
3. d
4. a
5. c
6. d
7. b
8. c
9. b
10. a
11. d

257

255

APPLYING CLEAR FINISHES

Goal:

The student will identify, explain and demonstrate the steps involved in applying clear finishes.

256

Performance Indicators:

The student will complete a Self Assessment and projects on a Job Sheet. The Job Sheet tasks will be completed to a professional finish.

258



Study Guide

In order to finish this module, do the following tasks. Check each item off as you complete it.

1. Read the Goal and Performance Indicators on the cover of the module. This will tell you what you will learn by studying the module, and how you will show you've learned it.
2. Study the the Information section. This section will give you the information you need to understand the subject.
3. Take the Self Assessment exam. This is a test for you to prove to yourself that you have learned the material you have studied. Compare your answers with the answers on the Self Assessment Answer Sheet, which is on the page following the Self Assessment. If you scored poorly, re-study the Information section or ask your teacher for help.
4. Do the Job Sheet. Follow the instructions at the top of the Job Sheet. The tasks listed on the Job Sheet will help you develop skills which will be helpful to you.

Supplementary References

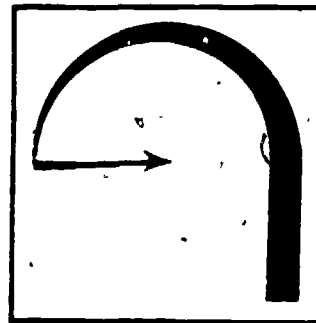

Painting and Decorating Encyclopedia. Goodheart - Willcox Co., 1973.
pp. 194-201.

Information

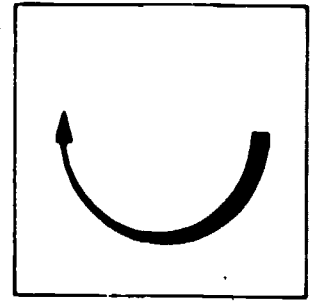

Applying clear finishes to wood surfaces takes a little extra work and care to produce a professional, smooth, durable finish on interior work

Following are the steps for making sure the finish is acceptable.

STEPS \ APPLYING SHELLAC

1. Sand to smooth. A clear finish will be only as smooth as the surface to which it's applied. Remove all old finishes.
 - a. Work from 3/0 abrasive paper to 6/0, sanding with grain.
 - b. The surface can be made extra smooth by dampening wood with sponge moistened with warm water, sanding when dry to remove "fuzziness." Use worn abrasive paper.
2. Wipe surface with tack rag.
 - a. Soft, no-lint cloth. Wet with water, squeeze lightly. Dip in turpentine, add a little varnish. Squeeze cloth until almost dry. Tack rag may be stored in closed jar or can.
3. Stain, if desired.
4. Apply paste filler if open-grained wood, if desired.
5. Apply sealer coat.
 - a. Four-pound cut shellac cut to 1 part shellac, 6 parts denatured alcohol. White shellac used on light woods, orange on dark woods.
6. Apply shellac:
 - a. Use top-quality shellac.
 - b. Shellac darkens with age.
 - c. Shellac is harmed by water or heat.
 - d. 1st coat is 1 part shellac, 3 parts alcohol. Apply with brush (with grain); don't overlap brush strokes.

- e. Allow to dry. Sand lightly.
- f. 2nd coat is 1 part shellac, 1 part alcohol. Apply as before.
- g. Allow to dry. Sand lightly. Drying time will take much longer.
- h. 3rd coat is same as 2nd.
- i. sand lightly.
- j. may be rubbed with paste wax finish.

STEPS IN APPLYING VARNISH

1. Complete 1st 4 steps listed under shellac finish.
2. Apply varnish sealer or shellac as sealer:
 - a. Thin varnish 1 to 1 with turpentine or thinner recommended by manufacturer.
 - b. If used over oil stain without using a filler, varnish may dry very slowly.
3. Clean brush in varnish before applying. Make sure no dust is floating around.
4. Thin varnish according to manufacturer's recommendations. Do not shake or stir too hard.
5. Brush on varnish:
 - a. Crisscross and brush out to uniform thickness.
 - b. Remove any dust specks quickly with small artist's brush.
6. Allow to dry (may take 6-8 hours). Sand lightly with 6/0 wet/dry paper, using water to lubricate. Wipe down with damp cloth. Allow to dry.
7. Repeat steps 5 and 6 until two or more coats have been applied.
8. Final coat may be rubbed with pumice and mineral oil or rubbing oil. Felt pad is used. Dip pad in oil, then in pumice. Use plenty of oil.
9. Rottenstone may be used for more gloss.

STEPS IN APPLYING LACQUER

1. Complete first 4 steps listed under shellac finish.
2. Seal with mixture of 1 part lacquer, 6 parts thinner.
3. Allow to dry. Sand lightly, using 6/0 paper.

4. Follow steps listed for applying varnish. Lacquer requires more coats, and sanding is often not done between coats.
5. Finish by rubbing down, as with varnish.

Just about any finish coat on the market today can be sprayed on. Spraying usually gives a nice even, smooth coat. Follow directions on can for spraying.

Self Assessment

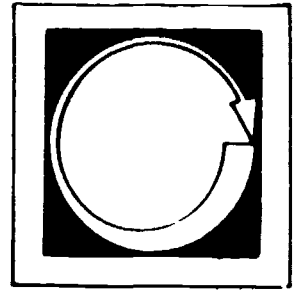

LISTED BELOW ARE SEVERAL STATEMENTS. IF THE STATEMENT IS TRUE, PLACE A "T" IN THE BLANK PROVIDED. IF THE STATEMENT IS FALSE, PLACE AN "F" IN THE BLANK.

1. ___ 6/0 abrasive paper is a good grit for sanding coats of clear finishes.
2. ___ Lacquer is always sanded between coats.
3. ___ Dampening wood with turpentine, then sanding after dry, will produce a smooth finish.
4. ___ Sealer coats are applied after the final coat to seal out water.
5. ___ Shellac may be used as a sealer coat for varnish.
6. ___ Varnish may be used as a sealer coat for shellac.
7. ___ Lacquer takes a long time to dry.
8. ___ Varnish should be shaken hard in the can to mix pigments.

Self Assessment Answers

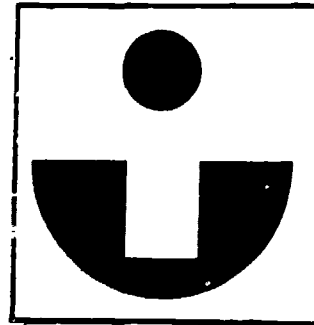

1. T

2. F

3. F

4. F

5. T

6. F

7. F

8. F

Job Sheet

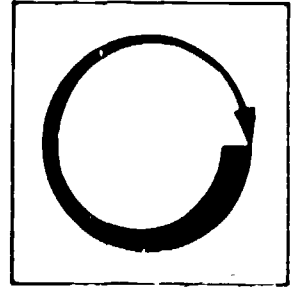

COMPLETE THE FOLLOWING TASKS.

Materials and Tools

lacquer

varnish

shellac

suitable thinners for finishes

proper brushes

3/0 and 6/0 abrasive paper

tack rag

spirit and water stain (optional)

clean containers

paste wood filler (may not be necessary)

wooden objects to finished--chairs, tables, etc.

felt

finishing oil

pumice

wood blocks, 6" x 6" x 6"

1. Following the steps you have learned:
 - a. prepare the wood objects for finishing.
 - b. stain, fill, seal.
 - c. apply lacquer to a professional finish on one object.
 - d. apply varnish " " " " " " "
 - e. apply shellac " " " " " " "

2. Apply the three clear finishes to three 6" X 6" X 6" blocks. Mark each block L (lacquer), V (varnish) or S (shellac). When the blocks have completely dried,
 - a. pour a small pool of water on the top surface of each block. Note what happens over time.

- b. Turn the block so another side is up. Pour a small pool of alcohol on the blocks. Note what happens over time.
- c. Turn the blocks so another side is on top. On the L block, paint half the top surface with shellac, half with varnish. On the V block, paint half the top surface with shellac, half with lacquer. On the S block, paint half the top surface with varnish, half with lacquer. Note what happens as these finishes are mixed.
- d. Turn the block so another side is up. Expose these to strong sunlight. Note what happens over time.
- e. On the remaining unused sides of the 3 blocks, try to scratch with your thumbnail or some hard object. Note closely what happens.
- f. Write down your findings on a sheet of paper and give them to your instructor.

PAIN TROUBLES AND POOR PAINT JOBS

Goal:

The student will be able to identify common paint failure problems and explain the reasons they probably failed to last.

266

Performance Indicators:

The student will complete an Assignment and a Post Assessment.

268

Study Guide

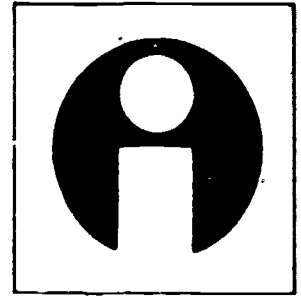

In order to finish this module, do the following tasks. Check each item off as you complete it.

1. ___ Read the Goal and Performance Indicators on the cover of the module. This will tell you what you will learn by studying the module, and how you will show you've learned it.
2. ___ Read the Introduction. The Introduction will tell you why the module is an important part of the painting trade.
3. ___ Study the Vocabulary section. Vocabulary words are important for a good understanding of the trade. After you have studied the vocabulary, ask your teacher to quiz you on the words and their meanings.
4. ___ Study the Information section. This section will give you the information you need to understand the subject.
5. ___ Do the Assignment page. Follow the instructions at the top of the Assignment page.
6. ___ Take the Post Assessment exam. Give the exam to your teacher after you have completed it. Your teacher will grade it for you.

Introduction

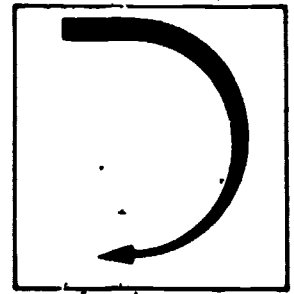

The purpose of applying paint or paint coverings (stains, clear finishes, etc.) is to beautify and protect the surface under the paint.

Most of these materials set and cure, but never really harden in the sense that cement hardens--like a rock. Paint materials form a continuous film of protection. When the film is damaged, the surface underneath may get badly damaged.

Paint failures can and should be avoided, but it is important to understand why they happened.

Vocabulary

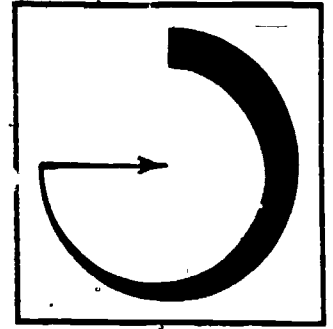

Trade terms are very important for a good understanding of the trade. Study these words and meanings. When you have learned them, ask your teacher to quiz you on the words and their meanings.

PAINT FAILURE--When paint peels, dries, flakes, etc.

LEAN PAINT--Having very little oil or no oil at all.

ELASTIC--Stretchable. Something that can be stretched out, then will go back in place.

Supplementary References

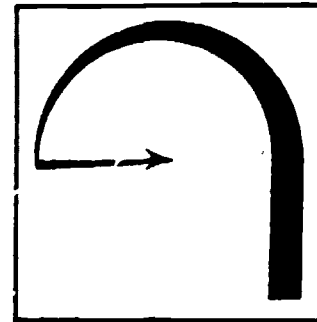

Painting and Decorating Craftsman's Manual and Textbook. Painting and
Decorating Contractors of America, 1975. pp. 517-559.

270

272

Information

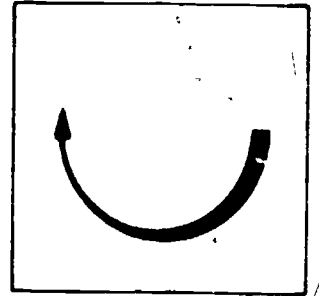

Paints can fail for 4 main reasons:

1. Poor surface preparation.
2. Incorrect application of material or wrong material applied to surface.
3. Poor quality paint or paint materials.
4. Too much moisture beneath surface.

Some common paint failures, the reasons and solutions are as follows:

1. Too Much Chalking.

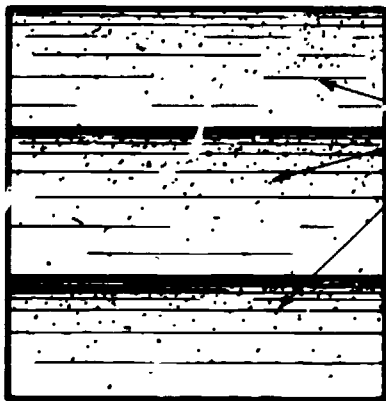

EXCESSIVE SMALL
PARTICLES OF
PAINT DUST

You'll recall that many exterior paints are designed to chalk a little. It is a form of cleaning. The very outer surface of the film eventually dries and flakes off (in very small flakes). Rain washes it away, leaving a clean paint surface underneath.

Heavy chalking is not good. It is generally due to a poor quality of paint or a poor quality of oil in the paint.

The chalk should be taken off by rubbing or wire brushing before repainting.

2. Wrinkling.

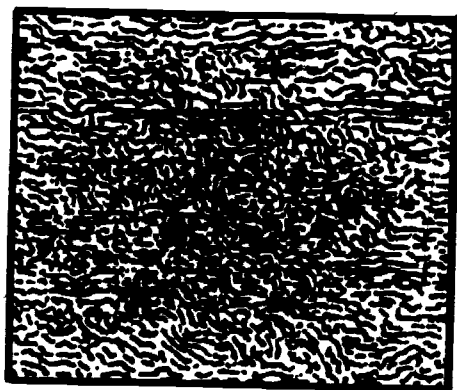

Solvent-thinned painted surfaces sometimes have a pattern of bumps and depressions. There are a few things which may cause this:

- a. Paint hasn't dried at an even, regular rate all the way through. If temperature is too high, surface of paint dries faster, leaving wet paint underneath.
- b. Paint has been applied too thickly. The same thing happens.

Remove paint by scraping and sanding to a smooth surface, then prime or finish.

3. Alligatoring.

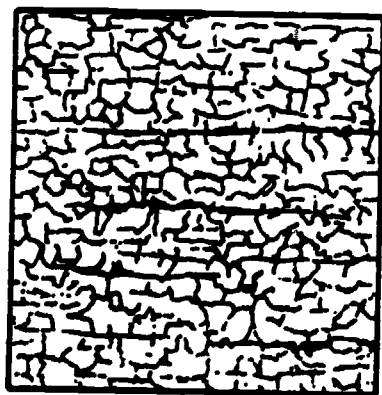

Usually happens because of:

- a. Applying hard finish coats over soft primers or undercoats.
- b. Not allowing undercoats to dry.
- c. Using finish coats with no elasticity.

There's an old saying in the painting trade, "work from lean to fat." This means that you shouldn't apply a paint with less oil (harder paint) over paint with more oil (softer paint). Undercoats should always be harder than outer coats.

Remove alligatored paint by scraping and sanding before repainting.

4. Cracking, Scaling.

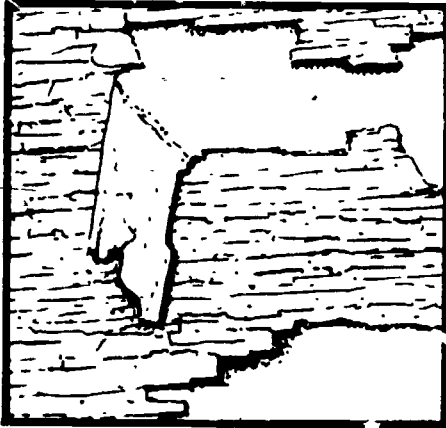

New paint is very flexible and elastic. As it ages, it becomes harder and less elastic. It becomes brittle. Cracking is caused by poor paint with no elasticity or old paint which has lost its flexibility. As the wood or material beneath the paint expands and contracts as it warms and cools, the paint stays rigid. This causes cracking. Moisture gets into the cracks and forces scaling.

Prepare the surface with wire brush and abrasive paper before priming.

5. Blistering, Peeling.

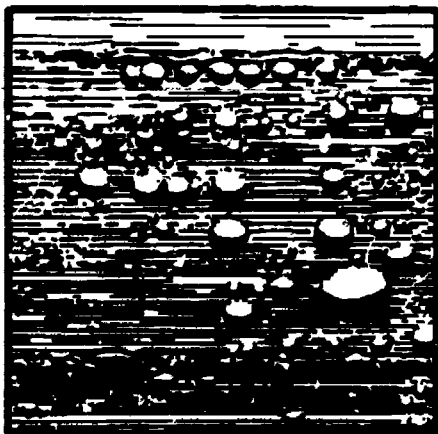

275
273

These are common surface problems. They're nearly always caused by moisture in the wood or surface that's been painted. Moisture travels to the paint as temperatures change, forcing the paint to blister and, later, peel.

The blistered paint must be wire brushed and sanded before priming and repainting, but it is important to find where the moisture is coming from and stop it. A few checks--worn out caulking material, plugged gutters, loose siding, leaky roof, or moisture building up inside the house--will prevent blistering.

6. Other Blistering.

Sometimes blistering occurs and moisture is not to blame. If dark-colored solvent-thinned paints are applied in the direct rays of the sun, blistering can occur. The paint is supposed to cure as solvents gradually evaporate, but the sun hardens the outer surface of paint and traps the solvents. The paint must be scraped or brushed off before applying more.

7. Peeling Gutters and Downspouts.

Occurs when paint has been applied to new galvanized metal that has not been wiped down with mineral spirits. New metal sometimes is coated very lightly with oil. The oil prevents the paint from adhering to the metal.

8. Mildew Growing on Paint.

Mildew is a fungus growth that lives in moist or humid places that the sun can't reach.

Remove it by brushing on solution of one cup trisodium phosphate, one quart bleach and three quarts warm water. Allow to remain for 5 minutes. Hose off and allow to dry thoroughly. Surface should be primed before painting.

9. Brown Stains.

These occur in cedar and redwood that have been painted, usually with a light-colored paint. These two woods have a lot of water-soluble dyes in them. When wet, the wood "bleeds" these dyes. They can usually be wiped off with a mixture of alcohol and water.

Assignment

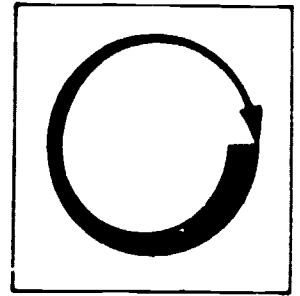

COMPLETE THE FOLLOWING ASSIGNMENT.

Try to find a real life example of the following paint failures (look around your home, neighborhood and town) and complete the form below.

	Where Found	What Caused It	How Would You Prevent It
Blistering			
Wrinkling			
Alligatoring			
Cracking			
Stains			

Give this page to your instructor.

Post Assessment

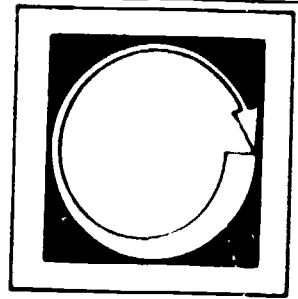

LISTED BELOW ARE QUESTIONS OR STATEMENTS FOLLOWED BY A NUMBER OF POSSIBLE ANSWERS OR COMPLETIONS. SELECT THE ANSWER OR COMPLETION WHICH ANSWERS THE QUESTION OR COMPLETES THE STATEMENT CORRECTLY AND PLACE THE LETTER IN THE BLANK PROVIDED.

1. ____ One cause of paint failure is
 - a. poor surface preparation
 - b. too much preparation
 - c. good quality of paint
 - d. none of the above

2. ____ When applying paint, you should always work from
 - a. fat to fat
 - b. fat to lean
 - c. lean to lean
 - d. lean to fat

3. ____ Hard paint has ____ than soft paint.
 - a. less water
 - b. more oil
 - c. less oil
 - d. more latex

4. ____ If solvent-thinned paint doesn't dry at an even, regular rate, it might
 - a. remain wet forever
 - b. chalk
 - c. crack
 - d. wrinkle

276

278

5. ____ If you apply hard paint over soft paint, it might
- alligator
 - crocodile
 - wrinkle
 - chalk
6. ____ Cracking is caused by paint
- which is brittle
 - that is too elastic
 - which is soft
 - none of the above
7. ____ Most blistering is caused by
- soft paint applied over hard paint
 - thick coats of paint
 - moisture beneath the paint
 - none of the above
8. ____ Peeling gutters are caused by
- working fat to lean
 - using latex paints
 - mineral spirits
 - oil on the metal surface
9. ____ Mildew is
- a type of paint
 - a fungus
 - a disease
 - a solvent
10. ____ What can be used to clean cedar or redwood stains?
- alcohol, water, rag
 - vinegar, water, rag
 - trisodium phosphate and bleach
 - mineral spirits

Instructor Post Assessment Answers

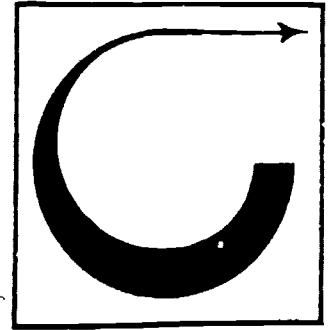

1. a
2. d
3. c
4. d
5. a
6. a
7. c
8. d
9. b
10. a

COLORS AND MIXING

Goal:

The student will be able explain the basics of color perception and demonstrate proper coloring/tinting techniques.

Performance Indicators:

The student will show an understanding of the subject by completing a Job Sheet and a Post Assessment.

Study Guide

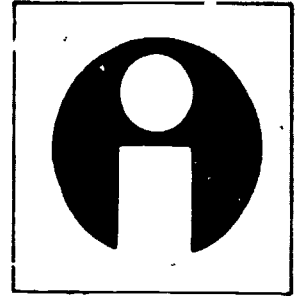

In order to finish this module, do the following tasks. Check each item off as you complete it.

1. Read the Goal and Performance Indicators on the cover of the module. This will tell you what you will learn by studying the module, and how you will show you've learned it. ✓
2. Read the Introduction. The Introduction will tell you why the module is an important part of the painting trade.
3. Study the Vocabulary section. Vocabulary words are important for a good understanding of the trade. After you have studied the vocabulary, ask your teacher to quiz you on the words and their meanings.
4. Study the Information section. This section will give you the information you need to understand the subject.
5. Do the Assignment page. Follow the instructions at the top of the Assignment page.
6. Do the Job Sheet. Follow the instructions at the top of the Job Sheet. The tasks listed on the Job Sheet will help you develop skills which will be helpful to you.
7. Take the Post Assessment exam. Give the exam to your teacher after you have completed it. Your teacher will grade it for you.

Introduction

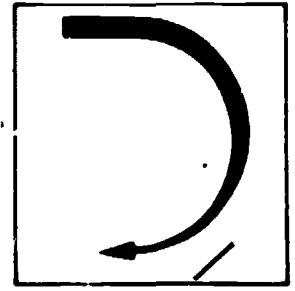

Although most colored paint is mixed to order in the paint store, it is important to know the correct process. Very rarely, a painter will have to adjust a color for someone, or mix another half-gallon to finish a job.

This module will look briefly at color, then at mixing colors to get the right color.

283

281

Vocabulary

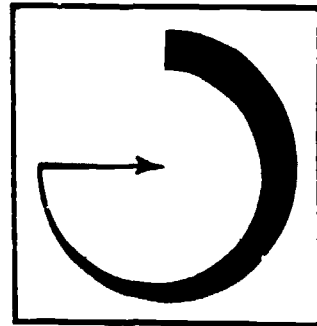

Trade terms are very important for a good understanding of the trade. Study these words and meanings. When you have learned them, ask your teacher to quiz you on the words and their meanings.

BASE COLORS--Basic colors which can be tinted to many different colors.

TINT--To change the color slightly, darker, lighter, different hue.

CONCENTRATED--Contain a lot of, is very strong.

Supplementary References

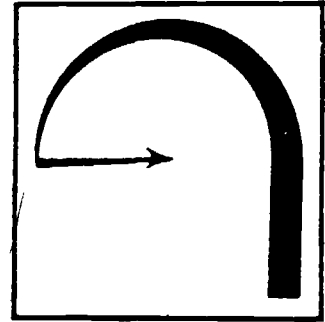

1. Painting and Decorating Encyclopedia. Goodheart - Willcox Co., 1973. pp. 145-170.
2. Painting and Decorating Craftsman's Manual and Textbook. Painting and Decorating Contractors of America, 1975. pp. 375-434.

Information

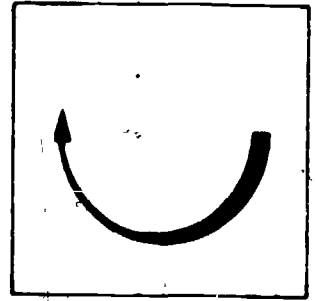

COLOR

Color is an impression. Different people have different ideas of the same color. A red chair may change slightly in color as it is placed outdoors in the direct sun, then brought inside and placed under a light bulb, then placed under a fluorescent light. The chair hasn't changed color, but the appearance of the color has changed.

What we see as color are light rays which have bounced off objects. Light rays from the sun or from lamps are made up of certain wave lengths. Different colors of light have different wave lengths. A rainbow is an example of light which has been separated into different wave lengths--it produces colors.

Different materials (wood, grass, skin, rocks) have the ability to absorb certain wave lengths, while other wave lengths bounce off its surface. Grass is green because it absorbs the wave lengths for red, yellow and blue and reflects the green ones.

There have been a number of systems developed to produce accurate colors of paint in thousands of colors. These systems are of interest to paint manufacturers and, to a degree, to paint store operators.

The painter need only know a few things about color to be a professional.

MIXING AND TINTING

Paints which come directly from paint manufacturers are usually of only white or basic colors. These are called bases or base colors. From these base colors, the paint store can mix up the hundreds of different colors, hues and shades we see.

The manufacturer produces its own paints and its own base colors. Certain base colors, like white, are used to create many different colors by adding a tint or tints in exact proportions. A gallon of white, tinted by a tablespoon of red, will produce a pink. The more red that is added, the darker the pink becomes. White, tinted by black, produces gray. The more black you add, the darker the gray is.

Paint manufacturers refer to their paints and their colors as color systems. Fuller-O'Brien has a color system, and so does Benjamin-Moore. All of the large manufacturers have color systems. Each color they "invent" for their system is given a number or classification. Paint manufacturers also produce a pamphlet showing all their colors with the matching numbers. The colors are called chips. Chips are just little squares or rectangles of paint, showing the true, dry color.

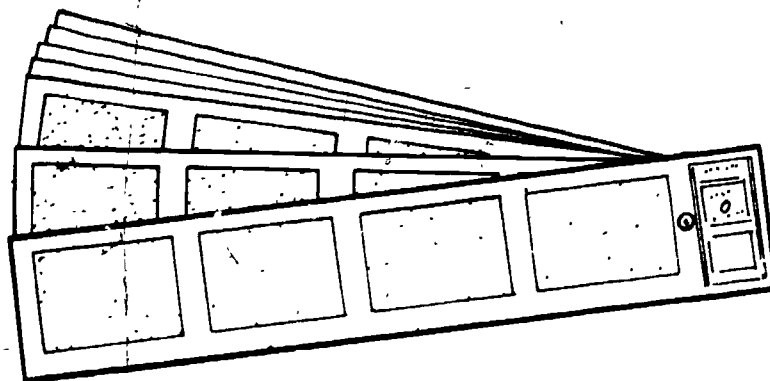

The classification number tells the paint store operator how to make the color. The color of apricot, for example, is a very pale orange color which Fuller-O'Brien has classified as (1) B12B. This indicates to the paint store, which mixes most paints for painters, how much of what colored tint or tints to add to the base. (Apricot is made by adding Venetian red and carmine lake [a crimson] to a base of medium yellow.)

Paint manufacturers may each have a system of over 800 different shades of colors. Each paint manufacturer may call the same color by a different name. What Benjamin-Moore calls "Willow Green" (and classifies as SP-42) is almost an identical color to what Fuller-O'Brien calls "Castle Shannon" (2) F102F. Both are a light green.

Following are a few of the colors these paint manufacturers might have in their color systems, with a short description of how the colors are made:

<u>COLOR</u>	<u>PIGMENTS AND BASE</u>
Fawn (a light brown)	White for base. Add medium chrome yellow, Venecian red, burnt umber.
Navy blue (purple-blue)	Ultramarine blue for base. Add ivory black.
Sky blue (pale blue)	White for base. Add Prussian blue.
Turquoise (greenish-blue)	White for base. Add Prussian blue and pale chrome green.
Salmon (orangish-pink)	White for base. Add ochre, burnt sienna, vermilion.
Olive green	Lemon yellow for base. Add Prussian blue and lampblack (dul! black).

The painter out on the job doesn't have the equipment or knowledge that a paint store operator has. There are a couple of cases when the painter may have to tint or change the color of paint.

1. If he or she runs out of paint, is miles and miles from the shop, and has to get the job done today.
2. If the homeowner sees the painter arrive, checks the paint and says, "Oh, I wanted something a little redder or greener," or whatever.

The painter carries "universal tints for these times. Universal tints are highly concentrated colors which can be mixed with paint to change the color or tint it. A painter may carry in the truck a dozen or 15 different colors --green, blue, red, black, orange, etc. Most painters carry tints in small bottles. The tint is a liquid which is carefully poured or eye-dropped in a container of paint. Sometimes tint comes in a can or tube. The tint is a kind of paste which must be thinned with a little of the paint, then completely

mixed, or it may be mixed without thinning. Universal tints can be used with latex or solvent-thinned paints.

Too much thinning or using too many different tints will harm the paint's quality. Most colors have no more than four tints, usually fewer.

Procedure

1. If using a paste tint:
 - a. Put some tint and a little paint in a clean container.
 - b. Stir thoroughly.
 - c. Combine with more paint in a large container and blend well.
 - d. Make sure there are no streaks.
 - e. Strain through a cloth strainer.
2. If liquid tints are used:
 - a. Pour a little into the base and stir.
 - b. Repeat step "a" until you reach the color you want.
3. If you are mixing paints, always pour dark into light, a little at a time, stirring continually.
4. If you will have to tint a lot of paint for a job, tint it all at once, and pour the containers back and forth into each other enough to make sure all containers have the same coloring.
5. If you have to tint paint to finish a job, remember one thing: You'll almost never get it exactly right. Try to use the color you mixed around a corner or in another room. Never begin to use your mix halfway across a wall.
6. Some colors lighten when they dry. Others darken when they dry. Always check dry paint when you are matching colors. Many painters carry electric hairdryers in their trucks. They can apply a little new paint over the old, plug in the hairdryer and dry out the new paint to see how closely it matches.
7. Always write down and keep track of any mixes you make. This could save you a lot of time later.

Assignment

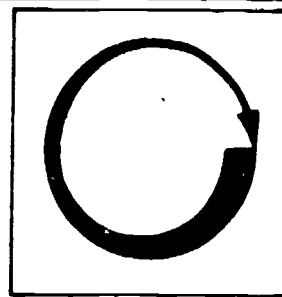

COMPLETE BOTH OF THE FOLLOWING ASSIGNMENTS.

1. Find a reference (or two) which show examples of a lot of colors. Write down beside each of the colors below the color or colors that describe it. This is necessary. Painters have to deal with colors all the time and must know their names.

Example:

- canary = moderate yellow
- crimson = red
- raw sienna =
- burnt sienna =
- burnt umber =
- raw umber =
- ochre =
- toluidine =
- copper =
- chartreuse =
- chamois =
- cafe-au-lait =
- chrome green =
- ultramarine =
- phthalocyanine green =
- carmine =
- madder lake =
- ivory black =
- yellow ochre =
- Indian red =
- russet =
- straw =
- navy blue =
- vermilion =
- robin's egg blue =
- pistachio =
- jonquil =
- magenta =
- mauve =
- maroon =

2. Collect paint chips from 3 different paint manufacturers. Compare them and try to find 10 colors which match. Write down the names which each manufacturer has given the 10 colors. Give the list to your instructor.

289

.291

Job Sheet

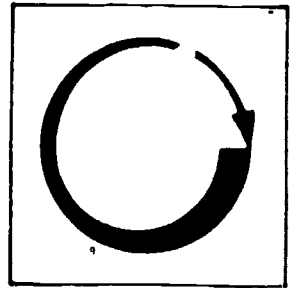

COMPLETE BOTH OF THE FOLLOWING 2 TASKS.

Materials and Tools

Universal tints

bases

clean containers

color chips or many different painted surfaces that can be matched for color.

1. Following the steps you have learned in this module, try to tint the base color(s) to match at least 10 chips or existing painted colors.

Materials and Tools

One of the books listed in Supplementary References of this module.

2. On a separate sheet of paper, which you will give to your instructor, describe what color base and tints you would use to create the following colors.
 - a. Golden Brown
 - b. Ivy Green
 - c. Sapphire
 - d. Emerald
 - e. Colonial Yellow
 - f. Ecru
 - g. Violet

Post Assessment

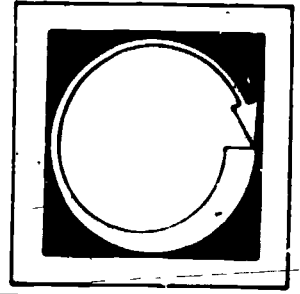

WRITE AN ANSWER TO THE FOLLOWING QUESTIONS.

What color, in words we use daily, is each of the following?

1. ochre =
2. raw sienna =
3. burnt sienna =
4. madder lake =
5. toluidine =
6. What is color?
7. What is the maximum number of tints usually used to get a color?
8. What is the purpose of straining tinted paint through a cloth?
9. What are tints added to?
10. Do paints lighten or darken when they dry?

Instructor Post Assessment Answers

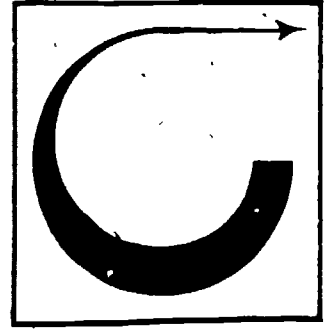

1. yellow
2. brownish yellow
3. orange-red or reddish brown
4. red
5. red
6. An impression the eye gets based on wave lengths.
7. Four
8. To remove paste tints which haven't been mixed in with the paint base.
9. Base
10. Some lighten, some darken.

BLUEPRINTS AND SPECIFICATIONS

Goal:

The student will be able to explain the general parts which make up a whole set of plans, and will interpret specific parts of the plans. He or she will also explain and interpret painting specifications.

293

Performance Indicators:

The student will show an understanding of the material by successfully completing an Assignment and a Post Assessment.

295

Study Guide

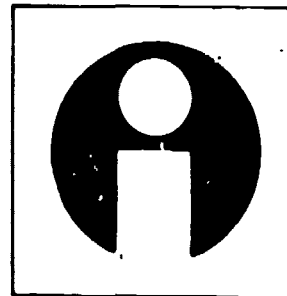

In order to finish this module, do the following tasks. Check each item off as you complete it.

1. Read the Goal and Performance Indicators on the cover of the module. This will tell you what you will learn by studying the module, and how you will show you've learned it.
2. Read the Introduction. The Introduction will tell you why the module is an important part of the painting trade.
3. Study the Information section. This section will give you the information you need to understand the subject.
4. Do the Assignment page. Follow the instructions at the top of the Assignment page.
5. Take the Post Assessment exam. Give the exam to your teacher after you have completed it. Your teacher will grade it for you.

Introduction

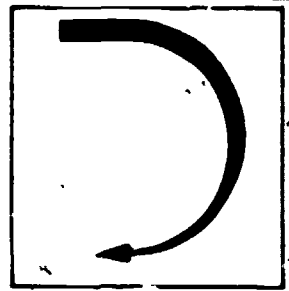

By now, you have studied scales and dimensions, the types of lines and the types of views used in working drawings. Now, all that remains is to put them to work for you.

Reading simple blueprints isn't hard, but it takes a long time to understand some of the more difficult parts. Understanding blueprints and specifications is very important. It is from these that you learn what you are supposed to paint, and what you paint it with.

This module will tell you what to expect to find on blueprints and how specifications work.

Information

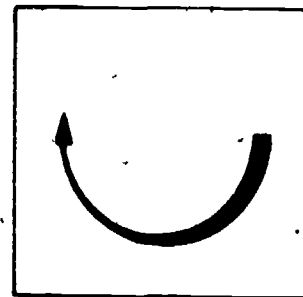

Many buildings being built today are very complex, and a complete set of drawings for such a building includes separate sheets of drawings for many trades.

A set of drawings includes the following parts:

1. Site Development Plan. This shows an overall top view of the building and the property it sits on. It is sometimes called a Plot Plan, because it shows the building on a plot of ground. The plot plan usually shows the following:
 - a. compass directions
 - b. property lines
 - c. slope of ground
 - d. location of building, roads, etc.
2. Foundation Plan. This shows the dimensions of the foundation of the building.
 - a. dimensions of foundation walls
 - b. width, depth, height of footings
 - c. imensions of any concrete slabs
 - d. reinforcing rods and large anchor bolts
3. Floor Plan. This shows the layout of a floor of the building.
 - a. arrangement, size, shape of the rooms
 - b. thickness of walls
 - c. locations of windows, doors
 - d. size, shape of plumbing fixtures
4. Exterior Elevation. This shows the view of one side, or of the front or back of the building.
 - a. shape of building
 - b. size and location of wall openings (windows, doors)
 - c. roof details and exterior features

5. Interior Elevations. This shows the placement of interior parts of the building.
6. Sectional Elevations. Shows the details of the interior. These drawings show details of:
 - a. wall construction
 - b. how material is joined
7. Detail Drawings. These are enlarged views of detailed work.
8. Notes and Schedules. These refer to the drawings or to symbols used on the drawings. They may list:
 - a. electrical fixtures, who makes them, etc.
 - b. an explanation of the symbols used, etc.
9. Specifications. These are not written on the large sheets of paper on which the drawings are made. Specifications, or specs, are combined in a notebook, which is delivered as part of the plans.

Specs are written information about the construction project or building. They give a detailed account of the quality of work, and what materials will be used. Specs usually cover every part of the job--cement, plumbing, electrical, painting, sheet metal, carpentry, masonry, roofing material, floor covering, etc.

Sometimes, on smaller projects like houses, the specs only cover major parts of the overall building. Things like painting and finishing and floor covering may be left to the building contractor to decide.

Working drawings and specs are both drawn up by the architect. If the plans or drawings say one thing, and the specs say another, the specifications are always right.

The painter looks at the drawings to see how much space has to be covered, then looks at the specs to see what they must be covered with.

Post Assessment

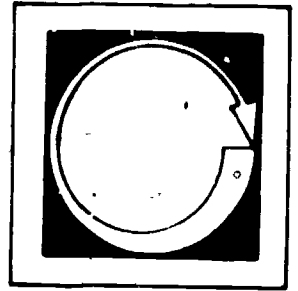

ANSWER THE FOLLOWING QUESTIONS. USE THE DRAWINGS AND SPECIFICATIONS (WHICH FOLLOW THE TEST) TO FIGURE OUT YOUR ANSWERS.

1. What material is the bathroom to be painted with?
2. How is it to be applied?
3. What are the kitchen walls to be painted with?
4. How is the material to be applied?
5. What finish is to be applied to the kitchen cabinets?
6. What material is to be applied to the exterior trim?
7. What is the exterior of the house to be painted with?
8. How many square feet are there to be painted on the bathroom ceiling?

9. What are the kitchen counter-tops to be painted with?

10. On what surfaces is fruitwood stain to be applied?

FINISH SCHEDULE - 'E'

DETAIL NO.	COATING SPECIFICATIONS	APPLICATION METHOD
1	GLIDDEN - LATEX ENAMEL 5702 - CEILING WHT.	SPRAY
2	GLIDDEN - OIL BASE ENAMEL 5732 - CEILING WHT.	BRUSH
3	GLIDDEN - OIL BASE ENAMEL 5744 - ANT. WHT.	BRUSH
4	GLIDDEN - LATEX ENAMEL 5700 - ANT. WHT.	SPRAY
5	OLYMPIC FRUITWOOD STAIN w/ MANNING MITCHELL URETHANE	AS PER SPEC.
6	GLIDDEN EX. FLAT OIL BASE 2520 - BRICK RED	BRUSH
7	GLIDDEN EX. FLAT OIL BASE 2550 - HOUSE WHT.	BRUSH
8	OLYMPIC EX. STAIN 1007 - REDWOOD	ROLLER
9	GLIDDEN - INT. LATEX FL. WALL 5701 - CEILING WHT.	ROLLER
10	GLIDDEN - INT. LATEX FL WALL 5707 - ANT. WHT	ROLLER
11	GLIDDEN - INT. LATEX FL WALL 5722 - DESERT SAND	ROLLER

302

304

303

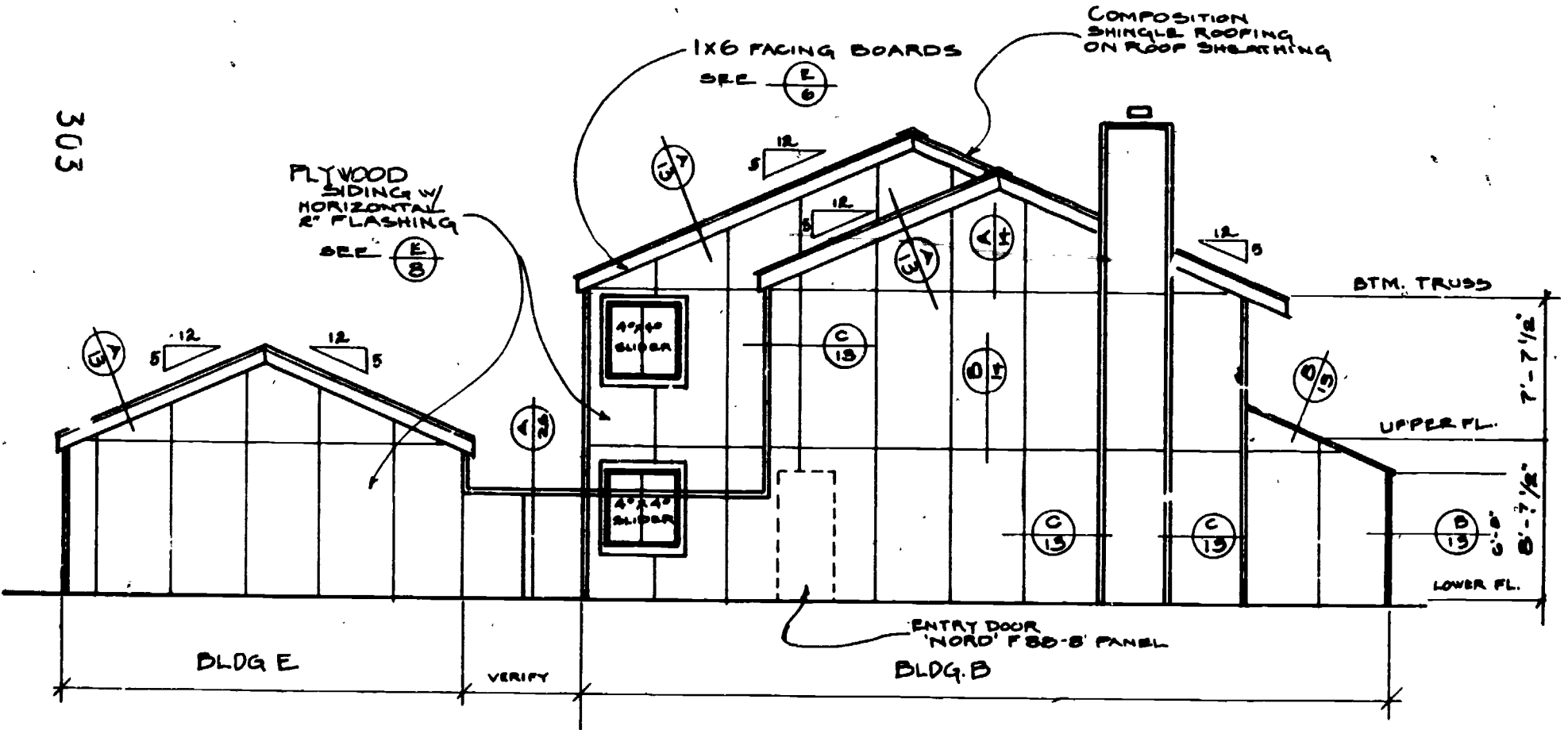

NORTH ELEVATION
SCALE: 1/8" = 1'0"

305

306

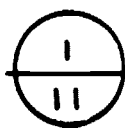
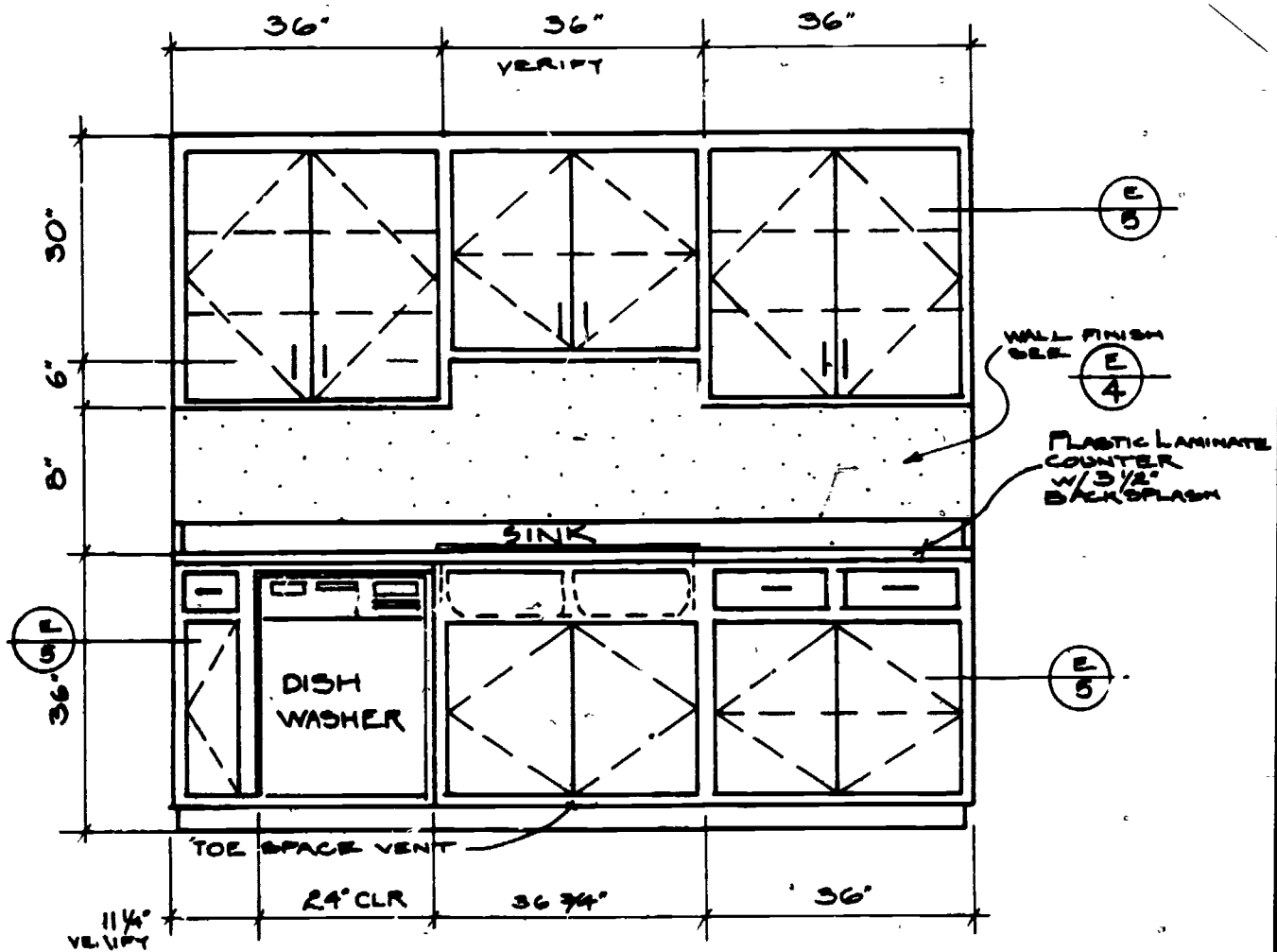

(FRONT)

1/2" = 1'0"

KITCHEN ELEVATION

307

304

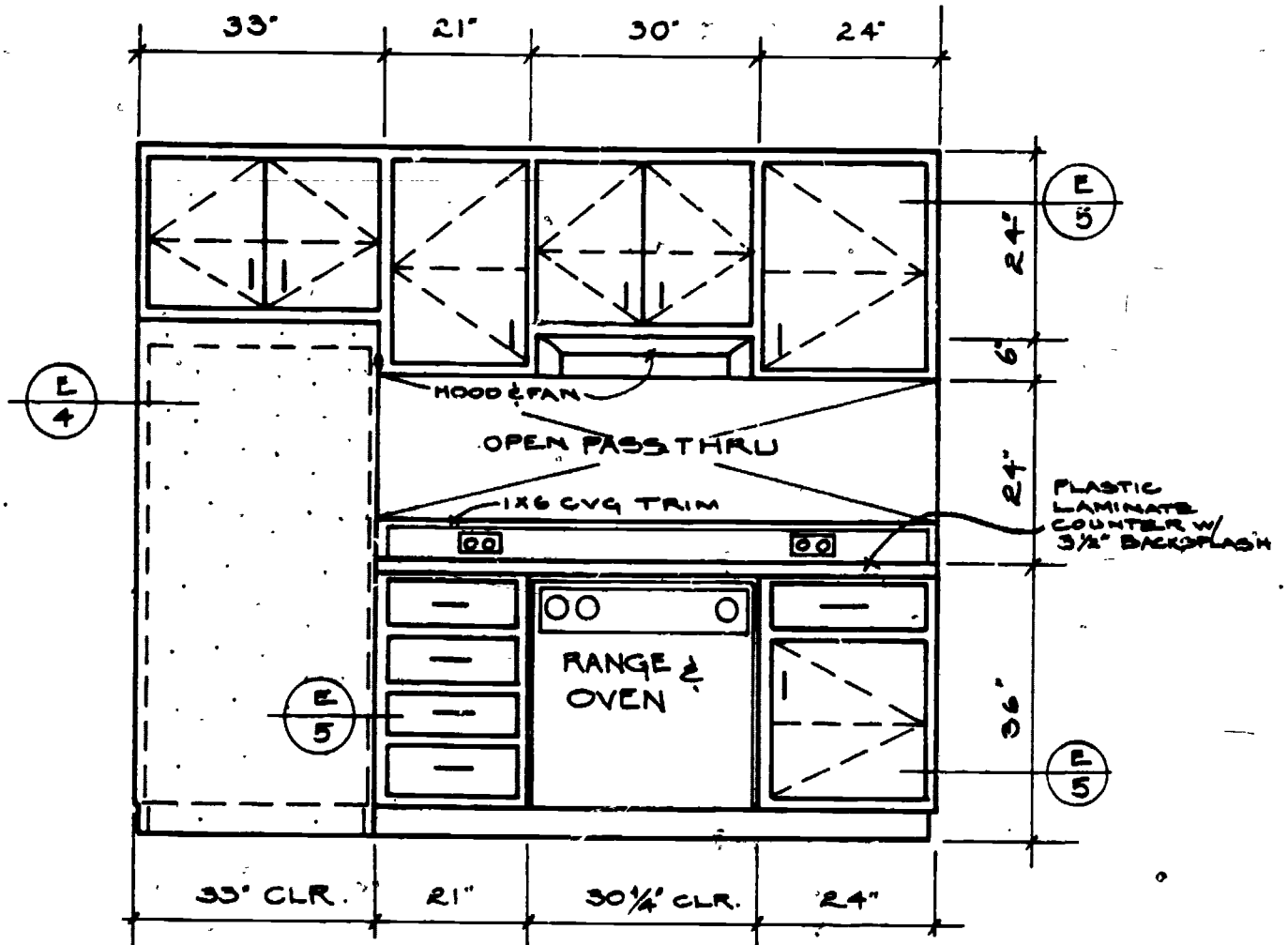

(1
11) (BACK) 1/2" = 1'0"
KITCHEN ELVATION

305 308

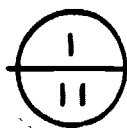
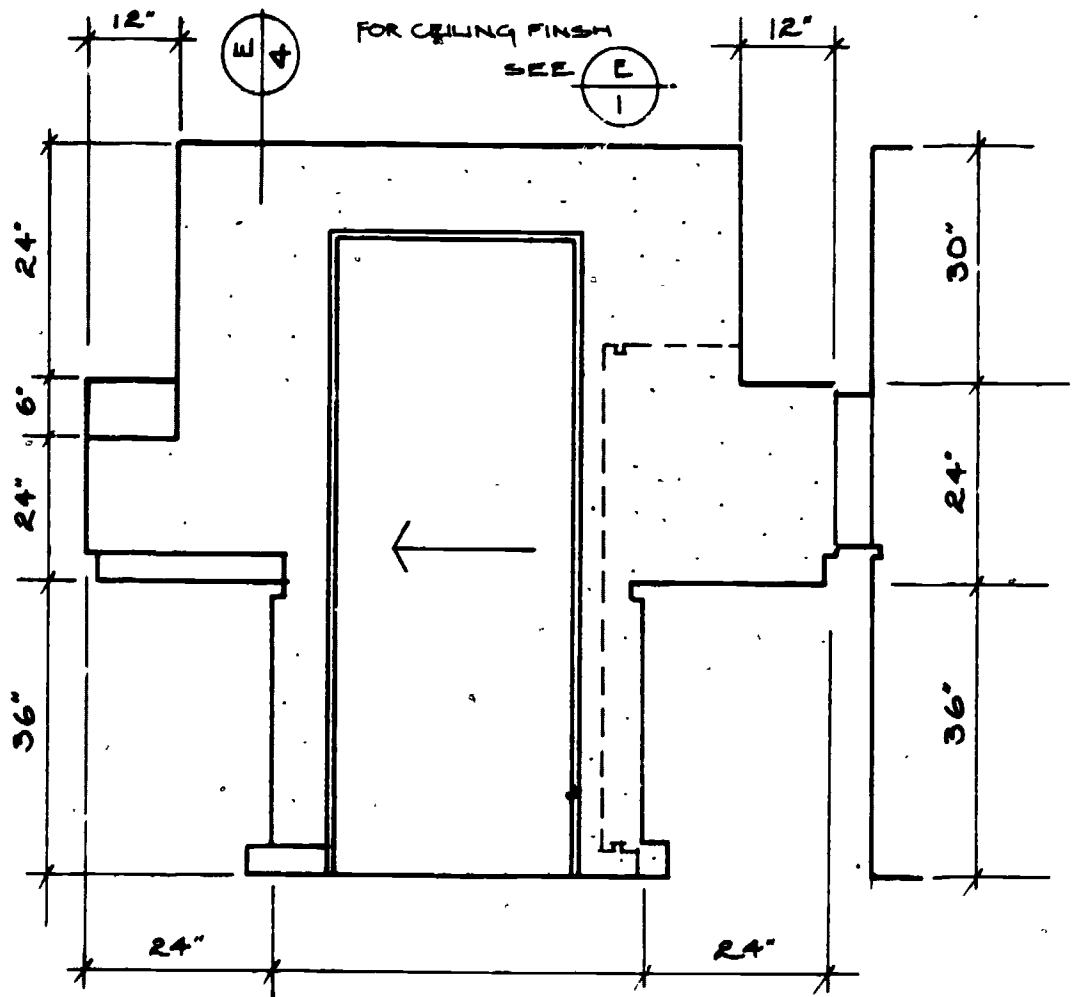

(LEFT) 1/2" = 1'0"
 KITCHEN ELEVATION

309

306

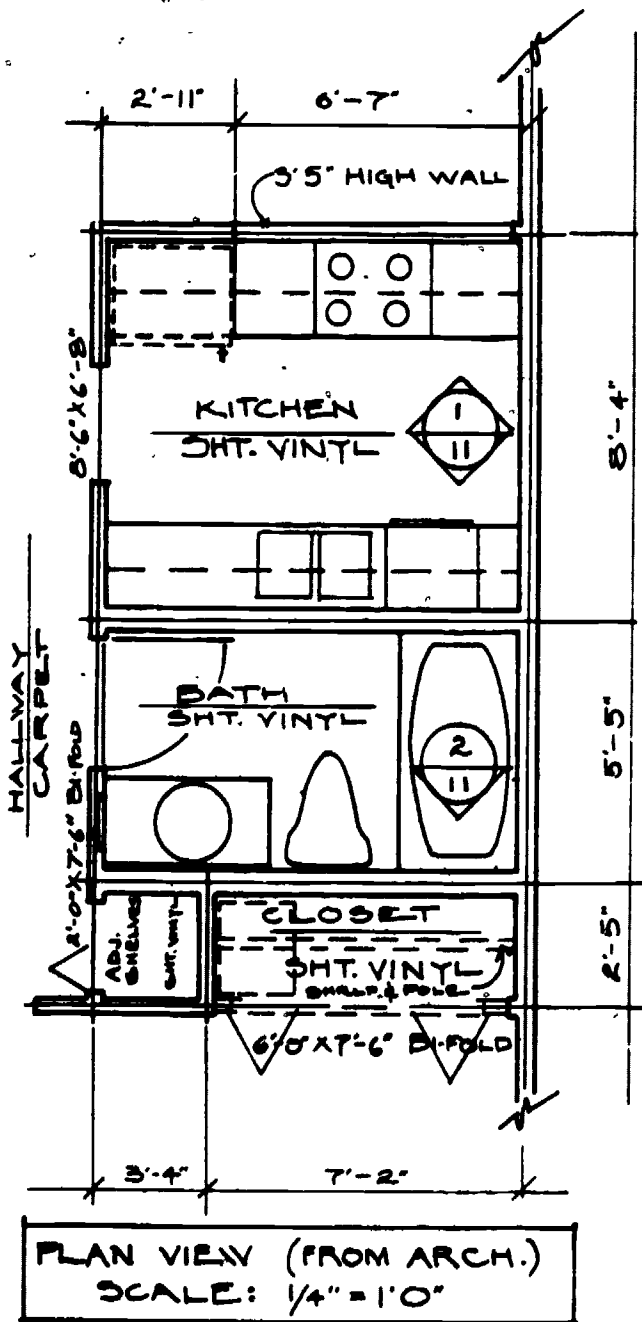

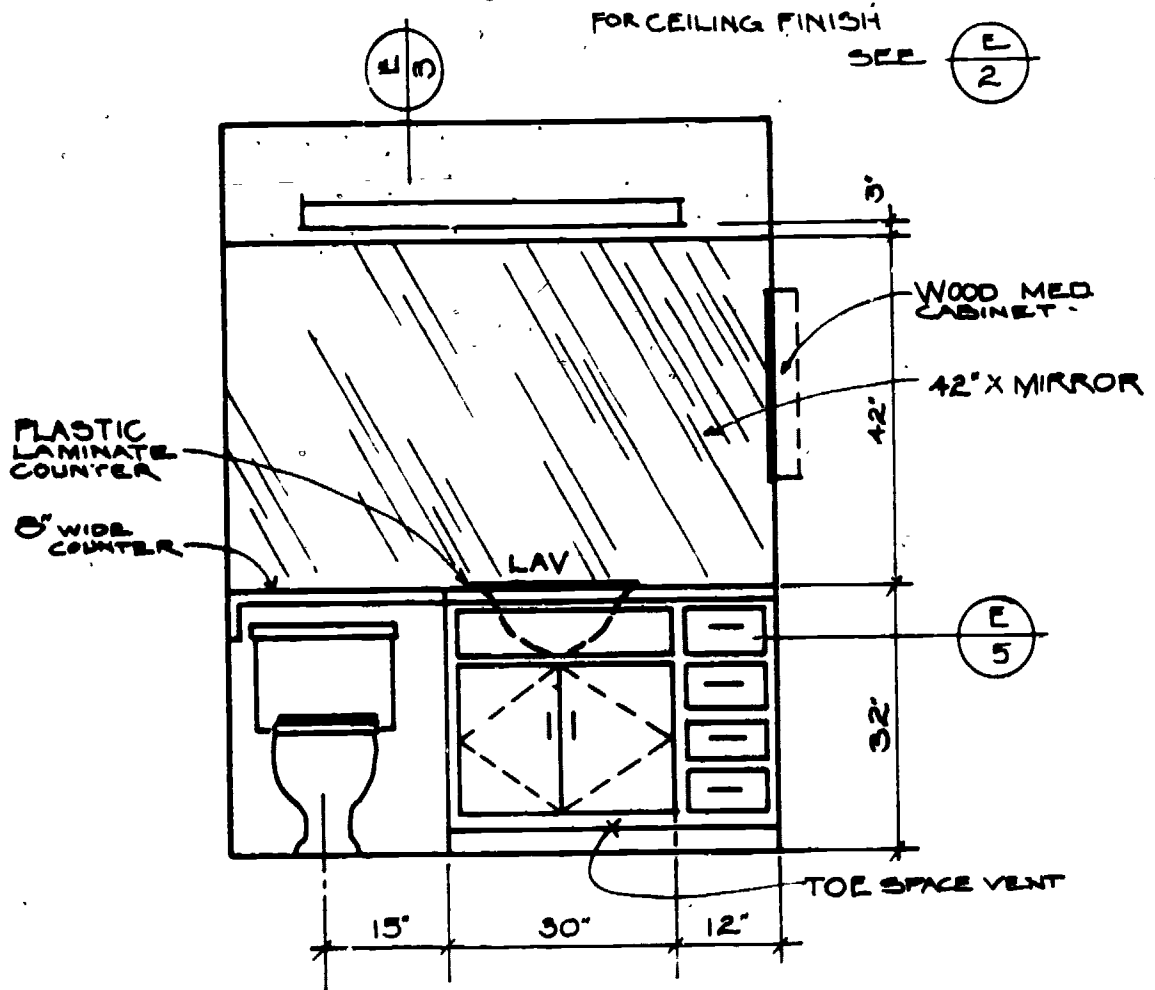

(2/11)

(FRONT) 1/2" = 1'0"

LAVATORY ELEVATION

311

308

Instructor Post Assessment Answers

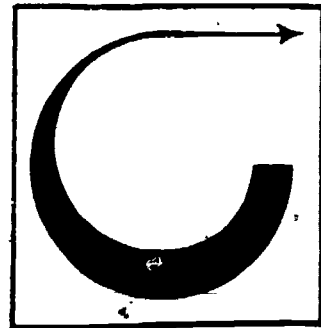

1. Glidden oil-base enamel
2. by brushing
3. Glidden latex enamel
4. by spraying
5. Olympic Fruitwood stain, covered with urethane
6. exterior oil-base, flat
7. Olympic exterior stain--redwood
8. 56.9 sq. ft.
9. Nothing, they are covered with plastic laminate (formica).
10. In the bathroom, on the lav cupboards
In the kitchen, on all cabinets and cupboards

312

309