

DOCUMENT RESUME

ED 213 858

CE 031 481

TITLE Machine and Woodworking Tool Safety. Module SH-24. Safety and Health.

INSTITUTION Center for Occupational Research and Development, Inc., Waco, Tex.

SPONS AGENCY Office of Vocational and Adult Education (ED). Washington, DC. Div. of National Vocational Programs.

PUB DATE 81

CONTRACT 300-79-0709

NOTE 51p.; For related documents see CE 031 450-507.

AVAILABLE FROM The Center for Occupational Research and Development, 601 Lake Air Dr., Suite C, Waco, TX 76710 (Instructor Guides, \$9.75 each; Learning Modules, \$3.00 each. Entire set of Learning Modules available as two subsets: SH-21, SH-41, SH-43, SH-45, and SH-48, \$12.00; remaining 45 modules, \$97.50).

EDRS PRICE MF01 Plus Postage. PC Not Available from EDRS.

DESCRIPTORS Behavioral Objectives; *Equipment Utilization; *Health Education; Learning Activities; Learning Modules; *Machine Tools; Postsecondary Education; *Safety Education; Secondary Education; *Vocational Education; *Woodworking

IDENTIFIERS *Occupational Safety and Health

ABSTRACT

This student module on machine and woodworking tool safety is one of 50 modules concerned with job safety and health. This module discusses specific practices and precautions concerned with the efficient operation and use of most machine and woodworking tools in use today. Following the introduction, 13 objectives (each keyed to a page in the text) the student is expected to accomplish are listed (e.g., Cite nine general safety rules that apply to all machine tools). Then each objective is taught in detail, sometimes accompanied by illustrations. Learning activities are included. A list of references and answers to learning activities complete the module. (CT)

 * Reproductions supplied by EDRS are the best that can be made *
 * from the original document. *

SAFETY AND HEALTH

ED213858

MACHINE AND WOODWORKING TOOL SAFETY

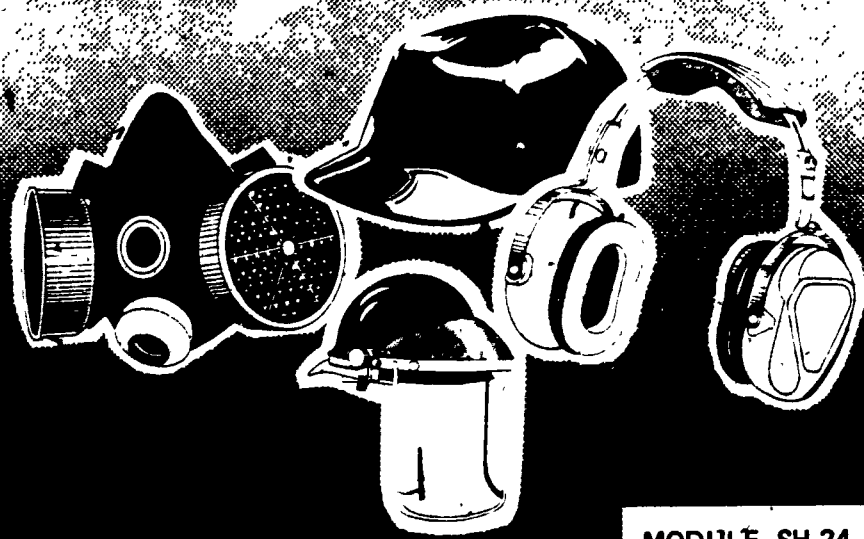

MODULE SH-24

U.S. DEPARTMENT OF EDUCATION
NATIONAL INSTITUTE OF EDUCATION
EDUCATIONAL RESOURCES INFORMATION
CENTER ERIC

PERMISSION TO REPRODUCE THIS
MATERIAL IN MICROFICHE ONLY
HAS BEEN GRANTED BY

D Hull

TO THE EDUCATIONAL RESOURCES
INFORMATION CENTER ERIC

ORD

CENTER FOR OCCUPATIONAL RESEARCH AND DEVELOPMENT

CE031481

DISCRIMINATION PROHIBITED – No person in the United States shall, on the ground of race, color, or national origin, be excluded from participation in, be denied the benefits of, or be subjected to discrimination under any program or activity receiving Federal financial assistance, or be so treated on the basis of sex under most education programs or activities receiving Federal assistance.

The activity which is the subject of this document was supported in whole or in part by the U. S. Department of Education. However, the opinions expressed herein do not necessarily reflect the position or policy of the Department of Education, and no official endorsement by the Department of Education should be inferred.

This work was developed under contract number 300790709 for the U. S. Department of Education, Office of Vocational and Adult Education.



The U. S. Department of Education and the Center for Occupational Research and Development assume no liability for personal injury or property damage incurred by any person or organization making use of the material contained herein. Use of the materials herein is for educational and training purposes and is not to be considered as an exemption from either Federal or State Regulations, and is to be considered as advisory only.

All rights reserved. No part of this work covered by the copyrights hereon may be reproduced or copied in any form or by any means – graphic, electronic, or mechanical, including photocopying, recording, taping, or information and retrieval systems – without the express permission of the Center for Occupational Research and Development.

COPYRIGHT © 1981

The Center for Occupational Research and Development
601 Lake Air Drive, Suite C
Waco, Texas 76710

INTRODUCTION

Almost every product known to man requires the use of machines for its manufacture or for its delivery to the customer. Modern machines and wood-working tools have made mass production methods possible. Without these tools, the life style we all take for granted would not exist. While being basically beneficial in their uses, these machines are potentially hazardous to the persons operating them.

Safety, applied to procedures in a school or industrial environment, is often a matter of common sense and good judgment. Modern machinery is equipped with guards and devices designed to protect the operator and make operating the equipment as safe as possible. However, statistics show that guards and other safety devices afford only 15% protection. Thus, 85% of all accidents in school and industrial environments are due to a factor (or factors) that cannot be guarded against by mechanical devices. Most accidents are a result of someone's thoughtlessness, carelessness, lack of knowledge, or lack of consideration for the safety of others, and these accidents may be avoided if workers acquire the habit of thinking before doing.

Safety is principally a matter of learning and following safe practices and procedures at all times. It is much more a matter of do's than don'ts. The basic text of this module provides general machine information. Some specific practices and precautions concerned with the efficient operation and use of most machine and woodworking tools in general use today are also discussed.

If these practices and procedures are observed, then needless injuries and equipment damage can be greatly reduced. The laboratory phase will afford first-hand observation of the safety practices and precautions presented.

OBJECTIVES

1. Cite nine general safety rules that apply to all machine tools. (Page 3)
2. List and describe the five general categories of machine tools and cite at least one safety hazard associated with each category. (Page 4)
3. Identify two types of turning machines and discuss nine causes of worker injury. (Page 6)

4. List three types of boring machines and discuss nine causes of worker injury associated with the use of these machines. (Page 9)
5. Name two general types of milling machines and describe nine causes of worker injury. (Page 12)
6. Describe two types of planing machines and discuss nine causes of work injury. (Page 16)
7. List four types of abrading machines and discuss the safety aspects of mounting, dressing, and using grinding wheels. (Page 16)
8. Identify two types of sawing machines and discuss the safety aspects of each. (Page 20)
9. Describe general design features, specific control requirements, and maintenance and inspection procedures for woodworking tools. (Page 25)
10. Name the three types of circular saws and list three safety features and procedures for each type. (Page 27)
11. Compare and contrast the hazards and safety features associated with the use of planers and jointers. (Page 33)
12. Describe the most significant hazard and one safety precaution associated with the use of (1) band saws, (2) shapers, (3) wood lathes, and (4) power sanders. (Page 36)
13. Briefly describe three safety considerations for (1) proper dress, (2) materials handling, (3) housekeeping, (4) electrical safety, and (5) general safety, when using woodworking tools. (Page 42)

SUBJECT MATTER

OBJECTIVE 1: Give nine general safety rules that apply to all machine tools.

Modern machine tools are equipped with guards and devices designed to protect the operator and to make operating the equipment as safe as possible. However, most accidents are due to factors that cannot be guarded against by mechanical devices. Most accidents are the result of some person's thoughtlessness, carelessness, lack of knowledge, or lack of consideration. Nine basic safety rules should be understood and observed by anyone operating any machine tool. These rules are listed below:

1. Never start a machine if the guard or guards have been removed or made inoperable as a result of a by-pass system.
2. Avoid wearing loose clothing.
3. Never leave a running machine unattended.
4. Wear proper eye protection.
5. Keep machine coolant clear and free of debris.
6. Never make adjustments to a machine while it is running.
7. Use brushes, vacuum equipment, or special tools to remove shavings and chips.
8. Keep all work surfaces and areas clean.
9. Use the correct hand tools when required.

Following these nine basic safety rules for machine tool safety will significantly reduce the chances of injury. Should an injury be received, it should be treated as a potential infection. All cuts and punctures should be cleaned thoroughly, antiseptic should be applied, and the wound covered with a bandage. Any injury, however minor, should be reported to the instructor or supervisor.

ACTIVITY 1:

Name nine items to be checked or rules to be followed when operating a machine tool:

1. _____

*Answers to Activities appear on page 46.

2. _____
3. _____
4. _____
5. _____
6. _____
7. _____
8. _____
9. _____

OBJECTIVE 2: List and describe the five general categories of machine tools and cite at least one safety hazard associated with each category.

According to the National Machine Tool Builders Association, a machine tool is defined as "a power-driven machine not portable by hand, used to shape or form metals and materials by cutting, impacting, forming, eroding, deplating, or a combination of these processes." From this definition it is obvious that machine tools vary in type and design. There are some 200 basic types of machine tools in a broad range of sizes and configurations, with each type having special work-holding devices, tooling features and attachments. Before attempting to operate any machine tool, the operator should become familiar with the operating mechanisms, procedures, and safety features. Machine tools may be generally categorized by the function they perform. Machine tool categories and a brief description of each follow:

Turning Machines. This category covers such machines as engine lathes, turret lathes, and automatic screw machines. A lathe is a device in which the work is rotating against a cutting tool. Its function is to change the size, shape, or finish of a revolving work piece, with an adjustable cutting tool. Engine lathes are used for one-of-a-kind or short production runs, while turret lathes and automatic screw machines are strictly production machines. Any piece of rotating equipment has pinch points capable of crushing or pinching off fingers, arms, toes, or other body parts.

Boring Machines. This category includes machines used to cut round holes into or through materials. The drill press is the most common machine in this category. It uses a variety of cutting tools that produce great quantities of chips. The

operator must be protected from these chips, as they fly from the machine as well as from the rotating parts.

- Milling Machines. Milling machines are a group of machine tools used to produce machined surfaces by removing a small amount of material from the work piece. This is done by feeding the work-piece into a rotating milling cutter. The principal hazard in using milling machines is that of injury to the fingers, hands, or arms, by contact with the cutter.
- Abrading Machines. The grinding wheel and the grinding machine are an important aspect of machining work. The grinding operation depends upon the abrasive or cutting qualities of Carborundum, corundum, emery, or other materials that are bonded and formed into a wheel, or coated on belts. Grinding machines vary in construction and design according to the type of grinding work the machine is intended to handle. It should be remembered that grinding and other abrasive processes are cutting processes. The grinding wheel, or coated abrasive, is a cutting tool, and it is similar in function to a milling cutter or a planer tool. The difference is that tiny chips are removed instead of large chips. One potential hazard with grinding machines is the grinding wheel. The wheels are easily cracked or broken, and because of their great operating speed, there is always danger of broken pieces flying out of the machine. Other hazards include small particles from the stock getting thrown toward the operator.
- Sawing Machines. These machines have become an important factor in machine work by providing stock cutting for other machine tool operations. The two general types of sawing machines in use include power hacksaws and band saws. Their main functions include cutting off stock, cutting stock to length, or cutting difficult shapes. The potential hazard with sawing machines is physical contact with the saw blade.

————— ACTIVITY 2: —————

Name the five categories of machine tools and list at least one safety hazard associated with each.

1. _____

2. _____

3. _____

4. _____

5. _____

OBJECTIVE 3: Identify two types of turning machines and discuss nine causes of worker injury.

A variety of operations that turning machines perform make them useful and necessary machine tools. The basic types of turning machines include the engine lathe, used primarily to make one-of-a-kind or limited production parts, turret lathes, and automatic screw machines, both of which are used for mass production of parts.

These machines can be used safely only if the operator is aware of hazards involved in their operation. Safe work habits should be developed in the use of setups, chip breakers, guards (Figures 1 and 2) and other protective

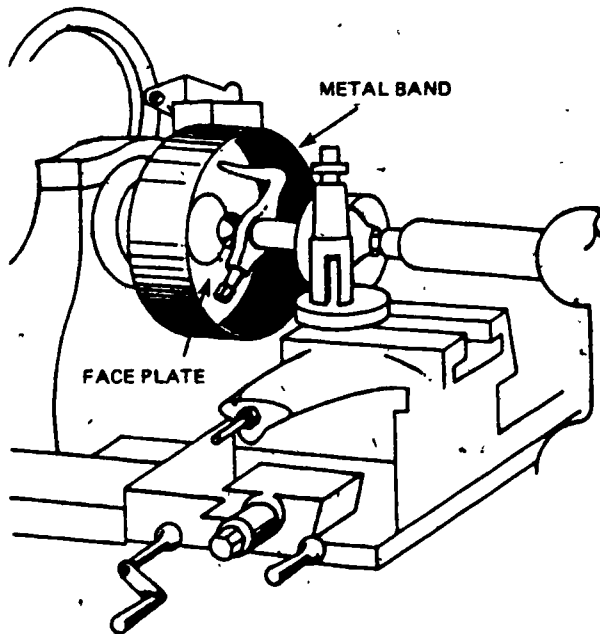

Figure 1. A metal band around the face plate.



Figure 2. A canopy guard.



Figure 3. Contact with protruding machine parts can cause dangerous wrapping.

devices. Worker injury on turning machines is associated with such bad practices as hand-braking, filing right-handed, using a file that has an unprotected tang, or using a hand instead of a stick to hold emory cloth against the work. Attempting to remove chips while the machine is in operation or removing them by hand under any circumstances, can lead to injury. A brush or a hooked rod should be used to clear the chips. Caliper or gaging the job while the machine is in operation can also cause injuries.

Injuries can be caused by contact with rotating stock that projects from turret lathes or screw machines, as shown in Figure 3. Other contact with projections on work or stock, such as face plates, chucks, or lathe dogs, especially those with projecting set screws, is also

dangerous. The hazard caused by leaving the chuck wrench in the chuck can be avoided by attaching a spring to the wrench.

Hazards can be minimized if the following safety precautions are followed:

1. Remove loose clothing, (neckties, long sleeves, and jewelry) before starting to work.
2. Protective eye wear should be worn at all times.
3. Remove the chuck wrench immediately after adjustments are completed, and start the lathe spindle by hand.
4. After shutting off the machine, allow it to coast to a stop; never use a brake.
5. Any defects in the machine should be reported immediately.
6. Be sure to understand the operation and safety precautions of the lathe before attempting to operate it.
7. Never let someone else handle the starting switch for you.
8. Do not distract a person who is operating a lathe.
9. Never oil, adjust, or change the speed of a running lathe.

10. Keep fingers away from all moving parts.
11. Remove chips with a brush, pliers, or a piece of wood; never use your hands.
12. Stop the machine before measuring the workpiece.
13. Keep waste and rags away from moving parts.
14. When making adjustments, be careful not to let a wrench slip.
15. Do not leave tools lying on the lathe.
16. Make sure the lathe is properly set for your work. Improper settings can ruin a workpiece or damage the lathe.
17. Never throw gears in or out while the lathe is running.
18. Make sure all guards and covers are in their proper place.
19. Make sure the tailstock is locked before starting the lathe.
20. Always put the lead screw in neutral whenever you are not using the feeds on the machine.
21. Never hammer on the lathe bed.
22. Never walk away and leave a lathe running.
23. Keep the bedways free from grit and shavings.

These safety precautions should be followed when using turret lathes and automatic screw machines:

1. Provide effective guards around all revolving stock.
2. Feed the bar stock through sections of piping to prevent whipping.
3. Before gaging or changing work, move the turret back as far as possible to reduce the hazard of injury from sharp tools.
4. Frequently, clean the floor of cutting oil. If machines splash oil, provide metal screens to intercept the oil. Provide nonslip floors in work areas around the machines.

ACTIVITY 3:

What is the recommended method of safe chip removal from an engine lathe? _____

OBJECTIVE 4: List three types of boring machines and discuss nine causes of worker injury associated with the use of these machines.

Drilling holes is one of the most basic of machining operations and one that is performed frequently in a machine shop. Safety is the first thing that should be learned about drilling machines. Metal cutting requires considerable feed pressure on the cutting edge. A drill press provides this pressure by hand or by power drive. The primary purpose of the drill press is to drill holes, but it can be used for other operations, such as counter-boring, spot facing, countersinking, reaming and tapping, all of which are processes to modify the drilled hole.

Before operating any machine, the operator should be familiar with the names and functions of all its parts. There are basically three types of drill presses used for general drilling operations - the sensitive drill press (Figure 4) used for light drilling; the upright drill press used for heavy duty drilling; and the radial drill press (Figure 5) used to drill large heavy workpieces that are difficult to move.

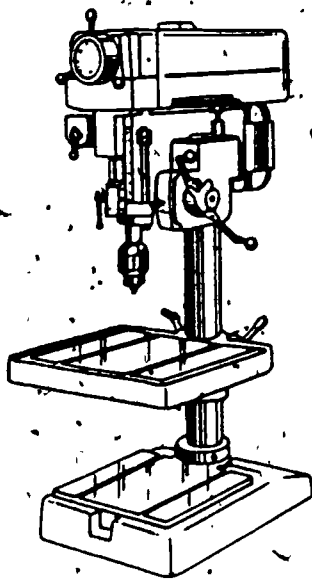

Figure 4. Drill press.

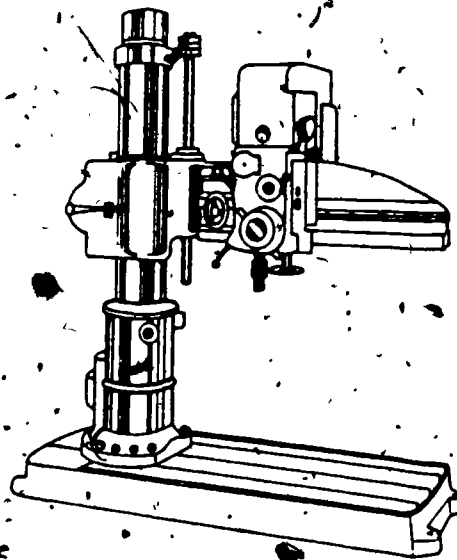

Figure 5. Radial drill press.

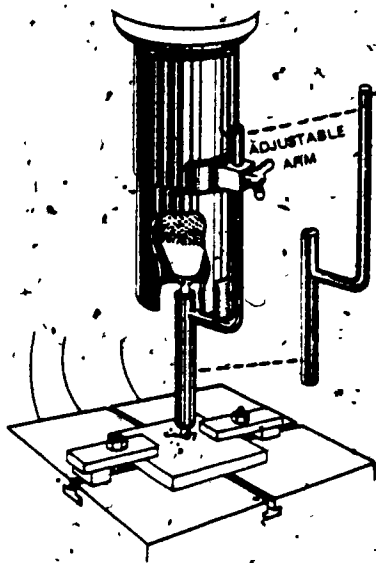

Figure 6. Enclosure for spindle and drill.

There are several common causes of worker injury in drilling operations. One of the most common causes is contact with the spindle or tool. The enclosure shown in Figure 6 covers the spindle and drill, protecting the user from a possible wrap injury that could occur if the rotating spindle caught loose hair or clothing. The tool should not be touched while the quick-change clutch is in use; a simple sleeve guard can be used to protect the spindle. Failure to replace the guard over the speed change pulley or the gears creates a hazardous situation also. Leaving the key or drift in the chuck is another dangerous practice. Insecure clamping of the work or failure to clamp a small workpiece can result in the worker's being struck by the work

as it flies out from the moving machine. Flying metal chips can cause injury, as can the operator's sweeping chips or trying to remove long, spiral chips by hand. Hair and clothing, if allowed to fly loose, can easily be caught in machine parts and can draw the operator into hazardous contact.

Injuries can be avoided if the following safety precautions are observed:

1. Never hold a small workpiece by hand — use a clamp, a special holder, or vise.
2. Watch that the hand feed lever does not fly into the face when adjusting the column.
3. Use a brush instead of hands to clean chips off the machine. Never use an air jet for removing chips as this will cause the chips to fly at a high velocity, and cuts or eye injuries may result. Do not clean up chips or wipe up oil while the machine is running.
4. Always remove chuck keys and drifts before starting the drill press.
5. Never clean the taper in the spindle when the drill is running, since this could result in broken fingers or worse injuries.
6. Never wear finger rings, wrist watches, arm bands, gloves, sweaters, or loose clothing around moving machinery.
7. Shirt sleeves should be rolled above elbows.
8. Keep hair from being caught in the drill press spindle.

9. Never try to remove materials that have become jammed while the spindle is revolving. If the work becomes loose, stop the machine.
10. Keep the floor clean around the machinery and immediately clean up oil spills.
11. Do not disturb a drill press operator while he or she is operating a machine.
12. Always shut the power off when work has been completed.
13. Use minimum feed pressure when the drill bit is about to break through the work.
14. Have a negative rake when drilling brass and bronze.
15. Never drill thin stock without proper support.
16. Always wear an apron, and stand erect at the machine.
17. Never stop the drill press spindle with the hands after the machine has been turned off. Sharp chips often collect around the chuck or spindle. Do not reach around, near, or behind a revolving drill.
18. When removing taper shank drills with a drift, use a piece of wood under the drills, so they will not drop onto the toes. This practice will also protect the drill points.
19. Remove burrs from a drilled workpiece as soon as possible, since any sharp edges or burrs can cause severe cuts.
20. When finished with a drill or other cutting tool, wipe it clean with a shop towel and store it properly.
21. Oily shop towels should be placed in a closed metal container to prevent a cluttered work area and to avoid a fire hazard.
22. Always wear safety goggles when operating drilling machines.

These additional guidelines protect the life of the machine, and also protect the user.

1. Do not drill into the drill press table or vise.
2. Occasionally interrupt the feed when drilling to break up the spiral chip formed, so that it will not begin a whipping action and present a hazard.
3. Check the size and condition of drills and reamers. Dull tools are unsafe.
4. Avoid hammering on the drill press table, except with a soft hammer to adjust the work.
5. Do not overtax the tools used. Broken, overheated, or dull tools will slow up production.
6. Always remove the drill when drilling beyond the flutes, and clean out the chips. Do not allow them to pile up and jam the drill.
7. A carbon drill should not be run as fast as a high-speed drill or it will lose its temper.

8. Do not leave tools lying on the drill press table.
9. When moving the head or table on sensitive drill presses, make sure a safety clamp is set just below the table or head on the column; this will prevent the table from suddenly dropping if the column clamp is prematurely released.
10. Guard all driving pulleys, belts, and all exposed gears.

ACTIVITY 4:

Name five common causes of worker injury associated with drilling machines, and list precautions that would help to avoid injury.

1. _____
2. _____
3. _____
4. _____
5. _____

OBJECTIVE 5: Name two general types of milling machines, and describe nine causes of worker injury.

The horizontal milling machine (Figure 7) and the vertical milling machine are two of the most useful and versatile machine tools. Both machines use one or more rotating milling cutters that have single or multiple cutting edges. The workpiece, which may be held in a vise, a fixture, or an accessory, or may be fastened to the table, is fed into a revolving cutter. Equipped with proper accessories, milling machines are capable of performing a wide variety of operations such as drilling, reaming, boring, counterboring, and spot facing, and of producing flat or contour surfaces, grooves, gear teeth, and helical forms.

The milling machine is not dangerous to operate if certain safeguards are

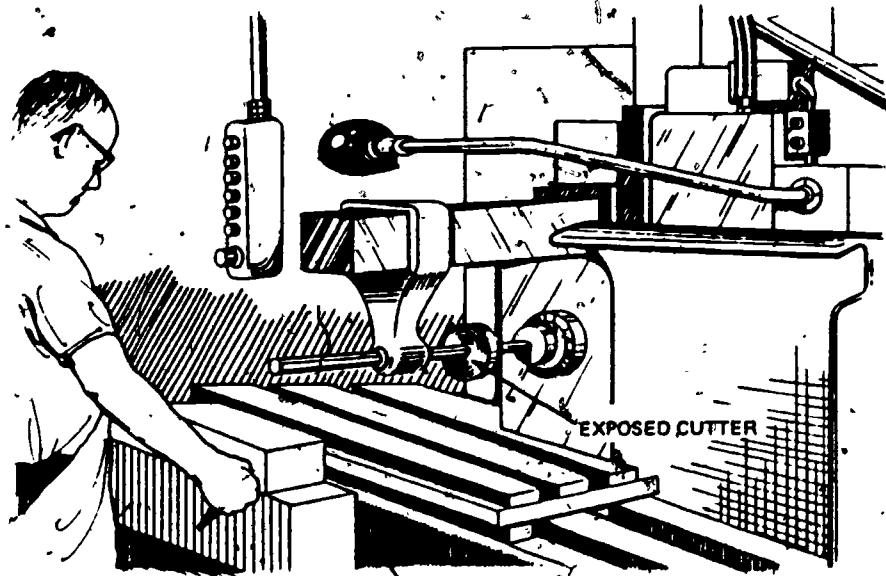

Figure 7. Horizontal milling machine without cutter enclosure.

installed and if the operator uses safe practices. However, there are some hazards associated with operating milling machines. Some common causes of worker injury include failure to draw a job back to a safe distance in loading or unloading procedures, leaving hand tools on the work table, reaching around the cutter or hob to remove chips while the machine is in motion, and using a rag to clean excess oil off the table while the cutter is turning. Leaving the cutter exposed after the job has been withdrawn is a hazardous practice (see exposed cutter in Figure 7). Using incorrectly dressed cutters and improperly storing cutters are also bad practices. Using a jig or vise that prevents close adjustment of the guard is inviting trouble, as is placing the jig or vise-locking arrangement in such a position that force must be exerted toward the cutter. There are many actions that should not be attempted while the machine is operating, especially calipering or measuring the work and adjusting the coolant flow. Attempting to remove a nut from the machine arbor by applying power is another dangerous practice.

Some errors made through carelessness or a desire to shortcut work procedures can be costly when they result in an accident. Such errors include leaving hand tools on the table, failing to clamp work securely, and removing swarf (filings) by hand instead of with a brush. Careless movements can result in striking the cutter with a hand or an arm while setting up or adjusting a stopped machine. Loose clothing and gloves are an invitation to accidents when they are worn around milling machines. Guarding the cutter with an enclosure can help to prevent accidents.

Injuries can be prevented when using milling machines if the following safety precautions are observed:

1. Wear appropriate clothing and approved safety goggles.
2. Know how to stop the machine quickly. (Never use your hand)
3. See that the table is clean and dry before mounting holding devices for the work.
4. Get help to lift and mount heavy attachments.
5. Be sure that the vise, index head, tailstock, or fixture is securely mounted to the table.
6. Check to see that the workpiece is fastened tightly in the holding device.
7. Use a lead or soft-head hammer to set workpiece in the vise for setups.
8. Select and mount the proper cutter, then check to see that it revolves in the proper direction.
9. Use a rag to handle sharp cutters.
10. Make sure the arbor, cutter, and collars are clean before mounting them on the machine.
11. Keep fingers clear of the arbor hole when replacing the overarm.
12. Be sure the overarm is fastened securely.
13. Use only correctly-fitting wrenches on the machine.
14. Tighten the arbor nut by using a hand wrench.
15. Select the proper spindle speed, feed rate, and depth of cut.
16. Make certain that the table, the holding device, and the workpiece will clear the arbor and the arbor support during the cut.
17. Disengage the handles when the automatic feed is to be used.
18. Make adjustments only while the machine is stopped.
19. Make measurements only while the machine is stopped.
20. Keep clear of the moving cutter. NEVER reach over the cutter.
21. Stop the cutter and use a brush to remove chips - do not use hands.
22. Make sure no one except the operator is inside the safety zone before starting the machine.
23. Keep the floor around the machine free of chips and oil.
24. Clean the machine and area with a brush before leaving.
25. Use first aid on any cut or scratch, no matter how minor.

These guidelines should be followed with the use of the vertical milling machine.

1. Do not attempt to operate the machine until thoroughly familiar with it. When in doubt, ask for assistance.

2. Wear appropriate clothing and goggles.
3. Get help to remove any heavy attachment like the vise, dividing head, rotary table, and so on.
4. Never handle a cutter with bare hands. Use a piece of heavy cloth for protection.
5. Use a small brush to remove chips. Never brush chips with hands.
6. Stop the machine before attempting to remove chips.
7. Never reach over or near the rotating cutter.
8. Make sure that the holding device is mounted solidly to the table and that the work is held firmly. Spring or vibration can cause thin cutters like the slitting saw to shatter.
9. Do not talk to anyone while operating the machine, nor allow anyone else to turn on the machine.
10. No adjustments or measurements should be made while the cutter is rotating.
11. Keep the floor around the machine clear of chips and wipe up spilled cutting fluid immediately.
12. Know how to stop the machine quickly.
13. Do not permit work clothes to become saturated with oil and cutting fluids. Greasy clothing is a fire hazard.
14. Place all oily rags used to wipe down the machine in a metal container that can be closed tightly.

ACTIVITY 5:

The rotating cutter on a milling machine is one of the most dangerous areas associated with vertical and horizontal milling machines. List four safety precautions that should be observed to avoid injuries associated with the horizontal milling cutter and three precautions when using the vertical milling machine.

1. Horizontal milling machine

2. Vertical milling machine

OBJECTIVE 6: Describe two types of planing machines, and discuss nine causes of work injury.

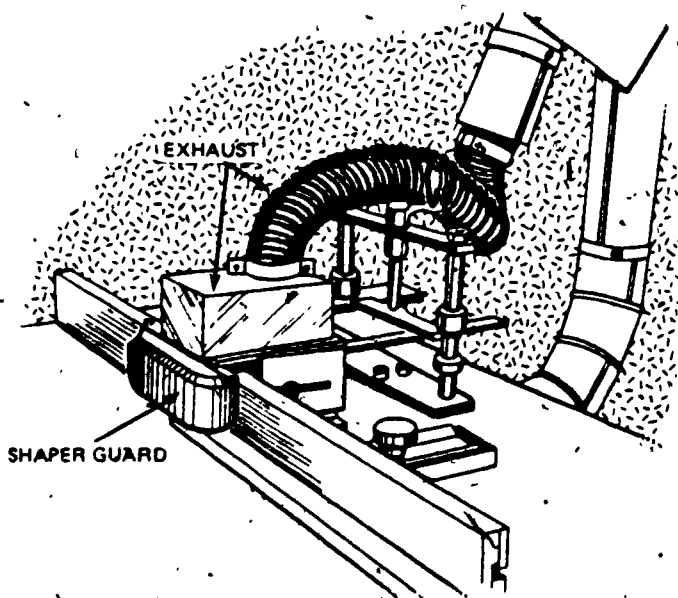

Figure 8. Shaper guard with attachment for chips to be exhausted through a flexible hose.

which has a reciprocating motion past the tool head. The tool cuts only on the cutting stroke of the platen (as it moves toward the rear of the machine), and is held stationary except for the feeding movement. The opposite is true of the shaper, in that the work is held on an adjustable worktable or in a vise fastened to the worktable. The cutting tool, which is given a reciprocating motion, peels off a chip on the cutting stroke. At the end of the return stroke, the feed operates to move the table (and work) the desired amount. The most common type of shaper is the horizontal type, used for producing flat, angular, and contour machined surfaces.

The cutting action of the slotter, which is sometimes called a vertical shaper, is similar to that of the shaper, except that the tool reciprocates vertically. The work may be fastened to a rotary table that can be fed in a circular, horizontal, or longitudinal direction for various types of operations. Slotters are generally used for cutting internal vertical surfaces that may be straight, angular, or contoured.

The two general types of planing machines include the planer and the shaper (Figure 8). Each machine has the primary function of producing flat surfaces, with the planer being used on work that is impracticable to machine on a shaper or milling machine. Both machines use a horizontal reciprocating motion (alternate forward and backward motion) to perform the work, but each applies it in a different manner. On a planer, for example, the work is fastened

The principal hazards with planing machines are flying chips and contact with the cutting tool. Other hazards also present potential for physical injury. Some common causes of worker injury include: the placement of hands between the tool and the work, using bare hands when handling or feeling sharp metal edges, and attempting to measure the job while the machine is running. As with other machining, care should be taken to secure work properly, and to create sufficient clearance. Riding the job is a dangerous practice and should be avoided. Other causes of planing machine accidents are: coming in contact with reversing dogs, failing to make sure the current is turned on when magnetic chucks are to be used, and unsafely adjusting the tool holder on the cross head.

Accidents and injuries can be avoided if the following safety precautions are observed by users of the planer:

1. Guard the openings under the planer table. Do not place tools under the planer table or reach under it when the machine is in motion.
2. Always clamp the work securely onto the planer table.
3. Check to be sure the work will clear the cross rails and the housing before starting the machine.
4. If possible, use chip guards on the planer. If a chip guard is not provided, the operator should be provided with, and required to wear, goggles with strength-tested lenses.
5. Stop the planer whenever making adjustments.
6. Cover the exposed reverse dogs on the side of the planer bed with a sheet metal housing, as they may cause leg and side injuries.
7. Locate each planer so that when the bed is fully extended it will not be within eighteen inches of the wall, or of a fixed object. If there are fewer than eighteen inches, the area should be closed off.
8. Do not pile materials so that they will be closer than eighteen inches to the end of the bed when it is fully extended.
9. Equip planers with a U-shaped guard made of pipe, mounted in friction bearings on the body of the machine, allowing the table to expand the guard to its maximum travel. It has been found that this setup ensures maximum protection with a minimum of floor space.
10. Before attempting to raise or lower the cross rail, the operator should make certain that the crossrail clamps have been loosened. When the cross rail has been set to the desired height, the clamps should be securely tightened.
11. The planer operator should make sure that the cutting tools are set in such a position that, if they shift away from the cut, they will rise away from the cut and not dig into the work.
12. When the planer is in motion, the operator should not attempt to shift the safety dogs, tighten down the work or the tool, make any adjustment to the

planer or the work, sit on the planer table, or oil the planer.

13. Chips should not be removed by hand or with a wiping rag. A suitable brush should be used for this purpose.

The following guidelines should be followed by workers using the shaper.

1. Make sure the work is fastened securely before starting the machine. The machine should be "turned over" slowly at first to be sure the tool and head clear both the housing and the work.
2. Remove all tools, such as wrenches and oil cans, from the working surface before starting the machine.
3. Stop the machine before making any adjustments to the length of the stroke or to the tool.
4. Use chip guards to prevent other persons from being struck.
5. Do not allow the rear end of the ram at its maximum stroke to come within eighteen inches of a wall or a fixed object.
6. Do not pile materials within eighteen inches of the maximum stroke of the end of the ram.
7. Operators should be provided with, and required to wear, goggles; unless the machine is provided with a chip guard.
8. Shaper operators should not wear gloves or loose or torn clothing.
9. Never touch the tool, clapper box, or workpiece while the machine is running.
10. Remove all chips with a brush - never use the hands.

ACTIVITY 6:

The principal hazards with planing machines are physical contact with the cutting tool and flying chips.

True False

OBJECTIVE 7: List four types of abrading machines and discuss the safety aspects of mounting, dressing, and using grinding wheels.

Grinders use an abrasive cutting tool to bring a workpiece to an accurate size and in some cases to produce a finished surface. In the grinding process, the surface of the work is brought into contact with the revolving grinding wheel. The most common types of grinders are the bench or pedestal type, the

surface type, the cylindrical grinder, and the cutter and tool grinders.

Bench or pedestal grinders are used for offhand grinding and for the sharpening of cutting tools such as chisels, punches, drills, and lathe and shaper tools.

Surface grinders are used to produce flat, angular, or contoured surfaces on a workpiece.

Cylindrical grinders are used to produce internal and external diameters that may be straight, tapered, or contoured.

Cutter and tool grinders are generally used to sharpen milling machine cutters.

Machine tools that perform a grinding operation will use abrasive wheels, abrasive belts, abrasive disks, abrasive points, buffing wheels, polishing wheels, stropers, lapping machines, and so forth.

Grinding wheels are safe and necessary cutting tools, but they are not unbreakable. They must be handled, mounted, and used carefully and with adequate protection. The American National Standards Institute (ANSI) B7.1 "Safety Requirements for the Use, Care, and Protection of Abrasive Wheels" tells how to use wheels safely and with confidence. Be sure to follow the basic instructions below when mounting the wheel:

1. Select the correct wheel for your operation. "Ring test" the wheel to be sure that it is not cracked.
2. Never exceed the maximum safe speed established for the wheel. Be sure the machine speed is not excessive.
3. Never alter the hold in the wheel or force the wheel onto the spindle.
4. Use clean, recessed matching flanges at least one third the wheel diameter.
5. Use a clean, smooth blotter on each side of the wheel under each flange.
6. Tighten the nut only enough to hold the wheel firmly.
7. Adjust the wheel guard and wear safety glasses or a face shield (see Figure 9) before starting the wheel.

When using the wheel, follow these precautions:

*To perform a ring test, insert a pipe or similar metal object through the mounting hole. Gently tap the wheel with another metal object on at least three places equally spaced around the wheel. If the same ringing noise is heard after each tap, the wheel is probably not cracked. If, however, a dull sound or thud is heard, the wheel is cracked and should not be used.

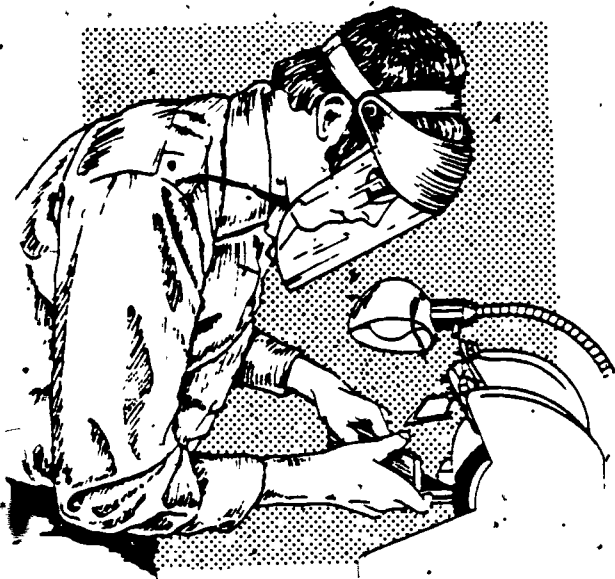

Figure 9. Face shields can protect the machine operator.

1. Adjust the dust hood and the coolant nozzle. On a bench or a floorstand grinder, keep the work rest adjusted within 1/18" of the wheel face (periphery).
2. Stand aside and allow the wheel to run idle a full minute before starting to grind.
3. True the wheel if it is not running true. (Truing a wheel is the operation of removing any high spots on the wheel, thereby causing it to run concentric with the spindle.)
4. Make grinding contact without "bumping" or impact.
5. Grind only on the face of a straight wheel. Use disk wheels for side grinding. Light side grinding is permitted on the cup or the saucer wheel.

6. Never force grinding so that the motor slows noticeably or the work gets hot.
7. Protect the wheel when not in use. Store safely if removed from grinding machine.

Dressing a wheel is the operation of removing the dull grains and metal particles. This operation exposes the sharp cutting edges of the abrasive grains to make the wheel cut better and more safely. Grinding wheel dressers are used for this purpose.

The chief accidents associated with grinding machines include eye injuries due to flying particles; injuries from contact with the revolving wheels, disks, or belts; and injuries due to bursting abrasive wheels. Inhalation of dust generated in the grinding or polishing process constitutes a health hazard unless the grinding is done "wet" (water dripping on the wheel) or unless the dust is removed by a suitable exhaust system. Injuries due to bursting wheels have been greatly reduced in recent years because of improved wheels and a better understanding of their use, but when accidents occur they are usually serious. Caution on the part of the operator is needed if abrasive wheels are to be operated safely. The following general precautions should be observed when operating grinding machines:

1. Always wear goggles or an eye shield when performing any grinding operation.
2. Never put a wheel on the grinder before checking it for soundness (use the ring test). Destroy wheels that are not sound.
3. Because it is not always possible to check the wheel on the grinder each time it is used, it is considered a good practice to stand to the side of the machine when it is first turned on and until it reaches operating speed. This will keep the operator clear of flying pieces if the wheel shatters.
4. Do not attempt to use a grinder unless the wheel guards are in place and securely fastened.
5. If the grinding operation is to be performed dry, do not forget to hook up the exhaust attachment before starting.
6. Check the machine thoroughly before using it. Lubricate it according to the manufacturer's specifications.
7. Keep hands clear of the rotating grinding wheel.
8. Never force work against the grinding wheel. (See Figure 10.)



Figure 10. Never force work against the grinding wheel.

9. Always stop the machine before making measurements or adjustments.
10. Make sure that the wheel is clear of the work before starting the machine.

11. If a magnetic chuck is used, make sure that it is holding the work solidly before starting to grind.
12. If an automatic feed is to be used, run the work through one cycle by hand. This procedure will ensure that there is adequate clearance and that the dogs are adjusted properly.

ACTIVITY 7:

Circle the correct answer.

The single most important item of personal protective equipment that should be used while operating grinding machines is:

- a. Eye goggles or eye shield.
- b. Gloves.
- c. Steel-toed shoes.
- d. None of the above.

OBJECTIVE 8: Identify two types of sawing machine and discuss the safety aspects of each.

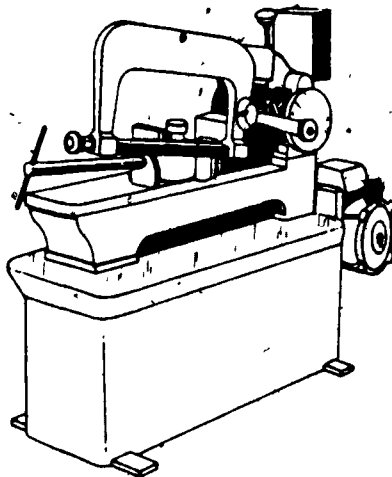

Figure 11. Typical power hacksaw.

Sawing machines make up an important part of today's machine tools. The two main types in general use are the power hacksaw and the metal cutting band saw.

The power hacksaw (Figure 11) is used for cutting various kinds, sizes, and shapes of metal to length. They are available in wet- or dry-cutting types and in a wide range of styles and sizes. Power hacksaws operate on the principle of a reciprocating stroke. On the cutting stroke, the saw blade engages the metal, removing small chips. At the end of the stroke, the saw blade is raised slightly and moves back to begin another cutting stroke.

The principal hazards are physical contact with the blade or injuries resulting from

handling long and heavy stock. Injuries can be avoided, however, if the following safety precautions are observed:

1. Mount work in the saw only when the saw is stopped.
2. Support protruding ends of long pieces to prevent them from falling and causing injury.
3. Hang a cloth over protruding ends of long pieces to help prevent others from running into the ends.
4. Be sure that saw blades are in good condition.
5. When raising the saw frame, always use the handle provided.
6. Do not bend over the saw frame while the machine is running.
7. Avoid getting the hands in the area of the saw blade while the saw is running.
8. Be careful to avoid cutting the hands on the burrs at the ends of parts that are cut off. The burrs may be removed with a file.
9. Wear approved safety goggles at all times when operating the machine.

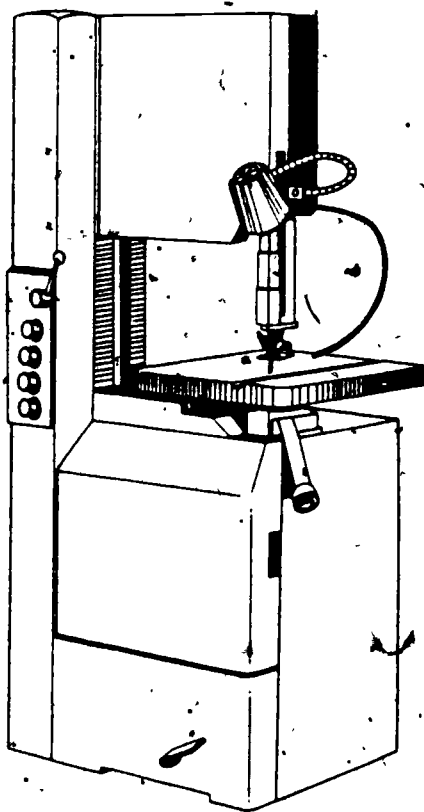

Figure 12. Typical band saw.

The band saw is a machine tool that employs a flexible saw blade driven in a continuous loop around two wheels. It employs a continuous cutting action that can cut through many materials, from zinc to asbestos, and even through difficult-to-cut metals.

Band saws are available in vertical models (Figure 12) and horizontal models. Such operations as shaping, slotting, and cut-off operations can be performed by both types. However, the horizontal band saw is used mainly for cut-off and cut-to-length operations, while the vertical band saw is used for a much wider range of sawing operations including cutting metal to desired contours. As with the power hacksaw, the principal hazard of band saws is physical contact with the blade. If the following safety precautions are observed, injuries can be avoided:

1. Keep the worktable clean, especially the T-slots, by removing the chips with a brush.
2. After the chips have been brushed away, wipe the worktable with an oily rag to prevent rust.
3. Keep the door housings around band saw wheels closed at all times.
4. Always adjust the saw blade guard opening, slightly above the metal thickness to be cut, with the power off.
5. Always wear safety goggles at all times when sawing.
6. Hold short workpieces in a workholding fixture; keep fingers at least 6-8" away from the cutting band.
7. Use the proper saw blade, blade tension, and cutting speed for the material being cut.
8. Provide sufficient working space around the machine; four feet at front and back, three feet on each side.
9. Do not allow more than one person to operate a machine at the same time.
10. Follow the manufacturer's operating and maintenance manuals.
11. Replace dull bands.
12. Inspect butt welds carefully before mounting the saw band to the machine.
13. Use the proper saw blade width for the radius to be cut.
14. Wear gloves when handling bands.
15. Have cuts and bruises treated immediately.
16. Remove burrs from cut workpieces; they can cause serious cuts.
17. If the machine is equipped with a blower, make sure that it points away from the operators.
18. On machines with power-feed worktables, make sure that all workholding fixtures are secure and properly positioned.
19. If uncertain about the setup or about some aspect of the cutting operation, have it checked before proceeding.
20. Use a stick to remove short pieces of work from the area close to the blade.

_____ **ACTIVITY 8:** _____

The primary hazard with sawing machines is physical contact with the _____

WOODWORKING TOOL SAFETY

OBJECTIVE 9: Describe general design features, specific control requirements, and maintenance and inspection procedures for woodworking tools.

Some machinery has been designed to be effectively used for both metal and woodworking activities. A band saw is an example of one of these tools. Other machinery has been specifically designed for use by either woodworkers or metal workers. Woodworking tools are often considered more hazardous to workers because they require the worker to be very close to the various mechanical cutting devices and turning parts.

Statistics have been gathered that identify two types of woodworking tools involved in a significant majority of accidents in school shops. These tools are jointers, and saws using circular blades, both of which are frequently used by many workers. Because these tools have been identified as being among the most hazardous, extra caution should be taken when using them.

Current OSHA regulations for woodworking tools can be found in 29 CFR 1910.213. A summary of some of the general safety features that should be looked for includes the following:

1. Machines should be capable of high-speed idle with the largest tool size without "sensible vibration" (vibration you can feel).
2. Arbors and mandrels should have a "firm and secure bearing and be free from play."
3. Automatic-cutoff saws must have mechanisms that allow the operator to control each stroke.
4. Saw frames or tables should have cast lugs that limit the size of the blade that can be mounted.
5. Fences on circular saws must remain parallel to the blade at all times and must be securely fastened to the table or table assembly.
6. Machines should be provided with disconnect switches that can be locked in the "off" position.
7. Portable machines operating on more than 90 volts must have separate ground wires and polarized plugs.
8. When performing activities that require the standard guard to be removed, combs (feather boards), or suitable jigs should be provided.

Many safety features are designed around the control mechanisms for the various machines. Some of these devices and requirements include:

1. Cutoff controls should be within easy reach without the operator having to leave his or her position.
2. A locking-type belt shifter, or equivalent positive device, should be found on belt- or shaft-driven devices.
3. Mechanisms should be installed to prevent automatic restarts after power failure.
4. Positive protection must be provided on electrically-powered machines to make them inoperative during repairs.
5. Feed rolls or other movable parts should be covered or guarded to prevent the operator from contacting hazardous points.

Inspection and maintenance procedures should be performed periodically. Cracks in tools, dull tools, badly set or improperly adjusted saw blades are items to check for. Dull or improperly adjusted knives or cutting heads should also be looked for, as these too present hazards. Tools with such deficiencies work poorly and may break; they may bind the piece being cut, or they may

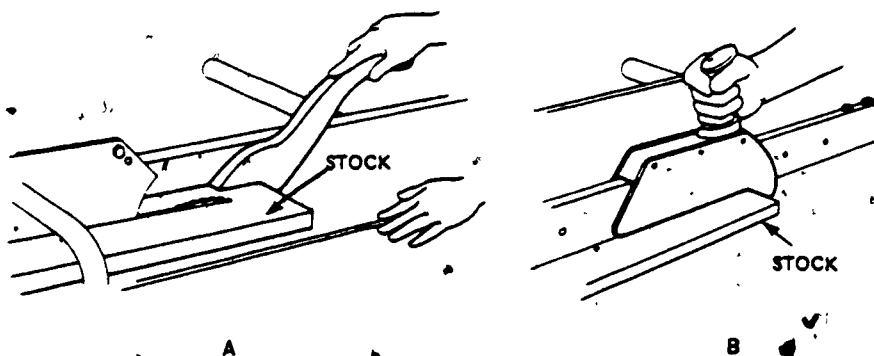

Figure 13. Push stick (A); push block (B).

even throw the work back at the operator. Lubrication requirements for all tools should be observed. Push sticks and blocks (Figure 13) of various sizes should be avail-

able to assist the stock through the cutting operation. Keeping the machine and the surrounding area free of sawdust is also very important.

Specific safety precautions that relate to individual pieces of equipment will be identified as they are discussed.

ACTIVITY 9:

1. Circular saw arbors and blades may be at some angle other than straight up and down as long as

- a. the piece being cut is less than 2" thick.
 - b. push sticks are available.
 - c. the fence remains parallel to the blade.
2. All woodworking tools should have
 - a. push sticks available at the work site.
 - b. cutoff controls within each reach for the operator.
 - c. a 12" safety zone around them.

OBJECTIVE 10: Name the three types of circular saws and list three safety features and procedures for each type.

Circular saws are those that use a round or circular blade for cutting. The three common types include the table saw, radial arm saw, and the portable circular saw (Figure 14).

Other variations exist, including swing and sliding-cutoff saws and motorized miter boxes. All variations use a round blade attached to an arbor (shaft) through the center of the blade. Cutting is possible as a result of a high-speed motor that spins the arbor and blade. These saws are common in construction and industry, in farm and home shops. Since any item used infrequently has a tendency to be taken for granted by its operator, anyone using a power saw should be particularly careful. Momentary relaxation of proper safety procedures can mean serious injury. Specific safety precautions associated with each of the three most common types will be described.

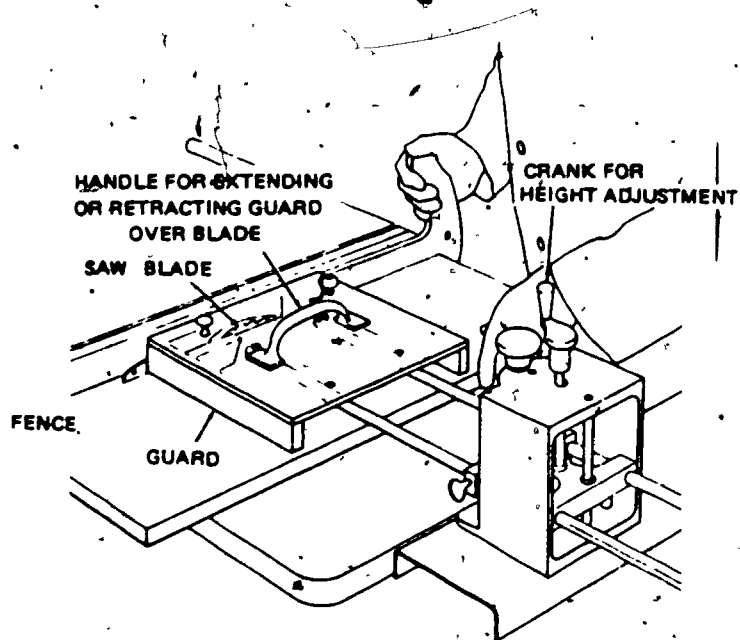

A. Table saw

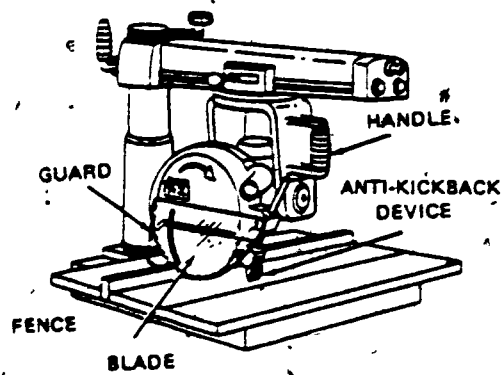

B. Radial arm saw.

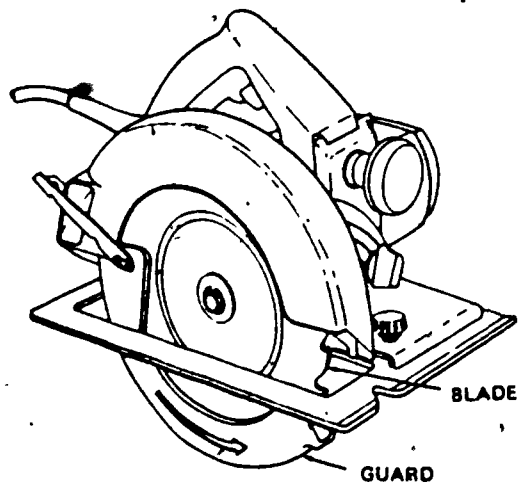

C. Portable circular saw.

Figure 14. Three types of circular saws.

TABLE SAW

The table saw (shown in Figure 15) is sometimes called a bench saw. It is one of the basic machines for woodworking, and a wide range of processes

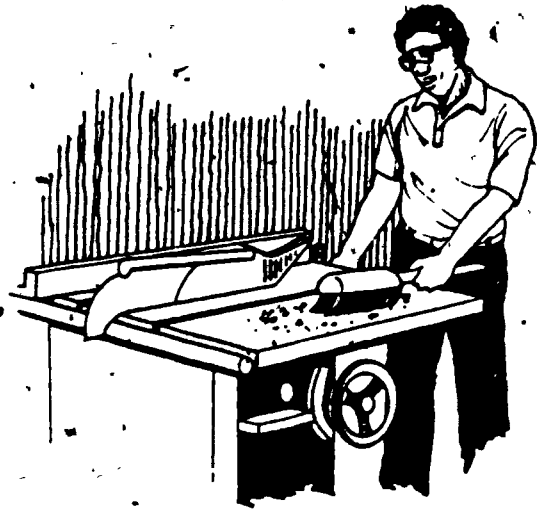

Figure 15. On the table saw, remove all scrap with a brush, never with fingers.

can be performed on it. These processes include crosscutting, ripping, mitering, chamfering, and rabbeting. With attachments, the machine can perform cone cutting, tapering, dadoing, sanding, shaping, and molding cutting. This machine demands the complete respect of the operator if it is to be used safely. This respect includes an understanding of what can be done, and what should not be attempted on the machine.

There are two basic types of table saws, the tilting table and the tilting arbor. For making certain angular cuts, either the table or the blade must tilt. The tilting arbor is recommended for accuracy, convenience, and safety. Sizes of table saws are designated by the diameter of the blade, such as 8", 10", or 12". Blades are designed for specific cuts, such as rip, crosscut, and planer. Combination blades are used for general purpose sawing. The rip blade is effective ONLY for ripping, just as the crosscut is ONLY for cutting across the grain. THEY SHOULD NOT BE USED INTERCHANGEABLY. The planer blade is hollow ground and is used for making very accurate cuts in joinery. The combination blade does both crosscutting and ripping satisfactorily. For safety, always use the proper blade for the job to be done.

Safety in table saw operation requires proper guards. The following is a list of guarding requirements that should be utilized:

1. Table saws must be provided with a hood guard that covers the saw at all times.
2. The standard hood guard may be impractical when rabbeting and dadoing. In this case, an effective guarding procedure is to use a jig to hold the work, keeping the hands away from the table.

3. Never reach over a revolving saw; instead, bring the cut piece back around the side of the machine.
4. Keep fingers away from the saw blade at all times.
5. Always keep the guard and splitter in place unless this is impossible for the kind of cut being made.
6. If the cut being made does not permit use of the regular guard, use a feather board or a special guard. A feather board is a piece of board with blade-width slots cut in it, used as a temporary guard.
7. When crosscutting with the miter gage, never use the fence for a stop unless a clearance block is used. A fence is an accessory used for guiding the workpiece.
8. Always push the stock through with a push stick when ripping stock that cannot be fed safely by hand.
9. Never stand directly behind the blade.
10. Always use a sharp blade.
11. When ripping, place the jointed edge against the fence.
12. Keep the saw table clean. Remove all scraps with a brush.
13. Remove rings, watches, and other items that might catch in the saw. Wear garments with short or tight sleeves.
14. Use the proper saw blade for the operation being performed.
15. Always hold the stock firmly against the miter gage when crosscutting, and against the ripping fence when ripping.
16. Be certain the fence is clamped securely.
17. When a helper assists, the helper should not pull the stock.
18. Do not saw warped material.
19. If stock must be lowered onto the revolving blade for certain cuts, use stops and guards. Never have hands in line with the blade.

RADIAL ARM SAW

The radial arm saw (Figure 16) can be thought of as an upside-down table saw. The motor and blade are suspended above the work rather than below it. In this position the blade can be raised, lowered, turned, and tilted to make an assortment of cuts. The actual operation of the saw is frequently done with one hand by using a handle to gently pull the motor through the work. The direction of the cut is such that the blade helps to feed itself, and little effort is required by the operator.

Numerous attachments are used on the radial arm saw, including the dado head, shaper, sander, drill, and saber saw.

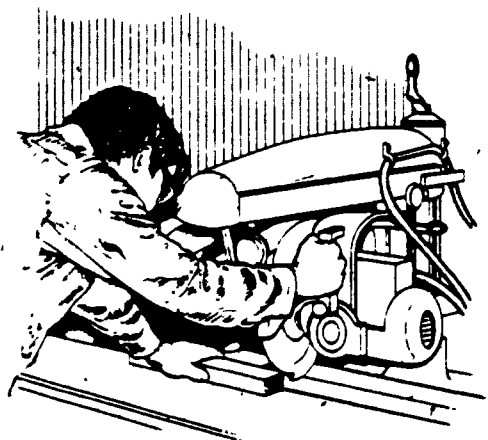

Figure 16. When using the radial arm saw, keep hands well away from the cutting blade.

The radial arm saw is especially convenient for certain cuts because the stock remains stationary on the table. Ripping operations, however, can also be completed by rotating the blade parallel to the fence and carefully pushing the stock into the blade. It is more dangerous to use the radial arm saw for ripping than to use the table saw, so if there is a choice, the table saw should be used to perform these operations.

For safe operation, the radial arm saw must be equipped with the following features:

1. An upper hood to enclose the top portion of the blade down to a point that will include the end of the saw arbor. The sides of the lower exposed portion of the blade must be guarded, to the full diameter of the blade, by a device that automatically adjusts to the thickness of the stock being cut.
2. Anti-kickback dogs on both sides of the saw designed to provide adequate holding power for all thicknesses of material being cut, if the saw is used for ripping.
3. An adjustable stop, limiting forward travel of the blade to the distance necessary to complete a cut in repetitive operations.
4. A head that automatically returns to its starting position.
5. Marking on the hood showing the direction of saw rotation. In addition, a permanent label must be affixed to the rear of the guard reading "DANGER. DO NOT RIP OR PLOUGH FROM THIS END."

The following safety precautions should be observed for safe operation of the radial arm saw.

1. Always keep the safety guard and the anti-kickback device in position.
2. Make sure the clamps and locking handles are tight.
3. Make sure the stock to be cut is held tightly against the fence.
4. For crosscutting, dadoing, and similar operations, pull the saw into the work.
5. Return the saw to the rear of the table after each cut, and lock it in place.
6. For ripping, make sure that the blade is rotating upwards toward you. Use

- the anti-kickback device to hold work firmly against the table. Feed the stock from the end opposite the anti-kickback device.
8. Keep hands away from the danger area — that is, the path of the saw blade.
 9. Be sure the power is off and the saw is not rotating before making any adjustments.
 10. Always use a sharp blade or cutter.
 11. Allow the saw to reach full speed before making a cut.
 12. Before turning on the power, hold the saw to prevent it from coming forward.
 13. The saw tends to feed itself into the work. Therefore, it may be necessary to regulate the rate of cutting by holding back the saw.
 14. Use a brush or stick to keep the table clear of all scraps and sawdust.

PORTABLE CIRCULAR SAW

Hand-held, portable circular saws are easy to use, accurate, fast-cutting, and potentially very dangerous. Before using one of these saws observe the following safety precautions:

1. Check the position of the lower guard. It should be covering the portion of the blade below the stage that rests on the stock being cut. It should move freely and not be locked in the up position, exposing the blade.
2. Make sure all adjusting mechanisms for depth of cut and angle of cut are secured.
3. Examine the condition of the blade: it should be sharp, not cracked or chipped, and should be tightened securely to the arbor.

Portable circular saws are picked up and held by the built-in handle that contains the start switch or trigger. Newer models are equipped with a safety button that must be depressed at the same time as the trigger, to start the motor. This feature prevents accidental starting. Other safety procedures include making sure the power cord is clear of the blade, and having the stock supported in a manner that will eliminate any binding during the cut.

Using circular saws correctly and carefully can increase the life of the tool and reduce the chances of accidents for the operator. Additional information concerning this equipment can usually be found in owner and servicing manuals, which should be kept available at all times.

ACTIVITY 10:

Read each statement and decide if it is true for: A) table saws, B) radial arm saws, or C) portable circular saws. If the statement is correct for more than one saw type, put each letter appropriate in the blank provided.

- _____ 1. Anti-kickback devices should be found on these saws.
- _____ 2. Cutting occurs from the top of the piece of stock.
- _____ 3. The stock remains stationary during the cutting operation.
- _____ 4. Push sticks are used during the ripping process.
- _____ 5. The blade and motor move as the cut is made.
- _____ 6. Best for ripping operations.

OBJECTIVE 11: Compare and contrast the hazards and safety features associated with the use of planers and jointers.

Any piece of equipment that uses a rotating shaft or arbor is a potentially dangerous tool. When razor-sharp blades are attached to those high-speed shafts, an increased element of danger is added. Planers and jointers use these sharp knife-like blades as their cutting tools.

PLANERS

A planer is a machine that removes wood from the surface of the stock until a desired thickness is achieved (Figure 17).

Common sizes of planers include 12", 24", and 36", and these dimensions refer to the width of stock that can be accommodated. Stock such as glued-up table tops can be surfaced in larger machines, saving hours of work with the hand plane. Usually the only adjustment to be made in the operation of the planer is for depth of cut. Light cuts generally produce smoother surfaces than heavy cuts. The stock is fed into the throat of the machine, which then

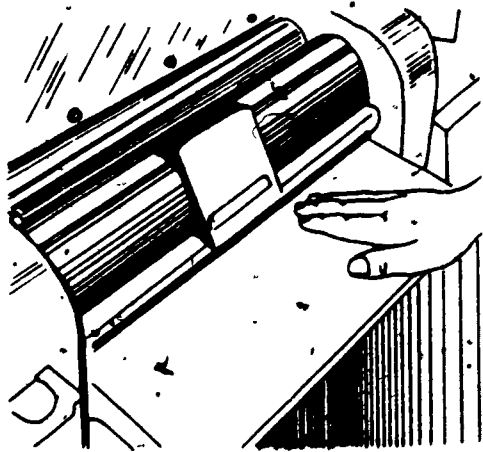

Figure 17. A single-surface planer. Note that there is no gap between the surface of the material being planed and the entrance to the cutterhead of the planer.

self-feeds as it smooths the surface. When the cut is completed, the stock is released on the opposite side of the machine.

Well-guarded, the machine is usually safe to operate, but it is extremely noisy. When it is running, it is important that operators of other machines double their efforts at concentrating on their own work. Only clean, nail-free lumber should be run through the planer. A nicked blade makes sharpening a major operation.

For safe operation, wood planers should be equipped with the following guards:

1. Cutting heads and saws must be guarded with metal — minimum 1/16" thick sheet metal or 3/16" thick cast iron.
2. Feed rolls must be guarded by a hood or by a suitable guard that will prevent the operator's hands from coming into contact with the in-running rolls.
3. Planers that can accept multiple pieces of wood simultaneously must be provided with either sectional infeed rolls that provide contact pressure on feed stock or with suitable section kickback finger devices at the in-feed end.

These safety precautions should be followed during the operation of a wood planer.

1. Always wear approved eye-protection devices.
2. Be sure that the workpiece meets the minimum length requirements of the machine. This length is equal to the distance from the infeed rollers to the delivery rollers, plus two inches.
3. Never allow any part of the body to pass beyond the front edge of the table bed when the machine is in operation or when the power supply is turned on. Use a push bar, if necessary, to help a stalled piece pass into the delivery rollers.
4. Stand to one side of the machine when the unit is in operation to avoid being struck by objects that may be thrown back.
5. Be sure that the workpiece is free of nonwood objects such as nails or screws before attempting to process it in the machine.

6. Check the grain direction on the face of the material to be surfaced to be sure that it points toward you.
7. Set the initial depth of cut by measuring the maximum thickness of the workpiece and then setting the table to a depth thickness 1/16 to 1/8 inch less than this thickness.

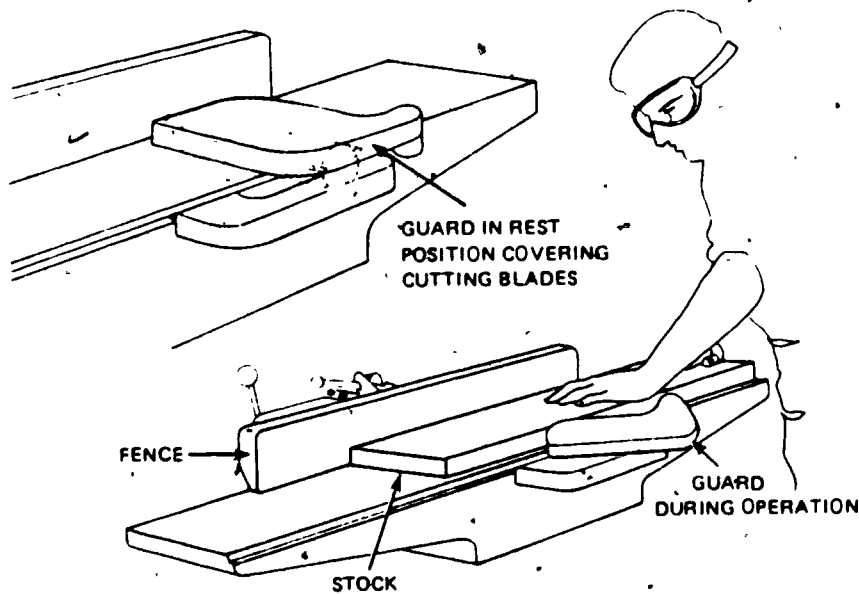

Figure 18, A jointer.

JOINTERS

The jointer is the mechanical equivalent of the hand plane (Figure 18). Basically, it smooths and straightens faces and edges of wood, but it can also cut rabbets, bevels, chamfers, and tapers. The working part is the cutter head. This is usually equipped with three knives, sharpened like plane

irons, that turn at speeds of between 3,500 and 6,000 revolutions per minute (rpm). This speed accounts for the smoothness of the cut. The depth of the cut is determined by the blade setting, and depends on the type of cut made and the kind of wood used. The main hazard associated with the jointer is physical contact with the cutter head. Guarding (as shown in Figure 18) can help to prevent this.

Safety requirements for jointers include the following:

1. Hand-fed with horizontal head — knives on the cylindrical cutting head should project no more than 1/8 inch beyond the cylinder.
2. Table openings — clearance between rear table and cutter head must be 1/8 inch maximum. Table throat opening (when tables are set with each other for zero cut) must be two and a half inches maximum.

3. Horizontal head — An automatic guard covering the head on the working side of the fence, and a guard covering the head behind the fence.
4. Vertical head — An exhaust hood or other guard completely enclosing the revolving head, except for a slot of the width necessary to perform the work.

These safety precautions should be observed in the operation of the jointer:

1. Always wear approved eye-protection devices.
2. Be sure guards are in position and operative before starting the machine.
3. Do not attempt to joint any surface less than eight inches long.
4. Use a push stick whenever the size of the workpiece brings fingers within four inches of the cutterhead.
5. Be sure the cutterhead knives are sharp.
6. Keep the jointer tables free of all objects when the machine is in use.
7. Be sure all loose clothing and hair is secured before turning the machine on.

The fact that while the stock is being cut the blades are above the table, and thus could quickly and easily remove fingers or other body parts, makes jointers very hazardous to use. Properly used, they are time- and labor-savers; improperly used, they become deadly instruments.

ACTIVITY 11:

Of the planer and jointer, which tool usually is considered more dangerous; and why? (Answer in one sentence.)

OBJECTIVE 12: Describe the most significant hazard and one safety precaution associated with the use of 1) band saws; 2) shapers, 3) wood lathes, and 4) power sanders.

BAND SAW

The woodcutting band saw is a very versatile machine. It has a continuous blade traveling around two wheels like a flat belt against two pulleys. The

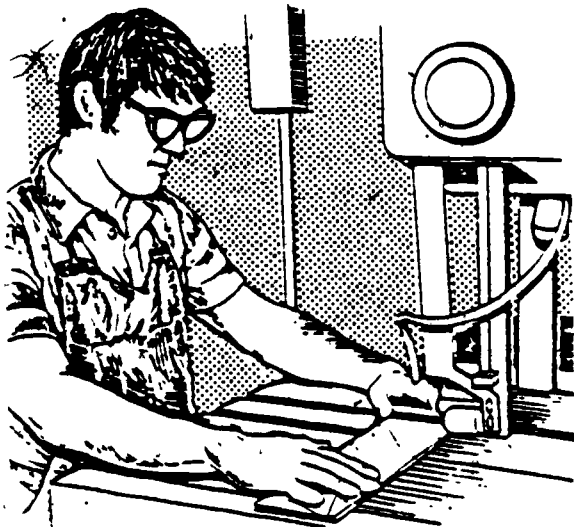

Figure 19. The band saw cuts curves and straight lines in thin or thick stock.

blade travels so that the cut is continuous and downward against the table. It cuts curves and straight lines in thin or thick stock (see Figure 19).

Blades come in various widths and with different numbers of teeth per inch. In general, a blade as wide as possible, and with as few teeth as the stock will allow, should be used. The thinner the material, the more teeth needed.

Band saws should be equipped with the following safety devices:

1. An enclosure for the entire blade except for the working portion.
2. An enclosure for its wheels.
3. A tension control device.
4. A suitable guard on its running feed rolls.

A band saw cuts so fast and so easily that the user must be careful not to get his or her fingers too close to the blade. To avoid injuries when using the band saw, the following safety precautions should be observed:

1. Be sure the blade is sharp, and positioned correctly with respect to blade supports and guides.
2. Have all guards and other safety devices in position.
3. Wear approved eye protection.
4. Keep both sides of the saw table clear. A clear work area provides less chance of accidents. Also, if the blade of the saw breaks, it can fly out to the right side of the machine.
5. Adjust the guidepost so that it is not more than 1/8" above the workpiece.
6. Make no adjustments while the blade is running.
7. Use a push stick when making through cuts on small pieces.
8. Stop the machine before attempting to pull a workpiece out of an incomplete cut.
9. Avoid excessive twisting of the blade, which causes friction between the blade and the blade guides.
10. Be sure that round or irregularly-shaped pieces are firmly supported by the table during cutting, to avoid possible blade kinking and breakage.

SHAPERS

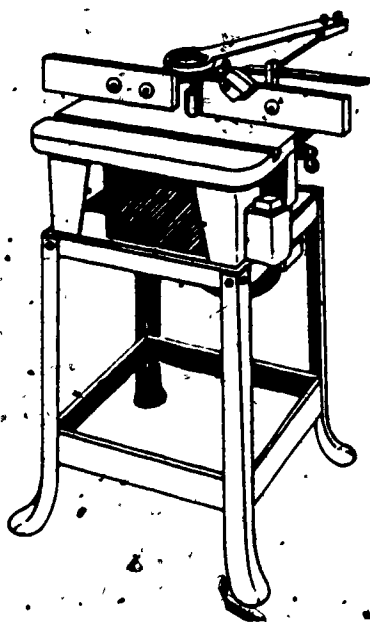

Figure 20. Single-spindle wood shaper.

The shaper (Figure 20) is primarily used for edge cutting on straight and curved pieces, for making decorative edges and moldings, for producing joints, and for grooving, fluting, and beading. While most of the work is done on the edge of stock, the shaper can also be used for face shaping. This relatively simple machine can do a wide variety of operations depending upon the kind of cutters available. However, the shaper is relatively dangerous because it operates at high speeds and its cutters are difficult to guard. Shapers are made in many types and sizes, and may be either single-spindle or double-spindle. The double-spindle shaper is used primarily in furniture factories:

These are the guarding requirements for wood shapers:

1. Cutting heads must be enclosed with a cage or with adjustable guards of a diameter at least as great as the diameter of the cutter. Warning devices of leather or of other material attached to the spindle are not acceptable.
2. Single cutter knives in shaper heads must be properly balanced.
3. Double-spindle shapers require a starting and stopping device for each spindle.

These are the safety precautions for wood shapers:

1. Whenever possible, install the cutter so the bottom of the stock is shaped. In this way the stock will cover most of the cutter and act as a guard.
2. Make sure the cutter is locked securely to the spindle.
3. Always position the left fence so that it will support the work that has passed the cutters.
4. Adjust the spindle for correct height and then lock it in position. Rotate the spindle by hand to make sure it clears all guards, fences, and so forth.
5. Check the direction of rotation by snapping the switch on and off; watch as the cutters come to rest. ALWAYS FEED AGAINST THE CUTTING EDGE; THAT IS; FEED THE WORK INTO THE CUTTERS IN THE DIRECTION OPPOSITE TO CUTTER ROTATION. Some shapers have a reversing switch so that the spindle can be rotated either clockwise or counterclockwise.

6. Examine the stock carefully before cutting, to make sure it is free of defects. Never cut through a loose knot, or through stock that is cracked or split.
7. Hold the stock down and against the fence with the hands on top of the material, yet out of range of the cutters.
8. Use guards, jigs, and clamping devices whenever possible.
9. Always use a depth collar when shaping irregular work. Put a guide pin in the table to start the cutting.
10. Do not set spring hold-down clips too tightly against the work. Use just enough tension to hold the work against the fence.
11. For contour work, when depth collars and a guide pin are used the operator must swing the work into the cutters. It is a good idea to keep the stock in motion in the direction of feed.
12. Never shape a piece shorter than 10 inches.

WOOD LATHES

Unlike any other machine commonly found in noncommercial shops, the wood lathe can produce a completely finished product. In most woodworking machines, the tool's cutting edges travel at a high rate of speed while the workpiece moves slowly into and through the rotating cutting edges. In the wood lathe, the cutting tool remains relatively stationary while the workpiece rotates rapidly past it. In normal operation, the lathe produces rounded designs such as table legs, spindles, and bowls.

These are the guarding requirements for wood lathes:

1. Cutting heads must be covered as completely as possible by hoods or shields hinged to the machines so that they can be thrown back for adjusting.
2. Shoe lasts and spoke lathes, doweling machines, and wood heel turning lathes of the rotating-knife type must have hoods covering the cutter blades, except at contact points.
3. Lathes used for turning pieces of stock held only between the two centers must have long curved guards extending over the top of the lathe, to prevent workpieces from being thrown out of the lathe if they become loose.

These are the safety precautions for wood lathes:

1. Always wear a face shield when operating the lathe.
2. Roll up sleeves and secure them, and remove all hand jewelry.
3. Secure or remove any loose clothing that might become entangled in the lathe.
4. Always operate the machine at the slowest possible speed when beginning work.

5. When work on the lathe is complete for an individual operation, return the speed setting to its low-speed position.
6. Rotate the workpiece in the machine by hand before turning the power on. This allows the clearance between the workpiece and the tool rest to be checked. It is also a test of the secureness of the workpiece.
7. Be sure that glued material is secured before attempting to turn it.
8. Whenever possible, pre-shape workpieces before attempting to turn them.
9. Avoid high spindle speeds for large-diameter workpieces.
10. At the first sign of any unusual vibration, turn the lathe off. Determine the cause of the vibration before restarting.
11. Use dust-collecting equipment when operating the lathe, or wear a suitable dust-filtering face mask.
12. Keep the tool rest within 1/8 inch of the surface of the workpiece being cut.
13. Stop the machine before making any adjustments.
14. Check the tool rest and the tailstock clamps frequently during operation, because vibration can cause them to loosen.
15. Always support the turning tool with the tool rest, and keep the cutting edge of the tool as close to the tool rest as possible.
16. Select turning stock that is straight-grained and free from defects such as knots and checks.
17. Do not leave tools on the lathe bed during turning operations. Vibration may cause them to "walk off" the bed and fall to the floor, with the possible result of injury to the operator.

POWER SANDERS

There are several types of power sanders, including disk, belt, drum, spindle, and sheet types. All use abrasive paper or cloth and set it in motion in such a manner as to remove wood from the workpiece in preparation for finishing. Belt and disk sanding machines are the most commonly used machines.

Although separate disk sanders are fairly common, belt sanders are often part of the disk-belt combination machines. In combination units, both the disk and belt are driven by a single motor via belts and pulleys. The disk sander consists of a metal disk to which a circular sheet of coated abrasive is attached. A tiltable table is attached to the front of the machine to support the workpiece. The sanding disk is surrounded with a housing that doubles as a guard for the protection of the operator and as part of the dust-collecting system. Dust-producing equipment of this type should always be provided with a dust-collecting vacuum system.

The belt portion of the machine consists of an abrasive-coated cloth belt that travels over two drums and a platen. One drum is fixed in position and is driven by the motor, while the other drum is adjustable to allow for belt tensioning, removal, or tracking.

These guarding requirements apply to sanding machines:

1. Self-feed sanding machines require a semicylindrical guard to protect operator's hands from the in-running rolls. The guard must be of heavy material, well secured to the frame carrying the rolls, so as to stay in adjustment for any thickness of stock. The bottom of the guard should come down to within 3/8 inch of the contact face of the feed roll where it touches the stock.
2. Drum sanders require an exhaust hood (or other guard if no exhaust system is necessary), and a guard to enclose the revolving drum, except that portion of the drum above the table.
3. Disk sanders require an enclosed disk, except for the portion of the disk above the table.
4. Belt sanders require guards at each nip point where the sanding belt runs onto a pulley. The unused part of the sanding belt must be guarded against accidental contact.

These are the safety precautions for the disk sander:

1. Always wear approved eye protection while operating this machine.
2. Only sand work that provides adequate clearance (at least three inches) for the fingers.
3. Use only the upper left quadrant of the disk for sanding. The right quadrant tends to lift the workpiece and force sawdust up into the air.
4. Keep the machine table free of objects that might "walk off" the table during the operation because of vibration.
5. Check the disk before operation to be sure it is securely adhered.
6. After adhering an abrasive to the disk, jog the machine before turning it on completely, to test the adherence of the disk.

The following are the safety precautions for the stationary belt sander:

1. Always wear approved eye-protection devices while operating this machine.
2. Maintain at least three inches between fingers and the abrasive belt.
3. Keep the table free of objects that might "walk off" during operation.
4. When tracking the belt, jog the machine to provide movement. Do not turn the unit on fully until tracking has been completed.
5. Always check to see that the unit is locked when in the vertical position. Tighten locknut if necessary.
6. Use a push stick when doing face sanding on the machine.

ACTIVITY 12:

Match the statement to the tool (or tools) it best describes. (Put the letter(s) representing the tool in the blank.)

- A. Band saw.
- B. Shaper.
- C. Wood lathe.
- D. Power sander.

- _____ 1. Creates a fine dust during use.
- _____ 2. Never use workpiece less than 10 inches.
- _____ 3. Cutter heads are difficult to guard.
- _____ 4. Guide posts are not more than 1/8" above workpiece.
- _____ 5. Workpiece moves, cutting tool remains relatively still.
- _____ 6. Cuts stock quickly, using a blade traveling over two wheels.
- _____ 7. Maintain at least three inches between where the stock is held and the work surface.
- _____ 8. Use safety glasses, goggles, or face shield.
- _____ 9. Stock is fed into cutters opposite to the cutter rotation.
- _____ 10. Low operating speed used when first cuts are made.

OBJECTIVE 13: Briefly describe at least three safety considerations for 1) proper dress, 2) materials handling, 3) housekeeping, 4) electrical safety, and 5) general safety when using woodworking tools.

Safety in a machine or woodworking shop requires more than just a knowledge of the safety procedures associated with the various mechanical devices. Five other areas should be considered for a greater degree of safety for operators and their fellow workers. These areas include 1) proper dress, 2) materials handling, 3) housekeeping, 4) electrical safety, and 5) general safety.

DRESS CONSIDERATIONS

Dressing appropriately for any work situation is important. When working with machinery it becomes even more important. Safety glasses, goggles, or face shields are necessary in many situations to protect against flying debris as workpieces are modified. Loose or improperly-fitted clothing should be avoided. Pants legs should not be so long that they could be a tripping hazard. Other items, such as neckties, loose jewelry, and unbuttoned shirt sleeves are inviting trouble. The proper footwear should include shoes with thick, sturdy soles, or with steel toes, depending on the type of work being done. Keeping hair away from machinery with hair nets or visors, and keeping hands clean and grease-free are also important precautions.

MATERIAL HANDLING CONSIDERATIONS

1. Two persons should carry long pieces of material.
2. Use the muscles of the legs and knees to lift heavy objects. Do not lift with the back muscles - to do so could result in painful back injuries.
3. Observe caution when carrying planks or other objects across wet or otherwise slippery footing.
4. Learn to watch footing; avoid objects that could be a tripping hazard.

HOUSEKEEPING CONSIDERATIONS

1. Stack materials and equipment neatly.
2. Keep aisles, walkways, and areas around machinery clear of tools, materials, and debris.
3. To prevent fires and reduce hazards that cause accidents, dispose of scraps and rubbish daily.
4. Keep tables of machines and other work surfaces free of tools and materials.

ELECTRICAL CONSIDERATIONS

1. Every machine should have a clearly identified "stop" switch within easy access of the operator.
2. Every machine should have a disconnect switch, or some means of keeping the machine inoperative while repairs or adjustments are being made.
3. Make sure the machine is properly grounded before attempting to operate it.

GENERAL SAFETY CONSIDERATIONS

The following is a list of general safety rules to be observed around machines in the shop or on the job site. Observing these rules will help to prevent injuries.

1. Always walk - do not run.
2. Never talk to anyone who is working with a machine. (See Figure 21.)

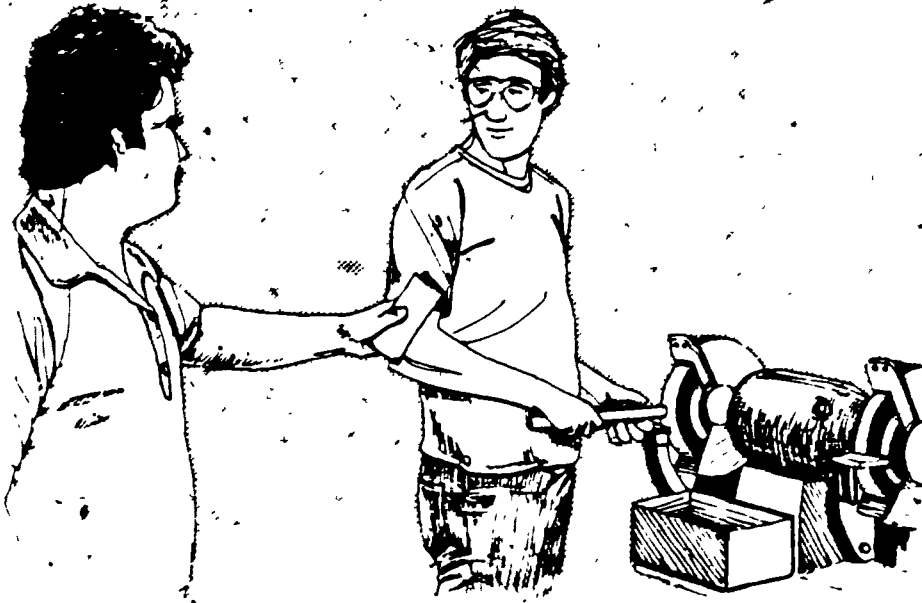

Figure 21. Never talk to anyone who is working with a machine.

3. Remove the power plug or turn off the power supply to a machine when changing or adjusting cutters or blades.
4. Never leave tools or pieces of stock lying on the table surface of a machine being used.
5. After using a machine, turn off the power and wait until the blade or cutter has come to a complete stop before leaving the machine.
6. Always carefully check stock for knots, splits, metal objects, and other defects before machining.
7. Do not use a machine until it is thoroughly understood. Any tool with a sharp cutting edge can cause serious injury if mishandled.
8. **USE GUARDS ON POWER EQUIPMENT.** It should be understood that using guards does not necessarily prevent accidents. Guards must be used correctly if they are to provide full protection. Also, it is impossible to carry out some operations, especially on the table saw, with the regular guard in place. Therefore, there are times when special guards should be used.

9. Always keep fingers away from the cutting edges. The most common accident is caused by trying to run too small a piece through the machine.
10. Keep the floor around the machine clean; the danger from falling or slipping is always great.
11. Always use a brush to clean the table surface.
12. Always keep eyes focused on where the cutting action is taking place. (See Figure 22.)



Figure 22. Focus eyes on cutting action.

13. Always use sharp tools.
14. When using tools for set-up work on a machine: 1) select the right tool for the job, 2) keep it in safe condition, 3) keep it in a safe place.
15. Report strange noises or faulty operation of machines to the instructor or person in charge.
16. Know the location of fire extinguishers and how to use them.
17. Injuries should be reported immediately for first aid and/or medical treatment.

ACTIVITY 13:

Cite at least three general safety considerations when using woodworking tools.

REFERENCES

- American National Standards Institute. Safety Requirements for the Use, Care, and Protection of Abrasive Wheels. B7.1 New York: 1978.
- Kibbe, Neely, Meyer and White. Machine Tool Practices. New York: John Wiley and Sons, Inc., 1979.
- Lento, Robert. Woodworking Tools, Fabrication, Design and Manufacturing. Englewood Cliffs, NJ: Prentice-Hall, Inc., 1979.
- National Institute for Occupational Safety and Health. Safety and Health for Industrial/Vocational Education. Cincinnati, OH: National Institute for Occupational Safety and Health, 1981.
- National Safety Council. Accident Prevention Manual for Industrial Operations. Chicago: The National Safety Council, 1979.
- Strong, Merle E., editor. Accident Prevention Manual for Training Programs. American Technical Society, 1975.
- U.S. Department of Labor. Concepts and Techniques of Machine Safeguarding. Occupational Safety and Health Administration, No. 3067. Washington, D.C.: U.S. Government Printing Office, 1981.
- Occupational Safety and Health Standards for General Industry (29 CFR 1910). Washington, D.C.: U.S. Government Printing Office, 1979.

ANSWERS TO ACTIVITIES

ACTIVITY 1 (Wording may vary but content for each should be as follows.)

1. Never start a machine if the guard or guards have been removed or made inoperable as a result of a by-pass system.
2. Avoid wearing loose clothing.
3. Never leave a running machine unattended.
4. Wear proper eye protection.
5. Keep machine coolant clean and free of debris.
6. Never make adjustments to a machine while it is running.
7. Use brushes, vacuum equipment, or special tools to remove shavings and chips.
8. Keep all work surfaces and areas clean.

9. Use the correct hand tools when required.

ACTIVITY 2

1. Turning machines — rotating pinch points.
2. Boring machines — flying chips.
3. Milling machines — contact with cutters.
4. Abrading machines — metal fragments in the eyes.
5. Sawing machines — contact with saw blade.

ACTIVITY 3

With a brush, pliers, or piece of wood.

ACTIVITY 4

(Typical answers could include:)

1. Cuts from flying metal fragments — interrupt the drilling process to break up the chip and wear eye protection.
2. Being drawn to the drill after having clothing, hair, or jewelry caught — eliminate or secure hair, clothing, or jewelry.
3. Punctures or cuts on fingers and hands — use brush to remove shavings and chips, or remove burrs.
4. Hit by chuck key — remove key from chuck before starting drill.
5. Being caught by pulleys or belts — keep all guards in place.

(See list on p. 11 for other possible answers.)

ACTIVITY 5

1. Horizontal Milling Machine —

Use a rag to handle sharp cutters; keep clear of the moving cutter; never reach over the cutter; stop the cutter and use a brush to remove chips.

2. Vertical Milling Machine —

Use a rag to handle cutter; never reach over or near rotating cutter; make no adjustments while cutter is rotating.

ACTIVITY 6

True.

ACTIVITY 7

a.

ACTIVITY 8

Blade.

ACTIVITY 9

1. c.
2. b.

ACTIVITY 10

1. A & B.
2. B & C.
3. B.
4. A & B.
5. B & C.
6. A.

ACTIVITY 11

Jointer. The cutting head is exposed during operation.

ACTIVITY 12

1. D.
2. B.
3. B.
4. A.
5. C.
6. A.
7. D.
8. A, B, C, & D.
9. B.
10. C.

ACTIVITY 13

(Any three from the list of 17 given under general safety considerations, pp. 44 and 45.)