

DOCUMENT RESUME

ED 213 219

EC 141 176

**AUTHOR** Roice, G. Robert, Ed.  
**TITLE** Teaching Handicapped Students Physical Education: A Resource Handbook for K-12 Teachers.  
**INSTITUTION** National Education Association, Washington, D.C.  
**REPORT NO** ISBN-0-8106-3178-4  
**PUB DATE** 81  
**NOTE** 46p.; For related documents, see EC 141 174-177 and EC 141 147.  
**AVAILABLE FROM** National Education Association, 1201 16th St., N.W., Washington, DC 20036 (\$7.50, Stock No. 3178-4-00).  
**EDRS PRICE** MF01 Plus Postage. PC Not Available from EDRS.  
**DESCRIPTORS** Adapted Physical Education; Deafness; \*Disabilities; Elementary Secondary Education; Individualized Education Programs; Learning Disabilities; \*Mainstreaming; \*Motor Development; Perceptual Motor Learning; Physical Disabilities; \*Physical Education; Psychomotor Skills; Teaching Methods; Visual Impairments

**ABSTRACT**

One of five volumes intended to help teachers of mainstreamed handicapped students, the book presents twelve papers on physical education instruction. The following titles and authors are included: "The Heartbreak of Kickball, Dodgeball, and Drop the Hankie--Elementary School Physical Education--The Bases for the Basics" (R. Benton); "Shared Victory (A Collection of Unusual World Records)" (R. Jones); "Fine Motor Development--Sometimes Neglected?" (J. Verderber); "IEP's and Mastery Learning Applied to Psychomotor Activities" (J. Chambless, et al.); "The Movement Mystic" (J. Ballinger); "Perceptual-Motor Activities for Children with Learning Disabilities" (R. Kraft); "Movement Exploration for the Learning Disabled, Mildly Retarded, and Visually Impaired" (S. Kottler); "Asthma and Physical Education" (W. Dennis); "Mainstreaming Visually Impaired Children in Vigorous Physical Education" (C. Buell); "Adapted Physical Education for the Deaf" (G. Lieberman); "Physical Activities for Individuals with Spinal Cord Injuries" (V. Hopkins); and "It Can Be Simple--Adapted Equipment for Physical Activity and Recreation for Special Populations" (R. Sotto). (CL)

\*\*\*\*\*  
 \* Reproductions supplied by EDRS are the best that can be made \*  
 \* from the original document. \*  
 \*\*\*\*\*

ED213219

G. Robert Roice, Editor

U.S. DEPARTMENT OF EDUCATION  
NATIONAL INSTITUTE OF EDUCATION  
EDUCATIONAL RESOURCES INFORMATION  
CENTER (ERIC)

- This document has been reproduced as received from the person or organization originating it
- Minor changes have been made to improve reproduction quality
- Points of view or opinions stated in this document do not necessarily represent official NIE position or policy

# Teaching Handicapped Students

# PHYSICAL EDUCATION

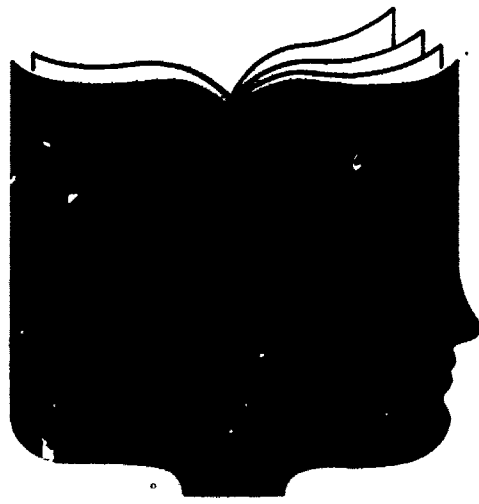

"PERMISSION TO REPRODUCE THIS  
MATERIAL IN MICROFICHE ONLY  
HAS BEEN GRANTED BY

*M. Fulton*

A National Education  
Association Publication

TO THE EDUCATIONAL RESOURCES  
INFORMATION CENTER (ERIC)."

ERIC  
Full Text Provided by ERIC

Copyright © 1981  
National Education Association of the United States

Stock No. 3178-4-00

**Note**

The opinions expressed in this publication should not be construed as representing the policy or position of the National Education Association. Materials published as part of the NEA Teaching Handicapped Students series are intended to be discussion documents for teachers who are concerned with specialized interests of the profession.

**Acknowledgment**

Several of the articles in this publication originally appeared in the syllabuses for the *Ninth National Conference on Physical Activity for the Exceptional Individual* and the *Seventh National Conference on Physical Activity for the Exceptional Individual*, presented by the Office of the Los Angeles County Superintendent of Schools in cooperation with the California State Department of Education and the California Association for Health, Physical Education, Recreation, and Dance. They are reprinted here with permission of their authors.

**Library of Congress Cataloging in Publication Data**

Main entry under title:

Teaching handicapped students physical education  
(Teaching handicapped students in the content areas)  
Includes bibliographies.

I. Physical education for handicapped children—  
Addresses, essays, lectures. I. Roice, G. Robert

II. Series

GV445.T38                    371.9'044                    81-11018

ISBN 0-8106-3178-4

AACR2

# CONTENTS

FOREWORD .....	7
EDITOR'S INTRODUCTION .....	9
1. THE HEARTBREAK OF KICKBALL, DODGEBALL, AND DROP THE HANKIE -ELEMENTARY SCHOOL PHYSICAL EDUCATION- THE BASES FOR THE BASICS Rudy Benten .....	11
2. SHARED VICTORY (A Collection of Unusual World Records) Ron Jones .....	13
3. FINE MOTOR DEVELOPMENT—SOMETIMES NEGLECTED? Joanie Verderber .....	15
4. IEP's AND MASTERY LEARNING APPLIED TO PSYCHOMOTOR ACTIVITIES Jim R. Chambless, Eugene Anderson, and Jennifer H. Poole .....	20
5. THE MOVEMENT MYSTIC James L. Ballinger .....	23
6. PERCEPTUAL-MOTOR ACTIVITIES FOR CHILDREN WITH LEARNING DISABILITIES Robert E. Kraft .....	27
7. MOVEMENT EXPLORATION FOR THE LEARNING DISABLED, MILDLY RETARDED, AND VISUALLY IMPAIRED Sylvia B. Kottler .....	30
8. ASTHMA AND PHYSICAL EDUCATION Warren Dennis .....	33
9. MAINSTREAMING VISUALLY IMPAIRED CHILDREN IN VIGOROUS PHYSICAL EDUCATION Charles Buell .....	37
10. ADAPTED PHYSICAL EDUCATION FOR THE DEAF Gary L. Lieberman .....	39
11. PHYSICAL ACTIVITIES FOR INDIVIDUALS WITH SPINAL CORD INJURIES Vicki McKeeman Hopkins .....	41
12. IT CAN BE SIMPLE—ADAPTED EQUIPMENT FOR PHYSICAL ACTIVITY AND RECREATION FOR SPECIAL POPULATIONS Remy Sotto .....	44

9

7

NEA Committee on Education of the Handicapped  
*Georgia L. Gibson*, Chairperson, Stratford, New Jersey;  
*Lee Betterman*, Mount Prospect, Illinois; *Eugenio del Valle*, Hatoy Rey, Puerto Rico; *Ruth D. Granich*, Bloomington, Indiana; *John Knapp*, Cleveland, Ohio; *Min Koblitz*, Scarsdale, New York; *James Rathbun*, Las Vegas, Nevada; *Ken Rosenbaum*, Louisville, Kentucky; *Ruth Watkins*, Raleigh, North Carolina.

## FOREWORD

Prepared by the

NEA Committee on Education of the Handicapped

Public Law 94-142, The Education for All Handicapped Children Act, the major federal education legislation for providing a free appropriate education for all handicapped children, must be in compliance with Section 504 of the Rehabilitation Act of 1973. Part D of Section 504 states, in part:

The quality of the educational services provided to handicapped students must be equal to that of the services provided to nonhandicapped students; thus, handicapped students' teachers must be trained in the instruction of persons with the handicap in question and *appropriate materials and equipment must be available.*

This federal regulation is supported by NEA policy. Point (e) of NEA Resolution 79-32, Education for All Handicapped Children, reads:

The appropriateness of educational methods, materials, and supportive services must be determined in cooperation with classroom teachers.

In the context of federal education policy and NEA policy, members of the NEA Committee on Education of the Handicapped have reviewed *Teaching Handicapped Students Physical Education*. Members of the Committee are teachers of English, social studies, mathematics, special education, and science who teach both general and handicapped students in elementary and high school.

The Committee cannot emphasize too strongly the importance of teachers of regular and special education working together. The Committee would also like to urge both groups of educators to use these publications in teaching content areas to handicapped students. Members of the Committee were particularly pleased that teachers wrote these materials, in an effort to successfully teach the handicapped in the least restrictive environment. Because of their firsthand knowledge of proper teaching strategies, teachers are the best source of information to aid their colleagues.

The NEA supports P.L. 94-142 because the Association is committed to education processes which allow all students to become constructive, functioning members of their communities. To this end, when handicapped students are appropriately placed in classrooms with nonhandicapped students, teachers need instructional strategies which provide for individual learning differences. This is not new. However, most regular education teachers have not been trained, as mandated by law, in pre-service or in-service experiences to work with students with handicapping conditions. Teachers are eager to carry out the mandate of the law, but they may shy away from or even object to teaching these students because of this lack of training.

The so-called "mainstreamed" classroom presents new challenges to regular classroom teachers because of the added responsibility of teaching students with handicapping conditions. It is particularly important, therefore, to understand the student with a handicapping condition as a whole person in order to emphasize this commonality among all students.

### **The Editor**

**G. Robert Roice is a Consultant, Adaptive Physical Education, Office of the Los Angeles County Superintendent of Schools. His selections for this book represent materials which he feels are especially pertinent and practical for physical education teachers.**

## EDITOR'S INTRODUCTION

Most people, if asked to define physical education, would speak in terms of team games such as basketball, baseball, and football; while others would include individual and dual sports such as tennis, archery, apparatus and tumbling activities. Some might emphasize fitness activities including isometrics, weight lifting, and running. All are part of a total physical education program, but successful performance in these activities should be viewed as outcomes rather than purposes of the program. Too often, ends and means become confused. For example, the objectives of the activity become the end rather than the means, in place of the specific contributions the activity can make to an individual's physical fitness and motor competence.

Physical education deals with the development of the basic skills of human performance on a day-to-day basis; it encompasses the use of the body in a variety of ways. Although the program is physically oriented, concomitant language learning and behavior improvement should also occur.

The student is, of course, a total being who does not learn by pieces. Motor skills are not taught and learned exclusively during the physical education period. All skills need to be practiced in order to be learned, and the student needs to see a point in learning a skill in order to be willing to practice it, whatever the subject matter. In the physical education class the teacher must deal with language, behavior, and conceptualization during teaching, thus reinforcing classroom learnings. In other words, both classroom and physical education learning should complement and supplement each other.

The very nature of the physical education program provides many opportunities for enhancing growth and

development in areas beyond traditional fitness and motor skills. Many other learnings, such as winning and losing graciously, working cooperatively, supporting others in a team situation, conforming to rules, playing fairly, acting responsibly as a follower and as a leader, add to a system of values, and are within the context of the physical education class. In addition, a good program is an ego-builder for the student. It starts at the assessed developmental level and applies developmental, adaptive, and remedial activities which are success-oriented and directed toward conceptualization and movement control abilities.

With the advent of PL 94-142, The Education for All Handicapped Children Act, has come a growing awareness that the handicapped child, perhaps more than any other, may need a program of specialized physical education. The law, in fact, singles out physical education as the only curriculum area required for all handicapped children. But while the law requires that every handicapped child receive a free appropriate public education, including physical education, it is silent on the issue of who should provide the physical education component. In some cases the movement needs of the child are addressed by a trained physical education teacher. More often, however, the instructor is the child's classroom teacher. Studies over the years have consistently shown that in spite of little or no training in physical education, the special education classroom teacher is routinely called upon to meet the child's physical education needs. The articles contained in this publication are, in small part, an attempt to better assist all teachers in understanding and meeting those needs.



# 1. THE HEARTBREAK OF KICKBALL, DODGEBALL, AND DROP THE HANKIE— ELEMENTARY SCHOOL PHYSICAL EDUCATION: THE BASES FOR THE BASICS

by Rudy Benton

*Creativity often leads to motivation and motivation frequently stimulates creativity. In this article the author outlines and gives examples of enjoyable movement activities that can stimulate both students and teacher. Rudy Benton is an Elementary School Physical Education Specialist in the Burlingame School District, California.*

## TRY BEING CREATIVE . . . IT MIGHT WORK!

One of the stated objectives physical educators have always championed is helping to develop a creative person. This is as it should be. I offer a suggestion I hope will effect the following: (1) Give a shot in the arm to your program. (2) Exercise the creative muscle of both the instructor and students.

Take one day a week when you try something you have never tried before in your physical education class. Use movement, music, and total involvement as the key features. I would advise not making this new activity just another game. I try to introduce a new activity, which acts as a catalyst for movement, or a stimulus for fun and excitement every Friday (grade level K-6). The following are just a few of the ideas or catalysts that have been used.

1. Everyone with a ping-pong paddle and ball.
2. All with a rug sample (approximately 6" x 12").
3. Each student with a sheet of newspaper.
4. Pencils—one per student.
5. Clothes hangers.
6. Baseball bats (plastic or wooden).
7. Cotton.

The majority of catalysts can be very inexpensive and, with proper direction on your part, can produce movement which activates both the small and large muscles of the body.

Here are examples of the types of challenges that can lead to thinking, creating, and movement with pencils: Each student creates an exercise to music or can follow you as you create movement to any music that makes you move. (Try Bette Midler's "Boogie Woogie Bugle Boy" or

Jim Croce's "Bad, Bad Leroy Brown.") Then, students try to manipulate the pencil with their fingers. Start with index fingers only and then move the pencil to the other fingers using only your fingers. Pretend the pencil is a 700 lb. weight, lift it, and after reaching the top of the lift, collapse to the ground. Ask each student to walk like a very old person using the pencil as a cane. Drop the pencil, eraser-end down, and catch it on the rebound. Skip around the room (to music) while twirling the pencil as if it were a baton. Ask students to think of a funny way to carry the pencil or to create movement with music using the pencil as the focus for action.

Possible movements are endless. All this and more with just a pencil. In the February 1973 issue of *Movement Education* another example with cups of water is described. Your creative mind can add new color to your program.

If you would like other ideas or catalysts for movement, I would be glad to share them with you, plus suggested challenges, but thinking up your own ideas can be quite rewarding. Good luck!

## STAR WARS—REVISITED

Taking advantage of the "Star Wars" movie popularity can add another dimension to your moving and learning program. Take, for instance, the "Star Wars" obstacle course, "May the course be with you." A long time ago in a school far, far away the physical education instructor designed a galactic experience (or obstacle) course prepared to stimulate both minds and muscles. A week in advance the students (K-6) were notified that on a certain date there would be the "Star Wars" obstacle course. On that day they could choose to wear their "Star Wars"

shirts, bring in any souvenir items, such as books, posters, buttons, etc., to be included as part of the course.

On the day of the "Star Wars" obstacle course, our multi-purpose (or muscle-purpose) room looked very colorful with "Star Wars" pictures on the walls and approximately twenty obstacle stations. A table called the "Rebel Reading Center" held all the items that the students brought in. A sign held up by a music stand identified each station of the obstacle. The sign was in color with a picture depicting a scene from the movie. Each sign was a laminated 11 x 14 inch card. Scenes for the signs came from both the "Star Wars" calendar and various "Star Wars" magazines.

The result of the colorful design of the course was an additional motivational tool to get students moving many muscles in many different ways. Participants had to remember the path of the course, respect the right-of-way of others, play act scenes from the movie, pace themselves to see how many times they could get through the galaxy experience, move in time to music, be aware of their body in space, remember what to do at each station, respect safety aspects and the condition/position of equipment, and be aware of others who might be having difficulty and assist them when necessary.

Here is a description of some of our stations:

**Robot Lane.** Ten traffic cones in a small area. Walk robot-like through the cone area as if computerized without touching the cones.

**Robot Malfunction Center:** After going through the cone field, the robot falls down and is forced to fix himself by adjusting the knees, hip joints, shoulders, etc., before proceeding to the next station.

**Lo the Bantha Walk (An elephant-like creature):** Walk slowly on all fours in a designated area on the way to the next challenge.

**Get Through the Death Rays:** Several chairs with ropes tied between them. Students step through a maze of ropes without touching them. The ropes represent the death rays.

**Storm Troopers-Duck for Cover:** Tumbling mats. Actors fall and roll and twist as if dodging the shots from a ray gun.

**Garbage Compact Area:** 30-40 aluminum soda cans in an outside area. Crush at least 3 cans before advancing to the next area.

**Do the Jawa Walk:** Walk as a very small person might walk the length of any designated area.

**Monsters Playing Chess:** Approximately 6-10 automobile or bicycle tires. Jump from tire to tire as if the student

were a monster chess piece acting out the manner in which a monster might make the jumps.

**Cantina Monsters:** When arriving near the phonograph, which is playing "Star Wars" music, act out how monsters would be playing instruments in a monster band.

**Death Star Leap:** Leaping from a designated line to a landing pit or soft landing area.

**Light Sabre Action:** At this station, pretend you have a light sabre (sword) in your hand and strike it downwards ten times.

**Jump the Giant Band Worm:** Using a table, stegel, or Lind climber with a mat draped over it, each class member vaults over as if it were a giant worm.

**Flying Fighters:** Students had to fall off the stage as if they were Rebel Fighters being shot down in their planes while landing on mats or other soft surfaces.

**Ride the Land Speeder:** At a certain point in the course, there are about 15 scooter boards parked by a wall. Each student rides one around two cones and returns to replace the scooter to its original position.

**Death Star Ledge.** The stegel now becomes the Death Star Planet. Walking across the balance beam(s) representing the ledge that Alec Guinness walked on and climbing the ladder to the top of the stegel represented the conquering of the Death Star. Once on top, students would then slide down to the mat and continue their journey through the galaxy.

**Rebel Reading Center:** As students passed these tables, they were to LOOK at the souvenir items brought in by other classmates.

To begin the action of the course, each student found his own place in the galaxy and started from that spot. The challenge was to see how many times they could get through the course with quality space travel. Travelers were also told to avoid any obstacle that might have a waiting line. Simply skip it and get through it the next time around.

The "Star Wars" obstacle course worked well with all grades. The kindergartners, rather than remembering all of the path directions, simply went to a station until a signal and then they would move to another area. For the kindergartners, it was the "Star Wars" experience course.

The course was designed so that no one had to have seen the movie. The actions at each station were quite self-explanatory. The newspaper was notified and parents and administrators were invited to attend.

Good luck on your course design. Warning: the students' excitement for moving may be contagious. "May the Hustle be with you."

## 2. SHARED VICTORY (A Collection of Unusual World Records)

by Ron Jones

*Trying to provide an introduction to "Shared Victory" is like trying to describe the smell of a rose—it must be experienced. Read the following article and enjoy it. Ron Jones is a Recreation Director, San Francisco Recreation Center for the Handicapped.*

### HOW IT ALL STARTED

I painted pink lines down the middle of the street. Racing lanes carved in asphalt with thick enamel. Before the paint dried I looked up to find a group of racers anxious to test this "do-it-yourself-track." The athletes were from the San Francisco Recreation Center for the Handicapped. That's where I work. And it was my job to get these young men and women ready for the Special Olympics. This was our first practice session. I carefully explained how a race starts and how you run in your lane and how to run as fast as possible. Everyone was ready. Each lane was filled with giggling bodies waiting to explode. Some rocking back and forth, others leaning forward and a few jumping up and down. I strung a tape at the finish line from a fire plug to a telephone pole. Then announced in a yell—"On Your Mark—Get Set—Go!"

Heads bobbing, arms flying, the racers careened like runaway bumper cars toward the finish line. Their wavelike rush, caused me to yell excited encouragement, "Come On! Come On!" The runners picked up this call and started yelling for themselves. "Come On!" "Come On!" The screams got closer to the finish. A few yards from the tape one youngster, then another, broke from the pack and was clearly going to reach the line in a one, two finish. That's what I thought. That's what I had seen all my life. That's what I had coached. I was wrong.

At the last possible second the lead runner suddenly stopped—grabbed the tape with one hand and reached backward with the other hand. The onslaught of other runners caught up with the first racer, then took the outstretched hand of their friend. When all the racers were holding hands they crossed the finish line in a walking heap. Jumping up and down. Laughing. Yelling. Holding on to each other in triumph. Surrounded by strands of finish tape.

Accustomed to races that have a single winner, a solitary figure slashing the finish tape, I didn't know what to say or do. What I saw was somehow all wrong. But then it was also very right. In their jubilation the runners broke my concentration with another irreverence. "Did we break a World Record?" "Did we?" "Was it a World Record?" I couldn't say no. I mean, who was counting? So I said loudly, "Yes!" That did it. The runners slapped hands, hugged, examined each other's shoes and pointed one finger in the air. This gave me a moment to reconsider what had happened.

Even the Chinese, with their motto of "Friendship first, competition second," could be in awe at this display of a "shared victory." Surely no other race in history had the apparent winner turn and wait for the other contestants. And, no race in history had the runners cross the finish line holding hands. It had to be a World Record, a New World Record. I began to think that perhaps there could be more World Records of this kind. World Records that have never been attempted before. World Records of cooperation, play, and inventiveness. World Records that express the challenge and enjoyment of a "shared victory."

The following section describes work in progress toward the discovery of some new World Records. The record holders mentioned are participants and staff members of the San Francisco Recreation Center for the Handicapped. Many of the participants are physically handicapped and most are mentally retarded. Some of the records are accompanied by marks of excellence. Others simply report an event in progress. The important quality of these records is that you and your friends can try them out and hopefully create some of your own. You might say that we've reached some temporary finish line and want to cross with you.

## SOME SAMPLE WORLD RECORDS

### Tallest Inner Tube Sandwich

The World's Record for the tallest inner tube sandwich is seven people compacted in between seven inner tubes. To try this record, place an inner tube on the ground. That's easy. Now lay a willing person, hopefully someone who is large, across the inner tube. It works best to lie across the inner tube with your belly snuggled into the center of the tube. Now you've got the idea. One tube followed by a person, followed by another tube and another person and so on. It's all right to have lots of help in the stacking process. In fact that's sometimes the best job. Don't be afraid to recruit passersby to join in your quest. All they have to do is lie on a tube. Who knows, they might be a part of a World's Record—that is, if they can keep from laughing.

### Tallest Paper Cup Tower

The World's Tallest Paper Cup Tower is unknown. That doesn't mean that effort is lacking. Or ingenuity. Or teamwork. It's paper cups and plates. They keep running out. Some recorded accomplishments are paper cup towers of twenty-six feet; thirty-one feet, three inches; and thirty-four feet, eight inches.

I should warn you that one enterprising group of tower builders deferred the bearing wall technique or hold-it plan in favor of taping some cups to the ceiling. They worked their way down—a distance of thirty-six feet. It's interesting to note that other builders faced with this upside-down phenomenon just kept right on building. It seems the building might be more enjoyable than reaching some ultimate height.

### Most Catches of a Tennis Ball with a Fish Net

If you think it's fun throwing balls at a stationary barrel, then consider the prospect of throwing at a target that moves to "swoop up" your throw. It takes two or more people to play Fish Net. The object is to see how many tennis balls can be thrown and caught in a fish net. Players can stand far apart, on opposite sides of a volleyball net, or even back to back. There can be more than one person throwing balls to the catcher with the fish net. The throwers can be blindfolded and asked to throw to a sound-producing catcher.

One accomplishment you might note is a record 163 catches without a miss. In this record attempt the throwers alternated throwing arms and bounced the ball to the catcher.

### Longest Inner Tube Hug

Start with two people facing each other. Now place an inner tube between them and ask them to hold the tube. That's easy. Now place a second inner tube between the two holders. That's easy. Now squeeze a third tube and a fourth and a fifth, sixth, seventh, eighth . . . Yes, the people "bookends" have a jellied mass they must try to hold and balance. Belly pushing is an apt description of the technique used to hold more than six inner tubes.

The World Record for greatest number of inner tubes supported accordion-style between two people is seventeen. The World Record for the longest hug using one inner tube as a chaperon is nine seconds. Both these records are extremely vulnerable to the East Germans and other Olympic contenders.

### First Human Domino Game

I'm sure you've seen the elaborate set up of dominoes followed by their collapsing march. Well, consider for a moment what could happen if the dominoes placed so close to one another were not chips of wood but people. Ah, now, that's an interesting proposition.

To play Human Dominoes, sit as many people as possible as close as possible in a formation of choice. Then, have the human dominoes stiffen. On a signal the lead person can fall backward, setting off a chain reaction of falling bodies. The World's Record for the longest human domino chain is one hundred eight people.

Now that you have the idea of falling together, you might try some creative dominoes. Can the group sit up together—lean one way together—lean another way together—stand up together—roll over together? These group moves require a lot of strength and a lot of cooperation.

Perhaps the best group exercise developed during a play session with human dominoes was suggested by Emery Weed. Emery normally works in aquatics, but seeing a domino game developing, he grabbed a place at the end of the line. While I was standing at the front of the line frantically instructing the group about the next stunt, Emery started massaging the neck and back of the person in front of him. And that person started doing the same for the person in front of him. And so on. I could n't figure out why or how the group suddenly went from hyperactive to relaxed snooze. Then the massage reached the first player who, having no one to reciprocate the back rub, asked me to sit down. I sat and enjoyed the massage. The World's Longest Domino Set became the World's First and Longest Group Massage.

### 3. FINE MOTOR DEVELOPMENT— SOMETIMES NEGLECTED?

by Joanie Verderber

*Movement is often classified as either fine or gross motor development; the physical educator is responsible for the latter. This article suggests that both the classroom teacher and the physical education teacher cooperatively give more attention to fine motor development. The author provides resources, planning strategies, teaching suggestions, assessment and recordkeeping techniques. Joanie Verderber is an Adapted Physical Education Teacher in the Office of the Los Angeles County Superintendent of Schools.*

Physical educators, more often than not, leave their colleges and universities significantly more prepared to teach gross motor skills than fine motor ones. They can effectively break a skill down into its component parts, analyze a jumping pattern, and teach sports and lead-up games with confidence. Since it is much easier to avoid something we are unsure of than to risk embarrassment, fine motor development is often neglected or dealt with minimally. (In this article, fine motor skills refer to those small muscle activities done primarily with the hands, thumbs, fingers, and wrists usually at a table or desk.)

Classroom teachers often incorporate many fine motor activities into their daily lesson plans which assist in "rounding out" the total curriculum. With the classroom teachers doing some fine motor work and the physical educator thus concentrating on gross motor activities, all seems well, with the exception of one flaw. Classroom teachers, parents, and many administrators regard physical educators as specialists in *all* areas of movement. If the task is movement-oriented, the physical educator is viewed as having the ability to analyze the skill, make appropriate suggestions for lead-up activities and advise parents of activities and materials for home use. The physical educator is often considered to be an authoritative resource.

It may not be necessary for the physical educator to teach a number of fine motor skills when support is received from other sources or when the student lacks the need for this instruction, but it is necessary for the physical educator to have the ability to assist when needed. This resource concept is not far from reality since the skills used in analyzing gross motor movements transfer easily to fine motor activities. The physical educator has the ability to become an expert in the area of fine motor

development. To become proficient in this area, one must be willing to invest some time. There is a need to gather materials, to identify tasks, to locate educational and commercial products, to sequence activities, and to assess levels of functioning. Some of this has already been done and will be presented in an attempt to aid those who are interested.

One may begin simply by gathering materials. The physical educator should become familiar with the items currently available from educational suppliers and toy stores. One should remember that the commercial market is an excellent source since it carries a large variety of fun and challenging games which often require fine motor and/or perceptual motor skills. Both of these sources while being extremely useful can also be costly and time consuming; we have all experienced placing an order, waiting at least four months, and then receiving only part of it. If the physical educator is willing to invest a little time and money while waiting for the order to come in, there are two other excellent sources: swap meets and garage sales. The items here are a lot less expensive and often can be picked up for under a dollar. Sometimes a used item may be a little damaged, but if it is still functional, the children will enjoy it just the same. Garage sales and swap meets also are excellent suggestions for parents with limited funds. Then there are all of those common things, just lying around, waiting to be gathered. The following list, which is by no means exhaustive, can aid the physical educator in getting started. These items are generally found in the home and at school in relative abundance.

beads  
beans, dried

bottles and caps  
boxes and lids

buttons	pegboard
cans	pencils, regular
chalk	and colored
clay	pens, ball point
clothespins	and marking
construction paper	pins, straight
cork board	and push
corks	plastic bottles
cotton balls	and spouts
crayons	playing cards
crepe paper	poker chips
ditto master	popcorn
duplicator paper	popsicle sticks
egg cartons	rubberbands
elastic	screwdriver
eye dropper	screws
fabrics	scissors
food containers	shoelaces
furniture tacks	spools
glitter	straws
gummed stickers	string
hairpins	styrofoam
hair rollers	tape
jars, lids and rings	thread
leather strips	tongue depressors
macaroni, spaghetti	tongs
magazines	toothpicks
magnets	tubes, paper
nails	and plastic
needles	tweezers
nuts and bolts	wallpaper
packing material	washers
paint brushes	wire
paints	wood
paper clips	yard

There are a number of fine motor movements and activities; each one requires a separate listing. Examples of movements and activities follow. It should be noted that many items commonly referred to as independent living skills are not included; an occupational therapist, classroom teacher, or perhaps a physical therapist can help you in this area. Independent living skills are not dealt with fully in this presentation due to the fact that they are usually part of the curriculum for many special education students.

assemble (with directions)	pincer grip
build	pour
chain	press
color	pull, remove
copy	push, insert
cut	put into place, release
draw	rub
drop, release	scratch, scrape
fit forms, puzzles	screw, turn, twist
flick	shake
fold	sort
grasp, grip, hold	squeeze
hit, strike	stack
lace	stitch
lift, raise	stretch
manipulate mediums (clay)	tie
mix	trace
paint	weave
paste, glue, stick together	wind
	wrap
	write

The physical educator who would like to spend more time on fine motor activities is presented with perfect times throughout the school year on those rainy and smog alert days. Fine motor skills often require little more than space for tables (desks) and chairs. If the physical educator is itinerant, a classroom or cafeteria may be used without moving furniture. It is best to store a box of fine motor activities at each school and when the need arises, the materials will be there. Often a classroom teacher will gladly provide a space for storage.

After the material-gathering process has begun, there is a need to organize activities into a format if the resource model is to be expanded. A simple scheme [Table 1] follows which can facilitate this process and is easily adaptable to 5" x 8" cards or to notebook paper.

Once a movement or activity has been identified, the next step is to sequentially list materials in the proper columns of homemade or gathered items, educational supplies, and commercial products. The numbers to the left in the model assist in this sequencing with number one being the easiest. [Table 2] illustrates this process. As one can see, the material listings are totally dependent upon the materials the physical educator has or is aware of and his/her ability to sequence. One should also note that several items can be grouped at the same level of difficulty and these can span the categories.

The last column on the listing card or sheet refers to areas of concentration. The physical educator may use this column to further describe the movement or activity when certain materials are used. Some of the descriptors may include: unilateral coordination, bilateral coordination, strength, accuracy, flexibility, and control. Conceivably, the card or notebook file could also be divided

**TABLE 1**  
Movement or Activity

Homemade or Gathered Items	Educational Supplies	Commercial Products	Areas of Concentration
1.			
2.			
3.			
4.			
5.			
etc			

**TABLE 2**  
Stacking

Homemade or Gathered Items	Educational Supplies	Commercial Products	Areas of Concentration
1. boxes with lids food containers	large plastic geometric shapes		
2.	1" cubed wood blocks	Tinker Toy discs	
3. corks with flat bottoms & tops			
4.		Stacking Clowns	

into categories corresponding to the areas of concentration. For example, the physical educator may prefer to have a system by which he/she can quickly find activities and materials which would enhance strength development while also being able to look up individual movements and activities. This cross-referencing would expand the system, but regardless of the organizational structure, one can see the potential usefulness of this resource tool.

Two other areas, assessment and record keeping, are of concern to the physical educator. Many assessment tools deal entirely or in part with some aspect of fine motor skills. A list of some of these is provided below.

- Arthur Point Scale of Performance Tests—Form 1
- Bruininks-Oseretsky Test of Motor Proficiency
- Developmental Test of Visual Perception, Marianne Frostig
- Grooved Pegboard

- Manipulative Aptitude Test
- Minnesota Rate of Manipulation Test
- Minnesota Spatial Relations Test
- O'Connor Dexterity Tests
- O'Connor Tweezer Dexterity Test
- Pennsylvania Bi-Manual Worksample
- Pintner Manikin And Knox-Kempf Profile Tests
- Purdue Pegboard Test
- Purdue Perceptual-Motor Survey
- Schiller Visual-Motor Diagnostic Program
- Southern California Sensory Integration Tests
- Test And Training Materials for Manipulative Dexterity and Vocational Readiness
- Visual Motor Inventory, Beery
- Visual Perception Assessment Program, Deborah Tiersch-Allen

As can be seen by the titles above, many of these tests assess perception as well as some aspect of fine motor skills. It is common knowledge that no one standardized test or inventory can accurately measure all aspects of movement, gross or fine. While the above instruments are necessary for credibility when determining need, one must not neglect the area of criterion-referenced testing. This method identifies the necessary components of a specific skill as well as identifying which components the student can and cannot perform competently. The ability to use criterion-referenced testing is directly related to the

physical educator's skills of analysis and observation. These abilities were referred to earlier and are commonly dealt with in colleges and universities as related to gross motor skills.

Record keeping can also present a problem. It is convenient to have a method by which one can consolidate a student's fine motor work. The following system has proven useful. Record keeping cards were made for each student by using a ditto duplicating process and 5" x 8" blank cards. Figure 1, has been modified slightly to present an alternative to the scoring code.



Name \_\_\_\_\_ Individual Fine Motor Activity Card

Scoring Code 5 = excellent, 4 = good, 3 = satisfactory, 2 = measurable difficulty with task,  
1 = extreme difficulty with task, 0 = cannot perform task

Movement, Area or Activity	1	2	3	4	5	6	7	8	9	10	Avg
etc											

Figure 1

The physical educator may list movements and activities or areas of concentration to the left and then place a score in each corresponding box after the student completes a fine motor task. If gummed stickers are available, the students enjoy putting a sticker in a box each time they complete an activity. The physical educator can write the scoring number and equipment used on top of the sticker for reference. This method permits the children to take their work home, reduces the amount of paper the physical educator needs to keep for reference, and keeps the educator aware of the students' progress. The average score is then easily achieved after the student completes ten items. A behavioral objective could be written for an increase in the average score.

The methods have been described and all one needs

to do is to make a commitment. There are numerous publications available to help you get started. A few are listed below and the rest is up to you!

"A Child Goes Forth," 5th Edition Revised, Barbara J. Taylor, Brigham Young University Press, Provo, Utah, 1980

"Basic Shapes, Cut and Paste, Word Relationships," Spirit Duplicating Masters, Patricia Ryan Sarka, Frank Schaffer Publications, Inc., Rancho Palos Verdes, Calif.

"Color-Cut and Paste," Ditto Masters, Grades 1, 2, 3, Joy Evans and Jo Ellen Moore, Frank Schaffer Publications, Inc., Rancho Palos Verdes, Calif.

"Color the Squares, Things That Go," A Whitman Book, Western Publishing Company, Inc., Racine, Wis



"Designs to Color" Book 1, Book 2, Book 3, Book 4, Book 5 (all individual publications), Betty Schaffner, Price/Stern/Sloan Publishers, Inc., Los Angeles, Calif.

"Getting Ready for Kindergarten," Duplicating Masters, Patricia Ryan Sarka, Frank Schaffer Publications, Palos Verdes Peninsula, Calif., 1979

"Learn to Fold—Fold to Learn, Teachers Edition," California State Series, published by Calif. State Dept. of Education, Sacramento, 1970

"Pre-school Games and Activities," Sandra Zeitlin Taetzch and Lyn Taetzch, Fearon Pitman Publisher, Inc., Belmont, Calif., 1974

"Reading Readiness, Fine Motor Skills," Patricia Ryan Sarka, Spirit Duplicating Masters, Frank Schaffer Publications, Palos Verdes Peninsula, Calif., 1979

"Sensorimotor Activities for the Remediation of Learning Disabilities," Academic Therapy Publications, San Rafael, Calif. 1977

"Workjobs, Activity-Centered Learning for Early Childhood Education," Mary Baratta Lorton, Addison-Wesley Publishing Company, Inc., Menlo Park, Calif., Reading, Mass.; London; Don Mills, Ont., 1972

## 4. IEP's AND MASTERY LEARNING APPLIED TO PSYCHOMOTOR ACTIVITIES

by Jim R. Chambless, Eugene Anderson, and Jennifer H. Poole

*Research into the motor ability of retarded children consistently shows that they are between two and four years behind their normal counterparts. The authors offer the mastery learning approach as advocated by Bloom as a remarkable educational process for learning when applied to the psychomotor domain. They have found their adaptation of this sequentially prepared, behaviorally oriented process very effective in improving the motor skills of mentally retarded children. Jim R. Chambless is Associate Dean of the School of Education, and Eugene Anderson is an Assistant Professor of Health, Physical Education, and Recreation at the University of Mississippi, University. Jennifer H. Poole is Director of Activities, Badour Memorial Center, Senatobia, Mississippi.*

Physical education can play a vital role in the learning process of mentally retarded children. Through the physical domain it is possible to dramatically alter the self-concept and self-esteem of the mentally retarded child in a positive manner. Although the advantages from the physical education program are primarily in the affective and psychomotor domains, the positive gains from these two domains can be readily transferred to the cognitive domain in the form of "Extrinsic Motivation for Success" (10:418; 11:178; 4:2-3).

In one study, 284 mentally retarded children with IQ's ranging from 50 to 90 and chronological ages ranging from 7.5 years to 14.5 years were given a battery of 11 gross motor tests designed to measure strength, power, balance, and agility. The researchers concluded that these children were two to four years behind the maturation levels of normal children and the discrepancy increased with each advancing age level (5:792).

Another study, comparing the motor skills of mentally retarded and normal children, revealed similar results. In this case, normal children began at higher levels and achieved higher absolute scores. This was particularly true in areas of strength and balance (6:352).

The sequence of motor development for both mentally retarded and normal children seems to be very similar; however, the retarded child progresses through the sequence at a slower or delayed rate. This is substantiated by studies which found that the motor development of mentally retarded children followed essentially the same trends as those of normal children. Flex differences in retarded boys and girls were similar to those noted in normal children, the boys showing superiority in all tests and at all ages (3:447-56; 8:509-19). Since the sequential phys-

ical development is the same for both the mentally retarded and the normal child, physical education programs for the retarded may be accomplished through a progressive set of learning tasks. Physical educators need to remember that although the mentally retarded are less able in many ways, they deviate less in motor ability than in any other characteristic.

Mastery learning as advocated by Bloom provides a remarkable educational structure for learning when applied to the psychomotor domain. The three primary components of this theory are *Student Entry Characteristics*, *Quality of Instruction*, and *Learning Outcomes* (2:9, 11). Psychomotor and affective entry characteristics for mentally retarded children are generally adequate in the psychomotor domain, particularly when compared to cognitive development. Most mentally retarded children have had some success in the psychomotor domain. If they have not, they can generally be readily elevated by verbal reinforcers of praise and self-testing activities that tend to bring strong intrinsic rewards to the learner.

The quality of instruction becomes crucial in mastery learning as it is in other types of learning theory. In other words, for psychomotor learning the "teaching" rather than the "teacher" is central, and the "environment for learning" rather than the physical characteristic of the class and physical activity is important. *Quality of Instruction* has been defined in terms of the "degree to which the presentation, explanation, and ordering of elements of the task to be learned approach the optimum for a given learner" (2:111). We accept this definition in part but with an important addition for our special population.

*Stability of presentation* is essential to the psycho-

motor learning process of the mentally retarded child. Our definition of this term refers to an orderly and systematic framework of presentation that maximizes the utilization of the mentally retarded child's senses. Within this framework four key elements of instruction occur—cues, participation, reinforcement, and feedback/corrections.

The Stability of Presentation Model that we devised to use with EMR and TMR children at North Mississippi Retardation Center is based on seven steps in the teaching of a learning task. The seven steps are as follows:

1. *Physical Demonstration*—the presentation of a psychomotor learning task (by the instructor or teacher aide) in its entirety. The purpose is to provide the students with a visual picture.
2. *Verbal Explanation*—an explanation of a learning task accompanying the physical demonstration which is enthusiastic and animated. (Students often request a repetition of the demonstration and explanation and such requests are granted.)
3. *Manual Manipulation*—actual manipulation of the student through each segment of the psychomotor learning task by the teacher or teacher aide.
4. *Minimal Physical Assistance*—limited physical contact between teacher and student.
5. *Verbal Prompt*—no physical contact between teacher and students. Each student receives verbal instruction and reinforcement as needed.
6. *Upon Request*—implies student mastery of the psychomotor learning task and the ability to perform the task when requested.
7. *Mastery Demonstration*—the incorporation of a variety of psychomotor learning tasks into a single combination or routine. The mastery demonstration is conducted before an audience composed of other students, teachers, teacher aides, parents.

Cues, participation, reinforcement, and feedback/corrections are used to varying degrees within each of the steps of the Stability of Presentation Model. Cues include visual, auditory, and kinesthetic stimuli as well as directions as to what the learner is to do in the psychomotor learning process. Students must understand or compre-

hend the cues in order to make use of them. The primary cue is a physical demonstration of the psychomotor learning task which the mentally retarded student is to reproduce. Cues may also be in the form of verbal expressions or sequences provided by position or spatial location (2:94-95). They generally become stronger by repetition, by adding dramatic intensity, and by other arrangements which bring them to the learner's attention. Physical educators need to keep in mind that cues which are easily understood in one form by some students will have to be expressed in other forms to become meaningful to other students.

Unless the learner can practice the cues, meaningfully through *participation*, the cues are useless. The *Stability of Presentation Model* moves from passive to active participation on the part of the learner. *Participation* or the amount of practice, particularly in the initial learning stage, is directly proportionate to the learning of a psychomotor task. Task specificity is essential in the structure of a learning task. Thus each segment of the psychomotor learning task must be identified and must have a specific instructional methodology. Repetition or practice of each segment is also essential in the mastery of a psychomotor learning task (7:227-28). All participation need not be overt and observable, however. Individual students differ in the amount of practice needed to master a psychomotor learning task. They often learn from their peers through several different modes of communication which may or may not be observed by the teacher.

Mentally retarded students are provided *reinforcement* in many ways, including simple recognition, attention, close physical proximity, gesturing, smiling, frowning, and verbal praise. Research at the North Mississippi Retardation Center found the preceding reinforcers more effective with residential clients than tokens or candy. In addition, reinforcers are available from sources other than the teacher; however, the teacher must plan and orchestrate the appropriate delivery if they are to be effective. As mastery occurs, the frequency of reinforcers decreases but intensity increases, with the greatest number occurring in the initial steps of the learning task.

The psychomotor mastery learning model is highly dependent upon the feedback/corrections component. With mentally retarded students, even the best use of cues, participation, and reinforcement will be differentially effective for individuals. A set of cues or the amount of participation or practice that is optimal for one child may be inappropriate for another. To maximize the efficiency of the learning process, it is essential that feedback (positive and corrective) be offered each student as soon as possible (9:94-99). Thus, teachers must have different approaches or alternative cues in their repertoire; as well as plans for additional practice time.

We have constructed a Schedule of Instruction to assist the teacher in evaluating each segment of the psychomotor learning task. Table 1 presents a psychomotor task entitled "Line Walking," which is the first psychomotor task of a progressive stunts and tumbling curriculum that we have tested. A comparable Schedule of Instruction should be prepared for each child with each psychomotor task partitioned into key progressive segments. This enables the teacher to identify and evaluate the components to be learned. It is also a starting point for the next session. By organizing curricular material in this manner, the teacher has a head-start on a meaningful Individual Educational Plan for the mentally retarded child.

Using a psychomotor mastery learning model requires a great deal of teacher time initially, as well as the assistance of some student aides. However, we believe that any psychomotor activity can be adapted to this model. In our progressive stunts and tumbling model, for example, the residential mentally retarded students achieved 74 percent mastery after four one-hour sessions each week for eighteen weeks. They also showed dramatic improvement in selected motor performance parameters related to occupational skills.

TABLE 1  
Schedule of Instruction

Date Initiated				Skill and Stunt	Date Mastered			
1	2	3	4		1	2	3	4
				<p>1 Line Walking according to given directions</p> <p>The student will be able to</p> <p>1.1 Stand with the weight evenly distributed on two feet</p> <p>1.2 Step forward and maintain erect body posture while transferring weight from one foot to the other</p> <p>1.3 Transfer his/her weight from heel to toe with arms in opposition to the legs</p> <p>COMMENTS The instructor should provide verbal cues allowing students to change direction on command. Alternative Method Many gymnasiums have color-coded boundary lines for various courts which can be used for determining changes in direction.</p>				

References

1. Bell, Virginia Lee. *Sensorimotor Learning*. Pacific Palisades, Calif. Goodyear Publishing Co., 1970 (pp. 94-95)
2. Bloom, Benjamin S. *Human Characteristics and School Learning*. St. Louis: McGraw-Hill Book Co., 1976.
3. Dobbins, Alan, and Rarick, G. L. "Structural Similarity of Motor Domain of Normal and Educable Retarded Boys." *Research Quarterly* 46:447-56; December 1975.
4. Edson, Tom A. "The Role of School in Stimulating Physical Development of Mentally Retarded Children." *Physical Activities Report* 449:1-8; August 1979.
5. Francis, R. J., and Rarick, G. L. "Motor Characteristics of the Mentally Retarded Youth." *Journal of Mental Deficiency* 63:792-93; March 1959.
6. Howe, Clifford E. "A Comparison of Motor Skills of Mentally Retarded and Normal Children." *Journal of Exceptional Children* 25:352-53.

7. Marteniuk, Ronald G. *Information Processing in Motor Skills*. Atlanta: Holt, Rinehart and Winston, 1976 (pp. 227-28)
8. Rarick, G. Lawrence; Widdop, James H.; and Broadhead, Geoffrey D. "The Physical Fitness and Motor Performance of Educable Mentally Retarded Children." *Journal of Exceptional Children* 36:509-19, March 1970.
9. Robb, Margaret D. *The Dynamics of Motor-Skill Acquisition*. Englewood Cliffs, N.J. Prentice-Hall, 1972 (pp. 91-99)
10. Sage, George H. *Introduction to Motor Behavior—A Neuropsychological Approach*. Reading, Mass.: Addison-Wesley Co., 1971 (417-21)
11. Singer, Robert N. *Motor Learning and Human Performance*. New York: Macmillan Co., 1971 (178-81).

## 5. THE MOVEMENT MYSTIC

by James L. Ballinger

*This article reviews the neurophysiological basis of movement as it applies to the development and refinement of readiness skills for learning with particular emphasis on the concept of time and the use of relaxation. James L. Ballinger is the Director of the Perceptual Motor Laboratory, University of Missouri, Columbia.*

Educators in the field of physical education have for a long time taught various types of motor activities, giving attention to the contribution of these activities to general health status, physical fitness, the social adjustment of the individual, and the provision of leisure time activities, etc. Little attention, however, has been placed on the importance of these motor activities in the development of the learning process itself.

Little attention has been given to the Caloric test and other similar reflex assessments, to the development of the vestibular organs, to the release given to the oculomotor pathways, and to the role of the corpus colosum in making an asymmetrical response on a bilateral nervous system. It is time to examine their respective roles.

In this society the primary responsibility of the child is that of learning. Our society frees the child for this enormous learning task, and to a large extent, relieves him of any other responsibilities. Thus, the child is presented in his childhood days with situations which will permit him to interact with the environment in such a way that the necessary skills, knowledge and attitudes can be acquired for living in our complex society.

The motor activities which contribute to the child's exploration of his environment may be of the greatest significance for education since the young child gains his information about his environment through exploration—this exploration involves movement through space and the manipulation of objects. These are dependent upon motor (movement) activities and the ability to control motor responses. The generalized movement patterns have been divided by Kephart into four categories: (1) balance and posture in which the force of gravity is the zero point for all spatial relations; (2) locomotion involving the exploration of space; (3) contact patterns which are concerned with the exploration and manipulation of objects; and (4) receipt and propulsion involving the exploration of objects in space.

The child through balance and posture activities is able to become spatially oriented to discern up from down, right from left, front from behind, change weight

relationships around the center of gravity and to maintain gravity orientation while the body or parts of the body are moving; the child who has difficulty with this orientation can also be expected to have difficulty with locomotion.

Our program is based on the following concepts: (1) movement is basic to biological growth; (2) play is innate in the human organism; (3) stimulation is essential to the development of associative tissue in the child's mind-directed movement; (4) realistic perception is based on sensory stimuli modification by movement performance; (5) school readiness can be improved or hindered by perceptual-motor learning or deficiency; (6) the child's orientation to his world is revealed in his overt actions—READING the body can be learned.

Thus we establish a purpose for movement given in a purposeful manner. Using improvised equipment and activities developed so that the program can be taught in any area in which a class can meet, we develop a perceptual-motor physical education curriculum that any teacher, teacher's aide or parent can administer. It must be the total program or movement to an associated command; each unit making its contribution but making little contribution by itself.

By manipulation of the environment we hope to stimulate neurological organization within each child.

Due to the fact that much of our professional attention has been directed toward how the handicapped child reacts to space, I will direct more of my discussion toward the time element and to relaxation considered in the context of the handicapped child.

### TIME AND THE HANDICAPPED CHILD

The universe manifests itself as time, space, and motion. Time is the manifestation of man's conscious awareness of the rhythmic operation of the universe and rhythmic-cognitive time is expressed as a flow of thought. Man learns to recognize and discriminate between rhythm and disrhythm. The discrimination between

rhythm and disrhythm gives man a "time sense" (White, 1940). Having a time sense or being able to discriminate rhythm is vital to man's perceptual motor functioning both cognitively and behaviorally (Barsch, 1968).

Time can be divided into three components. These are synchrony, rhythm, and sequencing. Synchrony is the point of origin at which the response to a stimulus begins. Rhythm is a time scale characterized by equal, stable units. Sequencing is the ordering of motor events. These three concepts are interrelated and combine to produce a "time sense."

The content of time is psychological rhythm or the rhythm of the perceptual-motor behavior. Sidereal time is the rhythm of the universe. Man cannot change sidereal time as measured by clocks and calendars but he can partially control psychological time. It seems reasonable to assume, therefore, that man can be trained to consciously discriminate rhythmic time and thereby develop a synchronicity with the rhythm of the universe.

The rhythm of life is the basis of our experience with time. Most time concepts depend upon what the individual has learned through the verbal expression of the timing of events.

Until these concepts are learned, time is an illusion. Because much of the behavior of people is dependent on society's concept of time, some individuals spend a lifetime of discomfort and inefficiency because they are disrhythmic and have an inadequately developed "time sense." To build a "time sense," which will synchronize with what is expected of most individuals, a certain amount of tension must be built into the individual through reinforcement which will produce a need to complete a task (Hull, 1943).

Physiologic time is a person's own individual time sense and defines the various rates of time or rhythms occurring within the individual's system. The human organism receives rhythm as a biological grant. Circulatory, respiratory, digestive, and neurologic patterns of rhythm are built into the design of the developing fetus. Physiologic time rates or rhythms are generally stable but vary under certain conditions such as stress, threat, fear, etc. (Barsch, 1968). Locking the body into a particular time rate or rhythm is a formidable task (Barsch, 1972). The disturbance of one rhythmic rate in the body such as an irregular heart beat or a disrhythmic gait can cause other rhythmic rates to vary to the detriment of the individual. Any disturbance to internal body rhythm manifests itself in the visible behavior of the individual (Barsch, 1968).

As an individual moves, he spans time. Each move leads to a future time. Each stimulus is separated from each response by a span of time which depends upon a previous action. A link in the chain of action can be recalled or eliminated through the use of memory. People

mentally search for learned responses. Because it is possible to mentally search for learned responses, it becomes possible to discriminate between appropriate and inappropriate responses in terms of rhythmic perceptual motor movement.

The synthesizing process which can occur in rhythmic-cognitive time is important to learning appropriate responses to particular stimuli. Building a chain for perceptual motor responses is a matter of forging the links (Travers, 1972). Furthermore, it seems to me that a person can expect to achieve certain results through rhythmic-cognitive activities. The first step in this process is that of helping the individual become an active listener. The development of rhythmic-cognitive time is a part of the listening and learning process.

The individual must develop a competent listening and observing learning process system which can move either forward or backward through memory in cognitive time so that rhythmic cognitive awareness is developed. The individual develops links in proper sequence to produce a chain which has been refined so that appropriate responses occur to particular stimuli (Travers, 1972). Performance efficiency can be sustained only if rhythmic-cognitive time is not locked into and imprinted on the individual's neurological system, then accurate perceptual motor movement cannot be sustained. Responses must become tied to appropriate stimuli and wrong habits from past experience eliminated (Travers, 1972)

### Results of Disrhythmic-Cognitive Processes

Once the motor pattern is fixed in the proprioceptors, it is assigned to automatic status and appears as requested without conscious attention to mechanics. The maintenance of body balance and the expression of rhythmic patterns are fundamental to readiness for more advanced perceptual motor experiences. The poorly coordinated or disrhythmic performer must devote a disproportionate amount of attention to the mechanics of movement thereby giving up the freedom to cognitively explore. To insure cognitive freedom, the mechanics of movement must be relegated to "ground" status so that cognitive freedom can become the "figure." The problem of "how" to move is sometimes set so forcibly into the foreground that "why," "when," and "where" are forced into the background.

The purpose of rhythmic exercises is to produce a sensory-motor integration which will generate a higher degree of comfort to the individual in his spatial explorations. The person needs to be able to accurately discriminate (a) near space, the space within which a person can reach out and touch objects, before he can effectively discriminate; (b) mid-space, the space just beyond his reach, and from which he can move to retrieve objects; and

(c) far space, which he can see but cannot touch or retrieve, such as the horizon or the stars. At the end of an automatic pacing rhythmic program, the individual is able to execute both fine and gross motor skills in a rhythmic sequence which will increase (a) his self-awareness, (b) his self-esteem, (c) his skills in games, and (d) indirectly his efficiency in academic areas.

### Teaching Perceptual Motor Skills

The teacher only has control over what he tells the student to think about and little control over how the task is thought about. The instructions in perceptual motor movement include subvocal verbalization and visual imagery. The student moves in a step-by-step order and develops his own skill (Travers, 1972).

Mental practice (Ten Brink, 1976\*) triggers minute movement of the appropriate muscles when the student visualizes the moves he must make to complete a motor movement. However, whether mental practice is effective or not depends upon the nature of the skill and the extent to which a high-level cognitive process is involved (Travers, 1972). The muscle action of the student, determined by perceptual tests such as the Purdue Perceptual Motor Survey, should be compared to the potential of the student for the particular movement while the student is in a state of normal relaxation. Relaxation is a neuromuscular accomplishment that results in the reduction of tension in the skeletal musculature (Barsch, 1968). The teacher should experiment with different time durations to see if there is an optimal motor practice time for each particular student (Cratty, 1969).

### Relaxation and the Handicapped Child

As the child with learning disorders learns to differentiate he tends to fall into two general types on the basis of his overall movement behavior. First there is the hyperkinetic child who seems to be put together with a series of springs. His movements are explosive, rapid-fire, and extremely tense. He looks as though, to make the simplest movement, he must tense all the muscles in his body to the maximum. If he moves an arm, you can see tension directly in the shoulder, trunk, and even the legs and feet.

The second type of child is the opposite. He is hypokinetic. Overall muscle tonus is low at all times. He slumps down and lops around. He has sometimes been called the "limp rag syndrome." His posture is limp and lacks tonus. If he moves an arm, only a mere minimum of muscle tension is developed. He appears to put forth only as much effort as absolutely necessary to produce overt

movement. General tonus, even in the moving arm, is extremely low at all times.

Kinesthetic stimulation is the sensation arising from the muscles and joints which tells the child the position of his limbs and changes in those positions which accompany his movements. The intensity of this kinesthetic stimulation is proportional to the intensity of the movement and the level of innervation of the muscles involved. Where muscle tension is high, kinesthetic information is high. Where muscle tension is low, kinesthetic information is limited. It is through this kinesthetic stimulation that the child becomes aware of his movements and of the position of the parts of his body.

In both the hyper- and hypokinetic child, one can hypothesize a failure to develop a kinesthetic figure-ground relationship. The well-known visual figure-ground is possible because of a recognition of contrast between the area of the figure and the area of the ground. The figure stands out in contrast to the ground. It can be considered that somewhat the same function occurs in the kinesthetic field. The pattern of muscles required to perform a given movement stands out over the pattern of the remaining musculature. The kinesthetic figure-ground relationship is created.

Such a relationship is recognizable only if the kinesthetic stimulation from the figure movement is sufficiently different from that of the ground to permit it to be readily identified. Such a necessary contrast may well be absent in the case of both the hyperkinetic and the hypokinetic child. In the former case, the kinesthetic level of the ground stimulation is so high that, when the figure is activated to its maximum, it is still little different from the ground. Even though the required movement is as strong as possible, there is not sufficient contrast to permit it to be recognized as different from the ground. It fails to stand out as figure because the level of the ground is too high.

In the case of the hypokinetic child, his level of kinesthetic stimulation is uniformly low. When he moves, the movement is made with an absolute minimum of effort and hence produces a minimum of kinesthetic stimulation. The pattern stimulation from the movement is so limited that it does not rise out of the ground and contrast with it. The figure-ground relationship is not recognizable because the level of the figure is too low.

Thus in both the hyperkinetic child and the hypokinetic child, kinesthetic figure-ground is difficult to develop. In such problems as perceptual-motor matching, eye-hand coordination, eye-foot activities, and complex motor coordinations, it would seem important that a kin-

\*In a personal conversation with the author concerning unpublished monograph.

esthetic figure-ground relationship exist so that the necessary comparisons between perceptual data and response data can be made. Without such a relationship the child cannot use perceptual data to determine a purposeful response but can only relate it to a vague overall movement which cannot be made directly applicable. The child has difficulty sorting out a particular response purposefully related to the perceptual data. Problem solving, either by perceptual information or motor information, becomes difficult.

In the training of children with these movement problems, the initial attack is designed to increase the contrast between the prescribed movement and the remainder of the musculature so that the figure-ground relationship in the movement can develop. In the case of the hypokinetic child, such training is directed toward raising the level of energy in the prescribed movement. Resistance is introduced so that the child is required to expend greater effort to overcome the resistance to the movement. Moving the arm with a weight held in the hand or pushing against the hands of the teacher are methods of introducing such resistance.

In the case of the hyperkinetic child, the training is designed to reduce the level of the background activity. The child is induced to relax as completely as possible and is aided to reduce the tonus of the overall musculature. A simple movement is then prescribed and the child is helped to produce this movement while remaining relaxed in all muscles not directly involved in the movement.

### Level of Kinesthetic Stimulation

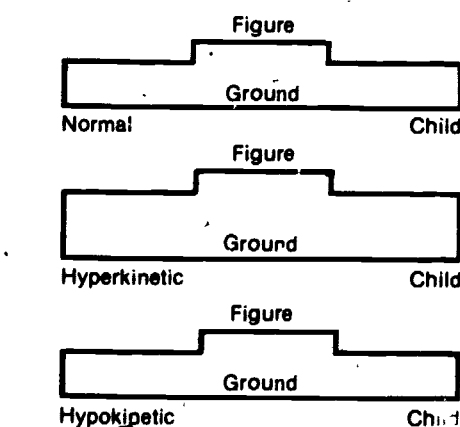

## Will Perceptual-Motor Training Improve Academic Functioning?

Improvement in school studies is the responsibility of the academic teachers. A reading teacher improves the reading ability of children. A language teacher improves the communication skills of verbally impaired children. A perceptual-motor specialist improves the perceptual-motor ability of children. However, by reviewing the subskills of academic readiness and perceptual-motor proficiency, commonalities between the two will be discerned. Following is tabled the subskills of both reading readiness and also skills emphasized in perceptual-motor training.

Reading Readiness	Perceptual-Motor
1 Auditory Discrimination	Body Image
2 Auditory Memory (short-long)	Directionality
3 Attention Span	Laterality
4 Figure-Ground Discrimination	Form Perception
5 Form Perception	Figure-Ground Discrimination
6 Visual Comprehension	Visual Auditory Memory
7 Vocal Expression	Fine-Motor
8 Association	Balance
9 Space Awareness	Uni-bi-cross Lateral Movements

If a child seems to improve functioning in academic areas, it is probably because the child has learned how to read, write, or compute. Perceptual-motor training, therefore, prepares a child in readiness skills in order for learning to occur.

This is an eclectic program based on research by Getman, Sherrington, Hebb, Piaget, Gesell, Kephart, Frostig, Montessori, Doman, Delacato and others.

### References

- Barsch, R. H. *Enriching Perception and Cognition Techniques for Teachers* Vol 2 Seattle: Special Child Publications, 1968.
- \_\_\_\_\_. *Each to a Different Drummer*. Canoga, Calif.: Center for Learning, 1974.
- Cratty, B. J. *Fifty Vigorous Games for Atypical Children*. Freeport, N.Y.: Educational Activities, Inc., 1968.
- \_\_\_\_\_. *Motor Activities and Education of Retardates*. Philadelphia: Lea and Febiger, 1969.
- Hull, C. I. *Principles of Behavior*. New York: Appleton-Century-Crofts, 1943.
- Travers, J. P. *Learning Analysis and Application*. 2d ed. New York: McKay Co., 1972.



## 6. PERCEPTUAL-MOTOR ACTIVITIES FOR CHILDREN WITH LEARNING DISABILITIES

by Robert E. Kraft

*Perception and cognition have long been known to be interrelated. Their relationship to motor skills has only recently been explored. This article suggests the relationship of the perceptual-motor process to the acquisition of cognitive skills in a simple and pragmatic manner. In addition, it provides many specific games and skills which may be helpful to the teacher in implementing a rich perceptual motor program for students. Robert E. Kraft is an Associate Professor, College of Physical Education, University of Delaware, Newark.*

How does perception relate to readiness for learning? Can teachers teach children perception? How do cognitive structure and perception relate to motor skills?

The perceptual-motor process integrates what the child perceives through the senses with an appropriate motor response. One of the causes of learning disabilities is a deficit in the perceptual-motor process, and adequate perception is a prerequisite to academic success. Perceptual-motor skills integrate cognitive skills with physical movements. Since children entering first grade are at various perceptual levels due to maturation lags and sensory experiences, the use of movement as a learning modality can enrich their experiences and bring perceptual deficits to the surface.

This article describes a variety of meaningful, creative perceptual-motor activities especially appropriate for children with cognitive or motor deficiencies, which teachers can implement with limited space and equipment. During the course of the activities, which are enjoyable in themselves, children should be permitted to express what they hear, feel, and see with their bodies. In this way, their learning is reinforced.

### AUDITORY PERCEPTION

#### Minefield

Divide the group into pairs and blindfold one of each pair. Scatter beanbags, representing mines, on the floor between the partners. Each child attempts to verbally guide the blindfolded partner across the minefield, avoiding the mines with directions like "Move forward," "Step to the left," or "Take one long step."

#### Noisemakers

Children respond with specific movements to the appropriate sounds. For example, tapping sticks = shake right arm; tapping a glass = nod your head; ringing the bell = shake left leg. Depending upon the level of the children, present more associations and sequence sounds for multiple responses. Children should practice first with eyes open to associate the noise source with the sound, and then perform blindfolded.

#### Match the Cans

Fill aluminum soda cans with various materials (sand, beans, stones, dried corn) in matching pairs. Distribute one can to each child, who shakes it and attempts to find the other can making the identical sound.

#### Sequential Memory

Children follow the teacher's varied clapping sequences with locomotor movements. For example, they may hop two times slowly and three times quickly.

Use a buzz board and small and large carpet squares. A short buzz represents a small carpet square, a long buzz a large square. Have the children move among the scattered carpet squares in response to short and long buzzer sequences.

#### Bouncing Balls

Give each child a rubber ball. Slowly read aloud a list of words and ask the children to bounce their balls to indicate which syllables are accented. A hard bounce represents the accented syllable, a soft bounce an unaccented syllable.

## Where's the Bell?

Have children sit in a circle with their hands cupped. Place a small bell in one child's hands. "It" attempts to guess who has the bell while all children shake their hands.

## Barnyard Partners

Divide the group into partners and ask each pair to decide to be a specific barnyard animal. Blindfold one of each pair and scatter the children about the classroom. The blindfolded child attempts to find his or her partner by listening for the particular animal sound and distinguishing it from the others.

## TACTILE PERCEPTION

### Back Tracing

Divide the children into partners. Ask each child to write letters or words with one finger on his or her partner's back. The partner endeavors to guess the written letters and words.

### Grab Bag

Cut uppercase and lowercase letters from pieces of cardboard and place them in a bag. Have each child blindfolded in turn, reach into the bag, and take out a letter. By feeling the shape, the child tries to identify the letter and then returns it to the bag.

### Puzzler

Cut out letters from thick pieces of cardboard and distribute letters to the children. Ask each child, while blindfolded, to replace the letter in the appropriate cut-out space, as in a puzzle.

### Object Discrimination

Occlude each child's vision. Have children feel a variety of objects, two of which should be identical, to determine which two objects are alike. Use similar textures, shapes, and sizes such as yarnballs or coins to challenge each child.

### Copy a Pose

Divide children into partners and blindfold one of the pair. Ask the sighted child to assume a body pose and the blindfolded child to copy the exact pose by touching his or her partner.

## Follow the Road

Each child while blindfolded attempts to follow the shape of a long tug-o-war rope with hands or feet. The design of the rope should be varied and obstacles may be placed along the road to crawl through or avoid. Use multiple ropes for relay races.

## Find Your Ball

Position children in relay race lines. Assign each team a ball identified by texture, size, and feel. Then have each team leader take a blindfolded partner to find the team's yarnball among a pile of many yarnballs. When the blindfolded child identifies the correct ball, he or she returns to tag the next player. A variation is to bring the ball to the team for mutual agreement that it is their ball before continuing the relay.

## Scavenger Hunt

Identify a blindfolded and a sighted child as partners. Pile a variety of objects in various locations in the classroom. Provide a list of objects for the sighted children who take their partners to the different locations to retrieve the objects.

## VISUAL PERCEPTION

### Find Your House

Prepare cards of horizontal and vertical "X's." Draw a pattern on each card from a starting point to the child's "house." The child must duplicate the pattern on the card by walking on "X's" marked on the floor.

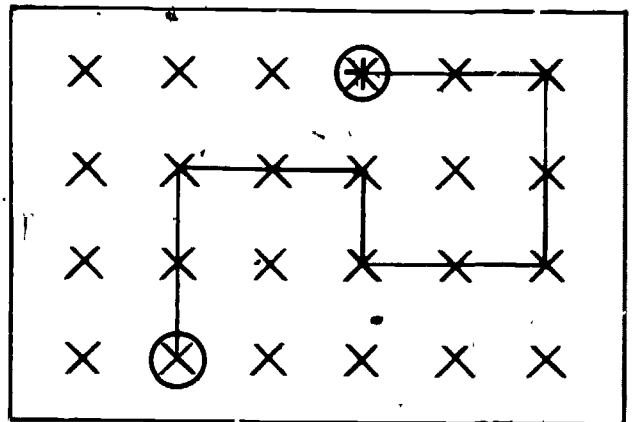

## Geometric Shapes

Using several colors of tagboard, cut various geometric shapes in different sizes, shapes, and colors. Distribute a geometric design to each child. At a signal, children must find another who has one or two of the same elements, or no common element.

Or scatter geometric shapes on the floor and use them as a coding activity. Children move from shape to shape and perform a specific movement decided previously by the class. For example, the rectangle means to stretch and curl, and the triangle means to jump.

## Stick Figures

Draw a series of stick figures with arms and legs in varied positions and angles. Have children attempt to form their bodies into the stick figure positions. They may mirror the positions or assume the figure's reference system.

## Patterning

Draw patterns of arrows on the chalkboard. Ask each child to accurately walk in the sequential directions of the arrows.

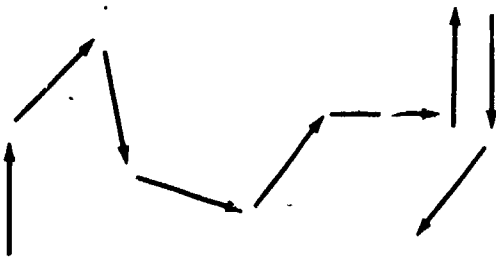

## Visual Memory

Divide children into pairs. Child A visually examines child B; then child A is blindfolded. Child B makes three body changes, either by altering parts of clothing or assuming different postures. (Encourage children to make small, subtle changes.) Then child A guesses what three changes occurred when the blindfold is removed.

## Concentration

Cut carpet remnants into one-foot square matched pairs, using a variety of plain and patterned colors. Scatter pairs of carpet squares face down on the floor. Have each child perform a locomotor movement to two carpet squares and turn them face up, attempting to match the identical pairs. If there is a match, the child continues. If there is no match, turn the squares face down. Then the next child takes a turn. All players must concentrate on the positions of the revealed squares to find a match.

## Magic Sheet

Tape a bedsheet or large piece of butcher paper to the floor. Divide the sheet into a six-by-five grid of 30 equal-size squares. Randomly write a different letter of the alphabet in each square, duplicating vowels in the four extra spaces. Children enjoy hopping and jumping from letter to letter to spell words designated by the teacher. Or they enjoy "twister" games in which a child simultaneously touches each letter of a word with a different body part; for example, right hand on the first letter, left foot on the second letter, and right knee on the third letter. Other possibilities are counting hops without a miss, distinguishing vowels from consonants, and reciting the alphabet.

## 7. MOVEMENT EXPLORATION FOR THE LEARNING DISABLED, MILDLY RETARDED, AND VISUALLY IMPAIRED

by Sylvia B. Kottler

*The author proposes a movement exploration approach for teaching both regular education and handicapped students in a mainstreamed, individual, or group setting. She provides many practical hints to stimulate both teacher and student to enjoy solving motor problems through a movement exploration approach. Sylvia B. Kottler is an Assistant Professor of Special Education at Purdue University, West Lafayette, Indiana.*

Although Public Law 94-142, The Education for All Handicapped Children Act of 1975, emphasizes the concept of "mainstreaming," it has been misinterpreted to mean the entry of all handicapped children into regular classrooms. While this is a serious misconception, nevertheless the regular educator must be prepared to individualize, adapt, and modify instruction for those children with special needs who are appropriate candidates for mainstreaming.

Until recently most teachers have been trained to teach pupils as members of a group rather than as individuals. Under P.L. 94-142, however, the regular classroom teacher has the responsibility for teaching exceptional students who require individualization—changes in the conventional instruction—in order to succeed. Ideally the regular and special education teachers will collaborate to develop and evaluate individualized programs for exceptional students who are mainstreamed. But what assistance can be offered the regular classroom teacher when consultation and/or resources are not available consistently or immediately?

I wish to share a program that will permit individualization and group activity simultaneously; a curriculum that will enrich all students—mainstreamed and regular—and reinforce the teacher so that he/she can be an effective teacher of all students. In addition, the program, although physical, is flexible and can be conducted indoors or outdoors, in a gym or classroom. (While it would be desirable to have daily physical education classes conducted by a physical education teacher, such expectations are unrealistic.) Finally, the program is more than physical education—it is cognitive because it requires children to process information as well as act upon it. Thus it is called motor problem solving or movement exploration.

From the viewpoint of the regular classroom teacher, no precise motor skills or special qualifications are necessary. The role of the teacher in a movement exploration program is not to model or offer solutions. Rather, the teacher is a facilitator, challenging students to search for solutions which have the effect of integrating body and mind. In the course of these discoveries, concepts of space, time, and directionality evolve; and children acquire the ability to control themselves within the group.

The following is a skeleton that the creative teacher can develop for an ongoing curriculum in movement exploration.

### Organization

#### 1. Phrasing the challenges

Do not direct student what to do or how to perform. Challenge students to use their imaginations and their bodies. In other words, do not use a command such as "Take three hops to get from your desk to my seat." More appropriate would be "Find a way to move forward on one foot."

#### 2. Equipment

A movement exploration program requires no apparatus. The use of materials is minimal. When necessary, the choices are commonly available and inexpensive: dowel rods, carpet samples, hula hoop, rope. However, it is essential that each participant have his/her own materials; there is little sharing or pooling.

#### 3. Procedures

Be flexible! Choose a few new activities from each

area every day. Adjust the complexity of language to meet the children's functional level. Most important, keep the challenges short, simple, specific.

#### 4. Body Language

Every child must organize subjective space. To aid a child in staking out his/her territory, offer a choice of a small mat or carpet sample, or a circle or square outlined with masking tape on the floor. The challenges are designed to help a child express simple ideas through expressive body positions and movements. For example:

- Show me how you would—  
Chop down a tree.  
Rake leaves.  
Shovel snow.  
Mow the lawn.  
Pound nails with a hammer.  
Play a pinball machine.  
Climb a tree.  
Mon the floor.  
Take a shower.  
Get into a sleeping bag.
- Make yourself—  
Into a letter "t," a ball, a snake.
- How small can you make yourself?
- How long can you make yourself?

#### 5. Gross Motor Activities

Each of the following locomotor patterns may be introduced into the challenges: *walking, running, jumping, gliding, galloping, skipping, hopping.*

- \_\_\_\_\_ among your classmates without touching anyone!
- Now let's make the space smaller and repeat what you have just done. Remember, don't touch!
- \_\_\_\_\_ and change directions when the whistle blows.
- Can you \_\_\_\_\_ backwards? Sidewise?
- How could you \_\_\_\_\_ and turn around?
- Show me how you \_\_\_\_\_ in a circle.
- \_\_\_\_\_ and take as few steps as possible from where you are to the door.
- Choose a partner and \_\_\_\_\_ together.
- How would you \_\_\_\_\_ on a snowy day, a rainy day, on an icy sidewalk?
- Change speeds when you \_\_\_\_\_.
- Change height while you \_\_\_\_\_.

#### 6. Ball Play

Be sure that each child has a ball and that subjective space has been identified for each participant.

- Can you bounce the ball if you change hands?
- Make the ball bounce chest high.
- Make the ball bounce very low.
- Find another part of your body to bounce the ball.
- Show me how you roll the ball around your body from front to back. Now do it again starting at your head and ending at your feet.
- Put the ball on the floor. Now find a way to go over without touching it.

#### 7. Dowel Rod

- How would you balance the rod on the back of your hand, your foot, your knee? Show me.
- Hold onto the rod at each end. Now, how will you step over it?
- How many different places behind your back can you place the rod? Hold on to both ends and show me.
- Place yourself behind the rod, beside the rod, in front of the rod.

#### 8. Hula Hoop

- How would you roll your hoop while walking forward?
- Roll your hoop and change directions when the whistle blows.
- While rolling your hoop, try to jump through it.
- Put the hoop on your arm. Can you make it go around without stopping? Will it do the same thing if you put it on your leg?
- Place the hoop on the floor. Can you jump in and out?

#### 9. Rope

- Place the rope on the floor. Now balance on it as if you were a circus tightrope walker. Can you close your eyes and do it? Now can you jump from one side of the rope to the other without touching it?
- Make a circle out of the rope. How will you cuddle up inside the circle without touching the rope?

As soon as they become familiar with activities requiring motor problem solving, teachers will observe that

every student is a winner because there is no *right* way or single manner of responding. The experiences will be joyful as well as enhancing to each child's motor development, self-concept, and cognitive growth. An exceptional child can be integrated with the group easily and effectively as each individual reacts to challenges of creative thinking and performing.

#### References

Arnheim, D., and Sinclair, W. *The Clumsy Child*. St. Louis, Mo.: C. V. Mosby Co., 1975.

Cratty, B. *Perceptual-Motor Behavior and Educational Processes*. Springfield, Ill. Charles C. Thomas, Publisher, 1969.

———. *Movement and Spatial Awareness in Blind Children and Youth*. Springfield, Ill. Charles C. Thomas, Publisher, 1971.

———. *Movement Behavior and Motor Learning*. 3d ed. Philadelphia, Pa.: Lea and Febiger, 1973.

Hackett, L., and Jensen, R. *A Guide to Movement Exploration*. Palo Alto, Calif.: Peek Publications, 1969.

Kephart, N. *The Slow Learner in the Classroom*. 2d ed. Columbus, Ohio: Charles E. Merrill Publishing Co., 1972.

Mosston, M. *Teaching Physical Education: From Command To Discovery*. Columbus, Ohio: Charles E. Merrill Publishing Co., 1966.

———. *Developmental Movement*. Columbus, Ohio: Charles E. Merrill Publishing Co., 1965

Nagel, C., and Moore, F. *Skill Development Through Games and Rhythmic Activities*. Palo Alto, Calif.: National Press, 1966

Roach, E. G., and Kephart, N. C. *The Purdue Perceptual-Motor Survey*. Columbus, Ohio: Charles E. Merrill Publishing Co., 1966.

## 8. ASTHMA AND PHYSICAL EDUCATION\*

by Warren Dennis

*Asthma has long been known as one of the leading causes of school absenteeism in this country. The traditional approach to dealing with it, however, neither solves the problem nor gives students the needed skills to meet the asthmatic challenge. The author provides very practical steps for assisting the asthmatic child in dealing with this condition in a physical education setting. Warren Dennis is the Director of Physical Education, National Jewish Hospital/National Asthma Center, Denver, Colorado.*

The following information provides a practical approach for physical educators to deal daily with asthmatic students, and it is strongly recommended that instructors seek additional information from medical personnel to gain a complete understanding of asthma.

### COLLECTIVE COMMITMENT

The American Academy of Pediatrics recommended several years ago that, before any asthmatic participates in a physical education program, a meeting should be set up that includes a "team" comprising the child, the parents, the physician, the school nurse, and the physical education teacher. The team members, at the first meeting, should define each individual's role and make a collective commitment to develop ongoing channels of communication. The child should be included, as much as possible, in the decisions made by the team. Diverting communications around the child only hinders the confidence the child has in the team, and the asthmatic must feel he is an integral part of this educational process.

Team meetings should be scheduled at regular intervals and, if there is resistance among any of the team members to have these meetings, it may be helpful to remind the members that all their efforts are necessary for effective progress of the asthmatic student.

### THE TEACHER-STUDENT CONFERENCE

After a collective commitment is made by the team, the next step is for the physical educator and the child to

confer. This pre-class conference can often create rapport between teacher and student that will carry through the semester. The meeting also must serve to establish guidelines for effective physical education planning and implementation.

It is extremely important for both the teacher and student to find out the factors that led the student or teacher to have either negative or positive physical education experiences in the past. This will help the instructor understand the child's attitudes toward physical education participation.

The following steps are offered as guidelines for the teacher/student meeting:

1. The physical education teacher should inquire into the child's past experiences pertaining to play, sports, physical education participation, and body exercise in general. (Was the child overprotected or forced to participate? Did the child have hesitations about exercise and why? Did the child ever have a special relationship with a teacher or coach who understood asthma? What made this relationship special? Were the child's activity levels different in individual vs. group-oriented play?)
2. The second phase of the discussion should focus on developing strategies to help the child have a positive physical education experience with a minimal amount of respiratory distress. Initially, the child needs to understand that the instructor comprehends asthma and asthma management. Explain the effects of exercise on asthma and how this relates to class activities. Let the child know

\*Copyright 1979, Warren Dennis, Director of Physical Education, National Jewish Hospital and Research Center, Denver, Colorado. Reprinted with permission.

that you are aware that he/she receives medication and how it can affect behavior and performance.

- a. Review self-care steps with the child and emphasize the importance of remaining in class during asthma attacks unless an emergency arises.
  - b. Practice the breathing and relaxation portion of the self-care steps with the child until he/she demonstrates good working-knowledge.
  - c. Explain to the child that he/she must learn to self-monitor and regulate activities according to messages provided by his/her body. The child must become aware of the messages that tell him/her when to slow down, when to stop and rest, when to practice special techniques, and when to reintegrate into the class activity. This self-regulation technique, conceptualized by Dennis, is called "listening to the body."
  - d. The child needs to learn to follow his/her feelings and regulate activity levels accordingly. When "listening to the body," the child should ask himself three "checkpoint" questions: First, am I breathing too fast? Second, is my heart beating too fast? Third, am I wheezing? If the child is wheezing, he should report it to the instructor and begin the self-care steps. When the child feels these "checkpoint" areas are under control, he/she should reintegrate into the class activities.
3. In concluding the initial teacher-student conference, the physical educator should summarize and reinforce the major points made previously, encourage the child not to go directly to medication unless he is in an emergency situation, remind the child that peers will not reject him if he/she practices the special techniques, and stress the importance of ongoing dialogue between child and physical educator throughout the child's physical education enrollment.

It is now the instructor's responsibility to contact the child's parents and inform them that this conference has been completed. The parents, in turn, can contact the physician and the school nurse to share this information. In this manner, the team members will now all be aware that the child has been adequately prepared to begin the physical education program.

## SELF-CARE

The following self-care steps have been developed by physicians at National Jewish Hospital/National Asthma Center, and have been used with remarkable success as part of the regular treatment in programs throughout the country. Physical education instructors can easily integrate these self-care techniques into their regular class routines; the child and parents should be encouraged to practice them at home.

It is important to consider that if, at any time, the child appears to be in extreme distress, the school nurse or physician, as well as the child's parents, should be contacted immediately to initiate emergency treatment.

However, there are three steps for a child to take that may stop wheezing, which will alleviate taking emergency medications. The school nurse can initially train the child, the parents, and the physical education instructor in these simple techniques:

1. *Relax.* When a wheeze is recognized, the first thing the child should do is sit down and relax in a comfortable position with the back straight and arms hanging down loosely at his/her sides. This technique can also be practiced lying on the back with the legs shoulder-width apart and the arms down at the sides, palms facing up. The eyes should be closed and breathing should be normal. Progressive relaxation is accomplished by relaxing specific muscle groups after they are initially tensed. Full concentration should be directed toward relaxing one muscle group at a time. The child should start with the toes and gradually work his/her way up through the body, alternately tensing and relaxing. Start with the lower body: toes, feet, ankles, lower leg, knees, thighs, hips, and pelvic area. Then move to the upper body: abdominal area, chest, shoulders, upper arms, elbows, lower arms, wrists, hands, and fingers. Finally go to the head: neck, mouth, lips, cheeks, eyes, forehead, and scalp. When this process has been completed, the child should check back through the body to see if there is any remaining tension. If tension still exists, the child should concentrate on relaxing these areas until the entire body is in a relaxed state. If the child's wheezing or distress does not improve after about five minutes of relaxation practice, go to the next self-care step.
2. *Relaxed Breathing.* The diaphragm is a major respiratory muscle that can be strengthened with regular exercise. For the asthmatic, the proper



use of this muscle can help remove the trapped air in the lungs and yield more effective air exchange. In diaphragmatic breathing, the diaphragm is moved downward and outward during inspiration and it is moved in and back during expiration. Any body position creating tension should be relaxed before this technique is initiated.

The most simple method of teaching this technique to children is to have them lie down on the floor with their fingertips placed upon their abdominal areas. When inhaling correctly, the diaphragm will cause their hands to rise upward toward the ceiling; when exhaling correctly their hands will come back down again. The rate of breathing should be slow, inhaling through the nose and exhaling through the mouth.

Relaxed breathing should be practiced for at least five minutes during an attack. If the child feels that this technique is helping, it should be continued for at least five more minutes or until the wheezing has subsided.

3. *Drink Warm Liquids.* If wheezing persists, have the child sit down and drink as many as three cups of warm water. The warm water should be sipped slowly, not gulped, taking about three to five minutes per cup. During this period the child should be encouraged to relax and breathe slowly and regularly. Drinking warm liquids can help relax muscle spasm in the upper respiratory tract and can help break up mucus lodged in the upper airways.

If these three primary steps are ineffective in stopping the child's wheezing, medication is the next step.

When the child's condition has improved, he or she should be reintegrated into the daily class activities. This serves to improve the child's self-image by increasing confidence in controlling these episodes. It also helps peers understand that asthma need not be a debilitating disease.

## CONSIDERATIONS FOR PROGRAM PLANNING

Integration of special modifications for the asthmatic child into present physical education programs is a relatively simple process. After reading the following guidelines and recommendations, teachers should be able to construct an effective physical education program based on realistic goals for their asthmatic students.

### A. Activity Selection

Many asthmatic children have poor body awareness and some may possess perceptual-motor dysfunction or gross motor problems. If the child is experiencing significant difficulty in this area, the physical education teacher may recommend special testing and remediation.

The activities presented in class should reflect both aerobic and anaerobic types of work. By employing both types of activities, the child and the instructor can better understand the child's activity levels, especially the potential for triggering an asthma attack. The child and instructor will then have a better understanding of which activities may require modification and which may be performed without respiratory distress.

Asthmatic children generally have weak upper body musculature. The physical education teacher should emphasize the importance of strengthening the upper body, including all primary and secondary muscles involved with breathing. The teacher can recommend exercises and training techniques for the child to use at home as well.

Asthmatics should be encouraged to participate in instructional and recreational swim programs. Not only does swimming offer practice in breath control and in strengthening the upper body musculature, it gives the asthmatic the opportunity to enhance endurance with minimal respiratory distress.

### B. Efficient Breathing

The asthmatic needs to be taught to make maximum use of his/her lungs while exercising. In endurance-oriented activities, slow, deep, rhythmic breathing should begin in conjunction with the first movement and continue until cessation of the exercise. The respiration rate should then be gradually slowed until normal breathing is restored. If the child is practicing interval training techniques, this same method of breathing should be used during exercise periods as well as in rest intervals. Because of filtering and warming qualities, nose breathing is recommended until the workload reaches the point where mouth breathing naturally takes over. Asthmatics tend to hold their breath when exercising and should be encouraged to fully ventilate (but not hyperventilate) their lungs as much as possible through controlled breathing techniques.

### C. Warm-Up

The body of the asthmatic child needs to be adequately prepared for the intensified workloads it will encounter in physical education and sports participation. Any exercise or technique that may contribute to more efficient use of oxygen, and ultimately yield better levels

of endurance, should be included in physical education programs for asthmatic children.

#### D. Cardiovascular Fitness

The asthmatic child has often been viewed as the one who usually drops out or is sidelined when the class participates in endurance-type activities. Cardiovascular fitness is a definite reality for an asthmatic so long as interval training techniques are used, proper warm-up is practiced, efficient breathing is included in the program, and close contact is maintained with the child's coach or teacher. It is especially important for the child to learn that warm-up, intensity, and warm-down are the three key elements of a physiologically sound exercise session.

#### E. Lifetime and Competitive Sports Participation

Asthmatic children need lifetime activities to maintain fitness and enhance self-image and social acceptance among peers. For these reasons, sports such as tennis, badminton, golf, volleyball, racquetball, handball, archery, jogging, hiking, and swimming should be included in the physical education program. The child should be encouraged to seek out recreational avenues of school to help meet this need.

Competitive sports participation for asthmatics should be encouraged. It is known from the experiences of asthmatics who have excelled in Olympic competition that the highest levels of physical performance can be attained.

The coach, teacher, and parents should share a common philosophy with the child regarding competition: winning for an asthmatic does not necessarily mean coming in first place or having more points than the op-

position. For an asthmatic, winning may be wheeze-free competition.

### PROGRAM EVALUATION

On the gross motor level, evaluations such as the *Purdue Perceptual Motor Survey* and the *Ayers Battery* can yield valuable information regarding the child's perceptual motor performance. A test of cardiovascular fitness such as the *Harvard Step Test* and a motor-performance test such as the *President's Council Youth Fitness Test* should be included in the test battery for asthmatics.

*Any measure of cardiovascular fitness should be administered only under a physician's supervision.*

Some asthmatics have participated in an 8-10 minute treadmill or bicycle ergometer challenge to test the effectiveness of the drugs they are using and to determine if they have exercise-induced asthma. This information is available from their physicians.

### FOR MORE INFORMATION

During the past year, a set of "aquasthenic" exercises has been specifically designed to give asthmatics direct experience in controlled breathing during water resistance exercise and to help strengthen the upper body musculature. Copies of these exercises are available upon request to Warren Dennis, Director of Physical Education, National Jewish Hospital/National Asthma Center, 3800 E. Colfax Ave., Denver, CO 80206.

## 9. MAINSTREAMING VISUALLY IMPAIRED CHILDREN IN VIGOROUS PHYSICAL EDUCATION

by Charles Buell

*Thousands of blind and partially sighted children are denied an active physical education program because of misperceptions about the visually handicapped or a lack of information concerning appropriate physical education activities. The author dispels these myths and provides practical suggestions for mainstreaming the visually impaired student into a vigorous program. Charles Buell is a retired Physical Educator of the Blind in San Juan Capistrano, California.*

### INTRODUCTION

Mainstreaming means the integration of visually impaired children into all courses which are feasible for them in the public schools of our country. In New Jersey blind children are included in vigorous physical education programs throughout the state. The benefits have been great, while the cost has been very little. School districts scattered throughout the country have also followed this practice. It is estimated that 5,000 visually impaired children are mainstreamed into physical education programs in public schools. On the other hand, it is estimated that at least 10,000 public school students are not being offered meaningful courses of physical education. This condition should not, and need not, exist.

Parents and educators who overprotect blind children do them harm, rather than helping them. Nearly 150 years of experience has confirmed Dr. Samuel Gridley Howe's belief that "Bumps and scratches affect only the bark, and do not injure the system like the rust of inaction." There is no evidence which indicates that visually handicapped children have more accidents than do their sighted peers. Experience has shown that only a few eye conditions can be endangered by vigorous physical activity.

Many parents and educators do not realize that visually impaired persons require higher levels of physical fitness than do their sighted peers. To attain the same goals, a blind person has to work harder and expend more energy. The only way any person can become physically fit is to participate in vigorous exercise. It is not as difficult to mainstream blind children in public school physical education as most people believe. The purpose of this article is to describe briefly how blind students can be integrated into vigorous public school physical education programs and become physically fit.

### TEACHING MODIFICATIONS AND CLASS ASSIGNMENT IN MAINSTREAMING

When a visually handicapped child becomes a member of a public school physical education class, only minor changes need to be made in instruction. Some children will need more help, while others will need little or none. First, it must be remembered that at least three-fourths of legally blind persons have some useful vision. The presence of some vision usually makes the integration process easier. It will be helpful to most partially seeing children to be stationed near the instructor. For those having some useful vision, the teacher should determine by trial and error what they can and cannot see. Teachers should give clear verbal descriptions of what they expect the class to do. This will be particularly helpful to visually handicapped boys and girls. For students who are sightless, or who have very little vision, it is helpful to assign a "buddy." If the blind child does not understand the verbal description of an activity, his or her buddy can give assistance. The buddy may demonstrate the movement and let the blind child feel his/her body. Sometimes it is more helpful when the buddy moves the body parts of a sightless classmate. Notice that no additional instruction is required from the teacher. Experience has shown that buddies soon learn to give only needed assistance.

In large secondary schools totally blind boys and girls should be permitted to select units, rather than be assigned to a single class. A boy might select wrestling, weight training, and physical fitness activities, while a girl might choose dancing, swimming, or gymnastics.

## THE ACTIVITY PROGRAM IN MAINSTREAMING

The activity program may be divided into activities which need no modification for visually impaired persons and activities which require minimal modification. Most blind individuals feel that the more an activity has to be modified for them to participate, the less desirable it is for mainstreaming.

### Unmodified Activities

There are many activities which require little or no modification for successful participation by visually handicapped students in public school physical education classes. The teacher will find that an activity may need to be modified for one child and not for another. How much vision a child has and how well he/she uses it will be an important factor in determining whether modification of an activity is necessary.

Wrestling is an activity which requires no modification, even for a sightless boy. If a sightless wrestler wishes to start in the "touch" position, he should be permitted to do so. Each year over 400 legally blind boys compete in interscholastic and intercollegiate wrestling against sighted opponents; the visually handicapped wrestlers win more such bouts than they lose. In high school wrestling 15 to 25 boys with little or no vision place in state meets each year.

Tumbling and gymnastics are activities which require little or no modification. Some blind gymnasts have won letters in interscholastic and intercollegiate gymnastics. Many gymnastic activities do not require vision, particularly rope climbing. Visually impaired students can perform on the trampoline. Somewhat more frequent and detailed verbal instruction may be required for some students.

Runners who have as little as 1/40 normal vision can safely run alone on tracks where hurdles and other obstacles have been removed. Many legally blind boys and a few girls have won letters in interscholastic and intercollegiate track and field.

Swimming, judo, and weight lifting are other activities which fit easily into a mainstreaming program. Dancing on the secondary level and rhythms on the elementary school level require little or no modification.

Relays in which students run in pairs are ideal for a class in which one of the members is blind. Relays run on oblong mats make it possible for blind boys and girls to identify turning points as stepping on a different surface at the end of the mat is the cue to turn.

There are a number of individual races in which blind students can participate. For example, a sack race re-

quires no modification except possibly a whistle blown at the finish line. Races in which pairs participate are ideal. Blind and sighted students can be paired in a three-legged race.

### Activities Which Usually Require Modification

Some students will not require modifications in ball games, but many will. Here are some methods which have been used successfully.

A number of legally blind boys have played on high school and college football teams. In public school physical education classes flag football is commonly played. Since vision is not required to snap the ball or block straight ahead, students with little or no vision usually play the center or guard positions.

Since many visually impaired children have some useful vision, it is desirable to obtain brightly colored balls for them to play kickball, basketball, and soccer.

In volleyball, a sightless boy or girl may serve for both teams. A sightless player might attempt free throws for both teams in basketball. In softball, a student might bat from a tee for both teams. When not batting or attempting free throws, a blind boy or girl could be performing physical fitness activities such as jumping rope, running in place, or squat jumps or squat thrusts.

In kickball, a totally blind player can place the ball on home plate, kick it, and run bases with a sighted teammate. On defense, sightless players can serve as pitchers. They roll the ball toward the sound of the clapping hands of the batter.

For a sightless boy or girl, running may be somewhat more difficult, but certainly not impossible. He/she may touch or hold the elbow of a sighted partner in distances of more than 50 or 60 yards. Using this method, totally blind Harry Cordellos finished the Boston Marathon ahead of 1,000 runners who had normal vision.

For sprints of 50 yards or so, it is best to have two students hold a sash rope about as high as the hips. The sightless runner lightly touches the rope to gain direction. Endurance can be gained by running back and forth using the sash rope as a guide.

## CONCLUSION

It is feasible to include visually handicapped students in public school physical education programs. Those educators who are not doing so should base their attitudes toward blindness on fact, rather than on supposition and emotion. When blindness is more generally understood, thousands of blind students who are now on the sidelines will be participating in physical education in the public schools.

## 10. ADAPTED PHYSICAL EDUCATION FOR THE DEAF

by Gary L. Lieberman

*The author of this article emphasizes the need to understand the various causes and severity of hearing loss and its effect upon the child's motor ability. He reviews examples of hearing and motor conditions and provides practical suggestions for designing appropriate physical education activities. Gary L. Lieberman is a Remedial Physical Education Teacher in the Marlon School, Los Angeles Unified School District.*

If anyone has ever attended an organized athletic event for the deaf, he might question whether there is any difference between a deaf individual and a hearing person. Research has shown that deaf athletes in residential schools show no significant differences when compared to the hearing. On the other hand the younger day school student has scored significantly lower in different studies. A study of hearing and deaf students aged 5-12 found that hearing boys scored higher on all 10 different tests. Hearing girls were superior to deaf girls on 9 out of 10 tests. Other research has shown that the deaf or hearing impaired student is in need of a program that will concentrate on assessing any motor problems and establishing a program to improve motor abilities.

The physical educator should be familiar with two different aspects of the hearing-impaired child. First, the etiology of the hearing loss and, second, the degree of hearing loss. The causes of hearing loss include heredity, rubella, diseases of the prenatal period, premature birth, complications of Rh factor, and other diseases such as meningitis and encephalitis.

About 50 to 60 percent of all deafness is due to genetic factors. Children deafened by genetic factors often achieve higher and have less chance of having other complications. A rubella child is likely to have visual problems as well as heart problems. Understanding the etiology of a child's hearing loss can better equip the physical educator to deal with the assessment and planning meeting for the child.

It is also important to know whether a hearing loss is conductive or sensorineural in nature. Unless the semicircular canals, which contain the organ of corti and the endolymph of the inner ear, are damaged, balance and equilibrium are not necessarily affected. Children with damage to the semicircular canals will have greater difficulty maintaining equilibrium. It should be noted that all hear-

ing loss does not result in inner ear damage. It is a misconception to think because a child has a hearing loss he or she will have balance problems. If, however, a child is known to have inner ear damage or a sensorineural loss, it is best to structure an individualized program centered on the aspects of motor behavior that are influenced by the loss.

Hearing loss is measured in decibels. It is important for the physical educator to know each child's degree of hearing loss. Many children can benefit with the use of different amplification, and the adapted specialist should know which child is able to hear when he speaks or if a child can hear better if he is very close to the person speaking. Hearing-impaired students also need to learn to use their residual hearing and the physical education activities can aid in this area. Hearing loss can be described as

**SLIGHT:** 25- to 40-decibel loss. The child may have difficulty hearing faint or distant speech.

**MILD TO MODERATE:** 40- to 55-decibel loss.  
Can understand conversational speech when the distance is limited.

**MODERATELY SEVERE:** 55- to 70-decibel loss.  
Sounds must be loud and distance small.

**SEVERE:** 70- to 90-decibel loss. Speech cannot be learned.

**PROFOUND:** Over 90-decibel loss. Only vibrations can be felt.

The term *motor retardation* implies that a child is below average in motor development. A child may be 14-years-old but function at the level of an 8-year-old on norms of motor maturation. Many hearing-impaired youngsters because of lack of experience fall into this

category This would be in contrast to a motor disturbance, which would involve incoordination, paralysis, ataxia, or apraxia. Cerebellar ataxia is not uncommon in the deaf. It is characterized by a staggering, swaying gait. The child gives the appearance that he is losing his balance. This condition is different from the destruction of the semicircular canals which results in problems with gait and balance. Cerebella ataxia in hearing-impaired children results in awkwardness in manual manipulations and poor coordination of the tongue. Apraxia is the inability to associate a mental image or idea with the motor system involved.

The hearing-impaired child needs to do more motor thinking, more acting out as compared to thinking out. Because the students are so visual, more can be accomplished through experiencing than through thinking it out. Concepts must be visualized before the hearing-impaired student will have success. Studies have shown that children with reading and speech disorders have problems with laterality. Laterality problems are common in those with early life deafness.

Realizing the differences in the degrees of hearing loss and the etiology of the hearing loss gives the educator a start in developing the program. Within any group of hearing-impaired students you will find those who are able to function normally in all situations, those who have some degree of motor retardation, and those who have a motor disturbance. At the secondary level I have found most students to be behind only because they lack the experience in different activities. The biggest problem in developing a program for secondary students is that they are at an age where they want to participate in sports and games. It is degrading to see themselves placed back at a level where they see themselves doing elementary activities. In teaching a volleyball unit I can remember how upset some of the girls were when I lowered the net to help promote play. The same thought is carried to the classroom where secondary students find it difficult to be taught from elementary textbooks.

Grouping is of vital importance. To nonchalantly place students in classes where their skills are obviously seen as inferior is inappropriate. An environment where they are not threatened will add to the success of the program. On the other hand, those students who excel should not be placed in a setting where their desire to compete is held back by other individuals.

During grades 7-9 the program should involve a wide range of activities that include tumbling and gymnastics. A basic introduction in a wide range of sports activities is needed to meet the hearing-impaired's desire to compete. Individual sports are thought to be highly recommended for the deaf since only a small amount of communication is needed. Hearing-impaired children

need to find a place of acceptance among themselves as well as with the hearing world; providing only individual sports activities will never help them overcome the problem of isolation. A closely supervised and structured play environment can help improve self-concept and social skills.

Ideally, a firm foundation in grades 7-9 will allow the student to choose a more individual program for grades 10-12. With the right skills individual sports can become more a part of the program. Interscholastic sports should be encouraged whenever possible. Successful intramural as well as interscholastic sports bring a great deal of pride to the school. At Marlton School the girls were able to perform as a drill team, incorporating some basic dance routines into their activities.

The elementary program should carefully follow developmental stages of motor development. Early diagnosis and treatment of motor problems can eliminate frustrations in later years as well as add to the cognitive development of the child. At all times the adapted physical education teacher should be aware of the hearing-impaired student's deficiency in acquiring language. In teaching different activities language should be incorporated into the lesson at all times. This awareness will also encourage positive rapport with the classroom teacher and other support personnel.

Reading does not come very easily to hearing-impaired children. Activities that develop visual perception and spatial awareness are necessary to help the student develop in that area. Basic rhythms are also called for; many hearing-impaired are able to hear at low frequencies, and rhythm activities with different percussion instruments have been successful. In the elementary environment I believe structure is very important. The ability to follow directions and pay attention is a skill that comes very slowly to the elementary hearing-impaired student. Language level often permits only a limited amount of conversation; nevertheless the child needs to learn to watch the person who is teaching the lesson.

In a 30-minute activity period it is best to have at least two different activities. An example would be to begin with jumping rope, doing some gross motor activities, or maybe running a track. From there you could move into your major activity for the day.

Working with the hearing-impaired presents quite a challenge. Understanding the basic cause and degree of hearing loss is the beginning for the adapted teacher.

Learning to communicate in a new language is a process that comes slowly. Deaf students have a culture of their own. It is the responsibility of the teacher to adapt him or herself to this culture to best meet the needs of the students.

## 11. PHYSICAL ACTIVITIES FOR INDIVIDUALS WITH SPINAL CORD INJURIES

by Vicki McKeeman Hopkins

*In order to effectively plan a physical education program for students with spinal cord injuries, it is necessary to have an understanding of the level and severity of the injury. This article gives a brief but complete classification of spinal cord injuries, including the types of activities appropriate for each. The author also provides practical information for a wheelchair sports program, including softball, volleyball, and square dancing. Vicki McKeeman Hopkins is an Assistant Professor of Adapted Physical Education at Arizona State University, Tempe.*



When planning an adapted physical education program for individuals with spinal cord injuries, it is essential to understand the classification of injuries. The level of injury will determine the type of program or activities to be included.

When the spinal cord is severed at or above the third cervical vertebra (C-3), death usually results. If the injury is incomplete, weakness results throughout the entire body. The term used to describe an injury that occurs from a severed cord at or about the second thoracic vertebra (T-2) is called *quadraplegia*, meaning involvement of all four limbs. *Paraplegia* is a term that describes involvement of the lower trunk and limbs resulting from an injury to the cord at or below the second thoracic vertebra. The degree of paralysis may vary.

If an injury occurs to the fourth cervical vertebra (C-4), the individual will have the use of his neck muscles and diaphragm. He will need total assistance in transferring to and from his wheelchair.

The functional muscles remaining from an injury to the fifth cervical vertebra include the deltoids and biceps. This allows the individual to perform many self-help and recreational activities. Due to the loss of the musculature of the hand and wrist, a grip is not present. However, if the cord is severed at the sixth vertebra (C-6), the grip is present along with the ability to extend the wrist. This provides a wider range of possibilities when planning a physical education program.

An injury occurring to the last cervical vertebra (C-7) will result in the ability to extend the elbows and flex and extend the fingers, providing a more functional grip and release. Of course, the individual will also possess all the muscle functions mentioned above in levels

C-4 through C-6. Now these individuals are able to perform many physical education activities, among them being push-ups, pull-ups, and independence in manipulating their own wheelchairs. With this independence comes the ability to participate in wheelchair sports.

Injury to the upper thoracic cord, T-1 to T-9 inclusive, results in total use of the upper limbs but little or no use of the lower limbs. Again, the term for this condition is *paraplegia*. There remains some control of the upper back, abdominal, and rib muscles. With the total use of the arms and some trunk control come a large capacity for independence and participation in physical activities.

The individuals with an injury to T-10 to T-12 inclusive, the lower thoracic level, have all of the above-mentioned capacities plus complete control of the upper back, abdominal, and rib muscles.

Lumbar level injuries (L-1 to L-3) involve the hip joint and the ability to flex the thigh. The fourth and fifth vertebrae work together to innervate all muscles that extend the hip (Fait). Walking is possible with lower level injuries with assistance.

The sacral level injuries involve control of the bladder, sphincter, and external genitals.

Injuries occurring at the sacral level (S-1 to S-5) result in the loss of bladder and bowel control. Also the genitals are affected.

With an understanding of the above-mentioned injury levels, adaptations can now be made to physical education and sport activities. A major objective when planning a program is to keep the activity or sport as near the original version as possible. Make changes only when absolutely necessary.

The adapted physical education program at Arizona

State includes the following activities: basketball, swimming, tennis, softball, dance, weight training, marathon training, and volleyball. The following will provide information for adapting these activities when necessary.

## WHEELCHAIR SOFTBALL RULES

Wheelchair softball is played under the official rules of 16-inch slow pitch softball as approved by the International Joint Rules Committee on Softball with the following exceptions:

1. All participants must be in wheelchairs, all chairs must have foot platforms.
2. The playing field shall be a smooth level surface of blacktop or similar material with 150' on the foul lines and from 180' to 220' to straight center.
3. The official diamond shall have 50' between all bases and 70'8½" from home to second base
4. A pitching stripe extending perpendicularly one foot on either side of the diagonal from home to second base shall be located 28' from home plate.
5. At first, second, and third bases, in fair territory shall be located a four-foot diameter circle around and centering on a one-foot square flat base; the defensive baseman has only to have one or more wheels touching within this defensive circle while the base runner must either cross over or touch the base with one or more wheels in order to tag the base.
6. If at any time a fielder should leave his chair in order to gain an advantage in catching or stopping a hit ball or to field a thrown ball, all base runners will be awarded two bases.
7. If a throwing error occurs and the ball leaves the playing area, all base runners shall be awarded one base beyond the last base each had reached before the error.

## WHEELCHAIR VOLLEYBALL RULES

In playing volleyball, there are some general rules and definitions of terms. There are six players on each side. Five players face the net to pass or spike the ball. The player at the net is the setter and receives the passes and sets the spikers. A team is allowed a maximum of three

contacts with which to play the ball over the net. A player may not distinctly contact the ball for an extended period of time. This is called a scoop or a carry. It is a side-out (loss of service) if one big wheel crosses the center line or the player or chair touches the net during play. The court is 20' by 20' per side with the official net height set at 6'.

To set, or set up, is the action of one player setting the ball up to another who then makes an attack play over the net. A spike is an attacking shot that is hit hard and with topspin. It is a one-hand overhead hit. A dig is when a player manages to "dig" up a ball that is seemingly impossible. A volley is a two-hand overhead pass made with the pads of the fingers. A bump is a one- or two-arm pass made with the forearm, and to serve is to put the ball into play.

## SQUARE DANCING ON WHEELS

Some Basic Maneuvers:

1. *Honor Your Partner or Bow to Your Partner:* Partners pull backwards on wheels from a side-by-side position to a position facing their partners, all dancers nod heads, and return to their original positions.
2. *Do Sa Do:* Two dancers face each other and roll toward each other passing right shoulders. When the axles of the two chairs are in line, both dancers make a sharp right-hand turn, and then make a left turn so that the dancers' chairs are back to back and about three feet apart. The two dancers then back up, turning slightly to the left, passing left shoulders, and backing up to their original starting position.
3. *Allemande Left:* Roll to corner and grasp each other's left vertical armrest support and turn 180 degrees and return to original positions.
4. *Grand Right and Left:* Roll toward your partner (counter-clockwise for men) and pass partner on right side, pass next dancer on the left side, pass next dancer on the right side, pass next dancer on the left side, and at this time all dancers shall be facing partners.
5. *Promenade:* Partners proceed side by side, men to center (ladies left), in a counter-clockwise direction until returning to the gent's home or proceeding into another movement. Partners should grasp each other's armrests with the inside arm, gent's arm in front, and continue to push on their



outer wheels. This means the lady must provide a major portion of the "push."

6. **Right-Hand Swing:** Roll toward your partner and grasp each other's right vertical armrest support, push with left hand, and turn 180 degrees and return to your home positions, facing center of square.

7. **Ladies' Chain:** Two opposite ladies designated, roll across the square, passing right shoulders and rolling to the left side of the opposite gent, and roll behind him to his right side facing the center of the square.

8. **Gents or Ladies or Designated Couples Star by the Right:** Indicated dancers roll into the center of the square facing in a clockwise direction and 90 degrees from each other. Each dancer grasps the right (inner) hand grip of the preceding dancer with his right hand and pushes forward with his left hand. (If the call is to reverse, the dancer re-

leases his right hand from the hand grip, turns to the outside 180 degrees and back into a star position grasping the left or inner hand grip of the preceding dancer with his left hand and pushes forward with his right hand—(same as circle four.)

#### References

1. Fait, Hollis. *Special Physical Education Adapted, Corrective, Developmental*. Philadelphia: W. B. Saunders Company, 1978.
2. "Wheeling Softball." *Sports and Spokes*, September 1967.
3. Cherenko, Dennis. "Volleyball." *Sports and Spokes*, July 1978.
4. Nunnenkamp, Bill. "Bowling from a Wheelchair." *Sports and Spokes*, July 1976.
5. Szyman, Robert. "Square Dancing on Wheels." *Sports and Spokes*, November 1976.

## 12. IT CAN BE SIMPLE—ADAPTED EQUIPMENT FOR PHYSICAL ACTIVITY AND RECREATION FOR SPECIAL POPULATIONS

by Remy Sotto

*Sometimes the modifications necessary to assist a handicapped child to fully participate in a sports program go beyond changing the rules or playing area. The author presents a collection of simple but effective equipment modifications which can enable the handicapped child to participate more fully and independently in such programs. Remy Sotto is a former Coordinator of Adapted Physical Education Activities, University of Arizona, Tucson.*

Simple modifications of rules, playing fields, and equipment have enabled disabled individuals to successfully and safely participate in a wide variety of activities. Educators and specialists have shared their ideas for adapting games and rules but little is available on adapting equipment. Some of the following ideas emphasize modifications for severely physically disabled individuals. The ideas have come from physical educators, physical and occupational therapists, and from the disabled individuals themselves. The adaptation of equipment has enabled a disabled person to participate in activities, sports, and games without changing any rules. It simply lets an individual participate as independently as possible. I want to share some of the ideas I have learned with you.

### WEIGHT TRAINING AIDS

For individuals with weak or little grip, rehabilitation programs have used wrist cuffs and mitts (Figure 1) to aid the individual in weight training programs. The wrist cuff (Figure 1-A) buckles on the individual's wrist and a double snap hook (Figure 1-B) attaches to the cuff and a pulley or weight training machine. The cuffs are made of either cloth or leather with the leather having greater durability. The cuffs are available at most medical supply stores or can easily be made.

The mitt (Figure 1-C) has a canvas T-strap at the top that has velcro attachments sewn at the ends of the T. There are also canvas straps with velcro at the bottom of the mitt. Slide the individual's hand inside the mitt keeping the fingers straight and the thumb outside the mitt. Wrap the bottom strap around the wrist. The top of the mitt can

be folded over a handle or a dumbbell and held in place by attaching the T-strap around the hand (Figure 1-D).

I personally have found that the wrist cuffs are much easier to utilize than the mitts. The mitts with excessive weight can loosen the velcro attachment.

Buying weight-lifting equipment can be expensive for some individuals or schools. People have made dumbbells by pouring concrete in tin cans with conduit pipe as the bar (Figure 2-A).

Wrist or ankle weights can easily be made by using denim from old jeans or any strong material. The appropriate length and width are determined by the size of the wrist or ankle. Cut two pieces of material and sew compartments along the length of the pieces (Figure 2-B). Fill the compartments with the pre-weighed amount of buckshot and sew the opening closed. Sew velcro on the ends and, voilà, a homemade wrist weight.

A temporary and easy weight can simply be made by using pillow cases and anything that weighs whatever amount you wish to lift. For example, if you want to do biceps curls with 5 pounds, fill the pillow case with 5 pounds worth of canned goods, books, a bag of sugar, anything that weighs 5 pounds. Hang on to the end of the pillow case and start curling. You may have to double the pillow case with heavier weights.

### RECREATIONAL ACTIVITIES

I feel it is important for disabled individuals to attempt and learn recreational and carryover activities. Some of the following activities can be accomplished by simply modifying the equipment.

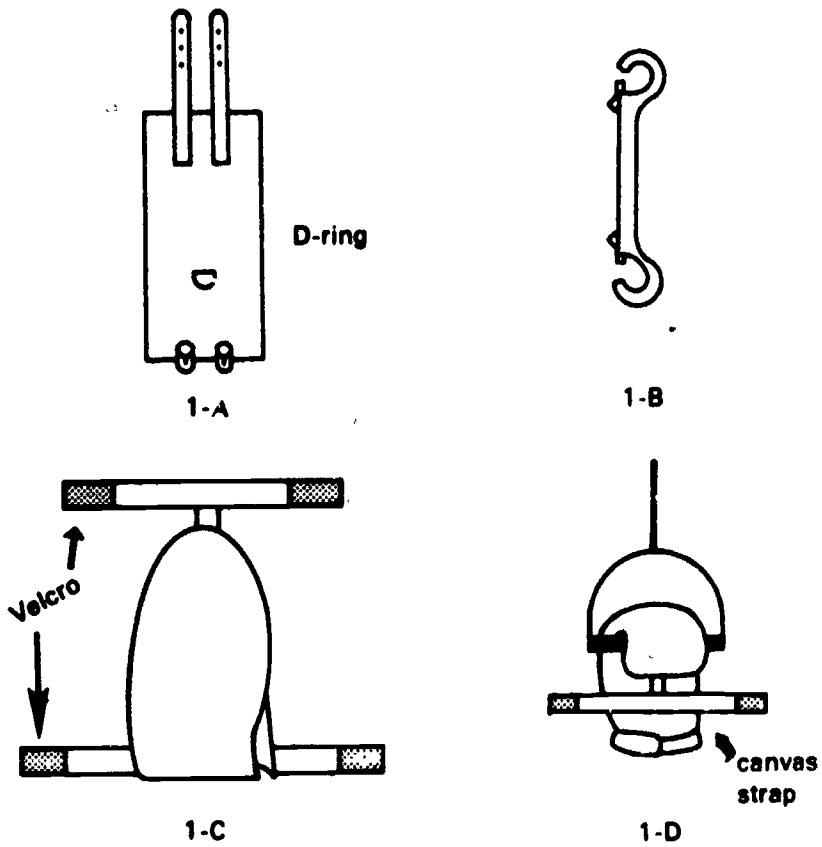

FIGURE 1  
Aids for Weak Hand Grip

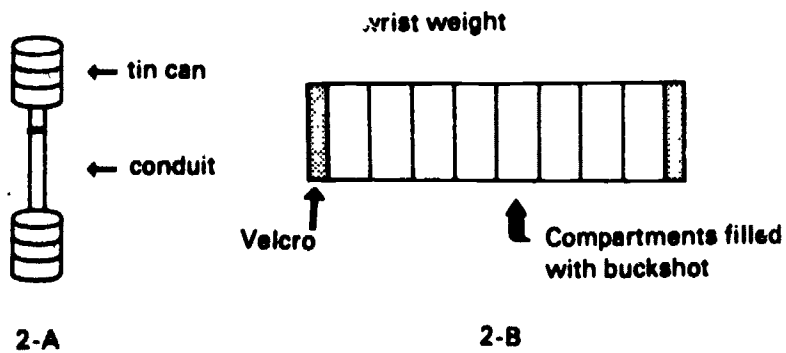

FIGURE 2  
Examples of Homemade Weight-Training Equipment

## Billiards

There are a few manufactured special pool cues (Figure 3). One is a spring-loaded cue (Figure 3-A) that works by pulling a trigger that releases the catch and propels the tip of the cue forward to hit the billiard ball. This is a good cue for someone with limited range of motion. Another cue has small wheels at the end of the cue (Figure 3-B) which requires the individual to just push the cue stick.

A modified bridge (Figure 3-C) has enabled a number of hemiplegics and stroke victims to more easily play billiards. Attach a screw-eye on a small piece of wood. The individual places the tip of the pool cue through the screw-eye (Figure 3-D) and thus can play billiards with just one arm.

## Ping-Pong and Racquet Sports

One problem for a disabled individual playing Ping-Pong is holding on to the paddle. A strap that slides on to the handle can be made from vinyl by sewing a tube the size of the handle (Figure 4). On the tube is sewn a canvas strap with velcro on the ends. Slide the tube on to the handle. The individual grasps the handle and the strap holds the hand in place by attaching the velcro. This strap can be used for most racquet sports.

These are just a few of the unlimited ideas and modifications that can be made on physical activity and recrea-

tional equipment. There are a few references, but the best resource for adapted equipment is your own creativity and ingenuity. Think and talk over ideas, projects, and activities with colleagues and friends. The simplest idea can mean more than you ever thought it could.

. . . The wise man looks into space, and does not regard the small as too little nor the great as too big; for he knows that there is no limit to dimensions. (Lao-Tse)

## References and Catalogs

Coward, James. *Instructional Aids for Adaptive Physical Education*. Hayward, Calif. Alameda County School Department, 1977.

Sosne, Michael. *Handbook of Adapted Physical Education Equipment and Its Use*. Springfield, Ill.: Charles C. Thomas, 1972.

Flaghouse, Inc. *Motor Activity Equipment for Special Populations*. 18 West 18th St., New York, N.Y. 10011. (212) 989-9700.

Preston Corp., 71 Fifth Ave., New York, N.Y. 10003. (212) 255-8484.

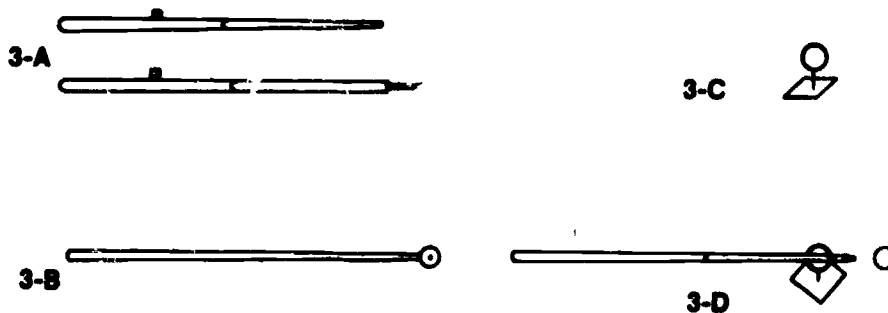

FIGURE 3  
Billiard Aids

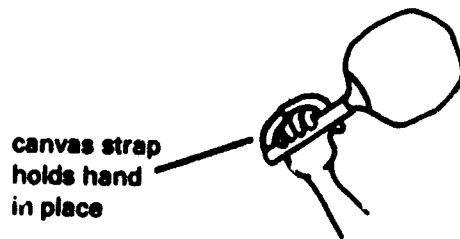
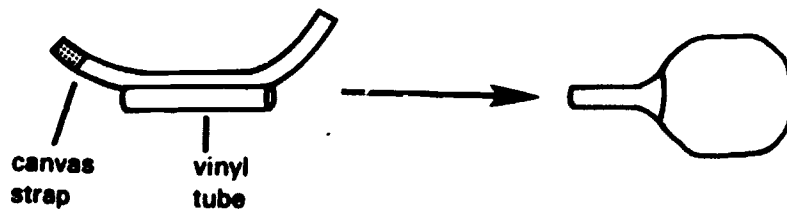

FIGURE 4  
Grip Aid for Racquet Sports

*NEA Resolution adopted by the NEA Representative Assembly*

**B-25. Education for All Handicapped Children**

The National Education Association supports a free, appropriate public education for all handicapped students in a least restrictive environment, which is determined by maximum teacher involvement. However, the Association recognizes that to implement Public Law 94-142 effectively—

- a. The educational environment, using appropriate instructional materials, support services, and pupil personnel services, must match the learning needs of both the handicapped and the nonhandicapped student.
- b. Regular and special education teachers, pupil personnel staff, administrators, and parents must share in planning and implementing programs for the handicapped.
- c. All staff must be adequately prepared for their roles through in-service training.
- d. The appropriateness of educational methods, materials, and supportive services must be determined in cooperation with classroom teachers.
- e. The classroom teacher(s) must have an appeal procedure regarding the implementation of the individualized education program, especially in terms of student placement.
- f. Modifications must be made in class size, using a weighted formula, scheduling, and curriculum design to accommodate the demands of each individualized education program.
- g. There must be a systematic evaluation and reporting of program developments using a plan that recognizes individual differences.
- h. Adequate funding must be provided and then used exclusively for handicapped students.
- i. The classroom teacher(s), both regular and special education, must have a major role in determining individual education programs.
- j. Adequate released time or funded additional time must be made available for teachers so that they can carry out the increased demands placed upon them by P.L. 94-142.
- k. Staff must not be reduced.
- l. Additional benefits negotiated for handicapped students through local collective bargaining agreements must be honored.
- m. Communications must be maintained among all involved parties.
- n. All teachers must be accorded by law the right of dissent concerning each individualized education program, including the right to have the dissenting opinion recorded.
- o. Individualized education programs should not be used as criteria for the evaluation of teachers.
- p. Teachers, as mandated by law, must be appointed to state advisory bodies on special education.
- q. Teachers must be allowed to take part in the U.S. Office of Special Education and Rehabilitative Services on-site visits to states. Teachers should be invited to these meetings.
- r. Incentives for teacher participation in in-service activities should, as mandated by law, be made available for teachers.
- s. Local associations must be involved in monitoring school systems' compliance with P.L. 94-142.
- t. Student placement must be based on individual needs rather than space availability (78, 80)