

DOCUMENT RESUME

ED 212 816

CE 031 258

**AUTHOR** Brown, Arthur  
**TITLE** Cold-Applied Roofing Systems and Waterproofing and Dampproofing. Roofing Workbook and Tests.  
**INSTITUTION** California Educational Advisory Committee for the Roofing Industry, Sacramento.; California State Dept. of Education, Sacramento. Bureau of Publications.  
**PUB DATE** 82  
**NOTE** 79p.; For a related document see ED 203-139.  
**AVAILABLE FROM** Publications Sales, California State Dept. of Education, P.O. Box 271, Sacramento, CA 95802 (\$5.25).

**EDRS PRICE** MF01 Plus Postage. PC Not Available from EDRS.  
**DESCRIPTORS** Apprenticeships; \*Building Trades; Postsecondary Education; \*Roofing; Secondary Education; Skilled Workers; \*Trade and Industrial Education; Workbooks  
**IDENTIFIERS** California; \*Dampproofing; \*Waterproofing

**ABSTRACT**

This workbook for students in California roofing apprenticeship programs provides information for classroom work in the area of cold-applied roofing systems and waterproofing and dampproofing. Eight topics are covered: introduction to cold-applied roofing systems and waterproofing and dampproofing, tools and equipment used in cold-applied roofing, cold-applied asphaltic built-up roofing, cold-applied bituminous sheet-membrane roofing, elastomeric sheet-membrane roofing, fluid-applied cold-process roofing, hot-applied waterproofing and dampproofing, and cold-applied waterproofing and dampproofing. A study assignment is given for each topic. A list of instructional materials required for the study assignments and a glossary are also provided. In a second section of the workbook are contained objective (multiple choice) tests for each topic of the workbook. (YLB)

\*\*\*\*\*  
 \* Reproductions supplied by EDRS are the best that can be made \*  
 \* from the original document. \*  
 \*\*\*\*\*

ED 212 816

CE 031 238

# Roofing

## Workbook and Tests

### Cold-Applied Roofing Systems and Waterproofing and Dampproofing

Prepared under the direction of the

**CALIFORNIA EDUCATIONAL ADVISORY COMMITTEE  
FOR THE ROOFING INDUSTRY**

and the

**BUREAU OF PUBLICATIONS, CALIFORNIA STATE  
DEPARTMENT OF EDUCATION**

U.S. DEPARTMENT OF EDUCATION  
NATIONAL INSTITUTE OF EDUCATION  
EDUCATIONAL RESOURCES INFORMATION  
CENTER (ERIC)

- This document has been reproduced as received from the person or organization originating it.
- Minor changes have been made to improve reproduction quality.

2

Points of view or opinions stated in this document do not necessarily represent official NIE position or policy.

PERMISSION TO REPRODUCE THIS MATERIAL IN MICROFICHE ONLY HAS BEEN GRANTED BY

T. Smith

TO THE EDUCATIONAL RESOURCES INFORMATION CENTER (ERIC)."

Copyright, 1982, by California State Department of Education

This publication was edited by Robert Klingensmith, Assistant Editor; prepared for photo-offset production by the Bureau of Publications, California State Department of Education; and published by the Department, 721 Capitol Mall, Sacramento, CA 95814.

Printed by the Office of State Printing  
and distributed under the provisions  
of the Library Distribution Act

---

Copies of this publication are available for \$5.25 each, plus sales tax (6 percent in most counties; 6½ percent in four Bay Area counties) for California residents, from:

**Publications Sales**

California State Department of Education  
P.O. Box 271  
Sacramento, CA 95802

Remittance or purchase order must accompany each order. Purchase orders without checks are accepted only from government agencies in California. Phone orders are not accepted.

The following titles, each containing workbook and tests in a single volume, are available in the roofing series:

|   |        |
|---|--------|
| <i>Built-up Roofing</i> (1981)  | \$4    |
| <i>Cold-Applied Roofing Systems and Waterproofing and Dampproofing</i> (1982) | \$5.25 |

|   |     |
|---|-----|
| <i>Entering the Roofing and Waterproofing Industry</i> (1980) | \$4 |
| <i>Rigid Roofing</i> (1980)                                   | \$4 |

Books on common roofing materials and first-aid practices are currently in production.

A complete list of publications available from the Department of Education, including instructional materials for some 23 other trades, is available from the address given above.

Questions and comments about existing apprenticeship materials or the development of new materials should be directed to:

Theodore R. Smith or Bob Klingensmith  
Bureau of Publications  
California State Department of Education  
721 Capitol Mall  
Sacramento, CA 95814  
(916) 445-7608

A column labeled "Date Assigned" has been provided at the right-hand side of each page number in the contents. Whenever your instructor assigns a topic, he or she should write this date in the appropriate blank. When you have completed the topic satisfactorily, your instructor should place his or her initials next to the assignment date. If this procedure has been followed, and you should transfer from one school to another, you will have an accurate record of the work you have completed. It should never be necessary for you to duplicate work on topics already studied or to skip topics not previously assigned.

To provide other school records needed, be sure to fill in below your name, home address, and telephone number. Then ask your instructor to fill in the official date of your enrollment in his or her class and to sign his or her name.

|                     |
|---------------------|
| NAME _____          |
| ADDRESS _____       |
| _____ PHONE _____   |
| DATE ENROLLED _____ |
| INSTRUCTOR(S) _____ |
| _____               |

---

## Foreword

In the California apprenticeship programs, experience gained on the job is supplemented by classroom work that is closely related to the job. This balanced system of training enables the apprentice to learn the "why" as well as the "how" of the trade. Both types of training are required for advancement in today's competitive industries.

The job-related courses for the skilled trades are highly specialized, and adequate training materials are for the most part not available commercially. To meet this need, the Department of Education, in cooperation with labor and management, develops the required training materials and makes them available to you at cost. This workbook is an example. It was written to provide you with up-to-date information you must have to meet the growing technical demands of the roofing and waterproofing trade. Every effort has been made to make the workbook clear, comprehensive, and current.

I congratulate you on your choice of roofing and waterproofing as a career. The effort you put forth today to become a competent journey-level worker will bring you many rewards and satisfactions, and the benefits will extend also to your community. We need your skills and knowledge, and I wish you every success in your new venture.



*Superintendent of Public Instruction*

# Preface

The State Department of Education, through the Bureau of Publications, provides for the development of instructional materials for apprentices under provisions of the California Apprentice Labor Standards Act. These materials are developed through the cooperative efforts of the Department of Education and employer-employee groups representing apprenticeable trades.

This edition of *Cold-Applied Roofing Systems and Waterproofing and Dampproofing* was planned and prepared under the direction of the California Educational Advisory Committee for the Roofing Industry, with the cooperation of the State Joint Roofing Industries Apprenticeship Committee. The members of this committee include representatives of the Roofing Contractors Association of California and representatives of local unions. Employer representatives serving on the Educational Advisory Committee are Herman Little, San Jose; Robert Culbertson, Sacramento; and Arthur Adams, San Carlos. Representing employees are Oscar Padilla, Los Angeles; Joe Guagliardo, Fresno; and William Penrose, San Jose. Special thanks and appreciation are extended to M. Duane Mongerson of Oakland, who served as Committee Adviser. Arthur Brown of Sacramento prepared the original copy for this publication.

This publication is one of a series of nine individually bound units of instruction for roofing apprenticeship classes. These new books reflect the continuing cooperative effort of labor, management, local schools, and the Department of Education to provide the best instructional materials possible for California apprenticeship classes. They are dedicated to excellence in the training of roofing apprentices.

THEODORE R. SMITH  
*Editor in Chief*  
Bureau of Publications

# Contents

|                       | <i>Page</i> | <i>Date assigned</i> |
|-----------------------|-------------|----------------------|
| Foreword* .....       | iii         |                      |
| Preface .....         | v           |                      |
| Acknowledgments ..... | viii        |                      |

## WORKBOOK

### Topic

|   |    |       |
|---|----|-------|
| 1 Introduction to Cold-Applied Roofing Systems and Waterproofing and Dampproofing ..... | 4  | _____ |
| 2 Tools and Equipment Used in Cold-Applied Roofing .....                                | 5  | _____ |
| 3 Cold-Applied Asphaltic Built-up Roofing .....   | 10 | _____ |
| 4 Cold-Applied Bituminous Sheet-Membrane Roofing .....                                  | 17 | _____ |
| 5 Elastomeric Sheet-Membrane Roofing .....  | 25 | _____ |
| 6 Fluid-Applied Cold-Process Roofing .....  | 30 | _____ |
| 7 Hot-Applied Waterproofing and Dampproofing .....                                      | 38 | _____ |
| 8 Cold-Applied Waterproofing and Dampproofing .....                                     | 45 | _____ |
| Instructional Materials .....   | 52 | _____ |
| Glossary .....  | 53 | _____ |

## TESTS

### Topic

|   | <i>Page</i> | <i>Score</i> |
|---|-------------|--------------|
| 1 Introduction to Cold-Applied Roofing Systems and Waterproofing and Dampproofing ..... | 57          | _____        |
| 2 Tools and Equipment Used in Cold-Applied Roofing .....                                | 59          | _____        |
| 3 Cold-Applied Asphaltic Built-up Roofing .....   | 61          | _____        |
| 4 Cold-Applied Bituminous Sheet-Membrane Roofing .....                                  | 63          | _____        |
| 5 Elastomeric Sheet-Membrane Roofing .....  | 65          | _____        |
| 6 Fluid-Applied Cold-Process Roofing .....  | 67          | _____        |
| 7 Hot-Applied Waterproofing and Dampproofing .....                                      | 69          | _____        |
| 8 Cold-Applied Waterproofing and Dampproofing .....                                     | 71          | _____        |

# Acknowledgments

Gratitude is expressed to the following manufacturers within the roofing and waterproofing industry who contributed valuable information, drawings, and photographs used in this workbook:

American Colloid Company  
The Flintkote Company  
Gaco Western, Inc.  
Koppers Company, Inc.  
Protecto Wrap Company  
Roofmaster Products Company  
Tremco

Special thanks are given to the Australian Information Service, San Francisco, for providing the photograph of the Sydney, Australia, Opera House that appears on page 30.



# Cold-Applied Roofing Systems and Waterproofing and Dampproofing

## TOPIC 1—INTRODUCTION TO COLD-APPLIED ROOFING SYSTEMS AND WATERPROOFING AND DAMPPROOFING

This topic and the related instruction classes are designed to enable the apprentice to do the following:

- Describe cold-applied roofing systems.
- Discuss the advantages and limitations of cold-applied roofing.
- Identify the major types of cold-applied roofing.
- Describe the general types of tools, equipment, and materials used in cold-applied roofing.
- Discuss the general requirements for preparing a roof deck to receive cold-applied roofing.
- Distinguish between waterproofing and dampproofing.

### Cold-Applied Roofing Systems

Cold-applied roofing, also called cold-process roofing, is the name given to roofing systems in which the conventional hot-applied asphalt or coal-tar materials are replaced by fluid adhesives and coatings that are usually delivered to the jobsite in factory-sealed pails and drums and that are ready to be applied just as they come from the container. (Depending on weather conditions cold-process fluids may require warming before they are applied, and on large jobs they may be pumped to the roof from a tanker.) Another type of cold-applied roofing consists of factory-assembled multilayer sheet membranes that are lapped and seamed on the job to form a continuous roof covering.

Some of the cold-process fluids are solvent-thinned or emulsified bitumens; they are used in basically the same way as the conventional hot materials to bond base sheets to a prepared deck (substrate) and to other plies. One type of bitumen emulsion is sprayed together with chopped-glass fibers directly on the substrate (deck) to form a monolithic roofing or waterproofing system. Other specially formulated cold-process fluids are applied to a prepared deck in one or more coats, then allowed to set or cure; the finished product is an elastomeric (rubberlike) membrane that serves as the basic component—and sometimes the only component—of a lightweight, watertight roofing system.

Cold-process materials are used for new work as well as for maintenance and repair. They have also

gained wide acceptance in waterproofing and dampproofing.

### Advantages and Limitations of Cold-Applied Roofing

The most obvious advantage of cold-applied roofing compared with hot-applied roofing is the elimination of hot kettles and with them the hazards of open flames and molten materials. Any roofer who has been burned with hotstuff or has seen a flash fire spread out of control from an overheated or dirty kettle will appreciate this point.

The following are some other advantages of cold-process roofing:

- The equipment used for applying cold-process roofing materials is simpler than that used for hot-applied roofing, and it is easier to transport to the jobsite and deliver to the roof. Often, particularly on small cold-process jobs, the construction elevators or service elevators in the building can be used instead of hoists and conveyors to load the deck. This saves the roofing contractor time and money. Also, the hazards involved in getting hotstuff up to the deck are eliminated on a cold-process job.
- Air pollution is negligible with cold-applied roofing methods. This can be a great advantage in cities where strict pollution-control ordinances are in force. Also, because cold-process materials are relatively clean and odor free, cleanup of the

jobsite and roofing equipment is easier, and the roofing environment is pleasanter for the workers and the building occupants.

- The problems that can arise from overheating or underheating molten bituminous materials are eliminated. For this reason, and because the cold-process materials are factory-formulated and manufactured under close quality control, uniform results are easier to obtain with cold-applied roofing.
- Cold-applied materials are generally light in weight and therefore reduce the dead load on the roof structure. This reduces deflection of the roof deck (the forming of a shallow basin produced by an accumulation of weight [water] on the deck) and helps to eliminate ponding.
- In general, cold-applied roofing is easier to maintain than hot-applied roofing. The bitumen-clay emulsions commonly used as surface coatings on cold-applied built-up roofs are not subject to alligatoring (cracking of the surfacing bitumen). These advantages apply also to cold-process sheet-membrane roofing and fluid-applied roofing.
- Cold-applied roofing is adaptable to any slope.

Cold-applied roofing also has some disadvantages and limitations:

- Cold-applied adhesives, coatings, and prefabricated membranes require more factory processing than hot-applied materials, and so their initial cost is usually higher.
- The application of cold-process sheet membranes is often more critical than the application of hot-mopped built-up roofing, particularly at seams, laps, and flashing. Careful application of cold adhesives is essential for good sealing at laps, and seams may have to be finished with a weighted roller after they are cemented.
- Some of the solvents and other chemicals used in cold-process roofing are toxic and highly flammable.
- Extra care must be taken in cold-process roofing to avoid contaminating the fluid materials or changing their formulations through use of the wrong solvents or other incompatible materials.
- Cold-weather application of cold-process roofing is usually not recommended.
- Some cold-applied built-up roofing is not suitable for aggregate surfacing, because the flood coat is too thin or is absent.
- Sometimes, cold-applied materials are chemically incompatible with each other, and a separation layer may be required. The manufacturer's instructions should be followed strictly in such cases.

## Types of Cold-Applied Roofing Systems

In recent years many new cold-process roofing materials and systems have appeared on the market. The major types of cold-applied roofing are described briefly in this topic, and each is covered in detail in later topics.

### Cold-Applied Asphaltic Built-up Roofing

Probably the most familiar and widely used cold-applied roofing system is cold-applied asphaltic built-up roofing, which differs from hot-mopped built-up roofing mainly in the kind of adhesive used and the way in which the adhesive is applied. Some of the common types of base sheets, felt plies, and cap sheets used in building up a hot-mopped roof may also be used with the cold adhesives and coatings, which are either asphaltic cutbacks (asphalt thinned with a solvent) or asphaltic emulsions (fine particles of asphalt suspended in a water vehicle with an emulsifier, usually bentonite clay). The cold asphaltic mixtures are applied to the prepared deck and to the base sheets and interplies with brooms, brushes, rollers, or spray equipment. In place of a cap sheet, the built-up roof may have a protective coating, usually an asphalt-clay emulsion because of its superior weathering characteristics. The protective coating also provides a decorative and reflective surface, or an additional coating may be applied for this purpose. Flashing methods are basically similar to those used in hot-applied roofing, except that cold mastics are used.

### Cold-Applied Bituminous Sheet-Membrane Roofing

The use of cold-applied adhesives and surface coatings in place of hot asphaltic or coal-tar materials has simplified the conventional built-up roofing process. In recent years the use of bitumen as a roofing material has been made even simpler through the development of factory-assembled bituminous sheet membranes that are marketed in rolls. A typical product of this type is a five-layer laminate consisting of a thick, flexible plastic core sheet with a layer of modified bitumen on each side and a protective film of polyethylene on the top and bottom. The bitumen layers increase the water resistance of the membrane, and they provide the means for heat-fusing the side and end laps as the membranes are laid on the prepared deck. A small propane torch is used to soften the bitumen enough to permit fusion. The standard membrane of this type is used on low-sloped roofs and is attached only at the perimeter of the deck and at projections, also by heat fusion. The completed roof is topped with a light aggregate, which may be secured with a special binder material. Another type of bituminous sheet membrane has a top layer of heavy aluminum foil instead

of the polyethylene film; it is used on steeper roofs, where an aggregate surface would not be feasible.

#### Elastomeric Roofing Materials

The newest types of cold-process roofing materials are the elastomeric materials, which are marketed in two forms—as prefabricated sheet membranes and as fluids that are brushed, rolled, or sprayed onto the prepared substrate. These tough, highly elastic materials have additional advantages of light weight, ability to conform to irregular surfaces, and relatively simple installation. Most of the elastomeric materials are not yet widely used, but they are gaining acceptance as architects, roofing contractors, and building owners use them more. Like other roofing materials the elastomeric materials have limitations as well as advantages; for example, they lose much of their elasticity in very cold weather. The ideal all-purpose roofing material has not yet been developed, and it probably never will be.

#### Other Fluid-Applied Roofing Materials

Other fluid-applied roofing and waterproofing materials include asphaltic emulsion coatings reinforced with chopped glass fibers and two-part plastic-resin materials, which may also be reinforced with glass fibers or mats. These materials are sprayed directly on prepared substrates with special applicators.

#### Tools, Equipment, and Materials Used in Cold-Applied Roofing

Most of the familiar tools and equipment used in conventional hot-applied roofing are also used in cold-process roofing and in waterproofing and damp-proofing. Hand tools and equipment used in cold-applied work include roller mops, brooms, brushes, squeegees, shears (for trimming membranes), joint tapers, weighted rollers (for setting seams), propane torches, fire extinguishers, and such common items as knives, handsaws, hammers, hatchets, pry bars, trowels, screwdrivers, tape rules, and chalk lines. Power tools and equipment include compressors, pumps, spray applicators, mixers, pressure-fed roller applicators, powered weighted rollers, disc grinders (for leveling high spots on decks), electric saws, and electric drills. The spudding machines and other tools and equipment used for removing old roofing materials are the same for all reroofing work.

Some of the materials used in cold-applied roofing and waterproofing, like the asphaltic cutbacks and emulsions, are familiar to all roofers; others, such as the elastomeric materials, are less well known, and some are so new that extensive field experience with them is lacking. In addition to the prefabricated

single-ply and multi-ply membranes, common cold-process materials include fluid-applied membranes and specially formulated adhesives, mastics, and resaturants. Cold-process materials are discussed in detail in subsequent topics in this book. However, the apprentice should keep informed about developments in this part of the trade by reading manufacturers' catalogs and sales manuals, sample specifications for cold-process roofing jobs, and articles on new materials in trade journals.

#### Deck Preparation for Cold-Applied Roofing

The steps in preparing a deck to receive cold-process roofing are essentially the same as those for a hot-applied roof, with some important differences. As in any roofing job, the deck must be inspected for weak or broken members, excessive deflection, and other structural defects before any work is begun. Drain outlets, pipes, and other projections must be securely attached to their supporting members. The deck must be clean and free of oil and grease, and usually it should be dry, although some cold-process materials may be applied directly over a damp substrate. Depressions should be filled and high spots leveled. If the roofing material will be one of the fluid elastomers, preparation of the deck must be given special attention. Ideally, the substrate for these fluid-applied materials should be an extremely stable, smooth, and unbroken surface, for example, steel-troweled concrete. In general, only water should be used as a curing agent on a concrete deck that is to receive a fluid elastomeric membrane; other curing agents may affect the bonding of the roofing material. For the same reason, all loose laitance (powdery residue) must be removed from the concrete surface before the roofing material is applied.

The manufacturers of cold-process roofing materials publish model specifications for the application of their products to new decks and existing roofs. The manufacturer's recommendations regarding deck inspection and preparation should always be followed.

#### Cold-Applied Roofing Repair and Maintenance

Cold-process roofing systems are generally easier to repair and maintain than hot-applied systems. Also, many of the cold-process fluids, mastics, and sheet membranes are suitable for making repairs to conventional built-up roofs and are widely used for this purpose. The manufacturers of cold-process roofing materials provide instructions for repairing and maintaining their roofing systems, and if their products can be used to repair other types of roofing, they also provide that information.

The importance of following the manufacturer's instructions when using cold-process materials cannot be overstressed. For example, asphaltic cutbacks should not be used on a coal-tar roof; the materials are not compatible.

#### **Waterproofing and Dampproofing**

Waterproofing and dampproofing are methods of treating exterior walls, floor slabs, on-grade decks, shower basins, and other parts of a structure below or above grade to prevent the passage of water or moisture. Waterproofing provides a greater degree of protection than dampproofing; its purpose is to prevent the passage of water under pressure, for example, through a basement wall below grade. Dampproofing is intended only to prevent the transmission of moisture, as through an above-grade exterior wall. Waterproofing and dampproofing require many of the same materials, methods, and skills that are used in hot-applied and cold-process roofing.

In the past, hot-applied bitumens, used alone or with felt plies, played the dominant role in waterproofing and dampproofing, and they are still widely

used for such work. In recent years, however, these time-tested materials have been challenged by many new types and combinations of cold-process fluids, mastics, and prefabricated membranes that have been specifically designed for use in waterproofing and dampproofing. In addition to these specialized products, most of the cold-process roofing materials described in later topics in this book may also be used for waterproofing and dampproofing. The many types and uses of waterproofing and dampproofing are discussed in topics 7 and 8.

#### **Safety in Cold-Applied Roofing Work**

The safety rules that apply in conventional roofing apply also in cold-process roofing and in waterproofing and dampproofing. Special safety rules, for example, the precautions that must be observed in handling and storing certain cold-process fluids, are provided in appropriate topics throughout this book. Some special hazards are associated with work on scaffolds and in excavations, which is often required in waterproofing and dampproofing; these are covered in Topic 7.

# COLD-APPLIED ROOFING SYSTEMS AND WATERPROOFING AND DAMPPROOFING

## TOPIC 2—TOOLS AND EQUIPMENT USED IN COLD-APPLIED ROOFING

This topic and the related instruction classes are designed to enable the apprentice to do the following:

- Identify the hand tools, power tools, and equipment commonly used in cold-process roofing and waterproofing.
- Discuss the methods and equipment used to pump cold-process fluids.
- Describe an in-line warming kettle for cold-process materials.
- Describe an air-operated material mixer.
- Explain the differences between air-operated and airless spray guns.
- Describe a cleaning procedure for cold-process spraying equipment.

The tools and equipment used in cold-applied roofing, waterproofing, and dampproofing include many of the items used in conventional hot-applied roofing operations. Common tools and equipment of the trade are described in *Entering the Roofing and Waterproofing Industry* and elsewhere in this course; other hand tools, power tools, and equipment that have special uses in cold-applied roofing, waterproofing, and dampproofing are described in this topic.

### Hand Tools and Power Tools

Listed below are some hand tools and power tools that are often required on cold-process jobs (see Fig. 2-1):

- Shears and roofing knives for cutting and trimming felts, vapor barrier materials, and single-ply roofing and waterproofing membranes
- Hand stitchers and smooth-faced rollers for setting seams at side and end laps of sheet membranes
- Weighted rollers (hand operated and power driven) for smoothing adhesive-bonded sheet membranes and strengthening the bonds
- Hand-operated or power staplers and nailing machines for fastening sheet materials, insulation, and kraft-board waterproofing panels
- Joint tapers for plywood decks and insulation boards
- A dull-edged, blunt-nosed trowel or similar job-made tool for pressing the edges of elastomeric membranes into reglets
- Propane torches for softening bitumen in laminated plastic-and-bitumen membranes to facilitate bonding
- Spray applicators (conventional and airless types) for applying primers, adhesives, and protective and decorative coatings; special applicator guns for simultaneous application of bitumen emulsion and chopped-glass fibers

- Disc grinders for leveling high spots on concrete decks, walls, and slabs and on sprayed-in-place foam insulation
- Mops, roller applicators, brooms, brushes, and squeegees for applying and spreading cold-process fluids; mop buckets; pourers; dippers; mop carts; and crack fillers
- Spudding bars, pry bars, scrapers, and other tools used to prepare existing roofs for reroofing

Some of the equipment used in hot-applied roofing also has equivalent uses on cold-process roofing jobs. Some other equipment items that are common to both kinds of work are spudding machines, weed burners, portable forced-air heaters (salamanders), industrial-type ventilating fans, air compressors, tankers, and material pumps.

### Pumps

On large cold-process roofing or waterproofing jobs, fluid adhesive or coating materials may be pumped to the work area from tankers similar to the bulk-asphalt types often used on large hot-process jobs. A tanker for cold-process roofing or waterproofing material may contain heating tubes or some other means for warming the contents in cold weather or when the material specifications call for warm application. Pumped material is usually applied with spray equipment. On small jobs cold-process fluids are often poured directly from 5-gallon (18.9-litre)\* pails and spread with mops, brushes, roller applicators, or squeegees. On most jobs, however, the fluid material is pumped to a spray gun from a 55-gallon (208.2-litre) drum by means of an air-operated or hydraulically operated pump that is clamped to the side of the drum. An air-operated pump is shown in Figure 2-2.

\*Metric equivalents provided herein are approximations and in most cases are rounded to the nearest tenth.



Fig. 2-1. Some tools used in cold-applied roofing and waterproofing

The pump shown in Figure 2-2 is capable of delivering heavy-bodied fluids at high pressures and over long distances (200 feet [61 metres] or more). Air to drive the pump is supplied from a large-capacity compressor (100 to 200 cubic feet per minute [2.8 to 5.7 cubic metres]), which also supplies the air needed to operate material mixers, air-operated spray guns, glass-fiber choppers, and any air-driven power tools, such as pneumatic staplers, that may be used on the job.

Air-operated pumps like the one shown in Figure 2-2 consist of two parts: (1) the pump unit, which is a long cylinder (the down tube) that contains a hardened and ground pump rod that is fitted with buna-rubber or Teflon packing; and (2) a piston-actuated air motor, which is mounted above the down tube and drives the pump rod. Check valves in the pump enable it to deliver fluid on both the up and down strokes of the air-motor piston. The fluid pressure available from the pump depends on the air pressure delivered to the pump motor (usually about 75 to 100 pounds per square inch [517.1 to 689.5 kilopascals], through an adjustable regulator) and the input-output pressure ratio of the pump (usually referred to as the pump ratio). The pump shown in Figure 2-2 has a pump ratio of 11 to 1, which means that if the air pressure delivered to the pump motor is 100 psi (689.5 kilopascals), the maximum fluid pressure at the pump outlet will be  $11 \times 100$  or 1,100 psi (7 584.5 kilopascals). Pumps are designed with different pump ratios

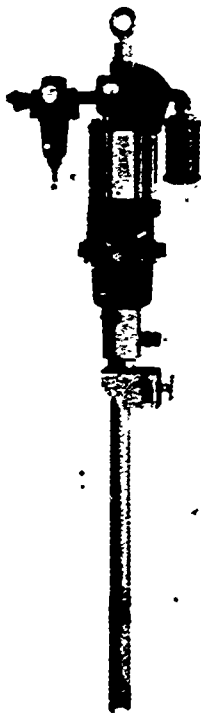

Fig. 2-2. An air-operated pump for cold-process fluids

to match the viscosity of the material they must pump; pumps designed for high-viscosity materials have high pump ratios and therefore high output pressures.

### Material Warmers

Heavy-bodied cold-process materials are hard to pump because they tend to cling to the inner liner of the hose. This difficulty can be overcome to some extent by thinning the material with an appropriate solvent (or diluting it with water if it is a water-based emulsion), but this may have an undesirable effect on the characteristics of the material. Another way to make cold-process material easier to pump (and also easier to apply) is to warm the material before it enters the long hose that delivers it to the spray gun. A convenient and safe way to do this is with an in-line warming kettle of the type shown in Figure 2-3. The skid-mounted unit is placed near the material barrel, and the kettle inlet is connected to the pump outlet with a short length of high-pressure hose. The material pumped from the barrel passes through warming coils in the kettle, which are immersed in a heated oil bath. The warm material then travels with reduced resistance through the supply hose to the spray gun. The oil bath is kept at the proper temperature by means of a thermostatically controlled LPG (liquefied petroleum gas) burner. An optional barrel-warmer unit may be used in conjunction with the warming kettle shown in Figure 2-3 to preheat the contents of the barrel for more efficient pumping in cold weather.

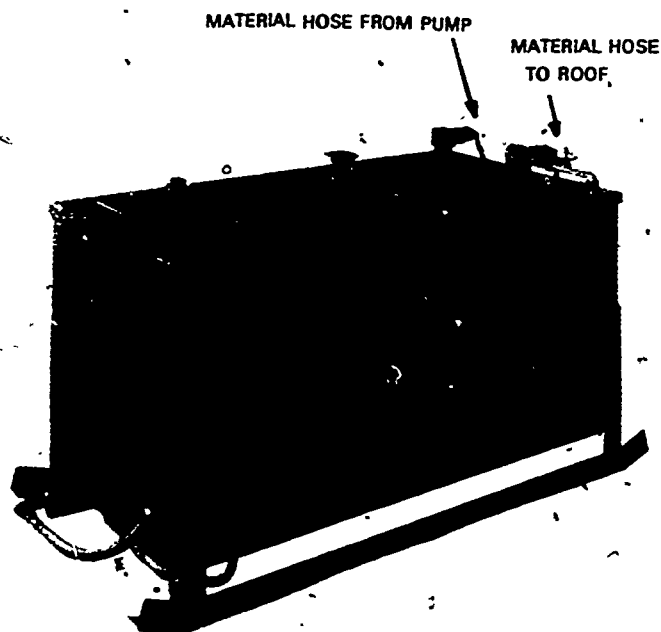

Fig. 2-3. An in-line warming kettle for cold-applied materials

### Material Mixers

Many cold-process adhesives and coating materials contain mineral fibers, bentonite clay, or other heavy additives to increase their "build" or give them other desired characteristics. These materials usually require frequent or constant stirring during application to keep the additives in suspension. Other cold-process coating materials are two-part compounds, consisting of a base polymer and a separately packaged curing agent, which must be mixed together on the job before the material is applied. A power mixer, such as the air-operated unit shown in Figure 2-4, simplifies the task of mixing or stirring the material.

The mixer shown is designed to clamp onto the rim of a 55-gallon (208.2-litre) drum; smaller versions are available for 5-gallon (18.9-litre) containers. The mixer may have a single impeller, like the unit shown, or it may have another impeller located higher up on the shaft. On some models the impeller may be in the form of a paddle, and on others a small gasoline engine may be used instead of an air motor to provide the power.

### Spray Guns and Hoses

The spray guns used to apply cold-process adhesives and coatings are of two general types: (1) air-operated; and (2) airless. A third type of gun is designed for the special purpose of spraying an asphalt-clay emulsion simultaneously with chopped

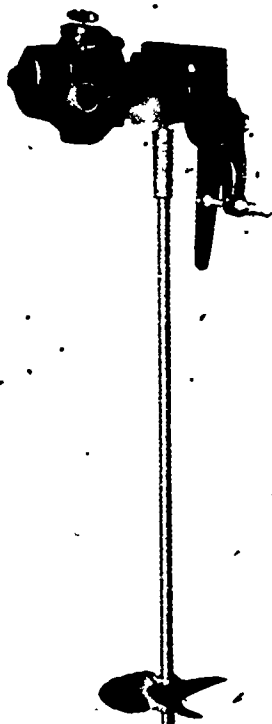

Fig.2-4. An air-operated mixer for cold-applied materials

glass-fiber reinforcement; it is described in Topic 6. Most of the spray guns used in roofing and waterproofing are about 4 to 6 feet (1.2 to 1.8 metres) in length; they are called pole guns. (See Fig. 2-5.)

### Air-operated Guns

An air-operated pole gun consists of two parallel metal pipes with a nozzle at one end and a handle with a trigger control at the other. The larger of the two pipes delivers the cold-process fluid to the nozzle, and the smaller pipe provides the compressed air that breaks up (atomizes) the fluid. The trigger-operated valve in the gun body permits the operator to start, stop, or throttle the spray action. The atomizing air is supplied from the same air compressor that powers the material pump and the mixer, but a separate regulator is provided to permit independent adjustment of the air pressure to the spray gun. The air pressure and fluid pressure must be in the correct proportion; too much air pressure results in a "starved" spray, and too little air pressure results in incomplete atomization of the fluid.

### Airless Guns

In an airless spray gun, the fluid to be sprayed is delivered to the nozzle at high pressure (1,000 to 3,000 psi [6 895 to 20 685 kilopascals]), and it breaks up into fine droplets as it emerges at high velocity from a slot in the nozzle tip. To prevent rapid wear of the slot,

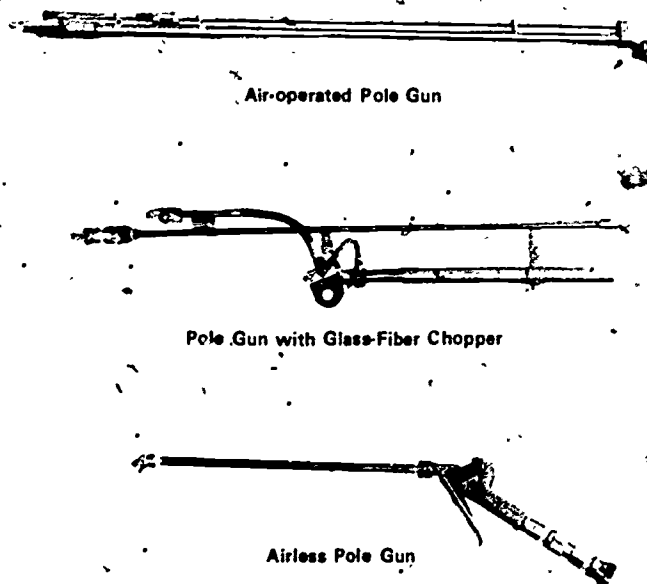

Fig.2-5. Spray guns for applying cold-process fluids



especially when an abrasive fluid is being sprayed, the nozzle tip is usually made of stainless steel or tungsten carbide. Since no compressed-air supply is needed to achieve atomization, an airless gun has only one tube—the material tube.

Because of the hazards associated with high-pressure sprays, the control valve of an airless gun is usually equipped with a locking device to prevent accidental operation. The trigger should always be locked off when the gun is left unattended.

### Hoses

The hoses that supply air and fluid material to an air-atomizing spray gun should be taped together at 18-inch (45.7-centimetre) intervals for convenience in handling. The air hose is usually a 1/2- or 3/4-inch (1.3 or 1.9-centimetre) diameter rayon-reinforced synthetic-rubber hose rated at a maximum working pressure of about 250 psi (1 723.8 kilopascals). The size and pressure rating of the hose that delivers fluid to the gun depends on the type of gun (air-operated or airless), the viscosity of the fluid, and the length of hose required. A medium-pressure wire-reinforced hose (about 1,000 psi [6 895 kilopascals] maximum working pressure) is usually adequate for delivering most fluid roofing or waterproofing materials to an air-operated spray gun. A high-pressure wire-reinforced hose is required if the gun is an airless type; the required maximum working pressure for such a hose may be as high as 3,500 psi (24 132.5 kilopascals).

The first section of material hose that is connected to the pump outlet should be no smaller in diameter than the pump outlet; 1-inch (2.5-centimetre) hose is recommended. Thereafter, smaller-diameter hose may be used if the total hose length will not exceed 200 feet (61 metres) and if the material to be pumped is not highly viscous. For pumping distances greater than 200 feet (61 metres), the first 200 feet (61 metres) of material hose should be 1 inch (2.5 centimetres) in diameter; additional lengths of hose may be 3/4 inch (1.9 centimetres) in diameter for most fluids. Often, the last 25 feet (7.6 metres) of material hose consists of

a 1/2-inch (1.3-centimetre) "whip line" for extra flexibility.

### Cleanup of the Spray Equipment

When the spraying is finished for the day, or when another type of material is to be sprayed, all equipment—the spray gun, material hose, and pump—should be flushed clean with an appropriate solvent. Kerosene is generally used for flushing asphaltic cutbacks; asphaltic emulsions may be flushed with water. Fluid neoprene and other exotic-type coating materials must be flushed with the solvent specified by the material manufacturer. Most fluid roofing or waterproofing materials may be flushed as follows:

1. Remove the pump and hang it on the outside of the barrel, with the foot of the pump in a 5-gallon (18.9-litre) pail of the flushing fluid.
2. Start the pump, and direct the spray from the gun into the material barrel. Pump the material that remains in the hose back into the drum, stopping the spray as soon as the flushing fluid appears.
3. Direct the spray into the pail of flushing material, and continue flushing for two to three minutes.
4. Shut down the pump, disconnect the material hose from the pump outlet, and drain the hose; then blow out the hose and the spray gun with compressed air. *NOTE:* Some materials can be left in the hose overnight if the hose is capped off or sealed so that no air can get into it.

### Study Assignment

1. *Entering the Roofing and Waterproofing Industry.* Sacramento: California State Department of Education, 1980. Read the information on common roofing and waterproofing tools and equipment.
2. Obtain and study catalogs and information sheets describing tools and equipment used in cold-applied roofing and waterproofing.

# COLD-APPLIED ROOFING SYSTEMS AND WATERPROOFING AND DAMPPROOFING

## TOPIC 3—COLD-APPLIED ASPHALTIC BUILT-UP ROOFING

This topic and the related instruction classes are designed to enable the apprentice to do the following:

- Compare the characteristics of asphaltic cutbacks and asphaltic emulsions.
- Describe a typical procedure for building up a roof using cold-process materials.
- Discuss the repair and maintenance of a cold-applied asphaltic built-up roof.
- Identify the safety considerations that are related to cold-process asphaltic built-up roofing.

### Characteristics of Cold-Applied Asphalt

The asphalt used in roofing and waterproofing is marketed in three basic forms: (1) as solid asphalt, which must be heated in a kettle and applied while in the molten state; (2) as a liquid or semisolid solvent-thinned cutback; and (3) as an emulsion, in which superfine particles of asphalt are held in suspension in water with an emulsifying agent. Asphalt in the first form is used in hot-applied roofing and waterproofing. The asphaltic cutbacks and emulsions are used as primers, adhesives, coatings, and mastics in cold-applied roofing, roofing repair and maintenance, and waterproofing and dampproofing. Filled asphaltic cutbacks and emulsions are also used extensively in commercial and industrial work as heavy-bodied waterproofing, insulating, and sound-deadening coatings, for example, on automobile underbodies. Among the fillers and extenders used in these materials are asbestos, glass, or rag fibers; mica; clay; diatomaceous earth; limestone; cork; vermiculite; and finely ground rock, slate, or slag. These and many other types of additives are often included in the cutbacks and emulsions to improve resistance to flow or deformation, mechanical abrasion, and the deteriorating effects of weather, heat, and sunlight.

### Asphaltic Cutbacks

The asphaltic cutbacks are so called because they are thinned, or cut, with solvents, which are usually of petroleum origin. Cutbacks can be made on the job by dissolving solid asphalt in a petroleum solvent, such as kerosene (but never in gasoline or paint thinner); however, most roofers prefer to use factory-made cutbacks, because their higher initial cost is offset by their convenience, their higher and more uniform quality, and the lower labor cost involved in their use.

The consistency of an asphaltic cutback depends on the amount of solvent it contains, and this in turn depends on the use for which the cutback is intended. The thinnest cutbacks are those used as primers; the heaviest-bodied cutbacks are the trowel-grade mastics

that are used in flashing, wet-patch sealing, and below-grade waterproofing. The primers usually consist of about 45 to 65 percent solvent; the rest is dissolved asphalt. The mastics may have as little as 15 percent solvent, the remainder being some combination of asphalt and various fillers.

The asphaltic cutback adhesives and coatings have good wetting and penetrating power, and they bond readily to new or old roofing materials that have been properly prepared. After a cutback has been applied, the solvent is lost through evaporation, and the asphalt returns to a semisolid form. In general, asphaltic cutbacks must be applied only to dry surfaces, but some modified types can be used on damp materials or even in standing water (asphaltic wet-patch, for example). Most of the cutbacks are highly flammable, and the usual precautions that apply in handling such materials must be observed. Also, asphaltic cutbacks are not compatible with coal-tar materials. With cutbacks, as with all other cold-process materials, the manufacturer's instructions for handling and use should be well understood and heeded.

### Asphaltic Emulsions

An emulsion is an intimate mixture of two liquids, or a liquid and a semisolid, that are not soluble in each other (for example, oil and water). Milk is a common oil-and-water emulsion. Emulsification is achieved by violent mechanical agitation of the two substances; no chemical change occurs in either component. The mixing process is aided by the presence of an emulsifying agent. In the asphaltic emulsions used in roofing and waterproofing, microscopic droplets of softened asphalt are held in suspension in a water-based vehicle together with bentonite clay, which is the emulsifying agent. The clay molecules surround each of the tiny particles of asphalt and prevent them from recombining into larger globules and settling out of the mixture. After the asphaltic emulsion is applied to a surface, the water vehicle evaporates, and what remains

is a solid asphaltic coating that has exceptional mechanical stability and long life. These advantages of asphaltic emulsions result mainly from the bonding action of the bentonite clay, which forms a network structure that links the particles of asphalt within the coating.

#### Asphaltic Cutbacks and Emulsions Compared

Asphaltic cutbacks and emulsions are the basic materials of cold-applied built-up roofing. The two types of materials have basically the same uses and methods of application, but they also have some important differences that make one type better suited than the other for specific kinds of work. In the comparison between the cutbacks and emulsions in Table 3-1, the listed advantages and limitations of the two materials are general characteristics only; they may vary considerably from product to product, depending on the formulation chosen by the manufacturer. For example, the normally high flammability of an asphaltic cutback can be much reduced by the use of special solvents and additives.

#### Installation of a Cold-Applied Built-up Roof

Except for the absence of hot kettles and the correspondingly simpler and cleaner working environment,

a cold-process built-up roofing job looks very much like a conventional hot-applied job. The preliminary work and the steps in applying the material are essentially the same in both methods.

#### Preparation of the Deck in New Work

In new work the roofer must first inspect the deck and make sure that it is ready to receive roofing, using the general procedures outlined in this topic and observing any special instructions provided by the manufacturer of the roofing materials. The deck must be structurally sound, with no broken or missing members and no excessive deflection that would encourage ponding. High spots should be leveled, and holes should be filled. Some manufacturers of cold-process asphaltic materials approve application on dead-flat decks, but the general recommendation is for a slope of at least  $\frac{1}{4}$  inch per foot (0.6 centimetre per 30.5 centimetres), which may also be written  $\frac{1}{4}/12$ , to provide adequate drainage. Drains must be properly located and clear. The deck must be clean, and usually it must be dry. If perimeter wood nailers and cant strips are specified, they must be in place before the roofing materials are applied. On a plywood deck all panels should have a solid bearing, and any knotholes or other voids should be filled or covered with metal. Concrete decks must be smooth

TABLE 3-1

General Characteristics of Asphaltic Cutbacks and Emulsions

| Asphaltic cutbacks   | Asphaltic emulsions   |
|--|---|
| <ul style="list-style-type: none"> <li>● Have good penetration and wetting ability.</li> <li>● Usually must be applied to dry surfaces.</li> <li>● Dry to a dense mass that is impervious to water vapor.</li> <li>● Are highly flammable in the fluid state.</li> <li>● Have fair fire resistance when dry (improved if the roof is aggregate surfaced).</li> <li>● Will not wash off after a short drying period.</li> <li>● Are subject to alligating.</li> <li>● Have excellent adhesive qualities.</li> <li>● Are generally not suitable for use as protective coatings.</li> </ul> | <ul style="list-style-type: none"> <li>● Have moderate penetration and wetting ability.</li> <li>● May be applied to damp or dry surfaces.</li> <li>● Produce a waterproof, but more permeable coating that "breathes."</li> <li>● Are highly stable and resistant to flow.</li> <li>● Are nonflammable in the fluid state.</li> <li>● Have good fire resistance when dry.</li> <li>● Must be allowed to dry thoroughly before exposure to rain.</li> <li>● Must not be allowed to freeze in storage or until dry after application.</li> <li>● Are highly resistant to alligating.</li> <li>● Have fairly good adhesive qualities.</li> <li>● Make excellent protective coatings.</li> </ul> |

and well cured. Metal decks should have no loose rust. If a primer is called for, the type used must be appropriate for the deck material and the roofing material. On a nonnailable deck, perimeter nailing strips are required to permit anchoring of the roofing material. Secure anchoring of the built-up membrane is important to prevent wind uplift and slippage. The roof covering is not in itself a structural element.

#### Preparation of an Existing Roof for Reroofing

If a cold-process built-up roof is to be applied over an existing roof, the old roof should be prepared as follows:

1. If the existing roof is covered with gravel, spud off or scrape off the gravel. An alternate method is to remove all the loose gravel and then apply a cushion layer of base sheet or rigid insulation to the clean roof before beginning the reroofing.
2. Cut across all buckles and blisters, and nail them down flat.
3. Spud off any fishmouths (openings caused by wrinkling at the edges of membranes) and wrinkles.
4. Fill in and level all low spots, using felt, insulation material, or other appropriate filler.
5. Remove any nails that protrude through the old roof. If left in, they may puncture the new covering and cause leaks.
6. If the existing roof has no cant strips at the base of parapets and other places where horizontal and vertical surfaces meet, install cant strips where space permits.
7. Repair or replace all defective flashing. Remove and clean the drain outlet boxes, and cut away and featheredge the old roofing material at least 12 inches (30.5 centimetres) out from the drain; this will prevent the new roofing material from building up around the drain and damming the water. If the outlet box is defective, install a new one, following the roofing material manufacturer's specifications.
8. Scrape off all old mastic, felt, and the like around pipe and vent flashing to help the new roofing material bond firmly to these metal surfaces. Replace any rusted or otherwise defective roof jacks around vents and any damaged metal coping on firewalls.
9. If a stucco or masonry wall has been flashed with plastic or three-course flashing, remove the flashing, and apply an appropriate primer. If the wall has a tile coping, remove the coping so that the new roofing material can be extended up and over the top of the wall or so that suit-

able flashing can be installed. Then, reinstall the coping with an appropriate cement or mastic.

10. Replace any damaged or deteriorated reglet flashing on walls and chimneys. If the flashing is still usable, the new roofing material must be extended up and under it.
11. Clean off the roof before applying the new covering. The roof may be hosed off, but never apply a cold-process material to a damp surface before making sure that the material is approved for damp application.

#### Application of a Vapor Barrier and Insulation

If the roofing specifications call for use of a vapor barrier, it will be the first covering to be installed over the prepared deck. When a vapor barrier is installed, a continuous, unbroken seal must be maintained.

A common type of vapor barrier consists of two or three moppings of asphalt and two plies of felt. Another version of a mopped vapor barrier consists of a single, coated base sheet and one or two moppings of asphalt. Other vapor-barrier materials include PVC (polyvinyl chloride) films, rubber sheeting, and laminated kraft-paper sheets with a bituminous filler.

Among the many types of thermal insulation used in built-up roofing systems are sprayed-in-place plastic foam, poured-in-place lightweight insulating concrete, dual-purpose structural decking that also serves as insulation, and preformed insulation boards.

All roof insulation must be protected from the elements before, during, and after installation; moisture can destroy its insulating properties.

#### Application of the Roofing Material

Except for the type of adhesive used and its method of application, the procedure for installing a cold-process asphaltic built-up roof is essentially the same as for a hot-applied roof. The cold adhesives may be brushed, rolled, or sprayed on. The following is a typical procedure for applying a base sheet and a two-ply cold-applied roofing system to a prepared nailable deck or over an existing roof, using 36-inch-wide (91.4-centimetre-wide) asphalt-coated base sheets:

1. Make sure that cant strips fit flush at the ends and to all wall surfaces. Bevel the cants back from scuppers. The cants should be nailed to the deck only. (See Fig. 3-1.)
2. Cut the base sheets to manageable lengths (12 to 18 feet [3.7 to 5.5 metres]), and lay them out flat or stack them in piles to remove curl. On nailable decks nail the base sheet only, 18 inches (45.7 centimetres) on center in all directions, with roofing nails long enough to penetrate at least  $\frac{3}{4}$  inch (1.9 centimetres) into the

sheathing. On nonnailable decks adhere the first layer to the prepared smooth roof with spot applications of asphaltic cement.

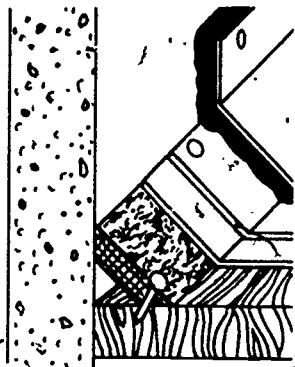

Fig. 3-1. Cant strip detail

3. Figure 3-2 shows a base sheet and a two-ply cold-applied roofing system over a nailable deck. Cut starter sheets to 18-inch (45.7-centimetre) widths and convenient lengths. Begin at the lowest point of the deck, and use plastic cement adhesive to apply the starter sheets over the base sheet.
4. Over the starter sheet, apply a full-width felt sheet, and cement it solidly to the starter sheet only (not to the deck) with a solvent-type asphaltic lap cement. (On a reroofing job where a cushion course of base sheet is placed first, the felts that follow are cemented solidly to the cushion course and to each other.)

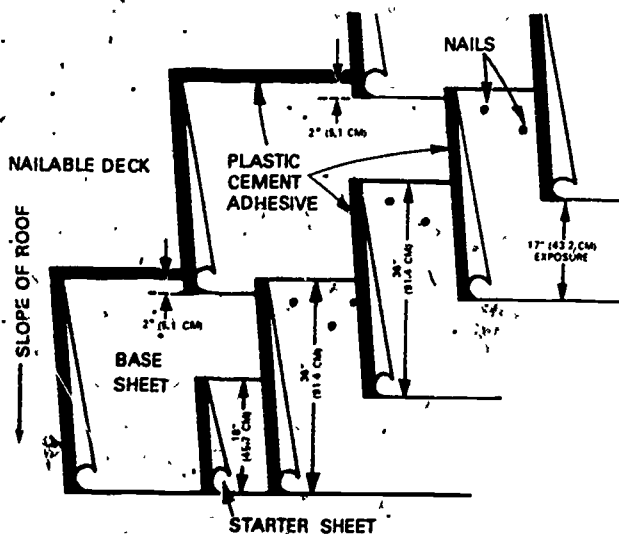
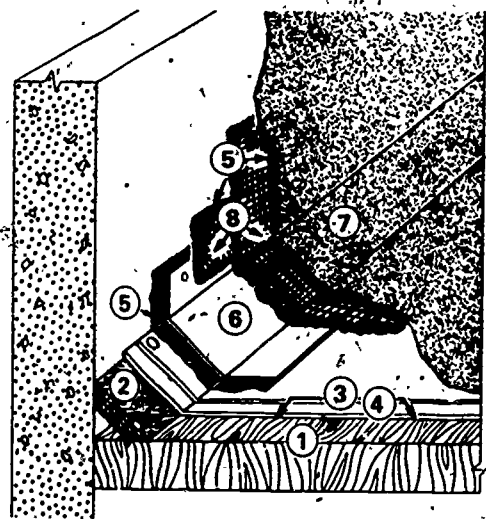

Fig. 3-2. One-ply base sheet with two-ply cold-applied roofing system

5. Continue to apply full-width felts in shingle fashion, lapped 19 inches (48.3 centimetres) at the sides and 4 inches (10.2 centimetres) at the ends. The felts should be cemented solidly where they overlap.
6. Extend the felts up the cant strips, and trim them to the vertical wall.
7. After the felts have been cemented and lapped, press them into the cement with a broom or a weighted roller.
8. Apply flashing consisting of plies of glass fabric embedded in flashing cement around the bases of vents, columns, or other projections through the roof.
9. Reinforce all angles at parapet walls with an extra strip of felt set in flashing cement. (See Fig. 3-3.) Apply the reinforcing strips, starting 4 inches (10.2 centimetres) from the cant strips on the field area of the roof. Cover the cant strip, and continue up the wall 8 inches (20.3 centimetres) or to within 2 inches (5.1 centimetres) of the reglet or the flashing line. Fasten the reinforcing strip to the wall with appropriate nails along the top edge of the strip. Apply a trowel coat of flashing mastic  $\frac{1}{8}$ -inch (0.3-centimetre) thick over the top edge of the reinforcing strip, and embed a 4-inch-wide (10.2-centimetre-wide) strip of glass fabric in the



- |                   |                            |
|-------------------|----------------------------|
| 1. WOOD ROOF DECK | 5. PLASTIC CEMENT          |
| 2. CANT STRIP     | 6. BASE FLASHING           |
| 3. CEMENT         | 7. PROTECTIVE ROOF COATING |
| 4. BASE SHEETS    | 8. GLASS FABRIC            |

Fig. 3-3. Base flashing at parapet wall (Flintkote system)

troweled mastic. Trowel another coat of mastic over the reinforcing strip, extending the mastic above and below the strip. Embed a wide strip of glass fabric in the mastic to cover entirely and overlap the reinforcing strip. Finally, apply a preliminary protective coating of asphaltic material topcoat over the entire built-up flashing. On a reroofing job where cant strips are lacking and it is not practical to install them, many roofers use extra reinforcement over the right-angle bends at parapet walls. (Cant strips should always be installed in new work.)

10. When all the roofing and flashing material is in place and thoroughly dry, prepare the roof to receive a protective coating of asphaltic material. Remove all surplus roofing material and all dirt and dust, hosing down the roof if necessary. Scrub any oxidized areas with a stiff brush, and flush them clean.

Usually, an asphaltic emulsion instead of an asphaltic cutback is used for the protective coating because of its better weathering qualities, mechanical stability, and fire resistance. However, since it is not water resistant and safe from freezing until it has dried (normally about 24 hours after application), it must not be applied in cold or wet weather or when rain is imminent. It can be applied to a damp surface.

11. Prepare the filled asphaltic-emulsion coating by mixing it thoroughly. Brush or spray the coating evenly over the entire roof area, including flashings. In brush application use two coats, each about 3 gallons (11.4 litres) per square. Allow full drying time between coats, and apply the second coat in a cross direction to the first. If spray application is used, apply the topcoat at the rate of 6 gallons (22.7 litres) per square.
12. The life expectancy of a roof can be increased by installing a reflective coating. If such a coating is called for in the specifications, apply it after the asphaltic-emulsion topcoat has dried thoroughly (a minimum of three days, or until the surface is dry enough, to take foot traffic without damage).

#### Repair of a Cold-Applied Built-up Roof

A correctly designed and installed cold-process built-up roof can be expected to have a long service life, but periodic inspection and maintenance are required if the roof is to attain or surpass its normal life span. The entire roof area should be inspected at

least once a year for defects that could allow moisture to penetrate the membrane or the flashings at valleys, parapet walls, skylights, drains, pipes, metal edging, and the like. Flashings are the principal sources of leaks in a roof, and if a leak is discovered, the flashings should be checked first unless another trouble spot is obvious.

Determining the source of a leak is seldom a simple matter. Often, the leak may show up some distance from the source, and more than one break may be contributing to the problem. Also, what appears to be a leak may instead be condensation or entrapped moisture within the structure, for example, moisture that may remain in lightweight insulating concrete under the roofing membrane because of inadequate venting. Skill in "chasing" existing leaks and identifying conditions that may cause leaks is an important asset for the roofer, but it is a skill that is acquired mainly through experience. Each roofing repair job presents its own special problems.

#### Common Sources of Leaks in Built-up Roofs

The following are some common causes of leaks in built-up roofs:

- Cracks in base flashings
- Dried caulking at counterflashing reglets on chimneys and masonry walls
- Nails that have backed out of the deck
- Improperly primed surfaces from which roofing material has peeled away
- Cracks where expansion joints should have been installed on large roofs
- Cracks in roll roofing material caused by wind uplift
- Incorrectly cut, folded, or sealed corners
- Broken copings on parapets
- Incorrectly installed air conditioning equipment or breaks caused by vibration of such equipment
- New vents incorrectly installed by others
- Breaks or openings around flagpoles, signposts, guy wire attachments, and the like
- Traffic damage due to missing or inadequate walkways
- Insufficient adhesive between felt layers
- Inadequate inspection and correction of deck defects prior to application of the roof
- Rusted outlet boxes and flashings
- Capillary action where flashings are set too low
- Blistered or wrinkled felts
- Fishmouths and open seams
- Poor patching
- Improperly installed gravel stops, edgings, and flashings

### Basic Repair Procedures

Emergency repairs have their place in the roofing trade, for example, when a temporary wet-patch repair must be quickly made during a heavy rain to prevent water damage to a building and its contents. However, relying on emergency repairs to maintain the integrity of a roof is poor economy. There is no substitute for an orderly preventive maintenance program that includes making permanent repairs when inspection reveals that they are needed or soon will be.

The repair procedures outlined in this topic are based on the use of cold-applied asphaltic flashing compounds, cements, and coatings; and they are adaptable to both hot-applied and cold-applied built-up roofs. It is assumed that the roof to be repaired is not aggregate surfaced. However, with some modifications the procedures can also be used for repairing an aggregate-covered roof. The procedures are general; on an actual repair job, the roofer should follow the specifications (if provided), the employer's directions, and or the manufacturer's instructions that accompany the roofing-repair materials.

**Repairing minor damage.** Minor damage and wear on an asphaltic cold-applied roof can usually be repaired satisfactorily with a compatible flashing compound or a fibrated coating material and glass fabric or other suitable reinforcement. The surface to be repaired should be clean and smooth, with any fishmouths and curled edges cut and cemented down. An embedding coat of compatible asphaltic material should be applied first, extending at least 4 inches (10.2 centimetres) beyond the damaged or worn area. Next, a layer of reinforcing fabric should be pressed in, followed by a heavy finish coat of the asphaltic material. Small defects in flashings often may be repaired by simply repointing with flashing compound.

**Repairing large breaks.** Where large splits and breaks have occurred, the area to be repaired should be cleaned, and any fishmouths and curled edges should be cut and cemented down. A layer of coated base sheet, trimmed so that it extends 6 inches (15.2 centimetres) beyond each side and 1 foot (30.5 centimetres) beyond each end of the split, should then be spot-cemented in place to serve as a slip sheet. Next, an embedding coat of fibrated asphaltic material should be applied over the slip sheet to receive glass-fabric reinforcement, which should be cut and placed so that it overlaps the slip sheet 2 inches (5.1 centimetres) on each side. Finally, a protective coat of the fibrated asphaltic material should be applied thick enough to cover the glass fabric completely.

**Repairing blisters, buckles, and wrinkles.** Blisters, buckles, and wrinkles in a built-up roof may be repaired by the following method:

1. Make a crosscut through the defect, clean out and thoroughly dry the area under the cut, and cement down the flaps.
2. Cement a layer of coated base sheet over the flattened blister or wrinkle so that it extends 6 inches (15.2 centimetres) beyond the defect.
3. Brush an embedding coat of fibrated asphaltic emulsion over the base sheet.
4. Press a layer of glass fabric into the emulsion, and smooth out any wrinkles in the fabric.
5. Apply an additional coat of fibrated asphaltic material so that the glass fabric is completely covered.

**Repairing valleys.** A leak in a valley may be repaired by first cleaning and smoothing the area to be repaired, then applying an embedding coat of fibrated asphaltic material and a layer of glass cloth, followed by two finish coats of the asphaltic material after the embedding coat has set. The glass cloth should be free of wrinkles, and it should extend up the valley incline at least 12 inches (30.5 centimetres).

**Repairing base flashings.** If a length of base flashing has pulled away from the wall at the upper edge of the flashing, it can usually be repaired by forcing asphalt cement behind the separated flashing, nailing the upper edge of the flashing through tin disks, and sealing the nailed edge with a strip of glass cloth and fibrated asphaltic material, as described previously under "Repairing minor damage." Minor breaks in the base flashing may be repaired by the reinforcing method described under "Repairing large breaks."

If the base flashing is extensively damaged or worn along its entire length, a different procedure is recommended for making the repair. First, the damaged or worn area is broomed clean, and an embedding coat of fibrated asphaltic emulsion is applied, beginning 2 inches (5.1 centimetres) above the flashing line and extending at least 24 inches (61 centimetres) out onto the field of the roof. Then, a layer of glass cloth is set in the fibrated emulsion coating and brushed out smooth. After the first coat has set up, a second embedding coat and a second layer of glass cloth are applied. Finally, a heavy finish coat of the fibrated asphaltic material is applied over the entire repaired area. This method may also be used to reinforce a weak base flashing along its entire length.

### Safety in Using Cold-Applied Asphaltic Materials

The general safety precautions that apply in all roofing work must be observed in applying a cold-process asphaltic built-up roof. Some important extra precautions must be taken, however. The solvents

used. In most of the asphaltic cutbacks are highly flammable and may be toxic. They must not be stored or used near heat or open flame. Roofers should avoid repeated skin contact with these materials and should avoid prolonged breathing of their vapors. The vapor hazard is greatest in confined areas. The work area should have adequate ventilation. Containers of asphaltic cutback material should be kept covered when not in use, and they should be kept out of the reach of children.

Cold-process materials are often used to recover or repair existing roofs. A special hazard that may be encountered in spudding off an old built-up roof is the presence of electrical conduits with live conductors under layers of old roofing material or aggregate. The location of such conduits should be determined before

tear-off of the old roof is begun, and care should be taken to avoid damaging them. If possible, the power to roof-mounted electrical equipment should be shut off and the conduits should be disconnected and temporarily moved out of the way.

#### Study Assignment

1. Study manufacturers' catalogs and specifications for cold-process asphaltic built-up roofing.
2. C. W. Griffin, *Manual of Built-up Roof Systems*. New York: McGraw-Hill Book Company, 1970. Read pp. 90—92.
3. *Handbook of Accepted Roofing Knowledge*. Oak Park, Ill.: The National Roofing Contractors Association, 1980. Read the information on vapor retarders and preformed roof insulation.



# COLD-APPLIED ROOFING SYSTEMS AND WATERPROOFING AND DAMPPROOFING

## TOPIC 4—COLD-APPLIED BITUMINOUS SHEET-MEMBRANE ROOFING

This topic and the related instruction classes are designed to enable the apprentice to do the following:

- Identify prefabricated bituminous sheet-membrane roofing materials.
- Describe the work that must be done before the bituminous sheet-membrane roofing materials are applied.
- Discuss the procedures for roofing and reroofing with standard-grade and aluminum-grade membranes.
- Discuss the uses of insulation and vapor barriers in roofing systems using the bituminous sheet membranes.
- Describe repair procedures for standard-grade and aluminum-grade membranes.

### Characteristics of Cold-Applied Bituminous Sheet-Membrane Roofing

With the increasing acceptance of cold-process materials and methods, many new types of prefabricated, ready-to-use membranes have made their appearance in the roofing and waterproofing industry. Included in this class of materials are plastic films (used principally as vapor barriers and in dampproofing), elastomeric (rubberlike) membranes, and composite membranes that consist of plastic or elastomeric sheets bonded to a dissimilar material, such as asbestos felt, urethane foam, or modified bitumen. One of the many available types of plastic-and-bitumen membranes is the subject of this topic.

The single-ply roofing system described in this topic is assembled from rolls of laminated plastic-and-bitumen membrane material that is marketed in two grades—standard and aluminum clad. The standard-grade laminated membrane consists of a flexible, heavy-duty plastic core sheet protected on each side with a layer of modified bitumen and an outer film of

polyethylene. The aluminum-grade version is constructed in the same way, except that a layer of heavy, embossed-aluminum foil is used in place of the top plastic film. (See Fig. 4-1.) The bitumen layers contribute to the water resistance of the membrane, protect the plastic core (the essential waterproofing component) during installation, and enable the applied sheets to be heat-fused to each other and to other parts of the roof.

The standard-grade laminate is normally used as a floating membrane on low-slope roofs, where it is protected and ballasted by a layer of river gravel, crushed aggregate, or other suitable topping. It can also be applied as a waterproofing membrane on horizontal and vertical surfaces. The aluminum-grade membrane is especially suited for use on roofs that are too steep to retain an aggregate cover, and it is also used as flashing material. Since the aluminum-grade material is not topped with a stabilizing layer of aggregate, it is set in a full bed of adhesive that is applied to the substrate ahead of the membrane.

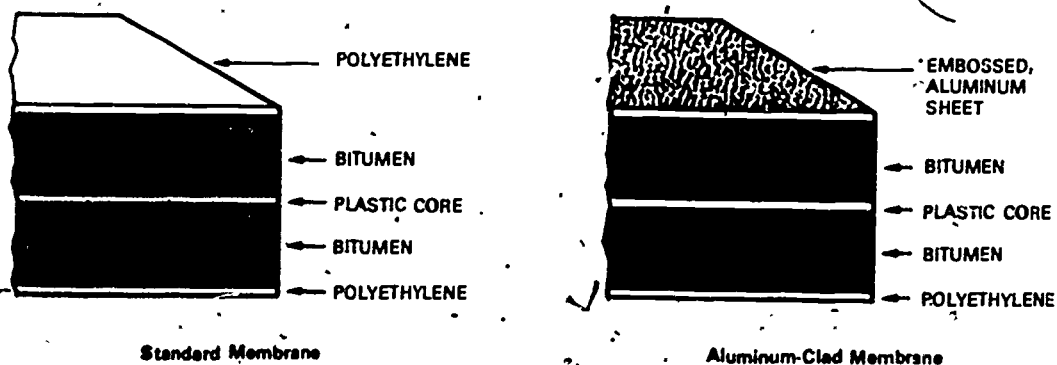

Fig. 4-1. Cold-applied standard-grade and aluminum-grade bituminous sheet membranes (Koppers KMM)

Both membrane grades have good elongation properties that enable them to withstand the normal movements that occur in a roof structure, and they are suitable for use over most decks and commonly used insulating materials that are capable of giving them continuous support. Because the membranes are factory-made materials that are produced under close quality control, they are of uniform composition and thickness. If properly installed, they provide a completely waterproof roofing system that is also airtight and impervious to water vapor.

### Roofing with Cold-Applied Bituminous Sheet-Membrane Materials

The cold-process bituminous sheet membranes are versatile materials that have many uses in roofing and waterproofing. Three procedures for using these membranes in roofing and reroofing are given in this topic; waterproofing applications are discussed in Topic 8. The procedures were adapted from industry publications, but they are intended for general information only. On an actual roofing job, the work must be done in accordance with the architect's or roofing engineer's specifications (if provided) and the manufacturer's instructions that accompany the roofing materials.

#### Preliminary Work

The work that must be done before application of a bituminous sheet-membrane roof is much the same as for other methods of roofing and reroofing. The deck or the existing roof must be inspected to ensure that it is structurally sound, correctly sloped to adequate drains, and free of defects that could affect the performance of the membrane or shorten its life. The deck must provide a firm, stable base for the membrane; and it must be clean, smooth, dry, and free of contaminants, such as release agents. All ridges, cracks, or voids that might cause rupture of the membrane must be repaired. Conduit runs, bolt heads, and the like should not extend above the surface of the deck. All projections or openings in the deck should be completed before roofing is begun. Any hot-water or steam pipes that project through the deck or are close to it should be insulated.

**Preparing metal decks.** Metal decks must have no loose or missing welds, and they must be free of oil, loose rust, and scale. A ribbed metal deck is not a suitable base for the membrane unless the deck is first covered with insulation boards or other material that can provide firm, continuous support for the membrane. (See Fig. 4-2.)

**Preparing nonnailable decks.** Concrete and other nonnailable decks must have wood nailing strips at

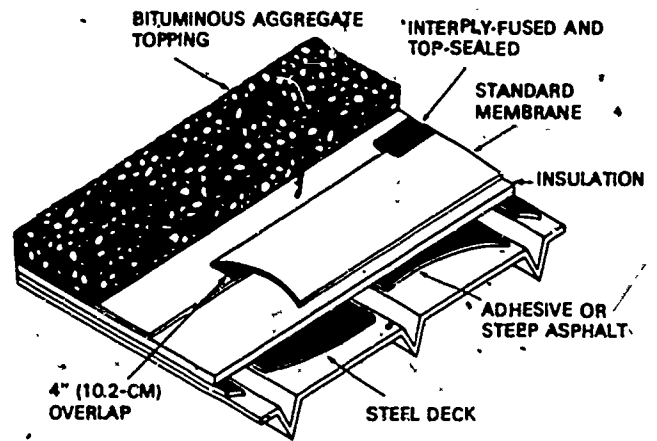

Fig. 4-2. Standard-grade cold-applied bituminous sheet membrane on a metal deck (*Koppers KMM*)

eaves, deck edges, roof openings, and the like to provide a nailing base for gravel stops or metal flanges that are used in such locations to finish and enclose the edges of the membrane. Pressure-treated wood should be used for the nailers. Additional wood strips may be set flush into the field of the deck at intervals to serve as nailers for insulation. All concrete, portland cement, gypsum, or other poured-in-place masonry decks must be cured, dry, and free of loose material before insulation or the membrane is applied. Any ridges or other high spots should be dressed down, and any cracks or voids should be filled with portland-cement mortar.

**Preparing lightweight insulating decks.** If standard-grade membrane is to be applied directly to a lightweight insulating deck made of gypsum, foamed concrete, or similar porous material, the deck must be capable of venting excess water vapor to the underside. (Aluminum-grade membrane should not be applied directly over such decks; a coated base sheet should be nailed in place first.) If the standard-grade material is installed as a floating membrane on a lightweight insulating deck, spot venting through the membrane or through notches in the perimeter nailers will usually prevent the build-up of vapor pressure under the membrane.

**Preparing wood-plank or plywood decks.** Wood decks that are to be roofed with bituminous sheet-membrane material must be clean and dry. Loose knots, voids, and cracks should be filled or covered with sheet metal, then covered with a cushioning strip of membrane. Planks and plywood panels must have adequate bearing. Planks should be pressure-treated, tongue-and-groove lumber of at least 1-inch (2.5 centimetre) nominal thickness. Plywood panels should be

exterior-grade material at least ½-inch (1.3 centimetres) thick. All panel joints must be taped, or a coated base sheet, must be nailed in place, before aluminum-grade membrane is applied.

#### Insulation and Vapor Barrier

A vapor barrier is normally used in a roof system if there is a possibility that moisture from within the building interior or the deck structure could condense on the underside of the roofing membrane or the insulation material. Condensed water can impair or destroy the effectiveness of the insulation. If the specifications for the roofing job call for a vapor barrier, it is installed between the membrane and the deck, or if insulation is used, between the insulation and the deck. The vapor barrier must be securely anchored to the deck below and to the insulation or membrane above, and it must be carefully protected until it has been covered. Insulation is normally included as a separate component in the roofing system, but on some jobs the deck may be a composite unit consisting of a layer of insulation material bonded to a stronger base, such as wood-fiber board. The composite deck material may itself have enough moisture resistance to eliminate the need for a separate vapor barrier.

Board-type insulation is often specified as part of a sheet-membrane roofing system. The preformed boards are marketed in various styles and thicknesses and in block sizes from 12 x 18 inches (30.5 x 45.7 centimetres) to 4 x 8 feet (1.2 x 2.4 metres). Care must be taken not to crush or otherwise damage the insulation boards before, during, or after their installation. A broken or damaged board can be used if the damaged portion is trimmed off, but the cut must be accurately made so that the trimmed board will fit squarely against adjacent pieces; the boards must be installed with close-fitting joints. When more than one layer of insulation is used, the joints in successive layers should be staggered.

The insulation must be securely anchored to its substrate with the specified adhesive or an approved mechanical fastening system. It must also be kept dry at all times. For prevention of moisture damage, no more insulation should be laid in a day than can be protected with the roofing membrane. At the end of each workday, the exposed edge of the last-laid course of insulation material must be protected by a temporary water stop, which can be made by extending the membrane at least 6 inches (15.2 centimetres) beyond the exposed edge and sealing the leading edge of the membrane to the deck. (See Fig. 4-3.) When the work is resumed the next day, the water stop must be cut cleanly along the top edge and removed so that vapor movement through the insulation will not be blocked.

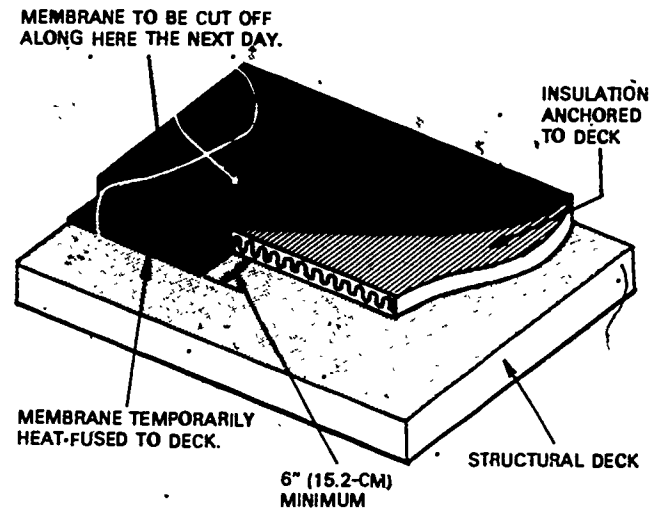

Fig. 4-3. A standard water stop

The membrane is then continued over the joint to the next course of insulation and is lapped and sealed by heat-fusion methods, which are described below.

#### Roofing with Cold-Applied Standard-Grade Bituminous Sheet Membrane

The procedure for applying standard-grade bituminous sheet membrane to a low-sloped roof is relatively simple. After the deck has been properly prepared, with the insulation and any needed reinforcement in place, the membrane is simply rolled out, one roll alongside another, with each roll overlapping 4 inches (10.2 centimetres) at the sides and ends. End joints are staggered. Next, all side and end laps are heat-fused, and the seamed membrane is then heat-fused to the substrate around the entire perimeter of the roof and around openings and projections. Flashing with strips of aluminum-grade membrane is installed where required as the work progresses. Finally, the completed roof is covered with a suitable topping material.

**Heat fusion.** The membranes described in this topic are joined to each other and to other components of the roof by heat fusion, in which a propane torch is used to heat the bitumen in the membrane until it becomes plastic enough to flow under pressure and fuse to an adjoining surface. (See Fig. 4-4.)



Fig. 4-4. Seaming adjacent cold-applied bituminous sheet membranes with heat fusion

When heat fusion is used to secure the membrane to a substrate surface, the process is called substrate fusion. The underside of the membrane is heated until the protective polyethylene film melts and the bitumen becomes plastic; then the membrane is quickly pressed against the substrate surface with enough force so that a slight run-out of the softened bitumen appears from beneath the membrane edge. The result is a fused, waterproof seal.

The type of heat fusion used to obtain a waterproof seal between two overlapping sections of membrane is called interply fusion. When standard-grade membrane is to be interply fused, the torch flame is applied simultaneously to both mating surfaces of the overlapping membranes until they become plastic, and the heated surfaces are then pressed together to make a waterproof, fused joint. As in substrate fusion a slight run-out of the bitumen should be observed. The installation is completed with top-sealing, which is used to provide an additional waterproof seal at substrate-fused and interply-fused joints on standard-grade membranes. Top-sealing is accomplished by heating the top of the newly formed seam edge until the bitumen is plastic and then troweling down the edge so that the joint is made smooth and continuous.

The same procedure is used to obtain interply fusion between aluminum-grade membranes, but top-sealing is not used. The edge of the lower sheet of aluminum-grade material has an exposed 4-inch-wide (10.2-centimetre-wide) bitumen band, and the overlapping edge of the upper sheet has an aluminum extension tab. The bitumen is heated, and the overlapping edge is then troweled down to complete the joint. The aluminum tab serves to conceal some of the bitumen run-out.

When aluminum-clad membranes are to be interply fused at their cut ends, the bottom surface of the overlapping membrane is heated simultaneously with the aluminum-clad surface of the underlying membrane, and the overlapping membrane is then pressed down and fused to the aluminum foil on the underlying membrane.

*Application of the membrane.* The procedure for applying standard-grade membrane to a prepared deck is as follows:

1. Before applying the main membrane, install cushioning or stripping layers of standard-grade membrane in areas of high stress and where the main membrane terminates or changes direction. Examples of such areas are interior and exterior corners, valleys, drains, joints, gravel stops and other metal flanges, and projections. The cushioning layers should be embedded in the specified adhesive, substrate-fused, and top-sealed. Multiple layers of cushioning may be used to form cants; fiber, wood, or smooth mortar cants may also be used. All flanges and other metal surfaces that will contact the membrane should be primed.
2. Determine the direction of water drainage, and begin applying the membrane at the low point of the deck. Lap successive sheets so that water will flow over the laps rather than against them. (See Fig. 4-5.) Change the direction of the overlap where the direction of water flow changes. Set each sheet of membrane in place, and stretch it slightly before heat-fusing the laps. (To keep the sheets smooth until they are seamed, the roofer may tack-fuse the ends to the deck.) Stagger end laps.

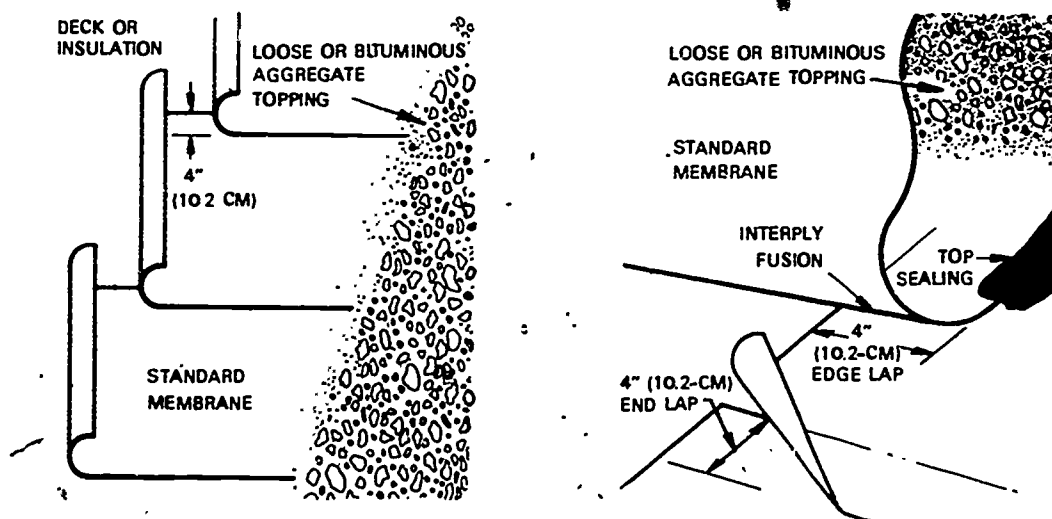

Fig. 4-5. Lapping the cold-applied bituminous membrane sheets (Koppers KMM)

3. Interply-fuse and top-seal side and end laps. Laps should be 4 inches (10.2 centimetres) wide.
4. Substrate-fuse the membrane to the deck around the entire perimeter of the roof; at parapets, walls, and metal edges; and around hatches, curbs, skylights, and other projections. Interply-fuse and top-seal all joints.
5. On parapets and other vertical intersections, extend the membrane at least 2 inches (5.1 centimetres) above the cants. Substrate-fuse and top-seal the terminal edge of the membrane to the wall.
6. Install flashings at parapets and other vertical intersections; around pipes, vents, and other projections; and in all other locations where the job specifications and good roofing practice require them.
7. When the flashings have been installed, cover the roof with an appropriate topping. If loose aggregate is used, it should be smooth gravel or crushed aggregate or stone of  $\frac{3}{4}$ -inch (1.9-centimetre) nominal size, applied at a rate of at least 1,000 pounds (453.6 kilograms) per square. If crushed aggregate or stone is used as the topping material, it should not be placed directly upon the membrane; a stress-distributing underlayment should be put down first. If an asphaltic-emulsion binder is used to stabilize the aggregate topping and provide additional protection for the membrane, clean gravel aggregate of  $\frac{3}{8}$ -inch (1-centimetre) nominal size should be used.

**Installation of flashing.** The basic flashing materials used in the roofing systems described in this topic are strips of aluminum-grade membrane that are installed by total heat fusion. A high-penetration asphaltic-cutback primer may be required on a porous, cementitious surface that is to receive flashing (for example, on a masonry parapet wall). Strips of standard-grade membrane may be specified as reinforcement under the flashing in certain locations. All surfaces that are to receive flashing must be dry, free of dirt and loose material, and reasonably smooth.

Some typical flashing details for the roofing systems described in this topic are shown in Figure 4-6.

Flashing failures are probably the most common causes of leaks in roofs. Because correct flashing is essential for good performance and long life of a roof system, the manufacturers of roofing materials usually provide detailed specifications for the flashing materials and methods that are to be used in roofing with their products. The manufacturer's instructions should be followed exactly unless the architect or roofing engineer provides different specifications for

the job. (The architect's or engineer's specifications always take precedence.)

#### Roofing with Cold-Applied Aluminum-Grade Bituminous Sheet Membrane

The procedure for roofing with aluminum-grade bituminous sheet membrane is basically the same as that for the standard-grade material. The principal differences are the methods of attaching the membrane to the deck and of interply-fusing the overlapping sheets. Preparation of the deck is similar for both membrane grades, with the differences that were discussed earlier in this topic under "Preliminary Work."

The procedure for applying aluminum-grade membrane to a prepared deck is as follows:

1. Install cushioning and reinforcing layers of standard-grade membrane as described in the procedure for applying standard-grade membrane on page 20.
2. Starting at the low point of the deck, set the first sheet in a full bed of the specified adhesive before the adhesive becomes dry to the touch. (See Fig. 4-7.) Apply the adhesive to the deck with a brush, roller, or squeegee. To obtain proper adhesion of the membrane and eliminate air bubbles, brush the applied membrane with a stiff broom, roll it with a weighted roller, or do both.
3. Lay subsequent courses with 4-inch (10.2-centimetre) side and end laps. Continue until the entire membrane has been placed, using interply fusion at the side and end laps. (Use the interply-fusion method for aluminum-grade membrane described on page 20.)
4. Extend the membrane at least 2 inches (5.1 centimetres) above the cants at parapets and other vertical intersections. Substrate-fuse the membrane at these locations.
5. Install flashings where the job specifications and good roofing practice require them, using specified materials and methods.
6. The aluminum-clad membrane normally requires no additional protection. However, varnish-base aluminum paint may be used to touch up any exposed streaks of bitumen, for example, at seams. Also, decorative acrylic-emulsion coatings are available in many colors for field application over the installed membrane.

#### Reroofing with Cold-Applied Bituminous Sheet Membranes

Both the standard-grade and aluminum-grade membranes are suitable for use as reroofing materials. In

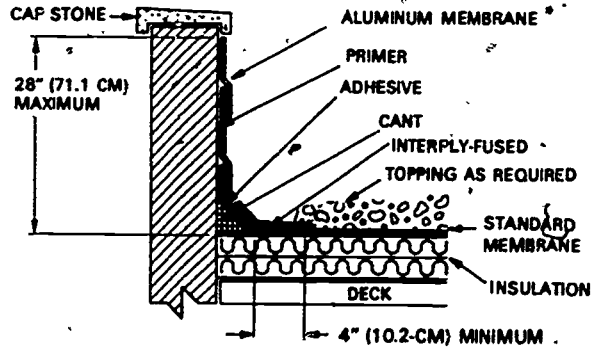
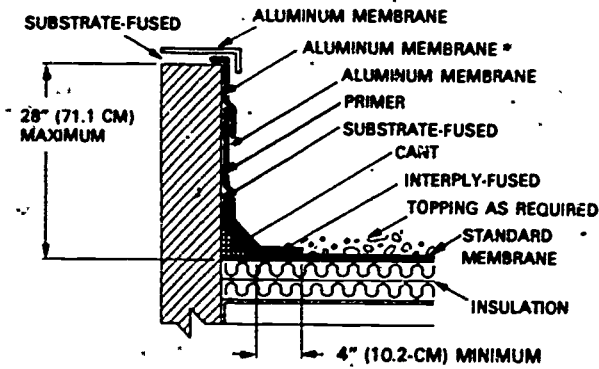
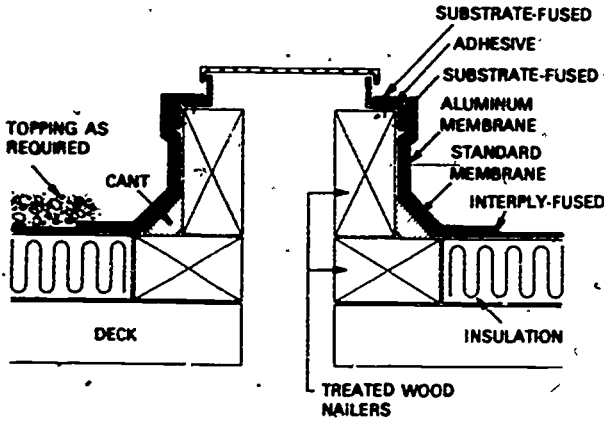
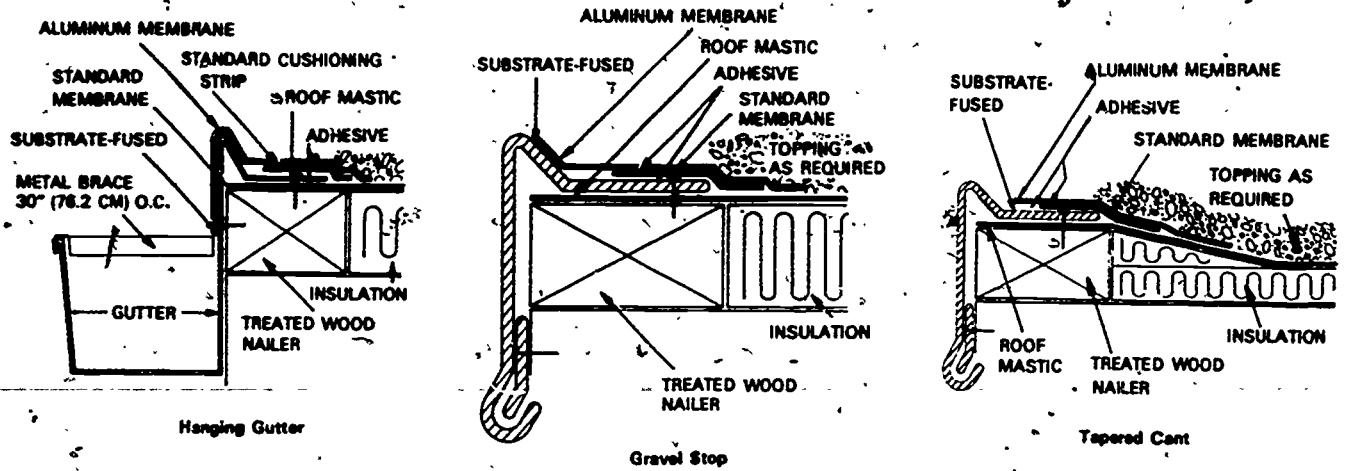

\*OVERLAP 4" (10.2 CM) AND SUBSTRATE-FUSE WHEN FLASHING HEIGHT EXCEEDS 12" (30.5 CM).

\*OVERLAP 4" (10.2 CM) AND SUBSTRATE-FUSE WHEN FLASHING HEIGHT EXCEEDS 12" (30.5 CM).

Parapet Wall Flashing with Aluminum Wall Cap

Parapet Wall Flashing

Fig. 4-6. Typical flashing details (Koppers KMM)

many instances the membrane may be installed over old roofing if the existing roof is structurally sound, reasonably clean and dry, and free of defects that could damage the membrane. (See Fig. 4-8.)

The preliminary work required for reroofing with bituminous-sheet membranes is much the same as for new roofing installations (described earlier in this topic). In reroofing with standard-grade material, the membrane sheets are loosely laid over the prepared existing roof and are seamed, anchored to the roof, flashed, and topped with aggregate by the methods previously described for new roofs. On a gravel-surfaced roof, loose gravel and any blisters or buckles must be removed, and a layer of insulation must be applied before the membrane is placed. On smooth-surfaced roofs any blisters, buckles, cracks, or similar defects in the substrate must be removed or repaired, and cuts or open areas must be cushioned with a layer of standard-grade membrane set in adhesive and substrate-fused.

If aluminum-grade membrane is used for the reroofing job, no aggregate topping is required, but the membrane must be secured to the substrate in a bed of the specified adhesive. Before the adhesive is applied, the roof surface should be primed with a thin asphalt

cutback. The aluminum-grade material should not be applied directly over a substrate that contains moisture unless the substrate is adequately vented to permit the water vapor to escape. The standard-grade membrane can tolerate some moisture in the substrate, but spot-venting or perimeter-venting may be required, depending on the job conditions.

#### Repair of Cold-Applied Bituminous Sheet Membranes

Any holes, tears, or imperfect seams in the standard-grade or aluminum-grade membranes can be repaired by patching with the appropriate membrane material. The patch must extend at least 4 inches (10.2 centimeters) in all directions from the outer limits of the defect. Patches on standard-grade membranes should be interply-fused and top-sealed. Patches on aluminum-grade membranes should be interply-fused only; and bitumen streaks may be touched up with varnish-based aluminum paint.

#### Study Assignment

Study trade publications that describe bituminous sheet-membrane roofing and waterproofing materials.

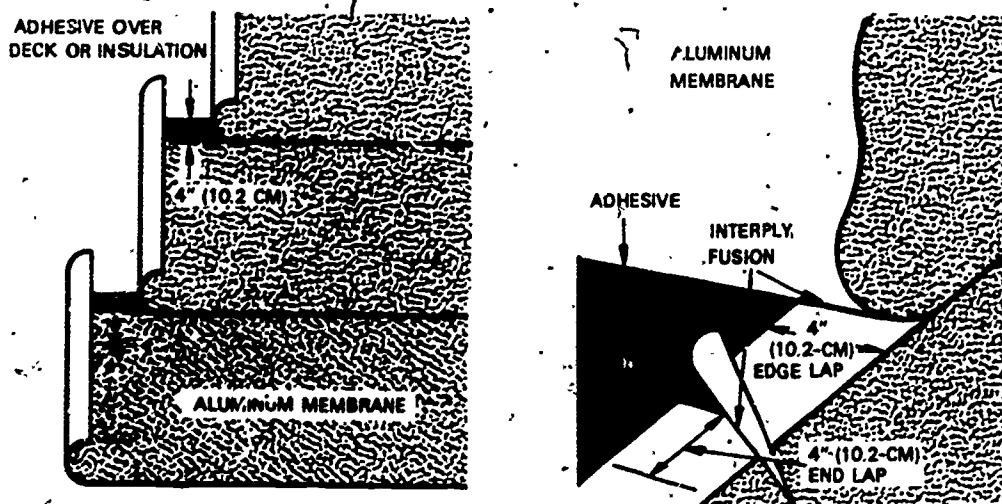

Fig. 4-7. Applying cold-process aluminum-grade bituminous sheet membrane (Koppers KMM)

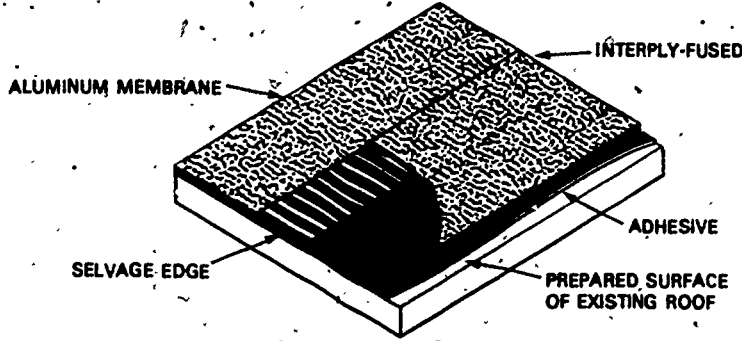
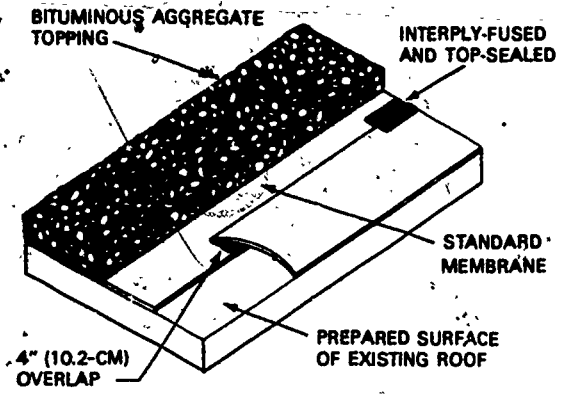
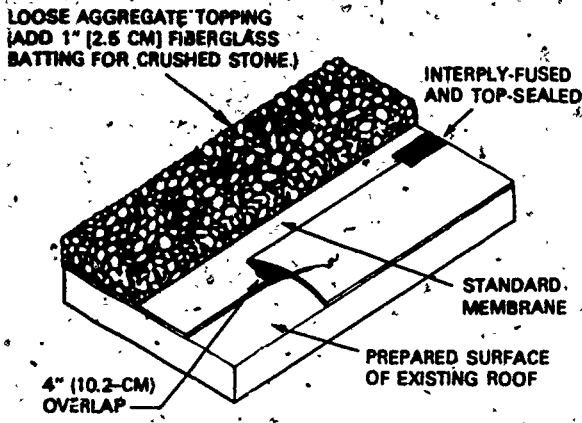

Fig. 4-8. Methods of reroofing with cold-applied bituminous sheet membranes (Koppers KMM)



# COLD-APPLIED ROOFING SYSTEMS AND WATERPROOFING AND DAMPPROOFING

## TOPIC 5—ELASTOMERIC SHEET-MEMBRANE ROOFING

This topic and the related instruction classes are designed to enable the apprentice to do the following:

- Define "elastomer,"
- Discuss the advantages and limitations of elastomeric roofing systems.
- Describe the polymerization process as it relates to the curing of elastomeric roofing and waterproofing materials.
- Describe procedures for roofing and reroofing with elastomeric sheet-membrane materials.
- Identify methods of fastening elastomeric sheet membranes to various substrates.
- Discuss the repair of elastomeric sheet membranes.

### Characteristics of Elastomeric Roofing Materials

An elastomer is a substance that has physical properties similar to those of natural rubber. Like natural rubber, the elastomers return to their original shape, or nearly so, after they have been stretched or compressed. This elastic quality distinguishes them from plastic substances, such as pure asphalt and coal tar, which can be stretched or deformed but do not resume their original shapes. The distinctions between the two classes of materials are not always clear-cut, however; asphalt and coal tar can be made elastic to some extent if they are modified with an elastomer. Also, many of the synthetic materials commonly known as plastics—so-called because they can be molded, cast, or extruded in almost any shape—may have elastomeric properties as finished products. An example is the polyvinyl chloride (PVC) films and sheet membranes that are often used in cold-process roofing, waterproofing, and dampproofing.

Roofing systems using elastomeric materials (sometimes called "exotic" systems) have achieved considerable popularity in Europe, and although they still account for only a small part of the roofing done in the United States, they are steadily gaining acceptance in this country. The single-ply elastomeric sheet membranes discussed in this topic offer some advantages compared with conventional built-up membranes:

- Their rubberlike properties (up to 400 percent elongation before rupture) enable them to conform to the substrate and remain waterproof even with some movement of the underlying structure.
- The equipment and methods used for installing them are simpler.
- They reflect heat well.
- They are adaptable to any roof slope.
- The factory-made sheets are uniform in thickness and composition, which simplifies quality control on the job.

On the negative side the elastomeric membranes usually must be tightly bonded to a firm substrate, and special primers and adhesives may be needed to ensure adequate bonding. Also, the elastomeric materials are generally more expensive than conventional materials, but the higher material cost may be offset by lower labor and equipment costs for the roofing job.

A partial list of elastomeric sheet-membrane roofing materials is given in Table 5-1.

Elastomeric roofing and waterproofing materials are also marketed as fluids that are rolled, brushed, or sprayed onto a substrate and become a seamless membrane after they have cured or set. Fluid-applied cold-process roofing materials are discussed in Topic 6, and the uses of elastomeric materials in waterproofing and dampproofing are discussed in Topic 8.

Most of the synthetic elastomers used to make roofing and waterproofing materials undergo a curing process called polymerization as they change from liquid to solid form. Polymerization is a chemical reaction in which the normally small molecules in a substance combine to form long chains or networks of large molecules that give the substance new properties, for example, the superior toughness, elasticity, and weather resistance that are typical of the synthetic roofing materials. The preformed elastomeric sheet materials are usually fully cured when they leave the factory, but some products of this type require additional curing time after they have been installed to achieve full strength.

### Roofing with Preformed Elastomeric Sheet Membranes

Factory-formed elastomeric sheet-membrane roofing material is usually packaged in rolls about 50 to 100 feet (15.2 to 30.5 metres) long and 36 to 54 inches (91.4 to 137.2 centimetres) wide. Some manufacturers

market the material in larger rolls (up to 300 feet [91.4 metres] long and 30 feet [9.1 metres] wide) that require less field joining; however, special equipment is needed for handling these heavy rolls, and special installation procedures must be followed if the deck area is interrupted by skylights, pipes, or other projections. Some elastomeric sheet materials are manufactured with a urethane-foam or asbestos-felt backing; the felt-backed materials usually require a coated base sheet as an underply.

Because of the many types of elastomeric roofing products now available, each with its own requirements for proper and safe installation, only general information about roofing with these materials can be given in this workbook. Elastomeric materials are not difficult to work with, but they must be installed in strict accordance with the architect's or roofing engineer's specifications and the instructions provided by the manufacturer. This is especially important with regard to the adhesives, primers, caulking compounds, solvents, and other fluids used in elastomeric roofing and waterproofing. These associated materials must be compatible with the elastomeric membrane and any tie-in roofing materials, and the only way to be sure of this is to follow the job specifications and the manufacturer's instructions exactly.

#### Preliminary Work

In general, the requirements for deck inspection and preparation outlined in previous topics apply also to roofing with elastomeric sheet membranes. The substrate that is to receive the membrane must have solid bearing and must be clean, dry, and smooth; it must also be free of fins, ridges, protruding nail heads, and any other sharp projections that could puncture or weaken the membrane. Cracks, voids, and depressions must be repaired by methods acceptable to the manufacturer of the roofing material. The deck must have adequate provision for drainage.

#### Insulation and Vapor Barrier

Elastomeric sheet membranes are versatile materials that can be adapted to almost any suitably prepared deck or existing roof. The usual substrate is insulation boards. The roofing specifications may also call for a vapor barrier between the deck and the insulation. Some means of venting the insulation is normally required when a vapor barrier is used. A typical pressure release vent is shown in Figure 5-1.

#### Methods of Applying the Membrane

Single-ply elastomeric sheet membranes may be installed on the substrate by adhesive bonding, mechan-

TABLE 5-1  
Some Preformed Elastomeric Sheet-Roofing Materials

| Type of membrane   | Approximate thickness, in mils | Typical substrates   |
|--|--------------------------------|--|
| Polyvinyl chloride (PVC) sheet                                       | 50<br>(1.3 millimetres)        | Concrete; sprayed-in-place urethane foam; existing smooth-surfaced roofs |
| Glass-fiber-reinforced PVC sheet                                     | 50<br>(1.3 millimetres)        | Concrete; plywood; insulation board                                      |
| Nylon-reinforced PVC sheet with synthetic-rubber backing             | 30<br>(0.8 millimetres)        | Concrete; plywood; insulation boards; existing smooth-surfaced roofs     |
| Chlorosulfonated polyethylene (Hypalon) sheet, asbestos-felt backing | 35<br>(0.9 millimetres)        | Plywood (over coated base sheet)   |
| Polychloroprene (neoprene) sheet                                     | 60<br>(1.5 millimetres)        | Concrete; sprayed-in-place insulation                                    |
| Hypalon-coated neoprene sheet  | 75<br>(1.9 millimetres)        | Concrete; sprayed-in-place insulation                                    |
| Polyethylene sheet, foam backing                                     | 80<br>(2.0 millimetres)        | Concrete; plywood  |
| Polyethylene sheet, modified-asphalt backing                         | 70<br>(1.8 millimetres)        | Sprayed-in-place insulation; existing smooth-surfaced roofs              |

ical fastening, or some combination of these methods. If the membrane is applied loose, it will require an aggregate ballast.

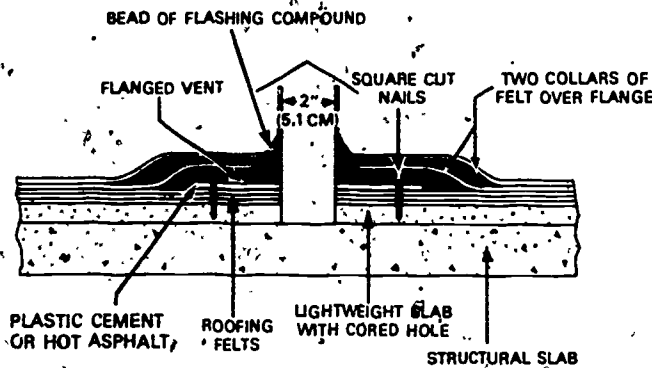

Fig. 5-1. A typical pressure release vent

*Application by adhesive bonding.* A common method of installing an elastomeric membrane, particularly on roofs that are too steep to hold an aggregate ballast, is to bond the entire membrane to the substrate with an appropriate adhesive. An advantage of full adhesive bonding is that if a break occurs at some point in the membrane, water will not travel under the membrane and leak through the substrate at a location far removed from the point of damage.

If an elastomeric sheet membrane is to be adhesive-bonded to a substrate, the adhesive must be the type specified by the membrane manufacturer. Synthetic-rubber membranes are commonly bonded to the substrate and seamed with a solvent-type neoprene contact adhesive, using a procedure like the following:

1. Make sure the surfaces to be joined are clean and dry. The membrane manufacturer may recommend use of a special cleaner to prepare the membrane and adjoining materials to receive the adhesive. Metal surfaces may require a light acid etch followed by a primer coat to ensure a good adhesive bond.
2. Starting at the lowest point of the deck, roll out the elastomeric sheet material at a nearby location on the roof, and apply a coat of contact adhesive by brush or roller to the surface that will be bonded to the substrate. (Always stir the adhesive thoroughly before use, and cover the container immediately after use to prevent evaporation of the solvent.) Similarly, apply a coat of the contact adhesive to the previously marked-off area on the substrate where the first course will be laid. Do not apply adhesive directly over joints in the substrate, since tight bonding at such places can concentrate stresses in the membrane.
3. When the adhesive on the unrolled sheet membrane has dried enough so that it does not stick or pull when touched with the back of the hand; reroll the sheet to protect it until time to install it. This is possible because the dried adhesive coating will not bond to the plastic release sheet that is normally provided on the reverse side of the roll material. If the material does not have a release sheet, a temporary plastic or cloth liner may be used to keep the rerolled membrane from sticking to itself.
 

The drying time for neoprene contact adhesive may be as little as ten minutes on a hot, dry day or as long as two hours in cooler, more humid weather. When the adhesive on both surfaces to be joined is adequately dry, a strong bond occurs between the coated surfaces immediately upon contact (hence, the name "contact adhesive"). The bond will be weak if the adhesive-coated surfaces are joined prematurely, and a weak bond will also result if too much time elapses before the surfaces are joined. The maximum allowable time after the adhesive has dried and before the coated surfaces are joined is called the open time. The open time for most neoprene contact adhesives in warm, dry weather is about four hours, but in cooler and more humid weather it can be 12 hours or more. The drying time and open time can vary considerably, depending on the job conditions and the type of product being used; the only sure guide is the manufacturer's recommendations.
4. To begin applying the adhesive-coated membrane, insert a bar through the core of the roll. Have assistants carry and unroll the material during the placing of the material. Place the first course to the chalk line, adhesive-side down, and smooth it down by hand as it is unrolled. Use great care when placing the membrane to keep it properly aligned and free of trapped air bubbles; remember that once the adhesive coatings contact each other, they are instantly and unalterably joined.
5. Apply adhesive to the substrate for the next course, lapping the adhesive 3 or 4 inches (7.6 or 10.2 centimetres) onto the previously placed sheet. When the adhesive is dry, unroll and apply the second course, lapping the sheets shingle fashion. An alternate layout method sometimes used on dead-flat roofs is to install every other sheet to a chalk-line or checkerboard pattern, then go back and install sheets over the uncovered spaces, lapping over both of the previously installed courses. This method provides more

working space and eliminates much of the delay of waiting for the adhesive to dry.

6. Continue with successive courses until the entire membrane is placed, trimming sheets to fit around projections as required.
7. Where end laps occur, make them about 6 inches (15.2 centimetres) wide, and adhesive-bond them in the same manner as side laps. Stagger the end laps so that they do not occur at the same location on adjacent courses. Roll all seams with a 2-inch-wide (5.1-centimetre-wide) flat-faced steel roller, and then stitch the seams with a 1/4-inch-wide (0.6-centimetre-wide) knurled stitcher to ensure an intimate bond. Most manufacturers recommend the use of caulking at end-lap intersections, and some recommend that all exposed seams be caulked.
8. Install flashing at the roof perimeter; at parapet walls and other vertical intersections; around skylights, vents, drains, and other projections and penetrations; and wherever else the job specifications and good roofing practice require it. Flashing is usually accomplished with elastomeric sheeting cut to the appropriate width and applied to the roofing membrane and adjoining surfaces with contact cement or another specified adhesive. Most manufacturers recommend application of a fillet of elastomeric caulking along all edges of the completed flashing.
9. If a topcoat is required, apply it on the clean, dry membrane in accordance with the job specifications and the membrane manufacturer's instructions. A fluid-applied Hypalon\* decorative and protective coating is commonly used over a neoprene elastomeric sheet-membrane roof.

**Application by mechanical fastening.** If the elastomeric sheet membrane is to be installed over a nailable deck, various methods of mechanical fastening can be used to secure both the membrane and the underlying insulation material to the deck. In one such system insulation boards are placed loose but without joint clearance on the deck, over a vapor barrier if this is required, and the elastomeric sheet roofing is then rolled out for the first course. Perforated metal strips are then placed over the properly aligned and smoothed elastomeric sheet, about 1 inch (2.5 centimetres) in from the edge on each side, and the metal strips are fastened in place with annular-ring nails or self-tapping screws that are driven through the holes in the strips, continuing through the membrane and insulation and into the deck.

\*Hypalon is a DuPont trademark.

After the first course is laid, the second course is rolled out, lapping over the metal strip and the previously laid sheet at least 4 inches (10.2 centimetres). The lap is sealed with contact adhesive, with the previously installed metal strip sealed within the lap. End laps are bonded with contact adhesive. The remaining edge of the second course is then secured with fasteners driven through a metal strip, as previously described, and the procedure is continued until the entire deck is covered. The remainder of the roof perimeter and any other terminal edges of the membrane (around skylights, for example) are then secured with fasteners driven through metal strips. Flashing is installed with appropriate adhesive so that it laps over the metal strips, using adhesive-bonded elastomeric sheeting or other specified flashing material. A fluid-applied decorative and protective coating may be applied over the completed roof, or protection may be provided on a low-sloped roof with an appropriate aggregate topping.

**Loose-laid application.** Elastomeric sheet roofing may be installed as a floating membrane with adhesive-bonded side and end laps. Terminations of the membrane at the roof perimeter and around skylights and similar projections are mechanically fastened to wood nailers, preferably with metal strips over the edge of the membrane to increase its tear-out resistance. Flashing at perimeters and penetrations is accomplished with adhesive-bonded strips of the elastomeric sheeting and appropriate caulking, as previously described. Roofs of this type must have an aggregate ballast to protect the membrane from physical damage and wind uplift.

**Inverted roof membrane assembly (IRMA).** Elastomeric sheet-membrane systems may be installed on flat or low-sloped roofs, with the membrane placed under the insulation material instead of over it, in accordance with the IRMA roofing specification. After the membrane has been installed and sealed on the prepared deck, moisture-stable Styrofoam insulation is applied over the membrane, and loose rock ballast is placed over the insulation to protect the assembly and prevent wind uplift.

#### Installation Over an Existing Roof

Because of their light weight, ease of installation, and ability to conform to a moderately irregular substrate, elastomeric sheet membranes are becoming increasingly popular for reroofing over existing built-up roofs. The existing roof must be prepared to receive the membrane in accordance with the job specifications and the instructions provided by the membrane manufacturer. The general procedures for preparing an existing built-up roof for reroofing given in

topics 3 and 4 can be used as a guide for this work. The membrane is usually mechanically fastened to the existing roof. If the roof has been graveled and the gravel is not removed, a cushioning layer of reinforced felt or insulation is placed before the membrane is installed.

An important consideration in using elastomeric materials for reroofing or repairing existing built-up roofs is whether the elastomer is chemically compatible with asphalt or coal-tar roofing materials. Before starting the job, the roofer should check the manufacturer's instructions to make sure that the new and old roofing materials can safely be used together.

#### Repair of Elastomeric Sheet Membranes

Most manufacturers of elastomeric sheet-roofing materials provide little or no information relating to the repair and maintenance of their products, probably because these so-called exotic materials are simple to repair and usually require no maintenance. A problem sometimes encountered during placement of an adhesive-bonded membrane is that a small bubble may appear under the sheet, usually because not enough care was taken to hand-smooth the sheet as it was being placed. One manufacturer suggests a simple

remedy for this problem: insert a hypodermic needle into the bubble and withdraw the air, which will allow the bubble to collapse. When the bubble has been smoothed down and the needle withdrawn, the tiny hole left by the needle can be sealed with a coat of adhesive.

In general, any tears or punctures that occur in an elastomeric sheet membrane can be repaired with a strip of the same material and an appropriate adhesive, using flashing methods. The membrane manufacturer may recommend the use of a special cleaner to prepare the surfaces for adhesive bonding.

#### Study Assignment

1. Review the information on deck preparation and reroofing in previous topics.
2. Study manufacturers' catalogs and manuals describing preformed elastomeric sheet-membrane roofing materials. Note especially any precautions relating to the safe handling, use, and storage of adhesives, primers, flashing compounds, solvents, and other potentially hazardous materials used in elastomeric roofing.
3. Griffin, *Manual of Built-up Roof Systems*. Read pp. 192—94 and 198—202.

# COLD-APPLIED ROOFING SYSTEMS AND WATERPROOFING AND DAMPPROOFING

## TOPIC 6—FLUID-APPLIED COLD-PROCESS ROOFING

This topic and the related instruction classes are designed to enable the apprentice to do the following:

- Describe the principal types of fluid-applied cold-process roofing materials.
- Discuss the uses, advantages, and limitations of fluid-applied cold-process roofing materials.
- Distinguish among the methods and equipment used to apply fluid roofing materials.
- Identify the preliminary work and application procedure for installing a neoprene/Hypalon fluid-applied roof.
- Describe a roofing job on which a modified asphaltic emulsion, with chopped glass-fiber reinforcement is used.
- Identify the safety rules that must be observed in storing, handling, and applying fluid roofing materials.

### Characteristics of Fluid-Applied Cold-Process Roofing Materials

In the great buildings of the past—for example, the castles and cathedrals of the Middle Ages—the roof was more than just a means of protecting the building and its occupants from the elements; it was also a prominent part of the architectural design and contributed much to the building's beauty. Beginning about the middle of the nineteenth century, the rapid growth of commerce and industry produced a great need for new factories, stores, and office buildings that could be erected quickly and economically. The resulting buildings were usually plain and starkly functional, often little more than rectangular boxes with simple gable or pitched roofs. Modern versions of these uncomplicated structures are still built, but new materials and construction techniques now permit architects to design buildings with bolder and more sweeping lines, and the roof is once again becoming an important architectural feature. Contemporary buildings often have dramatic roofs with parabolic curves or other unusual geometry. (See Fig. 6-1.) Fluid-applied cold-process roofing materials are particularly well suited to roofs of this type because of their light weight, toughness, excellent appearance, ability to conform to irregular surfaces, and relative ease of installation. These qualities of the fluid-applied materials are also making them increasingly popular for conventional roofing and reroofing work, especially where the roof to be covered has many vents, skylights, and other projections.

### Types of Fluid-Applied Cold-Process Roofing Materials

Fluid-applied cold-process roofing materials are marketed in many formulations to meet the needs of

specific roofing jobs. Some are highly elastic, and others are extra strong; some combine strength and elasticity. Some are used mainly as base coatings—the neoprene and butyl synthetic rubbers, for example. Others, such as Hypalon, have superior weathering characteristics and appearance and are often specified as topcoats. Hypalon is available in white and a wide range of colors, and it is often applied without a base coat directly over sprayed-in-place urethane foam insulation.

Most of the fluid-applied coatings are synthetic-rubber compounds or other elastomeric products. Another type is a modified-asphalt and bentonite-clay emulsion that is applied together with chopped-glass-fiber reinforcement by means of a specially designed

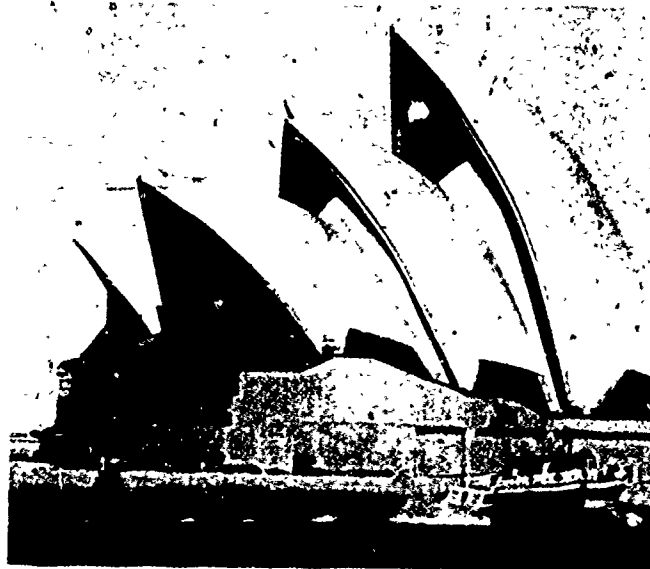

Fig. 6-1. Contemporary building with a dramatic roof (Sydney, Australia, Opera House)

applicator gun. Some of the coatings are one-part solvent-thinned materials or water-based emulsions; others are two- or three-part synthetic resins that must be mixed on the job. All the fluid-applied coatings form seamless, weatherproof membranes after they have been applied and allowed to set or cure. Some basic types of fluid-applied cold-process roofing materials are listed in Table 6-1.

#### Advantages and Limitations of Fluid-Applied Cold-Process Roofing Materials

Like all other roofing materials, the various cold-process coatings have individual characteristics that make them the best choice for some kinds of roofing jobs and less appropriate for others. The advantages and limitations listed in Table 6-2 are typical of this class of roofing materials, but they do not necessarily apply to every product of this type and, of course, not always in the same degree. The best sources of information about the characteristics of any roofing product are the manufacturer's publications and the advice

of field representatives, articles in trade journals and other publications of the roofing industry, and contractors' field experience with the product.

#### Roofing with Elastomeric Fluids

Fluid elastomeric roofing materials are applied to prepared roof decks with brushes, rollers, or spray equipment. Pump-fed power rollers are often used for coating large deck areas; hand rollers and brushes are employed for trim and edge work. Spray application is fast, and it simplifies material handling and clean-up, but it is not suitable for all of the fluid elastomers; fluid neoprene, for example, will "cobweb" rather than break up into droplets as it leaves the spray gun. Also, spray application may be difficult or impossible on a windy day because of the problem of controlling overspray. Spray guns, pumps, hoses, rollers, and any other equipment that has been used to apply a fluid elastomeric coating must be flushed clean, using the solvents and procedures recommended by the manufacturer of the fluid elastomer. This is important not

TABLE 6-1

Fluid-Applied Cold-Process Roofing Materials

| Type of fluid-applied membrane                | Approximate dry thickness of completed membrane, in mils | Typical substrates   |
|---|--|--|
| Neoprene                                      | 15—30<br>(0.4—0.8 millimetre)                            | Concrete; plywood; existing roofs  |
| Chlorosulfonated polyethylene (Hypalon)       | 20—45<br>(0.5 millimetre—1.1 millimetres)                | Sprayed-in-place foam insulation; protective/decorative coating for neoprene and other elastomeric membranes |
| Neoprene/Hypalon                              | 20<br>(0.5 millimetre)                                   | Concrete; plywood; sprayed-in-place foam insulation  |
| Butyl   | 15—30<br>(0.4—0.8 millimetre)                            | Concrete; plywood; existing roofs  |
| Urethane                                      | 20—60<br>(0.5 millimetre—1.5 millimetres)                | Concrete; plywood; sprayed-in-place foam insulation; existing roofs  |
| Silicone                                      | 20<br>(0.5 millimetre)                                   | Sprayed-in-place foam insulation   |
| Rubberized asphalt                            | 150—180<br>(3.8—4.6 millimetres)                         | Concrete   |
| Polyvinyl chloride (PVC)                      | 15—30<br>(0.4—0.8 millimetre)                            | Concrete; plywood; sprayed-in-place foam insulation  |
| Acrylic emulsion                              | 20<br>(0.5 millimetre)                                   | Concrete; sprayed-in-place foam insulation; existing roofs   |
| Asphalt-clay emulsion, glass-fiber reinforced | 100—300<br>(2.5—7.6 millimetres)                         | Concrete; plywood; existing roofs  |

only to keep the equipment from clogging but also to prevent traces of the elastomer from contaminating the next fluid that will be applied with the equipment.

A completed elastomeric roofing membrane often consists of two or more coats of a base material, such as neoprene, plus one or more coats of Hypalon or another suitable topping material. The specifications for the roofing job usually indicate the required number of coats of each material and the coverage or film thickness for each coat. The coverage is usually given as the number of gallons per square (100 square feet [9.3 square metres]) required to produce a dry film of the specified thickness in mils (thousandths of an inch). One gallon (3.8 litres) of any fluid is equal to 231 cubic inches (3 785.4 cubic centimetres), and 100 square feet (9.3 square metres) is equal to 14,400 square inches (92 903 square centimetres); therefore, one gallon (3.8 litres) of a fluid roofing material applied evenly over 100 square feet (9.3 square metres) produces a wet film with an average thickness of 16 mils (0.4 millimetre). The resulting dry-film thickness

depends on the percent of solids by volume in the fluid roofing material. A typical neoprene base-coat fluid might consist of 25 percent solids and 75 percent volatile solvents, in which case the dry-film thickness would be 4 mils (0.1 millimetre) at an application rate of 1 gallon (3.8 litres) per square. Similarly, a fluid urethane coating material consisting of 50 percent solids and 50 percent volatiles would produce a dry film 8 mils (0.2 millimetre) thick if applied at a rate of 1 gallon (3.8 litres) per square. Some heavy-bodied coatings are two-part mixtures that contain no evaporative solvents but instead change from fluid to solid form through chemical reaction of the two components. A fluid-applied coating of this type may lose none of its volume as it cures, in which case it is called (perhaps somewhat confusingly) a 100-percent-solids material. A 16-mil (0.4-millimetre) wet coating of a 100-percent-solids material produces a dry membrane 16 mils (0.4 millimetre) thick.

Note that roofing specifications vary in the way the information on coverage and film thickness is pre-

TABLE 6-2

## Advantages and Limitations of Fluid-Applied Cold-Process Roofing Materials

| Advantages   | Limitations  |
|--|--|
| <ul style="list-style-type: none"> <li>● Membranes conform to substrates of any shape and are adaptable to any slope.</li> <li>● Fluid materials simplify installation, especially on roofs with many projections</li> <li>● Membranes are thin, tough, abrasion resistant, and highly elastic.</li> <li>● Seamless construction eliminates a common source of leaks and improves appearance.</li> <li>● Topcoats are resistant to sunlight, heat, cold, ozone, and most chemicals and are available in many colors.</li> <li>● Membranes have excellent waterproofing properties and low permeance (transmission of water vapor).</li> <li>● Lightweight membranes reduce the dead load on the roof.</li> <li>● Flashing procedures are relatively simple.</li> <li>● Membranes resist flame spread after curing or setting.</li> </ul> | <ul style="list-style-type: none"> <li>● Deck preparation must be given special attention. Substrates must be firm, stable, and smooth.</li> <li>● Fluid coatings may penetrate or be partially absorbed by some substrate materials.</li> <li>● Substrate surface irregularities show up readily through the thin, conforming membranes.</li> <li>● Membranes may lose much of their elasticity when cold.</li> <li>● Many of the fluid materials have relatively short shelf life, and storage temperatures are critical.</li> <li>● Two-part synthetic resins require mixing on the job and may have a very short pot life, especially in warm weather.</li> <li>● Fluid roofing materials may irritate the skin and release toxic vapors, and many are highly flammable.</li> <li>● Extra care must be taken during and after application to avoid soiling or staining the membrane.</li> <li>● A curing period of several days may be required before the applied membrane can take foot traffic. Elapsed time between coats is often critical.</li> <li>● Bonded fluid-applied roof systems usually must be installed by a factory-approved contractor.</li> </ul> |



sented. Sometimes, only the maximum allowable coverage in square feet per gallon is listed (the maximum coverage for a primer or a sealer, for example, may be specified as 450 square feet [41.8 square metres] per gallon); sometimes, the specified dry-film thickness may be for the sum of all the coats, the number of coats being left up to the judgment of the roofing contractor; and sometimes only the wet-film thickness is given, in which case the dry-film thickness can be estimated if the percent solids is known. If some of the required information is not given, it can usually be determined by simple calculation from other given data.

Most fluid-applied elastomeric membranes require from two to six coats to achieve the required thickness. Multiple coats are desirable, because they tend to average out variations in film thickness and thus produce a more uniform membrane. Also, a too-heavy coating may run or sag, especially on a steep roof.

#### Preliminary Work

Deck preparation is especially critical if the building is to have a fluid-applied elastomeric roof. The general requirements for deck inspection and preparation outlined in previous topics apply also to roofing with fluid materials, but extra care must be taken to ensure that the deck is structurally sound and free of surface defects. Correction of deck defects is the responsibility of the general contractor. However, the roofing contractor must make sure that the deck is in satisfactory condition to receive the roofing before starting the job. Most roofing specifications state that the start of work constitutes acceptance of the deck by the roofing contractor.

Fluid-applied elastomeric coatings can be applied directly to a dry plywood or concrete deck, usually over a priming or sealing coat, but the deck surface must be smooth and free of untreated cracks, joints, and depressions to ensure the integrity and good appearance of the completed membrane. These requirements apply also when the elastomeric coatings are to be applied over insulation material. Most manufacturers of fluid elastomeric roofing materials accept sprayed-in-place foam insulation as a substrate, but insulation boards are usually banned because they are often too soft, too easily broken, and too porous to serve as a base for elastomeric membranes. Also, the many joints between the boards are potential trouble spots. A firm, continuous, and well-sealed base is important, because the fluid elastomers can flow into cracks and be absorbed by porous materials, and the tough but flexible elastomeric membranes depend entirely on the base material for mechanical stability.

*Preparation of a concrete deck.* Fluid-applied elastomeric membranes can be brushed, sprayed, or rolled onto a suitably prepared concrete deck. The concrete surface must have no fins or ridges and no rock pockets or other voids. It should be smooth but slightly textured to provide a "tooth" for the applied coating; a firm steel-troweled surface is best. After the concrete has cured, it should be allowed to dry for at least two weeks before a primer-sealer or other coating is applied.

Any shrinkage cracks, structural cracks, or cold joints that occur in the concrete must be repaired or treated in the manner recommended by the roofing-material manufacturer. The concrete surface must be free of dirt, laitance (powdery residue), scale, oil and grease, paint, asphalt, curing compounds, and other foreign materials. Sweeping or brushing will usually suffice to remove loose dirt, but removal of other foreign material may require washing with a detergent solution, solvent cleaning, or sandblasting. A few manufacturers recommend a light acid etch to ensure a thoroughly clean, uncontaminated surface.

Use of a low-viscosity primer-sealer is often recommended to provide a good bonding surface and to prevent outgassing of the concrete, which can cause blistering of the applied membrane. For best results the primer-sealer (or the first coating of the fluid elastomer if no primer-sealer is used) should be applied in the late afternoon, after the concrete has reached maximum temperature and has begun to cool. Moisture also contributes to blistering; an elastomeric coating should never be applied to a damp deck or damp insulation, and work should be postponed if rain threatens.

*Preparation of a plywood deck.* A clean, dry, soundly constructed plywood deck is a very satisfactory base for a fluid-applied roofing system. The deck construction must meet local code requirements with regard to type and thickness of plywood, allowable span between supports, and nailing. The plywood panels should be supported by two or more spans, and they should be arranged so that the face grain is across the supporting members. Tongue-and-groove panels are preferred. Plain joints that occur between supports should be blocked with 2-inch (5.1-centimetre) lumber to prevent differential movement at the joint. Face nails should be driven flush but not indented; an incompletely driven or "popped" nail may not immediately puncture the applied membrane, but it weakens the membrane at that point and makes it vulnerable to further damage. Also, any depressions, prominent nail heads, raised grain, untaped joints, or other surface irregularities on the plywood deck are likely to be

visible on the surface of the thin, close-conforming coating.

Where maximum smoothness is desired, the deck plywood should be EXT APA B-C or EXT APA A-C grade; if smooth appearance is not a factor, or if a textured finish is specified for the topcoat, EXT APA C-C plugged grade plywood (also called EXT Underlayment) may be used. Panels should be spaced apart  $\frac{1}{8}$  inch (0.3 centimetre) at the sides and  $\frac{1}{16}$  inch (0.2 centimetre) at the ends. Common nails are acceptable for panels on flat decks, but only annular-ring or spiral-thread nails should be used if the panels must be curved.\*

Joints between the plywood panels as well as junctures between the deck and another material, such as metal flashing or a masonry parapet wall, are usually taped.

**Application over insulation.** Urethane foam insulation, sprayed in place over a suitably prepared concrete, plywood, or metal deck, provides a seamless, tough-skinned substrate that is acceptable for most fluid-applied cold-process roofing materials. The foam insulation is applied by specially trained workers with specialized equipment, using techniques similar to those employed by roofers to install fluid-applied membranes. A disadvantage of sprayed-in-place foam insulation as a base, particularly where appearance is a factor, is the difficulty in applying the foam so that it is uniformly thick and level. Usually, however, a high spot in the cured foam can be dressed down satisfactorily with a disc sander, but the resulting shaved surface must be sealed with an appropriate mastic. This remedy for high spots should be used sparingly; the final appearance of the foam insulation is normally somewhat pebbly and slightly uneven.

Preparing the deck to receive foam insulation is basically the same as preparing it for directly applied fluid elastomeric coatings. The deck must be structurally sound, dry, and free of high spots, depressions, cracks, loose scale, laitance, dirt, grease and oil, and curing compounds. Since the thickness of the applied foam insulation is usually 1 inch (2.5 centimetres) or more, minor defects in the deck surface can usually be ignored. Construction work on the deck should be completed, with all drains, ducts, and other penetrations installed, before the foam insulation is placed. Roofing should begin as soon as possible after the foam has been applied and allowed to cure; the exposed foam has poor weathering properties. Not more than a week should elapse to avoid degradation of the foam.

**Inverted roof-membrane assembly (IRMA).** Some fluid-applied elastomeric materials may be applied under the insulation material instead of over it. The manufacturer's field representative should be consulted to ensure that the fluid elastomer is compatible with the Styrofoam insulation called for in the IRMA specification.

#### Flashing and Crack Sealing

Joints and cracks in a deck that is to receive fluid-applied elastomeric roofing are sealed after the deck is primed and before the base coat of elastomer is applied. Flashing may be applied before the base coat or after it, depending on the job requirements and the manufacturer's recommendations. If the roofing system includes insulation, flashing is normally applied after the insulation is placed. Use of sprayed-in-place foam insulation simplifies flashing, because the foam makes a smooth transition from horizontal to vertical surfaces and feathers out neatly at terminations. Some typical flashing and crack-sealing methods used in fluid-applied elastomeric roofing systems are shown in Figure 6-2.

A stable hairline crack in a concrete deck can often be sealed satisfactorily with a heavy stripe coat of the elastomeric base-coat material centered over the crack. Cracks or joints where movement may occur must have more extensive treatment, by a method like the one shown in Detail C in Figure 6-2.

Most manufacturers require the use of reinforcing tape or fabric wherever a change occurs in the material or direction of the substrate; for example, at valleys, parapet walls, nailing strips, metal edges, and flashing locations. (See Detail D in Fig. 6-2.) Simple flashings around small penetrations may often consist of just a bead of mastic around the base of the penetration, with the base coat and topcoat applied over the mastic and extending up the penetration to the primer line, as shown in Detail E in Figure 6-2. Larger-diameter penetrations are often flashed with neoprene collars made up on the job from sheet elastomeric material, as shown in Detail F in Figure 6-2.

Many methods are used for covering expansion joints; one method is shown in Detail B in Figure 6-2. The expansion joint is sometimes a complex, factory-assembled product, in which case the manufacturer may recommend methods of covering the joint. The specifications for a roofing job usually contain detailed instructions regarding the treatment of expansion joints because any location where relative movement occurs in a roof is a potential trouble spot.

#### Application of the Base Coat and Topcoat

The following is a typical procedure for installing a fluid-applied neoprene/Hypalon membrane to a clean,

\*American Plywood Association recommendations October, 1975

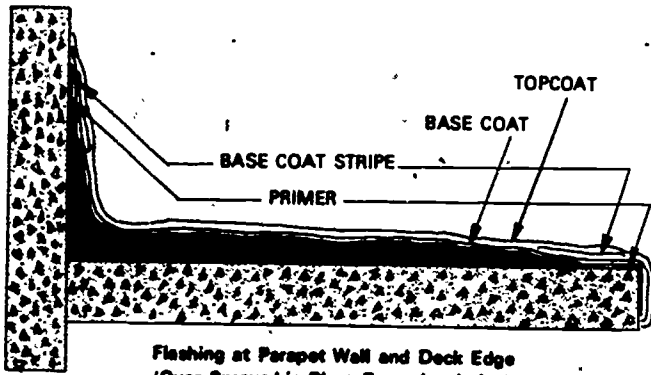

Flashing at Parapet Wall and Deck Edge  
(Over Sprayed-in-Place Foam Insulation)

DETAIL A

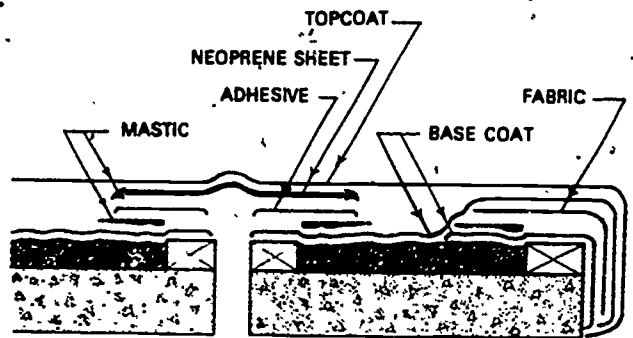

Flashing at Expansion Joint and Deck Edge

DETAIL B

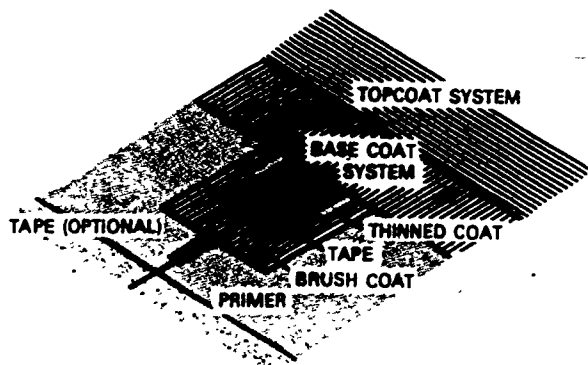

Sealing a Crack or Joint (inside corner)

DETAIL C

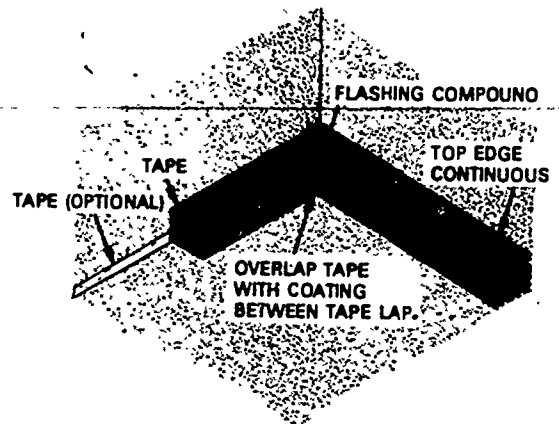

Flashing at a Vertical Section (outside corner)

DETAIL D

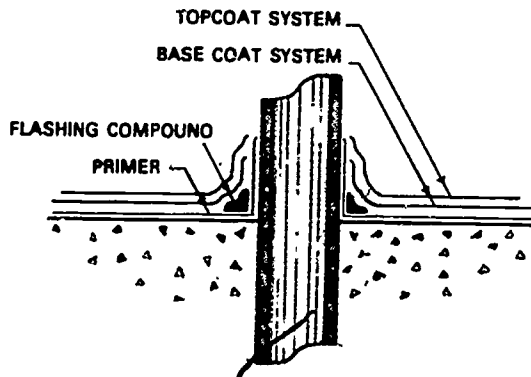

Flashing at a Small-Diameter Penetration

DETAIL E

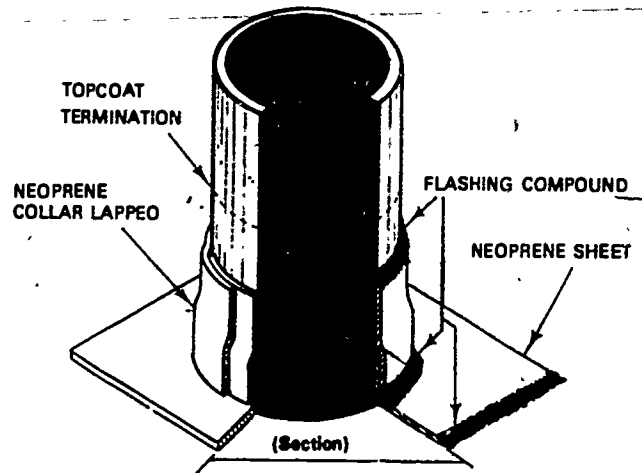

Flashing at a Large-Diameter Penetration

DETAIL F

Fig. 6-2. Typical flashing and crack-sealing details in fluid-applied elastomeric roofing systems (Gaco Western, Inc., systems)

dry plywood or concrete deck:

1. Apply primer of the recommended type and consistency to the entire deck surface, extending up projections and vertical surfaces beyond the flashing line. Prime all nailheads; scuppers and drains; vent pipes and other projections; cant strips; nailers; and cracks and joints. Allow the primer to dry, following the manufacturer's recommendations for drying time.
2. Apply tape where required, followed by a second coat of primer over the entire deck. Allow the second primer coat to dry.
3. Apply a neoprene base coat full strength at the recommended film thickness without skips, or "holidays." Stir the neoprene coating material well before use. Allow the base coat to dry, following the manufacturer's recommendations for drying time.
4. Apply additional base coats as required by the job specifications or as recommended by the manufacturer. Multiple coats are desirable because they reduce the chance of sags or runs and tend to average out variations in the membrane thickness.
5. When the final base coat is dry, apply the first Hypalon topcoat at the recommended film thickness, and allow it to dry in accordance with the manufacturer's recommendations for drying time. For good adhesion, the Hypalon topcoat should be applied as soon as possible after the base coat is dry; a surface film can begin to form on the neoprene base coat in as little as 48 hours. If the entire roofing job cannot be completed without interruption, the interruption should occur after application of the first base coat, not between application of the final base coat and the Hypalon.
6. Apply one or more additional Hypalon topcoats as required. Not more than 24 hours should elapse between application of the topcoats. A granular texture may be obtained for a walking deck by including ground walnut shells or a similar additive in the final Hypalon coating.

#### Roofing with Fluid-Applied Cold-Process Modified-Asphalt Emulsions

Another type of fluid-applied cold-process material that has achieved considerable popularity in the roofing and waterproofing industry is a modified-asphalt mineral-colloid emulsion that is reinforced with chopped-glass fibers. The asphaltic emulsion and the glass fibers are applied simultaneously to the deck by means of a specially designed applicator gun. The glass-fiber reinforcement is fed to the gun in a continu-

ous strand from a roll that is carried on the roofer's back. An air-driven mechanism in the gun chops the glass-fiber reinforcement into short, uniform lengths and expels it from a nozzle of the gun. The modified-asphalt emulsion is pumped to the gun through a high-pressure hose. (See Fig. 6-3.)

The asphaltic-emulsion/chopped-glass-fiber system can be applied to almost any suitably prepared deck, usually over a base sheet or insulation, and it is also well adapted to roof maintenance and reroofing over existing built-up roofs. The modified-asphalt membrane does not have the highly elastic property of the synthetic-rubber materials, but it has some elasticity, and it conforms readily to irregular surfaces.

The procedure that follows for applying an asphaltic emulsion/chopped-glass-fiber roofing membrane directly onto a thin-shell concrete deck is presented for general information only; on an actual job the work must be done in accordance with the job specifications and the manufacturer's published instructions.

#### Preliminary Work

The concrete deck must have a smooth, steel-troweled surface and be free of rough spots, sharp projections, frost, or the results of freezing. All rock pockets and other voids must be filled with approved grout. All drains, pipes, and other metal fittings must be in place. The deck must be clean and free of curing agents, form-release material, and dust.



Fig. 6-3. Application of an asphaltic emulsion/chopped-glass-fiber coating

The concrete surface should be dampened with cool, clean water directly ahead of the application of the asphaltic emulsion/chopped-glass-fiber coating. Alternatively, a prime coat of water-thinned asphaltic emulsion compound may be applied and allowed to dry.

#### Installation of Reinforcement and Flashing

Reinforcement and flashing are installed before the main coat as follows:

1. Apply a light coat of the asphaltic emulsion compound (without chopped-glass fibers) to the entire deck, and immediately embed a layer of glass fabric reinforcement, lapping the fabric 2 inches (5.1 centimetres) on the sides and 4 inches (10.2 centimetres) on the ends. Allow the reinforcement course to dry fully before proceeding.
2. Reinforce all valleys and ridges with an additional layer of glass fabric embedded in asphaltic emulsion compound.
3. Apply flashing around outlets, vent pipes and other projections, parapet walls and other vertical intersections, and wherever else it is required by the job specifications and good roofing practice. The flashing methods and materials should be as specified by the roofing-material manufacturer.

#### Application of the Coating

When the reinforcement course is thoroughly set, the asphaltic emulsion/chopped-glass-fiber roofing material is applied as follows:

1. With the glass cutter on the applicator gun set to produce cut fibers  $\frac{3}{4}$  inch (1.9 centimetres) long, cover the entire roof area, including flashings, with the asphaltic emulsion compound and the chopped-glass fiber at the rate of application called for in the job specifications. Be sure to set the gun controls so that the compound and the glass fiber are applied in the correct proportions;

if the mixture contains too much glass fiber or too little compound, the coating will have a "haystack" appearance, as shown at the right in Figure 6-4. A correctly proportioned coating is shown at the left in Figure 6-4.

2. If an additional coating is needed to produce the required membrane thickness, apply it after the first coating has set.
3. A manufacturer-approved decorative or reflective topcoat may be applied when the final asphaltic emulsion/chopped-glass-fiber coating is dry enough to withstand foot traffic.

#### Safety in Storing and Handling Fluid-Applied Cold-Process Roofing Materials

The general safety rules that apply in other types of roofing work also apply in roofing with fluid-applied materials. The following are some additional safety rules for fluid-applied roofing jobs:

- Special measures may be required to prevent falls from roofs of extreme slope or unusual contour.
- Workers applying light-colored coatings in bright sunlight should have eye protection against glare.
- When work is stopped for the day, all containers of coatings and thinners must be tightly covered.
- Containers of volatile materials must be stored in a cool, well-ventilated place.
- Open flame and welding operations should not be permitted in the work area until solvent-based coatings are dry.
- Work areas must be well ventilated; the fumes of coatings and thinners are often toxic as well as flammable.

#### Study Assignment

1. Study trade publications that describe fluid-applied roofing and waterproofing materials.
2. Griffin, *Manual of Built-up Roof Systems*. Read pp. 194—98 and 200—203.



Fig. 6-4. Correctly proportioned (left) and "haystacked" (right) coatings

# COLD-APPLIED ROOFING SYSTEMS AND WATERPROOFING AND DAMPPROOFING

## TOPIC 7—HOT-APPLIED WATERPROOFING AND DAMPPROOFING

This topic and the related instruction classes are designed to enable the apprentice to do the following:

- Define the terms "waterproofing" and "dampproofing."
- Discuss the importance of hydrostatic head in planning a waterproofing job.
- Identify the materials, tools, and equipment commonly used in hot-applied waterproofing and dampproofing.
- Describe the preliminary work that must be done on a structure to be waterproofed before hot-applied waterproofing can begin.
- Discuss procedures for waterproofing concrete foundation floor slabs and walls, shower basins, planter boxes, and traffic decks with hot-applied materials.
- Discuss the requirements for a dampproofing job using hot bitumen.
- Identify the safety procedures for hot-applied waterproofing and dampproofing.

### Purposes of Waterproofing and Dampproofing

The waterproofing of a building is so important that if it is improperly done, the almost certain result will be costly water damage, and the building may in time become unusable for any purpose. Intruding water causes direct damage to building components and finishes, and it also causes indirect damage by promoting dry rot and termite infestation. Waterproofing is important not only at foundation walls, basements, floor slabs, shower pans, and the like but also for such auxiliary structures as walkways, reflective pools and swimming pools, and planter boxes. It is also employed on a larger scale in the construction of tanks, reservoirs, tunnels, bridges, and canals.

Waterproofing and dampproofing differ mainly in the degree of protection they provide. "Waterproofing," as the term is used in the construction industry, means treating a surface or structure, usually below grade, to prevent the passage of water under hydrostatic pressure. "Dampproofing" means treating a surface or structure to prevent the passage of water in the absence of hydrostatic pressure.

Hydrostatic pressure is the pressure exerted by a head of water against the surface of a structure. The surface that must withstand the water pressure may be the outside of a foundation wall or the underside of a floor slab, or it may be the inside of a reservoir, a canal, or a swimming pool. The amount of hydrostatic pressure exerted at any point on the structure depends upon the height of the head of water (the hydrostatic head) above that point. Each foot of hydrostatic head produces a water pressure of 62.5 pounds per square foot (3 kilopascals). For example, a basement is to be built in an excavation where the surrounding groundwater could be expected to rise to a maximum height of 4 feet (1.2 metres) above the bottom of the floor slab. In this case the waterproof-

ing of the floor slab would have to withstand a maximum hydrostatic pressure of 250 pounds per square foot (12 kilopascals), or stated more simply, 4 feet (1.2 metres) of hydrostatic head. When the groundwater is at its maximum height, the pressure on the foundation wall at a point 1 foot (30.5 centimetres) above the bottom of the floor slab will be equal to 3 feet (0.9 metre) of hydrostatic head; at a point 3 feet (0.9 metre) above the bottom of the slab, it will be equal to 1 foot (30.5 centimetres) of hydrostatic head; and at 4 feet (1.2 metres) above the bottom of the slab (at the top of the groundwater), the hydrostatic head (and the hydrostatic pressure) will be zero. In practice, a hydrostatic head of 4 feet (1.2 metres) would usually be assumed for the entire below-grade structure in determining the amount and type of waterproofing needed.

### Materials, Tools, and Equipment Used in Hot-Applied Waterproofing

The materials, tools, and equipment used in hot-applied waterproofing are essentially the same as those used in hot-applied built-up roofing. The waterproofing membrane is made up of layers of number 15 saturated asphalt or coal-tar-pitch felt, sometimes in combination with one or more layers of cotton or glass fabric for added strength, and coatings of hot asphalt or coal-tar pitch. Low-melt bitumen is used on horizontal surfaces; high-melt bitumen is required on vertical surfaces. Other materials include a compatible primer (solvent-cut asphalt or coal-tar pitch) to ensure good bonding of the membrane; caulking compound for sealing cracks and joints; glass or cotton fabric webbing for reinforcement at joints and around corners; and heavy felt or 1/2-inch (1.3-centimetre) fiberboard as a protection course for the completed waterproofing membrane. In waterproofing as in

roofing work, asphalt and coal-tar-pitch materials should not be used together on the same job; they are not compatible.

The tools and equipment commonly used in hot-applied waterproofing include the following:

- Common hand tools, such as knives, tin snips, shears, trowels, hammers, hatchets, pliers, and wrenches
- Measuring and layout tools, such as push-pull rules, tapes, plumb bobs, chalk lines, and ply sticks
- Roofers' tool bags and belts
- Common power tools, such as portable electric saws, disc grinders, and electric drills
- Personal-safety items, such as goggles, face shields, safety shoes, hard hats, and respirators; safety belts and lanyards; first-aid kits; and protective ointments
- Hot kettles; hot-bitumen carriers and buckets; tankers, pumps, and supply lines; weed burners (for heating solidified bitumen in supply lines and valves); and fire extinguishers
- Mops, brooms, rollers, and squeegees for applying primers and hot bitumen; and caulking guns
- Spray equipment for applying primers and sealers (optional method)
- Portable fan-driven space heaters (salamanders) for preheating concrete substrates and removing frost or surface dampness; and ventilator fans for removing toxic fumes and vapors from confined work areas
- Scaffolds, ladders, and rigging

### Hot-Applied Waterproofing Procedures

Waterproofing membranes are installed on the water side of the structure to be waterproofed. Hot-applied membranes are built up with alternate layers of felt and hot bitumen (asphalt or coal-tar pitch). The material to be waterproofed is usually cast-in-place structural concrete, but it may also be precast concrete slabs, concrete blocks, slump stone, brick, tile, steel, or wood, including plywood, which in recent years has assumed a new role as a foundation material in light construction. Some typical procedures for installing hot-applied waterproofing membranes are given in this topic; cold-process waterproofing material and methods are discussed in the next topic.

#### Preliminary Work

The work that must be done before hot-applied waterproofing can begin is similar to that for hot-applied built-up roofing. The wall, slab, or other

structure to be waterproofed must be soundly constructed, clean, dry, and free of any ridges or depressions that could damage the membrane. Poured concrete walls and slabs must be well cured and dry, with no surface contaminants, such as curing agents, form-release materials, dirt, oil, or grease. All holes and cracks must be grouted, and any construction joints must be sealed. Concrete walls must have no protruding form-tie wires. Footing keys must be clean and free of surface irregularities. A treated wood nailer should be embedded in the wall above the grade line to provide a means for attaching the upper ends of the waterproofing felts. If such a nailer is not used, the membrane should be secured with concrete nails and tin discs. Concrete-block walls should have struck joints. Slump stone or other irregular surfaces should have a cement-plaster coat, which must be thoroughly dry before waterproofing is begun.

#### Waterproofing Method for a Concrete Floor Slab and Foundation Wall

A common type of construction for a below-grade concrete floor with a keyed foundation wall is shown in Figure 7-1. When hot-applied membrane waterproofing is specified to prevent entry of groundwater through the floor slab and wall, the waterproofing is installed as follows:

1. After the foundation footing and the base slab (also called a mud slab) have been placed and allowed to cure and dry, inspect the surfaces that are to receive waterproofing to make sure they have no defects that could damage the membrane. Do not proceed with the job until all such defects have been corrected; to do so is to risk liability for failure of the waterproofing membrane, when the true cause of the problem may be a faulty concrete substrate. As in roofing work, the correction of defects in the substrate is the responsibility of others. Also, groundwater must be kept below the slab level during waterproofing; if necessary, pumps must be used to keep the work area dry.
2. When the preliminary work has been completed and the concrete is clean and dry, prime the base slab and the top of the footing, including the key, with an appropriate solvent-thinned primer (asphalt or coal-tar pitch, depending on the type of waterproofing bitumen specified for the job). Apply the primer with brushes, rollers, or spray equipment, and allow the primer to dry thoroughly. A second primer coat may be required if the first coat is readily absorbed.
3. Starting at the low side of the slab and working across the slope, mop a strip of the concrete

with hot asphalt or coal-tar pitch, and immediately roll in the first layer of felt or glass fabric. Continue mopping and placing the felts, using the same application techniques as for hot-applied built-up roofing, until all required plies have been installed on the slab. The number of plies to use depends on the hydrostatic head of the groundwater that the membrane must withstand. For hydrostatic heads of 6 feet (1.8 metres) or less, two or three layers of felt or glass fabric are commonly used, with the layers overlapped and solidly mopped as shown in Figure 7-1. Additional plies are required for hydrostatic heads over 6 feet (1.8 metres). On a structure that extends far below the groundwater level, the waterproofing membrane at the lowest level may consist of as many as 14 plies (for a hydrostatic head of 100 feet [30.5 metres]). These are guidelines only; the waterproofing specifications for the job may differ regarding the required number of plies, and the specifications must be followed.

As in built-up roofing, apply the mop coats evenly, broom in the felts thoroughly, and use enough hot bitumen to ensure that felt does not touch felt. Allow the base-slab felts to extend about 12 inches (30.5 centimetres) beyond the foundation so that they can be lapped over the waterproofing on the keyed wall, which will be erected later. Fit the felts carefully around any

pipes or other projections in the slab, and press the felts firmly into the footing keys, using fabric reinforcement between the felt and the keys. Steam pipes and hot water pipes should be insulated from the membrane.

4. Apply a final mop coat to cover all ply laps and exposed felts.
5. Seal off any pipes or other projections in the slab with flashing compound. (NOTE: Avoid coating reinforcing steel with asphalt, which would interfere with the concrete-to-steel bond.)
6. Immediately after installing the membrane on the base slab, or if the job must be interrupted before the slab is completely covered, protect the membrane with bonded base sheets, insulation board, or other suitable material pending construction of the structural floor slab (also called a wear slab).
7. The concrete masons may now erect the foundation walls over the keyed footings. Ensure that the walls have nailing strips embedded above the grade line to secure the vertical felts. Also, embed a strip of webbing reinforcement in hot bitumen in the key before the wall is erected.
8. When the foundation wall forms have been stripped and the concrete has cured, inspect the outer surface of the wall, and make sure that any defects are corrected, as outlined earlier in this topic. Prime the outside of the clean and

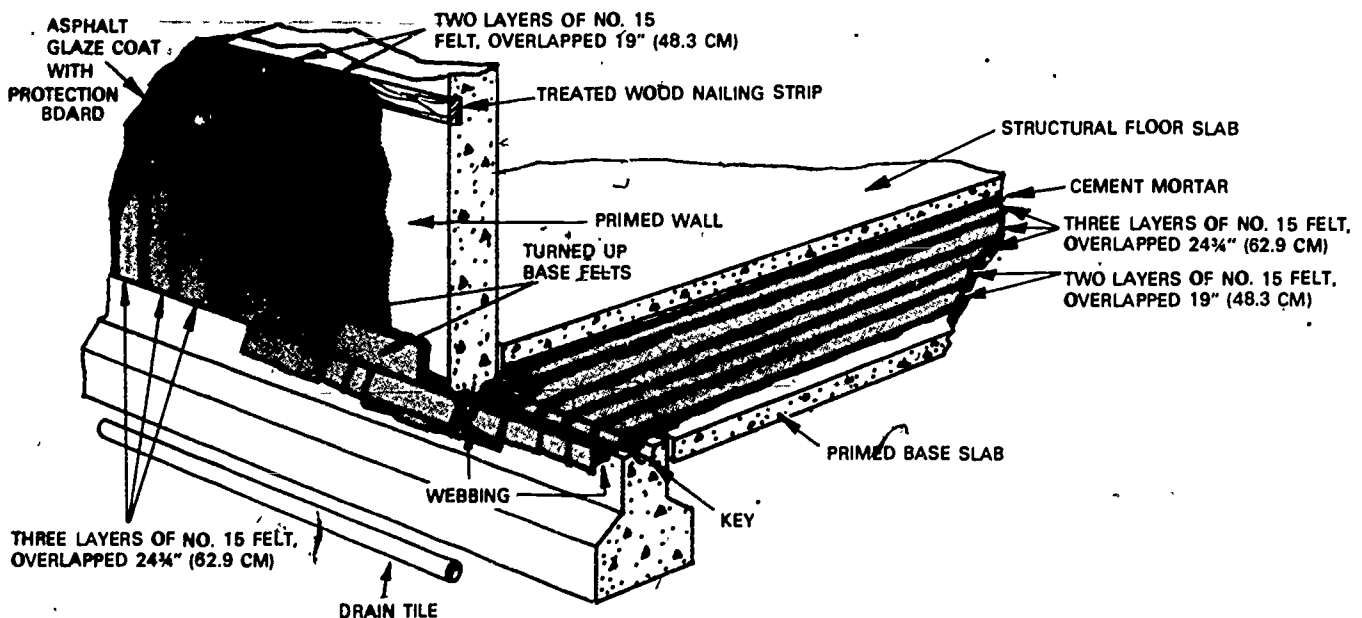

Fig.7-1. Waterproofing a concrete floor slab and foundation wall



dry wall, and allow the primer to dry thoroughly.

9. Mop the primed wall with hot bitumen, and begin applying the required number of felts for the anticipated hydrostatic head, working from the bottom up and lapping the felts as shown in Figure 7-1. Broom the felts well into the hot bitumen, and bond the successive plies with adequate moppings so that felt does not touch felt. Fasten the top ends of the vertical felts to the nailing strip with nails driven through tin discs. Reinforce all corners with webbing embedded in hot bitumen.
10. As the work progresses, fold up the extended ends of the base-slab felts, and interleave them with the wall felts, as shown in Figure 7-1.
11. Mop a final coat of hot bitumen over the completed wall membrane. Install protection board immediately after the waterproofing is completed. The protective covering previously laid over the base-slab membrane may be left in place to protect the membrane during forming of the wear slab, or a coating of cement mortar may be applied over the membrane for protection.

#### Inside Method of Waterproofing a Foundation Wall

Another method of waterproofing a foundation wall is illustrated in Figure 7-2. In this so-called inside method, the wall felts are enclosed by a protective brick or concrete facing. In all other respects the procedure is essentially the same as the one for outside waterproofing just described.

#### Hot-Applied Waterproofing of Other Structures.

The hot-applied waterproofing procedures for floor slabs and foundation walls outlined in this topic are adaptable to many other structures, such as planter boxes, shower basins, retaining walls, walkways, slabs on grade, traffic decks, pools, reservoirs, tunnels, and canals. A few of these uses of hot-applied waterproofing are described here; additional and more detailed information about waterproofing with hot-applied materials can be found in many publications of the roofing and waterproofing industry.

*Waterproofing a shower basin.* When a shower stall is built over a cement base, the procedure for waterproofing the basin by the hot method is essentially the same as for a split-slab concrete floor. If the shower stall is built over a wooden base, the following procedure is used for folding and installing a three-ply felt shower pan:

1. Measure the rough framed opening for the shower pan, add 12 inches (30.5 centimetres) on each side for turnups, and cut a piece of felt to that size for the first ply. Fold the felt as shown in Figure 7-3. (The ply felt may be installed in two sections, as shown in the illustration, but the sections must be lapped and sealed with mastic.)
2. Sprinkle-mop the basin floor, and press in the first ply of the built-up shower pan. (*NOTE:* Be careful not to clog the weep holes in the drain assembly with hot asphalt.) Cuff the ply into place, and nail the turnups at the top edges.

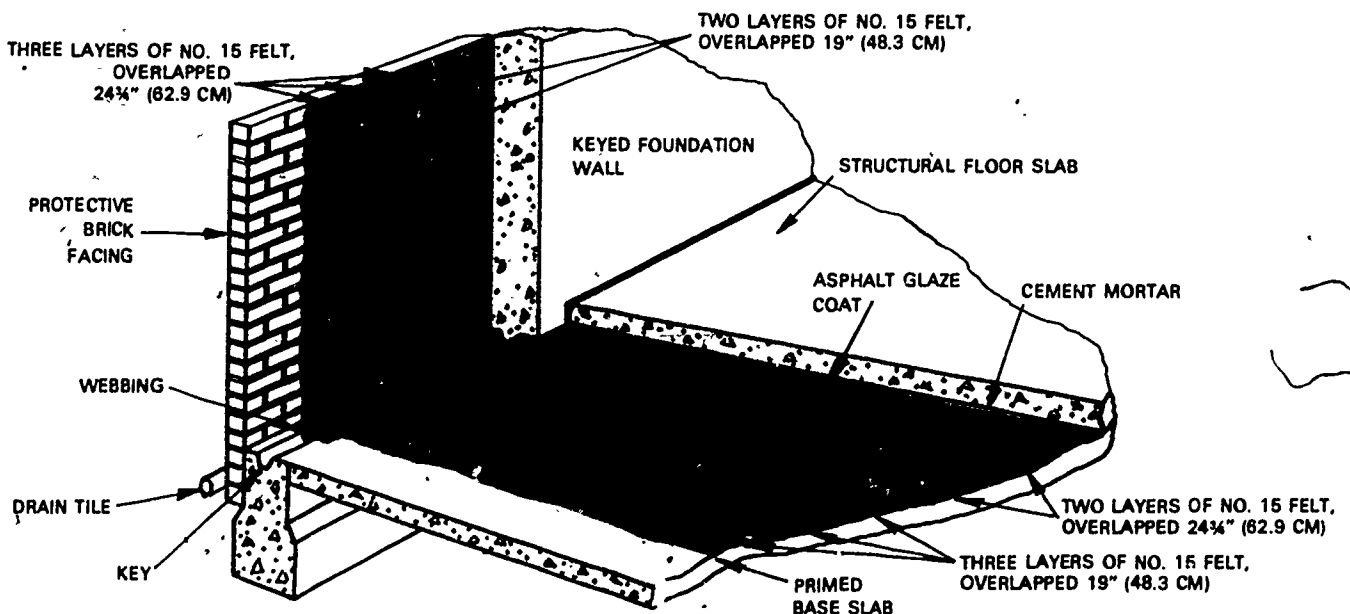

Fig.7-2. Inside method of waterproofing a foundation wall

3. Cut out the felt over the drain, making the hole in the felt slightly smaller than the inside diameter of the clamp ring, as shown in Figure 7-4.
4. Apply a thin coat of fibrated flashing compound where the drain meets the felt and at the pan corners.
5. Measure, cut, and fold the next ply to fit within the first. Fold the corners in the opposite direction to those of the first ply, as shown at (A) and (B) in Figure 7-3; this is done to reduce the membrane thickness at the corners. If the plies are made in two overlapping sections, as in Figure 7-3, turn the second ply so that its lap joint crosses the joint in the first ply at right angles. Install the second ply within the first, solid-mopping between plies and nailing the turnups at the top edges.
6. Fabricate and install the third ply in the same manner, again reversing the direction of the corner folds and crossing the lap joints at right angles.
7. Bolt the drain cap ring in place, and trim off any excess felt that extends into the drain. Hot-mop the completed shower basin, taking care to keep hot asphalt out of the drain assembly.
8. Water-test the completed basin for leaks.

*Waterproofing a planter box.* Several methods can be used to waterproof a planter box with hot-applied materials. A large planter box may be constructed on a concrete slab with keyed walls and brick or architectural concrete facings, in which case it may be waterproofed by a method similar to that for "inside" waterproofing of a floor slab and foundation wall described earlier in this topic.

More often, the entire waterproofing membrane is installed within the planter box, usually with a protective cement coating over the membrane. If the cement coating is not used, the membrane should be protected with fiberboard before gravel and soil are placed in the planter. A small wooden or masonry planter box may be waterproofed in much the same manner as a shower stall, again with a protection course of cement or fiberboard over the membrane.

*Waterproofing a traffic deck.* Decks for pedestrian traffic or light vehicular traffic are often waterproofed with a hot-applied built-up membrane installed over a base slab and covered by a wear slab, as in the foundation waterproofing methods described earlier in this topic. Waterproofing jobs for split-slab foundation floors and traffic decks differ mainly in the size of the work and the way the membrane edges are finished at the slab perimeter. A traffic deck may have a very large area, with numerous construction joints and

expansion joints that must be sealed before the waterproofing membrane can be placed. The choice of edge treatment for the membrane in a traffic deck depends on several variables, including the construction details at the terminations of the slab (whether the slab is finished with a simple curb or meets a keyed wall, for example). Both the edge treatment and the thickness of the membrane are also influenced by the amount of hydrostatic head the deck must withstand. The manufacturers of waterproofing materials provide sample specifications and information sheets that usually include waterproofing detail drawings for traffic decks and many other kinds of structures.

### Dampproofing

Dampproofing is intended only to protect a surface or structure against moisture or water in the absence of hydrostatic pressure. It may therefore be accomplished without a built-up membrane, using only hot asphalt or coal-tar pitch mopped onto the suitably prepared and primed surface. Sometimes, one or two coats of primer-sealer alone, without the hot-mopped bitumen, will provide sufficient dampproofing for mild exposures.

The surface to be dampproofed must be clean, free of curing or form-release agents, dry, and reasonably smooth. Any open cracks or voids should be filled with an appropriate grout, and the entire surface should then be primed. (Sometimes, the dampproofing specifications will call for a preliminary coat of high-penetration primer before the grout is applied.) After the primer has dried thoroughly, the surface is mopped with one or two coats of bitumen. Any part of the dampproofed surface that is below grade should be protected with heavy felt or fiberboard before backfilling is begun. Where appearance is important, as on an exposed wall, the dampproofed surface can be covered with a color coat.

### Safety in Hot-Applied Waterproofing and Dampproofing

All the safety rules that govern general roofing operations apply also to waterproofing and dampproofing. Waterproofing presents some special hazards, particularly when hot materials are being used, because the work is usually done in confined areas and often from scaffolds. Sufficient space must be provided in the work area to permit safe handling of hot bitumen and erection of any needed staging. The walls and faces of all excavations that expose workers to danger from moving ground must be effectively guarded by a shoring system, sloping of the ground, or other equivalent means. The floor of the excavation must be firm and dry.

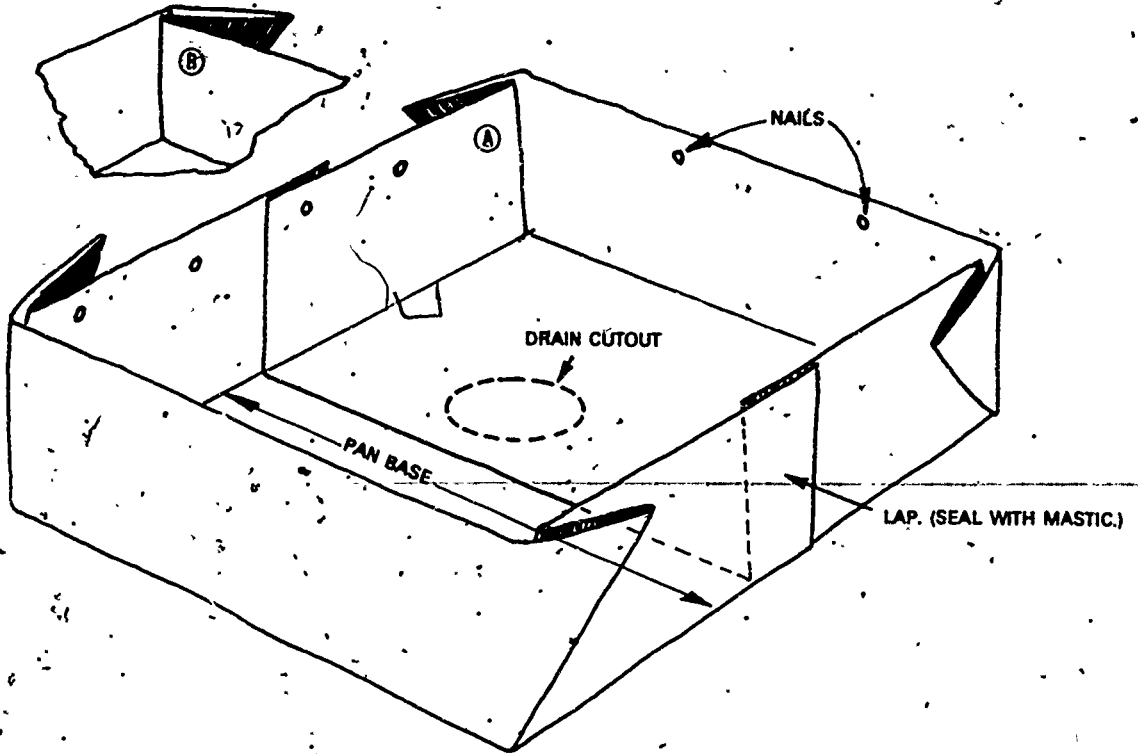

Fig.7-3. Construction of a shower pan (one ply shown)

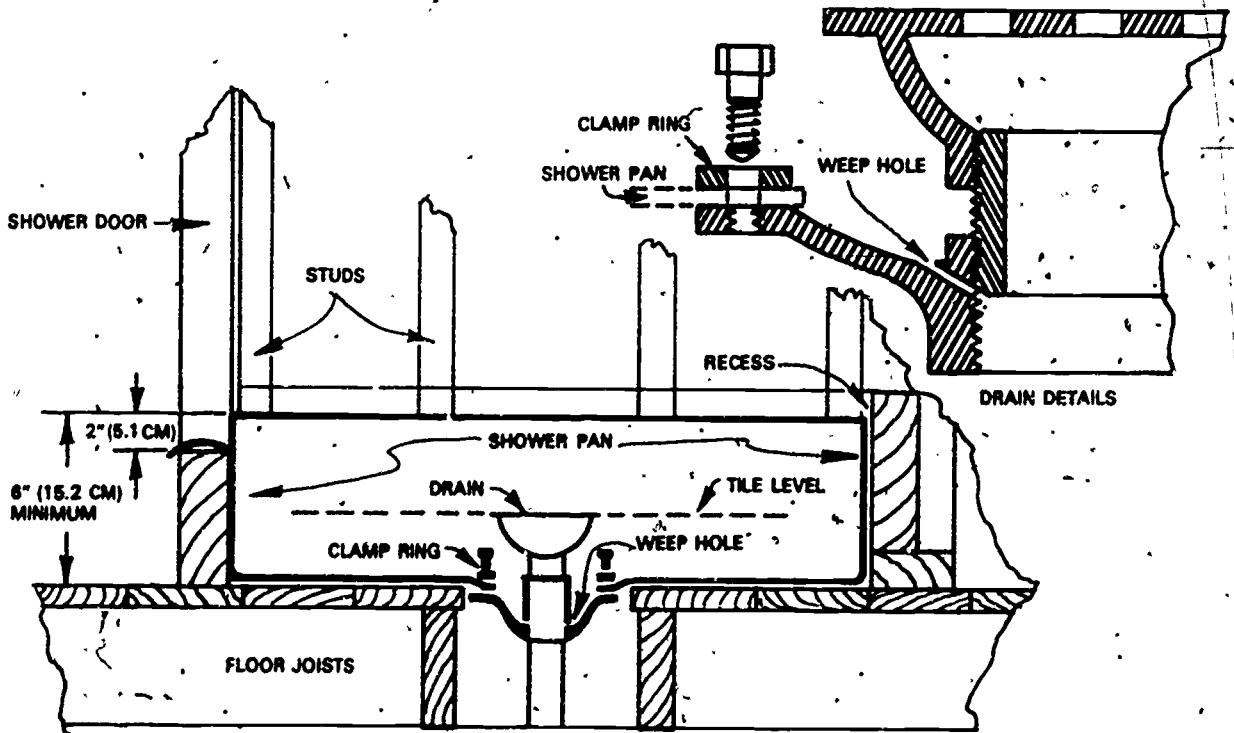

Fig.7-4. Installation of a shower pan and drain assembly

The following are some additional safety rules that must be observed in waterproofing and dampproofing:

- The work area must be well ventilated. If natural ventilation is not adequate to remove the fumes and vapors of solvent-thinned primers and hot bitumen, industrial-type ventilator fans or blowers should be used. The use of respirators may also be advisable. A waterproofer who experiences dizziness, headache, or nausea while working in an excavation or other confined area should immediately get out and take a breather.
- Good housekeeping is essential for safety in waterproofing. The work area should be kept clean and free of debris. Tools and equipment not being used should be removed from the area. Spills should be promptly cleaned up.
- Hot kettles must be kept clean and in good working order. Bitumens must not be allowed to overheat. A Class BC fire extinguisher of the proper size must be kept near the hot kettle.
- Waterproofers working with hotstuff must wear protective clothing like that worn for hot-applied roofing. Goggles or face shields are a must. Anyone working in an excavation or any other place where danger from falling objects exists should wear a hard hat.
- Waterproofers working with hot pitch should protect their skin with periodic applications of Vaseline or skin cream, particularly around the eyes and on the lips, nose, and neck. Use of a respirator is recommended.
- Scaffolds must be approved types, as listed in the *California Construction Safety Orders* handbook. They must have no loose, broken, or missing members. The scaffold leg pads must be on a firm footing, and the scaffold must be securely tied to the adjacent structure. Scaffold planks must be made of properly inspected and graded lumber (scaffold plank grade) and must have no splits or other defects that could affect their safety. Care must be taken to avoid overloading the scaffold.
- A worker on a scaffold should never pry between the scaffold and the adjacent structure.

- Help should be obtained for handling heavy or awkward loads on a scaffold or for moving the decking.
- A ladder should be used to gain access to a scaffold platform; climbing on the scaffold braces is dangerous. A ladder should never be used to gain extra height on a scaffold.
- Ladders must meet the requirements set forth in the *Construction Safety Orders* handbook. No more than one person should be on a ladder at one time. A waterproofer must never climb a ladder while carrying a bucket of hotstuff.
- Electrical power tools and equipment must be properly grounded. Extension cords must have a ground conductor.
- Whenever possible, persons other than waterproofers should be kept out of the work area when hot-applied waterproofing is being done. Those who must be in the area should be warned about the hazards associated with the application of hot bitumens.

#### Study Assignment

1. *Entering the Roofing and Waterproofing Industry and Built-up Roofing*. Review the information on roofing and waterproofing safety.
2. *Built-up Roofing*. Review the procedures for hot-applied built-up roofing.
3. Obtain and study manufacturers' catalogs and specification sheets describing hot-applied waterproofing and dampproofing.
4. *CAL/OSHA Construction Safety Orders*. Read Article 30, "Roofing Operations and Equipment." (This material can also be found on pages 67-68 of *Built-up Roofing*.) Also recommended for study are the following: Article 4, "Dusts, Fumes, Mists, Vapors, and Gases"; Article 6, "Excavations, Trenches, and Earthwork"; Article 21, "Scaffolds—General Requirements"; Article 22, "Scaffolds—Various Types"; Article 23, "Suspended Scaffolds"; and Article 25, "Ladders."

# COLD-APPLIED ROOFING SYSTEMS AND WATERPROOFING AND DAMPPROOFING

## TOPIC 8—COLD-APPLIED WATERPROOFING AND DAMPPROOFING

This topic and the related instruction classes are designed to enable the apprentice to do the following:

- Describe waterproofing with felt plies and cold adhesive.
- Distinguish among the factory-processed waterproofing sheets and panels.
- Compare fluid-applied materials used in waterproofing.
- Identify the general requirements for cold-applied dampproofing.
- Discuss safety considerations in cold-process waterproofing and dampproofing.

### Cold-Applied Waterproofing Materials and Methods

Cold-applied waterproofing is accomplished in much the same way as cold-applied roofing and with similar materials, tools, and equipment. Most of the materials described in the roofing topics of this workbook are also adaptable to waterproofing, and the surface preparation and methods of application are basically the same for both kinds of work. Besides the cold-process roofing materials, many other materials are available that are specifically designed for waterproofing and dampproofing; a partial list is presented in Table 8-1.

If the structure to be waterproofed must withstand hydrostatic pressure, membrane-type waterproofing is normally used. The membrane may be built up with plies of bitumen-saturated felt or mineral fabric, as in hot-mopped waterproofing, using cold asphaltic or coal-tar adhesive in place of hot bitumen to bond the plies to each other and to the structure. It may also be constructed with one or more plies of factory-processed sheet material and an appropriate adhesive, or it may be applied as a fluid that becomes a watertight membrane after it sets or cures, as in fluid-applied cold-process roofing. A concrete structure may also be protected against hydrostatic pressure by treating it with one of the fluid-applied crystalline waterproofing materials, which penetrate deeply into the concrete and combine chemically with its free lime, forming crystals that fill any channels or shrinkage cracks in the concrete and providing a watertight seal.

### Waterproofing with Felt Plies and Cold Adhesive

Except that hot kettles and related equipment are not used, cold-applied waterproofing with felt plies and bitumen cutbacks or emulsions is accomplished in much the same way as hot-applied waterproofing. The steps in preparing the surfaces and applying the felts are similar to those outlined for hot-applied waterproofing in Topic 7. The number of plies required depends on the hydrostatic head that will be encoun-

tered. A useful guide to the number of plies or coatings required for waterproofing with asphaltic materials is presented in Table 8-2. Note that the data given are intended as a guide only; the specifications for a given waterproofing job may vary.

Concrete surfaces must be structurally sound and free of projections, depressions, curing agents, and form-release materials. All cracks, surface voids, and joints should be filled with cement grout and struck off flush. All concrete must be fully cured, and it must be dry if a cutback primer or cutback adhesive coatings will be used. If the waterproofing must be applied while the concrete is still damp, the primer and coatings must be bitumen emulsions to achieve a good bond and prevent blistering. Reliable bonding to the substrate and between plies is essential; locating and correcting a failure in a waterproofing membrane many feet below grade can be very costly, particularly if landscaping and other improvements must be disturbed.

After the primer has been applied and allowed to dry, all joints, angles, and corners should be reinforced with felt or webbing embedded in mastic or an adhesive coating. After the reinforcement has set, the plies may be installed in basically the same manner as outlined in Topic 7. The interply adhesive and top-coating may be a bitumen cutback or emulsion that is sprayed, brushed, or rolled in place, or the waterproofing specification may instead call for use of a trowel-grade mastic for bonding and coating the membrane. Troweled mastics are often used on vertical surfaces, where a lower viscosity coating might sag or run. On most jobs the first felt course is installed directly on the primed concrete in a full bed of adhesive or mastic; occasionally, however, a base sheet is spot-mopped to the concrete as a first course. Full bonding of the waterproofing membrane is generally preferred; if a puncture should occur at some point, the continuous layer of adhesive prevents groundwater from creeping under the membrane to a location where it could find a path through the concrete.

As in hot-applied waterproofing, felts on vertical surfaces are fastened at the top end to wood nailers embedded in the concrete, or attached with concrete nails and tin discs; and the completed membrane is protected with fiberboard before backfilling is begun. On any waterproofing job the membrane should be water-tested before it is covered. The job specifica-

tions usually include instructions for performing the water test.

#### Waterproofing with Factory-Processed Sheets and Panels

Cold-process single-ply waterproofing is often done with factory-produced sheet materials, such as the

TABLE 8-1  
Cold-Process Waterproofing and Dampproofing Materials

| Sheet membranes and panels  | Approximate thickness, in mils            | Remarks   |
|---|---|---|
| Polyvinyl chloride (PVC) or polyethylene film or sheet                                    | 4—50<br>(0.1 millimetre—1.3 millimetres)  | Thin films used for dampproofing and as protection for bitumen layers in composite membranes.             |
| Fiber-reinforced bitumen/resin membrane, with or without asbestos-felt backing            | 30—60<br>(0.8 millimetre—1.5 millimetres) |   |
| Bitumen/resin membrane reinforced with fiber matting; plastic release film one side       | 60—70<br>(1.5—1.8 millimetres)            |   |
| Rubberized asphalt membrane with polyethylene film one side                               | 60<br>(1.5 millimeters)                   |   |
| Bentonite-clay/kraft-board panels   | 180—625<br>(4.6—15.9 millimetres)         | Clay granules expand on contact with moisture; kraft board decomposes after installation.                 |
| Bitumen-saturated ply felts bonded with cold-process adhesives and mastics                | —   | Construction similar to cold-applied built-up roofing.  |
| Plastic core sheet with layers of modified bitumen each side, plastic film top and bottom | 120-160<br>(3—4.1 millimetres)            | Bitumen laminate as described in Topic 4.   |
| Fluid-applied materials   | Approximate dry-film thickness, in mils   | Remarks   |
| Urethane rubber; other synthetic rubbers  | 40—60<br>(1—1.5 millimetres)              | Highly elastic; may require mixing; usually contain toxic and flammable components.                       |
| Tar-modified polyurethane   | 50  |   |
| Crystalline waterproofing   | —   | Penetrates deep into concrete; seals by growth of crystals.   |
| Asphaltic emulsion reinforced with chopped-glass fibers                                   | 100—300<br>(2.5—7.6 millimetres)          | Composition similar to spray-applied asphaltic emulsion/chopped-glass-fiber roofing described in Topic 6. |
| Rubberized asphalt  | 90—100<br>(2.3—2.5 millimetres)           |   |
| Asphalt or coal-tar cutback or emulsion primers, sealers, mastics, and adhesives          | —   | Have various uses in cold-process waterproofing and dampproofing.   |

TABLE 8-2  
Waterproofing Membrane Assembly Guide

| HYDROSTATIC CONDITIONS   |                                  |   |  | CONSTRUCTION  | MATERIALS    |        |                       |        |                |                                    |               |         |   | VERTICAL WALL PROTECTION |
|--------------------------|----------------------------------|---|--|---|--------------|--------|-----------------------|--------|----------------|------------------------------------|---------------|---------|---|--------------------------|
| Hydrostatic head in feet | Pressure in lbs. per square inch | Lifting Pressure in lbs. per sq. ft. under floors | Average Pressure in lbs. per sq. ft. wall surface effected |   | COLD APPLIED |        |                       |        |                |                                    | HOT           |         |   |                          |
|                          |                                  |   |  | E-M-W **<br>C-13-E Emulsion<br>& YELLOW JACKET<br>Glass Fabric      |              |        | MONOFORM<br>System ** |        |                | A-AF **<br>ASPHALT &<br>BASE SHEET |               |         |   |                          |
|                          |                                  |   |  | * NUMBER OF COURSES   |              |        |                       |        |                |                                    |               |         |   |                          |
|                          |                                  |   |  | Thickness<br>mass. conc.<br>no reinf<br>to balance<br>lifting force | Primer       | Fabric | Emul                  | Primer | No of<br>Coats | Primer                             | Base<br>Sheet | Asphalt |   |                          |
| 1                        | 0.43                             | 62.5  | 31.2   | 5"  | 1            | 1      | 2                     | 1      | 1              | 1                                  | 2             | 3       | 1 |                          |
| 2                        | 0.86                             | 125.0   | 62.5   | 10"   | 1            | 1      | 2                     | 1      | 1              | 1                                  | 2             | 3       | 1 |                          |
| 3                        | 1.30                             | 187.5   | 93.7   | 15"   | 1            | 1      | 3                     | 1      | 2              | 1                                  | 2             | 3       | 1 |                          |
| 4                        | 1.73                             | 250.0   | 125.0  | 20"   | 1            | 1      | 3                     | 1      | 2              | 1                                  | 2             | 3       | 1 |                          |
| 5                        | 2.17                             | 312.0   | 156.2  | 25"   | 1            | 1      | 3                     | 1      | 2              | 1                                  | 2             | 3       | 1 |                          |
| 6                        | 2.60                             | 375.0   | 187.5  | 2'- 6"  | 1            | 1      | 3                     | 1      | 2              | 1                                  | 3             | 4       | 1 |                          |
| 7                        | 3.01                             | 437.5   | 218.4  | 2'-11"  | 1            | 2      | 4                     | 1      | 2              | 1                                  | 3             | 4       | 1 |                          |
| 8                        | 3.47                             | 500.0   | 250.0  | 3'- 4"  | 1            | 2      | 4                     | 1      | 2              | 1                                  | 3             | 4       | 1 |                          |
| 9                        | 3.87                             | 562.5   | 280.8  | 3'- 9"  | 1            | 2      | 4                     | 1      | 2              | 1                                  | 4             | 5       | 1 |                          |
| 10                       | 4.34                             | 625.0   | 312.5  | 4'- 2"  | 1            | 2      | 4                     | 1      | 2              | 1                                  | 4             | 5       | 1 |                          |
| 12                       | 5.21                             | 750.0   | 375.0  | 5'- 0"  | 1            | 2      | 4                     | 1      | 2              | 1                                  | 5             | 6       | 1 |                          |
| 15                       | 6.51                             | 937.5   | 468.7  | 6'- 3"  | 1            | 3      | 5                     | 1      | 3              | 1                                  | 5             | 6       | 1 |                          |
| 20                       | 8.68                             | 1250.0  | 625.0  | 8'- 4"  | 1            | 3      | 5                     | 1      | 3              | 1                                  | 6             | 7       | 1 |                          |
| 25                       | 10.85                            | 1562.5  | 781.2  | 10'- 5"   | 1            | 4      | 6                     | 1      | 3              | 1                                  | 7             | 8       | 1 |                          |
| 30                       | 13.02                            | 1875.0  | 937.5  | 12'- 6"   | 1            | 4      | 6                     | 1      | 3              | 1                                  | 9             | 10      | 1 |                          |

- \* All C-13-E Emulsion Courses are at the rate of 3 gallons per 100 square feet, per course.
- \* All MONOFORM Courses are at the rate of 6 gallons of MONOFORM Compound FM-200 and two pounds of glass reinforcement per 100 square feet per coat
- \* All Hot Asphalt Courses are at the rate of 25 lbs. per 100 square feet, per course
- \*\* See Built-up Roof Specification Book

Reprinted with permission of The Flintkote Company.

laminated plastic-and-bitumen membranes and the elastomeric sheet membranes discussed in topics 4 and 5. The sheet materials may be installed between the base slab and the wear slab in a split-slab deck, and they may also be used to enclose completely a below-grade structure. Some application details for waterproofing with one type of plastic-and-bitumen sheet membrane are shown in Figure S-1. The sheet membranes are usually fully bonded to the structure to be waterproofed. An exception is the preformed membranes often used as reservoir and pool liners; they are usually placed directly over smooth, compacted earth and are held in place mainly or entirely by the weight of the contained water.

#### Waterproofing with Factory-Processed Sheets

The preliminary work and application procedures for waterproofing with single-ply sheet membranes are essentially the same as for roofing with such materials. Concrete must be smooth, clean, fully cured, and dry, and all cracks and joints must be sealed. (A minimum curing time of seven days is usually specified; additional time must be allowed for drying.) The typical application procedure that follows is for waterproofing a concrete slab or wall with a self-bonding, plastic-and-bitumen sheet membrane:

1. Using the primer recommended by the membrane manufacturer, coat all surfaces to be waterproofed, at a rate sufficient to provide adequate coverage (usually from  $\frac{1}{2}$  to 1 gallon [1.1 to 3.8 litres] per square, depending on the porosity of the surface). Prime only as much surface as can be covered in one workday. A second coat of primer may be required on vertical surfaces. Allow the primer to dry tack free before proceeding with the waterproofing.
2. Using strips of the sheet-membrane material, reinforce all corners and cover all joints as required in the job specifications. Coat areas around pipes and other penetrations with generous amounts of the recommended mastic.
3. Place the first strip of membrane, tack-side down, being careful to preserve alignment and avoid fishmouths, wrinkles, or blisters.
4. Place the remaining strips of membrane material, using the amount of overlap and the seaming method prescribed by the membrane manufacturer. Self-bonding membranes are joined by cold fusion of the bitumen at the lapped edges; no lap adhesive is required. Most manufacturers recommend pressure-rolling the laps to ensure a complete bond.

5. Inspect the completed membrane carefully to make sure that it has no blisters or wrinkles; if any are found, repair them by the methods specified by the manufacturer.
6. Apply additional generous coatings of mastic over the membrane at flashing locations.
7. Water-test the completed membrane.
8. Unless placement of a wear slab or other overlay is to follow immediately, provide a protection course for the completed membrane. When protection board is required to protect a waterproofed vertical surface from backfill damage, remove the plastic film from the installed membrane (if the membrane has such a film) to provide a tack surface, and apply the board with a cold mastic.

#### Waterproofing with Bentonite-Clay Panels

A unique system of waterproofing makes use of bentonite-clay granules packaged in corrugated, biodegradable, kraft-board panels. (See Fig. 8-2). The granules are loose-packed within the corrugations, but when they encounter moisture, they swell to as much as 15 times their dry volume, forming an expansive gel that serves as the waterproofing medium. The only purpose of the corrugated kraft board is to keep the bentonite granules in position until the backfill is placed and groundwater causes the granules to swell; it decomposes within a few months, leaving a permanent, watertight layer of expanded bentonite clay that bears against the underground structure.

Construction joints, form-tie voids, and wall penetrations are sealed with a bentonite-gel mastic that is applied with a trowel before the panels are placed. Plastic or kraft-board tubes filled with the bentonite granules are used at corners and intersections and in expansion joints to provide additional sealing at these points.

For underslab waterproofing the panels are simply laid in rows, with overlapped and staggered joints, over polyethylene sheeting on the compacted and level surface that is to receive the slab; another layer of poly sheeting is spread over the panels. (The sheeting protects the panels from moisture until the concrete is placed.) The panels extend beyond the edges of the slab to permit them to be tied to the vertical waterproofing when the walls are placed. The vertical panels are placed on the walls from the bottom up, with the seams staggered, and are folded around corners. They may be nailed in place on a nailable wall; they are attached to concrete walls with mastic. If the backfill contains material that could penetrate the kraft board, the wall panels should be protected with a course of fiberboard.



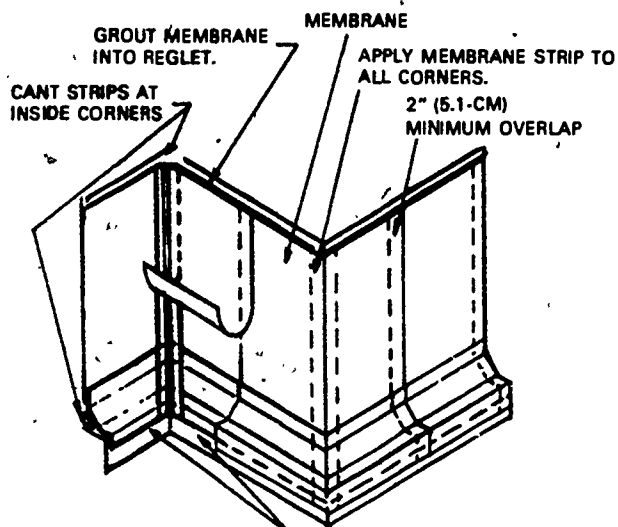

PRIMER SHOULD EXTEND BEYOND MEMBRANE.

Vertical

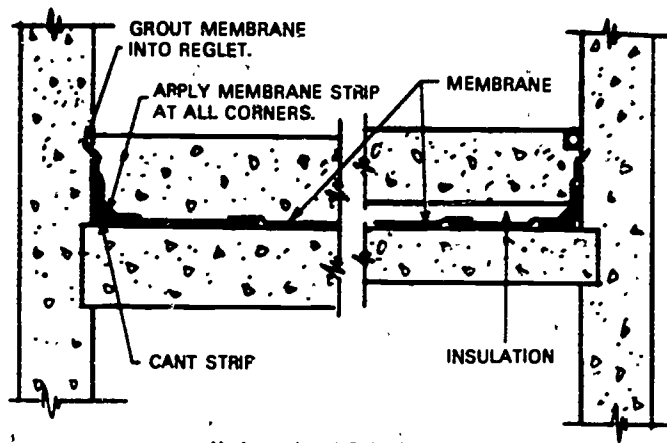

Horizontal and Split Slab

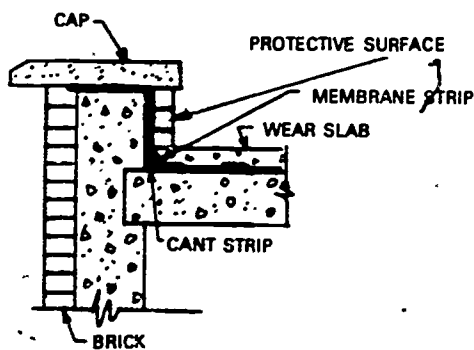

Split Slab Deck

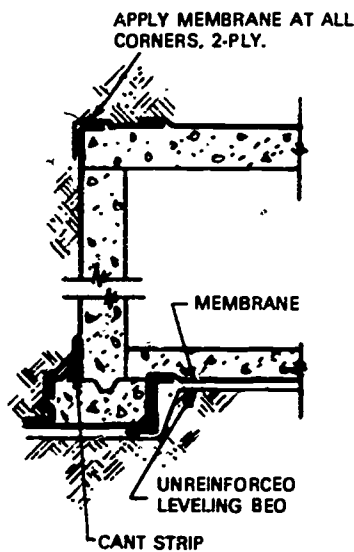

Slab on Grade

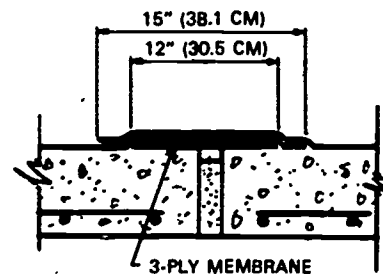

Expansion Joint

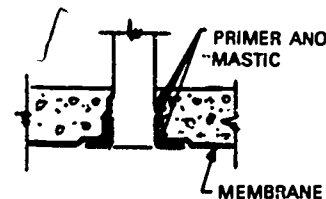

Drain and Post

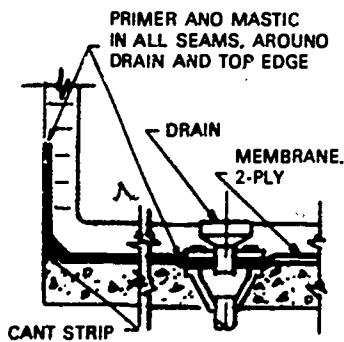

Planter-Shower Pan

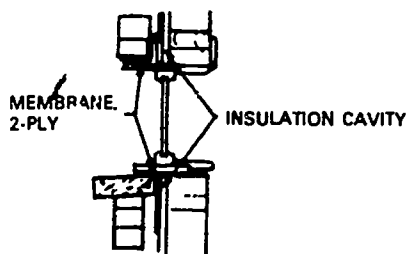

Head and Sill

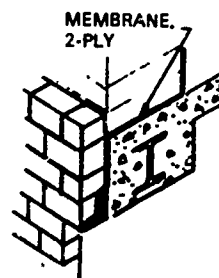

Spandrel Beam

Fig. 8-1. Sheet membrane waterproofing installation details (Protecto Wrap Company's Jilly Seal membrane)

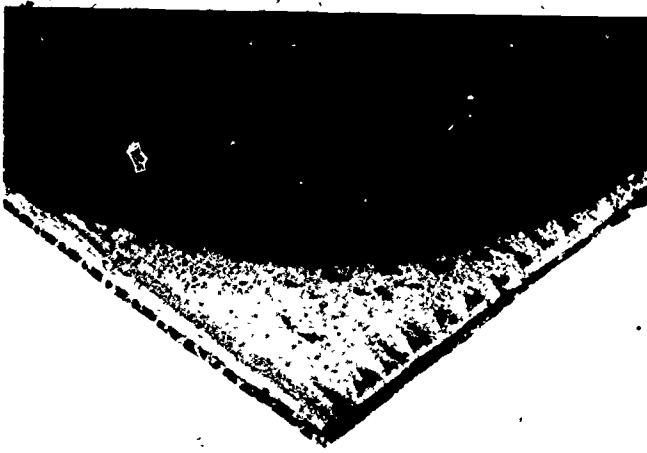

Fig. 8-2. Inner construction of a bentonite-clay/kraft-board panel (Volclay Panels, by American Colloid Company)

### Waterproofing with Fluid-Applied Cold-Process Materials

Fluid-applied cold-process membranes are used for waterproofing as well as for roofing. Two of the many available types of fluid-applied waterproofing will be discussed here: (1) a polyurethane-rubber elastomeric material; and (2) an asphalt-clay emulsion reinforced with chopped-glass fibers.

#### Waterproofing with a Fluid-Applied Polyurethane Membrane

Fluid-applied synthetic-rubber waterproofing materials have many of the advantages and limitations of the elastomeric roofing materials discussed in Topic 6. They are self-adhering and relatively easy to apply, and they form tough, seamless, flexible membranes that follow the contours of the substrate. On the other hand, they usually have a relatively short shelf life in unopened containers (six months is typical), they may require mixing on the job, and they often contain toxic and flammable chemicals. One such system is shown in Figure 8-3.

Strict adherence to the job specifications and the product instructions is essential in waterproofing with a fluid elastomer. Surface preparation is critical. Concrete should have a fine steel-troweled and lightly brushed surface, and it must be dry and free of dust, oil, and other contaminants. Sandblasting or a light acid etch may be specified to ensure a good bond. All exposed metal that will come in contact with the membrane must be free of rust, corrosion, and all other contaminants, and it must be coated with a primer approved by the manufacturer of the fluid elastomer. Hairline cracks may be treated with a stripe coat of the elastomer. Cracks subject to movement should be

routed out to about  $\frac{3}{8}$ -inch (1-centimetre) width and  $\frac{1}{2}$ -inch (1.3-centimetre) depth, blown clean, and then filled with closed-cell joint backing, primed, and covered with a heavy stripe coat of the elastomer. (See Fig. 8-3.) Flashing and reinforcements are placed before the membrane is installed. All preliminary coatings of the elastomer must be allowed to cure at least 12 hours before the main coating is applied.

When the surface preparation is complete and flashing and reinforcements are in place, the elastomeric coating may be applied by trowel, squeegee, or spray. Fluid elastomers are usually marketed in two grades—a heavy-bodied trowel-grade material for use on vertical surfaces and for preliminary work, such as crack sealing, and a thinner-bodied, self-leveling material for use on horizontal surfaces. Single-component elastomeric waterproofing materials are applied just as they come from the container. Two-part elastomers must be mixed on the job, a task that requires extreme care and precise timing. The manufacturer's instructions for mixing the Part A and Part B components must be followed exactly. The mixed elastomer must be applied within its specified pot life, which may be less than an hour. Containers of the Part A and Part B materials not in use must be kept covered; so must containers of primer, thinner, mastic, and cleaner. All the materials must be protected from moisture. Work should be postponed if rain threatens; most fluid elastomeric coatings must be kept dry for several hours after application.

Flashing is usually accomplished with compatible elastomeric sheet material and trowel-grade mastics. Some typical installation details for one system of fluid-applied elastomeric waterproofing are shown in Figure 8-4.

Because fluid-applied elastomeric membranes are extremely vulnerable to damage immediately after

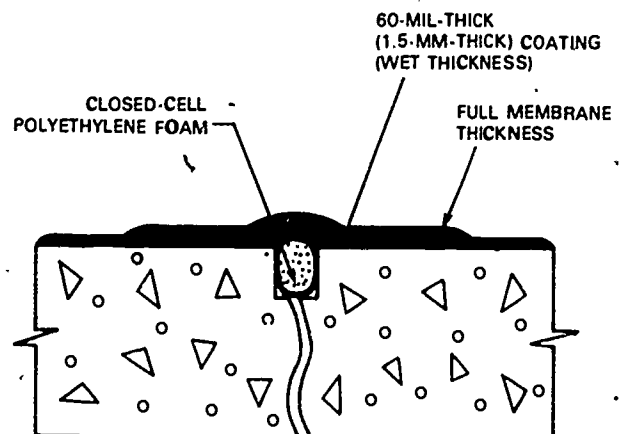

Fig. 8-3. Sealing a working crack (Tremco's TREMproof 50)

application and during the early part of the curing period, extra care must be taken to protect them at those times. Protection courses should be installed over membranes on slabs and walls as soon as it is practicable to do so.

#### Waterproofing with Spray-Applied Asphaltic Emulsion Reinforced with Chopped-Glass Fibers

The cold-process roofing technique in which a modified asphalt-clay emulsion is spray-applied to the deck along with chopped-glass fibers, as described in Topic 6, is also adaptable to waterproofing. The surface preparation and application procedures for waterproofing with these materials are essentially the same as for roofing with them. The asphalt-clay emulsion used in waterproofing is specially formulated for that purpose; the chopped-glass fibers are the same as those used in roofing. As in roofing, the surface to be waterproofed must be clean, smooth, and firm. All cracks, voids, and depressions must be filled, and all ridges and similar projections must be ground down. Concrete must be adequately cured and free of contaminants, but it need not be completely dry. The waterproofing procedure is as follows:

1. Apply a coat of the asphaltic emulsion thinned to primer consistency as specified by the manufacturer. A primer application rate of 1 gallon (3.8 litres) per square is usual. Allow the primer to damp dry.

2. Using the manufacturer-approved spray applicator, apply preliminary coatings of asphaltic emulsion and chopped-glass fiber where reinforcement is called for in the job specifications. Allow the reinforcement coatings to tack dry before proceeding with the waterproofing.
3. Observing the manufacturer's recommendations regarding coating thickness, apply the first course of asphaltic emulsion and chopped-glass fiber with the spray applicator. Allow the coating to dry.
4. Apply additional courses as required to provide the amount of waterproofing needed to withstand the anticipated hydrostatic head. (Typical data for this type of waterproofing will be found in Table 8-2.)
5. Install protection boards before backfilling is begun.

#### Cold-Applied Dampproofing

Because dampproofing is intended to give protection only against moisture and occasional exposure to water that is not under pressure, it is usually accomplished with fluid-applied dampproofing materials and without a membrane. Plastic sheeting is sometimes used to provide dampproofing in applications where the sheeting will have permanent protection against physical damage, as between an exterior wall and architectural facing.

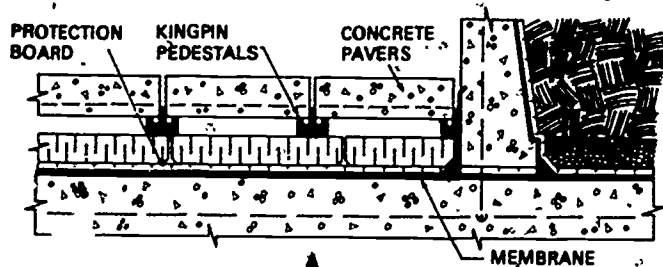

Insulated Plaza Deck Section with Planter

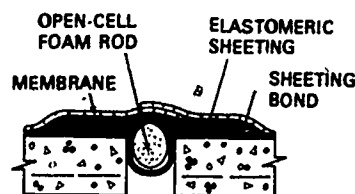

Deck Expansion Joint

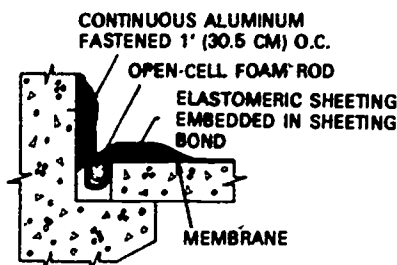

Expansion Joint at Wall

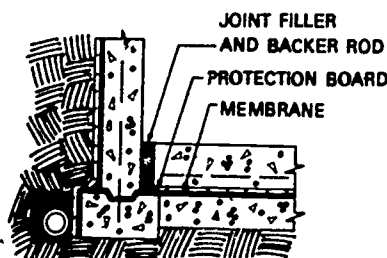

Foundation Wall

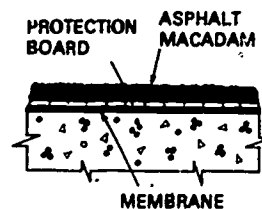

Vehicular Deck

Fig. 8-4. Typical installation details for cold-process fluid-applied polyurethane waterproofing (Tremco's TREMPROOF 60)

Surfaces to be dampproofed must be clean, dry, and smooth, with no high spots or depressions. (A slightly damp surface is usually an acceptable base for asphalt-clay emulsions or latex-type dampproofing materials.) Open cracks and depressions in concrete surfaces should be filled with cement grout and struck level. The dampproofing on an above-grade wall may be continued below grade if no hydrostatic head is anticipated; otherwise, the dampproofing should be tied into the waterproofing system. Any dampproofing below grade should be protected against backfill.

The surface to be dampproofed should have a first coat of an appropriate primer. In some cases a primer-sealer alone will provide adequate dampproofing.

### Safety in Cold-Applied Waterproofing and Dampproofing

Except for the hazards associated with the use of hot bitumen, the safety considerations that apply in hot-process waterproofing apply also in waterproofing with cold-process materials. The walls and faces of all excavations that expose workers to danger from moving ground must be effectively guarded by a shoring system, sloping of the ground, or other equivalent means. If scaffolding is required, it must meet the requirements set forth in the *Construction Safety Orders* handbook, and it must have firm bearing. The work area must be kept dry and well ventilated.

Many of the materials used in cold-process waterproofing are toxic and highly flammable. Flammable vapors and mists may occur in explosive concentrations in confined, poorly ventilated areas. Open flame and welding operations must not be permitted in work areas where danger of fire or explosion exists. If power tools must be used in such an environment, they should be explosion-proof types. All electrical equipment must be properly grounded. Class BC fire extinguishers of adequate size must be kept at hand.

Where the work area cannot be kept free of fumes and spray mists by natural or fan-assisted ventilation, the waterproofing applicators may be required to wear air-supplied respirators. Goggles and hard hats are essential safety items. Skin contact with solvents, catalysts, and similar irritants should be avoided or at least kept to a minimum. Special care must be taken to avoid eye contact with toxic or irritant materials.

The manufacturers of fluid-applied roofing and waterproofing materials provide specific instructions for the safe handling of their products, and every member of the waterproofing crew should know and follow them.

### Study Assignment

Obtain and study manufacturer's product literature and sample specifications for cold-applied waterproofing and dampproofing systems. Give special attention to safety information.

## Instructional Materials

*CAL/OSHA State of California Construction Safety Orders* (Current edition). Los Angeles: Building News, Inc. (Orders to: Building News, Inc., 3055 Overland Avenue, Los Angeles, CA 90034.)

Griffin, C. W. *Manual of Built-up Roof Systems*. New York: McGraw-Hill Book Company, 1970. (Orders to: McGraw-Hill Book Company, 1221 Avenue of the Americas, New York, NY 10020.)

*Handbook of Accepted Roofing Knowledge*. Oak Park, Ill.: National Roofing Contractors Association, 1980. (Orders to: National Roofing Contractors Association, 1515 North Harlem Avenue, Oak Park, IL 60302.)

*Entering the Roofing and Waterproofing Industry*. Sacramento: California State Department of Education, 1980. (Orders to: Publications Sales, California State Department of Education, P.O. Box 271, Sacramento, CA 95802.)

*Built-up Roofing*. Sacramento: California State Department of Education, 1981. (Orders to: Publications Sales, California State Department of Education, P.O. Box 271, Sacramento, CA 95802.)

# Glossary

The definitions of terms included in this glossary are those that are pertinent to the roofing and waterproofing industry and are not necessarily those found in standard dictionaries.

**Aggregate.** Crushed rock, crushed slag, or water-worn gravel used to surface built-up roofs and to provide ballast for floating membranes.

**Alligatoring.** Cracking of the top coat of bitumen on a built-up roof, in a pattern similar to that of an alligator's hide, due to prolonged exposure to the sun's rays.

**Base coat.** The first coat of adhesive in a built-up roofing system; also, the first coat of a fluid-applied elastomeric roofing system, usually covered with a protective topcoat.

**Base sheet.** A saturated or coated felt placed as the first ply in some roofing and waterproofing systems. (See "felt.")

**Base slab.** In split-slab construction the bottom slab that is in contact with compacted earth or drainage gravel. A waterproofing membrane is usually installed over the base slab before the upper slab (the wear slab) is placed. Also called a mud slab. (See "split-slab construction" and "wear slab.")

**Bentonite clay.** A soft clay mineral of volcanic origin used as a suspending agent in bitumen emulsions.

**Bitumen.** Coal-tar pitch or asphalt.

**Cant strip.** A beveled strip of wood or wood fiber that fits into the angle formed by the intersection of a horizontal and a vertical surface, for example, where a roof deck meets a parapet wall, to provide a smooth transition for the roofing and flashing.

**Capillary action.** The action by which the surface of a liquid (where it is in contact with a solid) is elevated or depressed, depending on the relative attraction of the molecules of the liquid for one another and for those of the solid.

**Cfm.** Cubic feet per minute.

**Construction joint.** A joint in a cast-in-place concrete slab or wall where successive pours meet.

**Curing.** The chemical process in which the two liquid components of a thermosetting plastic interact to become a solid or semisolid product; also, the chemical reaction in newly mixed concrete that results in hardening of the concrete.

**Curing agent.** The part B component in a two-part synthetic fluid-applied roofing or waterproofing material that chemically changes the part A component from a fluid to a solid or semisolid; also, a coating applied to fresh concrete to retain moisture and thus aid curing.

**Cutback.** An asphalt or coal-tar pitch primer, adhesive, mastic, or coating produced by blending the bitumen with a petroleum solvent or other volatile thinner.

**Dead load.** The load imposed on a roof structure by air-conditioning units and other roof-mounted equipment, the roof system, and the roof deck itself. (See "live load.")

**Deck.** The structural surface on which the roofing or waterproofing system is applied. (See "roof system.")

**Elastomer.** A synthetic material that has rubberlike properties. Elastomeric roofing and waterproofing materials are marketed as fully or partly cured roll sheeting or as fluids that cure after application to become tough, flexible membranes.

**Emulsion.** An intimate mixture of two liquids or a liquid and a semisolid (such as water and softened asphalt) that are not soluble in each other. Emulsification is achieved by violent agitation of the mixture and is aided by the presence of an emulsifying agent, such as bentonite clay.

**Expansion joint.** A planned structural separation between two adjoining sections of a deck, wall, or floor that minimizes the effect of stresses resulting from building movements and thermal expansion and contraction; requires special membrane reinforcement over the joint.

**Felt.** General term for all ply materials used in built-up roofing and waterproofing systems. Felts are manufactured from organic materials, such as vegetable fibers; from mineral fibers, such as asbestos; or from glass fibers. They may be saturated (with soft bitumen) or unsaturated; coated (with harder bitumen) or uncoated; or impregnated with resin.

**Flashing.** The system used to seal the edges of a roofing or waterproofing membrane at vertical and horizontal intersections, corners, expansion joints, gravel stops, drains, pipes and other projections, and wherever else the membrane is interrupted or terminated.

**Flashing cement (mastic).** A trowel-grade cement used alone or in conjunction with fabric reinforcement where flashing is required; usually contains mineral fibers for added body.

**Floating membrane.** A roofing membrane that is fastened to a flat or low-sloped deck at the perimeter only and held down by a ballasting layer of aggregate.

**Flood coat.** The top layer of bitumen on a built-up roof, into which aggregate may be embedded.

**Glaze coat.** The layer of bitumen over the last ply course in a smooth-surfaced built-up roofing or waterproofing membrane; also, a thin protective coat of bitumen applied to a ply course when completion of the membrane must be delayed.

**Groundwater.** The water in the zone of saturation in the soil surrounding a structure. Up to the surface of the groundwater, all openings in the rocks and soil are filled with water. The surface of the groundwater is called the water table.

**Holiday.** An area on a deck or wall where a fluid-applied coating is missing.

**Hydrostatic head.** A measure of pressure in a liquid, expressed as the height, in feet, of a column of the liquid which would produce that pressure. For example, a hydrostatic head of 10 feet (3 metres) is equal to the pressure that would be exerted at the bottom of a column of water 10 feet (3 metres) high.

**Hydrostatic pressure.** The water pressure produced by a given hydrostatic head.

**Laminate.** Multilayer sheet-membrane material, such as a layer of modified bitumen faced on one or both sides with plastic film.

**Live load.** The load imposed on a roof by workers and their equipment; may also include wind, rain, snow, and ice loads. (See "dead load.")

**Mastic.** See "flashing cement."

**Mil.** One-thousandth of an inch (0.03 millimetre).

**Nailer or nailing strip.** A strip of treated wood embedded at the edge of a concrete deck or above the grade line in a concrete wall to permit fastening of the roofing or waterproofing membrane.

**Permeance.** An index of a material's resistance to the transmission of water vapor.

**Ply.** A layer of felt in a built-up roofing or waterproofing membrane.

**Polymer.** A chemical compound formed by polymerization.

**Polymerization.** A chemical reaction in which the normally small molecules in a substance combine to form long chains or networks of large molecules.

**Pot life.** The length of time that a substance can be stored in the container once the container has been opened.

**Psi.** Pounds per square inch.

**Reglet.** A groove in a parapet wall or other vertical surface adjoining a roof deck for use in attaching flashing or counterflashing.

**Roof system.** A system of interacting roof components (not including the deck) designed to weatherproof and normally to insulate the top surface of a building.

**Shelf life.** The length of time that a substance can be stored in its unopened container.

**Shoring.** Timber or other material used to provide temporary support at the sides and faces of excavations.

**Split-slab construction.** Composite construction of a concrete floor or deck consisting of a base slab and a wear slab, usually with a waterproofing membrane and sometimes with insulation between the slabs. (See "base slab" and "wear slab.")

**Substrate.** The surface on which the roofing or waterproofing membrane is placed (i.e., the deck or insulation).

**Vapor barrier.** A material designed to restrict the passage of water vapor through a wall or roof; more properly called a vapor retarder.

**Viscosity.** The internal friction, due to molecular cohesion, that makes a fluid resistant to flowing.

**Wear slab.** The top element in split-slab construction. (See "split-slab construction" and "base slab.")

**Water stop.** A temporary strip of felt mopped in place over the exposed edge of the last-laid course of insulation at the end of each workday to protect the exposed edge from moisture. Also, a permanent water stop included in the roof system to confine possible leaks to a relatively small area.

# Roofing

## Cold-Applied Roofing Systems and Waterproofing and Dampproofing

### Tests

The following section contains objective tests for each topic of the workbook. The value of the tests depends to a great extent on the care taken by instructors and school supervisors in keeping them confidential.

Supervisors and instructors should feel free to modify the application of the workbook material and the tests to satisfy local needs. Also, the instructors will probably supplement the information in the workbook with other material that they themselves have developed, and they will need to augment the tests with questions based on any supplementary material they may use.

Instructors and supervisors should be aware that the test pages are perforated to facilitate removal of the tests, either individually or as a complete set, at the discretion of the instructor or supervisor.

# Cold-Applied Roofing Systems and Waterproofing and Dampproofing Tests

## TOPIC 1—INTRODUCTION TO COLD-APPLIED ROOFING SYSTEMS AND WATERPROOFING AND DAMPPROOFING

Decide which of the four answers is correct, or most nearly correct; then write the corresponding number in the blank at the right.

1. The advantages of cold-applied roofing include which of the following? 1: \_\_\_\_\_
  1. Cold-applied roofing can be adapted to any roof slope.
  2. Less air pollution is created than with hot-applied systems.
  3. Cold-applied roofing materials generally reduce the dead load on the roof structure.
  4. All of the above.
  
2. If a built-up roof shows signs of "alligatoring," which of the following is (are) visible? 2. \_\_\_\_\_
  1. Bitumen oozing from beneath membranes
  2. Cracks in the top coat of bitumen
  3. Fine particles of bentonite clay
  4. All of the above
  
3. Elastomeric roofing materials tend to lose their rubberlike quality: 3. \_\_\_\_\_
  1. In cold weather
  2. In hot weather
  3. At night only
  4. None of the above
  
4. Which of the following is recommended for use as a curing agent, or agents, on a concrete deck that is to receive a fluid elastomeric membrane? 4. \_\_\_\_\_
  1. A solvent
  2. An asphaltic cutback
  3. Water
  4. None of the above
  
5. Preventing the passage of water under pressure through exterior walls, floor slabs, and the like is the purpose of: 5. \_\_\_\_\_
  1. Waterproofing
  2. Laitance
  3. Heat fusion
  4. Dampproofing
  
6. Some bituminous sheet membranes are manufactured with a top layer of heavy aluminum foil; others are made with a top layer of: 6. \_\_\_\_\_
  1. Asphalt-clay emulsion
  2. Polyethylene film
  3. Aggregate
  4. Laitance



7. Cold asphaltic mixtures are applied to a prepared roof deck with: 7. \_\_\_\_\_
1. Spray equipment
  2. Rollers
  3. Brushes
  4. All of the above
8. Which of the following statements is false? 8. \_\_\_\_\_
1. Many cold-process fluids, mastics, and sheet membranes can be used to make repairs on conventional built-up roofs.
  2. Dampproofing provides a greater degree of protection than waterproofing.
  3. Cold-applied adhesives and coatings are generally ready to apply just as they come from the container.
  4. In some cases, a single elastomeric membrane may be the only component of a watertight roof.
9. Some solvents used in cold-process roofing are: 9. \_\_\_\_\_
1. Very expensive
  2. Toxic
  3. Nonflammable
  4. None of the above
10. Some asphaltic emulsions are reinforced with: 10. \_\_\_\_\_
1. Elastomers
  2. Plastic laminate
  3. Laitance
  4. Fibers of chopped glass

# COLD-APPLIED ROOFING SYSTEMS AND WATERPROOFING AND DAMPROOFING TESTS

## TOPIC 2—TOOLS AND EQUIPMENT USED IN COLD-APPLIED ROOFING

Decide which of the four answers is correct, or most nearly correct; then write the corresponding number in the blank at the right.

1. Which of the following is commonly used to soften bitumen in laminated plastic-and-bitumen membranes? 1. \_\_\_\_\_
  1. A salamander
  2. A kettle
  3. A propane torch
  4. None of the above
  
2. When leaving an airless spray gun unattended, the operator should: 2. \_\_\_\_\_
  1. Unscrew the nozzle tip.
  2. Be sure both pipes are unobstructed before leaving the gun.
  3. Lock off the trigger of the gun.
  4. All of the above.
  
3. The hoses that supply air and fluid material to an air-atomizing spray gun should be taped together at intervals of: 3. \_\_\_\_\_
  1. 16 inches (40.6 centimetres)
  2. 18 inches (45.7 centimetres)
  3. 19 inches (48.3 centimetres)
  4. 20 inches (50.8 centimetres)
  
4. Which of the following is usually used to flush asphaltic cutbacks from spray guns, material hoses, and the like? 4. \_\_\_\_\_
  1. Water
  2. Fluid neoprene
  3. Gasoline
  4. Kerosene
  
5. Spray equipment should be flushed for how many minutes? 5. \_\_\_\_\_
  1. One
  2. Two to three
  3. Five
  4. None of the above
  
6. If fluid material is to be pumped more than 100 feet (30.5 metres) through a hose, the hose should be how many inches in diameter? 6. \_\_\_\_\_
  1. 1 (2.5 centimetres)
  2. 1¼ (3.2 centimetres)
  3. 1½ (4.4 centimetres)
  4. 2 (5.1 centimetres)
  
7. Which of the following is (are) common to cold-applied and hot-applied roofing operations? 7. \_\_\_\_\_
  1. Salamanders
  2. Spudding machines
  3. Weed burners
  4. All of the above

8. Pails of what size are generally used to transport cold-process fluids on small jobs? 8. \_\_\_\_\_

1. 3 gallons (11.4 litres)

3. 5 gallons (18.9 litres)

2. 4 gallons (15.1 litres)

4. 7 gallons (26.5 litres)

9. Cold-process adhesives and coating materials that contain mineral fibers, bentonite clay, or other additives: 9. \_\_\_\_\_

1. Must be applied with rollers

2. Must be stirred frequently or constantly during application

3. Must be purchased in drums of at least 55-gallon (208.2-litre) capacity

4. None of the above

10. Warming heavy-bodied cold process materials: 10. \_\_\_\_\_

1. Makes them easier to pump

2. Is an economically sound practice

3. Is an unsafe practice

4. Is not recommended by CAL/OSHA



# COLD-APPLIED ROOFING SYSTEMS AND WATERPROOFING AND DAMPPROOFING TESTS

## TOPIC 3—COLD-APPLIED ASPHALTIC BUILT-UP ROOFING

Decide which of the four answers is correct, or most nearly correct; then write the corresponding number in the blank at the right.

1. Which of the following would be used to thin asphaltic cutbacks? 1. \_\_\_\_\_  
1. Water 3. Kerosene  
2. Gasoline 4. None of the above
2. Asphaltic cutbacks used as mastics usually consist of what percent solvent? 2. \_\_\_\_\_  
1. 5 3. 30  
2. 15 4. 45
3. A mixture of two liquids, or a liquid and a semisolid, that are not soluble in each other is called a (an): 3. \_\_\_\_\_  
1. Wetting agent 3. Cutback  
2. Mastic 4. Emulsion
4. Which of the following is (are) characteristic of asphaltic cutbacks? 4. \_\_\_\_\_  
1. They are not compatible with coal-tar materials.  
2. They must be applied to dry surfaces.  
3. They are highly flammable in the fluid state.  
4. All of the above.
5. The minimum recommended slope for a roof that is to receive a cold-process built-up roof is: 5. \_\_\_\_\_  
1.  $\frac{1}{4}/12$  3.  $\frac{3}{4}/12$   
2.  $\frac{1}{2}/12$  4.  $1/12$
6. Rubber sheeting, PVC films, and laminated kraft-paper sheets may all be used as: 6. \_\_\_\_\_  
1. Thermal insulation 3. Cap sheets  
2. Vapor barriers 4. Flashing
7. At temperatures of at least 60 degrees F. (15.6 degrees C), the normal drying time for an asphaltic emulsion used as a protective coating is at least: 7. \_\_\_\_\_  
1. 24 hours 3. 72 hours  
2. 48 hours 4. None of the above

8. Full-width base sheets on a cold-process built-up asphaltic roof are lapped 4 inches (10.2 centimetres) at the ends. How many inches should they be lapped at the sides? 8. \_\_\_\_\_
1. 17 (43.2 centimetres)                      3. 19 (48.3 centimetres)  
2. 18 (45.7 centimetres)                      4. 20 (50.8 centimetres)
9. In applying an asphaltic emulsion protective topcoat by brush, the roofer should apply about how many gallons per square? 9. \_\_\_\_\_
1. 2 (7.6 litres)                                      3. 6 (22.7 litres)  
2. 3 (11.4 litres)                                      4. 7 (26.5 litres)
10. If a blister or wrinkle in a built-up roof must be repaired, part of the procedure involves cementing a layer of coated base sheet over the flattened blister or wrinkle. How many inches beyond the defect should the base sheet extend? 10. \_\_\_\_\_
1. 4 (10.2 centimetres)                              3. 7 (17.8 centimetres)  
2. 6 (15.2 centimetres)                              4. 8 (20.3 centimetres)

# COLD-APPLIED ROOFING SYSTEMS AND WATERPROOFING AND DAMPPROOFING TESTS

## TOPIC 4—COLD-APPLIED BITUMINOUS SHEET-MEMBRANE ROOFING

Decide which of the four answers is correct, or most nearly correct; then write the corresponding number in the blank at the right.

1. Which of the following would indicate that a metal deck is not ready to receive bituminous sheet-membrane roofing materials? 1. \_\_\_\_\_  
1. Scale 3. Loose welds  
2. Rust 4. All of the above
2. Heat fusion to obtain a waterproof seal between two overlapping sections of membrane is called: 2. \_\_\_\_\_  
1. Substrate fusion 3. Dampproofing  
2. Interply fusion 4. None of the above
3. Before a main standard-grade bituminous sheet membrane is applied, cushioning or stripping layers of standard-grade membrane should be installed: 3. \_\_\_\_\_  
1. Where the main membrane ends  
2. Where the main membrane changes direction  
3. In areas of high stress  
4. All of the above
4. Standard-grade bituminous sheet membranes should be lapped 4 inches (10.2 centimetres) at the ends and how many inches at the sides? 4. \_\_\_\_\_  
1. 4 (10.2 centimetres) 3. 8 (20.3 centimetres)  
2. 6 (15.2 centimetres) 4. 9 (22.9 centimetres)
5. When loose aggregate is used as a topping over a standard-grade bituminous sheet-membrane roof system, the aggregate or stone should be what nominal size? 5. \_\_\_\_\_  
1.  $\frac{3}{8}$  inch (1 centimetre) 3.  $\frac{3}{4}$  inch (1.9 centimetres)  
2.  $\frac{1}{2}$  inch (1.3 centimetres) 4.  $\frac{7}{8}$  inch (2.2 centimetres)
6. Membranes should be extended at least how far beyond cant strips at parapets and other vertical intersections? 6. \_\_\_\_\_  
1.  $1\frac{1}{2}$  inches (3.8 centimetres) 3.  $2\frac{1}{2}$  inches (6.4 centimetres)  
2. 2 inches (5.1 centimetres) 4. 3 inches (7.6 centimetres)

7. Which of the following statements about aluminum-grade membrane and its application is (are) true? 7. \_\_\_\_\_
1. Under normal conditions aluminum-grade membrane requires no additional protection.
  2. Varnish-base aluminum paint can be used to touch up exposed streaks of bitumen.
  3. Aluminum-grade membrane can be used as flashing material.
  4. All of the above.
8. The layers of modified bitumen in aluminum- and standard-grade membranes: 8. \_\_\_\_\_
1. Increase the water resistance of the membrane.
  2. Provide protection for the membrane's plastic core.
  3. Enable the applied sheets to be heat-fused to each other and to other parts of the roof.
  4. All of the above.
9. To which type of deck must insulation boards or some other material be added before a bituminous sheet membrane can be applied? 9. \_\_\_\_\_
1. A concrete nonnailable deck
  2. A ribbed metal deck
  3. A plywood deck
  4. All of the above
10. Repair patches on aluminum-grade membranes should be: 10. \_\_\_\_\_
1. Interply-fused only
  2. Interply-fused and top sealed
  3. Top-sealed only
  4. None of the above

# COLD-APPLIED ROOFING SYSTEMS AND WATERPROOFING AND DAMPPROOFING TESTS

## TOPIC 5—ELASTOMERIC SHEET MEMBRANE ROOFING

Decide which of the four answers is correct, or most nearly correct; then write the corresponding number in the blank at the right.

1. The advantages of single-ply elastomeric sheet membranes include which of the following? 1. \_\_\_\_\_
  1. They reflect heat well.
  2. They can be adapted to any roof slope.
  3. They can retain their waterproof quality even with some movement of the underlying structure.
  4. All of the above.
  
2. Which of the following is (are) the most common substrate (deck) for elastomeric sheet membranes? 2. \_\_\_\_\_
  1. Insulation boards
  2. A noninsulating deck
  3. Sprayed-in-place foam insulation
  4. All of the above
  
3. Full adhesive bonding of an elastomeric membrane provides good protection against damage from: 3. \_\_\_\_\_
  1. Strong sunlight
  2. Heavy winds
  3. Leaks
  4. Foot traffic on the roof
  
4. The drying time required for neoprene contact adhesive in cool, humid weather may be as much as: 4. \_\_\_\_\_
  1. Thirty minutes
  2. One hour
  3. Two hours
  4. Three
  
5. The maximum allowable time after neoprene contact adhesive has dried and before coated surfaces are joined is called the: 5. \_\_\_\_\_
  1. Waiting period
  2. Open time
  3. Shelf time
  4. Drying time
  
6. Elastomeric sheet roofing laid as a floating membrane: 6. \_\_\_\_\_
  1. Requires an aggregate ballast
  2. Has little tear-out resistance
  3. Is not recommended
  4. None of the above



7. Which of the following statements is true about the use of an elastomeric sheet membrane roofing system over an existing built-up roof? 7. \_\_\_\_\_
1. The membrane is usually adhesive-bonded to the existing roof.
  2. The membrane can be applied directly over a layer of gravel, with no cushioning layer in between.
  3. The elastomer must be chemically compatible with the asphalt or coal-tar materials in the old roof.
  4. The existing roof will require no preparation to receive the elastomeric membrane.
8. Air bubbles in elastomeric membranes may be removed most effectively by using a (an): 8. \_\_\_\_\_
1. Roller
  2. Hypodermic needle
  3. Axe
  4. Blunt-nosed trowel
9. The thickest of the elastomeric membranes listed below is: 9. \_\_\_\_\_
1. Polyethylene sheet with foam backing
  2. Nylon-reinforced PVC sheet
  3. Hypalon
  4. Polychloroprene (neoprene) sheet
10. If an elastomeric sheet membrane is to be applied to metal, the metal may require which of the following to ensure a good adhesive bond? 10. \_\_\_\_\_
1. A primer coat only
  2. A light acid etch only
  3. A light acid etch and then a primer coat
  4. Twice as much adhesive as is required in other areas

# COLD-APPLIED ROOFING SYSTEMS AND WATERPROOFING AND DAMPPROOFING TESTS

## TOPIC 6—FLUID-APPLIED COLD-PROCESS ROOFING

Decide which of the four answers is correct, or most nearly correct; then write the corresponding number in the blank at the right.

1. Properly applied fluid-applied cold-process elastomeric membranes are *not* as susceptible to leaks as other roofing systems, because they: 1. \_\_\_\_\_
  1. Are extremely thick.
  2. Have no seams.
  3. Include substantial backing of some type.
  4. Are usually used on roofs that have few projections.
  
2. Fluid-applied membranes: 2. \_\_\_\_\_
  1. Require highly complex flashing procedures.
  2. Can be walked on almost immediately after application.
  3. Offer little resistance to fire.
  4. Become less elastic in cold weather.
  
3. A typical neoprene base-coat fluid is what percent solids? 3. \_\_\_\_\_
  1. 15
  2. 25
  3. 35
  4. 75
  
4. Generally, the number of coats of fluid-applied elastomeric membrane needed to attain the required thickness is: 4. \_\_\_\_\_
  1. One
  2. Two to six
  3. Seven to ten
  4. Eleven
  
5. A concrete deck should be allowed to cure for at least how long before a coating of any kind is applied to it? 5. \_\_\_\_\_
  1. One week
  2. Ten days
  3. Fourteen days
  4. Three weeks
  
6. On a plywood roof deck that is to receive a fluid-applied roofing system, the plywood panels should be spaced  $\frac{1}{16}$  inch (0.2 centimetre) at the ends. How far apart should the panels be spaced at the sides? 6. \_\_\_\_\_
  1.  $\frac{1}{16}$  inch (0.2 centimetre)
  2.  $\frac{1}{8}$  inch (0.3 centimetre)
  3.  $\frac{3}{8}$  inch (1 centimetre)
  4. None of the above

7. Joints and cracks in a deck that is to receive fluid-applied elastomeric roofing should be sealed: 7. \_\_\_\_\_
1. Before the elastomeric base coat is applied but after the deck is primed
  2. Before or after the base coat is applied
  3. Before the deck is primed
  4. After the flashing is applied
8. At which of the following do most manufacturers of fluid-applied membranes require reinforcing tape or fabric? 8. \_\_\_\_\_
1. Parapet walls
  2. Nailing strips
  3. Valleys
  4. All of the above
9. Which one of the fluid-applied roofing materials listed below produces the thickest membrane? 9. \_\_\_\_\_
1. Butyl
  2. Urethane
  3. Rubberized asphalt
  4. Acrylic emulsion
10. Of the times given below, which would generally be the best for applying a primer-sealer or the first coating of fluid elastomer over a concrete deck? 10. \_\_\_\_\_
1. 8 a.m.
  2. 10 a.m.
  3. Noon
  4. 4 p.m.

# COLD-APPLIED ROOFING SYSTEMS AND WATERPROOFING AND DAMPPROOFING TESTS

## TOPIC 7—HOT-APPLIED WATERPROOFING AND DAMPPROOFING

Decide which of the four answers is correct, or most nearly correct; then write the corresponding number in the blank at the right.

1. For hot-applied waterproofing, low-melt bitumen is used on: 1. \_\_\_\_\_
  1. Vertical surfaces
  2. Horizontal surfaces
  3. Vertical or horizontal surfaces
  4. Below-grade concrete only
  
2. Fiberboard used as a protection course for a completed hot-applied waterproofing membrane should have a thickness of: 2. \_\_\_\_\_
  1.  $\frac{1}{4}$  inch (0.6 centimetre)
  2.  $\frac{3}{8}$  inch (1 centimetre)
  3.  $\frac{1}{2}$  inch (1.3 centimetres)
  4.  $\frac{3}{4}$  inch (1.9 centimetres)
  
3. Asphalt and coal-tar pitch materials should not be used together, because: 3. \_\_\_\_\_
  1. They are not chemically compatible.
  2. Their use would involve tremendous expense.
  3. Such use is forbidden by CAL/OSHA regulations.
  4. None of the above.
  
4. As used in the roofing industry, the term "salamander" means a (an): 4. \_\_\_\_\_
  1. Small cutting tool resembling a lizard
  2. Accumulation of fine particles on the surface of concrete
  3. A gasoline-powered vehicle used for lifting small loads from the ground to the roof deck
  4. Portable fan-driven heater
  
5. If a below-grade slab is to be waterproofed and the hydrostatic head of the groundwater that the membrane must withstand will be 6 feet (1.8 metres) or less, how many plies of felt or glass fabric should be applied? 5. \_\_\_\_\_
  1. One or two
  2. Three or four
  3. Five or six
  4. More than six
  
6. In the waterproofing of a base slab and foundation wall, the base-slab felts should be extended how many inches beyond the foundation so that they can be lapped over the waterproofing on the keyed wall? 6. \_\_\_\_\_
  1. 4 (10.2 centimetres)
  2. 8 (20.3 centimetres)
  3. 12 (30.5 centimetres)
  4. 14 (35.6 centimetres)

7. Which of the following statements about hot-applied dampproofing is (are) true? 7. \_\_\_\_\_
1. A built-up membrane is not necessary.
  2. In some cases, one or two coats of primer-sealer alone will provide sufficient protection.
  3. Dampproofing is not sufficient for protection against water under hydrostatic pressure.
  4. All of the above.
8. According to the *Construction Safety Orders* handbook, buckets used to carry hotstuff may not be filled so full that the hotstuff is within how many inches of the top of the bucket? 8. \_\_\_\_\_
1. 2 (5.1 centimetres)
  2. 3 (7.6 centimetres)
  3. 4 (10.2 centimetres)
  4. 5 (12.7 centimetres)
9. The *Construction Safety Orders* handbook provides that whenever the burner flame of a kettle without an operating thermostat is on, the kettle operator or another attendant must be: 9. \_\_\_\_\_
1. Within the general area of the kettle
  2. Within sight of the kettle
  3. Within 50 feet (15.2 metres) of the kettle
  4. Within 100 feet (30.5 metres) of the kettle
10. Which of the following is (are) considered unsafe for workers on or around scaffolds? 10. \_\_\_\_\_
1. Handling heavy loads alone on a scaffold
  2. Using a ladder on a scaffold to gain extra height
  3. Working on a scaffold that is not securely tied to the adjacent structure
  4. All of the above

# COLD-APPLIED ROOFING SYSTEMS AND WATERPROOFING AND DAMPPROOFING TESTS

## TOPIC 2—COLD-APPLIED WATERPROOFING AND DAMPPROOFING

Decide which of the four answers is correct, or most nearly correct; then write the corresponding number in the blank at the right.

1. Primer on a deck that is to be waterproofed with spray-applied asphaltic emulsion reinforced with chopped-glass fibers is usually applied at a rate of how many gallons per square? 1. \_\_\_\_\_
  1.  $\frac{1}{3}$  (1.2 litres)
  2.  $\frac{1}{2}$  (1.9 litres)
  3. 1 (3.8 litres)
  4. None of the above
  
2. Fluid-applied polyurethane materials have a usual shelf life of: 2. \_\_\_\_\_
  1. Three months
  2. Six months
  3. Nine months
  4. One year
  
3. Preliminary coatings of fluid-applied polyurethane must cure for how long before the main coat is applied? 3. \_\_\_\_\_
  1. Thirty minutes
  2. Six hours
  3. Eight hours
  4. Twelve hours
  
4. What happens to the bentonite-clay granules in bentonite-clay panels used for waterproofing when they come in contact with moisture? 4. \_\_\_\_\_
  1. They expand.
  2. They decompose.
  3. Along with the water they form a gel mastic.
  4. All of the above.
  
5. Blisters or wrinkles in a completed single-ply membrane should be repaired: 5. \_\_\_\_\_
  1. Only if leaks or other potential causes of damage are likely
  2. In accordance with the manufacturer's recommendations
  3. By the least expensive but fastest method possible
  4. Only if they permit the entry of moisture when the membrane is water-tested

